

Square D™ Industrial Control Transformers

Class 9070

Catalog

R04/21

9070CT9901

SQUARE D™

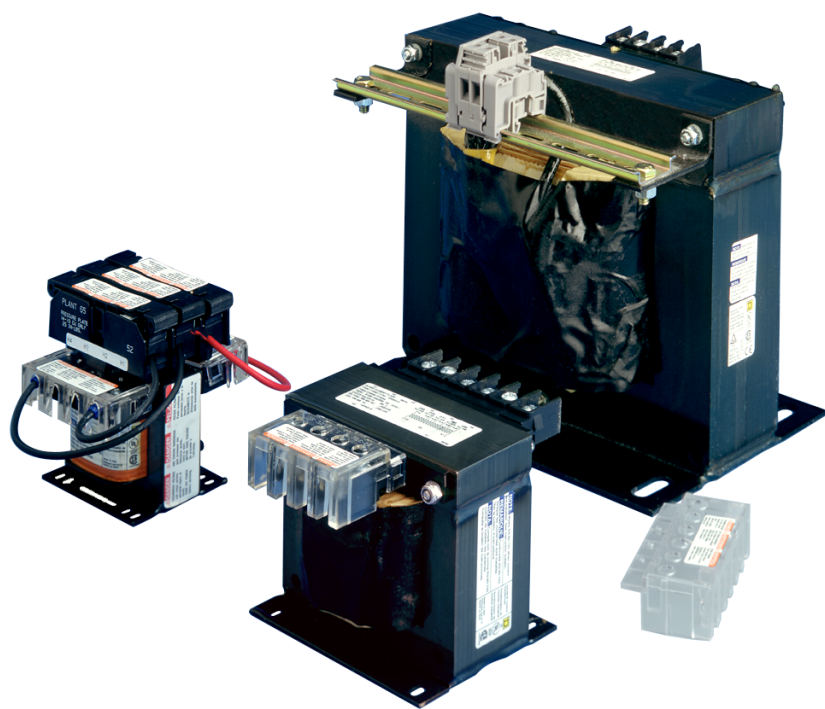

Legal Information

The Schneider Electric brand and any trademarks of Schneider Electric SE and its subsidiaries referred to in this guide are the property of Schneider Electric SE or its subsidiaries. All other brands may be trademarks of their respective owners.

This guide and its content are protected under applicable copyright laws and furnished for informational use only. No part of this guide may be reproduced or transmitted in any form or by any means (electronic, mechanical, photocopying, recording, or otherwise), for any purpose, without the prior written permission of Schneider Electric.

Schneider Electric does not grant any right or license for commercial use of the guide or its content, except for a non-exclusive and personal license to consult it on an "as is" basis. Schneider Electric products and equipment should be installed, operated, serviced, and maintained only by qualified personnel.

As standards, specifications, and designs change from time to time, information contained in this guide may be subject to change without notice.

To the extent permitted by applicable law, no responsibility or liability is assumed by Schneider Electric and its subsidiaries for any errors or omissions in the informational content of this material or consequences arising out of or resulting from the use of the information contained herein.

Table of Contents

Product Description.....	5
The Global Product Offering—Type T	5
Transformers with Fuse Block Protection—Type TF	5
Leaded Control Transformer Line	5
MultiTap	5
Type T Transformers.....	6
CE Marking.....	7
Type T Transformers Selection Guide	7
Custom-Built Type T Transformers.....	11
Type T MultiTap Transformers	14
Type T Transformers with Dual Secondary	18
Type T Transformers with 24 Volt Secondary	22
Multiple Secondary.....	26
Type T Units with Dual 24/120 Volt Secondary (Tapped Units).....	27
Type T Units with Dual 24/120 Volt Secondary (Separate Windings).....	32
Type T Performance Data	39
Transformers with Leads	41
Fuse Protection.....	43
Accessories	48
Primary Fusing to Meet NEC	49
Primary Fusing to Meet CE	50
Secondary Fusing to Meet NEC and CE.....	51
Type TF Transformers	52
120 Volt Control Secondary—Primary and Secondary Fuse Block	52
MultiTap for 120 Volt Control Secondary—Primary and Secondary Fuse Block.....	53
Field Installed Fuse Options	55
Primary Fusing.....	55
Primary and Secondary Fusing	57
Secondary Fusing	60
Secondary Fuse Clips	64
Terminal Blocks.....	65
Application	66
Example of Series and Parallel Connections	66
Example of a typical application.....	67
Technical Data	68
Frequently Asked Questions.....	69

Product Description

Control power transformers from Schneider Electric set the industry standard for design innovation and performance. They are designed with low impedance windings for voltage regulation, and can accommodate the high inrush current associated with contactors, starters, solenoids, and relays.

A variety of designs are available to meet the diverse needs of panel builders and machinery OEMs. The versatility of the control transformer line offers unparalleled options for design engineers.

The Global Product Offering—Type T

Type T is the most popular and complete line of control transformers. It comes with unmatched design innovations for top performance and is manufactured using the most advanced insulating materials. The Type T control transformer is a solid choice if size and cost are of concern.

Transformers with Fuse Block Protection—Type TF

Schneider Electric offers both product lines with factory installed overcurrent protection fuse blocks. Type TF transformers consist of two primary fuse blocks and one secondary fuse block, a configuration that meets the majority of overcurrent needs by panel builders and machinery OEMs. Since the fuse blocks are pre-wired and mounted on top of the transformer, the Type TF transformers have the same footprint as the Type T unit. This design frees up space normally used for separate fuse blocks.

We also have an extensive fuse block offering for custom applications. See the overcurrent section of this catalog for full details.

Leaded Control Transformer Line

Schneider Electric offers transformers with internally pre-wired 24-inch primary and secondary leads, instead of terminal boards, to make installation easier and faster for many applications. These are only available for single voltage primary and single voltage secondary applications.

MultiTap

Schneider Electric offers Type T transformers in the MultiTap version. The MultiTap control transformer was designed to respond to the increased need for voltage and stock flexibility. It combines multiple primary voltages with one or more secondary voltages, all in a single transformer.

The most flexible MultiTap voltage is the Universal, available on the Type T product line only. It allows for standard primary voltages of 208–600 V and 110, 115, or 120 V secondary voltages.

Type T Transformers

The Type T units are designed for the global market and are a great choice when size and cost are of concern. This is our most popular and complete offering of industrial control transformers. The following features are included:

- 50/60 Hz rated
- Customer installed accessories (FingerSafe™ covers, fuse blocks, fuse clips)
- Type T transformers are designed with various temperature classes:
 - 25–150 VA with a 55°C (131°F) temperature rise, 105°C (221°F) insulation
 - 200–350 VA with a 80°C (176°F) temperature rise, 130°C (266°F) insulation
 - 500–5000 VA with a 115°C (239°F) temperature rise, 180°C (356°F) insulation

Schneider Electric manufactures a wide variety of voltage combinations for control transformers. The voltage combinations are expressed as “Voltage Codes”, and are embedded within the catalog number of the transformer. Standard codes are listed. If the voltage combination you need is not listed, please call your Schneider Electric distributor for assistance.

Table 1 - Type T VA Ratings

UL, cUL, CSA and NOM VA Rating	CE VA Rating
25	25
50	50
75	75
100	100
150	150
200	200
250	160
300	200
350	250
500	300
750	500
1000	630
1500	1000
2000	1500
3000	2000
5000	3000

Table 2 - Type T Listings

Listing	File	VA Range
UL	E61239, Guide XPTQ	25–5000
cUL	E61239, Guide XPTQ7	25–5000
EN	EN 61 558	25–200
	EN 61 558	250–1000
	EN 61 558	1500–3000

CE Marking

Industrial control transformers (ICTs) entering the European Union (EU) after January 1, 1997 are required by EU standards to have CE marking or Declaration of Conformity to CE. EU documentation requires compliance with specification EN 61 558 of the Low Voltage Directive. Type T ICTs from Schneider Electric comply with this specification, which adhere to, and are accepted by, EU standards. A Declaration of Conformity for all Type T units is available upon request.

Because of different overload criteria in the CE specification, Schneider Electric dual rates these transformers for UL VA, cUL VA, NOM VA and CE VA ratings (see "Type T VA Ratings" table). Because they are widely used with control circuit panels, ICTs are also required to comply with EN 60 204 and EN 61 558 in these applications. The Type T transformer line complies with EN 60 204 when FingerSafe™ covers are installed.

For more information regarding CE marking, please contact your local Schneider Electric field sales office.



Type T Transformers Selection Guide

1. Determine inrush and sealed VA of each coil in the control circuit and VA of all other components.
2. Total all sealed VA of all operating coils and other loads VA (determines minimal VA size required for the circuit).
3. Total the inrush VA of all coils that are starting at the same time and all loads and coils that are running (using the regulation chart to give possible units to be used).
4. Take VA size from step 2, go to standard VA size in chart below. Make sure inrush VA from chart is greater than total VA from step 3. If not, go to next larger VA size and repeat.

If supply voltage is stable and fluctuates less than 5%, we recommend use the 90% secondary voltage column. If supply voltage is not stable and fluctuates more than 10%, we recommend use the 95% secondary voltage column. Another recommendation is that one that never use the 85% secondary voltage column since magnetic devices lose life expectancy if they are continuously started at 85% of rated voltage.

Example:

This example assumes the following:

- Two NEMA size 0 contactors do not start together, but one could be ON when the other starts.
 - One NEMA size 2 contactor can start with either of the other contactors.
 - One pilot light at 2 VA
1. VA and inrush are:
 - NEMA 0: sealed 27 VA; inrush 245 VA
 - NEMA 2: sealed 37 VA; inrush 311 VA; pilot light 2 VA
 2. Total VA: $27 + 27 + 37 + 2 = 93$ VA
 3. Total inrush VA: $245 + 311 + 27 + 2 = 582$ VA
 4. From Regulation Chart for Type T at right below:
 - VA minimum unit; inrush 499 VA will not work at 90%
 - VA (next standard size); inrush 666 VA will work at 95%

Table 3 - Regulation Chart for Type T

VA	Secondary Voltage					
	Inrush UL VA at 20% Power Factor			Inrush UL VA at 40% Power Factor		
	95%	90%	85%	95%	90%	85%
50	193	266	339	151	215	282
75	271	396	520	210	318	430
100	339	499	659	266	404	549
150	666	893	1120	529	731	942
200	588	815	1041	459	659	866
250	1416	1910	2388	1057	1494	1936
300	1634	2184	2709	1194	1681	2169
350	1894	2592	3261	1392	2005	2621
500	3197	4104	4981	2374	3195	4019
750	3770	5515	7231	2887	4391	5945
1000	6587	9079	11430	4706	6886	9051
1500	19324	23983	28607	15066	19361	23756
2000	31384	38777	46161	24794	31630	38667
3000	26539	39934	52713	19355	30721	42216
5000	53111	85265	116277	39368	66309	93882

Use the following table to quickly find a Type T transformer for a 120 volt load for your specific application. First, find the source and load voltages. Then, go to the indicated pages for details on the transformer(s) matching those voltages.

Table 4 - Type T Transformers for 120 Volt Loads

Source Voltage	Load Voltage	Voltage Code(s)	Go To Page(s)	Source Voltage	Load Voltage	Voltage Code(s)	Go To Page(s)	Source Voltage	Load Voltage	Voltage Code (s)	Go To Page(s)
110	110	D24, D55	9, 13	277	115	D18	11	440	110/220	D31	13
110	220	D55	13	277	120	D4, D60	9, 14	460	95	D32, D50	11, 12
110	110/220	D55	13	277	240	D60	14	460	115	D1, D20, D32, D95, D50, D31	8, 10, 11, 12, 13
115	115	D24, D55	9, 13	277	120/240	D60	14	460	125	D50	12
115	230	D55	13	364	85	D50	12	460	230	D31	13
115	115/230	D55	13	364	100	D50	12	460	115/230	D31	13
120	120	D24, D55	9, 13	364	110	D50	12	480	99	D50	12
120	240	D55	13	380	91	D50	12	480	100	D32	11
120	120/240	D55	13	380	95	D18	11	480	120	D1, D32, D40, D95, D50, D31	8, 11, 12, 13
190	110	D95	11	380	110	D6, D50	9, 12	480	130	D50	12
200	115	D93, D95	9, 11	380	115	D18, D33	11, 14	480	240	D31	13
208	85	D50	12	380	120	D40, D50	11, 12	480	120/240	D31	13
208	95	D18	11	380	230	D33	14	500	85	D50	12
208	100	D50	12	380	115/230	D33	14	500	100	D50	12
208	110	D50	12	400	95	D50	12	500	110	D50	12
208	115	D20, D18	10, 11	400	115	D33	14	550	90	D32	11
208	120	D3, D40	9, 11	400	120	D103, D50	9, 12	550	91	D50	12
220	90	D32	11	400	125	D50	12	550	110	D5, D32, D50, D37	9, 11, 12, 14
220	91	D50	12	400	230	D33	14	550	120	D50	12
220	110	D1, D32, D95, D50, D31, D55	8, 11, 12, 13	400	115/230	D33	14	550	220	D37	14
220	120	D50	12	415	110	D17	9	550	110/220	D37	14
220	220	D31, D55	13	415	115	D33	14	575	95	D32, D50	11, 12
220	110/220	D31, D55	13	415	230	D33	14	550	110/220	D37	14

Table 4 - Type T Transformers for 120 Volt Loads (Continued)

Source Voltage	Load Voltage	Voltage Code(s)	Go To Page(s)	Source Voltage	Load Voltage	Voltage Code(s)	Go To Page(s)	Source Voltage	Load Voltage	Voltage Code (s)	Go To Page(s)
230	95	D32, D50	11, 12	415	115/230	D33	14	575	95	D32, D50	11, 12
230	115	D1, D20, D32, D95, D50, D31, D55	8, 10, 11, 12, 13	416	99	D50	12	575	115	D5, D32, D50, D37	9, 11, 12, 14
230	125	D50	12	416	120	D40, D50	11, 12	575	125	D50	12
230	230	D31, D55	13	416	130	D50	12	575	230	D37	14
230	115/230	D31, D55	13	420	85	D50	12	575	115/230	D37	14
240	99	D50	12	420	100	D50	12	600	99	D50	12
240	100	D32	11	420	110	D50	12	600	100	D32	11
240	120	D1, D32, D40, D95, D50, D31, D55	8, 11, 12, 13	440	90	D32	11	600	120	D5, D32, D50, D37	9, 11, 12, 14
240	130	D50	12	440	91	D50	12	600	130	D50	12
240	240	D31, D55	13	440	110	D1, D32, D95, D50, D31	8, 11, 12, 13	600	240	D37	14
240	120/240	D31, D55	13	440	120	D50	12	600	120/240	D37	14
277	95	D18	11	440	220	D31	13				

Use the following table to quickly find a Type T transformer for a 24 volt load for specific application. First, find source and load voltages. Then, go to the indicated pages for details on the transformer(s) matching those voltages.

Table 5 - Type T Transformers for 24 Volt Loads

Source Voltage	Load Voltage	Voltage Code(s)	Go To Page(s)
115	24	D89	15
120	24	D23, D7	15, 16
208	24	D14, D19	16, 17
230	24	D89, D112	15, 16
240	24	D2, D23, D19	15, 17
277	24	D25, D19	16, 17
380	24	D88, D19	16, 17
460	24	D92	15
480	24	D2, D19	15, 17
600	24	D16	16

Custom-Built Type T Transformers

For voltage combinations not listed, Schneider Electric offers custom-built Type T transformers. Type T units are limited to the following:

Primary Voltage Range: 120 to 600 Volts

Secondary Voltage Range:

- 12 to 277 Volts (25 to 1000 VA)
- 12/24 to 277 Volts (25 to 2000 VA)
- 24/48 to 277 Volts (25 to 5000 VA)

	Single	Dual	One Primary Tap (two voltages)	Two Primary Taps (three voltages)	Three Primary Taps (four voltages)	Four Primary Taps (five Voltages)
Single	25 VA to 5000 VA	25 VA to 5000 VA	Voltages with 20% 25 VA to 5000 VA Voltages greater than 20% 25 VA to 3000 VA	Voltages with 20% 25 VA to 5000 VA Voltages greater than 20% 25 VA to 3000 VA	25 VA to 3000 VA	25 VA to 3000 VA
Dual	25 VA to 5000 VA	25 VA to 5000 VA	Voltages with 20% 25 VA to 5000 VA Voltages greater than 20% 25 VA to 3000 VA	Voltages with 20% 25 VA to 5000 VA Voltages greater than 20% 25 VA to 3000 VA	25 VA to 3000 VA	25 VA to 3000 VA

Schneider Electric also offers Secondary Tapped units and Multiple Winding Secondary units. Since the sizing of these units are determined by the secondary loading, they are limited to 3000 VA total secondary capacity in the 9070 Type T product.

To request a price quotation from Schneider Electric for a custom-built Type T transformer, use the price quote sheet on page 26.

120 Volt Control Secondary

Table 6 - Voltage and Connection Options

Voltage Code	Voltages		Connections	
	Primary	Secondary	Primary	Secondary
D1	220 x 440 230 x 460 240 x 480	110 115 120	220/230/240 V: Connect to H1 and H4 Jumper H1 and H3 440/460/480 V: Connect to H1 and H4 Jumper H2 with H3	Connect to X1 and X2

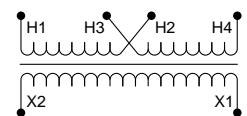

Table 7 - Dimensions

VA		Catalog Number	Fig.	Acc. Key	A		B		C		E		F		Slots	
UL	CE				in.	mm	in.	mm	in.	mm	in.	mm	in.	mm	in.	mm
25	25	9070T25D1	1	I	3.09	79	3.00	76	2.58	66	2.00	51	2.50	64	0.20 x 0.38	5 x 10
50	50	9070T50D1	1	I	3.09	79	3.00	76	2.58	66	2.00	51	2.50	64	0.20 x 0.38	5 x 10
75	75	9070T75D1	1	I	3.34	85	3.38	86	2.89	73	2.38	61	2.81	71	0.20 x 0.48	5 x 12
100	100	9070T100D1	1	I	3.34	85	3.38	86	2.89	73	2.38	61	2.81	71	0.20 x 0.48	5 x 12
150	150	9070T150D1	1	I	3.59	91	3.75	95	3.20	81	2.88	73	3.13	80	0.20 x 0.38	5 x 10
200	200	9070T200D1	1	I	3.59	91	3.75	95	3.20	81	2.88	73	3.13	80	0.20 x 0.38	5 x 10
250	160	9070T250D1	2	I	5.30	135	3.75	95	3.21	82	2.88	73	3.13	80	0.20 x 0.38	5 x 10
300	200	9070T300D1	2	I	4.74	120	4.50	114	3.84	98	2.56	65	3.75	95	0.20 x 0.38	5 x 10
350	250	9070T350D1	2	I	5.11	130	4.50	114	3.84	98	3.00	76	3.75	95	0.20 x 0.38	5 x 10
500	300	9070T500D1	2	I	5.49	139	4.50	114	3.84	98	3.56	90	3.75	95	0.20 x 0.38	5 x 10
750	500	9070T750D1	2	I	5.61	143	5.25	133	4.51	115	3.43	87	4.38	111	0.28 x 0.56	7 x 14
1000	630	9070T1000-D1	2	I	6.30	160	5.25	133	4.51	115	4.31	109	4.38	111	0.28 x 0.56	7 x 14
1500	1000	9070T1500-D1	2	I	5.92	150	7.06	179	6.17	157	4.13	105	5.81	148	0.28 x 0.56	7 x 14
2000	1500	9070T2000-D1	2	I	7.17	182	7.06	179	6.17	157	4.56	116	5.81	148	0.28 x 0.56	7 x 14
3000	2000	9070T3000-D1	3	I	7.24	184	9.00	229	8.75	222	4.63	118	7.63	194	0.44 x 1.13	11 x 29
5000	3000	9070T5000-D1	3	I	9.15	232	9.00	229	8.75	222	6.56	167	7.63	194	0.44 x 1.13	11 x 29

Figure 1 -

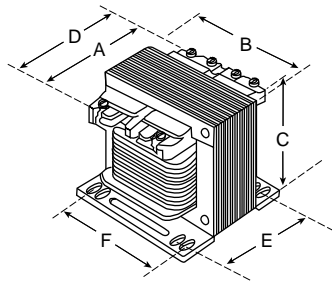

Figure 2 -

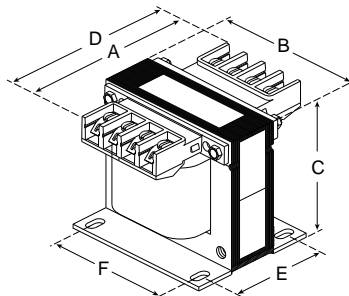

Figure 3 -

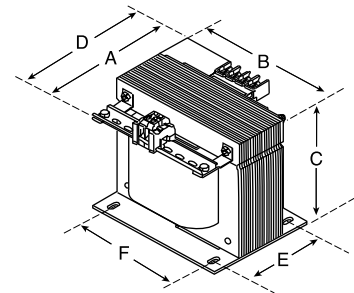

Table 8 - Voltage and Connection Options

Voltage Code	Voltages		Connections	
	Primary	Secondary	Primary	Secondary
D3	208	120	Connect to H1 and H2	Connect to X1 and X2
D4	277	120		
D5	550	110		
	575	115		
	600	120		
D6	380	110		
D17	415	110		
D24	110	110		
	115	115		
	120	120		
D93	200	115		
D103	400	120		

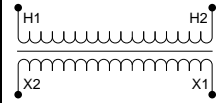

Table 9 - Dimensions

VA		Catalog Number ¹	Fig.	Acc. Key	A		B		C		E		F		Slots	
UL	CE				in.	mm	in.	mm	in.	mm	in.	mm	in.	mm	in.	mm
25	25	9070T25 ●	4	I	3.09	79	3.00	76	2.58	66	2.00	51	2.50	64	0.20 x 0.38	5 x 10
50	50	9070T50 ●	4	I	3.09	79	3.00	76	2.58	66	2.00	51	2.50	64	0.20 x 0.38	5 x 10
75	75	9070T75 ●	4	I	3.34	85	3.38	86	2.89	73	2.38	61	2.81	71	0.20 x 0.48	5 x 12
100	100	9070T100 ●	4	I	3.34	85	3.38	86	2.89	73	2.38	61	2.81	71	0.20 x 0.48	5 x 12
150	150	9070T150 ●	4	I	3.59	91	3.75	95	3.20	81	2.88	73	3.13	80	0.20 x 0.38	5 x 10
200	200	9070T200 ●	4	I	3.59	91	3.75	95	3.20	81	2.88	73	3.13	80	0.20 x 0.38	5 x 10
250	160	9070T250 ●	5	I	5.30	135	3.75	95	3.21	82	2.88	73	3.13	80	0.20 x 0.38	5 x 10
300	200	9070T300 ●	5	I	4.74	120	4.50	114	3.84	98	2.56	65	3.75	95	0.20 x 0.38	5 x 10
350	250	9070T350 ●	5	I	5.11	130	4.50	114	3.84	98	3.00	76	3.75	95	0.20 x 0.38	5 x 10
500	300	9070T500 ●	5	I	5.49	139	4.50	114	3.84	98	3.56	90	3.75	95	0.20 x 0.38	5 x 10
750	500	9070T750 ●	5	I	5.61	143	5.25	133	4.51	115	3.43	87	4.38	111	0.28 x 0.56	7 x 14
1000	630	9070T1000 ●	5	I	6.30	160	5.25	133	4.51	115	4.31	109	4.38	111	0.28 x 0.56	7 x 14
1500	1000	9070T1500 ●	5	I	5.92	150	7.06	179	6.17	157	4.13	105	5.81	148	0.28 x 0.56	7 x 14
2000	1500	9070T2000 ●	5	I	7.17	182	7.06	179	6.17	157	4.56	116	5.81	148	0.28 x 0.56	7 x 14
3000	2000	9070T3000 ● ²	5	I	6.38	162	9.00	229	7.63	194	4.63	118	7.63	194	0.44 x 1.13	11 x 29

- Complete the catalog number by replacing the ● with the appropriate Voltage Code from , page 13 above.
- Complete the catalog number by replacing the ● with Voltage Code D3 or D4 from 120 Volt Control Secondary, page 11 above.

Table 9 - Dimensions (Continued)

VA		Catalog Number ³	Fig.	Acc. Key	A		B		C		E		F		Slots	
UL	CE				in.	mm	in.	mm	in.	mm	in.	mm	in.	mm	in.	mm
		9070T3000 ● ₃	6	I	7.24	184	9.00	229	8.75	222	4.63	118	7.63	194	0.44 x 1.13	11 x 29
		9070T3000-D24	6	N/A	8.08	205	9.00	229	8.75	222	4.63	118	7.63	194	0.44 x 1.13	11 x 29
5000	3000	9070T5000 ●	6	I	9.15	232	9.00	229	8.75	222	6.56	167	7.63	194	0.44 x 1.13	11 x 29
		9070T5000-D24	6	N/A	9.99	254	9.00	229	8.75	222	6.56	167	7.63	194	0.44 x 1.13	11 x 29

Figure 4 -

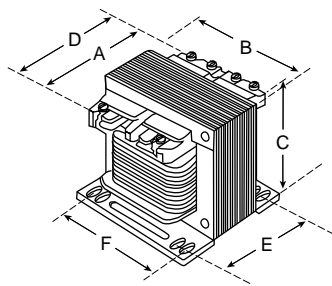

Figure 5 -

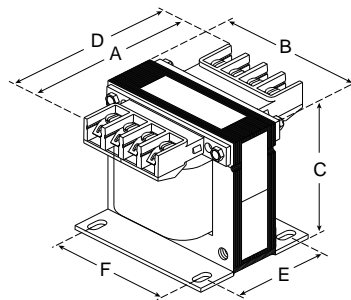
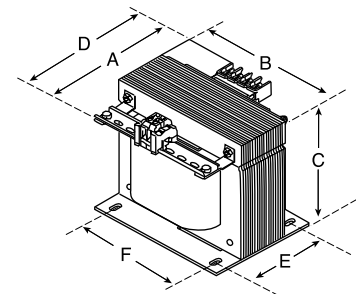

Figure 6 -



Type T MultiTap Transformers

120 Volt Control Secondary

Table 10 - Voltage and Connection Options

Voltage Code	Voltages		Connections	
	Primary	Secondary	Primary	Secondary
D20	208/230/460	115	208: Connect to H1 and H2 230: Connect to H1 and H3 460: Connect to H1 and H4	Connect to X1 and X2

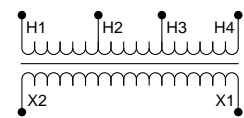

Table 11 - Dimensions

VA		Catalog Number	Fig.	Acc. Key	A		B		C		E		F		Slots	
UL	CE				in.	mm	in.	mm	in.	mm	in.	mm	in.	mm	in.	mm
25	25	9070T25D20	7	II	3.09	79	3.00	76	2.58	66	2.00	51	2.50	64	0.20 x 0.38	5 x 10
50	50	9070T50D20	7	II	3.34	85	3.38	86	2.89	73	2.38	61	2.81	71	0.20 x 0.48	5 x 12
75	75	9070T75D20	7	II	3.34	85	3.38	86	2.89	73	2.38	61	2.81	71	0.20 x 0.48	5 x 12
100	100	9070T100D20	7	II	3.59	91	3.75	95	3.20	81	2.88	73	3.13	80	0.20 x 0.38	5 x 10

3. Complete the catalog number by replacing the ● with the appropriate Voltage Code from , page 13 above.
 3. Complete the catalog number by replacing the ● with Voltage Code D5, D6, D17, D93, or D103 from 120 Volt Control Secondary, page 11 above.

Table 11 - Dimensions (Continued)

VA		Catalog Number	Fig.	Acc. Key	A		B		C		E		F		Slots	
UL	CE				in.	mm	in.	mm	in.	mm	in.	mm	in.	mm	in.	mm
150	150	9070T150D20	7	II	3.59	91	3.75	95	3.20	81	2.88	73	3.13	80	0.20 x 0.38	5 x 10
200	200	9070T200D20	8	II	4.70	119	3.75	95	3.20	81	2.88	73	3.13	80	0.20 x 0.38	5 x 10
250	160	9070T250D20	8	II	4.74	120	4.50	114	3.84	98	2.56	65	3.75	95	0.20 x 0.38	5 x 10
300	200	9070T300D20	8	II	5.11	130	4.50	114	3.84	98	3.00	76	3.75	95	0.20 x 0.38	5 x 10
350	250	9070T350D20	8	II	5.49	139	4.50	114	3.84	98	3.56	90	3.75	95	0.20 x 0.38	5 x 10
500	300	9070T500D20	8	II	5.61	143	5.25	133	4.51	115	3.43	87	4.38	111	0.28 x 0.56	7 x 14
750	500	9070T750D20	8	II	6.30	160	5.25	133	4.51	115	4.31	109	4.38	111	0.28 x 0.56	7 x 14
1000	630	9070T1000-D20	8	II	5.92	150	7.06	179	6.17	157	4.13	105	5.81	148	0.28 x 0.56	7 x 14
1500	1000	9070T1500-D20	8	II	7.17	182	7.06	179	6.17	157	4.56	116	5.81	148	0.28 x 0.56	7 x 14
2000	1500	9070T2000-D20	8	II	6.38	162	9.00	229	7.63	194	4.63	118	7.63	194	0.44 x 1.13	11 x 29
3000	2000	9070T3000-D20	8	II	8.31	211	9.00	229	7.63	194	6.56	167	7.63	194	0.44 x 1.13	11 x 29

Figure 7 -

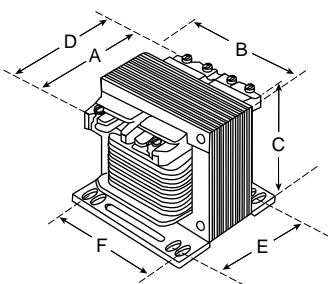

Figure 8 -

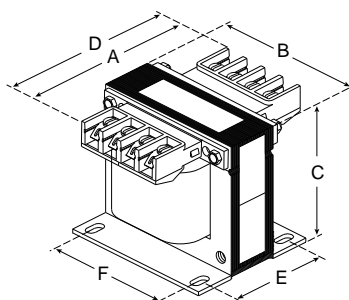

Figure 9 -

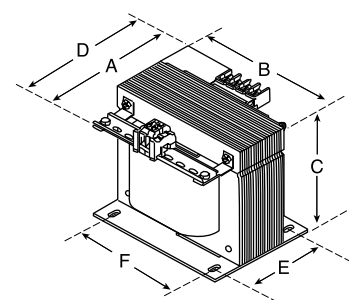

Table 12 - Voltage and Connection Options

Voltage Code	Voltages		Connections	
	Primary	Secondary	Primary	Secondary
D18	208/277/380	95/115	208: Connect to H1 and H2 277: Connect to H1 and H3 380: Connect to H1 and H4	95: Connect to X1 and X2 115: Connect to X1 and X3
D32	220/440/550 230/460/575 240/480/600	90/110 95/115 100/120	220 or 230 or 240: Connect to H1 and H2 440 or 460 or 480: Connect to H1 and H3 550 or 575 or 660: Connect to H1 and H4	90 or 95 or 100: Connect to X1 and X2 110 or 115 or 120: Connect to X1 and X3
D95	190/220/440 200/230/460 208/240/480	110 115 120	190 or 200 or 208: Connect to H1 and H2 220 or 230 or 240: Connect to H1 and H3 440 or 460 or 480: Connect to H1 and H4	110 or 115 or 120: Connect to X1 and X2

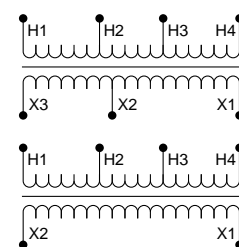

Table 13 - Dimensions

VA		Catalog Number ⁴	Fig.	Acc. Key	A		B		C		E		F		Slots	
UL	CE				in.	m-m	in.	m-m	in.	mm	in.	m-m	in.	mm	in.	mm
25	25	9070T25 ●	10	II	3.0-9	79	3.00	76	2.58	66	2.00	51	2.50	64	0.20 x 0.38	5 x 10
50	50	9070T50 ●	10	II	3.3-4	85	3.38	86	2.89	73	2.38	61	2.81	71	0.20 x 0.48	5 x 12
75	75	9070T75D32	10	II	3.3-4	85	3.38	86	2.89	73	2.38	61	2.81	71	0.20 x 0.48	5 x 12
75	75	9070T75 ● ₅	10	II	3.5-9	91	3.75	95	3.20	81	2.88	73	3.13	80	0.20 x 0.38	5 x 10
100	100	9070T100 ●	10	II	3.5-9	91	3.75	95	3.20	81	2.88	73	3.13	80	0.20 x 0.38	5 x 10
150	150	9070T150D32	11	II	4.7-0	119	3.75	95	3.20	81	2.88	73	3.13	80	0.20 x 0.38	5 x 10
150	150	9070T150 ● ₅	10	II	3.5-9	91	3.75	95	3.20	81	2.88	73	3.13	80	0.20 x 0.38	5 x 10
200	200	9070T200 ●	11	II	4.7-4	120	4.50	11-4	3.84	98	2.56	65	3.75	95	0.20 x 0.38	5 x 10
250	160	9070T250D32	11	II	5.11	130	4.50	11-4	3.84	98	3.00	76	3.75	95	0.20 x 0.38	5 x 10
250	160	9070T250 ● ₅	11	II	4.7-4	120	4.50	11-4	3.84	98	2.56	65	3.75	95	0.20 x 0.38	5 x 10
300	200	9070T300D32	11	II	5.4-9	139	4.50	11-4	3.84	98	3.56	90	3.75	95	0.20 x 0.38	5 x 10
300	200	9070T300 ● ₅	11	II	5.11	130	4.50	11-4	3.84	98	3.00	76	3.75	95	0.20 x 0.38	5 x 10
350	250	9070T350 ●	11	II	5.4-9	139	4.50	11-4	3.84	98	3.56	90	3.75	95	0.20 x 0.38	5 x 10
500	300	9070T500 ●	11	II	5.6-1	143	5.25	13-3	4.51	115	3.43	87	4.38	111	0.28 x 0.56	7 x 14
750	500	9070T750 ●	11	II	6.3-0	160	5.25	13-3	4.51	115	4.31	10-9	4.38	111	0.28 x 0.56	7 x 14
1000	630	9070T1000 ●	11	II	5.9-2	150	7.06	17-9	6.17	157	4.13	10-5	5.81	148	0.28 x 0.56	7 x 14
1500	1000	9070T1500 ●	11	II	7.1-7	182	7.06	17-9	6.17	157	4.56	116	5.81	148	0.28 x 0.56	7 x 14
2000	1500	9070T2000 ●	11	II	6.3-8	162	9.00	22-9	7.63	194	4.63	118	7.63	194	0.44 x 1.13	11 x 29
3000	2000	9070T3000 ●	12	II	9.1-5	232	9.00	22-9	8.75	222	6.56	16-7	7.63	194	0.44 x 1.13	11 x 29

4. Complete the catalog number by replacing the ● with the appropriate Voltage Code from Voltage and Connections Options, page 15 above.
5. Complete the catalog number by replacing the ● with Voltage Code D18 or D95 from Voltage and Connections Options, page 15 above.

Figure 10 -

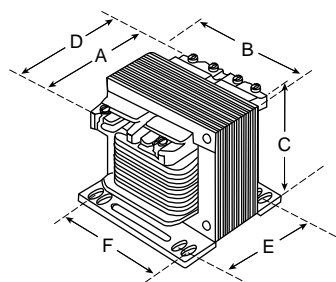

Figure 11 -

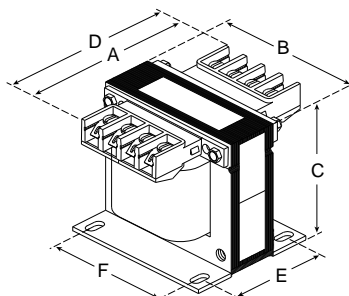
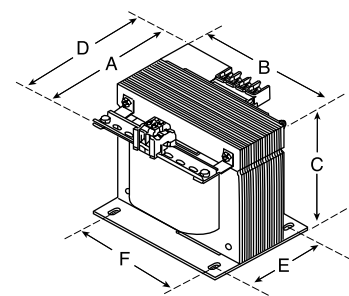

Figure 12 -



Universal

Table 14 - Voltage and Connections Options

Voltage Code	Voltages		Connections	
	Primary	Secondary	Primary	Secondary
D50	208/364/420/500 220/380/440/550 230/400/460/575 240/416/480/600	85/100/110 91/110/120 95/115/125 99/120/130	208 or 220 or 230 or 240: Connect to H1 and H2 364 or 380 or 400 or 416: Connect to H1 and H3 420 or 440 or 460 or 480: Connect to H1 and H4 500 or 550 or 575 or 600: Connect to H1 and H5	85 or 91 or 95 or 99: Connect to X1 and X2 100 or 110 or 115 or 120: Connect to X1 and X3 110 or 120 or 125 or 130: Connect to X1 and X4

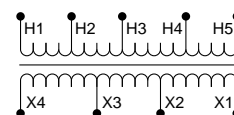

Table 15 - Dimensions

VA		Catalog Number	Fig.	Acc. Key	A		B		C		E		F		Slots	
UL	CE				in.	mm	in.	mm	in.	mm	in.	mm	in.	mm	in.	mm
25	25	9070T2-5D50	13	III	4.43	113	3.38	85.9	2.89	73.4	2.38	61	2.81	71.4	0.20 x 0.48	5 x 12
50	50	9070T5-0D50	13	III	4.43	113	3.38	85.9	2.89	73.4	2.38	61	2.81	71.4	0.20 x 0.48	5 x 12
75	75	9070T7-5D50	13	III	4.70	119.4	3.75	95.3	3.20	81.3	2.88	73.2	3.13	80	0.20 x 0.38	5 x 10
100	100	9070T1-00D50	13	III	4.70	119.4	3.75	95.3	3.20	81.3	2.88	73.2	3.13	80	0.20 x 0.38	5 x 10
150	150	9070T1-50D50	13	III	4.74	120.4	4.50	114.3	3.84	98	2.56	65	3.75	95.3	0.20 x 0.38	5 x 10
200	200	9070T2-00D50	13	III	5.11	129.8	4.50	114.3	3.84	98	3.00	76.2	3.75	95.3	0.20 x 0.38	5 x 10
250	160	9070T2-50D50	13	III	5.11	129.8	4.50	114.3	3.84	98	3.00	76.2	3.75	95.3	0.20 x 0.38	5 x 10
300	200	9070T3-00D50	13	III	5.49	139.4	4.50	114.3	3.84	98	3.56	90.4	3.75	95.3	0.20 x 0.38	5 x 10
350	250	9070T3-50D50	13	III	5.61	142.5	5.25	133.4	4.51	114.6	3.43	87.1	4.38	111.3	0.28 x 0.56	7 x 14
500	300	9070T5-00D50	13	III	5.61	142.5	5.25	133.4	4.51	114.6	3.43	87.1	4.38	111.3	0.28 x 0.56	7 x 14
750	500	9070T7-50D50	13	III	6.30	160	5.25	133.4	4.51	114.6	4.31	110	4.38	111.3	0.28 x 0.56	7 x 14
1000	630	9070T1-000D50	13	III	5.92	150.4	7.06	179.3	6.17	156.7	4.13	104.-9	5.81	147.6	0.28 x 0.56	7 x 14

Table 15 - Dimensions (Continued)

VA		Catalog Number	Fig.	Acc. Key	A		B		C		E		F		Slots	
UL	CE				in.	mm	in.	mm	in.	mm	in.	mm	in.	mm	in.	mm
1500	1000	9070T1-500D50	13	III	7.17	182.1	7.06	179.3	6.17	156.7	4.56	115.-8	5.81	147.6	0.28 x 0.56	7 x 14
2000	1500	9070T2-000D50	13	III	6.38	162.1	9.00	228.6	7.63	193.8	4.63	117.-6	7.63	193.8	0.44 x 1.13	11 x 29

Figure 13 -

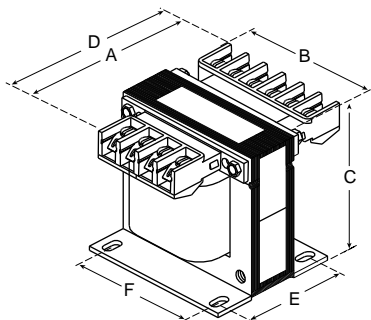

Type T Transformers with Dual Secondary

120/240 Volt Secondary

Table 16 - Voltage and Connection Options

Voltage Code	Voltages		Connections	
	Primary	Secondary	Primary	Secondary
D31	220 x 440 230 x 460 240 x 480	110/220 115/230 120/240	220 or 230 or 240: Connect to H1 and H4 Jumper H1 with H3 Jumper H2 with H4 440 or 460 or 480: Connect to H1 and H4 Jumper H2 with H3	110 or 115 or 120: Connect to X1 and X4 Jumper X1 with X3 Jumper X2 with X4 220 or 230 or 240: Connect to X1 and X4 Jumper X2 with X3
D55	110 x 220 115 x 230 120 x 240	110 x 220 115 x 230 120 x 240	110 or 115 or 120: Connect to H1 and H4 Jumper H1 with H3 Jumper H2 with H4 220 or 230 or 240: Connect to H1 and H4 Jumper H2 with H3	110 or 115 or 120: Connect to X1 and X4 Jumper X1 with X3 Jumper X2 with X4 220 or 230 or 240: Connect to X1 and X4 Jumper X2 with X3

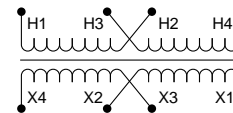

Table 17 - Dimensions

VA		Catalog Number ⁶	Fig.	Acc. Key	A		B		C		E		F		Slots	
UL	CE				in.	mm	in.	mm	in.	mm	in.	mm	in.	mm	in.	mm
25	25	9070T25 ●	14	I	3.09	79	3.00	76	2.58	66	2.00	51	2.50	64	0.20 x 0.38	5 x 10
50	50	9070T50 ●	14	I	3.09	79	3.00	76	2.58	66	2.00	51	2.50	64	0.20 x 0.38	5 x 10
75	75	9070T75 ●	14	I	3.34	85	3.38	86	2.89	73	2.38	61	2.81	71	0.20 x 0.48	5 x 12
100	100	9070T100 ●	14	I	3.34	85	3.38	86	2.89	73	2.38	61	2.81	71	0.20 x 0.48	5 x 12
150	150	9070T150 ●	14	I	3.59	91	3.75	95	3.20	81	2.88	73	3.13	80	0.20 x 0.38	5 x 10
200	200	9070T200 ●	14	I	3.59	91	3.75	95	3.20	81	2.88	73	3.13	80	0.20 x 0.38	5 x 10
250	160	9070T250 ●	15	I	5.30	135	3.75	95	3.21	82	2.88	73	3.13	80	0.20 x 0.38	5 x 10
300	200	9070T300 ●	15	I	4.74	120	4.50	114	3.84	98	2.56	65	3.75	95	0.20 x 0.38	5 x 10
350	250	9070T350 ●	15	I	5.11	130	4.50	114	3.84	98	3.00	76	3.75	95	0.20 x 0.38	5 x 10
500	300	9070T500 ●	15	I	5.49	139	4.50	114	3.84	98	3.56	90	3.75	95	0.20 x 0.38	5 x 10
750	500	9070T750 ●	15	I	5.61	143	5.25	133	4.51	115	3.43	87	4.38	111	0.28 x 0.56	7 x 14
1000	630	9070T1000 ●	15	I	6.30	160	5.25	133	4.51	115	4.31	109	4.38	111	0.28 x 0.56	7 x 14
1500	1000	9070T1500 ●	15	I	5.92	150	7.06	179	6.17	157	4.13	105	5.81	148	0.28 x 0.56	7 x 14
2000	1500	9070T2000 ●	15	I	7.17	182	7.06	179	6.17	157	4.56	116	5.81	148	0.28 x 0.56	7 x 14
3000	2000	9070T3000 ●	15	I	6.38	162	9.0	229	7.63	194	4.63	118	7.63	194	0.44 x 1.13	11 x 29
5000	3000	9070T5000 ●	15	I	8.31	211	9.00	229	7.63	194	6.56	167	7.63	194	0.44 x 1.13	11 x 29

6. ¹ Complete the catalog number by replacing the ● with the appropriate Voltage Code from Voltage and Connection Options, page 18 above.

Figure 14 -

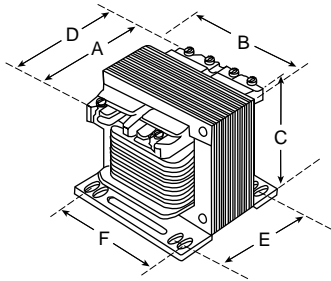

Figure 15 -

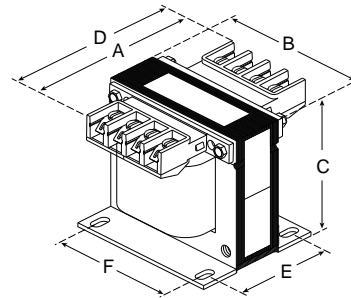

Table 18 - Voltage and Connection Options

Voltage Code	Voltages		Connections	
	Primary	Secondary	Primary	Secondary
D33	380/400/415	115/230	380: Connect to H1 and H2 400: Connect to H1 and H3 415: Connect to H1 and H4	115: Connect to X1 and X4 Jumper X1 with X3 Jumper X2 with X4 230: Connect to X1 and X4 Jumper X2 with X3
D37	550/575/600	110/220 115/230 120/240	550 or 575 or 600: Connect to H1 and H2	110 or 115 or 120: Connect to X1 and X4 Jumper X1 with X3 Jumper X2 with X4 220 or 230 or 240: Connect to X1 and X4 Jumper X2 with X3
D60	277	120/240	277: Connect to H1 and H2	120: Connect to X1 and X4 Jumper X1 with X3 Jumper X2 with X4 240: Connect to X1 and X4 Jumper X2 with X3

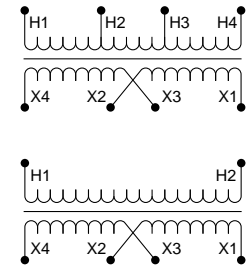

Table 19 - Dimensions

VA		Catalog Number ⁷	Fig.	Acc. Key	A		B		C		E		F		Slots	
UL	CE				in.	mm	in.	mm	in.	mm	in.	mm	in.	mm	in.	mm
25	25	9070T25 ●	16	I	3.09	79	3.00	76	2.58	66	2.00	51	2.50	64	0.20 x 0.38	5 x 10
50	50	9070T50 ●	16	I	3.09	79	3.00	76	2.58	66	2.00	51	2.50	64	0.20 x 0.38	5 x 10
75	75	9070T75 ●	16	I	3.34	85	3.38	86	2.89	73	2.38	61	2.81	71	0.20 x 0.48	5 x 12
100	100	9070T100 ●	16	I	3.34	85	3.38	86	2.89	73	2.38	61	2.81	71	0.20 x 0.48	5 x 12
150	150	9070T150 ●	16	I	3.59	91	3.75	95	3.20	81	2.88	73	3.13	80	0.20 x 0.38	5 x 10
200	200	9070T200 ●	16	I	3.59	91	3.75	95	3.20	81	2.88	73	3.13	80	0.20 x 0.38	5 x 10
250	160	9070T250 ●	17	I	5.30	135	3.75	95	3.21	82	2.88	73	3.13	80	0.20 x 0.38	5 x 10
300	200	9070T300 ●	17	I	4.74	120	4.50	114	3.84	98	2.56	65	3.75	95	0.20 x 0.38	5 x 10
350	250	9070T350 ●	17	I	5.11	130	4.50	114	3.84	98	3.00	76	3.75	95	0.20 x 0.38	5 x 10
500	300	9070T500 ●	17	I	5.49	139	4.50	114	3.84	98	3.56	90	3.75	95	0.20 x 0.38	5 x 10
750	500	9070T750 ●	17	I	5.61	143	5.25	133	4.51	115	3.43	87	4.38	111	0.28 x 0.56	7 x 14
1000	630	9070T1000 ●	17	I	6.30	160	5.25	133	4.51	115	4.31	109	4.38	111	0.28 x 0.56	7 x 14
1500	1000	9070T1500 ●	17	I	5.92	150	7.06	179	6.17	157	4.13	105	5.81	148	0.28 x 0.56	7 x 14
2000	1500	9070T2000 ●	17	I	7.17	182	7.06	179	6.17	157	4.56	116	5.81	148	0.28 x 0.56	7 x 14
3000	2000	9070T3000 ●	17	I	6.38	162	9.00	229	7.63	194	4.63	118	7.63	194	0.44 x 1.13	11 x 29
5000	3000	9070T5000 ●	17	I	8.31	211	9.00	229	7.63	194	6.56	167	7.63	194	0.44 x 1.13	11 x 29

Figure 16 -

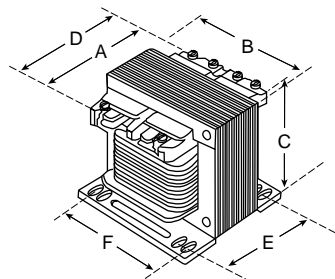
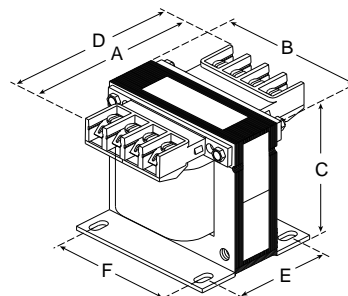

Figure 17 -



7. Complete the catalog number by replacing the ● with the appropriate Voltage Code from Voltage and Connection Options, page 20 above.

Type T Transformers with 24 Volt Secondary

24 Volt Secondary

Table 20 - Voltage and Connection Options

Voltage Code	Voltages		Connections	
	Primary	Secondary	Primary	Secondary
D2	240 x 480	24	240: Connect to H1 and H4 Jumper H1 with H3 Jumper H2 with H4 480: Connect to H1 and H4 Jumper H2 with H3	Connect to X1 and X2
D23	120 x 240	24	120: Connect to H1 and H4 Jumper H1 with H3 Jumper H2 with H4 240: Connect to H1 and H4 Jumper H2 with H3	
D89	115 x 230	24	115: Connect to H1 and H4 Jumper H1 with H3 Jumper H2 with H4 230: Connect to H1 and H4 Jumper H2 with H3	
D92	230 x 460	24	230: Connect to H1 and H4 Jumper H1 with H3 Jumper H2 with H4 460: Connect to H1 and H4 Jumper H2 with H3	

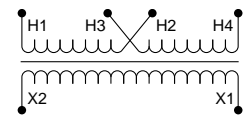

Table 21 - Dimensions

VA		Catalog Number ⁸	Fig.	Acc. Key	A		B		C		E		F		Slots	
UL	CE				in.	mm	in.	mm	in.	mm	in.	mm	in.	mm	in.	mm
25	25	9070T25 ●	18	I	3.09	79	3.00	76	2.58	66	2.00	51	2.50	64	0.20 x 0.38	5 x 10
50	50	9070T50 ●	18	I	3.09	79	3.00	76	2.58	66	2.00	51	2.50	64	0.20 x 0.38	5 x 10
75	75	9070T75 ●	18	I	3.34	85	3.38	86	2.89	73	2.38	61	2.81	71	0.20 x 0.48	5 x 12
100	100	9070T100 ●	18	I	3.34	85	3.38	86	2.89	73	2.38	61	2.81	71	0.20 x 0.48	5 x 12
150	150	9070T150 ●	18	I	3.59	91	3.75	95	3.20	81	2.88	73	3.13	80	0.20 x 0.38	5 x 10
200	200	9070T200 ●	18	I	3.59	91	3.75	95	3.20	81	2.88	73	3.13	80	0.20 x 0.38	5 x 10
250	160	9070T250 ●	19	I	5.30	135	3.75	95	3.21	82	2.88	73	3.13	80	0.20 x 0.38	5 x 10
300	200	9070T300 ●	19	I	4.74	120	4.50	114	3.84	98	2.56	65	3.75	95	0.20 x 0.38	5 x 10
350	250	9070T350 ●	19	I	5.11	130	4.50	114	3.84	98	3.00	76	3.75	95	0.20 x 0.38	5 x 10
500	300	9070T500 ●	19	I	5.49	139	4.50	114	3.84	98	3.56	90	3.75	95	0.20 x 0.38	5 x 10

8. Complete the catalog number by replacing the t with the appropriate Voltage Code from Voltage and Connection Options, page 22 above.

Figure 18 -

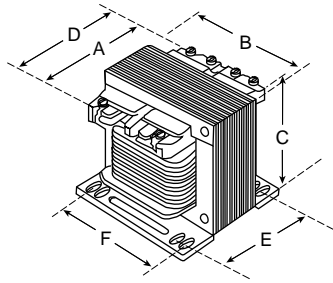

Figure 19 -

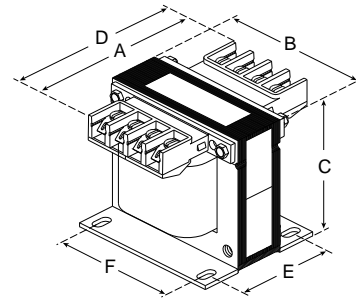

Table 22 - Voltage and Connection Options

Voltage Code	Voltages		Connections	
	Primary	Secondary	Primary	Secondary
D7	120	24	Connect to H1 and H2	Connect to X1 and X2
D14	208	24		
D16	600	24		
D25	277	24		
D88	380	24		
D112	230	24		

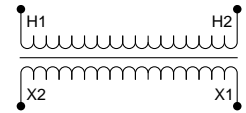

Table 23 - Dimensions

VA		Catalog Number ⁹	Fig.	Acc. Key	A		B		C		E		F		Slots	
UL	CE				in.	mm	in.	mm	in.	mm	in.	mm	in.	mm	in.	mm
25	25	9070T25 •	20	I	3.09	79	3.00	76	2.58	66	2.00	51	2.50	64	0.20 x 0.38	5 x 10
50	50	9070T50 •	20	I	3.09	79	3.00	76	2.58	66	2.00	51	2.50	64	0.20 x 0.38	5 x 10
75	75	9070T75 •	20	I	3.34	85	3.38	86	2.89	73	2.38	61	2.81	71	0.20 x 0.48	5 x 12
100	100	9070T100 •	20	I	3.34	85	3.38	86	2.89	73	2.38	61	2.81	71	0.20 x 0.48	5 x 12
150	150	9070T150 •	20	I	3.59	91	3.75	95	3.20	81	2.88	73	3.13	80	0.20 x 0.38	5 x 10
200	200	9070T200 •	20	I	3.59	91	3.75	95	3.20	81	2.88	73	3.13	80	0.20 x 0.38	5 x 10
250	160	9070T250 •	21	I	5.30	135	3.75	95	3.21	82	2.88	73	3.13	80	0.20 x 0.38	5 x 10
300	200	9070T300 •	21	I	4.74	120	4.50	114	3.84	98	2.56	65	3.75	95	0.20 x 0.38	5 x 10
350	250	9070T350 •	21	I	5.11	130	4.50	114	3.84	98	3.00	76	3.75	95	0.20 x 0.38	5 x 10
500	300	9070T500 •	21	I	5.49	139	4.50	114	3.84	98	3.56	90	3.75	95	0.20 x 0.38	5 x 10

9. ¹ Complete the catalog number by replacing the • with the appropriate Voltage Code from Voltage and Connection Options, page 23 above.

Figure 20 -

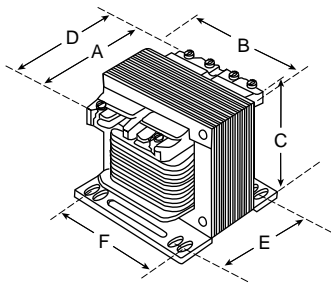

Figure 21 -

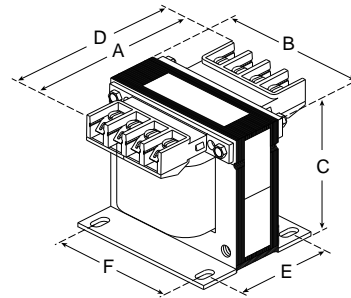

Table 24 - Voltage and Connection Options

Voltage Code	Voltages		Connections	
	Primary	Secondary	Primary	Secondary
D19	208 240 277 380 480	24	208: Connect to H1 and H2 240: Connect to H1 and H3 277: Connect to H1 and H4 380: Connect to H1 and H5 480: Connect to H1 and H6	Connect to X1 and X2

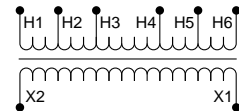
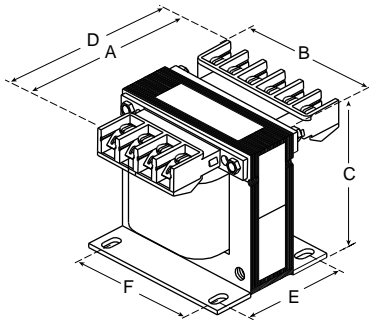

Table 25 - Dimensions

VA		Catalog Number	Fig.	Acc. Key	A		B		C		E		F		Slots	
UL	CE				in.	mm	in.	mm	in.	mm	in.	mm	in.	mm	in.	mm
50	50	9070T50-D19	22	III	4.43	113	3.38	85.9	2.89	73.4	2.38	61	2.81	71.4	0.20 x 0.48	5 x 12
75	75	9070T75-D19	22	III	4.70	119.-4	3.75	95.3	3.20	81.3	2.88	73.2	3.13	80	0.20 x 0.38	5 x 10
100	100	9070T10-0D19	22	III	4.70	119.-4	3.75	95.3	3.20	81.3	2.88	73.2	3.13	80	0.20 x 0.38	5 x 10
150	150	9070T15-0D19	22	III	4.70	119.-4	3.75	95.3	3.20	81.3	2.88	73.2	3.13	80	0.20 x 0.38	5 x 10
200	200	9070T20-0D19	22	III	4.74	120.-4	4.50	114.3	3.84	98	2.56	65	3.75	95.3	0.20 x 0.38	5 x 10
250	160	9070T25-0D19	22	III	5.11	129.-8	4.50	114.3	3.84	98	3.00	76.2	3.75	95.3	0.20 x 0.38	5 x 10
300	200	9070T30-0D19	22	III	5.11	129.-8	4.50	114.3	3.84	98	3.00	76.2	3.75	95.3	0.20 x 0.38	5 x 10
350	250	9070T35-0D19	22	III	5.49	139.-4	4.50	114.3	3.84	98	3.56	90.4	3.75	95.3	0.20 x 0.38	5 x 10
500	300	9070T50-0D19	22	III	5.61	142.-5	5.25	133.4	4.51	114.6	3.43	87.1	4.38	111.3	0.28 x 0.56	7 x 14

Figure 22 -



Type T Units with Dual 12/24 Volt Secondary

Table 26 - Voltage and Connection Options

Voltage Code	Voltages		Connections	
	Primary	Secondary	Primary	Secondary
D13	120	12/24	Connect to H1 and H2	12: Connect to X1 and X4 Jumper X1 with X3 Jumper X2 with X4 24: Connect to X1 and X4 Jumper X2 with X3
D36	600		Connect to H1 and H2	
D54	120 x 240		120: Connect to H1 and H4 Jumper H1 with H3 Jumper H2 with H4 240: Connect to H1 and H4 Jumper H2 with H3	
D59	240 x 480		240: Connect to H1 and H4 Jumper H1 with H3 Jumper H2 with H4 480: Connect to H1 and H4 Jumper H2 with H3	

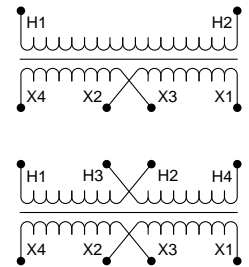

Table 27 - Dimensions

VA		Catalog Number ¹⁰	Fig.	Acc. Key	A		B		C		E		F		Slots	
UL	CE				in.	mm	in.	mm	in.	mm	in.	mm	in.	mm	in.	mm
25	25	9070T25 •	23	I	3.09	79	3.00	76	2.58	66	2.00	51	2.50	64	0.20 x 0.38	5 x 10
50	50	9070T50 •	23	I	3.09	79	3.00	76	2.58	66	2.00	51	2.50	64	0.20 x 0.38	5 x 10
75	75	9070T75 •	23	I	3.34	85	3.38	86	2.89	73	2.38	61	2.81	71	0.20 x 0.48	5 x 12
100	100	9070T100 •	23	I	3.34	85	3.38	86	2.89	73	2.38	61	2.81	71	0.20 x 0.48	5 x 12
150	150	9070T150 •	23	I	3.59	91	3.75	95	3.20	81	2.88	73	3.13	80	0.20 x 0.38	5 x 10
200	200	9070T200 •	23	I	3.59	91	3.75	95	3.20	81	2.88	73	3.13	80	0.20 x 0.38	5 x 10
250	160	9070T250 •	24	I	5.30	135	3.75	95	3.21	82	2.88	73	3.13	80	0.20 x 0.38	5 x 10
300	200	9070T300 •	24	I	4.74	120	4.50	114	3.84	98	2.56	65	3.75	95	0.20 x 0.38	5 x 10

10. Complete the catalog number by replacing the • with the appropriate Voltage Code from Voltage and Connection Options, page 25 above.

Table 27 - Dimensions (Continued)

VA		Catalog Number ¹¹	Fig.	Acc. Key	A		B		C		E		F		Slots	
UL	CE				in.	mm	in.	mm	in.	mm	in.	mm	in.	mm	in.	mm
350	250	9070T350 ●	24	I	5.11	130	4.50	114	3.84	98	3.00	76	3.75	95	0.20 x 0.38	5 x 10
500	300	9070T500 ●	24	I	5.49	139	4.50	114	3.84	98	3.56	90	3.75	95	0.20 x 0.38	5 x 10

Figure 23 -

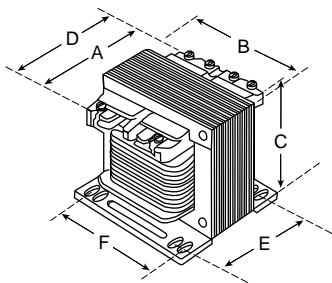
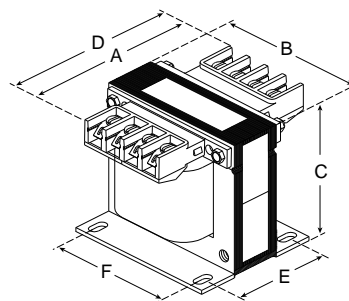

Figure 24 -



Multiple Secondary

Designed to meet the needs for both 24 and 120 V control. Available in the 9070 Type T product line, with all the type T features.

Tapped Secondary D15: 24 V rated for 20% capacity and 120 V rated for 80% capacity when simultaneous loading, or 100% loading when 120 V only.

20% rating at 24 V or 100% rating at 120 V gives equal output current from the device.

VA	24 V amps	120 V amps
50	0.416	0.416
75	0.625	0-Jan
100	0.833	0.833
150	1.25	1.25
200	1.67	1.67
250	2.08	2.08
300	2.5	2.5
350	2.9	2.9
500	4.17	4.17
750	6.25	6.25
1000	8.3	8.3
1500	12.5	12.5
2000	16.7	16.7
3000	25	25
5000	41.7	41.7

11. Complete the catalog number by replacing the ● with the appropriate Voltage Code from Voltage and Connection Options, page 25above.

Tapped Secondary D65: Both outputs fully rated for non-simultaneous loading, and simultaneous rated for any combination that does not exceed the nameplate VA rating.

Separate Windings Options: All voltage codes offer fully rated non-simultaneous loading, and simultaneous rated for any combination that does not exceed the nameplate VA rating.

Features of separate windings:

1. Allows two isolated control circuits, 24 V and 120 V, from the same device
2. Wire sizing for circuits for each voltage not highest current for common when simultaneous loading. (no common)
3. If a common is required, it can be obtained with a jumper kit.

Type T Units with Dual 24/120 Volt Secondary (Tapped Units)

Table 28 - Voltage and Connection Options

Voltage Code	Voltages		Connections	
	Primary	Secondary	Primary	Secondary
D15	240 x 480	23/110 24/ /120	240: Connect to H1 and H4 Jumper H1 with H3 Jumper H2 with H4 480: Connect to H1 and H4 Jumper H2 with H3	23 or 24 or 25: Connect to X1 and X2 110 or 115 or 120: Connect to X1 and X3

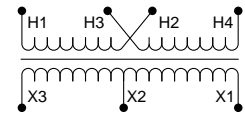

Table 29 - Dimensions

VA	Catalog Number	Fig.	Acc. Key	A		B		C		E		F		Slots		120 On-ly Max VA	24 On-ly Max VA	Simultaneous Loading Max UL VA	
				in.	mm	in.	mm	in.	mm	in.	mm	in.	mm	in.	mm				
50	9070T50D15	25	I	3.09	79	3.00	76	2.58	66	2.00	51	2.50	64	.20 x .38	5 x 10	50	10	40	10
75	9070T75D15	25	I	3.34	85	3.38	86	2.89	73	2.38	61	2.81	71	.20 x .48	5 x 12	75	15	60	10
100	9070T100D15	25	I	3.34	85	3.38	86	2.89	73	2.38	61	2.81	71	.20 x .48	5 x 12	100	20	80	20
150	9070T150D15	25	I	3.59	91	3.75	95	3.20	81	2.88	73	3.13	80	.20 x .38	5 x 10	150	30	120	30
200	9070T200D15	25	I	3.59	91	3.75	95	3.20	81	2.88	73	3.13	80	.20 x .38	5 x 10	200	40	160	40
250	9070T250D15	26	I	5.30	135	3.75	95	3.21	82	2.88	73	3.13	80	.20 x .38	5 x 10	250	50	200	50
300	9070T300D15	26	I	4.74	120	4.50	114	3.84	98	2.56	65	3.75	95	.20 x .38	5 x 10	300	60	240	60
350	9070T350D15	26	I	5.11	130	4.50	114	3.84	98	3.00	76	3.75	95	.20 x .38	5 x 10	350	70	280	70
500	9070T500D15	26	I	5.49	139	4.50	114	3.84	98	3.56	90	3.75	95	.20 x .38	5 x 10	500	100	400	100
750	9070T750D15	26	I	5.61	143	5.25	133	4.51	115	3.43	87	4.38	111	.28 x .56	7 x 14	750	150	600	150
1000	9070T1000D15	26	I	6.30	160	5.25	133	4.51	115	4.31	109	4.38	111	.28 x .56	7 x 14	1000	200	800	200
1500	9070T1500D15	26	I	5.92	150	7.06	179	6.17	157	4.13	105	5.81	148	.28 x .56	7 x 14	1500	300	1200	300
2000	9070T2000D15	26	I	7.17	182	7.06	179	6.17	157	4.56	116	5.81	148	.28 x .56	7 x 14	2000	400	1600	400

Table 29 - Dimensions (Continued)

VA	Catalog Number		Fig.	Acc. Key	A		B		C		E		F		Slots		120 On-ly Max VA	24 On-ly Max VA	Simultaneous Loading Max UL VA
	UL	CE			in.	mm	in.	mm	in.	mm	in.	mm	in.	mm	in.	mm			
300-0	200-0	9070T3000D15	26	I	6.38	162	9.00	229	7.63	194	4.63	118	7.63	194	.44 x 1.13	11 x 29	3000	600	600
500-0	300-0	9070T5000D15	27	I	9.15	232	9.00	229	8.75	222	6.56	167	7.63	194	.44 x 1.13	11 x 29	5000	1000	1000

Figure 25 -

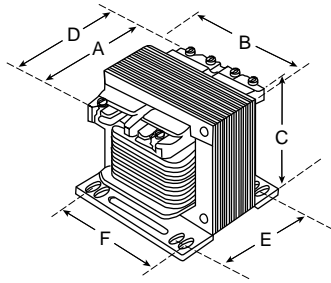

Figure 26 -

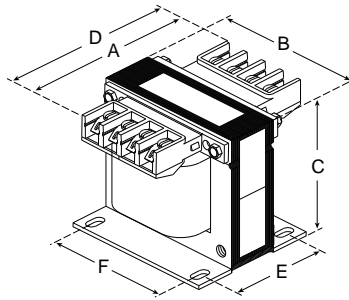

Figure 27 -

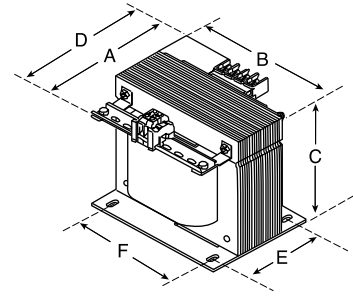

Table 30 - Voltage and Connection Options

Voltage Code	Voltages		Connections	
	Primary	Secondary	Primary	Secondary
D65	200/220/440 208/230/460 217/240/480	23/110 24/115 25/120	200 or 208 or 217: Connect to H1 and H2 220 or 230 or 240: Connect to H1 and H3 440 or 460 or 480: Connect to H1 and H4	23 or 24 or 25: Connect to X1 and X2 110 or 115 or 120: Connect to X1 and X3

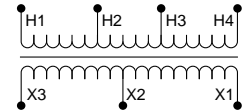

Table 31 - Dimensions

VA	Catalog Number	Fig.	Acc. Key	A		B		C		E		F		Slots		115 Only Max VA	24 Only Max VA	Simultaneous Loading Max UL VA	
				in.	m-	in.	m-	in.	m-	in.	m-	in.	m-	in.	mm			UL	115 V
50	9070T50D65	28	II	3.34	85	3.38	86	2.89	73	2.38	61	2.81	71	.20 x .48	5 x 12	50			Any combination that does not exceed Primary Max VA For example, T350 200 VA (120V) 150 VA (24V)
75	9070T75D65	28	II	3.59	91	3.75	95	3.20	81	2.88	73	3.13	80	.20 x .38	5 x 10	75			
100	9070T100D65	28	II	3.59	91	3.75	95	3.20	81	2.88	73	3.13	80	.20 x .38	5 x 10	100			
150	9070T150D65	28	II	3.59	91	3.75	95	3.20	81	2.88	73	3.13	80	.20 x .38	5 x 10	150			
200	9070T200D65	29	II	5.11	130	4.50	114	3.84	98	3.00	76	3.75	95	.20 x .38	5 x 10	200			
250	9070T250D65	29	II	5.11	130	4.50	114	3.84	98	3.00	76	3.75	95	.20 x .38	5 x 10	250			
300	9070T300D65	29	II	5.49	139	4.50	114	3.84	98	3.56	90	3.75	95	.20 x .38	5 x 10	300			
350	9070T350D65	29	II	5.61	143	5.25	133	4.51	115	3.43	87	4.38	111	.28 x .56	7 x 14	350			
500	9070T500D65	29	II	5.61	143	5.25	133	4.51	115	3.43	87	4.38	111	.28 x .56	7 x 14	500			

Figure 28 -

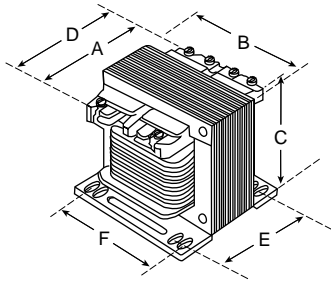
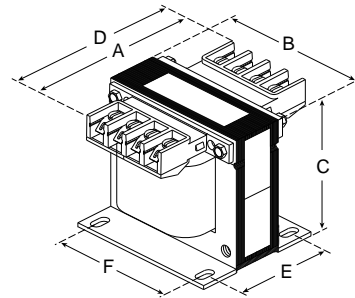

Figure 29 -



Type T Units with Dual 24/120 Volt Secondary (Separate Windings)

Table 32 - Voltage and Connection Options

Voltage Code	Voltages		Connections	
	Primary	Secondary	Primary	Secondary
D114	220 x 440 230 x 460 240 x 480	23/110 24/115 25/120	220/230/240: Connect to H1 and H4 Jumper H1 with H3 Jumper H2 with H4 440/460/480: Connect to H1 and H4 Jumper H2 with H3	23/24/25: Connect to X1 and X2 110/115/120: Connect to X3 and X4

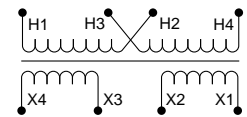

VA	Catalog Number		Fig.	Acc. Key	A		B		C		E		F		Slots		115 Only Max VA	24 Only Max VA	Simultaneous Loading Max UL VA	
	UL	CE			in.	mm	in.	mm	in.	mm	in.	mm	in.	mm	in.	mm			UL	115V
50	9070T50D114	30	I	3.34	85	3.38	86	2.89	73	2.38	61	2.81	71	.20 x .48	5 x 12	50	Any combination that does not exceed Primary Max VA For example, T350 200 VA (120V) 150 VA (24V)			
75	9070T75D114	30	I	3.59	91	3.75	95	3.20	81	2.88	73	3.13	80	.20 x .38	5 x 10	75				
100	9070T100D114	30	I	3.59	91	3.75	95	3.20	81	2.88	73	3.13	80	.20 x .38	5 x 10	100				
150	9070T150D114	30	I	3.59	91	3.75	95	3.20	81	2.88	73	3.13	80	.20 x .38	5 x 10	150				
200	9070T200D114	31	I	4.74	120	4.50	114	3.84	98	2.56	65	3.75	95	.20 x .38	5 x 10	200				
250	9070T250D114	31	I	4.74	120	4.50	114	3.84	98	2.56	65	3.75	95	.20 x .38	5 x 10	250				
300	9070T300D114	31	I	5.11	130	4.50	114	3.84	98	3	76	3.75	95	.20 x .38	5 x 10	300				
350	9070T350D114	31	I	5.49	139	4.50	114	3.84	98	3.56	90	3.75	95	.20 x .38	5 x 10	350				
500	9070T500D114	31	I	5.61	143	5.25	133	4.51	115	3.43	87	4.38	111	.28 x .56	7 x 14	500				

Figure 30 -

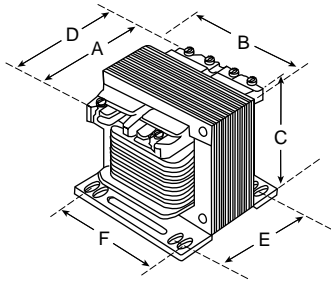

Figure 31 -

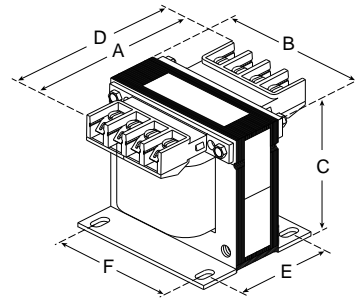

Table 33 - Voltage and Connection Options

Voltage Code	Voltages		Connections	Secondary
	Primary	Secondary	Primary	
D115	208/277	24/115	208: Connect to H1 and H2 277: Connect to H1 and H3	24: Connect to X1 and X2 115: Connect to X3 and X4
D116	550 575 600	23/110 24/115 25/120	Connect to H1 and H2	23/24/25: Connect to X1 and X2 110/115/120: Connect to X3 and X4
D119	380/400/415	24/115	380: Connect to H1 and H2 400: Connect to H1 and H3 415: Connect to H1 and H4	24: Connect to X1 and X2 115: Connect to X3 and X4

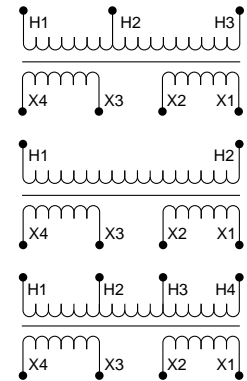

Table 34 - Dimensions

VA	Catalog Number ¹²		Fig.	Ac-c. Key	A		B		C		E		F		Slots		115 Only Max VA	24 Only Max VA	Simultaneous Loading Max UL VA	
	UL	CE			in.	mm	in.	m-m	in.	mm	in.	mm	in.	mm	in.	mm	in.	mm	UL	UL
50		9070T50 •	32	I	3.34	85	3.38	86	2.89	73	2.38	61	2.81	71	.20 x .48	5 x 12	50	50	Any combination that does not exceed Primary Max VA For example, T350 200 VA (120V) 150 VA (24V)	
75		9070T75 •	32	I	3.59	91	3.75	95	3.20	81	2.88	73	3.13	80	.20 x .38	5 x 10	75	75		
100		9070T100 •	32	I	3.59	91	3.75	95	3.20	81	2.88	73	3.13	80	.20 x .38	5 x 10	100	100		
150		9070T150 •	32	I	3.59	91	3.75	95	3.20	81	2.88	73	3.13	80	.20 x .38	5 x 10	150	150		
200		9070T200 •	33	I	4.74	120	4.50	114	3.84	98	2.56	65	3.75	95	.20 x .38	5 x 10	200	200		
250		9070T250 •	33	I	4.74	120	4.50	114	3.84	98	2.56	65	3.75	95	.20 x .38	5 x 10	250	250		
300		9070T300 •	33	I	5.11	130	4.50	114	3.84	98	3.00	76	3.75	95	.20 x .38	5 x 10	300	300		
350		9070T350 •	33	I	5.49	139	4.50	114	3.84	98	3.56	90	3.75	95	.20 x .38	5 x 10	350	350		
500		9070T500 •	33	I	5.61	143	5.25	133	4.51	115	3.43	87	4.38	111	.28 x .56	7 x 14	500	500		

12. Complete the catalog number by replacing the • with the appropriate Voltage Code from Voltage and Connection Options, page 34 above.

Figure 32 -

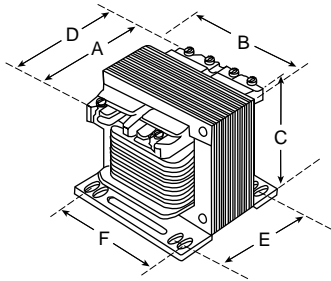

Figure 33 -

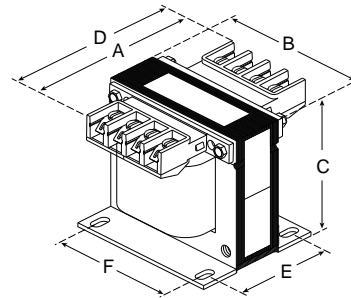

Table 35 - Voltage and Connection Options

Voltage Code	Voltages		Connections	
	Primary	Secondary	Primary	Secondary
D117	200/220/400 208/230/460 217/240/480	23/110 24/115 25/120	200/208/217: Connect to H1 and H2 220/230/240: Connect to H1 and H3 400/460/480: Connect to H1 and H4	23/24/25: Connect to X1 and X2 110/115/120: Connect to X3 and X4
D118	220/440/550 230/460/575 240/480/600	23/110 24/115 25/120	220/230/240: Connect to H1 and H2 440/460/480: Connect to H1 and H3 550/575/600: Connect to H1 and H4	

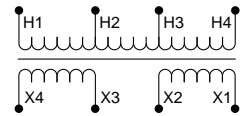

Table 36 - Dimensions

VA	Catalog Number ¹³		Fig.	Acc. Key	A		B		C		E		F		Slots		115 Only Max VA	24 Only Max VA	Simultaneous Loading Max UL VA	
	UL	CE			in.	mm	in.	mm	in.	mm	in.	mm	in.	mm	in.	mm			UL	24V
50	50	9070T50	34	II	3.34	85	3.38	86	2.89	73	2.38	61	2.81	71	.20 x .48	5 x 12	50	50	Any combination that does not exceed Primary Max VA For example: T350 200 VA (120V) 150 VA (24V)	
75	75	9070T75	34	II	3.59	91	3.75	95	3.20	81	2.88	73	3.13	80	.20 x .38	5 x 10	75	75		
100	100	9070T100	34	II	3.59	91	3.75	95	3.20	81	2.88	73	3.13	80	.20 x .38	5 x 10	100	100		
150	150	9070T150	34	II	3.59	91	3.75	95	3.20	81	2.88	73	3.13	80	.20 x .38	5 x 10	150	150		
200	200	9070T200	35	II	4.74	120	4.50	114	3.84	98	2.56	65	3.75	95	.20 x .38	5 x 10	200	200		
250	160	9070T250	35	II	4.74	120	4.50	114	3.84	98	2.56	65	3.75	95	.20 x .38	5 x 10	250	250		
300	200	9070T300	35	II	5.11	130	4.50	114	3.84	98	3.00	76	3.75	95	.20 x .38	5 x 10	300	300		
350	250	9070T350	35	II	5.49	139	4.50	114	3.84	98	3.56	90	3.75	95	.20 x .38	5 x 10	350	350		
500	300	9070T500	35	II	5.61	143	5.25	133	4.51	115	3.43	87	4.38	111	.28 x .56	7 x 14	500	500		

13. Complete the catalog number by replacing the t with the appropriate Voltage Code from Voltage and Connection Options, page 34above.

Figure 34 -

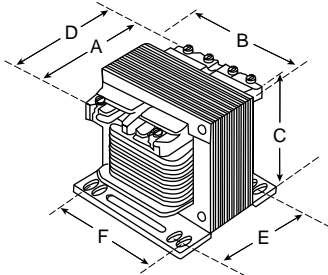
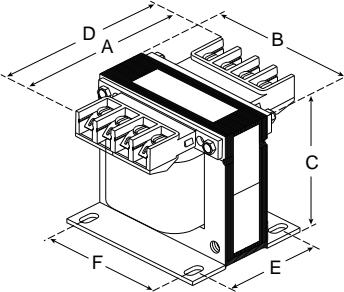

Figure 35 -



Type T Performance Data

Catalog Number	Core Watts	Coil Watts	FL Total Watts	Reg 1.0PF	Eff 100%	%IZ	X/R	BTU/hr					Inrush (x FL RMS)	
								100-%	75%	50%	25%	No Load	60 Hz	50 Hz
9070T25D1	4.5	3.7	8.2	3.81	75.3	3.84	10.9	28	22	19	16	15	25	30
9070T50D1	4.5	7.1	11.6	7.97	81.1	8.01	10.5	40	29	21	17	15	24.1	28.9
9070T75D1	7.3	6.8	14.1	4.94	84.2	5	15.9	48	38	31	26	25	28	33.6
9070T100D1	7.3	10.2	17.5	6.82	85.1	6.9	15.4	60	45	34	27	25	26.8	32.2
9070T150D1	10.5	10.8	21.3	4.77	87.6	5.25	20.2	73	57	45	38	36	31.2	37.4
9070T200D1	10.5	19.5	30	7.7	86.9	7.83	18	102	73	53	40	36	19.7	23.7
9070T250D1	14.1	17.8	31.9	5.73	88.7	5.73	3.5	109	82	63	52	48	22.9	27.5
9070T300D1	13.3	18.8	32.1	5.6	90.3	5.62	6	110	82	61	49	45	11	13.2
9070T350D1	16.4	19.9	36.3	5.07	90.6	5.08	4.9	124	94	73	60	56	16	19.2
9070T500D1	20.7	30.6	51.3	5.47	90.7	5.48	5.3	175	129	97	77	71	12.9	15.5
9070T750D1	30.8	37.9	68.7	4.57	91.6	4.58	5.7	235	178	138	113	105	17.4	20.9
9070T1000D1	35.4	51.3	86.7	4.83	92	4.84	6	296	219	165	132	121	10.3	12.3
9070T1500D1	51.5	51.3	102.8	3.25	93.6	3.3	8	351	274	220	187	176	10.5	12.6
9070T2000D1	81.8	50	131.8	2.31	93.8	2.31	6.3	450	375	322	290	279	15.6	18.8
9070T3000D1	81.9	67.2	149.1	2.24	96.1	2.04	9.3	532	415	338	294	285	7.7	9.3
9070T5000D1	143.3	83.7	227	1.67	95.6	1.52	7.2	781	648	558	507	495	8.5	10.2
9070T50D3	4.5	7.1	11.6	7.97	81.1	8.01	10.5	40	29	21	17	15	24.1	28.9
9070T75D3	7.3	6.8	14.1	4.94	84.2	5	15.9	48	38	31	26	25	28	33.6
9070T100D3	7.3	10.2	17.5	6.82	85.1	6.9	15.4	60	45	34	27	25	26.8	32.2
9070T150D3	10.5	10.8	21.3	4.77	87.6	5.25	20.2	73	57	45	38	36	31.2	37.4
9070T200D3	10.5	19.5	30	7.7	86.9	7.83	18	102	73	53	40	36	19.7	23.7
9070T250D3	14.1	17.8	31.9	5.73	88.7	5.73	3.5	109	82	63	52	48	22.9	27.5
9070T300D3	13.3	18.8	32.1	5.6	90.3	5.62	6	110	82	61	49	45	11	13.2
9070T350D3	16.4	19.9	36.3	5.07	90.6	5.08	4.9	124	94	73	60	56	16	19.2
9070T500D3	20.7	30.6	51.3	5.47	90.7	5.48	5.3	175	129	97	77	71	12.9	15.5
9070T750D3	30.8	37.9	68.7	4.57	91.6	4.58	5.7	235	178	138	113	105	17.4	20.9
9070T1000D3	35.4	51.3	86.7	4.83	92	4.84	6	296	219	165	132	121	10.3	12.3
9070T1500D3	51.5	51.3	102.8	3.25	93.6	3.3	8	351	274	220	187	176	10.5	12.6
9070T2000D3	81.8	50	131.8	2.31	93.8	2.31	6.3	450	375	322	290	279	15.6	18.8
9070T3000D3	81.9	74.5	156.4	2.37	95	2.39	11.9	534	423	343	296	280	7.7	9.3
9070T5000D3	142.5	90.6	233.1	1.81	95.5	1.62	15.3	801	657	560	505	488	8.5	10.2
9070T50D20	7.3	6.8	14.1	4.94	84.2	5	15.9	48	38	31	26	25	28	33.6
9070T75D20	7.3	10.2	17.5	6.82	85.1	6.9	15.4	60	45	34	27	25	26.8	32.2
9070T100D20	10.5	10.8	21.3	4.77	87.6	5.25	20.2	73	57	45	38	36	31.2	37.4
9070T150D20	10.5	19.5	30	7.7	86.9	7.83	18	102	73	53	40	36	19.7	23.7
9070T200D20	14.1	17.8	31.9	5.73	88.7	5.73	3.5	109	82	63	52	48	22.9	27.5
9070T250D20	13.3	18.8	32.1	5.6	90.3	5.62	6	110	82	61	49	45	11	13.2
9070T300D20	16.4	19.9	36.3	5.07	90.6	5.08	4.9	124	94	73	60	56	16	19.2
9070T350D20	20.7	30.6	51.3	5.47	90.7	5.48	5.3	175	129	97	77	71	12.9	15.5

Catalog Number	Core Watts	Coil Watts	FL Total Watts	Reg 1.0PF	Eff 100%	%IZ	X/R	BTU/hr					Inrush (x FL RMS)	
								100-%	75%	50%	25%	No Load	60 Hz	50 Hz
9070T500D20	30.8	37.9	68.7	4.57	91.6	4.58	5.7	235	178	138	113	105	17.4	20.9
9070T750D20	35.4	51.3	86.7	4.83	92	4.84	6	296	219	165	132	121	10.3	12.3
9070T1000D20	51.5	51.3	102.8	3.25	93.6	3.3	8	351	274	220	187	176	10.5	12.6
9070T1500D20	81.8	50	131.8	2.31	93.8	2.31	6.3	450	375	322	290	279	15.6	18.8
9070T2000D20	81.9	74.5	156.4	2.37	95	2.39	11.9	534	423	343	296	280	7.7	9.3
9070T3000D20	143.3	84.8	228.1	1.63	95.6	1.64	11.8	779	652	562	507	489	8.5	10.2

Type T - Special Quote Request Sheet

Determine VA by Load Requirements

Dual or CT Secondary
 Secondary Voltages: ____ x ____ or ____ CT
 Amps at higher of the two voltages _____

<p>Tapped Unit</p> Secondary 1: ____ Volts ____ Amps Secondary 2: ____ Volts ____ Amps Secondary 3: ____ Volts ____ Amps Secondary 4: ____ Volts ____ Amps Secondary 5: ____ Volts ____ Amps	<p>Separate Windings</p> Secondary 1: ____ Volts ____ Amps Secondary 2: ____ Volts ____ Amps Secondary 3: ____ Volts ____ Amps Secondary 4: ____ Volts ____ Amps
---	--

Secondary Simultaneous Loading?
 If Yes: VA Sizing _____
 S1: V x A + S2: V x A + S3: V x A + S4: V x A + S5: V x A
 If No: VA Sizing _____
 Largest VA of the secondary listed above: V x A

Dual Primary ____ x ____ Volts

Tapped Unit
 Primary 1: ____ Volts
 Primary 2: ____ Volts
 Primary 3: ____ Volts
 Primary 4: ____ Volts
 Primary 5: ____ Volts

Technical Data
 Regulation Requirements: ____ VA @ ____ PF for ____% Voltage Drop
 BTU Requirements: ____ No Load Max ____ Total Full Load Max

Dimensions
 If dimensions are critical, provide them below (or supply a drawing with dimensions clearly marked):
 Maximum size in inches: ____ H ____ W ____ D

All units will have standard Type T features:
 Temperature Rise, Insulation Material, Terminal Board, cULus and CE Marked,
 Footprints for VA frame created above.

Transformers with Leads

Transformers with leads instead of screw terminals are available. The lead length is 24 inches. See the following chart for VA sizes and voltage combinations. Contact your Schneider Electric representative for further details.

Table 37 - Voltage and Connection Options

Voltage Code	Primary Voltage	Connection	Secondary Voltage	Connection
D3	208	Connect to H1 and H2	120	Connect to X1 and X2
D4	277		120	
D5	550		110	
	575		115	
	600		120	
D6	380		110	
D8	220		110	
	230		115	
	240		120	
D9	440		110	
	460		115	
	480		120	
D17	415	110		
D24	110	110		
	115	115		
	120	120		
D93	200	115		
D103	400	120		

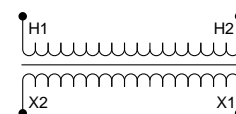
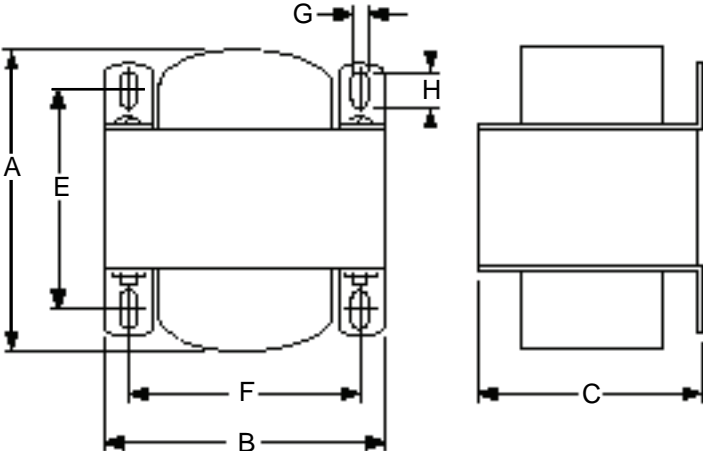

Table 38 - Class 9070 Type EL, KL

VA	Catalog Number	Weight		A		B		C		E		F		Slots	
		lbs.	kg	in.	mm	in.	mm	in.	mm	in.	mm	in.	mm	in.	mm
50	9070EL1	2.2	1.0	2.63	67	3.00	76	2.50	64	2.00	51	2.50	64	0.20 x 0.38	5 x 10
100	9070EL2	3.8	1.7	3.00	76	3.38	86	2.81	71	2.38	60	2.81	71	0.20 x 0.38	5 x 10
150	9070EL3	6.0	2.7	3.63	92	3.75	95	3.13	80	2.88	73	3.13	80	0.20 x 0.38	5 x 10
300	9070KL300	8.0	3.6	3.50	89	4.50	114	3.75	95	3.81	97	3.75	95	0.20 x 0.38	5 x 10



Fuse Protection

UL Standards and the National Electrical Code® require primary protection for Control Transformers, and many applications require secondary protection. Historically, the fuse options supplied by transformer manufacturers were designed for Line-to-Line primary (480 V) and Line-to-Neutral secondary (120 V).

Schneider Electric’s line of fuse options allows customers to obtain both factory- and field-installed fuse blocks. Factory installation saves you time and labor. For both options, the transformer footprint is identical to a Type T transformer of equivalent voltage, because the fuse block is mounted above the transformer or on the transformer terminal blocks. This frees up space normally used by separate fuse blocks.

Schneider Electric offers the most complete offering of fuse options to meet all applications for protection of the transformers and load applications. These are broken down into Line-to-Line and Line-to-Neutral protection options for both primary and secondary. Due to space limitations of the transformers, not all options are available for every VA size. Also, all fuse blocks supplied by Schneider Electric are 30 A fuse blocks, which limits the VA for each voltage.

All primary fuse blocks supplied by Schneider Electric require rejection style fuses. Rejection style fuses offer 100,000 AIC protection to comply with UL Standards. (Non-rejection style primary fuse blocks are available by request only and can be quoted through your Schneider Electric field sales office.)

Primary			Secondary	
Voltage	VA Range without Primary Protection	VA Range with Primary Protection	Voltage	VA Range with Secondary Protection
550/575/600	25–5000 VA	25–5000 VA	277	25–5000 VA
440/460/480	25–5000 VA	25–5000 VA	220/230/240	25–5000 VA
380/400/415	25–5000 VA	25–5000 VA	208	25–5000 VA
277	25–5000 VA	25–3000 VA	110/115/120	25–2000 VA
220/230/240	25–5000 VA	25–3000 VA	48	25–1000 VA
208	25–5000 VA	25–2000 VA	24	25–500 VA
110/115/120	25–2000 VA	25–1500 VA	12	25–250 VA

Table 39 - Matrix for Choosing Proper Fuse Configuration

	Primary Line-to-Line	Primary Line-to-Neutral	Primary Without Protection
Secondary Line-to-Line	No factory installed option	Type TF with R12	S22
Secondary Line-to-Neutral	Type TF	Type TF with R11	S12
Secondary Without Protection	Type TF with R02	Type TF with R01	Type T product line
Primary voltages requiring Line-to-Line protection:	200/208/220/230/240/380/400/415/440/460/480/550/575/600		
Primary voltages requiring Line-to-Neutral protection:	100/110/115/120/277/347 Europe: 220/230/240		

Secondary voltages requiring Line-to-Line protection:	208/220/230/240
Secondary voltages requiring Line-to-Neutral protection:	120/277 Europe: 220/230/240

NOTE: The following secondary voltages could be either Line-to-Line or Line-to-Neutral: 12/24/48.

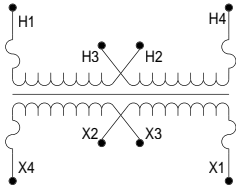

Applications for Line-to-Line Primary protection and Line-to-Line Secondary protection,
 Example would be 480 to 120/240 (Voltage Code D31)
 Available as field-installed only for 9070 Type T
 Must order one 9070FB2A(B)—Primary
 Must order one 9070S22A(B)—Secondary

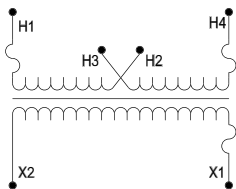

Application for Line-to-Line Primary protection and Line-to-Neutral Secondary protection
 Example would be 480 to 120 (Voltage Code D1)
 Available as factory- and field-installed
 Factory-installed—9070 Type TF or 9070
 Field-installed—9070 Type T: 9070FB3A or 9070FB3B

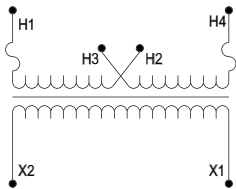

Application for Line-to-Line Primary protection and No Secondary protection
 Example would be 480 to 24 (Voltage Code D2)
 Available as factory- and field-installed
 Factory-installed—9070 Type TF with R02 suffix
 Field-installed—9070 Type T: 9070FB2A or 9070FB2B

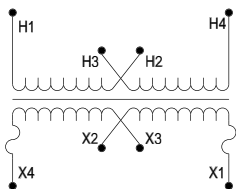

Application for No Primary protection and Line-to-Line Secondary
 Example would be 480 to 120/240 (Voltage Code D31)
 Primary protection done elsewhere in the circuit
 Available as factory- and field-installed
 Factory-installed—9070 Type T
 Field-installed—9070 Type T: 9070S22A or 9070S22B

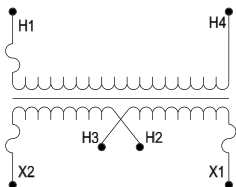

Application for Line-to-Neutral Primary and Line-to-Line Secondary
 Example would be 277 to 120/240
 Available as factory- and field-installed
 Factory-installed—9070 Type TF with R12 suffix
 Field-installed—9070 Type T: 9070R12A or 9070R12B

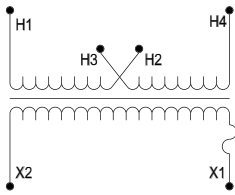

Application for No Primary protection and Line-to-Neutral Secondary

Example would be 480 to 120 (Voltage Code D1)

Primary protection done elsewhere in the circuit

Factory-installed options

1. 9070 Type T with S12 suffix Secondary fuse block; midget-type fuses
2. 9070 Type T with SF25 suffix Secondary fuse block; glass-type fuses
3. 9070 Type T with SF41 suffix Secondary fuse clips mounted on terminal block

Field-installed options

1. 9070 Type T:
Midget-type fuse block: 9070FB1A or 9070FB1B
Midget-type fuse clips: 9070SF41A or 9070SF41B (Limited to single secondary only)
Glass-type fuse holder: 9070AP2

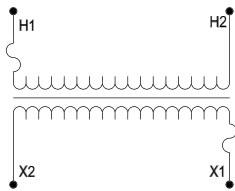

Application for Line-to-Neutral Primary and Line-to-Neutral Secondary

Example would be 277 to 120 (Voltage Code D4)

Factory-installed—9070 Type TF with R11 suffix

Field-installed—9070 Type T: 9070R11A or 9070R11B

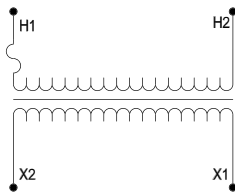

Application for Line-to-Neutral Primary and No Secondary

Example would be 277 to 24 (Voltage Code D24)

Factory-installed—9070 Type TF with R01 suffix

Field-installed—9070 Type T: 9070R01A or 9070R01B

Table 40 - Fuse Protection Options

Protection	Example	Factory Installed Option(s)	Field Installed Option(s)
Line-to-Line Primary and Secondary	480 to 120/240 (Voltage Code D31)	Not available	9070FB2A(B) - Primary 9070S22A(B) - Secondary
Line-to-Line Primary and Line-to-Neutral Secondary	480 to 120 (Voltage Code D1)	9070 Type TF	9070 Type T: 9070FB3A or 9070FB3B
Line-to-Line Primary and No Secondary	480 to 24 (Voltage Code D2)	9070 Type TF with R02 suffix	9070 Type T: 9070FB2A or 9070FB2B
No Primary and Line-to-Line Secondary	480 to 120/240 (Voltage Code D31)	9070 Type T	9070 Type T: 9070S22A or 9070S22B
Line-to-Neutral Primary and Line-to-Line Secondary	277 to 120/240 (Voltage Code D60)	9070 Type TF with R12 suffix	9070 Type T: 9070R12A or 9070R12B
No Primary and Line-to-Neutral Secondary	480 to 120 (Voltage Code D1)	9070 Type T with S12 suffix Secondary Fuse Block - midget fuses 9070 Type T with SF25 suffix Secondary Fuse Block - glass type fuses 9070 Type T with SF41 suffix Secondary Fuse Clips mounted on terminal block	9070 Type T: Midget type fuse block: 9070FB1A or 9070FB1B Midget type fuse clips: 9070SF41A or 9070SF41B (Limited to single secondary only) Glass type fuse block: 9070SF25A or 9070SF25B Glass type fuse holder: 9070AP2 Side mounted 2-inch x 9/16-inch: 9070AP1
Line-to-Neutral Primary and Line-to-Neutral Secondary	277 to 120 (Voltage Code D4)	9070 Type TF with R11 suffix	9070 Type T: 9070R11 or 9070R11
Line-to-Neutral Primary and No Secondary	277 to 24 (Voltage Code D24)	9070 Type TF with R01 suffix	9070 Type T: 9070R01A or 970R01B

Table 41 - Description of Accessory Keys

Catalog Number		Description
Accessory Key I	Accessory Keys II, III, IV	
9070FB2A	9070FB2B	Two-pole fuse block with rejection clips for primary fusing, field mounted on terminal board via Fingersafe cover, 1-1/2-inch x 13/32-inch midget fuse
9070R10A	9070R10B	One-pole fuse block with rejection clips for primary fusing, field mounted on terminal board via Fingersafe cover, 1-1/2-inch x 13/32-inch midget fuse
9070FB3A	9070FB3B	Three-pole fuse block, two poles with rejection clips for primary fusing and one pole standard clips for secondary fusing, field mounted on terminal board via Fingersafe cover, 1-1/2-inch x 13/32-inch midget fuse
9070R11A	9070R11B	Two-pole fuse block, one pole with rejection clips for primary fusing and one with standard clips for secondary fusing, field mounted on terminal board via Fingersafe cover, 1-1/2-inch x 13/32-inch midget fuse
9070R12A	9070R12B	Three-pole fuse block, one pole with rejection clips for primary fusing and two poles standard clips for secondary fusing, field mounted on terminal board via Fingersafe cover, 1-1/2-inch x 13/32-inch midget fuse
9070FB1A	9070FB1B	One-pole fuse block with standard clips for secondary fusing, field mounted on terminal board via Fingersafe cover, 1-1/2-inch x 13/32-inch midget fuse
9070S22A	9070S22B	Two-pole fuse block with standard clips for secondary fusing, field mounted on terminal board via Fingersafe cover, 1-1/2-inch x 13/32-inch midget fuse
9070SF41A	9070SF41B	Secondary fuse clips mounted on terminal board, prevents the use of Fingersafe covers, only field installable on single voltage secondary units, 1-1/2-inch x 13/32-inch midget fuse
9070SF25A	9070SF25B	One-pole fuse block with standard clips for secondary fusing, field mounted using Fingersafe cover notches, prevents the use of Fingersafe covers, 1-1/4-inch x 1/4-inch glass fuse
9070AP1	9070FB	One-pole fuse block with standard clips for secondary fusing, field mounted next to transformer using same mounting hardware, 2-inch x 9/16-inch fuse
9070AP2	9070FB	One-pole twist fuse block with standard clips for secondary fusing, field mounted next to transformer using same mounting hardware, 1-1/4-inch x 1/4-inch glass fuse

Table 42 - Fuse Sizing, Description, and Catalog Number (by manufacturer)

Size	Description	Manufacturer		
		Bussman	Littelfuse	Gould-Shawmut
1-1/2 x 13/32 in. midget fuse	Time delay, rejection-type, class CC	FNQ-R LP-CC	KLDR CCMR	ATDR ATQR ATMR
1-1/2 x 13/32 in. midget fuse	Time delay	FNM; FNQ	FLQ; FLM; FLA	ATQ; TRM; GFN
1-1/4 x 1/4 in.	Time delay	TDC-11; MDL; MDQ; MDA	3AG: 313/315 3AB: 326/325	GDL

NOTE:

These fuses are not supplied by Schneider Electric.

This table is provided for primary fusing recommendation ONLY. Secondary fusing must be specified by the customer.

All primary fuse options offered by Schneider Electric require rejection-type fuses.

Accessories

Table 43 - Fingersafe™ Covers (not supplied with unit) – Compliant with IP2X per EN-60529

Class	Type	VA Accessory Key ¹⁴			Description
		I	II	III	
9070	FSC-1 FSC-2 FSC-23	25–200 VA 250–5000 VA N/A	25–100 VA 150–5000 VA N/A	N/A N/A 25–5000 VA	2 covers per kit

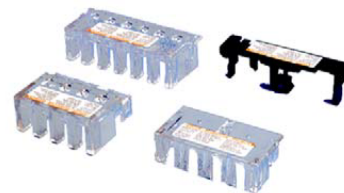

Table 44 - Fuse Puller—For ease in installing fuses and finger protection, used with fuse blocks with 1-1/2 in. x 13/32 in. fuses

Class	Type	VA Accessory Key			Description
		I	II	III	
9070	FP-1	ALL	ALL	ALL	Fuse puller kit complies with IP00 per EN-60529, 3 pullers per kit.

NOTE: Final IP rating is determined by the enclosure where the transformer is used.

14. Kits must be ordered separately. Also supplied in bulk packages of 100 individual covers. Add “B” to Type number if ordering bulk (available only on FSC-1B and FSC-2B).

Primary Fusing to Meet NEC

Table 45 - Recommended Fuse Sizes for the PRIMARY (use class CC time delay fuses) to Meet NEC

VA	120 Volts			240 Volts			480 Volts			600 Volts		
	Primary Current Am-peres	Fuse Rating with Secondary Protec-tion	Fuse Rating without Secondary Protec-tion	Primary Current Am-peres	Fuse Rating with Secondary Protec-tion	Fuse Rating without Secondary Protec-tion	Primary Current Am-peres	Fuse Rating with Secondary Protec-tion	Fuse Rating without Secondary Protec-tion	Primary Current Am-peres	Fuse Rating with Secondary Protec-tion	Fuse Rating without Secondary Protec-tion
25	0.21	1/2	1/2	0.1	1/4	1/4	0.05	1/8	1/8	0.04	1/10	1/10
50	0.41	1	1	0.21	1/2	1/2	0.1	2/10	2/10	0.08	2/10	2/10
75	0.63	1-1/2	1-1/2	0.31	6/10	6/10	0.16	3/10	3/10	0.13	3/10	3/10
100	0.83	2	2	0.42	1	1	0.21	1/2	1/2	0.17	4/10	4/10
150	1.25	3	3	0.63	1-1/2	1-1/2	0.31	6/10	6/10	0.25	6/10	6/10
200	1.67	4	4	0.83	2	2	0.42	1	1	0.33	8/10	8/10
250	2.08	5	3-2/10	1.04	2-1/2	2-1/2	0.52	1-1/2	1-1/4	0.42	1	1
300	2.5	6-1/4	4	1.25	3	3	0.63	2	1-1/2	0.5	1-1/8	1-1/8
350	2.92	7	4-1/2	1.46	3-1/2	3-1/2	0.73	2-1/2	1-8/10	0.58	1-4/10	1-4/10
500	4.17	10	6-1/4	2.08	5	3-2/10	1.04	3	2-1/2	0.83	2	2
750	6.25	15	10	3.13	7-1/2	5	1.56	3-1/2	3-1/2	1.25	3	3
1000	8.33	20	12	4.17	10	6-1/4	2.08	5	3-2/10	1.67	4	4
1500	12.5	N/A	15	6.25	15	10	3.13	7-1/2	5	2.5	6-1/4	4
2000	16.66	N/A	20	8.33	20	12	4.17	10	6 1/4	3.33	8	5

NOTE:

Recommended fuse sizes per NEC Article 450-3.

Transformers with primary only, select protection at 125%, if a standard size rating is not available, go to next higher rating.

Transformers with primary only and current rating is less than 9 A, select protection at no more than 167%.

Transformers with primary only and current rating is less than 2 A, select protection at no more than 300%.

Transformers with primary and secondary, select primary protection at not more than 250% and secondary at 125%.

If a standard size rating is not available, go to next higher standard rating.

Primary Fusing to Meet CE

Table 46 - Recommended Fuse Sizes for the PRIMARY (use time delay fuses) for CE Applications

CE VA Rating	Primary Voltage							
	120 V	208 V	240 V	277 V	380 V	416 V	480 V	600 V
25	1/2	3/10	2/10	2/10	1/10	1/10	1/10	1/10
50	1	6/10	1/2	4/10	3/10	3/10	2/10	2/10
75	1-1/2	8/10	6/10	6/10	4/10	4/10	3/10	3/10
100	2	1-1/8	1	8/10	6/10	6/10	1/2	4/10
150	3	1-8/10	1-1/2	1-1/4	8/10	8/10	6/10	6/10
160	3-2/10	1-8/10	1-6/10	1-4/10	1	8/10	8/10	6/10
200	4	2-1/4	2	1-8/10	1-1/4	1-1/8	1	8/10
250	4	3	2-1/2	2	1-6/10	1-1/2	1-1/4	1
300	5	3-1/2	3	2-1/2	1-8/10	1-8/10	1-1/2	1-1/8
500	7-1/2	4	3-2/10	4-1/2	3-2/10	3	2-1/2	2
630	9	6	5	4-1/2	4-1/2	4-1/2	3-1/2	3
1000	15	8	6-1/4	6	4	4	4	4
1500	15	12	10	9	6-1/4	6	6-1/4	5
2000	20	12	12	12	8	8	7	7
3000	n/a	25	25	20	15	15	12	12

NOTE: Recommended fuse sizes according to testing, EN 61558.

Secondary Fusing to Meet NEC and CE

Table 47 - Recommended Fuse Sizes for the SECONDARY to Meet NEC and CE

VA	24 Volts		120 Volts		240 Volts	
	Secondary Current Rating	Fuse Rating	Secondary Current Rating	Fuse Rating	Secondary Current Rating	Fuse Rating
25	1.04	8/10	0.21	3/10	0.1	15/100
50	2.08	3	0.42	6/10	0.21	3/10
75	3.13	5	0.63	1	0.31	1/2
100	4.17	6	0.83	1-1/4	0.42	6/10
150	6.25	10	1.25	2	0.63	1
200	8.33	12	1.67	2-1/2	0.83	1-1/4
250	10.42	15	2.08	3	1.04	1-3/4
300	12.5	20	2.5	4	1.25	2
350	14.58	20	2.92	5	1.46	2-1/2
500	20.83	30	4.17	7	2.08	3
750	n/a	n/a	6.25	10	3.13	5
1000	n/a	n/a	8.33	12	4.17	7
1500	n/a	n/a	12.5	15	6.25	10
2000	n/a	n/a	16.67	20	8.33	12

NOTE:

Recommended fuse sizes according to NEC Article 450-3.

Secondary select protection at 125%, if a standard size rating is not available, go to next higher standard size rating.

Current rating is less than 9 A, select protection at not more than 167%.

Type TF Transformers

120 Volt Control Secondary—Primary and Secondary Fuse Block

Table 48 - Voltage and Connection Options

Voltage Code	Voltages		Connections	
	Primary	Secondary	Primary	Secondary
D1	220 x 440 230 x 460 240 x 480	110 115 120	220 or 230 or 240: Connect to H1 and H4 Jumper H1 with H3 Jumper H2 with H4 440 or 460 or 480: Connect to H1 and H4 Jumper H2 with H3	Connect to X1 and X2

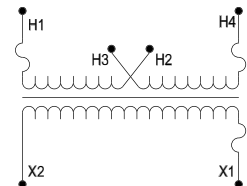

Table 49 - Dimensions

VA		Catalog Number	Fig.	Acc. Key	A		B		C		E		F		Slots	
UL	CE				in.	mm	in.	mm	in.	mm	in.	mm	in.	mm	in.	mm
25	25	9070TF25D1	40	I	3.09	79	3.00	76	4.00	102	2.00	51	2.50	64	0.20 x 0.38	5 x 10
50	50	9070TF50D1	40	I	3.09	79	3.00	76	4.00	102	2.00	51	2.50	64	0.20 x 0.38	5 x 10
75	75	9070TF75D1	40	I	3.34	85	3.38	86	4.18	106	2.38	61	2.81	71	0.20 x 0.48	5 x 12
100	100	9070TF100D1	40	I	3.34	85	3.38	86	4.18	106	2.38	61	2.81	71	0.20 x 0.48	5 x 12
150	150	9070TF150D1	40	I	3.59	91	3.75	95	4.50	114	2.88	73	3.13	80	0.20 x 0.38	5 x 10
200	200	9070TF200D1	40	I	3.59	91	3.75	95	4.50	114	2.88	73	3.13	80	0.20 x 0.38	5 x 10
250	160	9070TF250D1	41	I	5.30	135	3.75	95	4.50	114	2.88	73	3.13	80	0.20 x 0.38	5 x 10
300	200	9070TF300D1	41	I	4.74	120	4.50	114	5.13	130	2.56	65	3.75	95	0.20 x 0.38	5 x 10
350	250	9070TF350D1	41	I	5.11	130	4.50	114	5.13	130	3.00	76	3.75	95	0.20 x 0.38	5 x 10
500	300	9070TF500D1	41	I	5.49	139	4.50	114	5.13	130	3.56	90	3.75	95	0.20 x 0.38	5 x 10
750	500	9070TF750D1	41	I	5.61	143	5.25	133	5.80	147	3.43	87	4.38	111	0.28 x 0.56	7 x 14
1000	630	9070TF1000D1	41	I	6.30	160	5.25	133	5.80	147	4.31	109	4.38	111	0.28 x 0.56	7 x 14
1500	1000	9070TF1500D1	41	I	5.92	150	7.06	179	7.46	190	4.13	105	5.81	148	0.28 x 0.56	7 x 14
2000	1500	9070TF2000D1	41	I	7.17	182	7.06	179	7.46	190	4.56	116	5.81	148	0.28 x 0.56	7 x 14

Figure 36 -

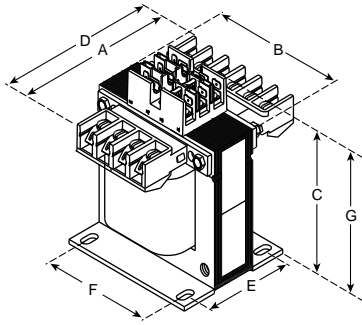
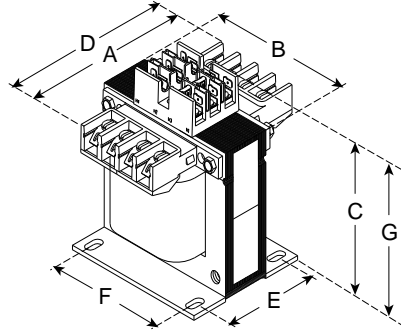

Figure 37 -



MultiTap for 120 Volt Control Secondary—Primary and Secondary Fuse Block

Table 50 - Voltage and Connection Options

Voltage Code	Voltages		Connections	
	Primary	Secondary	Primary	Secondary
D20	208 230 460	115	208: Connect to H1 and H2 230: Connect to H1 and H3 460: Connect to H1 and H4	Connect to X1 and X2

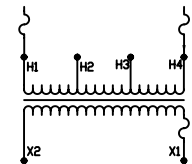

Table 51 - Dimensions

VA		Catalog Number	Fig.	Acc. Key	A		B		C		E		F		Slots	
UL	CE				in.	mm	in.	mm	in.	mm	in.	mm	in.	mm	in.	mm
25	25	9070TF25D20	42	II	3.09	79	3.00	76	4.00	66	2.00	51	2.50	64	0.20 x 0.38	5 x 10
50	50	9070TF50D20	42	II	3.34	85	3.38	86	4.18	73	2.38	61	2.81	71	0.20 x 0.48	5 x 12
75	75	9070TF75D20	42	II	3.34	85	3.38	86	4.18	73	2.38	61	2.81	71	0.20 x 0.48	5 x 12
100	100	9070TF100D20	42	II	3.59	91	3.75	95	4.50	81	2.88	73	3.13	80	0.20 x 0.38	5 x 10
150	150	9070TF150D20	42	II	3.59	91	3.75	95	4.50	81	2.88	73	3.13	80	0.20 x 0.38	5 x 10
200	200	9070TF200D20	43	II	4.70	119	3.75	95	4.50	114	2.88	73	3.13	80	0.20 x 0.38	5 x 10
250	160	9070TF250D20	43	II	4.74	120	4.50	114	5.13	98	2.56	65	3.75	95	0.20 x 0.38	5 x 10
300	200	9070TF300D20	43	II	5.11	130	4.50	114	5.13	98	3.00	76	3.75	95	0.20 x 0.38	5 x 10
350	250	9070TF350D20	43	II	5.49	139	4.50	114	5.13	98	3.56	90	3.75	95	0.20 x 0.38	5 x 10
500	300	9070TF500D20	43	II	5.61	143	5.25	133	5.80	115	3.43	87	4.38	111	0.28 x 0.56	7 x 14
750	500	9070TF750D20	43	II	6.30	160	5.25	133	5.80	115	4.31	109	4.38	111	0.28 x 0.56	7 x 14

Table 51 - Dimensions (Continued)

VA		Catalog Number	Fig.	Acc. Key	A		B		C		E		F		Slots	
UL	CE				in.	mm	in.	mm	in.	mm	in.	mm	in.	mm	in.	mm
1000	630	9070TF1000D20	43	II	5.92	150	7.06	179	7.46	157	4.13	105	5.81	148	0.28 x 0.56	7 x 14
1500	1000	9070TF1500D20	43	II	7.17	182	7.06	179	7.46	157	4.56	116	5.81	148	0.28 x 0.56	7 x 14
2000	1500	9070TF2000D20	43	II	6.38	162	9.00	229	8.92	227	4.63	118	7.63	194	0.44 x 1.13	11 x 29

Figure 38 -

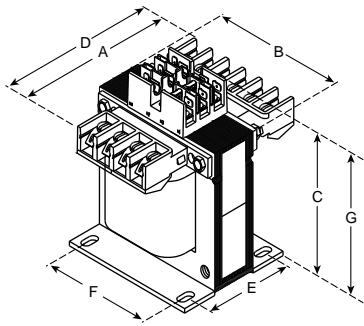
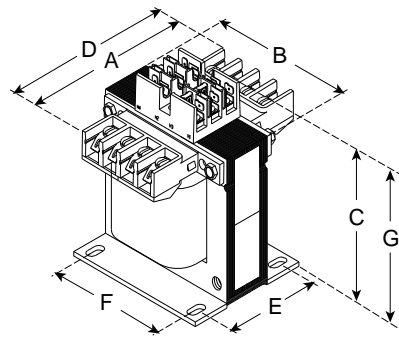

Figure 39 -



Field Installed Fuse Options

Primary Fusing

Figure 40 - FB2A

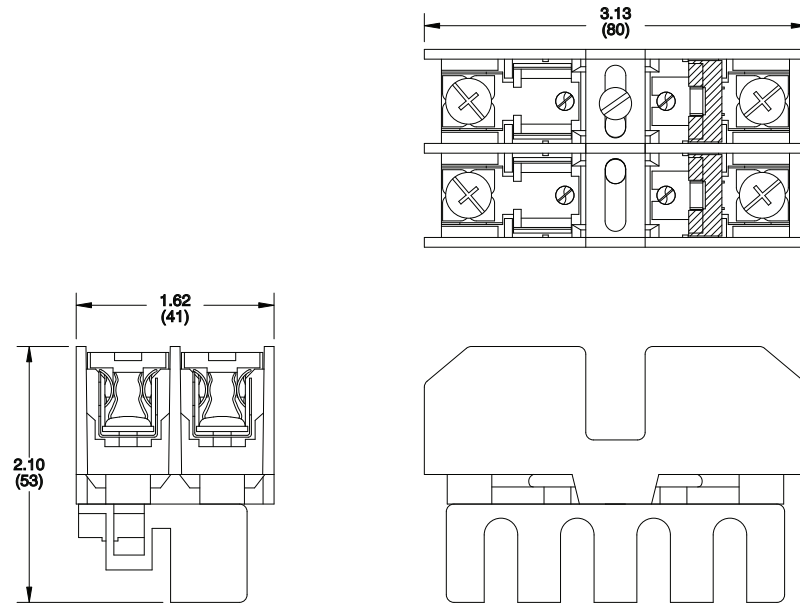
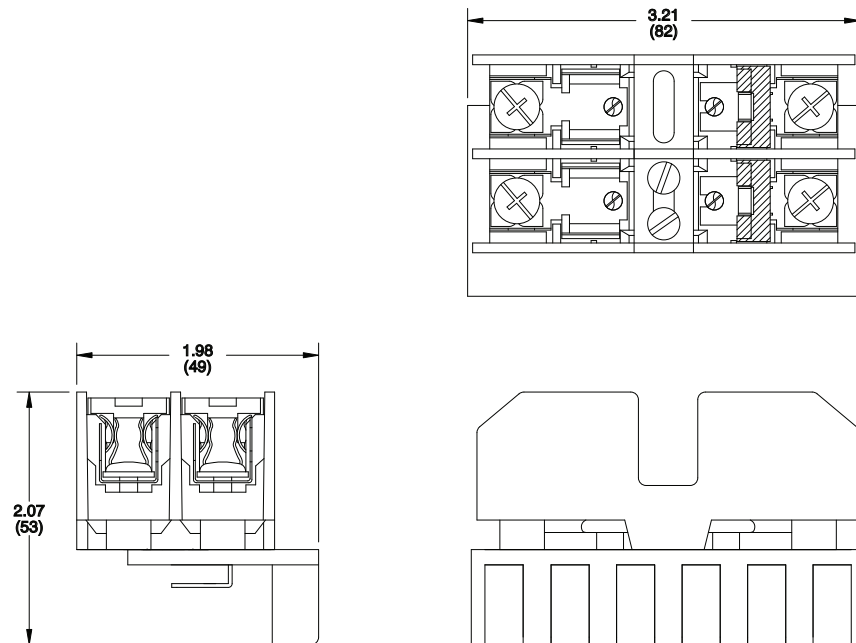

Figure 41 - FB2B



Dimensions: in (mm)

Figure 42 - R01A

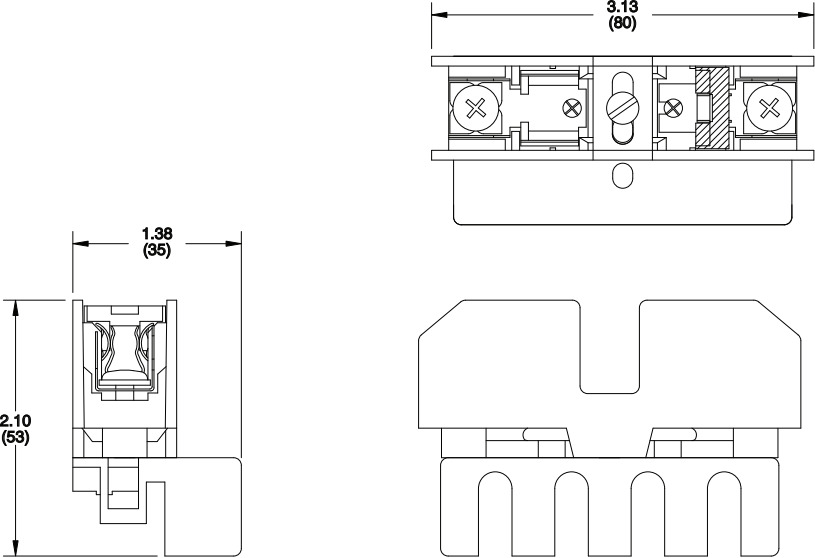
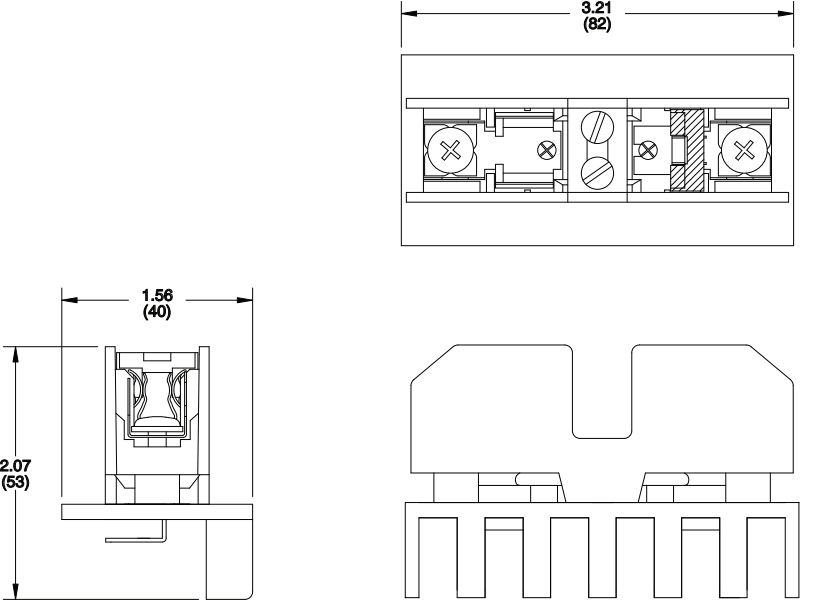

Figure 43 - R01B



Dimensions: in (mm)

Primary and Secondary Fusing

Figure 44 - FB3A

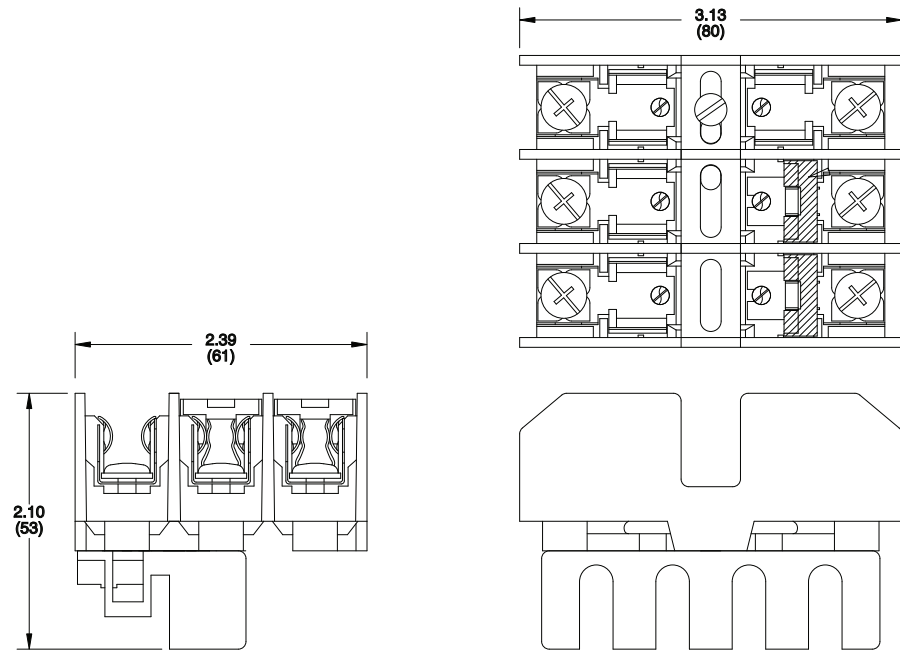
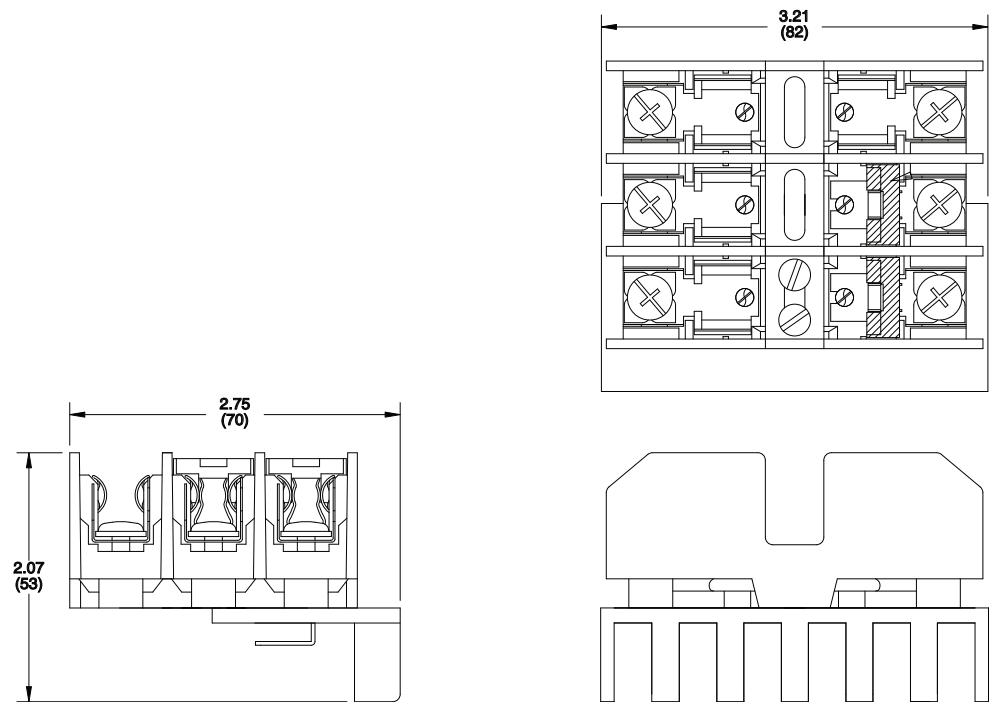

Figure 45 - FB3B



Dimensions: ⁱⁿ
(mm)

Figure 46 - R11A

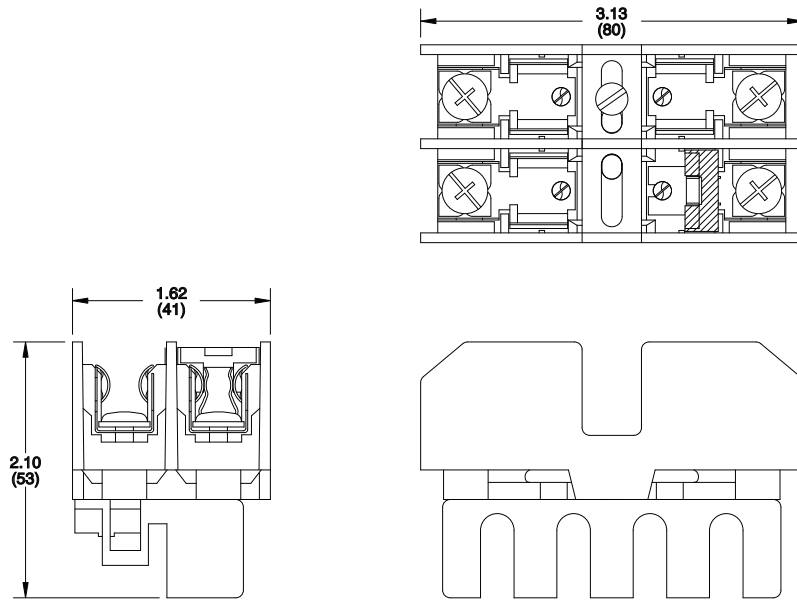
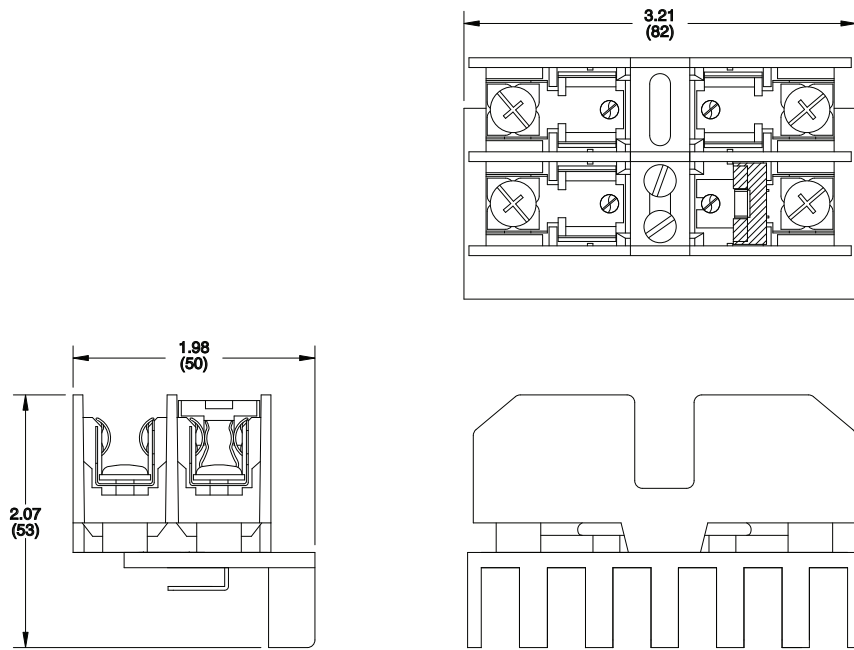

Figure 47 - R11B



Dimensions: in (mm)

Figure 48 - R12A

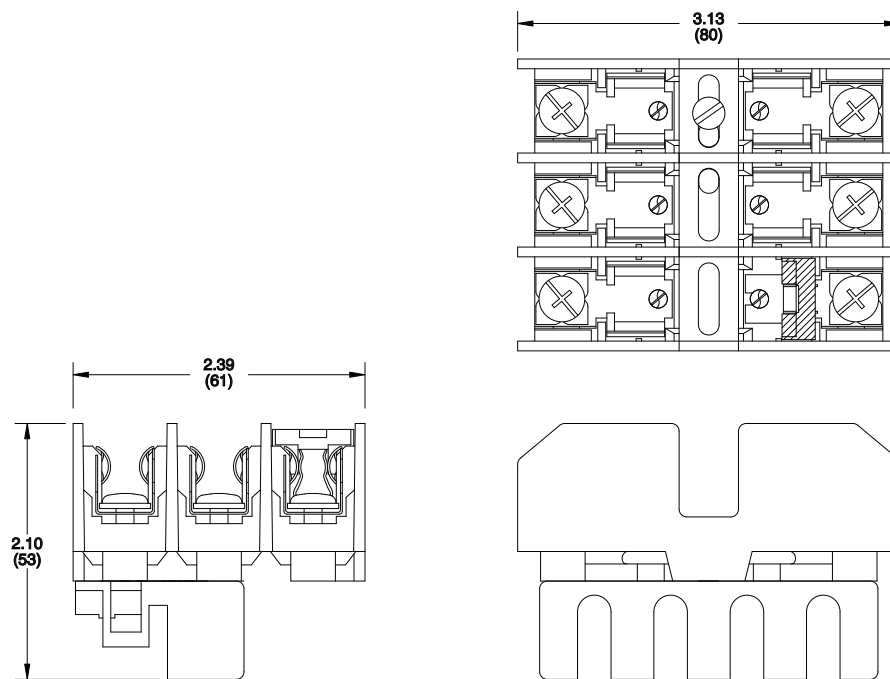
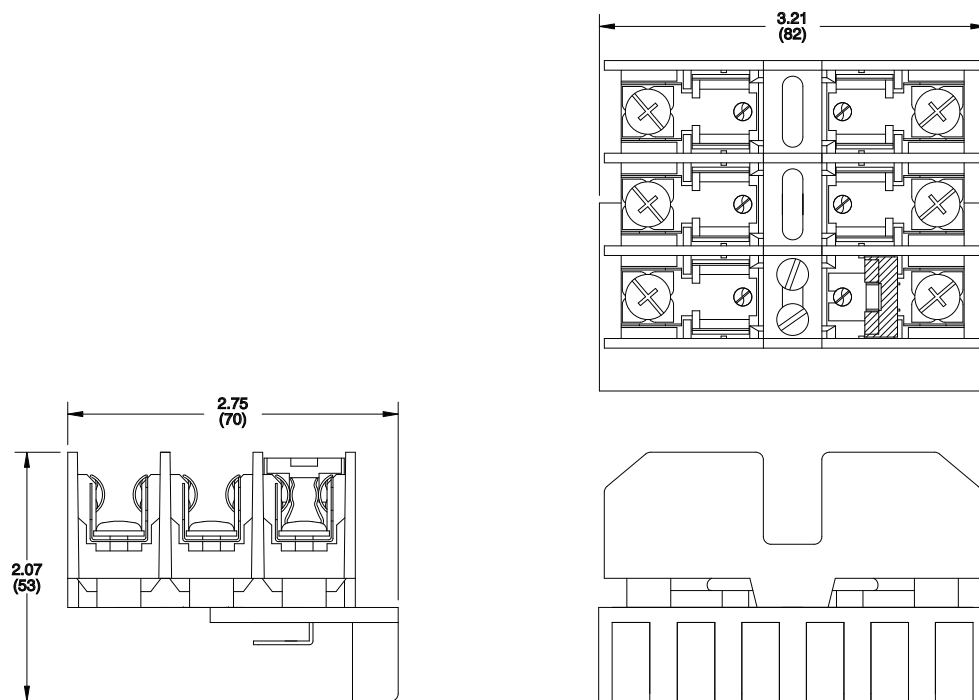

Figure 49 - R12B



Dimensions: in (mm)

Secondary Fusing

Figure 50 - FB1A

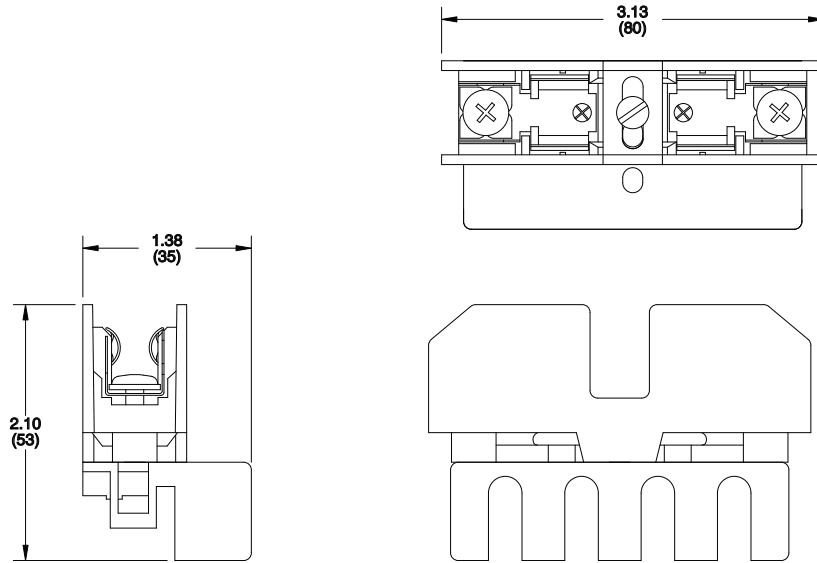
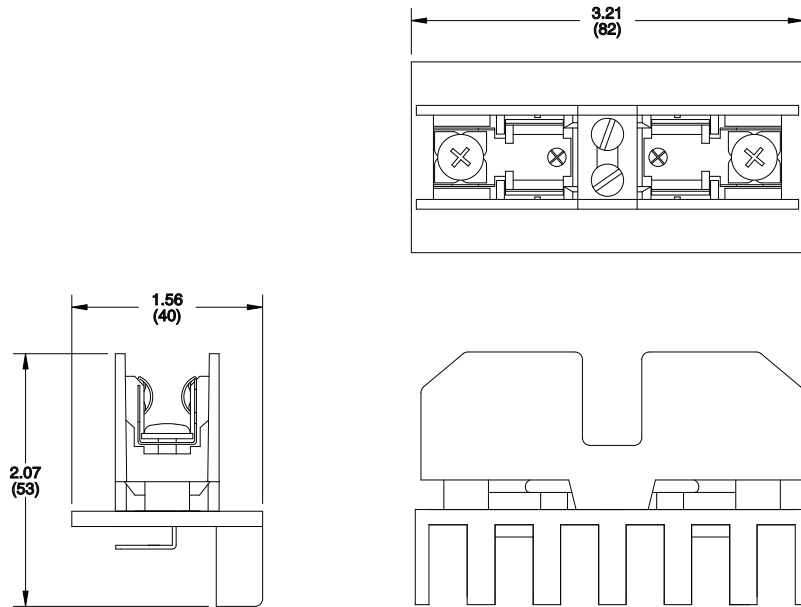

Figure 51 - FB1B



Dimensions: in (mm)

Figure 52 - S22A

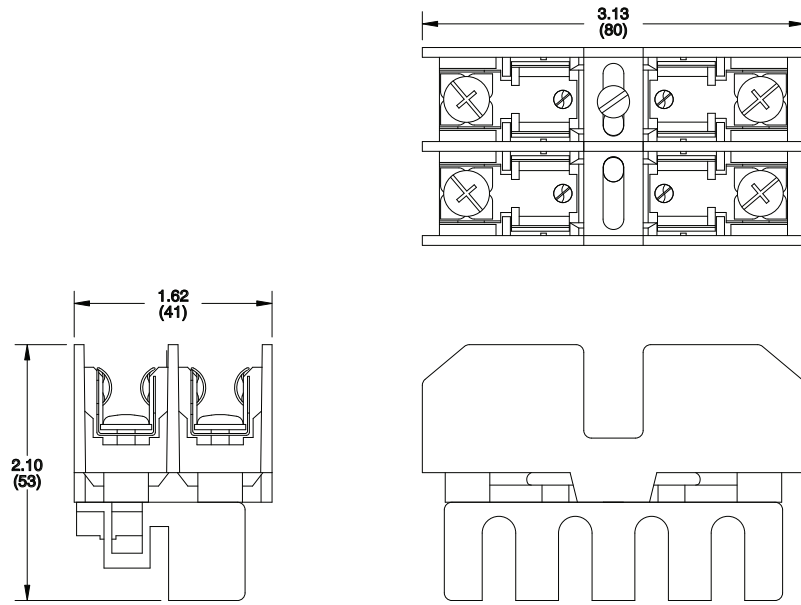
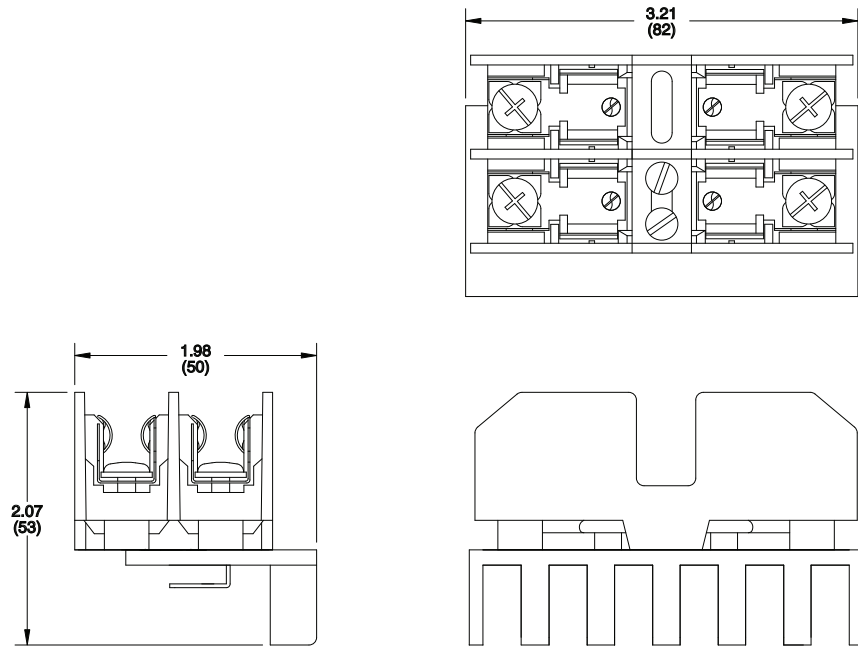

Figure 53 - S22B



Dimensions: in (mm)

Figure 54 - SF25A

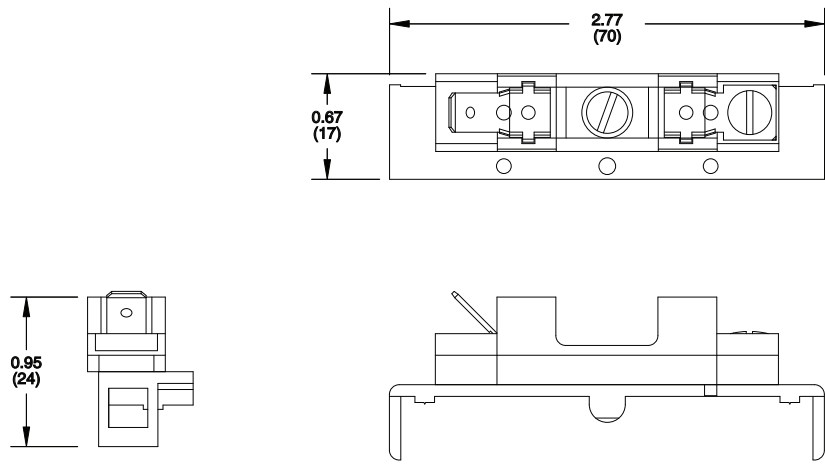
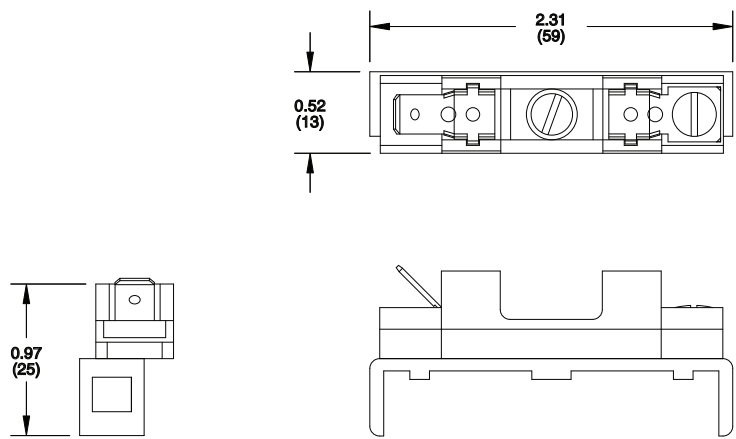

Figure 55 - SF25B



Dimensions: in (mm)

Figure 56 - AP1

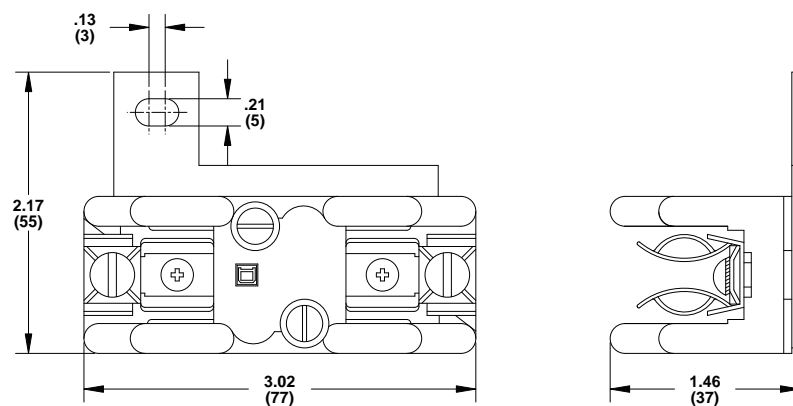
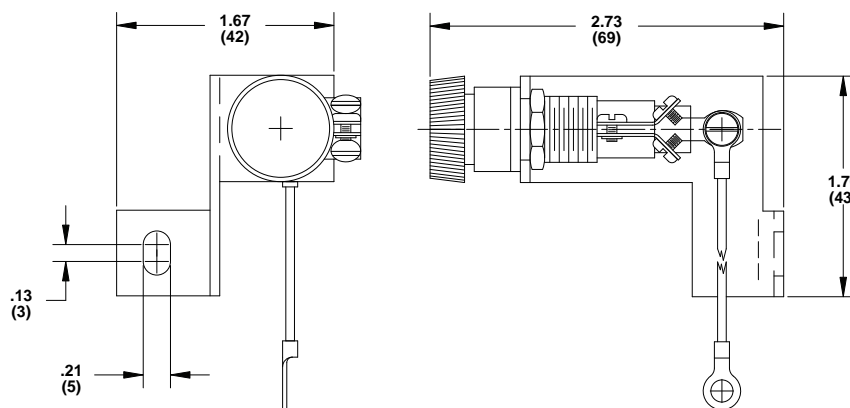

Figure 57 - AP2



Dimensions: in (mm)

Secondary Fuse Clips

Figure 58 - SF41A

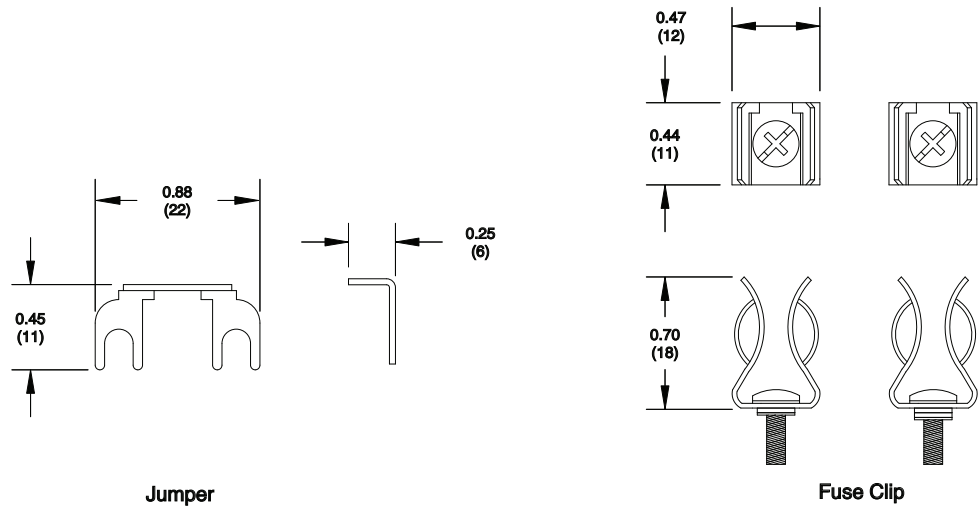
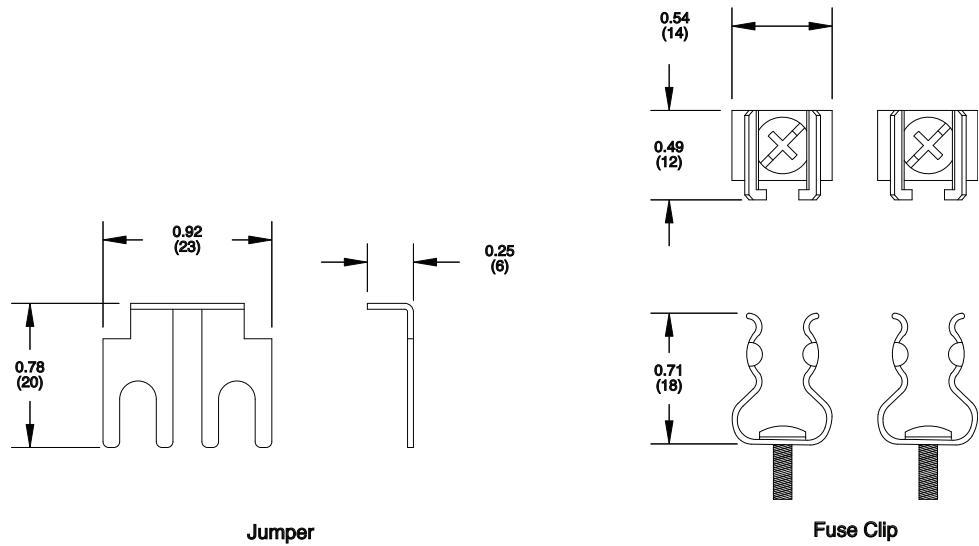

Figure 59 - SF41B



Dimensions: in (mm)

Terminal Blocks

Figure 60 -

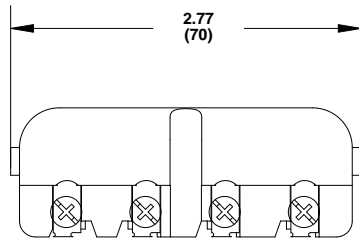

25–200 VA: Key I
25–150 VA: Key II

Screw size: 6-32
Ring lug: #6 stud with a 0.375 in. max O.D.
Torque: 6-9 in-lbs

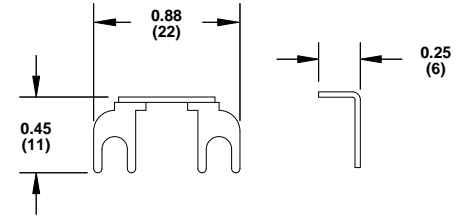

Jumper

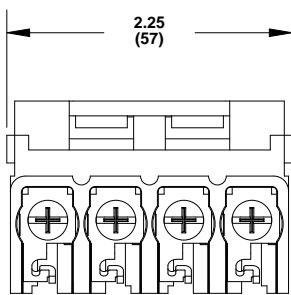

250–5000 VA: Key I
200–5000 VA: Key II

All four pole: Key III and IV

Screw size: 8-32
Ring lug: #8 stud with a 0.438 in. max O.D.
Torque: 13-16 in-lbs

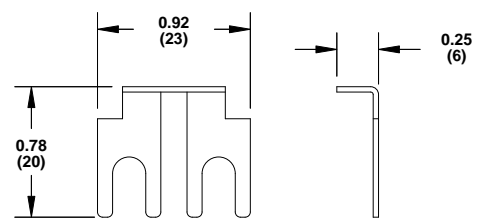

Jumper

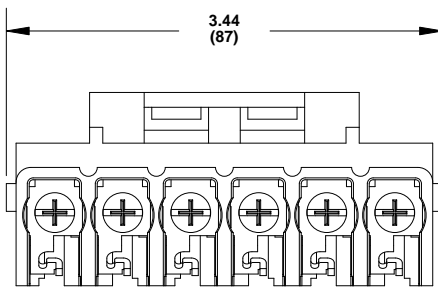

All six pole: Key III and IV

Screw size: 8-32
Ring lug: #8 stud with a 0.438 in. max O.D.
Torque: 13-16 in-lbs

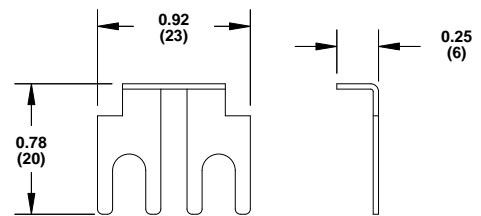

Jumper

Dimensions: in (mm)

Application

In preparation for connecting power to the primary side of dual voltage single-phase transformers, it's necessary to first wire the two windings in either series or parallel to match the incoming voltage. An example of this is common transformers with a primary voltage description of 240 x 480. The windings are rated for the lower of the two voltages show on either side of the 'x'. Connecting the windings in series allows for the higher of the two voltages. Connecting the windings in parallel allows for the lower of the two voltages.

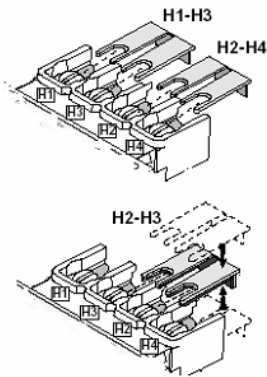

Example of Series and Parallel Connections

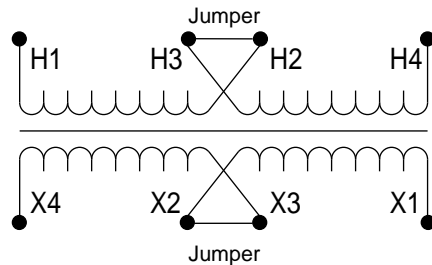

Series Connections

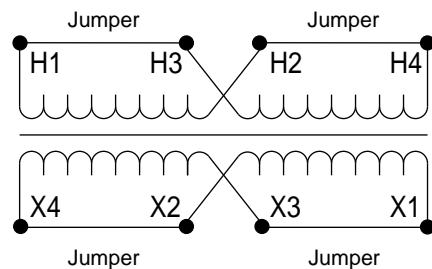

Parallel Connections

NOTE: This diagram is for illustration purposes only. Actual units will have different combinations. See diagrams for actual connections.

Example of a typical application

- OEM customer base source voltages in United States: 208, 240, or 480 volts (From past shipments 480 is 65% of the business, 208 is 20%, and 240 is 10%)
- 5% of business goes into Canada and needs 600 volts; customer always knows when equipment goes to Canada.
- Load requirement is for a 500 VA transformer, load is 120 volt control

For this customer, Schneider Electric has the following solutions:

Solution 1

Three standard units with interchangeable dimensions

9070T500D1—240 x 480 to 120; handles 75% of business. For details, see [Voltage and Connection Options](#), page 11.

9070T500D3—208 to 120; handles 20% of business. For details, see [Voltage and Connection Options](#), page 13.

9070T500D5—600 to 120; handles 5% of business. For details, see [Voltage and Connection Options](#), page 13.

Solution 2

Two MultiTap units with interchangeable dimensions

9070T500D20—208/230/460 to 115; handles 95% of business {US Voltage Code}. For details, see [Voltage and Connection Options](#), page 15.

9070T500D32—230/460/575 to 95/115; handles 5% of business {North American Voltage Code}; covers 460 and 575 Canadian sources. For details, see [Voltage and Connection Options](#), page 15.

Solution 3

One Universal Control Transformer

9070T500D50—240/416/480/600 to 99/120/130. For details, see [Voltage and Connections Options](#), page 17.

Technical Data

50/60 Hertz

Transformers that are dual rated for 50/60 Hz are truly global units and no derating is required for voltages or VA. Type T are 50/60 Hz.

Base Plates

The development of welded cores has allowed the incorporation of base plates on larger VA transformers. Base plates are usually welded to the core of the transformer for a solid connection to the transformer. They allow manufacturers to offer more standardized mounting for specific VA sizes by allowing multiple core stacks. Available for Type T transformers only.

Touch-Safe Terminals

Being able to offer touch-safe terminals is increasing in importance. Currently all equipment that must comply with EN 60-204 (Machine and Low Voltage Directives) must have some type of barrier for live parts. Besides the CE standard listed above, domestic customers are requiring barriers on live parts with voltages above 460 V. These customers allow Plexiglas® covers to be installed for these barriers.

Type T transformers can be made finger-safe by using snap-on covers that are removable with a screwdriver or other flat tool. Schneider Electric offers Fingersafe™ covers, which are sold separately. See Fingersafe™ Covers (not supplied with unit) – Compliant with IP2X per EN-60529, page 48 for ordering information.

Formed Terminal Board

Formed terminal boards are used on multiple VA ranges and different voltage combinations. This allows the manufacturer to punch jumpers for customer interconnections and gives the customer the same basic layout for all units. The snap-on covers for touch-safe terminations also are available on units with formed terminal boards. Available for Type T transformers only.

Varnish Vacuum Impregnation

This is a manufacturing process for the core and coil of industrial control transformers. The transformer is put into a tank of varnish, then the varnish is put into a vacuum, causing the varnish to be forced throughout the coil and core. After being vacuum impregnated, the units are cured in an oven to seal the varnish. The varnish is absorbed by any paper insulation system and coats other insulation with another layer of electrical strength. The process causes the coil to have a very tight connection because it is completely bonded and mechanically very strong. The cores are also tightly bonded with the varnish, causing the units to have better heat transfer and less vibration noise.

Schneider Electric uses this process on all control transformers, using a clear varnish with optimum electrical characteristics.

Frequently Asked Questions

Question	Answer
Should you consolidate your control transformer to a MultiTap or Universal Control Transformer?	<p>When a Multitap Unit might be for you:</p> <ol style="list-style-type: none"> 1. Transformer will be installed in a device whose source voltage is unknown at time of shipment; 2. Space is not critical (MultiTaps are larger than standard units); 3. You sell to markets with multiple source voltages; 4. Reduced number of parts will offset premium for MultiTap units. <p>When a MultiTap Unit might not be beneficial:</p> <ol style="list-style-type: none"> 1. High percentage of your business is 240 x 480 source voltage; 2. Space is an issue; 3. Source voltage is always known at time of shipment; 4. Source voltage changes other components in the control circuit; 5. Premium for MultiTap does not get offset by having fewer parts.
Can a 9070 type T or TF control transformer be used in a back (reverse) feed application as a step-up transformer?	No, they cannot. Industrial control transformers terminals are specifically marked "primary" and "secondary". As such, the National Electrical Code (NEC) and Underwriters Laboratories (UL) prohibit connecting the source to other than the primary terminals. Also, since industrial control transformers utilize compensated windings to accommodate the high regulation inherent in such small transformers, the resulting voltage ratio would be lower than desired. In other words, if a control transformer were reverse fed, the output voltage would be lower than desired.
Does Schneider Electric provide fuses for the primary and the secondary of a 9070 Type TF industrial control transformer?	While the 9070 Type TF industrial control transformer comes with a three-pole fuse block (two rejection-type, Class CC fuses for the primary, and one non-rejection-type, midget fuse for the secondary), Schneider Electric does not provide the fuses. Proper fuse selection is the installer's responsibility and is dictated by NEC table 450-3(b) and any specific application parameters that exist with any industrial control transformer installation.
My 9070 Type T or TF industrial control transformer has four terminals on both the primary and secondary, but only markings on the wiring diagram of H1 and H2 on the primary and X1 and X2 on the secondary. Which terminal do I use?	The nameplate of your Schneider Electric 9070 Type T or TF industrial control transformer clearly marks out that the outside terminals of each side are used for the customer installed wire connections. Schneider Electric makes a standard four- or six-terminal block for various transformer designs for commercial cost effectiveness. With only two terminals being used, it is standard practice for it to always be the outside terminals. Several different transformer voltage and wiring arrangements are shown in this catalog.
How do the 9070-FB3A, 9070-FB2A, and 9070-FB-1A fuse blocks mount on a 9070 Type T control transformer when factory installed? When field installed?	When factory installed on a 9070 Type TF control transformer, they mount on the center of the core on factory installed studs. When field installed by the customer on a 9070 Type T control transformer, they mount over one of the terminal strips using hardware supplied with the fuse block kit. (There are no studs on the 9070 Type T, only on the Type TF.)
Does Schneider Electric offer epoxy encapsulated versions of its 9070 Type T and TF control power transformers?	Schneider Electric does not offer epoxy encapsulated industrial control transformers. The 9070 Type T and TF industrial control transformer is the premier offering in the industry and is suitable for virtually any installation appropriate for a CPT.
What is the sound level for a 9070 Type T control transformer?	Sound levels for general purpose and control transformers are per NEMA ST-20 sound levels. For Type T control transformers, this level is 40dB maximum.
Are replacement jumper kits offered for Schneider Electric's 9070 Type T and TF industrial control transformers?	Yes. Replacement jumper kits contain two jumpers per kit and must be ordered in minimum quantities of 50 kits. Use kit number 30033-027-53 for Accessory Key I (25–200 VA) and Accessory Key II (25–150 VA). Use kit number 30033-027-54 for Accessory Key I (250–5000 VA), Accessory Key II (200–3000 VA), and Accessory Key III (25–3000 VA).
Do 9070 industrial control transformers contain any materials, such as PCBs, lead, or other heavy metals, that would require special disposal means?	Schneider Electric 9070 Type T and TF industrial control transformers do not contain any material that would require any special disposal means and can be disposed of in the normal manner. Since the majority of the transformer is built of recyclable material (steel, copper, etc.), Schneider Electric urges the customer to recycle the unit if possible.
What does a "triple rating" mean in terms of an industrial control transformers voltage code?	A triple rating on the control transformer's voltage code basically means that the transformer is designed to successfully operate at voltages slightly different than the nominal voltage at its full VA capacity. This is done to allow for different voltage systems that require the same voltage ratios, say 4:1 or 2:1. Example: The 9070T250D1 is a triple rated voltage code unit that can supply 250 VA with the following input voltages and the corresponding output: Input: 240 or 480 Output: 120 Input: 230 or 460 Output: 115 Input: 220 or 440 Output: 110
What is the maximum fuse ampere rating that can be used in a factory or field installed fuse block or fuse clip for a 9070 Type T control transformer?	The maximum ampere rating of the fuse blocks and fuse clips offered by Schneider Electric for the 9070 Type T control transformers is 30 amps. If higher fuse ratings are required, then the customer will have to provide the supplementary fuse holder provisions.

Question	Answer
On a 9070 Type T or TF industrial control transformer with more than one secondary voltage available, can more than one secondary voltage be utilized or only one?	The capabilities of the various 9070 Type T and TF transformers vary widely. Some units can only have one voltage out with a given voltage in. Others can have more than one. Contact your Schneider Electric representative for assistance. If a satisfactory model is not available, Schneider Electric has the capability of building virtually any industrial control transformer a customer may need.
What does the CE VA rating mean in selecting a 9070 Type T control transformer?	The CE mark is the official marking required by the European Community for all Electric and Electronic equipment that will be sold, or put into service for the first time, anywhere in the European community. CE VA is the rated capacity of the control transformer according to the CE standard. By bearing the CE marking, a transformer can be sold into any of the participating European countries without having to first clear with that country whether it will accept the UL rating.
An installer had been told by an electrical engineer to ground a 9070 Type T control transformer's frame to the enclosure with a star washer. If this is so important, why does Schneider Electric plate the base of the transformer?	The 9070s base is plated to keep it from rusting. Schneider Electric does not provide grounding provisions on transformer, as grounding is the responsibility of the installer per NEC requirements.
Does a Schneider Electric 9070 Type T or TF industrial control transformer have any continuous overload capacity? What about momentary overloads due to high inrush loads, such as may occur with a coil on a contactor?	Transformers are 100% rated devices. As such, they do not have any continuous overload capacity. They are specifically designed for momentary current draw in excess of their rating for high inrush type loads.
Does a 9070 Type T or TF transformer need to have its impedance listed on its nameplate to be used in any particular area in the world?	Industrial control transformers do not have to list their impedance on their nameplate. They can be used anywhere in the world where their UL, CSA, or CE listing allows, or where they are allowed by the local jurisdiction.
What is the difference between an old 9070 Type K transformer and a new 9070 Type T?	The CE rated, NOM approved Type T transformer replaces the Type K, which is no longer available. The Type T matches the Type K in function and form, but not necessarily in fit, i.e., the dimensions may vary.
Does Schneider Electric offer finger-safe covers for use with 9070 Type T and TF transformer fuse blocks?	The fuse puller accessories (9070FP1) do offer some protection when used and the fuse is in place, however they do not qualify the block for any additional standards. While the fuse block is CE marked, the fuse puller kit does not comply with European standards for finger-safe, as it does not require a tool to remove it. However, this may not be critical as Schneider Electric does not recommend shipping our fuse block or 9070TF to Europe, as the fuses used there are different than those used in North America. Thus, the customer should supply their own fuse block suitable for the European fuses when the transformer is to be used in Europe.
Can a 9070 Type T control power transformer or a general purpose transformer be used to provide power for 24V lighting, 120V to 24V application?	The NEC requires the transformer feeding the low voltage lighting system to be a part of the UL listed lighting system as assembled by the Original Equipment Manufacturer (OEM). A contractor, distributor, or end user cannot assemble their own low voltage lighting system and comply with the NEC without going through UL. If the OEM has a particular transformer listed in their UL file, then that unit may be used. So if the Schneider Electric 9070 Type T device is part of a lighting system that is UL listed, the answer is yes.

Schneider Electric
800 Federal Street
Andover, MA 01810
USA

888-778-2733

www.se.com

As standards, specifications, and design change from time to time,
please ask for confirmation of the information given in this publication.

© 1999 – 2021 Schneider Electric. All rights reserved.

9070CT9901