

4-POLE DEFINITE PURPOSE — 600 VAC,
50-60 HZ

FULL LOAD AMPERES CODE (2)	
TYPE	FLA
14	20 FLA
24	25 FLA
34	30 FLA
44	40 FLA

COIL VOLTAGE CODE (1)	VOLTAGE	
	60 HZ	50 HZ
V14	24	24
V02	120	110
V09	208-240	220
V04	277	-
V06	480	440
V07	600	550

QUICK CONNECT TERMINALS AND
BINDER HEAD SCREWS FOR EASY
WIRING.

* = BOX LUGS #14-#6 AWG
WIRE SIZE

ELECTRICAL CLEARANCE/WIRE
BENDING SPACE

MINIMUM TO WALL OR BARRIER TO INSURE ADEQUATE
WIRE BENDING SPACE TO LUG SURFACE WHEN THE
MAXIMUM WIRE SIZE IS USED. REF NEC 430-10

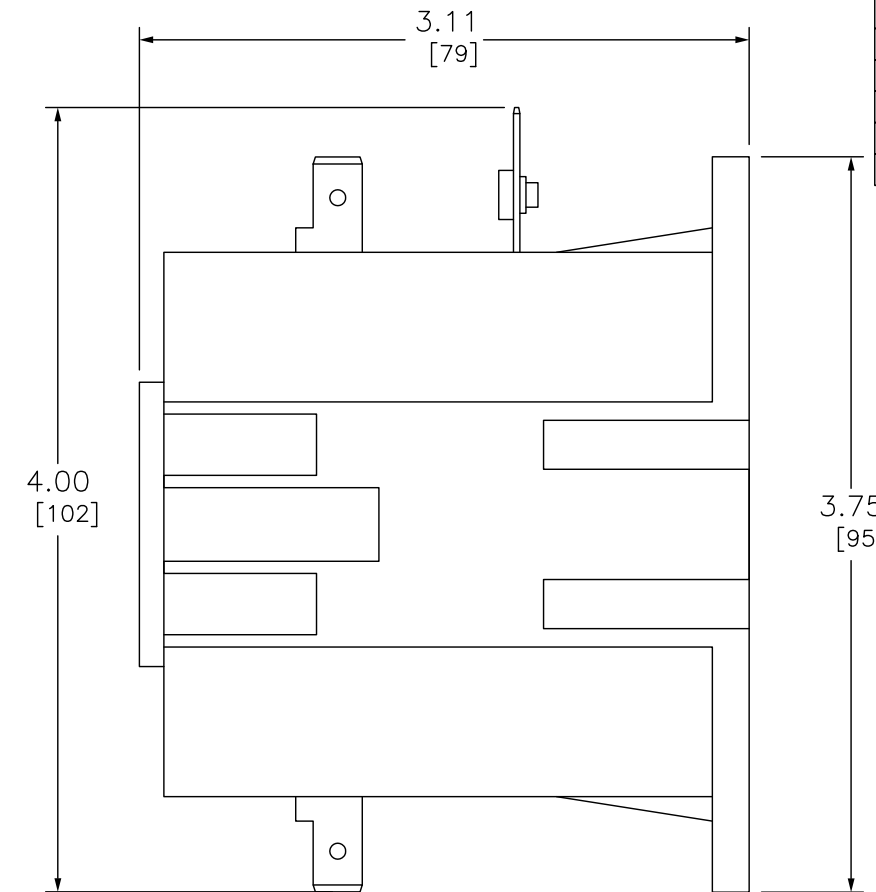
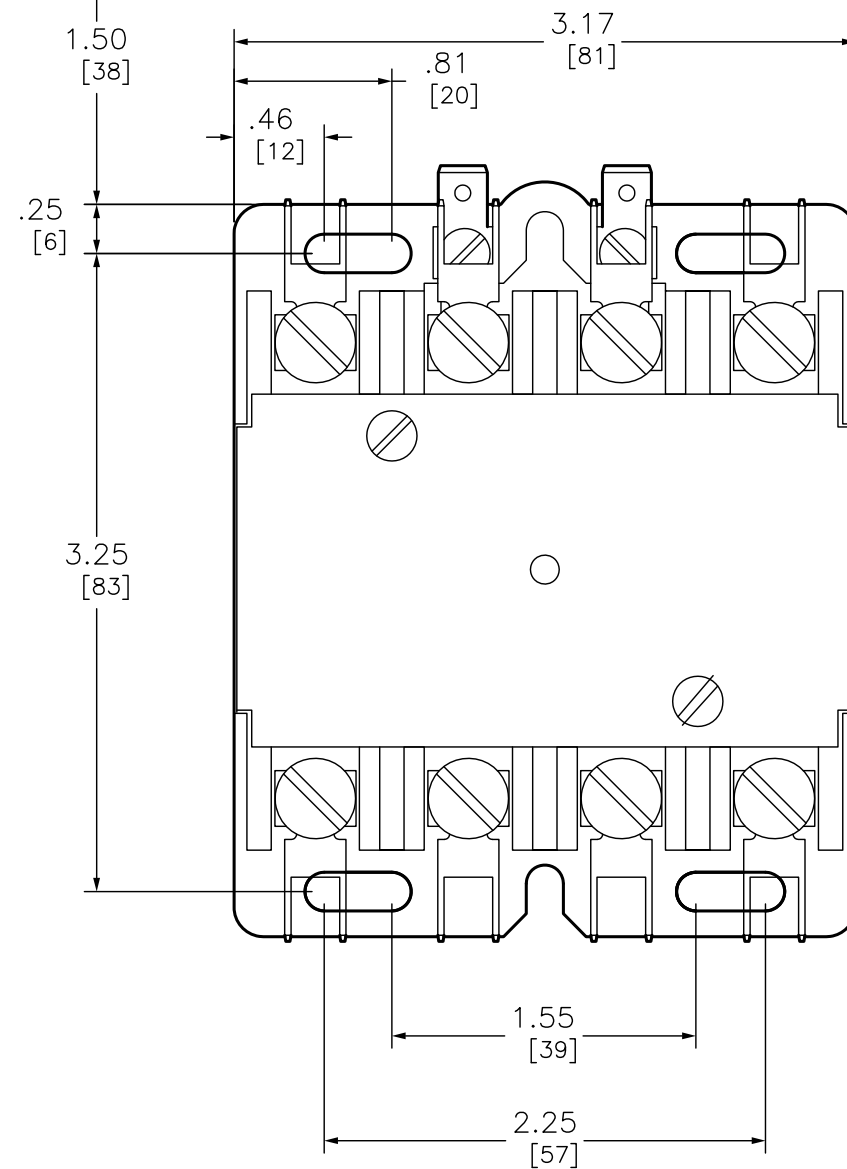

Catalog Number: 8910-DPA(2)(1)
Ratings: SEE CHART
UL File/CCN: E42240/CCN NLDX
CSA File/Class: LR25490/321104
Meets Standards: -
Weight: 1.50 LB
Wire Size: POWER -#14-#8
Terminal torque: 18lb - in (20 to 30 FLA) 25lb - in (40 FLA)
Mounting Hwd.: (4) #10 or M5 screws

DUAL DIMENSIONS: INCHES
MILLIMETERS

CONTACTOR 600VAC 30AMP DPA + OPTIONS

SQUARE D[™]
by Schneider Electric

DWG# 8910DPA34V02Y392
NO.