

Low Voltage

PowerLogic™ VL series

PF Correction Controller

User Manual





PowerLogic™ VL6 / VL12 PFC controller: to download the user manual or other documentation visit www.se.com. Type the device model (for e.g. PowerLogic™ VL12) in the search field.

Safety instructions	2
<hr/>	
Introduction	5
Packaging content	5
Dimensions	5
Mounting	5
<hr/>	
Wiring	6
Examples of electrical diagram for network voltage up to 480 VLL	6
Rear view with all connections	8
Terminal characteristics	9
Terminal description	9
<hr/>	
HMI display overview	10
Display	10
Navigation keys	10
Input of numerical values	11
<hr/>	
Menu presentation	12
Main menu	12
Measuring Values	13
INFO Menu (Step Database)	14
Menu for MANUAL operation	15
SETUP Menu (Quick start)	16
Menu ALARM	17
<hr/>	
Advanced menu presentation	18
100 Quick start menu	19
200 Measurement settings	20
300 Setup Control System	21
400 Setup Step Database	23
500 Setup Alarm	23
600 Reset menu	25
700 Communication Parameters	25
<hr/>	
Commissioning	26
Preliminary operation	26
Default configuration (Step size recognition On)	26
Step size entered manually (for panel builder pre-configuration)	28
<hr/>	
Troubleshooting	30
<hr/>	
Control algorithm	32
<hr/>	
Application	33
<hr/>	
Technical data	36
Technical characteristics	36
<hr/>	
Appendix	38

Important information

Read these instructions carefully and look at the equipment to become familiar with the device before trying to install, operate, service or maintain it. The following special messages may appear throughout this bulletin or on the equipment to warn of potential hazards or to call attention to information that clarifies or simplifies a procedure.



The addition of either symbol to a “Danger” or “Warning” safety label indicates that an electrical hazard exists which will result in personal injury if the instructions are not followed.

This is the safety alert symbol. It is used to alert you to potential personal injury hazards. Obey all safety messages that follow this symbol to avoid possible injury or death.

DANGER

DANGER indicates a hazardous situation which, if not avoided, **will result in death or serious injury**.

WARNING

WARNING indicates a hazardous situation which, if not avoided, **could result in death or serious injury**.

CAUTION

CAUTION indicates a hazardous situation which, if not avoided, **could result in minor or moderate injury**.

NOTICE

NOTICE is used to address practices not related to physical injury.

NOTE: Provides additional information to clarify or simply a procedure.

Please note

Electrical equipment should be installed, operated, serviced and maintained only by qualified personnel. No responsibility is assumed by Schneider Electric for any consequences arising out of the use of this material.

A qualified person is one who has skills and knowledge related to the construction, installation, and operation of electrical equipment and has received safety training to recognize and avoid the hazards involved.

Legal information

The Schneider Electric brand and any registered trademarks of Schneider Electric Industries SAS referred to in this guide are the sole property of Schneider Electric SA and its subsidiaries. They may not be used for any purpose without the owner's permission, given in writing. This guide and its content are protected, within the meaning of the French intellectual property code (Code de la propriété intellectuelle français, referred to hereafter as "the Code"), under the laws of copyright covering texts, drawings and models, as well as by trademark law. You agree not to reproduce, other than for your own personal, noncommercial use as defined in the Code, all or part of this guide on any medium whatsoever without Schneider Electric's permission, given in writing. You also agree not to establish any hypertext links to this guide or its content. Schneider Electric does not grant any right or license for the personal and noncommercial use of the guide or its content, except for a non-exclusive license to consult it on an "as is" basis, at your own risk. All other rights are reserved.

Electrical equipment should be installed, operated, serviced and maintained only by qualified personnel. No responsibility is assumed by Schneider Electric for any consequences arising out of the use of this material.

As standards, specifications and designs change from time to time, please ask for confirmation of the information given in this publication.

Before you begin

- This manual cannot be used to define or determine the suitability or reliability of these products for specific user applications. It is the duty of any such user or integrator to perform the appropriate and complete risk analysis, evaluation and testing of the products with respect to the relevant specific application or use thereof.
- When devices are used for applications with technical safety requirements, the relevant instructions must be followed.

DANGER

HAZARD OF ELECTRICAL SHOCK, EXPLOSION OR ARC FLASH

- Apply appropriate personal protective equipment (PPE) and follow safe electrical work practices. See NFPA 70E in the USA, CSA Z462 or applicable local standards.
- This equipment must only be installed and serviced by qualified electrical personnel.
- Do not exceed the device's ratings for maximum limits.
- Turn off all power supplying this equipment before working on or inside equipment.
- After removing power, wait 10 minutes to allow the capacitors to discharge before opening the doors or removing the covers.
- Always use a properly rated voltage sensing device to confirm power is off.
- Carefully inspect the interior for tools left behind before closing and sealing the door.
- Replace all devices, doors, and covers before turning on power to this equipment.
- Do not modify the mechanical or electrical parts.
- For installation with network nominal voltage higher than 480 V LL, add a step down transformer on voltage measurement input to comply with the PFC controller max. voltage.

Failure to follow these instructions will result in death or serious injury.

- The equipment is factory-assembled and does not require any action during the installation except those indicated below.

CAUTION

RISK OF DEGRADATION OF EQUIPMENT PERFORMANCE

Do not modify mechanical or electrical components.

Failure to follow these instructions can result in injury or equipment damage.

Packaging Content

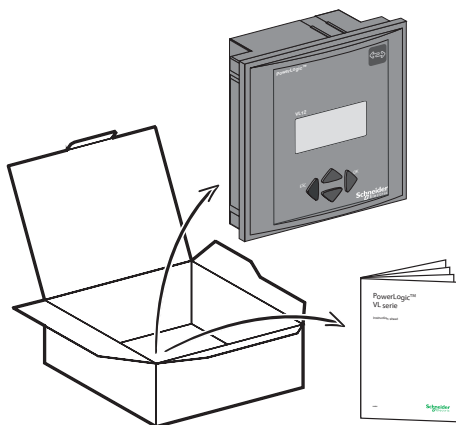

Dimensions

mm
in.

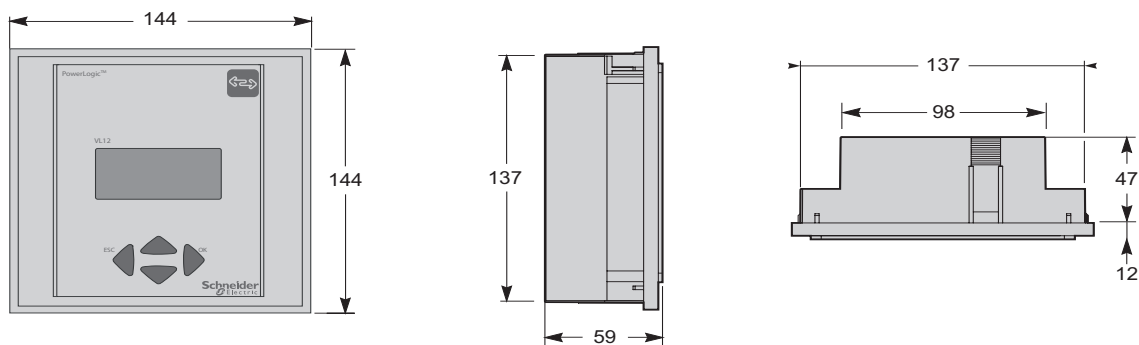

Mounting

mm
in.

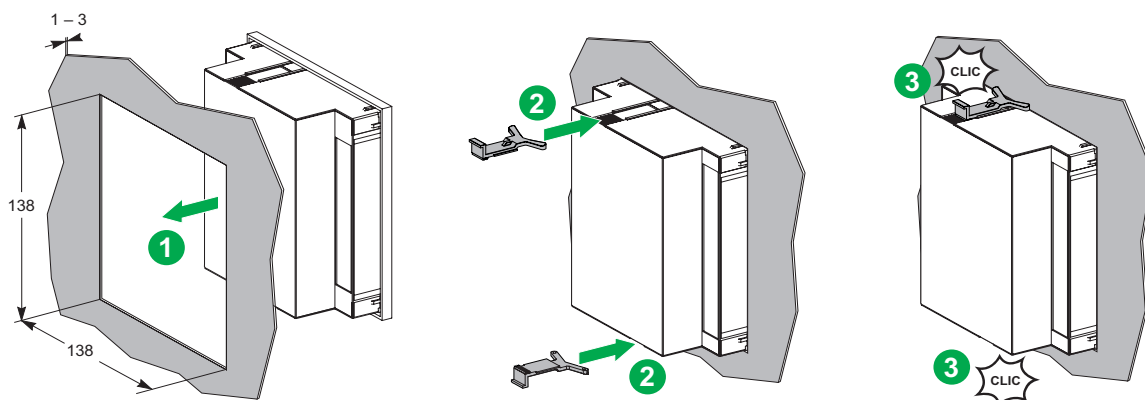

Examples of electrical diagram

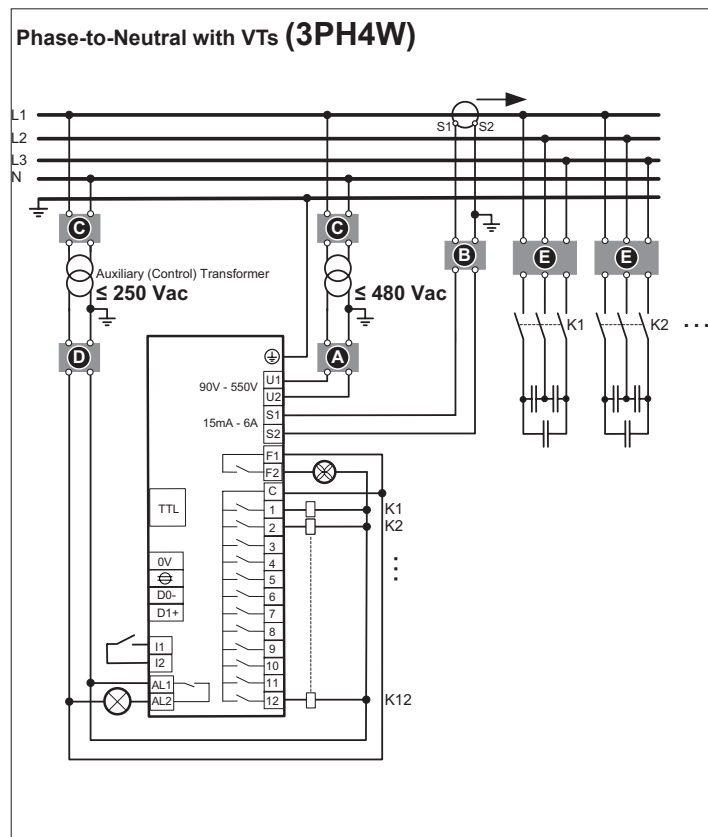
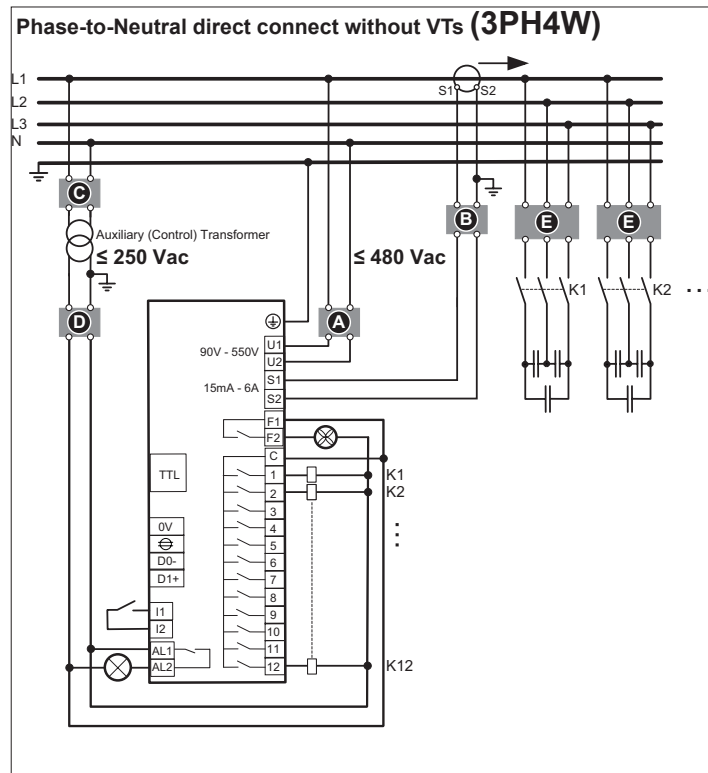

Examples of electrical diagram

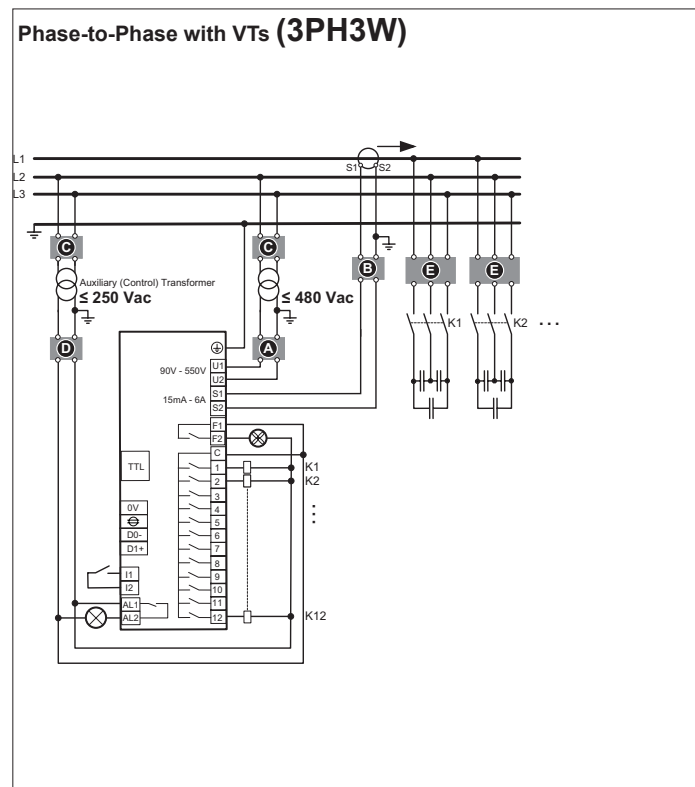
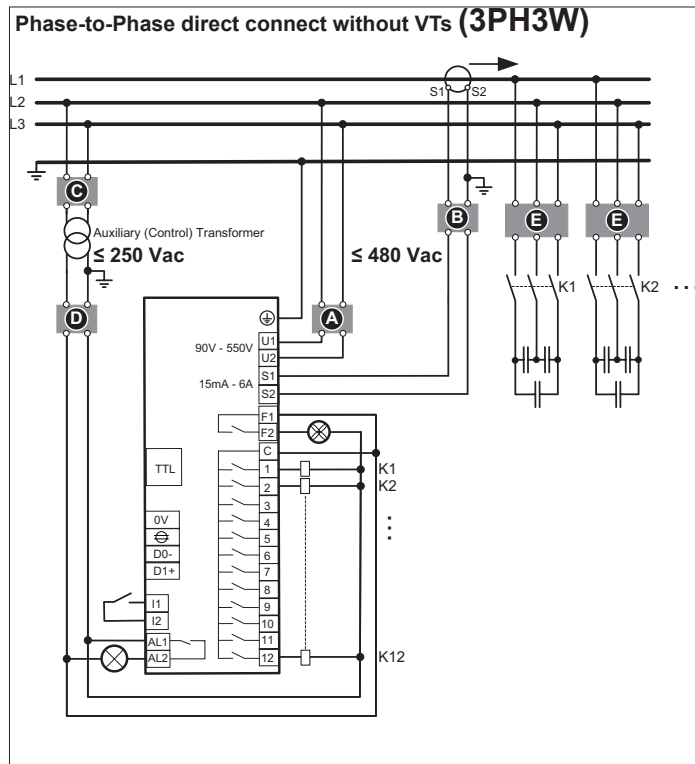

Note:

The wiring is different if you are replacing a VarLogic NR or VarLogic NRC controller with a PowerLogic™ VL controller. The wiring diagram for retrofit of VarLogic NR or VarLogic NRC with PowerLogic™ can be downloaded from www.se.com.

- A** Upstream protection
Voltage input: 2A certified circuit breakers or fuses
- B** Shorting block for CT
- C** VT primary fuses and disconnect switch
- D** Output relays: 10 A (max.) certified circuit breakers or fuses
- E** Capacitor primary fuses or circuit breakers.



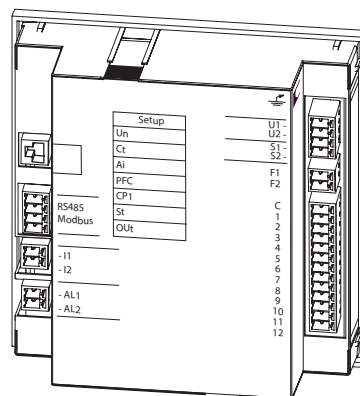

Note:

- Clearly label the device disconnect circuit mechanism and install it within easy reach of the operator.
- The fuses/circuit breakers must be rated for the installation voltage and sized for the available short-circuit fault current.
- Fuses or circuit breakers for neutral terminal are required if the source neutral connection is not grounded.
- Put the VT ratio in programming menu, if the VT is present on input voltage measurement.
- Before installation, see the wiring diagram behind the product (near the terminal), for the wiring connections.

Rear View with all Connections

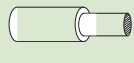
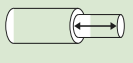

Terminal Characteristics

				
U1, U1, U2, S1, S2, F1, F2, C 1-12, AL1, AI2	0.2 - 2.5 mm ² (30 - 10 AWG)	6 mm (0.24 in)	Ø (M3)	0.5 - 5 N•m (4.4 - 44 in•lb)
I1, I2, D0-, D1+, Shield, GND	0.2 - 1 mm ² (30 - 19 AWG)			
GND	0.2 - 2.5 mm ² (30 - 10 AWG)	Faston lug 6.3 mm (0.25 in)  		

Terminal Description

Voltage input (U1, U2)	<ul style="list-style-type: none"> • Combined measurement and power supply (90-550 V, 50/60 Hz, < 10 VA). • Ph-Ph wiring: connect phase L2 to U1 and phase L3 to U2. • Ph-N wiring: connect phase L1 to U1 and Neutral to U2. • Upstream protection: 2 A max. certified circuit breaker or fuses. If using a voltage transformer, set the VT ratio in the PFC controller (see user manual sub-menu 200)
CT input (S1, S2)	<ul style="list-style-type: none"> • 1 A/5 A nominal, 15 mA to 5 A (overload 6 A max, 10 s), 10 VA burden class 1 minimum. • Install CT on phase L1 of incoming feeder and ground its secondary S2. Some specific requirements must be met, for details refer to "Appendix", page 38. • Connect CT S1 to S1 terminal and CT S2 to S2 terminal. Twist wires between the CT and PFC controller. Recommended section 2.5 mm² up to 10 m. If bigger diameter is used for longer run, use intermediate terminal. • Set the current transformer ratio CT in the PFC controller (see paragraph "setup", sub menu 100). • It may be possible to install CT and/or voltage measurement on other phase if needed: in this case, adjust the settings to ensure correct measurement (parameters 205 and 206). See user manual, sub menu 200.
Output relays (C, 1 to 12)	<ul style="list-style-type: none"> • VL6: 6 relays; VL12: 12 relays. • N/O contact, common root 10 A max. • Rating: 250 Vac/5 A - 48 Vdc/1 A. • Upstream protection: 10A max. certified circuit breaker or fuses.
Fan control (F1, F2)	<ul style="list-style-type: none"> • N/O contact. • Rating: 250 Vac/5 A - 48 Vdc/1 A.
Alarm control (AL1, AL2)	<ul style="list-style-type: none"> • The relay contact is open when the controller is energized with no alarm and will close in the event of an alarm. The relay is a NC (Normally Close) when the controller is not energized. • Rating: 250 Vac/5 A - 48 Vdc/1 A. • All circuit breakers or fuse protection must be rated for the installation voltage and sized for the available short-circuit fault current. Clearly label the device disconnect circuit mechanism and install it within easy reach of operator. If using a voltage transformer, fuse both primary and secondary sides of transformer.
Digital Input (I1, I2)	<ul style="list-style-type: none"> • To switch over to Cos φ2 target (I1, I2). Dry contact, internally supplied (5 V/10 mA) • Target Cos φ2 to be set in 303 (see user manual).
Modbus RS485 (D0-, DI1+, GND, shield)	See Modbus manual.
TTL Serial interface	Reserved for Service use.

Display

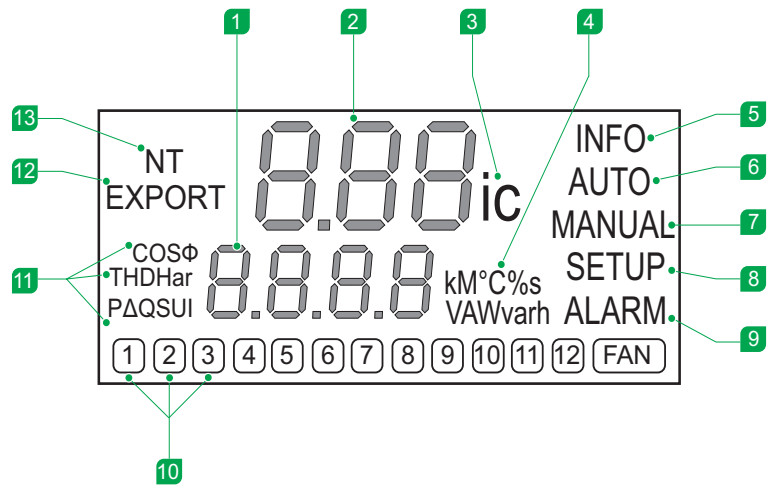

- | | |
|--|---|
| ① Digital display for measurement | ⑨ Flashing indicates Alarm is activated |
| ② Displacement Power Factor (DPF) | ⑩ Step Number illuminated when activated |
| ③ Inductive or Capacitive DPF (Lagging or Leading) | ⑪ Displayed Measurement |
| ④ Units of measurement | ⑫ Indicates exporting Power to Grid |
| ⑤ Step information | ⑬ Indicates Secondary DPF Target is activated |
| ⑥ Indicates Automatic mode | |
| ⑦ Indicates Manual Operation of Steps mode | |
| ⑧ Indicates Set Up Menu mode | |

Navigation Keys

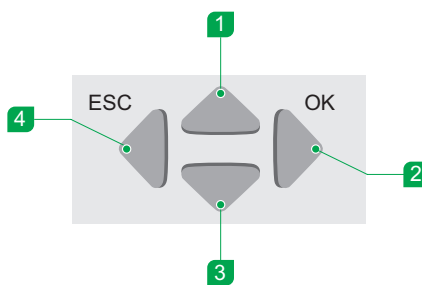

- | | |
|--|--|
| ① • Increase Values
• Select Menu Items | ③ • Decrease Values
• Select Menu Items |
| ② • Open Menu
• Move Cursor Right
• Settings | ④ • Exit Menu
• Move Cursor Left |
| ① + ③ Clear Alarms Log Buffer:
Press ▲ and ▼ for 3 seconds to clear alarm log buffer. | |

Display Parameters Explained	
NT	Two target power factors can be set on the controller. When the secondary target power factor is active, the NT light is illuminated on the display.
EXPORT	In conditions where the PFC unit is running in conjunction with a generator, the export light will be illuminated if active power is being exported to the grid (i.e., leading DPF). If there is no generator in the circuit and the light is illuminated, a connection problem is likely.
INFO	The info menu provides information regarding each step of the power factor correction unit. This includes the current size of the step in kVAr (only if the CT ratio is set), the remaining capacity of the step, the number of switch cycles and the operation of the step (automatic, permanently on or off, etc).
AUTO	The two modes of operation for the controller are automatic or manual. In automatic mode, the controller decides which steps are necessary to achieve the target power factor dependent upon the chosen switching algorithm. The Auto light is illuminated when the controller is in this mode.
MANUAL	The manual mode of operation is used when you want direct control of which steps should be on, off, etc. The manual light is illuminated when the controller is in this mode.
SETUP	The setup menu has all settings that are required to configure the controller. There is an advanced menu that can only be accessed by holding the select/continue button until the 100 menu appears. In some instances, a pin code may be required to access these menus. The PIN code is 242. After entering the code, you can navigate to all of the other menus (200, 300, 400, 500, 600, 700).
ALARM	<ul style="list-style-type: none"> Alarm(s) in progress: Alarm light is flashing alternatively with alarm(s) code(s). Alarm(s) log: displays the last five alarms that were logged. To view an alarm, enter into the menu with the ► button and scroll with the ▲ and ▼ keys. To reset the alarm log buffer, hold both ▲ and ▼ keys for 3 seconds.

Input of Numerical Values

When the controller prompts for the input of a value, the process is the same:

- A preset value is displayed with the first digit blinking.
 - You can change the digit using the ▲ and ▼ keys.
 - Use the ► button to move to the next smaller digit. Repeat the above step to change the digit.
 - After the final digit is modified, press the ► key. This position sets multipliers k (kilo) or M (Mega).
 - To store the value, press the ► key, the new value is saved
- The value is not stored if the value is outside the allowed range. For possible ranges, see the advanced menu described in this manual.
- At any time, to return to the menu without changing the value, press the ESC ◀ escape key.

Main Menu

The top menu structure is shown and described in the following pages. The ▲ and ▼ functions keys can be used to scroll between these menu items and the current menu item displayed along the right hand side of the screen. To select a menu item, press the ► function key. To step backward in the menu structure or get back to the home screen, press the ◀ key.



Measuring Values (selected using ▲, ▼)

ULL (voltage line-line), ULN voltage line-neutral), A (I), kW (P), kVar (Q), DkVar (DQ), kVA (S), THD U,3. -19. Har. U, OL, Cos φ, PF, APF, tan φ, Hz (F), °C (t), °C max (thi), operation hours (OPh).



INFO Step Database

Size and derating of steps,
Switch cycles, steptype (see menu INFO Step Database)



MANUAL Operation

Selective switching in and out of control outputs
(see menu MANUAL Operation)



SETUP Parameters

- Section 100: Quick Start menu (see menu SETUP)
- Section 200 to 700: Advanced menus. Menus are protected by a pin code 242



ALARM

- Alarm in progress: alarm is blinking, alternatively with alarm(s) code.
- Alarm menu (static message): shows the last five alarms logged (see menu ALARM)

Measuring Values

This menu displays view-only key measurements and is not configurable. Access the measurement menu from the home screen. The measurement menu is indicated when the right hand menu column is blank or displaying AUTO. All of the available measurements are shown below.

Press **▶** to enter into the measurement menu. Use the **▲**, **▼** to scroll through measurements.

Note: Grayed-out fields in this diagram are hidden and only display if the CT ratio is set in the "SETUP" menu.

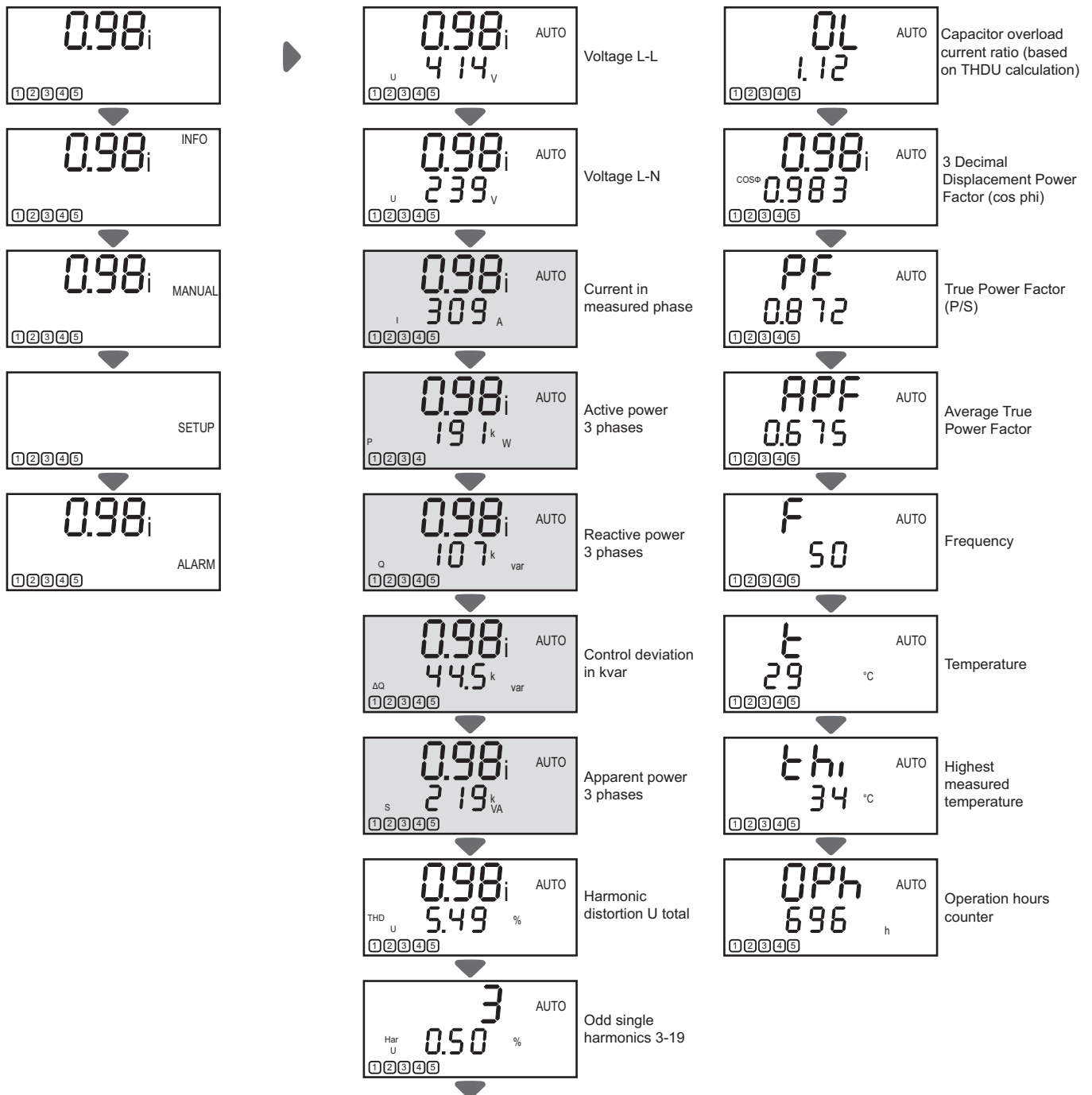

INFO Menu (Step Database)

In the INFO menu for each connected step, the controller stores the following:

- Current size (CC)
- Remaining step capacity (CC/initial step size)
- Number of switching cycles
- Step type

Using this data, conclusions can be drawn on the condition of the site and the condition of single steps.

- Step sizes are shown in kvar (only when the CT ratio is setup in Setup menu).
- The remaining step capacity (%) is displayed only when step size is entered manually, or the step size recognition mechanism is finished.

Choose step by ▲, ▼, then enter ►. The selected step blinks.
Use ▲, ▼, to select the information shown in the diagrams.

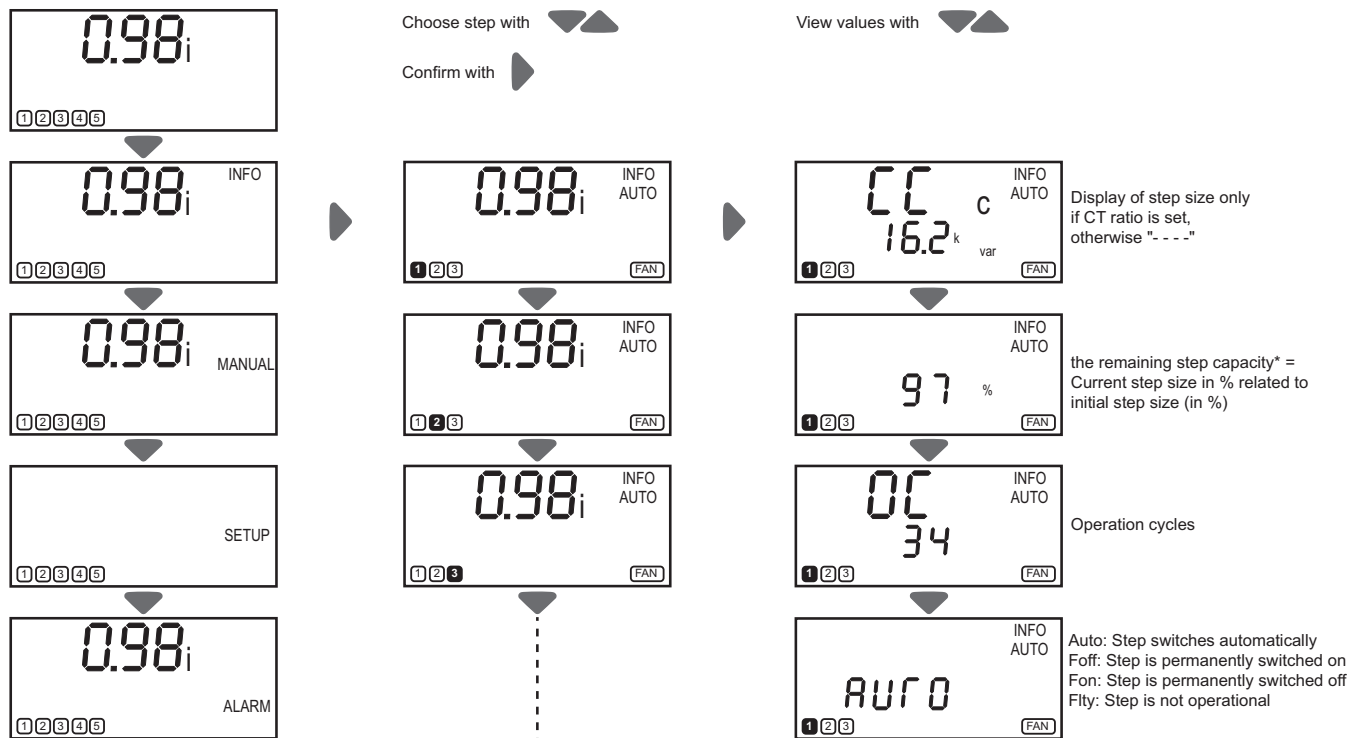

* Display of the remaining step capacity only when step recognition is finished.

Menu for MANUAL Operation

- To enter manual mode, select MANUAL from the main menu and press ► for 3 seconds. By entering the submenu, the automatic control is stopped and the outputs can be switched manually.
- Use the ▲, ▼ keys to select the step. Change the switching state by pressing the ► key.

Important Information

- Manual operation cannot be performed if the controller is in LIFO control mode and Ai is active.
- After the controller switches off an active step, the discharge time is active. The step can be switched on manually, only when the discharge time has passed.
- Manual switching is only possible when the measurement voltage is in the allowed range. Otherwise, the over- and under-voltage protection blocks this function.
- THD U-alarm, over temperature alarm, overload current ratio alarm and the hunting alarm prevents step switching in manual mode.
- Only steps with step type AUTO can be switched.
- After leaving the MANUAL menu, the controller will restart in AUTO mode. The controller returns to AUTO mode after 10 minutes without any action on the navigation keys.

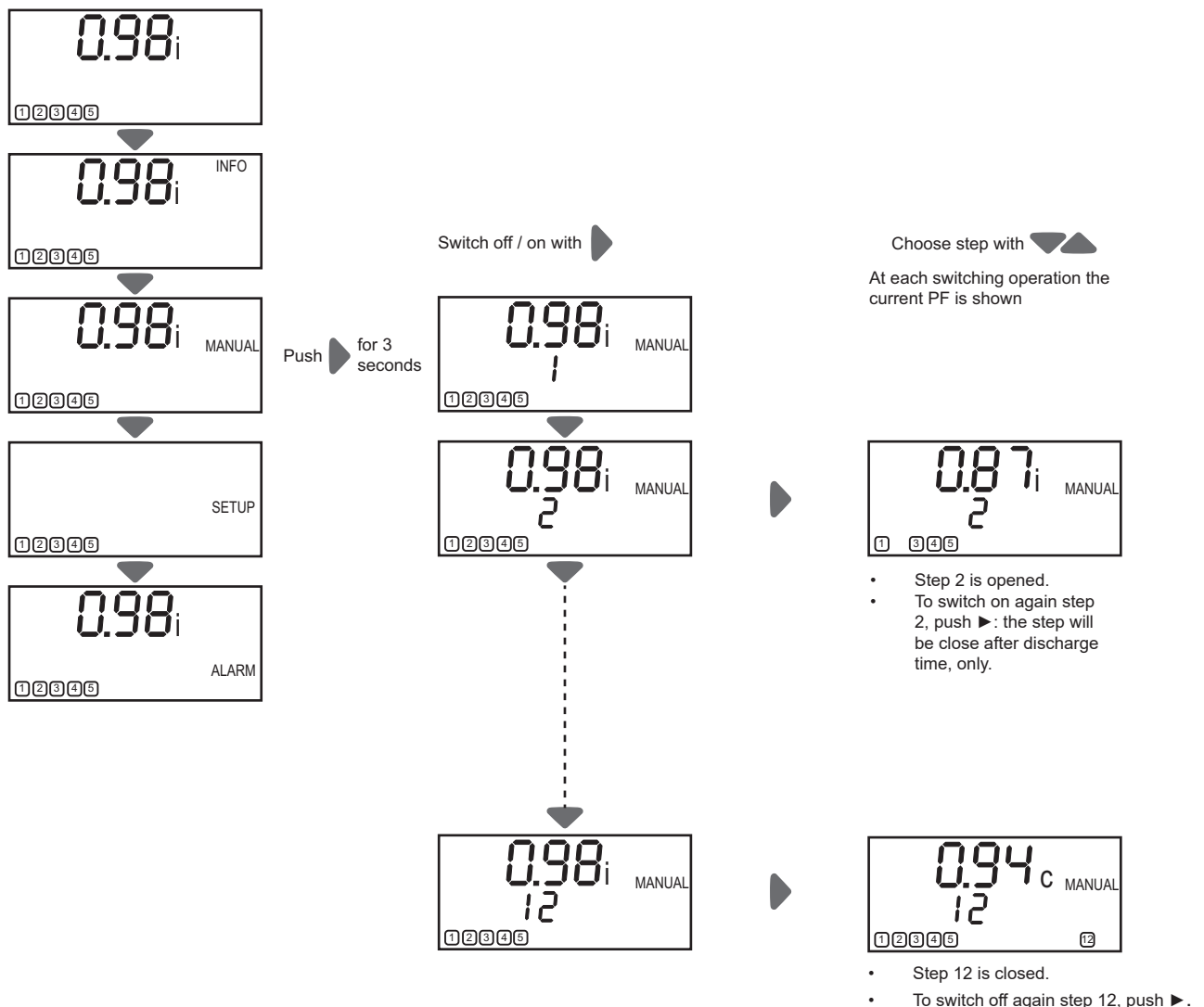

SETUP Menu (Quick Start)

The controller will start regulation if the nominal voltage set in the controller matches the voltage of the system. If your system is not 400 V, you must set the nominal voltage. The factory setting 400 V and all other settings are for optimal adaptation to the conditions of the system and to display system data appropriately.

To change a setting, press the ► key.

- Change the values with ▲, ▼ and confirm with ►.
- When you start the auto-initialization, the controller checks the connection of the measurement and outputs.
- At the end of the auto-initialization, the controller goes to Automatic mode and displays AUTO.

Note: All parameters of submenu 100 are also available in the sections 200 to 700 of Advanced menu, for example: Un = 201.

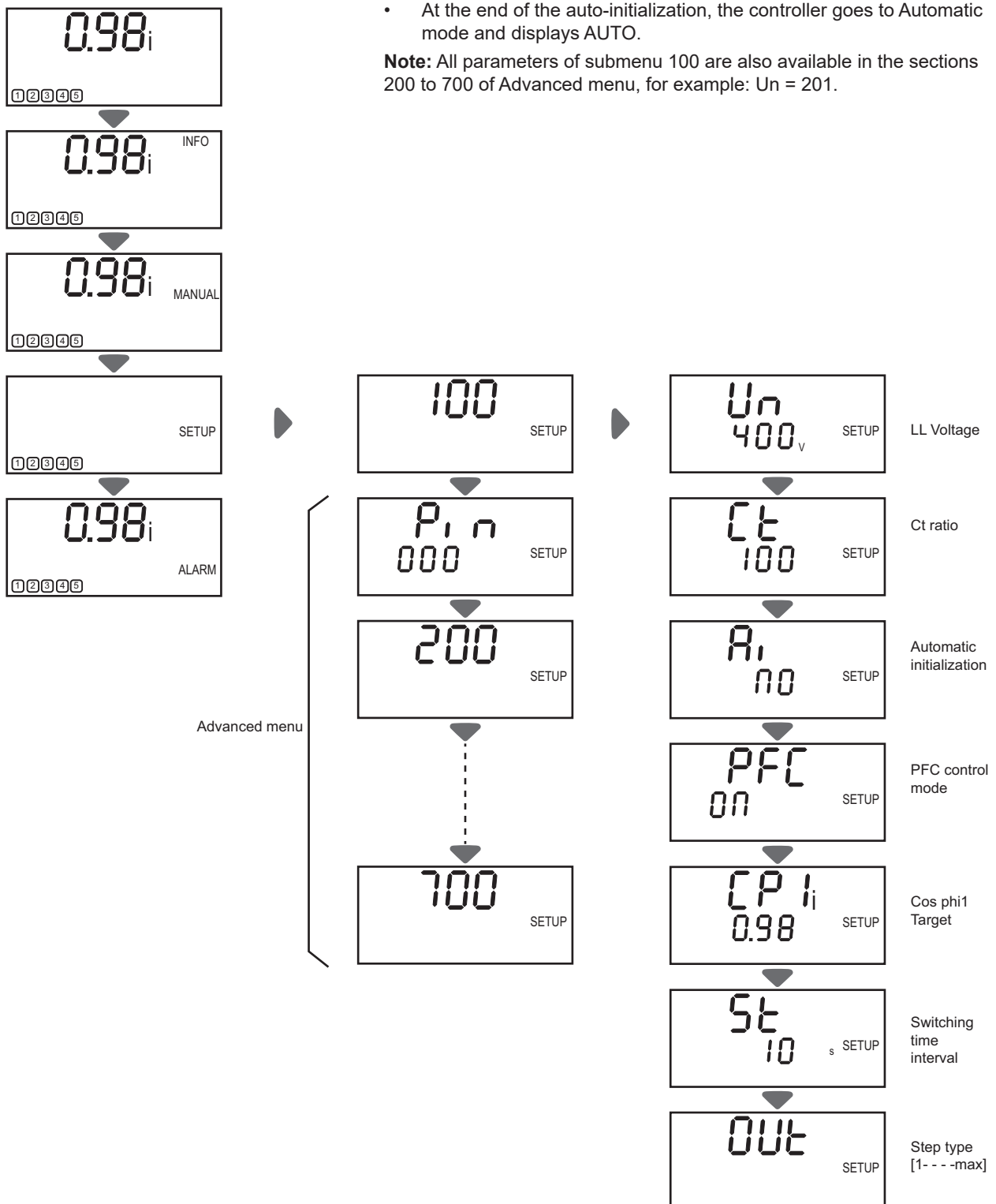

Menu ALARM

Alarm list

The table below gives an overview of all possible detected error codes. See more details about alarm settings in the section "500 Alarm Setup" on page 21.

List of alarm	
AI/Abt ALARM	This alarm is displayed when Auto-Initialization (AI) is aborted. PFC control is moved to Off (regulation is stopped).
U ALARM	Measured voltage is outside the voltage tolerance limit. Control is immediately stopped until voltage comes back into the tolerance limit.
I LO ALARM	Measured current is too low (less than 15 mA). All steps are opened in succession.
I Hi ALARM	Measured current is too high (more than 6 A). No action on control.
PFC ALARM	Under or over compensation, the controller cannot achieve the target Cos φ. No action on control.
HAr ALARM	THDU limit is exceeded. Steps are switched off until the alarm condition disappears. Steps remain locked for 30 minutes.
StEP/FLtY ALARM	One or more steps are broken. Detected faulty steps are blinking with the alarm message. Steps are locked for 24 hours.
SPL/Nr ALARM	One or more steps have fallen below 75% of initial power: risk of resonance for capacitor bank with detuned reactor. Step number and detected error code will flash alternately. Steps identified as "SPL" are moved to Fix Off.
Thi ALARM	The temperature limit (temperature 2) is exceeded. Steps are switched off successively until the alarm condition disappears. Steps remain locked for 30 minutes.
OPH ALARM	Maximum number of hours of operation has been exceeded. Maintenance should be planned on the equipment.
OPC/Nr ALARM	Maximum number of operation cycles has been exceeded for one or more steps. Maintenance should be planned on the equipment.
OL ALARM	The capacitor overload current ratio is exceeded. Steps are switched off until the alarm condition disappears. Steps remain locked for 30 minutes.
HU ALARM	One or more steps have exceeded the hunting limit. Step number and detected error code will flash alternately. Steps in alarm are moved to Fix Off.

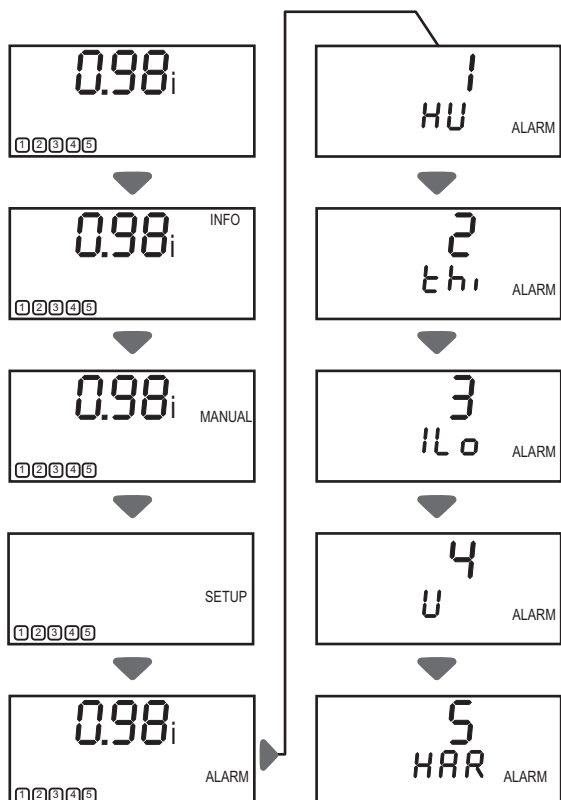

Current Alarms

When an alarm is active, ALARM and the detected error code flashes alternately on the display. When the alarm condition disappears, the display stops flashing.

Alarm log

The last five alarms are logged in the Alarm menu. To view the alarms in the log, press the ► key. Change the values with ▲ and ▼. To reset Alarm log, press ▲ and ▼ simultaneously for 3 seconds.

To enter the advanced menu of the controller:

1. Select the SETUP menu and confirm by pressing ►.
2. Press ▼ or ▲ and enter the PIN code 242. Press the ► key to confirm.

Select the submenus 100-700 by pressing the ▼ ▲ keys. The advanced menu of controller is divided into seven submenus:

- **100 Quick start:** Contains all settings for commissioning.
- **200 Measurements:** Contains settings that enable you to match the measurement settings of the controller to the network conditions of your system.
- **300 Setup control system:** Allows you to optimize the control or adapt to specific site requirements.
- **400 Setup step database:** Contains all information about the steps.
- **500 Setup alarm:** Allows you to set the alarm parameters.
- **600 Reset:** Lets you reset parameters back to the factory settings and clears stored data in the controller. It also contains the software version of the device. You can change the password for the setup menu.
- **700 Communication:** Allows setting of communication parameters.

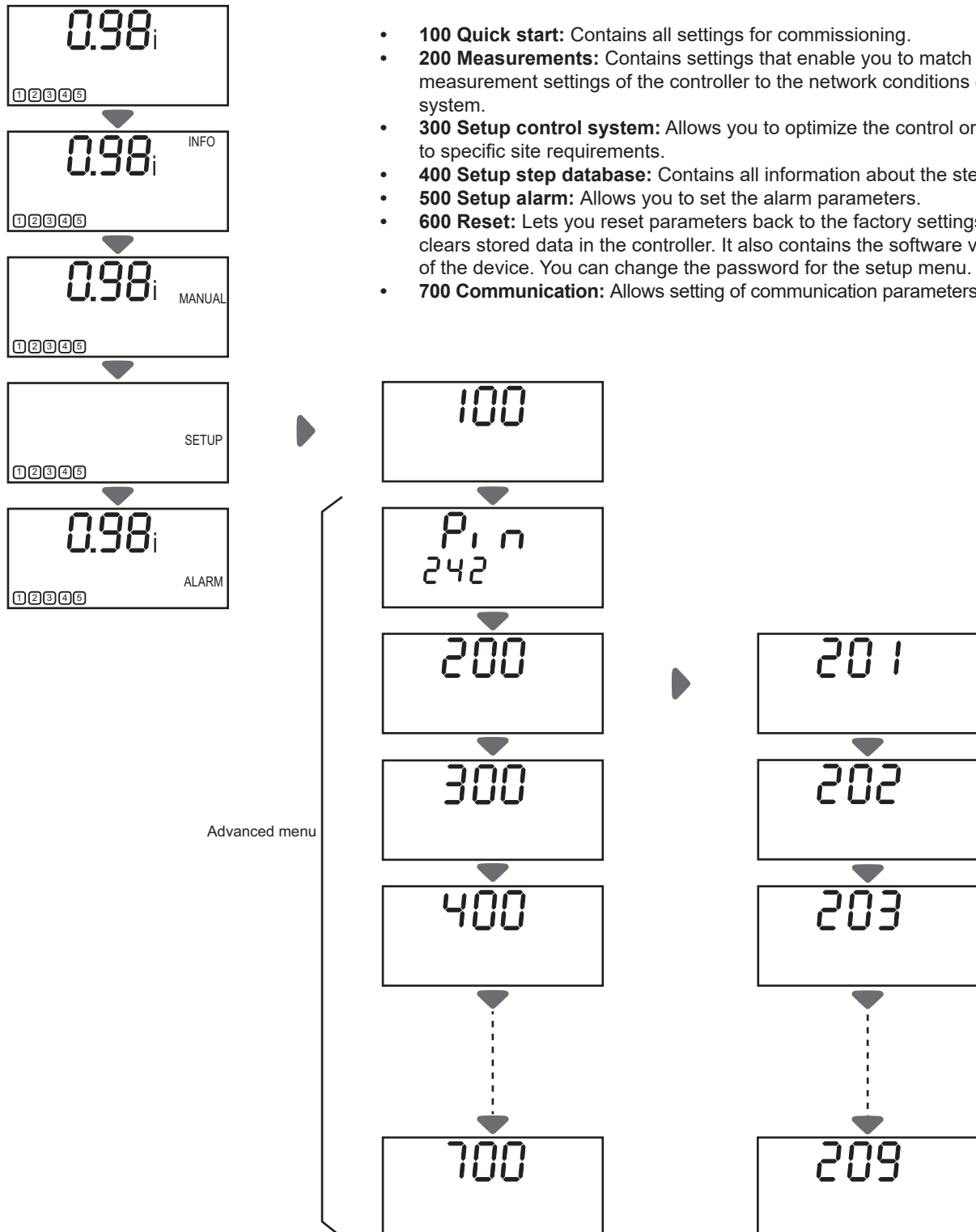

100 Quick Start Menu

Contains all information for commissioning.

Menu	Function	Range	Default Setting
Un (ph-ph)	<p>NOMINAL VOLTAGE = PHASE - PHASE Defines the nominal voltage of the system. Several parameters use the voltage setting:</p> <ul style="list-style-type: none"> • Threshold levels for under voltage and over voltage • Ratings of the capacitor sizes in step database, which are used for control and monitoring • Capacitor sizes are rated to the nominal voltage and are stored in step database 	100...242000 V	400 V
Ct	<p>CT-FACTOR CT FACTOR is the ratio of current transformer (For example, 1000/5 = ratio 200).</p>	1...9600	1
Ai	<p>START AUTO-INITIALIZATION Yes = starts auto-initializing. Automatic initialization switches all outputs one by one. During the test, it checks which outputs are connected and will correct the phase setting if voltage and current are miswired. Automatic initialization works only when capacitors are used for compensation. You must have an inductive load to be able to start the automatic initialization. The Ai feature will not work (may select incorrect settings, which will cause incorrect measurements and incorrect switching of the outputs.), if the controller has to switch reactors for compensation of a capacitive load. The Ai feature works best when load conditions are stable. During a new auto-initialization, steps with step type Fon will not be considered. Steps with step type "FON" will be not considered in case of new auto-initialization.</p>	Yes/No	(no setting)
PFC	<p>START/STOP/HOLD PF-CONTROL The following options are available:</p> <ul style="list-style-type: none"> • On: Control is in automatic mode. • Off: Control stops and active steps are disconnected in succession. • Hold: Control stops and active steps remain switched on. <p>If you select Off or Hold, the controller shows PFC in the display alternating with Off or Hold. To start the control, select On.</p>	On/Off/Hold	On
CP1	<p>Cos φ1 This is the setting for target Cos φ1. It will be valid during normal operation.</p>	0.70 c...0.70 i	0.95i
St	<p>SWITCH INTERVAL The switch interval is the time delay between switching steps in regulation. The switch interval has two different functions:</p> <ul style="list-style-type: none"> • Building the average of the reactive power during the switching time interval. • Protecting the contactors by reducing the number of switching cycles. <p>Note: if HV parameter (315) is selected, minimum time for the switch interval is 10 s and the default setting is moved to 120 s.</p>	1...6500 s	10 s
Out	<p>TYPE OF OUTPUT If step size recognition is active, you can leave the default setting. Active recognition is shown as Yes in menu 308. It will be automatically detected during Ai or during the step size recognition sequence. If the step size recognition is disabled, or if you want to force a step to Fon or Foff, you must configure the type of output. Disabled is shown as No in menu 308 of the advanced menus. The following step types can be selected:</p> <ul style="list-style-type: none"> • Auto = Step is used for normal regulation algorithm. • Fon = Step is permanently switched on (step is still monitored and shut down in critical situations). • Foff = Step is permanently switched off. Select this setting for used steps to avoid unnecessary alarm. • Flty = If parameter Lock detected faulty step (309) is set to Yes, a step switched three times without success is declared not operational and is no longer used for automatic control for 24 hours or until controller is restarted. After you have resolved the issue, a step stored as "flty" can be reset to the desired step type in this menu. 	Auto/FOn/FOff	Auto

200 Measurement Settings

Contains settings to adapt the measurement of the PowerLogic™ VL to the surrounding network conditions.

Menu	Function	Range	Default Setting
201 (Un)	<p>NOMINAL VOLTAGE = PHASE - PHASE Defines the nominal voltage of the system. Several parameters are based on the nominal voltage setting:</p> <ul style="list-style-type: none"> • Threshold levels for under voltage and over voltage • Ratings of the capacitor sizes in step database, which are used for control and monitoring • Capacitor size are rated to the nominal voltage and are stored in step database 	100...242000 V	400 V
202 (Ct)	<p>CT-FACTOR CT FACTOR is the ratio of current transformer (For example, 1000/5 = ratio 200).</p>	1...9600	1
203	<p>VT-FACTOR VT FACTOR is the ratio of the voltage transformer. If the regulator is connected directly to the measurement voltage without a voltage transformer, set this value to 1. (For example, 6000/100 = ratio 60).</p>	1...350	1
204	<p>V-TOLERANCE This is the percent of nominal voltage to provide the upper and lower limit of the permissible voltage range. (For example, 10 % at 400 V nominal voltage is a permissible range from 360 to 440 V).</p>	0...100 %	10 %
205	<p>CONNECTION MEASUREMENT</p> <ul style="list-style-type: none"> • Yes = voltage measurement L-L. • No = voltage measurement L-N. <p>The setting defines whether the voltage being measured is connected between two phases, or between one phase and neutral. The controller compares the nominal voltage setting and the actual measured voltage. If the measured voltage is within this tolerance, the voltage measurement setting is automatic and cannot be changed manually. If the actual measured voltage is outside the tolerance, you can set the measurement using this function.</p>	Yes/No	Automatically detected during power up if voltage is in tolerance.
206	<p>PHASE COMPENSATION Phase compensation lets you compensate for incorrectly wired current or voltage connections. Incorrect wiring may be an incorrectly wired voltage phase or reversed polarity of a current transformer. By manually changing the phase angle, you can correct the wiring in the firmware without physically changing the wiring. The phase angle must be set up properly for correct regulation.</p> <p>Under normal conditions, the phase compensation angle is set to 0° or 90° in accordance with the Connection Measurement parameter (205). Launching an Auto-initialization sequence will allow the controller to check the phase angle and in case of wiring error, it automatically corrects the angle. If the Auto-Initialization does not start due to adverse network conditions, you can manually set up the correct phase angle. See the Table "Phase-Angle Settings" at end of this manual for an overview of the connection options with corresponding phase angles.</p>	0...345°	Automatically set according to connection measurement. Ph-Ph connection : 90° Ph-N connection : 0°
207 (Ai)	<p>START AUTO-INITIALIZATION Yes = starts auto-initializing. Automatic initialization switches all outputs one by one. During the test, it checks which outputs are connected and will correct the phase setting if voltage and current are miswired. Automatic initialization works only when capacitors are used for compensation. You must have an inductive load to be able to start the automatic initialization. The Ai feature will not work (may select incorrect settings, which will cause incorrect measurements and incorrect switching of the outputs.), if the controller has to switch reactors for compensation of a capacitive load. The Ai feature works best when load conditions are stable. During a new auto-initialization, steps with step type Fon will not be considered. Steps with step type "FON" will not be considered in case of new auto-initialization.</p>	Yes/No	(no setting)
208	<p>SYNCHRONISATION FREQUENCY To obtain a precise measurement, the sampling rate has to be synchronized to the frequency of the grid. If the voltage mains are experiencing commutation notches, the automatic synchronizing will not work reliably and may not measure the voltage. To avoid these issues, use one of the following settings:</p> <ul style="list-style-type: none"> • Automatic synchronizing: Use this setting for the best measurement results when voltage on the mains is without commutation notches. • FIX-50HZ: For operation at 50 Hz grid when voltage quality on the mains is poor (notching present). • FIX-60HZ: For operation at 60 Hz grid when voltage quality on the mains is poor (notching present). 	Auto/Fix50/ Fix60	AUTO
209	<p>TEMPERATURE OFFSET The temperature offset lets you adjust the temperature reading by adding or subtracting a range of -10 to +10 °C to the actual reading. For example, you can use it when controller is in a different cabinet than capacitors. The fan relay and alarm relay will be switched on or off, using the corrected temperature.</p>	-10...+10 °C	0 °C

300 Setup Control System

The items in the menu "control system" allow an optimization of the control or an adaptation to specific site requirements.

Menu	Function	Range	Default Setting
301	<p>CONTROL SENSITIVITY</p> <p>Sensitivity is the switching threshold for switching on or switching off the capacitors in percent (%). The range of the sensitivity can be between 55 and 100%. The factory setting is 75%, which is the value used in the explanation below.</p> <p>A step Q will be switched on/off if:</p> <ul style="list-style-type: none"> the demand for compensation (dQ) is greater than 75% of Q value: $dQ > 75\% * Q$ the Q value is less than 125% of the demand for compensation (dQ): $Q < 125\% * dQ$ 	55...100 %	75 %
302 (CP1)	<p>Cos φ1</p> <p>This is the setting for target Cos φ1. It is valid during normal operation.</p>	0.70 c...0.70 i	0.95i
303	<p>Cos φ2</p> <p>This is the setting for target Cos φ2. It is valid when a switch over is caused by the digital input or another programmable action (see parameter 304 below)</p> <p>NT is displayed when target Cos φ2. is active.</p>	0.70 c...0.70 i	0.95i
304	<p>Cos φ2 FOR P EXPORT</p> <ul style="list-style-type: none"> Yes = the controller operates in P-export with the Cos φ2 as control target. No = the controller still operates in P-export with the Cos φ1. 	Yes/No	No
305 (St)	<p>SWITCH INTERVAL</p> <p>The switch interval is the time delay between switching steps in regulation.</p> <p>The switch interval has two different functions:</p> <ul style="list-style-type: none"> It builds the average reactive power during the switch interval. It protects the contactors by reducing the number of switching cycles. <p>Note: if HV parameter (315) is selected, minimum time for St is moved to 10 s and default value is moved to 120 s.</p>	1...6500 s	10 s
306	<p>STEP EXCHANGE INTERVAL</p> <p>This allows you to select an alternate time interval between steps. This is the interval when an active step is switched off until the next step is switched on to improve the power factor.</p> <p>Note: if HV parameter (315) is selected, the minimum time for St is 10 s.</p>	1...6500 s	2 s
307	<p>ACTIVATE STEP EXCHANGE</p> <ul style="list-style-type: none"> Yes = Step exchange is active. No = Step exchange is disabled. <p>Step exchange supports the automatic control and combined filter control algorithm to reach an optimum power factor. If the controller detects that the target has not been reached, it searches for a step that provides a better power factor. If the step exchange is active, the controller uses the alternate step exchange interval to replace the switched on step with a step that better matches the target. This function helps reach the target Cos φ more exactly when capacitors have different sizes. If all capacitor banks have the same size, do not use the step exchange function.</p> <p>Note: if HV parameter (315) is selected, default setting is automatically changed to No.</p>	Yes/No	No
308	<p>STEP RECOGNITION "On"</p> <ul style="list-style-type: none"> Yes = Step sizes are detected and corrected automatically during normal operation. Step recognition On (Yes) is the factory setting. No = Automatic step size detection is disabled and step sizes must be programmed manually. <p>The step sizes must be programmed manually if either of these conditions are true:</p> <ul style="list-style-type: none"> the capacitors bank is pre-configured (usually by a panel builder), a fast-oscillating load influences automatic step size recognition. <div style="border: 1px solid black; padding: 5px; margin: 10px 0;"> <p style="text-align: center;">NOTICE</p> <p>HAZARD OF WRONG COMPENSATION OR ALARMS</p> <ul style="list-style-type: none"> To manually configure step sizes, set STEP RECOGNITION (308) parameter to "NO." If STEP RECOGNITION (308) parameter is set to "YES," step sizes that have been programmed manually will be overwritten during the automatic recognition. Do not over write the settings. <p>Failure to follow these instructions can result in equipment damage.</p> </div> <p>Note: If HV parameter (315) is selected, default setting is automatically changed to No.</p>	Yes/No	Yes

Menu	Function	Range	Default Setting
309	<p>LOCK DEFECTIVE STEPS</p> <ul style="list-style-type: none"> Yes = If a step is switched three times without a measurable network reaction, the controller blocks the step and does not use it for control. The controller recognizes the step output as being inoperable, blinks in the display, and sets the value to "Flty" (detected faulty) in the step type menu (403). The controller will continue to test inoperable steps every 24 hours or after the controller is restarted. No = Steps are connected even if no network reaction is measurable. This results in unnecessary switching cycles. 	Yes/No	Yes
310 (PFC)	<p>START / STOP / HOLD PF-CONTROL</p> <p>Stopping the automatic control. The following options are available:</p> <ul style="list-style-type: none"> On: Control in automatic mode Off: Control stops and active steps are disconnected in succession. Hold: Control Stops and active steps remain switched on. <p>If "Off" or "Hold" is selected, the text flashes in the display as "PFC" alternating with "Off" or "Hold." To start the control, select "On."</p> <p>When the auto initialization (AI) aborts, the controller is changed to Off. After troubleshooting to solve issues, you can reset the PFC controller back to automatic mode "On."</p>	On/Off/Hold	On
311	<p>CONTROL ALGORITHM</p> <p>1=Automatic: The controller works on the principle of "best fit." Before it performs a switching operation, it compares all capacitor sizes in the step database to the control deviation. The available step with the best results will be switched.</p> <p>2=LIFO: "Last In, First Out" The controller starts regulation with step 1 and switches subsequent outputs step-by-step, switching on and off alternatively.</p> <p>3=Progressive: If required, the controller switches several steps in sequence using a 1s switching time, independent of the set switching time. Discharge time still applies in accordance with parameter 401.</p> <p>Furthermore, the automatic step-size detection is disabled and you must manually set up the step size. The input of the step sizes should be as accurate as possible, otherwise, the regulator will tend to oscillate. By selecting the "Progressive" algorithm and using a different algorithm, you can re-enable the set switching time and the step size detection.</p>	1/2/3	1 (Automatic)
312	<p>OFFSET REACTIVE POWER</p> <p>This feature lets you compensate for a permanent reactive load that cannot be measured, such as a transformer.</p> <p>The offset of reactive power affects the readings of these measured values: current, reactive power, control deviation, apparent power, power factor PF, and Cos φ.</p> <p>Maximum value that can be set is 9.9 Mvar.</p>	C999,9..i999,9	0 kvar
313	<p>ASYMMETRIC FACTOR</p> <p>ASYMMETRIC FACTOR of switch interval. The factor is the ratio between switch interval for switching on and switching off. This setting does not affect the switch interval for the step exchange.</p> <ul style="list-style-type: none"> X = 1 = equal. X = +2 to +127: delay switching off = switch interval multiplied by X. X = -2 to -127: delay switching on = switch interval multiplied by X. 	-127...127	1
314	<p>Q CAPACITIVE STEPS TURN OFF</p> <ul style="list-style-type: none"> Yes = As soon as a capacitive condition is recognized, the controller switches off without adhering to the switching time, which is the necessary step power to prevent leading network conditions. No = The controller works only with the set target Cos φ. <div style="border: 1px solid black; padding: 5px; margin-top: 10px;"> <p style="text-align: center;">NOTICE</p> <p>HAZARD OF HIGH STEP SWITCHING RATE (HUNTING) IF THIS PARAMETER IS USED WITH A COS PHI SETTING CLOSE TO 1</p> <p>If you want to use this parameter, make a test for a short period to check comportment on the steps.</p> <p>Failure to follow these instructions can result in equipment damage.</p> </div>	Yes/No	No
315	<p>HV CONFIGURATION</p> <p>Yes = some default parameters are automatically moved to a more appropriate value:</p> <ul style="list-style-type: none"> Discharge time (401) is set at 600 s, switching interval (305) is set a 120 s. Automatic step size recognition (308) and step exchange (307) are disabled. Delay before all calculation when a step is switched On or Off is move from 300 ms to 8 s to be compatible with all type of HV contactors. 	Yes/No	No

400 Setup Step Database

Contains all steps information.

Menu	Function	Range	Default setting
401	<p>DISCHARGE TIME</p> <p>The discharge time is defined once and is valid for all steps. The discharge time is a block of time that becomes active after the step is switched off. During the defined discharge time, this step is not available for the regulation. The discharge time should be adapted to the capacitor discharging unit.</p> <p>Note: if the HV parameter (315) is selected, default setting is automatically switched to 600 s.</p> <div style="border: 1px solid black; padding: 5px; margin-top: 10px;"> <p style="text-align: center;">⚠ WARNING</p> <p>HAZARD OF CAPACITOR DAMAGE</p> <p>To avoid capacitor failure, you must set the discharge time set in accordance with capacitor manufacturer recommendations.</p> <p>Failure to follow these instructions can result in death, serious injury, or equipment damage.</p> </div>	5...1200 s	50 s
402	<p>STEP NOMINAL VALUE [step 1 to step... 12 max]</p> <p>If STEP RECOGNITION is not active, you must manually enter the kvar size of each step used to properly operate the relay.</p> <p>No special sequence required. A step can be programmed as a capacitor (c) or as an inductor (i). Any step not used is set to Foff in step type (see 403) below.</p>	C9999..i 9999	3 var C [step 1... max 12]
403 (Out)	<p>STEP TYPE [step 1 to step... 12 max]</p> <p>If step size recognition is disabled (308 set to "No"), or if you want to force a step at Fon or Foff, you must configure the type of output.</p> <p>If step size recognition is active (308 set to "Yes," default setting), you do not need to select a step type. It will be automatically detected during auto-initialization (AI) or during the step-size recognition sequence.</p> <p>You can select the following step types:</p> <ul style="list-style-type: none"> • Auto = Step is used for the normal regulation algorithm. • Fon = Step is permanently switched on. The step is still monitored and shut down in critical situations. • Foff = Step is permanently switched off. To avoid unnecessary alarms, select this setting for used steps. • Flty = If the parameter lock detected faulty step (LOCK DEFECTIVE STEPS 309 is set to Yes), the controller has attempted to switch a step three times without success and declares the step inoperable. Also, it will not use the step setting for automatic control for 24 hours, or until the controller is restarted. After troubleshooting to resolve the issue, you can reset the detected faulty step back to auto, on, or off step type in this menu. 	Auto/Fon/Foff	Auto [step 1... max 12]
404	<p>SWITCH CYCLES [step 1 to step... 12 max]</p> <p>The controller counts the number of switching cycles of each step and displays the number in the INFO menu. If you replace a contactor, you can use this menu to reset the switching cycles to "0."</p>	0...262000	0 [step 1...max 12]

500 Setup Alarm

From the Alarm menu of controller, you can activate the alarm monitoring functions and set up the limits on which to alarm.

Menu	Function	Range	Default setting
501	<p>RESET ALARM MANUALLY</p> <ul style="list-style-type: none"> • Yes = Alarms must be reset manually (display and alarm relays). To reset alarms, press and hold the Esc button for 3 seconds. • No = Default setting. Alarms drop out when the alarm condition is no longer valid. <p>Note: The last five alarms are stored in the Alarm log independent of the this setting. See Alarm menu.</p>	Yes/No	No (i.e., alarm automatically reset)
502	<p>THDU limit</p> <p>When the THDU exceeds the limit for the time interval set in 504, the alarm contact closes and displays "Har" alarm.</p> <p>If 503 is set to Yes, in compliance with the interval time set in 504, the controller opens the steps in succession and blocks the steps for 30 minutes after the alarm disappears.</p>	3...20 %	7 %

Menu	Function	Range	Default setting
503	<p>DISCONNECT STEPS ON THDU, CAPACITOR OVERLOAD CURRENT RATIO AND TEMPERATURE ALARMS</p> <ul style="list-style-type: none"> Yes = When the set threshold for THDU, capacitor overload current ratio, and temperature are exceeded, all active steps are switched off in succession and blocked for 30 minutes after alarm disappears. The alarm disappears after the interval of time defined in 504. No = These alarms will not affect the control. <div style="border: 1px solid black; padding: 5px; margin-top: 10px;"> <p style="text-align: center;">NOTICE</p> <p>HAZARD OF EQUIPMENT DAMAGE IF THIS PARAMETER IS DISCONNECTED</p> <p>To avoid equipment damage or nuisance alarms, do not disable control for these alarms. Instead, check the equipment on first alarm and make adjustments to the alarm settings that best match your equipment.</p> <p>Failure to follow these instructions can result in equipment damage.</p> </div>	Yes/No	Yes
504	<p>INTERVAL TIME BEFORE TRIGGER FOR THDU, OVERLOAD CURRENT RATIO AND TEMPERATURE ALARMS</p> <p>Interval of time after exceeding the limit for THDU, overload current ratio, and temperature alarms. This delay is applied to actions on control or alarm relay, and before the opening of each step.</p>	1...255 s	60 s (for THDU, OL ratio and temperature alarm)
505	<p>FREEZE CONTROL IF I → LOW ALARM</p> <ul style="list-style-type: none"> Yes = When the current measured drops below 15 mA, the control freezes. All active steps remain switched on. No = Measuring current falls below 15 mA, the controller shuts down all active steps successively. 	Yes/No	No
506	<p>SERVICE ALARM</p> <ul style="list-style-type: none"> Yes = the alarm contact closes when the defined maximum switching cycles for one or more steps (507) have been exceeded, or if the set threshold for operation hours (508) is reached. No = no alarm when the maximum switching cycles or operation hours is exceeded. That alarm has no action on the control. 	Yes/No	Yes
507	<p>SWITCHING CYCLES LIMIT</p> <p>Maximum switching cycles before the service alarm is activated. Alarm displays as OPC (operation cycles) alarm.</p> <p>After maintenance, the alarm can be reset using parameter 404.</p>	1...262000	100 k
508	<p>OPERATION HOURS LIMIT (global PFC bank)</p> <p>Maximum hours of operation before service alarm. Alarm displays as OPH (operation hours) alarm.</p> <p>After maintenance, the alarm can be reset using parameter 603.</p>	1...65535 h	65.5 K hours (7 years)
509	<p>CAPACITOR OVERLOAD CURRENT RATIO LIMIT</p> <p>When the capacitor overload current ratio exceeds the limit for the defined time interval in 504, the alarm contact is closed and the display indicates "OL" alarm. The OL alarm is based on a calculation from the voltage distortion spectrum to inform you about possible high RMS current in the capacitor.</p> <p>If 503 is set to Yes (default setting) in compliance with the interval time defined in 504, the steps will be switched off successively and blocked for 30 minutes after the alarm disappears.</p>	1...1.5	1.3
510	<p>DIGITAL INPUT ACTIVE AT HIGH LEVEL</p> <ul style="list-style-type: none"> Yes = Digital input (to target Cos φ₂) is active when the digital input is closed. No = Digital input (to target Cos φ₂) is active when digital input is opened. 	Yes/No	Yes
511	<p>TEMPERATURE 1 LIMIT (FAN)</p> <p>When the temperature exceeds temperature 1 threshold, the controller closes the fan contact and displays "FAN."</p> <p>Fan relay will open if temperature decreases 5 °C below the limit.</p>	3 °C ... (Temp2 - 5 °C)	30 °C
512	<p>TEMPERATURE 2 LIMIT (ALARM)</p> <p>When the temperature exceeds the threshold, the alarm contact is closed and displays "thi" alarm.</p> <p>If 503 is set to Yes (default setting), in compliance with the interval time set in 504, steps will be switched off successively and blocked for 30 min after the alarm disappears.</p> <p>Fan relay will open if temperature decreases 5 °C below the limit.</p>	(Temp1 + 5 °C) ... 60 °C	50 °C
513	<p>PFC ALARM (target Cos φ can not be archived)</p> <ul style="list-style-type: none"> Yes = alarm is triggered after "75 * switching time" with $\Delta Q >$ smallest step (Over / under compensation). Controller closes the alarm contact and indicates "PFC" Alarm in the Display. This control is enabled only after the step recognition is complete. No = no monitoring for over / under compensation. <p>That alarm has no action on control.</p>	Yes/No	Yes
514	<p>DEFECTIVE STEP ALARM</p> <ul style="list-style-type: none"> Yes = after 3 unsuccessful switching actions, the alarm is triggered. The controller closes the alarm contact and displays "STEP" Alarm / "FLty" alarm. Steps recognized as defective flash in the step indication. If parameter 309 (lock detected faulty steps) is set at "Yes," the step is blocked for 24 hours or until the controller restarts. No = alarm disabled (control is still active when menu item 309 is set to "Yes"). 	Yes/No	Yes

515	<p>STEP POWER LOSS ALARM</p> <ul style="list-style-type: none"> Yes = if the current step size is less than 75% of the initial size, the controller closes the alarm contact and shows the detected error with output number "SPL" Alarm / "Nr" alarm in the display. Step type is changed to fixed off (Foff). No = Power loss of the capacitors is not monitored. There is no action on control or alarm. <div style="border: 1px solid black; padding: 5px; margin: 5px 0;"> <p style="text-align: center;">NOTICE</p> <p>HAZARD OF EQUIPMENT DAMAGE</p> <p>A capacitor loss can cause resonance on the system when a detuned reactor is used. To avoid this risk, do not disable the Step Power Loss alarm.</p> <p>Failure to follow these instructions can result in equipment damage.</p> </div>	Yes/No	Yes
516	<p>HUNTING ALARM</p> <ul style="list-style-type: none"> Yes = If the controller detects that regulation is unstable, the controller closes the alarm contact and indicates the detected error with output number "HU" Alarm / "Nr" Alarm on the display. The step is declared inoperable and moved to Fix off and will not be used for control. No = Hunting alarm is not monitored. There is no action on control or alarm. 	Yes/No	Yes
517	<p>HUNTING LIMIT</p> <p>Alarm if regulation is declared as unstable: limit corresponds to a maximum number of switching attempts during a period of 10 * discharge time.</p>	1... 10	7

600 Reset Menu

Allows you to reset all settings made by the controller and stored data. Additionally, it contains the software version of the device.

Menu	Function	Range	Default Setting
601	<p>RESET SETTINGS</p> <p>Sets all settings made to factory settings (except step database parameters 402, 403, 404)</p>	Yes/No	
602	<p>RESET STEP DATABASE</p> <p>Sets all step data base parameters (402, 403, 404) to factory settings</p> <div style="border: 1px solid black; padding: 5px; margin: 5px 0;"> <p style="text-align: center;">NOTICE</p> <p>HAZARD OF DATA BEING OVERWRITTEN</p> <p>If step size detection is set to Off and steps have been entered manually, reset step database will erase these values.</p> <p>Failure to follow these instructions can result in equipment damage.</p> </div>	Yes/No	
603	<p>RESET OPERATION HOURS</p> <p>Sets the counter for operation hours to "0."</p> <p><i>Note: to reset the switching cycles of each step, see "Info" menu.</i></p>	Yes/No	
604	<p>RESET AVERAGE TRUE PF</p> <p>Reset the average PF.</p>	Yes/No	
605	<p>RESET MAX. TEMPERATURE</p> <p>Reset the highest measured Temperature (Thi).</p>	Yes/No	
606	<p>RESET ALARMS</p> <p>Reset all upcoming alarms and log alarms</p>	Yes/No	
607	<p>DISPLAY SOFTWARE VERSION</p> <p>Contains the software version of the device.</p>		xxx.xxx.xxx
608	<p>ADJUSTMENT OF THE SETUP PASSWORD</p> <p>You can add your own password. However, the factory password remains active.</p>		242

700 Communication Parameters

Allows you to set Communication parameters

Menu	Function	Range	Default Setting
701	SPEED	1.2 K...115.2 K	19.2 K
702	PARITY	None - Even-Odd	Even
703	SECONDARY UNIT NUMBER	1.... 247	1

Preliminary Operation

1. Disconnect panel from mains voltage and check that the voltage is off.
2. Verify that PFC controller metal case is connected to \perp by earth protection cable.
3. Verify that the voltage and CT current input are suitable for the PFC controller.
4. Verify that all PFC controller inputs and outputs are connected according to wiring diagram with suitable protection (see chapter Wiring).
5. Verify CT position and proper connection (CT/P1 towards incoming feeder, CT/P2 towards load).
6. Remove short-circuit connection from CT.

Default Configuration (Step size recognition On)

The capacitor size of each steps can be entered:

- Manually for Panel builder pre-configuration: step size recognition parameter Off
- Automatically detected by the Step recognition mechanism: step size recognition parameter On

By default, the PowerLogic™ controller is configured with step size recognition On. In a 400 V system, this configuration allows the controller to start operation without any changes to the configuration settings. However, to have I, S, P, Q measurements and capacitors step size displayed (in Info menu), you must set up the CT ratio.

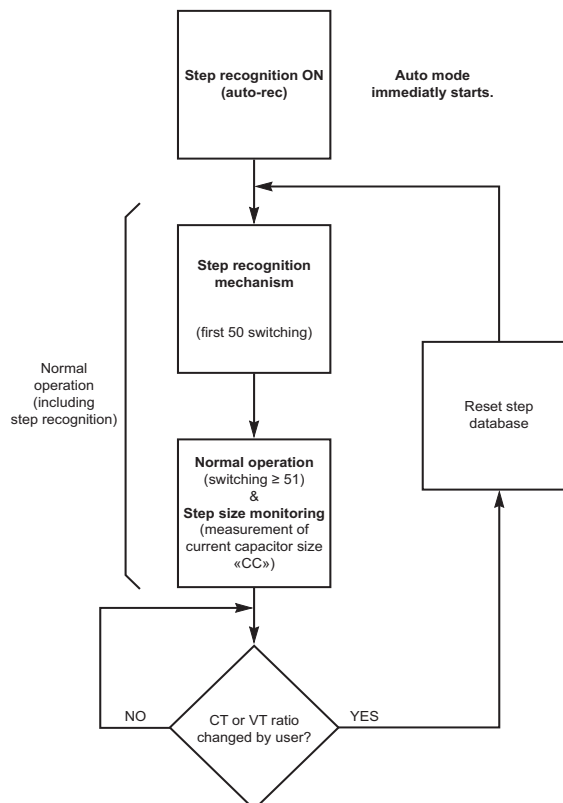

- Connect mains voltage to the panel. If the relay has been correctly connected and the mains voltage and CT output comply with the ratings and settings of PFC controller, the LCD on the controller displays **AUTO** and the control function starts automatically.
- Go to submenu 100: if necessary, modify the settings **Un** (LL voltage), **CT** (CT ratio), **CP1** (target Cos ϕ 1). You do not need to set the connected (**Out**) steps: during the first 2 switching operations, the **AI** or **Step size recognition** mechanism will detect all unused steps and will automatically move them to Foff.

At this point, we recommend that you launch an Automatic Initialization (AI)

- **Automatic Initialization (AI):**
The main task of AI is to check the voltage and current connections (polarity and phases), to allow the PFC controller to run correctly. **AI** attempts to connect and disconnect all control outputs several times (2 times minimum, 5 times maximum) by switching them on and off. This lasts several minutes. Outputs that are determined to be unconnected are designated as Foff (permanently off). Step sizes are not detected by this function (see below Step size Recognition).
To launch Ai, go to SETUP submenu 100, Select Ai, parameter and push ►. Modify the value from No to Yes with ▲, and ▼ during all the sequence, the display will show Ai on the main screen.
Note: After Ai is completed, go to SETUP submenu 100, Out parameter, and check consistency between step configured in Auto and compare it to the capacitor bank configuration.
- **Wrong connection / AI:** If the AI detects an incorrect connection, it will automatically correct the phase angle.
- **Requirements for successful operation of AI:**
 - Voltage is within tolerance
 - CT is connected
 - Capacitor banks are installed and fuses or CB steps are closed
- **Possible problems for function of AI:**
 - Load variations
 - Small current signals (big CT-ratio, small stepsizes)
- **Indication of incomplete AI / Abrt:**
AI is aborted, as no clear result could be achieved. PFC controller is moved to Off position (stopped). In this case, try to relaunch a new **AI**. If **AI** aborted again, the Voltage connection and Phase connection (phase angle between voltage and current) settings must be entered manually: see parameter 205 and 206 on page 20.
If second AI succeeded, the alarm message AI Abrt will disappear and the controller will only display PFC Off. Go to sub-menu 100 and move the setting PFC from Off to On. Then, PFC controller display should show AUTO.
- **Measurements I, S, P, Q, ΔQ not displayed ? :**
The PFC controller detects that CT ratio has not been set by user: Go to the submenu 100 and enter the CT ratio.
- **CT ratio / VT ratio change:**
Any change in the CT ratio or VT ratio will generate a reset of the step data base and a new step recognition mechanism is launched to take into account this change.

Step size entered manually (for panel builder pre-configuration)

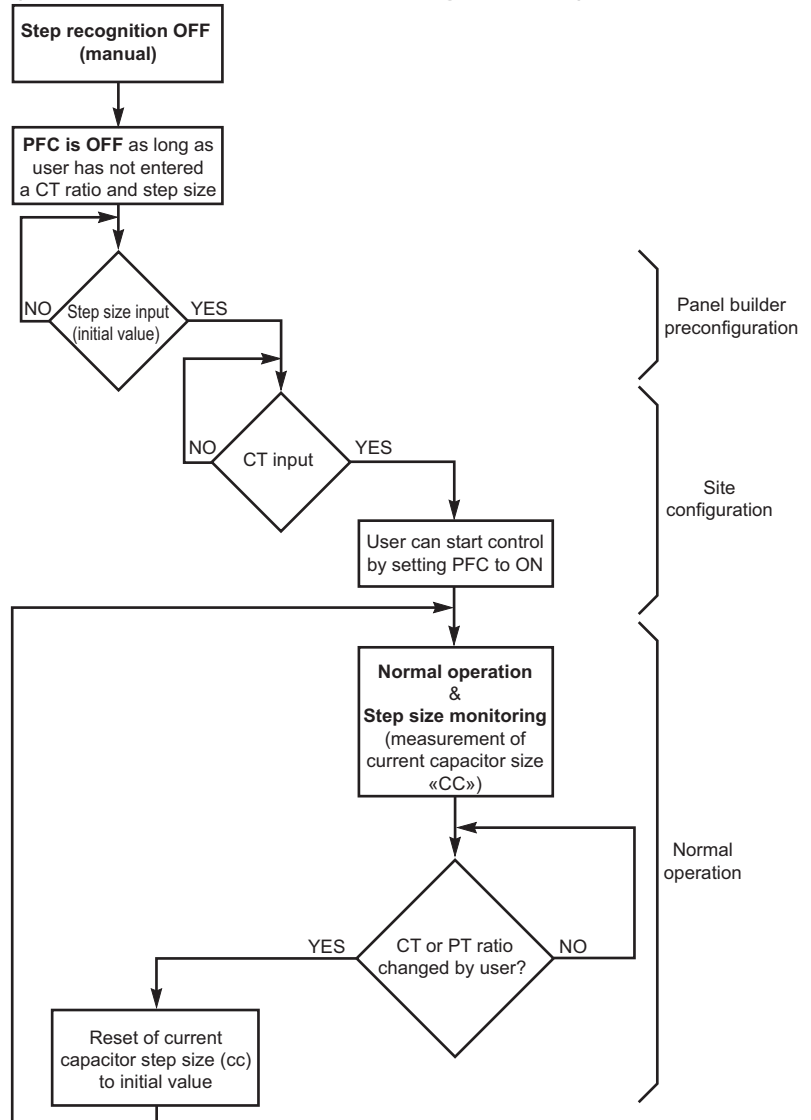

Panel builder pre-configuration:

- In Setup sub-menu 100 define **Un** (LL voltage).
- In sub-menu 300, move the setting **308** (Step recognition On) from Yes to No
- In sub-menu 400, enter Step size of each capacitor connected in 402. Steps not used must be set as Off in 403.

Customer site configuration:

Go to the Setup sub- menu 100, check **Un**, enter **CT** ratio and **CP1** (target Cos φ1).

If necessary, adjust VT ratio (sub-menu 200, parameter 203)

At this point, we recommend that you launch an Automatic Initialization (AI)

Automatic Initialization (AI):

The main task of AI is to check the voltage and current connections (polarity and phases), to allow the PFC controller to run correctly. AI attempts to connect and disconnect all control outputs several times (2 times minimum, 5 times maximum) by switching them on and off. This lasts several minutes. Outputs that are determined to be unconnected are designated as Foff (permanently off).

Step sizes are not detected by this function (see below Step size Recognition).

To launch Ai, go to SETUP submenu 100, Select Ai, parameter and push ►. Modify the value from No to Yes with ▲, and ▼ during all the sequence, the display will show Ai on the main screen.

Note: After Ai is completed, go to SETUP submenu 100, Out parameter, and check consistency between step configured in Auto and compare it to the capacitor bank configuration.

- **Wrong connection / Ai:**
If the Ai detects an incorrect connection, it will automatically correct the phase angle.
- **Requirements for successful operation of Ai:**
 - voltage is within tolerance
 - CT is connected
 - capacitor banks are installed and fuses or CB steps are closed
- **Possible problems for function of Ai:**
 - load variations
 - small current signals (big CT-ratio, small stepsizes)
- **Indication of incomplete Ai / Abrt:**
Ai is aborted, as no clear result could be achieved. PFC controller is moved to Off position (stopped). In this case, try to relaunch a new **Ai**. If **Ai** aborted again, the Voltage connection and Phase connection (phase angle between voltage and current) settings must be entered manually: see parameter 205 and 206 on page 20.
If second Ai succeeded, the alarm message Ai Abrt will disappear and the controller will only display PFC Off. Go to sub-menu 100 and move the setting PFC from Off to On. Then, PFC controller display should show AUTO.

Normal operation will start by moving PFC parameter to On in sub-menu 100. Then PFC controller display will show AUTO.

- **CT ratio/VT ratio change:**
Any change in the CT ratio or VT ratio will generate a reset of current capacitor step size to initial value (value entered during Panel Builder pre-configuration).

- Alarm flashes when there is an alarm.
- Alarm menu lists the 5 last alarms logged.

Alarm	Cause	Solutions
AI/Abt ALARM	Abort of auto-initialization	Variations in the load or too small measured current signals may abort Auto initialisation.
U ALARM	Measured voltage is outside the voltage tolerance.	Check settings for nominal voltage and voltage transformer.
I LO ALARM	Measured current is too low (CT current < 15 mA).	Connection issue of CT; short-link of CT is not removed; CT ratio is too high compared to real current; no current.
I HI ALARM	Measured current is too high.	Load is too high or Improper CT selection.
PFC ALARM	The controller cannot achieve the target Cos φ. Over or under compensation.	Verify that all steps are correctly defined and working. Verify that sizing of the PFC bank is enough compared to KVAR required by the load.
HAr ALARM	THDU limit is exceeded. Controller disconnects the steps to correct THDU.	Check installation, THD U too high or possible resonance.
Step/Flty ALARM (detected fault step is blinking)	One or more steps are defective (detected fault after connecting the step 3 times without any measurements).	Check steps connection, molded-case circuit breakers (MCCBs) or fuses position and capacitor status. See " Appendix ", page 38.
SPL/Nr ALARM	Step detected with remaining power less > 75 % of initial value.	Check settings and check capacitance of the capacitor.
Thi ALARM	The alarm temperature limit is exceeded.	Check fans and ambient temperature.
OPH ALARM	Set limit for max. allowable operation hours limit is exceeded.	Check the MCCBs/Fuses, contactors and capacitors in the step. Check the capacitance value; replace capacitors if the capacitance has fallen below tolerance limit.
OPC/Nr ALARM	Set limit for max. allowable operation cycles limit is exceeded.	Check the MCCBs/Fuses, contactors and capacitors in the PFC Bank. Check the capacitance value; replace capacitors if the capacitance has fallen below tolerance limit. Replace contactors if the number of cycles reach the max. allowable operation cycles.
OL ALARM	The capacitor over load current ratio limit (based on THDU calculation) is exceeded.	Check installation, THDU too high, or possible resonance.
HU ALARM	One or more steps are detected in hunting mode. Step number and detected error code will flash.	Check settings in order to allow a more stable regulation.
Anomaly	Cause	Solutions
No indication AUTO	Relays do not switch.	In SETUP/100 menu, the selection for PFC is set to OFF or HOLD; CT ratio is not set; temperature is too high; current is < 15 mA; voltage, THD U, or overload current ratio is out of tolerance.
EXPORT	kW export	If there is no real kW export, check the voltage and current connections to the controller.
Wrong Cosφ indication	Wiring does not correspond to controller settings.	Check voltage and current connections to the controller.
Frequent switching of steps	Size of capacitors is not completely detected / capacitors are inoperable.	Check size of capacitor in INFO menu.
All steps are set to "Fix off"	CT not correctly located or connected, CT short link not removed.	Check CT connection and position.

Alarms parameters can be adjust in Setup Sub-mernu 500. See page 23.

Problems with the Step Recognition

Situation: The controller is used in a system with rapid changes in load conditions and has problems with the automatic step recognition.

Solution:

To solve this problem, turn off step recognition and enter the step sizes manually.

Procedure:

1. Stop control: Set item PFC to "Off" in menu 100 (quick start menu).
2. Set item 308 (Step size recognition on), from "Yes" to "No" in the advanced menu.
3. Enter step sizes: Set the nominal value of the capacitors connected at point 402 in the advanced menu.
4. Enter Step type: Sets all the steps that are automatically controlled as AUTO at point 403 in the advanced menu.

For problems with the step detection, it may happen that a connected step will be stored by the controller incorrectly as "FIX-Off." Therefore, the step type of each step should be controlled under the menu item "403." All steps of the automatic control used, must be use the step type "AUTO".

Reset Inoperable Steps (Faulty Alarm)

Situation: If the controller has a step recognized as "faulty" (3 switching operations without a result) and parameter 309 (locked detected fault steps) is set at Yes (default value), it will be excluded for 24 hours from the regulation or until PFC controller restarts (voltage disconnection and reconnection).

After this period, the step is tested again from the controller.

If the controller can detect the step, it will again be included in the control. If not, the step is blocked again for 24 hours after 3 unsuccessful switching cycles.

Inoperable steps are in the "INFO" menu with the step type designation "flty" and flashing in the step indication.

Procedure to reset an inoperable step:

Select item "403" in advanced menu and use the ▼▲ buttons to select the corresponding step. Confirm with ► button and use the ▼▲ buttons to adjust step type "AUTO."

Step Power Loss and Hunting Alarm

When a step lost more than 25% of its initial power or when a step is detected as Hunting, the PFC controller will block the step (Fix off). To reset a step:

1. Determine the reason for the loss or hunting and fix the issue.
2. Manually reset the nominal step size. Select the step in the 402 menu and select the nominal step size.
3. Select item "403" in advanced menu and use the ▼▲ buttons to select the corresponding step. Confirm with ► button and use the ▼▲ buttons to adjust step type "AUTO."
4. If the step contactor is replaced, select item 404 in advanced menu and use the ▼▲ buttons to select the corresponding step. Confirm with the ► button and move the accumulated switching cycle to "0."

The PowerLogic™ controller contains three different control algorithms (SETUP parameter 311)

- **Automatic:** The controller works on the principle of “best fit.” Before a switching operation, all capacitor sizes in the step database are compared with control deviation. The available step that gives the best results will be switched.
- **LIFO:** “Last In, First Out” The controller starts regulation with step 1 and switches each output, one by one. Switching off is done vice versa.
- **Progressive:** If required, the controller switches several steps in sequence **with a switching time always at 1s** (independently of the set switching time). The discharge time remains active to protect the capacitors. Furthermore, the automatic step size detection is disabled and the step sizes must be entered manually. The input of the step sizes should be as accurate as possible; otherwise, the regulator tends to oscillate. Leaving the “progressive” algorithm and using a different algorithm, the set switching time and the step size detection are re-enabled. This menu is specially adapted for loads such as elevators with large inrush current, low power factor, and high cycle duty.

Additional parameters to adjust control performance

CONTROL SENSITIVITY (301) is the switching threshold for switching on or switching off the capacitors in percent (%). The range of the sensitivity can be between 55 and 100%. The factory setting is 75%, which is the value used in the the explanation below.

A step Q will be switched on/off if:

- the demand for compensation (dQ) is greater than 75% of Q value: $dQ > 75\% * Q$
- and Q value is less that 125% of the demand for compensation: $Q < 125\% * dQ$

For example, for a dQ of 100KVAR, any steps from 0 to 125KVAR could be used. The controller will select the step which has the closest value from dQ.

SWITCH INTERVAL (305): The switch interval is the time delay between switching steps in regulation.

The switch interval has two different functions:

- It builds the average of the reactive power during the switch interval.
- It protects the contactors by reducing the number of switching cycles

Default setting (10 s) is automatically moved to 120 s if HV parameter (315) is set at Yes.

STEP EXCHANGE INTERVAL (306): For step exchange, a separate time interval is used. This is the delay-time between switching off an active step and switching in the next step to get a better power factor.

Default setting (Yes) is automatically moved to No if HV parameter (315) is set at Yes.

ACTIVATE STEP EXCHANGE (307): The step exchange supports automatic control and combines a filter control algorithm to reach an optimum result. If the controller detects that the target power factor is not reached, it starts searching for a step that provides better results. To reach the target when the step exchange is active, the controller can replace a switched on step with a step that matches better. When capacitors have different sizes, this function helps to reach target Cos ϕ more precisely. If all capacitor banks have the same size, this function is not necessary.

Default setting (Yes) is automatically moved to No if HV parameter (315) is set at Yes.

ASYMMETRIC FACTOR of switch interval (313). The factor is the ratio between switch interval for switching on and switching off. The switch interval for step exchange is not affected by this setting.

X= 1 = equal (default setting)

X = +2 to +127: delay switching off = switch interval multiplied by X

X = -2 to -127: delay switching on = switch interval multiplied by X.

Fan Control and Temperature Alarm

Fan control and temperature alarm can be monitored through the PowerLogic™ controller.

- Fan temperature limit (setup parameter 511): The default is set at 30 °C. Exceeding temperature limit 1 will close the fan output contact and the fan symbol will be displayed. To avoid hunting for the fan relay, the fan is turned off only at a temperature below the set limit by 5 °C.
- Alarm temperature limit (setup parameter 512): The default is set at 50 °C. Exceeding temperature limit 2 will close the alarm output contact. Steps will be opened in succession (in accordance with interval time set in 503). Then, the steps are locked for 30 min after the alarm disappears.
- Minimum limit for alarm temperature is 5 °C more than fan temperature limit.
- The temperature (t) and highest temperature (thi) are displayed in the measurements menu. Highest temperature can be reset in setup parameter 605.
- A temperature offset (setup parameter 209) allows correction of temperature in a range of -10 °C to +10 °C. For example, this parameter can be used when a controller is located in a different cabinet than the capacitors. The fan relay and alarm relay will be switched on using the corrected temperature.

Switching on Cos ϕ 2 via Digital Input or P Export

If a dry contact is connected to the digital input terminal, the controller will switch to Cos ϕ 2 and display "NT."

- Connected output dry contact between terminal I1, I2. Voltage source internally supplied: 5 V DC - 10 mA. Recommended section $\geq 1 \text{ mm}^2$. Length of cable should be less than 100 m.
- Set item 510 in advanced menu:
 - **Yes** = digital input is activated with closed terminals I1 & I2
 - **No** = digital input is activated with open terminals I1 & I2.
- Set Cos ϕ 2 target in 303.

Also, the controller is able to switch to Cos ϕ 2 when P EXPORT is detected (from load to grid)

- Set item 304:
 - **Yes** = the controller operates in P-export with the Cos ϕ 2 as control target.
 - **No** = the controller operates in P-export with the Cos ϕ 1.

Transformer Compensation

When a distribution transformer permanently consumes the reactive power, you can use the controller to compensate for it using two different methods.

Setting a Reactive Power Offset

- You can set up the controller to add a reactive power offset to the required power compensation.
- Determine the required reactive power to compensate a downstream transformer. Enter the calculated value in the menu item "312."
- The reactive power offset entered will be added to the measured reactive power. This offset will affect current, reactive and apparent power, power factor and ΔQ .
- The result will be equivalent to a system in which the CT would be located in the primary of the distribution transformer.

Mixed Measurement

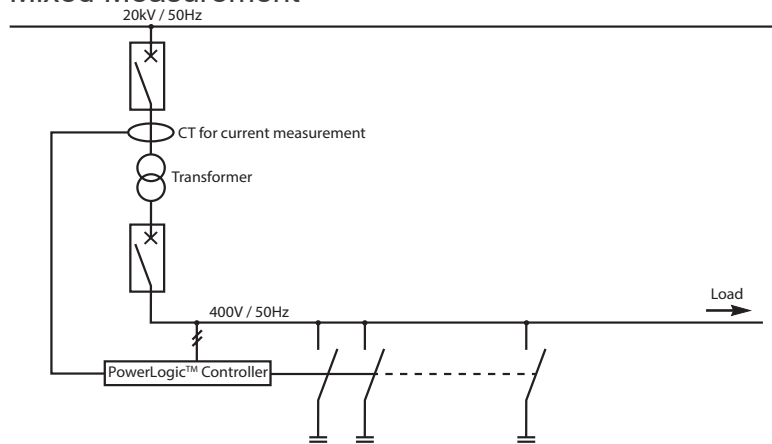

By the current measurement on medium voltage side, the reactive power caused by transformer is measured and regulated by the connected compensation system.

Connect the measurement of the controller as shown in the diagram above. Then, start the automatic initialization. The vector group of the transformer is automatically considered.

If auto-initialization is aborted, the most common transformer vector groups are listed below.

Connection for Mixed Measurement

Transformer Vector Group	CT	Voltage
Dy5	L1	L2-N
Dy5	L2	N-L3
Dy5	L3	N-L1
Yz5	L1	L2-N
Yz5	L2	N-L3
Yz5	L3	N-L1
Dx6	L1	L3-L2
Dx6	L2	L2-L1
Dx6	L3	L1-L3
Yy6	L1	L3-L2
Yy6	L2	L2-L1
Yy6	L3	L1-L3
Dy11	L1	N-L2
Dy11	L2	L3-N
Dy11	L3	L1-N
Yz11	L1	N-L2
Yz11	L2	L3-N
Yz11	L3	L1-N

Four quadrants operation

The PowerLogic™ controller is able to run in four quadrants mode.

- Reactive Power (Q) is displayed with indication of I for inductive or C for capacitive
 - Active power (P) is always displayed as a positive value, but the “Export” symbol appears if power flow from load to grid is detected
- In this “Export” mode, the controller can move automatically to Cos ϕ 2 (see “Switching on Cos ϕ 2 via Digital Input or P Export” on page 33.)

HV Voltage Applications

Special requirements for HV applications:

- Contactors are slower.
- Steps may be switched unnecessarily.

For HV applications, set the HV parameter (315) to Yes.

- Automatic step size recognition (308) and step exchange (307) will be disabled.
- Default setting of discharge time (401) is automatically moved from 50 s to 600 s and switch interval (ST or 305) from 10 s to 120 s.

To avoid unnecessary switching of steps, do not use the Automatic initialization AI by setting it to No.

- Adjust the VT ratio in menu 203.

For output relays, use a DC power supply up to 120 V, max. 0.2 A.

Inductive compensation with reactor steps

It is not possible to mix reactor steps and capacitor steps.

Modbus Communication

- The controller has a standard a modus RS-485 communication port.
- RS485 baud rate can be set from 1200 bds up to 115600 bds, with parity None, Even or Odd.
- Server number can be set from 1 to 247.
- 4-wire screw terminal: 0V / shield / D0- / D1+.
- For the Modbus register map and details about communications connections, see the PowerLogic™ VL Modbus manual.

Maintenance Operation

No maintenance required on the controller itself.

You need only to check that the display is operating and no alarm are flashing.

The controller can be used to regularly check Step database evolution (current capacitor value versus initial value, number of switches for each of steps,...), or any other installation parameters available on the display: Current, THDU, ambient and max Temperature.

Phase-Angle Settings (parameter 206)

Voltage Measurement (U)	L1-N	L2-N	L3-N	N-L1	N-L2	N-L1	L1-L2	L1-L3	L2-L3	L2-L1	L3-L1	L3-L2
CT on L1 (in °) direct	0	120	240	180	300	60	330	30	90	150	210	270
reverse	180	300	60	0	120	240	150	210	270	330	30	90
CT on L2 (in °) direct	240	0	120	60	180	300	210	270	330	30	90	150
reverse	60	180	300	240	0	120	30	90	150	210	270	330
CT on L3 (in °) direct	120	240	0	300	60	180	90	150	210	270	330	30
reverse	300	60	180	120	240	0	270	330	30	90	150	210

Note:

- Direct connection for CT:
 - CT terminal S1 is connected on the PFC controller, current terminal pin S1
 - CT terminal S2 is connected on the PFC controller, current terminal pin S2.
- Direct connection for LN voltage: ex U(L1-N):
 - L1 is connected on the PFC controller voltage terminal pin U1.
 - N is connected on the PFC controller voltage terminal pin U2.
- Direct connection for LL voltage: ex U(L2-L3):
 - L2 is connected on the PFC controller voltage terminal pin U1.
 - L3 is connected on the PFC controller voltage terminal pin U2.

Technical Characteristics

Type	Description
Voltage (common supply and input)	90 - 550 V, 1ph, 50/60 Hz, 6 VA 300 V LN / 519 V LL CAT III or 550 V CAT II.
Current	15 mA - 6 A, 1ph, < 1 VA, 100 A - 1 s
Control outputs (step output)	VL6: 6 relays VL12: 12 relays NO contact: 250 V LN or LL CAT III 48 Vdc/1 A, 250 Vac/5 A Common root: 10 A max
Fan control	Relay, NO normal open contact: 48 Vdc/1 A, 250 Vac/5 A
Alarm contact	The relay contact is open when the controller is energized with no alarm and will close in the event of an alarm. The relay is NC (Normally Closed) when the controller is not energized. Rating : 48 Vdc/1 A, 250 Vac/5 A
Digital Input for Cos phi 2 target	Dry contact (internal supply 5 V, 10 mA)
Modbus RS485 serial port (RTU)	Line polarization / termination, not included
Interface TTL	For internal uses only
Temperature for operation	-20 °C +60 °C
Internal Temperature probe	Yes
Storage	-40 °C +85 °C
Humidity	0 % - 95 %, without condensation for operation and storage
Maximum pollution degree	2
Maximum altitude	≤ 2000 m
Connection	Screw type, pluggable. Section: 0.2 - 2.5 mm ² (0.2 - 1 mm ² for Modbus and digital input)
Case	Front: instrument case plastic RAL 7016 Rear: metal
Degree of Protection	Front: IP41, (IP54 by using a gasket) Rear: IP20
Weight	0.6 kg
Size	144 x 144 x 58 mm (H x W x D)
Panel Cutout	138 x 138 (+0.5) mm, thickness 1 to 3 mm
Protection against voltage dips	Automatic disconnection of steps for dips > 15 ms (protection of capacitor)
Display	LCD graphic 56 x 25
Alarms log	5 last alarms
Distortion	H1 to H19
Measurement displayed and accuracy	U, I, F: ±1 % S, P, Q, DQ, PF, Cos phi, THDU: ±2 % U harmonics (H3 to H19): ±3 % Internal Temperature: ±3 °C
Standards	IEC 61010-1 IEC 61000 6-2 IEC 61000 6-4 IEC 61326-1 UL 61010
Conformity and listing	CE, NRTL, c NRTL, EAC
Program algorithm	AUTOMATIC (best fit) LIFO PROGRESSIVE
Regulation setting	From Cos φ 0.7c to 0.7i
Reconnection time	From 1 to 6500 s
Response time	From 1 to 6500 s
CT range	Primary range: up to 9600 A Secondary range: 1 A or 5 A. Some specific requirements must be met, for details refer to "Appendix", page 38

Note: Ensure you note the changes made on settings under customer setting column.

100 - Quick Setup Settings			400 - Step Database Settings		
Menu	Factory setting	Customer setting	Menu	Factory setting	Customer setting
Un	400 V		401	50 s	
Ct	1		402	3 var C [step 1...max 12]	
AI	(No setting)		403	Auto [step 1...max 12]	
PFC	On		404	0 [step 1...max 12]	
CP1	0.95i				
St	10 s		500 - Alarm Settings		
Out	AUTO [step 1... max 12]		501	No	
200 - Measurement settings			502	7 %	
201	400 V		503	Yes	
202	1		504	60 s	
203	1		505	No	
204	10 %		506	Yes	
205	Yes (LL meas.) / No (LN meas.)		507	100 k	
206	90° (LL meas.) / 0° (LN meas.)		508	65.5 k h (7 ans)	
207	(No setting)		509	1.3	
208	Auto		510	Yes	
209	0 °C		511	30 °C	
300 - Control Settings			512	50 °C	
301	75 %		513	Yes	
302	0.95i		514	Yes	
303	0.95i		515	Yes	
304	No		516	Yes	
305	10 s		517	7	
306	2 s		600 - Reset		
307	No		607	xxx.xxx.xxx	
308	Yes		608	242	
309	Yes		700 - Communication Settings		
310	On		701	19.2 k	
311	1		702	Even	
312	0		703	1	
313	1				
314	No				
315	No				

Requirement 1 :

Improper selection of the primary current and secondary current of the CT will cause a "Step/Flty" alarm for VPL controllers. Improper selection of the CT VA will result in a large measurement error detection.

Solution:

The primary selection of the CT must align with the nominal current of the system. It is recommended to use 1.1 to 1.5 times the nominal current as the primary current of the CT.

For example: CT on a transformer with 630 kVA at 400 V, the nominal current would be: $\frac{630 \text{ kVA}}{(\sqrt{3} \times 400 \text{ V})} \approx 910 \text{ A}$

Select 1000 A (1.1 times) or 1200 A (1.3 times) as the primary current of the CT.

If CT primary is higher than the nominal current of the source transformer, then you create a risk of wrong faulty step detection : see "[Requirement 2](#)", [page 39](#).

Select 5 A for the secondary current of CT, do not select 1 A. Only use 1 A CT, if the distance between the CT and the VPL is more, then follow the below rules:

It is recommended to use a CT of not less than 10 VA for common use. If you have to use a smaller CT capacity (example., 5 VA or 1 VA) or if there is a long distance between the CT and VPL, make sure that the CT capacity complies with the total impedance, including wires and VPL (0.1 Ohm burden).

Example 1:

CT is 5 VA, secondary current is 5 A, wire cross section is 2.5 mm² (0.0079 Ω/m)

The maximum distance between CT and VPL is

$$\frac{5 \text{ VA}}{(5 \text{ A})^2} \cdot 0.1 \Omega \cdot 2 \times 0.0079 \Omega/\text{m} \approx 6.3 \text{ m}$$

To conclude, it is not possible to use a 5 VA CT if the distance between CT and VPL is 10 m. Select 10 VA for CT capacity.

$$\frac{10 \text{ VA}}{(5 \text{ A})^2} \cdot 0.1 \Omega \cdot 2 \times 0.0079 \Omega/\text{m} \approx 19 \text{ m}$$

Example 2:

CT is 10 VA, secondary current is 5 A, wire cross section is 1.5 mm² (0.0136 Ω/m)

The maximum distance between CT and VPL is

$$\frac{10 \text{ VA}}{(5 \text{ A})^2} \cdot 0.1 \Omega \cdot 2 \times 0.0136 \Omega/\text{m} \approx 11 \text{ m}$$

To conclude, it is not possible to use a 10VA CT if the distance between CT and VPL is 15 m. Select 15 VA for CT capacity, or use 2.5 mm² wire.

$$\frac{15 \text{ VA}}{(5 \text{ A})^2} \cdot 0.1 \Omega \cdot 2 \times 0.0136 \Omega/\text{m} \approx 18.38 \text{ m}$$

$$\frac{10 \text{ VA}}{(5 \text{ A})^2} \cdot 0.1 \Omega \cdot 2 \times 0.0079 \Omega/\text{m} \approx 19 \text{ m}$$

Example 3:

CT is 10 VA, secondary current is 5 A, wire cross section is 2.5 mm² (0.0079 Ω/m)

The maximum distance between CT and VPL is

$$\frac{10 \text{ VA}}{(5 \text{ A})^2} \cdot 0.1 \Omega \cdot 2 \times 0.0079 \Omega/\text{m} \approx 19 \text{ m}$$

To conclude, it is not possible to use a 5 A secondary current if the distance between CT and VPL is 100 m, select 1 A as the secondary current.

$$\frac{10 \text{ VA} \cdot 0.1 \Omega}{(1 \text{ A})^2} \cdot \frac{1}{2 \times 0.0079 \Omega/\text{m}} \approx 626.6 \text{ m}$$

(The calculation is theoretical and considers factors such as noise/perturbation and phase shifting of the signal. Avoid connecting a current transformer (CT) over long distances from the measuring device).

Requirement 2 :

Improper selection on smallest step will cause “Step/Flty” alarm for VPL controller.

Solution:

It is recommended not to use a smallest step size lower than 2% of the source transformer, and this smallest step size should imperatively respect the rule below:

(Stepsize in VAr)/(ku*ki) >= 10 VAr
with ku: VT ratio (if no VT used ratio = 1)
with ki: CT ratio

Example 1:

If the smallest step size is 12 kVAr, the CT ratio is 1200:5, no PT, so no risk of raising “Step / Flty” alarm, because:

$$12 \text{ kVAr} / ((1200/5) * 1) = 50 \text{ VAr} (>10 \text{ VAr})$$

Example 2:

If the smallest step size is 12 kVAr, the CT ratio is 1200:1, no PT, then it is highly possible to raise “Step / Flty” alarm, because:

$$12 \text{ kVAr} / ((1200/1) * 1) = 10 \text{ VAr} (>10 \text{ VAr})$$

To conclude, select smallest step size as 15 kVAr:

$$15 \text{ kVAr} / ((1200/1) * 1) = 12.5 \text{ VAr} (>10 \text{ VAr})$$

Example 3:

If the smallest step size is 25 kVAr, the CT ratio is 500:5, the PT ratio is 3300:110, then the “Step / Flty” alarm will be raised, because:

$$25 \text{ kVAr} / ((500/5) * (3300/110)) = 8.33 \text{ VAr} (<10 \text{ VAr})$$

To conclude, select smallest step size as 35 kVAr:

$$35 \text{ kVAr} / ((500/5) * (3300/110)) = 11.66 \text{ VAr} (>10 \text{ VAr})$$

Schneider Electric

35, rue Joseph Monier
92500 Rueil Malmaison
France

Phone: +33 (0) 1 41 29 70 00
www.se.com

© 2025 Schneider Electric. All Rights Reserved.

7EN02-0375-03

Schneider Electric is the trademark or registered trademark of Schneider Electric in France, the USA and other countries. Other trademarks used are the property of their respective owners.