

753CF1

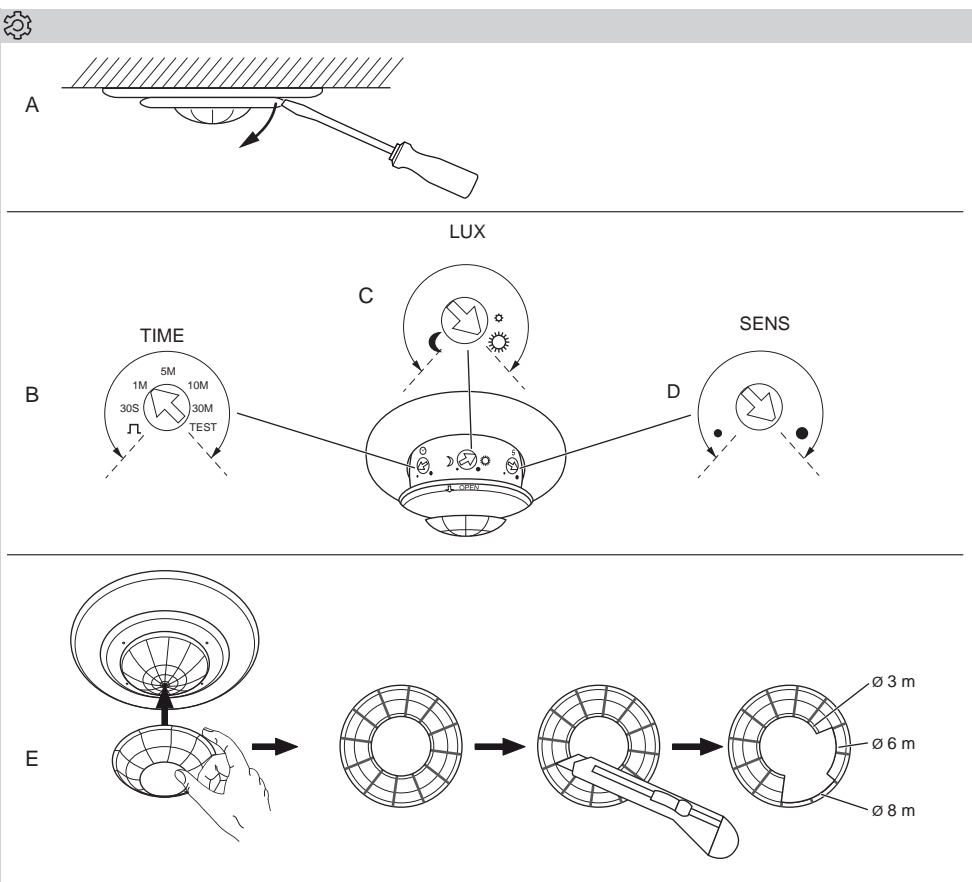
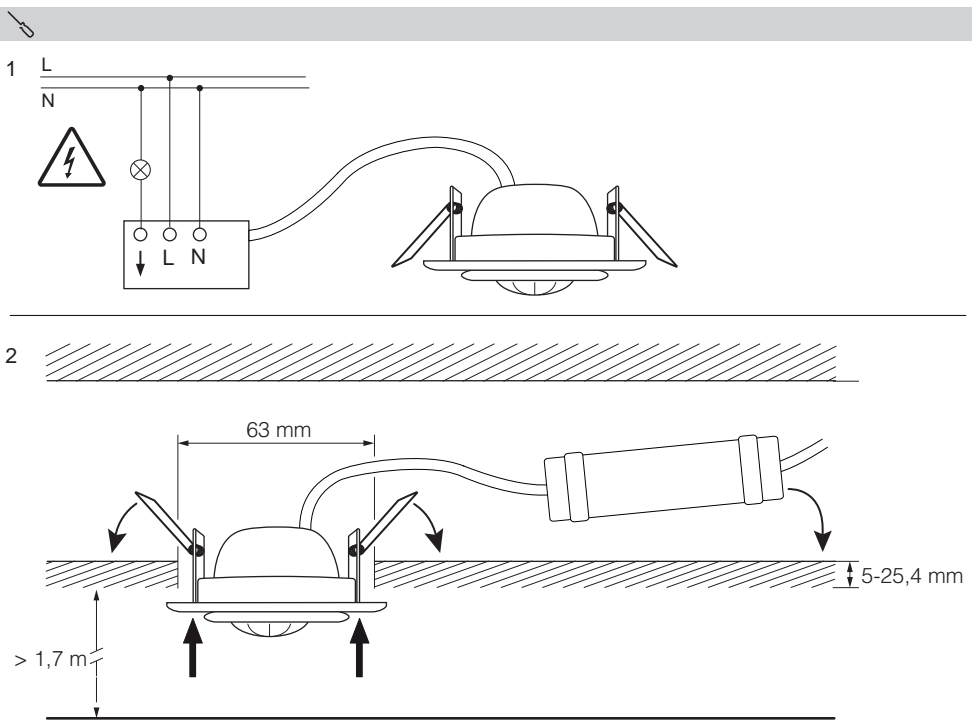
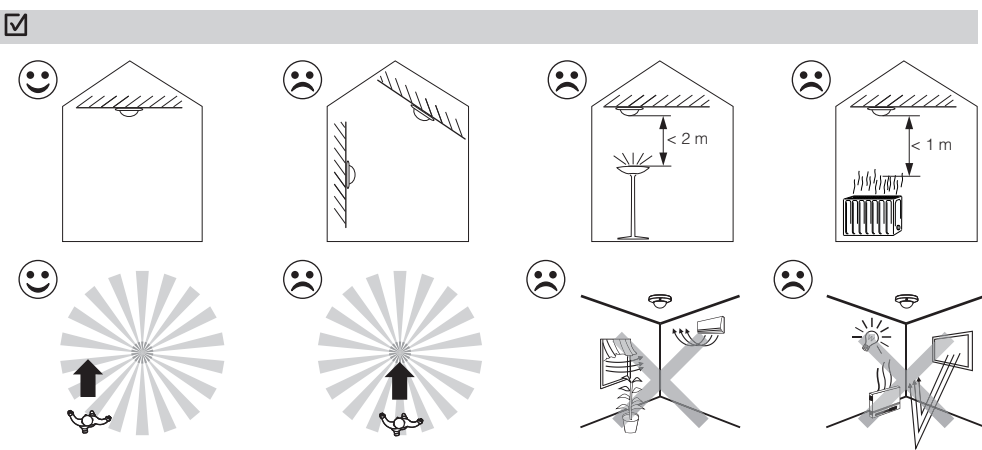
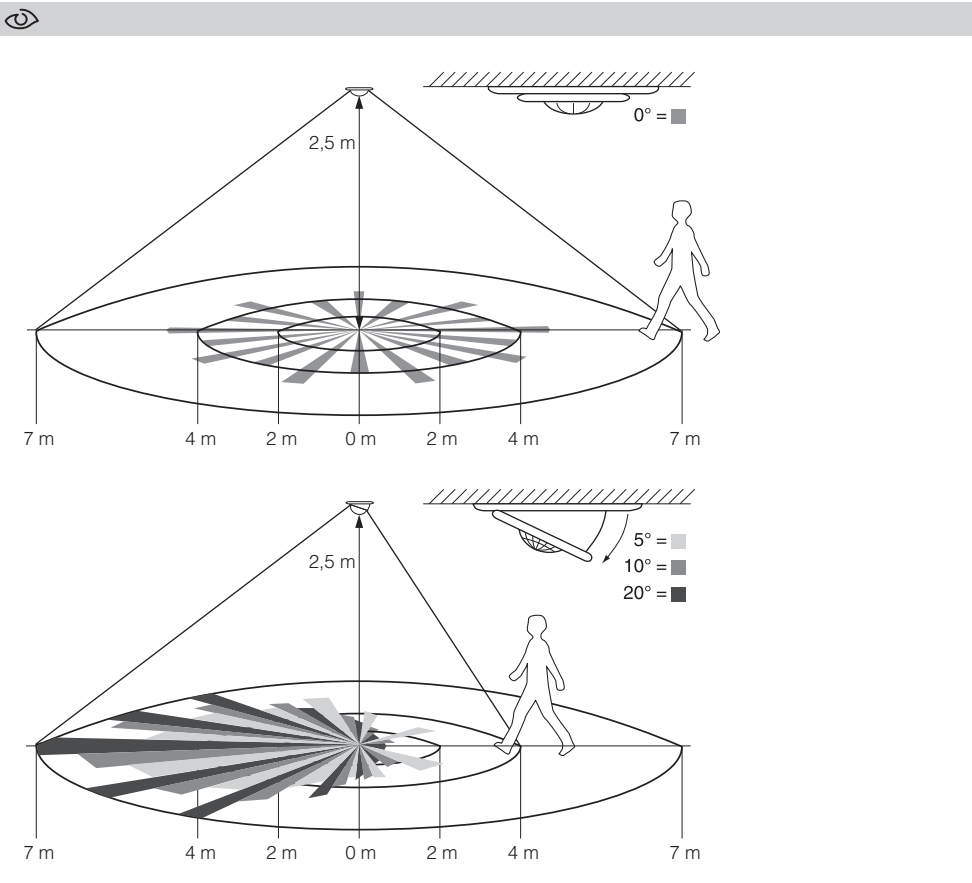

**en** PIR Sensor, 360deg, ceiling, One channel

**For your safety**

**⚠ DANGER HAZARD OF ELECTRIC SHOCK, EXPLOSION, OR ARC FLASH**  
It is illegal for persons other than an appropriately licensed electrical contractors or other persons authorised by legislation to work on the fixed wiring of any electrical installation.

- To comply with all safety standards, the product must be used only for the purpose described in this instruction and must be installed in accordance with the wiring rules and regulation in the location where it is installed.
- There are no user serviceable parts inside the product.

**Failure to follow these instructions will result in death or serious injury.**

**Getting to know the movement detector**

The 360° False ceiling indoor sensor (called sensor below) for automatic switching detects moving heat sources in its detection range (passive infra-red technology) and at each detection switches on a lamp, for example, for an adjustable period of time.

The sensor has an adjustable detection brightness, so that it is only active when the ambient brightness is below a certain level.

For information on the area of detection, see

**Selecting the installation site**

The sensor is intended only for indoor dropped-ceiling mounting (e.g. office, hall).

The sensor should be installed in such a way that there are no light or heat sources in the area of detection, to avoid unwanted switching.

For information on the installation site, see

**Mounting the movement detector**

For information on installation, see

**i** After switching the supply voltage on, the movement detector requires approximately 60s (initialisation) until it is ready for operation.

**Testing and setting the movement detector**

For information on the operating elements, see as possible.

**1. TIME (B)**  
The time can be set variably from "pulse", 30 s to 30 min. Timer starts counting from the latest detected movement. While there is still movement in the detecting area, the LED indicator and connected lighting loads will remain on and the timer will keep resetting.

**Pulse (leftmost position):**  
• The sensor reacts to any motion in the detecting area, and to the settings of lux level.  
• When the sensor is activated, the LED indicator and connected lighting loads will be turned on for 1 s and off for 9 s as a complete period before receiving another detection.

**Test (rightmost position):**  
• The lux level setting is deactivated.  
• When the sensor is activated by motion, the red LED and connected lighting loads will be turned on for 3 seconds.

**2. LUX (C)**  
The LUX adjustment controls the light level at which the unit will switch on the light when movement is sensed. If set to the maximum position, it will switch during daylight. If set to the minimum position, it will operate only in total darkness. Ideally it should be set at dusk or in the light conditions under which the sensor and lights are expected to operate.  
The sensor is now in automatic mode. The LED indicator blinks regularly. In case of movement detection the LED display lights up as long as a movement is detected.

**3. SENS (D)**  
SENSitivity adjustment controls the detection range and sensitivity of sensor.  
If set to the maximum position, the detection range is Ø7 m @ 2.5 m height.  
If set to the minimum position, the detection range is Ø2 m @ 2.5 m height.

**What should I do if there is a problem?**

- Load is not switching on.**
- Ensure power supply.
  - Check the detection area.
  - Increase detection brightness (C).
- Load is briefly switched on and off again.**
- Avoid reflecting surfaces in the detection range of the sensor.
  - Increase ambient temperature. Sensor sensitivity increases as ambient temperature decreases.
  - Check if the time period is not set to pulse (position leftmost) or test (position rightmost).
- Load is permanently switched on.**
- Check the connection of the sensor.
  - Reduce time period (B).
  - Increase the distance between the sensor and any heating, air conditioning or ventilation unit.

**Maintenance and care**

Clean the lens and the housing with a damp cloth when dirty.

**Technical data**

Mains voltage:	220-240 V~, 50/60 Hz
<b>Load</b>	
Channel 1:	
Incandescent lamps:	max. 1000 W
HV Halogen lamps:	max. 900 W
LV Halogen lamps with electronic transformer:	max. 250 VA
LV Halogen lamps with iron-core transformer:	max. 500 VA
Fluorescent lamps:	max. 200 VA
Energy saving lamps and LED:	max. 100 W
Time period:	pulse, 30 s, 1 min, 5 min, 10 min, 30 min, Test
Detection range at mounting height of 2.5 m:	max. Ø 7 m, 360°
Detection range adjustment:	Ø 2 ~ Ø 7 m
Detection brightness:	5-2000 lx
Fuse:	10 A circuit breaker

**Warranty**

Schneider Electric (Australia) Pty Ltd, (Clipsal by Schneider Electric), warrants this product to be free from defects in materials and workmanship for a period of three years from the date of installation. The benefits conferred herein are in addition to any other rights and remedies you may have at law in respect to this product. Australian and New Zealand customers please see the notes below.

**Australia:** Australian Consumer Law specifies that our goods come with guarantees that cannot be excluded. You are entitled to a replacement or refund for a major failure and compensation for any other reasonably foreseeable loss or damage. You are also entitled to have the goods repaired or replaced if the goods fail to be of acceptable quality and the failure does not amount to a major failure.

**New Zealand:** This guarantee is in addition to and does not affect your rights under applicable law, except where that law expressly provides otherwise. The Consumer Guarantee Act 1993 (NZ) will not apply if this product is purchased for the purpose of business.

This warranty is expressly subject to the Schneider Electric product being installed, wired, tested, operated and used in accordance with our instructions and specifications. Any alterations or modifications made to the product without our permission will void the warranty. Schneider Electric will at its option repair, replace or refund any defective product. The cost of replacement or repair of a defective product is limited to the price of the product only. Schneider Electric will not be responsible for the cost of retrieving, removing, reinstalling, transporting (including return of the defective product to us) or re-testing a product.

**How to make a claim:** Contact your electrical wholesaler or local supplier of Schneider Electric, PDL or Clipsal branded products and provide the details of the date of purchase, description of load or connections and the circumstances of the failure. Please provide adequate particulars of the defect within 28 days of the fault occurring.

**Australia Schneider Electric (Australia) Pty Ltd**

Customer Care Australia:  
1300 369 233  
Email: customercare.au@schneider-electric.com  
www.schneider-electric.com.au

**New Zealand Schneider Electric (NZ) Ltd**

38 Business Parade South, Highbrook, East Tamaki, Manukau 2013  
PO. Box 259370 Botany, Manukau 2163  
Telephone +64 9-829 0490, Fax +64 9-829 0491  
After hours service hotline:  
0800 735 4357 (New Zealand only)  
Customer Care: 0800 652 999  
Email: sales@nz.schneider-electric.com  
www.schneider-electric.com

**Technical Sales Support**  
For assistance and technical problems, contact your nearest Schneider Electric Sales representative.

Schneider Electric reserves the right to change specifications, modify designs and discontinue items without incurring obligation and whilst every effort is made to ensure that descriptions, specifications and other information in this catalogue are correct, no warranty is given in respect thereof and the company shall not be liable for any error therein.

© Schneider Electric 2016

This material is copyright under Australian and international laws. Except as permitted under the relevant law, no part of this work may be reproduced by any process without the prior written permission of and acknowledgment of Schneider Electric