

Universal super dimmer insert

Operating instructions

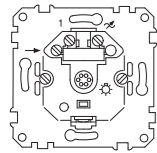

Art. no. 577099

For your safety

⚠️ ⚠️ DANGER

HAZARD OF ELECTRIC SHOCK, EXPLOSION, OR ARC FLASH

Safe electrical installation must be carried out only by skilled professionals. Skilled professionals must prove profound knowledge in the following areas:

- Connecting to installation networks
- Connecting several electrical devices
- Laying electric cables
- Safety standards, local wiring rules and regulations

Failure to follow these instructions will result in death or serious injury.

⚠️ ⚠️ DANGER

HAZARD OF ELECTRIC SHOCK

The outputs may carry an electrical current even when the device is switched off.

- Before working on the loads, always disconnect the device from the supply via the upstream miniature circuit breaker.

Failure to follow these instructions will result in death or serious injury.

Notice

HAZARD OF EQUIPMENT DAMAGE

- Connected devices can be damaged if you connect mixed loads (inductive and capacitive) at the same time.
- Only connect dimmable loads.
- Sockets must not be dimmed.
- Ensure that the device is disconnected from its circuit during the insulation resistance test.

Failure to follow these instructions can damage the device.

Universal super dimmer insert introduction

You can use the universal super dimmer insert (referred to below as **dimmer**) for switching and dimming ohmic, capacitive or inductive loads via a sensor cover or via radio.

The dimmer automatically recognises the connected load. The built-in memory function can store the brightness level that was last set (can be switched off).

The dimmer is overload-proof, short-circuit-proof and hum-free, and has a soft start function which softly dims up a connected load.

You can connect up to ten of the following electronic extension units:

- Extension TELE insert (art. no. 573998)
- Extension insert (art. no. 573999).

You can also connect any number of mechanical extensions (conventional push-buttons).

Mixed operation of the extension units is also possible.

Notice

HAZARD OF EQUIPMENT DAMAGE

- The dimmer requires a minimum load of 25 VA for operation. If this is not met, the dimmer may be damaged.

Failure to follow these instructions can damage the device.

i An excessive load will trigger the dimmer's overload protection. Reducing the connected load causes the overload protection to deactivate and the dimmer switches back on.

i The extension unit cable should not exceed 10 m in length.

i If the load on connected **wound transformers** is too low, the dimmer may malfunction during operation. The load on the transformer should therefore be at least 40 % of the nominal power of the transformer.

i If you do not install the dimmer in a single, standard flush mounting box, the maximum permissible load is reduced as follows, due to the restricted heat dissipation:

Load reduction by	Dimmer installed in cavity or wooden walls*	Several dimmers installed in combination *	Dimmer in 1-gang surface-mounted housing
10 %			X
15 %	X		
20 %		X	

* If several factors apply at once, add the load reductions together.

Completing the dimmer

Complete the dimmer with a frame and a

- sensor cover (art. no. 5776.., 5701.., 5704.., 5737.., 5738.., 5742..) or
- TELE sensor cover (art. no. 5779.., 5703.., 5711.., 5709.., 5749..) or
- comfort dial central plate (art. nos. 5678.., 5677..) or
- control electronics, 1-gang (art. no. 569090) and glass sensor cover (art. no. 569x..) or
- radio sensor cover (art. no. 5036.., 5026.., 5046..)

Installing the dimmer

⚠️ ⚠️ DANGER

HAZARD OF ELECTRIC SHOCK

The outputs may carry an electrical current even when the device is switched off.

- Before working on the loads, always disconnect the device from the supply via the upstream miniature circuit breaker.

Failure to follow these instructions will result in death or serious injury.

① Wire up the dimmer for the application.

Applications:

- Dimmer (A) as a stand-alone device:

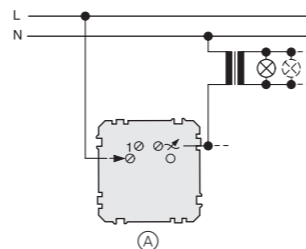

- Dimmer (A) with extension units: Connection example with a push-button (B) and two extension TELE inserts (C):

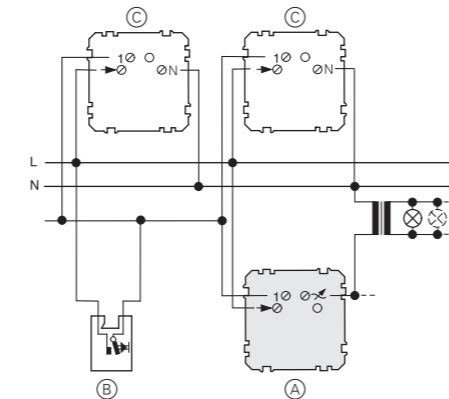

② Install the dimmer in the switch box so that the anti-rotation element is at the bottom.

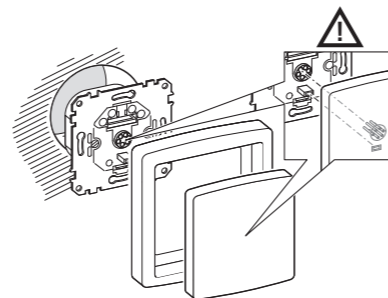

Notice

BENDING THE CONTACT PINS

- The contact pins on the rear of the sensor cover can become bent if tilted excessively. Therefore always plug the sensor cover in as straight as possible.

Failure to follow these instructions can damage the device.

③ Attach the accompanying sensor cover together with the frame. Hold the sensor cover so that the recess at the back is at the bottom to receive the pin of the dimmer insert.

i For glass sensor covers: refer to the accompanying installation instructions.

Putting the dimmer into operation

After installation:

① switch on the mains voltage.

The connected luminaires flicker for around ten seconds and then switch off again.

The dimmer has detected the load and is ready for operation.

i The lights will flicker in this way (load detection) after every interruption to the mains voltage.

Operating the dimmer

Operate the dimmer via one of the following:

- Sensor cover on the dimmer itself
- Sensor cover on an electrical extension unit
- Mechanical extension unit (conventional push-button)
- Radio push-button or remote control (when a sensor cover with radio receiver is fitted on the dimmer)
- IR remote control (with TELE sensor cover)

Operation is the same in all cases

Switching/dimming connected luminaires

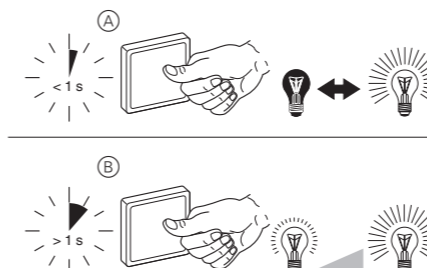

- Switching on/off: press the button briefly
- Dimming brighter/darker: press the button and hold it down

Switching the memory function on/off

① Switch the dimmer on and off at least ten times in quick succession.

Operate the dimmer using the comfort dial central plate

See the operating instructions for "Central plate, comfort rotating regulator for universal super dimmer insert".

What should I do if there is a problem?

The dimmer regularly dims down or switches off during operation.

Allow the dimmer to cool down and reduce the connected load.

The dimmer cannot be switched back on.

- Allow the dimmer to cool down further and reduce the connected load.
- Rectify any possible short circuits. The dimmer must now detect the load again. If necessary, switch on the dimmer once for load detection.

Technical data

Mains voltage:	AC 220–230 V, 50/60 Hz
Nominal power:	at 50 Hz: 25–420 VA, at 60 Hz: 25–340 VA
Residual brightness:	Permanently set
Features:	Short-circuit-proof, overload-proof, hum-free, soft start, memory function (can be switched off).

Dispose of the device separately from household waste at an official collection point. Professional recycling protects people and the environment against potential negative effects.

Merten GmbH

Fritz-Kotz-Str. 8
51674 Wiehl - Germany
se.com/contact

Schneider
Electric