

## Introduction to the floor thermostat

The freely mountable electronic floor thermostat insert with switch (referred to as **insert** from here on) is used to control the temperature of electrical underfloor heating in dry and enclosed spaces.

**i** The insert has a heating interrupter in accordance with EN 50559. If the heating has been on for an hour without interruption, the heating interrupter interrupts the circuit to the underfloor heating for five minutes.

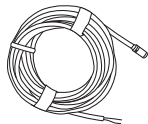

The remote sensor is fitted in the floor and monitors the floor temperature. When at the "0" position, the switch disconnects the device from the mains at one pole, thereby interrupting the circuit feeding the underfloor heating.

## Installing the insert

① Install the remote sensor in a protective pipe in the floor.

**i** The protective pipe protects the sensor against moisture and mechanical strain. The sensor can easily be replaced if it gets damaged.

You can extend the sensor cable up to a maximum of 50 m (cable cross-section 1.5 mm<sup>2</sup>). Use a shielded sensor cable when installing in cable ducts or close to live lines.

② Wire the insert according to the circuit diagram.

### Circuit diagram

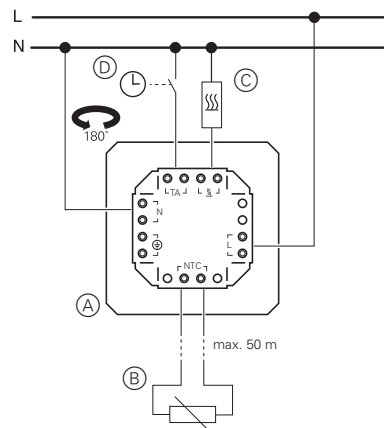

- Ⓐ Insert
- Ⓑ Remote sensor
- Ⓒ Underfloor heating
- Ⓓ External timer switch for night-time temperature reduction

**i** Observe the following:

- When using conductors with a cross-section of 2.5 mm<sup>2</sup>, we recommend using deep installation boxes to make installation easier.
- A protective conductor is not required as the connection serves the purpose of looping through.

③ Install the insert.

**i** To ensure that the insert functions properly, the support ring must always be fitted on a finished wall. It must not be wallpapered over, for example.

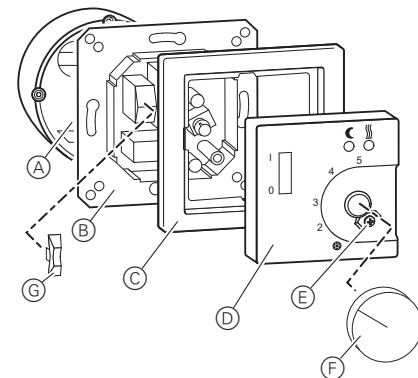

- ④ Insert rocker switch Ⓒ into the switch base.
- ⑤ Place frame Ⓒ and central plate Ⓓ on the insert and fasten using screw Ⓔ.
- ⑥ Push on setting knob Ⓕ.

## Operating the insert

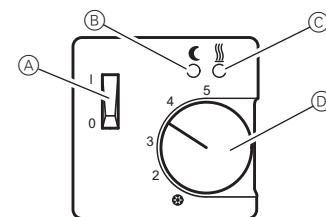

- Ⓐ On/off switch
- Ⓑ Display for night economy On (green LED)
- Ⓒ Display for heating On (red LED)
- Ⓓ Setting knob for temperature preselection

Use the setting knob to set the floor temperature required. The scale corresponds to a temperature range of approx. 10 to 50°C (note the instructions of the underfloor heating manufacturer here).

### Temperature setting scale with symbols/numbers

❄	= approx. 10°C	2	= approx. 20°C
3	= approx. 30°C	4	= approx. 40°C
5	= approx. 50°C		

If the floor temperature falls below the setpoint, the insert switches on the underfloor heating and the red LED Ⓒ lights up. When the temperature reaches the setpoint, the heating switches off and the red LED Ⓒ goes out.

If the insert is connected to an external timer switch and the timer switch is so set up (refer to the operating instructions for the external timer switch), a night-time temperature reduction of approx. 4°C can take effect in the evening and the green LED Ⓑ lights up.

## Floor thermostat insert

User Guide

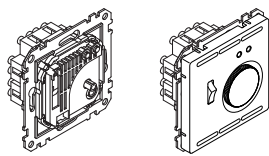

### Floor thermostat insert with switch

Art. no. 537100

### System design

#### Floor thermostat 230 V with switch and central plate

Art. no. MEG5764-60..

## Necessary accessories

– To be completed with:

- Central plate for floor thermostat insert
- Frame in corresponding design

## For your safety



### DANGER

#### HAZARD OF ELECTRIC SHOCK, EXPLOSION, OR ARC FLASH.

Safe electrical installation must be carried out only by skilled professionals. Skilled professionals must prove profound knowledge in the following areas:

- Connecting to installation networks
- Connecting several electrical devices
- Laying electric cables
- Safety standards, local wiring rules and regulations

**Failure to follow these instructions will result in death or serious injury.**



### DANGER

#### Risk of death from electric shock.

The outputs may carry an electrical current even when the device is switched off. Always disconnect the fuse in the incoming circuit from the supply before working on connected loads.

**Failure to follow these instructions will result in death or serious injury.**

## Limiting the temperature adjustment range

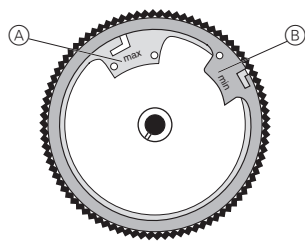

- Ⓐ Red ring (max.): highest temperature that can be set
- Ⓑ Blue ring (min.): lowest temperature that can be set

The insert is factory-set to a maximum adjustment range of 10 to 50°C.

There are 2 adjusting rings in the setting knob. These can be used to limit the temperature adjustment range within the minimum and maximum values.

### Setting procedure

- ① Turn the setting knob to roughly the middle of the required adjustment range.
- ② Remove the setting knob.
- ③ Insert the tip of a ballpoint pen into the hole and turn the ring to the required temperature limit.  
The red adjusting ring needs to be turned anticlockwise.  
The blue adjusting ring needs to be turned clockwise.
- ④ Put the setting knob back on.

## Technical data

### Insert

Operating voltage:	AC 230 V, 50 Hz
Temperature adjustment range:	10-50°C
Switching current at AC 250 V:	10 (4) A
Switching capacity:	2.3 kW
Temperature reduction:	approx. 4 K
Differential temperature gap:	approx. 1 K
IP code:	IP 30

### Remote sensor

Sensor element:	NTC
Sensor cable:	PVC, 4 m, 2 x 0.75 mm <sup>2</sup>
IP code:	IP 67
Sensor data:	33 kΩ at 25°C

Energy class: IV = 2%

Mode of operation: 1C

Protection class: II (once the cover has been fitted)

Connecting terminals: Plug-in terminals for 1 to 2.5 mm<sup>2</sup> solid conductors



Dispose of the device separately from household waste at an official collection point. Professional recycling protects people and the environment against potential negative effects.

## Merten GmbH

Fritz-Kotz-Str. 8  
51674 Wiehl - Germany  
se.com/contact

**Schneider**  
Electric