

# MZ09L

## Zone Valve Actuator

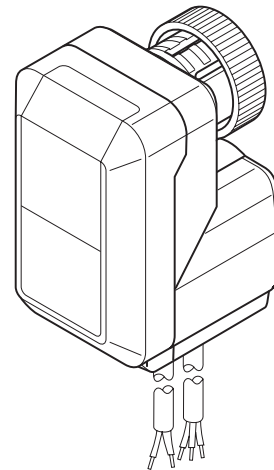

The LON actuator is targeted for decentralized building structures and gives customers an effective new capability in energy management and product flexibility. The actuator works with standard SNVTs to provide interoperability with controllers based on LonWorks technology.

The MZ09L small linear actuator is specifically designed to provide LonMark capabilities together with radiator valves and are used in fan coil units, induction units,

small reheaters, recoolers and for zone control applications.

The MZ09L actuator is suitable controllers based on LonWorks technology. Using standard Echelon configuration tools, the actuator can be configured with job specific settings.

### DIMENSIONS mm

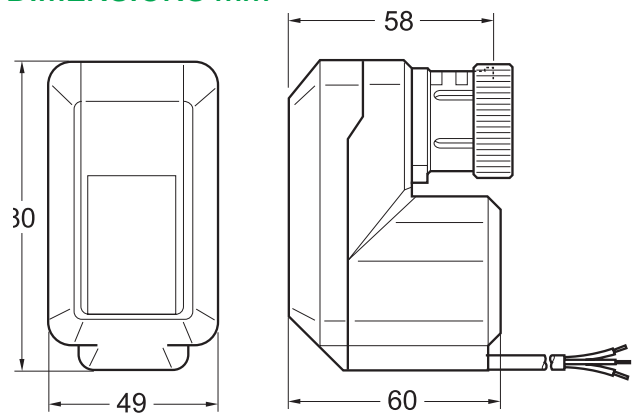

### SPECIFICATIONS

Item no. . . . .	.845-5112
Power supply . . . . .	24 VAC, ± 20%, 50/60 Hz
Power consumption . . . . .	1.4 VA
Control signal . . . . .	SNVT_lev_percent 0–100%
Network protocol . . . . .	LonTalk
Channel . . . . .	FTT10A
Stroke . . . . .	2.5 mm
Running time . . . . .	53 s at 50 Hz 44 s at 60 Hz
Stem force . . . . .	90 N (for valves DN 15–20)
Protection standard . . . . .	IP 42
Insulation class . . . . .	III
Connection cables . . . . .	1.5 m, three leads 1.5 m, two leads
Coupling ring . . . . .	M 30 x 1.5
Ambient operating temperature limits . . . . .	0 – +55 °C
Weight . . . . .	0.4 kg
Suitable for valves. . . . .	see table, last page

Echelon®, LON®, LonWorks®, LonTalk® Neuron®, and LonMark® are registered Trade marks of Echelon Corporation, USA.

### FUNCTION

The movement of the electric actuator is produced by a screw spindle which is driven in both directions by a synchronous motor through a set of gears. A magnetic clutch limits the torque of the gear assembly and the driving force of the actuator.

The actuator is fixed to the valve body by means of a coupling ring requiring no tools for mounting.

The actuator is maintenance-free and supplied completely with a ready-to-wire connecting cable.

The movement of the actuator stem (Fig. 1) indicates whether the valve is opening or closing.

If the direction of travel is not correct, the configuration parameter nciDirRev (SNVT-state) can be used for changing the direction of action.

A functional check of the valve actuator can be carried out by changing the nviManActPos (SNVT\_lev\_percent).

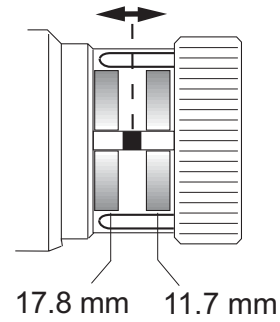

Fig. 1

## MOUNTING

The actuator may only be mounted beside or above the valve. Adjust the valve in the right position before mounting the actuator. (Fig. 3)

Before the actuator is fixed to the valve, the adjustment cap must be removed. Make sure that the actuator is in the open position (factory supplied position) before fixing the actuator to the valve body. (Fig. 4)

The actuator must be mounted by hand. Don't use tools or additional forces, because actuator and valve may be damaged.

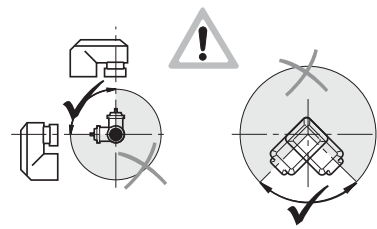

Fig. 3

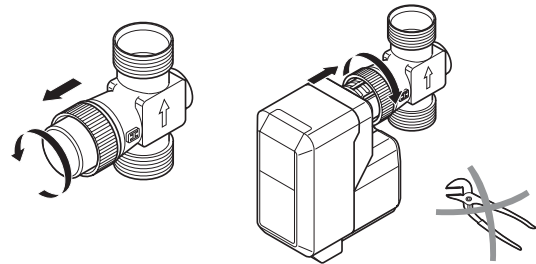

Fig. 4

## MMI DESCRIPTION

### Service LED

Defined by Echelon firmware in the neuron chip (see table 1)

### Status LED

Is blinking if wink was sent and indicates reverse or direct acting (see table 2 and diagram 1)

### Status PIN

Accessible under the cover and will be used to send the neuron ID over the network during the installation.

## SERVICE LED

Node state Service LED	hF01F Status code	Service LED	Pulse rate (Hz)
Applicationless and unconfigured	3	on	76
Unconfigured (but with an application)	2	Flashing	0.51
Configured, Hard Off-line	6	off	—
Configured	4	off	—

Table 1

## STATUS LED

Status LED	Blink Modes
Mode 1	1 s on, 1 s off, for 10 times - if a wink message was received
Mode 2	4 s on, 1 s off - direct acting and normal operation
Mode 3	4 s off, 1 s on - reverse acting and normal operation
Mode 4	continuously off - the device is in the offline-mode

Table 2

### VALVE TYPE AND OUTPUT SIGNAL

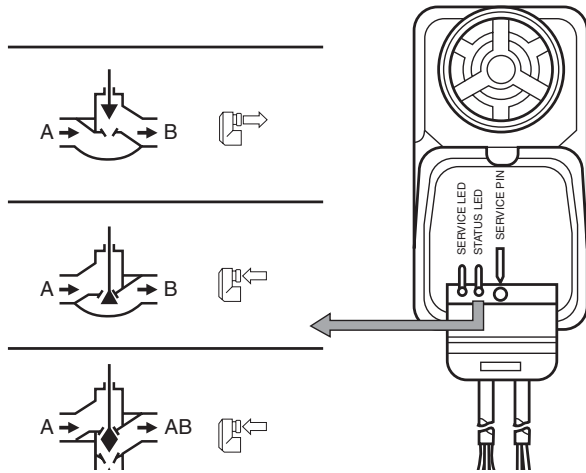

Fig. 2

### STATUS LED

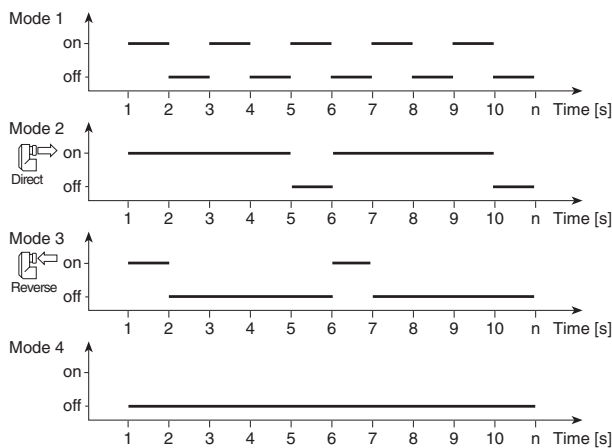

Diagram 1

### CONNECTIONS

The electrical installation must comply with the wiring diagram shown in Fig. 5 and Fig. 6.

### CONNECTIONS

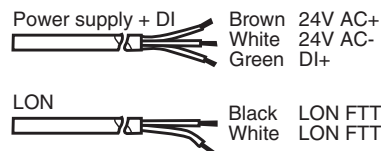

Fig. 5

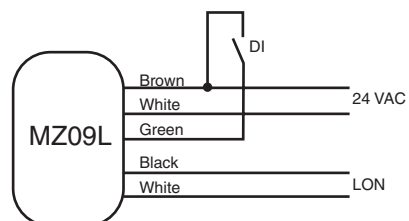
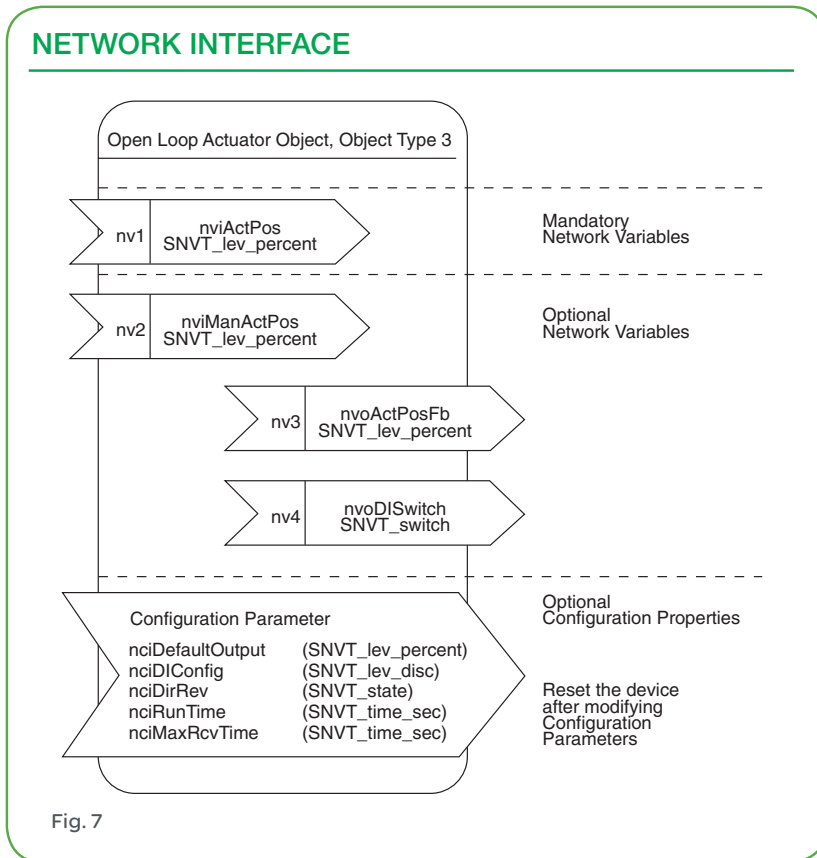

Fig. 6

## LONMARK NETWORK INTERFACE

The Actuator with LON Capabilities will support the following subset of the SNVT variables used for the communication and binding. The detailed specification of the network variables will be found in the LonMark Objects summary.



## DESCRIPTION OF USED SNVTS\* AND SCPTS\*\*

This table shows all used standard network variables and standard configuration parameters, their default values, a short description, the range and the send conditions and service of the outputs.



Standard Network Variable	Type {Range} {factory settings}	Adjustment of the different functionalities and the explanation of the shown values.	
Mandatory Network Variables		Definition	Explanation
nviActPos	SNVT_lev_percent	<p>nviActPos = 163.835 [INVALID]</p> <p>After Power-on or Reset</p> <p>Controller is sending [INVALID].</p> <p>The actuator will run to the safety position defined in [nciDefaultOutput].</p> <p>Watchdog has "detected";</p> <p>Only possible if the watchdog was selected in [nciMaxRcvTime] and will correspond on the made selection in [nciDefaultOutput].</p> <p>The actuator will run to the safety position defined in [nciDefaultOutput].</p> <p>nviActPos = 0% or 100%</p> <p>Synchronization with full running time + 30%.</p> <p>The synchronization can be interrupted if new values are received.</p> <p>(excluding during synchronization after Power-on or Reset)</p> <p>0% &lt; nviActPos &lt; 100%</p> <p>The actuator runs to the position received by the controller.</p> <p>(Exceptional case is after Power-on or Reset)</p>	<p>The actuating signal received from a controller defined in the range of 0-100% which defines the stroke position of the connected valve.</p> <p>Received values below 0% are calculated like 0% and values over 100% will be calculated with 100%. The only exception is the value 163.835 = [INVALID]. Is this value received, the actuator drives to the safety position which is defined in the [nciDefaultOutput].</p> <p>The received values will be never overwritten by the software of the actuator.</p> <p>The variable [nviActPos] is only be used, if the variable with higher priority [nviManActPos] for manual operation is set to [INVALID] = 163.835.</p> <p>The cyclic received actuating signal can be supervised. In this case, the maximum time frame for the cyclic received values can be defined in the configuration parameter [nciMaxRcvTime].</p> <p>Is this time frame passed, the actuator will be running to the safety position defined in the configuration parameter [nciDefaultOutput].</p>
Optional Network Variables		Definition	Explanation
mvoActPosFb	SNVT_lev_percent  {0...100 % ; 163.835}  {163.835} = INVALID	<p>mvoActPosFb = 163.835 (INVALID)</p> <p>After Power-on or Reset.</p> <p>No defined stroke position feedback possible.</p> <p>0% &lt;= mvoActPosFb &lt;= 100%</p> <p>The actual calculated position of the stem according to the time to stroke model.</p>	<p>This value shows the actual calculated stem position</p>

Optional Network Variables		Definition	Explanation
nviManActPos	SNVT_lev_percent  {0...100 % ; 163.835}  {163.835} = INVALID	nviManActPos = 163.835 (INVALID)  After Power-on or Reset  Manual operation is switched off  nviManActPos = 0% or 100%  Synchronization with full running time + 30%.  The synchronization can be interrupted if new values are received.  (excluding during synchronization after Power-on or Reset.  0% < nviManActPos < 100%  The actuator is running to the manual set value. (Exceptional case is after Power-on or Reset)	The actuator can be operated manually. To have most accuracy a synchronization to the completely retract position has to be done.  The watchdog [nciMaxRcvTime] is operating in the background (if selected).  The manual operation has in each case a higher priority than the received actuating signal [nviActPos]. After changing the value for manual operation [nviManActPos] to [INVALID] the actuator is running according to the received values of [nviActPos].  Received values below 0% are calculated like 0% and values over 100% will be calculated with 100%. The only exception is the value 163.835 = [INVALID]. Is this value received, the actuator drives to the safety position which is defined in [nciDefaultOutput].  The received values are never overwritten by the software of the actuator.
NvoDISwitch	SNVT_switch  Possible values  {0.0 , 0 }  {100.0 , 1}  {x, 0xFF=255=-1}	The possible conditions can be selected by the configuration parameter [nciDIConfig].	A detailed description is made in the Selection of Digital Input Usage section. Actual state of the sensor, connected to the digital input (e. g. window-contact or dewpoint-sensor).

Standard Configuration Parameters	SCPT Master List - Names from Echelon	Type {Range} {factory settings}	Adjustment of the different functionalities and the explanation of the shown values.	
			Definition	Explanation
nciDirRev	SCPTdirection	SNVT_state {Bits = 1 or 0} {1111111111111111}	<p><b>Direct Mode of the Actuator</b></p> <p>nviActPos = 0% (Stem retract)</p> <p>nviActPos = 100% (Stem extract)</p> <p>Status Led blinking : 4 s on / 1 s off</p> <p><b>Reverse Mode of the Actuator</b></p> <p>nviActPos = 0% (Stem extract)</p> <p>nviActPos = 100% (Stem retract)</p> <p>Status Led blinking : 1 s on / 4 s off</p>	<p>Inverse the direction of action</p> <p>1111111111111111= Direct</p> <p>0000000000000000= Reverse</p>
nciMaxRcvTime	SCPTmaxRcvTime	SNVT_time_sec {0...6553 sec} {0} Only integer values are accepted and numbers after a comma will be ignored.	<p>Is no value [nviActPos], in a certain time frame [nciMaxRcvTime] received, the actuator will run to the position defined in [nciDefaultOutput].</p> <p>This is called a heartbeat control or watchdog function.</p>	<p>Watchdog for the Controller / Actuator supervision</p> <p>[nciMaxRcvTime] = 0</p> <p>Watchdog is deactivated</p> <p>[nciMaxRcvTime] = for example 60 [sec]</p> <p>Watchdog expires, if for 60 seconds no new value is received on [nviActPos]. The actuator will run to the position, defined in the configuration parameter [nciDefaultOutput].</p>

Standard Configuration Parameters	SCPT Master List - Names from Echelon	Type {Range} {factory settings}	Adjustment of the different functionalities and the explanation of the shown values.	
			Definition	Explanation
nciDefaultOutput	SCPTdefOutput	SNVT_lev_percent {0...100 % ; 163.835} {163.835} = INVALID	<p>This configuration parameter defines the condition what will happen if the time frame [nciMaxRcvTime] of the watchdog is passed or if an undefined situation takes place.</p> <p>For example: The controller failed and no values are received. In this case the actuator can run to a safety position or stops immediately. The selection should be done according to the applications requirements.</p>	<p>Safety position in case of controller failure</p> <p>100 % = Actuator will do a synchronization to 100 %, 100% running time +30% safety.</p> <p>0 % = Actuator will do an synchronization to 0%, 100% running time +30% safety.</p> <p>[INVALID] = 163.835 = Actuator stops immediately</p>
nciDIconfig	SCPTInvertOut	SNVT_lev_disc {ST_ON} {ST_OFF}	See Selection of Digital Input Usage section	Configuration of the digital input
nciRunTime	SCPTDriveTime	SNVT_time_sec {0...6553.5 sec} {6553.5} = INVALID	<p>The selection of the running time will be done automatically.</p> <p>To adapt the valve stroke to the running time afterwards and to secure the accuracy for the time to stroke model this configuration parameter is used.</p>	<p>Possibility of overwriting the value for the running time, which is normally done automatically. This should only be done in case of adapting a different valve to the actuator.</p> <p>Setting nciRunTime to (INVALID) and resetting the node, the selection of runtime will be as factory setting.</p> <p>The running time is automatically selected and depending on the power supply frequency [50 Hz/60 Hz] which is measured by the hard-/software environment.</p>

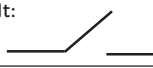
## SELECTION OF DIGITAL INPUT USAGE

Configuration parameter (SCPT...niDIconfig) Type: SNVT_lev_disc	Network variable (SNVT...nvoDIswitch) Type: SNVT_switch		Meaning	
	Value	State defined	User	DI not used or device offline or first 3 sec after
default:  nciDIconfig =ST_OFF switch closed switch opened	100.0	1	X	Power-on/Reset/online
	0	0	X	
 nciDIconfig =ST_ON switch opened switch closed	100.0	1	X	Power-on/Reset/online
	0	0	X	
nciDIconfig = ST_NUL (0xFF)	0	0xFF (=255=-1)		X

## WATCHDOG FOR THE SUPERVISION OF THE ACTUATION SIGNAL

### Activation of the watchdog-timer

Is the SCPT [nciMaxRcvTime] set to 0, the watchdog is generally switched off. To activate the watchdog, a value >0 has to be selected. This value has to be in the range of values. Values after a comma will be ignored.

### Start of the watchdog-timer after Power-on

The watchdog-timer is starting after a first value was received by [nviActPos]. Up to that point, the actuator will stay in the defined safety position [nciDefaultOutput].

### Watchdog-timer in case of manual operation.

Is the actuator working in the manual operation mode (nviManActPos INVALID) the watchdog-timer is working in the background. This means, if the controller fails, the watchdog-timer expires and after switching manual operation [nviManActPos] to [INVALID] the actuator is running to the safety position according to the definition in [nciDefaultOutput].

## FACTORY SETTINGS

State of the Network and Configuration Parameters	
nviActPos	163.835 (INVALID)
nviManActPos	163.835 (INVALID)
nviActPosFb	163.835 (INVALID)
nvoDIswitch	[0.0 -1 ] ... after frequency analysis (3 sec.) = [ 0.0 0 ]
	(if there is no switch connected)
nciDefaultOutput	163.835 (INVALID)
nciDirRev	1111111111111111
nciMaxRcvTime	0.0 sec
nciDIconfig	ST_OFF
nciRunTime	6553.5 (INVALID)

## BEHAVIOR OF THE ACTUATOR AFTER POWER-ON/RESET/OFFLINE-ONLINE

The behaviour of the motor is dependent on the configuration parameter nciDefaultOutput.

There are three possible states.

nciDefaultOutput	Behavior of the motor after Power-on/Reset
default: 163.835 = INVALID	The actuator makes no movement and waits. The first received value from the controller or manual will be saved as the actual position of the motor - no movement.
0%	The actuator synchronizes to the position referring to 0% and runs then to the position according to the controller/ manual value, if one is received. If not, the actuator waits.
100%	The actuator synchronizes to the position referring to 100% and runs then to the position according to the controller/ manual value, if one is received. If not, the actuator waits.

The interruption of the synchronization after Power-on / Reset (nciDefaultOutput = 0 or 100 %) is not possible.

Later synchronizations can be interrupted every time.

