

# MP-C

## SpaceLogic™ Plant Room Controllers

### EcoStruxure™ Building



#### Introduction

SpaceLogic\* MP-C is a multi-purpose, fully programmable, IP based field controller. The MP-C models offer a flexible mix of I/O point types that suit a wide range of HVAC applications. MP-C can either be used as a standalone BACnet/IP controller or as part of an EcoStruxure BMS with a SpaceLogic AS-P or AS-B server or an Enterprise Server as the parent server. The MP-C models support an optional display that provides insight and control of the inputs and outputs.

The MP-C has the following features:

- IP enabled with dual-port Ethernet switch

- Versatile onboard I/O point mix
- Highly available
- Sensor bus for living space sensors
- Commission mobile application for commissioning of the controller
- Full EcoStruxure Building Operation software support, providing efficient engineering tools
- SpaceLogic Operator Display support

\* Formerly known as SmartX.

# MP-C

## IP connectivity and flexible network topologies

The BACnet/IP controllers are based on open protocols that simplify interoperability, IP configuration, and device management:

- IP addressing
- BACnet/IP communications
- DHCP for easy network configuration

The BACnet/IP controllers have a dual-port Ethernet switch, which enables flexible network topologies:

- Star
- Daisy chain

- Rapid Spanning Tree Protocol (RSTP) ring

In a star topology, the controller and the parent EcoStruxure BMS server are individually connected to an Ethernet switch. Daisy-chain multiple controllers together to reduce installation time and cost. In the event of a broken IP network or a non-operational controller, RSTP will enable rapid identification of the location of the detected error while maintaining communication with the controllers on either side of the break.

## Models with a versatile mix of I/O points

MP-C comes in five models with different I/O point count and a versatile mix of I/O point types that match a wide variety of applications. The universal inputs/outputs are highly flexible and can be configured as either inputs or outputs.

### I/O Point Types by MP-C Models

I/O Point Types	MP-C-15A	MP-C-18A	MP-C-18B	MP-C-24A	MP-C-36A
Universal I/O Type Ub	8	10	10	16	20
Universal I/O Type Uc	-	-	-	4	8
Triac outputs	6	4	8	-	-
Relay outputs Form A	-	3	-	4	8
High power relay outputs Form A	1	1	-	-	-

### Configurations by I/O Point Types

Configurations	Universal I/O Type Ub	Universal I/O Type Uc	Triac Outputs	Relay Outputs Form A	High Power Relay Outputs Form A
Digital inputs	yes	yes	-	-	-
Counter inputs	yes	yes	-	-	-
Supervised inputs	yes	yes	-	-	-
Voltage inputs (0 to 10 VDC)	yes	yes	-	-	-
Current inputs (0 to 20 mA)	yes	yes	-	-	-
Temperature inputs	yes	yes	-	-	-
Resistive inputs	yes	yes	-	-	-
2-wire RTD temperature inputs	yes	yes	-	-	-
Voltage outputs (0 to 10 VDC)	yes	yes	-	-	-

# MP-C

Continued

Configurations	Universal I/O Type Ub	Universal I/O Type Uc	Triac Outputs	Relay Outputs Form A	High Power Relay Outputs Form A
Current outputs (0 to 20 mA)	-	yes	-	-	-
Digital outputs	-	-	yes	yes	yes
Digital pulsed outputs	-	-	yes	yes	yes
PWM outputs	-	-	yes	yes	yes
Tristate outputs	-	-	yes	yes	-
Tristate pulsed outputs	-	-	yes	yes	-

## Universal inputs/outputs

The universal inputs/outputs are ideal for any mix of temperature, pressure, flow, status points, and similar point types in a building control system.

As counter inputs, the universal inputs/outputs are commonly used in energy metering applications. As RTD inputs, they are ideal for temperature points in a building control system. As supervised inputs, they are used for security applications where it is critical to know whether or not a wire has been cut or shorted. These events provide a separate indication of alarms and events in the system.

For all analog inputs, maximum and minimum levels can be defined to automatically detect over-range and under-range values.

The universal inputs/outputs can also be used as voltage outputs or current outputs (Uc only), without the need for external bias resistors. Therefore, the universal inputs/outputs support a wide range of devices, such as actuators.

## Triac outputs

The triac outputs can be used in many applications to switch 24 VAC on or off for external loads such as actuators, relays, or indicators. The triac outputs are isolated from the controller. Triacs are silent and are not adversely affected by relay contact wear.

## Relay outputs

The relay outputs support digital Form A point types. The Form A relays are designed for direct load applications.

## High power relay output

MP-C-15A and MP-C-18A have a high power relay output, which is ideal for switching loads of up to 12 A, such as electrical heating elements.

## I/O expansion

For applications that require more I/O resources, the SpaceLogic IP-IO modules provide a versatile mix of I/O points for any application. For more information, see the SpaceLogic IP-IO Specification Sheet.

## Highly available

The BACnet/IP controllers support local trends, schedules, and alarms, enabling local operation when the controller is offline or used in standalone applications.

With user-defined fallback values, the IP-IO outputs will be in a predictable state in cases of network disruption.

The battery-free power backup of the memory and real-time clock helps prevent data loss and allows seamless and quick recovery after a power disruption.

All MP-C models can be equipped with the MP-C Display add-on module, which features an LCD display and five keys. With this module, you can manually override analog and digital outputs for testing, commissioning, and maintenance of equipment connected to the outputs. The module's dedicated processing power helps to ensure reliable override for maintenance applications. The override status can be viewed in EcoStruxure Building Operation WorkStation and WebStation, enabling more precise monitoring and control.

# MP-C



## MP-C Display

In WorkStation, you update the firmware of multiple BACnet/IP controllers at the same time and with minimum down time. The EcoStruxure BMS server keeps track of the installed firmware to support backup, restore, and replacement of the controllers and sensors. The server can host controllers of different firmware versions.

## Sensor bus for living space sensors

The BACnet/IP controllers provide an interface designed for the SpaceLogic Sensor family of living space sensors. The SpaceLogic Sensor devices offer an efficient way to sense the temperature, humidity, CO<sub>2</sub>, and occupancy in a room. The SpaceLogic Sensor devices are available with different combinations of sensor types and various covers and user interface options, such as touchscreen, setpoint and override buttons, and blank covers.



## SpaceLogic Sensor devices

The sensor bus provides both power and communications for up to four sensors that are daisy-chained using standard Cat 5 (or higher) cables. The maximum number of sensors that can be

connected to a controller varies depending on the sensor model and the combination of cover and sensor base type:

- Blank covers: Up to four sensors of any combination of sensor base types
- 3-button and touchscreen covers:
  - Up to two sensor bases with CO<sub>2</sub> option
  - Up to four sensor bases without CO<sub>2</sub> option
- SpaceLogic LCD temperature sensors: Up to four sensors are supported

The maximum total length of the sensor bus is 61 m (200 ft). For more information, see the SpaceLogic Sensors - SXWS Sensors for MP and RP IP Controllers - Specification Sheet.

## Commission mobile application

The Commission mobile application is designed for local configuration, field deployment, and commissioning of BACnet/IP controllers. The mobile application reduces the commissioning time, allows flexibility in project execution, and minimizes dependencies on network infrastructure.

The mobile application is designed for use with Android, Apple (iOS), and Microsoft Windows 10 devices. For more information, see the EcoStruxure Building Commission Specification Sheet.

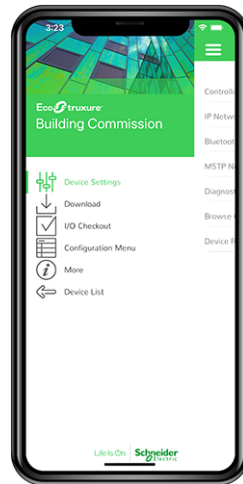

## Commission mobile application

Using the Commission mobile application, you can connect to one or many BACnet/IP controllers. You can connect to a single BACnet/IP controller using the SpaceLogic Bluetooth Adapter connected to a SpaceLogic Sensor. Using a wireless access point or a network switch, you can connect to a network of BACnet/IP controllers on the local IP network.

## Device configuration

With the Commission mobile application, you can easily discover BACnet/IP controllers on the IP network. You can change the

# MP-C

configuration of each controller, including the BACnet and IP network settings, location, and parent server. To save engineering time, you can save common device settings and then reuse them for controllers of the same model.

## Field deployment and I/O checkout

The Commission mobile application does not require an EcoStruxure BMS server or a network infrastructure to be in place. You can use the mobile application to load the controller application directly into the local BACnet/IP controller and deploy the controller. The controller application can be created offline using Project Configuration Tool or WorkStation. You can also perform an I/O checkout to verify that the controller's I/O points are configured, wired, and operating correctly.

## Full EcoStruxure Building Operation software support

The power of the BACnet/IP controller is fully realized when it is part of an EcoStruxure BMS, which provides the following benefits:

- WorkStation/WebStation interface
- Script and Function Block programming options
- Device discovery
- Engineering efficiency

## WorkStation/WebStation interface

WorkStation and WebStation provide a consistent user experience regardless of which EcoStruxure BMS server the user is logged on to. The user can log on to the parent EcoStruxure BMS server to engineer, commission, supervise, and monitor the BACnet/IP controller and its I/O as well as its attached SpaceLogic Sensor devices. For more information, see the WorkStation and WebStation specification sheets.

## Script and Function Block programming options

Unique to the industry, the BACnet/IP controllers have both Script and Function Block programming options. This flexibility assures that the best programming method can be selected for the application. Existing programs can easily be reused between the EcoStruxure BMS server and the controller.

## Device discovery

The enhanced Device Discovery in WorkStation enables you to easily identify BACnet/IP controllers on a BACnet network and to associate the controllers with their parent server.

## Engineering efficiency

The engineering and maintenance of BACnet/IP controllers can be done very efficiently using the EcoStruxure Building Operation reusability features. With these features, you can create library items (Custom Types) for a complete controller application that contains programs and all necessary objects such as trends,

alarms, and schedules. The controller application in the Custom Types library is reusable across all controllers of the same model. You can use the controller application as a base for creating new controllers intended for similar applications. You can then edit the controller application, and the changes are automatically replicated to all controllers, while each controller keeps its local values.

WorkStation supports both online and offline engineering of BACnet/IP controllers. You can make the configuration changes online or use database mode to make the changes offline. In database mode, the changes are saved to the EcoStruxure Building Operation database so that you can apply the changes to the controllers later.

Project Configuration Tool enables you to perform all the engineering off site, without the need for physical hardware, which minimizes the time you need to spend on site. You can run the EcoStruxure BMS servers virtually and engineer the BACnet/IP controllers before you deploy your server and controller applications to the servers and controllers on site. For more information, see the Project Configuration Tool specification sheet.

In addition, you can use Automated Engineering Tool to facilitate your engineering process when using BACnet/IP controllers. This tool provides access to a library of standard controller applications that can be quickly configured and customized using the wizards and mass edit functions provided in the tool. You can then load these customized applications into your target server. The tool also enables the quick creation of your own templates based on BACnet/IP controller applications that you have developed. These templates facilitate a standard approach and easy reuse and duplication of common controller applications. For more information, see the Automated Engineering Tool specification sheet.

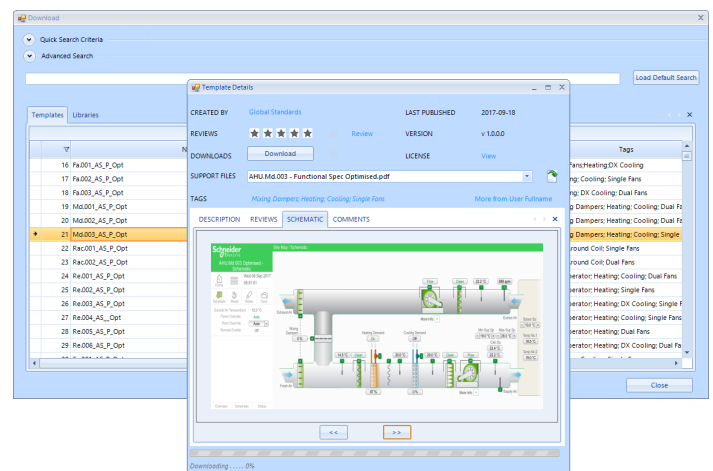

Library of standard HVAC applications

# MP-C

## SpaceLogic Operator Display support

SpaceLogic Operator Display is an easy HMI based on the BACnet B-OD profile. It can interface and interact with up to seven SpaceLogic BACnet/IP controllers in a small BMS without an EcoStruxure BMS server. It features a large 7-inch color touch

screen and a preloaded application. It is easy to install and use and does not require any programming. Built for the equipment room, the panel-mounted SpaceLogic Operator Display offers an ingress protection rating of IP65, which makes it both dust-tight and protected from low-pressure water jets. For more information, see the SpaceLogic Operator Display Specification Sheet.

### Part Numbers

Product	Part number
MP-C-15A	SXWMPC15A10001
MP-C-18A	SXWMPC18A10001
MP-C-18B	SXWMPC18B10001
MP-C-24A	SXWMPC24A10001
MP-C-36A	SXWMPC36A10001
MP-C DISPLAY (MP-C override display module)	SXWMPCDSP10001
Spare terminal blocks for all MP-C models (4 x 3-pin, 1 x 4-pin, 7 x 6-pin, 2 x 8-pin terminal blocks)	SXWMPCCON10001
DIN-RAIL-CLIP, DIN-rail end clip package of 25 pieces	SXWDINEND10001
SpaceLogic Bluetooth Adapter	SXWBTAECCX10001

For more information on part numbers for Network Connectivity Accessories, see the Product Selection Guide - EcoStruxure Building.

## Specifications

MP-C	
AC input	
Nominal voltage	24 VAC
Operating voltage range	+/- 20 %
Frequency	50/60 Hz
Maximum power consumption (MP-C-15A, -18A, -18B)	22 VA
Maximum power consumption (MP-C-24A)	28 VA
Maximum power consumption (MP-C-36A)	33 VA
Power input protection	MOV suppression and internal fuse
DC input	
Nominal voltage	24 to 30 VDC
Operating voltage range	21 to 33 VDC
Maximum power consumption (MP-C-15A, -18A, -18B)	12 W

# MP-C

Maximum power consumption (MP-C-24A) 15 W

Maximum power consumption (MP-C-36A) 18 W

Power input protection MOV suppression and internal fuse

## Environment

Ambient temperature, operating 0 to 50 °C (32 to 122 °F) at normal operation<sup>a</sup>  
 -40 to +60 °C (-40 to +140 °F) for rooftop applications, horizontal installation only<sup>a</sup>  
 a) MP-C Display has an operating temperature range of -30 to +60 °C (-22 to +140 °F).

Ambient temperature, storage -40 to +70 °C (-40 to +158 °F)

Maximum humidity 95 % RH non-condensing

## Material

Plastic flame rating UL94-5V

Ingress protection rating IP 20

## Mechanical

Dimensions (MP-C-15A, -18A, -18B) 153 W x 110 H x 64 D mm (6.0 W x 4.3 H x 2.5 D in.)

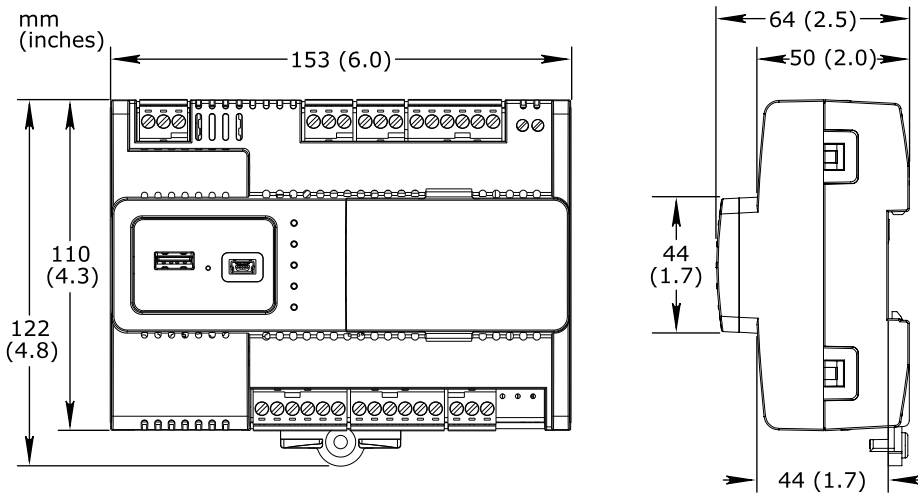

Dimensions (MP-C-24A, -36A) 234 W x 110 H x 64 D mm (9.2 W x 4.3 H x 2.5 D in.)

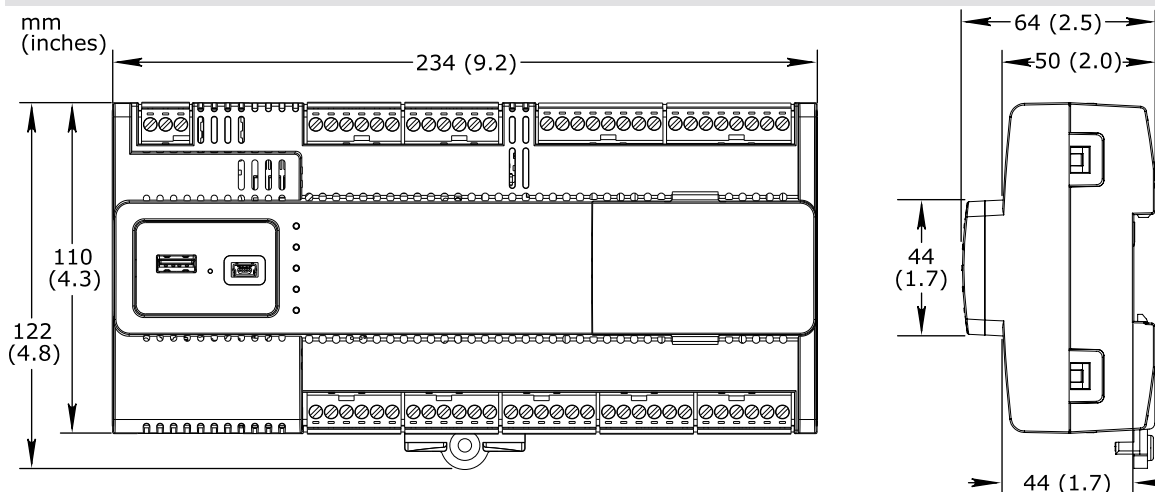

# MP-C

Weight, MP-C-15A Including terminal blocks	0.358 kg (0.789 lb)
Weight, MP-C-18A Including terminal blocks	0.371 kg (0.818 lb)
Weight, MP-C-18B Including terminal blocks	0.361 kg (0.796 lb)
Weight, MP-C-24A Including terminal blocks	0.495 kg (1.091 lb)
Weight, MP-C-36A Including terminal blocks	0.547 kg (1.206 lb)
Installation	DIN rail or other flat surface inside a cabinet
Terminal blocks	Removable
Software compatibility	
EcoStruxure Building Operation software	version 2.0 or later
Agency compliances	
Emission	RCM; BS/EN 61000-6-3; BS/EN 50491-5-2; FCC Part 15, Sub-part B, Class B
Immunity	BS/EN 61000-6-2; BS/EN 50491-5-3
Safety standards	BS/EN 60730-1; BS/EN 60730-2-11; BS/EN 50491-3; UL 916 C-UL US Listed
Real-time clock	
Accuracy, at 25 °C (77 °F)	+/-1 minute per month
Backup time, at 25 °C (77 °F)	7 days minimum
Communication ports	
Ethernet	Dual 10/100BASE-TX (RJ45)
USB	1 USB 2.0 device port (mini-B) 1 USB 2.0 host port (type-A), 5 VDC, 2.5 W
Sensor bus	24 VDC, 2 W, RS-485 (RJ45)
Sensor bus protection	Transient voltage suppressors on communication and power signals
Communications	
BACnet	BACnet/IP, port configurable, default 47808 BTL B-AAC (BACnet Advanced Application Controller) <sup>a</sup>
a) See the BTL Product Catalog for up-to-date details on BTL listed firmware revisions on BACnet International's home page.	
CPU	
Frequency	500 MHz
Type	ARM Cortex-A7 dual-core
DDR3 SDRAM	128 MB
NOR flash memory	32 MB
Memory backup	128 kB, FRAM, non-volatile

# MP-C

## MP-C Display (Optional)

Removable No

Dimensions 74 W x 46 H x 24 D mm (2.9 W x 1.8 H x 0.9 D in.)

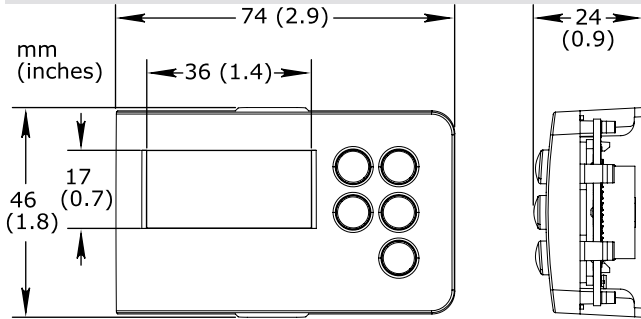

Display size 36 W x 17 H mm (1.4 W x 0.7 H in.)

Display resolution 128 x 64 pixels

Display type FSTN monochrome LCD, white color transfective backlight

Power consumption max. 0.15 W (45 mA at 3.3 V)

Ambient temperature, operating -30 to +60 °C (-22 to +140 °F)

Ambient temperature, storage -40 to +70 °C (-40 to +158 °F)

Maximum humidity 95 % RH non-condensing

Weight 0.035 kg (0.077 lb)

Compliance with standards EN ISO 16484-2

## Universal inputs/outputs, Ub and Uc

Channels, MP-C-15A 8 Ub, Ub1 to Ub8

Channels, MP-C-18A 10 Ub, Ub1 to Ub10

Channels, MP-C-18B 10 Ub, Ub1 to Ub10

Channels, MP-C-24A 16 Ub, Ub1 to Ub16  
4 Uc, Uc1 to Uc4

Channels, MP-C-36A 20 Ub, Ub1 to Ub20  
8 Uc, Uc1 to Uc8

Absolute maximum ratings -0.5 to +24 VDC

A/D converter resolution 16 bits

Universal input/output protection Transient voltage suppressor on each universal input/output

## Digital inputs

Range Dry contact switch closure or open collector/open drain, 24 VDC, typical wetting current 2.4 mA

Minimum pulse width 150 ms

## Counter inputs

Range Dry contact switch closure or open collector/open drain, 24 VDC, typical wetting current 2.4 mA

# MP-C

Minimum pulse width	20 ms
Maximum frequency	25 Hz
<b>Supervised inputs</b>	
5 V circuit, 1 or 2 resistors Monitored switch combinations	Series only, parallel only, and series and parallel
Resistor range For a 2-resistor configuration, each resistor must have the same value +/- 5 %	1 to 10 kohm
<b>Voltage inputs</b>	
Range	0 to 10 VDC
Accuracy	+/- (7 mV + 0.2 % of reading)
Resolution	1.0 mV
Impedance	100 kohm
<b>Current inputs</b>	
Range	0 to 20 mA
Accuracy	+/- (0.01 mA + 0.4 % of reading)
Resolution	1 µA
Impedance	47 ohm
<b>Resistive inputs</b>	
10 ohm to 10 kohm accuracy R = Resistance in ohm	+/- (7 + 4 x 10 <sup>-3</sup> x R) ohm
10 kohm to 60 kohm accuracy R = Resistance in ohm	+/- (4 x 10 <sup>-3</sup> x R + 7 x 10 <sup>-8</sup> x R <sup>2</sup> ) ohm
<b>Temperature inputs (thermistors)</b>	
Range	-50 to +150 °C (-58 to +302 °F)
<b>Supported thermistors</b>	
Honeywell	20 kohm
Type I (Continuum)	10 kohm
Type II (I/NET)	10 kohm
Type III (Satchwell)	10 kohm
Type IV (FD)	10 kohm
Type V (FD w/ 11k shunt)	Linearized 10 kohm
Satchwell D?T	Linearized 10 kohm
Johnson Controls	2.2 kohm
Xenta	1.8 kohm
Balco	1 kohm

# MP-C

## Measurement accuracy

20 kohm  
 -50 to -30 °C: +/-1.5 °C (-58 to -22 °F: +/-2.7 °F)  
 -30 to 0 °C: +/-0.5 °C (-22 to +32 °F: +/-0.9 °F)  
 0 to 100 °C: +/-0.2 °C (32 to 212 °F: +/-0.4 °F)  
 100 to 150 °C: +/-0.5 °C (212 to 302 °F: +/-0.9 °F)

10 kohm, 2.2 kohm, and 1.8 kohm  
 -50 to -30 °C: +/-0.75 °C (-58 to -22 °F: +/-1.35 °F)  
 -30 to +100 °C: +/-0.2 °C (-22 to +212 °F: +/-0.4 °F)  
 100 to 150 °C: +/-0.5 °C (212 to 302 °F: +/-0.9 °F)

Linearized 10 kohm  
 -50 to -30 °C: +/-2.0 °C (-58 to -22 °F: +/-3.6 °F)  
 -30 to 0 °C: +/-0.75 °C (-22 to +32 °F: +/-1.35 °F)  
 0 to 100 °C: +/-0.2 °C (32 to 212 °F: +/-0.4 °F)  
 100 to 150 °C: +/-0.5 °C (212 to 302 °F: +/-0.9 °F)

1 kohm  
 -50 to +150 °C: +/-1.0 °C (-58 to +302° F: +/-1.8 °F)

## RTD temperature inputs

Supported RTDs Pt1000, Ni1000, and LG-Ni1000

### Pt1000

Sensor range -50 to +150 °C (-58 to +302 °F)

#### BACnet/IP device environment

0 to 50 °C (32 to 122 °F)  
 0 to 50 °C (32 to 122 °F)  
 -40 to +60 °C (-40 to +140 °F)

#### Sensor range

-50 to +70 °C (-58 to +158 °F)  
 70 to 150 °C (158 to 302 °F)  
 -50 to +150 °C (-58 to +302 °F)

#### Measurement accuracy

+/-0.5 °C (+/-0.9 °F)  
 +/-0.7 °C (+/-1.3 °F)  
 +/-1.0 °C (+/-1.8 °F)

### Ni1000

Sensor range -50 to +150 °C (-58 to +302 °F)

#### BACnet/IP device environment

0 to 50 °C (32 to 122 °F)  
 -40 to +60 °C (-40 to +140 °F)

#### Sensor range

-50 to +150 °C (-58 to +302 °F)  
 -50 to +150 °C (-58 to +302 °F)

#### Measurement accuracy

+/-0.5 °C (+/-0.9 °F)  
 +/-0.5 °C (+/-0.9 °F)

### LG-Ni1000

Sensor range -50 to +150 °C (-58 to +302 °F)

#### BACnet/IP device environment

0 to 50 °C (32 to 122 °F)  
 -40 to +60 °C (-40 to +140 °F)

#### Sensor range

-50 to +150 °C (-58 to +302 °F)  
 -50 to +150 °C (-58 to +302 °F)

#### Measurement accuracy

+/-0.5 °C (+/-0.9 °F)  
 +/-0.5 °C (+/-0.9 °F)

## RTD temperature wiring

Maximum wire resistance 20 ohm/wire (40 ohm total)

Maximum wire capacitance 60 nF  
 The wire resistance and capacitance typically corresponds to a 200 m wire.

## Voltage outputs

Range 0 to 10 VDC

Accuracy +/-60 mV

Resolution 10 mV

# MP-C

## Continued

Minimum load resistance	5 kohm
Load range	-1 to +2 mA
Current outputs (Uc only)	
Range	0 to 20 mA
Accuracy	+/-0.2 mA
Resolution	21 µA
Load range	0 to 650 ohm
Relay outputs, DO	
Channels, MP-C-15A	0
Channels, MP-C-18A	3, DO5 to DO7
Channels, MP-C-18B	0
Channels, MP-C-24A	4, DO1 to DO4
Channels, MP-C-36A	8, DO1 to DO8
Contact rating	250 VAC/30 VDC, 2 A, Pilot Duty (C300)
Switch type	Form A Relay Single Pole Single Throw Normally Open
Isolation contact to system ground	3000 VAC
Cycle life (Resistive load)	At least 100,000 cycles
Minimum pulse width	100 ms
High power relay outputs, DO	
Channels, MP-C-15A	1, DO7
Channels, MP-C-18A	1, DO8
Channels, MP-C-18B	0
Channels, MP-C-24A	0
Channels, MP-C-36A	0
Contact rating	250 VAC/24 VDC, 12 A, Pilot Duty (B300)
Switch type	Form A Relay Single Pole Single Throw Normally Open
Isolation contact to system ground	5000 VAC
Cycle life (Resistive load)	At least 100,000 cycles
Minimum pulse width	100 ms

# MP-C

## Continued

Triac outputs, DO	
Channels, MP-C-15A	6, DO1 to DO6
Channels, MP-C-18A	4, DO1 to DO4
Channels, MP-C-18B	8, DO1 to DO8
Channels, MP-C-24A	0
Channels, MP-C-36A	0
Output rating (for each triac output)	Max. 0.5 A
Voltage	24 VAC +/-20 %
Commons	COM1 for DO1 and DO2 (on MP-C-15A, -18A, -18B) COM2 for DO3 and DO4 (on MP-C-15A, -18A, -18B) COM3 for DO5 and DO6 (on MP-C-15A, -18B) COM4 for DO7 and DO8 (on MP-C-18B only)
The common terminals can be connected to 24 VAC or to ground.	
Common voltage, high side output	24 VAC
Common voltage, low side output	0 VAC (ground)
Minimum pulse width	100 ms
Triac output protection	MOV and snubber across each triac output MOV from triac COM to ground

## Terminals

Follow proper installation wiring diagrams and instructions, including these instructions:

- All MP-C models have several RET terminals for connection of I/O returns, so a common chassis/signal ground rail is optional and may not be needed.

- Individual 24 V power sources to the field must be current limited to maximum 4 A for UL compliant installations, and maximum 6 A in other areas.
- For more information on wiring, see Hardware Reference Guide.

# MP-C

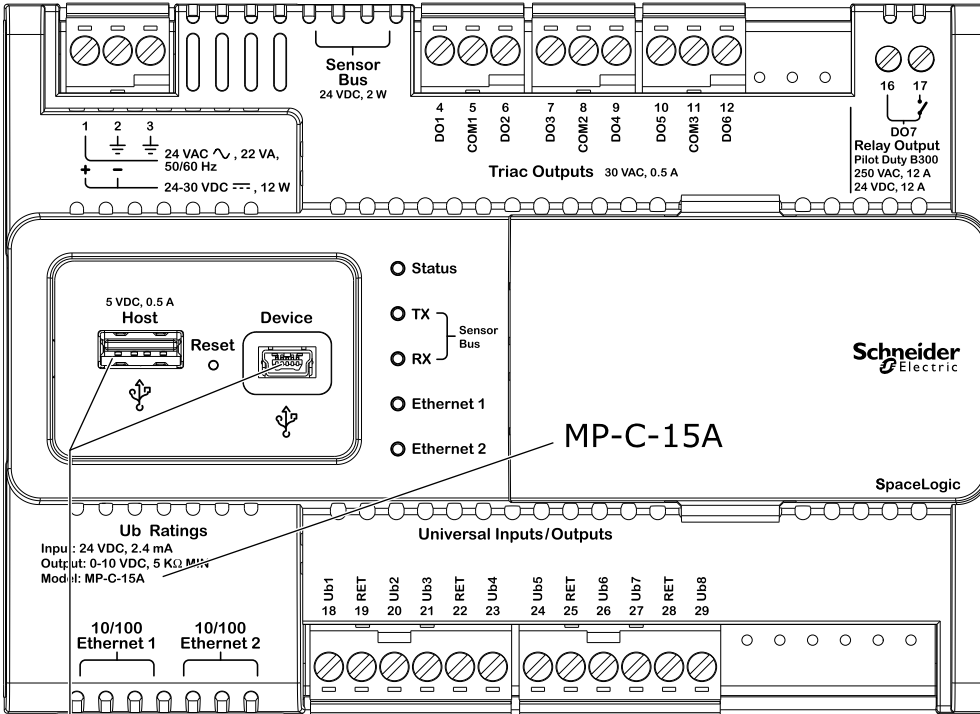

The connection cable for the USB ports must not exceed 3 m (10 ft).

MP-C-15A

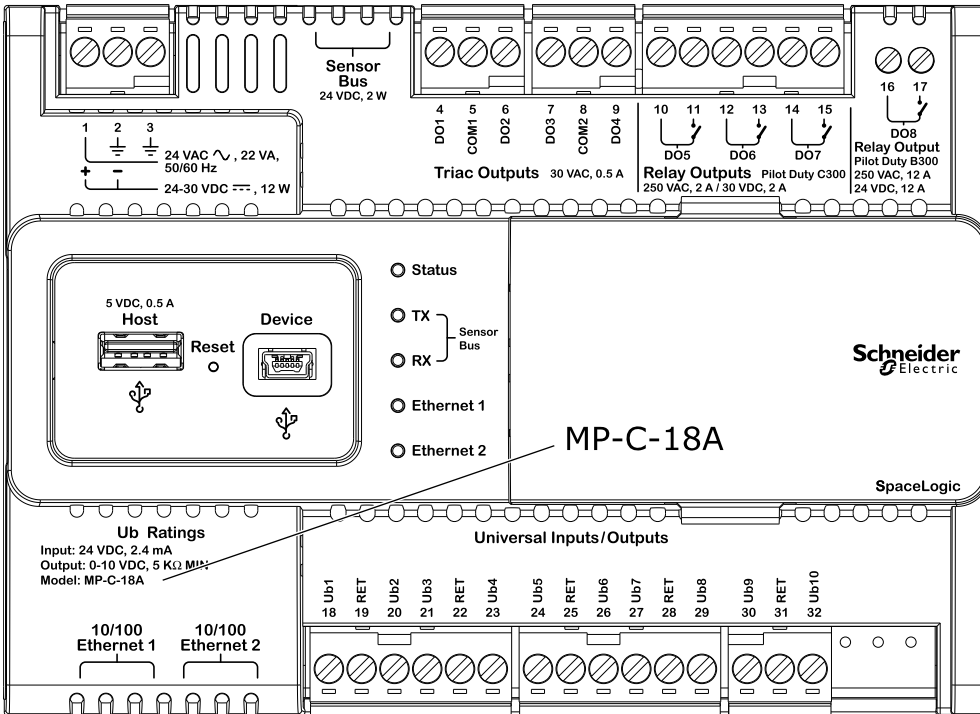

MP-C-18A

# MP-C

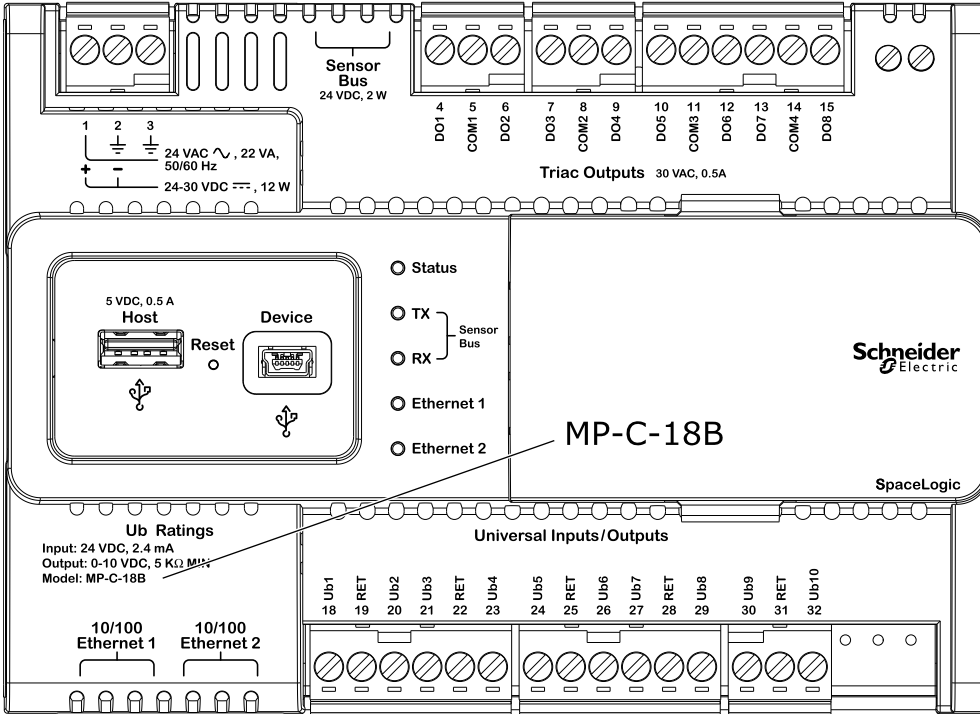

MP-C-18B

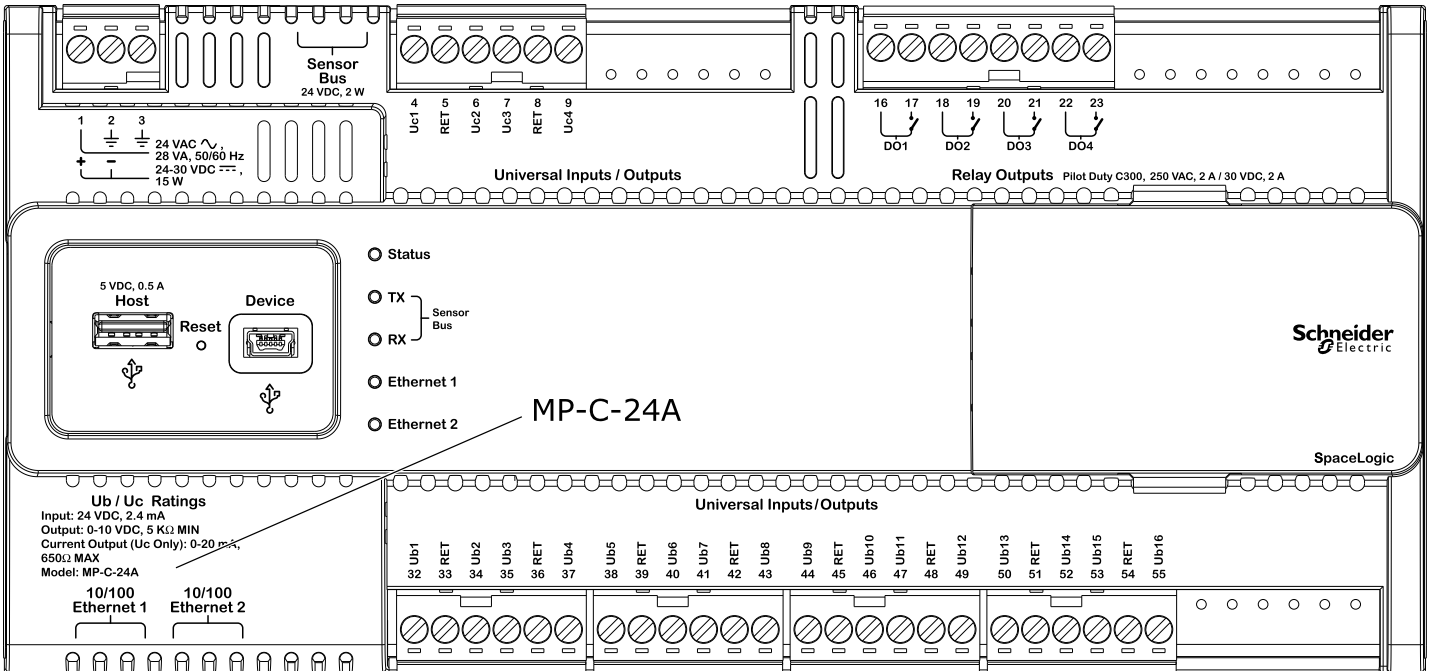

MP-C-24A

# MP-C

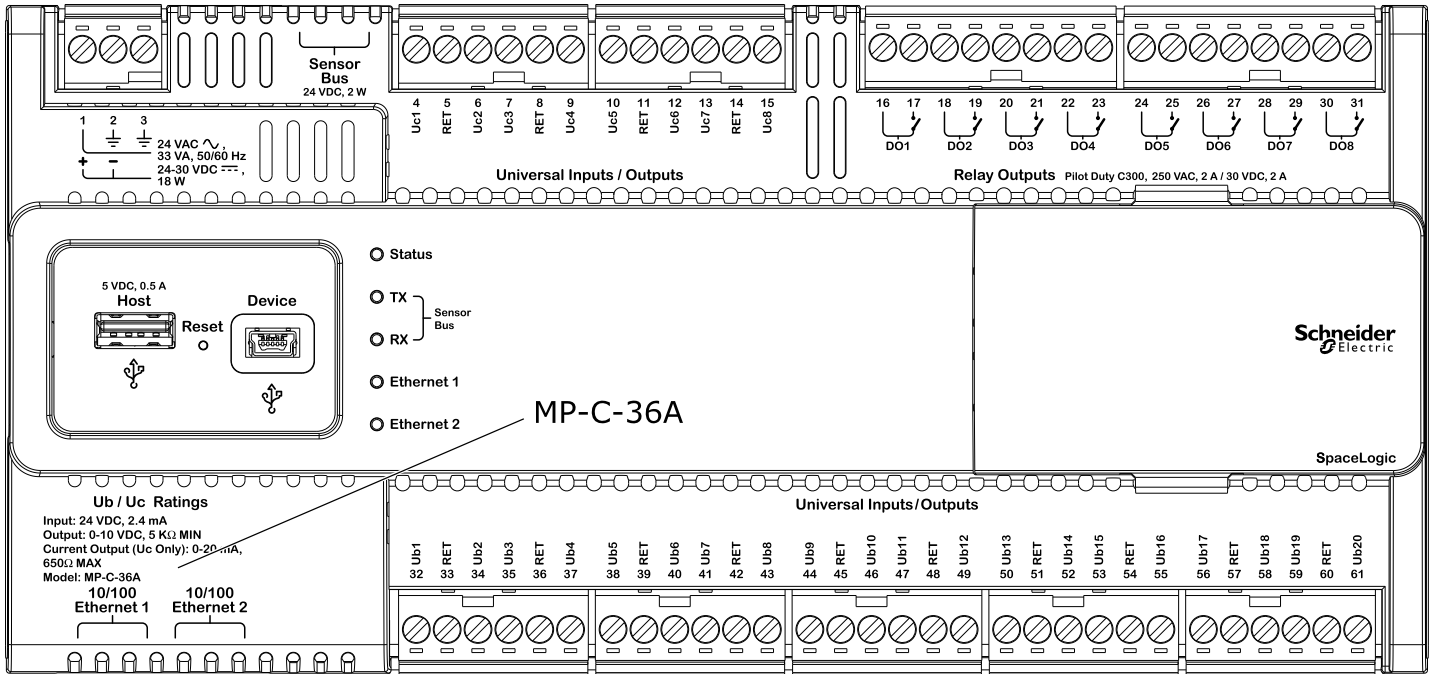

MP-C-36A

## Part Numbers for SpaceLogic Sensor Devices, Sensor Bases

Product	Part number
Sensor base with temperature sensor	SXWSBTXXXSXX
Sensor base with temperature and humidity sensors	SXWSBTHXXSXX
Sensor base with temperature and CO <sub>2</sub> sensors	SXWSBTXCXSXX
Sensor base with temperature, humidity, and CO <sub>2</sub> sensors	SXWSBTHCXSXX

## Part Numbers for SpaceLogic Sensors, Covers

Product	Housing	Part number
Blank cover	Medium matte white	SXWSCBXSSELXX
Blank cover	Optimum glass white	SXWSCBXSSELXW
Blank cover	Optimum glass black	SXWSCBXSSELXB
Blank cover with occupancy sensor	Medium matte white	SXWSCBPSELXX
Blank cover with occupancy sensor	Optimum glass white	SXWSCBPSELXW
Blank cover with occupancy sensor	Optimum glass black	SXWSCBPSELXB
3-button cover	Medium matte white	SXWSC3XSSELXX
3-button cover	Optimum glass white	SXWSC3XSSELXW
3-button cover	Optimum glass black	SXWSC3XSSELXB
3-button cover with occupancy sensor	Medium matte white	SXWSC3PSELXX

# MP-C

Continued

Product	Housing	Part number
3-button cover with occupancy sensor	Optimum glass white	SXWSC3PSELXW
3-button cover with occupancy sensor	Optimum glass black	SXWSC3PSELXB
Touchscreen display cover	Medium matte white	SXWSCDXSELXX
Touchscreen display cover	Optimum glass white	SXWSCDXSELXW
Touchscreen display cover	Optimum glass black	SXWSCDXSELXB
Touchscreen display cover with occupancy sensor	Medium matte white	SXWSCDPSELXX
Touchscreen display cover with occupancy sensor	Optimum glass white	SXWSCDPSELXW
Touchscreen display cover with occupancy sensor	Optimum glass black	SXWSCDPSELXB

## Part Numbers for SpaceLogic Sensor Devices, Combination Models

Product	Housing	Part number
Complete SpaceLogic Sensor model with temperature sensor, buttons for override and setpoint control, and LCD display cover	Medium matte white	SXWSATXXXSLX
Complete SpaceLogic Sensor model with temperature sensor, buttons for override and setpoint control, and LCD display cover	Optimum glass white	SXWSATXXXSLW
Complete SpaceLogic Sensor model with temperature sensor, buttons for override and setpoint control, and LCD display cover	Optimum glass black	SXWSATXXXSLB
Complete non-communicating <sup>a</sup> SpaceLogic Sensor model with resistive temperature sensor (10 kohm type 3 thermistor) and blank cover	Medium matte white	SLASXXX
Complete non-communicating <sup>a</sup> SpaceLogic Sensor model with resistive temperature sensor (10 kohm type 3 thermistor) and blank cover	Optimum glass white	SLAWXXX
Complete non-communicating <sup>a</sup> SpaceLogic Sensor model with resistive temperature sensor (10 kohm type 3 thermistor) and blank cover	Optimum glass black	SLABXXX

a) The SpaceLogic resistive temperature sensor (SLA...) is not designed to be connected to the sensor bus. This sensor is connected to I/O points/terminals on the BACnet/IP controller using a two-wire connection.

# MP-C

## Regulatory Notices



### Federal Communications Commission

FCC Rules and Regulations CFR 47, Part 15, Class B

This device complies with part 15 of the FCC Rules. Operation is subject to the following two conditions: (1) This device may not cause harmful interference. (2) This device must accept any interference received, including interference that may cause undesired operation.

### Industry Canada

This Class B digital apparatus complies with Canadian ICES-003.

Cet appareil numérique de la classe B est conforme à la norme NMB-003 du Canada.



### Regulatory Compliance Mark (RCM) - Australian Communications and Media Authority (ACMA)

This equipment complies with the requirements of the relevant ACMA standards made under the Radiocommunications Act 1992 and the Telecommunications Act 1997. These standards are referenced in notices made under section 182 of the Radiocommunications Act and 407 of the Telecommunications Act.



### UK Conformity Assessed

S.I. 2016/1091 - Electromagnetic Compatibility Regulations 2016

S.I. 2016/1101 - Electrical Equipment (Safety) Regulations 2016

S.I. 2012/3032 - Restriction of the Use of Certain Hazardous Substances in Electrical and Electronic Equipment Regulations 2012

S.I. 2013/3113 - Waste Electrical and Electronic Equipment Regulations 2013

This equipment complies with the rules, of the UK regulations, for governing the UKCA Marking for the United Kingdom specified in the above directive(s).



### CE - Compliance to European Union (EU)

2014/30/EU Electromagnetic Compatibility Directive

2014/35/EU Low Voltage Directive

2011/65/EU Restriction of Hazardous Substances (RoHS) Directive

2015/863/EU amending Annex II to Directive 2011/65/EU

This equipment complies with the rules, of the Official Journal of the European Union, for governing the Self Declaration of the CE Marking for the European Union as specified in the above directive(s).



### WEEE - Directive of the European Union (EU)

This equipment and its packaging carry the waste of electrical and electronic equipment (WEEE) label, in compliance with European Union (EU) Directive 2012/19/EU, governing the disposal and recycling of electrical and electronic equipment in the European community.



UL 916 Listed products for the United States and Canada, Open Class Energy Management Equipment. UL file E80146.

[www.se.com/buildings](http://www.se.com/buildings)

Life Is On

**Schneider**  
Electric