

Modicon M340

CANopen

User Guide

User Guide
Original instructions

35013944.12
02/2026

Legal Information

The information provided in this document contains general descriptions, technical characteristics and/or recommendations related to products/solutions.

This document is not intended as a substitute for a detailed study or operational and site-specific development or schematic plan. It is not to be used for determining suitability or reliability of the products/solutions for specific user applications. It is the duty of any such user to perform or have any professional expert of its choice (integrator, specifier or the like) perform the appropriate and comprehensive risk analysis, evaluation and testing of the products/solutions with respect to the relevant specific application or use thereof.

The Schneider Electric brand and any trademarks of Schneider Electric SE and its subsidiaries referred to in this document are the property of Schneider Electric SE or its subsidiaries. All other brands may be trademarks of their respective owner.

This document and its content are protected under applicable copyright laws and provided for informative use only. No part of this document may be reproduced or transmitted in any form or by any means (electronic, mechanical, photocopying, recording, or otherwise), for any purpose, without the prior written permission of Schneider Electric.

Schneider Electric does not grant any right or license for commercial use of the document or its content, except for a non-exclusive and personal license to consult it on an "as is" basis.

Schneider Electric reserves the right to make changes or updates with respect to or in the content of this document or the format thereof, at any time without notice.

To the extent permitted by applicable law, no responsibility or liability is assumed by Schneider Electric and its subsidiaries for any errors or omissions in the informational content of this document, as well as any non-intended use or misuse of the content thereof.

Table of Contents

Safety Information	7
Before You Begin.....	8
Start-up and Test.....	9
Operation and Adjustments	10
About the Document.....	11
CANopen Hardware Implementation.....	17
Hardware Implementation of BMX P34 Processors	18
Description of Processors: BMX P34 2010/20102/2030/20302.....	18
Standards and Certifications.....	20
Installation	20
Visual Diagnostics of CANopen Processors.....	21
M340 CANopen Compatibility Restrictions	24
Presentation of CANopen devices	26
CANopen Devices	26
CANopen motion command devices	27
CANopen Input/Output devices	32
Other Devices	35
Software Implementation of CANopen Communication	41
Generalities	42
Implementation Principle	42
Implementation Method.....	44
Performance	45
Device PDO and Memory Allocation	48
Configuration of Communication on the CANopen Bus.....	52
General Points	52
Generalities	52
Bus Configuration.....	53
How to Access the CANopen Bus Configuration Screen	53
CANopen Bus Editor.....	55
How to Add a Device on the Bus	56
How to Delete/Move/Duplicate a Bus Device.....	58
View CANopen Bus in the Project Browser	60

Device Configuration	61
Slave Functions	62
Configuration Using Control Expert with Controllers 2010/ 2030	64
Configuration Using Control Expert with Controllers 20102 / 20302.....	70
Configuration Using an External Tool: Configuration Software	80
Manual Configuration	83
Master Configuration	85
How to Access the CANopen Master Configuration Screen.....	85
CANopen Master Configuration Screen with CPUs 2010/ 2030	87
Description of Master Configuration Screen for CPUs 2010/ 2030	89
CANopen Master Configuration Screen with CPUs 20102/ 20302.....	93
Description of Master Configuration Screen for CPUs 20102/ 20302	94
Programming	99
Exchanges Using PDOs.....	100
Exchanges Using SDOs.....	104
SDO Abort Code Description	108
Communication functions example	109
Modbus request example	116
Debugging Communication on the CANopen Bus	118
How to Access the Debug Screens of Remote Devices	118
Debugging Screen of the CANopen Master for CPUs 2010/ 2030.....	119
Debugging Screen of the CANopen Master for CPUs 20102/ 20302	121
Slave Debug Screens	123
Diagnostics.....	126
How to perform a diagnostic	126
Master Diagnostics for CPUs 2010/ 2030	127
Master Diagnostics for CPUs 20102/ 20302.....	129
Slave Diagnostics.....	132
Language Objects	134
General Information	134
Introduction to the Language Objects for CANopen Communication	134
Implicit Exchange Language Objects Associated with the Application- Specific Function	135
Details of IODDT Implicit Exchange Objects of Type T_COM_STS_ GEN	136

Explicit Exchange Language Objects Associated with the Application-Specific Function	137
Details of IODDT Explicit Exchange Objects of Type T_COM_STS_GEN	138
Management of Exchanges and Reports with Explicit Objects	140
Language Object of the CANopen Specific IODDTs.....	141
Details of T_COM_CO_BMX IODDT	142
Details of T_COM_CO_BMX_EXPERT IODDT	155
Language Objects Associated with Configuration	169
Emergency objects	171
Emergency Objects.....	171
Quick start : example of CANopen implementation.....	176
Description of the application	177
Overview of the application.....	177
Installing the application using Control Expert.....	180
Presentation of the solution used	180
Technological choices used	180
The different steps in the process using Control Expert	181
Developing the application	182
Creating the project.....	183
Configuration of the CANopen Bus.....	184
Configuration of the CANopen Master	188
Configuration of the equipment	189
Declaration of variables	193
Creating the program in SFC for managing the move sequence	196
Creating a Program in LD for Application Execution.....	200
Creating a Program in LD for the operator screen animation.....	202
Creating a program in ST for the Lexium configuration	203
Creating an Animation Table	207
Creating the Operator Screen	208
Starting the Application.....	211
Execution of Application in Standard Mode	211
Appendices.....	217
CANopen Master Local Object Dictionary Entry.....	218
Object Dictionary Entries According to Profile DS301	218

Object Dictionary Entries According to Profile DS302	223
Midrange Manufacturer Specific Object Dictionary Entries	225
Relation between PDOs and STB variables	234
STB island configuration	234
Actions and transitions	237
Transitions	237
Actions	238
Glossary	241
Index	245

Safety Information

Important Information

Read these instructions carefully, and look at the equipment to become familiar with the device before trying to install, operate, service, or maintain it. The following special messages may appear throughout this documentation or on the equipment to warn of potential hazards or to call attention to information that clarifies or simplifies a procedure.



The addition of this symbol to a “Danger” or “Warning” safety label indicates that an electrical hazard exists which will result in personal injury if the instructions are not followed.



This is the safety alert symbol. It is used to alert you to potential personal injury hazards. Obey all safety messages that follow this symbol to avoid possible injury or death.

DANGER

DANGER indicates a hazardous situation which, if not avoided, **will result in** death or serious injury.

WARNING

WARNING indicates a hazardous situation which, if not avoided, **could result in** death or serious injury.

CAUTION

CAUTION indicates a hazardous situation which, if not avoided, **could result in** minor or moderate injury.

NOTICE

NOTICE is used to address practices not related to physical injury.

Please Note

Electrical equipment should be installed, operated, serviced, and maintained only by qualified personnel. No responsibility is assumed by Schneider Electric for any consequences arising out of the use of this material.

A qualified person is one who has skills and knowledge related to the construction and operation of electrical equipment and its installation, and has received safety training to recognize and avoid the hazards involved.

Before You Begin

Do not use this product on machinery lacking effective point-of-operation guarding. Lack of effective point-of-operation guarding on a machine can result in serious injury to the operator of that machine.

▲ WARNING

UNGUARDED EQUIPMENT

- Do not use this software and related automation equipment on equipment which does not have point-of-operation protection.
- Do not reach into machinery during operation.

Failure to follow these instructions can result in death, serious injury, or equipment damage.

This automation equipment and related software is used to control a variety of industrial processes. The type or model of automation equipment suitable for each application will vary depending on factors such as the control function required, degree of protection required, production methods, unusual conditions, government regulations, etc. In some applications, more than one processor may be required, as when backup redundancy is needed.

Only you, the user, machine builder or system integrator can be aware of all the conditions and factors present during setup, operation, and maintenance of the machine and, therefore, can determine the automation equipment and the related safeties and interlocks which can be properly used. When selecting automation and control equipment and related software for a particular application, you should refer to the applicable local and national standards and regulations. The National Safety Council's Accident Prevention Manual (nationally recognized in the United States of America) also provides much useful information.

In some applications, such as packaging machinery, additional operator protection such as point-of-operation guarding must be provided. This is necessary if the operator's hands and

other parts of the body are free to enter the pinch points or other hazardous areas and serious injury can occur. Software products alone cannot protect an operator from injury. For this reason the software cannot be substituted for or take the place of point-of-operation protection.

Ensure that appropriate safeties and mechanical/electrical interlocks related to point-of-operation protection have been installed and are operational before placing the equipment into service. All interlocks and safeties related to point-of-operation protection must be coordinated with the related automation equipment and software programming.

NOTE: Coordination of safeties and mechanical/electrical interlocks for point-of-operation protection is outside the scope of the Function Block Library, System User Guide, or other implementation referenced in this documentation.

Start-up and Test

Before using electrical control and automation equipment for regular operation after installation, the system should be given a start-up test by qualified personnel to verify correct operation of the equipment. It is important that arrangements for such a check are made and that enough time is allowed to perform complete and satisfactory testing.

▲ WARNING

EQUIPMENT OPERATION HAZARD

- Verify that all installation and set up procedures have been completed.
- Before operational tests are performed, remove all blocks or other temporary holding means used for shipment from all component devices.
- Remove tools, meters, and debris from equipment.

Failure to follow these instructions can result in death, serious injury, or equipment damage.

Follow all start-up tests recommended in the equipment documentation. Store all equipment documentation for future references.

Software testing must be done in both simulated and real environments.

Verify that the completed system is free from all short circuits and temporary grounds that are not installed according to local regulations (according to the National Electrical Code in the U.S.A, for instance). If high-potential voltage testing is necessary, follow recommendations in equipment documentation to prevent accidental equipment damage.

Before energizing equipment:

- Remove tools, meters, and debris from equipment.

- Close the equipment enclosure door.
- Remove all temporary grounds from incoming power lines.
- Perform all start-up tests recommended by the manufacturer.

Operation and Adjustments

The following precautions are from the NEMA Standards Publication ICS 7.1-1995:

(In case of divergence or contradiction between any translation and the English original, the original text in the English language will prevail.)

- Regardless of the care exercised in the design and manufacture of equipment or in the selection and ratings of components, there are hazards that can be encountered if such equipment is improperly operated.
- It is sometimes possible to misadjust the equipment and thus produce unsatisfactory or unsafe operation. Always use the manufacturer's instructions as a guide for functional adjustments. Personnel who have access to these adjustments should be familiar with the equipment manufacturer's instructions and the machinery used with the electrical equipment.
- Only those operational adjustments required by the operator should be accessible to the operator. Access to other controls should be restricted to prevent unauthorized changes in operating characteristics.

About the Document

Document Scope

This manual describes the implementation of a CANopen network on controllers of the Modicon M340 range.

NOTE: “Emergency objects” and “Fatal error” are mentioned in this manual in conformance with the definition from the DS301 document of the CiA (CAN in Automation).

Validity Note

This documentation is valid for EcoStruxure™ Control Expert 14.0 or later.

Related Documents

Title of documentation	Reference number
EcoStruxure™ Control Expert, Program Languages and Structure, Reference Manual	35006144 (English), 35006145 (French), 35006146 (German), 35013361 (Italian), 35006147 (Spanish), 35013362 (Chinese)
EcoStruxure™ Control Expert, Operating Modes	33003101 (English), 33003102 (French), 33003103 (German), 33003104 (Spanish), 33003696 (Italian), 33003697 (Chinese)
Modicon M580, M340, and X80 I/O Platforms, Standards and Certifications	EIO0000002726 (English), EIO0000002727 (French), EIO0000002728 (German), EIO0000002730 (Italian), EIO0000002729 (Spanish), EIO0000002731 (Chinese)
Premium and Atrium using EcoStruxure™ Control Expert, CANopen Field Bus, User Manual	35008147 (ENG) 35008148 (FRE) 35008149 (GER) 35013933 (ITA) 35008150 (SPA) 35012194 (CHS)

To find documents online, visit the Schneider Electric download center (www.se.com/ww/en/download/).

Product Related Information

DANGER

HAZARD OF ELECTRIC SHOCK, EXPLOSION, OR ARC FLASH

- Disconnect all power from all equipment, including connected devices, prior to removing any covers or doors or installing or removing any accessories, hardware, cables, or wires except under the specific conditions specified in the appropriate hardware guide for this equipment.
- Always use a properly rated voltage-sensing device to confirm the power is off where and when indicated.
- Replace and secure all covers, accessories, hardware, cables, and wires and confirm that a proper ground connection exists before applying power to the equipment.
- Use only the specified voltage when operating the equipment and any associated products.

Failure to follow these instructions will result in death or serious injury.

WARNING

LOSS OF CONTROL

- Perform a Failure Mode and Effects Analysis (FMEA) or equivalent risk analysis of your application and apply preventive and detective controls before implementation.
- Provide a fallback state for undesired control events or sequences.
- Provide separate or redundant control paths wherever required.
- Supply appropriate parameters, particularly for limits.
- Review the implications of transmission delays and take actions to mitigate them.
- Review the implications of communication link interruptions and take actions to mitigate them.
- Provide independent paths for control functions (for example, emergency stop, over-limit conditions, and error conditions) according to your risk assessment, and applicable codes and regulations.
- Apply local accident prevention and safety regulations and guidelines.¹
- Test each implementation of a system for proper operation before placing it into service.

Failure to follow these instructions can result in death, serious injury, or equipment damage.

¹ For additional information, refer to NEMA ICS 1.1 (latest edition), *Safety Guidelines for the Application, Installation, and Maintenance of Solid State Control* and to NEMA ICS 7.1

(latest edition), *Safety Standards for Construction and Guide for Selection, Installation and Operation of Adjustable-Speed Drive Systems* or their equivalent governing your particular location.

▲ WARNING

UNINTENDED EQUIPMENT OPERATION

- Only use software approved by Schneider Electric for use with this equipment.
- Update your application program every time you change the physical hardware configuration.

Failure to follow these instructions can result in death, serious injury, or equipment damage.

▲ WARNING

UNINTENDED EQUIPMENT OPERATION

Follow all local and national safety codes and standards.

Failure to follow these instructions can result in death, serious injury, or equipment damage.

General Cybersecurity Information

In recent years, the growing number of networked machines and production plants has seen a corresponding increase in the potential for cyber threats, such as unauthorized access, data breaches, and operational disruptions. You must, therefore, consider all possible cybersecurity measures to help protect assets and systems against such threats.

To help keep your Schneider Electric products secure and protected, it is in your best interest to implement the cybersecurity best practices as described in the [Cybersecurity Best Practices](#) document.

Schneider Electric provides additional information and assistance:

- [Subscribe to the Schneider Electric security newsletter.](#)
- [Visit the Cybersecurity Support Portal web page to:](#)
 - [Find Security Notifications.](#)
 - [Report vulnerabilities and incidents.](#)
- [Visit the Schneider Electric Cybersecurity and Data Protection Posture web page to:](#)
 - [Access the cybersecurity posture.](#)
 - [Learn more about cybersecurity in the cybersecurity academy.](#)
 - [Explore the cybersecurity services from Schneider Electric.](#)

Terminology Derived from Standards

The technical terms, terminology, symbols and the corresponding descriptions in the information contained herein, or that appear in or on the products themselves, are generally derived from the terms or definitions of international standards.

In the area of functional safety systems, drives and general automation, this may include, but is not limited to, terms such as *safety*, *safety function*, *safe state*, *fault*, *fault reset*, *malfunction*, *failure*, *error*, *error message*, *dangerous*, etc.

Among others, these standards include:

Standard	Description
IEC 61131-2:2007	Programmable controllers, part 2: Equipment requirements and tests.
ISO 13849-1:2023	Safety of machinery: Safety related parts of control systems. General principles for design.
EN 61496-1:2013	Safety of machinery: Electro-sensitive protective equipment. Part 1: General requirements and tests.
ISO 12100:2010	Safety of machinery - General principles for design - Risk assessment and risk reduction
EN 60204-1:2006	Safety of machinery - Electrical equipment of machines - Part 1: General requirements
ISO 14119:2013	Safety of machinery - Interlocking devices associated with guards - Principles for design and selection
ISO 13850:2015	Safety of machinery - Emergency stop - Principles for design
IEC 62061:2021	Safety of machinery - Functional safety of safety-related electrical, electronic, and electronic programmable control systems
IEC 61508-1:2010	Functional safety of electrical/electronic/programmable electronic safety-related systems: General requirements.
IEC 61508-2:2010	Functional safety of electrical/electronic/programmable electronic safety-related systems: Requirements for electrical/electronic/programmable electronic safety-related systems.
IEC 61508-3:2010	Functional safety of electrical/electronic/programmable electronic safety-related systems: Software requirements.
IEC 61784-3:2021	Industrial communication networks - Profiles - Part 3: Functional safety fieldbuses - General rules and profile definitions.
2006/42/EC	Machinery Directive
2014/30/EU	Electromagnetic Compatibility Directive
2014/35/EU	Low Voltage Directive

In addition, terms used in the present document may tangentially be used as they are derived from other standards such as:

Standard	Description
IEC 60034 series	Rotating electrical machines
IEC 61800 series	Adjustable speed electrical power drive systems
IEC 61158 series	Digital data communications for measurement and control – Fieldbus for use in industrial control systems

Finally, the term zone of operation may be used in conjunction with the description of specific hazards, and is defined as it is for a hazard zone or danger zone in the Machinery Directive (2006/42/EC) and ISO 12100:2010.

NOTE: The aforementioned standards may or may not apply to the specific products cited in the present documentation. For more information concerning the individual standards applicable to the products described herein, see the characteristics tables for those product references.

CANopen Hardware Implementation

What's in This Part

Hardware Implementation of BMX P34 Processors.....	18
Presentation of CANopen devices.....	26

Subject of this Part

This part describes the various hardware configuration possibilities of a CANopen bus architecture.

Hardware Implementation of BMX P34 Processors

What's in This Chapter

Description of Processors: BMX P34 2010/20102/2030/20302	18
Standards and Certifications	20
Installation	20
Visual Diagnostics of CANopen Processors	21
M340 CANopen Compatibility Restrictions	24

Aim of this Chapter

This chapter presents BMX P34 processors equipped with a CANopen port as well as their implementation.

To see the differences between the CPU P34 201/2030 and 20102/20302, please refer to the chapter CANopen Compatibility Restrictions, page 24.

Description of Processors: BMX P34 2010/20102/2030/20302

At a Glance

Each PLC station is equipped with a BMX P34 •••• processor.

There are five processors in the Modicon M340 range that have a CANopen port:

- The BMX P34 2010/20102, which also has a USB port and serial port,
- The BMX P34 2030/20302/20302H, which also has a USB port and Ethernet port.

BMX P34 •••• processors have a simple design, and include a memory card slot.

The following figures present the front sides of the BMX P34 2010 and BMX P34 2030:

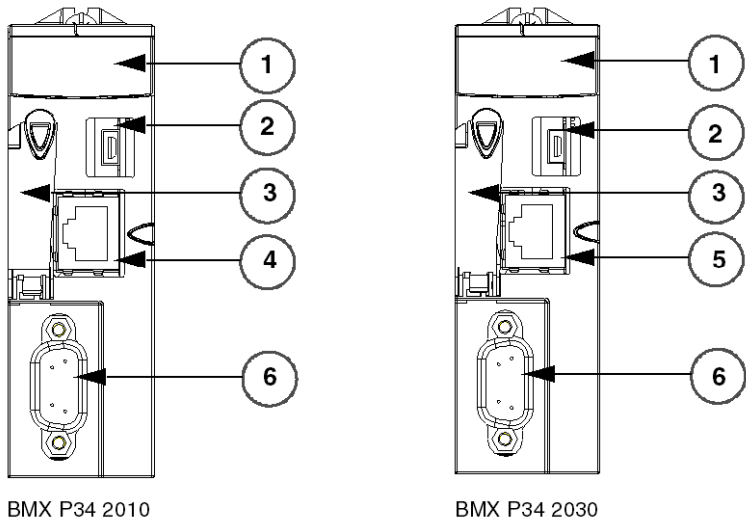

Number	Designation
1	Display panel
2	USB Port.
3	SD-Card slot
4	SerialPort
5	Ethernet Port
6	CANopen Port

These processors are bus masters; they cannot function as slaves. They are linked by SUB-D 9 connector points and allow the connection of slave devices which support the CANopen protocol.

NOTE: There is only one BMX P34 •••• master by bus.

Standards and Certifications

Online Help

From the Control Expert online help, you can access the standards and certifications that apply to the modules in this product line by referring to the *Modicon M580, M340, and X80 I/O Platforms, Standards and Certifications* guide.

Download

Click the link that corresponds to your preferred language to download the standards and certifications (PDF format) that apply to the modules in this product line:

Language	
English	Modicon M580, M340, and X80 I/O Platforms, Standards and Certifications
French	Modicon M580, M340, and X80 I/O Platforms, Standards and Certifications
German	Modicon M580, M340, and X80 I/O Platforms, Standards and Certifications
Italian	Modicon M580, M340, and X80 I/O Platforms, Standards and Certifications
Spanish	Modicon M580, M340, and X80 I/O Platforms, Standards and Certifications
Chinese	Modicon M580, M340, and X80 I/O Platforms, Standards and Certifications

Installation

At a Glance

BMX P34 2010/20102 2030/20302 processors equipped with a CANopen port are mounted on racks fed by power supply modules.

NOTE: After an extract/insert of the processor while running, the bus is no longer operational. In order to restart the bus, the power supply must be re-initialized.

CANopen Connectors

The CANopen processor port is equipped with a SUB-D9 connection.

The following figure represents the CANopen connector for modules (male) and cables (female).



Pin	Signal	Description
1	-	Reserved
2	CAN_L	CAN_L bus line (Low)
3	CAN_GND	CAN mass
4	-	Reserved
5	Reserved	CAN optional protection
6	GND	Optional mass
7	CAN_H	CAN_H bus line (High)
8	-	Reserved
9	Reserved	CAN External Power Supply. (Dedicated to the optocouplers power and transmitters-receivers.) Optional

NOTE: CAN_SHLD and CAN_V+ are not installed on the Modicon M340 range processors. These are reserved connections.

Visual Diagnostics of CANopen Processors

At a Glance

BMX P34 processors form the Modicon M340 range are equipped with several Module Status visualization LEDs.

BMX P34 2010/20102/2030/20302 processors equipped with a CANopen port have 2 LEDs on their facade that indicate the bus status:

- a green CAN RUN LED,
- a red CAN ERR LED.

In normal operation, the CAN ERR LED is off and the CAN RUN LED is on.

The following figures show the LEDs on the facade of modules:

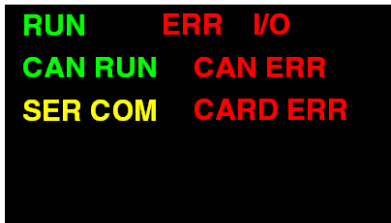

Visualization screen of BMX P34 2010

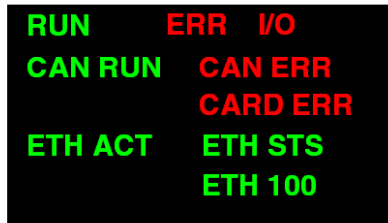

Visualization screen of BMX P34 2030



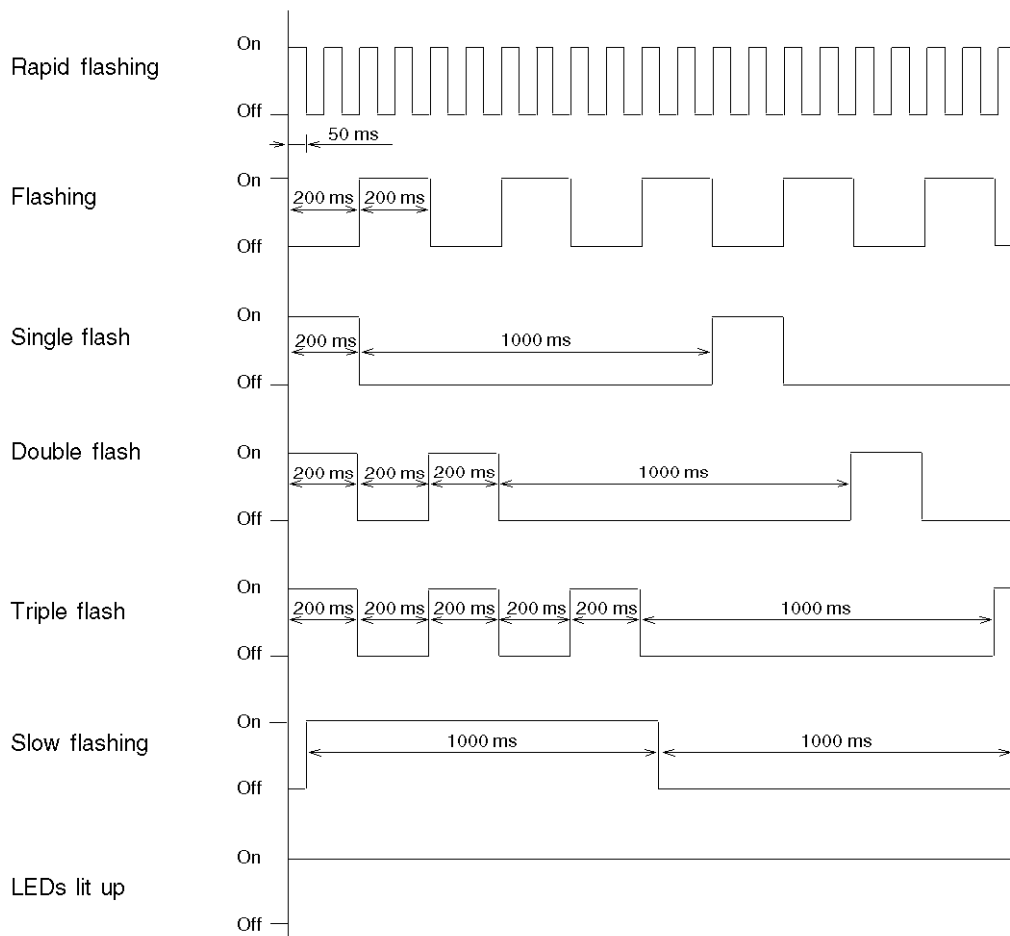

LED Status

The following trend diagram represents the possible status of LEDs:



Description

The following table describes the role of CAN RUN and CAN ERR LEDs:

Display LED	On	Flash	Flashing	Off	Slow flashing
					
CAN RUN (green)	The master is operational.	Simple : The master is stopped. Triple : Loading of CANopen firmware in process.	The master is pre-operational or initialization in progress.	-	Starting CANopen master self-test.
CAN ERR (red)	Bus stopped. The CAN controller has status "BUS OFF".	The CAN network is disturbed. Simple : at least one of the counters has attained or exceeded the alert level. Double : Monitoring detected fault (Nodeguarding or Heartbeat)	Invalid configuration, or logic configuration different from physical configuration: missing, different or additional slaves detected.	OK.	An anomaly occurred during the CANopen coprocessor start. The CANopen master cannot start. If this state is maintained, you must change the CPU.

M340 CANopen Compatibility Restrictions

Compatibility Table

In a CANopen compatibility point of view, the CPU 2010/2030 are identical. Please note that there is no ascendant compatibility between an application developed with a CPU 2010/2030 and 20102/20302/20302H. Before launching your application, please refer to the following table in order to check its compatibility with your configuration:

Developed application with	Restrictions
Unity Pro V3.0 or Unity Pro V4.0 with a CPU 2010/ 2030.	Download on CPU 20102/20302/20302H: not compatible without doing replace CPU command.
Unity Pro V4.1 or later with a CPU 2010/ 2030.	Open with Unity Pro V3.0: compatible with import of the XEF file. Download on CPU 20102/20302/20302H: not compatible without doing replace CPU command.

Developed application with	Restrictions
Unity Pro V4.1 or later with a CPU 20102/ 20302/20302H. Note: CANopen expert functions are only viable with these CPU.	Open with Unity Pro V3.0: not compatible. Download on CPU 2010/2030: not compatible without doing replace CPU command, but Expert Functions (BootUp Procedure and Object Dictionary) will be no longer available.
NOTE: Unity Pro is the former name of Control Expert for version 13.1 or earlier.	

Presentation of CANopen devices

What's in This Chapter

CANopen Devices	26
CANopen motion command devices.....	27
CANopen Input/Output devices.....	32
Other Devices.....	35

Subject of this Section

This section presents the different CANopen devices.

CANopen Devices

At a Glance

The devices that you can connect to a CANopen bus and that can be configured in Control Expert are grouped according to their functions:

- motion command devices,
- input/output devices,
- other devices.

NOTE: Only devices from the **Hardware Catalog** can be used with Control Expert. New devices have to be imported to the **Hardware Catalog** from the **Hardware Catalog Manager**.

NOTE: An overview of the **Hardware Catalog Manager** in read only mode is available in Control Expert through the **Hardware Catalog**.

Motion Command Devices

Motion command devices enable you to control motors.

These devices are:

- Altivar,
- Lexium,

- ICLA,
- Osicoder,
- Telsys T,
- SD328A Stepper Drive.

Input/Output Devices

Input/Output modules function as remote modules. These devices are:

- Tego Power devices,
- Advantys FTB,
- Advantys OTB,
- Advantys FTM,
- Preventa devices.

Other Devices

These are:

- Advantys islands STB,
- Tesys U,
- Festo Valve Terminal,
- Parker Moduflex.

The STB islands also allow the monitoring of inputs/outputs.

CANopen motion command devices

At a glance

Motion command devices enable you to control motors.

These devices are:

- Altivar,
- Lexium,

- ICLA,
- Osicoder,
- Tesys T,
- SD328A Stepper Drive.

Altivar devices

An Altivar device enables to control the speed of a motor by flux vector control.

The following figure gives an example of an Altivar device:



NOTE: The minimum version of the firmware is V1.3 for ATV31 T.

NOTE: The minimum version of the firmware is V1.1 for ATV31, ATV61 and ATV71.

NOTE: ATV31 V1.7 is not supported. However, it can be used by configuring it with ATV31 1.2 profile. In this case, only the ATV31 V1.2 functions will be available

NOTE: ATV71: if you have to disconnect it from the CANopen bus, power off the device, else, when reconnecting it on the bus, it will provoke a Bus Fatal error. This is fixed with the ATV71 firmware version V1.2 and later.

NOTE: ATV61: if you have to disconnect it from the CANopen bus, power off the device, else, when reconnecting it on the bus, it will provoke a Bus Fatal error. This is fixed with the ATV61 firmware version V1.4 and later.

Lexium devices

The range of Lexium 05 servo drives that are compatible with BSH servo motors constitutes a compact and dynamic combination for machines across a wide power (0,4...6 kW) and power supply voltage range.

The compact design of the Lexium 05 servo drive and the integrated components (line filter, braking resistor and safety function) reduces the space required in the switch cabinet to a minimum. It integrates the Power Removal safety function which prevents accidental starting of the motor.

Another advantage of the servodrive Lexium 05 is the versatile application options:

- as torque or speed controller via the analogue inputs,
- as electronic gearbox via the RS422 interface,
- as positioning or speed controller via the field bus interface.

The servodrive is available in four voltage types:

- 115 VAC single-phase,
- 230 VAC single-phase and 3-phase,
- 400/480 VAC 3-phase.

The following figure gives an example of a Lexium device:



NOTE: The minimum version of the firmware for Lexium 05 MFB device is V1.003

NOTE: The minimum version of the firmware for Lexium 05 device is V1.120.

NOTE: The minimum version of the firmware for Lexium 15 LP is V1.45.

NOTE: The minimum version of the firmware for Lexium 15 MH is V6.64.

IcLA devices

IcLA devices are intelligent compact drives. They integrate everything required for motion tasks: positioning controller, power electronics and servo, EC or stepper motor.

The following figure gives an example of an ICLA device:

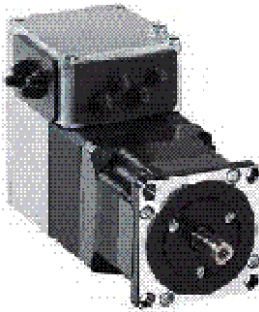

▲ WARNING

UNINTENDED EQUIPMENT OPERATION

- Use ICLA IFA devices with minimum firmware version V1.105.
- Use ICLA IFE devices with minimum firmware version V1.104.
- Use ICLA IFS devices with minimum firmware version V1.107.

Failure to follow these instructions can result in death, serious injury, or equipment damage.

Osicoder devices

The Osicoder device is an angular position sensor.

Mechanically coupled to a driving spindle of a machine, the shaft of the encoder rotates a disc that comprises a succession of opaque and transparent sectors. Light from LEDs passes through the transparent sectors of the disc as they appear and is detected by photosensitive diodes. The photosensitive diodes, in turn, generate an electrical signal which is amplified and converted into a digital signal before being transmitted to a processing system or an electronic variable speed drive. The electrical output of the encoder therefore represents, in digital form, the angular position of the input shaft.

The following figure gives an example of an Osicoder device:

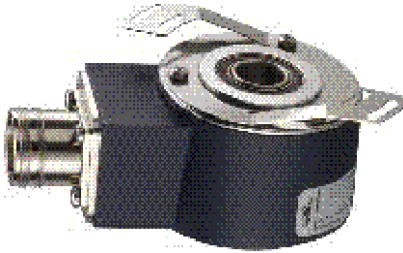

NOTE: The minimum version of the firmware for Osicoder devices is V1.0.

Tesys T Motor Management System

Tesys T is a motor management system that provides overload detection, metering and monitoring functions for single-phase and 3-phase, constant speed, a.c. motors up to 810 A.

Using Tesys T in a motor control panels makes it possible to:

- Increase the operational availability of installations,
- improve flexibility from project design through to implementation,
- increase productivity by making available all information needed to run the system.

The following figure gives an example of a Tesys T device:

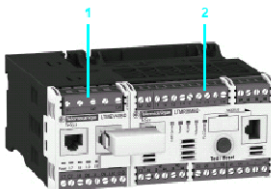

1 LTM EV40BD extension module
2 LTM R09MBD controller

SD328A Stepper Drive

The SD328A is a universally applicable stepper drive.

It offers a very compact and powerful drive system in combination with selected stepper motors by Schneider Electric Motion.

The device has an output for direct connection of an optional holding brake.

The following figure gives an example of a SD328A Stepper Drive device:



CANopen Input/Output devices

At a glance

The Input/Output modules function as remote modules.

These devices are:

- Tego Power devices,
- Advantys FTB,
- Advantys OTB,
- Advantys FTM,
- Preventa devices.

Tego Power devices

Tego Power is a modular system which standardizes and simplifies the implementation of motor starters with its pre-wired control and power circuits. In addition, this system enables the motor starter to be customized at a later date, reduces maintenance time and optimizes panel space by reducing the number of terminals and intermediate interfaces and also the amount of ducting.

The following figure gives an example of a Tego Power device:

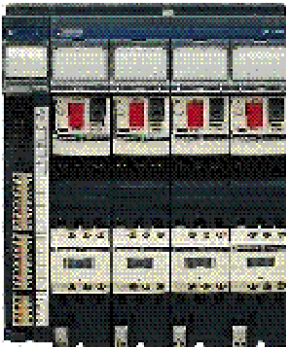

NOTE: The minimum version for TegoPower APP_1CCO0 and TegoPower APP_1CCO2 is V1.0

Advantys FTB devices

The Advantys FTB dispatcher is composed of several input/outputs that allow sensors and activators to be connected.

NOTE: The minimum firmware version for FTB is V1.5.

The following figure gives an example of an Advantys FTB device:

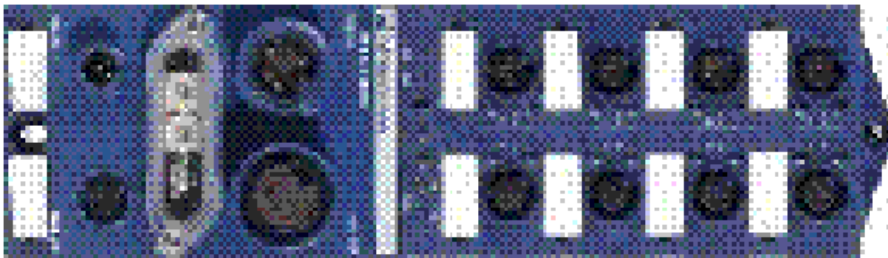

Advantys OTB devices

An Advantys OTB device enables you to constitute discrete input/output islands (max.132 channels in boundaries) or analog (max. 48 channels) IP20 and to connect them close to the active captors.

The following figure gives an example of an Advantys OTB device:

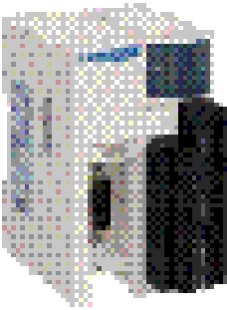

NOTE: The minimum firmware version for OTB is V2.0

▲ WARNING

UNINTENDED EQUIPMENT OPERATION

Use Advantys OTB devices with minimum firmware version V2.0.

Failure to follow these instructions can result in death, serious injury, or equipment damage.

Advantys FTM CANopen

The Advantys FTM modular system enables you to connect a variable number of input/output splitter boxes, using a single communication interface (field bus module).

These splitter boxes are connected to the module using a hybrid cable which includes the internal bus and power supply (internal, sensor and actuator).

The input/output splitter boxes are independent of the field bus type, thus reducing the number of splitter box references. Once installed, the system is ready to begin operation.

The following figure gives an example of an Advantys FTM CANopen device:



Preventa devices

Preventa devices are electronic safety controllers for monitoring safety functions.

The following figure gives an example of a Preventa device:



Other Devices

At a Glance

These devices are:

- STB Island,
- Tesys U,

- Festo Valve Terminal,
- Parker Moduflex.

STB Island

An Advantys STB island is composed of several input/output modules.

The modular elements of the island are connected by a CANopen local bus using a network interface module NIM.

STB modules can only be used in an STB island.

The following figure gives an example of an island:

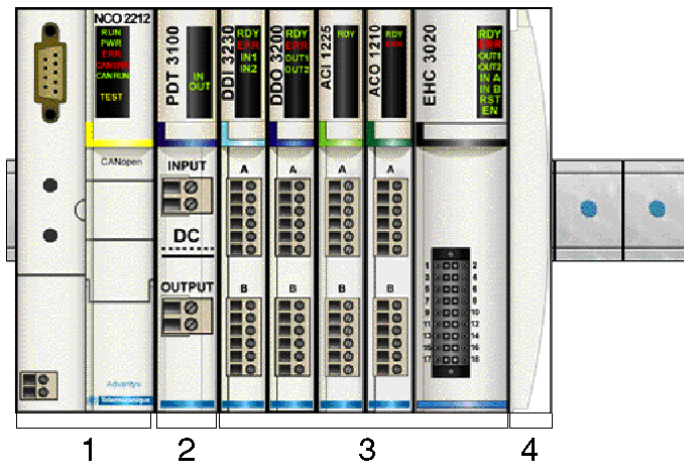

Description:

Number	Designation
1	Network Interface Module.
2	Power supply Distribution Module.
3	Distributed input/output modules. These modules can be: <ul style="list-style-type: none"> • digital input/output modules, • analog input/output modules, • special purposes.
4	Termination plate of island bus.

Tesys U Devices

TeSys U-Line motor starters provide motor control for choices ranging from a basic motor starter with solid-state thermal overload protection to a sophisticated motor controller which communicates on networks and includes programmable motor protection.

This device performs the following functions:

- Protection and control of 1-phase or 3-phase motors:
 - Isolation breaking function
 - Electronic short-circuit protection
 - Electronic overload protection
 - Power switching
- Control of the application:
 - Status (protection functions, e.g. overload pending)
 - Status monitoring (running, ready,)
 - Application monitoring (running time, number of anomalies, motor current values)
 - Detected fault logging (last 5 anomalies saved, together with motor parameter values).

The following figure gives an example of a Tesys U device:

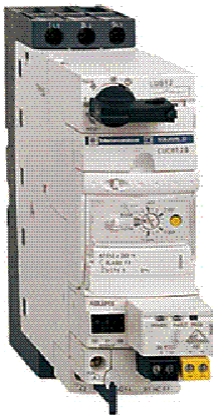

Festo valve terminal

CPV Direct:

CPV valves are series manifold valves, in addition to the valve function they contain all of the pneumatic ducts for supply, exhaust and the working lines.

The supply ducts are a central component of the valve slices and allow a direct flow of air through the valve slices. This helps achieve maximum flow rates. All valves have a pneumatic pilot control for optimising performance.

The fieldbus node is directly integrated in the electrical interface of the valve terminal and therefore takes up only a minimal amount of space.

The optional string extension allows an additional valve terminal and I/O modules to be connected to the Fieldbus Direct fieldbus node.

The CPV valve terminal is available in three sizes:

- CPV10
- CPV14
- CPV18

The following figure gives an example of a Festo valve terminal device:



CPX Terminal:

The electrical terminal CPX is a modular peripheral system for valve terminals. The system is specifically designed so that the valve terminal can be adapted to suit different applications.

Variable connection options for the valve terminal pneumatic components (MPA/CPA/VTSA)

Flexible electrical connection technology for sensors and actuators

The CPX terminal can also be used without valves as a remote I/O system.

The following figure gives an example of a CPX terminal device:

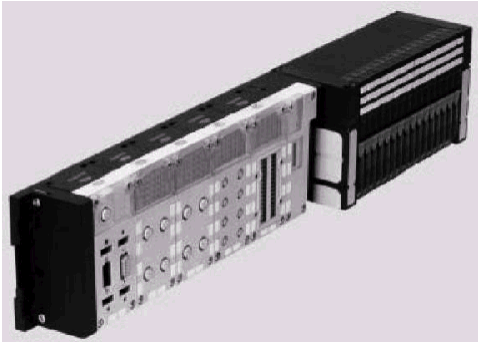

Parker Moduflex

Parker Moduflex Valve System provides flexible pneumatic automation.

Depending on application, you can assemble short or long islands (up to 16 outputs). IP 65-67 water and dust protection allows the valve to be installed near the cylinders for shorter response time and lower air consumption. The Parker Moduflex Valve System CANopen module (P2M2HBVC11600) can be used as an enhanced CANopen device in an Modicon M340 configuration.

The firmware version of the P2M2HBVC11600 must be V 1.4 or later.

For detailed descriptions of P2M2HBVC11600 wiring, LED patterns, set-up procedures, and functionality, refer to user documentation provided by Parker.

"S" Series Stand-Alone Valves:

For isolated cylinders on a machine, it is preferable to locate the valve close by. Therefore a stand-alone module is ideal, response time and air consumption are then reduced to a minimum. Peripheral modules can be installed directly into the valve.

The following figure gives an example of a "S" Series Single Solenoid device:



The following figure gives an example of a "S" Series Single Air Pilot device:



"T" Series Valve Island Modules

For small groups of cylinders requiring short localized valve islands.

Modules with different functions and flow passages may be combined in the same island manifold, giving total flexibility to adapt to all machine requirements.

The following figure gives an example of a "T" Series Valve Island Module device:

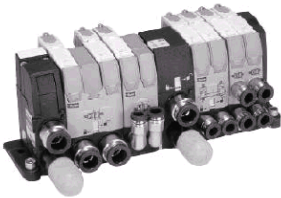

Software Implementation of CANopen Communication

What's in This Part

Generalities	42
Configuration of Communication on the CANopen Bus	52
Programming.....	99
Debugging Communication on the CANopen Bus.....	118
Diagnostics	126
Language Objects.....	134

Subject of this Part

This part describes the various possibilities for software configuration, programming and diagnostics in a CANopen application.

Generalities

What's in This Chapter

Implementation Principle	42
Implementation Method	44
Performance.....	45
Device PDO and Memory Allocation.....	48

Subject of this Chapter

This chapter describes CANopen software implementation principles on the Modicon M340 bus.

Implementation Principle

At a Glance

In order to implement a CANopen bus, it is necessary to define the physical context of the application in which the bus is integrated (rack, supply, controller, modules), and then ensure that the necessary software is implemented.

The software is implemented in two ways with Control Expert:

- In offline mode
- In online mode

Implementation Principle

The following table shows the different implementation phases:

Mode	Phase	Description
Offline	Configuration	Entry of configuration parameters.
Offline or online	Symbolization	Symbolization of the variables associated with the CANopen port of the BMX P34 controller.
	Programming	Programming the specific functions: <ul style="list-style-type: none"> • Bit objects or associated words • Specific instructions
Online	Transfer	Transferring the application to the controller.
	Debugging Diagnostics	Different resources are available for debugging the application, controlling inputs/outputs and diagnostic messages: <ul style="list-style-type: none"> • Language objects or IODDTs • The Control Expert debugging screen • Signaling by LED
Offline or online	Documentation	Printing the various information relating to the configuration of the CANopen port.

NOTE: The above order is given for your information. Control Expert software enables you to use editors in the desired order of interactive manner.

In case of disturbed communication, the response time can be too high.

▲ WARNING
UNINTENDED EQUIPMENT OPERATION
Use diagnosis system information and monitor the response time of the communication.
Failure to follow these instructions can result in death, serious injury, or equipment damage.

Implementation Method

Overview

The following flowchart shows the CANopen port implementation method for BMX P34 processors:

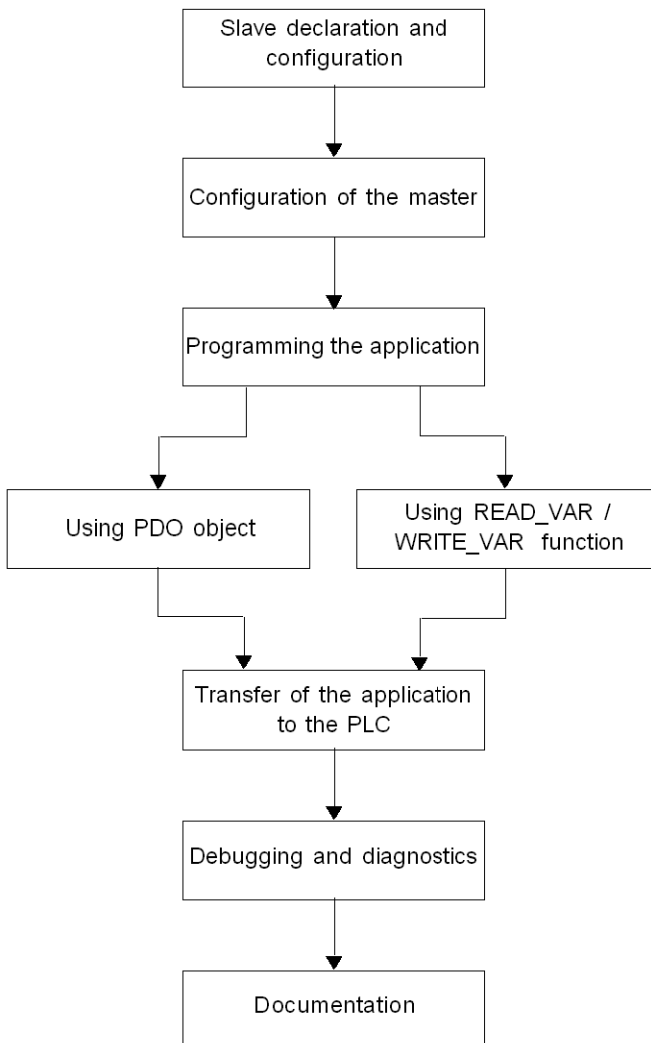

Performance

Introduction

Various CANopen performances are detailed below.

Impact on Task Cycle Time

The time given to each task cycle is as follows:

Task	Typical
CANopen inputs	10 μ s / PDO
CANopen outputs	80 μ s + 15 μ s / PDO
Diagnostics	120 μ s

Communication by SDO

The following figure gives an overview of the SDO management:

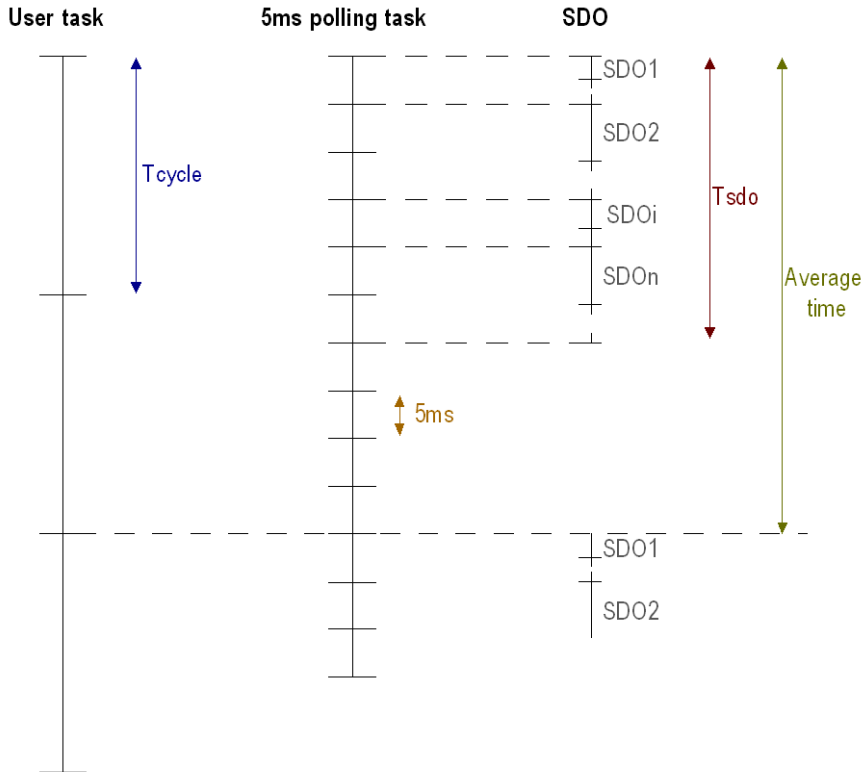

The following table defines the terms that are used to describes the 'Communication by SDO' graphic:

Term	Definition
T_{cycle}	User task cycle
n	Number of SDO to execute in parallel
T_{sdo}	Time to process the n SDOs (multiple of 5 ms due to the polling task)
Average time	Average time to execute all the SDO from SDO1 to SDO n . The average time depends on the T_{cycle} , n and T_{sdo} : <ul style="list-style-type: none"> • If $T_{cycle} > T_{sdo}$ then Average time=T_{cycle} • If $T_{cycle} < T_{sdo}$ then Average time=$NB * T_{cycle}$ and $NB = T_{sdo} / (T_{cycle} + 1)$

NOTE: A polling task runs every 5 ms and at each task cycle in order to check the end of the exchange. This is useful if the user runs many SDOs.

Example: for a task cycle of 50 ms, a number of 10 SDOs/Mast Cycle and a SDO exchange time of 3 ms.

With the polling task, you can treat 2 SDOs/5ms. In order to do that, these SDOs must be addressed to two different devices.

Therefore, we can launch 10 SDOs/task cycle.

Bus Start

The CANopen bus start time depends on the number of devices.

The minimum time to start a CANopen bus is 7 seconds.

The time to configure one device is about 0.8 second.

The start time of a CANopen bus with 64 devices is about 1 minute.

Disconnection/Reconnection of a Device

Disconnection:

The time to detect the disconnection of a device depends on the error control:

Error control	Description
Guardtime	The time to detect the disconnection is Guardtime * life time factor
Heartbeat	The time to detect the disconnection is Heartbeat producer time + (Heartbeat producer time /2)

Reconnection:

Each second, the master polls on the device to check the reconnection of the device. The time to reconnect the device is about 1 second if the device is not alone on the bus.

If the device is alone on the bus, the disconnection of the device set the master in the same case as the disconnection of the complete bus. After this state, the master restarts the bus and the reconnection time of the device is about 7 seconds.

Device PDO and Memory Allocation

At a glance

The following table describes limits for each device and therefore specifies the maximum configuration of the application:

Family	Device	F*	Tx PDO	Rx PDO	Tx Cob Id	Rx Cob Id	Extra Cob Id	%MW IN	%MW OUT	%M IN	%M OUT
Motor Control	APP_1CC00		5	5	4	4	2	4	2	0	0
	APP_1CC02		5	5	4	4	2	8	6	0	0
	TeSysT_MMC_L		4	4	4	4	0	46	8	0	0
	TeSysT_MMC_L_EV40		4	4	4	4	0	62	12	0	0
	TeSysT_MMC_R		4	4	4	4	0	46	8	0	0
	TeSysT_MMC_R_EV40		4	4	4	4	0	62	12	0	0
	TeSysU_C_Ad		4	4	4	4	0	16	8	0	0
	TeSysU_C_Mu_L		4	4	4	4	0	50	10	0	0
	TeSysU_C_Mu_R		4	4	4	4	0	38	12	0	0
	TeSysU_Sc_Ad		4	4	4	4	0	14	10	0	0
	TeSysU_Sc_Mu_L		4	4	4	4	0	48	10	0	0
	TeSysU_Sc_Mu_R		4	4	4	4	0	36	12	0	0
	TeSysU_Sc_St		4	4	4	4	0	14	10	0	0
Detection	Osicoder		2	0	2	0	0	2	0	0	0
Distributed I/O	FTB_1CN08E08C-MO		2	2	2	2	0	2	0	40	8

Family	Device	F*	Tx PDO	Rx PDO	Tx Cob Id	Rx Cob Id	Extra Cob Id	%MW IN	%MW OUT	%M IN	%M OUT
	FTB_1CN08E08S-P0		2	2	2	2	0	2	0	0	8
	FTB_1CN12E04S-P0		2	2	2	2	0	2	0	28	4
	FTB_1CN16CM0		2	2	2	2	0	2	0	56	16
	FTB_1CN16CP0		2	2	2	2	0	2	0	56	16
	FTB_1CN16EM0		2	2	2	2	0	2	0	24	0
	FTB_1CN16EP0		2	2	2	2	0	2	0	24	0
	FTM_1CN10		5	5	4	4	2	54	50	0	0
	OTB Island	Sta	8	8	4	4	8	68	20	0	0
		Ext	6	8	4	4	6	102	54	0	0
	OTB_1C0_DM9LP		8	8	4	4	8	38	10	0	0
	STB_NCO_1010	Sim	32	32	4	4	56	132	96	0	0
		Ext	32	32	4	4	56	228	192	0	0
	STB_NCO_2212	Sim	32	32	4	4	56	132	96	0	0
		Ext	32	32	4	4	56	228	192	0	0
		Adv	32	32	4	4	56	278	244	0	0
		Lar	32	32	4	4	56	694	484	0	0
Motion & Drives	ATV31_V1_1	Bas	2	2	2	2	0	4	4	0	0
		Sta	2	2	2	2	0	6	10	0	0
		Ext	2	2	2	2	0	20	16	0	0
	ATV31_V1_2	Bas	2	2	2	2	0	4	4	0	0
		Sta	2	2	2	2	0	6	10	0	0
		Ext	2	2	2	2	0	20	16	0	0
		MFB	2	2	2	2	0	2	2	0	0
	ATV31_V1_7	Bas	2	2	2	2	0	4	4	0	0
		Sta	2	2	2	2	0	6	10	0	0
		Ext	2	2	2	2	0	20	16	0	0

Family	Device	F*	Tx PDO	Rx PDO	Tx Cob Id	Rx Cob Id	Extra Cob Id	%MW IN	%MW OUT	%M IN	%M OUT
	ATV31T_V1_3	Bas	2	2	2	2	0	4	4	0	0
		Sta	2	2	2	2	0	6	10	0	0
		Ext	2	2	2	2	0	20	16	0	0
	ATV61_V1_1	Bas	3	3	3	3	0	8	8	0	0
		Sta	3	3	3	3	0	32	20	0	0
		Ext	3	3	3	3	0	70	62	0	0
		Con	3	3	3	3	0	76	62	0	0
	ATV71_V1_1	Bas	3	3	3	3	0	8	8	0	0
		Sta	3	3	3	3	0	16	10	0	0
		Ext	3	3	3	3	0	22	14	0	0
		Con	3	3	3	3	0	80	58	0	0
		MFB	3	3	3	3	0	6	6	0	0
	IclA_IFA	Def	1	1	1	1	0	8	10	0	0
		MFB	1	1	1	1	0	6	6	0	0
	IclA_IFE	Def	1	1	1	1	0	8	10	0	0
		MFB	1	1	1	1	0	6	6	0	0
	IclA_IFS	Def	1	1	1	1	0	8	10	0	0
		MFB	1	1	1	1	0	6	6	0	0
	LXM05_MFB		4	4	4	4	0	10	10	0	0
	LXM05_V1_12		4	4	4	4	0	24	26	0	0
	LXM15LP_V1_45		4	4	4	4	0	8	10	0	0
LXM15MH_V6_64	Def	4	4	4	4	0	96	134	0	0	
	MFB	4	4	4	4	0	8	10	0	0	
SD3_28		4	4	4	4	0	22	20	0	0	
Safety	XPSMC16ZC		4	0	4	0	0	28	0	0	0
	XPSMC32ZC		4	0	4	0	0	28	0	0	0
Third-party devices	CPV_C02	Bas	1	1	1	1	0	8	4	0	0
		Adv	1	1	1	1	0	10	6	0	0
		CpEx	1	1	1	1	0	10	4	0	0
	CPX_FB14	BDIO	4	4	4	4	0	56	50	0	0

Family	Device	F*	Tx PDO	Rx PDO	Tx Cob Id	Rx Cob Id	Extra Cob Id	%MW IN	%MW OUT	%M IN	%M OUT
		GDIO	4	4	4	4	0	26	20	0	0
		Adv	4	4	4	4	0	72	66	0	0
	P2M2HBV-C11600		1	1	1	1	0	2	2	0	0

Legend for F*	
Ext	Extended
Sta	Standard
Sim	Simple
Lar	Large
Bas	Basic
MFB	MFB
Con	Controler
Def	Default
Adv	Advanced
CpEx	CP Extension
BDIO	Basic DIO only
GDIO	Generic DIO AIO

F* : Function

Configuration of Communication on the CANopen Bus

What's in This Chapter

General Points.....	52
Bus Configuration	53
Device Configuration.....	61
Master Configuration.....	85

Aim of this Chapter

This chapter presents the configuration of the CANopen field bus and of the bus master and slaves.

General Points

Subject of this Section

This section presents the configuration of the CANopen communication.

Generalities

Introduction

Configuration of a CANopen architecture is integrated into Control Expert.

When the channel of the CANopen master has been configured, a node is automatically created in the project browser. It is then possible to launch Bus Editor from this node in order to define the topology of the bus and configure the CANopen elements.

NOTE: You cannot modify the configuration of the CANopen bus in connected mode.

Bus Configuration

Subject of this Section

This section presents the configuration of the CANopen bus.

How to Access the CANopen Bus Configuration Screen

At a Glance

This describes how to access the configuration screen of the CANopen bus for a Modicon M340 PLC with a built-in CANopen link.

Procedure

To access the CANopen field bus, perform the following actions:

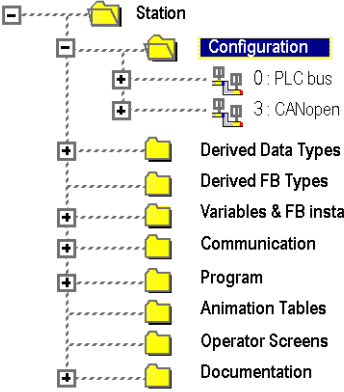
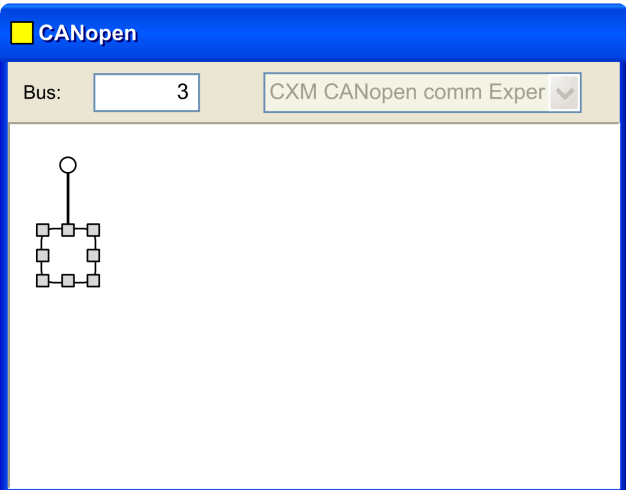
Step	Action
1	<p>From the project navigator, deploy the Configuration directory.</p> <p>Result: the following screen appears:</p> 
2	<p>To open the CANopen bus screen, select one of the following methods:</p> <ul style="list-style-type: none"> • double-click on the CANopen directory, • select the CANopen sub-directory and select Open in the contextual menu. <p>Result: the CANopen window appears:</p> 

CANopen Bus Editor

At a Glance

This screen is used to declare devices which are connected to the bus.

Illustration

The CANopen bus editor looks like this:

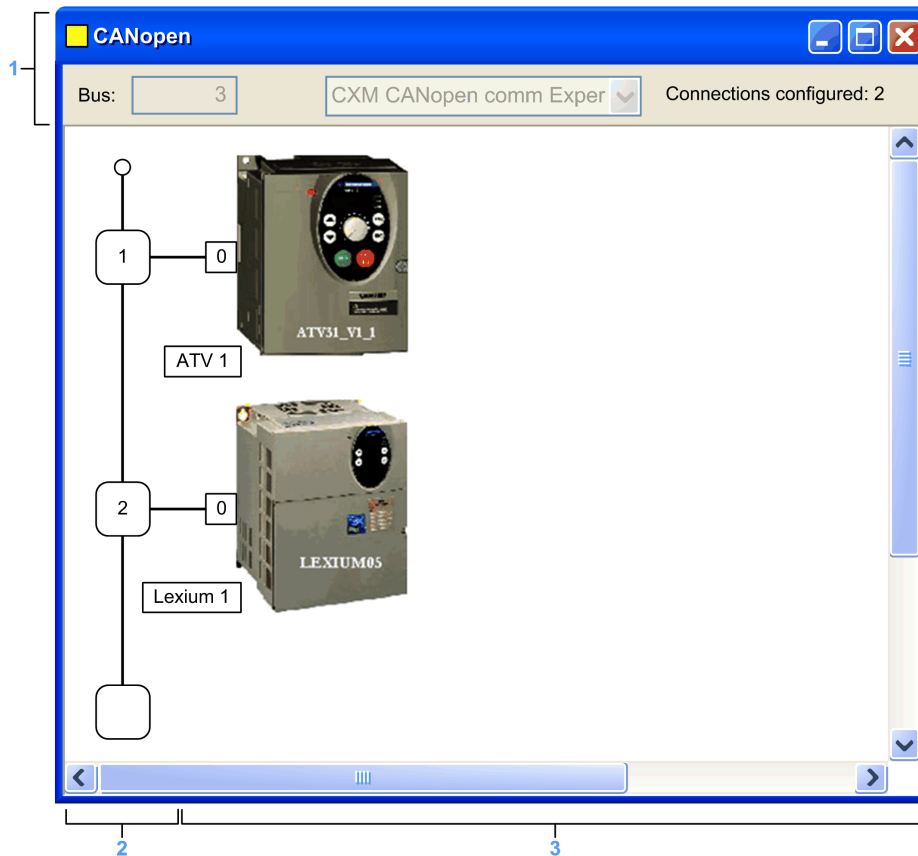

Elements and Functions

This table describes the different areas that make up the configuration screen:

Number	Element	Function
1	Bus	Bus number.
	Connections configured	Indicates the number of connection points configured.
2	Logical address area	This area includes the addresses of the devices connected to the bus.
3	Module area	This area includes the devices that are connected to the bus.

Available connection points are indicated by an empty white square.

How to Add a Device on the Bus

Procedure

This operation is used to add, via the software, a device connected to the CANopen bus:

Step	Action
1	Access the CANopen, page 53 configuration screen.
2	Double-click on the place where the module should be connected.

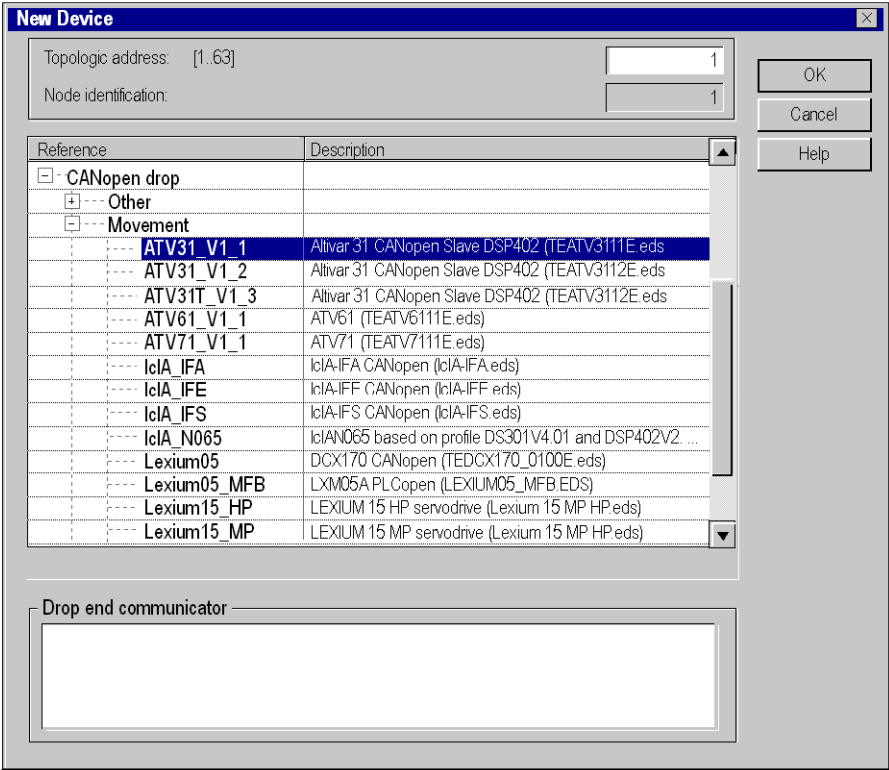
Step	Action
	<p>Result: the New Device screen appears.</p> 
3	<p>Enter the number of the connection point corresponding to the address.</p> <p>By default, the Control Expert software offers the first free consecutive address.</p>

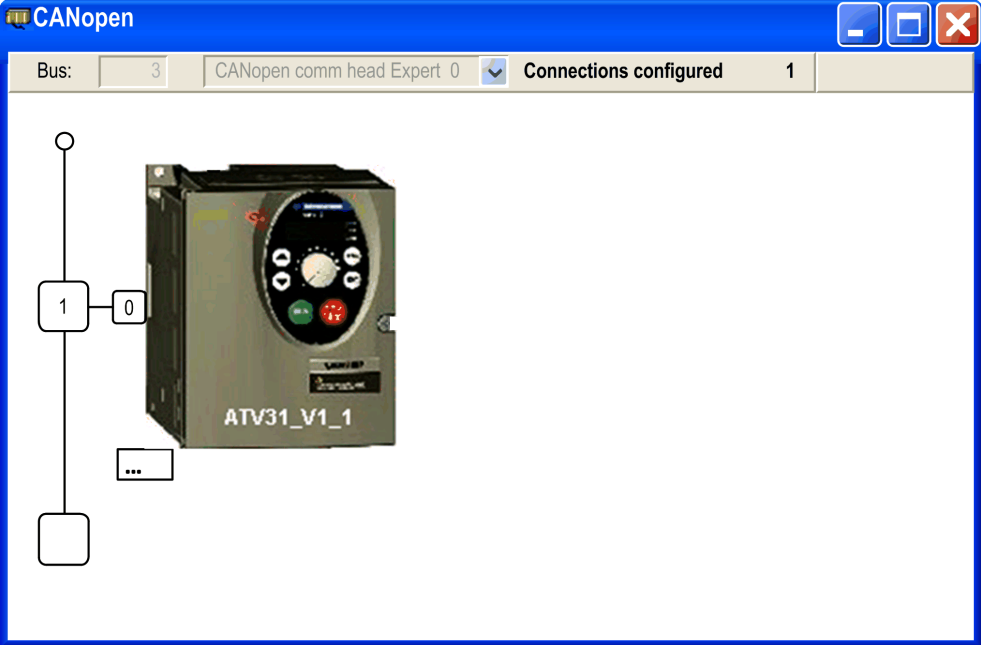
Step	Action
4	In the Communicator field, select the element type enabling communication on the CANopen bus. For modules with built-in communicators, this window does not appear.
5	Validate with OK . Result: the module is declared. 

How to Delete/Move/Duplicate a Bus Device

Procedure for Deleting a Device

This operation is used to delete, via the software, a device connected to the CANopen bus:

Step	Action
1	Access the CANopen configuration screen.
2	Right-click on the connection point of the device to be deleted, then click on Delete the drop .

Procedure for Moving a Device

Moving a device does not involve a physical move on the bus, but rather a change in the device address logic. A movement thus triggers modification of the address of inputs/ outputs objects in the program and movement of the variables associated with these objects.

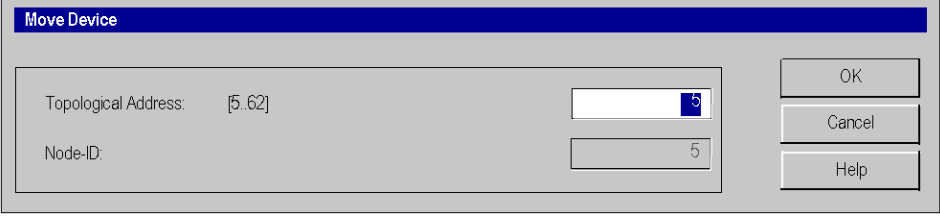
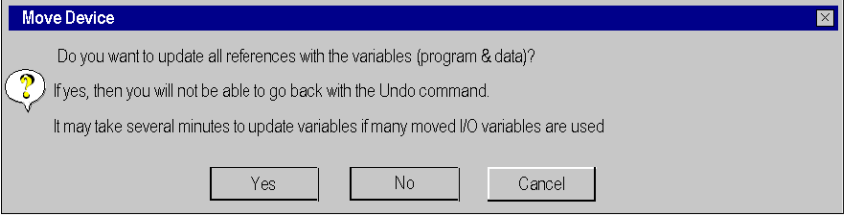
Step	Action
1	Access the CANopen configuration screen.
2	Select the connection point to be moved (a frame surrounds the selected connection point).
3	<p>Drag and drop the connection point to be moved to an empty connection point.</p> <p>Result: the Move Device screen appears:</p> 
4	Enter the number of the destination connection point.
5	<p>Confirm the new connection point by pressing OK.</p> <p>Result: the Move Device screen appears:</p> 
6	Confirm the modification by pressing Yes to modify the addresses of the inputs/outputs objects in the program and move the variables associated with these objects.

Procedure for Duplicating a Device

This feature is similar to the function for moving a device:

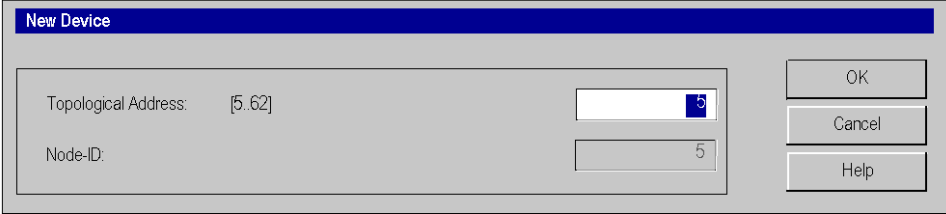
Step	Action
1	Access the CANopen configuration screen.
2	Right-click on the device to be copied, then click on Copy .
3	<p>Right-click on the connection point desired, then click on Paste.</p> <p>Result: the New Device screen appears:</p> 
4	Enter the number of the destination connection point.
5	Confirm the new connection point by pressing OK .

View CANopen Bus in the Project Browser

At a Glance

The CANopen bus is shown in the configuration directory in the project browser. The number of the bus is calculated automatically by Control Expert.

NOTE: The value of the bus number cannot be modified.

The following illustration shows the CANopen bus and slaves in the project browser:

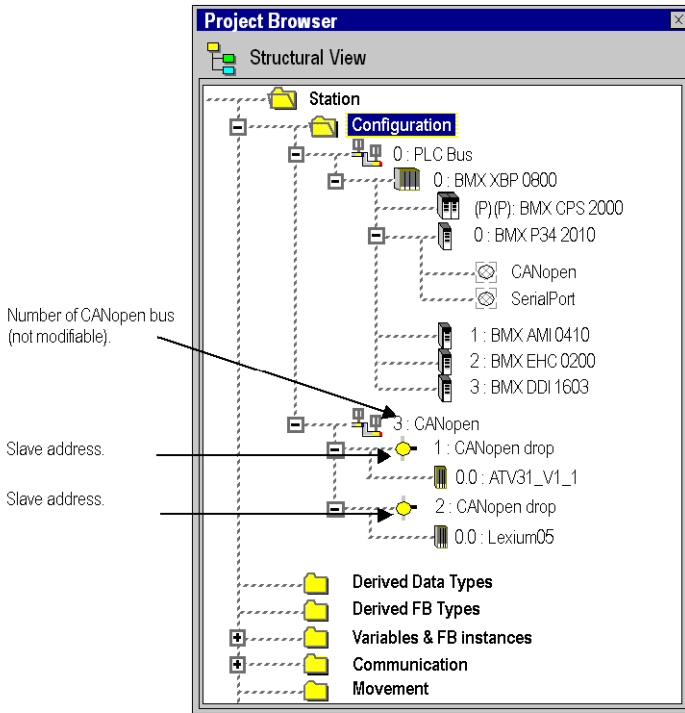

Device Configuration

Subject of this Section

This section presents the configuration of the initial parameters of the CANopen devices.

There are three ways of configuring the initial parameters:

- Configuration using Control Expert,
- Configuration using an external tool,
- Manual Configuration.

NOTE: Before configuring a device, it is strongly recommended to select the function, when available.

Slave Functions

At a Glance

So as to facilitate their configuration, certain CANopen devices are represented through functions.

Each function defines premapped PDOs, as well as certain debugging variables which can be mapped (**PDO** tab of the slave configuration screen).

NOTE: The function should be selected before configuring the slave.

Available Functions

The available functions are as follows:

Function	Description	Devices involved
Basic	This function allows a simple control of the speed.	Altivar
MFB	This function allows control of the device through PLCOpen Motion function block library.	
Standard	This function allows control of the speed and/or torque. All the parameters that can be mapped are mapped in the supplemental PDOs for: <ul style="list-style-type: none"> • an adjustment of the operating parameters (length of acceleration,) • additional surveillance (current value,...), • additional control (PID, outputs command,...). 	
Advanced	This function allows control of the speed and/or torque. Certain parameters can be configured and can also be mapped in the PDOs to allow: <ul style="list-style-type: none"> • an adjustment of the operating parameters (length of acceleration,) • additional surveillance (current value,...), • additional control (PID, outputs command,...). 	
Simple	Use this profile if the island does not contain high resolution analog I/O module or the TeSys U STB modules. This profile contains: <ul style="list-style-type: none"> • NIM diagnostic information (index 4000-index 4006), • 8-bit discrete input information (index 6000), • 16-bit discrete information (index 6100), • 8-bit discrete output information (index 6200), • 16-bit discrete output information (index 6300), • low resolution analog input information (index 6401), 	STB NCO1010 & NCO2212

Function	Description	Devices involved
	<ul style="list-style-type: none"> low resolution analog output information (index 6411). <p>This profile limits the number of index or subindex entries for any of the above objects to 32. If the island configuration exceeds this limitation, please use the Large profile.</p>	
Extended	<p>Use this profile if the island contains high resolution analog I/O module or the TeSys U STB modules.</p> <p>This profile contains</p> <ul style="list-style-type: none"> NIM diagnostic information (index 4000-index 4006), 8-bit discrete input information (index 6000), 16-bit discrete information (index 6100), 8-bit discrete output information (index 6200), 16-bit discrete output information (index 6300), low resolution analog input information (index 6401), low resolution analog output information (index 6411), high resolution analog input information or HMI words (index 2200-221F), high resolution analog output information or HMI words (index 3200-321F), TeSys U input information (index 2600-261F), TeSys U output information (index 3600-361F). <p>This profile limits the number of index or subindex entries for any of the above objects to 32. If the island configuration exceeds this limitation, please use the Large profile.</p>	
Advanced	<p>Use this profile if the island contains enhanced CANopen devices, special features as run-time parameters along with high resolution analog I/O module or HMI or the TeSys U STB modules.</p> <p>This profile contains:</p> <ul style="list-style-type: none"> NIM diagnostic information (index 4000-index 4006), 8-bit discrete input information (index 6000), 16-bit discrete information (index 6100), 8-bit discrete output information (index 6200), 16-bit discrete output information (index 6300), low resolution analog input information (index 6401), low resolution analog output information (index 6411), high resolution analog input information or HMI words (index 2200-221F), high resolution analog output information or HMI words (index 3200-321F), TeSys U input information (index 2600-261F), TeSys U output information (index 3600-361F), 3rd party CANopen devices (index 2000-201F), RTP information (index 4100 & index 4101). <p>This profile limits the number of index or subindex entries for any of the above objects to 32. If the island configuration exceeds this limitation, please use the Large profile.</p>	STB NCO2212

Function	Description	Devices involved
Large Profile	Use this profile if the island configuration does not fit any of the above profiles. This profile contains all the objects available for the STB island and hence will consume more memory address location in the CANopen master.	STB NCO1010 & NCO2212
Controlling	This function is especially created for CANopen communications with the built-in controller card and all the application cards (pump control,...).	Altivar 61/ 71
Basic	The basic level is designed to configure the valve terminal without CP extension.	Festo CPV
CP_Extension	This level is designed to configure I/Os including the CP extension.	
Basic_DIO_only	The basic level is designed to configure the CPX with pneumatic valves and Digital I/O only.	Festo CPX
Generic_DIO_AIO	The generic DS401 level is designed to configure CPX valves and I/Os, including Analogue I/O modules.	
Advanced	The advanced level is designed to configure the maximum I/Os and the complete parameters set.	
Default	This feature is the default function for certain devices. It may not be modified.	All the slaves except ATV and Lexium

NOTE: Some devices can only handle one function. In this case, the function appears grayed out and cannot be modified.



Configuration Using Control Expert with Controllers 2010/ 2030

At a Glance

The devices which can be configured using Control Expert are displayed in the Hardware Catalog:

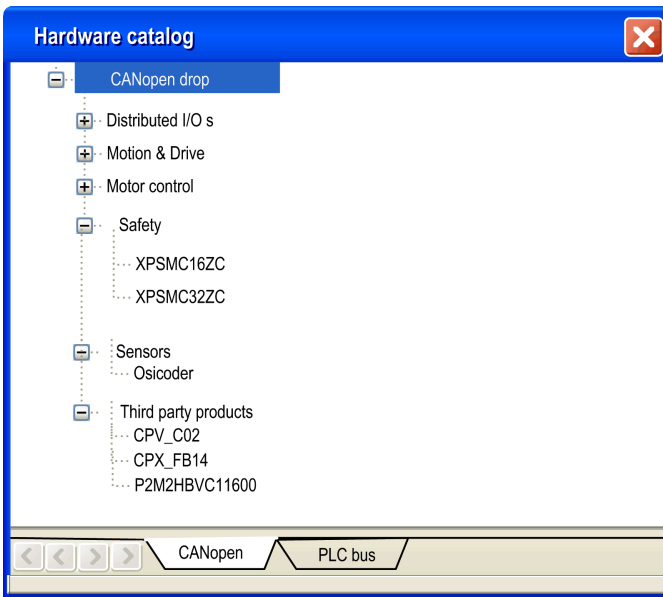

Procedure

To configure a slave, perform the following actions:

Step	Action
1	Access the CANopen , page 53 bus configuration screen.
2	Double-click on the slave to be configured.
3	Configure the usage function using the Config tab.
4	Configure the PDOs using the PDO tab.
5	Select the error control using the Error control tab.

Config tab

The following figure shows an example of the configuration screen of a slave:

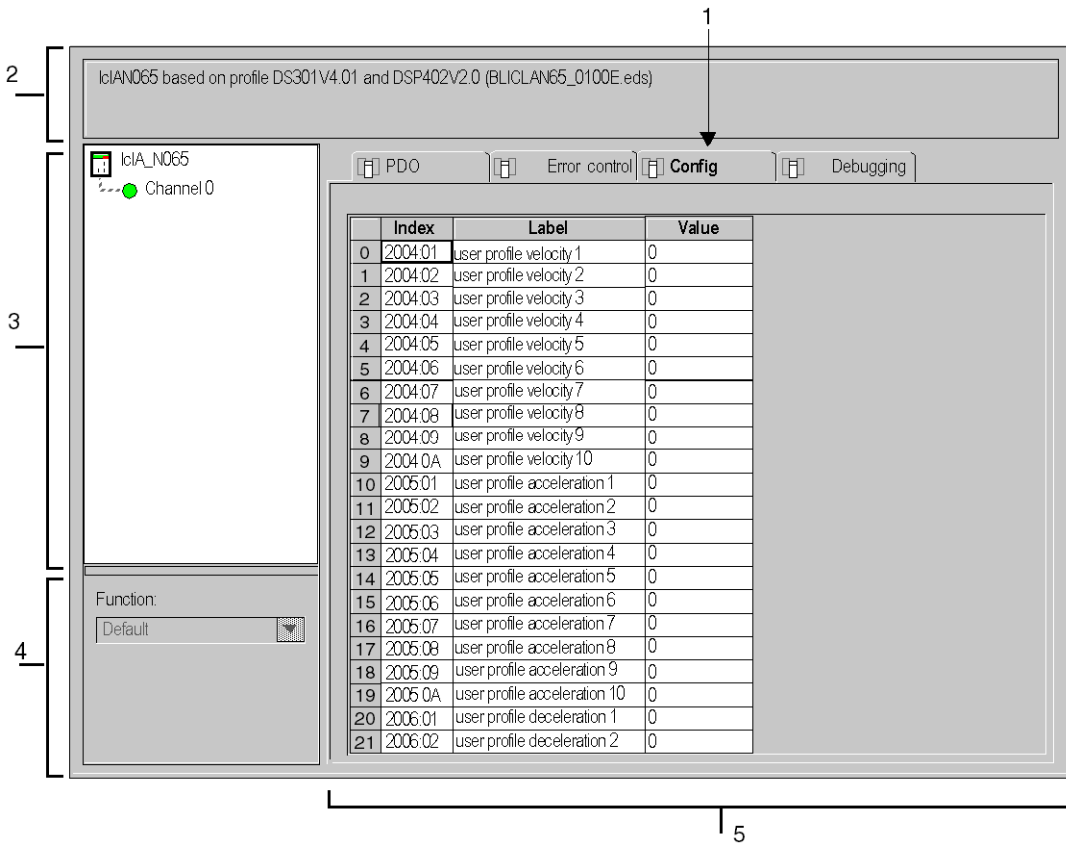

The following table shows the various elements of the configuration screen and their functions:

Number	Element	Function
1	Tabs	The tab in the foreground indicates the type of screen displayed. In this case, it is the configuration screen.
2	Module area	Displays the shortened name of the device.

Number	Element	Function
3	Channel area	<p>This zone allows you to select the communication channel to be configured.</p> <p>By clicking on the device, you display the following tabs:</p> <ul style="list-style-type: none"> • Description: displays the characteristics of the device • CANopen: allows you to access SDO, page 104 (in online mode) • I/O Objects: allows pre-symbolizing of the input/output objects • Fault: accessible in online mode only <p>By clicking on the channel, you display the following tabs:</p> <ul style="list-style-type: none"> • PDO (input/output objects) • Error control • Configuration • Debugging which can be accessed only in online mode • Diagnostics, accessible only in Online mode
4	General parameters area	This field allows you to select the slave function.
5	Configuration area	<p>This area is used to set up the channels of the devices.</p> <p>Some devices can be configured with an external tool. In this case, the configuration is stored in the device and you cannot enter configuration parameters because this field is empty.</p>

NOTE: Refer to the documentation of each device for information on general, configuration, adjustment and debugging parameters.

NOTE: Not all parameters are sent when the device receives its configuration. The controller send only parameters which are different from the default values.

PDO Tab

PDOs are used to manage the communication flow between the CANopen Master and the slaves. The **PDO** tab allows to configure a PDO.

This screen is divided into 3 parts:

The screenshot shows the configuration interface for CANopen PDOs and variables. It is divided into three main sections:

- Transmit (%I):** A table showing PDOs transmitted from the Slave to the Master. PDO 1 and 2 are active, while PDO 3 and 4 are disabled.
- Receive (%Q):** A table showing PDOs received by the Slave from the Master. PDO 1 and 2 are active, while PDO 3 and 4 are disabled.
- Variables:** A list of variables that can be mapped to the PDOs. The list includes parameters like RAMPsym, _IO_act, ANA1_act, etc.

Transmit (%I)									
PDO	Tr. Ty...	Inhibi...	Even...	Symbol	Topo. Addr	%M...	CO...	Index	
<input checked="" type="checkbox"/> PDO 1 (...)	255	0	0	lexium...	%IW3.110.0...	%MW16	16#181	6041...	
Status...				lexium...	%IW3.110.0...	%MW16		6041...	
<input checked="" type="checkbox"/> PDO 2 (...)	255	0	100	lexium...	%IW3.110.0...	%MW16	16#281	6041...	
Status...				lexium...	%IW3.110.0...	%MW16		6041...	
Positi...				lexium...	%ID3.110.0.0...	%MW8		6064...	
<input type="checkbox"/> PDO 3 (...)	255	0	100				-		
Status...				lexium...	%IW3.110.0...	%MW16		6041...	
Veloci...				lexium...	%ID3.110.0.0...	%MW10		606C...	
<input type="checkbox"/> PDO 4 (...)	254	0	0				-		

Receive (%Q)									
PDO	Tr. Ty...	Inhibi...	Even...	Symbol	Topo. Addr	%M...	CO...	Index	
<input checked="" type="checkbox"/> PDO 1 (...)	255						16#281		
Contr...				lexium...	%QW3.110.0...	%MW425		6040...	
<input checked="" type="checkbox"/> PDO 2 (...)	255						16#381		
Contr...				lexium...	%QW3.110.0...	%MW425		6040...	
Target...				lexium...	%QD3.110.0...	%MW414		607A...	
<input type="checkbox"/> PDO 3 (...)	255						-		
Contr...				lexium...	%QW3.110.0...	%MW425		6040...	
Target...				lexium...	%QD3.110.0...	%MW418		60FF...	
<input type="checkbox"/> PDO 4 (...)	254						-		

Parameter Name	Ind...
RAMPsym	3006.01
_IO_act	3008.01
ANA1_act	3009.01
ANA2_act	3009.05
PLCopenRx1	301B.05
PLCopenRx2	301B.06
PLCopenTx1	301B.07
PLCopenTx2	301B.08
JOActivate	301B.09
_actionStatus	301C.04
_p_actRAMPusr	301F.02
CUR_I_target	3020.04
SPEEDn_target	3021.04
PTPp_abs	3023.01
PTPp_relpref	3023.03
PTPp_target	3023.05
PTPp_relpact	3023.06
GEARdenom	3026.03
GEARnum	3026.04
Controlword	6040.00
Statusword	6041.00
position actual valu...	6063.00

- **Transmit PDOs:** information transmitted by the Slave to the Master,
- **Receive PDOs:** information received by the Slave from the Master,
- **Variables:** variables that can be mapped to the PDOs. To assign a variable to a PDO, drag and drop the variable into the desired PDO. No variable can be assigned with a static PDO.

NOTE: To configure the STBNCO1010, determine all the objects that are valid for this device and configure them manually in the PDOs.

For more information about the list of the associated objects, refer to the STB user manual.

For more information about the use of the PDOs, see [...].

Error Control Tab

The **Error control** tab for CANopen slave modules allows you to configure monitoring.

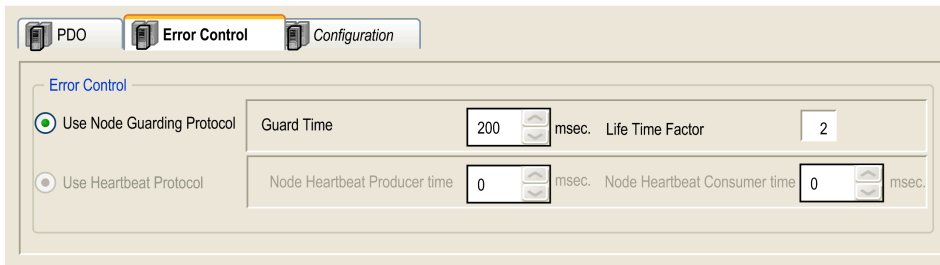

Two choices are possible:

- Heartbeat:** The Heartbeat mechanism consists of sending cyclical presence messages generated by a Heartbeat Producer. A Heartbeat transmitter (producer) sends recurring messages. The sending time is configured with the `Node Heartbeat Producer Time` value. One or several elements connected to the network receive this message. The Heartbeat consumer surveys the Heartbeat message reception. The default value of consumer time is set to $1.5 * \text{Producer Heartbeat Time}$. If its duration exceeds the `Heartbeat Consumer Time` ($1.5 * \text{Producer Heartbeat Time}$), a `Heartbeat event` is created and the device is in default.

If an M340 Master controller is used on the CANopen bus, all the nodes using the Heartbeat control mode are producers. The master surveys the transmission and the reception of the messages and it is the only receiver of the Heartbeat messages sent by the nodes.

Control Expert supports devices that are only heartbeat producer (no consumer) and does not support the node guarding. In this case, the value of node heartbeat consumer time is set to 0. This value is displayed on the **Error Control** tab of the device.

The Master can send Heartbeat messages to the slaves. The Master Heartbeat producer time is set at 100 ms and is not modifiable.

- Node guarding:** Node Guarding is the monitoring of network nodes. The NMT (Network Management) master sends an RTR (Remote Transmission Request) at regular intervals (this period is called `Guard Time`) and the node must answer in a given time lapse (the `Node Life Time` equals the `Guard Time` multiplied by the `Life Time Factor`).

The `Life Time` value is set at 2 and is not modifiable.

NOTE: Some devices only support Heartbeat or Node Guarding. For devices which support Heartbeat and Node Guarding, the only choice in Control Expert is the Heartbeat mechanism.

Configuration Using Control Expert with Controllers 20102 / 20302

Introduction

The devices that can be configured using Control Expert are displayed in the **Hardware catalog**:

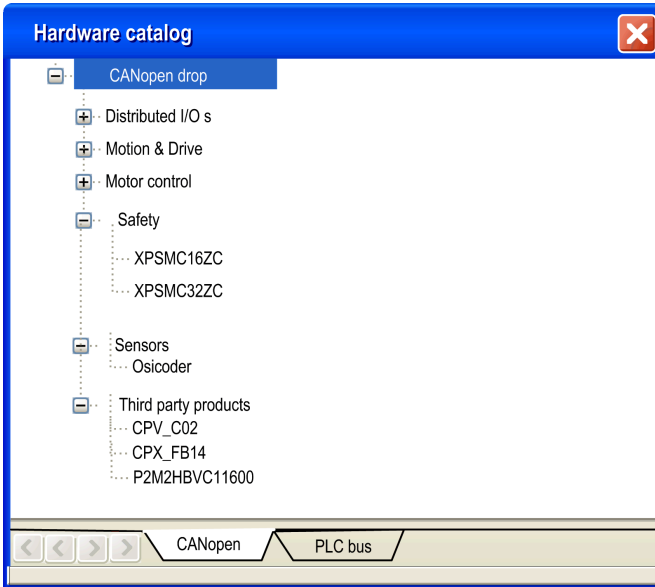

Procedure

To configure a secondary, perform the following actions:

Step	Action
1	Access the CANopen, page 53 bus configuration screen.
2	Double-click the secondary to be configured.
3	Configure the Bootup procedure using the Bootup tab.
4	Integrate a third-party product using the Object Dictionary tab.
5	Configure the usage function using the Config tab.

Step	Action
6	Configure the PDOs using the PDO tab.
7	Select the error control using the Error control tab.

Configuration Tab

The following figure shows an example of the configuration screen of a secondary device:

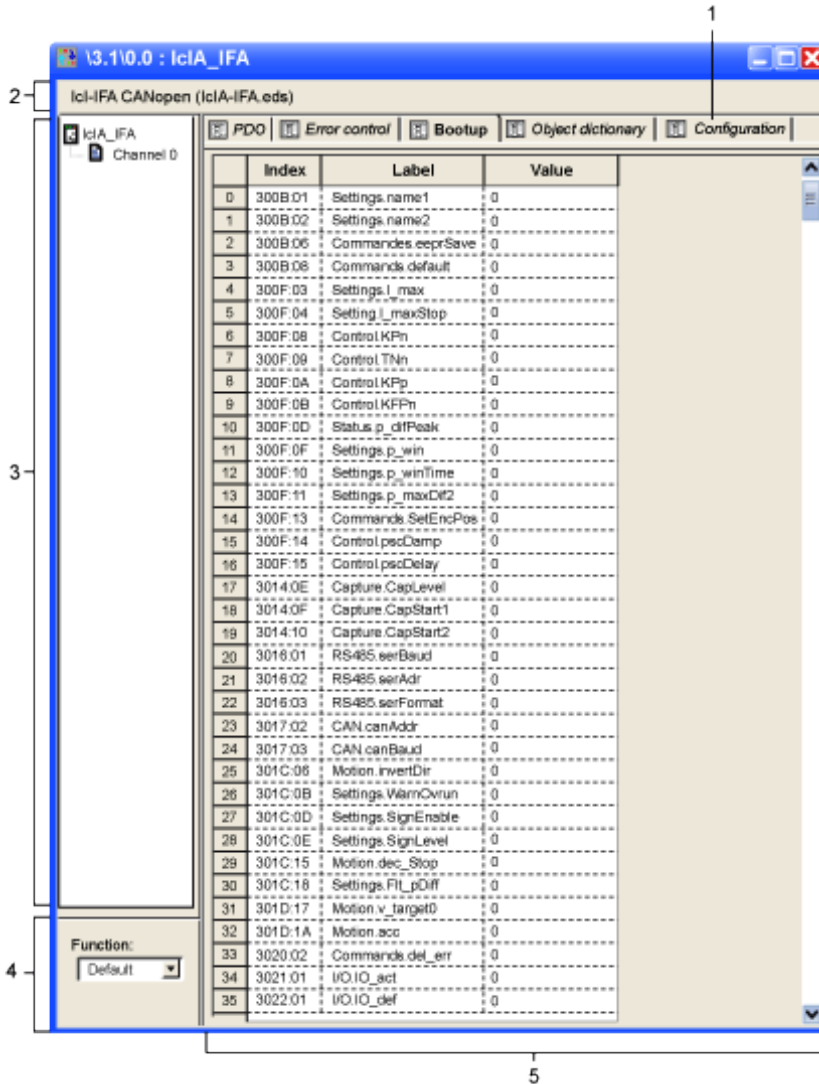

The following table shows the various elements of the configuration screen and their functions:

Number	Element	Function
1	Tabs	The tab in the foreground indicates the type of screen displayed. In this case, it is the configuration screen.
2	Module area	Displays the shortened name of the device.
3	Channel area	<p>This zone allows you to select the communication channel to be configured.</p> <p>By clicking the device, you display the following tabs:</p> <ul style="list-style-type: none"> • Description: Gives the characteristics of the device • CANopen: Allows you to access SDO (in online mode) • I/O Objects: Allows pre-symbolizing of the input/output objects • Fault: Accessible in online mode only <p>By clicking the channel, you display the following tabs:</p> <ul style="list-style-type: none"> • PDO (input/output objects) • Error control • Bootup • Object Dictionary • Configuration • Debugging (Can be accessed only in online mode) • Diagnostics (Accessible only in online mode)
4	General parameters area	This field allows you to select the secondary function.
5	Configuration area	<p>This area is used to set up the channels of the devices.</p> <p>Some devices can be configured with an external tool. In this case, the configuration is stored in the device and you cannot enter configuration parameters because this field is empty.</p>

NOTE: Refer to the documentation of each device for information on general, configuration, adjustment, and debugging parameters.

NOTE: Not all parameters are sent when the device receives its configuration. The controller sends only parameters that are different from the default values.

PDO Tab

PDOs are used to manage the communication flow between the CANopen primary and the secondary. The **PDO** tab allows you to configure a PDO.

This screen is divided into three parts:

IclA-IFA CANopen(IclA-IFA.eds)

IclA-IFA
Channel 0

Transmit(%I) Display only active PDO

PDO	Tr.Type	Inhibit Time	Event Tim...	Symbol	Topo.Addr.	%M..	COBID	Index
<input checked="" type="checkbox"/> PDO4(Static)	254	0	0				16#481	
<input type="checkbox"/> pdo4_drivestat					%IWL3.110.0.5			301E.04
<input type="checkbox"/> pdo4_modestat					%IWL3.110.0.4			301E.03
<input type="checkbox"/> pdo4_Act8					%IWL3.110.0.6			301E.07
<input type="checkbox"/> pdo4_Act32					%IWL3.110.0.2			301E.08

Receive(%Q) Display only active PDO

PDO	Tr.Type	Inhibit Time	Event Tim...	Symbol	Topo.Addr.	%M..	COBID	Index
<input checked="" type="checkbox"/> PDO4(Static)	254		0				16#501	
<input type="checkbox"/> pdo4_drivectrl					%IWL3.110.0.7			301E.01
<input type="checkbox"/> pdo4_modectrl					%IWL3.110.0.8			301E.02
<input type="checkbox"/> pdo4_Ref16					%IWL3.110.0.9			301E.05
<input type="checkbox"/> pdo4_Ref32					%IWL3.110.0.0			301E.06

Function:
Default

- **Transmit PDOs:** Information transmitted by the secondary to the primary.
- **Receive PDOs:** Information received by the secondary from the primary.
- **Variables:** Variables that can be mapped to the PDOs. To assign a variable to a PDO, drag and drop the variable into the desired PDO. No variable can be assigned with a static PDO.

NOTE: To configure the STBNCO1010, determine all objects that are valid for this device and configure them manually in the PDOs.

For more information about the list of the associated objects, refer to the respective STB user manual.

For more information about the use of the PDOs, see [...].

Error Control Tab

The **Error Control** tab for CANopen secondary modules allows you to configure monitoring.

Two choices are possible:

- **Heartbeat:** The heartbeat mechanism consists of sending cyclical presence messages generated by a heartbeat producer. A heartbeat transmitter (producer) sends recurring messages. The sending time is configured with the `Node Heartbeat Procucer Time` value. One or several elements connected to the network receive this message. The heartbeat consumer surveys the heartbeat message reception. The default value of consumer time is set to $1.5 * \text{Producer Heartbeat Time}$. If its duration exceeds the `Heartbeat Consumer Time` ($1.5 * \text{Producer Heartbeat Time}$), a heartbeat event is created and the device is in default.

If an M340 primary controller is used on the CANopen bus, all nodes using the heartbeat control mode are producers. The primary surveys the transmission and reception of messages and it is the only receiver of the heartbeat messages sent by the nodes.

Control Expert supports devices that are only heartbeat producer (no consumer) and does not support node guarding. In this case, the value of node heartbeat consumer time is set to 0. This value is displayed on the **Error Control** tab of the device.

The primary can send heartbeat messages to the secondary. The primary heartbeat producer time is set at 100 ms and is not modifiable.

- **Node guarding:** Node guarding is the monitoring of network nodes. The NMT (network management) primary sends an RTR (remote transmission request) at regular intervals (this period is called guard time) and the node must answer in a given time lapse. (The node life time equals the guard time multiplied by the life time factor.)

The life time value is set at 2 and is not modifiable.

NOTE: Some devices only support heartbeat or node guarding. For devices that support heartbeat and node guarding, the only choice in Control Expert is the heartbeat mechanism.

Bootup Tab

If you change the default parameters of the Bootup tab, standard system verifications are bypassed.

⚠ WARNING

UNINTENDED EQUIPMENT OPERATION

Verify deactivated standard verifications on the device before operating the system.

Failure to follow these instructions can result in death, serious injury, or equipment damage.

The **Bootup tab** allows you to configure the Bootup procedure:

The screenshot displays the 'Bootup procedure configuration' window in the IclA_IFA software. The window is titled '13.1\10.0 : IclA_IFA' and shows the 'Bootup' tab selected. The configuration is organized into a vertical flowchart starting with 'Power ON'. The steps are as follows:

- Restore:** Includes options for 'No Restore', 'Restore communications parameters (1011:02)', 'Restore application parameters (1011:03)', and 'Restore all parameters (1011:01)'. A text box explains that the restore option defines the allowed restore procedure for a CANopen device during startup, with communication parameters ranging from 0x1000 to 0x1FFF and application parameters from 0x6000 to 0x9FFF.
- Reset:** Includes options for 'Reset communication parameters' and 'Reset node'. A text box explains that the reset option is used to configure the type of reset sent to the device, with communication parameters from 0x1000 to 0x1FFF and application parameters from 0x6000 to 0x9FFF.
- Check node:** Includes options for 'Device type (1000:00)' and 'Device identity (1018:xx)'. A text box explains that the check option is used to bypass the device type (0x1000) or the device identity (0x1018) test.
- Download configuration:** Includes options for 'Force communication parameters' and 'Force application parameters'. A text box explains that the download configuration option is used to force the parameters to be sent even if they are equal to the default value.
- Start:** Includes the option 'Start node'. A text box explains that the start option is used to configure whether the device should be started automatically by the master or not.

The process concludes with 'PDO transfer'. A 'Function:' dropdown menu at the bottom left is set to 'Default'.

The goal of the Bootup procedure tab is to bypass the standard procedure for devices that do not comply with CANopen standards.

The following list defines the different functionalities of the Bootup procedure:

- The type of restore:
 - **No restore**: Option selected by default.
 - **Restore communication parameters**: Option selected according to the object 0x1011sub02. If the option is selected, the parameters between 0x1000 to 0x1FFF are restored.
 - **Restore application parameters**: Option selected according to the object 0x1011sub03. If the option is selected and if the device correctly implements the service, the application parameters are restored.
 - **Restore all parameters**: Option selected according to the object 0x1011sub01. If the option is selected, all parameters are restored (default value).
- The type of reset:
 - **Reset communication parameters**: If the option is selected, the communication parameters are reset.
 - **Reset node** (default value): If the option is selected, all parameters are reset.
- The **Device type** and **Device identity** (selected by default):
 - If the device type identification value for the secondary in object dictionary 0x1F84 is not 0x0000 ('do not care'), compare it to the present value.
 - If the configured vendor ID in object dictionary 0x1F85 is not 0x0000 ('do not care'), read secondary index 0x1018, sub-index 1 and compare it to the present value.
 - The same comparison is done with ProductCode, RevisionNumber and SerialNumber with the respective objects 0x1F86-0x1F88.

NOTE: The cleared **Device type** option sets the object dictionary 0x1F84 to 0x0000.

NOTE: The cleared **Device identity** option sets the object dictionary 0x1F86-0x1F88 (sub device nodeID) to 0x0000.

- **Download configuration** forces the download of communication or configuration parameters (cleared by default). If the option is selected, it forces the corresponding objects to be downloaded, and you must follow these rules:
 - Parameters are downloaded if they are different from the default value.
 - Parameters are downloaded if they are forced in the object dictionary.
 - Parameters are not downloaded in other cases.

- The **Start node**:

If the option is selected (default value), the CANopen primary starts the device automatically after the bootup procedure.

If the option is cleared, the device stays in pre-operational state after the bootup procedure. In this case, the device must be started by the application program.

Object Dictionary Tab

If you change the default values of the Object Dictionary table, unintended equipment operation may occur.

⚠ WARNING
UNINTENDED EQUIPMENT OPERATION
Verify all Object Dictionary values.
Failure to follow these instructions can result in death, serious injury, or equipment damage.

The **Object Dictionary tab** allows you to configure and integrate third party products to:

- Force parameters to be transmitted even if they are unchanged, by selecting the associated checkbox of each parameter.
- Block parameters that do not need to be sent to the device, by clearing the associated checkbox of each parameter.
- Set objects to a specific value just before (prologue), or just after (epilogue) the standard bootup procedure.
- Modify the value of an object (except read only objects) if the value box is not grayed out by typing the desired value in the box. By default, if the value is modified, the object is sent. After filling the box, you can modify this behavior by clearing the checkbox in order to block the sending object. To prevent programming redundancies or conflicts, parameters that can be modified in other tabs, like Configuration, PDO or Error Control, are grayed out in the Object Dictionary tab.

The following illustration describes the **Object Dictionary** tab:

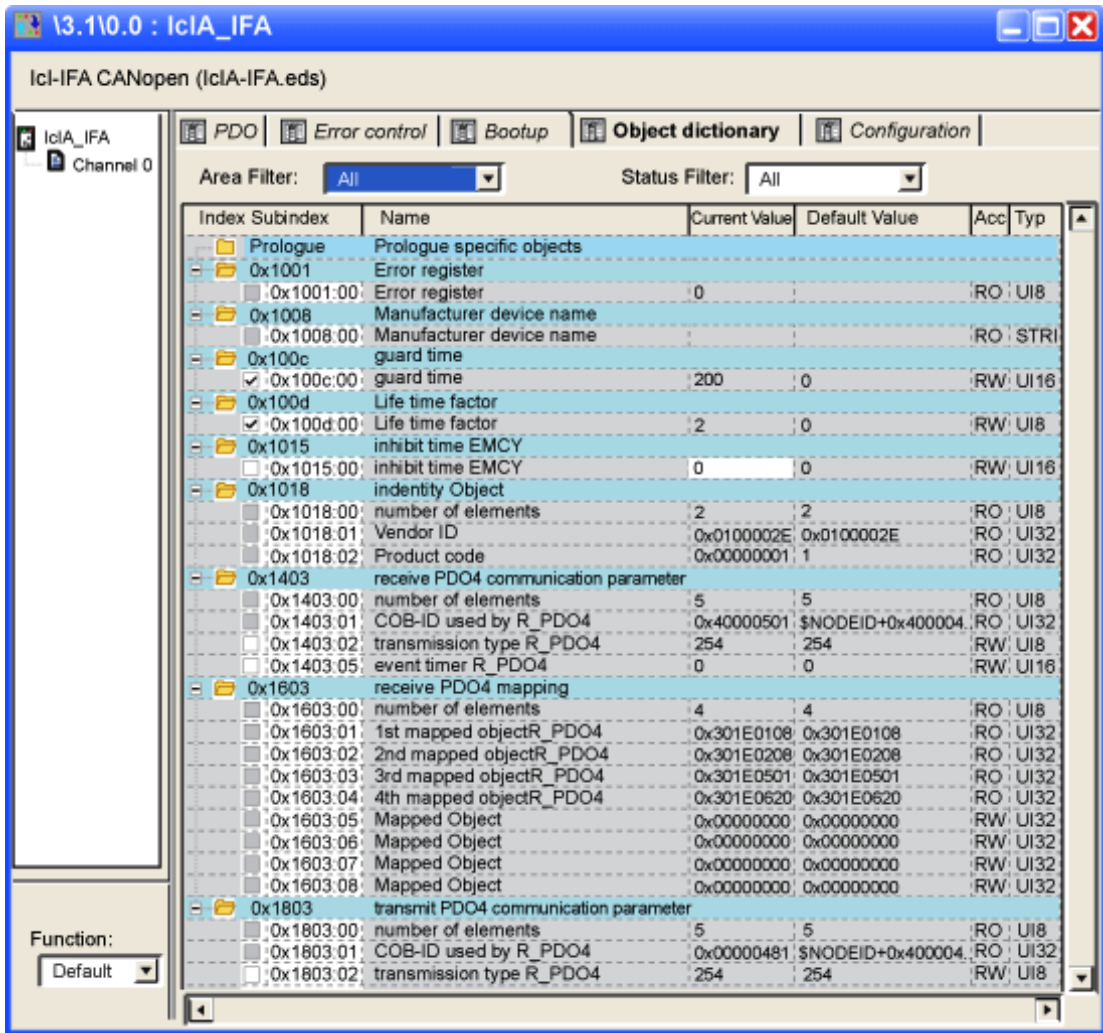

You can drag and drop available objects from the index folder to the prolog or epilog section. If some objects are not allowed to be inserted, like PDOs or read-only, a pop-up appears.

NOTE: An object which has been put in the prolog or epilog section is always sent.

You can select the following filters to reduce the number of displayed objects on the grid:

Area filter	
All	Shows all projects.
Prologue / epilogue	Shows only prologue and epilogue projects.

[XXXX...YYYY]	Shows only objects from XXXX to YYYY.
Status filter	
All	Shows all objects.
Configured	Shows only transmitted objects to the device during boot up.
Not configured	Shows only untransmitted objects to the device.
Modified	Shows only objects from which values are different from default values.

You can right-click an object to execute the following functions:

Right-click an object in the prologue and epilogue sections.	
Cut	Cut the row and copy the object in the clipboard.
Copy	Copy the object in the clipboard.
Paste	Paste the object in the selected row.
Delete	Delete the selected object.
Move up	Used to manage the order of the list.
Move down	Used to manage the order of the list.
Configured	If selected, the object is transmitted to the device.
Expand all	Expand all nodes of the tree.
Collapse all	Collapse all nodes of the tree.
Right-click an object in the other sections.	
Copy	Copy the object in the clipboard
Configured	If selected, the object is transmitted to the device
Expand all	Expand all nodes of the tree
Collapse all	Collapse all nodes of the tree

Configuration Using an External Tool: Configuration Software

At a Glance

To configure a Lexium 05/15, an IclA, a Tesys U or an ATV61/71 device, it is necessary to use an external tool:

- Advantys Configuration Software for the STB,
- PowerSuite V2.5 Software for Lexium 05,
- Powersuite V2.5 Software for the ATV31, ATV61, ATV71 and the Tesys U,
- UNILINK V1.5 for the Lexium 15 LP,
- UNILINK V4.0 for the Lexium 15 MH,
- EasyIcIA V1.104 for ICLA_IFA, ICLA_IFE, ICLA_IFS.

NOTE: To facilitate the configuration and programming of the motion and drives devices, use the software in conjunction with the Control Expert MFBs.

NOTE: You can do autoconfiguration with NCO2212, as with a NCO1010.

Advantys Configuration Software

Advantys Configuration Software (Version 2.5 or higher) has to be used to configure an STB NCO 2212. The Advantys Configuration Software validates the configuration and creates a DCF file that contains all the objects used in the configuration ordered in the correct sequence. The DCF file can be imported from Control Expert.

NOTE: The creation of the DCF file is only possible from the full version of Advantys.

CANopen devices are not supported during an *.xsy file import from Advantys to Control Expert. The %MW objects that are assigned in the PDO table are not in the same range as those defined in the configuration for the CANopen head.

▲ WARNING

UNINTENDED EQUIPMENT OPERATION

Do not use the symbol file *.xsy generated by Advantys in Control Expert during the configuration of an STB Island.

Failure to follow these instructions can result in death, serious injury, or equipment damage.

The procedure for adding an island to a CANopen bus is as follows:

Step	Action
1	In Advantys Configuration Software (Version 2.2 or above), create a new Island.
2	Select the STB NCO 2212 Network Interface Module.
3	Select the modules which will be used in the application.
4	Configure the island.

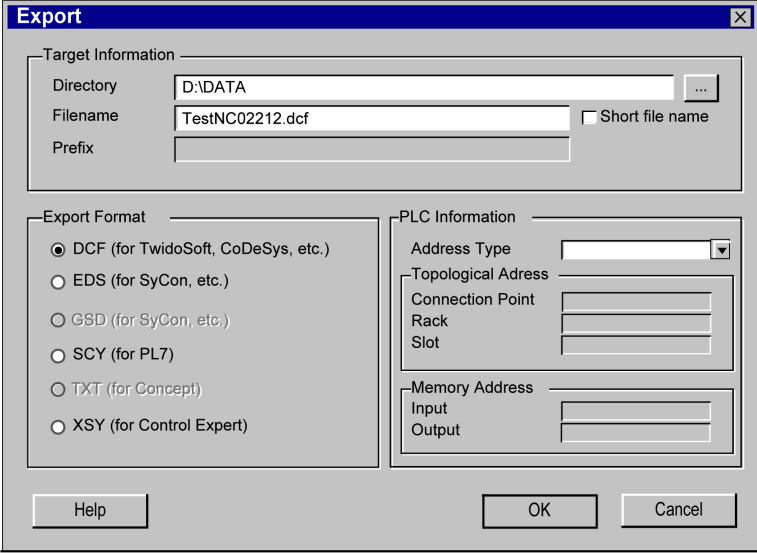
Step	Action
5	<p>When the configuration is over, click on File/Export to export the island in DCF format.</p> <p>The following window is displayed:</p> 
6	Click OK to confirm.
7	Once the file is exported, launch Control Expert and open the project in which the island will be used.
8	Add an STB device to the Bus Editor (see How to Add a Device on the Bus , page 56).
9	Right-click on the STB device, then click on Open the module .
10	In the PDO tab, click the button Import DCF .
11	Confirm by clicking OK . The PDOs are configured automatically.

NOTE: The modification of the topology of an island requires recommencing this procedure.

For more information about the STB configuration, refer to the STB user manual.

Powersuite Software

The PowerSuite software development is a tool meant to implement the following Altivar speed drives. It should be used to configure an ATV31/61/71, a Tesys U or a Lexium 05 device (Powersuite 2)

Various functions are integrated for being used on implementing phases such as:

- configurations preparations,
- setting to work,
- maintenance.

The configuration is directly stored in the device.

For more information about the configuration of an ATV31/61/71 and Tesys U using Powersuite Software or about the configuration of a Lexium 05 with Power Suite 2, refer to the device user manual.

UNILINK Software

UNILINK provides simplified parameter setting for Lexium 05/ Lexium15 servo drives. It is used to configure, sets and adjusts Lexium 15LP/MP/HP drives according to the associated SER/BPH brushless motor and the application requirements.

For more information about the configuration of a Lexium 15 using UNILINK, refer to the Lexium user manual.

Manual Configuration

At a Glance

ATV 31 and Icla devices can be configured manually from their front panel.

Configuration of the ATV 31

The following figure presents the different front panels of the ATV 31 servodrive.

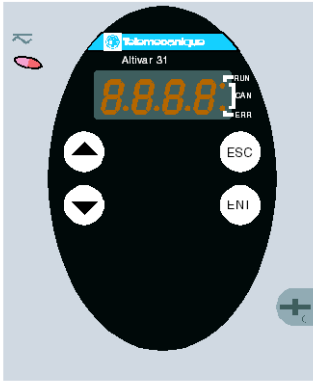

ATV31xxxx

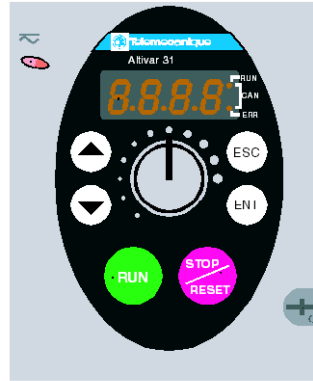

ATV31xxxxxA

The ATV 31 may be configured as follows:

Step	Action
1	Press on the "ENT" key to enter the ATV31 configuration menu.
2	Use the "Arrows" keys to select the "COM" Communication menu then confirm using the "ENT" key.
3	Use the "Arrows" keys to select the "AdCO" menu then confirm using the "ENT" key. Enter a value (Address on the CANopen bus). Confirm using the "ENT" key then exit the menu using the "ESC" key
4	Use the "Arrows" keys to select the "bdCO" menu then confirm using the "ENT" key. Enter a value (Speed on the CANopen bus). Confirm using the "ENT" key then exit the menu using the "ESC" key
5	Press several times on the "ESC" key to exit the configuration menu.

NOTE: The configuration may be modified only when the motor is stopped and when the variable speed controller is locked (cover closed). Any modification entered will become effective after an "Off/On" cycle of the speed controller.

For more information about the ATV31 configuration, please refer to the Altivar speed drive user manual.

Master Configuration

Subject of this Section

This section presents the master configuration.

How to Access the CANopen Master Configuration Screen

At a Glance

This describes how to access the configuration screen of the master for a Modicon M340 PLC with a built-in CANopen link.

Procedure

To access the master, carry out the following actions:

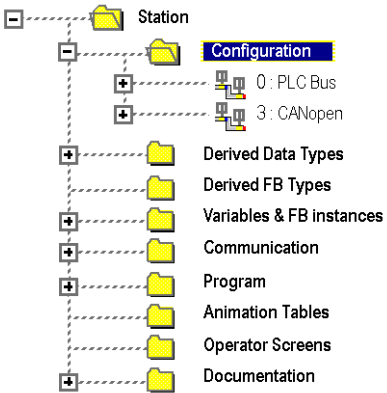
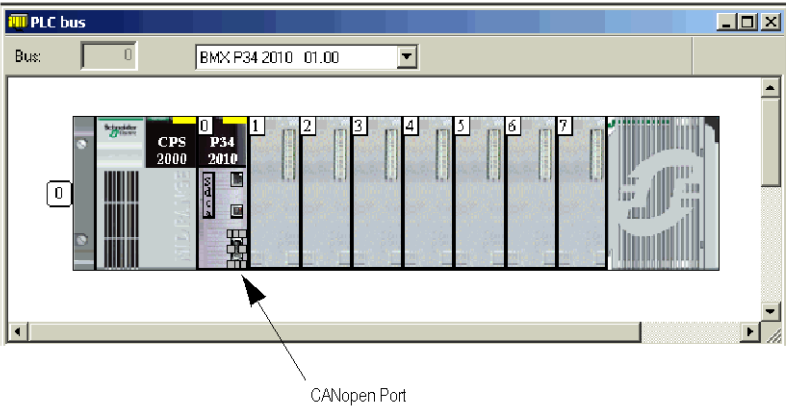
Step	Action
1	<p>From the project navigator, deploy the <code>Configuration</code> directory.</p> <p>Result: the following screen appears:</p> 
2	<p>Double-click on the <code>PLC Bus</code> subdirectory.</p> <p>Result: the following screen appears:</p>  <p>Double-click on the processor's CANopen port.</p>
3	<p>The master configuration screen appears:</p>

Step	Action
	<p>The screenshot displays the configuration interface for a CANopen master. The main window is titled "0.0 : CANopen: CANopen comm head". On the left, a tree view shows the project structure with "CANopen comm head" and "Channel 2". The "Config" tab is selected, showing two main sections: "Inputs" and "Outputs". Each section has four parameters: "No. of words (%MW)", "Index of 1st %MW", "Nb. of bits (%M)", and "Index of first %M", all set to 32, 0, 32, and 0 respectively. Below these is the "Bus parameters" section, which includes "Transmission speed" (250 kBaud), "SYNC message COB-ID" (128), and "SYNC message period" (100 ms). At the bottom left, there are dropdown menus for "Function" (set to "CANopen") and "Task" (set to "MAST").</p>

CANopen Master Configuration Screen with CPUs 2010/2030

At a Glance

This screen is used to declare and configure the master of the CANopen network from a Modicon M340 PLC station.

Illustration

The configuration screen of the master is as follows:

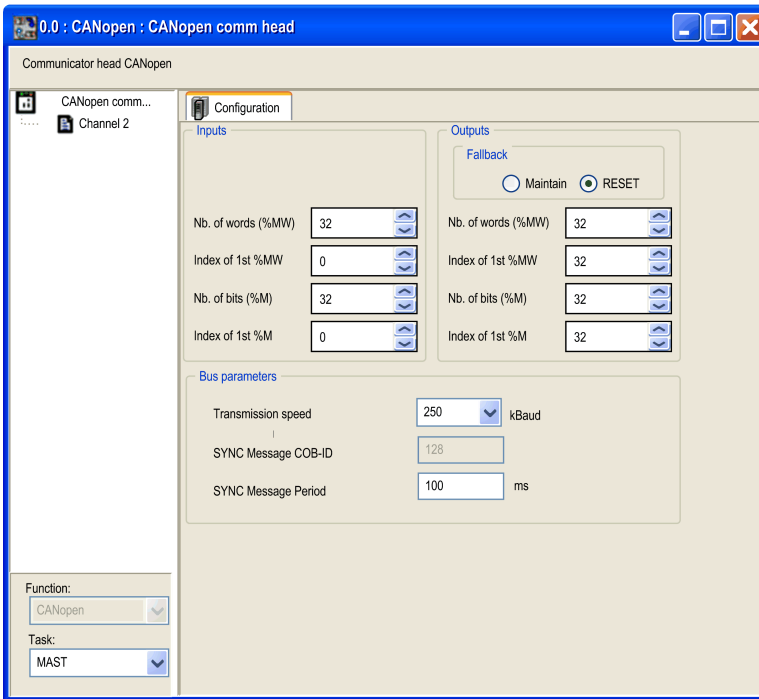

Elements and functions

The table below describes the different areas which make up the master configuration screen:

Read	Number	Function
1	Tab	The tab in the foreground indicates the type of screen displayed. In this case, it is the configuration screen.
2	Module	This area is made up of the abbreviated heading of the processor equipped with a CANopen port.
3	Channel	This zone allows you to select the communication channel to be configured. By clicking on the device, you display the tabs: <ul style="list-style-type: none"> • Description : gives the characteristics of the built-in CANopen port, • Inputs/outputs objects: allows pre-symbolizing of the input/output objects, By clicking on a channel, you display the tabs:

Read	Number	Function
		<ul style="list-style-type: none"> • Config . enables you to declare and configure the CANopen master, • Debug : accessible in online mode only, • Fault: accessible in online mode only.
4	General parameters	<p>This field enables you to:</p> <ul style="list-style-type: none"> • associate the CANopen bus to an application task: <ul style="list-style-type: none"> ◦ MAST which is the master task, ◦ FAST which is the rapid task. <p>The tasks are asynchronous in relation to exchanges on the bus.</p>
5	Configuration	<p>This field enables you to:</p> <ul style="list-style-type: none"> • configure the PLC internal memory addresses where inputs from the CANopen devices will periodically be copied. • configure the PLC internal memory addresses where outputs from the CANopen devices will periodically be read. • configure the parameters of the CANopen bus.

Description of Master Configuration Screen for CPUs 2010/ 2030

At a Glance

The configuration screen allows configuration of the bus parameters as well as the inputs and outputs.

Inputs

The figure below illustrates the inputs configuration area:

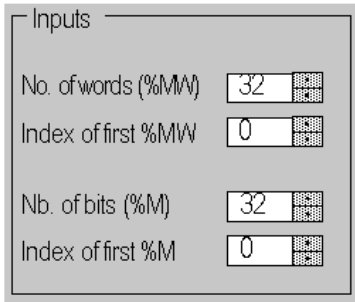

The screenshot shows a configuration window titled "Inputs". It contains four rows of controls:

- "No. of words (%MW)" with a text box containing "32" and a small grid icon to its right.
- "Index of first %MW" with a text box containing "0" and a small grid icon to its right.
- "Nb. of bits (%M)" with a text box containing "32" and a small grid icon to its right.
- "Index of first %M" with a text box containing "0" and a small grid icon to its right.

To configure the inputs of the bus slaves, it is necessary to indicate the memory areas to which they will be periodically recopied. To define this zone, you must indicate:

- a number of words (%MW): from 0 to 32,464,
- the address of the first word: from 0 to 32,463,
- the number of bits (%M): from 0 to 32,634,
- the address of the first bit: from 0 to 32,633.

Outputs

The figure below illustrates the outputs configuration area:

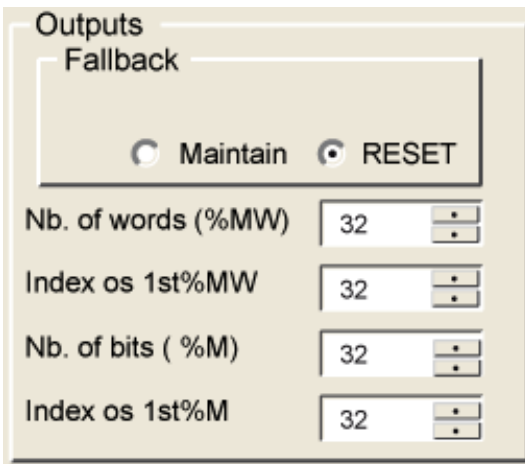

The screenshot shows a configuration window titled "Outputs". It contains a "Fallback" section with two radio buttons: "Maintain" (unselected) and "RESET" (selected). Below this are four rows of controls:

- "Nb. of words (%MW)" with a text box containing "32" and a small grid icon to its right.
- "Index os 1st%MW" with a text box containing "32" and a small grid icon to its right.
- "Nb. of bits (%M)" with a text box containing "32" and a small grid icon to its right.
- "Index os 1st%M" with a text box containing "32" and a small grid icon to its right.

The fallback information area contains two radio buttons as well, which defines the behavior of the device when the controller is in STOP or in HALT:

- **Maintain:** maintains outputs (values are kept),
- **Reset:** resets outputs (values are set to 0).

To configure the outputs, it is necessary to indicate, as for the inputs, the word and bits tables that will contain the values of the bus slave outputs:

- a number of words (%MW): from 1 to 32,464,
- the address of the first word: from 0 to 32,463,
- the number of bits (%M): from 1 to 32,634,
- the address of the first bit: from 0 to 32,633.

NOTE: The word tables and bit tables are found in the controller internal memory. Any crossover between two areas of each table is prohibited. The bits area for the inputs cannot overlap the bits area for the outputs. The words area for the inputs cannot overlap the words area for the outputs.

⚠ WARNING

UNINTENDED EQUIPMENT OPERATION

After a CANopen bus interruption, verify that the fallback positions of all devices on the bus are as expected.

Failure to follow these instructions can result in death, serious injury, or equipment damage.

Consult the relevant equipment documentation for additional information.

Bus Parameters

The figure below illustrates the bus parameters configuration area:

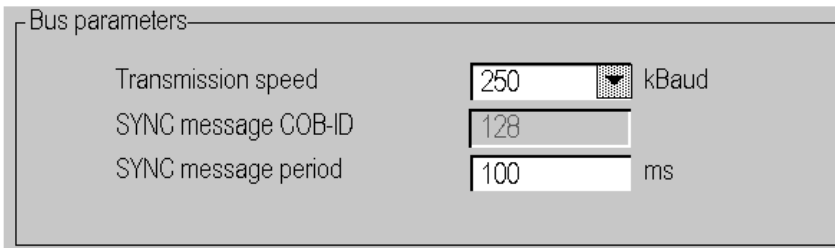

To configure the bus, it is necessary to indicate:

- The transmission speed (see Premium and Atrium using EcoStruxure™ Control Expert, CANopen Field Bus, User manual): 250 kBauds default,
- the COB-ID of the synchronization message: 128 default,
- the synchronization message period: 100 ms default.

Language Objects

The parameters presented below are represented in the %KW language objects:

Read	Parameter	Language object
Inputs	Number of words %MW	%KW8
	Index of the first word	%KW10
	Number of bits %M	%KW4
	Index of the first bit	%KW6
Outputs	Fallback mode	%KW0 Least Significant Byte : 16#00, Bit 2 to 7= 0, and : <ul style="list-style-type: none"> • Bit 0= 0 and Bit 1= 0: reset of outputs if task in STOP or HALT • Bit 0= 1 and Bit 1= 0: maintain of outputs if task in STOP or HALT • Bit 0= 0 and Bit 1= 1: bus in STOP if task in STOP or HALT
	Number of words %MW	%KW9
	Index of the first word	%KW11
	Number of bits %M	%KW5
	Index of the first bit	%KW7
Bus parameters	Transmission speed	%KW1
	SYNC message COB-ID	%KW2
	SYNC message period	%KW3

CANopen Master Configuration Screen with CPUs 20102/20302

At a Glance

This screen is used to declare and configure the master of the CANopen network from a Modicon M340 PLC station.

Illustration

The configuration screen of the master is as follows:

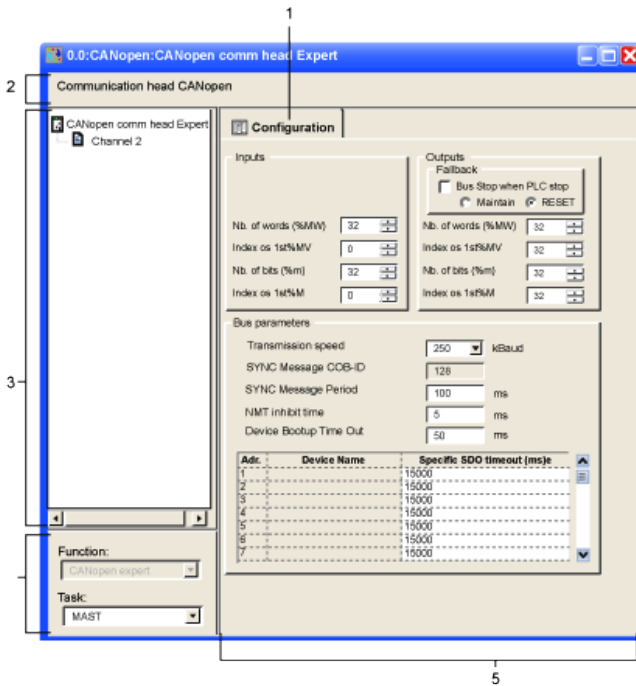

Elements and functions

The table below describes the different areas which make up the master configuration screen:

Read	Number	Function
1	Tab	The tab in the foreground indicates the type of screen displayed. In this case, it is the configuration screen.
2	Module	This area is made up of the abbreviated heading of the processor equipped with a CANopen port.
3	Channel	<p>This zone allows you to select the communication channel to be configured.</p> <p>By clicking on the device, you display the tabs:</p> <ul style="list-style-type: none"> • Description : gives the characteristics of the built-in CANopen port, • Inputs/outputs objects: allows pre-symbolizing of the input/output objects, <p>By clicking on a channel, you display the tabs:</p> <ul style="list-style-type: none"> • Config . enables you to declare and configure the CANopen master, • Debug : accessible in online mode only, • Fault: accessible in online mode only.
4	General parameters	<p>This field enables you to:</p> <ul style="list-style-type: none"> • associate the CANopen bus to an application task: <ul style="list-style-type: none"> ◦ MAST which is the master task, ◦ FAST which is the rapid task. <p>The tasks are asynchronous in relation to exchanges on the bus.</p>
5	Configuration	<p>This field enables you to:</p> <ul style="list-style-type: none"> • configure the PLC internal memory addresses where inputs from the CANopen devices will periodically be copied. • configure the PLC internal memory addresses where outputs from the CANopen devices will periodically be read. • configure the parameters of the CANopen bus.

Description of Master Configuration Screen for CPUs 20102/ 20302

At a Glance

The configuration screen allows configuration of the bus parameters as well as the inputs and outputs.

Inputs

The figure below illustrates the inputs configuration area:

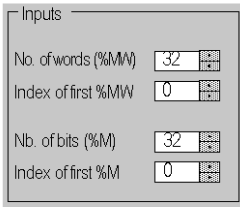

The screenshot shows a dialog box titled "Inputs" with four input fields:

No. of words (%MW)	32
Index of first %MW	0
Nb. of bits (%M)	32
Index of first %M	0

To configure the inputs of the bus slaves, it is necessary to indicate the memory areas to which they will be periodically recopied. To define this zone, you must indicate:

- a number of words (%MW): from 0 to 32,464,
- the address of the first word: from 0 to 32,463,
- the number of bits (%M): from 0 to 32,634,
- the address of the first bit: from 0 to 32,633.

Outputs

The figure below illustrates the outputs configuration area:

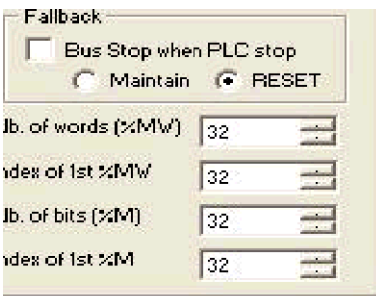

The screenshot shows a dialog box titled "Fallback" with the following configuration:

Bus Stop when PLC stop

Maintain RESET

Nb. of words (%MW)	32
Index of 1st %MW	32
Nb. of bits (%M)	32
Index of 1st %M	32

NOTE: The checkbox **Bus Stop when PLC stop** in the fallback area configuration is only available in CANopen expert mode.

- **If it is not checked:** the CANopen bus remains in RUN after a controller stop and the global strategy of fallback is applied to the outputs according to Maintain or Reset radio button.
- **If it is checked:** the CANopen bus is stopped when a controller stop; in this case, **Maintain** and **Reset** radio buttons are greyed out.

The fallback information area contains two radio buttons as well, which defines the behavior of the device when the controller is in STOP or in HALT:

- **Maintain:** maintains outputs (values are kept)
- **Reset:** resets outputs (values are set to 0)

To configure the outputs, it is necessary to indicate, as for the inputs, the word and bits tables that will contain the values of the bus slave outputs:

- A number of words (%MW): from 1 to 32,464
- The address of the first word: from 0 to 32,463
- The number of bits (%M): from 1 to 32,634
- The address of the first bit: from 0 to 32,633

NOTE: The word tables and bit tables are found in the controller internal memory. Any crossover between two areas of each table is prohibited. The bits area for the inputs cannot overlap the bits area for the outputs. The words area for the inputs cannot overlap the words area for the outputs.

▲ WARNING

UNINTENDED EQUIPMENT OPERATION

After a CANopen bus interruption, verify that the fallback positions of all devices on the bus are as expected.

Failure to follow these instructions can result in death, serious injury, or equipment damage.

Consult the relevant equipment documentation for additional information.

Bus Parameters

The figure below illustrates the bus parameters configuration area:

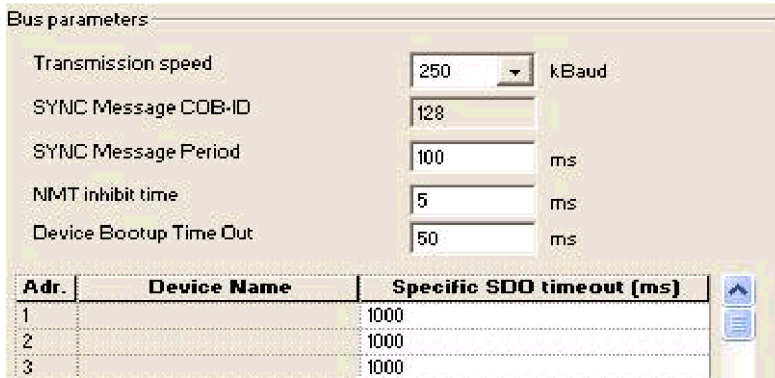

To configure the bus, it is necessary to indicate:

- the transmission speed (see Premium and Atrium using EcoStruxure™ Control Expert, CANopen Field Bus, User manual): 250 kBauds default,
- the COB-ID of the synchronization message: 128 default,
- the synchronization message period: 100 ms default.
- the NMT inhibit time: 5 ms default. During Bootup, the CANopen Master implements a delay between each NMT messages to avoid slave overload. The value must be given in multiple of 100 µs. The value 0 disables the inhibit time.
- the Device Bootup Time Out: 50 ms default. The global SDO timeout for the master is related to the scanning of the network. During this time, the master reads the object 1000 of each slave to analyze the CANopen bus configuration.
- the Specific SDO timeout: 15000 ms default. The slaves SDO timeout is necessary for devices with long response times i.e. for accesses to the objects 1010,1011,1F50. A grid displays all present devices with the Nodeld, the name and the timeout value.

Language Objects

The parameters presented below are represented in the %KW language objects:

Read	Parameter	Language object
Inputs	Number of words %MW	%KW8
	Index of the first word	%KW10
	Number of bits %M	%KW4

Read	Parameter	Language object
	Index of the first bit	%KW6
Outputs	Fallback mode	%KW0 Least Significant Byte : 16#00, Bit 2 to 7= 0, and : <ul style="list-style-type: none"> • Bit 0= 0 and Bit 1= 0: reset of outputs if task in STOP or HALT • Bit 0= 1 and Bit 1= 0: maintain of outputs if task in STOP or HALT • Bit 0= 0 and Bit 1= 1: bus in STOP if task in STOP or HALT
	Number of words %MW	%KW9
	Index of the first word	%KW11
	Number of bits %M	%KW5
	Index of the first bit	%KW7
Bus parameters	Transmission speed	%KW1
	SYNC message COB-ID	%KW2
	SYNC message period	%KW3

Programming

What's in This Chapter

Exchanges Using PDOs	100
Exchanges Using SDOs	104
SDO Abort Code Description	108
Communication functions example	109
Modbus request example	116

Introduction

This section describes the programming of a CANopen architecture.

Exchanges Using PDOs

At a Glance

PDOs use topologic addresses (%I, %IW, %Q, %QW) and internal variables (%M or %MW).

The screenshot shows a software interface for configuring CANopen PDOs. It is divided into two main sections: 'Transmit (%I)' and 'Receive (%Q)'. Each section contains a table with columns for PDO, Tr. Ty., Inhibi., Even., Symbol, Topo. Addr., and %M... (Internal Variable). A 'Variables' panel on the right lists various parameters and their addresses.

Transmit (%I) Table:

PDO	Tr. Ty.	Inhibi.	Even.	Symbol	Topo. Addr.	%M...
PDO 1 (...)	255	0	0	lexium...	%IW3.1\0.0.0.16	%MW16
Status...				lexium...	%IW3.1\0.0.0.16	%MW16
PDO 2 (...)	255	0	100	lexium...	%ID3.1\0.0.0.8	%MW8
Status...				lexium...	%IW3.1\0.0.0.16	%MW16
Positi...				lexium...	%ID3.1\0.0.0.10	%MW10
Veloci...				lexium...	%ID3.1\0.0.0.10	%MW10
PDO 3 (...)	255	0	100			
Status...				lexium...	%IW3.1\0.0.0.16	%MW16
PDO 4 (...)	254	0	0			

Receive (%Q) Table:

PDO	Tr. Ty.	Inhibi.	Even.	Symbol	Topo. Addr.	%M...
PDO 1 (...)	255	0	0	lexium...	%QW3.1\0.0.0.16	%MW16
Status...				lexium...	%QW3.1\0.0.0.16	%MW16
PDO 2 (...)	255	0	100	lexium...	%QW3.1\0.0.0.16	%MW16
Status...				lexium...	%QW3.1\0.0.0.16	%MW16
Positi...				lexium...	%QD3.1\0.0.0.8	%MW8
PDO 3 (...)	255	0	100			
Status...				lexium...	%QW3.1\0.0.0.16	%MW16
Veloci...				lexium...	%QD3.1\0.0.0.10	%MW10
PDO 4 (...)	254	0	0			

Variables Panel:

Parameter Name	Ind.
RAMPsym	3006.01
_JO_act	3008.01
ANA1_act	3009.01
ANA2_act	3009.05
PLCopenRx1	301B.05
PLCopenRx2	301B.06
PLCopenTx1	301B.07
PLCopenTx2	301B.08
JOGactivate	301B.09
_actionStatus	301C.04
_p_actRAMPusr	301F.02
CUR_I_target	3020.04
SPEEDn_target	3021.04
PTPp_abs	3023.01
PTPp_relpref	3023.03
PTPp_target	3023.05
PTPp_relpact	3023.06
GEARdenom	3026.03
GEARnum	3026.04
Controlword	6040.00
Statusword	6041.00
position actual valu...	6063.00

Red circles highlight the topologic addresses and internal variables in the tables. Arrows point from the labels 'Topologic address' and 'Internal variable' to these circles.

There is an equivalence between topologic addresses and internal variables. For example, in the figure above, the topologic address %IW3.1\0.0.0.16 is equivalent to %MW16 for the PDO 1.

A PDO can be enabled or disabled.

According with the EDS file, some PDOs are already mapped.

A double click on the `transmission type` column displays the following window:

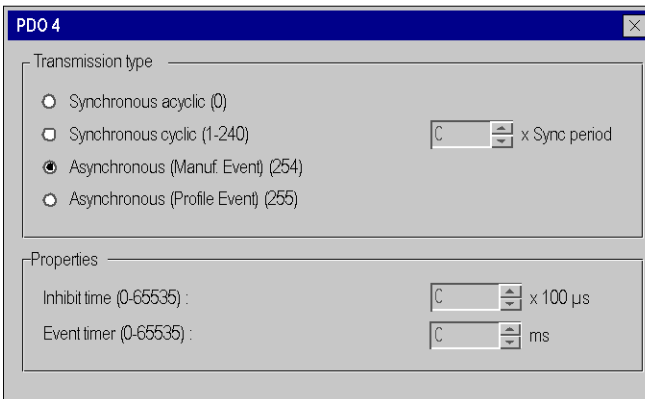

This window allows to configure:

- the transmission type:
 - synchronous acyclic (0): a transmission type of 0 means that the message shall be transmitted synchronously with the SYNC message but not periodically according with the value.
 - synchronous cyclic (1-240): a value between 1 and 240 means that the PDO is transmitted synchronously and cyclically, the transmission type value indicating the number of SYNC messages between two PDO transmissions.
 - asynchronous (Manuf. Event)(254): the transmission type 254: the PDO is transmitted asynchronous. It is fully depending on the implementation in the device. Mainly used for digital I/O.
 - asynchronous (Profile Event)(255): the transmission type 255: the PDO is transmitted asynchronous when the value changes.

Verify that the configured transmission type is supported by the selected device.

- the inhibit time: to mask the communication during this time,
- the event timer: time to manage an event in order to start a PDO.

NOTE: PDOs can only be configured using Control Expert.

Structure of Topologic Address

The topologic address of input/output objects of a CANopen bus slave is structured in the following way:

`% I, Q X, W, D, F \ b.e \ r . m . c . d`

Family	Element	Values	Meaning
Symbol	%	-	Indicates an IEC object.
Object type	I	-	Input object.
	Q	-	Output object.
Format (size)	X	8 bits (Ebool)	Ebool type Boolean (not compulsory).
	W	16 bits	16 bit WORD-type word.
	D	32 Bit	32 bit DINT-type word.
	F	32 Bit	32 bit REAL-type word.
Module/channel address and connection point	b	3 to 999	Bus number.
	e	1 to 63	Connection point number (CANopen slave number).
Rack number	r	0	Virtual rack number, always 0.
Module number	m	0	Virtual module number, always 0.
Channel number	c	Equal to 0 for all devices except the FTBs (channels numbered 0 to 7, then from 10 to 17).	Channel number.
Rank of data in the channel	d	0...999	Data number of slave. This number can vary from 0 to 999 because a slave can only have a maximum of 1000 input and output words.

Example of Topologic Addressing

Example of topologic addressing of an item connected to point 4 of the CANopen bus number 3:

Module digital/TOR autonomous with Boolean vision	
%I\3.4\0.0.5	Boolean value is entered on channel 5 (rang 0 omitted).
Module digital standard	
%IW\3.4\0.0.0.2.5	Boolean value is entered on unique channel 0, rank 2, bit 5. The mapping is given when the DCF file is imported.
Digital module on an Advantys STB island	
%IW\3.4\0.0.0.3.2	Word 3, bit 2, data by Advantys Configuration Software.

Numbering starts at:

- 0 for channel,
- 0 for rank.

NOTE: Virtual objects (racks, modules) always have a rank number equal to 0.

Object addressing of CANopen digital input/output follows the same rules as object addressing of digital input/output on rack: words, double words and floating words are in the same block.

Example: device at connection point 4 of CANopen bus 3, on channel 0, with:

Type of data	Topologic address:
2 input words	%IW \3.4\0.0.0.0 or %IW \3.4\0.0.0.1
1 double input word	%ID \3.4\0.0.0.2
1 floating input	%IF \3.4\0.0.0.4
1 output word	%QW\3.4\0.0.0.6

An object can be mapped in a PDO only once. If the same object is mapped several times in the same PDO, Control Expert displays a message.

If there's several PDOs with the same mapped object, only one PDO can be enabled. If several PDOs with the same mapped object are enabled, Control Expert displays a message when the application is rebuilt.

Example with a Lexium 05:

Detected error: the same object is mapped in two enabled PDOs

The screenshot shows two tables: 'Transmit (%I)' and 'Receive (%Q)'. Both tables have columns for PDO, Tr. Ty., Inhibi..., Even..., Symbol, and Topo. Addr.

Transmit (%I) Table:

PDO	Tr. Ty..	Inhibi...	Even...	Symbol	Topo. Addr.
<input checked="" type="checkbox"/> PDO 1 (Static)	255	0	0		
<input checked="" type="checkbox"/> Statusword					%IW3.110.0.0.16
<input checked="" type="checkbox"/> PDO 2 (Static)	255	0	100		
<input checked="" type="checkbox"/> Statusword					%IW3.110.0.0.16
<input type="checkbox"/> Position actual...					%ID3.110.0.0.8
<input type="checkbox"/> PDO 3 (Static)	255	0	100		
<input type="checkbox"/> Statusword					%IW3.110.0.0.16
<input type="checkbox"/> Velocity actual...					%ID3.110.0.0.10
<input type="checkbox"/> PDO 4...	254	0	0		

Receive (%Q) Table:

PDO	Tr. Ty..	Inhibi...	Even...	Symbol	Topo. Addr.
<input checked="" type="checkbox"/> PDO 1 (Static)	255				
<input checked="" type="checkbox"/> Controlword					%IW3.110.0.0.16
<input type="checkbox"/> PDO 2 (Static)	255				
<input checked="" type="checkbox"/> Controlword					%IW3.110.0.0.16
<input type="checkbox"/> Target position					%ID3.110.0.0.8
<input type="checkbox"/> PDO 3 (Static)	255				
<input checked="" type="checkbox"/> Controlword					%IW3.110.0.0.16
<input type="checkbox"/> Target velocity					%ID3.110.0.0.10
<input type="checkbox"/> PDO 4...	254				

Only one PDO is enabled.

Exchanges Using SDOs

At a Glance

The explicit exchange of messages on a CANopen bus is done by read/write protocol SDO.

There are 3 ways of accessing SDOs:

- using communication functions `READ_VAR` and `WRITE_VAR`,
- using the Control Expert debugging screen,
- using the request ModBus FC43/0xD.

⚠ WARNING

UNINTENDED EQUIPMENT OPERATION

When modifying a variable, verify the consequences of the SDO command in the documentation of the specific target CANopen device.

Failure to follow these instructions can result in death, serious injury, or equipment damage.

Communication Functions

It is possible to access SDOs using the communication functions `READ_VAR` and `WRITE_VAR`.

NOTE: It is possible to send up to 16 `READ_VAR/WRITE_VARS` simultaneously. A polling task runs every 5 ms and each task cycle in order to check the end of the exchange. This is useful if the user runs many SDOs during a task cycle.

For more information about the use of the communication function, see [Communication functions example](#), page 109

NOTE: Changing outputs of a device with a write SDO has no effect on the %QW.

Control Expert

SDO objects allow the access to the variables.

In online mode, the **CANopen** screen (see [Slave Diagnostics](#), page 132) allows access to:

- various device objects in read/write mode (only through a listbox),
- description of the variables,
- repeat of communication.
- the supported IODDT (only `T_COM_CO_BMX` and `T_COM_CO_BMX_EXPERT`).

The **CANopen** screen is as follows:

The screenshot shows the CANopen software interface with three tabs: Overview, CANopen (selected), and I/O objects. The main content area is divided into three sections:

- CANopen slave details:** Contains three text input fields: "Device name" with the value "CPV_CO2", "Vendor name" with "FESTO AG & Co. KG", and "Description" with "FESTO Valve terminal CPV CO2 (CPV-CO2S.EDS)".
- Request to send:** Contains a "Request to send" dropdown menu set to "Read SDO", and three input fields for "Parameter name", "Parameter size (Byte)", and "Value". Below these is a "Send request" button.
- Response received:** A large horizontal text area with scrollbars, currently empty.
- Status:** A small text input field at the bottom.

SDO information (read or written) are displayed in their native format (Byte, Word and DWord). You can change the display format to Binary, Decimal and Hexadecimal with popup menu.

The Status Box can display OK or an abort code, page 108.

Modbus Request

From a Human/Machine interface (example: XBT), it is possible to access the SDOs using the Modbus FC43 request

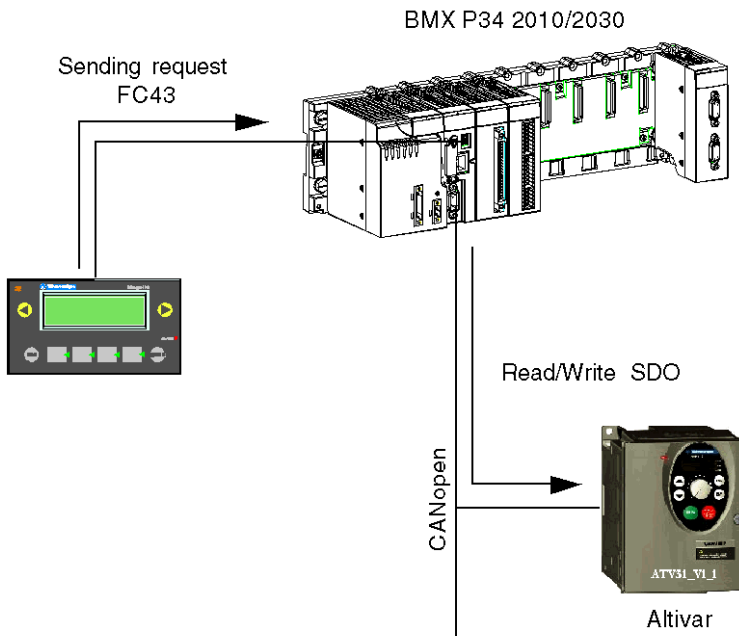

For more information about the use of the Modbus request FC43/0xD, see Modbus request example, page 116

SDO Timeouts

Various time-outs are implemented. They depend on the type of object as well as the type of access (read/write):

Object	Timeout
1010h	15 s
1011h	3 s

Object	Timeout
2000h to 6000h	8 s
All other objects	1 s
- SDO Reading	2 s
- SDO Writing	

SDO Abort Code Description

Table

The following table describes the Abort Code Description:

0503 0000h	Toggle bit not alternated.
0504 0000h	SDO protocol , page 104timed out.
0504 0001h	Client/ Server command specifier not valid or unknown.
0504 0002h	Invalid block size (block mode only).
0504 0003h	Invalid sequence number (block mode only).
0504 0004h	CRC error (block mode only).
0504 0005h	Out of memory.
0601 0000h	Unsupported access to an object.
0601 0001h	Attempt to read a write only object.
0601 0002h	Attempt to write a read only object
0602 0000h	Object does not exist in the object dictionary.
0604 0041h	Object cannot be mapped to the PDO.
0604 0042h	The number and length of the objects to be mapped would exceed PDO length.
0604 0043h	General parameter incompatibility reason.
0604 0047h	General internal incompatibility in the device.
0606 0000h	Access failed due to an hardware anomaly.
0607 0010h	Data type does not match, length of service parameter does not match.
0607 0012h	Data type does not match, length of service parameter too high.

0607 0013h	Data type does not match, length of service parameter too low.
0609 0011h	Sub-index does not exist.
0609 0030h	Value range of parameter exceeded (only for write access).
0609 0031h	Value of parameter written too high.
0609 0032h	Value of parameter written too low.
0609 0036h	Maximum value is less than minimum value.
0800 0000h	General anomaly.
0800 0020h	Data cannot be transferred or stored to the application.
0800 0021h	Data cannot be transferred or stored to the application because of local control.
0800 0022h	Data cannot be transferred or stored to the application because of the present device state.
0800 0023h	Object dictionary dynamic generation is inoperative or no object dictionary is present (for example object dictionary is generated from file and generation becomes inoperative because of an file anomaly).

Communication functions example

At a Glance

It is possible to access SDOs using the communication functions `READ_VAR` and `WRITE_VAR`

There are 3 possible representations:

- the FBD representation,
- the Ladder representation,
- the IL representation.

FBD representation

The FBD representations of the communication functions are the following:

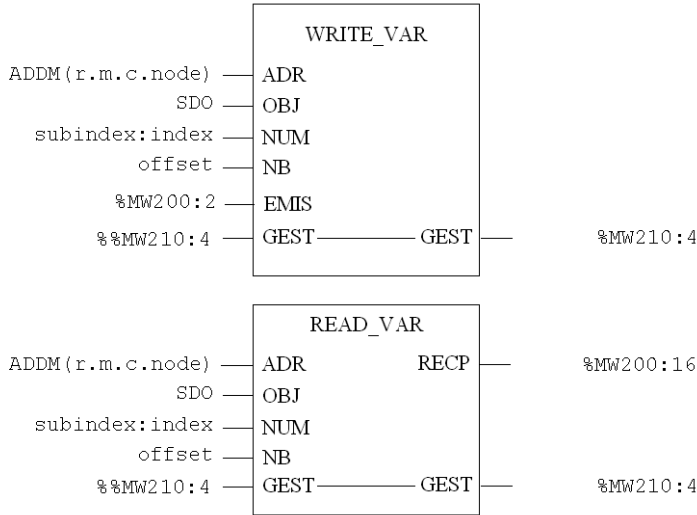

Ladder representation

The Ladder representations of the communication functions are the following:

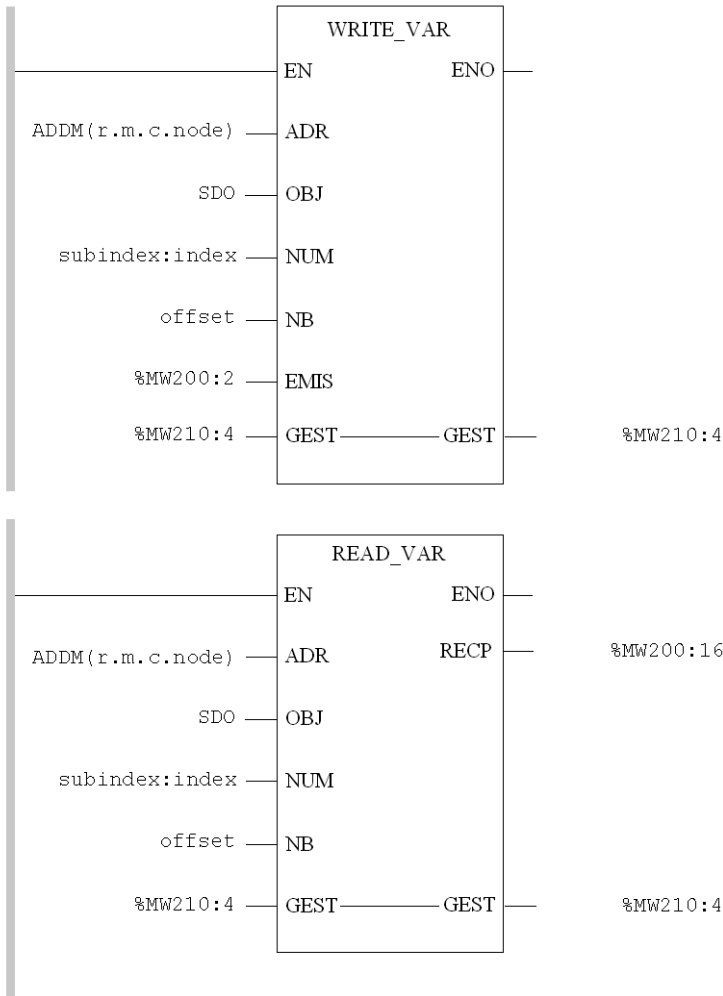

IL representation

The communication function syntax is as follows:

ADDM (

```
IN := ' 0.0.2.2'
)
ST %MW2100:8
LD 50
ST %MW2182 (* timeout 5 secondes *)
LD 2
ST %MW2183 (* Length *)
(* Read the "Vendor ID" object, slave @2, CANopen Network *)
READ_VAR (
ADR := %MW2100:8,
OBJ := 'SDO',
NUM := 16#00011018,
NB := 0,
GEST := %MW2120:4,
RECP := %MW2110:4
)
(* Write the value 16#FFFF, slave @2 outputs, CANopen Network *)
LD 16#ffff
ST %MW2200
WRITE_VAR (
ADR := %MW2100:8
OBJ := 'SDO',
NUM := 16#00016300,
NB := 0,
EMIS := %MW2200:1,
GEST := %MW2180:4
)
```

NOTE: The `offset` parameter must be set to 0.

NOTE: The `subindex : index` parameter is encoded in a simple word (`subindex` is the higher byte).

Parameter Description of the WRITE_VAR Function

The following table outlines the various parameters of the `WRITE_VAR` function:

Parameter	Description
<code>ADDM('r.m.c.node')</code>	Address of the destination entity of the exchange: <ul style="list-style-type: none"> r: the processor rack number, m: processor slot in the rack (0) c: channel (only use the channel 2 for CANopen), node: identifier of the transmitting device on the CANopen bus.
<code>'SDO'</code>	SDO object type.
<code>subindex:index</code>	Double word or immediate value identifying the CANopen SDO index or subindex: The most significant word making up the double word contains the sub-index and the least significant word contains the index. Example: if you use the double word <code>subindex:index</code> : <ul style="list-style-type: none"> the 16 most significant bits contain the subindex, the 16 least significant bits contain the index.
<code>EMIS</code>	Table of words containing the SDO datum to send (%MW200:2). The receipt buffer of the <code>WRITE_VAR</code> function must be greater than the SDO. The length of a SDO is indicated in device documentation.
<code>GEST</code>	Table of words with 4 inputs (%MW210:4).

Parameter Description of the READ_VAR Function

The following table outlines the various parameters for the `READ_VAR` function:

Parameter	Description
<code>ADDM('r.m.c.node')</code>	Address of the destination entity of the exchange: <ul style="list-style-type: none"> r: the processor rack number, m: processor slot in the rack (0) c: channel (only use the channel 2 for CANopen), node: identifier of the destination device on the bus.
<code>'SDO'</code>	SDO object type.

Parameter	Description
subindex:index	<p>Double word or immediate value identifying the CANopen SDO index or subindex:</p> <p>The most significant word making up the double word contains the sub-index and the least significant word contains the index.</p> <p>Example: if you use the double word subindex:index:</p> <ul style="list-style-type: none"> the 16 most significant bits contain the subindex, the 16 least significant bits contain the index.
GEST	Table of words with 4 inputs (%MW210:4).
RECP	<p>Table of words with at least one input to receive the SDO datum received (%MW200:16).</p> <p>The receipt buffer of the READ_VAR function must be greater than the SDO. The length of a SDO is indicated in device documentation.</p>

Description of control block words

The following table describes the various words of the control block:

Fields	Word	Type	Description
Control byte	0 (least significant)	BYTE	<p>Bit 0 = activity bit</p> <p>Bit 1 = cancellation bit</p>
Exchange ID	0 (most significant)	BYTE	Single number, identifier of the exchange.
ComState	1 (least significant)	BYTE	<p>0x00 = Exchange completed</p> <p>0x01 = Time Out</p> <p>0x02 = User cancelled</p> <p>0x03 = Incorrect address format</p> <p>0x04 = Incorrect destination address</p> <p>0x06 = Incorrect Com Fb parameters</p> <p>0x07 = Generic transmission interruption</p> <p>0x09 = Reception buffer is too small</p> <p>0x0B = No system resources</p> <p>0xFF = Network exchange detected error</p>
ExchState	1 (most significant)	BYTE	<p>If ComState = 0x00 :</p> <p>0x00: request treated</p> <p>0x01: Cannot be treated</p>

Fields	Word	Type	Description
			0x02: Incorrect response If ComState = 0xFF 0x07: Generic exchange detected error 0x0B: The destination device has no more resources. 0x0D: The device cannot be reached. 0x2B: SDO exchange detected error
Timeout	2	WORD	Timeout value (x 100 ms)
Length	3	WORD	Length in bytes

Example in ST language

```

(* read the node 5 SDO, index 1018, subindex 3 *)
if (%M400) then
  subindex_index := 16#00031018 ;
  %MW1052 := 50; (* timeout 5 secondes *)
  READ_VAR(ADDM('0.0.2.5'), 'SDO', subindex_index, 0, %MW1050:4, %
  MW1100:2);
  %M400 := 0;
end_if;

(* Write the node 31 SDO, index 203C, subindex 2 *)
if (%M401) then
  subindex_index := 16#0002203C;
  %MW1152 := 50; (* timeout 5 secondes *)
  %MW1153 := 2; (* length 2 bytes *)
  %MW1200 := 16#03E8; (* value of object *)
  WRITE_VAR(ADDM('0.0.2.31'), 'SDO', subindex_index, 0, %MW1200:1, %
  MW1150:4);
  %M401 := 0;

```

```
end_if;
```

Modbus request example

At a Glance

From a Man Machine Interface (example : XBT), it is possible to access the SDOs using the Modbus FC43 request

SDO read example

Node reading 1F, object 1005, subindex 00, length 8 bytes

FC	MEI	Prot	Nid	Index	Sub	Offset	Length
2B	0D	00	1F	10 05	00	00 00	00 08

Response OK: reception of 4 bytes

FC	MEI	Prot	Nid	Index	Sub	Offset	Length	Object value
2B	0D	00	1F	10 05	00	00 00	00 04	80 00 00 00

Failure: SDO cancellation code

FC	MEC	Ext length	MEI	Excpt code	SDO abort code
AB	FF	00 06	0D	EC	06 02 00 00

Write SDO example

Node reading 1F, object 203C, subindex 02, length 2 bytes 03 E8

FC	MEI	Prot	Nid	Index	Sub	Offset	Length	Data
2B	0D	01	1F	20 C3	02	00 00	00 02	03 E8

Response OK: reception of 4 bytes

FC	MEI	Prot	Nid	Index	Sub	Offset	Length
2B	0D	00	1F	20 3C	02	00 00	00 00

Failure: SDO cancellation code

FC	MEC	Ext length	MEI	Excpt code	SDO abort code
AB	FF	00 06	0D	EC	06 02 00 00

Debugging Communication on the CANopen Bus

What's in This Chapter

How to Access the Debug Screens of Remote Devices.....	118
Debugging Screen of the CANopen Master for CPUs 2010/ 2030	119
Debugging Screen of the CANopen Master for CPUs 20102/ 20302	121
Slave Debug Screens.....	123

Aim of this Chapter

This chapter presents the debugging of the CANopen bus master and slaves.

How to Access the Debug Screens of Remote Devices

At a Glance

The following operations describe how to access different debug screens of the CANopen network elements.

NOTE: The debug screens can only be accessed in online mode.

Master Debug Screen

To access the master debug screen, perform the following actions:

Step	Action
1	Connect to the manager PLC.
2	Access the CANopen master configuration screen, page 85.
3	Select the Debug tab.

Slave Debug Screen

To access the slave debug screen, perform the following actions:

Step	Action
1	Connect to the manager PLC.
2	Access the CANopen slave configuration screen, page 64.
3	Select the Debug tab.

Debugging Screen of the CANopen Master for CPUs 2010/ 2030

At a Glance

This screen can only be used in online mode.

Illustration

The figure below shows a master debug screen:

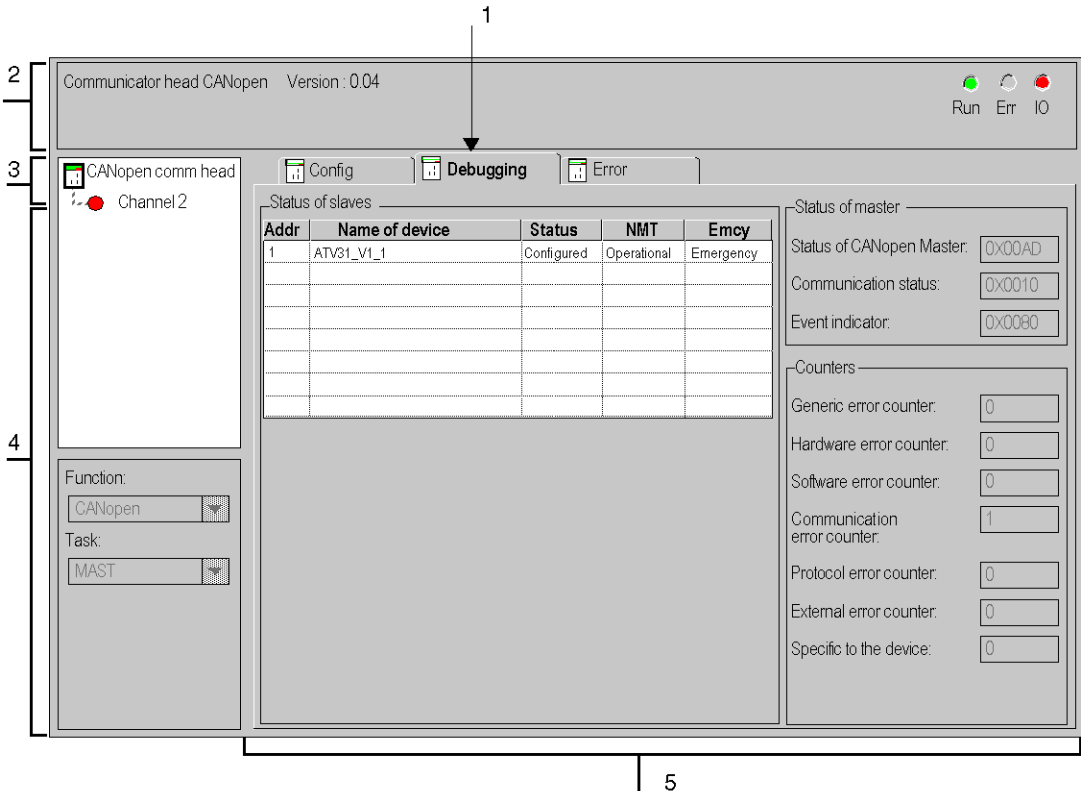

Elements and Functions

The table below describes the different areas which make up the master debug screen:

Read	Number	Channel
1	Tab	The tab in the foreground indicates the type of screen displayed. In this case, the debug screen.
2	Module	This area is made up of the abbreviated heading of the module equipped with a CANopen port, as well as 3 LEDs indicating the status of the module.
3	Channel	This area allows you to select the communication channel to be debugged.

Read	Number	Channel
		<p>By clicking on the device, you display the tabs:</p> <ul style="list-style-type: none"> • Description : gives the characteristics of the built-in CANopen port, • Inputs/outputs objects: allows pre-symbolizing of the input/output objects, <p>By clicking on the channel, you display the tabs:</p> <ul style="list-style-type: none"> • Configuration : enables you to declare and configure the CANopen master, • Debug: accessible in online mode only. • Faults: accessible in online mode only. <p>This area also has an LED indicating the channel status.</p>
4	General parameters	<p>This area is used to view:</p> <ul style="list-style-type: none"> • the communication function, • the task associated with the CANopen bus
5	Display and command	<p>This area is composed of 3 windows which let you know:</p> <ul style="list-style-type: none"> • the CANopen slaves status, • the status of the CANopen master, page 108, • the status of the detected error counters.

Debugging Screen of the CANopen Master for CPUs 20102/ 20302

At a Glance

This screen can only be used in online mode.

Illustration

The figure below shows a master debug screen:

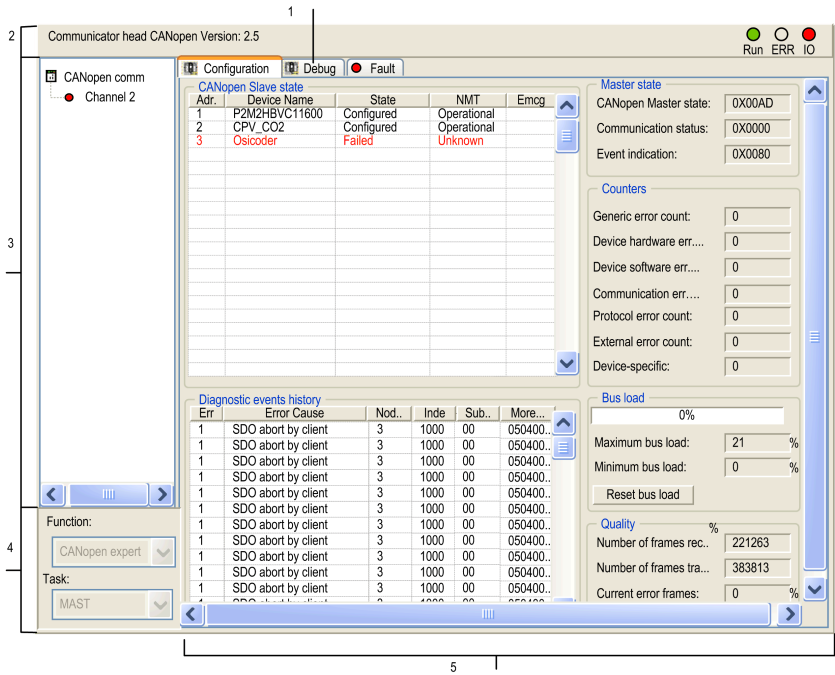

Elements and Functions

The table below describes the different areas which make up the master debug screen:

Read	Number	Channel
1	Tab	The tab in the foreground indicates the type of screen displayed. In this case, the debug screen.
2	Module	This area is made up of the abbreviated heading of the module equipped with a CANopen port, as well as 3 LEDs indicating the status of the module.
3	Channel	This area allows you to select the communication channel to be debugged. By clicking on the device, you display the tabs: <ul style="list-style-type: none"> • Description : gives the characteristics of the built-in CANopen port, • Inputs/outputs objects: allows pre-symbolizing of the input/output objects,

Read	Number	Channel
		<p>By clicking on the channel, you display the tabs:</p> <ul style="list-style-type: none"> • Configuration : enables you to declare and configure the CANopen master, • Debug: accessible in online mode only. • Faults: accessible in online mode only. <p>This area also has an LED indicating the channel status.</p>
4	General parameters	<p>This area is used to view:</p> <ul style="list-style-type: none"> • the communication function, • the task associated with the CANopen bus
5	Display and command	<p>This area is composed of 3 windows which let you know:</p> <ul style="list-style-type: none"> • the CANopen slaves status, • The status of the CANopen master., page 142 • the status of the detected error counters. • the status of bus load, page 131. • the status of bus quality, page 131. • the status of the diagnostics events table, page 130.

Slave Debug Screens

At a Glance

This screen can only be used in online mode.

Illustration

The figure below shows a slave debug screen:

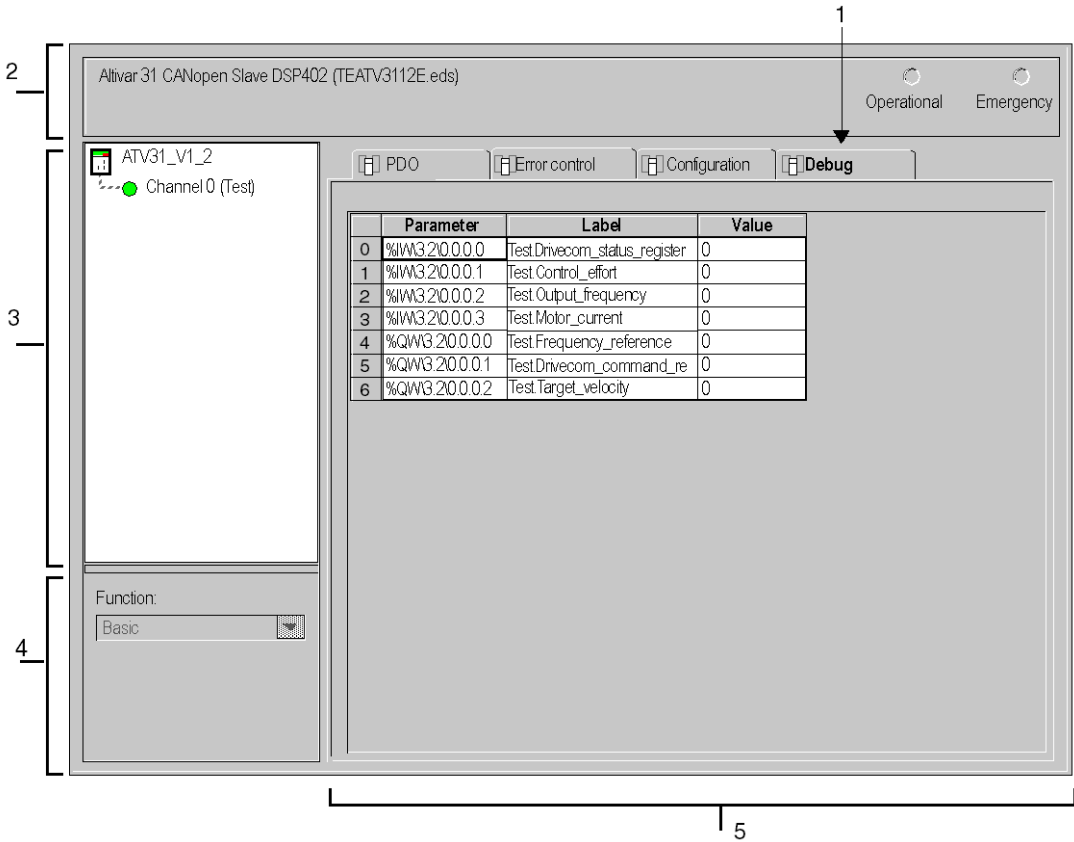

Description of the Debug Screen for Standard Devices

The following table shows the various parts of the debugging screen and their functions:

Number	Element	Function
1	Tabs	The tab in the foreground indicates the type of screen displayed. In this case, the debug screen.
2	Module area	Contains the abbreviated title of the module. Two LEDs are found in the same area:

Number	Element	Function
		<ul style="list-style-type: none"> • a green LED indicating that the device is operational (ON/OFF), • a red LED indicating an emergency (ON/OFF).
3	Channel area	<p>This area allows you to select the communication channel to be debugged.</p> <p>By clicking on the device, you display the tabs:</p> <ul style="list-style-type: none"> • Description: gives the characteristics of the built-in CANopen port. • Inputs/outputs objects: allows pre-symbolizing of the input/output objects. • CANopen: allows read/write of SDO. • Defaults: accessible in online mode only. <p>By clicking on the channel, you display the tabs:</p> <ul style="list-style-type: none"> • PDO: enables you to configure the PDOs. • Configuration: enables you to declare and configure the CANopen master. • Debug: accessible in online mode only. • Error control: accessible in online mode only. <p>This area also has an LED indicating the channel status.</p>
4	General parameters area	Recalls the function associated with the channel.
5	Parameters in progress area	<p>This area displays the information of an inputs/outputs datum for all the channels. It is divided into 3 columns:</p> <ul style="list-style-type: none"> • the Parameter column displays the inputs/outputs objects and the unmarked objects on which the inputs/outputs datum is mapped, • the Label column shows the name of the inputs/outputs datum, • the Value column shows the value of the inputs/outputs datum.

NOTE: For standard devices, the values are displayed in the following formats:

- decimal (default),
- hexadecimal,
- binary.

To select the format, right-click on a value in the debug screen, then choose the **display mode**.

For devices with boolean vision (FTB) the value can be forced.

NOTE: In the **Value** column, when a variable appears in red, it shows that it's out of range. The range of the variable can be seen by clicking on it. The range is displayed in the status bar.

Diagnostics

What's in This Chapter

How to perform a diagnostic	126
Master Diagnostics for CPUs 2010/ 2030.....	127
Master Diagnostics for CPUs 20102/ 20302	129
Slave Diagnostics	132

Aim of this Chapter

This section introduces the diagnostic means of the CANopen bus.

How to perform a diagnostic

At a Glance

You can start by using the LEDs located on the forward face of the processor to search for detected errors, page 142 on the CANopen bus. Next, you can use the procedure (described below) which details bus start up management and the checks to be carried out using the language objects provided by the PLC.

Procedure

The following diagram indicates the different phases of the procedure:

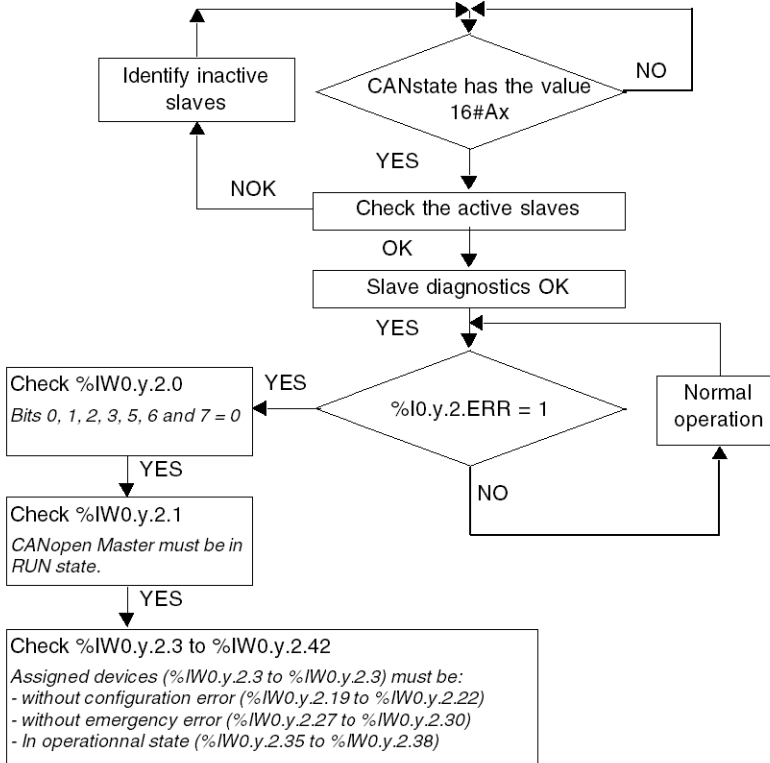

How to check %IW0.y.2

For the various states of %IW, refer to the T_COM_CO_BMX IODDT, page 142.

Master Diagnostics for CPUs 2010/ 2030

At a Glance

The CANopen bus master can be diagnosed:

- at module level,
- at channel level.

Module Diagnostics

The Module diagnostics screen displays current errors classed according to their category:

- Internal,
- External,
- Other.

Channel Diagnostics

The Channel diagnostics screen displays current anomalies classed according to their category:

- External,
- Other.

The table below presents the possible anomalies of a CANopen function:

Error type	Error	Language object
External	The CANopen master is not operational.	%MWr.m.c.2.0
	One or several slaves are not operational.	%MWr.m.c.2.1
Other	Configuration detected error.	%MWr.m.c.2.3
	Overrun of the reception queue low priority.	%lWr.m.c.0.0
	CAN controller overrun.	%lWr.m.c.0.1
	CAN controller disconnected from the bus.	%lWr.m.c.0.2
	CAN controller detected error.	%lWr.m.c.0.3
	The CAN controller is no longer in error state.	%lWr.m.c.0.4
	Overrun of the transmission queue low priority.	%lWr.m.c.0.5
	Overrun of the reception queue high priority.	%lWr.m.c.0.6
	Overrun of the transmission queue high priority.	%lWr.m.c.0.7
	The task cycle time is greater than the CANopen master cycle time.	%lWr.m.c.0.8

Master Diagnostics for CPUs 20102/ 20302

At a Glance

The CANopen bus master can be diagnosed:

- at module level,
- at channel level.

Module Diagnostics

The Module diagnostics screen displays current errors classed according to their category:

- Internal,
- External,
- Other.

Channel Diagnostics

The Channel diagnostics screen displays current anomalies classed according to their category:

- External,
- Other.

The table below presents the possible anomalies of a CANopen function:

Error type	Error	Language object
External	The CANopen master is not operational.	%MWr.m.c.2.0
	One or several slaves are not operational.	%MWr.m.c.2.1
Other	Configuration detected error.	%MWr.m.c.2.3
	Overrun of the reception queue low priority.	%lWr.m.c.0.0
	CAN controller overrun.	%lWr.m.c.0.1
	CAN controller disconnected from the bus.	%lWr.m.c.0.2
	CAN controller detected error.	%lWr.m.c.0.3
	The CAN controller is no longer in error state.	%lWr.m.c.0.4
	Overrun of the transmission queue low priority.	%lWr.m.c.0.5

Error type	Error	Language object
	Overrun of the reception queue high priority.	%IWm.c.0.6
	Overrun of the transmission queue high priority.	%IWm.c.0.7
	The task cycle time is greater than the CANopen master cycle time.	%IWm.c.0.8

Diagnostic Events History

The diagnostics events history is mainly used to analyze the boot up procedure of the CANopen bus. You can clear or refresh the diagnostic: right-click on the box, and select the clear or refresh command in the pop up menu.

The events are displayed on the following 6 columns table :

Error Code	Error Cause	Node ID	Index	Subindex	Additional Information MSB LSB
1	SDO abort by client	Slave Node ID	Index	Subindex	SDO abort code, page 108
2	SDO abort by server	Slave Node ID	Index	Subindex	SDO abort code
3	Identity mismatch	Slave Node ID	Index	Subindex	SDO response shows the read ID
4	Error control event	Slave Node ID	0	0	0, 0, 0, 0
5	Device in wrong state	Slave Node ID	0	0	0, 0, actual_state, exp_state
6	COMMstatus event	0	0	0	0, 0, 0, COMMstatus
7	A module uses the Node ID of the CANopen manager	Manager Node ID	0	0	0, 0, 0, 0
8	Unexpected present device	Slave Node ID	0	0	0, 0, 0, 0
9	Unexpected bootup message	Slave Node ID	0	0	0, 0, 0, 0
10	Received PDO with wrong length	0	0	0	COB-ID of RPDO
11	Manager is the only device on network	0	0	0	0, 0, 0, 0

Error Code	Error Cause	Node ID	Index	Subindex	Additional Information MSB LSB
from 12 to 127	Reserved				
from 128 to 255	Reserved for internal detected errors	Any debug information			

Bus Load

The bus load panel gives information about the load of the bus: current load in real time, maximum and minimum loads. The values can be reset by clicking on the button Reset Bus Load

The following table shows the language objects associated to this function:

Function	Request	Language Object
Bus Load	Read_IW	%IW0.0.2.63
		%IW0.0.2.62
		%IW0.0.2.64
	Write QW	%QW0.0.2.0.4

Bus Quality

The Bus Quality panel provides information from counters about the frames: received, transmitted, current with anomalies, maximum and minimum with anomalies in percent of the entire traffic. The values can be reset by clicking on the button Reset Counter.

The following table shows the language objects associated to this function:

Function	Request	Language Objects
Bus Quality	Read_IW	%ID0.0.2.66
		%ID0.0.2.68
		%IW0.0.2.70
		%IW0.0.2.71
		%IW0.0.2.72
	Write QW	%QW0.0.2.0.3

Slave Diagnostics

At a Glance

Slave diagnostics are only performed at the device level.

The slave diagnostic screen displays:

- the received emergency messages counter,
- The last four emergency messages, page 171 received in chronological order.

Illustration

The figure below shows a slave diagnostic screen:

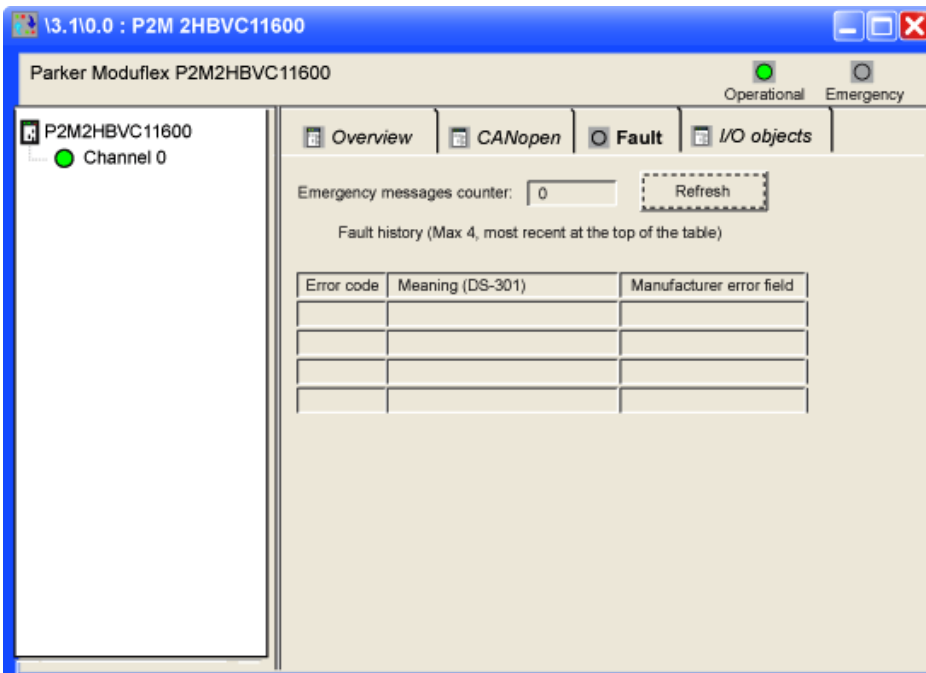

Elements and Functions

The table below describes the different areas which make up the master debug screen:

Read	Number	Channel
1	Tab	The tab in the foreground indicates the type of screen displayed. In this case, the diagnostic screen.
2	Module	This area is made up of the abbreviated heading of the module equipped with a CANopen port, as well as 2 LEDs indicating the status of the module.
3	Channel	<p>This area allows you to select the communication channel to be debugged.</p> <p>By clicking on the device, you display the tabs:</p> <ul style="list-style-type: none"> • Overview: gives the characteristics of the device, • CANopen: allows read/write of SDO, page 104 (online mode only), • Faults: allows you to see the last 4 emergency messages, page 171 generated by the slave module (tab only accessible in online mode) (see manufacturer's documentation), • I/O Objects: allows pre-symbolizing , page 192of the input/output objects. <p>This area also has an LED indicating the channel status.</p>
4	Display	<p>This area is composed:</p> <ul style="list-style-type: none"> • of detected error counters, • of the last 4 messages (the last received message is in the upper line).

NOTE: The error counter cannot be reset to 0.

NOTE: There is no polling on emergency messages. Messages are updated once after opening the screen only. The user can refresh them with the refresh button.

NOTE: The emergency messages counter is automatically refreshed. If some new messages appear, the back color of the refresh button becomes red to indicate that the user must refresh the list.

Language Objects

What's in This Chapter

General Information	134
Language Object of the CANopen Specific IODDTs	141
Emergency objects	171

Aim of this Chapter

This chapter describes the implicit and explicit language objects associated with the CANopen master embedded in CPU modules.

NOTE: The system bits %S9 and system words %SW8 and %SW9 are not applicable on CANopen.

General Information

Subject of this Section

This section describes:

- The language objects and IODDT of CANopen communication.
- The language objects and generic IODDT applicable to communication protocol except Fipio and Ethernet.

Introduction to the Language Objects for CANopen Communication

General

The IODDTs are predefined by the manufacturer and contain inputs/outputs language objects belonging to a channel of a specific application module.

CANopen communication has one associated IODDT:

- `T_COM_STS_GEN` used by communication protocols except Fipio and Ethernet,

NOTE: the creation of an IODDT-type variable is performed in two ways:

- **I/O object** tab,
- Data editor.

Language Object Types

Each IODDT contains a group of language objects which are used to control them and check their operation.

There are two types of language objects:

- implicit exchange objects automatically exchanged at each cycle of the task associated with the module,
- explicit exchange objects exchanged at the request of the application, using explicit exchange instructions.

Implicit exchanges concern the status of the modules, the communication signals, the slaves, etc.

Explicit exchanges allow module parametering and diagnostics.

NOTE: Each slave device has an IODDT (except FTB). For more information, please refer to the user manual of the concerned device.

Implicit Exchange Language Objects Associated with the Application-Specific Function

At a Glance

An integrated application-specific interface or the addition of a module automatically enhances the language objects application used to program this interface or module.

These objects correspond to the input/output images and software data of the module or integrated application-specific interface.

Reminders

The module inputs (%I and %IW) are updated in the PLC memory at the start of the task, the PLC being in RUN or STOP mode.

The outputs (%Q and %QW) are updated at the end of the task, only when the PLC is in RUN mode.

NOTE: For BMX P34 processors, when the task occurs in STOP mode, depending on the configuration selected:

- Outputs are set to fallback position (fallback mode),
- Outputs are maintained at their last value (maintain mode).

Figure

The following diagram shows the operating cycle of a PLC task (cyclical execution).

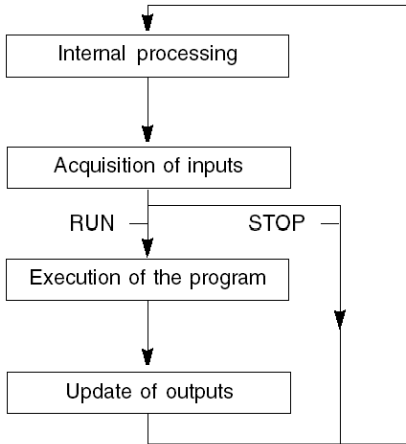

Details of IODDT Implicit Exchange Objects of Type T_COM_STS_GEN

Introduction

The following table presents the IODDT implicit exchange objects of type T_COM_STS_GEN applicable to all communication protocols except Fipio and Ethernet.

Error Bit

The table below presents the meaning of the detected error bit CH_ERROR (%I r . m . c . ERR).

Standard Symbol	Type	Access	Meaning	Address
CH_ERROR	EBOOL	R	Communication channel error bit.	%I.r.m.c.ERR

Explicit Exchange Language Objects Associated with the Application-Specific Function

At a Glance

Explicit exchanges are exchanges performed at the user program's request, and using the READ_STS instructions (read of status words).

These exchanges apply to a set of %MW objects of the same type (status) belonging to a channel.

NOTE: These objects provide information about the module (e.g.: type of fault on a channel).

General Principle for Using Explicit Instructions

The diagram below shows the different types of explicit exchanges that can be made between the processor and module.

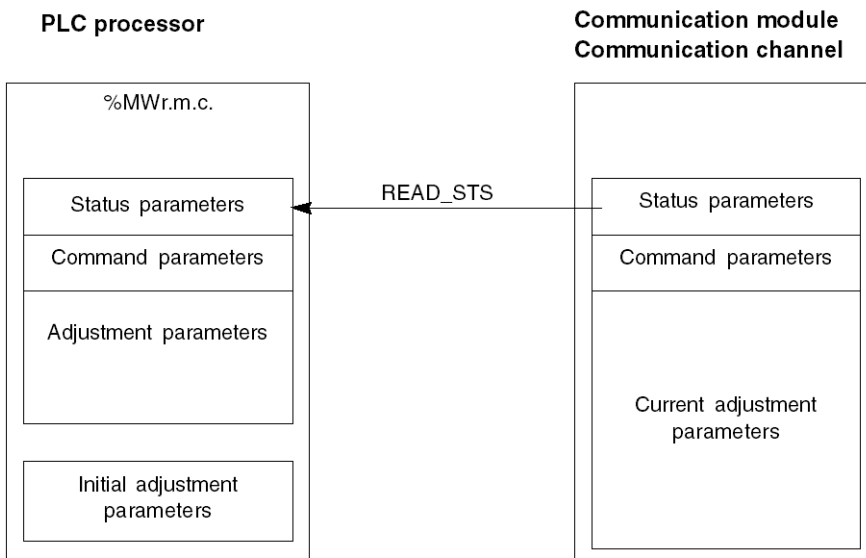

Managing Exchanges

During an explicit exchange, it is necessary to check its performance in order that data is only taken into account when the exchange has been correctly executed.

To do this, two types of information are available:

- Information concerning the exchange in progress
- The exchange report.

The following diagram describes the management principle for an exchange

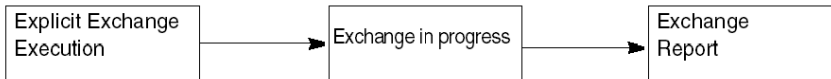

NOTE: In order to avoid several simultaneous explicit exchanges on the same channel, it is necessary to test the value of the word EXCH_STS (%MWr.m.c.0) of the IODDT associated to the channel before to call any EF using this channel.

Details of IODDT Explicit Exchange Objects of Type T_COM_STS_GEN

Introduction

This section presents the T_COM_STS_GEN type IODDT explicit exchange objects applicable to all communication protocols except Fipio and Ethernet. It includes the word type objects whose bits have a specific meaning. These objects are presented in detail below.

Sample Variable Declaration: IODDT_VAR1 of type T_COM_STS_GEN

Observations

- In general, the meaning of the bits is given for bit status 1. In specific cases an explanation is given for each status of the bit.
- Not all bits are used.

Execution Flags of an Explicit Exchange: EXCH_STS

The table below shows the meaning of channel exchange control bits from channel EXCH_STS (%MWr.m.c.0).

Standard Symbol	Type	Access	Meaning	Address
STS_IN_PROGR	BOOL	R	Reading of channel status words in progress.	%MWr.m.c.0.0
CMD_IN_PROGR	BOOL	R	Current parameter exchange in progress.	%MWr.m.c.0.1
ADJ_IN_PROGR	BOOL	R	Adjustment parameter exchange in progress.	%MWr.m.c.0.2

Explicit Exchange Report: EXCH_RPT

The table below presents the meaning of the exchange report bits EXCH_RPT (%MWr.m.c.1).

Standard Symbol	Type	Access	Meaning	Address
STS_ERR	BOOL	R	Reading error for channel status words.	%MWr.m.c.1.0
CMD_ERR	BOOL	R	Error during command parameter exchange.	%MWr.m.c.1.1
ADJ_ERR	BOOL	R	Error during adjustment parameter exchange.	%MWr.m.c.1.2

Standard Channel Faults, CH_FLT

The table below shows the meaning of the bits of the status word CH_FLT (%MWr.m.c.2). Reading is performed by a READ_STS (IODDT_VAR1).

Standard Symbol	Type	Access	Meaning	Address
NO_DEVICE	BOOL	R	No device is working on the channel.	%MWr.m.c.2.0
1_DEVICE_FLT	BOOL	R	A device on the channel is inoperative.	%MWr.m.c.2.1
BLK	BOOL	R	Terminal block not connected.	%MWr.m.c.2.2
TO_ERR	BOOL	R	Time out exceeded anomaly.	%MWr.m.c.2.3
INTERNAL_FLT	BOOL	R	Internal detected error or channel self-testing.	%MWr.m.c.2.4
CONF_FLT	BOOL	R	Different hardware and software configurations.	%MWr.m.c.2.5
COM_FLT	BOOL	R	Interruption of the communication with the PLC.	%MWr.m.c.2.6
APPLI_FLT	BOOL	R	Application detected error (adjustment or configuration).	%MWr.m.c.2.7

Management of Exchanges and Reports with Explicit Objects

At a Glance

When data is exchanged between the PLC memory and the module, the module may require several task cycles to acknowledge this information. All IODDTs use two words to manage exchanges:

- EXCH_STS (%MWr.m.c.0): exchange in progress,
- EXCH_RPT (%MWr.m.c.1): report.

NOTE: Depending on the localization of the module, the management of the explicit (%MW0.0.MOD.0.0 for example) will not be detected by the application:

- for in-rack modules, explicit exchanges are done immediately on the local PLC Bus and are finished before the end of the execution task, so the READ_STS, for example, is always finished when the %MW.0.0.MOD.0.0 bit is checked by the application.
- for remote bus (Fipio for example), explicit exchanges are not synchronous with the execution task, so the detection is possible by the application.

Illustration

The illustration below shows the different significant bits for managing exchanges:

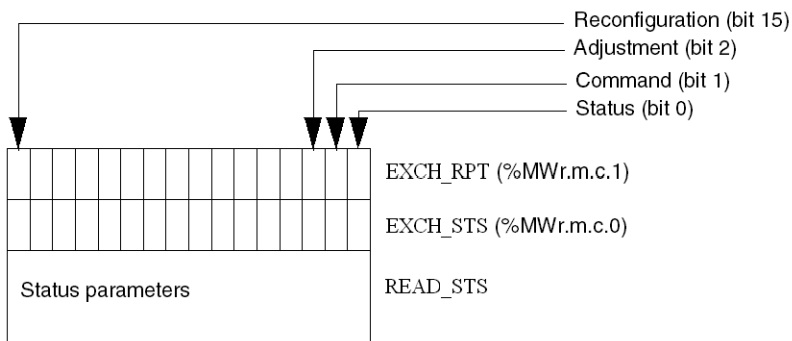

Description of Significant Bits

The rank 0 bits of the words EXCH_STS (%MWr.m.c.0) and EXCH_RPT (%MWr.m.c.1) are associated with the status parameters:

- The `STS_IN_PROGR` bit (`%MWr.m.c.0.0`) indicates whether a read request for the status words is in progress.
- The `STS_ERR` bit (`%MWr.m.c.1.0`) specifies whether a read request for the status words is accepted by the module channel.

Execution Indicators for an Explicit Exchange: EXCH_STS

The table below shows the `EXCH_STS` (`%MWr.m.c.0`) explicit exchange control bits:

Standard symbol	Type	Access	Meaning	Address
<code>STS_IN_PROGR</code>	BOOL	R	Reading of channel status words in progress	<code>%MWr.m.c.0.0</code>

NOTE: If the module is not present or is disconnected, explicit exchange objects (`READ_STS`, for example) are not sent to the module (`STS_IN_PROG` (`%MWr.m.c.0.0`) = 0), but the words are refreshed.

Explicit Exchange Report: EXCH_RPT

The table below presents the `EXCH_RPT` (`%MWr.m.c.1`) report bits:

Standard symbol	Type	Access	Meaning	Address
<code>STS_ERR</code>	BOOL	R	Detected error reading channel status words (1 = failure)	<code>%MWr.m.c.1.0</code>

Language Object of the CANopen Specific IODDTs

Subject of this Section

This section describes the implicit and explicit language objects of the CANopen specific IODDTs, `T_COM_CO_BMX` and `T_COM_CO_BMX_EXPERT`.

Details of T_COM_CO_BMX IODDT

Implicit Exchange Objects of the IODDT

Implicit exchange objects are automatically exchanged at each cycle of a task associated with the channel. These objects are %I, %IW, %Q and %QW.

The table below presents the various implicit exchange objects of IODDT T_COM_CO_BMX.

The parameters r, m and c shown in the following-tables represent the topological addressing of the module. Each parameter has the following signification:

- **r** represents the rack number
- **m** represents the module number
- **c** represents the channel number

Channel Error

The table below presents the bit %Ir.m.c.ERR:

Standard symbol	Type	Access	Description	Address
CH_ERROR	BOOL	R	Channel detected error	%Ir.m.c.ERR

Master Status and Event Indicator

The table below shows the words %IW_{r.m.c.0} to %IW_{r.m.c.2}:

Standard symbol	Type	Access	Description	Address
COMM_STS	INT	R	Communication status of master	%IW _{r.m.c.0}
CAN_STS	INT	R	Status of CANopen Master	%IW _{r.m.c.1}
EVT_STS	INT	R	Event indicator	%IW _{r.m.c.2}

The following figure gives an example of Master status indicator:

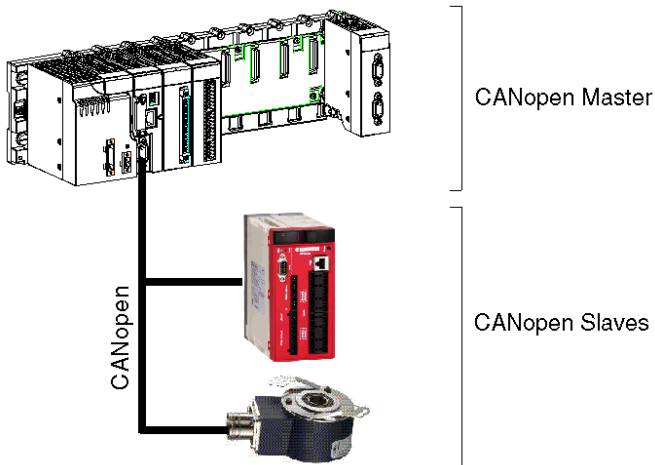

In this example, the word `%IWO.0.2.1` gives the status of the CANopen Master. The parameters are as follows:

- **r:** 0
- **m:** 0
- **c:** 2 The master is the only CAN device on the network. It gets no acknowledge to its transmit frames. All nodes marked as absent. The master keeps its state until the "alone" situation is released (CANopen channel)

The last parameter ('1') indicates the used word (`CAN_STS`).

The table below shows the meaning of bits from various status words from the master and event indicators:

Addresses	Description	Bit meaning
%IWrr.m.c.0	Communication status of master	<p>Bit 0=1: Overflow of the reception queue low priority. The CANopen master is receiving "Heartbeat" and "Node guarding" messages as well as SSDOs and CSDOs via the low priority queue.</p> <p>Bit 1=1: FIFO overwrite of CAN controller</p> <p>Bit 2=1: The CAN controller has status "BUS Off".</p> <p>Bit 3=1: CAN controller doesn't run correctly and stops. Bit reset when the condition disappears.</p> <p>Bit 4=1: The CAN controller has left abnormal state.</p> <p>Bit 5=1: Overflow of the emission queue low priority. The CANopen master is transmitting "Heartbeat" and "Node guarding" messages as well as SSDOs and CSDOs via the low priority transmission queue.</p> <p>Bit 6=1: Overflow of the reception queue high priority. The CANopen master is receiving RPDOs, NMT commands, the message Sync and emergency messages via the high priority reception queue.</p> <p>Bit 7=1: Overflow of the reception queue high priority. The CANopen master is sending TPDOs, NMT commands, the message Sync and emergency messages via the high priority queue.</p> <p>Bit 8=1: Indicates the task cycle is faster than the CANopen master cycle (outputs can be overwritten). To avoid overwrite, you are advised to set a longer task cycle time that the CANopen cycle. The cycle values are available in the words %IWrr.m.c.59 to %IWrr.m.c.61.</p>
%IWrr.m.c.1	Status of CANopen Master	<p>0x00: INIT: The CANopen master is not initialized. This corresponds to the "INITIALISATION" status of the CANopen module. In this state, the CANopen master cannot communicate with the network.</p> <p>0x40: RESET: The CANopen master is configured as master during "NMT startup". The object dictionary of CANopen master can be configured by SDOs via the CAN bus and the interface of the SDO command. The application has access rights to read/write to the object dictionary via the SDO command. The initialization of network manager has not started yet.</p> <p>= 0x60: NET –INIT: Starting according to CIA DSP-302. The CANopen master is checking the allocation of slaves.</p> <p>= 0x61: NET RESET: The network is re-initialized by the NMT command "Reset communication all nodes"</p> <p>= 0x62: NET –WAIT: The CANopen master is waiting for the modules to be able to run the command "Reset communication".</p> <p>0x64: BOOT –CONF: The CANopen master is running the individual initialization of modules according to CIA DSP-302.</p> <p>0x8x: CLEAR: The network is scanned. The master is waiting for a start command ("Start CANopen Master/Manager" or "Start network").</p> <p>0xAx: RUN The network is in "Operational" state.</p> <p>0xCx: STOP The network is in "Stop" state.</p>

Addresses	Description	Bit meaning
		<p>0xEx: PREOPERATIONAL: The network is in "Pre-operational" status.</p> <p>0x9x: FATAL ERROR: An unexpected behavior has occurred. The CANopen master must be re-initialized.</p> <p>The network is scanned. The four most significant bits of the status variable indicate the state of the network (CLEAR, RUN, STOP, PREOPERATIONAL). The four less significant bits contain additional information:</p> <p>Bit 0: Error bit for optional modules.</p> <ul style="list-style-type: none"> • = 0: OK. • = 1: At least one of the optional modules doesn't correspond to the configuration of the expected network. <p>Bit 1: Error bit for obligatory modules.</p> <ul style="list-style-type: none"> • = 0: OK. • = 1: At least one of the obligatory modules is not in the expected status. <p>Bit 2: Bit "Operational"</p> <ul style="list-style-type: none"> • = 0: No module including the CANopen Master is in CANopen "Operational" status • = 1: At least one of the modules is in "Operational" status (excluding the CANopen Master) <p>Bit 3: "Operational" bit of CANopen Master</p> <ul style="list-style-type: none"> • = 0: The CANopen master is not in "Operational" state • = 1: The CANopen Master is in "Operational" status.
%IWr.m.c.2	Event indicator	<p>Bit 0 = 1: This bit is always set when a detected error has occurred in the communication with the network. The communication status of CANopen Master gives the exact reason. (The CANopen master is unable to run correctly and stops).</p> <p>Bit 1 = 1: A module is using the node number of CANopen Master. (The CANopen master is unable to run correctly and stops).</p> <p>Bit 2 = 1: Detected error control event of a mandatory module. The reaction to this event depends on the configuration of the NMT startup object. This bit is relevant if the configuration of the NMT startup object does not stipulate a reset of the whole network including the CANopen master. In this case, a reset is carried out without the application being informed beforehand.</p> <p>Bit 3 = 1: Identity detected error or incorrect DCF of a mandatory module. (The CANopen master is unable to run correctly and stops).</p> <p>Bit 4 = 1: The concerned module is in "Stop" state.</p> <p>Bit 5 = 1: During auto-configuration, the creation of a configuration of the process image and the PDOs are incorrect. (The CANopen master is unable to run correctly and stops).</p> <p>Bit 6 = 1: During the network scanning in the auto-configuration mode, a detected error control event of an already scanned module occurred. (The CANopen master is unable to run correctly and stops)</p> <p>Bit 7 = 1: This bit is always set if a bit in one of the bit list changes.</p>

Addresses	Description	Bit meaning
		<p>Bit 8 = 1: At the beginning of the Boot Up procedure, the CANopen master checks the individual slave assignment. This bit is set by the slave assignment of a module contain features which are not supported by the CANopen master (e.g bit 4 to bit 6 of object 1F81H). (The CANopen master is unable to run correctly and stops).</p> <p>Bit 9 = 1: The CANopen Master has received an RPDO with too few databytes. (The CANopen master is unable to run correctly and stops).</p> <p>Bit 10 = 1: A concise DCF is faulty: If the state < CLEAR then the CANopen master is unable to run correctly and stops; if the state >= CLEAR then the indication is in the event queue and slave is not rebooted.</p> <p>There is a mismatch between the DCF and the slave's Object Dictionary, resulting in the SDO abort during the concise DCF's download: the indication is in the event queue and the manager retries the download of the DCF; or the indication does not match with the Object Dictionary of the slave module, therefore the CANopen master is unable to run correctly and stops.</p> <p>Bit 11 = 1: This bit indicates an indication queue overrun of the application-specific SDO interface.</p> <p>Bit 12 = 1: The last master cycle time is greater than 256 ms.</p> <p>Bit 13 = 1: The master is the only CAN device on the network. It gets no acknowledgment to its transmitted frames. All nodes are marked as absent. The master keeps its state until the "alone" situation is released.</p> <p>Bit 14 = 1: Reserved.</p> <p>Bit 15 = 1: The Master is alone on the bus (Check that the cable is connected).</p>

Assigned Slaves

The table below shows the words %IWr.m.c.3 to %IWr.m.c.6:

Standard symbol	Type	Access	Description	Address
SLAVE_ASSIGNED_1_16	INT	R	For assigned slaves from 1 to 16	%IWr.m.c.3
SLAVE_ASSIGNED_17_32	INT	R	For assigned slaves from 17 to 32	%IWr.m.c.4
SLAVE_ASSIGNED_33_48	INT	R	For assigned slaves from 33 to 48	%IWr.m.c.5
SLAVE_ASSIGNED_49_63	INT	R	For assigned slaves from 49 to 63	%IWR.m.c.6

If the bit is equal to 0, no slave is assigned to this bit.

If the bit is equal to 1, a slave is assigned to this bit.

The node number corresponds to the number of the bit + 1.

Slaves Configured

The table below shows the words %IWr.m.c.11 to %IWr.m.c.14:

Standard symbol	Type	Access	Description	Address
SLAVE_CONF_1_16	INT	R	For configured slaves from 1 to 16	%IWr.m.c.11
SLAVE_CONF_17_32	INT	R	For configured slaves from 17 to 32	%IWr.m.c.12
SLAVE_CONF_33_48	INT	R	For configured slaves from 33 to 48	%IWr.m.c.13
SLAVE_CONF_49_63	INT	R	For configured slaves from 49 to 63	%IWr.m.c.14

If the bit is equal to 0, the slave is not configured and cannot start.

If the bit is equal to 1, the slave is configured and can be started.

The node number corresponds to the number of the bit + 1.

Slaves with Configuration Faults

The table below shows the words %IWr.m.c.19 to %IWr.m.c.22:

Standard symbol	Type	Access	Description	Address
SLAVE_FLT_1_16	INT	R	Slaves with configuration faults from 1 to 16	%IWr.m.c.19
SLAVE_FLT_17_32	INT	R	Slaves with configuration faults from 17 to 32	%IWr.m.c.20
SLAVE_FLT_33_48	INT	R	Slaves with configuration faults from 33 to 48	%IWr.m.c.21
SLAVE_FLT_49_63	INT	R	Slaves with configuration faults from 49 to 63	%IWr.m.c.22

If the bit is equal to 0, the assigned slave corresponds to the configuration.

If the bit is equal to 1, the assigned slave does not correspond to the configuration.

The node number corresponds to the number of the bit + 1.

Inoperative Slaves

The table below shows the words %IWr.m.c.27 to %IWr.m.c.30:

Standard symbol	Type	Access	Description	Address
SLAVE_EM CY_1_16	INT	R	Slaves from 1 to 16	%IWr.m.c.27
SLAVE_EM CY_17_32	INT	R	Slaves from 17 to 32	%IWr.m.c.28

Standard symbol	Type	Access	Description	Address
SLAVE_EMCY_33_48	INT	R	Slaves from 33 to 48	%IW _r .m.c.29
SLAVE_EMCY_49_63	INT	R	Slaves from 49 to 63	%IW _r .m.c.30

If the bit is equal to 0, the slave is properly operating.

If the bit is equal to 1, the slave is improperly operating.

The node number corresponds to the number of the bit + 1.

Operational Slaves from 1 to 16

The table below presents the word %IW_r.m.c.35:

Standard symbol	Type	Access	Description	Address
SLAVE_ACTIV_1	BOOL	R	Slave operational on the bus: device 1	%IW _r .m.c.35.0
SLAVE_ACTIV_2	BOOL	R	Slave operational on the bus: device 2	%IW _r .m.c.35.1
SLAVE_ACTIV_3	BOOL	R	Slave operational on the bus: device 3	%IW _r .m.c.35.2
SLAVE_ACTIV_4	BOOL	R	Slave operational on the bus: device 4	%IW _r .m.c.35.3
SLAVE_ACTIV_5	BOOL	R	Slave operational on the bus: device 5	%IW _r .m.c.35.4
SLAVE_ACTIV_6	BOOL	R	Slave operational on the bus: device 6	%IW _r .m.c.35.5
SLAVE_ACTIV_7	BOOL	R	Slave operational on the bus: device 7	%IW _r .m.c.35.6
SLAVE_ACTIV_8	BOOL	R	Slave operational on the bus: device 8	%IW _r .m.c.35.7
SLAVE_ACTIV_9	BOOL	R	Slave operational on the bus: device 9	%IW _r .m.c.35.8
SLAVE_ACTIV_10	BOOL	R	Slave operational on the bus: device 10	%IW _r .m.c.35.9
SLAVE_ACTIV_11	BOOL	R	Slave operational on the bus: device 11	%IW _r .m.c.35.10
SLAVE_ACTIV_12	BOOL	R	Slave operational on the bus: device 12	%IW _r .m.c.35.11
SLAVE_ACTIV_13	BOOL	R	Slave operational on the bus: device 13	%IW _r .m.c.35.12
SLAVE_ACTIV_14	BOOL	R	Slave operational on the bus: device 14	%IW _r .m.c.35.13
SLAVE_ACTIV_15	BOOL	R	Slave operational on the bus: device 15	%IW _r .m.c.35.14
SLAVE_ACTIV_16	BOOL	R	Slave operational on the bus: device 16	%IW _r .m.c.35.15

The node number corresponds to the number of the bit + 1.

Operational Slaves from 17 to 32

The table below presents the word `%IWrr.m.c.36:`

Standard symbol	Type	Access	Description	Address
SLAVE_ACTIV_17	BOOL	R	Slave operational on the bus: device 17	<code>%IWrr.m.c.36.0</code>
SLAVE_ACTIV_18	BOOL	R	Slave operational on the bus: device 18	<code>%IWrr.m.c.36.1</code>
SLAVE_ACTIV_19	BOOL	R	Slave operational on the bus: device 19	<code>%IWrr.m.c.36.2</code>
SLAVE_ACTIV_20	BOOL	R	Slave operational on the bus: device 20	<code>%IWrr.m.c.36.3</code>
SLAVE_ACTIV_21	BOOL	R	Slave operational on the bus: device 21	<code>%IWrr.m.c.36.4</code>
SLAVE_ACTIV_22	BOOL	R	Slave operational on the bus: device 22	<code>%IWrr.m.c.36.5</code>
SLAVE_ACTIV_23	BOOL	R	Slave operational on the bus: device 23	<code>%IWrr.m.c.36.6</code>
SLAVE_ACTIV_24	BOOL	R	Slave operational on the bus: device 24	<code>%IWrr.m.c.36.7</code>
SLAVE_ACTIV_25	BOOL	R	Slave operational on the bus: device 25	<code>%IWrr.m.c.36.8</code>
SLAVE_ACTIV_26	BOOL	R	Slave operational on the bus: device 26	<code>%IWrr.m.c.36.9</code>
SLAVE_ACTIV_27	BOOL	R	Slave operational on the bus: device 27	<code>%IWrr.m.c.36.10</code>
SLAVE_ACTIV_28	BOOL	R	Slave operational on the bus: device 28	<code>%IWrr.m.c.36.11</code>
SLAVE_ACTIV_29	BOOL	R	Slave operational on the bus: device 29	<code>%IWrr.m.c.36.12</code>
SLAVE_ACTIV_30	BOOL	R	Slave operational on the bus: device 30	<code>%IWrr.m.c.36.13</code>
SLAVE_ACTIV_31	BOOL	R	Slave operational on the bus: device 31	<code>%IWrr.m.c.36.14</code>
SLAVE_ACTIV_32	BOOL	R	Slave operational on the bus: device 32	<code>%IWrr.m.c.36.15</code>

Operational Slaves from 33 to 48

The table below shows the word `%IWrr.m.c.37:`

Standard symbol	Type	Access	Description	Address
SLAVE_ACTIV_33	BOOL	R	Slave operational on the bus: device 33	%IWr.m.c.37.0
SLAVE_ACTIV_34	BOOL	R	Slave operational on the bus: device 34	%IWr.m.c.37.1
SLAVE_ACTIV_35	BOOL	R	Slave operational on the bus: device 35	%IWr.m.c.37.2
SLAVE_ACTIV_36	BOOL	R	Slave operational on the bus: device 36	%IWr.m.c.37.3
SLAVE_ACTIV_37	BOOL	R	Slave operational on the bus: device 37	%IWr.m.c.37.4
SLAVE_ACTIV_38	BOOL	R	Slave operational on the bus: device 38	%IWr.m.c.37.5
SLAVE_ACTIV_39	BOOL	R	Slave operational on the bus: device 39	%IWr.m.c.37.6
SLAVE_ACTIV_40	BOOL	R	Slave operational on the bus: device 40	%IWr.m.c.37.7
SLAVE_ACTIV_41	BOOL	R	Slave operational on the bus: device 41	%IWr.m.c.37.8
SLAVE_ACTIV_42	BOOL	R	Slave operational on the bus: device 42	%IWr.m.c.37.9
SLAVE_ACTIV_43	BOOL	R	Slave operational on the bus: device 43	%IWr.m.c.37.10
SLAVE_ACTIV_44	BOOL	R	Slave operational on the bus: device 44	%IWr.m.c.37.11
SLAVE_ACTIV_45	BOOL	R	Slave operational on the bus: device 45	%IWr.m.c.37.12
SLAVE_ACTIV_46	BOOL	R	Slave operational on the bus: device 46	%IWr.m.c.37.13
SLAVE_ACTIV_47	BOOL	R	Slave operational on the bus: device 47	%IWr.m.c.37.14
SLAVE_ACTIV_48	BOOL	R	Slave operational on the bus: device 48	%IWr.m.c.37.15

Operational Slaves from 49 to 63

The table below shows the word %IWr.m.c.38:

Standard symbol	Type	Access	Description	Address
SLAVE_ACTIV_49	BOOL	R	Slave operational on the bus: device 49	%IWr.m.c.38.0
SLAVE_ACTIV_50	BOOL	R	Slave operational on the bus: device 50	%IWr.m.c.38.1
SLAVE_ACTIV_51	BOOL	R	Slave operational on the bus: device 51	%IWr.m.c.38.2
SLAVE_ACTIV_52	BOOL	R	Slave operational on the bus: device 52	%IWr.m.c.38.3
SLAVE_ACTIV_53	BOOL	R	Slave operational on the bus: device 53	%IWr.m.c.38.4
SLAVE_ACTIV_54	BOOL	R	Slave operational on the bus: device 54	%IWr.m.c.38.5

Standard symbol	Type	Access	Description	Address
SLAVE_ACTIV_55	BOOL	R	Slave operational on the bus: device 55	%IW _{r.m.c.} 38.6
SLAVE_ACTIV_56	BOOL	R	Slave operational on the bus: device 56	%IW _{r.m.c.} 38.7
SLAVE_ACTIV_57	BOOL	R	Slave operational on the bus: device 57	%IW _{r.m.c.} 38.8
SLAVE_ACTIV_58	BOOL	R	Slave operational on the bus: device 58	%IW _{r.m.c.} 38.9
SLAVE_ACTIV_59	BOOL	R	Slave operational on the bus: device 59	%IW _{r.m.c.} 38.10
SLAVE_ACTIV_60	BOOL	R	Slave operational on the bus: device 60	%IW _{r.m.c.} 38.11
SLAVE_ACTIV_61	BOOL	R	Slave operational on the bus: device 61	%IW _{r.m.c.} 38.12
SLAVE_ACTIV_62	BOOL	R	Slave operational on the bus: device 62	%IW _{r.m.c.} 38.13
SLAVE_ACTIV_63	BOOL	R	Slave operational on the bus: device 63	%IW _{r.m.c.} 38.14

Slave in Stop State

The table below shows the words %IW_{r.m.c.}43 to %IW_{r.m.c.}46:

Standard symbol	Type	Access	Description	Address
SLAVE_STOPPED_1_16	INT	R	Stopped slaves from 1 to 16	%IW _{r.m.c.} 43
SLAVE_STOPPED_17_32	INT	R	Stopped slaves from 17 to 32	%IW _{r.m.c.} 44
SLAVE_STOPPED_33_48	INT	R	Stopped slaves from 33 to 48	%IW _{r.m.c.} 45
SLAVE_STOPPED_49_63	INT	R	Stopped slaves from 49 to 63	%IW _{r.m.c.} 46

Pre-Operational Slaves

The table below shows the words %IW_{r.m.c.}51 to %IW_{r.m.c.}54:

Standard symbol	Type	Access	Description	Address
SLAVE_PREOP_1_16	INT	R	Pre-operational slaves from 1 to 16.	%IW _{r.m.c.} 51
SLAVE_PREOP_17_32	INT	R	Pre-operational slaves from 17 to 32.	%IW _{r.m.c.} 52
SLAVE_PREOP_33_48	INT	R	Pre-operational slaves from 33 to 48.	%IW _{r.m.c.} 53
SLAVE_PREOP_49_63	INT	R	Pre-operational slaves from 49 to 63.	%IW _{r.m.c.} 54

Master Cycle Time

The table below shows the meaning of status words relative to the time cycle of the master:

Addresses	Description	Meaning
%IW _{r.m.c.} 59	Minimum master cycle time	Minimum value of the CANopen master cycle time in ms.
%IW _{r.m.c.} 60	Current master cycle time	Current value of the CANopen master cycle time in ms.
%IW _{r.m.c.} 61	Maximum master cycle time	Maximum value of the CANopen master cycle time in ms.

The following symbols are accessible %IW_{r.m.c.}59 to %IW_{r.m.c.}61:

- INT_ERR_BIT -> Bit 0

Reset Emergency Default

The table below shows the meaning of the Reset Emergency Default objects:

Addresses	Description	Standard Symbol	Bit meaning
%QW _{r.m.c.} 0	Command word of the CANopen master	INT_ERR_BIT	Bit 0 = 1: Reset emergency slaves bit list. This bit is set to zero after the reset of the bitlist.
			Bit 1 = 1: Reset bit 8 (overrun) in common status (%IW _{0.0.2.0}). The bit 1 is set to zero after the reset of the bit 8.
			Bit 2 = 1: Reset bit 7 (change bit list) of event indicator (%IW _{0.0.2.2}). The bit 2 is set to zero after the reset of the bit 7.
			Bit 3 = 1: Reset quality information: %ID _{0.y.2.66} to %IW _{0.y.2.72} . This bit is set to zero after the reset of the words and the measure restarts.
			Bit 4 = 1: Reset bus load information: %IW _{0.y.2.62} to %IW _{0.y.2.64} . This bit is set to zero after the reset of the words and the measure restarts.
			Bit 5 = 1: Reset the CANopen master (useful to restart in Fatal Error without power down/up). The bit is set to zero after the reset of the master.
			Bit 6 to bit 15: Reserved

Explicit Exchanges Objects of the IODDT

This part shows the explicit exchange language objects for the CANopen master.

These objects are exchanged on the application's request, using the instruction `READ_STS`.

The parameters `r`, `m` and `c` shown in the following tables represent the topological addressing of the module. Each parameter has the following signification:

- **r**: represents the rack number,
- **m**: represents the position of the module on the rack,
- **c**: represents the channel number.

Execution Indicator: EXCH_STS

The table below shows the meanings of channel exchange control bits from channel `EXCH_STS` (`%MWr.m.c.0`):

Symbol	Type	Access	Description	Number
STS_IN_PROGR	BOOL	R	Status parameter read in progress	%MWr.m.c.0.0

Exchange Report: EXCH_RPT

The table below presents the meaning of the run report bits of the channel `EXCH_RPT` (`%MWr.m.c.1`):

Symbol	Type	Access	Description	Number
STS_ERR	BOOL	R	Detected error while reading channel status	%MWr.m.c.1.0

Standard Channel Faults: CH_FLT

The following table explains the meaning of the `CH_FLT` (`%MWr.m.c.2`) status word bits. Reading is performed by a `READ_STS`:

Object	Function	Standard Symbol	Type	Access	Meaning
%MWr.m.c.2	Status of the CANopen Master	CAN_FLT	BOOL	R	Bit 0 = 1 : The CANopen Master is not in operational state.
		FEW_SLAVE_FLT	BOOL	R	Bit 1 = 1 : One or more slaves are not in an operational state.
		CAN_OFF	BOOL	R	Bit 2 : Reserved.
		CONF_FLT	BOOL	R	Bit 3 = 1 : Configuration detected error.

Object	Function	Standard Symbol	Type	Access	Meaning
					<p>Bit 4 to bit 7: Reserved.</p> <p>Bit 8 to Bit 10: CAN ERR led:</p> <ul style="list-style-type: none"> • 000 = off • 001 = single flash • 010 = double flash • 011 = triple flash • 111 = on <p>Bit 11 to Bit 13: CAN RUN led:</p> <ul style="list-style-type: none"> • 001 = single flash • 100 = blinking • 111 = on <p>Bit 14 to Bit 15: Reserved.</p>
%MWr.m.c.3	Generic detected error count				Number of received emergency messages with code 10xxH
%MWr.m.c.4	Device hardware detected error count				Number of received emergency messages with code 50xxH
%MWr.m.c.5	Device software detected error count				Number of received emergency messages with code 60xxH
%MWr.m.c.6	Communication detected error count				Number of received emergency messages with code 81xxH
%MWr.m.c.7	Protocol detected error count				Number of received emergency messages with code 82xxH
%MWr.m.c.8	External detected error count				Number of received emergency messages with code 90xxH
%MWr.m.c.9	Device-specific				Number of received emergency messages with code FFxxH

Details of T_COM_CO_BMX_EXPERT IODDT

Implicit Exchange Objects of the IODDT

Implicit exchange objects are automatically exchanged at each cycle of a task associated with the channel. These objects are %I, %IW, %Q and %QW.

The table below presents the various implicit exchange objects of IODDT T_COM_CO_BMX_EXPERT.

The parameters r, m and c shown in the following-tables represent the topological addressing of the module. Each parameter has the following signification:

- **r** represents the rack number
- **m** represents the module number
- **c** represents the channel number

Channel Error

The table below presents the bit %I_{r.m.c}.ERR:

Standard symbol	Type	Access	Description	Address
CH_ERROR	BOOL	R	Channel detected error	%I _{r.m.c} .ERR

Master Status and Event Indicator

The table below shows the words %IW_{r.m.c.0} to %IW_{r.m.c.2}:

Standard symbol	Type	Access	Description	Address
COMM_STS	INT	R	Communication status of Master	%IW _{r.m.c.0}
CAN_STS	INT	R	Status of CANopen Master	%IW _{r.m.c.1}
EVT_STS	INT	R	Event indicator	%IW _{r.m.c.2}

The following figure gives an example of Master status indicator.

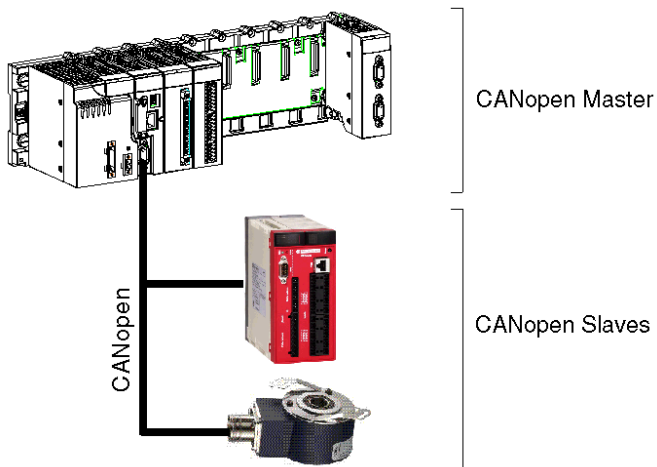

In this example, the word `%IWO.0.2.1` gives the status of the CANopen Master. The parameters are as follows:

- **r:** 0
- **m:** 0
- **c:** 2 (CANopen channel)

The last parameter ('1') indicates the used word (`CAN_STS`).

The table below shows the meaning of bits from various status words from the master and event indicators:

Addresses	Description	Bit meaning
%IW _r .m.c.0	Communication status of Master	<p>Bit 0 = 1: Overflow of the low priority reception queue. The CANopen Master receives "Heartbeat" and "Node guarding" messages as well as SSDOs and CSDOs via the low priority queue.</p> <p>Bit 1 = 1: FIFO overwrites the CAN controller.</p> <p>Bit 2 = 1: The CAN controller has the status BUS OFF.</p> <p>Bit 3 = 1: CAN controller doesn't run correctly and stops. This bit is reset when the condition disappears.</p> <p>Bit 4 = 1:The CAN controller has left an abnormal state.</p> <p>Bit 5 = 1: Overflow of the low priority emission queue. The CANopen Master transmits "Heartbeat" and "Node guarding" messages as well as SSDOs and CSDOs via the low priority transmission queue.</p> <p>Bit 6 = 1: Overflow of the high priority reception queue. The CANopen Master receives RPDOs, NMT commands, the message Sync and emergency messages via the high priority reception queue.</p> <p>Bit 7 = 1: Overflow of the high priority transmit queue. The CANopen Master sends TPDOs, NMT commands, the message Sync and emergency messages via the high priority queue.</p> <p>Bit 8 = 1: Indicates that the task cycle is faster than the CANopen Master cycle (outputs can be overwritten). To avoid overwriting, it is recommended to set a longer task cycle time than the CANopen cycle. The cycle values are available in the words %IW_r.m.c.59 to %IW_r.m.c.61.</p>
%IW _r .m.c.1	Status of CANopen Master	<p>= 0x00 INIT: The CANopen Master is not initialized. This corresponds to the INITIALISATION status of the CANopen module. In this state, the CANopen Master cannot communicate with the network.</p> <p>= 0x40 RESET: The CANopen Master is configured as master during NMT STARTUP. The object dictionary of CANopen Master can be configured by SDOs via the CAN bus and the interface of the SDO command. The application has read/write access rights to the object dictionary via the SDO command. The initialization of network manager has not yet started.</p> <p>= 0x60 NET INIT: Start-up according to CIA DSP-302. The CANopen Master checks the allocation of the slaves.</p> <p>= 0x61 NET RESET: The network is re-initialized by the NMT command RESET COMMUNICATION ALL NODES.</p> <p>= 0x62 NET WAIT: The CANopen Master waits (waiting time be defined) to allow the modules to run the command RESET COMMUNICATION.</p> <p>= 0x64 BOOT CONF: The CANopen Master initializes modules according to CIA DSP-302 by scanning the network.</p> <p>The high nibble of the state variable indicates the general network state: CLEAR, RUN, STOP and PREOPERATIONAL.</p> <p>The low nibble contains additional information:</p> <ul style="list-style-type: none"> • Bit 0: Detected error bit for optional and unexpected modules: <ul style="list-style-type: none"> ◦ 0: No error is detected.

Addresses	Description	Bit meaning
		<ul style="list-style-type: none"> ◦ 1: There is at least one optional or unexpected module that does not correspond to the expected network configuration. • Bit 2: General operational bit: <ul style="list-style-type: none"> ◦ 0: No module (including the CANopen Master) is in the CANopen OPERATIONAL state. ◦ 1: At least one module (but not including the CANopen Master) is in the CANopen OPERATIONAL state. • Bit 3: General operational bit: <ul style="list-style-type: none"> ◦ 0: The CANopen Master is not in the OPERATIONAL state. ◦ 1: The CANopen Master is in the OPERATIONAL state. <p>= 0x8x CLEAR: The network is scanned. The Master is waiting for a start command (START CANopen MASTER/MANAGER or START NETWORK).</p> <p>= 0xAx RUN: The network is in the OPERATIONAL state.</p> <p>= 0xCx STOP: The network is in the STOP state.</p> <p>= 0Ex PREOPERATIONAL: The network is in the PREOPERATIONAL state.</p> <p>= 0x9x FATAL ERROR: The CANopen Master is inoperative and must be re-initialized.</p>
%IW0.y.2.2	Event indicator	<p>Bit 0 = 1: This bit is always set when a detected error has occurred in communication with the network. The communication status of CANopen Master gives the exact reason. (The CANopen Master is unable to run correctly and stops).</p> <p>Bit 1 = 1: A module is using the node number of CANopen Master. (The CANopen Master is unable to run correctly and stops).</p> <p>Bit 2 and Bit 3: Reserved.</p> <p>Bit 4 = 1: There is a detected identity error for an optional module. The boot slave process is repeated.</p> <p>Bit 5 and Bit 6: Reserved.</p> <p>Bit 7 = 1: This bit is set if a bit in one of the bitlists changes.</p> <p>Bit 8 = 1: At the beginning of the start-up procedure, the CANopen Master checks the individual slave assignments. This bit is set by the slave assignment if a module that contain features which are not supported by the CANopen Master (for example, bit 4 to bit 6 of object 1F81H: the CANopen Master is unable to run correctly and stops).</p> <p>Bit 9 = 1: The CANopen Master has received an RPDO with not enough data bytes. (The CANopen Master does not change its state.)</p> <p>Bit 10 = 1: Inconsistent or mismatch DCF bit.</p> <p>If a DCF inconsistent error is detected and if the state is:</p> <ul style="list-style-type: none"> • < CLEAR, then the CANopen Master is unable to run correctly and stops • >= CLEAR, then there is an indication in the event queue and slave is not rebooted

Addresses	Description	Bit meaning
		<p>If there is a mismatch between a DCF and the slave's Object Dictionary, which results in an SDO abort during the DCF download, then there is an indication in the event queue and the manager retries downloading the DCF.</p> <p>Bit 11: Reserved.</p> <p>Bit 12 = 1: The last Master/Manager cycle time is greater than 256 ms.</p> <p>Bit 13 = 1: The Master is the only CAN device on the network. It gets no acknowledgment to its transmitted frames. All nodes are marked as absent. The Master keeps its state until the "alone" situation is released.</p> <p>Bit 14 and Bit 15: Reserved.</p>

Assigned Slaves

The table below shows the words `%IWr.m.c.3` to `%IWr.m.c.10`:

Standard symbol	Type	Access	Description	Address
SLAVE_ASSIGNED_1_16	INT	R	For assigned slaves from 1 to 16	<code>%IWr.m.c.3</code>
SLAVE_ASSIGNED_17_32	INT	R	For assigned slaves from 17 to 32	<code>%IWr.m.c.4</code>
SLAVE_ASSIGNED_33_48	INT	R	For assigned slaves from 33 to 48	<code>%IWr.m.c.5</code>
SLAVE_ASSIGNED_49_63	INT	R	For assigned slaves from 49 to 63	<code>%IWR.m.c.6</code>

If the bit is equal to 0, no slave is assigned to this bit.

If the bit is equal to 1, a slave is assigned to this bit.

The node number corresponds to the number of the bit + 1.

Slaves Configured

The table below shows the words `%IWr.m.c.11` to `%IWr.m.c.14`:

Standard symbol	Type	Access	Description	Address
SLAVE_CONF_1_16	INT	R	For configured slaves from 1 to 16	<code>%IWr.m.c.11</code>
SLAVE_CONF_17_32	INT	R	For configured slaves from 17 to 32	<code>%IWr.m.c.12</code>
SLAVE_CONF_33_48	INT	R	For configured slaves from 33 to 48	<code>%IWr.m.c.13</code>
SLAVE_CONF_49_63	INT	R	For configured slaves from 49 to 63	<code>%IWr.m.c.14</code>

If the bit is equal to 0, the slave is not configured and cannot start.

If the bit is equal to 1, the slave is configured and can be started.

The node number corresponds to the number of the bit + 1.

Slaves with Configuration Faults

The table below shows the words `%IWr.m.c.19` to `%IWr.m.c.22`:

Standard symbol	Type	Access	Description	Address
SLAVE_FLT_1_16	INT	R	Slaves with configuration faults from 1 to 16	<code>%IW_r.m.c.19</code>
SLAVE_FLT_17_32	INT	R	Slaves with configuration faults from 17 to 32	<code>%IW_r.m.c.20</code>
SLAVE_FLT_33_48	INT	R	Slaves with configuration faults from 33 to 48	<code>%IW_r.m.c.21</code>
SLAVE_FLT_49_63	INT	R	Slaves with configuration faults from 49 to 63	<code>%IW_r.m.c.22</code>

If the bit is equal to 0, the assigned slave corresponds to the configuration.

If the bit is equal to 1, the assigned slave does not correspond to the configuration.

The node number corresponds to the number of the bit + 1.

Inoperative Slaves

The table below shows the words `%IWr.m.c.27` to `%IWr.m.c.30`:

Standard symbol	Type	Access	Description	Address
SLAVE_EM CY_1_16	INT	R	Slaves from 1 to 16	<code>%IW_r.m.c.27</code>
SLAVE_EM CY_17_32	INT	R	Slaves from 17 to 32	<code>%IW_r.m.c.28</code>
SLAVE_EM CY_33_48	INT	R	Slaves from 33 to 48	<code>%IW_r.m.c.29</code>
SLAVE_EM CY_49_63	INT	R	Slaves from 49 to 63	<code>%IW_r.m.c.30</code>

If the bit is equal to 0, the slave is properly operating.

If the bit is equal to 1, the slave is improperly operating.

The node number corresponds to the number of the bit + 1.

Operational Slaves from 1 to 16

The table below presents the word `%IWrr.m.c.35:`

Standard symbol	Type	Access	Description	Address
SLAVE_ACTIV_1	BOOL	R	Slave operational on the bus: device 1	<code>%IWrr.m.c.35.0</code>
SLAVE_ACTIV_2	BOOL	R	Slave operational on the bus: device 2	<code>%IWrr.m.c.35.1</code>
SLAVE_ACTIV_3	BOOL	R	Slave operational on the bus: device 3	<code>%IWrr.m.c.35.2</code>
SLAVE_ACTIV_4	BOOL	R	Slave operational on the bus: device 4	<code>%IWrr.m.c.35.3</code>
SLAVE_ACTIV_5	BOOL	R	Slave operational on the bus: device 5	<code>%IWrr.m.c.35.4</code>
SLAVE_ACTIV_6	BOOL	R	Slave operational on the bus: device 6	<code>%IWrr.m.c.35.5</code>
SLAVE_ACTIV_7	BOOL	R	Slave operational on the bus: device 7	<code>%IWrr.m.c.35.6</code>
SLAVE_ACTIV_8	BOOL	R	Slave operational on the bus: device 8	<code>%IWrr.m.c.35.7</code>
SLAVE_ACTIV_9	BOOL	R	Slave operational on the bus: device 9	<code>%IWrr.m.c.35.8</code>
SLAVE_ACTIV_10	BOOL	R	Slave operational on the bus: device 10	<code>%IWrr.m.c.35.9</code>
SLAVE_ACTIV_11	BOOL	R	Slave operational on the bus: device 11	<code>%IWrr.m.c.35.10</code>
SLAVE_ACTIV_12	BOOL	R	Slave operational on the bus: device 12	<code>%IWrr.m.c.35.11</code>
SLAVE_ACTIV_13	BOOL	R	Slave operational on the bus: device 13	<code>%IWrr.m.c.35.12</code>
SLAVE_ACTIV_14	BOOL	R	Slave operational on the bus: device 14	<code>%IWrr.m.c.35.13</code>
SLAVE_ACTIV_15	BOOL	R	Slave operational on the bus: device 15	<code>%IWrr.m.c.35.14</code>
SLAVE_ACTIV_16	BOOL	R	Slave operational on the bus: device 16	<code>%IWrr.m.c.35.15</code>

The node number corresponds to the number of the bit + 1.

Operational Slaves from 17 to 32

The table below presents the word `%IWrr.m.c.36:`

Standard symbol	Type	Access	Description	Address
SLAVE_ACTIV_17	BOOL	R	Slave operational on the bus: device 17	<code>%IWrr.m.c.36.0</code>
SLAVE_ACTIV_18	BOOL	R	Slave operational on the bus: device 18	<code>%IWrr.m.c.36.1</code>

Standard symbol	Type	Access	Description	Address
SLAVE_ACTIV_19	BOOL	R	Slave operational on the bus: device 19	%IWr.m.c.36.2
SLAVE_ACTIV_20	BOOL	R	Slave operational on the bus: device 20	%IWr.m.c.36.3
SLAVE_ACTIV_21	BOOL	R	Slave operational on the bus: device 21	%IWr.m.c.36.4
SLAVE_ACTIV_22	BOOL	R	Slave operational on the bus: device 22	%IWr.m.c.36.5
SLAVE_ACTIV_23	BOOL	R	Slave operational on the bus: device 23	%IWr.m.c.36.6
SLAVE_ACTIV_24	BOOL	R	Slave operational on the bus: device 24	%IWr.m.c.36.7
SLAVE_ACTIV_25	BOOL	R	Slave operational on the bus: device 25	%IWr.m.c.36.8
SLAVE_ACTIV_26	BOOL	R	Slave operational on the bus: device 26	%IWr.m.c.36.9
SLAVE_ACTIV_27	BOOL	R	Slave operational on the bus: device 27	%IWr.m. c.36.10
SLAVE_ACTIV_28	BOOL	R	Slave operational on the bus: device 28	%IWr.m. c.36.11
SLAVE_ACTIV_29	BOOL	R	Slave operational on the bus: device 29	%IWr.m. c.36.12
SLAVE_ACTIV_30	BOOL	R	Slave operational on the bus: device 30	%IWr.m. c.36.13
SLAVE_ACTIV_31	BOOL	R	Slave operational on the bus: device 31	%IWr.m. c.36.14
SLAVE_ACTIV_32	BOOL	R	Slave operational on the bus: device 32	%IWr.m. c.36.15

Operational Slaves from 33 to 48

The table below shows the word %IWr.m.c.37:

Standard symbol	Type	Access	Description	Address
SLAVE_ACTIV_33	BOOL	R	Slave operational on the bus: device 33	%IWr.m.c.37.0
SLAVE_ACTIV_34	BOOL	R	Slave operational on the bus: device 34	%IWr.m.c.37.1
SLAVE_ACTIV_35	BOOL	R	Slave operational on the bus: device 35	%IWr.m.c.37.2
SLAVE_ACTIV_36	BOOL	R	Slave operational on the bus: device 36	%IWr.m.c.37.3
SLAVE_ACTIV_37	BOOL	R	Slave operational on the bus: device 37	%IWr.m.c.37.4
SLAVE_ACTIV_38	BOOL	R	Slave operational on the bus: device 38	%IWr.m.c.37.5
SLAVE_ACTIV_39	BOOL	R	Slave operational on the bus: device 39	%IWr.m.c.37.6
SLAVE_ACTIV_40	BOOL	R	Slave operational on the bus: device 40	%IWr.m.c.37.7

Standard symbol	Type	Access	Description	Address
SLAVE_ACTIV_41	BOOL	R	Slave operational on the bus: device 41	%IWr.m.c.37.8
SLAVE_ACTIV_42	BOOL	R	Slave operational on the bus: device 42	%IWr.m.c.37.9
SLAVE_ACTIV_43	BOOL	R	Slave operational on the bus: device 43	%IWr.m.c.37.10
SLAVE_ACTIV_44	BOOL	R	Slave operational on the bus: device 44	%IWr.m.c.37.11
SLAVE_ACTIV_45	BOOL	R	Slave operational on the bus: device 45	%IWr.m.c.37.12
SLAVE_ACTIV_46	BOOL	R	Slave operational on the bus: device 46	%IWr.m.c.37.13
SLAVE_ACTIV_47	BOOL	R	Slave operational on the bus: device 47	%IWr.m.c.37.14
SLAVE_ACTIV_48	BOOL	R	Slave operational on the bus: device 48	%IWr.m.c.37.15

Operational Slaves from 49 to 64

The table below shows the word %IWr.m.c.38:

Standard symbol	Type	Access	Description	Address
SLAVE_ACTIV_49	BOOL	R	Slave operational on the bus: device 49	%IWr.m.c.38.0
SLAVE_ACTIV_50	BOOL	R	Slave operational on the bus: device 50	%IWr.m.c.38.1
SLAVE_ACTIV_51	BOOL	R	Slave operational on the bus: device 51	%IWr.m.c.38.2
SLAVE_ACTIV_52	BOOL	R	Slave operational on the bus: device 52	%IWr.m.c.38.3
SLAVE_ACTIV_53	BOOL	R	Slave operational on the bus: device 53	%IWr.m.c.38.4
SLAVE_ACTIV_54	BOOL	R	Slave operational on the bus: device 54	%IWr.m.c.38.5
SLAVE_ACTIV_55	BOOL	R	Slave operational on the bus: device 55	%IWr.m.c.38.6
SLAVE_ACTIV_56	BOOL	R	Slave operational on the bus: device 56	%IWr.m.c.38.7
SLAVE_ACTIV_57	BOOL	R	Slave operational on the bus: device 57	%IWr.m.c.38.8
SLAVE_ACTIV_58	BOOL	R	Slave operational on the bus: device 58	%IWr.m.c.38.9
SLAVE_ACTIV_59	BOOL	R	Slave operational on the bus: device 59	%IWr.m.c.38.10
SLAVE_ACTIV_60	BOOL	R	Slave operational on the bus: device 60	%IWr.m.c.38.11
SLAVE_ACTIV_61	BOOL	R	Slave operational on the bus: device 61	%IWr.m.c.38.12

Standard symbol	Type	Access	Description	Address
SLAVE_ACTIV_62	BOOL	R	Slave operational on the bus: device 62	%IW _r .m.c.38.13
SLAVE_ACTIV_63	BOOL	R	Slave operational on the bus: device 63	%IW _r .m.c.38.14

Slave in Stop State

The table below shows the words %IW_r.m.c.43 to %IW_r.m.c.46:

Standard symbol	Type	Access	Description	Address
SLAVE_STOPPED_1_16	INT	R	Stopped slaves from 1 to 16	%IW _r .m.c.43
SLAVE_STOPPED_17_32	INT	R	Stopped slaves from 17 to 32	%IW _r .m.c.44
SLAVE_STOPPED_33_48	INT	R	Stopped slaves from 33 to 48	%IW _r .m.c.45
SLAVE_STOPPED_49_63	INT	R	Stopped slaves from 49 to 63	%IW _r .m.c.46

Pre-Operational Slaves

The table below shows the words %IW_r.m.c.51 to %IW_r.m.c.54:

Standard symbol	Type	Access	Description	Address
SLAVE_PREOP_1_16	INT	R	Pre-operational slaves from 1 to 16.	%IW _r .m.c.51
SLAVE_PREOP_17_32	INT	R	Pre-operational slaves from 17 to 32.	%IW _r .m.c.52
SLAVE_PREOP_33_48	INT	R	Pre-operational slaves from 33 to 48.	%IW _r .m.c.53
SLAVE_PREOP_49_63	INT	R	Pre-operational slaves from 49 to 63.	%IW _r .m.c.54

Master Cycle Time

The table below shows the meaning of status words relative to the time cycle of the master:

Addresses	Description	Meaning
%IW _r .m.c.59	Minimum master cycle time	Minimum value of the CANopen master cycle time in ms.
%IW _r .m.c.60	Current master cycle time	Current value of the CANopen master cycle time in ms.
%IW _r .m.c.61	Maximum master cycle time	Maximum value of the CANopen master cycle time in ms.

The following symbols are accessible %IW.r.m.c.59 to %IW.r.m.c.61:

- INT_ERR_BIT -> Bit 0
- BUS_QUALITY_RESET_COUNTER -> Bit 3
- BUS_LOAD_RESET_COUNTER -> Bit 4

Bus Analysis Information

The table below shows the meaning of status words relative to Bus Analysis Information:

BUS_LOAD_MIN	INT	R	Minimum bus load in %	%IW.r.m.c.62
BUS_LOAD_CURRENT	INT	R	Current busload in %	%IW.r.m.c.63
BUS_LOAD_MAX	INT	R	Maximum busload in %	%IW.r.m.c.64
BUS_QUALITY_NB_RX_FRAMES	DINT	R	Number of received frames	%IDr.m.c.66
BUS_QUALITY_NB_TX_FRAMES	DINT	R	Number of transmitted frames	%IDr.m.c.68
BUS_QUALITY_NB_CURRENT_ERROR_FRAMES	INT	R	Current number of error frames in % for last 10000 exchanged frames	%IW.r.m.c.70
BUS_QUALITY_NB_MAX_ERROR_FRAMES	INT	R	Maximum number of error frames in %	%IW.r.m.c.71
BUS_QUALITY_NB_MIN_ERROR_FRAMES	INT	R	Minimum number of error frames in %	%IW.r.m.c.72
STATUS_NMT	INT	R	Return the status of NMT command	%IW.r.m.c.73
STATUS_NMT_CMD	INT	R	Return the current NMT command and node number	%IW.r.m.c.74
BUS_QUALITY_RESET_COUNTER	BOOL	W	Reset all the bus analysis informations	%QW.r.m.c.0.3
BUS_LOAD_RESET_COUNTER	BOOL	W	Reset all the bus load informations	%QW.r.m.c.0.4
CMD_NMT	INT	W	Send NMT commands	%QW.r.m.c.1

Reset Emergency Default

The table below shows the meaning of the Reset Emergency Default objects:

Addresses	Description	Standard Symbol	Bit meaning
%QW.r.m.c.0	Command word of the CANopen master	INT_ERR_BIT	Bit 0 = 1: Reset emergency slaves bit list. This bit is set to zero after the reset of the bit list.

Addresses	Description	Standard Symbol	Bit meaning
			Bit 1 = 1: Reset bit 8 (overflow) in common status (%IW0.0.2.0). The bit 1 is set to zero after the reset of the bit 8.
			Bit 2 = 1: Reset bit 7 (change bit list) of event indicator (%IW0.0.2.2). The bit 2 is set to zero after the reset of the bit 7.
		BUS_QUALITY_RESET_COUNTER	Bit 3 = 1: Reset quality information: %ID0.y.2.66 to %IW0.y.2.72. This bit is set to zero after the reset of the words and the measure restarts.
		BUS_LOAD_RESET_COUNTER	Bit 4 = 1: Reset bus load information: %IW0.y.2.62 to %IW0.y.2.64. This bit is set to zero after the reset of the words and the measure restarts.
			Bit 5 = 1: Reset the CANopen master (useful to restart in Fatal Error without power down/up). The bit is set to zero after the reset of the master.
			Bit 6 to bit 15: Reserved
%QWr.m.c.1	NMT command		<p>High byte: NMT command:</p> <ul style="list-style-type: none"> • 81: reset node • 82: reset com • 80: pre-op • 01: start • 02: stop <p>Low byte: node number:</p> <ul style="list-style-type: none"> • 0: all nodes • 1..63: node number <p>NOTE: After the command start, %QWr.m.c.1 is set to zero.</p> <p>NOTE: %IW.r.m.c.73 and %IW.r.m.c.74 are used to control the command processing (command state, return code and last NMT command).</p>

Addresses	Description	Standard Symbol	Bit meaning
<code>%IW_{r.m.c}.73</code>	Return the status of NMT command		High byte: command state: <ul style="list-style-type: none"> • 01: idle: a new command can be started if <code>%QW0.r.m.c.1</code> is different from zero. • 02: waiting: the stack interface is used by another command, and the program is waiting until the command is finished. • 03: running: the command is started. • 04: ended: the command is finished. Low byte: return code of the command: <ul style="list-style-type: none"> • 0: command successfully executed • 1: bad command • 2: bad node number • 3: detected error during the command execution
<code>%IW_{r.m.c}.74</code>	Return the current NMT command and node number		Last command executed: <ul style="list-style-type: none"> • High byte: NMT connected • Low byte: node number

Explicit Exchanges Objects of the IODDT

This part shows the explicit exchange language objects for the CANopen master.

These objects are exchanged on the application's request, using the instruction `READ_STS`.

The parameters `r`, `m` and `c` shown in the following tables represent the topological addressing of the module. Each parameter has the following signification:

- **r**: represents the rack number,
- **m**: represents the position of the module on the rack,
- **c**: represents the channel number.

Execution Indicator: EXCH_STS

The table below shows the meanings of channel exchange control bits from channel `EXCH_STS` (`%Mw.r.m.c.0`):

Symbol	Type	Access	Description	Number
<code>STS_IN_PROGR</code>	BOOL	R	Status parameter read in progress	<code>%M_{w.r.m.c}.0.0</code>

Exchange Report: EXCH_RPT

The table below presents the meaning of the run report bits of the channel EXCH_RPT (%MWr.m.c.1):

Symbol	Type	Access	Description	Number
STS_ERR	BOOL	R	Detected error while reading channel status	%MWr.m.c.1.0

Standard Channel Faults: CH_FLT

The following table explains the meaning of the CH_FLT (%MWr.m.c.2) status word bits. Reading is performed by a READ_STS:

Object	Function	Standard Symbol	Type	Access	Meaning
%MWr.m.c.2	Status of the CANopen Master	CAN_FLT	BOOL	R	Bit 0 = 1: The CANopen Master is not in operational state.
		FEW_SLAVE_FLT	BOOL	R	Bit 1 = 1: One or more slaves are not in an operational state.
		CAN_OFF	BOOL	R	Bit 2: Reserved.
		CONF_FLT	BOOL	R	Bit 3 = 1: Configuration detected error.
					Bit 4 to bit 7: Reserved. Bit 8 to Bit 10: CAN ERR led: <ul style="list-style-type: none"> • 000 = off • 001 = single flash • 010 = double flash • 011 = triple flash • 111 = on Bit 11 to Bit 13: CAN RUN led: <ul style="list-style-type: none"> • 001 = single flash • 100 = blinking • 111 = on Bit 14 to Bit 15: Reserved.
%MWr.m.c.3	Generic detected error count				Number of received emergency messages with code 10xxH
%MWr.m.c.4	Device hardware detected error count				Number of received emergency messages with code 50xxH

Object	Function	Standard Symbol	Type	Access	Meaning
%MWr.m.c.5	Device software detected error count				Number of received emergency messages with code 60xxH
%MWr.m.c.6	Communication detected error count				Number of received emergency messages with code 81xxH
%MWr.m.c.7	Protocol detected error count				Number of received emergency messages with code 82xxH
%MWr.m.c.8	External detected error count				Number of received emergency messages with code 90xxH
%MWr.m.c.9	Device-specific				Number of received emergency messages with code FFxxH

Language Objects Associated with Configuration

At a Glance

The configuration of a CANopen master is stored in the configuration constants (%KW).

The parameters *r*, *m* and *c* shown in the following tables represent the topologic addressing of the module. Each parameter has the following signification:

- **r**: represents the rack number,
- **m**: represents the position of the module on the rack,
- **c**: represents the channel number.

Configuration Objects

The following table lists all process control language objects associated with the configuration of CANopen network:

Number	Type	Function	Description
%KWr.m.c.0	INT	Constant value used by the system	Least significant byte: Bit 2 to 7= 0, and : <ul style="list-style-type: none"> • Bit 0= 0 and Bit 1= 0: reset of outputs if task in STOP or HALT • Bit 0= 1 and Bit 1= 0: maintain of outputs if task in STOP or HALT • Bit 0= 0 and Bit 1= 1: bus in STOP if task in STOP or HALT Most significant byte: 16#38.
%KWr.m.c.1	INT	Baud Rate (see Premium and Atrium using EcoStruxure™ Control Expert, CANopen Field Bus, User manual)	Values are encoded : <ul style="list-style-type: none"> • 0 = 1000 Kbaud, • 2 = 500 Kbaud, • 3 = 250 Kbaud, • 4 = 125 Kbaud, • 5 = 50 Kbaud, • 6 = 20 Kbaud.
%KWr.m.c.2	INT	COB-ID Synchronization	Default value: 0080h.
%KWr.m.c.3	INT	Synchronization period	1 .. 5000 ms.
%KWr.m.c.4	INT	Configuration bits	Size of input image zone TOR in the memory (in number of bits).
%KWr.m.c.5	INT	Configuration bits	Size of output image zone TOR in the memory (in number of bits).
%KWr.m.c.6	INT	Configuration bits	Address of the start of the input image zone TOR(%M).
%KWr.m.c.7	INT	Configuration bits	Address of the start of the output image zone TOR (%M).
%KWr.m.c.8	INT	Configuration words	Size of input image zone in the memory (in number of words).
%KWr.m.c.9	INT	Configuration words	Size of output image zone in the memory (in number of words).
%KWr.m.c.10	INT	Configuration words	Address of the start of the input image zone (%MW).
%KWr.m.c.11	INT	Configuration words	Address of the start of the input image zone (%MW).
%KWr.m.c.12	INT	NMT inhibit time	Minimum time in 1/10ms between 2 NMT commands on the bus. Default value= 50 (5 ms)
%KWr.m.c.13	INT	Device Bootup timeout	Timeout in ms for reading object 1000 during configuration of the devices. Default value= 50 ms
%KWr.m.c.14	INT	Device SDO timeout	SDO timeout in ms used for the device with node ID= 1 Default value= 1000 ms

Number	Type	Function	Description
%KWr.m.c.15	INT	Device SDO timeout	SDO timeout in ms used for the device with node ID= 2 Default value= 1000 ms
...	INT	...	SDO timeout in ms used for the device with node ID= ... Default value= 1000 ms
%KWr.m.c.76	INT	Device SDO timeout	SDO timeout in ms used for the device with node ID= 63 Default value= 1000 ms

Emergency objects

Subject of this Section

This section presents the emergency objects of CANopen communication.

Emergency Objects

At a Glance

Emergency objects (EMCY) have been defined for CANopen for diagnostic applications.

The COB-ID of these objects contain the identity of the node of the device which produced the emergency message. The COB-ID of emergency objects are constructed in the following manner:

$$\text{COB-ID}_{\text{EMCY}} = 0x80 + \text{node identity}$$

The data field of an EMCY object is composed of 8 bytes containing:

- Emergency detected error code (2 bytes),
- The detected error register (1 byte),
- The factory-specific error information (5 bytes).

The following illustration shows the structure of an EMCY object:

COB-ID	Error code		Register error	Error Information manufacturer specific					
	Byte 0	Byte 1		Byte 2	Byte 3	Byte 4	Byte 5	Byte 6	Byte 7
0x80+node-ID									

NOTE: the contents of the detected error code and error register are specified by CiA.

With the `Error` tab, page 132, you can consult the 4 last emergency messages received, in chronological order.

NOTE: Regarding Safety considerations, “Emergency objects” and “Fatal error” are mentioned in this manual in conformance with the definition from the DS301 document of the CiA (CAN in Automation).

Detected error code 00xx

The following table describes the content of detected error code 00xx:

Detected error code (hex)	Description
00xx	Error reset to zero or no error

Detected error code 10xx

The following table describes the content of detected error code 10xx:

Detected error code (hex)	Description
10xx	Generic error

Detected error code 2xxx

The following table describes the content of detected error code 2xxx:

Detected error code (hex)	Description
20xx	Current
21xx	Current, input side of the device
22xx	Internal current to the device
23xx	Current, output side of the device

Detected error code 3xxx

The following table describes the content of detected error code 3xxx:

Detected error code (hex)	Description
30xx	Voltage
31xx	Principal voltage
32xx	Internal voltage to the device
33xx	Output voltage

Detected error code 4xxx

The following table describes the content of detected error code 4xxx:

Detected error code (hex)	Description
40xx	Temperature
41xx	Ambient temperature
42xx	Device temperature

Detected error code 50xx

The following table describes the content of detected error code 50xx:

Detected error code (hex)	Description
50xx	Device hardware

Detected error code 6xxx

The following table describes the content of detected error code 6xxx:

Detected error code (hex)	Description
60xx	Device software
61xx	Internal software

Detected error code (hex)	Description
62xx	User software
63xx	Data set

Detected error code 70xx

The following table describes the content of detected error code 70xx:

Detected error code (hex)	Description
70xx	Additional modules

Detected error code 8xxx

The following table describes the content of detected error code 8xxx:

Detected error code (hex)	Description
80xx	Monitoring
81xx	Communication
8110	CAN overflow (objects lost)
8120	CAN in passive error mode
8130	Life Guard error or Heartbeat error
8140	Recovered from bus
8150	Collision during COB-ID transmission
82xx	Protocol error
8210	PDO not processed due to length error
8220	PDO length exceeded

Detected error code 90xx

The following table describes the content of detected error code 90xx:

Detected error code (hex)	Description
90xx	External error

Detected error code Fxxx

The following table describes the content of detected error code Fxxx:

Detected error code (hex)	Description
F0xx	Additional functions
FFxx	Specific to the device

Quick start : example of CANopen implementation

What's in This Part

Description of the application	177
Installing the application using Control Expert	180
Starting the Application	211

Overview

This section presents an example of CANopen implementation.

Description of the application

What's in This Chapter

Overview of the application 177

Subject of this chapter

This chapter states the application specifications and illustrates the end result to be obtained using the example of an operator screen.

Overview of the application

At a glance

The application described in this document is used for the driving of a working mobile.

The mobile goes to different working positions following a defined position sequence. The mobile stops for few seconds at these positions.

The application's control resources are based on an operator screen which shows the status of the various position sensors and the actual mobile position value. A red message blinks when the mobile is moving.

Illustration of the application

This is the application's final operator screen:

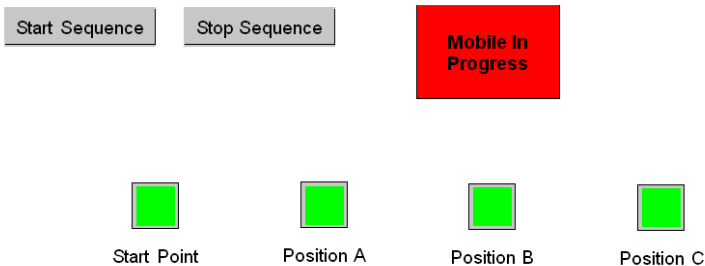

The equipments can be connected as follow:

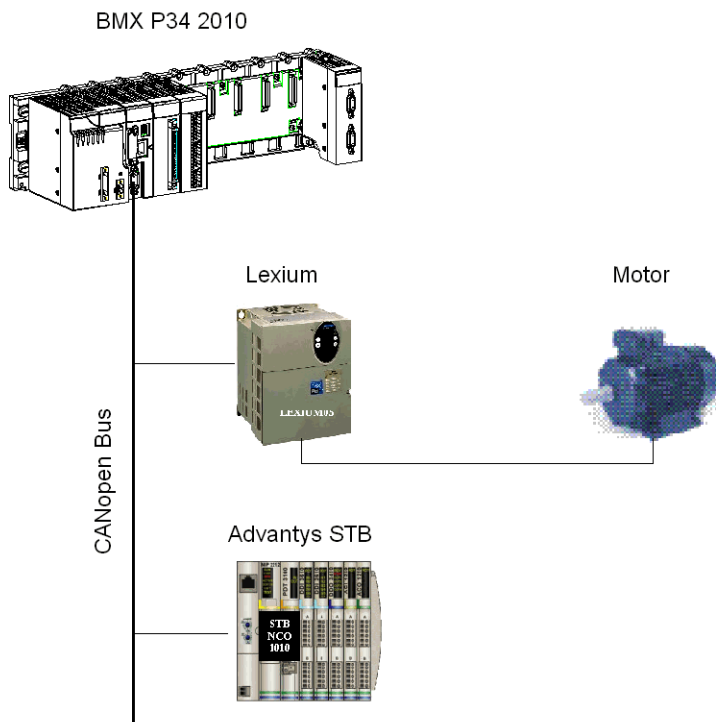

Operating mode

The operating mode is as follows:

- A **Start Sequence** button is used to start the defined sequence.
- In this example, the mobile first goes to B position then to the A position and, at the end, to the C position, before coming back to the Start Point, waiting for a new start-up request.
- The mobile stops for few seconds at each position to simulate an action time.
- A **Stop Sequence** button interrupts the mobile sequence. The mobile stops to the last targeted position and comes back to the Start Point, waiting for a new start-up request.

Installing the application using Control Expert

What's in This Chapter

Presentation of the solution used	180
Developing the application.....	182

Subject of this chapter

This chapter describes the procedure for creating the application described. It shows, in general and in more detail, the steps in creating the different components of the application.

Presentation of the solution used

Subject of this section

This section presents the solution used to develop the application. It explains the technological choices and gives the application's creation timeline.

Technological choices used

At a glance

There are several ways of writing a mobile driving application using Control Expert. The one proposed, uses a Lexium 05 servo drives and Advantys STB island set up on a CANopen network.

Technological choices

The following table shows the technological choices used for the application:

Objects	Choices used
Lexium Operating Mode	Use of the Positioning Mode. This mode allows you to send a target position to the Lexium 05 servo drives through the CANopen network.
Sensor Interface	Use of a STB Advantys. This device is an assembly of distributed I/O, power, and other modules that function together as an island node on an open field bus network
Supervision screen	Use of elements from the library and new objects.
Main supervision program	This program is developed using a sequential function chart (SFC), also called GRAFCET. The various sections and transitions are created in Ladder Diagram (LD) language and in Structured Text language (ST).

NOTE: This example shows PDO and SDO exchange towards a speed drive. However, for speed drive configuration and control, the use of Motion Function Block is recommended.

The different steps in the process using Control Expert

At a glance

The following logic diagram shows the different steps to follow to create the application. A chronological order must be respected in order to correctly define all of the application elements.

Description

Description of the different types:

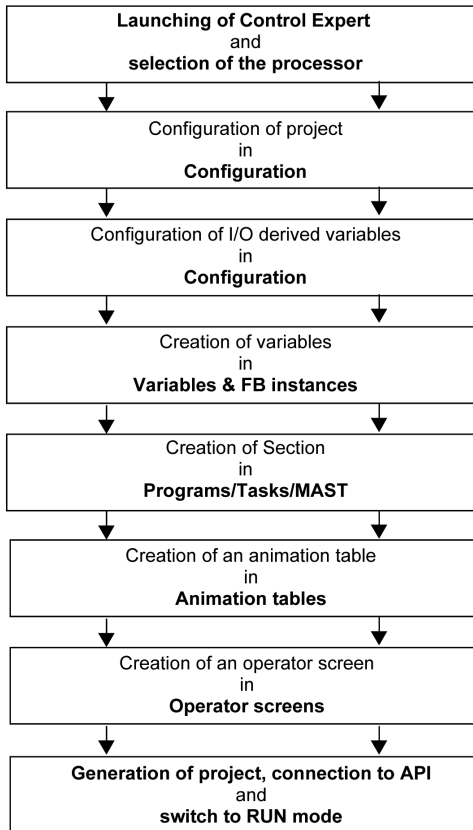

Developing the application

Subject of this section

This section gives a step-by-step description of how to create the application using Control Expert.

Creating the project

At a glance

Developing an application using Control Expert involves creating a project associated with a PLC.

Procedure for creating a project

The table below shows the procedure for creating the project using Control Expert.

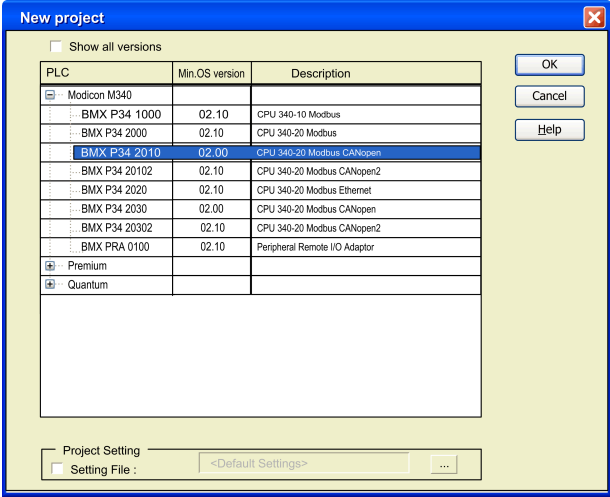
Step	Action
1	Launch the Control Expert software.
2	Click on File then New to select a CANopen Master PLC (BMX P34 2010 for example): 
3	To see all PLC versions, click on the box Show all versions.
4	Select the processor you wish to use from those proposed.
5	To create a project with specific values of project settings, check the box Settings File and use the browser button to localize the .XSO file (Project Settings file). It is also possible to create a new one. If the Settings File box is not checked , default values of project settings are used.
6	Confirm with OK.

Configuration of the CANopen Bus

At a glance

Developing a CANopen application involves choosing the right slave devices and appropriate configuration.

Illustration of the CANopen bus

The following screen shows the configured CANopen bus:

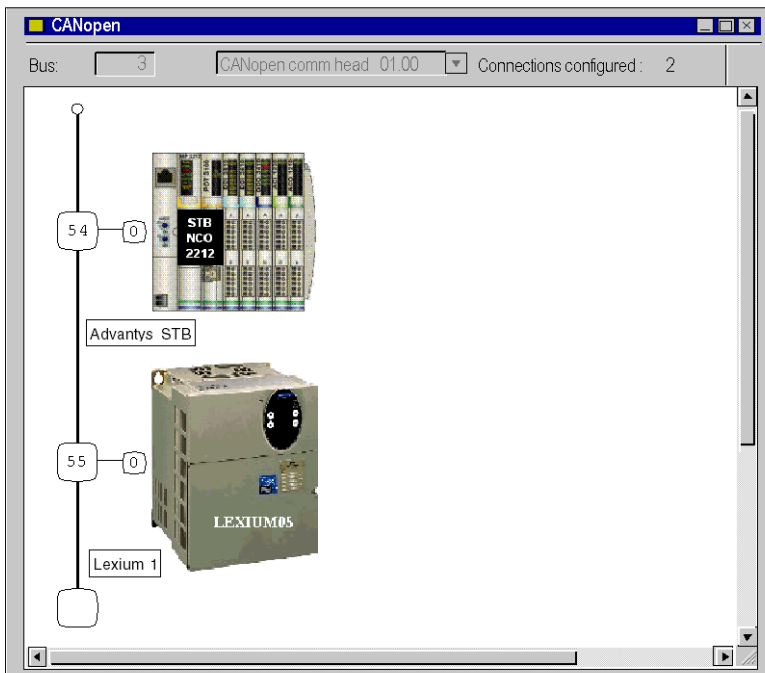

CANopen bus Configuration

The table below shows the procedure for selecting the CANopen slaves:

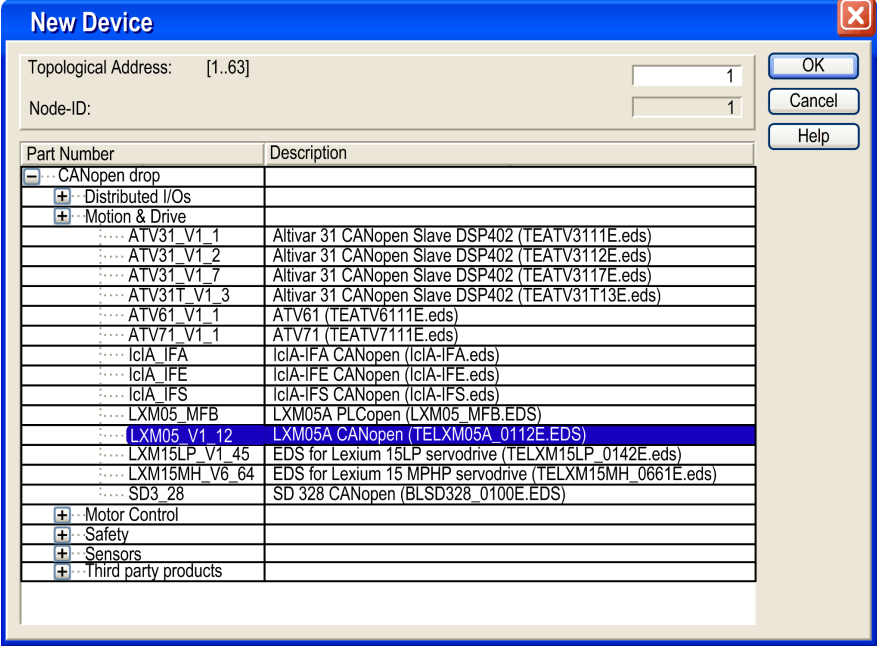
Step	Action																																												
1	In the Project browser, double-click on Configuration then on 3 : CANopen. The CANopen window opens.																																												
2	<p>In the CANopen window, double-click on the node where the slave must be linked to.</p> <p>Result: the following window opens.</p>  <table border="1" data-bbox="252 483 987 922"> <thead> <tr> <th>Part Number</th> <th>Description</th> </tr> </thead> <tbody> <tr><td>- CANopen drop</td><td></td></tr> <tr><td>+ Distributed I/Os</td><td></td></tr> <tr><td>+ Motion & Drive</td><td></td></tr> <tr><td>.... ATV31_V1_1</td><td>Altivar 31 CANopen Slave DSP402 (TEATV3111E.eds)</td></tr> <tr><td>.... ATV31_V1_2</td><td>Altivar 31 CANopen Slave DSP402 (TEATV3112E.eds)</td></tr> <tr><td>.... ATV31_V1_7</td><td>Altivar 31 CANopen Slave DSP402 (TEATV3117E.eds)</td></tr> <tr><td>.... ATV31T_V1_3</td><td>Altivar 31 CANopen Slave DSP402 (TEATV31T13E.eds)</td></tr> <tr><td>.... ATV61_V1_1</td><td>ATV61 (TEATV6111E.eds)</td></tr> <tr><td>.... ATV71_V1_1</td><td>ATV71 (TEATV7111E.eds)</td></tr> <tr><td>.... lclA_IFA</td><td>lclA-IFA CANopen (lclA-IFA.eds)</td></tr> <tr><td>.... lclA_IFE</td><td>lclA-IFE CANopen (lclA-IFE.eds)</td></tr> <tr><td>.... lclA_IFS</td><td>lclA-IFS CANopen (lclA-IFS.eds)</td></tr> <tr><td>.... LXM05_MFB</td><td>LXM05A PLCopen (LXM05_MFB.EDS)</td></tr> <tr><td>.... LXM05_V1_12</td><td>LXM05A CANopen (TELX05A_0112E.EDS)</td></tr> <tr><td>.... LXM15LP_V1_45</td><td>EDS for Lexium 15LP servodrive (TELXM15LP_0142E.eds)</td></tr> <tr><td>.... LXM15MH_V6_64</td><td>EDS for Lexium 15 MPHP servodrive (TELXM15MH_0661E.eds)</td></tr> <tr><td>.... SD3_28</td><td>SD 328 CANopen (BLSD328_0100E.EDS)</td></tr> <tr><td>+ Motor Control</td><td></td></tr> <tr><td>+ Safety</td><td></td></tr> <tr><td>+ Sensors</td><td></td></tr> <tr><td>+ Third party products</td><td></td></tr> </tbody> </table>	Part Number	Description	- CANopen drop		+ Distributed I/Os		+ Motion & Drive	 ATV31_V1_1	Altivar 31 CANopen Slave DSP402 (TEATV3111E.eds) ATV31_V1_2	Altivar 31 CANopen Slave DSP402 (TEATV3112E.eds) ATV31_V1_7	Altivar 31 CANopen Slave DSP402 (TEATV3117E.eds) ATV31T_V1_3	Altivar 31 CANopen Slave DSP402 (TEATV31T13E.eds) ATV61_V1_1	ATV61 (TEATV6111E.eds) ATV71_V1_1	ATV71 (TEATV7111E.eds) lclA_IFA	lclA-IFA CANopen (lclA-IFA.eds) lclA_IFE	lclA-IFE CANopen (lclA-IFE.eds) lclA_IFS	lclA-IFS CANopen (lclA-IFS.eds) LXM05_MFB	LXM05A PLCopen (LXM05_MFB.EDS) LXM05_V1_12	LXM05A CANopen (TELX05A_0112E.EDS) LXM15LP_V1_45	EDS for Lexium 15LP servodrive (TELXM15LP_0142E.eds) LXM15MH_V6_64	EDS for Lexium 15 MPHP servodrive (TELXM15MH_0661E.eds) SD3_28	SD 328 CANopen (BLSD328_0100E.EDS)	+ Motor Control		+ Safety		+ Sensors		+ Third party products	
Part Number	Description																																												
- CANopen drop																																													
+ Distributed I/Os																																													
+ Motion & Drive																																													
.... ATV31_V1_1	Altivar 31 CANopen Slave DSP402 (TEATV3111E.eds)																																												
.... ATV31_V1_2	Altivar 31 CANopen Slave DSP402 (TEATV3112E.eds)																																												
.... ATV31_V1_7	Altivar 31 CANopen Slave DSP402 (TEATV3117E.eds)																																												
.... ATV31T_V1_3	Altivar 31 CANopen Slave DSP402 (TEATV31T13E.eds)																																												
.... ATV61_V1_1	ATV61 (TEATV6111E.eds)																																												
.... ATV71_V1_1	ATV71 (TEATV7111E.eds)																																												
.... lclA_IFA	lclA-IFA CANopen (lclA-IFA.eds)																																												
.... lclA_IFE	lclA-IFE CANopen (lclA-IFE.eds)																																												
.... lclA_IFS	lclA-IFS CANopen (lclA-IFS.eds)																																												
.... LXM05_MFB	LXM05A PLCopen (LXM05_MFB.EDS)																																												
.... LXM05_V1_12	LXM05A CANopen (TELX05A_0112E.EDS)																																												
.... LXM15LP_V1_45	EDS for Lexium 15LP servodrive (TELXM15LP_0142E.eds)																																												
.... LXM15MH_V6_64	EDS for Lexium 15 MPHP servodrive (TELXM15MH_0661E.eds)																																												
.... SD3_28	SD 328 CANopen (BLSD328_0100E.EDS)																																												
+ Motor Control																																													
+ Safety																																													
+ Sensors																																													
+ Third party products																																													
3	In the New Device window, enter the node number (55), then double click on Motion and select the Lexium05.																																												

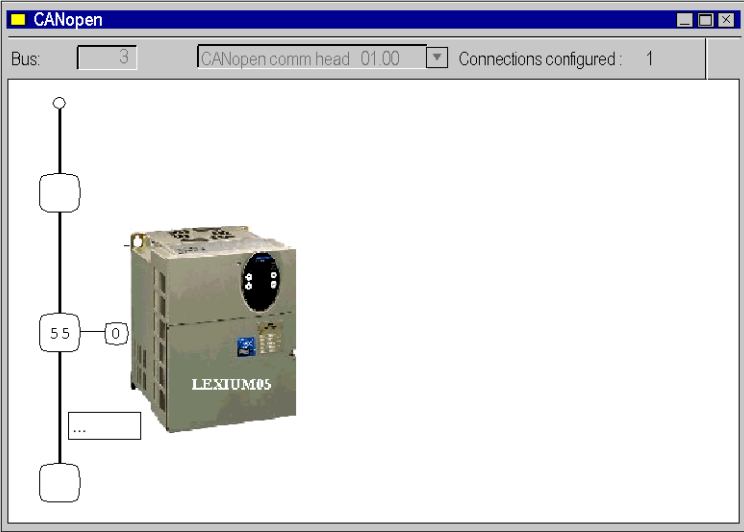
Step	Action
4	<p>Confirm with OK.</p> <p>Result: the slave module is declared.</p> 
5	<p>Follow the same procedure to declare the Advantys STB island. In the <i>New Device</i> window, enter the node number (54), then double click on <i>Other</i> and select the <i>STB_NCO_2212</i>.</p>

NOTE: This example shows PDO and SDO exchange towards a speed drive. However, for speed drive configuration and control, use Motion Function Blocks.

NOTE: This Advantys STB island configuration has to be set up using the Advantys Configuration Software.

STB island configuration

The table below shows the procedure to configure a STB island with Advantys Configuration Software:

Step	Action
1	Open Advantys Configuration Software Version 2.2.0.2 and create a new STB Island.
2	Insert a STB NCO2212 supply module, a STB DDI3420 discrete input module and a STB DD03410 discrete output module on the island.

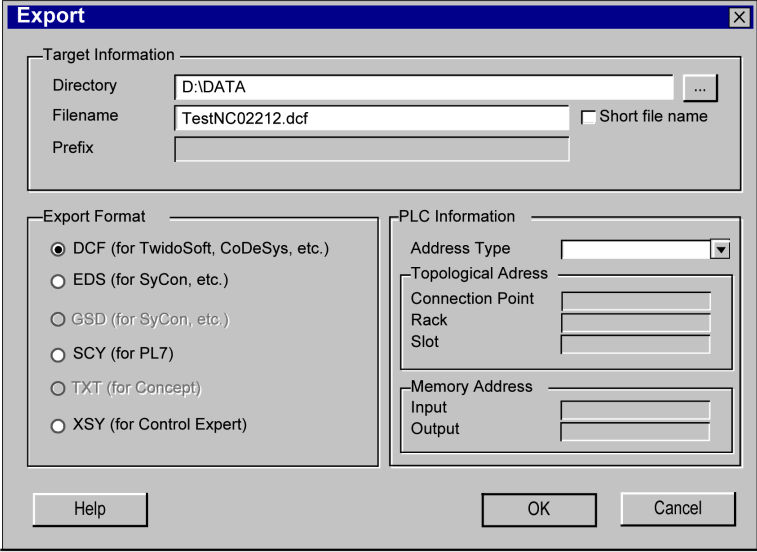
Step	Action
3	<p>Save the configuration and click on <code>File/Export</code> for exporting the island in DCF format.</p> <p>The <code>Export</code> window opens:</p> 
4	Click on <code>OK</code>
5	Launch Control Expert and open a project where an STB island will be used.
6	Add the STB equipment in the bus editor.
7	Right-click on the STB equipment then click on <code>Open the module</code>
8	In the <code>PDO</code> tab, click on the <code>Import DCF</code> button (see <code>Configuration of the STB</code> , page 190).
9	Click on <code>OK</code> to validate.

CANopen devices are not supported during an `*.xsy` file import from Advantys to Control Expert. The `%MW` objects that are assigned in the `PDO` table are not in the same range as those defined in the configuration for the CANopen head.

⚠ WARNING

UNINTENDED EQUIPMENT OPERATION

Do not use the symbol file `*.xsy` generated by Advantys in Control Expert during the configuration of an STB Island.

Failure to follow these instructions can result in death, serious injury, or equipment damage.

Configuration of the CANopen Master

At a glance

Developing a CANopen application involves choosing the right CANopen Master PLC configuration.

CANopen Master PLC configuration

The table below show the procedure for configuring the CANopen Master PLC:

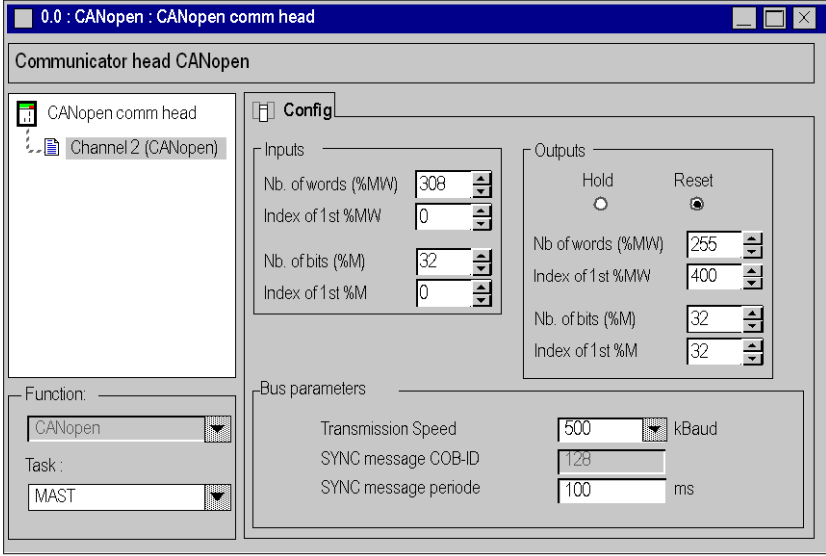
Step	Action
1	In the Project browser double-click on Configuration then on 0 : BMS XBP 0800 then on 0 : BMX P34 2010. double click on CANopen to access to the CANopen Comm Head window.
2	In the input and output configuration zones, enter the index of the 1st word (%MW) and the needed number of words.
3	<p>In the Bus Parameter zone, select the application transmission speed. In this example, select 500 kBauds.</p> 
4	Click on the <input checked="" type="checkbox"/> button in the toolbarto validate the configuration.

NOTE: When the project is built, warning and error messages can be displayed in the output window. If not displayed, click on *View/Output Window*.

Warning messages indicates that there are more configured words than necessary on the bus.

Error messages indicate that configured words are missing.

Configuration of the equipment

At a glance

Once the slave is declared, it's possible to have access to its configuration window.

Configuration of the Lexium Servo Drives

The table below shows the procedure for the Lexium configuration:

Step	Action
1	In the <i>Project browser</i> , double-click on <i>Configuration then 3: CANopen</i> .
2	In the <i>CANopen</i> window, double-click on the Lexium representation. The Lexium configuration window opens.
3	Click on the <i>PDO</i> tab to see the PDO configuration, the variables and their topological addresses.
4	For this example, select <i>PDO2 (Static)</i> in the <i>Transmit (%I)</i> and the <i>Received (%Q)</i> windows.

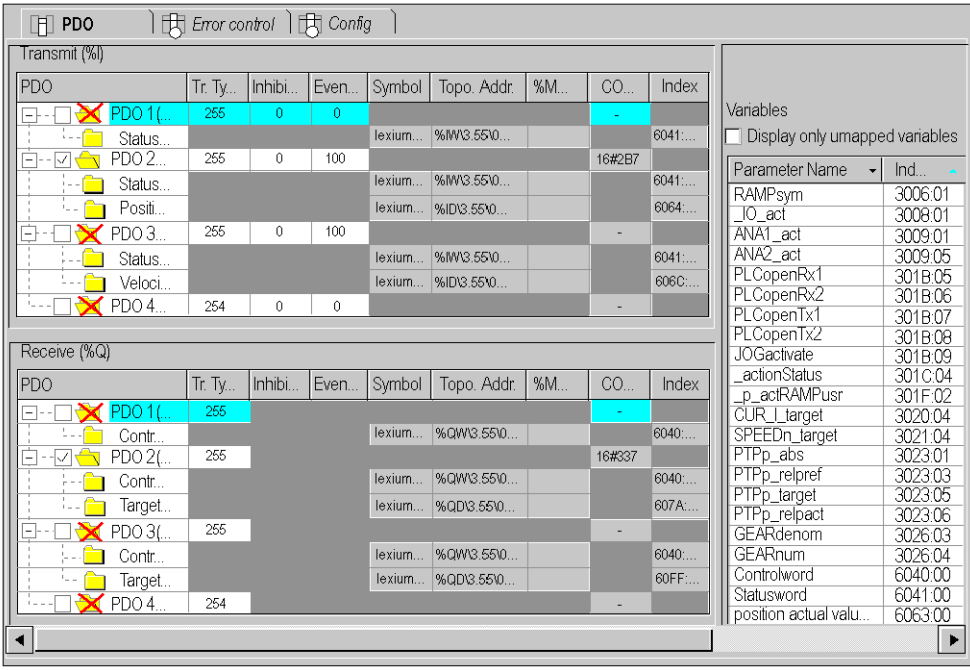
Step	Action
	 <p>The screenshot shows the 'PDO' configuration window. At the top, there are tabs for 'PDO', 'Error control', and 'Config'. Below the tabs are two tables: 'Transmit (%I)' and 'Receive (%Q)'. The 'Transmit' table has columns for PDO, Tr. Ty., Inhibi..., Even..., Symbol, Topo. Addr., %M..., CO..., and Index. It lists PDO 1, 2, 3, and 4 with their respective parameters. The 'Receive' table has similar columns and lists PDO 1, 2, 3, and 4. To the right of the tables is a 'Variables' section with a checkbox 'Display only unmapped variables' and a list of parameter names and their indices.</p>
5	Click on the <code>Error control</code> tab and set the <code>Node Heartbeat producer time</code> to <code>300ms</code>
6	Click on the <input checked="" type="checkbox"/> button in the toolbar to validate the configuration.
7	Close the window.

Configuration of the STB

The table below shows the procedure to load the configuration defined with the Advantys Configuration software:

Step	Action
1	In the <code>Project browser</code> , double-click on <code>Configuration then 3 : CANopen</code> .
2	In the <code>CANopen</code> window, double-click on the Advantys STB representation. The STB NCO2212 configuration window opens.
3	In <code>Function zone</code> , select <code>Autoconf</code> .

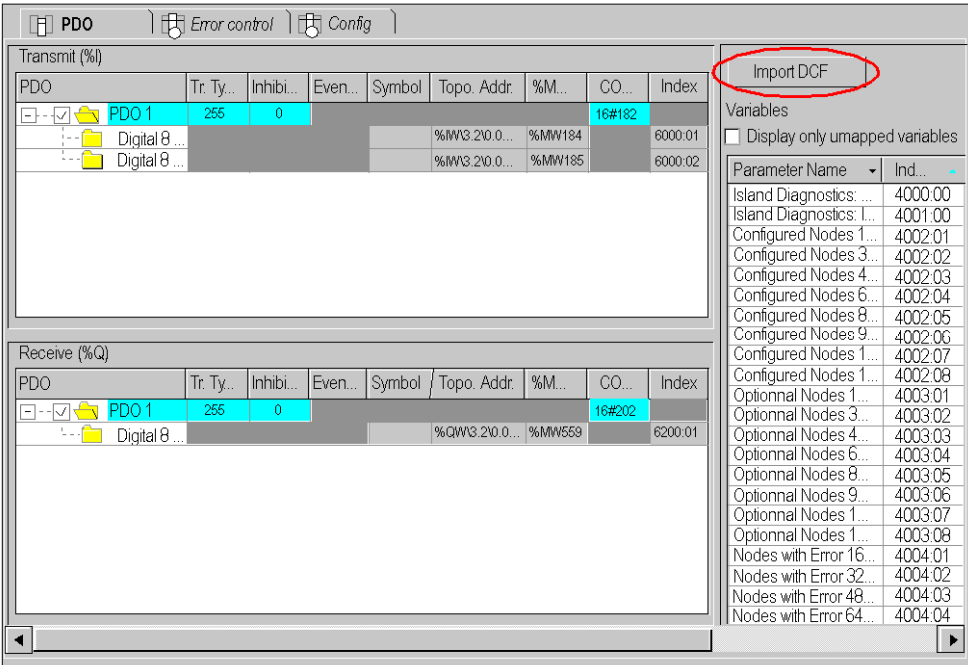
Step	Action
	<div style="text-align: center;">  </div> <p>In this example, we use the <code>Autoconf</code> function because autoconfigurable modules are inserted on the STB island, page 215.</p>
4	<p>Click on the <code>PDO</code> tab to see the PDO configuration, the variables and their topological addresses. Click on the right button of the horizontal scroll bar to see the <code>Import DCF</code> button.</p>
5	<p>Click on <code>Import DCF</code> button to load the DCF configuration file generated with the Advantys Configuration Software.</p> 
6	<p>Click on the <code>Error control</code> tab and set the <code>Node Heartbeat producer time</code> to 300ms</p>
7	<p>Click on the <input checked="" type="checkbox"/> button in the toolbar to validate the configuration.</p>
8	<p>Close the window.</p> <p>For more information refer to STB configuration, page 234.</p>

Declaration of I/O objects

The table below shows the procedure to load the configuration defined with the Advantys Configuration software:

Step	Action
1	Open the \3.55\0.0 : Lexium05 window by clicking on the Lexium module icon in the CANopen window. Click on the Lexium05 and then on the I/O object tab.
2	Click on the I/O object prefix address %CH then on the Update grid button, the channel address appears in the I/O object grid.
3	Click on the line %CH\3.55\0.0 and then, in the I/O object creation window, enter a channel name in the prefix for name zone, Lexium for example.
4	Now click on different Implicit I/O object prefix addresses then on update grid button to see the names and addresses of the homicide I/O objects.

Overview
CANopen
I/O objects

I/O variable creation

Prefix for name:

Type:

Comment:

I/O object

Channel: %CH

Configuration %KW %KD %KF

System %MW

Status %MW

Parameter %MW %MD %MF

Command %MW %MD %MF

Implicits %I %IW %ID %IF %ERR
 %Q %QW %QD %QF

Update

	Address	Name
1	%CH3.550.0.0	Lexium
2	%DI3.550.0.0	Lexium.Cap1Pos
3	%DI3.550.0.0.2	Lexium.Cap2Pos
4	%DI3.550.0.0.4	Lexium.param27
5	%DI3.550.0.0.6	Lexium.param27
6	%DI3.550.0.0.8	Lexium.p_actRAM
7	%DI3.550.0.0.10	Lexium.position_a
8	%DI3.550.0.0.12	Lexium.position
9	%DI3.550.0.0.14	Lexium.Velocity_a
10	%IW3.550.0.0.16	Lexium.IO_act
11	%IW3.550.0.0.17	Lexium.ANA1_act
12	%IW3.550.0.0.18	Lexium.ANA2_act
13	%IW3.550.0.0.19	Lexium.Cap1Cou
14	%IW3.550.0.0.20	Lexium.Cap2Cou
15	%IW3.550.0.0.21	Lexium.actionStat
16	%IW3.550.0.0.22	Lexium.Statuswo
17	%QD3.550.0.0	Lexium.param27
18	%QD3.550.0.0.2	Lexium.param35
19	%QD3.550.0.0.4	Lexium.param35
20	%QD3.550.0.0.6	Lexium.param35
21	%QD3.550.0.0.8	Lexium.param35
22	%QD3.550.0.0.10	Lexium.GEARden
23	%QD3.550.0.0.12	Lexium.GEARnu
24	%QD3.550.0.0.14	Lexium.Target P
25	%QD3.550.0.0.16	Lexium.Profile_Ve
26	%QD3.550.0.0.18	Lexium.Target_Ve
27	%QW3.550.0.0.20	Lexium.Param_6
28	%QW3.550.0.0.21	Lexium.JOGactiva
29	%QW3.550.0.0.22	Lexium.CUR_Lta
30	%QW3.550.0.0.23	Lexium.SPEEDn
31	%QW3.550.0.0.24	Lexium.param35
32	%QW3.550.0.0.25	Lexium.Controlw

NOTE: Repeat the same procedure to create a CANopen I/O object named BusMaster (%CH0.0.2). In the PLC bus window, double-click on the CANopen port then click on CANopen comm head to access the I/O objects tab.

Declaration of variables

At a glance

All of the variables used in the different sections of the program must be declared.

Undeclared variables cannot be used in the program.

NOTE: For more information, refer to chapter *Data Editor* (see EcoStruxure™ Control Expert, Operating Modes).

Procedure for declaring variables

The table below shows the procedure for declaring application variables:

Step	Action
1	In Project browser / Variables & FB instances, double-click on Elementary variables
2	In the Data editor window, select the box in the Name column and enter a name for your first variable.
3	Now select a Type for this variable.
4	When all your variables are declared, you can close the window.

Variables used for the application

The following table shows the details of the variables used in the application:

Variable	Type	Definition
Action_Time	TIME	Mobile stopping time at each position.
Configuration_Done	BOOL	The Lexium configuration is done.
Homing_Done	BOOL	The definition of the origin point is done.
index_subindex	DINT	CANopen parameter addresses for the WRITE_VAR block.
Lexium_Config_Step	INT	Configuration steps (program)
Lexium_Disabling	INT	Shutdown command
Lexium_operation_enable	INT	Command to start the Lexium drive.
Mobile_at_Position_A	BOOL	Mobile at the A position.
Mobile_at_Position_B	BOOL	Mobile at the B position.

Variable	Type	Definition
Mobile_at_Position_C	BOOL	Mobile at the C position.
Mobile_at_start_position	BOOL	Mobile at the start position.
Mobile_in_Progress	BOOL	The mobile is moving.
New_SetPoint	BOOL	Start the next move.
Operation_done	BOOL	The mobile operation is done.
Position_A	DINT	First positioning value.
Position_B	DINT	Second positioning value.
Position_C	DINT	Third positioning value.
Ready_For_Stop	BOOL	The mobile goes to the last targeted position indicated before stopping the application. Then it comes back to the start position.
Run	BOOL	Start of the sequence.
Sequence_Number	INT	Number of displacements made by the mobile.
Start_Configuration	EBOOL	Start the Lexium configuration.
Stop	BOOL	The mobile stops the sequence and comes back to the start point.
Target_Reached	BOOL	The target position is reached.

The following screen shows the application variables created using the data editor :

Name	Type	Address	Value	Comment
Action_Time	TIME		#3s	
Configuration_Done	BOOL...			
Homing_Done	BOOL	%IW3.5510.0.0.22.14		
index_subindex	DINT			
Lexium_Config_Step	INT			
Lexium_Disabling	INT		6	
Lexium_operation_enable	INT		15	
Mobile_at_Position_A	BOOL			
Mobile_at_Position_B	BOOL			
Mobile_at_Position_C	BOOL			
Mobile_at_Start_Position	BOOL			
Mobile_In_Progress	BOOL			
New_SetPoint	BOOL	%QW3.5510.0.0.25.4		
Operation_Done	BOOL			
Position_A	DINT		50000	
Position_B	DINT		100000	
Position_C	DINT		200000	
Ready_For_Stop	BOOL			
Run	BOOL			
Sequence_Number	INT			
Start_Configuration	EBOOL			
Stop	BOOL			
Target_Reached	BOOL	%IW3.5510.0.0.22.10		

NOTE: At start-up, the Lexium 05 is in *Ready to switch on state* (*rdy* is displayed). To be able to drive the motor, the Lexium must be in *Operation enable state*. To switch in this state, a bus command sets the 4 last bits of the Lexium control word to '1' (00001111 (binary) = 15 (decimal)).

To switch the Lexium 05 to the *Ready to switch on state*, a bus command sets the sixth and the seventh bit of the Lexium control word to '1' (00000110 (binary) = 6 (decimal)).

For more information on Lexium control word, consult the Lexium manufacturer manual.

Creating the program in SFC for managing the move sequence

At a glance

The main program is written in SFC (Grafcet). The different sections of the grafcet steps and transitions are written in LD. This program is declared in a MAST task, and depends on the status of a Boolean variable.

The main advantage of SFC language is that its graphic animation allows you to monitor in real time the execution of an application.

Several sections are declared in the MAST task:

- The **Move_Sequence** section (See Illustration of the Move_Sequence section, page 199), written in SFC and describing the operate mode.
- The **Application** section (See Creating a Program in LD for Application Execution, page 200), written in LD, which executes the mobile action delay time and resets the positioning start bit `New_Setpoint`.
- The **Operator_Screen_Animation** section (See Creating a Program in LD for the operator screen animation, page 202), written in LD which is used to animate the operator screen.
- The **Lexium_Config** section (See Creating a program in ST for the Lexium configuration, page 203), written in ST and describing the different steps of the Lexium configuration.

In the project browser, the sections are represented as follow:

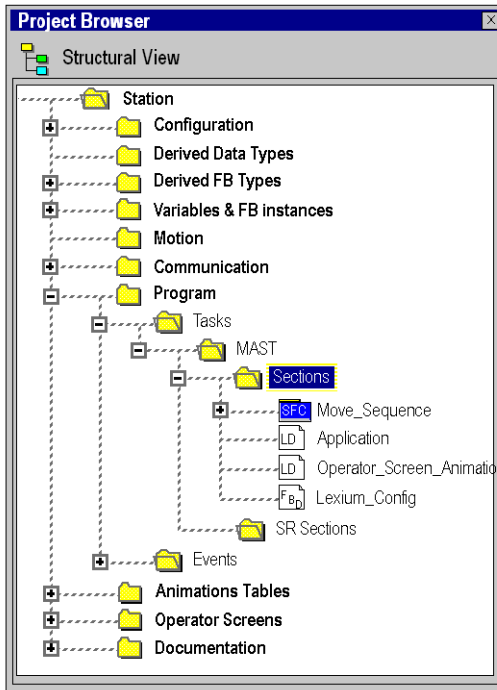

NOTE: The LD, SFC and FBD-type sections used in the application must be animated in online mode (See Execution of Application in Standard Mode, page 211), with the controller in RUN

NOTE: If task cycle is faster than CANopen Master cycle, outputs can be overwritten. To help avoid this situation, have a task cycle higher than the CANopen Master cycle.

Procedure for Creating an SFC Section

The table below shows the procedure for creating an SFC section for the application.

Step	Action
1	In Project Browser\Program\Tasks, double-click on MAST.
2	Right click on Section then select New section. Give your section a name (Movement_ sequence for the SFC section) then select SFC language.



Step	Action
3	The name of your section appears, and can now be edited by double clicking on it.
4	<p>The SFC edit tools appear in the window, which you can use to create your Grafset.</p> <p>For example, to create a step with a transition:</p> <ul style="list-style-type: none"><li data-bbox="340 337 911 370">• To create the step, click on  then place it in the editor,<li data-bbox="340 391 1137 451">• To create the transition, click on  then place it in the editor (generally under the preceding step).

Illustration of the Move_Sequence section

The following screen shows the application Grafcet. There is no condition defined:

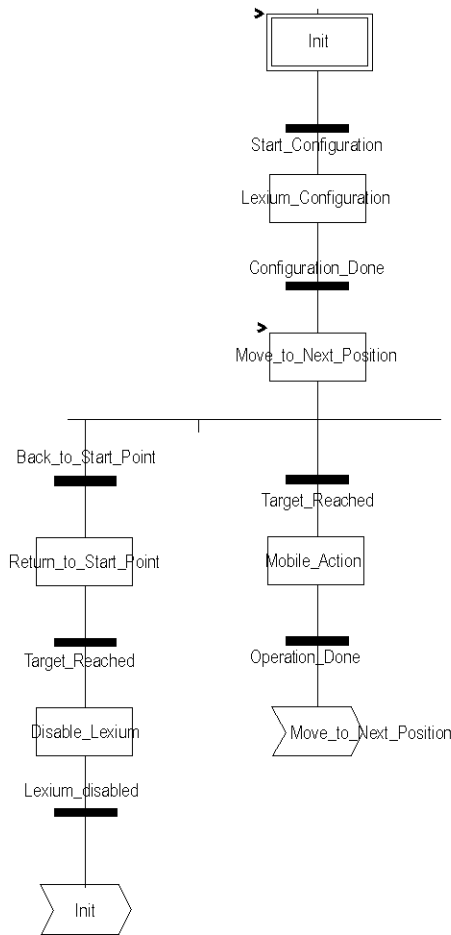

For actions and transitions used in the grafcet, see *Actions and transitions*, page 237

NOTE: For more information on creating an SFC section, refer to chapter *SFC Editor* (see EcoStruxure™ Control Expert, Operating Modes).

Description of the Move_Sequence Section

The following table describes the different steps and transitions of the Move_Sequence Grafcet:

Step / Transition	Description
Init	This is the initial state.
Start_Configuration	This transition is active when the variables: <ul style="list-style-type: none"> • Stop = 0, • Run = 1.
Lexium_Configuration	The Lexium 05 is enabled and the 0 position is defined (using the Lexium Homing function).
Configuration_done	The transition is active when the Lexium is initialized.
Move_to_next_position	The next target position is loaded in the Lexium 05. When this step is activated, the sequence number is incremented.
Target_reached	This variable is set to '1' by the Lexium 5 when the target position is reached.
Mobile_action	The mobile is at the target position and is operating an action.
Operation_done	This transition is active when the mobile operation is over.
Back_to_start_point	This transition is active when the sequence is over or when a stop request is ordered.
Return_to_start_point	The start point is defined at the target position.
Disable_Lexium	The Lexium 05 drive is disabled.
Lexium_disabled	This transition is valid when the Lexium is disabled.

NOTE: You can see the steps, actions and transitions of your SFC by clicking on  in front of the name of your SFC section.

Creating a Program in LD for Application Execution

At a glance

This section executes the mobile action delay time and resets the positioning start bit `New_Setpoint`.

Illustration of the Application Section

The section below is part of the MAST task. It has no condition defined for it so is permanently executed:

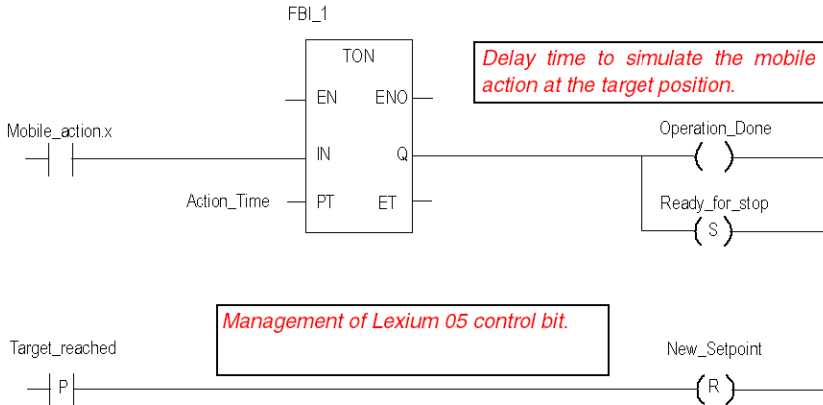



Description of the Application Section

- The first line is used to simulate the action time once the mobile is at the target position. When the `Mobile_Action` step is active, a TON timer is triggered. When the PT time is reached, the TON output switches to '1', validate the transition variable `Operation_done` and set the `Ready_for_stop` variable.
- The second line resets the variable `New_Setpoint` on the `Target_reached` positive transition.

Procedure for Creating an LD Section

The table below describes the procedure for creating part of the **Application** section.

Step	Action
1	In Project Browser\Program\Tasks, double-click on MAST.
2	Right click on Section then select New section. Name this section Application, then select the language type LD. The edit window opens.

Step	Action
3	<p>To create the contact Action_Mobile.x, click on  then place it in the editor.</p> <p>Double-click on this contact then enter the name of the step with the suffix ".x" at the end (signifying a step of an SFC section).</p> <p>Confirm with OK.</p>
4	<p>To use the TON block you must instantiate it. Right click in the editor then click on <i>Data Selection</i> and on . Click on the <i>Function and Function Block Types</i> tab. Click on <i>Libset</i>, select the TON block in the list then confirm with OK and position your block.</p> <p>To link the Action_Mobile.x contact to the Input of the TON function block, align the contact and the input horizontally, click on  and position the link between the contact and the input.</p>

NOTE: For more information on creating an LD section, refer to chapter *LD Editor* (see EcoStruxure™ Control Expert, Operating Modes).

Creating a Program in LD for the operator screen animation

At a glance

This section animates the operator screen.

Illustration of the Operator_Screen_Animation section

The section below is part of the MAST task. It has no condition defined for it so is permanently executed:

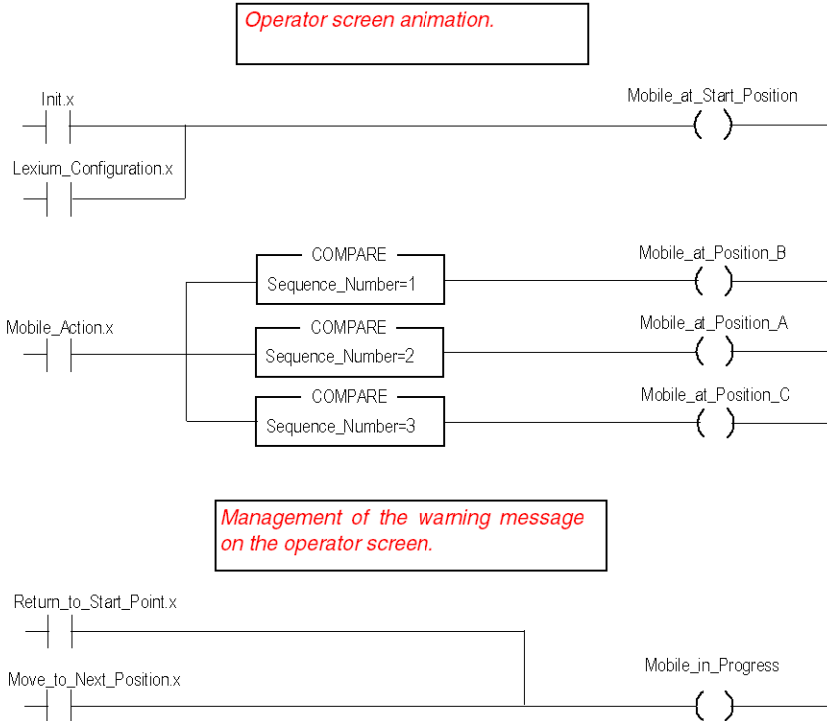

Procedure for Creating an LD Section

For creating a LD section, see Procedure for Creating an LD Section, page 201

Creating a program in ST for the Lexium configuration

At a glance

This section executes the different steps of the Lexium configuration. This section is only active when the step `Lexium_Configuration` is reached in the grafcet (see Illustration of the `Move_Sequence` section, page 199)

Programming structure

The programming structure is as follow:

Step number	Step description
0	Starting command of the Lexium.
10	If the Lexium is in Run State , then it switch in Homing mode using a WRITE_VAR function.
20	If the result of WRITE_VAR is conclusive then go to step 30.
30	Homing method definition using a WRITE_VAR function. For more information about the reference movement method, please refer to the Lexium user manual).
40	If the result of WRITE_VAR is conclusive then go to step 50.
50	Starting of the Homing method.
60	The Homing is done.
70	The Lexium switches in Positioning Mode using a WRITE_VAR function.
80	If the result of WRITE_VAR is conclusive then the Lexium configuration is done.

NOTE: For a correct variable declaration, click on **Tools/Project Settings/Language extension** then check "Directly represented array variables" and "Allow dynamic arrays".

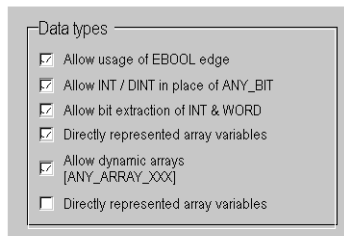

ST Program

The example is programmed in ST structured litteral language. The dedicated section is under the same master task (MAST).

```
CASE Lexium_Config_Step OF
0: (* Lexium is in "Ready to switch on" position *)
IF (Lexium.statusword.0) THEN
```

```
Lexium.controlword:=Lexium_operation_enable;
Lexium_Config_Step := 10;
END_IF;

10: (* Lexium is in "Run" position *)
IF (Lexium.statusword.2) THEN (* Operating mode: Homing *)
index_subindex:=16#00006060 (*CANopen parameter address*)
%MW200:=6; (*Definition of the Lexium Function: Homing*)
%MW162:=5; (*Time out 500ms*)
%MW163:=1; (*Length 1 byte*)
WRITE_VAR(ADDM('0.0.2.55'),'SDO',index_subindex,0,%MW200:1,%
MW160:4);
Lexium_Config_Step:=20;
END_IF;

20: (* Test WRITE_VAR function result *)
IF (NOT %MW160.0) THEN (* test activity bit*)
IF (%MW161=0) THEN (* correct exchange*)
Lexium_Config_Step := 30;
END_IF;
END_IF;

30: (* Homing method: set dimensions *)
index_subindex:=16#00006098
%MW150:=35; (*Definition of Homing method*)
%MW252:=5; (*Time out 500ms*)
%MW253:=1; (*Length 1 byte*)
WRITE_VAR(ADDM('0.0.2.55'),'SDO',index_subindex,0,%MW150:1,%
MW250:4);
Lexium_Config_Step:=40;
```

```
40: (* Test WRITE_VAR function result *)
IF (NOT %MW250.0) THEN (* test activity bit*)
IF (%MW251=0) THEN (* correct exchange*)
New_Setpoint:=0;
Lexium_Config_Step := 50;
END_IF;
END_IF;

50: (* Trigger homing *)
New_Setpoint :=1;
Lexium_Config_Step:=60;

60: (* Homing done *)
IF (Target_Reached) AND (Homing_Done) THEN
New_Setpoint:=0;
Lexium_Config_Step:=70;
END_IF;

70: (* Operating mode: Positioning *)
index_subindex:=16#00006060
%MW450:=1; (*Definition of Positioning method*)
%MW352:=5; (*Time out 500ms*)
%MW353:=1; (*Length 1 byte*)
WRITE_VAR(ADDM('0.0.2.55'),'SDO',index_subindex,0,%MW450:1,%MW350:4);
Lexium_Config_Step:=80;
80: (* Test WRITE_VAR function result *)
```

```

IF (NOT %MW350.0) THEN (* test activity bit*)
IF (%MW351=0) THEN (* correct exchange*)
Configuration_Done := 1;
END_IF;
END_IF;
END_CASE;

```

Creating an Animation Table

At a glance

An animation table is used to monitor the values of variables, and modify and/or force these values. Only those variables declared in *Variables & FB instances* can be added to the animation table

NOTE: For more information, refer to chapter *Animation Tables* (see EcoStruxure™ Control Expert, Operating Modes).

Procedure for Creating an Animation Table

The table below shows the procedure for creating an animation table.

Step	Action
1	In the Project browser, right click on Animation tables then click on New Animation Table. The edit window opens.
2	Click on first cell in the Name column, then on the  button, and add the variables you require.

Animation Table Created for the Application

The following screen shows the animation table used by the application:

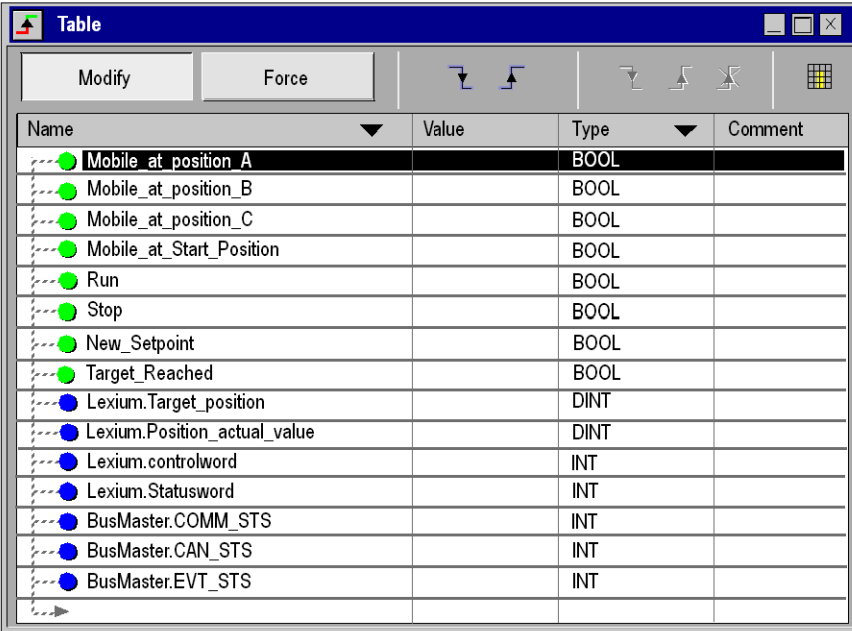

Name	Value	Type	Comment
Mobile_at_position_A		BOOL	
Mobile_at_position_B		BOOL	
Mobile_at_position_C		BOOL	
Mobile_at_Start_Position		BOOL	
Run		BOOL	
Stop		BOOL	
New_Setpoint		BOOL	
Target_Reached		BOOL	
Lexium.Target_position		DINT	
Lexium.Position_actual_value		DINT	
Lexium.controlword		INT	
Lexium.Statusword		INT	
BusMaster.COMM_STS		INT	
BusMaster.CAN_STS		INT	
BusMaster.EVT_STS		INT	

For more information about the creation of the Lexium and the BusMaster objects, see Declaration of I/O objects, page 192

NOTE: The animation table is dynamic only in online mode (display of variable values)

NOTE: COMM_STS, CAN_STS and EVT_STS words are used to check the application good operating. For more information, consult the CANopen user manual.

NOTE: To fill the animation table quickly, select several variables by maintaining the Control button.

Creating the Operator Screen

At a glance

The operator screen is used to animate graphic objects that symbolize the application. These objects can belong to the Control Expert library, or can be created using the graphic editor.

NOTE: For more information, refer to chapter *Operator screen* (see EcoStruxure™ Control Expert, Operating Modes).

Illustration of the Operator Screen

The following illustration shows the application operator screen:

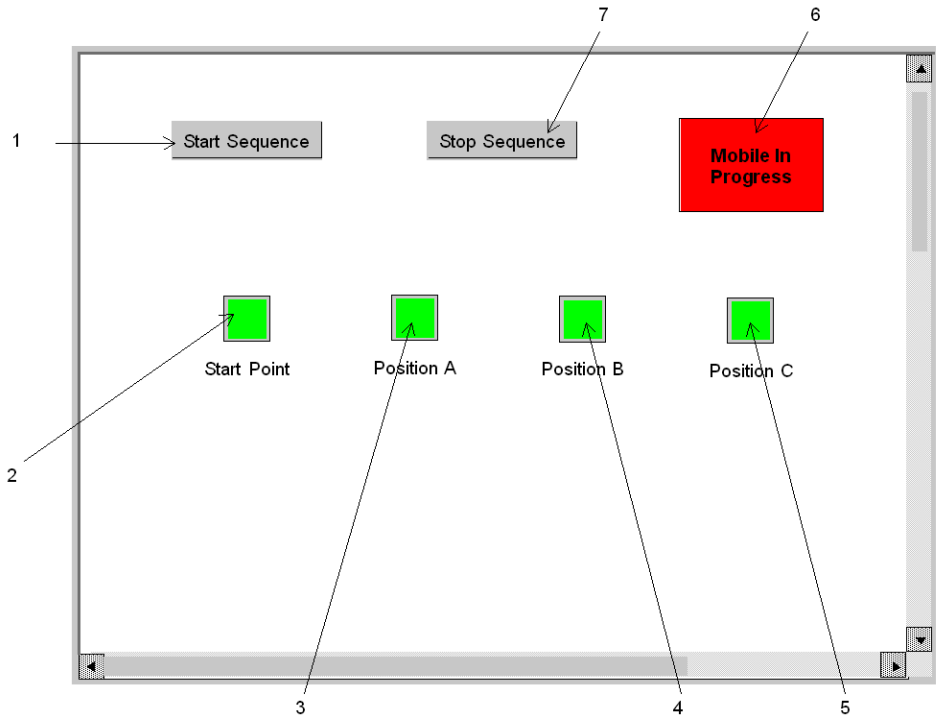

The associated variables are presented in the table below:



N°	Description	Associated variable
1	Start button	Run
2	Start point light indicator	Mobile_At_Start_Position
3	"Position" A light indicator	Mobile_At_Position_A
4	"Position B" light indicator	Mobile_At_Position_B
5	"Position C" light indicator	Mobile_At_Position_C

N°	Description	Associated variable
6	"Mobile in progress" light indicator	Mobile_in_Progress
7	Stop button	Stop



NOTE: To animate objects in online mode, you must click on . By clicking on this button, you can validate what is written.

Procedure for Creating an Operator Screen

The table below shows the procedure for creating the Start button.

Step	Action
1	In the <code>Project browser</code> , right click on <code>Operator screens</code> and click on <code>New screen</code> . The operator screen editor appears.
2	Click on the  and position the new button on the operator screen. Double click on the button and in the <code>Control</code> tab, select the <code>Run</code> variable by clicking the button  and confirm with <code>OK</code> . Then, enter the button name in the text zone.

The table below shows the procedure for inserting and animating indicator light.

Step	Action
1	In the <code>Tools</code> menu, select <code>Operator screens Library</code> . Double click on <code>Display unit then Indicator light</code> . Select the dynamic green light from the runtime screen and <code>Copy (Ctrl+C)</code> then <code>Paste (Ctrl+V)</code> it into the drawing in the operator screen editor.
2	The light is now in your operator screen. Select your light then click on  . Press enter and the object properties window opens. Select the <code>Animation</code> tab and enter the concerned variable, by clicking on  (in the place of <code>%MW1.0</code>). Click on  and enter the same variable.
3	Confirm with apply and <code>OK</code> .

Starting the Application

What's in This Chapter

Execution of Application in Standard Mode 211

Subject of this chapter

This chapter shows the procedure for starting the application. It describes the different types of application executions

Execution of Application in Standard Mode

At a glance

To work in standard mode, you need to associate defined variables to PDO addresses of the equipment declared on CANopen Bus.

NOTE: For more information on addressing, refer to chapter *Data Instances* (see EcoStruxure™ Control Expert, Program Languages and Structure, Reference Manual).

Assignment of variables

The table below shows the procedure for direct addressing of variables:

Step	Action
1	In the Project browser and in Variables & FB instances, double-click on Elementary variables.
2	In the Address column, enter the address associated with the variable in the form \Bus.Node \Rack.Module.Channel.Data. 
3	Repeat the same procedure for all located variables.

Illustration of assigned variables

The following screen shows the application variables assignment:

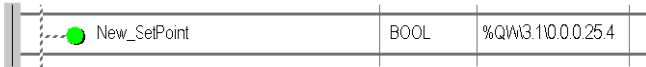
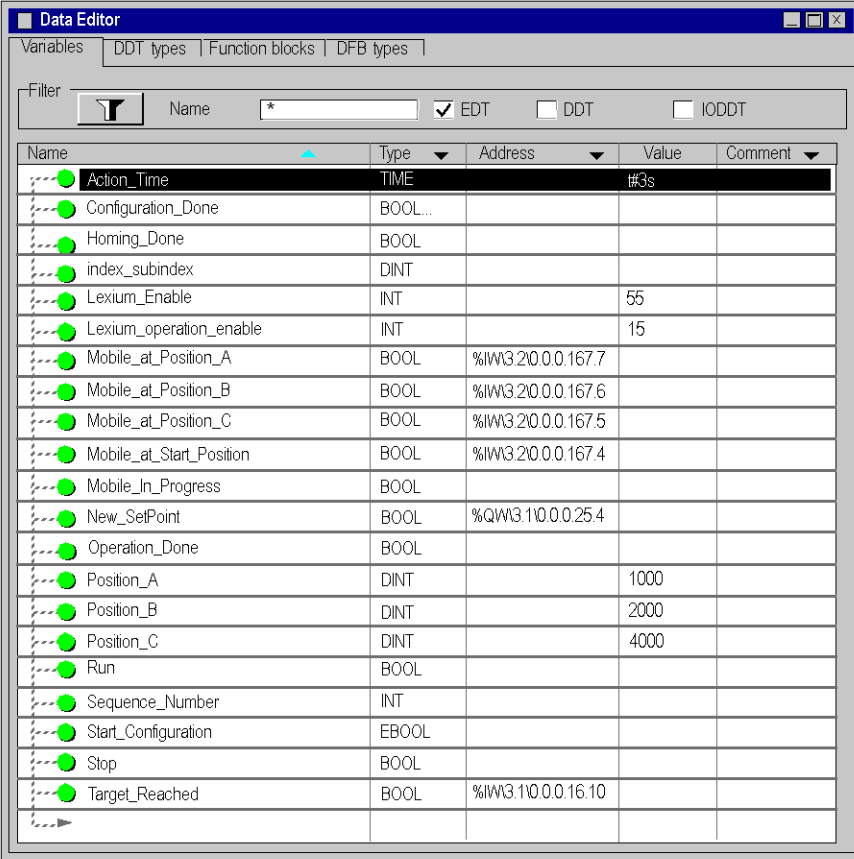

The screenshot shows a window titled "Data Editor" with tabs for "Variables", "DDT types", "Function blocks", and "DFB types". Below the tabs is a filter section with a funnel icon, a "Name" input field containing an asterisk, and checkboxes for "EDT" (checked), "DDT", and "IODDT". The main area contains a table with the following columns: Name, Type, Address, Value, and Comment. The table lists 20 variables with their respective types and values.

Name	Type	Address	Value	Comment
Action_Time	TIME		#3s	
Configuration_Done	BOOL...			
Homing_Done	BOOL			
index_subindex	DINT			
Lexium_Enable	INT		55	
Lexium_operation_enable	INT		15	
Mobile_at_Position_A	BOOL	%IW3.20.0.0.167.7		
Mobile_at_Position_B	BOOL	%IW3.20.0.0.167.6		
Mobile_at_Position_C	BOOL	%IW3.20.0.0.167.5		
Mobile_at_Start_Position	BOOL	%IW3.20.0.0.167.4		
Mobile_In_Progress	BOOL			
New_SetPoint	BOOL	%QW3.10.0.0.25.4		
Operation_Done	BOOL			
Position_A	DINT		1000	
Position_B	DINT		2000	
Position_C	DINT		4000	
Run	BOOL			
Sequence_Number	INT			
Start_Configuration	EBOOL			
Stop	BOOL			
Target_Reached	BOOL	%IW3.10.0.0.16.10		

Description of variables assignment.

- The first four Boolean variables are assigned to the four discrete inputs of the STB DDI 3420 module.
- New_Setpoint is assigned to the Lexium 05 control bit. A positive transition of this bit triggers a new positioning.
- Target_Reached is assigned to the Lexium 05 status bit which is set to '1' when the target is reached.

CANopen bus wiring

The CANopen bus is connected as follow:

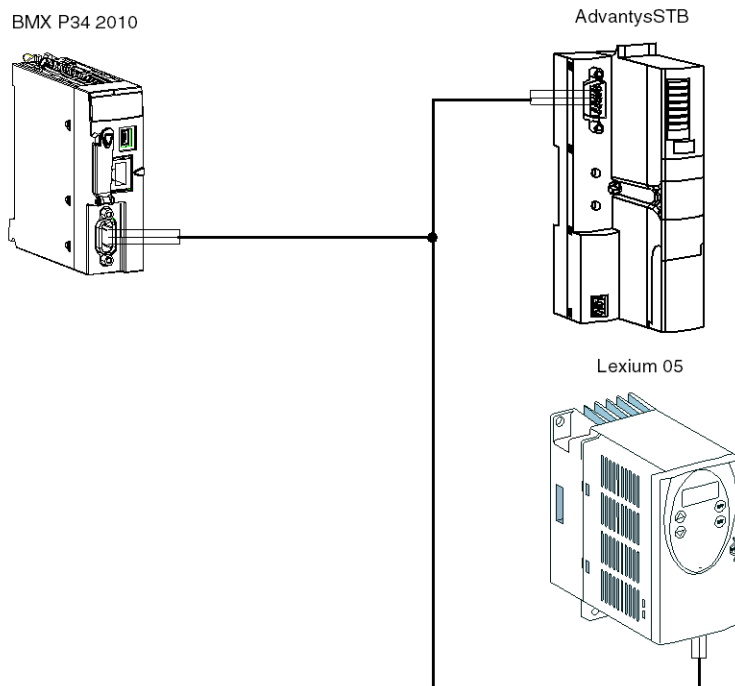

NOTE: The Lexium 05 is at the end of the CANopen Bus. Set the Terminating resistor CAN switch to '1'.

The assignment of the pins connectors is as follow:

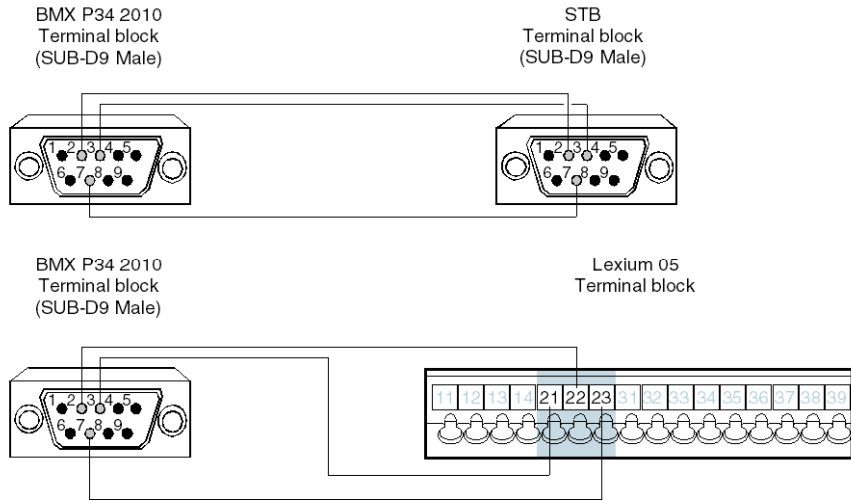

BMX P34 2010/20102 terminal block description:

Pin number	Symbol	Description
1	-	Reserved
2	CAN_L	CAN_L bus line (Low)
3	CAN_GND	CAN ground
4	-	Reserved
5	Reserved	Optional CAN protection
6	(GND)	Optional ground
7	CAN_H	CAN_H bus line (High)
8	-	Reserved
9	Reserved	CAN external positive supply (optionnal)

STB terminal block description:

Pin number	Symbol	Description
1	-	Reserved
2	CAN_L	CAN_L bus line (Low)
3	CAN_GND	CAN ground

Pin number	Symbol	Description
4	-	Reserved
5	(CAN_SHLD)	Optional CAN protection
6	(GND)	Optional ground
7	CAN_H	CAN_H bus line (High)
8	-	Reserved
9	-	Reserved

Lexium 05 terminal block description:

Pin number	Symbol	Description
21	CAN_GND	CAN ground
22	CAN_L	CAN_L bus line (Low)
23	CAN_H	CAN_H bus line (High)

Advantys STB configuration

The table below shows the procedure for configuring the Lexium 05:

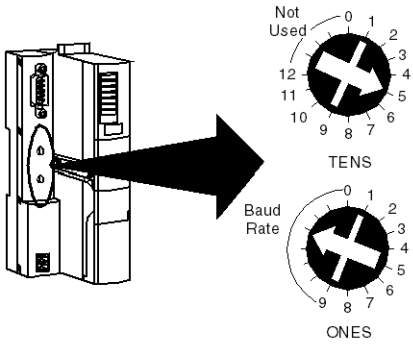
Step	Action
1	Shut down the STB.
2	<p>Using the rotary switches (located on the front of the CANopen NIM), configure the baud rate. The rotary switches are positioned as followed (5 = 500 kbits/s):</p> 
3	Start up then shut down the STB.

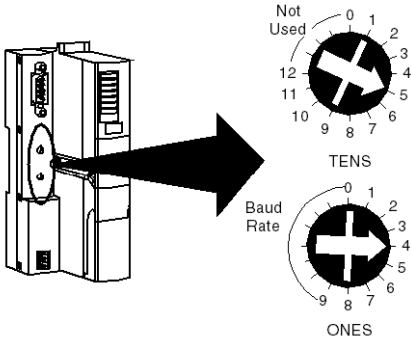
Step	Action
4	<p>Using the rotary switches, configure the address of the STB. For example, if the node number of the equipment is '54', the rotary switches are positioned as followed:</p> 
5	Start up the STB and press the reset button located on the STB NCO module during for 5 seconds.
6	The STB is configured automatically.

Lexium configuration

The table below shows the procedure for configuring the Lexium 05:

Step	Action
1	Start up the Lexium 05. RDY is displayed on the interface.
2	Press <code>Enter</code>
3	Press the down arrow key until <code>COM-</code> is displayed. Then press <code>Enter</code> .
4	Press the down arrow key until <code>CoAD</code> (CANopen Address) is displayed. Then press <code>Enter</code> .
5	Using the arrow keys, configure the node number. Then press <code>Esc</code> .
6	Press the down arrow key until <code>CoBD</code> (CANopen Baud Rate) is displayed. Then press <code>Enter</code> .
7	Using the arrow keys, configure the baud rate (500). Then press <code>Esc</code> .
8	Press the <code>Esc</code> until RDY displayed.

Appendices

What's in This Part

CANopen Master Local Object Dictionary Entry.....	218
Relation between PDOs and STB variables	234
Actions and transitions	237

Overview

These appendices contain information that should be useful for programming the application.

CANopen Master Local Object Dictionary Entry

What's in This Chapter

Object Dictionary Entries According to Profile DS301.....	218
Object Dictionary Entries According to Profile DS302.....	223
Midrange Manufacturer Specific Object Dictionary Entries	225

Subject of This Chapter

This chapter contains the local object dictionary entry for CANopen Master.

Object Dictionary Entries According to Profile DS301

Object Dictionary Entries

The table below presents the object dictionary entries according to profile DS301.

Index (Hex)	Subindex	Description	Object type	Data type	Comments
1000	–	Device type	VAR	Unsigned32	0x000F 0191
1001	–	Error register	VAR	Unsigned8	–
1005	–	COB-ID SYNC	VAR	Unsigned32	–
1006	–	Communication cycle period	VAR	Unsigned32	–
1007	–	Synchronous window length	VAR	Unsigned32	–
1008	–	Manufacturer device name	VAR	String	BMX CPU 20x0
1009	–	Manufacturer hardware version	VAR	String	MIDRANGE BASIC
100A	–	Manufacturer software version	VAR	String	COMM_FW_01_xx
1012	–	COB-ID time stamp message	VAR	Unsigned32	–
1016	–	Consumer heartbeat time	ARRAY	–	–

Index (Hex)	Subindex	Description	Object type	Data type	Comments
	0	Number of entries: 64		Unsigned8	
	1...64	Consumer heartbeat time		Unsigned32	
1017	–	Producer heartbeat time	VAR	Unsigned16	–
1018	–	Identity object	RECORD	–	–
	0	Number of entries		Unsigned8	4
	1	Vendor ID		Unsigned32	0x0600 005A
	2	Product code		Unsigned32	0x3300 FFFF
	3	Revision number		Unsigned32	0xyyyy xxxx
	4	Serial number		Unsigned32	0x0
1020	–	Verify configuration	ARRAY	–	–
	0	Number of entries: 2		Unsigned8	
	1	Configuration date		Unsigned32	
	2	Configuration time		Unsigned32	
102A	–	NMT inhibit time	VAR	Unsigned16	–
1200	–	1. Server SDO	RECORD	–	–
	0	Number of entries		Unsigned8	–
	1	COB-ID client -> server (Rx)		Unsigned32	600H + Node-ID
	2	COB-ID server -> client (Tx)		Unsigned32	580H + Node-ID
1280	–	1. Client SDO	RECORD	–	–
	0	Number of entries		Unsigned8	
	1	COB-ID client -> Server (Rx)		Unsigned32	
	2	COB-ID server -> Client (Tx)		Unsigned32	
	3	Node-ID of the server SDO		Unsigned8	
1281	–	2. Client SDO	RECORD	–	–
	0	Number of entries		Unsigned8	
	1	COB-ID client -> server (Rx)		Unsigned32	
	2	COB-ID server -> client (Tx)		Unsigned32	
	3	Node-ID of the server SDO		Unsigned8	
1282	–	3. Client SDO	RECORD	–	–

Index (Hex)	Subindex	Description	Object type	Data type	Comments
	0	Number of entries		Unsigned8	
	1	COB-ID client -> server (Rx)		Unsigned32	
	2	COB-ID server -> client (Tx)		Unsigned32	
	3	Node-ID of the server SDO		Unsigned8	
1400	–	1. Receive PDO	RECORD	–	–
	0	Largest subindex supported		Unsigned8	
	1	COB-ID used by PDO		Unsigned32	
	2	Transmission type		Unsigned8	
	3	–		Unsigned16	
	4	–		Unsigned8	
	5	Event timer		Unsigned16	
1401	–	2. Receive PDO	RECORD	–	–
	0	Largest subindex supported		Unsigned8	
	1	COB-ID used by PDO		Unsigned32	
	2	Transmission type		Unsigned8	
	3	–		Unsigned16	
	4	–		Unsigned8	
	5	Event timer		Unsigned16	
.....	–	–	–	–	–
14FF	–	256. Receive PDO	RECORD	–	–
	0	Largest subindex supported		Unsigned8	
	1	COB-ID used by PDO		Unsigned32	
	2	Transmission type		Unsigned8	
	3	–		Unsigned16	
	4	–		Unsigned8	
	5	Event timer		Unsigned16	
1600	–	1. Receive PDO mapping	–	–	–
	0	Number of mapped application objects in PDO		Unsigned8	

Index (Hex)	Subindex	Description	Object type	Data type	Comments
	1	PDO mapping for the 1. Application object to be mapped		Unsigned32	Index (16 bit) subindex (8 bit) length (8 bit)
	2	PDO mapping for the 2. Application object		Unsigned32	–
	–		–	–
	8	PDO mapping for the 8. Application object		Unsigned32	–
1601	–	2. Receive PDO mapping	–	–	–
	0	Number of mapped application objects in PDO		Unsigned8	Depends on PDO mapping of the application
	1	PDO mapping for the 1. Application object to be mapped		Unsigned32	Index (16 bit) subindex (8 bit) length (8 bit)
	2	PDO mapping for the 2. Application object		Unsigned32	–
	–		–	–
	8	PDO mapping for the 8. Application object		Unsigned32	–
.....	–	–	–	–	–
16FF	–	256. Receive PDO mapping	–	–	–
	0	Number of mapped application objects in PDO		Unsigned8	Depends on PDO mapping of the application
	1	PDO mapping for the 1. Application object to be mapped		Unsigned32	Index (16 bit) subindex (8 bit) length (8 bit)
	2	PDO mapping for the 2. Application object		Unsigned32	–
	–		–	–
	8	PDO mapping for the 8. Application object		Unsigned32	–
1800	–	1. Transmit PDO	RECORD	–	–
	0	Largest subindex supported		Unsigned8	
	1	COB-ID used by PDO		Unsigned32	
	2	Transmission type		Unsigned8	
	3	Inhibit time		Unsigned16	
	4	Reserved		Unsigned8	

Index (Hex)	Subindex	Description	Object type	Data type	Comments
	5	Event timer		Unsigned16	
1801	–	2. Transmit PDO	RECORD	–	–
	0	Largest subindex supported		Unsigned8	
	1	COB-ID used by PDO		Unsigned32	
	2	Transmission type		Unsigned8	
	3	Inhibit time		Unsigned16	
	4	Reserved		Unsigned8	
	5	Event timer		Unsigned16	
.....	–	–	–	–	–
18FF	–	256. Transmit PDO	RECORD	–	–
	0	Largest subindex supported		Unsigned8	
	1	COB-ID used by PDO		Unsigned32	
	2	Transmission type		Unsigned8	
	3	Inhibit time		Unsigned16	
	4	Reserved		Unsigned8	
	5	Event timer		Unsigned16	
1A00	–	1. Transmit PDO mapping	–	–	–
	0	Number of mapped application objects in PDO		Unsigned8	Depends on PDO mapping of the application
	1	PDO mapping for the 1. Application object to be mapped		Unsigned32	Index (16 bit) subindex (8 bit) length (8 bit)
	2	PDO mapping for the 2. Application object		Unsigned32	–
	–		–	–
	8	PDO mapping for the 8. Application object		Unsigned32	–
1A01	–	2. Transmit PDO mapping	–	–	–
	0	Number of mapped application objects in PDO		Unsigned8	Depends on PDO mapping of the application
	1	PDO mapping for the 1. Application object to be mapped		Unsigned32	Index (16 bit) subindex (8 bit) length (8 bit)

Index (Hex)	Subindex	Description	Object type	Data type	Comments
	2	PDO mapping for the 2. Application object		Unsigned32	–
	–		–	–
	8	PDO mapping for the 8. Application object		Unsigned32	–
.....	–	–	–	–	–
1AFF	–	256. Transmit PDO mapping	–	–	–
	0	Number of mapped application objects in PDO		Unsigned8	Depends on PDO mapping of the application
	1	PDO mapping for the 1. Application object to be mapped		Unsigned32	Index (16 bit) sub-index (8 bit) length (8 bit)
	2	PDO mapping for the 2. Application object		Unsigned32	–
	–		–	–
	8	PDO mapping for the 8. Application object		Unsigned32	–

Object Dictionary Entries According to Profile DS302

Object Dictionary Entries

The table below presents the object dictionary entries according to profile DS302.

Index (Hex)	Subindex	Description	Object type	Data type
1F22	–	Concise DCF	ARRAY	–
	0	Number of entries	VAR	Unsigned8
	1	Device with Node-ID 1	VAR	DOMAIN
	...	–	–	–
	127	Device with Node-ID 127	–	DOMAIN
1F26	–	Expected configuration date	ARRAY	–

Index (Hex)	Subindex	Description	Object type	Data type
	0	Number of entries		Unsigned8
	1	Device with Node-ID 1		Unsigned32
	...	–		–
	127	Device with Node-ID 127		Unsigned32
1F27	–	Expected configuration time	ARRAY	–
	0	Number of entries		Unsigned8
	1	Device with Node-ID 1		Unsigned32
	...	–		–
	127	Device with Node-ID 127		Unsigned32
1F80	–	NMT startup	VAR	Unsigned32
1F81	...	Slave assignment	ARRAY	–
	0	Number of entries		Unsigned8
	1	Device with Node-ID 1		Unsigned32
	...	–		–
	127	Device with Node-ID 127		Unsigned32
1F82	...	Request NMT	ARRAY	–
	0	Number of entries		Unsigned8
	1	Request NMT for Node-ID 1		Unsigned8
	...	–		–
	128	Request NMT for all nodes		Unsigned8
1F84	...	Device type identification	ARRAY	–
	0	Number of entries		Unsigned8
	1	Device with Node-ID 1		Unsigned32
	...	–		–
	127	Device with Node-ID 127		Unsigned32
1F85	...	Vendor identification	ARRAY	–
	0	Number of entries		Unsigned8
	1	Device with Node-ID 1		Unsigned32
	...	–		–
	127	Device with Node-ID 127		Unsigned32

Index (Hex)	Subindex	Description	Object type	Data type
1F86	...	Product code	ARRAY	–
	0	Number of entries		Unsigned8
	1	Device with Node-ID 1		Unsigned32
	...	–		–
	127	Device with Node-ID 127		Unsigned32
1F87	...	Revision number	ARRAY	–
	0	Number of entries		Unsigned8
	1	Device with Node-ID 1		Unsigned32
	...	–		–
	127	Device with Node-ID 127		Unsigned32
1F8A	–	Restore configuration	ARRAY	–
	0	Number of entries		Unsigned8
	1	Restore for Node-ID 1		Unsigned8
	...	–		–
	64	Restore for Node-ID 64		Unsigned8

Midrange Manufacturer Specific Object Dictionary Entries

Project Data

The table below presents the Object Entry 2010 (Project Data).

Index (Hex)	Sub-index	Description	Object type	Data type	Comments
2010		Project Data	RECORD		
	0	Number of entries		Unsigned8	

Index (Hex)	Sub-index	Description	Object type	Data type	Comments
	1	Current byte length		Unsigned16	Read only access Updated by the Master Manager
	2	Project data domain		DOMAIN	

CANopen Master Timing Control

The table below presents the Object Entry 2100 (CANopen Master Timing Control).

Index (Hex)	Sub-index	Description	Object type	Data type	Comments
2100		CANopen Master Timing Control	ARRAY		
	0	Number of entries		Unsigned8	
	1	Max. number of TPDOs to transmit during one cycle		Unsigned8	
	2	Max. number of high priority receive queue accesses during one cycle (RPDOs, EMCY)		Unsigned8	
	3	Max. number of low priority receive queue accesses during one cycle (SDOs, Heartbeat/Guarding)		Unsigned8	

CANopen Master Status

The table below presents the Object Entry 4100 (CANopen Master Status).

Index (Hex)	Sub-index	Description	Object type	Data type	Comments
4100		CANopen Master Status	ARRAY		
	0	Number of entries		Unsigned8	
	1	Global_events		Unsigned16	
	2	COMM_state		Unsigned8	
	3	COMM_diagnostic		Unsigned8	

Index (Hex)	Sub-index	Description	Object type	Data type	Comments
	4	Config_bits		Unsigned16	
	5	LED_control		Unsigned16	
	6	Minimum Cycle Time		Unsigned8	
	7	Maximum Cycle Time		Unsigned8	

Nd_asg

The table below presents the Object Entry 4101 (Nd_asg).

Index (Hex)	Sub-index	Description	Object type	Data type	Comments
4101		Nd_asg	ARRAY		
	0	Number of entries		Unsigned8	
	1	Nd_asg[0,1,2,3		Unsigned32	
	2	Nd_asg[4,5,6,7		Unsigned32	
	3	Nd_asg[8,9,10,11		Unsigned32	
	4	Nd_asg[12,13,14,15		Unsigned32	

Nd_cfg

The table below presents the Object Entry 4102 (Nd_cfg).

Index (Hex)	Sub-index	Description	Object type	Data type	Comments
4102		Nd_cfg	ARRAY		
	0	Number of entries		Unsigned8	
	1	Nd_cfg[0,1,2,3		Unsigned32	
	2	Nd_cfg[4,5,6,7		Unsigned32	
	3	Nd_cfg[8,9,10,11		Unsigned32	
	4	Nd_cfg[12,13,14,15		Unsigned32	

Nd_asf

The table below presents the Object Entry 4103 (Nd_asf).

Index (Hex)	Sub-index	Description	Object type	Data type	Comments
4103		Nd_asf	ARRAY		
	0	Number of entries		Unsigned8	
	1	Nd_asf[0,1,2,3		Unsigned32	
	2	Nd_asf[4,5,6,7		Unsigned32	
	3	Nd_asf[8,9,10,11		Unsigned32	
	4	Nd_asf[12,13,14,15		Unsigned32	

Nd_oper

The table below presents the Object Entry 4104 (Nd_oper).

Index (Hex)	Sub-index	Description	Object type	Data type	Comments
4104		Nd_oper	ARRAY		
	0	Number of entries		Unsigned8	
	1	Nd_oper[0,1,2,3		Unsigned32	
	2	Nd_oper[4,5,6,7		Unsigned32	
	3	Nd_oper[8,9,10,11		Unsigned32	
	4	Nd_oper[12,13,14,15		Unsigned32	

Nd_stop

The table below presents the Object Entry 4105 (Nd_stop).

Index (Hex)	Sub-index	Description	Object type	Data type	Comments
4105		Nd_stop	ARRAY		
	0	Number of entries		Unsigned8	
	1	Nd_stop[0,1,2,3		Unsigned32	
	2	Nd_stop[4,5,6,7		Unsigned32	
	3	Nd_stop[8,9,10,11		Unsigned32	
	4	Nd_stop[12,13,14,15		Unsigned32	

Nd_preop

The table below presents the Object Entry 4106 (Nd_preop).

Index (Hex)	Sub-index	Description	Object type	Data type	Comments
4106		Nd_preop	ARRAY		
	0	Number of entries		Unsigned8	
	1	Nd_preop[0,1,2,3		Unsigned32	
	2	Nd_preop[4,5,6,7		Unsigned32	
	3	Nd_preop[8,9,10,11		Unsigned32	
	4	Nd_preop[12,13,14,15		Unsigned32	

Nd_err

The table below presents the Object Entry 4107 (Nd_err).

Index (Hex)	Sub-index	Description	Object type	Data type	Comments
4107		Nd_err	ARRAY		
	0	Number of entries		Unsigned8	
	1	Nd_err[0,1,2,3		Unsigned32	
	2	Nd_err[4,5,6,7		Unsigned32	

Index (Hex)	Sub-index	Description	Object type	Data type	Comments
	3	Nd_err[8,9,10,11		Unsigned32	
	4	Nd_err[12,13,14,15		Unsigned32	

Node Error Count

The table below presents the Object Entry 4110 (Node Error Count).

Index (Hex)	Sub-index	Description	Object type	Data type	Comments
4110		Node Error Count	ARRAY		
	0	Number of entries		Unsigned8	
	1	Number of the received emergency messages of node number 1		Unsigned8	
	...				
	127	Number of the received emergency messages of node number 127		Unsigned8	

Error Code Specific Error Counters

The table below presents the Object Entries 4111 to 4117 (Error Code Specific Error Counters).

Index (Hex)	Sub-index	Description	Object type	Data type	Comments
4111		Generic_error_count (Code 10xxH)	VAR	Unsigned8	
4112		Device_hardware_error_count (Code 50xxH)	VAR	Unsigned8	
4113		Device_software_error_count (Code 60xxH)	VAR	Unsigned8	
4114		Communication_error_count (Code 81xxH)	VAR	Unsigned8	
4115		Protocol_error_count (Code 82xxH)	VAR	Unsigned8	
4116		External_error_count (Code 90xxH)	VAR	Unsigned8	
4117		Device_specific (Code FFxxH)	VAR	Unsigned8	

Emergency History

The table below presents the Object Entry 4118 (Emergency History).

Index (Hex)	Sub-index	Description	Object type	Data type	Comments
4118		Emergency History	ARRAY		
	0	Number of entries		Unsigned8	
	1	Emergency history of node number 1		Domain	
	...				
	127	Emergency history of node number 127		Domain	

input Process Image

The table below presents the Object Entry 4200 (Input Process Image).

Index (Hex)	Sub-index	Description	Object type	Data type	Comments
4200		Input Process Image	RECORD		
	0	Number of entries		Unsigned8	
	1	Current byte length		Unsigned16	Read only access Updated by the Master Manager

Output Process Image

The table below presents the Object Entry 4201 (Output Process Image).

Index (Hex)	Sub-index	Description	Object type	Data type	Comments
4201		Output Process Image	RECORD		
	0	Number of entries		Unsigned8	
	1	Current byte length		Unsigned16	Read only access Updated by the Master Manager

Additional Master Information

The table below presents the Object Entry 4205 (Additional Master Information).

Index (Hex)	Sub-index	Description	Object type	Data type	Comments
4205		Additional Master Information	RECORD		
	0	Number of entries		Unsigned8	ro
	1	Coupler (CPU) type		Unsigned8	rw
	2	CAN baudrate table index		Unsigned8	ro
	3	Highest used Node-ID		Unsigned8	ro
	4	Number of used RxPDOs		Unsigned16	ro
	5	Number of used TxPDOs		Unsigned16	ro
	6	Number of mapped objects PI input		Unsigned16	ro
	7	Number of mapped objects PI output		Unsigned16	ro
	8	Covered bytes by the concise DCF		Unsigned8	ro
	9	Byte size of the concise DCF buffer		Unsigned16	ro
	10	Configuration signature		Unsigned16	rw
	11	Control		Unsigned16	rw

Access type : ro (read only), rw (read / write)

Additional Slave Assignment

The table below presents the Object Entry 4250 (Additional Slave Assignment).

Index (Hex)	Sub-index	Description	Object type	Data type	Comments
4250		Additional Slave Assignment	ARRAY		
	0	Number of entries		Unsigned8	
	1	Boot behaviour for Node-ID 1		Unsigned8	
	...				
	127	Boot behaviour for Node-ID 127		Unsigned8	

Bit 0 = 0 : Bootup according DS-302

Bit 1 = 1 : Bootup do not overwrite config parameter

Relation between PDOs and STB variables

What's in This Chapter

STB island configuration..... 234

Subject of this chapter

This chapter presents the equivalence between the configuration of PDOs on Control Expert and the STB variables on Advantys Configuration Software.

STB island configuration

At a glance

STB islands can be configured:

- using Advantys Configuration Software (STB NCO 2212),
- using Control Expert Software (STB NCO 2212 and NCO 1010).

Configuration using Advantys Configuration Island

The procedure for configuring a STB island using Advantys Configuration Software is as follow. It only concerns the STB NCO 2212 module:

Step	Action
1	In Advantys Configuration Software (Version 2.2.0.2 or above), create a new island
2	Select the STBNCO2212 Network Interface Module
3	Select the modules which will be used in the application

Step	Action																																																																																																																																																																																																																																																																																																																																																																																																																																																																																																																	
4	<p data-bbox="232 199 790 224">In the menu click on <code>Island</code> and on <code>I/O image overview</code></p> <div data-bbox="360 264 1081 695" style="border: 1px solid gray; padding: 5px;"> <table border="1" style="width: 100%; border-collapse: collapse; text-align: center;"> <thead> <tr> <th style="width: 15%;"></th> <th colspan="15" style="border-bottom: none;">Fieldbus Image</th> <th colspan="15" style="border-bottom: none;">Modbus Image</th> </tr> <tr> <th style="border-top: none;"></th> <th colspan="30" style="border-top: none;">Input Data</th> </tr> <tr> <th style="border-top: none;">Object</th> <th>15</th><th>14</th><th>13</th><th>12</th><th>11</th><th>10</th><th>9</th><th>8</th><th>7</th><th>6</th><th>5</th><th>4</th><th>3</th><th>2</th><th>1</th><th>0</th> <th>15</th><th>14</th><th>13</th><th>12</th><th>11</th><th>10</th><th>9</th><th>8</th><th>7</th><th>6</th><th>5</th><th>4</th><th>3</th><th>2</th><th>1</th><th>0</th> </tr> </thead> <tbody> <tr> <td style="border-top: none;">6100:01</td> <td>9</td><td>9</td><td>9</td><td>9</td><td>9</td><td>9</td><td>9</td><td>9</td><td>9</td><td>9</td><td>9</td><td>9</td><td>9</td><td>9</td><td>9</td><td>9</td> <td>9</td><td>9</td><td>9</td><td>9</td><td>9</td><td>9</td><td>9</td><td>9</td><td>9</td><td>9</td><td>9</td><td>9</td><td>9</td><td>9</td><td>9</td><td>9</td> </tr> <tr> <td style="border-top: none;">6000:01</td> <td>-</td><td>-</td><td>-</td><td>-</td><td>-</td><td>-</td><td>-</td><td>-</td><td>-</td><td>-</td><td>2</td><td>2</td><td>2</td><td>2</td><td>1</td><td>1</td><td>1</td><td>1</td> <td>-</td><td>-</td><td>-</td><td>-</td><td>-</td><td>-</td><td>-</td><td>-</td><td>-</td><td>-</td><td>-</td><td>-</td><td>-</td><td>-</td><td>-</td> </tr> <tr> <td style="border-top: none;">6000:02</td> <td>-</td><td>-</td><td>-</td><td>-</td><td>-</td><td>-</td><td>-</td><td>-</td><td>-</td><td>-</td><td>4</td><td>4</td><td>4</td><td>4</td><td>3</td><td>3</td><td>3</td><td>3</td> <td>-</td><td>-</td><td>-</td><td>-</td><td>-</td><td>-</td><td>-</td><td>-</td><td>-</td><td>-</td><td>-</td><td>-</td><td>-</td><td>-</td><td>-</td> </tr> <tr> <td style="border-top: none;">6000:03</td> <td>-</td><td>-</td><td>-</td><td>-</td><td>-</td><td>-</td><td>-</td><td>-</td><td>-</td><td>-</td><td>6</td><td>6</td><td>6</td><td>6</td><td>5</td><td>5</td><td>5</td><td>5</td> <td>-</td><td>-</td><td>-</td><td>-</td><td>-</td><td>-</td><td>-</td><td>-</td><td>-</td><td>-</td><td>-</td><td>-</td><td>-</td><td>-</td><td>-</td> </tr> <tr> <td style="border-top: none;">6000:04</td> <td>-</td><td>-</td><td>-</td><td>-</td><td>-</td><td>-</td><td>-</td><td>-</td><td>-</td><td>-</td><td>8</td><td>8</td><td>8</td><td>8</td><td>7</td><td>7</td><td>7</td><td>7</td> <td>-</td><td>-</td><td>-</td><td>-</td><td>-</td><td>-</td><td>-</td><td>-</td><td>-</td><td>-</td><td>-</td><td>-</td><td>-</td><td>-</td><td>-</td> </tr> <tr> <td style="border-top: none;">6000:05</td> <td>-</td><td>-</td><td>-</td><td>-</td><td>-</td><td>-</td><td>-</td><td>-</td><td>-</td><td>-</td><td>10</td><td>10</td><td>10</td><td>10</td><td>10</td><td>10</td><td>10</td><td>10</td> <td>-</td><td>-</td><td>-</td><td>-</td><td>-</td><td>-</td><td>-</td><td>-</td><td>-</td><td>-</td><td>-</td><td>-</td><td>-</td><td>-</td><td>-</td> </tr> <tr> <td style="border-top: none;">6000:06</td> <td>-</td><td>-</td><td>-</td><td>-</td><td>-</td><td>-</td><td>-</td><td>-</td><td>-</td><td>-</td><td>10</td><td>10</td><td>10</td><td>10</td><td>10</td><td>10</td><td>10</td><td>10</td> <td>-</td><td>-</td><td>-</td><td>-</td><td>-</td><td>-</td><td>-</td><td>-</td><td>-</td><td>-</td><td>-</td><td>-</td><td>-</td><td>-</td><td>-</td> </tr> <tr> <td style="border-top: none;">6401:01</td> <td>10</td><td>10</td><td>10</td><td>10</td><td>10</td><td>10</td><td>10</td><td>10</td><td>10</td><td>10</td><td>10</td><td>10</td><td>10</td><td>10</td><td>10</td><td>10</td><td>10</td> <td>10</td><td>10</td><td>10</td><td>10</td><td>10</td><td>10</td><td>10</td><td>10</td><td>10</td><td>10</td><td>10</td><td>10</td><td>10</td><td>10</td><td>10</td> </tr> <tr> <td style="border-top: none;">6401:02</td> <td>10</td><td>10</td><td>10</td><td>10</td><td>10</td><td>10</td><td>10</td><td>10</td><td>10</td><td>10</td><td>10</td><td>10</td><td>10</td><td>10</td><td>10</td><td>10</td><td>10</td> <td>10</td><td>10</td><td>10</td><td>10</td><td>10</td><td>10</td><td>10</td><td>10</td><td>10</td><td>10</td><td>10</td><td>10</td><td>10</td><td>10</td><td>10</td> </tr> <tr> <td style="border-top: none;">2600:00</td> <td>32</td><td>32</td><td>32</td><td>32</td><td>32</td><td>32</td><td>32</td><td>32</td><td>32</td><td>32</td><td>32</td><td>32</td><td>32</td><td>32</td><td>32</td><td>32</td><td>32</td> <td>32</td><td>32</td><td>32</td><td>32</td><td>32</td><td>32</td><td>32</td><td>32</td><td>32</td><td>32</td><td>32</td><td>32</td><td>32</td><td>32</td><td>32</td> </tr> <tr> <td style="border-top: none;">2801:00</td> <td>32</td><td>32</td><td>32</td><td>32</td><td>32</td><td>32</td><td>32</td><td>32</td><td>32</td><td>32</td><td>32</td><td>32</td><td>32</td><td>32</td><td>32</td><td>32</td><td>32</td> <td>32</td><td>32</td><td>32</td><td>32</td><td>32</td><td>32</td><td>32</td><td>32</td><td>32</td><td>32</td><td>32</td><td>32</td><td>32</td><td>32</td><td>32</td> </tr> <tr> <td style="border-top: none;"></td> <td>32</td><td>32</td><td>32</td><td>32</td><td>32</td><td>32</td><td>32</td><td>32</td><td>32</td><td>32</td><td>32</td><td>32</td><td>32</td><td>32</td><td>32</td><td>32</td><td>32</td> <td>32</td><td>32</td><td>32</td><td>32</td><td>32</td><td>32</td><td>32</td><td>32</td><td>32</td><td>32</td><td>32</td><td>32</td><td>32</td><td>32</td><td>32</td> </tr> </tbody> </table> </div> <p data-bbox="232 727 1180 776">This window represents an I/O image overview while offline. The variable indexes are the same as for Control Expert Software. It allows to find the content of PDO quickly and easily.</p>		Fieldbus Image															Modbus Image																Input Data																														Object	15	14	13	12	11	10	9	8	7	6	5	4	3	2	1	0	15	14	13	12	11	10	9	8	7	6	5	4	3	2	1	0	6100:01	9	9	9	9	9	9	9	9	9	9	9	9	9	9	9	9	9	9	9	9	9	9	9	9	9	9	9	9	9	9	9	9	6000:01	-	-	-	-	-	-	-	-	-	-	2	2	2	2	1	1	1	1	-	-	-	-	-	-	-	-	-	-	-	-	-	-	-	6000:02	-	-	-	-	-	-	-	-	-	-	4	4	4	4	3	3	3	3	-	-	-	-	-	-	-	-	-	-	-	-	-	-	-	6000:03	-	-	-	-	-	-	-	-	-	-	6	6	6	6	5	5	5	5	-	-	-	-	-	-	-	-	-	-	-	-	-	-	-	6000:04	-	-	-	-	-	-	-	-	-	-	8	8	8	8	7	7	7	7	-	-	-	-	-	-	-	-	-	-	-	-	-	-	-	6000:05	-	-	-	-	-	-	-	-	-	-	10	10	10	10	10	10	10	10	-	-	-	-	-	-	-	-	-	-	-	-	-	-	-	6000:06	-	-	-	-	-	-	-	-	-	-	10	10	10	10	10	10	10	10	-	-	-	-	-	-	-	-	-	-	-	-	-	-	-	6401:01	10	10	10	10	10	10	10	10	10	10	10	10	10	10	10	10	10	10	10	10	10	10	10	10	10	10	10	10	10	10	10	10	6401:02	10	10	10	10	10	10	10	10	10	10	10	10	10	10	10	10	10	10	10	10	10	10	10	10	10	10	10	10	10	10	10	10	2600:00	32	32	32	32	32	32	32	32	32	32	32	32	32	32	32	32	32	32	32	32	32	32	32	32	32	32	32	32	32	32	32	32	2801:00	32	32	32	32	32	32	32	32	32	32	32	32	32	32	32	32	32	32	32	32	32	32	32	32	32	32	32	32	32	32	32	32		32	32	32	32	32	32	32	32	32	32	32	32	32	32	32	32	32	32	32	32	32	32	32	32	32	32	32	32	32	32	32	32
	Fieldbus Image															Modbus Image																																																																																																																																																																																																																																																																																																																																																																																																																																																																																																		
	Input Data																																																																																																																																																																																																																																																																																																																																																																																																																																																																																																																	
Object	15	14	13	12	11	10	9	8	7	6	5	4	3	2	1	0	15	14	13	12	11	10	9	8	7	6	5	4	3	2	1	0																																																																																																																																																																																																																																																																																																																																																																																																																																																																																		
6100:01	9	9	9	9	9	9	9	9	9	9	9	9	9	9	9	9	9	9	9	9	9	9	9	9	9	9	9	9	9	9	9	9																																																																																																																																																																																																																																																																																																																																																																																																																																																																																		
6000:01	-	-	-	-	-	-	-	-	-	-	2	2	2	2	1	1	1	1	-	-	-	-	-	-	-	-	-	-	-	-	-	-	-																																																																																																																																																																																																																																																																																																																																																																																																																																																																																	
6000:02	-	-	-	-	-	-	-	-	-	-	4	4	4	4	3	3	3	3	-	-	-	-	-	-	-	-	-	-	-	-	-	-	-																																																																																																																																																																																																																																																																																																																																																																																																																																																																																	
6000:03	-	-	-	-	-	-	-	-	-	-	6	6	6	6	5	5	5	5	-	-	-	-	-	-	-	-	-	-	-	-	-	-	-																																																																																																																																																																																																																																																																																																																																																																																																																																																																																	
6000:04	-	-	-	-	-	-	-	-	-	-	8	8	8	8	7	7	7	7	-	-	-	-	-	-	-	-	-	-	-	-	-	-	-																																																																																																																																																																																																																																																																																																																																																																																																																																																																																	
6000:05	-	-	-	-	-	-	-	-	-	-	10	10	10	10	10	10	10	10	-	-	-	-	-	-	-	-	-	-	-	-	-	-	-																																																																																																																																																																																																																																																																																																																																																																																																																																																																																	
6000:06	-	-	-	-	-	-	-	-	-	-	10	10	10	10	10	10	10	10	-	-	-	-	-	-	-	-	-	-	-	-	-	-	-																																																																																																																																																																																																																																																																																																																																																																																																																																																																																	
6401:01	10	10	10	10	10	10	10	10	10	10	10	10	10	10	10	10	10	10	10	10	10	10	10	10	10	10	10	10	10	10	10	10																																																																																																																																																																																																																																																																																																																																																																																																																																																																																		
6401:02	10	10	10	10	10	10	10	10	10	10	10	10	10	10	10	10	10	10	10	10	10	10	10	10	10	10	10	10	10	10	10	10																																																																																																																																																																																																																																																																																																																																																																																																																																																																																		
2600:00	32	32	32	32	32	32	32	32	32	32	32	32	32	32	32	32	32	32	32	32	32	32	32	32	32	32	32	32	32	32	32	32																																																																																																																																																																																																																																																																																																																																																																																																																																																																																		
2801:00	32	32	32	32	32	32	32	32	32	32	32	32	32	32	32	32	32	32	32	32	32	32	32	32	32	32	32	32	32	32	32	32																																																																																																																																																																																																																																																																																																																																																																																																																																																																																		
	32	32	32	32	32	32	32	32	32	32	32	32	32	32	32	32	32	32	32	32	32	32	32	32	32	32	32	32	32	32	32	32																																																																																																																																																																																																																																																																																																																																																																																																																																																																																		
5	<p data-bbox="232 800 1153 849">When the configuration is over, click on <code>File/Export</code> to export the island in DCF format, which will be imported in Control Expert.</p>																																																																																																																																																																																																																																																																																																																																																																																																																																																																																																																	

CANopen devices are not supported during an ***.xsy** file import from Advantys to Control Expert. The %MW objects that are assigned in the PDO table are not in the same range as those defined in the configuration for the CANopen head.

⚠ WARNING

UNINTENDED EQUIPMENT OPERATION

Do not use the symbol file ***.xsy** generated by Advantys in Control Expert during the configuration of an STB Island.

Failure to follow these instructions can result in death, serious injury, or equipment damage.

Configuration using Control Expert Software

The procedure to configure a STB island using Control Expert Software is as follow:

Step	Action
1	In the Project browser, double-click on Configuration then 3:CANopen.
2	In the CANopen window, double-click on the Advantys STB representation. The STB configuration window opens
3	In Function zone, select Advanced. <div data-bbox="642 350 884 418" style="text-align: center; border: 1px solid gray; padding: 5px; margin: 10px auto; width: fit-content;"> Function: <input type="text" value="Advanced"/> </div>
4	Click on the PDO tab to see the PDO configuration, the variables and their topological addresses. <div data-bbox="239 537 1206 1195" style="border: 1px solid gray; padding: 10px; margin: 10px auto; width: 90%;"> </div>
5	On the right side of the window, there is the list of STB mapped or unmapped variables. The indexes are the same as Advantys Configuration Software. Variables can be found quickly and easily. <p>Drag and drop the variables to the right PDO to configure the STB island.</p> <p>NOTE: It is possible to import the DCF file by clicking on the Import DCF button</p>

Actions and transitions

What's in This Chapter

Transitions	237
Actions.....	238

Subject of this chapter

This chapter contains the actions and the transitions used in the grafcet (See Creating the program in SFC for managing the move sequence, page 196)

Transitions

At a glance

The next tasks, written in LD, are used in different transitions of the grafcet.

Back_to_Start_Point transition

The action associated to the **Back_to_Start_Point** transition is as follows:

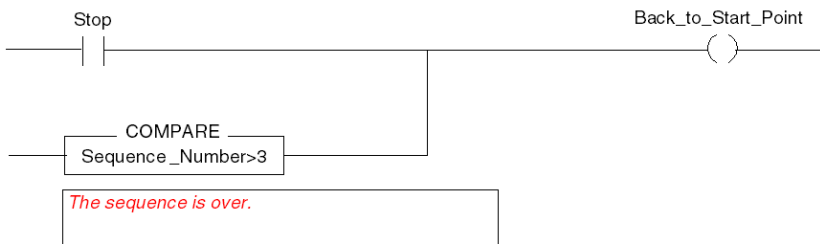

Lexium_Disabled transition

The action associated to the **Lexium_Disabled** transition is as follows:

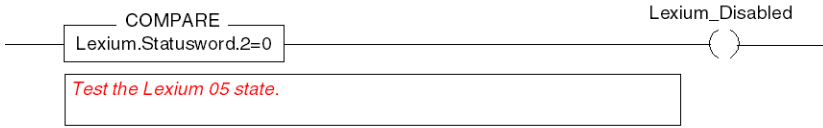

Actions

At a glance

The next tasks, written in LD and ST are used in different steps of the grafcet.

NOTE: To use the following actions, in Tools/Project Setting/Languages extension, **select** Allow dynamic arrays **and** Directly represented array variables **options**.

Init step

The action associated to the **Init** step is as follows:

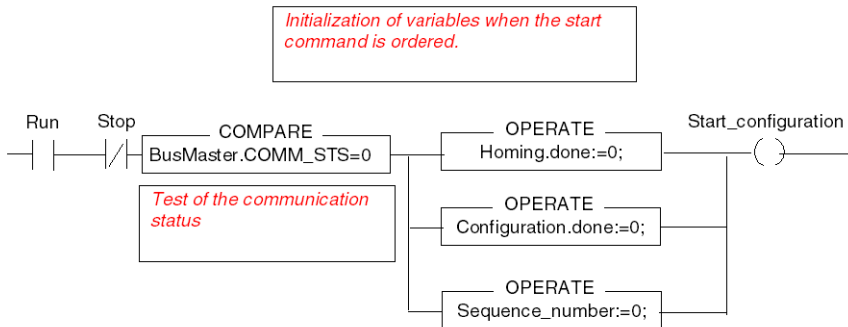

Move_to_Next_Position step

Two actions are associated to the **Move_to_Next_Position** step.

The first action is as follows:

```
(* Definition of the target position*)
CASE Sequence_number OF
1: Lexium.Target_Position:=Position_B;
2: Lexium.Target_Position:=Position_A;
3: Lexium.Target_Position:=Position_C;
END_CASE;
IF (Sequence_number<4) AND NOT (Stop) THEN
(* Start the new positioning *)
New_SetPoint:=1;
Ready_for_Stop:=0;
END IF;
```

The second action is as follows:

```
(*Incrementation before new move starts*)
INC (Sequence_Number);
```

NOTE: For the incrementation action, the qualifier must be positioned on P (rising edge).

Return_to_Start_Point step

The action associated to the **Return_to_Start_Point** step is as follows:

```
(*Target Position Loading*)
Lexium.Target_Position:=0;
(*Start a new positioning*)
New_Setpoint:=1;
```

Disable_Lexium

The action associated to the **Disable_Lexium** step is as follows:

(*Lexium voltage disabling*)

```
Lexium.Controlword:=Lexium_disabling;
```

Glossary

A

ADVANTYS:

Schneider CANopen Configuration tool for PLC islands.

B

BOOL:

Boolean.

C

CAN :

Controller Area Network : field bus originally developed for automobile applications and now used in many sectors.

CiA :

CAN in Automation : international organization of users and manufacturers of CAN devices.

COB-ID:

COB Identifier : unique identifier of a COB on a CANopen network. The identifier determines the priority of a COB.

COB:

Communication Object: transport unit on CANopen bus. A COB is identified by a unique identifier, which is coded on 11 bits, [0, 2047]. A COB contains a maximum of 8 data bytes. The transmission priority of a COB is given by its identifier. The weaker the identifier, the more the associated COB is priority.

CSDO:

SDO Client

D

DINT:

Double integer : 32 bit word.

Discrete Module:

Tout Ou Rien.

DS:

Draft Standard: specifications document created by the CIA organization.

E

EBOOL:

Boolean with edge detection and forcing possibilities.

EDM:

Multi-language Electronic Data Sheet : extended version of EDS file. Extensions include European multilingual support as well as a description of physical characteristics of a device.

EDS :

Electronic Data Sheet: Description of a CANopen device profile description normalized by the DSP306 CiA specification.

EMCY:

Emergency : A trigger event, generated by an internal error/fault. This object is transmitted with each new error, since error codes are independent mechanisms.

ETS :

Empty Terminal Support : Additional information is stored in the PLC application for uploading.

H

HEALTH:

bit from 1 : Mode functions correctly

bit from 0 :

- Bad configuration, or,
- Module configured but absent, or;
- module already configures, but with the same address as an existing module, or
- No Communication

I**INT:**

Integer : Integer 16 bit word.

IODDT :

Input/Output **Derived Data Type**

M**Mapping :**

Transformation of data consigned in a special and different format.

N**NIM :**

Network Interface Module : Communication between the device and field bus.

NMT:

Network Management : This is responsible for managing the execution, configuration and errors in a CAN network.

P**PDO:**

Process Data Object: object for data exchange between different elements is CAN open.

PROCESS IMAGE:

Part of the system memory where the E/S values are stored from PDO exchanges on the CANopen bus. This section is managed by the CANopen stack.

The inputs are copied in the user application memory at the start of each task cycle and the outputs at the end of each task cycle.

R**REAL:**

Real number.

RPDO:

Received PDO

S

SDO:

Service Data Object: peer to peer communication with access to Dictionary Object of a CANopen bus element.

SSDO:

SDO Server

STB:

Small Terminal Block.

SYNC:

Synchronisation Object

T

TPDO:

PDO Transmission

U

UDINT:

Unsigned double integer : Unsigned double integer

UINT:

Unsigned integer : Unsigned integer

Index

A	
addressing	
topological.....	100
B	
BMXP342010	18
BMXP342030	18
C	
CANopen	
connectors	20
certifications	20
channel data structure for communication	
protocols	
T_COM_CO_BMX	141
T_COM_CO_BMX_EXPERT	141
T_COM_STS_GEN	134
COB-ID	171
configuring.....	52
steps of configuration	44
configuring the devices	
STB	80
Tesy U	80
configuring the servodrives	
ATV31.....	80
ATV61.....	80
ATV71.....	80
IcIA.....	80
Lexium 05	80
D	
debugging	118
devices.....	26
diagnosing.....	21
diagnostics	126
E	
emergency objects (EMCY)	171
error codes	171
error control	
heartbeat	64, 70
node guarding	64, 70
event timer	100
I	
inhibit time	100
N	
NMT (network management).....	64, 70
O	
object dictionary	218
P	
parameter settings	134
PDO mapping	103
PDOs	100
performance	45
programming	99
Q	
quick start.....	176
R	
READ_VAR	109
S	
SDOs	104
standards	20

T

T_COM_CO_BMX	141
T_COM_CO_BMX_EXPERT	141
T_COM_STS_GEN.....	134
transmission type	100

W

WRITE_VAR.....	109
----------------	-----

Schneider Electric
35 rue Joseph Monier
92500 Rueil Malmaison
France

www.se.com

As standards, specifications, and design change from time to time, please ask for confirmation of the information given in this publication.

© 2026 Schneider Electric. All rights reserved.

35013944.12