

Altivar® 61/71

Adjustable Speed Drives

Spare Parts Kits

Instruction Bulletin

30072-452-98

Retain for future use.



For Frame Size 14B:
ATV61HC50N4 and ATV71HC40N4

Contents



Hazard Categories and Special Symbols	4
Product Support	4
Before You Begin	5
Introduction	7
Related Documentation	7
Receiving, Handling, and Storage	8
Electrostatic Precautions	8
Inspecting the Spare Part Kits	8
Preliminary Recommendations	9
Qualified Personnel	9
Working Procedures	9
Tools Required	10
Power Removal and Bus Voltage Measurement	11
Discharging Stored Energy in Capacitors	12
Parts Locations	13
Level 1 Parts	13
Level 2 Parts	15
Installation Procedures for Level 1 Parts	19
Removing and Replacing the Front Cover VY1A1216	19
Replacing the Internal Fans VZ3V1213	21
Replacing the Plastic Parts Kit VY1A1406	22
Replacing the Soft Charge Boards VX5A1300	26
Replacing the Fan Control Boards VX5A1400	28
Replacing the Filter Board VX4A1117	31
Replacing the SCR Snubber Board VX4A1200	37
Installation Procedures for Level 2 Parts	49
Disassembly Steps for Accessing Level 2 Parts	49
Replacing the Power Board VX5A1HC4050	78
Replacing the Brake Board VZ3F1113	83
Replacing the Power Board Assembly Shields	84
Replacing the Motor Current Sensors VY1A1109	95
Replacing the Gate Driver Boards VX5A1203	121
Replacing the Temperature Sensors, VZ3G1104	125
Replacing the Power IGBT Modules VZ3IM1603M1271	127
Replacing the Capacitors VY1ADC1112	130
Replacing the SCR Modules and Diode Modules (VZ3TM1425M1671 and VZ3DM1600M1671)	132
Reassembly Steps for Level 2 Parts	144
Wiring	172

Hazard Categories and Special Symbols

The following symbols and special messages may appear in this document or on the equipment to warn of potential hazards or to call attention to information that clarifies or simplifies a procedure.

A lightning bolt or ANSI man symbol in a “Danger” or “Warning” safety label on the equipment indicates an electrical hazard which, as indicated below, can or will result in personal injury if the instructions are not followed.

The exclamation point symbol in a safety message in a manual indicates potential personal injury hazards. Obey all safety messages introduced by this symbol to avoid possible injury or death.

Symbol	Name
	Lightning Bolt
	ANSI Man
	Exclamation Point

⚠ DANGER
DANGER indicates an imminently hazardous situation which, if not avoided, will result in death or serious injury.

⚠ WARNING
WARNING indicates a potentially hazardous situation which, if not avoided, can result in death or serious injury.

⚠ CAUTION
CAUTION indicates a potentially hazardous situation which, if not avoided, can result in minor or moderate injury.

CAUTION
CAUTION , used without the safety alert symbol, indicates a potentially hazardous situation which, if not avoided, can result in property damage.

Product Support

For support and assistance, contact the Product Support Group. The Product Support Group is staffed from Monday through Friday, 8:00 am until 6:00 pm Eastern time, to assist with product selection, start-up, and diagnosis of product or application problems. Emergency phone support is available 24 hours a day, 365 days a year.

Toll free: 888-SquareD (888-778-2733)
 E-Mail: drive.products.support@us.schneider-electric.com
 Fax: 919-217-6508

Before You Begin

Read and follow these precautions before performing any procedure with this drive.

The word “drive” as used in this bulletin refers to the controller portion of the adjustable speed drive as defined in the National Electrical Code (NEC).

⚠ DANGER

HAZARD OF ELECTRIC SHOCK, EXPLOSION, OR ARC FLASH

- Read and understand this manual before installing or operating the Altivar 61 or 71 drive. Installation, adjustment, repair, and maintenance must be performed by qualified personnel.
- The user is responsible for compliance with all international and national electrical code requirements with respect to grounding of all equipment.
- Many parts of this drive, including the printed circuit boards, operate at the line voltage. **DO NOT TOUCH.** Use only electrically insulated tools.
- **DO NOT** touch unshielded components or terminal strip screw connections with voltage present.
- **DO NOT** short across terminals PA/+ and PC/- or across the DC bus capacitors.
- Before servicing the drive:
 - Disconnect all power, including external control power that may be present.
 - Place a “DO NOT TURN ON” label on all power disconnects.
 - Lock all power disconnects in the open position.
 - **WAIT 15 MINUTES** to allow the DC bus capacitors to discharge. Then follow the “Bus Voltage Measurement Procedure” on page 11 to verify that the DC voltage is less than 42 V. The drive LED is not an indicator of the absence of DC bus voltage.
- Install and close all covers before applying power or starting and stopping the drive.

Failure to follow these instructions will result in death or serious injury.

Introduction

This instruction bulletin contains replacement procedures for the Altivar[®] 61 and 71 spare parts kits identified in Table 1. Read and understand the instructions in this document and other referenced documents before installing the kits.

Table 1: Altivar[®] 61 and 71 Spare Parts Kits¹

Kit Catalog No.	Description	For Use On Drive:	For Location of Parts, See:
VY1A1216	Front Cover Assembly	ATV61HC50N4, ATV71HC40N4	page 20
VY1A1406	Plastic Parts Kit	ATV61HC50N4, ATV71HC40N4	pages 13, 15, 22
VZ3V1213	Internal Fan	ATV61HC50N4, ATV71HC40N4	page 13
VX5A1300	Soft Charge Board	ATV61HC50N4, ATV71HC40N4	page 13
VX5A1400	Fan Control Board	ATV61HC50N4, ATV71HC40N4	page 13
VZ3F1113	Brake Board	ATV61HC50N4, ATV71HC40N4	page 13
VX4A1117	Filter Board	ATV61HC50N4, ATV71HC40N4	page 13
VX5A1HC4050	Power Board	ATV61HC50N4, ATV71HC40N4	page 13
VY1A1109	Motor Current Sensor	ATV61HC50N4, ATV71HC40N4	page 15
VX5A1203	Gate Driver Board	ATV61HC50N4, ATV71HC40N4	page 16
VZ3G1104	Temperature Sensors	ATV61HC50N4, ATV71HC40N4	page 17
VZ3IM1603M1271	Power IGBT ² Module	ATV61HC50N4, ATV71HC40N4	page 17
VY1ADV1110	Screw Kit	ATV61HC50N4, ATV71HC40N4	—
VY1ADC1112	Capacitors	ATV61HC50N4, ATV71HC40N4	page 17
VX4A1200	SCR Snubber Board	ATV61HC50N4, ATV71HC40N4	page 14
VZ3TM1425M1671	SCR ³ Module	ATV61HC50N4, ATV71HC40N4	page 18
VZ3DM1600M1671	Diode Module	ATV61HC50N4, ATV71HC40N4	page 18
VZ3N1333	Wire Kit	ATV61HC50N4, ATV71HC40N4	—

¹ For kit contents, refer to document 30072-452-44.

² IGBT: Insulated-gate bipolar transistor

³ SCR: Silicon controlled rectifier

Related Documentation

NOTE: All documentation referenced in this bulletin is provided with the drive or on the CD-ROM included with the spare parts kits. You can also download the documentation from the Technical Library at www.schneider-electric.us.

For drive installation instructions, refer to the following documents:

- *Altivar[®] 61 Installation Manual 0.5 to 100 HP*, module no. 1760643
- *Supplementary Instructions to ATV61 Variable Speed Drives Installation Manual—Low Horsepower*, document no. 30072-452-63
- *Altivar[®] 61 Installation Manual 75 to 900 HP*, module no. 1760655
- *Supplementary Instructions to ATV61 Variable Speed Drives Installation Manual—High Horsepower*, document no. 30072-452-49
- *Altivar[®] 71 Installation Manual 0.5 to 100 HP*, module no. 1755843
- *Altivar[®] 71 Installation Manual 75 to 700 HP*, module no. 1755849
- *Altivar[®] 71 Drive Controllers Errata to Bulletin atv71e_installation_manual_en_v3*, document no. 30072-452-25

Receiving, Handling, and Storage

Electrostatic Precautions

⚠ CAUTION

STATIC SENSITIVE COMPONENTS

Circuit boards and option cards can be damaged by static electricity. Observe the electrostatic precautions below when handling controller circuit boards or testing components.

Failure to follow these instructions can result in injury or equipment damage.

Observe the following precautions for handling static-sensitive components:

- Keep static-producing material such as plastic, upholstery, and carpeting out of the immediate work area.
- Store static-sensitive components in protective packaging when they are not installed in the drive.
- When handling a static-sensitive component, wear a conductive wrist strap connected to the component or drive through a minimum of 1 megohm resistance.
- Avoid touching exposed conductors and component leads with skin or clothing.

Inspecting the Spare Part Kits

After receiving the ATV61/ATV71 spare parts kit:

- Ensure that the catalog number printed on the kit label is the same as that on the packing slip and corresponding purchase order. Contact your Schneider Electric representative if there are any errors.
- Remove the kit from its packaging and inspect it for damage. If any damage is found, notify the carrier and your Schneider Electric representative.
- To store the kit, replace any static-sensitive parts in their protective packaging and store them at -25 to +70 °C (-13 to +158 °F).

⚠ WARNING

DAMAGED EQUIPMENT

Do not install or operate any equipment that appears damaged.

Failure to follow these instructions can result in death, serious injury, or equipment damage.

Preliminary Recommendations

Before beginning the installation procedures, read and understand all the information in this section.

Qualified Personnel

For the protection of personnel and equipment, a qualified person must perform the procedures detailed in this instruction bulletin.

A qualified person is one who has skills and knowledge related to the construction and operation of this electrical equipment and the installation, and has received safety training to recognize and avoid the hazards involved. Refer to the most current release of NFPA 70E®, “Standard for Electrical Safety in the Workplace,” for safety training requirements.

In addition, the person must be:

- Able to read, interpret, and follow the instructions and precautions in this instruction bulletin and the other documentation referenced.
- Able to use the required tools listed in this instruction bulletin in a safe and correct manner.

Working Procedures

Observe the following working procedures:

- Use only the components provided with the kits listed in Table 1 beginning on page 7. Do not attempt to repair the drive with other spare parts or equipment.
- If the part being replaced includes labels, ensure that the labels are applied to the replacement part. If the labels are not available in the kit, contact your Schneider Electric representative.
- Mount the spare parts only in the locations specified in the installation procedures.
- Route and position the wires as shown in the instructions. Use the wires and cables provided with the spare parts kits or with the drive. Do not modify the wires and cables. Do not route wires and cables outside of the drive enclosure.
- Install all shields as described in the installation procedures.
- Observe the hardware and torque requirements specified in the installation procedures. Do not substitute hardware. Carefully segregate and label all removed hardware and parts for use in reassembly of the drive.
- Mount all panels and covers as specified in the installation procedures.

Tools Required

- Needle-nose pliers
- Torque wrench, 0–45 N•m (0–398 lb-in)
- Voltmeter, 1–1000 Vdc
- Driver bits:
 - T-10 Torx[®] driver
 - T-20 Torx[®] driver
 - T-30 Torx[®] driver
 - T-30 right-angle Torx[®] driver
 - Size 2 magnetic tip Phillips[®] driver
 - Size 3 magnetic tip Phillips[®] driver
- Socket wrenches:
 - 7 mm
 - 10 mm
 - 16 mm
 - 18 mm
 - 21 mm

Power Removal and Bus Voltage Measurement

⚠ DANGER

HAZARD OF ELECTRIC SHOCK, EXPLOSION, OR ARC FLASH

Read and understand the precautions in "Before You Begin" starting on page 5 before performing this procedure.

Failure to follow these instructions will result in death or serious injury.

The DC bus voltage can exceed 1,000 Vdc. Use a properly rated voltage-sensing device when performing this procedure. To measure the DC bus voltage:

1. Disconnect all power.
2. Wait 15 minutes to allow the DC bus to discharge.
3. Measure the voltage of the DC bus between the PA/+ and PC/- terminals to ensure that the voltage is less than 42 Vdc. These terminals are clearly labeled on each drive.
4. If the DC bus capacitors do not discharge completely, contact your local Schneider Electric representative. Do not repair or operate the drive.

⚠ CAUTION

IMPROPER DRIVE OPERATION

- If no power is applied to the drive for a long period, the performance of its electrolytic capacitors will be reduced.
- If the drive is not in active service, apply power to the drive every two years using the following procedure. Do not initially connect the drive directly to full line voltage. Without a motor connected to the drive, gradually increase the voltage using an adjustable AC source connected between drive terminals L1 and L2:
 - 25% of rated voltage for 30 minutes
 - 50% of rated voltage for 30 minutes
 - 75% of rated voltage for 30 minutes
 - 100% of rated voltage for at least 5 hours
- Check drive operation before placing the drive into service.

Failure to follow these instructions can result in injury or equipment damage.

Discharging Stored Energy in Capacitors

⚠ DANGER

HAZARD OF ELECTRIC SHOCK, EXPLOSION, OR ARC FLASH

- When the controller is damaged, voltage may remain on certain energy storage capacitors after de-energization of the controller and discharge of the main capacitor bank.
- Before working on or near assemblies containing energy storage capacitors, verify that the capacitor voltages are less than 42 Vdc.
- The following assemblies have energy-storing capacitors:
 - Filter board
 - SCR snubber board
- Always check for the presence of voltage using a voltmeter set to the 1000 Vdc scale. When voltage is present, allow the voltmeter to discharge the capacitor's stored charge.

Failure to follow these instructions will result in death or serious injury.

Capacitors are used throughout the drive as energy storage devices. Some of the capacitors can store potentially lethal amounts of energy during normal controller operation.

When power is removed from an undamaged controller, the stored energy in these capacitors is automatically discharged to nonhazardous levels. However, the discharge mechanisms in a damaged controller may not be operating properly, and stored energy may be present on printed circuit boards.

Do not touch traces on printed circuit boards, such as the line filter board and SCR snubber board, unless you have first checked for voltage with a voltmeter!

To discharge the filter board and SCR snubber board capacitors, use a voltmeter set to the 1000 Vdc scale. It will take approximately 6.6 minutes for a 10 megohm input impedance voltmeter to discharge a 10 microfarad capacitor from 700 V to less than 42 V. It will take approximately 40 seconds for a 1 megohm input impedance voltmeter to discharge a 10 microfarad capacitor from 700 V to less than 50 V.

⚠ DANGER

HAZARD OF ELECTRIC SHOCK, EXPLOSION, OR ARC FLASH

- Do not use a voltmeter to discharge stored energy on the DC bus capacitors.
- If the energy on the DC bus capacitors remains greater than 42 Vdc after 15 minutes, contact Product Support.

Failure to follow these instructions will result in death or serious injury.

Parts Locations

Refer to the figures in this section to familiarize yourself with the layout of the drive and the location of the parts before performing the installation procedures.

Level 1 Parts

Figure 1: Level 1 Parts and Power Board

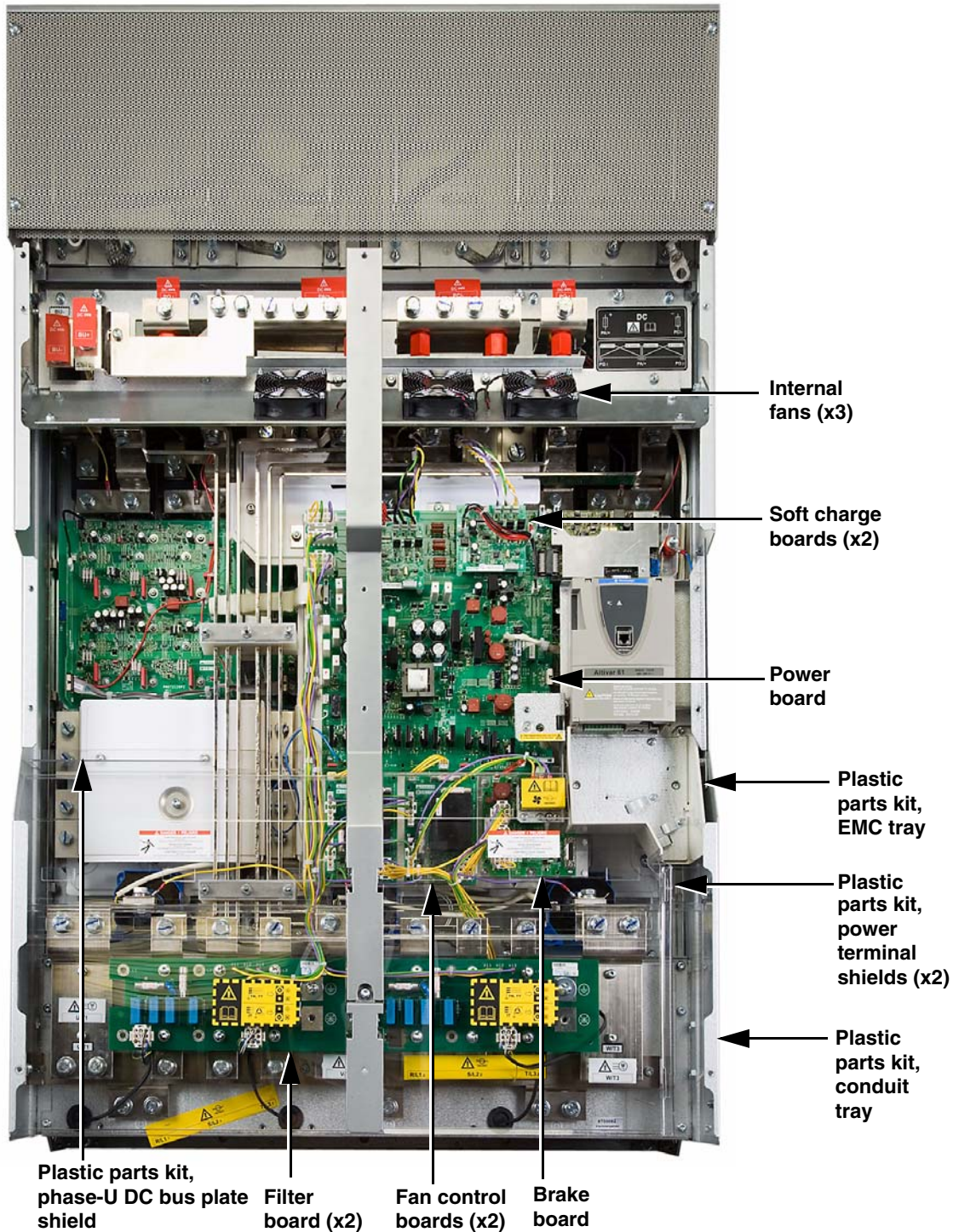
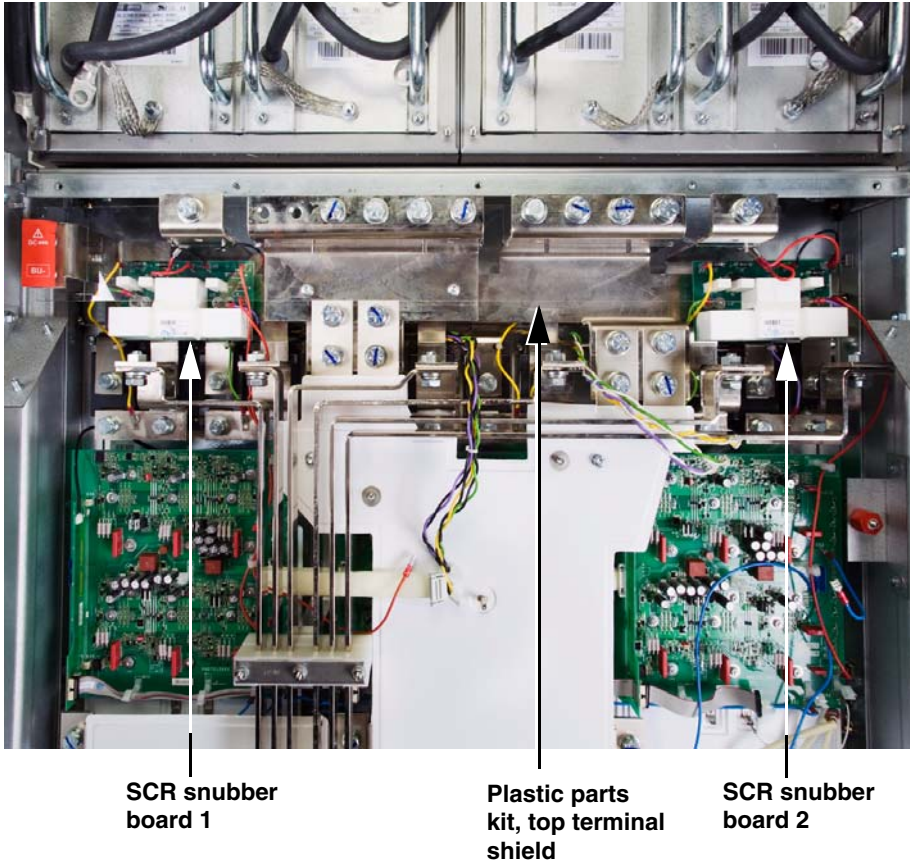

Figure 2: SCR Snubber Board and Top Terminal Shield



Level 2 Parts

Figure 3: Motor Current Sensors and Input Bus Bar Brackets (Plastic Kit)

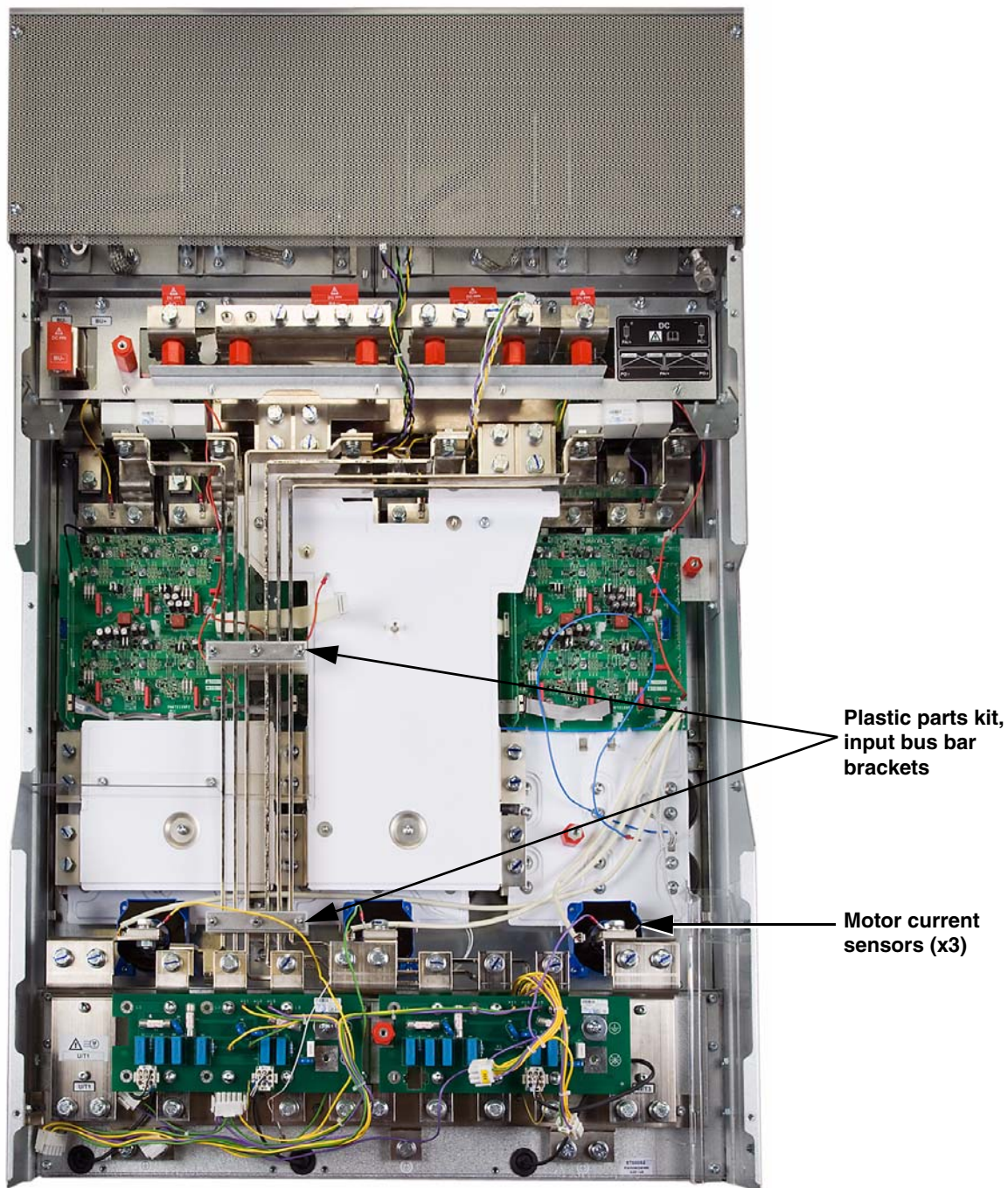

Figure 4: Gate Driver Boards

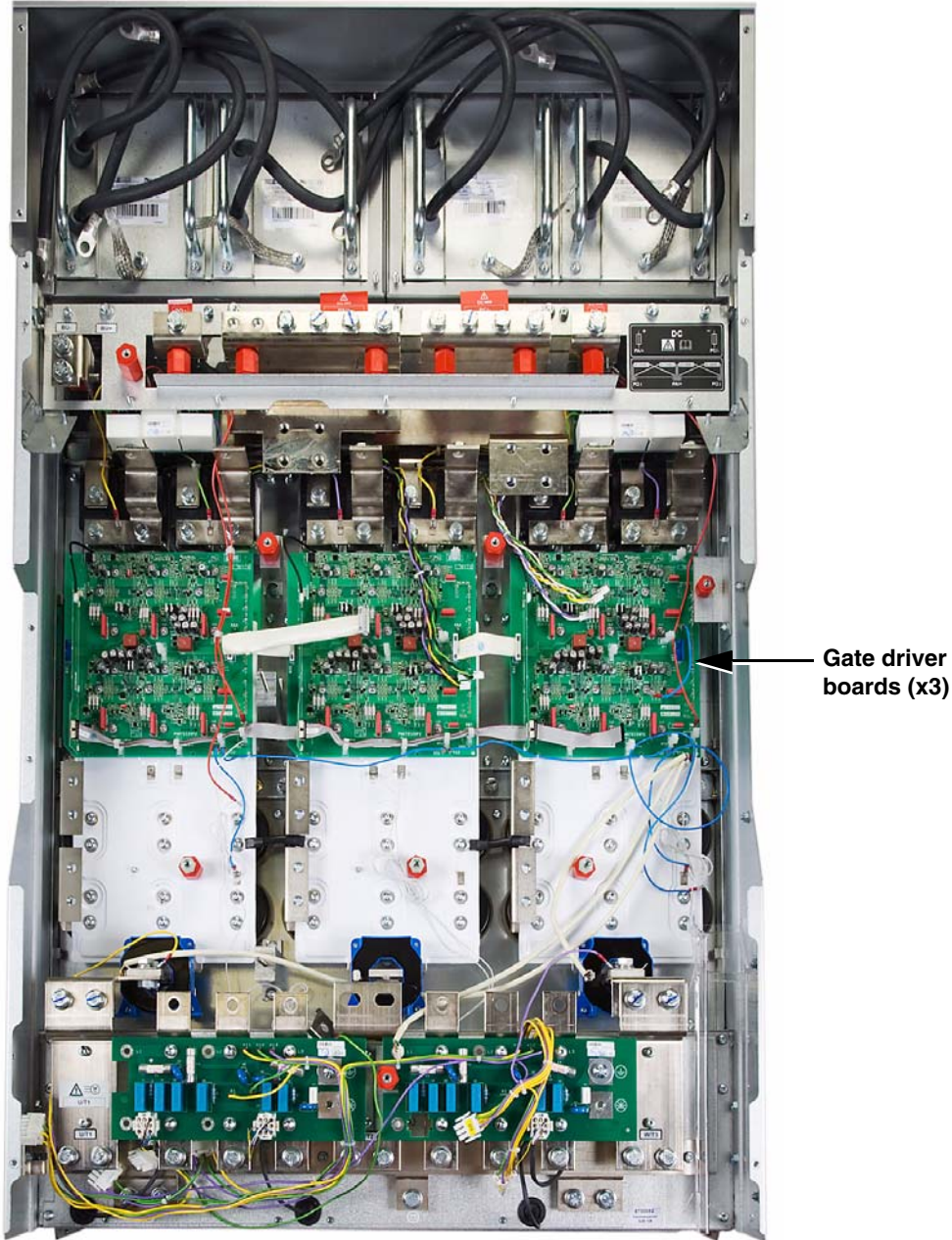

Figure 5: Temperature Sensors, Power IGBT Modules, and Capacitors

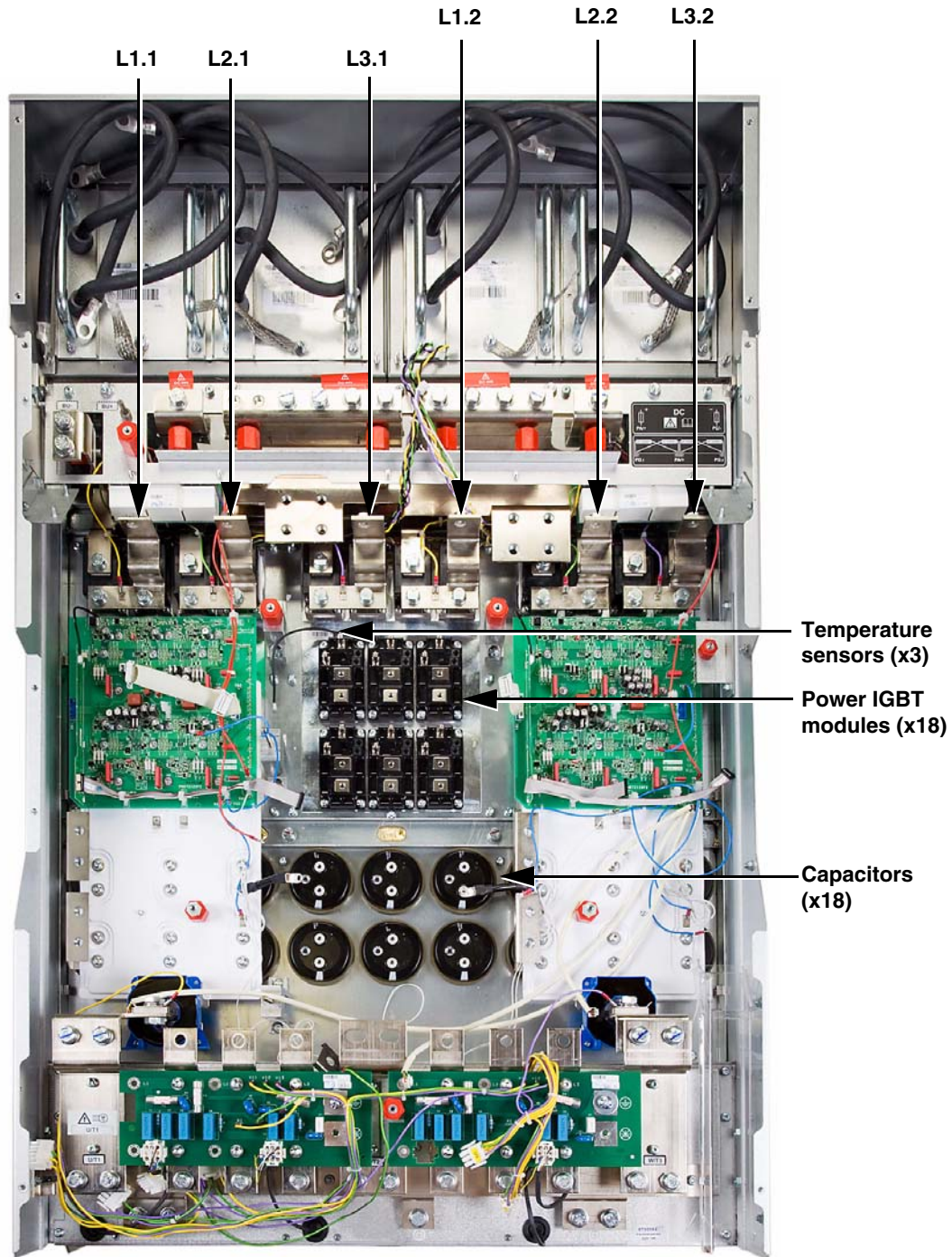
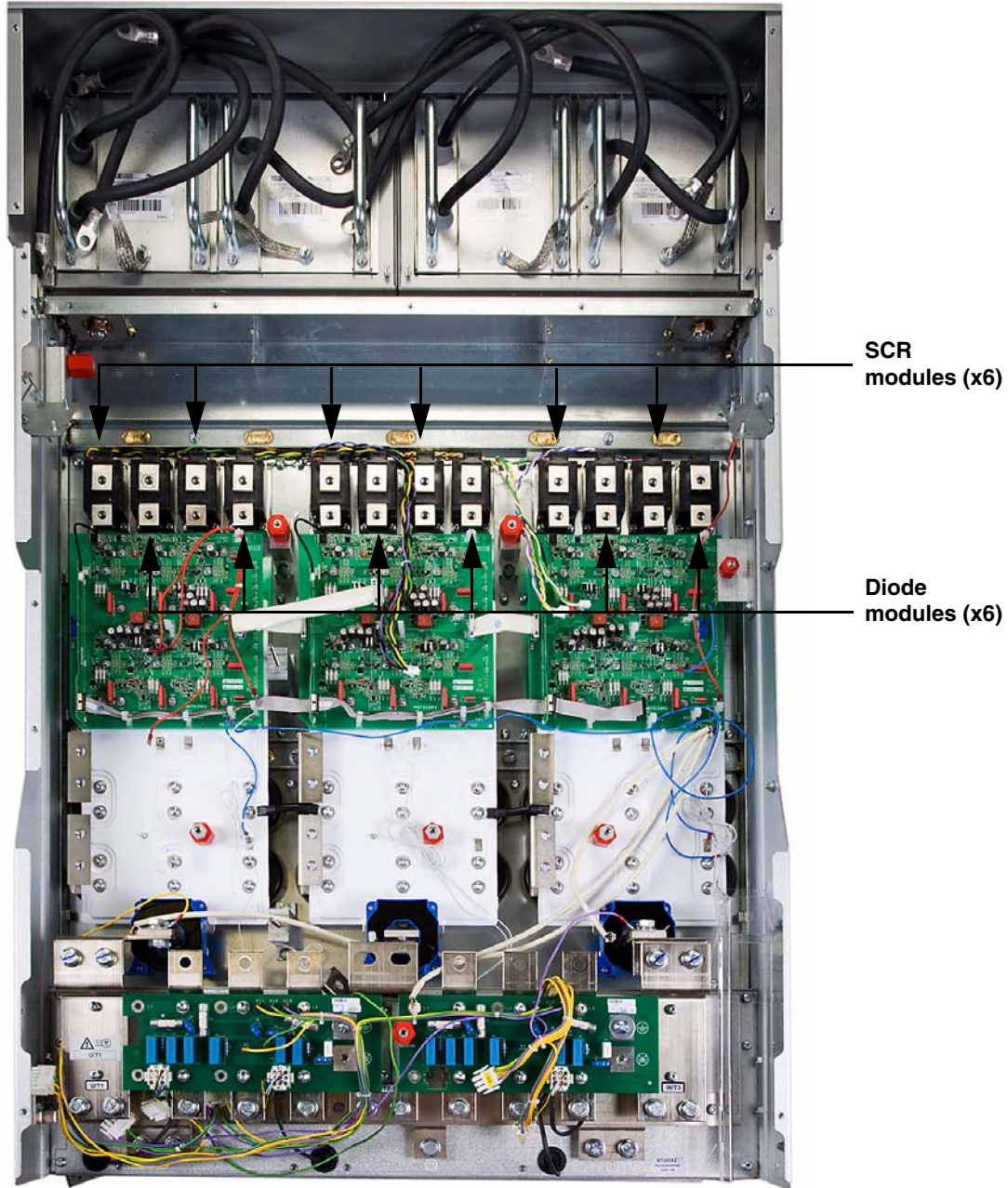

Figure 6: SCR Modules and Diode Modules



Installation Procedures for Level 1 Parts

Level 1 parts consist of the front cover and parts that are accessible directly under the front cover. They are:

Front cover	Soft charge board
Internal fans	Fan control board
Power terminal shield (plastic kit)	Filter board
Conduit tray (plastic kit)	SCR snubber board
EMC tray (plastic kit)	

Removing and Replacing the Front Cover VY1A1216

IMPORTANT: Label and retain all removed hardware and cables for use in reassembly.

DANGER

HAZARD OF ELECTRIC SHOCK, EXPLOSION, OR ARC FLASH

- Read and understand the precautions in “Before You Begin” starting on page 5 before performing this procedure.
- Before working on this equipment, turn off all power supplying it and perform the DC bus voltage measurement procedure on page 11.

Failure to follow these instructions will result in death or serious injury.

The procedures in this manual require removal and replacement of the front cover. See Figure 7.

- To remove the front cover, using a size 2 Phillips driver, remove thirteen screws (**A**) and take the front cover off the drive.
- To replace the front cover, using a size 2 Phillips driver secure the front cover with thirteen screws (**A**). Tighten the screws to 5.5 N•m (48.7 lb-in).

If you are replacing the rectifier snubber board, SCR modules, or diode modules, you may also need to remove the top grille as follows.

- Using a size 2 Phillips driver, remove four screws (**B**) securing the top grille to the drive frame.
- To replace the top grille, using a size 2 Phillips driver secure the grille to the drive frame with four screws (**B**). Tighten the screws to 5.5 N•m (48.7 lb-in).

Figure 7: Front Cover

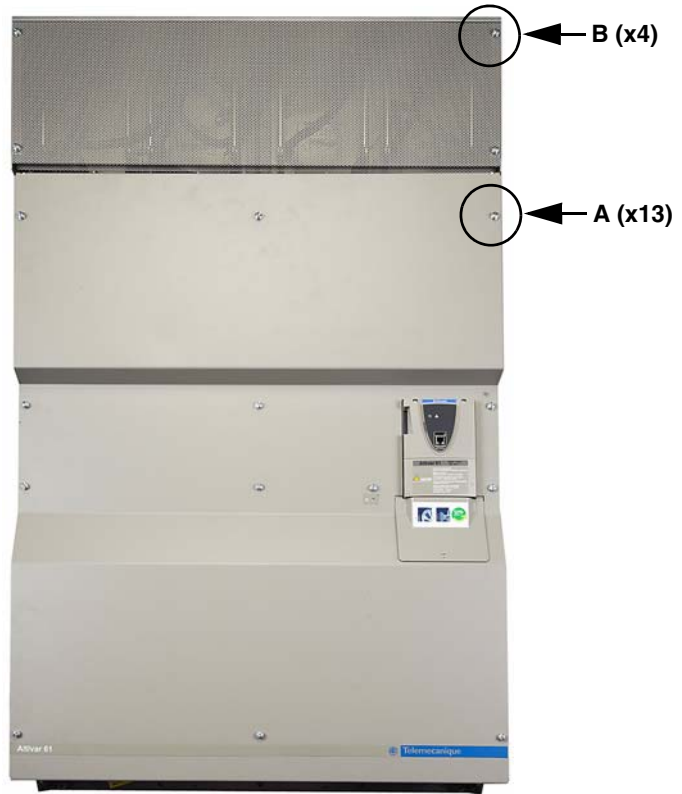

Replacing the Internal Fans VZ3V1213

IMPORTANT: Label and retain all removed hardware and cables for use in reassembly.

Remove the Front Cover

Replace the Internal Fan

⚠ DANGER

HAZARD OF ELECTRIC SHOCK, EXPLOSION, OR ARC FLASH

- Read and understand the precautions in “Before You Begin” starting on page 5 before performing this procedure.
- Before working on this equipment, turn off all power supplying it and perform the DC bus voltage measurement procedure on page 11.

Failure to follow these instructions will result in death or serious injury.

1. Using a size 2 Phillips driver, remove thirteen screws and take the front cover off the drive. See Figure 7 on page 20.
2. Remove the internal fan you are replacing as follows. See Figure 8.
 - Using needle-nose pliers, carefully unplug the fan’s 2-pin connector (**A**) from the fan bracket.
 - Using a T-20 Torx driver, remove four screws (**B**) securing the fan to the fan bracket, and remove the fan from the drive.

Figure 8: Internal Fans

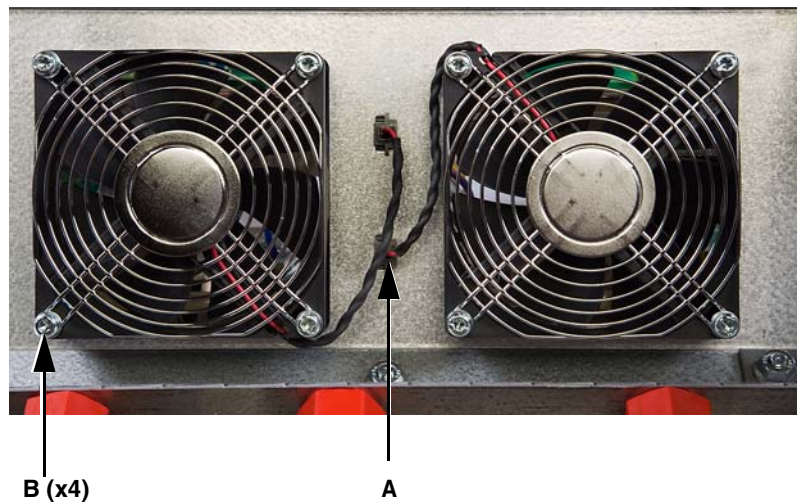

3. Install the new fan as follows. See Figure 8.
 - Using a T-20 Torx driver, secure the fan to the fan bracket with four screws (**B**). Tighten the screws to 1.1–1.7 N•m (9.7–15 lb-in).
 - Plug the fan’s 2-pin connector (**A**) into the terminal on the fan bracket.
4. Replace the front cover. Using a size 2 Phillips driver, secure the front cover with thirteen screws. See Figure 7 on page 20. Tighten the screws to 5.5 N•m (48.7 lb-in).

Replace the Front Cover

Replacing the Plastic Parts Kit VY1A1406

IMPORTANT: Label and retain all removed hardware and cables for use in reassembly.

⚠ DANGER

HAZARD OF ELECTRIC SHOCK, EXPLOSION, OR ARC FLASH

- Read and understand the precautions in “Before You Begin” starting on page 5 before performing this procedure.
- Before working on this equipment, turn off all power supplying it and perform the DC bus voltage measurement procedure on page 11.

Failure to follow these instructions will result in death or serious injury.

The replacement steps for some parts of the plastic kit are covered in other procedures. See Table 2.

Table 2: Plastic Kit Contents

Description	For replacement steps, see
Power terminal shields	“Replacing the Power Terminal Shields” beginning on page 22
EMC tray	“Replacing the EMC Tray” beginning on page 24
Conduit tray	“Replacing the Conduit Tray” beginning on page 25
Top rectifier shield	“Replace the Rectifier Shield” on page 159
Phase-U DC bus plate shield	“Replace the Phase-U DC Bus Plate” on page 149
Input bus bar brackets	“Replace the Input Bus Bar Brackets (Bottom)” on page 150 and “Replace the Power Board Assembly” on page 163
Power board assembly shields	“Replacing the Power Board Assembly Shields” beginning on page 84

Replacing the Power Terminal Shields

If the transparent terminal shields are cracked, broken, or damaged, replace them as follows.

⚠ DANGER

HAZARD OF ELECTRIC SHOCK, EXPLOSION, OR ARC FLASH

- Install the power terminal shields as shown in Figures 9 and 10 on pages 23 and 23.
- Before installing the shields, ensure that they have no tears or cracks. If the shields are damaged, install new pieces from the plastic kit. See page 21.
- Do not install a damaged shield.

Failure to follow these instructions will result in death or serious injury.

1. Using a size 2 Phillips driver, remove thirteen screws and take the front cover off the drive. See Figure 7 on page 20.
2. The right terminal shield has two tabs **(A)** on the right side that fit into slots on the conduit tray, and two tabs **(B)** on the left side that fit into slots on the middle crossbrace. See Figure 9 on page 23.

The left terminal shield has two tabs on the right **(C)** that fit into retaining slots in the middle crossbrace and two mounting holes **(D)** on the left that fit over posts on the side panel of the drive. See Figure 10 on page 23.

Disengage the shields and remove them from the drive.

NEXT STEP: If you are also replacing the EMC tray, perform the steps in “Replacing the EMC Tray” beginning on page 24 before installing the new power terminal shields.

If you are replacing the conduit tray, perform the steps in “Replacing the Conduit Tray” on page 25 before installing the new power terminal shields.

3. If you are only replacing the power terminal shields, install the new shields as shown in Figures 9 and 10.
Labels for the new shield are included in the plastic kit. Add the new labels in the same positions as on the old shield.
4. Replace the front cover. Using a size 2 Phillips driver, secure the front cover with thirteen screws. See Figure 7 on page 20. Tighten the screws to 5.5 N•m (48.7 lb-in).

Figure 9: Right Terminal Shield

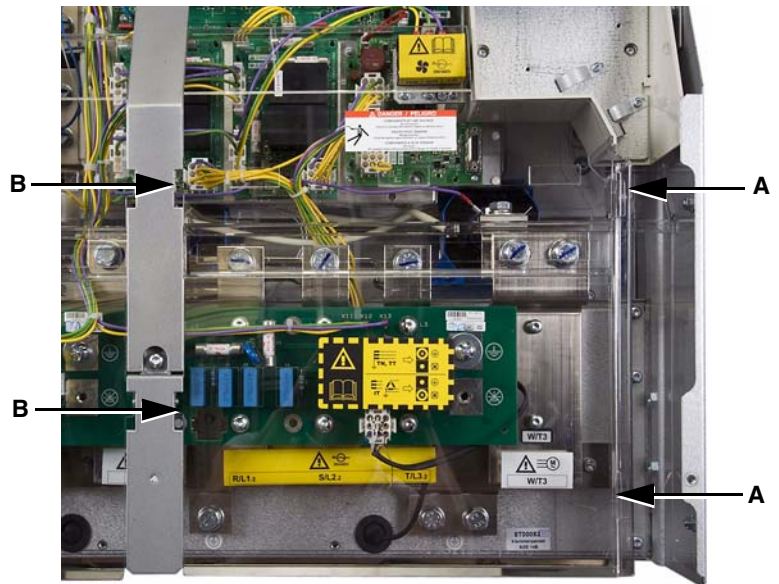
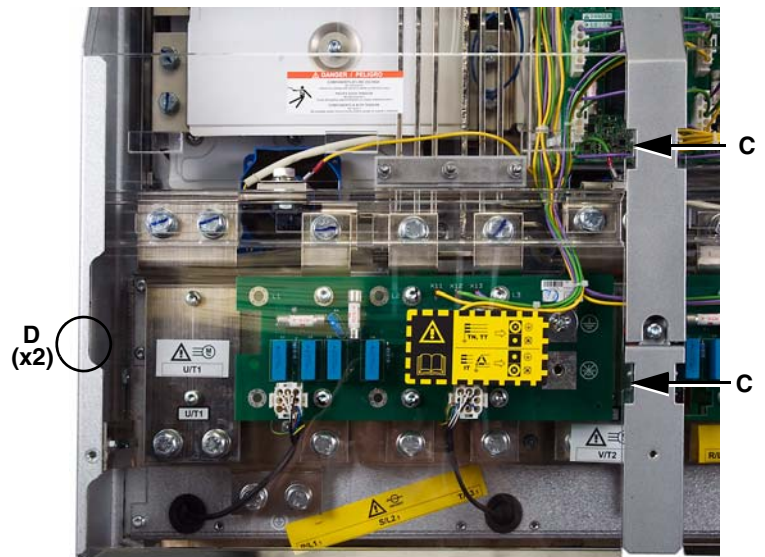

Figure 10: Left Terminal Shield



Replacing the EMC Tray

Replace the EMC tray as follows.

1. Using a size 2 Phillips driver, remove thirteen screws and take the front cover off the drive. See Figure 7 on page 20.
2. Remove the right power terminal shield. See Step 2 on page 22.
3. Using a T-20 Torx driver, remove three screws (**A**) securing the EMC tray to the control module mounting plate and remove the tray from the drive. See Figure 11.

Figure 11: EMC Tray

Table 3: EMC Tray Hardware Torque Values

Item	Description	Torque Range	
		N•m	lb-in
A	(3) T-20 screws	0.4–0.6	3.5–5.3
B	(1) Size 2 Phillips screw (20 mm length)	0.4–0.6	3.5–5.3
C	(2) Size 2 Phillips screws (10 mm length)	0.4–0.6	3.5–5.3



4. Using a size 2 Phillips driver, remove three screws (**B** and **C**) securing the cable clamps to the metal EMC plate, and remove the clamps from the plate. See Figure 11.

NOTE: Note the differences in the cable clamps and screws. The screw (**B**) in the large clamp is longer than the screws (**C**) in the two shorter clamps.

5. Remove the metal EMC plate from the plastic tray and discard the plastic tray.
6. Place the metal EMC plate into the new plastic tray.
7. Using a size 2 Phillips driver, install the cable clamps on the EMC plate with three screws (**B** and **C**). See Figure 11.
8. Using a T-20 Torx driver, secure the plastic EMC tray to the control module mounting plate with mounting three screws (**A**). See Figure 11.
9. Tighten the hardware to the torque values listed in Table 3.

NEXT STEP: If you are also replacing the conduit tray, install it before replacing the power terminal shields. See page 25.

10. Replace the right terminal shield as illustrated in Step 3 on page 23.
11. Replace the front cover. Using a size 2 Phillips driver, secure the front cover with thirteen screws. See Figure 7 on page 20. Tighten the screws to 5.5 N•m (48.7 lb-in).

Replacing the Conduit Tray

Replace the conduit tray as follows.

1. Using a size 2 Phillips driver, remove thirteen screws and take the front cover off the drive. See Figure 7 on page 20.
2. Remove the right power terminal shield. See Step 2 on page 22.
3. Using a 10 mm socket wrench, remove two nuts securing the conduit tray to the drive frame. See Figure 12.
4. Install the new conduit tray and secure it with the two 10 mm nuts as illustrated in Figure 12. Tighten the nuts to 5.5 N•m (48.7 lb-in).
5. Replace the right terminal shield as illustrated in Step 3 on page 23.
6. Replace the front cover. Using a size 2 Phillips driver, secure the front cover with thirteen screws. See Figure 7 on page 20. Tighten the screws to 5.5 N•m (48.7 lb-in).

Figure 12: Conduit Tray

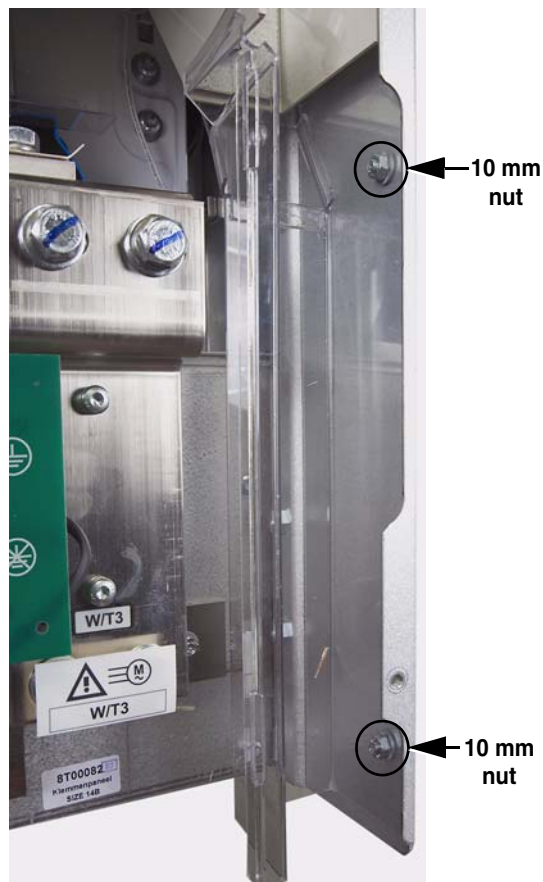

Replacing the Soft Charge Boards VX5A1300

IMPORTANT: Label and retain all removed hardware and cables for use in reassembly.

⚠ DANGER

HAZARD OF ELECTRIC SHOCK, EXPLOSION, OR ARC FLASH

- Read and understand the precautions in “Before You Begin” starting on page 5 before performing this procedure.
- Before working on this equipment, turn off all power supplying it and perform the DC bus voltage measurement procedure on page 11.

Failure to follow these instructions will result in death or serious injury.

1. Using a size 2 Phillips driver, remove 13 screws and take the front cover off the drive. See Figure 7 on page 20.
2. Remove the power terminal shields as illustrated in “Replacing the Power Terminal Shields” on page 22.
3. Remove the middle crossbrace as follows.
 - Using a 10 mm socket wrench, remove two nuts (**A**) securing the crossbrace to the fan bracket. See Figure 13.
 - Using a T-30 Torx driver, remove one screw (**B**) securing the crossbrace to the filter board and remove the crossbrace from the drive. See Figure 14.

Figure 13: Middle Crossbrace Top

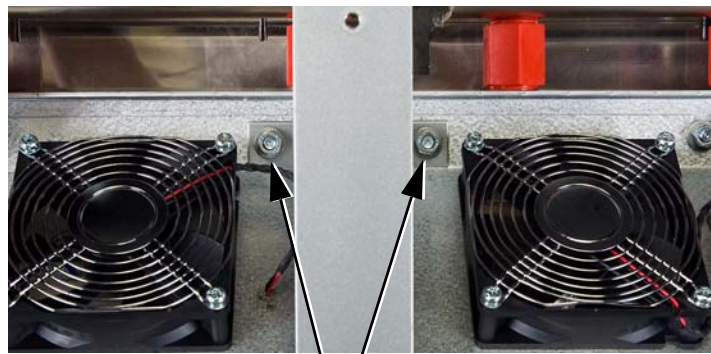

A (x2)

Table 4: Crossbrace Hardware Torque Values

Item	Description	Torque Range	
		N•m	lb-in
A	(2) 10 mm nuts	5.5	48.7
B	(1) T-30 screw	5.5	48.7

Figure 14: Middle Crossbrace Bottom

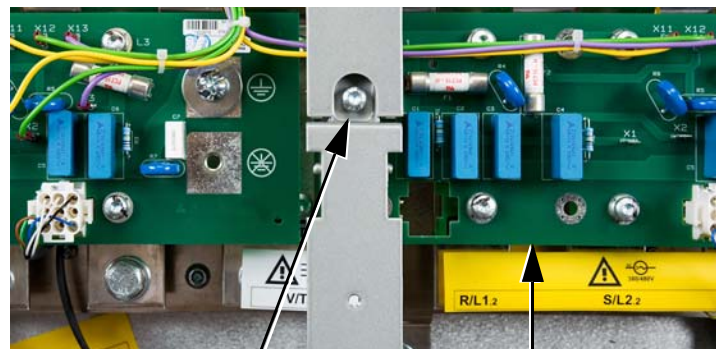

B

Filter board

Table 5: Soft Charge Board Wiring

Wire No. ¹	Terminal No.	Description	To:
Soft Charge Board 1 (Left Board)			
E110	CN2A	9-pin, red	PB ² X30 (9-pin)
E109	CNL3G	2-pin, violet/black	SCR ³ L3.1 Terms. 4 & 5
E108	CNL2G	2-pin, green/black	SCR L2.1 Terms. 4 & 5
E107	CNL1G	2-pin, yellow/black	SCR L1.1 Terms. 4 & 5
E111	CN7A	2-pin, black	PB X31
—	CNP	Not used	—
Soft Charge Board 2 (Right Board)			
E156	CN2A	9-pin, red	PB ² X40 (9-pin)
E152	CNL3G	2-pin, violet/white	SCR ³ L3.2 Terms. 4 & 5
E153	CNL2G	2-pin, green/white	SCR L2.2 Terms. 4 & 5
E154	CNL1G	2-pin, yellow/white	SCR L1.2 Terms. 4 & 5
E155	CN7A	2-pin, black	PB ² X41
—	CNP	Not used	—

¹ See the schematic on page 175 for complete drive wiring. Wire numbers are given for cross referencing the wires with the wiring table and the schematic. The numbers do not appear on the wires.

² PB: Power board

³ SCR: Silicon controlled rectifier. L1.1, L2.1, and L3.1 are associated with input rectifier 1; L1.2, L2.2, and L3.2 are associated with input rectifier 2.

- Using needle-nose pliers, carefully remove the following connections from the soft charge board you are replacing. See Table 5 and Figure 15 for connector locations.
 - At the top of the soft charge board, from left to right remove the connectors from terminals CN2A, CNL3G, CNL2G, and CNL1G.
 - At the left side of the board, remove the connector from terminal CN7A.

Figure 15: Soft Charge Board: Board 1 (Left) Shown

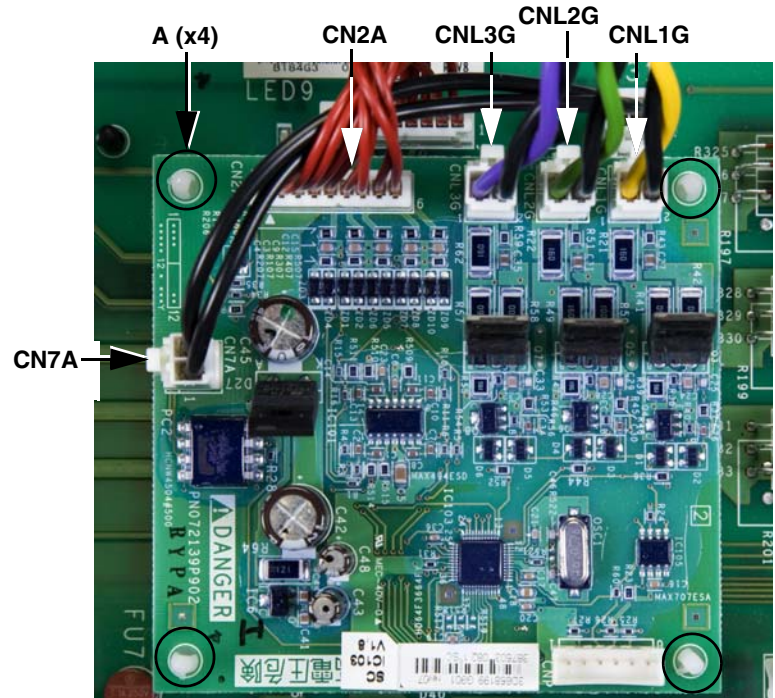

- Using needle-nose pliers, compress the four plastic mounting posts (**A**, Figure 15), one at a time, while lifting the soft charge board off the posts. Remove the soft charge board from the drive.
- Press the new soft charge board down over the four mounting posts (**A**, Figure 15) until it is securely seated.
- Install five connections on the new soft charge board. See Table 5 and Figure 15 for connector locations.
- Replace the middle crossbrace as follows.
 - Using a 10 mm socket wrench, secure the crossbrace to the fan bracket with two nuts (**A**). See Figure 13 on page 26.
 - Using a T-30 Torx driver, secure the crossbrace to the filter board with one screw (**B**). See Figure 14 on page 26.
 - Tighten the hardware to the torque values specified in Table 4 on page 26.
- Replace the power terminal shield as illustrated in “Replacing the Power Terminal Shields” on page 22.
- Replace the front cover. Using a size 2 Phillips driver, secure the front cover with 13 screws. See Figure 7 on page 20. Tighten the screws to 5.5 N•m (48.7 lb-in).

Replacing the Fan Control Boards VX5A1400

IMPORTANT: Label and retain all removed hardware and cables for use in reassembly.

⚠ DANGER

HAZARD OF ELECTRIC SHOCK, EXPLOSION, OR ARC FLASH

- Read and understand the precautions in “Before You Begin” starting on page 5 before performing this procedure.
- Before working on this equipment, turn off all power supplying it and perform the DC bus voltage measurement procedure on page 11.

Failure to follow these instructions will result in death or serious injury.

1. Using a size 2 Phillips driver, remove thirteen screws and take off the front cover of the drive. See Figure 7 on page 20.
2. Remove the power terminal shields as illustrated in “Replacing the Power Terminal Shields” on page 22.
3. Remove the middle crossbrace as follows.
 - Using a 10 mm socket wrench, remove two nuts (**A**) securing the crossbrace to the fan bracket. See Figure 16.
 - Using a T-30 Torx driver, remove one screw (**B**) securing the crossbrace to the filter board and remove the crossbrace from the drive. See Figure 17.

Figure 16: Middle Crossbrace Top

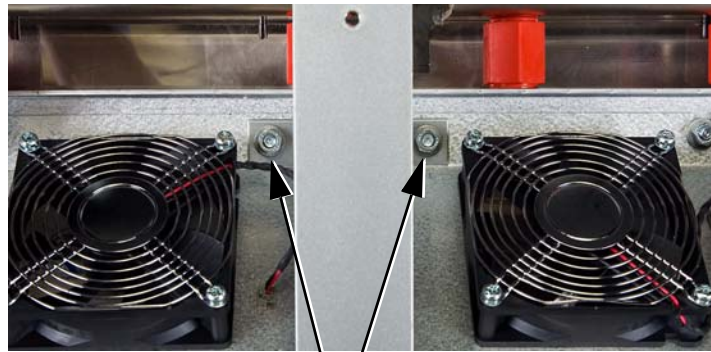

A (x2)

Table 6: Crossbrace Hardware Torque Values

Item	Description	Torque Range	
		N•m	lb-in
A	(2) 10 mm nuts	5.5	48.7
B	(1) T-30 screw	5.5	48.7

Figure 17: Middle Crossbrace Bottom

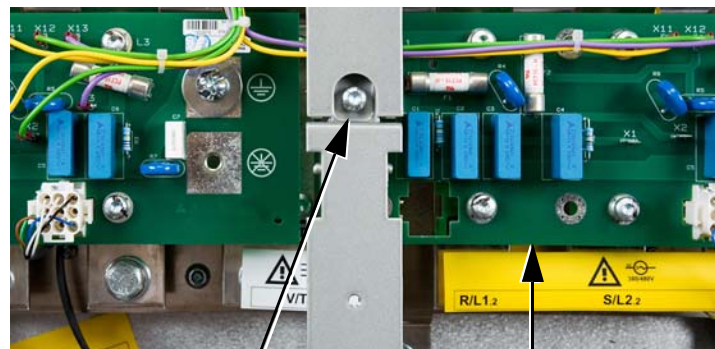

B

Filter board

- The drive has two fan control boards. Remove the following connections from the fan control board you are replacing.

NOTE: If you are replacing fan control board 1, see Table 7 and Figure 18. If you are replacing fan control board 2, see Table 8 and Figure 19 on page 30.

Table 7: Fan Control Board 1 Wiring

Wire No. ¹	Terminal No.	Description	To:
E105	X2	3-pin, yellow	PB ² X14
E120	X1	5-pin, 2 wire, violet/green	FCB ³ X1
E124	X4	5-pin, 2 wire, violet/green	TB1 and FCB2 X4
E114	X3	9-pin, green/yellow/violet with yellow and green ground wire	FB ⁴ 1, X11 and X12; FB2, X13; and BB ⁵ X33
—	X6	Not used	—

¹ See the schematic on page 174 for complete drive wiring. Wire numbers are given for cross referencing the wires with the wiring table and the schematic. The numbers do not appear on the wires.

² PB: Power board

³ FCB: Fan control board

⁴ FB: Filter board

⁵ BB: Brake board

- From top to bottom, remove: the 3-pin connector from terminal X2, the 5-pin connector from terminal X1, and the 5-pin connector from terminal X4.
- From the bottom right of the board, remove the 9-pin connector from terminal X3.

Figure 18: Fan Control Board 1

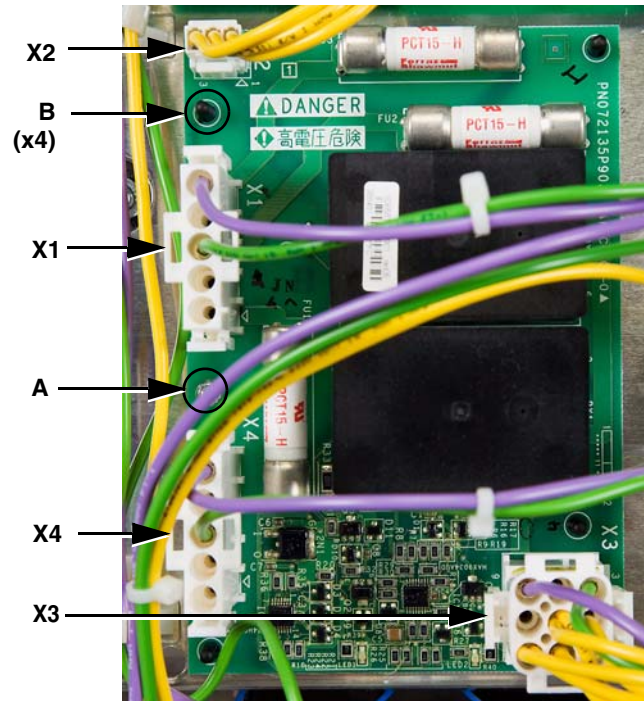

Table 8: Fan Control Board 2 Wiring

Wire No. ¹	Terminal No.	Description	To:
E147	X2	3-pin, yellow	PB ² X15
E120	X1	5-pin, violet/green/yellow	FCB ³ 1, X1; FB ⁴ 1, X1, X2, and X3
E124	X4	5-pin, 2 wire, green/yellow/violet	TB1 and FCB1 X4
E151	X3	9-pin, green/yellow/violet with yellow and green ground wire	BB ⁵ X3
—	X6	Not used	—

¹ See the schematic on page 174 for complete drive wiring. Wire numbers are given for cross referencing the wires with the wiring table and the schematic. The numbers do not appear on the wires.

² PB: Power board

³ FCB: Fan control board

⁴ FB: Filter board

⁵ BB: Brake board

Figure 19: Fan Control Board 2

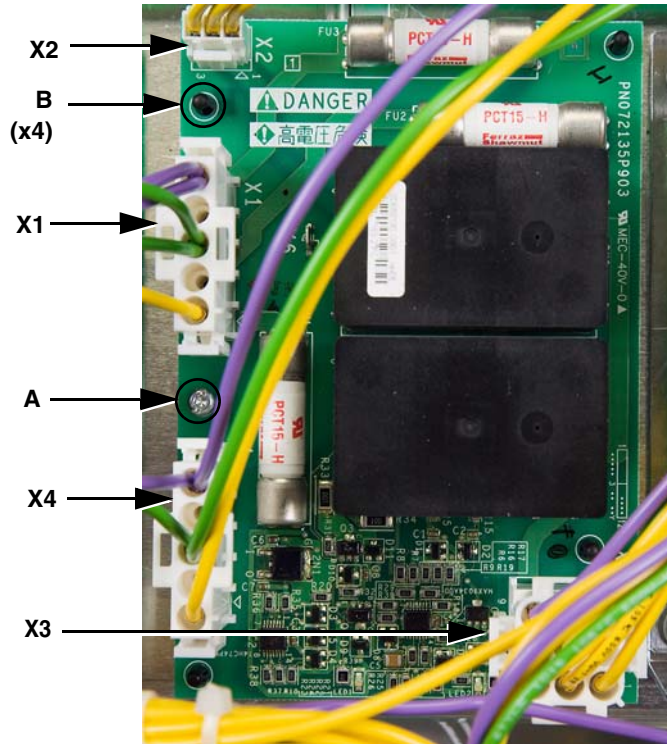

5. Using a T-10 Torx driver, remove 1 screw (**A**, Figure 18 or 19) from the board between connectors X1 and X4.
6. Using needle-nose pliers, compress the four plastic mounting posts (**B**, Figure 18 or 19), one at a time, while lifting the board off the posts. Remove the board from the drive.
7. Press the new fan control board down over the four mounting posts until it is securely seated.
8. Using a T-10 Torx driver secure the board with one screw (**A**, Figure 18 or 19). Tighten the screw to 0.8 N•m (7.1 lb-in).
9. Install the four connections on the new fan control board. For fan control board 1, see Table 7 and Figure 18 on page 29. For fan control board 2, see Table 8 and Figure 19.
10. Replace the middle crossbrace as follows.
 - Using a 10 mm socket wrench, secure the crossbrace to the fan bracket with two nuts (**A**). See Figure 16 on page 28.
 - Using a T-30 Torx driver, secure the crossbrace to the filter board with one screw (**B**). See Figure 17 on page 28.
 - Tighten the hardware to the torque values specified in Table 6 on page 28.
11. Replace the power terminal shield as illustrated in “Replacing the Power Terminal Shields” on page 22.
12. Replace the front cover. Using a size 2 Phillips driver, secure the front cover with thirteen screws. See Figure 7 on page 20. Tighten the screws to 5.5 N•m (48.7 lb-in).

Replacing the Filter Board VX4A1117

IMPORTANT: Label and retain all removed hardware and cables for use in reassembly.

⚠ DANGER

HAZARD OF ELECTRIC SHOCK, EXPLOSION, OR ARC FLASH

- Read and understand the precautions in “Before You Begin” starting on page 5 before performing this procedure.
- Before working on this equipment, turn off all power supplying it and perform the DC bus voltage measurement procedure on page 11.

Failure to follow these instructions will result in death or serious injury.

⚠ DANGER

HAZARD OF ELECTRIC SHOCK, EXPLOSION, OR ARC FLASH

- When the controller is damaged, voltage may remain on certain energy storage capacitors after de-energization of the controller and discharge of the main capacitor bank.
- Before working on or near assemblies containing energy storage capacitors, verify that the capacitor voltages are less than 42 Vdc.
- The following assemblies have energy-storing capacitors:
 - Filter board. See Figure 21 on page 32.
- Always check for the presence of voltage using a voltmeter set to the 1000 Vdc scale. When voltage is present, allow the voltmeter to discharge the capacitor’s stored charge. Refer to “Discharging Stored Energy in Capacitors” on page 12.

Failure to follow these instructions will result in death or serious injury.

Remove the Front Cover

1. Using a size 2 Phillips driver, remove 13 screws and take the front cover off the drive. See Figure 7 on page 20.

Remove the Power Terminal Shields

2. Remove the power terminal shields as illustrated in “Replacing the Power Terminal Shields” on page 22.

Remove the Middle Crossbrace

3. Remove the middle crossbrace as follows.
 - Using a 10 mm socket wrench, remove two nuts (**A**) securing the crossbrace to the fan bracket. See Figure 20.
 - Using a T-30 Torx driver, remove one screw (**B**) securing the crossbrace to the filter board and remove the crossbrace from the drive. See Figure 21.

Table 9: Crossbrace Hardware Torque Values

Item	Description	Torque Range	
		N•m	lb-in
A	(2) 10 mm nuts	5.5	48.7
B	(1) T-30 screw	5.5	48.7

Figure 20: Middle Crossbrace Top

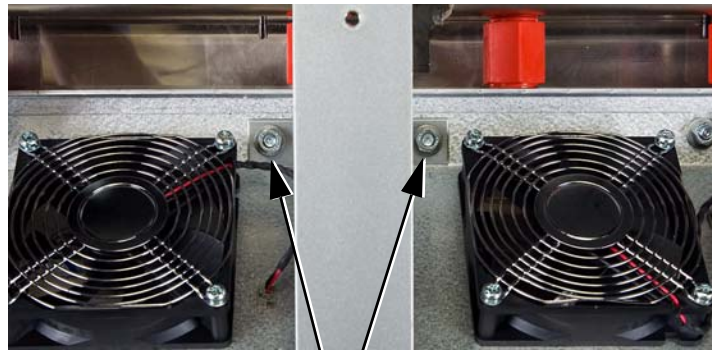

A (x2)

Figure 21: Middle Crossbrace Bottom

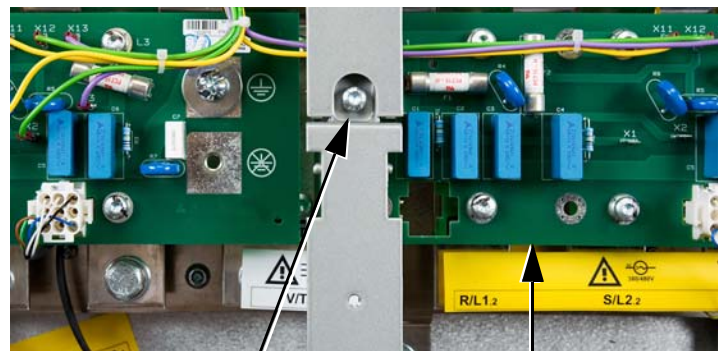

B

Filter board

Remove the Filter Board and Fan Connections

Table 10: Filter Board Wiring

Wire No. ¹	Terminal No.	Description	To:
Filter Board 1 (Left)			
E120	X1	Yellow, 0.25 in. connector	FCB ² 1, X1 and FCB 2, X1
	X2	Green, 0.25 in. connector	
	X3	Violet, 0.25 in. connector	
E120	X11	Yellow, 0.19 in. connector	PB ³ X7
	X12	Green, 0.19 in. connector	
	X13	Violet, 0.19 in. connector	
E115	X11	Black sleeve, 9-pin	Heatsink fan 1
E125	X12	Black sleeve, 9-pin	Heatsink fan 2
Filter Board 2 (Right)			
E120	X11	Yellow, 0.19 in. connector	PB ³ X7
	X12	Green, 0.19 in. connector	
	X13	Violet, 0.19 in. connector	
E165	X13	Black sleeve, 9-pin	Heatsink fan 3

¹ See the schematic on page 174 for complete drive wiring. Wire numbers are given for cross referencing the wires with the wiring table and the schematic. The numbers do not appear on the wires.

² FCB: Fan control board

³ PB: Power board

- Using needle-nose pliers, remove the six (filter board 1) or three (filter board 2) 1-pin connections from the filter board you are replacing. See Table 10 and Figures 22 or 23 for connector locations.
- Disconnect the 9-pin fan connectors from terminals X11 and X12 (filter board 1, Figure 22) or from terminal X13 (filter board 2, Figure 23).

Figure 22: Filter Board 1

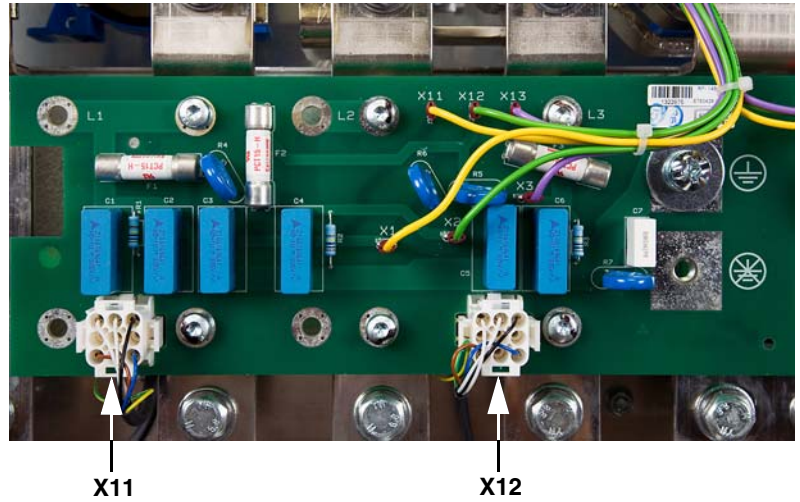
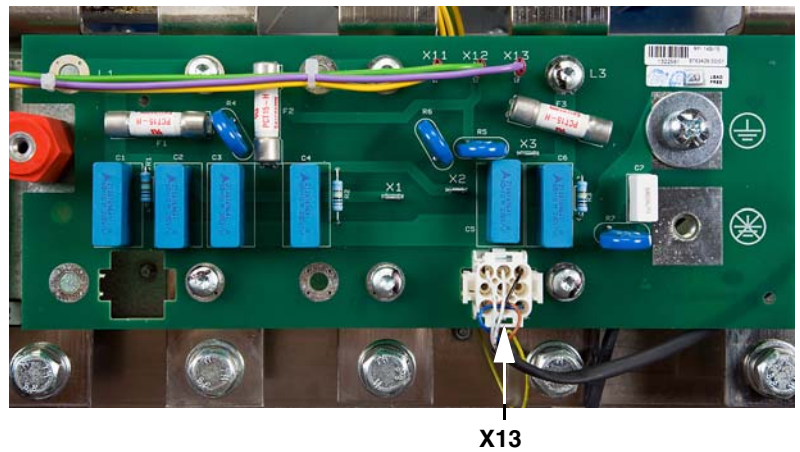
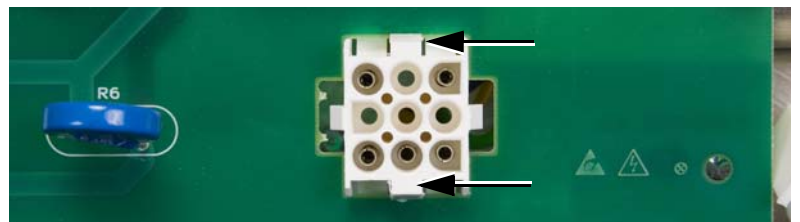

Figure 23: Filter Board 2



- Gently press in on the tabs at the top and bottom of the fan connectors and push the three connectors down through the cutouts in the filter board. See Figure 24.

Figure 24: Fan Connector Detail



Remove the Filter Board

7. Remove the filter board you are replacing as follows.
 - Using a T-30 Torx driver, remove six screws (**A**, Figure 25) securing the filter board to the input bus bars R/L1, S/L2, and T/L3.
 - Using a size 3 Phillips driver, remove the grounding screw and washer (**B**, Figure 25) securing the filter board to the drive frame.

NOTE: Note whether the screw is installed in the grounded or non-grounded position for reinstallation. Figure 25 shows the screw in the grounded position.

- Remove the filter board from the drive.

Figure 25: Filter Board Mounting Hardware (Board 2 Shown)

Table 11: Filter Board Hardware Torque Values

Item	Description	Torque Range	
		N•m	lb-in
A	(6) T-30 screws	5.5	48.7
B	(1) Size 3 Phillips screw and washer	5.5	48.7

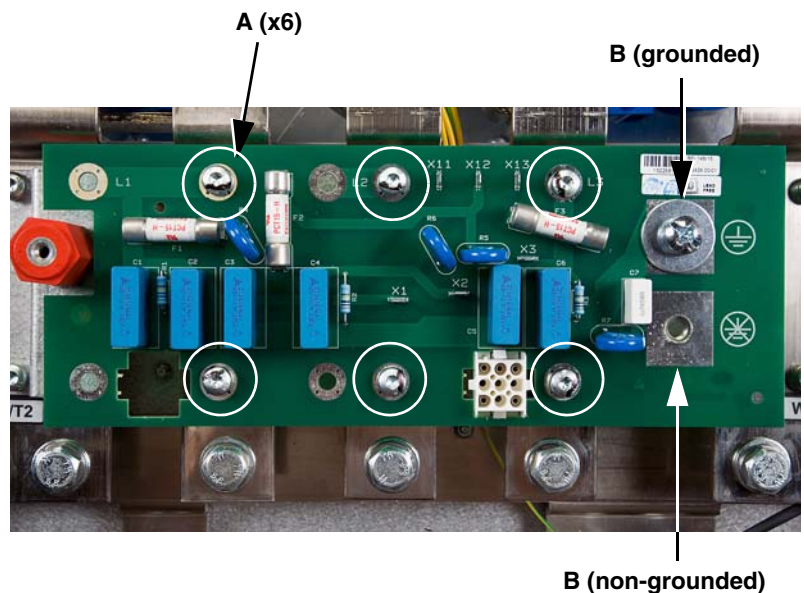

Install the New Filter Board

8. Install the new filter board as follows:
 - Position the filter board in the drive as shown in Figure 25.
 - Using a T-30 Torx driver, secure the filter board to the input bus bars R/L1, S/L2, and T/L3 with six screws (**A**, Figure 25).
 - Using a size 3 Phillips driver, install the grounding screw and washer (**B**, Figure 25).

NOTE: Be sure to install the size 3 Phillips screw and washer (**B**) in the original position. Figure 25 shows the screw in the grounded position.

- Tighten the hardware to the torque values specified in Table 11.

Replace the Filter Board and Fan Connections

Table 12: Filter Board Wiring

Wire No. ¹	Terminal No.	Description	To:
Filter Board 1 (Left)			
E120	X1	Yellow, 0.25 in. connector	FCB ² 1, X1 and FCB 2, X1
	X2	Green, 0.25 in. connector	
	X3	Violet, 0.25 in. connector	
E120	X11	Yellow, 0.19 in. connector	PB ³ X7
	X12	Green, 0.19 in. connector	
	X13	Violet, 0.19 in. connector	
E115	X11	Black sleeve, 9-pin	Heatsink fan 1
E125	X12	Black sleeve, 9-pin	Heatsink fan 2
Filter Board 2 (Right)			
E120	X11	Yellow, 0.19 in. connector	PB ³ X7
	X12	Green, 0.19 in. connector	
	X13	Violet, 0.19 in. connector	
E165	X13	Black sleeve, 9-pin	Heatsink fan 3

¹ See the schematic on page 174 for complete drive wiring. Wire numbers are given for cross referencing the wires with the wiring table and the schematic. The numbers do not appear on the wires.

² FCB: Fan control board

³ PB: Power board

9. Gently press the top and bottom tabs on the fan connectors and push them up through the cutouts on the filter board. See Figure 26.

Figure 26: Fan Connector Detail

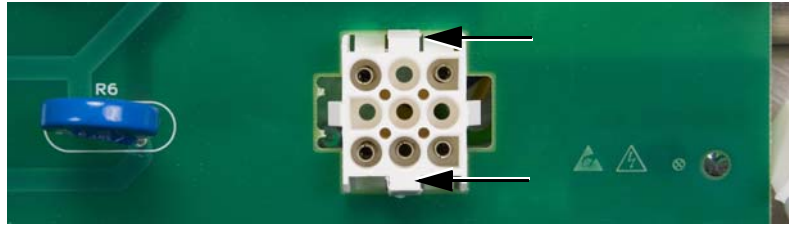

10. Connect the 9-pin fan connectors at terminals X11 and X12 (filter board 1, Figure 27) or X13 (filter board 2, Figure 28).

11. Replace the six (filter board 1) or three (filter board 2) 1-pin connections on the filter board. See Table 12 and Figures 27 and 28 for connector locations.

Figure 27: Filter Board 1

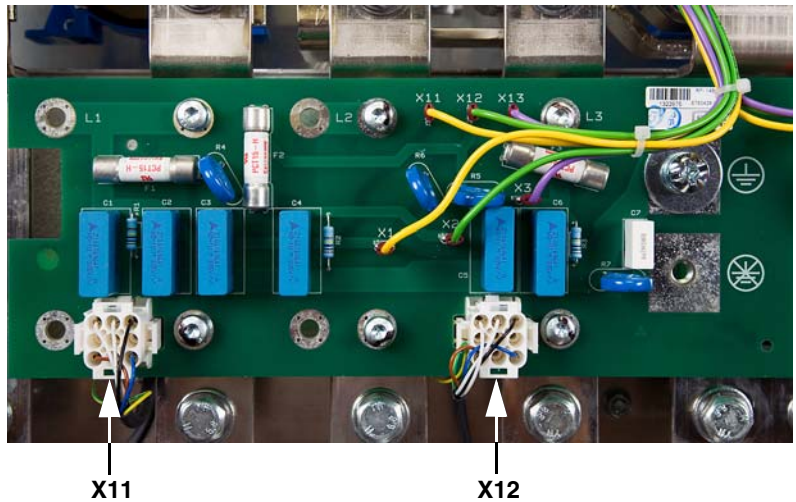
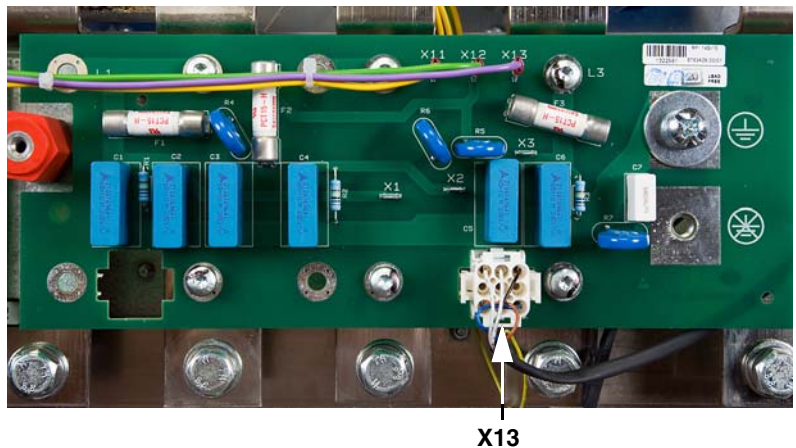

Figure 28: Filter Board 2



Replace the Middle Crossbrace

12. Replace the middle crossbrace as follows.

- Using a 10 mm socket wrench, secure the crossbrace to the fan bracket with two nuts (**A**). See Figure 29.
- Using a T-30 Torx driver, secure the crossbrace to the filter board with one screw (**B**). See Figure 30.
- Tighten the hardware to the torque values specified in Table 13.

Table 13: Crossbrace Hardware Torque Values

Item	Description	Torque Range	
		N•m	lb-in
A	(2) 10 mm nuts	5.5	48.7
B	(1) T-30 screw	5.5	48.7

Figure 29: Middle Crossbrace Top

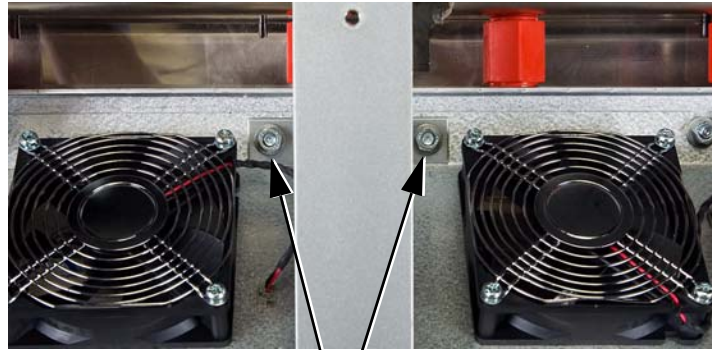

A (x2)

Figure 30: Middle Crossbrace Bottom

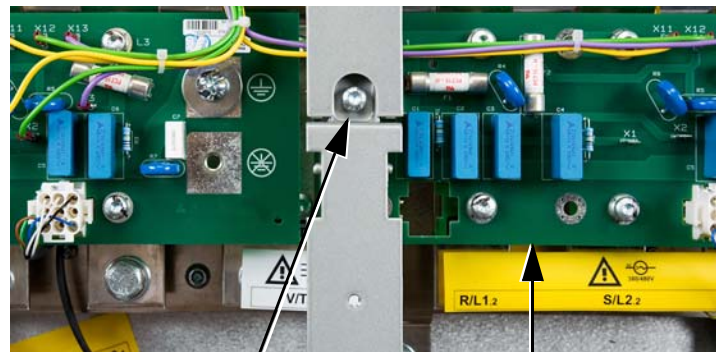

B

Filter board

Replace the Power Terminal Shields

13. Replace the power terminal shield as illustrated in “Replacing the Power Terminal Shields” on page 22.

Replace the Front Cover

14. Replace the front cover. Using a size 2 Phillips driver, secure the front cover with thirteen screws. See Figure 7 on page 20. Tighten the screws to 5.5 N•m (48.7 lb-in).

Replacing the SCR Snubber Board VX4A1200

IMPORTANT: Label and retain all removed hardware and cables for use in reassembly.

⚠ DANGER

HAZARD OF ELECTRIC SHOCK, EXPLOSION, OR ARC FLASH

- Read and understand the precautions in “Before You Begin” starting on page 5 before performing this procedure.
- Before working on this equipment, turn off all power supplying it and perform the DC bus voltage measurement procedure on page 11.

Failure to follow these instructions will result in death or serious injury.

⚠ DANGER

HAZARD OF ELECTRIC SHOCK, EXPLOSION, OR ARC FLASH

- When the controller is damaged, voltage may remain on certain energy storage capacitors after de-energization of the controller and discharge of the main capacitor bank.
- Before working on or near assemblies containing energy storage capacitors, verify that the capacitor voltages are less than 42 Vdc.
- The following assemblies have energy-storing capacitors:
 - SCR snubber board. See Figures 40 and 42 on pages 42–43.
- Always check for the presence of voltage using a voltmeter set to the 1000 Vdc scale. When voltage is present, allow the voltmeter to discharge the capacitor’s stored charge. Refer to “Discharging Stored Energy in Capacitors” on page 12.

Failure to follow these instructions will result in death or serious injury.

Remove the Front Cover

1. Using a size 2 Phillips driver, remove 17 screws and take the front cover and top grille off the drive. See Figure 7 on page 20.

Remove the Power Terminal Shields

2. Remove the power terminal shields as illustrated in “Replacing the Power Terminal Shields” on page 22.

Remove the Middle Crossbrace

3. Remove the middle crossbrace as follows.
 - Using a 10 mm socket wrench, remove two nuts (**A**) securing the crossbrace to the fan bracket. See Figure 31.
 - Using a T-30 Torx driver, remove one screw (**B**) securing the crossbrace to the filter board and remove the crossbrace from the drive. See Figure 32.

Figure 31: Middle Crossbrace Top

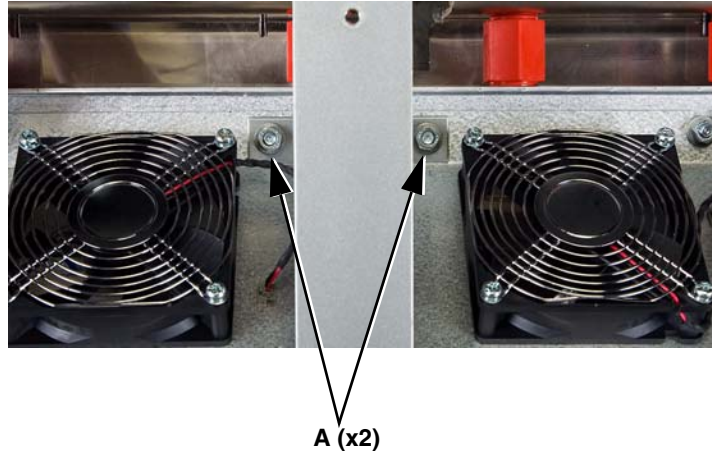
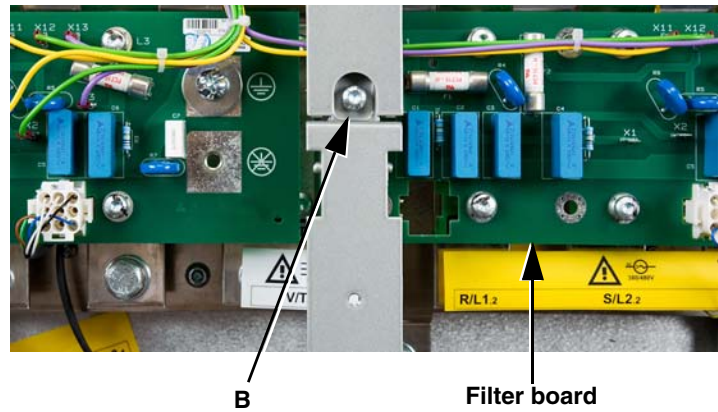

Figure 32: Middle Crossbrace Bottom



Remove the BU (+) Bus Bar

4. Remove the BU (+) bus bar (located at the top of the drive) as follows. See Figure 33.
 - Using an 18 mm socket wrench, remove two bolts and washers (**A**) securing the BU (+) bus bar to the PA/+ bus.
 - Using a T-30 Torx driver, remove one screw (**B**) securing the BU (+) bus bar to the red insulator on the top terminal bracket.

Figure 33: BU (+) Bus Bar

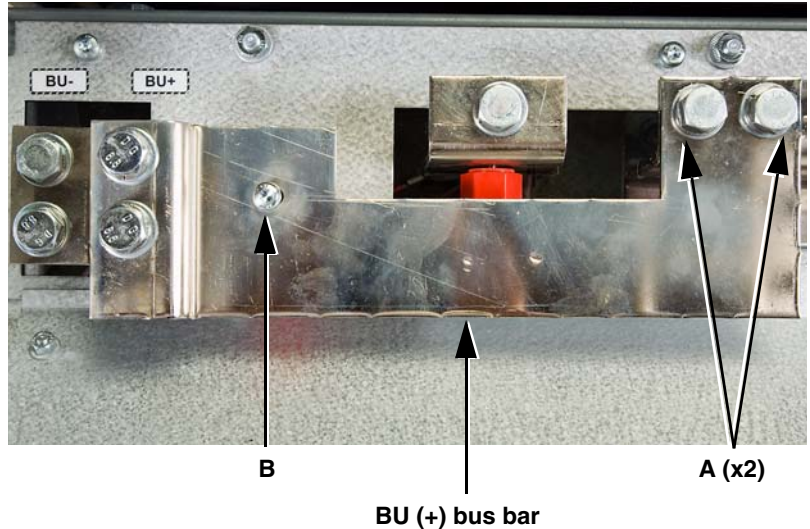

Remove the Fan Bracket

5. Remove the fan bracket as follows.
 - Remove the connections from terminals X21 and X22 on the power board. See Figure 88 on page 79.
 - Using a 10 mm socket wrench, remove nine nuts (**C**) securing the fan bracket to the top terminal bracket and the drive frame and remove the fan bracket. See Figure 34.

Figure 34: Fan Bracket

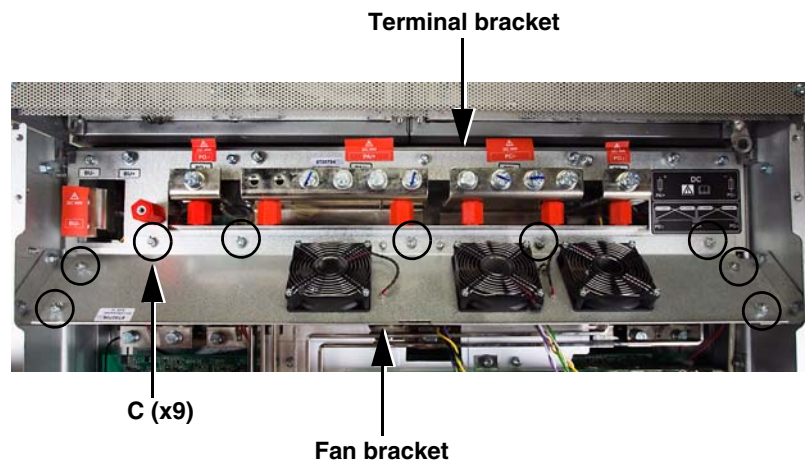

Remove the Top Terminal Bracket

6. Remove the top terminal bracket as follows.
 - Using a T-30 right-angle Torx driver, remove six screws (A, Figures 35 and 36) securing the PO.1, PA/+, PC/-, and PO.2 bus bars to the red insulators on the terminal bracket.
 - Using a T-30 Torx driver, remove five screws (B, Figure 37) securing the terminal bracket to the drive frame and remove the terminal bracket from the drive.
 - Using an 18 mm socket wrench, remove ten bolts (C, Figure 38 on page 41) from the PO.1, PA/+, PC/-, and PO.2 bus bars.

Figure 35: Top Terminal Bracket Bus Bar Connections

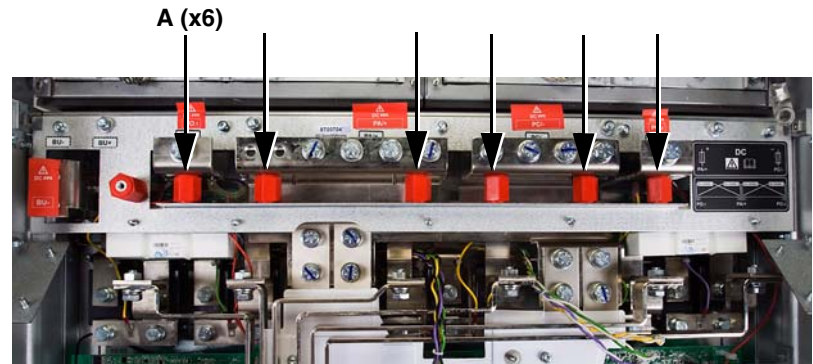

Figure 36: Bus Bar Connection Detail



Figure 37: Top Terminal Bracket Mounting Hardware



Figure 38: Bus Bar Connections

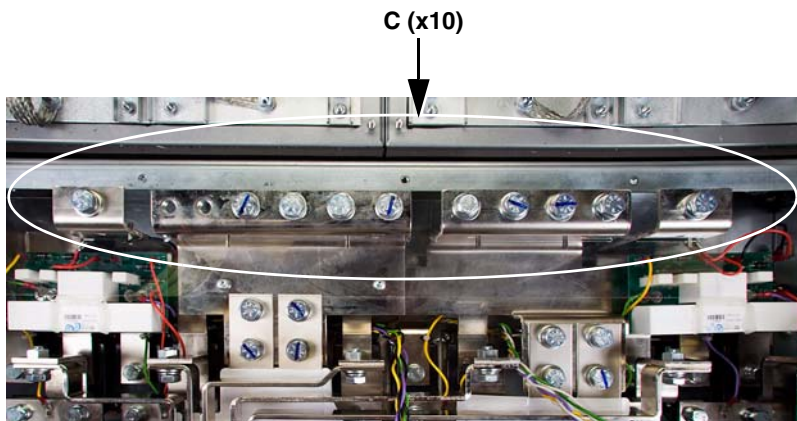

Remove the Rectifier Shield

7. Remove the plastic rectifier shield from the bus bars. See Figure 39.

Figure 39: Rectifier Shield

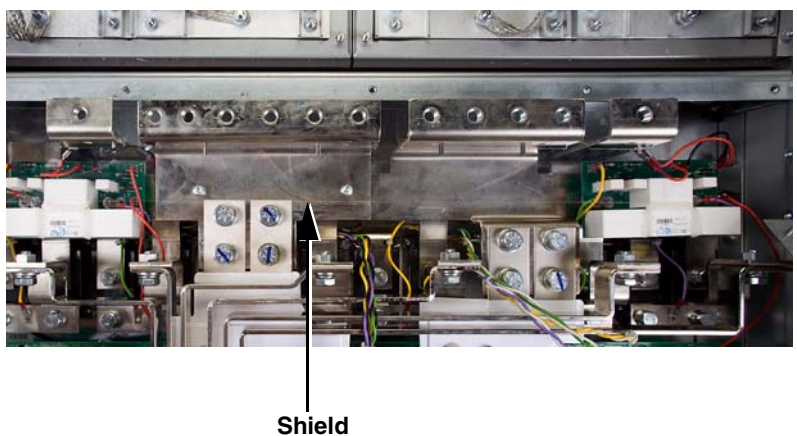

Replace SCR Snubber Board 1

Table 14: SCR Snubber Board 1 Wiring

Wire No. ¹	Terminal No.	Description	To:
E131	X1	Yellow, 1-pin	L1.1 rectifier
E130	X4	Red, 1-pin	PO.1 rectifier bus bar
E133	X5	Black, 1-pin	PC/- rectifier bus bar
E126	X10	Red, 0.25 in., 1-pin	GDB ² U X61
E126	X11	Red, 0.19 in., 1-pin	PB ³ RFS31+X11
E167	L2	Green, 1-pin	L2.1 Line input bar
E168	X3	Violet, 1-pin	L3.1 Line input bar

¹ See the schematic on page 175 for complete drive wiring. Wire numbers are given for cross referencing the wires with the wiring table and the schematic. The numbers do not appear on the wires.
² GDB: Gate driver board
³ PB: Power board

8. Remove SCR snubber board 1 (left board) as follows.
 - Using needle-nose pliers, carefully remove the connections from SCR snubber board 1 (left board) terminals X1, X4, X5, X10, and X11. See Table 14 and Figure 40 for the connection locations.
 - Using a 7 mm socket wrench, remove two nuts securing the snubber board to the insulators on the DC (-) bus and remove the wires from terminals L2 and X3. See Figure 40.
 - Remove the snubber board from the drive.

Figure 40: SCR Snubber Board 1

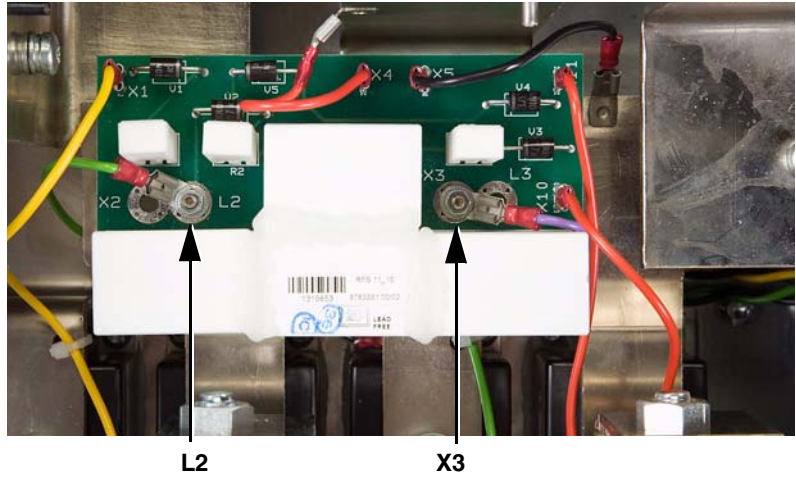

9. Replace SCR snubber board 1 (left board) as follows.
 - Seat the SCR snubber board on the DC (-) bus standoffs. See Figure 41.
 - Replace the wires at terminals L2 and X3. Using a 7 mm socket wrench, secure the wires and the snubber board to the DC (-) bus with two bolts. See Figure 40. Tighten the bolts to 1.2 N•m (10.6 lb-in).
 - Replace the connections on SCR snubber board terminals X1, X4, X5, X10, and X11. See Table 14 and Figure 40 for the terminal locations.

Figure 41: DC (-) Bus

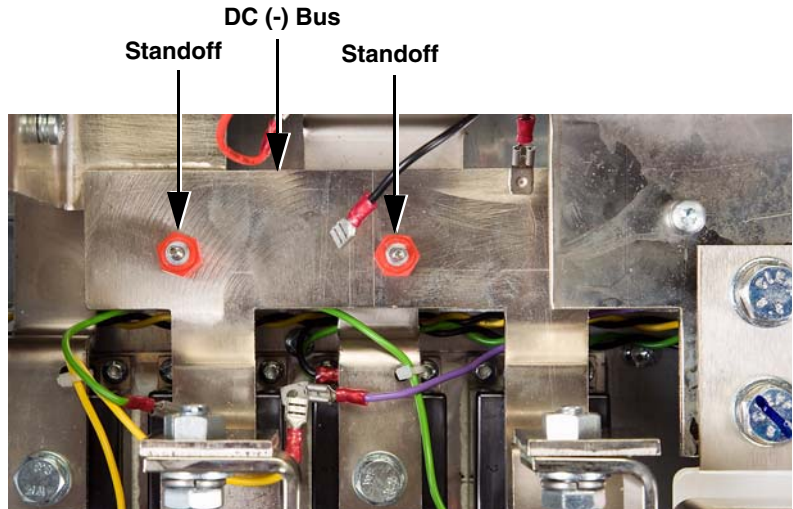

Replace SCR Snubber Board 2

Table 15: SCR Snubber Board 2 Wiring

Wire No. ¹	Terminal No.	Description	To:
E157	X1	Yellow, 1-pin	L1.2 rectifier
E158	X4	Red, 1-pin	PO.2 rectifier bus bar
E159	X5	Black, 1-pin	PC/- rectifier bus bar
E160	X10	Red, 0.25 in., 1-pin	GDB ² W X61
E158	X11	Red, 0.19 in., 1-pin	PO.2 rectifier bus bar
E169	L2	Green, 1-pin	L2.2 line input bar
E170	X3	Violet, 1-pin	L3.2 Line input bar

¹ See the schematic on page 175 for complete drive wiring. Wire numbers are given for cross referencing the wires with the wiring table and the schematic. The numbers do not appear on the wires.

² GDB: Gate driver board

10. Remove SCR snubber board 2 (right board) from the drive as follows.
 - Using needle-nose pliers, carefully remove the connections from SCR snubber board 2 (right board) terminals X1, X4, X5, X10, and X11. See Table 15 and Figure 42 for the connection locations.
 - Using a 7 mm socket wrench, remove two nuts securing the snubber board to the insulators on the DC (-) bus and remove the wires from terminals L2 and X3. See Figure 42.
 - Remove the board from the drive.

Figure 42: SCR Snubber Board 2

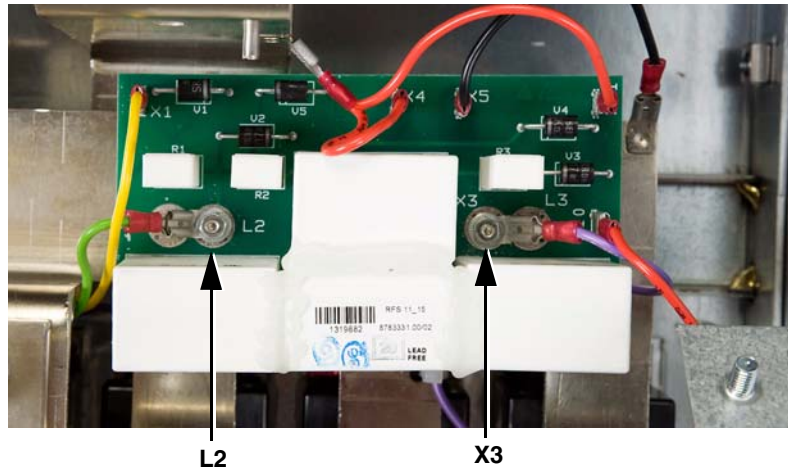

11. Replace SCR snubber board 2 (left board) as follows.
 - Seat the SCR snubber board on the DC (-) bus standoffs. See Figure 43.
 - Replace the wires at terminals L2 and X3. Using a 7 mm socket wrench, secure the wires and the snubber board to the DC (-) bus with two bolts. See Figure 42. Tighten the bolts to 1.2 N•m (10.6 lb-in).
 - Replace the connections on SCR snubber board terminals X1, X4, X5, X10, and X11. See Table 15 and Figure 42 for the terminal locations.

Figure 43: DC (-) Bus

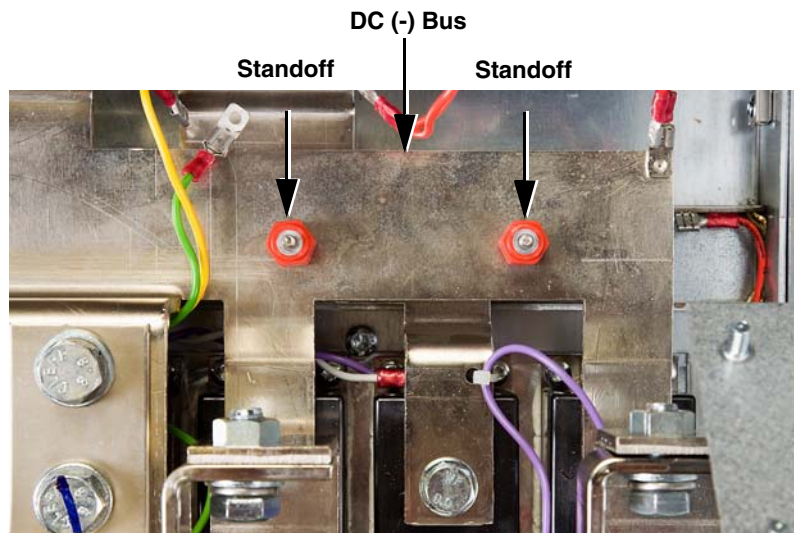

Replace the Rectifier Shield

12. Replace the plastic rectifier shield over the bus bars. See Figure 44. If the rectifier shield is cracked, broken, or damaged, replace it with a piece from the plastic kit. See "Replacing the Plastic Parts Kit VY1A1406" on page 22.

⚠ DANGER

HAZARD OF ELECTRIC SHOCK, EXPLOSION, OR ARC FLASH

- Install the rectifier shield as shown in Figure 44.
- Before installing the shield, ensure that it has no tears or cracks. If the shield is damaged, install a new piece from the plastic kit. See page 22.
- Do not install a damaged shield.

Failure to follow these instructions will result in death or serious injury.

Figure 44: Rectifier Shield

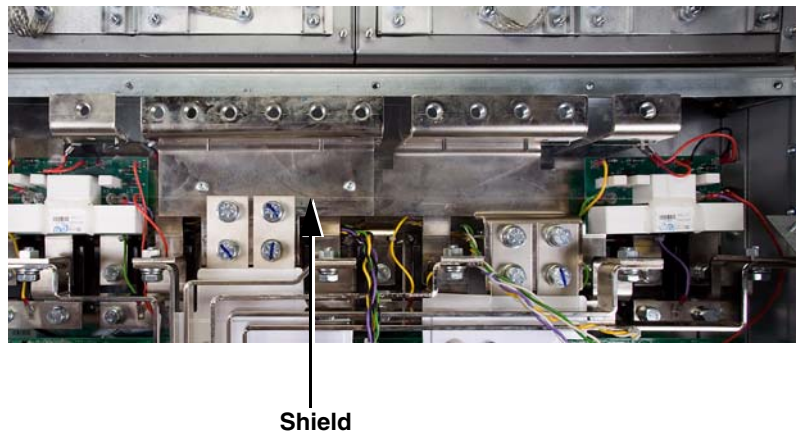

Replace the Top Terminal Bracket

Table 16: Top Terminal Bracket and Bus Bar Hardware Torque Values

Item	Description	Torque Range	
		N•m	lb-in
A	(6) T-30 screws	5.5	48.7
B	(5) T-30 screws	5.5	48.7
C	(10) 18-mm bolts	45	398

13. Replace the top terminal bracket as follows.

- Using a T-30 Torx driver, secure the top terminal bracket to the drive frame with five screws (**B**, Figure 45). Tighten the screws to the torque values specified in Table 16.
- Using a T-30 right-angle Torx driver, secure the PO.1, PA/+, PC/-, and PO.2 bus bars to the red insulators on the terminal bracket with six screws (**A**, Figures 46 and 47). Tighten the screws to the torque values specified in Table 16.
- Using an 18 mm socket wrench, replace ten bolts (**C**, Figure 48 on page 46) in the PO.1, PA/+, PC/-, and PO.2 bus bars. Tighten the bolts to the torque values specified in Table 16.

Figure 45: Top Terminal Bracket Mounting Hardware



Figure 46: Top Terminal Bracket Bus Bar Connections

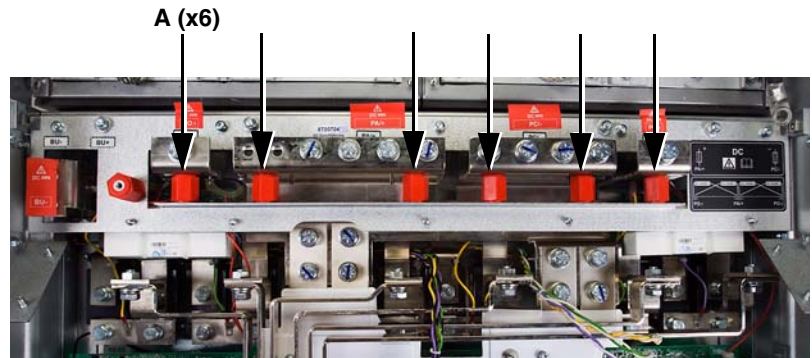

Figure 47: Bus Bar Connection Detail

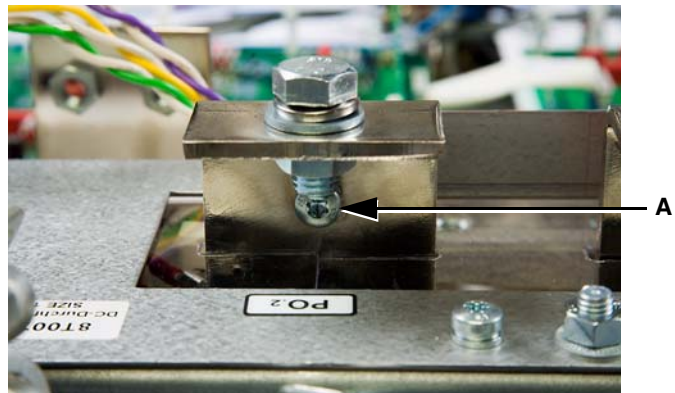
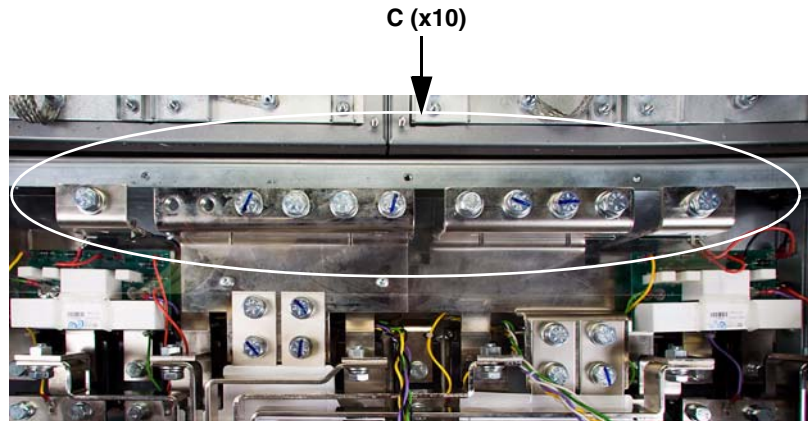

Figure 48: Bus Bar Connections



Replace the Fan Bracket

14. Replace the fan bracket as follows.

- Using a 10 mm socket wrench, secure the fan bracket to the top terminal bracket (C) and the drive frame with nine nuts. See Figure 49. Tighten the nuts to the torque values specified in Table 17.
- Replace the connections at terminals X21 and X22 on the power board. See Figure 88 on page 79.

Table 17: Fan Bracket Hardware Torque Values

Item	Description	Torque Range	
		N•m	lb-in
C	(9) 10-mm nuts	5.5	48.7

Figure 49: Fan Bracket

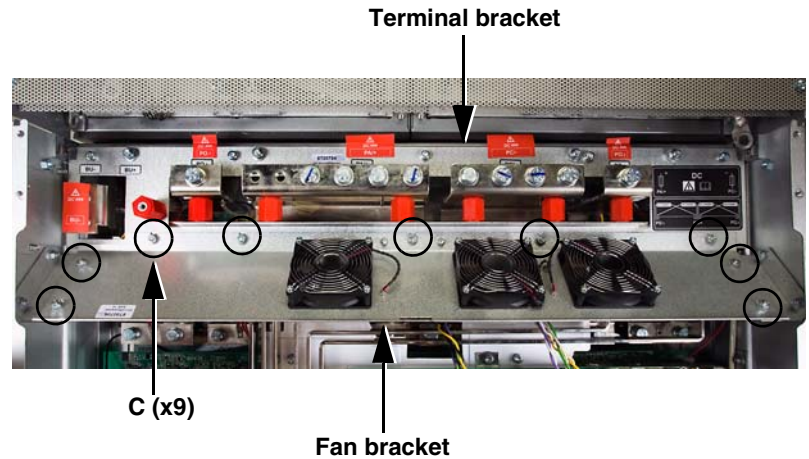

Replace the BU (+) Bus Bar

Table 18: BU (+) Bus Bar Hardware Torque Values

Item	Description	Torque Range	
		N•m	lb-in
A	(2) 18-mm nuts	45	398
B	(1) T-30 screw	5.5	48.7

15. Replace the BU (+) bus bar as follows. See Figure 50.

- Using an 18 mm socket wrench, secure the BU (+) bus bar to the PA/+ bus with two bolts and washers (A).
- Using a T-30 Torx driver, secure the BU (+) bus bar to the red insulator on the top terminal bracket with one screw (B).
- Tighten the hardware to the torque values specified in Table 18.

Figure 50: BU (+) Bus Bar

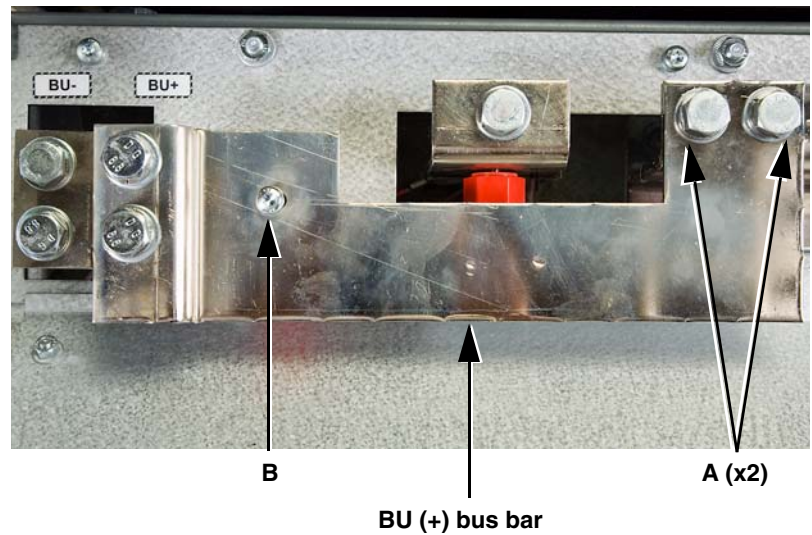

Replace the Middle Crossbrace

Table 19: Crossbrace Hardware Torque Values

Item	Description	Torque Range	
		N•m	lb-in
A	(2) 10 mm nuts	5.5	48.7
B	(2) T-30 screws	5.5	48.7

16. Replace the middle crossbrace as follows.

- Using a 10 mm socket wrench, secure the crossbrace to the fan bracket with two nuts (A). See Figure 51.
- Using a T-30 Torx driver, secure the crossbrace to the filter board with one screw (B). See Figure 52.
- Tighten the hardware to the torque values specified in Table 19.

Figure 51: Middle Crossbrace Top

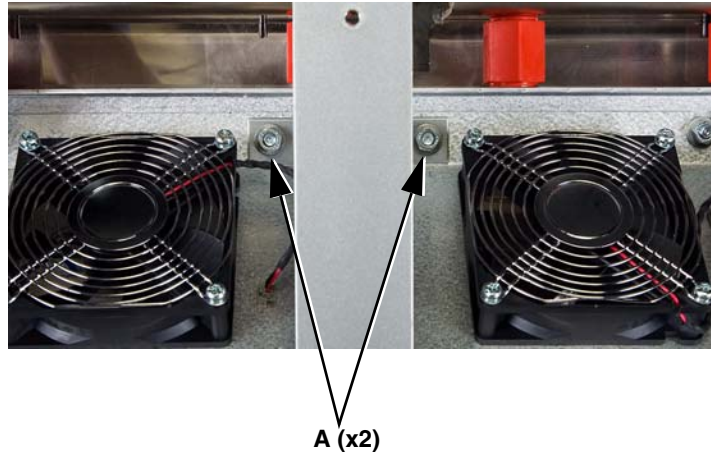
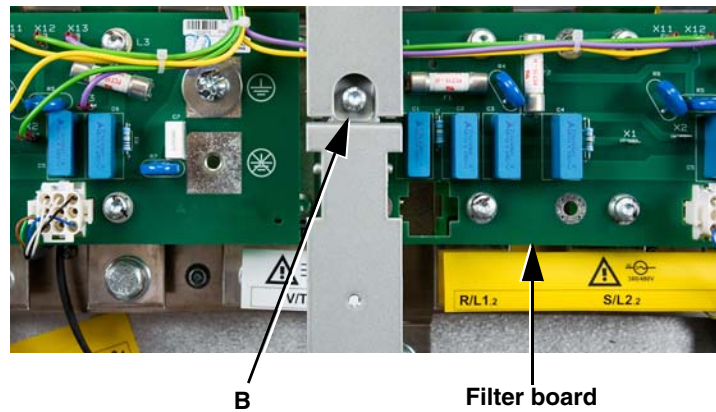

Figure 52: Middle Crossbrace Bottom



Replace the Power Terminal Shields

17. Replace the power terminal shields as illustrated in “Replacing the Power Terminal Shields” on page 22.

Replace the Front Cover

18. Replace the front cover and top grille. Using a size 2 Phillips driver, secure the front cover with 17 screws. See Figure 7 on page 20. Tighten the screws to 5.5 N•m (48.7 lb-in).

Installation Procedures for Level 2 Parts

The level 2 parts are under the control module assembly, the bus assembly, or the fan plate. They are:

Power board	Temperature sensors
Brake board	Power IGBT modules
Power board assembly shields	Capacitors
Motor current sensors	SCR modules
Gate driver boards	Diode modules

You must remove equipment from the drive as described in the following section to access the level 2 parts.

Disassembly Steps for Accessing Level 2 Parts

IMPORTANT: Label and retain all removed hardware and cables for use in reassembly.

⚠ DANGER

HAZARD OF ELECTRIC SHOCK, EXPLOSION, OR ARC FLASH

- Read and understand the precautions in “Before You Begin” starting on page 5 before performing this procedure.
- Before working on this equipment, turn off all power supplying it and perform the DC bus voltage measurement procedure on page 11.

Failure to follow these instructions will result in death or serious injury.

This section contains instructions for removing the following parts from the drive:

- | | |
|--------------------------------------------------------|--------------------------------------------------------|
| <input type="checkbox"/> Front cover | <input type="checkbox"/> Fan bracket |
| <input type="checkbox"/> Power terminal shields | <input type="checkbox"/> Top terminal bracket |
| <input type="checkbox"/> Middle crossbrace | <input type="checkbox"/> Rectifier shield |
| <input type="checkbox"/> EMC tray | <input type="checkbox"/> Top input bus bar brackets |
| <input type="checkbox"/> Control module assembly | <input type="checkbox"/> Input bus bars |
| <input type="checkbox"/> Soft charge board connections | <input type="checkbox"/> Bottom input bus bar brackets |
| <input type="checkbox"/> Power board connections | <input type="checkbox"/> Top phase-U DC bus plate |
| <input type="checkbox"/> Fan control board connections | <input type="checkbox"/> Top DC bus plate |
| <input type="checkbox"/> Power board assembly | <input type="checkbox"/> Gate driver boards |
| <input type="checkbox"/> BU (+) bus bar | <input type="checkbox"/> Bottom DC bus plate |

You must perform some or all of the steps in this section to access the level 2 parts. Consult Table 20 for the disassembly steps that must be performed to access the spare parts you are replacing.

Table 20: Disassembly Steps

If you are replacing:	Perform disassembly steps:	Then follow procedure:
Power board VX5A1HC4050	Steps 1–5	“Replacing the Power Board VX5A1HC4050” beginning on page 78
Brake board VZ3F1113	Steps 1–5	“Replacing the Brake Board VZ3F1113” beginning on page 83

Table 20: Disassembly Steps *(continued)*

If you are replacing:	Perform disassembly steps:	Then follow procedure:
Power board assembly shields (Plastic Parts Kit VY1A1406)	Steps 1–9	“Replacing the Power Board Assembly Shields” beginning on page 84
Motor current sensors VY1A1109	Steps 1–11	“Replacing the Motor Current Sensors VY1A1109” beginning on page 95
Gate driver boards VX5A1203	Steps 1–23	“Replacing the Gate Driver Boards VX5A1203” beginning on page 121
SCR modules VZ3TM1425M1671	Steps 1–23	“Replacing the SCR Modules and Diode Modules (VZ3TM1425M1671 and VZ3DM1600M1671)” beginning on page 132
Diode modules VZ3DM1600M1671		
Temperature sensors VZ3G1104	Steps 1–24	“Replacing the Temperature Sensors, VZ3G1104” beginning on page 125
Power IGBT modules VZ3IM1603M1271	Steps 1–25	“Replacing the Power IGBT Modules VZ3IM1603M1271” beginning on page 127
Capacitors VY1ADC1112		“Replacing the Capacitors VY1ADC1112” beginning on page 130

Remove the Front Cover

1. Using a size 2 Phillips driver, remove thirteen screws and take the front cover off the drive. See Figure 7 on page 20.

Remove the Power Terminal Shields

2. Remove the power terminal shields as follows:
The right terminal shield has two tabs (A) on the right side that fit into slots on the conduit tray, and two tabs (B) on the left side that fit into slots on the middle crossbrace. See Figure 53.

The left terminal shield has two tabs on the right (C) that fit into retaining slots in the middle crossbrace and two mounting holes (D) on the left that fit over posts on the side panel of the drive. See Figures 54.

Disengage the shields and remove them from the drive.

Figure 53: Right Terminal Shield

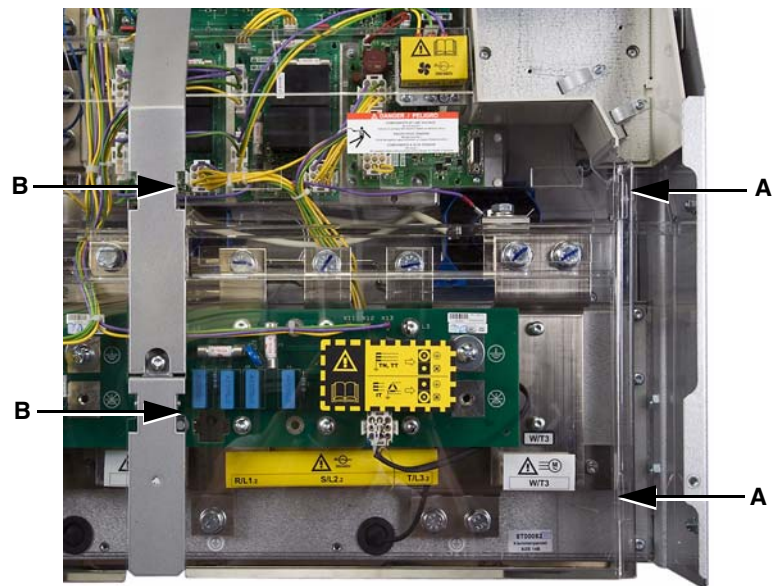
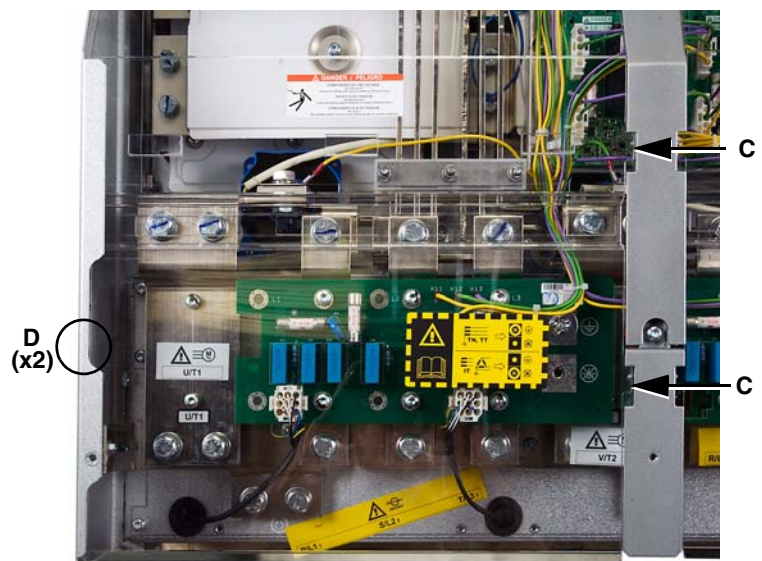

Figure 54: Left Terminal Shield



Remove the Middle Crossbrace

3. Remove the middle crossbrace as follows.
 - Using a 10 mm socket wrench, remove two nuts (**A**) securing the crossbrace to the fan bracket. See Figure 55.
 - Using a T-30 Torx driver, remove one screw (**B**) securing the crossbrace to the filter board and remove the crossbrace from the drive. See Figure 56.

Figure 55: Middle Crossbrace Top

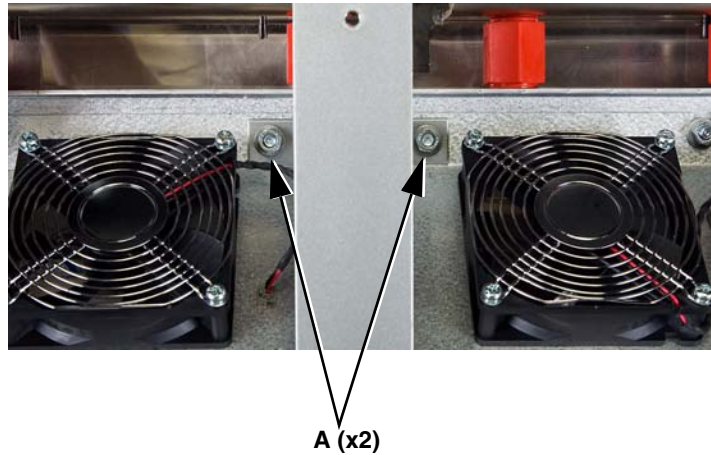
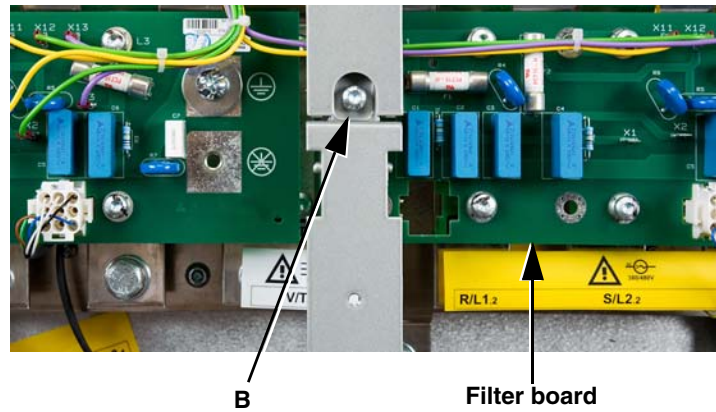

Figure 56: Middle Crossbrace Bottom



Remove the EMC Tray

- Using a T-20 Torx driver, remove three screws (A) securing the EMC tray to the control module mounting plate and remove the tray from the drive. See Figure 57.

Figure 57: EMC Tray



Remove the Control Module Assembly

5. Remove the control module assembly as follows.
 - Remove the 5-pin connector from terminal X4 of fan control boards 1 and 2. See Figure 58.
 - Remove the 26-pin ribbon cable from motor control board terminal X3. See Figure 59.

Figure 58: Fan Control Boards 1 and 2, Terminal X4

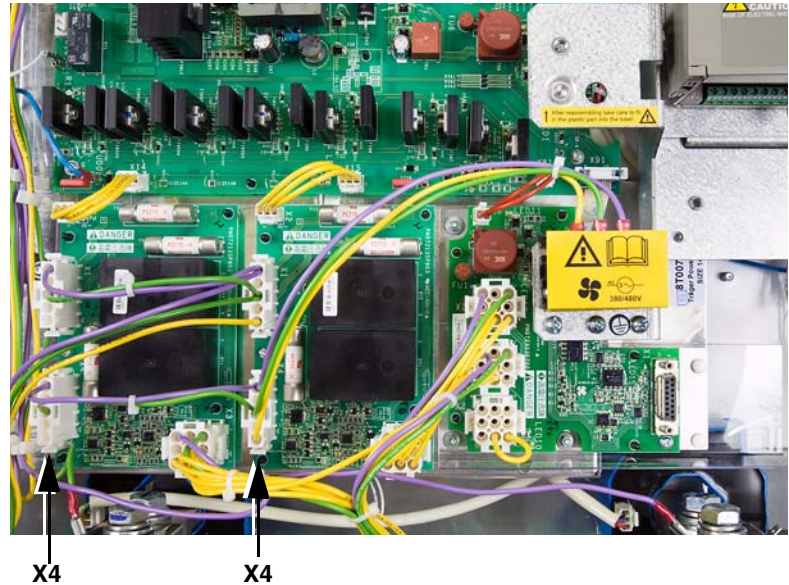
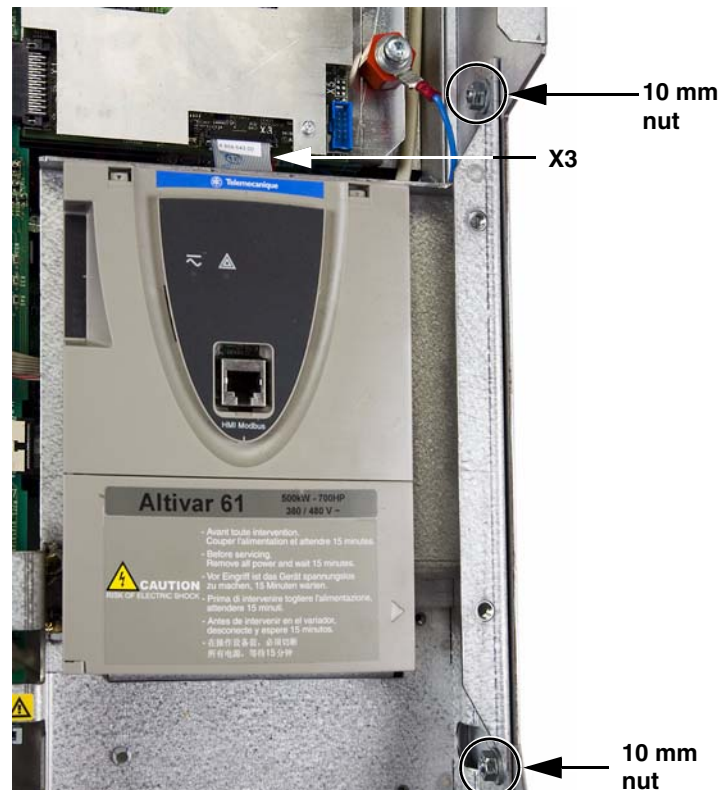
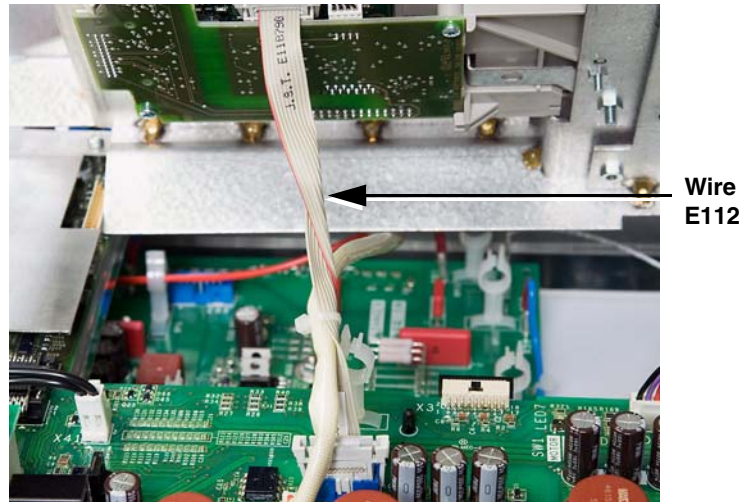

Figure 59: Control Module Assembly, Front



- Using a 10 mm socket wrench, remove two nuts securing the control module assembly to the drive frame. See Figure 59 on page 54.
- Turn the assembly over, disconnect the ribbon cable from the back (wire E112, Figure 60), and remove the assembly from the drive.
Note: wire E112 originates from terminal X4 on the power board.

Figure 60: Control Module Assembly Back



NEXT STEP: If you are replacing the power board, skip to “Replacing the Power Board VX5A1HC4050” beginning on page 78.

If you are replacing the brake board, skip to “Replacing the Brake Board VZ3F1113” beginning on page 83.

Remove the Connections from Soft Charge Boards 1 and 2

Table 21: Soft Charge Board Wiring

Wire No. ¹	Terminal No.	Description	To:
Soft Charge Board 1 (Left Board)			
E110	CN2A	9-pin, red	PB ² X30 (9-pin)
E109	CNL3G	2-pin, violet/black	SCR ³ L3.1 Terms. 4 & 5
E108	CNL2G	2-pin, green/black	SCR L2.1 Terms. 4 & 5
E107	CNL1G	2-pin, yellow/black	SCR L1.1 Terms. 4 & 5
E111	CN7A	2-pin, black	PB X31
—	CNP	Not used	—
Soft Charge Board 2 (Right Board)			
E156	CN2A	9-pin, red	PB ² X40 (9-pin)
E152	CNL3G	2-pin, violet/white	SCR ³ L3.2 Terms. 4 & 5
E153	CNL2G	2-pin, green/white	SCR L2.2 Terms. 4 & 5
E154	CNL1G	2-pin, yellow/white	SCR L1.2 Terms. 4 & 5
E155	CN7A	2-pin, black	PB ² X41
—	CNP	Not used	—

¹ See the schematic on page 175 for complete drive wiring. Wire numbers are given for cross referencing the wires with the wiring table and the schematic. The numbers do not appear on the wires.

² PB: Power board

³ SCR: Silicon controlled rectifier. L1.1, L2.1, and L3.1 are associated with input rectifier 1; L1.2, L2.2, and L3.2 are associated with input rectifier 2.

- Using needle-nose pliers, connections CNL1G, CNL2G, and CNL3G from soft charge boards 1 and 2. See Table 21 for wiring and Figure 61 for terminal locations.

Figure 61: Soft Charge Board: Board 1 (Left) Shown

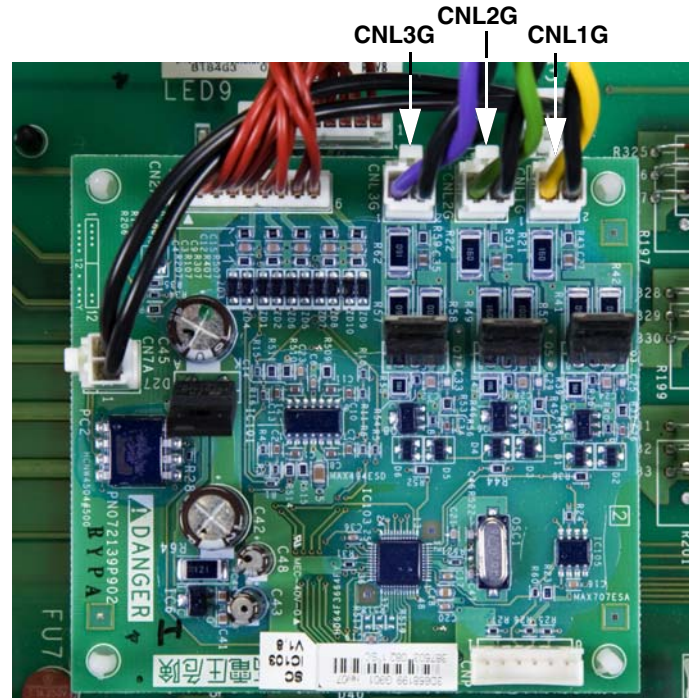

Remove the Power Board Connections

Table 22: Power Board Wiring

Wire No. ¹	Terminal No.	Description	To:
E103	X11	9-pin, multi color	Motor current sensors
E136	UD0	1-pin, blue	Phase-W DC bus plate
E126	RFS 31+ X11	1-pin, red	SB ² X11
E141	UD -R1	1-pin, white	Bleeder resistor 1
E142	X3	18-pin, gray	GDB ³ W X32
E112	X4	10-pin, gray	Control module
E150	X5	5-pin, yellow/green/violet	Sensor plates on output bus bars T1, T2, T3
E120	X7	15-pin, yellow/green/violet	FB ⁴ 1&2 X11, X12, X13
E100	X8	14-pin, white	GDB U X82
E106	X21	2-pin, red/black	Internal fan
E106	X22	2-pin, red/black	Internal fan

¹ See the schematic on page 175 for complete drive wiring. Wire numbers are given for cross referencing the wires with the wiring table and the schematic. The numbers do not appear on the wires.

² SB: SCR Snubber board

³ GDB: Gate driver board

⁴ FB: Filter board

NOTE: Take care not to damage the LED (see Figure 62) when removing, handling, or installing the power board.

7. Using needle-nose pliers, carefully remove the power board connections listed in Table 22. See Figure 62 for the connection locations.

Figure 62: Power Board Connections

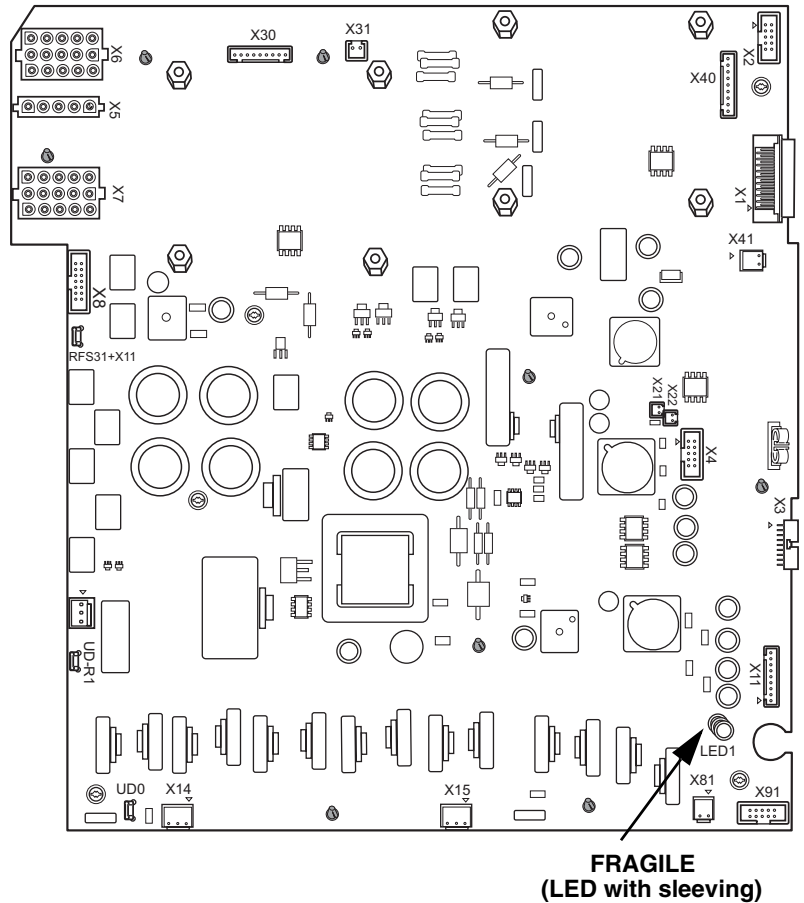

Remove the Fan Control Board Connections

8. Remove the following connections. See Figure 63 for terminal locations.
 - Remove the connections from terminal X1 of fan control boards 1 and 2.
 - Remove the connection from terminal X3 of fan control board 1.
 - Remove the connection from terminal X33 of the brake board.

Figure 63: Fan Control Board and Brake Board Connections

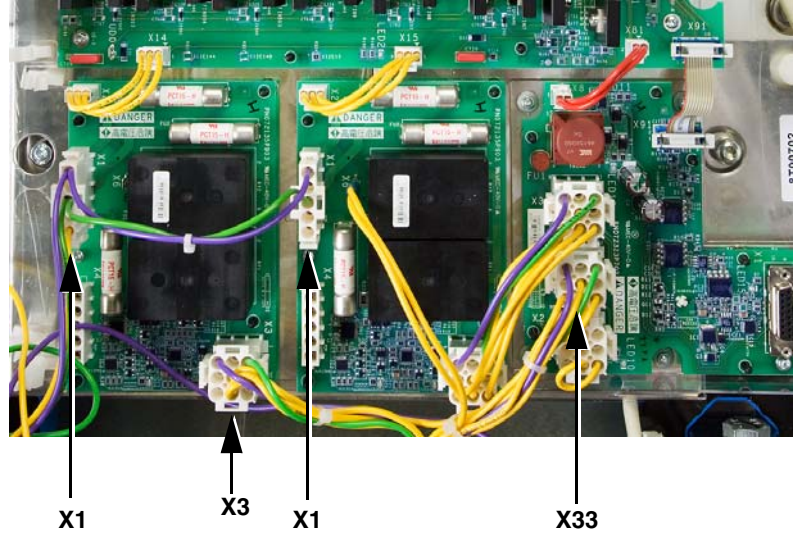

Remove the Power Board Assembly

NOTE: The power board assembly consists of the power board, the motor control board, fan control boards 1 and 2, and the brake board.

9. Remove the power board assembly as follows.
 - Disconnect wire E132 (see Figure 64) near the motor control board. The wire originates from terminal X53 on gate driver board W.
 - Using a 21 mm socket wrench, remove the red insulator (A, Figure 64).

Figure 64: Wire E132 Connection

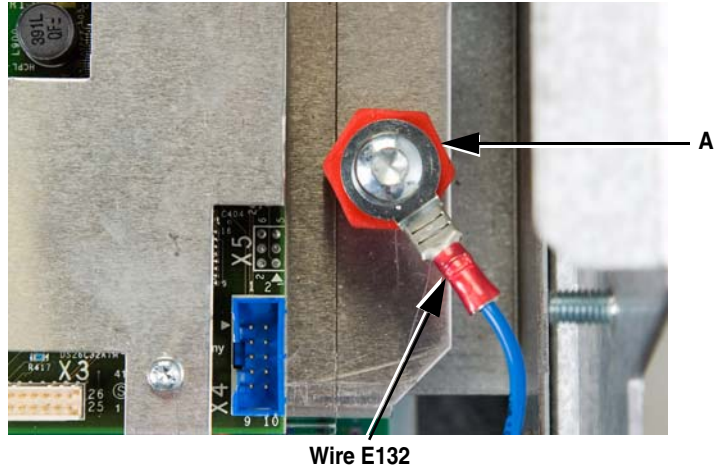

- Using a T-10 Torx driver, remove one screw (B, Figure 65) from power board terminal UD+1.
- Using a 10 mm socket wrench, remove three nuts (C, Figure 66 on page 60) securing the power board assembly to the bus plate assembly.
- Using a T-30 Torx driver, remove one screw and washer (D, Figure 66 on page 60) securing the power board assembly to the phase-W DC bus plate.
- Remove the power board assembly from the drive.

Figure 65: Power Board, Terminal UD+1

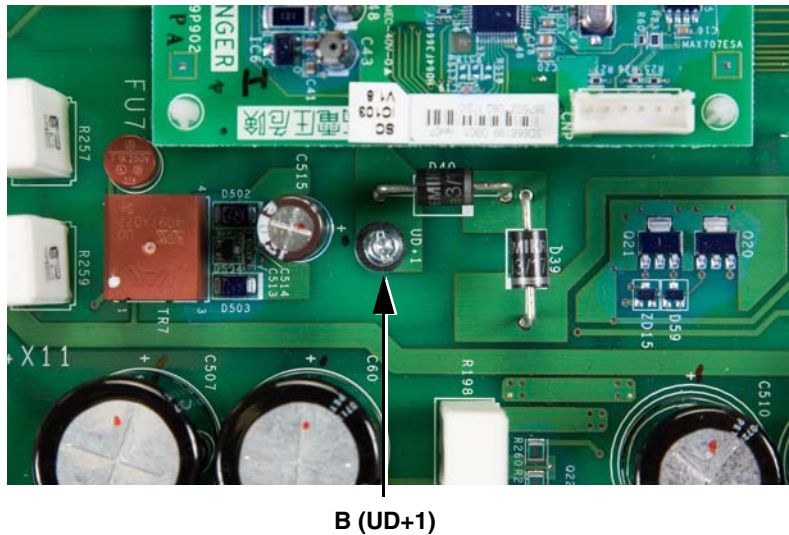
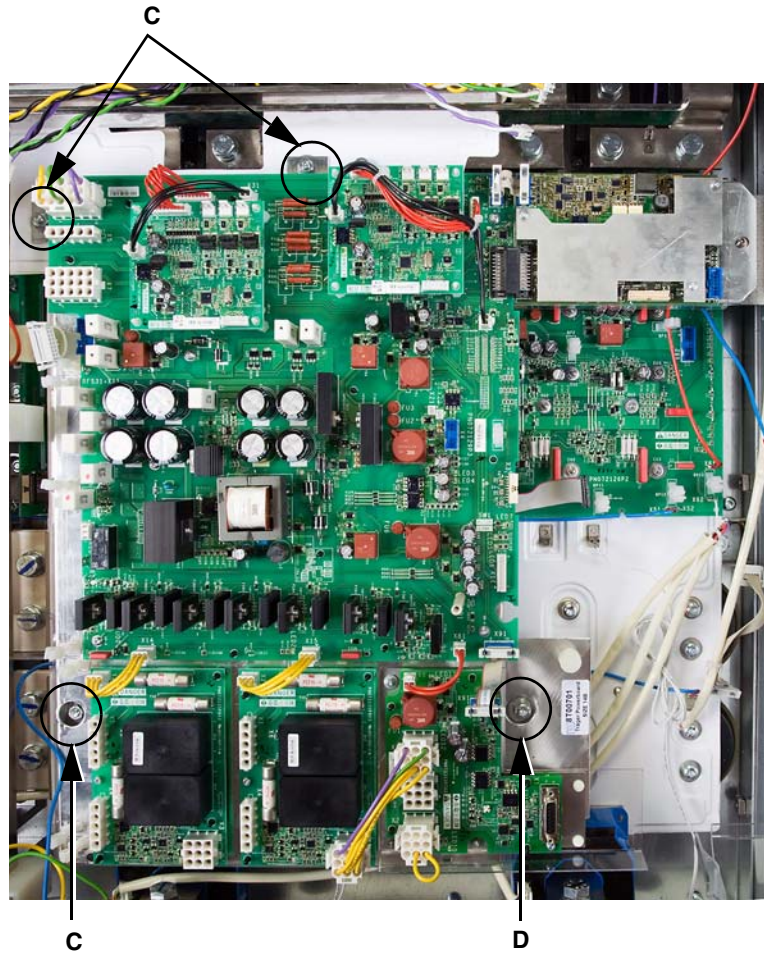

Figure 66: Power Board Assembly



NEXT STEP: If you are replacing the power board assembly plastic shields, skip to “Replacing the Power Board Assembly Shields” beginning on page 84.

Remove the BU (+) Bus Bar

10. Remove the BU (+) bus bar (located at the top of the drive) as follows. See Figure 67.
 - Using an 18 mm socket wrench, remove two bolts and washers (A) securing the BU (+) bus bar to the PA/+ bus.
 - Using a T-30 Torx driver, remove one screw (B) securing the BU (+) bus bar to the red insulator on the top terminal bracket.

Figure 67: BU (+) Bus Bar

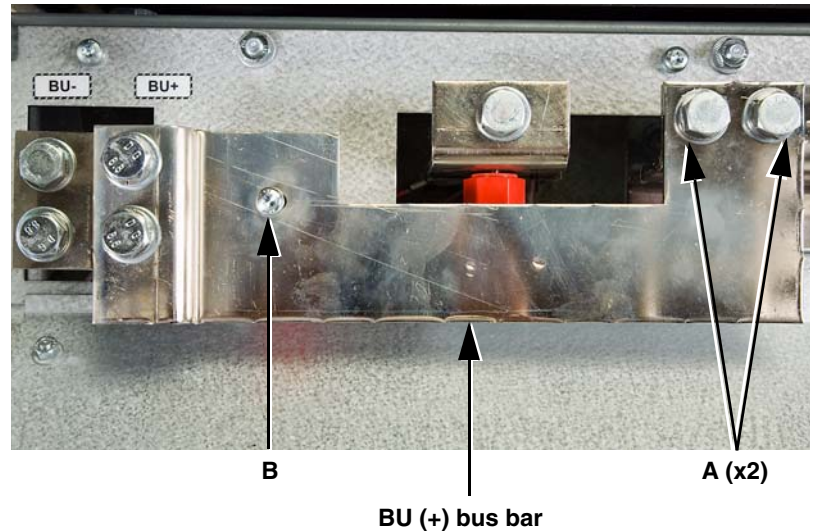

Remove the Fan Bracket

11. Using a 10 mm socket wrench, remove nine nuts (C) securing the fan bracket to the top terminal bracket and the drive frame and remove the fan bracket. See Figure 68.

Figure 68: Fan Bracket

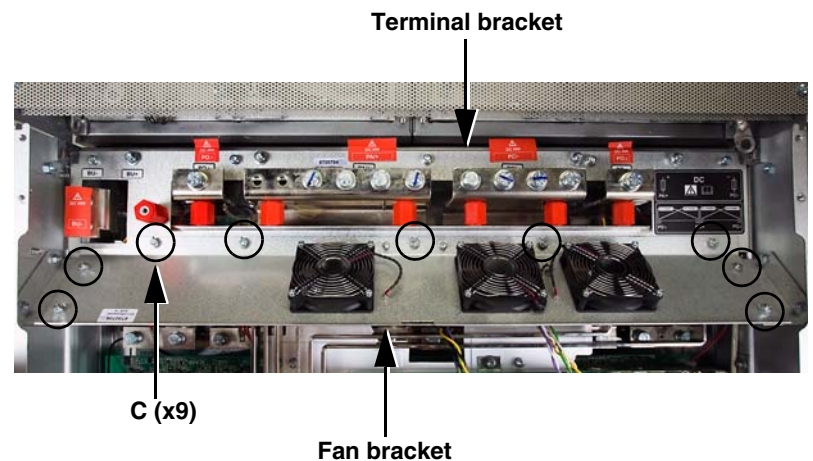

NEXT STEP: If you are replacing the motor current sensors, skip to “Replacing the Motor Current Sensors VY1A1109” beginning on page 95.

Remove the Top Terminal Bracket

12. Remove the top terminal bracket as follows.

- Using a T-30 right-angle Torx driver, remove six screws (**A**, Figures 69 and 70) securing the PO.1, PA/+, PC/-, and PO.2 bus bars to the red insulators on the terminal bracket.
- Using a T-30 Torx driver, remove five screws (**B**, Figure 71 on page 63) securing the terminal bracket to the drive frame and remove the terminal bracket from the drive.
- Using an 18 mm socket wrench, remove ten bolts (**C**, Figure 72 on page 63) from the PO.1, PA/+, PC/-, and PO.2 bus bars.

Figure 69: Top Terminal Bracket Bus Bar Connections

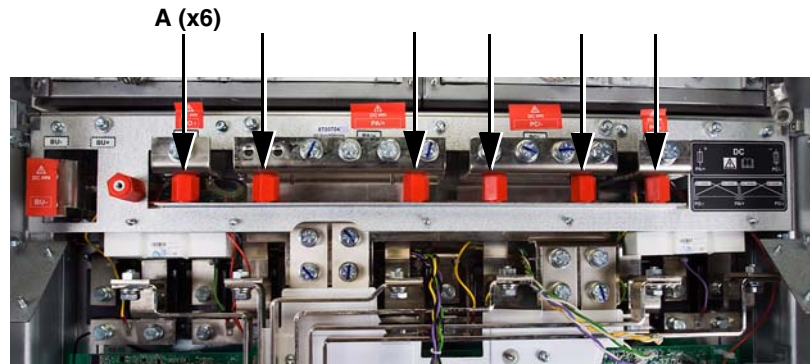

Figure 70: Bus Bar Connection Detail



Figure 71: Top Terminal Bracket Mounting Hardware



Figure 72: Bus Bar Connections

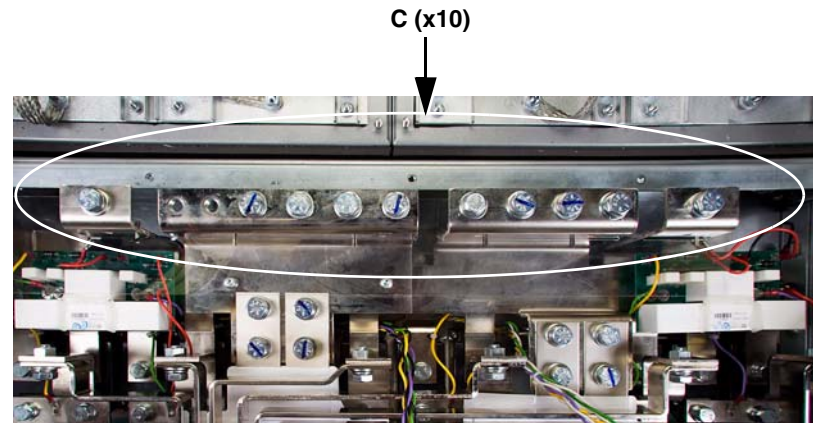

Remove the Rectifier Shield

13. Remove the plastic rectifier shield from the bus bars. See Figure 73.

Figure 73: Rectifier Shield

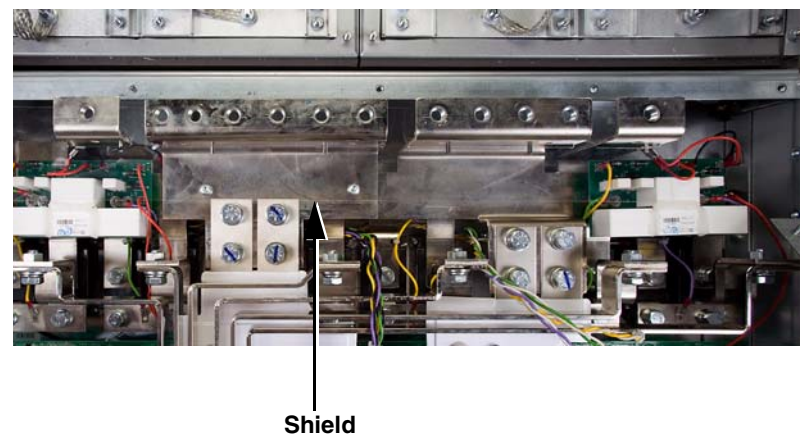

Remove the Input Bus Bar Brackets (Top)

14. Using a 10 mm socket wrench, remove six nuts (**A**, Figure 74) securing the top half of the input bus bar brackets to the bottom half, and remove the top part of the brackets.

Figure 74: Input Bus Bar Brackets (Top)

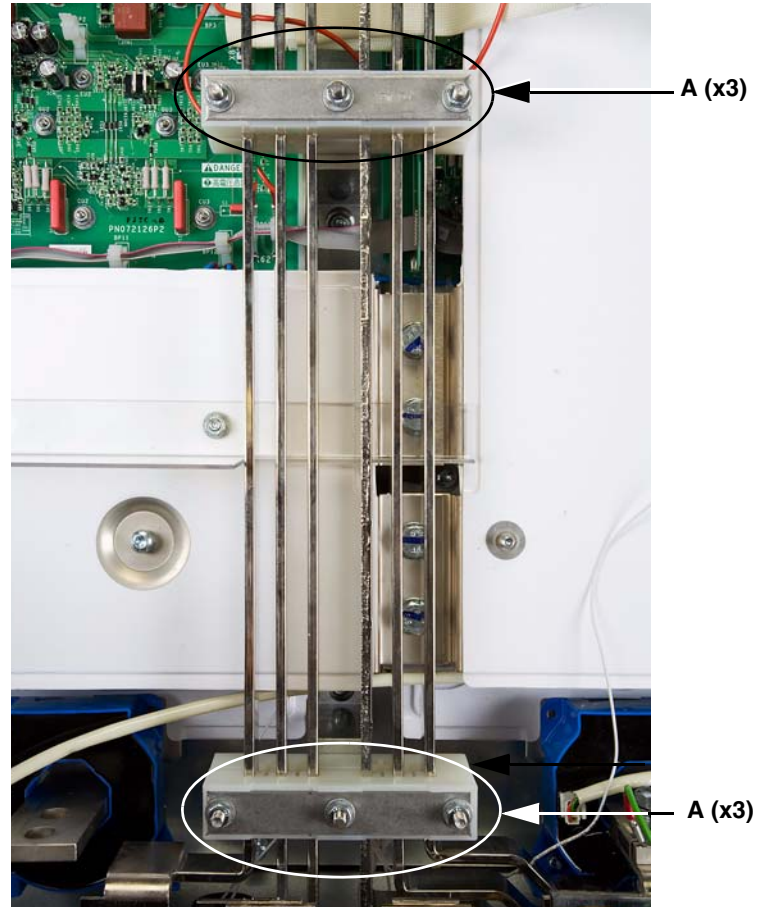

Remove the Input Bus Bars

NOTE: L1.1, L2.1, and L3.1 are associated with input rectifier 1. L1.2, L2.2, and L3.2 are associated with input rectifier 2.

15. Remove the L1.1 input bus bar as follows.

- Using an 18 mm socket wrench, remove one bolt and washer (**B**, Figure 75) securing the bottom of the L1.1 input bus bar to the R/L1.1 bus bar.
- Using an 18 mm socket wrench, remove one bolt (**C**, Figure 75) securing the top of the L1.1 input bus bar to the L1.1 rectifier and remove the bus bar.

Figure 75: L1.1 Input Bus Bar

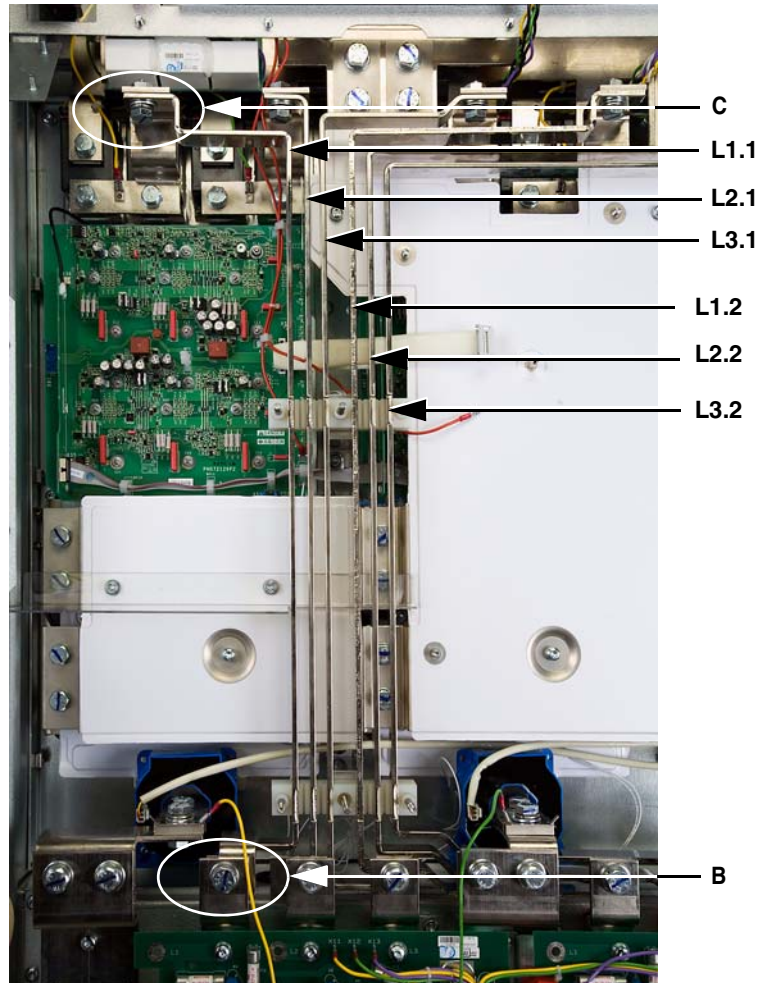

16. Remove the L2.1 input bus bar as follows.

- Using an 18 mm socket wrench, remove one bolt and washer (**D**, Figure 76) securing the bottom of the L2.1 input bus bar to the S/L2.1 bus bar.
- Using an 18 mm socket wrench, remove one bolt (**E**, Figure 76) securing the top of the L2.1 input bus bar to the L2.1 rectifier and remove the bus bar.

Figure 76: L2.1 Input Bus Bar

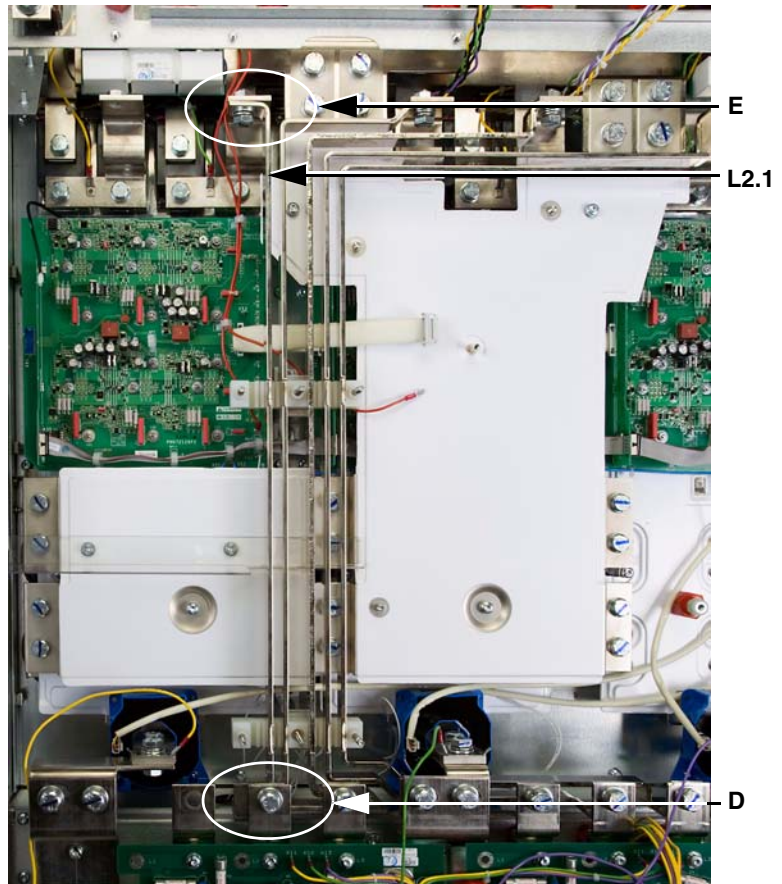

17. Remove the L3.2 input bus bar as follows. See Figure 77 and Figure 78 page 68.

- Using an 18 mm socket wrench, remove two bolts and washers (F, Figure 77) securing the V-phase DC bus plate to the L-shaped bracket on the V/T2 output.

NOTE: An output sensor plate (G, Figure 77) with a green lead is under the front bolt. Remove the sensor plate.

- Using an 18 mm socket wrench, remove two bolts and washers (H, Figure 77) securing the L-shaped bracket to the V/T2 output and remove the bracket.
- Using an 18 mm socket wrench, remove one bolt and washer (J, Figure 78) securing the bottom of the L3.2 input bus bar to the T/L3.2 bus bar.
- Using an 18 mm socket wrench, remove one bolt (K, Figure 78) securing the top of the L3.2 input bus bar to the L3.2 rectifier and remove the bus bar.

Figure 77: V/T2 Bus Bar

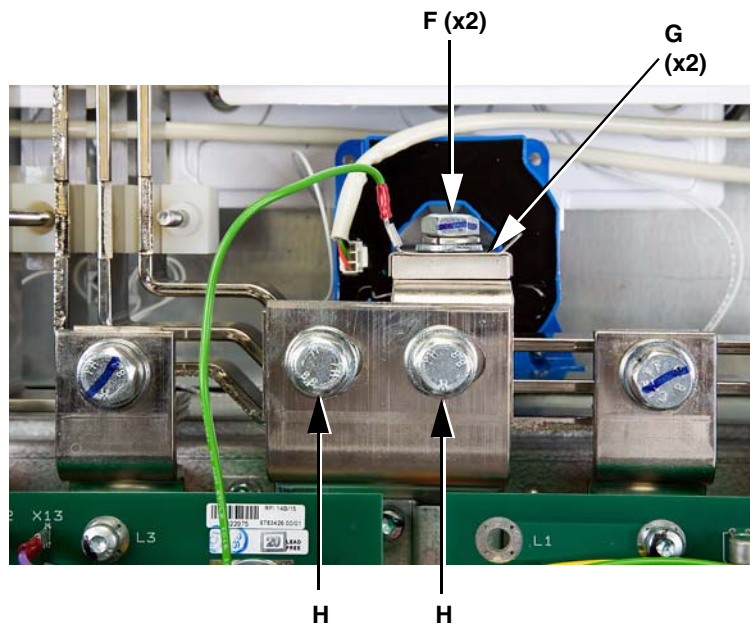
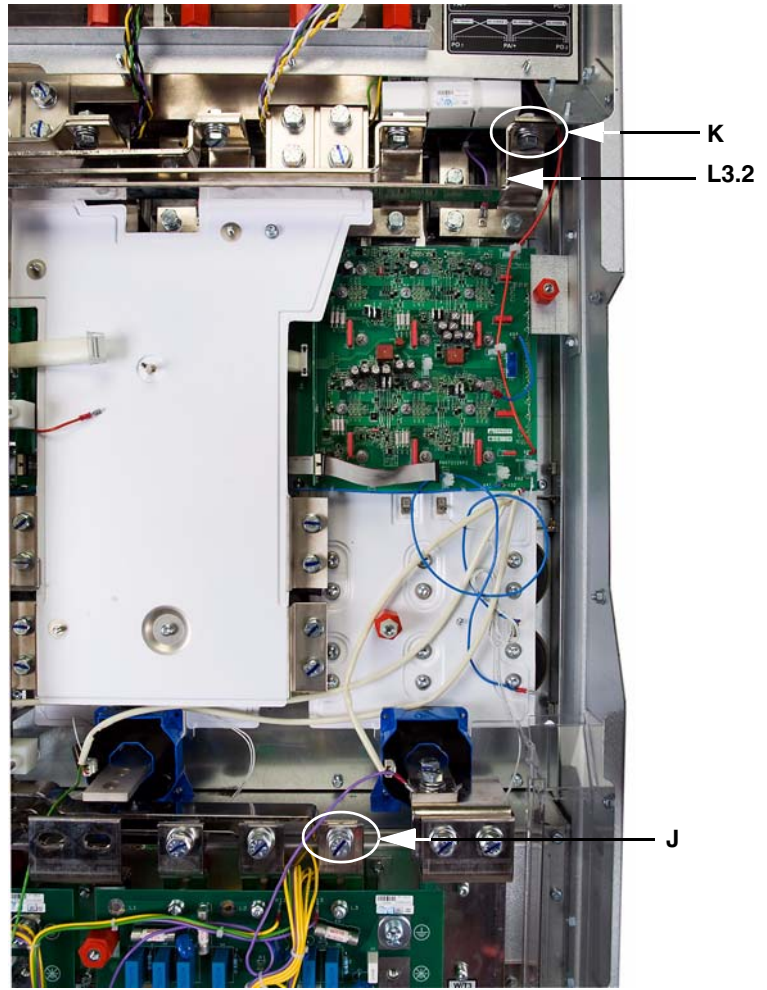
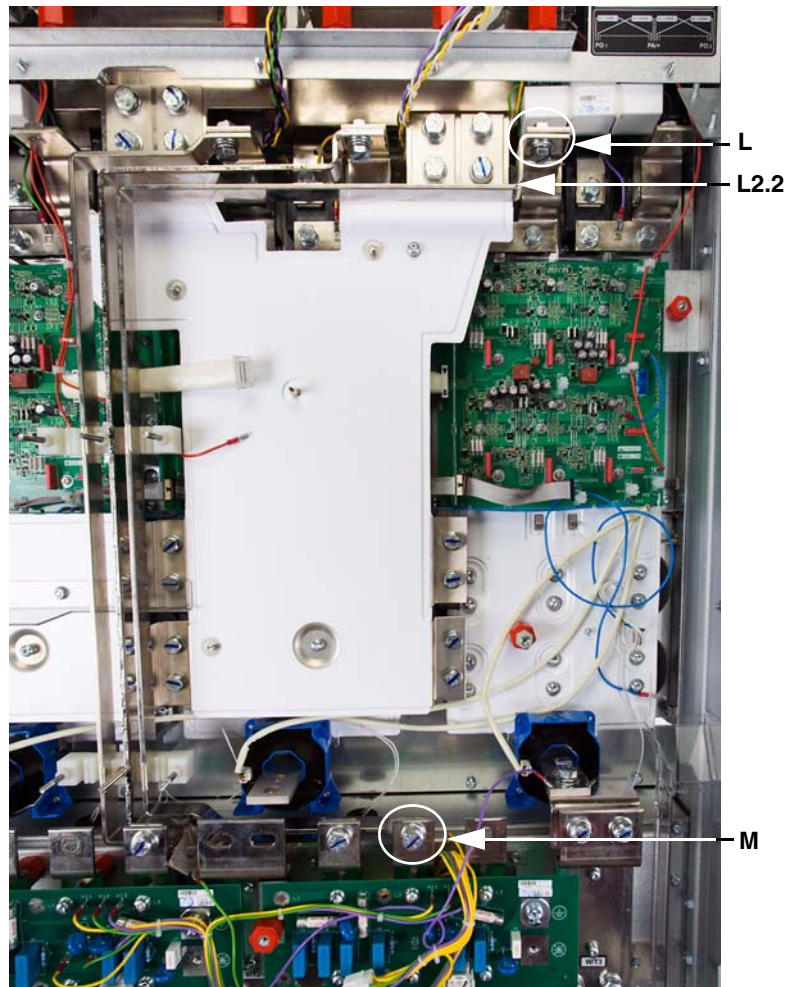

Figure 78: L3.2 Input Bus Bar



18. Remove the L2.2 input bus bar as follows. See Figure 79.
- Using an 18 mm socket wrench, remove one bolt and washer (**M**, Figure 79) securing the bottom of the L2.2 input bus bar to the S/L2.2 bus bar.
 - Using an 18 mm socket wrench, remove one bolt (**L**, Figure 79) securing the top of the L2.2 input bus bar to the L2.2 rectifier and remove the bus bar.

Figure 79: L2.2 Input Bus Bar



19. Remove the L1.2 input bus bar as follows. See Figure 80.
- Using an 18 mm socket wrench, remove one bolt and washer (**O**, Figure 80) securing the bottom of the L1.2 input bus bar to the R/L1.2 bus bar.
 - Using a 16 mm socket wrench, remove one bolt (**N**, Figure 80) securing the top of the L1.2 input bus bar to the L1.2 rectifier and remove the bus bar.

Figure 80: L1.2 Input Bus Bar

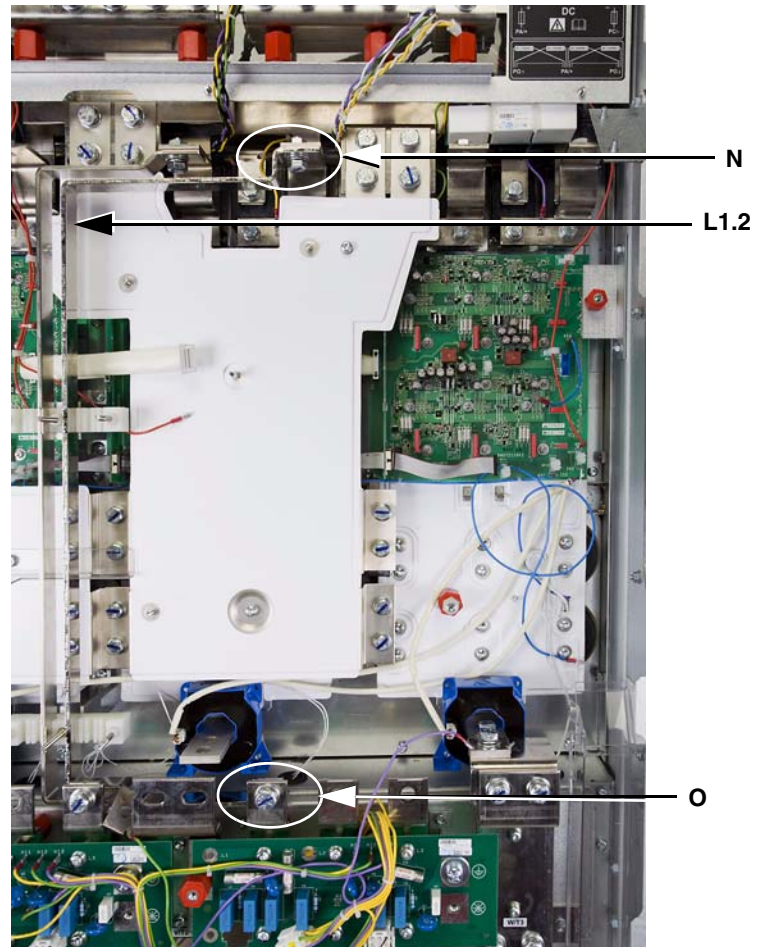

20. Remove the L3.1 input bus bar as follows. See Figure 81.

- Using an 18 mm socket wrench, remove one bolt and washer (**P**, Figure 81) securing the bottom of the L3.1 input bus bar to the T/L3.1 bus bar.
- Using an 18 mm socket wrench, remove one bolt (**R**, Figure 81) securing the top of the L3.1 input bus bar to the L3.1 rectifier and remove the bus bar.

Figure 81: L3.1 Input Bus Bar

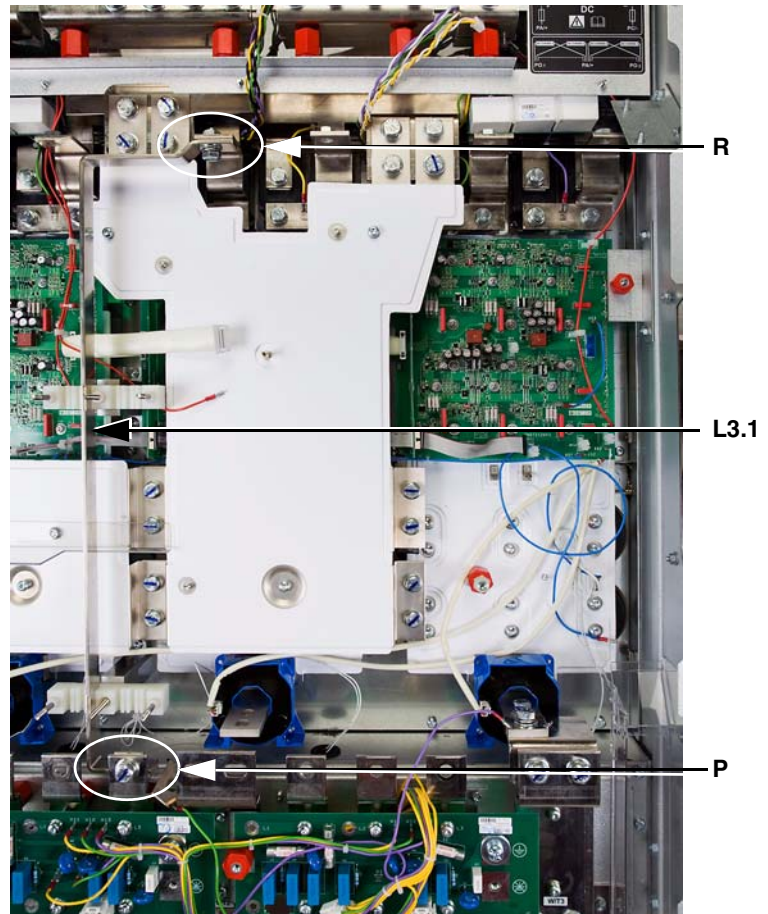

**Remove the Input Bus Bar Brackets
(Bottom)**

21. Remove the bottom half of the bus bar mounting brackets from the mounting posts on the drive frame. See Figure 82.

Figure 82: Input Bus Bar Brackets, Bottom

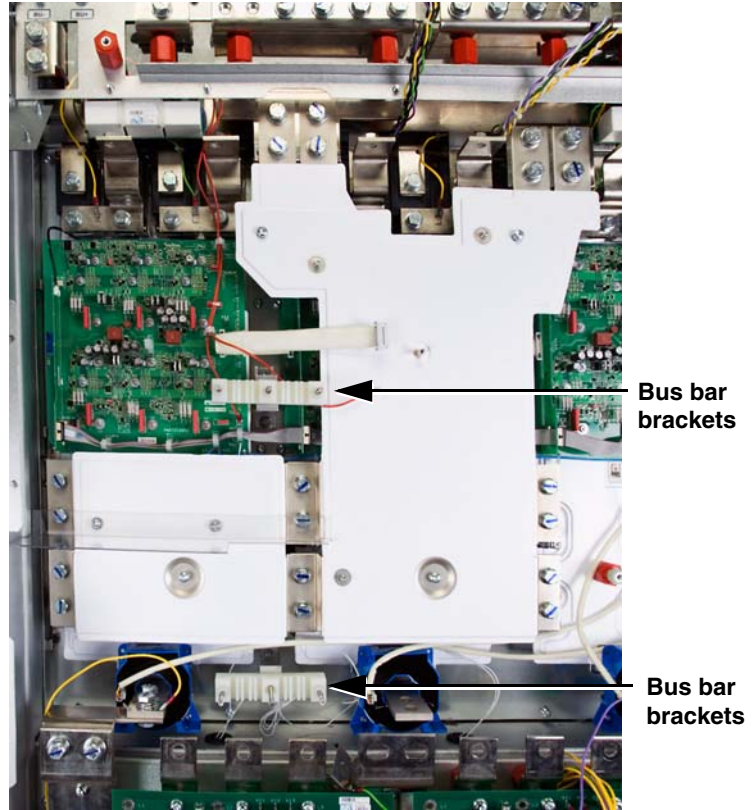

Remove the Top Phase-U Bus Plate

22. Remove the top phase-U DC bus plate as follows. See Figure 83.
- Using a 10 mm socket wrench, remove two nuts (**A**) securing the plastic shield to the bus plate and remove the shield.
 - Using a 16 mm socket wrench, remove eight bolts securing the bus plate to the positive (+) bus at the top (**B**) and to the negative (-) bus (**C**) at the bottom.
 - Using a T-30 Torx driver, remove one screw (**D**) securing the bus plate to the standoff on the bottom DC bus plate.
 - Remove the bus plate from the drive.

Figure 83: Phase-U DC Bus Plate

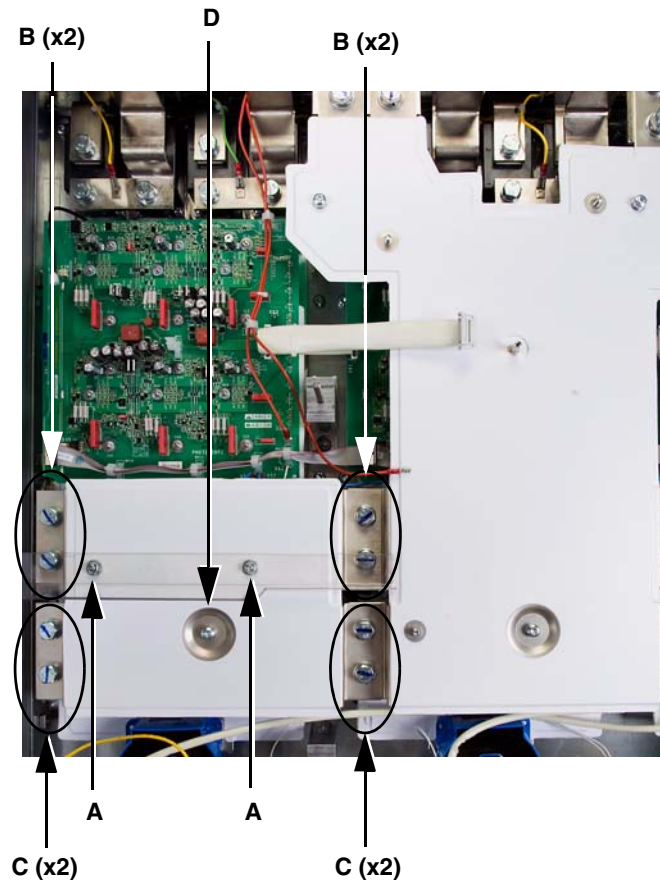

Remove the Top DC Bus Plate

23. Remove the top DC bus plate as follows. See Figure 84.

- Using a 16 mm socket wrench, remove two bolts securing the bus plate to the positive (+) DC bus (**A**).
- Using a 16 mm socket wrench, remove two bolts securing the bus plate to the negative (-) DC bus (**B**).
- Using an 18 mm socket wrench, remove four bolts securing the bus plate to the positive (+) rectifier bus (**C**).
- Using an 18 mm socket wrench, remove four bolts securing the bus plate to the negative (-) rectifier bus (**D**).
- Using a T-30 Torx driver, remove three screws (**E**) securing the bus plate to the red insulators on the heatsink and remove the bus plate.

Figure 84: Top DC Bus Plate

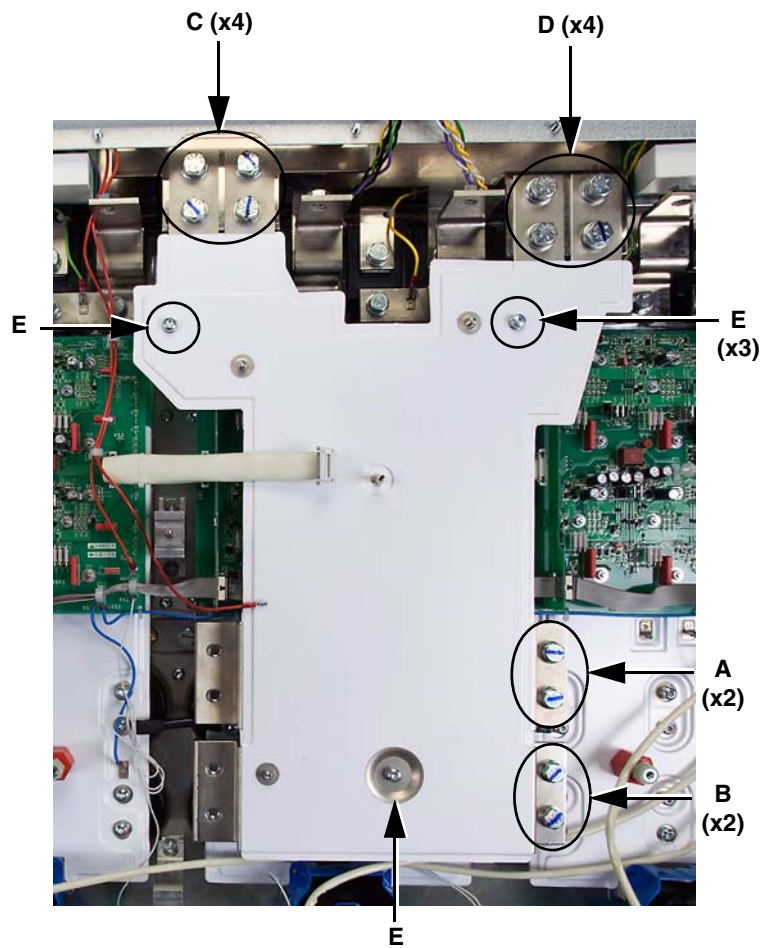

NEXT STEP: If you are replacing a gate driver board, skip to “Replacing the Gate Driver Boards VX5A1203” beginning on page 121.

If you are replacing an SCR or diode module, skip to “Replacing the SCR Modules and Diode Modules (VZ3TM1425M1671 and VZ3DM1600M1671)” beginning on page 132.

Remove the Gate Driver Boards

NOTE: Perform the steps in this section if you are removing a gate driver board to access parts under the DC bus plate.

If you are replacing a gate driver board, skip to “Replacing the Gate Driver Boards VX5A1203” on page 121.

If you are removing equipment to make repairs in **phase U**, remove the left gate driver board.

If you are removing equipment to make repairs in **phase V**, remove the center gate driver board.

If you are removing equipment to make repairs in **phase W**, remove the right gate driver board.

24. Remove the gate driver board in the phase that you are repairing as follows.

- Remove the connections from the gate driver board in the phase you are repairing. See Table 23 and Figure 85 on page 76.
- Using a 7 mm socket wrench, remove 18 nuts securing the gate driver board to the power IGBT modules and the DC bus plate and remove the board from the drive. See Figure 85 on page 76.

NEXT STEP: If you are replacing a temperature sensor, skip to “Replacing the Temperature Sensors, VZ3G1104” beginning on page 125.

Table 23: Gate Driver Board Wiring¹

Wire No. ²	Terminal No.	Description	To:
Gate Driver Board U (Left)			
E144	X4	2-pin, black	Temperature sensor U
E138	X32	18-pin, gray	GDB ³ V X31
E129	X51	1-pin, blue	UD0 (neutral) on DC bus plate
E127	X52	1-pin, blue	GDB V, X51
E126	X61	1-pin, red	SB ⁴ X10
E139	X62	1-pin, white	Bleeder resistor 1
E100	X82	14-pin, white	GDB V, X81 and PB ⁵ X8
—	X31	No connection	
—	X81	No connection	
Gate Driver Board V (Center)			
E128	X4	2-pin, black	Temperature sensor V
E138	X31	18-pin, gray	GDB U, X32
E146	X32	18-pin, gray	GDB W, X31
E127	X51	1-pin, blue	GDB U, X52
E123	X52	1-pin, blue	GDB W, X51
E100	X81	14-pin, white	GDB U, X82
E102	X82	14-pin, white	GDB W, X81
—	X61	No connection	
Gate Driver Board W (Right)			
E145	X4	2-pin, black	Temperature sensor W
E146	X31	18-pin, gray	GDB V, X32
E142	X32	18-pin, gray	PB, X3
E123	X51	1-pin, blue	GDB V, X52
E102	X81	14-pin, white	GDB V, X82
E132	X53	1-pin, blue	Insulator near MCB
E160	X61	1-pin, red	SB32, X10
E164	X62	1-pin, white	Bleeder resistor 3
—	X52	No connection	
—	X82	No connection	

¹ Terminals X4, X81, and X82 are connected to a daughter board on the gate driver board assembly.
² See the schematic on page 175 for complete drive wiring. Wire numbers are given for cross referencing the wires with the wiring table and the schematic. The numbers do not appear on the wires.
³ GDB: Gate driver board
⁴ SB: SCR Snubber board
⁵ PB: Power board

Figure 85: Gate Driver Boards

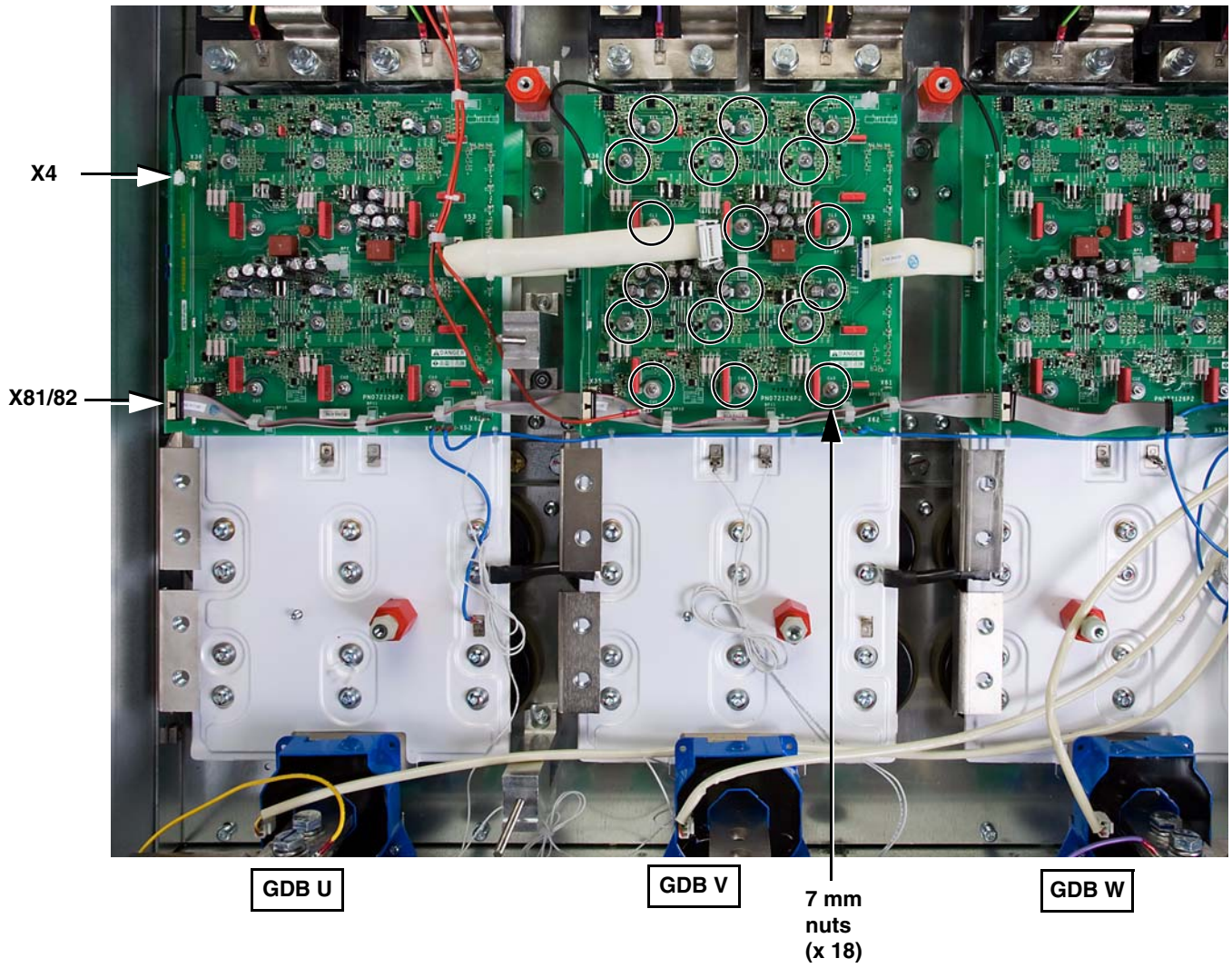

Remove the Bottom DC Bus Plate

NOTE: If you are removing equipment to make repairs in **phase U**, remove the left DC bus plate.

If you are removing equipment to make repairs in **phase V**, remove the center DC bus plate.

If you are removing equipment to make repairs in **phase W**, remove the right DC bus plate.

25. Remove the bottom DC bus plate as follows. See Figure 86.

- Using a T-30 Torx driver, remove three 20 mm screws (**B**) securing the DC bus plate to terminal E on the IGBT modules.
- Using a T-30 Torx driver, remove fifteen 14 mm screws securing the DC bus plate to terminal E on the IGBT modules (**A**) and to the capacitors (**C**).
- Using a 10 mm socket wrench, remove three 6 mm standoffs (**D**) and three 11 mm standoffs (**E**).
- Unplug the bleeder resistor connections (**F**). Note: In phase U, the bleeder resistors are connected to phase-U gate driver board terminal X62 and power board terminal UD-R1.
- Remove the bottom DC bus plate from the drive.

NEXT STEP: If you are replacing the power IGBT modules, skip to “Replacing the Power IGBT Modules VZ3IM1603M1271” beginning on page 127.

If you are replacing the capacitors, skip to “Replacing the Capacitors VY1ADC1112” beginning on page 130.

Figure 86: DC Bus Plate (Phase V Shown)

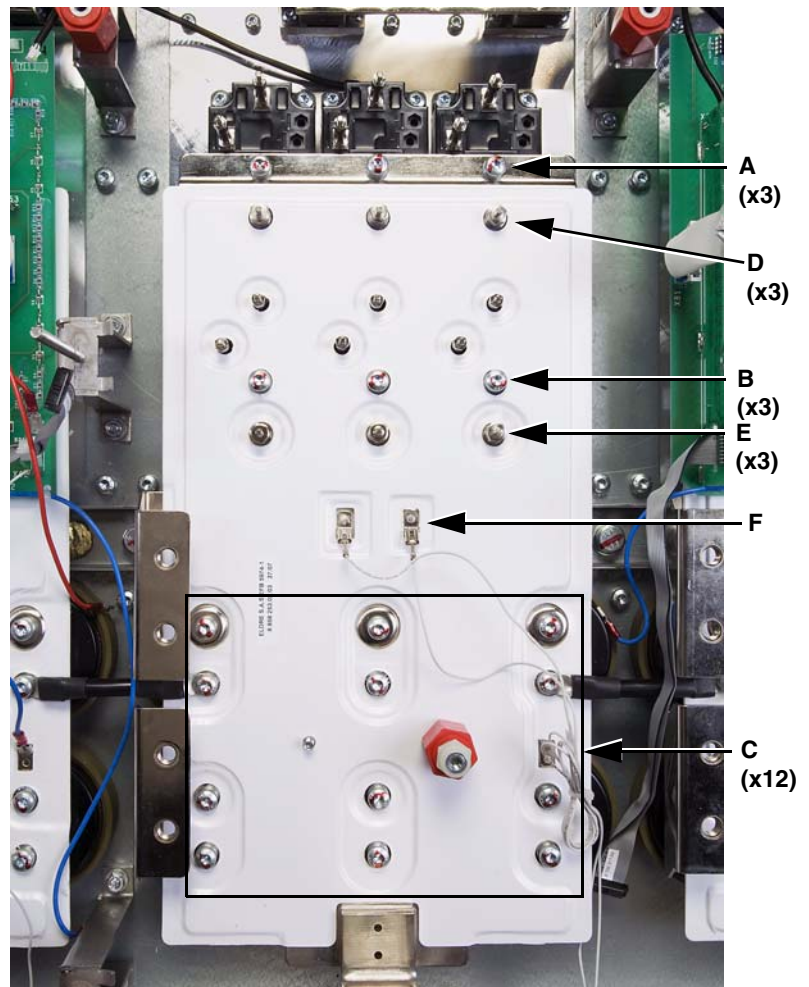

Replacing the Power Board VX5A1HC4050

IMPORTANT: Label and retain all removed hardware and cables for use in reassembly.

⚠ DANGER

HAZARD OF ELECTRIC SHOCK, EXPLOSION, OR ARC FLASH

- Read and understand the precautions in “Before You Begin” starting on page 5 before performing this procedure.
- Before working on this equipment, turn off all power supplying it and perform the DC bus voltage measurement procedure on page 11.

Failure to follow these instructions will result in death or serious injury.

Before performing the steps in this procedure, perform Steps 1–5 of “Disassembly Steps for Accessing Level 2 Parts” beginning on page 49 to remove the following parts from the drive:

- Front cover
- EMC tray
- Power terminal shields
- Control module assembly
- Middle crossbrace

Remove the Soft Charge Boards

Table 24: Soft Charge Board Wiring

Wire No. ¹	Terminal No.	Description	To:
Soft Charge Board 1 (Left Board)			
E110	CN2A	9-pin, red	PB ² X30 (9-pin)
E109	CNL3G	2-pin, violet/black	SCR ³ L3.1 Terms. 4 & 5
E108	CNL2G	2-pin, green/black	SCR L2.1 Terms. 4 & 5
E107	CNL1G	2-pin, yellow/black	SCR L1.1 Terms. 4 & 5
E111	CN7A	2-pin, black	PB X31
—	CNP	Not used	—
Soft Charge Board 2 (Right Board)			
E156	CN2A	9-pin, red	PB ² X40 (9-pin)
E152	CNL3G	2-pin, violet/white	SCR ³ L3.2 Terms. 4 & 5
E153	CNL2G	2-pin, green/white	SCR L2.2 Terms. 4 & 5
E154	CNL1G	2-pin, yellow/white	SCR L1.2 Terms. 4 & 5
E155	CN7A	2-pin, black	PB ² X41
—	CNP	Not used	—

¹ See the schematic on page 175 for complete drive wiring. Wire numbers are given for cross referencing the wires with the wiring table and the schematic. The numbers do not appear on the wires.

² PB: Power board

³ SCR: Silicon controlled rectifier. L1.1, L2.1, and L3.1 are associated with input rectifier 1; L1.2, L2.2, and L3.2 are associated with input rectifier 2.

- Using needle-nose pliers, carefully remove the following connections from soft charge boards 1 and 2. See Table 24 and Figure 87 for connector locations.
 - At the top of the soft charge boards, from left to right remove the connectors from terminals CN2A, CNL3G, CNL2G, and CNL1G.
 - At the left side of the boards, remove the connector from terminal CN7A.
 - Using needle-nose pliers, compress the four plastic mounting posts (A, Figure 87), one at a time, while lifting the soft charge board off the posts.

Figure 87: Soft Charge Board: Board 1 (Left) Shown

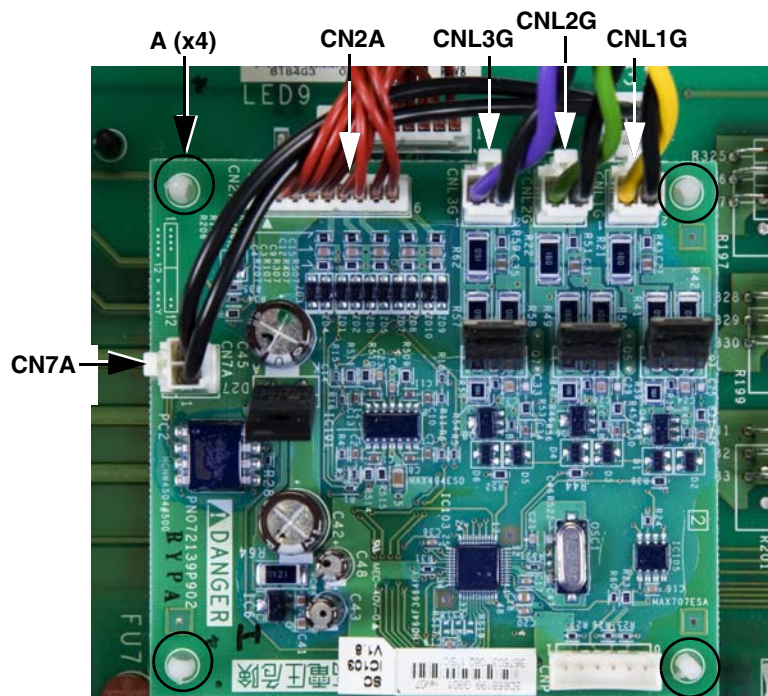

Remove the Power Board Connections

Table 25: Power Board Wiring

Wire No. ¹	Terminal No.	Description	To:
E103	X11	9-pin, multi color	Motor current sensors
E105	X14	3-pin, yellow	FCB ² X2
E136	UD0	1-pin, blue	Phase-W DC bus plate
E126	RFS 31+ X11	1-pin, red	SB ³ X11
E141	UD -R1	1-pin, white	Bleeder resistor 1
—	X2	10-pin, gray	MCB ⁴ X2
E142	X3	18-pin, gray	GDB ⁵ W X32
E112	X4	10-pin, gray	Control module
E150	X5	5-pin, yellow/green/violet	Sensor plates on output bus bars T1, T2, T3
—	X6	15-pin, yellow/green/violet	Retain plug and install in new board
E120	X7	15-pin, yellow/green/violet	FB ⁶ 1&2 X11, X12, X13
E100	X8	14-pin, white	GDB U X82
E106	X21	2-pin, red/black	Internal fan
E106	X22	2-pin, red/black	Internal fan
E110	X30	9-pin, red	SCB ⁷ 1 CN2A
E111	X31	2-pin, black	SCB1 CN7A
E148	X81	2-pin, red	BB ⁸ X8
E149	X91	10-pin, gray	BB X91
E147	X15	3-pin, yellow	FCB2 X2
E156	X40	9-pin, red	SCB2 CN2A
E155	X41	2-pin, black	SCB2 CN7A

¹ See the schematic on page 175 for complete drive wiring. Wire numbers are given for cross referencing the wires with the wiring table and the schematic. The numbers do not appear on the wires.

² FCB: Fan control board
³ SB: SCR Snubber board
⁴ MCB: Motor control board
⁵ GDB: Gate driver board
⁶ FB: Filter board
⁷ SCB: Soft charge board
⁸ BB: Brake board

NOTE: Take care not to damage the LED (see Figure 88) when removing, handling, or installing the power board.

- Using needle-nose pliers, carefully remove all connections from the power board **except** the connections at terminals X6, X30, X31, X40, and X41. See Table 25 and Figure 88 for the connection locations.

Figure 88: Power Board Connections

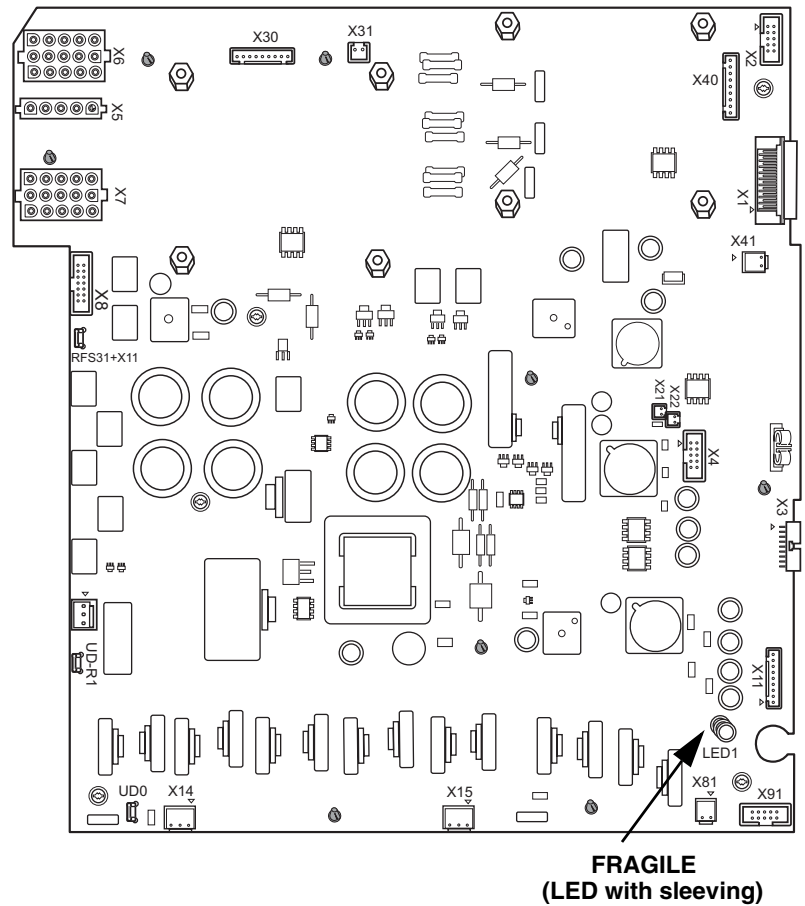

Remove the Power Board

NOTE: Take care not to damage the LED (see Figure 89) when removing, handling, or installing the power board.

3. Remove the power board as follows. See Figure 89.
 - Using a T-10 Torx driver, remove five screws (A) securing the power board to the assembly plate.
 - Using needle-nose pliers, gently compress the seven plastic mounting posts (B), one at a time, while lifting the power board off the posts. Carefully disconnect the power board from the motor control board (C) as you remove the power board.

Figure 89: Power Board

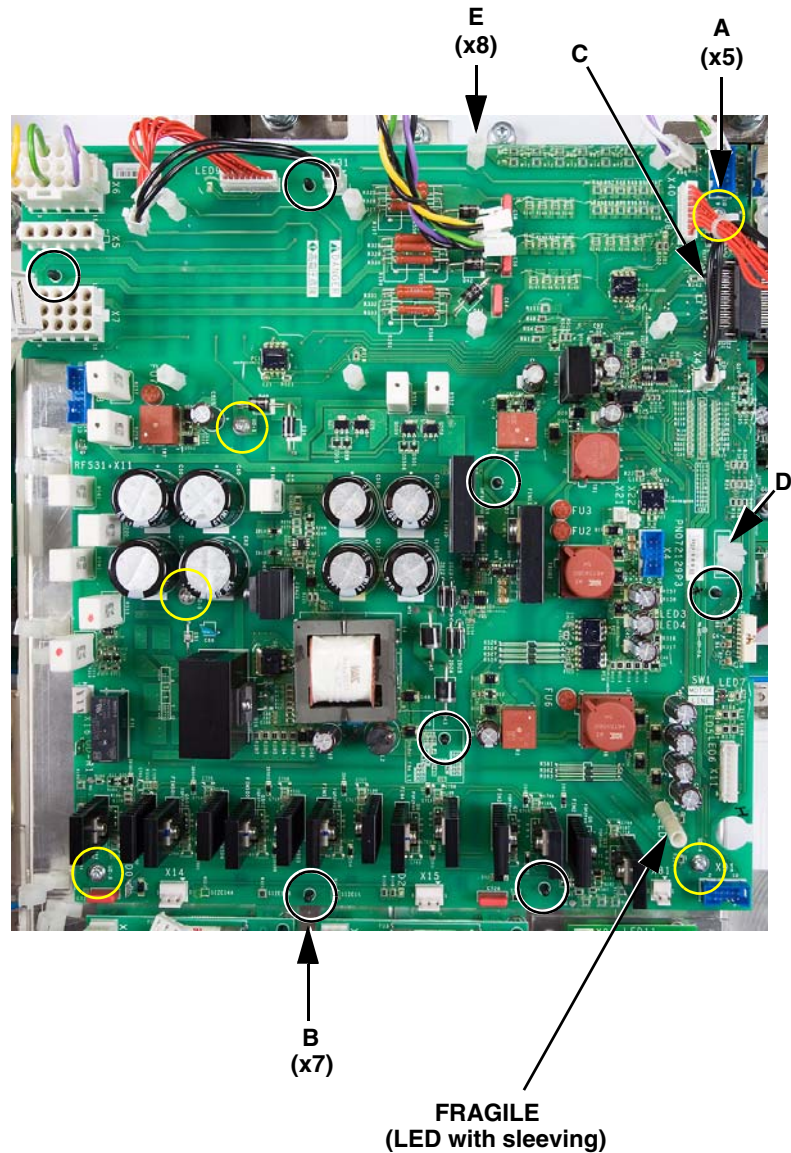

Install the New Power Board

4. Transfer the jumper and cables from terminals X6, X30, X31, X40, and X41 of the old power board to the corresponding terminals on the new board. See Figure 88 on page 79 for terminal locations.
5. Transfer the plastic cable clamp (**D**, Figure 89) from the old power board onto the new one as follows.
 - Pinch the clamp on the bottom side of the board and push it up through the mounting hole.
 - Snap the cable clamp into the mounting holes on the new board.
6. Transfer the eight soft charge board mounting posts (**E**, Figure 89 on page 80) from the old power board onto the new one as follows:
 - Using a 7 mm socket wrench, remove the plastic nuts securing the soft charge board mounting posts to the power board. The nuts are on the back of the board.
 - Push the posts into the corresponding mounting holes from the front of the new power board and secure them at the back with the 7 mm nuts. Tighten the nuts to 0.4–0.6 N•m (3.5–5.3 lb-in).
7. Gently push the new power board down over the seven plastic mounting posts (**B**, Figure 89 on page 80) until it is securely seated. Carefully connect the power board to the motor control board (**C**) as you push it into place.
8. Using a T-10 Torx driver, secure the power board to the assembly plate with five screws (**A**, Figure 89 on page 80). Tighten the screws to 0.5–0.7 N•m (4.4–6.2 lb-in).
9. Replace the power board wiring. See Table 25 and Figure 88 on page 79 for the connection locations.

Replace the Soft Charge Board

Table 26: Soft Charge Board Wiring

Wire No. ¹	Terminal No.	Description	To:
Soft Charge Board 1 (Left Board)			
E110	CN2A	9-pin, red	PB ² X30 (9-pin)
E109	CNL3G	2-pin, violet/black	SCR ³ L3.1 Terms. 4 & 5
E108	CNL2G	2-pin, green/black	SCR L2.1 Terms. 4 & 5
E107	CNL1G	2-pin, yellow/black	SCR L1.1 Terms. 4 & 5
E111	CN7A	2-pin, black	PB X31
—	CNP	Not used	—
Soft Charge Board 2 (Right Board)			
E156	CN2A	9-pin, red	PB ² X40 (9-pin)
E152	CNL3G	2-pin, violet/white	SCR ³ L3.2 Terms. 4 & 5
E153	CNL2G	2-pin, green/white	SCR L2.2 Terms. 4 & 5
E154	CNL1G	2-pin, yellow/white	SCR L1.2 Terms. 4 & 5
E155	CN7A	2-pin, black	PB ² X41
—	CNP	Not used	—

¹ See the schematic on page 175 for complete drive wiring. Wire numbers are given for cross referencing the wires with the wiring table and the schematic. The numbers do not appear on the wires.

² PB: Power board

³ SCR: Silicon controlled rectifier. L1.1, L2.1, and L3.1 are associated with input rectifier 1; L1.2, L2.2, and L3.2 are associated with input rectifier 2.

Reassemble the Drive

10. Replace soft charge boards 1 and 2 as follows.

- Press the soft charge board down over the four mounting posts (A, Figure 90) until it is securely seated.
- Replace the five connections to the board. See Table 26 and Figure 90 for connector locations.

Figure 90: Soft Charge Board: Board 1 (Left) Shown

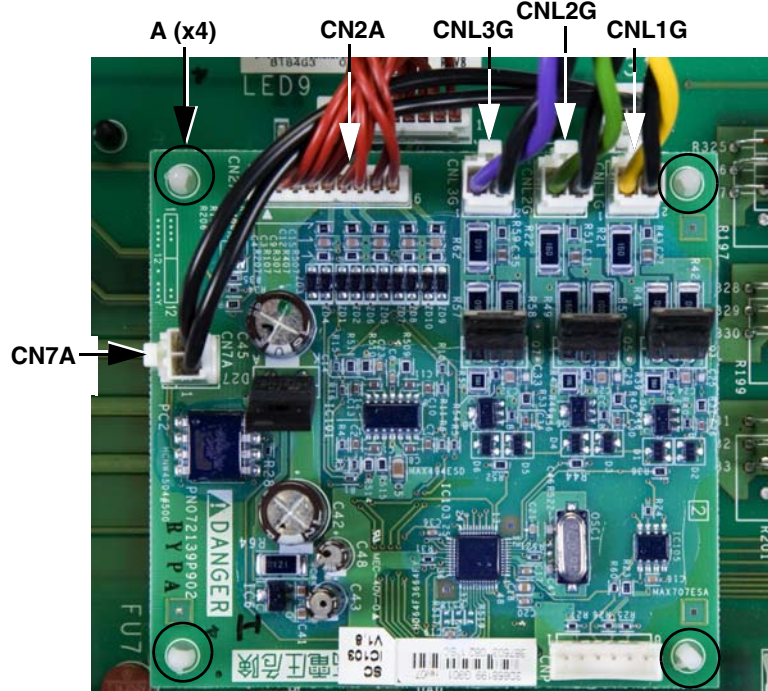

If you are only replacing the power board, perform Steps 21–25 of “Reassembly Steps for Level 2 Parts” beginning on page 144 to replace the following parts.

- Control module assembly
- EMC tray
- Middle crossbrace
- Power terminal shields
- Front cover

Replacing the Brake Board VZ3F1113

IMPORTANT: Label and retain all removed hardware and cables for use in reassembly.

Table 27: Brake Board Wiring

Wire No. ¹	Terminal No.	Description	To:
E149	X91	10-pin, gray	PB ² X91
E148	X8	2-pin, red	PB X81
E151	X3	9-pin, violet/green/yellow	FCB ³ X3
E114	X33	9-pin, violet/green/yellow	FB ⁴ X11 and X12; FB2, X13; FCB1, X3
—	X2	9-pin, yellow jumper	Retain and install in new board
—	X1	15-pin	Not used

¹ See the schematic on page 175 for complete drive wiring. Wire numbers are given for cross referencing the wires with the wiring table and the schematic. The numbers do not appear on the wires.

² PB: Power board

³ FCB: Fan control board

⁴ FB: Filter board

⚠ DANGER

HAZARD OF ELECTRIC SHOCK, EXPLOSION, OR ARC FLASH

- Read and understand the precautions in “Before You Begin” starting on page 5 before performing this procedure.
- Before working on this equipment, turn off all power supplying it and perform the DC bus voltage measurement procedure on page 11.

Failure to follow these instructions will result in death or serious injury.

Before performing the steps in this procedure, perform Steps 1–5 of “Disassembly Steps for Accessing Level 2 Parts” beginning on page 49 to remove the following parts from the drive:

- Front cover
- EMC tray
- Power terminal shields
- Control module assembly
- Middle Crossbrace

1. Using needle-nose pliers, carefully remove all connections from the brake board. See Table 27 and Figure 91 for connector locations.
2. Using needle-nose pliers, gently compress the six plastic mounting posts (**A**), one at a time, while lifting the brake board off the posts.
3. Transfer the jumper at terminal X2 from the old brake board to the new one.
4. Gently push the new brake board down over the six plastic mounting posts (**A**) until it is securely seated.
5. Replace the brake board wiring. See Table 27 and Figure 91 for the connection locations.

Figure 91: Brake Board

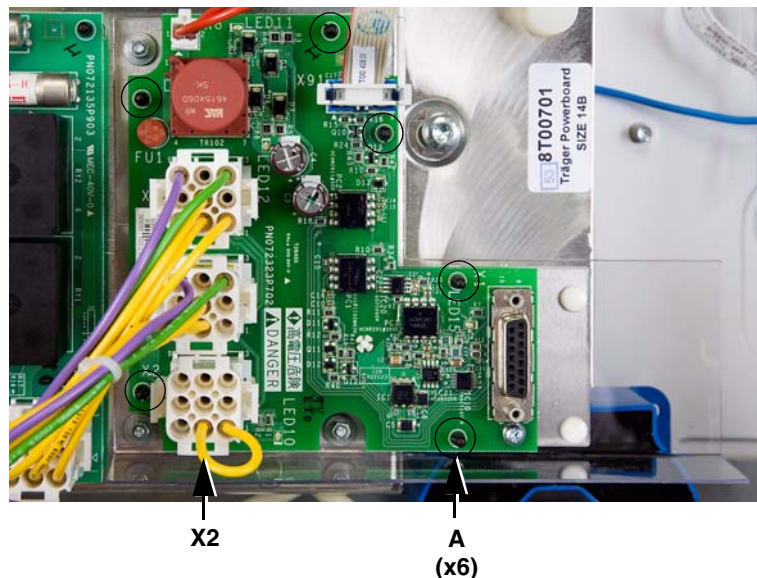

Reassemble the Drive

If you are only replacing the brake board, perform Steps 21–25 of “Reassembly Steps for Level 2 Parts” beginning on page 144 to replace removed parts. See the list above.

Replacing the Power Board Assembly Shields

IMPORTANT: Label and retain all removed hardware and cables for use in reassembly.

⚠ DANGER

HAZARD OF ELECTRIC SHOCK, EXPLOSION, OR ARC FLASH

- Read and understand the precautions in “Before You Begin” starting on page 5 before performing this procedure.
- Before working on this equipment, turn off all power supplying it and perform the DC bus voltage measurement procedure on page 11.

Failure to follow these instructions will result in death or serious injury.

Before performing the steps in this procedure, perform Steps 1–9 of “Disassembly Steps for Accessing Level 2 Parts” beginning on page 49 to remove the following parts from the drive:

- | | |
|--------------------------------------------------|--------------------------------------------------------|
| <input type="checkbox"/> Front cover | <input type="checkbox"/> Soft charge board connections |
| <input type="checkbox"/> Power terminal shields | <input type="checkbox"/> Power board connections |
| <input type="checkbox"/> Middle crossbrace | <input type="checkbox"/> Fan control board connections |
| <input type="checkbox"/> EMC tray | <input type="checkbox"/> Power board assembly |
| <input type="checkbox"/> Control module assembly | |

The power board assembly consists of the motor control board (**A**), the power board (**B**), the brake board assembly (**C**), fan control boards 1 (**D**) and 2 (**E**), and the power board assembly plate (**F**). See Figure 92.

There are three plastic shields in the power board assembly: one under the power board, one under the motor control board, and one under the brake board.

Figure 92: Power Board Assembly

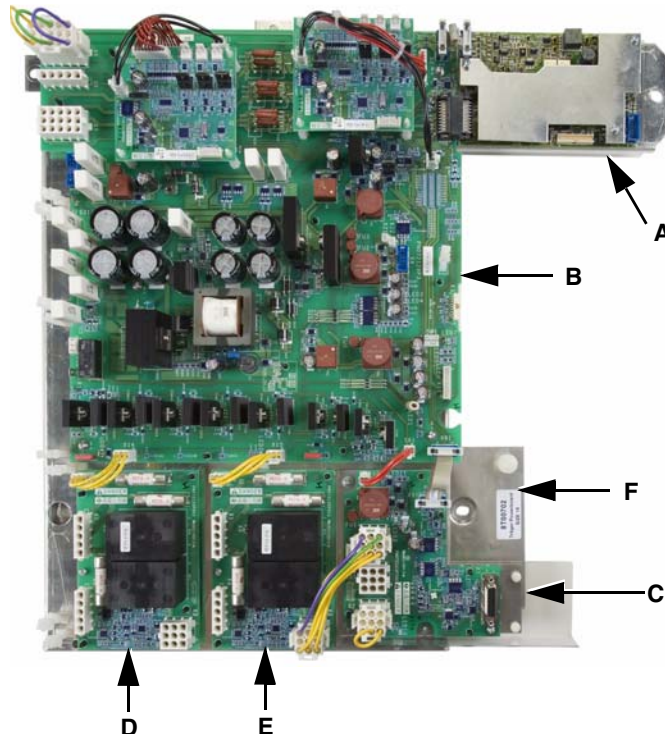

Remove the Power Board Assembly Connections

1. Remove the connections listed in Table 28, if present.

Table 28: Power Board Assembly Wiring

Wire No. ¹	Terminal No.	Description	To:
—	MCB ² X2	10-pin, white	PB X2
E105	PB ³ X14	3-pin, yellow	FCB 1 X2
E147	PB X15	3-pin, yellow	FCB 2 X2
E148	PB X81	2-pin, red	BB ⁴ X8
E149	PB X91	10-pin, gray	BB X91
E151	FCB ⁵ X3	9-pin, green/yellow/violet with yellow and green ground wire	BB X3

¹ See the schematic on page 175 for complete drive wiring. Wire numbers are given for cross referencing the wires with the wiring table and the schematic. The numbers do not appear on the wires.

² MCB: Motor control board

³ PB: Power board

⁴ BB: Brake board

⁵ FCB: Fan control board

Replace the Plastic Shield Under the Brake Board

2. Using a 7/32 in. socket wrench, remove four nuts (**A**) securing the brake board assembly to the power board assembly plate, and remove the brake board assembly. See Figure 93.

Figure 93: Brake Board Assembly

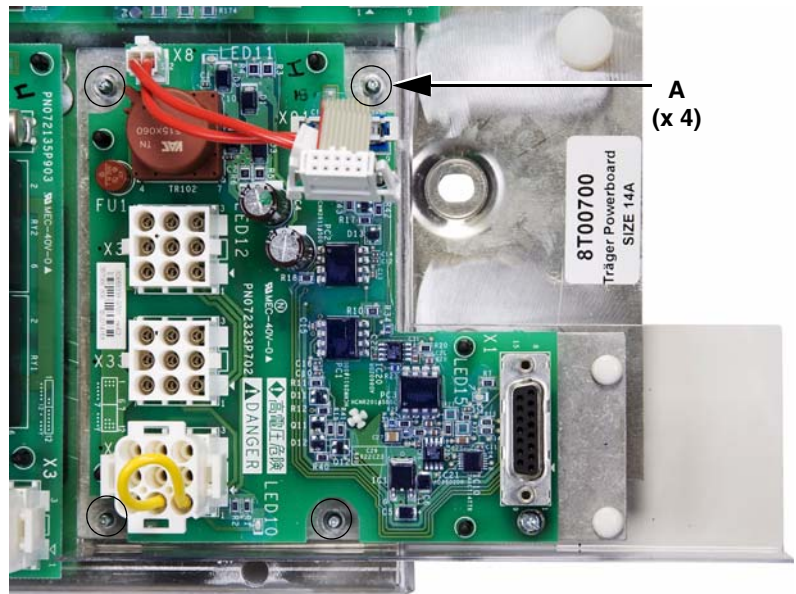

- Using needle-nose pliers, gently compress the six plastic mounting posts (B), one at a time, while lifting the brake board off the posts. See Figure 94.

Figure 94: Brake Board

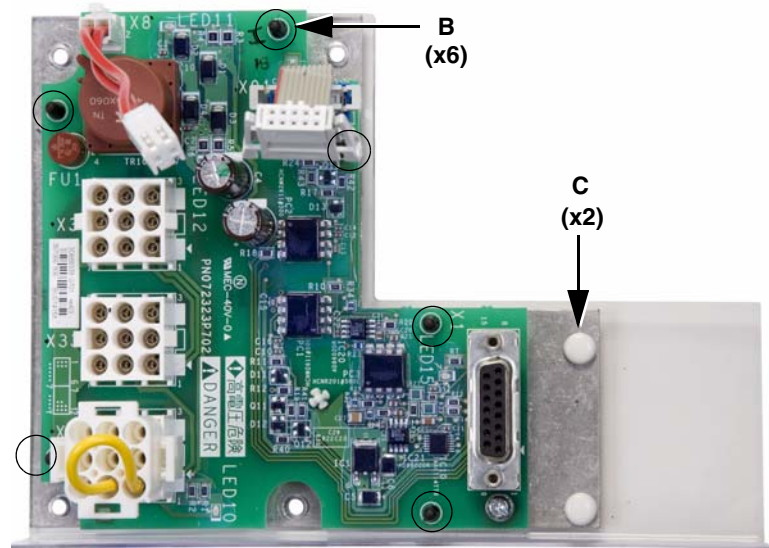

- Remove the two white fasteners (C, Figures 94 and 95) securing the plastic shield to the metal plate, and remove the shield from the plate.
- Replace the shield with a new piece from the plastic kit and secure it with the two fasteners (C, Figures 94 and 95).
- Gently push the brake board down over the plastic mounting posts on the shield assembly (B, Figure 94) until it is securely seated.

NEXT STEP: Set the brake board assembly aside and continue with Step 7 on page 87 to replace the other plastic shields.

⚠ DANGER

HAZARD OF ELECTRIC SHOCK, EXPLOSION, OR ARC FLASH

- Install the shield as shown in Figure 95.
- Before installing the shield, ensure that it has no tears or cracks. If the shield is damaged, install a new piece from the plastic kit.
- Do not install a damaged shield.

Failure to follow these instructions will result in death or serious injury.

Figure 95: Brake Board Plate

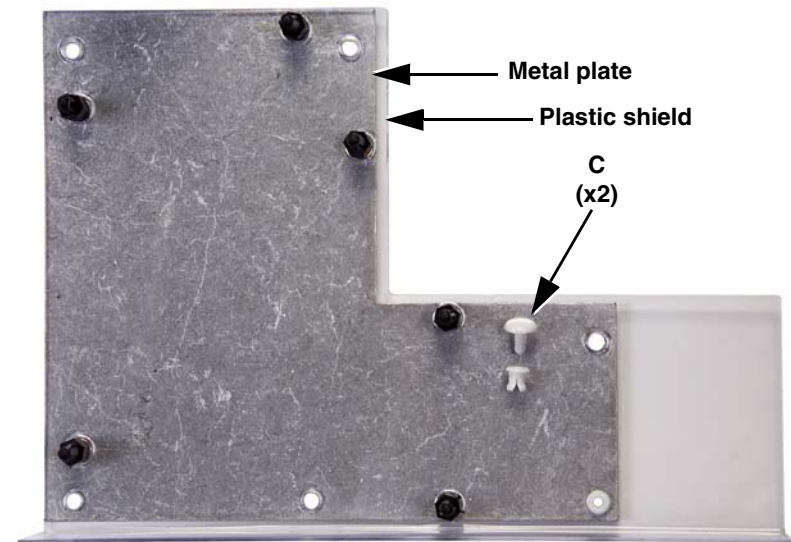

Remove the Motor Control Board

7. Remove the motor control board as follows.
 - Using a T-10 Torx driver, remove three screws (**D**, Figure 96) securing the metal plate to the standoffs on the motor control board.
 - Using a 7/32 in. socket wrench, remove the three standoffs (**E**, Figure 97) securing the motor control board to the power board assembly plate, and remove the motor control board.
 - Carefully disconnect the motor control board from the power board (**F**, Figure 97) as you remove the motor control board.

Figure 96: Motor Control Board Plate

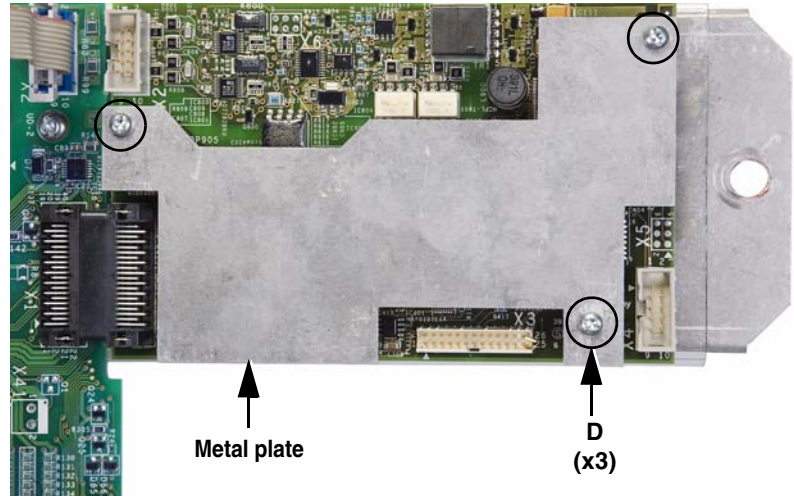
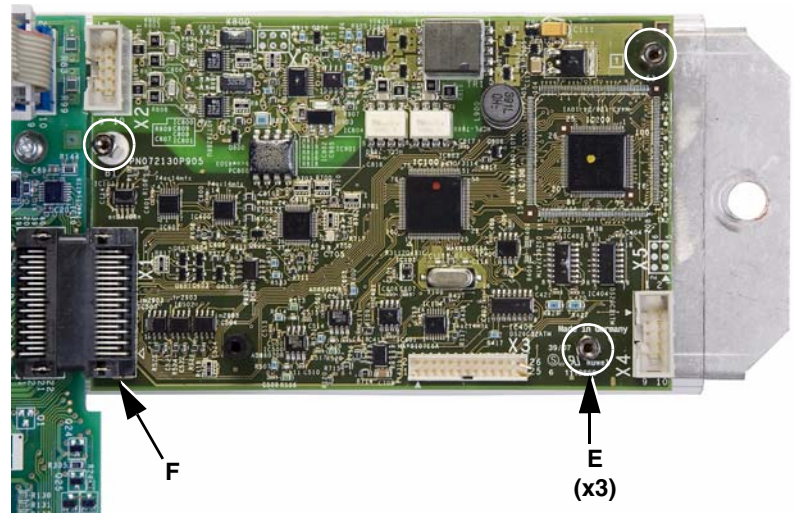

Figure 97: Motor Control Board



Remove the Power Board

8. Remove the power board as follows. See Figure 98.
 - Using a T-10 Torx driver, remove five screws (G) securing the power board to the assembly plate.
 - Using needle-nose pliers, gently compress the seven plastic mounting posts (H), one at a time, while lifting the power board off the posts.

Figure 98: Power Board

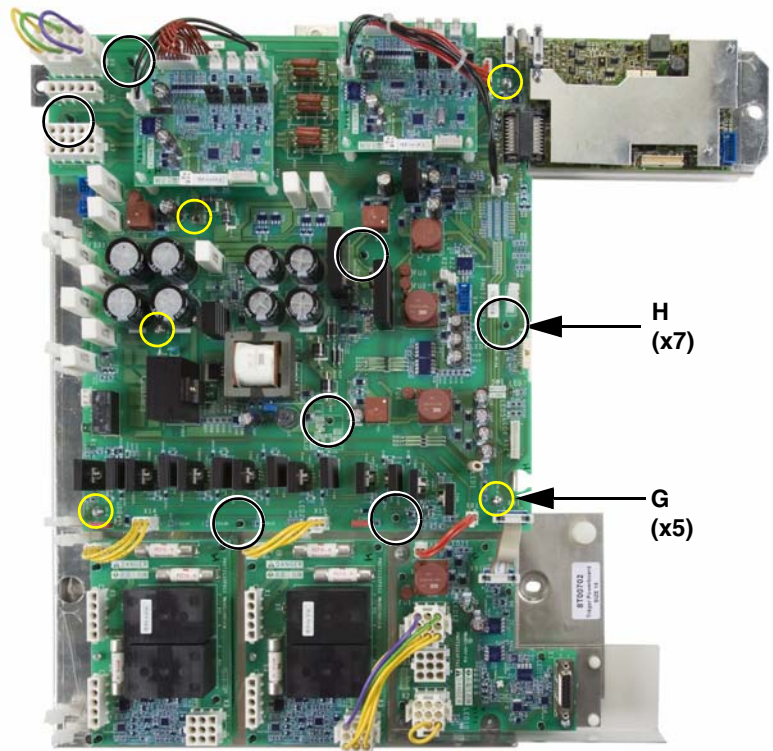

Remove Fan Control Boards 1 and 2

9. Remove fan control boards 1 and 2 from the assembly plate as follows. See Figure 99.
 - Using a T-10 Torx driver, remove 1 screw (J) from each board.
 - Using needle-nose pliers, compress the four plastic mounting posts (K), one at a time, while lifting the board off the posts. Remove the boards from the assembly plate.

Figure 99: Fan Control Boards

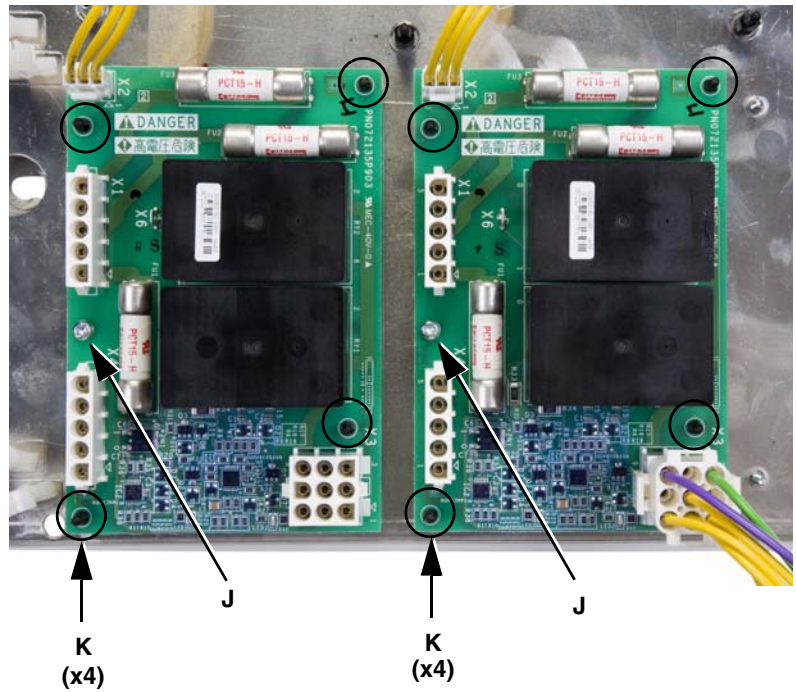

Replace the Plastic Shields

⚠ DANGER

HAZARD OF ELECTRIC SHOCK, EXPLOSION, OR ARC FLASH

- Install the shields as shown in Figure 100.
- Before installing the shield, ensure that it has no tears or cracks. If the shield is damaged, install a new piece from the plastic kit.
- Do not install a damaged shield.

Failure to follow these instructions will result in death or serious injury.

10. Remove the two plastic shields (**L** and **M**) from the assembly plate and replace them with new pieces from the plastic kit. See Figure 100.

Figure 100: Power Board Assembly Plate

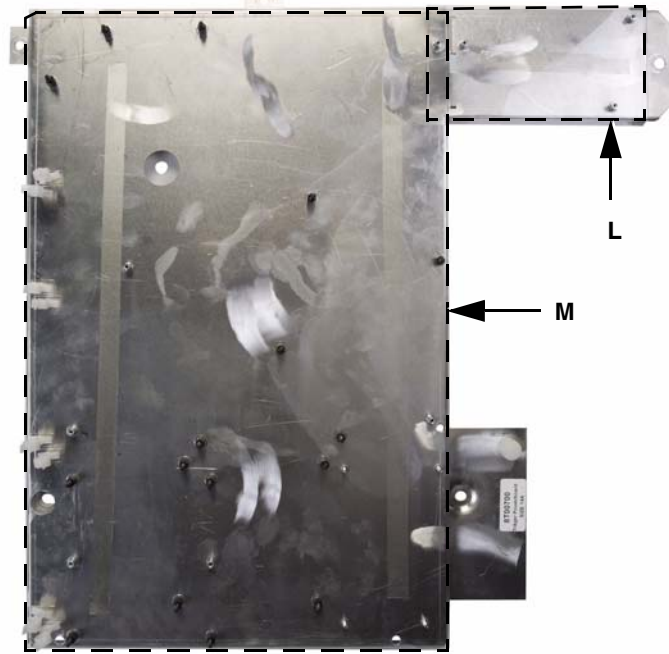

Reinstall Fan Control Boards 1 and 2

11. Reinstall fan control boards 1 and 2 on the assembly plate as follows. See Figure 101.

- Gently push the fan control boards down over the four plastic mounting posts (**K**) until they are securely seated.
- Using a T-10 Torx driver, secure the fan control boards to the assembly plate with one screw each (**J**).
- Tighten the screws to 0.8 N•m (7.1 lb-in).

Figure 101: Fan Control Boards

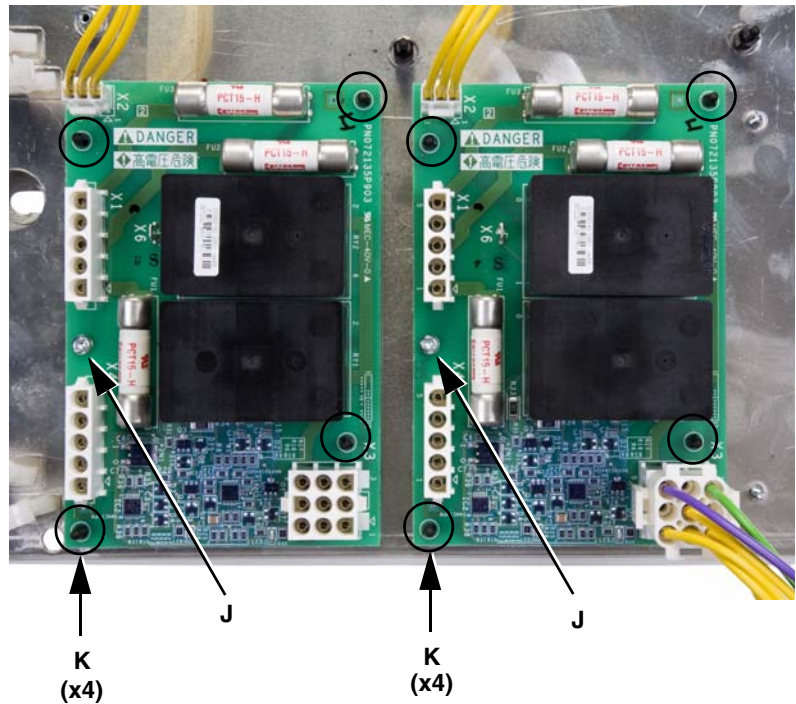

Reinstall the Power Board

12. Reinstall the power board as follows. See Figure 102.

- Gently push the new power board down over the seven plastic mounting posts (**H**) until it is securely seated.
- Using a T-10 Torx driver, secure the power board to the assembly plate with five screws (**G**). Tighten the screws to 0.5–0.7 N•m (4.4–6.2 lb-in).

Figure 102: Power Board

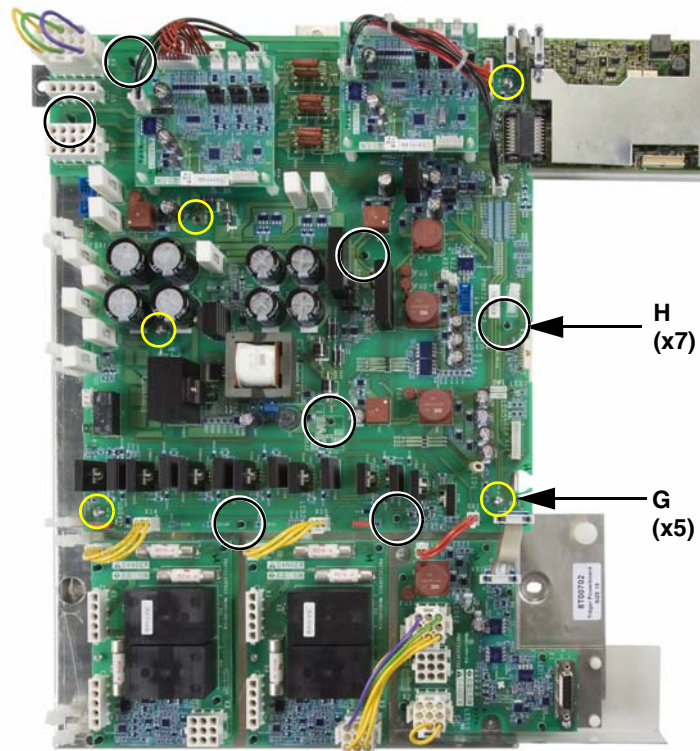

Reinstall the Motor Control Board

13. Reinstall the motor control board as follows.
 - Carefully connect the motor control board to the power board (F, Figure 103).
 - Using a 7/32 in. socket wrench, secure the motor control board to the power board assembly plate with the three standoffs (E, Figure 103). Tighten the standoffs to 0.8 N•m (7.1 lb-in).
 - Using a T-10 Torx driver, secure the metal plate to the standoffs on the motor control board with three screws (D). See Figure 104. Tighten the screws to 0.8 N•m (7.1 lb-in).

Figure 103: Motor Control Board

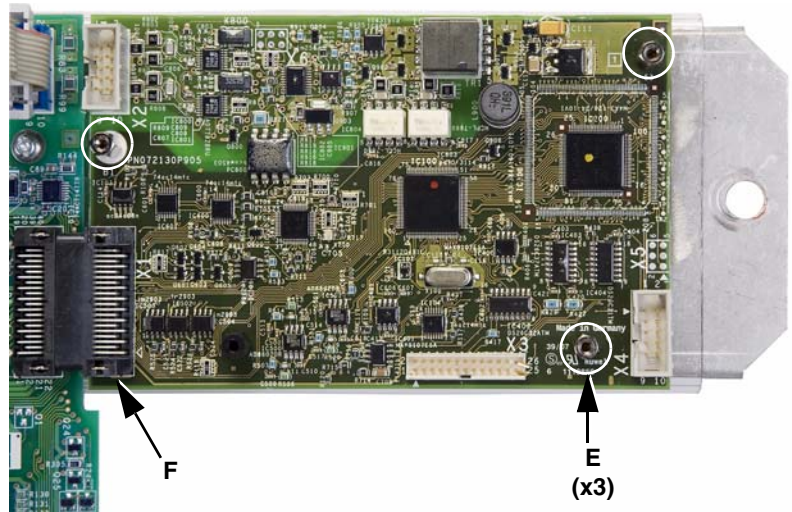
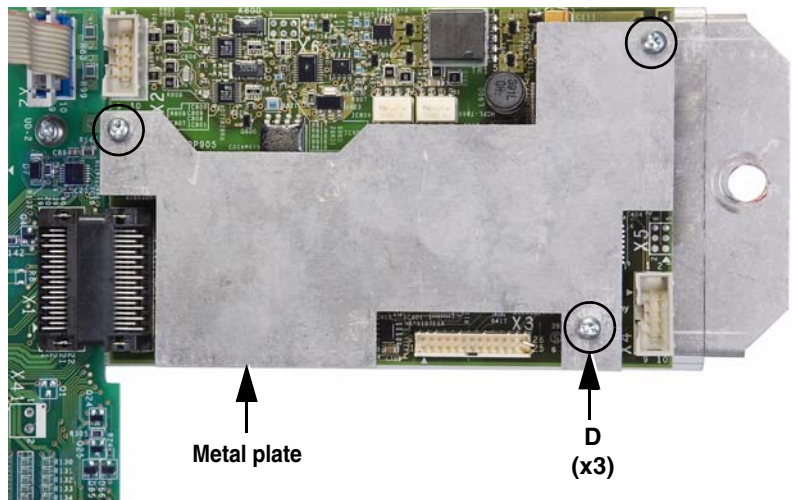

Figure 104: Motor Control Board Plate



Reinstall the Brake Board Assembly

14. Using a 7/32 in. socket wrench, secure the brake board assembly to the power board assembly plate with four nuts (A). See Figure 105. Tighten the nuts to 0.8 N•m (7.1 lb-in).

Figure 105: Brake Board Assembly

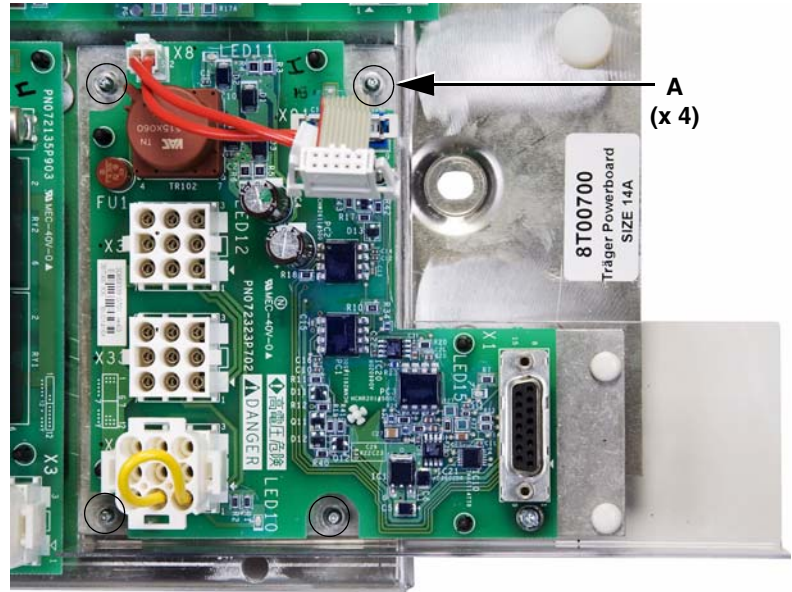

Replace the Power Board Assembly Connections

15. Replace the connections listed in Table 29.

Table 29: Power Board Assembly Wiring

Wire No. ¹	Terminal No.	Description	To:
—	MCB ² X2	10-pin, white	PB X2
E105	PB ³ X14	3-pin, yellow	FCB 1 X2
E147	PB X15	3-pin, yellow	FCB 2 X2
E148	PB X81	2-pin, red	BB ⁴ X8
E149	PB X91	10-pin, gray	BB X91
E151	FCB ⁵ X3	9-pin, green/yellow/violet with yellow and green ground wire	BB X3

¹ See the schematic on page 175 for complete drive wiring. Wire numbers are given for cross referencing the wires with the wiring table and the schematic. The numbers do not appear on the wires.

² MCB: Motor control board

³ PB: Power board

⁴ BB: Brake board

⁵ FCB: Fan control board

Reassemble the Drive

If you are only replacing the power board assembly shields, perform Steps 17–25 of “Reassembly Steps for Level 2 Parts” beginning on page 144 to replace the following parts:

- Power board assembly
- Fan control board connections
- Power board connections
- Soft charge board connections
- Control module assembly
- EMC tray
- Middle crossbrace
- Power terminal shields
- Front cover

Replacing the Motor Current Sensors VY1A1109

IMPORTANT: Label and retain all removed hardware and cables for use in reassembly.

⚠ DANGER

HAZARD OF ELECTRIC SHOCK, EXPLOSION, OR ARC FLASH

- Read and understand the precautions in “Before You Begin” starting on page 5 before performing this procedure.
- Before working on this equipment, turn off all power supplying it and perform the DC bus voltage measurement procedure on page 11.

Failure to follow these instructions will result in death or serious injury.

Before performing the steps in this procedure, perform Steps 1–11 of “Disassembly Steps for Accessing Level 2 Parts” beginning on page 49 to remove the following parts from the drive:

- | | |
|--------------------------------------------------------|--------------------------------------------------------|
| <input type="checkbox"/> Front cover | <input type="checkbox"/> Power board connections |
| <input type="checkbox"/> Power terminal shields | <input type="checkbox"/> Fan control board connections |
| <input type="checkbox"/> Middle crossbrace | <input type="checkbox"/> Power board assembly |
| <input type="checkbox"/> EMC tray | <input type="checkbox"/> BU (+) bus bar |
| <input type="checkbox"/> Control module assembly | <input type="checkbox"/> Fan bracket |
| <input type="checkbox"/> Soft charge board connections | |

Replacing the Phase-W Motor Current Sensor

Remove the W/T3 Bus Bar

1. Remove the W/T3 bus bar as follows.
 - Using an 18 mm socket wrench, remove two bolts and washers (A, Figure 106) securing the output from the phase-W DC bus plate to the W/T3 bus bar.

NOTE: An output sensor plate (B, Figure 106) with a violet lead is under the front bolt. Remove the sensor plate.

- Using a T-30 Torx driver, remove two screws and washers (C, Figure 106) securing the W/T3 bus bar to the insulators on the bottom terminal bracket and remove the bus bar.

Figure 106: W/T3 Bus Bar

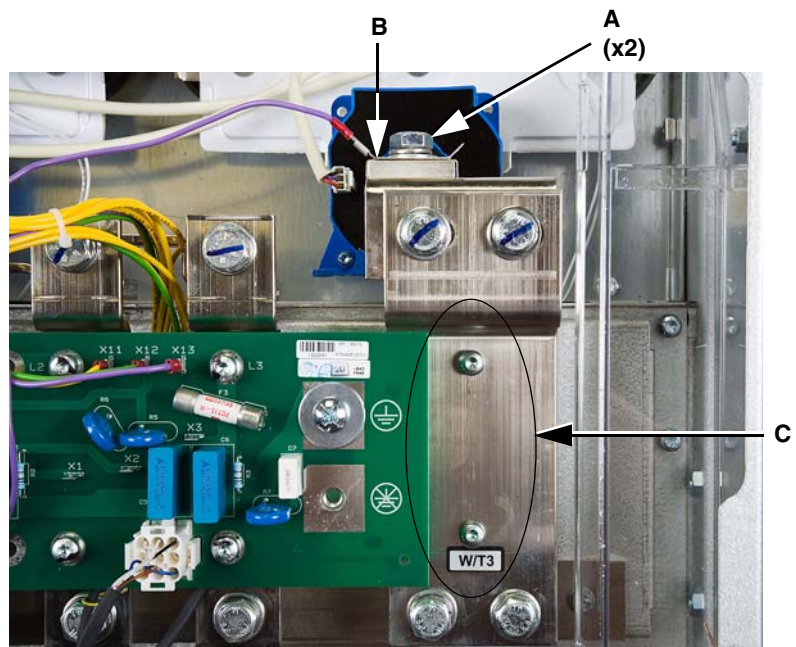

Replace the Phase-W Motor Current Sensor

2. Replace the phase-W motor current sensor as follows.
 - Unplug the connection (**D**, Figure 107) from the phase-W motor current sensor.
 - Using a T-20 Torx driver, remove two screws (**E**, Figure 107) securing the motor current sensor to the brace on the phase-W bus plate.
 - Install the new motor current sensor on the brace and secure it with the two T-20 screws (**E**, Figure 107). Tighten the screws to 1.2 N•m (10.6 lb-in).
 - Plug the connector (**D**, Figure 107) into the new motor current sensor.

Figure 107: Phase-W Motor Current Sensor

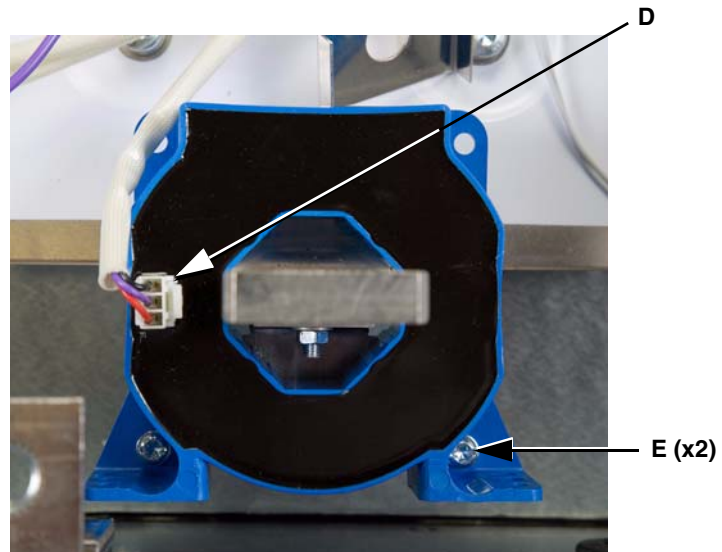

NEXT STEP: If you are only replacing the phase-W motor current sensor, skip to Step 15 on page 120 to replace the W/T3 bus bar and other removed equipment.

Replacing the Phase-U Motor Current Sensor

Remove Filter Board 1 (Left Board)

1. Remove filter board 1 (the left board) as follows.
 - Using a T-30 Torx driver, remove six screws (**A**, Figure 108) securing the filter board to input bus bars R/L1.1, S/L2.1, and T/L3.1.

NOTE: Note whether the grounding screw (**B**) is installed in the grounded or non-grounded position for reinstallation. Figure 108 shows the screw in the grounded position.

- Using a size 3 Phillips driver, remove the grounding screw and washer (**B**, Figure 108) securing the filter board to the drive frame.
- Unplug fan connections X11 and X12 from the filter board.
- Gently press in on the tabs at the top and bottom of the fan connectors and push them down through the cutouts in the filter board. See Figure 109.
- Move the filter board under the terminals and out of the way.

Figure 108: Filter Board 1 (Left Board)

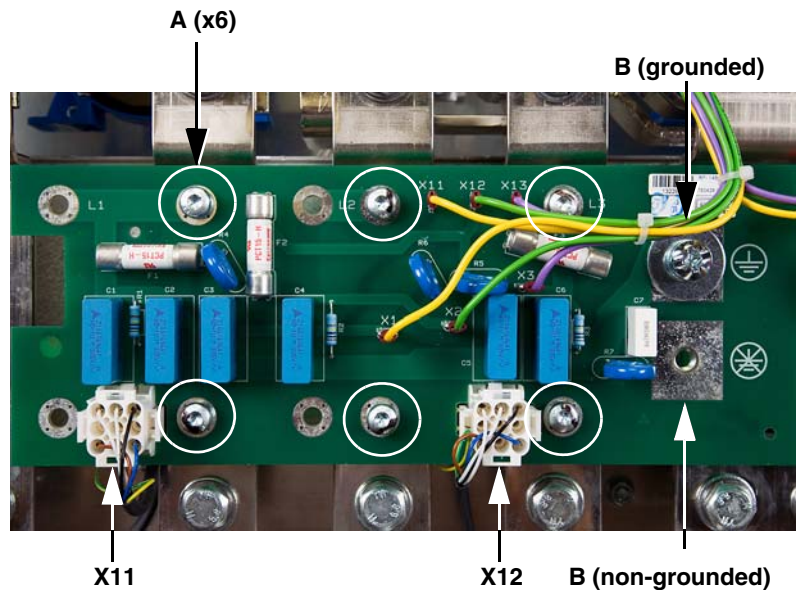
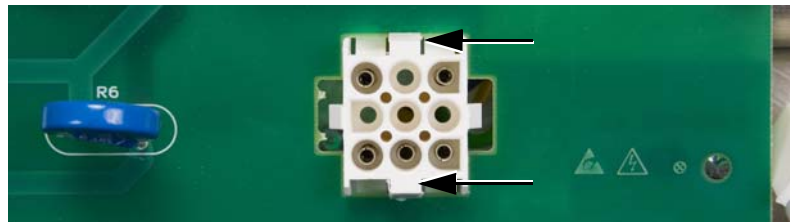

Figure 109: Fan Connector Detail



Remove the U/T1 Bus Bar

2. Remove the U/T1 bus bar as follows.
 - Using an 18 mm socket wrench, remove two bolts and washers (C, Figure 110) securing the output from the U-phase DC bus plate to the U/T1 bus bar.

NOTE: An output sensor plate (D, Figure 110) with a yellow lead is under the front bolt. Remove the sensor plate.

- Using a T-30 Torx driver, remove two screws and washers (E, Figure 110) securing the U/T1 bus bar to the insulators on the bottom terminal bracket and remove the U/T1 bus bar.

Figure 110: U/T1 Bus Bar

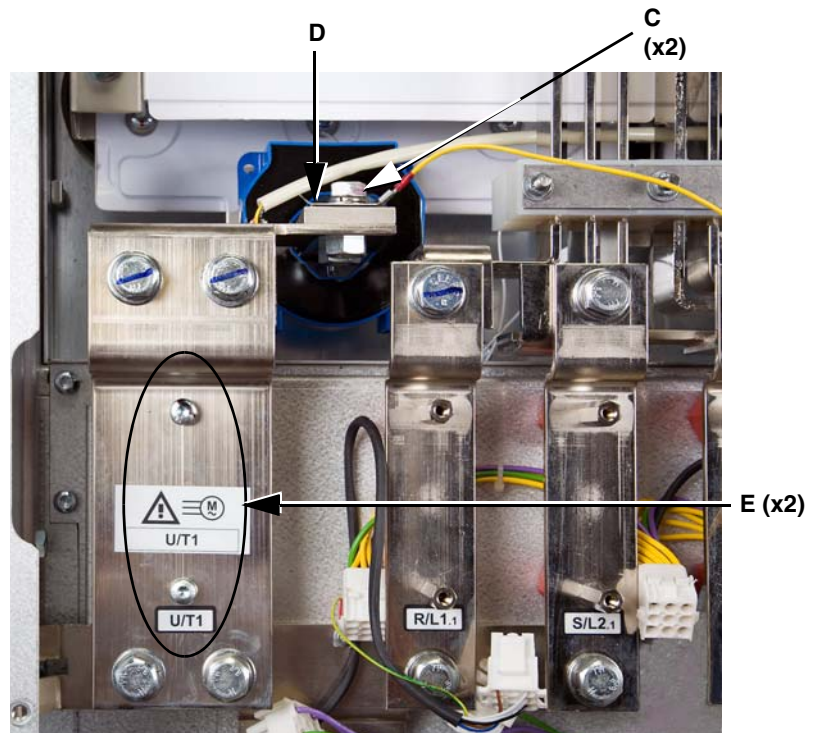

Remove the R/L1.1 Bus Bar

3. Remove the R/L1.1 bus bar as follows.
 - Using an 18 mm socket wrench, remove one bolt and washer (**F**, Figure 111) securing the bottom of the L1.1 input bus bar to the R/L1.1 bus bar.
 - Using a 10 mm socket wrench, remove two standoffs (**G**, Figure 111) securing the R/L1.1 bus bar to the red insulators on the bottom terminal bracket and remove the bus bar.

Figure 111: R/L1.1 Bus Bar

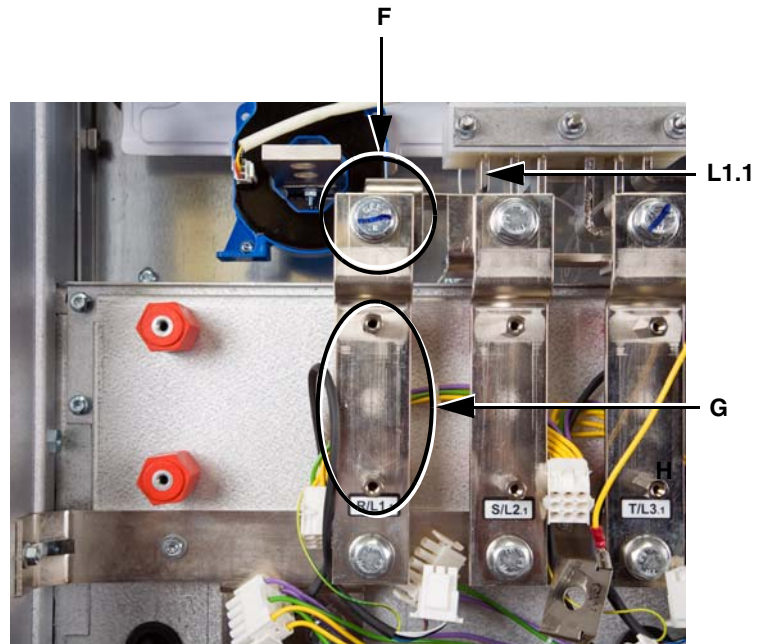

Remove the Input Bus Bar Brackets

- Using a 10 mm socket wrench, remove six nuts (**H**, Figure 112) securing the top half of the input bus bar brackets to the bottom half, and remove the top part of the brackets.

Figure 112: Input Bus Bar Brackets (Top)

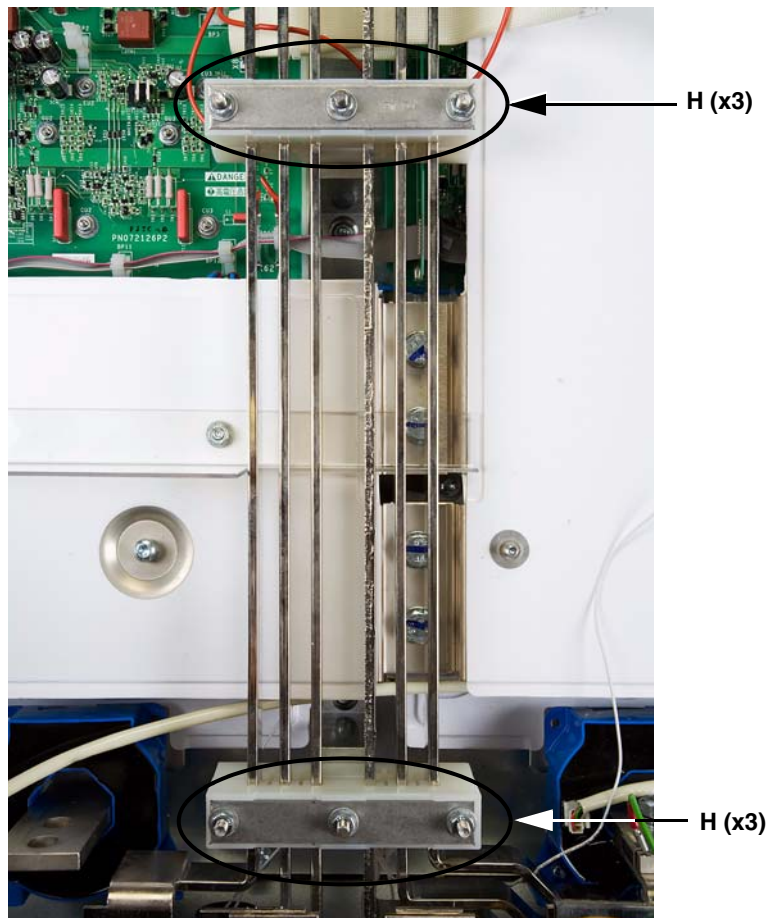

Remove the L1.1 Input Bus Bar

- Using an 18 mm socket wrench, remove one bolt (**J**, Figure 113) securing the top of the L1.1 input bus bar to the L1.1 rectifier and remove the bus bar.

Figure 113: L1.1 Input Bus Bar

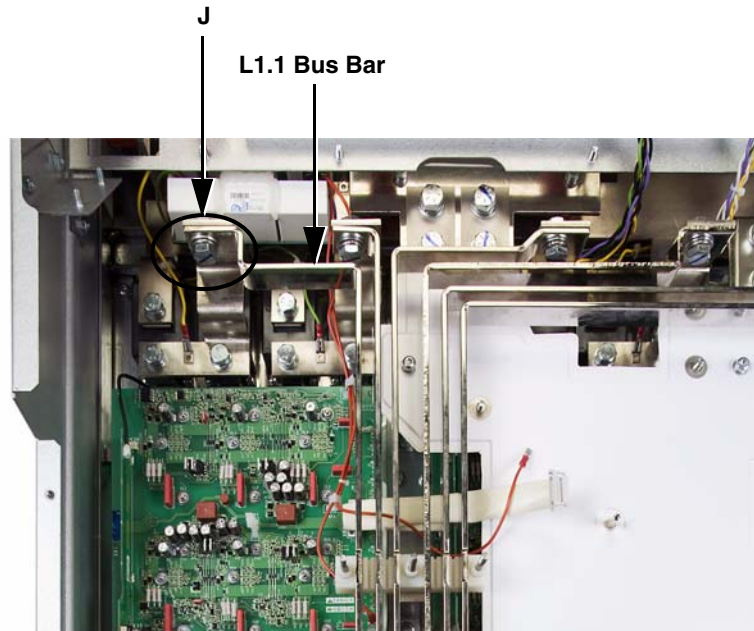

Replace the Phase-U Motor Current Sensor

6. Replace the phase-U motor current sensor as follows.
 - Unplug the connection (K, Figure 114) from the phase-U motor current sensor.
 - Using a T-20 Torx driver, remove two screws (L, Figure 114) securing the motor current sensor to the brace on the phase-U bus plate.
 - Install the new motor current sensor on the brace and secure it with two T-20 screws. Tighten the screws to 1.2 N•m (10.6 lb-in).
 - Plug the connector (L, Figure 114) into the new motor current sensor.

Figure 114: U-Phase Motor Current Sensor

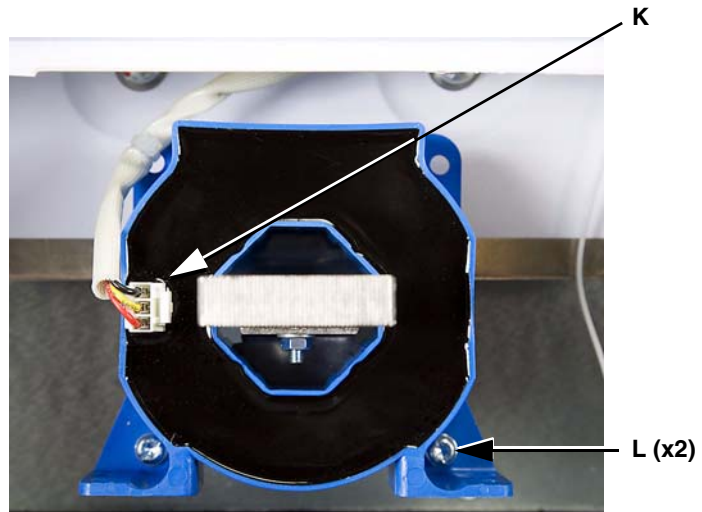

NEXT STEP: If you are only replacing the phase-U motor current sensor, skip to Step 10 on page 115 to replace the L1.1 input bus bar and other removed equipment.

Replacing the Phase-V Motor Current Sensor

1. Remove filter board 2 (the right board) as follows.
 - Using a T-30 Torx driver, remove six screws (**A**, Figure 115) securing the filter board to input bus bars R/L1.2, S/L2.2, and T/L3.2.

NOTE: Note whether the grounding screw (**B**, Figure 115) is installed in the grounded or non-grounded position for reinstallation. Figure 115 shows the screw in the grounded position.

- Using a size 3 Phillips driver, remove the grounding screw and washer (**B**, Figure 115) securing the filter board to the drive frame.
- Unplug fan connections X13 and X14 (Figure 115) from the filter board.
- Gently press in on the tabs at the top and bottom of the fan connectors and push them down through the cutouts in the filter board. See Figure 116.
- Move the filter board under the terminals and out of the way.

Figure 115: Filter Board 2 (Right Board)

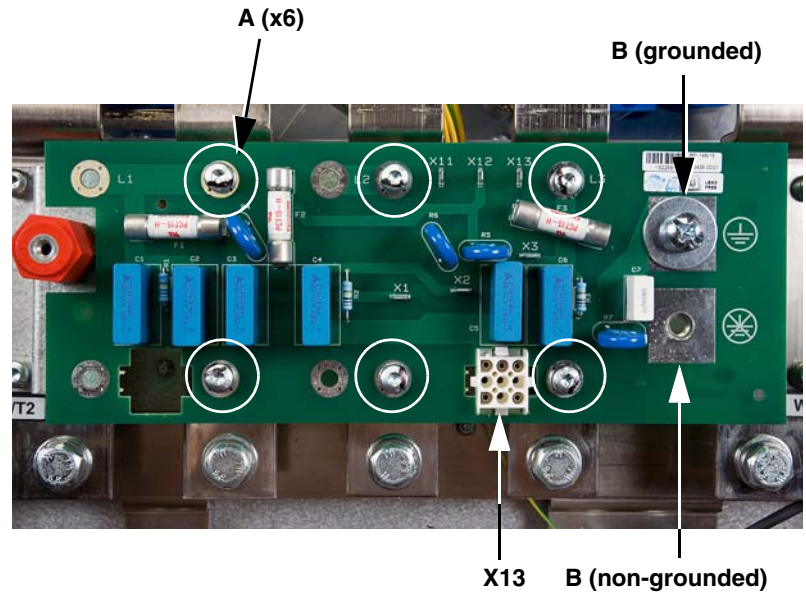
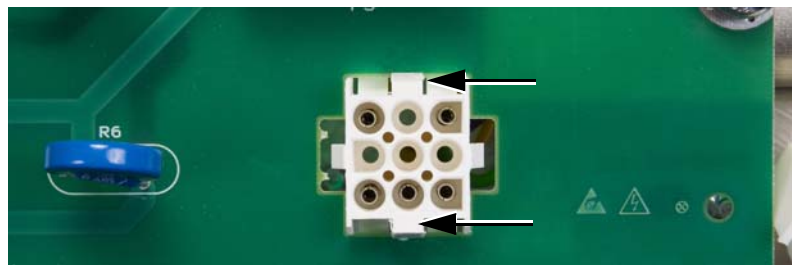

Figure 116: Fan Connector Detail



Remove the V/T2 Bus Bar

2. Remove the V/T2 bus bar as follows. See Figure 117 and Figure 118 on page 106.
 - Using an 18 mm socket wrench, remove two bolts and washers (C, Figure 117) securing the output from the phase-V DC bus plate to the V/T2 bus bar.

NOTE: An output sensor plate (D, Figure 117) with a green lead is under the front bolt. Remove the sensor plate.

- Using a T-30 Torx driver, remove two screws (E, Figure 118) securing the insulator plate to the V/T2 bus bar, and remove the plate and bus bar from the drive.

Figure 117: V/T2 Bus Bar

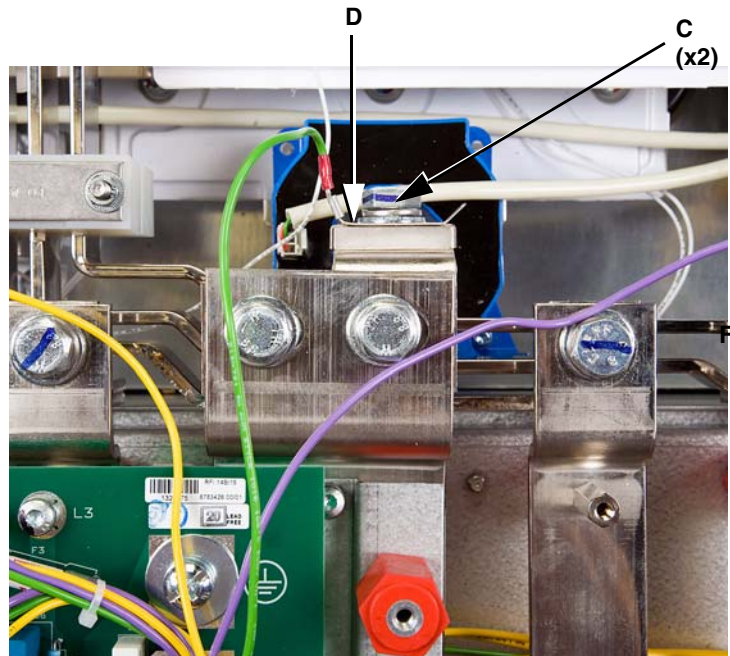
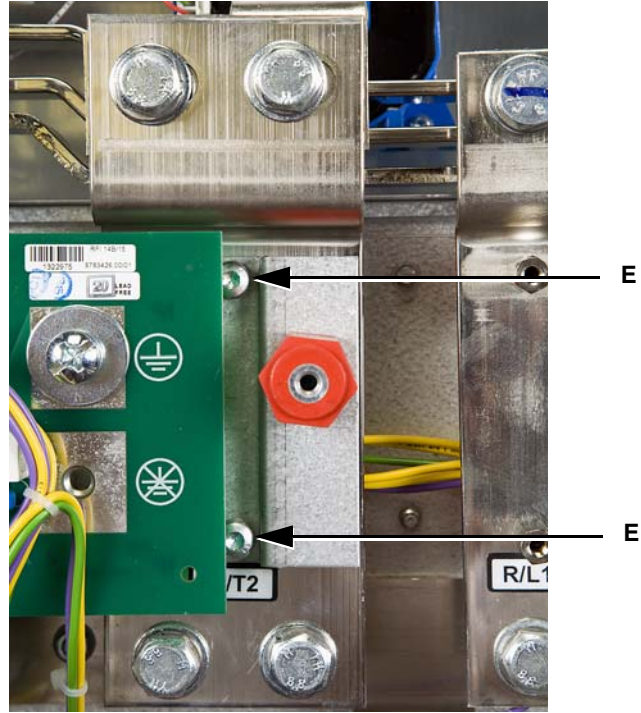

Figure 118: V/T2 Bus Bar



Remove the Input Bus Bar Brackets

- Using a 10 mm socket wrench, remove six nuts (**H**, Figure 119) securing the top half of the input bus bar brackets to the bottom half, and remove the top part of the brackets.

Figure 119: Input Bus Bar Brackets (Top)

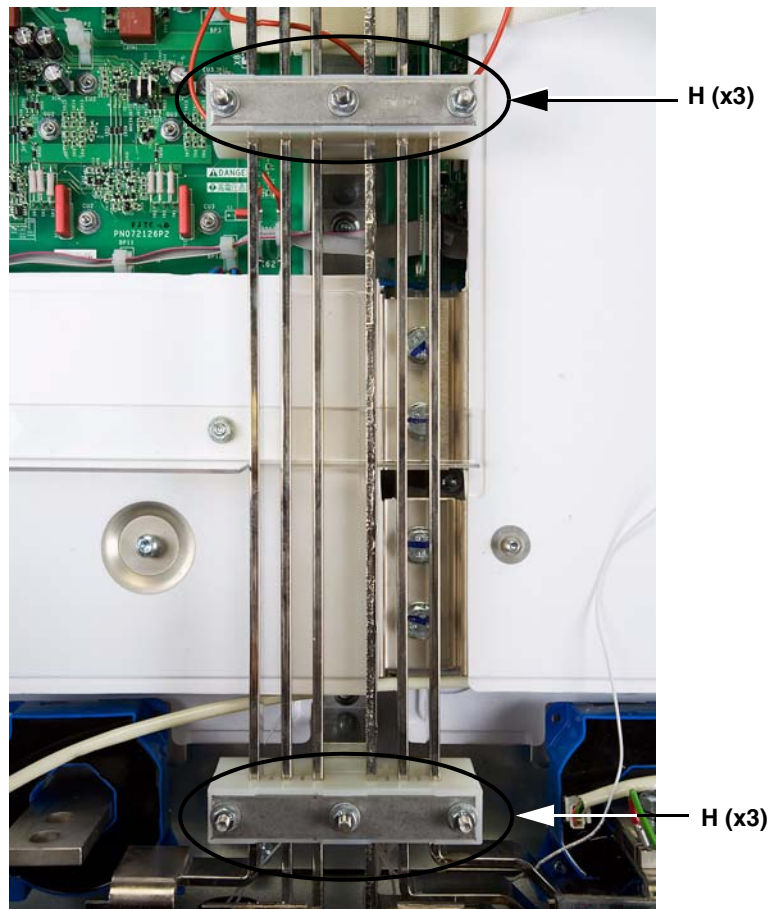

Remove the L3.2 Input Bus Bar

4. Remove the L3.2 input bus bar as follows.
 - Using an 18 mm socket wrench, remove one bolt and washer (**J**, Figure 120) securing the bottom of the L3.2 input bus bar to the T/L3.2 bus bar.
 - Using an 18 mm socket wrench, remove one bolt (**K**, Figure 120) securing the top of the L3.2 input bus bar to the L3.2 rectifier and remove the bus bar.

Figure 120: L3.2 Input Bus Bar

Table 30: L3.2 Input Bus Bar Hardware Torque Values

Item	Description	Torque Range	
		N•m	lb-in
J	(1) 18-mm bolt and washer	45	398
K	(1) 16-mm bolt	27	239

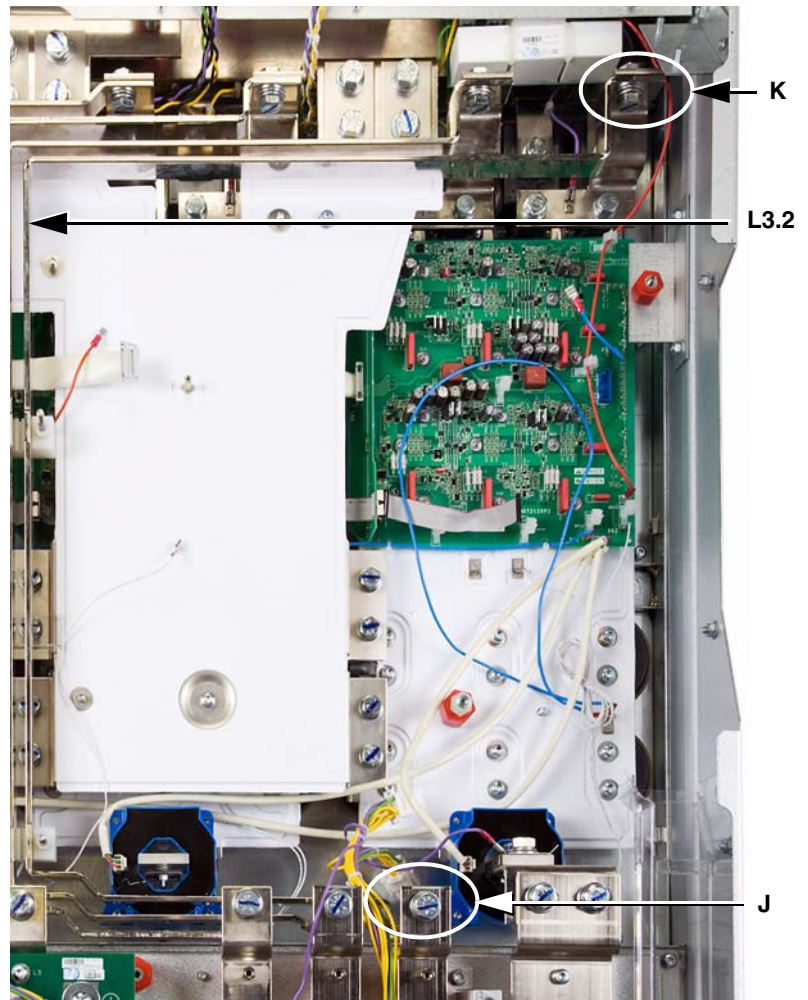

Replace the Phase-V Motor Current Sensor

5. Replace the phase-V motor current sensor as follows.
 - Using an 18 mm socket wrench, remove the 18 mm bolt securing input bus bar L2.2 to the S/L2.2 bus bar. This allows the L2.2 to flex if necessary for clearance in removing the motor current sensor.
 - Unplug the connection (L, Figure 121) from the phase-V motor current sensor.
 - Using a T-20 Torx driver, remove two screws (M, Figure 121) securing the motor current sensor to the brace on the phase-V bus plate.
 - Install the new motor current sensor on the brace and secure it with two T-20 screws (M, Figure 121). Tighten the screws to 1.2 N•m (10.6 lb-in).
 - Plug the connector (L, Figure 121) into the new motor current sensor.

Figure 121: Phase-V Motor Current Sensor

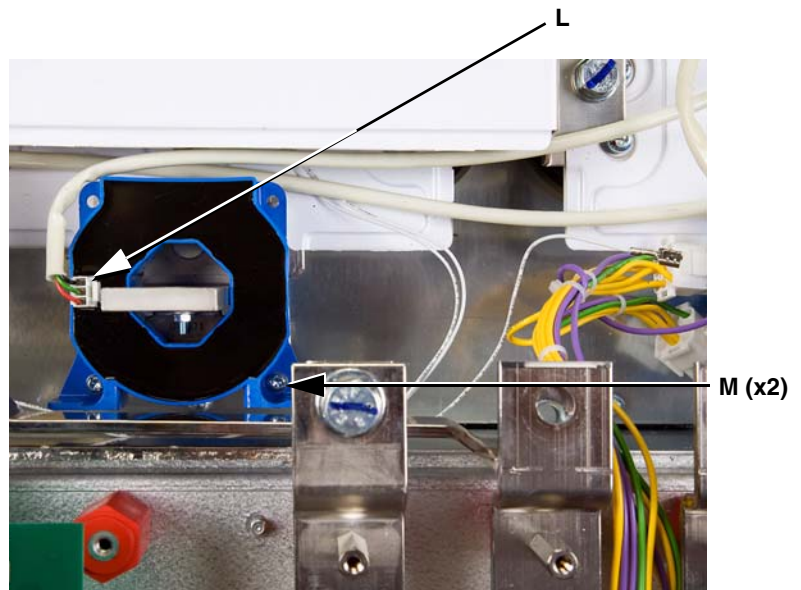

Replace the L3.2 Input Bus Bar

6. Replace the L3.2 input bus bar as follows.
 - Position the bus bar in the drive as shown in Figure 120 on page 108.
 - Using an 16 mm socket wrench, secure the top of the bus bar to the rectifier line input (K, Figure 120) with one bolt.
 - Using an 18 mm socket wrench, secure the bottom of the bus bar to the T/L3.2 bus bar with one bolt and washer (J, Figure 120).
 - Tighten the hardware to the torque values specified in Table 30 on page 108.

Replace the Input Bus Bar Brackets (Top)

- Using a 10 mm socket wrench, secure the top half of the input bus bar brackets to the bottom half with six nuts (**H**). See Figure 122. Tighten the nuts to 5.5 N•m (48.7 lb-in).

Before installing the brackets, ensure that they have no tears or cracks. If the brackets are damaged, install a new piece from the plastic kit. See page 22.

Figure 122: Input Bus Bar Brackets (Top)

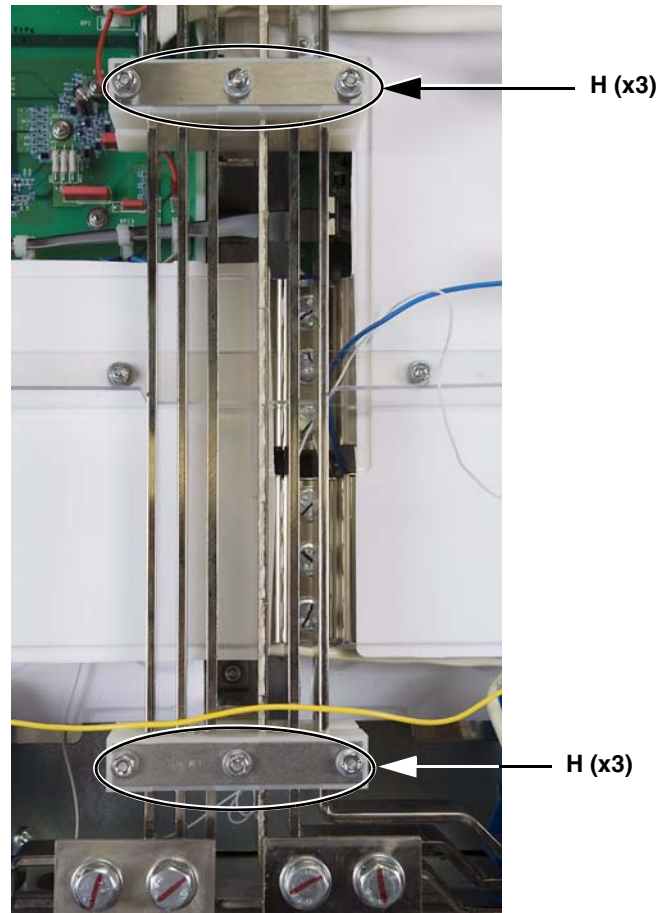

Replace the V/T2 Bus Bar

Table 31: V/T2 Bus Bar Hardware Torque Values

Item	Description	Torque Range	
		N•m	lb-in
C	(2) 18-mm bolts and washers	45	398
E	(2) T-30 screws	5.5	48.7

8. Replace the V/T2 bus bar as follows.

- Position the V/T2 bus bar over the insulators on the bottom terminal bracket as shown in Figures 123 and 124 (page 112).
- Using a T-30 Torx driver, secure the insulator plate to the V/T2 bus bar, and secure the bus bar to the insulators on the bottom terminal bracket, with two screws (E, Figure 124).
- Using an 18 mm socket wrench, secure the V/T2 bus bar to the output on the phase-V DC bus plate with two bolts and washers (C, Figure 125 on page 112).

NOTE: Replace the output sensor plate (D, Figure 125) under the front bolt.

- Tighten the hardware to the torque values specified in Table 31.

Figure 123: Insulators

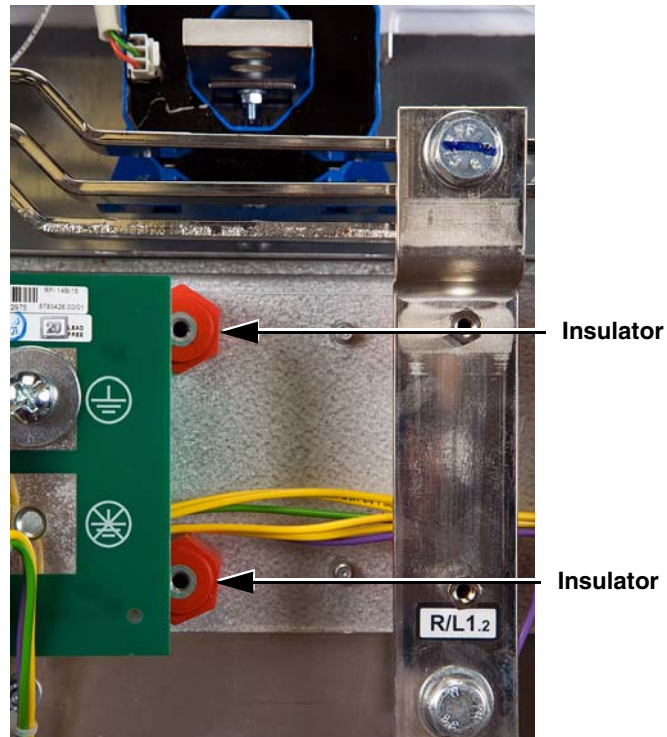

Figure 124: V/T2 Bus Bar

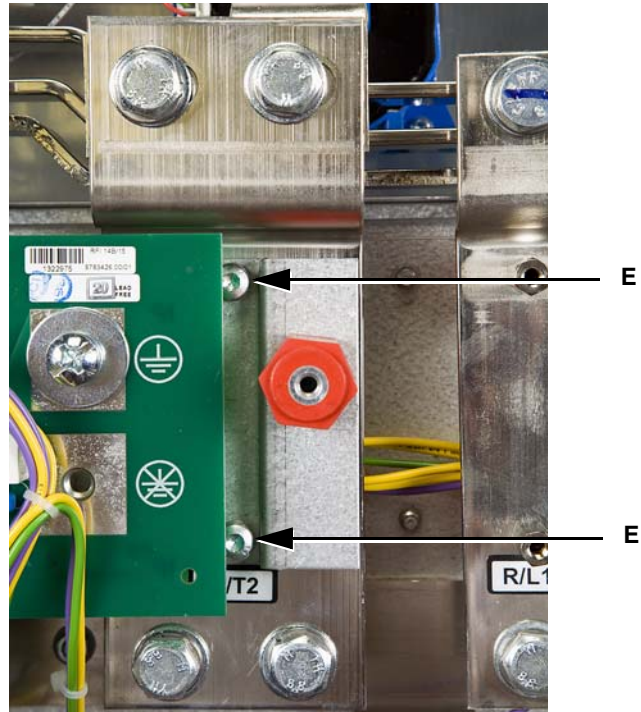
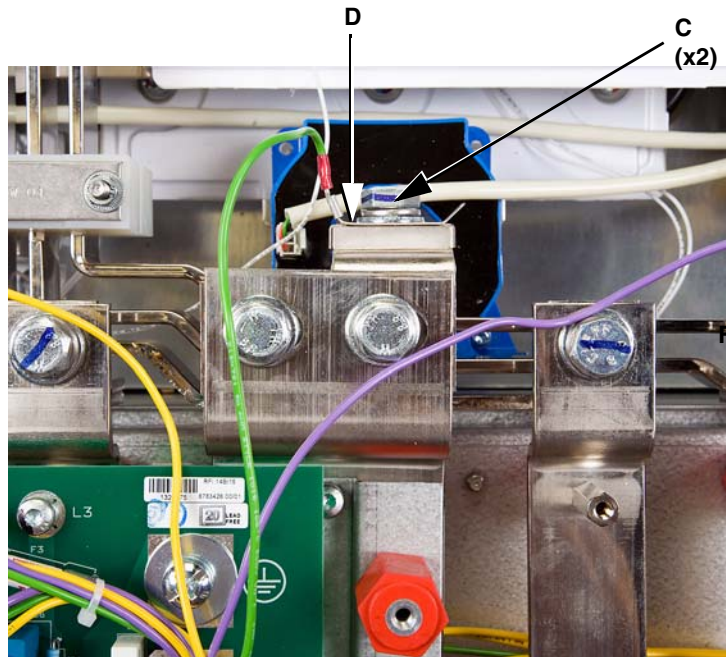

Figure 125: V/T2 Bus Bar



Replace Filter Board 2 (Right Board)

9. Replace filter board 2 as follows.
 - Gently press the top and bottom tabs on the fan connector and push it up through the cutout on the filter board. See Figure 126.

Figure 126: Fan Connector Detail

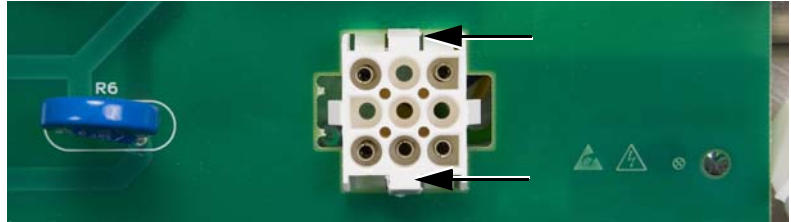

- Position the filter board over the standoffs on input bus bars R/L1.2, S/L2.2, and T/L3.2 as shown in Figure 127.

Figure 127: R/L1.2, S/L2.2, T/L3.2 Bus Bars

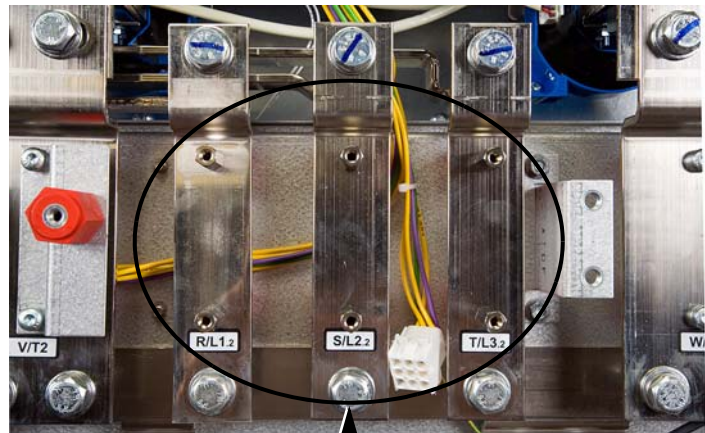

Standoffs

- Using a T-30 Torx driver, secure the filter board to the input bus bars with six screws (**A**, Figure 128 on page 114).

NOTE: Be sure to install the grounding screw and washer (**B**) in the original position. Figure 128 shows the screw in the grounded position.

- Using a size 3 Phillips driver, install the grounding screw and washer (**B**, Figure 128). Tighten the hardware to the torque values specified in Table 32 on page 114.
- Connect the 9-pin fan connector at terminal X13. See Figure 128.

Figure 128: Filter Board 2 (Right Board)

Table 32: Filter Board Hardware Torque Values

Item	Description	Torque Range	
		N•m	lb-in
A	(6) T-30 screws	5.5	48.7
B	(1) Size 3 Phillips screw and washer	5.5	48.7

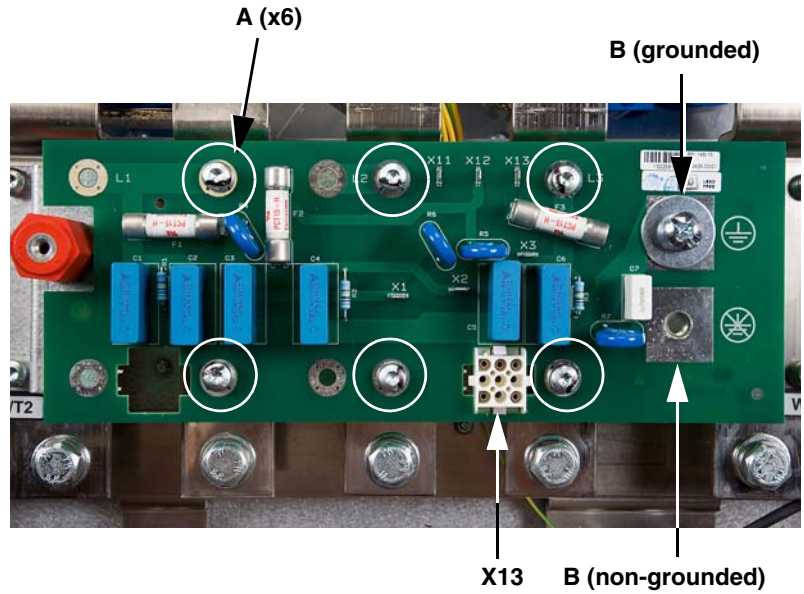

NEXT STEP: If you only replaced the phase-V motor current sensor, skip to “Reassemble the Drive” on page 120.

Replace the L1.1 Input Bus Bar

10. Replace the L1.1 input bus bar as follows.
 - Position the L1.1 input bus bar in the drive as shown in Figure 129.
 - Using a 16 mm socket wrench, secure the top of the bus bar to the L1.1 rectifier with one bolt (J, Figure 129). Tighten the bolt to 27 N•m (239 lb-in).

Figure 129: L1.1 Input Bus Bar

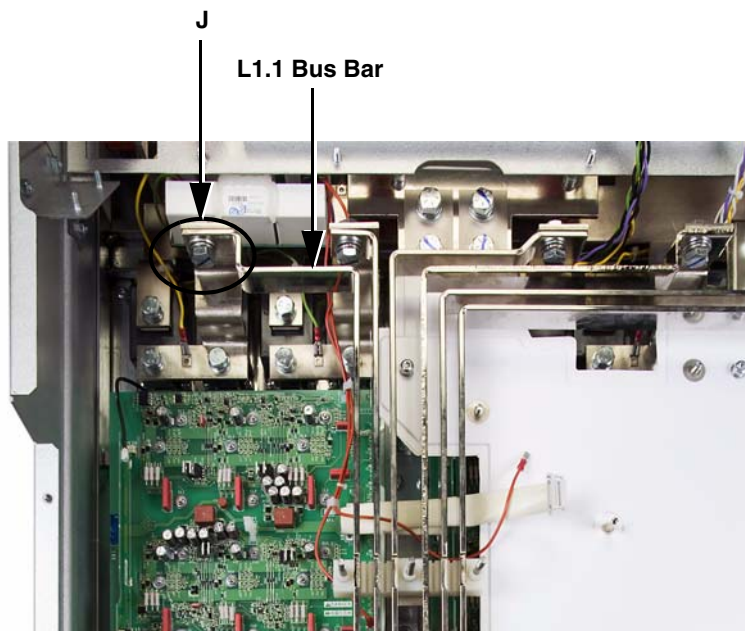

Replace the Input Bus Bar Brackets (Top)

11. Using a 10 mm socket wrench, secure the top half of the input bus bar brackets to the bottom half with six nuts (**H**). See Figure 130. Tighten the nuts to 5.5 N•m (48.7 lb-in).

Before installing the brackets, ensure that they have no tears or cracks. If the brackets are damaged, install a new piece from the plastic kit. See page 22.

Figure 130: Input Bus Bar Brackets (Top)

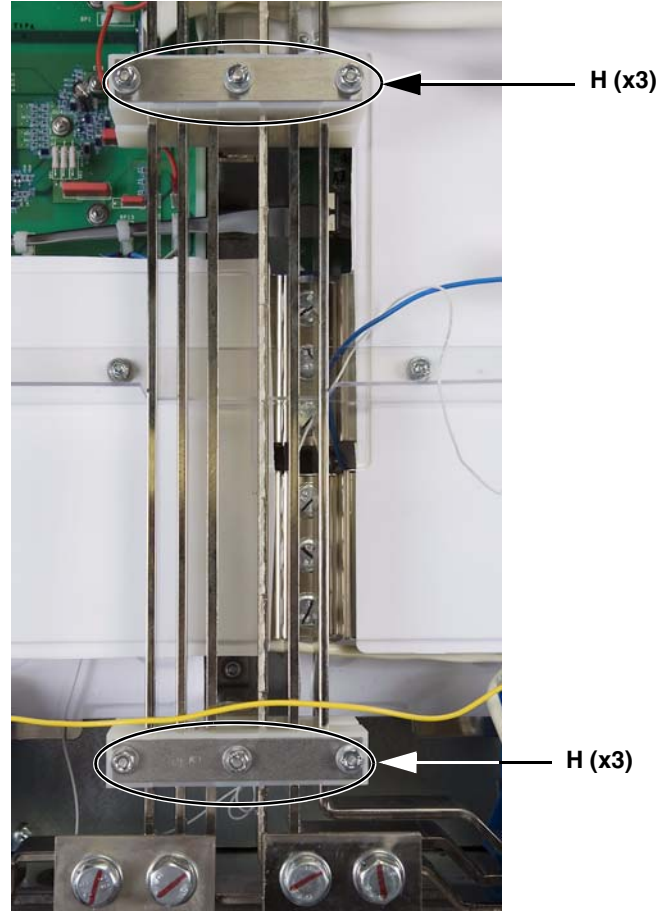

Replace the R/L1.1 Bus Bar

Table 33: L1.1 and R/L1.1 Bus Bar Hardware Torque Values

Item	Description	Torque Range	
		N•m	lb-in
F	(1) 18-mm bolt and washer	45	398
G	(2) 10-mm standoffs	5.5	48.7

12. Replace the R/L1.1 bus bar as follows.

- Using a 10 mm socket wrench, secure the R/L1.1 bus bar to the red insulators on the bottom terminal bracket with two standoffs (G, Figure 131).
- Using an 18 mm socket wrench, secure the bottom of the L1.1 input bus bar to the R/L1.1 bus bar with one bolt and washer (F, Figure 131).
- Tighten the hardware to the torque values specified in Table 33.

Figure 131: R/L1.1 Bus Bar

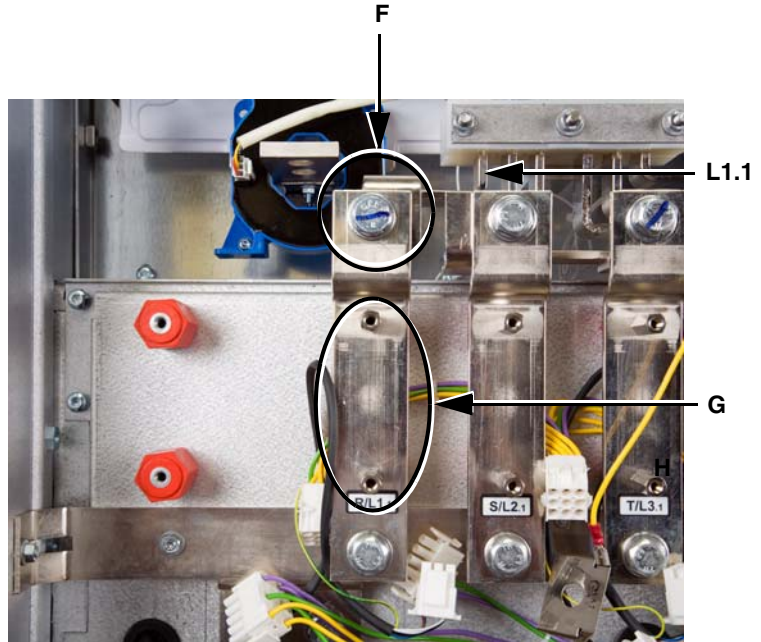

Replace the U/T1 Bus Bar

Table 34: U/T1 Bus Bar Hardware Torque Values

Item	Description	Torque Range	
		N•m	lb-in
C	(2) 18-mm bolts and washers	45	398
E	(2) T-30 screws and washers	5.5	48.7

13. Replace the U/T1 bus bar as follows.

- Using a T-30 Torx driver, secure the U/T1 bus bar to the insulators on the bottom terminal bracket with two screws and washers (E, Figure 132).
- Using an 18 mm socket wrench, secure the output from the U-phase DC bus plate to the U/T1 bus bar with two bolts and washers (C, Figure 132).

NOTE: Replace the output sensor plate (D, Figure 132) under the front bolt.

- Tighten the hardware to the torque values specified in Table 34.

Figure 132: U/T1 Bus Bar

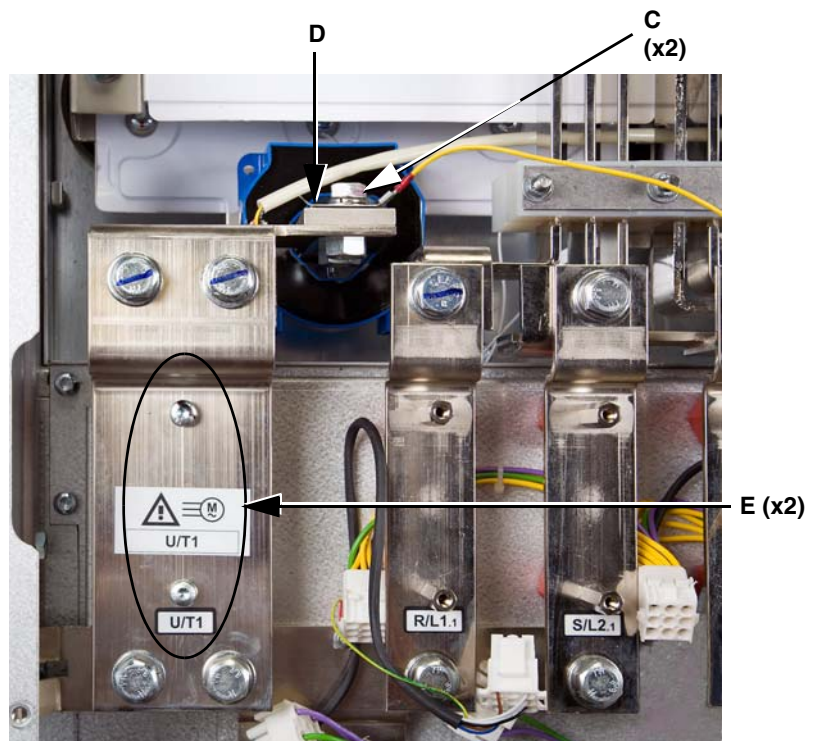

Replace Filter Board 1

14. Replace filter board 1 as follows.

- Gently press the top and bottom tabs on the fan connectors and push them up through the cutouts on the filter board. See Figure 133.

Figure 133: Fan Connector Detail

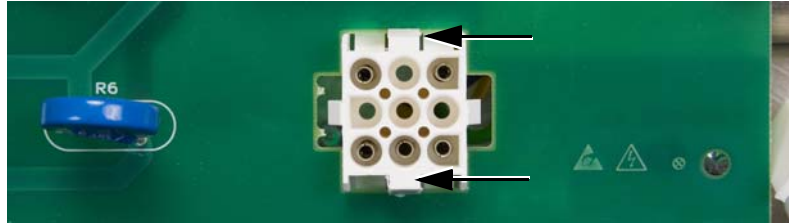

- Position the filter board over the standoffs on input bus bars R/L1.1, S/L2.1, and T/L3.1.
- Using a T-30 Torx driver, secure the filter board to the input bus bars with six screws (A, Figure 134).

NOTE: Be sure to install the grounding screw and washer (B) in the original position. Figure 134 shows the screw in the grounded position.

- Using a size 3 Phillips driver, install the grounding screw and washer (B, Figure 134).
- Tighten the hardware to the torque values specified in Table 35.
- Connect the two 9-pin fan connectors at terminals X11 and X12. See Figure 134.

Figure 134: Filter Board 1 (Left Board)

Table 35: Filter Board 1 Hardware Torque Values

Item	Description	Torque Range	
		N•m	lb-in
A	(6) T-30 screws	5.5	48.7
B	(1) Size 3 Phillips screw and washer	5.5	48.7

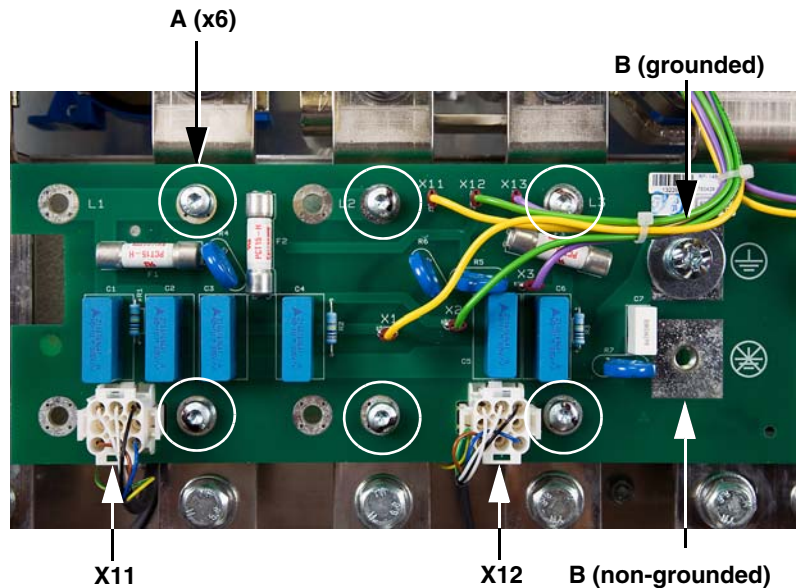

NEXT STEP: If you only replaced the phase-U motor current sensor, skip to “Reassemble the Drive” on page 120.

Replace the W/T3 Bus Bar

Table 36: W/T3 Bus Bar Hardware Torque Values

Item	Description	Torque Range	
		N•m	lb-in
A	(2) 18-mm bolts and washers	45	398
C	(2) T-30 screws and washers	5.5	48.7

15. Replace the W/T3 bus bar as follows.

- Using a T-30 Torx driver, secure the W/T3 bus bar to the insulators on the bottom terminal bracket with two screws and washers (C, Figure 135).
- Using an 18 mm socket wrench, secure the output from the phase-W DC bus plate to the W/T3 bus bar with two bolts and washers (A, Figure 135).

NOTE: An output sensor plate (B, Figure 135) with a violet lead is under the front bolt. Remove the sensor plate.

- Tighten the hardware to the torque values specified in Table 36.

Figure 135: W/T3 Bus Bar

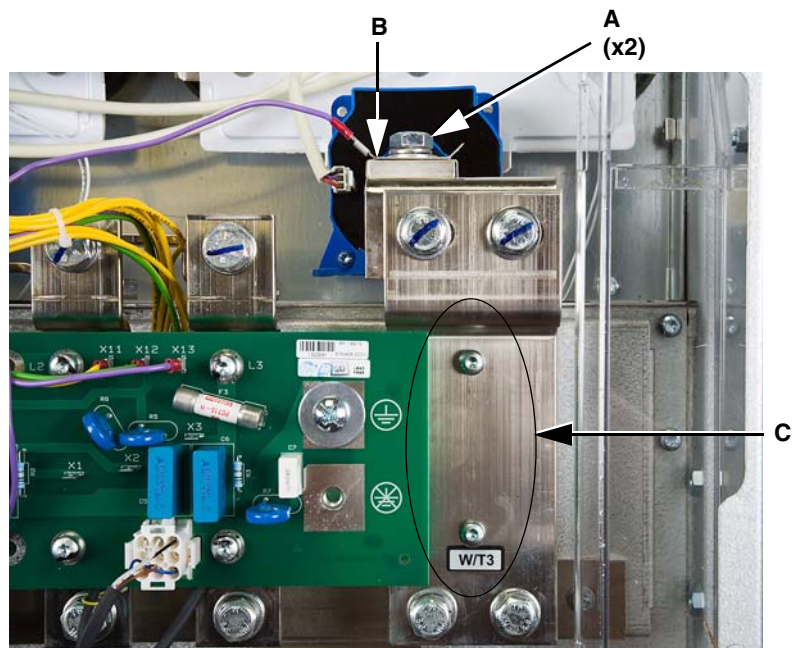

Reassemble the Drive

If you are only replacing the motor current sensors, perform Steps 15–25 of “Reassembly Steps for Level 2 Parts” beginning on page 144 to replace the following parts:

- | | |
|--------------------------------------------------------|--------------------------------------------------|
| <input type="checkbox"/> Fan bracket | <input type="checkbox"/> Control module assembly |
| <input type="checkbox"/> BU (+) bus bar | <input type="checkbox"/> EMC tray |
| <input type="checkbox"/> Power board assembly | <input type="checkbox"/> Middle crossbrace |
| <input type="checkbox"/> Fan control board connections | <input type="checkbox"/> Power terminal shields |
| <input type="checkbox"/> Power board connections | <input type="checkbox"/> Front cover |
| <input type="checkbox"/> Soft charge board connections | |

Replacing the Gate Driver Boards VX5A1203

IMPORTANT: Label and retain all removed hardware and cables for use in reassembly.

⚠ DANGER

HAZARD OF ELECTRIC SHOCK, EXPLOSION, OR ARC FLASH

- Read and understand the precautions in “Before You Begin” starting on page 5 before performing this procedure.
- Before working on this equipment, turn off all power supplying it and perform the DC bus voltage measurement procedure on page 11.

Failure to follow these instructions will result in death or serious injury.

Before performing the steps in this procedure, perform Steps 1–23 of “Disassembly Steps for Accessing Level 2 Parts” beginning on page 49 to remove the following parts from the drive:

- | | |
|--------------------------------------------------------|--------------------------------------------------------|
| <input type="checkbox"/> Front cover | <input type="checkbox"/> BU (+) bus bar |
| <input type="checkbox"/> Power terminal shields | <input type="checkbox"/> Fan bracket |
| <input type="checkbox"/> Middle crossbrace | <input type="checkbox"/> Top terminal bracket |
| <input type="checkbox"/> EMC tray | <input type="checkbox"/> Rectifier shield |
| <input type="checkbox"/> Control module assembly | <input type="checkbox"/> Top input bus bar brackets |
| <input type="checkbox"/> Soft charge board connections | <input type="checkbox"/> Input bus bars |
| <input type="checkbox"/> Power board connections | <input type="checkbox"/> Bottom input bus bar brackets |
| <input type="checkbox"/> Fan control board connections | <input type="checkbox"/> Top phase-U DC bus plate |
| <input type="checkbox"/> Power board assembly | <input type="checkbox"/> Top DC bus plate |

Remove the Gate Driver Board

1. Remove the connections from the gate driver board that you are replacing. See Table 37.
2. Using a 7 mm socket wrench, remove 18 nuts securing the gate driver board to the DC bus plate and the power IGBT modules, and remove the board from the drive. See Figure 136 on page 123.

Table 37: Gate Driver Board Wiring¹

Wire No. ²	Terminal No.	Description	To:
Gate Driver Board U (Left)			
E144	X4	2-pin, black	Temperature sensor U
E138	X32	18-pin, gray	GDB ³ V, X31
E129	X51	1-pin, blue	UD0 (neutral) on DC bus plate
E127	X52	1-pin, blue	GDB V, X51
E126	X61	1-pin, red	SB ⁴ X10
E139	X62	1-pin, white	Bleeder resistor 1
E100	X82	14-pin, white	GDB V, X81 and PB ⁵ X8
—	X31	No connection	
—	X81	No connection	
Gate Driver Board V (Center)			
E128	X4	2-pin, black	Temperature sensor V
E138	X31	18-pin, gray	GDB U, X32
E146	X32	18-pin, gray	GDB W, X31
E127	X51	1-pin, blue	GDB U, X52
E123	X52	1-pin, blue	GDB W, X51
E100	X81	14-pin, white	GDB U, X82
E102	X82	14-pin, white	GDB W, X81
—	X61	No connection	
Gate Driver Board W (Right)			
E145	X4	2-pin, black	Temperature sensor W
E146	X31	18-pin, gray	GDB V, X32
E142	X32	18-pin, gray	PB, X3
E123	X51	1-pin, blue	GDB V, X52
E102	X81	14-pin, white	GDB V, X82
E132	X53	1-pin, blue	Insulator near MCB
E160	X61	1-pin, red	SB32, X10
E164	X62	1-pin, white	Bleeder resistor 3
—	X52	No connection	
—	X82	No connection	

¹ Terminals X4, X81, and X82 are connected to a daughter board on the gate driver board assembly.

² See the schematic on page 175 for complete drive wiring. Wire numbers are given for cross referencing the wires with the wiring table and the schematic. The numbers do not appear on the wires.

³ GDB: Gate driver board

⁴ SB: SCR Snubber board

⁵ PB: Power board

Figure 136: Gate Driver Boards

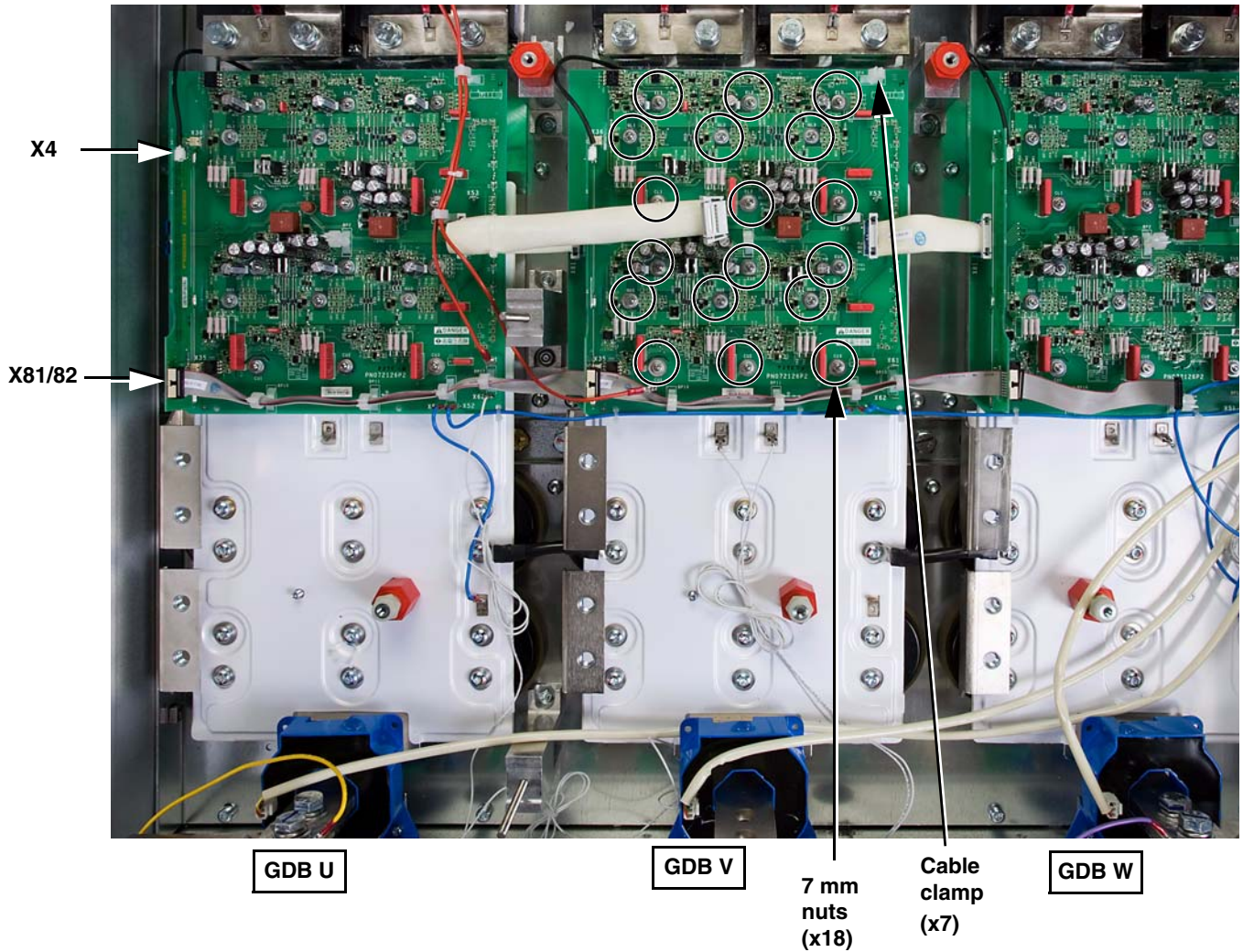

Install the New Gate Driver Board

3. Transfer the seven plastic cable clamps (see Figure 136) from the old gate driver board onto the new one as follows.
 - To remove a clamp, pinch the clamp on the bottom side of the board and push it up through the mounting hole.
 - Snap the cable clamps into the mounting holes on the new board.
4. Seat the gate driver board on the DC bus plate standoffs.
5. Using a 7 mm socket wrench, secure the board with 18 nuts. See Figure 136. Tighten the nuts to 1.2 N•m (10.6 lb-in).
6. Replace the gate driver board wiring. See Table 37 on page 122 for the connections.

Reassemble the Drive

If you are only replacing a gate driver board, perform Steps 3–25 of “Reassembly Steps for Level 2 Parts” beginning on page 144 to replace the following parts:

- Top DC bus plate
- Top phase-U DC bus plate
- Input bus bar brackets (bottom)
- Input bus bars
- Input bus bar brackets (top)
- Rectifier shield
- Top terminal bracket
- Fan bracket
- BU (+) bus bar
- Power board assembly
- Fan control board connections
- Power board connections
- Soft charge board connections
- Control module assembly
- EMC tray
- Middle crossbrace
- Power terminal shields
- Front cover

Replacing the Temperature Sensors, VZ3G1104

IMPORTANT: Label and retain all removed hardware and cables for use in reassembly.

⚠ DANGER

HAZARD OF ELECTRIC SHOCK, EXPLOSION, OR ARC FLASH

- Read and understand the precautions in “Before You Begin” starting on page 5 before performing this procedure.
- Before working on this equipment, turn off all power supplying it and perform the DC bus voltage measurement procedure on page 11.

Failure to follow these instructions will result in death or serious injury.

There is one temperature sensor for each phase in the drive. The sensors are located under the gate driver boards on the DC bus plate.

Before performing the steps in this procedure, perform Steps 1–24 of “Disassembly Steps for Accessing Level 2 Parts” beginning on page 49 to remove the following parts from the drive:

- | | |
|--------------------------------------------------------|--------------------------------------------------------|
| <input type="checkbox"/> Front cover | <input type="checkbox"/> Fan bracket |
| <input type="checkbox"/> Power terminal shields | <input type="checkbox"/> Top terminal bracket |
| <input type="checkbox"/> Middle crossbrace | <input type="checkbox"/> Rectifier shield |
| <input type="checkbox"/> EMC tray | <input type="checkbox"/> Top input bus bar brackets |
| <input type="checkbox"/> Control module assembly | <input type="checkbox"/> Input bus bars |
| <input type="checkbox"/> Soft charge board connections | <input type="checkbox"/> Bottom input bus bar brackets |
| <input type="checkbox"/> Power board connections | <input type="checkbox"/> Top phase-U DC bus plate |
| <input type="checkbox"/> Fan control board connections | <input type="checkbox"/> Top DC bus plate |
| <input type="checkbox"/> Power board assembly | <input type="checkbox"/> Gate driver board |
| <input type="checkbox"/> BU (+) bus bar | |

1. Using a T-10 Torx driver, remove one screw securing the temperature sensor to the DC bus plate. See Figure 137.
2. Replace the temperature sensor and secure it with the T-10 screw. Tighten the screw to 0.4–0.6 Nm (3.5–5.3 lb-in).

Figure 137: Temperature Sensor

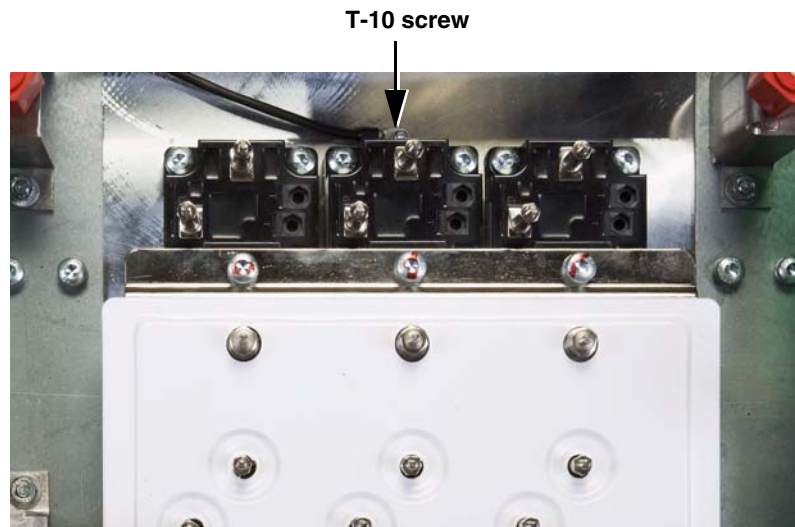

Reassemble the Drive

If you are only replacing a temperature sensor, perform Steps 2–25 of “Reassembly Steps for Level 2 Parts” beginning on page 144 to replace the following parts:

- Gate driver boards
- Top DC bus plate
- Top phase-U DC bus plate
- Input bus bar brackets (bottom)
- Input bus bars
- Input bus bar brackets (top)
- Rectifier shield
- Top terminal bracket
- Fan bracket
- BU (+) bus bar
- Power board assembly
- Fan control board connections
- Power board connections
- Soft charge board connections
- Control module assembly
- EMC tray
- Middle crossbrace
- Power terminal shields
- Front cover

Replacing the Power IGBT Modules VZ3IM1603M1271

IMPORTANT: Label and retain all removed hardware and cables for use in reassembly.

⚠ DANGER

HAZARD OF ELECTRIC SHOCK, EXPLOSION, OR ARC FLASH

- Read and understand the precautions in “Before You Begin” starting on page 5 before performing this procedure.
- Before working on this equipment, turn off all power supplying it and perform the DC bus voltage measurement procedure on page 11.

Failure to follow these instructions will result in death or serious injury.

Before performing the steps in this procedure, perform Steps 1–25 of “Disassembly Steps for Accessing Level 2 Parts” beginning on page 49 to remove the following parts from the drive:

- | | |
|--------------------------------------------------------|--------------------------------------------------------|
| <input type="checkbox"/> Front cover | <input type="checkbox"/> Fan bracket |
| <input type="checkbox"/> Power terminal shields | <input type="checkbox"/> Top terminal bracket |
| <input type="checkbox"/> Middle crossbrace | <input type="checkbox"/> Rectifier shield |
| <input type="checkbox"/> EMC tray | <input type="checkbox"/> Top input bus bar brackets |
| <input type="checkbox"/> Control module assembly | <input type="checkbox"/> Input bus bars |
| <input type="checkbox"/> Soft charge board connections | <input type="checkbox"/> Bottom input bus bar brackets |
| <input type="checkbox"/> Power board connections | <input type="checkbox"/> Top phase-U DC bus plate |
| <input type="checkbox"/> Fan control board connections | <input type="checkbox"/> Top DC bus plate |
| <input type="checkbox"/> Power board assembly | <input type="checkbox"/> Gate driver board |
| <input type="checkbox"/> BU (+) bus bar | <input type="checkbox"/> Bottom DC bus plate |

You must replace the power IGBT modules in sets of three as follows. See Figure 139 on page 128.

- Replace modules 1, 2, and 3 together.
- Replace modules 4, 5, and 6 together.

Figure 138: Torque Sequence

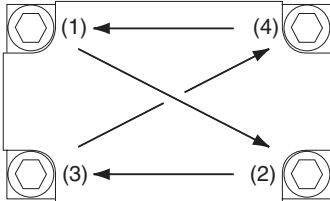

1. Using a T-30 Torx driver, remove four screws (**A**, Figure 139) securing the module to the heatsink and remove the module from the drive.
2. Using a 7 mm socket wrench, remove two standoffs (**B**) from the old IGBT module, and install them on terminals E and G of the new module. Tighten the standoffs to 1.2 N•m (10.6 lb-in).
3. Clean the portion of the heatsink that makes contact with the power IGBT module.
4. Evenly coat the bottom of the new power IGBT module with a thin layer of thermal compound, included in the kit, and position the module on the heatsink.
5. Using a T-30 Torx driver, secure the module to the heatsink with four screws (**A**, Figure 139). Initially tighten the screws, in the sequence shown in Figure 138, to 0.7–1.0 N•m (6.2–8.9 lb-in), and then to a final torque of 3.3–4.4 N•m (29.2–38.9 lb-in).

NEXT STEP: If you are also replacing the capacitors, skip to “Replacing the Capacitors VY1ADC1112” beginning on page 130.

If you are only replacing the power IGBT modules, continue with “Reassemble the Drive” on page 129.

Figure 139: Power IGBT Modules, Phase V Shown

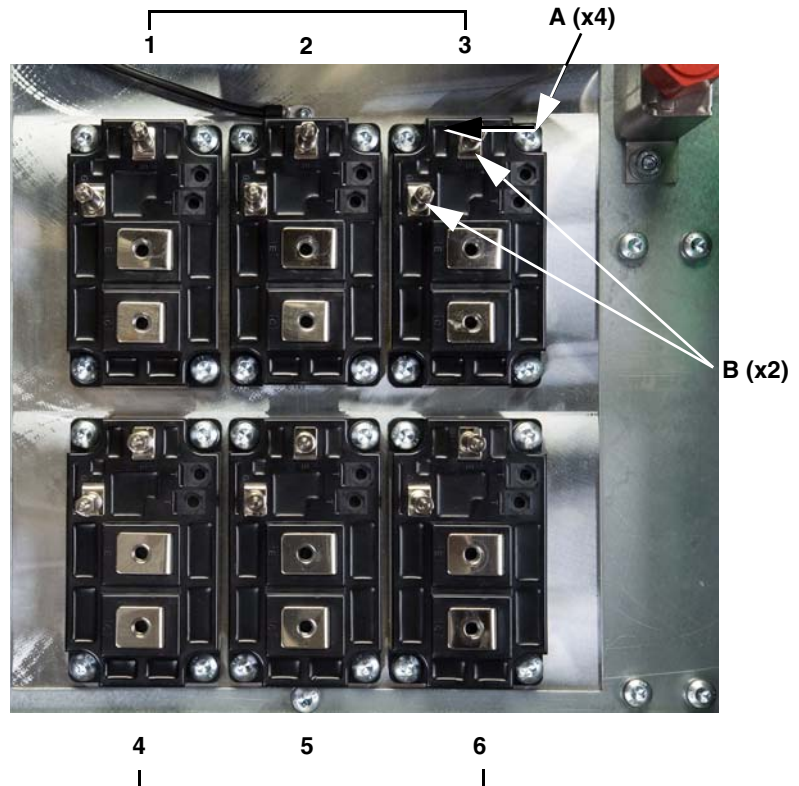

Reassemble the Drive

If you are only replacing the power IGBT modules, perform Steps 1–25 of “Reassembly Steps for Level 2 Parts” beginning on page 144 to replace the following parts:

- Bottom DC bus plate
- Gate driver boards
- Top DC bus plate
- Top phase-U DC bus plate
- Input bus bar brackets (bottom)
- Input bus bars
- Input bus bar brackets (top)
- Rectifier shield
- Top terminal bracket
- Fan bracket
- BU (+) bus bar
- Power board assembly
- Fan control board connections
- Power board connections
- Soft charge board connections
- Control module assembly
- EMC tray
- Middle crossbrace
- Power terminal shields
- Front cover

Replacing the Capacitors VY1ADC1112

IMPORTANT: Label and retain all removed hardware and cables for use in reassembly.

⚠ DANGER

HAZARD OF ELECTRIC SHOCK, EXPLOSION, OR ARC FLASH

- Read and understand the precautions in “Before You Begin” starting on page 5 before performing this procedure.
- Before working on this equipment, turn off all power supplying it and perform the DC bus voltage measurement procedure on page 11.

Failure to follow these instructions will result in death or serious injury.

This kit contains six capacitors. If a capacitor has shorted, you must replace **all** of the capacitors in the drive.

Before performing the steps in this procedure, perform Steps 1–25 of “Disassembly Steps for Accessing Level 2 Parts” beginning on page 49 to remove the following parts from the drive:

- | | |
|--------------------------------------------------------|--------------------------------------------------------|
| <input type="checkbox"/> Front cover | <input type="checkbox"/> Fan bracket |
| <input type="checkbox"/> Power terminal shields | <input type="checkbox"/> Top terminal bracket |
| <input type="checkbox"/> Middle crossbrace | <input type="checkbox"/> Rectifier shield |
| <input type="checkbox"/> EMC tray | <input type="checkbox"/> Top input bus bar brackets |
| <input type="checkbox"/> Control module assembly | <input type="checkbox"/> Input bus bars |
| <input type="checkbox"/> Soft charge board connections | <input type="checkbox"/> Bottom input bus bar brackets |
| <input type="checkbox"/> Power board connections | <input type="checkbox"/> Top phase-U DC bus plate |
| <input type="checkbox"/> Fan control board connections | <input type="checkbox"/> Top DC bus plate |
| <input type="checkbox"/> Power board assembly | <input type="checkbox"/> Gate driver boards |
| <input type="checkbox"/> BU (+) bus bar | <input type="checkbox"/> Bottom DC bus plate |

1. Replace a capacitor as follows. See Figure 140 on page 131.
 - Unlock the capacitor by turning it counterclockwise, and remove it from the drive.
 - Install the new capacitor and lock it into place.

NOTE: Ensure that the positive terminal (+) is oriented toward the top of the drive and negative terminal (-) toward the bottom.

Figure 140: Capacitors, Phase V Shown

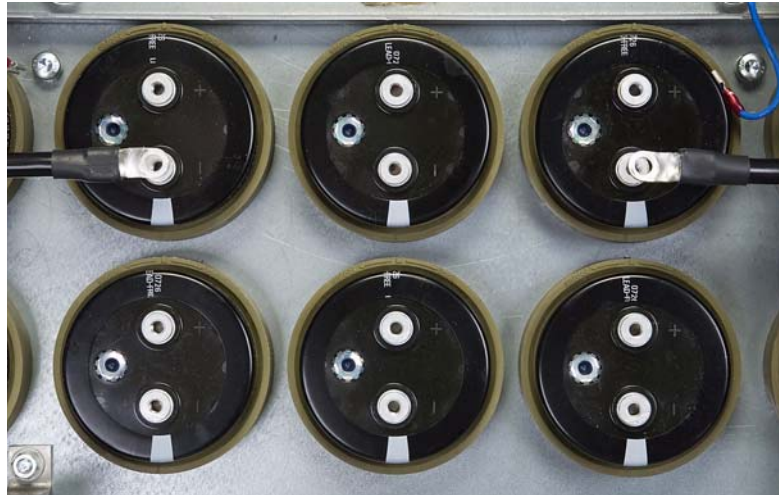

Reassemble the Drive

If you are only replacing the capacitors, perform Steps 1–25 of “Reassembly Steps for Level 2 Parts” beginning on page 144 to replace the following parts:

- | | |
|----------------------------------------------------------|--------------------------------------------------------|
| <input type="checkbox"/> Bottom DC bus plate | <input type="checkbox"/> BU (+) bus bar |
| <input type="checkbox"/> Gate driver boards | <input type="checkbox"/> Power board assembly |
| <input type="checkbox"/> Top DC bus plate | <input type="checkbox"/> Fan control board connections |
| <input type="checkbox"/> Top phase-U DC bus plate | <input type="checkbox"/> Power board connections |
| <input type="checkbox"/> Input bus bar brackets (bottom) | <input type="checkbox"/> Soft charge board connections |
| <input type="checkbox"/> Input bus bars | <input type="checkbox"/> Control module assembly |
| <input type="checkbox"/> Input bus bar brackets (top) | <input type="checkbox"/> EMC tray |
| <input type="checkbox"/> Rectifier shield | <input type="checkbox"/> Middle crossbrace |
| <input type="checkbox"/> Top terminal bracket | <input type="checkbox"/> Power terminal shields |
| <input type="checkbox"/> Fan bracket | <input type="checkbox"/> Front cover |

Replacing the SCR Modules and Diode Modules (VZ3TM1425M1671 and VZ3DM1600M1671)

IMPORTANT: Label and retain all removed hardware and cables for use in reassembly.

⚠ DANGER

HAZARD OF ELECTRIC SHOCK, EXPLOSION, OR ARC FLASH

- Read and understand the precautions in “Before You Begin” starting on page 5 before performing this procedure.
- Before working on this equipment, turn off all power supplying it and perform the DC bus voltage measurement procedure on page 11.

Failure to follow these instructions will result in death or serious injury.

⚠ DANGER

HAZARD OF ELECTRIC SHOCK, EXPLOSION, OR ARC FLASH

- When the controller is damaged, voltage may remain on certain energy storage capacitors after de-energization of the controller and discharge of the main capacitor bank.
- Before working on or near assemblies containing energy storage capacitors, verify that the capacitor voltages are less than 42 Vdc.
- The following assemblies have energy-storing capacitors:
 - SCR snubber boards. See Figures 141 and 142 on page 133.
- Always check for the presence of voltage using a voltmeter set to the 1000 Vdc scale. When voltage is present, allow the voltmeter to discharge the capacitor’s stored charge. Refer to “Discharging Stored Energy in Capacitors” on page 12.

Failure to follow these instructions will result in death or serious injury.

Before performing the steps in this procedure, perform Steps 1–23 of “Disassembly Steps for Accessing Level 2 Parts” beginning on page 49 to remove the following parts from the drive:

- | | |
|--------------------------------------------------------|--------------------------------------------------------|
| <input type="checkbox"/> Front cover | <input type="checkbox"/> BU (+) bus bar |
| <input type="checkbox"/> Power terminal shields | <input type="checkbox"/> Fan bracket |
| <input type="checkbox"/> Middle crossbrace | <input type="checkbox"/> Top terminal bracket |
| <input type="checkbox"/> EMC tray | <input type="checkbox"/> Rectifier shield |
| <input type="checkbox"/> Control module assembly | <input type="checkbox"/> Top input bus bar brackets |
| <input type="checkbox"/> Soft charge board connections | <input type="checkbox"/> Input bus bars |
| <input type="checkbox"/> Power board connections | <input type="checkbox"/> Bottom input bus bar brackets |
| <input type="checkbox"/> Fan control board connections | <input type="checkbox"/> Top phase-U DC bus plate |
| <input type="checkbox"/> Power board assembly | <input type="checkbox"/> Top DC bus plate |

Remove SCR Snubber Board 1

Table 38: SCR Snubber Board 1 Wiring

Wire No. ¹	Terminal No.	Description	To:
E131	X1	Yellow, 1-pin	L1.1 rectifier
E130	X4	Red, 1-pin	PO.1 rectifier bus bar
E133	X5	Black, 1-pin	PC/- rectifier bus bar
E126	X10	Red, 0.25 in., 1-pin	GDB ² U X61
E126	X11	Red, 0.19 in., 1-pin	PB ³ RFS31+X11
E167	L2	Green, 1-pin	L2.1 Line input bar
E168	X3	Violet, 1-pin	L3.1 Line input bar

¹ See the schematic on page 175 for complete drive wiring. Wire numbers are given for cross referencing the wires with the wiring table and the schematic. The numbers do not appear on the wires.
² GDB: Gate driver board
³ PB: Power board

1. Remove SCR snubber board 1 (left board) from the drive as follows.
 - Using needle-nose pliers, carefully remove the connections from SCR snubber board 1 (left board) terminals X1, X4, X5, X10, and X11. See Table 38 and Figure 141 for the connection locations.
 - Using a 7 mm socket wrench, remove two nuts securing the snubber board to the insulators on the PC (-) bus and remove the wires from terminals L2 and X3. See Figure 141.
 - Remove the board from the drive.

Figure 141: SCR Snubber Board 1

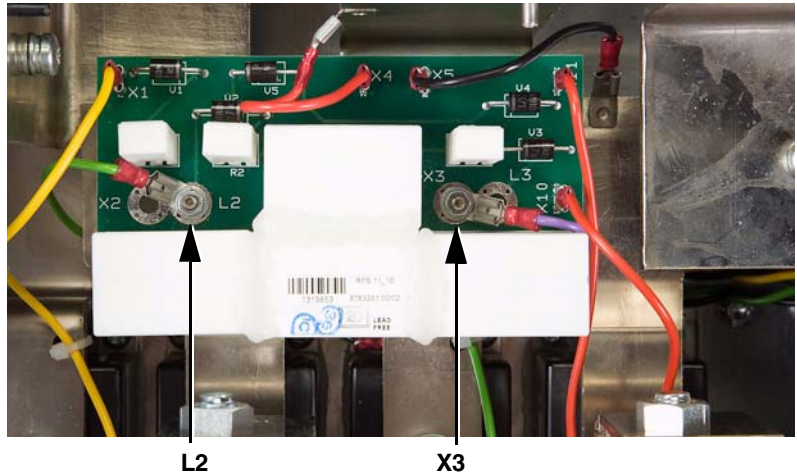

Remove SCR Snubber Board 2

Table 39: SCR Snubber Board 2 Wiring

Wire No. ¹	Terminal No.	Description	To:
E157	X1	Yellow, 1-pin	L1.2 rectifier
E158	X4	Red, 1-pin	PO.2 rectifier bus bar
E159	X5	Black, 1-pin	PC/- rectifier bus bar
E160	X10	Red, 0.25 in., 1-pin	GDB ² W X61
E158	X11	Red, 0.19 in., 1-pin	PO.2 rectifier bus bar
E169	L2	Green, 1-pin	L2.2 line input bar
E170	X3	Violet, 1-pin	L3.2 Line input bar

¹ See the schematic on page 175 for complete drive wiring. Wire numbers are given for cross referencing the wires with the wiring table and the schematic. The numbers do not appear on the wires.
² GDB: Gate driver board

2. Remove SCR snubber board 2 (right board) from the drive as follows.
 - Using needle-nose pliers, carefully remove the connections from SCR snubber board 2 (right board) terminals X1, X4, X5, X10, and X11. See Table 39 and Figure 142 for the connection locations.
 - Using a 7 mm socket wrench, remove two nuts securing the snubber board to the insulators on the PC (-) bus and remove the wires from terminals L2 and X3. See Figure 142.
 - Remove the board from the drive.

Figure 142: SCR Snubber Board 2

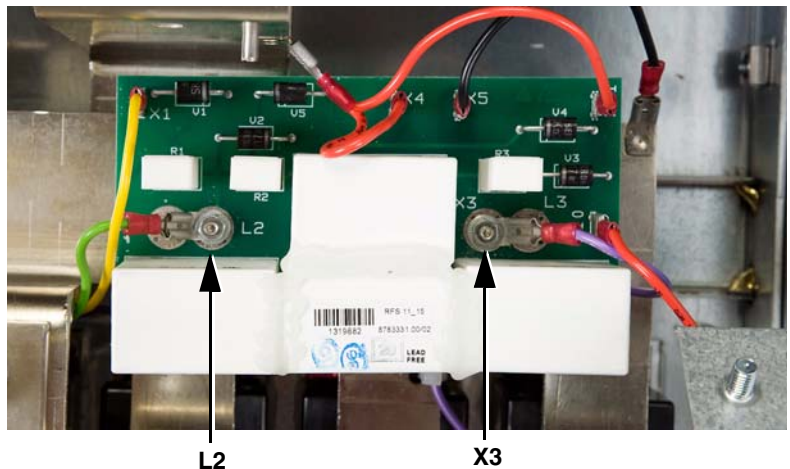

Remove the SCR Bus Work

- Using a T-30 Torx driver, remove two screws (**A**, Figure 143) securing the PA/+ bus bar to the red insulators on the PC/- bus and remove the PA/+ bus bar.

Figure 143: PA/+ Bus Connections

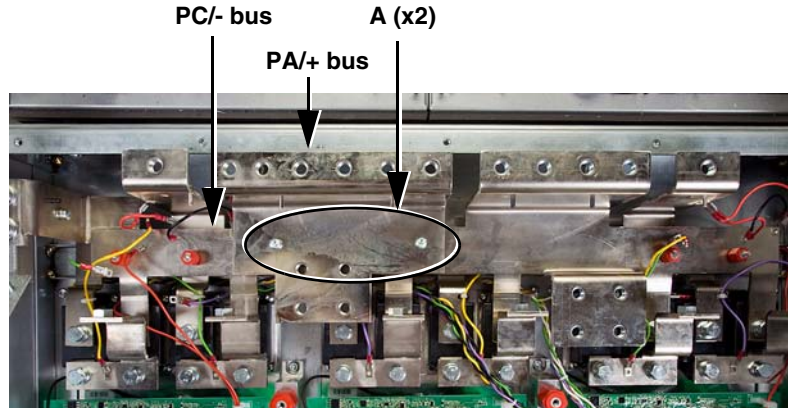

- Remove the six leads (**B**, Figures 144 and 145) from the six rectifier bus bars.
- Using a 16 mm socket wrench, remove twelve bolts (**C**, Figures 144 and 145) securing the rectifier bus bars to the SCR and diode modules (two bolts per rectifier bus bar).

Figure 144: Rectifier Bus Bars

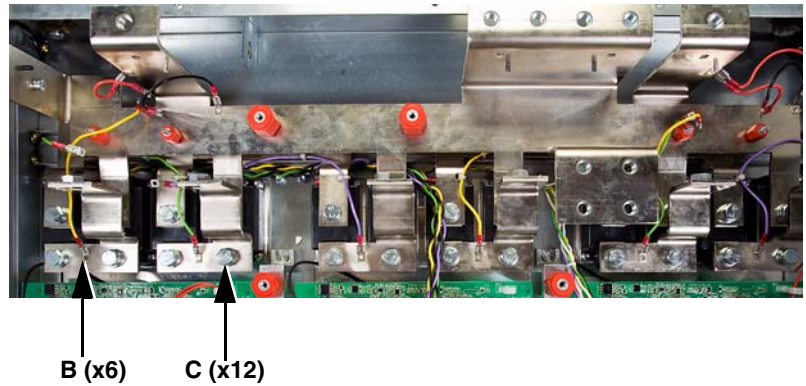
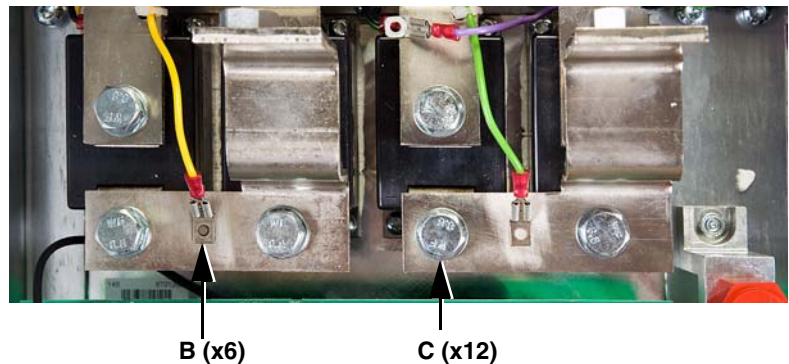
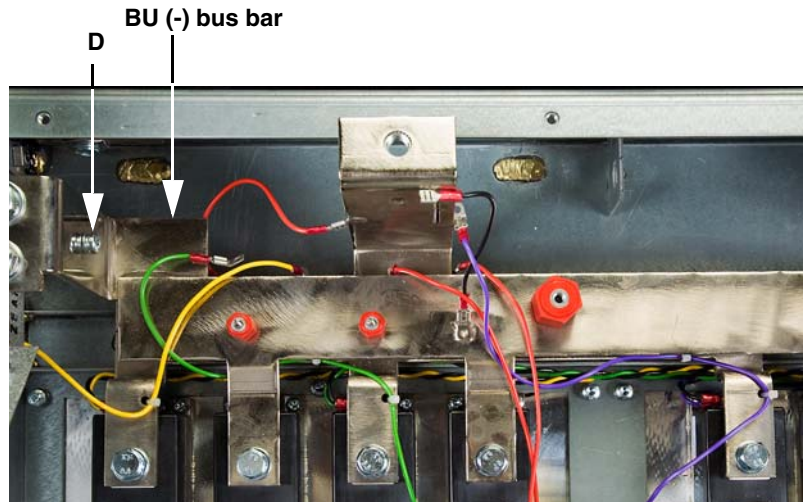

Figure 145: Rectifier Bus Bars, Detail



- Using a T-30 Torx driver, remove one screw (**D**, Figure 146) securing the BU (-) bus to the red insulator on the drive frame.

Figure 146: BU (-) Bus Bar



- Using a 16 mm socket wrench, remove six bolts (**E**, Figure 147) securing the PC/- bus bar to the diode and SCR modules and remove the bus bar.

Figure 147: PC/- Bus Bar

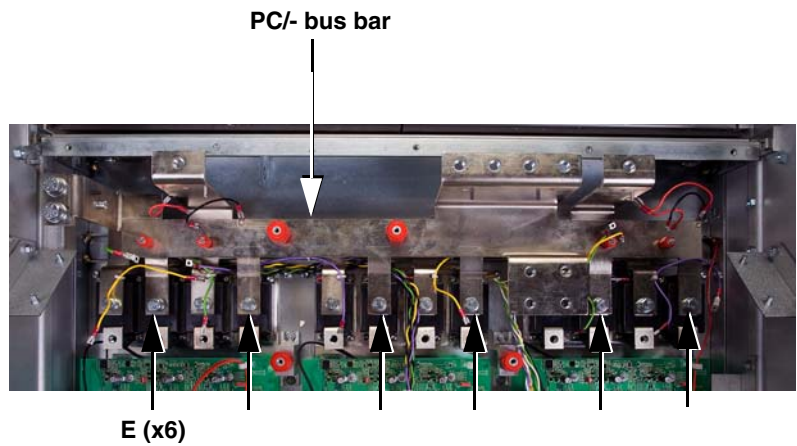

- Using a 16 mm socket wrench, remove six bolts (F, Figure 148) securing the PO.1 and PO.2 bus bars to SCR modules 1.1, 2.1, 3.1, 1.2, 2.2, and 3.2. Remove the bus bars.

Figure 148: PO.1 and PO.2 Bus Bars

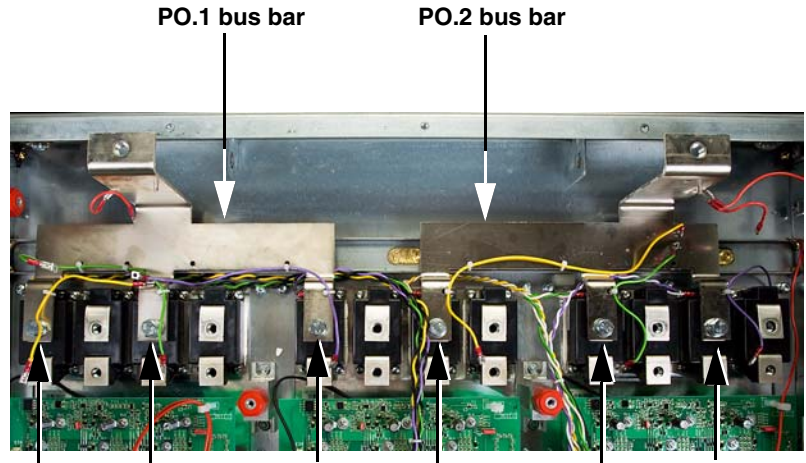

F (x6)

Replace the SCR or Diode Module

Figure 149: Torque Sequence

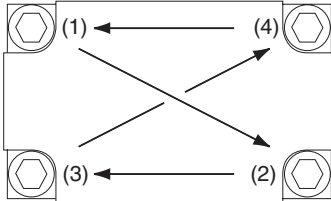

Table 40: SCR Module Wiring

SCR Module No.	Wire Color
1.1	Yellow/black
2.1	Green/black
3.1	Violet/black
1.2	Yellow/white
2.2	Green/white
3.2	Violet/white

9. Replace an SCR module or diode module as follows.
 - If you are replacing an SCR module, remove the connections from terminals 4 (black wire) and 5 (color wire). See Figure 151.
 - Using a T-20 Torx driver, remove four screws (A) securing the SCR or diode module to the heatsink and remove the module from the drive. See Figure 151.
 - Clean the portion of the heatsink that makes contact with the SCR or diode module.
 - Evenly coat the bottom of the new module with a thin layer of thermal compound included in the kit.
 - Position the new SCR or diode module on the heatsink under the input bus bar.
 - Using a T-20 Torx driver, secure the module with four screws (A). See Figure 151. Initially tighten the screws, in the sequence shown in Figure 149, to 0.7–1.0 N•m (6.2–8.9 lb-in), and then to a final torque of 3.3–4.4 N•m (29.2–38.9 lb-in).
 - If you are replacing an SCR module, replace the connections to terminals 4 and 5. See Figure 151.

NOTE: Note the cable positions. See Table 40 for SCR module wiring.

Figure 150: SCR Module Positions

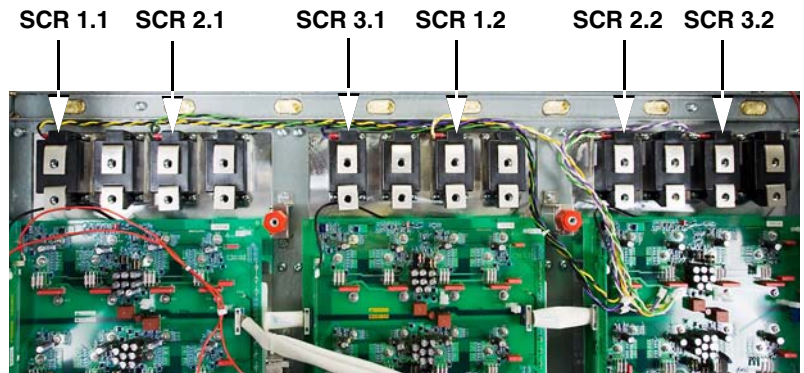
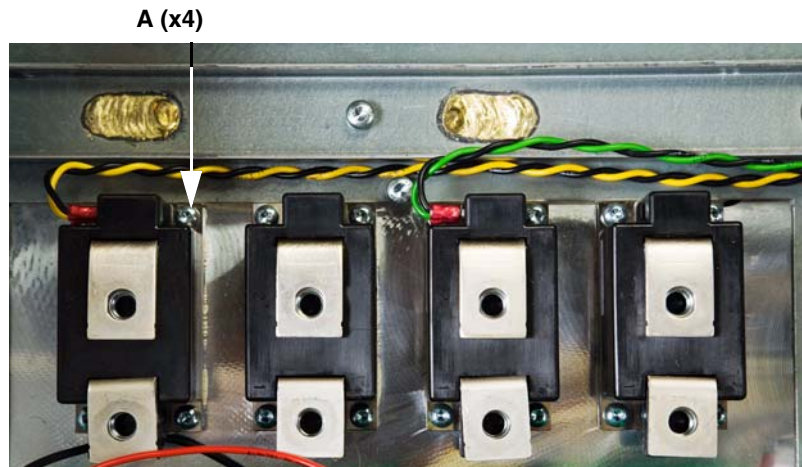

Figure 151: SCR and Diode Modules



Reinstall the SCR Buswork

Table 41: SCR Buswork Hardware Torque Values

Item	Description	Torque Range	
		N•m	lb-in
C	(12) 16-mm bolts	13.5	119.5
D	(1) T-30 screw	5.5	48.7
E	(6) 16-mm bolts	13.5	119.5
F	(6) 16-mm bolts	13.5	119.5

10. Using a 16 mm socket wrench, secure the PO.1 and PO.2 bus bars to the SCR modules with six bolts (F, Figure 152). Tighten the bolts to the torque values specified in Table 41.

Figure 152: PO.1 and PO.2 Bus Bars

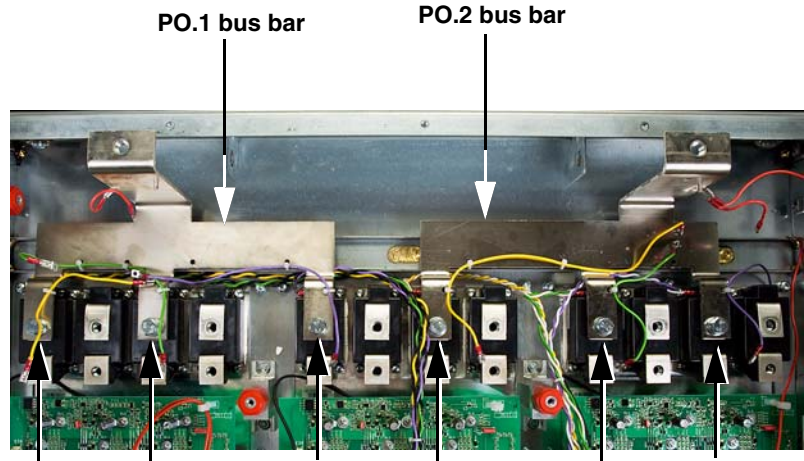

F (x6)

11. Using a 16 mm socket wrench, secure the PC/- bus bar to the diode and SCR modules with six bolts (E, Figure 153). Tighten the bolts to the torque values specified in Table 41.

Figure 153: PC/- Bus Bar

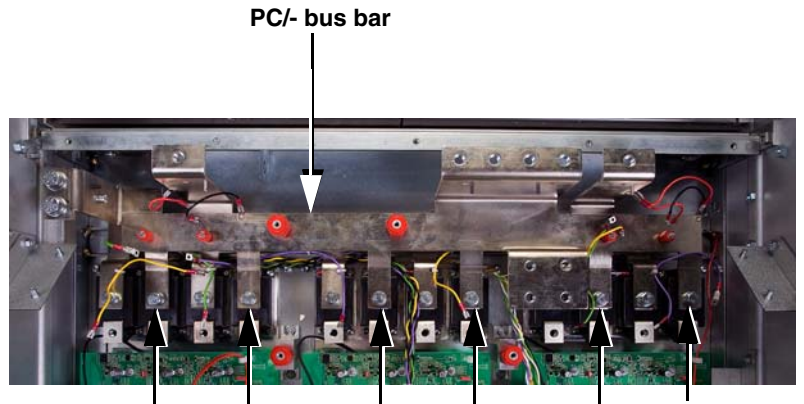

E (x6)

- Using a T-30 Torx driver, secure the BU (-) bus to the red insulator on the drive frame with one screw (D, Figure 154). Tighten the screw to the torque values specified in Table 41 on page 138.

Figure 154: BU (-) Bus Bar

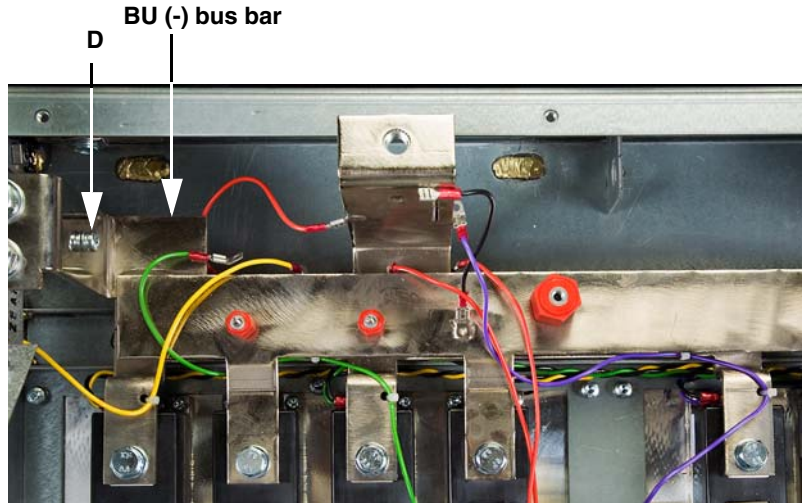

- Using a 16 mm socket wrench, secure the six rectifier bus bars to terminal 1 of each SCR/diode module pair with twelve bolts—two bolts per rectifier bus bar (C, Figures 155 and 156). Tighten the bolts to the torque values specified in Table 41.

- Replace six leads (B, Figures 155 and 156) on the rectifier bus bars.

Figure 155: Rectifier Bus Bars

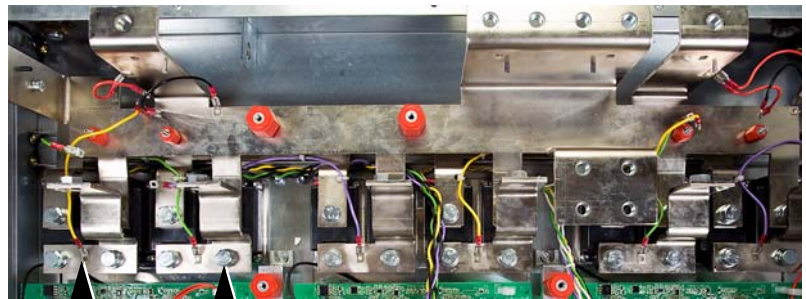
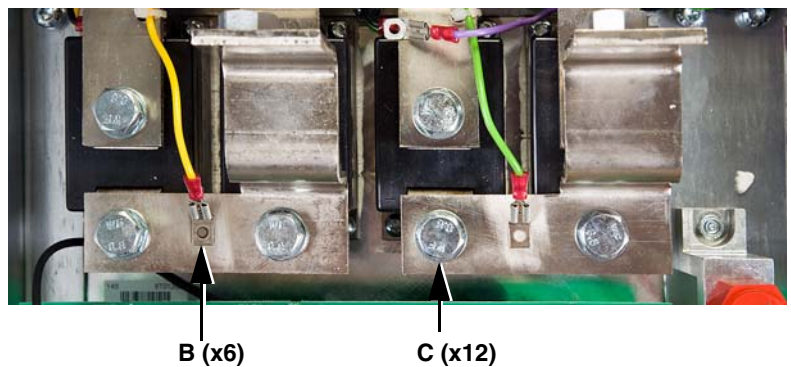
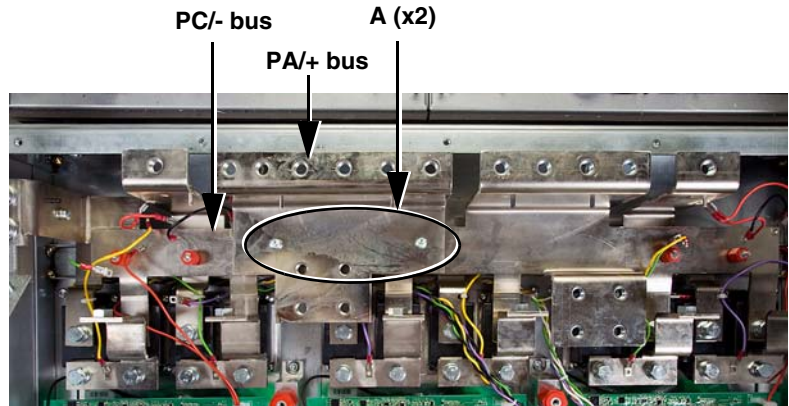

Figure 156: Rectifier Bus Bars, Detail



- Using a T-30 Torx driver, secure the PA/+ bus bar to the red insulators on the PC/- bus with two screws (A, Figure 157). Tighten the bolts to 5.5 N•m (48.7 lb-in).

Figure 157: PA/+ Bus Connections



Replace the SCR Snubber Boards

Table 42: SCR Snubber Board 1 Wiring

Wire No. ¹	Terminal No.	Description	To:
E131	X1	Yellow, 1-pin	L1.1 rectifier
E130	X4	Red, 1-pin	PO.1 rectifier bus bar
E133	X5	Black, 1-pin	PC/- rectifier bus bar
E126	X10	Red, 0.25 in., 1-pin	GDB ² U X61
E126	X11	Red, 0.19 in., 1-pin	PB ³ RFS31+X11
E167	L2	Green, 1-pin	L2.1 Line input bar
E168	X3	Violet, 1-pin	L3.1 Line input bar

¹ See the schematic on page 175 for complete drive wiring. Wire numbers are given for cross referencing the wires with the wiring table and the schematic. The numbers do not appear on the wires.

² GDB: Gate driver board

³ PB: Power board

16. Replace SCR snubber board 1 (left board) as follows.

- Seat the SCR snubber board on the DC (-) bus standoffs. See Figure 158.
- Replace the wires at terminals L2 and X3. Using a 7 mm socket wrench, secure the wires and the snubber board to the DC (-) bus with two bolts. See Figure 159. Tighten the bolts to 1.2 N•m (10.6 lb-in).
- Replace the connections on SCR snubber board terminals X1, X4, X5, X10, and X11. See Table 42 and Figure 159 for the terminal locations.

Figure 158: DC (-) Bus

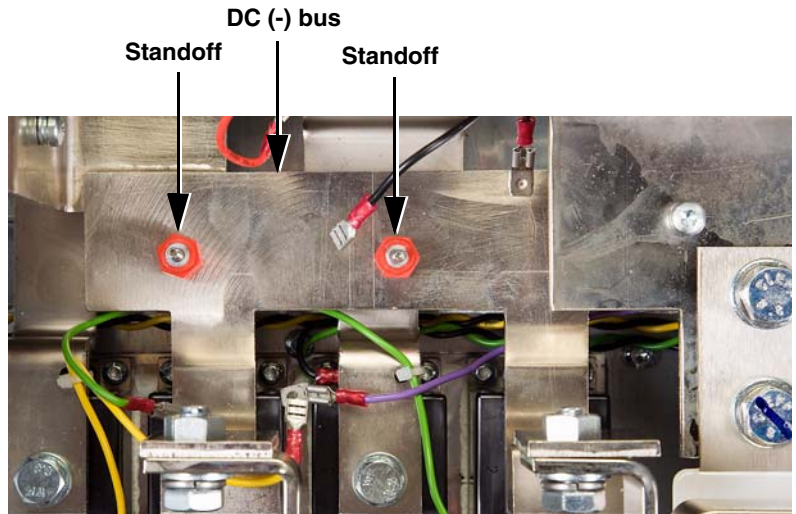

Figure 159: SCR Snubber Board 1

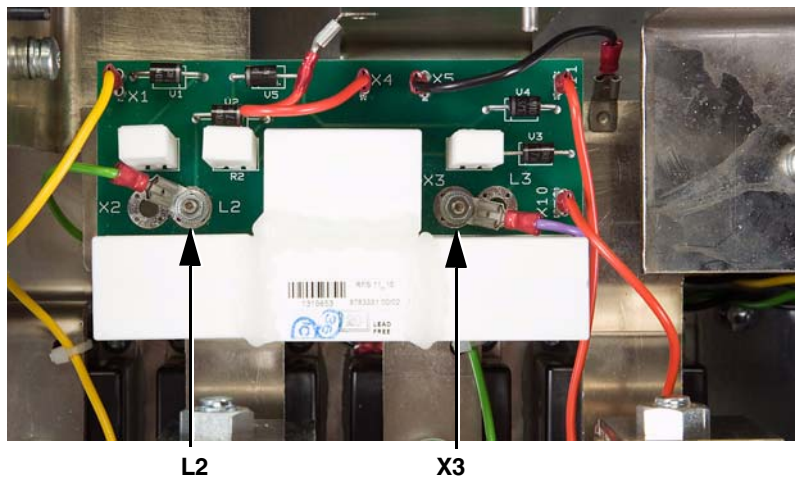

Table 43: SCR Snubber Board 2 Wiring

Wire No. ¹	Terminal No.	Description	To:
E157	X1	Yellow, 1-pin	L1.2 rectifier
E158	X4	Red, 1-pin	PO.2 rectifier bus bar
E159	X5	Black, 1-pin	PC/- rectifier bus bar
E160	X10	Red, 0.25 in., 1-pin	GDB ² W X61
E158	X11	Red, 0.19 in., 1-pin	PO.2 rectifier bus bar
E169	L2	Green, 1-pin	L2.2 line input bar
E170	X3	Violet, 1-pin	L3.2 Line input bar

¹ See the schematic on page 175 for complete drive wiring. Wire numbers are given for cross referencing the wires with the wiring table and the schematic. The numbers do not appear on the wires.

² GDB: Gate driver board

17. Replace SCR snubber board 2 (left board) as follows.

- Seat the SCR snubber board on the DC (-) bus standoffs. See Figure 160.
- Replace the wires at terminals L2 and X3. Using a 7 mm socket wrench, secure the wires and the snubber board to the DC (-) bus with two bolts. See Figure 161. Tighten the bolts to 1.2 N•m (10.6 lb-in).
- Replace the connections on SCR snubber board terminals X1, X4, X5, X10, and X11. See Table 43 and Figure 161 for the terminal locations.

Figure 160: DC (-) Bus

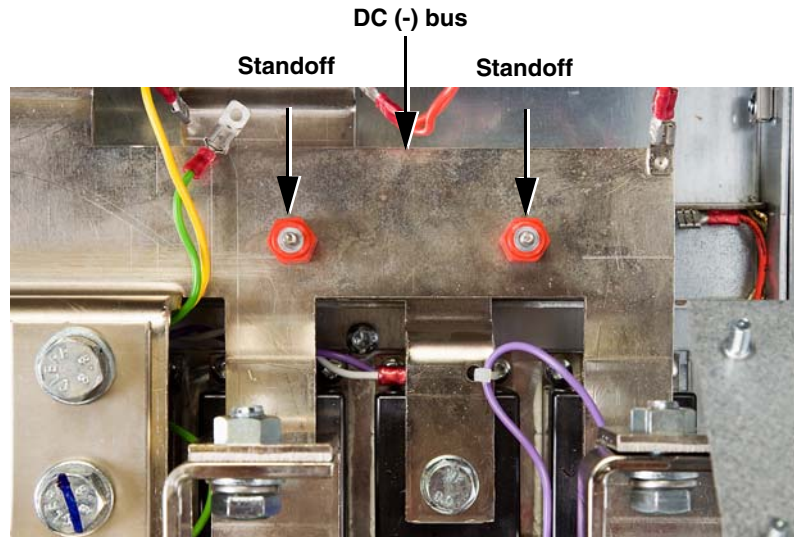
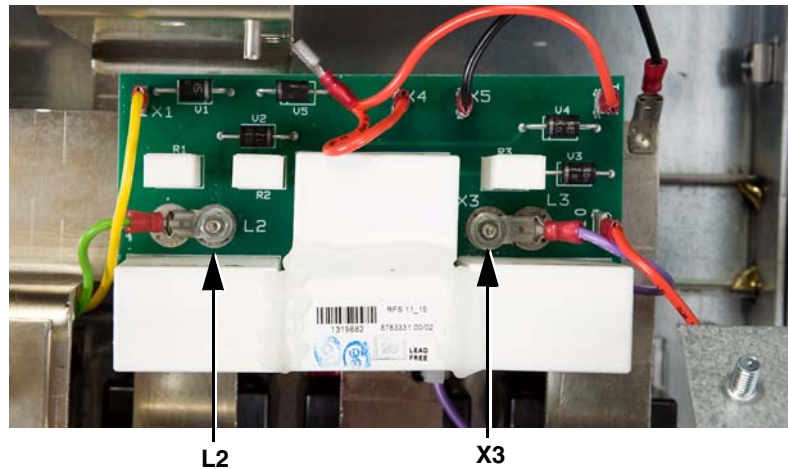

Figure 161: SCR Snubber Board 2



Reassemble the Drive

If you are only replacing the SCR modules or the diode modules, perform Steps 3–25 of “Reassembly Steps for Level 2 Parts” beginning on page 144 to replace the following parts:

- Top DC bus plate
- Top phase-U DC bus plate
- Input bus bar brackets (bottom)
- Input bus bars
- Input bus bar brackets (top)
- Rectifier shield
- Top terminal bracket
- Fan bracket
- BU (+) bus bar
- Power board assembly
- Fan control board connections
- Power board connections
- Soft charge board connections
- Control module assembly
- EMC tray
- Middle crossbrace
- Power terminal shields
- Front cover

Reassembly Steps for Level 2 Parts

IMPORTANT: Label and retain all removed hardware and cables for use in reassembly.

⚠ DANGER

HAZARD OF ELECTRIC SHOCK, EXPLOSION, OR ARC FLASH

- Read and understand the precautions in “Before You Begin” starting on page 5 before performing this procedure.
- Before working on this equipment, turn off all power supplying it and perform the DC bus voltage measurement procedure on page 11.

Failure to follow these instructions will result in death or serious injury.

This section contains instructions for replacing the following parts in the drive:

- | | |
|---------------------------------------------------------------------------------------------------------------------------------------------------------------------------------------------------------------------------------------------------------------------------------------------------------------------------------------------------------------------------------------------------------------------------------------------------------------------------------------------------------------------------------------------------------------------------------------------------------|------------------------------------------------------------------------------------------------------------------------------------------------------------------------------------------------------------------------------------------------------------------------------------------------------------------------------------------------------------------------------------------------------------------------------------------------------------------------------------------------------------------------------------------------------------------------------------------------------------|
| <ul style="list-style-type: none"> <input type="checkbox"/> Bottom DC bus plate <input type="checkbox"/> Gate driver boards <input type="checkbox"/> Top DC bus plate <input type="checkbox"/> Phase-U DC bus plate <input type="checkbox"/> Input bus bar brackets (bottom) <input type="checkbox"/> Input bus bars <input type="checkbox"/> Input bus bar brackets (top) <input type="checkbox"/> Rectifier shield <input type="checkbox"/> Top terminal bracket <input type="checkbox"/> Fan bracket | <ul style="list-style-type: none"> <input type="checkbox"/> BU (+) bus bar <input type="checkbox"/> Power board assembly <input type="checkbox"/> Fan control board connections <input type="checkbox"/> Power board connections <input type="checkbox"/> Soft charge board connections <input type="checkbox"/> Control module assembly <input type="checkbox"/> EMC tray <input type="checkbox"/> Middle crossbrace <input type="checkbox"/> Power terminal shields <input type="checkbox"/> Front cover |
|---------------------------------------------------------------------------------------------------------------------------------------------------------------------------------------------------------------------------------------------------------------------------------------------------------------------------------------------------------------------------------------------------------------------------------------------------------------------------------------------------------------------------------------------------------------------------------------------------------|------------------------------------------------------------------------------------------------------------------------------------------------------------------------------------------------------------------------------------------------------------------------------------------------------------------------------------------------------------------------------------------------------------------------------------------------------------------------------------------------------------------------------------------------------------------------------------------------------------|

You must perform some or all of the procedures in this section after replacing the spare parts identified in Table 44. Consult Table 44 for the reassembly steps that must be performed for the corresponding spare parts.

Table 44: Reassembly Steps

If you replaced:	Perform reassembly steps:
Power board VX5A1HC4050	Steps 21–25
Brake board VZ3F1113	Steps 21–25
Power board assembly shields (Plastic Parts Kit VY1A1406)	Steps 17–25
Motor current sensors VY1A1109	Steps 15–25
Gate driver boards VX5A1203	Steps 3–25
SCR modules VZ3TM1425M1671	Steps 3–25
Diode modules VZ3DM1600M1671	
Temperature sensors VZ3G1104	Steps 2–25
Power IGBT modules VZ3IM1603M1271	Steps 1–25
Capacitors VY1ADC1112	

Replace the Bottom DC Bus Plate

1. Replace the Bottom DC bus plate as follows. See Figure 162.
 - Position the DC bus plate in the drive as illustrated in Figure 162.
 - Using a T-30 Torx driver, secure the DC bus plate to terminal E on the IGBT modules with three 20 mm screws (**B**).
 - Using a T-30 Torx driver, secure the DC bus plate to terminal E on the IGBT modules (**A**) with three 14-mm screws.
 - Replace the bus neutral jumpers as shown in Figure 162. Using a T-30 Torx driver, secure the DC bus plate to the capacitors (**C**) with twelve 14 mm screws.
 - Using a 10 mm socket wrench, install three short standoffs (**D**) and three long standoffs (**E**).
 - Replace the bleeder resistor connections (**F**). Note: In phase U, the bleeder resistors are connected to phase-U gate driver board terminal X62 and power board terminal UD-R1.
 - Tighten the hardware to the torque values specified in Table 45.

Figure 162: DC Bus Plate (Phase V Shown)

Table 45: Bottom DC Bus Plate Hardware Torque Values

Item	Description	Torque Range	
		N•m	lb-in
A	(3) Short T-30 screws (14 mm length)	5.5	48.7
B	(3) Long T-30 screws (20 mm length)	5.5	48.7
C	(12) Short T-30 screws (14 mm length)	3.3	29.2
D	(3) Short 10-mm standoffs (6 mm barrel length)	5.5	48.7
E	(3) Long 10-mm standoffs (11 mm barrel length)	5.5	48.7

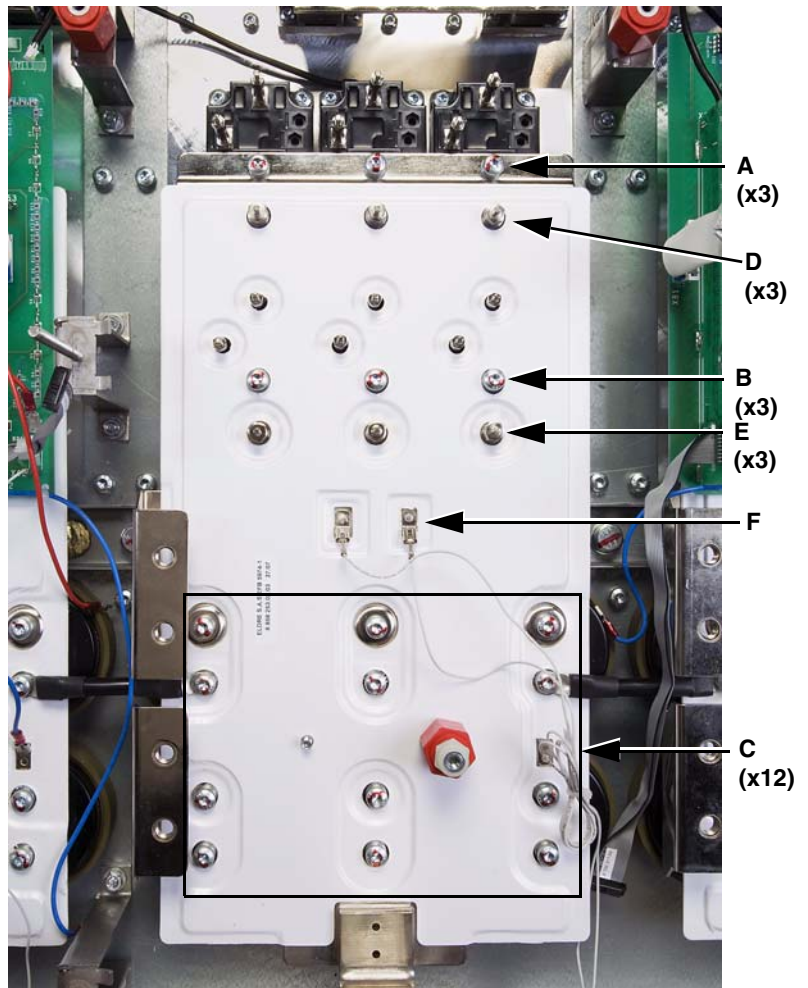

Replace the Gate Driver Boards

2. Replace the gate driver board(s) as follows.

- Using a 7 mm socket wrench, secure the gate driver board(s) to the power IGBT modules and the DC bus plate with 18 nuts each. See Figure 163 on page 147. Tighten the nuts to 1.2 N•m (10.6 lb-in).
- Replace the gate driver board connections. See Table 46 and Figure 163 on page 147.

Table 46: Gate Driver Board Wiring¹

Wire No. ²	Terminal No.	Description	To:
Gate Driver Board U (Left)			
E144	X4	2-pin, black	Temperature sensor U
E138	X32	18-pin, gray	GDB ³ V X31
E129	X51	1-pin, blue	UD0 (neutral) on DC bus plate
E127	X52	1-pin, blue	GDB V, X51
E126	X61	1-pin, red	SB ⁴ X10
E139	X62	1-pin, white	Bleeder resistor 1
E100	X82	14-pin, white	GDB V, X81 and PB ⁵ X8
—	X31	No connection	
—	X81	No connection	
Gate Driver Board V (Center)			
E128	X4	2-pin, black	Temperature sensor V
E138	X31	18-pin, gray	GDB U, X32
E146	X32	18-pin, gray	GDB W, X31
E127	X51	1-pin, blue	GDB U, X52
E123	X52	1-pin, blue	GDB W, X51
E100	X81	14-pin, white	GDB U, X82
E102	X82	14-pin, white	GDB W, X81
—	X61	No connection	
Gate Driver Board W (Right)			
E145	X4	2-pin, black	Temperature sensor W
E146	X31	18-pin, gray	GDB V, X32
E142	X32	18-pin, gray	PB, X3
E123	X51	1-pin, blue	GDB V, X52
E102	X81	14-pin, white	GDB V, X82
E132	X53	1-pin, blue	Insulator near MCB
E160	X61	1-pin, red	SB32, X10
E164	X62	1-pin, white	Bleeder resistor 3
—	X52	No connection	
—	X82	No connection	

¹ Terminals X4, X81, and X82 are connected to a daughter board on the gate driver board assembly.

² See the schematic on page 175 for complete drive wiring. Wire numbers are given for cross referencing the wires with the wiring table and the schematic. The numbers do not appear on the wires.

³ GDB: Gate driver board

⁴ SB: SCR Snubber board

⁵ PB: Power board

Figure 163: Gate Driver Boards

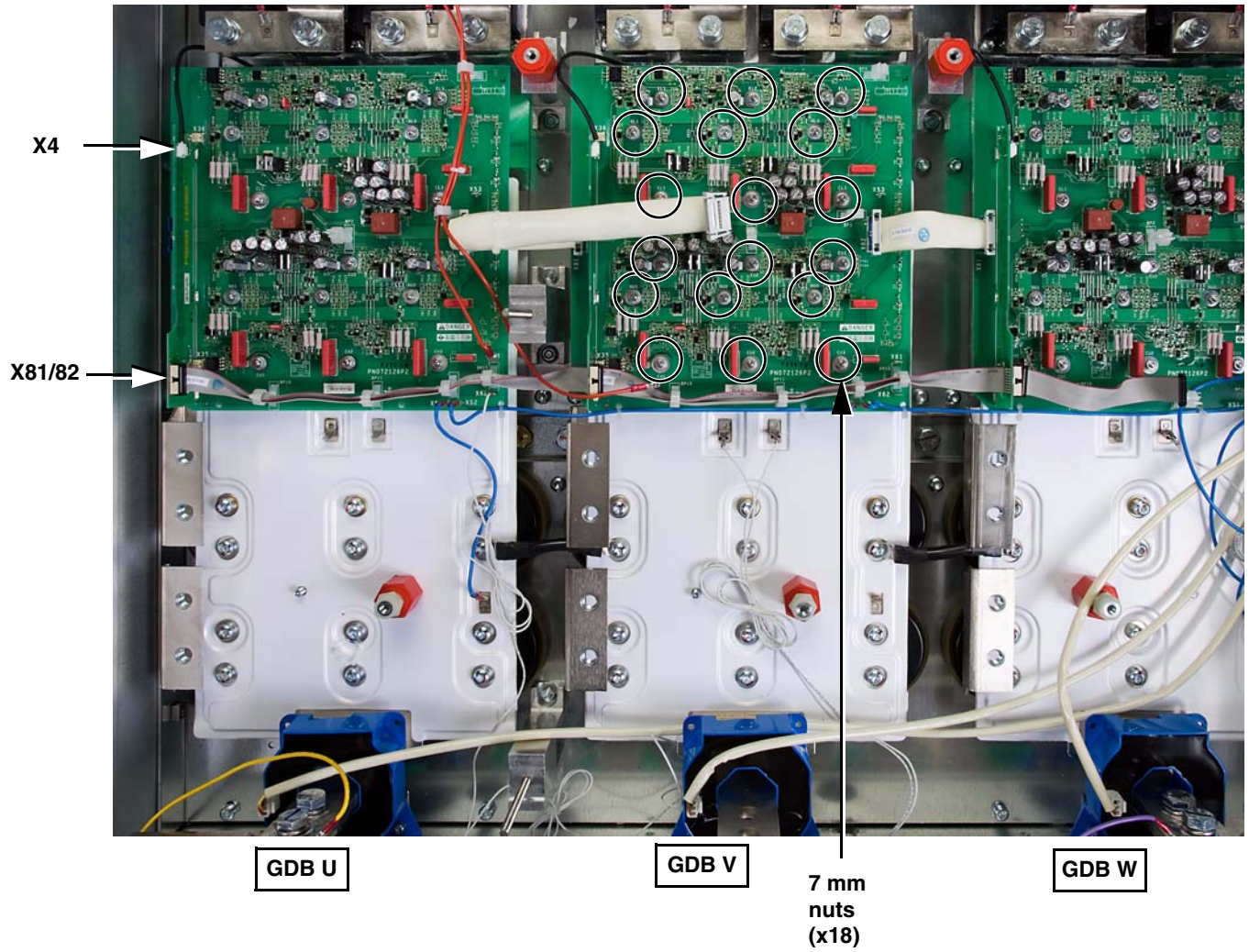

Replace the Top DC Bus plate

3. Replace the top DC bus plate as follows. See Figure 164.
 - Position the bus plate in the drive as illustrated in Figure 164.
 - Using an 18 mm socket wrench, secure the bus plate to the positive (+) rectifier bus with four bolts (C).
 - Using an 18 mm socket wrench, secure the bus plate to the negative (-) rectifier bus with four bolts (D).
 - Using a T-30 Torx driver, secure the bus plate to the red insulators on the heatsink with three screws (E).
 - Using a 16 mm socket wrench, secure the bus plate to the positive (+) bus with two bolts (A).
 - Using a 16 mm socket wrench, secure the bus plate to the negative (-) bus with two bolts (B).
 - Tighten the hardware to the torque values specified in Table 47.

Figure 164: Top DC Bus Plate

Table 47: Top DC Bus Plate Hardware Torque Values

Item	Description	Torque Range	
		N•m	lb-in
A	(2) 16-mm bolts	27.5	243
B	(2) 16-mm bolts	27.5	243
C	(4) 18-mm bolts	45	398
D	(4) 18-mm bolts	45	398
E	(3) T-30 screws	5.5	48.7

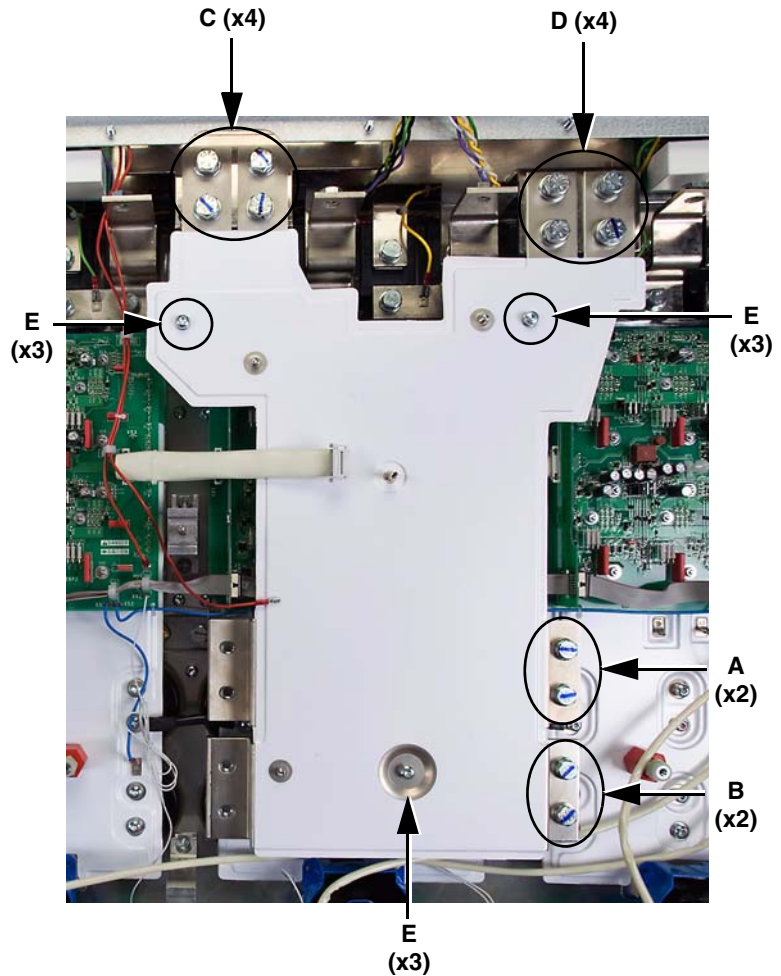

Replace the Phase-U DC Bus Plate

⚠ DANGER

HAZARD OF ELECTRIC SHOCK, EXPLOSION, OR ARC FLASH

- Install the bus plate shield as shown in Figure 165.
- Before installing the shield, ensure that it has no tears or cracks. If the shield is damaged, install a new piece from the plastic kit. See page 22.
- Do not install a damaged shield.

Failure to follow these instructions will result in death or serious injury.

4. Replace the phase-U DC bus plate as follows. See Figure 165.
 - Position the bus plate in the drive as illustrated in Figure 165.
 - Using a 16 mm socket wrench, secure the bus plate to the positive (+) bus with four bolts (B).
 - Using a 16 mm socket wrench, secure the bus plate to the negative (-) bus with four bolts (C).
 - Using a T-30 Torx driver, secure the bus plate to the standoff on the top DC bus plate with one screw (D).
 - Using a 10 mm socket wrench, secure the plastic shield to the bus plate with two screws (A).

If the shield is torn, cracked, or damaged, replace it with a new piece from the plastic parts kit. See “Replacing the Plastic Parts Kit VY1A1406” beginning on page 22.

 - Tighten the hardware to the torque values specified in Table 48.

Table 48: Phase-U DC Bus Plate Hardware Torque Values

Item	Description	Torque Range	
		N•m	lb-in
A	(2) T-30 screws	5.5	48.7
B	(4) 16-mm bolts	27.5	243
C	(4) 16-mm bolts	27.5	243
D	(1) T-30 screw	5.5	48.7

Figure 165: Phase-U DC Bus Plate

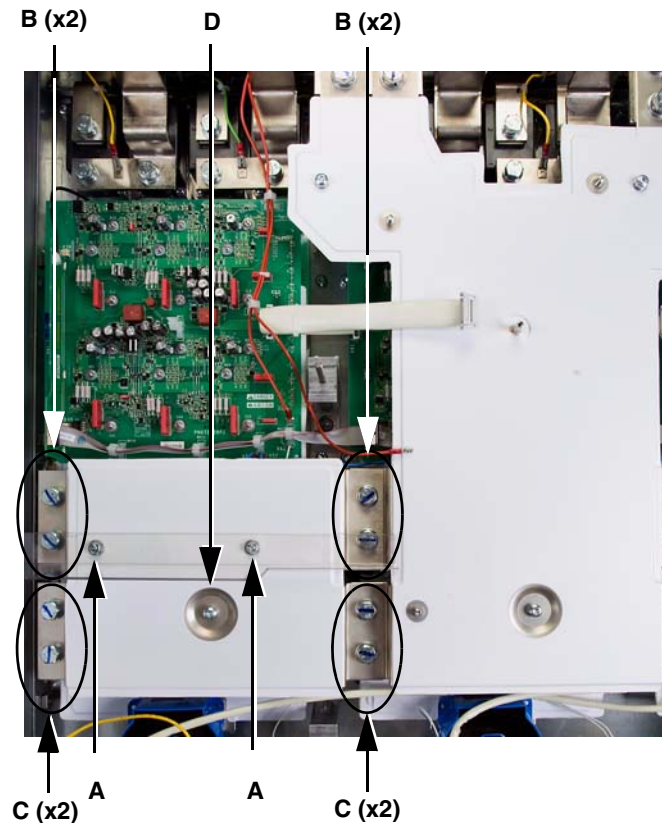

**Replace the Input Bus Bar Brackets
(Bottom)**

5. Install the bottom half of the input bus bar brackets on the mounting posts on the drive frame.
Before installing the brackets, ensure that they have no tears or cracks.
If the brackets are damaged, install a new piece from the plastic kit. See page 22.

Figure 166: Input Bus Bar Brackets, Bottom

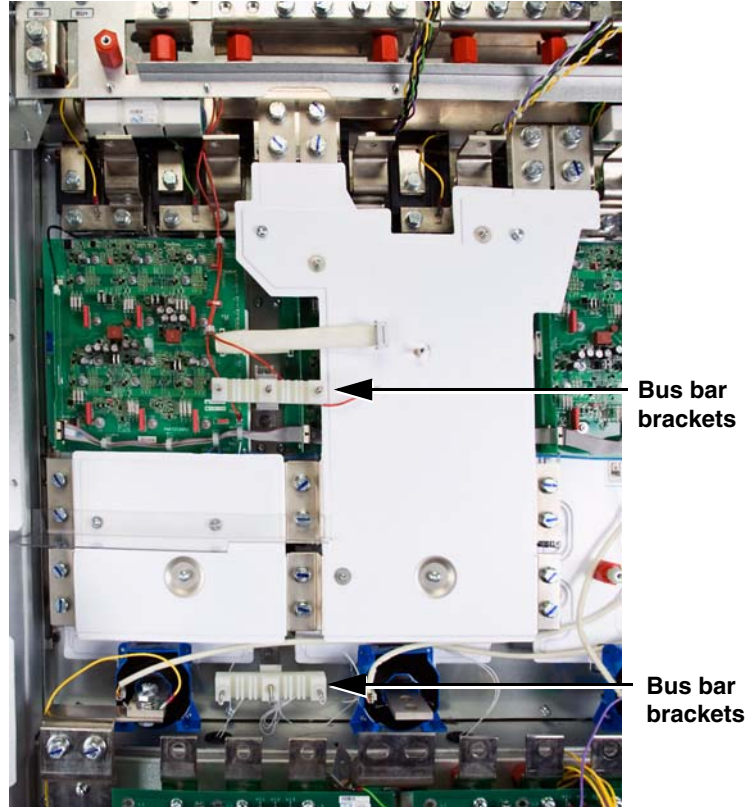

Replace the Input Bus Bars

NOTE: L1.1, L2.1, and L3.1 are associated with input rectifier 1. L1.2, L2.2, and L3.2 are associated with input rectifier 2.

6. Replace the L3.1 input bus bar as follows. See Figure 167.
 - Position the bus bar in the drive as illustrated in Figure 167.
 - Using an 18 mm socket wrench, secure the top of the L3.1 input bus bar to the L3.1 rectifier with one bolt and washer (**R**, Figure 167).
 - Using an 18 mm socket wrench, secure the bottom of the L3.1 input bus bar to the T/L3.1 bus bar with one bolt and washer (**P**, Figure 167).
 - Tighten the hardware to the torque values specified in Table 49.

Figure 167: L3.1 Input Bus Bar

Table 49: L3.1 Input Bus Bar Hardware Torque Values

Item	Description	Torque Range	
		N•m	lb-in
R	(1) 18-mm bolt and washer	45	398
P	(1) 18-mm bolt and washer	45	398

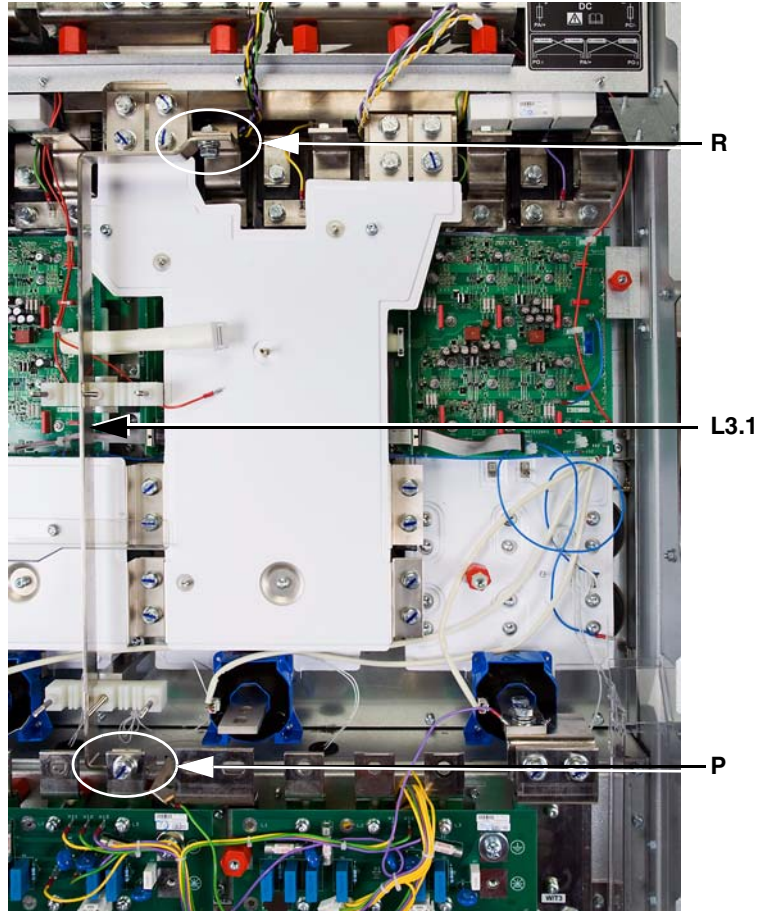

7. Replace the L1.2 input bus bar as follows. See Figure 168.
 - Position the bus bar in the drive as illustrated in Figure 168.
 - Using an 18 mm socket wrench, secure the top of the L1.2 input bus bar to the L2.1 rectifier with one bolt and washer (**N**, Figure 168).
 - Using an 18 mm socket wrench, secure the bottom of the L1.2 input bus bar to the R/L1.2 bus bar with one bolt and washer (**O**, Figure 168).
 - Tighten the hardware to the torque values specified in Table 50.

Figure 168: L1.2 Input Bus Bar

Table 50: L1.2 Input Bus Bar Hardware Torque Values

Item	Description	Torque Range	
		N•m	lb-in
N	(1) 18-mm bolt and washer	45	398
O	(1) 18-mm bolt and washer	45	398

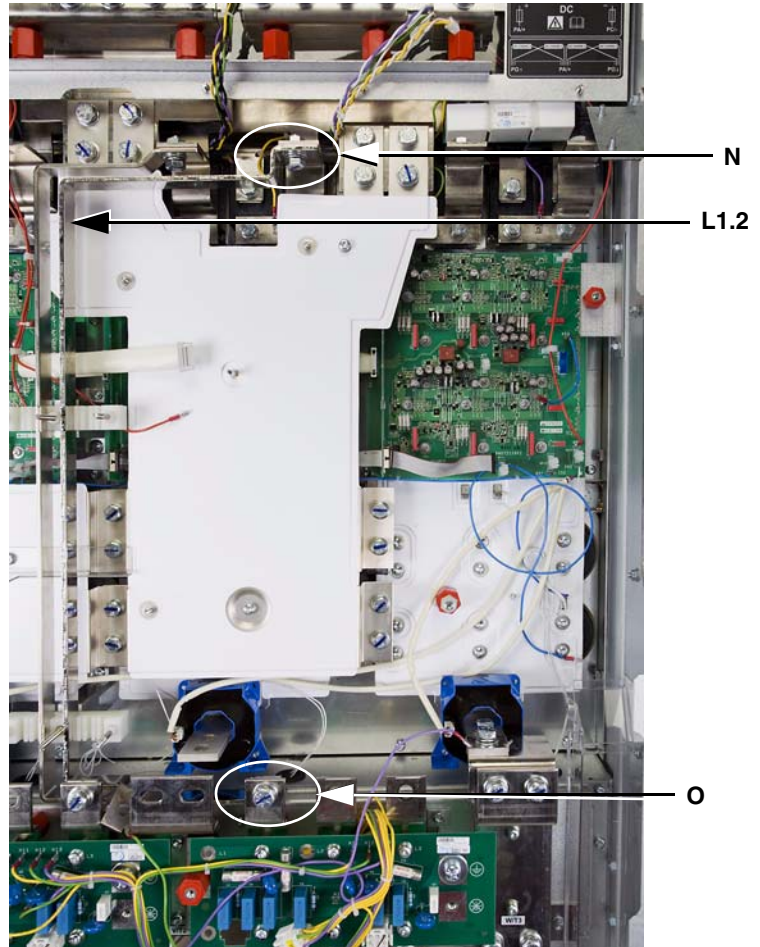

8. Replace the L2.2 input bus bar as follows. See Figure 169.
 - Position the bus bar in the drive as illustrated in Figure 169.
 - Using an 18 mm socket wrench, secure the top of the L2.2 input bus bar to the L2.2 rectifier with one bolt and washer (**L**, Figure 169).
 - Using an 18 mm socket wrench, secure the bottom of the L2.2 input bus bar to the S/L2.2 bus bar with one bolt and washer (**M**, Figure 169).
 - Tighten the hardware to the torque values specified in Table 51.

Figure 169: L2.2 Input Bus Bar

Table 51: L2.2 Input Bus Bar Hardware Torque Values

Item	Description	Torque Range	
		N•m	lb-in
L	(1) 18-mm bolt and washer	45	398
M	(1) 18-mm bolt and washer	45	398

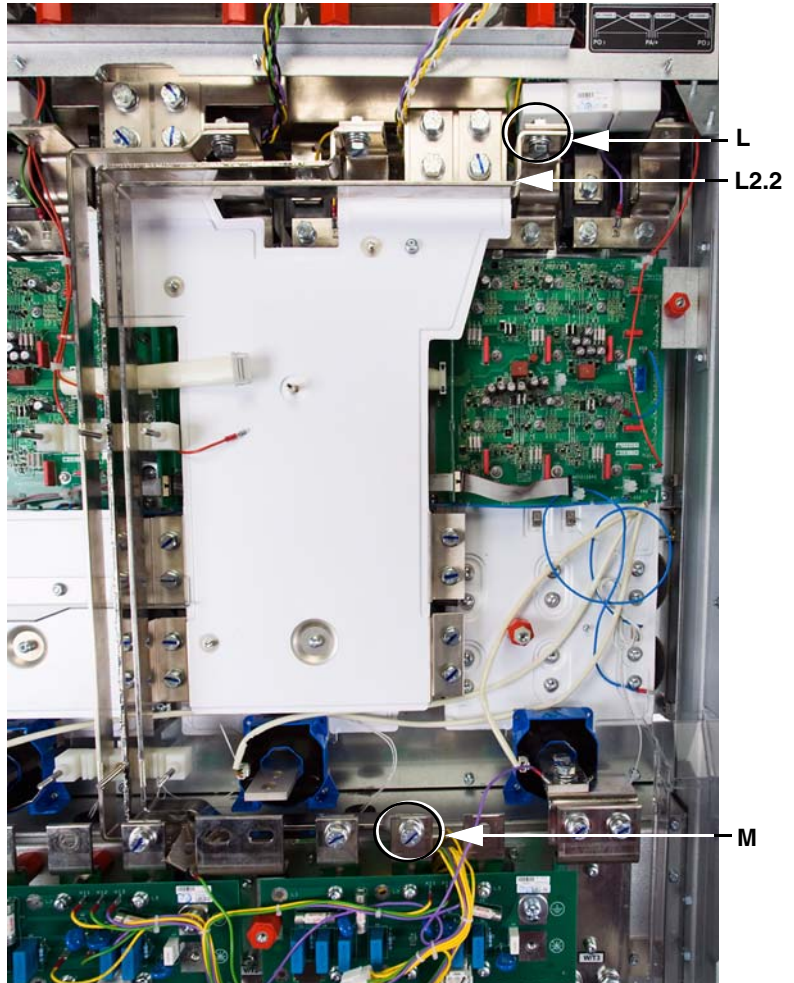

9. Replace the L3.2 input bus bar as follows.
 - Position the bus bar in the drive as illustrated in Figure 170.
 - Using an 18 mm socket wrench, secure the top of the L3.2 input bus bar to the L3.2 rectifier with one bolt and washer (**K**, Figure 170).
 - Using an 18 mm socket wrench, secure the bottom of the L3.2 input bus bar to the T/L3.2 bus bar with one bolt and washer (**J**, Figure 170).

Figure 170: L3.2 Input Bus Bar

Table 52: L3.2 Input Bus Bar Hardware Torque Values

Item	Description	Torque Range	
		N•m	lb-in
J	(1) 18-mm bolt and washer	45	398
K	(1) 18-mm bolt and washer	45	398

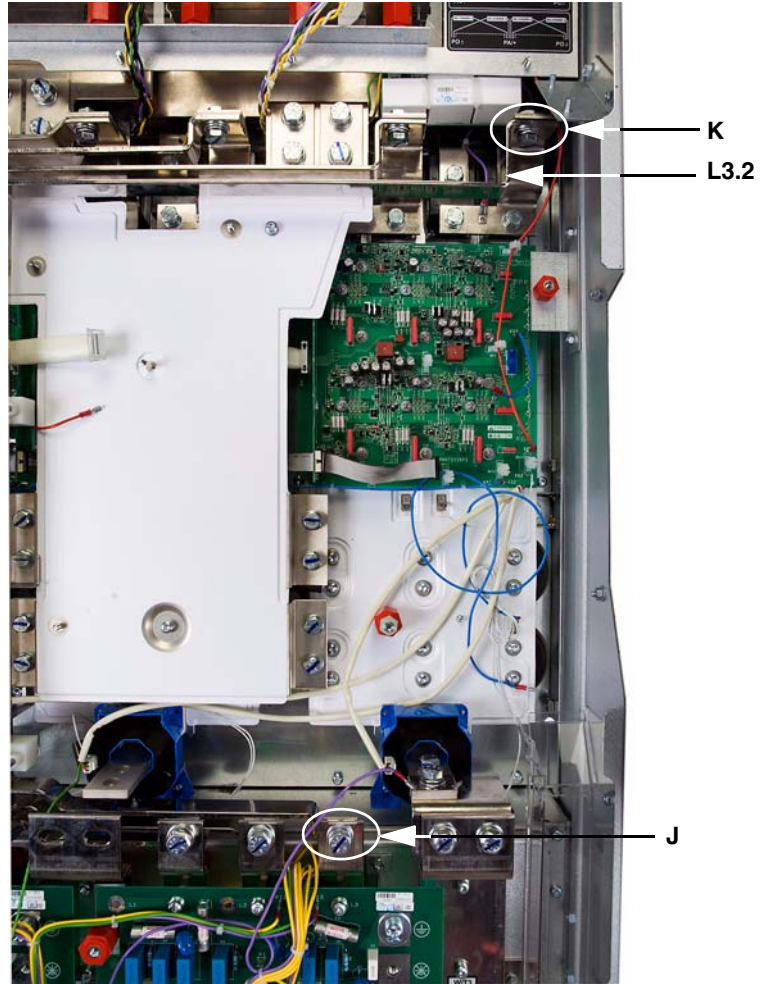

- Using an 18 mm socket wrench, secure the L-shaped bracket to the V/T2 output with two bolts and washers (H). See Figure 171.
- Using an 18 mm socket wrench, secure the V-phase DC bus plate to the L-shaped bracket on the V/T2 output with two bolts and washers (F). See Figure 171.

NOTE: Replace the output sensor plate (G) under the front bolt. See Figure 171.

- Tighten the hardware to the torque values specified in Table 53.

Figure 171: V/T2 Bus Bar

Table 53: V/T2 Bus Bar Hardware Torque Values

Item	Description	Torque Range	
		N•m	lb-in
F	(2) 18-mm bolts and washers	45	398
H	(2) 18-mm bolts and washers	45	398

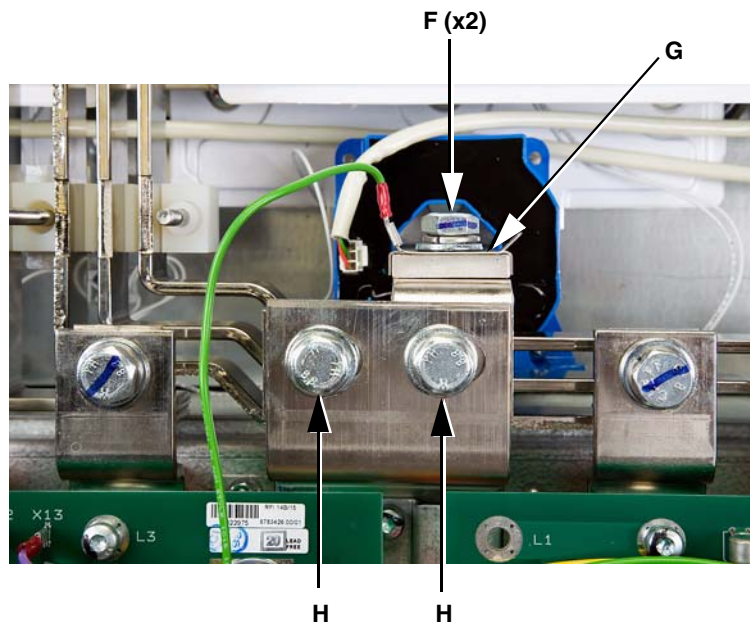

10. Replace the L2.1 input bus bar as follows.
 - Position the bus bar in the drive as illustrated in Figure 172.
 - Using an 18 mm socket wrench, secure the top of the L2.1 input bus bar to the L2.1 rectifier with one bolt and washer (**E**, Figure 172).
 - Using an 18 mm socket wrench, secure the bottom of the L2.1 input bus bar to the S/L2.1 bus bar with one bolt and washer (**D**, Figure 172).
 - Tighten the hardware to the torque values specified in Table 54.

Figure 172: L2.1 Input Bus Bar

Table 54: L2.1 Input Bus Bar Hardware Torque Values

Item	Description	Torque Range	
		N•m	lb-in
D	(1) 18-mm bolt and washer	45	398
E	(1) 18-mm bolt and washer	45	398

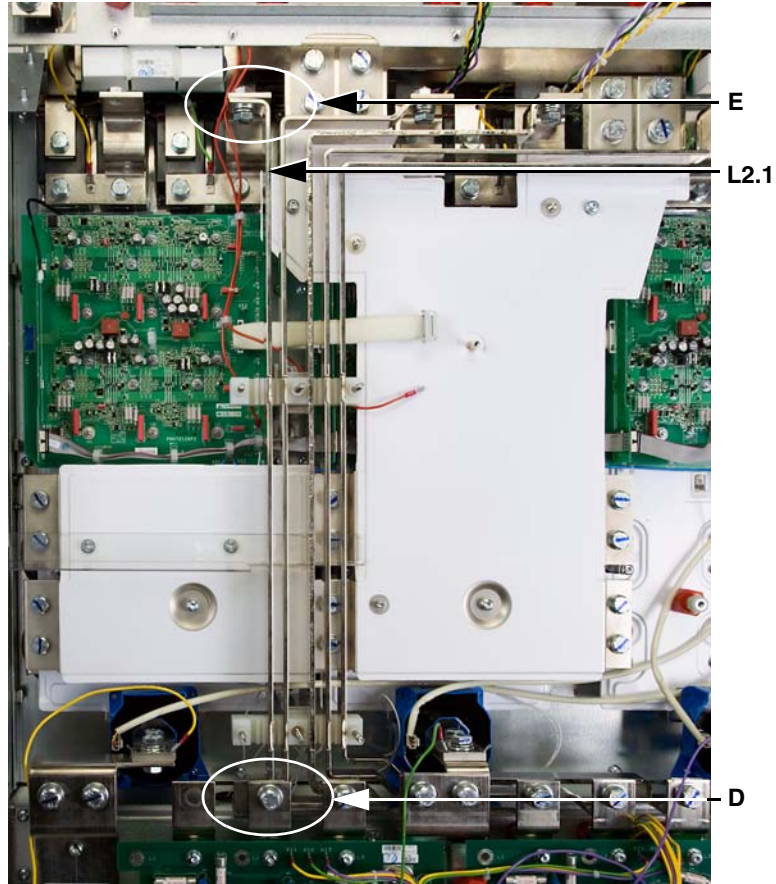

11. Replace the L1.1 input bus bar as follows.
 - Position the bus bar in the drive as illustrated in Figure 173.
 - Using an 18 mm socket wrench, secure the top of the L1.1 input bus bar to the L1.1 rectifier with one bolt and washer (**C**, Figure 173).
 - Using an 18 mm socket wrench, secure the bottom of the L1.1 input bus bar to the R/L1.1 bus bar with one bolt and washer (**B**, Figure 173).
 - Tighten the hardware to the torque values specified in Table 55.

Figure 173: L1.1 Input Bus Bar

Table 55: L1.1 Input Bus Bar Hardware Torque Values

Item	Description	Torque Range	
		N•m	lb-in
B	(1) 18-mm bolt and washer	45	398
C	(1) 18-mm bolt and washer	45	398

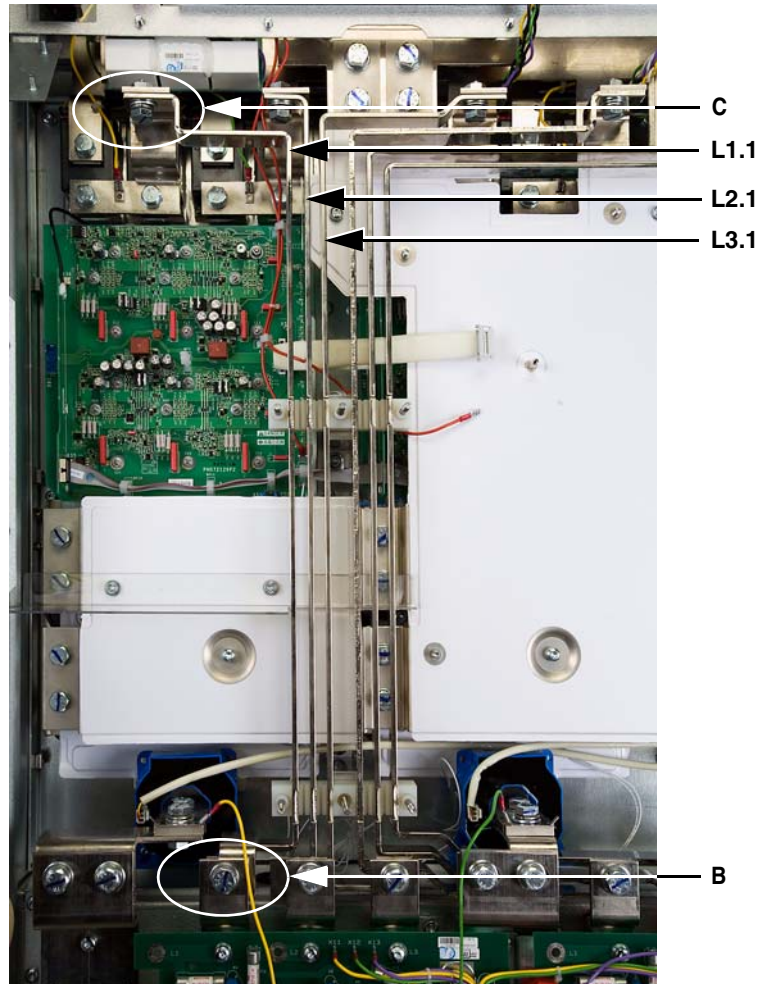

Replace the Input Bus Bar Brackets (Top)

12. Using a 10 mm socket wrench, secure the top half of the input bus bar brackets to the bottom half with six nuts (A). See Figure 174. Tighten the nuts to 5.5 N•m (48.7 lb-in).

Before installing the brackets, ensure that they have no tears or cracks. If the brackets are damaged, install a new piece from the plastic kit. See page 22.

Figure 174: Input Bus Bar Brackets, Top

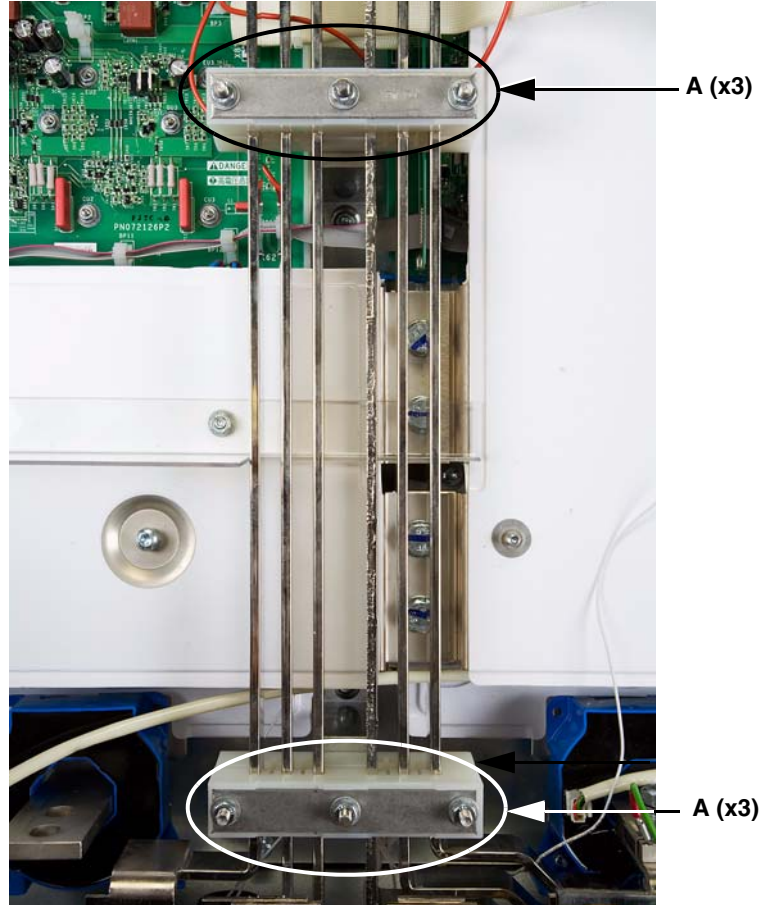

Replace the Rectifier Shield

13. Replace the plastic rectifier shield over the bus bars. See Figure 175. If the rectifier shield is cracked, broken, or damaged, replace it with a piece from the plastic kit. See "Replacing the Plastic Parts Kit VY1A1406" on page 22.

⚠ DANGER

HAZARD OF ELECTRIC SHOCK, EXPLOSION, OR ARC FLASH

- Install the rectifier shield as shown in Figure 175.
- Before installing the shield, ensure that it has no tears or cracks. If the shield is damaged, install a new piece from the plastic kit. See page 22.
- Do not install a damaged shield.

Failure to follow these instructions will result in death or serious injury.

Figure 175: Rectifier Shield

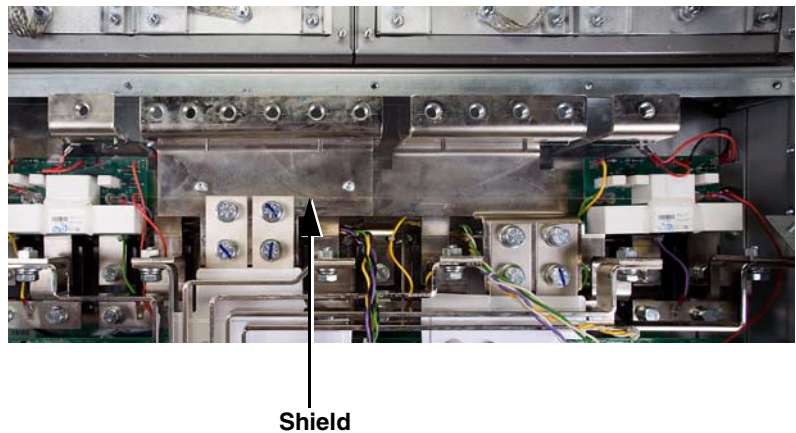

Replace the Top Terminal Bracket

Table 56: Top Terminal Bracket and Bus Bar Hardware Torque Values

Item	Description	Torque Range	
		N•m	lb-in
A	(6) T-30 screws	5.5	48.7
B	(5) T-30 screws	5.5	48.7
C	(10) 18-mm bolts	45	398

14. Replace the top terminal bracket as follows.

- Using a T-30 Torx driver, secure the top terminal bracket to the drive frame with five screws (B, Figure 176). Tighten the screws to the torque values specified in Table 56.
- Using a T-30 right-angle Torx driver, secure the PO.1, PA/+, PC/-, and PO.2 bus bars to the red insulators on the terminal bracket with six screws (A, Figures 177 and 178). Tighten the screws to the torque values specified in Table 56.
- Using an 18 mm socket wrench, replace ten bolts (C, Figure 179 on page 161) in the PO.1, PA/+, PC/-, and PO.2 bus bars. Tighten the bolts to the torque values specified in Table 56.

Figure 176: Top Terminal Bracket Mounting Hardware



Figure 177: Top Terminal Bracket Bus Bar Connections

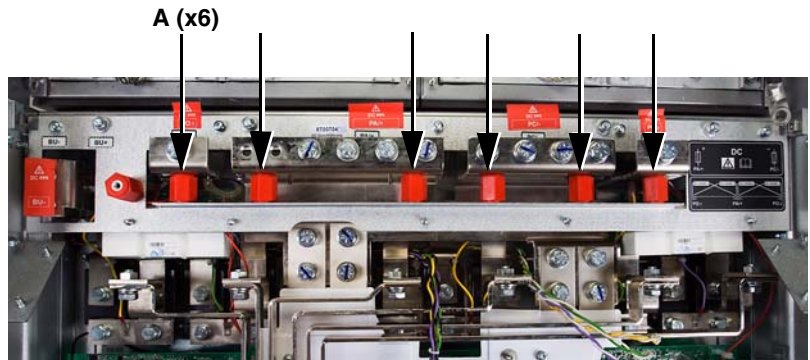
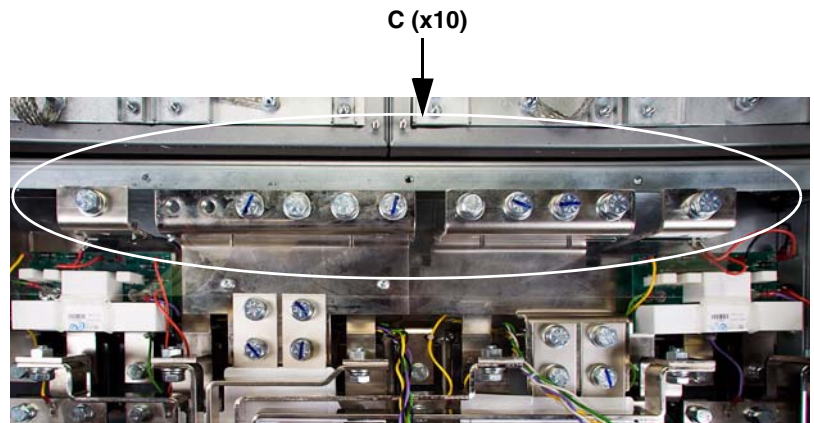

Figure 178: Bus Bar Connection Detail



Figure 179: Bus Bar Connections



Replace the Fan Bracket

Table 57: Fan Bracket and BU (+) Bus Bar Hardware Torque Values

Item	Description	Torque Range	
		N•m	lb-in
A	(2) 18-mm bolts and washers	45	398
B	(1) T-30 screw	5.5	48.7
C	(6) 10-mm nuts	5.5	48.7

15. Using a 10 mm socket wrench, secure the fan bracket to the top terminal bracket (C) and the drive frame with nine nuts. See Figure 180. Tighten the nuts to the torque values specified in Table 57.

Figure 180: Fan Bracket

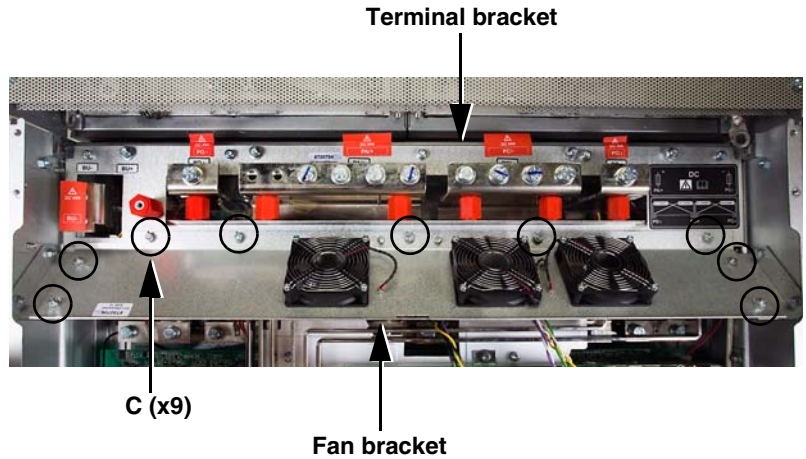

Replace the BU (+) Bus Bar

16. Replace the BU (+) bus bar as follows. See Figure 181.

- Using an 18 mm socket wrench, secure the BU (+) bus bar to the PA/+ bus with two bolts and washers (A).
- Using a T-30 Torx driver, secure the BU (+) bus bar to the red insulator on the top terminal bracket with one screw (B).
- Tighten the hardware to the torque values specified in Table 57.

Figure 181: BU (+) Bus Bar

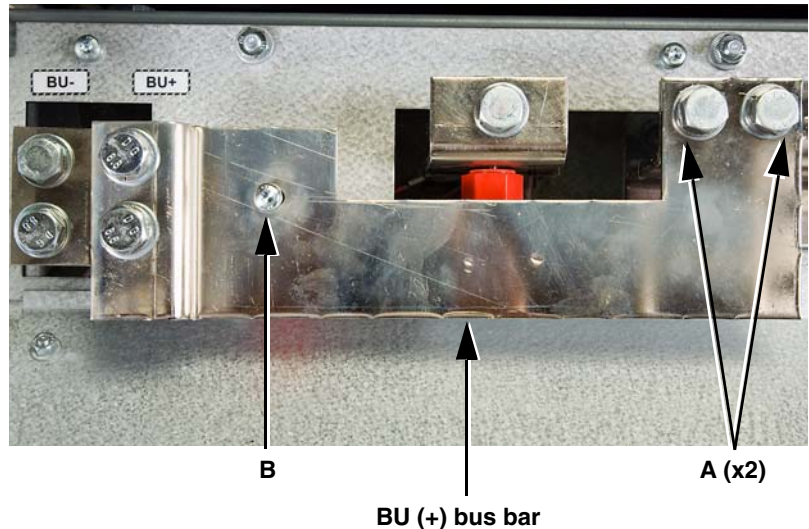

Replace the Power Board Assembly

NOTE: The power board assembly consists of the power board, the motor control board, fan control boards 1 and 2, and the brake board.

17. Replace the power board assembly as follows.

- Position the assembly in the drive as shown in Figure 182.
- Using a T-30 Torx driver, secure the power board assembly to the phase W DC bus plate with one screw and washer (**D**, Figure 182).
- Using a 10 mm socket wrench, secure the power board assembly to the bus plate assembly with three nuts (**C**, Figure 182).

Figure 182: Power Board Assembly

Table 58: Power Board Assy Hardware Torque Values

Item	Description	Torque Range	
		N•m	lb-in
A	(1) 21-mm insulator	5.5	48.7
B	(1) T-10 screw	0.8	7.1
C	(3) 10-mm nuts	5.5	48.7
D	(1) T-30 screw and washer	5.5	48.7

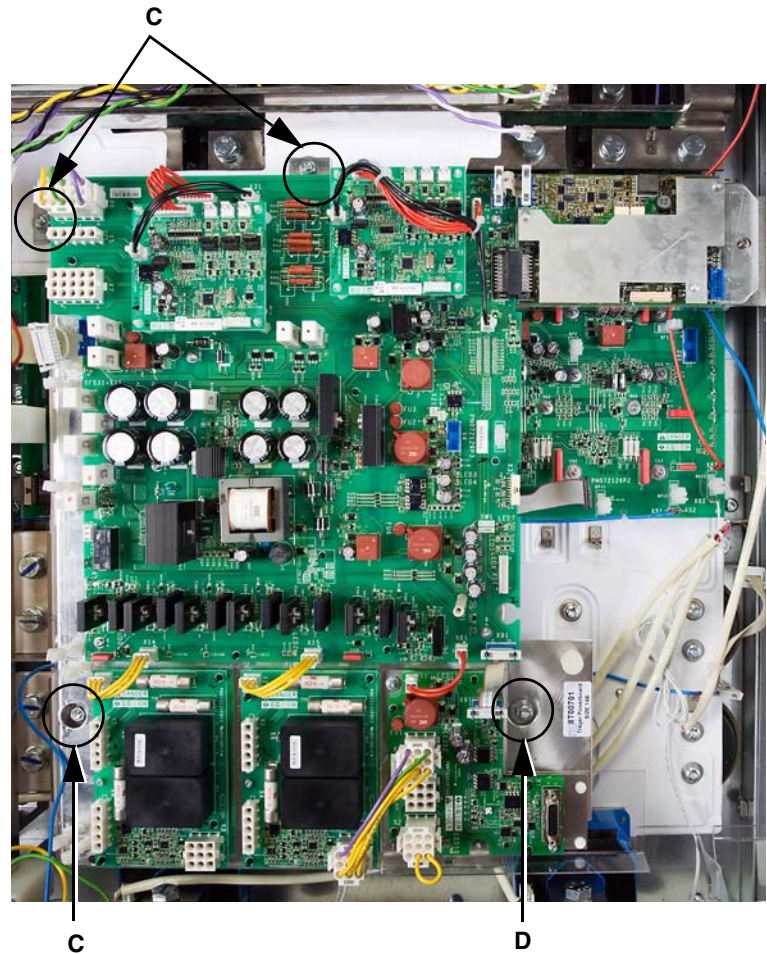

- Using a T-10 Torx driver, replace one screw (**B**, Figure 183) in power board terminal UD+1.
- Using a 21 mm socket wrench, replace the red insulator (**A**) on the assembly plate. See Figure 184.
- Connect wire E132 to the lug on the insulator. See Figure 184. The wire originates from terminal X53 on gate driver board W.
- Tighten the hardware to the torque values specified in Table 58 on page 163.

Figure 183: Power Board, Terminal UD+1

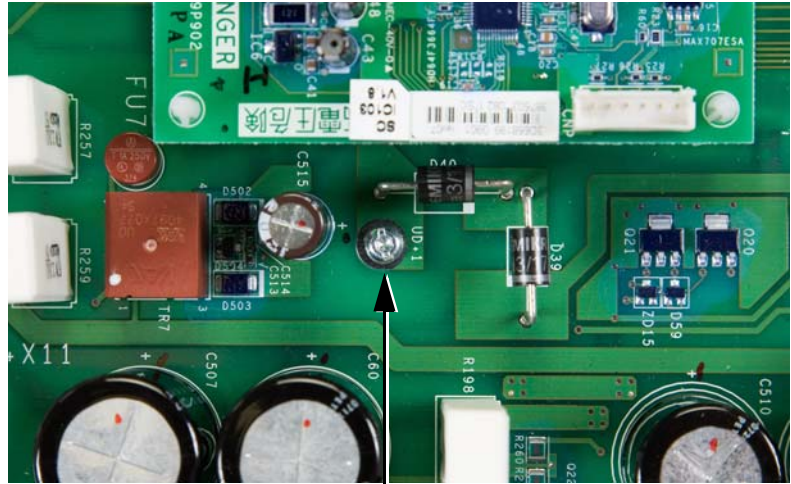

B (UD+1)

Figure 184: Wire E132 Connection

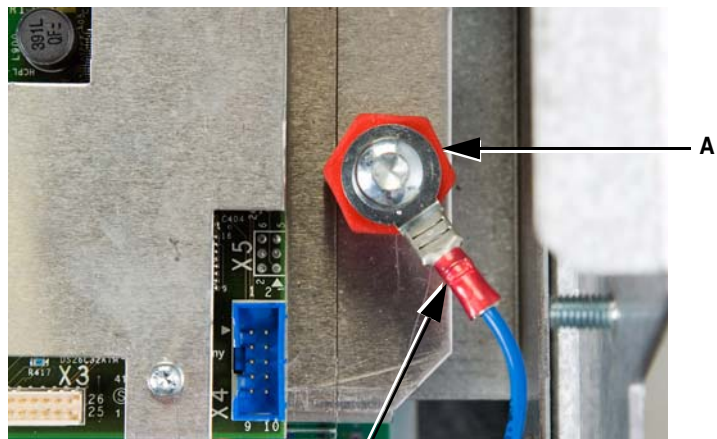

Wire E132

Replace the Fan Control Board Connections

18. Replace the following connections. See Figure 185 for terminal locations.
 - Replace the connections on terminal X1 of fan control boards 1 and 2.
 - Replace the connection on terminal X3 of fan control board 1.
 - Replace the connection on terminal X33 of the brake board.

Figure 185: Fan Control Board and Brake Board Connections

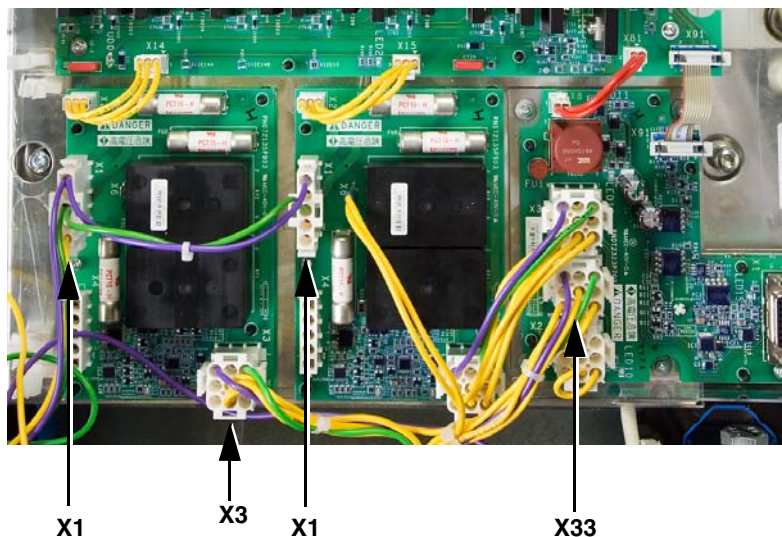

Replace the Power Board Connections

Table 59: Power Board Wiring

Wire No. ¹	Terminal No.	Description	To:
E103	X11	9-pin, multi color	Motor current sensors
E136	UD0	1-pin, blue	Phase-W DC bus plate
E126	RFS 31+ X11	1-pin, red	SB ² 1 X11
E141	UD -R1	1-pin, white	Bleeder resistor 1
E142	X3	18-pin, gray	GDB ³ W X32
E112	X4	10-pin, gray	Control module
E150	X5	5-pin, yellow/green/violet	Sensor plates on output bus bars T1, T2, T3
E120	X7	15-pin, yellow/green/violet	FB ⁴ 1&2 X11, X12, X13
E100	X8	14-pin, white	GDB U X82
E106	X21	2-pin, red/black	Internal fan
E106	X22	2-pin, red/black	Internal fan
—	X16	Not used	—

¹ See the schematic on page 175 for complete drive wiring. Wire numbers are given for cross referencing the wires with the wiring table and the schematic. The numbers do not appear on the wires.
² SB: SCR Snubber board
³ GDB: Gate driver board
⁴ FB: Filter board

NOTE: Take care not to damage the LED (see Figure 186) when removing, handling, or installing the power board.

19. Replace the power board connections listed in Table 59. See Figure 186 for the connection locations.

Figure 186: Power Board Connections

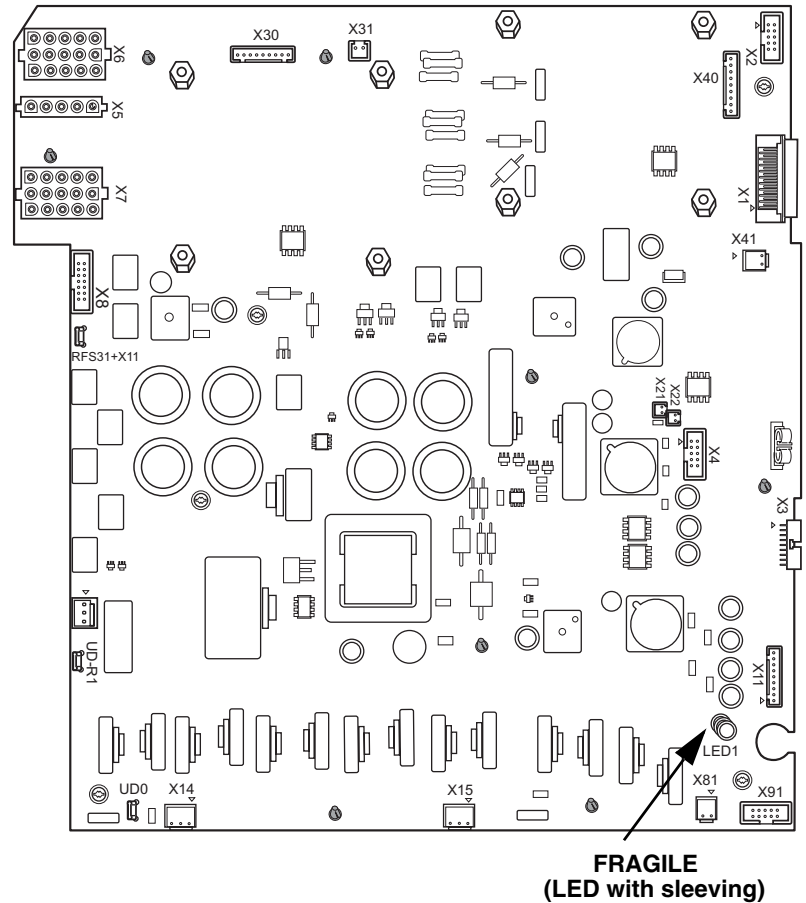

Replace the Connections on Soft Charge Boards 1 and 2

20. Replace soft charge board connections CNL1G, CNL2G, and CNL3G on soft charge boards 1 and 2. See Figure 187 for terminal locations.

Figure 187: Soft Charge Board: Board 1 (Left) Shown

Table 60: Soft Charge Board Wiring

Wire No. ¹	Terminal No.	Description	To:
Soft Charge Board 1 (Left Board)			
E110	CN2A	9-pin, red	PB ² X30 (9-pin)
E109	CNL3G	2-pin, violet/black	SCR ³ L3.1 Terms. 4 & 5
E108	CNL2G	2-pin, green/black	SCR L2.1 Terms. 4 & 5
E107	CNL1G	2-pin, yellow/black	SCR L1.1 Terms. 4 & 5
E111	CN7A	2-pin, black	PB X31
—	CNP	Not used	—
Soft Charge Board 2 (Right Board)			
E156	CN2A	9-pin, red	PB ² X40 (9-pin)
E152	CNL3G	2-pin, violet/white	SCR ³ L3.2 Terms. 4 & 5
E153	CNL2G	2-pin, green/white	SCR L2.2 Terms. 4 & 5
E154	CNL1G	2-pin, yellow/white	SCR L1.2 Terms. 4 & 5
E155	CN7A	2-pin, black	PB ² X41
—	CNP	Not used	—

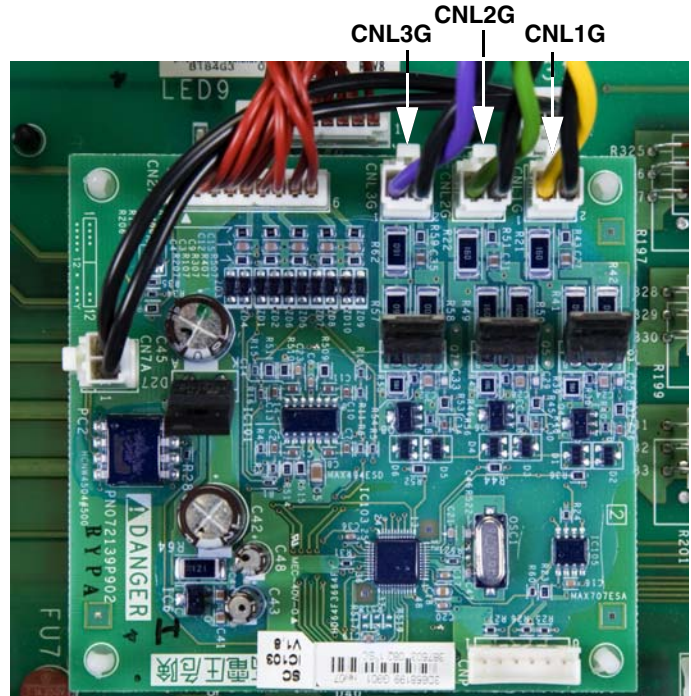

¹ See the schematic on page 175 for complete drive wiring. Wire numbers are given for cross referencing the wires with the wiring table and the schematic. The numbers do not appear on the wires.

² PB: Power board

³ SCR: Silicon controlled rectifier. L1.1, L2.1, and L3.1 are associated with input rectifier 1; L1.2, L2.2, and L3.2 are associated with input rectifier 2.

Replace the Control Module Assembly

21. Replace the control module assembly as follows.

- Connect the ribbon cable (wire **E112**, Figure 188) from power board terminal X4 to the back of the control module assembly.

Figure 188: Control Module Assembly Back

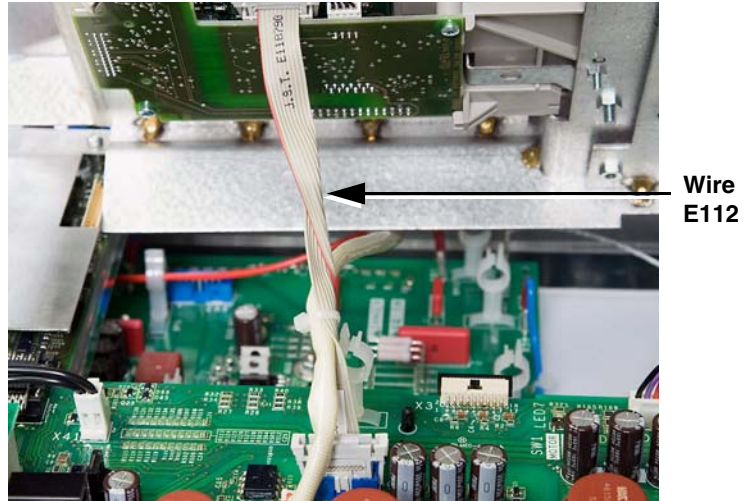

- Using a 10 mm socket wrench, secure the control module assembly to the drive frame with two nuts (Figure 189). Tighten the nuts to 5.5 N•m (48.7 lb-in).

Figure 189: Control Module Assembly, Front

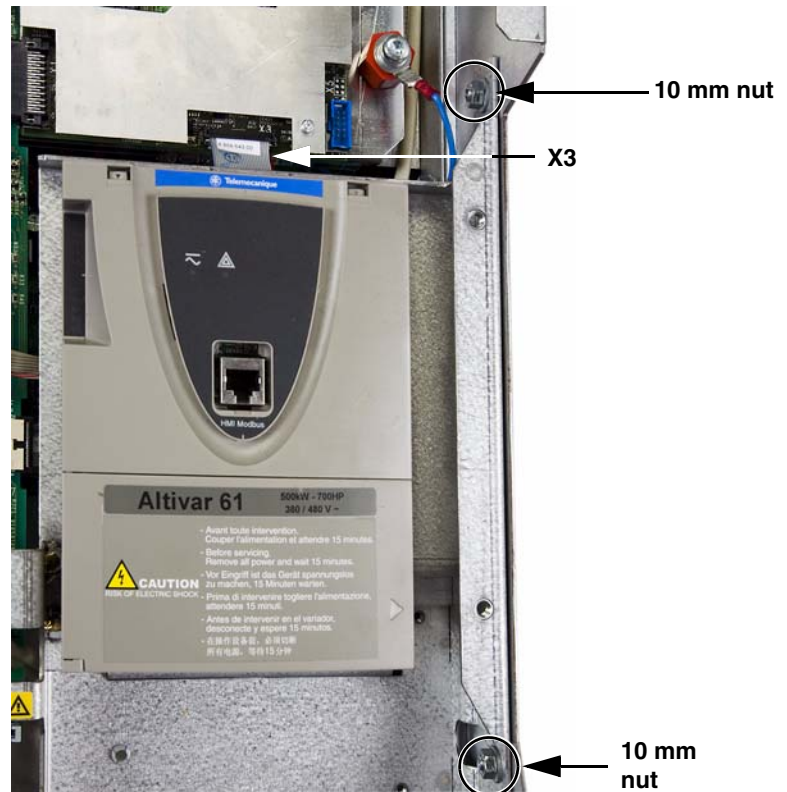

- Install the 26-pin ribbon cable from the control module assembly to motor control board terminal X3. See Figure 189 on page 168.
- Install the 5-pin connectors at terminal X4 of fan control boards 1 and 2. See Figure 190.

Figure 190: Fan Control Boards 1 and 2, Terminal X4

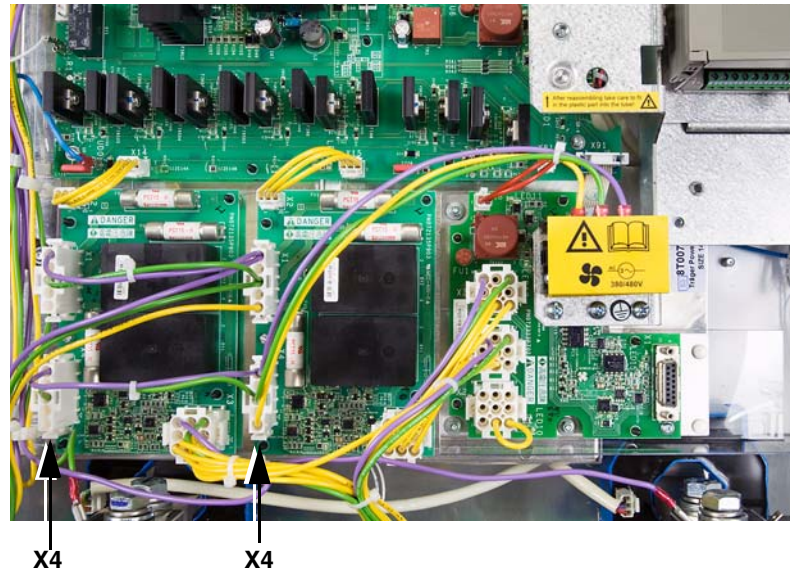

Replace the EMC Tray

22. Using a T-20 Torx driver, secure the EMC tray to the control module plate with three screws. See Figure 191. Tighten the screws to 1.1–1.7 N•m (9.7–15.0 lb-in).

Figure 191: EMC Tray



Replace the Middle Crossbrace

23. Replace the middle crossbrace as follows.

- Using a 10 mm socket wrench, secure the crossbrace to the fan bracket with two nuts (**A**). See Figure 192.
- Using a T-30 Torx driver, secure the crossbrace to the filter board with one screw (**B**). See Figure 193.
- Tighten the hardware to the torque values specified in Table 61.

Table 61: Crossbrace Hardware Torque Values

Item	Description	Torque Range	
		N•m	lb-in
A	(2) 10 mm nuts	5.5	48.7
B	(1) T-30 screw	5.5	48.7

Figure 192: Middle Crossbrace Top

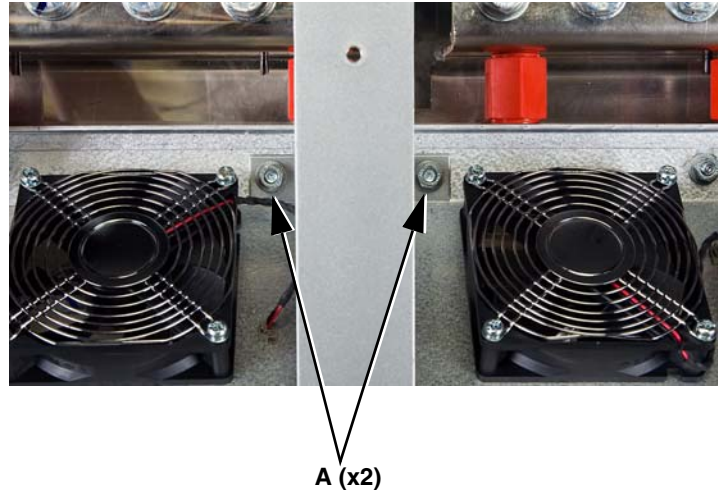
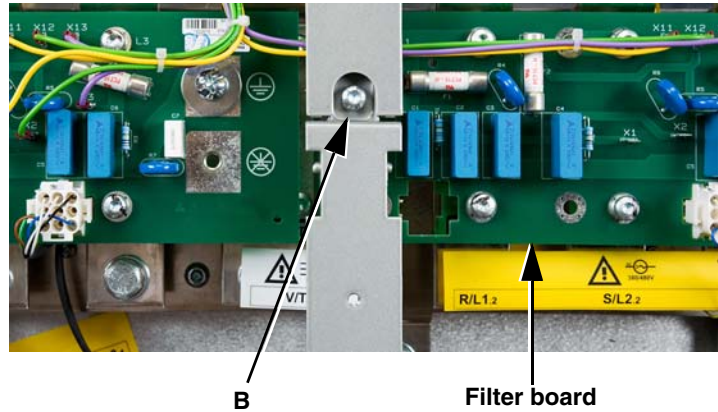

Figure 193: Middle Crossbrace Bottom



Replace the Power Terminal Shields

24. Replace the power terminal shields as follows:

- The right terminal shield has two tabs (**A**) on the right side that fit into slots on the conduit tray, and two tabs (**B**) on the left side that fit into slots on the middle crossbrace. See Figure 194.
- The left terminal shield has two tabs on the right (**C**) that fit into retaining slots in the middle crossbrace and two mounting holes (**D**) on the left that fit over posts on the side panel of the drive. See Figure 195.

Figure 194: Right Terminal Shield

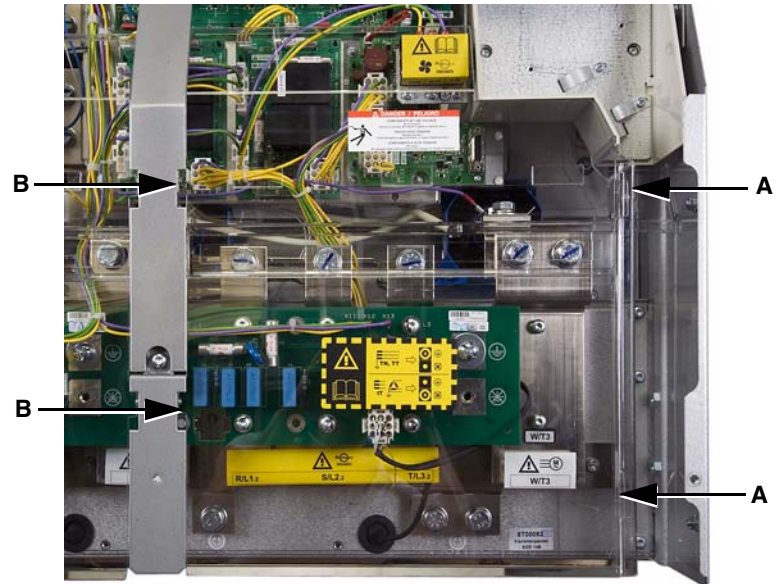
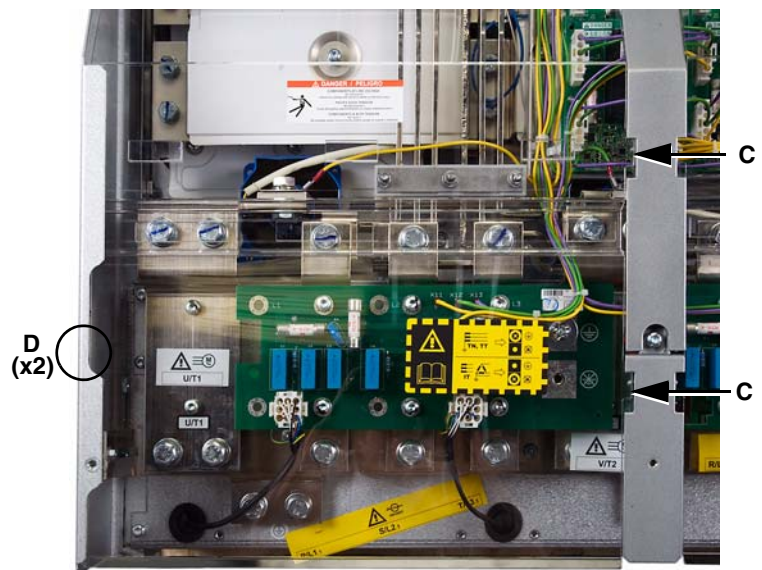

Figure 195: Left Terminal Shield



Replace the Front Cover

25. Replace the front cover. Using a size 2 Phillips driver, secure the front cover with thirteen screws. See Figure 7 on page 20. Tighten the screws to 5.5 N•m (48.7 lb-in).

Wiring

NOTE: See page 174 for the notes to the table.

Table 62: Wiring Table

Wire No. ¹	Description	From:		To:	
		Component	Terminal No.	Component	Terminal No.
E100	14-pin, white	PB ²	X8	GDB ³ U	X82
		GDB U	X82	GBD V	X81
E102	14-pin, white	GDB V	X82	GDB W	X81
E103	9-pin, multi color	PB	X11	Motor current sensors	
E105	3-pin, yellow	PB	X14	FCB ⁴ 1	X2
E106	2-pin, red/black	PB	X21	Internal fan	—
	2-pin, red/black	PB	X22	Internal fan	—
E107	2-pin, yellow/black	SCB ⁵ 1	CNL1G	SCR ⁶ L1.1	4&5
E108	2-pin, green/black	SCB1	CNL2G	SCR L2.1	4 & 5
E109	2-pin, violet/black	SCB1	CNL3G	SCR L3.1	4 & 5
E110	9-pin, red	PB	X30	SCB1	CN2A
E111	2-pin, black	PB	X31	SCB1	CN7A
E112	10-pin, gray	PB	X4	Control module	—
E114	9-pin, yellow/green/violet	FCB 1	X3	FB ⁷ 1	X11, X12
				FB2	X13
				BB	X33
E115	9-pin, black	FB1	X11	Heatsink fan 1	—
E120	15-pin, yellow/green/violet	PB	X7	FB 1 & 2	X11, X12, X13
	5-pin, yellow/green/violet	FCB 2	X1	FCB1	X1
				FB1	X1, X2, X3
E123	1-pin, blue	GDB V	X52	GDB W	X51
E124	5-pin, 2-wire, violet/green	FCB 1	X4	FCB 2	TB1, X4
E125	9-pin, black	FB1	X12	Heatsink fan 2	—
E126	1-pin, red	PB	RFS 31+X11	SB ⁸ 1	X11
	1-pin, red	SB1	X10	GDB U	X61
E127	1-pin, blue	GDB U	X52	GDB V	X51
E128	2-pin, black	GDB V	X4	Temp. sensor V	—
E129	1-pin, blue	GDB U	X51	DC bus plate	UD0
E130	1-pin, red	SB1	X4	PO.1 bus bar	—
E131	1-pin, yellow	SB1	X1	SCR L1.1	—
E132	1-pin, blue	GDB W	X53	Insulator near MCB ⁹	—
E133	1-pin, black	SB1	X5	PC/- bus bar	—

Table 62: Wiring Table (continued)

Wire No. ¹	Description	From:		To:	
		Component	Terminal No.	Component	Terminal No.
E136	1-pin, blue	PB	UD0	Phase W DC bus plate	—
E138	18-pin, gray	GDB U	X32	GDB V	X31
E139	1-pin, white	GDB U	X62	Bleeder resistor 1	—
E141	1-pin, white	PB	UD -R1	Bleeder resistor 1	—
E142	18-pin, gray	PB	X3	GDB W	X32
E144	2-pin, black	GDB U	X4	Temp. sensor U	—
E145	2-pin, black	GDB W	X4	Temp. sensor W	—
E146	18-pin, gray	GDB V	X32	GDB W	X31
E147	3-pin, yellow	PB	X15	FCB 2	X2
E148	2-pin, red	PB	X81	BB ¹⁰	X8
E149	10-pin, gray	PB	X91	BB	X91
E150	5-pin, yellow/green/violet	PB	X5	Sensor plates on output bus bars T1, T2, T3	—
E151	9-pin, yellow/green/violet	FCB 2	X3	BB	X3
E152	2-pin, violet/white	SCB 2	CNL3G	SCR L3.2	4 & 5
E153	2-pin, green/white	SCB 2	CNL2G	SCR L2.2	4 & 5
E154	2-pin, yellow/white	SCB 2	CNL1G	SCR L1.2	4 & 5
E155	2-pin, black	PB	X41	SCB2	CN7A
E156	9-pin, red	PB	X40	SCB2	CN2A
E157	1-pin, yellow	SB 2	X1	Phase L 1.2 input bar	—
E158	1-pin, red	SB 2	X4	P0.2 input bar	—
E159	1-pin, black	SB 2	X5	PC/- bus bar	—
E160	1-pin, red	SB 2	X10	GDB W	X61
E161	1-pin, white	Bleeder resistor 2	—	UDV + Bus	—
E162	1-pin, white	Bleeder resistor 2	—	UDV - Bus	—
E163	1-pin, white	Bleeder resistor 3	—	UDW - Bus	—
E164	1-pin, white	Bleeder resistor 3	—	GDB W	X62
E165	9-pin, black	FB2	X13	Heatsink fan 3	—
E167	1-pin, green	SB1	L2	SCR L2.1	—
E168	1-pin, violet	SB1	X3	SCR L3.1	—

Table 62: Wiring Table (continued)

Wire No. ¹	Description	From:		To:	
		Component	Terminal No.	Component	Terminal No.
E169	1-pin, green	SB 2	L2	Phase L2.2 input bar	—
E170	1-pin, violet	SB 2	X3	Phase L3.2 input bar	—
—	10-pin, white	PB	X2	MCB	X2
—	15-pin, yellow/green/violet	PB	X6	—	—

¹ Wire numbers are given for cross referencing the wires with the schematic on page 175. The numbers do not appear on the wires.

² PB: Power board

³ GDB: Gate driver board

⁴ FCB: Fan control board

⁵ SCB: Soft charge board

⁶ SCR: Silicon controlled rectifier

⁷ FB: Filter board

⁸ SB: SCR snubber board

⁹ MCB: Motor control board

¹⁰ BB: Brake board

Figure 196: Wiring Schematic

NOTE: The wiring schematic illustrates connections between the components in the drive. It does not illustrate the layout of the various boards or the connector locations on them.

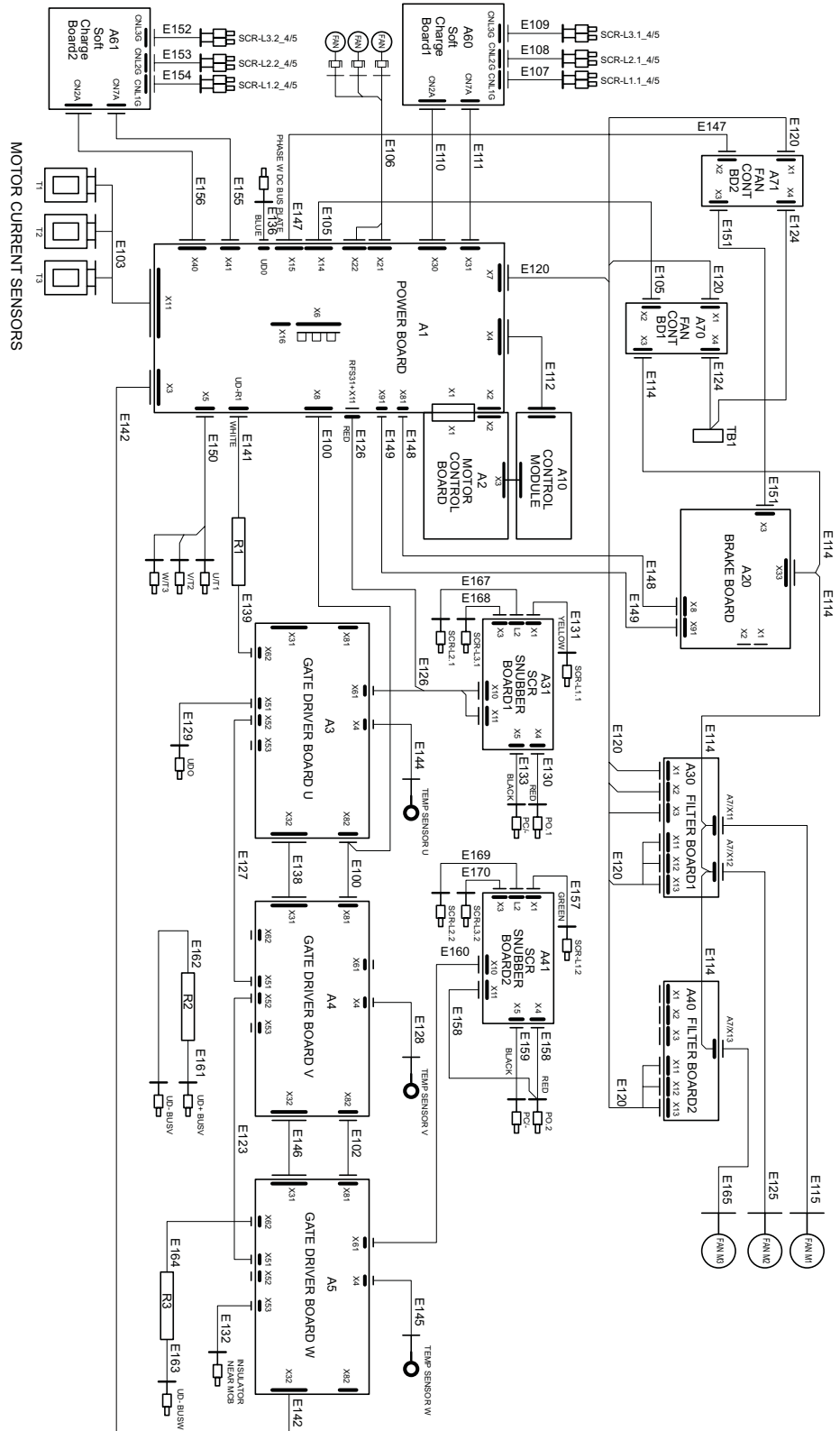

**Spare Parts Kits for Altivar[®] 61/71 Drives, Frame Size 14B
Instruction Bulletin**

Schneider Electric

8001 Knightdale Blvd.
Knightdale, NC 27545 USA
1-888-SquareD
(1-888-778-2733)
www.schneider-electric.us

Altivar[®] is a registered trademark of Schneider Electric. Other trademarks used herein are the property of their respective owners.

Electrical equipment should be installed, operated, serviced, and maintained only by qualified personnel. No responsibility is assumed by Schneider Electric for any consequences arising out of the use of this material.

30072-452-98 © 2009 Schneider Electric All Rights Reserved