

SpaceLogic Sensors

SLP Series Humidity Sensors – BACnet and Modbus



Note: A subset of models shown.

Product Description

The SpaceLogic SLP Series of humidity sensors for living space is a flexible multisensor platform for use with BAS controllers designed to accept BACnet MSTP or Modbus outputs. Housings are available in Medium matte white and Optimum faces available in black and white. All housing types are available with three user interface options: touchscreen, LCD with three buttons and blank. Humidity and temperature sensors are included with all SLP Series air quality sensors.

Features

- Medium matte white housing or optimum glass panel housing available in white or black
- Replaceable RH element available in 1% & 2% with NIST certificate
- Temperature transmitter output on all models
- 61 mm (2.4") backlit color touchscreen and LCD, three button display options available
 - Digital temperature indication (0.1° display resolution of °F or °C)
 - Digital humidity indication (0.1% RH display resolution)
 - Selectable temp, RH and fan speed setpoint
 - Configurable screen/button lock and display timeout
 - Override
- Selectable BACnet and Modbus outputs via RS-485
- 18-24 AWG screw terminals

Available Products

Model Number	RH*	Temp	Housing	User Interface
SLPWTX2	X	X	Optimum White	Touchscreen
SLPWXL2	X	X	Optimum White	LCD / 3 Buttons
SLPWXX2	X	X	Optimum White	Blank
SLPBTX2	X	X	Optimum Black	Touchscreen
SLPBLX2	X	X	Optimum Black	LCD / 3 Buttons
SLPBXX2	X	X	Optimum Black	Blank
SLPSTX2	X	X	Medium White	Touchscreen
SLPSLX2	X	X	Medium White	LCD / 3 Buttons
SLPSXX2	X	X	Medium White	Blank

*Replaceable RH module available to be ordered separately per table below.

Replaceable RH Elements

Model	Description	Temp. Calibration	RH Calibration
SLXRHS2N	Replaceable RH sensor, 2% with NIST certificate	N/A	2-point calibration
SLXRHS2X	Replaceable RH sensor, 2%	N/A	2-point calibration
SLXRHS1N	Replaceable RH sensor, 1% with NIST certificate	N/A	2-point calibration

USA: +1 888-444-1311
 Europe: +46 10 478 2000
 Asia: +65 6484 7877
www.schneider-electric.com

Life Is On

Schneider
Electric

Specifications

Operating Environment	
Input power	Class 2; 20 to 30 Vdc, 24 Vac, 50 to 60 Hz
Protocol output	BACnet or Modbus via RS-485, selectable
Operating temp. range	0 to 50 °C (32 to 122 °F)
Operating humidity range	0 to 95% RH non-condensing
Housing material	High impact ABS plastic
IP rating	IP 30
Mounting location	For indoor use only. Not suitable for wet locations.
Surface mount	The device can be surface mounted on Single Gang J-Box, British Standard and CE60 wall boxes
RH Sensor	
HS sensor	Solid state capacitive, replaceable
Accuracy (includes hysteresis)*	±3.8% RH from 10 to 60% RH @ 25°C (77 °F) ±4.8% RH from 60 to 80% RH @ 25°C (77 °F) ±5.8% RH from 80 to 100% RH @ 25°C (77 °F)
Linearity	Included in accuracy specification
Stability	±1% @ 20°C (68 °F) annually for 2 years
Output range	0 to 100% RH
Temperature coefficient	±0.1% RH/°C above or below 25 °C (77 °F) typical
Temperature Sensor	
Sensor type	Solid state, integrated circuit
Accuracy	±0.2 °C (±0.4 °F) typical
Resolution	0.1 °C (0.1 °F)
Range	0 to 50 °C (32 to 122 °F)
Display Models	
Touchscreen	61 mm (2.4 in), color, backlit, capacitive, 240x300px Setpoint: Temperature, humidity or fan speed selectable Timeout override: Display timeout Lockout override: Touchscreen/button lockout
LCD	52mm (2.05 in), segmented with 3 buttons Setpoint: Temperature, humidity or fan speed selectable Timeout override: Display timeout Lockout override: Touchscreen/button lockout
Setpoints**	
Temperature setpoint	Scale: 0 to 50 °C (32 to 122 °F) max., adjustable span
Humidity setpoint	Scale: 0 to 100% RH
Fan speed setpoint	Off, Low, Med., High, Auto
Override	
Override button	Display models feature momentary override button

Wiring Terminals	
Terminal blocks	Screw terminals, 18-24 AWG
Screw terminal torque	0.2 N-m (2.0 in-lbF) max.
Regulatory Information	
	UL 916
	European Conformance CE: EN 60730-1, EN 60730-2-9, EN 60730-2-13, EN 61000-6-2, EN 61000-6-3, EN 61000 Series - Industrial Immunity, EN 61326-1
Agency approvals	FCC Part 15 Class B, REACH, RoHS, Green Premium, RCM (Australia), ICES-003 (Canada), EAC (Russia), UKCA (UK)

*Humidity sensor overall accuracy should include: accuracy, temperature coefficient and stability. Humidity accuracy is shown as an absolute value, so if testing accuracy with a hand-held device, you must check for deviation in its readings instead of calculating the percentual deviation. Additionally, you must consider the overall accuracy of the hand-held device in the comparison.

**On display models only.

Dimensions mm (in.)

Optimum Housing

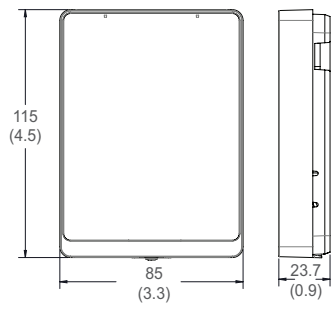

Medium Housing

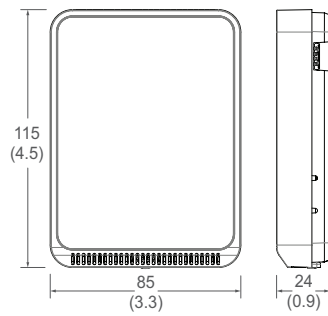

Power Table

Model	Description	Max. VA
SLPxLxx	LCD Temperature/Humidity	1.08
SLPxTxxx	Touch Temperature/Humidity	1.248
SLPxXxxx	Blank Temperature/Humidity	1.08

Note: Model numbers based on supported product matrix.

Housing Finishes



Optimum White



Optimum Black



Medium White

User Interface Types



Touchscreen



LCD with Buttons



Blank