

SpaceLogic Sensors

SLA Series Air Quality Sensors – Analog



Note: A subset of models shown.

Product Description

The SpaceLogic SLA Series of air quality sensors for living space is a flexible multisensor platform for use with BAS controllers designed to accept 4 to 20mA, 0 to 5Vdc or 0 to 10Vdc outputs. Housings are available in Medium matte white and Optimum faces available in black and white. All housing types are available with three user interface options: touchscreen, LCD with three buttons and blank. CO₂ and temperature sensors are included with all SLA Series air quality sensors. Models with VOC sensors and relative humidity sensors are also available.

Features

- Medium matte white housing or optimum glass panel housing available in white or black
- Field calibratable non-dispersive infrared CO₂ sensor
- Replaceable RH element available in 1% & 2% with NIST certificate
- VOC sensor available
- Temperature output on all models
- 61 mm (2.4") backlit color touchscreen and LCD, three button display options available
 - Digital temperature indication (0.1° display resolution of °F or °C)
 - Digital humidity indication (0.1% RH display resolution)
 - Digital CO₂ indication
 - 0 to 10,000 ppm output
 - 1 ppm resolution
 - Stoplight feature for visual indication at user-configurable CO₂ threshold levels (touchscreen models only)
 - Selectable temp, RH and fan speed setpoint (0-10V)
 - Configurable screen/button lock and display timeout
 - Override
- Selectable 4 to 20mA, 0 to 5V and 0 to 10V analog outputs
- 18-24 AWG screw terminals

Available Products

Model Number	Description	User Interface	CO ₂ / VOC	RH*	Housing Finish
SLABLC2	SLA Prem HSG CO ₂ LCD/3 Button	LCD / 3 Buttons	NDIR CO ₂	2% RH Sensor	Optimum, Black
SLABLCV2	SLA Prem HSG CO ₂ LCD/3 Button	LCD / 3 Buttons	NDIR CO ₂ / VOC	2% RH Sensor	Optimum, Black
SLABLCVX	SLA Prem HSG CO ₂ LCD/3 Button	LCD / 3 Buttons	NDIR CO ₂ / VOC	None	Optimum, Black
SLABLCX	SLA Prem HSG CO ₂ LCD/3 Button	LCD / 3 Buttons	NDIR CO ₂	None	Optimum, Black
SLABTC2	SLA Prem HSG CO ₂ Touchscreen	Touchscreen	NDIR CO ₂	2% RH Sensor	Optimum, Black
SLABTCV2	SLA Prem HSG CO ₂ Touchscreen	Touchscreen	NDIR CO ₂ / VOC	2% RH Sensor	Optimum, Black
SLABTCVX	SLA Prem HSG CO ₂ Touchscreen	Touchscreen	NDIR CO ₂ / VOC	None	Optimum, Black
SLABTCX	SLA Prem HSG CO ₂ Touchscreen	Touchscreen	NDIR CO ₂	None	Optimum, Black
SLABXC2	SLA Prem HSG CO ₂ Blank	None	NDIR CO ₂	2% RH Sensor	Optimum, Black
SLABXCV2	SLA Prem HSG CO ₂ Blank	None	NDIR CO ₂ / VOC	2% RH Sensor	Optimum, Black
SLABXCVX	SLA Prem HSG CO ₂ Blank	None	NDIR CO ₂ / VOC	None	Optimum, Black
SLABXCX	SLA Prem HSG CO ₂ Blank	None	NDIR CO ₂	None	Optimum, Black
SLASLC2	SLA CO ₂ LCD/3 Button	LCD / 3 Buttons	NDIR CO ₂	2% RH Sensor	Medium, White

USA: +1 888-444-1311
 Europe: +46 10 478 2000
 Asia: +65 6484 7877
www.schneider-electric.com

Life Is On

Schneider
Electric

Available Products Matrix

Model Number	Description	User Interface	CO2 / VOC	RH*	Housing Finish
SLASLCV2	SLA CO2 LCD/3 Button	LCD / 3 Buttons	NDIR CO2 / VOC	2% RH Sensor	Medium, White
SLASLCVX	SLA CO2 LCD/3 Button	LCD / 3 Buttons	NDIR CO2 / VOC	None	Medium, White
SLASLCX	SLA CO2 LCD/3 Button	LCD / 3 Buttons	NDIR CO2	None	Medium, White
SLASTC2	SLA CO2 Touchscreen	Touchscreen	NDIR CO2	2% RH Sensor	Medium, White
SLASTCV2	SLA CO2 Touchscreen	Touchscreen	NDIR CO2 / VOC	2% RH Sensor	Medium, White
SLASTCVX	SLA CO2 Touchscreen	Touchscreen	NDIR CO2 / VOC	None	Medium, White
SLASTCX	SLA CO2 Touchscreen	Touchscreen	NDIR CO2	None	Medium, White
SLASXC2	SLA CO2 Blank	None	NDIR CO2	2% RH Sensor	Medium, White
SLASXCV2	SLA CO2 Blank	None	NDIR CO2 / VOC	2% RH Sensor	Medium, White
SLASXCVX	SLA CO2 Blank	None	NDIR CO2 / VOC	None	Medium, White
SLASXCX	SLA CO2 Blank	None	NDIR CO2	None	Medium, White
SLAWLC2	SLA Prem HSG CO2 LCD/3 Button	LCD / 3 Buttons	NDIR CO2	2% RH Sensor	Optimum, White
SLAWLCV2	SLA Prem HSG CO2 LCD/3 Button	LCD / 3 Buttons	NDIR CO2 / VOC	2% RH Sensor	Optimum, White
SLAWLCVX	SLA Prem HSG CO2 LCD/3 Button	LCD / 3 Buttons	NDIR CO2 / VOC	None	Optimum, White
SLAWLCX	SLA Prem HSG CO2 LCD/3 Button	LCD / 3 Buttons	NDIR CO2	None	Optimum, White
SLAWTC2	SLA Prem HSG CO2 Touchscreen	Touchscreen	NDIR CO2	2% RH Sensor	Optimum, White
SLAWTCV2	SLA Prem HSG CO2 Touchscreen	Touchscreen	NDIR CO2 / VOC	2% RH Sensor	Optimum, White
SLAWTCVX	SLA Prem HSG CO2 Touchscreen	Touchscreen	NDIR CO2 / VOC	None	Optimum, White
SLAWTCX	SLA Prem HSG CO2 Touchscreen	Touchscreen	NDIR CO2	None	Optimum, White
SLAWXC2	SLA Prem HSG CO2 Blank	None	NDIR CO2	2% RH Sensor	Optimum, White
SLAWXCV2	SLA Prem HSG CO2 Blank	None	NDIR CO2 / VOC	2% RH Sensor	Optimum, White
SLAWXCVX	SLA Prem HSG CO2 Blank	None	NDIR CO2 / VOC	None	Optimum, White
SLAWXCX	SLA Prem HSG CO2 Blank	None	NDIR CO2	None	Optimum, White

*Replaceable RH module available to be ordered separately per table below.

Replaceable RH Elements

Model	Description	Temp. Calibration	RH Calibration
SLXRHS2N	Replaceable RH sensor, 2% with NIST certificate	N/A	2-point calibration
SLXRHS2X	Replaceable RH sensor, 2%	N/A	2-point calibration
SLXRHS1N	Replaceable RH sensor, 1% with NIST certificate	N/A	2-point calibration

USA: +1 888-444-1311
 Europe: +46 10 478 2000
 Asia: +65 6484 7877
www.schneider-electric.com

Life Is On

Schneider
Electric

Operating Environment

Input power	Class 2; 20 to 30 Vdc, 24 Vac, 50 to 60 Hz
Analog output	Selectable 4 to 20 mA, 0 to 5 V, 0 to 10 V
Operating temp. range	0 to 50 °C (32 to 122 °F)
Operating humidity range	0 to 95% RH non-condensing
Housing material	High impact ABS plastic
IP rating	IP 30
Mounting location	For indoor use only. Not suitable for wet locations.
Surface mount	The device can be surface mounted on Single Gang J-Box, British Standard and CE60 wall boxes

CO₂ Sensor

Sensor type	Non-dispersive infrared (NDIR), diffusion sampling
Output range	0 to 2000/5000 ppm (selectable)
Accuracy	±30 ppm ±3% of measured value
Repeatability	±20 ppm ±1% of measured value
Response time	<60 seconds for 90% step change

VOC Sensor

Sensor type	Solid state
Output range	0 to 100% AQI for VOC
Accuracy	±15% of measured value
Output scale	0 to 1,000 ppb of total VOC (TVOC)

	Level	Ventilation Recommendation	TVOC (ppb)
AQI table*	>61%	Greatly increased	>610
	20 to 61%	Significantly increased	200 to 610
	10 to 20%	Slightly increased	100 to 200
	5 to 10%	Average	50 to 100
	0 to 5%	Target value	0 to 50

RH Sensor

HS sensor	Solid state capacitive, replaceable
Accuracy (includes hysteresis)**	±3.8% RH from 10 to 60% RH @ 25°C (77 °F) ±4.8% RH from 60 to 80% RH @ 25°C (77 °F) ±5.8% RH from 80 to 100% RH @ 25°C (77 °F)
Linearity	Included in accuracy specification
Stability	±1% @ 20°C (68 °F) annually for 2 years
Output range	0 to 100% RH
Temperature coefficient	±0.1% RH/°C above or below 25 °C (77 °F) typical

Temperature Sensor

Sensor type	Solid state, integrated circuit
Accuracy	±0.2 °C (±0.4 °F) typical
Resolution	0.1 °C (0.1 °F)
Range	0 to 50 °C (32 to 122 °F)

Display Models

Touchscreen	61 mm (2.4 in), color, backlit, capacitive, 240x300px Setpoint: 0-10Vdc. Temperature, humidity or fan speed selectable Timeout override: Display timeout*** Lockout override: Touchscreen/button lockout***
LCD	52mm (2.05 in), segmented with 3 buttons Setpoint: 0-10Vdc. Temperature, humidity or fan speed selectable Timeout override: Display timeout*** Lockout override: Touchscreen/button lockout***

Setpoints****

Temperature setpoint	0 to 10V output Scale: 10 to 35 °C (50 to 95 °F) / 0 to 50 °C (32 to 122 °F)
Humidity setpoint	0 to 10V output Scale: 0 to 100% RH
Fan speed setpoint	0 to 10V output Off 0V, Auto 1.5V, Low 3.3V, Med. 6.7V, High 10.0V

Override

Override button	Display models feature momentary-to-ground override button
-----------------	--

Wiring Terminals

Terminal blocks	Screw terminals, 18-24 AWG
Screw terminal torque	0.2 N-m (2.0 in-lbf) max.

Regulatory Information

Agency approvals	UL 916
	European Conformance CE: EN 60730-1, EN 60730-2-9, EN 60730-2-13, EN 61000-6-2, EN 61000-6-3, EN 61000 Series - Industrial Immunity, EN 61326-1 FCC Part 15 Class B, REACH, RoHS, Green Premium, RCM (Australia), ICES-003 (Canada), EAC (Russia), UKCA (UK)

* Air Quality Index for VOC aligns with TVOC levels for IAQ as specified by the WHO (World Health Organization).

** Humidity sensor overall accuracy should include: accuracy, temperature coefficient and stability. Humidity accuracy is shown as an absolute value, so if testing accuracy with a hand-held device, you must check for deviation in its readings instead of calculating the percentual deviation. Additionally, you must consider the overall accuracy of the hand-held device in the comparison.

*** DIP switch selectable.

**** One setpoint type is selectable via DIP switch on display models only.

USA: +1 888-444-1311
 Europe: +46 10 478 2000
 Asia: +65 6484 7877
 www.schneider-electric.com

Life Is On



Dimensions mm (in.)

Optimum Housing

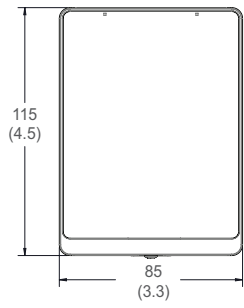

Medium Housing

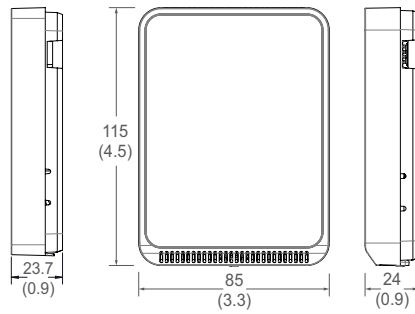

Power Table

Model	Description	Max. VA
SLAxLCxx	LCD CO2/VOC/Temperature/Humidity	3.312
SLAxTCxx	Touch CO2/VOC/Temperature/Humidity	3.504
SLAxXCxx	Blank CO2/VOC/Temperature/Humidity	3.312

Note: Model numbers based on supported product matrix.

Housing Finishes



Optimum White



Optimum Black



Medium White

User Interface Types



Touchscreen



LCD with Buttons



Blank