

Vigilohm IM9 Insulation Monitor

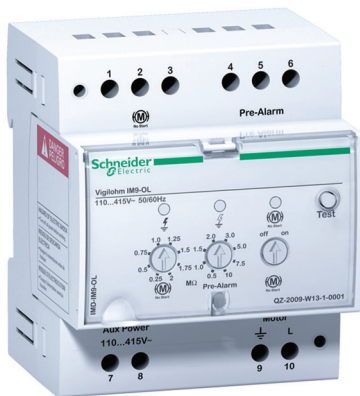

IM9



Functions

IM9 monitors the insulation resistance of an IT network by injecting a DC signal between this network and the ground

- Measures the insulation resistance of the network
- Detects an insulation fault according to the set alarm threshold
- Close or open a contact relay in case of alarm.

Main features

- Injection of a DC measuring signal
- Power supply: 110...415 VAC, or 125...250 VDC
- 1 settable alarm and 1 settable pre-alarm thresholds
- 1 NO-NC alarm relay
- Local and remote self test

Commercial references

- IMD-IM9.

Application

- Pure AC networks with no DC component.
- Network of limited dimension (<5km de cable) with low or none disturbances loads

Compatible auxiliaries

- Earthing Impedance: Zx
- Surge Limiter: Cardew C
- Mobile insulation fault locator: XGR + XRM + probes.

Standard & certification

- IEC61557-8 Ed.2014
- IEC61010-1 Ed.2010
- UL 61010-1 Ed3.2012
- IEC61326-4 Ed.2012



Connection

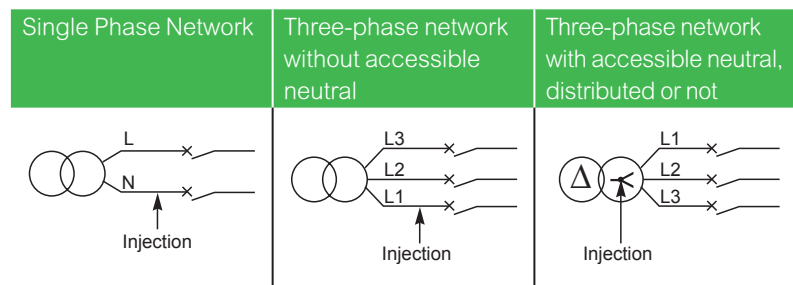

Example of architecture

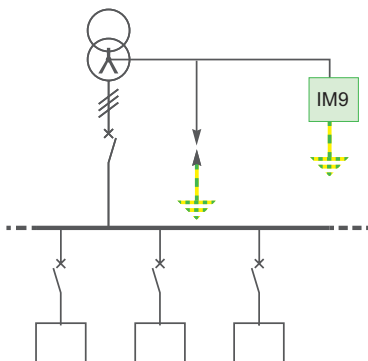

Dimensions

Dimensions (mm)

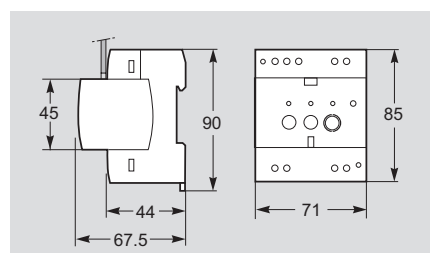

Flush mounting (mm)

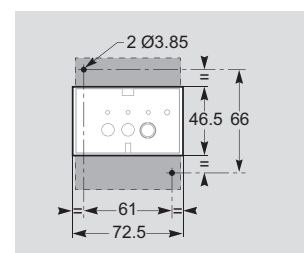

General characteristics

Commercial name		IM9
Type of network to monitor		
AC (max phase to phase voltage)	Connected to neutral	600 VAC
	Connected to phase	480 VAC
DC (max line voltage)		N.A.
Frequency		45-440Hz
Grounding arrangement		IT / ungrounded
Power Supply		
Alimentation auxiliaire	Voltage	118-415 VAC / 125-250 VDC
	Tolerance	+/-15%
	Frequency	45-440 Hz
	Maximum consumption	7VA
	Recommended protection	1A
Product Performances		
Insulation resistance	Accuracy at 10 kΩ, 1 μF	<15%
Fault signaling thresholds	Preventive alarm	2; 5; 10; 20; 50; 100; 200; 500 kΩ
	Alarm	1; 2,5; 5; 10; 25; 50; 100; 250 kΩ
Response time		≤ 7 s
Self test	Manual	Local and remote
Output relay	Quantity	1
	Type of contact	Changeover
	Breaking capacity AC	250V / 6A
	Breaking capacity DC	12-24V / 6A
	Setting	Failsafe or standard
Measurement voltage (peak)		16V
Measurement current (peak)		70μA
Measuring frequency		DC
Internal resistance		230 kΩ
Environment		
Protection degree	Front	IP40
	Rear	IP20
Protection degree		OVC3
Pollution degree		-
Temperature strength	For operation	-25°C to +55°C
	For storage	-40°C to +70°C
Relative humidity		≤92%

Physical Description

Failsafe wiring

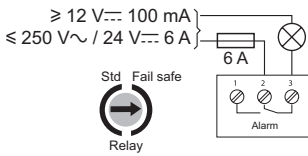

Standard wiring

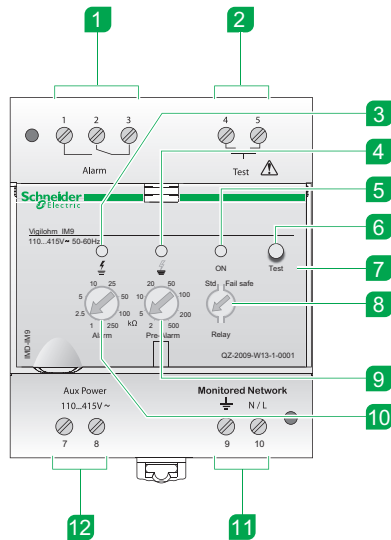
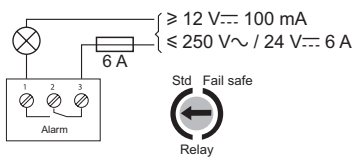

- 1 Alarm relay
- 2 Remote test
- 3 Alarm LED
- 4 Pre-alarm LED
- 5 Test button
- 6 Test button
- 7 Transparent sealable cover
- 8 Failsafe or standard alarm relay setting
- 9 Pre-alarm setting
- 10 Alarm setting
- 11 Injection
- 12 Auxiliary power supply

Motor off-line Insulation Monitor



IM9-OL

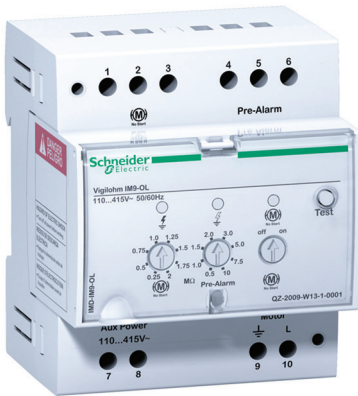

Functions

IM9-OL monitors the insulation resistance of Off-Line equipment (motors) by injecting a DC signal between this equipment and the ground.

- Measures the insulation resistance.
- Detects an insulation fault according to the set alarm thresholds.
- Opens the contacts of the Prev-Alarm relay in case the threshold is breached.
- Close the contacts of the «Motor» relay in case the alarm threshold is breached. Can also be used to prevent the equipment from starting

Main features

- Injection of a DC measuring signal
- Power supply: 110...415 VAC, or 125...250 VDC.
- 1 settable alarm (motor no start) and 1 settable pre-alarm thresholds.
- 2 NO-NC relays.
- Local self test.
- 1 rotary switch to allow or not motor to start.

Commercial references

- IMD-IM9-OL.

Application

- Compatible with any grounding arrangement, such as TT or TN or IT.
- Off-Line equipment such as fire pumps, motors or generators.

Standard & certification

- IEC61557-8 Ed.2014
- IEC61010-1 Ed.2010
- UL 61010-1 Ed3.2012
- IEC61326-4 Ed.2012



Dimensions

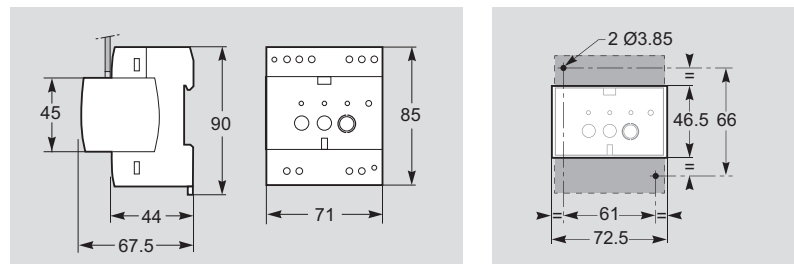

Example of architectures

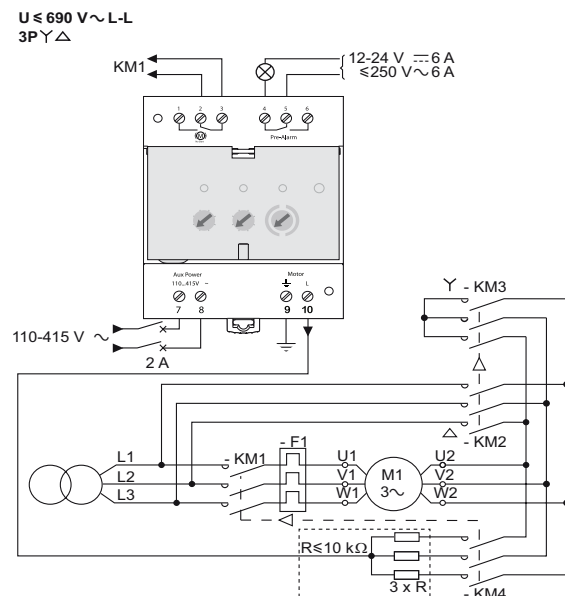
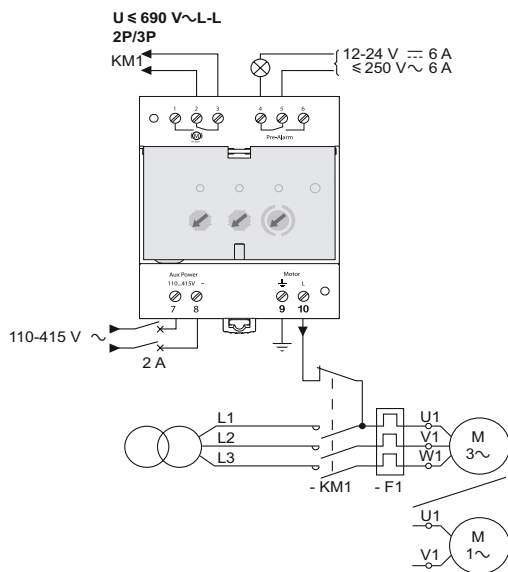

Motor off-line Insulation Monitor

Physical Description

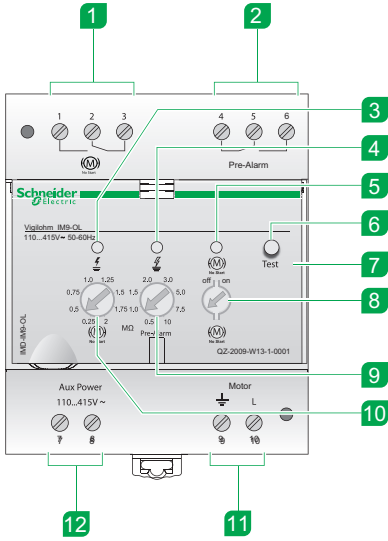

- 1 Motor no start relay (control of KM1)
- 2 Failsafe pre-alarm relay
- 3 Motor insulation fault LED
- 4 Pre-alarm LED
- 5 Motor no start LED
- 6 Test button
- 7 Transparent sealable cover
- 8 Motor no start selector
ON: Motor no start on
OFF: Motor no start off
- 9 Pre-alarm threshold setting
- 10 Motor no start threshold setting
- 11 Injection
- 12 Auxiliary power supply

General characteristics

Commercial name		IM9-OL
Type of network to monitor		
Max phase to phase voltage		≤ 690 VAC
Frequency		45-440Hz
Grounding arrangement		IT/ TT / TN
Power Supply		
Auxiliary power supply	Voltage	110...415 VAC / 125...250 VDC
	Tolerance (%)	+/-15%
	Frequency	45-400 Hz
	Maximum consumption	7VA
Product Performances		
Range for insulation resistance	Accuracy at 10 kΩ, 1 μF	< 15%
Settable alarm delays	Preventive alarm	0.5; 1; 1.5; 2; 3; 5; 7.5; 10 MΩ
	Alarm	0.25; 0.5; 0.75; 1; 1.25; 1.5; 1.75; 2 MΩ
Response time		≤ 2 s
Self test	Manual	Local
Output relay	Quantity	2
	Type of contact	Changeover
	Breaking capacity AC	250V / 6A
	Breaking capacity DC	12...24V / 6A
	Setting	Prev-Alarm: Failsafe Motor no start: Standard
Tension de mesure (max)		20V
Courant de mesure (max)		20 μA
Measuring frequency		DC
Internal resistance		500 kΩ
Environment		
Protection degree	Front	IP40
	Rear	IP20
Surge category		OVC3
Temperature strength	For operation	-25°C to +55°C
	For storage	-40°C to +70°C
Relative humidity		≤ 92%

Vigilohm IM10 and IM20 Insulation Monitor



IM10



IM20

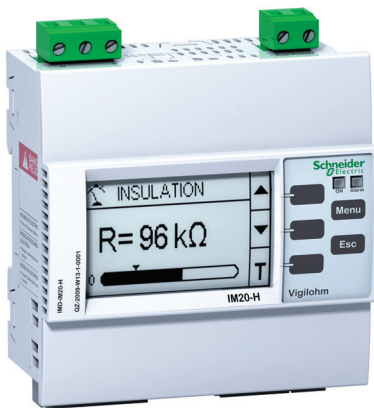

Commercial references

- IMD-IM10.
- IMD-IM20.

Functions

IM10 and IM20 monitors the insulation resistance of an IT network by injecting an AC signal between this network and the ground.

- IM10 measures and displays the insulation resistance of the network
- IM20 measures and displays in addition the capacitance and the impedance
- Detects an insulation fault according to the set alarm thresholds.
- IM10 triggers an alarm via the output relay and the display.
- IM20 in addition displays an alarm through its communication port

Main features

- AC measuring signal, for AC, DC and AC/DC systems.
- Power supply: 110...230 VAC, or 125...250 VDC.
- Measures the insulation resistance from 10 Ω to 10 MΩ.
- Measures earth leakage capacitance from 1 to 70 μF (IM20)
- 1 settable alarm (and 1 settable pre-alarm threshold on IM20).
- Automatic and manual Self test.

Application

- Industrial AC, DC and ACDC networks.
- Typical segments: Industry, Power generation, Marine, Railways, Airport, Oil&Gas, Mining, Water, Heating& Cooling, lifts, etc Heating.

Compatible auxiliaries

- Voltage adaptors: IM20-1700 with IM20.
- Earthing Impedance: ZX.
- Surge Limiter: Cardew C.
- Mobile insulation fault locator: XGR + XRM + probes.
- Gateways and supervision with IM20 only. Example: Com'X510, Link150, spaceLYnk, PME, PSO.

Standard & certification

- IEC61557-8 Ed.2014
- IEC61010-1 Ed.2010
- UL 61010-1 Ed3.2012
- IEC61326-4 Ed.2012



Example of architectures

Local alarm

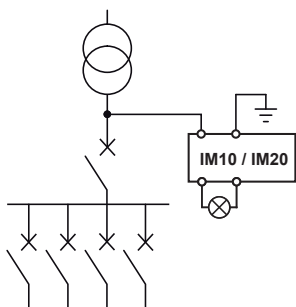

Local + Remote alarm via relay output

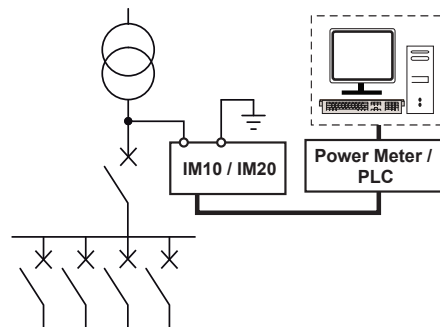

Local + Remote alarm via communication port

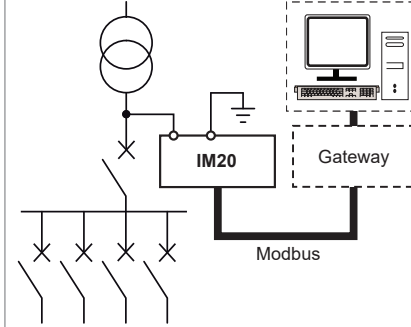

Physical Description

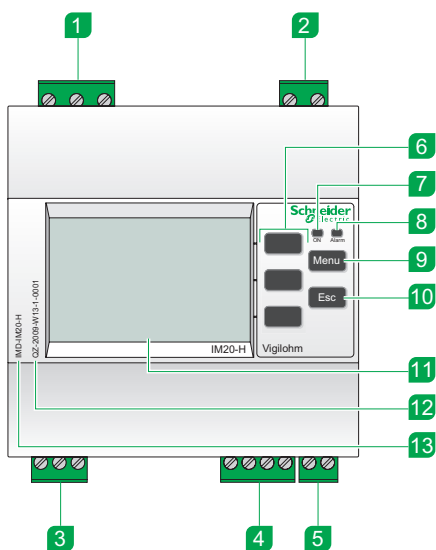

- 1 Injection terminal block
- 2 Vigilohm auxiliary power supply terminal block
- 3 Alarm relay terminal block
- 4 Modbus port terminal block (IM20)
- 5 Injection inhibition input (IM20)
- 6 Contextual menu buttons
- 7 Operating indicator light
- 8 Insulation alarm indicator light
- 9 Menu button
- 10 Back button to return to the previous menu or cancel a parameter entry
- 11 Display screen
- 12 Serial number
- 13 Part Number (IMD-IM10 or IMD-IM20)

Dimensions

Dimensions (mm)

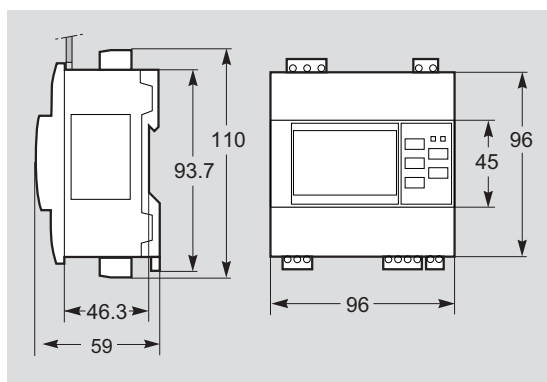

Flush mounting (mm)

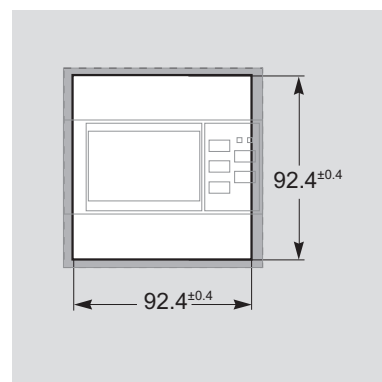

Connection

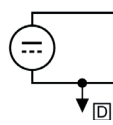
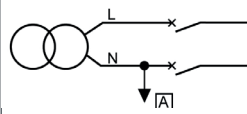
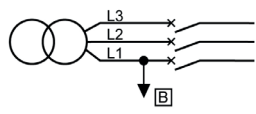
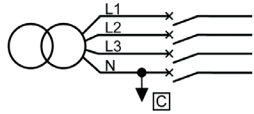
	Direct current	Single Phase Network	Three-phase network without accessible neutral	Three-phase network with accessible neutral, distributed or not
	DC $U \leq 345 \text{ V} \sim \text{max.}$ 	P+N $U \leq 480 \text{ V} \sim \text{max.}$ 	3P $U \leq 480 \text{ V} \sim \text{L-L max.}$ 	3P+N $U \leq 600 \text{ V} \sim \text{L-L max.}$ 
AC Connection to Line			$U_{LL} \leq 480 \text{ V AC}$	$U_{LL} \leq 600 \text{ V AC}$
AC Connection to Neutral		$U_{LL} \leq 480 \text{ V AC}$		
DC Connection to Line	$U < 345 \text{ V DC}$			

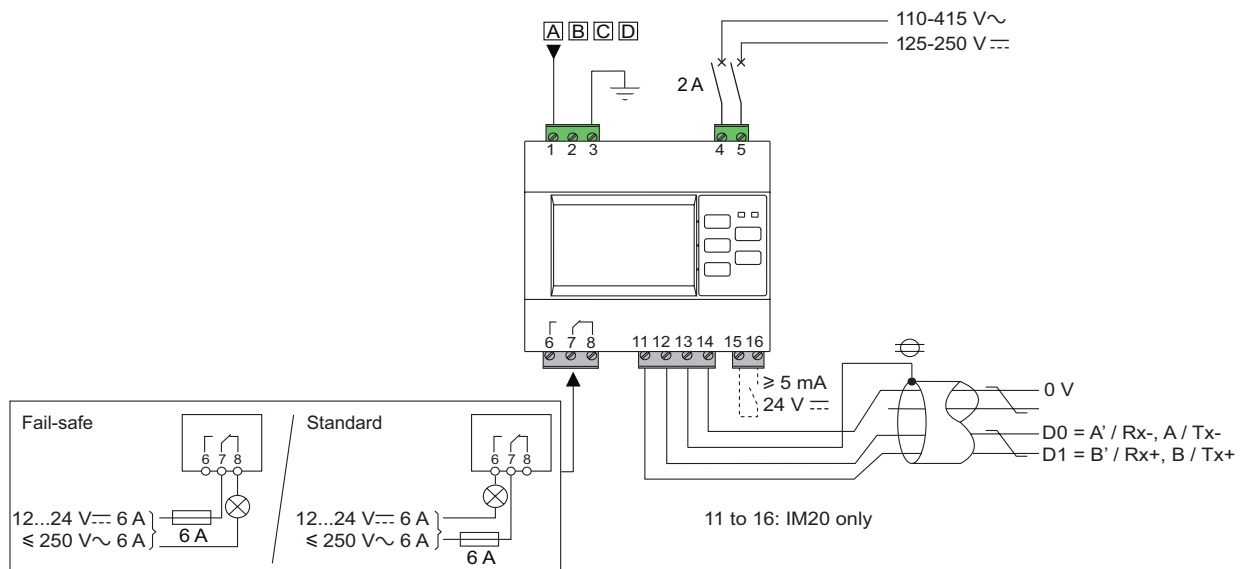

General characteristics

Commercial name		IM10	IM20
Type of network to monitor			
Max phase to phase voltage	Connected to neutral	600 VAC	
	Connected to phase	480 VAC	
Max line voltage		345 VDC	
Network max capacitance		40µF	70µF
Frequency		45-440Hz	
Grounding arrangement		IT / ungrounded	
Power Supply			
Auxiliary power supply	Voltage	110...415 VAC / 125...250 VDC	
	Tolerance (%)	+/-15%	
	Frequency	45...440 Hz	
	Maximum consumption	12VA	
	Recommended protection	2A	
Product Performances			
Range for insulation resistance	Reading	0.1KΩ to 10MΩ	
	Accuracy at 10 kΩ, 1 µF	< 5%	
Earth leakage capacitance	Reading	No	0.1µF to 70µF
	Accuracy at 10 kΩ, 1 µF	No	5%
Fault signaling thresholds	Alarm	0,5KΩ to 500KΩ	
Settable alarm delays	Alarm	0s to 7200s	
Response time		≤ 5 seconds	
Transient capture		No	Yes
Injection inhibition		No	Yes, settable as NO or NC contact
Self test	Automatic	Every 5 hours	
	Manual	Yes via HMI	
Output relay	Quantity	1	
	Type of contact	Changeover	
	Breaking capacity AC	250V / 6A	
	Breaking capacity DC	12...24V / 6A	
	Setting	Fail-safe or standard	
Communication port		No	Modbus RS485
Measurement voltage (peak)		53V	
Measurement current (peak)		< 0.5mA	
Measuring frequency		1,25Hz	
Internal resistance		110KΩ	
Environment			
Protection degree	Front	IP52	
	Rear	IP20	
Protection degree		OVC3	
Pollution degree		2	
Temperature strength	For operation	-25°C to +55°C	
	For storage	-40°C to +70°C	
Altitude max.		Up to 3000 m	
Relative humidity		≤ 92%	
Human Machine Interface			
Multilingual interface	8 languages	En, Fr, Es, Po, Zh, It, De, Ru	
Others	Historical resistance log	None	Yes
	Time stamped Event log	None	Yes

Vigilohm IM10-H, IM15H, IM20-H

Insulation monitoring devices for medical premises



IM10-H



IM20-H

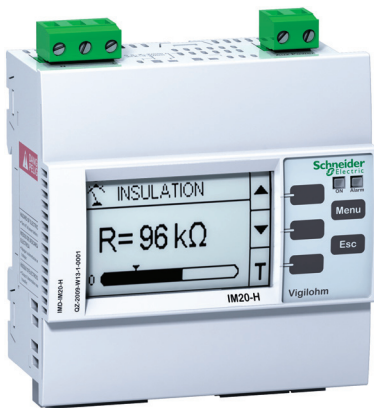

Functions

IM10-H, IM15H, IM20-H monitors the insulation resistance of an IT network by injecting a signal between this network and the ground.

- IM10-H measures and displays the insulation resistance of the network and detects an insulation fault according to the set alarm thresholds. IM10-H triggers an alarm on insulation resistance via the output relay and the display.
- IM15H in addition to IM10-H, monitors the Insulation transformer and the current consumed by the loads and triggers alarms related to transformer overheat and/or overload via the output relays and the display.
- IM20-H in addition to IM15-H, is equipped with Modbus RS485 communication port.
- IM10-H, IM15H, IM20-H allows fault location with IFL12H or XD312-H.

Commercial references

- IMD-IM10-H.
- IMDIM15H.
- IMD-IM20-H.

Main features

- AC measuring signal, designed for medical premises AC, DC and AC/DC systems
- Power supply: 110-230 VAC, or 125-250 VDC.
- Measures the insulation resistance from 100 Ω to 10 MΩ.
- 1 settable alarm > 50 KΩ.
- Automatic and manual Self test.

Standard & certification

- IEC61557-8 Ed.2014
- IEC61010-1 Ed.2010
- UL 61010-1 Ed3.2012
- IEC61326-4 Ed.2012
- IEC60364-7-710



Application

- IT Medical network only as per IEC60364-7-710.

Compatible auxiliaries

- Insulation Fault locator: IFL12H and XD312-H
- Gateways and supervision. Example: Com'X510, Link150, spaceLYnk, PME, PSO (IM20-H).
- Remote Displays: HRP (IM10-H, IM15H, IM20-H); IMDLRDH (IM20-H).

Example of architectures

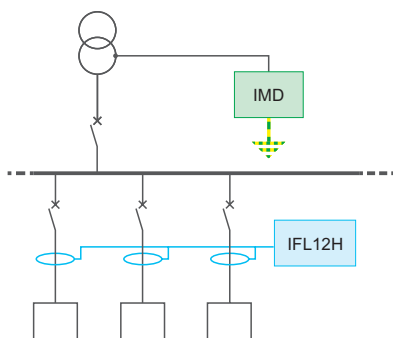

Dimensions

Dimensions (mm)

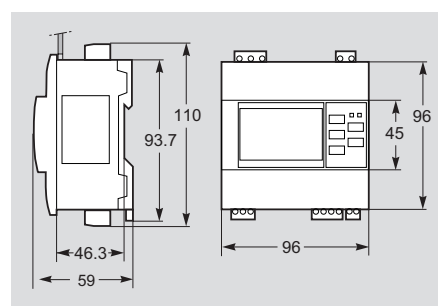

Flush mounting (mm)

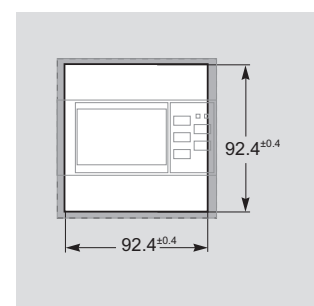

Vigilohm IM10-H, IM15H, IM20-H Insulation monitoring devices for medical premises

Physical Description

IM10-H

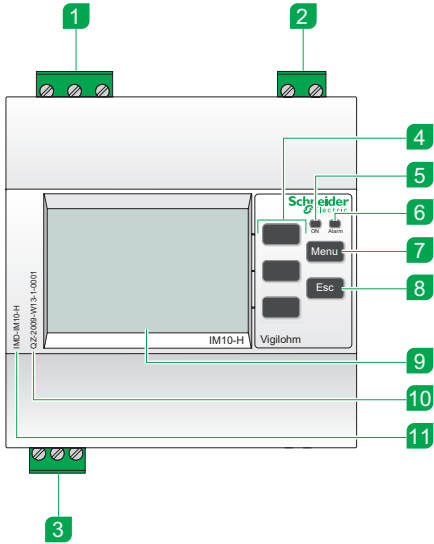

- 1 Injection terminal block
- 2 Auxiliary power supply terminal block
- 3 Insulation alarm relay terminal block
- 4 Contextual menu buttons
- 5 Operating indicator light
- 6 Insulation alarm indicator light
- 7 Menu button
- 8 Back button to return to the previous menu or cancel a parameter entry
- 9 Display
- 10 Serial number
- 11 Product catalog number

IM15H and IM20-H

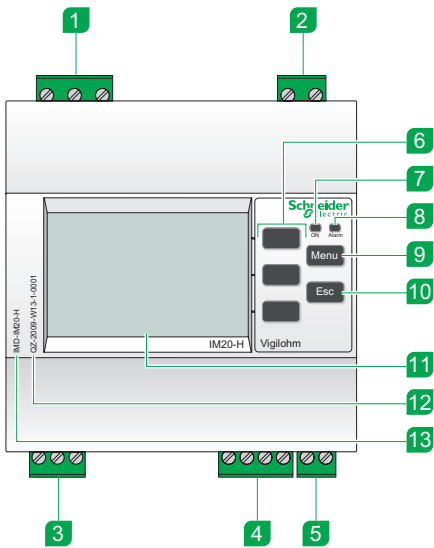

- 1 Injection terminal block
- 2 Auxiliary power supply terminal block
- 3 Insulation alarm relay and overheat/overload alarm relay
- 4 Modbus communication terminal block (IM20-H only)
- 5 Transformer temperature sensors
- 6 Contextual menu buttons
- 7 Operating indicator light
- 8 Insulation alarm indicator light
- 9 Menu button
- 10 Back button to return to the previous menu or cancel a parameter entry
- 11 Display
- 12 Serial number
- 13 Product catalog number

Vigilohm IM10-H, IM15H, IM20-H

Insulation monitoring devices for medical premises

Connection

IM10-H

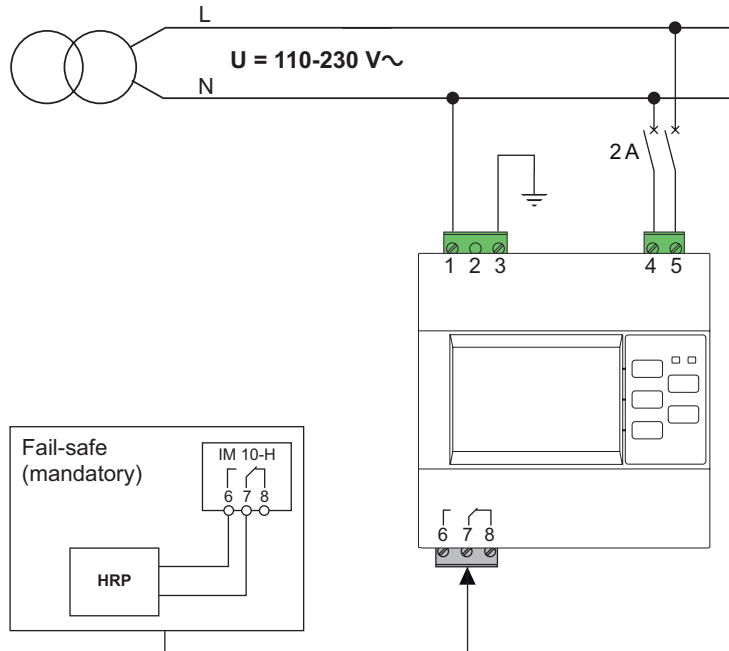

IM15H and IM20-H

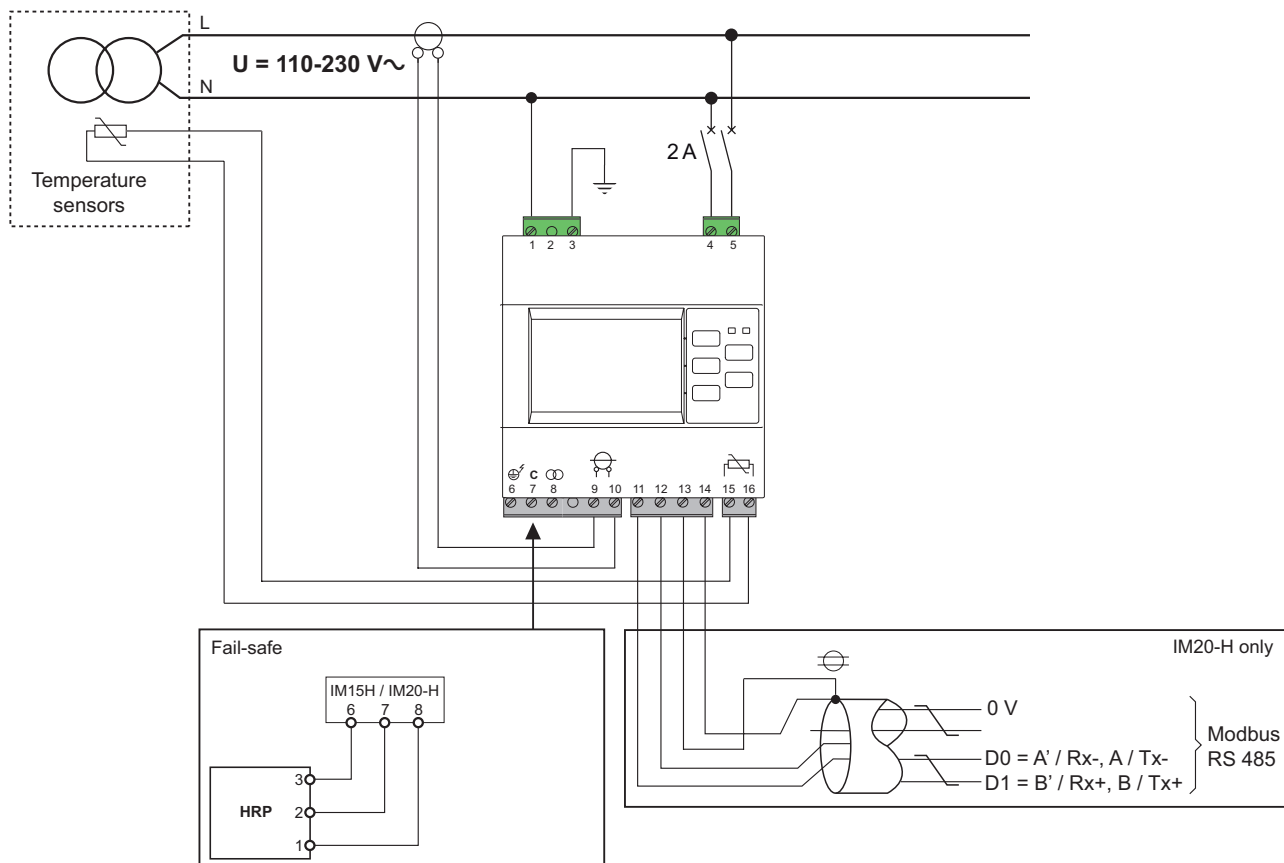

Vigilohm IM10-H, IM15H, IM20-H

Insulation monitoring devices for medical premises

General characteristics

Commercial name		IM10-H	IM15H	IM20-H
Type of network to monitor				
AC (max phase to phase voltage)	Connected to neutral		≤ 230 VAC +15 %	
DC (max line voltage)			≤ 230 VDC +15 %	
Frequency			50/60Hz	
Grounding arrangement			Medical IT / ungrounded	
Power Supply				
Power supply	Voltage	110...230 VAC / 125...250 VDC		
	Tolerance (%)	+/-15%		
	Frequency	45-440 Hz		
	Maximum consumption	12VA		
	Recommended protection	2A		
Product Performances				
Range for insulation resistance	Reading	0.1KΩ to 10MΩ		
	Accuracy at 10 kΩ, 1 μF	< 5%		
Settable alarm threshold		50KΩ to 500KΩ		
Response time		≤ 4s		
Self test	Automatic	Every 5 hours		
	Manual	Yes via menu		
Inputs	Transformer overheat	No	Yes	
	Transformer overload	No	Yes	
Output relay	Quantity	1	2	
	Type of contact	Changeover	Static	
	Breaking capacity AC	250V / 6A	-	
	Breaking capacity DC	12...24V / 6A	12-48VDC ≤ 50mA	
Communication port		No	Modbus RS485	
Measurement voltage (peak)		25V		
Measurement current (peak)		0.2 mA		
Measuring frequency		2,5Hz		
Internal resistance		141 kΩ		
Environment				
Protection degree	Front	IP52		
	Rear	IP20		
Protection degree		OVC3		
Pollution degree		2		
Temperature strength	For operation	-25°C to +55°C		
	For storage	-40°C to +70°C		
Altitude max.		Up to 3000 m		
Relative humidity		≤ 92%		
Human Machine Interface				
Multilingual interface	8 languages	En, Fr, Es, Po, Zh, It, De, Ru		
Others	Historical resistance log	No	Yes	
	Time stamped Event log	No	Yes	

Vigilohm IM400 / IM400L / IM400C

Insulation Monitor



IM400



IM400L



IM400C



Functions

Monitors the insulation resistance of IT/ungrounded or High Resistance Grounded (HRG) networks by injecting a low frequency signal between network and earth.

- Measures and displays the insulation resistance, capacitance and impedance of the network.
- Detects an insulation fault according to the set alarm thresholds.
- Triggers a pre-alarm and alarm via the 2 relays, the modbus port and the display.
- Compatible with the range of Insulation Fault Locators.

Main features

- Adaptive multifrequency measuring signal, for AC, DC and AC/DC networks.
- Power supply: 100-440 VACDC, and 24-48VDC (IM400L).
- Measures the insulation resistance from 10 Ω to 10 MΩ.
- Measures earth leakage capacitance from 1 to 500μF or 5500μF (IM400C).
- 1 settable alarm and 1 settable pre-alarm thresholds.
- Large screen, event log and historical data.
- Native Modbus RS485 communication port.
- Tropicalized (IM400C).

Commercial references

- IMD-IM400 (standard).
- IMDIM400L (24-48VDC power supply)
- IMD-IM400C (tropicalized).

Application

- Control Command networks, including sensitive loads such as PLCs, I/Os, sensors.
- Power Circuits networks, including power loads and power electronics such as speed drives, inverters, rectifiers, etc...
- Photovoltaic utility scale sites, e.g. 4 MW per inverter (IM400C).
- Typical segments: Industry, Power generation, Marine, Railways, Airport, Oil&Gas, Mining, Water, Heating & Cooling, lifts, ...requesting continuity of service even in case of earth insulation fault.
- Harsh environment with IM400C.

Standard & certification

- IEC61557-8 Ed.2014
- IEC61010-1 Ed.2010
- UL 61010-1 Ed3.2012
- IEC61326-4 Ed.2012
- UL1998 (IM400C)
- UL Functional Safety (IM400C)
- SIL2 (IM400C)
- ATEX (IM400C)



Compatible auxiliaries

- Voltage adaptors: PHT1000; IM400-1700 & IM400-1700C; IM400VA2 (IM400C),
- Earthing Impedance: ZX.
- Surge Limiter: Cardew C.
- Insulation Fault locator: IFL12 series, except IFL12H
- Mobile insulation fault locator: XRM + probes.
- Gateways and supervision. Example: Com'X510, Link150, spaceLYnk, PME, PSO.

Example of architectures

Control Command mode

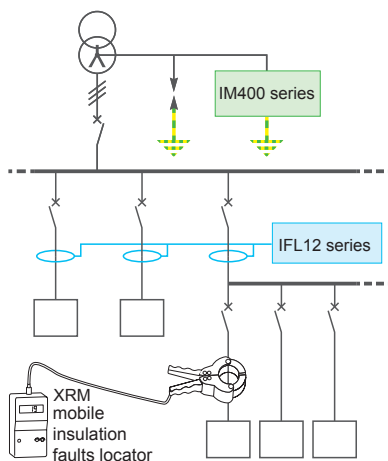

Power Circuit mode

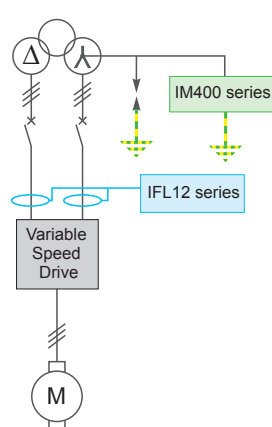

Photovoltaic mode

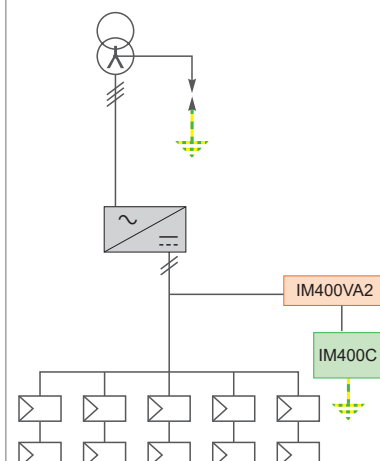

Physical Description

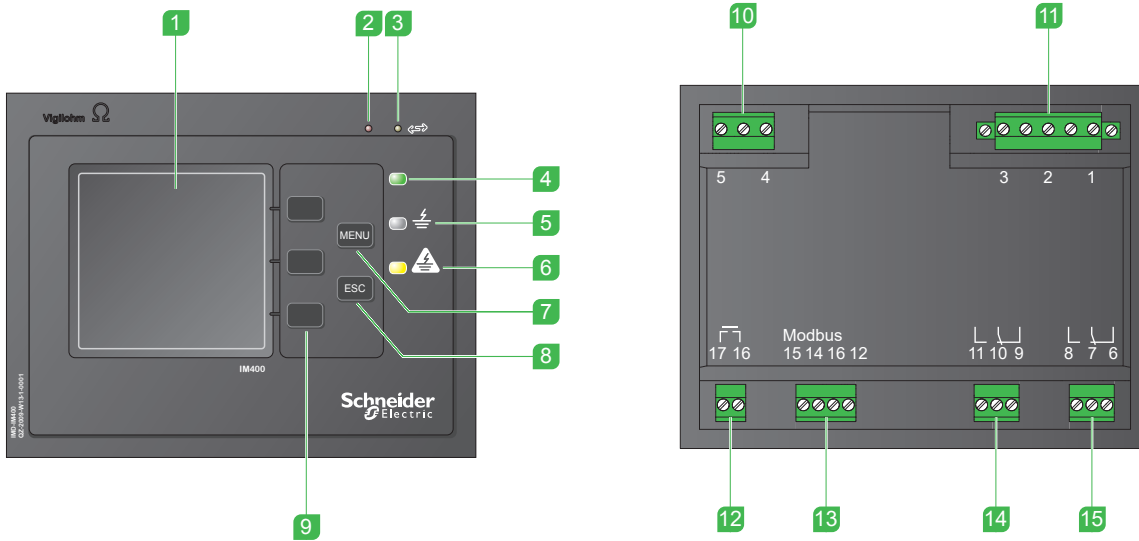

- 1 Display
- 2 Red indicator light for product status
- 3 Yellow indicator light for Modbus communication indication
- 4 Green indicator light for correct insulation indication
- 5 White indicator light for preventive insulation alarm
- 6 Yellow indicator light for insulation alarm
- 7 MENU button
- 8 ESC button for returning to previous menu or canceling a parameter entry

- 9 Contextual menu buttons
- 10 Auxiliary power supply terminal
- 11 Injection terminal
- 12 Insulation alarm relay terminal
- 13 Preventive insulation alarm relay terminal
- 14 Modbus RS-485 terminal
- 15 Injection inhibition input terminal

Dimensions

Dimensions (mm)

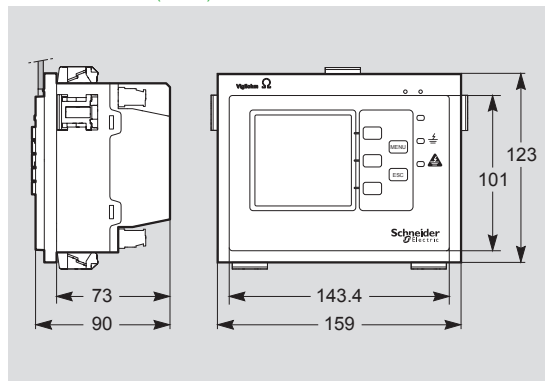

Flush mounting (mm)

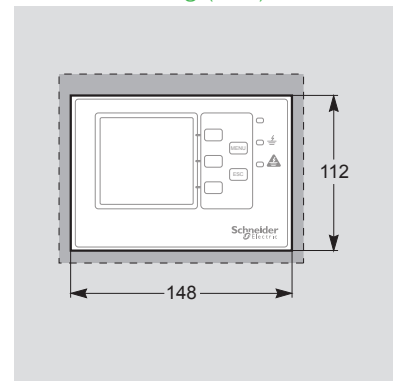

Connection

	Direct current	Single Phase Network	Three-phase network without accessible neutral	Three-phase network with accessible neutral, distributed or not
AC Connection to Line			$U_{LL} \leq 480 \text{ VAC}$	$U_{LL} \leq 480 \text{ VAC}$
AC Connection to Neutral		$U_{LL} \leq 830 \text{ VDC}$		
DC Connection to Line	$U_{LN} \leq 480 \text{ VDC}$			
Fault localization	Yes	Yes	Yes	Yes

Compatibility between Insulation Monitors and Voltage Adaptors

IM400-1700 / IM400-1700C	PHT1000	IM400VA2
IM400 / IM400L / IM400C	IM400 / IM400L / IM400C	IM400C
$U_{LL} < 1700 \text{ VAC}$ neutral injection	$U_{LL} < 1700 \text{ VAC}$ neutral injection	$U_{LL} < 1700 \text{ VAC}$ neutral injection
$U < 1000 \text{ VDC}$, injection at (+) or (-) not compatible fault location	$U < 1200 \text{ VDC}$, injection at (+) or (-) compatible fault location	$U < 1500 \text{ VDC}$, injection at (+) or (-) not compatible fault location

Refer to the Voltage Adaptor pages for features and localization capabilities

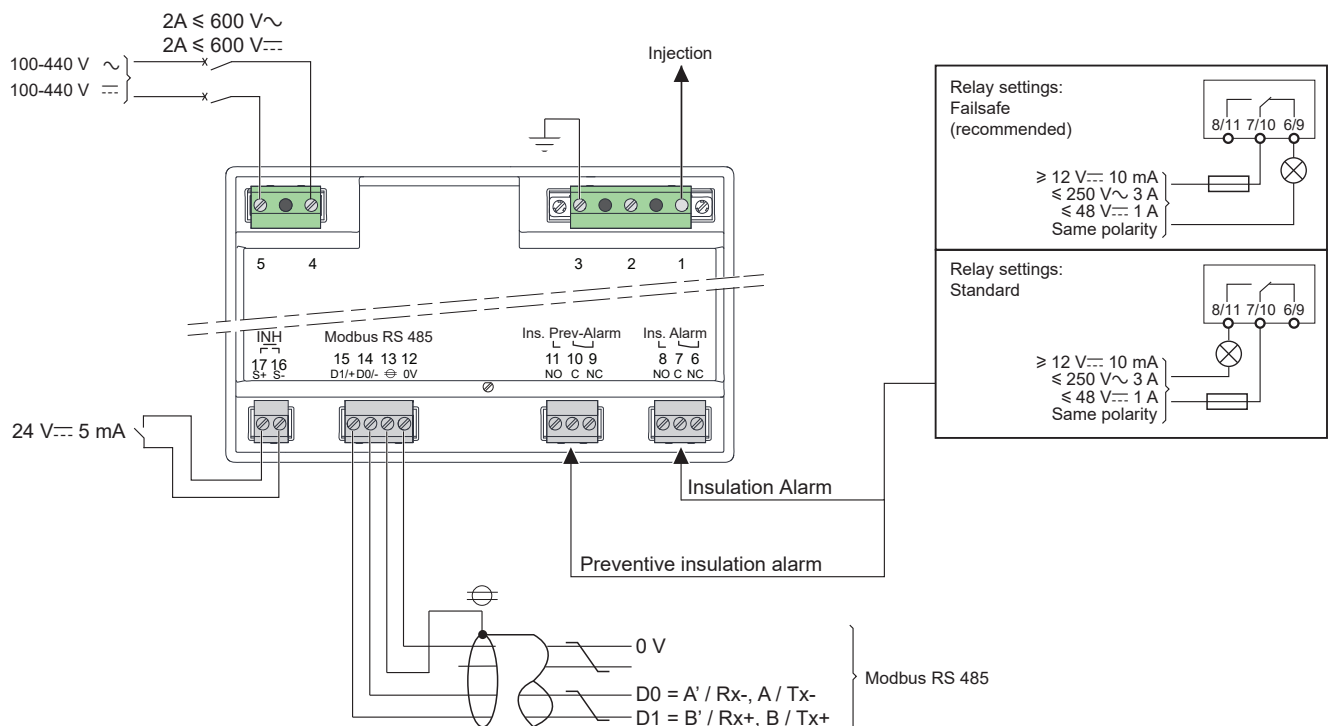

General characteristics

Commercial name		IM400	IM400L	IM400C
Type of network to monitor				
AC (max phase to phase voltage)	Connected to neutral	≤ 830VAC		
	Connected to phase	≤ 480VAC		
DC (max line voltage)		≤ 480VDC		
Network max capacitance		500 μF		5500 μF
Frequency		45-440Hz		
Grounding arrangement		IT / High resistance grounded		
Power Supply				
Auxiliary supply voltage	Voltage	100-440 VACDC	24-48 VDC	100-440 VACDC
	Tolerance	+/-15%		
	Frequency	50 / 60 / 400 Hz	-	50 / 60 / 400 Hz
	Maximum consumption	25 VA / 10 W		
	Recommended protection	2A		
Product Performances				
Range for insulation resistance	Reading	10 Ω to 10 MΩ		
	Accuracy at 10 kΩ, 1 μF	< 5%		
Earth leakage capacitance	Reading	0.1 μF to 500 μF	0.1 μF to 500 μF 0.1 μF to 5500 μF for Photovoltaic application	
	Accuracy at 10 kΩ, 1 μF	5%		
Fault signaling thresholds	Preventive alarm	1 kΩ to 1 MΩ		
	Alarm	0.1 kΩ to 500 kΩ		
Settable alarm delays	Preventive alarm	0s to 7200s		
	Alarm	0s to 7200s		
Response time		4 or 40s (depending on filtering)	4 or 40 or 400s (depending on filtering)	
Transient capture		Yes		
Self test	Automatic	Every 5 hours		
	Manual	Yes		
Input	Injection inhibition	Yes, settable as NC or NO contact		
Output relay	Quantity	2		
	Type of contact	Changeover		
	Breaking capacity AC	250V / 3A		
	Breaking capacity DC	48V / 1A, 3mA min.		
	Setting	Failsafe or standard or mirror		
Communication port		Modbus RS485		
Operating Modes		Control-Command or Power Circuit	Control-Command or Power Circuit or Photovoltaic	
Measurement voltage (peak)		15V, 33V, 120V		
Measurement current (peak)		375 μA, 825 μA, 3mA		
Measuring frequency		1.25 and 2.5Hz	1.25 and 2.5Hz or 0.0625Hz	
Internal resistance		40 kΩ		
Environment				
Protection degree	Front	IP54		
	Rear	IP20		
Overvoltage category		300 V/OVC3 / 600 V/OVC2		
Pollution degree		2		
Temperature strength	For operation	-25°C to +55°C	-25°C to +70°C	
	For storage	-40°C to +70°C	-40°C to +85°C	
Altitude max.		Up to 3000m		
Relative humidity		≤ 92%	≤ 95%	
Tropicalization		No	Yes	
Human Machine Interface				
Multilingual interface	8 languages	En, Fr, Es, Po, Zh, It, De, Ru		
Others	Historical resistance log	Yes		
	Time stamped Event log	Yes		

Vigilohm IM400THR / IM400LTHR Insulation Monitor



IM400THR



Functions

Monitors the insulation resistance of IT medium voltage networks (AC) by injecting a DC signal between network and earth.

- Detects an insulation fault according to the set alarm thresholds.
- Triggers a pre-alarm and alarm via the 2 relays, the modbus port and the display.
- Measures and displays the insulation resistance of the network.

Main features

- Compatible with alternative MV networks in association with the properly rated Voltage transformer.
- Power supply:
 - IM400THR: 100-440 VAC / 100-440 VDC
 - IM400LTHR: 24-48 VDC
- Measures the insulation resistance from 10 Ω to 10 MΩ.
- 1 settable alarm and 1 settable pre-alarm thresholds.
- Large screen, event log and historical data.
- Native RS485 communication port.

Commercial references

- IMDIM400THR.
- IMDIM400LTHR.

Standard & certification

- IEC61557-8 Ed.2014
- IEC61010-1 Ed.2010
- UL 61010-1 Ed3.2012
- IEC61326-4 Ed.2012
- NFC13200, Medium Voltage



Application

- Suited for IT Medium Voltage distribution networks and loads
- Typical segments: Electrical Distribution, Industry, Power generation, Marine, Airport, Oil&Gas, Mining, lifts, etc requesting continuity of service even in case of earth insulation fault.

Compatible auxiliaries

- Voltage adaptors: P1N and voltage transformer.
- Gateways and supervision. Example: Com'X510, Link150, spaceLYnk, PME, PSO.

Example of architectures

Three-phase network with accessible neutral

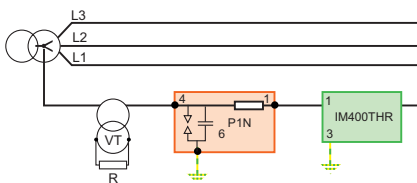

Three-phase network without accessible neutral

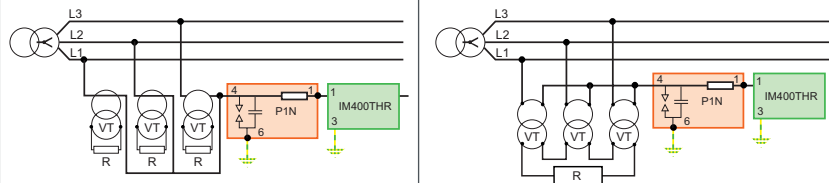

Physical Description

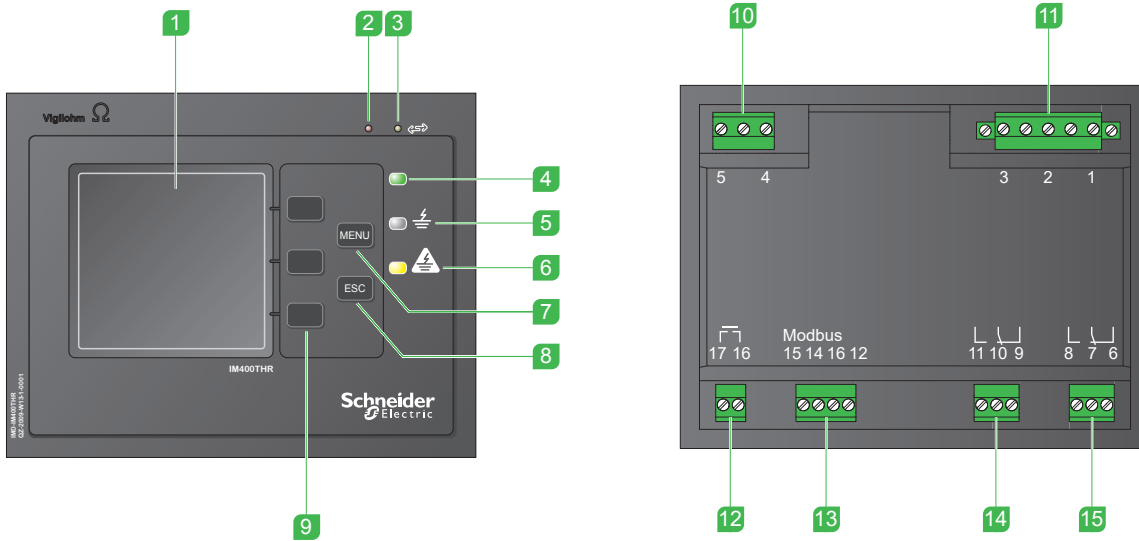

- 1 Display
- 2 Red indicator light for product status
- 3 Yellow indicator light for Modbus communication indication
- 4 Green indicator light for correct insulation indication
- 5 White indicator light for preventive insulation alarm.
- 6 Yellow indicator light for insulation alarm
- 7 MENU button
- 8 ESC button for returning to previous menu or canceling a parameter entry

- 9 Contextual menu buttons
- 10 Auxiliary power supply terminal
- 11 Injection terminal
- 12 Insulation alarm relay terminal
- 13 Preventive insulation alarm relay terminal
- 14 Modbus RS-485 terminal
- 15 Injection inhibition input terminal

Dimensions

Dimensions (mm)

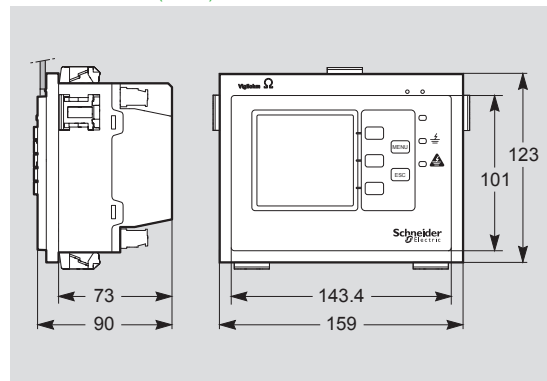

Flush mounting (mm)

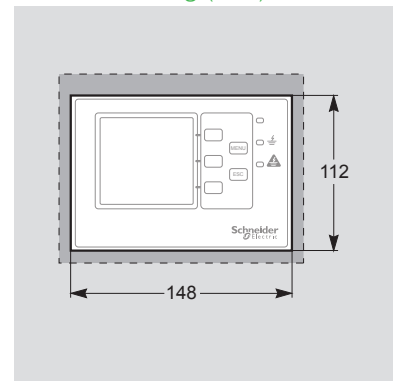

Vigilohm IM400THR / IM400LTHR Insulation Monitor

Connection

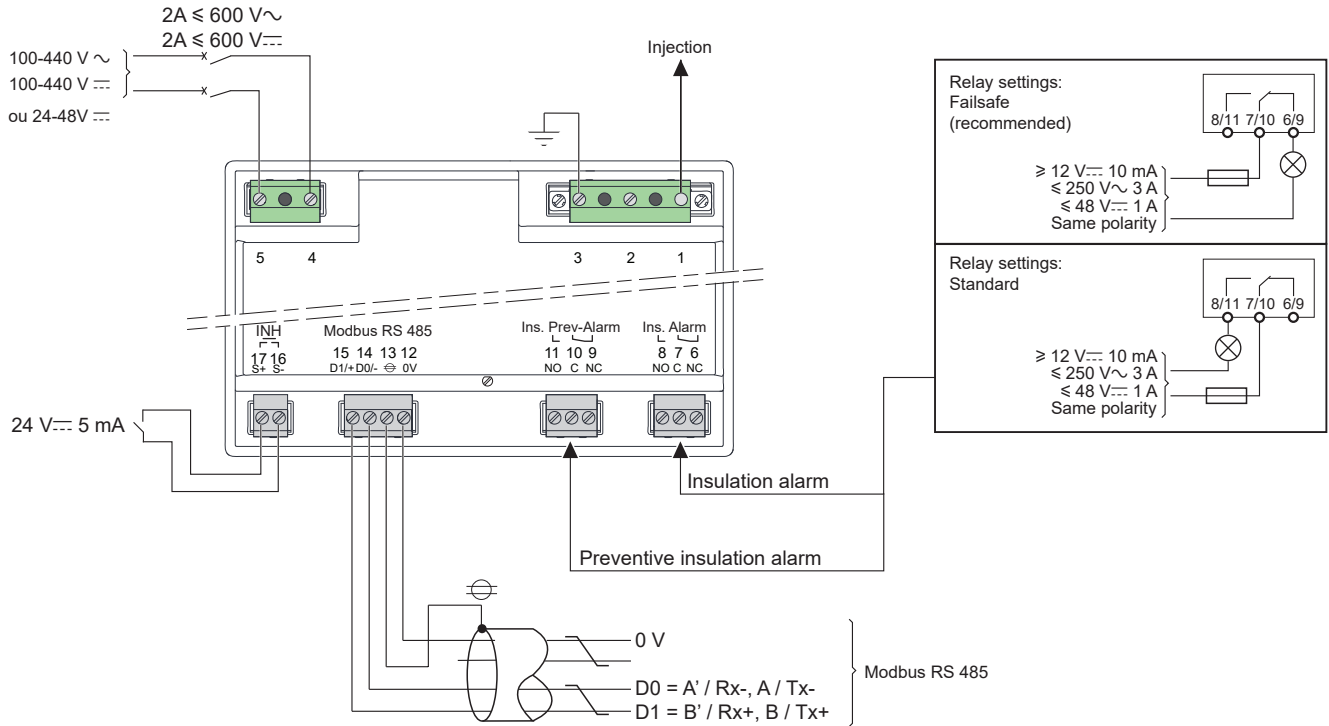

General characteristics

Commercial name		IM400THR	IM400LTHR
Type of network to monitor			
AC (max phase to phase voltage)	Connected to neutral	< assigned voltage of the Voltage transformer	
	Connected to phase	< assigned voltage of the Voltage transformer	
DC (max line voltage)		No	
Frequency		45-440Hz	
Grounding arrangement		IT / ungrounded medium voltage	
Power Supply			
Auxiliary supply voltage	AC	100-440 VAC	-
	DC	100-440 VDC	24-48 VDC
	Tolerance	+/-15%	
	Maximum consumption	25 VA / 10 W	
	Recommended protection	2A	
Product Performances			
Range for insulation resistance	Reading	10 Ω to 10 MΩ	
	Accuracy at 10 kΩ, 1 μF	5%	
Fault signaling thresholds	Preventive alarm	1 kΩ to 1 MΩ	
	Alarm	0.1 kΩ to 500 kΩ	
Settable alarm delays	Preventive alarm	0s to 7200s	
	Alarm	0s to 7200s	
Response time		2 or 8s (depending on filtering)	
Filtering		2, 20 or 40s	
Transient capture		Yes	
Self test	Automatic	Every 5 hours	
	Manual	Yes	
Input	Injection inhibition	Yes, settable as NO or NC contact	
Output relay	Quantity	2	
	Type de contact	Changeover	
	Breaking capacity AC	250V / 3A	
	Breaking capacity DC	48V / 1A, 3mA min. load	
	Setting	Failsafe or standard or mirror	
Communication port		Modbus RS485	
Operating Modes		Medium Voltage	
Measurement voltage (peak)		20V, 40V, 60V, 80V	
Measurement current (peak)		500 μA, 1mA, 1.5mA, 2mA	
Measuring frequency		DC	
Internal resistance		40 KΩ	
Environment			
Protection degree	Front	IP54	
	Rear	IP20	
Overvoltage category		300 V/OVC3 / 600 V/OVC2	
Pollution degree		2	
Temperature strength	For operation	-25°C to +55°C	
	For storage	-40°C to +70°C	
Altitude max.		Up to 3000m	
Relative humidity		≤ 92%	
Tropicalization		No	
Human Machine Interface			
Multilingual interface	8 languages	En, Fr, Es, Po, Zh, It, De, Ru	
Others	Historical resistance log	Yes	
	Time stamped Event log	Yes	

Communicating Insulation Fault Locator



IFL12C



Commercial references

- IMDIFL12C.

Standard & certification

- IEC61557-9 Ed.2014
- IEC61010-1 Ed.2010
- UL 61010-1 Ed.2012
- IEC61326-2-4 Ed.2012
- IEC60364-4-41 Ed.2005



Functions

- When associated with IM400 series, acts as Insulation Fault Locator, simultaneously for 12 feeders.
- Monitors the insulation to ground of each individual feeder.
- Detect an insulation fault based to the set alarm threshold.
- Triggers an alarm via the output contact relay in case of insulation fault on any feeder and through the communication port.

Main features

- Power Supply: 100-440VAC/DC.
- 3 pre-set alarm threshold for all feeders (Low or Medium or High).
- Fast response time: 5s.
- Filtering for highly disturbed system.
- Transient insulation fault reporting.
- Insulation fault is displayed on the LCD.
- Simple and user friendly human machine interface.
- Fast dedicated commissioning procedure.
- Simple installation: Stand alone device, no wire connection to the Insulation Monitor.
- User friendly LCD HMI in 8 languages.
- Communicate via Modbus RS485 to allow remote settings and report of measurement and event to the supervision system.
- Timestamped event log.
- Unlimited number of IFL12 in the same power system.

Application

- All type of network with feeders to be monitored individually.
- Power Circuits networks, including power loads and power electronics such as speed drives, inverters, rectifiers, etc...
- Typical segments: Industry, Power generation, Marine, Railways, Airport, Oil&Gas, Mining, Water, Heating & Cooling, Lifts, etc requesting continuity of service even in case of earth insulation fault.
- Mobile insulation fault locator kit complementary to IFL.

Compatible auxiliaries

- Toroids: TA30, PA50, IA80, MA120, SA200, GA300, TOA80 & TOA120.
- Voltage adaptors: PHT1000.
- Earthing Impedance: ZX.
- Surge Limiter: Cardew C.
- Mobile insulation fault locator: XRM + probes.
- Gateways and supervision: Com'X510, Link150, spaceLYnk, EcoStruxure Power Monitoring Expert, EcoStruxure Power SCADA Operations.

Example of architectures

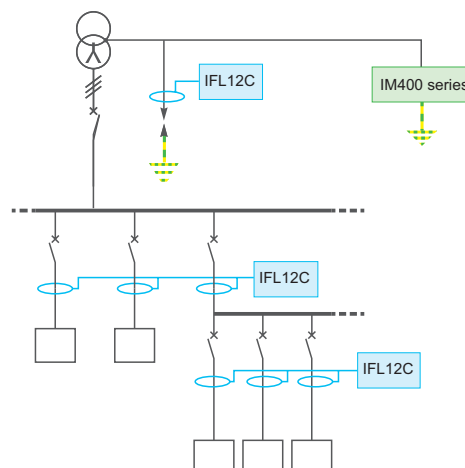

Vigilohm IFL12C Communicating Insulation Fault Locator

Physical Description

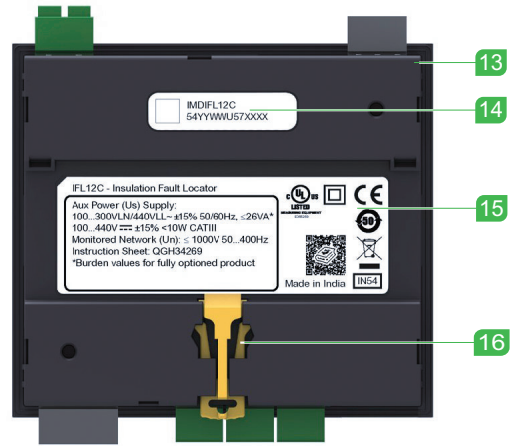
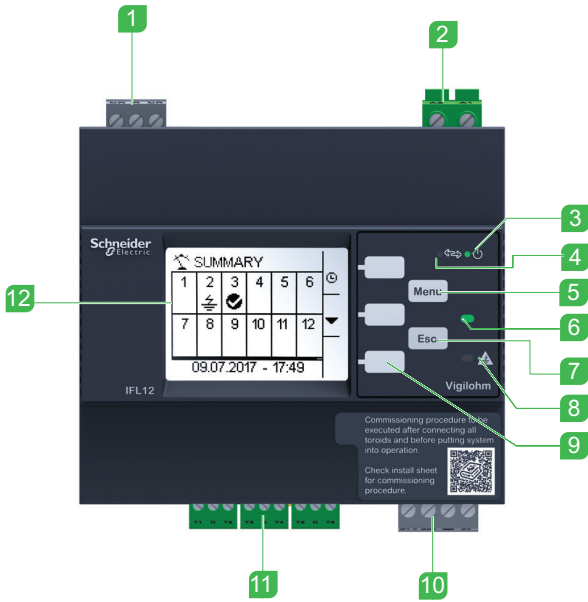

- 1 Alarm relay
- 2 Auxiliary power supply
- 3 Product status LED
- 4 Communications LED
- 5 Menu button
- 6 No alarm LED
- 7 Esc button
- 8 Alarm LED
- 9 Contextual menu buttons
- 10 RS-485 communication
- 11 12 toroid connections
- 12 LCD screen
- 13 Gasket
- 14 Commercial reference and manufacturing data
- 15 Label
- 16 DIN mounting clip

Dimensions

Dimensions mm / (inch)

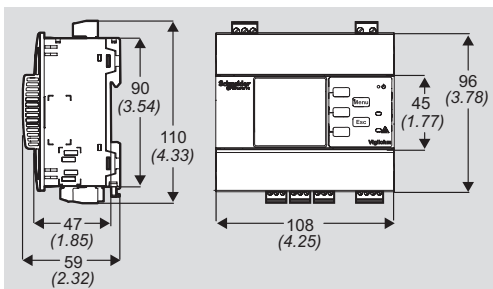

Cut-out for flush mount mm / (inch)

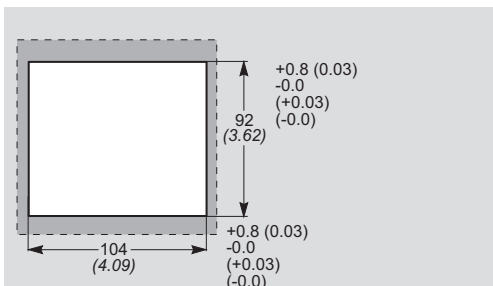

Minimum clearance between flush mounted devices mm / (inch)

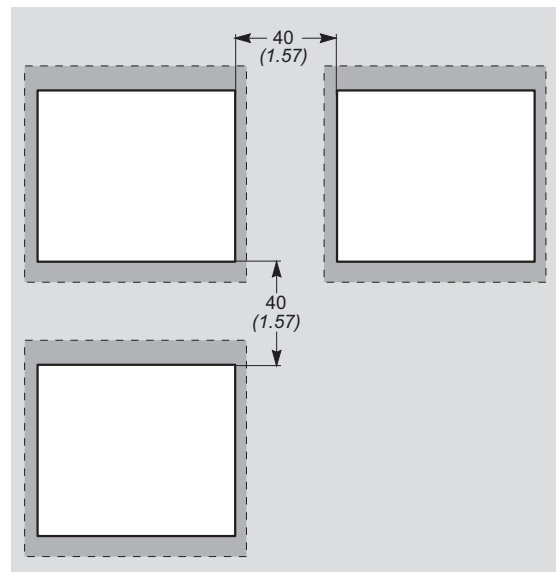

Communicating Insulation Fault Locator

Connection

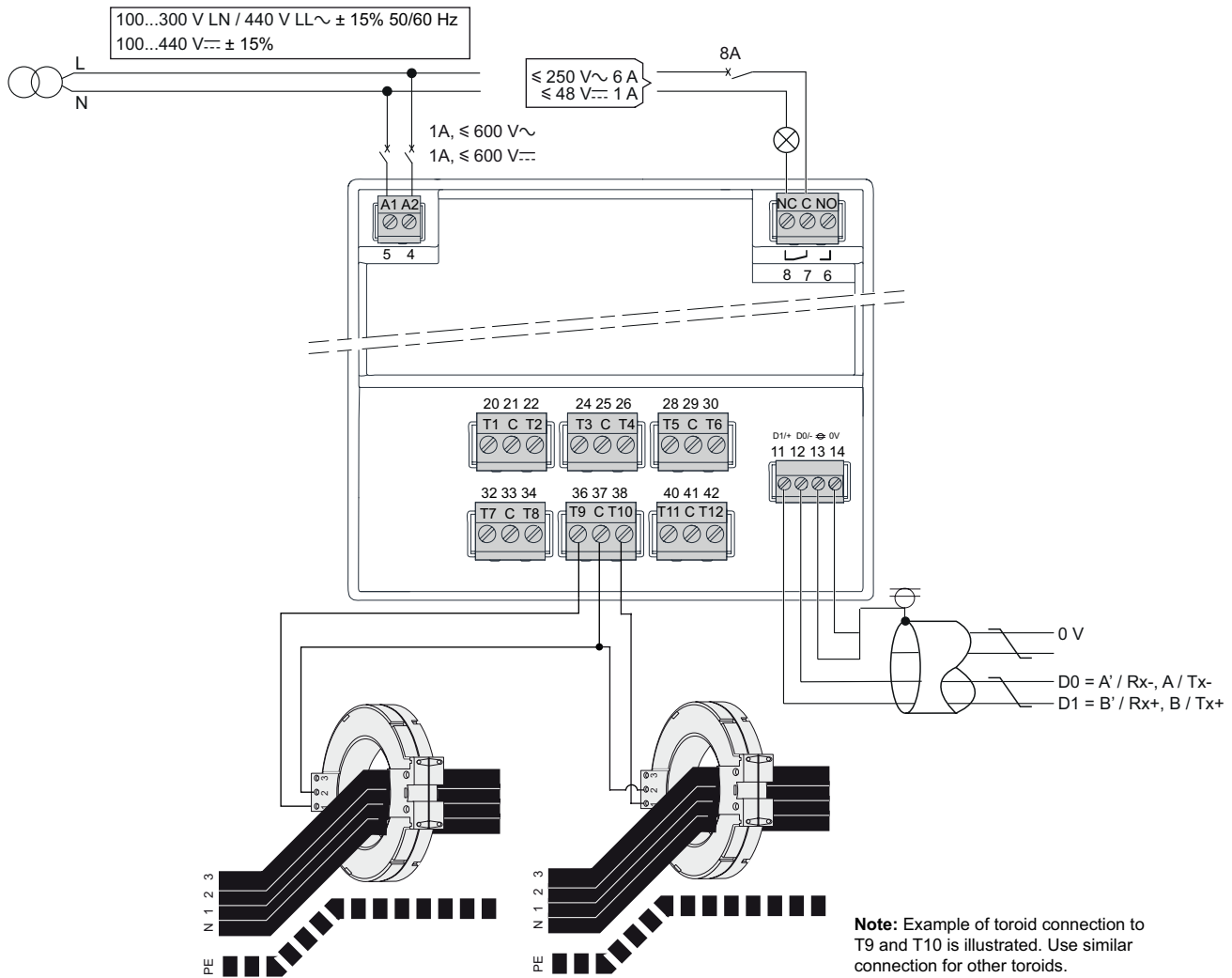

{T1, C, T2}, {T3, C, T4}, {T5, C, T6}, {T7, C, T8}, {T9, C, T10}, {T11, C, T12}	1 conductor - 1.5 mm ² (16 AWG) 2 conductors - 0.75 mm ² (18 AWG)	7mm (0.28 in) ± 1 mm (0.040 in)	∅ 2.5 mm (7/64 in)	0.22 - 0.25 Nm (1.9 - 2.2 in lb)
A1, A2	0.2 - 2.5 mm ² (24 - 14 AWG)	7mm (0.28 in) ± 1 mm (0.040 in)	∅ 3 mm (1/8 in)	0.5 - 0.6 Nm (4.4 - 5.3 in lb)
NC, C, NO	0.2 - 2.5 mm ² (24 - 14 AWG)	7mm (0.28 in) ± 1 mm (0.040 in)	∅ 3 mm (1/8 in)	0.5 - 0.6 Nm (4.4 - 5.3 in lb)
N/L, ⚡	0.82 - 3.31 mm ² (18 - 12 AWG)	7mm (0.28 in) ± 1 mm (0.040 in)	∅ 3 mm (1/8 in)	0.5 - 0.6 Nm (4.4 - 5.3 in lb)
+, -, ∅, C	0.13 - 0.82 mm ² (26 - 18 AWG)	7mm (0.28 in) ± 1 mm (0.040 in)	∅ 3 mm (1/8 in)	0.5 - 0.6 Nm (4.4 - 5.3 in lb)

Vigilohm IFL12C

Communicating Insulation Fault Locator

General characteristics

Commercial name		IFL12C
Type of network to monitor		
Max phase to phase voltage		≤1000VAC
Max line voltage		≤1000VDC
Network max capacitance		150μF
Frequency		45-440Hz
Grounding arrangement		IT / HRG
Power Supply		
Auxiliary supply voltage	Voltage	100-440VAC/DC
	Frequency	50-60 Hz
	Tolerance	+/-15%
	Maximum consumption	<26VA <10W
	Recommended protection	1A
Product Performances		
Number of Channel		12
Range for insulation resistance	Reading	N.A.
	Accuracy at 10 kΩ, 1 μF	N.A.
Range for earth leakage capacitance	Reading	N.A.
	Accuracy at 10 kΩ, 1 μF	N.A.
Fault signaling thresholds	Alarm	High impedance, medium impedance or low impedance
Settable alarm delay		N.A.
Polling (12 channels)		All channels simultaneously
Response time		5s, 40s
Transient capture		Yes
Self test	Automatic	Yes
	Manual	Yes
Output relay	Quantity	1
	Type de contact	Changeover
	Breaking capacity AC	250VAC / 6A
	Breaking capacity DC	48VDC / 1A, 3mA min. load
	Setting	Failsafe or standard
Communication port		Modbus RS485
Operating Modes	Power Circuit	Yes
	Control Circuit	No
Environment		
Protection degree	Front	IP54
	Rear	IP20
Overvoltage category		300V OVC3 / 600V OVC2
Pollution degree		2
Temperature strength	For operation	-25°C to +55°C
	For storage	-40°C to +85°C
Altitude max.		up to 3000m
Relative humidity		≤ 92%
Human Machine Interface		
HMI		LCD+Buttons
Multilingual interface	8 languages	En, Fr, Es, Po, Zh, It, De, Ru
Others	Historical resistance log	N.A.
	Time stamped Event log	N.A.
Others characteristics		
Compatible Insulation Monitor		IM400, IM400C & IM400L

Insulation Fault Locator for Healthcare facilities



IFL12H



Commercial references

- IMDIFL12H.

Standard & certification

- IEC61557-8 Ed.2014
- IEC61010-1 Ed.2010
- UL 61010-1 Ed.2012
- IEC61326-2-4 Ed.2012
- IEC60364-7-710 Ed.2002



Functions

- When associated with IM20-H, monitors simultaneously up to 12 feeders.
- Measure the insulation resistance to ground of each individual feeder.
- Detect an insulation fault based on the set alarm threshold.
- Generate an alarm via the output contacts relay in case of insulation fault on any feeder and via the communication port.

Main features

- Power Supply 110...230 VAC and 125...250 VDC.
- Each feeder has its own alarm threshold set from 50KΩ to 200KΩ .
- Fast response time: 5s.
- Transient insulation fault reporting.
- Large screen and interactive human-machine interface to ease operation & maintenance.
- Displays product status according to standard.
- Measures and displays each feeder's insulation resistance from 200Ω to 250KΩ.
- Fast dedicated commissioning procedure.
- Simple installation: Stand alone device, no wire connection to the Insulation monitor.
- User friendly LCD HMI in 8 languages.
- Communicate via modbus RS485 to allow remote settings and report of measurement and event to the supervision system.
- Timestamped event log.
- Unlimited number of IFL12H in the same power system.

Application

- All electrical network in Healthcare critical rooms with feeders to be monitored individually.
- For Medical premises according to IEC60364-7-710.
- Operation theater, Intensive care unit, ...
- Mobile insulation fault locator kit complementary to IFL.

Compatible auxiliaries

- Toroids: TA30.
- Mobile insulation fault locator: XGR + XRM + probes,
- Gateways and supervision: Link150, spaceLYnk, Ecostruxure Power Monitoring Expert, Ecostruxure Building Operations.
- Remote Displays: Operating Theater Display.

Example of architectures

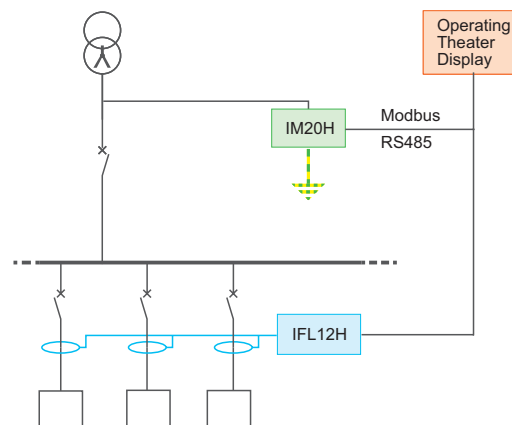

Vigilohm IFL12H Insulation Fault Locator for Healthcare facilities

Physical Description

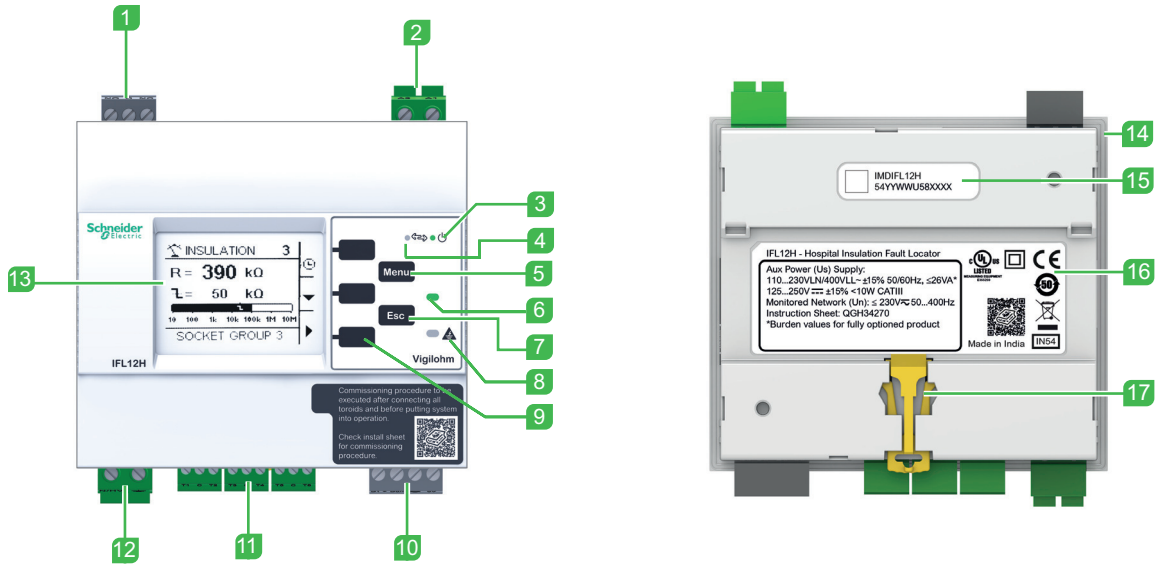

- 1 Alarm relay
- 2 Auxiliary power supply
- 3 Product status LED
- 4 Communications LED
- 5 Menu button
- 6 No alarm LED
- 7 Esc button
- 8 Alarm LED
- 9 Contextual menu buttons
- 10 RS-485 communication
- 11 12 toroid connections
- 12 Voltage input
- 13 LCD screen
- 14 Gasket
- 15 Commercial reference and manufacturing data
- 16 Label
- 17 DIN mounting clip

Dimensions

Dimensions mm / (inch)

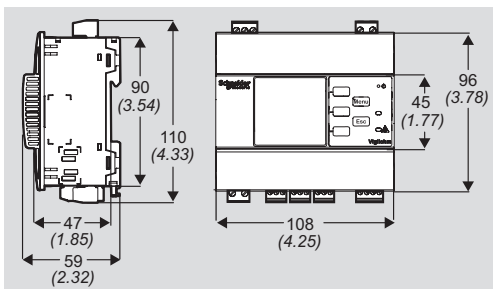

Cut-out for flush mount mm / (inch)

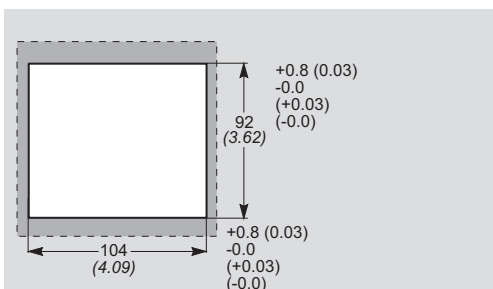

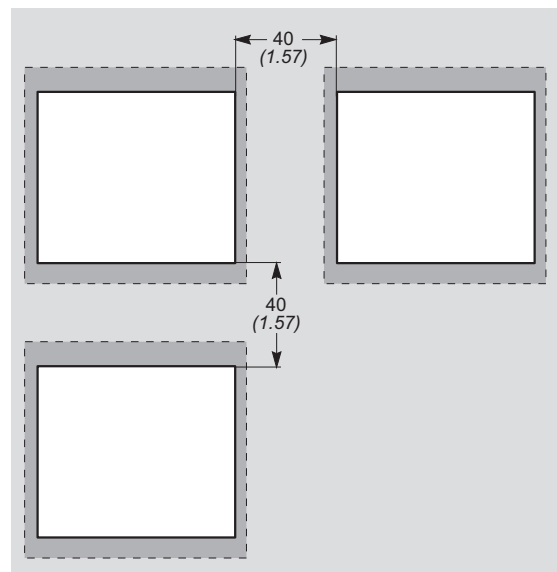

Minimum clearance between flush mounted devices mm / (inch)

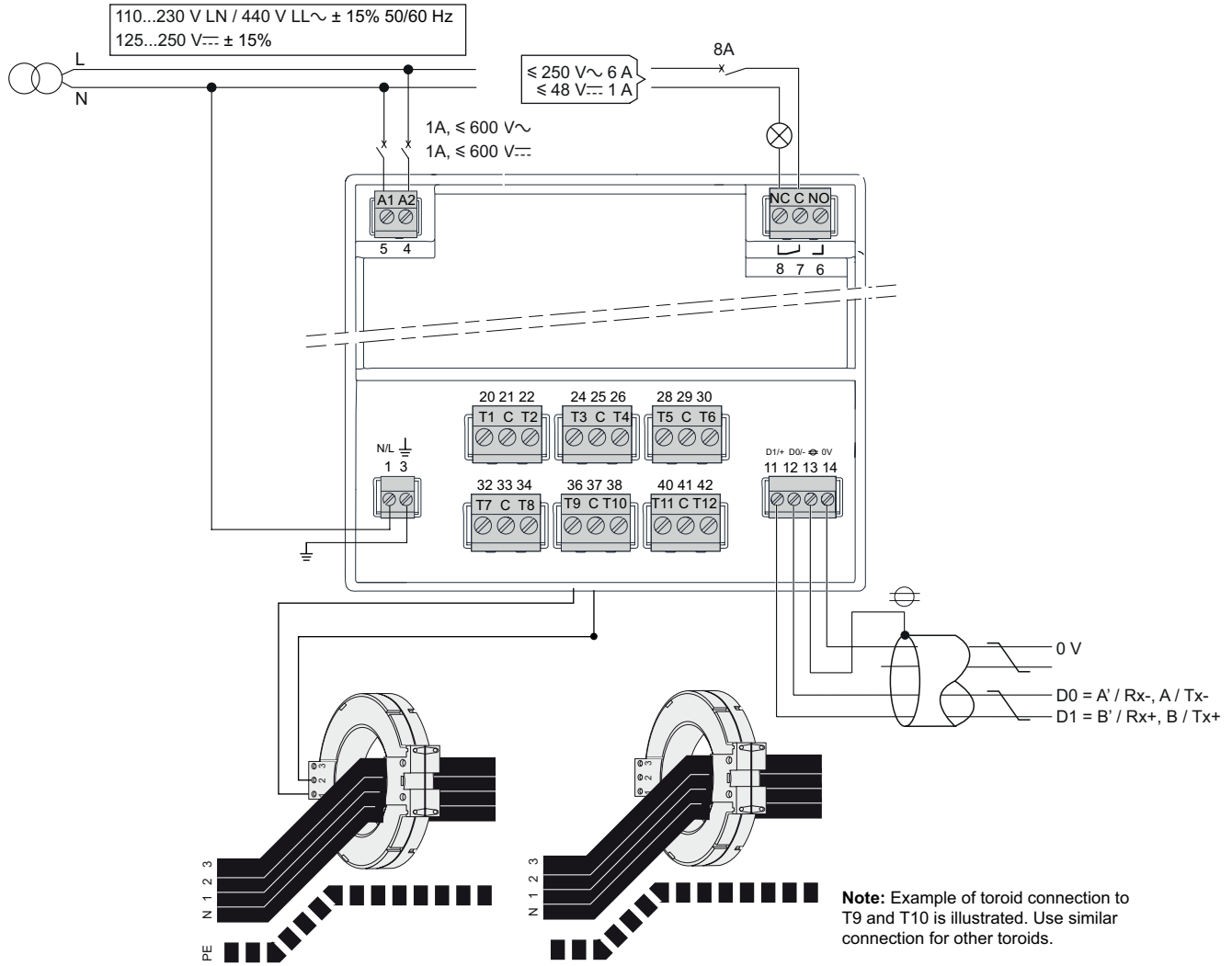

Insulation Fault Locator for Healthcare facilities

Connection

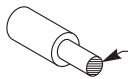
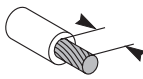
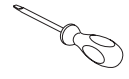

				
{T1, C, T2}, {T3, C, T4}, {T5, C, T6}, {T7, C, T8}, {T9, C, T10}, {T11, C, T12}	1 conductor - 1.5 mm ² (16 AWG) 2 conductors - 0.75 mm ² (18 AWG)	7mm (0.28 in) ± 1 mm (0.040 in)	∅ 2.5 mm (7/64 in)	0.22 - 0.25 Nm (1.9 - 2.2 in lb)
A1, A2	0.2 - 2.5 mm ² (24 - 14 AWG)	7mm (0.28 in) ± 1 mm (0.040 in)	∅ 3 mm (1/8 in)	0.5 - 0.6 Nm (4.4 - 5.3 in lb)
NC, C, NO	0.2 - 2.5 mm ² (24 - 14 AWG)	7mm (0.28 in) ± 1 mm (0.040 in)	∅ 3 mm (1/8 in)	0.5 - 0.6 Nm (4.4 - 5.3 in lb)
N/L, \perp	0.82 - 3.31 mm ² (18 - 12 AWG)	7mm (0.28 in) ± 1 mm (0.040 in)	∅ 3 mm (1/8 in)	0.5 - 0.6 Nm (4.4 - 5.3 in lb)
+, -, ∅, C	0.13 - 0.82 mm ² (26 - 18 AWG)	7mm (0.28 in) ± 1 mm (0.040 in)	∅ 3 mm (1/8 in)	0.5 - 0.6 Nm (4.4 - 5.3 in lb)

Vigilohm IFL12H

Insulation Fault Locator for Healthcare facilities

General characteristics

Commercial name		IFL12H
Type of network to monitor		
Max phase to neutral voltage		≤ 230 VAC +15 %
Max line voltage		≤ 230 VDC +15 %
Frequency		45-65Hz
Grounding arrangement		IT
Power Supply		
Auxiliary supply voltage	Voltage	110...230 VAC and 125...250 VDC
	Frequency	50-60 Hz
	Tolerance	+/-15%
	Maximum consumption	<26VA <10W
	Recommended protection	1A
Product Performances		
Number of Channel		12
Range for insulation resistance	Reading	200Ω...250KΩ
	Accuracy at 10 kΩ, 1 μF	10%
Fault signaling thresholds	Alarm	50K...200KΩ
Polling (12 channels)		All channels simultaneously
Response time		5s
Transient capture		Yes
Self test	Automatic	Yes
	Manual	Yes
Output relay	Quantity	1
	Type de contact	Changeover
	Breaking capacity AC	250VAC / 6A
	Breaking capacity DC	48VDC / 1A, 3mA min. load
	Setting	Failsafe or standard
Communication port		Modbus RS485
Environment		
Protection degree	Front	IP54
	Rear	IP20
Overvoltage category		300V OVC3 / 600V OVC2
Pollution degree		2
Temperature strength	For operation	-25°C to +55°C
	For storage	-40°C to +85°C
Altitude max.		up to 3000m
Relative humidity		≤ 92%
Human Machine Interface		
HMI		LCD+Buttons
Multilingual interface	8 languages	En, Fr, Es, Po, Zh, It, De, Ru
Others	Time stamped Event log	Yes
Others characteristics		
Compatible Insulation Monitor		IM20H & IM10

Vigilohm IFL12 / IFL12L

Insulation Fault Locator



IFL12



IFL12L



Functions

- When associated with IM400 series, acts as Insulation Fault Locator, simultaneously for 12 feeders.
- Monitors the insulation to ground of each individual feeder.
- Detect an insulation fault according to the set alarm threshold.

Main features

- Power Supply: 100-440VAC/DC or 24-48VDC.
- 3 pre-set alarm threshold for all feeders (Low or Medium or High).
- Fast response time: 5s.
- Filtering for highly disturbed power system.
- Transient insulation fault reporting.
- Insulation fault is displayed via 12 LED, one per feeder.
- Simple and user friendly human machine interface.
- Fast dedicated commissioning procedure.
- Simple installation: Stand alone device, no wire connection to the Insulation Monitor.
- Unlimited number of IFL12 in the same power system.

Commercial references

- IMDIFL12.
- IMDIFL12L.

Standard & certification

- IEC61557-9 Ed.2014
- IEC61010-1 Ed.2010
- UL 61010-1 Ed.2012
- IEC61326-2-4 Ed.2012
- IEC60364-4-41 Ed.2005



Application

- All type of network with feeders to be monitored individually.
- Power Circuits networks, including power loads and power electronics such as speed drives, inverters, rectifiers, etc.
- Typical segments: Industry, Power generation, Marine, Railways, Airport, Oil&Gas, Mining, Water, heating & Cooling, Lifts, etc, requesting continuity of service even in case of earth insulation fault.
- Mobile insulation fault locator kit complementary to IFL.

Compatible auxiliaries

- Toroids: TA30, PA50, IA80, MA120, SA200, GA300, TOA80 & TOA120.
- Voltage adaptors: PHT1000.
- Earthing Impedance: ZX.
- Surge Limiter: Cardew C.
- Mobile insulation fault locator: XRM + probes.

Example of architectures

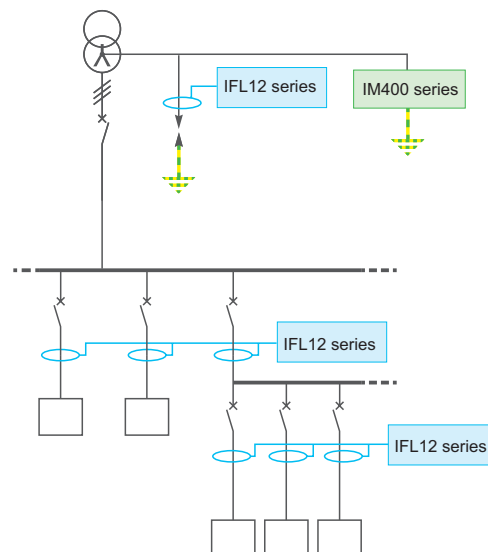

Physical Description

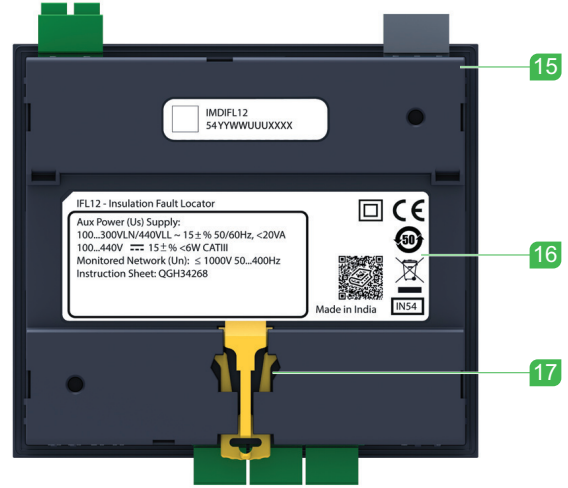
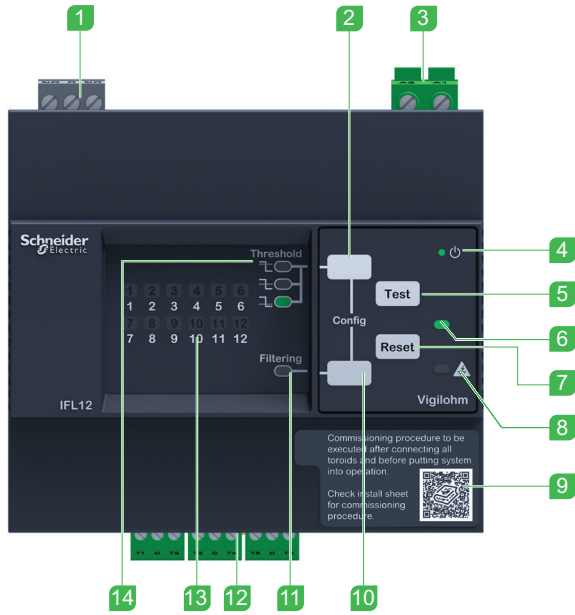

- 1 Alarm relay
- 2 Alarm threshold selection button
- 3 Auxillary power supply
- 4 Product status LED
- 5 Test button
- 6 No alarm LED
- 7 Reset button
- 8 Alarm LED
- 9 Peel off label
- 10 Filtering enable/disable button
- 11 Filtering enable/disable LED
- 12 12 toroid connections
- 13 12 channel LEDs
- 14 Low / Medium / High threshold LEDs
- 15 Gasket
- 16 Label
- 17 DIN mounting clip

Dimensions

Dimensions mm / (inch)

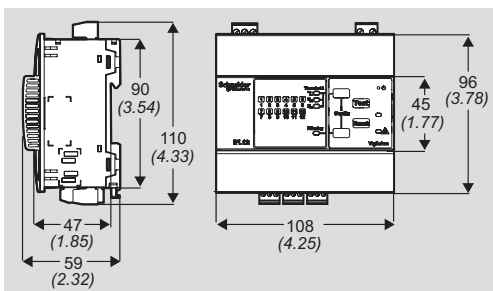

Minimum clearance between flush mounted devices mm / (inch)

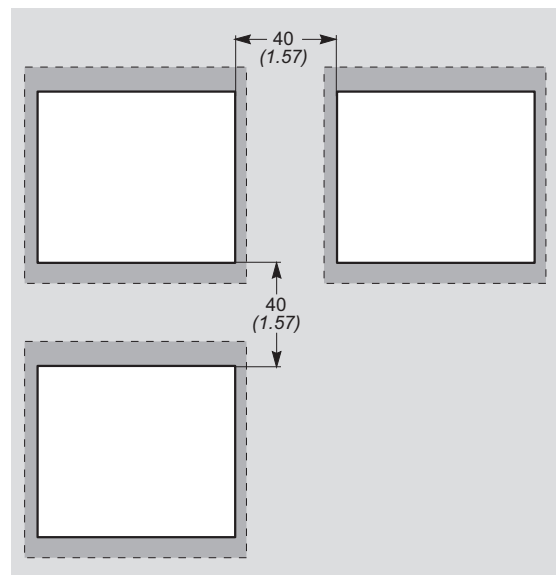

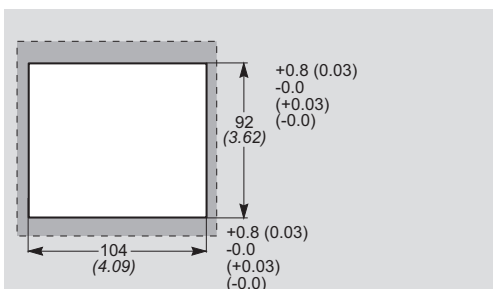

Cut-out for flush mount mm / (inch)

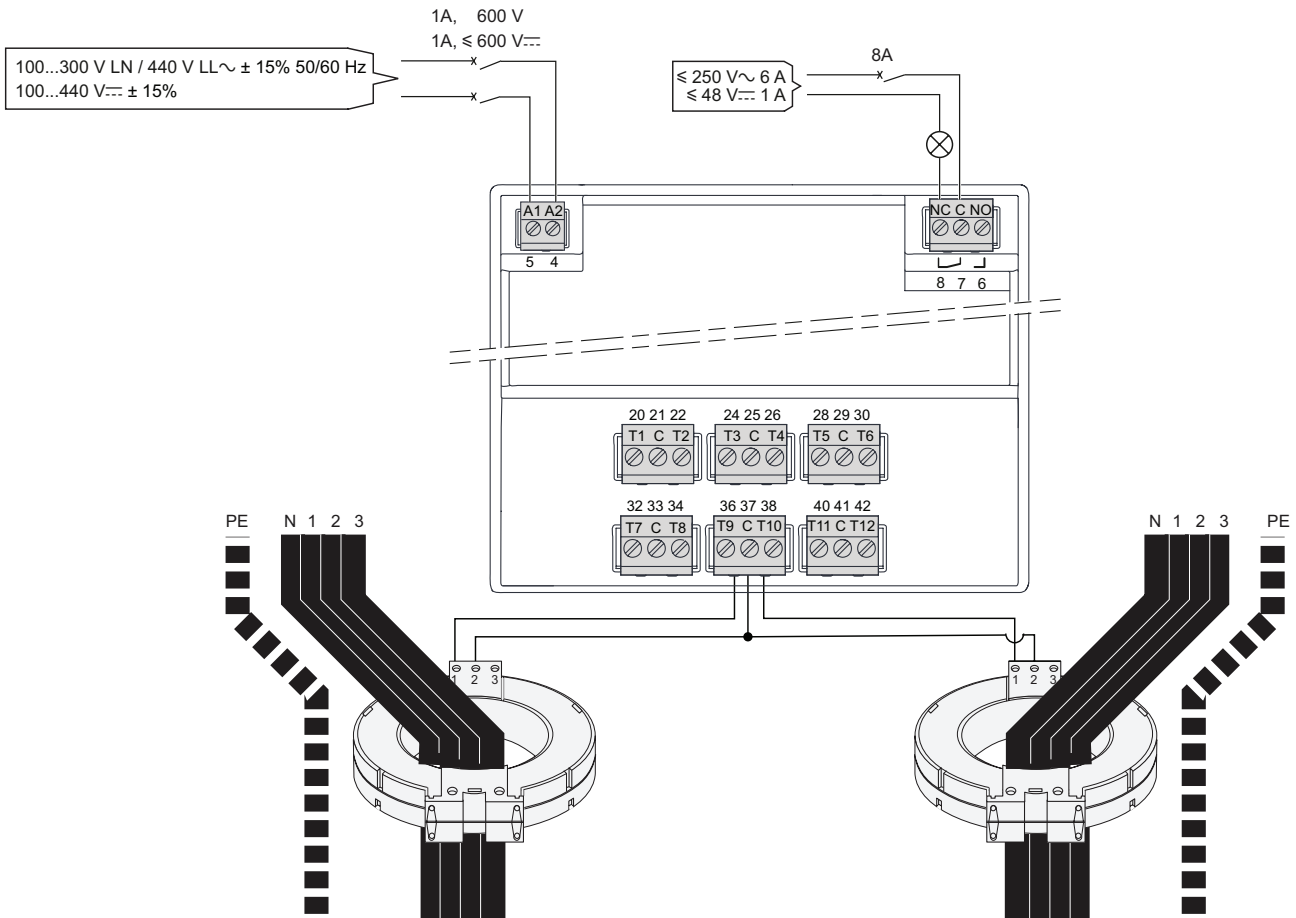

Vigilohm IFL12 / IFL12L Insulation Fault Locator

Connection

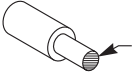
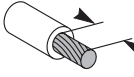
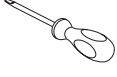

				
{T1, C, T2}, {T3, C, T4}, {T5, C, T6}, {T7, C, T8}, {T9, C, T10}, {T11, C, T12}	1 conductor - 1.5 mm ² (16 AWG) 2 conductors - 0.75 mm ² (18 AWG)	7mm (0.28 in) ± 1 mm (0.040 in)	∅ 2.5 mm (7/64 in)	0.22 - 0.25 Nm (1.9 - 2.2 in lb)
A1, A2	0.2 - 2.5 mm ² (24 - 14 AWG)	7mm (0.28 in) ± 1 mm (0.040 in)	∅ 3 mm (1/8 in)	0.5 - 0.6 Nm (4.4 - 5.3 in lb)
NC, C, NO	0.2 - 2.5 mm ² (24 - 14 AWG)	7mm (0.28 in) ± 1 mm (0.040 in)	∅ 3 mm (1/8 in)	0.5 - 0.6 Nm (4.4 - 5.3 in lb)

General characteristics

Commercial name		IFL12	IFL12L
Type of network to monitor			
Max phase to phase voltage		≤1000VAC	≤1000VAC
Max line voltage		≤1000VDC	≤1000VDC
Network max capacitance		150μF	150μF
Frequency		45-65Hz	45-65Hz
Grounding arrangement		IT / HRG	IT / HRG
Power Supply			
Auxiliary supply voltage	Voltage	100-440VAC/DC	24-48VDC
	Frequency	50-60 Hz	-
	Tolerance	+/-15%	+/-15%
	Maximum consumption	<20VA <6W	<8W
	Recommended protection	1A	1A
Product Performances			
Number of Channel		12	12
Range for insulation resistance	Reading	N.A.	N.A.
	Accuracy at 10 kΩ, 1 μF	N.A.	N.A.
Range for earth leakage capacitance	Reading	N.A.	N.A.
	Accuracy at 10 kΩ, 1 μF	N.A.	N.A.
Fault signaling thresholds	Alarm	High impedance, medium impedance or low impedance	High impedance, medium impedance or low impedance
Settable alarm delay		N.A.	N.A.
Polling (12 channels)		All channels simultaneously	All channels simultaneously
Response time		5s, 40s	5s, 40s
Transient capture		Yes	Yes
Self test	Automatic	Yes	Yes
	Manual	Yes	Yes
Output relay	Quantity	1	1
	Type de contact	Changeover	Changeover
	Breaking capacity AC	250VAC / 6A	250VAC / 6A
	Breaking capacity DC	48VDC / 1A, 3mA min. load	48VDC / 1A, 3mA min. load
	Setting	Standard	Standard
Operating Modes	Power Circuit	Yes	Yes
	Control Circuit	No	No
Environment			
Protection degree	Front	IP54	IP54
	Rear	IP20	IP20
Overvoltage category		300V OVC3 / 600V OVC2	300V OVC3 / 600V OVC2
Pollution degree		2	2
Temperature strength	For operation	-25°C to +55°C	-25°C to +55°C
	For storage	-40°C to +85°C	-40°C to +85°C
Altitude max.		up to 3000m	up to 3000m
Relative humidity		≤ 92%	≤ 92%
Human Machine Interface			
HMI		LED+Buttons	LED+Buttons
Multilingual interface	8 languages	N.A.	N.A.
Others	Historical resistance log	N.A.	N.A.
	Time stamped Event log	N.A.	N.A.
Others characteristics			
Compatible Insulation Monitor		IM400, IM400C & IM400L	IM400, IM400C & IM400L

Vigilohm IFL12MC / LMC / MCT / LMCT

Advanced Insulation Fault Locator



IFL12MC



IFL12LMC



IFL12MCT



IFL12LMCT



Functions

- When associated with IM400 series, acts as Insulation Fault Locator, simultaneously for 12 feeders.
- Measure the insulation resistance to ground and the leakage capacitance of each individual feeder.
- Detect an insulation fault based to the set alarm threshold.
- Generate an alarm via the output contacts relay in case of insulation fault on any feeder and via the communication port.

Main features

- Power Supply 100-440VAC/DC or 24-48VDC.
- Each feeder has its own Alarm threshold set from 200Ω to 200KΩ.
- Fast response time: 5s.
- Filtering for highly disturbed power system.
- Transient insulation fault reporting.
- Large screen and interactive human-machine interface to ease operation & maintenance.
- Displays product status according to standard.
- Measures and displays each feeder's insulation resistance from 200Ω to 250KΩ, and leakage capacitance from 1μF to 15μF.
- Fast dedicated commissioning procedure.
- Simple installation: Stand alone device, no wire connection to the Insulation Monitor.
- User friendly LCD HMI in 8 languages.
- Communicate via the modbus RS485 to report settings and event log to the supervision system.
- Timestamped event log.
- Insulation and Capacitance measurement trending log and curves for preventive maintenance.
- Unlimited number of IFL12 in the same power system.
- Exists in tropicalized versions for harsh environments.

Commercial references

- IMDIFL12MC.
- IMDIFL12LMC.
- IMDIFL12MCT.
- IMDIFL12LMCT.

Standard & certification

- IEC61557-9 Ed.2014
- IEC61010-1 Ed.2010
- UL 61010-1 Ed.2012
- IEC61326-2-4 Ed.2012
- IEC60364-4-41 Ed.2005



Application

- All type of network with feeders to be monitored individually.
- Power Circuits networks, including power loads and power electronics such as speed drives, inverters, rectifiers, etc.
- Control Command networks, including sensitive loads such as PLCs, I/Os, sensors.
- Typical segments: Electrical Distribution, Industry, Power generation, Marine, Airport, Oil&Gas, Mining, Lifts, etc. requesting continuity of service even in case of earth insulation fault.
- Mobile insulation fault locator kit complementary to IFL.

Example of architectures

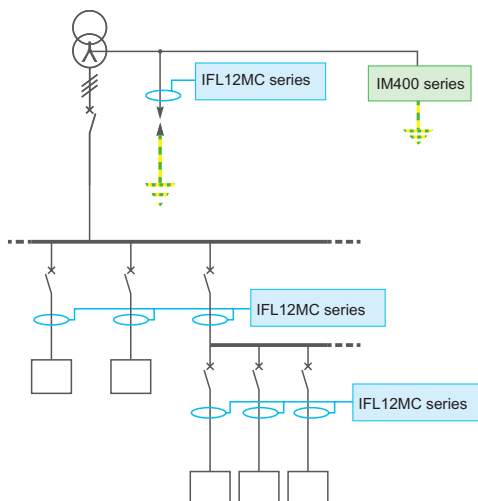

Compatible auxiliaries

- Toroids: TA30, PA50, IA80, MA120, SA200, GA300, TOA80 & TOA120.
- Voltage adaptors: PHT1000.
- Earthing Impedance: ZX.
- Surge Limiter: Cardew C.
- Mobile insulation fault locator: XRM + probes.
- Gateways and supervision: Com'X510, Link150, spaceLYnk, EcoStruxure Power Monitoring Expert, EcoStruxure Power SCADA Operations.

Vigilohm IFL12MC / LMC / MCT / LMCT Advanced Insulation Fault Locator

Physical Description

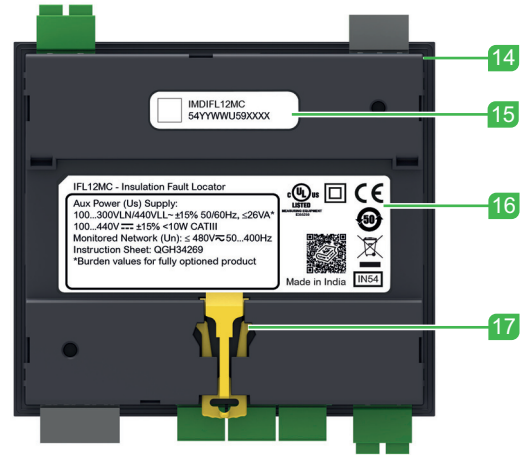
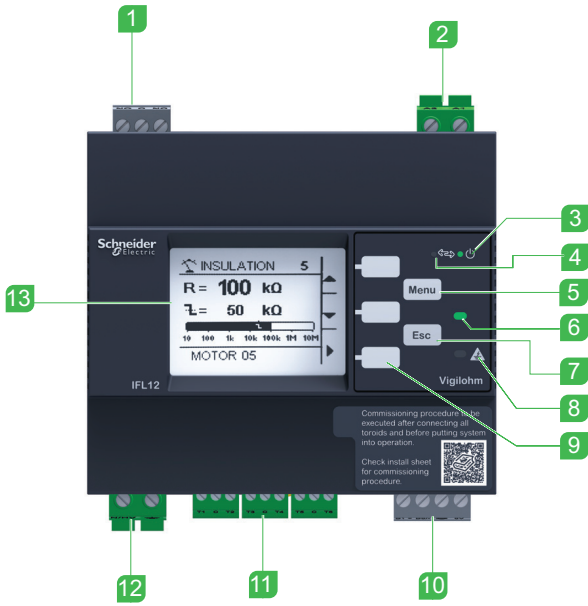

- 1 Alarm relay
- 2 Auxiliary power supply
- 3 Product status LED
- 4 Communications LED
- 5 Menu button
- 6 No alarm LED
- 7 Esc button
- 8 Alarm LED
- 9 Contextual menu buttons

- 10 RS-485 communication
- 11 12 toroid connections
- 12 Voltage input
- 13 LCD screen
- 14 Gasket
- 15 Commercial reference and manufacturing data
- 16 Label
- 17 DIN mounting clip

Dimensions

Dimensions mm / (inch)

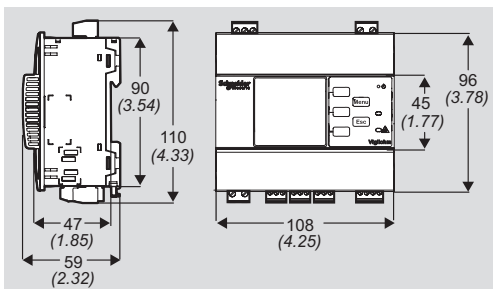

Cut-out for flush mount mm / (inch)

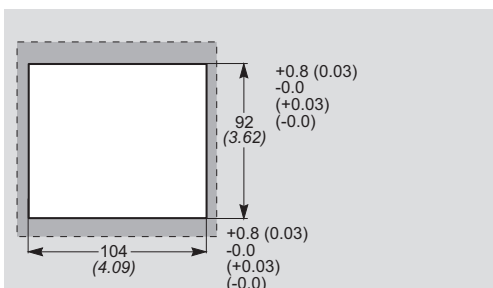

Minimum clearance between flush mounted devices mm / (inch)

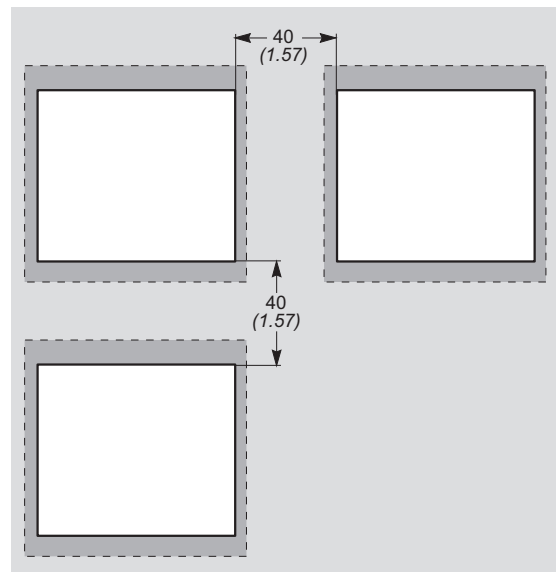

Vigilohm IFL12MC / LMC / MCT / LMCT

Advanced Insulation Fault Locator

Connection

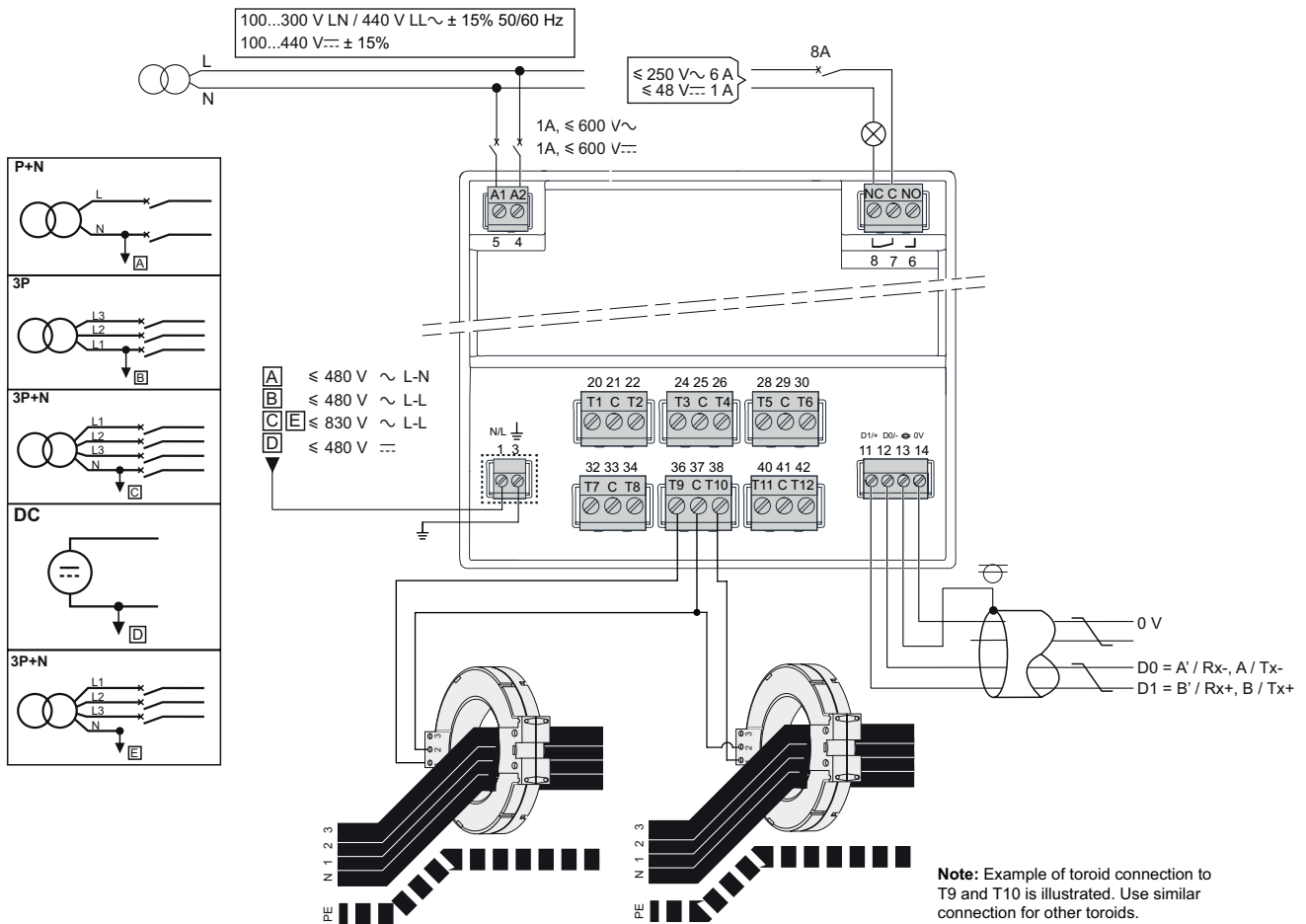

{T1, C, T2}, {T3, C, T4}, {T5, C, T6}, {T7, C, T8}, {T9, C, T10}, {T11, C, T12}	1 conductor - 1.5 mm ² (16 AWG) 2 conductors - 0.75 mm ² (18 AWG)	7mm (0.28 in) ± 1 mm (0.040 in)	∅ 2.5 mm (7/64 in)	0.22 - 0.25 Nm (1.9 - 2.2 in lb)
A1, A2	0.2 - 2.5 mm ² (24 - 14 AWG)	7mm (0.28 in) ± 1 mm (0.040 in)	∅ 3 mm (1/8 in)	0.5 - 0.6 Nm (4.4 - 5.3 in lb)
NC, C, NO	0.2 - 2.5 mm ² (24 - 14 AWG)	7mm (0.28 in) ± 1 mm (0.040 in)	∅ 3 mm (1/8 in)	0.5 - 0.6 Nm (4.4 - 5.3 in lb)
N/L, ⊥	0.82 - 3.31 mm ² (18 - 12 AWG)	7mm (0.28 in) ± 1 mm (0.040 in)	∅ 3 mm (1/8 in)	0.5 - 0.6 Nm (4.4 - 5.3 in lb)
+, -, ∅, C	0.13 - 0.82 mm ² (26 - 18 AWG)	7mm (0.28 in) ± 1 mm (0.040 in)	∅ 3 mm (1/8 in)	0.5 - 0.6 Nm (4.4 - 5.3 in lb)

Vigilohm IFL12MC / LMC / MCT / LMCT

Advanced Insulation Fault Locator

General characteristics

Commercial name		IFL12MC	IFL12LMC	IFL12MCT	IFL12LMCT
Type of network to monitor					
Max phase to phase voltage	Connected to neutral	≤ 830 VAC ⁽¹⁾	≤ 830 VAC ⁽¹⁾	≤ 830 VAC ⁽¹⁾	≤ 830 VAC ⁽¹⁾
	Connected to phase	≤ 480 VAC ⁽¹⁾	≤ 480 VAC ⁽¹⁾	≤ 480 VAC ⁽¹⁾	≤ 480 VAC ⁽¹⁾
Max line voltage		≤ 480 VDC ⁽¹⁾	≤ 480 VDC ⁽¹⁾	≤ 480 VDC ⁽¹⁾	≤ 480 VDC ⁽¹⁾
Network max capacitance		150μF	150μF	150μF	150μF
Frequency		45-440Hz	45-440Hz	45-440Hz	45-440Hz
Grounding arrangement		IT / HRG	IT / HRG	IT / HRG	IT / HRG
Power Supply					
Auxiliary supply voltage	Voltage	100-440VACDC	24-48VDC	100-440VACDC	24-48VDC
	Frequency	50-60 Hz	-	50-60 Hz	-
	Tolerance	+/-15%	+/-15%	+/-15%	+/-15%
	Maximum consumption	<26VA <10W	<12W	<26VA <10W	<12W
	Recommended protection	1A	1A	1A	1A
Product Performances					
Number of Channel		12	12	12	12
Range for insulation resistance	Reading	200Ω...250KΩ	200Ω...250KΩ	200Ω...250KΩ	200Ω...250KΩ
	Accuracy at 10 kΩ, 1 μF	10%	10%	10%	10%
Earth leakage capacitance	Reading	0.1μF...15μF	0.1μF...15μF	0.1μF...15μF	0.1μF...15μF
	Accuracy at 10 kΩ, 1 μF	10%	10%	10%	10%
Fault signaling thresholds	Alarm	200Ω...200KΩ	200Ω...200KΩ	200Ω...200KΩ	200Ω...200KΩ
Settable alarm delays	Alarm	0..7200s	0..7200s	0..7200s	0..7200s
Polling (12 channels)		All channels simultaneously	All channels simultaneously	All channels simultaneously	All channels simultaneously
Response time		5s, 40s, 400s	5s, 40s, 400s	5s, 40s, 400s	5s, 40s, 400s
Transient capture		Yes	Yes	Yes	Yes
Self test	Automatic	Yes	Yes	Yes	Yes
	Manual	Yes	Yes	Yes	Yes
Output relay	Quantity	1	1	1	1
	Type de contact	Changeover	Changeover	Changeover	Changeover
	Breaking capacity AC	250VAC / 6A	250VAC / 6A	250VAC / 6A	250VAC / 6A
	Breaking capacity DC	48VDC / 1A, 3mA min. load	48VDC / 1A, 3mA min. load	48VDC / 1A, 3mA min. load	48VDC / 1A, 3mA min. load
	Setting	Failsafe or standard	Failsafe or standard	Failsafe or standard	Failsafe or standard
Communication port		Modbus RS485	Modbus RS485	Modbus RS485	Modbus RS485
Operating Modes	Power Circuit	Yes	Yes	Yes	Yes
	Control Circuit	Yes	Yes	Yes	Yes
Environment					
Protection degree	Front	IP54	IP54	IP54	IP54
	Rear	IP20	IP20	IP20	IP20
Overvoltage category		300V OVC3 / 600V OVC2	300V OVC3 / 600V OVC2	300V OVC3 / 600V OVC2	300V OVC3 / 600V OVC2
Pollution degree		2	2	2	2
Temperature strength	For operation	-25°C to +55°C	-25°C to +55°C	-25°C to +55°C	-25°C to +55°C
	For storage	-40°C to +85°C	-40°C to +85°C	-40°C to +85°C	-40°C to +85°C
Altitude max.		up to 3000m	up to 3000m	up to 3000m	up to 3000m
Relative humidity		≤ 92%	≤ 92%	≤ 95%	≤ 95%
Tropicalization		No	No	Yes	Yes
Human Machine Interface					
HMI		LCD+Buttons	LCD+Buttons	LCD+Buttons	LCD+Buttons
Multilingual interface	8 languages	En, Fr, Es, Po, Zh, It, De, Ru	En, Fr, Es, Po, Zh, It, De, Ru	En, Fr, Es, Po, Zh, It, De, Ru	En, Fr, Es, Po, Zh, It, De, Ru
Others	Historical resistance log	Yes	Yes	Yes	Yes
	Time stamped Event log	Yes	Yes	Yes	Yes
Others characteristics					
Compatible Insulation Monitor		IM400, IM400C & IM400L	IM400, IM400C & IM400L	IM400, IM400C & IM400L	IM400, IM400C & IM400L

⁽¹⁾ 1000VAC / 1000VDC if the IFL12MC and the IM400 are connected through a common PHT1000.