

Altivar 71

Network braking units

User's manual

VW3 A7 201... 241

11/2010

Contents

Before you begin	4
Steps for setting up the braking unit	5
Checking the installation	6
Recommendations	13
Characteristics	14
Sizing	15
Dimensions	19
Mounting and temperature conditions	21
Recommendations for the electrical installation	22
Connection diagrams, fuses and associated cables	23
Operation on a neutral IT (isolated or impedance grounded neutral) system	28
Electromagnetic compatibility and wiring	29
Starting tests	33
Configuration	34
Troubleshooting	36

Read and understand these instructions before performing any procedure with this braking unit.

DANGER

HAZARDOUS VOLTAGE

- Read and understand this User's Manual before installing or operating the braking unit. Installation, adjustment, repair, and maintenance must be performed by qualified personnel.
- The user is responsible for compliance with all international and national electrical standards in force concerning protective grounding of all equipment.
- Many parts in this equipment, including printed circuit boards, operate at line voltage. DO NOT TOUCH.
Use only electrically insulated tools.
- DO NOT touch unshielded components or terminal strip screw connections with voltage present.
- DO NOT short across terminals PA and PC or across the DC bus capacitors.
- Install and close all the covers before applying power or starting and stopping the drive.
- Before servicing the braking unit
 - Disconnect the power and the control power supply.
 - Place a "DO NOT TURN ON" label on the disconnect at the head of the installation.
 - Lock the disconnect in the open position.
- Disconnect the power supply, including the 230 V control power supply, before working on the equipment. Wait for the charging LED to go off. Then follow the DC bus voltage measurement procedure described in the drive Installation Manual to verify that the DC voltage is less than 45 VDC. The LEDs on the speed drive are not accurate indicators of the absence of DC bus voltage.

Electric shock will result in death or serious injury.

■ 1 Take delivery of the braking unit (see page [13](#))

- Check that the catalog number printed on the label is the same as that on the purchase order.
- Remove the braking unit from its packaging and check that it has not been damaged in transit.

■ 2 Check the line voltage (see page [14](#))

- Check that the line voltage is compatible with the voltage range of the braking unit

■ 3 Install the braking unit (see page [21](#))

- Mount the braking unit in accordance with the instructions in this document
- Install any internal and external options

■ 4 Wire the braking unit (see page [23](#))

- Connect the braking unit to the 3-phase supply (L1,L2,L3)
- Connect the braking unit to the drive DC bus
- Connect the control cable

Steps 1 to 4 must be performed with the power off

Checking the installation

Length of the DC bus

The maximum inductance of the DC bus connecting output PA/+, PC/- on the drive to the braking unit must not exceed a set level, as this inductance results in an additional difference in potential on the DC bus when the IGBTs are open. To avoid an overload on the components of the braking unit, this difference in potential must not exceed 100 VDC. The maximum inductance can be calculated using this and other characteristics of the braking unit (value of the DC bus capacitors and absolute value of the grid current).

$$L_{\max} = \frac{C \cdot (\Delta U_{GL})^2}{i^2}$$

This inductance must always be greater than or equal to the sum of the inductance of the DC bus on the frequency inverter and the inductance of the DC bus connection cables. The inductance of the DC bus on the frequency inverter must always be taken into consideration. The inductance per unit of length of the cables generally used for the power supply is in the region of 0.6 µH/m. The maximum length of the conductors l_{\max} is calculated according to the following information:

- Values of the input capacities **C**
- Maximum DC voltage edge permitted during motor generator operation ($\Delta U_{GL}=100$ VDC)
- Maximum AC current level for the equipment \hat{i} ($=2 \cdot I_{rms}$)
- Inductance per unit of length **L'**
- Inductance of the coil **L_{ZKD}** of the DC bus

The equation below can be used to calculate l_{\max} :

$$l_{\max} = \frac{C \cdot \Delta U_{GL}^2}{i^2 \cdot L'} - \frac{L_{ZKD}}{L'}$$

Typical capacity of the DC connection inside the braking unit

Braking unit	Power	DC capacity
VW3 A7 ...	7 - 45 kW	100 µF
	70 - 135 kW	200 µF
	160 - 200 kW	420 µF

Example:

$C = 200 \mu\text{F}$, $\Delta U_{GL} = 100 \text{ V}$, $i = 271 \text{ A}$, $a = 80 \text{ mm}$, $r = 8.5 \text{ mm}$, $\mu_0 = 1.257 \cdot 10^{-6} \text{ H/m}$

For longer DC bus cables, additional capacitors must be installed (Please contact your local representative)

Checking the installation

Operation on a generator

It is possible to use a braking unit with an isolated line supply (for example: a diesel engine generating set), but there are restrictive rules limiting the power.

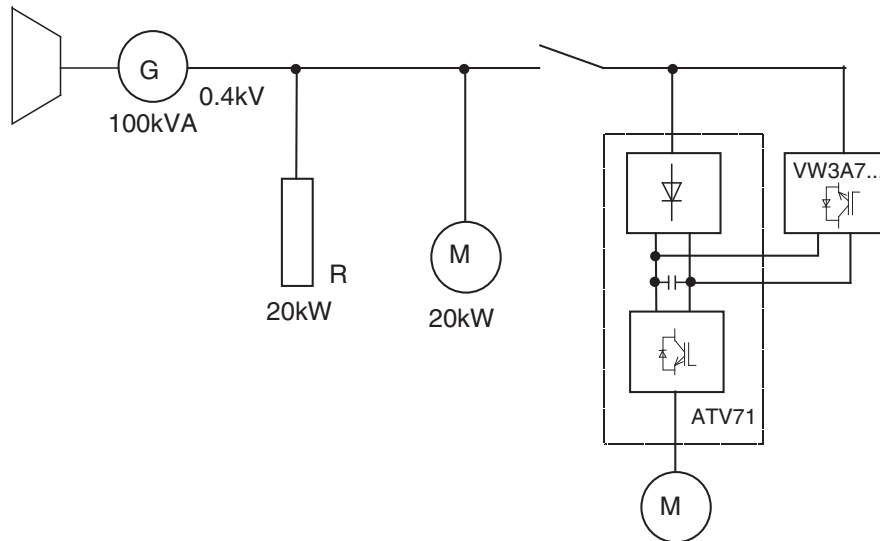

With a line supply whose architecture is similar to that shown in the diagram above, there are 2 additional restrictions:

- The power of the motor connected to the inverter must be less than half the nominal power of the generator.
- The total power of the two other loads must be more than double the power returned on the line supply.

If these conditions are not verified, changing the motor to operation as a generator could result in a sudden overload. This overload is too high for the voltage regulator of the generator. The regulator reacts with an overshoot which leads to an overvoltage with the isolated line supply.

CAUTION

RISKS OF INTERFERENCE

Overvoltages can cause serious damage to the frequency inverter and/or the braking unit and the other loads.

Failure to follow this precaution can result in equipment damage.

Checking the installation

Operation on a transformer

If only some loads are operating on one section of the line supply, then the transformer that is connected must be capable of transporting the unused generated power from this section to the next voltage level without exceeding the voltage edge permitted in the line supply section. The nominal power of the transformer must therefore be one and a half times greater than the power generated outside the section, so that the harmonic and reactive components of the current can be transmitted. In the line supply section shown in the diagram below, these conditions are verified even if the other loads are disconnected.

If the power that is generated is in the region of the nominal power of the transformer, then the transformer short circuit voltage must be fairly low (6% maximum) to limit the voltage increase in this section.

The operation of the braking unit used with a sized transformer (for example in the case of a slip ring induction motor) is only permitted if the ratio of the power generated to the nominal power is considerably less than 1.

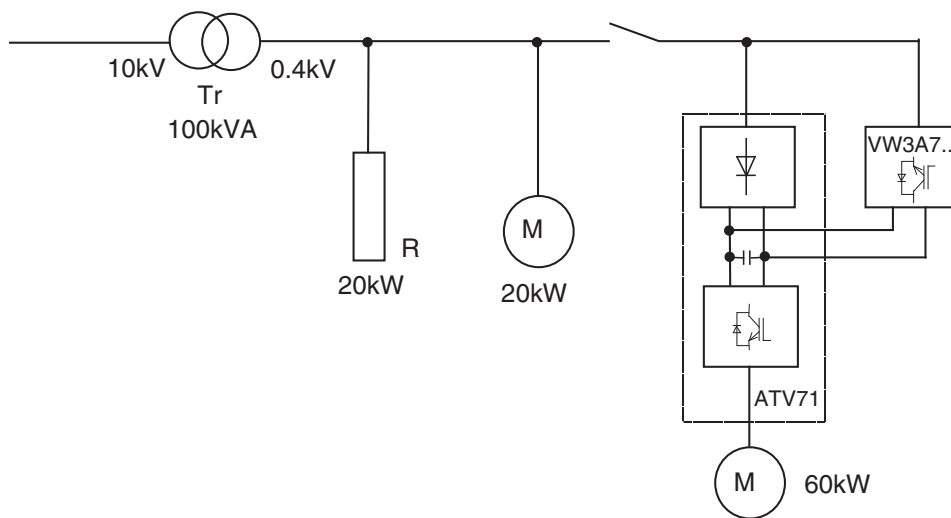

Checking the installation

Position of the commutation reactor

If the frequency inverter is connected to an external commutation reactor, then the braking unit must be connected to the line supply (diagram below). If the braking unit is connected downstream of the commutation reactor, then the inductance of the reactor prevents the braking unit from synchronizing on the line supply and generates overvoltages, which can result in damage to the components of the braking unit.

CAUTION
RISKS OF INTERFERENCE Overvoltages can cause serious damage to the frequency inverter and/or the braking unit and the other loads. Failure to follow this precaution can result in equipment damage.

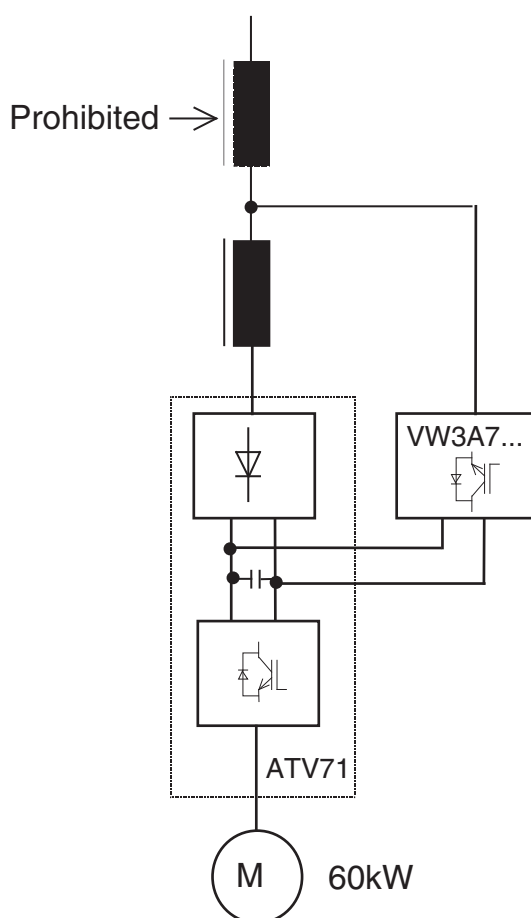

Same warning about the presence, also not permitted, of other commutation reactors upstream of the braking unit.

Checking the installation

Line resistances and contact resistances

The values of the capacitive currents of the cables depend on the conductive material. This is relevant for sizing. Aluminum conductors must have a larger cross-section than copper conductors due to their high resistivity.

Whatever conductive material is used, the contact resistances of the connections must have a low impedance and the number of connections must be kept to the absolute minimum.

Too many connections or contact resistances that are too high can result in overvoltages during power generation.

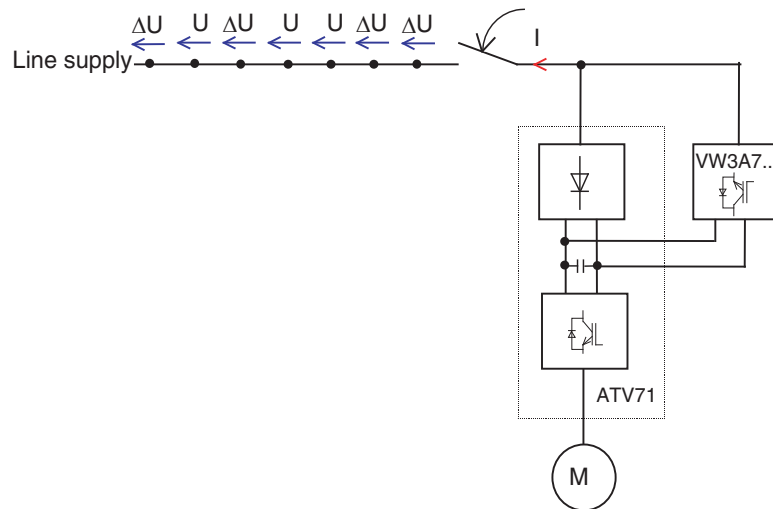

Based on a stable line supply with for example a nominal voltage of 400 V with a return current of 80 A, and a connection with a contact resistance of 100 m Ω , a voltage dip of 8 V occurs (a correct connection has a contact resistance of approximately 1 m Ω). During power generation if there are 7 connection points to the line supply, this results in a total voltage of 456 V.

Checking the installation

Connection of other loads

Connection of other loads (for example ventilation or air conditioning enclosure) in parallel on the frequency inverter and the braking unit with a common circuit-breaker is not permitted (see diagram below). If this is nevertheless performed, then if the circuit-breaker trips, the connection to the line supply will be absent (loss of power and synchronization information for the braking units). The IGBTs then transfer the DC voltage directly to the other loads. The resulting quasi-rectangular supply voltage signal sends a current across the loads, whose waveform and level depend on their impedance. If the power consumption of the loads is too low, then the DC voltage and the output voltage of the braking unit increase during generation. This overvoltage can damage all the components that are connected.

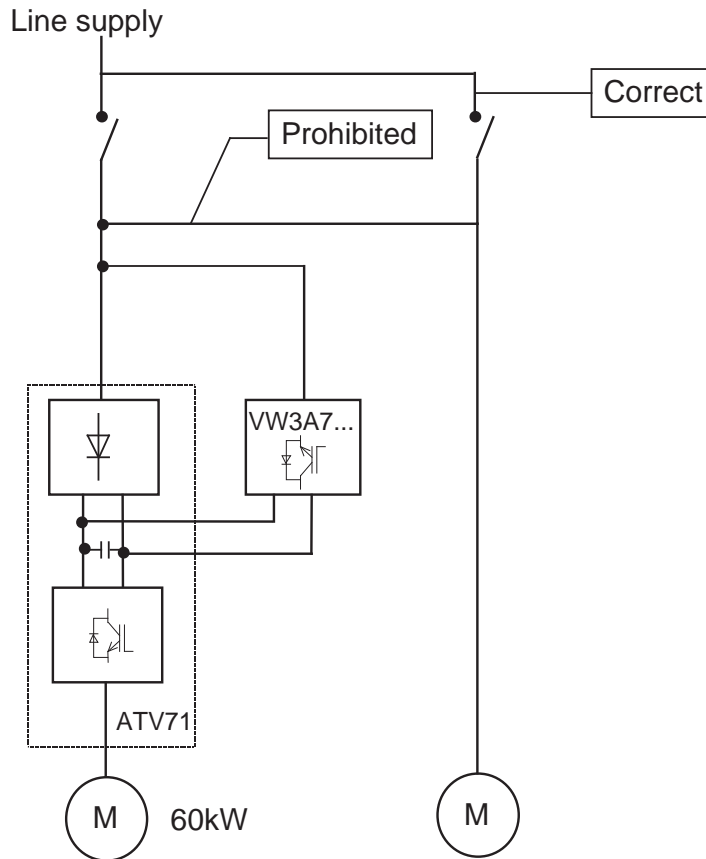

CAUTION

RISKS OF INTERFERENCE

Overvoltages can cause serious damage to the frequency inverter and/or the braking unit and the other loads.

Failure to follow this precaution can result in equipment damage.

Checking the installation

Connection of other loads (continued)

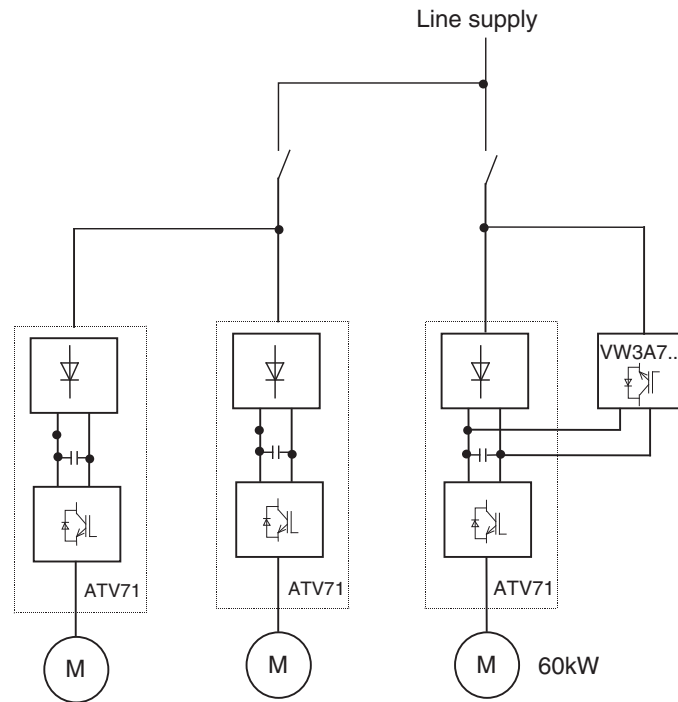

There are also risks of overvoltage for a structure such as that shown above. Even in this case, a circuit-breaker must be placed in each current return circuit.

Correction circuit without reactor

Correction circuits are used at the center of the line supply of a company. Interference and damage on these circuits have consequences on the line supply and can result in stoppage of the production process.

Although they are no longer currently made, many correction circuits without reactor are in use. A wide variety of problems arise from the use of such correction equipment without reactor:

- Direct resonance
- Increase in resonance
- Switching transient
- Attenuation of central oscillations

The fact that a company returns energy to the line supply is not the only reason for the creation of a resonance phenomenon. The power of the medium voltage transformer $\cos \varphi$ correction unit is the decisive element. The higher this power, the greater the risk of resonance. The second important factor is the harmonic load of the medium voltage line supply.

This harmonic load is transmitted via the transformer and affects the low voltage level. More often than not the limits are exceeded by the 5th harmonic.

Recommendations

Receipt

Ensure that the equipment reference marked on the label conforms to the delivery note corresponding to the purchase order. Open the packaging and check that the equipment has not been damaged in transit.

For successful setup, it is important to check that the braking unit, protection devices and mounting are correct. For more information, please contact your local representative.

Capacitor discharge!

Before any operation on or in the braking unit, disconnect the power line supply and wait 15 minutes for the DC bus to discharge completely. Measure the voltage on the DC bus before any intervention. This should be less than 60 V DC.

Automatic restart!

In certain cases, depending on its parameter setting, the drive may restart automatically when the power is restored. The safety of nearby equipment and people must be assured.

General

As a motor slows down on a deceleration ramp, it is working as a generator. A drive uses a rectifier and cannot return electrical energy to the distribution network.

During operation as a generator, the voltage at the DC bus terminals increases due to the restoration of energy from the motor to the drive. This locks out the drive on a DC bus overvoltage fault.

The restored power in the drive depends on the inertia of the load to be braked and the required braking time.

The drive protects itself against locking out due to DC bus overvoltage by auto-adapting its deceleration ramp. If a shorter deceleration time is required, a BRAKING UNIT must be used.

Characteristics

General characteristics

Degree of protection			IP 20
Maximum relative humidity			Class F humidity without condensation 5...85%
Ambient temperature around the unit	<i>Operation</i>	°C (°F)	5...+ 40 (41...+ 104) without derating Up to 55°C (131°F) with current derating of 3% per °C (34°F) above 40°C (104°F)
	<i>Storage</i>	°C (°F)	- 25...+ 55 (-77...+ 131)
Maximum operating altitude		m	1000 without derating 1000...4000 derating the current by 5% per additional 1000 m

Electrical characteristics

Type of module		VW3 A7 201...212	VW3 A7 231...241
Supply voltage	V	~ 400	~ 460
Nominal voltage ± 10%	V	~ 380...415	~ 440...480
Operating frequency	Hz	40...60 ± 10%	
Overload capacity	A	1.2 x maximum current (I _{rms})	
Efficiency		97% (3% of thermal losses)	
Power factor		1	
Fundamental frequency component		0.7...0.95	

Connection characteristics

Type of module	Maximum wire size
VW3 A7 201	25 mm ² , connected on a bar, M5
VW3 A7 202...205, VW3 A7 231, 232	35 mm ² , connected on a bar, M6
VW3 A7 206...209, VW3 A7 233...238	95 mm ² , connected on a bar, M8
VW3 A7 210...212, VW3 A7 239...241	150 mm ² , connected on a bar, M10

Sizing

Line voltage: \sim 400 V

Maximum current I _{rms}			Continuous braking power	Fast-acting semi-conductor fuses		Catalog number	Weight
\sim	\equiv			\sim	\sim		
A	A		kW	A	V		kg
11	13		7	20	660	VW3 A7 201	20.000
20	24		13	30	690	VW3 A7 202	25.000
32	38		11	50	690	VW3 A7 203	26.000
48	58		21.5	80	690	VW3 A7 204	30.000
65	78		26	100	690	VW3 A7 205	32.000
102	123		32	160	660	VW3 A7 206	43.000
130	157		38	200	660	VW3 A7 207	48.000
195	236		38	315	660	VW3 A7 208	52.000
231	279		86	350	660	VW3 A7 209	90.000
289	350		120	400	1000	VW3 A7 210	100.000
360	433		135	500	1000	VW3 A7 211	115.000
500	600		200	630	1000	VW3 A7 212	125.000

Line voltage: \sim 460 V

Maximum current I _{rms}			Continuous braking power	Fast-acting semi-conductor fuses		Catalog number	Weight
\sim	\equiv			\sim	\sim		
A	A		kW	A	V		kg
28	33		–	50	690	VW3 A7 231	26.000
41	50		21.5	80	690	VW3 A7 232	30.000
57	69		26	100	690	VW3 A7 233	36.000
88	107		32	160	660	VW3 A7 234	43.000
113	137		38	200	660	VW3 A7 235	48.000
138	166		38	250	660	VW3 A7 236	48.000
157	189		38	250	660	VW3 A7 237	50.000
176	212		38	315	660	VW3 A7 238	90.000
201	243		86	315	660	VW3 A7 239	100.000
289	346		120	500	1000	VW3 A7 240	105.000
500	600		240	630	1000	VW3 A7 241	125.000

Sizing



To calculate the correct value of the power that is generated, the fact that the actual instantaneous power generated depends on the actual voltage of the line supply at each moment must be taken into account. The following formula is used to calculate the power generated (during operation as a generator: $\cos\varphi = 1$):

$$P = U_{rms} \cdot I_{rms} \cdot \sqrt{3} \cdot \cos\varphi$$

The maximum power generated is calculated according to the instantaneous rms voltage of the line supply and according to the maximum rms current of the device in question.

Example: The VW3 A7 205 has a maximum generated power of 45 kW and a maximum rms current of 65 A (refer to the technical data). The nominal voltage of the line supply is, for example, 400 V. This gives:

$$P = 400V \times 65A \times \sqrt{3} = 45033W$$

That is, approximately 45.0 kW.

If the instantaneous rms voltage of the line supply is less than 395 V for a moment, then the maximum power generated is also reduced:

$$P = 395V \times 65A \times \sqrt{3} = 44470W$$

That is, approximately 44.5 kW.

Sizing

Example of how to use characteristic curves

Note: These curves are given for a voltage of 400 V or 460 V, depending on the model.

VW3 A7 204, A7 232 (Continuous braking power = 21.5 kW) (1)

Example of how to use the curves:

Required braking power of 27 kW.
The intersection point between the braking time and the time between 2 braking operations must be on or below the relevant curve.

Point **A** for a braking time of 2 minutes, there must be at least 50 seconds between 2 braking operations.

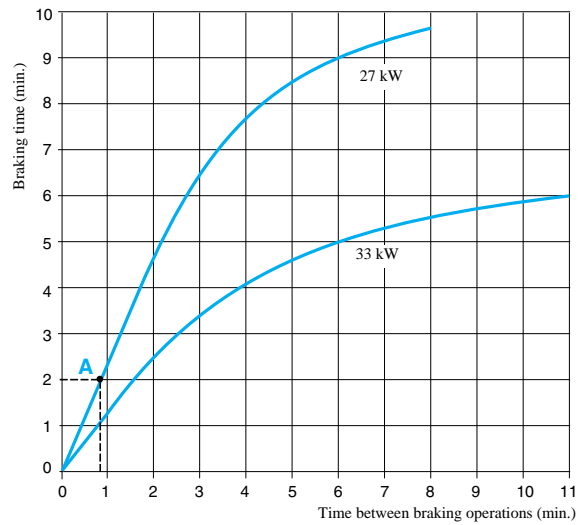

VW3 A7 204, A7 232 (Continuous braking power = 21.5 kW) (1)

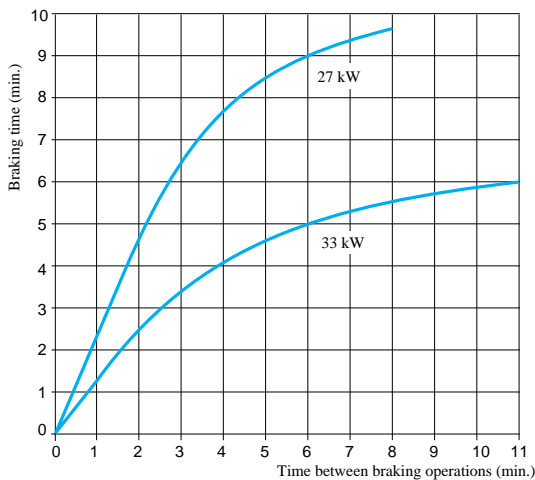

VW3 A7 205, A7 233 (Continuous braking power = 26 kW) (1)

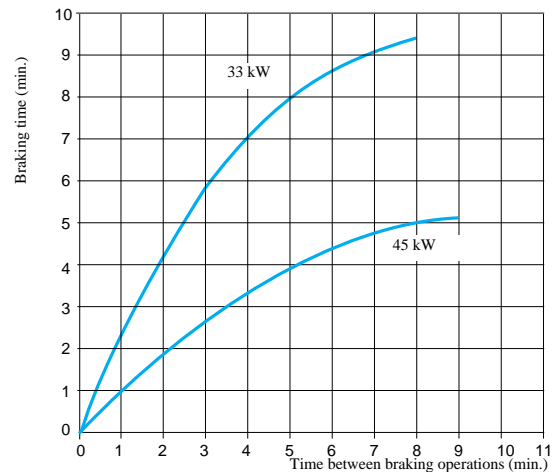

VW3 A7 206, A7 234 (Continuous braking power = 32 kW) (1)

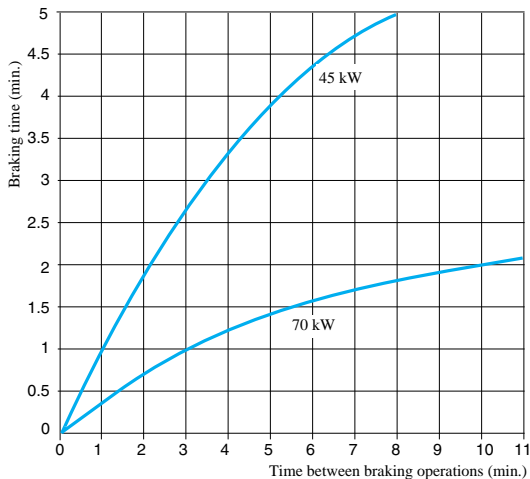

VW3 A7 207, A7 235 (Continuous braking power = 38 kW) (1)

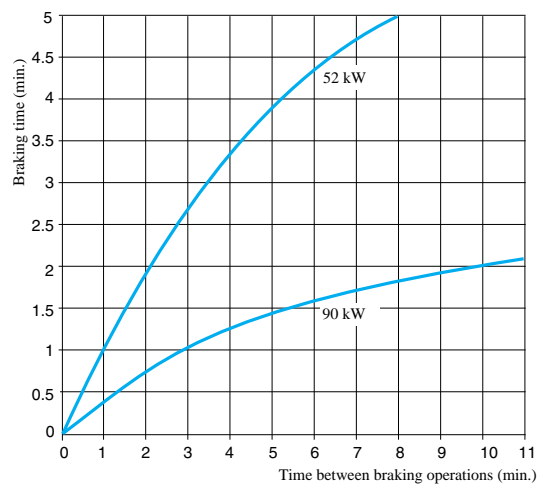

(1) Power indicated for a temperature of 35°C (95°F).

Sizing

VW3 A7 208 (Continuous braking power = 38 kW) (1)

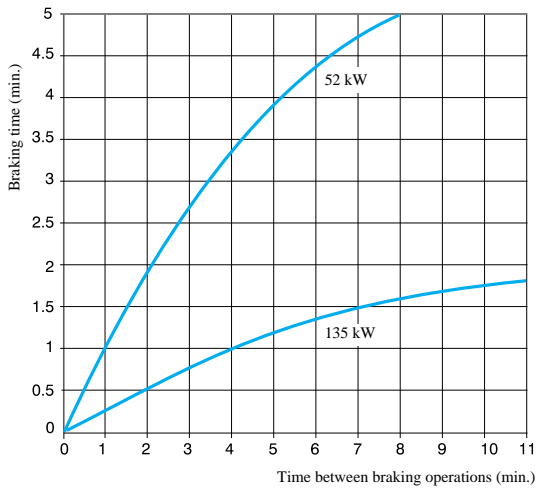

VW3 A7 209, A7 239 (Continuous braking power = 86 kW) (1)

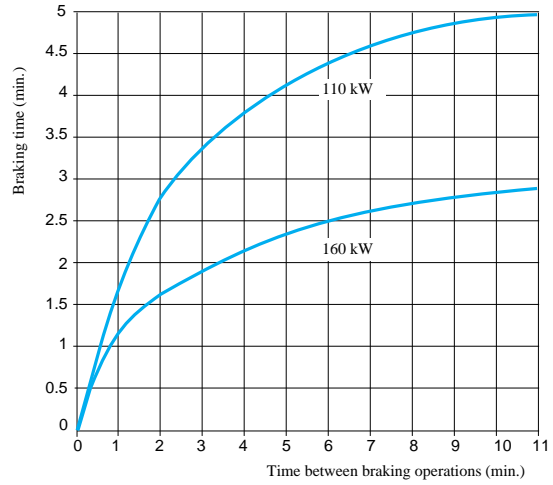

VW3 A7 210, A7 240 (Continuous braking power = 120 kW) (1)

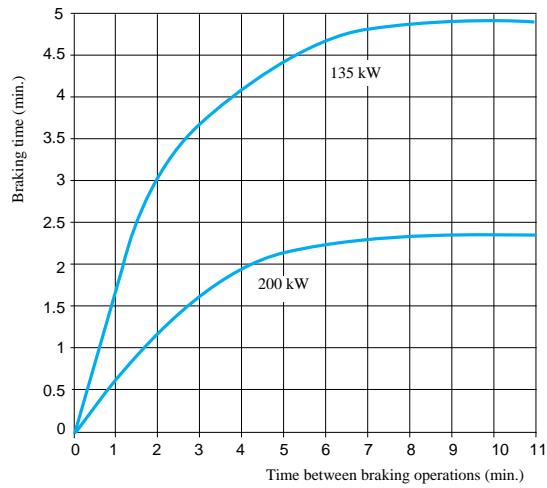

VW3 A7 211 (Continuous braking power = 135 kW)

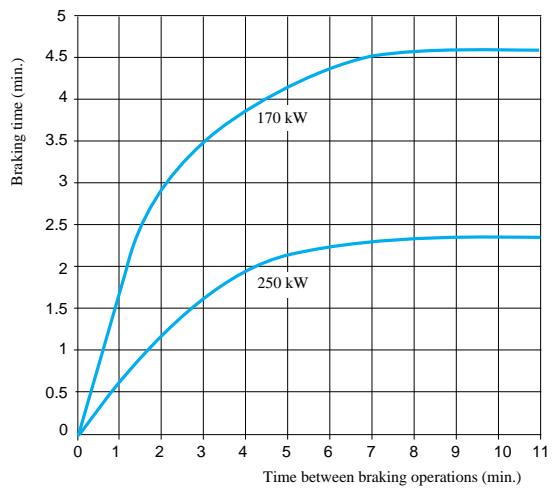

VW3 A7 212 (Continuous braking power = 200 kW)

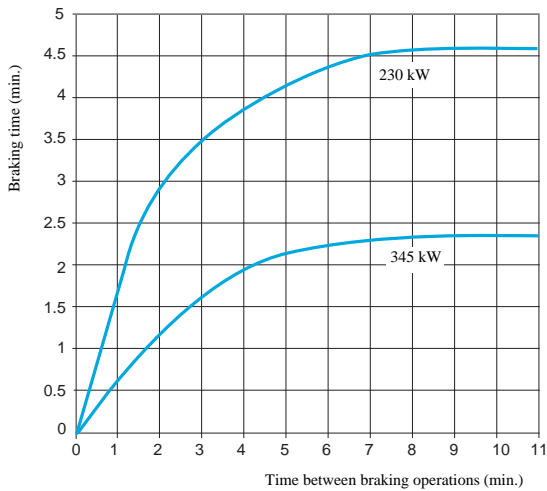

VW3 A7 241 (Continuous braking power = 240 kW)

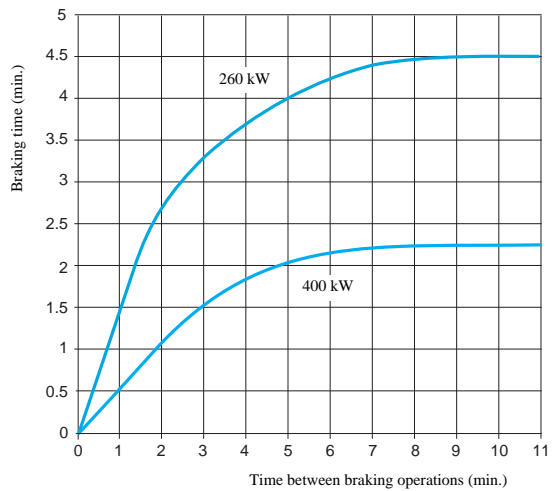

(1) Power indicated for a temperature of 35°C (95°F).

Dimensions

VW3 A7 201...205, 231, 232

Mounting recommendations

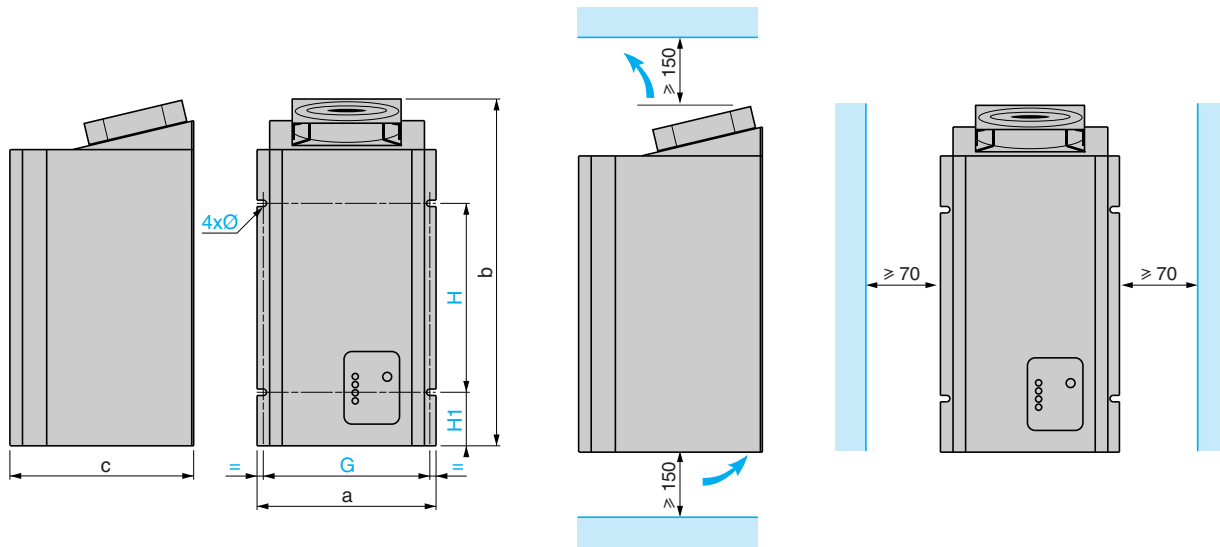

VW3	a	b	c	G	H	H1	Ø
A7 201, 202	270	500	295	260	260	80	7
A7 203...205 A7 231...232	270	580	295	260	340	80	7

VW3 A7 206...208, 233...237

Mounting recommendations

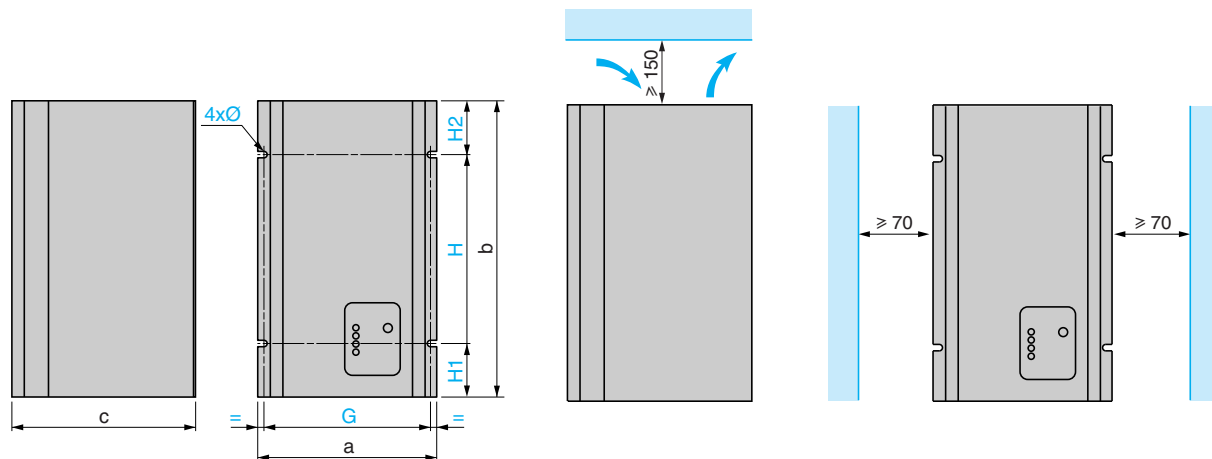

VW3	a	b	c	G	H	H1	H2	Ø
A7 206...208	245	700	272	260	440	80	180	7
A7 233...237	272	700	295	260	440	80	180	7

Dimensions

VW3 A7 209, 210, 238, 239

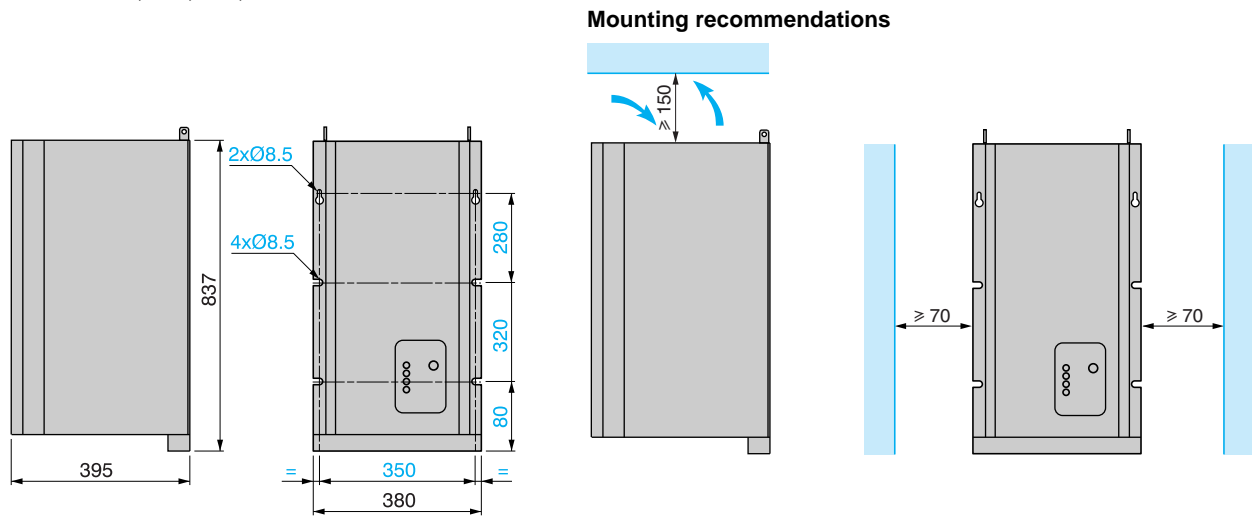

VW3 A7 211, 212, 240, 241

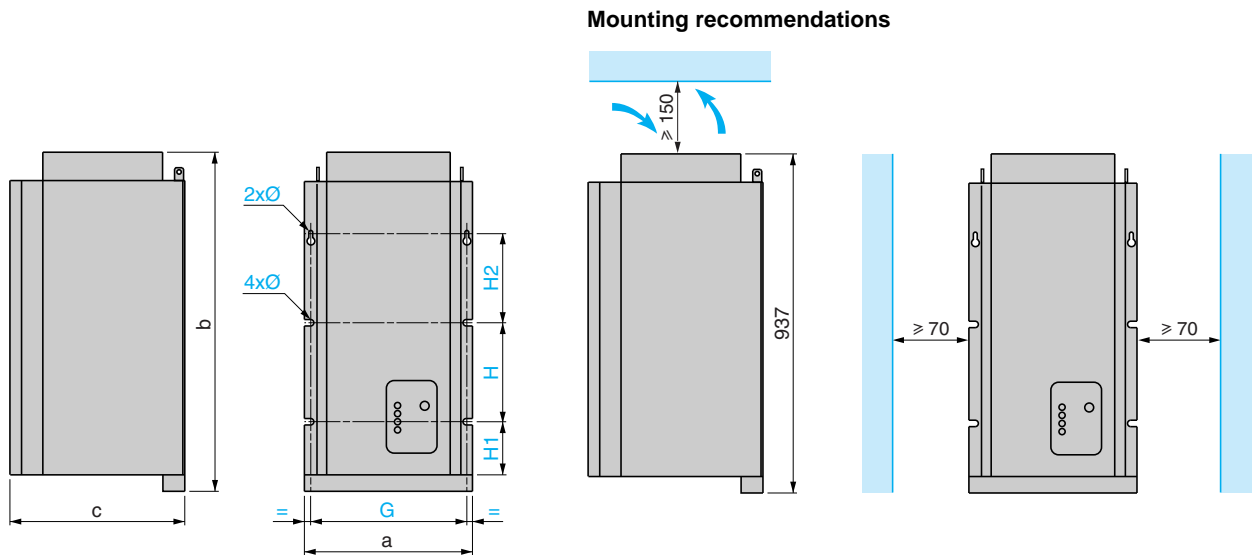

VW3	a	b	c	G	H	H1	H2	Ø
A7 211, 240	380	937	395	350	320	80	280	8.5
A7 212, 241	380	1037	395	350	320	80	280	8.5

Mounting and temperature conditions

Required mounting position

The braking unit has been designed to be mounted on a vertical wall only (+/- 15°). The unit can only be mounted on a smooth surface without the use of any type of spacer. It must be mounted in this way to ensure correct circulation of the cooling air.

Important recommendations

- Leave sufficient free space!
 - Leave a horizontal distance of at least 70 mm between the braking units and the other components, and between the braking units and the enclosure walls.
 - Leave a vertical distance of at least 70 mm between the braking units and the other components, and between the braking units and the enclosure walls.
- Check that there are no obstacles to the entry and exit of the cooling air. Leave a minimum distance of 15 cm at the air intake and outlet apertures.
- If the cooling air is polluted (dust, grease, corrosive gas) this may hamper some of the functions of the braking unit.
 - Take appropriate measures, for example: Keep the cooling air separate, fit air filters, clean regularly.
- Do not exceed the acceptable ambient temperature during use.

A dissipated thermal power of 3% of the maximum nominal power must be taken into account. The air temperature must not exceed 40°C (104°F) in the vicinity of the braking unit. The air intake and outlet apertures at the top and bottom of the braking unit must not be covered by installation equipment such as cable ducts or other equipment.

The required air flow rate depends on the size of the braking unit (nominal power and nominal voltage).

Braking module	Required air flow rate (m ³ /h)
VW3A7 4-230, 7-230, 12-230, 18-230, 22-230, 25-230 VW3A7 7-400, 13-400, 22-400, 33-400, 45-400 VW3A7 22-460, 33-460, 45-460 VW3A7 18-500, 33-500, 45-500	200
VW3A7 38-230, 50-230, 75-230 VW3A7 70-400, 90-400, 135-400 VW3A7 70-460, 90-460, 110-460, 125-460 VW3A7 70-500, 90-500, 110-500, 125-500	350
VW3A7 75-230 (1) VW3A7 135-400 (1) VW3A7 125-460 (1) VW3A7 125-500 (1) VW3A7 70-690 (1)	450
VW3A7 90-230, 115-230 VW3A7 160-400, 200-400, 250-400 VW3A7 140-460, 160-460 VW3A7 140-500, 160-500 VW3A7 150-690, 250-690	700

(1) Some specific models have slightly different dimensions.

Recommendations for the electrical installation

Protection of the braking unit

CAUTION
RISKS OF INTERFERENCE The braking unit contains components that are sensitive to electrostatic discharge. During the installation and wiring phases, personnel must comply with the rules of international standard IEC 747.1, section 9. Basically, before starting work, personnel must discharge themselves of any electrostatic voltage by touching the grounding cable screw located on the unit or a grounded surface of the enclosure. Failure to follow these precautions can result in equipment damage.

Connection diagrams, fuses and associated cables

The connections can be accessed by removing the side screws and connection terminal cover from the unit. The cables must pass through a cable gland located on the wiring plate.

CAUTION
RISKS OF INTERFERENCE
When you remove the cover, take care not to damage the cables that lead to the display. Failure to follow this precaution can result in equipment damage.

Electrical power supply

Fuses

The braking unit is equipped with fuses for semi-conductors.

- The on-load voltage drop must be taken into consideration when choosing the cable cross-section (See section "Checking the installation", page 6).
- Protection of the braking unit cables (L1,L2,L3) and the connections to the line supply:
 - by commercially available cable protection fuses
 - the fuses must comply with the appropriate standards for the site.
 - the nominal voltage of the fuse must comply with the voltages for the site.
- Protection of the braking unit and the connections to the DC bus (+UG,-UG):
 - The fuses are part of the braking unit

The installer/user of the circuit is responsible for compliance with the appropriate standards.

 WARNING
<ul style="list-style-type: none">• Overcurrent protective devices must be properly coordinated.• Use the fuses recommended in this document. Failure to follow these instructions can result in death or serious injury.

Connections

- All the connections must be as short as possible and have a low impedance.
- Shielded cables must be used in order to comply the EMC directives (in accordance with current standards such as EN 61800.3).
- Connect the line supply (line reactor) to terminals L1, L2 and L3 on the braking unit. Only a three-phase supply is permitted.
- A defined phase sequence (indirect rotation of the field) must be followed when connecting the braking unit to the line supply. The braking unit has a phase sequence check. If the rotating field is incorrect, an error message is displayed via an LED as follows: "incorrect phase rotation direction" or "phase loss". In this case, two phases connected to the braking unit must be inverted.
- Connect the ground of the power supply cables to the ground connection screw on the braking unit.
- The DC bus wires used to connect the drive and braking unit must be connected to the DC fuse carrier. It is essential to comply with the correct polarities.



The inversion of the + (PLUS) and the - (MINUS) will prevent correct operation of the braking unit.

Connection diagrams, fuses and associated cables

Wiring diagram

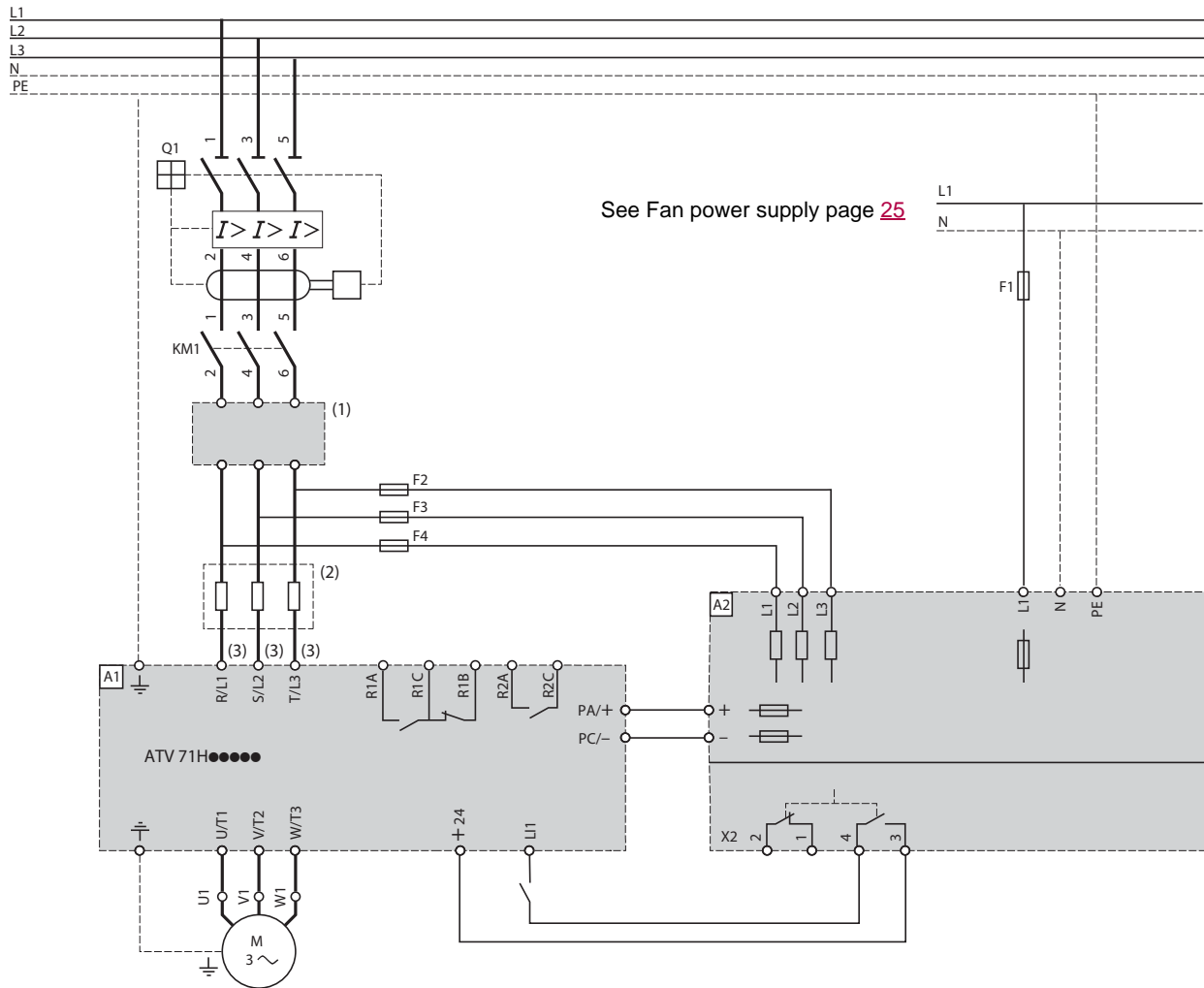

Components for use with the unit (for a complete list of references, see our “Motor starter solutions. Power control and protection components” specialist catalogue).

Ref.	Description
A1	ATV 71 drive
A2	Network braking unit
F1	2 A fuse, ~ 230 V
F2...F4	For the fuses, refer to the reference tables on page 15
Q1	Residual current circuit breaker 300 mA. Provides protection against earth leakage faults.

(1) Optional additional EMC input filter

(2) Line reactor recommended

(3) For ATV 71HC40N4 drives combined with a 400 kW motor and ATV 71HC50N4, see the drive Installation Manual.

Connection diagrams, fuses and associated cables

Size of DC bus fuses (F1, F2, F3) depending on the drive rating

For drives	Fast-acting semi-conductor fuses (1)
	A
ATV 71H037M3...HU15M3	25
ATV 71HU22M3...HU40M3	50
ATV 71HU55M3, HU75M3	100
ATV 71HD11M3X...HD18M3X	160
ATV 71HD22M3X, HD30M3X	250
ATV 71HD37M3X, HD45M3X	350
ATV 71HD55M3X	500
ATV 71HD75M3X	630
ATV 71H075N4...HU22N4	25
ATV 71H075N4...HU40N4	50
ATV 71HU55N4...HD11N4	80
ATV 71HD15N4...HD22N4	100
ATV 71HD30N4, HD37N4	160
ATV 71HD45N4	200
ATV 71HD55N4	250
ATV 71HD75N4	350
ATV 71HD90N4	315
ATV 71HC11N4, HC13N4	400
ATV 71HC16N4	500
ATV 71HC20N4	630
ATV 71HC25N4, HC28N4	800
ATV 71HC31N4	1000
ATV 71HC40N4, HC50N4	1250

(1) Nominal voltage of fast-acting semi-conductor fuse

Line voltage	Nominal voltage of fast-acting semi-conductor fuse
~ V	V
230	690
400	690
440	800
460	800
480	800

Fan power supply

Braking units (except for VW3A7201... 205, VW3A7231 and VW3A7232) have two terminals (blue terminal = neutral [N], grey fuse terminal = phase [L]) for supplying internal fan(s) (VW3A7206...7212 : 230 Vac, VW3A7233...7241 : 115 Vac). The fuse inside the fuse terminal is installed in order to protect the internal wiring and is the following type: 2 A, 500 V, size: 5*30 mm

Control cable

Connect the control cable to the X2 terminals on the braking unit control panel.
Do not place the control cables near the power supply cables as the power supply cables cause interference.
Connect the shielding of the control cables with the metal connector on the guide, over as large an area as possible.

Control functions

The control terminals are on the braking unit control card and are indicated by X2. These terminals can be removed easily using a simple operation. (see diagram "Use of the terminals", page 27)
The control card must always be configured for the voltage of the line supply.

The contacts of the fault relay on the X2 terminals can be connected to the outside. It is also possible to perform an external reset or switching functions by connecting them to the drive or the PLC.

Connection diagrams, fuses and associated cables

Layout of the control panel

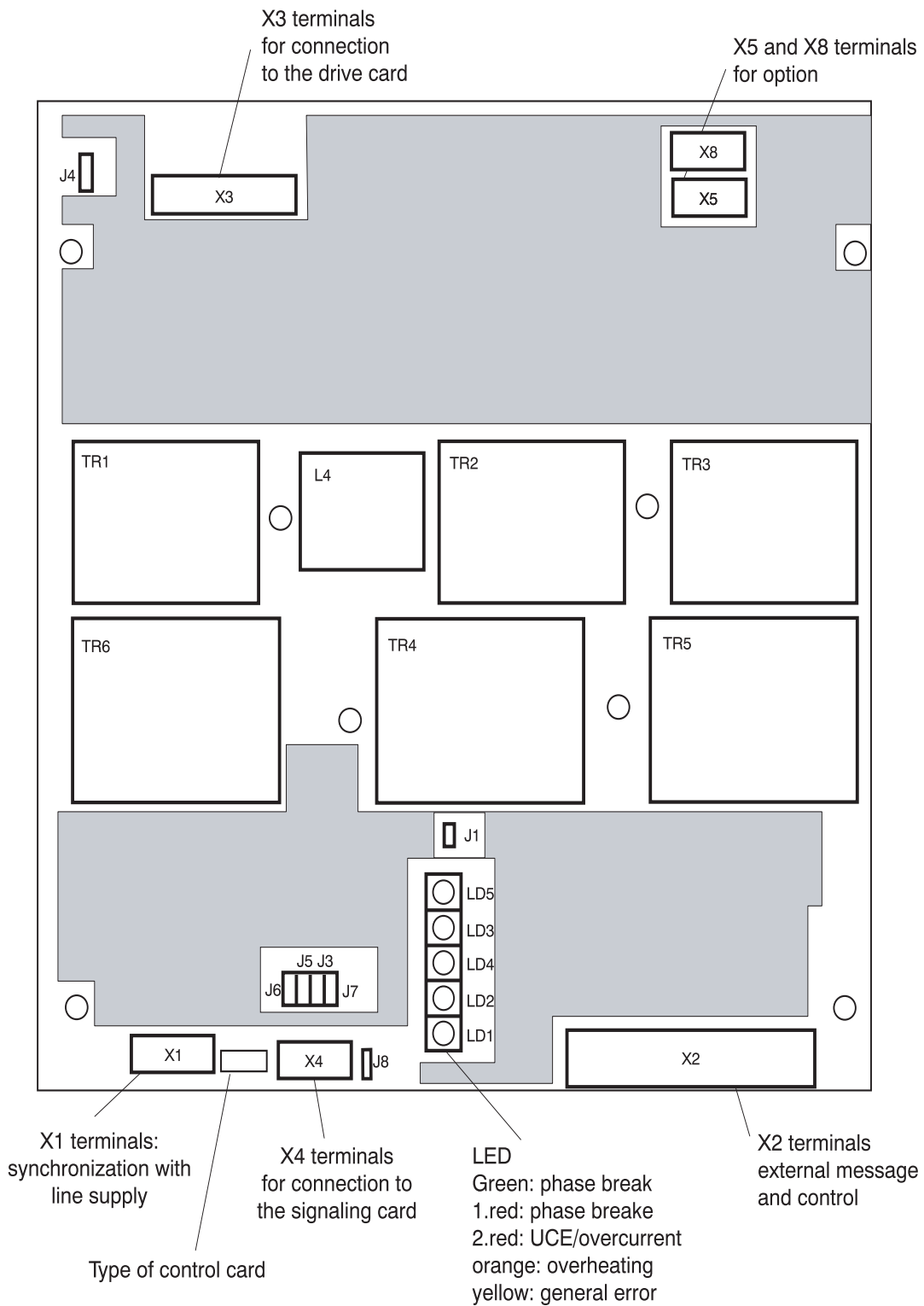

Connection diagrams, fuses and associated cables

Use of the terminals

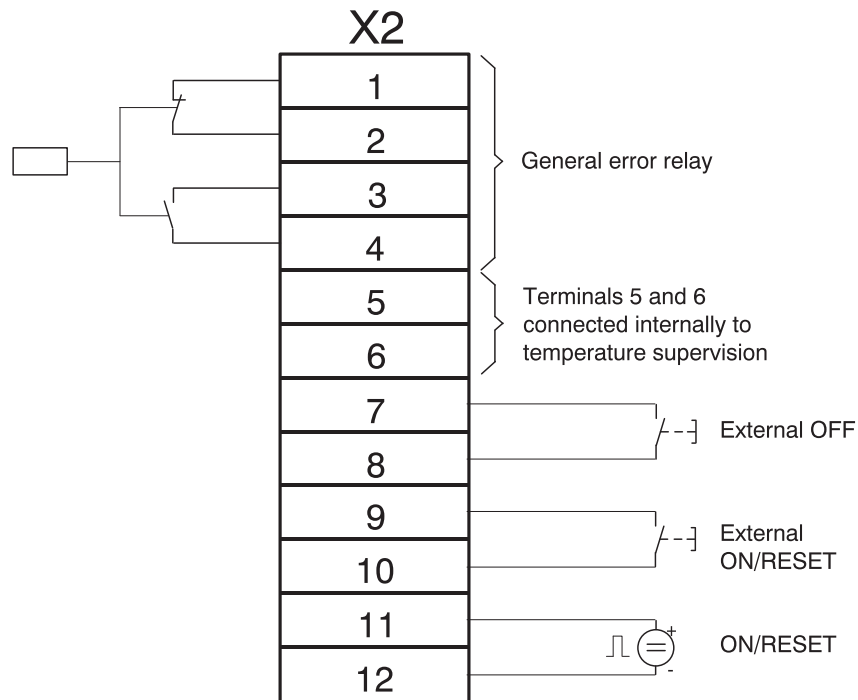

Terminals 1 to 4 (refer to the diagram above)

These terminals are connected to two volt-free relays (one is normally open, the other is normally closed) with a maximum load current of 5 A AC or 3 A DC.

Maximum voltage V DC, V AC.

The relay is shown in open position in the above diagram.

The relay closes if:

- 1 The line supply is OK
- 2 There is no fault

and possibly after an ON/RESET pulse.

After an OFF pulse, a general fault is displayed while the relay opens.

Terminals 5 and 6

These terminals are already used for supervision of the internal temperature of the heatsink.

Terminals 7 and 8

(use shielded cables only, maximum length: 1.5 m)

OFF signal

These terminals can be used for an external OFF signal (normally open contact) to stop the braking unit.



The OFF signal stops the braking immediately. If this is performed in generator mode, the drive trips immediately afterwards, due to the excessively high voltage of the DC bus.

Terminals 9 and 10

(use shielded cables only, maximum length 1.5 m)

ON / RESET signal

These connections can be used for an external ON signal (normally open contact) to start/reinitialize the braking unit.

CAUTION

RISKS OF INTERFERENCE

Do not use external voltage in the connections of terminals 5 to 10: unexpected actions and damage can occur.

Failure to follow these precautions can result in equipment damage.

Terminals 11 and 12

(use shielded cables only)

These connections can be used for an external ON signal (external voltage of 12 - 24 V DC, for example from a PLC, short duration pulse) to start or reinitialize the braking unit.

(Connect the "Plus" to terminal 11 and the "Minus" to terminal 12)

Operation on a neutral IT (isolated or impedance grounded neutral) system

Types of electrical network and their main characteristics

Comply with the restrictions relating to each type of network.

If you want to use braking units on types of network that are not listed in the table below, please contact our technical experts.

Network type	Use of the braking unit	Note
Star connection with grounded neutral	Permitted	Comply with the technical data for the unit
Star connection with isolated or impedance grounded neutral	Permitted after consultation with the manufacturer and possible modification of the unit	
With grounded active neutral	Permitted after checking with the manufacturer	

Specification of the cables used



- The cables used must comply with the specifications for the site (for example UL or UL-c)
 - The restrictions concerning the minimum cross-section of the grounding cables must be adhered to!
 - The efficiency of a shielded cable is dependent on:
 - A correctly shielded connection
 - The quality of the connection of the shielding
 - Low impedance of the shielding (only use tinned copper or nickel-plated copper shielding!).
-

Electromagnetic compatibility and wiring

To install a braking unit in an EC approved control system, the following measures and warnings must be taken into account:

General	<ul style="list-style-type: none">• The user is responsible for compliance of the application with EC directives.
Assembly	<ul style="list-style-type: none">• Connect the braking unit and the EMC filter to the grounded mounting plate with a cable whose cross-section is as large as possible:<ul style="list-style-type: none">- Mounting plates with conductive surfaces (coated zinc or stainless steel) provide a permanent contact.- Varnished cards must not be used for installations that are to comply with EMC standards.• If you use several mounting plates:<ul style="list-style-type: none">- Connect as large an area as possible of the mounting plate (for example with copper strips).• Check that the power supply cables and control cables are separated.
Filters	<ul style="list-style-type: none">• Use the EMC filters that are assigned to the braking unit. EMC filters reduce high frequency interference from a prohibited value to a permitted value.
Shielding	<ul style="list-style-type: none">• Metal cable connectors provide a connection between the shielding and the unit over a large area.• If there are breaks in the shielding at all the ends in the cable route:<ul style="list-style-type: none">- Connect the cable shielding to the mounting plate over a large area• If the power supply cables between the EMC filter and the braking unit are longer than 300 mm:<ul style="list-style-type: none">- Use shielded power supply cables- Connect the shielding directly to the drive/braking unit mounting plate and to the EMC filter mounting plate.• Shield the control cables:<ul style="list-style-type: none">- Connect the shielding to their terminals via the shortest possible route.
Grounding	<ul style="list-style-type: none">• All metal parts (braking unit, drive, EMC filter) must be connected to a common ground (PE).• Comply with the minimum cable cross-sections defined in the safety directives:<ul style="list-style-type: none">- From an EMC point of view, it is the area of the cable and the contact with the mounting plate that is important for operation, rather than the cable cross-section.

Braking units are electrical units for use in industrial and commercial equipment. In accordance with the EMC directive, 2004/108/EC, it is not compulsory to mark these braking units, although in the sense of the directive and the EMC law these components are designed for installation by an electromechanical engineer and cannot be used autonomously. Compliance with the protection objectives of the EMC directive must be proved by the installer or the user of the machine or the equipment. If EMC filters provided by Schneider-Electric are used, and if the conditions below and the installation directives are followed, then the compliance of the measures is assured.

Conditions:

The braking unit, combined with the connected EMC filters, has been designed for use under the conditions defined by class "A" ("B" on request).

Definition conforming to the basic standards:

- EN50081-2 for emission
- EN50082-2 for immunity

Electromagnetic compatibility and wiring

Installation

To avoid coupling interference, the following cables must be at least 15 cm apart:

- a) **Network/power supply cables**
- b) **Motor and drive cables**
- c) **Control and data cables (low voltage range < 48 V)**

To obtain a low impedance HF connection, the grounding cables, the shielding and other metal connections (for example: mounting plate/mounted units) must be made using as large an area as possible with the metal conductive part. Use grounding cables and a grounding network with as large a cross-section as possible (minimum 10 mm²) or metal strips.

Use shielded copper or tinned copper cables. Shielded steel cables are not suitable for high frequency applications. Connect the shielding using metal clips or connectors to the grounding connections. Do not extend the shielding with a single wire!

If external EMC filters are used, they must be installed no more than 30 cm away from the noise source, and must have low impedance connections and contacts.

Relays, magnetic contactors, etc, must always be fitted with varistors, RC circuits or diode filters.

All connections must be as short as possible and must be positioned as close as possible to the ground. Unconnected wires act like antennae.

Avoid current loops in all cables. Connect unused cables to the ground at both ends.

If unshielded cables are used, twist the pairs to attenuate the non asymmetric noise.

Connection of an EMC filter

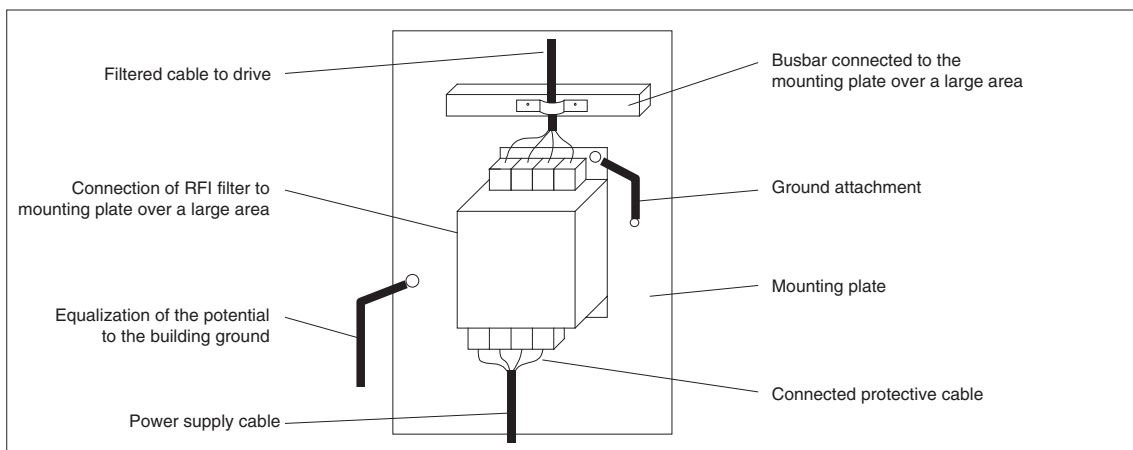

Electromagnetic compatibility and wiring

Design of EMC compliant enclosure

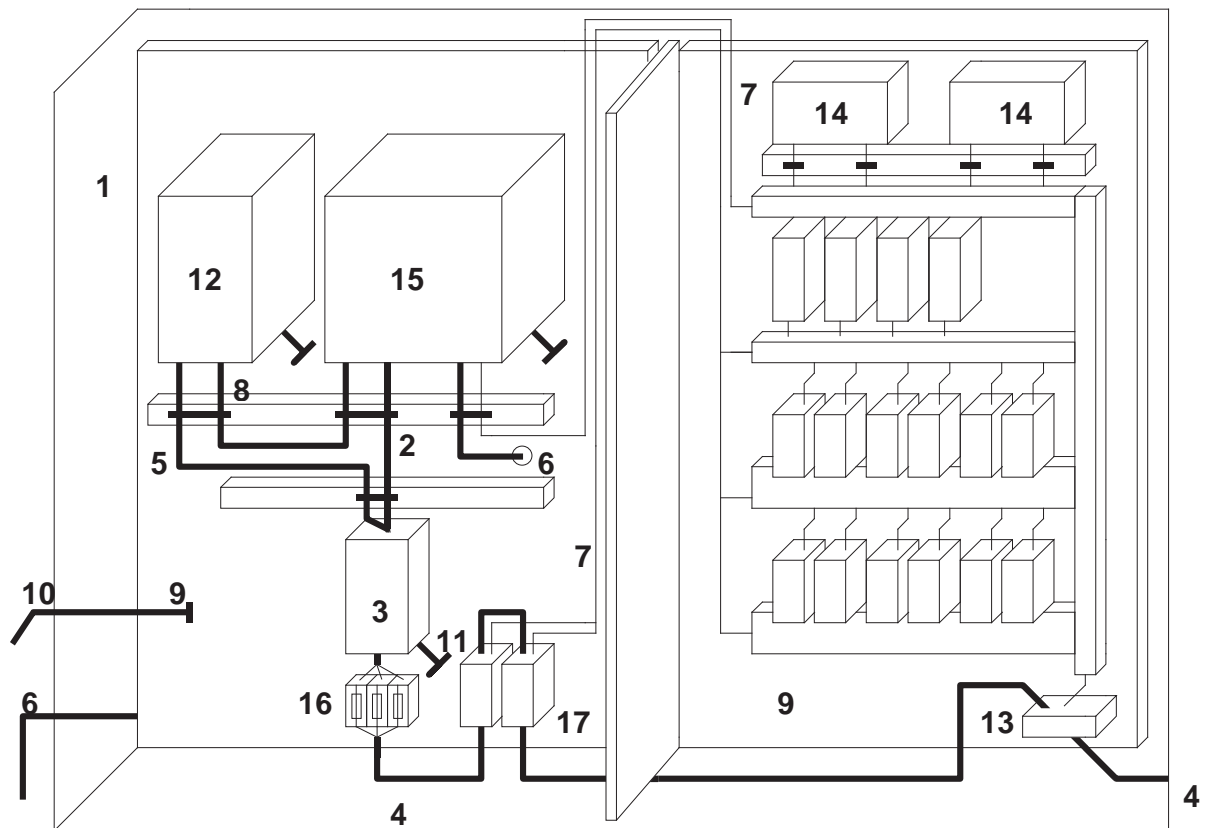

- 1 Enclosure
- 2 Wiring between the EMC filter and the drive
- 3 EMC filter
- 4 Line supply cable
- 5 Wiring between the EMC filter and the braking unit: cable cross-section conforming to the short circuit protection
- 6 Motor wiring
- 7 Control wiring
- 8 Wiring from the DC bus to the braking unit (DC)
- 9 Common central point mounting plate (Star connection)
- 10 Equipotential link
- 11 Additional grounding cable
- 12 Braking unit
- 13 Connection to the power supply
- 14 PLC
- 15 Drive
- 16 Power supply fuses
- 17 Magnetic power supply switch

Comments

A system is generally divided into one zone for the power electronics and one zone for the control electronics. This is important, whether the system is installed in one enclosure or spread over several enclosures. It is recommended that a shielding screen is fitted, due to the high noise emission of the power supply cables. This screen must have a low contact resistance with the frame or the mounting plate (remove the varnish!).

The installed braking unit and the connected EMC filter must form one unit, that is, they must be connected via a mounting plate with no insulating varnish.

The connection between the braking unit and the EMC filter must be shielded. The shielding must be connected to ground at each end. The cable must not exceed 300 mm.

The braking unit mounting plate must be the connection point for the grounding and the shielding of the machine or the equipment. If the drive or another component of the equipment causes interference, the HF connection of this component will be poor. It can be improved by an additional grounding network.

The leakage currents increase when EMC filters are used. When the leakage current is greater than 3.5 mA, one of the following conditions must be met:

- Copper protective cable whose cross-section is greater than 10 mm²
- Supervision of the protective cable by a module that trips in the event of a fault.
- Second cable connected in parallel with the protective cable via separate terminals. This cable must be VDE 0100 / part 540 compliant.

Installation of the control cables

The shielding of the digital signal cables, which are connected to the terminals, must be connected to the shielding strips or directly to the grounded plate, in order to reduce the impedance.

The shielding of the digital signal cables, which are connected to the terminals, must be connected over as large a surface area as possible.

If the screen is grounded via a single wire, there is a 70% increase in the noise.

Commercially available cable clips are suitable for connecting the shielding.

If unshielded signal cables are used, use twisted pairs only.

CAUTION

RISKS OF INTERFERENCE

- Check the wiring of the braking unit (short circuits and ground faults) before it is turned on for the first time
- If the wiring is not correct, unexpected operation of the drive and/or the braking unit is possible.

Failure to follow these precautions can result in equipment damage.

Initial power-up

- **Step 1:** Connect the line supply.
 - The braking unit is ready to operate after approximately 1 s.
- **Step 2:** Check that the braking unit is ready to be used.
 - If the green LED only is on, the braking unit is ready to be used.
 - If all the other LEDs are also on, as well as the green LED, there is interference. Eliminate the interference before starting up (See section: "Troubleshooting", page [36](#)).
- **Step 3:** Check that the drive is ready to be started up.
 - Proceed in accordance with the drive manual.

Configuration

The configuration of the jumpers provides various control possibilities and different internal functions in accordance with the specific error messages.

Various definitions resulting from the specific configuration possibilities of the jumpers are explained in the following paragraphs.

"Autostart"

Jumper J1 closed: Autostart.

Autostart means that the device starts automatically one second after being connected to the line supply ("automatic power-up").

Configuration of the jumpers, see the table below.

If the braking unit must not start up automatically, even if the phase control is deactivated, terminals 7 and 8 must be linked until 4 seconds after power-up. Then, to activate braking there must be a short pulse on the RESET input.

"Power-up" - "Stop"

"Stop" means that the control of the semi-conductors and the braking unit will be interrupted. It is no longer possible to brake the frequency inverter with the braking unit.

"Power-up" is the activation of the control of the semi-conductors.

"Memorize"

The braking unit has a fault memory in which special faults can be assigned. Memorized error messages must be deleted using RESET or by breaking the line supply. "Memorize" always results in a stop and tripping of the general fault relay.

"RESET"

When a fault has been deleted, if it was memorized, it must be reset to zero:

- Either by pressing the RESET button
- Or by disconnecting and reconnecting the line supply (three phase).

CAUTION	
RISKS OF INTERFERENCE	
Resetting to zero in the case of excessive DC bus voltage during generation is not recommended. If this is performed, the power semi-conductors are exposed to increased stress, which can result in accelerated aging.	
Failure to follow this precaution can result in equipment damage.	

"Phase loss"

Phase loss supervision monitors the 3 phases of the line supply.

If one phase fails, the braking unit continues to operate, but with reduced generated power.

The braking unit reacts in different ways when there is a phase loss. One possibility is "two phase operation". The other is to allow the system to exit operation and the general fault relay indicates the fault.

Configuration using the jumpers, see the table below:

J3	J5	J6	J7	Phase loss supervision
—	0	0	—	Sensitive, fault memory ON
—	—	—	—	Not sensitive, fault memory ON
0	X	X	—	Stop, fault memory ON
0	X	X	0	Stop, fault memory OFF

- 0 Jumper open
- Jumper closed
- X Jumper in either position

Note: Fault memory "ON" means that the "phase loss" fault is indicated by an LED until it is cleared, if the fault no longer exists. Fault memory "OFF" means that the "phase loss" fault is indicated by an LED only as long as the fault exists.

CAUTION

RISKS OF INTERFERENCE

- Jumper J3 can only be removed after the frequency inverter or the braking unit has been turned off if the line supply has been cut-off by opening the series switches (contactors, line supply switch, etc).
- To avoid a dangerous voltage rise in the devices located in the section that is not powered up: power generation must be stopped.
- Jumper J3 must always be removed before removing jumper J7. If not, if phase loss supervision is active, the "phase loss" fault remains displayed as long as it exists (it is not memorized in the fault memory).

Failure to follow these precautions can result in equipment damage.

"Overvoltage supervision"

The braking module has overvoltage supervision for the line supply, which stops the device if the voltage level is greater than $1.15 \times U_N$. Fault code 3 will be shown as the error message (See the "LED messages", "Troubleshooting", page 36). To differentiate between phase loss and overvoltage error messages you can deactivate phase loss supervision by removing jumper 3 from the control card. If, after doing so, there is a stop with indication via the red and yellow LEDs (fault code 3), this will then be due to an overvoltage.

J3	J5	J6	J7	J8	LED message			Assessment (overvoltage)
—	X	X	—	—	Green	1.Red	Yellow	Overvoltage and/or phase loss/switching fault
—	X	X	0	—	Green	—	Yellow	Overvoltage
0	X	X	—	—	Green	1.Red	Yellow	Overvoltage and/or phase loss/switching fault
0	X	X	0	—	Green	—	Yellow	Overvoltage
0	X	X	0	—	Green	1.Red	Yellow	Constant phase loss

- 0 Jumper open
- Jumper closed
- X Jumper in either position

Standard adjustment of the device:

Autostart and no stop in the case of phase loss

Troubleshooting

The 4 LEDs on the cover of the braking unit display the operating conditions. For simplified display during operation and the first time the unit is turned on, similar LEDs are placed on the control card. The orange and green LEDs are separate on the control card, while there is a two-color LED (green/orange) on the cover.

CAUTION	
RISKS OF INTERFERENCE	
<p>If the braking unit trips during a slow-down, it must not be reset to zero before the end of the slow-down, or before the DC bus voltage has fallen to a normal value.</p> <p>To avoid any problems, you can block the release of the inverter pulse by connecting the general fault relay contact on the braking unit to the corresponding connection on the frequency inverter.</p>	
Failure to follow these precautions can result in equipment damage.	

Tripping on VCE:

The braking unit trips via the VCE protection circuit, if the specific maximum current of the device is exceeded. The principle of this protection circuit means that for a short time (less than a millisecond), the IGBT is subjected to stress beyond its specifications for normal operation. In an exceptional case this is no problem for the braking unit. However, if there are frequent or periodic current surges at braking voltage, the high power semi-conductors will age rapidly and become prematurely faulty.

The cause of periodic tripping on VCE may be an overload, a fall in line voltage, an oscillating or faulty drive, an oscillating input reference or poor design of the equipment.

LED messages

LED display fault code	LED display					Assessment	
	Operati on	Phase loss	VCE	Overheatin g	Fault	First start (after approx. 1 s)	During operation
	green	red	red	orange	yellow		
1	X					Ready to operate	System in operation
2	X					Ready to operate, but no power generated => check the DC fuse	
3	X			X	X		Heatsink overheating => error message cannot be reset to zero while overheating continues
4	X				X		Fault code 3 => the heatsink temperature has fallen to normal and the fault can be reset to zero
5	X				X	The system has stopped, (external OFF) => reset to zero required	The system has stopped, (external OFF) => reset to zero required
6	X				X	An overvoltage has been detected (J8 closed) => a reset to zero is required when the grid voltage falls to its nominal value	
7	X	X			X	Incorrect phase rotation direction or a phase missing.	Phase loss detected => reset required
8	X		X		X		Overcurrent detected => reset required
9	X	X	X		X	Faults 7 and 8	Overcurrent and phase loss detected simultaneously
10	X	X	X	X	X	Several faults have been detected simultaneously	Several faults have been detected simultaneously
11						System stopped, at least 2 phases missing	System stopped, at least 2 phases missing
12	X				X		Trip-I2t => reset required
13	X	X					Voltage drop during switching but no trip, while jumpers 3 and 7 are open (See the "Configuration", page 34) => operation possible, improvement of the line voltage recommended.

