

Altivar Process ATV930 Altivar 61/71

Braking units

VW3A7101

VW3A7102

VW3A7103

VW3A7104

10/2025



The information provided in this documentation contains general descriptions and/or technical characteristics of the performance of the products contained herein. This documentation is not intended as a substitute for and is not to be used for determining suitability or reliability of these products for specific user applications. It is the duty of any such user or integrator to perform the appropriate and complete risk analysis, evaluation and testing of the products with respect to the relevant specific application or use thereof. Neither Schneider Electric nor any of its affiliates or subsidiaries shall be responsible or liable for misuse of the information contained herein. If you have any suggestions for improvements or amendments or have found errors in this publication, please notify us.

No part of this document may be reproduced in any form or by any means, electronic or mechanical, including photocopying, without express written permission of Schneider Electric.

All pertinent state, regional, and local safety regulations must be observed when installing and using this product. For reasons of safety and to help ensure compliance with documented system data, only the manufacturer should perform repairs to components.

When devices are used for applications with technical safety requirements, the relevant instructions must be followed. Failure to use Schneider Electric software or approved software with our hardware products may result in injury, harm, or improper operating results.

Failure to observe this information can result in injury or equipment damage.

© 2025 Schneider Electric. All rights reserved.

Table of Contents



About the Book	4
Safety Information	6
Chapter 1 Introduction	11
Steps for setting up the braking unit.....	12
Preliminary recommendations.....	13
Chapter 2 Characteristics of the Braking unit	16
Electrical characteristic	17
Braking unit Installation characteristics	18
Dimensions	19
Chapter 3 Installation and wiring	20
Installation recommendation	21
Description of the various steps in the mechanical and electrical installation of the VW3A7101 braking unit	22
Description of the various steps in the mechanical and electrical installation of VW3A7102, VW3A7103 and VW3A7104 braking units.....	26
Wiring Instructions.....	31
Chapter 4 Setting the braking unit parameters/Diagnostics	33
Braking parameter to be set on ATV61/71 drive	34
Braking parameter to be set on ATV930 drive	35
Chapter 5 Connection	36
Chapter 6 Braking principle and calculation	37

About the Book



At a Glance

Document Scope

The purpose of this document is:

- To give you the mechanical and electrical information related to the braking module option,
- To show you how to install and wire this option.

Validity Note

Original instructions and information given in the present document have been written in English (before optional translation).

NOTE: The products listed in the document are not all available at the time of publication of this document

online. The data, illustrations and product specifications listed in the guide will be completed and updated

as the product availabilities evolve. Updates to the guide will be available for download once products are

released on the market.

This documentation is valid for the Altivar Process drive.

The technical characteristics of the devices described in the present document also appear online. To access the information online:

Step	Action
1	Go to the Schneider Electric home page www.se.com .
2	In the Search box type the reference of a product or the name of a product range <ul style="list-style-type: none">• Do not include blank spaces in the reference or product range.• To get information on grouping similar modules, use asterisks (*).
3	If you entered a reference, go to the Product Datasheets search results and click on the reference that interests you. If you entered the name of a product range, go to the Product Ranges search results and click on the product range that interests you.
4	If more than one reference appears in the Products search results, click on the reference that interests you.
5	Depending on the size of your screen, you may need to scroll down to see the datasheet.
6	To save or print a datasheet as a .pdf file, click Download XXX product datasheet.

The characteristics that are presented in the present document should be the same as those characteristics that appear online. In line with our policy of constant improvement, we may revise content over time to improve clarity and accuracy. If you see a difference between the document and online information, use the online information as your reference.

Related Documents

Use your tablet or your PC to quickly access detailed and comprehensive information on all our products on www.se.com.

Braking Unit	Title of Documentation	Catalog Number
VW3A7101 VW3A7102 VW3A7103 VW3A7104	Altivar Process ATV930, Altivar 61/71	1757084 (English)

Drive	Title of Documentation	Catalog Number
ATV930	Catalog: Variable speed drives Altivar Process ATV900	DIA2ED2150601EN (English), DIA2ED2150601FR (French)
	ATV900 Installation Manual	NHA80932 (English), NHA80933 (French), NHA80934 (German), NHA80935 (Spanish), NHA80936 (Italian), NHA80937 (Chinese), NHA80932PT (Portuguese), NHA80932TR (Turkish)
	ATV900 Programming manual	NHA80757 (English), NHA80758 (French), NHA80759 (German), NHA80760 (Spanish), NHA80761 (Italian), NHA80762 (Chinese), NHA80757PT (Portuguese), NHA80757TR (Turkish)
	ATV900 DC BUS Sharing Technical Note	PHA25028 (English)
ATV61	Catalog: Variable speed drives Altivar 61 and Altivar 61 Plus	DIA2ED2140406EN (English), DIA2ED2140406FR (French)
	Altivar 61 Installation Manual	1760655 (English), 1760654 (French), 1760656 (German), 1760657 (Spanish), 1760658 (Italian), 1760659 (Chinese),
	Altivar 61 Programming manual	1760649 (English), 1760648 (French), 1760650 (German), 1760651 (Spanish), 1760652 (Italian), 1760653 (Chinese),
ATV71	Catalog: Variable speed drives Altivar 71 and Altivar 71 plus	DIA2ED2140407EN (English), DIA2ED2140407FR (French)
	Altivar 71 Installation Manual	1755849 (English), 1755848 (French), 1755850 (German), 1755851 (Spanish), 1755852 (Italian),
	Altivar 71 Programming manual	1755855 (English), 1755854 (French), 1755856 (German), 1755857 (Spanish), 1755858 (Italian), 1755859 (Chinese)

Contact Us

Select your country on:

www.se.com/contact

Schneider Electric Industries SAS

Head Office
35, rue Joseph Monier
92500 Rueil-Malmaison
France

Safety Information



Important Information

NOTICE

Read these instructions carefully, and look at the equipment to become familiar with the device before trying to install, operate, or maintain it. The following special messages may appear throughout this documentation or on the equipment to inform of potential hazards or to call attention to information that clarifies or simplifies a procedure.



The addition of this symbol to a Danger safety label indicates that an electrical hazard exists, which will result in personal injury if the instructions are not followed.



This is the safety alert symbol. It is used to alert you to potential personal injury hazards. Obey all safety messages that follow this symbol to avoid possible injury or death.

DANGER

DANGER indicates an imminently hazardous situation which, if not avoided, **will result in** death or serious injury.

WARNING

WARNING indicates a hazardous situation which, if not avoided, **could result in** death or serious injury.

CAUTION

CAUTION indicates a hazardous situation which, if not avoided, **could result in** minor or moderate injury.

NOTICE

NOTICE is used to address practices not related to physical injury.

PLEASE NOTE

Electrical equipment should be installed, operated, serviced, and maintained only by qualified personnel. No responsibility is assumed by Schneider Electric for any consequences arising out of the use of this material.

A qualified person is one who has skills and knowledge related to the construction and operation of electrical equipment and its installation, and has received safety training to recognize and avoid the hazards involved.

Qualification Of Personnel

Only appropriately trained persons who are familiar with and understand the contents of this manual and all other pertinent product documentation are authorized to work on and with this product. In addition, these persons must have received safety training to recognize and avoid hazards involved. These persons must have sufficient technical training, knowledge and experience and be able to foresee and detect potential hazards that may be caused by using the product, by changing the settings and by the mechanical, electrical and electronic equipment of the entire system in which the product is used. All persons working on and with the product must be fully familiar with all applicable standards, directives, and accident prevention regulations when performing such work.

Intended Use

This product is a drive for three-phase synchronous, asynchronous motors and intended for industrial use according to this manual. The product may only be used in compliance with all applicable safety standard and local regulations and directives, the specified requirements and the technical data. The product must be installed outside the hazardous ATEX zone. Prior to using the product, you must perform a risk assessment in view of the planned application. Based on the results, the appropriate safety measures must be implemented. Since the product is used as a component in an entire system, you must ensure the safety of persons by means of the design of this entire system (for example, machine design). Any use other than the use explicitly permitted is prohibited and can result in hazards.

Product Related Information

Read and understand these instructions before performing any procedure with this drive.

 DANGER
HAZARD OF ELECTRIC SHOCK OR ARC FLASH
<ul style="list-style-type: none">• Only appropriately trained persons who are familiar with and understand the contents of this manual• and all other pertinent product documentation and who have received safety training to recognize and• avoid hazards involved are authorized to work on and with this drive system. Installation, adjustment,• repair and maintenance must be performed by qualified personnel.• The system integrator is responsible for compliance with all local and national electrical code requirements as well as all other applicable regulations with respect to grounding of all equipment.• Many components of the product, including the printed circuit boards, operate with mains voltage.• Only use properly rated, electrically insulated tools and measuring equipment.• Do not touch unshielded components or terminals with voltage present.• Motors can generate voltage when the shaft is rotated. Prior to performing any type of work on the drive system, block the motor shaft to prevent rotation.• AC voltage can couple voltage to unused conductors in the motor cable. Insulate both ends of unused• conductors of the motor cable.• Do not short across the DC bus terminals or the DC bus capacitors or the braking resistor terminals.• Before performing work on the drive system:<ul style="list-style-type: none">○ Disconnect all power, including external control power that may be present. Take into account that the circuit breaker or main switch does not de-energize all circuits.○ Place a Do Not Turn On label on all power switches related to the drive system.○ Lock all power switches in the open position.○ Wait 15 minutes to allow the DC bus capacitors to discharge.○ Follow the instructions given in the chapter "Verifying the Absence of Voltage" in the installation manual of the product.• Before applying voltage to the drive system:<ul style="list-style-type: none">○ Verify that the work has been completed and that the entire installation cannot cause hazards.○ If the mains input terminals and the motor output terminals have been grounded and short-circuited, remove the ground and the short circuits on the mains input terminals and the motor output terminals.• <input type="checkbox"/> Verify proper grounding of all equipment.• <input type="checkbox"/> Verify that all protective equipment such as covers, doors, grids is installed and/or closed.
Failure to follow these instructions will result in death or serious injury.

Damaged products or accessories may cause electric shock or unanticipated equipment operation.

 DANGER
ELECTRIC SHOCK OR UNANTICIPATED EQUIPMENT OPERATION
Do not use damaged products or accessories.
Failure to follow these instructions will result in death or serious injury.

Contact your local Schneider Electric sales office if you detect any damage whatsoever.

This equipment has been designed to operate outside of any hazardous location. Only install this equipment in zones known to be free of a hazardous atmosphere.

DANGER

POTENTIAL FOR EXPLOSION

Install and use this equipment in non-hazardous locations only.

Failure to follow these instructions will result in death or serious injury.

Your application consists of a whole range of different interrelated mechanical, electrical, and electronic components, the drive being just one part of the application. The drive by itself is neither intended to nor capable of providing the entire functionality to meet all safety-related requirements that apply to your application. Depending on the application and the corresponding risk assessment to be conducted by you, a whole variety of additional equipment is required such as, but not limited to, external encoders, external brakes, external monitoring devices, guards, etc. As a designer/manufacturer of machines, you must be familiar with and observe all standards that apply to your machine. You must conduct a risk assessment and determine the appropriate Performance Level (PL) and/or Safety Integrity Level (SIL) and design and build your machine in compliance with all applicable standards. In doing so, you must consider the interrelation of all components of the machine. In addition, you must provide instructions for use that enable the user of your machine to perform any type of work on and with the machine such as operation and maintenance in a safe manner. The present document assumes that you are fully aware of all normative standards and requirements that apply to your application. Since the drive cannot provide all safety-related functionality for your entire application, you must ensure that the required Performance Level and/or Safety Integrity Level is reached by installing all necessary additional equipment.

WARNING

INSUFFICIENT PERFORMANCE LEVEL/SAFETY INTEGRITY LEVEL AND/OR UNINTENDED EQUIPMENT OPERATION

- Conduct a risk assessment according to EN ISO 12100 and all other standards that apply to your application.
- Use redundant components and/or control paths for all critical control functions identified in your risk assessment.
- If moving loads can result in hazards, for example, slipping or falling loads, operate the drive in closed loop mode.
- Verify that the service life of all individual components used in your application is sufficient for the intended service life of your overall application.
- Perform extensive commissioning tests for all potential error situations to verify the effectiveness of the safety-related functions and monitoring functions implemented, for example, but not limited to, speed monitoring by means of encoders, short circuit monitoring for all connected equipment, correct operation of brakes and guards.
- Perform extensive commissioning tests for all potential error situations to verify that the load can be brought to a safe stop under all conditions.

Failure to follow these instructions can result in death, serious injury, or equipment damage.

Drive systems may perform unexpected movements because of incorrect wiring, incorrect settings, incorrect data or other errors.

WARNING

UNANTICIPATED EQUIPMENT OPERATION

- Carefully install the wiring in accordance with the EMC requirements.
- Do not operate the product with unknown or unsuitable settings or data.
- Perform a comprehensive commissioning test.

Failure to follow these instructions can result in death, serious injury, or equipment damage.

WARNING

LOSS OF CONTROL

- The designer of any control scheme must consider the potential failure modes of control paths and, for critical control functions, provide a means to achieve a safe state during and after a path failure. Examples of critical control functions are emergency stop, overtravel stop, power outage and restart.
- Separate or redundant control paths must be provided for critical control functions.
- System control paths may include communication links. Consideration must be given to the implications of unanticipated transmission delays or failures of the link.
- Observe all accident prevention regulations and local safety guidelines (1).
- Each implementation of the product must be individually and thoroughly tested for proper operation before being placed into service.

Failure to follow these instructions can result in death, serious injury, or equipment damage.

(1) For USA: Additional information, refer to NEMA ICS 1.1 (latest edition), Safety Guidelines for the Application, Installation, and Maintenance of Solid State Control and to NEMA ICS 7.1 (latest edition), Safety Standards for Construction and Guide for Selection, Installation and Operation of Adjustable-Speed Drive Systems.

The temperature of the products described in this manual may exceed 80 °C (176 °F) during operation.

WARNING

HOT SURFACES

- Ensure that any contact with hot surfaces is avoided.
- Do not allow flammable or heat-sensitive parts in the immediate vicinity of hot surfaces.
- Verify that the product has sufficiently cooled down before handling it.
- Verify that the heat dissipation is sufficient by performing a test run under maximum load conditions.

Failure to follow these instructions can result in death, serious injury, or equipment damage.

NOTICE

DESTRUCTION DUE TO INCORRECT MAINS VOLTAGE

Before switching on and configuring the product, verify that it is approved for the mains voltage.

Failure to follow these instructions can result in equipment damage.

CAUTION

SHARP EDGES



Use all necessary personal protective equipment (PPE) such as gloves when performing any type of work whatsoever on or with this product.

Failure to follow these instructions can result in equipment damage.

Chapter 1

Introduction

What is in This Chapter?

This chapter contains the following topics:

Topic	Page
Steps for setting up the breaking unit	12
Preliminary recommendations	13

Steps for setting up the braking unit

1 Take delivery of braking unit

- Check that the catalog number printed on the label is the same as that on the purchase order.
- Remove the braking unit from its packaging and check that it has not been damaged in transit

2 Check the line voltage

- Check that the line voltage is compatible with the voltage of the braking unit

Steps 1 to 4 must be performed with the power off

3 Install the braking unit

- Install the braking unit before mounting the DC choke chassis on the drive, taking care to follow the installation instructions described in this document.

4 Wire the braking unit

- Connect power terminals BU– and BU+ on the braking unit to the drive

Drive terminals label name of:	ATV930	ATV61/71
DC bus +	PA/+	BU+
DC bus –	PC/–	BU–

- Connect the command cables

5 Set the braking unit on the drive

- Set the parameter to inhibit automatic adaptation of the deceleration ramp
[Dec ramp adapt.] (**bra**) for ATV61/71
[Braking resistor] (**brC**) for ATV930
- Set the parameters necessary for protecting the braking resistor
[DB RES. PROTECTION] (**brP-**) for ATV61/71
[Braking Resistor monit] (**brP-**) for ATV930
- See the recommendation on page 33 and the Programming Manual (*see page 5*)

Preliminary recommendations

Receipt

Damaged products or accessories may cause electric shock or unanticipated equipment operation.

  DANGER	
ELECTRIC SHOCK OR UNANTICIPATED EQUIPMENT OPERATION	
<ul style="list-style-type: none"> Do not use damaged products or accessories. 	
Failure to follow these instructions will result in death or serious injury.	

Contact your local Schneider Electric sales office if you detect any damage whatsoever.

Step	Action
1	Ensure that the equipment reference marked on the label conforms to the delivery note corresponding to the purchase order.
2	Open the packaging and check that the equipment has not been damaged in transit.

Accessories

This braking module is composed of the unit and following accessories. Unpack a parcel and check to make sure the contents.

Part according to the braking unit:

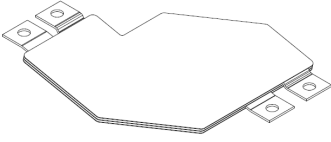
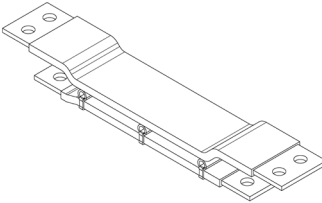
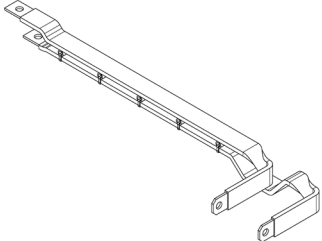
	VW3A7101	VW3A7102 and VW3A7104	VW3A7103
DC busbar			
DC busbar screw	Hexagon screw M10x20 with captive spring lock washer and captive plain washer (x4)	delivered pre-assembled in BU and drive, so not part of packaging list	
Screw to mount the braking unit to the drive	Hexagon M8x20 with captive spring lock washer and captive plain washer (x5)	-	-

Note: The braking resistor must be order separately

Handling

 WARNING
INCORRECT HANDLING What to do to avoid the danger: <ul style="list-style-type: none">• Handle the braking module by two people or more.• Handle and store the product in its original packaging.• Do not handle and store the product if the packaging is damaged or appears to be damaged.• Take all measures required to avoid damage to the product and other hazards when handling or opening the packaging. Failure to follow these instructions can result in death, serious injury, or equipment damage.

 CAUTION
SHARP EDGE Use all necessary personal protective equipment (PPE) such as gloves when performing any type of work whatsoever on or with the braking unit. Failure to follow these instructions can result in injury or equipment damage.

General

As a motor slows down on a deceleration ramp, it can operate as a generator. A standard drive uses a rectifier that cannot return electrical energy to the distribution network. During operation as a generator, the voltage at the DC bus terminals increases due to the regeneration of energy from the motor to the drive. This locks out the drive on a DC bus overvoltage.

The regenerated power in the drive depends on the inertia of the load to be braked and the required braking time.

The drive acquires itself against locking out due to DC bus overvoltage by auto-adapting its deceleration ramp. If a shorter deceleration time is required, a BRAKING UNIT AND A BRAKING RESISTOR must be used.

The braking unit is an external module that is controlled by the drive. If the voltage at the DC bus terminals exceeds a preset value, an external resistor is connected in the DC circuit to dissipate the energy.

The minimum resistance should be chosen in relation to the braking unit characteristics tables, and its power rating depends on the application.

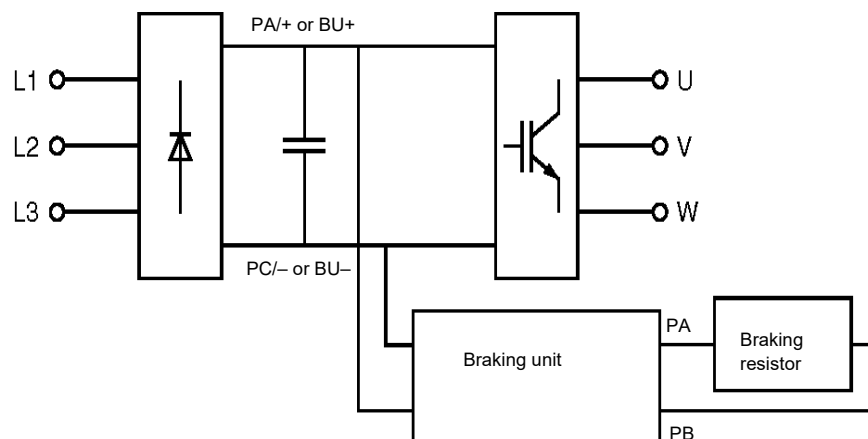

It is advisable to use a line contactor in the drive power supply sequence. This contactor must open when an error is detected. See installation manual for more information ([see page 5](#)).

  **DANGER**

HAZARD OF ARC FLASH, EXPLOSION OR FIRE

- Do not short-circuit the DC bus or PA - PB terminals.
- The braking resistors should be installed in a non-flammable atmosphere with no humidity.
- Ensure that the braking unit is connected with the correct polarity.

Failure to follow these instructions will result in death or serious injury

Chapter 2

Characteristics of the Braking unit

What is in This Chapter?

This chapter contains the following sections:

Topic	Page
Electrical characteristic	17
Braking unit Installation characteristics	18
Dimensions	19

Electrical characteristic

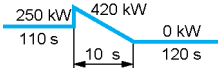
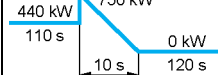
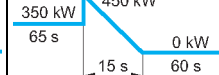
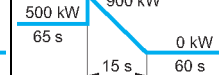
Type of braking unit		<u>VW3A7101</u>	<u>VW3A7102</u>	<u>VW3A7103</u>	<u>VW3A7104</u>	
Nominal voltage of line supply and drive supply (rms value)	V	380~ -15%...480~ +10%		500~ -15%...690~ +10%		
Braking level (Vbr)	V	785 ⁼⁼ ± 1%		1075 ⁼⁼ ± 1%		
Maximum DC bus voltage	V	820		1100		
Maximum braking power at	785 V = (1)	kW	420	750	-	
	1075 V = (1)		-		450	900
Maximum continuous power	kW	200	400	300	400	
Percentage of conduction time at constant power at	785 V = (1)		5% at 420 kW	5% at 750 kW	-	
			15% at 320 kW	15% at 550 kW		
			50% at 250 kW	50% at 440 kW		
Percentage of conduction time at constant power at	1075 V = (1)		-		5% at 450 kW	5% at 900 kW
					15% at 400 kW	15% at 600 kW
					50% at 350 kW	50% at 500 kW
Cycle time (2)	S	≤ 240		≤ 140		
Braking power on a vertical movement (3)						
Thermal protection		thermal probe integrated to the braking unit and controlled by the drive.				

(1) Braking level of braking unit

(2) A longer cycle is possible, but the maximum continuous power of the braking unit must not be exceeded.

(3) Values given for a cycle time of

- 240 s for VW3A7101, 102

- 140 s for VW3A7103, 104.

Braking unit Installation characteristics

		VW3A7101	VW3A7102	VW3A7103	VW3A7104
For Drive		ATV61HC25N4 ATV61HC31N4	ATV61HC40N4 ATV61HC50N4 ATV61HC63N4	ATV61HC25Y ATV61HC31Y ATV61HC40Y	ATV61HC50Y ATV61HC63Y ATV61HC80Y
		ATV71HC20N4 ATV71HC25N4 ATV71HC28N4	ATV71HC31N4 ATV71HC40N4 ATV71HC50N4	ATV71HC20Y ATV71HC25Y ATV71HC31Y	ATV71HC40Y ATV71HC50Y ATV71HC63Y
		ATV930C25N4C ATV930C31N4C			
Ambient air temperature around the device	Operation	°C (°F)	– 10...+ 50 (14...122)		
	Storage	°C (°F)	– 25...+ 70 (– 13...+ 158)		
Degree of protection	Top	IP20 (1)	IP20		
	Bottom	IP00 (1)	IP00		
Loss at nominal power	W	550	1050	650	1150
Forced ventilation	m ³ /h (ft ³ /min)	100 (59)	600 (353)		
Position		Always on the left of the drive			
Installation		Vertical Mounted on drive	Vertical Wall-mounted or in the bottom of the enclosure next to the drive		
Weight	Kg (lb)	30 (66.14)	80 (176.37)		
Distance from the drive	mm (in.)	-	Between 110 (4.4) and 1000 (39.4).		
Power connection		Supplied with the braking unit	Supplied with the braking unit for a distance of 110 ± 5 mm (4,4 ± 0.2 in.). If a "flexible busbar" type connection is used. If necessary, it can be cut at the appropriate distance. In this case, care must be taken not to damage the insulation. The mounting holes must also be remade. <i>(see page 21 in mechanical installation section)</i>		
Control connection		Supplied with the braking unit			

(1) IP31 with VW3A9114 kit

Dimensions

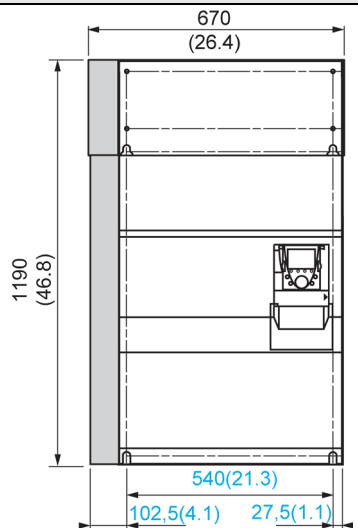
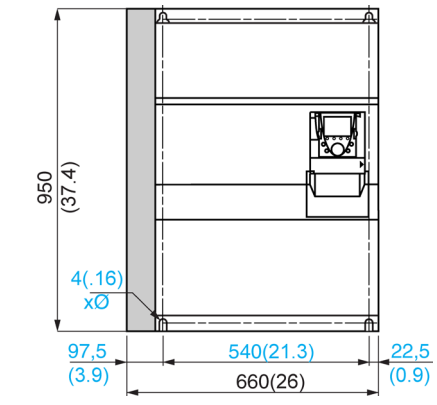
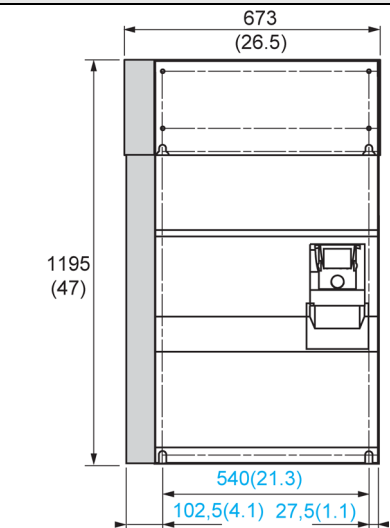
VW3A7101 braking unit		
ATV61HC25N4...HC31N4 with braking unit ATV71HC20N4...HC28N4 with braking unit	ATV71HC20N4D...HC28N4D with braking unit	ATV930C25N4C, ATV930C31N4C with braking unit
mm (in.)		
		
<p>Note: The presence of the VW3A7101 braking unit does not change the depth of the drive + braking unit assembly.</p>		

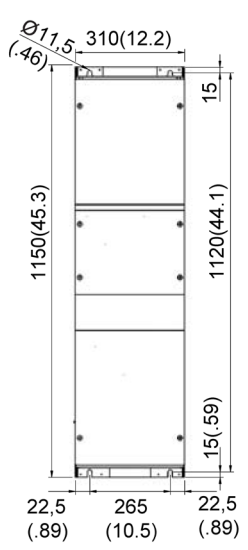
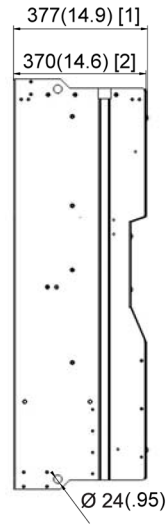
VW3A7102, VW3A7103, VW3A7104 braking unit	
[1] with the screws [2] without the screws	
mm (in.)	
	

Chapter 3

Installation and wiring

What is in This Chapter?

This chapter contains the following topics:

Topic	Page
Installation recommendation	21
Description of the various steps in the mechanical and electrical installation of the VW3A7101 braking unit	22
Description of the various steps in the mechanical and electrical installation of VW3A7102, VW3A7103 and VW3A7104 braking units	26

Installation recommendation

Mechanical installation

The **VW3A7101** braking unit is mechanically mounted on the left-hand side of the drive.

VW3A7102, 103 and 104 braking units are mechanically mounted on the wall or the bottom of an enclosure on the left of the drive. Braking units must be placed $110 \text{ mm} \pm 5 \text{ mm}$ ($4.33 \text{ in} \pm 0.2 \text{ in.}$) from the drive. This distance is imposed by the connecting bars supplied with the braking unit. It is, however, possible to increase the distance up to 1 meter with connecting bars ($63 \times 5 \times 1 \text{ mm}$ ($2.5 \times 0.2 \times 0.04 \text{ in.}$) for VW3A7102 and VW3A7104 or $32 \times 4 \times 1 \text{ mm}$ ($1.26 \times 0.16 \times 0.04 \text{ in.}$) for VW3A7103) supplied by the user.

Important: The distance between the flexible bars connecting the PA/+ and PC/-* power must not exceed 10 mm (0.4 in.).

Electrical connection

After the mechanical installation, connect the power section between the drive and the braking unit (PA/+ and PC/-*). Connect control cables X20, X92, X3, X3A and X3B.

Connect the braking resistor to terminals PA and PB.

*Note: for drive ATV61/71, PA/+ is for BU+ and PC/- is for BU-

Clearance

For braking units VW3A7102, VW3A7103 and VWA3104

The braking unit is designed to be installed vertically. It is connected from below. If it is wired correctly, the braking unit provides IP20 protection.

The braking unit is cooled by a built-in fan. It is therefore important that air can circulate freely around the braking unit. The cooling air should be dry and contain no dust or gas. Install the unit vertically $\pm 10^\circ$.

Avoid placing it close to heating elements. It is especially important to ensure there are no heating elements under the drive or braking unit.

Leave sufficient free space to ensure that the air required for cooling purposes can circulate.

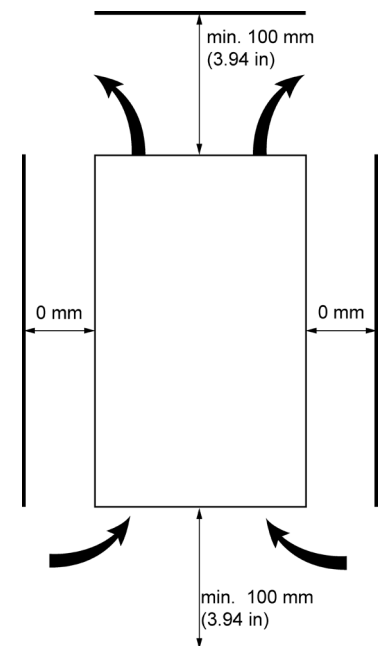

Installation recommendation for braking resistors

The resistor body (degree of protection IP23) can reach a temperature of 350°C (662°F).

These resistors must be placed where there is no risk of direct contact and kept away from all other equipment. Ventilation must be provided to evacuate the dissipated energy.

Description of the various steps in the mechanical and electrical installation of the VW3A7101 braking unit

NOTICE

DESTRUCTION DUE TO INCORRECT MOUNTING

Strictly follow the procedures described below.

Failure to follow these instructions can result in equipment damage.

Mechanical installation

Step	Action
1	Mechanically install the drive.
2	Remove the drive cover in accordance with the safety instructions given in this document and in the installation manual (see page 5).
3	Detach removable part A from the left-hand side of the drive.

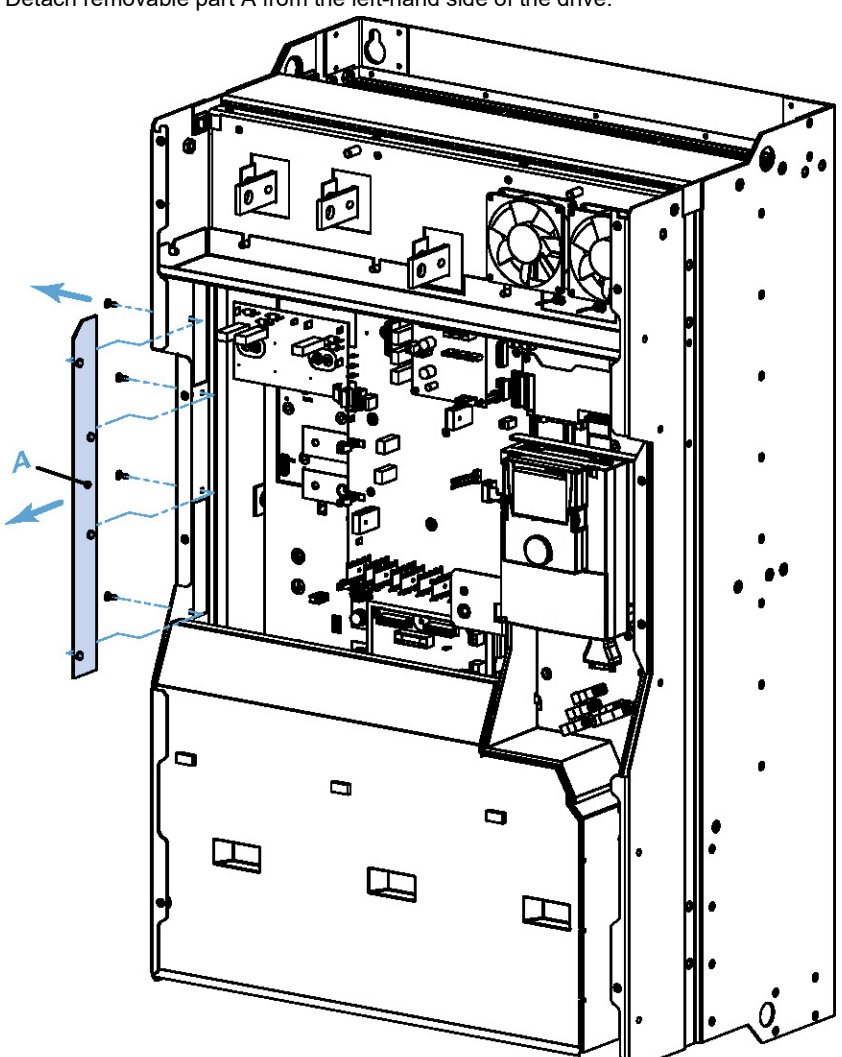

The diagram shows a detailed view of the drive unit's internal components. A vertical panel on the left side, labeled 'A', is shown being detached from the main assembly. Blue arrows indicate the direction of removal. The unit contains various electrical components, including a fan, capacitors, and a terminal block.

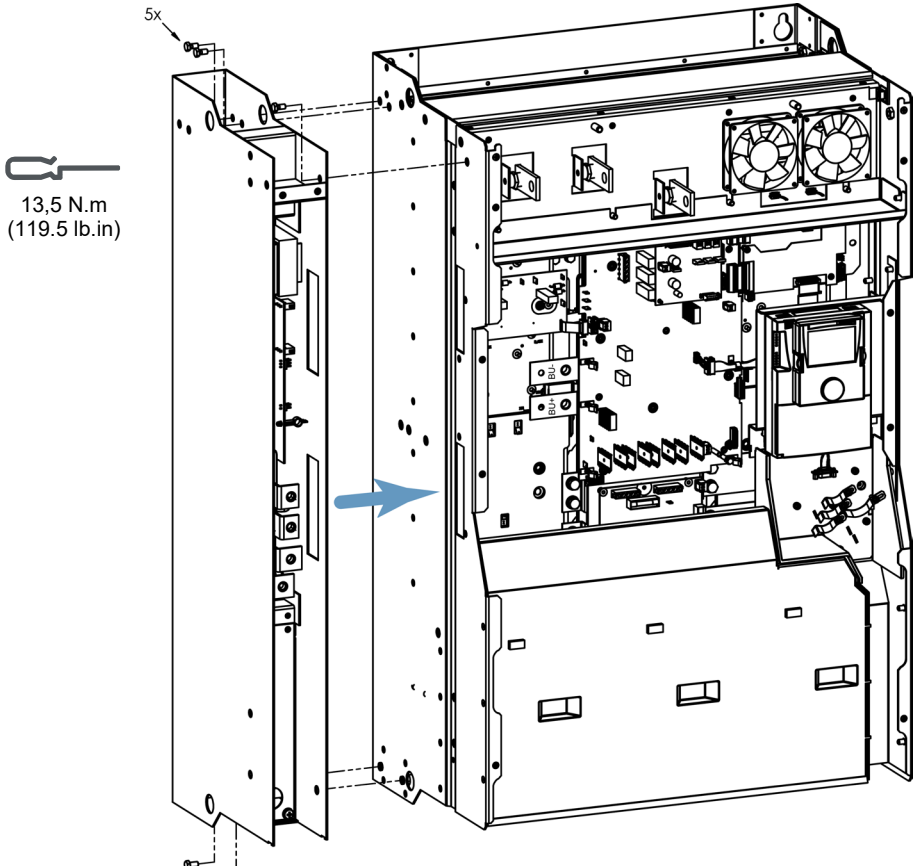
Step	Action
4	<p>Mount the braking unit on the left-hand side of the drive. There are 5 mounting points (5xM8).</p>  <p>5x</p> <p>13,5 N.m (119.5 lb.in)</p>

Electrical installation

Signal interference can cause unexpected responses of the drive.

WARNING

SIGNAL AND EQUIPMENT INTERFERENCE

Fix the interconnection cable in the unit according to the figure in the procedure below.

Failure to follow these instructions can result in death, serious injury, or equipment damage.

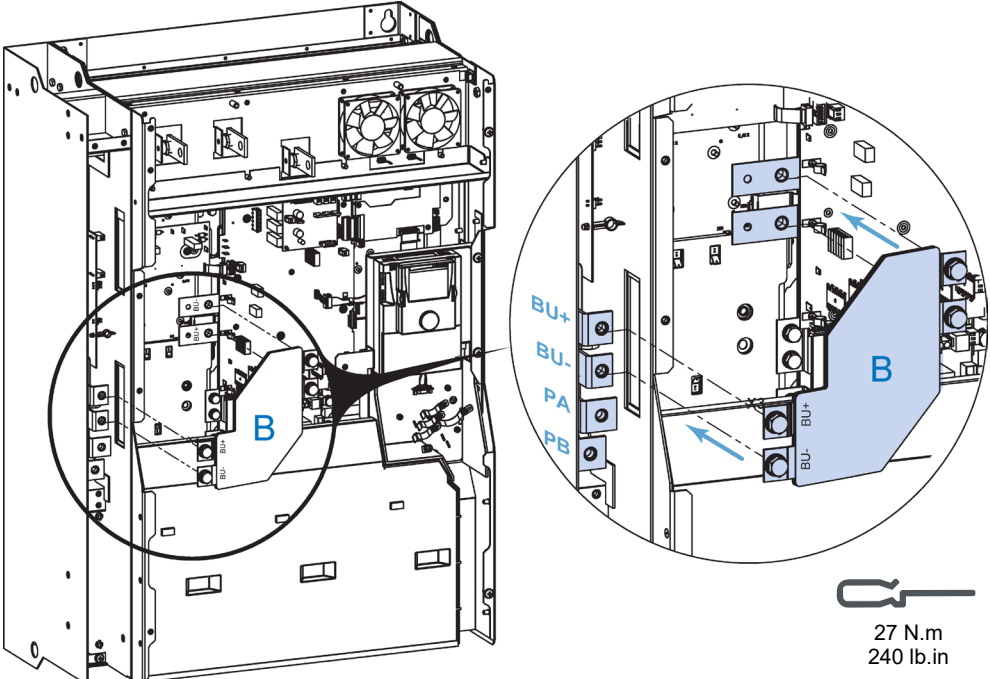
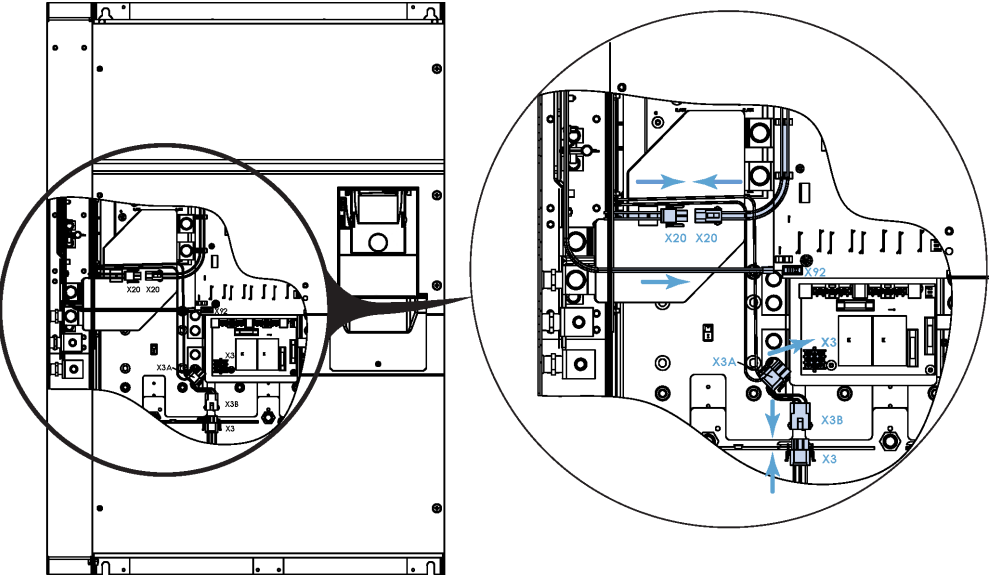
Step	Action
1	<p>Connect the busbars (B) between terminals PA/+ and PC/- on the drive and terminals BU- and BU+ on the braking unit (4xM10).</p>  <p>27 N.m 240 lb.in</p>
2	<p>Connect the braking resistor to PA and PB.</p>
3	<p>Connect the control cables:</p> <ul style="list-style-type: none"> - Connect control cable X20 from the braking unit to cable X20 on the drive - Connect control cable X92 from the braking unit to connector X92 on the drive - Unplug cable X3 from the drive from connector X3 on the drive card - Connect cable X3 from the drive to cable X3B on the braking unit - Connect cable X3A from the braking unit to connector X3 on the drive card 

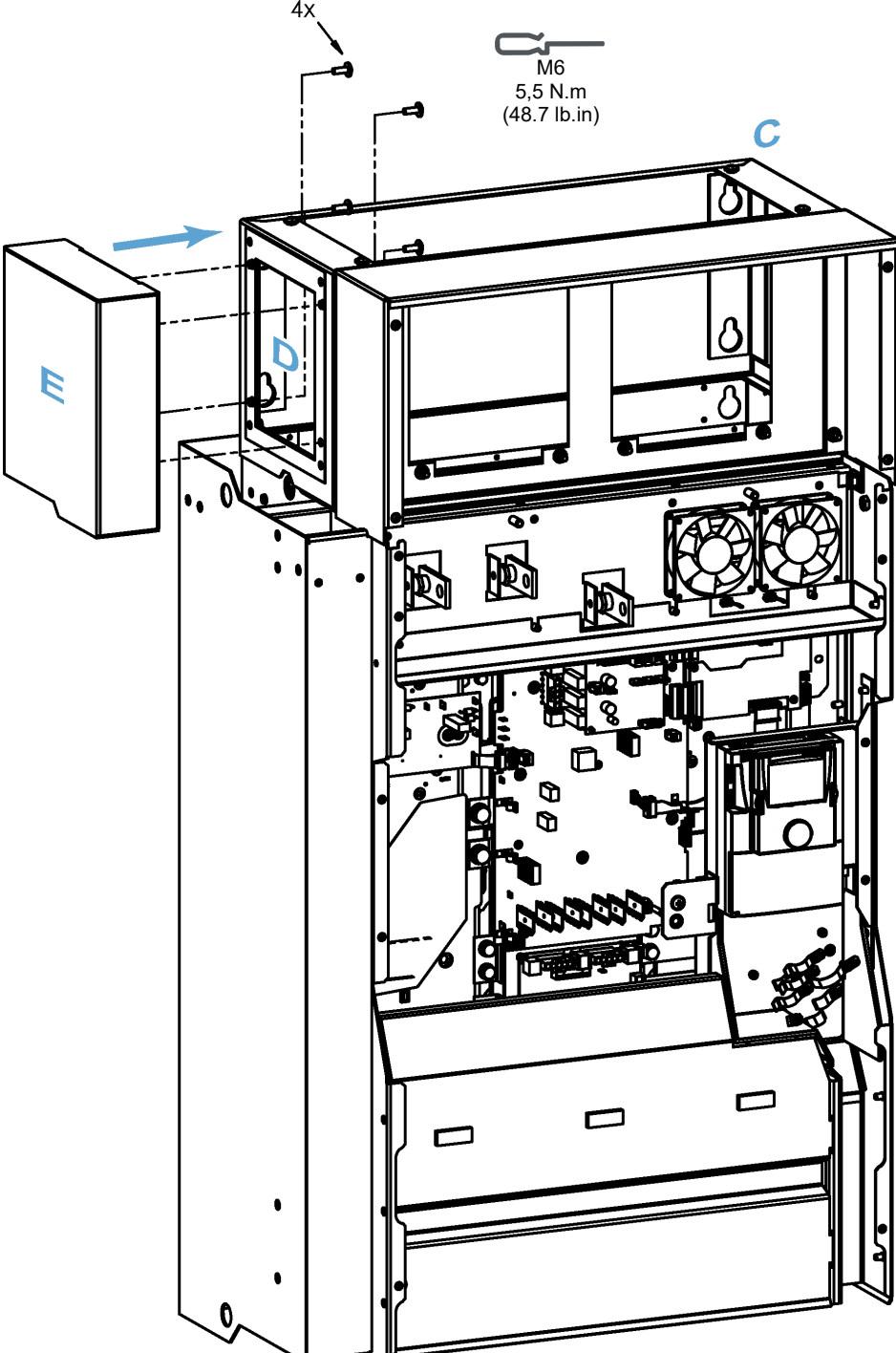
Step	Action
4	<p data-bbox="470 235 1396 291">Mount the DC choke chassis (C) on the wall or on the bottom of the enclosure. See the recommendations in the drive Installation Manual (see page 5).</p> 
5	Detach removable part (D) from the DC choke chassis.
6	Mount the braking unit cover (E) on the DC choke chassis.
7	Install the DC choke(s) in accordance with the recommendations in the drive Installation Manual.

Description of the various steps in the mechanical and electrical installation of VW3A7102, VW3A7103 and VW3A7104 braking units

NOTICE

DESTRUCTION DUE TO INCORRECT MOUNTING

Strictly follow the procedures described below.

Failure to follow these instructions can result in equipment damage.

 **WARNING**

SIGNAL AND EQUIPMENT INTERFERENCE

Fix the interconnection cable in the unit according to the figure in the procedure below.

Failure to follow these instructions can result in death, serious injury, or equipment damage.

Step	Action
1	Mechanically install the drive and the braking unit.
2	Remove the drive cover in accordance with the safety instructions given in this document.
3	Detach removable part A located inside the drive.
4	Connect the BU+ and BU- terminals on the drive to the BU+ and BU- terminals on the braking unit using connecting bars B . Important: The distance between the flexible bars connecting the BU+ and BU- power must not exceed 10 mm (0.4 in.).

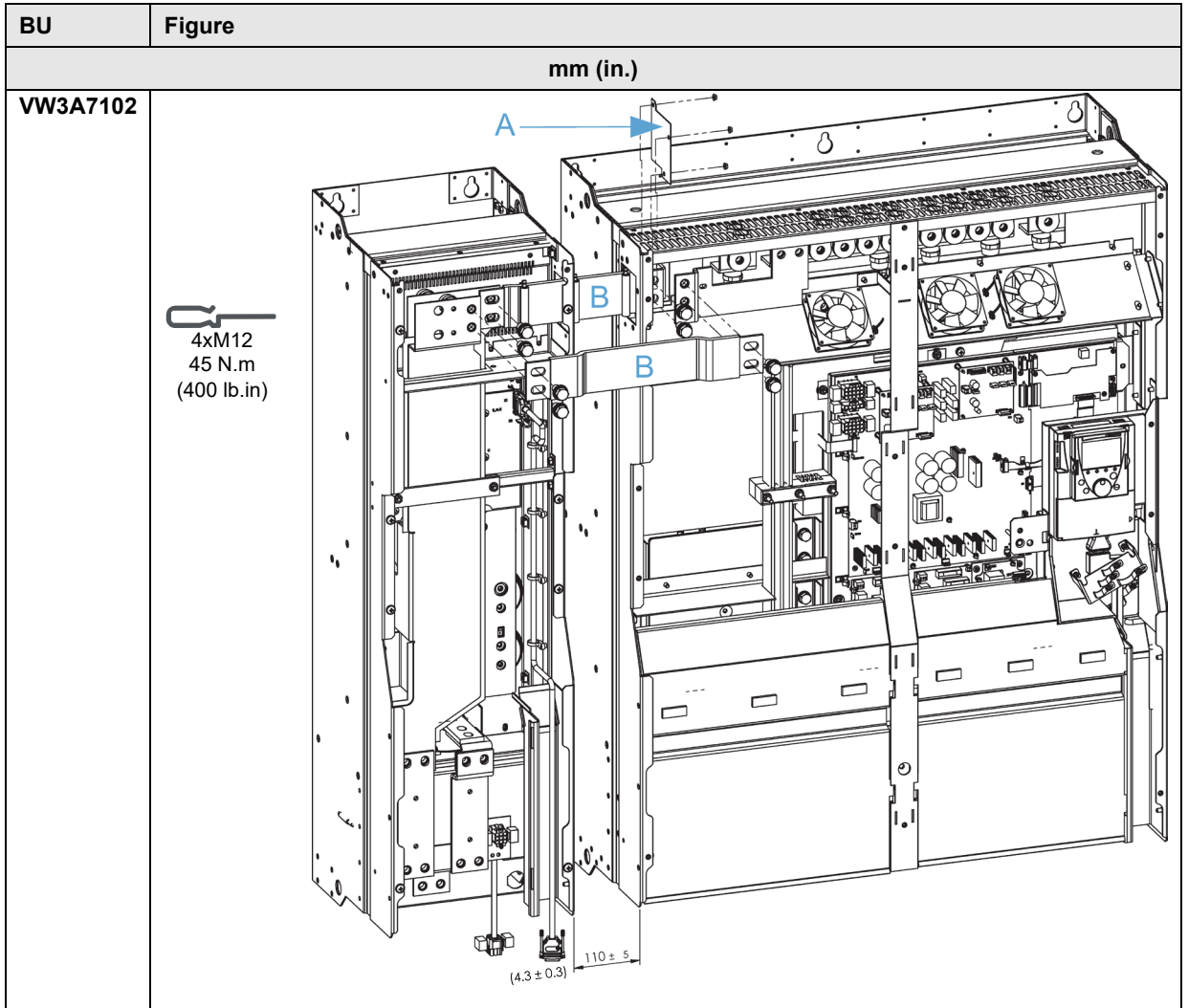

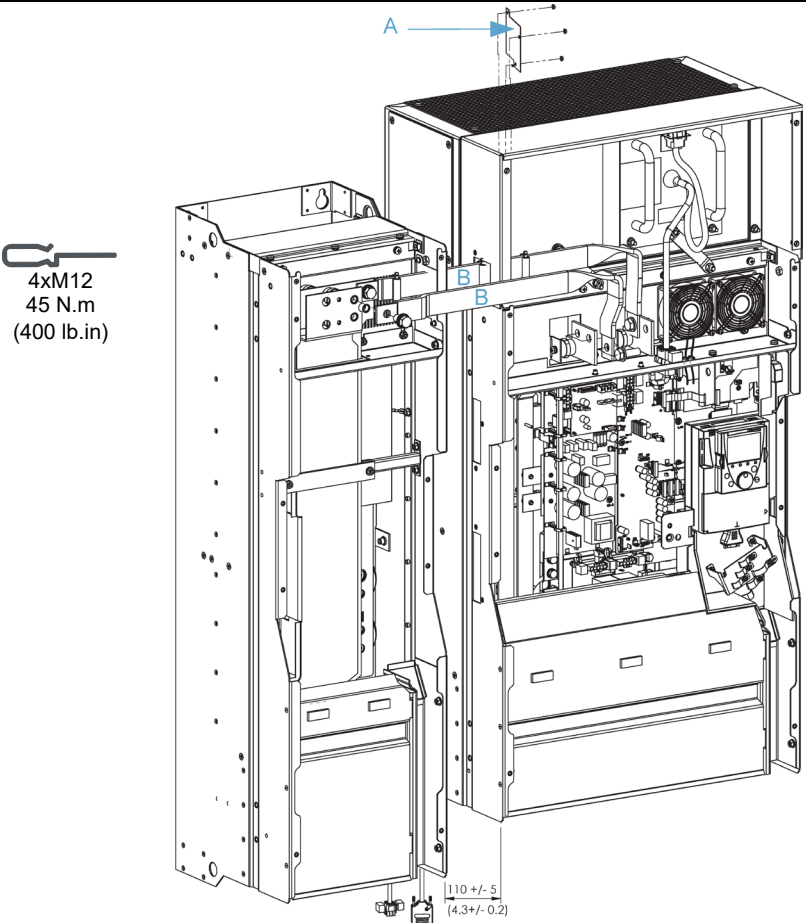
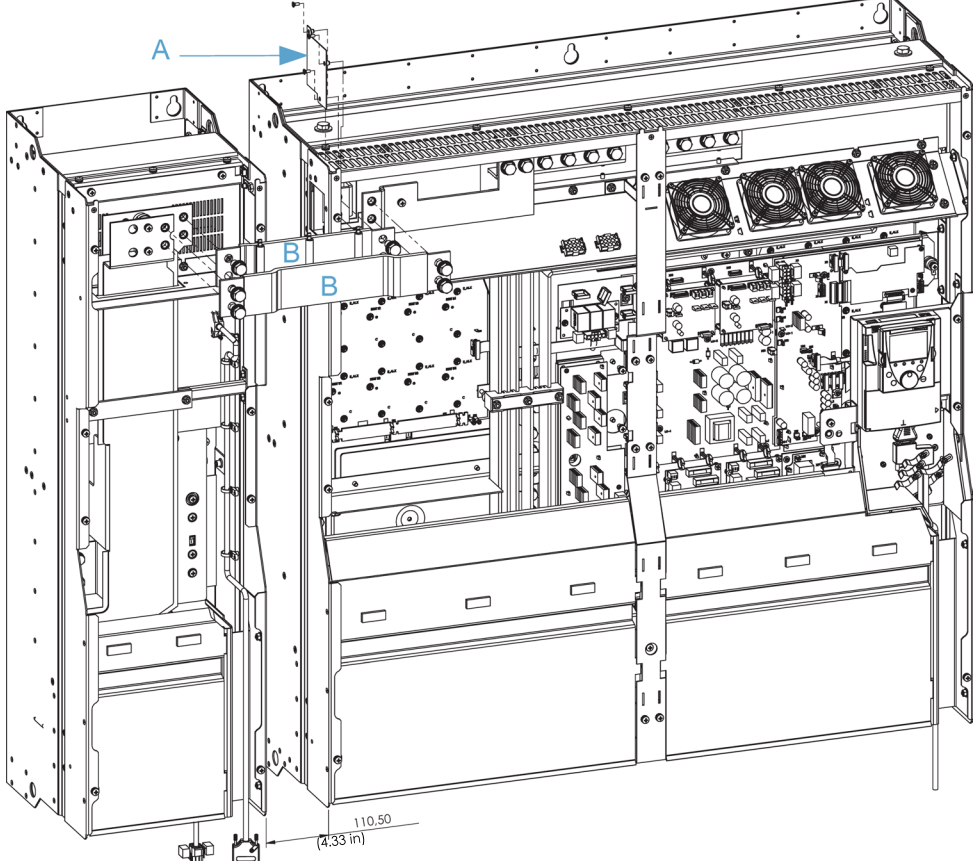
BU	Figure
<p data-bbox="220 241 347 271">VW3A7103</p>	<p data-bbox="778 208 874 237" style="text-align: center;">mm (in.)</p>  <p data-bbox="419 510 523 589">4xM12 45 N.m (400 lb.in)</p> <p data-bbox="858 1126 922 1160">110 +/- 5 (4.3 +/- 0.2)</p>
<p data-bbox="220 1182 347 1211">VW3A7104</p>	 <p data-bbox="276 1429 395 1529">4xM12 45 N.m (400 lb.in)</p> <p data-bbox="770 1989 834 2022">110.50 (4.33 in)</p>

Step	Action
5	Connect the fan control and power supply cables: <ul style="list-style-type: none"> • Connect the X1 control cable from the braking unit to the X1 connector on the drive via the control cable hole. • Connect the fan power supply cable from the braking unit to connector X2 on the drive.

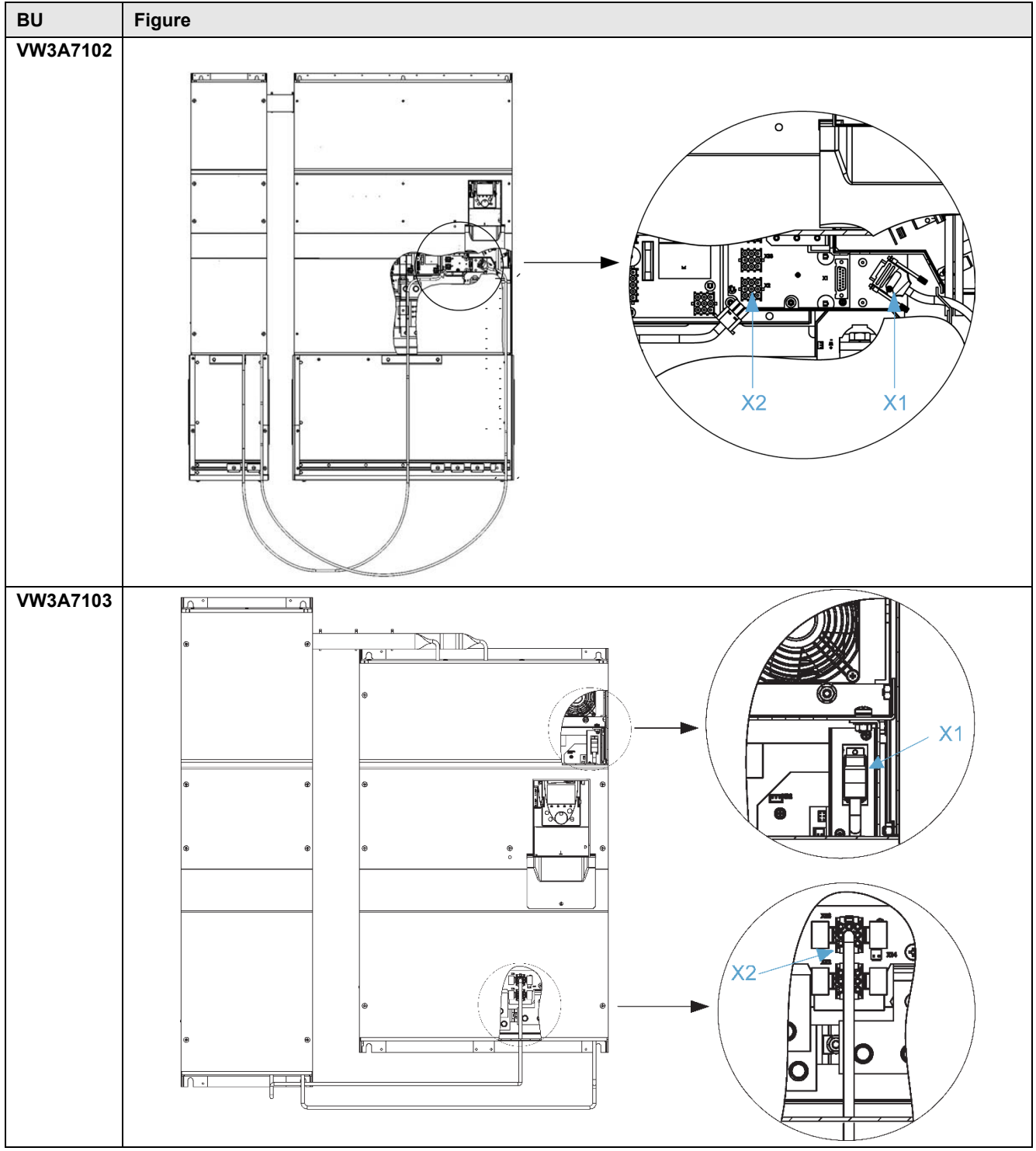

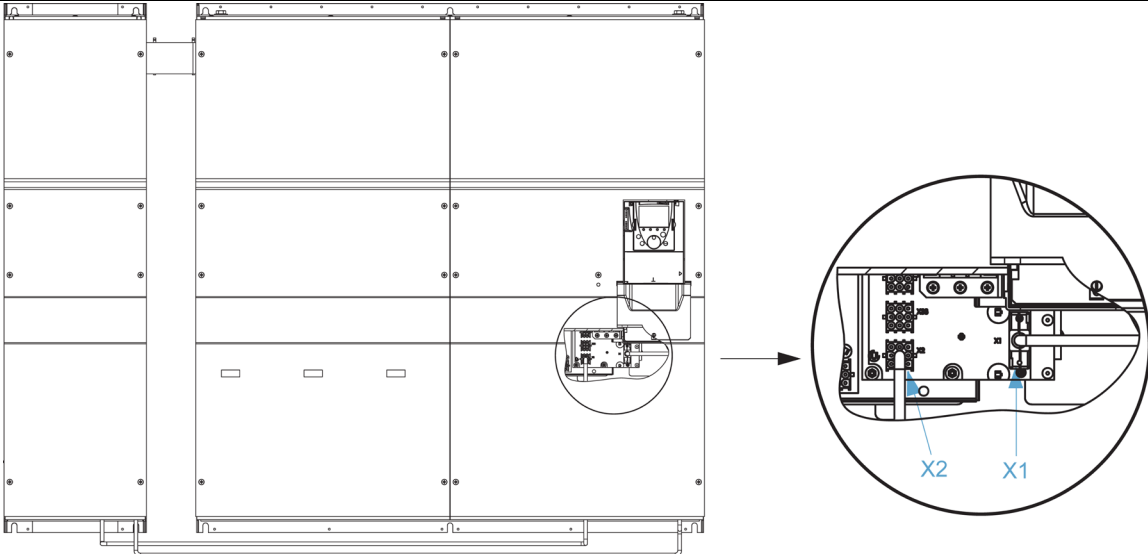
BU	Figure
VW3A7104	 <p>The figure shows a technical drawing of a rack-mounted device, model VW3A7104. The main drawing is a perspective view of a rack with four vertical slots. The rightmost slot contains a device with a control panel on its front face. A circular callout on the right side of the device provides a magnified view of its internal components. In this magnified view, two specific components are labeled with blue arrows and the text 'X1' and 'X2'. 'X1' points to a component on the right side of the internal assembly, and 'X2' points to a component on the left side.</p>

Wiring Instructions

General instructions

The entire installation procedure must be performed without voltage present.

 DANGER
HAZARD OF ELECTRIC SHOCK, EXPLOSION OR ARC FLASH
Read and understand the instructions in Safety Information chapter before performing any procedure in this chapter.
Failure to follow these instructions will result in death or serious injury.

systems may perform unexpected movements because of incorrect wiring, incorrect settings, incorrect data or other errors.

 WARNING
UNANTICIPATED EQUIPMENT OPERATION
<ul style="list-style-type: none">• Carefully install the wiring in accordance with the EMC requirements.• Do not operate the product with unknown or unsuitable settings or data.• Perform a comprehensive commissioning test.
Failure to follow these instructions will result in death or serious injury.

Unsuitable settings or unsuitable data or unsuitable wiring may trigger unintended movements, trigger signals, damage parts and disable monitoring functions.

 WARNING
UNANTICIPATED EQUIPMENT OPERATION
<ul style="list-style-type: none">• Only start the system if there are no persons or obstructions in the zone of operation.• Verify that a functioning emergency stop push-button is within reach of all persons involved in the operation.• Do not operate the drive system with unknown settings or data.• Verify that the wiring is appropriate for the settings.• Never modify a parameter unless you fully understand the parameter and all effects of the modification.• When commissioning, carefully run tests for all operating states, operating conditions and potential error situations.• Anticipate movements in unintended directions or oscillation of the motor.
Failure to follow these instructions will result in death or serious injury.

 DANGER
HAZARD OF FIRE OR ELECTRIC SHOCK
<ul style="list-style-type: none">• Wire cross sections and tightening torques must comply with the specifications provided in this document• If you use flexible multi-wire cables for a connection with a voltage higher than 25 Vac, you must use ring type cable lugs or wire ferrules, depending on the connection.
Failure to follow these instructions will result in death or serious injury.

Selection table

		VW3A7101	VW3A7102	VW3A7103	VW3A7104
Minimum braking resistance value to be used with the braking unit (1)	Ohm	1.05	0.7	2	1
Maximum wire size		2 x 185 mm ² 2 x 350 MCM	4 x 185 mm ² 4 x 350 MCM	4 x 185 mm ² 4 x 350 MCM	4 x 185 mm ² 4 x 350 MCM
Thermal protection		- By internal drive calculation (see Programming Manual (see page 5), parameter brP-). - Via external thermal overload relay			

(1) It is possible to install several braking resistors in parallel on the same braking unit. In this case, do not forget to take the total resistance value into account.

Chapter 4

Setting the braking unit parameters/Diagnostics

What is in This Chapter?

This chapter contains the following sections:

Topic	Page
Braking parameter to be set on ATV61/71 drive	34
Braking parameter to be set on ATV930 drive	35

Please refer to the Programming Manual ([see page 5](#)).

Braking parameter to be set on ATV61/71 drive

Step	Action
1	In the [1.7 APPLICATION FUNCT.] (<i>FUn-</i>) menu, [RAMP] (<i>rPt-</i>) submenu, set parameter [Dec ramp adapt.] (<i>brA</i>) to position [No] (<i>nO</i>).
2	Protecting the braking resistor via the drive: In the [1.8 FAULT MANAGEMENT] (<i>FLt-</i>) menu, adjust the parameters in the [DB RES. PROTECTION] (<i>brP-</i>) submenu.
3	The braking unit braking level is factory set and is suitable for all types of line supply. However, expert users can modify this setting to meet the requirements of certain specific applications. In the [1.4 MOTOR CONTROL] (<i>drC-</i>) menu, set the [Braking level] (<i>Ubr</i>) parameter.

For ATV71H C20N4 to C50N4 and ATV61H C25N4 to C63N4:

- The braking level for a 400 V three-phase line supply is between 660 V DC and 820 V DC
- The braking level for a 440 V three-phase line supply is between 720 V DC and 820 V DC
- The braking level for a 460 V three-phase line supply is between 750 V DC and 820 V DC
- The braking level for a 480 V three-phase line supply is between 770 V DC and 820 V DC

Recommended value: 785 V DC (factory setting)

For ATV71H C20Y to C63Y and ATV61H C25Y to C80Y:

- The braking level for a 500 V three-phase line supply is between 817 V DC and 1080 V DC
- The braking level for a 600 V three-phase line supply is between 980 V DC and 1080 V DC
- The braking level for a 690 V three-phase line supply is 1080 V DC

Recommended value: 1080 V DC (factory setting)

If several drives, each with a braking unit, are connected to the same DC bus, the braking level can be adjusted automatically:

Step	Action
4	In the [1.4 MOTOR CONTROL] (<i>drC-</i>) menu, set the [Braking balance] (<i>bbA</i>) parameter to [Yes] (<i>YES</i>).

Diagnostics

The braking unit and the associated braking resistor are monitored by the drive.

Monitoring applies in particular to:

- Resistor overload
- Resistor short-circuit

Please refer to the Programming Manual ([see page 5](#))

Braking parameter to be set on ATV930 drive

Step	Action
1	In the [Complete settings] (Cst-) → [Generic functions] → [Ramp] (rAMP) submenu, set parameter [Braking resistor] (brC) to [Yes] (yes) .
2	Protecting the braking resistor via the drive: In the [Complete settings] (Cst-) → [Error/Warning handling] (CSWN) menu → adjust the parameter in the [Braking Resistor monit] (brP-) submenu.
3	The braking unit braking level is factory set and is suitable for all types of line supply. However, expert users can modify this setting to meet the requirements of certain specific applications. In the [Complete settings] (Cst-) → [Motor control] (drC-) sub-menu → set the [Braking level] (Vbr-) parameter.

- The braking level for a 380 V three-phase line supply is between 620 V DC and 780 V DC
- The braking level for a 400 V three-phase line supply is between 660 V DC and 780 V DC
- The braking level for a 440 V three-phase line supply is between 720 V DC and 780 V DC
- The braking level for a 460 V three-phase line supply is between 750 V DC and 780 V DC
- The braking level for a 480 V three-phase line supply is 780 V DC

Recommended value: 785 V DC (factory setting)

If **several drives**, each with a braking unit, are connected to the same DC bus, the braking level can be adjusted automatically:

Step	Action
4	In the [complete settings] (CSt-) → [Generic functions] → [Ramp] (rAMP) submenu, set the [Braking balance] (bbA) parameter to [Yes] (yes)

Diagnostics

The braking unit and the associated braking resistor are monitored by the drive.

Monitoring applies in particular to:

- Resistor overload
- Resistor short-circuit

Please refer to the Programming Manual ([see page 5](#))

Chapter 5

Connection

Connecting a drive to a braking unit and a braking resistor

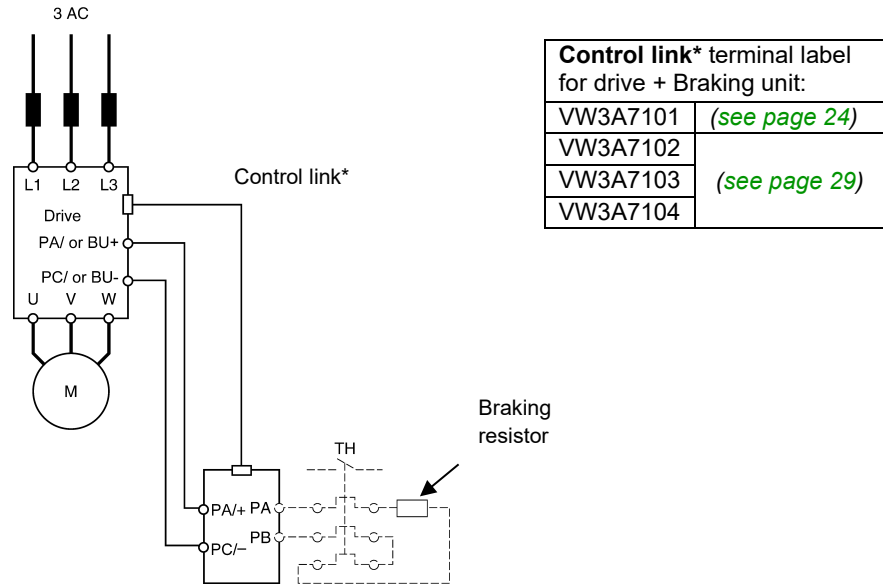

Connecting two drives, both connected to a braking unit, to a single DC BUS

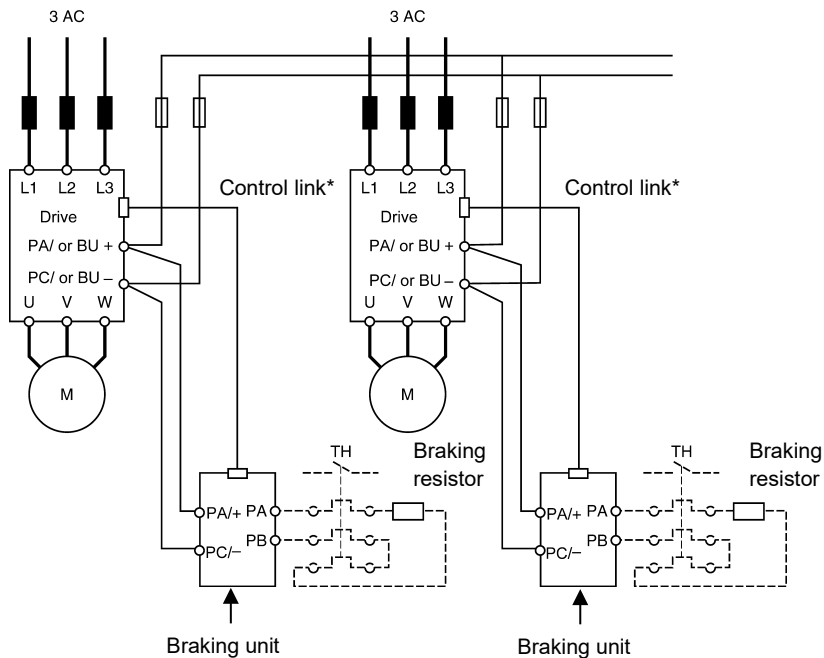

Note: DC bus

It is possible to have drives of different ratings connected to one DC bus (with the recommendation that there is a maximum of 1 size between ratings). For ATV930, refer to the [ATV900 DC BUS Sharing Technical note PHA25028](#) for more information. For ATV61 and ATV71, find the according installation manual in the relative document (see page 5) for more information.

Chapter 6

Braking principle and calculation

To obtain a good operating ratio between a drive and a braking unit, the exact motor torque and speed must be known in the various operating quadrants.

If these two values have an opposing sign, we get the following speed-torque diagram:

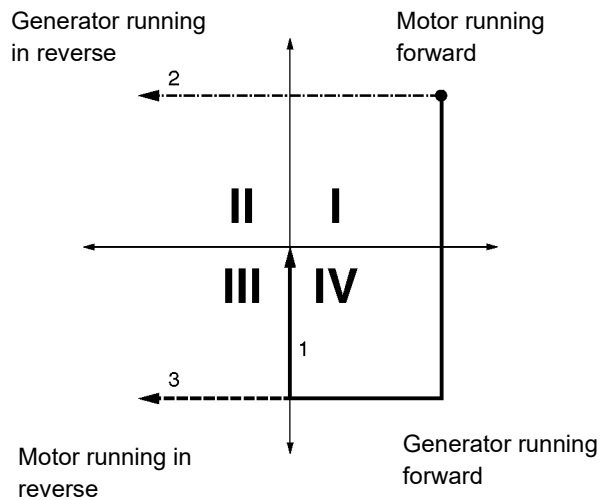

- 1 Motor slowing down to zero speed with constant torque
- 2 Transient state in a hoisting movement during reversal of up/down direction
- 3 Slowdown and change of direction for a motor at constant torque

As a general rule, the power is: $P = \frac{C \cdot n}{9.55}$

Hence, the motor power (+P) is expressed in quadrant I (+T, +n) and III (-T, -n). The generator power (-P) is expressed in quadrant II (+T, -n) and IV (-T, +n).

In principle, generating loads are divided into two groups:

- 1 Braking power during deceleration

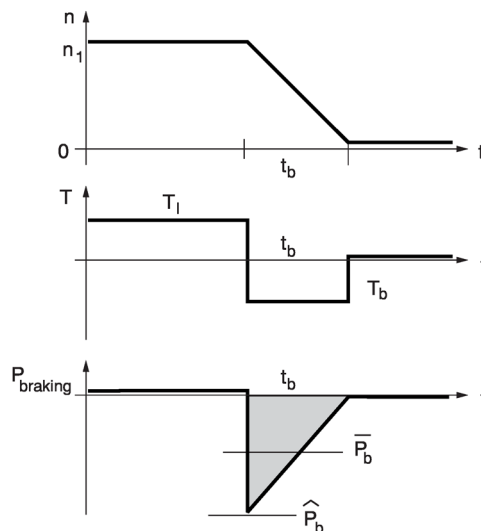

- n_1 Motor speed
- T_l Load torque
- T_b Braking torque
- \hat{P}_b Max. braking power
- \bar{P}_b Average braking power during t_b
- t_b Braking time

The braking power is characterized by a peak power \hat{P}_b obtained at the start of deceleration, which decrease to 0 in proportion to speed.

Example: Stopping centrifuges, translational movement, change of direction, etc.

2 Braking at constant speed

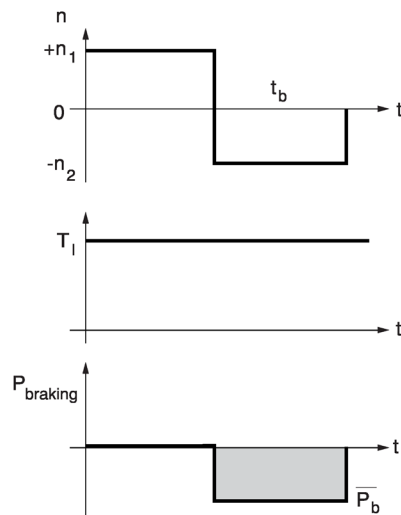

At constant speed, the braking power is constant throughout braking. With fast dynamic braking (deceleration ramp < 2 s) the peak power lasts longer due to the inertia of the load.

Example: Vertical downward movement, motor/generator test bench, gravity conveyors, etc.

Using a drive

Using an asynchronous machine in quadrants II and IV makes the motor work as a generator and restores the electrical energy to the drive DC bus via its inverter bridge.

The drive DC voltage cannot be returned to the line supply.

This is why the DC bus voltage increases when the motor is operating as a generator.

If the energy returned to the DC bus during braking exceeds the losses generated in the motor and the drive, then the DC bus voltage increases.

To deal with this problem, it is necessary to increase the deceleration time or to use a braking unit.

The regenerated power depends on the inertia of the load and the deceleration ramp time.

The drive helps to prevent itself from being locked out due to overvoltage by tuning the deceleration ramp time. To retain a short ramp time (or follow the deceleration ramp) or to work with a driving load, it is necessary to use a braking option such as the braking unit.

Calculating the braking power

1. Calculating the braking time from the inertia

$$t_b = \frac{J \cdot \omega}{T_b + T_r}$$

$$\hat{P}_b = \frac{T_b \cdot n_1}{9.55}$$

$$\omega = \frac{2\pi \cdot n}{60}$$

$$\hat{P} = \frac{\hat{P}_b}{2}$$

$$T_b = \frac{\sum J \cdot (n_1 + n_2)}{9.55 \cdot t_b}$$

T_b	Motor braking torque	[Nm]
$\sum J$	Total inertia applied to the motor	[kgm ²]
n_1	Motor speed ahead of gearbox	[rpm]
n_2	Motor speed after gearbox	[rpm]
t_b	Braking time	[s]
\hat{P}_b	Peak braking power	[W]

\bar{P}_b Average braking power during time t_b [W]

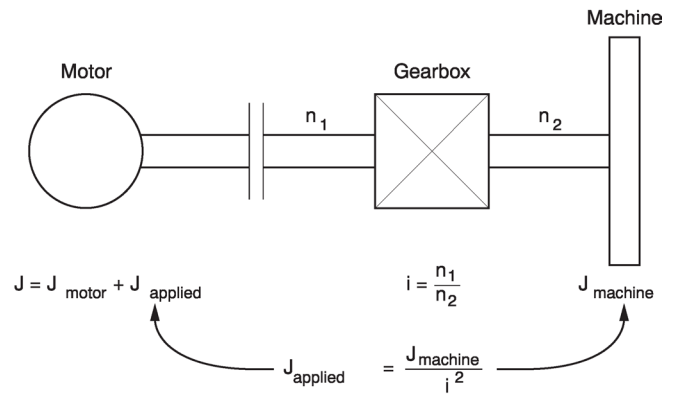

2. Braking a load moving horizontally with constant deceleration (e.g., carriage)

$$W = \frac{m \cdot v^2}{2}$$

$$\bar{P}_b = \frac{W}{t_b}$$

$$\hat{P}_b = \bar{P}_b \cdot 2$$

W	Kinetic energy	[Joule]
m	Mass	[kg]
v	speed	[m/s]
t_b	Braking time	[s]
\hat{P}_b	Peak braking power	[W]
\bar{P}_b	Average braking power during time t_b	[W]

3. Braking an active load (e.g., test bench)

$$\bar{P}_b = \frac{T_b \cdot n}{9.55}$$

\bar{P}_b	Average braking power during time t_b	[W]
T_b	Motor braking torque	[Nm]
n	Motor braking speed	[rpm]

4. Braking a downward vertical movement

$$\bar{P}_b = m \cdot g \cdot v$$

$$\hat{P}_b = m \cdot (g + a) \cdot v + \frac{J \cdot \omega^2}{t_b}$$

$$\omega = \frac{2\pi \cdot n}{60}$$

\bar{P}_b	Average braking power during time t_b	[W]
\hat{P}_b	Peak braking power	[W]
m	Mass	[kg]
g	acceleration	9.81 m/s ²
a	deceleration	[m/s ²]
v	Linear downward speed	[m/s]
J	Moment of inertia	[kgm ²]
t_b	Braking time	[s]

All the braking power calculations are only true if it is assumed that there are no losses ($\eta = 1$) and that there is no resistive torque. Since all these points are important, an accurate assumption must be made:

- Losses in the system

The losses generated in the motor (working as a generator, quadrants II and IV) are of some help during the braking phase. Without exception, efficiency must be calculated to the braking power squared.

- Resistive torque

There may sometimes be resistive torque connected with mechanical friction, air and opposing quadratic torque of the fans. These phenomena, which are rarely taken into consideration, reduce the braking power. The resistive torque or the power should be deducted from the calculated braking power.

- Driving torque

Additional phenomena, such as the wind, can cause an increase in the braking power.

The required braking power is calculated as follows:

$$\hat{P}_{bR} = (\bar{P} - P_{load}) \times \eta_{total}^2 \quad \bar{P}_{bR} = (\bar{P} - P_{load}) \times \eta_{total}^2 \quad \eta_{total} = \eta_{mec} \times \eta_{mot} \times 0.98$$

\hat{P}_{bR}	Max. actual braking power	[W]
\bar{P}_{bR}	Max. actual continuous braking power	[W]
η_{total}	Total efficiency	
P_{load}	Braking power connected with the resistive torque	[W]
η_{drive}	Drive efficiency = 0.98	

Selecting the braking unit

For braking, the braking resistor is selected to match the required power and the braking cycle.

In general:

$$\hat{P}_{max} = \frac{U_d^2}{R}$$

\hat{P}_{max}	Maximum braking power available with the braking unit	[W]
P_{contin}	Continuous thermal braking power	[W]
U_d	Braking unit control level	[V]
I	Braking resistor thermal current (see the TH setting)	[A]

Note: The drive has a protection device inside the braking resistor. (See the Programming Manual [page 5](#)). A thermal overload relay can also be used.

Thermal overload relay

P = nominal braking resistor power

R = resistance value

$$P = RI^2 \rightarrow I = \sqrt{\frac{P}{R}} = \text{thermal overload relay rated value}$$

In the formulae, we have: $\hat{P}_{max} = \frac{U_d^2}{R}$

\hat{P}_{max} = Braking unit power

$P_{continuous} = I^2R$ (P Resistor)



MANUFACTURER
Schneider Electric Industries SAS
35 rue Joseph Monier
Rueil Malmaison 92500 France

UK REPRESENTATIVE
Schneider Electric Limited
Stafford Park 5
Telford, TF3 3BL United Kingdom



Опция для продуктов Altivar и Altistart.
Пожалуйста, обратитесь к сообщению о преобразователе частоты EAC / программном сартере в приложении к началу работы, размещенном на веб-сайте производителя.
Авторизованный поставщик в Республике Казахстан:
ТОО «Шнейдер Электрик»
Адрес: 050010, РК, г. Алматы, пр. Достык, 38, бизнес-центр «Кен Дала», 5 этаж, левое крыло.
Тел.: +7 (727) 339 23 57
Номер службы поддержки клиентов:
Тел.: +7 (727) 339 24 52

Altivar және Altistart өніміне арналған опция.
Өндірушінің веб-сайтында орналастырылған «Жұмысқа кірісу» қосымшасындағы EAC жиілік инвертер / бірқалыпты іске қосу құрылғысы хабарламасына сілтеме жасауыңызды сұраймыз.
Қазақстан Республикасындағы уәкілетті жеткізуші:
ЖШС «Шнейдер Электрик»
Мекен-жайы: 050010, ҚР, Алматы қаласы, Достық даңғылы, 38, «Кең дала» бизнес орталығы, 5-қабат, сол қанат.
тел.: +7 (727) 339 23 57
Клиенттерге қызмет көрсету нөмірі:
тел.: +7 (727) 339 24 52



00175708414081



www.se.com/contact

ATV930_ATV61_71_IS_Braking Unit_VW3A7101-04_1757084_08

10/2025