

Altivar 61 / 71

Standard Fipio card

User's manual

VW3 A3 311

11/2009

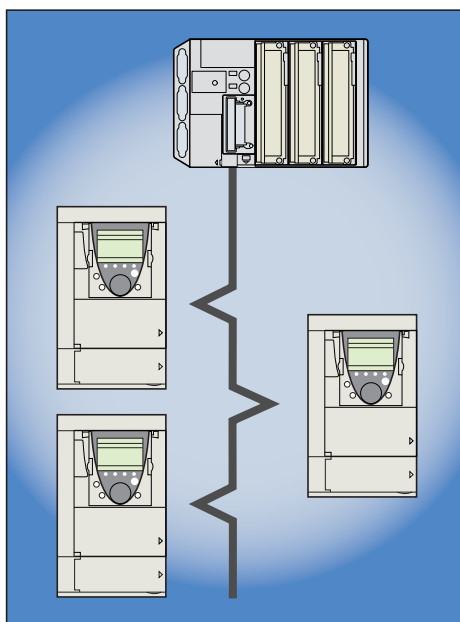

Contents

1. Before you begin	3
2. Documentation structure	4
3. Introduction	5
3. 1. Presentation	5
3. 2. Notation	5
4. Hardware setup	6
4. 1. Receipt	6
4. 2. Hardware description	6
4. 3. Installing the card in the drive	6
4. 4. Switch coding	7
5. Connecting to the bus	8
5. 1. Card connector pinout	8
5. 2. Connection accessories	8
5. 3. Wiring example	8
6. Configuration	9
6. 1. Control - Signaling	9
6. 2. Communication scanner	12
6. 3. Communication faults	14
6. 4. Monitored parameters	15
7. Diagnostics	16
7. 1. Checking the address	16
7. 2. LEDs	16
7. 3. Control - Signaling	17
7. 4. Communication scanner	18
7. 5. Communication fault	19
7. 6. Card fault	19
8. Software setup	20
8. 1. Configuration in PL7	20
8. 2. Available objects	21
8. 3. Periodic variables	22
8. 4. PKW service	23
8. 5. Examples	24
8. 6. Diagnostics in PL7	26

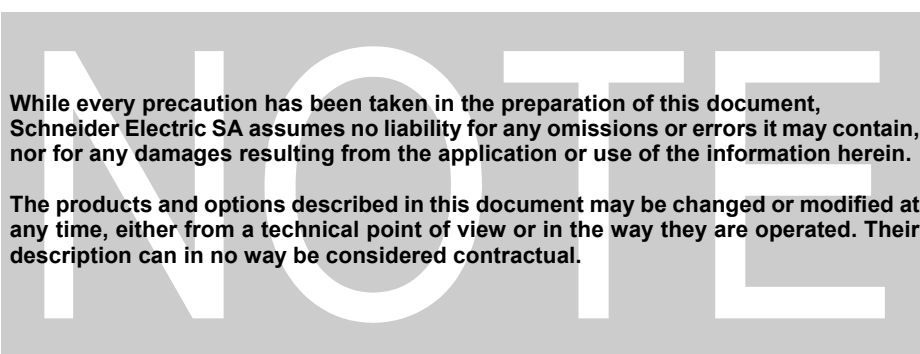

1. Before you begin

Read and understand these instructions before performing any procedure with this drive.

DANGER

HAZARDOUS VOLTAGE

- Read and understand the Installation Manual before installing or operating the Altivar drive. Installation, adjustment, repair, and maintenance must be performed by qualified personnel.
- The user is responsible for compliance with all international and national electrical standards in force concerning protective grounding of all equipment.
- Many parts of this variable speed drive, including the printed circuit boards, operate at the line voltage. **DO NOT TOUCH.** Use only electrically insulated tools.
- **DO NOT** touch unshielded components or terminal strip screw connections with voltage present.
- **DO NOT** short across terminals PA and PC or across the DC bus capacitors.
- Install and close all the covers before applying power or starting and stopping the drive.
- Before servicing the variable speed drive
 - Disconnect all power.
 - Place a "DO NOT TURN ON" label on the variable speed drive disconnect.
 - Lock the disconnect in the open position.
- Disconnect all power including external control power that may be present before servicing the drive. **WAIT 15 MINUTES** to allow the DC bus capacitors to discharge. Then follow the DC bus voltage measurement procedure given in the Installation Manual to verify that the DC voltage is less than 45 VDC. The drive LEDs are not accurate indicators of the absence of DC bus voltage.

Electric shock will result in death or serious injury.

CAUTION

DAMAGED EQUIPMENT

Do not install or operate any drive that appears damaged.
Failure to follow this instruction can result in equipment damage.

2. Documentation structure

The following Altivar technical documents are available on the Web site www.schneider-electric.com and on the CDROM delivered with each drive.

■ Installation Manual

This manual describes:

- How to assemble the drive
- How to connect the drive

■ Programming Manual

This manual describes:

- The functions
- The parameters
- How to use the drive display terminal (integrated display terminal and graphic display terminal)

■ Communication Parameters Manual

This manual describes:

- The drive parameters with specific information (addresses, formats, etc.) for use via a bus or communication network
- The operating modes specific to communication (state chart)
- The interaction between communication and local control

■ Modbus, CANopen, Ethernet, Profibus, INTERBUS, Uni-Telway, DeviceNet, Modbus Plus, Fipio, etc., manuals

These manuals describe:

- Connection to the bus or network
- Configuration of the communication-specific parameters via the integrated display terminal or the graphic display terminal
- Diagnostics
- Software setup
- The communication services specific to the protocol

■ Altivar 58/58F Transition Manual

This manual describes the differences between the Altivar 71 and the Altivar 58/58F.

- It explains how to replace an Altivar 58 or 58F, including how to replace drives communicating on a bus or network.

■ Altivar 38 Transition Manual

This manual describes the differences between the Altivar 61 and the Altivar 38.

It explains how to replace an Altivar 38, including how to replace drives communicating on a bus or network.

3. Introduction

3. 1. Presentation

The standard Fipio communication card VW3 A3 311 is used to connect an Altivar 61 or Altivar 71 drive to a Fipio bus.

The data exchanges permit full drive functionality:

- Control
- Monitoring
- Adjustment
- Configuration

The profile used is FED C 32.

The periodic variables can be configured using the "Communication scanner" function.

The following assignment selections can be made:

- Output: Command, references, frequent adjustments
- Input: Monitoring information (states, measurements, etc.)

The least frequent adjustments and configuration parameters can be written or read using the indexed periodic variables service (PKW).

The card has a 9-way male SUB-D connector for connection to the Fipio bus.

The cable and accessories for connection to the Fipio bus must be ordered separately.

The address of the drive is configured using the switches on the Fipio card.

The graphic display terminal or the integrated display terminal can be used to access numerous functions for communication diagnostics.

3. 2. Notation

Drive terminal displays

The graphic display terminal menus are shown in square brackets.

Example: **[1.9 COMMUNICATION]**.

The integrated 7-segment display terminal menus are shown in round brackets.

Example: **(L D P -)**.

Parameter names are displayed on the graphic display terminal in square brackets.

Example: **[Fallback speed]**

Parameter codes are displayed on the integrated 7-segment display terminal in round brackets.

Example: **(L F F)**.

Formats

Hexadecimal values are written as follows: 16#

Binary values are written as follows: 2#

4. Hardware setup

4. 1. Receipt

- Check that the card catalog number marked on the label is the same as that on the delivery note corresponding to the purchase order.
- Remove the option card and floppy disk from their packaging and check that they have not been damaged in transit.

4. 2. Hardware description

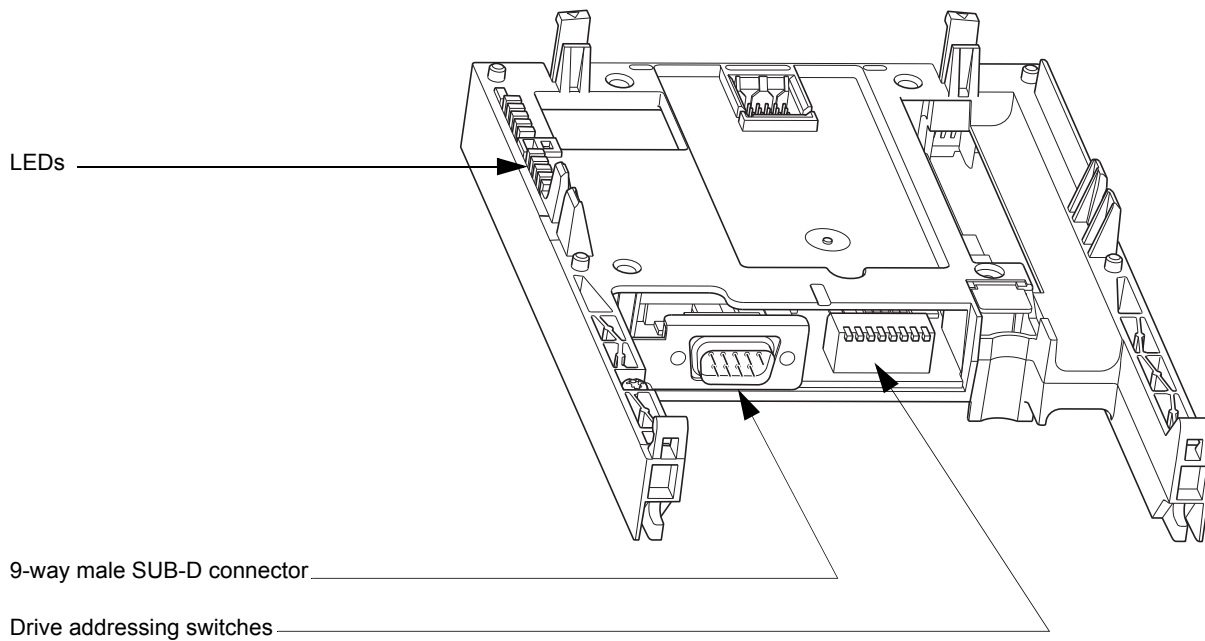

4. 3. Installing the card in the drive

See the Installation Manual.

4. Hardware setup

4. 4. Switch coding

The switches are used to encode the address (1 to 62) of the drive on the bus.

The switch settings can only be changed when the drive is powered down.

The correspondence between the drive and the position of the switch is as follows:

- 0 = OFF = Switch in upper position
- 1 = ON = Switch in lower position

The address is binary-coded.

The table below indicates the positions of the switches for all configurable addresses:

Address	Switches	Address	Switches	Address	Switches	Address	Switches
0	0000 0000	16	0001 0000	32	0010 0000	48	0011 0000
1	0000 0001	17	0001 0001	33	0010 0001	49	0011 0001
2	0000 0010	18	0001 0010	34	0010 0010	50	0011 0010
3	0000 0011	19	0001 0011	35	0010 0011	51	0011 0011
4	0000 0100	20	0001 0100	36	0010 0100	52	0011 0100
5	0000 0101	21	0001 0101	37	0010 0101	53	0011 0101
6	0000 0110	22	0001 0110	38	0010 0110	54	0011 0110
7	0000 0111	23	0001 0111	39	0010 0111	55	0011 0111
8	0000 1000	24	0001 1000	40	0010 1000	56	0011 1000
9	0000 1001	25	0001 1001	41	0010 1001	57	0011 1001
10	0000 1010	26	0001 1010	42	0010 1010	58	0011 1010
11	0000 1011	27	0001 1011	43	0010 1011	59	0011 1011
12	0000 1100	28	0001 1100	44	0010 1100	60	0011 1100
13	0000 1101	29	0001 1101	45	0010 1101	61	0011 1101
14	0000 1110	30	0001 1110	46	0010 1110	62	0011 1110
15	0000 1111	31	0001 1111	47	0010 1111	63	0011 1111

On Fipio, address 0 is reserved for the PLC, which is the bus manager. Address 63 is reserved for the programming or operator terminal.

These two addresses must not, therefore, be used for a drive.

If address 0 has, nevertheless, been configured on the drive, its Fipio card will be deactivated.

No two devices on the Fipio bus should ever have the same address. Continued simultaneous flashing of the LEDs indicates that the drive cannot connect to the Fipio bus because its address is already occupied by another device.

Examples:



Address 11 = 2#0000 1011



Address 34 = 2#0010 0010

5. Connecting to the bus

5. 1. Card connector pinout

9-way male SUB-D

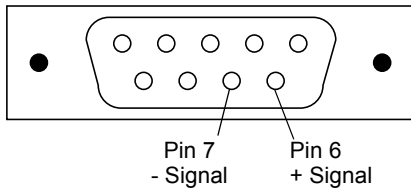

Only pins 6 and 7 are used.

5. 2. Connection accessories

TSX FPACC2 female connector

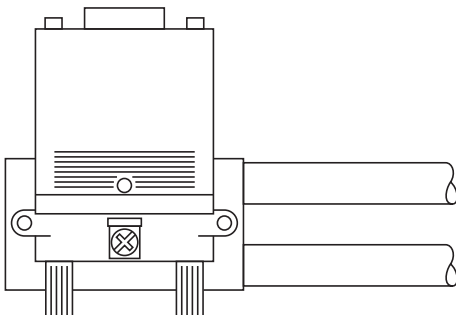

The drive must be powered down when it is connected to the Fipio bus.

Connection is made via a TSX FP ACC 12 or TSX FP ACC 2 daisy chain or tap junction connector, which is attached to the Fipio card connector.

If a TSX FP ACC 2 tap junction connector is used the Fipio cables and/or the TSX FP ACC 7 line terminator must be located on the right-hand side.

5. 3. Wiring example

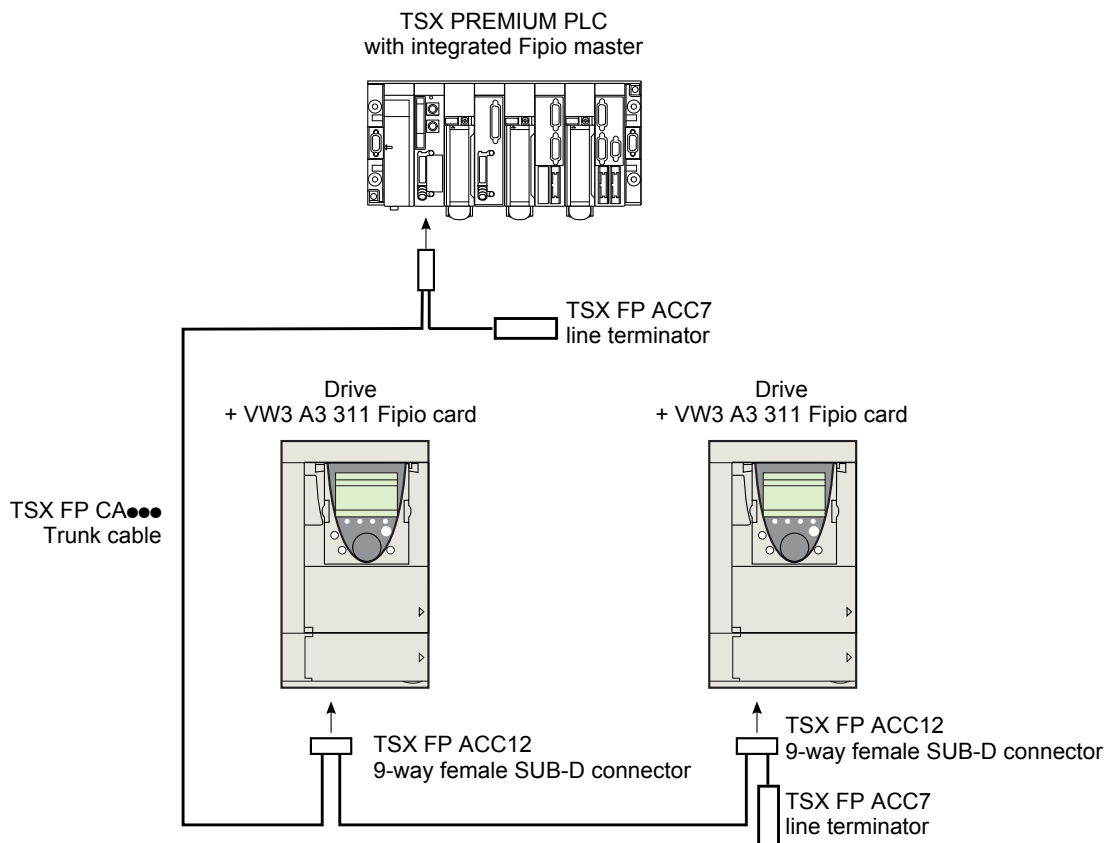

6. Configuration

6. 1. Control - Signaling

Numerous configurations are possible. For more information, refer to the Programming Manual and the Parameters Manual. The following configurations are just some of the possibilities available.

■ Control via Fipio in I/O profile

The command and reference come from Fipio. The command is in I/O profile.

Configure the following parameters:

Parameter	Value	Comment
Profile	I/O profile	The run command is simply obtained by bit 0 of the control word.
Reference 1 configuration	Network card	The reference comes from Fipio.
Command 1 configuration	Network card	The command comes from Fipio.

Configuration via the graphic display terminal or the integrated display terminal:

Menu	Parameter	Value
[1.6 - COMMAND] (CEL-)	[Profile] (CHEF)	[I/O profile] (ID)
	[Ref.1 channel] (FrI)	[Com. card] (nEk)
	[Cmd channel 1] (CdI)	[Com. opt card] (nEk)

■ Control via Fipio or the terminals in I/O profile

Both the command and reference come from Fipio or the terminals. Input LI5 at the terminals is used to switch between Fipio and the terminals.

The command is in I/O profile.

Configure the following parameters:

Parameter	Value	Comment
Profile	I/O profile	The run command is simply obtained by bit 0 of the control word.
Reference 1 configuration	Network card	Reference 1 comes from Fipio.
Reference 1B configuration	Analog input 1 on the terminals	Reference 1B comes from input AI1 on the terminals.
Reference switching	Input LI5	Input LI5 switches the reference (1 ↔ 1B).
Command 1 configuration	Network card	Command 1 comes from Fipio.
Command 2 configuration	Terminals	Command 2 comes from the terminals.
Command switching	Input LI5	Input LI5 switches the command.

Warning: Reference 1B is directly connected to the drive reference limit. If switching is performed, the functions that affect the reference (summing, PID, etc) are inhibited.

Configuration via the graphic display terminal or the integrated display terminal:

Menu	Parameter	Value
[1.6 - COMMAND] (CEL-)	[Profile] (CHEF)	[I/O profile] (ID)
	[Ref. 1] (FrI)	[Com. card] (nEk)
	[Cmd channel 1] (CdI)	[Com. card] (nEk)
	[Cmd channel 2] (Cd2)	[Terminals] (EER)
	[Cmd switching] (CS)	[LI5] (LI5)
[1.7 APPLICATION FUNCT.] (FUN-) [REFERENCE SWITCH.]	[Ref.1B channel] (Fr1b)	[Ref. AI1] (AI1)
	[Ref 1B switching] (rCb)	[LI5] (LI5)

6. Configuration

■ Control via Fipio in Drivecom profile

The command and reference come from Fipio.
The command is in Drivecom profile.

Configure the following parameters:

Parameter	Value	Comment
Profile	Drivecom profile not separate	The run commands are in Drivecom profile, the command and the reference come from the same channel.
Reference 1 configuration	Network card	The command comes from Fipio.

Configuration via the graphic display terminal or the integrated display terminal:

Menu	Parameter	Value
[1.6 - COMMAND] (CEL-)	[Profile] (CHEF)	[Not separ.] (SIN) (factory setting)
	[Ref.1 channel] (Fr1)	[Com. card] (NET)

■ Control via Fipio or the terminals in Drivecom profile

Both the command and reference come from Fipio or the terminals. Input LI5 at the terminals is used to switch between Fipio and the terminals.

The command is in Drivecom profile.

Configure the following parameters:

Parameter	Value	Comment
Profile	Drivecom profile not separate	The run commands follow the Drivecom profile, and the command and reference come from the same channel.
Reference 1 configuration	Network card	Reference 1 comes from Fipio.
Reference 2 configuration	Analog input 1 on the terminals	Reference 2 comes from input AI1 on the terminals.
Reference switching	Input LI5	Input LI5 switches the reference (1 ↔ 2) and the command.

Warning: Reference 2 is directly connected to the drive reference limit. If switching is performed, the functions that affect the reference (summing, PID, etc) are inhibited.

Configuration via the graphic display terminal or the integrated display terminal:

Menu	Parameter	Value
[1.6 - COMMAND] (CEL-)	[Profile] (CHEF)	[Not separ.] (SIN)
	[Ref. 1] (Fr1)	[Com. card] (NET)
	[Ref. 2] (Fr2)	[Ref. AI1] (AI1)
	[Ref. 2 switching] (rFL)	[LI5] (LI5)

6. Configuration

■ Command in Drivecom profile via Fipio and reference switching at the terminals

The command comes from Fipio.

The reference comes either from Fipio or from the terminals. Input LI5 at the terminals is used to switch the reference between Fipio and the terminals.

The command is in Drivecom profile.

Configure the following parameters:

Parameter	Value	Comment
Profile	Separate Drivecom profile	The run commands follow the Drivecom profile, and the command and reference can come from different channels.
Reference 1 configuration	Network card	Reference 1 comes from Fipio.
Reference 1B configuration	Analog input 1 on the terminals	Reference 1B comes from input AI1 on the terminals.
Reference switching	Input LI5	Input LI5 switches the reference (1 ↔ 1B).
Command 1 configuration	Network card	Command 1 comes from Fipio.
Command switching	Channel 1	Channel 1 is the command channel.

Warning: Reference 1B is directly connected to the drive reference limit. If switching is performed, the functions that affect the reference (summing, PID, etc) are inhibited.

Configuration via the graphic display terminal or the integrated display terminal:

Menu	Parameter	Value
[1.6 - COMMAND] (CLL-)	[Profile] (CHF)	[Separate] (SEP)
	[Ref.1 channel] (FrI)	[Com. card] (NEE)
	[Cmd channel 1] (CdI)	[Com. card] (NEE)
	[Cmd switching] (CES)	[ch1 active] (CdI)
[1.7 APPLICATION FUNCT.] (FUN-) [REFERENCE SWITCH.]	[Ref.1B channel] (FrIb)	[Ref. AI1] (R1I)
	[Ref 1B switching] (rCb)	[LI5] (LI5)

6. Configuration

6. 2. Communication scanner

Periodic variables are selected by configuring the communication scanner.

The 8 periodic output variables are assigned by means of the 8 parameters **[Scan. Out \bullet address]** (n L R \bullet). They are configured using the graphic display terminal via the **[1.9 - COMMUNICATION]** (C D P -) menu, **[COM. SCANNER OUTPUT]** (D C S -) submenu.

The 8 periodic input variables are assigned by means of the 8 parameters **[Scan. IN \bullet address]** (n P R \bullet). They are configured using the graphic display terminal via the **[1.9 - COMMUNICATION]** (C D P -) menu, **[COM. SCANNER INPUT]** (I C S -) submenu.

Enter the logic address of the parameter (see the Parameters Manual).

If an **[Scan. Out \bullet address]** (n L R \bullet) or **[Scan. IN \bullet address]** (n P R \bullet) parameter is equal to zero, the corresponding period variable is not used by the drive.

These 16 assignment parameters are described in the tables below:

Parameter name	Output variable	Default assignment
[Scan. Out1 address] (n L R 1)	%QWp.2.c\0.0	Control word (CMd)
[Scan. Out2 address] (n L R 2)	%QWp.2.c\0.0.1	Speed reference (LFrd)
[Scan. Out3 address] (n L R 3)	%QWp.2.c\0.0.2	Not used
[Scan. Out4 address] (n L R 4)	%QWp.2.c\0.0.3	Not used
[Scan. Out5 address] (n L R 5)	%QWp.2.c\0.0.4	Not used
[Scan. Out6 address] (n L R 6)	%QWp.2.c\0.0.5	Not used
[Scan. Out7 address] (n L R 7)	%QWp.2.c\0.0.6	Not used
[Scan. Out8 address] (n L R 8)	%QWp.2.c\0.0.7	Not used

Parameter name	Input variable	Default assignment
[Scan. IN1 address] (n P R 1)	%IWp.2.c\0.0	Status word (EtA)
[Scan. IN2 address] (n P R 2)	%IWp.2.c\0.0.1	Output speed (rFrd)
[Scan. IN3 address] (n P R 3)	%IWp.2.c\0.0.2	Not used
[Scan. IN4 address] (n P R 4)	%IWp.2.c\0.0.3	Not used
[Scan. IN5 address] (n P R 5)	%IWp.2.c\0.0.4	Not used
[Scan. IN6 address] (n P R 6)	%IWp.2.c\0.0.5	Not used
[Scan. IN7 address] (n P R 7)	%IWp.2.c\0.0.6	Not used
[Scan. IN8 address] (n P R 8)	%IWp.2.c\0.0.7	Not used

Example of configuration via the graphic display terminal:

RDY	NET	+0.00Hz	0A
COM. SCANNER INPUT			<input type="checkbox"/>
Scan. IN1 address	:		3201
Scan. IN2 address	:		8604
Scan. IN3 address	:		0
Scan. IN4 address	:		0
Scan. IN5 address	:		0
Code		Quick	<input checked="" type="checkbox"/>
Scan. IN6 address	:		0
Scan. IN7 address	:		0
Scan. IN8 address	:		0

RDY	NET	+0.00Hz	0A
COM. SCANNER OUTPUT			<input type="checkbox"/>
Scan. Out1 address	:		8501
Scan. Out2 address	:		8602
Scan. Out3 address	:		0
Scan. Out4 address	:		0
Scan. Out5 address	:		0
Code		Quick	<input checked="" type="checkbox"/>
Scan. Out6 address	:		0
Scan. Out7 address	:		0
Scan. Out8 address	:		0

Note:

All modifications to parameters **[Scan. Out \bullet address]** (n L R \bullet) or **[Scan. IN \bullet address]** (n P R \bullet) must be made with the motor stopped. The master PLC program should be updated to take account of this modification.

6. Configuration

■ Example of configuring periodic variables

The following periodic output and input variables are to be configured:

Output variable	Parameter assigned
%QW\p.2.c\0.0	Control word (CMd)
%QW\p.2.c\0.0.1	Speed reference (LFrd)
%QW\p.2.c\0.0.2	Acceleration (ACC)
%QW\p.2.c\0.0.3	Deceleration (dEC)
%QW\p.2.c\0.0.4	Ramp increment (Inr)
%QW\p.2.c\0.0.5	—
%QW\p.2.c\0.0.6	—
%QW\p.2.c\0.0.7	—

Input variable	Parameter assigned
%IW\p.2.c\0.0	Status word (EtA)
%IW\p.2.c\0.0.1	Output speed (rFrd)
%IW\p.2.c\0.0.2	Speed reference before ramp (FrHd)
%IW\p.2.c\0.0.3	Logic input map (IL1r)
%IW\p.2.c\0.0.4	Physical image of analog input 1
%IW\p.2.c\0.0.5	Physical image of analog input 2
%IW\p.2.c\0.0.6	—
%IW\p.2.c\0.0.7	—

Configuring the communication scanner:

Output variable address	Parameter logic address
[Scan. Out1 address] (n L A 1)	8501
[Scan. Out2 address] (n L A 2)	8602
[Scan. Out3 address] (n L A 3)	9001
[Scan. Out4 address] (n L A 4)	9002
[Scan. Out5 address] (n L A 5)	9020
[Scan. Out6 address] (n L A 6)	0
[Scan. Out7 address] (n L A 7)	0
[Scan. Out8 address] (n L A 8)	0

Input variable address	Parameter logic address
[Scan. IN1 address] (n P A 1)	3201
[Scan. IN2 address] (n P A 2)	8605
[Scan. IN3 address] (n P A 3)	8604
[Scan. IN4 address] (n P A 4)	5202
[Scan. IN5 address] (n P A 5)	5242
[Scan. IN6 address] (n P A 6)	5243
[Scan. IN7 address] (n P A 7)	0
[Scan. IN8 address] (n P A 8)	0

6. Configuration

6.3. Communication faults

The response of the drive in the event of a Fipio communication fault can be configured.

Configuration can be performed using the graphic display terminal or integrated display terminal using the **[Network fault mgt] (L L L)** parameter in the **[1.8 FAULT MANAGEMENT] (F L E -)** menu, **[COM. FAULT MANAGEMENT] (L L L -)** submenu.

RDY	NET	+0.00Hz	0A
COM. FAULT MANAGEMENT			<input type="checkbox"/>
Network fault mgt	:		Freewheel
CANopen fault mgt	:		Freewheel
Modbus fault mgt	:		Freewheel
Code			Quick <input type="checkbox"/>

The values of the **[Network fault mgt] (L L L)** parameter, which trigger a drive fault **[Com. network] (L n F)**, are:

Value	Meaning
[Freewheel] (Y E S)	Freewheel stop (factory setting)
[Ramp stop] (r P P)	Stop on ramp
[Fast stop] (F S E)	Fast stop
[DC injection] (d C I)	DC injection stop

The values of the **[Network fault mgt] (L L L)** parameter, which do not trigger a drive fault, are:

Value	Meaning
[Ignore] (n D)	Fault ignored
[Per STT] (S E E)	Stop according to configuration of [Type of stop] (S E E) .
[fallback spd] (L F F)	Switch to fallback speed, maintained as long as the fault is present and the run command is not disabled.
[Spd maint.] (r L S)	The drive maintains the speed at the time the fault occurred, as long as the fault persists and the run command has not been removed.

The fallback speed can be configured in the **[1.8 – FAULT MANAGEMENT] (F L E -)** menu using the **[Fallback speed] (L F F)** parameter.

6. Configuration

6. 4. Monitored parameters

It is possible to select up to 4 parameters to display their values in the [1.2 - MONITORING] menu ([COMMUNICATION MAP] submenu) on the graphic display terminal.

The selection is made via the [6 – MONITOR CONFIG.] menu ([6.3 - CONFIG. COMM. MAP] submenu).

Each parameter [Address 1 select] ... [Address 4 select] can be used to choose the logic address of the parameter. Select an address of zero to disable the function.

In the example given here, the monitored words are:

- Parameter 1 = Motor current (LCr): Logic address 3204; signed decimal format
- Parameter 2 = Motor torque (Otr): logic address 3205; signed decimal format
- Parameter 3 = Last fault occurred (LFt): logic address 7121; hexadecimal format
- Disabled parameter: address 0; default format: hexadecimal format

RDY	NET	+0.00Hz	0A
6.3 CONFIG. COMM. MAP.			<input type="checkbox"/>
Address 1 select	:		3204
FORMAT 1	:		Signed
Address 2 select	:		3205
FORMAT 2	:		Signed
Address 3 select	:		7121
Code		Quick	<input checked="" type="checkbox"/>
FORMAT 3	:		Hex
Address 4 select	:		0
FORMAT 4	:		Hex

One of the three display formats below can be assigned to each monitored word:

Format	Range	Terminal display
Hexadecimal	0000 ... FFFF	[Hex]
Signed decimal	-32 767 ... 32 767	[Signed]
Unsigned decimal	0 ... 65 535	[Unsigned]

7. Diagnostics

7. 1. Checking the address

On the graphic display terminal or integrated display terminal, check the address using the **[Address]** (*A d r C*) parameter in the **[1.9 - COMMUNICATION]** (*C O M -*) menu, **[FIP311]** (*F I P -*) submenu.

7. 2. LEDs

The Fipio card features 4 LEDs, which are visible through the drive cover.

1.1
1.2
1.3
1.4
1.5

2.1 I/O
2.2 COM
2.3 ERR
2.4 RUN
2.5

LED no.	Color	Meaning	On	Flashing slowly or quickly	
2.1	Red	I/O	Minor internal fault		Self-test on initialization
2.2	Yellow	COM		Exchanges on the Fipio bus	
2.3	Red	ERR	Serious fault	Communication fault	
2.4	Green	RUN	Normal operation		

7. Diagnostics

7.3. Control - Signaling

On the graphic display terminal only, the **[1.2 - MONITORING]** menu (**[COMMUNICATION MAP]** submenu) can be used to display control-signal diagnostic information between the drive and the Fipio PLC:

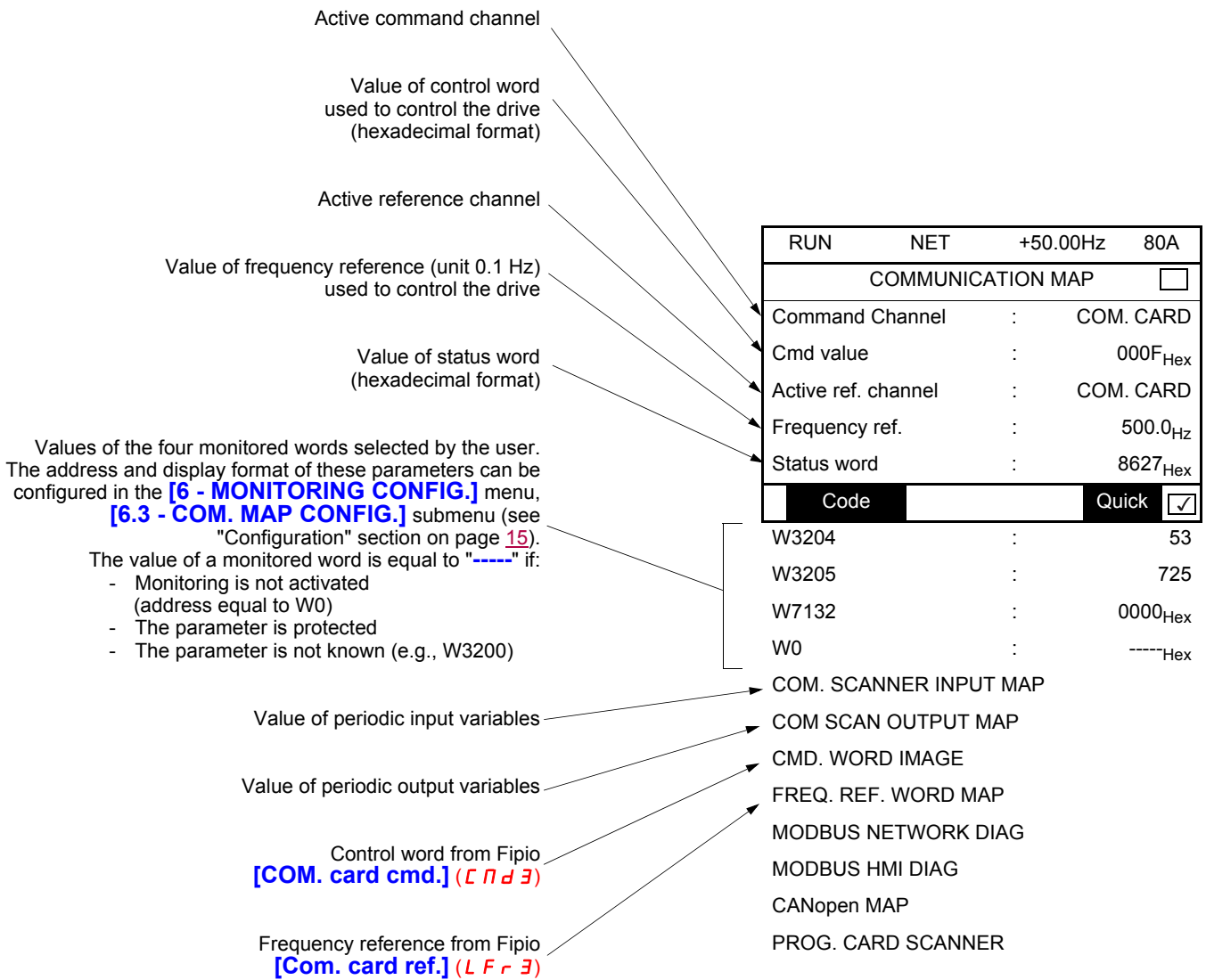

7. Diagnostics

7. 4. Communication scanner

On the graphic display terminal, in the [1.2 - MONITORING] (5 U P -) menu ([COMMUNICATION MAP] (C П П -) submenu):

- The [COM. SCANNER INPUT MAP] (I S A -) submenu is used to display the value of the 8 communication scanner input variables [Com Scan In● val.] (NM●).
- The [COM SCANNER OUTPUT MAP] (O S A -) submenu is used to display the value of the 8 communication scanner output variables [Com Scan Out● val.] (NC●).

Input variable	Scanner parameter	Output variable	Scanner parameter
%IWp.2.c\0.0	[Com Scan In1 val.] (NM1)	%QWp.2.c\0.0	[Com Scan Out1 val.] (NC1)
%IWp.2.c\0.0.1	[Com Scan In2 val.] (NM2)	%QWp.2.c\0.0.1	[Com Scan Out2 val.] (NC2)
%IWp.2.c\0.0.2	[Com Scan In3 val.] (NM3)	%QWp.2.c\0.0.2	[Com Scan Out3 val.] (NC3)
%IWp.2.c\0.0.3	[Com Scan In4 val.] (NM4)	%QWp.2.c\0.0.3	[Com Scan Out4 val.] (NC4)
%IWp.2.c\0.0.4	[Com Scan In5 val.] (NM5)	%QWp.2.c\0.0.4	[Com Scan Out5 val.] (NC5)
%IWp.2.c\0.0.5	[Com Scan In6 val.] (NM6)	%QWp.2.c\0.0.5	[Com Scan Out6 val.] (NC6)
%IWp.2.c\0.0.6	[Com Scan In7 val.] (NM7)	%QWp.2.c\0.0.6	[Com Scan Out7 val.] (NC7)
%IWp.2.c\0.0.7	[Com Scan In8 val.] (NM8)	%QWp.2.c\0.0.7	[Com Scan Out8 val.] (NC8)

Configuration of these periodic variables is described in the "Configuration" section.

Example of communication scanner display on the graphic display terminal:

RUN	NET	+50.00Hz	80A
COM. SCANNER INPUT MAP <input type="checkbox"/>			
Com Scan In1 val.	:		34359
Com Scan In2 val.	:		600
Com Scan In3 val.	:		0
Com Scan In4 val.	:		0
Com Scan In5 val.	:		0
Code		Quick	<input checked="" type="checkbox"/>
Com Scan In6 val.	:		0
Com Scan In7 val.	:		0
Com Scan In8 val.	:		0

RUN	NET	+50.00Hz	80A
COM SCAN OUTPUT MAP <input type="checkbox"/>			
Com Scan Out1 val.	:		15
Com Scan Out2 val.	:		598
Com Scan Out3 val.	:		0
Com Scan Out4 val.	:		0
Com Scan Out5 val.	:		0
Code		Quick	<input checked="" type="checkbox"/>
Com Scan Out6 val.	:		0
Com Scan Out7 val.	:		0
Com Scan Out8 val.	:		0

In this example, only the first two parameters have been configured (default assignment).

- [Com Scan In1 val.] = [34343] Status word = 34359 = 16#8637 → Drivecom state "Operation enabled", reverse operation, speed reached.
- [Com Scan In2 val.] = [600] Output speed = 600 → 600 rpm
- [Com Scan Out1 val.] = [15] Control word = 15 = 16#000F → "Enable operation" (Run) command
- [Com Scan Out2 val.] = [598] Speed reference = 600 → 598 rpm

7. Diagnostics

7. 5. Communication fault

Fipio faults are indicated by the red LED 2.2 (Err) on the Fipio card.

In the factory configuration, if Fipio is involved in the command or reference, a Fipio fault will trigger a resettable drive fault **[Com. network] (C n F)** and initiate a freewheel stop.

The Parameters Manual contains a detailed description of how to manage communication faults (see the "Communication monitoring" section).

- Following initialization (power-up), the drive checks that at least one command or reference parameter has been written for the first time by Fipio.
- Then, if a communication fault occurs on Fipio, the drive will react according to the configuration (fault, maintain, fallback, etc.).

The response of the drive in the event of a Fipio communication fault can be changed (see the Configuration section).

- Drive fault **[Com. network] (C n F)** (freewheel stop, stop on ramp, fast stop or DC injection braking stop)
- No drive fault (stop, maintain, fallback)

The **[Network fault] (C n F)** parameter can be used to obtain more detailed information about the origin of the last **[Com. network] (C n F)** fault. It can be accessed on the graphic display terminal only, in the **[1.10 DIAGNOSTICS] (d G t -)** menu, **[MORE FAULT INFO] (R F I -)** submenu.

Value	Description of the values of the [Network fault] (C n F) parameter
0	No fault
1	Loss of communication with the master
2	PLC in STOP
3	Fipio card fault (FIPCO initialization error)
4	Fipio card fault (STATE_UF update error)
5	Fipio card fault (CHANNEL_STATE update error)

7. 6. Card fault

The **[internal com. link] (I L F)** fault appears when the following serious problems occur:

- Hardware fault on the Fipio card
- Dialog fault between the Fipio card and the drive

The response of the drive in the event of an **[internal com. link] (I L F)** fault cannot be configured, and the drive trips with a freewheel stop. This fault cannot be reset.

Two diagnostic parameters can be used to obtain more detailed information about the origin of the **[internal com. link] (I L F)** fault:

- **[Internal link fault 1] (I L F 1)** if the fault has occurred on option card no. 1 (installed directly on the drive)
- **[Internal link fault 2] (I L F 2)** if the fault has occurred on option card no. 2 (installed on option card no. 1)

The Fipio card can be in position 1 or 2.

The **[Internal link fault 1] (I L F 1)** and **[Internal link fault 2] (I L F 2)** parameters can only be accessed on the graphic display terminal in the **[1.10 DIAGNOSTICS] (d G t -)** menu, **[MORE FAULT INFO] (R F I -)** submenu.

Value	Description of the values of the [Internal link fault 1] (I L F 1) and [Internal link fault 2] (I L F 2) parameters
0	No fault
1	Loss of internal communication with the drive
2	Hardware fault detected
3	Error in the EEPROM checksum
4	Faulty EEPROM
5	Faulty Flash memory
6	Faulty RAM memory
7	Faulty NVRAM memory
8	Faulty analog input
9	Faulty analog output
10	Faulty logic input
11	Faulty logic output
101	Unknown card
102	Exchange problem on the drive internal bus
103	Time out on the drive internal bus (500 ms)

8. Software setup

8. 1. Configuration in PL7

1 In PL7, open the "Hardware Configuration" window for the TSX Premium PLC, followed by the "Fipio Configuration" window.

1

2

3

2 In this window, you can add a Fipio device by double-clicking on a connection point located between addresses 0 and 62.

The "Add/Modify Device" window will appear.

3 Enter the Fipio address of the drive in the "Connection point number" field (see the section on coding the drive address on page 7) and add a description (if required) in the "Comment" field.

Next, select the "STD_P" (*standard profiles*) family and the "FED C32" base module in this family (*extended profile of a compact device with 32 periodic input and output words*). Click "OK" to confirm your selections.

When you return to the "Hardware Configuration" window, the new device will appear in the list of Fipio logic addresses used.

Note: No configuration or adjustment settings can be made in PL7 for this type of base module. These settings must, therefore, be made either via the integrated display terminal or the graphic display terminal (see "Programming Manual"). Alternatively, the indexed periodic variables service (PKW) described in this manual can be used.

8. Software setup

8. 2. Available objects

OBJECT	DESCRIPTION	ACCESS	FORMAT
%QW\p.2.c\0.0.i	Periodic output variables (drive control and adjustment)	Implicit write operation	32 words
%IW\p.2.c\0.0.i	Periodic input variables (drive monitoring)	Implicit read operation	32 words
%I\p.2.c\0.0.ERR	Channel fault	Implicit read operation	1 bit
%MW\p.2.c\0.0.2	Channel status (drive and communication diagnostics)	Explicit read operation	1 word

The Fipio card on the drive does not provide PL7 configuration (%KW\...), adjustment (%MW\...), or Fipio message handling services. Configuration and adjustments can be accessed via the PKW service (indexed periodic values).

Syntax:

Word access

Output: %QW\p.2.c\0.0.i

Input: %IW\p.2.c\0.0.i

- p: Processor slot (0 or 1)
- c: Number of the connection point on the Fipio bus (device address: 1 to 62)
- i: Number of the periodic output or input variable (0 to 31)
Note: If i = 0, it is not displayed: %QW\p.2.c\0.0

Bit access

Output: %QW\p.2.c\0.0.i:Xj

Input: %IW\p.2.c\0.0.i:Xj

- p: Processor slot (0 or 1)
- c: Number of the connection point on the Fipio bus (device address: 1 to 62)
- i: Number of the periodic output or input variable (0 to 31)
- j: Bit number (0 to 15)

8. Software setup

8. 3. Periodic variables

PLC address	Description	Default assignment
%QWp.2.c\0.0	Periodic output variable no. 1	Control word (CMd)
%QWp.2.c\0.0.1	Periodic output variable no. 2	Speed reference (LFrd)
%QWp.2.c\0.0.2	Periodic output variable no. 3	not assigned
%QWp.2.c\0.0.3	Periodic output variable no. 4	not assigned
%QWp.2.c\0.0.4	Periodic output variable no. 5	not assigned
%QWp.2.c\0.0.5	Periodic output variable no. 6	not assigned
%QWp.2.c\0.0.6	Periodic output variable no. 7	not assigned
%QWp.2.c\0.0.7	Periodic output variable no. 8	not assigned
%QWp.2.c\0.0.8 to %QWp.2.c\0.0.27	Not used	-
%QWp.2.c\0.0.28	Output PKWs	PKEout: Parameter logic address
%QWp.2.c\0.0.29		PWout: Request code
%QWp.2.c\0.0.30		PWEout: Parameter value
%QWp.2.c\0.0.31	Not used	-

PLC address	Description	Default assignment
%IWp.2.c\0.0	Periodic input variable no. 1	Status word (EtA)
%IWp.2.c\0.0.1	Periodic input variable no. 2	Output speed (rFrd)
%IWp.2.c\0.0.2	Periodic input variable no. 3	not assigned
%IWp.2.c\0.0.3	Periodic input variable no. 4	not assigned
%IWp.2.c\0.0.4	Periodic input variable no. 5	not assigned
%IWp.2.c\0.0.5	Periodic input variable no. 6	not assigned
%IWp.2.c\0.0.6	Periodic input variable no. 7	not assigned
%IWp.2.c\0.0.7	Periodic input variable no. 8	not assigned
%IWp.2.c\0.0.8 to %IWp.2.c\0.0.27	Not used	-
%IWp.2.c\0.0.28	Input PKWs	PKEin: Parameter logic address
%IWp.2.c\0.0.29		RWin: Response code
%IWp.2.c\0.0.30		PWEin: Parameter value/error code
%IWp.2.c\0.0.31	Not used	-

See "Configuration - Communication scanner" for information about how periodic variables are assigned.
See "Diagnostics - Communication scanner" for information about how periodic variables are displayed.

8. Software setup

8. 4. PKW service

The PKW service provides read and write access to the drive parameters.

■ Output PKWs

- **PKEout**
Parameter logic address
- **RWout**
= 0: PKW service not active
= 1: Read
= 2: Write
If PKEout and RWout (not 0) remain unchanged, the drive will execute the function permanently. Therefore, if you wish a service to be confirmed, you must reset RWout to zero between each transaction.
- **PWEout**
Write operation: Value of parameter to be written

■ Input PKWs

- **PKEin**
The availability of the result of the PKW transaction is indicated by the value of PKEin changing to the same as that of PKEout.
- **RWin**
= 0: PKW service not active
= 1: Read operation correct
= 2: Write operation correct
= 7: Read or write error
- **PWEin**
 - If the write operation is completed without errors: Parameter value. During a write operation, this value may differ from the value of PKWout if PKWout is not within the permissible limits (the write operation is accepted but an upper or lower limit is applied).
 - If there is an error:
 - = 0: Incorrect address
 - = 1: Write operation not accepted (read-only parameter or local forcing preventing a configuration or adjustment parameter being written)

Note: The parameters configured in the periodic output variables should not be changed by the PKW indexed variable.

8. Software setup

8. 5. Examples

■ Example 1: Cyclic reading of HSP (3104)

Result of 500 read (50 Hz)

Output PKWs		Input PKWs	
PKEout	3104	PKEin	3104
RWout	1	RWin	1
PWEout	–	PWEin	–

■ Example 2: Cyclic writing of LSP (3105) to the value 100 (10 Hz)

Output PKWs		Input PKWs	
PKEout	3105	PKEin	3105
RWout	2	RWin	2
PWEout	100	PWEin	100

■ Example 3: Incorrect write operation: RFR parameter (3202) is read-only

Output PKWs		Input PKWs	
PKEout	3202	PKEin	3202
RWout	2	RWin	7
PWEout	500	PWEin	1

■ Example 4: Writing the value 1000 (100 Hz) to HSP, limited to 600 (60 Hz) by the drive

1 Write

Output PKWs		Input PKWs	
PKEout	3104	PKEin	3104
RWout	2	RWin	2
PWEout	1000	PWEin	1000

The input PKW responds in the bus scan cycle. The request is subsequently transmitted to the drive. The parameter is limited several milliseconds later. It will be taken note of during the next cycle.

2 followed by a read operation

Output PKWs		Input PKWs	
PKEout	3104	PKEin	3104
RWout	1	RWin	1
PWEout	–	PWEin	600

8. Software setup

■ Example 5: Display of I/O in debug mode

Example of an animation table in PL7 containing the periodic data exchanged with a drive at address 11 on the Fipio bus:

Modification	Address	Symbol / Name	Current value	Nature	Kind	Comment
F3 <input type="button" value="Modify"/>	%QW0.2.11\0.0	Nc1_cmd_command_register	16#000F			
F7 <input type="button" value="0"/>	%QW0.2.11\0.0.1	Nc2_lfrd_nominal_speed	1000			
F8 <input type="button" value="1"/>	%QW0.2.11\0.0.2	Nc3_acc_acceleration_time	50			
	%QW0.2.11\0.0.3	Nc4_dec_deceleration_time	100			
	%QW0.2.11\0.0.4	Nc5_inr_ramp_increment	1			
	%QW0.2.11\0.0.5	Nc6	0			
	%QW0.2.11\0.0.6	Nc7	0			
	%QW0.2.11\0.0.7	Nc8	0			
	%IW0.2.11\0.0	Nm1_eta_status_word	16#0627			
	%IW0.2.11\0.0.1	Nm2_frhd_reference_speed	1000			
	%IW0.2.11\0.0.2	Nm3_rfrd_actual_speed	1000			
	%IW0.2.11\0.0.3	Nm4_ili_logic_inputs_image	16#0005			
	%IW0.2.11\0.0.4	Nm5_aile_ai1_image	3925			
	%IW0.2.11\0.0.5	Nm6_ai2cai2_image	2513			
	%IW0.2.11\0.0.6	Nm7	0			
	%IW0.2.11\0.0.7	Nm8	0			
	%QW0.2.11\0.0.28	Out_pke	3105			
	%QW0.2.11\0.0.29	Out_rw	2			
	%QW0.2.11\0.0.30	Out_pwe	100			
	%IW0.2.11\0.0.28	In_pke	3105			
	%IW0.2.11\0.0.29	In_rwn	2			
	%IW0.2.11\0.0.30	In_pwe	100			

The periodic variables shown here are the same as those described in the example on page 13.

Their values are described below (see the Parameters Manual):

- Periodic control of drive (%QW0.2.11\0.0 to %QW0.2.11\0.0.7):
 - Control word (CMD) = 16#000F = "Enable operation": Command to switch to or maintain the "Operation enabled" state of the drive (ATV running) in the DSP402 state graph
 - Speed reference (LFrd) = 1000: Motor controlled at 1000 rpm
 - Ramp increment (Inr) = 1: Unit of 0.1 s applied to ACC and DEC (among others)
 - Acceleration (ACC) = 50: Acceleration 5.0 s (50 x 0.1 s)
 - Deceleration (dEC) = 100: Deceleration 10.0 s (100 x 0.1 s)
- Periodic monitoring of drive (%IW0.2.11\0.0 to %IW0.2.11\0.0.7):
 - Status word (EtA) = 16#0627: Drive in "Operation enabled" state (ATV running) in the DSP402 state graph with reference reached/in steady state (bit 10 = 1)
 - Output speed (FrHd) and Speed reference before ramp (rFrd) = 1000: 1000 rpm
 - Logic input map (IL1r) = 16#0005: Logic inputs LI1 and LI3 active
 - Physical image of analog input AI1 (AI1r) = 3925: 3.925 V (or mA) on AI1
 - Physical image of analog input AI2 (AI2r) = 2513: 2.513 V (or mA) on AI2
- Use of PKW service for indexed periodic variables (request = %QW0.2.11\0.0.28 to %QW0.2.11\0.0.30 and response = %IW0.2.11\0.0.28 to %IW0.2.11\0.0.30):
 - Request for cyclic writing (RWout = 2) of the LSP variable (PKEout = 3105) at 10 Hz (PWEout = 100)
 - Positive response: Write operation performed successfully (RWin = 2)

In this state, the motor runs forward at the reference speed (1000 rpm).

8. Software setup

8. 6. Diagnostics in PL7

1 Monitoring system words %SW128 to %SW131.

Each bit in this group of words is indicative of the state of a device connected to the Fipio bus.

2 Monitoring the implicit word "Module fault" %I\p.2.c\0.MOD.ERR, which checks the connection point.
Normally at 0. A value of 1 indicates a fault.

3 For more information, read the "Channel status" %MW\p.2.c\0.0.2.

This information is updated by the explicit command READ_STS %CH\p.2.c\0.0.

p: Processor slot (0 or 1)

c: Connection point number

Definition of "Channel status"

Bit	Description
0	Reserved
1	Reserved
2	Reserved
3	Supply fault
4	Reserved
5	Hardware configuration fault (CFI)
6	PLC communication fault
7	Reserved
8	Configuration fault
9	Module missing
10	Module inoperative
11	Module faulty
12	Internal fault, TSX hardware fault
13	Internal fault, TSX system fault
14	Dialog fault, Fipio communication fault
15	Dialog fault, drive parameterization fault

