

# TeSys T DTM for FDT Container

## Online Help

1672614EN-03  
03/2026

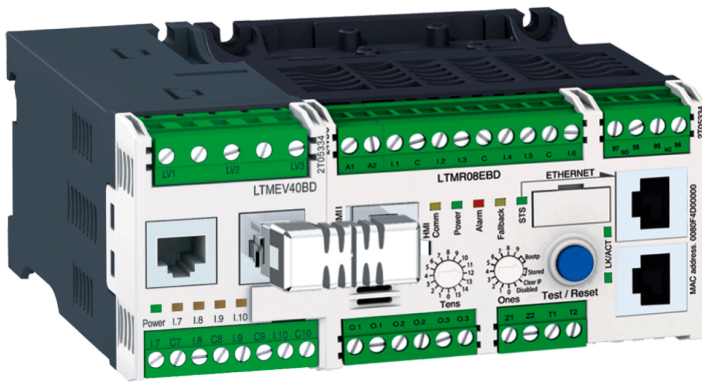

# Legal Information

The information provided in this document contains general descriptions, technical characteristics and/or recommendations related to products/solutions.

This document is not intended as a substitute for a detailed study or operational and site-specific development or schematic plan. It is not to be used for determining suitability or reliability of the products/solutions for specific user applications. It is the duty of any such user to perform or have any professional expert of its choice (integrator, specifier or the like) perform the appropriate and comprehensive risk analysis, evaluation and testing of the products/solutions with respect to the relevant specific application or use thereof.

The Schneider Electric brand and any trademarks of Schneider Electric SE and its subsidiaries referred to in this document are the property of Schneider Electric SE or its subsidiaries. All other brands may be trademarks of their respective owner.

This document and its content are protected under applicable copyright laws and provided for informative use only. No part of this document may be reproduced or transmitted in any form or by any means (electronic, mechanical, photocopying, recording, or otherwise), for any purpose, without the prior written permission of Schneider Electric.

Schneider Electric does not grant any right or license for commercial use of the document or its content, except for a non-exclusive and personal license to consult it on an "as is" basis.

Schneider Electric reserves the right to make changes or updates with respect to or in the content of this document or the format thereof, at any time without notice.

**To the extent permitted by applicable law, no responsibility or liability is assumed by Schneider Electric and its subsidiaries for any errors or omissions in the informational content of this document, as well as any non-intended use or misuse of the content thereof.**

---

# Table of Contents

|                                                              |    |
|--------------------------------------------------------------|----|
| Safety Information.....                                      | 9  |
| BEFORE YOU BEGIN .....                                       | 9  |
| START UP AND TEST .....                                      | 10 |
| OPERATION AND ADJUSTMENTS.....                               | 11 |
| About the Book.....                                          | 12 |
| Presentation of the TeSys T DTM.....                         | 14 |
| Introduction.....                                            | 14 |
| Presentation of the TeSys T Motor Management System .....    | 14 |
| Definitions .....                                            | 19 |
| Installing SoMove and the TeSys DTM Library.....             | 20 |
| Installing Update TeSys DTM Library .....                    | 21 |
| User Interface .....                                         | 22 |
| General Description .....                                    | 22 |
| Menu Bar and Tool Bar.....                                   | 24 |
| Command Submenu .....                                        | 27 |
| Password Management.....                                     | 28 |
| Device Version Management .....                              | 29 |
| Status Bar and Synchronization Data Bar .....                | 30 |
| My Device .....                                              | 32 |
| Operate .....                                                | 33 |
| Tab Zone.....                                                | 35 |
| Parameter List .....                                         | 38 |
| Trip.....                                                    | 40 |
| Monitoring .....                                             | 41 |
| Diagnostic.....                                              | 44 |
| Metering and Monitoring Functions.....                       | 45 |
| Measurement.....                                             | 45 |
| Line Currents.....                                           | 45 |
| Ground Current.....                                          | 46 |
| Average Current .....                                        | 48 |
| Current Phase Imbalance .....                                | 49 |
| Thermal Capacity Level.....                                  | 50 |
| Motor Temperature Sensor .....                               | 50 |
| Frequency.....                                               | 51 |
| Line-to-Line Voltages .....                                  | 51 |
| Line Voltage Imbalance .....                                 | 52 |
| Average Voltage .....                                        | 52 |
| Power Factor.....                                            | 53 |
| Active Power and Reactive Power.....                         | 54 |
| Active Power Consumption and Reactive Power Consumption..... | 55 |
| System and Device Monitoring Trips .....                     | 55 |
| Controller Internal Trip.....                                | 56 |
| Controller Internal Temperature.....                         | 56 |
| Control Command Detected Error Diagnostic .....              | 58 |
| Wiring Trips .....                                           | 60 |
| Configuration Checksum .....                                 | 62 |
| Communication Loss.....                                      | 62 |

|                                               |           |
|-----------------------------------------------|-----------|
| Time to Trip .....                            | 64        |
| LTMR Configuration Trip.....                  | 64        |
| LTME Configuration Trip and Alarm .....       | 65        |
| External Trip.....                            | 65        |
| Trip and Alarm Counters .....                 | 66        |
| Introducing Trip and Alarm Counters .....     | 66        |
| All Trips Counter .....                       | 67        |
| All Alarms Counter .....                      | 67        |
| Auto-Reset Counter .....                      | 67        |
| Protection Trips and Alarms Counters .....    | 67        |
| Control Command Detected Errors Counter.....  | 68        |
| Wiring Trips Counter .....                    | 68        |
| Communication Loss Counters .....             | 68        |
| Internal Trip Counters.....                   | 69        |
| Trip History.....                             | 69        |
| Motor History.....                            | 70        |
| Motor Starts Counters .....                   | 70        |
| Motor Starts Per Hour Counter.....            | 70        |
| Load Sheddings Counter .....                  | 71        |
| Auto Restart Counters.....                    | 71        |
| Motor Last Start Current Ratio .....          | 71        |
| Motor Last Start Duration.....                | 71        |
| Operating Time.....                           | 72        |
| System Operating Status .....                 | 72        |
| Motor State .....                             | 72        |
| Minimum Wait Time.....                        | 73        |
| <b>Motor Protection Functions .....</b>       | <b>74</b> |
| Motor Protection Functions Introduction ..... | 74        |
| Definitions .....                             | 74        |
| Motor Protection Characteristics .....        | 75        |
| Thermal Motor Protection Functions.....       | 77        |
| Thermal Overload .....                        | 77        |
| Thermal Overload - Inverse Thermal .....      | 78        |
| Thermal Overload - Definite Time.....         | 82        |
| Motor Temperature Sensor .....                | 84        |
| Motor Temperature Sensor - PTC Binary .....   | 85        |
| Motor Temperature Sensor - PT100.....         | 86        |
| Motor Temperature Sensor - PTC Analog .....   | 88        |
| Motor Temperature Sensor - NTC Analog .....   | 90        |
| Rapid Cycle Lockout .....                     | 92        |
| Current Motor Protection Functions.....       | 93        |
| Current Phase Imbalance .....                 | 94        |
| Current Phase Loss .....                      | 96        |
| Current Phase Reversal .....                  | 98        |
| Long Start .....                              | 99        |
| Jam .....                                     | 101       |
| Undercurrent .....                            | 103       |
| Overcurrent.....                              | 105       |
| Ground Current.....                           | 107       |
| Internal Ground Current.....                  | 107       |
| External Ground Current .....                 | 110       |

|                                                         |            |
|---------------------------------------------------------|------------|
| Voltage Motor Protection Functions.....                 | 112        |
| Voltage Phase Imbalance .....                           | 112        |
| Voltage Phase Loss .....                                | 115        |
| Voltage Phase Reversal .....                            | 117        |
| Undervoltage.....                                       | 118        |
| Overvoltage.....                                        | 120        |
| Voltage Dip Management .....                            | 122        |
| Load Shedding .....                                     | 122        |
| Automatic Restart .....                                 | 124        |
| Power Motor Protection Functions .....                  | 129        |
| Underpower .....                                        | 129        |
| Overpower .....                                         | 131        |
| Under Power Factor.....                                 | 133        |
| Over Power Factor.....                                  | 135        |
| <b>Motor Control Functions.....</b>                     | <b>138</b> |
| Control Channels and Operating States .....             | 138        |
| Control Channels .....                                  | 138        |
| Operating States.....                                   | 141        |
| Start Cycle .....                                       | 143        |
| Operating Modes.....                                    | 146        |
| Control Principles.....                                 | 146        |
| Predefined Operating Modes .....                        | 147        |
| Control Wiring and Trip Management .....                | 150        |
| Overload Operating Mode .....                           | 151        |
| Independent Operating Mode .....                        | 153        |
| Reverser Operating Mode .....                           | 155        |
| Two-Step Operating Mode.....                            | 159        |
| Two-Speed Operating Mode .....                          | 164        |
| Custom Operating Mode .....                             | 168        |
| Trip Management and Clear Commands .....                | 168        |
| Trip Management - Introduction .....                    | 168        |
| Manual Reset .....                                      | 171        |
| Automatic Reset .....                                   | 172        |
| Remote Reset .....                                      | 176        |
| Trip and Alarm Codes.....                               | 177        |
| LTMR Controller Clear Commands.....                     | 179        |
| <b>Communication Functions .....</b>                    | <b>181</b> |
| Configuration of LTMR Ports.....                        | 181        |
| Configuration of the LTMR Modbus Network Port .....     | 181        |
| Configuration of the LTMR PROFIBUS DP Network Port..... | 182        |
| Configuration of the LTMR CANopen Network Port.....     | 183        |
| Configuration of the LTMR DeviceNet Network Port.....   | 184        |
| Configuration of the LTMR Ethernet Network Port.....    | 185        |
| Configuration of the HMI Port.....                      | 188        |
| Miscellaneous .....                                     | 189        |
| User Map Variables.....                                 | 189        |
| E_TeSys T Fast Access Profile Registers .....           | 190        |
| EIOS_TeSys T Profile Registers.....                     | 191        |
| Using Ethernet Services.....                            | 193        |
| Primary IP .....                                        | 193        |
| I/O Scanning Configuration.....                         | 195        |

|                                                               |            |
|---------------------------------------------------------------|------------|
| Ethernet Link Management.....                                 | 196        |
| IP Addressing .....                                           | 197        |
| Fast Device Replacement.....                                  | 203        |
| Rapid Spanning Tree Protocol .....                            | 209        |
| Ethernet Diagnostics .....                                    | 209        |
| <b>Introduction to Custom Logic Editor .....</b>              | <b>216</b> |
| Presentation of the Custom Logic Editor .....                 | 216        |
| Using the Custom Logic Editor.....                            | 219        |
| Characteristics of the Custom Logic Program .....             | 221        |
| Definition of the Custom Logic Variables.....                 | 222        |
| Definition of the LTMR Variables .....                        | 222        |
| CALL_EOM Command Description.....                             | 224        |
| <b>Structured Text Language .....</b>                         | <b>233</b> |
| Creating a Structured Text Program .....                      | 233        |
| Introducing the Structured Text Editor .....                  | 233        |
| Structured Text Editor User Interface .....                   | 234        |
| Logic Commands.....                                           | 236        |
| Logic Commands .....                                          | 241        |
| Program Logic Commands .....                                  | 241        |
| Boolean Logic Commands.....                                   | 242        |
| Register Logic Commands .....                                 | 251        |
| Timer Logic Commands .....                                    | 260        |
| Latch Logic Commands.....                                     | 262        |
| Counter Logic Commands .....                                  | 263        |
| Math Logic Commands.....                                      | 265        |
| Structured Text Program Examples.....                         | 267        |
| How to Check Timers and Multiply Commands.....                | 267        |
| How to Create a Truth Table .....                             | 268        |
| <b>Function Block Diagram Language .....</b>                  | <b>272</b> |
| Overview of FBD Language.....                                 | 272        |
| Introduction to the FBD Editor .....                          | 272        |
| FBD Elements .....                                            | 274        |
| Computation Blocks .....                                      | 274        |
| Inputs Blocks.....                                            | 276        |
| Function Blocks .....                                         | 279        |
| Logic Blocks .....                                            | 282        |
| Outputs Blocks .....                                          | 283        |
| Programming with the FBD Language .....                       | 285        |
| Inserting FBD Blocks.....                                     | 285        |
| Creation of Links between Blocks.....                         | 286        |
| FBD Blocks Properties .....                                   | 287        |
| FBD Resource Management.....                                  | 288        |
| Manipulating FBD Blocks .....                                 | 289        |
| How to Select Blocks.....                                     | 289        |
| How to Delete and Duplicate Objects.....                      | 289        |
| FBD Editor Display Options .....                              | 290        |
| Other Display Options .....                                   | 290        |
| Workspace Appearance and Graph Options .....                  | 291        |
| <b>Compiling, Simulating, and Transferring a Program.....</b> | <b>294</b> |
| Introduction.....                                             | 294        |

---

|                                                                                      |            |
|--------------------------------------------------------------------------------------|------------|
| PCode Window .....                                                                   | 295        |
| Error Window .....                                                                   | 296        |
| LTMR Controller Logic Simulator .....                                                | 297        |
| Initialization and Connection.....                                                   | 299        |
| Transferring Logic Files between the LTMR Controller and Custom Logic<br>Editor..... | 300        |
| Custom Logic Program Transfer and Execution .....                                    | 301        |
| <b>Maintenance .....</b>                                                             | <b>303</b> |
| Updating the LTMR Controller Firmware.....                                           | 303        |
| Self Test with Motor On .....                                                        | 306        |
| <b>Connection to the LTMR Controller.....</b>                                        | <b>308</b> |
| Hardware Connection for SoMove .....                                                 | 308        |
| Hardware Connection for the Firmware Update.....                                     | 310        |
| <b>Index .....</b>                                                                   | <b>315</b> |



# Safety Information

## Important Information

Read these instructions carefully, and look at the equipment to become familiar with the device before trying to install, operate, service, or maintain it. The following special messages may appear throughout this documentation or on the equipment to warn of potential hazards or to call attention to information that clarifies or simplifies a procedure.





The addition of this symbol to a "Danger" or "Warning" safety label indicates that an electrical hazard exists which will result in personal injury if the instructions are not followed.



This is the safety alert symbol. It is used to alert you to potential personal injury hazards. Obey all safety messages that follow this symbol to avoid possible injury or death.

|                                                                                                                     |
|---------------------------------------------------------------------------------------------------------------------|
|  <b>DANGER</b>                     |
| <b>DANGER</b> indicates a hazardous situation which, if not avoided, <b>will result in</b> death or serious injury. |

|                                                                                                                       |
|-----------------------------------------------------------------------------------------------------------------------|
|  <b>WARNING</b>                      |
| <b>WARNING</b> indicates a hazardous situation which, if not avoided, <b>could result in</b> death or serious injury. |

|                                                                                                                        |
|------------------------------------------------------------------------------------------------------------------------|
|  <b>CAUTION</b>                     |
| <b>CAUTION</b> indicates a hazardous situation which, if not avoided, <b>could result in</b> minor or moderate injury. |

|                                                                            |
|----------------------------------------------------------------------------|
| <b>NOTICE</b>                                                              |
| <b>NOTICE</b> is used to address practices not related to physical injury. |

## Please Note

Electrical equipment should be installed, operated, serviced, and maintained only by qualified personnel. No responsibility is assumed by Schneider Electric for any consequences arising out of the use of this material.

A qualified person is one who has skills and knowledge related to the construction and operation of electrical equipment and its installation, and has received safety training to recognize and avoid the hazards involved.

## BEFORE YOU BEGIN

Do not use this product on machinery lacking effective point-of-operation guarding. Lack of effective point-of-operation guarding on a machine can result in serious injury to the operator of that machine.

## ▲ WARNING

### UNGUARDED MACHINERY CAN CAUSE SERIOUS INJURY

- Do not use this software and related automation equipment on packaging equipment which does not have point-of-operation protection.
- Do not reach into machinery during operation.

**Failure to follow these instructions can result in death, serious injury, or equipment damage.**

This automation equipment and related software is used to control a variety of industrial processes. The type or model of automation equipment suitable for each application will vary depending on factors such as the control function required, degree of protection required, production methods, unusual conditions, government regulations, etc. In some applications, more than one processor may be required, as when backup redundancy is needed.

You can be aware of all the conditions and factors present during setup, operation and maintenance of the machine; therefore, only you can determine the automation equipment and the related safeties and interlocks which can be properly used. When selecting automation and control equipment and related software for a particular application, you should refer to the applicable local and national standards and regulations. The Accident Prevention Manual (nationally recognized in the United States of America) also provides much useful information.

In some applications, such as packaging machinery, additional operator protection such as point-of-operation guarding must be provided. This is necessary if the operators hands and other parts of the body are free to enter the pinch point area and serious injury can occur. Software products cannot protect an operator from injury. For this reason the software cannot be substituted for or take the place of point-of-operation protection.

Make sure that appropriate safeties and interlocks related to point-of-operation protection have been installed and are operational before placing the equipment into service. All interlocks and safeties related to point-of-operation protection must be coordinated with the related automation equipment and software programming.

**NOTE:** Coordination of safeties and interlocks for point-of-operation is outside the scope of this Defined Function Block (DFB).



**WARNING:** This product can expose you to chemicals including lead and lead compounds, which are known to the State of California to cause cancer and birth defects or other reproductive harm. For more information go to [www.P65Warnings.ca.gov](http://www.P65Warnings.ca.gov).

## START UP AND TEST

Before using electrical control and automation equipment for regular operation after installation, the system should be given a start up test by qualified personnel to verify correct operation of the equipment. It is important that arrangements for such a check be made and that enough time is allowed to perform complete and satisfactory testing.

## ▲ CAUTION

### EQUIPMENT OPERATION HAZARD

- Verify that all installation and set up procedures have been completed.
- Before operational tests are performed, remove all blocks or other temporary holding means used for shipment from all component devices.
- Remove tools, meters, and debris from equipment.

**Failure to follow these instructions can result in injury or equipment damage.**

Follow all start up tests recommended in the equipment documentation. Store all equipment documentation for future references.

**NOTE:** Software testing must be done in both simulated and real environments.

Verify that the completed system is free from all short circuits and grounds, except those grounds installed according to local regulations (according to the National Electrical Code in the U.S.A, for instance). If high-potential voltage testing is necessary, follow recommendations in equipment documentation to prevent accidental equipment damage.

Before energizing equipment:

- Remove tools, meters and debris from equipment.
- Close the equipment enclosure door.
- Remove ground from incoming power lines.
- Perform all start-up tests recommended by the manufacturer.

## OPERATION AND ADJUSTMENTS

The following precautions are from the NEMA Standards Publication ICS 7.1-1995 (English version prevails):

- Regardless of the care exercised in the design and manufacture of equipment or in the selection and ratings of components, there are hazards that can be encountered if such equipment is improperly operated.
- It is sometimes possible to misadjust the equipment and thus produce unsatisfactory or unsafe operation. Always use the manufacturer's instructions as a guide for functional adjustments. Personnel who have access to these adjustments should be familiar with the equipment manufacturer's instructions and the machinery used with the electrical equipment.
- Only those operational adjustments actually required by the operator should be accessible to the operator. Access to other controls should be restricted to prevent unauthorized changes in operating characteristics.

# About the Book

## Document Scope

This online help describes the TeSys T DTM for TeSys T motor management system.

The purpose of this online help is to:

- Describe the metering, monitoring, protection, and control functions of the TeSys T motor management system.
- Describe the custom logic editor embedded in the TeSys T DTM which allows the customization of the control functions of the TeSys T motor management system.
- Provide all the information necessary to implement and support a solution that meets application requirements.

The online help describes the 4 key parts of a successful system implementation:

- Installing the TeSys DTM library
- Entering and setting parameters
- Monitoring the status of the device
- Maintaining and upgrading the TeSys T DTM library

The online help is intended for TeSys T DTM users:

- Design engineers
- System integrators
- System operators
- Maintenance engineers

## Validity Note

This document has been updated with the release of SoMove Lite V1.9.2.0 and TeSys DTM library 2.7.6.0.

The availability of some functions depends on the LTMR controller version .

The characteristics presented in this online help should be the same as those that appear online. In line with our policy of constant improvement, we may revise content over time to improve clarity and accuracy. In the event that you see a difference between the online help and online information, use the online information as your reference.

## Related Documents

| Title of Documentation                                              | Reference Number |
|---------------------------------------------------------------------|------------------|
| TeSys® T LTMR Modbus Motor Management Controller - User Manual      | 1639501          |
| TeSys® T LTMR Profibus DP Motor Management Controller - User Manual | 1639502          |
| TeSys® T LTMR CANopen Motor Management Controller - User Manual     | 1639503          |
| TeSys® T LTMR DeviceNet Motor Management Controller - User Manual   | 1639504          |
| TeSys® T LTMR Ethernet Motor Management Controller - User Manual    | 1639505          |

| Title of Documentation                                                                     | Reference Number |
|--------------------------------------------------------------------------------------------|------------------|
| TeSys® T LTM CU Control Operator Unit - User Manual                                        | 1639581          |
| TeSys® T LTMR Motor Management Controller<br>TeSys T DTM Custom Logic Editor - User Manual | 1639507          |

You can download these technical publications and other technical information from our website at [www.se.com/ww/en/download/](http://www.se.com/ww/en/download/) .

---

# Presentation of the TeSys T DTM

## Introduction

### Overview

This section describes the prerequisites for using the TeSys T motor management system with SoMove and the TeSys T DTM.

## Presentation of the TeSys T Motor Management System

### Product Overview

The TeSys T motor management system offers protection, control, and monitoring capabilities for single-phase and 3-phase AC induction motors.

The system is flexible, modular, and can be configured to meet the requirements of applications in industry. The system is designed to meet the needs of integrated protections systems with open communications and a global architecture.

Highly accurate sensors and solid-state full motor protection provide better utilization of the motor. Complete monitoring functions enable analysis of motor operating conditions and faster responses to help prevent system downtime.

The system offers diagnostic and statistics functions and configurable alarms and trips, allowing better predictive maintenance of components, and provides data to continuously improve the entire system.

### Examples of Supported Machine Segments

The motor management system supports the following machine segments:

| Machine Segment                      | Examples                                                                                                                                                                                                                                                                                                                                                                                                                                                                                                                                                                                                                                                                                                                                                                                                                                                                                                                                                                             |
|--------------------------------------|--------------------------------------------------------------------------------------------------------------------------------------------------------------------------------------------------------------------------------------------------------------------------------------------------------------------------------------------------------------------------------------------------------------------------------------------------------------------------------------------------------------------------------------------------------------------------------------------------------------------------------------------------------------------------------------------------------------------------------------------------------------------------------------------------------------------------------------------------------------------------------------------------------------------------------------------------------------------------------------|
| Process and special machine segments | <p>Water and waste water treatment</p> <ul style="list-style-type: none"> <li>• water treatment (blowers and agitators)</li> </ul> <p>Metal, minerals, and mining</p> <ul style="list-style-type: none"> <li>• Cement</li> <li>• Glass</li> <li>• Steel</li> <li>• Ore extraction</li> </ul> <p>Oil and gas</p> <ul style="list-style-type: none"> <li>• Oil and gas processing                             <ul style="list-style-type: none"> <li>◦ Petrochemical</li> <li>◦ Refineries, offshore platforms</li> </ul> </li> </ul> <p>Microelectronic</p> <p>Pharmaceutical</p> <p>Chemical industry</p> <ul style="list-style-type: none"> <li>• Cosmetics</li> <li>• Detergents</li> <li>• Fertilizers</li> <li>• Paint</li> </ul> <p>Transportation industry</p> <ul style="list-style-type: none"> <li>• Automotive transfer lines</li> <li>• Airports</li> </ul> <p>Other industries</p> <ul style="list-style-type: none"> <li>• Tunnel machines</li> <li>• Cranes</li> </ul> |
| Complex machine segments             | <p>Includes highly automated or coordinated machines used in:</p> <ul style="list-style-type: none"> <li>• Pumping systems</li> <li>• Paper conversion</li> <li>• Printing lines</li> <li>• HVAC</li> </ul>                                                                                                                                                                                                                                                                                                                                                                                                                                                                                                                                                                                                                                                                                                                                                                          |

## Supported Industries

The motor management system supports the following industries and associated business sectors:

| Industry                  | Sectors                                                                                                                                                                                                                                                                                         | Application                                                                                                                                                                                                                                                                                                                                           |
|---------------------------|-------------------------------------------------------------------------------------------------------------------------------------------------------------------------------------------------------------------------------------------------------------------------------------------------|-------------------------------------------------------------------------------------------------------------------------------------------------------------------------------------------------------------------------------------------------------------------------------------------------------------------------------------------------------|
| Building                  | <ul style="list-style-type: none"> <li>• Office buildings</li> <li>• Shopping centers</li> <li>• Industrial buildings</li> <li>• Ships</li> <li>• Hospitals</li> <li>• Cultural facilities</li> <li>• Airports</li> </ul>                                                                       | Control and manage the building facilities: <ul style="list-style-type: none"> <li>• Critical HVAC systems</li> <li>• water</li> <li>• Air</li> <li>• Gas</li> <li>• Electricity</li> <li>• Steam</li> </ul>                                                                                                                                          |
| Industry                  | <ul style="list-style-type: none"> <li>• Metal, mineral, and mining: cement, glass, steel, ore-extraction</li> <li>• Microelectronic</li> <li>• Petrochemical</li> <li>• Ethanol</li> <li>• Chemical: pulp and paper industry</li> <li>• Pharmaceutical</li> <li>• Food and beverage</li> </ul> | <ul style="list-style-type: none"> <li>• Control and monitor pump motors</li> <li>• Control ventilation</li> <li>• Control load traction and movements</li> <li>• View status and communicate with machines</li> <li>• Process and communicate the data captured</li> <li>• Remotely manage data for one or several sites via the internet</li> </ul> |
| Energy and Infrastructure | <ul style="list-style-type: none"> <li>• Water treatment and transportation</li> <li>• Transportation infrastructure for people and freight: airports, road tunnels, subways, and tramways</li> <li>• Power generation and transport</li> </ul>                                                 | <ul style="list-style-type: none"> <li>• Control and monitor pump motors</li> <li>• Control ventilation</li> <li>• Remotely control wind turbine</li> <li>• Remotely manage data for one or several sites via the internet</li> </ul>                                                                                                                 |

## TeSys T Motor Management System

The hardware components of the system are the LTMR controller, the LTME expansion module and the LTM CU Control Operator Unit.

The system can be configured and controlled:

- Using an HMI (Human Machine Interface) device: Magelis® XBT or TeSys® T LTM CU
- Using a PC running an FDT container or SoMove with the TeSys T DTM
- Using a PLC connected to the system via the communication network
- Using the Ethernet web server of the LTMR Ethernet controller

Components such as external motor load current transformers and ground current transformers add additional range to the system.

## LTMR Controller

The microprocessor-based LTMR controller is the central component in the system that manages the control, protection, and monitoring functions of single-phase or 3-phase AC induction motors.

The LTMR controller is designed to work over the following fieldbus protocols:

- Modbus (reference code = M)
- Profibus DP (reference code = P)
- CANopen (reference code = C)
- DeviceNet (reference code = D)
- Ethernet (reference code = E)

The following table lists the 6 LTMR controller models using one of the above communication protocols. To obtain the comprehensive reference number, replace • by the reference code of the relevant protocol.

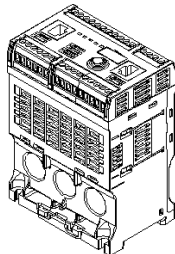
| LTMR Controller                                                                   | Functional Description                                                                                                                                                                                                                                                                                                                                                                                                                                                                                                                                                                                                                                                                                  | Reference Number                           |
|-----------------------------------------------------------------------------------|---------------------------------------------------------------------------------------------------------------------------------------------------------------------------------------------------------------------------------------------------------------------------------------------------------------------------------------------------------------------------------------------------------------------------------------------------------------------------------------------------------------------------------------------------------------------------------------------------------------------------------------------------------------------------------------------------------|--------------------------------------------|
|  | <ul style="list-style-type: none"> <li>• Current sensing 0.4...100 A</li> <li>• Current inputs</li> <li>• 6 discrete logic inputs</li> <li>• 4 relay outputs: 3 SPST, 1 DPST</li> <li>• Connections for a ground current sensor</li> <li>• Connection for a motor temperature sensor</li> <li>• Connection for network</li> <li>• Connection for HMI device or expansion module</li> <li>• Current protection, metering, and monitoring functions</li> <li>• Motor control functions</li> <li>• Power indicator</li> <li>• Trip and alarm LED indicators</li> <li>• Network communication and alarm indicators</li> <li>• HMI communication LED indicator</li> <li>• Test and reset function</li> </ul> | LTMR08•BD (24 VDC, 0.4...8 A FLC)          |
|                                                                                   |                                                                                                                                                                                                                                                                                                                                                                                                                                                                                                                                                                                                                                                                                                         | LTMR27•BD (24 VDC, 1.35...27 A FLC)        |
|                                                                                   |                                                                                                                                                                                                                                                                                                                                                                                                                                                                                                                                                                                                                                                                                                         | LTMR100•BD (24 VDC, 5...100 A FLC)         |
|                                                                                   |                                                                                                                                                                                                                                                                                                                                                                                                                                                                                                                                                                                                                                                                                                         | LTMR08•FM (100...240 VAC, 0.4...8 A FLC)   |
|                                                                                   |                                                                                                                                                                                                                                                                                                                                                                                                                                                                                                                                                                                                                                                                                                         | LTMR27•FM (100...240 VAC, 1.35...27 A FLC) |
|                                                                                   |                                                                                                                                                                                                                                                                                                                                                                                                                                                                                                                                                                                                                                                                                                         | LTMR100•FM (100...240 VAC, 5...100 A FLC)  |

### LTME Expansion Module

There are 2 models of LTME expansion modules that provide voltage monitoring functionality and 4 additional logic inputs. The LTME expansion modules are powered by the LTMR controller via a connector cable.

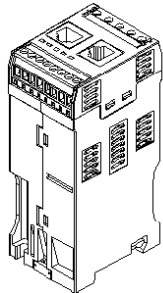
| LTME expansion module                                                               | Functional Description                                                                                                                                                                                                                                                                                                                                                                                                                                                                    | Reference Number                       |
|-------------------------------------------------------------------------------------|-------------------------------------------------------------------------------------------------------------------------------------------------------------------------------------------------------------------------------------------------------------------------------------------------------------------------------------------------------------------------------------------------------------------------------------------------------------------------------------------|----------------------------------------|
|  | <ul style="list-style-type: none"> <li>• Voltage sensing 110...690 VAC</li> <li>• 3 voltage inputs</li> <li>• 4 additional discrete logic inputs</li> <li>• Additional voltage protection, metering, and monitoring functions</li> <li>• Power LED indicator</li> <li>• Logic input status LED indicators</li> </ul> <p>Additional components required for an optional expansion module:</p> <ul style="list-style-type: none"> <li>• LTMR controller to LTME connection cable</li> </ul> | LTMEV40BD (24 VDC logic inputs)        |
|                                                                                     |                                                                                                                                                                                                                                                                                                                                                                                                                                                                                           | LTMEV40FM (100...240 VAC logic inputs) |

### HMI Device: Magelis XBTN410

The system uses the Magelis® XBTN410 HMI device with a liquid crystal display.

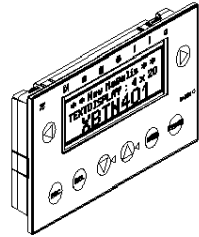
| Magelis® XBTN410                                                                    | Functional Description                                                                                                                                                                                                                                                                                                                                                                           | Reference Number    |
|-------------------------------------------------------------------------------------|--------------------------------------------------------------------------------------------------------------------------------------------------------------------------------------------------------------------------------------------------------------------------------------------------------------------------------------------------------------------------------------------------|---------------------|
|  | <ul style="list-style-type: none"> <li>• System configuration through menu entries</li> <li>• Display of parameters, alarms, and trips</li> </ul> <p>Additional components required for an optional HMI device:</p> <ul style="list-style-type: none"> <li>• Separate power source</li> <li>• LTMR / LTME to HMI communication cable</li> <li>• Magelis XBTL1000 programming software</li> </ul> | XBTN410 (HMI)       |
|                                                                                     |                                                                                                                                                                                                                                                                                                                                                                                                  | XBTZ938 (cable)     |
|                                                                                     |                                                                                                                                                                                                                                                                                                                                                                                                  | XBTL1000 (software) |

### HMI Device: LTMCU Control Operator Unit

The system uses the TeSys® T LTMCU Control Operator Unit HMI device with a liquid crystal display and contextual navigation keys. The LTMCU is internally

powered by the LTMR. Refer to the *TeSys T LTMCU Control Operator Unit User Manual* for more information.

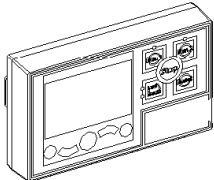
| LTM CU Control Operator Unit                                                      | Functional Description                                                                                                                                                                                                                                                                                                   | Reference Number                      |
|-----------------------------------------------------------------------------------|--------------------------------------------------------------------------------------------------------------------------------------------------------------------------------------------------------------------------------------------------------------------------------------------------------------------------|---------------------------------------|
|  | <ul style="list-style-type: none"> <li>System configuration through menu entries</li> <li>Display of parameters, alarms, and trips</li> <li>Motor control</li> </ul> Additional components required for an optional HMI device: <ul style="list-style-type: none"> <li>LTMR / LTME to HMI communication cable</li> </ul> | LTMCU                                 |
|                                                                                   |                                                                                                                                                                                                                                                                                                                          | LTM9CU-0<br>(HMI communication cable) |
|                                                                                   |                                                                                                                                                                                                                                                                                                                          | LTM9KCU<br>kit for portable LTMCU     |

## SoMove with the TeSys T DTM

SoMove software is a Microsoft® Windows®-based application, using the open FDT/DTM technology.

SoMove contains many DTMs. A specific DTM exists for the TeSys T motor management system.

| SoMove with the TeSys T DTM                                                        | Functional Description                                                                                                                                                                                                                                                                                                                                                                                                  | Reference Number              |
|------------------------------------------------------------------------------------|-------------------------------------------------------------------------------------------------------------------------------------------------------------------------------------------------------------------------------------------------------------------------------------------------------------------------------------------------------------------------------------------------------------------------|-------------------------------|
|  | <ul style="list-style-type: none"> <li>System configuration through menu entries</li> <li>Display of parameters, alarms, and trips</li> <li>Motor control</li> <li>Customization of operating modes</li> </ul> Additional components required for the SoMove FDT container: <ul style="list-style-type: none"> <li>PC</li> <li>Separate power source</li> <li>LTMR / LTME / LTMCU to PC communication cables</li> </ul> | SoMove with the TeSys T DTM   |
|                                                                                    |                                                                                                                                                                                                                                                                                                                                                                                                                         | TCSMCNAM3M002P<br>(cable kit) |

## Load Current Transformers

External load current transformers expand the current range for use with motors greater than 100 full load Amperes.

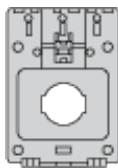
| Schneider Electric Load Current Transformers                                        | Primary                                                                                                                                                     | Secondary | Inside Diameter |      | Reference Number |
|-------------------------------------------------------------------------------------|-------------------------------------------------------------------------------------------------------------------------------------------------------------|-----------|-----------------|------|------------------|
|                                                                                     |                                                                                                                                                             |           | mm              | in.  |                  |
|  | 100                                                                                                                                                         | 1         | 35              | 1.38 | LT6CT1001        |
|                                                                                     | 200                                                                                                                                                         | 1         | 35              | 1.38 | LT6CT2001        |
|                                                                                     | 400                                                                                                                                                         | 1         | 35              | 1.38 | LT6CT4001        |
|                                                                                     | 800                                                                                                                                                         | 1         | 35              | 1.38 | LT6CT8001        |
|  | <b>NOTE:</b> The following load current transformers are also available: Schneider Electric LUTC0301, LUTC0501, LUTC1001, LUTC2001, LUTC4001, and LUTC8001. |           |                 |      |                  |

The lug-lug kit provides bus bars and lug terminals that adapt the pass through wiring windows and provide line and load terminations for the power circuit.

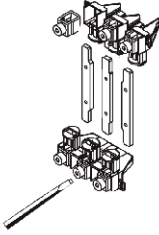
| Square D Lug-lug Kit                                                              | Description          | Reference Number |
|-----------------------------------------------------------------------------------|----------------------|------------------|
|  | Square D Lug-lug Kit | MLPL9999         |

## Ground Current Transformers

External ground current transformers measure ground current trip conditions.

| Schneider Electric Vigirex Ground Current Transformers                            | Type  | Maximum Current | Inside Diameter |       | Transformation Ratio | Reference Number |
|-----------------------------------------------------------------------------------|-------|-----------------|-----------------|-------|----------------------|------------------|
|                                                                                   |       |                 | mm              | in.   |                      |                  |
|  | TA30  | 65 A            | 30              | 1.18  | 1000:1               | 50437            |
|                                                                                   | PA50  | 85 A            | 50              | 1.97  |                      | 50438            |
|                                                                                   | IA80  | 160 A           | 80              | 3.15  |                      | 50439            |
|                                                                                   | MA120 | 250 A           | 120             | 4.72  |                      | 50440            |
|                                                                                   | SA200 | 400 A           | 200             | 7.87  |                      | 50441            |
|                                                                                   | PA300 | 630 A           | 300             | 11.81 |                      | 50442            |
|                                                                                   | POA   | 85 A            | 46              | 1.81  |                      | 50485            |
|                                                                                   | GOA   | 250 A           | 110             | 4.33  |                      | 50486            |

## Definitions

### FDT (Field Device Tool)

FDT technology:

- Standardizes the communication and configuration interface between all field devices and host systems
- Provides a common environment for accessing the devices features

For more information about FDT technology, refer to the following website: <http://www.fdtgroup.org/index.php>

### FDT Container

The FDT container is software that uses the FDT technology. It is used to:

- Install a DTM library to add new devices
- Modify an already installed DTM library to update existing devices

### DTM (Device Type Manager)

The DTM is a software module installed in an FDT container for a specific device. It provides a unified structure for:

- Accessing device parameters
- Configuring and operating the devices
- Diagnosing problems

The TeSys T or TeSys U DTM can be in extended mode or in basic mode, depending on the FDT container used:

- The extended mode is only available with SoMove, and gives access to all functions of the DTM.
- The basic mode is available with other compatible FDT containers, and gives access to certain functions of the DTM.

## DTM Library

A DTM library is a set of DTMs that works with an FDT container.

The TeSys DTM library includes:

- TeSys T DTM
- TeSys U DTM

## SoMove Project File

A SoMove project file is a configuration file for a pre-determined device, that can be created offline and saved for later use.

A project file contains the following information:

- Device type
- Selected characteristics, such as firmware version
- All parameters settings

**NOTE:**

- The project file does not contain the customized program.
- This file is saved with the extension \*.psx.

For more information on how to create a project, see the *SoMove Lite online help*.

## Installing SoMove and the TeSys DTM Library

### Overview

The installation of SoMove includes some DTMs such as the TeSys DTM library.

The TeSys DTM library includes:

- TeSys T DTM
- TeSys U DTM

These DTM are automatically installed during the SoMove installation process.

### Downloading SoMove

SoMove can be downloaded from the Schneider Electric website ([www.se.com](http://www.se.com)) by entering `SoMove Lite` in the **Search** field.

### Installing SoMove

| Step | Action                                                                                                                                                                                              |
|------|-----------------------------------------------------------------------------------------------------------------------------------------------------------------------------------------------------|
| 1    | Unzip the downloaded file: the SoMove file is unzipped in a folder named <i>SoMove_Lite - V.X.X.X.X</i> (where X.X.X.X is the version number). Open this folder and double-click <b>setup.exe</b> . |
| 2    | In the <b>Choose Setup Language</b> dialog box, select the installation language.                                                                                                                   |
| 3    | Click <b>OK</b> .                                                                                                                                                                                   |

| Step | Action                                                                                                                                                                                                                                                                                                                                                                                                                                                                                                                                                                                                 |
|------|--------------------------------------------------------------------------------------------------------------------------------------------------------------------------------------------------------------------------------------------------------------------------------------------------------------------------------------------------------------------------------------------------------------------------------------------------------------------------------------------------------------------------------------------------------------------------------------------------------|
| 4    | In the <b>Welcome to the Installation Wizard for SoMove Lite</b> dialog box, click the <b>Next</b> button.                                                                                                                                                                                                                                                                                                                                                                                                                                                                                             |
| 5    | If an <b>Install Shield Wizard</b> dialog box appears and informs you that you must install Modbus driver, click the <b>Install</b> button.<br><b>Result:</b> Modbus driver is installed automatically.                                                                                                                                                                                                                                                                                                                                                                                                |
| 6    | In the <b>Readme and Release Notes</b> dialog box, click the <b>Next</b> button.                                                                                                                                                                                                                                                                                                                                                                                                                                                                                                                       |
| 7    | In the <b>Readme</b> dialog box, click the <b>Next</b> button.                                                                                                                                                                                                                                                                                                                                                                                                                                                                                                                                         |
| 8    | In the <b>License Agreement</b> dialog box: <ul style="list-style-type: none"> <li>• Read carefully the license agreement.</li> <li>• Select <b>I accept the terms</b> in the license agreement option.</li> <li>• Click the <b>Next</b> button.</li> </ul>                                                                                                                                                                                                                                                                                                                                            |
| 9    | In the <b>Customer Information</b> dialog box: <ul style="list-style-type: none"> <li>• Enter the following information in the corresponding fields: <ul style="list-style-type: none"> <li>◦ First name</li> <li>◦ Last name</li> <li>◦ Company name</li> </ul> </li> <li>• Select an installation option: <ul style="list-style-type: none"> <li>◦ Either the <b>Anyone who uses this computer</b> option if SoMove Lite is used by all users of this computer, or</li> <li>◦ <b>Only for me</b> if SoMove Lite is used only by you.</li> </ul> </li> <li>• Click the <b>Next</b> button.</li> </ul> |
| 10   | In the <b>Destination Folder</b> dialog box: <ul style="list-style-type: none"> <li>• If necessary, modify the SoMove Lite destination folder by clicking the <b>Change</b> button.</li> <li>• Click the <b>Next</b> button.</li> </ul>                                                                                                                                                                                                                                                                                                                                                                |
| 11   | In the <b>Shortcuts</b> dialog box: <ul style="list-style-type: none"> <li>• If you want to create a shortcut on the desktop and/or in the quick launch bar, select the corresponding options.</li> <li>• Click the <b>Next</b> button.</li> </ul>                                                                                                                                                                                                                                                                                                                                                     |
| 12   | In the <b>Ready to Install the Program</b> dialog box, click the <b>Install</b> button.<br><b>Result:</b> The SoMove Lite components are installed automatically: <ul style="list-style-type: none"> <li>• Modbus communication DTM library which contains the communication protocol</li> <li>• DTM libraries which contain different drive catalogs</li> <li>• SoMove Lite itself</li> </ul>                                                                                                                                                                                                         |
| 13   | In the <b>Installation Wizard Completed</b> dialog box, click the <b>Finish</b> button.<br><b>Result:</b> SoMove Lite is installed on your computer.                                                                                                                                                                                                                                                                                                                                                                                                                                                   |

## Installing Update TeSys DTM Library

### Overview

The TeSys DTM library includes:

- TeSys T DTM
- TeSys U DTM

These DTM are automatically installed during the SoMove installation process.

### Downloading TeSysDTMLibrary

TeSysDTMLibrary can be downloaded from the Schneider Electric website ([www.se.com](http://www.se.com)) by entering `TeSysDTMLibrary` in the **Search** field.

## Installing Update TeSys DTM Library

| Step | Action                                                                                                                                                                                                                                                                                                                                                                                                                                                                                                                                                                                                             |
|------|--------------------------------------------------------------------------------------------------------------------------------------------------------------------------------------------------------------------------------------------------------------------------------------------------------------------------------------------------------------------------------------------------------------------------------------------------------------------------------------------------------------------------------------------------------------------------------------------------------------------|
| 1    | Unzip the downloaded file. Open this folder and double-click <b>setup.exe</b> . The TeSysDTMLibrary file is unzipped in a folder named <i>TeSysDTMLibrary - V.X.X.X.X</i> (where X.X.X.X is the version number).                                                                                                                                                                                                                                                                                                                                                                                                   |
| 2    | In the <b>Choose Setup Language</b> dialog box, select the installation language.                                                                                                                                                                                                                                                                                                                                                                                                                                                                                                                                  |
| 3    | Click <b>OK</b> .                                                                                                                                                                                                                                                                                                                                                                                                                                                                                                                                                                                                  |
| 4    | In the <b>Welcome to the Installation Wizard for TeSysDTMLibrary</b> dialog box, click the <b>Next</b> button.                                                                                                                                                                                                                                                                                                                                                                                                                                                                                                     |
| 5    | In the <b>Readme and Release Notes</b> dialog box, click the <b>Next</b> button.                                                                                                                                                                                                                                                                                                                                                                                                                                                                                                                                   |
| 6    | In the <b>License Agreement</b> dialog box: <ul style="list-style-type: none"> <li>• Read carefully the license agreement.</li> <li>• Select <b>I accept the terms</b> in the license agreement option.</li> <li>• Click the <b>Next</b> button.</li> </ul>                                                                                                                                                                                                                                                                                                                                                        |
| 7    | In the <b>Customer Information</b> dialog box: <ul style="list-style-type: none"> <li>• Enter the following information in the corresponding fields: <ul style="list-style-type: none"> <li>◦ First name</li> <li>◦ Last name</li> <li>◦ Company name</li> </ul> </li> <li>• Select an installation option: <ul style="list-style-type: none"> <li>◦ Either the <b>Anyone who uses this computer</b> option if TeSys DTM library is used by all users of this computer, or</li> <li>◦ <b>Only for me</b> if TeSys DTM library is used only by you.</li> </ul> </li> <li>• Click the <b>Next</b> button.</li> </ul> |
| 8    | In the <b>Destination Folder</b> dialog box: <ul style="list-style-type: none"> <li>• If necessary, modify the TeSys DTM library destination folder by clicking the <b>Change</b> button.</li> <li>• Click the <b>Next</b> button.</li> </ul>                                                                                                                                                                                                                                                                                                                                                                      |
| 9    | In the <b>Setup Type</b> dialog box: <ul style="list-style-type: none"> <li>• Select the setup type: recommended <b>Typical</b>.</li> <li>• Click the <b>Next</b> button.</li> </ul>                                                                                                                                                                                                                                                                                                                                                                                                                               |
| 10   | In the <b>Ready to Install the Program</b> dialog box, click the <b>Install</b> button.<br><b>Result:</b> The TeSys DTM library components are installed automatically.                                                                                                                                                                                                                                                                                                                                                                                                                                            |
| 11   | In the <b>Installation Wizard Completed</b> dialog box, click the <b>Finish</b> button.<br><b>Result:</b> The TeSys DTM library is installed on your computer.                                                                                                                                                                                                                                                                                                                                                                                                                                                     |

## User Interface

### Overview

This section describes the different menus and tabs available in SoMove with the TeSys T DTM.

## General Description

### Overview

The TeSys T DTM can be in extended mode or in basic mode, depending on the FDT container used:

- The extended mode is only available with SoMove, and gives access to all functions of the DTM.
- The basic mode is available with other compatible FDT containers, and gives access to certain functions of the DTM.

## Extended Mode Presentation

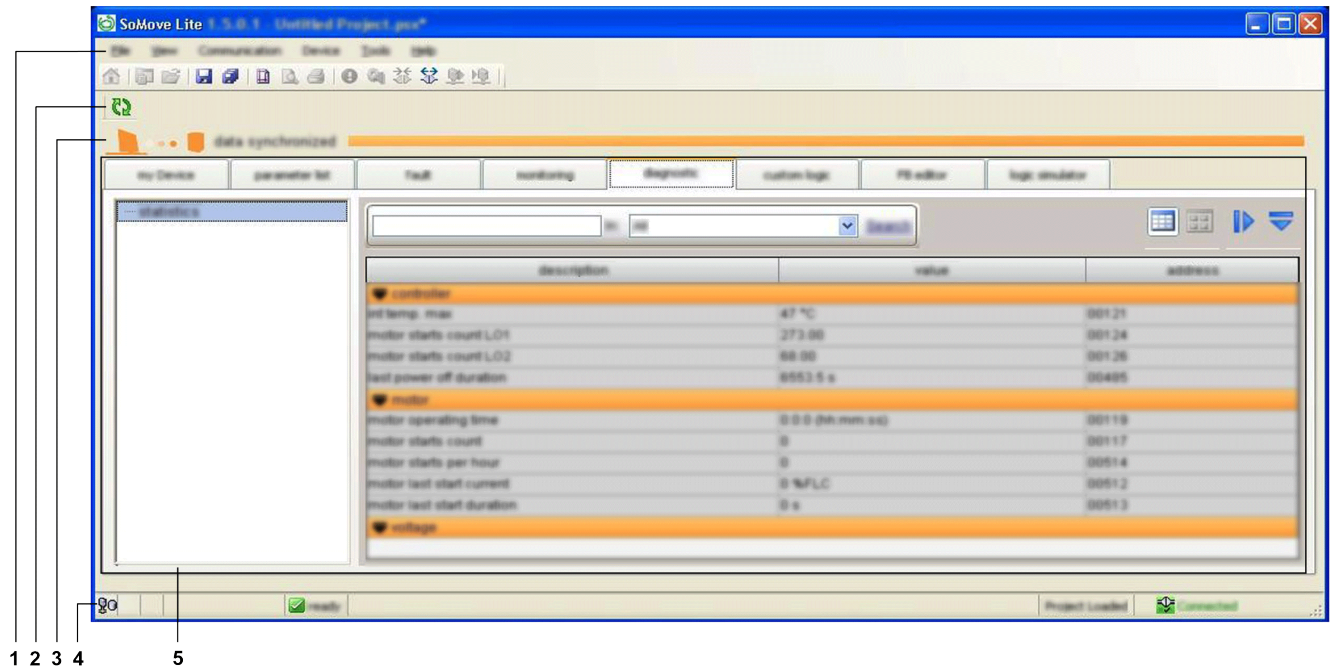

The working space is divided into the following zones:

|   |                                                  |
|---|--------------------------------------------------|
| 1 | menu bar, page 24                                |
| 2 | tool bar, page 24                                |
| 3 | synchronization data area, page 30               |
| 4 | status bar, page 30                              |
| 5 | tab zone (content depending on the selected tab) |

## Basic Mode Presentation

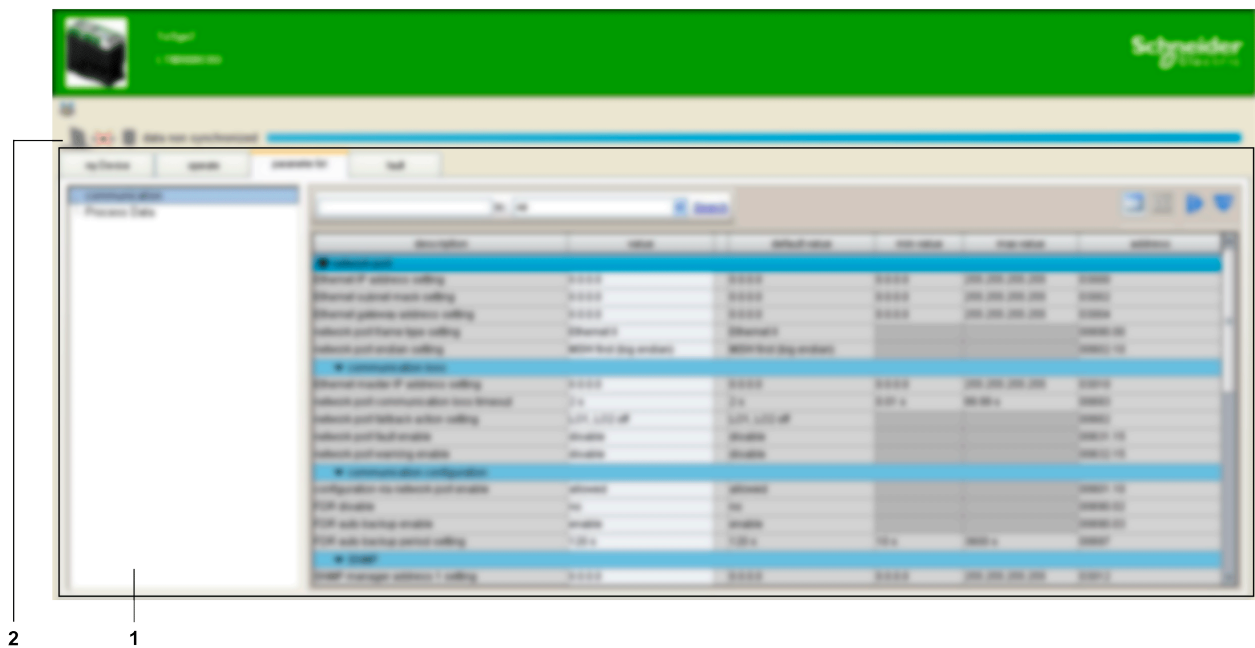

The working space is divided into the following zones:

|   |                                                  |
|---|--------------------------------------------------|
| 1 | tab zone (content depending on the selected tab) |
| 2 | synchronization data area, page 30               |

## Tab Zone

The table below shows the tab zone available for the basic mode and extended mode.

| Tab Name                          | Description                                                                                                | Basic Mode | Extended Mode |
|-----------------------------------|------------------------------------------------------------------------------------------------------------|------------|---------------|
| <b>my Device</b>                  | Tab displays the device modules and characteristics tab, page 32                                           | XX         | XX            |
| <b>operate</b>                    | Tab displays the operate data tab, page 33                                                                 | XX         | XX            |
| <b>parameter list</b>             | Tabs display the LTMR controller parameters and status                                                     | X          | XX            |
| <b>trip</b>                       |                                                                                                            | XX         | XX            |
| <b>monitoring</b>                 |                                                                                                            | –          | XX            |
| <b>diagnostic</b>                 |                                                                                                            | –          | XX            |
| <b>custom logic</b>               | Tab to create or modify a structured text program, page 233                                                | –          | XX            |
| <b>FB diagram</b>                 | Tab to create or modify an FBD program, page 285                                                           | –          | XX            |
| <b>logic simulator</b>            | Tab to simulate and debug a custom logic program before transferring it into the LTMR controller, page 297 | –          | XX            |
| – Not available                   |                                                                                                            |            |               |
| X Available with restrictions     |                                                                                                            |            |               |
| XX Available without restrictions |                                                                                                            |            |               |

## Menu Bar and Tool Bar

### Menu Bar

These functions are available with the extended mode using SoMove. The menu bar, at the top of the working space, is represented below:

File View Communication Device Tools Help

Only the functions specific to the LTMR controller are described here:

- **Device** menu that contains the TeSys T DTM specific functions according to the connection mode.
- **File** menu where the SoMove **Configuration Recovery** function is adapted to the TeSys T DTM.

Other menus are generic and are described in the *SoMove Lite online help*.

### Tool Bar

The tool bar, at the top of the working space directly beneath the menu bar, is specific to the DTM:

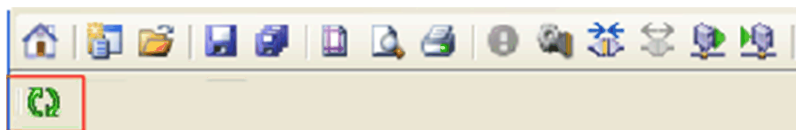

The buttons of the tool bar enable the user to directly access the main functions without using the menu bar.

The tool bar Refresh button  is used to refresh all parameters from the connected LTMR controller.

## Device Menu in the Disconnected Mode

| Submenu                               | Function                                | Description                                                                                                                                 |
|---------------------------------------|-----------------------------------------|---------------------------------------------------------------------------------------------------------------------------------------------|
| <b>Maintenance</b> , page 303         | <b>Firmware update</b>                  | Updates the firmware of the LTMR controller                                                                                                 |
| <b>custom logic</b> , page 233        | <b>New custom program</b>               | Creates a new empty structured text program                                                                                                 |
|                                       | <b>Open custom program</b>              | Opens the configuration directory to select an existing structured text program                                                             |
|                                       | <b>Save custom program</b>              | Saves the modifications made to the structured text program                                                                                 |
|                                       | <b>Save custom program as</b>           | Saves the modifications made to the structured text program to a chosen directory                                                           |
|                                       | <b>Close custom program</b>             | Closes the currently open structured text program                                                                                           |
|                                       | <b>Compile custom program</b>           | Compiles the currently open structured text program                                                                                         |
| <b>FB diagram</b> , page 272          | <b>New FB diagram</b>                   | Creates a new empty FBD program                                                                                                             |
|                                       | <b>Open FB diagram</b>                  | Opens the configuration directory to select an existing FBD program                                                                         |
|                                       | <b>Save FB diagram</b>                  | Saves the modifications made to the FBD program                                                                                             |
|                                       | <b>Save FB diagram as</b>               | Saves the modifications made to the FBD program to a chosen directory                                                                       |
|                                       | <b>Compile FB diagram to ST program</b> | Transforms the currently open FBD program to a structured text file                                                                         |
|                                       | <b>FBD editor</b>                       | Allows users to manipulate FBD blocks ( <b>Copy</b> , <b>Cut</b> , <b>Paste</b> , <b>Delete</b> , <b>Select all</b> , and <b>Unselect</b> ) |
|                                       | <b>View\Show grid</b>                   | Displays the grid lines                                                                                                                     |
|                                       | <b>View\Hide grid</b>                   | Hides the grid lines                                                                                                                        |
|                                       | <b>View\Properties windows</b>          | Displays the properties of the selected object                                                                                              |
|                                       | <b>View\Toolbox</b>                     | Displays the different categories of blocks                                                                                                 |
|                                       | <b>View\Zoom out</b>                    | Displays more of the program                                                                                                                |
|                                       | <b>View\Zoom in</b>                     | Displays the program in more detail                                                                                                         |
|                                       | <b>View\Zoom to</b>                     | Displays a customized view of the program (zooms to 50%, 75%, 100%, 150%, 200%, or 400%)                                                    |
|                                       | <b>Tools\Renumber links</b>             | Sorts link numbers in ascending order                                                                                                       |
|                                       | <b>Tools\Show all links</b>             | Displays which blocks are linked together                                                                                                   |
|                                       | <b>Tools\Hide all links</b>             | Provides a better overall view of the blocks                                                                                                |
| <b>Tools\Renumber Function Blocks</b> | Sorts block numbers in ascending order  |                                                                                                                                             |

## Device Menu in the Connected Mode

| Submenu                  | Function                    | Description                                                                                                                                               |
|--------------------------|-----------------------------|-----------------------------------------------------------------------------------------------------------------------------------------------------------|
| File transfer , page 203 | backup command              | Specific function of the LTMR Ethernet controller that copies the operating parameter file in the controller to the server                                |
|                          | restore command             | Specific function of the LTMR Ethernet controller that copies the operating parameter file on the server to the controller                                |
| Command , page 27        | run1                        | Activates the function associated to the output O.1                                                                                                       |
|                          | run2                        | Activates the function associated to the output O.2                                                                                                       |
|                          | stop                        | De-activates outputs                                                                                                                                      |
|                          | loc/rem                     | Switches between local and remote control mode                                                                                                            |
|                          | enter configuration         | Allows modification of main parameters in the connected mode                                                                                              |
|                          | exit configuration          | Exits the previous state.                                                                                                                                 |
| Reset , page 168         | trip reset                  | Resets detected trips                                                                                                                                     |
| password , page 28       | create password             | Creates a new password                                                                                                                                    |
|                          | modify password             | Modifies the password                                                                                                                                     |
|                          | delete password             | Deletes the password                                                                                                                                      |
| Maintenance              | Set Device Date & Time      | Synchronizes the date and time of the LTMR controller with the date and time of the PC                                                                    |
|                          | test , page 306             | Simulates a thermal trip                                                                                                                                  |
| custom logic , page 233  | New custom program          | Creates a new empty structured text program                                                                                                               |
|                          | Open custom program         | Opens the configuration directory to select an existing structured text program                                                                           |
|                          | Save custom program         | Saves the modifications made to the structured text program                                                                                               |
|                          | Save custom program as      | Saves the modifications made to the structured text program to a chosen directory                                                                         |
|                          | Close custom program        | Closes the currently open structured text program                                                                                                         |
|                          | Compile custom program      | Compiles the currently open structured text program                                                                                                       |
|                          | Device custom program to PC | Transfers a structured text program from the connected LTMR controller to the custom logic editor                                                         |
|                          | PC Custom program to device | Transfers a structured text program from the custom logic editor to the connected LTMR controller                                                         |
| FB diagram , page 272    | –                           | See the description of the <b>FB diagram</b> submenu in the disconnected mode                                                                             |
| clear , page 179         | clear all                   | Erases all parameters (history, statistics, network, etc.) except the Motor LO1 and LO2 Closings Count and Controller Internal Temperature Max parameters |
|                          | clear LTMR settings         | Restores the LTMR controller protection factory settings                                                                                                  |
|                          | clear network settings      | Restores the network port factory settings (address, etc.)                                                                                                |
|                          | clear statistics            | Erases statistics except the Motor LO1 and LO2 Closings Count and Controller Internal Temperature Max parameters                                          |
|                          | clear Th capa level         | Erases thermal information to bypass a thermal trip for emergency restart, page 78                                                                        |

## Configuration Recovery

The Configuration Recovery function allows loading a PowerSuite 2 project file using the TeSys T DTM in SoMove.

| Step | Action                                                                   |
|------|--------------------------------------------------------------------------|
| 1    | Click <b>File &gt; Open</b> .                                            |
| 2    | In the file type selection list, select <b>PS2 Configuration Files</b> . |
| 3    | Open the PowerSuite 2 project file <i>.impr</i> to recover.              |

**NOTE:** Missing information in the PowerSuite 2 project file can be completed during the recovery process if some parameters cannot be retrieved from the PowerSuite 2 project file.

More details about this function can be found in the *SoMove Lite online help*.

## Command Submenu

### Overview

This function is available with the extended mode using SoMove. The **command** submenu functions allow to:

- Control the LTMR controller logic outputs
- Choose between local and remote mode
- Enter the configuration mode

### Output Control Functions

Control functions **run1**, **run2**, and **stop** are used to control LTMR controller outputs O.1 and O.2.

The result of these functions depends on the following parameters:

- The motor operating mode
- The device status
- The control mode
- The channel setting

The following table lists the functions for each operating mode:., page 146

| Operating Mode | Assignment          | run1                    | run2                | stop                                             |
|----------------|---------------------|-------------------------|---------------------|--------------------------------------------------|
| Overload       | 2-wire (maintained) | No action               | No action           | No action                                        |
|                | 3-wire (impulse)    |                         |                     |                                                  |
| Independent    | 2-wire (maintained) | Control motor (O.1)     | Control O.2         | Stop motor (open O.1) and open O.2 while pressed |
|                | 3-wire (impulse)    | Start motor (close O.1) | Close O.2           | Stop motor (open O.1) and open O.2               |
| Reverser       | 2-wire (maintained) | Forward run             | Reverse run         | Stop while pressed                               |
|                | 3-wire (impulse)    | Start motor forward     | Start motor reverse | Stop motor                                       |
| Two-step       | 2-wire (maintained) | Control motor           | No action           | Stop while pressed                               |
|                | 3-wire (impulse)    | Start motor             | No action           | Stop motor                                       |
| Two-speed      | 2-wire (maintained) | Low speed control       | High speed control  | Stop while pressed                               |
|                | 3-wire (impulse)    | Low speed start         | High speed start    | Stop motor                                       |

### Local and Remote Control Function

The **loc/rem** control function is used to switch between the local and remote control modes.

This function does not depend on the operating mode.

## Configuration Mode

In the disconnected mode, the main parameters can be modified at any time.

In the connected mode, the **enter configuration** command allows entering the configuration mode to:

- Set the main parameters of the LTMR controller,
- Upload custom logic files.

The **exit configuration** command exits the configuration mode.

**NOTE:** If an incorrect parameter is set, the device ignores the **exit configuration** command and remains in the configuration mode. The LTMR configuration trip bit is set , page 64.

### ⚠ WARNING

#### UNINTENDED EQUIPMENT OPERATION

- The motor is forced to stop when activating the configuration mode.
- Consider the effect on all connected equipment before performing any operations.
- Never assume that the motor is in a certain motor state before commanding a change of state.
- Always positively confirm the motor state before acting on a motor.

**Failure to follow these instructions can result in death, serious injury, or equipment damage.**

## Password Management

### Overview

This function is available with the extended mode using SoMove, in the connected mode. It allows the creation of a password to avoid modification of LTMR parameters by unauthorized people. When a password is set, unauthorized users can view the displayed information, but cannot edit parameter values.

The password must be an integer from 0001 to 9999.

The password is also required to execute the SoMove **Store to Device** function.

### Creating a Password

| Step | Action                                                                                                   |
|------|----------------------------------------------------------------------------------------------------------|
| 1    | Click <b>Device &gt; password &gt; create password</b> .<br>The <b>create password</b> dialog box opens. |
| 2    | In the <b>enter new password</b> field, enter a new password.                                            |
| 3    | In the <b>confirm new password</b> field, enter the new password again.                                  |
| 4    | Click <b>OK</b> to activate the password and close the dialog box.                                       |

## Modifying a Password

| Step | Action                                                                                                   |
|------|----------------------------------------------------------------------------------------------------------|
| 1    | Click <b>Device &gt; password &gt; modify password</b> .<br>The <b>modify password</b> dialog box opens. |
| 2    | In the <b>old password</b> field, enter the current password.                                            |
| 3    | In the <b>enter new password</b> field, enter a new password.                                            |
| 4    | In the <b>confirm new password</b> field, enter the new password again.                                  |
| 5    | Click <b>OK</b> to activate the new password and close the dialog box.                                   |

## Deleting a Password

| Step | Action                                                                                                  |
|------|---------------------------------------------------------------------------------------------------------|
| 1    | Click <b>Device &gt; password &gt; delete password</b> .<br>The <b>delete password</b> dialog box open. |
| 2    | In the <b>old password</b> field, enter the current password.                                           |
| 3    | Click <b>OK</b> to delete the password and close the dialog box.                                        |

## Device Version Management

### Overview

This function is available with the basic mode or with the extended mode using SoMove.

A project is created for a specific firmware version of the LTMR controller and the LTME expansion module.

A project can be stored to a TeSys T device only when its firmware version is the same as the firmware version set in the project.

If it is not the case, the firmware version set in the project must be modified, and the content of the project must be converted to match the firmware version of the TeSys T device.

### Edit Topology Window

This procedure describes how to modify the device firmware in the project:

| Step | Action                                                                                                                             |
|------|------------------------------------------------------------------------------------------------------------------------------------|
| 1    | Select the <b>my Device</b> tab.                                                                                                   |
| 2    | Click the <b>Modify</b> button.                                                                                                    |
| 3    | Change the firmware version of the project to match the firmware version of your LTMR controller and/or the LTME expansion module. |
| 4    | Click the <b>Convert</b> button.                                                                                                   |

**NOTE:** If the firmware versions do not match when doing a **Store to device** command, the **Edit topology** window opens with the connected device firmware version selected.



- 1 LTMR controller status
- 2 Project status
- 3 Connection status
- 4 Synchronization data bar

## Basic Mode Description

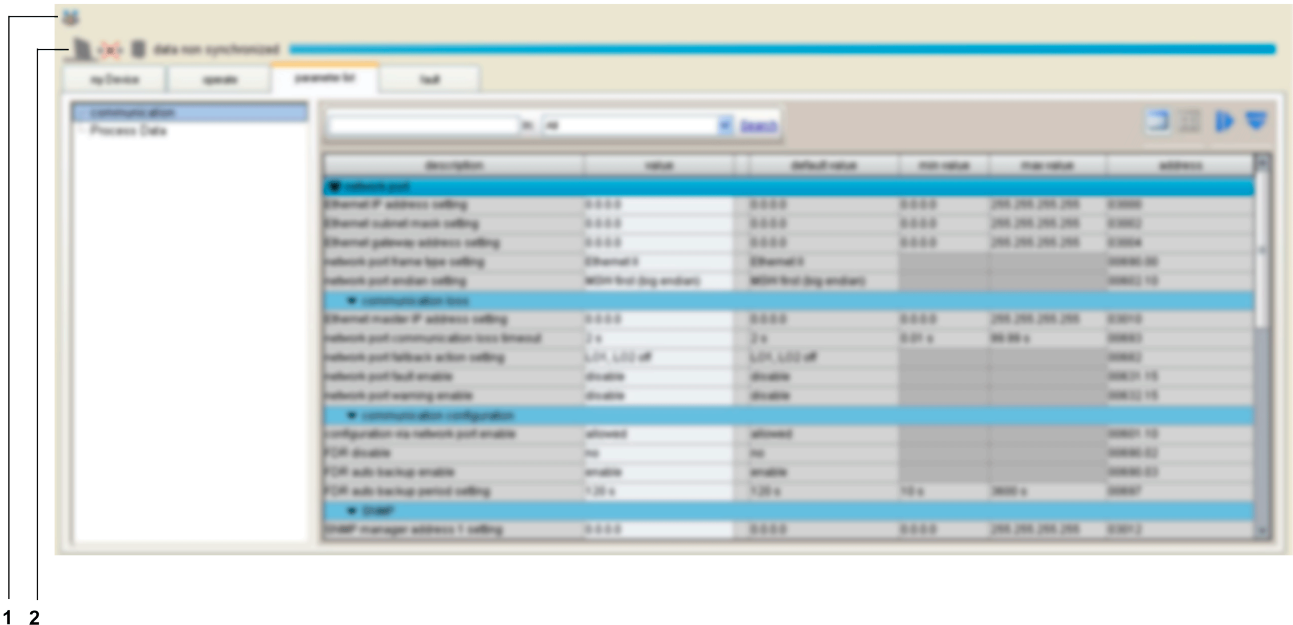

- 1 Connection status
- 2 Synchronization data bar

## LTMR Controller Status

This bar is available with the basic mode or with the extended mode using SoMove.

The TeSys T DTM displays the status of the LTMR controller. The status is available only in the connected mode.

The LTMR controller status can be one of the following:

- **in config.:** The LTMR controller is in the configuration mode, page 28.
- **trip:** The LTMR controller is in tripped state.
- **trip:** A trip is detected by the LTMR controller. Details of the trip are available in the **trip** tab, page 40.
- **running:** The LTMR controller detects that the motor is running.
- **starting:** The motor controlled by the LTMR controller is starting up.
- **alarm:** A alarm is detected by the LTMR controller. Details of the alarm are available in the **trip** tab, page 40.
- **ready:** No trip is detected by the LTMR controller.
- **Not ready:** The LTMR controller is in a temporary intermediate state.

## Project Status

This bar is available only with the extended mode using SoMove.

The status of the SoMove project can be:



- **Project Loaded:** A project is displayed in the working space.
- **No Project Open:** The project working space is empty.

For more information, see the section about working in the disconnected mode in the *SoMove Lite online help*.

## Connection Status

This bar is available with the basic mode or with the extended mode using SoMove.

The connection status indicates the connection mode between the LTMR controller and the PC:

|             | Disconnected Mode                                                                              | Disturbed Mode                                                                               | Connected Mode                                                                                |
|-------------|------------------------------------------------------------------------------------------------|----------------------------------------------------------------------------------------------|-----------------------------------------------------------------------------------------------|
| Icon        |  Disconnected |  Disturbed! |  Connected |
| Description | The LTMR controller is not connected to the PC.                                                | The connection between the LTMR controller and the PC is disturbed or lost.                  | The LTMR controller is connected to the PC.                                                   |

## Synchronization Data Area

This bar is available with the basic mode or with the extended mode using SoMove.

When the LTMR controller is in the connected mode, displayed data is automatically synchronized.

The synchronization data area indicates the synchronization status of the parameters between the LTMR controller and the PC:

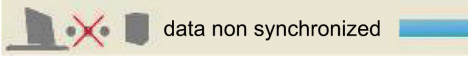
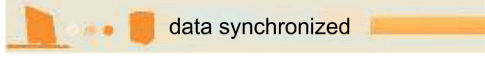
|             | Disconnected Mode                                                                                                                                                                                                                                                                                                                                                                                                                                                     | Connected Mode                                                                                                                                                                                                                                                                                                                                                                                                                                                  |
|-------------|-----------------------------------------------------------------------------------------------------------------------------------------------------------------------------------------------------------------------------------------------------------------------------------------------------------------------------------------------------------------------------------------------------------------------------------------------------------------------|-----------------------------------------------------------------------------------------------------------------------------------------------------------------------------------------------------------------------------------------------------------------------------------------------------------------------------------------------------------------------------------------------------------------------------------------------------------------|
| Icon        |  data non synchronized                                                                                                                                                                                                                                                                                                                                                             |  data synchronized                                                                                                                                                                                                                                                                                                                                                          |
| Description | <p>The LTMR controller is not synchronized with the PC:</p> <ul style="list-style-type: none"> <li>• Parameters list headers and synchronization data area are blue.</li> <li>• Parameters are not read in real time from the LTMR controller.</li> <li>• All settings can be modified as in configuration mode.</li> <li>• Modified parameters are written locally in the SoMove project on PC. The project should be saved to store these modifications.</li> </ul> | <p>The LTMR controller is synchronized with the PC:</p> <ul style="list-style-type: none"> <li>• Parameters list headers and synchronization data area are orange.</li> <li>• Parameters displayed are read in real time from the LTMR controller.</li> <li>• Some main settings can be modified only in configuration mode, page 28.</li> <li>• Modified parameters are written in real time to the LTMR controller without requiring confirmation.</li> </ul> |

## My Device

### Overview

This tab is available with the basic mode or with the extended mode using SoMove.

The **my Device** tab displays the main characteristics and modules of the selected LTMR controller.

## Description

This figure presents the information about the TeSys T motor management system.

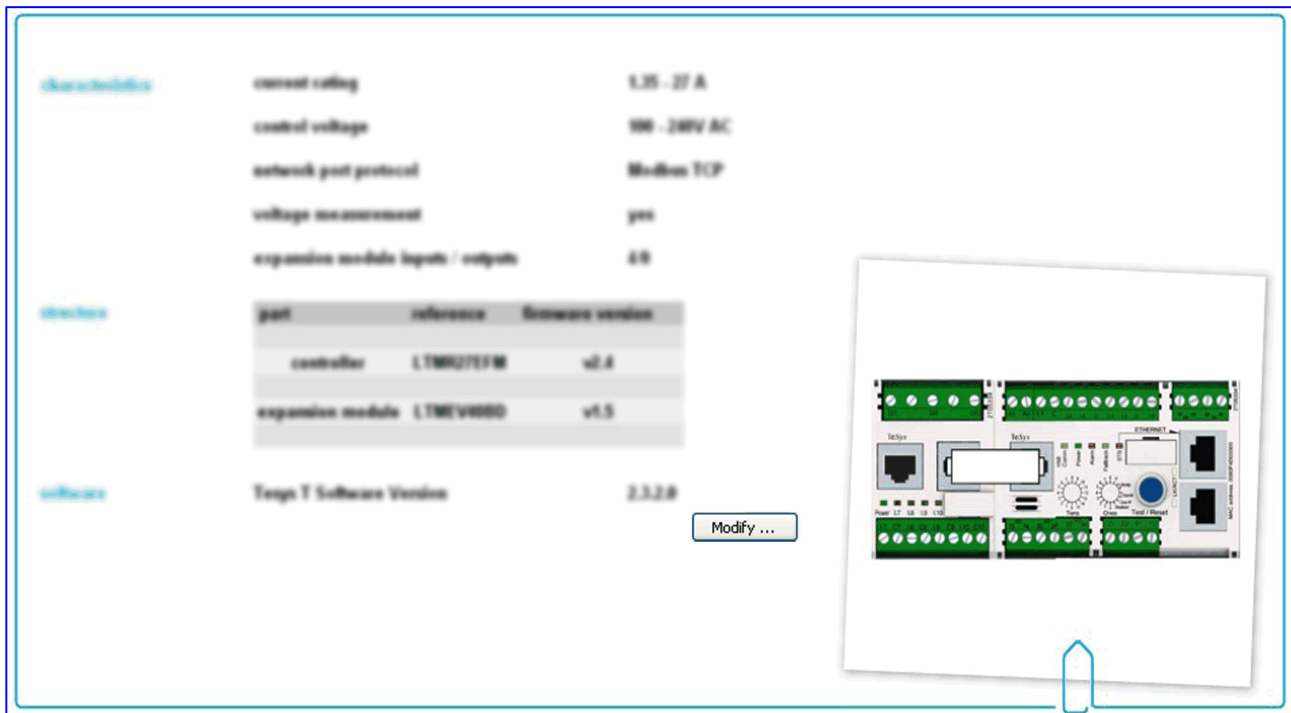

## Information Displayed

The **my Device** tab displays the following information about the TeSys T motor management system:

- Characteristics:
  - Current rating in Amperes
  - Control voltage: LTMR controller power supply in Volts
  - Network port protocol
  - Presence of voltage measurement
  - Number of logic inputs/outputs from the expansion module
- Structure of the TeSys T motor management system:
  - Reference number of each module
  - Firmware version of each module
  - **Modify** button to convert the current project firmware to match the connected product firmware, page 29
- Software:
  - Version of the TeSys T DTM
- Visual elements:
  - A picture represents the LTMR controller corresponding to the selected type.

## Operate

## Overview

This tab is available with the basic mode or with the extended mode using SoMove.

The **operate** tab is used to set and display the LTMR controller operating data.

## Description

The working space is divided in 3 zones:

- Monitoring: to list of parameters to observe in operate tab
- Input / Output Terminals: to simulate the activity on an Input / Output
- Settings: to change parameters online

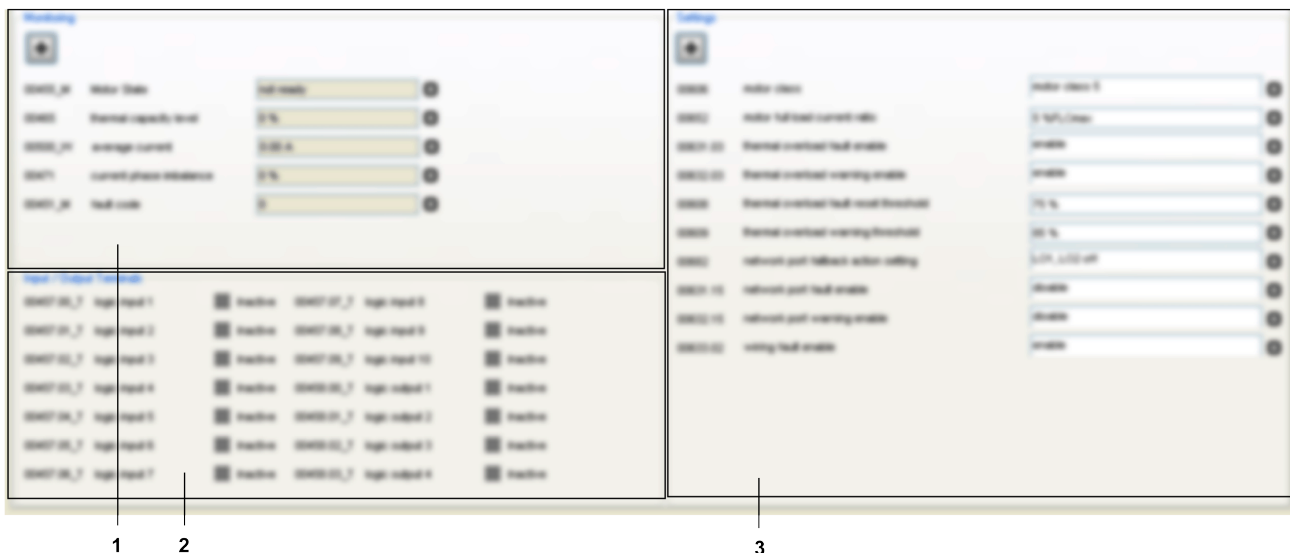

1 Monitoring area

2 Input / Output Terminals area

3 Settings area

## Monitoring Parameters

Add a parameter in the Monitoring area:

| Step | Action                                                                                                |
|------|-------------------------------------------------------------------------------------------------------|
| 1    | Click the  button. |
| 2    | Select the parameter to add in Monitoring.                                                            |
| 3    | Click the <b>ADD</b> button.<br>The parameter is displayed in the Monitoring area.                    |

To remove a parameter from the Monitoring area, click the button  in front of the parameter to remove.

## Input / Output Terminals Status

The table below shows the status of the input/output of the LTMR controller.

| Status Input/Output | Color Status Box | Descriptive Text |
|---------------------|------------------|------------------|
| Active              | Green            | Active           |
| Inactive            | Grey             | Inactive         |

## Settings Parameters

Add a parameter in the Settings area:

| Step | Action                                                                                              |
|------|-----------------------------------------------------------------------------------------------------|
| 1    | Click the  button. |
| 2    | Select the parameter to add in the Settings area.                                                   |
| 3    | Click the <b>ADD</b> button.<br>The parameter is displayed in the Settings area.                    |

To remove a parameter from the Settings area, click the button  in front of the parameter to remove.

## Tab Zone

### Overview

The following tabs display information in the same way.

| Tab Name                                                                  | Description                                            | Basic Mode | Extended Mode |
|---------------------------------------------------------------------------|--------------------------------------------------------|------------|---------------|
| <b>parameter list</b>                                                     | Tabs display the LTMR controller parameters and status | X          | XX            |
| <b>trip</b>                                                               |                                                        | XX         | XX            |
| <b>monitoring</b>                                                         |                                                        | –          | XX            |
| <b>diagnostic</b>                                                         |                                                        | –          | XX            |
| This topic presents the different parts of the screen and their function. |                                                        |            |               |
| – Not available                                                           |                                                        |            |               |
| X Available with restrictions                                             |                                                        |            |               |
| XX Available without restrictions                                         |                                                        |            |               |

## Description

This figure presents the common information in these tabs:

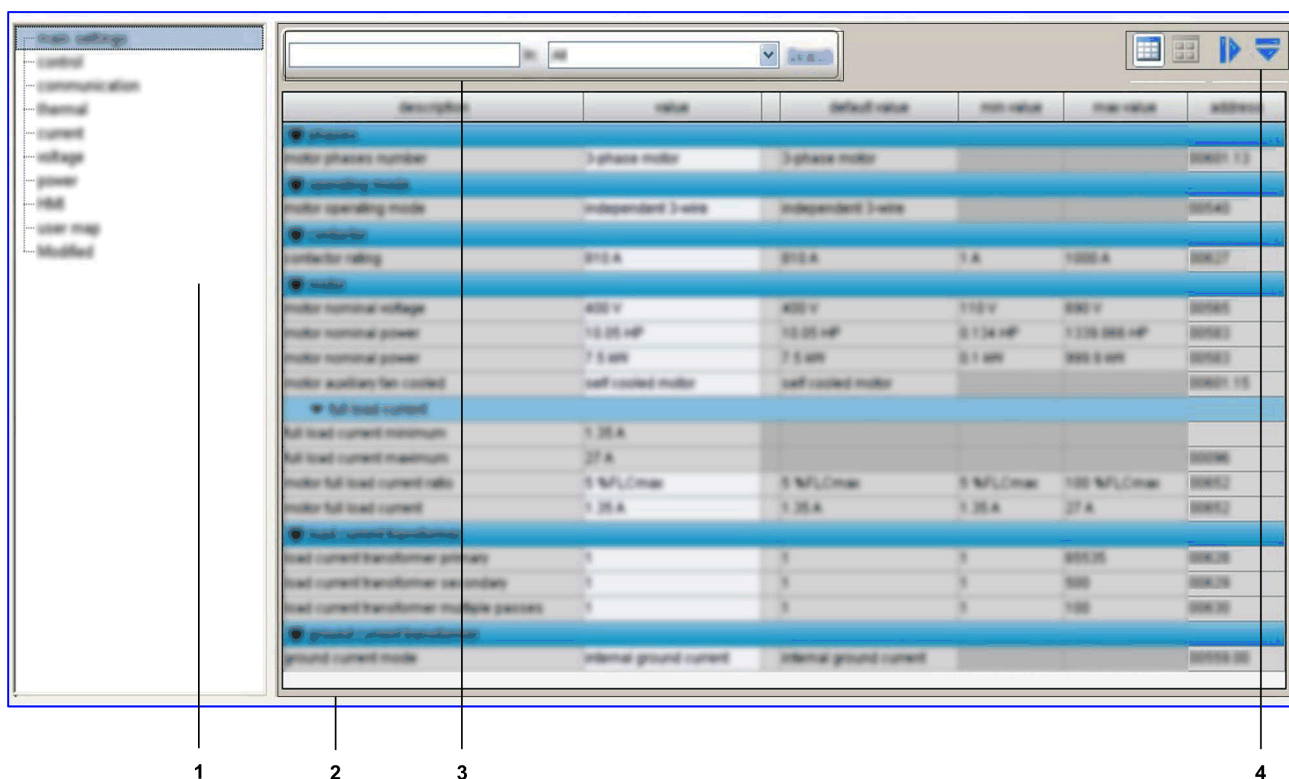

- 1 Tree view with items and subitems used to access to different tables of parameters.
- 2 Display area with the table of parameters.
- 3 Search function.
- 4 Display area tool bar.

## Tree View

The tree view is composed of items with or without subitems. Select an item or subitem in the tree to update the display area on the right. The displayed table includes the corresponding parameters grouped in families and subfamilies.

## Display Area Tool Bar

The view of the display area can be modified using the following buttons available on the top right corner of the display area:

| Button | Function     | Description                                                                                                                                                                 |
|--------|--------------|-----------------------------------------------------------------------------------------------------------------------------------------------------------------------------|
|        | Grid view    | Parameters are listed by family and subfamily in a table.                                                                                                                   |
|        | Sketch view  | Parameters are presented with diagrams (charts, drawings, etc.) to explain parameters settings in a user-friendly way. Currently, TeSys T DTM does not provide such a view. |
|        | Expand All   | Expand all families and subfamilies to display all parameters.                                                                                                              |
|        | Collapse All | Collapse all families and subfamilies in the display area.                                                                                                                  |

## Display Area in Grid View

| description                               | value       | default value | min value   | max value    | address  |
|-------------------------------------------|-------------|---------------|-------------|--------------|----------|
| motor full load current ratio             | 3 %FL.Cmax  |               |             |              | 00652    |
| <b>Ground current protection</b>          |             |               |             |              |          |
| ground current fault enable               | Enable      | Enable        |             |              | 00631.02 |
| internal ground current fault threshold   | 30 %FL.Cmin | 30 %FL.Cmin   | 20 %FL.Cmin | 100 %FL.Cmin | 00611    |
| internal ground current fault timeout     | 1 s         | 1 s           | 0.5 s       | 25 s         | 00610    |
| ground current warning enable             | Enable      | Enable        |             |              | 00632.02 |
| internal ground current warning threshold | 30 %FL.Cmin | 30 %FL.Cmin   | 20 %FL.Cmin | 100 %FL.Cmin | 00612    |
| <b>Phase</b>                              |             |               |             |              |          |
| ▶ Phase imbalance                         |             |               |             |              |          |
| ▼ Phase loss                              |             |               |             |              |          |
| current phase loss fault enable           | Enable      | Enable        |             |              | 00633.04 |
| current phase loss fault timeout          | 2 s         | 3 s           | 0.1 s       | 30 s         | 00555    |
| current phase loss warning enable         | Enable      | Enable        |             |              | 00634.04 |
| ▶ Phase reversal                          |             |               |             |              |          |
| ▶ Long Start protection                   |             |               |             |              |          |
| ▶ Jerk protection                         |             |               |             |              |          |
| ▶ Under Current protection                |             |               |             |              |          |
| ▶ Over Current protection                 |             |               |             |              |          |

1 2 3 4 5

1 Column header.

2 Parameter family.

3 Parameter subfamily.

4 Parameters:

- There is one line per parameter with some of its properties displayed in the different cells of the line.
- Content of white cells can be modified, gray cells are read-only.

5 Collapse/Expand icon: to collapse or expand a parameter family or subfamily, click the arrow of the corresponding colored line.

## Sorting Parameters

To sort the parameters according to the values in a column:

| Step | Action                             | Result                                                                                                                                                                                                                                                          | Header Example |
|------|------------------------------------|-----------------------------------------------------------------------------------------------------------------------------------------------------------------------------------------------------------------------------------------------------------------|----------------|
| 1    | Click a first time on the header.  | <ul style="list-style-type: none"> <li>• Parameters are sorted in ascending order of the values column (alphabetically or numerically) in their respective subfamily and family.</li> <li>• Header appears with an arrow pointing upwards.</li> </ul>           | address ▲      |
| 2    | Click a second time on the header. | <ul style="list-style-type: none"> <li>• Parameters are sorted in descending order of the values in the column (alphabetically or numerically) in their respective subfamily and family.</li> <li>• Header appears with an arrow pointing downwards.</li> </ul> | address ▼      |
| 3    | Click a third time on the header.  | <ul style="list-style-type: none"> <li>• Parameters are displayed in their initial order.</li> <li>• Header appears according to its initial representation.</li> </ul>                                                                                         | address        |

## Modifying the Order of Columns

To modify the order of columns in the display:

| Step | Action                                   |
|------|------------------------------------------|
| 1    | Click the header of the column.          |
| 2    | Drag the column to the correct location. |

## Search Function

To find a specific text in a displayed table:

| Step | Action                                                                                                                                                                                                                                                                                              |
|------|-----------------------------------------------------------------------------------------------------------------------------------------------------------------------------------------------------------------------------------------------------------------------------------------------------|
| 1    | In the first field of the search bar at the top of the display area, enter the characters to search for (part of word, code, unit, etc.).                                                                                                                                                           |
| 2    | Select the column to search from the list.<br>If you select the <b>All</b> option, the search is performed in all columns of the table.                                                                                                                                                             |
| 3    | Click <b>Search</b> : <ul style="list-style-type: none"> <li>The first matching text found is highlighted.</li> <li>To search for other instances, click again the <b>Search</b> button.</li> <li>If no matching text is found, the color of characters in the search field becomes red.</li> </ul> |

## Parameter List

### Overview

This tab is available with the basic mode but with restrictions or with the extended mode using SoMove.

The **parameter list** tab is used to set and display the LTMR controller setting parameters.

Only parameter values in the white entry fields can be modified.

### Description

For a global description of the tab, refer to the tab zone description, page 35.

| description                               | value       | default value | min value   | max value    | address  |
|-------------------------------------------|-------------|---------------|-------------|--------------|----------|
| motor full load current ratio             | 3 %FL.Cmax  |               |             |              | 00652    |
| <b>Ground current protection</b>          |             |               |             |              |          |
| ground current fault enable               | Enable      | Enable        |             |              | 00631.02 |
| internal ground current fault threshold   | 30 %FL.Cmax | 30 %FL.Cmax   | 20 %FL.Cmax | 100 %FL.Cmax | 00611    |
| internal ground current fault timeout     | 1 s         | 1 s           | 0.5 s       | 25 s         | 00610    |
| ground current warning enable             | Enable      | Enable        |             |              | 00632.02 |
| internal ground current warning threshold | 30 %FL.Cmax | 30 %FL.Cmax   | 20 %FL.Cmax | 100 %FL.Cmax | 00612    |
| <b>Phase</b>                              |             |               |             |              |          |
| ▶ Phase imbalance                         |             |               |             |              |          |
| ▼ Phase loss                              |             |               |             |              |          |
| current phase loss fault enable           | Enable      | Enable        |             |              | 00633.04 |
| current phase loss fault timeout          | 2 s         | 3 s           | 0.1 s       | 30 s         | 00555    |
| current phase loss warning enable         | Enable      | Enable        |             |              | 00634.04 |
| ▶ Phase reversal                          |             |               |             |              |          |
| ▶ Long Start protection                   |             |               |             |              |          |
| ▶ Jem protection                          |             |               |             |              |          |
| ▶ Under Current protection                |             |               |             |              |          |
| ▶ Over Current protection                 |             |               |             |              |          |

- 1 Parameter value column.
- 2 Modification column: a pen appears if the corresponding value is different from its factory settings.
- 3 Modifiable parameter factory settings column.
- 4 Numerical parameter minimum value column.
- 5 Numerical parameter maximum value column.
- 6 Address column: displays the parameter register and bit number when relevant.

## Setting Numerical Values

There are 2 ways to set a parameter with a numerical value:

- direct entry of the numerical value
- value selection using the spin buttons

To set a numerical value by direct entry:

| Step | Action                                                                                                                                                                                                                                                                                                                                                                                                                                                                                                                                                                                                                                                                                                                                                                                                |
|------|-------------------------------------------------------------------------------------------------------------------------------------------------------------------------------------------------------------------------------------------------------------------------------------------------------------------------------------------------------------------------------------------------------------------------------------------------------------------------------------------------------------------------------------------------------------------------------------------------------------------------------------------------------------------------------------------------------------------------------------------------------------------------------------------------------|
| 1    | Select an item from the tree view.                                                                                                                                                                                                                                                                                                                                                                                                                                                                                                                                                                                                                                                                                                                                                                    |
| 2    | Type the parameter value in the white entry field.                                                                                                                                                                                                                                                                                                                                                                                                                                                                                                                                                                                                                                                                                                                                                    |
| 3    | Press ENTER to validate the new parameter value entry: <ul style="list-style-type: none"> <li>• If the value is between the minimum and maximum values and consistent with the resolution interval, the parameter value is set to the new value.</li> <li>• If the value is between the minimum and maximum values but not consistent with the resolution interval, the parameter value is rounded up to an authorized value.</li> <li>• If the value is not between the minimum and maximum values:               <ul style="list-style-type: none"> <li>◦ If the value requested is below the minimum value, the parameter value is set to the minimum value.</li> <li>◦ If the value requested is above the maximum value, the parameter value is set to the maximum value.</li> </ul> </li> </ul> |

To set a numerical value with the spin buttons:

| Step | Action                                                                                                                                                                     |
|------|----------------------------------------------------------------------------------------------------------------------------------------------------------------------------|
| 1    | Select an item from the tree view.                                                                                                                                         |
| 2    | Click in the white entry field of the parameter to set it with the spin buttons that are displayed on the right of the entry field.                                        |
| 3    | Increase or decrease the value with the spin buttons. You cannot increase the value above the maximum authorized value, or decrease it below the minimum authorized value. |

## Editing a String

To set a string parameter:

| Step | Action                                    |
|------|-------------------------------------------|
| 1    | Select an item from the tree view.        |
| 2    | Type the string in the white entry field. |
| 3    | Press ENTER to validate.                  |

## Selecting Values in a List

To select a value in a list:

| Step | Action                                                                                                                                  |
|------|-----------------------------------------------------------------------------------------------------------------------------------------|
| 1    | Select an item from the tree view.                                                                                                      |
| 2    | Click in the white entry field of the parameter to set it with the down arrow button that is displayed on the right of the entry field. |

| Step | Action                                                       |
|------|--------------------------------------------------------------|
| 3    | Click the arrow button to open the drop-down selection list. |
| 4    | Select a value.                                              |
| 5    | Press ENTER to validate the selection.                       |

## Setting User Map Addresses (For Extended Mode Only)

To set user map addresses:

| Step | Action                                                                                                                                                                                                                                                       |
|------|--------------------------------------------------------------------------------------------------------------------------------------------------------------------------------------------------------------------------------------------------------------|
| 1    | Select <b>user map</b> in the tree view: <ul style="list-style-type: none"> <li>Addresses are ranked from 0 to 98 and correspond to registers 800–898.</li> <li>Addresses are divided into 4 groups.</li> </ul>                                              |
| 2    | Enter an address value in the table: <ul style="list-style-type: none"> <li>The entered address must be in the decimal format.</li> <li>Enter the address 0 to remove the address from the user map.</li> </ul>                                              |
| 3    | Press ENTER to validate the new address: <ul style="list-style-type: none"> <li>If the address is accepted, the address is added to the user map.</li> <li>If the address is not accepted, the previous accepted address is kept in the user map.</li> </ul> |

**NOTE:** For more information about the user map variable, refer to the relevant section.

## Setting Process Channel Mode

For LTMR Ethernet controller you can select the profile:

- E\_TeSysT Fast Access
- EIOS\_TeSysT

Each profile contains a limited list of registers whose values are returned directly in the variables table of the IO scanner controller:

- registers for E\_TeSysT Fast Access , page 190
- registers for EIOS\_TeSysT , page 191

Set the parameter **UNIT ID** to 1 in the I/O scanning configuration of the controller.

## Trip

### Overview

This tab is available with the basic mode or with the extended mode using SoMove.

The **trip** tab displays the detected trips or alarms related to the connected LTMR controller.

The data in this tab is only significant in the connected mode.

### Description

For a global description of the tab, refer to the tab zone description, page 35.





This tab displays:

- The status of detected trips and alarms in the LTMR controller:
  - The trip and alarm statuses
  - the trip and alarm counters, page 66
  - History of the detected trips, page 69

## Status Item in Tree View

The table in the display area shows the trips and alarms that can be detected by the LTMR controller. In the connected mode, it displays in real time the status of the trips and alarms detected by the connected LTMR controller.

The different columns provide the following information:

| Column             | Information                                                                                                                                                                                                                                                                                                                                                                                                                                                                                |
|--------------------|--------------------------------------------------------------------------------------------------------------------------------------------------------------------------------------------------------------------------------------------------------------------------------------------------------------------------------------------------------------------------------------------------------------------------------------------------------------------------------------------|
| <b>description</b> | Name of the trip or alarm.                                                                                                                                                                                                                                                                                                                                                                                                                                                                 |
| <b>trip</b>        | Detected trip status: <ul style="list-style-type: none"> <li>• : A red light indicates that the cause of the trip is not resolved.</li> <li>• : A grayed out light indicates that there is no trip.</li> <li>• When a trip detection is disabled, no light is displayed in the corresponding cell.</li> </ul>            |
| <b>trip count</b>  | Number of detected trips since the last clear all or clear statistics action.                                                                                                                                                                                                                                                                                                                                                                                                              |
| <b>alarm</b>       | Detected alarm status: <ul style="list-style-type: none"> <li>• : An orange light indicates that the cause of the alarm is not resolved.</li> <li>• : A grayed out light indicates that there is no alarm.</li> <li>• When a alarm detection is disabled, no light is displayed in the corresponding cell.</li> </ul> |
| <b>alarm count</b> | Number of detected alarms since the last clear all or clear statistics action.                                                                                                                                                                                                                                                                                                                                                                                                             |

## Trip History Item in Tree View

The LTMR controller stores the history of the 5 last detected trips. Each record contains monitoring data when the trip occurred, this helps investigation about the trip cause. Trip N-0 contains the most recent trip record, and trip N-4 contains the oldest retained trip record.

For each trip, the following information is displayed:

- The trip code and its description
- Date and time of trip detection
- Value of important settings when the trip occurred
- Value of measurements recorded when the trip was detected, page 69

## Monitoring

### Overview

This tab is available with the extended mode using SoMove.







The **monitoring** tab is used to monitor in real time the status and measurements of the connected LTMR controller.

The data in this tab are only significant in the connected mode.

## Description

For a global description of the tab, refer to the tab zone description, page 35.

The following table lists the available tree view items in the **monitoring** tab and their functions:

| Tree View Item           | Description                                                                                                                                                                                                                                                                                                                                                                                                                                                                                                                                                                                                                                                                                                                                                                                                                                               |
|--------------------------|-----------------------------------------------------------------------------------------------------------------------------------------------------------------------------------------------------------------------------------------------------------------------------------------------------------------------------------------------------------------------------------------------------------------------------------------------------------------------------------------------------------------------------------------------------------------------------------------------------------------------------------------------------------------------------------------------------------------------------------------------------------------------------------------------------------------------------------------------------------|
| <b>device status</b>     | <p>Displays general information about the LTMR controller status.</p> <p>This status is represented by:</p> <ul style="list-style-type: none"> <li>• Values</li> <li>• Texts</li> <li>• Colored lights: <ul style="list-style-type: none"> <li>◦ : A red light indicates a major problem in the system.</li> <li>◦ : An orange light indicates a minor problem in the system.</li> <li>◦ : A green light indicates a normal operation.</li> <li>◦ : A gray light indicates an inactive status.</li> </ul> </li> </ul> |
| <b>I/O</b>               | <p>Displays the input/output status of the LTMR controller.</p> <p>The status of each input and output is represented by a colored light:</p> <ul style="list-style-type: none"> <li>• : A green light indicates that the logic inputs/outputs are on.</li> <li>• : A gray light indicates that the logic inputs/outputs are off.</li> </ul>                                                                                                                                                                                                                                                                                                                                            |
| <b>user map</b>          | <p>Displays the values of the LTMR controller user map addresses:</p> <ul style="list-style-type: none"> <li>• Only the valid addresses are displayed (addresses different from 0).</li> <li>• The displayed value is the content of the related register only in the decimal format.</li> </ul> <p>A specific interpretation is necessary in the 2 following cases:</p> <ul style="list-style-type: none"> <li>◦ If the register is a set of 16 bits (all the bits are merged in value)</li> <li>◦ If the register is a part of a double registers (LSW or MSW, depending on endianness)</li> </ul>                                                                                                                                                                                                                                                      |
| <b>metering</b>          | <p>Displays the LTMR controller metering values grouped by type (thermal, current, voltage, or power).</p>                                                                                                                                                                                                                                                                                                                                                                                                                                                                                                                                                                                                                                                                                                                                                |
| <b>custom monitoring</b> | <p>Allows the user to select measures from tree list, and displays them in a widget representation.</p> <p>In the connected mode, the values are automatically refreshed in real time.</p>                                                                                                                                                                                                                                                                                                                                                                                                                                                                                                                                                                                                                                                                |

## Custom Monitoring

You can select a number of parameters in the tree view to display the corresponding value with widgets in the display area.

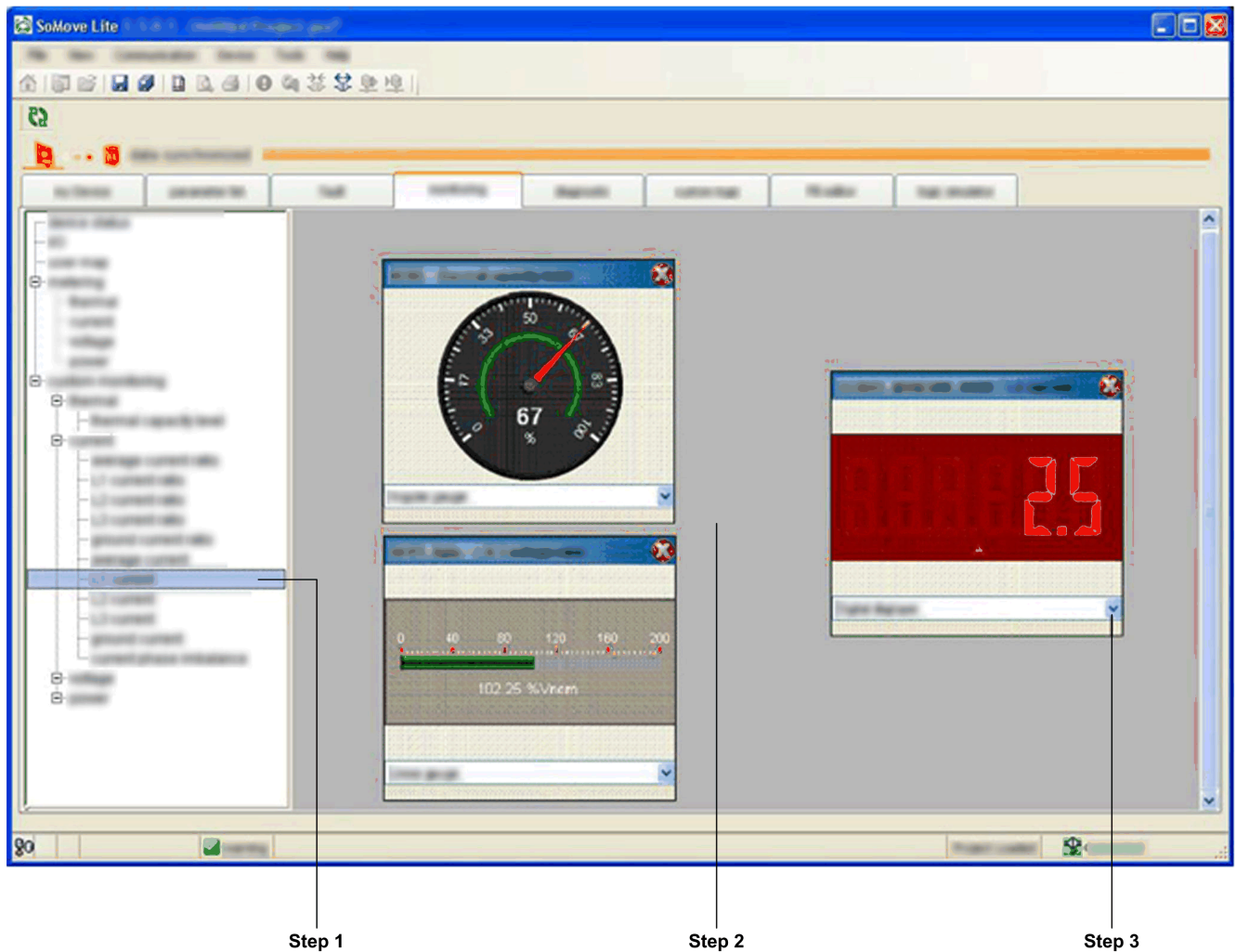

To select a parameter displayed by widgets in the **custom monitoring** display area proceed as follows:

| Step | Action                                                                                                                                                                        |
|------|-------------------------------------------------------------------------------------------------------------------------------------------------------------------------------|
| 1    | Select the parameter to display in the tree view on the left. Multiple parameters can be selected and organized simultaneously in the display area.                           |
| 2    | Click the display area on the right, the value of the selected parameter is displayed by a widget at the click location. The values are automatically refreshed in real time. |
| 3    | Modify the widget type in the selection list.                                                                                                                                 |

## Types of Widgets

Depending on the selected parameter, 3 types of widgets can be displayed:

| Type   | Angular Gauge | Linear Gauge | Digital Display |
|--------|---------------|--------------|-----------------|
| Widget |               |              |                 |

# Diagnostic

## Overview

This tab is available with the extended mode using SoMove.

The **diagnostic** tab displays statistics of the connected LTMR controller.

The data in this tab is only significant in the connected mode.

## Description

For a global description of this tab, refer to the tab zone description, page 35.

This table lists tree view items available in the **diagnostic** tab and their functions:

| Tree View Item    | Description                                                                                                                           |
|-------------------|---------------------------------------------------------------------------------------------------------------------------------------|
| <b>Eth</b>        | Monitors the Ethernet statistics of LTMR Ethernet controller , page 202.                                                              |
| <b>statistics</b> | Displays: <ul style="list-style-type: none"><li>• The LTMR controller history, page 55</li><li>• The motor history, page 70</li></ul> |

# Metering and Monitoring Functions

## Overview

The LTMR controller provides measurement, metering, and monitoring in support of the current, temperature, and ground current trip protection functions. When connected to an LTME expansion module, the LTMR controller also provides voltage and power measurement functions.

## Measurement

### Overview

The LTMR controller uses these measurements to perform protection, control, monitoring, and logic functions. Each measurement is detailed in this section.

The measurements can be accessed via:

- PC running SoMove with the TeSys T DTM
- HMI device
- PLC via the network port

## Line Currents

### Description

The LTMR controller measures line currents and provides the value of each phase in amperes and as a percentage of Full Load Current (FLC).

The line currents function returns the rms value in amperes of the phase currents from the 3 CT inputs:

- L1: phase 1 current
- L2: phase 2 current
- L3: phase 3 current

The LTMR controller performs true rms calculations for line currents up to the 7th harmonic.

Single-phase current is measured from L1 and L3.

### Line Current Characteristics

The line currents function has the following characteristics:

| Characteristic   | Value                                                                                                                   |
|------------------|-------------------------------------------------------------------------------------------------------------------------|
| Unit             | A                                                                                                                       |
| Accuracy         | <ul style="list-style-type: none"> <li>• +/- 1 % for 8 A and 27 A models</li> <li>• +/- 2 % for 100 A models</li> </ul> |
| Resolution       | 0.01 A                                                                                                                  |
| Refresh interval | 100 ms                                                                                                                  |

## Line Current Ratio

The L1, L2 and L3 current ratio parameter provides the phase current as a percentage of FLC.

## Line Current Ratio Formulas

The line current value for the phase is compared to the FLC parameter setting, where FLC is FLC1 or FLC2, whichever is active at that time.

| Calculated Measurement                                                                                                                                                                         | Formula                |
|------------------------------------------------------------------------------------------------------------------------------------------------------------------------------------------------|------------------------|
| Line current ratio                                                                                                                                                                             | $100 \times I_n / FLC$ |
| Where:                                                                                                                                                                                         |                        |
| <ul style="list-style-type: none"> <li>• FLC = FLC1 or FLC2 parameter setting, whichever is active at the time</li> <li>• <math>I_n</math> = L1, L2, or L3 current value in amperes</li> </ul> |                        |

## Line Current Ratio Characteristics

The line current ratio function has the following characteristics:

| Characteristic   | Value                                     |
|------------------|-------------------------------------------|
| Unit             | % of FLC                                  |
| Accuracy         | See Line Current Characteristics, page 45 |
| Resolution       | 1% FLC                                    |
| Refresh interval | 100 ms                                    |

## Ground Current

### Description

The LTMR controller measures ground currents and provides values in Amperes and as a percentage of FLC<sub>min</sub>.

- The internal ground current ( $I_{gr\Sigma}$ ) is calculated by the LTMR controller from the 3 line currents measured by the load current transformers. It reports 0 when the current falls below 10 % of FLC<sub>min</sub>.
- The external ground current ( $I_{gr}$ ) is measured by the external ground current sensor connected to Z1 and Z2 terminals.

## Configurable Parameters

The control channel configuration has the following configurable parameter settings:

| Parameter            | Setting Range                                                                                                                                           | Factory Setting |
|----------------------|---------------------------------------------------------------------------------------------------------------------------------------------------------|-----------------|
| Ground Current Mode  | <ul style="list-style-type: none"> <li>• Internal</li> <li>• External</li> </ul>                                                                        | Internal        |
| Ground Current Ratio | <ul style="list-style-type: none"> <li>• None</li> <li>• 100:1</li> <li>• 200:1.5</li> <li>• 1000:1</li> <li>• 2000:1</li> <li>• Other Ratio</li> </ul> | None            |

| Parameter           | Setting Range | Factory Setting |
|---------------------|---------------|-----------------|
| Ground CT Primary   | • 1...65,535  | 1               |
| Ground CT Secondary | • 1...65,535  | 1               |

## External Ground Current Formula

The external ground current value depends on the parameter settings:

| Calculated Measurement  | Formula                                                                                           |
|-------------------------|---------------------------------------------------------------------------------------------------|
| External ground current | $(\text{Current through Z1-Z2}) \times (\text{Ground CT Primary}) / (\text{Ground CT Secondary})$ |

## Ground Current Characteristics

The ground current function has the following characteristics:

| Characteristic   | Value                                          |                                      |                                      |
|------------------|------------------------------------------------|--------------------------------------|--------------------------------------|
|                  | Internal Ground Current ( $I_{gr\Sigma}$ )     | External Ground Current ( $I_{gr}$ ) |                                      |
| Unit             | A                                              | A                                    |                                      |
| Accuracy         |                                                |                                      |                                      |
| LTMR 08xxx       | $I_{gr} \geq 0.3 \text{ A}$                    | +/- 10 %                             | The greater of +/- 5 % or +/- 0.01 A |
|                  | $0.2 \text{ A} \leq I_{gr} \leq 0.3 \text{ A}$ | +/- 15 %                             |                                      |
|                  | $0.1 \text{ A} \leq I_{gr} \leq 0.2 \text{ A}$ | +/- 20 %                             |                                      |
|                  | $I_{gr} < 0.1 \text{ A}$                       | N/A <sup>(1)</sup>                   |                                      |
| LTMR 27xxx       | $I_{gr} \geq 0.5 \text{ A}$                    | +/- 10 %                             |                                      |
|                  | $0.3 \text{ A} \leq I_{gr} \leq 0.5 \text{ A}$ | +/- 15 %                             |                                      |
|                  | $0.2 \text{ A} \leq I_{gr} \leq 0.3 \text{ A}$ | +/- 20 %                             |                                      |
|                  | $I_{gr} < 0.2 \text{ A}$                       | N/A <sup>(1)</sup>                   |                                      |
| LTMR 100xxx      | $I_{gr} \geq 1.0 \text{ A}$                    | +/- 10 %                             |                                      |
|                  | $0.5 \text{ A} \leq I_{gr} \leq 1.0 \text{ A}$ | +/- 15 %                             |                                      |
|                  | $0.3 \text{ A} \leq I_{gr} \leq 0.5 \text{ A}$ | +/- 20 %                             |                                      |
|                  | $I_{gr} < 0.3 \text{ A}$                       | N/A <sup>(1)</sup>                   |                                      |
| Resolution       | 0.01 A                                         | 0.01 A                               |                                      |
| Refresh interval | 100 ms                                         | 100 ms                               |                                      |

## Ground Current Ratio

The Ground Current Ratio parameter provides the ground current value as a percentage of FLCmin.

## Ground Current Ratio Formulas

The ground current value is compared to FLCmin.

| Calculated Measurement | Formula                                            |
|------------------------|----------------------------------------------------|
| Ground current ratio   | $100 \times \text{ground current} / \text{FLCmin}$ |

(1) For currents of this magnitude or lower, the internal ground current function should not be used. Instead, use external ground current transformers.

## Ground Current Ratio Characteristics

The ground current ratio function has the following characteristics:

| Characteristic   | Value                                     |
|------------------|-------------------------------------------|
| Unit             | 0...2,000 % of FLCmin                     |
| Accuracy         | See Ground Current Characteristics, above |
| Resolution       | 0.1 % FLCmin                              |
| Refresh interval | 100 ms                                    |

## Average Current

### Description

The LTMR controller calculates average current and provides the value for phase in amperes and as a percentage of FLC.

The average current function returns the rms value of the average current.

### Average Current Formulas

The LTMR controller calculates the average current using the measured line currents. The measured values are internally summed using the following formula:

| Calculated Measurement              | Formula                        |
|-------------------------------------|--------------------------------|
| Average current, three phase motor  | $I_{avg} = (L1 + L2 + L3) / 3$ |
| Average current, single-phase motor | $I_{avg} = (L1 + L3) / 2$      |

### Average Current Characteristics

The average current function has the following characteristics:

| Characteristic   | Value                                                                                                                   |
|------------------|-------------------------------------------------------------------------------------------------------------------------|
| Unit             | A                                                                                                                       |
| Accuracy         | <ul style="list-style-type: none"> <li>• +/- 1 % for 8 A and 27 A models</li> <li>• +/- 2 % for 100 A models</li> </ul> |
| Resolution       | 0.01 A                                                                                                                  |
| Refresh interval | 100 ms                                                                                                                  |

### Average Current Ratio

The Average Current Ratio parameter provides the average current value as a percentage of FLC.

### Average Current Ratio Formulas

The average current value for the phase is compared to the FLC parameter setting, where FLC is FLC1 or FLC2, whichever is active at that time.

| Calculated Measurement                                                                                                                                                                       | Formula                    |
|----------------------------------------------------------------------------------------------------------------------------------------------------------------------------------------------|----------------------------|
| Average current ratio                                                                                                                                                                        | $100 \times I_{avg} / FLC$ |
| Where:                                                                                                                                                                                       |                            |
| <ul style="list-style-type: none"> <li>• FLC = FLC1 or FLC2 parameter setting, whichever is active at the time</li> <li>• <math>I_{avg}</math> = average current value in amperes</li> </ul> |                            |

## Average Current Ratio Characteristics

The average current ratio function has the following characteristics:

| Characteristic   | Value                                      |
|------------------|--------------------------------------------|
| Unit             | % of FLC                                   |
| Accuracy         | See Average Current Characteristics, above |
| Resolution       | 1 % FLC                                    |
| Refresh interval | 100 ms                                     |

## Current Phase Imbalance

### Description

The current phase imbalance function measures the maximum percentage of deviation between the average current and the individual phase currents.

### Formulas

The current phase imbalance measurement is based on imbalance ratio calculated from the following formulas:

| Calculated Measurement                         | Formula                                          |
|------------------------------------------------|--------------------------------------------------|
| Imbalance ratio of current in phase 1 (in %)   | $I_{i1} = ( L1 - I_{avg}  \times 100) / I_{avg}$ |
| Imbalance ratio of current in phase 2 (in %)   | $I_{i2} = ( L2 - I_{avg}  \times 100) / I_{avg}$ |
| Imbalance ratio of current in phase 3 (in %)   | $I_{i3} = ( L3 - I_{avg}  \times 100) / I_{avg}$ |
| Current imbalance ratio for three phase (in %) | $I_{imb} = \text{Max}(I_{i1}, I_{i2}, I_{i3})$   |

## Characteristics

The line current imbalance function has the following characteristics:

| Characteristic   | Value                                                                                                                   |
|------------------|-------------------------------------------------------------------------------------------------------------------------|
| Unit             | %                                                                                                                       |
| Accuracy         | <ul style="list-style-type: none"> <li>• +/- 1.5% for 8 A and 27 A models</li> <li>• +/- 3% for 100 A models</li> </ul> |
| Resolution       | 1%                                                                                                                      |
| Refresh interval | 100 ms                                                                                                                  |

## Thermal Capacity Level

### Description

The thermal capacity level function uses two thermal models to calculate the number of thermal capacity used: one for copper stator and rotor windings of the motor and the other for the iron frame of the motor. The thermal model with the maximum utilized capacity is reported.

This function also estimates and displays:

- The time remaining before a thermal overload trip is triggered (see Time to Trip, page 64), and
- The time remaining until the trip condition is cleared after a thermal overload trip has been triggered (see Minimum Wait Time, page 73).

### Trip Current Characteristics

The thermal capacity level function uses one of the following selected trip current characteristics (TCCs):

- Definite time
- Inverse thermal (factory setting)

### Thermal Capacity Level Models

Both copper and iron models use the maximum measured phase current and the Motor Trip Class parameter value to generate a non-scaled thermal image. The reported thermal capacity level is calculated by scaling the thermal image to FLC.

### Thermal Capacity Level Characteristics

The thermal capacity level function has the following characteristics:

| Characteristic   | Value   |
|------------------|---------|
| Unit             | %       |
| Accuracy         | +/- 1 % |
| Resolution       | 1 %     |
| Refresh interval | 100 ms  |

## Motor Temperature Sensor

### Description

The motor temperature sensor function displays:

- The resistance value in ohms measured by a PTC or NTC resistance temperature sensor.
- The temperature value in °C or °F measured by a PT100 temperature sensor.

Refer to the product documentation for the specific temperature sensor being used. One of 4 types of temperature sensors can be used:

- PTC Binary
- PT100
- PTC Analog
- NTC Analog

## Characteristics

The motor temperature sensor function has the following characteristics:

| Characteristic   | PT100 Temperature Sensor                                                                   | Other Temperature Sensor |
|------------------|--------------------------------------------------------------------------------------------|--------------------------|
| Unit             | °C or °F, according to the value of the HMI Display Temperature Sensor Degree CF parameter | Ω                        |
| Accuracy         | +/- 2 %                                                                                    | +/- 2 %                  |
| Resolution       | 1 °C or 1 °F                                                                               | 0.1 Ω                    |
| Refresh interval | 500 ms                                                                                     | 500 ms                   |

## Frequency

### Description

The frequency function provides the value measured based on the line voltage measurements. If the frequency is unstable (+/- 2 Hz variations), the value reported is 0 until the frequency stabilizes.

If no LTME expansion module is present, the frequency value is 0.

## Characteristics

The frequency function has the following characteristics:

| Characteristic   | Value  |
|------------------|--------|
| Unit             | Hz     |
| Accuracy         | +/- 2% |
| Resolution       | 0.1 Hz |
| Refresh interval | 30 ms  |

## Line-to-Line Voltages

### Description

The line-to-line voltages function provides the rms value of the phase-to-phase voltage (V1 to V2, V2 to V3, and V3 to V1):

- L1-L2 voltage: phase 1 to phase 2 voltage
- L2-L3 voltage: phase 2 to phase 3 voltage
- L3-L1 voltage: phase 3 to phase 1 voltage

The expansion module performs true rms calculations for line-to-line voltage up to the 7th harmonic.

Single phase voltage is measured from L1 and L3.

## Characteristics

The line-to-line voltages function has the following characteristics:

| Characteristic | Value   |
|----------------|---------|
| Unit           | VAC     |
| Accuracy       | +/- 1 % |

| Characteristic   | Value  |
|------------------|--------|
| Resolution       | 1 VAC  |
| Refresh interval | 100 ms |

## Line Voltage Imbalance

### Description

The line voltage imbalance function displays the maximum percentage of deviation between the average voltage and the individual line voltages.

### Formulas

The line voltage imbalance calculated measurement is based on the following formulas:

| Calculated Measurement                                                                                                                                                                                                                                                                                                | Formula                                         |
|-----------------------------------------------------------------------------------------------------------------------------------------------------------------------------------------------------------------------------------------------------------------------------------------------------------------------|-------------------------------------------------|
| Imbalance ratio of voltage in phase 1 in %                                                                                                                                                                                                                                                                            | $V_{i1} = 100 \times  V_1 - V_{avg}  / V_{avg}$ |
| Imbalance ratio of voltage in phase 2 in %                                                                                                                                                                                                                                                                            | $V_{i2} = 100 \times  V_2 - V_{avg}  / V_{avg}$ |
| Imbalance ratio of voltage in phase 3 in %                                                                                                                                                                                                                                                                            | $V_{i3} = 100 \times  V_3 - V_{avg}  / V_{avg}$ |
| Voltage imbalance ratio for three phase in %                                                                                                                                                                                                                                                                          | $V_{imb} = \text{Max}(V_{i1}, V_{i2}, V_{i3})$  |
| Where:                                                                                                                                                                                                                                                                                                                |                                                 |
| <ul style="list-style-type: none"> <li>• <math>V_1</math> = L1-L2 voltage (phase 1 to phase 2 voltage)</li> <li>• <math>V_2</math> = L2-L3 voltage (phase 2 to phase 3 voltage)</li> <li>• <math>V_3</math> = L3-L1 voltage (phase 3 to phase 1 voltage)</li> <li>• <math>V_{avg}</math> = average voltage</li> </ul> |                                                 |

### Characteristics

The line voltage imbalance function has the following characteristics:

| Characteristic   | Value     |
|------------------|-----------|
| Unit             | %         |
| Accuracy         | +/- 1.5 % |
| Resolution       | 1 %       |
| Refresh interval | 100 ms    |

## Average Voltage

### Description

The LTMR controller calculates average voltage and provides the value in volts. The average voltage function returns the rms value of the average voltage.

### Formulas

The LTMR controller calculates average voltage using the measured line-to-line voltages. The measured values are internally summed using the following formula:

| Calculated Measurement              | Formula                                                                                 |
|-------------------------------------|-----------------------------------------------------------------------------------------|
| Average voltage, three phase motor  | $V_{avg} = (L1-L2 \text{ voltage} + L2-L3 \text{ voltage} + L3-L1 \text{ voltage}) / 3$ |
| Average voltage, single-phase motor | $V_{avg} = L3-L1 \text{ voltage}$                                                       |

## Characteristics

The average voltage function has the following characteristics:

| Characteristic   | Value  |
|------------------|--------|
| Unit             | VAC    |
| Accuracy         | +/- 1% |
| Resolution       | 1 VAC  |
| Refresh interval | 100 ms |

## Power Factor

### Description

The power factor function displays the phase displacement between the phase currents and phase voltages.

### Formula

The Power Factor parameter (also called cosine phi or  $\cos \phi$ ) represents the absolute value of the ratio of Active Power to Apparent Power.

The following diagram displays an example of the average rms current sinusoidal curve lagging slightly behind the average rms voltage sinusoidal curve, and the phase angle difference between the 2 curves:

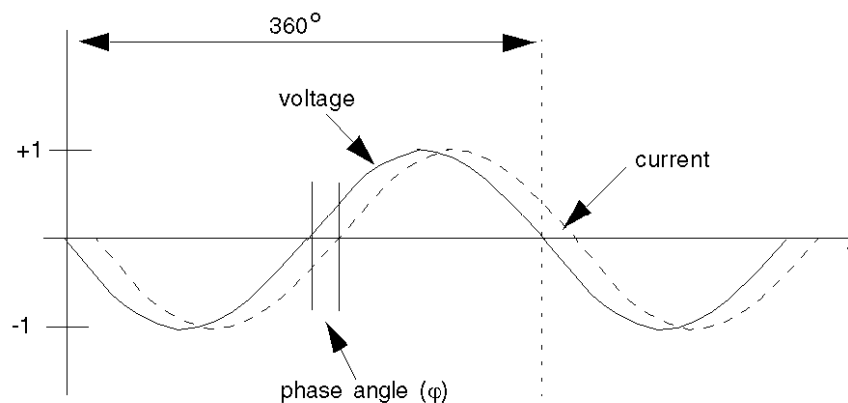

After the phase angle ( $\phi$ ) is measured, the power factor can be calculated as the cosine of the phase angle ( $\phi$ )—the ratio of side a (Active Power) over the hypotenuse h (Apparent Power):

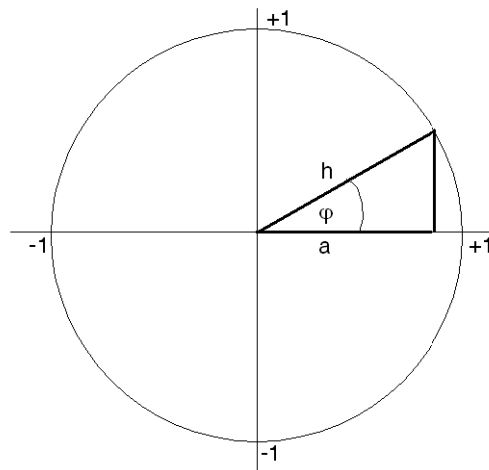

## Characteristics

The active power function has the following characteristics:

| Characteristic   | Value                             |
|------------------|-----------------------------------|
| Accuracy         | +/- 10 % for $\cos \phi \geq 0.6$ |
| Resolution       | 0.01                              |
| Refresh interval | 30 ms (typical) <sup>(2)</sup>    |

## Active Power and Reactive Power

### Description

The calculation of the active power and reactive power is based on the:

- Average rms phase voltage of L1, L2, L3
- Average rms phase current of L1, L2, L3
- Power factor
- Number of phases

### Formulas

Active power, also known as true power, measures average rms power. It is derived from the following formulas:

| Calculated Measurement                                                                                                                               | Formula                                                  |
|------------------------------------------------------------------------------------------------------------------------------------------------------|----------------------------------------------------------|
| Active power for three phase motor                                                                                                                   | $\sqrt{3} \times I_{avg} \times V_{avg} \times \cos\phi$ |
| Active power for single-phase motor                                                                                                                  | $I_{avg} \times V_{avg} \times \cos\phi$                 |
| Where:                                                                                                                                               |                                                          |
| <ul style="list-style-type: none"> <li>• <math>I_{avg}</math> = Average rms current</li> <li>• <math>V_{avg}</math> = Average rms voltage</li> </ul> |                                                          |

<sup>(2)</sup> The refresh interval depends on the frequency.

The reactive power measurement is derived from the following formulas:

| Calculated Measurement                                                                                                                               | Formula                                                  |
|------------------------------------------------------------------------------------------------------------------------------------------------------|----------------------------------------------------------|
| Reactive power for three phase motor                                                                                                                 | $\sqrt{3} \times I_{avg} \times V_{avg} \times \sin\phi$ |
| Reactive power for single-phase motor                                                                                                                | $I_{avg} \times V_{avg} \times \sin\phi$                 |
| Where:                                                                                                                                               |                                                          |
| <ul style="list-style-type: none"> <li>• <math>I_{avg}</math> = Average rms current</li> <li>• <math>V_{avg}</math> = Average rms voltage</li> </ul> |                                                          |

## Characteristics

The active and reactive power functions have the following characteristics:

| Characteristic   | Active Power | Reactive Power |
|------------------|--------------|----------------|
| Unit             | kW           | KVAR           |
| Accuracy         | +/- 15 %     | +/- 15 %       |
| Resolution       | 0.1 kW       | 0.1 KVAR       |
| Refresh interval | 100 ms       | 100 ms         |

## Active Power Consumption and Reactive Power Consumption

### Description

The active and reactive power consumption functions display the accumulated total of the active and reactive electrical power delivered, and used or consumed by the load.

### Characteristics

The active and reactive power consumption functions have the following characteristics:

| Characteristic   | Active Power Consumption | Reactive Power Consumption |
|------------------|--------------------------|----------------------------|
| Unit             | kWh                      | kVARh                      |
| Accuracy         | +/- 15 %                 | +/- 15 %                   |
| Resolution       | 0.1 kWh                  | 0.1 kVARh                  |
| Refresh interval | 100 ms                   | 100 ms                     |

## System and Device Monitoring Trips

### Overview

The LTMR controller and the LTME expansion module detect trips which affect the LTMR controller ability to work properly (internal controller check and check of communications, wiring, and configuration trips).

The system and device monitoring trip records can be accessed via:

- a PC running SoMove with the TeSys T DTM
- an HMI device

- a PLC via the network port

## Controller Internal Trip

### Description

The LTMR controller detects and records trips that are internal to the device itself. Internal trips can be either major or minor. Major and minor trips can change the state of output relays. Cycling power to the LTMR controller may clear an internal trip.

When an internal trip occurs, the Controller Internal Trip parameter is set.

### Major Internal Trips

During a major trip, the LTMR controller is unable to reliably execute its own programming and can only attempt to shut itself down. During a major trip, communication with the LTMR controller is not possible. Major internal trips include:

- Stack overflow trip
- Stack underflow trip
- Watchdog time-out
- Firmware checksum trip
- CPU trip
- Internal temperature trip (at 100 °C / 212 °F)
- RAM test trip

### Minor Internal Trips

Minor internal trips indicate that the data being provided to the LTMR controller is unreliable and protection could be compromised. During a minor trip, the LTMR controller continues to attempt to monitor status and communications, but does not accept any start commands. During a minor trip condition, the LTMR controller continues to detect and report major trips, but not additional minor trips. Minor internal trips include:

- Internal network communications detected error
- EEPROM trip
- A/D out of range detected error
- Reset button stuck
- Internal temperature trip (at 85 °C / 185 °F)
- Invalid configuration trip (conflicting configuration)
- Detected improper logic function action (for example, attempting to write to a read-only parameter)

## Controller Internal Temperature

### Description

The LTMR controller monitors its Controller Internal Temperature, reports alarm, minor trip, and major trip conditions. Trip detection cannot be disabled. Alarm detection can be enabled or disabled.

The controller retains a record of the highest attained internal temperature.

## Characteristics

The Controller Internal Temperature measured values have the following characteristics:

| Characteristic   | Value                 |
|------------------|-----------------------|
| Unit             | °C                    |
| Accuracy         | +/- 4 °C (+/- 7.2 °F) |
| Resolution       | 1 °C (1.8 °F)         |
| Refresh interval | 100 ms                |

## Parameters

The Controller Internal Temperature function includes one editable parameter:

| Parameter                                    | Setting Range                                                                 | Factory Setting |
|----------------------------------------------|-------------------------------------------------------------------------------|-----------------|
| Controller internal temperature alarm enable | <ul style="list-style-type: none"> <li>• Enable</li> <li>• Disable</li> </ul> | Enable          |

The Controller Internal Temperature function includes the following fixed alarm and trip thresholds:

| Condition                       | Fixed Threshold Value | Sets Parameter                        |
|---------------------------------|-----------------------|---------------------------------------|
| Internal temperature alarm      | 80 °C (176 °F)        | Controller Internal Temperature Alarm |
| Internal temperature minor trip | 85 °C (185 °F)        | Controller Internal Trip              |
| Internal temperature major trip | 100 °C (212 °F)       |                                       |

A alarm condition ceases when LTMR controller Internal Temperature falls below 80 °C (176 °F).

## Block Diagram

Controller internal temperature alarm and trip:

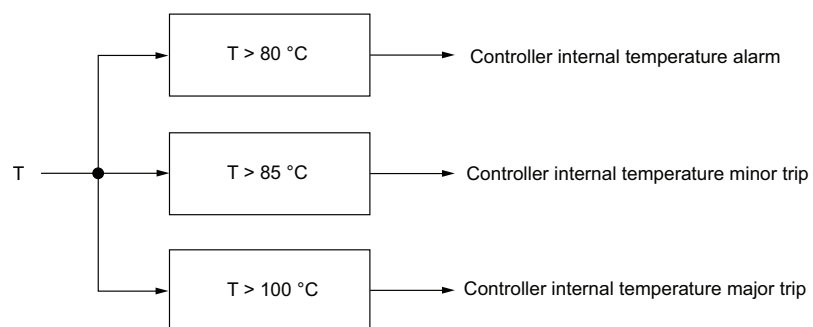

T: Temperature

T > 80 °C (176 °F): Fixed alarm threshold

T > 85 °C (185 °F): Fixed minor trip threshold

T > 100 °C (212 °F): Fixed major trip threshold

## Maximum Internal Controller Temperature

The Controller Internal Temperature Max parameter contains the highest internal temperature, expressed in °C, detected by the LTMR controller internal

temperature sensor. The LTMR controller updates this value whenever it detects an internal temperature greater than the current value.

The maximum internal temperature value is not cleared when factory settings are restored using the Clear All Command, or when statistics are reset using a Clear Statistics Command.

## Control Command Detected Error Diagnostic

### Description

The LTMR controller performs diagnostic tests that detect and monitor the proper functionality of control commands.

There are 4 control command diagnostic functions:

- Start Command Check
- Run Check Back
- Stop Command Check
- Stop Check Back

### Parameter Settings

All 4 diagnostic functions are enabled and disabled as a group. The configurable parameter settings are:

| Parameters              | Setting Range | Factory Setting |
|-------------------------|---------------|-----------------|
| Diagnostic Trip Enable  | Yes/No        | Yes             |
| Diagnostic Alarm Enable | Yes/No        | Yes             |

### Start Command Check

The Start Command Check begins after a Start command, and causes the LTMR controller to monitor the main circuit to verify that current is flowing.

- The Start Command Check reports a Start Command trip or alarm if current is not detected after a delay of 1 second.
- The Start Command Check conditions ends if the motor is in Run state and the LTMR controller detects that the current is equal or more than 10% of FLCmin.

### Run Check Back

The Run Check Back causes the LTMR controller to continuously monitor the main circuit to verify current is flowing.

- The Run Check Back reports a trip or alarm if average phase current is not detected for longer than 0.5 seconds without a Stop command.
- The Run Check Back ends when a Stop command executes.

### Stop Command Check

The Stop Command Check begins after a Stop command, and causes the LTMR controller to monitor the main circuit and verify that no current is flowing.

- The Stop Command Check reports a trip or alarm if current is detected after a delay of 1 second.

- The Stop Command Check ends if the LTMR controller detects that the current is equal or less than 5% of FLCmin.

## Stop Check Back

The Stop Check Back causes the LTMR controller to continuously monitor the main circuit to verify that no current is flowing.

- The Stop Check Back reports a Stop Check Back trip or alarm if average phase current is detected for longer than 0.5 seconds after a Stop command.
- The Stop Check Back condition ends when a Run command executes.

## Timing Sequence

The following diagram is an example of the timing sequence for the Start Command Check and Stop Command Check:

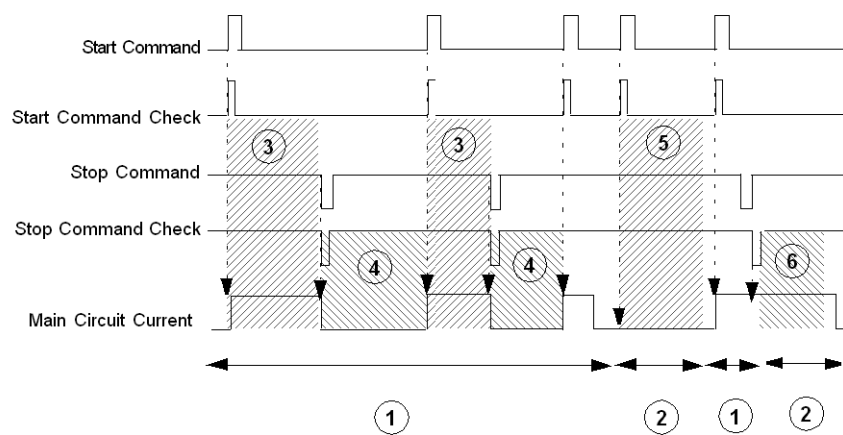

**1** Normal operation

**2** Trip or alarm condition

**3** The LTMR controller monitors the main circuit to detect current

**4** The LTMR controller monitors the main circuit to detect no current

**5** The LTMR controller reports a Start Command Check trip and/or alarm if current is not detected after 1 second

**6** The LTMR controller reports a Stop Command Check trip and or alarm if current is detected after 1 second

The following diagram is an example of the timing sequence for the Run Check Back and Stop Check Back:

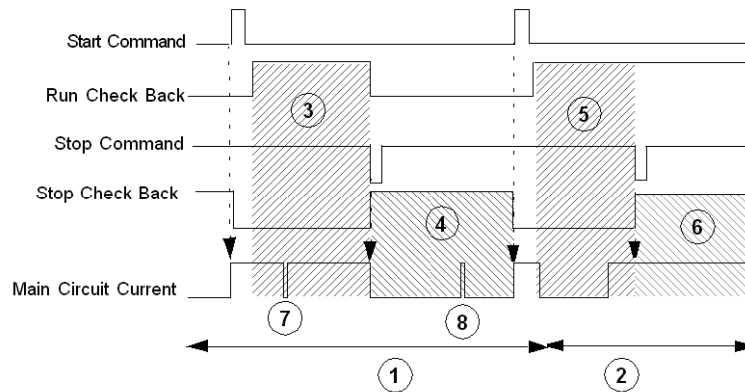

**1** Normal operation

**2** Trip or alarm condition

**3** After the motor enters the run state, the LTMR controller continuously monitors the main circuit to detect current until a Stop command is given or the function is disabled

**4** The LTMR controller continuously monitors the main circuit to detect no current until a Start command is given or the function is disabled

**5** The LTMR controller reports a Run Check Back trip and/or alarm if the current is not detected for longer than 0.5 seconds without a Stop command

**6** The LTMR controller reports a Stop Check Back trip or alarm if the current is detected for longer than 0.5 seconds without a Start command

**7** No current flowing for less than 0.5 seconds

**8** Current flowing for less than 0.5 seconds

## Wiring Trips

### Description

The LTMR controller checks external wiring connections and reports a trip when it detects incorrect or conflicting external wiring. The LTMR controller can detect 4 wiring trips:

- CT Reversal Trip
- Phase Configuration Trip
- Motor Temperature Sensor Wiring Trips (short-circuit or open-circuit)

### Enabling Trip Detection

Wiring diagnostics are enabled using the following parameters:

| Protection                      | Enabling Parameters                                                            | Setting Range                                                                                                                               | Factory Setting |
|---------------------------------|--------------------------------------------------------------------------------|---------------------------------------------------------------------------------------------------------------------------------------------|-----------------|
| CT Reversal                     | Wiring Trip Enable                                                             | <ul style="list-style-type: none"> <li>• Yes</li> <li>• No</li> </ul>                                                                       | Yes             |
| Phase Configuration             | Motor Phases, if set to single-phase                                           | <ul style="list-style-type: none"> <li>• Single-phase</li> <li>• Three-phase</li> </ul>                                                     | Three-phase     |
| Motor Temperature Sensor Wiring | Motor Temperature Sensor Type, if set to a sensor type, and not to <b>None</b> | <ul style="list-style-type: none"> <li>• None</li> <li>• PTC binary</li> <li>• PT100</li> <li>• PTC analog</li> <li>• NTC analog</li> </ul> | None            |

## CT Reversal Trip

When individual external load CTs are used, they must all be installed in the same direction. The LTMR controller checks the CT wiring and reports a trip if it detects one of the current transformers is wired backwards when compared to the others.

This function can be enabled and disabled.

## Phase Configuration Trip

The LTMR controller checks all 3 motor phases for On Level current, then checks the Motor Phases parameter setting. The LTMR controller reports a trip if it detects current in phase 2 if the LTMR controller is configured for single-phase operation.

This function is enabled when the LTMR controller is configured for single-phase operation. It has no configurable parameters.

## Motor Temperature Sensor Trips

When the LTMR controller is configured for motor temperature sensor protection, the LTMR controller provides short-circuit and open-circuit detection for the temperature sensing element.

The LTMR controller signals a trip when calculated resistance at the T1 and T2 terminals:

- Falls below the fixed short-circuit detection threshold, or
- Exceeds the fixed open-circuit detection threshold.

The trip must be reset according to the configured Reset Mode: manual, automatic, or remote.

Short-circuit and open-circuit detection thresholds have no trip time delay. There are no alarms associated with the short-circuit and the open-circuit detection.

Short-circuit and open-circuit detection of the motor temperature sensing element is available for all operating states.

This protection is enabled when a temperature sensor is employed and configured, and cannot be disabled.

The motor temperature sensor function has the following characteristics:

| Characteristic         | Value                                                   |
|------------------------|---------------------------------------------------------|
| Unit                   | $\Omega$                                                |
| Normal operating range | 15...6500 W                                             |
| Accuracy               | at 15 $\Omega$ : +/- 10 %<br>at 6500 $\Omega$ : +/- 5 % |

| Characteristic   | Value        |
|------------------|--------------|
| Resolution       | 0.1 $\Omega$ |
| Refresh interval | 100 ms       |

The fixed thresholds for the open-circuit and short-circuit detection functions are:

| Detection Function      |            | Fixed Results For PTC Binary, or PT100, or PTC/<br>NTC Analog | Accuracy |
|-------------------------|------------|---------------------------------------------------------------|----------|
| Short-circuit detection | Threshold  | 15 $\Omega$                                                   | +/- 10 % |
|                         | Re-closing | 20 $\Omega$                                                   | +/- 10 % |
| Open-circuit detection  | Threshold  | 6500 $\Omega$                                                 | +/- 5 %  |
|                         | Re-closing | 6000 $\Omega$                                                 | +/- 5 %  |

## Configuration Checksum

### Description

The LTMR controller calculates a checksum of parameters based on all configuration registers. The EEPROM trip code (64) is reported.

## Communication Loss

### Description

The LTMR controller monitors communication through:

- The network port
- The HMI port

## Network Port Parameter Settings

The LTMR controller monitors network communication creates both a trip and a alarm report when the network communications are lost.

| On LTMR Version...                                                                                | The communication loss...                                                                                                                                       |
|---------------------------------------------------------------------------------------------------|-----------------------------------------------------------------------------------------------------------------------------------------------------------------|
| <ul style="list-style-type: none"> <li>• LTMR•C•</li> <li>• LTMR•D•</li> <li>• LTMR•P•</li> </ul> | Is detected as part of the protocol management, without specific adjustable parameters.                                                                         |
| <ul style="list-style-type: none"> <li>• LTMR•M•</li> </ul>                                       | Is detected if no communication exchanges occurred for a time period equal to, or longer than, the network port comm loss timeout.                              |
| <ul style="list-style-type: none"> <li>• LTMR•E•</li> </ul>                                       | Is detected if no communication exchanges occurred with the Primary IP for a time period equal to, or longer than, the network port communication loss timeout. |

The network port communications have the following configurable settings:

| Parameter                                                                | Setting Range                          | Factory Setting |
|--------------------------------------------------------------------------|----------------------------------------|-----------------|
| Network port trip enable                                                 | Enable/Disable                         | Enable          |
| Network port alarm enable                                                | Enable/Disable                         | Enable          |
| Network port comm loss timeout (Modbus, EtherNet/IP and Modbus/TCP only) | 0...99.99 s<br>In increments of 0.01 s | 2 s             |

| Parameter                                            | Setting Range                                                                                                                                                | Factory Setting |
|------------------------------------------------------|--------------------------------------------------------------------------------------------------------------------------------------------------------------|-----------------|
| Network port fallback setting <sup>(3)</sup>         | <ul style="list-style-type: none"> <li>• Hold</li> <li>• Run</li> <li>• O.1, O.2 off</li> <li>• O.1, O.2 on</li> <li>• O.1 off</li> <li>• O.2 off</li> </ul> | O.1, O.2 off    |
| Primary IP address (EtherNet/IP and Modbus/TCP only) | 0.0.0.0 to 255.255.255.255                                                                                                                                   | 0.0.0.0         |

## HMI Port Parameter Settings

The LTMR controller monitors HMI port communications and reports both a alarm and a trip if no valid communication has been received by the HMI port for longer than 7 seconds.

The HMI port communication has the following fixed and configurable settings:

| Parameter                                | Setting Range                                                                                                                                                | Factory Setting |
|------------------------------------------|--------------------------------------------------------------------------------------------------------------------------------------------------------------|-----------------|
| HMI port trip enable                     | Enable/Disable                                                                                                                                               | Enable          |
| HMI port alarm enable                    | Enable/Disable                                                                                                                                               | Enable          |
| HMI port fallback setting <sup>(4)</sup> | <ul style="list-style-type: none"> <li>• Hold</li> <li>• Run</li> <li>• O.1, O.2 off</li> <li>• O.1, O.2 on</li> <li>• O.1 off</li> <li>• O.2 off</li> </ul> | O.1, O.2 off    |

## Fallback Condition

When the communication between the LTMR controller and either the network or the HMI is lost, the LTMR controller is in a fallback condition. When the communication recovers, the fallback condition is no longer applied by the LTMR controller.

The behavior of logic outputs O.1 and O.2 when the LTMR controller is in fallback condition is determined by:

- The operating mode (see *Operating Modes*, page 146).
- The Network Port Fallback Setting and HMI Port Fallback Setting parameters.

Fallback setting selection can include:

| Port Fallback Setting | Description                                                                                                          |
|-----------------------|----------------------------------------------------------------------------------------------------------------------|
| Hold (O.1, O.2)       | Directs the LTMR controller to hold the state of logic outputs O.1 and O.2 as of the time of the communication loss. |
| Run                   | Directs the LTMR controller to perform a Run command for a 2-step control sequence on the communication loss.        |
| O.1, O.2 Off          | Directs the LTMR controller to turn off both logic outputs O.1 and O.2 following a communication loss.               |
| O.1, O.2 On           | Directs the LTMR controller to turn on both logic outputs O.1 and O.2 following a communication loss.                |
| O.1 On                | Directs the LTMR controller to turn on only logic output O.1 following a communication loss.                         |
| O.2 On                | Directs the LTMR controller to turn on only logic output O.2 following a communication loss.                         |

<sup>(3)</sup> The operating mode affects the configurable parameters for the network port fallback settings.

<sup>(4)</sup> The operating mode affects the configurable parameters for the HMI port fallback settings.

The following table indicates which fallback options are available for each operating mode:

| Port Fallback Setting | Operating Mode |             |          |        |         |        |
|-----------------------|----------------|-------------|----------|--------|---------|--------|
|                       | Overload       | Independent | Reverser | 2-step | 2-speed | Custom |
| Hold (O.1, O.2)       | Yes            | Yes         | Yes      | Yes    | Yes     | Yes    |
| Run                   | No             | No          | No       | Yes    | No      | No     |
| O.1, O.2 Off          | Yes            | Yes         | Yes      | Yes    | Yes     | Yes    |
| O.1, O.2 On           | Yes            | Yes         | No       | No     | No      | Yes    |
| O.1 On                | Yes            | Yes         | Yes      | No     | Yes     | Yes    |
| O.2 On                | Yes            | Yes         | Yes      | No     | Yes     | Yes    |

**NOTE:** When you select a network or HMI fallback setting, your selection must identify an active control source.

## Time to Trip

### Description

When a thermal overload condition exists, the LTMR controller reports the time to trip before the trip occurs in the Time To Trip parameter.

When the LTMR controller is not in a thermal overload condition, to avoid the appearance of being in a trip state, the LTMR controller reports the time to trip as 9999.

If the motor has an auxiliary fan and the Motor Aux Fan Cooled parameter has been set, the cooling period is 4 times shorter.

### Characteristics

The time to trip function has the following characteristics:

| Characteristic   | Value    |
|------------------|----------|
| Unit             | s        |
| Accuracy         | +/- 10 % |
| Resolution       | 1 s      |
| Refresh interval | 100 ms   |

## LTMR Configuration Trip

### Description

The LTMR controller checks the Load CT parameters set in configuration mode.

An LTMR configuration trip is detected when the Load CT Primary, Load CT Secondary, and Load CT Multiple Passes parameters are not consistent, and generates a System and Device Monitoring Trip. The trip condition is cleared once the parameters are correct. The LTMR controller remains in configuration mode as long as the parameters are not consistent.

## LTME Configuration Trip and Alarm

### Description

The LTMR controller checks the presence of the LTME expansion module. Its absence generates a System and Device Monitoring Trip.

### LTME Configuration Trip

LTME configuration trip:

- If LTME based protection trips are enabled but no LTME expansion module is present, this will cause an LTME configuration trip.
- It does not have any delay setting.
- The trip condition clears when no protection trip requiring an LTME is enabled, or when the LTMR has been power-cycled with an appropriate LTME being present.

### LTME Configuration Alarm

LTME configuration alarm:

- If LTME based protection alarms are enabled but no LTME expansion module is present, this will cause an LTME configuration alarm.
- The alarm clears when no protection alarm requiring an LTME is enabled, or when the LTMR has been power-cycled with an appropriate LTME being present.

## External Trip

### Description

The LTMR controller has an external trip feature, which detects if an error happened on an external system linked to it.

An external trip is triggered by setting a bit in the custom logic command register 1 (see table below). This external trip sets the controller into a trip state based on different parameters in the system.

An external trip can be reset only by clearing the external trip bit in the register.

### External Trip Parameter Settings

| Parameter                          | Description                                                                    |
|------------------------------------|--------------------------------------------------------------------------------|
| Custom logic external trip command | The value is written                                                           |
| External system trip               | Reads Custom logic external trip command parameter                             |
| Trip code                          | Number is 16: External trip set by program customized with custom logic editor |

# Trip and Alarm Counters

## Overview

The LTMR controller counts and records the number of trips and alarms that occur. In addition, it counts the number of auto-reset attempts. This information can be accessed to assist with system performance and maintenance.

Trip and alarm counters can be accessed via:

- a PC running SoMove with the TeSys T DTM
- an HMI device
- a PLC via the network port

## Introducing Trip and Alarm Counters

### Detecting Alarms

If a alarm detection function is enabled, the LTMR controller detects a alarm immediately when the monitored value rises above, or falls below, a threshold setting.

### Detecting Trips

Before the LTMR controller detects a trip, certain preconditions must exist. These conditions can include

- The trip detecting function must be enabled,
- Monitored value (for example, current, voltage, or thermal resistance) must rise above, or fall below, a threshold setting,
- The monitored value must remain above or below the threshold setting for a specified time duration.

## Counters

When a trip occurs, the LTMR controller increments at least 2 counters:

- Counter for the specific trip detecting function, and
- Ccounter for all trips.

When a alarm occurs, the LTMR controller increments a single counter for all alarms. However, when the LTMR controller detects a thermal overload alarm, it also increments the thermal overload alarms counter.

A counter contains a value from 0 to 65,535 and increments by a value of 1 when a trip, alarm, or reset event occurs. A counter stops incrementing when it reaches a value of 65,535.

When a trip is automatically reset, the LTMR controller increments only the auto-resets counter. Counters are saved on power loss.

## Clearing Counters

All trip and alarm counters are reset to 0 by executing the Clear Statistics Command or Clear All Command.

## All Trips Counter

### Description

The Trips Count parameter contains the number of trips that have occurred since the Clear All Statistics Command last executed.

The Trips Count parameter increments by a value of 1 when the LTMR controller detects any trip.

## All Alarms Counter

### Description

The Alarms Count parameter contains the number of alarms that have occurred since the Clear All Statistics Command last executed.

The Alarms Count parameter increments by a value of 1 when the LTMR controller detects any alarm.

## Auto-Reset Counter

### Description

The Auto-Reset Count parameter contains the number of times the LTMR controller attempted, but unsuccessful, to auto-reset a trip. This parameter is used for the 3 auto-reset trip groups.

If an auto-reset attempt is successful (defined as the same trip not recurring within 60 s), this counter is reset to zero. If a trip is reset either manually or remotely, the counter is not incremented.

For information on trip management, see [Trip Management and Clear Commands](#), page 168.

## Protection Trips and Alarms Counters

### Protection Trip Counts

Protection trip counters include:

- Current Phase Imbalance Trips Count
- Current Phase Loss Trips Count
- Current Phase Reversal Trips Count
- Ground Current Trips Count
- Jam Trips Count
- Long Start Trips Count
- Motor Temp Sensor Trips Count
- Over Power Factor Trips Count
- Overcurrent Trips Count
- Overpower Trips Count
- Overvoltage Trips Count
- Thermal Overload Trips Count
- Under Power Factor Trips Count

- Undercurrent Trips Count
- Underpower Trips Count
- Undervoltage Trips Count
- Voltage Phase Imbalance Trips Count
- Voltage Phase Loss Trips Count
- Voltage Phase Reversal Trips Count

## Protection Alarm Counts

The Thermal Overload Alarms Count parameter contains the total number of alarms for the thermal overload protection function.

When any alarm occurs, including a thermal overload alarm, the LTMR controller increments the Alarms Count parameter.

## Control Command Detected Errors Counter

### Description

A Diagnostic Trip occurs when the LTMR controller detects any of the following control command errors:

- Start Command Check detected errors
- Stop Command Check detected errors
- Stop Check Back detected errors
- Run Check Back detected errors

For information on these control command functions, see [Control Command Detected Error Diagnostic](#), page 58.

## Wiring Trips Counter

### Description

The Wiring Trips Count parameter contains the total number of the following wiring trips that have occurred since the Clear Statistics Command last executed:

- Wiring Trip, which is triggered by a:
  - CT Reversal Trip
  - Phase Configuration Trip
  - Motor Temperature Sensor Wiring Trip
- Voltage Phase Reversal Trip
- Current Phase Reversal Trip

The LTMR controller increments the Wiring Trips Count parameter by a value of 1 each time any one of the above 3 trips occurs. For information on connection errors and related trips, see [Wiring Trips](#), page 60.

## Communication Loss Counters

### Description

Trips detected for the following communication functions:

| Counter                           | Contains                                                                                                                                                        |
|-----------------------------------|-----------------------------------------------------------------------------------------------------------------------------------------------------------------|
| HMI Port Trips Count              | The number of times communications via the HMI port was lost.                                                                                                   |
| Network Port Internal Trips Count | The number of internal trips experienced by the network module, reported by the network module to the LTMR controller.                                          |
| Network Port Config Trips Count   | The number of major trips experienced by the network module, exclusive of network module internal trips, reported by the network module to the LTMR controller. |
| Network Port Trips Count          | The number of times communications via the network port was lost.                                                                                               |

## Internal Trip Counters

### Description

Trips detected for the following internal trips:

| Counter                         | Contains                                                                                                                                           |
|---------------------------------|----------------------------------------------------------------------------------------------------------------------------------------------------|
| Controller Internal Trips Count | The number of major and minor internal trips.<br>For information on internal trips, see <a href="#">Controller Internal Trip</a> , page 56.        |
| Internal Port Trips Count       | The number of LTMR controller internal communication trips, plus the number of unsuccessful attempts to identify the network communication module. |

## Trip History

### Trip History

The LTMR controller stores a history of LTMR controller data that was recorded at the time of the last 5 detected trips. Trip n-0 contains the most recent trip record, and trip n-4 contains the oldest retained trip record.

Each trip record includes:

- Trip Code
- Date and Time
- Value of Settings
  - Motor Full Load Current Ratio (% of FLCmax)
- Value of Measurements
  - Thermal Capacity Level
  - Average Current Ratio
  - L1, L2, L3 Current Ratio
  - Ground Current Ratio
  - Full Load Current Max
  - Current Phase Imbalance
  - Voltage Phase Imbalance
  - Power Factor
  - Frequency
  - Motor Temp Sensor
  - Average Voltage
  - L3-L1 Voltage, L1-L2 Voltage, L2-L3 Voltage
  - Active Power

# Motor History

## Overview

The LTMR controller tracks and saves motor operating statistics.

Motor statistics can be accessed using:

- PC running SoMove with the TeSys T DTM
- HMI device
- PLC via the network port

## Motor Starts Counters

### Description

The LTMR controller tracks motor starts and records the data as a statistic that can be retrieved for operational analysis. The following statistics are tracked:

- Motor Starts Count
- Motor LO1 Closings Count (logic output O.1 starts)
- Motor LO2 Closings Count (logic output O.2 starts)

The Clear Statistics Command resets the Motor Starts Count parameter to 0.

**NOTE:** The Motor LO1 Closings Count and Motor LO2 Closings Count parameters cannot be reset to 0, because these parameters together indicate the usage of the relay outputs over time.

## Motor Starts Per Hour Counter

### Description

The LTMR controller tracks the number of motor starts during the past hour and records this figure in the Motor Starts Per Hour Count parameter.

The LTMR controller sums start in 5 minute intervals with an accuracy of 1 interval (+0/- 5 minutes), which means that the parameter will contain the total number of starts within either the previous 60 minutes or the previous 55 minutes.

This function is used as a maintenance function to avoid thermal strain on the motor.

### Characteristics

The motor starts per hour function has the following characteristics:

| Characteristic   | Value                       |
|------------------|-----------------------------|
| Accuracy         | 5 minutes (+ 0/- 5 minutes) |
| Resolution       | 5 minutes                   |
| Refresh interval | 100 ms                      |

## Load Sheddings Counter

### Description

The Load Sheddings Count parameter contains the number of times the load sheddings protection function has been activated since the last Clear Statistics Command.

For information on the Load Sheddings protection function, see [Load Shedding](#), page 122.

## Auto Restart Counters

### Description

There are 3 types of counting statistics:

- Auto restart immediate count
- Auto restart delayed count
- Auto restart manual count

For information on the Auto restart protection function, see [Automatic Restart](#), page 124.

## Motor Last Start Current Ratio

### Description

The LTMR controller measures the maximum current level reached during the last start of the motor and reports the value in the Motor Last Start Current Ratio parameter for analysis of the system for maintenance purposes.

This value may also be used to help configure the long start threshold setting in the long start protection function.

The value is not stored in the non-volatile memory: it is lost at a power cycle.

### Characteristics

The motor last start current ratio function has the following characteristics:

| Characteristic   | Value                                                                                                                   |
|------------------|-------------------------------------------------------------------------------------------------------------------------|
| Unit             | % of FLC                                                                                                                |
| Accuracy         | <ul style="list-style-type: none"> <li>• +/- 1 % for 8 A and 27 A models</li> <li>• +/- 2 % for 100 A models</li> </ul> |
| Resolution       | 1 % FLC                                                                                                                 |
| Refresh interval | 100 ms                                                                                                                  |

## Motor Last Start Duration

### Description

The LTMR controller tracks the duration of the last motor start and reports the value in the Motor Last Start Duration parameter for analysis of the system for maintenance purposes.

This value may also be useful in setting the long start delay timeout used in the long start and definite trip overload protection functions.

The value is not stored in the non-volatile memory: it is lost at a power cycle.

## Characteristics

The motor last start duration function has the following characteristics:

| Characteristic   | Value   |
|------------------|---------|
| Unit             | s       |
| Accuracy         | +/- 1 % |
| Resolution       | 1 s     |
| Refresh interval | 1 s     |

## Operating Time

### Description

The LTMR controller tracks motor operating time and records the value in the Operating Time parameter. Use this information to help schedule motor maintenance, such as lubrication, inspection, and replacement.

## System Operating Status

### Overview

The LTMR controller monitors the motor operating state and the minimum time to wait to restart the motor.

The Motor states can be accessed via:

- PC running SoMove with the TeSys T DTM
- HMI device
- PLC via the network port

## Motor State

### Description

The LTMR controller tracks the motor state and reports the following states by setting the corresponding boolean parameters:

| Motor state | Parameter      |
|-------------|----------------|
| Run         | Motor Running  |
| Ready       | System Ready   |
| Start       | Motor Starting |

## Minimum Wait Time

### Description

The LTMR controller tracks the time remaining to restart the motor according to one of the following events:

- Automatic reset, page 172
- Thermal overload, page 77
- Rapid cycle lockout, page 92
- Load shedding, page 122
- Automatic restart, page 124
- transition time.

If more than one timer is active, the parameter displays the maximum timer, which is the minimum wait for the trip response or the control function to reset.

**NOTE:** Even with an LTMR powered off, time is tracked down for at least 30 mn.

### Characteristics

The Minimum Wait Time function has the following characteristics:

| Characteristic   | Value   |
|------------------|---------|
| Unit             | s       |
| Accuracy         | +/- 1 % |
| Resolution       | 1 s     |
| Refresh interval | 1 s     |

# Motor Protection Functions

## Overview

This chapter describes the motor protection functions provided by the LTMR controller.

## Motor Protection Functions Introduction

### Overview

This section introduces you to the motor protection functions provided by the LTMR controller, including protection parameters and characteristics.

### Definitions

#### Defined Functions and Data

The LTMR controller monitors current, ground-current and motor temperature sensor parameters. When the LTMR controller is connected to an expansion module, it also monitors voltage and power parameters. The LTMR controller uses these parameters in protection functions to detect trip and alarm conditions. The LTMR controller response to trip and alarm conditions is fixed for the predefined operating modes. Logic output O.4 activates on a trip, and logic output O.3 activates on an alarm. For more information about predefined operating modes, see *Operating Modes*, page 146.

You can configure these motor protection functions to detect the existence of undesirable operating conditions that, if not resolved, can cause motor and equipment damage.

All motor protection functions include trip detection, and most protection functions also include alarm detection.

#### Customized Functions and Data

In addition to using the protection functions and parameters included in a predefined operating mode, you can use the Custom Logic Editor in the TeSys T DTM to create a new, customized operating mode. To create a custom operating mode, select any predefined operating mode, then edit its code to meet the needs of your application.

Using the Custom Logic Editor, you can create a customized operating mode by:

- Modifying the LTMR controller responses to protection trips or alarms
- Adding new functions, based on either predefined or newly created parameters

### Trips

A trip is a serious undesirable operating condition. Trip-related parameters can be configured for most protection functions.

The response of the LTMR controller to a trip include the following:

- Output O.4 contacts:
  - Contact 95-96 is open
  - Contact 97-98 is closed
- Trip status bits are set in a trip parameter
- Text message is displayed in an HMI screen (if an HMI is attached)
- Trip status indicator is displayed in the TeSys T DTM, if connected

The LTMR controller counts and records the number of trips for each protection function.

After a trip has occurred, merely resolving the underlying condition does not clear the trip. To clear the trip, the LTMR controller must be reset. See Trip Management - Introduction, page 168.

## Alarms

A alarm is a less-serious, though still undesirable, operating condition. A alarm indicates corrective action may be required to help prevent a problem condition from occurring. If left unresolved, a alarm may lead to a trip condition. Alarm-related parameters can be configured for most protection functions.

The response of the LTMR controller to a alarm include the following:

- Output O.3 is closed
- Alarm status bits are set in a alarm parameter
- Text message is displayed in an HMI screen (if attached)
- Alarm status indicator is displayed in the TeSys T DTM

**NOTE:** For some protection functions, alarm detection shares the same threshold as trip detection. For other protection functions, alarm detection has a separate alarm threshold.

The LTMR controller clears the alarm whenever the measured value no longer exceeds the alarm threshold—plus or minus a 5 % hysteresis band.

## Motor Protection Characteristics

### Operation

The following diagram describes the operation of a typical motor protection function. This diagram, and the following diagrams, are expressed in terms of current. However, the same principles apply to voltage.

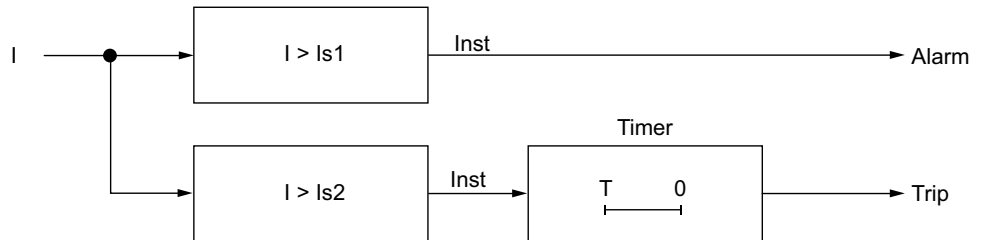

**I** Measurement of the monitored parameter

**Is1** Alarm threshold setting

**Is2** Trip threshold setting

**T** Trip timeout setting

**Inst** Instantaneous alarm/trip detection

## Settings

Some protection functions include configurable settings, including:

- Trip threshold: A limit setting for the monitored parameter that triggers a protection function trip.
- Alarm threshold: A limit setting for the monitored parameter that triggers a protection function alarm.
- Trip timeout: A time delay that must expire before the protection function trip is triggered. The behavior of a timeout depends on its trip current characteristic profile.
- Trip curve characteristic (TCC): The LTMR controller includes a definite trip characteristic for all protection functions, except the Thermal Overload Inverse Thermal protection function, which has both an inverse trip and definite trip curve characteristic, as described below.

**Definite TCC:** The duration of the trip timeout remains a constant regardless of changes in the value of the measured quantity (current), as described in the following diagram:

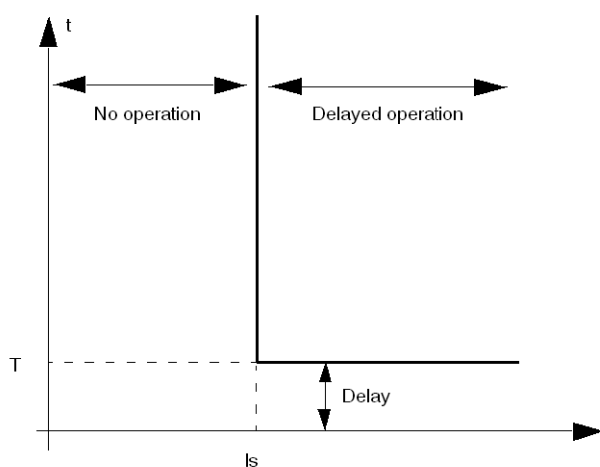

**Inverse TCC:** The duration of the time delay varies inversely with the value of the measured quantity (here, thermal capacity). As the measured quantity increases, the potential for harm also increases, thereby causing the duration of the time delay to decrease, as described in the following diagram:

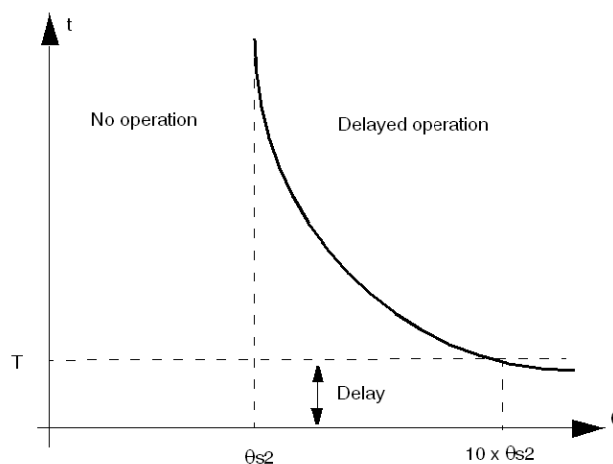

## Hysteresis

To improve stability, motor protection functions apply a hysteresis value that is added to or subtracted from limit threshold settings before a trip or alarm response is reset. The hysteresis value is calculated as a percentage, typically 5%, of the limit threshold and is

- Subtracted from the threshold value for upper limit thresholds,
- Added to the threshold value for lower limit thresholds.

The following diagram describes the logic result of measurement processing (Inst) when hysteresis is applied to an upper limit threshold:

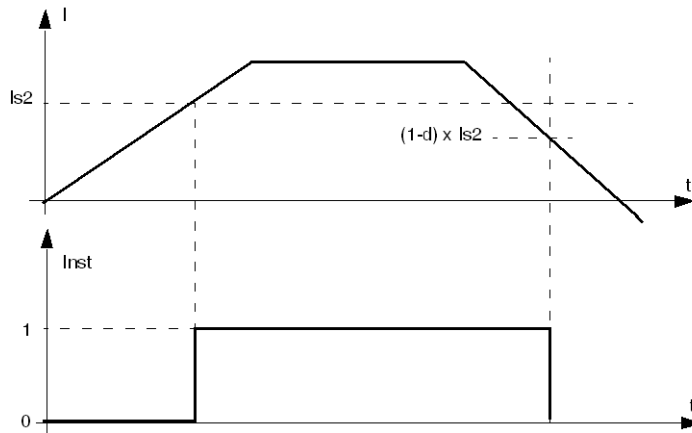

**d** Hysteresis percentage

## Thermal Motor Protection Functions

### Overview

This section describes the thermal motor protection functions of theLTMR controller.

### Thermal Overload

#### Overview

The LTMR controller can be configured to provide thermal protection, by selecting one of the following settings:

- Inverse Thermal, page 78 (factory setting)
- Definite Time, page 82

Each setting represents a Trip Curve Characteristic. The LTMR controller stores the selected setting in its Thermal Overload Mode parameter. Only one setting can be activated at a time. See the topics that immediately follow, for information on the operation and configuration of each setting.

#### Parameter Settings

The Thermal Overload function has the following configurable parameter settings, which apply to every trip current characteristic:

| Parameters                 | Setting Range                                                                                | Factory Setting |
|----------------------------|----------------------------------------------------------------------------------------------|-----------------|
| Mode                       | <ul style="list-style-type: none"> <li>• Inverse thermal</li> <li>• Definite time</li> </ul> | Inverse thermal |
| Trip enable                | Enable/Disable                                                                               | Enable          |
| Alarm enable               | Enable/Disable                                                                               | Enable          |
| Motor auxiliary fan cooled | Enable/Disable                                                                               | Disable         |

## Thermal Overload - Inverse Thermal

### Description

When you set the Thermal Overload Mode parameter to Inverse Thermal and select a motor trip class, the LTMR controller monitors the motor's utilized thermal capacity and signals

- A alarm when utilized thermal capacity exceeds a configured alarm threshold,
- A trip when utilized thermal capacity is greater than 100 %.

#### **⚠ CAUTION**

##### **RISK OF MOTOR OVERHEATING**

The Motor Trip Class parameter must be set to the thermal heating characteristics of the motor. Refer to the motor manufacturer's instructions before setting this parameter.

**Failure to follow these instructions can result in injury or equipment damage.**

There is no time delay for the thermal overload alarm.

The LTMR controller calculates the Thermal Capacity Level in all operating states. When power to the LTMR controller is lost, the LTMR controller retains the last measurements of the motor's thermal state for a period of 30 minutes, allowing it to estimate the motor's thermal state when power is re-applied.

Trip and alarm monitoring can be separately enabled and disabled.

- The thermal overload alarm is cleared by the LTMR controller when the utilized thermal capacity falls 5 % below the alarm threshold.
- The thermal overload trip can be reset by the user when the utilized thermal capacity falls below the trip reset threshold and after the trip reset timeout is elapsed.

### Reset for Emergency Restart

You can use the Clear Thermal Capacity Level Command, issued from the PLC or an HMI, to re-start an overloaded motor in an emergency situation. This command resets the thermal capacity utilization value to 0 and bypasses the cooling period required by the thermal model before the motor can be restarted.

This command also resets the Rapid Cycle Lockout Timeout to allow an immediate restart without lock.

The Clear All Command does not perform a Clear Thermal Capacity Level.

#### **⚠ WARNING**

##### **LOSS OF MOTOR PROTECTION**

Clearing the thermal capacity level inhibits thermal protection and can cause equipment overheating and fire. Continued operation with inhibited thermal protection should be limited to applications where immediate restart is vital.

**Failure to follow these instructions can result in death, serious injury, or equipment damage.**

The Clear Thermal Capacity Level Command will not reset the trip response. Instead

- Only an action external to the LTMR controller (for example, a reduction in the motor load) can clear the trip condition,

- Only a reset command, from the valid reset means configured in the Trip Reset Mode parameter, will reset the trip response.

|                                                                                                       |
|-------------------------------------------------------------------------------------------------------|
| <b>▲ WARNING</b>                                                                                      |
| <b>UNINTENDED EQUIPMENT OPERATION</b>                                                                 |
| A reset command may re-start the motor if the LTMR controller is used in a 2-wire control circuit.    |
| Equipment operation must conform to local and national safety regulations and codes.                  |
| <b>Failure to follow these instructions can result in death, serious injury, or equipment damage.</b> |

## Operation

The thermal overload inverse thermal protection function is based on a thermal model of the motor that combines 2 thermal images:

- A copper-based image representing the thermal state of the stator and rotor windings, and
- An iron-based image representing the thermal state of the motor frame.

Using measured current and the input motor trip class setting, the LTMR controller considers only the highest thermal state, iron or copper, when calculating thermal capacity utilized by the motor, as described below:

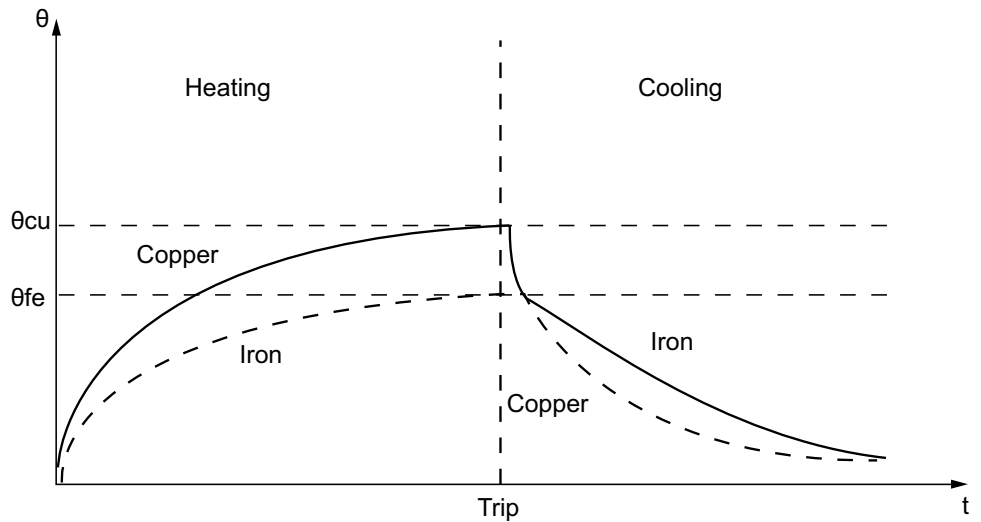

- θ** Thermal value
- θfe** Iron tripping threshold
- θcu** Copper tripping threshold
- t** Time

When inverse thermal trip mode is selected, the Thermal Capacity Level parameter, indicating utilized thermal capacity due to load current, is incremented during both start and run states. When the LTMR controller detects that the thermal capacity level ( $\theta$ ) exceeds the trip threshold ( $\theta_s$ ), it triggers a thermal overload trip, as described below:

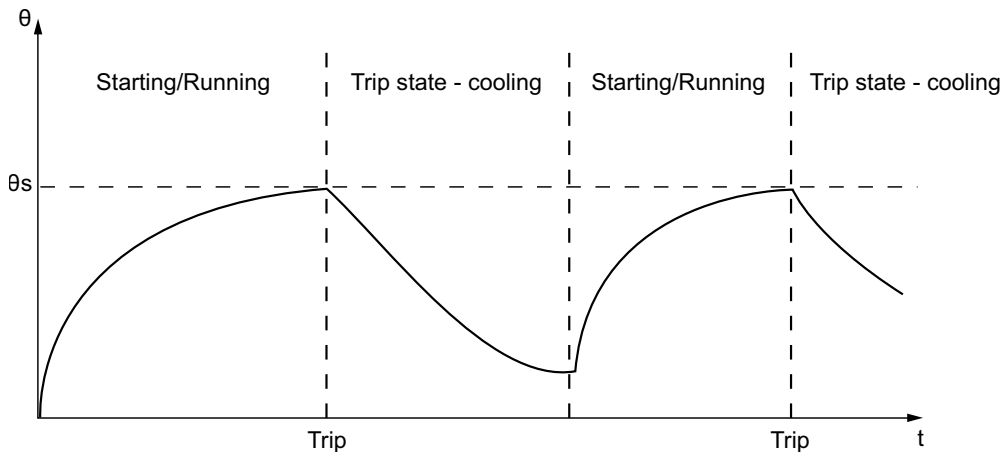

## Functional Characteristics

The Thermal Overload inverse thermal functions include the following features:

- 1 motor trip class setting:
  - Motor Trip Class
- 4 configurable thresholds:
  - Motor Full Load Current Ratio (FLC1)
  - Motor High Speed Full Load Current Ratio (FLC2)
  - Thermal Overload Alarm Threshold
  - Thermal Overload Trip Reset Threshold
- 1 time delay:
  - Trip Reset Timeout
- 2 function outputs:
  - Thermal Overload Alarm
  - Thermal Overload Trip
- 2 counting statistics:
  - Thermal Overload Trips Count
  - Thermal Overload Alarms Count
- 1 setting for an external auxiliary motor cooling fan:
  - Motor Aux Fan Cooled
- 1 measure of utilized thermal capacity:
  - Thermal Capacity Level

**NOTE:** For LTMR controller configured for 2-speed predefined operating mode, 2 trip thresholds are used: FLC1 and FLC2.

## Block Diagram

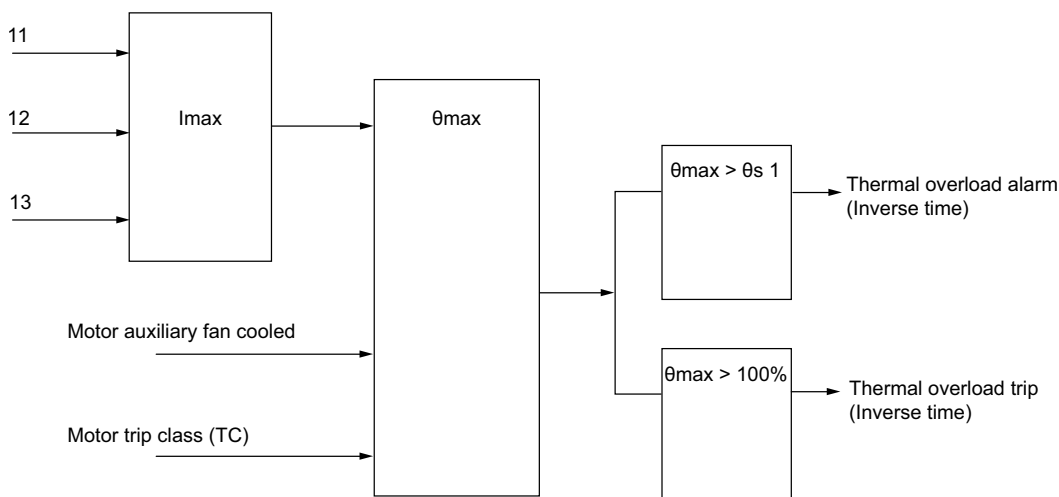

**I<sub>max</sub>** Maximum current

**θ<sub>max</sub>** Thermal capacity level

**θ<sub>s1</sub>** Thermal overload alarm threshold

## Parameter Settings

The thermal overload inverse thermal functions have the following configurable parameter settings:

| Parameters           | Setting Range                                                                                                                                                                                                  | Factory Setting                                                                                                        |
|----------------------|----------------------------------------------------------------------------------------------------------------------------------------------------------------------------------------------------------------|------------------------------------------------------------------------------------------------------------------------|
| FLC1, FLC2           | <ul style="list-style-type: none"> <li>0.4...8.0 A in increments of 0.08 A for LTMR08</li> <li>1.35...27.0 A in increments of 0.27 A for LTMR27</li> <li>5...100 A in increments of 1 A for LTMR100</li> </ul> | <ul style="list-style-type: none"> <li>0.4 A for LTMR08</li> <li>1.35 A for LTMR27</li> <li>5 A for LTMR100</li> </ul> |
| Alarm threshold      | 10...100 % of thermal capacity                                                                                                                                                                                 | 85 % of thermal capacity                                                                                               |
| Motor trip class     | 5...30 in increments of 5                                                                                                                                                                                      | 5                                                                                                                      |
| Trip reset timeout   | 50...999 in 1 s increments                                                                                                                                                                                     | 120 s                                                                                                                  |
| Trip reset threshold | 35...95 % of thermal capacity                                                                                                                                                                                  | 75 % of thermal capacity                                                                                               |

The thermal overload inverse thermal functions have the following non-configurable parameter settings:

| Parameter                       | Fixed Setting             |
|---------------------------------|---------------------------|
| Thermal overload trip threshold | 100 % of thermal capacity |

## Technical Characteristics

The thermal overload inverse thermal functions have the following characteristics:

| Characteristics    | Value                                    |
|--------------------|------------------------------------------|
| Hysteresis         | -5 % of thermal overload alarm threshold |
| Trip time accuracy | +/- 0.1 s                                |

## Thermal Overload - Definite Time

### Description

When you set the Thermal Overload Mode parameter to **Definite Time**, the LTMR controller signals:

- A alarm when measured maximum phase current exceeds a configurable threshold (OC1 or OC2).
- A trip when the maximum phase current continuously exceeds the same threshold (OC1 or OC2) for a set time delay.

The thermal overload definite time trip includes a time delay of constant magnitude, following a start command, before the protection is active and a trip timeout duration, as described below:

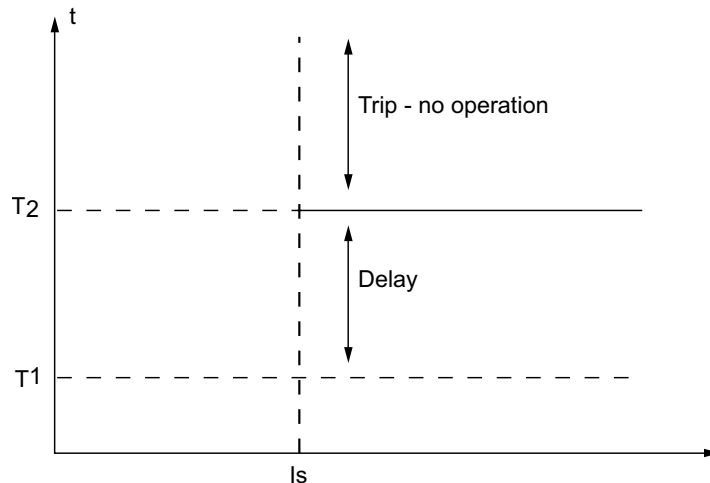

**Is** Trip and alarm threshold (OC1 or OC2)

**T1** Start command

**T2** Elapsed time delay

There is no time delay for the thermal overload definite time alarm.

Trip and alarm monitoring can be separately enabled and disabled.

The definite time protection function is disabled following a start by a delay defined by the Long Start Trip Timeout setting. The LTMR controller, when configured for overload predefined operating mode, uses the change in state from off to on level current to begin the Start state. This delay allows the motor to draw current on startup required to overcome the inertia of the motor at rest.

**NOTE:** Configuration of this protection function requires configuration of the Long Start protection function, including the Long Start Trip Timeout parameter.

### Functional Characteristics

The thermal overload definite time function includes the following features:

- 2 configurable threshold settings; one setting (OC1) is used for single speed motors, both settings are required for 2-speed motors:
  - OC1(Motor Full Load Current Ratio) or
  - OC2 (Motor High Speed Full Load Current Ratio)
- 1 time delay:
  - Overcurrent Time (O-Time, set by the Thermal Overload Trip Definite Timeout parameter)

- 2 function outputs:
  - Thermal Overload Alarm
  - Thermal Overload Trip
- 2 counting statistics:
  - Thermal Overload Trips Count
  - Thermal Overload Alarms Count

## Block Diagram

**Thermal overload alarm and trip:**

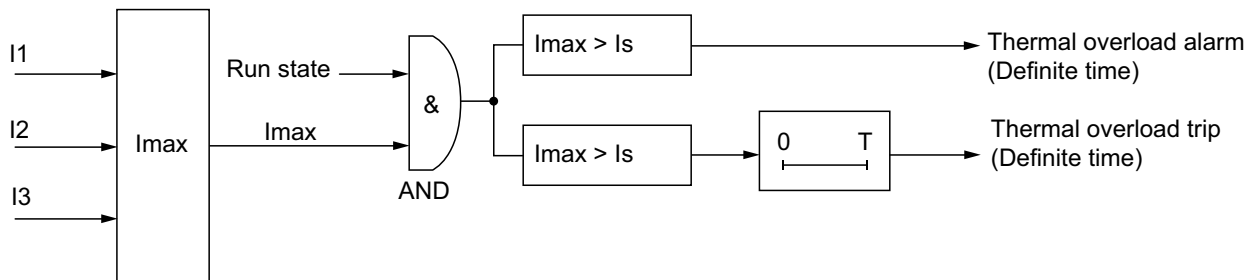

**I1** Phase 1 current

**I2** Phase 2 current

**I3** Phase 3 current

**Is** Trip and alarm threshold (OC1 or OC2)

**T** Trip timeout

## Parameter Settings

The definite time thermal overload function has the following configurable parameter settings:

| Parameters                                                                                                                                                                        | Setting Range                                                                                                                                                                                         | Factory Setting |
|-----------------------------------------------------------------------------------------------------------------------------------------------------------------------------------|-------------------------------------------------------------------------------------------------------------------------------------------------------------------------------------------------------|-----------------|
| Trip threshold: <ul style="list-style-type: none"> <li>• Motor full load current ratio (OC1)</li> <li>- or -</li> <li>• Motor high speed full load current ratio (OC2)</li> </ul> | 5...100 % of FLCmax, in 1 % increments.<br><br>Note: OC1 and OC2 settings can be set directly (in Amperes) in the <b>Settings</b> menu of an HMI, or in the <b>Parameters</b> tab of the TeSys T DTM. | 5 % FLCmax      |
| Thermal overload trip definite timeout (O-time or over-current time)                                                                                                              | 1...300 s in 1 s increments                                                                                                                                                                           | 10 s            |
| Thermal overload alarm threshold                                                                                                                                                  | 20...800 % of OC in 1 % increments                                                                                                                                                                    | 80 % of OC      |
| Long start trip timeout <sup>(5)</sup> (D-time)                                                                                                                                   | 1...200 s in 1 s increments                                                                                                                                                                           | 10 s            |

## Technical Characteristics

The definite time thermal overload function has the following characteristics:

| Characteristics    | Value                             |
|--------------------|-----------------------------------|
| Hysteresis         | -5 % of alarm and trip thresholds |
| Trip time accuracy | +/- 0.1 s                         |

<sup>(5)</sup> The definite time thermal overload function requires the simultaneous use of the Long start motor protection function, both of which employ the Long start trip timeout setting.

## Example

The following diagram describes a definite time thermal overload trip:

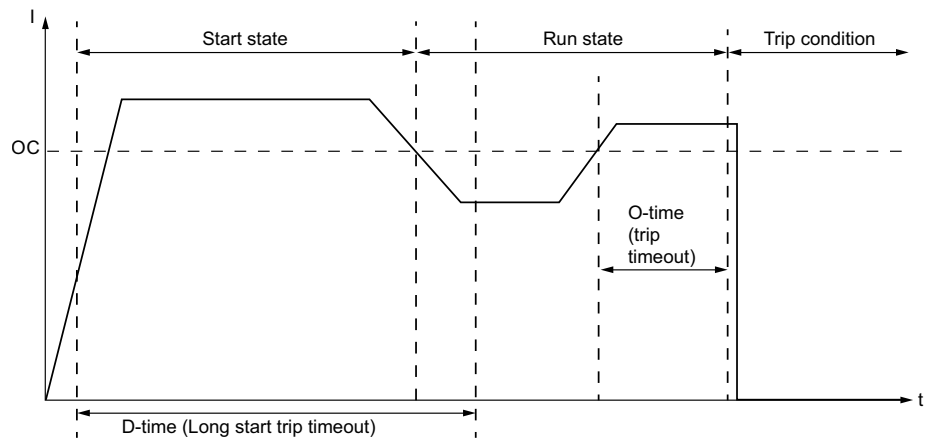

**OC** Trip threshold (OC1 or OC2)

## Motor Temperature Sensor

### Overview

The LTMR controller has 2 terminals T1 and T2 that can be connected to a motor temperature sensing element to provide protection for motor windings by detecting high temperature conditions that could lead to damage or degradation.

These protections are activated when the Motor Temp Sensor Type parameter is set to one of the following settings:

- PTC Binary, page 85
- PT100, page 86
- PTC Analog, page 88
- NTC Analog, page 90

Only one of these motor protection sensing elements can be enabled at a time.

**NOTE:** Motor temperature sensor protection is based in ohms. PTC Binary protection thresholds are pre-set to IEC standards and are non-configurable. PTC Analog and NTC Analog protection functions may require that you scale the resistance value to the corresponding threshold level in degrees, based on the properties of the selected sensing element.

When a sensor type is changed, the LTMR controller motor temperature sensing configuration settings revert to their factory settings. If a sensor type is replaced with another sensor of the same type, the setting values are retained.

### Parameter Settings

The motor temperature sensor function has the following configurable parameter settings, which apply to the selected motor temp sensor type:

| Parameters   | Setting Range                                                                                                                               | Factory Setting |
|--------------|---------------------------------------------------------------------------------------------------------------------------------------------|-----------------|
| Sensor type  | <ul style="list-style-type: none"> <li>• None</li> <li>• PTC Binary</li> <li>• PT100</li> <li>• PTC Analog</li> <li>• NTC Analog</li> </ul> | None            |
| Trip enable  | Enable/Disable                                                                                                                              | Disable         |
| Alarm enable | Enable/Disable                                                                                                                              | Disable         |

## Motor Temperature Sensor - PTC Binary

### Description

The PTC Binary motor temperature sensing function is enabled when the Motor Temp Sensor Type parameter is set to **PTC Binary** and the LTMR controller is connected to a binary positive temperature coefficient thermistor embedded in the motor.

The LTMR controller monitors the state of the temperature sensing element and signals:

- a motor temperature sensor alarm when the measured resistance exceeds a fixed threshold.
- a motor temperature sensor trip when the measured resistance exceeds the same fixed threshold.

The trip and alarm conditions continue until measured resistance falls below a separate fixed motor temperature sensor re-closing threshold.

Motor temperature sensing trip thresholds are factory pre-set and are not configurable. Trip monitoring can be enabled or disabled.

The function is available for all operating states.

### Functional Characteristics

The PTC Binary motor temperature sensor function includes the following features:

- 2 function output:
  - Motor Temp Sensor Alarm
  - Motor Temp Sensor Trip
- 1 counting statistic:
  - Motor Temp Sensor Trips Count

### Block Diagram

**Motor temperature sensor trip/alarm:**

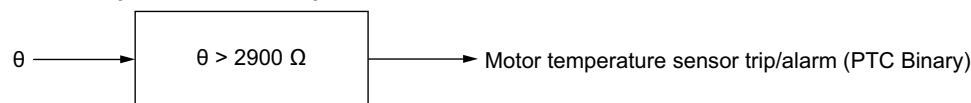

**θ** Temperature sensing element resistance

## Parameter Settings

The PTC binary motor temperature sensor function has the following non-configurable parameter settings:

| Parameter                       | Fixed settings | Accuracy |
|---------------------------------|----------------|----------|
| Trip/Alarm threshold            | 2900 $\Omega$  | +/- 2 %  |
| Trip/Alarm re-closing threshold | 1575 $\Omega$  | +/- 2 %  |

## Technical Characteristics

The PTC binary motor temperature sensor function has the following characteristics:

| Characteristic          | Value       |
|-------------------------|-------------|
| Detection time          | 0.5...0.6 s |
| Detection time accuracy | +/- 0.1 s   |

## Example

The following diagram describes the occurrence of a PTC binary motor temp sensor trip with an automatic reset:

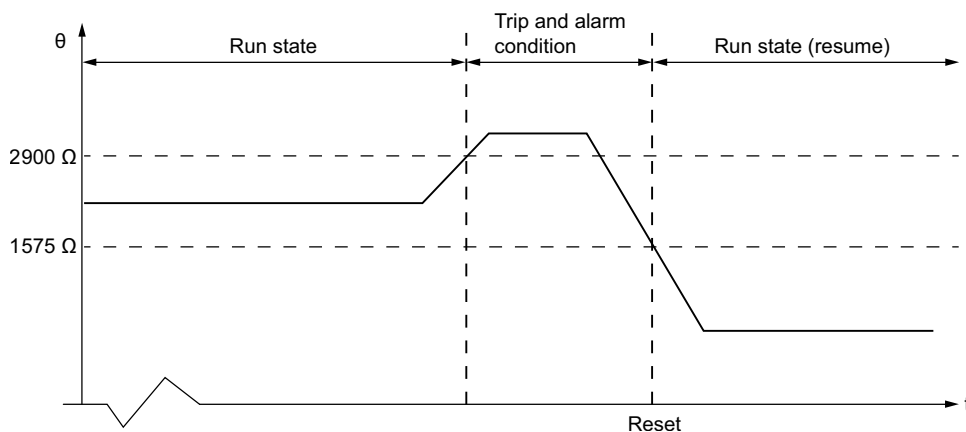

**2900  $\Omega$**  Trip threshold

**1575  $\Omega$**  Trip re-closing threshold

**Reset** This marks the time after which a reset can be executed. A start command is required before run state can be resumed. In this example, auto-reset has been enabled.

## Motor Temperature Sensor - PT100

### Description

The PT100 motor temperature sensing function is enabled when the Motor Temperature Sensor Type parameter is set to **PT100** and the LTMR controller is connected to a PT100 sensor embedded in the motor.

The LTMR controller monitors the state of the temperature sensing element and signals:

- Motor temperature sensor alarm when the measured temperature exceeds a configurable alarm threshold.

- Motor temperature sensor trip when the measured temperature exceeds a separately set trip threshold.

The LTMR directly measures the temperature with a PT100 sensor. The temperature measured by the PT100 sensor, either in °C (factory setting) or in °F, is displayed on the HMI or the TeSys T DTM, according to the Motor Temperature Sensor Display Degree CF parameter:

The trip or alarm condition continues until the measured temperature falls below 95 % of the trip or alarm threshold.

There is a fixed detection time of 0.5 s to 0.6 s to the motor temperature sensor trip or alarm.

Trip and alarm monitoring can be separately enabled and disabled.

The function is available for all operating states.

**NOTE:**

The temperature is derived from the following equation:  $T = 2.6042 * R - 260.42$ ,

where R = resistance (Ω).

**NOTE:** To connect a 3-wire PT100 sensor to an LTMR controller, simply do not wire the compensation pin of the 3-wire PT100 sensor.

## Functional Characteristics

The PT100 motor temperature sensor function includes the following features:

- 2 configurable thresholds:
  - Motor Temperature Sensor Alarm Threshold Degree
  - Motor Temperature Sensor Trip Threshold Degree
- 2 function outputs:
  - Motor Temperature Sensor Alarm
  - Motor Temperature Sensor Trip
- 1 counting statistic:
  - Motor Temperature Sensor Trips Count
- 1 display configuration:
  - Motor Temperature Sensor Display Degree CF

## Block Diagram

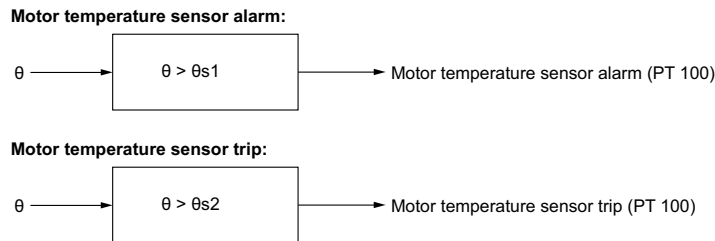

**θ** Temperature measured by the PT100 sensor

**θs1** Motor temperature sensor alarm threshold

**θs2** Motor temperature sensor trip threshold

## Parameter Settings

The PT100 motor temperature sensor function has the following configurable parameter settings:

| Parameters                                 | Setting Range                 | Factory Setting |
|--------------------------------------------|-------------------------------|-----------------|
| Trip threshold degree                      | 0...200 °C in 1 °C increments | 0 °C            |
| Alarm threshold degree                     | 0...200 °C in 1 °C increments | 0 °C            |
| Motor temperature sensor display degree CF | °C (0)<br>°F (1)              | °C              |

## Technical Characteristics

The PT100 motor temperature sensor function has the following characteristics:

| Characteristic     | Value                                      |
|--------------------|--------------------------------------------|
| Hysteresis         | -5 % of Alarm threshold and Trip threshold |
| Detection time     | 0.5...0.6 s                                |
| Trip time accuracy | +/-0.1 s                                   |

## Example

The following diagram describes a Motor temperature sensor PT100 trip with automatic reset and an active Run command:

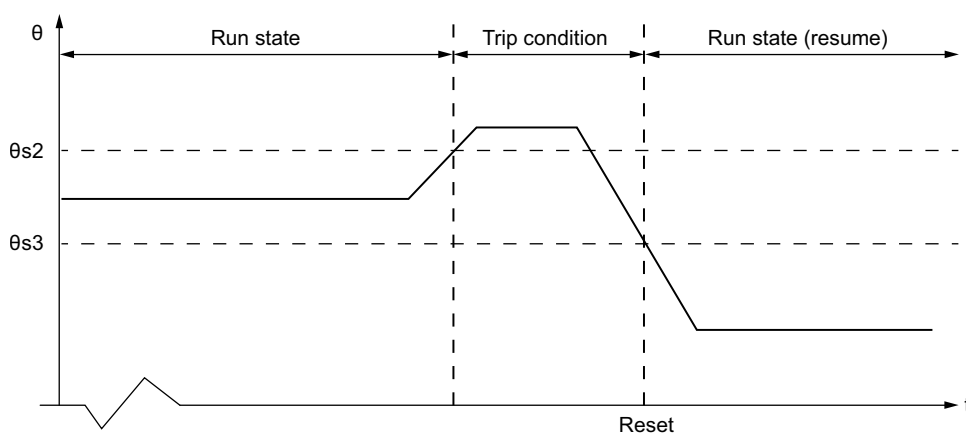

**θs2** Trip threshold

**θs3** Trip re-closing threshold (95% of trip threshold)

## Motor Temperature Sensor - PTC Analog

### Description

The PTC Analog motor temperature sensing function is enabled when the Motor Temp Sensor Type parameter is set to **PTC Analog** and the LTMR controller is connected to an analog PTC thermistor embedded in the motor.

The LTMR controller monitors the state of the temperature sensing element and signals:

- Motor temperature sensor alarm when the measured resistance exceeds a configurable alarm threshold.

- Motor temperature sensor trip when the measured resistance exceeds a separately set trip threshold.

The trip or alarm condition continues until the measured resistance falls below 95 % of the trip or alarm threshold.

Trip and alarm monitoring can be separately enabled and disabled.

The function is available for all operating states.

## Functional Characteristics

The PTC Analog motor temperature sensor function includes the following features:

- 2 configurable thresholds:
  - Motor Temp Sensor Alarm Threshold
  - Motor Temp Sensor Trip Threshold
- 2 function outputs:
  - Motor Temp Sensor Alarm
  - Motor Temp Sensor Trip
- 1 counting statistic:
  - Motor Temp Sensor Trips Count

## Block Diagram

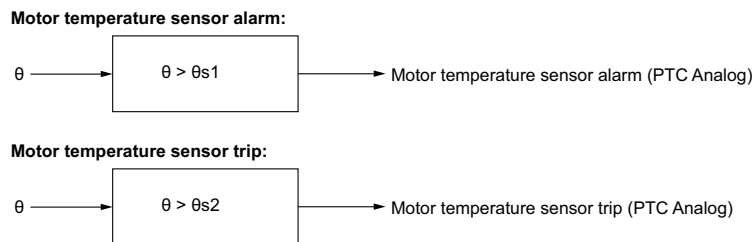

$\theta$  Temperature sensing element resistance

$\theta_{s1}$  Motor temperature sensor alarm threshold

$\theta_{s2}$  Motor temperature sensor trip threshold

## Parameter Settings

The PTC analog motor temperature sensor function has the following configurable parameter settings:

| Parameters      | Setting Range                                 | Factory Setting |
|-----------------|-----------------------------------------------|-----------------|
| Trip threshold  | 20...6500 $\Omega$ in 0.1 $\Omega$ increments | 20 $\Omega$     |
| Alarm threshold | 20...6500 $\Omega$ in 0.1 $\Omega$ increments | 20 $\Omega$     |

## Technical Characteristics

The PTC analog motor temperature sensor function has the following characteristics:

| Characteristic          | Value                                      |
|-------------------------|--------------------------------------------|
| Hysteresis              | -5 % of Alarm threshold and Trip threshold |
| Detection time          | 0.5...0.6 s                                |
| Detection time accuracy | +/-0.1 s                                   |

## Example

The following diagram describes a Motor temperature sensor PTC analog trip with automatic reset and an active Run command:

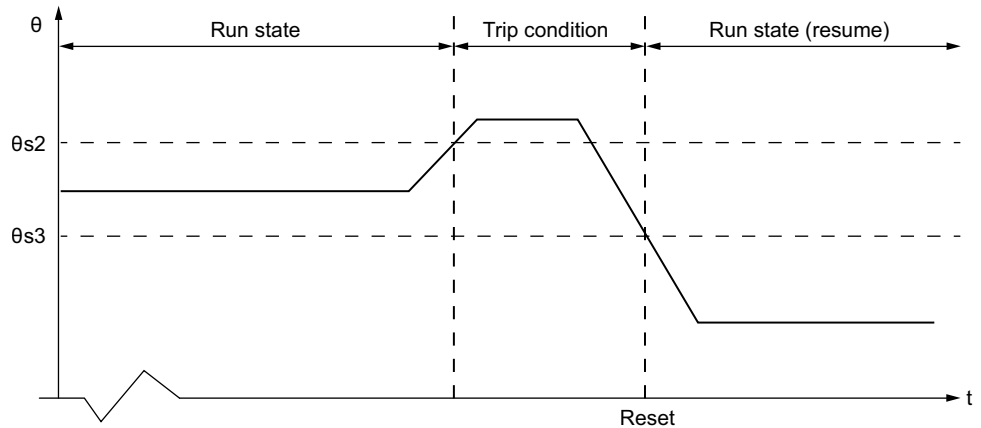

**theta\_s2** Trip threshold

**theta\_s3** Trip re-closing threshold (95% of trip threshold)

## Motor Temperature Sensor - NTC Analog

### Description

The NTC Analog motor temperature sensing function is enabled when the Motor Temp Sensor Type parameter is set to **NTC Analog** and the LTMR controller is connected to an analog NTC thermistor embedded in the motor.

The LTMR controller monitors the state of the temperature sensing element and signals:

- Motor temperature sensor alarm when the measured resistance falls below a configurable alarm threshold.
- Motor temperature sensor trip when the measured resistance falls below a separately set trip threshold.

The trip or alarm condition continues until the measured resistance exceeds 105 % of the trip or alarm threshold.

Trip and alarm monitoring can be separately enabled and disabled.

The function is available for all operating states.

### Functional Characteristics

The NTC Analog motor temperature sensor function includes the following features:

- 2 configurable thresholds:
  - Alarm Threshold
  - Trip Threshold

- 2 function outputs:
  - Motor Temp Sensor Alarm
  - Motor Temp Sensor Trip
- 1 counting statistic:
  - Motor Temp Sensor Trips Count

## Block Diagram

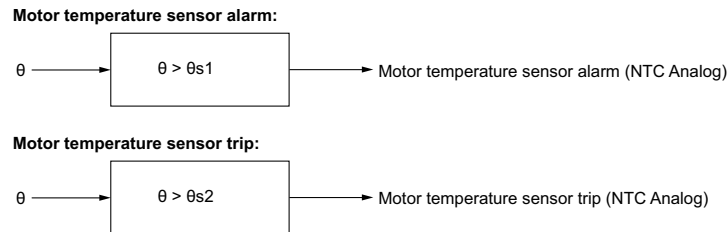

**$\theta$**  Temperature sensing element resistance

**$\theta_{s1}$**  Motor temperature sensor alarm threshold

**$\theta_{s2}$**  Motor temperature sensor trip threshold

## Parameter Settings

The NTC analog motor temperature sensor function has the following configurable parameter settings:

| Parameters      | Setting Range                                 | Factory Setting |
|-----------------|-----------------------------------------------|-----------------|
| Trip threshold  | 20...6500 $\Omega$ in 0.1 $\Omega$ increments | 20 $\Omega$     |
| Alarm threshold | 20...6500 $\Omega$ in 0.1 $\Omega$ increments | 20 $\Omega$     |

## Technical Characteristics

The NTC analog motor temperature sensor function has the following characteristics:

| Characteristics         | Value                                        |
|-------------------------|----------------------------------------------|
| Hysteresis              | + 5 % of Alarm threshold and Trip thresholds |
| Detection time          | 0.5...0.6 s                                  |
| Detection time accuracy | +/- 0.1 s                                    |

## Example

The following diagram describes a Motor temperature sensor NTC analog trip with automatic reset:

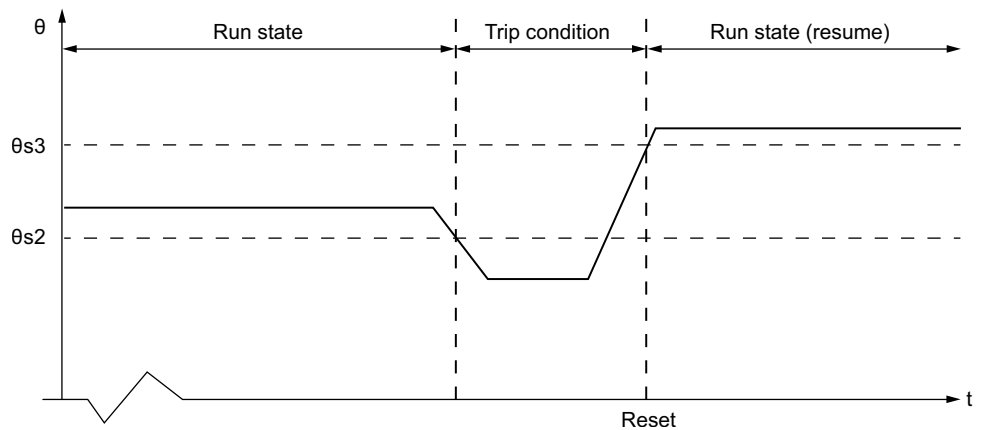

**θr2** Trip threshold

**θr3** Trip re-closing threshold (105% of trip threshold)

## Rapid Cycle Lockout

### Description

The rapid cycle lockout function helps prevent potential harm to the motor caused by repetitive, successive inrush currents resulting from too little time between starts.

The rapid cycle lockout function provides a configurable timer, which begins its count when the LTMR controller detects On Level Current—defined as 20 % of FLC. At the same time the Rapid Cycle Lockout bit is set.

If the LTMR controller detects a Run command before the rapid cycle lockout has elapsed, the:

- Rapid Cycle Lockout bit remains set
- LTMR controller ignores the Run command. It helps prevent the motor from restarting
- HMI device (if attached) displays "WAIT"
- LTMR controller Alarm LED flashes red 5 times per second, indicating the LTMR controller has disabled motor outputs thereby helping prevent an undesirable condition caused by starting the motor
- LTMR controller monitors the wait time—if more than 1 timer is active, the LTMR controller reports the minimum wait time before the longest timer elapses

On power loss, the LTMR controller helps preserve the state of the lockout timer in non-volatile memory. When the LTMR controller next powers up, the timer restarts its count and again ignores Run commands until the timer completes the timeout.

Setting the Rapid Cycle Lockout Timeout parameter to 0 disables this function.

The Rapid Cycle Lockout Timeout setting can be edited when the LTMR controller is in its normal operating state. If an edit is made while the timer is counting, the edit is effective when the timer finishes counting.

This function has no alarm and no trip.

**NOTE:** The Rapid Cycle Lockout function is not active when the overload operating mode is selected.

## Functional Characteristics

The rapid cycle lockout function includes the following parameters:

- 1 time delay:
  - Rapid Cycle Lockout Timeout
- 1 status bit:
  - Rapid Cycle Lockout

In addition, the Rapid Cycle Lockout function:

- Disables motor outputs
- Causes the LTMR Alarm LED to flash 5 times per second

## Parameter Settings

The rapid cycle lockout function has the following parameters:

| Parameters                  | Setting Range                   | Factory Setting |
|-----------------------------|---------------------------------|-----------------|
| Rapid cycle lockout timeout | 0...9999 s in increments of 1 s | 0 s             |

## Technical Characteristics

The rapid cycle lockout function has the following characteristics:

| Characteristics    | Value               |
|--------------------|---------------------|
| Trip time accuracy | +/- 0.1 s or +/- 5% |

## Example

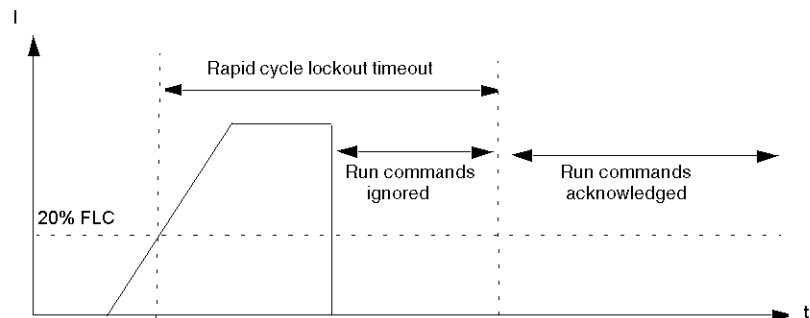

## Current Motor Protection Functions

### Overview

This section describes the current motor protection functions of the LTMR controller.

## Current Phase Imbalance

### Description

The current phase imbalance function signals:

- Alarm when the current in any phase differs by more than a set percentage from the average current in all 3 phases.
- Trip when the current in any phase differs by more than a separately set percentage from the average current in all 3 phases for a set period of time.

#### ▲ CAUTION

##### RISK OF MOTOR OVERHEATING

The Current Phase Imbalance Trip Threshold must be properly set to help protect the wiring and motor equipment from harm caused by motor overheating.

- The setting you input must conform to national and local safety regulations and codes.
- Refer to the motor manufacturer's instructions before setting this parameter.

**Failure to follow these instructions can result in injury or equipment damage.**

**NOTE:** Use this function to detect and guard against smaller current phase imbalances. For larger imbalances, in excess of 80 % of the average current in all 3 phases, use the current phase loss motor protection function.

This function has 2 adjustable trip time delays:

- One applies to current imbalances occurring while the motor is in start state, and
- One applies to current imbalances occurring after startup while the motor is in run state

Both timers begin if the imbalance is detected in start state.

The function identifies the phase causing a current imbalance. If the maximum deviation from the 3 phase current average is the same for 2 phases, the function identifies both phases.

Trip and alarm monitoring can be separately enabled and disabled.

The function applies only to 3-phase motors.

### Functional Characteristics

The current phase imbalance function includes the following features:

- 2 thresholds:
  - Alarm Threshold
  - Trip Threshold
- 2 trip time delays:
  - Trip Timeout Starting
  - Trip Timeout Running
- 2 function outputs:
  - Current Phase Imbalance Alarm
  - Current Phase Imbalance Trip
- 1 counting statistic:
  - Current Phase Imbalance Trips Count

- 3 indicators identifying the phase or phases with the highest current imbalance:
  - L1 Current Highest Imbalance
  - L2 Current Highest Imbalance
  - L3 Current Highest Imbalance

## Block Diagram

Current phase imbalance alarm and trip:

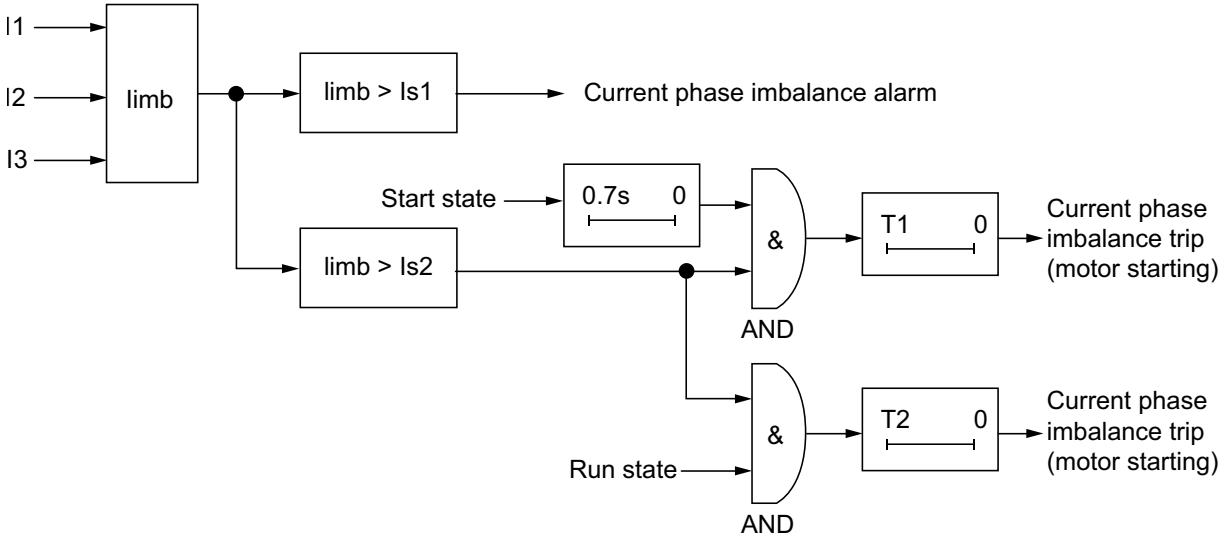

**I1** Phase 1 current

**I2** Phase 2 current

**I3** Phase 3 current

**limb** Current imbalance ratio for 3-phase

**Is1** Alarm threshold

**Is2** Trip threshold

**T1** Trip timeout starting

**T2** Trip timeout running

## Parameter Settings

The current phase imbalance function has the following parameters:

| Parameters            | Setting Range                                          | Factory Setting |
|-----------------------|--------------------------------------------------------|-----------------|
| Trip enable           | Enable/Disable                                         | Enable          |
| Trip timeout starting | 0.2...20 s in 0.1 s increments                         | 0.7 s           |
| Trip timeout running  | 0.2...20 s in 0.1 s increments                         | 5 s             |
| Trip threshold        | 10...70 % of the calculated imbalance in 1% increments | 10 %            |
| Alarm enable          | Enable/Disable                                         | Disable         |
| Alarm threshold       | 10...70 % of the calculated imbalance in 1% increments | 10 %            |

**NOTE:** A time of 0.7 second is added to the Trip timeout starting parameter to avoid nuisance tripping during the start phase.

## Technical Characteristics

The current phase imbalance function has the following characteristics:

| Characteristics    | Value                           |
|--------------------|---------------------------------|
| Hysteresis         | -5 % of trip or alarm threshold |
| Trip time accuracy | +/-0.1 s or +/-5 %              |

## Example

The following diagram describes the detection of a current phase imbalance occurring during run state.

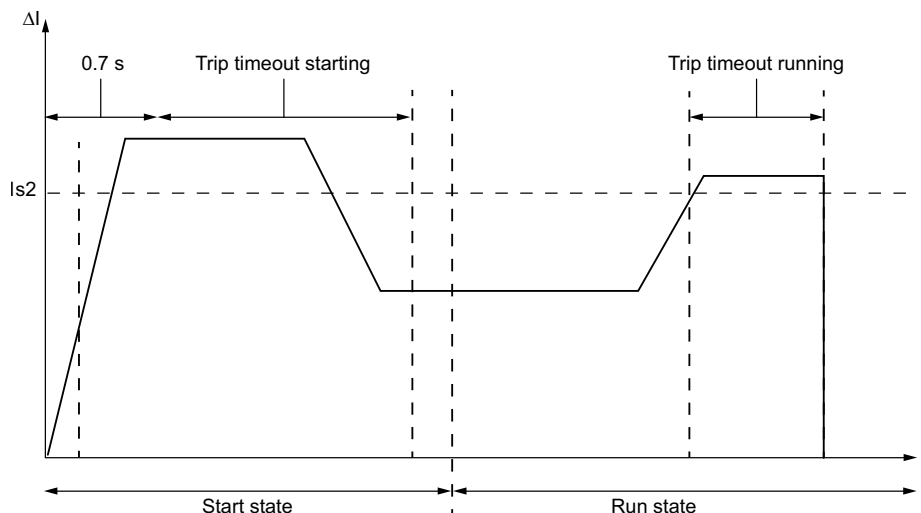

$\Delta I$  Percentage difference between current in any phase and the 3 phase current average

$I_{s2}$  Trip threshold

## Current Phase Loss

### Description

The current phase loss function signals:

- Alarm when the current in any phase differs by more than 80 % from the average current in all 3 phases.
- Trip when the current in any phase differs by more than 80 % from the average current in all 3 phases for a set period of time.

**NOTE:** Use this function to detect and guard against large current phase imbalances, in excess of 80 % of the average current in all 3 phases. For smaller current imbalances, use the current phase imbalance motor protection function.

This function has a single adjustable trip time delay, which is applied when the motor is in start state or run state.

The function identifies the phase experiencing a current loss. If the maximum deviation from the 3 phase current average is the same for 2 phases, the function identifies both phases.

Trip and alarm monitoring can be separately enabled and disabled.

The function applies only to 3-phase motors.

## Functional Characteristics

The current phase loss function includes the following features:

- 1 fixed trip and alarm threshold equal to 80 % of the 3 phase average current.
- 1 trip time delay:
  - Current Phase Loss Timeout
- 2 function outputs:
  - Current Phase Loss Alarm
  - Current Phase Loss Trip
- 1 counting statistic:
  - Current Phase Loss Trips Count
- 3 indicators identifying the phase or phases experiencing the current loss:
  - L1 Current loss
  - L2 Current loss
  - L3 Current loss

## Block Diagram

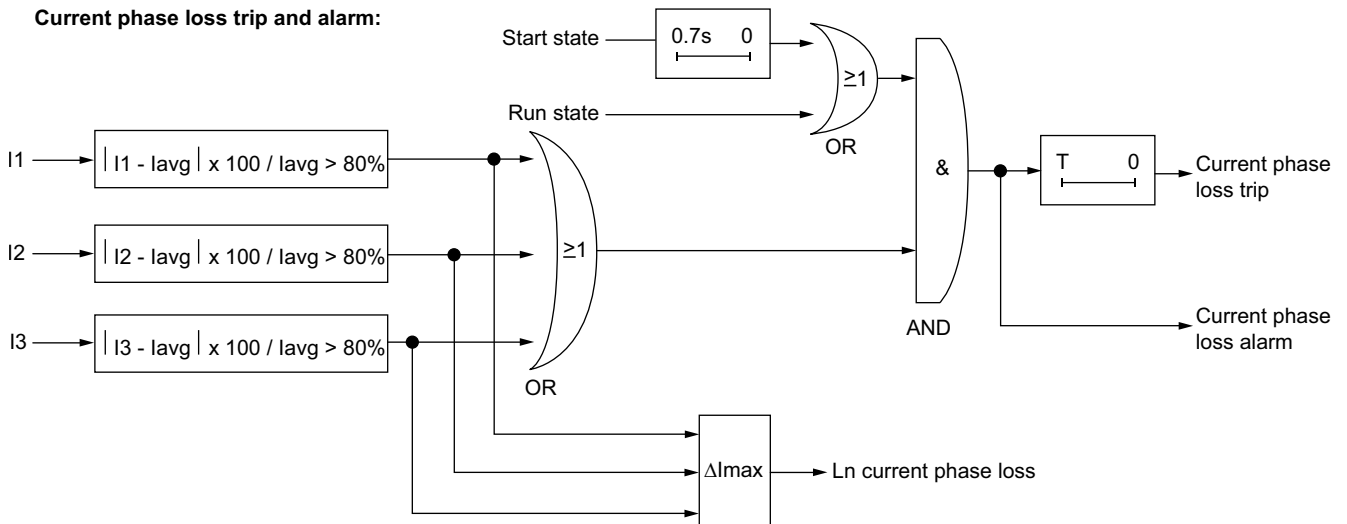

**I1** Phase 1 current

**I2** Phase 2 current

**I3** Phase 3 current

**Ln** Line current number or numbers with the greatest deviation from lavg

**lavg** 3 phase current average

**T** Trip timeout

## Parameter Settings

The current phase loss function has the following configurable parameters:

| Parameters   | Setting Range                  | Factory Setting |
|--------------|--------------------------------|-----------------|
| Trip enable  | Enable/Disable                 | Enable          |
| Timeout      | 0.1...30 s in 0.1 s increments | 3 s             |
| Alarm enable | Enable/Disable                 | Enable          |

**NOTE:** A time of 0.7 second is added to the Trip timeout parameter to avoid nuisance tripping during the start phase.

## Technical Characteristics

The current phase loss function has the following characteristics:

| Characteristics    | Value                               |
|--------------------|-------------------------------------|
| Hysteresis         | 75 % of the 3 phase average current |
| Trip time accuracy | +/-0.1 s or +/-5 %                  |

## Example

The following diagram describes the occurrence of a current phase loss trip of a motor in run state.

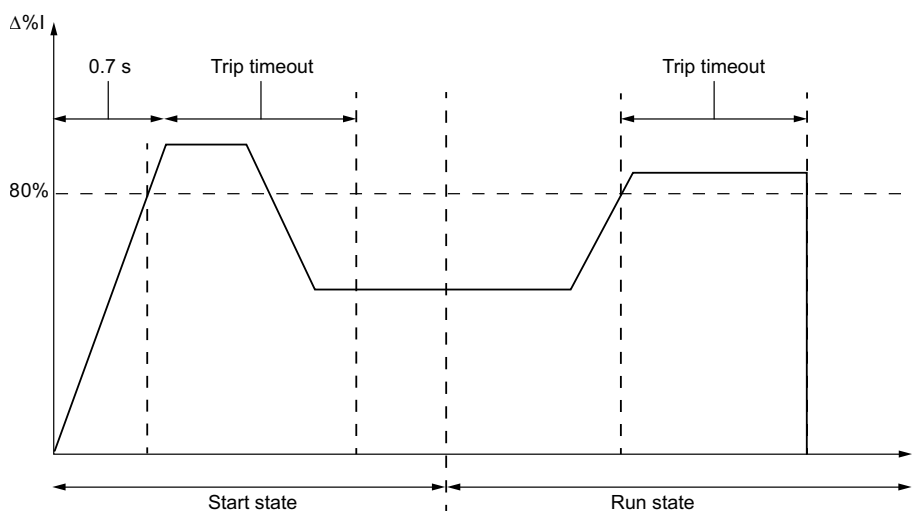

$\Delta\%I$  Percentage difference between current in any phase and the 3 phase current average

## Current Phase Reversal

### Description

The current phase reversal function signals a trip when it detects that the current phases of a 3-phase motor are out of sequence with the Motor Phases Sequence parameter, ABC or ACB.

**NOTE:** When the LTMR controller is connected to an expansion module, phase reversal protection is based on voltage phase sequence before the motor starts, and on current phase sequence after the motor starts.

This function:

- Is active when the motor is in start state or run state
- Applies only to 3-phase motors
- Has no alarm and no timer.

This function can be enabled or disabled.

## Functional Characteristics

The current phase reversal function adds to one counting statistic, Wiring Trips Count.

## Parameter Settings

The current phase reversal function has the following configurable parameters:

| Parameters     | Setting Range                                                              | Factory Setting |
|----------------|----------------------------------------------------------------------------|-----------------|
| Trip enable    | Enable/Disable                                                             | Disable         |
| Phase sequence | <ul style="list-style-type: none"> <li>• A-B-C</li> <li>• A-C-B</li> </ul> | A-B-C           |

## Technical Characteristics

The current phase reversal function has the following characteristics:

| Characteristic             | Value                         |
|----------------------------|-------------------------------|
| Trip time at motor startup | within 0.2 s of motor startup |
| Trip time accuracy         | +/-0.1 s or +/-5%             |

## Long Start

### Description

The long start function detects a locked or stalled rotor in start state and signals a trip when current continuously exceeds a separately set threshold for the same period of time.

Each predefined operating mode has its own current profile, representing a successful start cycle for the motor. The LTMR controller detects a long start trip condition whenever the actual current profile, occurring after a start command, varies from the expected profile.

Trip monitoring can be separately enabled and disabled.

This function has no alarm.

### Start Cycle

The configurable parameters for the Long Start protection function, Long Start Trip Threshold and Long Start Trip Timeout, are used by the LTMR controller in defining and detecting the motor's start cycle. See Start Cycle, page 143.

## Functional Characteristics

The long start function includes the following features:

- 1 threshold:
  - Trip Threshold
- 1 trip time delay:
  - Trip Timeout

- 1 function outputs:
  - Long Start Trip
- 1 counting statistic:
  - Long Start Trips Count

## Block Diagram

Long start trip:

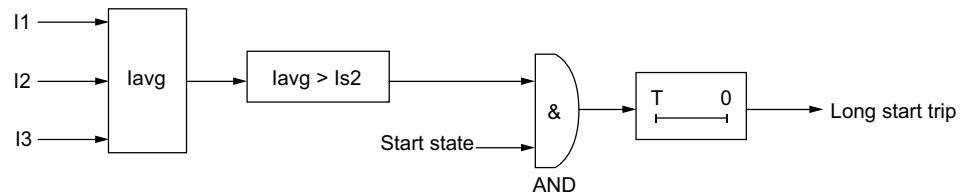

**I1** Phase 1 current

**I2** Phase 2 current

**I3** Phase 3 current

**Is2** Trip threshold

**T** Trip timeout

## Parameter Settings

The long start function has the following parameters:

| Parameters     | Setting Range               | Factory Setting |
|----------------|-----------------------------|-----------------|
| Trip enable    | Enable/Disable              | Enable          |
| Trip timeout   | 1...200 s in 1 s increments | 10 s            |
| Trip threshold | 100...800 % of FLC          | 100 % of FLC    |

## Technical Characteristics

The long start function has the following characteristics:

| Characteristic     | Value                  |
|--------------------|------------------------|
| Hysteresis         | -5 % of Trip threshold |
| Trip time accuracy | +/- 0.1 s or +/- 5 %   |

## Example

The following diagram describes the occurrence of a single threshold cross long start trip:

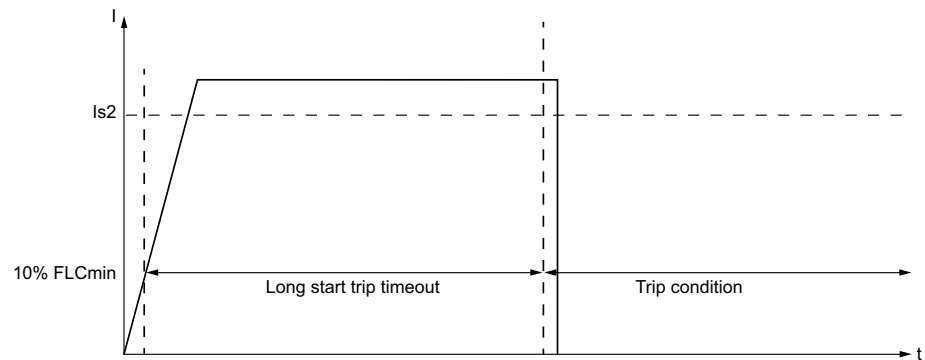

**Is2** Long start trip threshold

## Jam

### Description

The jam function detects a locked rotor during run state and signals:

- a alarm when current in any phase exceeds a set threshold, after the motor has reached run state.
- a trip when current in any phase continuously exceeds a separately set threshold for a specified period of time, after the motor has reached run state.

The jam function is triggered when the motor is jammed during run state and stops, or is suddenly overloaded and draws excessive current.

Trip and alarm monitoring can be separately enabled and disabled.

### Functional Characteristics

The jam function includes the following features:

- 2 thresholds:
  - Alarm Threshold
  - Trip Threshold
- 1 trip time delay:
  - Trip Timeout
- 2 function outputs:
  - Jam Alarm
  - Jam Trip
- 1 counting statistic:
  - Jam Trips Count

## Block Diagram

Jam alarm and trip:

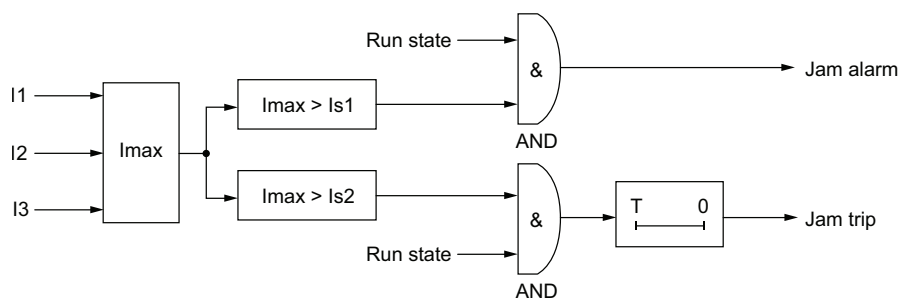

**I1** Phase 1 current

**I2** Phase 2 current

**I3** Phase 3 current

**Is1** Alarm threshold

**Is2** Trip threshold

**T** Trip timeout

## Parameter Settings

The jam function has the following parameters:

| Parameters      | Setting Range                        | Factory Setting |
|-----------------|--------------------------------------|-----------------|
| Trip enable     | Enable/Disable                       | Enable          |
| Trip timeout    | 1...30 s in 1 s increments           | 5 s             |
| Trip threshold  | 100...800 % of FLC in 1 % increments | 200 % of FLC    |
| Alarm enable    | Enable/Disable                       | Disable         |
| Alarm threshold | 100...800 % of FLC in 1 % increments | 200 % of FLC    |

## Technical Characteristics

The jam function has the following characteristics:

| Characteristics    | Value                                     |
|--------------------|-------------------------------------------|
| Hysteresis         | -5 % of Trip threshold or Alarm threshold |
| Trip time accuracy | +/-0.1 s or +/- 5 %                       |

## Example

The following diagram describes the occurrence of a jam trip.

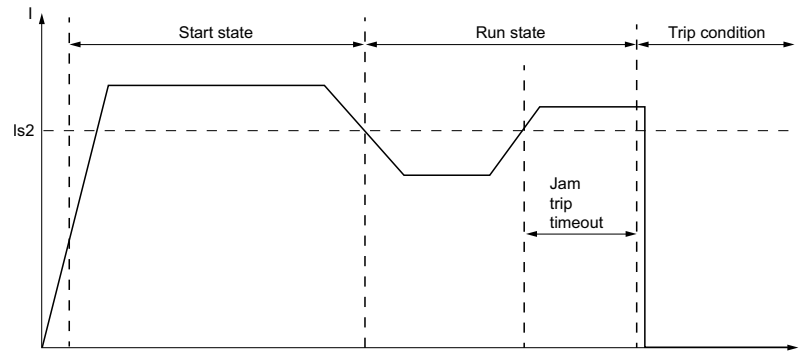

**Is2** Jam trip threshold

## Undercurrent

### Description

The undercurrent function signals:

- Alarm when the 3-phase Average Current falls below a set threshold, after the motor has reached run state.
- Trip when the 3-phase Average Current falls and remains below a separately set threshold for a set period of time, after the motor has reached run state.

The undercurrent function is triggered when the motor current falls below a defined level for the driven load, for example, if a drive belt or shaft has broken, allowing the motor to run free rather than under load. This function has a single trip time delay. Trip and alarm monitoring can be separately enabled and disabled.

### Functional Characteristics

The undercurrent function includes the following features:

- 2 thresholds:
  - Alarm Threshold
  - Trip Threshold
- 1 trip time delay:
  - Trip Timeout
- 2 function outputs:
  - Undercurrent Alarm
  - Undercurrent Trip
- 1 counting statistic:
  - Undercurrent Trips Count

## Block Diagram

### Undercurrent alarm and trip:

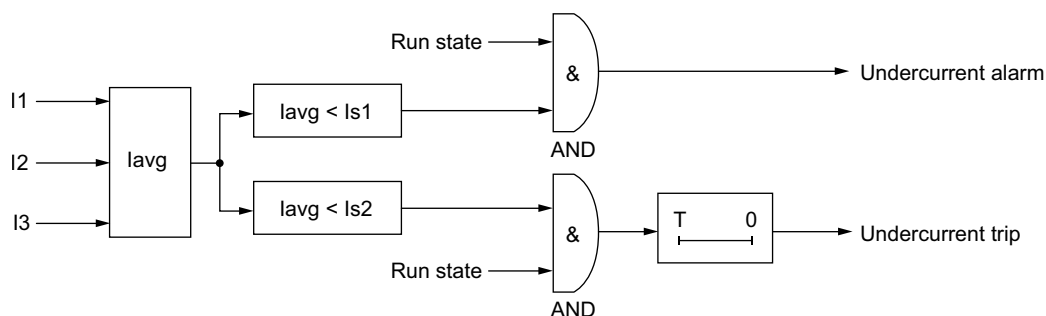

**lavg** Average current

**Is1** Alarm threshold

**Is2** Trip threshold

**T** Trip timer delay

## Parameter Settings

The undercurrent function has the following parameters:

| Parameters      | Setting Range                       | Factory Setting |
|-----------------|-------------------------------------|-----------------|
| Trip enable     | Enable/Disable                      | Disable         |
| Trip timeout    | 1...200 s in 1 s increments         | 1 s             |
| Trip threshold  | 30...100 % of FLC in 1 % increments | 50 % of FLC     |
| Alarm enable    | Enable/Disable                      | Disable         |
| Alarm threshold | 30...100 % of FLC in 1 % increments | 50 % of FLC     |

## Technical Characteristics

The undercurrent function has the following characteristics:

| Characteristics    | Value                                     |
|--------------------|-------------------------------------------|
| Hysteresis         | -5 % of Trip threshold or Alarm threshold |
| Trip time accuracy | +/- 0.1 s or +/- 5 %                      |

## Example

The following diagram describes the occurrence of an undercurrent trip.

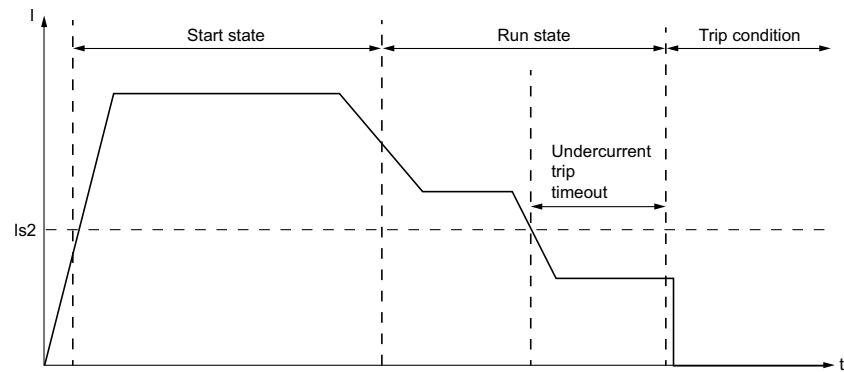

**Is2** Undercurrent trip threshold

## Overcurrent

### Description

The overcurrent function signals:

- Alarm when current in a phase exceeds a set threshold, after the motor has reached run state.
- Trip when current in a phase continuously exceeds a separately set threshold for a set period of time, after the motor has reached run state.

The overcurrent function can be triggered when the equipment is overloaded or a process condition is detected causing current to increase beyond the set threshold. This function has a single trip time delay. Trip and alarm monitoring can be separately enabled and disabled.

### Functional Characteristics

The overcurrent function includes the following features:

- 2 thresholds:
  - Alarm Threshold
  - Trip Threshold
- 1 trip time delay:
  - Trip Timeout
- 2 function outputs:
  - Overcurrent Alarm
  - Overcurrent Trip
- 1 counting statistic:
  - Overcurrent Trips Count

## Block Diagram

Overcurrent alarm and trip:

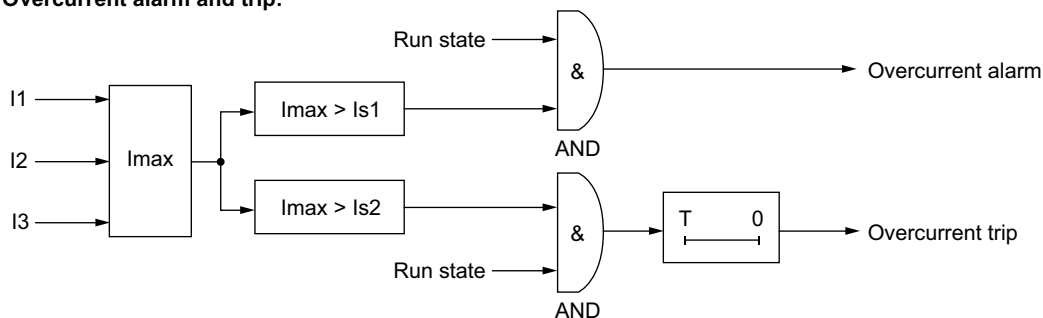

**I1** Phase 1 current

**I2** Phase 2 current

**I3** Phase 3 current

**Is1** Alarm threshold

**Is2** Trip threshold

**T** Trip timeout

## Parameter Settings

The overcurrent function has the following parameters:

| Parameters      | Setting Range                       | Factory Setting |
|-----------------|-------------------------------------|-----------------|
| Trip enable     | Enable/Disable                      | Disable         |
| Trip timeout    | 1...250 s in 1 s increments         | 10 s            |
| Trip threshold  | 30...800 % of FLC in 1 % increments | 200 % of FLC    |
| Alarm enable    | Enable/Disable                      | Disable         |
| Alarm threshold | 30...800 % of FLC in 1 % increments | 200 % of FLC    |

## Technical Characteristics

The overcurrent function has the following characteristics:

| Characteristics    | Value                                     |
|--------------------|-------------------------------------------|
| Hysteresis         | -5 % of Trip threshold or Alarm threshold |
| Trip time accuracy | +/- 0.1 s or +/- 5%                       |

## Example

The following diagram describes the occurrence of an overcurrent trip.

Overcurrent alarm and trip:

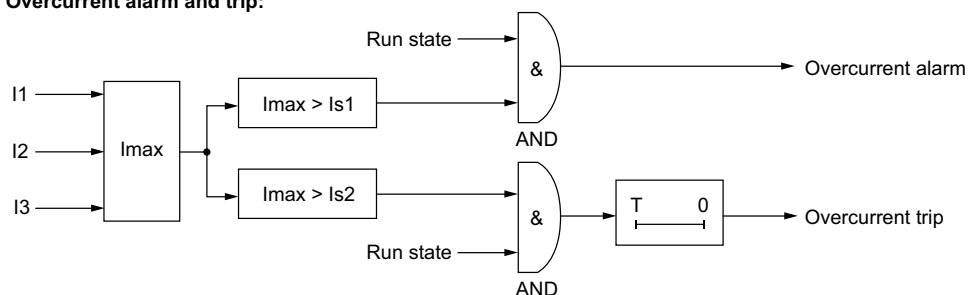

**Is2** Overcurrent trip threshold

## Ground Current

### Overview

The LTMR controller can be configured to detect ground current:

- Internally, by summing the 3-phase current signals from the secondary of the internal current transformers, page 107.
- Externally, by measuring the current delivered by the secondary of an external ground current sensor, page 110.

Use the Ground Current Mode parameter to select either internal or external ground current trip protection. Only one of these ground current mode settings can be activated at a time.

### Parameter Settings

The ground current protection function has the following configurable parameter settings, which apply to both internal and external ground current protection:

| Parameters                          | Setting Range                                                                    | Factory Setting |
|-------------------------------------|----------------------------------------------------------------------------------|-----------------|
| Ground current mode                 | <ul style="list-style-type: none"> <li>• Internal</li> <li>• External</li> </ul> | Internal        |
| Trip enable                         | Enable/Disable                                                                   | Enable          |
| Alarm enable                        | Enable/Disable                                                                   | Enable          |
| Ground trip disabled while starting | Enable/Disable                                                                   | Enable          |

## Internal Ground Current

### Description

The internal ground current function is enabled when the Ground Current Mode parameter is set to **Internal** and disabled when set to **External**.

**DANGER**
**IMPROPER TRIP DETECTION**

Internal ground current function will not protect people from harm caused by ground current.

Ground current trip thresholds must be set to protect the motor and related equipment.

Ground current trip settings must conform to national and local safety regulations and codes.

**Failure to follow these instructions will result in death or serious injury.**

The internal ground current function sums the current readings from the secondary of the internal current transformers and signals:

- Alarm when the summed current exceeds a set threshold.
- Trip when the summed current continuously exceeds a separately set threshold for a set period of time.

The internal ground current function has a single trip time delay.

The internal ground current function can be enabled when the motor is in ready state, start state, or run state. This function can be configured so that it is disabled during start state, and enabled only during ready state and run state.

Trip and alarm monitoring can be separately enabled and disabled.

## Functional Characteristics

The internal ground current function includes the following features:

- 1 measure of ground current in amperes:
  - Ground Current
- 1 measure of ground current as a % of FLCmin:
  - Ground Current Ratio
- 2 thresholds:
  - Alarm Threshold
  - Trip Threshold
- 1 trip time delay:
  - Trip Timeout
- 2 function outputs:
  - Internal Ground Current Alarm
  - Internal Ground Current Trip
- 1 counting statistic:
  - Ground Current Trips Count

## Block Diagram

### Internal ground current alarm and trip:

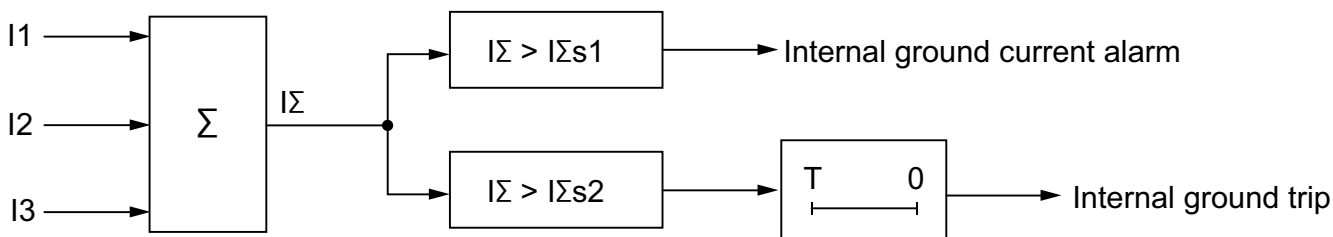

- I1** Phase 1 current
- I2** Phase 2 current
- I3** Phase 3 current
- IΣ** Summed current
- IΣs1** Alarm threshold
- IΣs2** Trip threshold
- T** Trip timeout

## Parameter Settings

The internal ground current function has the following parameters:

| Parameters                              | Setting Range                          | Factory Setting |
|-----------------------------------------|----------------------------------------|-----------------|
| Internal ground current trip timeout    | 0.5...25 s in 0.1 s increments         | 1 s             |
| Internal ground current trip threshold  | 50...500 % of FLCmin in 1 % increments | 50 % of FLCmin  |
| Internal ground current alarm threshold | 50...500 % of FLCmin in 1 % increments | 50 % of FLCmin  |

## Technical Characteristics

The internal ground current function has the following characteristics:

| Characteristics    | Value                                     |
|--------------------|-------------------------------------------|
| Hysteresis         | -5 % of Trip threshold or Alarm threshold |
| Trip time accuracy | +/- 0.1 s or +/-5 %                       |

## Example

The following diagram describes the occurrence of an internal ground current trip occurring during run state.

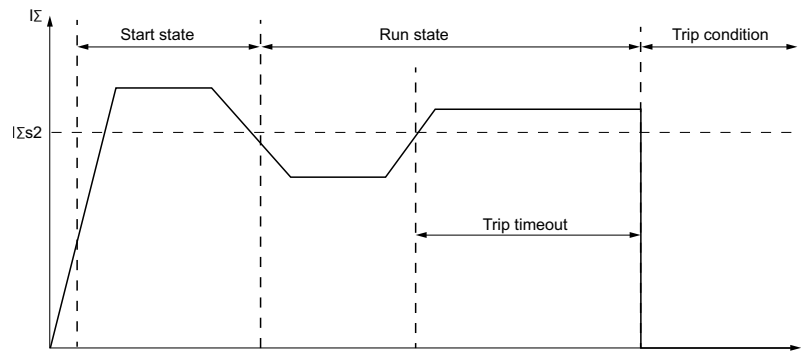

$I_{\Sigma s2}$  internal ground current trip threshold

## External Ground Current

### Description

The external ground current function is enabled when:

- The Ground Current Mode parameter is set to **External**, and
- A current transformation ratio is set.

When Ground Current Mode is set to **Internal**, the external ground current function is disabled.

⚡⚠ **DANGER**

**IMPROPER TRIP DETECTION**

External ground current function will not protect people from harm caused by ground current.

Ground current trip thresholds must be set to protect the motor and related equipment.

Ground current trip settings must conform to national and local safety regulations and codes.

**Failure to follow these instructions will result in death or serious injury.**

The LTMR controller has 2 terminals—Z1 and Z2—that can be connected to an external ground current sensor. The external ground current function measures ground current delivered by the secondary of the external current transformer and signals:

- Alarm when the delivered current exceeds a set threshold.
- Trip when the delivered current continuously exceeds a separately set threshold for a set period of time.

The external ground current function has a single trip time delay.

The external ground current function can be enabled when the motor is in ready state, start state, or run state. This function can be configured so that it is disabled only during start state, and enabled during ready state and run state.

Trip and alarm monitoring can be separately enabled and disabled.

## Functional Characteristics

The external ground current function includes the following features:

- 1 measure of ground current in amperes:
  - Ground Current
- 2 thresholds:
  - Alarm Threshold
  - Trip Threshold
- 1 trip time delay:
  - Trip Timeout
- 2 function outputs:
  - External Ground Current Alarm
  - External Ground Current Trip
- 1 counting statistic:
  - Ground Current Trips Count

## Block Diagram

External ground current alarm and trip:

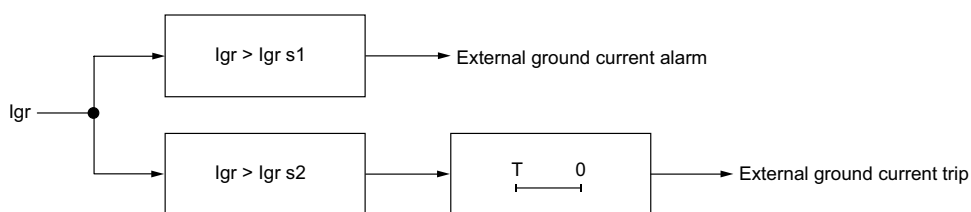

**Igr** Ground current from external ground CT

**Igr s1** Alarm threshold

**Igr s2** Trip threshold

**T** Trip timeout

## Parameter Settings

The external ground current function has the following parameters:

| Parameters                              | Setting Range                    | Factory Setting |
|-----------------------------------------|----------------------------------|-----------------|
| External ground current trip timeout    | 0.1...25 s in 0.01 s increments  | 0.5 s           |
| External ground current trip threshold  | 0.02...20 A in 0.01 A increments | 1 A             |
| External ground current alarm threshold | 0.02...20 A in 0.01 A increments | 1 A             |

## Technical Characteristics

The external ground current function has the following characteristics:

| Characteristics    | Value                                     |
|--------------------|-------------------------------------------|
| Hysteresis         | -5 % of Trip threshold or Alarm threshold |
| Trip time accuracy | +/- 0.1 s or +/- 5 %                      |

## Example

The following diagram describes the occurrence of an external ground current trip occurring during run state.

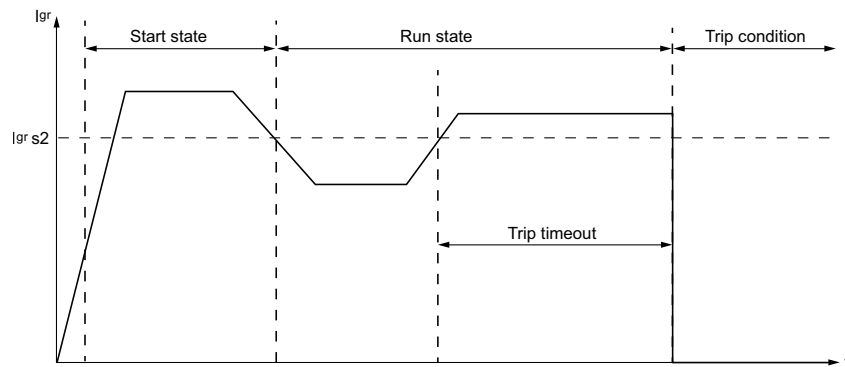

**Igr s2** External ground current trip threshold

## Voltage Motor Protection Functions

### Overview

This section describes the voltage motor protection functions provided by the LTMR controller.

### Voltage Phase Imbalance

#### Description

The voltage phase imbalance function signals:

- Alarm when the voltage in any composed phase differs by more than a set percentage from the average voltage in all 3 phases
- Trip when the voltage in any composed phase differs by more than a separately set percentage from the average voltage in all 3 phases for a set period of time

**NOTE:** A composed phase is the combined measure of 2 phases: L1 + L2, L2 + L3, or L3 + L1.

This function is:

- Active when the LTMR controller is connected to an expansion module
- Active when the average voltage is between 50 % and 120 % of the nominal voltage
- Available when the motor is in ready state, start state and run state
- Applies only to 3-phase motors

This function has 2 adjustable trip time delays:

- One applies to voltage imbalances occurring while the motor is in start state, and
- One applies to voltage imbalances occurring while the motor is in run state, or when the long start time duration expires

Both timers begin if the imbalance is detected in start state.

**NOTE:** Use this function to detect and guard against smaller voltage phase imbalances. For larger imbalances, in excess of 40 % of the average voltage in all 3 phases, use the voltage phase loss motor protection function.

Trip and alarm monitoring can be separately enabled and disabled.

## Functional Characteristics

The voltage phase imbalance function includes the following features:

- 2 thresholds:
  - Alarm Threshold
  - Trip Threshold
- 2 trip time delays:
  - Trip Timeout Starting
  - Trip Timeout Running
- 2 function outputs:
  - Voltage Phase Imbalance Alarm
  - Voltage Phase Imbalance Trip
- 1 counting statistic:
  - Voltage Phase Imbalance Trips Count
- 3 indicators identifying the phase with the highest voltage imbalance:
  - L1-L2 Highest Imbalance
  - L2-L3 Highest Imbalance
  - L3-L1 Highest Imbalance

## Block Diagram

Voltage phase imbalance alarm:

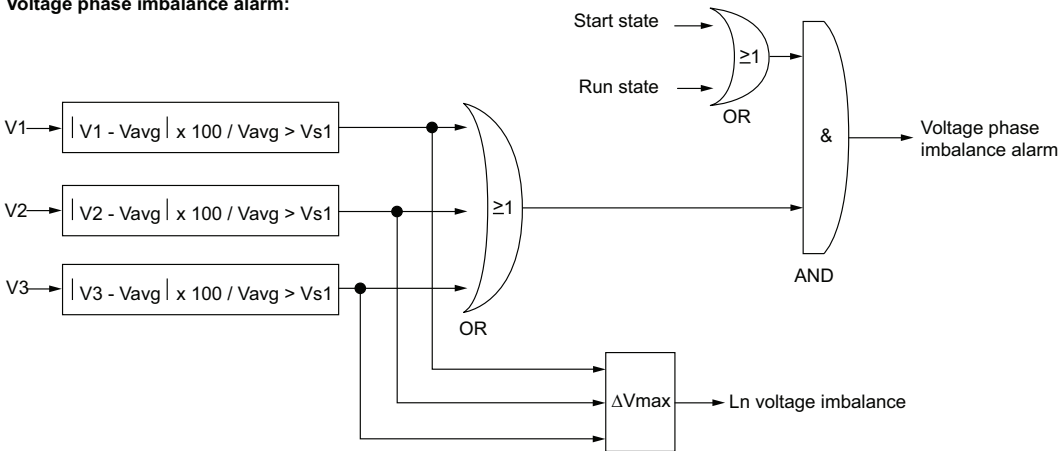

Voltage phase imbalance trip:

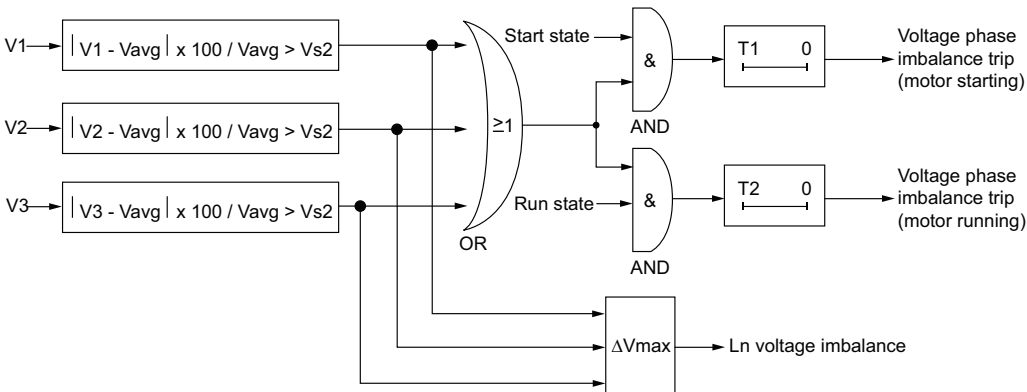

- V1** L1-L2 voltage
- V2** L2-L3 voltage
- V3** L3-L1 voltage
- Ln** Line number or numbers with greatest deviation from  $V_{avg}$
- Vs1** Alarm threshold
- Vs2** Trip threshold
- Vavg** 3 phase voltage average
- T1** Trip timeout starting
- T2** Trip timeout running

## Parameter Settings

The voltage phase imbalance function has the following parameters:

| Parameters            | Setting Range                                          | Factory Setting |
|-----------------------|--------------------------------------------------------|-----------------|
| Trip enable           | Enable/Disable                                         | Disable         |
| Trip timeout starting | 0.2...20 s in 0.1 s increments                         | 0.7 s           |
| Trip timeout running  | 0.2...20 s in 0.1 s increments                         | 2 s             |
| Trip threshold        | 3...15 % of the calculated imbalance in 1 % increments | 10 %            |
| Alarm enable          | Enable/Disable                                         | Disable         |
| Alarm threshold       | 3...15 % of the calculated imbalance in 1 % increments | 10 %            |

## Technical Characteristics

The voltage phase imbalance function has the following characteristics:

| Characteristics    | Value                                     |
|--------------------|-------------------------------------------|
| Hysteresis         | -5 % of Trip threshold or Alarm threshold |
| Trip time accuracy | +/- 0.1 s or +/- 5 %                      |

## Example

The following diagram describes the occurrence of a voltage phase imbalance:

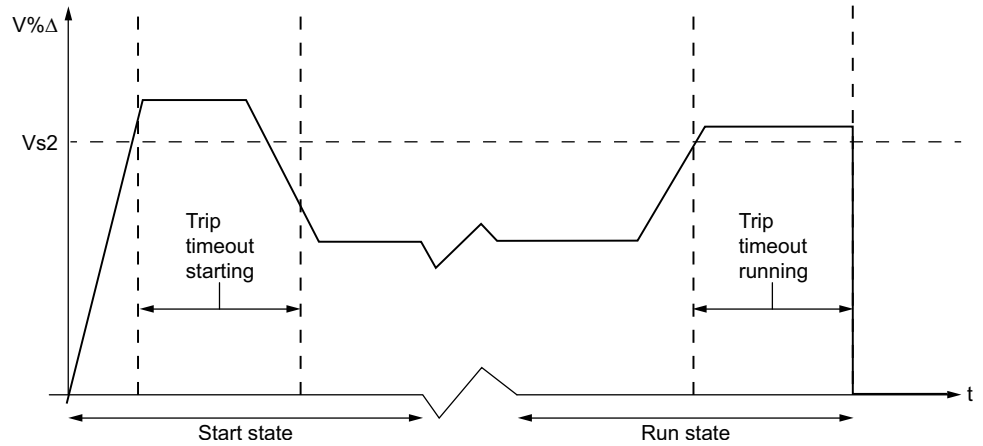

**V%Δ** Percentage difference between voltage in any phase and the 3 phase average voltage

**Vs2** Trip threshold

## Voltage Phase Loss

### Description

The voltage phase loss function is based on the Voltage Phase Imbalance function and signals:

- a alarm when the voltage in any phase differs by more than a 38 % from the average voltage in all 3 phases.
- a trip when the voltage in any phase differs by more than 38 % from the average voltage in all 3 phases for a set period of time.

This function is:

- Active when the LTMR controller is connected to an expansion module
- Active when the average voltage is between 50 % and 120 % of the nominal voltage
- Available when the motor is in ready state, start state or run state
- Applies only to 3-phase motors

This function has a single adjustable trip time delay.

**NOTE:** Use this function to detect and guard against large voltage phase imbalances, in excess of 40 % of the average voltage in all 3 phases. For smaller voltage imbalances, use the voltage phase imbalance motor protection function.

The function identifies the phase experiencing a voltage loss. If the maximum deviation from the 3 phase voltage average is the same for 2 phases, the function identifies both phases.

Trip and alarm monitoring can be separately enabled and disabled.

## Functional Characteristics

The voltage phase loss function includes the following features:

- A fixed trip and alarm threshold equal to 38 % of the 3 phase average voltage.
- A single, adjustable trip time delay:
  - Voltage Phase Loss Timeout

- 2 function outputs:
  - Voltage Phase Loss Alarm
  - Voltage Phase Loss Trip
- 1 counting statistic:
  - Voltage Phase Loss Trips Count
- 3 indicators identifying the phase experiencing the voltage loss:
  - L1-L2 Voltage loss
  - L2-L3 Voltage loss
  - L3-L1 Voltage loss

## Block Diagram

Voltage phase loss trip and alarm:

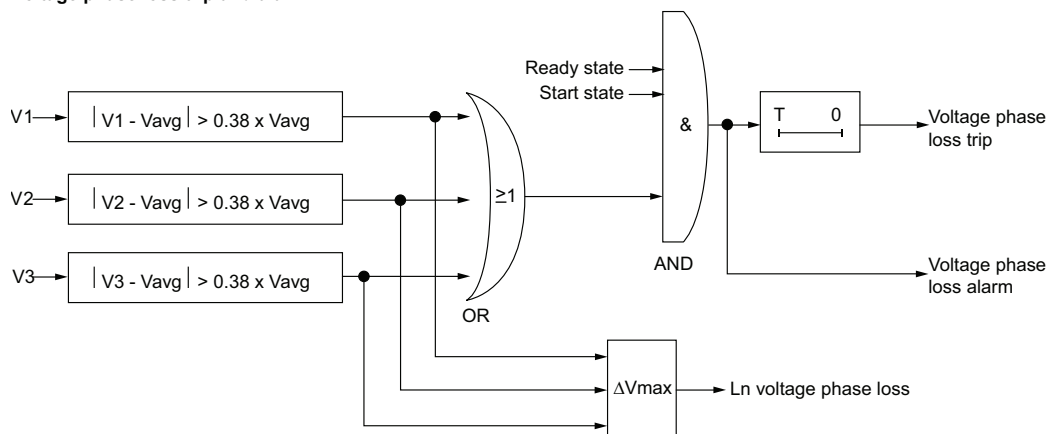

**V1** L1-L2 voltage

**V2** L2-L3 voltage

**V3** L3-L1 voltage

**Ln** Line voltage number or numbers with the greatest deviation from Vavg

**Vavg** 3 phase average voltage

**T** Trip timeout

## Parameter Settings

The voltage phase loss function has the following configurable parameters:

| Parameters   | Setting Range                  | Factory Setting |
|--------------|--------------------------------|-----------------|
| Trip enable  | Enable/Disable                 | Enable          |
| Trip timeout | 0.1...30 s in 0.1 s increments | 3 s             |
| Alarm enable | Enable/Disable                 | Enable          |

## Technical Characteristics

The voltage phase loss function has the following characteristics:

| Characteristics    | Value                               |
|--------------------|-------------------------------------|
| Hysteresis         | 45 % of the 3 phase average voltage |
| Trip time accuracy | +/- 0.1 s or +/- 5%                 |

## Example

The following diagram describes the occurrence of a voltage phase loss trip of a motor in run state:

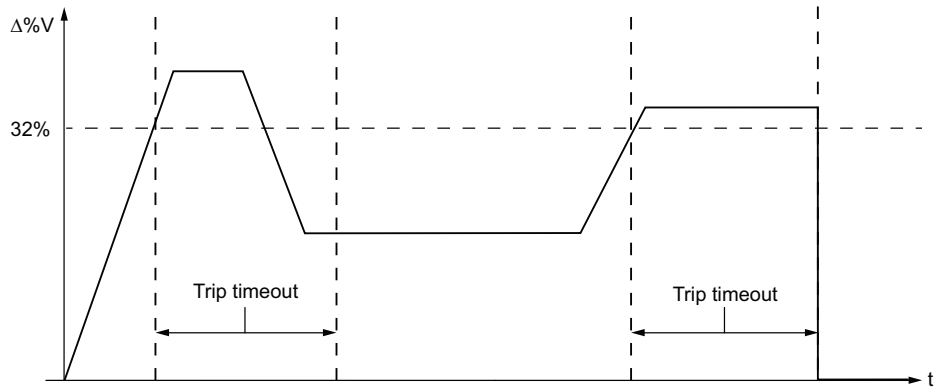

**ΔV%** Percentage difference between voltage in any phase and the 3 phase average voltage

## Voltage Phase Reversal

### Description

The voltage phase reversal function signals a trip when it detects that the voltage phases of a 3-phase motor are out of sequence, usually indicating a wiring trip. Use the Motor Phases Sequence parameter to configure the direction, ABC or ACB, in which the motor will turn.

This function :

- Available when the LTMR controller is connected to an expansion module
- Active when the average voltage is between 50 % and 120 % of the nominal voltage
- Available when the motor is in ready state, start state and run state
- Applies only to 3-phase motors
- Has no alarm and no timer

This function can be enabled or disabled.

### Functional Characteristics

The voltage phase reversal function adds one counting statistic, Wiring Trips Count.

### Parameter Settings

The voltage phase reversal function has the following configurable parameters:

| Parameters            | Setting Range                                                              | Factory Setting |
|-----------------------|----------------------------------------------------------------------------|-----------------|
| Trip enable           | Enable/Disable                                                             | Disable         |
| Motor phases sequence | <ul style="list-style-type: none"> <li>• A-B-C</li> <li>• A-C-B</li> </ul> | A-B-C           |

## Technical Characteristics

The voltage phase reversal function has the following characteristics:

| Characteristics    | Value        |
|--------------------|--------------|
| Trip time          | within 0.2 s |
| Trip time accuracy | +/- 0.1 s    |

## Undervoltage

### Description

The undervoltage function signals:

- Alarm when voltage in a phase falls below a set threshold.
- Trip when voltage in a phase falls and remains below a separately set threshold for a set period of time.

This function has a single trip time delay. Both the trip and alarm thresholds are defined as a percentage of the Motor Nominal Voltage (Vnom) parameter setting.

The undervoltage function is available only in ready state and run state, when the LTMR controller is connected to an expansion module.

Trip and alarm monitoring can be separately enabled and disabled.

### Functional Characteristics

The undervoltage function includes the following features:

- 2 thresholds:
  - Alarm Threshold
  - Trip Threshold
- 1 trip time delay:
  - Trip Timeout
- 2 function outputs:
  - Undervoltage Alarm
  - Undervoltage Trip
- 1 counting statistic:
  - Undervoltage Trips Count

## Block Diagram

Undervoltage alarm and trip:

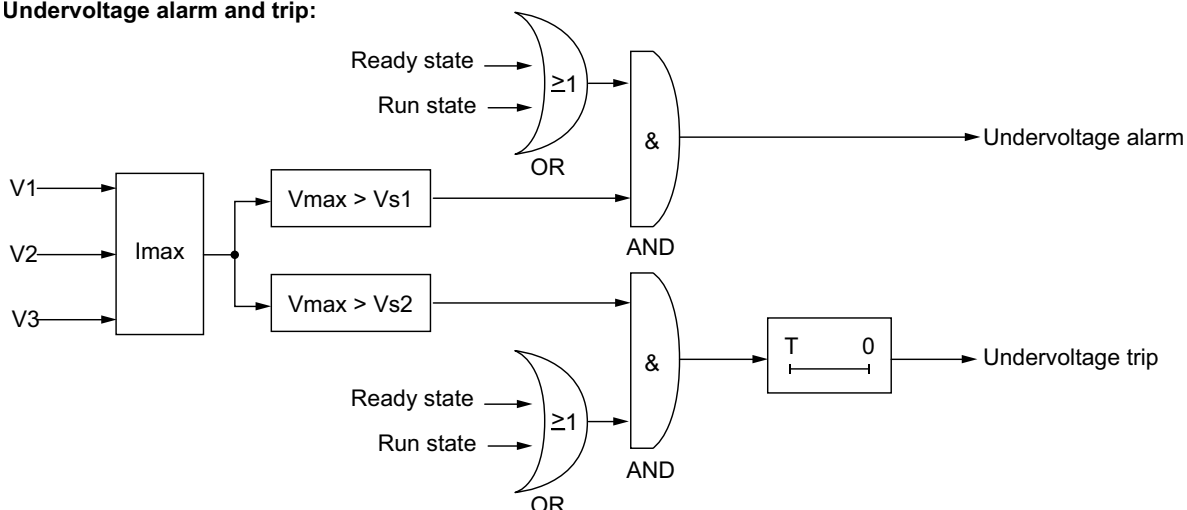

**V1** L1-L2 voltage

**V2** L2-L3 voltage

**V3** L3-L1 voltage

**Vs1** Alarm threshold

**Vs2** Trip threshold

**T** Trip timeout

## Parameter Settings

The undervoltage function has the following parameters:

| Parameters      | Setting Range                                        | Factory Setting |
|-----------------|------------------------------------------------------|-----------------|
| Trip enable     | Enable/Disable                                       | Disable         |
| Trip timeout    | 0.2...25 s in 0.1 s increments                       | 3 s             |
| Trip threshold  | 70...99 % of Motor nominal voltage in 1 % increments | 85 %            |
| Alarm enable    | Enable/Disable                                       | Disable         |
| Alarm threshold | 70...99 % of Motor nominal voltage in 1 % increments | 85 %            |

## Technical Characteristics

The undervoltage function has the following characteristics:

| Characteristics    | Value                                     |
|--------------------|-------------------------------------------|
| Hysteresis         | -5 % of Trip threshold or Alarm threshold |
| Trip time accuracy | +/- 0.1 s or +/- 5 %                      |

## Example

The following diagram describes the occurrence of an undervoltage trip.

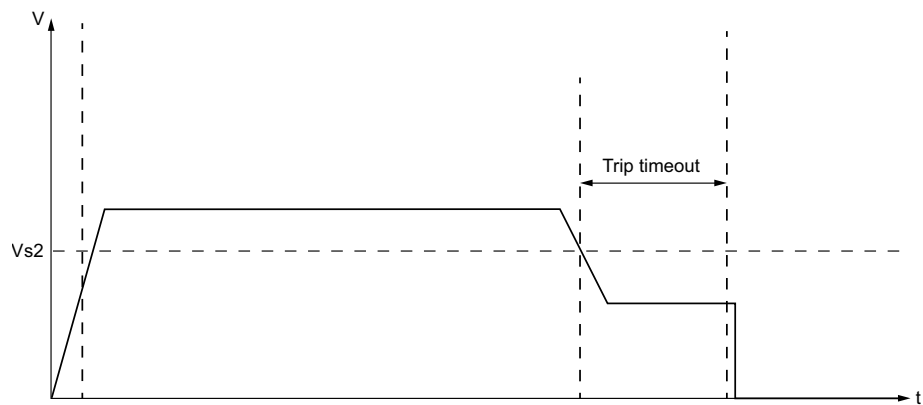

**Vs2** Undervoltage trip threshold

## Overvoltage

### Description

The overvoltage function signals:

- Alarm when voltage in a phase exceeds a set threshold.
- Trip when voltage in a phase continuously exceeds a separately set threshold for a specified period of time.

This function has a single trip time delay. Both the trip and alarm thresholds are defined as a percentage of the Motor Nominal Voltage ( $V_{nom}$ ) parameter setting.

The overvoltage function is available in ready state and run state, when the LTMR controller is connected to an expansion module.

Trip and alarm monitoring can be separately enabled and disabled.

## Functional Characteristics

The overvoltage function includes the following features:

- 2 thresholds:
  - Alarm Threshold
  - Trip Threshold
- 1 trip time delay:
  - Trip Timeout
- 2 function outputs:
  - Overvoltage Alarm
  - Overvoltage Trip
- 1 counting statistic:
  - Overvoltage Trips Count

## Block Diagram

Overvoltage alarm and trip:

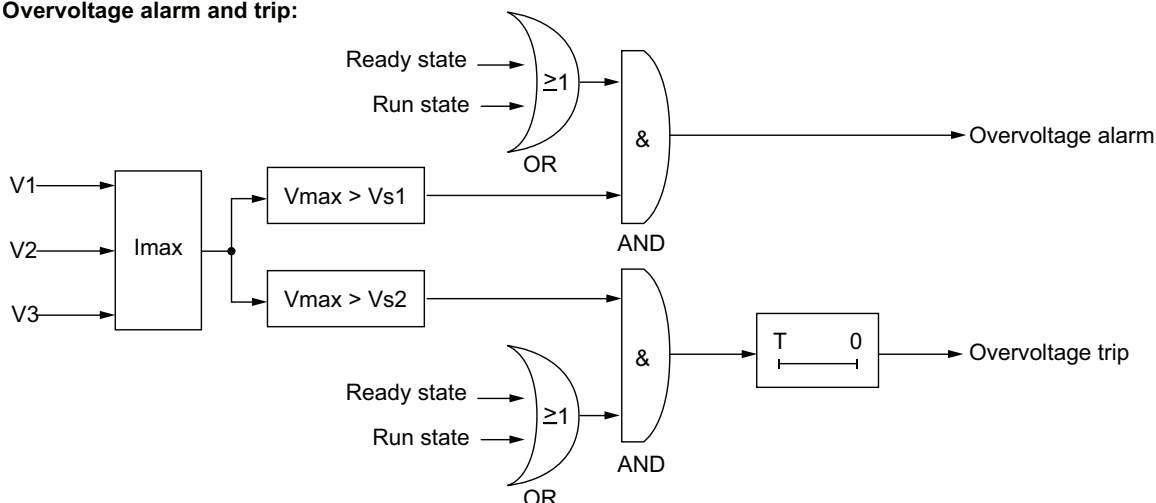

**V1** L1-L2 voltage

**V2** L2-L3 voltage

**V3** L3-L1 voltage

**Vs1** Alarm threshold

**Vs2** Trip threshold

**T** Trip timeout

## Parameter Settings

The overvoltage function has the following parameters:

| Parameters      | Setting Range                                          | Factory Setting |
|-----------------|--------------------------------------------------------|-----------------|
| Trip enable     | Enable/Disable                                         | Disable         |
| Trip timeout    | 0.2...25 s in 0.1 s increments                         | 3 s             |
| Trip threshold  | 101...115 % of Motor nominal voltage in 1 % increments | 110 %           |
| Alarm enable    | Enable/Disable                                         | Disable         |
| Alarm threshold | 101...115 % of Motor nominal voltage in 1 % increments | 110 %           |

## Technical Characteristics

The overvoltage function has the following characteristics:

| Characteristics    | Value                                     |
|--------------------|-------------------------------------------|
| Hysteresis         | -5 % of Trip threshold or Alarm threshold |
| Trip time accuracy | +/-0.1 s or +/- 5%                        |

## Example

The following diagram describes the occurrence of an overvoltage trip.

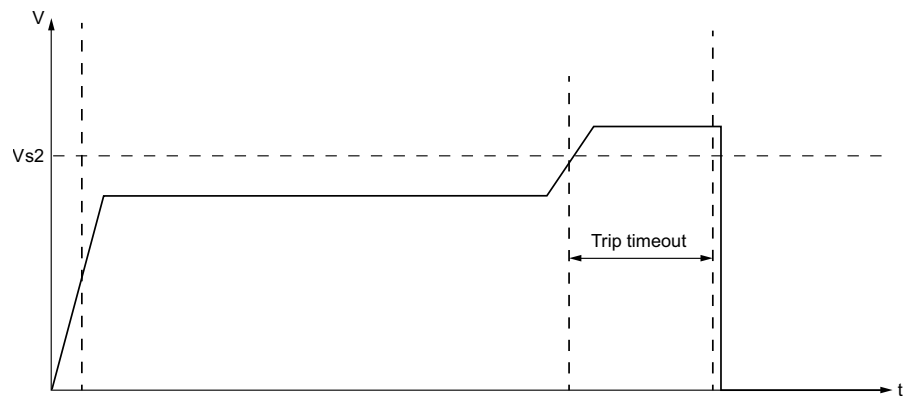

**Vs2** Overvoltage trip threshold

## Voltage Dip Management

### Overview

When a voltage dip is detected, the LTMR can perform 2 different functions to shed and reconnect automatically the load:

- Load shedding, page 122
- Automatic restart, page 124

Selection is done via the Voltage dip mode parameter:

| If Voltage dip mode is... | Then...                               |
|---------------------------|---------------------------------------|
| 0                         | nothing happens                       |
| 1                         | load shedding function is enabled     |
| 2                         | automatic restart function is enabled |

Load Shedding and Automatic Restart functions exclude each other.

## Load Shedding

### Description

The LTMR controller provides load shedding, which you can use to deactivate non-critical loads if voltage level is substantially reduced. For example, use load shedding when power is transferred from a main utility supply to a backup generator system, where the backup generator system can supply power only to a limited number of critical loads.

The LTMR only monitors load shedding when Load Shedding is selected.

With the load shedding function enabled, the LTMR controller monitors the average phase voltage and:

- Reports a load shedding condition and stops the motor when voltage falls below a configurable Voltage dip threshold and stays below the threshold for the duration of a configurable load shedding timer,
- Clears the load shedding condition when voltage rises above a configurable Voltage dip restart threshold and remains above the threshold for the duration of a configurable Load shedding restart timer.

When the LTMR controller clears the load shedding condition:

- in 2-wire (maintained) configuration, it issues a Run command to re-start the motor,
- in 3-wire (impulse) configuration, it does not automatically re-start the motor.

In Overload motor operating mode, load shedding conditions do not affect O.1 and O.2 operating states.

In Independent motor operating mode, load shedding conditions do not affect O.2 state.

If your application includes another device that externally provides load shedding, the LTMR controller load shedding function should not be enabled.

All voltage dip thresholds and timers can be adjusted when the LTMR controller is in its normal operating state. When a load shedding timer is counting at the time it is adjusted, the new duration time does not become effective until the timer expires.

This function is available only when your application includes an LTME expansion module.

## Functional Characteristics

The load shedding function includes the following features:

- 2 thresholds:
  - Voltage Dip Threshold
  - Voltage Dip Restart Threshold
- 2 time delays:
  - Load Shedding Timeout
  - Voltage Dip Restart Timeout
- 1 status flag
  - Load Shedding
- 1 counting statistic:
  - Load Sheddings Count

In addition, the load shedding function:

- Disables logic outputs O.1 and O.2
- Causes the alarm LED to flash 5 times per second

## Parameter Settings

The load shedding function has the following parameters:

| Parameters                    | Setting Range                                     | Factory Setting |
|-------------------------------|---------------------------------------------------|-----------------|
| Voltage dip mode              | 0 = None<br>1 = Load shedding<br>2 = Auto restart | 0 = None        |
| Load shedding timeout         | 1...9999 s in increments of 1 s                   | 10 s            |
| Voltage dip threshold         | 50...115 % of Motor nominal voltage               | 70 %            |
| Voltage dip restart timeout   | 1...9999 s in increments of 1 s                   | 2 s             |
| Voltage dip restart threshold | 65...115 % of Motor nominal voltage               | 90 %            |

## Technical Characteristics

The load shedding function has the following characteristics:

| Characteristics    | Value               |
|--------------------|---------------------|
| Trip time accuracy | +/- 0.1 s or +/- 5% |

## Timing Sequence

The following diagram is an example of the timing sequence for the load shedding function, for a 2-wire configuration with automatic restart:

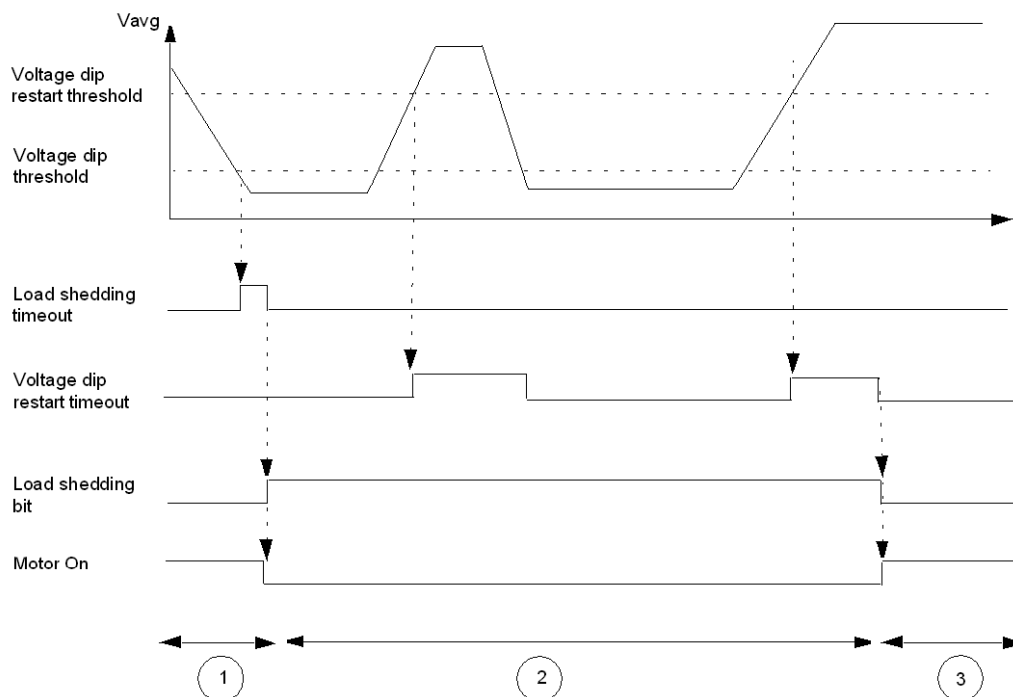

1 Motor running

2 Load shed; motor stopped

3 Load shed cleared; motor auto-restart (2-wire operation)

## Automatic Restart

### Description

The LTMR controller provides automatic restart.

With the automatic restart function enabled, the LTMR controller monitors the instantaneous phase voltage and detects voltage dip conditions. The voltage dip detection shares some parameters with the Load shedding function.

3 restart sequences are managed by the function according to the duration of the voltage dip:

- Immediate restart: the motor restarts automatically.
- Delayed restart: the motor restarts automatically after a timeout.
- Manual restart: the motor restarts manually. A Run command is necessary.

All automatic restart timers can be adjusted when the LTMR controller is in its normal operating state. When an automatic restart timer is counting at the time it is adjusted, the new duration time does not become effective until the timer expires.

This function is available only when your application includes an LTME expansion module.

## Functional Characteristics

The automatic restart function includes the following features:

- 3 time delays:
  - Auto Restart Immediate Timeout
  - Auto Restart Delayed Timeout
  - Voltage Dip Restart Timeout
- 5 status flags:
  - Voltage Dip Detection: the LTMR is in a dip condition
  - Voltage Dip Occurred: a dip has been detected in the last 4.5 seconds
  - Auto Restart Immediate Condition
  - Auto Restart Delayed Condition
  - Auto Restart Manual Condition
- 3 counting statistics:
  - Auto Restart Immediate Count
  - Auto Restart Delayed Count
  - Auto Restart Manual Count

## Parameter Settings

The automatic restart function has the following parameters:

| Parameters                     | Setting Range                                                                                                                          | Factory Setting |
|--------------------------------|----------------------------------------------------------------------------------------------------------------------------------------|-----------------|
| Voltage dip mode               | 0 = None<br>1 = Load shedding<br>2 = Auto restart                                                                                      | 0 = None        |
| Voltage dip threshold          | 50...115 % of Motor nominal voltage                                                                                                    | 65 %            |
| Voltage dip restart threshold  | 65...115 % of Motor nominal voltage                                                                                                    | 90 %            |
| Auto restart immediate timeout | 0...0.4 s in increments of 0. 1 s                                                                                                      | 0.2 s           |
| Auto restart delayed timeout   | <ul style="list-style-type: none"> <li>• 0...300 s: timeout setting in increments of 1 s</li> <li>• 301 s: timeout infinite</li> </ul> | 4 s             |
| Voltage dip restart timeout    | 0...9999 s in increments of 1 s                                                                                                        | 2 s             |

## Technical Characteristics

The automatic restart function has the following characteristics:

| Characteristics | Value               |
|-----------------|---------------------|
| Timing accuracy | +/- 0.1 s or +/- 5% |

## Automatic Restart Behavior

The automatic restart behavior is characterized by the voltage dip duration, that is the number of time passed from the voltage loss until the voltage restoration.

The 2 possible settings are:

- Immediate restart timeout,
- Delayed restart timeout (with delay defined by Restart Delay Time).

The following diagram shows the automatic restart phases:

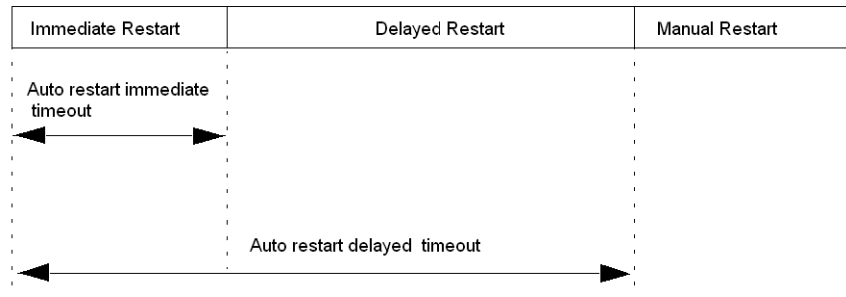

If the voltage dip duration is less than the immediate restart timeout and if the voltage dip is the second one occurring within 1 second, then the motor will require a delayed restart.

When a delayed restart is active (the delay timer is running):

- The timer is paused for the duration of the dip if a voltage dip occurs,
- The delayed restart is canceled if a start or stop command occurs.

## Timing Sequence - Immediate Restart

The following diagram is an example of the timing sequence when an immediate restart occurs:

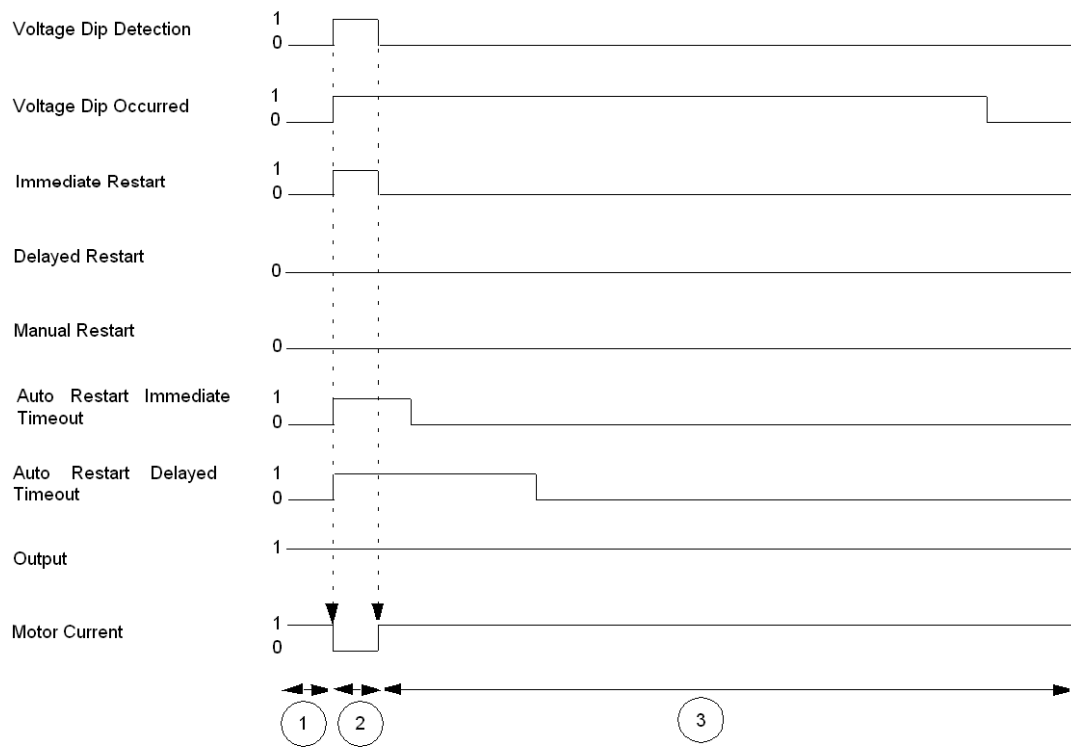

**1** Motor running

**2** Voltage dip detected, motor stopped

**3** Voltage dip cleared, motor automatic restart

## Timing Sequence - Delayed Restart

The following diagram is an example of the timing sequence when a delayed restart occurs:

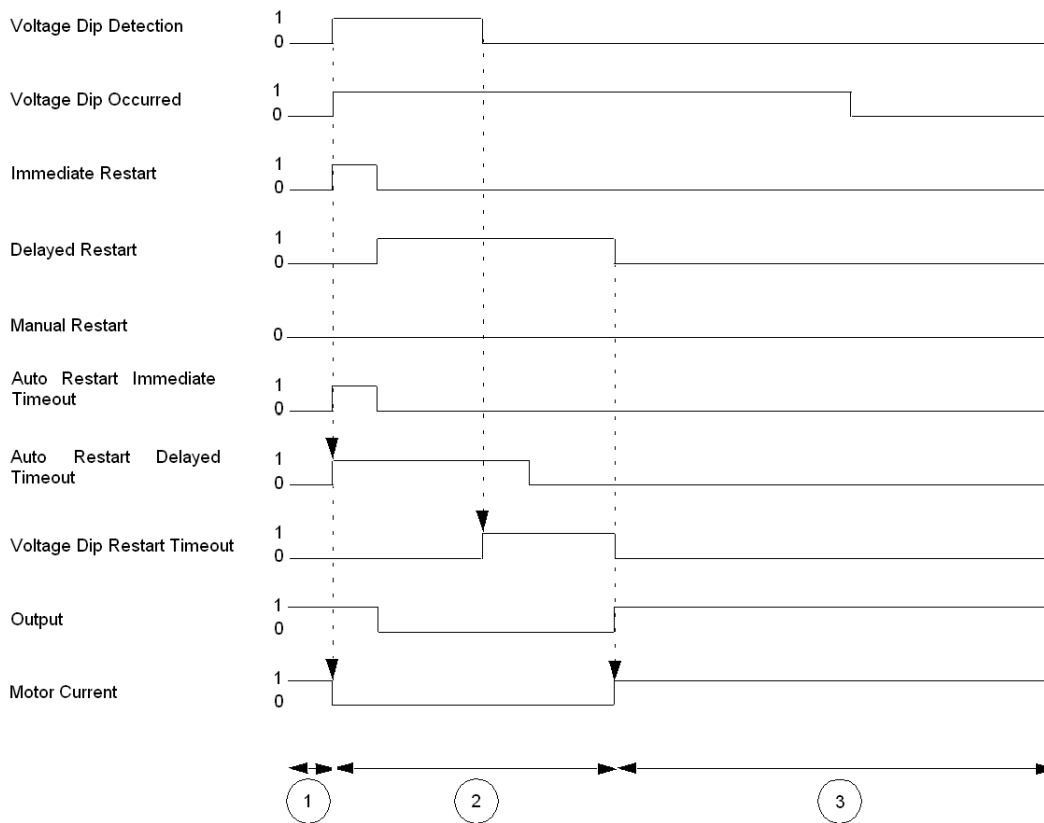

**1** Motor running

**2** Voltage dip detected, motor stopped

**3** Voltage dip cleared, motor automatic restart

## Timing Sequence - Manual Restart

The following diagram is an example of the timing sequence when a manual restart occurs:

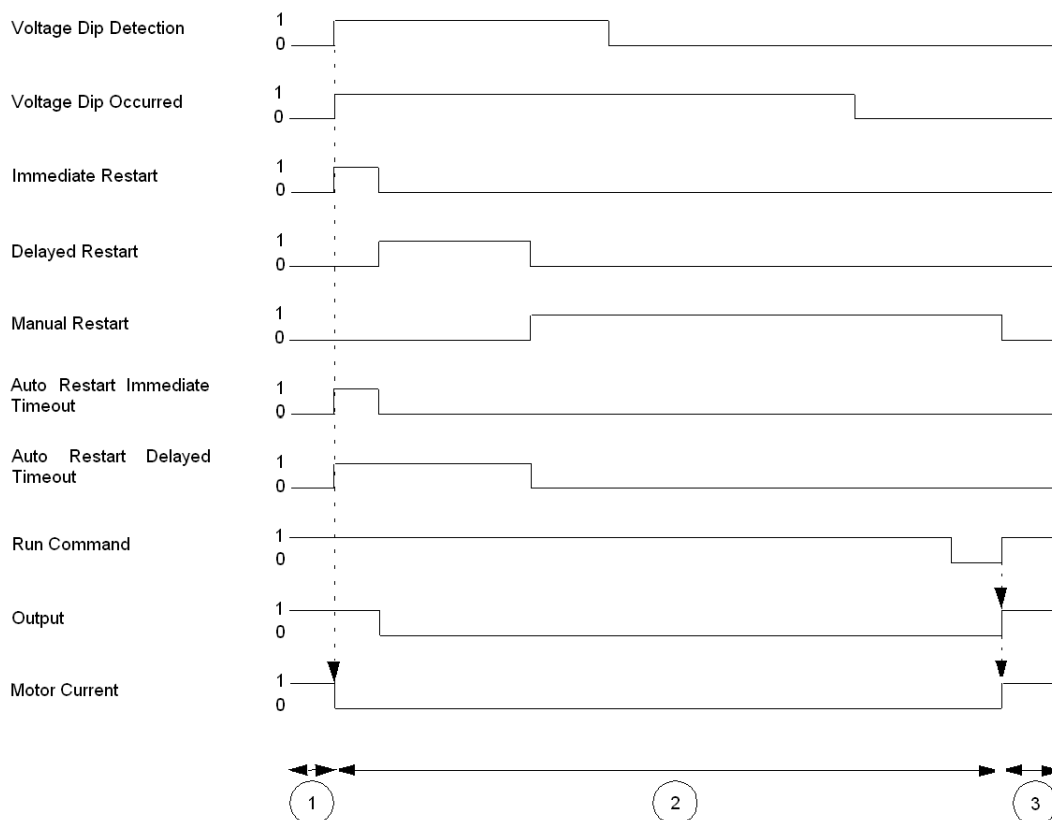

- 1 Motor running
- 2 Voltage dip detected, motor stopped
- 3 Voltage dip cleared, motor automatic restart

## Power Motor Protection Functions

### Overview

This section describes the power motor protection functions provided by the LTMR controller.

### Underpower

#### Description

The underpower function signals:

- Alarm when the value of active power falls below a set threshold.
- Trip when the value of active power falls and remains below a separately set threshold for a set period of time.

This function has a single trip time delay. Both the trip and alarm thresholds are defined as a percentage of the Motor Nominal Power parameter setting (Pnom).

The underpower function is available only in run state, when the LTMR controller is connected to an expansion module.

Trip and alarm monitoring can be separately enabled and disabled.

## Functional Characteristics

The underpower function includes the following features:

- 2 thresholds:
  - Underpower Alarm Threshold
  - Underpower Trip Threshold
- 1 trip time delay:
  - Underpower Trip Timeout
- 2 function outputs:
  - Underpower Alarm
  - Underpower Trip
- 1 counting statistic:
  - Underpower Trips Count

## Block Diagram

Underpower alarm and trip:

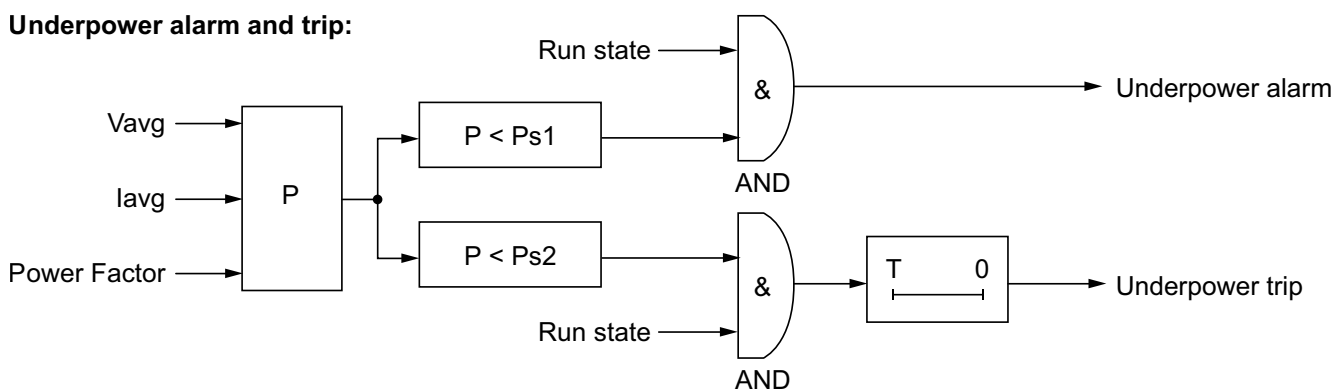

**Vavg** Average rms voltage

**Iavg** Average rms current

**P** Power

**Ps1** Alarm threshold

**Ps2** Trip threshold

**T** Trip timeout

## Parameter Settings

The underpower function has the following parameters:

| Parameters      | Setting Range                                       | Factory Setting |
|-----------------|-----------------------------------------------------|-----------------|
| Trip enable     | Enable/Disable                                      | Disable         |
| Trip timeout    | 1...100 s in 1 s increments                         | 60 s            |
| Trip threshold  | 20...800 % of Motor nominal power in 1 % increments | 20 %            |
| Alarm enable    | Enable/Disable                                      | Disable         |
| Alarm threshold | 20...800 % of Motor nominal power in 1 % increments | 30 %            |

## Technical Characteristics

The underpower function has the following characteristics:

| Characteristics | Value                                     |
|-----------------|-------------------------------------------|
| Hysteresis      | -5 % of Trip threshold or Alarm threshold |
| Accuracy        | +/- 5%                                    |

## Example

The following diagram describes the occurrence of an underpower trip.

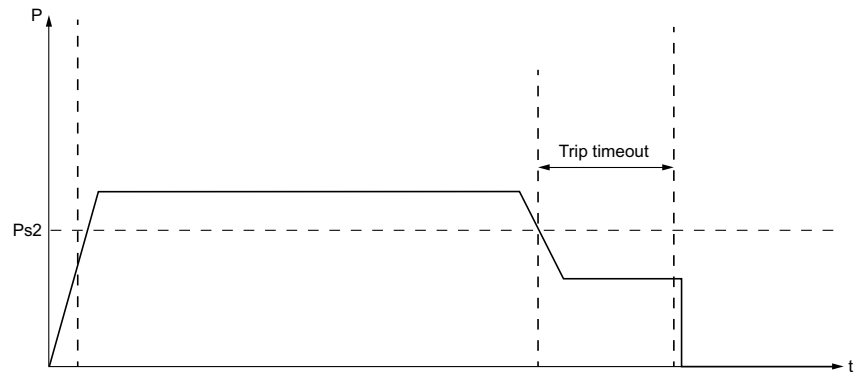

**Ps2** Underpower trip threshold

## Overpower

### Description

The overpower function signals:

- Alarm when the value of active power exceeds a set threshold.
- Trip when the value of active power exceeds a separately set threshold and remains above that threshold for a set period of time.

This function has a single trip time delay. Both the trip and alarm thresholds are defined as a percentage of the Motor Nominal Power parameter setting (Pnom).

The overpower function is available only in run state, when the LTMR controller is connected to an expansion module.

Trip and alarm monitoring can be separately enabled and disabled.

## Functional Characteristics

The overpower function includes the following features:

- 2 thresholds:
  - Overpower Alarm Threshold
  - Overpower Trip Threshold
- 1 trip time delay:
  - Overpower Trip Timeout
- 2 function outputs:
  - Overpower Alarm
  - Overpower Trip

- 1 counting statistic:
  - Overpower Trips Count

## Block Diagram

Overpower alarm and trip:

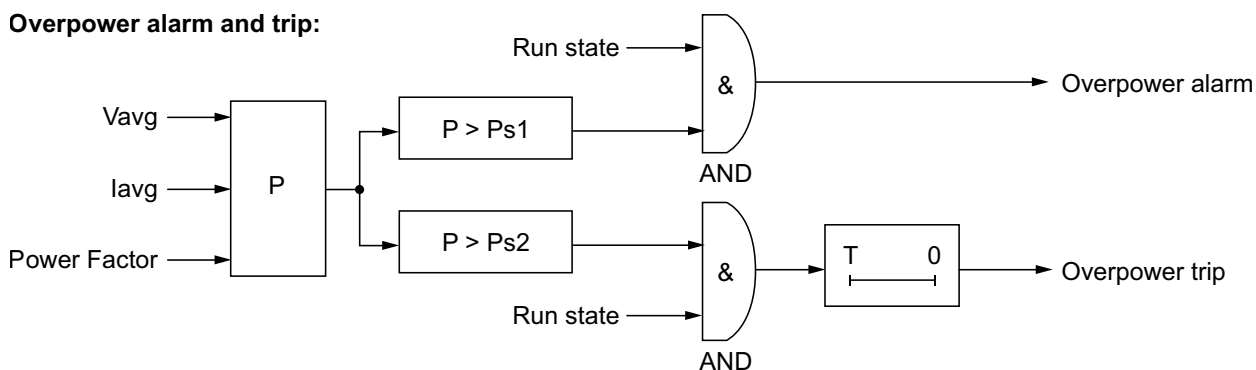

**Vavg** Average rms voltage

**Iavg** Average rms current

**P** Power

**Ps1** Alarm threshold

**Ps2** Trip threshold

**T** Trip timeout

## Parameter Settings

The overpower function has the following parameters:

| Parameters      | Setting Range                                       | Factory Setting |
|-----------------|-----------------------------------------------------|-----------------|
| Trip enable     | Enable/Disable                                      | Disable         |
| Trip timeout    | 1...100 s in 1 s increments                         | 60 s            |
| Trip threshold  | 20...800 % of Motor nominal power in 1 % increments | 150 %           |
| Alarm enable    | Enable/Disable                                      | Disable         |
| Alarm threshold | 20...800 % of Motor nominal power in 1 % increments | 150 %           |

## Technical Characteristics

The overpower function has the following characteristics:

| Characteristics | Value                                     |
|-----------------|-------------------------------------------|
| Hysteresis      | -5 % of Trip threshold or Alarm threshold |
| Accuracy        | +/- 5 %                                   |

## Example

The following diagram describes the occurrence of an overpower trip.

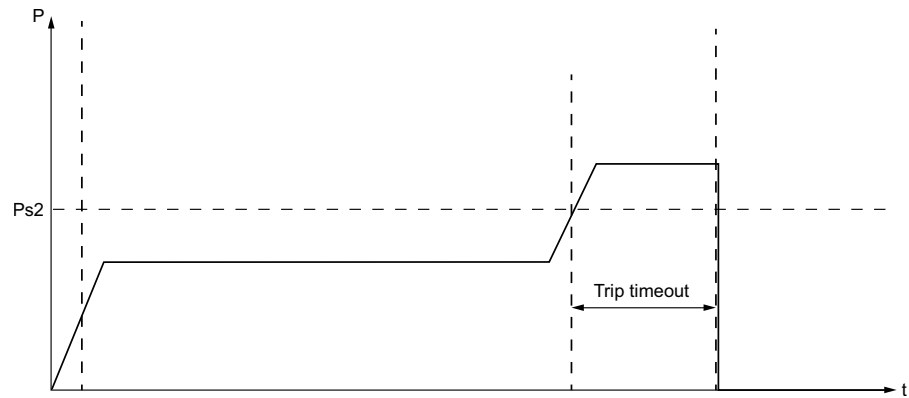

**Ps2** Overpower trip threshold

## Under Power Factor

### Description

The under power factor protection function monitors the value of the power factor and signals:

- Alarm when the value of the power factor falls below a set threshold.
- Trip when the value of the power factor falls below a separately set threshold and remains below that threshold for a set period of time.

This function has a single trip time delay.

The under power factor protection function is available only in run state, when the LTMR controller is connected to an expansion module.

Trip and alarm monitoring can be separately enabled and disabled.

### Functional Characteristics

The under power factor function includes the following features:

- 2 thresholds:
  - Under Power Factor Alarm Threshold
  - Under Power Factor Trip Threshold
- 1 trip time delay:
  - Under Power Factor Trip Timeout
- 2 function outputs:
  - Under Power Factor Alarm
  - Under Power Factor Trip
- 1 counting statistic:
  - Under Power Factor Trips Count

## Block Diagram

**Under power factor alarm:**

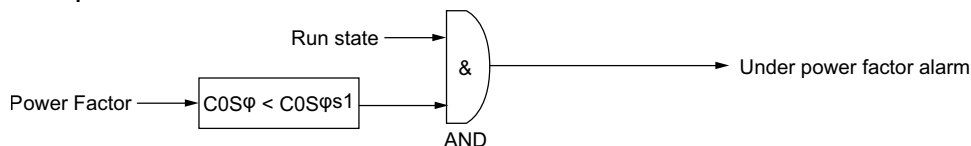

**Under power factor trip:**

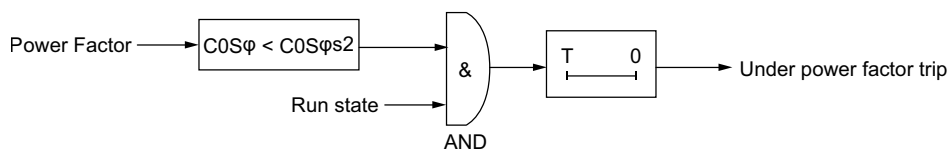

**cosφs1** Under power factor alarm threshold

**cosφs2** Under power factor trip threshold

**T** Under power factor trip timeout

## Parameter Settings

The under power factor function has the following parameters:

| Parameters      | Setting Range                           | Factory Setting |
|-----------------|-----------------------------------------|-----------------|
| Trip enable     | Enable/Disable                          | Disable         |
| Trip timeout    | 1...25 s in 0.1 s increments            | 10 s            |
| Trip threshold  | 0...1 x Power factor in 0.01 increments | 0.60            |
| Alarm enable    | Enable/Disable                          | Disable         |
| Alarm threshold | 0...1 x Power factor in 0.01 increments | 0.60            |

## Technical Characteristics

The under power factor function has the following characteristics:

| Characteristics    | Value                                     |
|--------------------|-------------------------------------------|
| Hysteresis         | -5 % of Trip threshold or Alarm threshold |
| Accuracy           | +/-3° or +/- 10 % (for cos φ ≥ 0.6)       |
| Trip time accuracy | +/- 0.1 s or +/- 5 %                      |

## Example

The following diagram describes the occurrence of an under power factor trip.

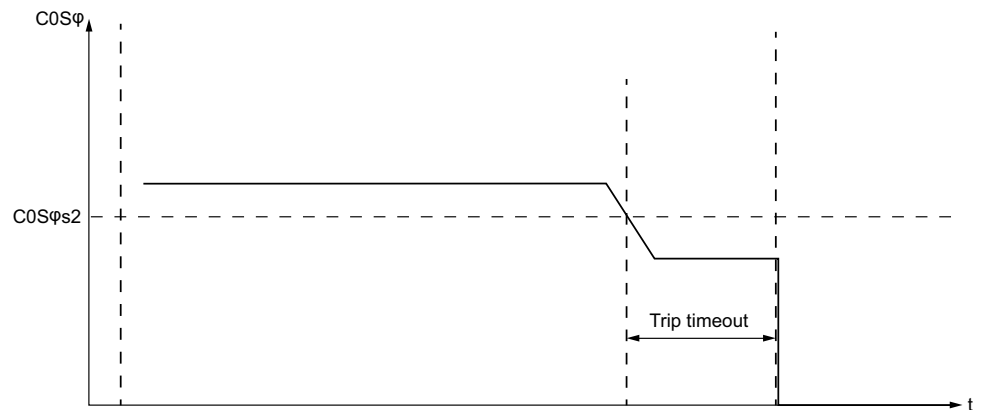

**cosφs2** Under power factor trip threshold

## Over Power Factor

### Description

The over power factor protection function monitors the value of the power factor and signals:

- Alarm when the value of the power factor exceeds a set threshold.
- Trip when the value of the power factor exceeds a separately set threshold and remains above that threshold for a set period of time.

This function has a single trip time delay.

The over power factor protection function is available only in run state, when the LTMR controller is connected to an expansion module.

Trip and alarm monitoring can be separately enabled and disabled.

### Functional Characteristics

The over power factor function includes the following features:

- 2 thresholds:
  - Over Power Factor Alarm Threshold
  - Over Power Factor Trip Threshold
- 1 trip time delay:
  - Over Power Factor Trip Timeout
- 2 function outputs:
  - Over Power Factor Alarm
  - Over Power Factor Trip
- 1 counting statistic:
  - Over Power Factor Trips Count

## Block Diagram

### Over power factor alarm:

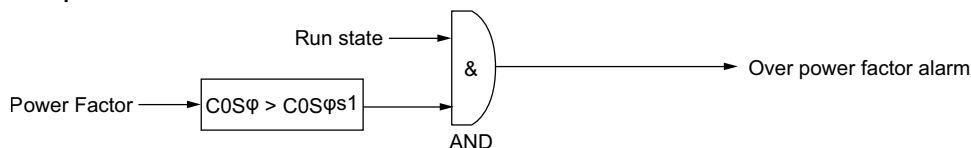

### Over power factor trip:

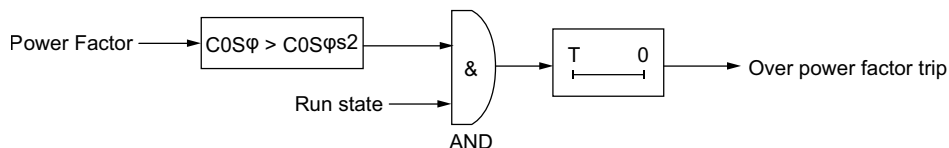

**cosφs1** Over power factor alarm threshold

**cosφs2** Over power factor trip threshold

**T** Over power factor trip timeout

## Parameter Settings

The over power factor function has the following parameters:

| Parameters      | Setting Range                           | Factory Setting |
|-----------------|-----------------------------------------|-----------------|
| Trip enable     | Enable/Disable                          | Disable         |
| Trip timeout    | 1...25 s in 0.1 s increments            | 10 s            |
| Trip threshold  | 0...1 x Power factor in 0.01 increments | 0.90            |
| Alarm enable    | Enable/Disable                          | Disable         |
| Alarm threshold | 0...1 x Power factor in 0.01 increments | 0.90            |

## Technical Characteristics

The over power factor function has the following characteristics:

| Characteristics    | Value                                          |
|--------------------|------------------------------------------------|
| Hysteresis         | -5 % of Trip threshold or Alarm threshold      |
| Accuracy           | +/- 3° or +/- 10 % (for $\cos \phi \geq 0.6$ ) |
| Trip time accuracy | +/-0.1 s or +/- 5 %                            |

## Example

The following diagram describes the occurrence of an over power factor trip.

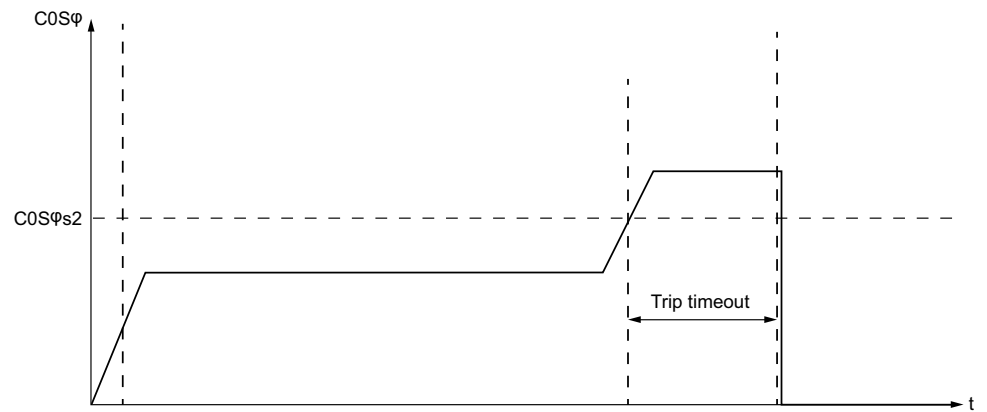

**$\cos\phi_{s2}$**  Over power factor trip threshold

# Motor Control Functions

## Overview

The topics in this chapter describe the LTMR controller operating states which determine the operating modes, and the trip reset mode (manual, remote, automatic).

This chapter also introduces custom operating mode, which you can use to customize a predefined control program.

## Control Channels and Operating States

### Overview

This section describes:

- How to configure control of the LTMR controller outputs, and
- The LTMR controller's operating states, including:
  - How the LTMR controller transitions between operating states during startup, and
  - The motor protection functions provided by the LTMR controller in each operating state

### ⚠ WARNING

#### UNINTENDED EQUIPMENT OPERATION

The application of this product requires expertise in the design and programming of control systems. Only persons with such expertise should be allowed to program, install, alter and apply this product. Follow all local and national safety codes and standards.

**Failure to follow these instructions can result in death, serious injury, or equipment damage.**

## Control Channels

### Overview

The LTMR can be configured for 1 control channel out of 3:

- Terminal strip: Input devices wired to the input terminals on the front face of the LTMR controller.
- HMI: An HMI device connected to the LTMR controller's HMI port.
- Network: A network PLC connected to the controller network port.

### Control Channel Selection

You can easily select between 2 control channels, assigning one channel to be the local control source and the second channel to be the remote control source.

The possible channel assignments are:

| Control Channel                  | Local | Remote                     |
|----------------------------------|-------|----------------------------|
| Terminal strip (factory setting) | Yes   | Only with an LTMCU present |
| HMI                              | Yes   | Only with an LTMCU present |
| Network                          | No    | Yes                        |

In local control, the control channel selection (Terminal strip or HMI) is determined by setting the Control local channel setting in the Control setting register.

In remote control, the control channel selection is always Network, unless an LTMCU is present. In this case, the control channel selection is determined by setting the Control remote channel setting in the Control setting register.

If an LTMCU is present, the logic input I.6 and the local/remote button on the LTMCU are used together to select between local and remote control source:

| Logic Input I.6 | LTMCU Local/Remote Status | Active Control Source |
|-----------------|---------------------------|-----------------------|
| Inactive        | -                         | Local                 |
| Active          | Local                     | Local                 |
|                 | Remote (or not present)   | Remote                |

**NOTE:**

- The Network control channel is always considered as 2-wire control, regardless of the operating mode selected.
- In 3-wire mode, Stop commands can be disabled in the Control setting register.
- In 2-wire mode, Stop commands given by the non-controlling channel shall always be ignored.
- Run commands from a channel other than the selected control channel shall be ignored.

For a predefined operating mode, only one control source may be enabled to direct the outputs. You can use the custom logic editor to add one or more additional control sources.

## Terminal Strip

In Terminal Strip control, the LTMR controller commands its outputs according to the state of its inputs. This is the control channel factory setting when logic input I.6 is inactive.

The following conditions apply to Terminal Strip control channel:

- Any terminal inputs assigned to start and stop commands control the outputs according to the motor operating mode.
- HMI and network start commands are ignored.

When using LTMCU, the parameter Stop Terminal Strip Disable is set in the Control Setting register.

## HMI

In HMI control, the LTMR controller commands its outputs in response to start and stop commands received from an HMI device connected to the HMI port.

The following conditions apply to HMI control channel:

- Any HMI start and stop commands control the outputs according to the motor operating mode.
- Network start commands and terminal strip start commands are ignored.

When using LTMCU, the parameter Stop HMI Disable is set in the Control Setting register.

## Network

In Network control, a remote PLC sends commands to the LTMR controller through the network communication port.

The following conditions apply to Network control channel:

## Control Transfer Mode

Select the Control Transfer Mode parameter to enable bumpless transfer when changing the control channel; clear this parameter to enable bump transfer. The configuration setting for this parameter determines the behavior of logic outputs O.1 and O.2, as follows:

| Control Transfer Mode Setting | LTMR controller Behavior When Changing Control Channel                                                                                                                                                                                                                                                                                                                                                                                                                                                                       |
|-------------------------------|------------------------------------------------------------------------------------------------------------------------------------------------------------------------------------------------------------------------------------------------------------------------------------------------------------------------------------------------------------------------------------------------------------------------------------------------------------------------------------------------------------------------------|
| Bump                          | <p>Logic outputs O.1 and O.2 open (if closed) or remain open (if already open) until the next valid signal occurs. The motor stops.</p> <ul style="list-style-type: none"> <li>Any network start and stop commands control the outputs according to the motor operating mode.</li> <li>The HMI unit can read (but not write) the LTMR controller parameters.</li> </ul> <p>Note: In overload predefined operating mode, logic outputs O.1 and O.2 are user-defined and therefore may not be affected by a Bump transfer.</p> |
| Bumpless                      | <p>Logic outputs O.1 and O.2 are not affected and remain in their original position until the next valid signal occurs. The motor does not stop.</p>                                                                                                                                                                                                                                                                                                                                                                         |

When you start the motor in Remote control mode with the PLC, the LTMR controller changes to Local control mode (I.6=1 to I.6=0) and the status of the motor changes depending on the control transfer mode, as follows:

| If the LTMR controller configuration is... | Then the control mode changes from Remote to Local and the motor... |
|--------------------------------------------|---------------------------------------------------------------------|
| 3-Wire Bumpless                            | Keeps running                                                       |
| 2-Wire Bumpless                            | Keeps running if the logic inputs I.1 or I.2 are activated          |
| 3-Wire Bump                                | Stops                                                               |
| 2-Wire Bump                                |                                                                     |

When the LTMR controller changes from Local to Remote control mode (I.6=0 to I.6=1), the status of the motor in Local control mode, whether running or stopped, remains unchanged. The control transfer mode selected does not affect the status of the motor as the LTMR controller only takes account of the last control command (logic outputs O.1 or O.2) sent by the PLC.

|                                                                                                                                                                                                                                                                                                                                                                                                                                                                                                                                                                                                                                                                   |
|-------------------------------------------------------------------------------------------------------------------------------------------------------------------------------------------------------------------------------------------------------------------------------------------------------------------------------------------------------------------------------------------------------------------------------------------------------------------------------------------------------------------------------------------------------------------------------------------------------------------------------------------------------------------|
| <b>⚠ CAUTION</b>                                                                                                                                                                                                                                                                                                                                                                                                                                                                                                                                                                                                                                                  |
| <p><b>FAILURE TO STOP AND RISK OF UNINTENDED OPERATION</b></p> <p>LTMR controller operation cannot be stopped from the terminals when control channel is changed to Terminal Strip control channel if the LTMR controller is:</p> <ul style="list-style-type: none"> <li>Operating in Overload operating mode- and -</li> <li>Configured in Bumpless- and -</li> <li>Operated over a network using Network control channel- and -</li> <li>Operating in Run state- and -</li> <li>Configured for 3-wire (impulse) control.</li> </ul> <p>See instructions below.</p> <p><b>Failure to follow these instructions can result in injury or equipment damage.</b></p> |

Whenever control channel is changed to Terminal Strip control channel, operation of the LTMR controller cannot be stopped from the terminals because no terminal input is assigned to a STOP command.

If this behavior is not intended, the control channel must be changed to either Network control channel or HMI control channel to command a STOP. To implement this change, take one of the following precautionary steps:

- The commissioner should configure the LTMR controller for either bump transfer of control channel or 2-wire control.
- The installer should provide the LTMR controller with a means of interrupting current to the contactor coil - for example, a push button station wired in series with the LTMR controller outputs.
- The controls engineer should assign a terminal input to disable the Run command using Custom Configuration Mode assignments.

## Fallback Transitions

The LTMR controller enters a fallback state when communication with the control source is lost, and exits the fallback state when communication is restored. The transition into and out of the fallback state is as follows:

| Transition                  | Control Source Transfer                                                                                           |
|-----------------------------|-------------------------------------------------------------------------------------------------------------------|
| Entering the fallback state | Bumpless, when the Control Direct Transition bit is on                                                            |
| Exiting the fallback state  | Determined by the settings for Control Transfer Mode (bump or bumpless) and Control Direct Transition (on or off) |

For information on how to configure communications fallback parameters, refer to the topic [Communication Loss](#), page 63.

When using LTMCU, the parameters Control Transfer Mode and Control Direct Transition parameters are set in the Control Setting register.

## Operating States

### Introduction

The LTMR controller responds to the state of the motor and provides control, monitoring and protection functions appropriate to each of the motor’s operating states. A motor can have many operating states. Some operating states are persistent while others are transitional.

A motor’s primary operating states are:

| Operating State | Description                                                                                                                                                                                                                                                                                                                     |
|-----------------|---------------------------------------------------------------------------------------------------------------------------------------------------------------------------------------------------------------------------------------------------------------------------------------------------------------------------------|
| Ready           | <ul style="list-style-type: none"> <li>• The motor is stopped.</li> <li>• The LTMR controller:                             <ul style="list-style-type: none"> <li>◦ Detects no trip</li> <li>◦ Not performing load shedding</li> <li>◦ Not counting down the rapid cycle timer</li> <li>◦ Ready to start</li> </ul> </li> </ul> |
| Not Ready       | <ul style="list-style-type: none"> <li>• The motor is stopped.</li> <li>• The LTMR controller:                             <ul style="list-style-type: none"> <li>◦ Detects a trip</li> <li>◦ Performing load shedding</li> <li>◦ Counting down the rapid cycle timer</li> </ul> </li> </ul>                                    |

| Operating State | Description                                                                                                                                                                                                                                                                                                                                                                      |
|-----------------|----------------------------------------------------------------------------------------------------------------------------------------------------------------------------------------------------------------------------------------------------------------------------------------------------------------------------------------------------------------------------------|
| Start           | <ul style="list-style-type: none"> <li>The motor starts.</li> <li>The LTMR controller: <ul style="list-style-type: none"> <li>Detects that current has reached the On Level Current threshold</li> <li>Detects that current has not both crossed and re-crossed the long start trip threshold</li> <li>Continues to count down the long start trip timer.</li> </ul> </li> </ul> |
| Run             | <ul style="list-style-type: none"> <li>The motor is running.</li> <li>The LTMR controller detects that current has both crossed and re-crossed the long start trip threshold before the LTMR controller fully counted down the long start trip timer.</li> </ul>                                                                                                                 |

## Operating State Chart

The operating states of the LTMR controller firmware, as the motor progresses from Off to Run state, are described below. The LTMR controller verifies current in each operating state. The LTMR controller can transition to an internal trip condition from any operating state.

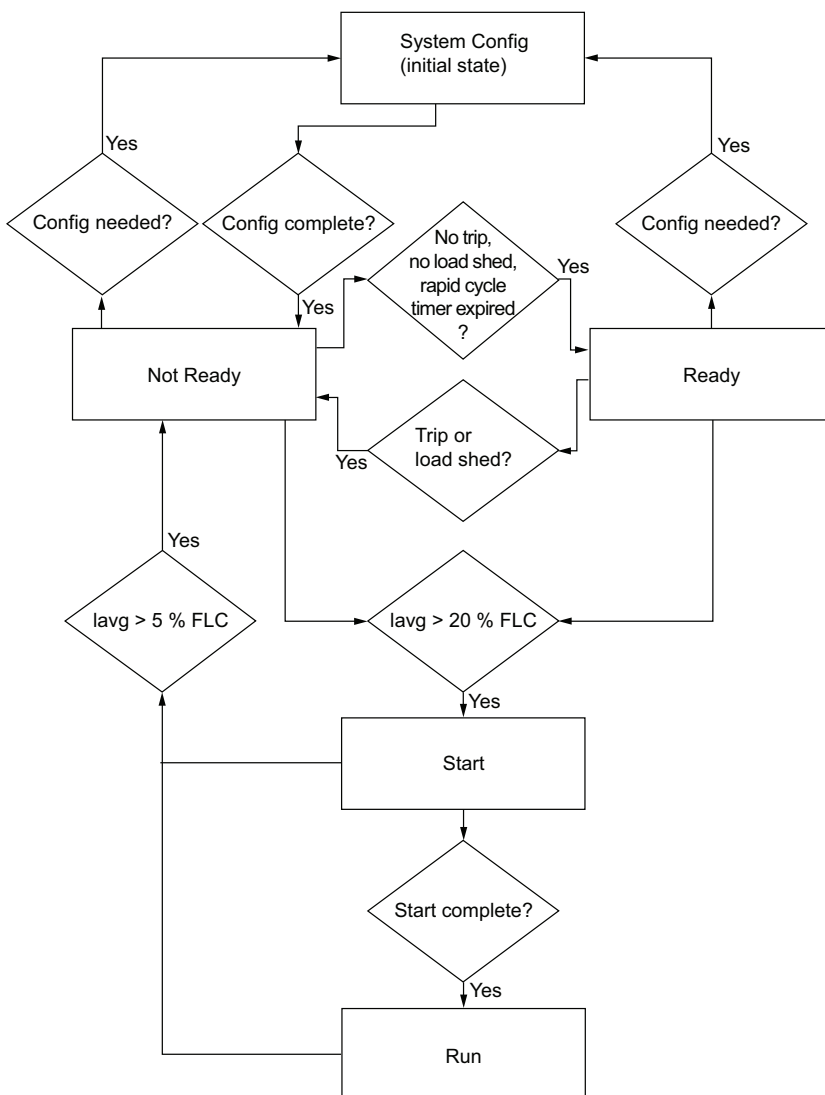

## Protection Monitoring by Operating States

The motor operating states, and the trip and alarm protections provided by the LTMR controller while the motor is in each operating state (denoted with an X), are described below. It can transition to an internal trip condition from any operating state.

| Protection Category                   | Monitored Trip/Alarm           | Operating States |       |           |       |     |
|---------------------------------------|--------------------------------|------------------|-------|-----------|-------|-----|
|                                       |                                | Sys Config       | Ready | Not Ready | Start | Run |
| Diagnostic                            | Run Command Check              | -                | X     | -         | -     | -   |
|                                       | Stop Command Check             | -                | -     | X         | X     | X   |
|                                       | Run Check Back                 | -                | -     | -         | X     | X   |
|                                       | Stop Check Back                | -                | -     | -         | X     | X   |
| Wiring / configuration trips          | PTC connection                 | -                | X     | X         | X     | X   |
|                                       | CT Reversal                    | -                | -     | -         | X     | -   |
|                                       | Voltage Phase Loss             | -                | X     | X         | -     | -   |
|                                       | Phase Configuration            | -                | -     | -         | X     | -   |
| Internal trips                        | Minor                          | X                | X     | X         | X     | X   |
|                                       | Major                          | X                | X     | X         | X     | X   |
| Motor temp sensor                     | PTC Binary                     | -                | X     | X         | X     | X   |
|                                       | PT100                          | -                | X     | X         | X     | X   |
|                                       | PTC Analog                     | -                | X     | X         | X     | X   |
|                                       | NTC Analog                     | -                | X     | X         | X     | X   |
| Thermal overload                      | Definite                       | -                | -     | -         | -     | X   |
|                                       | Inverse Thermal                | -                | X     | X         | X     | X   |
| Current                               | Long Start                     | -                | -     | -         | X     | -   |
|                                       | Jam                            | -                | -     | -         | -     | X   |
|                                       | Current Phase Imbalance        | -                | -     | -         | X     | X   |
|                                       | Current Phase Loss             | -                | -     | -         | X     | X   |
|                                       | Overcurrent                    | -                | -     | -         | -     | X   |
|                                       | Undercurrent                   | -                | -     | -         | -     | X   |
|                                       | Ground Current Trip (Internal) | -                | -     | -         | X     | X   |
| Ground Current Trip (External)        | -                              | -                | -     | X         | X     |     |
| Voltage                               | Overvoltage Level              | -                | X     | X         | -     | X   |
|                                       | Undervoltage Level             | -                | X     | X         | -     | X   |
|                                       | Voltage Phase Imbalance        | -                | -     | -         | X     | X   |
| Power / Power Factor                  | Over Power Factor Level        | -                | -     | -         | -     | X   |
|                                       | Under Power Factor Level       | -                | -     | -         | -     | X   |
|                                       | Overpower Level                | -                | -     | -         | -     | X   |
|                                       | Underpower Level               | -                | -     | -         | -     | X   |
| <b>X</b> Monitored<br>- Not monitored |                                |                  |       |           |       |     |

## Start Cycle

### Description

The start cycle is the time period allowed for the motor to reach its normal FLC level. The LTMR controller measures the start cycle in seconds, beginning when it detects On Level Current, defined as maximum phase current equal to 20 % of FLC.

During the start cycle, the LTMR controller compares:

- Detected current against the configurable Long Start Trip Threshold parameter, and
- Elapsed start cycle time against the configurable Long Start Trip Timeout parameter.

There are 3 start cycle scenarios, each based on the number of times (0,1 or 2) maximum phase current crosses the Long Start Trip Threshold. A description of each scenario is described below.

For information on the statistics the LTMR controller retains describing motor starts, see [Motor Starts Counters](#), page 70. For information about the long start protection function, see [Long Start](#), page 99.

## Start Cycle Operating States

During the start cycle, the LTMR controller transitions through the motor's operating states as follows:

| Step | Event                                                                                                                                                                    | Operating State |
|------|--------------------------------------------------------------------------------------------------------------------------------------------------------------------------|-----------------|
| 1    | LTMR controller receives a start command input signal.                                                                                                                   | Ready           |
| 2    | The LTMR controller confirms that all startup preconditions exist (e.g. no trips, load shedding, or rapid cycle timer).                                                  | Ready           |
| 3    | The LTMR controller closes the appropriate output contacts designated as terminals 13-14 or 23-24, thereby closing the control circuit of the motor starting contactors. | Ready           |
| 4    | The LTMR controller detects that maximum phase current exceeds the On Level Current threshold.                                                                           | Start           |
| 5    | The LTMR controller detects that current rises above and then falls below the Long Start Trip Threshold before the Long Start Trip Timeout timer expires.                | Run             |

## 2 Threshold Crosses

In this start cycle scenario, the start cycle executes successfully:

- Current rises above, then drops below, the trip threshold.
- The LTMR controller reports the actual start cycle time, i.e. the time elapsed from detection of On Level Current until the maximum phase current drops below the trip threshold.

**Start cycle with 2 threshold crosses, single step:**

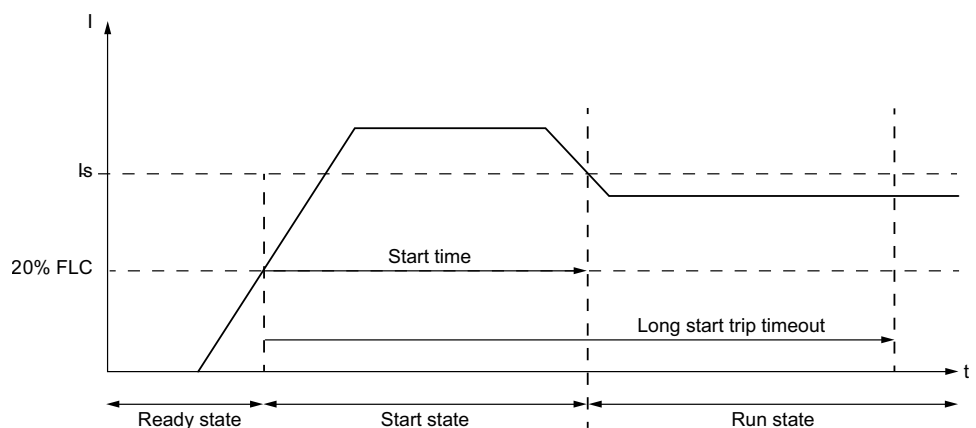

$I_s$  Long start trip threshold

**Start cycle with 2 threshold crosses, 2 step:**

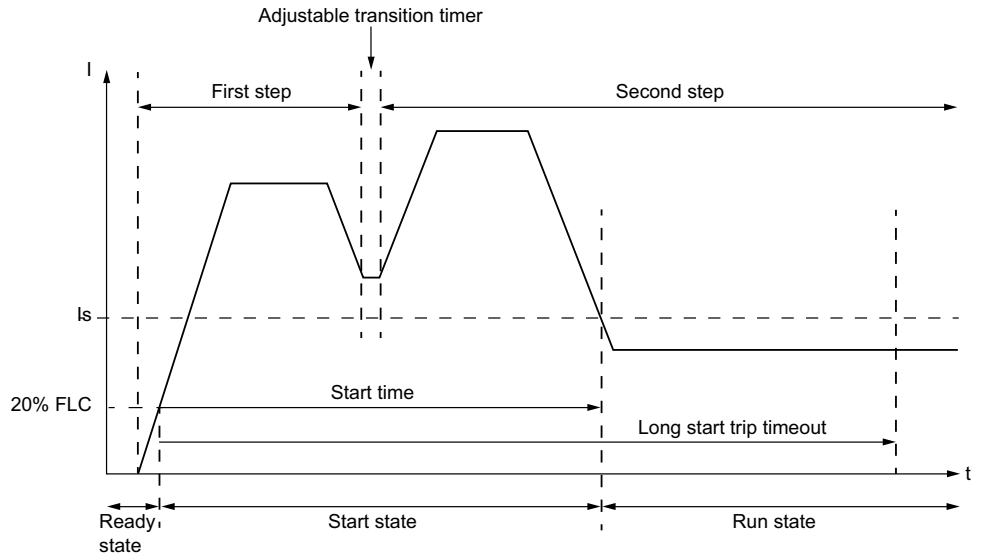

**1 Threshold Cross**

In this start cycle scenario, the start cycle does not occur.:

- Current rises above, but does not drop below, the Long Start Trip Threshold.
- If Long Start protection is enabled, the LTMR controller signals a trip when the Long Start Trip Timeout is reached
- If Long Start protection is disabled, the LTMR controller does not signal a trip and the run cycle begins after the Long Start Trip Timeout has expired.
- Other motor protection functions begin their respective duration times after the Long Start Trip Timeout.
- The LTMR controller reports start cycle time as 9999, indicating that current exceeded and remained above the trip threshold.
- The LTMR controller reports the maximum current detected during the start cycle.

**Start cycle with 1 threshold cross:**

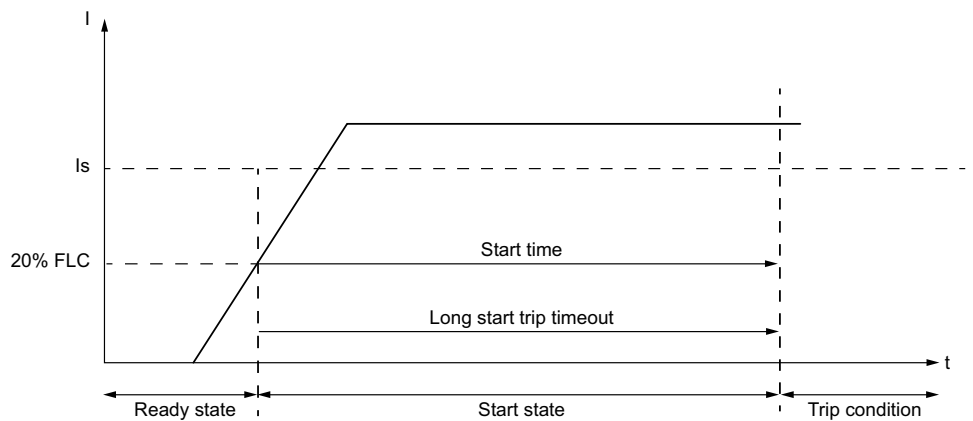

**0 Threshold Cross**

In this start cycle scenario, the start cycle does not occur.:

- Current never rises above the trip threshold.
- If Long Start protection is enabled, the LTMR controller signals a trip when the Long Start Trip Timeout is reached

- If Long Start protection is disabled, the LTMR controller does not signal a trip and the run cycle begins after the Long Start Trip Timeout has expired.
- Other motor protection functions begin their respective duration times after the Long Start Trip Timeout.
- The LTMR controller reports both the start cycle time and the maximum current detected during start cycle as 0000, indicating current never reached the trip threshold.

**Start cycle with 0 threshold cross:**

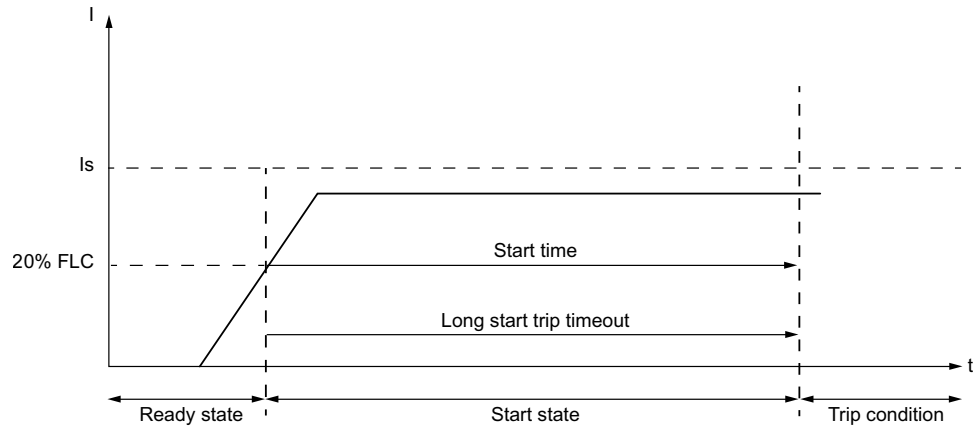

**$I_s$**  Long start trip threshold

## Operating Modes

### Overview

The LTMR controller can be configured to 1 of 10 predefined operating modes. Selecting custom operating mode allows you to select one of the 10 predefined operating modes and customize it to your specific application.

The selection of a predefined operating mode determines the behavior of all LTMR controller inputs and outputs.

Each predefined operating mode selection includes a control wiring selection:

- 2-wire (maintained), or
- 3-wire (impulse)

## Control Principles

### Overview

The LTMR controller performs control and monitoring functions for single-phase and 3-phase electric motors.

- These functions are predefined and fit the applications most frequently used. They are ready to use and are implemented by simple parameter setting after the LTMR controller has been commissioned.
- The predefined control and monitoring functions can be adapted for particular needs using the custom logic editor in the TeSys T DTM to:
  - Customize the use of results of protection functions
  - Change the operation of control and monitoring functions
  - Alter the predefined LTMR controller I/O logic

## Operating Principle

The processing of control and monitoring functions has 3 parts:

- Acquisition of input data:
  - The output of protection function processing
  - External logic data from logic inputs
  - Telecommunication commands (TCC) received from the control source
- Logic processing by the control or monitoring function
- Utilization of the processing results:
  - Activation of logic outputs
  - Display of predefined messages
  - Activation of LEDs
  - Telecommunication signals (TCS) sent via a communications link.

The control and monitoring function process is displayed below:

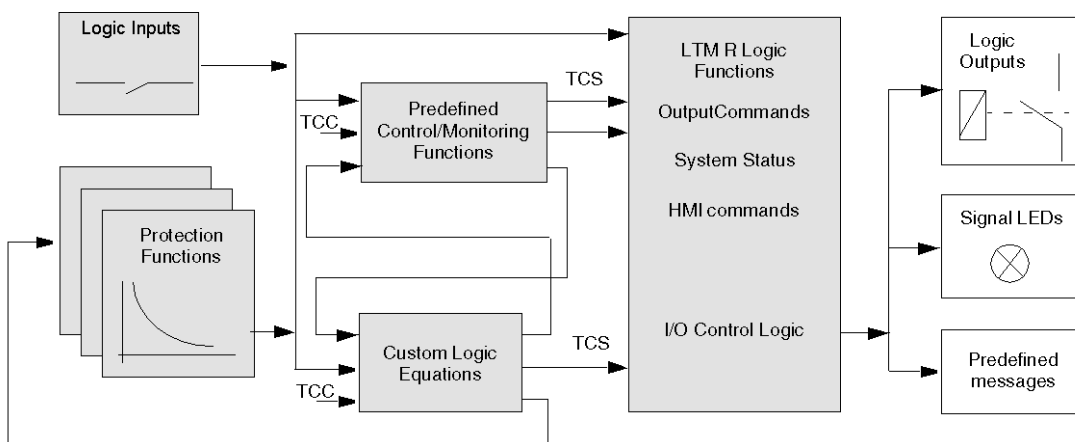

## Logic Inputs and Outputs

The LTMR controller provides 6 logic inputs and 4 logic outputs. By adding an LTME expansion module, you can add 4 more logic inputs.

Selecting a predefined operating mode automatically assigns the logic inputs to functions and defines the relationship between logic inputs and outputs. Using the custom logic editor, you can change these assignments.

## Predefined Operating Modes

### Overview

The LTMR controller can be configured in 1 out of 10 predefined operating modes. Each operating mode is designed to meet the requirements of a common application configuration.

When you select an operating mode, you specify both the:

- Operating mode type, which determines the relationship between logic inputs and logic outputs, and
- Control circuit type, which determines logic input behavior, based on the control wiring design

## Operating Mode Types

There are 10 types of operating modes:

| Operating Mode Type   | Best used for:                                                                                                                                                                                                                                                                                                                                                                                                         |
|-----------------------|------------------------------------------------------------------------------------------------------------------------------------------------------------------------------------------------------------------------------------------------------------------------------------------------------------------------------------------------------------------------------------------------------------------------|
| Overload, page 151    | All motor starter applications in which the user defines assignment of: <ul style="list-style-type: none"> <li>• Logic inputs I.1, I.2, I.3 and I.4</li> <li>• Logic outputs O.1 and O.2</li> <li>• Aux1, Aux2 and Stop commands from the HMI keypad.</li> </ul> The I/O can be defined using a control program managed by the primary network controller in remote control, by an HMI tool, or by using custom logic. |
| Independent, page 153 | Direct-on-line (across-the-line) full-voltage non-reversing motor starting applications                                                                                                                                                                                                                                                                                                                                |
| Reverser, page 155    | Direct-on-line (across-the-line) full-voltage reversing motor starting applications                                                                                                                                                                                                                                                                                                                                    |
| Two-Step, page 159    | Reduced voltage starting motor applications, including: <ul style="list-style-type: none"> <li>• Wye-Delta</li> <li>• Open Transition Primary Resistor</li> <li>• Open Transition Autotransformer</li> </ul>                                                                                                                                                                                                           |
| Two-Speed, page 164   | Two-speed motor applications for motor types, including: <ul style="list-style-type: none"> <li>• Dahlander (consequent pole)</li> <li>• Pole Changer</li> </ul>                                                                                                                                                                                                                                                       |

## Logic Input Behavior

When you select an operating mode, you also specify that logic inputs are wired for either 2-wire (maintained) or 3-wire (impulse) control. Your selection determines the valid start and stop commands from the various control sources, and sets the behavior of the input command following the return of power after an outage:

| Control Circuit Type | Behavior of Logic Inputs I.1 and I.2                                                                                                                                                                                                                                                                                                                                                                                                            |
|----------------------|-------------------------------------------------------------------------------------------------------------------------------------------------------------------------------------------------------------------------------------------------------------------------------------------------------------------------------------------------------------------------------------------------------------------------------------------------|
| 2-wire (maintained)  | The LTMR controller, after detecting the rising edge on the input assigned to start the motor, issues a run command. The run command remains active only while the input is active. The signal is not latched.                                                                                                                                                                                                                                  |
| 3-wire (impulse)     | The LTMR controller: <ul style="list-style-type: none"> <li>• After detecting the rising edge on the input assigned to start the motor, latch the run command, and</li> <li>• After a stop command, disables the run command to disable the output relay wired in series with the coil of the contactor that turns the motor on or off</li> <li>• Following a stop, must detect a rising edge on the input to latch the run command.</li> </ul> |

Control logic assignments for logic inputs I.1, I.2, I.3 and I.4 are described in each of the predefined motor operating modes.

**NOTE:** In Network control channel, network commands behave as 2-wire control commands, regardless of the control circuit type of the selected operating mode. For information on Control Channels, see [Control Channels](#), page 138.

In each predefined operating mode, logic inputs I.3, I.4, I.5 and I.6 behave as follows:

| Logic Input | Behavior                                                                                                                                                                                                                                                                                                                                                                                                                                                                                                                                                                                                                                                                                                                                  |
|-------------|-------------------------------------------------------------------------------------------------------------------------------------------------------------------------------------------------------------------------------------------------------------------------------------------------------------------------------------------------------------------------------------------------------------------------------------------------------------------------------------------------------------------------------------------------------------------------------------------------------------------------------------------------------------------------------------------------------------------------------------------|
| I.3         | <ul style="list-style-type: none"> <li>When it is configured to be used as the external system ready input (Logic Input 3 External Ready Enable = 1), this input provides a feedback on the system state (Ready or not):                             <ul style="list-style-type: none"> <li>If I.3 = 0, the external system is not ready. System Ready bit (455.0) is set to 0.</li> <li>If I.3 = 1, the external system is ready. System Ready bit (455.0) can be set to 1 depending on other conditions on the system.</li> </ul> </li> <li>When it is not configured to be used as the external system ready input (Logic Input 3 External Ready Enable = 0), this input is user defined and only sets a bit in a register.</li> </ul> |
| I.4         | <ul style="list-style-type: none"> <li>In 3-wire (impulse) control: a Stop command. Note that this stop command can be disabled in terminal strip control by setting the parameter Stop terminal strip disable in the Control setting register.</li> <li>In 2-wire (maintained) control: a user-defined input that can be configured to send information to a PLC address over the network.</li> </ul> <p>Note: In Overload operating mode, logic input I.4 is not used and can be user-defined.</p>                                                                                                                                                                                                                                      |
| I.5         | <p>A Trip Reset command is recognized when this input receives the rising edge of a signal.</p> <p><b>Note:</b> this input must first become inactive, and then receive the rising edge of a subsequent signal, for another reset to occur.</p>                                                                                                                                                                                                                                                                                                                                                                                                                                                                                           |
| I.6         | <p>Local/Remote control of the LTMR controller's outputs:</p> <ul style="list-style-type: none"> <li>Active: Remote control (can be associated to any Control channel).</li> <li>Inactive: Local control through either the terminal strip or the HMI port, as determined by the Control Local Channel Setting parameter.</li> </ul>                                                                                                                                                                                                                                                                                                                                                                                                      |

|                                                                                                                              |
|------------------------------------------------------------------------------------------------------------------------------|
| ⚠ WARNING                                                                                                                    |
| LOSS OF MOTOR PROTECTION IN HMI CONTROL                                                                                      |
| If the terminal strip Stop is disabled, the trip output (terminal NC 95-96) must be wired in series with the contactor coil. |
| Failure to follow these instructions can result in death, serious injury, or equipment damage.                               |

## Logic Output Behavior

The behavior of logic outputs O.1 and O.2 is determined by the selected operating mode. See the topics that follow for a description of the 10 predefined operating mode types and the behavior of logic outputs O.1 and O.2.

When the LTMR controller has lost communication with either the network or the HMI, the LTMR controller enters a fallback condition. When it receives a stop command in a fallback condition, logic outputs O.1 and O.2 behave as follows:

| Control Circuit Type | Response of Logic Outputs O.1 and O.2 to a Stop Command                                                                                                                                                                                    |
|----------------------|--------------------------------------------------------------------------------------------------------------------------------------------------------------------------------------------------------------------------------------------|
| 2-wire (maintained)  | A stop command overrides the fallback condition and turns off logic outputs O.1 and O.2 while the stop command is active. After the stop command is no longer active, logic outputs O.1 and O.2 return to their programmed fallback state. |
| 3-wire (impulse)     | A stop command overrides the fallback condition and turns off logic outputs O.1 and O.2. The outputs remain off after the stop command is removed and do not return to their programmed fallback state.                                    |

For more information about configuring fallback parameters, refer to the [Fallback Condition](#), page 63 portion of the topic describing Communication Loss.

In all operating mode types, the following logic outputs behave as described below:

| Logic Output | Behavior                                                                                                                                                                                                                                                                                       |
|--------------|------------------------------------------------------------------------------------------------------------------------------------------------------------------------------------------------------------------------------------------------------------------------------------------------|
| O.3          | Activated by any enabled protection alarm: <ul style="list-style-type: none"> <li>Terminals NO 33-34</li> </ul>                                                                                                                                                                                |
| O.4          | Activated by any enabled protection trip: <ul style="list-style-type: none"> <li>Terminals NC 95-96</li> <li>Terminals NO 97-98</li> </ul> <p><b>Note:</b> When control voltage is too low or off:</p> <ul style="list-style-type: none"> <li>NC 95-96 open</li> <li>NO 97-98 close</li> </ul> |

## Control Wiring and Trip Management

### Overview

When Overload predefined operating mode is selected, the LTMR controller does not manage logic output O.1, O.2, and O.3.

For all other predefined operating modes (Independent, Reverser, 2-Step, and 2-Speed) the predefined control logic in the LTMR controller is designed to meet the objectives of many common motor starting applications. This includes managing motor behavior in response to:

- Start and stop actions, and
- Trip and reset actions

Because the LTMR controller can be used in special applications, such as fire pumps that require the motor to run despite a known external trip condition, the predefined control logic is designed so that the control circuit, and not the predefined control logic, determines how the LTMR controller interrupts current flow to the contactor coil.

### Control Logic Action on Starts and Stops

Predefined control logic acts upon start and stop commands as follows:

- For all 3-wire (impulse) control wiring diagrams, when input 4 is configured as a stop command, the LTMR controller must detect input current at logic input I.4 in order to act on a start command.
- If logic input I.4 is active and a user start action initiates current at logic inputs I.1 or I.2, the LTMR controller detects the rising edge of the current and sets an internal (firmware) latch command that directs the appropriate relay output to close and remain closed until the latch command is disabled.
- A stop action that interrupts current at logic input I.4, causes the LTMR controller to disable the latch command. Disabling the firmware latch causes the output to open—and remain open—until the next valid start condition.
- For all 2-wire (maintained) control wiring diagrams, the LTMR controller detects the presence of current at logic inputs I.1 or I.2 as start commands, and the absence of current disables the start command.

### Control Logic Action on Trips and Resets

Predefined control logic manages trips and reset commands as follows:

- Logic output O.4 opens in response to a trip condition.
- Logic output O.4 closes in response to a reset command.

## Control Logic and Control Wiring Together Managing Trips

The control circuits, shown in the wiring diagrams in this chapter and in the Appendix, indicate how the LTMR controller's control logic and the control circuit combine to stop a motor in response to a trip:

- For 3-wire (impulse) control circuits, the control strategy links the state of logic output O.4 to the state of the current at logic input I.4:
  - Control logic opens logic output O.4 in response to a trip.
  - Logic output O.4 opening interrupts current at logic input I.4, disabling the control logic latch command on logic output O.1.
  - Logic output O.1 opens, due to control logic described above, and stops the flow of current to the contactor coil.

In order to restart the motor, the trip must be reset and a new start command must be issued.

- For 2-wire (maintained) control circuits, the control strategy links the state of logic output O.4 directly with the logic inputs I.1 or I.2.
  - Control logic opens logic output O.4 in response to a trip.
  - Logic output O.4 opening interrupts current to the logic inputs I.1 or I.2
  - Control logic disables the start commands opening logic outputs O.1 or O.2.

In order to restart the motor, the trip must be reset and the state of Start/Stop operators determines the state of logic inputs I.1 or I.2.

The control circuits needed to run a motor, during a motor protection trip, are not shown in the wiring diagrams that follow. However, the control strategy is to not link the state of logic output O.4 to the state of the input commands. In this way, trip conditions may be annunciated, while control logic continues to manage Start and Stop commands.

## Overload Operating Mode

### Description

Use Overload operating mode when motor load monitoring is required and motor load control (start/stop) is performed by a mechanism other than the LTMR controller.

### Functional Characteristics

The Overload operating mode includes the following features:

- The LTMR controller overload operating mode does not manage logic outputs O.1, O.2, and O.3. The logic output O.1 and O.2 commands are accessible in Network control channel.
- Logic output O.4 opens in response to a diagnostic detected error.
  - NOTE:** In Overload operating mode, diagnostic detected error is disabled by default. If needed, it can be enabled by the user.
- The LTMR controller sets a bit in a status word when it detects an active signal:
  - On logic inputs I.1, I.2, I.3, or I.4, or
  - From the Aux 1, Aux 2, or Stop buttons on the HMI keypad.

**NOTE:** When a bit is set in the input status word, it can be read by a PLC which can write a bit to the LTMR controller's command word. When the LTMR controller detects a bit in its command word, it can turn on the respective output (or outputs).

## Overload Application Diagram

The following wiring diagram represents a simplified example of the LTMR controller in a 3-wire (impulse) terminal strip control overload application.

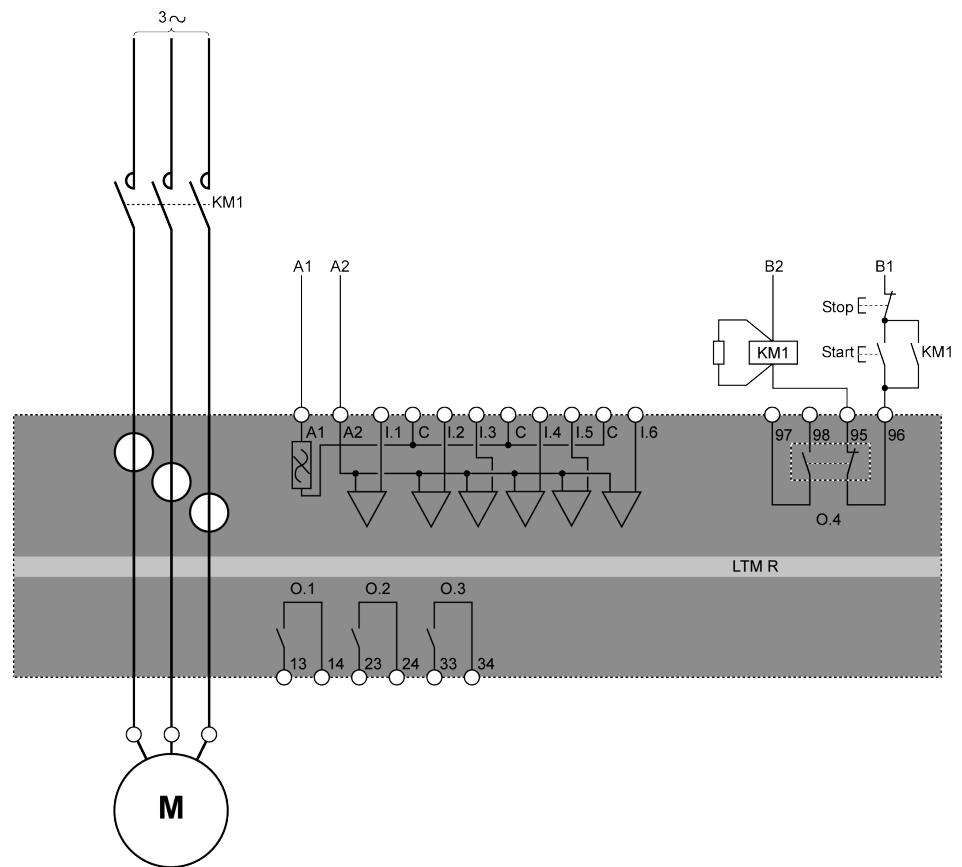

For additional examples of overload operating mode IEC diagrams, refer to relevant diagrams .

For examples of overload operating mode NEMA diagrams, refer to relevant diagrams .

## I/O Assignment

Overload operating mode provides the following logic inputs:

| Logic Inputs | Assignment              |
|--------------|-------------------------|
| I.1          | Free                    |
| I.2          | Free                    |
| I.3          | Free                    |
| I.4          | Free                    |
| I.5          | Reset                   |
| I.6          | Local (0) or Remote (1) |

Overload operating mode provides the following logic outputs:

| Logic Outputs            | Assignment                           |
|--------------------------|--------------------------------------|
| O.1 (13 and 14)          | Responds to network control commands |
| O.2 (23 and 24)          | Responds to network control commands |
| O.3 (33 and 34)          | Alarm signal                         |
| O.4 (95, 96, 97, and 98) | Trip signal                          |

Overload operating mode uses the following HMI keys:

| HMI Keys | Assignment |
|----------|------------|
| Aux 1    | Free       |
| Aux 2    | Free       |
| Stop     | Free       |

## Parameters

Overload operating mode requires no associated parameter settings.

## Independent Operating Mode

### Description

Use Independent operating mode in single direct-on-line (across-the-line) full-voltage, non-reversing motor starting applications.

### Functional Characteristics

This function includes the following features:

- Accessible in 3 control channels: Terminal Strip, HMI, and Network.
- The LTMR controller does not manage the relationship between logic outputs O.1 and O.2.
- In terminal strip control channel, logic input I.1 controls logic output O.1, and logic input I.2 controls logic output O.2.
- In network or HMI control channels, the Motor Run Forward Command parameter controls logic output O.1 and the Logic Output 23 Command parameter controls logic output O.2.
- Logic input I.3 is not used in the control circuit, but can be configured to set a bit in memory.
- Logic outputs O.1 and O.2 deactivate (and the motor stops) when control voltage becomes too low.
- Logic outputs O.1 and O.4 deactivate (and the motor stops) in response to a diagnostic detected error.

**NOTE:** See *Control Wiring and Trip Management*, page 150 for information about the interaction between

- The LTMR controller's predefined control logic, and
- The control wiring, an example of which appears in the following diagram.

## Independent Application Diagram

The following wiring diagram represents a simplified example of the LTMR controller in a 3-wire (impulse) terminal strip control independent application.

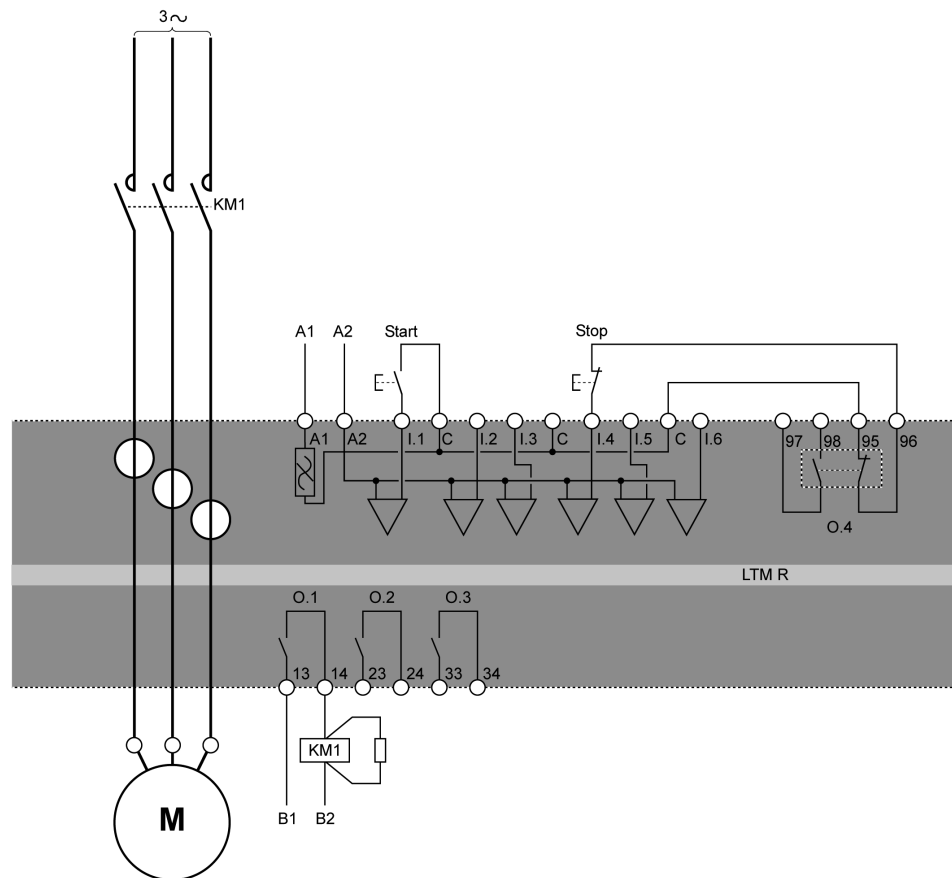

For additional examples of independent operating mode IEC diagrams, refer to relevant diagrams .

For examples of independent operating mode NEMA diagrams, refer to relevant diagrams .

## I/O Assignment

Independent operating mode provides the following logic inputs:

| Logic Inputs | 2-Wire (Maintained) Assignment | 3-Wire (Impulse) Assignment     |
|--------------|--------------------------------|---------------------------------|
| I.1          | Start/Stop motor               | Start motor                     |
| I.2          | Open/Close O.2                 | Close O.2                       |
| I.3          | Free                           | Free                            |
| I.4          | Free                           | Stop motor and open O.1 and O.2 |
| I.5          | Reset                          | Reset                           |
| I.6          | Local (0) or Remote (1)        | Local (0) or Remote (1)         |

Independent operating mode provides the following logic outputs:

| Logic Outputs   | Assignment            |
|-----------------|-----------------------|
| O.1 (13 and 14) | KM1 contactor control |
| O.2 (23 and 24) | Controlled by I.2     |

| Logic Outputs            | Assignment   |
|--------------------------|--------------|
| O.3 (33 and 34)          | Alarm signal |
| O.4 (95, 96, 97, and 98) | Trip signal  |

Independent operating mode uses the following HMI keys:

| HMI Keys | 2-Wire (Maintained) Assignment        | 3-Wire (Impulse) Assignment |
|----------|---------------------------------------|-----------------------------|
| Aux 1    | Control motor                         | Start motor                 |
| Aux 2    | Control O.2                           | Close O.2                   |
| Stop     | Stop motor and open O.2 while pressed | Stop motor and open O.2     |

## Timing Sequence

The following diagram is an example of the timing sequence for the Independent operating mode that shows the inputs and outputs for a 3-wire (impulse) configuration:

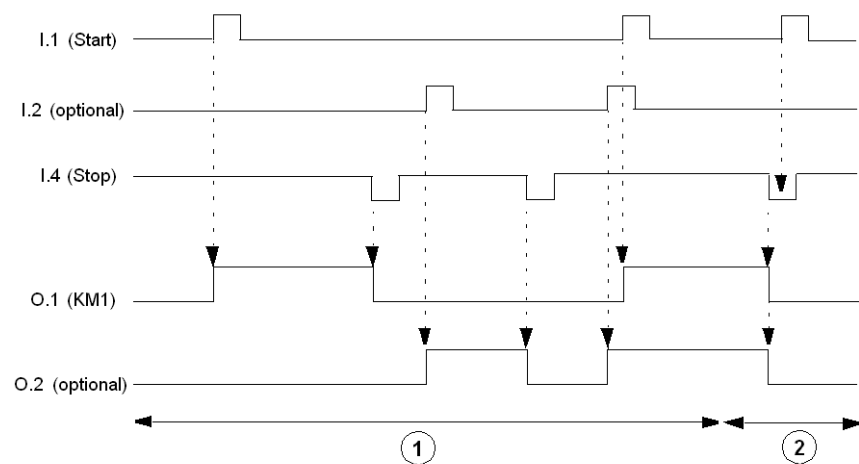

- 1 Normal operation
- 2 Start command ignored: stop command active

## Parameters

Independent operating mode requires no associated parameters.

## Reverser Operating Mode

### Description

Use Reverser operating mode in direct-on-line (across-the-line) full-voltage, reversing motor starting applications.

### Functional Characteristics

This function includes the following features:

- Accessible in 3 control channels: Terminal Strip, HMI, and Network.

- Firmware interlocking helps prevent simultaneous activation of the O.1 (forward) and O.2 (reverse) logic outputs: in case of simultaneous forward and reverse commands, only the logic output O.1 (forward) is activated.
- The LTMR controller can change direction from forward to reverse and reverse to forward in 1 of 2 modes:
  - Standard Transition mode: The Control Direct Transition bit is Off. This mode requires a Stop command followed by count-down of the adjustable Motor Transition Timeout (anti-backspin) timer.
  - Direct Transition mode: The Control Direct Transition bit is On. This mode automatically transitions after the count-down of the adjustable Motor Transition Timeout (anti-backspin) timer.
- In terminal strip control channel, logic input I.1 controls logic output O.1, and logic input I.2 controls logic output O.2.
- In Network or HMI control channels, the Motor Run Forward Command parameter controls logic output O.1 and the Motor Run Reverse Command controls logic output O.2.
- Logic input I.3 is not used in the control circuit, but can be configured to set a bit in memory.
- Logic outputs O.1 and O.2 deactivate (and the motor stops) when control voltage becomes too low.
- Logic outputs O.1, O.2 and O.4 deactivate (and the motor stops) in response to a diagnostic detected error.

**NOTE:** See *Control Wiring and Trip Management*, page 150 for information about the interaction between

- The LTMR controller's predefined control logic, and
- The control wiring, an example of which appears in the following diagram.

## Reverser Application Diagram

The following wiring diagram represents a simplified example of the LTMR controller in a 3-wire (impulse) terminal strip control reverser application.

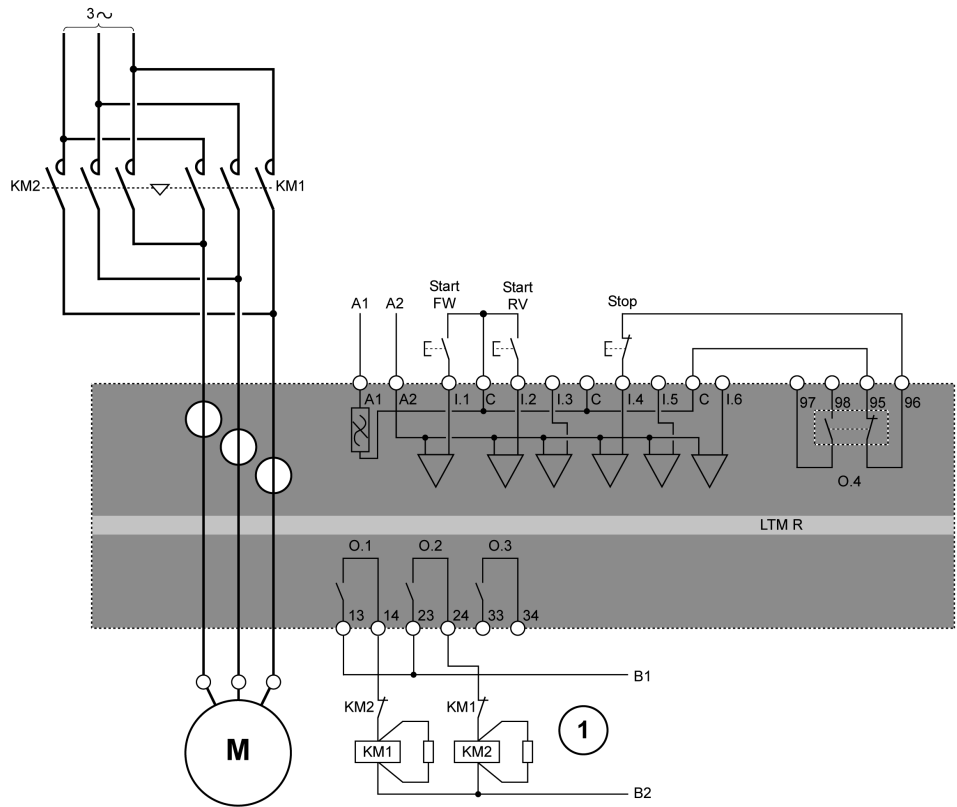

**Start FW** Start forward

**Start RV** Start reverse

**1** The N.C. interlock contacts KM1 and KM2 are not mandatory because the LTMR controller firmware interlocks O.1 and O.2.

For additional examples of reverser operating mode IEC diagrams, refer to relevant diagrams .

For examples of reverser operating mode NEMA diagrams, refer to relevant diagrams .

## I/O Assignment

Reverser operating mode provides the following logic inputs:

| Logic Inputs | 2-Wire (Maintained) Assignment | 3-Wire (Impulse) Assignment |
|--------------|--------------------------------|-----------------------------|
| I.1          | Forward run                    | Start motor forward         |
| I.2          | Reverse run                    | Start motor reverse         |
| I.3          | Free                           | Free                        |
| I.4          | Free                           | Stop motor                  |
| I.5          | Reset                          | Reset                       |
| I.6          | Local (0) or Remote (1)        | Local (0) or Remote (1)     |

Reverser operating mode provides the following logic outputs:

| Logic Outputs            | Assignment                    |
|--------------------------|-------------------------------|
| O.1 (13 and 14)          | KM1 contactor control Forward |
| O.2 (23 and 24)          | KM2 contactor control Reverse |
| O.3 (33 and 34)          | Alarm signal                  |
| O.4 (95, 96, 97, and 98) | Trip signal                   |

Reverser operating mode uses the following HMI keys:

| HMI Keys | 2-Wire (Maintained) Assignment | 3-Wire (Impulse) Assignment |
|----------|--------------------------------|-----------------------------|
| Aux 1    | Forward run                    | Start motor forward         |
| Aux 2    | Reverse run                    | Start motor reverse         |
| Stop     | Stop while pressed             | Stop                        |

## Timing Sequence

The following diagram is an example of the timing sequence for the Reverser operating mode that shows the inputs and outputs for a 3-wire (impulse) configuration when the control direct transition bit is On:

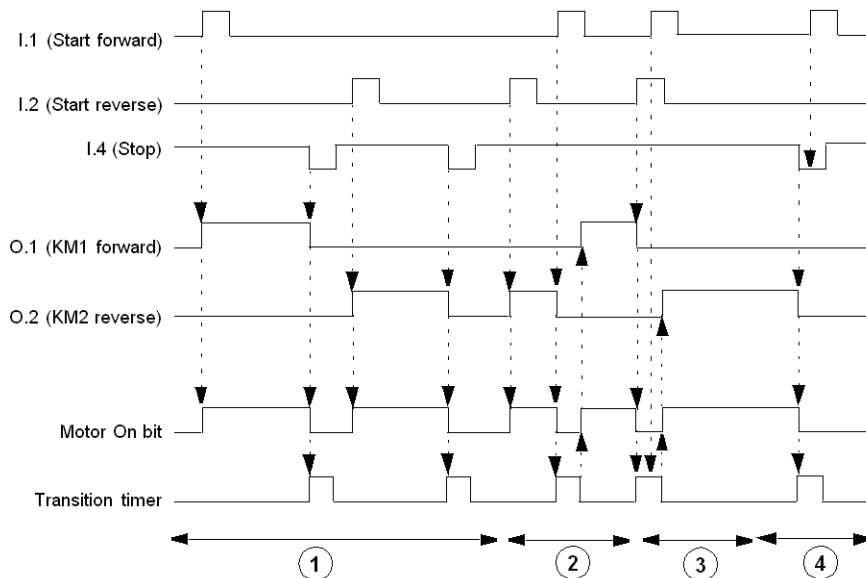

- 1 Normal operation with stop command
- 2 Normal operation without stop command
- 3 Forward run command ignored: transition timer active
- 4 Forward run command ignored: stop command active

## Parameters

Reverser operating mode has the following parameters:

| Parameters                | Setting Range | Factory Setting |
|---------------------------|---------------|-----------------|
| Motor transition timeout  | 0...999.9 s   | 0.1 s           |
| Control direct transition | On/Off        | Off             |

## Two-Step Operating Mode

### Description

Use Two-Step operating mode in reduced voltage starting motor applications such as:

- Wye-Delta
- Open Transition Primary Resistor
- Open Transition Autotransformer

### Functional Characteristics

This function includes the following features:

- Accessible in 3 control channels: Terminal Strip, HMI, and Network.
- Two-Step operation settings include:
  - A Motor Step 1 To 2 Timeout that starts when current reaches 10% of FLC min.
  - A Motor Step 1 To 2 Threshold setting.
  - A Motor Transition Timeout setting that starts upon the earlier of the following events: expiration of the Motor Step 1 To 2 Timeout, or current falling below the Motor Step 1 To 2 Threshold.
- Firmware interlocking helps prevent simultaneous activation of O.1 (step 1) and O.2 (step 2) logic outputs.
- In terminal strip control channel, logic input I.1 controls logic outputs O.1 and O.2.
- In Network or HMI control channels, the Motor Run Forward Command parameter controls logic outputs O.1 and O.2. The Motor Run Reverse Command parameter is ignored.
- Logic outputs O.1 and O.2 deactivate, and the motor stops, when control voltage becomes too low.
- Logic outputs O.1, O.2 and O.4 deactivate, and the motor stops, in response to a diagnostic detected error.

**NOTE:** See [Control Wiring and Trip Management](#), page 150 for information about the interaction between:

- LTMR controller's predefined control logic, and
- Control wiring, an example of which appears in the following diagrams.

## Two-Step Wye-Delta Application Diagram

The following wiring diagram represents a simplified example of the LTMR controller in a two-step 3-wire (impulse) terminal strip control wye-delta application.

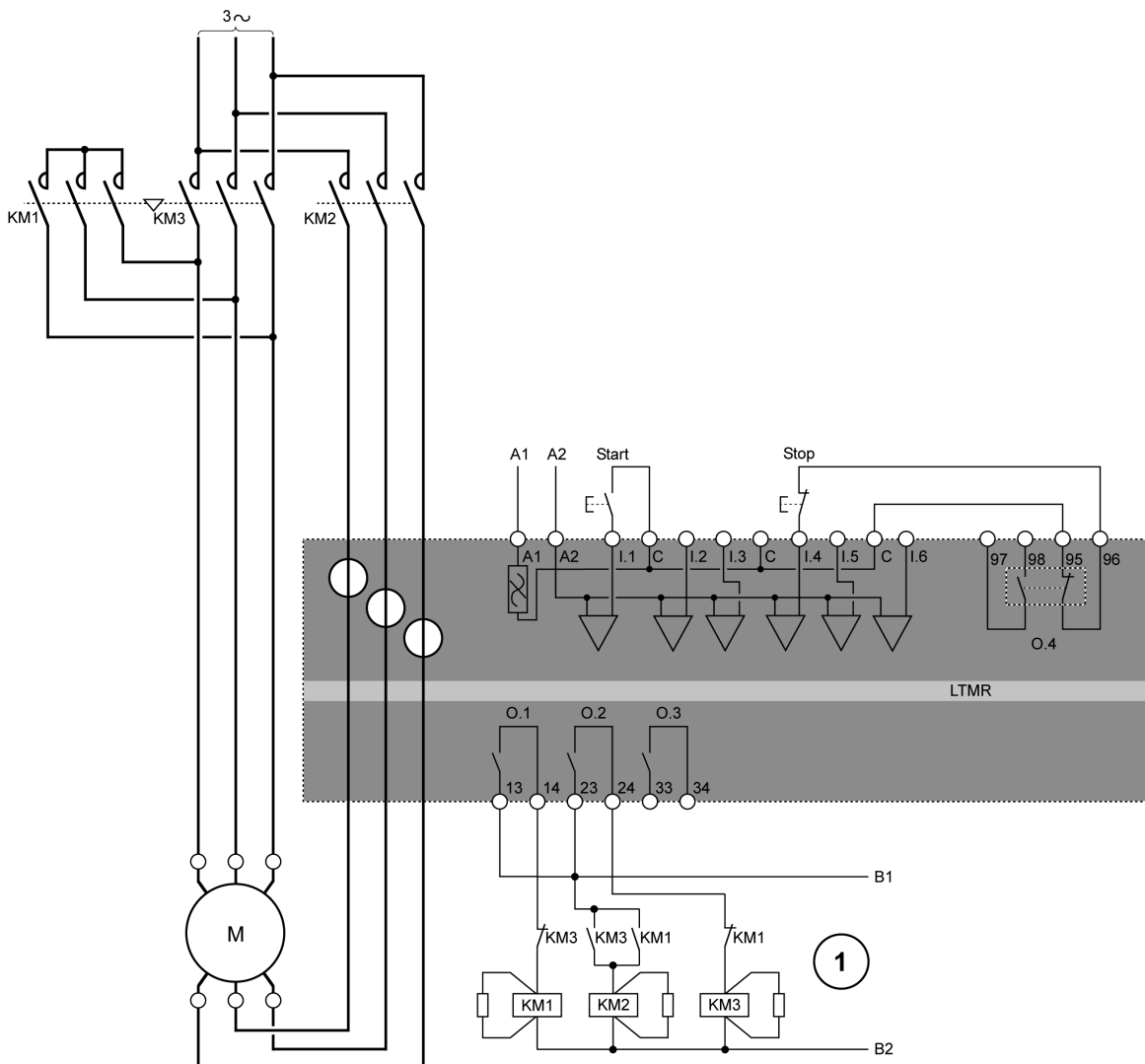

**1** The N.C. interlock contacts KM1 and KM3 are not mandatory because the LTMR controller electronically interlocks O.1 and O.2.

For additional examples of two-step Wye-Delta IEC diagrams, refer to relevant diagrams .

For examples of two-step Wye-Delta NEMA diagrams, refer to relevant diagrams .

## Two-Step Primary Resistor Application Diagram

The following wiring diagram represents a simplified example of the LTMR controller in a two-step 3-wire (impulse) terminal strip control primary resistance application.

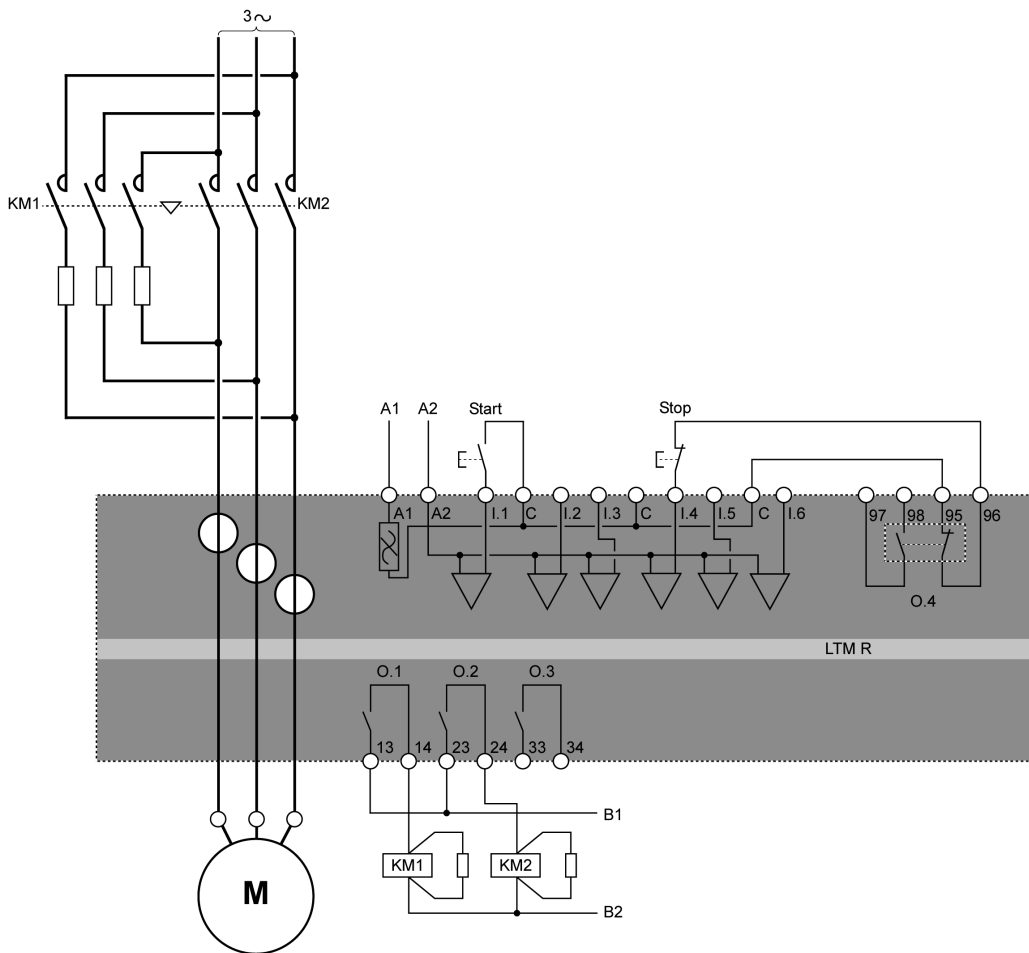

For additional examples of two-step primary resistor IEC diagrams, refer to relevant diagrams .

For examples of two-step primary resistor NEMA diagrams, refer to relevant diagrams .

## Two-Step Autotransformer Application Diagram

The following wiring diagram represents a simplified example of the LTMR controller in a two-step 3-wire (impulse) terminal strip control autotransformer application.

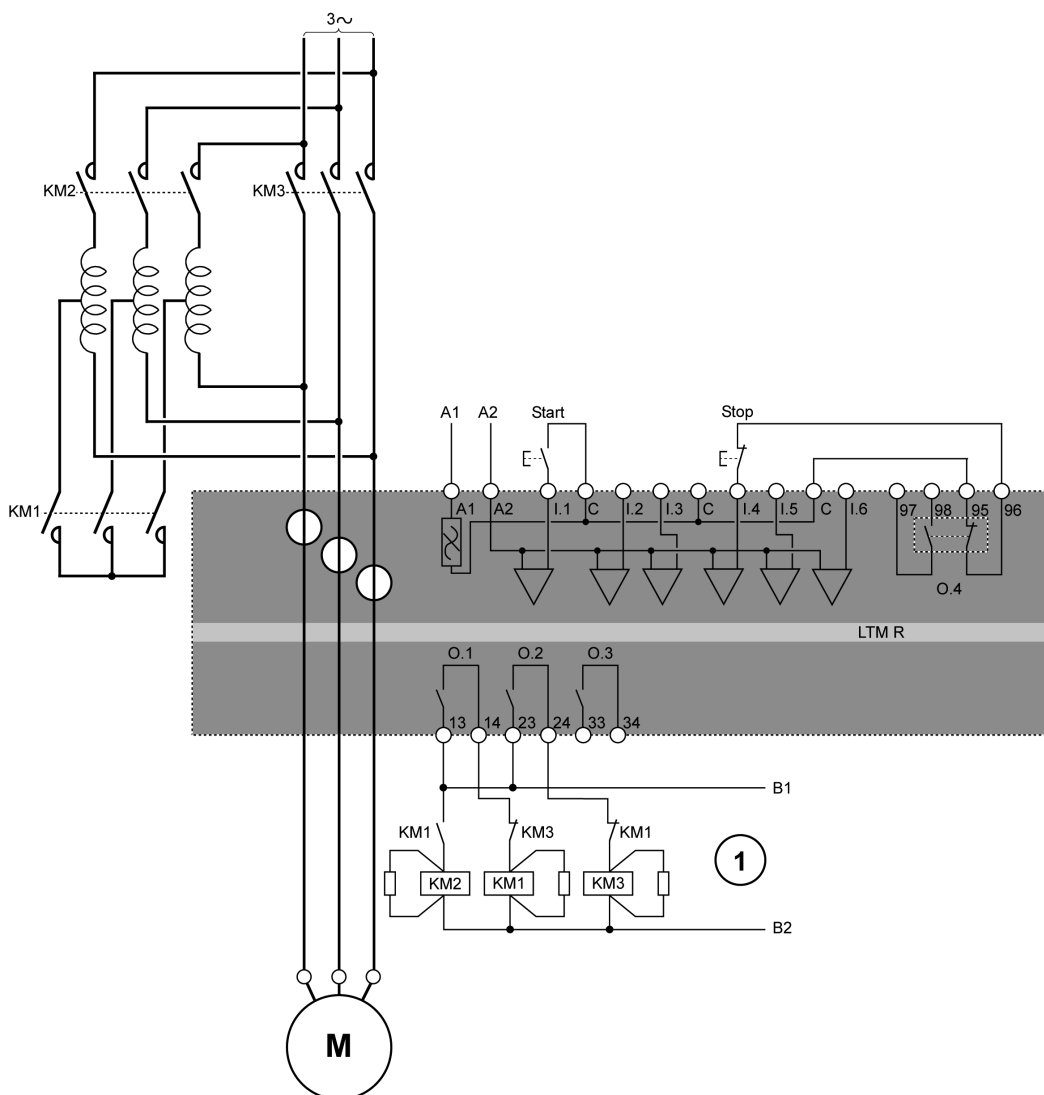

1 The N.C. interlock contacts KM1 and KM3 are not mandatory because the LTMR controller electronically interlocks O.1 and O.2.

For additional examples of two-step autotransformer IEC diagrams, refer to relevant diagrams .

For examples of two-step autotransformer NEMA diagrams, refer to relevant diagrams .

## I/O assignment

Two-step operating mode provides the following logic inputs:

| Logic Inputs | 2-Wire (Maintained) Assignment | 3-Wire (Impulse) Assignment |
|--------------|--------------------------------|-----------------------------|
| I.1          | Control motor                  | Start motor                 |
| I.2          | Free                           | Free                        |
| I.3          | Free                           | Free                        |
| I.4          | Free                           | Stop motor                  |
| I.5          | Reset                          | Reset                       |
| I.6          | Local (0) or Remote (1)        | Local (0) or Remote (1)     |

Two-step operating mode provides the following logic outputs:

| Logic Outputs            | Assignment               |
|--------------------------|--------------------------|
| O.1 (13 and 14)          | Step 1 contactor control |
| O.2 (23 and 24)          | Step 2 contactor control |
| O.3 (33 and 34)          | Alarm signal             |
| O.4 (95, 96, 97, and 98) | Trip signal              |

Two-step operating mode uses the following HMI keys:

| HMI Keys | 2-Wire (Maintained) Assignment | 3-Wire (Impulse) Assignment |
|----------|--------------------------------|-----------------------------|
| Aux 1    | Control motor                  | Start motor                 |
| Aux 2    | Free                           | Free                        |
| Stop     | Stop motor while pressed       | Stop motor                  |

## Timing Sequence

The following diagram is an example of the timing sequence for the Two-Step operating mode that shows the inputs and outputs for a 3-wire (impulse) configuration:

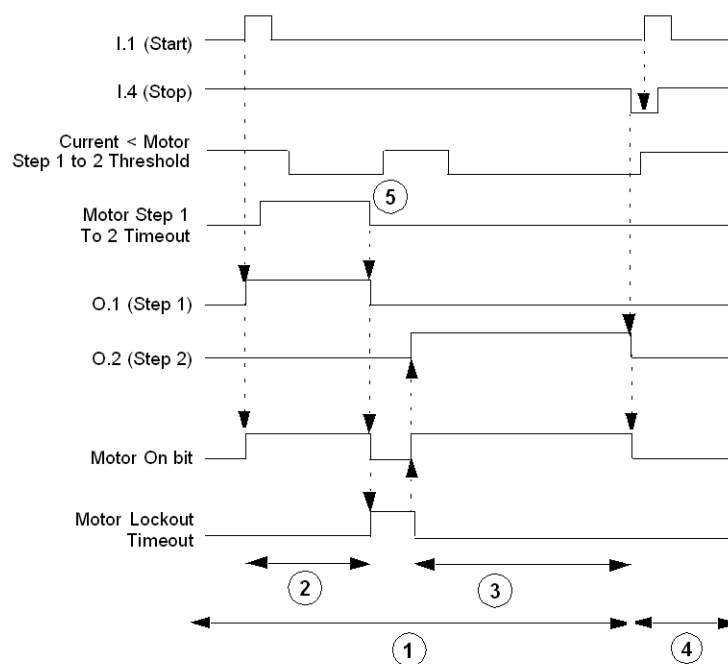

- 1 Normal operation
- 2 Step 1 start
- 3 Step 2 start
- 4 Start command ignored: Stop command active
- 5 Current falling below the Motor Step 1 To 2 Threshold ignored: preceded by expiration of the Motor Step 1 To 2 Timeout.

## Parameters

Two-step operating mode has the following parameters:

| Parameter                   | Setting Range                  | Factory Setting |
|-----------------------------|--------------------------------|-----------------|
| Motor step 1 to 2 timeout   | 0.1...999.9 s                  | 5 s             |
| Motor transition timeout    | 0...999.9 s                    | 100 ms          |
| Motor step 1 to 2 threshold | 20-800 % FLC in 1 % increments | 150 % FLC       |

## Two-Speed Operating Mode

### Description

Use Two-Speed operating mode in two-speed motor applications for motor types such as:

- Dahlander (consequent pole)
- Pole Changer

### Functional Characteristics

This function includes the following features:

- Accessible in 3 control channels: Terminal Strip, HMI, and Network.
- Firmware interlocking helps prevent simultaneous activation of O.1 (low speed) and O.2 (high speed) logic outputs.
- 2 measures of FLC:
  - FLC1 (Motor Full Load Current Ratio) at low speed
  - FLC2 (Motor High Speed Full Load Current Ratio) at high speed
- The LTMR controller can change speed in 2 scenarios:
  - The Control Direct Transition bit is Off: requires a Stop command followed by expiration of the Motor Transition Timeout.
  - The Control Direct Transition bit is On: automatically transitions from high speed to low speed after a time-out of the adjustable Motor Transition Timeout.
- In terminal strip control channel, logic input I.1 controls logic output O.1, and logic input I.2 controls logic output O.2.
- In Network or HMI control channels, when the Motor Run Forward Command parameter is set to 1 and:
  - Motor Low Speed Command is set to 1, logic output O.1 is enabled.
  - Motor Low Speed Command is set to 0, logic output O.2 is enabled.
- Logic input I.3 is not used in the control circuit, but can be configured to set a bit in memory.
- Logic outputs O.1 and O.2 deactivate (and the motor stops) when control voltage becomes too low.
- Logic outputs O.1, O.2 and O.4 deactivate (and the motor stops) in response to a diagnostic detected error.

**NOTE:** See *Control Wiring and Trip Management*, page 150 for information about the interaction between:

- LTMR controller's predefined control logic, and
- Control wiring, an example of which appears in the following diagrams

## Two-Speed Dahlander Application Diagram

The following wiring diagram represents a simplified example of the LTMR controller in a two-speed 3-wire (impulse) terminal strip control Dahlander consequent pole application.

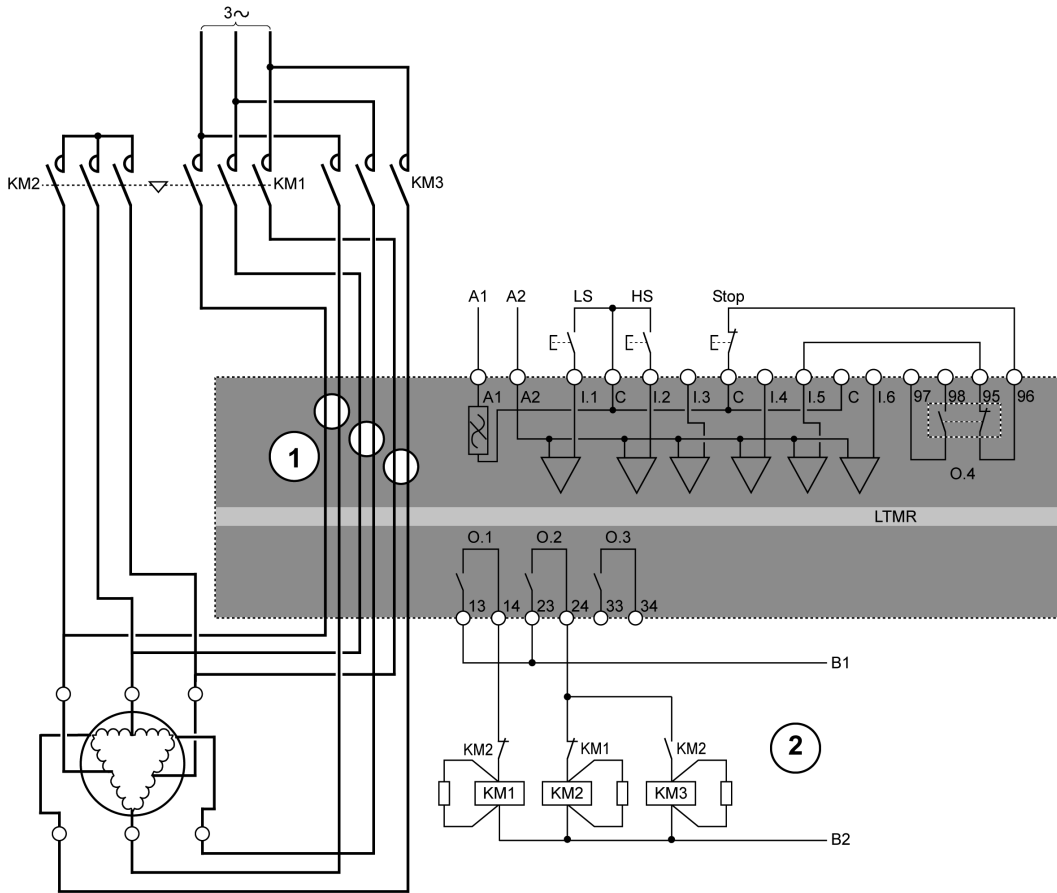

**LS** Low speed

**HS** High speed

**1** A Dahlander application requires 2 sets of wires passing through the CT windows. The LTMR controller can also be placed upstream of the contactors. If this is the case, and if the Dahlander motor is used in variable torque mode, all the wires downstream of the contactors must be the same size.

**2** The N.C. interlock contacts KM1 and KM2 are not mandatory because the LTMR controller firmware interlocks O.1 and O.2.

For additional examples of two-speed Dahlander IEC diagrams, refer to relevant diagrams .

For examples of two-speed Dahlander NEMA diagrams, refer to relevant diagrams .

## Two-Speed Pole-Changing Application Diagram

The following wiring diagram represents a simplified example of the LTMR controller in a two-speed 3-wire (impulse) terminal strip control pole-changing application.

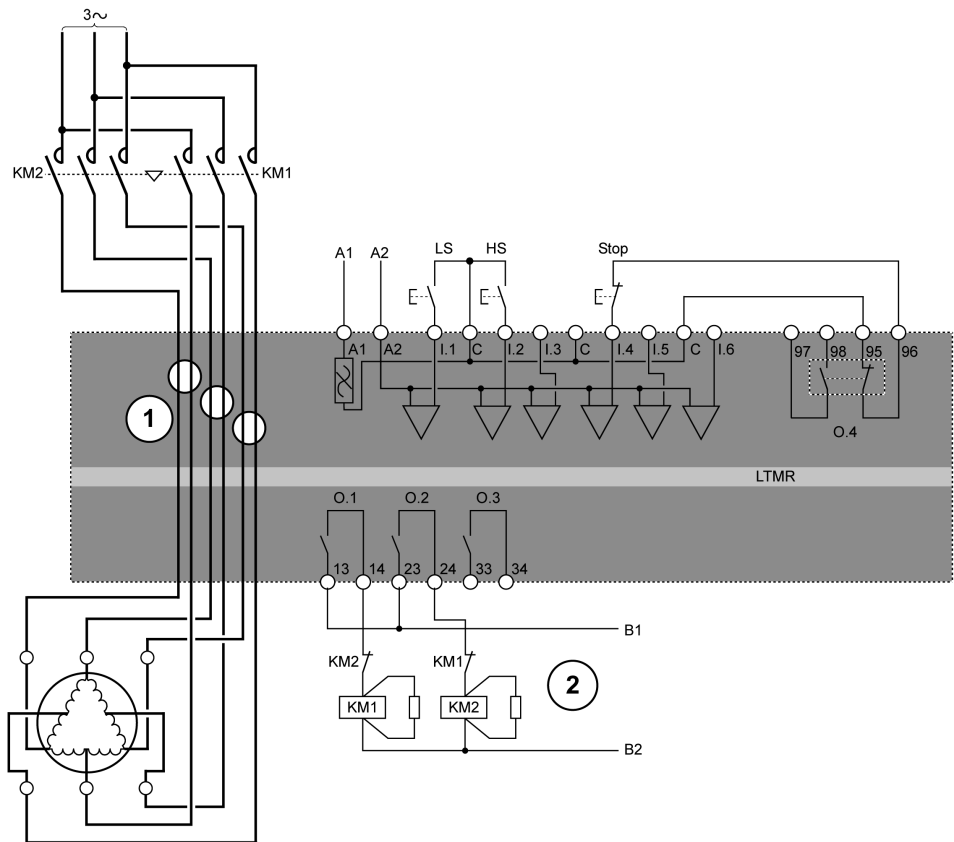

**LS** Low speed

**HS** High speed

**1** A pole-changing application requires 2 sets of wires passing through the CT windows. The LTMR controller can also be placed upstream of the contactors. If this is the case, all the wires downstream of the contactors must be the same size.

**2** The N.C. interlock contacts KM1 and KM2 are not mandatory because the LTMR controller firmware interlocks O.1 and O.2.

For additional examples of pole-changing IEC diagrams, refer to relevant diagrams .

For examples of pole-changing NEMA diagrams, refer to relevant diagrams .

## I/O Assignment

Two-Speed operating mode provides the following logic inputs:

| Logic Inputs | 2-Wire (Maintained) Assignment | 3-Wire (Impulse) Assignment |
|--------------|--------------------------------|-----------------------------|
| I.1          | Low speed command              | Low speed start             |
| I.2          | High speed command             | High speed start            |
| I.3          | Free                           | Free                        |
| I.4          | Free                           | Stop                        |
| I.5          | Reset                          | Reset                       |
| I.6          | Local (0) or Remote (1)        | Local (0) or Remote (1)     |

Two-Speed operating mode provides the following logic outputs:

| Logic outputs            | Assignment         |
|--------------------------|--------------------|
| O.1 (13 and 14)          | Low speed control  |
| O.2 (23 and 24)          | High speed control |
| O.3 (33 and 34)          | Alarm signal       |
| O.4 (95, 96, 97, and 98) | Trip signal        |

Two-speed operating mode uses the following HMI keys:

| HMI Keys | 2-Wire (Maintained) Assignment | 3-Wire (Impulse) Assignment |
|----------|--------------------------------|-----------------------------|
| Aux 1    | Low speed control              | Low speed start             |
| Aux 2    | High speed control             | High speed start            |
| Stop     | Stop the motor                 | Stop the motor              |

## Timing Sequence

The following diagram is an example of the timing sequence for the two-speed operating mode that shows the inputs and outputs for a 3-wire (impulse) configuration when the Control Direct Transition bit is On:

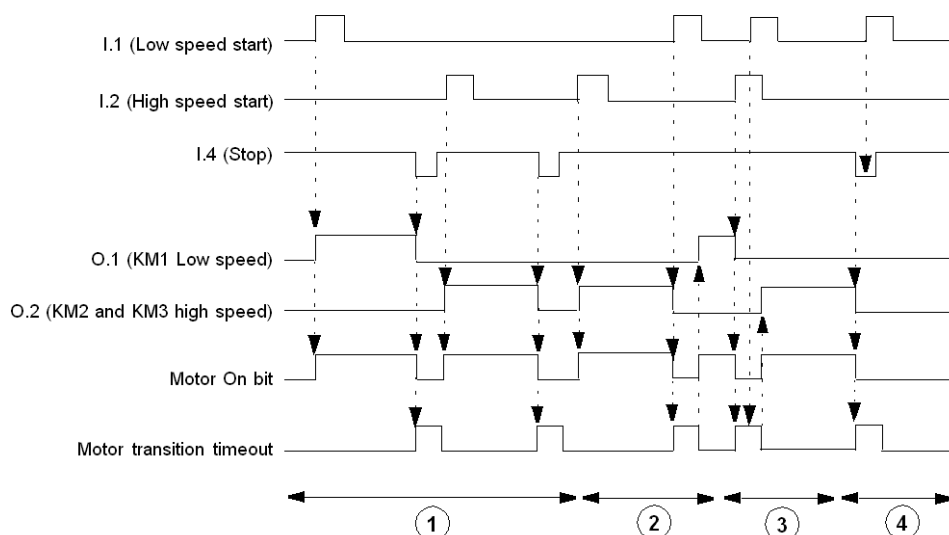

- 1 Normal operation with stop command
- 2 Normal operation without stop command
- 3 Low-speed start command ignored: motor transition timeout active
- 4 Low-speed start command ignored: stop command active

## Parameters

The following table lists the parameters associated with the Two-Speed operating mode.

| Parameters                                         | Setting Range | Factory Setting |
|----------------------------------------------------|---------------|-----------------|
| Motor transition timeout (high speed to low speed) | 0...999.9 s   | 100 ms          |
| Control direct transition                          | On/Off        | Off             |

**NOTE:** The low speed to high speed timer is fixed at 100 ms.

## Custom Operating Mode

### Overview

The predefined control and monitoring functions can be adapted for particular needs using the custom logic editor in the TeSys T DTM to:

- Customize the use of results of protection functions
- Change the operation of control and monitoring functions
- Alter the predefined LTMR controller I/O logic

### Configuration Files

The configuration of the LTMR controller consists of 2 files:

- Configuration file that contains parameter configuration settings
- Logic file that contains a series of logic commands that manage LTMR controller behavior, including:
  - Motor start and stop commands
  - Motor transitions between steps, speeds and directions
  - Valid control source and transitions between control sources
  - Trip and alarm logic for relay outputs 1 and 2, and the HMI
  - Terminal strip reset functions
  - PLC and HMI communication loss and fallback
  - Load shed
  - Rapid cycle
  - Starting and stopping LTMR controller diagnostics

When a predefined operating mode is selected, the LTMR controller applies a predefined logic file that permanently resides in the LTMR controller.

When custom operating mode is selected, the LTMR controller uses a customized logic file created in the custom logic editor and downloaded to the LTMR controller from the TeSys T DTM.

## Trip Management and Clear Commands

### Overview

This section describes how the LTMR controller manages the trip handling process, and explains:

- How to select a trip reset mode, and
- Controller behavior for each trip reset mode selection.

### Trip Management - Introduction

#### Overview

When the LTMR controller detects a trip condition and activates the appropriate response, the trip becomes latched. Once a trip becomes latched, it remains latched, even if the underlying trip condition is eliminated, until cleared by a reset command.

The setting of the Trip Reset Mode parameter determines how the LTMR controller manages trips. The trip reset mode selections, listed below, are described in the topics that follow:

- Manual, page 171 (Factory setting)
- Automatic, page 172
- Remote, page 176

The trip reset mode cannot be changed while a trip remains active. All trips must be reset before the trip reset mode can be changed.

## Trip Reset Methods

A Reset command can be issued using any of the following means:

- cycling power
- reset button on the LTMR controller
- reset button on the HMI keypad
- reset command from the HMI engineering tool
- logic input I.5
- a network command
- automatic reset

### **▲ WARNING**

#### **RISK OF UNINTENDED OPERATION**

When the LTMR controller is operating in 2-wire control with an active Run command, a Reset command will immediately restart the motor.

**Failure to follow these instructions can result in death, serious injury, or equipment damage.**

## Trip Specific Reset Behaviors

The LTMR controller's response to trips depends on the nature of the trip that has occurred and how the related protection function is configured. For example:

- Thermal trips can be reset after the Trip Reset Timeout counts down and the utilized thermal capacity falls below the Trip Reset Threshold level.
- If the trip includes a reset timeout setting, the timeout must fully count down before a reset command executes.
- Internal device trips can be reset only by cycling power.
- LTMR controller memory does not retain diagnostic and wiring trips after a power loss, but does retain all other trips after a power loss.
- Internal, diagnostic, and wiring trips cannot be automatically reset.
- All wiring and diagnostic trips can be manually reset by local reset methods.
- For diagnostic trips, network reset commands are valid only in remote (network) control channel.
- For wiring trips, network reset commands are not valid in any control channel.

## Trip Characteristics

The LTMR controller trip monitoring functions save the status of communications monitoring and motor protection trips on a power loss so that these trips must be acknowledged and reset as part of an overall motor maintenance strategy.

| Protection Category                   | Monitored Trip          | LTMR controller | LTMR with LTME | Saved On Power Loss |
|---------------------------------------|-------------------------|-----------------|----------------|---------------------|
| Diagnostic                            | Run Command Check       | X               | X              | –                   |
|                                       | Stop Command Check      | X               | X              | –                   |
|                                       | Run Check Back          | X               | X              | –                   |
|                                       | Stop Check Back         | X               | X              | –                   |
| Wiring / configuration trips          | PTC connection          | X               | X              | –                   |
|                                       | CT Reversal             | X               | X              | –                   |
|                                       | Voltage Phase Reversal  | –               | X              | –                   |
|                                       | Current Phase Reversal  | X               | X              | –                   |
|                                       | Voltage Phase Loss      | –               | X              | –                   |
|                                       | Phase Configuration     | X               | X              | –                   |
| Internal                              | Stack Overflow          | X               | X              | –                   |
|                                       | Watchdog                | X               | X              | –                   |
|                                       | ROM Checksum            | X               | X              | –                   |
|                                       | EEROM                   | X               | X              | –                   |
|                                       | CPU                     | X               | X              | –                   |
|                                       | Internal Temperature    | X               | X              | –                   |
| Motor temp sensor                     | PTC Binary              | X               | X              | X                   |
|                                       | PT100                   | X               | X              | X                   |
|                                       | PTC Analog              | X               | X              | X                   |
|                                       | NTC Analog              | X               | X              | X                   |
| Thermal overload                      | Definite                | X               | X              | X                   |
|                                       | Inverse Thermal         | X               | X              | X                   |
| Current                               | Long Start              | X               | X              | X                   |
|                                       | Jam                     | X               | X              | X                   |
|                                       | Current Phase Imbalance | X               | X              | X                   |
|                                       | Current Phase Loss      | X               | X              | X                   |
|                                       | Overcurrent             | X               | X              | X                   |
|                                       | Undercurrent            | X               | X              | X                   |
|                                       | Internal Ground Current | X               | X              | X                   |
|                                       | External Ground Current | X               | X              | X                   |
| Voltage                               | Overvoltage             | –               | X              | X                   |
|                                       | Undervoltage            | –               | X              | X                   |
|                                       | Voltage Phase Imbalance | –               | X              | X                   |
| Power                                 | Underpower              | –               | X              | X                   |
|                                       | Overpower               | –               | X              | X                   |
|                                       | Under Power Factor      | –               | X              | X                   |
|                                       | Over Power Factor       | –               | X              | X                   |
| Communication loss                    | PLC to LTMR             | X               | X              | X                   |
|                                       | HMI to LTMR             | X               | X              | X                   |
| <b>X</b> Monitored<br>– Not monitored |                         |                 |                |                     |

# Manual Reset

## Introduction

When the Trip Reset Mode parameter is set to **Manual**, the LTMR controller allows resets—usually performed by a person—via a power cycle of the control power or by using a local reset means, including:

- Terminal Strip (logic input I.5)
- Reset button on the LTMR controller
- Reset commands from the HMI

A manual reset provides on-site personnel the opportunity to inspect the equipment and wiring before performing the reset.

**NOTE:** A manual reset blocks all reset commands from the LTMR controller’s network port—even when the Control Channel is set to **Network**.

## Manual Reset Methods

The LTMR controller provides the following manual reset methods:

| Protection Category          | Monitored Trip         | Control Channel |             |                        |
|------------------------------|------------------------|-----------------|-------------|------------------------|
|                              |                        | Terminal Strip  | HMI         | Network <sup>(1)</sup> |
| Diagnostic                   | Run Command Check      | RB, PC, I.5     | RB, PC, I.5 | RB, PC, I.5            |
|                              | Stop Command Check     | RB, PC, I.5     | RB, PC, I.5 | RB, PC, I.5            |
|                              | Run Check Back         | RB, PC, I.5     | RB, PC, I.5 | RB, PC, I.5            |
|                              | Stop Check Back        | RB, PC, I.5     | RB, PC, I.5 | RB, PC, I.5            |
| Wiring / configuration trips | PTC connection         | RB, PC, I.5     | RB, PC, I.5 | RB, PC, I.5            |
|                              | CT Reversal            | RB, PC, I.5     | RB, PC, I.5 | RB, PC, I.5            |
|                              | Voltage Phase Reversal | RB, PC, I.5     | RB, PC, I.5 | RB, PC, I.5            |
|                              | Current Phase Reversal | RB, PC, I.5     | RB, PC, I.5 | RB, PC, I.5            |
|                              | Voltage Phase Loss     | RB, PC, I.5     | RB, PC, I.5 | RB, PC, I.5            |
|                              | Phase Configuration    | RB, PC, I.5     | RB, PC, I.5 | RB, PC, I.5            |
| Internal                     | Stack Overflow         | PC              | PC          | PC                     |
|                              | Watchdog               | PC              | PC          | PC                     |
|                              | ROM Checksum           | PC              | PC          | PC                     |
|                              | EEROM                  | PC              | PC          | PC                     |
|                              | CPU                    | PC              | PC          | PC                     |
|                              | Internal Temperature   | PC              | PC          | PC                     |
| Motor temp sensor            | PTC Binary             | RB, I.5         | RB, I.5     | RB, I.5                |
|                              | PT100                  | RB, I.5         | RB, I.5     | RB, I.5                |
|                              | PTC Analog             | RB, I.5         | RB, I.5     | RB, I.5                |
|                              | NTC Analog             | RB, I.5         | RB, I.5     | RB, I.5                |
| Thermal overload             | Definite               | RB, I.5         | RB, I.5     | RB, I.5                |
|                              | Inverse Thermal        | RB, I.5         | RB, I.5     | RB, I.5                |

| Protection Category                                                                                                                                                              | Monitored Trip          | Control Channel |         |                        |
|----------------------------------------------------------------------------------------------------------------------------------------------------------------------------------|-------------------------|-----------------|---------|------------------------|
|                                                                                                                                                                                  |                         | Terminal Strip  | HMI     | Network <sup>(1)</sup> |
| Current                                                                                                                                                                          | Long Start              | RB, I.5         | RB, I.5 | RB, I.5                |
|                                                                                                                                                                                  | Jam                     | RB, I.5         | RB, I.5 | RB, I.5                |
|                                                                                                                                                                                  | Current Phase Imbalance | RB, I.5         | RB, I.5 | RB, I.5                |
|                                                                                                                                                                                  | Current Phase Loss      | RB, I.5         | RB, I.5 | RB, I.5                |
|                                                                                                                                                                                  | Undercurrent            | RB, I.5         | RB, I.5 | RB, I.5                |
|                                                                                                                                                                                  | Overcurrent             | RB, I.5         | RB, I.5 | RB, I.5                |
|                                                                                                                                                                                  | External Ground Current | RB, I.5         | RB, I.5 | RB, I.5                |
|                                                                                                                                                                                  | Internal Ground Current | RB, I.5         | RB, I.5 | RB, I.5                |
| Voltage                                                                                                                                                                          | Undervoltage            | RB, I.5         | RB, I.5 | RB, I.5                |
|                                                                                                                                                                                  | Overvoltage             | RB, I.5         | RB, I.5 | RB, I.5                |
|                                                                                                                                                                                  | Voltage Phase Imbalance | RB, I.5         | RB, I.5 | RB, I.5                |
| Power                                                                                                                                                                            | Underpower              | RB, I.5         | RB, I.5 | RB, I.5                |
|                                                                                                                                                                                  | Overpower               | RB, I.5         | RB, I.5 | RB, I.5                |
|                                                                                                                                                                                  | Under Power Factor      | RB, I.5         | RB, I.5 | RB, I.5                |
|                                                                                                                                                                                  | Over Power Factor       | RB, I.5         | RB, I.5 | RB, I.5                |
| Communication loss                                                                                                                                                               | PLC to LTMR             | RB, I.5         | RB, I.5 | RB, I.5                |
|                                                                                                                                                                                  | LTME to LTMR            | RB, I.5         | RB, I.5 | RB, I.5                |
| <b>RB</b> Test/Reset button on the LTMR controller front face or an HMI<br><b>PC</b> Power cycle on the LTMR controller<br><b>I.5</b> Set I.5 logic input on the LTMR controller |                         |                 |         |                        |
| (1) Remote network reset commands are not allowed even when the LTMR controller is configured for network control channel.                                                       |                         |                 |         |                        |

## Automatic Reset

### Introduction

Setting the Trip Reset Mode parameter to **Automatic** lets you:

- Configure the LTMR controller to attempt to reset motor protection and communications trips without the intervention of either a human operator or the remote PLC, for example:
  - For a non-networked LTMR controller installed at a location that is physically remote, or locally hard to access
- Configure trip handling for each protection trip group in a manner that is appropriate to the trips in that group:
  - Set a different timeout delay
  - Permit a different number of reset attempts
  - Disable automatic trip resetting

The Trip Reset Mode parameter selection determines the available reset methods.

Each protection trip is included in 1 of 3 auto-reset trip groups, based on the characteristics of that trip, as described below. Each trip group has 2 configurable parameters:

- A timeout: the Auto-Reset Group (number 1, 2, or 3) Timeout parameter, and
- Maximum number of permissible trip resets: the Auto-Reset Attempts Group (number 1, 2, or 3) Setting parameter

**▲ WARNING****UNINTENDED EQUIPMENT OPERATION**

An auto-reset command may restart the motor if the LTMR controller is used in a 2-wire control circuit.

Equipment operation must conform to local and national safety regulations and codes.

**Failure to follow these instructions can result in death, serious injury, or equipment damage.**

## Reset Behavior

After power is cycled, the LTMR controller clears and sets to 0 the values of the following parameters:

- Auto-Reset Group (number 1, 2, or 3) Timeout and
- Auto Reset Group (number 1, 2, or 3) Setting.

On a successful reset, the Number of Resets count is cleared and set to 0. A reset is successful if, after reset, the motor runs for 1 minute without a trip of a type in the designated group.

If the maximum number of automatic resets has been reached and if the last reset has is unsuccessful, the reset mode turns to Manual. When the motor restarts, the automatic mode parameters are set to 0.

## Emergency Restart

Use the Clear Thermal Capacity Level Command, in applications where it is necessary, to clear the Thermal Capacity Level parameter following a Thermal Overload inverse thermal trip. This command permits an emergency restart before the motor has actually cooled.

**▲ WARNING****LOSS OF MOTOR PROTECTION**

Clearing the thermal capacity level inhibits thermal protection and can cause equipment overheating and fire. Continued operation with inhibited thermal protection must be limited to applications where immediate restart is vital.

**Failure to follow these instructions can result in death, serious injury, or equipment damage.**

## Number of Resets

Each protection group can be set to manual, 1, 2, 3, 4 or 5.

Select 0 to disable automatic reset of protection trip groups—and require a manual reset—even though the Trip Reset Mode parameter is configured for automatic reset.

Select 5 to enable unlimited auto-reset attempts. After the time delay has expired the LTMR controller continually attempts to reset every trip in that reset group.

## Auto-Reset Group 1 (AU-G1)

Group 1 trips require a predefined cooling time after the monitored parameter returns to and falls below a predefined threshold. Group 1 trips include Thermal

Overload and Motor Temp Sensor trips. The cooling time delay is non-configurable. However, you can:

- Add to the cooling time delay by setting the Auto-Reset Group 1 Timeout parameter to a value greater than 0, or
- Disable auto-reset by setting the Auto-Reset Group 1 Timeout parameter to 0

Auto-reset group 1 has the following configurable parameters:

| Parameters                          | Setting Range                                                  | Factory Setting |
|-------------------------------------|----------------------------------------------------------------|-----------------|
| Auto-Reset Attempts Group 1 Setting | 0 = manual, 1, 2, 3, 4, 5 = unlimited number of reset attempts | 5               |
| Auto-Reset Group 1 Timeout          | 0...65,535 s                                                   | 480 s           |

## Auto-Reset Group 2 (AU-G2)

Group 2 trips generally do not include a predefined cooling time delay before a reset can be executed, but can be reset as soon as the trip condition clears. Many group 2 trips can result in some motor overheating, depending upon the severity and duration of the trip condition, which in turn depends upon the protection function configuration.

You can add a cooling time delay, if appropriate, by setting the Auto-Reset Group 2 Timeout parameter to a value greater than 0. You may also want to limit the number of reset attempts to help prevent premature wear or incorrect operation of the equipment.

Auto-reset group 2 has the following configurable parameters:

| Parameters                          | Setting Range                                                  | Factory Setting |
|-------------------------------------|----------------------------------------------------------------|-----------------|
| Auto-Reset Attempts Group 2 Setting | 0 = manual, 1, 2, 3, 4, 5 = unlimited number of reset attempts | 0               |
| Auto-Reset Group 2 Timeout          | 0...65,535 s                                                   | 1,200 s         |

## Auto-Reset Group 3 (AU-G3)

Group 3 trips often apply to equipment monitoring and generally do not require a motor cooling period. These trips can be used to detect equipment conditions—for example, an undercurrent trip that detects the loss of a belt, or an overpower trip that detects an increased loading condition in a mixer. You may want to configure group 3 trips in a way that differs significantly from groups 1 or 2, for example by setting the number of resets to 0, thereby requiring a manual reset after the equipment event has been discovered and corrected.

Auto-reset group 3 has the following configurable parameters:

| Parameters                          | Setting Range                                                  | Factory Setting |
|-------------------------------------|----------------------------------------------------------------|-----------------|
| Auto-Reset Attempts Group 3 Setting | 0 = manual, 1, 2, 3, 4, 5 = unlimited number of reset attempts | 0               |
| Auto-Reset Group 3 Timeout          | 0...65,535 s                                                   | 60 s            |

## Auto-Reset Methods

The LTMR controller allows the following auto-reset methods:

- RB - Test / Reset button on the LTMR or the HMI
- PC - Power cycle on the LTMR controller
- I.5 - Set I.5 logic input on the LTMR
- NC - Network command

- Automatic with conditions configured for the protection function group (where AU-GX = AU-G1, AU-G2, or AU-G3)

The table below lists the possible auto-reset methods for each monitored trip:

| Protection Category          | Monitored Trip          | Control Channel |                |                    |
|------------------------------|-------------------------|-----------------|----------------|--------------------|
|                              |                         | Terminal Strip  | HMI            | Network            |
| Diagnostic                   | Run Command Check       | RB, PC, I.5     | RB, PC, I.5    | RB, PC, I.5, NC    |
|                              | Stop Command Check      | RB, PC, I.5     | RB, PC, I.5    | RB, PC, I.5, NC    |
|                              | Run Check Back          | RB, PC, I.5     | RB, PC, I.5    | RB, PC, I.5, NC    |
|                              | Stop Check Back         | RB, PC, I.5     | RB, PC, I.5    | RB, PC, I.5, NC    |
| Wiring / configuration trips | PTC connection          | RB, PC, I.5     | RB, PC, I.5    | RB, PC, I.5        |
|                              | CT Reversal             | RB, PC, I.5     | RB, PC, I.5    | RB, PC, I.5        |
|                              | Voltage Phase Reversal  | RB, PC, I.5     | RB, PC, I.5    | RB, PC, I.5        |
|                              | Current Phase Reversal  | RB, PC, I.5     | RB, PC, I.5    | RB, PC, I.5        |
|                              | Voltage Phase Loss      | RB, PC, I.5     | RB, PC, I.5    | RB, PC, I.5        |
|                              | Phase Configuration     | RB, PC, I.5     | RB, PC, I.5    | RB, PC, I.5, NC    |
| Internal                     | Stack Overflow          | PC              | PC             | PC                 |
|                              | Watchdog                | PC              | PC             | PC                 |
|                              | ROM Checksum            | PC              | PC             | PC                 |
|                              | EEROM                   | PC              | PC             | PC                 |
|                              | CPU                     | PC              | PC             | PC                 |
|                              | Internal Temperature    | PC              | PC             | PC                 |
| Motor temp sensor            | PTC Binary              | AU-G1           | AU-G1          | AU-G1              |
|                              | PT100                   | AU-G1           | AU-G1          | AU-G1              |
|                              | PTC Analog              | AU-G1           | AU-G1          | AU-G1              |
|                              | NTC Analog              | AU-G1           | AU-G1          | AU-G1              |
| Thermal overload             | Definite                | AU-G1           | AU-G1          | AU-G1              |
|                              | Inverse Thermal         | AU-G1           | AU-G1          | AU-G1              |
| Current                      | Long Start              | RB, I.5, AU-G2  | RB, I.5, AU-G2 | RB, I.5, NC, AU-G2 |
|                              | Jam                     | RB, I.5, AU-G2  | RB, I.5, AU-G2 | RB, I.5, NC, AU-G2 |
|                              | Current Phase Imbalance | RB, I.5, AU-G2  | RB, I.5, AU-G2 | RB, I.5, NC, AU-G2 |
|                              | Current Phase Loss      | RB, I.5         | RB, I.5        | RB, I.5, NC        |
|                              | Undercurrent            | RB, I.5, AU-G3  | RB, I.5, AU-G3 | RB, I.5, NC, AU-G3 |
|                              | Overcurrent             | RB, I.5, AU-G3  | RB, I.5, AU-G3 | RB, I.5, NC, AU-G3 |
|                              | External Ground Current | RB, I.5, AU-G2  | RB, I.5, AU-G2 | RB, I.5, NC, AU-G2 |
|                              | Internal Ground Current | RB, I.5, AU-G2  | RB, I.5, AU-G2 | RB, I.5, NC, AU-G2 |
| Voltage                      | Undervoltage            | RB, I.5, AU-G2  | RB, I.5, AU-G2 | RB, I.5, NC, AU-G2 |
|                              | Overvoltage             | RB, I.5, AU-G2  | RB, I.5, AU-G2 | RB, I.5, NC, AU-G2 |
|                              | Voltage Phase Imbalance | RB, I.5, AU-G2  | RB, I.5, AU-G2 | RB, I.5, NC, AU-G2 |
| Power                        | Underpower              | RB, I.5, AU-G3  | RB, I.5, AU-G3 | RB, I.5, NC, AU-G3 |
|                              | Overpower               | RB, I.5, AU-G3  | RB, I.5, AU-G3 | RB, I.5, NC, AU-G3 |
|                              | Under Power Factor      | RB, I.5, AU-G2  | RB, I.5, AU-G2 | RB, I.5, NC, AU-G2 |
|                              | Over Power Factor       | RB, I.5, AU-G2  | RB, I.5, AU-G2 | RB, I.5, NC, AU-G2 |
| Communication Loss           | PLC to LTMR             | RB, I.5, AU-G3  | RB, I.5, AU-G3 | RB, I.5, NC, AU-G3 |
|                              | LTME to LTMR            | RB, I.5, AU-G3  | RB, I.5, AU-G3 | RB, I.5, NC, AU-G3 |

## Remote Reset

### Introduction

Setting the Trip Reset Mode parameter to **Remote** adds resetting trips from the PLC over the LTMR network port. This provides centralized monitoring and control of equipment installations. The Control channel parameter selection determines the available reset methods.

Both manual reset methods and remote reset methods reset a trip.

### Remote Reset Methods

The LTMR controller provides the following remote reset methods:

| Protection Category          | Monitored Trip          | Control Channel |                 |                 |
|------------------------------|-------------------------|-----------------|-----------------|-----------------|
|                              |                         | Terminal Strip  | HMI             | Network         |
| Diagnostic                   | Run Command Check       | RB, PC, I.5, NC | RB, PC, I.5, NC | RB, PC, I.5, NC |
|                              | Stop Command Check      | RB, PC, I.5, NC | RB, PC, I.5, NC | RB, PC, I.5, NC |
|                              | Run Check Back          | RB, PC, I.5, NC | RB, PC, I.5, NC | RB, PC, I.5, NC |
|                              | Stop Check Back         | RB, PC, I.5, NC | RB, PC, I.5, NC | RB, PC, I.5, NC |
| Wiring / configuration trips | PTC connection          | RB, PC, I.5, NC | RB, PC, I.5, NC | RB, PC, I.5, NC |
|                              | CT Reversal             | RB, PC, I.5, NC | RB, PC, I.5, NC | RB, PC, I.5, NC |
|                              | Voltage Phase Reversal  | RB, PC, I.5, NC | RB, PC, I.5, NC | RB, PC, I.5, NC |
|                              | Current Phase Reversal  | RB, PC, I.5, NC | RB, PC, I.5, NC | RB, PC, I.5, NC |
|                              | Voltage Phase Loss      | RB, PC, I.5, NC | RB, PC, I.5, NC | RB, PC, I.5, NC |
|                              | Phase Configuration     | RB, PC, I.5, NC | RB, PC, I.5, NC | RB, PC, I.5, NC |
| Internal                     | Stack Overflow          | PC              | PC              | PC              |
|                              | Watchdog                | PC              | PC              | PC              |
|                              | ROM Checksum            | PC              | PC              | PC              |
|                              | EEROM                   | PC              | PC              | PC              |
|                              | CPU                     | PC              | PC              | PC              |
|                              | Internal Temperature    | PC              | PC              | PC              |
| Motor temp sensor            | PTC Binary              | RB, I.5, NC     | RB, I.5, NC     | RB, I.5, NC     |
|                              | PT100                   | RB, I.5, NC     | RB, I.5, NC     | RB, I.5, NC     |
|                              | PTC Analog              | RB, I.5, NC     | RB, I.5, NC     | RB, I.5, NC     |
|                              | NTC Analog              | RB, I.5, NC     | RB, I.5, NC     | RB, I.5, NC     |
| Thermal overload             | Definite                | RB, I.5, NC     | RB, I.5, NC     | RB, I.5, NC     |
|                              | Inverse Thermal         | RB, I.5, NC     | RB, I.5, NC     | RB, I.5, NC     |
| Current                      | Long Start              | RB, I.5, NC     | RB, I.5, NC     | RB, I.5, NC     |
|                              | Jam                     | RB, I.5, NC     | RB, I.5, NC     | RB, I.5, NC     |
|                              | Current Phase Imbalance | RB, I.5, NC     | RB, I.5, NC     | RB, I.5, NC     |
|                              | Current Phase Loss      | RB, I.5, NC     | RB, I.5, NC     | RB, I.5, NC     |
|                              | Undercurrent            | RB, I.5, NC     | RB, I.5, NC     | RB, I.5, NC     |
|                              | Overcurrent             | RB, I.5, NC     | RB, I.5, NC     | RB, I.5, NC     |
|                              | External Ground Current | RB, I.5, NC     | RB, I.5, NC     | RB, I.5, NC     |
|                              | Internal Ground Current | RB, I.5, NC     | RB, I.5, NC     | RB, I.5, NC     |

| Protection Category | Monitored Trip          | Control Channel |             |             |
|---------------------|-------------------------|-----------------|-------------|-------------|
|                     |                         | Terminal Strip  | HMI         | Network     |
| Voltage             | Undervoltage            | RB, I.5, NC     | RB, I.5, NC | RB, I.5, NC |
|                     | Overvoltage             | RB, I.5, NC     | RB, I.5, NC | RB, I.5, NC |
|                     | Voltage Phase Imbalance | RB, I.5, NC     | RB, I.5, NC | RB, I.5, NC |
| Power               | Underpower              | RB, I.5, NC     | RB, I.5, NC | RB, I.5, NC |
|                     | Overpower               | RB, I.5, NC     | RB, I.5, NC | RB, I.5, NC |
|                     | Under Power Factor      | RB, I.5, NC     | RB, I.5, NC | RB, I.5, NC |
|                     | Over Power Factor       | RB, I.5, NC     | RB, I.5, NC | RB, I.5, NC |
| Communication Loss  | PLC to LTMR             | RB, I.5, NC     | RB, I.5, NC | RB, I.5, NC |
|                     | LTME to LTMR            | RB, I.5, NC     | RB, I.5, NC | RB, I.5, NC |

**RB** Test/Reset button on the LTMR controller front face or the HMI  
**PC** Power cycle on the LTMR controller  
**I.5** Set I.5 logic input on the LTMR controller  
**NC** Network command

## Trip and Alarm Codes

### Trip Codes

Each trip is identified by a numerical trip code.

| Trip code | Description                          |
|-----------|--------------------------------------|
| 0         | No detected error                    |
| 3         | Ground current                       |
| 4         | Thermal overload                     |
| 5         | Long start                           |
| 6         | Jam                                  |
| 7         | Current phase imbalance              |
| 8         | Undercurrent                         |
| 10        | Test                                 |
| 11        | HMI port detected error              |
| 12        | HMI port communication loss          |
| 13        | Network port internal detected error |
| 16        | External trip                        |
| 18        | On-Off diagnostic                    |
| 19        | Wiring diagnostic                    |
| 20        | Overcurrent                          |
| 21        | Current phase loss                   |
| 22        | Current phase reversal               |
| 23        | Motor temp sensor                    |
| 24        | Voltage phase imbalance              |
| 25        | Voltage phase loss                   |
| 26        | Voltage phase reversal               |
| 27        | Undervoltage                         |

| Trip code | Description                                                 |
|-----------|-------------------------------------------------------------|
| 28        | Overvoltage                                                 |
| 29        | Underpower                                                  |
| 30        | Overpower                                                   |
| 31        | Under power factor                                          |
| 32        | Over power factor                                           |
| 33        | LTME configuration                                          |
| 34        | Temperature sensor short-circuit                            |
| 35        | Temperature sensor open-circuit                             |
| 36        | CT reversal                                                 |
| 37        | Out of boundary CT ratio                                    |
| 46        | Start check                                                 |
| 47        | Run checkback                                               |
| 48        | Stop check                                                  |
| 49        | Stop checkback                                              |
| 51        | Controller internal temperature detected error              |
| 55        | Controller internal detected error (Stack overflow)         |
| 56        | Controller internal detected error (RAM detected error)     |
| 57        | Controller internal detected error (RAM checksum trip)      |
| 58        | Controller internal detected error (Hardware watchdog trip) |
| 60        | L2 current detected in single-phase mode                    |
| 64        | Non volatile memory detected error                          |
| 65        | Expansion module communication detected error               |
| 66        | Stuck reset button                                          |
| 67        | Logic function detected error                               |
| 100-104   | Network port internal detected error                        |
| 109       | Network port comm detected error                            |
| 111       | Fast device replacement trip                                |
| 555       | Network port configuration detected error                   |

## Alarm Codes

Each alarm is identified by a numerical alarm code.

| Alarm code | Description               |
|------------|---------------------------|
| 0          | No alarm                  |
| 3          | Ground current            |
| 4          | Thermal overload          |
| 5          | Long start                |
| 6          | Jam                       |
| 7          | Current phase imbalance   |
| 8          | Undercurrent              |
| 10         | HMI port                  |
| 11         | LTMR internal temperature |
| 18         | Diagnostic                |

| Alarm code | Description                |
|------------|----------------------------|
| 19         | Wiring                     |
| 20         | Overcurrent                |
| 21         | Current phase loss         |
| 23         | Motor temp sensor          |
| 24         | Voltage phase imbalance    |
| 25         | Voltage phase loss         |
| 27         | Undervoltage               |
| 28         | Overvoltage                |
| 29         | Underpower                 |
| 30         | Overpower                  |
| 31         | Under power factor         |
| 32         | Over power factor          |
| 33         | LTME configuration         |
| 46         | Start check                |
| 47         | Run checkback              |
| 48         | Stop check                 |
| 49         | Stop checkback             |
| 109        | Network port comm loss     |
| 555        | Network port configuration |

## LTMR Controller Clear Commands

### Overview

Clear commands allow the user to clear specific categories of LTMR controller parameters:

- Clear all parameters
- Clear the statistics
- Clear the thermal capacity level
- Clear the controller settings
- Clear the network port settings

The Clear commands can be executed from:

- PC running SoMove with the TeSys T DTM
- An HMI device
- PLC via the network port

### Clear All Command

If you want to change the configuration of the LTMR controller, you may want to clear all existing parameters in order to set new parameters for the controller.

The Clear All Command forces the controller to enter configuration mode. A power-cycle is performed to restart correctly in this mode. This enables the controller to pick up the new values for the cleared parameters.

When you clear all parameters, static characteristics are also lost. Only the following parameters are not cleared after a Clear All Command:

- Motor LO1 Closings Count
- Motor LO2 Closings Count
- Controller Internal Temperature Max

## Clear Statistics Command

Statistics parameters are cleared without the LTMR controller being forced into configuration mode. Static characteristics are preserved.

The following parameters are not cleared after a Clear Statistics Command:

- Motor LO1 Closings Count
- Motor LO2 Closings Count
- Controller Internal Temperature Max

## Clear Thermal Capacity Level Command

The Clear Thermal Capacity Level Command clears the following parameters:

- Thermal Capacity Level
- Rapid Cycle Lockout Timeout

Thermal memory parameters are cleared without the controller being forced into configuration mode. Static characteristics are preserved.

**NOTE:** This bit is writable at any time, even when the motor is running.

For more information about the Clear Thermal Capacity Level Command, see [Reset for Emergency Restart](#), page 78.

## Clear Controller Settings Command

The Clear Controller Settings Command restores the LTMR controller protection factory settings (timeouts and thresholds).

The following settings are not cleared by this command:

- Controller characteristics
- Connections (CT, temperature sensor, and I/O settings)
- Operating mode

Controller setting parameters are cleared without the controller being forced into configuration mode. Static characteristics are preserved.

## Clear Network Port Settings Command

The Clear Network Port Settings Command restores the LTMR controller network port factory settings (address, and so on).

Network port settings are cleared without the controller being forced into configuration mode. Static characteristics are preserved. Only the network communication becomes ineffective.

After the IP addressing parameters are cleared, power must be cycled to the LTMR controller for it .

# Communication Functions

This chapter presents the TeSys T communication functions using the network port or HMI port.

## Configuration of LTMR Ports

### Overview

This section describes how to configure the LTMR network port for every communication protocol and the LTMR HMI port.

## Configuration of the LTMR Modbus Network Port

### Communication Parameters

Before any communication can start, use the TeSys T DTM or the HMI to configure the Modbus port communication parameters:

- Network port address setting
- Network port baud rate setting
- Network port parity setting
- Network port comm loss timeout
- Network port endian setting

### Network Port Address Setting

The device address can be set between 1 and 247.

Factory setting is 1, which corresponds to an undefined value.

### Network Port Baud Rate Setting

Possible transmission rates are:

- 1200 Baud
- 2400 Baud
- 4800 Baud
- 9600 Baud
- 19,200 Baud
- Autodetection

Factory settings is Autodetection. In Autodetection, the controller is able to adapt its baud rate to that of the primary. 19,200 Baud is the first baud rate to be tested.

### Network Port Parity Setting

The parity can be selected from:

- Even
- Odd
- None

When Network port baud rate setting is in Autodetection, the controller is able to adapt its parity and stop bit to that of the primary. Even parity is the first parity to be tested.

In Autodetection, the parity is set automatically; any previous setting is ignored.

Parity and stop bit behavior is linked:

| If the parity is... | Then the number of stop bits is... |
|---------------------|------------------------------------|
| even or odd         | 1                                  |
| none                | 2                                  |

## Network Port Comm Loss Timeout

Network port comm loss timeout is used to determine the timeout value after a loss of communication with the PLC.

- Range: 1-9,999

## Network Port Fallback Setting

Network port fallback setting, page 63 is used to adjust the fallback mode in case of a loss of communication with the PLC.

## Network Port Endian Setting

The Network port endian setting allows to swap the 2 words in a double word.

- 0 = least significant word first (little endian)
- 1 = most significant word first (big endian, factory setting)

## Configuration of the LTMR PROFIBUS DP Network Port

### Communication Parameters

Use the TeSys T DTM or the HMI to configure the PROFIBUS DP communication parameters:

- Network port address setting
- Network port baud rate setting
- Configuration channel setting

### Setting the Node-ID

The Node-ID is the address of the module on the PROFIBUS DP bus. You can assign an address from 1 to 125. The factory setting for the address is 126.

You must set the Node-ID before any communication can begin. Use the TeSys T DTM or the HMI to configure the communication parameter Network Port Address Setting.

**NOTE:** Address 0 is an invalid value and is not permitted. A return to factory settings command sets the Node-ID to the invalid value 126.

### Setting the Baud Rate

Set the baud rate to the only possible speed: 65,535 = Autobaud.

Use the TeSys T DTM or the HMI to configure the communication parameter Network Port Baud Rate Setting.

The factory setting for the Network Port Baud Rate Setting parameter is Autobaud (0xFFFF). Using Autobaud, the LTMR controller adapts its baud rate to that of the primary.

## Setting the Configuration Channel

The LTMR configuration can be managed:

- Locally through the HMI port using the TeSys T DTM or the HMI
- Remotely through the network.

**To manage the configuration locally**, the Configuration via Network Port Enable parameter must be disabled to help prevent an overwrite of the configuration through the network.

**To manage the configuration remotely**, the Configuration via Network Port Enable parameter must be enabled (factory setting).

## Configuration of the LTMR CANopen Network Port

### Communication Parameters

Use the TeSys T DTM or the HMI to configure the CANopen communication parameters:

- Network port address setting
- Network port baud rate setting
- Configuration channel setting

### Setting the Node-ID

The Node-ID is the address of the module on the CANopen bus. With CANopen class S20, you can assign an address from 1 to 127.

You must set the Node-ID before any communication can begin. Use the TeSys T DTM or the HMI to configure the communication parameter Network Port Address Setting.

**NOTE:** A return to factory settings command sets the Node-ID to the invalid value 0.

### Setting the Baud Rate

Set the baud rate to one of the following speeds:

- 10 kBaud
- 20 kBaud
- 50 kBaud
- 250 kBaud
- 500 kBaud
- 800 kBaud
- 1000 kBaud

To set the baud rate, use the TeSys T DTM or the HMI to configure the communication parameter Network Port Baud Rate Setting.

The parameter has the following possible settings:

| Network Port Baud Rate Setting | Baud Rate                   |
|--------------------------------|-----------------------------|
| 0                              | 10 kBaud                    |
| 1                              | 20 kBaud                    |
| 2                              | 50 kBaud                    |
| 3                              | 125 kBaud                   |
| 4                              | 250 kBaud                   |
| 5                              | 500 kBaud                   |
| 6                              | 800 kBaud                   |
| 7                              | 1000 kBaud                  |
| 8                              | Autobaud                    |
| 9                              | Factory setting (250 kBaud) |

The factory setting for the Network Port Baud Rate Setting parameter is 250 kBaud. Using Autobaud, the LTMR controller adapts its baud rate to that of the primary.

**NOTE:** The Autobaud functionality can only be used if at least one primary and one secondary are already communicating on the network.

## Setting the Configuration Channel

The LTMR configuration can be managed:

- locally through the HMI port using the TeSys T DTM or the HMI
- remotely through the network.

**To manage the configuration locally**, the Config via Network Port Enable parameter must be disabled to help prevent an overwrite of the configuration through the network.

**To manage the configuration remotely**, the Config via Network Port Enable parameter must be enabled (factory setting).

## Configuration of the LTMR DeviceNet Network Port

### Communication Parameters

Use the TeSys T DTM or the HMI to configure the DeviceNet communication parameters:

- Network Port Address Setting
- Network Port Baud Rate Setting
- Configuration Via Network Port Enable

### Setting the MAC-ID

The MAC-ID is the address of the module on the DeviceNet™ bus. A DeviceNet network is limited to 64 addressable nodes (node IDs 0 to 63). This means that you can assign a MAC-ID of 0-63.

You must set the MAC-ID before any communication can start. To do this, use the TeSys T DTM or the HMI to configure the communication parameter Network Port Address Setting. The factory setting for the address is 63.

### Setting the Baud Rate

You can also set a baud rate of the following speeds:

- 125 kBaud
- 250 kBaud
- 500 kBaud

To set the baud rate, use the TeSys T DTM or the HMI to configure the communication parameter Network Port Baud Rate Setting.

The parameter has the following possible settings:

| Network Port Baud Rate Setting | Baud Rate                   |
|--------------------------------|-----------------------------|
| 0                              | 125 kBaud (factory setting) |
| 1                              | 250 kBaud                   |
| 2                              | 500 kBaud                   |
| 3                              | Autobaud                    |

Autobaud automatically detects the baud rate required.

**NOTE:** The Autobaud functionality can only be used if a valid communication is already present on the network, that is to say, that at least one primary and one secondary are already communicating.

## Setting the Configuration Channel

The LTMR configuration can be managed via 2 different modes:

- Locally through the HMI port using the TeSys T DTM or the HMI
- Remotely through the network

To manage the configuration locally, parameter Configuration Via Network Port Enable must be disabled to help prevent overwriting of the configuration through the network.

To manage the configuration remotely, parameter Configuration Via Network Port Enable must be enabled (factory setting).

## Configuration of the LTMR Ethernet Network Port

### Communication Parameters

Before network port communication can begin, configure the following Ethernet communication services and settings:

- Primary IP address setting
- Frame type setting
- Stored IP addressing settings
- Network port endian setting
- Fast device replacement (FDR) service
- Network Protocol selection
- Rapid Spanning Tree Protocol (RSTP)
- Communication loss settings
- Configuration control

**NOTE:** Only the TeSys T DTM software can configure all of these services and settings.

## Primary IP Address Setting

Configure the Ethernet Primary IP Address Setting parameter to add the IP address of the client device, page 193 dedicated to remotely control the motor. This parameter consists of 4 integer values, from 0 to 255, separated by dots (xxx.xxx.xxx.xxx).

## Frame Type Setting

Configure the Network Port Frame Type Setting parameter by selecting an Ethernet frame type:

- Ethernet II (Factory setting)
- 802.3

## IP Addressing Settings

Unique IP address settings must be assigned to the LTMR controller (including an IP address, a subnet mask, and a gateway address) to be able to communicate over an Ethernet network. The positions of the controller's 2 rotary switches determine the source of the controller's IP address settings, page 197, which can be:

- a DHCP server
- a BootP server
- stored IP address settings

If the controller's *Ones* rotary switch is set to **Stored IP**, the controller will apply its stored IP address settings, page 199.

To input the LTMR controller stored IP address settings, configure the following parameters:

- Ethernet IP Address Setting
- Ethernet Subnet Mask Setting
- Ethernet Gateway Address Setting

Each of these parameters consists of 4 integer values, from 0 to 255, separated by dots (xxx.xxx.xxx.xxx).

## Network Port Endian Setting

The Network port endian setting allows to swap the 2 words in a double word.

- 0 = least significant word first (little endian)
- 1 = most significant word first (big endian, factory setting)

## Fast Device Replacement Service

The Fast Device Replacement, page 203 (FDR) service stores the LTMR controller operating parameters on a remote server and, if the controller is replaced, sends the replacement controller a copy of the original device's operating parameters.

To verify the server always contains an accurate, updated copy of the controller's operating parameters, the FDR service can be configured to automatically backup these parameter settings to the FDR server.

To enable the automatic backup of the controller's operating parameters to the FDR server, configure the following parameters:

- Network Port FDR Auto Backup Enable parameter. It can be set to:
  - no auto backup
  - automatic backup (copies the parameters from the controller to the FDR server)
- Network Port FDR Controller Interval parameter: the time (in seconds) between automatic backup transmissions.
  - Range = 1...65535s
  - Factory setting = 120s

## Network Protocol Setting

Select with this parameter the network protocol you want to use:

- Modbus/TCP
- EtherNet/IP

## Rapid Spanning Tree Protocol

The Rapid Spanning Tree Protocol (RSTP) service manages the state on every port of each device in the local area network (LAN) loop. The RSTP is configured to respond and resolve a communication loss of a device on the network within 50 milliseconds.

**NOTE:** 16 devices are the maximum connections allowed on the loop network for the 50 milliseconds to be fully efficient.

To enable the Rapid Spanning Tree Protocol (RSTP) service, set the parameter RSTP Disable to No.

## Network Port Comm Loss Settings

Configure the following parameters to determine how the LTMR controller will handle communication loss with the PLC:

- Network Port Comm Loss Timeout: the length of time communication with the PLC defined as Primary IP must be lost before the controller will trigger a trip or alarm.
  - Range = 0...9999 s
  - Increments = 0.01 s
  - Factory setting = 2 s
- Network Port Fallback Setting: determines—with the controller's operating mode, page 146—the behavior of logic outputs 1 and 2, when communication with the PLC is lost. For more information, refer to the explanation of the Fallback Condition, page 63. Values include:
  - Hold
  - Run
  - O.1, O.2 off
  - O.1, O.2 on
  - O.1 on
  - O.2 on

The factory setting is O.1, O.2 off.

- Network Port Trip Enable: reports a network trip after the Network Port Comm Loss Timeout setting has expired.
- Network Port Alarm Enable: reports a network alarm after the Network Port Comm Loss Timeout setting has expired.

## Configuration of the HMI Port

### HMI Port

The HMI port is the RJ45 port on the LTMR controller, or on the LTME expansion module used to connect the LTMR controller to an HMI device, such as a Magelis® XBT or a TeSys® T LTMCU, or to a PC running SoMove with the TeSys T DTM.

### Communication Parameters

Use the TeSys T DTM or the HMI to modify the HMI port communication parameters:

- HMI port address setting
- HMI port baud rate setting
- HMI port parity setting
- HMI port endian setting

### HMI Port Address Setting

The HMI port address can be set between 1 and 247.

Factory setting is 1.

### HMI Port Baud Rate Setting

Possible transmission rates are:

- 4800 Baud
- 9600 Baud
- 19,200 Baud (Factory setting)

### HMI Port Parity Setting

The parity can be selected from:

- Even (Factory setting)
- None

Parity and stop bit behavior is linked:

| If the parity is... | Then the number of stop bits is... |
|---------------------|------------------------------------|
| Even                | 1                                  |
| None                | 2                                  |

### HMI Port Endian Setting

The HMI port endian setting allows to swap the 2 words in a double word.

- 0 = least significant word first (little endian)
- 1 = most significant word first (big endian, factory setting)

### HMI Port Fallback Setting

HMI port fallback setting, page 63 is used to adjust the fallback mode in case of a loss of communication with the PLC.

# Miscellaneous

## User Map Variables

### Overview

User Map variables are designed to optimize the access to several non-contiguous registers in one single request.

You can define several read and write areas.

The user map can be defined via:

- PC running SoMove with TeSys T DTM
- PLC via the network port

### User Map Variables

User Map Variables are described below:

| User map variable groups        |                                | Modbus/TCP (Register addresses) | EtherNet/IP (Object addresses) |  |
|---------------------------------|--------------------------------|---------------------------------|--------------------------------|--|
| User Map addresses              |                                | 800 - 899                       | 6D : 01 : 01 - 6D : 01 : 64    |  |
| User Map values                 |                                | 900 - 999                       | 6E : 01 : 01 - 6E : 01 : 64    |  |
| Modbus/TCP (Register addresses) | EtherNet/IP (Object addresses) | Variable type                   | Read/Write variables           |  |
| 800-898                         | 6D : 01 : 01 - 6D : 01 : 63    | Word[99]                        | User map addresses setting     |  |
| 899                             | 6D : 01 : 64                   | Word                            | <i>(Reserved)</i>              |  |
| Modbus/TCP (Register addresses) | EtherNet/IP (Object addresses) | Variable type                   | Read/Write variables           |  |
| 900-998                         | 6E : 01 : 01 - 6E : 01 : 63    | Word[99]                        | User map values                |  |
| 999                             | 6E : 01 : 64                   | Word                            | <i>(Reserved)</i>              |  |

The User Map Address group is used to select a list of addresses to read or write. It can be considered as a configuration area.

The User Map Value group is used to read or write values associated to addresses configured in the User Map Address area:

- Read or write of register 900 allows to read or write the register address defined in register 800
- Read or write of register 901 allows to read or write the register address defined in register 801,...

### Example of Use

The User Map Address configuration below gives an example of user map address configuration to access non-contiguous registers:

| Modbus/TCP (Register addresses) | EtherNet/IP (Object addresses) | Value configured | Read/Write variables |
|---------------------------------|--------------------------------|------------------|----------------------|
| 800                             | 6D : 01 : 01                   | 452              | Trip register 1      |
| 801                             | 6D : 01 : 02                   | 453              | Trip register 2      |
| 802                             | 6D : 01 : 03                   | 461              | Alarm register 1     |

| Modbus/TCP (Register addresses) | EtherNet/IP (Object addresses) | Value configured | Read/Write variables         |
|---------------------------------|--------------------------------|------------------|------------------------------|
| 803                             | 6D : 01 : 04                   | 462              | Alarm register 2             |
| 804                             | 6D : 01 : 05                   | 450              | Minimum wait time            |
| 805                             | 6D : 01 : 06                   | 500              | Average current (0.01 A) MSW |
| 806                             | 6D : 01 : 07                   | 501              | Average current (0.01 A) LSW |
|                                 |                                |                  |                              |
| 850                             | 6D : 01 : 51                   | 651              | HMI display items register 1 |
| 851                             | 6D : 01 : 52                   | 654              | HMI display items register 2 |
| 852                             | 6D : 01 : 53                   | 705              | Control register 2           |

With this configuration, monitoring information is accessible with one single read request through register addresses 900 to 906.

Configuration and command can be written with one single write using register addresses 950 to 952.

## E\_TeSys T Fast Access Profile Registers

### Overview

The profile E\_TeSys T Fast Access for LTMR Modbus/TCP controller is selected in the **Setting Process Channel Mode** of the parameter tab, page 40.

### Status Registers (Read)

| Status Registers (Read) | Signification                    |
|-------------------------|----------------------------------|
| 2500                    | Mirror status register           |
| 2501                    | Reserved                         |
| 2502                    | System status 1 (= reg 455)      |
| 2503                    | System status 2 (= reg 456)      |
| 2504                    | Logic input status 3 (= reg 457) |
| 2505                    | Logic output status (= reg 458)  |

### Status Registers (Write)

| Status Registers (Write) | Signification                                           |
|--------------------------|---------------------------------------------------------|
| 2506                     | Logic output command (= reg 700). Used for custom Logic |
| 2507                     | Control register (= reg 704)                            |
| 2508                     | Analog output command 1 (= reg 706). For future use     |

## EIOS\_TeSys T Profile Registers

### Overview

The profile EIOS\_TeSys T for LTMR Modbus/TCP controller is selected in the **Setting Process Channel Mode** of the parameter tab, page 40.

### Status Registers (Read)

| Status Registers (Read) | Signification                    |
|-------------------------|----------------------------------|
| 451                     | Trip code                        |
| 452                     | Trip register 1                  |
| 453                     | Trip register 2                  |
| 454                     | Logic input status 3 (= reg 457) |
| 455                     | System Status register 1         |
| 456                     | System Status register 1         |
| 457                     | Logic Input status               |
| 458                     | Logic Output status              |
| 459                     | I/O status                       |
| 460                     | Alarm code                       |
| 461                     | Alarm register 1                 |
| 462                     | Alarm register 2                 |
| 463                     | Alarm register 3                 |
| 464                     | Motor Temperature Sensor Degree  |
| 465                     | Thermal Capacity Level           |
| 466                     | Average current Ratio            |
| 467                     | L1 current ratio                 |
| 468                     | L2 current ratio                 |
| 469                     | L3 current ratio                 |
| 470                     | Ground Current ratio             |
| 471                     | Current phase Imbalance          |
| 472                     | Controller: Internal Temperature |
| 473                     | Controller config checksum       |
| 474                     | Frequency                        |
| 475                     | Motor temperature sensor         |
| 476                     | Average voltage                  |
| 477                     | L3L1 voltage                     |
| 478                     | L1L2 voltage                     |
| 479                     | L2L3 voltage                     |
| 480                     | Voltage phase Imbalance          |
| 481                     | Power factor                     |
| 482                     | Active power                     |
| 483                     | Reactive power                   |
| 484                     | Auto restart status register     |

| Status Registers (Read) | Signification                       |
|-------------------------|-------------------------------------|
| 485                     | Controller: Last power off duration |
| 486                     | Reserved                            |
| 487                     | Reserved                            |
| 488                     | Reserved                            |
| 489                     | Reserved                            |
| 490                     | Network port monitoring register 1  |
| 491                     | Network port monitoring register 2  |
| 492                     | Network port monitoring register 3  |
| 493                     | Network port monitoring register 4  |
| 494                     | Network port monitoring register 5  |
| 495                     | Network port monitoring register 6  |
| 496                     | Network port monitoring register 7  |
| 497                     | Network port monitoring register 8  |
| 498                     | Network port monitoring register 9  |
| 499                     | Network port monitoring register 10 |
| 500                     | Average current MSB                 |
| 501                     | Average current LSB                 |
| 502                     | L1 current MSB                      |
| 503                     | L1 current LSB                      |
| 504                     | L2 current MSB                      |
| 505                     | L2 current LSB                      |
| 506                     | L3 current MSB                      |
| 507                     | L3 current LSB                      |
| 508                     | Ground current MSB                  |
| 509                     | Ground current LSB                  |
| 510                     | Controller port ID                  |
| 511                     | Time to trip                        |
| 512                     | Motor Last start current ratio      |
| 513                     | Motor Last start duration           |
| 514                     | Motor Starts per hour count         |

## Status Registers (Write)

| Status Registers (Write) | Signification                  |
|--------------------------|--------------------------------|
| 700                      | Logic outputs command register |
| 701                      | Reserved                       |
| 702                      | Reserved                       |
| 703                      | Reserved                       |
| 704                      | Control register 1             |

# Using Ethernet Services

## Overview

This section describes the Ethernet services, and the related Ethernet configuration parameters, supported by EtherNet/IP and Modbus®/TCP.

**NOTE:** Changes in parameter settings for any Ethernet service take effect only after a power cycle of the LTMR controller.

|                                                                                                                                                                                                                                                                                                                                                                                                                                                                                                                                                                                                                                                                                                                                                                                                                                                                                                                                                      |
|------------------------------------------------------------------------------------------------------------------------------------------------------------------------------------------------------------------------------------------------------------------------------------------------------------------------------------------------------------------------------------------------------------------------------------------------------------------------------------------------------------------------------------------------------------------------------------------------------------------------------------------------------------------------------------------------------------------------------------------------------------------------------------------------------------------------------------------------------------------------------------------------------------------------------------------------------|
| <b>▲ WARNING</b>                                                                                                                                                                                                                                                                                                                                                                                                                                                                                                                                                                                                                                                                                                                                                                                                                                                                                                                                     |
| <p><b>LOSS OF CONTROL</b></p> <ul style="list-style-type: none"> <li>• The designer of any control scheme must consider the potential failure modes of control paths and, for certain critical functions, provide a means to achieve a safe state during and after a detected path failure. Examples of critical control functions are emergency stop and overtravel stop.</li> <li>• Separate or redundant control paths must be provided for critical control functions.</li> <li>• System control paths may include communication links. Consideration must be given to the implications of anticipated transmission delays or failures of the link.<sup>(1)</sup></li> <li>• Each implementation of an LTMR controller must be individually and thoroughly tested for proper operation before being placed into service.</li> </ul> <p><b>Failure to follow these instructions can result in death, serious injury, or equipment damage.</b></p> |

(1) For additional information, refer to NEMA ICS 1.1 (latest edition), "Safety Guidelines for the Application, Installation, and Maintenance of Solid State Control".

|                                                                                                                                                                                                                                                                                                                                                                                                                                                                                                                                                                                                                                                                                                                                                                                                    |
|----------------------------------------------------------------------------------------------------------------------------------------------------------------------------------------------------------------------------------------------------------------------------------------------------------------------------------------------------------------------------------------------------------------------------------------------------------------------------------------------------------------------------------------------------------------------------------------------------------------------------------------------------------------------------------------------------------------------------------------------------------------------------------------------------|
| <b>▲ WARNING</b>                                                                                                                                                                                                                                                                                                                                                                                                                                                                                                                                                                                                                                                                                                                                                                                   |
| <p><b>UNEXPECTED RESTART OF THE MOTOR</b></p> <p>Check that the PLC application software</p> <ul style="list-style-type: none"> <li>• considers the change from local to remote control,</li> <li>• manages appropriately the motor control commands during those changes.</li> <li>• manages appropriately the motor control to avoid contradictory commands from all possible Ethernet connections</li> </ul> <p>When switching to the Network control channels, depending on the communication protocol configuration, the LTMR controller can take into account the latest known state of the motor control commands issued from the PLC and restart automatically the motor.</p> <p><b>Failure to follow these instructions can result in death, serious injury, or equipment damage.</b></p> |

## Primary IP

### Overview

Each LTMR controller, in its role as communication server, could be configured to recognize another Ethernet device (typically a PLC) as the client device that controls the motor. This device is usually a device that initiates communication to exchange Process Data (control and status). The Primary IP is the IP address of this device.

The PLC should continuously maintain at least 1 connection, called a virtual connection or socket, with the communication server.

If all connections between the communication clients and the LTMR server do not occur, the LTMR controller waits a prescribed time, the Network Port Comm Loss Timeout, for a new connection to be established and messages sent between the PLC and the communication server.

If a connection is not opened and messages are not received, the LTMR controller assumes its fallback state, set by the Network Port Fallback Setting.

## ▲ WARNING

### LOSS OF CONTROL

- Configure a server IP on the Ethernet network.
- Do not use an IP address other than Primary IP to send network start and stop commands to the LTMR controller.
- Design the Ethernet network to block unauthorized network start and stop commands sent to the LTMR controller.

**Failure to follow these instructions can result in death, serious injury, or equipment damage.**

## Prioritized Primary IP Connections with Modbus/TCP

Connections between the LTMR controller and the Modbus client has a priority over connections between the controller and other Ethernet devices.

After the controller has reached its maximum number of 8 simultaneous Modbus connections, the controller must close an existing connection to be able to open a new connection. The controller closes existing connections based on the time of a connection's most recent transaction, closing the connection whose most recent transaction is the oldest.

However, all connections between the LTMR controller and the Modbus client are preserved. The controller will not close a connection with the Modbus server in order to open a new connection.

## Configuring Primary IP

To enable connections to be made to a Modbus client, use a configuration tool to configure the following parameters:

| Parameter                                       | Setting Range                                                                                                                                                | Factory Setting |
|-------------------------------------------------|--------------------------------------------------------------------------------------------------------------------------------------------------------------|-----------------|
| Ethernet Primary IP address setting (3010-3011) | Valid Class A, B, and C addresses in the range:<br>0.0.0.0...223.255.255.255                                                                                 | 0.0.0.0         |
| Network port comm loss timeout (693)            | 0...9999 s<br>in increments of 0.01 s                                                                                                                        | 2 s             |
| Network port fallback setting (682)             | <ul style="list-style-type: none"> <li>• Hold</li> <li>• Run</li> <li>• O.1, O.2 Off</li> <li>• O.1, O.2 On</li> <li>• O.1 Off</li> <li>• O.2 Off</li> </ul> | O.1, O.2 Off    |

# I/O Scanning Configuration

## Mirroring High Priority Registers

The LTMR controller provides a block of 9 contiguous registers dedicated to scanning that mirror the values and functionality of selected high priority registers.

The LTMR controller reads the values of all high priority registers whenever it detects a change to any single high priority register, and writes the values of all high priority registers to the mirroring registers.

Because the mirroring registers are contiguous, it is possible to execute a single Modbus block read or block write request to these registers, thereby saving the time it would take to make separate Modbus read/write requests directly to each underlying high priority register.

## Mirroring Status

Mirroring status is the first register, in the sequence of eight contiguous mirroring registers. Bits 0...2 of this register describe the status of read-only commands, and bits 8...10 describe the status of read/write commands.

**NOTE:** Use only the 2 Ethernet ports to read mirroring status register bit values. Using the HMI/LTME port produces an invalid, constant value of 0 for each bit.

All other mirroring status registers can be read accurately using either the HMI/LTME port or the 2 Ethernet ports.

## Configuring I/O Scanning

Your success in configuring I/O scanning of registers depends upon:

- Register type
- I/O scanning period
- I/O scanning health timeout period

The following table describes the I/O scanning and I/O scanning health timeout settings for read and write transactions for registers of varying types with only 1 connection on the LTMR controller:

| Transaction                                    | Register Type                                                                                                                                          | I/O Scan Period (Minimum) | I/O Scan Health Timeout (Minimum) |
|------------------------------------------------|--------------------------------------------------------------------------------------------------------------------------------------------------------|---------------------------|-----------------------------------|
| Any combination of 100 read/write transactions | Any register except:<br>Mirroring, FDR, or diagnostic                                                                                                  | 200 ms                    | 500 ms                            |
| 10 max, and 5 max write transactions           | Any register except:<br>Mirroring, FDR, or diagnostic                                                                                                  | 50 ms                     | 200 ms                            |
| Read transactions                              | Mirroring registers:<br>2500 to 2505 address range                                                                                                     | 5 ms                      | 100 ms                            |
| Write transactions                             | Mirroring registers:<br>2506 to 2508 address range                                                                                                     | 50 ms                     | 200 ms                            |
| Read/Write transaction                         | Mirroring registers: <ul style="list-style-type: none"> <li>• 2500 to 2505 address range: read</li> <li>• 2506 to 2508 address range: write</li> </ul> | 50 ms                     | 200 ms                            |
| Any number of read transactions                | FDR registers:<br>10001 to 10010 address range                                                                                                         | 200 ms                    | 500 ms                            |
| Any number of read transactions                | Diagnostic registers:<br>2000 to 2039 address range                                                                                                    | 1000 ms                   | 2000 ms                           |

**NOTE:** Any settings for I/O scan period or I/O scan health timeout, lower than described above, can cause the LTMR controller to send Modbus exception packets.

If there are multiple connections to the LTMR controller, the I/O scanning and I/O scanning health timeout settings for read and write transactions for registers are reduced.

For example, with 8 connections:

| Connection | Start of Read Register | Number of Read Register | Start of Write Register | Number of Write Registers | Scan Rate |
|------------|------------------------|-------------------------|-------------------------|---------------------------|-----------|
| 1          | 2500                   | 7                       | –                       | –                         | 50        |
| 2          | 451                    | 64                      | 2503                    | 3                         | 200       |
| 3          | 900                    | 99                      | –                       | –                         | 200       |
| 4          | 2000                   | 39                      | –                       | –                         | 1000      |
| 5          | 1001                   | 10                      | –                       | –                         | 200       |
| 6          | 600                    | 20                      | –                       | –                         | 500       |
| 7          | 660                    | 20                      | –                       | –                         | 500       |
| 8          | 680                    | 20                      | –                       | –                         | 500       |

## Ethernet Link Management

### Overview

The LTMR controller can receive or provide Ethernet services only if an Ethernet communications link exists. An Ethernet communications link can exist only when a cable connects one of the controller's network ports to the network. If no network cable connection exists, no Ethernet service can start.

The behavior of the controller is described in each of the following situations:

- The LTMR powers up with no network cable connected.
- A network cable is connected to a previously unconnected controller after startup.
- All network cables are disconnected from the controller after startup.
- One (or more) network cables are re-connected to a controller after all network cables had previously been disconnected.

### No link while LTMR is powered up

When the LTMR powers up with no network cable connected, the LTMR:

- goes into an FDR Trip, if the rotary switches are in DHCP position,
- goes into an FDR Trip for 10s and then clears the trip automatically, if the rotary switches are in Stored, BootP, ClearIP or Disabled positions.

### No Link at Startup

When, after controller startup, an Ethernet network cable is initially attached to a previously unconnected controller

- the controller starts its IP addressing service, page 197, which
  - Obtains IP address settings,
  - Validates IP address settings,
  - Checks that the obtained IP address settings are not duplicate,
  - Assigns the received IP address settings to the controller.

- After its IP address settings are assigned, the controller
  - Starts the FDR service and obtains its operating parameter settings, then
  - Starts its Modbus service.

The time to recover the link and start Ethernet services takes about 1 second.

## Link Disconnected After Startup

When all Ethernet network cables are disconnected from the controller after startup:

- FDR service is disabled,
- All Modbus service connections are re-set,
- If a Primary IP connection exists and:
  - the link cannot be re-established, i.e., the cable is not plugged back into the controller, before the Network Port Comm Loss Timeout expires, the controller enters its pre-configured fallback state if the LTMR is in Network control,
  - the link is re-established before the Network Port Comm Loss Timeout expires, the connection to the Primary IP is maintained and the controller does not enter its fallback state.

## Link Reconnected After Disconnection

When one or more Ethernet network cables are re-attached to the controller, after all network cables had been detached after startup, the controller performs many, but not all, of the same tasks as when there is No Link at Startup, page 196. Specifically, the controller

- Presumes the previously obtained IP address settings remain valid, then
  - Checks that the IP address settings are not duplicate,
  - Re-assigns the IP address settings to the controller.
- After the IP address settings are assigned, the controller
  - Starts its FDR service and obtains its operating parameter settings, then
  - Starts its Modbus service.

The time to recover the link and start Ethernet services takes about 1 second.

## IP Addressing

### Overview

The LTMR controller must obtain a unique IP address, subnet mask and gateway address to communicate over an Ethernet network. The settings of the 2 rotary switches on the front of the LTMR controller determine the source of these essential settings. These settings are applied only on power-up. The rotary switches look like this:

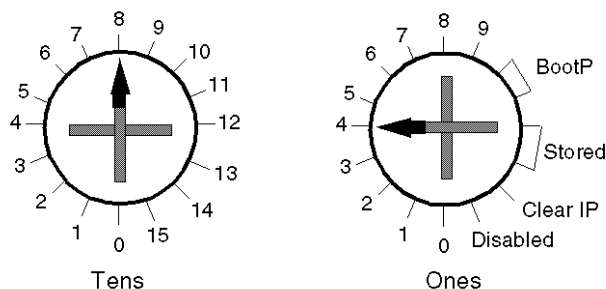

The settings of the rotary switches determine the source of the LTMR controller IP address parameters and the FDR service activation, as follows:

| Left switch (Tens)     | Right switch (Ones)   | Source of IP parameters                                                                                                                                                                                                                                                                                                                                               |
|------------------------|-----------------------|-----------------------------------------------------------------------------------------------------------------------------------------------------------------------------------------------------------------------------------------------------------------------------------------------------------------------------------------------------------------------|
| 0 to 15 <sup>(6)</sup> | 0 to 9 <sup>(6)</sup> | DHCP server and FDR service                                                                                                                                                                                                                                                                                                                                           |
| N/A <sup>(7)</sup>     | BootP                 | BootP server                                                                                                                                                                                                                                                                                                                                                          |
| N/A <sup>(7)</sup>     | Stored                | The rotary switch is not used to determine IP parameters. LTMR configured settings are used. If none, IP parameters are derived from the MAC address. Modbus service is disabled.                                                                                                                                                                                     |
| N/A <sup>(7)</sup>     | Clear IP              | Clears the stored IP settings. No IP addressing settings are assigned. The network port is disabled.                                                                                                                                                                                                                                                                  |
| N/A <sup>(7)</sup>     | Disabled              | The LTMR controller is not available for network communication. The LTMR controller does not initiate any IP acquisition process (host register, DHCP...) or announcements of IP on the network. Network related errors do not occur.<br><br>However, the LTMR controller stays active on at the Ethernet switch level allowing the daisy chain to function normally. |

(1) The 2 switches yield a value from 000 to 159, which uniquely identifies the device to the DHCP server. In the above figure, this value is 084, which is the concatenation of the:

- Tens switch (08), and the
- Ones switch (4)

The individual values of each rotary switch - in this case 08 and 4 - are incorporated into the device name, as described below.

(2) The left (Tens) rotary switch is not used. The right (Ones) rotary switch alone determines the source of IP parameters.

IP settings are assigned to the following parameters:

- Ethernet IP Address
- Ethernet subnet Mask
- Ethernet Gateway

## Getting IP Parameters from a DHCP Server

To obtain IP parameters from a DHCP server, point each rotary switch to a numerical setting, as follows:

| Step | Description                                           |
|------|-------------------------------------------------------|
| 1    | Set the left–Tens–switch to a value from 0 to 15, and |
| 2    | Set the right–Ones–switch to a value from 0 to 9      |

**Device Name:** The settings of the 2 rotary switches are used to determine each LTMR controller device name. The device name consists of a fixed part ("TeSysT") and a dynamic part, composed of:

The two-digit value (00 to 15) of the Tens rotary switch (xx), and

The one-digit value (0 to 9) of the Ones rotary switch (y)

The DHCP server must be pre-configured with the LTMR controller device name and its associated IP parameters. When the DHCP server receives the LTMR controller broadcast request, it returns:

(6) (1) The 2 switches yield a value from 000 to 159, which uniquely identifies the device to the DHCP server. In the above figure, this value is 084, which is the concatenation of the:

- Tens switch (08), and the
- Ones switch (4)

The individual values of each rotary switch - in this case 08 and 4 - are incorporated into the device name, as described below.

(7) The left (Tens) rotary switch is not used. The right (Ones) rotary switch alone determines the source of IP parameters.

- The LTMR controller:
  - IP address
  - Subnet mask
  - Gateway address
- the DHCP server's IP address

**NOTE:** While the IP address is not provided by the DHCP server, the TeSys T product declares a major trip network port FDR (Alarm LED steady red).

**NOTE:** The LTMR controller uses the DHCP server's IP address during the Fast Device Replacement (FDR) process , page 197, when making an FTP or TFTP request for device configuration parameters.

In the figure, above, the device name is: TeSysT084.

**NOTE:** The DHCP server can provide an IP address to a server device only after the DHCP server has been configured with the Device Name, described above, for a server device.

## Getting IP Parameters from a BootP Server

To obtain IP parameters from a BootP server, point the right—Ones—rotary switch to either of the 2 **BootP** settings. (The left—Tens—rotary switch is not used.) The LTMR controller broadcasts a request for IP parameters to a BootP server, and includes its MAC address in the request.

The BootP server must be pre-configured with the LTMR controller MAC address and associated IP parameters. When the BootP server receives the LTMR controller broadcast request, it returns to the LTMR controller its:

- IP address
- Subnet mask
- Gateway address

**NOTE:** The Fast Device Replacement (FDR) service is not available if the LTMR controller is configured to receive IP parameters from a BootP server.

## Using Stored IP Parameters

You can configure the LTMR controller to apply IP settings that have been previously configured and stored in the device itself. These stored IP parameters can be configured using your choice of configuration tool.

To apply stored IP parameters set the right—Ones—switch to either of the **Stored** positions. (The left—Tens—switch is not used.)

The LTMR controller uses as its:

- IP address: the Ethernet IP Address Setting parameter
- Subnet mask: the Ethernet Subnet Mask Setting parameters
- Gateway address: the Ethernet Gateway Address Setting parameter

**NOTE:** If these parameters are not pre-configured, the LTMR controller cannot apply stored settings, but instead applies default IP parameters, as described below.

**NOTE:** The FDR service is not available if the LTMR controller is configured to use stored IP parameters.

## Configuring Default IP Parameters from the MAC Address

The LTMR controller derives its default IP parameters from its MAC address, (stored in the device's Ethernet MAC Address parameter). The MAC address is a unique identifier associated with the device's network interface card (NIC).

As a prerequisite for using the default IP address, all bytes of the configured IP address must be set to zero.

To apply the LTMR controller default IP parameters, you must proceed in two steps:

| Step | Action                                                                                                            |
|------|-------------------------------------------------------------------------------------------------------------------|
| 1    | Clear the existing IP address by setting the right—Ones—rotary switch to <b>Clear IP</b> , then cycle power.      |
| 2    | Apply the stored IP address settings by setting the right—Ones—rotary switch to <b>Stored</b> , then cycle power. |

The default IP parameters are generated as follows:

- The first 2 byte values of the IP address are always 85.16
- The last 2 byte values of the IP address are derived from the last 2 bytes of the MAC address
- The default subnet mask are always 255.0.0.0
- The default gateway is the same as the device's default IP address

For example, for a device with a hexadecimal MAC address of 0x000054EF1001, the last two bytes are 0x10 and 0x01. These hexadecimal values translate to decimal values of "16" and "01". The default IP parameters for this MAC address are:

- IP address: 85.16.16.01
- Subnet mask: 255.0.0.0
- Gateway address: 85.16.16.01

**NOTE:** Both the Fast Device Replacement (FDR) service and the Modbus service are not available when default IP parameters are used.

## IP Assignment Process

As depicted in the following graphic, the LTMR controller performs a sequence of inquiries to determine its IP address:

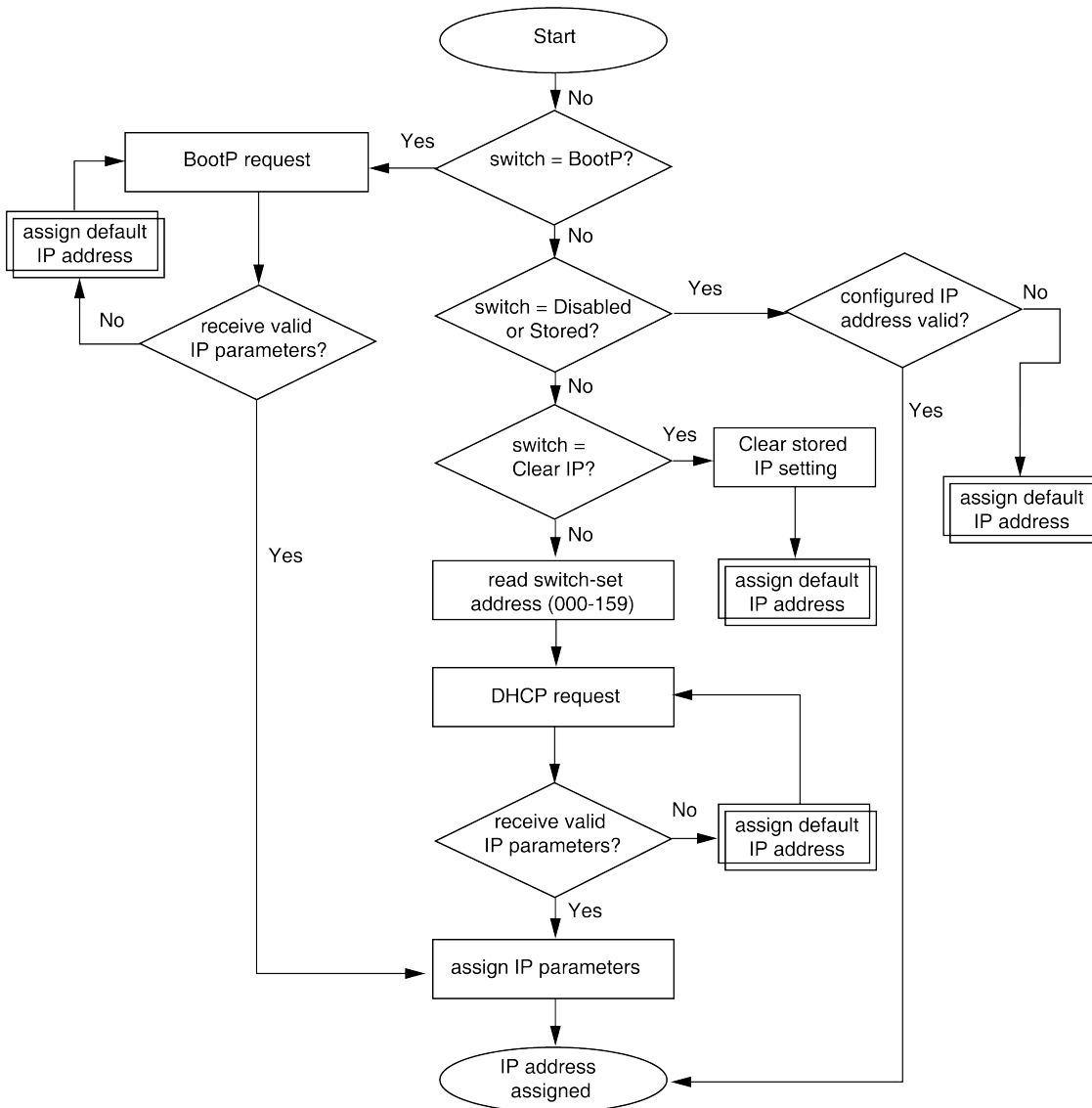

**NOTE:** Both the Fast Device Replacement (FDR) service and the Modbus service are not available when default IP parameters are used.

The following diagram depicts the *assign default IP address* process, referenced above:

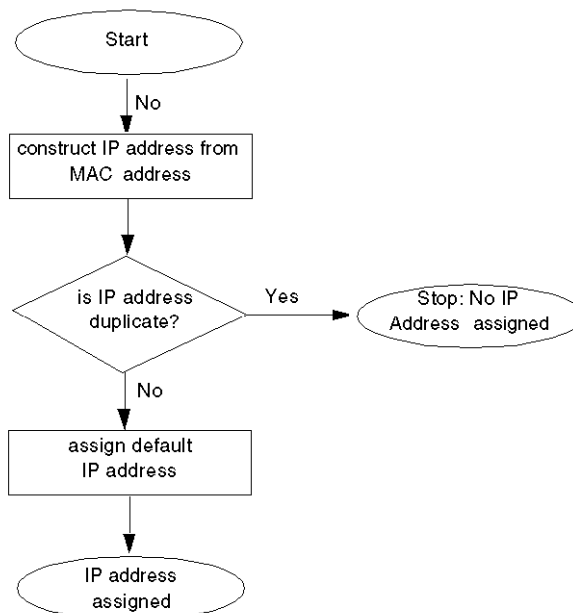

## IP Assignment and STS/NS LED

During the IP address assignment process, while the LTMR is operating normally and is not experiencing an internal trip, the green STS/NS LED may indicate the following conditions:

| Switch setting(s)                                                         | STS/NS LED behavior            | Description                                                                                                                                                                  |
|---------------------------------------------------------------------------|--------------------------------|------------------------------------------------------------------------------------------------------------------------------------------------------------------------------|
| BootP                                                                     | Flashes 5 times, then repeats  | The controller sent a BootP request, but the BootP server did not deliver valid, unique IP address settings. Waiting for BootP server.                                       |
|                                                                           | Flashes 5 times, then solid ON | The controller sent a BootP request, and the BootP server delivered valid and unique IP address settings.                                                                    |
| Stored                                                                    | Solid ON                       | The LTMR controller is configured with valid, unique stored IP address settings.                                                                                             |
|                                                                           | Flashes 6 times, then repeats  | No valid, unique IP parameters are stored. Default IP settings are generated using the MAC address.                                                                          |
| Clear IP                                                                  | Flashes 2 times, then repeats  | IP address settings have been cleared. No IP address settings are available. Controller cannot communicate using its Ethernet network ports.                                 |
| Disabled                                                                  | Solid ON                       | The LTMR controller is configured with valid, unique stored IP address settings.                                                                                             |
|                                                                           | Flashes 6 times, then repeats  | No valid, unique IP parameters are stored. Default IP settings are generated using the MAC address.                                                                          |
| Left (Tens) switch set to 0-15 (xx)<br>Right (Ones) switch set to 0-9 (y) | Flashes 5 times, then repeats  | The controller sent a DHCP request for device name (TeSysT <sub>xx</sub> y), but the DHCP server did not deliver valid, unique IP address settings. Waiting for DHCP server. |
|                                                                           | Flashes 5 times, then solid ON | The controller sent a DHCP request for device name (TeSysT <sub>xx</sub> y), and the DHCP server delivered valid and unique IP address settings.                             |

**NOTE:** A repeating series of 8 flashes by the STS/NS LED indicates an unrecoverable FDR inoperable condition. The causes and potential cures for an unrecoverable FDR event include:

- An internal communication loss within the LTMR controller: Cycle power to the controller; if communication is not restored, replace the controller.
- An invalid configuration of the Ethernet properties (typically IP address settings or the Primary IP address): Verify the IP address parameter settings.
- An invalid or corrupt operating parameter file: Transfer a corrected parameter file from the controller to the parameter file server, page 207. Refer to the topic Handling Unrecoverable FDR Trips for additional information. The transfer of a parameter file to the FDR server is only available with the LTMR controller Ethernet version.

## Fast Device Replacement

### Overview

The FDR service employs a central server to store both the IP addressing parameters and the operating parameters for an LTMR controller. When an inoperable LTMR controller is replaced, the server automatically configures the replacement LTMR controller with the same IP addressing and operating parameters as the inoperable controller.

**NOTE:** The FDR service is available only when the controller's Ones rotary switch is set to integers. The FDR service is not available when the Ones rotary switch is set to *BootP*, *Stored*, *Clear IP*, or *Disabled*.

The FDR service includes configurable commands and settings that you can access using your choice of configuration tool. These commands and settings include:

- Commands that let you manually:
  - Backup the LTMR controller operating parameters, by uploading a copy of the device's parameter file to the server from the controller, or
  - Restore the LTMR controller parameters, by downloading a copy of the device's operating parameter file from the server to the controller.
- Settings that cause the FDR server to automatically synchronize the operating parameter files, in both the LTMR controller and the server, at configurable time intervals. If a difference is detected, a parameter file is sent from the controller to the FDR server (auto backup).

### Preconditions to FDR

Before the FDR service can function, the FDR server must be configured with:

- The LTMR controller network address and related IP addressing parameters, this is done as part of the IP addressing service, page 197,
- Copy of the LTMR controller operating parameter file, this can be sent from the controller to the server either manually or automatically, as described below.

### FDR and Custom Logic File

The FDR service save custom logic to the operating parameters file if the custom logic file size is lower than 3 kbytes.

If the custom logic file size is bigger than 3 kbytes, only the operating parameters file is saved.

In this case, when you are replacing a device with a custom logic file size bigger than 3 kbytes, the STS/NS LED of the new device flashes 8 times signaling the detection of a system recoverable FDR trip condition.

To resolve the trip and resume operations:

| Step | Action                                                     |
|------|------------------------------------------------------------|
| 1    | Use the TeSys T DTM software to download the configuration |
| 2    | Cycle power to the LTMR controller                         |

## FDR Process

The FDR process consists of 3 parts:

- The assignment of IP address settings,
- Check of the operating parameter file at every LTMR controller startup,
- If auto-synchronization is enabled, periodic checks of the LTMR controller operating parameter file.

These 3 processes are described below:

### IP address settings assignment process:

| Sequence | Event                                                                                                                                                                                                                                                                    |
|----------|--------------------------------------------------------------------------------------------------------------------------------------------------------------------------------------------------------------------------------------------------------------------------|
| 1        | Your service personnel uses the rotary switches on the front of the replacement LTMR controller to assign it the same network address (000 to 159) as the replaced device.                                                                                               |
| 2        | Your service personnel places the replacement LTMR controller on the network.                                                                                                                                                                                            |
| 3        | The LTMR controller automatically sends a DHCP request to the server for its IP parameters.                                                                                                                                                                              |
| 4        | The server sends the LTMR controller: <ul style="list-style-type: none"> <li>• IP parameters, including: <ul style="list-style-type: none"> <li>◦ IP address</li> <li>◦ Subnet mask</li> <li>◦ Gateway address</li> </ul> </li> <li>• The server's IP address</li> </ul> |
| 5        | The LTMR controller applies its IP parameters.                                                                                                                                                                                                                           |

### Startup FDR process:

| Sequence                                                                                                                                                                                                                                                                                                           | Event                                                                                                                                                                                                                                                                                                                                                                                                                                                          |
|--------------------------------------------------------------------------------------------------------------------------------------------------------------------------------------------------------------------------------------------------------------------------------------------------------------------|----------------------------------------------------------------------------------------------------------------------------------------------------------------------------------------------------------------------------------------------------------------------------------------------------------------------------------------------------------------------------------------------------------------------------------------------------------------|
| 6                                                                                                                                                                                                                                                                                                                  | <ul style="list-style-type: none"> <li>If FDR is enabled in the FDR configuration screen:</li> </ul>                                                                                                                                                                                                                                                                                                                                                           |
|                                                                                                                                                                                                                                                                                                                    | a The controller sends a request to the FDR server for a copy of the served configuration file.                                                                                                                                                                                                                                                                                                                                                                |
|                                                                                                                                                                                                                                                                                                                    | b The FDR server sends the controller a copy of the served file.                                                                                                                                                                                                                                                                                                                                                                                               |
|                                                                                                                                                                                                                                                                                                                    | c The controller checks the served file's version number and size for compatibility with the device. If the served file is <ul style="list-style-type: none"> <li>Compatible, the served file is applied,</li> <li>Not compatible, the controller will attempt to manage the compatibility and upload the new file to the server. If not able to manage the compatibility, the controller then signals a system recoverable FDR trip<sup>(8)</sup>.</li> </ul> |
| <b>Notes:</b><br>1. Because the factory setting of <b>FDR Enable</b> is <b>selected</b> , a new LTMR controller always downloads and attempts to apply a served file on initial startup.<br>2. If the downloaded file is empty, the controller will use its local file and send a copy of that file to the server. |                                                                                                                                                                                                                                                                                                                                                                                                                                                                |
| <ul style="list-style-type: none"> <li>If <b>FDR Enable</b> is de-selected: The controller applies the operating parameter file stored in the LTMR controller non-volatile memory.</li> </ul>                                                                                                                      |                                                                                                                                                                                                                                                                                                                                                                                                                                                                |
| 7                                                                                                                                                                                                                                                                                                                  | The LTMR controller resumes operation.                                                                                                                                                                                                                                                                                                                                                                                                                         |

**Auto-synchronization FDR process:**

| Sequence | Event                                                                                                                                                                                                                                                                              |
|----------|------------------------------------------------------------------------------------------------------------------------------------------------------------------------------------------------------------------------------------------------------------------------------------|
| 8        | The controller checks the <i>Network Port FDR Auto Backup Period Setting (697)</i> parameter to determine if the FDR auto-synchronization timer has expired.                                                                                                                       |
| 9        | If the timer has: <ul style="list-style-type: none"> <li><b>Not expired:</b> No action is taken.</li> <li><b>Expired:</b> The controller checks the <i>Network Port FDR Auto Backup Enable (690.3)</i> parameter.</li> </ul>                                                       |
| 10       | If the <i>Network Port FDR Auto Backup Enable (690.3)</i> parameter is: <ul style="list-style-type: none"> <li><b>Auto backup (1):</b> The controller sends a copy of the local file to the FDR server.</li> <li><b>No synchro (0):</b> The controller takes no action.</li> </ul> |
| 11       | The LTMR controller resumes operation.                                                                                                                                                                                                                                             |

<sup>(8)</sup> In the event the controller enters the Not Ready state, the underlying problem must be resolved and power must be cycled to the controller before operations can resume.

The following diagrams describe the controller's FDR processes after the assignment of an IP address:

**FDR Startup Process:**

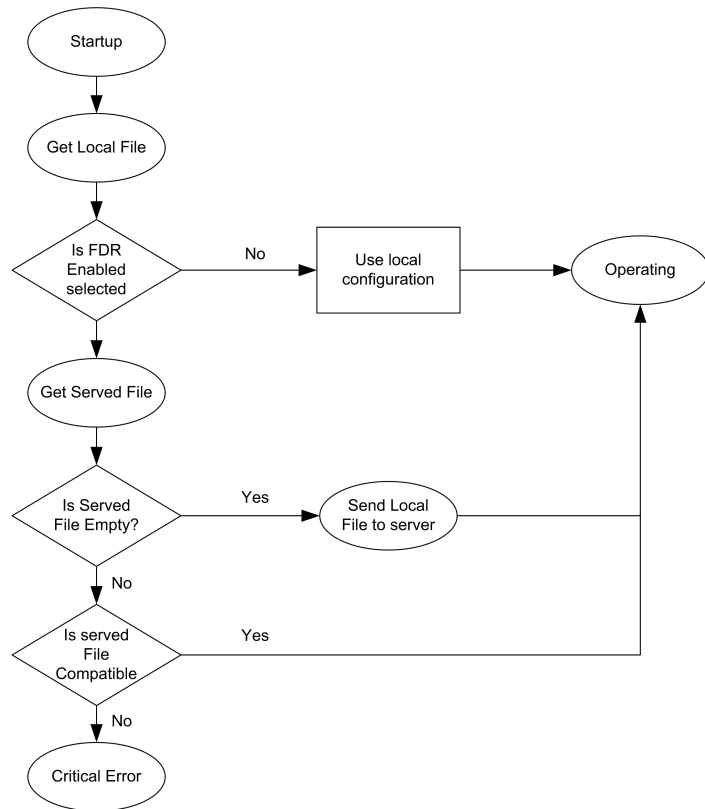

**FDR Auto-Synchro Process:**

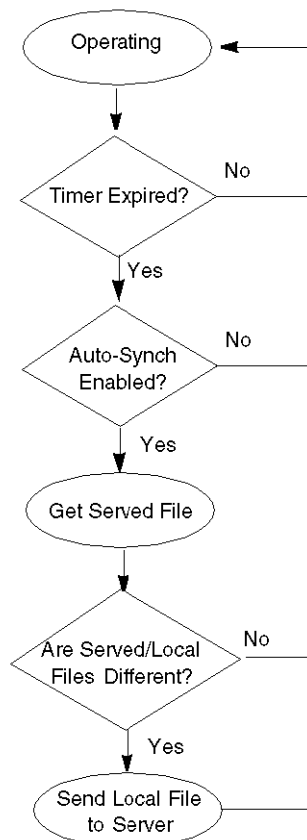

## Configuring FDR

The FDR service monitors the operating parameter file maintained in your LTMR controller and compares it against the corresponding operating parameter file stored in the server.

When the FDR service detects a discrepancy between these 2 files:

- the Network Port FDR Status, page 208 parameter is set, and
- the 2 operating parameter files, 1 in the server, the other in the controller, must be synchronized.

Synchronizing operating parameter files can be performed either automatically or manually, using your choice of configuration tool.

**Automatically Backup Settings:** By setting the following parameters, you can configure your LTMR controller to automatically synchronize its operating parameters with the FDR server:

| Parameter Name                              | Description                                                                                                                                                                                                                                                                                                                                                                                                                             |
|---------------------------------------------|-----------------------------------------------------------------------------------------------------------------------------------------------------------------------------------------------------------------------------------------------------------------------------------------------------------------------------------------------------------------------------------------------------------------------------------------|
| Network Port FDR Auto Backup Enable         | Use this setting to enable/disable automatic synchronization of the operating parameter files. Selections are: <ul style="list-style-type: none"> <li>• <b>No auto backup:</b> Automatic file synchronization is turned OFF (parameter = 0).</li> <li>• <b>Auto backup:</b> Automatic file synchronization is turned ON, and the file in the controller will be copied to the server in case of discrepancy (parameter = 1).</li> </ul> |
| Network Port FDR Auto Backup Period Setting | The frequency, in seconds, between comparisons of the parameter file in the controller against the parameter file stored in the server. <ul style="list-style-type: none"> <li>• Range = 1...65535 s</li> <li>• Increments = 1 s</li> <li>• Factory setting = 120 s</li> </ul>                                                                                                                                                          |

**NOTE:** When automatic synchronization is enabled, it is recommended to set the *Network Port FDR Auto Backup Period Setting* parameter to a value greater than **120 s**.

**Manually Backup and Restore Settings:** By executing the commands described below, you can manually synchronize the operating parameter files in the controller and server:

| Command Name             | Description                                                          |
|--------------------------|----------------------------------------------------------------------|
| FDR Data Backup Command  | Copies the operating parameter file in the controller to the server. |
| FDR Data Restore Command | Copies the operating parameter file in the server to the controller. |

**NOTE:**

- If FDR Data Backup Command and FDR Data Restore Command bits are set to 1 simultaneously, an FDR Data Restore Command is proceeded.
- FDR Data Restore Command is active whether Config via network is enabled or not.
- FDR Data Restore Command cannot be done while the LTMR detects line currents.
- Any time the LTMR controller configuration changes, you should manually backup the new configuration file to the server by clicking **Device > File transfer > backup command**.

## FDR Trip Recovery

When the LTMR controller detects a trip condition that requires intervention during the FDR startup process, the STS/NS LED flashes as follows:

| Number of flashes...  | Indicates the trip is... |
|-----------------------|--------------------------|
| 8 flashes per second  | LTMR Recoverable         |
| 10 flashes per second | System Recoverable       |

### System Recoverable Trips:

Operations can resume after fixing the cause of the trip outside of the LTMR. System recoverable trips include:

- No file on the parameter server (Network Port FDR Status = 3)
- The parameter file server, or TFTP service, is down (Network Port FDR Status = 2)

### LTMR Recoverable Trips:

When the parameter file in the server is invalid or corrupt, the trip requires manual intervention to be cleared. Operations can resume only after a new parameter file is manually copied from the controller to the server using the FDR Data Backup Command and power is cycled to the controller. LTMR recoverable trips include:

- Version mismatch of the parameter file on the parameter server and the LTMR controller (Network Port FDR Status = 13)
- CRC mismatch between parameter file on the server and the LTMR controller (Network Port FDR Status = 9)
- Content of the parameter file is invalid (Network Port FDR Status = 4)

## FDR Status

The Network Port FDR Status parameter describes the state of the FDR service, as described below.

FDR Status:

| Value | Description                                                                                                         |
|-------|---------------------------------------------------------------------------------------------------------------------|
| 0     | Ready, IP available                                                                                                 |
| 1     | No response from IP server                                                                                          |
| 2     | No response from parameter server                                                                                   |
| 3     | No file on parameter server                                                                                         |
| 4     | Corrupt file on parameter server                                                                                    |
| 5     | Empty file on parameter server                                                                                      |
| 6     | Detection of Internal Communication error                                                                           |
| 7     | Backup of settings from Device to Parameter Server unsuccessful                                                     |
| 8     | Invalid settings provided by the controller                                                                         |
| 9     | CRC mismatch between parameter server and controller                                                                |
| 10    | Invalid IP                                                                                                          |
| 11    | Duplicate IP                                                                                                        |
| 12    | FDR disabled                                                                                                        |
| 13    | Device Parameter File Version Mismatch (for example, when attempting to replace an LTMR 08EBD with an LTMR 100 EBD) |

# Rapid Spanning Tree Protocol

## Overview

The Rapid Spanning Tree Protocol (RSTP) service manages the state on every port of each device in the local area network (LAN) loop. The RSTP is configured to respond and resolve a communication loss of a device on the network within 50 milliseconds.

**NOTE:** 16 devices are the maximum connections allowed on the loop network for the 50 milliseconds to be fully efficient.

## Discovery Procedure

Discovery is an automated connection to a device with an unknown IP address, using a direct PC connection and a web page access interface.

Discovery only operates on MS Windows Vista, 7 and 8 operating systems.

| Step | Automated Action                                                                                                                                                                                                                                                                                                                                                            |
|------|-----------------------------------------------------------------------------------------------------------------------------------------------------------------------------------------------------------------------------------------------------------------------------------------------------------------------------------------------------------------------------|
| 1    | Stop the antivirus on the PC that is connected to the TeSys T.                                                                                                                                                                                                                                                                                                              |
| 2    | Connect the PC to the TeSys T using a RJ45 cable.                                                                                                                                                                                                                                                                                                                           |
| 3    | <ul style="list-style-type: none"> <li>• Open Windows Explorer</li> <li>• Expand Network to view all network connections</li> <li>• The Connected device should appear in the list within a few seconds</li> </ul>                                                                                                                                                          |
| 4    | Double-click the connected TeSys T.<br><br>To find the name of TeSys T: <ul style="list-style-type: none"> <li>• TeSys T is not configured in DHCP mode: TeSysT-XXYYZZ with XXYYZZ the last 3 bytes of MAC address.</li> <li>• TeSys T is configured in DHCP mode TeSysTXYZ with XY the position of Tens rotary switch and Z the position of Ones rotary switch.</li> </ul> |
| 5    | Access the TeSys T in the webpage interface.                                                                                                                                                                                                                                                                                                                                |

**NOTE:** If the product cannot be detected, retry the procedure with the antivirus deactivated. Do not forget to restart the antivirus when finished.

# Ethernet Diagnostics

## Overview

The LTMR controller reports diagnostic data describing its Ethernet network communications interface, including:

- data parameters that describe the controller's:
  - IP addressing settings
  - IP address assignment processes
  - Virtual connections
  - Communication history
  - Communication services and their status
- One parameter that describes the validity of the data in each data parameter

**NOTE:** It is recommended to read the diagnostics registers every second.

**NOTE:** The response to the first request contains either all zeroes or old data. The response to the second and subsequent requests contains current network port diagnostic data.

## Ethernet Basic HW Diag Validity

The Ethernet Basic HW Diag Validity parameter evaluates and reports the validity of Ethernet network diagnostic data. A bit in this parameter represents the state of an associated Ethernet network data parameter.

Bit values are:

| Value | Indicates the parameter data is... |
|-------|------------------------------------|
| 0     | Invalid                            |
| 1     | Valid                              |

The Ethernet Basic HW Diag Validity parameter is 32 bits long.

The bits of this parameter represent the validity of the following Ethernet data parameters:

| Bit     | Describes the validity of data in this parameter... |
|---------|-----------------------------------------------------|
| 0       | IP address assignment mode                          |
| 1       | Ethernet device name                                |
| 2       | Ethernet MB messages received counter               |
| 3       | Ethernet MB messages sent counter                   |
| 4       | Ethernet MB detected error messages sent counter    |
| 5       | Ethernet opened servers counter                     |
| 6       | Ethernet opened clients counter                     |
| 7       | Ethernet transmitted correct frames counter         |
| 8       | Ethernet received correct frames counter            |
| 9       | Ethernet frame format                               |
| 10      | Ethernet MAC address                                |
| 11      | Ethernet gateway                                    |
| 12      | Ethernet subnet mask                                |
| 13      | Ethernet IP address                                 |
| 14      | Ethernet service status                             |
| 15      | (not applicable - always 0)                         |
| 16      | Ethernet services                                   |
| 17      | Ethernet global status                              |
| 18...31 | (Reserved - always 0)                               |

## Ethernet Global Status

The Ethernet Global Status parameter indicates the status of the following services provided by the LTMR controller:

- fast device replacement (FDR)
- Modbus port 502 messaging (Modbus/TCP only)

This parameter is 2 bits long.

Parameter values are:

| Bit | Indicates...                                                             |
|-----|--------------------------------------------------------------------------|
| 0   | Atleast 1 enabled service is operating with an unresolved detected error |
| 1   | All enabled services are operating properly                              |

Ethernet Global Status is cleared on power cycle and controller reset.

## Ethernet Services Validity

The Ethernet Services Validity parameter indicates whether the LTMR controller supports the port 502 messaging service.

**NOTE:** Port 502 is exclusively reserved for Modbus messages.

The Ethernet Supported Services parameter is 1 bit long.

Parameter values are:

| Value | Indicates the port 502 messaging service is... |
|-------|------------------------------------------------|
| 0     | Not supported                                  |
| 1     | Supported                                      |

## Ethernet Services Status

The Ethernet Services Status parameter indicates the status of the Ethernet Supported Services parameter, i.e., the status of the controller's port 502 messaging service.

This parameter is 3 bits long.

Parameter values are:

| Value | Indicates the port 502 messaging service is... |
|-------|------------------------------------------------|
| 1     | Idle                                           |
| 2     | Operational                                    |

Ethernet Services Status is cleared on power cycle and controller reset.

## Ethernet IP Address

The Ethernet IP Address parameter describes the IP address that has been assigned to the LTMR controller by the IP address assignment process, page 197.

The Ethernet IP Address consists of 4 byte values, in dot-decimal notation. Each byte value is an integer from 000 to 255.

## Ethernet Subnet Mask

The Ethernet Subnet Mask parameter is applied to the Ethernet IP Address value to define the host address of the LTMR controller.

The Ethernet Subnet Mask consists of 4 byte values, in dot-decimal notation. Each byte value is an integer from 000 to 255.

## Ethernet Gateway Address

The Ethernet Gateway Address parameter describes the address of the default gateway, i.e., the node that serves as an access point to other networks for communications from or to the LTMR controller.

The Ethernet Gateway Address consists of 4 byte values, in dot-decimal notation. Each byte value is an integer from 000 to 255.

## Ethernet MAC Address

The Ethernet MAC Address parameter describes the media access control (MAC) address, or hardware identifier, uniquely assigned to an LTMR controller.

The Ethernet MAC Address consists of 6 hexadecimal byte values, from 0x00 to 0xFF.

## Ethernet II Framing

The Ethernet II Framing parameter describes the Ethernet frame formats supported by the LTMR controller, including:

- Capability: can the device support a frame format?
- Configuration: is the device configured to support a frame format?
- Operational: is the configured frame format operating successfully?

**NOTE:** The Ethernet frame type, Ethernet II or 802.3, is configured using the Network Port Frame Type Setting parameter.

This parameter is 3 words long.

Ethernet II framing data is stored as follows:

| Word | Bit  | Description                                     | Values                                                                                             |
|------|------|-------------------------------------------------|----------------------------------------------------------------------------------------------------|
| 1    | 0    | Ethernet II framing <b>supported</b>            | <ul style="list-style-type: none"> <li>• 0 = not supported</li> <li>• 1 = supported</li> </ul>     |
|      | 1    | Ethernet II framing receiver <b>supported</b>   | <ul style="list-style-type: none"> <li>• 0 = not supported</li> <li>• 1 = supported</li> </ul>     |
|      | 2    | Ethernet II framing sender <b>supported</b>     | <ul style="list-style-type: none"> <li>• 0 = not supported</li> <li>• 1 = supported</li> </ul>     |
|      | 3    | Ethernet auto detection <b>supported</b>        | <ul style="list-style-type: none"> <li>• 0 = not supported</li> <li>• 1 = supported</li> </ul>     |
|      | 4-15 | <i>(Reserved)</i>                               | Always 0                                                                                           |
| 2    | 0    | Ethernet II framing <b>configured</b>           | <ul style="list-style-type: none"> <li>• 0 = not configured</li> <li>• 1 = configured</li> </ul>   |
|      | 1    | Ethernet II framing receiver <b>configured</b>  | <ul style="list-style-type: none"> <li>• 0 = not configured</li> <li>• 1 = configured</li> </ul>   |
|      | 2    | Ethernet II framing sender <b>configured</b>    | <ul style="list-style-type: none"> <li>• 0 = not configured</li> <li>• 1 = configured</li> </ul>   |
|      | 3    | Ethernet auto detection <b>configured</b>       | <ul style="list-style-type: none"> <li>• 0 = not configured</li> <li>• 1 = configured</li> </ul>   |
|      | 4-15 | <i>(Reserved)</i>                               | Always 0                                                                                           |
| 3    | 0    | Ethernet II framing <b>operational</b>          | <ul style="list-style-type: none"> <li>• 0 = not operational</li> <li>• 1 = operational</li> </ul> |
|      | 1    | Ethernet II framing receiver <b>operational</b> | <ul style="list-style-type: none"> <li>• 0 = not operational</li> <li>• 1 = operational</li> </ul> |
|      | 2    | Ethernet II framing sender <b>operational</b>   | <ul style="list-style-type: none"> <li>• 0 = not operational</li> <li>• 1 = operational</li> </ul> |
|      | 3    | Ethernet auto detection <b>operational</b>      | <ul style="list-style-type: none"> <li>• 0 = not operational</li> <li>• 1 = operational</li> </ul> |
|      | 4-15 | <i>(Reserved)</i>                               | Always 0                                                                                           |

## Ethernet Received Correct Frames Counter

The Ethernet Received Correct Frames Counter parameter contains a count of the total number of Ethernet frames that have been successfully received by the LTMR controller.

This parameter is an UDInt parameter. It is cleared on power cycle and controller reset.

The Ethernet Received Correct Frames Counter consists of 4 hexadecimal values, from 0x00 to 0xFF.

## Ethernet Transmitted Correct Frames Counter

The Ethernet Transmitted Correct Frames Counter parameter contains a count of the total number of Ethernet frames that have been successfully transmitted by the LTMR controller.

This parameter is an UDInt parameter. It is cleared on power cycle and controller reset.

The Ethernet Transmitted Correct Frames Counter consists of 4 hexadecimal values, from 0x00 to 0xFF.

## Ethernet Opened Clients Counter

The Ethernet Opened Clients Counter parameter contains a count of the number of open TCP client connections. It applies only to devices with TCP clients.

This parameter is an UInt parameter. It is cleared on power cycle and controller reset.

The Ethernet Opened Clients Counter consists of 2 hexadecimal values, from 0x00 to 0xFF.

## Ethernet Opened Servers Counter

The Ethernet Opened Servers Counter parameter contains a count of the number of open TCP server connections. It applies only to devices with TCP servers.

This parameter is an UInt parameter. It is cleared on power cycle and controller reset.

The Ethernet Opened Servers Counter consists of 2 hexadecimal values, from 0x00 to 0xFF.

## Ethernet MB Detected Error Messages Sent Counter

The Ethernet MB Detected Error Messages Sent Counter parameter contains a count of the number of:

- EtherNet/IP or Modbus/TCP request packets with errors in the header that have been received by this LTMR controller (does not count errors in the data portion of EtherNet/IP or Modbus/TCP request packets)
- EtherNet/IP or Modbus/TCP exceptions due to incorrect combination of physical port and Unit ID

This parameter is an UDInt parameter. It is cleared on power cycle and controller reset.

## Ethernet MB Messages Sent Counter

The Ethernet MB Messages Sent Counter parameter contains the total number of Modbus messages, excluding Modbus detected error messages, that have been sent by this LTMR controller.

This parameter is an UDInt parameter. It is cleared on power cycle and controller reset.

## Ethernet MB Messages Received Counter

The Ethernet MB Messages Received Counter parameter contains the total number of Modbus messages that have been received by this LTMR controller.

This parameter is an UDInt parameter. It is cleared on power cycle and controller reset.

## Ethernet Device Name

The Ethernet Device Name parameter contains the 16 character string used to identify the LTMR controller.

This parameter is 16 bytes long.

## Ethernet IP Assignment Capability

The Ethernet IP Assignment Capability parameter describes the available IP addressing sources for the LTMR controller. Up to 4 different IP addressing sources can be described.

This parameter is 4 bits long.

The Ethernet IP Assignment Capability parameter stores data as follows:

| Bit | IP addressing source...                                                                                                                                                                                  | Values                                                                                         |
|-----|----------------------------------------------------------------------------------------------------------------------------------------------------------------------------------------------------------|------------------------------------------------------------------------------------------------|
| 0   | A DHCP server, using the device name set by the 2 rotary switches                                                                                                                                        | <ul style="list-style-type: none"> <li>• 0 = not available</li> <li>• 1 = available</li> </ul> |
| 1   | Derived from the MAC address. The Ones rotary switch is set to BootP, but no IP address was received from the server.                                                                                    | <ul style="list-style-type: none"> <li>• 0 = not available</li> <li>• 1 = available</li> </ul> |
| 2   | Derived from the MAC address. Both rotary switches are set to integers, but no IP address was received from the DHCP server.                                                                             | <ul style="list-style-type: none"> <li>• 0 = not available</li> <li>• 1 = available</li> </ul> |
| 3   | The stored configuration parameters: <ul style="list-style-type: none"> <li>• Ethernet IP Address Setting</li> <li>• Ethernet Subnet Mask Setting</li> <li>• Ethernet Gateway Address Setting</li> </ul> | <ul style="list-style-type: none"> <li>• 0 = not available</li> <li>• 1 = available</li> </ul> |

## Ethernet IP Assignment Operational

The Ethernet IP Assignment Operational parameter describes how the current IP address was assigned to the LTMR controller. Only 1 (of 4) different IP address sources can be operational at any one time.

This parameter is 4 bits long.

The Ethernet IP Assignment Operational parameter stores data as follows:

| Bit | IP addressing source...                                                                                                                                                                              | Values                                                                                          |
|-----|------------------------------------------------------------------------------------------------------------------------------------------------------------------------------------------------------|-------------------------------------------------------------------------------------------------|
| 0   | A DHCP server, using the device name set by the 2 rotary switches                                                                                                                                    | <ul style="list-style-type: none"><li>• 0 = not operational</li><li>• 1 = operational</li></ul> |
| 1   | Derived from the MAC address. The Ones rotary switch is set to BootP, but no IP address was received from the server.                                                                                | <ul style="list-style-type: none"><li>• 0 = not operational</li><li>• 1 = operational</li></ul> |
| 2   | Derived from the MAC address. Both rotary switches are set to integers, but no IP address was received from the DHCP server.                                                                         | <ul style="list-style-type: none"><li>• 0 = not operational</li><li>• 1 = operational</li></ul> |
| 3   | The stored configuration parameters: <ul style="list-style-type: none"><li>• Ethernet IP Address Setting</li><li>• Ethernet Subnet Mask Setting</li><li>• Ethernet Gateway Address Setting</li></ul> | <ul style="list-style-type: none"><li>• 0 = not operational</li><li>• 1 = operational</li></ul> |

# Introduction to Custom Logic Editor

## Overview

This chapter provides a description of the custom logic editor.

## Presentation of the Custom Logic Editor

### Overview

A programmable controller reads inputs, solves logic based on a control program, and writes to outputs. You can customize LTMR controller pre-defined control programs using the custom logic editor. The custom logic editor is a powerful programming tool that is only available in SoMove with the TeSys T DTM. Creating a control program for an LTMR controller consists of writing a series of instructions (logic commands) in one of the custom logic programming languages.

### Purpose of the Custom Logic Editor

The primary purpose of the custom logic editor is to modify the commands used in the control program that:

- Manage local/remote control source.
- Define LTMR controller I/O logic assignment.
- Direct timers such as those used to manage the transitions from low-voltage to high-voltage contactor in a two-step reduced voltage starter used to implement the start, stop, and reset function of a motor controller.
- Manage trips.
- Manage resets.

The custom logic editor enables you to add specific functions to the LTMR controller pre-defined logic programs (operating modes) to meet individual application needs.

### Logic ID

All operating mode programs are identified with a unique logic ID. The logic ID of pre-defined operating mode program are numbers from 2 to 11. When a pre-defined operating mode program is customized, the logic ID of the customized program must be equal to the logic ID of the pre-defined program + 256.

This table gives the logic ID according to the operating mode:

| Operating Mode     | Logic ID of Pre-Defined Program | Logic ID of Customized program |
|--------------------|---------------------------------|--------------------------------|
| Reserved           | 0...1                           | 256...257                      |
| 2-wire overload    | 2                               | 258                            |
| 3-wire overload    | 3                               | 259                            |
| 2-wire independent | 4                               | 260                            |
| 3-wire independent | 5                               | 261                            |
| 2-wire reverser    | 6                               | 262                            |
| 3-wire reverser    | 7                               | 263                            |
| 2-wire 2-step      | 8                               | 264                            |

| Operating Mode | Logic ID of Pre-Defined Program | Logic ID of Customized program |
|----------------|---------------------------------|--------------------------------|
| 3-wire 2-step  | 9                               | 265                            |
| 2-wire 2-speed | 10                              | 266                            |
| 3-wire 2-speed | 11                              | 267                            |
| Reserved       | 12...255                        | 268...511                      |

## Customized Programs

A customized program is an LTMR controller pre-defined logic program with specific functions to meet individual application needs.

When configured with one of the pre-defined operating modes, the LTMR motor controller manages the control functions using both the firmware in the LTMR controller microprocessor and the PCode.

When configured with a customized program, the LTMR controller retains the functions controlled by the LTMR controller microprocessor. Those functions include the following characteristics that are inherent to the "parent" pre-defined operating mode:

- Restrictions to what can be written to register 704 (network command register).
- Display of the operating state in presentation mode (Forward/Reverse, Low Speed/High Speed for example)
- Automatic adjustment of power and power factor measurement in 2-step mode with Star-Delta starting selected
- Restrictions on which fallback modes may be set through the menus.
- Specific behaviors regarding the start cycle in 2-step mode.
- Restrictions on whether the transition timer may be set through the menus.

## Pre-Defined Program Structure

There are 10 pre-defined programs available with the TeSys T DTM on SoMove.

The pre-defined programs executes the following different parts, one after the other:

- Logic identification of the program with the logic ID
- Input management
- Operating mode execution
- Output update

The execution of the operating mode is embedded and called with the function `CALL_EOM`.

This provides the possibility to customize the input and output management of your custom program without modifying the operating mode execution.

## Custom Logic Editor Programming Languages and Tools

The custom logic editor provides 2 programming languages and tools:

- Structured text language, which is a list instruction language editable via the structured text editor programming tool.
- Function Block Diagram (FBD), which is an object-oriented programming language editable via the FBD editor programming tool.

Each programming method satisfies your programming objectives. However, the custom logic editor allows you to select the style of programming method that you prefer.

## Logic Commands

Both structured text and FBD languages implement the following types of commands:

- Program logic commands
- Boolean logic commands
- Register logic commands
- Timer logic commands
- Counter logic commands
- Latch logic commands
- Math logic commands

## Structured Text Editor

The following illustration shows the structured text editor, integrated in the TeSys T DTM:

```

77: ON SET_TMP_REG 1 0 //Increment 500 on Step 1
78: LOAD_BIT 457 5 //L200
79: SET_TMP_BIT 0 0 //Increment L20 on arrival
80: LOAD_BIT 1020 10 //L200 L20 button stop
81: SET_TMP_BIT 0 1 //Increment 500 local remote button
82: // Manage 500 Remote State counter
83: // Increment 10 enabled
84: LOAD_TMP_BIT 1 4 //L200 L20 Disabled 500
85: AND_TMP_BIT 0 0 //L200 disabled
86: AND_TMP_BIT 0 1 //L200 L20 button debounced
87: AND_NOT_TMP_BIT 56 2 //L200 L20 history
88: SET_TMP_BIT 55 4 //Increment counter on button close partial result
89: LOAD_TMP_BIT 0 1 //L200 L20 button debounced
90: SET_TMP_BIT 56 2 //L200 L20 button history
91: LOAD_TMP_BIT 1 4 //L200 L20 enabled 500
92: AND_NOT_TMP_BIT 56 0 //L200 L20 enabled 500 history
93: AND_TMP_BIT 1 2 //Default Power 50 state (chrome, 1-1000)
94: OR_TMP_BIT 55 4 //Exclude partial increment value
95: SET_TMP_BIT 55 4 //L200 Local increment value
96: COUNTER 54 0 55 //L2000 Counter
97: // L200 L20 enable 500 history
98: LOAD_TMP_BIT 1 4 //L200 L20 enabled 500
99: SET_TMP_BIT 56 0 //L200 L20 enabled 500 history
100: // Force 500 L20 Latch State to Remote (0) if not enabled 500
101: AND_TMP_BIT 54 0 //L200 L20 Latch State (L20)
102: SET_TMP_BIT 54 0 //L200 L20 Latch State (L20)
103: // Manage Remote L20 State
104: LOAD_NOT_TMP_BIT 1 4 //L200 L20 enabled 500
105: AND_TMP_BIT 0 0 //L200 disabled
106: SET_TMP_BIT 56 1 //L200 L20 Remote L20 state
107: LOAD_NOT_TMP_BIT 54 0 //L200 L20 Latch State (L20) (chrome)
108: AND_TMP_BIT 1 4 //L200 L20 enabled 500
109: AND_TMP_BIT 0 0 //L200 disabled
110: OR_TMP_BIT 56 1 //Exclude partial Remote L20 state

```

## FBD Editor

The following illustration shows the FBD editor, integrated in TeSys T DTM:

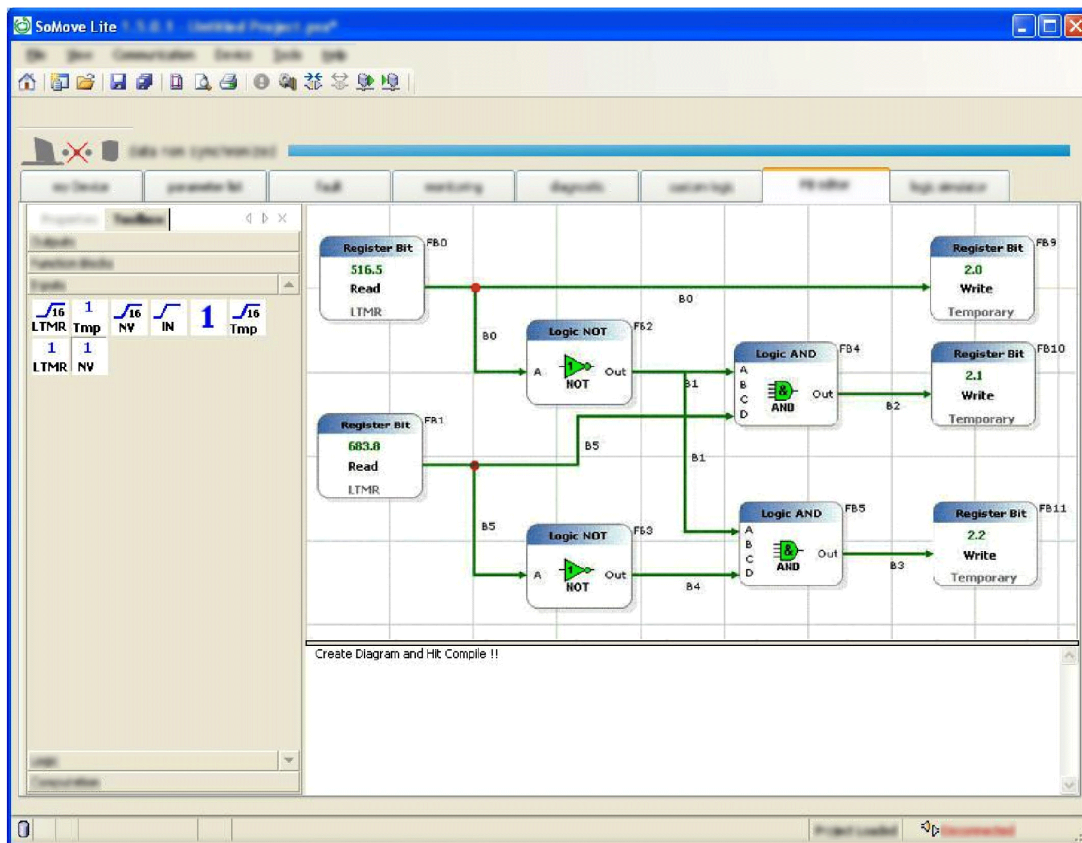

## Using the Custom Logic Editor

### Overview

The custom logic editor enables you to create and validate your own custom logic program to match with your needs. Once it is made, the LTMR controller firmware loads and executes instructions you created.

### Task Flow Diagram

The following diagram shows all of the tasks to be carried out during the creation and modification of a custom logic program.

**Note:** The order defined is provided as an example. The order you use will depend on your own work methods.

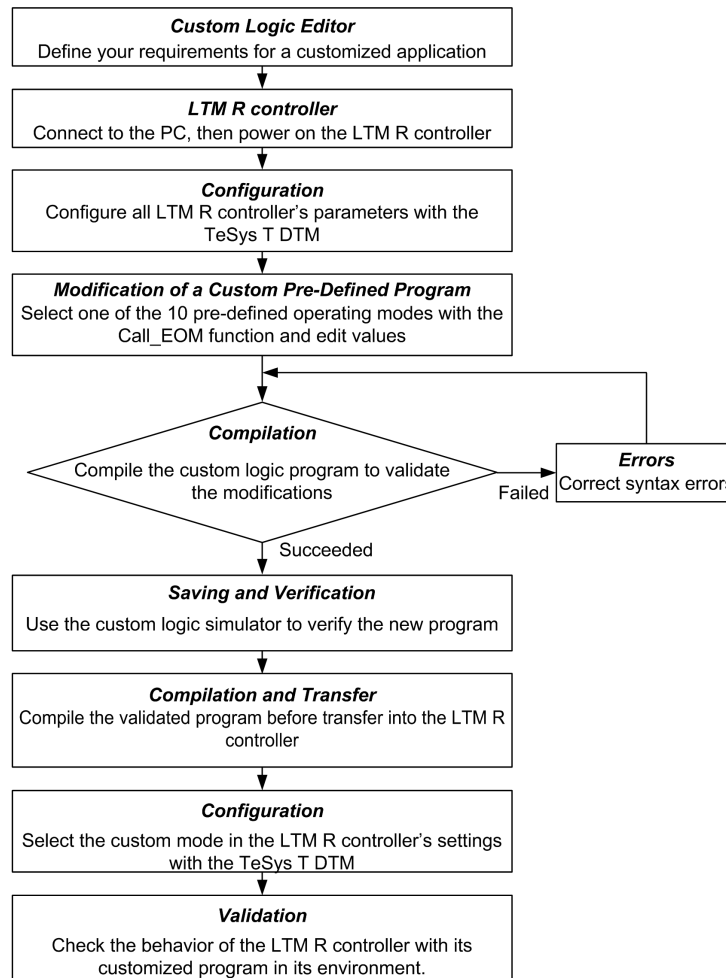

## Customization Method in Structured Text

| Step | Action                                                                                                                                                                                                                                                                                                                                                                                                                                                                                                                                                                                                  |
|------|---------------------------------------------------------------------------------------------------------------------------------------------------------------------------------------------------------------------------------------------------------------------------------------------------------------------------------------------------------------------------------------------------------------------------------------------------------------------------------------------------------------------------------------------------------------------------------------------------------|
| 1    | Define the operating modes that matches your application needs.                                                                                                                                                                                                                                                                                                                                                                                                                                                                                                                                         |
| 2    | Open the pre-defined operating mode program file (*.rtf) in the custom logic editor.                                                                                                                                                                                                                                                                                                                                                                                                                                                                                                                    |
| 3    | Edit the pre-defined program in structured text, customize the program following one of the 3 methods: <ul style="list-style-type: none"> <li>the pre-defined operating mode matches your application needs: use only the CALL_EOM function.</li> <li>the pre-defined operating mode matches your application needs but additional functions are required: use the CALL_EOM function and add the additional instructions after the CALL_EOM instructions.</li> <li>the pre-defined operating mode does not match your application needs: start a new program from scratch (not recommended).</li> </ul> |
| 4    | If required, edit the inputs of the customized program.                                                                                                                                                                                                                                                                                                                                                                                                                                                                                                                                                 |
| 5    | If required, edit the outputs of the customized program.                                                                                                                                                                                                                                                                                                                                                                                                                                                                                                                                                |
| 6    | Update the Logic ID, page 216 according to the CALL_EOM and the control mode.                                                                                                                                                                                                                                                                                                                                                                                                                                                                                                                           |
| 7    | Simulate the customized program.                                                                                                                                                                                                                                                                                                                                                                                                                                                                                                                                                                        |
| 8    | Compile the customized program.                                                                                                                                                                                                                                                                                                                                                                                                                                                                                                                                                                         |

## Customization Method in FBD

| Step | Action                                                                                                                                                                                                                                                                                                                                                                                                                                                                                                                                                                                       |
|------|----------------------------------------------------------------------------------------------------------------------------------------------------------------------------------------------------------------------------------------------------------------------------------------------------------------------------------------------------------------------------------------------------------------------------------------------------------------------------------------------------------------------------------------------------------------------------------------------|
| 1    | Open a blank FBD program page.                                                                                                                                                                                                                                                                                                                                                                                                                                                                                                                                                               |
| 2    | Create the inputs management of the customized program.                                                                                                                                                                                                                                                                                                                                                                                                                                                                                                                                      |
| 3    | Create the operating mode execution following one of the 3 methods: <ul style="list-style-type: none"> <li>• one of the operating mode matches your application needs: use only the <code>CALL_EOM</code> function</li> <li>• one of the operating mode matches your application needs but additional functions are required: use the <code>CALL_EOM</code> function and add the additional instructions after the <code>CALL_EOM</code> instructions.</li> <li>• none of the operating mode matches your application needs: create a new program from scratch (not recommended).</li> </ul> |
| 4    | Create the output management of the customized program.                                                                                                                                                                                                                                                                                                                                                                                                                                                                                                                                      |
| 5    | Update the Logic ID, page 216 according to the <code>CALL_EOM</code> and the control mode.                                                                                                                                                                                                                                                                                                                                                                                                                                                                                                   |
| 6    | Simulate the customized program.                                                                                                                                                                                                                                                                                                                                                                                                                                                                                                                                                             |
| 7    | Compile the customized program.                                                                                                                                                                                                                                                                                                                                                                                                                                                                                                                                                              |

## Characteristics of the Custom Logic Program

### Introduction

The data transferred to or from the LTMR controller is in the form of 16-bit registers. The registers are numerically ordered and referenced by a 16-bit register address (0...65,535).

The custom logic program can modify the values of 3 types of registers:

- LTMR controller variables
- Temporary registers
- Non-volatile registers

### Logic Memory Characteristics

The list of commands for the control program is saved in an area of the internal non-volatile memory of the LTMR controller.

The format of this logic memory is illustrated in this table:

| Memory location | Item                     | Range                                                      | Description                                                       |
|-----------------|--------------------------|------------------------------------------------------------|-------------------------------------------------------------------|
| 0               | Logic Program Size (n)   | 0...8,191<br>0 means that no customized program is loaded. | 16-bit word                                                       |
| 1               | Logic Checksum           | 0...65,535                                                 | Sum of program memory from offset 2...n+2                         |
| 2               | Logic ID                 | 0...511, page 216                                          | Identifier of the custom logic program within the LTMR controller |
| 3               | Logic Command/Argument 1 | Depending on the logic command type, page 241              | One word of logic function                                        |
| 4               | Logic Command/Argument 2 |                                                            |                                                                   |
| 5               | Logic Command/Argument 3 |                                                            |                                                                   |
| ...             | ...                      | ...                                                        | ...                                                               |
| n+2             | Logic Command/Argument n | –                                                          | One word of logic function                                        |

## Logic Memory Limits

The program size is dependent on the number of logic commands. While in the text editor a command and its arguments will occupy a single line, in the memory, it will occupy as many memory locations as there are arguments.

As an example, the command timer 0.1 980 will use 4 memory locations.

## Definition of the Custom Logic Variables

### Introduction

The custom logic editor enables you to implement commands in the control program which direct the LTMR controller to read or write to the temporary or non-volatile or LTMR variables.

The LTMR controller defines each custom logic register by an integer describing its address in custom logic memory space. The value of this integer begins at address 0 and the maximum address is equal to 1 less than the number of memory locations available for temporary registers in the LTMR controller. The LTMR controller lists the number of temporary registers available as a value in the LTMR controller register 1204, which is the parameter for Custom Logic Temporary Space.

### Temporary Registers

The controller provides registers in temporary memory that can be accessed by logic commands. Because these registers exist in temporary or volatile memory, they do not retain their value settings when power to the controller is cycled.

Variables can be stored in temporary registers from 0 to 299. Thus, 300 temporary registers are available.

### Non-Volatile Registers

The LTMR controller provides registers in non-volatile memory for use by logic commands. Because these registers exist in non-volatile memory, they retain their value settings when power to the controller is cycled.

Variables can be stored in non-volatile registers from 0 to 63. Thus, 64 non-volatile registers are available.

## Definition of the LTMR Variables

### Overview

Custom logic commands can be used to change the values of read-write data registers of the LTMR controller.

### LTMR Variables

Controller memory includes data registers at addresses ranging from 0 to 1399.

Each register is a 16-bit word and is either:

- Read-only, with values that cannot be edited.
- Read-write, with values that can be edited.

## Accessing Variables

Using the custom logic editor, you can access all LTMR controller variables defined in the sections on Communication Variables in the *Use* chapter of the *TeSys T LTMR Motor Management Controller User Manuals*.

## Custom Logic Register

Registers 1200...1205 are used by the TeSys T DTM to access internal register data within the LTMR controller. These registers are also the custom logic registers accessible from the communication ports. These read-only registers are described in the following sections.

This table lists these registers:

| Register | Definition                      | Range (value) |
|----------|---------------------------------|---------------|
| 1200     | Custom logic status register    | 0...65,535    |
| 1201     | Custom logic version            |               |
| 1202     | Custom logic memory space       |               |
| 1203     | Custom logic memory used        |               |
| 1204     | Custom logic temporary space    |               |
| 1205     | Custom logic non-volatile space |               |

## Register 1200

Register 1200 is the custom logic status register. It enables the customized program to configure I/O assignment.

This table describes each bit in this register:

| Bit number | Description                                                         |
|------------|---------------------------------------------------------------------|
| 0          | Custom logic run                                                    |
| 1          | Custom logic stop                                                   |
| 2          | Custom logic reset                                                  |
| 3          | Custom logic second step                                            |
| 4          | Custom logic transition                                             |
| 5          | Custom logic phase reverse                                          |
| 6          | Custom logic network control                                        |
| 7          | Custom logic FLC selection                                          |
| 8          | <i>(Reserved)</i>                                                   |
| 9          | Custom logic auxiliary 1 LED of the LTMCU Control Operator Unit     |
| 10         | Custom logic auxiliary 2 LED of the LTMCU Control Operator Unit     |
| 11         | Custom logic stop LED of the LTMCU Control Operator Unit (not used) |
| 12         | Custom logic LO1                                                    |
| 13         | Custom logic LO2                                                    |

| Bit number | Description      |
|------------|------------------|
| 14         | Custom logic LO3 |
| 15         | Custom logic LO4 |

## Register 1201

Register 1201 indicates the custom logic capability version. The version number identifies a specific group of logic commands supported by the LTMR controller.

## Register 1202

Register 1202 defines the logic memory space available, that is, the number of non-volatile LTMR controller logic memory words (16 bits) available to save logic commands.

## Register 1203

Register 1203 defines the logic memory used, that is, the number of non-volatile LTMR logic memory words (16 bits) used by logic commands which are currently stored in the LTMR controller.

## Register 1204

Register 1204 defines the number of temporary registers provided by the LTMR controller.

## Register 1205

Register 1205 defines the number of non-volatile registers provided by the LTMR controller.

## Registers 1301...1399

Registers 1301...1399 are the General Purpose Registers for logic functions. They are used to exchange information between external sources (such as the PLC) and the custom logic applications.

These volatile registers are read/write and can be edited either by the custom logic functions or via the communication port.

# CALL\_EOM Command Description

## Overview

The `CALL_EOM` function allows to execute an operating mode.

For this purpose, the function uses the temporary registers 0 to 61.

To build a customized program around the `CALL_EOM` function, it is necessary to understand how the different registers of the application and the LTMR are used:

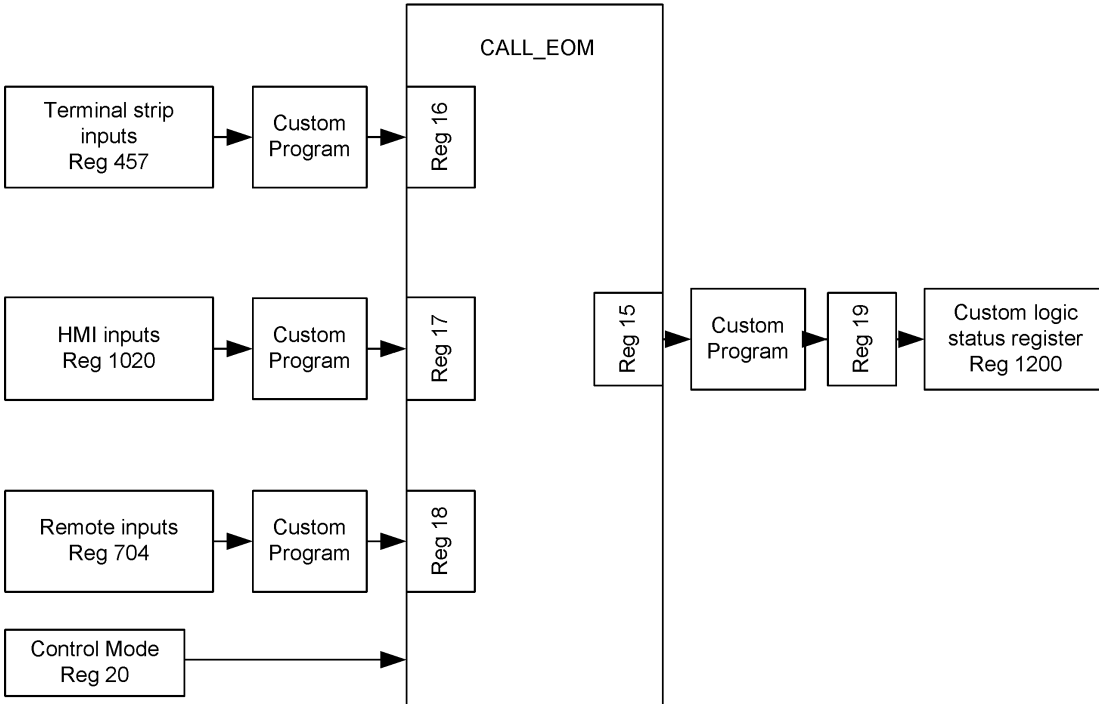

- Register 16 to 18 are the input registers of the `CALL_EOM` function, when customized, they must be assigned bit per bit.
- Register 15 is the output register of the `CALL_EOM` function, its value is given after the execution of the operating mode.
- Register 19 is a temporary register used to set the register 1200 in one time. The customization of the `CALL_EOM` outputs must be done using the register 19.
- Register 20 bit 0 is the temporary bit used to set the terminal strip control (2-wire or 3-wire).

## CALL\_EOM 1 Description

When the `CALL_EOM` argument equals 1, the function executes the overload operating mode.

The logic ID to use in your customized program is:

- LOGID\_ID 258 for 2-wire overload operating mode
- LOGID\_ID 259 for 3-wire overload operating mode

The registers are used as follows:

| Input assignment                              |                        |
|-----------------------------------------------|------------------------|
| TMP REG 16: Copy of the terminal strip inputs |                        |
| Bit 0...3                                     | Not used               |
| Bit 4                                         | Reset                  |
| Bit 5                                         | Local / Remote control |
| Bit 6...15                                    | Not used               |
| TMP REG 17: Copy of the HMI inputs            |                        |
| Bit 0                                         | HMI key Aux 1          |
| Bit 1                                         | HMI key Aux 2          |

| Input assignment                      |                        |
|---------------------------------------|------------------------|
| Bit 2                                 | Not used               |
| Bit 3                                 | HMI key Stop           |
| Bit 4                                 | Not used               |
| Bit 5                                 | Local / Remote control |
| Bit 6...15                            | Not used               |
| TMP REG 18: Copy of the remote inputs |                        |
| Bit 0...2                             | Not used               |
| Bit 3                                 | Reset                  |
| Bit 4...15                            | Not used               |

| TMP REG 20 |                                                                                                                                                   |
|------------|---------------------------------------------------------------------------------------------------------------------------------------------------|
| Bit 0      | Terminal strip control (in ST only, set as a property in FBD): <ul style="list-style-type: none"> <li>• 0= 2-wire</li> <li>• 1= 3-wire</li> </ul> |
| Bit 1...15 | Not used                                                                                                                                          |

| Output assignment                                                                     |                                |
|---------------------------------------------------------------------------------------|--------------------------------|
| TMP REG 15: outputs of the CALL_EOM instruction to assign to LTMR controller outputs. |                                |
| Bit 0                                                                                 | CL "Motor Running" information |
| Bit 1                                                                                 | CL "Motor Stopped" information |
| Bit 2                                                                                 | CL "Reset" information         |
| Bit 3...8                                                                             | Not used                       |
| Bit 9                                                                                 | CL "Run1 LED" information      |
| Bit 10                                                                                | CL "Run2 LED" information      |
| Bit 11                                                                                | CL "Stop LED" information      |
| Bit 12                                                                                | CL "Run1 Cde" information      |
| Bit 13                                                                                | CL "Run2 Cde" information      |
| Bit 14                                                                                | CL "Alarm" information         |
| Bit 15                                                                                | CL "No Trip" information       |

## CALL\_EOM 2 Description

When the CALL\_EOM argument equals 2, the function executes the independent operating mode.

The logic ID to use in your customized program is:

- LOGID\_ID 260 for 2-wire independent operating mode
- LOGID\_ID 261 for 3-wire independent operating mode

The registers are used as follows:

| Input assignment                              |                        |
|-----------------------------------------------|------------------------|
| TMP REG 16: Copy of the terminal strip inputs |                        |
| Bit 0                                         | Run1                   |
| Bit 1                                         | Run2                   |
| Bit 2...3                                     | Not used               |
| Bit 4                                         | Reset                  |
| Bit 5                                         | Local / Remote control |

| Input assignment                                                                      |                                                                                                                                                   |
|---------------------------------------------------------------------------------------|---------------------------------------------------------------------------------------------------------------------------------------------------|
| Bit 6...15                                                                            | Not used                                                                                                                                          |
| TMP REG 17: Copy of the HMI inputs                                                    |                                                                                                                                                   |
| Bit 0                                                                                 | HMI key Aux 1                                                                                                                                     |
| Bit 1                                                                                 | HMI key Aux 2                                                                                                                                     |
| Bit 2                                                                                 | Not used                                                                                                                                          |
| Bit 3                                                                                 | HMI key Stop                                                                                                                                      |
| Bit 5                                                                                 | Local / Remote control                                                                                                                            |
| Bit 6...15                                                                            | Not used                                                                                                                                          |
| TMP REG 18: Copy of the remote inputs                                                 |                                                                                                                                                   |
| Bit 0                                                                                 | Run1                                                                                                                                              |
| Bit 1                                                                                 | Run2                                                                                                                                              |
| Bit 2                                                                                 | Not used                                                                                                                                          |
| Bit 3                                                                                 | Reset                                                                                                                                             |
| Bit 4...15                                                                            | Not used                                                                                                                                          |
| TMP REG 20                                                                            |                                                                                                                                                   |
| Bit 0                                                                                 | Terminal strip control (in ST only, set as a property in FBD): <ul style="list-style-type: none"> <li>• 0= 2-wire</li> <li>• 1= 3-wire</li> </ul> |
| Bit 1...15                                                                            | Not used                                                                                                                                          |
| Output assignment                                                                     |                                                                                                                                                   |
| TMP REG 15: outputs of the CALL_EOM instruction to assign to LTMR controller outputs. |                                                                                                                                                   |
| Bit 0                                                                                 | CL "Motor Running" information                                                                                                                    |
| Bit 1                                                                                 | CL "Motor Stopped" information                                                                                                                    |
| Bit 2                                                                                 | CL "Reset" information                                                                                                                            |
| Bit 3...8                                                                             | Not used                                                                                                                                          |
| Bit 9                                                                                 | CL "Run1 LED" information                                                                                                                         |
| Bit 10                                                                                | CL "Run2 LED" information                                                                                                                         |
| Bit 11                                                                                | CL "Stop LED" information                                                                                                                         |
| Bit 12                                                                                | CL "Run1 Cde" information                                                                                                                         |
| Bit 13                                                                                | CL "Run2 Cde" information                                                                                                                         |
| Bit 14                                                                                | CL "Alarm" information                                                                                                                            |
| Bit 15                                                                                | CL "No Trip" information                                                                                                                          |

## CALL\_EOM 3 Description

When the CALL\_EOM argument equals 3, the function executes the reverser operating mode.

The logic ID to use in your customized program is:

- LOGID\_ID 262 for 2-wire reverser operating mode
- LOGID\_ID 263 for 3-wire reverser operating mode

The registers are used as follows:

| Input assignment                                                                      |                                                                                                                                                   |
|---------------------------------------------------------------------------------------|---------------------------------------------------------------------------------------------------------------------------------------------------|
| TMP REG 16: Copy of the terminal strip inputs                                         |                                                                                                                                                   |
| Bit 0                                                                                 | Forward                                                                                                                                           |
| Bit 1                                                                                 | Reverse                                                                                                                                           |
| Bit 2...3                                                                             | Not used                                                                                                                                          |
| Bit 4                                                                                 | Reset                                                                                                                                             |
| Bit 5                                                                                 | Local / Remote control                                                                                                                            |
| Bit 6...15                                                                            | Not used                                                                                                                                          |
| TMP REG 17: Copy of the HMI inputs                                                    |                                                                                                                                                   |
| Bit 0                                                                                 | HMI key Aux 1                                                                                                                                     |
| Bit 1                                                                                 | HMI key Aux 2                                                                                                                                     |
| Bit 2                                                                                 | Not used                                                                                                                                          |
| Bit 3                                                                                 | HMI key Stop                                                                                                                                      |
| Bit 4                                                                                 | Not used                                                                                                                                          |
| Bit 5                                                                                 | Local / Remote control                                                                                                                            |
| Bit 6...15                                                                            | Not used                                                                                                                                          |
| TMP REG 18: Copy of the remote inputs                                                 |                                                                                                                                                   |
| Bit 0                                                                                 | Forward                                                                                                                                           |
| Bit 1                                                                                 | Reverse                                                                                                                                           |
| Bit 2                                                                                 | Not used                                                                                                                                          |
| Bit 3                                                                                 | Reset                                                                                                                                             |
| Bit 4...15                                                                            | Not used                                                                                                                                          |
| TMP REG 20                                                                            |                                                                                                                                                   |
| Bit 0                                                                                 | Terminal strip control (in ST only, set as a property in FBD): <ul style="list-style-type: none"> <li>• 0= 2-wire</li> <li>• 1= 3-wire</li> </ul> |
| Bit 1...15                                                                            | Not used                                                                                                                                          |
| Output assignment                                                                     |                                                                                                                                                   |
| TMP REG 15: outputs of the CALL_EOM instruction to assign to LTMR controller outputs. |                                                                                                                                                   |
| Bit 0                                                                                 | CL "Motor Running" information                                                                                                                    |
| Bit 1                                                                                 | CL "Motor Stopped" information                                                                                                                    |
| Bit 2                                                                                 | CL "Reset" information                                                                                                                            |
| Bit 3...8                                                                             | Not used                                                                                                                                          |
| Bit 9                                                                                 | CL "Run1 LED" information                                                                                                                         |
| Bit 10                                                                                | CL "Run2 LED" information                                                                                                                         |
| Bit 11                                                                                | CL "Stop LED" information                                                                                                                         |
| Bit 12                                                                                | CL "Run1 Cde" information                                                                                                                         |
| Bit 13                                                                                | CL "Run2 Cde" information                                                                                                                         |
| Bit 14                                                                                | CL "Alarm" information                                                                                                                            |
| Bit 15                                                                                | CL "No Trip" information                                                                                                                          |

## CALL\_EOM 4 Description

When the CALL\_EOM argument equals 4, the function executes the 2-step operating mode.

The logic ID to use in your customized program is:

- LOGID\_ID 264 for 2-wire 2-step operating mode
- LOGID\_ID 265 for 3-wire 2-step operating mode

The registers are used as follows:

| <b>Input assignment</b>                                                               |                                                                                                                                                   |
|---------------------------------------------------------------------------------------|---------------------------------------------------------------------------------------------------------------------------------------------------|
| TMP REG 16: Copy of the terminal strip inputs                                         |                                                                                                                                                   |
| Bit 0                                                                                 | Run1                                                                                                                                              |
| Bit 1...3                                                                             | Not used                                                                                                                                          |
| Bit 4                                                                                 | Reset                                                                                                                                             |
| Bit 5                                                                                 | Local / Remote control                                                                                                                            |
| Bit 6...15                                                                            | Not used                                                                                                                                          |
| TMP REG 17: Copy of the HMI inputs                                                    |                                                                                                                                                   |
| Bit 0                                                                                 | HMI key Aux 1                                                                                                                                     |
| Bit 1...2                                                                             | Not used                                                                                                                                          |
| Bit 3                                                                                 | HMI key Stop                                                                                                                                      |
| Bit 4                                                                                 | Not used                                                                                                                                          |
| Bit 5                                                                                 | Local / Remote control                                                                                                                            |
| Bit 6...15                                                                            | Not used                                                                                                                                          |
| TMP REG 18: Copy of the remote inputs                                                 |                                                                                                                                                   |
| Bit 0                                                                                 | Run1                                                                                                                                              |
| Bit 1                                                                                 | Run2                                                                                                                                              |
| Bit 2                                                                                 | Not used                                                                                                                                          |
| Bit 3                                                                                 | Reset                                                                                                                                             |
| Bit 4...15                                                                            | Not used                                                                                                                                          |
| TMP REG 20                                                                            |                                                                                                                                                   |
| Bit 0                                                                                 | Terminal strip control (in ST only, set as a property in FBD): <ul style="list-style-type: none"> <li>• 0= 2-wire</li> <li>• 1= 3-wire</li> </ul> |
| Bit 1...15                                                                            | Not used                                                                                                                                          |
| <b>Output assignment</b>                                                              |                                                                                                                                                   |
| TMP REG 15: outputs of the CALL_EOM instruction to assign to LTMR controller outputs. |                                                                                                                                                   |
| Bit 0                                                                                 | CL "Motor Running" information                                                                                                                    |
| Bit 1                                                                                 | CL "Motor Stopped" information                                                                                                                    |
| Bit 2                                                                                 | CL "Reset" information                                                                                                                            |
| Bit 3...8                                                                             | Not used                                                                                                                                          |
| Bit 9                                                                                 | CL "Run1 LED" information                                                                                                                         |
| Bit 10                                                                                | CL "Run2 LED" information                                                                                                                         |
| Bit 11                                                                                | CL "Stop LED" information                                                                                                                         |
| Bit 12                                                                                | CL "Run1 Cde" information                                                                                                                         |
| Bit 13                                                                                | CL "Run2 Cde" information                                                                                                                         |
| Bit 14                                                                                | CL "Alarm" information                                                                                                                            |
| Bit 15                                                                                | CL "No Trip" information                                                                                                                          |

## CALL\_EOM 5 Description

When the `CALL_EOM` argument equals 5, the function executes the 2-speed operating mode.

The logic ID to use in your customized program is:

- LOGID\_ID 266 for 2-wire 2-speed operating mode
- LOGID\_ID 267 for 3-wire 2-speed operating mode

The registers are used as follows:

| Input assignment                              |                        |
|-----------------------------------------------|------------------------|
| TMP REG 16: Copy of the terminal strip inputs |                        |
| Bit 0                                         | Run1                   |
| Bit 1                                         | Run2                   |
| Bit 2...3                                     | Not used               |
| Bit 4                                         | Reset                  |
| Bit 5                                         | Local / Remote control |
| Bit 6...15                                    | Not used               |
| TMP REG 17: Copy of the HMI inputs            |                        |
| Bit 0                                         | HMI key Aux 1          |
| Bit 1                                         | HMI key Aux 2          |
| Bit 2                                         | Not used               |
| Bit 3                                         | HMI key Stop           |
| Bit 4                                         | Not used               |
| Bit 5                                         | Local / Remote control |
| Bit 6...15                                    | Not used               |
| TMP REG 18: Copy of the remote inputs         |                        |
| Bit 0                                         | Run1                   |
| Bit 1                                         | Run2                   |
| Bit 2                                         | Not used               |
| Bit 3                                         | Reset                  |
| Bit 4...15                                    | Not used               |

| TMP REG 20 |                                                                                                                                                   |
|------------|---------------------------------------------------------------------------------------------------------------------------------------------------|
| Bit 0      | Terminal strip control (in ST only, set as a property in FBD): <ul style="list-style-type: none"> <li>• 0= 2-wire</li> <li>• 1= 3-wire</li> </ul> |
| Bit 1...15 | Not used                                                                                                                                          |

| Output assignment                                                                                  |                                |
|----------------------------------------------------------------------------------------------------|--------------------------------|
| TMP REG 15: outputs of the <code>CALL_EOM</code> instruction to assign to LTMR controller outputs. |                                |
| Bit 0                                                                                              | CL "Motor Running" information |
| Bit 1                                                                                              | CL "Motor Stopped" information |
| Bit 2                                                                                              | CL "Reset" information         |
| Bit 3...8                                                                                          | Not used                       |
| Bit 9                                                                                              | CL "Run1 LED" information      |
| Bit 10                                                                                             | CL "Run2 LED" information      |
| Bit 11                                                                                             | CL "Stop LED" information      |
| Bit 12                                                                                             | CL "Run1 Cde" information      |

| Output assignment |                           |
|-------------------|---------------------------|
| Bit 13            | CL "Run2 Cde" information |
| Bit 14            | CL "Alarm" information    |
| Bit 15            | CL "No Trip" information  |

## Program Example

```

LOGIC_ID 256 //2 WIRE INDEPENDENT MODE
// Temp register allocation
Temp 0 and Temp 1 as scratch
Temp 2 as Requested Control Mode
    0=PLC
    1=HMI
    2=TS (terminal strip)
Temp 3 as Active Control Mode
    0=PLC
    1=HMI
    2=TS (terminal strip)
Temp 4 as state bits group 1
    0=Control Transfer in process
    1=L01 PLC fallback value
    2=L02 PLC fallback value
    3=L01 HMI fallback value
    4=L02 HMI fallback value
    5=Global Stop
    6=Stop1
    7=Stop2
    8=Run1
    9=Run2
    10=Forward
    11=Reverse
    12=Reversing Timer
    13=Swapping
    14=Last Direction
    15=Two Wire Swap
Temp 5 as 2 Step states
Temp 6,7,8 as Step 1 Timer
Temp 9,10,11 as Step 2 Timer
Temp 12 as INPUT History
    1=PLC Run 1
    2=PLC Run 2
    3=HMI Run 1
    4=HMI Run 2
    5=TS Run 1
    6=TS Run 2
    7=Mode Change 1
    8=Spare
    9=Mode Change 2
    10=Spare
    11=Bumpless in Process
    12=Power up Done
Temp 13 as Voltage Dip and HMI keypad group
    0=Normal Load Shed
    1=Dip Auto Enable
    2=Dip Stop
    3=Dip Stop History
    4=Dip Set Inhibit Latch
    5=Dip Clear Inhibit Latch
    6=Dip Inhibit Run
    7 11=Spare
    12=HMI Aux 1
    13=HMI Aux 2
    14=HMI Stop
Temp 14 Voltage Dip Latch status
    0=State
    1=Set
    2=Clear
Temp 15 Custom Logic Outputs
    0=CL "Motor Running" information
    1=CL "Motor Stopped" information
    2=CL "Reset" information
    9=CL "Run1 LED" information
    10=CL "Run2 LED" information
    11=CL "Stop LED" information
    12=CL "Run1 Cde" information
    13=CL "Run2 Cde" information

```

```

//          14=CL "Alarm" information
//          15=CL "No Fault" information
Temp 16 Custom Logic Terminal Strip inputs
//          0=Run 1
//          1=Run 2
//          2=External fault
//          4=Reset
//          5=Local/Remote Control
Temp 17 Custom Logic HMI inputs
//          0=Aux 1
//          1=Aux 2
//          3=Stop
//          5=Local/Remote Control
Temp 18 Custom Logic REMOTE inputs
//          0=Run 1
//          1=Run 2
//          3=Reset
Temp 19 Speedup image of LTMR Register 1200.
Temp 20 three wire status
//          0=3_wire / not 3 wire(2 wire)
Temp 50+ as general status registers
Temp 50 as ONSET status transition time value
Temp 51 as ONSET status Low to High timer
Temp 52 as ONSET status High to Low timer
Temp 53 Last Speed Latch Save Requested Control.in Temp 2
Temp 54, 55 HMI Remote State Counter (LSB is significant)
Temp 56 as HMI Local/Remote state bits
//          0=HMI Remote Active
//          1=Remote LED Status
//          2=HMI L/R button history
Temp 57, 58, 59, 60, 61 as OFF TIME adjustment of Transition Timer Reg 541.
//define 2_wire or 3_wire
//LOAD_K_BIT 1
//SET_TMP_BIT 20 0 //3 wire
LOAD_K_BIT 1 //2 wire
SET_NOT_TMP_BIT 20 0 //2 wire
//Input
LOAD_BIT 457 0 //LI1
SET_TMP_BIT 16 0
LOAD_BIT 457 1 //LI2
SET_TMP_BIT 16 1
LOAD_BIT 457 2 //LI3
SET_TMP_BIT 16 2
LOAD_BIT 457 3 //LI4
SET_TMP_BIT 16 3
LOAD_BIT 457 4 //LI5
SET_TMP_BIT 16 4
LOAD_BIT 457 5 //LI6
SET_TMP_BIT 16 5
LOAD_BIT 1020 12 //HMI Aux1 button
SET_TMP_BIT 17 0
LOAD_BIT 1020 13 //HMI Aux2 button
SET_TMP_BIT 17 1
LOAD_BIT 1020 14 //HMI Stop button
SET_TMP_BIT 17 2
LOAD_BIT 1020 11 //HMI Reset button
SET_TMP_BIT 17 4
LOAD_BIT 1020 10 //HMI L/R button
SET_TMP_BIT 17 5
LOAD_BIT 704 0 //PLC Run1 command
SET_TMP_BIT 18 0
LOAD_BIT 704 1 //PLC Run2 command
SET_TMP_BIT 18 1
LOAD_BIT 704 3 //PLC Run2 command
SET_TMP_BIT 18 3
//End customer Zone
//Call Command
//Output
//=====

//-----
// Customer Zone: Custom application
// Add specific code for Custom Logic function here
CALL_EOM 2 //Independent mode
//-----
// Customer Zone: outputs management
//HMI Aux 1 Led
LOAD_TMP_BIT 15 9 //Image of HMI Aux1 LED
SET_TMP_BIT 19 9
//HMI Aux 2 Led
LOAD_TMP_BIT 15 10 //Image of HMI Aux2 LED
SET_TMP_BIT 19 10
//HMI Stop Led
LOAD_TMP_BIT 15 11 //Image of HMI Stop LED
SET_TMP_BIT 19 11
// Output Lo1
LOAD_TMP_BIT 15 12 //Image of output LO1
SET_TMP_BIT 19 12
// Output LO2
LOAD_TMP_BIT 15 13 //Image of output LO2
SET_TMP_BIT 19 13
// Output LO3
LOAD_TMP_BIT 15 14 //Image of output LO3
SET_TMP_BIT 19 14
// Output Lo4
LOAD_TMP_BIT 15 15 //Image of output LO4
SET_TMP_BIT 19 15
//-----
// End Customer Zone
//-----
// Schneider Zone (Do not modify)
LOAD_K_BIT 1
SET_NOT_TMP_BIT 0 3 //Get image of 1200
LOAD_TMP_REG 19 //Put it into 1200
ON_SET_REG 1200 0

```

# Structured Text Language

## Overview

The structured text editor enables you to create a custom logic program based on the structured text programming language.

## Creating a Structured Text Program

### Summary

This section describes the creation of a program with the structured text editor.

Use the structured text editor to modify the pre-defined operating program by:

- Changing the input and output assignments of the logic functions
- Adding new logic functions that will change the step by step instructions of the original program

Create a new program by designing the step instructions customized to the specific requirements of the application.

## Introducing the Structured Text Editor

### Overview

The structured text editor is a feature of SoMove with the TeSys T DTM. Use the structured text editor to view an existing logic file or to create a logic file using an instruction based text language, rather than a graphics based programming language.

## Editing a Structured Text Program

The easiest way to create a logic file is to begin with a logic file for one of the pre-defined operating modes, page 220. Your installation of the custom logic editor comes with 10 pre-defined logic files, one for each combination of:

- Operating mode (2-speed, 2-step, independent, overload, reverser), and
- Control wiring selection (2-wire, 3-wire).

Each logic file bears a descriptive name (e.g. "3-wire-reverser") and a file extension of *.lf*.

## Custom Logic Editor User Interface

To open the structured text editor, click **Device** → **custom logic** → **New custom program**.

The structured text editor is available regardless of whether the TeSys T DTM is in connected mode. However, the transfer of programs between the TeSys T DTM and the device works only in connected mode.

# Structured Text Editor User Interface

## Introduction

A program written in list language consists of a series of instructions executed sequentially by the LTMR controller. Each list instruction is represented by a single program line and consists of 4 components:

- Line number
- Logic command (Mnemonics)
- Argument(s)
- Comment(s)

## Example of a Structured Text Program

The following illustration is an example of a program created with the structured text editor.

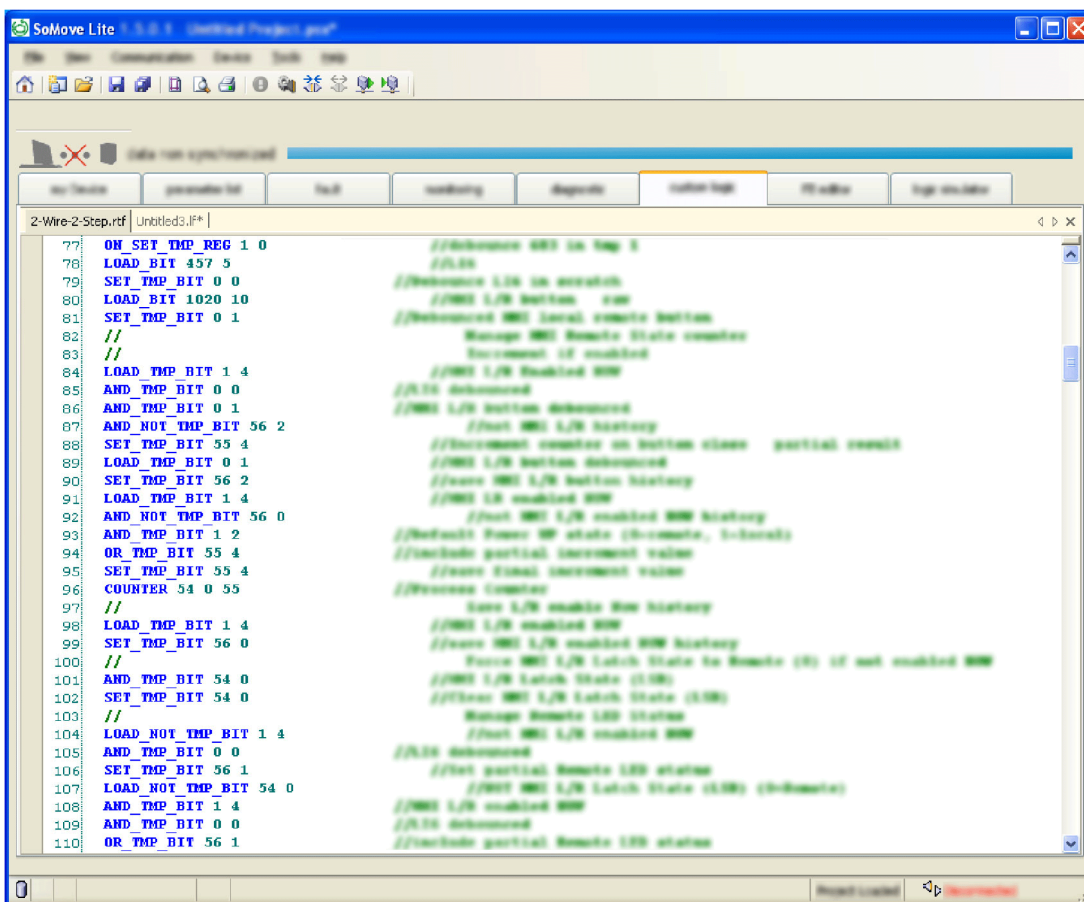

```

77: OH_SET_TMP_REG 1 0           //Increment 001 in Reg 1
78: LOAD_BIT 457 5              //LSB
79: SET_TMP_BIT 0 0             //Increment L20 in scratch
80: LOAD_BIT 1020 10            //MSB L20 button run
81: SET_TMP_BIT 0 1             //Increment 002 Serial counter button
82: //                          //Manage 002 Serial State counter
83: //                          //Increment L2 enabled
84: LOAD_TMP_BIT 1 4            //MSB L20 enabled 000
85: AND_TMP_BIT 0 0             //LSB debounced
86: AND_TMP_BIT 0 1             //MSB L20 button debounced
87: AND_NOT_TMP_BIT 56 2        //not 002 L20 history
88: SET_TMP_BIT 55 4            //Increment counter in bottom class partial result
89: LOAD_TMP_BIT 0 1            //MSB L20 button debounced
90: SET_TMP_BIT 56 2            //save 002 L20 button history
91: LOAD_TMP_BIT 1 4            //MSB L2 enabled 000
92: AND_NOT_TMP_BIT 56 0        //not 002 L20 enabled 000 history
93: AND_TMP_BIT 1 2            //default Power 00 state (0=normal, 1=lock)
94: OR_TMP_BIT 55 4            //include partial increment value
95: SET_TMP_BIT 55 4            //save final increment value
96: COUNTER 54 0 55           //Process Counter
97: //                          //save L20 enable 000 history
98: LOAD_TMP_BIT 1 4            //MSB L20 enabled 000
99: SET_TMP_BIT 56 0            //save 002 L20 enabled 000 history
100: //                          //save 002 L20 Latch State to 002 (0) if not enabled 000
101: AND_TMP_BIT 54 0            //MSB L20 Latch State (LSB)
102: SET_TMP_BIT 54 0            //Clear 002 L20 Latch State (LSB)
103: //                          //Manage 002 L20 State
104: LOAD_NOT_TMP_BIT 1 4        //not 002 L20 enabled 000
105: AND_TMP_BIT 0 0            //LSB debounced
106: SET_TMP_BIT 56 1            //not partial 002 L20 status
107: LOAD_NOT_TMP_BIT 54 0        //not 002 L20 Latch State (LSB) (0=002)
108: AND_TMP_BIT 1 4            //MSB L20 enabled 000
109: AND_TMP_BIT 0 0            //LSB debounced
110: OR_TMP_BIT 56 1            //include partial 002 L20 status
  
```

## Editing Several Programs

You can create or modify several custom logic programs at the same time. Click on the file name to switch between them.

For instance, in the Text view above, click either **2-wire-2-Step.rtf** or **Untitled3.If** depending on the program you wish to edit.

## Instruction Elements

The following illustration is a sample of structured text program:

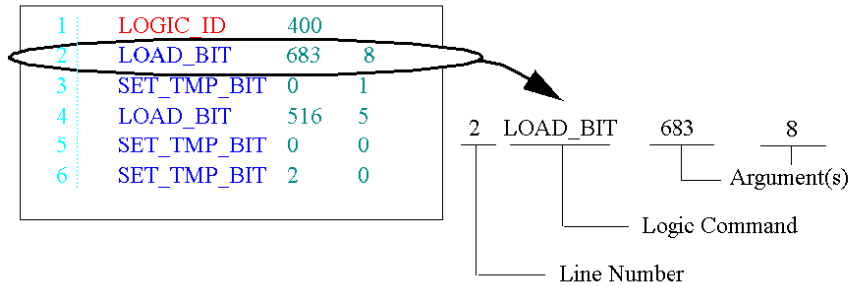

## Line Number

The line number is an additional information:

- It is defined only by the editor.
- It does not have any importance in the custom logic function itself.

## Logic Command

A logic command is an instruction which identifies the operation to be performed using one or more arguments. In the example, the `LOAD_BIT` command loads the value of the argument into an internal register called the 1-bit accumulator.

There are 2 types of commands:

- Setup commands
 

These set-up or test for the necessary conditions to perform an action (for example, `LOAD` and `AND` commands).
- Actions commands
 

These commands direct the LTMR controller to perform an action based on info in the setup instructions (for example, assignment commands such as `COMP`).

**NOTE:** When you type a logic command, either uppercase or lowercase, it is automatically recognized and displayed in blue.

## Argument

An argument is a number representing a value (register address, bit number, or constant) that the LTMR controller can manipulate in an instruction. For example, in the sample program, the second instruction `LOAD_BIT 683 8` includes a logic command `LOAD_BIT` and 2 arguments, `683` and `8`. This instructs the LTMR controller to load the value of register 683 bit 8 into the accumulator. A logic command can have from 0 to 3 arguments depending on the type of logic command.

Using instructions with commands and arguments, the LTMR controller program can:

- Read the status of controller inputs.
- Read or write the status of controller outputs.
- Activate basic logic functions such as timers and counters.
- Perform arithmetic, logical, comparisons, and numerical operations.
- Read or write to the LTMR controller's internal registers or to individual bits in those registers.

**NOTE:** When you type an argument, it is automatically recognized and displayed in the color assigned to the arguments.

## Comments

In the structured text editor, it is possible to add comments to the program:

- At the end of each line after the arguments
- In a whole line

**NOTE:**

- When you type //, the custom logic editor automatically recognizes the text after it as comments and displays it in green.
- Comments can not be retrieved from the LTMR controller.

## Syntax

In the structured text editor, it is possible to write instructions:

- With blanks, commas or dots between arguments
- In upper or lower characters

## Syntax Check

During typing, the text editor checks the instruction syntax:

- Correct instructions are displayed in bold blue characters.
- Incorrect instructions stay displayed in black and must be corrected before the compilation.

## Keyboard Commands

Keyboard commands and shortcuts are the same as those for Windows operating systems: press DEL or DELETE to delete a character or line, press ENTER to go to the next line, etc.

## Saving

To save the program you edited or created, click **Device > custom logic** then select **Save custom program** or **Save custom program as**.

**NOTE:** This file is saved with the extension *\*.lf*.

## Logic Commands

### Overview

All controller project files consist of a series of logic commands. Each logic command consists of the command itself, plus up to 3 arguments.

Each logic command performs its operation linked to either a 1-bit Boolean accumulator (value 0 or 1) or a 16-bit unsigned accumulator (value range 0...65,535).

The custom logic editor provides the following kinds of logic commands:

- Boolean
- Register

- Timers
- Latch
- Counters
- Math

## Rising Edge Detection Mechanism

Some logic commands work on a rising edge of the 1-bit accumulator.

The rising edge of a bit is detected when its current state is 1 and its previous state was 0. The previous state of the bit is stored in a dedicated history bit.

**NOTE:** If this history bit is modified, the detection of the rising edge can be disturbed.

## Boolean Logic Commands

Boolean commands evaluate and control simple Boolean (On/Off) values. Boolean commands include:

| Command          | Argument 1                    | Argument 2                | Argument 3 | Description                                                                                                                                                          |
|------------------|-------------------------------|---------------------------|------------|----------------------------------------------------------------------------------------------------------------------------------------------------------------------|
| LOAD_K_BIT       | Constant value (0 or 1)       | –                         | –          | Loads a constant value into the 1-bit accumulator.                                                                                                                   |
| LOAD_BIT         | Register address              | Register bit no. (0...15) | –          | Loads a register bit from the address identified in Argument 1, and the bit identified in Argument 2 into the 1-bit accumulator.                                     |
| LOAD_TMP_BIT     | Temporary register address    | Register bit no. (0...15) | –          | Loads a temporary register bit into the 1-bit accumulator.                                                                                                           |
| LOAD_NV_BIT      | Non-volatile register address | Register bit no. (0...15) | –          | Loads a non-volatile register bit into the 1-bit accumulator.                                                                                                        |
| LOAD_NOT_BIT     | Register address              | Register bit no. (0...15) | –          | Loads an inverted Boolean value of a register bit into the 1-bit accumulator.                                                                                        |
| LOAD_NOT_TMP_BIT | Temporary register address    | Register bit no. (0...15) | –          | Loads an inverted Boolean value of a temporary register bit into the 1-bit accumulator.                                                                              |
| LOAD_NOT_NV_BIT  | Non-volatile register address | Register bit no. (0...15) | –          | Loads an inverted Boolean value of a non-volatile register bit into the 1-bit accumulator.                                                                           |
| AND_BIT          | Register address              | Register bit no. (0...15) | –          | Loads the result of a logical AND link between the register bit value and the 1-bit accumulator content. The result is stored in the 1-bit accumulator.              |
| AND_TMP_BIT      | Temporary register address    | Register bit no. (0...15) | –          | Loads the result of a logical AND link between the temporary register bit value and the 1-bit accumulator content. The result is stored in the 1-bit accumulator.    |
| AND_NV_BIT       | Non-volatile register address | Register bit no. (0...15) | –          | Loads the result of a logical AND link between the non-volatile register bit value and the 1-bit accumulator content. The result is stored in the 1-bit accumulator. |
| AND_NOT_BIT      | Register address              | Register bit no. (0...15) | –          | Loads the result of a logical AND of the inverted register bit and the 1-bit accumulator. The result is stored in the 1-bit accumulator.                             |
| AND_NOT_TMP_BIT  | Temporary register address    | Register bit no. (0...15) | –          | Loads the result of a logical AND of the inverted temporary register bit and the 1-bit accumulator. The result is stored in the 1-bit accumulator.                   |
| AND_NOT_NV_BIT   | Non-volatile register address | Register bit no. (0...15) | –          | Loads the result of a logical AND of the inverted non-volatile register bit and the 1-bit accumulator. The result is stored in the 1-bit accumulator.                |
| OR_BIT           | Register address              | Register bit no. (0...15) | –          | Makes a logical OR link between the register bit value and the 1-bit accumulator content. The result is stored in the 1-bit accumulator.                             |

| Command                                     | Argument 1                    | Argument 2                | Argument 3 | Description                                                                                                                                           |
|---------------------------------------------|-------------------------------|---------------------------|------------|-------------------------------------------------------------------------------------------------------------------------------------------------------|
| OR_TMP_BIT                                  | Temporary register address    | Register bit no. (0...15) | –          | Makes a logical OR link between the temporary register bit value and the 1-bit accumulator content. The result is stored in the 1-bit accumulator.    |
| OR_NV_BIT                                   | Non-volatile register address | Register bit no. (0...15) | –          | Makes a logical OR link between the non-volatile register bit value and the 1-bit accumulator content. The result is stored in the 1-bit accumulator. |
| OR_NOT_BIT                                  | Register address              | Register bit no. (0...15) | –          | Makes an logical OR of the inverted register bit and the 1-bit accumulator. The result is stored in the 1-bit accumulator.                            |
| OR_NOT_TMP_BIT                              | Temporary register address    | Register bit no. (0...15) | –          | Makes an logical OR of the inverted temporary register bit and the 1-bit accumulator. The result is stored in the 1-bit accumulator.                  |
| OR_NOT_NV_BIT                               | Non-volatile register address | Register bit no. (0...15) | –          | Makes an logical OR of the inverted non-volatile register bit and the 1-bit accumulator. The result is stored in the 1-bit accumulator.               |
| SET_BIT                                     | Register address              | Register bit no. (0...15) | –          | Sets value of the 1-bit accumulator into a register bit.                                                                                              |
| SET_TMP_BIT                                 | Temporary register address    | Register bit no. (0...15) | –          | Sets value of the 1-bit accumulator into a temporary register bit.                                                                                    |
| SET_NV_BIT                                  | Non-volatile register address | Register bit no. (0...15) | –          | Sets value of the 1-bit accumulator into a non-volatile register bit.                                                                                 |
| SET_NOT_BIT                                 | Register address              | Register bit no. (0...15) | –          | Sets inverted value of the 1-bit accumulator into a register bit.                                                                                     |
| SET_NOT_TMP_BIT                             | Temporary register address    | Register bit no. (0...15) | –          | Sets inverted value of the 1-bit accumulator into a temporary register bit.                                                                           |
| SET_NOT_NV_BIT                              | Non-volatile register address | Register bit no. (0...15) | –          | Sets inverted value of the 1-bit accumulator into a non-volatile register bit.                                                                        |
| – Argument not applicable to logic command. |                               |                           |            |                                                                                                                                                       |

## Register Logic Commands

Register commands evaluate and control 16-bit values. Register commands include:

| Command      | Argument 1                    | Argument 2                 | Argument 3 | Description                                                                                                                                                                                                                                                                                                                |
|--------------|-------------------------------|----------------------------|------------|----------------------------------------------------------------------------------------------------------------------------------------------------------------------------------------------------------------------------------------------------------------------------------------------------------------------------|
| LOAD_K_REG   | Constant value (0...65,535)   | –                          | –          | Loads a constant value into the 16-bit accumulator.                                                                                                                                                                                                                                                                        |
| LOAD_REG     | Register address              | –                          | –          | Loads a copy of a register into the 16-bit accumulator.                                                                                                                                                                                                                                                                    |
| LOAD_TMP_REG | Temporary register address    | –                          | –          | Loads a copy of a temporary register into the 16-bit accumulator.                                                                                                                                                                                                                                                          |
| LOAD_NV_REG  | Non-volatile register address | –                          | –          | Loads a copy of a non-volatile register into the 16-bit accumulator.                                                                                                                                                                                                                                                       |
| COMP_K_REG   | Constant value (0...65,535)   | Temporary register address | –          | Compares the content of the Argument 1 to the 16-bit accumulator content and sets status Argument 2 bits as follows:<br><br>BIT 1 ON if 16-bit accumulator < content of the Argument 1<br><br>BIT 2 ON if 16-bit accumulator = content of the Argument 1<br><br>BIT 3 ON if 16-bit accumulator > content of the Argument 1 |

| Command      | Argument 1                    | Argument 2                 | Argument 3 | Description                                                                                                                                                                                                                                                                                                                                                                                                |
|--------------|-------------------------------|----------------------------|------------|------------------------------------------------------------------------------------------------------------------------------------------------------------------------------------------------------------------------------------------------------------------------------------------------------------------------------------------------------------------------------------------------------------|
| COMP_REG     | Register address              | Temporary register address | –          | Compares the content of the register defined by Argument 1 to the 16-bit accumulator content and sets status Argument 2 bits as follows:<br><br>BIT 1 ON if 16-bit accumulator < content of the register defined by Argument 1<br><br>BIT 2 ON if 16-bit accumulator = content of the register defined by Argument 1<br><br>BIT 3 ON if 16-bit accumulator > content of the register defined by Argument 1 |
| COMP_TMP_REG | Temporary register address    | Temporary register address | –          | Compares the content of the register defined by Argument 1 to the 16-bit accumulator content and sets status Argument 2 bits as follows:<br><br>BIT 1 ON if 16-bit accumulator < content of the register defined by Argument 1<br><br>BIT 2 ON if 16-bit accumulator = content of the register defined by Argument 1<br><br>BIT 3 ON if 16-bit accumulator > content of the register defined by Argument 1 |
| COMP_NV_REG  | Non-volatile register address | Temporary register address | –          | Compares the content of the register defined by Argument 1 to the 16-bit accumulator content and sets status Argument 2 bits as follows:<br><br>BIT 1 ON if 16-bit accumulator < content of the register defined by Argument 1<br><br>BIT 2 ON if 16-bit accumulator = content of the register defined by Argument 1<br><br>BIT 3 ON if 16-bit accumulator > content of the register defined by Argument 1 |
| AND_K        | Constant value (0...65,535)   | –                          | –          | Makes a logical AND link between the constant value and the 16-bit accumulator content. The result is stored in the 16-bit accumulator.                                                                                                                                                                                                                                                                    |
| AND_REG      | Register address              | –                          | –          | Makes a logical AND link between the register value and the 16-bit accumulator content. The result is stored in the 16-bit accumulator.                                                                                                                                                                                                                                                                    |
| AND_TMP_REG  | Temporary register address    | –                          | –          | Makes a logical AND link between the temporary register value and the 16-bit accumulator content. The result is stored in the 16-bit accumulator.                                                                                                                                                                                                                                                          |
| AND_NV_REG   | Non-volatile register address | –                          | –          | Makes a logical AND link between the non-volatile register value and the 16-bit accumulator content. The result is stored in the 16-bit accumulator.                                                                                                                                                                                                                                                       |
| OR_K         | Constant value (0...65,535)   | –                          | –          | Makes a logical OR link between the constant value and the 16-bit accumulator content. The result is stored in the 16-bit accumulator.                                                                                                                                                                                                                                                                     |
| OR_REG       | Register address              | –                          | –          | Makes a logical OR link between the register value and the 16-bit accumulator content. The result is stored in the 16-bit accumulator.                                                                                                                                                                                                                                                                     |
| OR_TMP_REG   | Temporary register address    | –                          | –          | Makes a logical OR link between the temporary register value and the 16-bit accumulator content. The result is stored in the 16-bit accumulator.                                                                                                                                                                                                                                                           |
| OR_NV_REG    | Non-volatile register address | –                          | –          | Makes a logical exclusive OR link between the non-volatile register value and the 16-bit accumulator content. The result is stored in the 16-bit accumulator.                                                                                                                                                                                                                                              |
| XOR_K        | Constant value (0...65,535)   | –                          | –          | Makes a logical exclusive OR link between the constant value and the 16-bit accumulator content. The result is stored in the 16-bit accumulator.                                                                                                                                                                                                                                                           |
| XOR_REG      | Register address              | –                          | –          | Makes a logical exclusive OR link between the register value and the 16-bit accumulator content. The result is stored in the 16-bit accumulator.                                                                                                                                                                                                                                                           |

| Command                                     | Argument 1                    | Argument 2                 | Argument 3 | Description                                                                                                                                                   |
|---------------------------------------------|-------------------------------|----------------------------|------------|---------------------------------------------------------------------------------------------------------------------------------------------------------------|
| XOR_TMP_REG                                 | Temporary register address    | –                          | –          | Makes a logical exclusive OR link between the temporary register value and the 16-bit accumulator content. The result is stored in the 16-bit accumulator.    |
| XOR_NV_REG                                  | Non-volatile register address | –                          | –          | Makes a logical exclusive OR link between the non-volatile register value and the 16-bit accumulator content. The result is stored in the 16-bit accumulator. |
| ON_SET_REG                                  | Register address              | Temporary register address | –          | Stores the 16-bit accumulator content into the register defined by Argument 1 on a rising edge of the 1-bit accumulator.                                      |
| ON_SET_TMP_REG                              | Temporary register address    | Temporary register address | –          | Stores the 16-bit accumulator content into the temporary register defined by Argument 1 on a rising edge of the 1-bit accumulator.                            |
| ON_SET_NV_REG                               | Non-volatile register address | Temporary register address | –          | Stores the 16-bit accumulator content into the non-volatile register defined by Argument 1 on a rising edge of the 1-bit accumulator.                         |
| – Argument not applicable to logic command. |                               |                            |            |                                                                                                                                                               |

## Timer Logic Commands

Timers have a range from 0 to 65,535 and measure time in intervals of seconds or tenths of seconds:

- Argument 1 specifies the time period.
- Argument 2 is a calculated end time.
- Argument 3 is the timer status register.

Timer commands include:

| Command        | Argument 1                             | Argument 2                               | Argument 3                  | Description                                                                                           |
|----------------|----------------------------------------|------------------------------------------|-----------------------------|-------------------------------------------------------------------------------------------------------|
| TIMER_SEC      | Temporary register (time period)       | Temporary register (calculated end time) | Temporary register (status) | Counts in seconds the time period input in Argument 1 as described by status register bits.           |
| TIMER_TENTHS   | Temporary register (time period)       | Temporary register (calculated end time) | Temporary register (status) | Counts in tenths of seconds the time period input in Argument 1 as described by status register bits. |
| TIMER_K_SEC    | Constant value 0..65,535 (time period) | Temporary register (calculated end time) | Temporary register (status) | Counts in seconds the time period input in Argument 1 as described by status register bits.           |
| TIMER_K_TENTHS | Constant value 0..65,535 (time period) | Temporary register (calculated end time) | Temporary register (status) | Counts in tenths of seconds the time period input in Argument 1 as described by status register bits. |

## Latch Logic Commands

Latch commands include:

| Command                                     | Argument 1                     | Argument 2 | Argument 3 | Description                                                           |
|---------------------------------------------|--------------------------------|------------|------------|-----------------------------------------------------------------------|
| LATCH                                       | Temporary register (status)    | –          | –          | Records and retains in a temporary register a history of a signal.    |
| LATCH_NV                                    | Non-volatile register (status) | –          | –          | Records and retains in a non-volatile register a history of a signal. |
| – Argument not applicable to logic command. |                                |            |            |                                                                       |

## Counter Logic Commands

Counters have a range from 0 to 65,535 and transition to 0 upon counting to the maximum value of 65,535.

Counter commands include:

| Command    | Argument 1                            | Argument 2                               | Argument 3                     | Description                                                                               |
|------------|---------------------------------------|------------------------------------------|--------------------------------|-------------------------------------------------------------------------------------------|
| COUNTER    | Temporary register (counter value)    | Constant value 0...65,535 (preset value) | Temporary register (status)    | Performs a comparative count, saving both the count and status to temporary registers.    |
| COUNTER_NV | Non-volatile register (counter value) | Constant value 0...65,535 (preset value) | Non-volatile register (status) | Performs a comparative count, saving both the count and status to non-volatile registers. |

## Math Logic Commands

Math commands perform unsigned math functions using the 16-bit accumulator and temporary registers. Math commands are executed on a rising edge of the 1-bit accumulator. Math commands include:

| Command                                     | Argument 1                                 | Argument 2                                  | Argument 3                  | Description                                                         |
|---------------------------------------------|--------------------------------------------|---------------------------------------------|-----------------------------|---------------------------------------------------------------------|
| ON_ADD                                      | Temporary register (value)                 | Temporary register (status)                 | –                           | Argument 1 = Argument 1 + 16-bit accumulator.                       |
| ON_SUB                                      | Temporary register (value)                 | Temporary register (status)                 | –                           | Argument 1 = Argument 1 - 16-bit accumulator.                       |
| ON_MUL                                      | Temporary register (most significant word) | Temporary register (least significant word) | Temporary register (status) | Argument 1:Argument 2 = 16-bit accumulator x Argument 2.            |
| ON_DIV                                      | Temporary register (most significant word) | Temporary register (least significant word) | Temporary register (status) | Argument 1:Argument 2 = Argument 1:Argument 2 / 16-bit accumulator. |
| – Argument not applicable to logic command. |                                            |                                             |                             |                                                                     |

## Logic Commands

### Summary

This section describes in detail the logic commands and arguments provided by the custom logic editor.

## Program Logic Commands

### Overview

Program logic commands are used to:

- identify the logic file to the custom logic editor.
- execute a pre-defined operating mode

The following commands can be used:

- LOGIC\_ID
- CALL\_EOM
- NOP

## LOGIC\_ID

The `LOGIC_ID` statement acts as an identifier for the logic file.

`LOGIC_ID` values have an integer value range from 256 to 511.

| Arguments | Representation |
|-----------|----------------|
| 1         | LOGIC_ID ID#   |

| Input Argument | Type | Range     | Description                        |
|----------------|------|-----------|------------------------------------|
| ID#            | UINT | 256...511 | Logic ID of the customized program |

No output arguments.

## CALL\_EOM

The `CALL_EOM` executes a pre-defined operating mode in the customized program.

| Arguments | Representation    |
|-----------|-------------------|
| 1         | CALL_EOM OP_MODE# |

| Input Argument | Type | Range | Representation                                                                                                                                                                                  |
|----------------|------|-------|-------------------------------------------------------------------------------------------------------------------------------------------------------------------------------------------------|
| OP_MODE#       | INT  | 1...5 | Embedded operating mode (EOM): <ul style="list-style-type: none"> <li>• 1 = Overload</li> <li>• 2 = Independent</li> <li>• 3 = Reverser</li> <li>• 4 = 2-Step</li> <li>• 5 = 2-Speed</li> </ul> |

No output arguments.

## NOP

The `NOP` command performs no operation.

Use the `NOP` command as a placeholder in a logic file to replace a pre-existing command, or to reserve space for a future command.

| Arguments | Representation |
|-----------|----------------|
| 0         | NOP            |

The `NOP` command has no arguments.

## Boolean Logic Commands

### Overview

The custom logic editor uses the following boolean logic commands:

- `LOAD_K_BIT`
- `LOAD_BIT`
- `LOAD_TMP_BIT`
- `LOAD_NV_BIT`

- LOAD\_NOT\_BIT
- LOAD\_NOT\_TMP\_BIT
- LOAD\_NOT\_NV\_BIT
- AND\_BIT
- AND\_TMP\_BIT
- AND\_NV\_BIT
- AND\_NOT\_BIT
- AND\_NOT\_TMP\_BIT
- AND\_NOT\_NV\_BIT
- OR\_BIT
- OR\_TMP\_BIT
- OR\_NV\_BIT
- OR\_NOT\_BIT
- OR\_NOT\_TMP\_BIT
- OR\_NOT\_NV\_BIT
- SET\_BIT
- SET\_TMP\_BIT
- SET\_NV\_BIT
- SET\_NOT\_BIT
- SET\_NOT\_TMP\_BIT
- SET\_NOT\_NV\_BIT

## LOAD\_K\_BIT

The `LOAD_K_BIT` command loads a constant Boolean value (0 or 1) into the 1-bit accumulator.

| Arguments | Representation                 |
|-----------|--------------------------------|
| 1         | <code>LOAD_K_BIT KValue</code> |

| Input Argument | Type | Range | Description      |
|----------------|------|-------|------------------|
| KValue         | BOOL | 0/1   | A constant value |

No output arguments.

## LOAD\_BIT

The `LOAD_BIT` command loads the Boolean value (0 or 1) of a register bit into the 1-bit accumulator.

| Arguments | Representation                      |
|-----------|-------------------------------------|
| 2         | <code>LOAD_BIT RegAddr BitNo</code> |

| Input Argument | Type | Range    | Description          |
|----------------|------|----------|----------------------|
| RegAddr        | UINT | 0...1399 | The register address |
| BitNo          | UINT | 0...15   | The bit number       |

No output arguments.

## LOAD\_TMP\_BIT

The `LOAD_TMP_BIT` command loads the Boolean value (0 or 1) of a temporary register bit into the 1-bit accumulator.

| Arguments | Representation                         |
|-----------|----------------------------------------|
| 2         | <code>LOAD_TMP_BIT TmpReg BitNo</code> |

| Input Argument      | Type | Range   | Description                   |
|---------------------|------|---------|-------------------------------|
| <code>TmpReg</code> | UINT | 0...299 | The temporary register number |
| <code>BitNo</code>  | UINT | 0...15  | The bit number                |

No output arguments.

## LOAD\_NV\_BIT

The `LOAD_NV_BIT` command loads the Boolean value (0 or 1) of a non-volatile register bit into the 1-bit accumulator.

| Arguments | Representation                       |
|-----------|--------------------------------------|
| 2         | <code>LOAD_NV_BIT NVReg BitNo</code> |

| Input Argument     | Type | Range  | Description                      |
|--------------------|------|--------|----------------------------------|
| <code>NVReg</code> | UINT | 0...63 | The non-volatile register number |
| <code>BitNo</code> | UINT | 0...15 | The bit number                   |

No output arguments.

## LOAD\_NOT\_BIT

The `LOAD_NOT_BIT` command:

- inverts the Boolean value (0 or 1) of a specified register bit, then
- loads the inverted value into the 1-bit accumulator.

| Arguments | Representation                          |
|-----------|-----------------------------------------|
| 2         | <code>LOAD_NOT_BIT RegAddr BitNo</code> |

| Input Argument       | Type | Range    | Description          |
|----------------------|------|----------|----------------------|
| <code>RegAddr</code> | UINT | 0...1399 | The register address |
| <code>BitNo</code>   | UINT | 0...15   | The bit number       |

No output arguments.

## LOAD\_NOT\_TMP\_BIT

The `LOAD_NOT_TMP_BIT` command:

- Inverts the Boolean value (0 or 1) of a specified temporary register bit, then
- Loads the inverted value into the 1-bit accumulator.

| Arguments | Representation                             |
|-----------|--------------------------------------------|
| 2         | <code>LOAD_NOT_TMP_BIT TmpReg BitNo</code> |

| Input Argument | Type | Range   | Description                   |
|----------------|------|---------|-------------------------------|
| TmpReg         | UINT | 0...299 | The temporary register number |
| BitNo          | UINT | 0...15  | The bit number                |

No output arguments.

## LOAD\_NOT\_NV\_BIT

The `LOAD_NOT_NV_BIT` command:

- Inverts the Boolean value (0 or 1) of a selected non-volatile register bit, then
- Loads the inverted value into the 1-bit accumulator.

| Arguments | Representation              |
|-----------|-----------------------------|
| 2         | LOAD_NOT_NV_BIT NVReg BitNo |

| Input Argument | Type | Range  | Description                      |
|----------------|------|--------|----------------------------------|
| NVReg          | UINT | 0..63  | The non-volatile register number |
| BitNo          | UINT | 0...15 | The bit number                   |

No output arguments.

## AND\_BIT

The `AND_BIT` command makes a logical `AND` link between a register bit value and the accumulator content in logic memory:

- If the 1-bit accumulator equals 1 and the linked register bit equals 1, the result of the `AND` process is also 1.
- In all other cases the result of the `AND` process is 0.

The result is saved in the 1-bit accumulator.

| Arguments | Representation        |
|-----------|-----------------------|
| 2         | AND_BIT RegAddr BitNo |

| Input Argument | Type | Range    | Description          |
|----------------|------|----------|----------------------|
| RegAddr        | UINT | 0...1399 | The register address |
| BitNo          | UINT | 0...15   | The bit number       |

No output arguments.

## AND\_TMP\_BIT

The `AND_TMP_BIT` command makes a logical `AND` link between a temporary register bit value and the accumulator content in logic memory.

- If the 1-bit accumulator equals 1 and the linked temporary register bit equals 1, the result of the `AND` process is also 1.
- In all other cases the result of the `AND` process is 0.

The result is saved in the 1-bit accumulator.

| Arguments | Representation           |
|-----------|--------------------------|
| 2         | AND_TMP_BIT TmpReg BitNo |

| Input Argument | Type | Range   | Description                   |
|----------------|------|---------|-------------------------------|
| TmpReg         | UINT | 0...299 | The temporary register number |
| BitNo          | UINT | 0...15  | The bit number                |

No output arguments.

## AND\_NV\_BIT

The `AND_NV_BIT` command makes a logical `AND` link between a non-volatile register bit value and the accumulator content in logic memory.

- If the 1-bit accumulator equals 1 and the linked non-volatile register bit equals 1, the result of the `AND` process is also 1.
- In all other cases the result of the `AND` process is 0.

The result is saved in the 1-bit accumulator.

| Arguments | Representation                      |
|-----------|-------------------------------------|
| 2         | <code>AND_NV_BIT NVReg BitNo</code> |

| Input Argument | Type | Range  | Description                      |
|----------------|------|--------|----------------------------------|
| NVReg          | UINT | 0...63 | The non-volatile register number |
| BitNo          | UINT | 0...15 | The bit number                   |

No output arguments.

## AND\_NOT\_BIT

The `AND_NOT_BIT` command inverts the Boolean value (0 or 1) of a specified register bit, then makes a logical `AND` link between it and the accumulator content in logic memory:

- If the 1-bit accumulator equals 1 and the linked register bit equals 0, the result of the `AND` process is also 1.
- In all other cases the result of the `AND` process is 0.

The result is saved in the 1-bit accumulator.

| Arguments | Representation                         |
|-----------|----------------------------------------|
| 2         | <code>AND_NOT_BIT RegAddr BitNo</code> |

| Input Argument | Type | Range    | Description          |
|----------------|------|----------|----------------------|
| RegAddr        | UINT | 0...1399 | The register address |
| BitNo          | UINT | 0...15   | The bit number       |

No output arguments.

## AND\_NOT\_TMP\_BIT

The `AND_NOT_TMP_BIT` command inverts the Boolean value (0 or 1) of a specified temporary register bit, then makes a logical `AND` link between it and the accumulator content in logic memory:

- If the 1-bit accumulator equals 1 and the linked temporary register bit equals 0, the result of the `AND` process is also 1.
- In all other cases the result of the `AND` process is 0.

The result is saved in the 1-bit accumulator.

| Arguments | Representation               |
|-----------|------------------------------|
| 2         | AND_NOT_TMP_BIT TmpReg BitNo |

| Input Argument | Type | Range  | Description                   |
|----------------|------|--------|-------------------------------|
| TmpReg         | UINT | 0..299 | The temporary register number |
| BitNo          | UINT | 0..15  | The bit number                |

No output arguments.

## AND\_NOT\_NV\_BIT

The `AND_NOT_NV_BIT` command inverts the Boolean value (0 or 1) of a selected non-volatile register bit, then makes a logical `AND` link between it and the accumulator content in logic memory:

- If the 1-bit accumulator equals 1 and the linked non-volatile register bit equals 0, the result of the `AND` process is also 1.
- In all other cases the result of the `AND` process is 0.

The result is saved in the 1-bit accumulator.

| Arguments | Representation             |
|-----------|----------------------------|
| 2         | AND_NOT_NV_BIT NVReg BitNo |

| Input Argument | Type | Range | Description                      |
|----------------|------|-------|----------------------------------|
| NVReg          | UINT | 0..63 | The non-volatile register number |
| BitNo          | UINT | 0..15 | The bit number                   |

No output arguments.

## OR\_BIT

The `OR_BIT` command makes a logical `OR` link between a register bit value and the accumulator content in logic memory:

- If the value of either the 1-bit accumulator or the register bit equals 1, the result of the `OR` process is also 1.
- If the values of all compared bits equal 0, the result of the `OR` process is 0.

The result is saved in the 1-bit accumulator.

| Arguments | Representation       |
|-----------|----------------------|
| 2         | OR_BIT RegAddr BitNo |

| Input Argument | Type | Range   | Description          |
|----------------|------|---------|----------------------|
| RegAddr        | UINT | 0..1399 | The register address |
| BitNo          | UINT | 0..15   | The bit number       |

No output arguments.

## OR\_TMP\_BIT

The `OR_TMP_BIT` command makes a logical OR link between a temporary register bit value and the accumulator content in logic memory.

- If the value of either the 1-bit accumulator or the temporary register bit equals 1, the result of the OR process is also 1.
- If the values of all compared bits equal 0, the result of the OR process is 0.

The result is saved in the 1-bit accumulator.

| Arguments | Representation          |
|-----------|-------------------------|
| 2         | OR_TMP_BIT TmpReg BitNo |

| Input Argument | Type | Range   | Description                   |
|----------------|------|---------|-------------------------------|
| TmpReg         | UINT | 0...299 | The temporary register number |
| BitNo          | UINT | 0...15  | The bit number                |

No output arguments.

## OR\_NV\_BIT

The `OR_NV_BIT` command makes a logical OR link between a non-volatile register bit value and the accumulator content in logic memory.

- If the value of either the 1-bit accumulator or the non-volatile register bit equals 1, the result of the OR process is also 1.
- If the values of all compared bits equal 0, the result of the OR process is 0.

The result is saved in the 1-bit accumulator.

| Arguments | Representation        |
|-----------|-----------------------|
| 2         | OR_NV_BIT NVReg BitNo |

| Input Argument | Type | Range  | Description                      |
|----------------|------|--------|----------------------------------|
| NVReg          | UINT | 0...63 | The non-volatile register number |
| BitNo          | UINT | 0...15 | The bit number                   |

No output arguments.

## OR\_NOT\_BIT

The `OR_NOT_BIT` command inverts the Boolean value (0 or 1) of a specified register bit, then makes a logical OR link between it and the accumulator content in logic memory:

- If the value of either the 1-bit accumulator or the register bit equals 0, the result of the OR process is also 1.
- If the values of all compared bits equal 0, the result of the OR process is 0.

The result is saved in the 1-bit accumulator.

| Arguments | Representation           |
|-----------|--------------------------|
| 2         | OR_NOT_BIT RegAddr BitNo |

| Input Argument | Type | Range    | Description          |
|----------------|------|----------|----------------------|
| RegAddr        | UINT | 0...1399 | The register address |
| BitNo          | UINT | 0...15   | The bit number       |

No output arguments.

## OR\_NOT\_TMP\_BIT

The `OR_NOT_TMP_BIT` command inverts the Boolean value (0 or 1) of a specified temporary register bit, then makes a logical `OR` link between it and the accumulator content in logic memory:

- If the value of either the 1-bit accumulator or the temporary register bit equals 0, the result of the `OR` process is also 1.
- If the values of all compared bits equal 0, the result of the `OR` process is 0.

The result is saved in the 1-bit accumulator.

| Arguments | Representation                           |
|-----------|------------------------------------------|
| 2         | <code>OR_NOT_TMP_BIT TmpReg BitNo</code> |

| Input Argument | Type | Range   | Description                   |
|----------------|------|---------|-------------------------------|
| TmpReg         | UINT | 0...299 | The temporary register number |
| BitNo          | UINT | 0...15  | The bit number                |

No output arguments.

## OR\_NOT\_NV\_BIT

The `OR_NOT_NV_BIT` command inverts the Boolean value (0 or 1) of a selected non-volatile register bit, then makes a logical `OR` link between it and the accumulator content in logic memory:

- If the value of either the 1-bit accumulator or the non-volatile register bit equals 0, the result of the `OR` process is also 1.
- If the values of all compared bits equal 0, the result of the `OR` process is 0.

The result is saved in the 1-bit accumulator.

| Arguments | Representation                         |
|-----------|----------------------------------------|
| 2         | <code>OR_NOT_NV_BIT NVReg BitNo</code> |

| Input Argument | Type | Range  | Description                      |
|----------------|------|--------|----------------------------------|
| NVReg          | UINT | 0..63  | The non-volatile register number |
| BitNo          | UINT | 0...15 | The bit number                   |

No output arguments.

## SET\_BIT

The `SET_BIT` command sets the value of the 1-bit accumulator to a specified register bit.

| Arguments | Representation                     |
|-----------|------------------------------------|
| 2         | <code>SET_BIT RegAddr BitNo</code> |

No input arguments.

| Output Argument | Type | Range    | Description                                               |
|-----------------|------|----------|-----------------------------------------------------------|
| RegAddr         | UINT | 0...1399 | The address of the specified register                     |
| BitNo           | UINT | 0...15   | The number of the bit to be set in the specified register |

## SET\_TMP\_BIT

The SET\_TMP\_BIT command sets the value of the 1-bit accumulator to a specified temporary register bit.

| Arguments | Representation           |
|-----------|--------------------------|
| 2         | SET_TMP_BIT TmpReg BitNo |

No input arguments.

| Output Argument | Type | Range   | Description                                                         |
|-----------------|------|---------|---------------------------------------------------------------------|
| TmpReg          | UINT | 0...299 | The address of the specified temporary register                     |
| BitNo           | UINT | 0...15  | The number of the bit to be set in the specified temporary register |

## SET\_NV\_BIT

The SET\_NV\_BIT command sets the value of the 1-bit accumulator to a specified non-volatile register bit.

| Arguments | Representation         |
|-----------|------------------------|
| 2         | SET_NV_BIT NVReg BitNo |

No input arguments.

| Output Argument | Type | Range  | Description                                                            |
|-----------------|------|--------|------------------------------------------------------------------------|
| NVReg           | UINT | 0...63 | The address of the specified non-volatile register                     |
| BitNo           | UINT | 0...15 | The number of the bit to be set in the specified non-volatile register |

## SET\_NOT\_BIT

The SET\_NOT\_BIT command sets the inverted value of the 1-bit accumulator to a specified register bit.

| Arguments | Representation            |
|-----------|---------------------------|
| 2         | SET_NOT_BIT RegAddr BitNo |

No input arguments.

| Output Argument | Type | Range    | Description                                               |
|-----------------|------|----------|-----------------------------------------------------------|
| RegAddr         | UINT | 0...1399 | The address of the specified register                     |
| BitNo           | UINT | 0...15   | The number of the bit to be set in the specified register |

## SET\_NOT\_TMP\_BIT

The `SET_NOT_TMP_BIT` command sets the inverted value of the 1-bit accumulator to a specified temporary register bit.

| Arguments | Representation                            |
|-----------|-------------------------------------------|
| 2         | <code>SET_NOT_TMP_BIT TmpReg BitNo</code> |

No input arguments.

| Output Argument     | Type | Range  | Description                                                         |
|---------------------|------|--------|---------------------------------------------------------------------|
| <code>TmpReg</code> | UINT | 0..299 | The address of the specified temporary register                     |
| <code>BitNo</code>  | UINT | 0..15  | The number of the bit to be set in the specified temporary register |

## SET\_NOT\_NV\_BIT

The `SET_NOT_NV_BIT` command sets the inverted value of the 1-bit accumulator to a specified non-volatile register bit.

| Arguments | Representation                          |
|-----------|-----------------------------------------|
| 2         | <code>SET_NOT_NV_BIT NVReg BitNo</code> |

No input arguments.

| Output Arguments   | Type | Range | Description                                                            |
|--------------------|------|-------|------------------------------------------------------------------------|
| <code>NVReg</code> | UINT | 0..63 | The address of the specified non-volatile register                     |
| <code>BitNo</code> | UINT | 0..15 | The number of the bit to be set in the specified non-volatile register |

## Register Logic Commands

### Overview

Register commands evaluate and control 16-bit values.

The custom logic editor uses the following register commands:

- `LOAD_K_REG`
- `LOAD_REG`
- `LOAD_TMP_REG`
- `LOAD_NV_REG`
- `COMP_K_REG`
- `COMP_REG`
- `COMP_TMP_REG`
- `COMP_NV_REG`
- `AND_K`
- `AND_REG`
- `AND_TMP_REG`
- `AND_NV_REG`
- `OR_K`
- `OR_REG`

- OR\_TMP\_REG
- OR\_NV\_REG
- XOR\_K
- XOR\_REG
- XOR\_TMP\_REG
- XOR\_NV\_REG
- ON\_SET\_REG
- ON\_SET\_TMP\_REG
- ON\_SET\_NV\_REG

## LOAD\_K\_REG

The `LOAD_K_REG` command loads a 16-bit constant value into the 16-bit accumulator in logic memory.

| Arguments | Representation    |
|-----------|-------------------|
| 1         | LOAD_K_REG KValue |

| Input Argument | Type | Range      | Description      |
|----------------|------|------------|------------------|
| KValue         | UINT | 0...65,535 | A constant value |

No output arguments.

## LOAD\_REG

The `LOAD_REG` command loads a copy of a register into the 16-bit accumulator in logic memory.

| Arguments | Representation   |
|-----------|------------------|
| 1         | LOAD_REG RegAddr |

| Input Argument | Type | Range    | Description          |
|----------------|------|----------|----------------------|
| RegAddr        | UINT | 0...1399 | The register address |

No output arguments.

## LOAD\_TMP\_REG

The `LOAD_TMP_REG` command loads a copy of a temporary register into the 16-bit accumulator in logic memory.

| Arguments | Representation      |
|-----------|---------------------|
| 1         | LOAD_TMP_REG TmpReg |

| Input Argument | Type | Range   | Description                   |
|----------------|------|---------|-------------------------------|
| TmpReg         | UINT | 0...299 | The temporary register number |

No output arguments.

## LOAD\_NV\_REG

The `LOAD_NV_REG` command loads a copy of a non-volatile register into the 16-bit accumulator in logic memory.

| Arguments | Representation    |
|-----------|-------------------|
| 1         | LOAD_NV_REG NVReg |

| Input Argument | Type | Range | Description                      |
|----------------|------|-------|----------------------------------|
| NVReg          | UINT | 0..63 | The non-volatile register number |

No output arguments.

## COMP\_K\_REG

The `COMP_K_REG` command compares the 16-bit accumulator content to the Argument 1 constant value and sets the result of the comparison in one bit of the Argument 2 temporary register.

| Arguments | Representation           |
|-----------|--------------------------|
| 2         | COMP_K_REG KValue TmpReg |

| Input Argument | Type | Range/Bit | Description      |
|----------------|------|-----------|------------------|
| KValue         | UINT | 0..65,535 | A constant value |

| Output Argument | Type | Range/Bit | Description                 |
|-----------------|------|-----------|-----------------------------|
| TmpReg          | UINT | Bit1      | 16-bit accumulator < KValue |
|                 |      | Bit2      | 16-bit accumulator = KValue |
|                 |      | Bit3      | 16-bit accumulator > KValue |

## COMP\_REG

The `COMP_REG` command compares the 16-bit accumulator content to the content of the register defined by Argument 1 and sets the result of the comparison in one bit of the Argument 2 temporary register.

| Arguments | Representation          |
|-----------|-------------------------|
| 2         | COMP_REG RegAddr TmpReg |

| Input Argument | Type | Range/Bit | Description          |
|----------------|------|-----------|----------------------|
| RegAddr        | UINT | 0..1399   | The register address |

| Output Argument | Type | Range/Bit | Description                  |
|-----------------|------|-----------|------------------------------|
| TmpReg          | UINT | Bit1      | 16-bit accumulator < RegAddr |
|                 |      | Bit2      | 16-bit accumulator = RegAddr |
|                 |      | Bit3      | 16-bit accumulator > RegAddr |

## COMP\_TMP\_REG

The COMP\_TMP\_REG command compares the 16-bit accumulator content to the content of the temporary register defined by Argument 1 and sets the result of the comparison in one bit of the Argument 2 temporary register.

| Arguments | Representation               |
|-----------|------------------------------|
| 2         | COMP_TMP_REG TmpReg1 TmpReg2 |

| Input Argument | Type | Range/Bit | Description               |
|----------------|------|-----------|---------------------------|
| TmpReg1        | UINT | 0...299   | Temporary register number |

| Output Argument | Type | Range/Bit | Description                  |
|-----------------|------|-----------|------------------------------|
| TmpReg2         | UINT | Bit1      | 16-bit accumulator < TmpReg1 |
|                 |      | Bit2      | 16-bit accumulator = TmpReg1 |
|                 |      | Bit3      | 16-bit accumulator > TmpReg1 |

## COMP\_NV\_REG

The COMP\_NV\_REG command compares the 16-bit accumulator content to the content of the non-volatile register defined by Argument 1 and sets the result of the comparison in one bit of the Argument 2 temporary register.

| Arguments | Representation           |
|-----------|--------------------------|
| 2         | COMP_NV_REG NVReg TmpReg |

| Input Argument | Type | Range/Bit | Description                  |
|----------------|------|-----------|------------------------------|
| NVReg          | UINT | 0...63    | Non-volatile register number |

| Output Argument | Type | Range/Bit | Description                |
|-----------------|------|-----------|----------------------------|
| TmpReg          | UINT | Bit1      | 16-bit accumulator < NVReg |
|                 |      | Bit2      | 16-bit accumulator = NVReg |
|                 |      | Bit3      | 16-bit accumulator > NVReg |

## AND\_K

The AND\_K command makes a logical AND link between a 16-bit constant value and the 16-bit accumulator content in logic memory. The result is saved in the 16-bit accumulator.

The AND process compares each bit in the 16-bit accumulator with the corresponding bit in the linked 16-bit constant value:

- If both bits equal 1, the result of the AND process for that bit number is also 1.
- In all other cases the result of the AND process for that bit number is 0.

| Arguments | Representation |
|-----------|----------------|
| 1         | AND_K KValue   |

| Input Argument | Type | Range      | Description      |
|----------------|------|------------|------------------|
| KValue         | UINT | 0...65,535 | A constant value |

No output arguments.

## AND\_REG

The `AND_REG` command makes a logical `AND` link between the register value and the 16-bit accumulator content in logic memory. The result is saved in the 16-bit accumulator.

The `AND` process compares each bit in the 16-bit accumulator with the corresponding bit in the linked register:

- If both bits equal 1, the result of the `AND` process for that bit number is also 1.
- In all other cases the result of the `AND` process for that bit number is 0.

| Arguments | Representation               |
|-----------|------------------------------|
| 1         | <code>AND_REG RegAddr</code> |

| Input Argument | Type | Range    | Description          |
|----------------|------|----------|----------------------|
| RegAddr        | UINT | 0...1399 | The register address |

No output arguments.

## AND\_TMP\_REG

The `AND_TMP_REG` command makes a logical `AND` link between the temporary register value and the 16-bit accumulator content in logic memory. The result is saved in the 16-bit accumulator.

The `AND` process compares each bit in the 16-bit accumulator with the corresponding bit in the linked temporary register:

- If both bits equal 1, the result of the `AND` process for that bit number is also 1.
- In all other cases the result of the `AND` process for that bit number is 0.

| Arguments | Representation                  |
|-----------|---------------------------------|
| 1         | <code>AND_TMP_REG TmpReg</code> |

| Input Argument | Type | Range   | Description                   |
|----------------|------|---------|-------------------------------|
| TmpReg         | UINT | 0...299 | The temporary register number |

No output arguments.

## AND\_NV\_REG

The `AND_NV_REG` command makes a logical `AND` link between the non-volatile register value and the 16-bit accumulator content in logic memory. The result is saved in the 16-bit accumulator.

The `AND` process compares each bit in the 16-bit accumulator with the corresponding bit in the linked non-volatile register:

- If both bits equal 1, the result of the `AND` process for that bit number is also 1.
- In all other cases the result of the `AND` process for that bit number is 0.

| Arguments | Representation   |
|-----------|------------------|
| 1         | AND_NV_REG NVReg |

| Input Argument | Type | Range  | Description                      |
|----------------|------|--------|----------------------------------|
| NVReg          | UINT | 0...63 | The non-volatile register number |

No output arguments.

## OR\_K

The `OR_K` command makes a logical `OR` link between a 16-bit constant value and the 16-bit accumulator content in logic memory. The result is saved in the 16-bit accumulator.

The `OR` process compares each bit in the 16-bit accumulator with the corresponding bit in the linked 16-bit constant value:

- If any compared bit equals 1, the result of the `OR` process for that bit number is also 1.
- If all compared bits equal 0, the result of the `OR` process for that bit number is 0.

| Arguments | Representation |
|-----------|----------------|
| 1         | OR_K KValue    |

| Input Argument | Type | Range      | Description      |
|----------------|------|------------|------------------|
| KValue         | UINT | 0...65,535 | A constant value |

No output arguments.

## OR\_REG

The `OR_REG` command makes a logical `OR` link between the register value and the 16-bit accumulator content in logic memory. The result is saved in the 16-bit accumulator.

The `OR` process compares each bit in the 16-bit accumulator with the corresponding bit in the linked register:

- If any compared bit equals 1, the result of the `OR` process for that bit number is also 1.
- If all compared bits equal 0, the result of the `OR` process for that bit number is 0.

| Arguments | Representation |
|-----------|----------------|
| 1         | OR_REG RegAddr |

| Input Argument | Type | Range    | Description          |
|----------------|------|----------|----------------------|
| RegAddr        | UINT | 0...1399 | The register address |

No output arguments.

## OR\_TMP\_REG

The `OR_TMP_REG` command makes a logical OR link between the temporary register value and the 16-bit accumulator content in logic memory. The result is saved in the 16-bit accumulator.

The OR process compares each bit in the 16-bit accumulator with the corresponding bit in the linked temporary register:

- If any compared bit equals 1, the result of the OR process for that bit number is also 1.
- If all compared bits equal 0, the result of the OR process for that bit number is 0.

| Arguments | Representation    |
|-----------|-------------------|
| 1         | OR_TMP_REG TmpReg |

| Input Argument | Type | Range   | Description                   |
|----------------|------|---------|-------------------------------|
| TmpReg         | UINT | 0...299 | The temporary register number |

No output arguments.

## OR\_NV\_REG

The `OR_NV_REG` command makes a logical OR link between the non-volatile register value and the 16-bit accumulator content in logic memory. The result is saved in the 16-bit accumulator.

The OR process compares each bit in the 16-bit accumulator with the corresponding bit in the linked non-volatile register:

- If any compared bit equals 1, the result of the OR process for that bit number is also 1.
- If all compared bits equal 0, the result of the OR process for that bit number is 0.

| Arguments | Representation  |
|-----------|-----------------|
| 1         | OR_NV_REG NVReg |

| Input Argument | Type | Range | Description                      |
|----------------|------|-------|----------------------------------|
| NVReg          | UINT | 0..63 | The non-volatile register number |

No output arguments.

## XOR\_K

The `XOR_K` command makes a logical exclusive OR link between a 16-bit constant value and the 16-bit accumulator content in logic memory. The result is saved in the 16-bit accumulator.

The XOR process compares each bit in the 16-bit accumulator with the corresponding bit in the linked 16-bit constant value and yields these results:

- If one bit equals 1 and the other equals 0, the result of the XOR process is 1.
- In all other cases, the result of the XOR process is 0.

| Arguments | Representation |
|-----------|----------------|
| 1         | XOR_K KValue   |

| Input Argument | Type | Range      | Description      |
|----------------|------|------------|------------------|
| KValue         | UINT | 0...65,535 | A constant value |

No output arguments.

## XOR\_REG

The `XOR_REG` command makes a logical exclusive OR link between the register value and the 16-bit accumulator content in logic memory. The result is saved in the 16-bit accumulator.

The `XOR` process compares each bit in the 16-bit accumulator with the corresponding bit in the linked register and yields these results:

- If one bit equals 1 and the other equals 0, the result of the `XOR` process is 1.
- In all other cases, the result of the `XOR` process is 0.

| Arguments | Representation               |
|-----------|------------------------------|
| 1         | <code>XOR_REG RegAddr</code> |

| Input Argument | Type | Range    | Description          |
|----------------|------|----------|----------------------|
| RegAddr        | UINT | 0...1399 | The register address |

No output arguments.

## XOR\_TMP\_REG

The `XOR_TMP_REG` command makes a logical exclusive OR link between the temporary register value and the 16-bit accumulator content in logic memory. The result is saved in the 16-bit accumulator.

The `XOR` process compares each bit in the 16-bit accumulator with the corresponding bit in the linked temporary register and yields these results:

- If one bit equals 1 and the other equals 0, the result of the `XOR` process is 1.
- In all other cases, the result of the `XOR` process is 0.

| Arguments | Representation                  |
|-----------|---------------------------------|
| 1         | <code>XOR_TMP_REG TmpReg</code> |

| Input Argument | Type | Range   | Description                   |
|----------------|------|---------|-------------------------------|
| TmpReg         | UINT | 0...299 | The temporary register number |

No output arguments.

## XOR\_NV\_REG

The `XOR_NV_REG` command makes a logical exclusive OR link between the non-volatile register value and the 16-bit accumulator content in logic memory. The result is saved in the 16-bit accumulator.

The `XOR` process compares each bit in the 16-bit accumulator with the corresponding bit in the linked non-volatile register and yields these results:

- If one bit equals 1 and the other equals 0, the result of the `XOR` process is 1.
- In all other cases, the result of the `XOR` process is 0.

| Arguments | Representation   |
|-----------|------------------|
| 1         | XOR_NV_REG NVReg |

| Input Argument | Type | Range  | Description                      |
|----------------|------|--------|----------------------------------|
| NVReg          | UINT | 0...63 | The non-volatile register number |

No output arguments.

## ON\_SET\_REG

The ON\_SET\_REG command copies the value of the 16-bit accumulator to a specified register on a rising edge of the 1-bit accumulator.

| Arguments | Representation            |
|-----------|---------------------------|
| 2         | ON_SET_REG RegAddr TmpReg |

No input argument.

| Output Argument | Type | Range/Bit | Description                           |
|-----------------|------|-----------|---------------------------------------|
| RegAddr         | UINT | 0...1399  | The address of the register to be set |
| TmpReg          | UINT | Bit3      | 1-bit accumulator history bit         |

## ON\_SET\_TMP\_REG

The ON\_SET\_TMP\_REG command copies the value of the 16-bit accumulator to a specified temporary register on a rising edge of the 1-bit accumulator.

| Arguments | Representation                 |
|-----------|--------------------------------|
| 2         | ON_SET_TMP_REG TmpReg1 TmpReg2 |

No input argument.

| Output Argument | Type | Range/Bit | Description                                     |
|-----------------|------|-----------|-------------------------------------------------|
| TmpReg1         | UINT | 0...299   | The address of the temporary register to be set |
| TmpReg2         | UINT | Bit3      | 1-bit accumulator history bit                   |

## ON\_SET\_NV\_REG

The ON\_SET\_NV\_REG command copies the value of the 16-bit accumulator to a specified non-volatile register on a rising edge of the 1-bit accumulator.

| Arguments | Representation              |
|-----------|-----------------------------|
| 1         | ON_SET_NV_REG NVReg1 NVReg2 |

No input argument.

| Output Argument | Type | Range/Bit | Description                                        |
|-----------------|------|-----------|----------------------------------------------------|
| NVReg1          | UINT | 0...63    | The address of the non-volatile register to be set |
| NVReg2          | UINT | Bit3      | 1-bit accumulator history bit                      |

## Timer Logic Commands

### Overview

The custom logic editor uses the following timer commands:

- `TIMER_SEC`
- `TIMER_TENTHS`
- `TIMER_K_SEC`
- `TIMER_K_TENTHS`

### TIMER\_SEC

The `TIMER_SEC` command:

- Counts time in seconds, up to the number of counts specified by a temporary register
- Calculates the end time in a second temporary register
- Enabled by, and reports its counting status to, a third temporary register

| Arguments | Representation                                 |
|-----------|------------------------------------------------|
| 3         | <code>TIMER_SEC TmpReg1 TmpReg2 TmpReg3</code> |

| Input Argument       | Type | Range/Bit  | Description                                                                                                                        |
|----------------------|------|------------|------------------------------------------------------------------------------------------------------------------------------------|
| <code>TmpReg1</code> | UINT | 0...65,535 | Timer preset value                                                                                                                 |
| <code>TmpReg3</code> | UINT | Bit0       | <ul style="list-style-type: none"> <li>• Starts the timer on a rising edge</li> <li>• Stops the timer on a falling edge</li> </ul> |

| Output Argument      | Type | Range/Bit  | Description                                                                                                                                                                                                                                                                 |
|----------------------|------|------------|-----------------------------------------------------------------------------------------------------------------------------------------------------------------------------------------------------------------------------------------------------------------------------|
| <code>TmpReg2</code> | UINT | 0...65,535 | Calculated end time                                                                                                                                                                                                                                                         |
| <code>TmpReg3</code> | UINT | Bit1       | Timer done: <ul style="list-style-type: none"> <li>• bit set when timer reaches <code>TmpReg2</code></li> <li>• bit reset when:               <ul style="list-style-type: none"> <li>◦ <code>TmpReg3.Bit0</code> is reset</li> <li>◦ power is cycled</li> </ul> </li> </ul> |
|                      |      | Bit2       | Timer execution in progress<br>Bit reset when timer reaches <code>TmpReg2</code>                                                                                                                                                                                            |
|                      |      | Bit3       | <code>TmpReg3.Bit0</code> history bit                                                                                                                                                                                                                                       |
|                      |      | Bit4       | Reserved                                                                                                                                                                                                                                                                    |

### TIMER\_TENTHS

The `TIMER_TENTHS` command:

- Counts time in tenths of seconds, up to the number of counts specified by a temporary register
- Calculates the end time in a second temporary register
- Enabled by, and reports its counting status to, a third temporary register

| Arguments | Representation                                    |
|-----------|---------------------------------------------------|
| 3         | <code>TIMER_TENTHS TmpReg1 TmpReg2 TmpReg3</code> |

| Input Argument | Type | Range/Bit | Description                                                                                                                    |
|----------------|------|-----------|--------------------------------------------------------------------------------------------------------------------------------|
| TmpReg1        | UINT | 0..65,535 | Timer preset value                                                                                                             |
| TmpReg3        | UINT | Bit0      | <ul style="list-style-type: none"> <li>Starts the timer on a rising edge</li> <li>Stops the timer on a falling edge</li> </ul> |

| Output Argument | Type | Range/Bit | Description                                                                                                                                                                                                                               |
|-----------------|------|-----------|-------------------------------------------------------------------------------------------------------------------------------------------------------------------------------------------------------------------------------------------|
| TmpReg2         | UINT | 0..65,535 | Calculated end time                                                                                                                                                                                                                       |
| TmpReg3         | UINT | Bit1      | Timer done: <ul style="list-style-type: none"> <li>bit set when timer reaches TmpReg2</li> <li>bit reset when:               <ul style="list-style-type: none"> <li>TmpReg3.Bit0 is reset</li> <li>power is cycled</li> </ul> </li> </ul> |
|                 |      | Bit2      | Timer execution in progress<br>Bit reset when timer reaches TmpReg2                                                                                                                                                                       |
|                 |      | Bit3      | TmpReg3.Bit0 history bit                                                                                                                                                                                                                  |
|                 |      | Bit4      | Reserved                                                                                                                                                                                                                                  |

## TIMER\_K\_SEC

The `TIMER_K_SEC` command:

- Counts time in seconds, up to the number of counts specified by a constant value
- Calculates the end time in a temporary register
- Enabled by, and reports its counting status to, a second temporary register

| Arguments | Representation                                  |
|-----------|-------------------------------------------------|
| 3         | <code>TIMER_K_SEC KValue TmpReg1 TmpReg2</code> |

| Input Argument | Type | Range/Bit | Description                                                                                                                    |
|----------------|------|-----------|--------------------------------------------------------------------------------------------------------------------------------|
| KValue         | UINT | 0..65,535 | Timer preset value                                                                                                             |
| TmpReg2        | UINT | Bit0      | <ul style="list-style-type: none"> <li>Starts the timer on a rising edge</li> <li>Stops the timer on a falling edge</li> </ul> |

| Output Argument | Type | Range/Bit | Description                                                                                                                                                                                                                               |
|-----------------|------|-----------|-------------------------------------------------------------------------------------------------------------------------------------------------------------------------------------------------------------------------------------------|
| TmpReg1         | UINT | 0..65,535 | Calculated end time                                                                                                                                                                                                                       |
| TmpReg2         | UINT | Bit1      | Timer done: <ul style="list-style-type: none"> <li>bit set when timer reaches TmpReg1</li> <li>bit reset when:               <ul style="list-style-type: none"> <li>TmpReg2.Bit0 is reset</li> <li>power is cycled</li> </ul> </li> </ul> |
|                 |      | Bit2      | Timer execution in progress<br>Bit reset when timer reaches TmpReg1                                                                                                                                                                       |
|                 |      | Bit3      | TmpReg2.Bit0 history bit                                                                                                                                                                                                                  |
|                 |      | Bit4      | Reserved                                                                                                                                                                                                                                  |

## TIMER\_K\_TENTHS

The `TIMER_K_TENTHS` command:

- Counts time in tenths of seconds, up to the number of counts specified by a constant value
- Calculates the end time in a temporary register
- Enabled by, and reports its counting status to, a second temporary register

| Arguments | Representation                                     |
|-----------|----------------------------------------------------|
| 3         | <code>TIMER_K_TENTHS KValue TmpReg1 TmpReg2</code> |

| Input Argument       | Type | Range/Bit  | Description                                                                                                                        |
|----------------------|------|------------|------------------------------------------------------------------------------------------------------------------------------------|
| <code>KValue</code>  | UINT | 0...65,535 | Timer preset value                                                                                                                 |
| <code>TmpReg2</code> | UINT | Bit0       | <ul style="list-style-type: none"> <li>• Starts the timer on a rising edge</li> <li>• Stops the timer on a falling edge</li> </ul> |

| Output Argument      | Type | Range/Bit  | Description                                                                                                                                                                                                                                                                 |
|----------------------|------|------------|-----------------------------------------------------------------------------------------------------------------------------------------------------------------------------------------------------------------------------------------------------------------------------|
| <code>TmpReg1</code> | UINT | 0...65,535 | Calculated end time                                                                                                                                                                                                                                                         |
| <code>TmpReg2</code> | UINT | Bit1       | Timer done: <ul style="list-style-type: none"> <li>• bit set when timer reaches <code>TmpReg1</code></li> <li>• bit reset when:               <ul style="list-style-type: none"> <li>◦ <code>TmpReg2.Bit0</code> is reset</li> <li>◦ power is cycled</li> </ul> </li> </ul> |
|                      |      | Bit2       | Timer execution in progress<br>Bit reset when timer reaches <code>TmpReg1</code>                                                                                                                                                                                            |
|                      |      | Bit3       | <code>TmpReg2.Bit0</code> history bit                                                                                                                                                                                                                                       |
|                      |      | Bit4       | Reserved                                                                                                                                                                                                                                                                    |

## Latch Logic Commands

### Overview

The Custom Logic Editor uses the following latch commands:

- `LATCH`
- `LATCH_NV`

### LATCH

The `LATCH` command:

- Stores a Boolean value (0 or 1) in a temporary register
- Provides a method for setting and resetting the stored value
- Saves the clear and set status from the previous scan

| Arguments | Representation            |
|-----------|---------------------------|
| 1         | <code>LATCH TmpReg</code> |

| Input Argument | Type | Bit  | Description                                               |
|----------------|------|------|-----------------------------------------------------------|
| TmpReg         | UINT | Bit1 | Sets the <code>TmpReg.Bit0</code> to 1 on a rising edge   |
|                |      | Bit2 | Resets the <code>TmpReg.Bit0</code> to 0 on a rising edge |

| Output Argument | Type | Bit  | Description                          |
|-----------------|------|------|--------------------------------------|
| TmpReg          | UINT | Bit0 | State of the latch                   |
|                 |      | Bit3 | <code>TmpReg.Bit1</code> history bit |
|                 |      | Bit4 | <code>TmpReg.Bit2</code> history bit |

## LATCH\_NV

The `LATCH_NV` command:

- Stores a Boolean value (0 or 1) in a non-volatile register
- Provides a method for setting and resetting the stored value
- Saves the clear and set status from the previous scan

Use the `LATCH_NV` command, instead of the `LATCH` command, to retain the latch state during a power cycle.

| Arguments | Representation              |
|-----------|-----------------------------|
| 1         | <code>LATCH_NV NVReg</code> |

| Input Argument | Type | Bit  | Description                                               |
|----------------|------|------|-----------------------------------------------------------|
| NVReg          | UINT | Bit1 | Sets the <code>TmpReg.Bit0</code> to 1 on a rising edge   |
|                |      | Bit2 | Resets the <code>TmpReg.Bit0</code> to 0 on a rising edge |

| Output Argument | Type | Bit  | Description                          |
|-----------------|------|------|--------------------------------------|
| NVReg           | UINT | Bit0 | State of the latch                   |
|                 |      | Bit3 | <code>TmpReg.Bit1</code> history bit |
|                 |      | Bit4 | <code>TmpReg.Bit2</code> history bit |

## Counter Logic Commands

### Overview

The custom logic editor uses the following counter logic commands:

- `COUNTER`
- `COUNTER_NV`

### COUNTER

The `COUNTER` command:

- Increments or decrements a count value
- Provides a method for setting the count value to a preset value
- Indicates when the count value equals 0

- Indicates the relationship between the count value and the preset value - equal to, greater than or less than
- Saves the increment, decrement and set status from the previous scan

| Arguments | Representation                 |
|-----------|--------------------------------|
| 3         | COUNTER TmpReg1 KValue TmpReg2 |

| Input Argument | Type | Range/Bit  | Description                                                                                                    |
|----------------|------|------------|----------------------------------------------------------------------------------------------------------------|
| KValue         | UINT | 0...65,535 | Counter preset value                                                                                           |
| TmpReg2        | UINT | Bit4       | Increments the counter current value on a rising edge. Counter current value shall roll over from 65,535 to 0. |
|                |      | Bit5       | Decrements the counter current value on a rising edge. Counter current value shall roll over from 0 to 65,535. |
|                |      | Bit6       | Sets the current counter value to the preset value on a rising edge                                            |

| Output Argument | Type | Range/Bit  | Description                                                                |
|-----------------|------|------------|----------------------------------------------------------------------------|
| TmpReg1         | UINT | 0...65,535 | Counter current value                                                      |
| TmpReg2         | UINT | Bit0       | The counter current value is 0: TmpReg1=0                                  |
|                 |      | Bit1       | The counter current value is lower than the preset value: TmpReg1<KValue   |
|                 |      | Bit2       | The counter current value is equal to the preset value: TmpReg1=KValue     |
|                 |      | Bit3       | The counter current value is greater than the preset value: TmpReg1>KValue |
|                 |      | Bit7       | TmpReg2.Bit4 history bit                                                   |
|                 |      | Bit8       | TmpReg2.Bit5 history bit                                                   |
|                 |      | Bit9       | TmpReg2.Bit6 history bit                                                   |

## COUNTER\_NV

The COUNTER\_NV command:

- Increments or decrements a count value
- Provides a method for setting the count value to a preset value
- Indicates when the count value equals 0
- Indicates the relationship between the count value and the preset value - equal to, greater than or less than
- Saves the increment, decrement and set status from the previous scan

Use the COUNTER\_NV command, instead of the COUNTER command, to retain the count during a power cycle.

| Arguments | Representation               |
|-----------|------------------------------|
| 3         | COUNTER NVReg1 KValue NVReg2 |

| Input Argument | Type | Range/Bit  | Description                                                         |
|----------------|------|------------|---------------------------------------------------------------------|
| KValue         | UINT | 0...65,535 | Counter preset value                                                |
| NVReg2         | UINT | Bit4       | Increments the counter current value on a rising edge               |
|                |      | Bit5       | Decrements the counter current value on a rising edge               |
|                |      | Bit6       | Sets the current counter value to the preset value on a rising edge |

| Output Argument | Type | Range/Bit | Description                                                               |
|-----------------|------|-----------|---------------------------------------------------------------------------|
| NVReg1          | UINT | 0..65,535 | Counter current value                                                     |
| NVReg2          | UINT | Bit0      | The counter current value is 0: NVReg1=0                                  |
|                 |      | Bit1      | The counter current value is lower than the preset value: NVReg1<KValue   |
|                 |      | Bit2      | The counter current value is equal to the preset value: NVReg1=KValue     |
|                 |      | Bit3      | The counter current value is greater than the preset value: NVReg1>KValue |
|                 |      | Bit7      | NVReg2.Bit4 history bit                                                   |
|                 |      | Bit8      | NVReg2.Bit5 history bit                                                   |
|                 |      | Bit9      | NVReg2.Bit6 history bit                                                   |

## Math Logic Commands

### Overview

The custom logic editor uses the following math commands:

- ON\_ADD
- ON\_SUB
- ON\_MUL
- ON\_DIV

### ON\_ADD

The ON\_ADD command performs unsigned addition when the 1-bit accumulator transitions from 0 to 1. It adds the value from Argument 1 to the 16-bit accumulator value, then posts the result back to the value in Argument 1.

A status register:

- Indicates an overflow if the result of the addition process exceeds 65,535
- Indicates the status of the 1-bit-accumulator from the previous scan

| Arguments | Representation         |
|-----------|------------------------|
| 2         | ON_ADD TmpReg1 TmpReg2 |

| Input Argument | Type | Range/Bit | Description                            |
|----------------|------|-----------|----------------------------------------|
| TmpReg1        | UINT | 0..65,535 | Value to add to the 16-bit accumulator |

| Output Argument | Type | Range/Bit | Description                                                                                                                               |
|-----------------|------|-----------|-------------------------------------------------------------------------------------------------------------------------------------------|
| TmpReg1         | UINT | 0..65,535 | Result of the addition operation                                                                                                          |
| TmpReg2         | UINT | Bit0      | Overflow: the result of the addition is greater than 65,535.<br>In this case, the result of the addition is equal to Argument 1 + 65,536. |
|                 |      | Bit3      | 1-bit accumulator history bit                                                                                                             |

### ON\_SUB

The ON\_SUB command performs unsigned subtraction when the 1-bit accumulator transitions from 0 to 1. It subtracts the 16-bit accumulator value from the value in Argument 1, then posts the result back to the value in Argument 1.

A status register:

- Indicates an underflow if the result of the subtraction process is less than 0
- Indicates the status of the 1-bit-accumulator from the previous scan

| Arguments | Representation         |
|-----------|------------------------|
| 2         | ON_SUB TmpReg1 TmpReg2 |

| Input Argument | Type | Range/Bit  | Description                                   |
|----------------|------|------------|-----------------------------------------------|
| TmpReg1        | UINT | 0...65,535 | Value to subtract from the 16-bit accumulator |

| Output Argument | Type | Range/Bit  | Description                                                                                                                                                |
|-----------------|------|------------|------------------------------------------------------------------------------------------------------------------------------------------------------------|
| TmpReg1         | UINT | 0...65,535 | Result of the subtraction operation                                                                                                                        |
| TmpReg2         | UINT | Bit0       | Underflow: the result of the subtraction is less than 0.<br>In this case, the true result of the operation equals the value output to Argument 1 - 65,536. |
|                 |      | Bit3       | 1-bit accumulator history bit                                                                                                                              |

## ON\_MUL

The ON\_MUL command performs unsigned multiplication when the 1-bit accumulator transitions from 0 to 1. The ON\_MUL procedure multiplies the value from Argument 2 against the 16-bit accumulator value, then posts the result back to Argument 1 (most significant word) and Argument 2 (least significant word).

A status register indicates the status of the 1-bit accumulator from the previous scan.

| Arguments | Representation                 |
|-----------|--------------------------------|
| 3         | ON_MUL TmpReg1 TmpReg2 TmpReg3 |

| Input Argument | Type | Range/Bit  | Description                                      |
|----------------|------|------------|--------------------------------------------------|
| TmpReg2        | UINT | 0...65,535 | Value to be multiply with the 16-bit accumulator |

| Output Argument     | Type | Range/Bit  | Description                                                                                                                                                                             |
|---------------------|------|------------|-----------------------------------------------------------------------------------------------------------------------------------------------------------------------------------------|
| TmpReg1 and TmpReg2 | UINT | 0...65,535 | Result of the multiplication operation: <ul style="list-style-type: none"> <li>• TmpReg1 holds the most significant word</li> <li>• TmpReg2 holds the least significant word</li> </ul> |
| TmpReg3             | UINT | Bit3       | 1-bit accumulator history bit                                                                                                                                                           |

## ON\_DIV

The ON\_DIV command performs unsigned division when the 1-bit accumulator transitions from 0 to 1. The ON\_DIV procedure divides the combined value of Argument 1 and Argument 2 by the 16-bit accumulator value, then posts the result back to Argument 1 (most significant word) and Argument 2 (least significant word).

A status register indicates:

- An overflow if division is by 0
- The status of the 1-bit-accumulator from the previous scan

| Arguments | Representation                 |
|-----------|--------------------------------|
| 3         | ON_DIV TmpReg1 TmpReg2 TmpReg3 |

| Input Argument      | Type | Range/Bit  | Description                                   |
|---------------------|------|------------|-----------------------------------------------|
| TmpReg1 and TmpReg2 | UINT | 0...65,535 | Value to be divided by the 16-bit accumulator |

| Output Argument     | Type | Range/Bit  | Description                                                                                                                                                                       |
|---------------------|------|------------|-----------------------------------------------------------------------------------------------------------------------------------------------------------------------------------|
| TmpReg1 and TmpReg2 | UINT | 0...65,535 | Result of the division operation: <ul style="list-style-type: none"> <li>• TmpReg1 holds the most significant word</li> <li>• TmpReg2 holds the least significant word</li> </ul> |
| TmpReg3             | UINT | Bit0       | Division by 0                                                                                                                                                                     |
|                     |      | Bit3       | 1-bit accumulator history bit                                                                                                                                                     |

## Structured Text Program Examples

### Summary

This section shows the structured text program of 2 typical situations which you may need to use in your applications:

- Checking timers and multiply commands
- Creating a truth table

## How to Check Timers and Multiply Commands

### Overview

When customizing your application you may need to check timers and multiply commands.

## Checking Timers and Multiply Commands with a Structured Text Program

The following diagram gives the structured text program in Text View of how to check timers and multiply commands:

```

LOGIC_ID 356
// A very simple test that checks timers and MUL (multiply command)
// It should switch LO1 and LO2 ON OFF if OK !!
//
LOAD_K_BIT 1
SET_TMP_BIT 115 3
LOAD_TMP_REG 115
ON_SET_TMP_REG 105 111
ON_SET_TMP_REG 108 112
LOAD_NOT_TMP_BIT 110 2 // timer 2 not timing
SET_TMP_BIT 107 0
TIMER_TENTHS 105 106 107
LOAD_NOT_TMP_BIT 107 2 // timer 1 not timing
SET_TMP_BIT 110 0
TIMER_TENTHS 108 109 110
LOAD_TMP_BIT 107 2
SET_BIT 1200 12 // Switch LO1 if timer 1 is working
LOAD_K_REG 50 // Load value of 50
LOAD_K_BIT 1
SET_NOT_TMP_BIT 123 3 // Clear history bit
ON_SET_TMP_REG 122 123 // Save the 50 in temporary register 22
LOAD_K_REG 2 // Load value of 2
SET_NOT_TMP_BIT 123 3
ON_MUL 121 122 123 // Multiply 50x2
LOAD_TMP_REG 122
COMP_K_REG 100 101 // Is result 100?
LOAD_TMP_BIT 110 2 // timer 2 timing
AND_TMP_BIT 101 2 // =100?
SET_BIT 1200 13 // Don't switch LO2 if MUL did not work OK

```

## How to Create a Truth Table

### Overview

When customizing your application you may need to create a truth table.

## Creating a Truth Table with a Structured Text Program

The following diagram gives the structured Text program in Text View of the creation of a truth table:

```
LOGIC_ID 444
//
//
// Truth table example
//
//   I1  I2  I3   Output
//   0   0   0     0   (0)
//   0   0   1     1   (1)
//   0   1   0     1   (2)
//   0   1   1     0   (3)
//   1   0   0     1   (4)
//   1   0   1     0   (5)
//   1   1   0     0   (6)
//   1   1   1     0   (7)

LOAD_BIT 457.0           //SET INPUTS
SET_TMP_BIT 1.1
LOAD_BIT 457.1
SET_TMP_BIT 1.2
LOAD_BIT 457.2
SET_TMP_BIT 1.3

//
//**** 3x1 TRUTH TABLE TEMPLATE
//**** Inputs defined as bits 1.1 through 1.3)
//**** Output defined as bit 1.15
//
LOAD_K_BIT 0             //default output OFF
SET_TMP_BIT 1.15        //save partial result

//*****0** Inputs 1-2-3 are OFF OFF OFF
//
LOAD_NOT_TMP_BIT 1.1    //include this SECTION
AND_NOT_TMP_BIT 1.2    //if output is to be ON
AND_NOT_TMP_BIT 1.3    //REMOVE if output to be OFF
SET_TMP_BIT 1.15       //save partial result
//
```

## Creating a Truth Table with a Structured Text Program (cont'd)

```

LOAD_NOT_TMP_BIT 1.1 //include this SECTION
AND_NOT_TMP_BIT 1.2 //if output is to be ON
AND_TMP_BIT 1.3 //REMOVE if output to be OFF
OR_TMP_BIT 1.15 //include previous result
SET_TMP_BIT 1.15 //save partial result
//
//*****2** Inputs 1-2-3 are OFF ON OFF
//
LOAD_NOT_TMP_BIT 1.1 //include this SECTION
AND_TMP_BIT 1.2 //if output is to be ON
AND_NOT_TMP_BIT 1.3 //REMOVE if output to be OFF
OR_TMP_BIT 1.15 //include previous result
SET_TMP_BIT 1.15 //save partial result
//
//*****3** Inputs 1-2-3 are OFF ON ON
//
LOAD_NOT_TMP_BIT 1.1 //include this SECTION
AND_TMP_BIT 1.2 //if output is to be ON
AND_TMP_BIT 1.3 //REMOVE if output to be OFF
OR_TMP_BIT 1.15 //include previous result
SET_TMP_BIT 1.15 //save partial result
//
//*****4** Inputs 1-2-3 are ON OFF OFF
//
LOAD_TMP_BIT 1.1 //include this SECTION
AND_NOT_TMP_BIT 1.2 //if output is to be ON
AND_NOT_TMP_BIT 1.3 //REMOVE if output to be OFF
OR_TMP_BIT 1.15 //include previous result
SET_TMP_BIT 1.15 //save partial result
//
//*****5** Inputs 1-2-3 are ON OFF ON
//
LOAD_TMP_BIT 1.1 //include this SECTION
AND_NOT_TMP_BIT 1.2 //if output is to be ON
AND_TMP_BIT 1.3 //REMOVE if output to be OFF
OR_TMP_BIT 1.15 //include previous result
SET_TMP_BIT 1.15 //save partial result

```

## Creating a Truth Table with a Structured Text Program (cont'd)

```
//  
//*****6** Inputs 1-2-3 are ON ON OFF  
//  
LOAD_TMP_BIT 1.1 //include this SECTION  
AND_TMP_BIT 1.2 //if output is to be ON  
AND_NOT_TMP_BIT 1.3 //REMOVE if output to be OFF  
OR_TMP_BIT 1.15 //include previous result  
SET_TMP_BIT 1.15 //save partial result  
//  
//*****7** Inputs 1-2-3 are ON ON ON  
//  
LOAD_TMP_BIT 1.1 //include this SECTION  
AND_TMP_BIT 1.2 //if output is to be ON  
AND_TMP_BIT 1.3 //REMOVE if output to be OFF  
OR_TMP_BIT 1.15 //include previous result  
SET_TMP_BIT 1.15 //save partial result  
  
LOAD_TMP_BIT 1.15 //SET OUTPUT  
SET_BIT 1200.14
```

---

# Function Block Diagram Language

## Overview

The function block diagram editor enables you to create a custom logic program based on the function block diagram programming language.

## Overview of FBD Language

### Summary

This section provides a general description of FBD language. Use the FBD language to customize a pre-defined operating mode or to create a new program to suit the requirements of a specific application created using FBD.

## Introduction to the FBD Editor

### Overview

The FBD editor is a feature of the TeSys T DTM. Use the FBD editor to view an existing FBD file or to create an FBD file using FBD language, rather than an instruction-based text programming language.

### Creating an FBD Program

To open the FBD editor, select **Device** → **FB diagram** → **New FB diagram** or click the **FB diagram** tab. The FBD editor appears in the main window.

### Saving an FBD Program

Before compiling the FBD program, you must save it. To save the program you created or edited, select **Device** → **FB diagram** → **Save FB diagram as**.

**NOTE:** The file is saved with the extension *\*.Gef*.

### FBD Editor User Interface

The FBD editor is available even when the TeSys T DTM is in connected mode. However, many of the menu items are enabled only when an FBD program is open in the FBD editor.

When an FBD file is open the FBD editor looks like this:

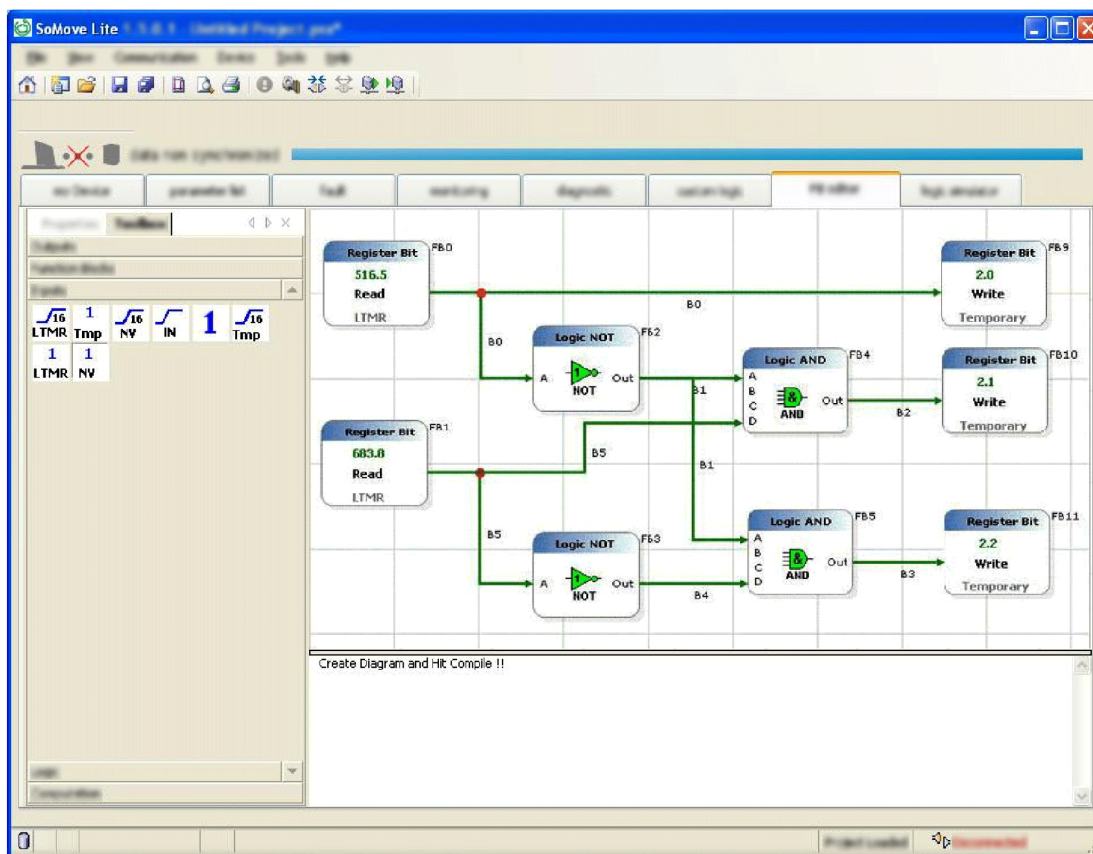

## Workspace

FBD programs are edited and created in the workspace.

The workspace is made up of 2 elements:

- Blocks
- Wires to link the blocks

## Execution of FBD Programs

FBD programs are executed line by line, from the left to the right and from top to bottom. In the example below, the instructions are executed from instruction 1 to instruction 9, in the order indicated by the arrows.

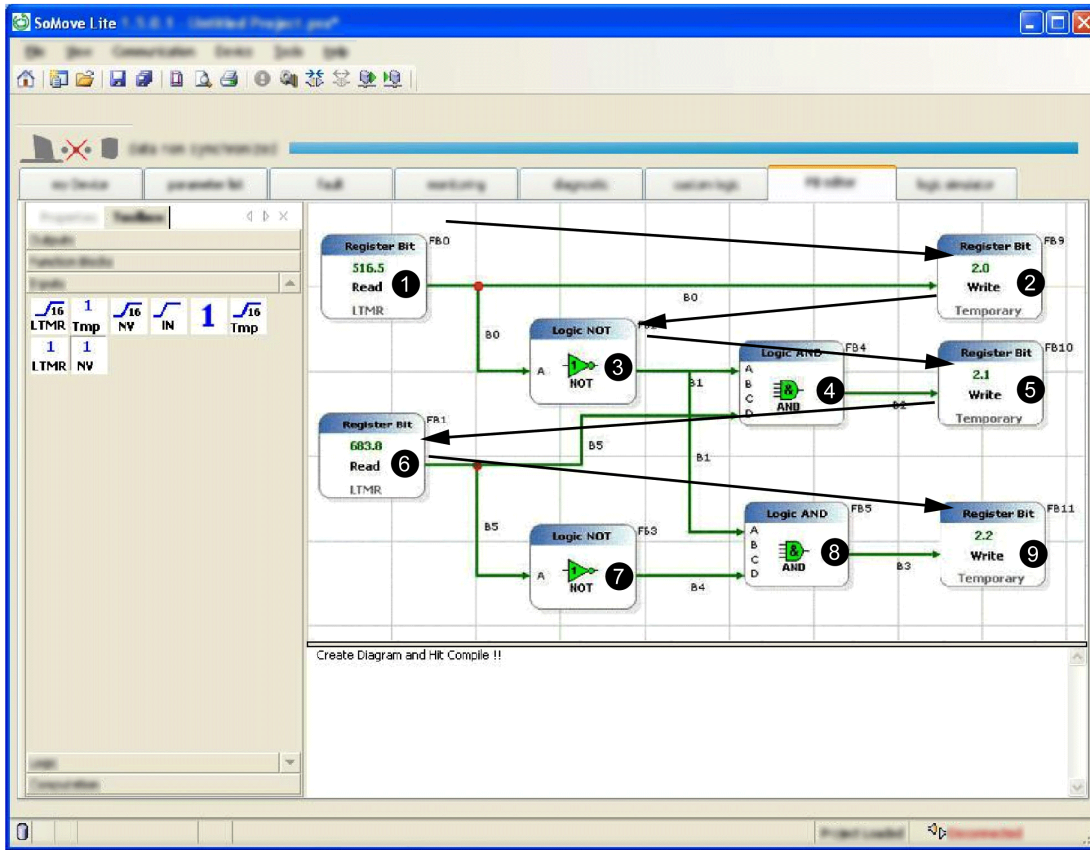

## FBD Elements



### Summary



This section describes in detail the FBD elements provided by the FBD editor, and their arguments.

## Computation Blocks

### Overview

The FBD editor uses various Computation blocks accessible through the **Computation** bar in the Toolbox:

| Block                                                                               | Description |
|-------------------------------------------------------------------------------------|-------------|
|  | Compare     |
|  | Add         |
|  | Division    |

| Block                                                                             | Description    |
|-----------------------------------------------------------------------------------|----------------|
|  | Multiplication |
|  | Subtraction    |

**NOTE:** Placing cursor over the icon will reveal a tool tip defining the icon. This will help you distinguish which type of block is represented by that icon.

## Compare Block

The  block compares two 16-bit register values.

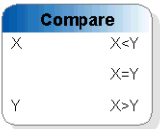
| FBD Symbol                                                                        | Arguments | Description                                                                                                                                                                                                                                                                                                                 |
|-----------------------------------------------------------------------------------|-----------|-----------------------------------------------------------------------------------------------------------------------------------------------------------------------------------------------------------------------------------------------------------------------------------------------------------------------------|
|  | Inputs    | <ul style="list-style-type: none"> <li>X: 16-bit unsigned register value (0..65,535).</li> <li>Y: 16-bit unsigned register value (0..65,535).</li> </ul>                                                                                                                                                                    |
|                                                                                   | Outputs   | <ul style="list-style-type: none"> <li>X &lt; Y: ON/OFF temporary bit that is ON if the value X is less than the value Y.</li> <li>X = Y: ON/OFF temporary bit that is ON if the value X is equal to the value Y.</li> <li>X &gt; Y: ON/OFF temporary bit that is ON if the value X is greater than the value Y.</li> </ul> |

## Add Block

The  block performs an unsigned addition of two 16-bit register values.

| FBD Symbol                                                                          | Arguments or Example | Description                                                                                                                                                                                                                     |
|-------------------------------------------------------------------------------------|----------------------|---------------------------------------------------------------------------------------------------------------------------------------------------------------------------------------------------------------------------------|
|  | Inputs               | <ul style="list-style-type: none"> <li>X: 16-bit unsigned register value (0..65,535).</li> <li>Y: 16-bit unsigned register value (0..65,535).</li> </ul>                                                                        |
|                                                                                     | Outputs              | <ul style="list-style-type: none"> <li>Z: 16-bit unsigned register result (<math>Z = X + Y</math>).</li> <li>Overflow: ON or OFF value which when set ON carries a value of 65,536. The value is initialized to OFF.</li> </ul> |
|                                                                                     | Example              | Assuming $X = 60,000$ and $Y = 7,000$ , the overflow will be ON because $60,000 + 7,000 = 67,000$ , which is superior to 65,536. The result Z is then equal to 1,464 ( $1,464 + 65,356 = 67,000$ ).                             |

## Subtraction Block

The  block performs an unsigned subtraction of two 16-bit register values.

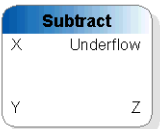
| FBD Symbol                                                                          | Arguments or Example | Description                                                                                                                                                                                                                                 |
|-------------------------------------------------------------------------------------|----------------------|---------------------------------------------------------------------------------------------------------------------------------------------------------------------------------------------------------------------------------------------|
|  | Inputs               | <ul style="list-style-type: none"> <li>X: 16-bit unsigned register value (0..65,535).</li> <li>Y: 16-bit unsigned register value (0..65,535).</li> </ul>                                                                                    |
|                                                                                     | Outputs              | <ul style="list-style-type: none"> <li>Z: 16-bit unsigned register result (<math>Z = X - Y</math>).</li> <li>Underflow: ON or OFF value, which when set ON, carries a value of negative 65,536. The value is initialized to OFF.</li> </ul> |
|                                                                                     | Example              | Assuming $X = 5$ and $Y = 10$ , the underflow will be ON because the result is negative. The result Z is then equal to 65,531 ( $65,531 - 65,536 = -5$ )                                                                                    |

## Multiplication Block

The  block performs an unsigned multiplication of two 16-bit register values.

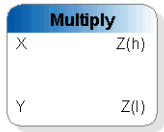
| FBD Symbol                                                                        | Arguments or Example | Description                                                                                                                                                                                                                                                    |
|-----------------------------------------------------------------------------------|----------------------|----------------------------------------------------------------------------------------------------------------------------------------------------------------------------------------------------------------------------------------------------------------|
|  | Inputs               | <ul style="list-style-type: none"> <li>X: 16-bit unsigned register value (0..65,535)</li> <li>Y: 16-bit unsigned register value (0..65,535)</li> </ul>                                                                                                         |
|                                                                                   | Outputs              | <ul style="list-style-type: none"> <li>Z(h): 16 most significant bits of the 32-bit result,<br/><math>Z(h) = (X * Y) / 65,536</math></li> <li>Z(l): 16 least significant bits of the 32-bit result,<br/><math>Z(l) = (X * Y) - Z(h) * 65,536</math></li> </ul> |
|                                                                                   | Example              | Assuming X = 20,000 and Y = 10, the result will be Z(h) = 3 and Z(l) = 3,392 because $200,000 = 3 * 65,536 + 3,392$                                                                                                                                            |

## Division Block

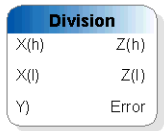

The  block performs an unsigned division of two 16-bit register values.





| FBD Symbol                                                                          | Arguments or Example | Description                                                                                                                                                                                                                                                                                                                                                                                    |
|-------------------------------------------------------------------------------------|----------------------|------------------------------------------------------------------------------------------------------------------------------------------------------------------------------------------------------------------------------------------------------------------------------------------------------------------------------------------------------------------------------------------------|
|  | Inputs               | <ul style="list-style-type: none"> <li>X(h): 16 most significant bits of an unsigned register value (0..65,535).</li> <li>X(l): 16 least significant bits of an unsigned register value (0..65,535).</li> <li>Y: 16-bit unsigned register divisor (0..65,535).</li> </ul>                                                                                                                      |
|                                                                                     | Outputs              | <ul style="list-style-type: none"> <li>Z(h): 16 most significant bits of the 32-bit quotient,<br/><math>Z(h) = (X / Y) / 65,536</math></li> <li>Z(l): 16 least significant bits of the 32-bit quotient,<br/><math>Z(l) = (X / Y) - Z(h) * 65,536</math></li> <li>Detected Error: ON or OFF value, which is set ON when a division by zero occurs. This value is initialized to OFF.</li> </ul> |
|                                                                                     | Example              | Assuming X(h) = 3, X(l) = 3,392 and Y = 40, the result will be Z(h) = 0 and Z(l) = 5,000 because $X(h) * 65,536 + X(l) = 3 * 65,536 + 3,392 = 200,000$ and $200,000 / Y = 5,000 = 0 * 65,536 + 5,000$                                                                                                                                                                                          |

## Inputs Blocks

### Overview

The FBD editor uses various inputs blocks accessible through the **Inputs** bar in the Toolbox:

| Block                                                                               | Description     |
|-------------------------------------------------------------------------------------|-----------------|
|  | Constant Bit    |
|  | Constant Word   |
|  | Register Bit In |

| Block                                                                             | Description          |
|-----------------------------------------------------------------------------------|----------------------|
|  | Register Word In     |
|  | Register NV Bit In   |
|  | Register NV Word In  |
|  | Register Temp Bit In |
|  | Temp Word In         |

**NOTE:** Placing cursor over the icon will reveal a tool tip defining the icon. This will help you distinguish which type of block is represented by that icon.

### Constant Bit Block

The  block is used to set other blocks' inputs to 0 or 1.

| FBD Symbol                                                                          | Arguments  | Description                                                                                      |
|-------------------------------------------------------------------------------------|------------|--------------------------------------------------------------------------------------------------|
|  | Properties | <ul style="list-style-type: none"> <li>a: Constant bit value 0 or 1 (ON=1 and OFF=0).</li> </ul> |
|                                                                                     | Outputs    | <ul style="list-style-type: none"> <li>Constant value 0 or 1 (ON=1 and OFF=0).</li> </ul>        |

### Constant Word Block

The  block is used to set other blocks' inputs values.

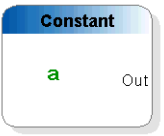
| FBD Symbol                                                                          | Arguments  | Description                                                                           |
|-------------------------------------------------------------------------------------|------------|---------------------------------------------------------------------------------------|
|  | Properties | <ul style="list-style-type: none"> <li>a: Constant value from 0 to 65,535.</li> </ul> |
|                                                                                     | Outputs    | <ul style="list-style-type: none"> <li>Constant value from 0 to 65,535.</li> </ul>    |

### Register Bit In Block

The  block enables the reading and use of a register bit value from the LTMR controller addresses from 0 to 1399.

| FBD Symbol                                                                        | Arguments  | Description                                                                                                            |
|-----------------------------------------------------------------------------------|------------|------------------------------------------------------------------------------------------------------------------------|
|  | Properties | <ul style="list-style-type: none"> <li>a: Any register from 0 to 1399.</li> <li>b: Bit number from 0 to 15.</li> </ul> |
|                                                                                   | Outputs    | <ul style="list-style-type: none"> <li>Value 0 or 1 (ON=1 and OFF=0).</li> </ul>                                       |

## Register Word In Block

The  block enables the reading and use of a register value from the LTMR controller addresses from 0 to 1399.

| FBD Symbol                                                                        | Arguments  | Description                                                                       |
|-----------------------------------------------------------------------------------|------------|-----------------------------------------------------------------------------------|
|  | Properties | <ul style="list-style-type: none"> <li>a: Any register from 0 to 1399.</li> </ul> |
|                                                                                   | Outputs    | <ul style="list-style-type: none"> <li>Value from 0 to 65,535.</li> </ul>         |

## Register NV Bit In Block

The  block enables the reading and use of a non-volatile register bit value.

| FBD Symbol                                                                          | Arguments  | Description                                                                                                                      |
|-------------------------------------------------------------------------------------|------------|----------------------------------------------------------------------------------------------------------------------------------|
|  | Properties | <ul style="list-style-type: none"> <li>a: Any non-volatile register from 0 to 63</li> <li>b: Bit number from 0 to 15.</li> </ul> |
|                                                                                     | Outputs    | <ul style="list-style-type: none"> <li>Value 0 or 1 (ON=1 and OFF=0).</li> </ul>                                                 |

## Register NV Word In Block

The  block enables the reading and use of a non-volatile register value.

| FBD Symbol                                                                          | Arguments  | Description                                                                                  |
|-------------------------------------------------------------------------------------|------------|----------------------------------------------------------------------------------------------|
|  | Properties | <ul style="list-style-type: none"> <li>a: Any non-volatile register from 0 to 63.</li> </ul> |
|                                                                                     | Outputs    | <ul style="list-style-type: none"> <li>Value from 0 to 65,535.</li> </ul>                    |

## Register Temp Bit In Block

The  block enables the reading and use of a temporary register bit value.

| FBD Symbol                                                                        | Arguments  | Description                                                                                                                     |
|-----------------------------------------------------------------------------------|------------|---------------------------------------------------------------------------------------------------------------------------------|
|  | Properties | <ul style="list-style-type: none"> <li>a: Any temporary register from 0 to 299.</li> <li>b: Bit number from 0 to 15.</li> </ul> |
|                                                                                   | Outputs    | <ul style="list-style-type: none"> <li>Value 0 or 1 (ON=1 and OFF=0).</li> </ul>                                                |

## Temp Word In Block



The  block enables the reading and use of a temporary register value.

| FBD Symbol                                                                        | Arguments  | Description                                                                                |
|-----------------------------------------------------------------------------------|------------|--------------------------------------------------------------------------------------------|
|  | Properties | <ul style="list-style-type: none"> <li>a: Any temporary register from 0 to 299.</li> </ul> |
|                                                                                   | Outputs    | <ul style="list-style-type: none"> <li>Value from 0 to 65,535.</li> </ul>                  |

## Function Blocks

### Overview

The FBD editor uses various functions blocks accessible through the **function bar** in the Toolbox:

| Block                                                                               | Description        |
|-------------------------------------------------------------------------------------|--------------------|
|  | CALL_EOM           |
|  | Counter            |
|  | Counter NV         |
|  | Volatile Latch     |
|  | Non Volatile Latch |
|  | Multiplexer        |
|  | TimerSeconds       |
|  | TimerTenthSeconds  |

**NOTE:** Placing cursor over the icon will reveal a tool tip defining the icon. This will help you distinguish which type of block is represented by that icon.

## CALL\_EOM Block



The **OP MODE** function executes a pre-defined operating mode in the customized program.

| FBD Symbol | Arguments  | Description                                                                                                                                                                                                                                                                                                                                                                                       |
|------------|------------|---------------------------------------------------------------------------------------------------------------------------------------------------------------------------------------------------------------------------------------------------------------------------------------------------------------------------------------------------------------------------------------------------|
|            | Properties | Property 1 = Embedded operating mode (EOM): <ul style="list-style-type: none"> <li>• Overload (1)</li> <li>• Independent (2)</li> <li>• Reverser (3)</li> <li>• 2-Step (4)</li> <li>• 2-Speed (5)</li> </ul> Property 2 = Terminal strip control: <ul style="list-style-type: none"> <li>• ON = 3-wire terminal strip control (3W)</li> <li>• OFF = 2-wire terminal strip control (2W)</li> </ul> |

## Counter Block



The **Counter** function performs a comparative count, saving both the counter current and counter preset values to temporary registers.

| FBD Symbol | Arguments  | Description                                                                                                                                                                                                                                                                                                                                                                                 |
|------------|------------|---------------------------------------------------------------------------------------------------------------------------------------------------------------------------------------------------------------------------------------------------------------------------------------------------------------------------------------------------------------------------------------------|
|            | Properties | K: Counter preset value (UINT 0...65,535).                                                                                                                                                                                                                                                                                                                                                  |
|            | Inputs     | <ul style="list-style-type: none"> <li>• Inc: Increments the counter current value on a rising edge. Counter current value shall roll over from 65,535 to 0.</li> <li>• Dec: Decrements the counter current value on a rising edge. Counter current value shall roll over from 0 to 65,535.</li> <li>• Set: Sets the current counter value to the preset value on a rising edge.</li> </ul> |
|            | Outputs    | <ul style="list-style-type: none"> <li>• Count: Counter current value (UINT 0...65,535). Count is initialized to zero on power-up.</li> <li>• &lt;K: The counter current value is lower than the preset value K.</li> <li>• =K: The counter current value is equal to the preset value K.</li> <li>• &gt;K: The counter current value is greater than the preset value K.</li> </ul>        |

**NOTE:** The Counter preset value range is from 0 to 65,535. Cascading counters and compare functions can be used if you need larger values or multiple preset values.

## Counter NV Block

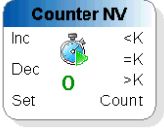

The **Counter NV** function performs a comparative count, saving both the counter current and counter preset values to non-volatile registers.

| FBD Symbol                                                                        | Arguments  | Description                                                                                                                                                                                                                                                                                                                                                                                                                      |
|-----------------------------------------------------------------------------------|------------|----------------------------------------------------------------------------------------------------------------------------------------------------------------------------------------------------------------------------------------------------------------------------------------------------------------------------------------------------------------------------------------------------------------------------------|
|  | Properties | K: Counter preset value (UINT 0...65,535).                                                                                                                                                                                                                                                                                                                                                                                       |
|                                                                                   | Inputs     | <ul style="list-style-type: none"> <li>Inc: Increments the counter current value on a rising edge. Counter current value shall roll over from 65,535 to 0.</li> <li>Dec: Decrements the counter current value on a rising edge. Counter current value shall roll over from 0 to 65,535.</li> <li>Set: Sets the current counter value to the preset value on a rising edge.</li> </ul>                                            |
|                                                                                   | Outputs    | <ul style="list-style-type: none"> <li>Count: Counter current value (UINT 0...65,535). This value is saved in non-volatile memory and initialized to the previous value on power-up.</li> <li>&lt;K: The counter current value is lower than the preset value K.</li> <li>=K: The counter current value is equal to the preset value K.</li> <li>&gt;K: The counter current value is greater than the preset value K.</li> </ul> |

**NOTE:** The Counter preset value range is from 0 to 65,535. Cascading counters and compare functions can be used if you need larger values or multiple preset values

### Volatile Latch Block

The  function records and retains signal history in a temporary register.

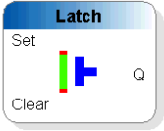
| FBD Symbol                                                                         | Arguments | Description                                                                                                                                                                                                                                                 |
|------------------------------------------------------------------------------------|-----------|-------------------------------------------------------------------------------------------------------------------------------------------------------------------------------------------------------------------------------------------------------------|
|  | Inputs    | <ul style="list-style-type: none"> <li>Set: ON/OFF input value. The latch value is set ON when this input transitions from OFF to ON.</li> <li>Clear: ON/OFF input value. The latch value is set OFF when this input transitions from OFF to ON.</li> </ul> |
|                                                                                    | Outputs   | <ul style="list-style-type: none"> <li>Q: ON or OFF latch value which represents the state of this latch. This value remains ON/OFF until the next rising edge of Set or Clear. This value is initialized to OFF.</li> </ul>                                |

### Non Volatile Latch Block

The  function records and retains signal history in a non-volatile register.

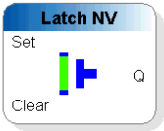
| FBD Symbol                                                                          | Arguments | Description                                                                                                                                                                                                                                                                                             |
|-------------------------------------------------------------------------------------|-----------|---------------------------------------------------------------------------------------------------------------------------------------------------------------------------------------------------------------------------------------------------------------------------------------------------------|
|  | Inputs    | <ul style="list-style-type: none"> <li>Set: ON/OFF input value. The latch value is set ON when this input transitions from OFF to ON.</li> <li>Clear: ON/OFF input value. The latch value is set OFF when this input transitions from OFF to ON.</li> </ul>                                             |
|                                                                                     | Outputs   | <ul style="list-style-type: none"> <li>Q: ON or OFF non-volatile register bit value that represents the state of this latch. This value remains ON/OFF until the next rising edge of Set or Clear. This value is saved in non-volatile memory and initialized to previous state on power-up.</li> </ul> |

### Multiplexer Block

The  function enables you to choose between two 16-bit unsigned values.

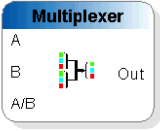
| FBD Symbol                                                                                                                                                                                                                                                                     | Arguments | Description                                                                                                                                                                                          |
|--------------------------------------------------------------------------------------------------------------------------------------------------------------------------------------------------------------------------------------------------------------------------------|-----------|------------------------------------------------------------------------------------------------------------------------------------------------------------------------------------------------------|
|  <p>The Multiplexer symbol shows two inputs labeled 'A' and 'B', a selector input labeled 'A/B', and an output labeled 'Out'. The selector input is shown with a red and green indicator.</p> | Inputs    | <ul style="list-style-type: none"> <li>A: 16-bit unsigned value (0...65,535).</li> <li>B: 16-bit unsigned value (0...65,535).</li> <li>A/B: ON/OFF input value that selects value A or B.</li> </ul> |
|                                                                                                                                                                                                                                                                                | Outputs   | <ul style="list-style-type: none"> <li>Out: Selected 16-bit value: <ul style="list-style-type: none"> <li>If A/B is ON then Out = A.</li> <li>If A/B is OFF then Out = B.</li> </ul> </li> </ul>     |

## Timer Seconds Block

The  function measures time in intervals of seconds.

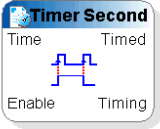
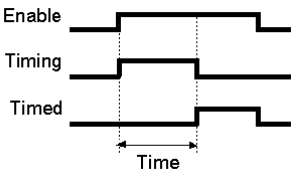
| FBD Symbol                                                                                                                                                                                                                                                                                                                                                                             | Timing Diagram                                                                                                                                                                                                                                                                                                                                                                                                                                                                                                                                                | Arguments | Description                                                                                                                                                                                                                                                                                                                                                                                   |
|----------------------------------------------------------------------------------------------------------------------------------------------------------------------------------------------------------------------------------------------------------------------------------------------------------------------------------------------------------------------------------------|---------------------------------------------------------------------------------------------------------------------------------------------------------------------------------------------------------------------------------------------------------------------------------------------------------------------------------------------------------------------------------------------------------------------------------------------------------------------------------------------------------------------------------------------------------------|-----------|-----------------------------------------------------------------------------------------------------------------------------------------------------------------------------------------------------------------------------------------------------------------------------------------------------------------------------------------------------------------------------------------------|
|  <p>The Timer Second symbol shows three inputs: 'Time', 'Enable', and 'Timing'. It has two outputs: 'Timed' and 'Timing'. The 'Time' input is shown with a blue square wave, 'Enable' with a red square wave, and 'Timing' with a blue square wave. The outputs are also shown with square waves.</p> |  <p>The timing diagram shows three input signals: Enable (red), Timing (blue), and Timed (black). Enable is a square wave that goes high and then low. Timing is a square wave that goes high when Enable is high and low when Enable is low. Timed is a square wave that goes high when Enable is high and Timing is high, and low when Enable is low or Timing is low. A horizontal arrow labeled 'Time' indicates the duration of the high pulse of the Timed output.</p> | Inputs    | <ul style="list-style-type: none"> <li>Time: 16-bit unsigned value (0...65,535) that specifies time period in seconds.</li> <li>Enable: ON/OFF input value. The time period is loaded on the rising edge of the Enable input. Time measuring continues while Enable is ON. Timing stops and outputs are OFF when Enable is OFF.</li> </ul>                                                    |
|                                                                                                                                                                                                                                                                                                                                                                                        |                                                                                                                                                                                                                                                                                                                                                                                                                                                                                                                                                               | Outputs   | <ul style="list-style-type: none"> <li>Timed: ON/OFF value which turns ON while Enable is ON and time period expires. It is OFF while measuring time or while Enable is OFF.</li> <li>Timing: ON/OFF value that is ON while Enable is ON and while measuring time. It is OFF after time period expires or Enable is OFF.</li> </ul> <p>Note: Both outputs can never be simultaneously ON.</p> |

## Timer TenthSeconds Block



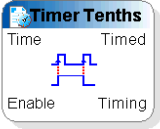
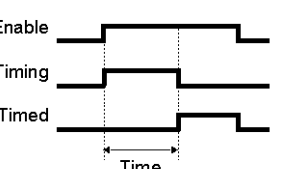

The  function measures time in intervals of tenths of seconds.

| FBD Symbol                                                                                                                                                                                                                                                                                                                                                                               | Timing Diagram                                                                                                                                                                                                                                                                                                                                                                                                                                                                                                                                                  | Arguments | Description                                                                                                                                                                                                                                                                                                                                                                                   |
|------------------------------------------------------------------------------------------------------------------------------------------------------------------------------------------------------------------------------------------------------------------------------------------------------------------------------------------------------------------------------------------|-----------------------------------------------------------------------------------------------------------------------------------------------------------------------------------------------------------------------------------------------------------------------------------------------------------------------------------------------------------------------------------------------------------------------------------------------------------------------------------------------------------------------------------------------------------------|-----------|-----------------------------------------------------------------------------------------------------------------------------------------------------------------------------------------------------------------------------------------------------------------------------------------------------------------------------------------------------------------------------------------------|
|  <p>The Timer Tenths symbol shows three inputs: 'Time', 'Enable', and 'Timing'. It has two outputs: 'Timed' and 'Timing'. The 'Time' input is shown with a blue square wave, 'Enable' with a red square wave, and 'Timing' with a blue square wave. The outputs are also shown with square waves.</p> |  <p>The timing diagram shows three input signals: Enable (red), Timing (blue), and Timed (black). Enable is a square wave that goes high and then low. Timing is a square wave that goes high when Enable is high and low when Enable is low. Timed is a square wave that goes high when Enable is high and Timing is high, and low when Enable is low or Timing is low. A horizontal arrow labeled 'Time' indicates the duration of the high pulse of the Timed output.</p> | Inputs    | <ul style="list-style-type: none"> <li>Time: 16-bit unsigned value (0...65,535) that specifies time periods in tenths of seconds.</li> <li>Enable: ON/OFF input value. The time period is loaded on the rising edge of the Enable input. Time measuring continues while Enable is ON. Timing stops and outputs are OFF when Enable is OFF.</li> </ul>                                         |
|                                                                                                                                                                                                                                                                                                                                                                                          |                                                                                                                                                                                                                                                                                                                                                                                                                                                                                                                                                                 | Outputs   | <ul style="list-style-type: none"> <li>Timed: ON/OFF value that turns ON while Enable is ON and time period expires. It is OFF while measuring time or while Enable is OFF.</li> <li>Timing: ON/OFF value which is ON while Enable is ON and while measuring time. It is OFF after time period expires or Enable is OFF.</li> </ul> <p>Note: Both outputs can never be simultaneously ON.</p> |

## Logic Blocks

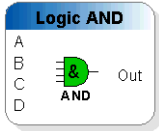
### Overview

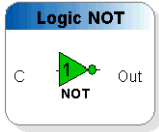
The FBD editor uses various logic blocks accessible through the **Logic blocks** bar in the Toolbox:

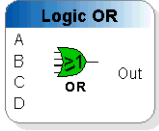





| Function | Icon                                                                              | FBD Symbol                                                                        | Description                                                                                                                                                                                                        |
|----------|-----------------------------------------------------------------------------------|-----------------------------------------------------------------------------------|--------------------------------------------------------------------------------------------------------------------------------------------------------------------------------------------------------------------|
| AND      |  |  | If all the inputs (ON or OFF values, respectively 1 or 0) are ON or not connected, the output is ON.<br>If at least one input is OFF, the output is OFF.<br><b>NOTE:</b> unconnected inputs are assumed to be ON.  |
| NOT      |  |  | If the input (ON or OFF values, respectively 1 or 0) is ON, the output is OFF.<br>If the input is OFF, the output is ON.                                                                                           |
| OR       |  |  | If at least one input (ON or OFF values, respectively 1 or 0) is ON, the output is ON.<br>If all the inputs are OFF or not connected, the output is OFF.<br><b>NOTE:</b> unconnected inputs are assumed to be OFF. |

**NOTE:** Placing cursor over the icon will reveal a tool tip defining the icon. This will help you distinguish which type of block is represented by that icon.

## Outputs Blocks

### Overview

The FBD editor uses various outputs blocks accessible through the **Outputs** bar in the Toolbox:

| Block                                                                               | Description           |
|-------------------------------------------------------------------------------------|-----------------------|
|  | Register Bit Out      |
|  | Register Word Out     |
|  | Register NV Bit Out   |
|  | Register NV Word Out  |
|  | Register Temp Bit Out |
|  | Temp Word Out         |

**NOTE:** Placing cursor over the icon will reveal a tool tip defining the icon. This will help you distinguish which type of block is represented by that icon.

### Register Bit Out Block

The  block is used to set an LTMR controller register bit value to 0 or 1 from the LTMR controller addresses from 0 to 1399.

| FBD Symbol                                                                        | Arguments  | Description                                                                                                            |
|-----------------------------------------------------------------------------------|------------|------------------------------------------------------------------------------------------------------------------------|
|  | Properties | <ul style="list-style-type: none"> <li>a: Any register from 0 to 1399.</li> <li>b: Bit number from 0 to 15.</li> </ul> |
|                                                                                   | Inputs     | <ul style="list-style-type: none"> <li>0 or 1 (ON=1 and OFF=0)</li> </ul>                                              |

## Register Word Out Block

The  block is used to set an LTMR controller register value from the LTMR controller addresses from 0 to 1399.

| FBD Symbol                                                                        | Arguments  | Description                                                                               |
|-----------------------------------------------------------------------------------|------------|-------------------------------------------------------------------------------------------|
|  | Properties | <ul style="list-style-type: none"> <li>a: Any register from 0 to 1399.</li> </ul>         |
|                                                                                   | Inputs     | <ul style="list-style-type: none"> <li>16-bit unsigned value from 0 to 65,535.</li> </ul> |

## Register NV Bit Out Block

The  block is used to set a non-volatile register bit value to 0 or 1.

| FBD Symbol                                                                          | Arguments  | Description                                                                                                                       |
|-------------------------------------------------------------------------------------|------------|-----------------------------------------------------------------------------------------------------------------------------------|
|  | Properties | <ul style="list-style-type: none"> <li>a: Any non-volatile register from 0 to 63.</li> <li>b: Bit number from 0 to 15.</li> </ul> |
|                                                                                     | Inputs     | <ul style="list-style-type: none"> <li>0 or 1 (ON=1 and OFF=0)</li> </ul>                                                         |

## Register NV Word Out Block

The  block is used to set a non-volatile register value.

| FBD Symbol                                                                          | Arguments  | Description                                                                                  |
|-------------------------------------------------------------------------------------|------------|----------------------------------------------------------------------------------------------|
|  | Properties | <ul style="list-style-type: none"> <li>a: Any non-volatile register from 0 to 63.</li> </ul> |
|                                                                                     | Inputs     | <ul style="list-style-type: none"> <li>16-bit unsigned value from 0 to 65,535</li> </ul>     |

## Register Temp Bit Out Block

The  block is used to set a temporary register bit value to 0 or 1.

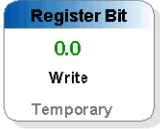
| FBD Symbol                                                                        | Arguments  | Description                                                                                                                     |
|-----------------------------------------------------------------------------------|------------|---------------------------------------------------------------------------------------------------------------------------------|
|  | Properties | <ul style="list-style-type: none"> <li>a: Any temporary register from 0 to 299.</li> <li>b: Bit number from 0 to 15.</li> </ul> |
|                                                                                   | Inputs     | <ul style="list-style-type: none"> <li>0 or 1 (ON=1 and OFF=0)</li> </ul>                                                       |

## Temp Word Out Block

The  block is used to set a temporary register value.

| FBD Symbol                                                                        | Arguments  | Description                                                                                |
|-----------------------------------------------------------------------------------|------------|--------------------------------------------------------------------------------------------|
|  | Properties | <ul style="list-style-type: none"> <li>a: Any temporary register from 0 to 299.</li> </ul> |
|                                                                                   | Inputs     | <ul style="list-style-type: none"> <li>16-bit unsigned value from 0 to 65,535</li> </ul>   |

# Programming with the FBD Language

## Summary

This section describes how to create and modify a program using the FBD language.

## Inserting FBD Blocks

### Overview

To create an FBD program, insert blocks into the workspace, then link them together. All types of blocks can be placed in the workspace.

### Inserting Blocks from the Toolbox

The following procedure describes how to insert a block from the toolbox into the workspace:

| Step | Action                                                                                                                                                                     |
|------|----------------------------------------------------------------------------------------------------------------------------------------------------------------------------|
| 1    | Select <b>Device &gt; FB diagram &gt; View &gt; Toolbox</b> or click the <b>Toolbox</b> tab on the left side.                                                              |
| 2    | Select the type of block to insert: <ul style="list-style-type: none"> <li>Computation</li> <li>Inputs</li> <li>Function Blocks</li> <li>Logic</li> <li>Outputs</li> </ul> |
| 3    | Left-click on the icon corresponding to the block to insert.                                                                                                               |
| 4    | Drag and drop the block from the toolbox to the workspace.                                                                                                                 |

| Step | Action                                                                 |
|------|------------------------------------------------------------------------|
| 5    | Position the block in the required location on the workspace.          |
| 6    | Repeat steps 2 to 5 to insert all the blocks required for the program. |

## Inserting Blocks from the Workspace

The following procedure describes how to insert a block directly from the workspace:

| Step | Action                                                                                                                                                                               |
|------|--------------------------------------------------------------------------------------------------------------------------------------------------------------------------------------|
| 1    | Right-click anywhere on a blank space in the workspace.<br><b>Result:</b> A menu opens and enables you to select the type of block you wish to insert.                               |
| 2    | Select the type of block to insert: <ul style="list-style-type: none"> <li>• Computation</li> <li>• Inputs</li> <li>• Function Blocks</li> <li>• Logic</li> <li>• Outputs</li> </ul> |
| 3    | Left-click on the block you wish to insert.                                                                                                                                          |
| 4    | Position the block in the required location in the workspace.                                                                                                                        |
| 5    | Repeat steps 1 to 5 to insert all the blocks required for the program.                                                                                                               |

## Creation of Links between Blocks

### Overview

After you have positioned the blocks in the workspace, you can link them together. To do this, you link a block's output to the input of another block. You can also loop an output back to the input of the same block.



### General Rules

There are some basic rules that apply when placing and connecting blocks:

- One or more connecting wires attached together form a "wire node". This is indicated in the workspace by a red dot. If wires cross without a red connection dot, it means they are not connected.
- Only one output can be attached to each wire node.
- Connections between boolean and register data are prohibited.
- Data typically flows from left to right.

### Link between Blocks

The following procedure describes how to link blocks together:

| Step | Action                                                                                                                                                                                                                                                                                                                                                                                                                                                                                                                                                                                                                                                                                                                                      |
|------|---------------------------------------------------------------------------------------------------------------------------------------------------------------------------------------------------------------------------------------------------------------------------------------------------------------------------------------------------------------------------------------------------------------------------------------------------------------------------------------------------------------------------------------------------------------------------------------------------------------------------------------------------------------------------------------------------------------------------------------------|
| 1    | <p>Place the mouse over the first block.</p> <p><b>Result:</b> One or more squares become visible on the block border, and the type of output (analog or boolean) is indicated.</p>                                                                                                                                                                                                                                                                                                                                                                                                                                                                        |
| 2    | <p>Click the left mouse button and hold it down.</p>                                                                                                                                                                                                                                                                                                                                                                                                                                                                                                                                                                                                                                                                                        |
| 3    | <p>With the button held down, move the cursor over the input of the block you want to link to.</p> <p><b>Result:</b> One or more squares become visible on the block border. If the square is green, a connection between the 2 blocks is possible. A red square indicates that a connection is not possible. The type of output (analog or boolean) is also indicated.</p>  <p>Note: Inputs and outputs have to be of the same type: a boolean output is linked to another boolean output. If the inputs or outputs are not the same, the FBD editor will display a pop-up window to indicate that origins and destinations are not of the same type.</p> |
| 4    | <p>Release the mouse button.</p> <p><b>Result:</b> A line and a number are shown between the 2 linked blocks.</p>                                                                                                                                                                                                                                                                                                                                                                                                                                                                                                                                                                                                                           |
| 5    | <p>Repeat steps 1 to 4 to link all the blocks.</p>                                                                                                                                                                                                                                                                                                                                                                                                                                                                                                                                                                                                                                                                                          |

## Link Number

There are 2 types of wires:

- The boolean wire, which will have a number beginning with B.
- The register wire, which will have a number beginning with R.

The wire number is automatically incremented in chronological order.

## FBD Blocks Properties

### Overview

Each of the blocks has a properties window. To display this window, left-click on a block.

The Properties window consists of several tabs, separated in 1 or 2 categories, depending on the type of block:

- General settings, which contain the block ID and comments (common to all types of blocks).
- Specific settings, depending on the type of block (register settings for registers, counter settings for counters, etc.).

For example, if you wish to display non-volatile register properties, select a non-volatile register block and left-click on it. The following window is displayed:

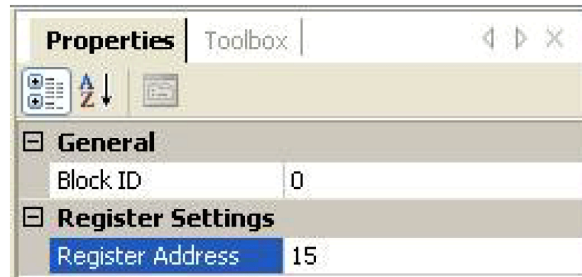

## Comments



In the Comment zone, in the white box on the right of Comments, you can enter a comment. Select any object or any free location in the workspace to save the comment.

## Settings

Most blocks have a specific settings tab. In this tab, Set the specific settings of blocks. These settings are described in detail in the help for each of the FBD blocks.

## Properties Display

The properties of each block can be displayed in 2 different ways:

- by category, clicking  or
- by alphabetical order, clicking .

## FBD Resource Management

### Overview

The LTMR controller memory is equipped with the following resources:

- Logic memory space size equal to 8,192 words
- 300 temporary registers
- 64 non-volatile registers

### Reserved Resources

When a custom logic program is developed using the structured text editor, all resources are available, whereas, when using the FBD editor, some temporary and non-volatile registers are reserved for use by the FBD compiler.

### Register Allocation

The following table lists all reserved registers and their allocation. It also indicates how these registers are controlled:

| Register Type | Address Range | Controlled by    | Description                                                                               |
|---------------|---------------|------------------|-------------------------------------------------------------------------------------------|
| Temporary     | 0...69        | The user         | Temporary storage of bit and registers assigned by the user when creating an FBD program. |
| Temporary     | 70...299      | The FBD compiler | Reserved temporary registers for use by the compiler.                                     |
| Non-volatile  | 0...31        | The user         | Non-volatile bits or registers assigned by the user when creating an FBD program.         |
| Non-volatile  | 32...63       | The FBD compiler | Reserved non-volatile registers for use by the compiler.                                  |

## Manipulating FBD Blocks

### Summary

This section describes the manner in which blocks in the workspace can be manipulated, including how to select, move, duplicate or delete blocks.

### How to Select Blocks

#### Overview

When you add blocks to the workspace, you can select them to reposition them within the workspace.

#### How to Select One or More Blocks

The following table describes how to select one or more blocks:

| If you would like to select...                     | Then                                                                                                                                                                                                                                              |
|----------------------------------------------------|---------------------------------------------------------------------------------------------------------------------------------------------------------------------------------------------------------------------------------------------------|
| An isolated block                                  | Click block.                                                                                                                                                                                                                                      |
| Several contiguous blocks                          | <p>Frame the blocks to be selected by defining a selection zone.</p> <p><b>Result:</b> All of the selected blocks are highlighted with an orange outline.</p>  |
| Several blocks in different areas of the workspace | <p>Press the SHIFT key, then click the blocks to be selected while continuing to hold down the SHIFT key.</p> <p><b>Result:</b> All of the selected blocks are highlighted with an orange outline.</p>                                            |
| All objects including wires                        | <p>Select <b>Device &gt; FB diagram &gt; FBD editor &gt; Select all</b></p> <p><b>Note:</b> The keyboard shortcut CTRL+A can also be used to select all objects.</p>                                                                              |

### How to Delete and Duplicate Objects

#### Overview

Sometimes it may be necessary to delete a block or duplicate a block in the workspace.

## How to Delete Blocks

The following table describes how to delete one or more blocks:

| Step | Action                                                                                                                                                                                                       |
|------|--------------------------------------------------------------------------------------------------------------------------------------------------------------------------------------------------------------|
| 1    | <p>Select the block(s) to be deleted</p> <p><b>Result:</b> The selected blocks are highlighted with an orange outline.</p>  |
| 2    | <p>Press the DELETE or BACKSPACE key or select <b>Device &gt; FB diagram &gt; FBD editor &gt; Delete</b>.</p> <p><b>Result:</b> The selected blocks are deleted.</p>                                         |

## How to Cut, Copy or Paste Blocks

The following table describes how to cut, copy, or paste one or more blocks:

| Step | Action                                                                                                                                                                                                                                                                                                                                                                                                                                                                                                                                                                                                  |
|------|---------------------------------------------------------------------------------------------------------------------------------------------------------------------------------------------------------------------------------------------------------------------------------------------------------------------------------------------------------------------------------------------------------------------------------------------------------------------------------------------------------------------------------------------------------------------------------------------------------|
| 1    | <p>Select the block(s) to be manipulated.</p> <p><b>Result:</b> The selected blocks are highlighted with an orange outline.</p>                                                                                                                                                                                                                                                                                                                                                                                       |
| 2    | <p>Click <b>Device &gt; FB diagram &gt; FBD editor</b> and select one of the following commands:</p> <ul style="list-style-type: none"> <li>• <b>Copy</b></li> <li>• <b>Cut</b></li> <li>• <b>Paste</b></li> </ul> <p><b>Result:</b> <b>Cut</b> deletes the selected blocks and stores them in the clipboard. <b>Copy</b> duplicates the selected blocks in the clipboard and <b>Paste</b> duplicates the clipboard contents on the workspace.</p> <p><b>Note:</b> The keyboard shortcuts CTRL+C, CTRL+V, and CTRL+X can also be used to copy the selected blocks, and either paste or delete them.</p> |

## FBD Editor Display Options

### Summary

The following section describes the different FBD editor display options.

### Other Display Options

#### Summary

You can customize the following display options to suit your requirements:

- Zoom
- Links
- Arguments

## Zoom Display Options

To access zoom options, click **Device > FB diagram > View**.

3 options are offered:

- Zoom out to see more of the program at once.
- Zoom in to focus on the program in more detail.
- Zoom to 50 %, 75 %, 100 %, 150 %, 200 %, or 400 % to have a customized view of the program.

## Links Display Options

To access links display options, click **Device > FB diagram > Tools**.

3 options are offered. You can:

- Renumber links, to aid in understanding the execution of the program.
- Show all links, to see which blocks are linked together.
- Hide all links, to have a better overall view of the blocks.

When you click a link, its properties window opens and enables you to customize the text that appears next to the link.

## Arguments Display Options

The following procedure describes how to access and change argument display options:

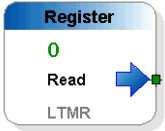
| Step | Action                                                                                                                                                                                                                                                            |
|------|-------------------------------------------------------------------------------------------------------------------------------------------------------------------------------------------------------------------------------------------------------------------|
| 1    | <p>Position the mouse over a block.</p> <p><b>Result:</b> One or more squares become visible on the block border. It also indicates if the argument is analog or boolean.</p>  |
| 2    | <p>Click on this square.</p> <p><b>Result:</b> The display options appear.</p>                                                                                                                                                                                    |
| 3    | <p>Choose if you want the label to be displayed and what text should appear.</p>                                                                                                                                                                                  |

## Workspace Appearance and Graph Options

### Summary

The FBD editor enables you to customize the workspace by changing its appearance and graph options.

### Appearance and Graph Options

To access appearance and graph options, left-click anywhere in the workspace, except on an object.

## Appearance Options

The following table lists all the possible appearance customization options:

| Appearance Option     | Description                                                                                                                                     | Possible Choices                                                                                                                                               |
|-----------------------|-------------------------------------------------------------------------------------------------------------------------------------------------|----------------------------------------------------------------------------------------------------------------------------------------------------------------|
| Background Color      | Enables you to set the background color of the workspace by clicking the box where the color is displayed.                                      | Choose between the colors available in the <b>Custom</b> , <b>Web</b> , and <b>System</b> tabs.                                                                |
| Background Image Path | Enables you to insert an image from your hard disk drive or any removable device and to define it as the background.                            | Any image you select as the background.<br><b>Note:</b> Only possible when the background type is set to image.                                                |
| Background Type       | Enables you to set the background type.                                                                                                         | Choose between a flat color, gradient, or image background.                                                                                                    |
| Enable Context Menu   | Shows or hides the context menu.                                                                                                                | True or false                                                                                                                                                  |
| Enable Tooltip        | Shows or hides tooltips.                                                                                                                        | True or false                                                                                                                                                  |
| Gradient Bottom       | Enables you to set the color of the bottom of the gradient.                                                                                     | Choose between the colors available in the Custom, Web, and System tabs.<br><b>Note:</b> Only possible when the background type is set to gradient.            |
| Gradient Top          | Enables you to set the color of the top of the gradient.                                                                                        | Choose between the colors available in the Custom, Web, and System tabs.<br><b>Note:</b> Only possible when the background type is set to gradient.            |
| Gradient Mode         | Enables you to set the type of gradient                                                                                                         | Choose between horizontal, vertical, forward diagonal, and backward diagonal modes.<br><b>Note:</b> Only possible when the background type is set to gradient. |
| Restrict to Canvas    | Enables you to choose whether the FBD program should be kept inside the canvas.                                                                 | True or false                                                                                                                                                  |
| Show Grid             | Enables you to choose whether the accurate grid is visible.                                                                                     | True or false<br><b>Note:</b> This grid must not be confused with the grid line, which is accessed from the top-level <b>View</b> menu bar.                    |
| Snap                  | Enables you to choose whether the objects are snapped with the grid. When set to true, if you move objects, they will move along the grid step. | True or false                                                                                                                                                  |

## Graph Options

The following table lists all the possible graph customization options:

| Graph option         | Description                                                              | Possible choices |
|----------------------|--------------------------------------------------------------------------|------------------|
| Allow Add Connection | Enables you to choose whether connections can be added to the workspace. | True or false    |
| Allow Add Shape      | Enables you to choose whether blocks can be added to the workspace.      | True or false    |
| Allow Delete Shape   | Enables you to choose whether blocks can be deleted.                     | True or false    |
| Allow Move Shape     | Enables you to choose whether blocks can be moved in the workspace.      | True or false    |
| Locked               | Enables you to choose whether the FBD program can be edited.             | True or false    |

## Display Grid

You may wish to display the grid lines. In order to do so, click **Device > FB diagram > View > Show grid**.

# Compiling, Simulating, and Transferring a Program

## Overview

This chapter describes how to compile a structured text and a Function Block Diagram language program. It also describes the user interface windows involved in compiling the program, simulating it with the logic simulator, and transferring it to the LTMR controller.

## Introduction

### Compiling Overview

The customized program must be compiled before being downloaded to the LTMR controller:

- The programs in structured text language can be compiled directly.
- The programs in FBD language must be first converted in structured text language programs before compilation as structured text programs.

Compiling includes a check for program errors, such as:

- Syntax and structure errors
- Symbols without corresponding addresses
- Resources used by the program that are not available
- Whether the program fits in available controller memory

### Converting FBD to Structured Text

To compile into structured text the FBD program you created or edited, select **Device > FB diagram > Compile FB diagram to ST program**.

The program is automatically copied into the structured text editor if there is no detected error.

**NOTE:** Remember to save the FBD program in the FBD editor before converting it, because it is not possible to convert a structured text program file into an FBD file.

### Compiling Structured Text

Follow these steps in order to compile the structured text program just created into PCode:

| Step | Action                                                                                                                                                             |
|------|--------------------------------------------------------------------------------------------------------------------------------------------------------------------|
| 1    | Select <b>Device &gt; custom logic</b> .                                                                                                                           |
| 2    | Click <b>Compile custom program</b> .<br><b>NOTE:</b> If no errors are detected, the PCode window is displayed. Otherwise, the Detected Error window is displayed. |

# PCode Window

## Overview

When a custom logic program is compiled successfully, the **PCode** (Pseudo Code) window is displayed:

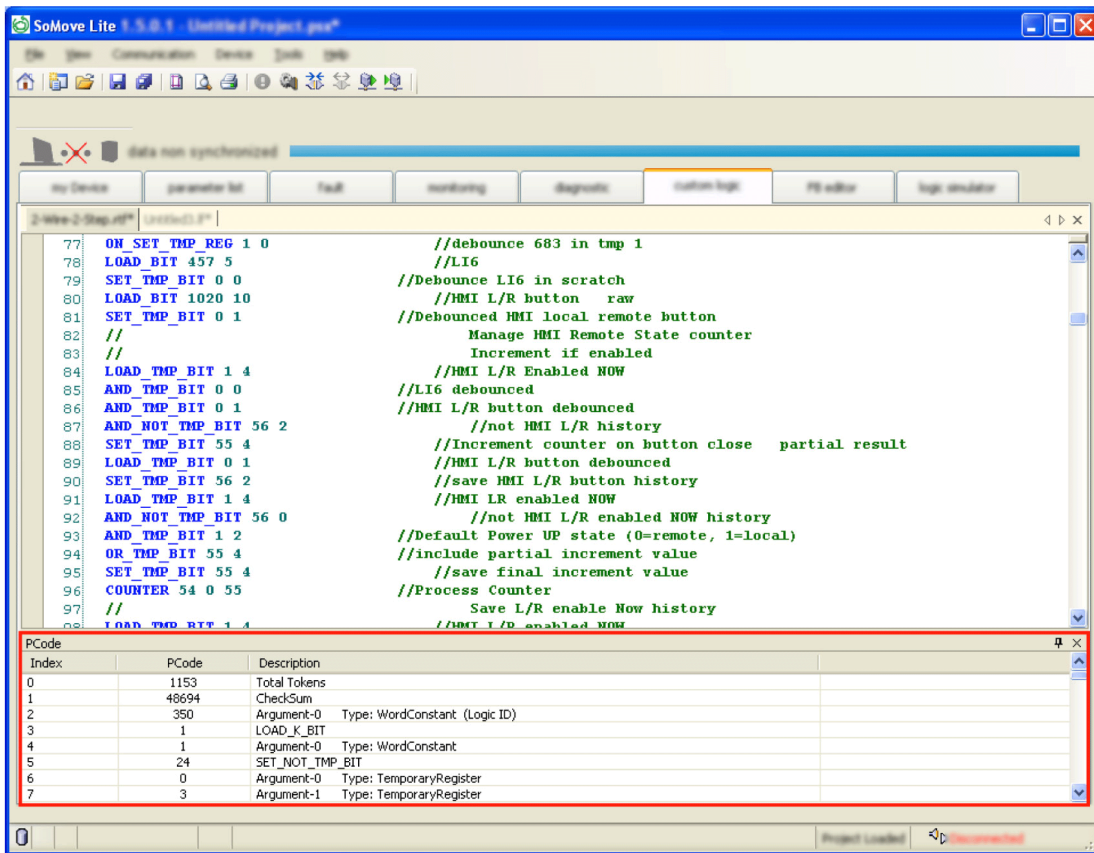

## PCode Window Elements

The following table lists the different elements which make up the **PCode** window:

| Item          | Description                                                                                                             |
|---------------|-------------------------------------------------------------------------------------------------------------------------|
| Total tokens  | Size of PCode (in 16-bits word). Count including checksum, logic ID, and all logic commands and arguments.              |
| Checksum      | Module 16 summation of all logic commands and arguments.                                                                |
| Logic command | Each logic command in the program and its related PCode.                                                                |
| Argument      | Each argument in the program, and the type of register (temporary, non-volatile, or data) that it refers to or affects. |

**NOTE:** Logic commands and arguments are listed in the same order as in the structured text language program.

## Error Window

### Overview

When a structured text language program is compiled, it may contain errors. In this case, the **Error** window is displayed:

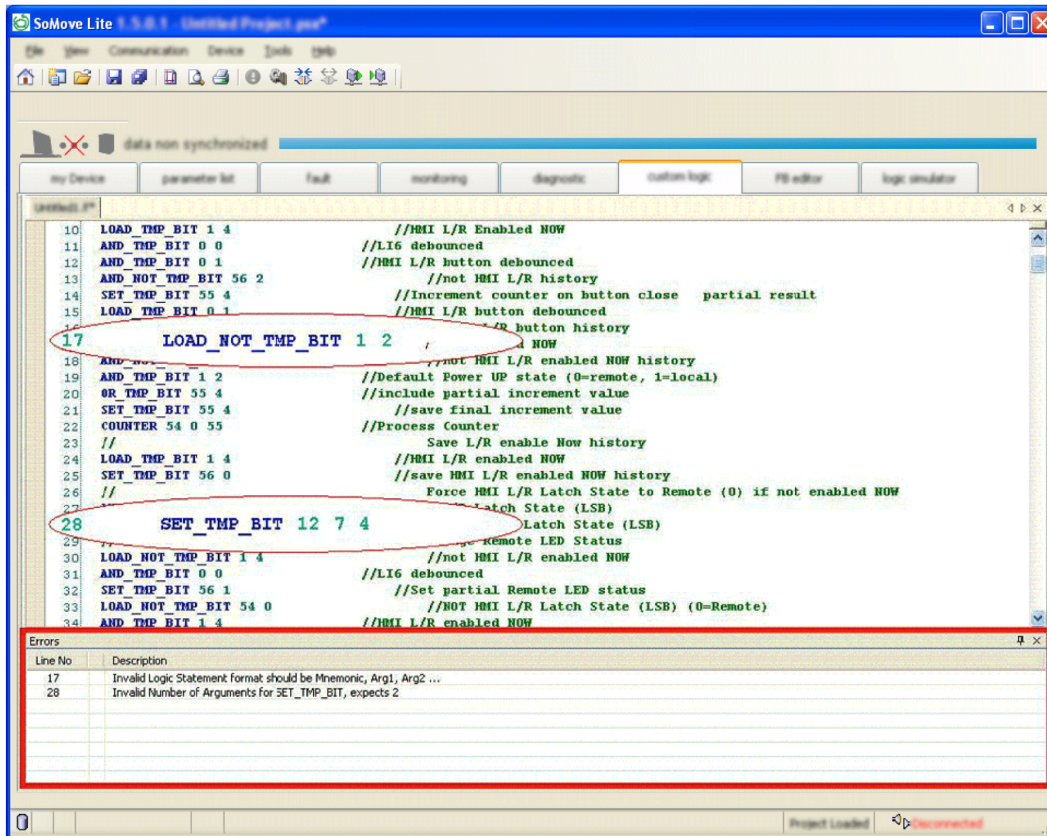

### Error Window Elements

In the example above, 2 mistakes were made.

The Error window indicates:

- The line numbers with detected errors, and
- Description of the detected error.

### Detected Error Types

The following list describes the different types of detected coding errors that may occur:

- Syntax and structure errors
- Logic commands without corresponding addresses
- Resources used by the program that are not available
- Program size is too large

# LTMR Controller Logic Simulator

## Overview

SoMove with the TeSys T DTM comes with the LTMR controller logic simulator. It enables to test the functioning of a structured text custom logic program before transferring it into the LTMR controller.

**NOTE:** To simulate an FBD program, it must be first converted and saved as a structured text program with the extension *\*.lf*.

## Logic Simulator Interface

To open the logic simulator, click the **logic simulator** tab. The logic simulator is then displayed. In the right bottom corner (see part 5 on the illustration below), click **Open Logic Function File** to import your previously saved structured text program.

**NOTE:** When you import a program with syntax errors, an information window appears: correct all detected errors in the structure text editor and compile the program after corrections before starting the simulation.

The logic simulator with a loaded custom logic file is then displayed:

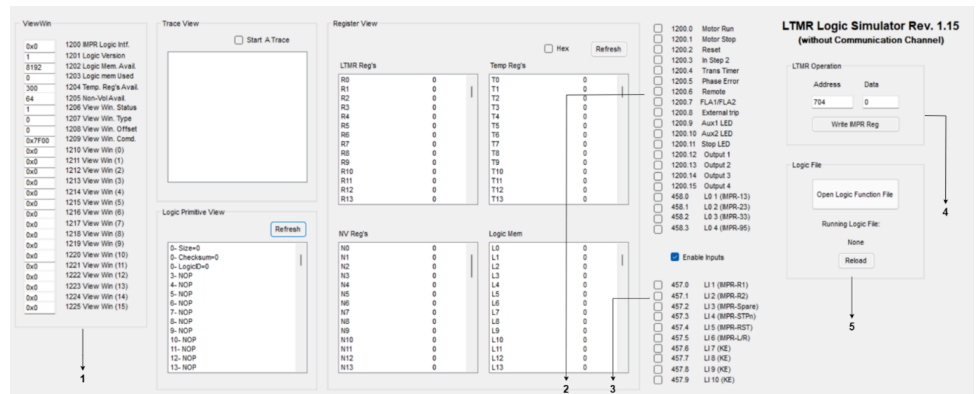

- 1 View window: used to display register 1200...1225.
- 2 Used to display the status of registers 1200 and 458.
- 3 Used to writes values to register 457.
- 4 Used to write data in decimal format to any register address.
- 5 Used to open and reload the logic file.

## Register View

4 kinds of registers are displayed by the logic simulator:

- LTMR controller registers
- Temporary registers
- Non-volatile registers
- Logic memory

Those registers can be displayed at the same time. In the example above, the content of all register view is displayed.

**NOTE:** By default, registers values are displayed in decimal code. Tick the **Hex** box if you would prefer them to be in hexadecimal code.

## Logic Primitives Window

The Logic Primitives window displays the compiled PCode, page 295.

**NOTE:** The PCode may read or write to any READ/WRITE register that is accessible by serial port communications.

## View Window

The logic simulator displays the content of LTMR controller registers 1200...1225 in hexadecimal code (see part 1 on the illustration above). Registers 1200...1205 are the custom logic registers.

## Registers 1200 and 458

The logic simulator displays the status of registers 1200 and 458 (See part 2 on the illustration above). The LTMR controller firmware then reads those PCode register values to direct device functions and physical outputs. For more information about those registers see the sections on Communication Variables in the *Use* chapter of the *TeSys T LTMR Motor Management Controller User Manual*.

The logic simulator displays an X in each output status checkbox to indicate that a bit value of 1 exists in the output status register.

## Register 457

The logic simulator enables to write values to register 457 bits (see part 3 on the illustration above). For more information about this register see the sections on Communication Variables in the *Use* chapter of the *TeSys T LTMR Motor Management Controller User Manual*. To be allowed to write to register 457, tick the **Enables Inputs** box.

Ticking a box on the left of a register bit will assign a value of 1 to this bit. Untick this box to assign 0 to this bit.

**Example:** If you tick the 3 first boxes, bits 457.0, 457.1, and 457.2 will get the value of 1. Click on the upper refresh button, and then check the value of register 457. You can see that it has the value of 7, which is in binary code 000000000000111.

## Writing to a Register Address

The logic simulator enables to write data in decimal format to any register address (see part 4 on the illustration above). Follow these steps to assign a value to a register:

| Step | Action                                                                           |
|------|----------------------------------------------------------------------------------|
| 1    | Specify to which register you wish write data in the <b>Address</b> box.         |
| 2    | Specify which value in decimal format you wish to assign in the <b>Data</b> box. |
| 3    | Click <b>Write IMPR Reg.</b>                                                     |

## Start a Trace

The **Start a Trace** box is an integrated debugging tool which captures the 1-bit and the 16-bit accumulator content.

## Refresh

When you load your \*.If file into the logic simulator, it emulates the LTMR controller behavior. However, values are assigned when you load the file, regardless of changes you made in the logic simulator. Click the **Register View** refresh button to take into accounts the changes made to registers' values. Click the **Logic Primitive View** refresh button to refresh the displayed PCode.

## Reload

After a file is loaded, its content is displayed in the corresponding sections. Click the **Logic File** reload button will re-import the same file and reset all sections to how they appeared when the file was opened.

## Initialization and Connection

### Initialization

When you connect the LTMR controller to the PC, the controller automatically initializes. This initialization process enables the controller and the PC to exchange identification information.

During this process, the custom logic editor indicates "Wait" until initialization is complete.

### Connection

After initialization, the LTMR controller should automatically connect to the PC.

To verify that the controller is connected, check the status bar in the custom logic editor.

If the status bar reads **Disconnected**, then click **Communication > Connect to Device** or click the **Connect to Device** icon.

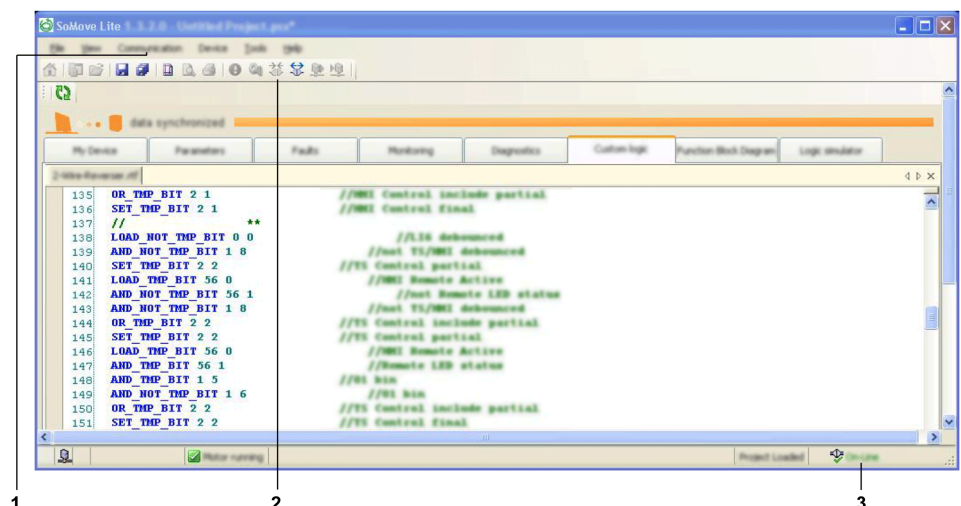

**1 Communication menu**

**2 Connect to Device icon**

**3 Connection status**

A progress bar briefly appears as your PC connects to the controller, and the word **Connected** appears in the status bar when the connection process successfully completes.

When the LTMR controller is connected, you can

- Upload custom logic files from the controller to SoMove with the TeSys T DTM for editing,
- Download edited custom logic files from SoMove with the TeSys T DTM to the controller.

## Transferring Logic Files between the LTMR Controller and Custom Logic Editor

### File Transfer - Device Custom Logic to PC

To transfer the custom logic file from the LTMR controller to the custom logic editor:

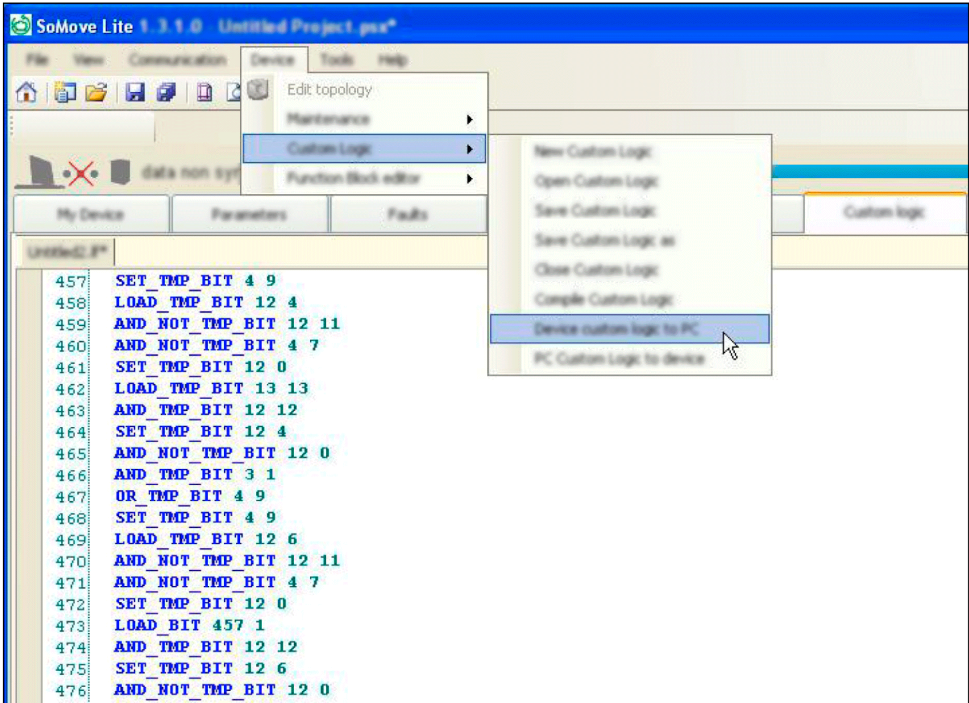
| Step | Action                                                                                                                                                                                                                                                                                                                                                             |
|------|--------------------------------------------------------------------------------------------------------------------------------------------------------------------------------------------------------------------------------------------------------------------------------------------------------------------------------------------------------------------|
| 1    | Ensure that the LTMR controller is connected to the PC, page 299.                                                                                                                                                                                                                                                                                                  |
| 2    | <p>Select <b>Device &gt; custom logic &gt; Device custom program to PC</b> or click the  icon to transfer the custom logic file from the LTMR controller to the custom logic editor.</p>  |
| 3    | <p>When the custom logic file has been transferred, you can use the custom logic editor to edit it as a structured text program.</p> <p><b>NOTE:</b> Programs retrieved from LTMR controller are in structured text only without comments. Programs such as FBD programs cannot be retrieved from the LTMR controller.</p>                                         |
| 4    | <p>After your logic file edits are complete, save your work to a file.</p> <p>Select the <b>Save</b> command in either the icon bar or the <b>File</b> menu, browse to the correct location and click <b>Save</b>.</p>                                                                                                                                             |



## File Transfer Procedure - PC Custom Logic to Device

After you have edited and compiled your custom logic file, you can transfer the file to the LTMR controller. Before SoMove with the TeSys T DTM makes this transfer, the following conditions must be met:

- The custom logic file to transfer must be different than the logic file present in the LTMR controller, i.e., the software does not transfer the same program.
- Current must not be detected, that is, online current must be less than 10% of FLC.

If these conditions are not met, the file cannot be transferred to the controller.

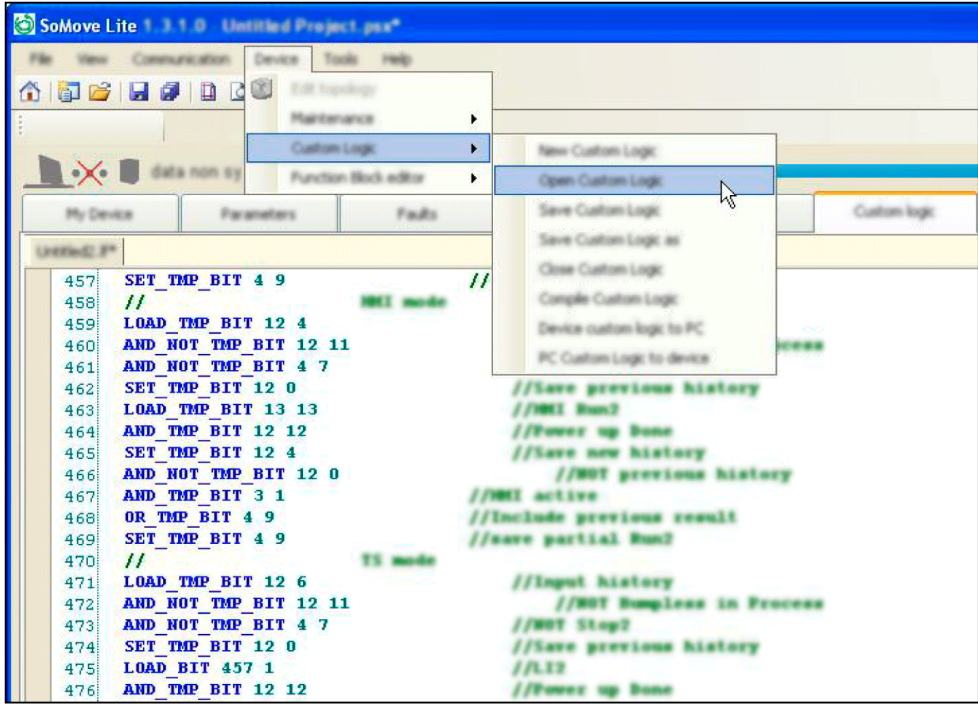
To transfer a logic file from the custom logic editor to the LTMR controller:

| Step | Action                                                                                                                                                                                                                                                                                                                                                                                                                                                                                                                                                                                                                                                                        |
|------|-------------------------------------------------------------------------------------------------------------------------------------------------------------------------------------------------------------------------------------------------------------------------------------------------------------------------------------------------------------------------------------------------------------------------------------------------------------------------------------------------------------------------------------------------------------------------------------------------------------------------------------------------------------------------------|
| 1    | Ensure that the LTMR controller is connected to the PC, page 299.                                                                                                                                                                                                                                                                                                                                                                                                                                                                                                                                                                                                             |
| 2    | <p>Ensure that the file to be transferred is in the main window. To open a file, select <b>Open custom program</b> from the <b>custom logic</b> submenu of the <b>Device</b> menu. Then, browse to the correct location and click <b>Open</b>.</p>  <p>The screenshot shows the SoMove Lite software interface. The 'Device' menu is open, and the 'Custom Logic' submenu is selected. The 'Open Custom Logic' option is highlighted by the mouse cursor. The main window displays a list of logic instructions, including SET_TMP_BIT, LOAD_TMP_BIT, AND_NOT_TMP_BIT, and OR_TMP_BIT.</p> |
| 3    | Select <b>Device &gt; custom logic &gt; Compile custom program</b> to compile the structured text program.                                                                                                                                                                                                                                                                                                                                                                                                                                                                                                                                                                    |
| 4    | <p>After the compilation of the program, select <b>Device &gt; custom logic &gt; PC custom program to device</b> or click the  icon to transfer the logic file from the custom logic editor to the controller.</p>                                                                                                                                                                                                                                                                                                                                                                       |
| 5    | The transfer is now successful. A new window appears, click <b>Ok</b> to close it.                                                                                                                                                                                                                                                                                                                                                                                                                                                                                                                                                                                            |

## Custom Logic Program Transfer and Execution

### Overview

Custom logic programs may be uploaded to or downloaded from the LTMR controller via SoMove with the TeSys T DTM. Only one custom logic program can be loaded into the LTMR controller at a time.

---

## Transfer Validity Check

During the upload or download of a custom logic program, outputs are turned off and logic execution is stopped.

A specific mechanism is used to upload or download a custom logic file. This mechanism uses a size register, checksum, and custom logic ID code to help detect an incomplete or corrupt logic function. SoMove with the TeSys T DTM does not allow a logic file to be uploaded with a bad checksum. However, an interruption to the connection during the upload is detected by the checksum mechanism.

## Custom Logic Program Selection

When a custom logic file is uploaded to the LTMR controller, that program can be selected by choosing **Custom** from the motor controller mode selection menu or by writing its logic ID code to register 540.

## Custom Logic Program Replacement

In the situation where a custom logic program is replaced by another one with a different logic ID code and the installed custom program is selected, when the new program is uploaded, the value in register 540 is automatically changed to the new logic ID code. In cases, when a standard motor controller mode is currently active (i.e. Logic ID = 2 through 11) the value in register 540 does not change.

## Invalid Program

If the custom logic program that is stored in memory has a bad checksum, an invalid size or invalid logic ID, or if there is no program stored in memory, it is impossible to select "Custom" from the motor controller mode selection menu. Writing a logic ID value to register 540 that does not match one of the pre-defined operating modes or the logic ID of the valid, checksummed custom logic program in memory is blocked by the LTMR controller.

## Corrupted Program

If the custom logic program in memory is already selected and becomes corrupted (either by loading a corrupt function over it or by data loss in the memory) then the LTMR controller issues a minor internal trip as soon as the corruption is detected.

# Maintenance

## Updating the LTMR Controller Firmware

### Overview

As newer firmware versions become available, you can upgrade the firmware in the LTMR controller. This action can be performed from the TeSys T DTM **Device** menu, page 25.

The LTMR controller firmware update process is broken has 3 parts:

- Checking the version of the LTMR controller firmware present in the device
- Downloading the latest version of the LTMR controller firmware
- Installing the latest version of the LTMR controller firmware in the device

Installation of a newer firmware stops the LTMR if it is running and erases all users configurations.

### Safety Instructions

| <b>⚠ CAUTION</b>                                                                                                                                                                                                                                                                                                                                                                                         |  |
|----------------------------------------------------------------------------------------------------------------------------------------------------------------------------------------------------------------------------------------------------------------------------------------------------------------------------------------------------------------------------------------------------------|--|
| <b>RISK OF FIRMWARE CORRUPTION</b>                                                                                                                                                                                                                                                                                                                                                                       |  |
| <ul style="list-style-type: none"> <li>• Once programming has begun, do not close TeSys T programmer until the process is complete.</li> <li>• Do not interrupt power to the device.</li> <li>• Do not disconnect the communication cable if programming is in progress.</li> <li>• Remove I/O scanner for Ethernet TeSys T.</li> <li>• Close all other programs before starting programming.</li> </ul> |  |
| <b>Failure to follow these instructions can result in injury or equipment damage.</b>                                                                                                                                                                                                                                                                                                                    |  |

### Checking the Current LTMR Controller Firmware Version

| Step | Action                                                                                                             |
|------|--------------------------------------------------------------------------------------------------------------------|
| 1    | Click <b>my Device</b> tab.                                                                                        |
| 2    | In the display area, locate the LTMR firmware version which is displayed in the <b>structure</b> section, page 32. |

### Downloading the Latest Version of the LTMR Controller Firmware

| Step | Action                                                                            |
|------|-----------------------------------------------------------------------------------|
| 1    | Open the Schneider Electric website: <a href="http://www.se.com">www.se.com</a> . |
| 2    | Type <i>TeSys T</i> in the Search field.                                          |
| 3    | In the list to the right, select <b>Software/Firmware</b> .                       |

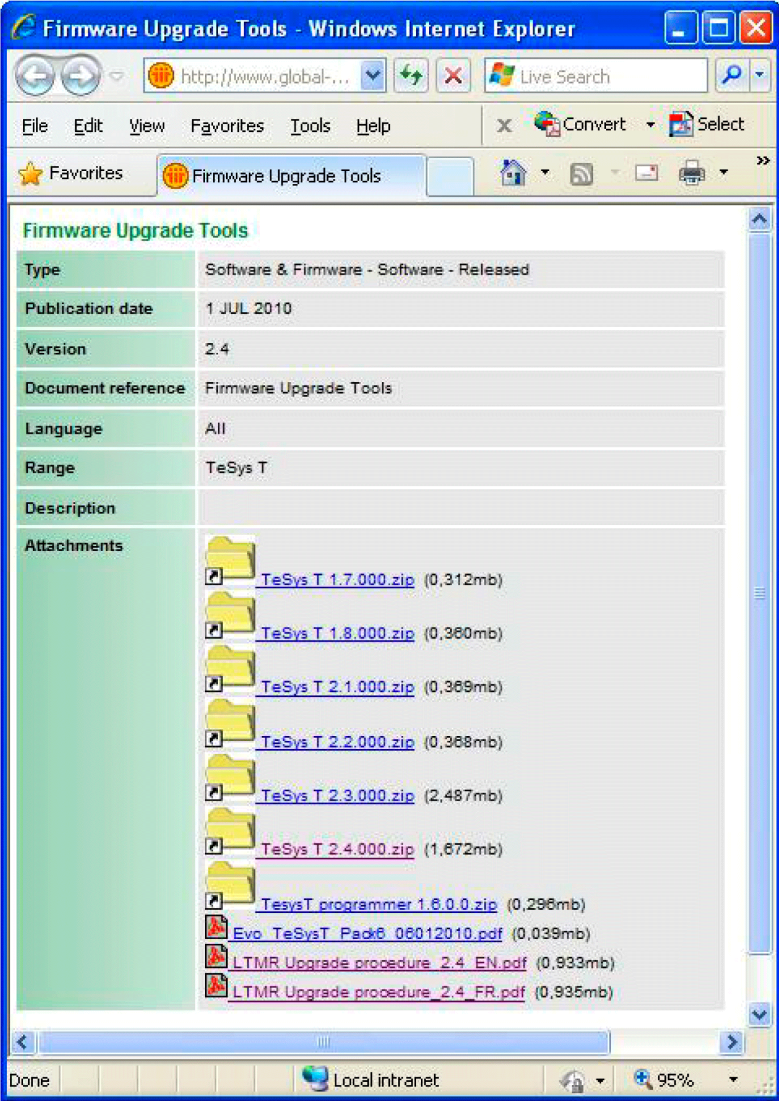
| Step | Action                                                                                                                                                                                                                                                                                                         |
|------|----------------------------------------------------------------------------------------------------------------------------------------------------------------------------------------------------------------------------------------------------------------------------------------------------------------|
| 4    | <p>Click <b>Firmware Upgrade Tools</b> file. A new window opens.</p>                                                                                                                                                        |
| 5    | <p>If the version of the LTMR controller firmware currently installed in the device is not the latest version available for download, it is recommended to download and update the LTMR controller firmware in the device.</p> <p>If this is not the case, it is not necessary to continue this procedure.</p> |
| 6    | <p>Click the <b>.zip</b> file corresponding to the latest version of the firmware update. It contains all LTMR controller firmware protocols. Click <b>Save</b> in the dialog box that opens.</p>                                                                                                              |
| 7    | <p>Browse to download the <b>.zip</b> file on your hard disk.</p>                                                                                                                                                                                                                                              |
| 8    | <p>Unzip the downloaded file: all LTMR controller firmware protocol are unzipped in a folder named <i>TeSys T X.X.XXX</i> (where X.X.XXX is the version number).</p>                                                                                                                                           |

## LTMR Controller Connection

The LTMR controller must be connected to a PC running SoMove with the TeSys T DTM.

For all LTMR controller types a USB connection is establish between the LTMR controller and the PC to update the firmware, page 311.

For the LTMR Modbus/TCP, an additional Ethernet connection is necessary.



# Updating the LTMR Controller Firmware

**Prerequisites:**

- The specific hardware connection for the firmware update between the PC and the LTMR must be done, page 310.
- The LTMR HMI port must be set to 19,200 Baud, even parity.

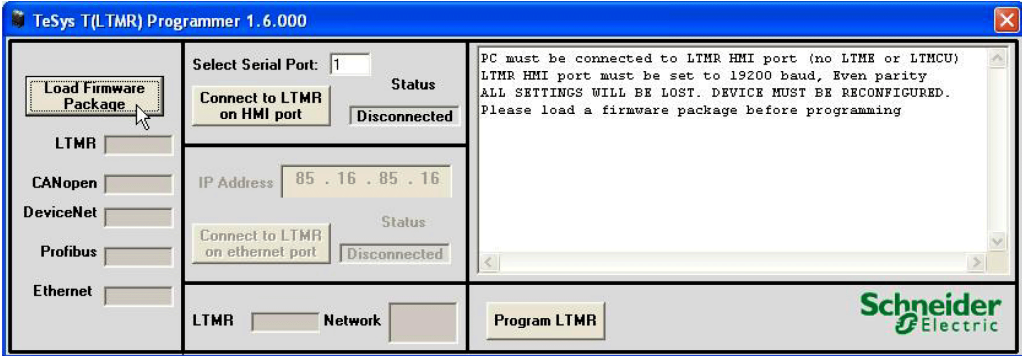
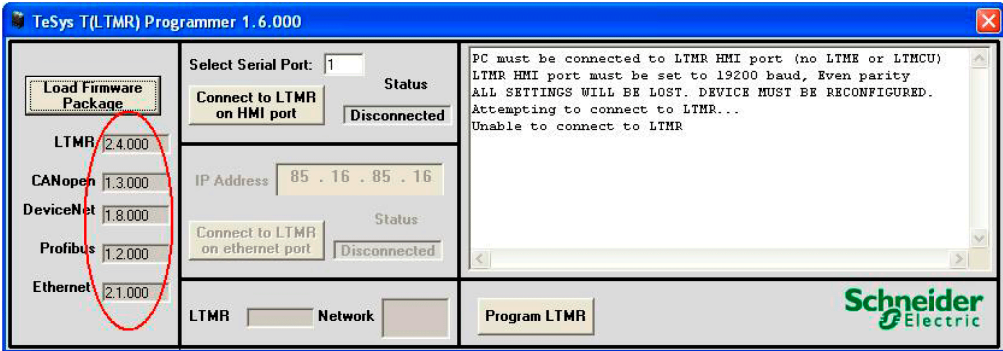
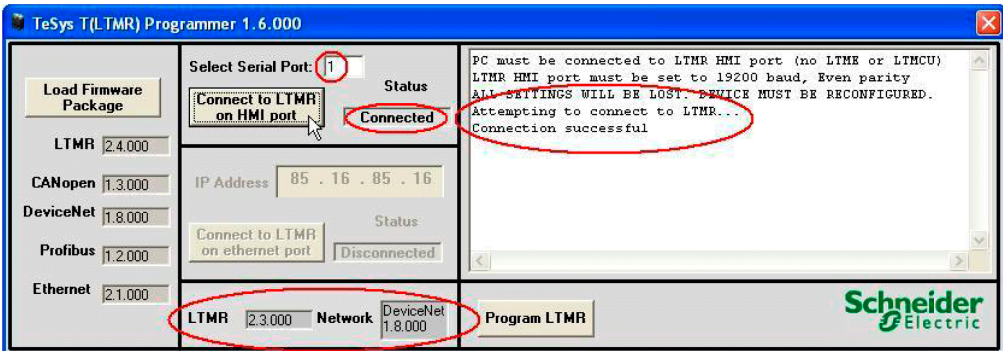
**NOTE:** The firmware update clears all existing settings, the LTMR controller must be reconfigured after the update.

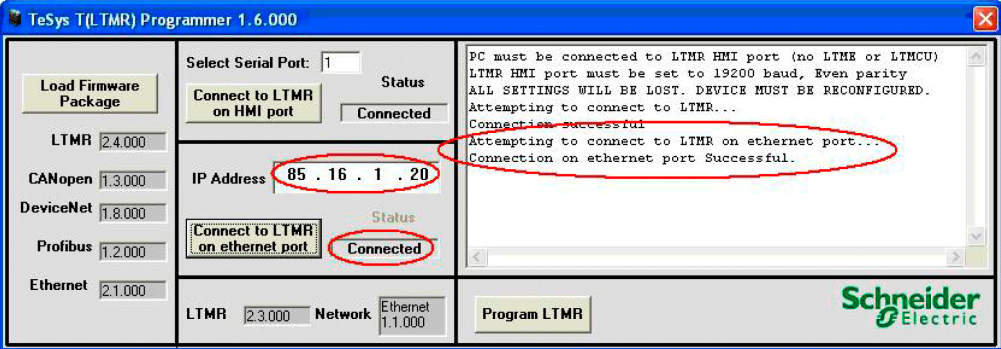
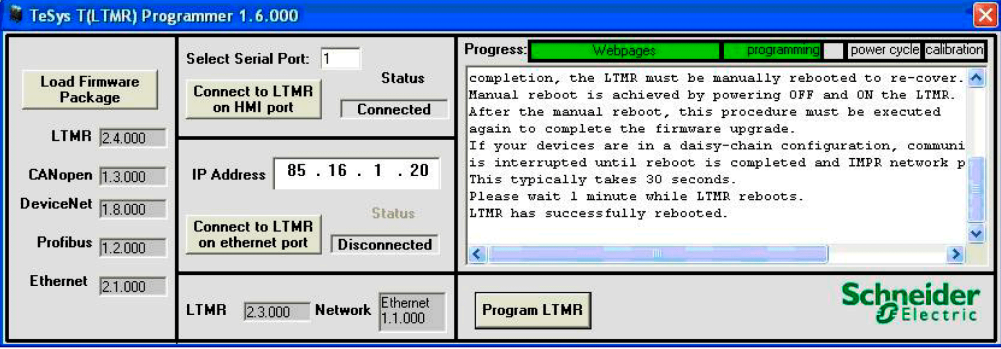
| Step | Action                                                                                                                                                                                                                                                                                                                            |
|------|-----------------------------------------------------------------------------------------------------------------------------------------------------------------------------------------------------------------------------------------------------------------------------------------------------------------------------------|
| 1    | <p>In the <b>Device</b> menu, point to the <b>Maintenance</b> submenu, and then click <b>Firmware update</b> to open the <b>TeSys T(LTMR) Programmer</b> window.</p>                                                                            |
| 2    | <p>Click <b>Load Firmware Package</b>. A new window opens.</p>                                                                                                                                                                                                                                                                    |
| 3    | <p>Browse to the <i>TeSys T X.X.XXX</i> folder (where X.X.XXX is the version number) and double-click the latest version of the <i>.fw</i> file. All firmware releases ready to be updated are displayed.</p>                                 |
| 4    | <p>Set the serial port number according to your configuration and click <b>Connect to LTMR on HMI port</b>. The serial connection status is updated, the firmware version and type are displayed, and a message confirms the connection.</p>  |

| Step | Action                                                                                                                                                                                                                                                                                                                                                                                                                                    |
|------|-------------------------------------------------------------------------------------------------------------------------------------------------------------------------------------------------------------------------------------------------------------------------------------------------------------------------------------------------------------------------------------------------------------------------------------------|
| 5    | <p>Follow this step only with an LTMR Modbus/TCP. Go to the next step if another type of LTMR controller is used.</p> <p>Enter the TeSys T default IP address (in our example 85.16.1.20) and click <b>Connect to LTMR on ethernet port</b>. The Ethernet connection status is updated and a message confirms the connection to the Ethernet port.</p>  |
| 6    | <p>Click <b>Program LTMR</b>. A new window appears with safety instructions, page 303.</p> <p>After carefully reading the safety message, click <b>Proceed</b> to install the new firmware.</p>                                                                                                                                                                                                                                           |
| 7    | <p>During the installation of the new firmware, a progress bar is displayed and the LEDs on the LTMR controller blink. The installation process takes about 8 minutes.</p>                                                                                                                                                                             |
| 8    | <p>At the end of the installation, a window opens to give the final instructions:</p>                                                                                                                                                                                                                                                                  |
| 9    | <p>Restart the LTMR controller and click <b>OK</b>. A message displays <b>Programming finished successfully</b> and the updated firmware version is displayed.</p>                                                                                                                                                                                                                                                                        |

## Self Test with Motor On

### Description

Use the self test command to check the internal operation of both the LTMR controller and the LTME expansion module. The self test command can be performed from the **Device** menu in the connected mode, page 26.

When the motor is On, performing a self test simulates a thermal trip to check if the logic output O.4 is working correctly. It triggers a thermal overload trip.

During a self test, the LTMR controller sets the self test command parameter to 1. When the self test finishes, this parameter is reset to 0.

# Connection to the LTMR Controller

## Overview

This chapter describes how to physically connect the PC running SoMove with the TeSys T DTM to the LTMR controller, including connection accessories that are used. It also describes how to connect the PC running the TeSys T (LTMR) Programmer to the LTMR controller to update its firmware.

## Hardware Connection for SoMove

### Overview

This section describes how to physically connect the LTMR controller to a PC running SoMove with the TeSys T DTM.

The PC requires its own power source and must be connected to the RJ45 port on the LTMR controller or the HMI interface port (RJ45) on the LTME expansion module when attached to the LTMR controller.

The PC can be connected in a 1-to-1 configuration to a single LTMR controller, or in a 1-to-many configuration to multiple controllers.

### Connecting to a PC Running SoMove with the TeSys T DTM in 1-to-1 Mode

The diagrams below show a 1-to-1 connection from a PC running SoMove with the TeSys T DTM to the LTMR controller, with and without the LTME expansion module and the LTMCU control operator unit:

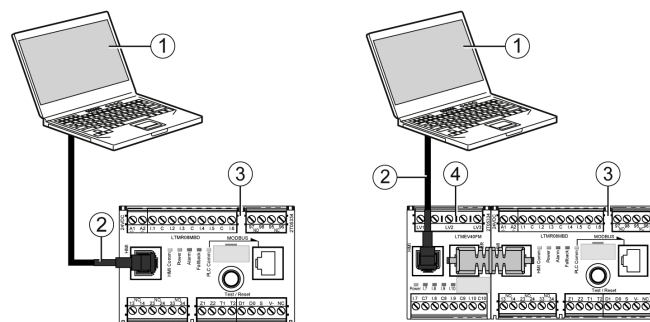

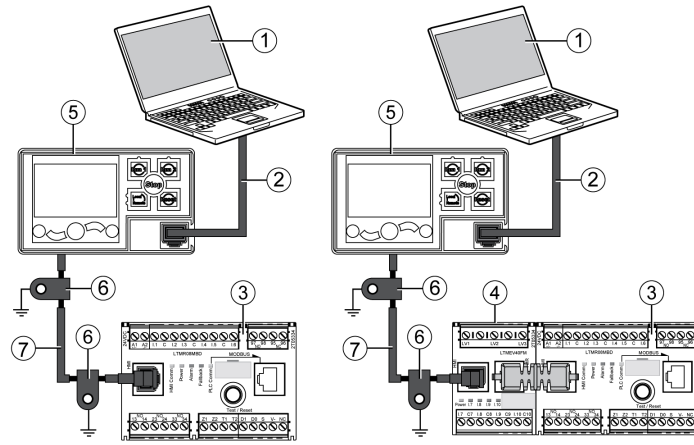

- 1 PC running SoMove with the TeSys T DTM
- 2 Cable kit TCSMCNAM3M002P
- 3 LTMR controller
- 4 LTME expansion module
- 5 LTMCU control operator unit
- 6 Grounding collar
- 7 HMI device connection cable LTM9CU••

## Connecting to a PC Running SoMove with the TeSys T DTM in 1-to-Many Mode

The diagram below shows a 1-to-many connection from a PC running SoMove with the TeSys T DTM with up to 8 controllers (with or without the LTME expansion module):

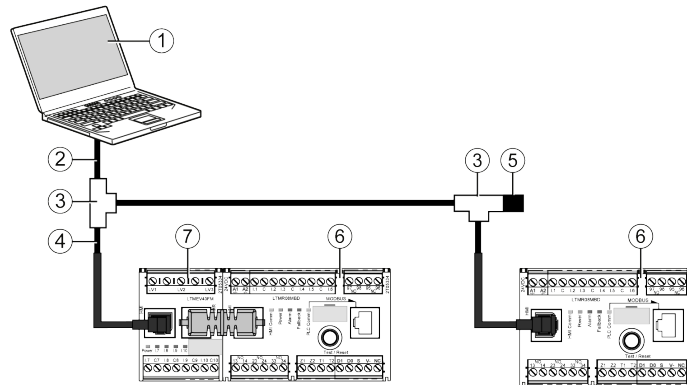

- 1 PC running SoMove with the TeSys T DTM
- 2 Cable kit TCSMCNAM3M002P
- 3 T-junction boxes VW3 A8 306 TF••
- 4 Shielded cable with 2 RJ45 connectors VW3 A8 306 R••
- 5 Line terminator VW3 A8 306 R
- 6 LTMR controller
- 7 LTME expansion module

**NOTE:** This connection requires defining additional HMI communication addresses because the default address for each LTMR controller is 1.

## Connection Accessories

The following table lists connection accessories:

| Designation                        | Description                                        | Reference       |
|------------------------------------|----------------------------------------------------|-----------------|
| T-junction boxes                   | With 0.3 m (1 ft) integrated cable                 | VW3 A8 306 TF03 |
|                                    | With 1 m (3.2 ft) integrated cable                 | VW3 A8 306 TF10 |
| Line terminator for RJ45 connector | R = 150 $\Omega$                                   | VW3 A8 306 R    |
| Cable kit                          | Length = 2.5 m (8.2 ft)<br>USB to RS-485 converter | TCSMCNAM3M002P  |
| Communication cables               | Length = 0.3 m (1 ft)                              | VW3 A8 306 R03  |
|                                    | Length = 1 m (3.2 ft)                              | VW3 A8 306 R10  |
|                                    | Length = 3 m (3.2 ft)                              | VW3 A8 306 R30  |
| HMI device connection cable        | Length = 1 m (3.2 ft)                              | LTM9CU10        |
|                                    | Length = 3 m (9.6 ft)                              | LTM9CU30        |

## Hardware Connection for the Firmware Update

### Overview

This section describes how to physically connect the R controller to a PC running the TeSys T (LTMR) Programmer to update the LTMR controller firmware.

The PC must be connected in a 1-to-1 configuration to the HMI port of the LTMR controller with or without the LTME expansion module.

An additional connection is necessary to update the LTMR Modbus/TCP firmware.

Do not connect the PC to the HMI port on the LTMCU control operator unit.

## Connecting an LTMR controller to a PC Running SoMove with the TeSys T DTM

The diagram below shows the connection with or without the LTME expansion module for all LTMR controller types except the LTMR Modbus/TCP:

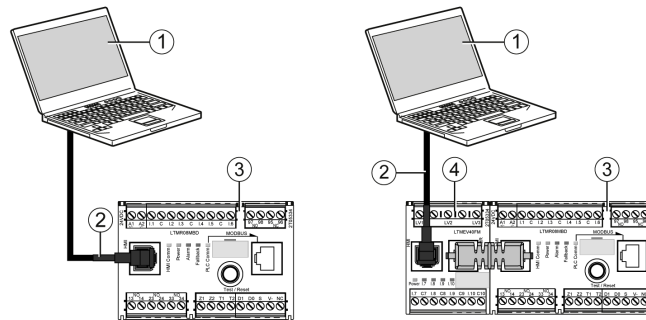

**1** PC running SoMove with the TeSys T DTM

**2** Cable kit TCSMCNAM3M002P

**3** LTMR controller

**4** LTME expansion module

To establish a USB connection, follow these steps:

| Step | Action                                                                                 |
|------|----------------------------------------------------------------------------------------|
| 1    | Plug the USB connector of the TCSMCNAM3M002P cable into the PC USB port.               |
| 2    | Plug the RJ45 connector of the TCSMCNAM3M002P cable into the LTMR controller HMI port. |
| 3    | Turn on the LTMR controller. The power LED is green.                                   |

## Connecting an LTMR Modbus/TCP to a PC Running SoMove with the TeSys T DTM

The diagram below shows the connection with or without the LTME expansion module for the LTMR Modbus/TCP:

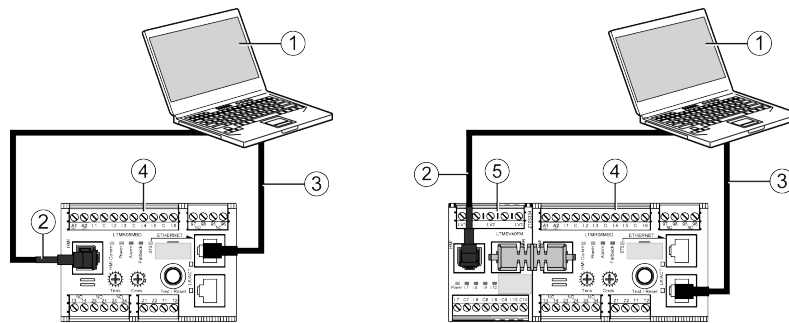

- 1 PC running SoMove with the TeSys T DTM
- 2 Cable kit TCSMCNAM3M002P
- 3 Cat 5 shielded or unshielded twisted pair Ethernet cable  
LTMR controller
- 5 LTME expansion module

To establish an additional Ethernet connection, follow these steps:

| Step | Action                                                                                 |
|------|----------------------------------------------------------------------------------------|
| 1    | Plug the USB connector of the TCSMCNAM3M002P cable into the PC USB port.               |
| 2    | Plug the RJ45 connector of the TCSMCNAM3M002P cable into the LTMR controller HMI port. |
| 3    | Plug one end of the Ethernet cable into the TeSys T network port.                      |
| 4    | Plug the other end of the Ethernet cable into the Ethernet RJ45 port of the computer.  |
| 5    | Turn on the LTMR controller. The power LED is green.                                   |

## Connection Accessories

The following table lists connection accessories:

| Designation                 | Description                                        | Reference      |
|-----------------------------|----------------------------------------------------|----------------|
| Cable kit                   | Length = 2.5 m (8.2 ft)<br>USB to RS-485 converter | TCSMCNAM3M002P |
| Communication cables        | Length = 0.3 m (1 ft)                              | VW3 A8 306 R03 |
|                             | Length = 1 m (3.2 ft)                              | VW3 A8 306 R10 |
|                             | Length = 3 m (9.8 ft)                              | VW3 A8 306 R30 |
| HMI device connection cable | Length = 1 m (3.2 ft)                              | VW3 A1 104 R10 |
|                             | Length = 3 m (9.6 ft)                              | VW3 A1 104 R30 |

## Establishing and Configuring a Connection for the LTMR Modbus/TCP Controller

| Step | Action                                                                                                                                                                                                                                                                                                                                                                                                                                                                                                                                                                                                              |
|------|---------------------------------------------------------------------------------------------------------------------------------------------------------------------------------------------------------------------------------------------------------------------------------------------------------------------------------------------------------------------------------------------------------------------------------------------------------------------------------------------------------------------------------------------------------------------------------------------------------------------|
| 1    | On the PC, open the network status window and click <b>Properties</b> .<br>The network properties window opens.                                                                                                                                                                                                                                                                                                                                                                                                                                                                                                     |
| 2    | Select <b>Internet Protocol (TCP/IP)</b> , and then click <b>Properties</b> .<br>The Internet Protocol (TCP/IP) properties window opens.                                                                                                                                                                                                                                                                                                                                                                                                                                                                            |
| 3    | There are 2 possibilities: <ul style="list-style-type: none"> <li>• If the LTMR controller is a part of a configured network and the IP address is known: configure your PC IP address according to the LTMR controller address<sup>(9)</sup>.</li> <li>• If the LTMR controller has an unknown or unconfigured IP address: click <b>Use the following IP address</b>. Then in the <b>IP address</b> field, enter the value <b>85.16.0.1</b> and in the <b>Subnet mask</b> field, enter <b>255.0.0.0</b>.</li> </ul>                                                                                                |
| 4    | Click <b>OK</b> and close all the windows.<br>Stop the procedure (without doing step 5) in the following cases: <ul style="list-style-type: none"> <li>• The LTMR controller has never been put into service.</li> <li>• The LTMR controller is already configured on a network with a known IP address.</li> </ul>                                                                                                                                                                                                                                                                                                 |
| 5    | Configure the R controller with the default IP address: <ul style="list-style-type: none"> <li>• Either by setting the <b>Ones</b> switch on the right to the <b>Disabled</b> position on the LTMR controller front panel and executing a power cycle,</li> <li>• Or by setting the IP address to 0.0.0.0:                             <ul style="list-style-type: none"> <li>◦ Either using a <b>Clear All</b> command. This action can be performed from the <b>Device</b> menu,</li> <li>◦ Or rotating the <b>Ones</b> switch to the <b>Clear IP</b> position and executing a power cycle</li> </ul> </li> </ul> |

**NOTE:**

- The steps of the procedure may be different depending on the operating system of the PC.
- The default address response starts with 85.16 and finishes with the last 2 bytes (converted in decimal format) of the product MAC address.
- The Ethernet connection can be set with other parameters as long as the configurations of the PC and LTMR controller are made correctly to establish a communication.

## Checking the USB Connection

To check the port number of the serial or USB connection, follow these steps:

| Step | Action                                                                                                                                                                                                                                                   |
|------|----------------------------------------------------------------------------------------------------------------------------------------------------------------------------------------------------------------------------------------------------------|
| 1    | On the PC, open the device manager and expand the <b>Ports (COM &amp; LPT)</b> line of the tree. (1)                                                                                                                                                     |
| 2    | In the expanded tree, the <b>Communication Port (COMX)</b> line corresponds to your serial connection and the <b>TSX C USB 485 (COMX)</b> line corresponds to the TCSMCNAM3M002P cable connection (where COMX is the number of your communication port). |

**NOTE:** The steps of the procedure may be different depending on the operating system of the PC.

## Checking the Ethernet Connection

To check the Ethernet connection of the LTMR Modbus/TCP, follow these steps:

<sup>(9)</sup> The fixed and configurable part of an IP network address is defined by the subnet mask. Configure your PC IP address by changing the configurable part to obtain a different IP address than the LTMR controller. The subnet mask must be the same as the LTMR controller.

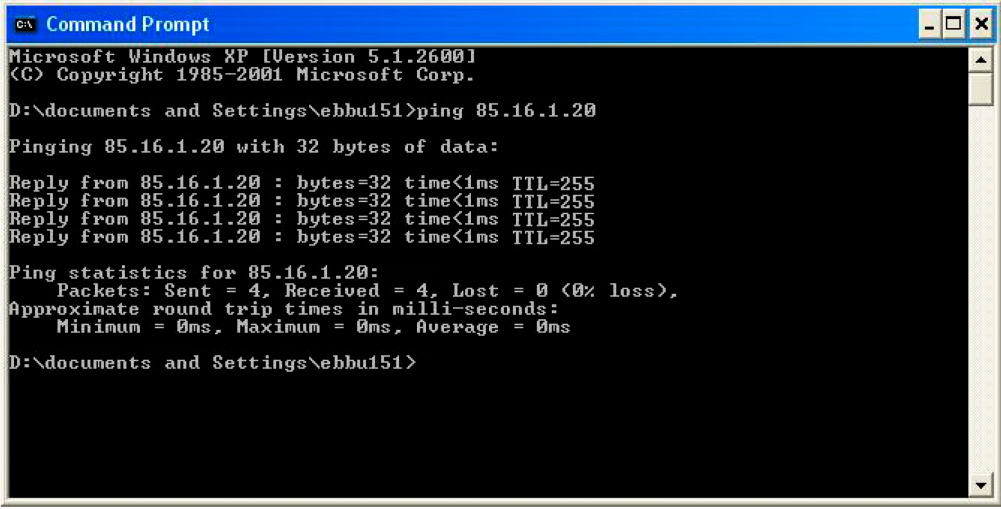
| Step | Action                                                                                                                                                                                               |
|------|------------------------------------------------------------------------------------------------------------------------------------------------------------------------------------------------------|
| 1    | On the PC, open a <b>Command Prompt</b> window. (1)                                                                                                                                                  |
| 2    | Execute a ping command to the TeSys T default IP address (in our example 85.16.1.20): <b>ping 85.16.1.20</b> .<br> |
| 3    | Check in the ping statistics that you have received all the packets sent.                                                                                                                            |

**NOTE:** The steps of the procedure may be different depending on the operating system of the PC.

# Index

## A

|                                  |           |
|----------------------------------|-----------|
| Accumulator.....                 | 236       |
| active power .....               | 53–54, 69 |
| consumption.....                 | 55        |
| Addition                         |           |
| Addition FBD Function Block..... | 275       |
| alarm counters                   |           |
| protection .....                 | 68        |
| alarms count .....               | 67–68     |
| AND                              |           |
| AND FBD Function Block.....      | 282       |
| AND_BIT .....                    | 245       |
| AND_K.....                       | 254       |
| AND_NOT_BIT .....                | 246       |
| AND_NOT_NV_BIT.....              | 247       |
| AND_NOT_TMP_BIT .....            | 246       |
| AND_NV_BIT .....                 | 246       |
| AND_NV_REG .....                 | 255       |
| AND_REG.....                     | 255       |
| AND_TMP_BIT .....                | 245       |
| AND_TMP_REG.....                 | 255       |
| apparent power .....             | 53        |
| Argument.....                    | 235       |
| auto restart                     |           |
| delayed timeout .....            | 125       |
| immediate timeout.....           | 125       |
| auto-reset                       |           |
| attempts group 1 setting .....   | 174       |
| attempts group 2 setting .....   | 174       |
| attempts group 3 setting .....   | 174       |
| count.....                       | 67        |
| group 1 timeout.....             | 174       |
| group 2 timeout.....             | 174       |
| group 3 timeout.....             | 174       |
| automatic restart .....          | 124       |
| average current ratio .....      | 69        |
| average voltage .....            | 52, 69    |

## B

|                 |         |
|-----------------|---------|
| baud rate ..... | 182–184 |
|-----------------|---------|

## C

|                                    |                    |
|------------------------------------|--------------------|
| CALL_EOM .....                     | 242                |
| CANopen                            |                    |
| baud rate.....                     | 183                |
| node address.....                  | 183                |
| command                            |                    |
| clear all .....                    | 58, 179            |
| clear controller settings.....     | 180                |
| clear network port settings .....  | 180                |
| clear statistics .....             | 66, 180            |
| clear thermal capacity level ..... | 78, 173, 180       |
| FDR data backup .....              | 207                |
| FDR data restore .....             | 207                |
| motor low speed .....              | 164                |
| motor run forward.....             | 153, 156, 159, 164 |
| motor run reverse.....             | 156, 159, 164      |
| statistics .....                   | 58                 |
| Comments .....                     | 236                |
| communication loss.....            | 62                 |
| COMP_K_REG .....                   | 253                |
| COMP_NV_REG .....                  | 254                |

|                                               |            |
|-----------------------------------------------|------------|
| COMP_REG.....                                 | 253        |
| COMP_TMP_REG .....                            | 254        |
| Compare                                       |            |
| Compare FBD Function Block.....               | 275        |
| Compiling .....                               | 294        |
| Computation Blocks .....                      | 274        |
| configurable settings.....                    | 76         |
| configuration checksum .....                  | 62         |
| configuration file.....                       | 168        |
| Connected.....                                | 299        |
| Constant Bit                                  |            |
| Constant Bit FBD Function Block.....          | 277        |
| Constant Word                                 |            |
| Constant Word FBD Function Block .....        | 277        |
| control                                       |            |
| direct transition .....                       | 158, 164   |
| principles.....                               | 146        |
| control channels.....                         | 138        |
| HMI.....                                      | 139        |
| network .....                                 | 140        |
| selecting.....                                | 138        |
| terminal strip.....                           | 139        |
| control circuit                               |            |
| 2-wire.....                                   | 148        |
| 3-wire.....                                   | 148        |
| control transfer mode.....                    | 140        |
| control wiring .....                          | 148        |
| controller                                    |            |
| internal temperature .....                    | 56         |
| internal temperature alarm enable .....       | 57         |
| internal temperature max.....                 | 57         |
| internal trip .....                           | 56         |
| internal trips count.....                     | 69         |
| counter                                       |            |
| Ethernet MB detected error messages sent..... | 213        |
| Ethernet MB messages received.....            | 214        |
| Ethernet MB messages sent .....               | 214        |
| Ethernet open clients.....                    | 213        |
| Ethernet opened servers .....                 | 213        |
| Ethernet received correct frames.....         | 213        |
| Ethernet transmitted correct frames.....      | 213        |
| Counter                                       |            |
| Counter FBD Function Block.....               | 280        |
| COUNTER.....                                  | 263        |
| Counter NV                                    |            |
| Counter NV FBD Function Block .....           | 280        |
| COUNTER_NV .....                              | 264        |
| counters                                      |            |
| communication loss.....                       | 68         |
| internal trips.....                           | 69         |
| current                                       |            |
| average.....                                  | 48         |
| current phase imbalance.....                  | 49, 69, 94 |
| alarm enable.....                             | 95         |
| alarm threshold .....                         | 95         |
| trip enable .....                             | 95         |
| trip threshold.....                           | 95         |
| trip timeout running .....                    | 95         |
| trip timeout starting.....                    | 95         |
| trips count .....                             | 67         |
| current phase loss .....                      | 96         |
| alarm enable.....                             | 97         |
| timeout.....                                  | 97         |
| trip enable .....                             | 97         |
| trips count .....                             | 67         |
| current phase reversal .....                  | 98         |
| phase sequence .....                          | 99         |
| trip enable .....                             | 99         |
| trips count .....                             | 67         |

|                                                |              |                    |     |
|------------------------------------------------|--------------|--------------------|-----|
| current ratio                                  |              | trip timeout ..... | 111 |
| average .....                                  | 48           |                    |     |
| L1 .....                                       | 45           |                    |     |
| L2 .....                                       | 46           |                    |     |
| L3 .....                                       | 45           |                    |     |
| Custom logic editor                            |              |                    |     |
| Boolean logic commands .....                   | 237          |                    |     |
| Commands .....                                 | 236          |                    |     |
| Counter logic commands .....                   | 241          |                    |     |
| Latch logic commands .....                     | 240          |                    |     |
| Math logic commands .....                      | 241          |                    |     |
| Register logic commands .....                  | 238          |                    |     |
| Timer logic commands .....                     | 240          |                    |     |
| custom operating mode .....                    | 168          |                    |     |
| customized program .....                       | 216–217      |                    |     |
| <br>                                           |              |                    |     |
| <b>D</b>                                       |              |                    |     |
| data transfer .....                            | 221          |                    |     |
| date and time .....                            | 69           |                    |     |
| DeviceNet                                      |              |                    |     |
| baud rate .....                                | 184          |                    |     |
| node address .....                             | 184          |                    |     |
| diagnostic                                     |              |                    |     |
| alarm enables .....                            | 58           |                    |     |
| trip .....                                     | 68           |                    |     |
| trip enable .....                              | 58           |                    |     |
| trips count .....                              | 68           |                    |     |
| diagnostic trips                               |              |                    |     |
| wiring trips .....                             | 60           |                    |     |
| diagnostics                                    |              |                    |     |
| Ethernet .....                                 | 209          |                    |     |
| Display                                        |              |                    |     |
| Options .....                                  | 290          |                    |     |
| Division                                       |              |                    |     |
| Division FBD Function Block .....              | 276          |                    |     |
| <br>                                           |              |                    |     |
| <b>E</b>                                       |              |                    |     |
| Error .....                                    | 296          |                    |     |
| Ethernet                                       |              |                    |     |
| basic HW diag validity .....                   | 210          |                    |     |
| device name .....                              | 214          |                    |     |
| diagnostics .....                              | 209          |                    |     |
| frame status .....                             | 212          |                    |     |
| gateway .....                                  | 211          |                    |     |
| gateway address setting .....                  | 186, 214     |                    |     |
| global status .....                            | 210          |                    |     |
| IP address .....                               | 211          |                    |     |
| IP address setting .....                       | 186, 214     |                    |     |
| IP assignment capability .....                 | 214          |                    |     |
| IP assignment operational .....                | 214          |                    |     |
| MAC address .....                              | 212          |                    |     |
| MB detected error messages sent counter .....  | 213          |                    |     |
| MB messages received counter .....             | 214          |                    |     |
| MB messages sent counter .....                 | 214          |                    |     |
| opened clients counter .....                   | 213          |                    |     |
| opened servers counter .....                   | 213          |                    |     |
| primary IP address setting .....               | 194          |                    |     |
| received correct frames counter .....          | 213          |                    |     |
| services status .....                          | 211          |                    |     |
| services validity .....                        | 211          |                    |     |
| subnet mask .....                              | 211          |                    |     |
| subnet mask setting .....                      | 186, 214     |                    |     |
| transmitted correct frames counter .....       | 213          |                    |     |
| external ground current .....                  | 110          |                    |     |
| alarm threshold .....                          | 111          |                    |     |
| trip threshold .....                           | 111          |                    |     |
| <br>                                           |              |                    |     |
| <b>F</b>                                       |              |                    |     |
| fallback                                       |              |                    |     |
| control transition .....                       | 141          |                    |     |
| fallback condition .....                       | 63           |                    |     |
| fast device replacement (FDR) .....            | 203          |                    |     |
| FBD                                            |              |                    |     |
| Resource management .....                      | 288          |                    |     |
| FBD Blocks                                     |              |                    |     |
| Deleting .....                                 | 289          |                    |     |
| Duplicating .....                              | 289          |                    |     |
| Inserting .....                                | 285          |                    |     |
| Linking .....                                  | 286          |                    |     |
| Properties .....                               | 287          |                    |     |
| Selecting .....                                | 289          |                    |     |
| FBD Blocks Properties .....                    | 287          |                    |     |
| FBD editor                                     |              |                    |     |
| Creating an FBD file .....                     | 272          |                    |     |
| Using the FBD language .....                   | 272          |                    |     |
| FBD Elements                                   |              |                    |     |
| Computation Blocks .....                       | 274          |                    |     |
| Function Blocks .....                          | 279          |                    |     |
| Inputs Blocks .....                            | 276          |                    |     |
| Logic Blocks .....                             | 282          |                    |     |
| Outputs Blocks .....                           | 283          |                    |     |
| FBD language .....                             | 272          |                    |     |
| FDR (fast device replacement) .....            | 203          |                    |     |
| FLC .....                                      | 143, 164     |                    |     |
| FLC1 .....                                     | 164          |                    |     |
| FLC2 .....                                     | 164          |                    |     |
| frequency .....                                | 51, 69       |                    |     |
| full load current max .....                    | 69           |                    |     |
| Function Block Diagram .....                   | 272          |                    |     |
| Function Blocks .....                          | 279          |                    |     |
| <br>                                           |              |                    |     |
| <b>G</b>                                       |              |                    |     |
| ground CT                                      |              |                    |     |
| primary .....                                  | 47, 110      |                    |     |
| secondary .....                                | 47, 110      |                    |     |
| ground current .....                           | 46, 107      |                    |     |
| alarm enable .....                             | 107          |                    |     |
| ground trip disabled .....                     | 107          |                    |     |
| mode .....                                     | 46, 107, 110 |                    |     |
| ratio .....                                    | 46           |                    |     |
| trip enable .....                              | 107          |                    |     |
| trips count .....                              | 67           |                    |     |
| ground current ratio .....                     | 69           |                    |     |
| <br>                                           |              |                    |     |
| <b>H</b>                                       |              |                    |     |
| high priority registers                        |              |                    |     |
| mirroring .....                                | 195          |                    |     |
| HMI display temperature sensor degree CF ..... | 51           |                    |     |
| HMI keys                                       |              |                    |     |
| independent operating mode .....               | 155          |                    |     |
| overload operating mode .....                  | 153          |                    |     |
| reverser operating mode .....                  | 158          |                    |     |
| two-speed operating mode .....                 | 167          |                    |     |
| two-step operating mode .....                  | 163          |                    |     |
| HMI port                                       |              |                    |     |
| address setting .....                          | 188          |                    |     |
| baud rate setting .....                        | 188          |                    |     |
| comm loss timeout .....                        | 188          |                    |     |
| fallback setting .....                         | 188          |                    |     |

|                                    |     |                                  |     |
|------------------------------------|-----|----------------------------------|-----|
| parity setting .....               | 188 | AND_K .....                      | 254 |
| trips count .....                  | 69  | AND_NOT_BIT .....                | 246 |
| hysteresis .....                   | 76  | AND_NOT_NV_BIT .....             | 247 |
|                                    |     | AND_NOT_TMP_BIT .....            | 246 |
| <b>I</b>                           |     | AND_NV_BIT .....                 | 246 |
| Initialization .....               | 299 | AND_NV_REG .....                 | 255 |
| Inputs Blocks .....                | 276 | AND_REG .....                    | 255 |
| Inserting FBD Blocks .....         | 285 | AND_TMP_BIT .....                | 245 |
| internal ground current .....      | 107 | AND_TMP_REG .....                | 255 |
| alarm threshold .....              | 109 | CALL_EOM .....                   | 242 |
| trip threshold .....               | 109 | COMP_K_REG .....                 | 253 |
| trip timeout .....                 | 109 | COMP_NV_REG .....                | 254 |
| internal port                      |     | COMP_REG .....                   | 253 |
| trips count .....                  | 69  | COMP_TMP_REG .....               | 254 |
| I/O scanning                       |     | COUNTER .....                    | 263 |
| configuring .....                  | 195 | COUNTER_NV .....                 | 264 |
| IP addressing .....                | 197 | LATCH .....                      | 262 |
|                                    |     | LATCH_NV .....                   | 263 |
| <b>J</b>                           |     | LOAD_BIT .....                   | 243 |
| jam .....                          | 101 | LOAD_K_BIT .....                 | 243 |
| alarm enable .....                 | 102 | LOAD_K_REG .....                 | 252 |
| alarm threshold .....              | 102 | LOAD_NOT_BIT .....               | 244 |
| trip enable .....                  | 102 | LOAD_NOT_NV_BIT .....            | 245 |
| trip threshold .....               | 102 | LOAD_NOT_TMP_BIT .....           | 244 |
| trip timeout .....                 | 102 | LOAD_NV_BIT .....                | 244 |
| trips count .....                  | 67  | LOAD_NV_REG .....                | 253 |
|                                    |     | LOAD_REG .....                   | 252 |
|                                    |     | LOAD_TMP_BIT .....               | 244 |
|                                    |     | LOAD_TMP_REG .....               | 252 |
|                                    |     | LOGIC_ID .....                   | 242 |
|                                    |     | NOP .....                        | 242 |
| <b>L</b>                           |     | ON_ADD .....                     | 265 |
| L1 current highest imbalance ..... | 95  | ON_DIV .....                     | 266 |
| L1 current ratio .....             | 69  | ON_MUL .....                     | 266 |
| L1-L2 highest imbalance .....      | 113 | ON_SET_NV_REG .....              | 259 |
| L1-L2 voltage .....                | 69  | ON_SET_REG .....                 | 259 |
| L2 current highest imbalance ..... | 95  | ON_SET_TMP_REG .....             | 259 |
| L2 current ratio .....             | 69  | ON_SUB .....                     | 265 |
| L2-L3 highest imbalance .....      | 113 | OR_BIT .....                     | 247 |
| L2-L3 voltage .....                | 69  | OR_K .....                       | 256 |
| L3 current highest imbalance ..... | 95  | OR_NOT_BIT .....                 | 248 |
| L3 current ratio .....             | 69  | OR_NOT_NV_BIT .....              | 249 |
| L3-L1 highest imbalance .....      | 113 | OR_NOT_TMP_BIT .....             | 249 |
| L3-L1 voltage .....                | 69  | OR_NV_BIT .....                  | 248 |
| LATCH .....                        | 262 | OR_NV_REG .....                  | 257 |
| LATCH_NV .....                     | 263 | OR_REG .....                     | 256 |
| line currents .....                | 45  | OR_TMP_BIT .....                 | 248 |
| link                               |     | OR_TMP_REG .....                 | 257 |
| ethernet .....                     | 196 | SET_BIT .....                    | 249 |
| Linking FBD Blocks .....           | 286 | SET_NOT_BIT .....                | 250 |
| load shedding .....                | 122 | SET_NOT_NV_BIT .....             | 251 |
| timeout .....                      | 123 | SET_NOT_TMP_BIT .....            | 251 |
| load sheddings count .....         | 71  | SET_NV_BIT .....                 | 250 |
| LOAD_BIT .....                     | 243 | SET_TMP_BIT .....                | 250 |
| LOAD_K_BIT .....                   | 243 | TIMER_K_SEC .....                | 261 |
| LOAD_K_REG .....                   | 252 | TIMER_K_TENTHS .....             | 262 |
| LOAD_NOT_BIT .....                 | 244 | TIMER_SEC .....                  | 260 |
| LOAD_NOT_NV_BIT .....              | 245 | TIMER_TENTHS .....               | 260 |
| LOAD_NOT_TMP_BIT .....             | 244 | XOR_K .....                      | 257 |
| LOAD_NV_BIT .....                  | 244 | XOR_NV_REG .....                 | 258 |
| LOAD_NV_REG .....                  | 253 | XOR_REG .....                    | 258 |
| LOAD_REG .....                     | 252 | XOR_TMP_REG .....                | 258 |
| LOAD_TMP_BIT .....                 | 244 | Logic Commands .....             | 236 |
| LOAD_TMP_REG .....                 | 252 | logic file .....                 | 168 |
| Logic Blocks .....                 | 282 | logic input behavior .....       | 148 |
| Logic command                      |     | independent operating mode ..... | 154 |
| Text view .....                    | 235 | overload operating mode .....    | 152 |
| logic commands                     |     | reverser operating mode .....    | 157 |
| AND_BIT .....                      | 245 | two-speed operating mode .....   | 166 |

|                                          |                 |                                             |                    |
|------------------------------------------|-----------------|---------------------------------------------|--------------------|
| two-step operating mode .....            | 162             | ground current .....                        | 107                |
| logic output behavior .....              | 149             | internal ground current .....               | 107                |
| independent operating mode .....         | 154             | jam .....                                   | 101                |
| overload operating mode .....            | 152             | long start .....                            | 99                 |
| reverser operating mode .....            | 157             | motor temperature sensor .....              | 84                 |
| two-speed operating mode .....           | 167             | motor temperature sensor-NTC analog .....   | 90                 |
| two-step operating mode .....            | 163             | motor temperature sensor-PT100 .....        | 86                 |
| Logic Primitive window .....             | 298             | motor temperature sensor-PTC analog .....   | 88                 |
| Logic Simulator .....                    | 297             | motor temperature sensor-PTC binary .....   | 85                 |
| LOGIC_ID .....                           | 242             | operation .....                             | 75                 |
| long start .....                         | 99              | over power factor .....                     | 135                |
| trip enable .....                        | 100             | overcurrent .....                           | 105                |
| trip threshold .....                     | 100, 144        | overpower .....                             | 131                |
| trip timeout .....                       | 83, 100, 144    | overvoltage .....                           | 120                |
| trips count .....                        | 67              | thermal overload .....                      | 77                 |
|                                          |                 | thermal overload - definite time .....      | 82                 |
|                                          |                 | thermal overload - inverse thermal .....    | 78                 |
|                                          |                 | under power factor .....                    | 133                |
|                                          |                 | undercurrent .....                          | 103                |
|                                          |                 | underpower .....                            | 129                |
|                                          |                 | undervoltage .....                          | 118                |
|                                          |                 | voltage phase imbalance .....               | 112                |
|                                          |                 | voltage phase loss .....                    | 115                |
|                                          |                 | voltage phase reversal .....                | 117                |
|                                          |                 | motor running .....                         | 72                 |
|                                          |                 | motor starting .....                        | 72                 |
|                                          |                 | motor temperature sensor .....              | 69, 84             |
|                                          |                 | alarm .....                                 | 85                 |
|                                          |                 | alarm threshold .....                       | 89, 91             |
|                                          |                 | alarm threshold degree .....                | 88                 |
|                                          |                 | display degree CF .....                     | 88                 |
|                                          |                 | PT100 .....                                 | 86                 |
|                                          |                 | trip enable .....                           | 85                 |
|                                          |                 | trip threshold .....                        | 89, 91             |
|                                          |                 | trip threshold degree .....                 | 88                 |
|                                          |                 | trips count .....                           | 67                 |
|                                          |                 | type .....                                  | 61, 85, 88, 90     |
|                                          |                 | Multiplexer                                 |                    |
|                                          |                 | Multiplexer FBD Function Block .....        | 281                |
|                                          |                 | Multiplication                              |                    |
|                                          |                 | Multiplication FBD Function Block .....     | 276                |
|                                          |                 | <b>N</b>                                    |                    |
|                                          |                 | network port                                |                    |
|                                          |                 | address setting .....                       | 181                |
|                                          |                 | alarm enable .....                          | 187                |
|                                          |                 | baud rate setting .....                     | 181                |
|                                          |                 | comm loss timeout .....                     | 181, 187, 194, 197 |
|                                          |                 | config trips count .....                    | 69                 |
|                                          |                 | endian setting .....                        | 181                |
|                                          |                 | fallback setting .....                      | 182, 187, 194      |
|                                          |                 | FDR auto backup enable .....                | 207                |
|                                          |                 | FDR auto backup period setting .....        | 207                |
|                                          |                 | FDR controller interval .....               | 187                |
|                                          |                 | FDR status .....                            | 207–208            |
|                                          |                 | FDR synchro setting .....                   | 187                |
|                                          |                 | frame type .....                            | 186, 212           |
|                                          |                 | internal trips count .....                  | 69                 |
|                                          |                 | parity setting .....                        | 181                |
|                                          |                 | trip enable .....                           | 187                |
|                                          |                 | trips count .....                           | 69                 |
|                                          |                 | node-ID .....                               | 182–183            |
|                                          |                 | Non Volatile Latch                          |                    |
|                                          |                 | Non Volatile Latch FBD Function Block ..... | 281                |
|                                          |                 | NOP .....                                   | 242                |
|                                          |                 | NOT                                         |                    |
|                                          |                 | NOT FBD Function Block .....                | 282                |
|                                          |                 | NTC analog .....                            | 90                 |
| <b>M</b>                                 |                 |                                             |                    |
| MAC-ID .....                             | 184             |                                             |                    |
| memory                                   |                 |                                             |                    |
| logic memory characteristics .....       | 221             |                                             |                    |
| metering and monitoring functions .....  | 45              |                                             |                    |
| mirroring high priority registers .....  | 195             |                                             |                    |
| Modbus                                   |                 |                                             |                    |
| primary IP .....                         | 193             |                                             |                    |
| motor                                    |                 |                                             |                    |
| auxiliary fan cooled .....               | 77, 80          |                                             |                    |
| full load current ratio .....            | 69, 80, 83, 164 |                                             |                    |
| full load power .....                    | 129, 131        |                                             |                    |
| high speed full load current ratio ..... | 80, 83, 164     |                                             |                    |
| last start current ratio .....           | 71              |                                             |                    |
| last start duration .....                | 71              |                                             |                    |
| LO1 starts count .....                   | 70              |                                             |                    |
| LO2 starts count .....                   | 70              |                                             |                    |
| nominal voltage .....                    | 118, 120        |                                             |                    |
| phases .....                             | 61              |                                             |                    |
| phases sequence .....                    | 117             |                                             |                    |
| predefined operating mode .....          | 148             |                                             |                    |
| starts count .....                       | 70              |                                             |                    |
| starts per hour count .....              | 70              |                                             |                    |
| step 1 to 2 threshold .....              | 159             |                                             |                    |
| step 1 to 2 timeout .....                | 159             |                                             |                    |
| transition timeout .....                 | 158–159, 164    |                                             |                    |
| trip class .....                         | 80              |                                             |                    |
| motor control functions .....            | 138             |                                             |                    |
| motor history .....                      | 70              |                                             |                    |
| last start max current .....             | 71              |                                             |                    |
| last start time .....                    | 71              |                                             |                    |
| motor operating time .....               | 72              |                                             |                    |
| motor starts .....                       | 70              |                                             |                    |
| motor starts per hour .....              | 70              |                                             |                    |
| motor operating mode                     |                 |                                             |                    |
| independent .....                        | 148             |                                             |                    |
| overload .....                           | 148             |                                             |                    |
| reverser .....                           | 148             |                                             |                    |
| two-speed .....                          | 148             |                                             |                    |
| two-step .....                           | 148             |                                             |                    |
| motor phases sequence .....              | 98              |                                             |                    |
| motor predefined operating mode          |                 |                                             |                    |
| independent .....                        | 153             |                                             |                    |
| overload .....                           | 151             |                                             |                    |
| reverser .....                           | 155             |                                             |                    |
| two-speed .....                          | 164             |                                             |                    |
| two-step .....                           | 159             |                                             |                    |
| motor protection functions .....         | 76              |                                             |                    |
| current phase imbalance .....            | 94              |                                             |                    |
| current phase loss .....                 | 96              |                                             |                    |
| current phase reversal .....             | 98              |                                             |                    |
| external ground current .....            | 110             |                                             |                    |

## O

|                             |          |
|-----------------------------|----------|
| on level current .....      | 143      |
| ON_ADD .....                | 265      |
| ON_DIV .....                | 266      |
| ON_MUL .....                | 266      |
| ON_SET_NV_REG .....         | 259      |
| ON_SET_REG .....            | 259      |
| ON_SET_TMP_REG .....        | 259      |
| ON_SUB .....                | 265      |
| operating modes .....       | 146      |
| custom .....                | 168      |
| independent .....           | 153      |
| introduction .....          | 147      |
| overload .....              | 151      |
| reverser .....              | 155      |
| two speed .....             | 164      |
| two-step .....              | 159      |
| operating states .....      | 138, 141 |
| chart .....                 | 142      |
| not ready .....             | 141      |
| protection functions .....  | 142      |
| ready .....                 | 141      |
| run .....                   | 142      |
| start .....                 | 142      |
| operating time .....        | 72       |
| OR                          |          |
| OR FBD Function Block ..... | 282      |
| OR_BIT .....                | 247      |
| OR_K .....                  | 256      |
| OR_NOT_BIT .....            | 248      |
| OR_NOT_NV_BIT .....         | 249      |
| OR_NOT_TMP_BIT .....        | 249      |
| OR_NV_BIT .....             | 248      |
| OR_NV_REG .....             | 257      |
| OR_REG .....                | 256      |
| OR_TMP_BIT .....            | 248      |
| OR_TMP_REG .....            | 257      |
| Outputs Blocks .....        | 283      |
| over power factor .....     | 135      |
| alarm enable .....          | 136      |
| alarm threshold .....       | 136      |
| trip enable .....           | 136      |
| trip threshold .....        | 136      |
| trip timeout .....          | 136      |
| trips count .....           | 67       |
| overcurrent .....           | 105      |
| alarm enable .....          | 106      |
| alarm threshold .....       | 106      |
| trip enable .....           | 106      |
| trip threshold .....        | 106      |
| trip timeout .....          | 106      |
| trips count .....           | 67       |
| overpower .....             | 131      |
| alarm enable .....          | 132      |
| alarm threshold .....       | 132      |
| trip enable .....           | 132      |
| trip threshold .....        | 132      |
| trip timeout .....          | 132      |
| trips count .....           | 67       |
| overvoltage .....           | 120      |
| alarm enable .....          | 121      |
| alarm threshold .....       | 121      |
| trip enable .....           | 121      |
| trip threshold .....        | 121      |
| trip timeout .....          | 121      |
| trips count .....           | 67       |

## P

|                                          |               |
|------------------------------------------|---------------|
| PCode .....                              | 295           |
| power factor .....                       | 53, 69        |
| predefined operating modes               |               |
| control wiring and trip management ..... | 150           |
| primary IP .....                         | 193           |
| PROFIBUS DP                              |               |
| baud rate .....                          | 182           |
| node address .....                       | 182           |
| Program validity .....                   | 302           |
| protection functions .....               | 74            |
| alarms .....                             | 75            |
| communication .....                      | 170           |
| configuration .....                      | 143, 170      |
| current .....                            | 93, 143, 170  |
| customized .....                         | 74            |
| diagnostic .....                         | 143, 170      |
| internal .....                           | 143, 170      |
| motor temperature sensor .....           | 143, 170      |
| operating states .....                   | 142           |
| power .....                              | 129, 143, 170 |
| thermal .....                            | 77            |
| thermal overload .....                   | 143, 170      |
| trips .....                              | 74            |
| voltage .....                            | 112, 143, 170 |
| wiring .....                             | 143, 170      |
| PT100 .....                              | 86            |
| PTC analog .....                         | 88            |
| PTC binary .....                         | 85            |

## R

|                                                |     |
|------------------------------------------------|-----|
| rapid cycle                                    |     |
| lockout .....                                  | 92  |
| lockout timeout .....                          | 92  |
| reactive power .....                           | 54  |
| consumption .....                              | 55  |
| register                                       |     |
| non-volatile register .....                    | 222 |
| register 1200 .....                            | 223 |
| register 1201 .....                            | 224 |
| register 1202 .....                            | 224 |
| register 1203 .....                            | 224 |
| register 1204 .....                            | 224 |
| register 1205 .....                            | 224 |
| registers 1301...1399 .....                    | 224 |
| temporary register .....                       | 222 |
| Register 1200 .....                            | 298 |
| Register 457 .....                             | 298 |
| Register 458 .....                             | 298 |
| Register Bit In                                |     |
| Register Bit In FBD Function Block .....       | 277 |
| Register Bit Out                               |     |
| Register Bit Out FBD Function Block .....      | 283 |
| Register NV Bit In                             |     |
| Register NV Bit In FBD Function Block .....    | 278 |
| Register NV Bit Out                            |     |
| Register NV Bit Out FBD Function Block .....   | 284 |
| Register NV Word In                            |     |
| Register NV Word In FBD Function Block .....   | 278 |
| Register NV Word Out                           |     |
| Register NV Word Out FBD Function Block .....  | 284 |
| Register Temp Bit In                           |     |
| Register Temp Bit In FBD Function Block .....  | 278 |
| Register Temp Bit Out                          |     |
| Register Temp Bit Out FBD Function Block ..... | 284 |
| Register View .....                            | 297 |
| Register Word In                               |     |

|                                            |     |
|--------------------------------------------|-----|
| Register Word In FBD Function Block .....  | 278 |
| Register Word Out                          |     |
| Register Word Out FBD Function Block ..... | 284 |
| Resource management .....                  | 288 |

## S

|                                         |     |
|-----------------------------------------|-----|
| Saving .....                            | 236 |
| Selecting FBD Blocks .....              | 289 |
| SET_BIT .....                           | 249 |
| SET_NOT_BIT .....                       | 250 |
| SET_NOT_NV_BIT .....                    | 251 |
| SET_NOT_TMP_BIT .....                   | 251 |
| SET_NV_BIT .....                        | 250 |
| SET_TMP_BIT .....                       | 250 |
| Simulator .....                         | 297 |
| Start a Trace .....                     | 299 |
| start cycle .....                       | 143 |
| Structured text editor                  |     |
| Editing a structured text file .....    | 233 |
| Using the structured text editor .....  | 233 |
| Structured text program .....           | 233 |
| Subtraction                             |     |
| Subtraction FBD Function Block .....    | 275 |
| system and device monitoring            |     |
| trips .....                             | 55  |
| system and device monitoring trips      |     |
| control command diagnostic errors ..... | 58  |
| system operating status .....           | 72  |
| minimum wait time .....                 | 73  |
| motor state .....                       | 72  |
| system ready .....                      | 72  |

## T

|                                              |                |
|----------------------------------------------|----------------|
| Temp Word In                                 |                |
| Temp Word In FBD Function Block .....        | 279            |
| Temp Word Out                                |                |
| Temp Word Out FBD Function Block .....       | 285            |
| TeSys T                                      |                |
| motor management system .....                | 14             |
| thermal capacity level .....                 | 50, 69, 78, 80 |
| thermal overload .....                       | 77             |
| alarm .....                                  | 80             |
| alarm enable .....                           | 77             |
| alarm threshold .....                        | 80, 83         |
| alarms count .....                           | 68, 80, 83     |
| definite time .....                          | 82             |
| inverse thermal .....                        | 78             |
| mode .....                                   | 77             |
| time to trip .....                           | 64             |
| trip .....                                   | 80             |
| trip definite timeout .....                  | 83             |
| trip enable .....                            | 77             |
| trip reset mode .....                        | 169            |
| trip reset threshold .....                   | 80, 169        |
| trip reset timeout .....                     | 169            |
| trips count .....                            | 67, 80, 83     |
| time to trip .....                           | 64             |
| Timer Seconds                                |                |
| Timer Seconds FBD Function Block .....       | 282            |
| Timer TenthSeconds                           |                |
| Timer TenthSeconds FBD Function Blocks ..... | 282            |
| TIMER_K_SEC .....                            | 261            |
| TIMER_K_TENTHS .....                         | 262            |
| TIMER_SEC .....                              | 260            |
| TIMER_TENTHS .....                           | 260            |
| Toolbox                                      |                |

|                                 |             |
|---------------------------------|-------------|
| Computation Blocks .....        | 274         |
| Function Blocks .....           | 279         |
| Inputs Blocks .....             | 276         |
| Logic Blocks .....              | 282         |
| Outputs Blocks .....            | 283         |
| Transferring                    |             |
| Device custom logic to PC ..... | 300         |
| Execution .....                 | 301         |
| Logic files .....               | 300         |
| trip                            |             |
| reset timeout .....             | 80          |
| trip code .....                 | 69, 177–178 |
| trip counters                   |             |
| protection .....                | 67          |
| trip management .....           | 168         |
| introduction .....              | 168         |
| trip reset mode                 |             |
| automatic .....                 | 172         |
| manual .....                    | 171         |
| remote .....                    | 176         |
| trip statistics .....           | 66          |
| history .....                   | 69          |
| trips count .....               | 67          |

## U

|                                  |     |
|----------------------------------|-----|
| under power factor .....         | 133 |
| alarm enable .....               | 134 |
| alarm threshold .....            | 134 |
| trip enable .....                | 134 |
| trip threshold .....             | 134 |
| trip timeout .....               | 134 |
| trips count .....                | 67  |
| undercurrent .....               | 103 |
| alarm enable .....               | 104 |
| alarm threshold .....            | 104 |
| trip enable .....                | 104 |
| trip threshold .....             | 104 |
| trip timeout .....               | 104 |
| trips count .....                | 68  |
| underpower .....                 | 129 |
| alarm enable .....               | 130 |
| alarm threshold .....            | 130 |
| trip enable .....                | 130 |
| trip threshold .....             | 130 |
| trip timeout .....               | 130 |
| trips count .....                | 68  |
| undervoltage .....               | 118 |
| alarm enable .....               | 119 |
| alarm threshold .....            | 119 |
| trip enable .....                | 119 |
| trip threshold .....             | 119 |
| trip timeout .....               | 119 |
| trips count .....                | 68  |
| user map addresses setting ..... | 189 |
| user map values .....            | 189 |

## V

|                                         |     |
|-----------------------------------------|-----|
| variables                               |     |
| custom logic variables .....            | 222 |
| LTMR variables .....                    | 222 |
| View window .....                       | 298 |
| Volatile Latch                          |     |
| Volatile Latch FBD Function Block ..... | 281 |
| voltage                                 |     |
| average .....                           | 52  |
| L1-L2 .....                             | 51  |

---

|                               |             |
|-------------------------------|-------------|
| L2-L3 .....                   | 51          |
| L3-L1 .....                   | 51          |
| voltage dip                   |             |
| restart threshold .....       | 123, 125    |
| restart timeout .....         | 123, 125    |
| threshold .....               | 123, 125    |
| voltage dip mode .....        | 125         |
| voltage imbalance .....       | 52          |
| voltage mode .....            | 123         |
| voltage phase imbalance ..... | 52, 69, 112 |
| alarm enable .....            | 114         |
| alarm threshold .....         | 114         |
| trip enable .....             | 114         |
| trip threshold .....          | 114         |
| trip timeout running .....    | 114         |
| trip timeout starting .....   | 114         |
| trips count .....             | 68          |
| voltage phase loss .....      | 115         |
| alarm enable .....            | 116         |
| trip enable .....             | 116         |
| trip timeout .....            | 116         |
| trips count .....             | 68          |
| voltage phase reversal .....  | 117         |
| trip enable .....             | 117         |
| trips count .....             | 68, 99, 117 |

## W

|                          |     |
|--------------------------|-----|
| wiring                   |     |
| trip .....               | 60  |
| trip enable .....        | 61  |
| trips count .....        | 68  |
| Workspace                |     |
| Appearance options ..... | 291 |
| Graph options .....      | 291 |
| Options .....            | 290 |

## X

|                   |     |
|-------------------|-----|
| XOR_K .....       | 257 |
| XOR_NV_REG .....  | 258 |
| XOR_REG .....     | 258 |
| XOR_TMP_REG ..... | 258 |

Schneider Electric  
800 Federal Street  
Andover, MA 01810  
USA

888-778-2733

[www.se.com](http://www.se.com)

As standards, specifications, and design change from time to time, please ask for confirmation of the information given in this publication.

© 2014 – 2026 Schneider Electric. All rights reserved.

1672614EN-03