

MZ18B-US

3-Point Valve Actuator



Product Description

The MZ18B-US actuator is specifically designed to provide 3-point control together with the VZ23, VZ33, VZ24 and VZ34 series of small valves.

The MZ18B-US actuator is used in fan-coil-units, induction units, small reheaters and coolers and for zone control applications.

The absence of endswitches or feedback potentiometer ensures longtime reliability.

The MZ18B-US is Underwriter Laboratories Inc. rated for plenum use (UL94-5V).

Specifications

Part number	845-5104
Input voltage	24 Vac + 10 % ...-30 %; 50/60 Hz
Power consumption	0.7 VA
Control mode	floating (3-point)
Stroke	6.5 mm (0.26 in.)
Running time	150 s at 50 Hz
.....	120 s at 60 Hz
Stem force	180 N (40 lbf) for valves DN 15-20
Protection standard	IP 43 in accordance with EN 60529
Insulation class	III in accordance with EN 60730
Connection cable	1.5 m (4.9 ft.)
Coupling ring	M 30 x 1.5
Ambient operating temperature limits	0–60 °C (32–140 °F)
Weight	0.4 kg (0.88 lb.)
Suitable valves	see table on last page

Dimensions (mm)

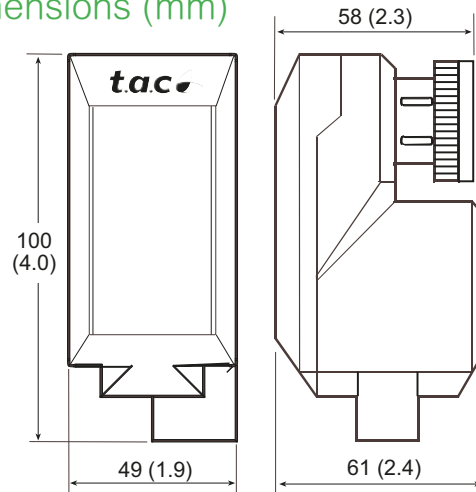

Function

The movement of the electric actuator is produced by a screw spindle which is driven in both directions by a synchronous motor through a set of gears.

A magnetic clutch limits the torque of the gear assembly and the driving force of the actuator. The actuator is fixed to the valve body by means of a coupling ring requiring no tools for mounting.

The actuator is maintenance-free and supplied completely with a ready-to-wire connecting cable.

The movement of the actuator stem indicates whether the valve is opening or closing. (Fig. 1)

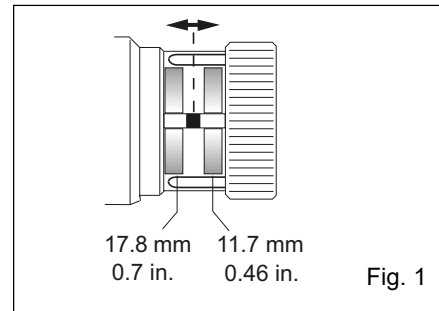

Fig. 1

Mounting Orientation

The actuator may only be mounted beside or above the valve. Adjust the valve in the right position before mounting the actuator. (Fig. 2)

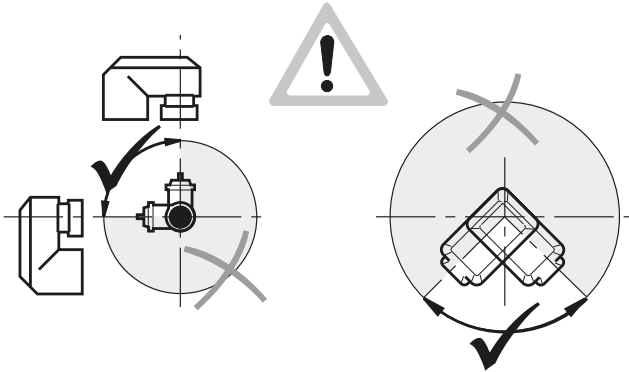

Figure 2

Mounting

Before the actuator is fixed to the valve, the adjustment cap must be removed. Make sure that the actuator is in the open position (factory supplied position) before fixing the actuator to the valve body. (Fig. 3)

The actuator must be mounted by hand. Don't use tools or additional forces, because actuator and valve may be damaged.

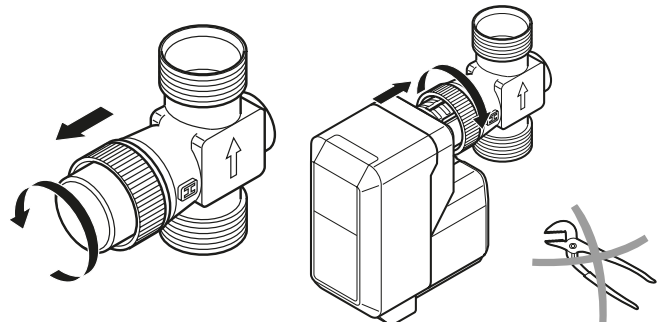

Figure 3

Connections

The electrical installation must comply with the wiring diagram shown in Fig 4.

G0		
Red	Blue	White

Flow Capacities and Close-off Pressure Ratings

Pipe size mm in.	Cv	VZ23, VZ24 two-way		VZ33, VZ34 three-way	
		kPa	psi	kPa	psi
13 ½	0.19	1600	232	–	–
13 ½	0.29	1600	232	790	115
13 ½	0.47	1600	232	790	115
13 ½	0.74	1600	232	790	115
13 ½	1.2	1200	174	250	36
13 ½	1.9	1200	174	250	36
19 ¾	2.9	400	58	235	34
19 ¾	4.9	400	58	235	34