

MZ18A-US

Modulating Valve Actuator



Product Description

The MZ18A-US actuator is specifically designed to provide modulating control together with the VZ23, VZ33, VZ24 and VZ34 series of small linear valves.

The MZ18A-US is used in fan-coil-units, induction units, small reheaters and recoolers, and for zone control applications. The actuator is compatible with controllers providing 0–10 V or 2–10 V output signals.

Reliable longtime operation is ensured due to the fact that no mechanical feedback potentiometer and no mechanical endswitches are needed. Due to an automatic synchro-nization function the close-off point is self-adjusting.

Based on a running time of 125 s, valve positioning and flow adjustment is very exact.

The MZ18A-US is Underwriter Laboratories Inc. rated for plenum use (UL94-5V).

Specifications

Part number	845-5103
Input voltage	24 VAC, ± 15%, 50/60 Hz
Power consumption	1.4 VA
Input signal	modulating 0-10 V, 2-10 V
.....	adjustable <0.1 mA
Operation	direct/reverse (adjustable)
Stroke	6.5 mm (0.26 in.)
Running time	150 s at 50 Hz
.....	125 s at 60 Hz
Stem force	180 N (40 lbf) for valves DN 15–20
Protection class	IP 40 in accordance with EN 60529
Insulation class	III in accordance with EN 60730
Connection cable	1.5 m (4.9 ft.)
Coupling ring	M 30 x 1.5
Ambient operating temp. limits	0 – +60 °C (32–140 °F)
Weight	0.4 kg (0.88 lb.)
Valve close-off ratings	see table on page no. 3

Dimensions mm (in.)

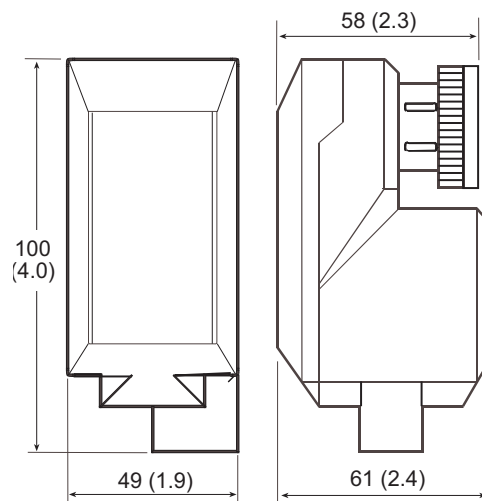

Function

The movement of the electric actuator is produced by a screw spindle which is driven in both directions by a synchronous motor through a set of gears. A magnetic clutch limits the torque of the gear assembly and the driving force of the actuator.

The actuator is fixed to the valve body by means of a coupling ring requiring no tools for mounting.

The actuator is maintenance-free and supplied completely with a ready-to-wire connecting cable.

A microprocessor-based high performance positioner guarantees accurate control.

The close-off position is self adjusting by means of an automatic synchronization function.

Synchronization is carried out when power is switched on and each time the stem reaches 0 % or 100 % of its travel. As long as the synchronization is active the input signal is ignored!

The movement of the actuator stem indicates whether the valve is opening or closing. (Fig. 1)

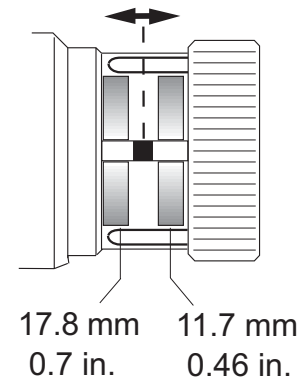

Fig. 1

Mounting

The actuator may only be mounted beside or above the valve. Adjust the valve in the right position before mounting the actuator. (Fig. 2)

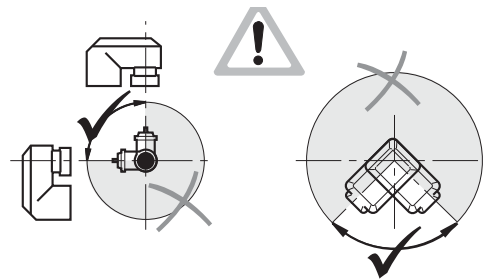

Fig. 2

Mounting

Before the actuator is fixed to the valve, the adjustment cap must be removed. Make sure that the actuator is in the open position (factory supplied position) before fixing the actuator to the valve body. (Fig. 3)

The actuator must be mounted by hand. Don't use tools or additional forces, because actuator and valve may be damaged.

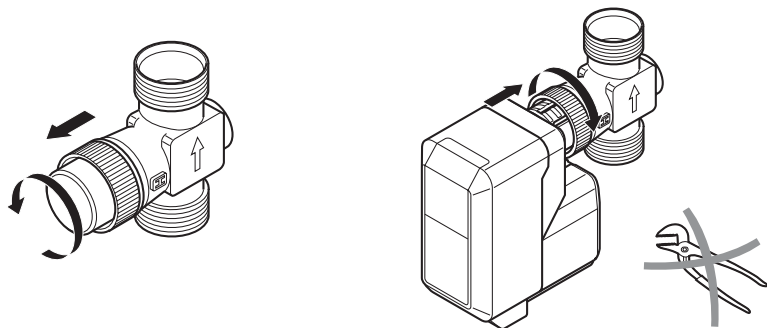

Fig. 3

Connections

The electrical installation must comply with the wiring diagram shown in Fig 4.

A functional check of the valve actuator can be carried out by changing the Y input signal.

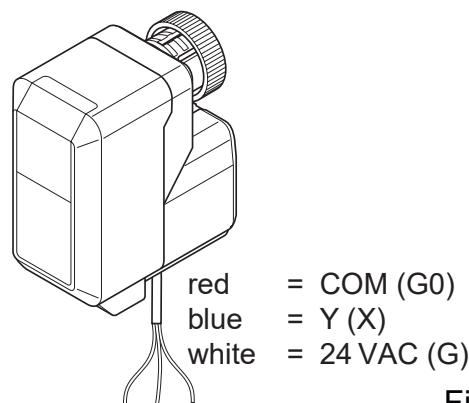
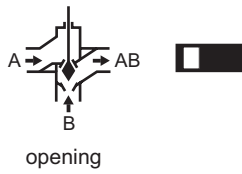
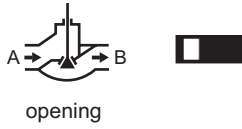

Fig. 4

Switch Selection

Valve Type



Output Signal

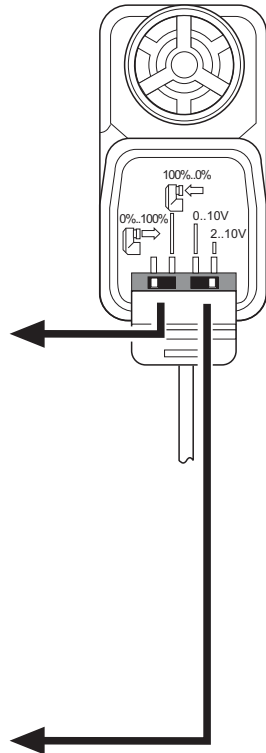

Fig. 5

Valve Data

Flow Capacities and Close off Pressure Ratings

Pipe size mm in.	Cv	VZ23, VZ24 two-way		VZ33, VZ34 three-way	
		kPa	psi	kPa	psi
13 ½	0.19	1600	232	—	—
13 ½	0.29	1600	232	790	115
13 ½	0.47	1600	232	790	115
13 ½	0.74	1600	232	790	115
13 ½	1.2	1200	174	250	36
13 ½	1.9	1200	174	250	36
19 ¾	2.9	400	58	235	34
19 ¾	4.9	400	58	235	34

