

SCP110

Installation

Condensation switch
Kondensationsvakt
Kondensationswächter
Countroleur de condensation
Interruptor de condensacion
Interruttore di condensazione

Instruction
Montageanvisning
Bedienungsanleitung
Instructions d'installation
Instrucciones de empleo
Istruzioni per installazioni

Schneider Electric

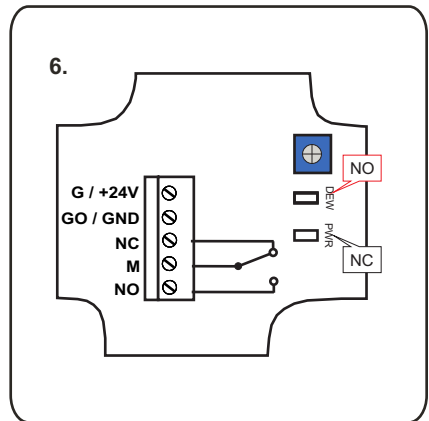
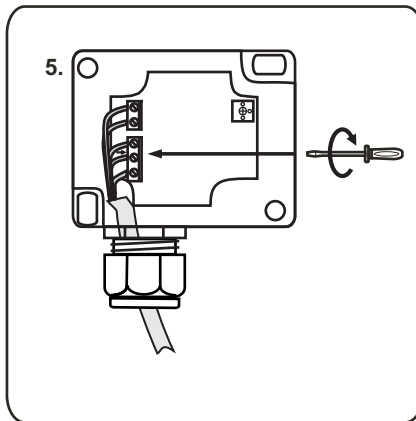
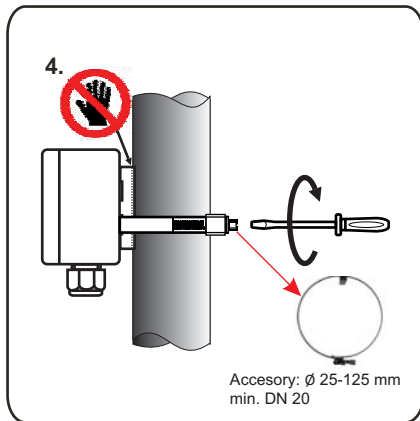
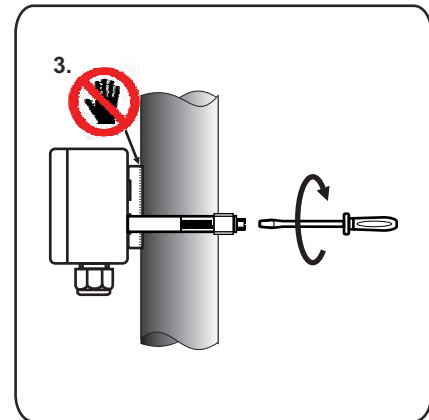
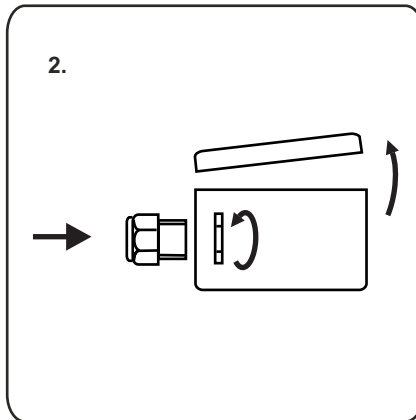
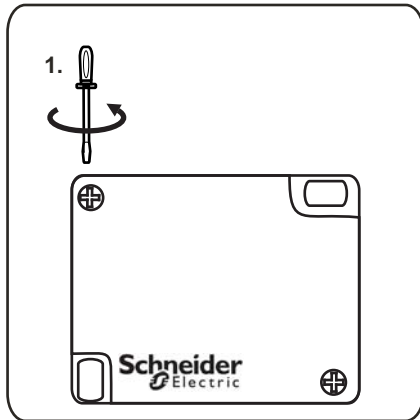

<p>7. Attention!</p> <p>Unscrew terminal block before connecting wires.</p> <p>Switching point: app. 93% r.H. (permanently set)</p> <p>Medium: clean air, non-aggressive, non-flammable gases</p> <p>Installation: The installation position must be selected so that no condensation can get into the sensors in the event of condensation.</p>	<p>OBS!</p> <p>Lossa plintskruven innan du ansluter.</p> <p>Kopplingspunkt: ca 93% RF. (permanent inställd)</p> <p>Medium: Ren luft, icke-aggressiva, icke-brandfarliga gaser</p> <p>Installation: Installationsläget måste väljas så att ingen kondens kan komma in i sensorerna vid kondens.</p>	<p>Achtung!</p> <p>Vor dem Anschließen Klemmblock lösen.</p> <p>Schaltpunkt: ca. 93% r.H. (fest eingestellt)</p> <p>Medium: saubere Luft, nicht aggressive, nicht brennbare Gase</p> <p>Montage: Die Einbaulage ist so zu wählen, dass im Kondensationsfall kein Kondensat in die Sensorik gelangen kann.</p>
<p>Attention!</p> <p>Avant la connexion bornier dissoudre.</p> <p>Point de commutation: environ 93% h.r. (défini en permanence)</p> <p>Moyen: l'air pur, Gaz non agressifs et non inflammables</p> <p>Installation: La position d'installation doit être choisie de manière à ce qu'aucune condensation ne puisse pénétrer dans les capteurs en cas de condensation.</p>	<p>Atencion!</p> <p>Antes de conectar suelte el bloque de terminales.</p> <p>Punto de conmutación: aprox. 93% h.r. (configurado fijo)</p> <p>Medio: aire limpio, gases no agresivos ni inflamables</p> <p>Instalación: La posición de instalación debe seleccionarse de modo que en caso de condensación no pueda entrar en los sensores.</p>	<p>Attenzione!</p> <p>Prima di conettere avvitare il morsetto.</p> <p>Punto di commutazione: ca. 93% r.H. (impostato in modo permanente)</p> <p>Medio: aria pulita, Gas non aggressivi, non infiammabili</p> <p>Installazione: La posizione di installazione deve essere selezionata in modo che la condensa non possa entrare nei sensori in caso di condensa.</p>

SCP110

Installation



Condensation switch
Kondensationsvakt
Kondensationswächter
Countroleur de condensation
Interruptor de condensacion
Interruttore di condensazione

Instruction
Montageanvisning
Bedienungsanleitung
Instructions d'installation
Instrucciones de empleo
Istruzioni per installazioni



部件名称 Part Name	有害物 - Hazardous Substances					
	(Pb)	汞 (Hg)	(Cd)	六价 (Cr (VI))	多溴 苯 (PBB)	多溴二苯醚 (PBDE)
金属部件 Metal parts	O	O	O	O	O	O
塑料部件 Plastic parts	O	O	O	O	O	O
子件 Electronic	X	O	O	O	O	O
触点 Contacts	O	O	O	O	O	O
和 附件 Cables & cabling accessories	O	O	O	O	O	O

本表格依据SJ/T11364的 定 制。

O: 表示 有害物 在 部件所有均 材料中的含量均在GB/T 26572 定的限量要求以下。

X: 表示 有害物 至少在 部件的某一均 材料中的含量超出GB/T 26572 定的限量要求。

(企 可在此处，根据实 情况对上表中打的技术原因 行 一步 明。)



This table is made according to SJ/T 11364.

O: indicates that the concentration of hazardous substance in all of the homogeneous materials for this part is below the limit as stipulated in GB/T 26572.

X: indicates that concentration of hazardous substance in at least one of the homogeneous materials used for this part is above the limit as stipulated in GB/T 26572