

Legal Information

The Schneider Electric brand and any registered trademarks of Schneider Electric Industries SAS referred to in this guide are the sole property of Schneider Electric SA and its subsidiaries. They may not be used for any purpose without the owner's permission, given in writing. This guide and its content are protected, within the meaning of the French intellectual property code (Code de la propriété intellectuelle français, referred to hereafter as "the Code"), under the laws of copyright covering texts, drawings and models, as well as by trademark law. You agree not to reproduce, other than for your own personal, noncommercial use as defined in the Code, all or part of this guide on any medium whatsoever without Schneider Electric's permission, given in writing. You also agree not to establish any hypertext links to this guide or its content. Schneider Electric does not grant any right or license for the personal and noncommercial use of the guide or its content, except for a non-exclusive license to consult it on an "as is" basis, at your own risk. All other rights are reserved.

Electrical equipment should be installed, operated, serviced, and maintained only by qualified personnel. No responsibility is assumed by Schneider Electric for any consequences arising out of the use of this material.

As standards, specifications, and designs change from time to time, please ask for confirmation of the information given in this publication.

Schneider Electric, EverLink, Green Premium, I-Line, Masterpact, Micrologic, PowerPact and Square D are trademarks and the property of Schneider Electric SE, its subsidiaries and affiliated companies. All other trademarks are the property of their respective owners.

Table of Contents

Safety Information.....	5
Masterpact MTZ1 User Guide.....	7
Related Documents	8
Masterpact MTZ1 Description.....	9
Masterpact MTZ1 Range.....	9
Masterpact MTZ1 Fixed Device	10
Masterpact MTZ1 Drawout Device	13
Masterpact MTZ1 Device Identification.....	19
Micrologic X Control Unit Description	23
Go2SE Landing Page	27
Masterpact MTZ1 Operating Conditions	29
Masterpact MTZ1 Normal Operation	31
Masterpact MTZ1 Operation Actions	31
Masterpact MTZ1 Device Operation	31
Masterpact MTZ1 Control Modes	36
Opening Masterpact MTZ Devices	41
Closing Masterpact MTZ Devices.....	43
Resetting Masterpact MTZ Devices.....	45
Conditions for Engaging the ERMS Function.....	46
Masterpact MTZ1 Operating Accessories	48
Masterpact Shunt Close (XF), Shunt Trip (MX) and Undervoltage Release (MN) Accessories	48
Masterpact Shunt Close (XF).....	48
Masterpact Shunt Trip (MX).....	48
Masterpact Undervoltage Release (MN)	48
Masterpact Communicating Internal Isolation Module	49
Masterpact Electrical Closing Pushbutton (BPFE)	49
Masterpact Ready-to-Close Contact (PF).....	49
Masterpact Spring Charging Motor (MCH)	49
Masterpact Electrical Remote Reset (RES).....	50
Masterpact ERMS Switch Module (ESM).....	50
Masterpact Grounding Kit (KMT).....	50
Masterpact Mechanical Operation Counter (CDM).....	50
Masterpact ULP Port Module	51
Masterpact Embedded Ethernet Interface (EIFE)	51
Masterpact Ethernet Interface (IFE) for One Circuit Breaker	52
Masterpact Ethernet Switchboard Server (IFE).....	52
Masterpact IFM Modbus-SL (RTU) Interface for One Circuit Breaker	52
Masterpact IO Input/Output Application Module.....	53
Lifting and Transporting Masterpact MTZ1 Devices	54
Lifting a Masterpact MTZ1 Device	54
Lifting a Masterpact MTZ1 Cradle.....	54
Masterpact MTZ1 Drawout Device Racking	55
Masterpact MTZ1 Drawout Status	55
Masterpact MTZ1 Disconnection.....	59
Masterpact MTZ1 Connection	61

Masterpact MTZ1 Removal from Cradle	63
Masterpact MTZ1 Installation in the Cradle	66
Masterpact MTZ1 Locking Actions	69
Locking the Masterpact MTZ1 Pushbuttons	69
Locking the Masterpact MTZ1 Device Open with Padlocks	71
Locking the Masterpact MTZ1 Device Open with Keylocks	73
Locking the Masterpact MTZ1 Cradle in the Disconnected Position	76
Locking the Masterpact MTZ1 Cradle in Any Position	81
Masterpact MTZ1 Interlocking Actions	87
Masterpact MTZ1 Cradle Rejection Feature	87
Masterpact MTZ1 Door Interlock (VPEC)	89
Masterpact MTZ1 Open-Door Racking Interlock (VPOC)	92
Masterpact MTZ1 Cable-Type Door Interlock (IPA)	94
Masterpact MTZ Critical Cases	95
Finding the Cause of a Masterpact MTZ Trip or Alarm	95
Resetting the Circuit Breaker after a Trip Due to an Electrical Fault	100
Resetting the Circuit Breaker after a Trip Due to an Invalid Micrologic X Control Unit Self-Test	102
Diagnosing Micrologic X Control Unit Alarms	104
Diagnosing Masterpact X Error Messages	109
Masterpact MTZ Commissioning	111
Masterpact MTZ1 Commissioning	111
Masterpact MTZ1 Inspection and Micrologic X Control Unit Settings	113
Masterpact MTZ1 Device Commissioning Tests	115
Masterpact MTZ1 Communication Tests	120
Masterpact MTZ1 Setup Final Checks and Reporting	121
Masterpact MTZ1 Test Form	122
Masterpact MTZ1 Troubleshooting	125
Troubleshooting the Masterpact MTZ1 Device	125
Troubleshooting the Masterpact MTZ Device with Assistance	125
Events Related to a Masterpact MTZ Closing Action	126
Events Related to an Masterpact MTZ Opening Action	126
Events Related to the Masterpact MTZ Cradle	127
Unexpected Tripping of the Masterpact MTZ Device	128
Maintenance of the Masterpact MTZ Device	128
Schneider Electric Green Premium™ Ecolabel	129
Description of the Green Premium Label	129
Accessing the Green Premium Ecolabel	129
Check Product Environmental Criteria	129
Environmental Criteria of the Green Premium Ecolabel	130
RoHs Requirements Compliance	130
REACH Regulation Compliance	130
PEP Ecopassport Compliance	130
EoLI Compliance	130

Safety Information

Hazard Categories and Special Symbols

Read these instructions carefully and look at the equipment to become familiar with the device before trying to install, operate, service, or maintain it. The following special messages may appear throughout this bulletin or on the equipment to warn of hazards or to call attention to information that clarifies or simplifies a procedure.



The addition of either symbol to a “Danger” or “Warning” safety label indicates that an electrical hazard exists which will result in personal injury if the instructions are not followed.



This is the safety alert symbol. It is used to alert you to personal injury hazards. Obey all safety messages that follow this symbol to avoid possible injury or death.

⚠ DANGER

DANGER indicates a hazardous situation which, if not avoided, **will result in** death or serious injury.

⚠ WARNING

WARNING indicates a hazardous situation which, if not avoided, **could result in** death or serious injury.

⚠ CAUTION

CAUTION indicates a hazardous situation which, if not avoided, **could result in** minor or moderate injury.

NOTICE

NOTICE is used to address practices not related to physical injury.

NOTE: Provides additional information to clarify or simplify a procedure.

Please Note

Electrical equipment should be installed, operated, serviced, and maintained only by qualified personnel. No responsibility is assumed by Schneider Electric for any consequences arising out of the use of this material.

A qualified person is one who has skills and knowledge related to the construction, installation, and operation of electrical equipment and has received safety training to recognize and avoid the hazards involved.

FCC Notice

This equipment has been tested and found to comply with the limits for a Class A digital device, pursuant to part 15 of the FCC Rules. These limits are designed to provide reasonable protection against harmful interference when the equipment is operated in a commercial environment. This equipment generates, uses, and can radiate radio frequency energy and, if not installed and used in accordance with the instruction manual, may cause harmful interference to radio communications. Operation of this equipment in a residential area is likely to cause harmful interference in which case the user will be required to correct the interference at his own expense. This Class A digital apparatus complies with Canadian ICES-003.

Masterpact MTZ1 User Guide

Validity Scope

This document applies to Masterpact MTZ1 circuit breakers and switches.

Document Scope

The aim of this guide is to provide users, installers, and maintenance personnel with technical information needed to operate Masterpact™ MTZ1 circuit breakers and switches.

These devices comply with the following standards:

Low-Voltage Power Circuit Breaker (Drawout/Fixed-Mounted)	Insulated Case Circuit Breaker (Drawout/Fixed-Mounted)
ANSI C37.13	UL 489 ²
ANSI C37.16	CSA C22.2 No. 5-02 ³
ANSI C37.17	
ANSI C37.50	
UL1066 ¹	
CSA C22.2 No 311	

The information provided in this documentation contains general descriptions and/or technical characteristics of the performance of the products contained herein. This documentation is not intended as a substitute for and is not to be used for determining suitability or reliability of these products for specific user applications. It is the duty of any such user or integrator to perform the appropriate and complete risk analysis, evaluation and testing of the products with respect to the relevant specific application or use. Neither Schneider Electric nor any of its affiliates or subsidiaries shall be responsible or liable for misuse of the information contained herein. If you have any suggestions for improvements or amendments or have found errors in this publication, please notify Schneider Electric.

No part of this document may be reproduced in any form or by any means, electronic or mechanical, including photocopying, without express written permission of Schneider Electric.

All pertinent state, regional, and local safety regulations must be observed when installing and using this product. For reasons of safety and to help ensure compliance with documented system data, only the manufacturer should perform repairs to components.

When devices are used for applications with technical safety requirements, the relevant instructions must be followed.

Trademarks

Schneider Electric, Square D, Masterpact, Micrologic, Enerlin'X and Ecoeach are trademarks owned by Schneider Electric Industries SAS or its affiliated companies. All other trademarks are the property of their respective owners.

1. cULus
2. UL® Listed
3. CSA® Certified

Related Documents

Title of Documentation	Language	Part Number
Micrologic X Control Unit - User Guide	English	DOCA0102EN
	Spanish	DOCA0102ES
	French	DOCA0102FR
	Chinese	DOCA0102ZH
Masterpact MTZ - Modbus Communication Guide	English	DOCA0105EN
	Spanish	DOCA0105ES
	French	DOCA0105FR
	Chinese	DOCA0105ZH
Masterpact MTZ Circuit Breakers - Maintenance Guide	English	DOCA0099EN
	Spanish	DOCA0099ES
	French	DOCA0099FR
	Chinese	DOCA0099ZH
Masterpact MTZ Circuit Breakers and Switches - Catalog	English	0614CT1701
Enerlin'X IO Input/Output Application Module for One Circuit Breaker - User Guide	English	0613IB1317
	Spanish	0613IB1318
	French	0613IB1319
	Chinese	0613IB1320
Enerlin'X IFE Ethernet Interface for One Circuit Breaker - User Guide	English	DOCA0084EN
	Spanish	DOCA0084ES
	French	DOCA0084FR
	Chinese	DOCA0084ZH
Enerlin'X EIFE Embedded Ethernet Interface for One Masterpact MTZ Drawout Circuit Breaker - User Guide	English	DOCA0106EN
	Spanish	DOCA0106ES
	French	DOCA0106FR
	Chinese	DOCA0106ZH
Enerlin'X FDM128 - Ethernet Display for Eight Devices - User Guide	English	DOCA0037EN
	Spanish	DOCA0037ES
	French	DOCA0037FR
	Chinese	DOCA0037ZH
ULP System - User Guide	English	DOCA0093EN
	Spanish	DOCA0093ES
	French	DOCA0093FR
	Chinese	DOCA0093ZH

You can download these technical publications and other technical information from our website at

<http://www.schneider-electric.com/ww/en/download>

Masterpact MTZ1 Description

Masterpact MTZ1 Range

Masterpact MTZ1 Range Description

The Masterpact MTZ1 range of circuit breakers and switches offers current ratings from 800 to 1600 A, for AC power systems up to 600 Vac. The range is covered by one frame size.

Masterpact MTZ1 devices are available for the following power systems:

- Three-pole (3P)
- Four-pole (4P)

Devices are available in the following installation types:

- Fixed-mounted devices
- Drawout devices

For complete information on available circuit breaker and switch models, frame sizes, interrupting ratings, sensor sizes and trip units, refer to *Masterpact MTZ Circuit Breakers and Switches – Catalog (0614CT1701)*.

Masterpact MTZ1 Range Convention

In this guide, the term Masterpact MTZ device covers circuit breakers and switches.

Masterpact MTZ1 Circuit Breakers

The following performance levels are available:

- H, N, N1: high short-circuit level
- L, L1, LF: extremely high short-circuit level with strong current limitation and significant discrimination

Circuit breakers are fitted with a Micrologic™ X control unit.

For full information about available circuit breaker models, frame sizes, interrupting ratings, sensor ratings, and control units, refer to *Masterpact MTZ Circuit Breakers and Switches – Catalog (0614CT1701)*.

Masterpact MTZ1 Switches

For information about available switch models and frame sizes, refer to *Masterpact MTZ Circuit Breakers and Switches – Catalog (0614CT1701)*.

Masterpact MTZ1 Neutral Position on Four Pole (4P) Devices

On four-pole devices, the neutral is on the left side as standard. A right side neutral version is not available for circuit breakers. For switches, the user can change the neutral position to the right side. A labelling kit is provided with the switch.

Masterpact MTZ1 Fixed Device

Fixed Masterpact MTZ1 Description

The following image shows the standard version of the fixed device.

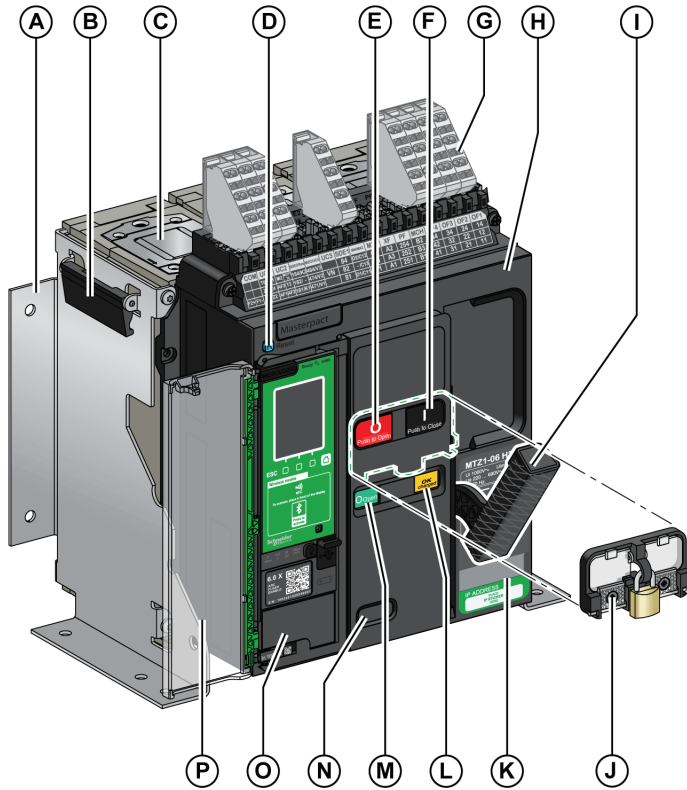

- A. Mounting side plate
- B. Carrying grip
- C. Arc chute
- D. Fault-trip reset button
- E. Opening pushbutton
- F. Closing pushbutton
- G. Terminal blocks for standard accessories
- H. Front cover
- I. Spring charging handle
- J. Pushbutton locking cover (VBP) (optional)
- K. Rating plate
- L. Spring charged and ready-to-close indicator
- M. Main-contacts position indicator
- N. Window to read the (optional) mechanical operation counter (CDM)
- O. Control unit
- P. Control unit transparent cover

Fixed Masterpact MTZ1 Accessories Description

The following image shows the accessories available for the fixed device. For Z1 and Z2, see the following images.

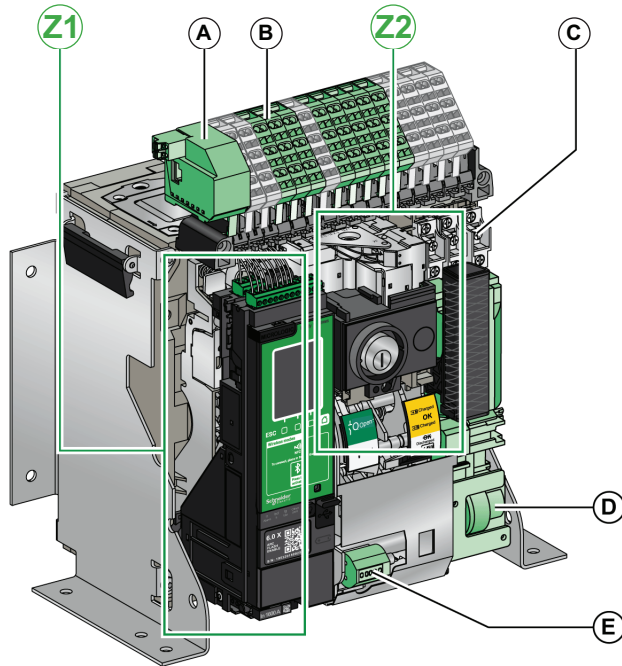

- A. ULP port module
- B. Terminal blocks for optional accessories
- C. Four auxiliary switches (OF) (delivered as standard)
- D. Spring charging motor (MCH)
- E. Mechanical operation counter (CDM)
- F. Standard overcurrent trip switch (SDE1)
- G. Optional overcurrent trip switch (SDE2) or electrical remote reset (RES)
- H. Microswitch
- I. Programmable contacts (M2C)
- J. Isolation module
- K. Undervoltage release (MN) or shunt trip (MX2)
- L. Shunt close (XF)
- M. Shunt trip (MX1)
- N. Ready-to-close contact (PF)
- O. Open-position locking by keylocks (VSPO) (incompatible with BPFE pushbutton)
- P. Open-position locking by padlocks (VCPO)
- Q. Electrical closing pushbutton (BPFE)

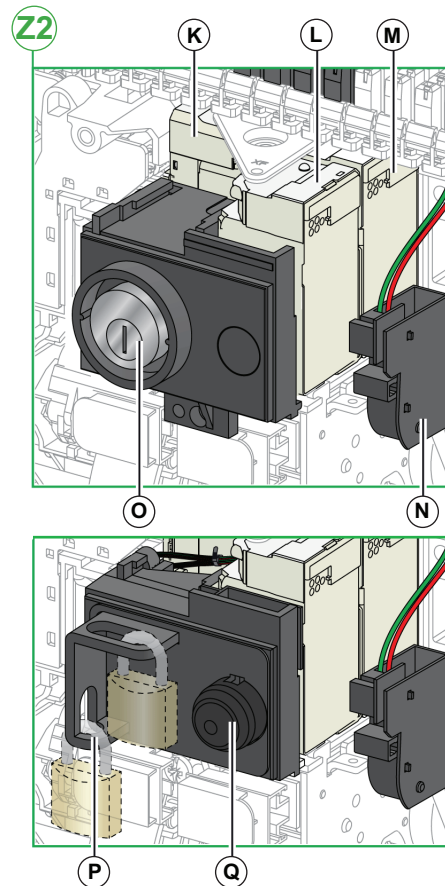
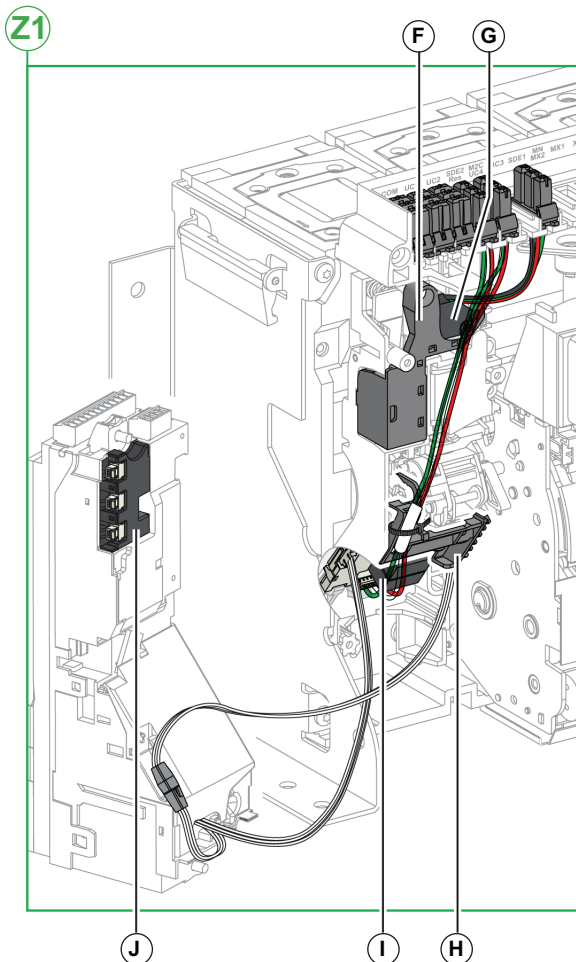

Fixed Masterpact MTZ1 Terminal Block Description

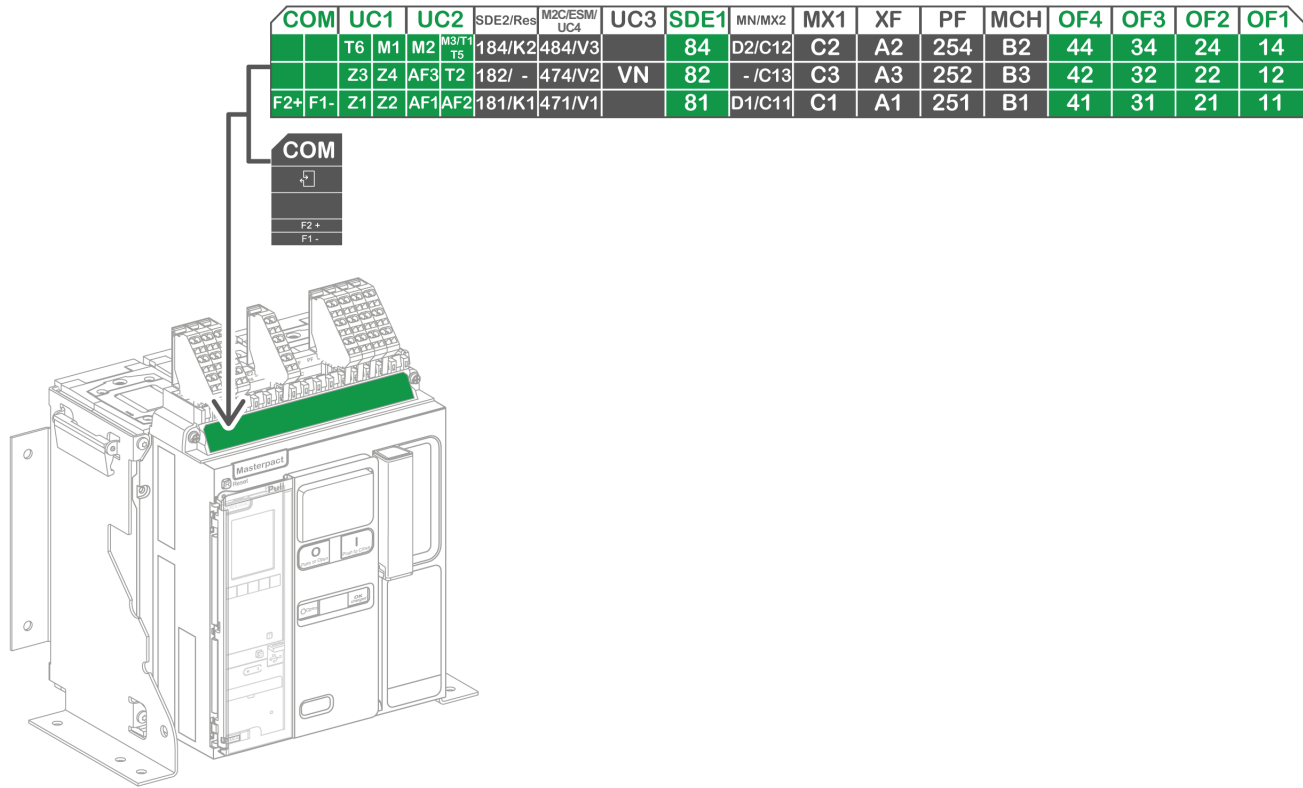

- Terminal block supplied as standard
- Terminal block for optional accessories

Assignment of the Terminal Blocks

Marking	Description	Standard/Optional
COM	Terminal block for the external power supply of the Micrologic X control unit or ULP port module	Standard Optional
UC1	Zone selective interlocking (UC1), rectangular sensor, or MDGF module input	Standard
UC2	Neutral external sensors, rectangular sensor, or MDGF module input	Standard
SDE2/RES	Overcurrent trip switch 2 (SDE2) or electrical remote reset (RES)	Optional
M2C/UC4/ESM	Programmable contacts (M2C) or external voltage connector	Optional
UC3	External voltage connector	<ul style="list-style-type: none"> Standard on 3P devices Optional on 4P devices
SDE1	Overcurrent trip switch 1 (SDE1)	Standard
MN/MX2	Undervoltage release (MN) or shunt trip (MX2)	Optional
MX1	Shunt trip (MX1)	Optional
XF	Shunt close (XF)	Optional
PF	Ready-to-close contact (PF)	Optional
MCH	Spring charging motor (MCH)	Optional
OF21–OF24	4 auxiliary switches (OF)	Standard

Masterpact MTZ1 Drawout Device

Drawout Masterpact MTZ1 Definition

A drawout device is composed of the circuit breaker or switch (the Masterpact device, also called the moving part) and the cradle (or fixed part).

Masterpact MTZ1 Moving Part Description

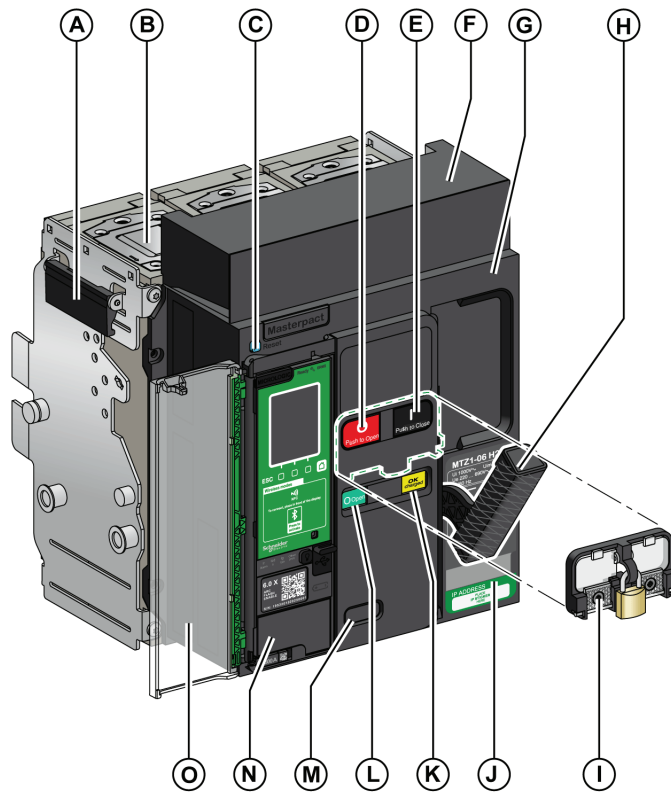

- A. Carrying handle
- B. Arc chute
- C. Fault-trip reset button
- D. Opening pushbutton
- E. Closing pushbutton
- F. Disconnectable contact block cover
- G. Front cover
- H. Spring charging handle
- I. Pushbutton locking cover (VBP) (optional)
- J. Rating plate
- K. Spring charged and ready-to-close indicator
- L. Main-contact position indicator
- M. Window to consult the (optional) mechanical operation counter (CDM)
- N. Control unit
- O. Control unit transparent cover

Drawout Masterpact MTZ1 Accessories Description

The following image shows the accessories available for the moving part of a drawout device. For Z1 and Z2, see the following images.

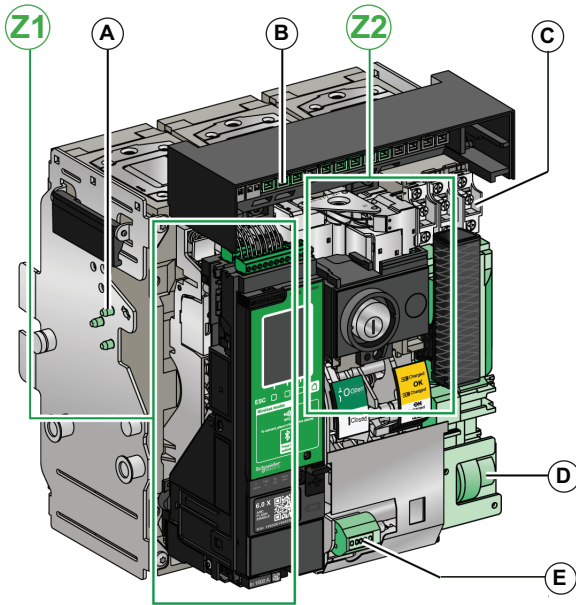

- A. Cradle rejection feature
- B. Disconnectable contact block
- C. Auxiliary switches (OF) (delivered as standard)
- D. Spring charging motor (MCH)
- E. Mechanical operation counter (CDM)
- F. Overcurrent trip switch (SDE1)
- G. Optional overcurrent trip switch (SDE2) or electrical remote reset (RES)
- H. Microswitch
- I. Programmable contacts (M2C)
- J. Isolation module
- K. Undervoltage release (MN) or shunt trip (MX2)
- L. Shunt close (XF)
- M. Shunt trip (MX1)
- N. Ready-to-close contact (PF)
- O. Open-position locking by keylocks (VSPO) (incompatible with BPF E pushbutton)
- P. Open-position locking by padlocks (VCPO)
- Q. Electrical closing pushbutton (BPF E)

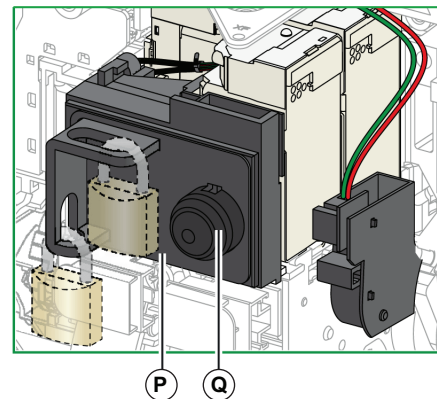
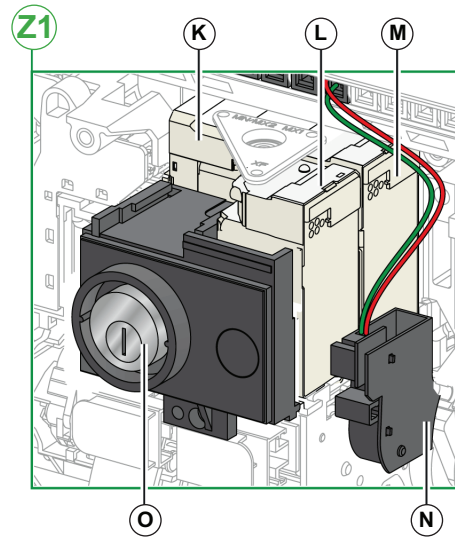
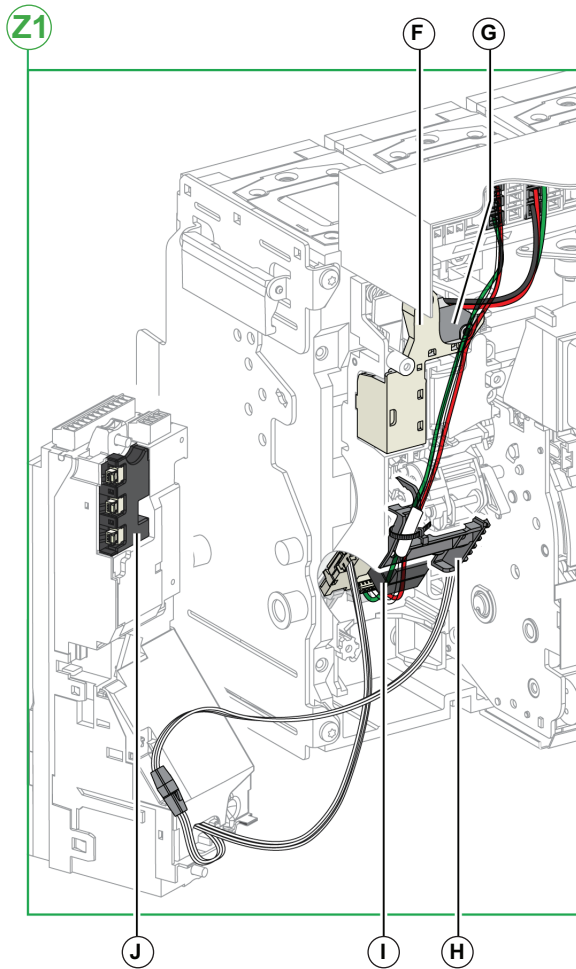

Masterpact MTZ1 Cradle Description

The following image shows the standard cradle.

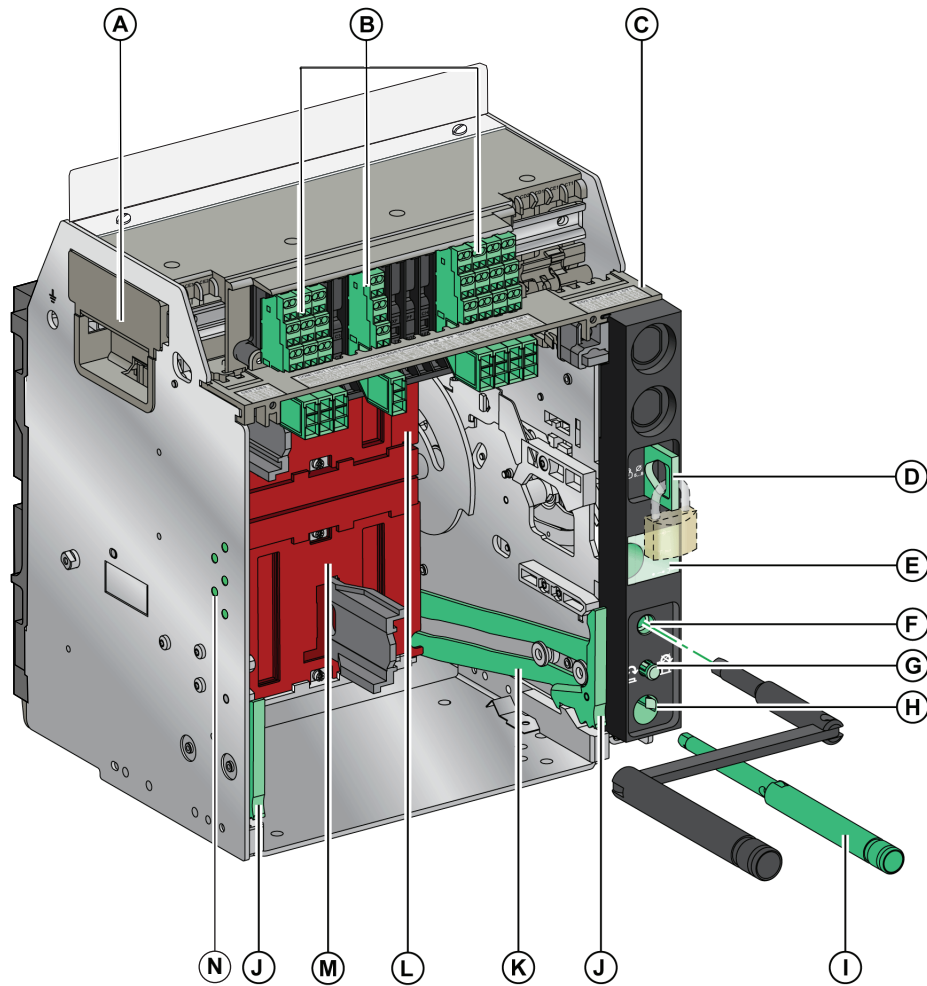

- A. Carrying grip
- B. Terminal blocks for standard accessories
- C. Terminal block identification plate
- D. Cradle locking by padlocks
- E. Moving part position indicator
- F. Racking handle socket
- G. Stop release button
- H. Racking handle storage space
- I. Racking handle
- J. Drawout grip
- K. Extension rail
- L. Top safety shutter (optional for UL/ANSI devices)
- M. Bottom safety shutter (optional for UL/ANSI devices)
- N. Cradle rejection feature (optional for IEC devices)

Masterpact MTZ1 Cradle Accessories Description

Accessories available for the cradle.

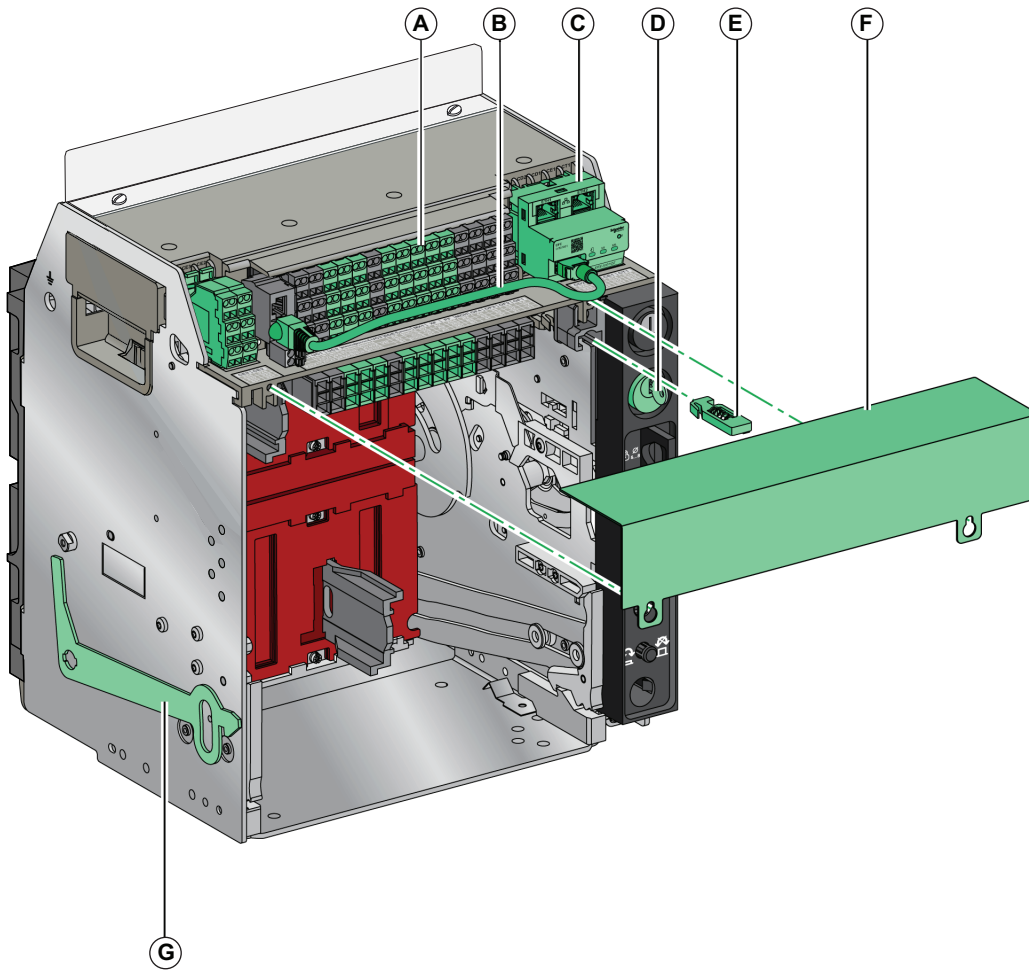

- A. Terminal blocks for optional accessories
- B. Cord between ULP port module and EIFE interface
- C. Embedded Ethernet interface (EIFE)
- D. Cradle locking by keylocks (VSPD)
- E. Open-door racking interlock (VPOC)
- F. Auxiliary terminal shield (CB)
- G. Door interlock (VPEC)

Masterpact MTZ1 Cradle Terminal Block Description

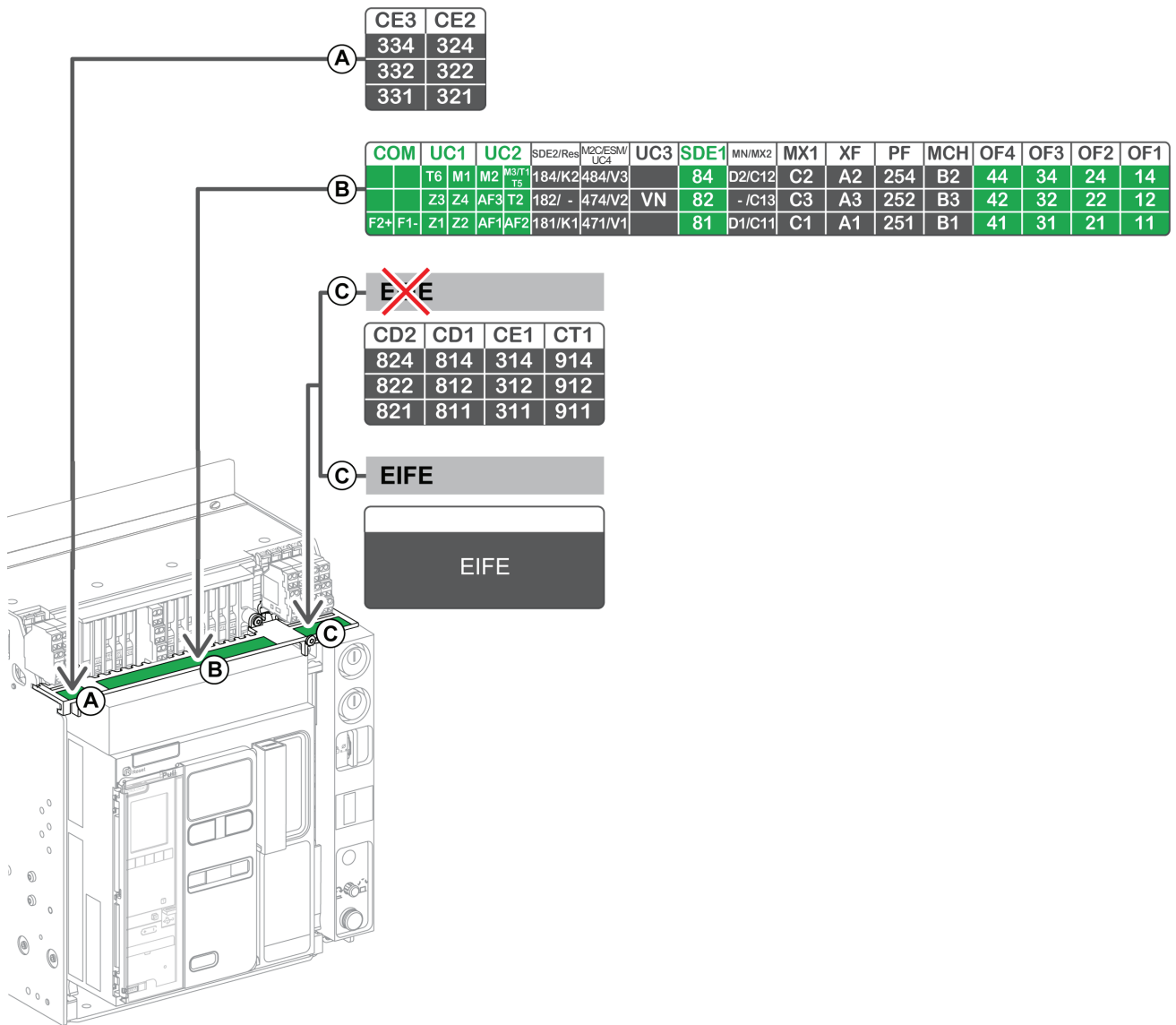

Terminal block supplied as standard



Terminal block for optional accessories

Block	Marking	Description	Standard or optional
A	CE2–CE3	2 connected position contacts (CE)	Optional
B	COM	Terminal block for the external power supply of the Micrologic X control unit or ULP port module	Standard Optional
	UC1	Zone selective interlocking (ZSI), rectangular sensor, or MDGF module input	Standard
	UC2	Neutral external sensors, rectangular sensor, or MDGF module input	Standard
	SDE2/RES	Overcurrent trip switch 2 (SDE2) or electrical remote reset (RES)	Optional
	MTC/UC4/ESM	Programmable contact (M2C) or external voltage connector	Optional
	UC3	Voltage connector	<ul style="list-style-type: none"> • Standard on 3P devices • Optional on 4P devices
	SDE1	Overcurrent trip switch 1 (SDE1)	Standard
	MN/MX2	Undervoltage release (MN) or shunt trip (MX2)	Optional
	MX1	Shunt trip (MX1)	Optional
	XF	Shunt close (XF)	Optional
	PF	Ready-to-close contact (PF)	Optional
	MCH	Spring charging motor (MCH)	Optional
	OF1-OF4	4 auxiliary switches (OF)	Standard
C (no EIFE)	CD1-CD2	2 disconnected position contacts (CD)	Optional
	CE1	1 connected position contact (CE)	Optional
	CT1	1 test position contact (CT)	Optional
D (with EIFE)	EIFE	Embedded Ethernet interface (EIFE)	Optional

Masterpact MTZ1 Device Identification

The Masterpact MTZ1 device can be identified in the following ways:

- Rating plate on device
- QR code on the Micrologic X control unit
- Identification labels on the device and on the cradle

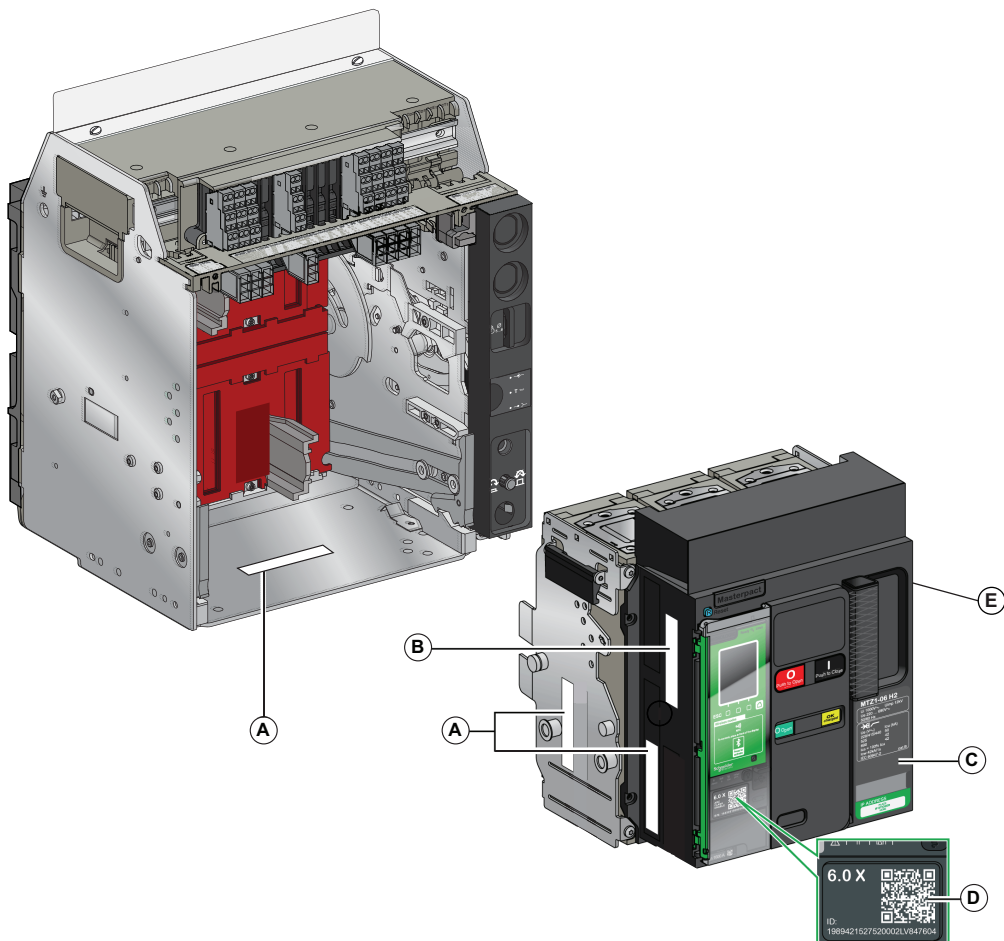

- A. Product identification label
- B. Product checked label
- C. Faceplate plate
- D. QR code
- E. Accessory voltages label

Masterpact MTZ1 Product Identification Label

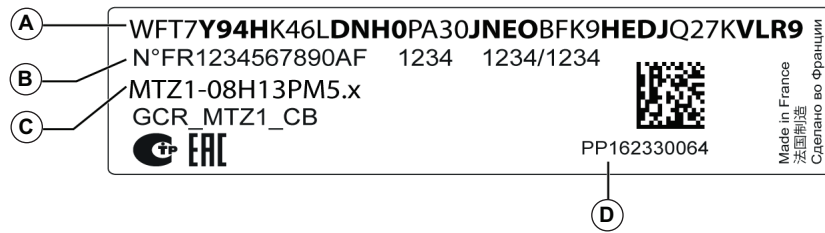

Legend	Description	Explanation
A	Product code	<p>The product code is a line of code representing the complete configuration of a Masterpact circuit breaker or switch-disconnector. The product code:</p> <ul style="list-style-type: none"> • Is automatically generated for each Masterpact device after completing the configuration by using the MyPact configuration tool. • Appears on the invoice and on the delivery documents as well as on the Masterpact device and packaging labels. • Can be entered in the MyPact configuration tool, which generates the complete configuration of the Masterpact device.
B	Schneider Electric internal identification numbers	—
C	Description of device	<p>The following characteristics are specified:</p> <ul style="list-style-type: none"> • Range • Rating • Performance level • Number of poles • Control unit type
D	Device serial number	—

Masterpact MTZ1 Product Checked Label



Legend	Description	Explanation
A	Device serial number	—
B	Device test date code	<p>The device test date code is coded PPLYWWD HH:MM, where:</p> <ul style="list-style-type: none"> • PP: plant code • YY: year of test • WW: week of test • D: day of the week of test (Monday = 1) • HH:MM: the time of test in hours and minutes.

Masterpact MTZ1 Faceplate Label

The faceplate with the device information is located on the front cover of the device.

Circuit Breaker Faceplate

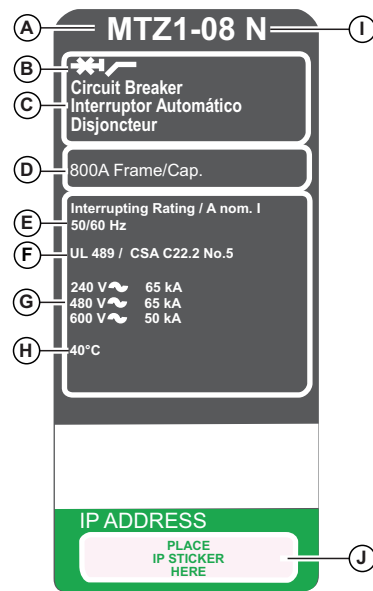

Switch Faceplate

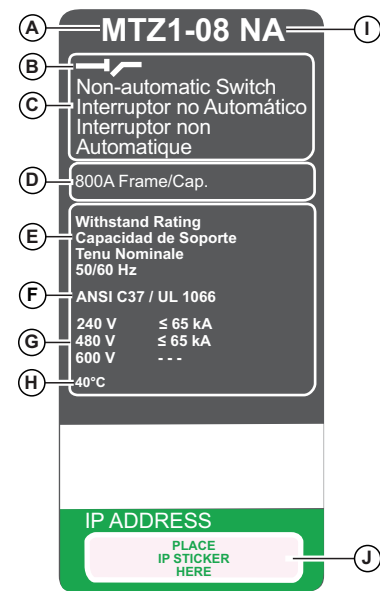

- A. Device size and rated current x 100 A
- B. Device type symbol
- C. Type of device: circuit breaker or switch
- D. Frame size
- E. Frequency
- F. Standard
- G. Interrupting ratings
- H. Temperature rating
- I. Performance level
- J. Place for IP address sticker

Masterpact MTZ1 QR Code

When the QR code on the front face of a Micrologic X control unit is scanned with a smartphone running a QR code reader and connected to the internet, the Go2SE landing page is displayed (see *Go2SE Landing Page Description, page 27*). The landing page displays some information about the device and a list of menus.

Masterpact MTZ1 Side Label

The accessory side label gives the accessories which have been installed in the device, and the voltages of the installed accessories which need to be connected to a power supply.

Cust.	Fact.	Aux.
	X	COM
	X	PTE
		M2C
		SDE2
		RES
	X	SDE1
		MN
		MX2
	24 30V $\overline{=}$	MX1
	24 30V $\overline{=}$	XF
	X	PF
	24 30V $\overline{=}$	MCH
		OF
		ESM

Micrologic X Control Unit Description

The Micrologic X control unit includes:

- Micrologic X status LEDs.
- A local HMI comprising a graphic display with colored backlight, contextual buttons, and dedicated buttons.
- LEDs to monitor circuit breaker operations as well as the source of trips and alarms.

Control Unit Layout

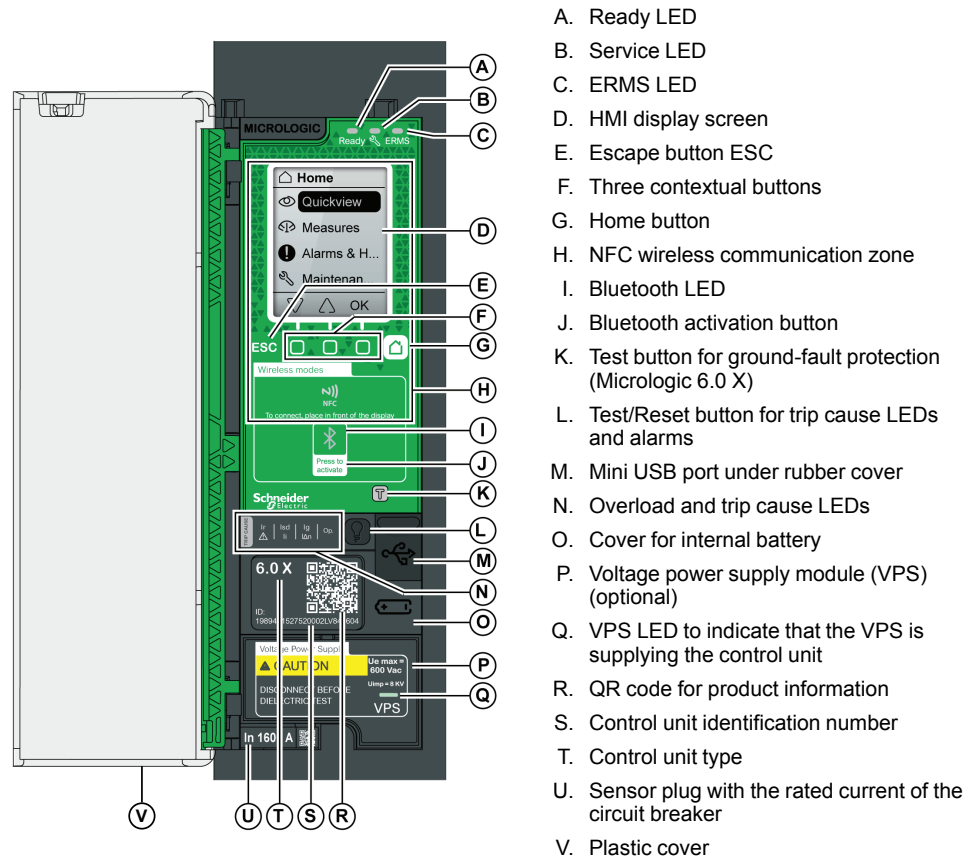

Micrologic X Status LEDs

LED	Description
Ready	The Ready LED flashes when the control unit is ready to provide standard protection.
	The service LED indicates the overall health of the circuit breaker: <ul style="list-style-type: none"> • Unlit LED: the circuit breaker is in good working order • Orange LED: non-urgent alert message • Red LED: alert message that requires immediate action
ERMS	The ERMS (Energy Reduction Maintenance Setting) LED has the following statuses: <ul style="list-style-type: none"> • Blue LED: ERMS engaged • Off LED: ERMS disengaged

Local HMI Display Screen with Contextual and Dedicated Buttons

Use the local HMI screen and buttons to:

- Navigate the menu structure
- Display monitored values
- Access and edit configuration settings

NFC Communication Zone

Use the NFC communication zone to create an NFC connection between a smartphone running the Masterpact MTZ Mobile App and the Micrologic X control unit. When the connection is established, the circuit breaker operating data is automatically uploaded to the smartphone.

Bluetooth Activation Button and LED

Use the Bluetooth activation button to create a Bluetooth low-energy connection between a smartphone running the Masterpact MTZ Mobile App and the Micrologic X control unit. When the connection is established, the circuit breaker can be monitored and controlled from the smartphone.

The Bluetooth LED blinking indicates that a Bluetooth device is in communication.

Micrologic X Control Unit Test Button

Use the test button to test the ground-fault protection for Micrologic 6.0 X control units.

Micrologic X Control Unit Test/Reset Button

The Test/Reset button performs the following functions:

- Test internal battery or check LED functionality: press and hold the Test/Reset button for less than three seconds, the four trip cause LEDs switch off for one second. One of the following results:
 - The four trip cause LEDs switch on for two seconds: the battery is OK.
 - The four trip cause LEDs flash sequentially for two seconds: the battery is near the end of its life. Replace the battery.
 - The four trip cause LEDs do not light: replace the battery.
- Reset: press and hold the Test/Reset button for more than three seconds to reset the control unit. The trip cause LEDs and the service LED switch off.

NOTE: When the Micrologic X control unit is not powered by an external 24 Vdc power supply or through a USB connection, the Micrologic X control unit can be restarted by pressing and holding the Test/Reset button for 15 seconds. The standard protection functions remain active during the restart.

Micrologic X Control Unit Mini USB Port







Remove the rubber cover of the mini USB port to connect the following devices:

- A Mobile Power Pack to supply power to the Micrologic X control unit.
- A smartphone running the Masterpact MTZ Mobile App through USB OTG connection.
- A PC equipped with Ecoreach software.

NOTE: The Micrologic X control unit does not support USB keys. Even if a USB key is connected using an adaptor, data is not transferred.

Micrologic X Control Unit Overload and Trip Cause LEDs

The indications of the four trip cause LEDs depend on the type of control unit.

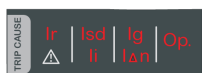
LEDs	Description
	Micrologic 3.0 X, 5.0 X, 6.0 X: Overload pre-alarm, the load exceeds 90% and is lower than 105% of the Ir setting of the long-time protection.
	Micrologic 3.0 X, 5.0 X, 6.0 X: Overload alarm, the load exceeds 105% of the Ir setting of the long-time protection.
	Micrologic 3.0 X, 5.0 X, 6.0 X: Trip due to long-time protection.
	Micrologic 3.0 X: Trip due to instantaneous protection. Micrologic 5.0 X, 6.0 X: Trip due to short-time protection or instantaneous protection.
	Micrologic 3.0 X, 5.0 X: Not used. Micrologic 6.0 X: Trip due to ground-fault protection.
	Micrologic 3.0 X, 5.0 X, 6.0 X: Trip due to other protection (optional protections activated via digital modules).
	Micrologic 3.0 X, 5.0 X, 6.0 X: Invalid Micrologic control unit self-test

NOTE: If the Micrologic X control unit is not powered, the trip cause LEDs go off after four hours. After this period, press the Test/Reset button to light them again.

Micrologic X Internal Battery

The internal battery powers the trip cause LEDs and the main diagnostic functions in the absence of any other power supply.

Micrologic X VPS Voltage Power Supply Module

The optional VPS power supply module provides an internal voltage supply to the Micrologic X control unit.

Micrologic Control Unit QR Code

When the QR code on the front face of a Micrologic X control unit is read with a smartphone running a QR code reader and connected to the internet, the Go2SE landing page is displayed (see *Go2SE Landing Page, page 27*). The landing page displays information about the device and a list of menus.

Micrologic X Control Unit Identification Number

The identification number consists of:

- The serial number of the Micrologic X control unit in the format FFFFFFFYYWDXXXXX.
- The commercial reference of the control unit in the format LV8XXXX.

Use the identification number to register the Micrologic X control unit.

Registering the Micrologic X control unit enables up-to-date record keeping and traceability.

Micrologic X Control Unit Type

This code indicates the type of Micrologic control unit:

- The number (for example, 3.0) defines the types of protection provided by the control unit.
- The letter (X) identifies the range.

Micrologic X Sensor Plug

The protection ranges depend on the rated current I_n , defined by the sensor plug present below the Micrologic X control unit.

Go2SE Landing Page

Go2SE Presentation

When the QR code on the front face of a Micrologic X control unit is read with a smartphone running a QR code reader and connected to the Internet, the Go2SE landing page is displayed. The landing page displays information about the device and a list of menus.

Go2SE Landing Page Description

The landing page is accessible from Android and iOS smartphones. It displays the same list of menus with slight differences in presentation.

The following example shows the landing page displayed on an Android smartphone:

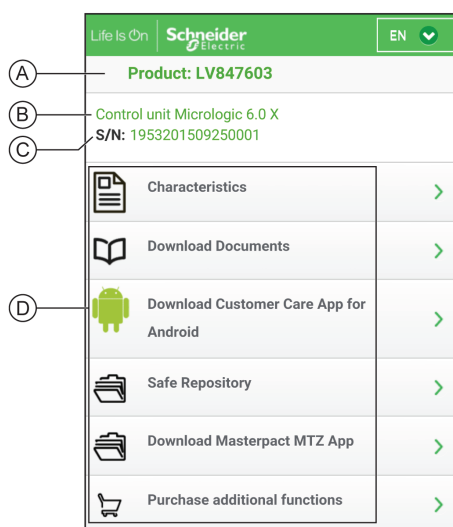

- A. Commercial reference of Micrologic X control unit
- B. Type of Micrologic X control unit
- C. Serial number of Micrologic X control unit
- D. Landing page menus. See the following menu descriptions for details.

Go2SE Characteristics

Select “Go2SE Characteristics” to access a product datasheet with detailed information about the Micrologic X control unit.

Go2SE Download Documents

Select “Go2SE Download Documents” to access documentation, including the following:

- Micrologic X Control Unit - User Guide
- Masterpact MTZ1 Circuit Breakers and Switches - User Guide
- Masterpact MTZ2/MTZ3 Circuit Breakers and Switches - User Guide
- Instruction sheets for Masterpact MTZ devices and Micrologic X control units

Go2SE Download Customer Care App

Select “Go2SE Download Customer Care App” to access the Schneider Electric customer care mobile application mySchneider that can be downloaded on Android and iOS smartphones. The customer care application offers self-service instructions and easy access to expert support and information.

Go2SE Download EcoStruxure Facility Expert App

Select “Go2SE Download EcoStruxure Facility Expert App” to access the EcoStruxure Facility Expert mobile application that can be downloaded on Android and iOS smartphones. For smartphone compatibility, check on an application store.

The EcoStruxure Facility Expert mobile application is designed to:

- Make operations simpler, more effective, and more convenient.
- Make processes and assets more reliable.

Go2SE Safe Repository

Select “Go2SE Safe Repository” to access a web service allowing documentation linked to assets to be consulted, stored, and shared in a Schneider Electric environment. Access to the safe repository is restricted to authorized users.

Safe Repository gives access to the bill of materials of the Masterpact MTZ device.

Go2SE Download Masterpact MTZ Mobile App

Select “Go2SE Download Masterpact MTZ Mobile App” to access the Masterpact MTZ Mobile App that can be downloaded and installed on Android and iOS smartphones.

Go2SE Purchase Additional Features

Select “Go2SE Purchase Additional Features” to access the GoDigital marketplace webpage. Digital Modules are available for purchase in the marketplace.

Masterpact MTZ1 Operating Conditions

Masterpact MTZ devices are designed and tested for operation in industrial atmospheres. It is recommended that equipment be cooled or heated to the proper operating temperature and kept free of excessive vibration and dust.

Masterpact MTZ—Ambient Temperature

Masterpact MTZ devices can operate under the following temperature conditions:

- Electrical and mechanical characteristics specified for an ambient temperature of -25°C to $+70^{\circ}\text{C}$ (-13°F to $+158^{\circ}\text{F}$).
- Circuit breaker closing specified down to -35°C (-31°F) by manual operation with closing pushbutton.

Storage conditions are as follows:

- -40°C to $+85^{\circ}\text{C}$ (-40°F to $+185^{\circ}\text{F}$) for the device without the control unit.
- -25°C to $+85^{\circ}\text{C}$ (-13°F to $+185^{\circ}\text{F}$) for the control unit.

Masterpact MTZ—Extreme Atmospheric Condition

Masterpact MTZ devices have successfully passed tests for extreme atmospheric conditions, defined by the following standards:

Standard	Title
IEC 60068-2-1	Dry cold, at -40°C (-40°F)
IEC 60068-2-2	Dry heat, at $+85^{\circ}\text{C}$ ($+185^{\circ}\text{F}$)
IEC 60068-2-30	Damp heat (temperature $+55^{\circ}\text{C}$ ($+131^{\circ}\text{F}$), relative humidity 95%)
IEC 60068-2-52 level 2	Salt mist

Masterpact MTZ—Industrial Environments

Masterpact MTZ devices can operate in the industrial environments defined by IEC 60947 (pollution degree up to 3).

Check that devices are installed in suitably cooled switchboards without excessive dust.

Conditions	Standard
Corrosive industrial atmospheres	Category 3C3 compliant with IEC 60721-3-3
Sea salts 0.8 to 8 mg/m ² day average over the year	Compliant with IEC 60721-2-5
Mechanically active substances	Category 3S3 compliant with IEC 60721-3-3

Beyond these conditions, Masterpact MTZ devices must be installed inside switchboards with an IP rating equal to or greater than IP54.

Masterpact MTZ—Vibration

Masterpact MTZ devices have successfully passed tests for the following vibration levels, in compliance with IEC 60068-2-6 and IEC 60068-2-27:

- 2 Hz to 13.2 Hz: amplitude +/- 1 mm.
- 13.2 Hz to 100 Hz: constant acceleration of 0.7 g.

Masterpact MTZ—Altitude

Masterpact MTZ devices are designed and tested to operate at altitudes below 2,000 m (6562 ft.).

At altitudes above 2,000 m (6562 ft.), the characteristics of the ambient air (electrical resistance, cooling capacity) lower product characteristics as follows:

Characteristics	Altitude			
	2,000 m (6,562 ft.)	3,000 m (9,843 ft.)	4,000 m (13,123 ft.)	5,000 m (16,505 ft.)
Impulse withstand voltage (kV)	12	11	10	8
Rated insulation voltage (V)	1,000	900	780	700
Maximum rated operational voltage 50/60 Hz (V)	690	690	630	560
Rated current (A) at 40°C (104°F)	1 x In	0.99 x In	0.96 x In	0.94 x In

NOTE: Intermediate values can be obtained by interpolation.

Masterpact MTZ—Electromagnetic Disturbances

Masterpact MTZ devices have protection against:

- Overvoltages caused by devices that generate electromagnetic disturbance.
- Overvoltages caused by atmospheric disturbance or by a distribution-system outage (for example, a lighting system outage).
- Devices emitting radio waves (for example, radio transmitters, walkie-talkies, or radar).
- Electrostatic discharge produced by users.

Masterpact MTZ devices have successfully passed the electromagnetic-compatibility tests (EMC) defined by IEC 60947-2, appendix F.

The devices have passed the above tests and therefore:

- Nuisance tripping from electromagnetic interference does not occur.
- Tripping times are respected.

Masterpact MTZ1 Normal Operation

Masterpact MTZ1 Operation Actions

Masterpact MTZ1 Device Operation

Masterpact MTZ1 Device Status Indication

The indicators on the front of the device show the following information:



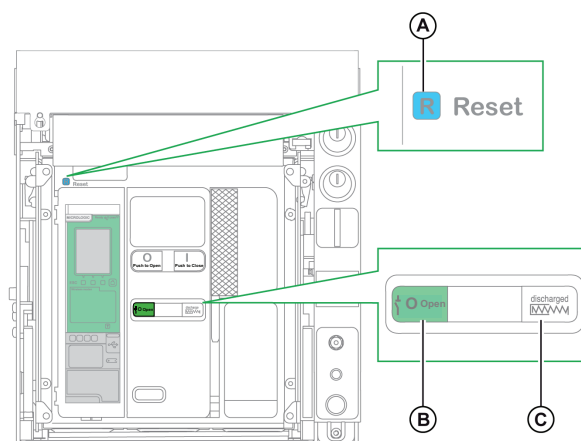





- Reset button:
 - In: the device is closed or open voluntarily (not tripped).
 - Out: the device has tripped.
- Position indicator of main contacts: Open or Closed.
- Closing spring and ready-to-close indicator. The state can be one of the following:
 - Discharged (no energy to close the circuit breaker).
 - Charged not ready-to-close.
 - Charged ready-to-close.



- A. Reset button
- B. Position indicator of main contacts
- C. Closing spring and ready-to-close indicator

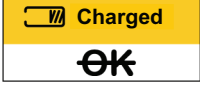

The combination of both indicators gives the device status.

Masterpact MTZ1 Device Status Description

Position Indicator of Main Contacts	Closing Spring and Ready-to-Close Indicator	Device Status Description
		<p>Device is off (contacts are open) and closing spring is discharged.</p>
		<p>Device is off (contacts are open) and closing spring is charged. The device is not ready-to-close because at least one of the following conditions is true:</p> <ul style="list-style-type: none"> • The device has tripped and must be reset. • The shunt trip (MX) is energized. • The undervoltage release (MN) is not energized. • The device is mechanically locked (by using padlock and/or keylock or by using interlocking cables) in the open position.
		<p>Device is off (contacts are open) and closing spring is charged.</p> <p>The device is ready-to-close.</p>
		<p>Device is on (contacts are closed) and closing spring is discharged.</p>
		<p>Device is on (contacts are closed) and closing spring is charged.</p> <p>The device is not ready-to-close because it is already closed.</p>

Masterpact MTZ1 Auxiliary Switches (OF)

The position of the device main contacts is indicated by auxiliary switches (OF).

Name	Contact Number	Position of Indicators and Auxiliary Switches		
		ON	OFF	Tripped (by Micrologic X control unit)
Device status	—	ON	OFF	Tripped (by Micrologic X control unit)
Position indicator of main contacts	—	 Closed	 Open	 Open
Main contact position	—	Closed	Open	Open
Reset button position	—	IN	IN	OUT
Auxiliary switches (OF)	1–2	Open	Closed	Closed
	1–4	Closed	Open	Open
Overcurrent trip switch (SDE)	1–2	Closed	Closed	Open
	1–4	Open	Open	Closed

Masterpact MTZ1 Anti-Pumping Function

Masterpact MTZ devices provide a mechanical anti-pumping function. In the event of simultaneous maintained opening and closing orders, the standard mechanism blocks the main contacts in the open position. After a trip due to an electrical fault or intentional opening using the manual or electrical controls, the closing order must first be discontinued, then reactivated to close the circuit breaker. This prevents a cycle of closing and opening.

When remote operation features are used, allow at least four seconds for the spring charging motor (MC) to charge the device closing spring completely before actuating the shunt close (XF).

To prevent the device from closing prematurely, the ready-to-close contact (PF) can be connected in series with the shunt close (XF).

Masterpact MTZ1 Closing Spring Charging

The closing spring must be charged with sufficient energy to close the Masterpact MTZ:

- Manual charge: Charge the mechanism by pulling the spring charging handle down seven times.

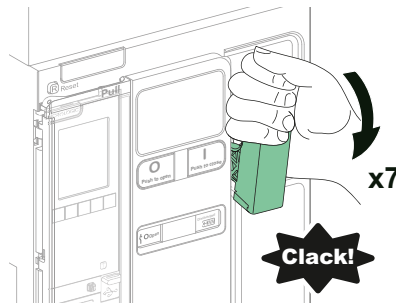

- Automatic charge: If the optional spring charging motor (MCH) is installed, the spring is automatically charged after closing.

Masterpact MTZ Manual Operation with the Spring Charging Handle

The following image shows an Open/Close/Open (OCO) cycle for manually charged devices without an spring charging motor (MCH):

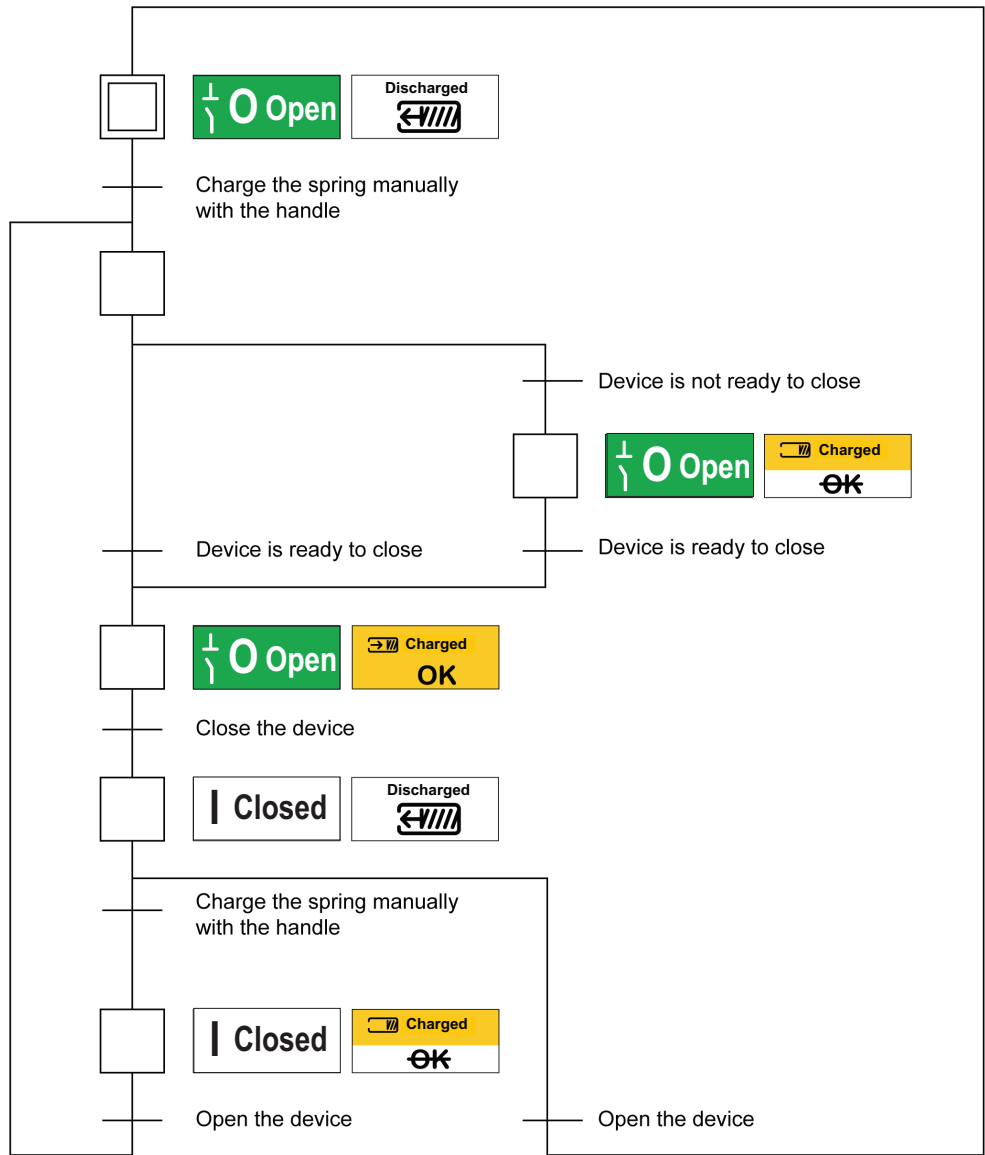

Masterpact MTZ Electrical Operation with a Spring Charging Motor (MCH)

The following image shows an Open/Close/Open (OCO) cycle for electrically charged devices using a spring charging motor (MCH):

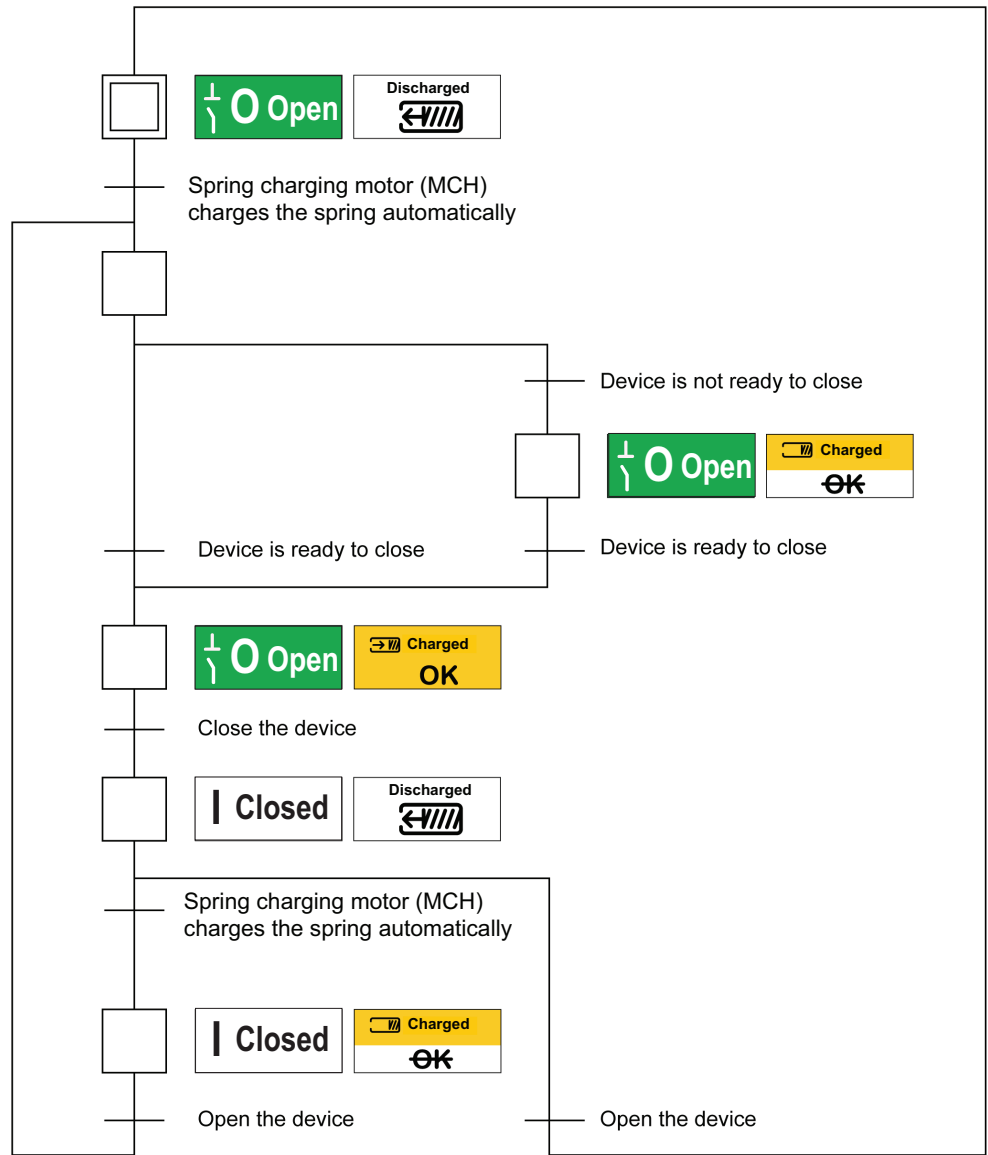

Masterpact MTZ1 Control Modes

The control mode of the Micrologic X control unit sets how the opening and closing functions of the circuit breaker are controlled.

Two control modes are available: Manual and Auto.

Manual mode only accepts orders made using one of the following:

- The mechanical buttons on the front of the circuit breaker.
- The external pushbutton connected to the undervoltage release (MN)/shunt trip (MX)/shunt close (XF).
- The electrical closing pushbutton (BPFE).

Auto mode has two settings: Local or Remote. All orders accepted in manual mode are accepted in auto mode, as well as orders from local or remote communication as follows:

- Auto Local: the operator needs to be close to the circuit breaker to establish communication and only orders sent from a local source through communication are accepted:
 - Ecoeach software through the USB connection.
 - Masterpact MTZ Mobile App through Bluetooth with the Masterpact Operation Assistant Digital Module.
- Auto Remote: the operator does not need to be next to the circuit breaker to establish communication and orders are only accepted sent from a remote source through the communication network.

NOTE: Ecoeach software connected through the communication network can be used to send control orders to the circuit breaker.

The control mode factory setting is Auto Remote.

Masterpact MTZ Operation According to Control Mode Configuration

The following table summarizes the opening and closing operations available, depending on the control mode configured:

Control Mode	Type of Order and Delivery Method							
	Mechanical	Electrical		Through Communication				
	Pushbutton	BPFE	Point to point (voltage release)	IO module ⁴	Ecoeach software through USB	Masterpact MTZ Mobile App through Bluetooth + Masterpact Operation Assistant Digital Module	Ethernet Modbus/TCP	IFE/IEFE Webpages
Manual	●	●	●	—	—	—	—	—
Auto: Local	●	●	●	●	●	●	—	—
Auto: Remote	●	●	●	●	—	—	●	●

4. According to IO input mode setting.

Masterpact MTZ Operation in Manual Mode

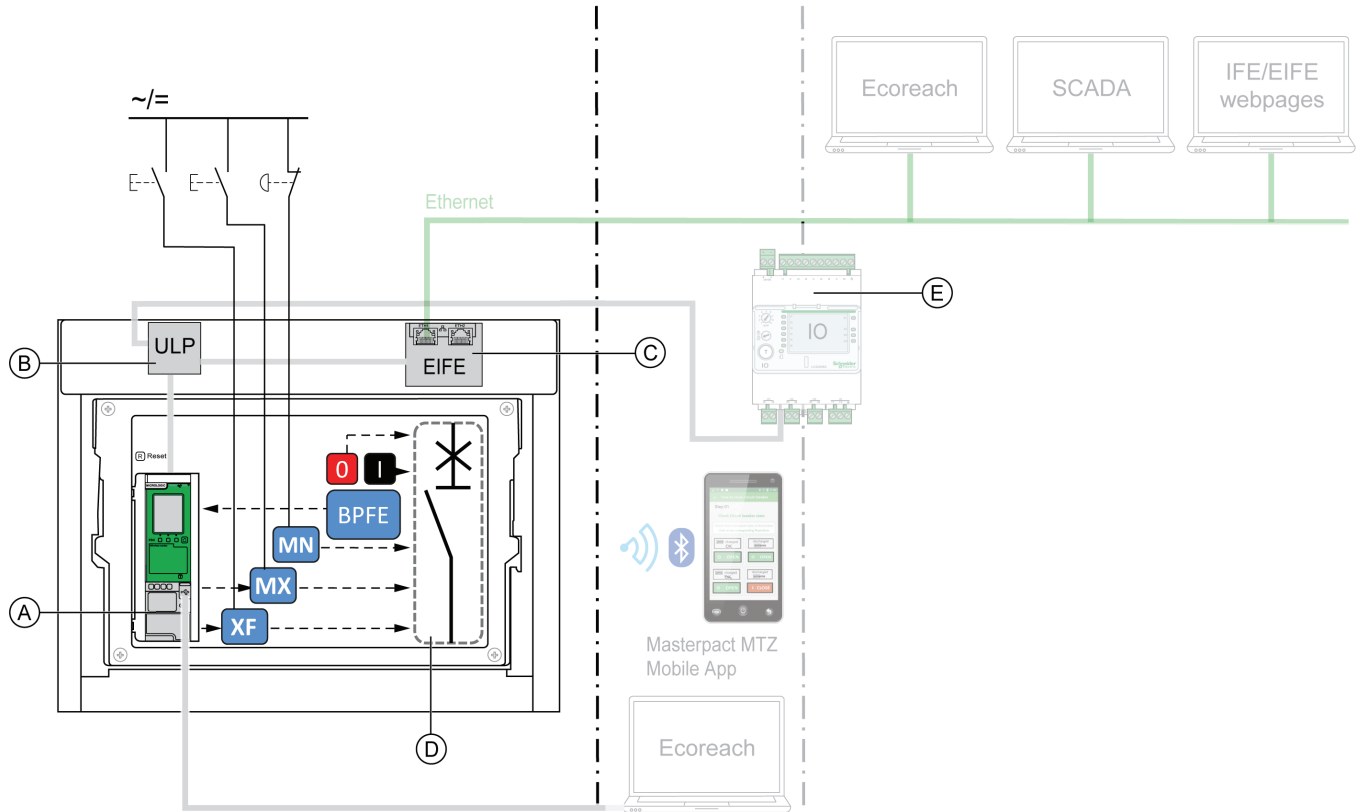

- A. Micrologic X control unit
- B. ULP port module
- C. Embedded Ethernet interface (EIFE)
- D. Circuit breaker mechanism
- E. Input/output application module (IO)

Opening and closing operations available in Manual mode:

- 0: mechanical opening pushbutton
- 1: mechanical closing pushbutton
- BPFE: electrical closing pushbutton
- External pushbuttons wired by customer, and connected to:
 - XF: standard or communicating and diagnostic shunt close
 - MX: standard or communicating and diagnostic shunt trip
 - MN: standard or diagnostic undervoltage release

Masterpact MTZ Operation in Auto: Local Mode

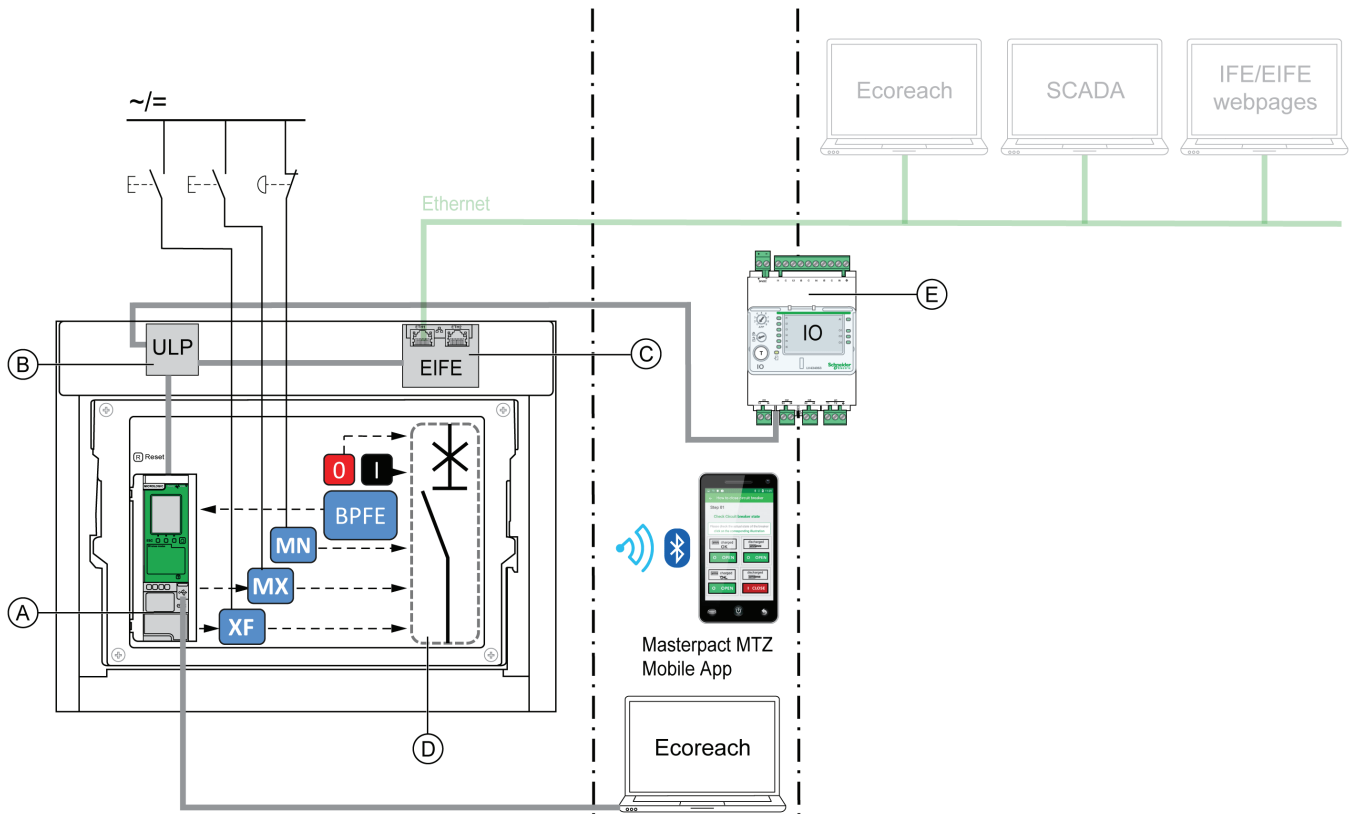

- A. Micrologic X control unit
- B. ULP port module
- C. Embedded Ethernet interface (EIFE)
- D. Circuit breaker mechanism
- E. Input/output application module (IO)

Opening and closing operations available in Auto: Local mode:

- 0: mechanical opening pushbutton
- 1: mechanical closing pushbutton
- BPFE: electrical closing pushbutton
- External pushbuttons wired by customer, and connected to:
 - XF: communicating and diagnostic shunt close
 - MX: communicating and diagnostic shunt trip
 - MN: standard or diagnostic undervoltage release
- IO: with the Breaker Operation predefined application of the IO module set to local control mode
- Ecoreach software: command sent through USB connection
- Masterpact MTZ Mobile App with Masterpact Operation Assistant Digital Module: through Bluetooth low energy wireless communication

Masterpact MTZ Operation in Auto: Remote Mode

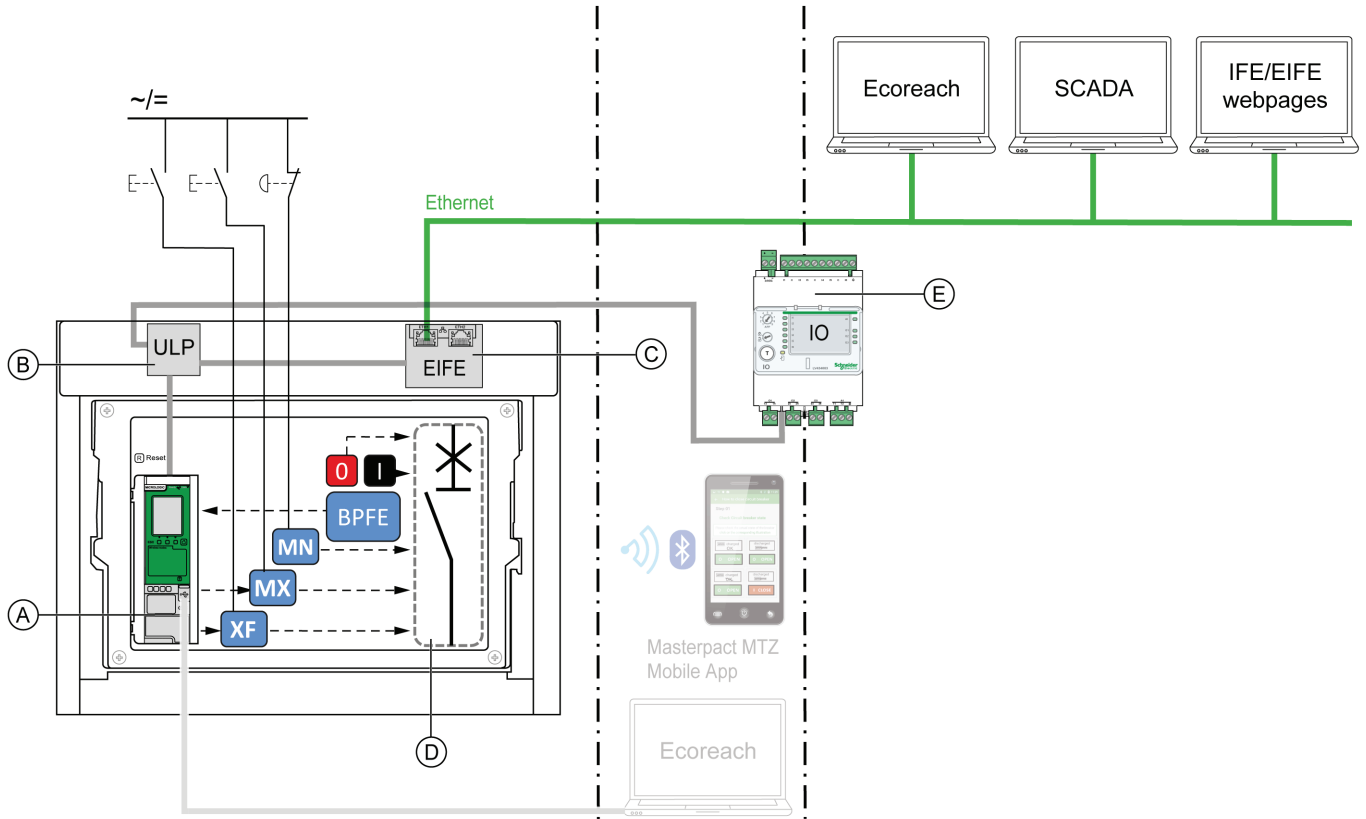

- A. Micrologic X control unit
- B. ULP port module
- C. Embedded Ethernet interface (EIFE)
- D. Circuit breaker mechanism
- E. Input/output application module (IO)

Opening and closing operations available in Auto: Remote mode:

- 0: mechanical opening pushbutton
- 1: mechanical closing pushbutton
- BPFE: electrical closing pushbutton
- External pushbuttons wired by customer, and connected to:
 - XF: communicating and diagnostic shunt close
 - MX: communicating and diagnostic shunt trip
 - MN: standard or diagnostic undervoltage release
- IO: with the Breaker Operation predefined application of the IO module set to remote control mode
- Communication: remote command through IFE or EIFE interface

Setting the Micrologic X Control Mode

The Auto or Manual mode can be set as follows:

- On the Micrologic X display screen, at **Home** → **Configuration** → **Communication** → **Control Mode** → **Mode**.
- With the Masterpact MTZ Mobile App through Bluetooth or USB OTG connection.

The Local or Remote mode can be set as follows:

- When the IO module is used with the Breaker Operation predefined application, the local or remote mode is defined only by the control mode selector switch wired to the digital input I1 of the IO module.
- When the IO module is not used with the Breaker Operation predefined application, the local or remote mode can be set as follows:
 - With Ecoreach software through a USB connection.
 - With the Masterpact MTZ Mobile App through Bluetooth or a USB OTG connection.

NOTE:

- The Local or Remote mode cannot be set on the Micrologic X display screen.
- When Auto mode is set, the control mode is Auto Local or Auto Remote, depending on the last setting.

Displaying the Micrologic X Control Mode

The control mode (Manual, Auto Local, or Auto Remote) is displayed as follows:

- On the Micrologic X display screen, at **Home** → **Configuration** → **Communication** → **Control Mode** → **Mode**.
- With Ecoreach software through the USB connection.
- With the Masterpact MTZ Mobile App through Bluetooth or the USB OTG connection.
- On the IFE/EIFE webpages.
- By a remote controller using the communication network.

Micrologic X Control Mode Predefined Events

Changing the control mode settings generates the following events:

Event	History	Severity
Manual mode enabled	Operation	Low
Local mode enabled	Operation	Low
Config. error IO and CU - Local/Remote mode	Configuration	Medium

Opening Masterpact MTZ Devices

Conditions Required to Open

To open the device, the device must be closed (I).

NOTE: An opening order always takes priority over a closing order.

Opening the Masterpact MTZ1 Mechanism

The device can be opened in the following ways in all control modes:

⚠️ DANGER

HAZARD OF ELECTRIC SHOCK, EXPLOSION, OR ARC FLASH

- Turn off all power supplying the downstream equipment by manually opening the circuit breaker.
- Before working on or inside equipment, always use a properly rated voltage sensing device to confirm power is off.

Failure to follow these instructions will result in death or serious injury.

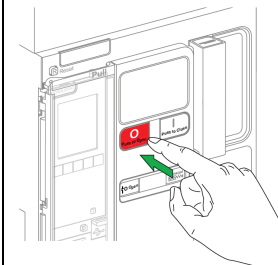
Opening Type	Control Mode	Accessories	Opening Action
Mechanical	Manual, Auto: Local, or Auto: Remote	—	<p>Press the opening pushbutton on the front of the device.</p> <p>This opening action is possible at any time.</p> 
Automatic	Manual, Auto: Local, or Auto: Remote	Undervoltage release (MN), with or without MN delay unit	The undervoltage release (MN) opens the device automatically in the case of voltage drop.
By external pushbutton	Manual, Auto: Local, or Auto: Remote	<p>External pushbutton wired by customer</p> <p>MX or MN accessory:</p> <ul style="list-style-type: none"> • Communicating (XF diag&com) or standard (F) shunt close • Undervoltage release (MN), with or without MN delay unit 	<p>Press the external pushbutton which is connected to the shunt trip (MN) or to the undervoltage release (MN) via the customer terminal block.</p> <p>When the undervoltage release (MN) is connected to the MN delay unit, the device opens with the corresponding time delay.</p>

If the device does not open, refer to *Masterpact MTZ1 Troubleshooting, page 125*.

Opening the Masterpact MTZ1 Mechanism in Auto Control Mode

In addition, the device can be opened in the following ways when Auto control mode is configured.

⚡ ⚠ DANGER

HAZARD OF ELECTRIC SHOCK, EXPLOSION, OR ARC FLASH

Do not allow any person to work on the electrical network without physically validating the successful execution of the local or remote software actions for opening the circuit breaker or switching off the electrical circuit.

Failure to follow these instructions will result in death or serious injury.

Opening Type	Control Mode	Accessories	Opening Action
Through IO module	Auto: Local or Auto: Remote	Communicating shunt trip (MX diag&com)	Open the device by using the predefined application 2 Breaker Operation of the IO module. <ul style="list-style-type: none"> When the device is set to local control mode by the IO module, the command to open is issued from local pushbuttons wired on digital inputs. When the device is set to remote control mode by the IO module, the command to open is issued from remote PLC outputs wired on digital inputs. Refer to <i>Enerlin'X IO Input/Output Application Module for One Circuit Breaker - User Guide (0613IB1317)</i> .
		ULP port	
		IO module	
Through Ecoreach software	Auto: Local	Communicating shunt trip (MX diag&com)	Send a command to open to the device from Ecoreach software running on a PC connected locally to the device through the mini USB port on the Micrologic X control unit. This opening action is password-protected. Refer to <i>Ecoreach Online Help (DOCA0069EN)</i> .
Through Masterpact MTZ Mobile App	Auto: Local	Communicating shunt trip (MX diag&com)	Send a command to open to the device from the Masterpact MTZ Mobile App with Masterpact Operation Assistant Digital Module, through Bluetooth wireless communication. The opening action is password-protected.
		Masterpact Operation Assistant Digital Module	
Through communication	Auto: Remote	Communicating shunt trip (MX diag&com)	Send a command to open to the device through the communication network. This opening action is password-protected. Refer to <i>Masterpact MTZ - Modbus Communication Guide (OCA0105EN)</i> . NOTE: Ecoreach software running on a PC connected to the device through the communication network can be used to send commands to open.
		ULP port	
		Communication interface	
Through IFE/EIFE webpages	Auto: Remote	Communicating shunt trip (MX diag&com)	Send a command to open to the device from the IFE/EIFE control webpage. This opening action is password-protected. Refer to: <ul style="list-style-type: none"> <i>Enerlin'X IFE Ethernet Interface for One Circuit Breaker - User Guide (DOCA0084EN)</i> <i>Enerlin'X EIFE Embedded Ethernet Interface for One Masterpact MTZ Drawout Circuit Breaker - User Guide (DOCA0106EN)</i>
		ULP port module	
		Communication interface	

If the device does not open, refer to *Masterpact MTZ1 Troubleshooting, page 125*.

Closing Masterpact MTZ Devices

Conditions Required to Close

▲ WARNING

HAZARD OF CLOSING ON ELECTRICAL FAULT

Do not close the circuit breaker again without first inspecting and, if necessary, repairing the downstream electrical equipment.

Failure to follow these instructions can result in death, serious injury, or equipment damage.

To close the device, the following conditions must be met:

- Device is open (O).
- Closing spring is charged.
- The device is ready to close, OK is displayed.

NOTE: An opening order always takes priority over a closing order. The device cannot be closed while an opening order is being received. If OK is crossed-out on the ready-to-close indicator, an order to open is being received (either electrically or mechanically) and must be ended before OK can be displayed.

Closing the Masterpact MTZ1 Mechanism

The following tables present how to close the device in the different control modes.

The device can be closed in the following ways in all control modes:

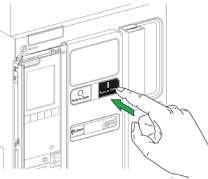
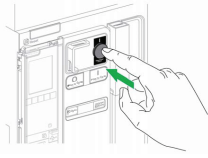
Closing Type	Control Mode	Accessories	Closing Action	
Mechanical	Manual, Auto: Local, or Auto: Remote	—	Press the closing pushbutton on the front of the device. This closing action is possible when the closing conditions are met.	
Electrical with BPF	Manual, Auto: Local, or Auto Remote	<ul style="list-style-type: none"> • Electrical closing pushbutton (BPF) • Communicating shunt close (XF diag&com) 	Press the electrical closing pushbutton (BPF), mounted on the front cover. The closing action takes into account internal closing conditions of the device and the external conditions that are part of the control and monitoring system of the installation.	
External pushbutton	Manual, Auto: Local, or Auto: Remote	<ul style="list-style-type: none"> • External pushbutton wired by customer • Communicating (XF diag&com) or standard (XF) shunt close • Spring charging motor (MCH) 	Press the external pushbutton, which is connected to the XF shunt close through the customer terminal block.	

In addition, the device can be closed in the following ways when Auto control mode is configured.

⚡ ⚠ DANGER

HAZARD OF ELECTRIC SHOCK, EXPLOSION, OR ARC FLASH

Do not allow any person to work on the electrical network without physically validating the successful execution of the local or remote software actions for closing the circuit breaker or switching on the electrical circuit.

Failure to follow these instructions will result in death or serious injury.

Closing Type	Control Mode	Accessories	Closing Action
Through IO module	Auto: Local or Auto: Remote	Communicating shunt close (XF diag&com)	Close the device by using the predefined application 2 Breaker Operation of the IO module. <ul style="list-style-type: none"> When the device is set to local control mode by the IO module, the command to close is issued from local pushbuttons wired on digital inputs. When the device is set to remote control mode by the IO module, the command to close is issued from remote PLC outputs wired on digital inputs. Refer to <i>Enerlin'X IO Input/Output Application Module for One Circuit Breaker - User Guide (0613B1317)</i> .
		Spring charging motor (MCH)	
		ULP port module	
		IO module	
Through Ecoreach software	Auto: Local	Communicating shunt close (XF com&diag)	Send a command to close to the device from Ecoreach software running on a PC connected locally to the device through the mini USB port on the Micrologic X control unit. The closing action is password-protected. Refer to <i>Ecoreach Online Help (DOCA0069EN)</i> .
		Spring charging motor (MCH)	
		ULP port module	
		IO module	
Through Masterpact MTZ Mobile App	Auto: Local	Communicating shunt close (XF diag&com)	Send a command to close to the device from the Masterpact MTZ Mobile App with Masterpact Operation Assistant Digital Module, through Bluetooth wireless communication. The closing action is passwordprotected.
		Spring charging motor (MCH)	
		Masterpact Operation Assistant Digital Module	
Through communication	Auto: Remote	Communicating shunt close (XF diag&com)	Send a command to close to the device through the communication network. This closing action is password-protected. Refer to <i>Masterpact MTZ - Modbus Communication Guide (OCA0105EN)</i> . NOTE: Ecoreach software running on a PC connected to the device through the communication network can be used to send commands to close.
		Spring charging motor (MCH)	
		ULP port module	
		Communication interface	
Through IFE/ EIFE webpages	Auto: Remote	Communicating shunt close (XF diag&com)	Send a command to close to the device from the IFE/ EIFE control webpage. This closing action is password-protected. Refer to: <ul style="list-style-type: none"> <i>Enerlin'X IFE Ethernet Interface for One Circuit Breaker - User Guide (DOCA0084EN)</i> <i>Enerlin'X EIFE Embedded Ethernet Interface for One Masterpact MTZ Drawout Circuit Breaker - User Guide (DOCA0106EN)</i>
		Spring charging motor (MCH0)	
		ULP port module	
		Communication interface	

If the device does not close, refer to *Masterpact MTZ1 Troubleshooting, page 125*.

Inhibiting the Masterpact MTZ1 Closing Function

The closing function can be inhibited by sending a command through:

- The communication network through Ethernet Modbus/TCP.
- The IO module.

⚠ WARNING
RESTRICTED CLOSING INHIBITION
Do not use the inhibit closing order to lock the device in open position.
Failure to follow these instructions can result in death, serious injury, or equipment damage.

The inhibit close order inhibits only the closing orders allowed in Auto control mode. The closing orders issued from the mechanical closing pushbutton or BPF, or from the pushbutton directly connected to the shunt close (XF), are not inhibited.

Resetting Masterpact MTZ Devices

Conditions Required to Reset

After a trip, the device must be reset before closing it.

Resetting is possible in all control modes.

Resetting the Masterpact MTZ1 Mechanism

The device can be reset in different ways, according to the device configuration and its accessories:

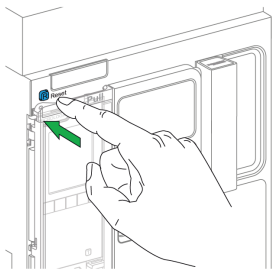
Type of Resetting	Accessories	Resetting Action
Mechanical	—	<p>Push in the fault-trip reset pushbutton on the front of the device. This resetting action is always possible. Pushing in the fault-trip reset pushbutton resets the overcurrent trip switch (SDE), and allows the device to be closed.</p> 
Automatic (RAR automatic reset)	Communicating (XF diag&com) or standard (XF) shunt close	<p>After a trip, RAR automatic reset allows the device to be closed without the fault-trip reset pushbutton being pushed in. The use of shunt close (XF) is required with this option.</p> <p>The mechanical indicator and the overcurrent trip switch (SDE) remain in detected fault position.</p>
	Spring charging motor (MCH)	<p>To reset the overcurrent trip switch (SDE) and the mechanical indicator, push in the fault-trip reset pushbutton</p>
External Pushbutton (RES electrical remote reset)	External pushbutton	<p>Press the external pushbutton which is connected to the electrical remote reset (RES) via the customer terminal block.</p> <p>The use of a shunt close (XF) is required with this option.</p>
	Electrical remote reset (RES)	<p>The electrical remote reset (RES) resets the overcurrent trip switch (SDE) and the mechanical indicator, and allows the device to be closed.</p>
	Communicating (XF diag&com) or standard (XF) shunt close	<p>NOTE: The electrical remote reset (RES) cannot be installed if SDE2 is already installed.</p>

Conditions for Engaging the ERMS Function

The Energy Reducing Maintenance Setting (ERMS) function is available when the Energy Reducing Maintenance Settings Digital Module is purchased and installed on the Micrologic X control unit.

Energy Reducing Maintenance Setting (ERMS) Function Operating Principles

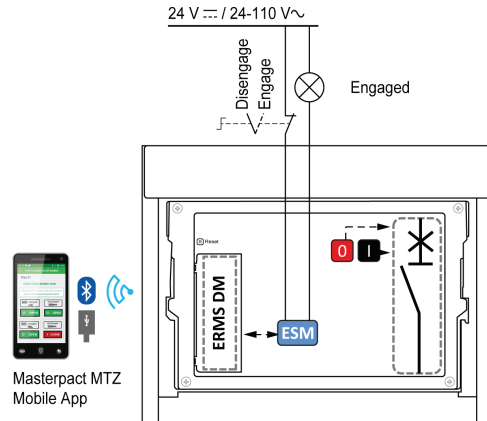

The ERMS function can be engaged as follows:

- With the Masterpact MTZ Mobile App (password-protected). There is a digital lock between a smartphone running the Masterpact MTZ Mobile App and the Micrologic X control unit.
- By using an external selector switch connected to the optional ERMS switch module (ESM). The ESM module is installed in the circuit breaker and is connected to an external selector switch, which can be padlocked. The ERMS function is engaged by turning the external selector switch.

The ERMS function can be engaged with both the Masterpact MTZ Mobile App (password-protected) and an external selector switch.

The ERMS function must be disengaged by the interface that engaged it:

- If it is engaged on a smartphone, it must be disengaged by the same smartphone.
- If it is engaged by the external ERMS switch connected to the ESM module, it must be disengaged by the ERMS switch.
- If it is engaged by both a smartphone and the ERMS switch, it must be disengaged by both that smartphone and the ERMS switch.

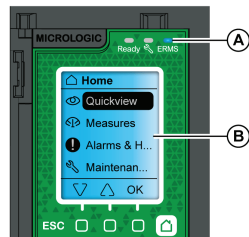

While the ERMS function is engaged:

- A blue ERMS LED (A) is lit on the front face of the Micrologic X control unit.
- Quick View scrolling is interrupted and the ERMS engaged message is displayed with a blue backlight.
- All screens, except pop-up messages, are displayed with a blue backlight.

For more information, refer to the Micrologic X - Control Unit - User Guide (see *Related Documents, page 8*).

Engaging the ERMS Function

NOTICE

HAZARD OF LOSS OF POWER

Confirm that the Energy Reducing Maintenance Setting (ERMS) protection settings are properly configured prior to engagement.

Failure to follow these instructions can result in loss of service due to power loss.

The ERMS can be engaged in different ways, according to the device configuration and its accessories:

Type	Accessories	Action
Through Masterpact MTZ Mobile App	—	Send a command from the Masterpact MTZ Mobile App to engage the ERMS function, through Bluetooth wireless communication or USB OTG connection. The action is password-protected.
Through an external selector switch connected to the ESM module	<ul style="list-style-type: none"> ERMS switch module (ESM) External selector switch 	Turn the external selector switch to the Engaged position

Disengaging the Energy Reducing Maintenance Setting (ERMS) Function

DANGER

HAZARD OF ELECTRICAL SHOCK, EXPLOSION, OR ARC FLASH

Prior to disengaging the Energy Reducing Maintenance Setting (ERMS) function:

- Carefully inspect your work area, and remove any tools and objects left inside the equipment.
- Ensure that all personnel are away from the equipment, and devices, doors, and covers are in place.

Failure to follow these instructions will result in death or serious injury.

A digital lock function establishes a digital lock between a smartphone running the Masterpact MTZ Mobile App and the Micrologic X control unit when ERMS is engaged by the smartphone. The digital lock function ensures that when the ERMS function is engaged by a smartphone, it must be disengaged by the same smartphone.

The way to disengage the ERMS function depends on how it was engaged:

Type	Accessories	Action
Through Masterpact MTZ Mobile App	—	Disengage the ERMS function on the same smartphone that engaged it
Through an external selector switch	<ul style="list-style-type: none"> ERMS switch module (ESM) External selector switch 	Turn the external selector switch to the Disengaged position
Through Masterpact MTZ Mobile App and an external selector switch	<ul style="list-style-type: none"> ERMS switch module (ESM) External selector switch 	<ul style="list-style-type: none"> Disengage the ERMS function on the same smartphone that engaged it Turn the external selector switch to the Disengaged position

Masterpact MTZ1 Operating Accessories

Masterpact Shunt Close (XF), Shunt Trip (MX) and Undervoltage Release (MN) Accessories

The shunt close (XF), shunt trip (MX), and undervoltage release (MN) are optional accessories mounted inside the device. They can be of standard type or diagnostic and communicating type (standard or with diagnostic function for the undervoltage release [MN]).

The standard XF, MX, and MN accessories can have either impulse-type or maintained actions, depending on the incoming commands.

Masterpact Shunt Close (XF)

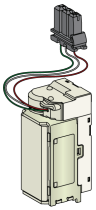

The Masterpact shunt close (XF) is available as standard or with the diagnostic and communicating function.

The shunt close closes the circuit breaker instantaneously when powered if the spring mechanism is charged. The minimum duration of the pulse operating order must be 200 ms.

For information on installation, consult the instruction sheet on the Schneider Electric website:

- Standard shunt close (XF): *NVE40749*
- Diagnostic and communicating shunt close (XF diag&com): *NVE40766*

Masterpact Shunt Trip (MX)

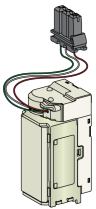

The Masterpact shunt trip (MX) is available as standard or with the diagnostic and communicating function.

The shunt trip opens the circuit breaker instantaneously when powered. The minimum duration of the pulse operating order must be 200 ms. The MX standard trip locks the circuit breaker in OFF position if the command is maintained.

For information on installation, consult the instruction sheet on the Schneider Electric website:

- Standard shunt trip (MX): *NVE40749*
- Diagnostic and communicating shunt trip (MX diag&com): *NVE40766*

Masterpact Undervoltage Release (MN)

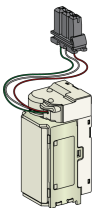

The Masterpact undervoltage release (MN) is available as standard or with the diagnostic and communicating function.

The undervoltage release instantaneously opens the circuit breaker when its supply voltage drops to a value between 35% and 70% of its rated voltage. If there is no supply to the release, it is impossible to close the circuit breaker, either manually or electrically. Any attempt to close the circuit breaker has no effect on the main contacts. Circuit breaker closing is enabled again when the supply voltage of the release returns to 85% of its rated value.

For information on installation, consult the instruction sheet on the Schneider Electric website:

- Standard undervoltage release (MN): *NVE40749*
- Diagnostic undervoltage release (MN diag): *NVE40766*

Masterpact Communicating Internal Isolation Module

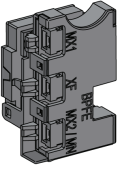

The internal isolation module for Micrologic X control units provides double isolation in compliance with IEC 60664-1 (up to 12 kV). It also provides isolation between the diagnostic and communicating shunt close (XF diag&com), diagnostic and communicating shunt trip (MX diag&com), diagnostic undervoltage release (MN diag), and the electrical closing pushbutton (BPF).

For information on accessory installation, consult instruction sheet *NVE40748* on the Schneider Electric website.

Masterpact Electrical Closing Pushbutton (BPF)

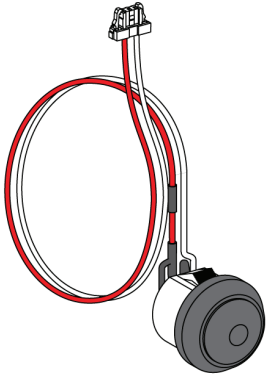

The electrical closing pushbutton (BPF) carries out electrical closing of the circuit breaker. It takes into account the internal closing conditions of the device and the external conditions that are part of the control and monitoring system of the installation. It connects to the standard shunt closes (XF) or the communicating shunt close (XF diag&com).

If the BPF is being used, it is recommended to lock access to the closing pushbutton using the VBP accessory because the closing pushbutton does not take into account internal and external conditions.

This optional accessory is mounted on the front cover of the device.

For information on accessory installation, consult instruction sheet *NVE40773* on the Schneider Electric website.

Masterpact Ready-to-Close Contact (PF)

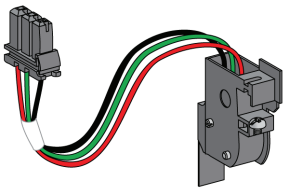

The ready-to-close contact (PF) indicates remotely that the circuit breaker is ready to close..

It indicates that the circuit breaker is ready to close when:

- The circuit breaker is in the open position.
- The spring mechanism is charged.
- There is no maintained opening order.

This optional accessory is mounted inside the device.

For information on accessory installation, consult instruction sheet *NVE35466* on the Schneider Electric website.

Masterpact Spring Charging Motor (MCH)

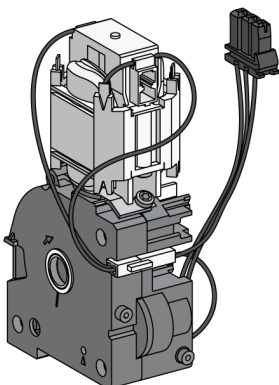

This is an optional accessory that is mounted inside the device.

The spring charging motor (MCH) automatically charges the spring mechanism when the circuit breaker is closed, allowing instantaneous closing of the circuit breaker following opening.

For information on accessory installation, consult instruction sheet *NVE35483*, available on the Schneider Electric website.

Masterpact Electrical Remote Reset (RES)

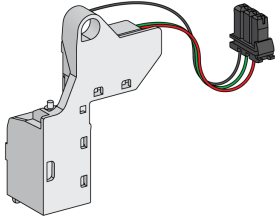

This is an optional accessory that is mounted inside the device.

Following tripping, this function resets the overcurrent trip switch (SDE), and the mechanical indicator and enables circuit breaker closing.

The use of an closing release (XF) is required with this option.

The additional overcurrent trip switch (SDE2) is not compatible with RES.

For information on accessory installation, consult instruction sheet *NVE35503*, available on the Schneider Electric website.

Masterpact ERMS Switch Module (ESM)

The ERMS switch module (ESM) is an optional accessory mounted inside of the device.

It is used to engage ERMS protection settings with an external selector switch. The ESM module works in conjunction with the ERMS Digital Module, which must also be installed.

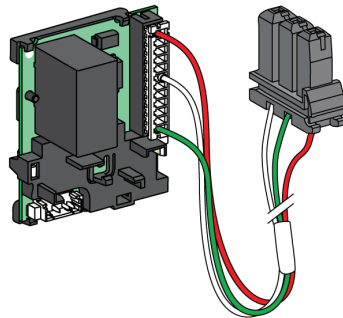

The ERMS switch module (ESM) is not compatible with M2C programmable contacts because they are installed in the same physical place.

Masterpact Grounding Kit (KMT)

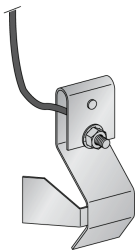

The grounding kit (KMT) allows the circuit breaker mechanism to be grounded when the front cover is removed. The grounding is made through the cradle for the drawout version and through the mounting side plate for the fixed version.

This optional accessory is mounted inside the device.

For information on accessory installation, consult instruction sheet *NVE35480* on the Schneider Electric website.

Masterpact Mechanical Operation Counter (CDM)

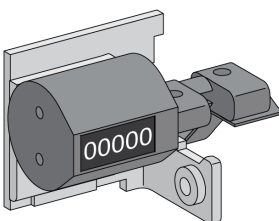

The mechanical operation counter (CDM) counts the number of operating cycles and is visible on the front panel. It is compatible with manual and electrical control functions.

This optional accessory is mounted inside the device.

This accessory is required for all source-changeover systems.

For information on accessory installation, consult instruction sheet *NVE35485* on the Schneider Electric website.

Masterpact ULP Port Module

The ULP port module is optional on the fixed device and standard on the drawout device. It is mounted with the terminal blocks of the device.

The ULP port module:

- Supplies the Micrologic X control unit.
- Integrates the ULP termination.
- Allows the connection to external ULP modules, like the IO module or the IFE Ethernet interface.

Fixed Device

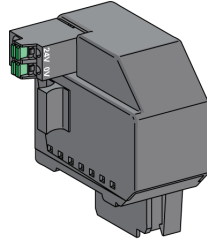

Drawout Device

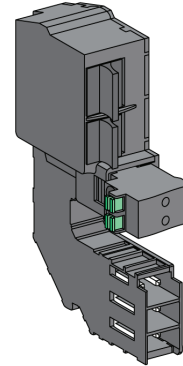

For information on accessory installation, consult the instruction sheets available on the Schneider Electric website:

- ULP port module for fixed Masterpact MTZ2/MTZ3: *NVE40791*.
- ULP port module for drawout Masterpact MTZ2/MTZ3: *NVE40797*.

Masterpact Embedded Ethernet Interface (EIFE)

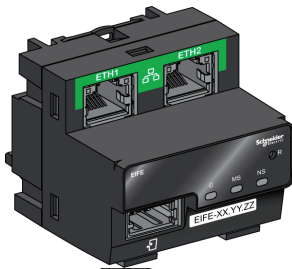

The embedded Ethernet interface (EIFE) enables drawout Masterpact MTZ circuit breakers to be connected to an Ethernet network. It provides digital access to all the data delivered by the Micrologic X control unit.

In addition, it monitors the position of the device in the cradle: connected, test, and disconnected.

This optional accessory is mounted on the cradle of the drawout device.

For information on accessory installation, consult instruction sheet *NVE23550* on the Schneider Electric website.

For information on accessory usage, refer to user *Enerlin'X EIFE Embedded Ethernet Interface for One Masterpact MTZ Drawout Circuit Breaker - User Guide (DOCA0106EN)*, available on the Schneider Electric website.

Masterpact Ethernet Interface (IFE) for One Circuit Breaker

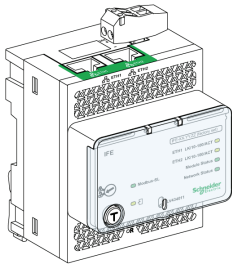

The Ethernet interface (IFE) provides an Ethernet access to a single device. The device is connected to the IFE interface through the ULP port module and a prefabricated ULP cord.

For information on accessory installation, consult instruction sheet *HRB49218* on the Schneider Electric website.

For information on accessory usage, refer to *Enerlin'X IFE Ethernet Interface for One Circuit Breaker - User Guide (DOCA0084EN)*, available on the Schneider Electric website.

Masterpact Ethernet Switchboard Server (IFE)

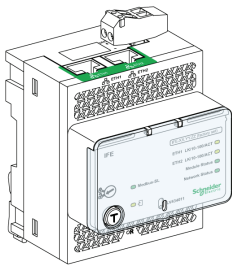

The Ethernet switchboard server (IFE) provides Ethernet access to one or several circuit breakers. It allows the following communication architectures:

- One single circuit breaker connected to the IFE server through the ULP port module.
- Up to 20 circuit breakers, including up to 12 Compact NSX devices, through the IFM Modbus-SL (RTU) interface for one circuit breaker stacked to the IFE server.

For information on accessory installation, consult instruction sheet *HRB49218*, available at the Schneider Electric website.

For information on accessory usage, refer to *Enerlin'X IFE Ethernet Interface for One Circuit Breaker - User Guide (DOCA0084EN)* on the Schneider Electric website.

Masterpact IFM Modbus-SL (RTU) Interface for One Circuit Breaker

The IFM Modbus-SL (RTU) interface provides access from a single device to a Modbus serial line communication network. The device is connected to the IFM interface through the ULP port module and a prefabricated ULP cord.



For information on installation, consult the instruction sheet on the Schneider Electric website: <https://www.schneider-electric.us/en/download/document/NVE85393/>.

Masterpact IO Input/Output Application Module

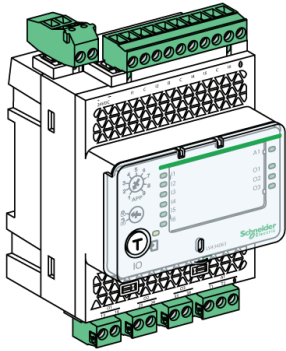

The IO input/output application module for one circuit breaker is one component of the ULP architecture.

The IO input/output application module uses built-in applications to enhance control and monitoring functions. Its resources are:

- Six self-powered digital inputs for either NO and NC dry contact or pulse counters.
- Three digital outputs that are bistable relay (5 A maximum).
- One analog input for a Pt100 temperature sensor.

For information on accessory installation, consult instruction sheet *HRB49217* on the Schneider Electric website.

For information on accessory usage, refer to *Enerlin'X IO Input/Output Application Module for One Circuit Breaker - User Guide (0613IB1317)* on the Schneider Electric website.

Lifting and Transporting Masterpact MTZ1 Devices

▲ CAUTION

HAZARD OF DEVICE FALLING

- Always have two people lift the device.
- Wear hard hat, safety shoes and heavy gloves.

Failure to follow these instructions can result in injury or equipment damage.

Lifting a Masterpact MTZ1 Device

Lifting requires two people, one on each side.

Lift cradle using lifting tabs (A) on sides of device.

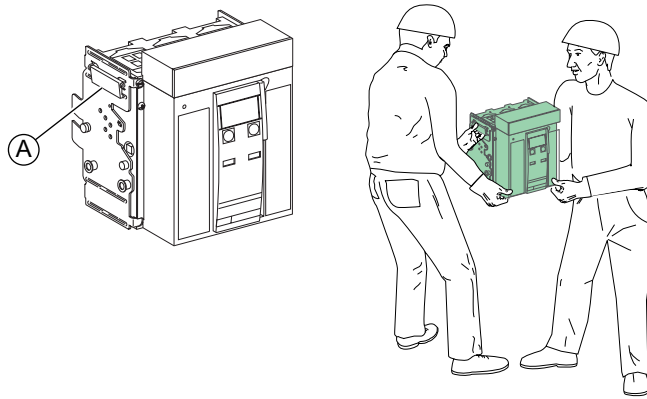

Lifting a Masterpact MTZ1 Cradle

Lifting requires two people, one on each side.

Lift cradle using lifting tabs (A) on sides of cradle.

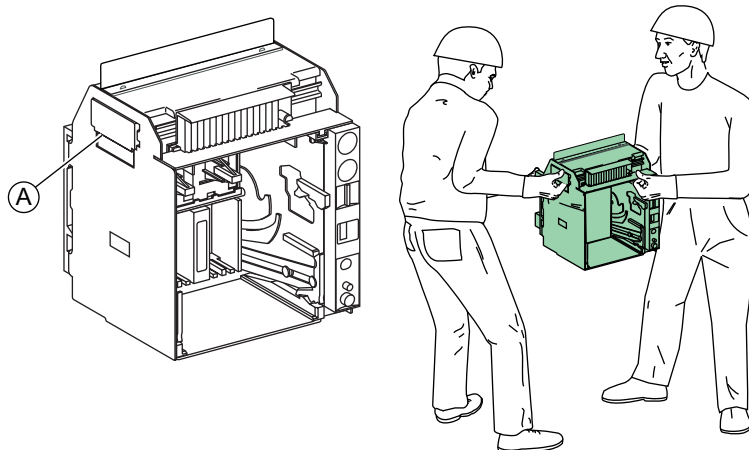

Masterpact MTZ1 Drawout Device Racking

Masterpact MTZ1 Drawout Status

Masterpact MTZ1 Drawout Handling Conditions

⚡ ⚠ DANGER

HAZARD OF ELECTRIC SHOCK, EXPLOSION OR ARC FLASH

- Apply appropriate personal protective equipment (PPE) and follow safe electrical work practices. See NFPA 70E, CSA Z462, NOM 029-STPS or local equivalent.
- This equipment must only be installed and serviced by qualified electrical personnel.

Failure to follow these instructions will result in death or serious injury.

Connection or disconnection of the drawout device requires insertion of the racking handle. When interlocks, padlocks, or an open door lock are in place, the racking handle cannot be inserted.

Masterpact MTZ1 Drawout Positions

The indicator located on the front of the cradle locally signals the position of the device in the cradle.

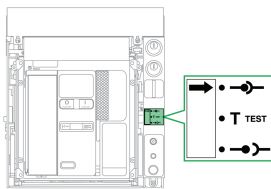

Device Position	Position Indicator and Position Contact State	Connector position	Device Status
Connected	 	<ul style="list-style-type: none"> • Disconnecting contact clusters: engaged • Control: engaged 	<ul style="list-style-type: none"> • Can be operated. • Ready for service.
Test	 	<ul style="list-style-type: none"> • Disconnecting contact clusters: disengaged • Control: engaged 	<ul style="list-style-type: none"> • Can be operated. • Can have operation and control systems tested.

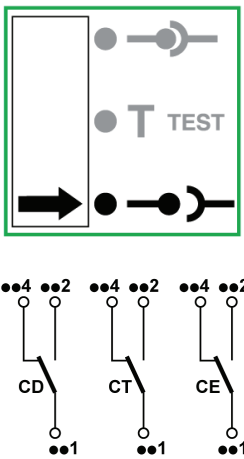
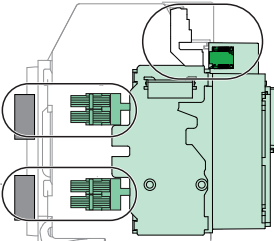
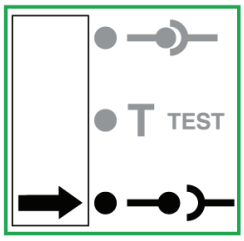
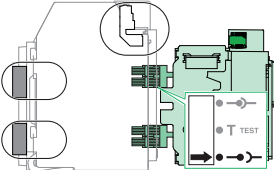
Device Position	Position Indicator and Position Contact State	Connector position	Device Status
Disconnected		 <ul style="list-style-type: none"> • Disconnecting contact clusters: disengaged • Control: disengaged 	<ul style="list-style-type: none"> • Can be operated. • Can be removed from the cradle.
Withdrawn		 <ul style="list-style-type: none"> • Disconnecting contact clusters: disengaged • Control: disengaged 	<p>Removed from the cradle.</p>

Masterpact MTZ1 Drawout Position Contacts

The position of the device in the cradle is indicated remotely by the following position contacts:

- CE: connected position.
- CT: test position.
- CD: disconnected position. The device is in the disconnected position when the minimum isolation distance between the main contacts and the auxiliary contacts is reached.

The state of the position contacts changes according to the device position during the racking-in and racking-out operations, as shown in the diagram below.

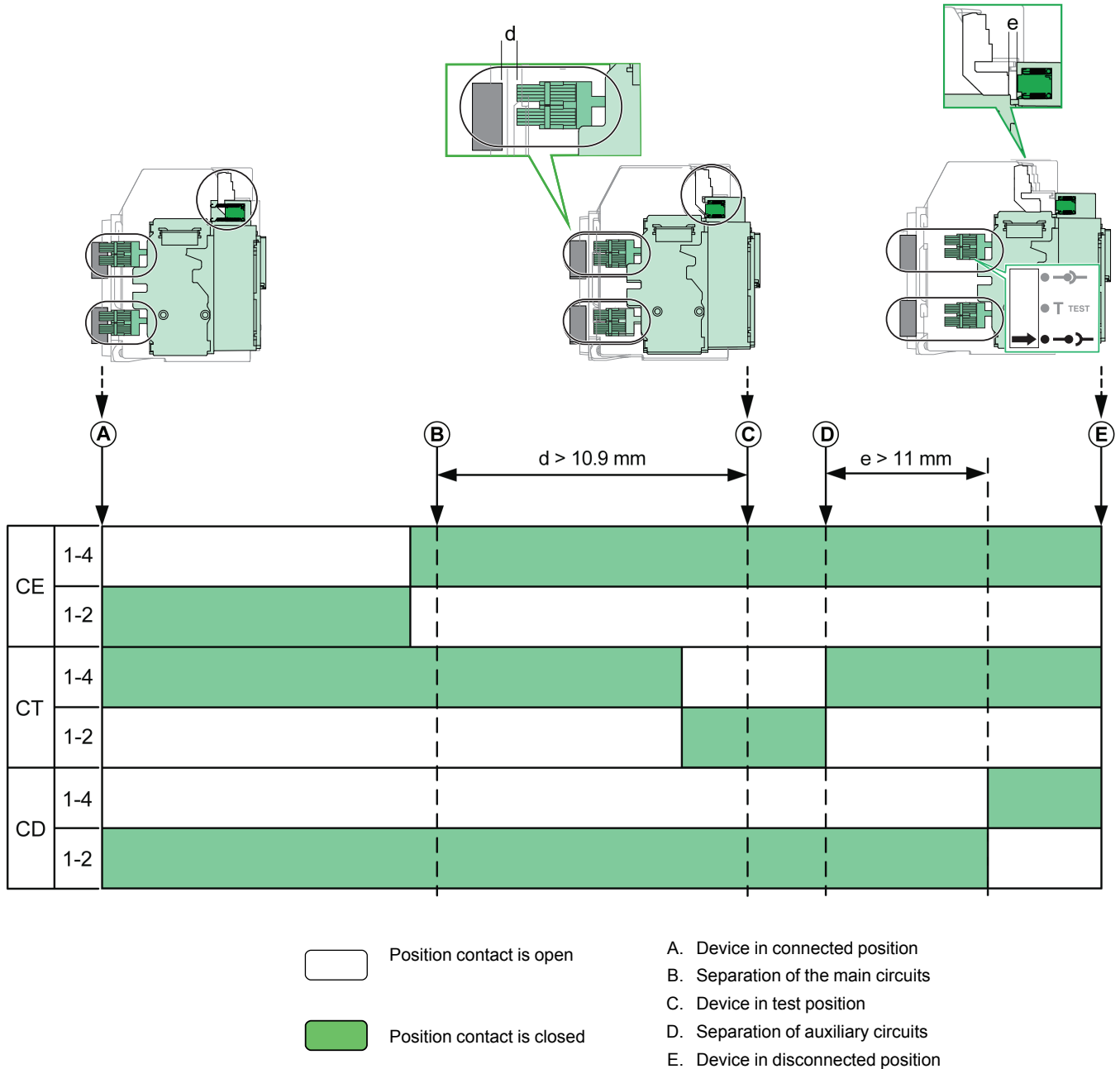

Masterpact MTZ1 Drawout Position Contact Without EIFE Ethernet Interface

Without EIFE Ethernet interface, the standard configuration of the position contacts can be added as follows:

- 2 CD disconnected position contacts
- 3 CE connected position contacts
- 1 CT test position contacts

Masterpact MTZ1 Drawout Position Contacts with EIFE Ethernet Interface

With EIFE Ethernet interface, two optional CE connected position contacts can be added.

Masterpact MTZ1 Cradle Management Function

The cradle management function is used to:

- Record and check the position of the moving part of the drawout device in the cradle.
- Provide information about preventive maintenance actions.
- Notify the remote controller about the position of the drawout device.

The cradle management function is performed by:

- The EIFE Ethernet interface (refer to *Enerlin'X IFE Ethernet Interface for One Circuit Breaker - User Guide (DOCA0084EN)*, available on the Schneider Electric website).
- The IO module (refer to *Enerlin'X IO Input/Output Application Module for One Circuit Breaker - User Guide (06131B1317)*, available on the Schneider Electric website).

Masterpact MTZ1 Disconnection

Masterpact MTZ1 Drawout Handling Conditions

⚠️ ⚠️ DANGER

HAZARD OF ELECTRIC SHOCK, EXPLOSION OR ARC FLASH

- Apply appropriate personal protective equipment (PPE) and follow safe electrical work practices. See NFPA 70E, CSA Z462, NOM 029-STPS or local equivalent.
- This equipment must only be installed and serviced by qualified electrical personnel.

Failure to follow these instructions will result in death or serious injury.

Connection or disconnection of the drawout device requires insertion of the racking handle. When interlocks, padlocks, or an open door lock are in place, the racking handle cannot be inserted.

Racking Out Masterpact MTZ1 Devices from Connected to Test Position

Step	Action	
1	Remove the racking handle from its storage space.	
2	Press the opening pushbutton to open the device.	
3	Hold the opening pushbutton in and insert the racking handle into the racking handle socket.	
4	Push in the stop release button.	
5	Turn the racking handle counterclockwise.	
6	When the test position is reached, the stop release button pops out and the mechanism blocks the racking handle. Result: The device is in the test position.	

Racking Out Masterpact MTZ1 Devices from Test to Disconnected Position

Step	Action	
1	Push in the stop release button.	
2	Turn the racking handle counterclockwise.	
3	<p>When the disconnected position is reached, the stop release button pops out and the mechanism blocks the racking handle.</p> <p>Result: The device is in the disconnected position.</p>	
4	Remove the racking handle from the racking socket.	
5	Put the racking handle back into its storage space.	

Masterpact MTZ1 Connection

Masterpact MTZ1 Drawout Handling Conditions

⚠️ ⚠️ DANGER

HAZARD OF ELECTRIC SHOCK, EXPLOSION OR ARC FLASH

- Apply appropriate personal protective equipment (PPE) and follow safe electrical work practices. See NFPA 70E, CSA Z462, NOM 029-STPS or local equivalent.
- This equipment must only be installed and serviced by qualified electrical personnel.

Failure to follow these instructions will result in death or serious injury.

Connection or disconnection of the drawout device requires insertion of the racking handle. When interlocks, padlocks, or an open door lock are in place, the racking handle cannot be inserted.

Racking In Masterpact MTZ1 Devices from Disconnected to Test Position

Step	Action	
1	Remove the racking handle from its storage space.	
2	Press the opening pushbutton in and insert the racking handle into the racking handle socket.	
3	Push the stop release button.	
4	Turn the racking handle clockwise.	
5	When the test position is reached, the stop release button pops out and the mechanism blocks the racking handle. Result: The device is in the test position.	

Racking In Masterpact MTZ1 Devices from Test to Connected Position

Step	Action	
1	Push the stop release button.	
2	Turn the racking handle clockwise.	
3	<p>When the connected position is reached, the stop release button pops out and the mechanism blocks the racking handle.</p> <p>Result: The device is in the connected position.</p>	
4	Remove the racking handle from the racking socket.	
5	Put the racking handle back into its storage space.	

Masterpact MTZ1 Removal from Cradle

Masterpact MTZ1 Device Removal

NOTICE

HAZARD OF EQUIPMENT DAMAGE

The cradle must be securely fastened when installing or removing the device.

Failure to follow these instructions can result in equipment damage.

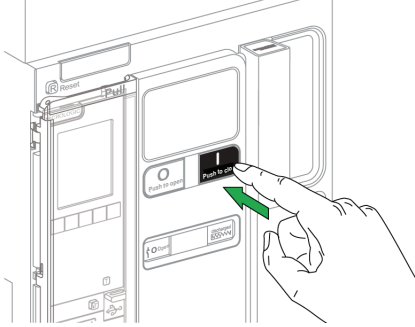
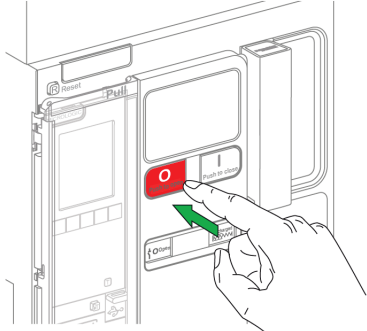
Step	Action	
1	<p>Discharge the closing spring. With the device in the disconnected position, press the closing pushbutton (see <i>Masterpact MTZ1 Disconnection</i>, page 59). The device will close if the closing spring is charged.</p>	
2	<p>Press the opening pushbutton to open the device.</p>	

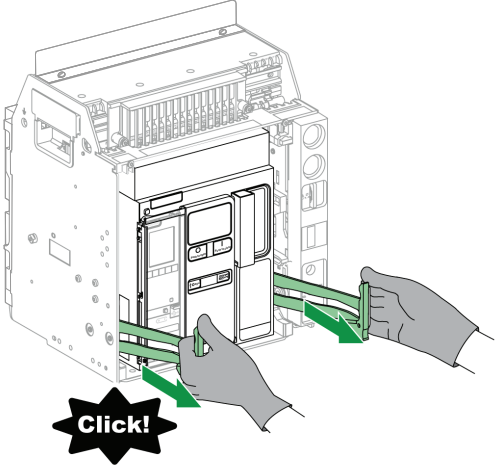
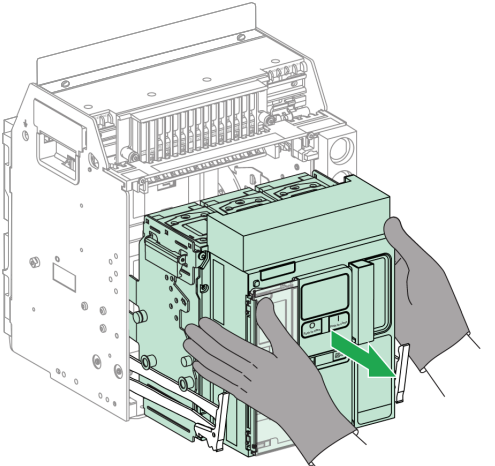
Step	Action	
3	<p>Pull out the rails to the maximum by pulling on the drawout grips. The moving part of the drawout device stays in disconnected position in the cradle.</p>	
4	<p>Pull out the moving part of the drawout device to the maximum, by rolling it along the rails.</p> <p>Result: The device is supported on the rails, clear of the cradle and ready to be lifted.</p>	

Lifting the Masterpact MTZ1 Device

Both the device and cradle have a carrying grip for lifting. To lift, use an overhead lifting device attached to the carrying grip, following the directions given in this section.

⚠ DANGER

HAZARD OF DEVICE FALLING

- Be sure that lifting equipment has lifting capacity for the device being lifted.
- Follow manufacturer's instructions for use of lifting equipment.
- Wear hard hat, safety shoes, and heavy gloves.

Failure to follow these instructions will result in death or serious injury.

Lift the device from the cradle rails by using the carrying handles located on the sides of the device.

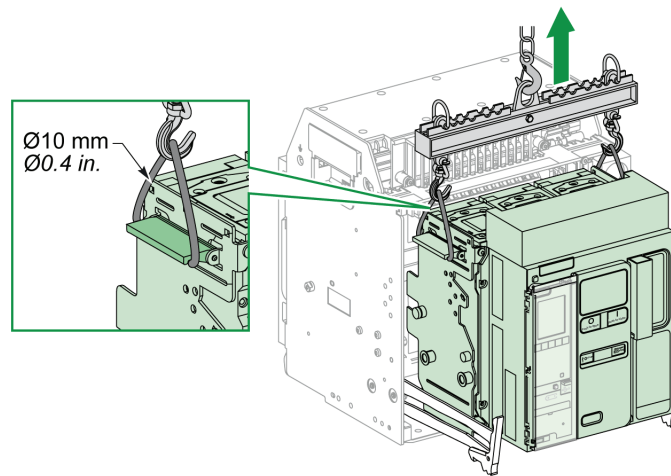

Masterpact MTZ1 Circuit Breaker Weights

Number of Poles	Device	Weight
3P	Drawout Circuit Breaker	31 lbs (14 kg)
	Cradle	35 lbs (16 kg)
	Fixed Circuit Breaker	31 lbs (14 kg)
4P	Drawout Circuit Breaker	40 lbs (18 kg)
	Cradle	46 lbs (21 kg)
	Fixed Circuit Breaker	40 lbs (18 kg)

Masterpact MTZ1 Installation in the Cradle

Masterpact MTZ1 Drawout Handling Conditions

<p style="text-align: center;"> DANGER</p> <p>HAZARD OF ELECTRIC SHOCK, EXPLOSION OR ARC FLASH</p> <ul style="list-style-type: none">• Apply appropriate personal protective equipment (PPE) and follow safe electrical work practices. See NFPA 70E, CSA Z462, NOM 029-STPS or local equivalent.• This equipment must only be installed and serviced by qualified electrical personnel. <p>Failure to follow these instructions will result in death or serious injury.</p>

Connection or disconnection of the drawout device requires insertion of the racking handle. When interlocks, padlocks, or an open door lock are in place, the racking handle cannot be inserted.

Rejecting the Masterpact MTZ1 Device

The cradle rejection feature (see *Masterpact MTZ1 Cradle Rejection Feature*, page 87) allows the installation of a drawout device only in a cradle with compatible characteristics.

Installing Masterpact MTZ1 Devices in the Cradle

⚠ DANGER

HAZARD OF DEVICE FALLING

- Be sure that lifting equipment has lifting capacity for the device being lifted.
- Follow manufacturer’s instructions for use of lifting equipment.
- Wear hard hat, safety shoes, and heavy gloves.

Failure to follow these instructions will result in death or serious injury.

NOTICE

HAZARD OF EQUIPMENT DAMAGE

- Cradle must be securely fastened when installing or removing the device.
- Before mounting the device, make sure that it matches the cradle.

Failure to follow these instructions can result in equipment damage.

Step	Action
1	If the cradle is not installed in a switchboard or panelboard, securely fasten the cradle on a pallet.
2	Inspect the circuit breaker clusters for missing or misaligned clusters. See the bulletin shipped with the circuit breaker for information on checking, installing, and lubricating clusters.
3	Remove the racking handle from its storage space.
4	Check that the cradle indicator is in the disconnected position: If the cradle indicator is not in the disconnected position, follow the steps on disconnecting the drawout device (see <i>Masterpact MTZ1 Disconnection</i> , page 59) .

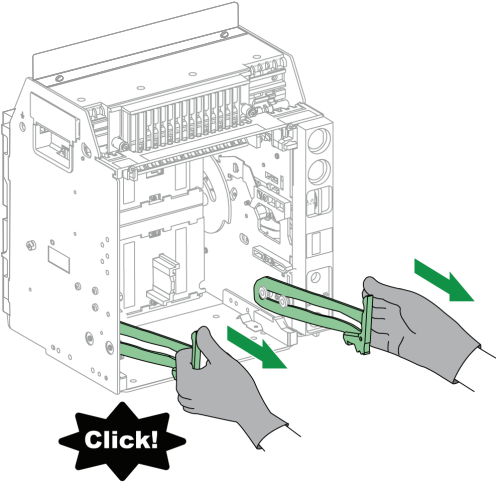
5	<p>Pull out the drawout grips until the extension rails are fully extended.</p>	
---	---	--

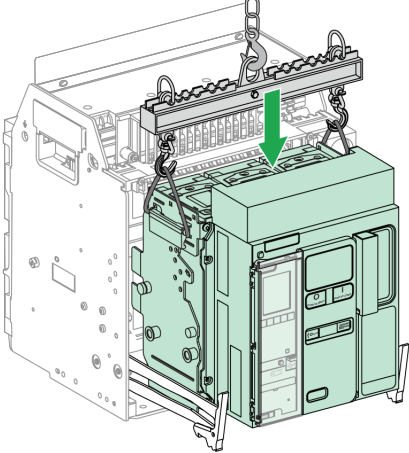
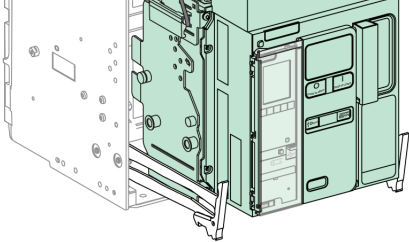
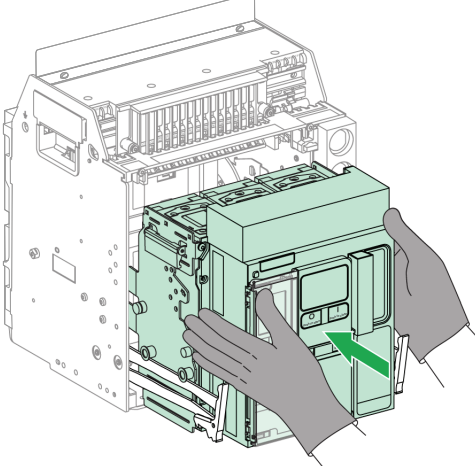
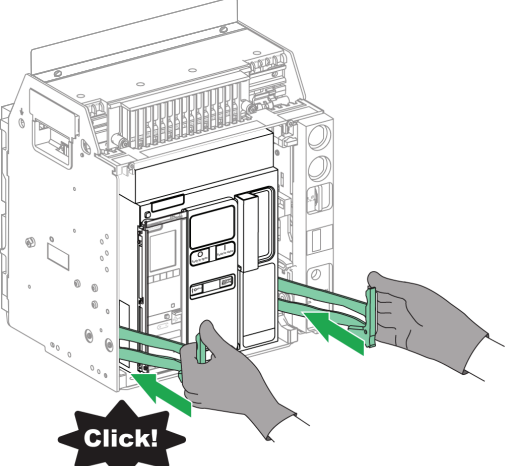
Step	Action	
6	Install the device on the extension rails by using appropriate lifting equipment. Check that the four wheels on the sides of device are resting on the rails.	
7	Detach the lifting equipment.	
8	Check that the device is in the open position.	
9	Using both hands, push in the device to the maximum in the cradle. Take care not to push the control unit. The rails stay extended.	
10	When the device is fully inserted into the cradle, lift and push in the rails to the maximum.	

Masterpact MTZ1 Locking Actions

Locking the Masterpact MTZ1 Pushbuttons

The pushbutton locking cover is an optional accessory for the Masterpact MTZ1 device that prevents access to the closing and opening pushbuttons:

- Together or separately.
- By using a padlock (shackle diameter 5–8 mm [3/16–5/16 in.]).
- By using a lead seal.
- By using screws.

Masterpact MTZ1 Pushbutton Locking Accessory (VBP)

The pushbutton locking accessory is an optional transparent cover, mounted on the front cover of the device, which covers the closing and opening pushbuttons.

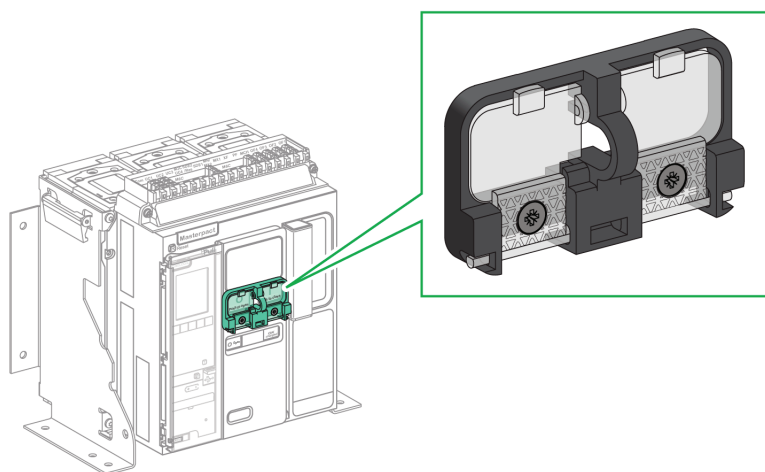

For information on the accessory installation, consult instruction sheet *NVE56769*, available on the Schneider Electric website.

Masterpact MTZ1 Device with the VBP Pushbutton

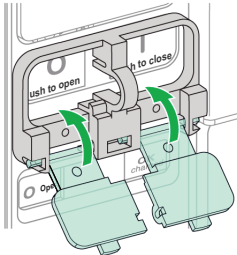
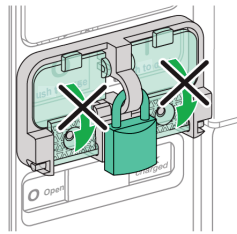
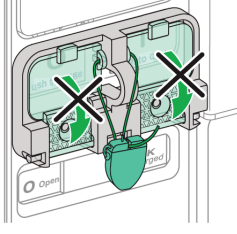
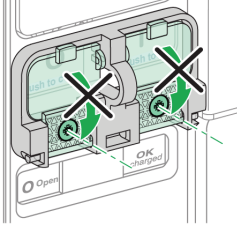
Step	Action	
1	Close the transparent covers of the locking accessory. NOTE: One or both transparent covers of the locking accessory can be closed and locked.	
2	Lock the transparent covers in place by using a padlock, lead seal, or screws.	<p data-bbox="1039 546 1112 577">Padlock</p>  <p data-bbox="1039 840 1128 871">Wire Seal</p>  <p data-bbox="1039 1144 1112 1176">Screws</p> 

Locking the Masterpact MTZ1 Device Open with Padlocks

Locking the Masterpact MTZ1 Device with VCPO Open

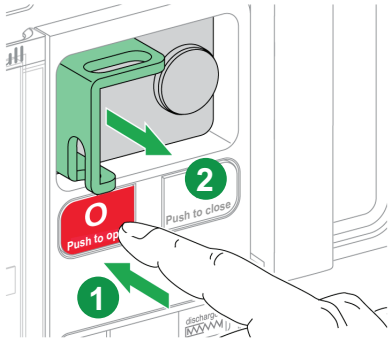
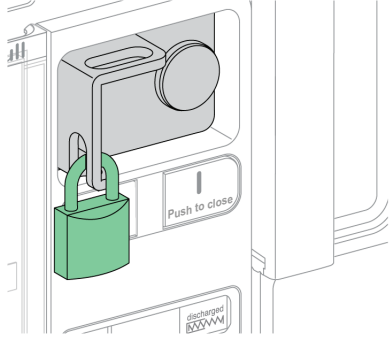
Step	Action	
1	Press and hold down the opening pushbutton.	
2	With the opening button pressed, pull out the tab of the off-position locking accessory.	
3	Insert the padlock in the tab and close the padlock. Release the opening pushbutton.	

Unlocking the Masterpact MTZ1 Device with VCPO

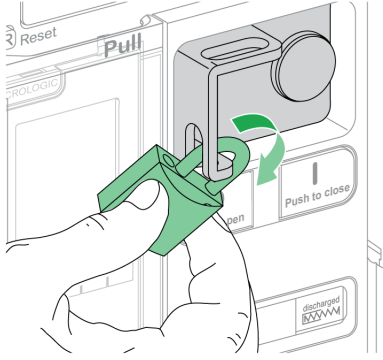
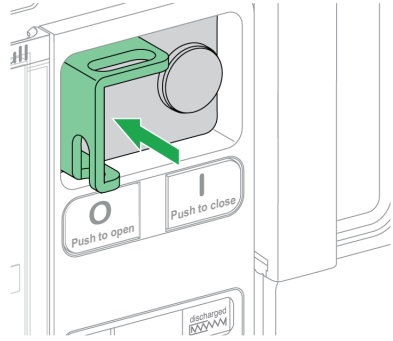
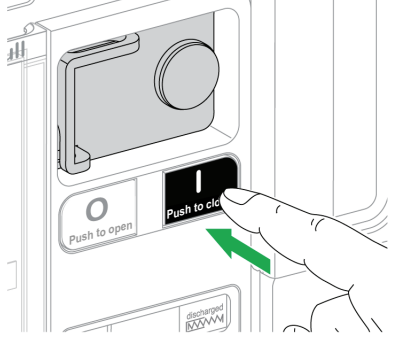
Step	Action	
1	Remove the padlock.	
2	The tab of the OFF-position locking accessory retracts.	
3	Press the closing pushbutton to close the device.	

Locking the Masterpact MTZ1 Device Open with Keylocks

Optional keylocks can be used:

- To lock one Masterpact MTZ1 in the open position. When locked the device cannot be closed either locally with the closing pushbutton or remotely.
- To interlock several Masterpact MTZ devices locked with the same key.

To use keylocks to lock the device in the open position, an optional OFF-position locking accessory is necessary.

Keylocks cannot be used if padlocks are used.

Masterpact MTZ1 Open-Position Locking Accessory (VSPO)

The OFF-position keylocking accessory is an optional accessory that is mounted on the front of the device. It can be fitted with one keylock.

The following types of keylocks can be fitted:

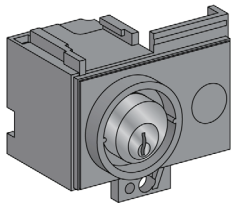

Ronis keylock	Profalux keylock	Castell keylock	Kirk keylock

For information on the accessory installation, consult the instruction sheet on the Schneider Electric website: [NVE56770](#).

Locking the Masterpact MTZ1 Device with VSPO Open

For devices equipped with two keylocks, locking with one key is sufficient to lock the device in the open position.

Step	Action	
1	Press and hold the opening pushbutton.	
2	With the opening pushbutton pressed, turn the key counterclockwise to lock the device.	
3	Remove the key.	
3	Release the opening pushbutton.	
5	Check that the device is locked in the open position and cannot be closed either locally with the closing pushbutton or remotely.	

Unlocking the Masterpact MTZ1 Locked Open with VSPO

For devices equipped with two keylocks, locking with one key is sufficient to lock the device in the open position.

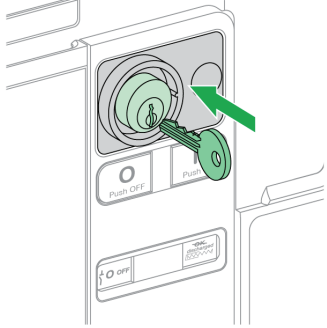
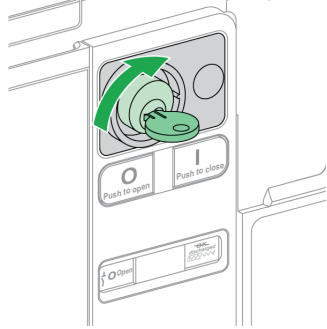
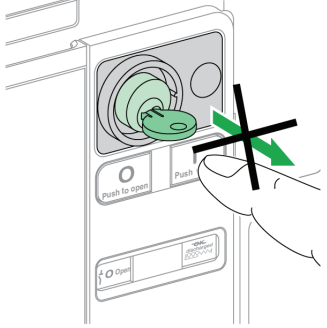
Step	Action	
1	Put the key in the keylock.	
2	Turn the key clockwise to unlock the device.	
3	Press the closing pushbutton to close the device. NOTE: The key remains captive in the keylock.	

Locking the Masterpact MTZ1 Cradle in the Disconnected Position

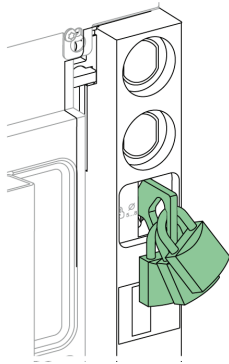

The cradle can be locked in the disconnected position. When the cradle is locked in the disconnected position, the racking handle cannot be inserted.

The cradle can be locked in the disconnected position:

- By up to three padlocks with shackle diameter 5–8 mm (3/16–5/16 in.).
- By optional keylocks.

Keylocks can be used in addition to padlocks.

Cradle locking by padlock is always possible and does not require any accessory.

Locking the Masterpact MTZ1 Cradle with VSPD

A cradle locking by keylock accessory can be fitted with either:

- One keylock.
- Two keylocks with identical keys or different keys.

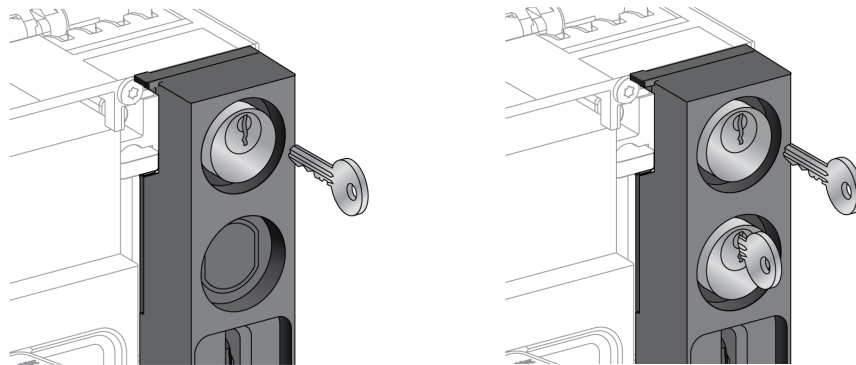

The following types of keylocks can be fitted:

Ronis keylock	Profalux keylock	Castell keylock	Kirk keylock

For information on the accessory installation, consult instruction sheet *NVE56768*, available on the Schneider Electric website.

Locking the Masterpact MTZ1 with Padlocks

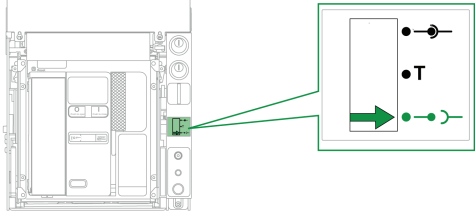
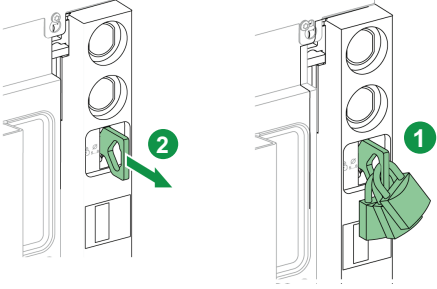
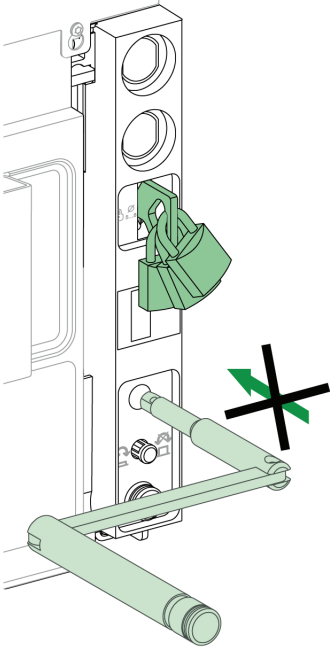
Step	Action	
1	Check that the cradle indicator is in the disconnected position.	
2	Pull out the padlocking tab.	
3	Insert the padlock(s) in the tab and close the padlock(s).	
4	Press and hold down the opening pushbutton, then check that the racking handle cannot be inserted into the racking handle socket.	

Unlocking Padlocked Masterpact MTZ1 Cradle

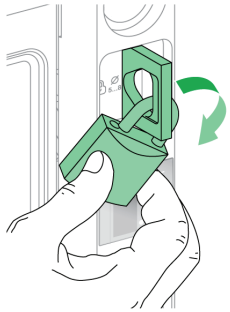
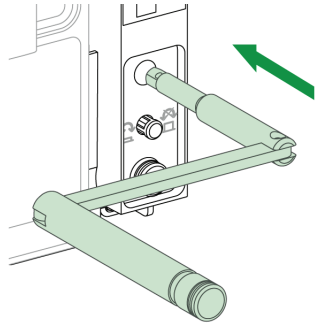
Step	Action	
1	Remove the padlock. The tab retracts.	
2	Press and hold down the opening pushbutton, then check that the racking handle can be inserted into the racking handle socket.	

Locking Masterpact MTZ1 Cradle with Keylocks

For a cradle equipped with two keylocks, locking with one key is sufficient to lock the cradle in the disconnected position.

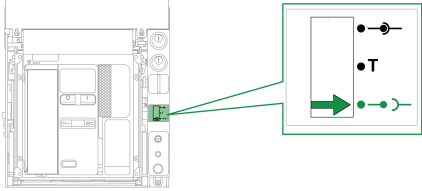
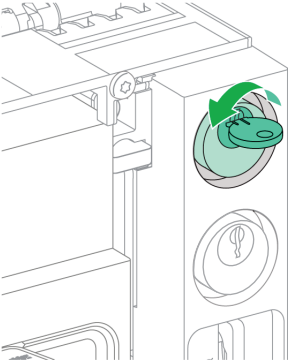
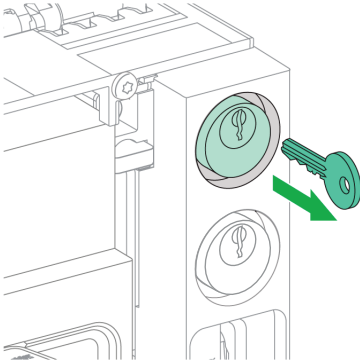
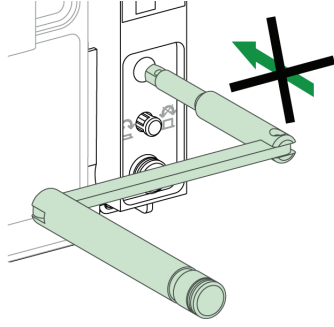
Step	Action	
1	Check that the cradle indicator is in the disconnected position.	
2	Turn the key counterclockwise to lock the cradle.	
3	Remove the key.	
4	Press and hold down the opening pushbutton, then check that the racking handle cannot be inserted into the racking handle socket.	

Unlocking Keylocked Masterpact MTZ1 Cradle

For a cradle equipped with two keylocks, both keys must be inserted in the keylocks to unlock the cradle.

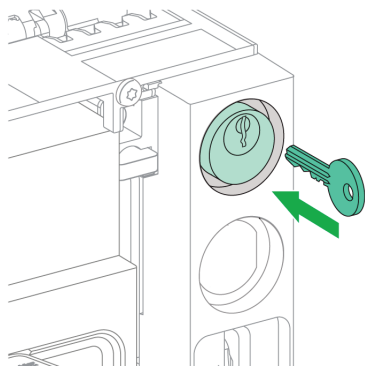
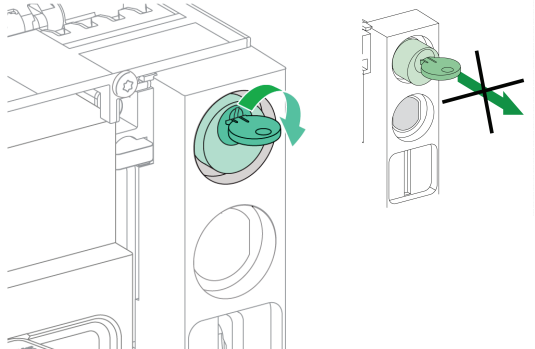
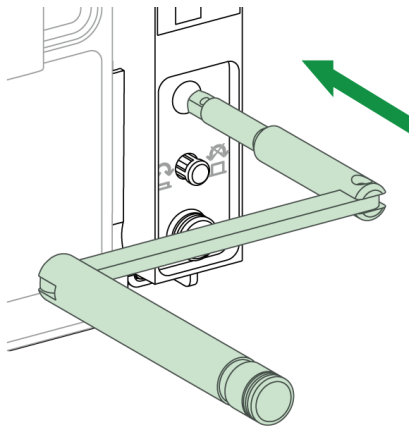
Step	Action	
1	Put the key in the lock.	
2	Turn the key clockwise to unlock the cradle NOTE: The key remains captive in the keylock.	
3	Press and hold down the opening pushbutton, then check that the racking handle can be inserted into the racking handle socket.	

Locking the Masterpact MTZ1 Cradle in Any Position

The cradle can be locked in any position (connected, test, or disconnected position).

This locking function requires a mechanical adaptation of the cradle, explained in the following procedure.

When the cradle is locked, the racking handle cannot be inserted in the racking handle socket.

Masterpact MTZ1 Cradle Locking with VSPD Keylock Accessory

The cradle locking by keylock accessory and the locking and unlocking procedures are the same as for cradle locking in disconnected position (see *Locking the Masterpact MTZ1 Cradle in the Disconnected Position*, page 76).

Converting the Masterpact MTZ1 Cradle for Keylocking

⚠ DANGER

HAZARD OF DEVICE FALLING

- Be sure that lifting equipment has lifting capacity for the device being lifted.
- Follow manufacturer's instructions for use of lifting equipment.
- Wear hard hat, safety shoes, and heavy gloves.

Failure to follow these instructions will result in death or serious injury.

NOTICE

HAZARD OF EQUIPMENT DAMAGE

The cradle must be securely fastened when installing or removing the device.

Failure to follow these instructions can result in equipment damage.

Follow these stages to adapt the cradle locking mechanism so that the cradle can be locked in any position.

Step	Action
1	Removing the terminal block identification plate and the cradle front cover. (Refer to the following procedure).
2	Changing the position of the lock (see page 79, page 83).
3	Reinstalling the cradle front cover and the terminal block identification plate (see page 81, page 86).

Removing the Terminal Block Identification Plate and Cradle Front Cover

Before starting the procedure, check that the device is in the disconnected position (see *Masterpact MTZ1 Disconnection*, page 59) and remove the device from the cradle (see *Masterpact MTZ1 Removal from Cradle*, page 63).

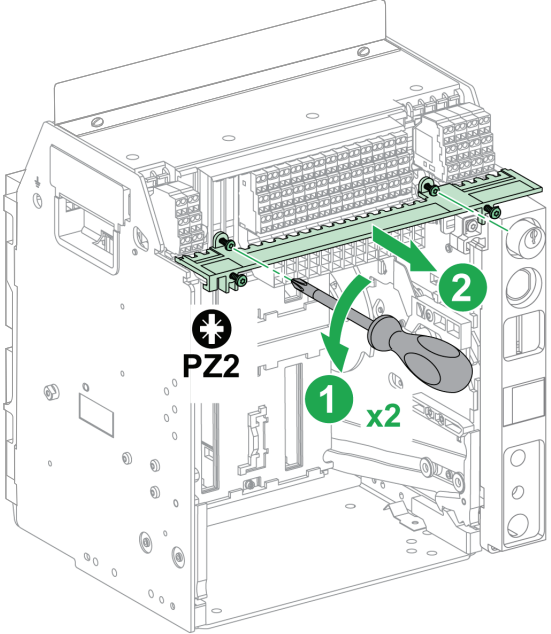
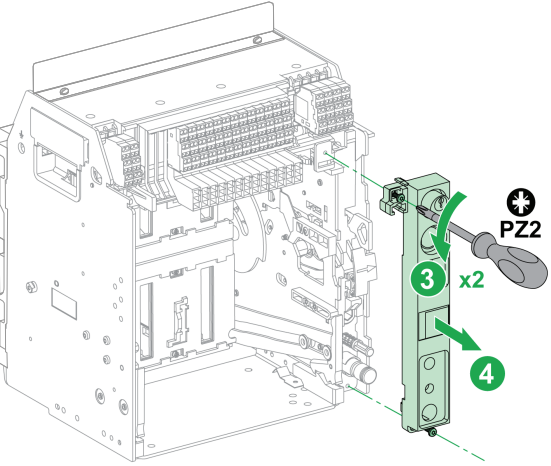
Step	Action	
1	Remove the two screws holding the terminal block identification plate in place, by using a PZ2 screwdriver.	
2	Carefully pull out the terminal block identification plate.	
3	Remove the two screws holding the cradle front cover in place, by using a PZ2 screwdriver.	
4	Pull off the cradle front cover.	

Changing the Position of the Masterpact MTZ1 Lock

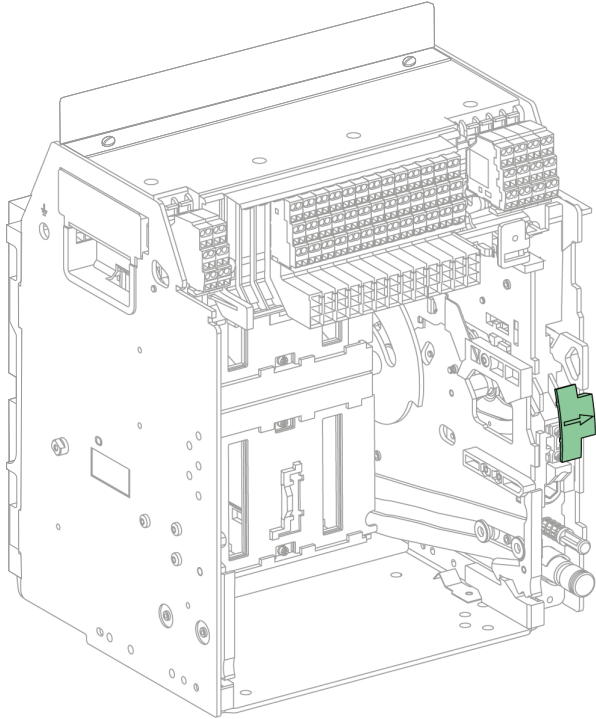
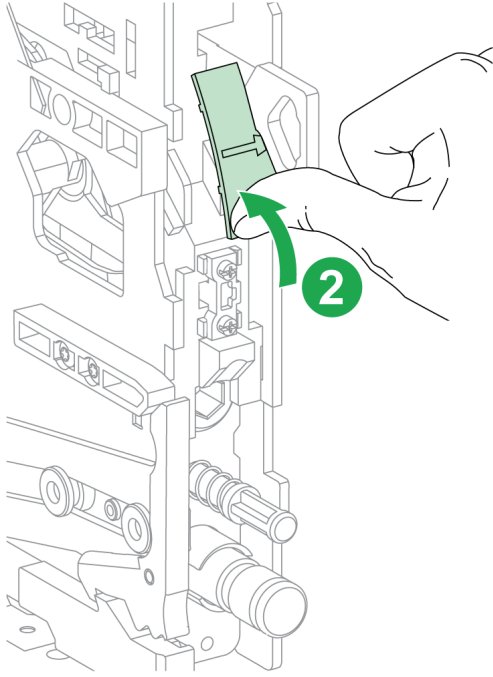
Step	Action	
1	Identify the position of the plastic cover of the lock.	 <p>A perspective line drawing of a Masterpact MTZ1 circuit breaker. A green cross is overlaid on the right side of the device, indicating the location of the lock cover.</p>
2	Lift the plastic cover of the lock and hold it up.	 <p>A detailed line drawing of the lock mechanism area. A hand is shown lifting a green plastic cover. A green arrow points upwards from the cover, and a green circle with the number '2' is next to the arrow, indicating the second step of the process.</p>

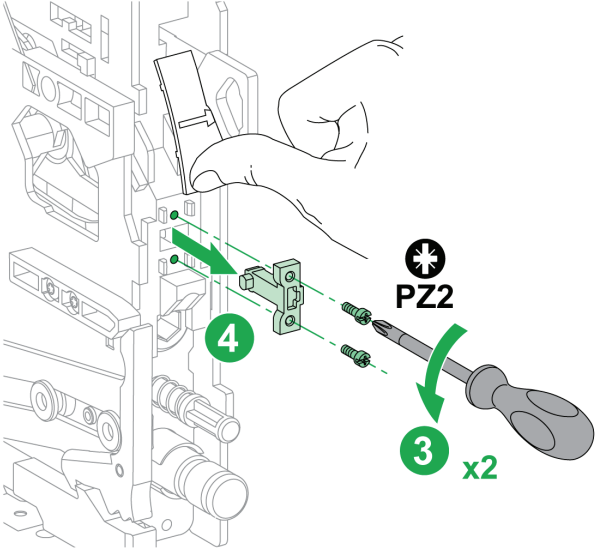
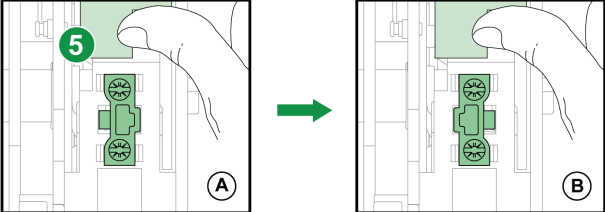
Step	Action	
3	Remove the two screws holding the lock in place, by using a PZ2 screwdriver.	
4	Remove the lock.	
5	Rotate the lock through 180° to change from locking in disconnected position (A) to locking in any position (B).	

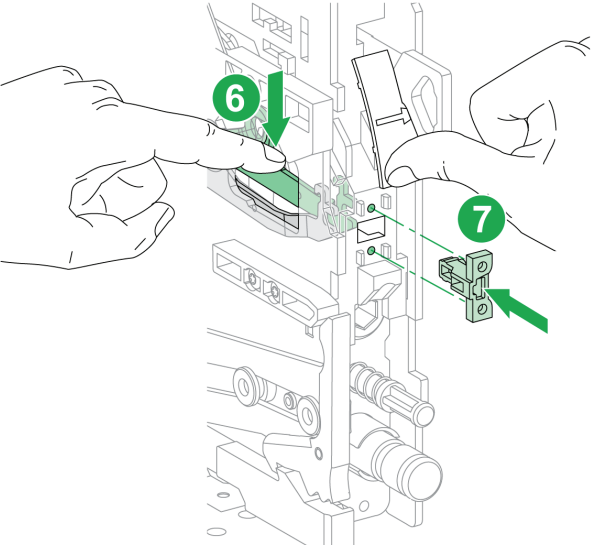
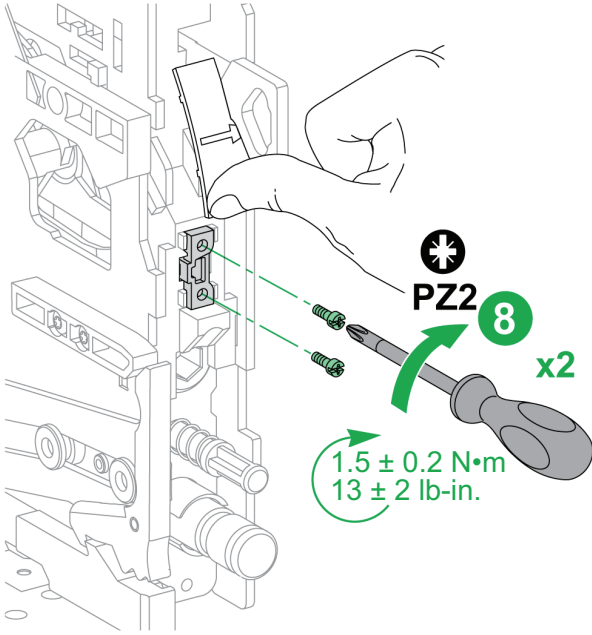
Step	Action	
6	Use your finger to press down the tab behind the lock slot.	
7	Insert the lock, making sure that the notch is on the left side.	
8	<p>Screw the lock into position with the two screws, using a PZ2 screwdriver.</p> <p>Release the plastic cover to allow it to drop back into place.</p>	

Reinstalling the MTZ1 Cradle Front Cover and Terminal Block Identification Plate

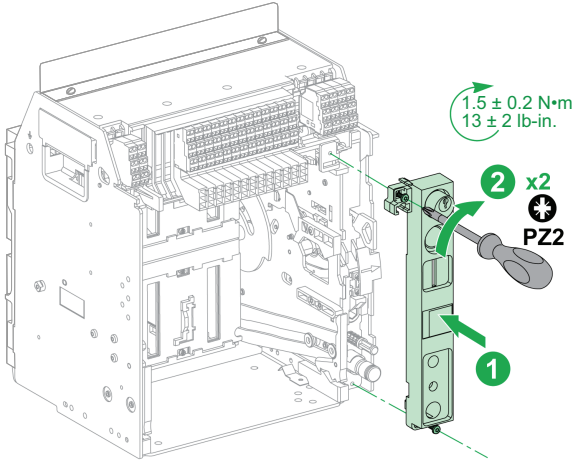
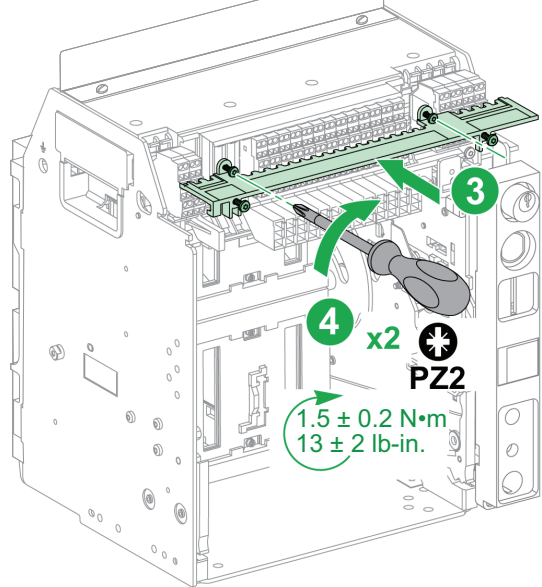
Step	Action	
1	Reinstall the cradle front cover.	
2	Screw the front cover into position with the two screws, by using a PZ2 screwdriver.	 <p>1.5 ± 0.2 N·m 13 ± 2 lb-in.</p> <p>2 x2 PZ2</p>
3	Slide the terminal block identification plate into place.	
4	Screw the terminal block identification plate in with the two screws, using a PZ2 screwdriver.	 <p>1.5 ± 0.2 N·m 13 ± 2 lb-in.</p> <p>4 x2 PZ2</p>

Masterpact MTZ1 Interlocking Actions

An interlocking action is an automatic locking operation provided by interlocking accessories added to the Masterpact MTZ1 device or cradle.

A number of optional interlocking accessories are available for the Masterpact MTZ1 device and cradle. For a complete listing of available interlocks, refer to *Masterpact MTZ Circuit Breakers and Switches – Catalog (0614CT1701)*, available on the Schneider Electric website.

For detailed installation instructions on field-installable interlocks, refer to the installation instructions shipped with these accessories.

Masterpact MTZ1 Cradle Rejection Feature

The cradle rejection feature allows the installation of a Masterpact MTZ1 device only in a cradle with compatible characteristics.

Cradle rejection pins offer over 100 different combinations that can be selected so that a device can only be mounted on a cradle with the matching combination.

Masterpact MTZ1 Cradle Rejection

The use of cradle rejection pins is optional. One cradle rejection accessory is required for each device.

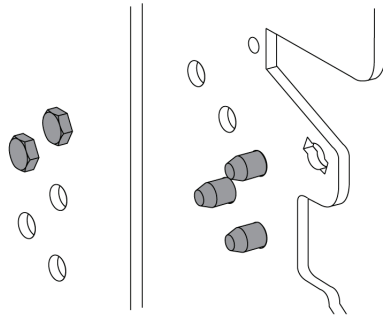

For information on the accessory installation, consult instruction sheet *NVE35465*, available on the Schneider Electric website.

Masterpact MTZ1 Cradle Rejection Pin Locations

The following illustration shows the pin location on the cradle and device, respectively.

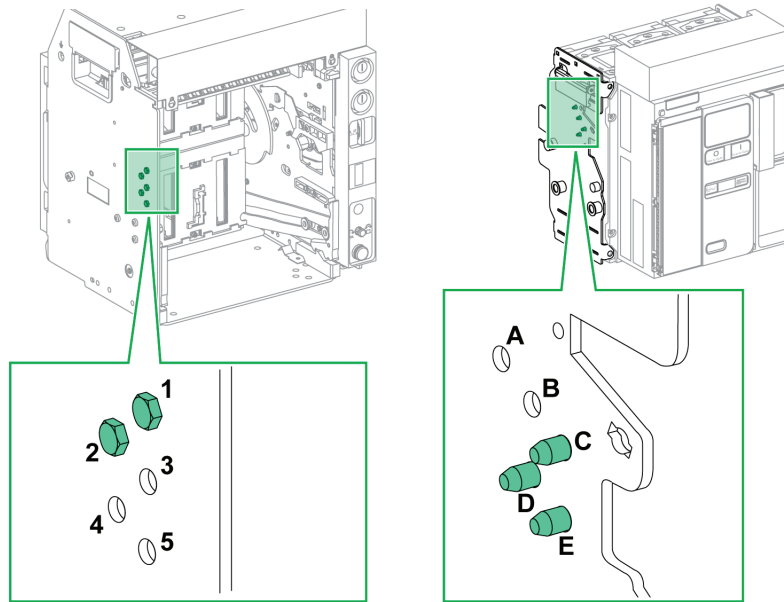

The pin combination selected on the cradle must correspond to the pin combination selected on the device (see following table). For example, the combination ABC on the cradle corresponds to the combination 45 on the device.

Pins on the cradle are labeled 1, 2, 3, 4, 5.

Pins on the device are labeled A, B, C, D, E.

Masterpact MTZ1 Cradle Rejection Recommended Pin Combinations

The following are the recommended pin combinations:

Pins on Cradle	Pins on Device	Pins on Cradle	Pins on Device
45	ABC	15	BCD
35	ABD	14	BCE
34	ABE	145	BC
345	AB	13	BDE
25	ACD	135	BD
24	ACE	134	BE
245	AC	12	CDE
23	ADE	125	CD
235	AD	124	CE
234	AE	123	DE

Masterpact MTZ1 Door Interlock (VPEC)

With the door interlock:

- The equipment door is locked and cannot be opened when the drawout device is in the connected or test position.
- The equipment door can be opened when the drawout device is in the disconnected position.
- The equipment door can be closed with the drawout device in any position.

Door Interlock Accessory (VPEC)

The door interlock accessory (VPEC) is an optional accessory that is mounted on the left side or on the right side of the cradle. One door interlock is necessary for one cradle.

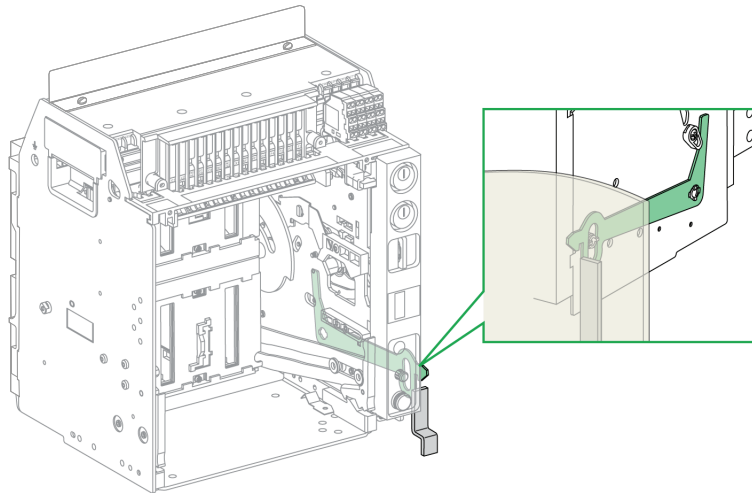

For information on the accessory installation, consult instruction sheet *NVE35519*, available on the Schneider Electric website.

Using Masterpact MTZ1 VPEC Accessory to Lock Equipment Door

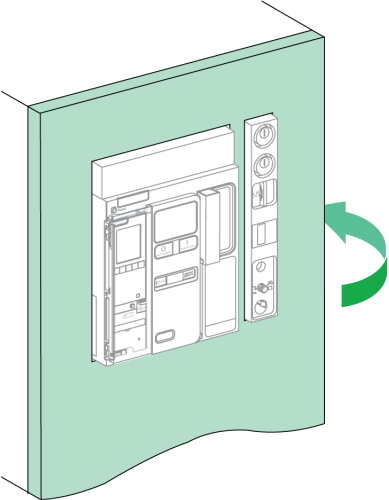
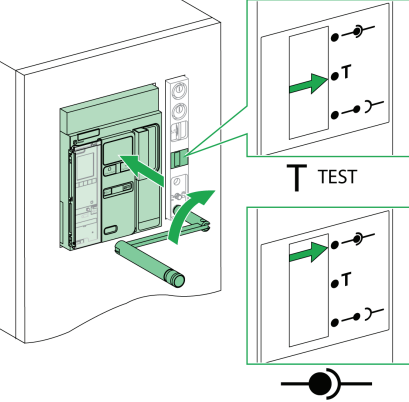
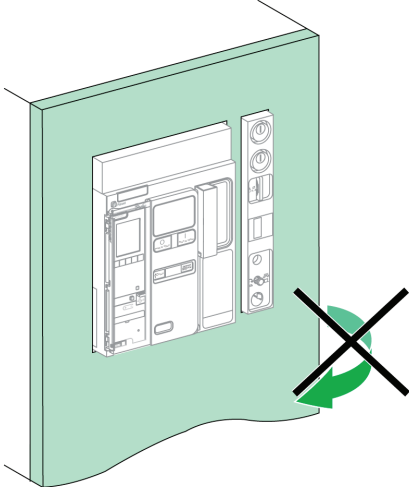
Step	Action	
1	Close the equipment door.	
2	Put the device into the test or connected position (see <i>Masterpact MTZ1 Connection</i> , page 61).	
3	Check that the equipment door is locked.	

Unlocking Equipment Door Locked with a Masterpact MTZ1 VPEC Accessory

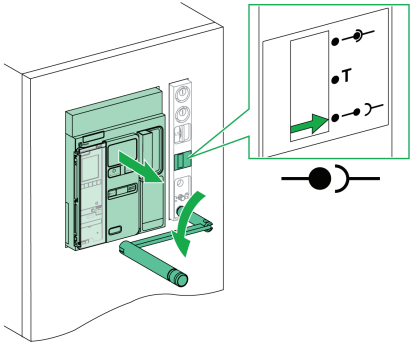
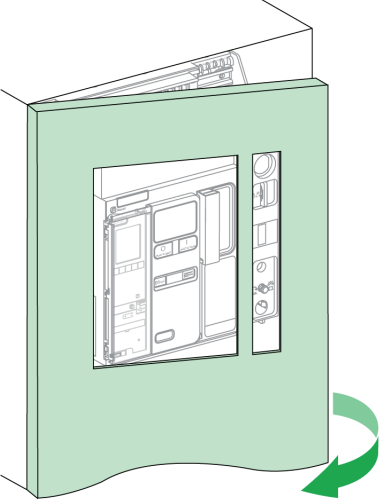
Step	Action	
1	Put the device into the disconnected position (see <i>Masterpact MTZ1 Disconnection</i> , page 59).	
2	Check that the equipment door is unlocked.	

Masterpact MTZ1 Open-Door Racking Interlock (VPOC)

With the racking interlock installed, a drawout Masterpact MTZ1 device cannot be racked in or out when the equipment door is open because the racking handle cannot be inserted.

Open-Door Racking Interlock (VPOC)

The optional VPOC racking interlock can be installed on the right side of the cradle.

For information on the accessory installation, consult instruction sheet *NVE35520*, available on the Schneider Electric website.

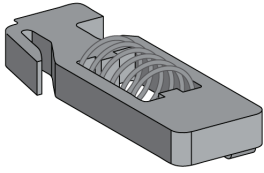

Activating the VPOC Racking Interlock

Step	Action	
1	Insert the racking interlock.	
2	Press and hold down the opening pushbutton, then check that the racking handle cannot be inserted into the racking handle socket when the equipment door is open.	
3	Press and hold down the opening pushbutton, then check that the racking handle can be inserted into the racking handle socket when the equipment door is closed.	

Deactivating the VPOC Racking Interlock

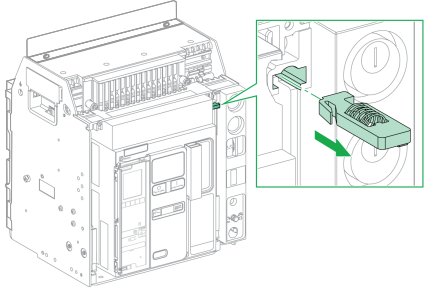
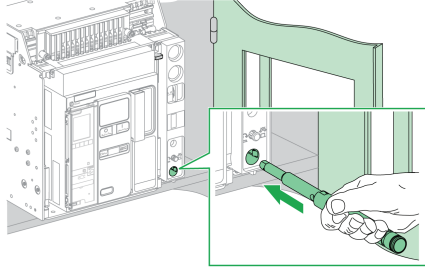
Step	Action	
1	Pull out the racking interlock.	 A technical line drawing of a circuit breaker assembly. A green callout box on the right shows a close-up of a racking interlock mechanism. A green arrow points to the right, indicating the direction to pull the interlock out of its housing.
2	Press and hold down the opening pushbutton, then check that the racking handle can be inserted into the racking handle socket when the equipment door is open or closed.	 A technical line drawing of the circuit breaker assembly with the equipment door open. A green callout box on the right shows a close-up of a hand pressing a green pushbutton. A green arrow points to the right, indicating the direction of the push.

Masterpact MTZ1 Cable-Type Door Interlock (IPA)

When the cable-type door interlock is installed, the door cannot be opened when the device is closed and the device cannot be closed when the door is open.

The cable-type door interlock comprises a plate, a lock, and a cable. It is mounted on the right-hand side of the device.

When the interlock is installed, the mechanical interlock for transfer switches cannot be implemented.

Masterpact MTZ1 Cable-Type Door Interlock (IPA) Description

The cable-type door interlock (IPA) is an optional accessory.

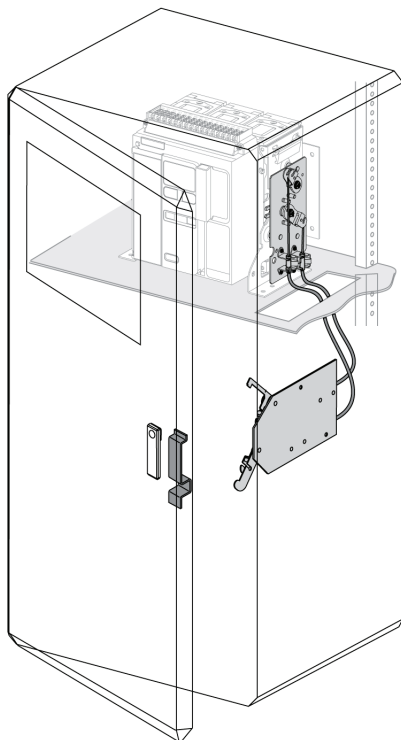

For information on the accessory installation, consult instruction sheet *NVE35521*, available on the Schneider Electric website.

Masterpact MTZ Critical Cases

Finding the Cause of a Masterpact MTZ Trip or Alarm

While operating the device, the user may face two critical cases:

- The circuit breaker has tripped automatically, interrupting the power supply.
- The circuit breaker has not tripped, but the Micrologic X control unit has detected an alarm:
 - For a high severity alarm, the service LED is red, indicating that urgent corrective action is required.
 - For a medium severity alarm, the service LED is orange, indicating that corrective action needs to be scheduled.

Notification of a Masterpact MTZ Trip or Alarm

A trip or alarm event is signaled:

- On the Micrologic X control unit HMI, by the trip cause LEDs or the service LED. When the control unit is powered, a red or orange pop-up message is displayed on the screen.
- By the overcurrent trip switch (SDE).

Depending on the options installed, a trip or alarm can also be signaled:

- By an additional overcurrent trip switch (SDE2).
- By the outputs of the programmable contacts (M2C).
- By the outputs of an IO application module.
- By an email sent through IFE or EIFE Ethernet interface.
- On a remote controller connected to the communication network (application customized by user).
- On the FDM128 display.

Active alarms can also be consulted in the following ways:

- On a smartphone with Masterpact MTZ Mobile App connected to the Micrologic X control unit:
 - Through Bluetooth.
 - Through the USB OTG connection.
- On Ecoeach software connected to the Micrologic X control unit:
 - Through the USB connection.
 - Through the Ethernet interface.
 - Through the IFM Modbus-SL (RTU) interface.

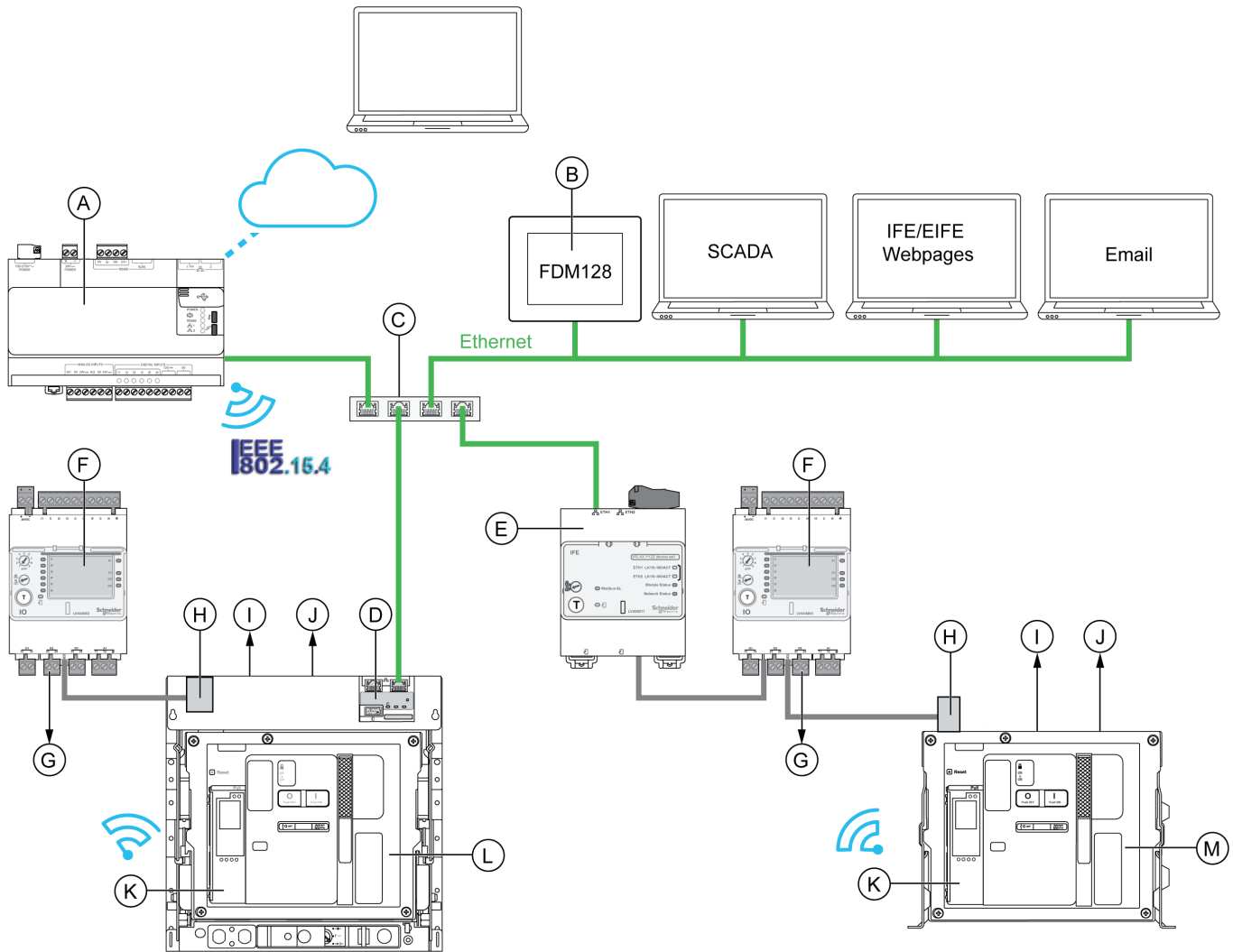

- A. Com'X energy server
- B. FDM128 Ethernet display for eight devices
- C. Ethernet switch
- D. EIFE embedded Ethernet interface for one Masterpact MTZ drawout circuit breaker
- E. IFE Ethernet interface for one Masterpact MTZ circuit breaker
- F. IO input/output application module for one circuit breaker
- G. IO module outputs used for event notification
- H. ULP port module
 - I. One or two overcurrent trip switches (SDE)
 - J. Two optional programmable contacts (M2C)
- K. Micrologic X control unit HMI
- L. Drawout Masterpact MTZ circuit breaker
- M. Fixed Masterpact MTZ circuit breaker

Identifying the Cause of a Masterpact MTZ Trip or Alarm Using the Micrologic X Control Unit

The cause of a trip or an alarm can be identified locally by using one of the following:

- The indicators on the Micrologic X control unit HMI (see *Identifying the Cause of a Masterpact MTZ Trip or Alarm Using the Micrologic X Control Unit*, page 97):
 - The fault trip reset button on the circuit breaker (A).
 - The Micrologic X health status LEDs (Ready and service LEDs) (B).
 - The Micrologic X display screen (C).
 - The trip cause LEDs (D).
- A smartphone with Masterpact MTZ Mobile App installed to get the tripping cause, the trip or alarm context, and the device ID:
 - Through NFC.
 - Through Bluetooth.
 - Through the USB OTG connection.

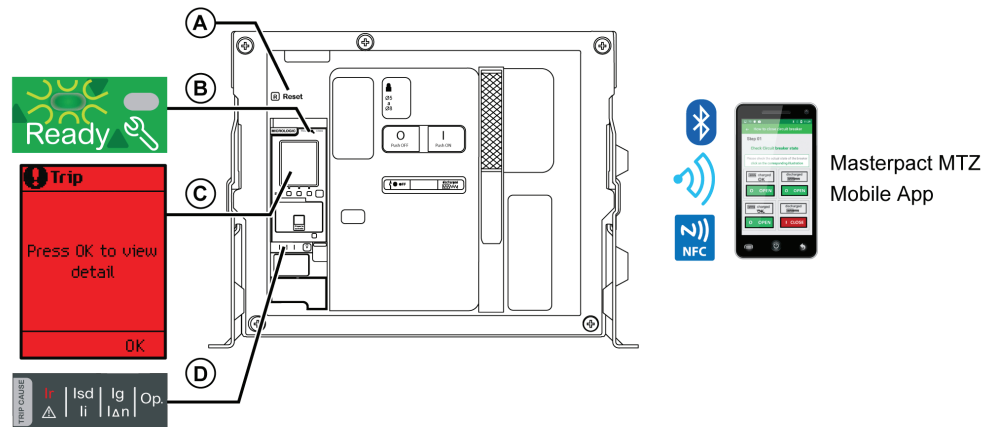

- A. Fault trip reset button
- B. Health status LEDs
- C. Micrologic X display screen
- D. Trip cause LEDs

NOTE: The optional Power Restoration Assistant Digital Module provides assistance with restoring power after a trip.

For more information, refer to the Micrologic X - Control Unit - User Guide (see *Related Documents*, page 8).

Diagnostic Data after a Masterpact MTZ Circuit Breaker Trip

The diagnostic data is available when the Micrologic X control unit is powered.

If the Micrologic X control unit is not permanently powered by an external 24 Vdc power source, connect the Micrologic X control unit to an external power supply (such as the Mobile Power Pack as an example) through the mini USB port to have access to the diagnostic data.







When the Micrologic X control unit is powered externally, the availability of diagnostic data depends on the Micrologic X control unit status:

- If the Micrologic X control unit is healthy, all diagnostic data is available.
- If there is an invalid Micrologic X control unit self-test, what diagnostic data is available will vary.
- If the Micrologic X control unit is inoperative, no data is directly available. However, some data can be extracted using the NFC function with the Masterpact MTZ Mobile App.

The trip cause LEDs and the service LED are powered by the Micrologic X control unit internal lithium battery and will remain on for four hours when there is no other power to the control unit. To switch on the trip cause LEDs again after four hours, press the Test/Reset button.

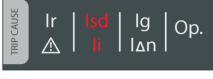
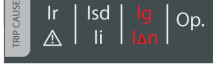
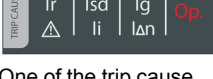







Using the Display Screen and LEDs to Find the Cause of a Trip

The circuit breaker has tripped automatically, interrupting the power supply, and the fault-trip reset button has popped out.

Status LEDs	Micrologic X Display Screen	Trip Cause LEDs	Probable Cause
 <p>Ready LED flashing green. Service LED off.</p>		    <p>One of the trip cause LEDs is on red.</p>	<p>Electrical fault on the network (see <i>Resetting the Circuit Breaker after a Trip Due to an Electrical Fault</i>, page 100).</p>
 <p>Ready LED off. Service LED red.</p>		 <p>All LEDs are on.</p>	<p>Invalid Micrologic X control unit self-test (see <i>Resetting the Circuit Breaker after a Trip Due to an Invalid Micrologic X Control Unit Self-Test</i>, page 102).</p>

Using the Display Screen and LEDs to Find the Cause of an Alarm

The circuit breaker has not tripped, but the Micrologic X control unit service LED is on.

Status LEDs	Micrologic X Display Screen	Trip Cause LEDs	Probable Cause
 <p>Ready LED flashing green. Service LED orange.</p>		 <p>All LEDs are off.</p>	<p>Medium severity alarm (see <i>Recommended Action after Detection of a Medium Severity Micrologic X Alarm</i>, page 106).</p>
 <p>Service LED red. Ready LED flashing green.</p>  <p>Service LED red. Ready LED off.</p>		 <p>All LEDs are off.</p>  <p>All LEDs are on.</p>	<p>High severity alarm (see <i>Recommended Action after Detection of a High Severity Micrologic X Control Unit Alarm</i>, page 105).</p>

Resetting the Circuit Breaker after a Trip Due to an Electrical Fault

Masterpact MTZ1 Circuit Breaker Reset Sequence

The table shows the sequence of actions to follow after a trip due to an electrical fault. Further explanation of each action is given in the following paragraphs.

Step	Description
1	Identify the trip cause by using the Micrologic X control unit HMI.
2	Acknowledge the trip message on the Micrologic X control unit.
3	Clear the electrical fault on the network .
4	Inspect the circuit breaker and switchboard after a short circuit.
5	Reset the circuit breaker (see <i>Resetting Masterpact MTZ Devices, page 45</i>).
6	When the circuit breaker is ready-to-close, re-close it (see <i>Closing the Masterpact MTZ1 Mechanism, page 43</i>).

Identifying the Masterpact MTZ Trip Cause

Trip Cause LEDs	Control Unit	Description
	Micrologic 3.0 X, 5.0 X, 6.0 X	Trip due to the long-time protection.
	Micrologic 5.0 X, 6.0 X	Trip due to the short-time protection or instantaneous protection.
	Micrologic 3.0 X, 5.0 X	Not used.
	Micrologic 6.0 X	Trip due to the ground-fault protection.
	Micrologic 3.0 X, 5.0 X, 6.0 X	Trip due to other protection (optional protections).

NOTE: Diagnostic assistance can be obtained by using a smartphone running the Masterpact MTZ Mobile App.

Acknowledging a Trip Message on Micrologic X Control Units

Step	Action
1	Press OK to view details of the trip cause on the display screen.
2	Consult the two tripping context screens: <ul style="list-style-type: none"> • Screen 1: Name and settings of the tripping protection. Date and time of the trip. • Screen 2: Current values recorded before the trip.
3	Press OK to acknowledge the trip and return to the Home menu. NOTE: If the trip is not acknowledged within the event timeout, the pop-up is displayed again.
4	Press the Test/Reset button for 3 seconds to reset the control unit and switch off the trip cause and service LEDs.

Clearing the Electrical Fault Before Reclosing the Masterpact MTZ Circuit Breaker

The fact that a circuit breaker has tripped does not remedy the cause of the electrical fault detected on the downstream electrical equipment.

⚠ CAUTION

HAZARD OF CLOSING ON ELECTRICAL FAULT

Do not close the circuit breaker again without first inspecting and, if necessary, repairing the downstream electrical equipment.

Failure to follow these instructions can result in injury or equipment damage.

The feed must be isolated before inspecting the electrical equipment downstream of the protection.

⚠⚠ DANGER

HAZARD OF ELECTRIC SHOCK, EXPLOSION, OR ARC FLASH

- Apply appropriate personal protective equipment (PPE) and follow safe electrical work practices. See NFPA 70E, CSA Z462, NOM 029-STPS or local equivalent.
- This equipment must be installed and serviced by qualified electrical personnel.
- Disconnect all power sources before performing maintenance inspections. Assume that all circuits are live until they are de-energized, tested, grounded, and tagged. Consider all sources of power, including the possibility of backfeeding and control power.
- Always use a properly rated voltage sensing device to confirm that power is off.
- Replace all devices, doors, and covers before turning on power to this equipment.

Failure to follow these instructions will result in death or serious injury.

Inspecting the Masterpact MTZ Circuit Breaker and Switchboard after a Trip on a Short Circuit

After a trip on a short circuit due to short-time or instantaneous protection, the circuit breaker and switchboard must be inspected for smoke deposits or cracks in the device casing.

Refer to *Masterpact MTZ Circuit Breakers - Maintenance Guide (DOCA0099EN)* and contact a Schneider Electric field service representative.



Resetting the Circuit Breaker after a Trip Due to an Invalid Micrologic X Control Unit Self-Test

Masterpact MTZ1 Circuit Breaker Reset Sequence

The table shows the sequence of actions to follow after a trip due to an electrical fault. Further explanation of each action is given in the following paragraphs.

Step	Description
1	Identify the trip cause by using the Micrologic X control unit HMI.
2	Acknowledge the trip message on the Micrologic X control unit.
3	Clear the electrical fault on the network .
4	Inspect the circuit breaker and switchboard after a short circuit.
5	Reset the circuit breaker (see <i>Resetting Masterpact MTZ Devices, page 45</i>).
6	When the circuit breaker is ready-to-close, re-close it (see <i>Closing the Masterpact MTZ1 Mechanism, page 43</i>).

Masterpact MTZ Circuit Breaker Trip Cause Identification

Status LEDs	Micrologic X display screen T	Trip Cause LEDs	Probable Cause
 <p>Ready LED off. Service LED red.</p>		 <p>All LEDs are on.</p>	<p>Invalid Micrologic control unit self test (see <i>Resetting the Circuit Breaker after a Trip Due to an Invalid Micrologic X Control Unit Self-Test, page 102</i>).</p>

Micrologic X Display Screen Trip Message Acknowledgement

Step	Action
1	<p>Press OK.</p> <p>The screen displays:</p> <ul style="list-style-type: none"> • A description of the trip cause. • The date and time that the trip cause occurred.
2	Consult the list of possible detected trip causes in the following table and perform the actions recommended.
3	Press OK to acknowledge the trip and return to the Home menu.
4	Press the Test/Reset button for 3 seconds to reset the control unit and switch off the trip cause and service LEDs.

Recommended Actions After a Trip Due to Invalid Micrologic X Control Unit Self Test

Code	Trip Message	Description	Recommended Action
0x1400 0x1404 0x1405 0x1406 0x1416	CU self-test major malfunction	The control unit self-test detected a major malfunction in the control unit operation. NOTE: The control unit may or may not trip the circuit breaker, depending on how the fallback position is configured.	Call Schneider Electric field service to replace the control unit.
0x1402	Internal current sensor disconnected	The control unit self-test detected the disconnection of an internal sensor of the circuit breaker.	Call Schneider Electric field service to replace the control unit.
0x1403	ENCT disconnected	The control unit self-test detected the disconnection of the external neutral current sensor of the circuit breaker.	Reconnect the external neutral current sensor (ENCT).
0x6407	Self diagnostic trip	The control unit tripped the circuit breaker for an unknown reason.	Call Schneider Electric field service to replace the control unit.

Diagnosing Micrologic X Control Unit Alarms

Micrologic X Control Unit Diagnosis Sequence

The following table shows the sequence of actions to take after an alarm is detected by the Micrologic X control unit. Further explanation of each action is given in the following paragraphs.

Step	Description
1	Identify the alarm detected.
2	Acknowledge the alarm cause on the Micrologic X display screen.
3	Consult the list of alarms and perform the recommended actions.







Identifying the Micrologic X Control Unit Alarm

The Micrologic X control unit indicates alarms with:

- The ready LED (flashing green or off).
- The service LED (red or orange).
- A pop-up alarm screen (red or orange).

Two levels of alarm are detected and indicated by the color of the service LED:

- Red for high-severity alarms.
- Orange for medium-severity alarms.

Health Status LEDs	Micrologic X Display Screen	Trip Cause LEDs	Probable Cause
 <p>Ready LED flashing green. Service LED orange.</p>		 <p>All LEDs are off.</p>	<p>Medium severity alarm (see <i>Recommended Action after Detection of a Medium Severity Micrologic X Alarm</i>, page 106).</p>
 <p>Service LED red. Ready LED flashing green.</p>  <p>Service LED red. Ready LED off.</p>		 <p>All LEDs are on.</p>	<p>High severity alarm (see <i>Recommended Action after Detection of a High Severity Micrologic X Control Unit Alarm</i>, page 105).</p>

Acknowledging the Alarm on the Micrologic X Display Screen

Step	Action
1	Press OK. The display screen displays: <ul style="list-style-type: none"> • An alarm message. • The date and time that the alarm occurred.
2	Consult the list of alarm messages in the following tables and perform the actions recommended.
3	Press OK to acknowledge the trip and return to the Home menu.
4	Press the Test/Reset button for three seconds to reset the control unit and switch off the service LED.

Recommended Action after Detection of a High Severity Micrologic X Control Unit Alarm

Code	Alarm Message	Alarm Description	Recommended Action
0x1400 0x1404 0x1405 0x1406 0x1416	CU self-test major malfunction	The control unit self-test detected a major malfunction in the control unit operation. NOTE: The malfunction trips or does not trip the device, depending on how the fallback position is configured. The control unit self-test had invalid results. NOTE: The invalid self-test result trips or does not trip the device, depending on how the fallback position is configured.	Call Schneider Electric field service to replace the control unit.
0x1409	Unable to read sensor plug	The control unit is unable to read the value of the sensor plug.	Check connection of the sensor plug and performer plugs. If the connection is good but the control unit is still unable to reach the value, replace the sensor plug or the control unit.
0x1413	Ig test - no trip	The ground fault (I _g) test trip not executed.	Restart the test. If it does not execute again, replace the control unit.
0x1430	Protection reset to default setting if rebooted.	If switched off, the control unit will be reset at next reboot to the default values of the protection settings.	Call Schneider Electric field service to replace the control unit.
0x1442	Contact wear > 100%. Replace CB	The contact wear indicator reached the threshold of 100%.	Replace the circuit breaker.
0x1444	CB has reached the max number of operations	The circuit breaker reached the maximum number of operations.	Replace the circuit breaker.
0x1451	MCH has reached the max number of operations	The spring charging motor (MCH) reached the maximum number of operations.	Replace the MCH.

Contact a Schneider Electric field service representative for more information about who can carry out the recommended actions.

Recommended Action after Detection of a Medium Severity Micrologic X Alarm

Code	Alarm Message	Alarm Description	Recommended Action
0x03F5	Ir prealarm (I > 90% Ir)	The long time protection prealarm started: at least one of the phase or neutral currents is higher than 90% Ir threshold. The circuit breaker is operating close to Ir threshold.	Check the load.
0x0D00	Critical hardware modules discrepancy	There is a major hardware discrepancy between the installed modules that prevent them from operating.	In the Ecoreach Firmware menu, see which module has the discrepancy. Replace the module.
0x0D01	Critical firmware modules discrepancy	There is a major software discrepancy between the installed ULP modules that prevent them from operating.	With Ecoreach software, upgrade the firmware in the module .
0x0D02	Non-critical hardware modules discrepancy	There is a minor hardware discrepancy between the installed modules that prevent them from operating correctly.	Plan to replace the module.
0x0D03	Non-critical firmware modules discrepancy	There is a minor software discrepancy between the installed modules that prevent them from operating correctly.	With Ecoreach software, upgrade the firmware in the module.
0x0D06	Config error IO/CU: dual settings or inhibit cls.	There is a declaration discrepancy between the IO module and the control unit.	Use Ecoreach software to correct the mismatch, as follows: <ul style="list-style-type: none"> • Dual settings configuration mismatch: <ol style="list-style-type: none"> 1. Set Switch mode to IO-1 Wire or IO-2 Wire. 2. Set IO module with dual setting assignment.. • Inhibit close order configuration mismatch <ol style="list-style-type: none"> 1. Set Allow control by digital input under breaker close as enabled . 2. Set IO module with Enable/Inhibit close order assignment.
0x0D08	Address conflict between modules	The control unit self-test detected the unexpected presence of IO2 module when IO1 is not present.	Check the supply of the IO#1 module.
0x0D09	Firmware discrepancy within control unit	The control unit self-test detected a discrepancy between the firmware versions of control unit processors.	Use Ecoreach software to upgrade the firmware in the control unit.
0x0D0C	Config mismatch IO/CU - optional protection inhibit	There is a declaration discrepancy between the IO module and the control unit for inhibition of optional protection functions.	Using Ecoreach software: <ul style="list-style-type: none"> • If you want optional protection inhibition to be controlled by an IO module, connect an IO with inhibit optional protection assignment. • If you do not want optional protection inhibition to be controlled by an IO module, connect an IO without inhibit optional protection assignment.
0x0D0D	Config.error IO/CU- Local/Remote mode	There is a declaration discrepancy between the IO module and the control unit for local/ remote mode assignment.	Using Ecoreach software: <ul style="list-style-type: none"> • If you want the L/R mode to be controlled by an IO module, connect an IO with L/R mode assignment. • If you do not want the L/R mode to be controlled by IO module, connect an IO without L/R mode assignment.
0x101C	Circuit breaker did not open or close	The circuit breaker did not open or to close as expected.	Visually check circuit breaker position and plan maintenance.
0x1108	Protection changed by Bluetooth / USB / IFE	The protection parameters were changed by communication through Modbus, Ecoreach, or the MTZ mobile app..	For information: No action is required.
0x1120	Communication lost with IO#1 module	The control unit lost communication with the IO#1 module	Check the power supply of the IO#1 module. Check the ULP cable connection.

Code	Alarm Message	Alarm Description	Recommended Action
0x1121	Communication lost with IO#2 module	The control unit lost communication with the IO#2 module	Check the power supply of the IO#2 module. Check the ULP cable connection.
0x1122	Communication lost with EIFE or IFE module	The control unit lost communication with the EIFE or IFE module	Check the power supply of the IFE module. Check the ULP cable connection.
0x1123	Communication lost with IFM module	The control unit lost communication with the IFM module.	Check the power supply of the IFM module. Check the ULP cable connection.
0x112C	Control unit firmware upgrade unsuccessful	The firmware upgrade of the control unit was unsuccessful.	Restart the upgrade procedure. If the message is displayed again, call Schneider Electric field service.
0x1407 0x1470 0x1471 0x1472 0x1473	Control unit self test	The control unit self-test had unexpected results.	Plan to replace the control unit.
0x140A 0x147A 0x147B	Invalid display screen or wireless communication	Control unit self-test detected an invalid result on display screen or the wireless module.	Plan to replace the embedded display screen, which contains the wireless antenna.
0x1411	Invalid measurement and optional protection	Control unit self test detected an invalid result for metering and other protection	Monitor the control unit. If other invalid self-test results occur, plan to replace the control unit.
0x1412 0x1414 0x1415	NFC invalid communication	The control unit self-test detected an invalid NFC communication	Plan to replace the control unit.
0x1422	Bluetooth communication lost	The control unit self-test found no Bluetooth communication	Plan to replace the control unit.
0x1433	Replace battery	The lithium battery is under 3 V and needs to be replaced soon.	Replace the battery.
0x1434	Self diagnostic test – firmware	The control unit self-test detected a firmware internal problem.	Use Ecoreach software to upgrade the firmware version of the control unit.
0x1436	Control unit alarm reset	The control unit self-test detected an invalid result in the control unit and corrected it.	Monitor the control unit. If other self-test invalid results occur and are corrected, plan to replace the control unit.
0x1437	Battery not detected	The required battery is not present.	Add battery.
0x1438	Main voltage loss and circuit breaker is closed	The circuit breaker is closed but no voltage is detected.	Check main voltage.
0x1440	Contact wear is above 60%. Check contacts.	The contact wear indicator has reached or is above the threshold of 60%.	Check contact wear.
0x1441	Contact wear is above 95%. Plan for replacement.	The contact wear indicator has reached or is above the threshold of 95%.	Plan to replace the circuit breaker.
0x1443	Less than 20% CB operation remaining	The remaining number of operations of the circuit breaker is less than 20%.	Plan to replace the circuit breaker.
0x1450	MCH charging operations above threshold	The number of operations of the spring charging motor (MCH) reached the alarm threshold.	Plan to replace the MCH.
0x1460	Invalid self test – MX1 shunt trip	The control unit self-test detected an invalid result for the shunt trip (MX1).	Replace the shunt trip (MX1).
0x1461	MX1 shunt trip not detected.	The control unit self-test detected the unexpected absence of the shunt trip (MX1).	Check the connection of the shunt trip (MX1).
0x1462	Invalid self test – XF shunt close	The control unit self-test detected an invalid result for the shunt close (XF).	Replace the shunt close (XF).
0x1463	XF shunt close not detected.	The control unit self-test detected the unexpected absence of the shunt close (XF).	Check the connection of the shunt close (XF).
0x1464	Invalid self test – MN undervoltage release	The control unit self-test detected an invalid result for the undervoltage release (MN).	Replace the undervoltage release (MN).
0x1465	MN undervoltage release not detected	The control unit cannot detect the undervoltage release (MN).	Check the connection of the undervoltage release (MN).

Code	Alarm Message	Alarm Description	Recommended Action
0x1466	Voltage loss on MN undervoltage release	—	Check the control voltage.
0x1468	Invalid self test – MX2 shunt trip	The control unit self-test detected an invalid result for the shunt trip (MX2).	Replace the shunt trip (MX2).
0x1469	MX2 shunt trip not detected	The control unit cannot detect the shunt trip (MX2).	Check the connection of the shunt trip (MX2).
0x1474 0x1475 0x1476 0x1477	Protection settings no longer accessible	The control unit cannot access the protection settings.	Call Schneider Electric field service to replace the control unit.
0x1411 0x1478 0x1479	Invalid measurement and optional protection	The control unit self-test detected an invalid result in the metering or optional protection functions of the control unit.	Plan to replace the control unit.
0x6200	I _r start (I > 105% I _r)	The long time protection started: at least one of the phase or neutral currents is higher than the I _r threshold. The circuit breaker will trip at the end of the time delay.	Operation information. No action required.
0x6300	I _r operate	The long time protection operated: at least one of the phase or neutral currents is higher than the I _r threshold and the time delay is elapsed.	Reset the device (see <i>Resetting Masterpact MTZ Devices, page 45</i>) or use the Masterpact MTZ Mobile App Power restoration assistant.
0x6301	I _{sd} operate	The short time protection operated: at least one of the phase or neutral currents is higher than the I _{sd} threshold and the time delay is elapsed.	Reset the device (see <i>Resetting Masterpact MTZ Devices, page 45</i>) or use the Masterpact MTZ Mobile App Power restoration assistant.
0x6302	I _i operate	The instantaneous protection operated: at least one of the phase or neutral currents is higher than the I _i threshold (no time delay).	Reset the device (see <i>Resetting Masterpact MTZ Devices, page 45</i>) or use the Masterpact MTZ Mobile App Power restoration assistant.
0x6303	I _g operate	The ground-fault protection operated: the ground-fault current is higher than the I _g threshold and the time delay t _g is elapsed.	Reset the device (see <i>Resetting Masterpact MTZ Devices, page 45</i>) or use the Masterpact MTZ Mobile App Power restoration assistant.
0x6306	Ultimate self-protection (SELLIM) operate	The integrated instantaneous protection (SELLIM) operates: at least one of the phase or neutral currents is higher than the SELLIM threshold (no time delay).	Reset the device (see <i>Resetting Masterpact MTZ Devices, page 45</i>) or use the Masterpact MTZ Mobile App Power restoration assistant.
0x631D	Ultimate self-protection trip (DIN/DINF) operate	The integrated instantaneous protection (DIN/DINF) operates: at least one of the phase or neutral currents is higher than the DIN/DINF threshold (no time delay).	Reset the device (see <i>Resetting Masterpact MTZ Devices, page 45</i>) or use the Masterpact MTZ Mobile App Power restoration assistant.

Contact a Schneider Electric field service representative for more information about who can carry out the recommended actions.

Diagnosing Masterpact X Error Messages

The following table shows the sequence of actions to take after an error message is received from the Micrologic X control unit. Further explanation of each action is given in the following paragraphs.

Stage	Description
1	Identify the problem detected.
2	Acknowledge the cause on the Micrologic X display screen.
3	Consult the list of error messages and perform the recommended actions.

Identify the Problem

An error message is displayed when the Micrologic X control unit detects an internal problem.

Example of error message:

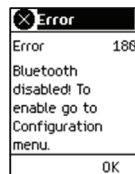

Acknowledging the Error Message

Acknowledge the error message on the Micrologic X control unit display screen.

Step	Action
1	Consult the list of error messages in the following tables and perform the actions recommended.
2	Press OK to acknowledge the message and return to the Home menu.
3	Press the Test/Reset button for 3 seconds to reset the control unit.

Action after Receiving Error Message

Recommended action after receiving a Micrologic X control unit error message.

Code	Error Message	Description	Recommended Action
1 to 24 157 190	Service not performed - internal problem	The requested action was not performed due to an internal problem.	Repeat the action that caused the error message. If the message is displayed again, switch off the 24 Vdc of the Micrologic X control unit and switch it on again. If the problem persists, call Schneider Electric field service.
158	Command rejected, already in progress	The Micrologic X control unit has detected simultaneous orders (for example between IO and control unit).	Repeat the command.
169	Command rejected, already in asked state.	The Micrologic X control unit is already in the requested state.	Check that the Micrologic X control unit is in the required state. If it is not, repeat the command.
174	Session Key is invalid	The request action was not performed because the session key is not valid.	Repeat the action that caused the error message. If the message is displayed again, switch off the 24 Vdc of the Micrologic X control unit and switch it on again. If the problem persists, call Schneider Electric field service.
175	Out of session scope	The requested action was not performed because it is not within the session scope.	Repeat the action that caused the error message. If the message is displayed again, switch off the 24 Vdc of the Micrologic X control unit and switch it on again. If the problem persists, call Schneider Electric field service.
176	Session is already opened	The Micrologic X control unit has detected simultaneous settings sessions (for example, Ecoreach and control unit).	Press OK to clear the message and then repeat the command.
177	No session is open	Submit/apply operations have not been performed within five minutes.	Start a new session, re-enter the settings, then submit and apply them.
180	Bluetooth disabled! To enable go to Configuration menu.	Bluetooth communication has not been enabled for the Micrologic X control unit.	Enable Bluetooth communication from the Micrologic X control unit menu > Configuration > Communication > Bluetooth.

Contact a Schneider Electric field service representative for more information about who can carry out the recommended actions.

Masterpact MTZ Commissioning

Masterpact MTZ1 Commissioning

Masterpact MTZ Devices Overview

⚠️⚠️ DANGER

HAZARD OF ELECTRIC SHOCK, EXPLOSION, OR ARC FLASH

- Apply appropriate personal protective equipment (PPE) and follow safe electrical work practices. See NFPA 70E, CSA Z462, NOM 029-STPS, or local equivalent.
- This equipment must only be installed and serviced by qualified electrical personnel.
- Unless specified otherwise in the commissioning procedures, all operations (inspection, test, and preventive maintenance) must be carried out with the device, the cradle, and the auxiliary circuits deenergized.
- Check that the device and the cradle are de-energized on the upstream and downstream terminals.
- Always use a properly rated voltage sensing device to confirm that the device, the cradle, and the auxiliary circuits are de-energized.
- Install safety barriers and display a danger sign.
- During the tests, it is strictly forbidden for anyone to touch the device, the cradle, or the conductors while voltage is applied.
- Before putting the equipment back into operation, it is mandatory to check that all connections are made with the correct tightening torque, there are no tools or objects inside the equipment, all devices, doors, and protective covers are in position, and the device is off (open position).

Failure to follow these instructions will result in death or serious injury.

This chapter details the testing and commissioning procedure for Masterpact MTZ devices that must be done before the device can be accepted as fit for service and connected to a power supply.

The commissioning procedure must be done by an authorized commissioning engineer with appropriate training and experience:

- Only qualified electrical personnel with training and experience on low voltage circuits must perform the work described in this chapter. Personnel must understand the hazards involved in working with or near low-voltage equipment. Such work must be performed only after reading the complete set of instructions.
- Some inspections or procedures require that certain parts of the electrical system remain energized at hazardous voltage during the procedure. Observe all safety messages (Danger, Warning, Caution) throughout this chapter and the corresponding instruction notices.
- Wear personal protective equipment, recognize potential hazards, and take adequate safety precautions when performing the procedures outlined in this chapter and the corresponding instruction notices.

The commissioning procedure assumes that the following conditions are met at the start of the procedure:

- The device is not connected to a power system or a control system.
- A drawout device is in the disconnected position.
- The device is not connected to a communication network.

The results of all observations, tests, adjustments, together with any relevant comments must be recorded on the appropriate form, if applicable.

Wherever possible, testing must be done without disconnecting or disturbing existing wiring.

Masterpact MTZ Devices Scope

The commissioning procedure applies to the Masterpact MTZ intelligent modular unit (IMU), made up of:

- Masterpact MTZ circuit breaker
- Micrologic X control unit
- Optional ULP modules:
 - One IFE, EIFE or IFM Modbus SL (RTU)
 - One or two IO modules

The associated information, which must be read with this procedure, includes specific schematic diagrams, connections, and trip levels for the devices covered by this document.

Masterpact MTZ Devices Equipment

The following equipment is required to do the tests detailed in the commissioning procedure:

- Insulation resistance tester
- Multimeter
- A PC equipped with updated Ecoreach software
- A USB to mini USB cable (LV850067SP) to connect the PC to the Micrologic X control unit

Masterpact MTZ1 Devices Test Form

A test form (see *Masterpact MTZ1 Test Form, page 122*) is available to guide you through the commissioning procedure and to record the results of the commissioning tests. Each test is described in detail in the Commissioning chapter.

Do only the tests required, depending on the Masterpact MTZ device type and the functions in use.

Masterpact MTZ1 Inspection and Micrologic X Control Unit Settings

Masterpact MTZ Devices Visual Inspection

Step	Action
1	Record the equipment identification, including substation name, switchboard name, Masterpact MTZ device type, Micrologic X model type and serial number, Micrologic X type, and protection settings.
2	Check that the device is undamaged, correctly mounted, and securely fastened in the switchboard.
3	Check the three-phase clearance at terminal blocks.
4	Check that there is no debris remaining at the back of the device housing/enclosure.
5	Check that the ground terminals of the device are securely connected with the correct grounding cables.
6	Check that all external surfaces are undamaged.
7	Rectify any non-conformities, if possible. All equipment non-conformities must be referred to asset management.

Masterpact MTZ Devices Condition of Connections and Auxiliaries

Check device mounting in the switchboard and the tightness of all connections (main connection and auxiliary wiring).

Check that all auxiliaries and accessories are correctly installed:

- Electrical auxiliaries
- Terminal blocks
- Connections of auxiliary circuits

Masterpact MTZ Devices Firmware Compatibility Check

Using Ecoreach software, check that the firmware of the Micrologic X control unit and ULP modules in the intelligent modular unit (IMU) are up-to-date and compatible with each other. The ULP modules are the EIFE, IFE or IFM communication interfaces, and the IO module.

Step	Action
1	Connect a PC running Ecoreach software by using a cable connected to the mini USB port on the front face of the Micrologic X control unit.
2	Establish a connection. Ecoreach software reads the parameters of the control unit.
3	On Ecoreach, use the Overall System firmware status/compatibility matrix to display: <ul style="list-style-type: none"> • The installed firmware version of the IMU devices (Micrologic X control unit and ULP modules). • The latest firmware version of the devices that are available on the Schneider Electric System Updates Internet site. • The recommended actions to get a compatible system. For more information, refer to <i>Ecoreach Online Help (DOCA0069EN)</i> .
4	Follow the recommended actions to get a compatible system.

Micrologic X Control Unit Settings

NOTICE

RISK OF UNINTENDED OPERATION

- The device must only be configured and set by qualified personnel, using the results of the installation protection system study.
- During commissioning of the installation and following any modification, check that the Micrologic X configuration and protection function settings are consistent with the results of this study.
- Micrologic X protection functions are set by default to the minimum value, except for the long time protection function which is set to the maximum value, by default.

Failure to follow these instructions can result in equipment damage.

Check the settings with Ecoreach software connected to the Micrologic X control unit.

Step	Action
1	Connect a PC running Ecoreach software by using a cable connected to the mini USB port on the front face of the Micrologic X control unit.
2	Establish a connection. Ecoreach software will read the parameters of the control unit.
3	Check that the settings read in the control unit match the requirements of the application. If necessary, correct the settings with Ecoreach software: <ul style="list-style-type: none"> • The protection settings must be defined according to the installation protection system study. • Other settings must be defined according to the application.
4	Complete the project and device data.
5	Generate the project report with Ecoreach software, and save or print the project report as needed.

NOTE: The protection functions available depend on the type of Micrologic X control unit and its associated options.

Masterpact MTZ1 Device Commissioning Tests

The tests to do while commissioning an MTZ device are described in this section:

- Functional checks
- Check spring charging motor (MCH) (if fitted)
- Check M2C programmable contacts and IO module (if fitted)
- Check electrical continuity
- Check high-voltage insulation
- Check Micrologic X Ready LED status
- Test the tripping mechanism with Ecoreach software
- Test the tripping mechanism with the test button (Micrologic 6.0 X control units)

Only do the tests required, depending on the Masterpact MTZ type and the functions in use, and record the results on the test form (see *Masterpact MTZ1 Test Form*, page 122). In the event of non-conformance, the result must be recorded and the Masterpact MTZ device must not be accepted into service.

Masterpact MTZ Devices Functional Checks

Check the Masterpact MTZ device operation and record the results on the test form.

Step	Action
1	Manually charge the mechanism by pulling the spring charging handle down.
2	Close the device. Check the device closing in the different control modes and means designed for the application.
3	Open the device. Check the device opening in the different control modes and means designed for the application.

Masterpact MTZ Devices Check of Spring Charging Motor (MCH) (If Installed)

Check the spring charging motor (MCH) operation and record the results on the test form.

Step	Action
1	Remove the spring charging motor (MCH) power supply.
2	Do an opening/closing/opening cycle to discharge the mechanism.
3	With the device in the open position and the mechanism discharged, check electrical continuity between terminals B1 and B2, and electrical non-continuity between terminals B1 and B3.
4	Manually charge the mechanism.
5	Reconnect the spring charging motor (MCH) power supply. The device closes and the mechanism is automatically charged.
6	Check electrical continuity between terminals B1 and B3.
7	Operate the device several times to check that the spring mechanism automatically recharges after every closing operation.

Check Masterpact MTZ Devices M2C Programmable Contact and IO Module (If Installed)

Check the operation of inputs and outputs, and record the results on the test form.

Step	Action
1	Connect a PC running Ecoreach software by using a cable to the mini USB port on the front face of the Micrologic X control unit.
2	Force the state of both inputs of the M2C programmable contacts and check that the operation is correct.
3	Force the state of the six digital inputs and three outputs of the one or two IO modules in the IMU to check the wiring to the circuit breaker. Check that the operation is correct.

Check Masterpact MTZ Devices Electrical Continuity

Check electrical continuity using a multimeter or continuity checker and record the results on the test form.

Step	Action
1	Close the device.
2	Check electrical continuity, for each phase, between the upper and lower power terminals: <ul style="list-style-type: none">• For a fixed device: on the power terminals.• For a drawout device: on the cradle power terminals, with the device in the connected position.

Check Masterpact MTZ Devices High-Voltage Insulation

Dielectric tests (high potential and insulation resistance tests) are used to check the insulation between phases and between each phase and ground. The equipment used to conduct these tests creates a high potential voltage (thousands of volts) to check dielectric or insulation integrity.

If included in the Micrologic X control unit, the voltage power supply (VPS) module connects and disconnects the control unit from the voltage connections in the circuit breaker.

Before conducting any high-voltage insulation tests, move the VPS module to the disconnected position and unplug any cables from the mini USB port on the front face of the Micrologic X control unit. For information on VPS disconnection, consult instruction sheet *NVE40741* on the Schneider Electric website.

▲ CAUTION
DETERIORATION OF VPS MODULE
Disconnect the VPS module by pulling it out to the disconnected position before running a dielectric test on the equipment.
Failure to follow these instructions can result in injury or equipment damage.

Check insulation resistance and record the results on the test form.

Step	Action
1	Disconnect the VPS module and unplug any cables from the mini USB port on the front face of the Micrologic X control unit.
2	Close the device.
3	Measure the insulation resistance using a 500 Vdc insulation resistance tester between one of the phases and the other two phases grounded. Repeat for each phase.
4	Open the Masterpact MTZ device by pressing the opening pushbutton.
5	Measure the insulation resistance using a 500 Vdc insulation resistance tester between one of the phases and ground, with all other phases grounded. Repeat for each phase.
6	Check that the insulation resistance is above 5 MΩ in each case. If this result is not obtained, contact a Schneider Electric field service representative.

Check Micrologic X Control Unit Ready LED Status

Check the functioning of the Micrologic X control unit and record the results on the test form.

Step	Action
1	Provide power to the Micrologic X control unit, for example, by connecting a PC or Mobile Power Pack to the mini USB port on the front face.
2	Check that the Micrologic X Ready LED is flashing green. The Ready LED flashes green to indicate that: <ul style="list-style-type: none"> • The sensors are correctly wired. • The tripping mechanism is functioning correctly. • The Micrologic X control unit is functioning correctly.
3	If the Ready LED is not flashing green, refer to chapter Critical Cases (see <i>Masterpact MTZ Critical Cases</i> , page 95).

Test the Tripping Function with EcoReach Software

Test the Masterpact MTZ tripping mechanism and record the results on the test form.

Step	Action
1	Close the circuit breaker.
2	Connect a PC running Ecoeach software by using a cable to the mini USB port on the front face of the Micrologic X control unit.
3	On Ecoeach software, select the circuit breaker and connect to it.
4	Force the circuit breaker to trip by clicking the Force Trip button on the Ecoeach screen. This action is password-protected.
5	Check that the circuit breaker is open.
6	Check that the blue fault-trip reset button has popped out.
7	Check that the I _{sd} /I _i LED is on.
8	Check that the SDE contacts have switched.
9	After the test, reset the circuit breaker.

Test the Tripping Mechanism with the Test Button (Micrologic 6.0X Control Units)

Test the Masterpact MTZ tripping mechanism when fitted with a Micrologic 6.0 X control unit, and record the results on the test form.

Step	Action
1	Close the circuit breaker.
2	Use a thin screwdriver to briefly push in (<1 s) the test button on the control unit.
3	Check that the circuit breaker is open.
4	Check that the blue fault-trip reset button has popped out.
5	Check that the I _g /I _{Δn} LED is on.
6	Check that the SDE contacts have switched.
7	After the test, reset the circuit breaker.

Masterpact MTZ1 Communication Tests

Communication Network Test with Ecoreach Software

Use Ecoreach software to test the communication network between all the communicating devices of the project:

- Devices connected to the Ethernet network through an IFE or EIFE Ethernet interface.
- Devices connected to a Modbus serial line network through an IFM Modbus SL (RTU) interface stacked through at Ethernet server.
- Devices connected to a Modbus serial line network from an IFM Modbus SL (RTU) interface.

Step	Action
1	Connect a PC running Ecoreach software by using an RJ45 cable to the Ethernet network, on the IFE or EIFE Ethernet interface, or IFM interface, for example.
2	In Ecoreach software, at Create report → Communication test & report , select devices to be tested from the list of communicating devices defined in the project.
3	Click Run test . All selected devices are tested.
4	Results are displayed at the end of the test.
5	Generate the communication test report with Ecoreach software, and save or print the project report as needed.

Masterpact MTZ Devices Remote Control Tests

If the Masterpact MTZ device can be opened and closed remotely through the communication network, use the following tests to check for the correct operation of remote control:

Step	Action
1	Connect a PC running Ecoreach software by using an RJ45 cable to the Ethernet network, on the IFE or EIFE Ethernet interface for example.
2	Check that the control mode is set to Auto: Remote.
3	In Ecoreach software, select the circuit breaker and connect to it.
4	Click the Device tab to access the Open and Close buttons.
5	Check that it is possible to open and close the Masterpact MTZ device remotely. These actions are password-protected.

Masterpact MTZ1 Setup Final Checks and Reporting

Masterpact MTZ Devices Final Checks

After completing the commissioning tests, check the following:

Step	Action
1	Check that connections are made with the correct tightening torque, that there are no tools or objects inside the equipment, and that all devices, doors, and protective covers are in position.
2	Check that the device is off (open position) and the closing spring is charged.

Project Report Generated by Ecoreach Software

Ecoreach software generates a project report with a list of the devices for that project. For each device it provides the following information:

- The circuit breaker identification data.
- The Micrologic X identification data, including the list of digital modules installed.
- The list of accessories including internal accessories (for example, M2C programmable contacts), and external modules (for example, IO module).
- The protection settings for the Micrologic X control unit.
- The alarm settings.
- The IFE, EIFE, or IFM communication interface settings.

Communication Test Report Generated by Ecoreach Software

Ecoreach software performs a communication test and generates a report of the test. For each device it provides the following information:

- The name and type of the device.
- The type of communication.
- The address of the device or gateway.
- The status of the connection.

Masterpact MTZ1 Test Form

How to Use the Masterpact MTZ Test Form

Print this test form to record the results of the commissioning tests.

Check the box (✓) when the test has been made and is conclusive.

This test form, the project report, and the communication test report should be left on-site in a plastic wallet and in an easily accessible, safe place.

Each test is described in detail in the Commissioning chapter.

Only do the tests required, depending on the Masterpact MTZ type and the functions in use.

When all the tests have been satisfactorily completed, sign and date the test form.

Masterpact MTZ Device Identification

Workstation		Tests conducted on:	By:
			Signature:
Substation name		Comments:	
Substation number			
Switchboard/switchgear name			
Voltage			

Masterpact MTZ device	
Manufacturer	Schneider Electric
Type of Masterpact MTZ device	
Serial number	
Hardware version	

Micrologic X Control Unit			
Micrologic X type CT		CT ratio	
Firmware version			

Masterpact MTZ Devices Preliminary Checks

Type of check	(✓)
Visual inspection satisfactory (for example, no visible signs of damage).	
Grounding satisfactory.	
Connection tightness checked.	
Firmware compatibility satisfactory.	
Micrologic X settings applied.	
Project report generated.	

Masterpact MTZ Devices Functional and Interlock Checks

Type of check	(✓)
Mechanism charges when spring charging handle is pulled.	
Masterpact MTZ device closes.	
Masterpact MTZ device opens.	
Mechanism charges automatically after closing when the device is fitted with a spring charging motor (MCH) .	
M2C programmable contacts function correctly.	
IO module functions correctly.	
Interlocking systems of the circuit breaker function correctly.	
Interlocking systems between two or three circuit breakers function correctly.	

Masterpact MTZ Devices Electrical Continuity Checks

Masterpact MTZ device status	Tested terminals		Electrical continuity
	Incoming side	Outgoing side	
Closed	L1	L1	Ω
Closed	L2	L2	Ω
Closed	L3	L3	Ω

Masterpact MTZ Device Insulation Test

Masterpact MTZ device status	Terminals under test	Voltage	Insulation resistance
Closed	Closed L1, with L2 and L3 grounded	500 Vdc	MΩ
Closed	Closed L2, with L1 and L3 grounded	500 Vdc	MΩ
Closed	Closed L3, with L1 and L3 grounded	500 Vdc	MΩ
Open	Open L1, with L1, L2, L3 grounded on the other side	500 Vdc	MΩ
Open	Open L2, with L1, L2, L3 grounded on the other side	500 Vdc	MΩ
Open	Open L3, with L1, L2, L3 grounded on the other side	500 Vdc	MΩ

Micrologic X Control Unit Ready LED Check

Type of check	(✓)
Micrologic X Ready LED flashes green.	

Micrologic X Control Unit Tripping Mechanism Test

Type of check	(✓)
With the circuit breaker closed, force the circuit breaker to trip using Ecoreach software.	
Check that the circuit breaker is open.	
Check that the blue fault-trip reset button has popped out.	
Check that the Isd/Ii LED is on.	
Check that the SDE contacts have switched.	

Micrologic 6.0X Test Button Tripping Mechanism Test

Type of check	(✓)
With the circuit breaker closed, briefly press (<1 s) the test button on the front face of the control unit.	
Check that the circuit breaker is open.	
Check that the blue fault-trip reset button has popped out.	
Check that the Ig/IΔn LED is on.	
Check that the SDE contacts have switched.	

Masterpact MTZ Communication Tests

Type of check	(✓)
Communication network tested.	
Communication test report generated.	
Remote opening and closing tested.	

Masterpact MTZ Device Final Checks

Type of check	(✓)
All doors and protected covers are in position.	
The device is off (open position) and the closing spring is charged.	

Masterpact MTZ1 Troubleshooting

Troubleshooting the Masterpact MTZ1 Device

This chapter contains information for troubleshooting problems in a working system. It assumes that the system is correctly installed and that all the commissioning tests (see *Masterpact MTZ1 Device Commissioning Tests, page 115*) have been completed successfully. The troubleshooting operations are described under the following headings:

- Cradle operation
- Unexpected tripping
- Mechanical control operations
- Electrical control operations
- Control operations from Masterpact MTZ Mobile App
- Control operations from IO module
- Control operations from Ecoreach software
- Control operations from IFE/EIFE webpages
- Control operations from communication network
- Control operations from FDM128 display

Troubleshooting the Masterpact MTZ Device with Assistance

Assistance for troubleshooting is provided by the Masterpact Operation Assistant Digital Module, which is available to be downloaded from GoDigital.

The Masterpact Operation Assistant Digital Module helps to close a circuit breaker after a trip or an opening.

The following features are available:

- Ready-to-close status
- Reset (if applicable)
- Spring charging (if applicable)
- Diagnostics on related reclosing information, for example, no power supply to shunt trip (MX), undervoltage release (MN), or spring charging motor (MCH)

Refer to *Micrologic X Control Unit - User Guide (DOCA0102EN)* for more information about downloading Digital Modules.

Events Related to a Masterpact MTZ Closing Action

Problem Description	Probable Causes	Solutions
Device cannot be closed locally or remotely.	Device is padlocked or keylocked in the open position.	Disable the locking function.
	Device is interlocked mechanically in a mechanical interlocking system.	<ul style="list-style-type: none"> Check the position of the other device in the changeover system. Modify the situation to release the interlock.
	Device is not correctly connected.	Rack device in to connected position.
	The fault-trip reset button has not been reset.	<ul style="list-style-type: none"> Clear the fault. Push the fault-trip reset button.
	Stored energy mechanism is not charged.	<ul style="list-style-type: none"> Charge the mechanism manually. If the device is equipped with a spring charging motor (MCH), check the supply of power to the motor. If the problem persists, replace the spring charging motor (MCH).
	Shunt trip (MX) is permanently supplied.	As there is an opening order, determine the origin of the order. The order must be canceled before the device can be closed.
	MN undervoltage release is not supplied.	<ul style="list-style-type: none"> As there is an opening order, determine the origin of the order. Check the voltage and the supply circuit ($U > 0.85 U_n$). If the problem persists, replace the undervoltage release (MN).
Device cannot be closed remotely but can be closed locally using the closing pushbutton.	Shunt close (XF) is continuously supplied, but device is not ready-to-close (XF is not wired in series with ready-to-close contact (PF)).	<ul style="list-style-type: none"> Remove the power supply to the shunt close (XF). Only if the device is ready-to-close, send the closing order again via the shunt close (XF).
	Closing order not executed by the shunt close (XF).	Check the voltage and the supply circuit ($0.85-1.1 V_n$). If the problem persists, replace the shunt close (XF).
	Insufficient supply voltage for the spring charging motor (MCH).	Check the voltage and the supply circuit ($0.7-1.1 V_n$). If the problem persists, replace the spring charging motor (MCH).

Events Related to an Masterpact MTZ Opening Action

Problem Description	Probable Causes	Solutions
Device cannot be opened locally.	Operating mechanism did not open or welded contacts.	Contact a Schneider Electric service center.
	Opening order is not executed by the shunt trip (MX).	Check the voltage and the supply circuit ($0.7-1.1 V_n$). If the problem persists, replace the shunt trip (MX).
Device cannot be opened remotely, but can be opened locally.	Opening order is not executed by the undervoltage release (MN).	Drop in voltage insufficient or residual voltage ($> 0.35 V_n$) across the terminals of the undervoltage release (MN). If the problem persists, replace the MN undervoltage release.

Events Related to the Masterpact MTZ Cradle

Problem Description	Probable Causes	Solutions
Impossible to insert the racking handle in connected, test, or disconnected position.	A padlock or keylock is present on the cradle or a door interlock is present.	Disable the locking function.
Impossible to turn the racking handle.	The stop release button has not been pressed and so the racking handle cannot be rotated.	Press the stop release button.
Device cannot be removed from cradle.	Device is not in the disconnected position.	Turn the racking handle until the device is in the disconnected position and the stop release button pops out.
	Rails are not completely out.	Pull the rails of the cradle out.
Device cannot be connected (racked in).	Cradle and device do not match (cradle rejection kit pins do not align).	Check that the cradle corresponds with the device.
	Safety shutters are locked.	Remove the locks.
	Device clusters are incorrectly positioned.	Reposition the device clusters.
	Cradle is locked in the disconnected position.	Disable the cradle locking function.
	The stop release button has not been pressed and so the racking handle cannot be rotated.	Press the stop release button.
Device cannot be locked in the disconnected position.	Device has not been sufficiently inserted in the cradle.	Insert the device completely so that it is engaged in the racking mechanism.
	Device is not in the right position.	Check the device position by verifying that the stop release button is out.
Device cannot be locked in the connected, test, or disconnected position.	Racking handle is still in the cradle.	Remove the racking handle and store it.
	Locking in any position is not enabled.	Contact a Schneider Electric service center.
	Device is not in the right position.	Check the device position by verifying that the stop release button is out.
The racking handle cannot be inserted to connect or disconnect the device.	Racking handle is still in the cradle.	Remove the racking handle and store it.
	Rails are not completely in.	Push the rails all the way in.
The right-hand rail (cradle alone) or the device cannot be drawn out.	Racking handle is still in the cradle.	Remove the racking handle and store it.

Unexpected Tripping of the Masterpact MTZ Device

Problem Description	Probable Causes	Solutions
Unexpected opening without activation of the fault-trip reset button.	Undervoltage release (MN) supply voltage is too low.	Check the voltage and the supply circuit ($V > 0.85 U_n$).
	Load-shedding order sent to the shunt trip (MX) by another device.	<ul style="list-style-type: none"> Check the overall load on the distribution system. If necessary, modify the settings of devices in the installation.
	Unnecessary opening order from the MX shunt trip.	Determine the origin of the order and cancel it.
Unexpected tripping with activation of the fault-trip reset button.	An electrical fault is present, among: <ul style="list-style-type: none"> Overload Ground-fault Short-circuit detected by the control unit 	Refer to Masterpact MTZ critical cases (see <i>Masterpact MTZ Critical Cases, page 95</i>).
Instantaneous tripping after each attempt to close the device with activation of the fault-trip reset button.	Thermal memory.	<ul style="list-style-type: none"> Reset the thermal memory on screen. Refer to Micrologic X Control Unit - User Guide. Press the fault-trip reset button.
	Transient overcurrent when closing.	<ul style="list-style-type: none"> Modify the distribution system or the control unit settings. Check the condition of the device before putting it back into service. Press the fault-trip reset button.
	Closing on a short-circuit.	Refer to Masterpact MTZ critical cases (see <i>Masterpact MTZ Critical Cases, page 95</i>).
Nuisance tripping of the device with activation of the fault-trip reset button.	Fault-trip reset button is not pushed in completely.	Push in the fault-trip reset button completely.

Maintenance of the Masterpact MTZ Device

For information about the preventive maintenance program and maintenance procedures, refer to *Micrologic X Control Unit - User Guide (DOCA0102EN)*.

Schneider Electric Green Premium™ Ecolabel

Description of the Green Premium Label



Green Premium by Schneider Electric is a label that allows you to develop and promote an environmental policy while preserving your business efficiency. This ecolabel is compliant with up-to-date environmental regulations.

Accessing the Green Premium Ecolabel

Green Premium data on labeled products can be accessed online through any of the following ways:

- By navigating through the Schneider Electric website.
- By scanning the QR code displayed below.



Check Product Environmental Criteria

To check the product environmental criteria of a product on the Schneider Electric website using a PC or smartphone, follow these steps:

Step	Action
1	From http://www.schneider-electric.com/ , select Support → Additional Links → Green Premium Eco Label .
2	Click Find Green Premium Products to open the search tool webpage.
3	Fill in the fields: <ul style="list-style-type: none"> • Enter the commercial reference or product range of the product to search for. • Optional: Enter the manufacturing date code of the product with format YYWW. By default, this field is filled with the date of the search.
4	To search for several products simultaneously, click the Add product button, and then fill in the fields.
5	Click Check product(s) to generate a report of the environmental criteria available for the products with the entered commercial references.

Environmental Criteria of the Green Premium Ecolabel

The Green Premium ecolabel provides documentation on the following criteria about the environmental impact of the products:

- RoHs: European Union Restriction of Hazardous Substances (RoHS) directive.
- REACh: European Union Registration, Evaluation, Authorization, and Restriction of Chemicals regulation.
- PEP: Product Environmental Profile.
- EoLI: End of Life Instructions.

RoHs Requirements Compliance

Schneider Electric products are subject to RoHS requirements at a worldwide level, even for the many products that are not required to comply with the terms of the regulation. Compliance certificates are available for products that fulfill the criteria of this European initiative, which aims to eliminate hazardous substances.

REACh Regulation Compliance

Schneider Electric applies the strict REACh regulation on its products at a worldwide level, and discloses extensive information concerning the presence of SVHC (Substances of Very High Concern) in all of these products.

PEP Ecopassport Compliance

Schneider Electric publishes a complete set of environmental data, including carbon footprint and energy consumption data for each of the life cycle phases on all of its products, in compliance with the ISO 14025 PEP ecopassport program. PEP is especially useful for monitoring, controlling, saving energy, and/or reducing carbon emissions.

EoLI Compliance

These instructions provide:

- Recyclability rates for Schneider Electric products.
- Guidance to mitigate personnel hazards during the dismantling of products and before recycling operations.
- Part identification for recycling or for selective treatment, to mitigate environmental hazards/incompatibility with standard recycling processes.

Schneider Electric USA, Inc.
800 Federal Street
Andover, MA 01810 USA

888-778-2733

www.schneider-electric.us

As standards, specifications, and design change from time to time,
please ask for confirmation of the information given in this publication.

© 2018 – Schneider Electric. All rights reserved.

0614IB1702