

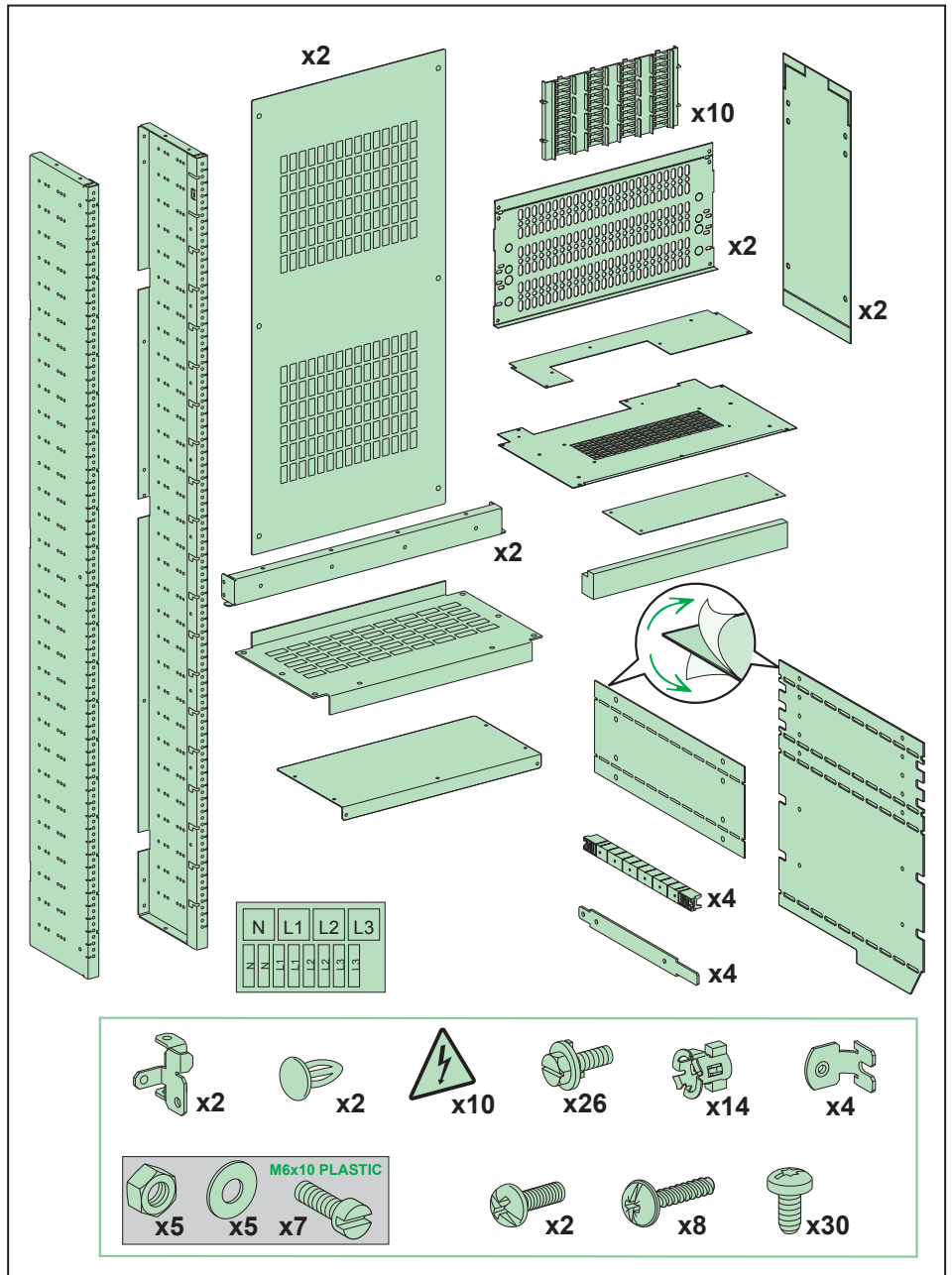

en fr es de it pt zh ru

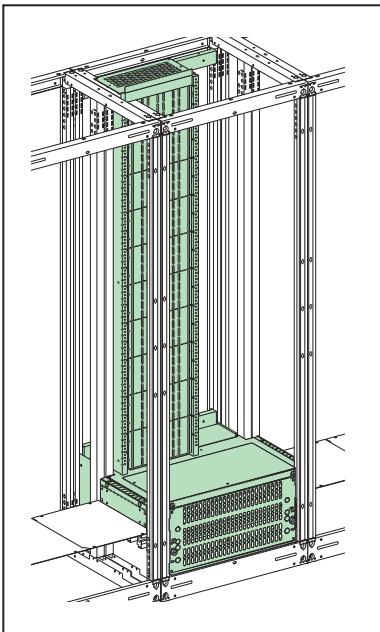

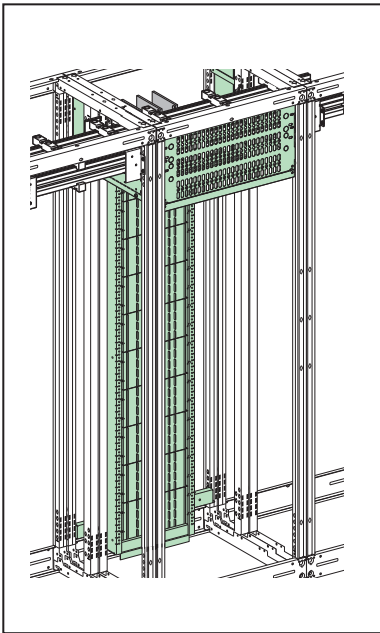

<p>PLEASE NOTE Electrical equipment should be installed, operated, serviced, and maintained only by qualified personnel. No responsibility is assumed by Schneider Electric for any consequences arising out of the use of this material.</p>	<p>REMARQUE IMPORTANTE L'installation, l'utilisation, la réparation et la maintenance des équipements électriques doivent être assurées uniquement par du personnel qualifié. Schneider Electric décline toute responsabilité quant aux conséquences de l'utilisation de ce matériel.</p>	<p>TENGA EN CUENTA La instalación, manejo, puesta en servicio y mantenimiento de equipos eléctricos deberán ser realizados sólo por personal cualificado. Schneider Electric no se hace responsable de ninguna de las consecuencias del uso de este material.</p>	<p>BITTE BEACHTEN Elektrische Geräte dürfen nur von Fachpersonal installiert, betrieben, bedient und gewartet werden. Schneider Electric haftet nicht für Schäden, die durch die Verwendung dieses Materials entstehen.</p>
<p>NOTA Manutenzione, riparazione, installazione e uso delle apparecchiature elettriche si devono affidare solo a personale qualificato. Schneider Electric non si assume alcuna responsabilità per qualsiasi conseguenza derivante dall'uso di questo materiale.</p>	<p>NOTA A instalação, utilização e manutenção do equipamento eléctrico devem ser efectuadas exclusivamente por pessoal qualificado. A Schneider Electric não assume qualquer responsabilidade pelas consequências resultantes da utilização deste material.</p>	<p>请注意 电气设备的安装、操作、维修和维护工作仅限于合格人员执行。Schneider Electric 不承担由于使用本资料所引起的任何后果。</p>	<p>ОБРАТИТЕ ВНИМАНИЕ Установка, эксплуатация, ремонт и обслуживание электрического оборудования может выполняться только квалифицированными электриками. Компания Schneider Electric не несет никакой ответственности за любые возможные последствия использования данной документации.</p>

A

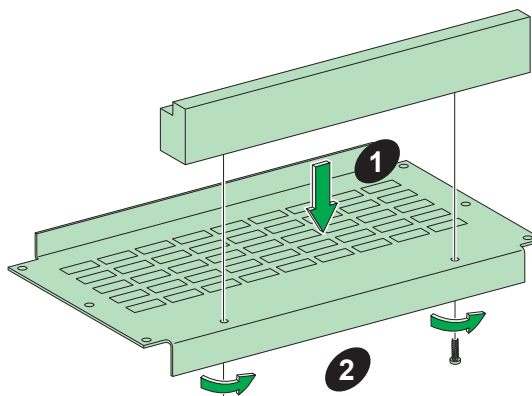
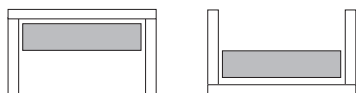
 **x2**
M5 x 19



B

 **x8**
M6 x 16
 **x8**

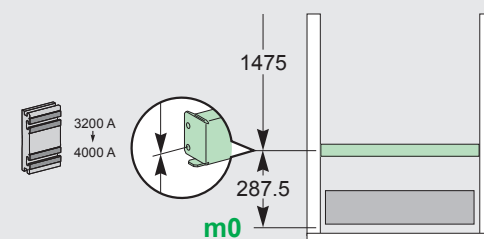
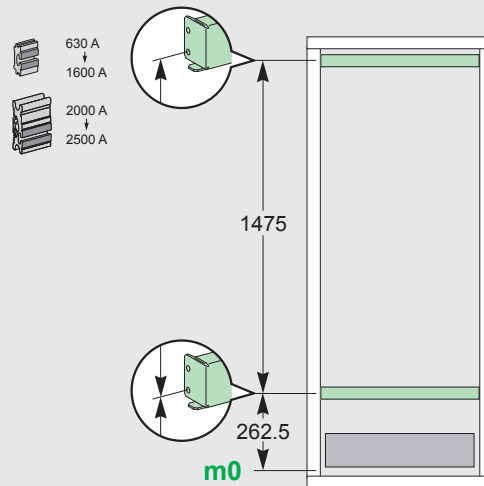
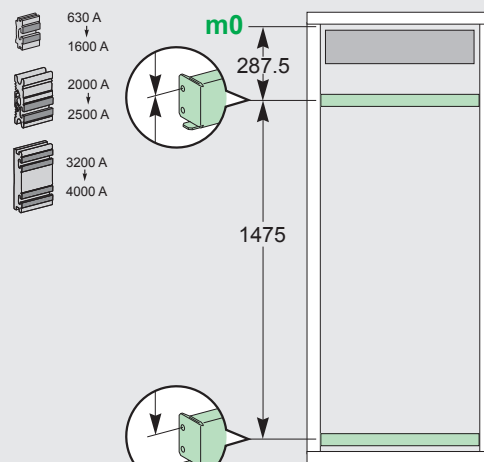
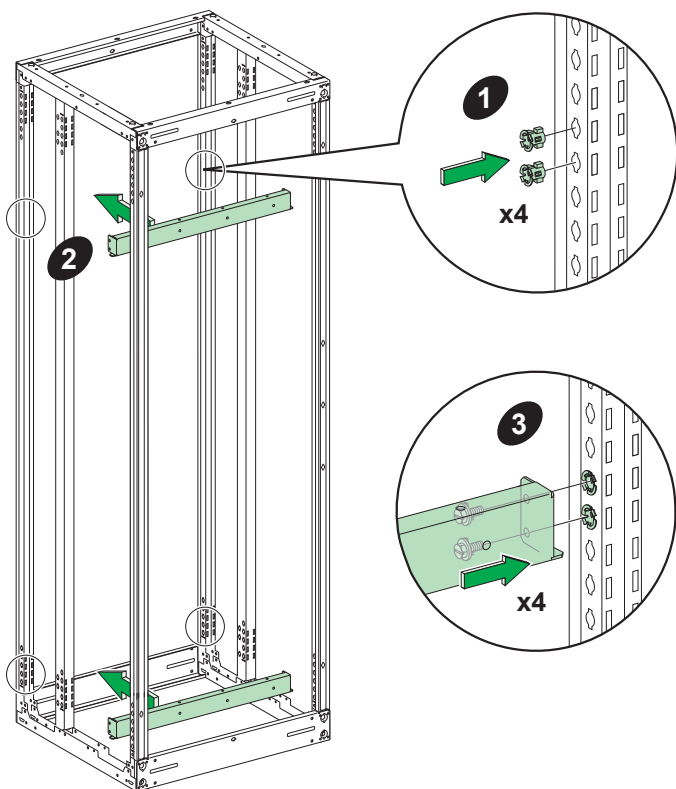

C

 **x4**
M6 x 13

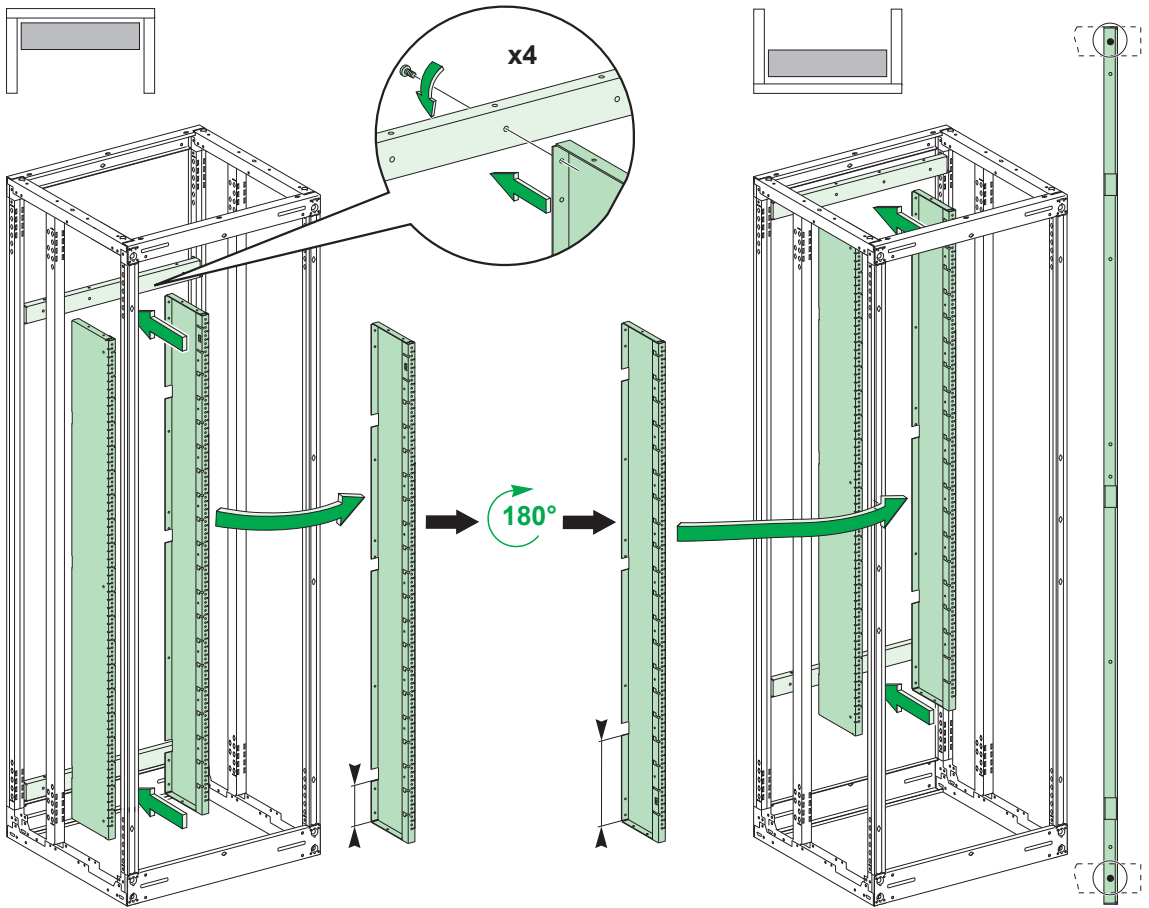

D

 **x2**
M6 x 13

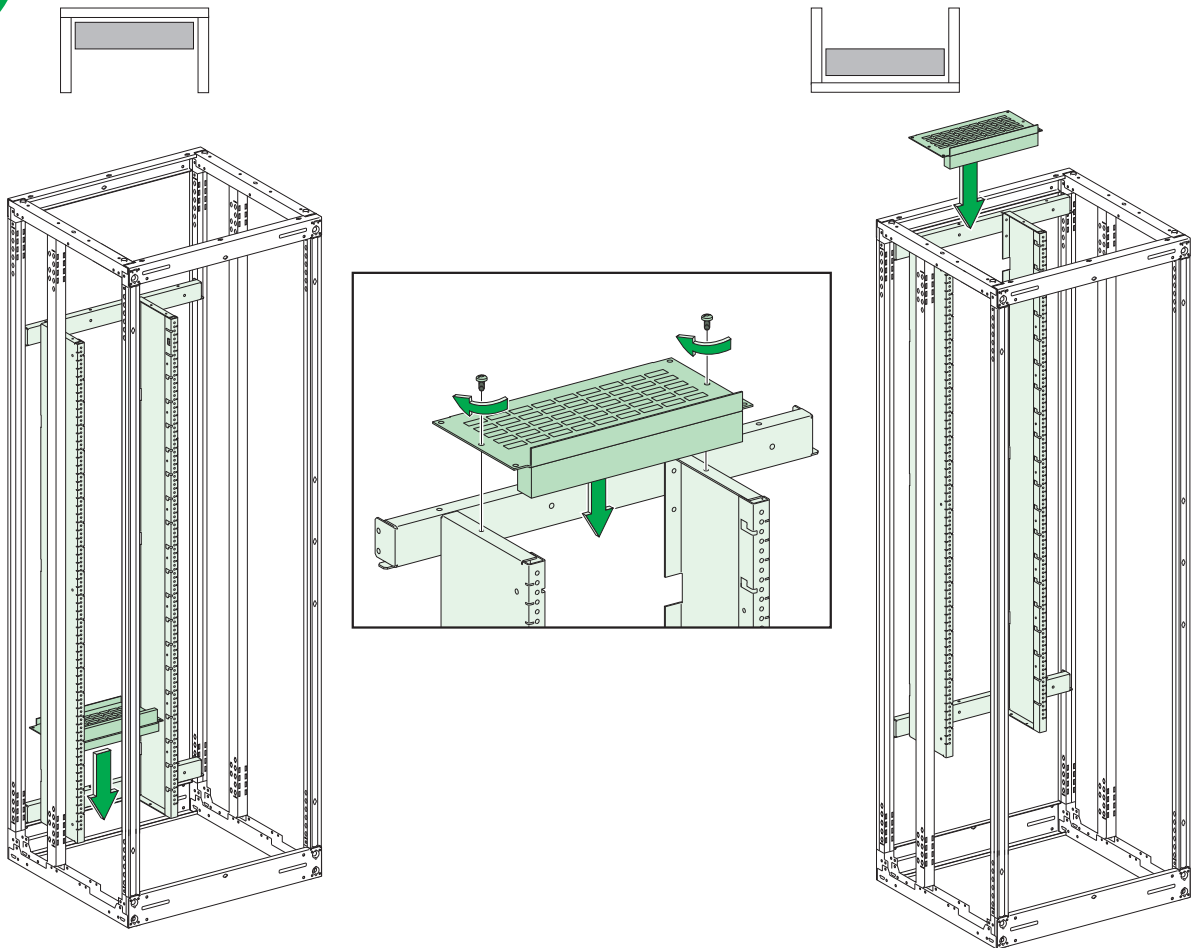

E

88005
88006

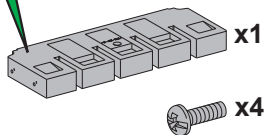

88005

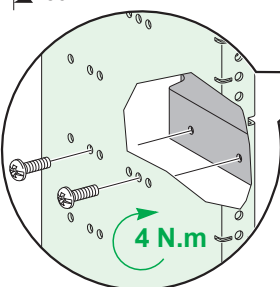
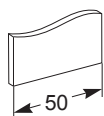

88006

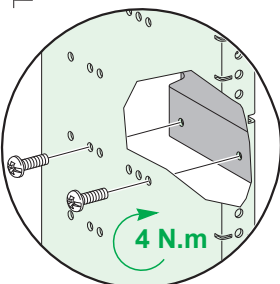
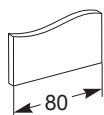

88006

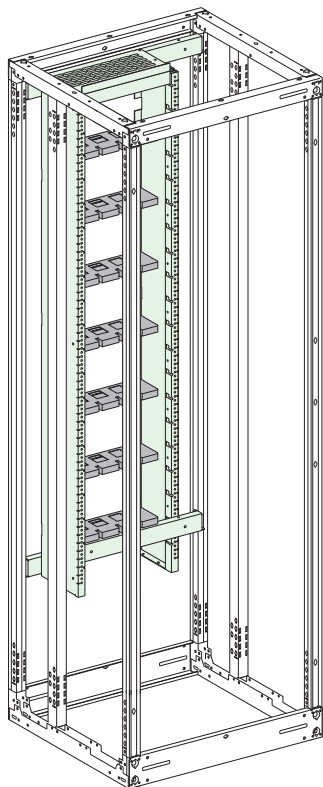
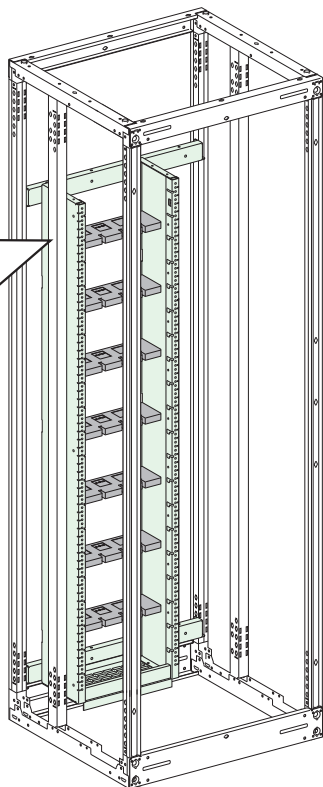
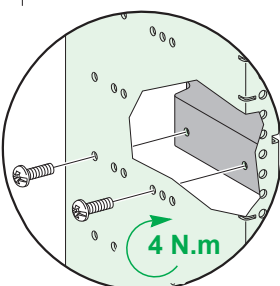
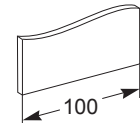

	IP ≤ 31		IP > 31		Icw (kA eff. / 1 s)		
	50 x 10	1200 A	1050 A	6	70	85	
50 x 10	1200 A	1050 A	6				
80 x 10	1750 A	1530 A	6	7	8		
100 x 10	2100 A	1840 A	6	7	8		

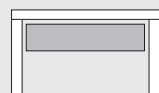

Icw (kA eff. / 1 s)

50

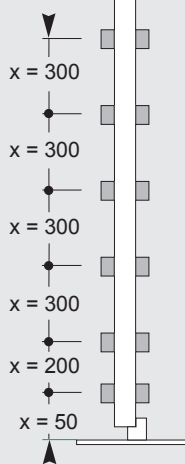

Icw (kA eff. / 1 s)

70

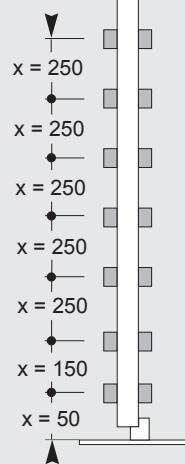

Icw (kA eff. / 1 s)

85

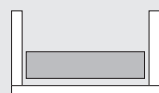
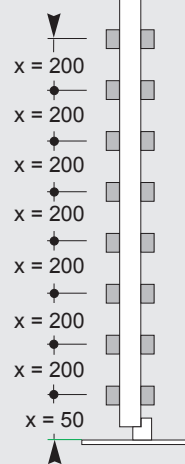

Icw (kA eff. / 1 s)

50

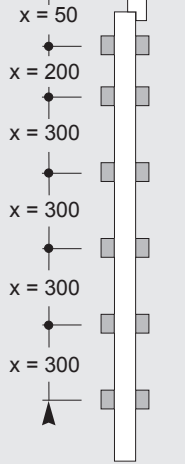

Icw (kA eff. / 1 s)

70

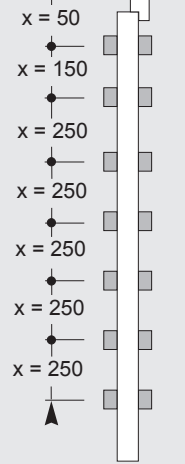

Icw (kA eff. / 1 s)

85

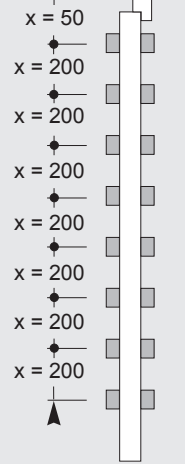

F

 x2

M6 x 13

 x2

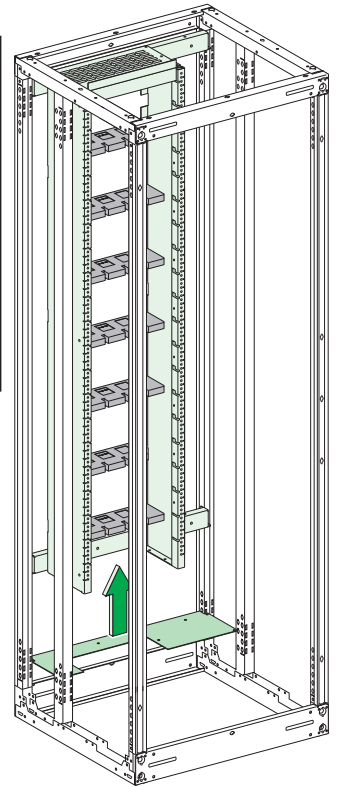
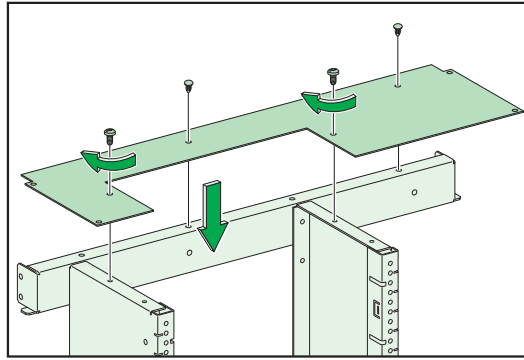
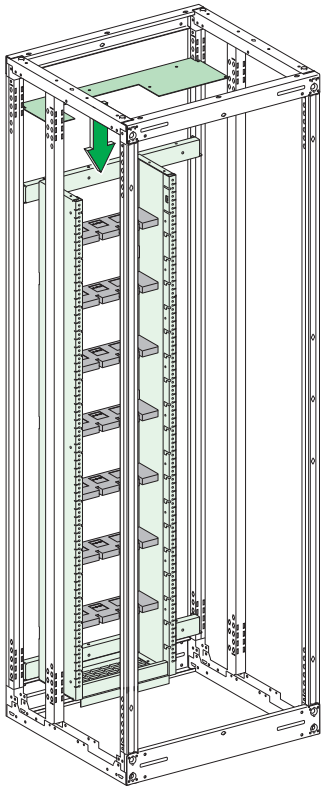

G

 x12

M6 x 13

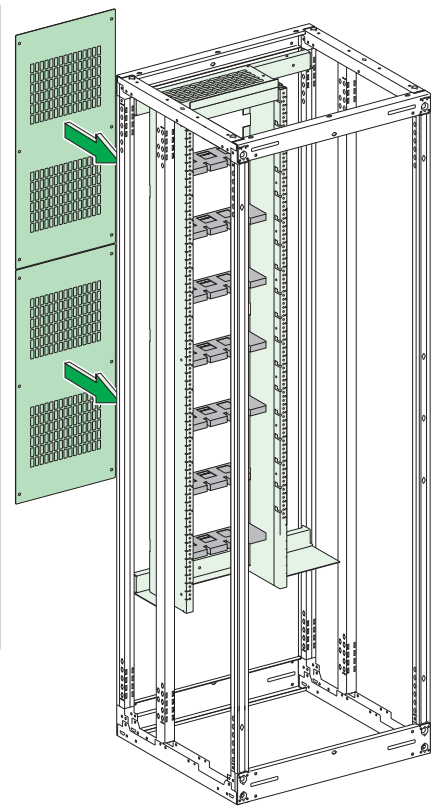
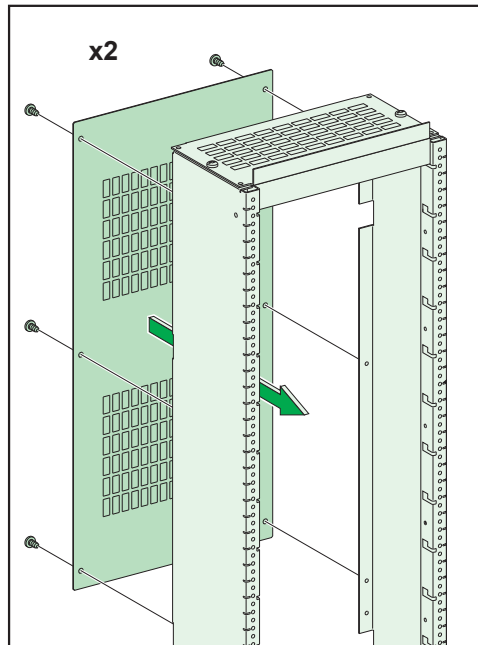
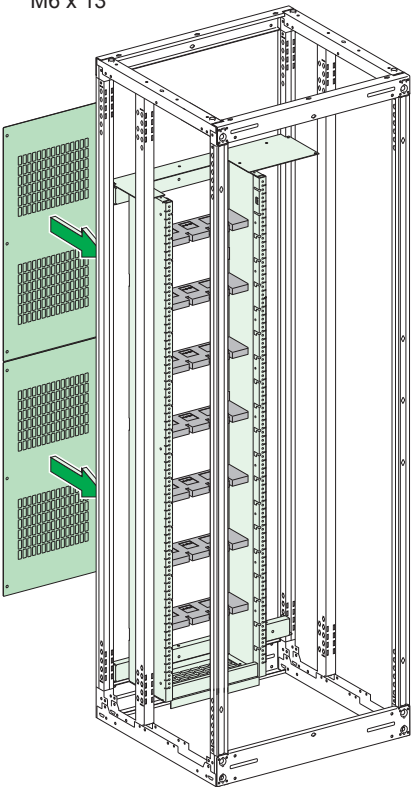

H

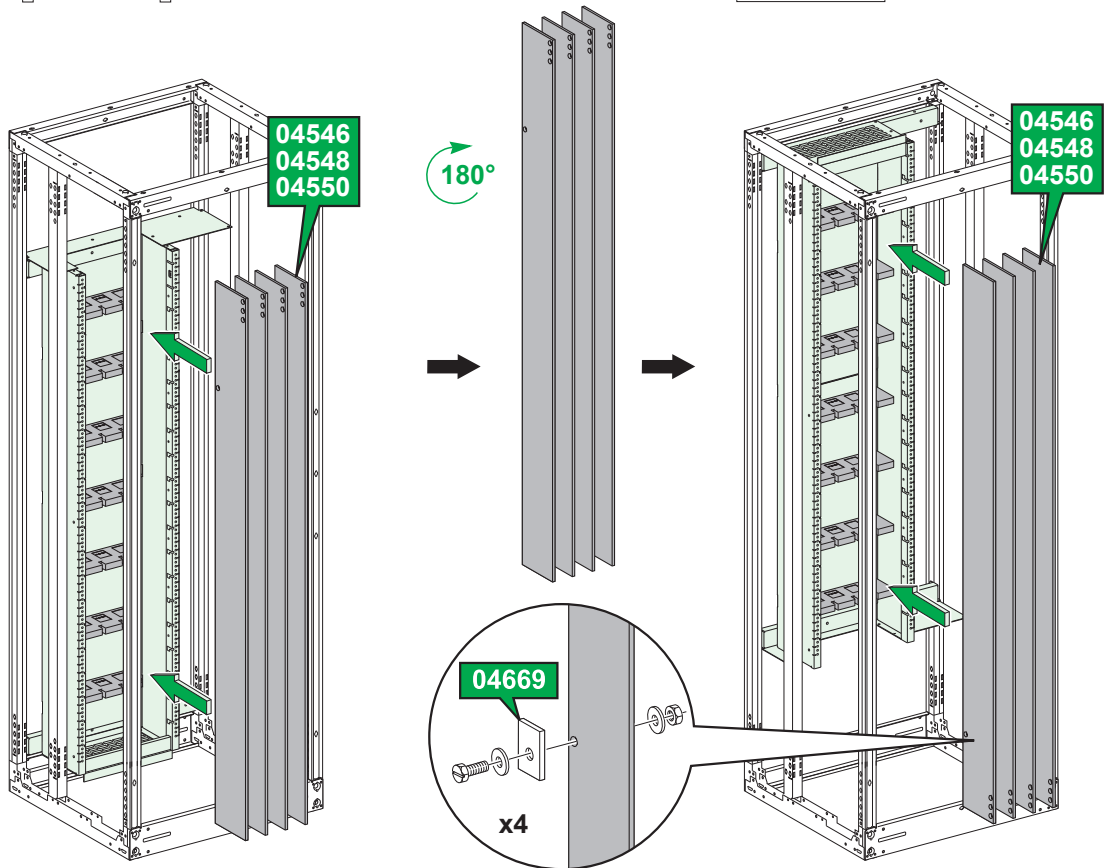
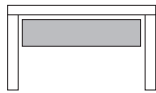



⚠ CAUTION / ATTENTION / ATENCIÓN / VORSICHT / ATTENZIONE / CUIDADO / 小心 / ВНИМАНИЕ

BUSBAR TILTING HAZARD

■ Mount the barriers as quickly as possible after installing the busbars as described in section H above.
■ Start with the top barrier to prevent the busbars tilting when mounting the other barriers.
Failure to follow these instructions can result in injury or equipment damage.

RISQUE DE BASCULEMENT DES BARRES

■ Montez les écrans le plus rapidement possible après le montage des barres (opération H).
■ Commencez par monter l'écran du haut pour empêcher le basculement des barres pendant le montage des autres écrans.
Si ces directives ne sont pas respectées, cela peut entraîner des blessures ou des dommages matériels.

RIESGO DE BALANCEO DE LAS BARRAS

■ Monte las pantallas lo más rápido posible tras el montaje de las barras descrito en la sección H.
■ Comience por montar la pantalla por la parte superior para impedir que las barras se balanceen durante el montaje de otras pantallas.
El incumplimiento de estas instrucciones puede causar lesiones o daño al equipo.

GEFAHR KIPPENDER SCHIENEN

■ Befestigen Sie die Abschirmungen so schnell wie möglich nach Montage der Schienen, wie in H beschrieben.
■ Beginnen Sie mit der oberen Abschirmung, um ein Umkippen der Schienen bei der Montage der anderen Abschirmungen zu verhindern.
Die Nichtbeachtung dieser Anweisungen kann Körperverletzungen oder Sachschäden zur Folge haben.

RISCHIO DI OSCILLAZIONE DELLE SBARRE

■ Montare gli schermi il più velocemente possibile dopo il montaggio delle sbarre descritto in H.
■ Cominciare montando lo schermo superiore per evitare l'oscillazione delle sbarre durante il montaggio degli altri schermi.
Il mancato rispetto di queste istruzioni può provocare infortuni o danni alle apparecchiature.

RISCO DE INCLINAÇÃO DAS BARRAS

■ Monte as protecções o mais rapidamente possível após a montagem das barras, conforme descrito em H.
■ Comece por montar a protecção superior para impedir a inclinação das barras durante a montagem das restantes protecções.
A não observância destas instruções pode provocar ferimentos pessoais, ou danos no equipamento.

小心母线倾斜危险

■ 在按照先前 H 部分所述内容安装母线之后请尽快安装隔板。
■ 请首先安装顶端隔板，以避免在安装其他隔板时母线倾斜。
不遵循上述说明可能导致人身伤害或设备损坏。

ОПАСНОСТЬ СМЕЩЕНИЯ ШИННОЙ СИСТЕМЫ

■ Установите барьеры сразу после установки шин, как показано в разделе H выше.
■ Начните с верхнего барьера, чтобы предотвратить смещение шин при установке других барьеров.
Несоблюдение этих инструкций может привести к травме или повреждению оборудования.

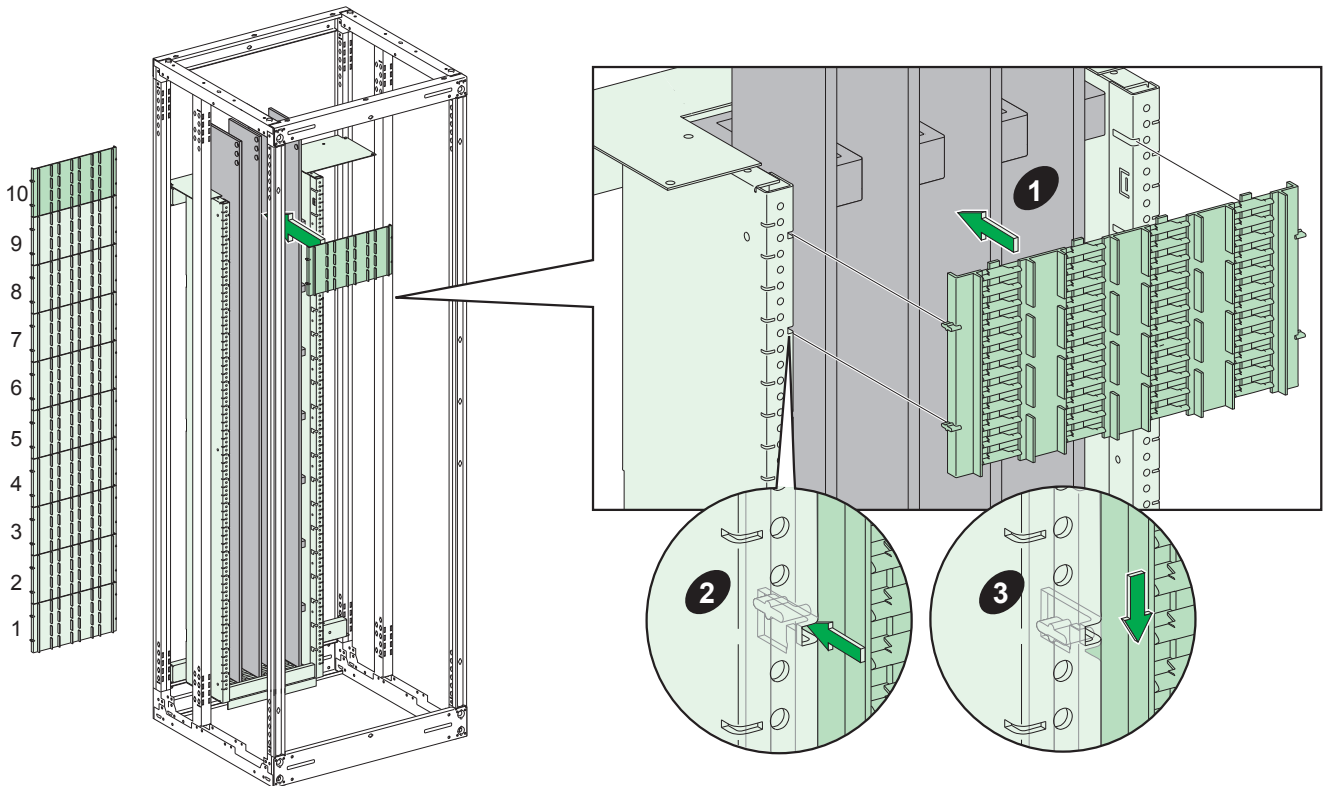

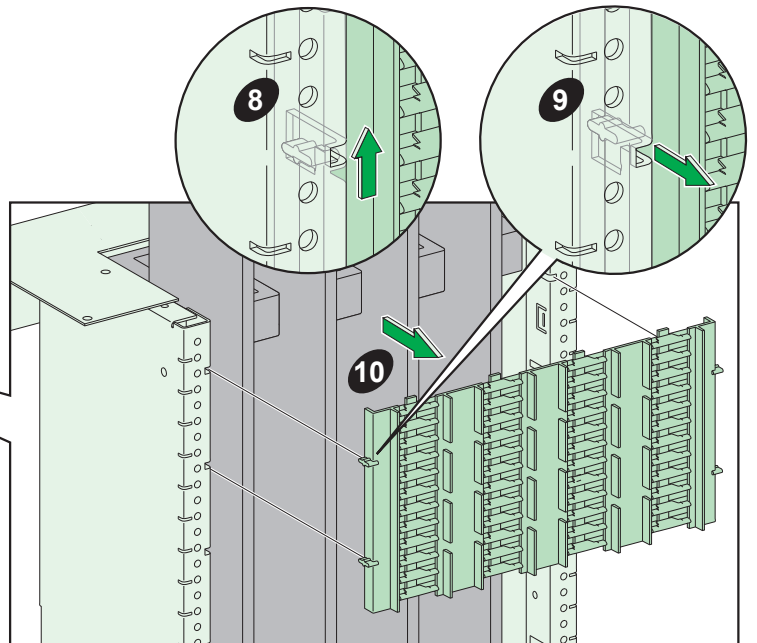
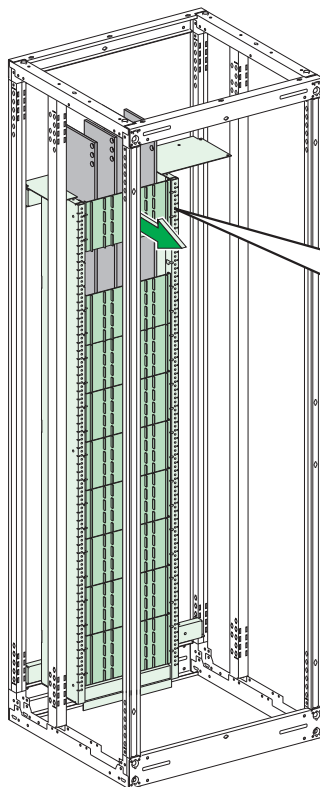
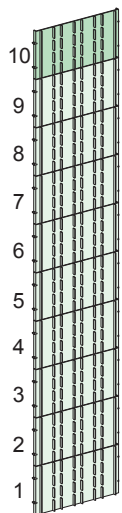
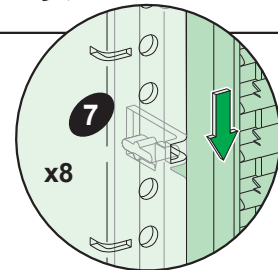
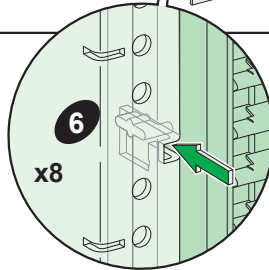
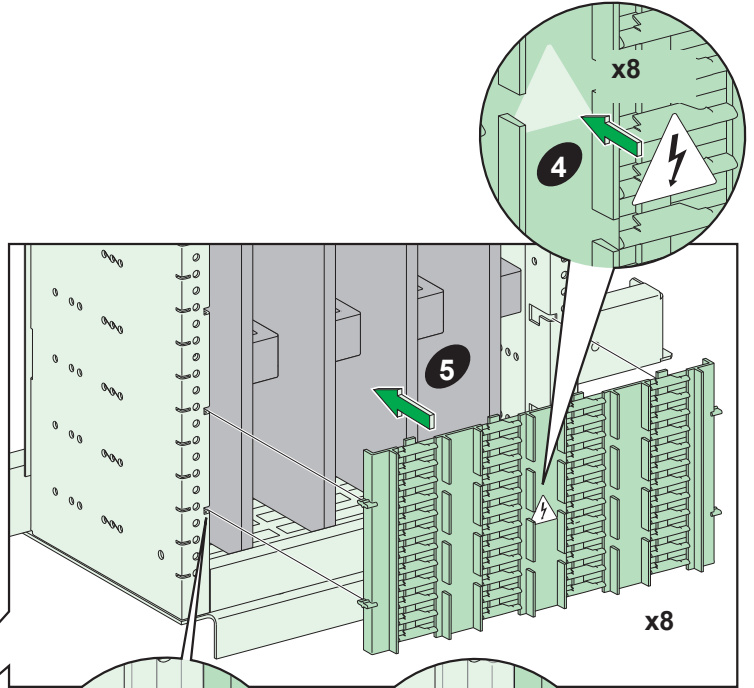
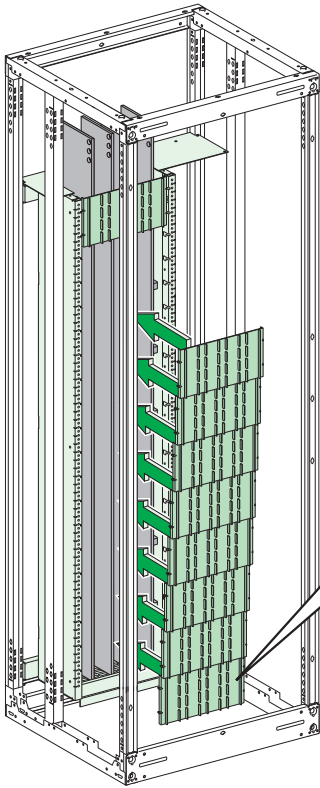
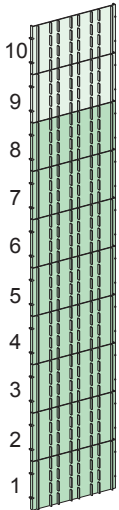
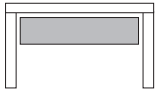

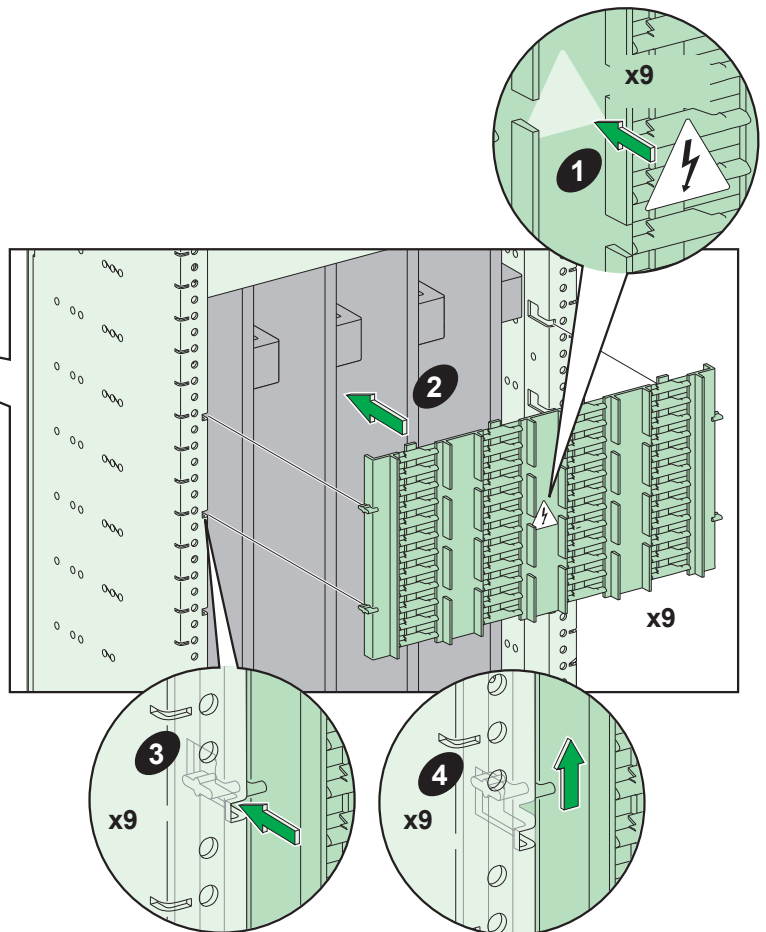
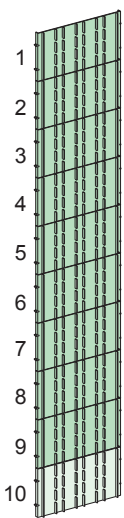
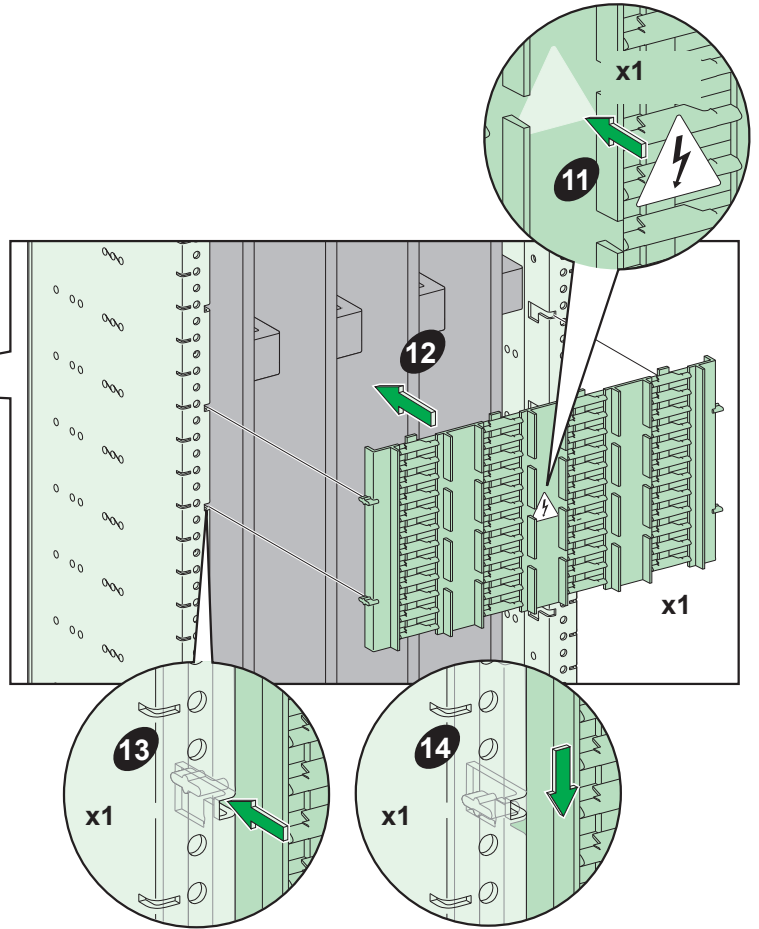
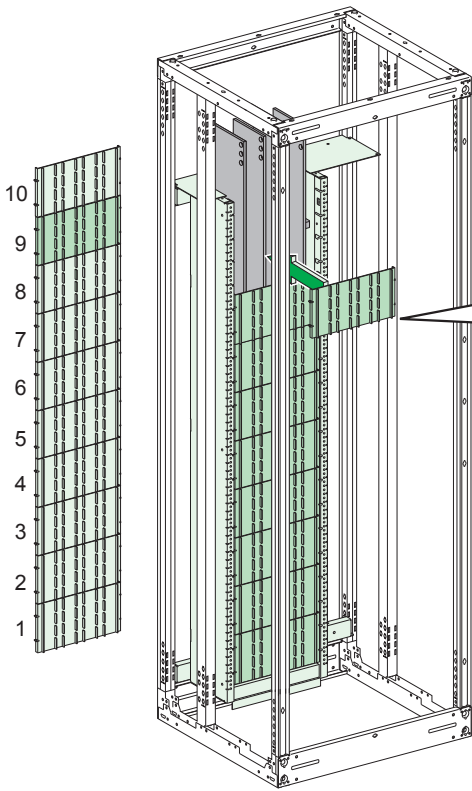
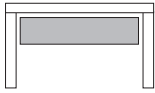

J

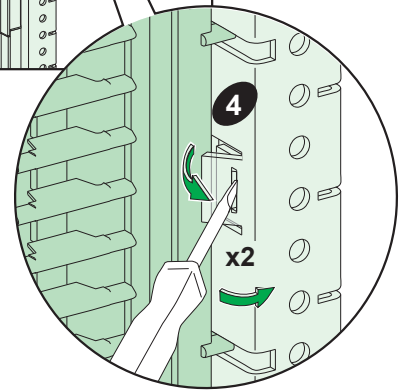
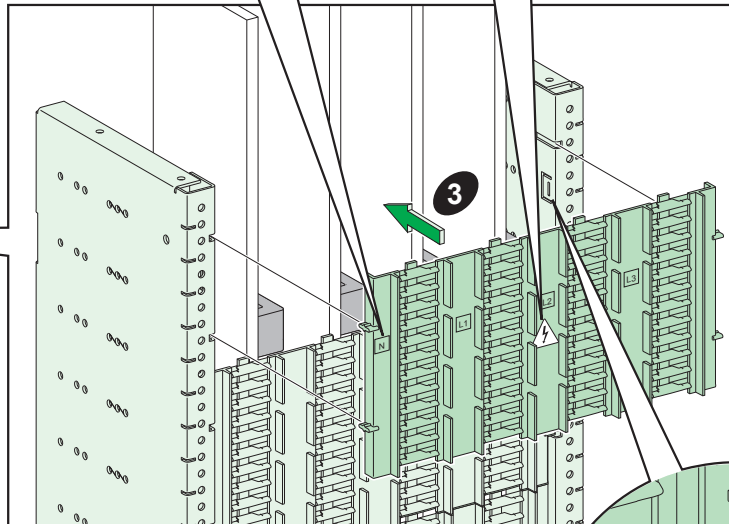
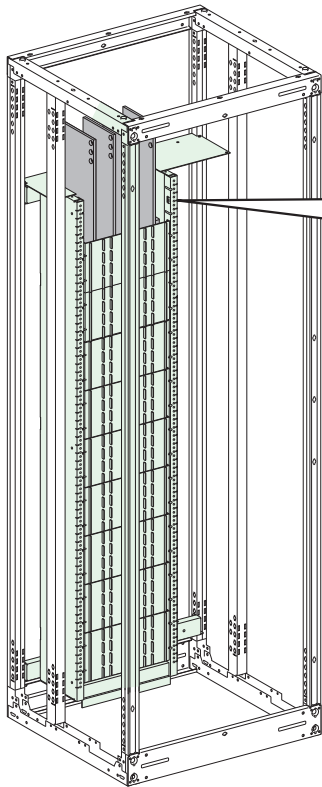
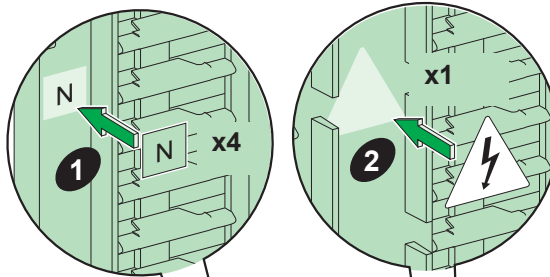
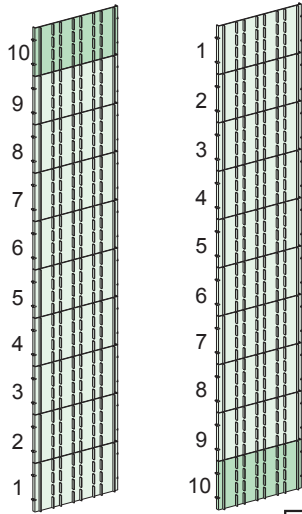
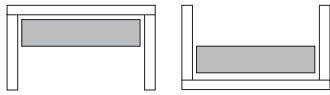

i

88007
88008
88014
88015

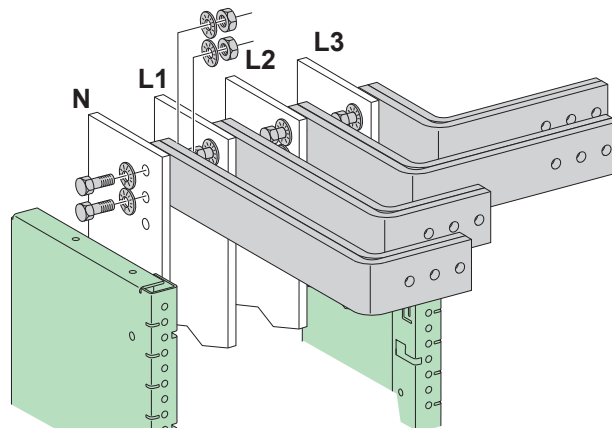

K

M6 x 16 x2

x2

M6 x 13 x4

M6x10 PLASTIC
x5 x5 x5

630 A
1600 A
2000 A
2500 A
3200 A
4000 A

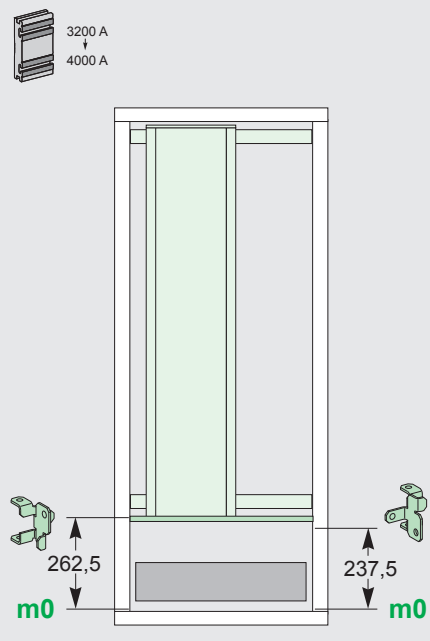
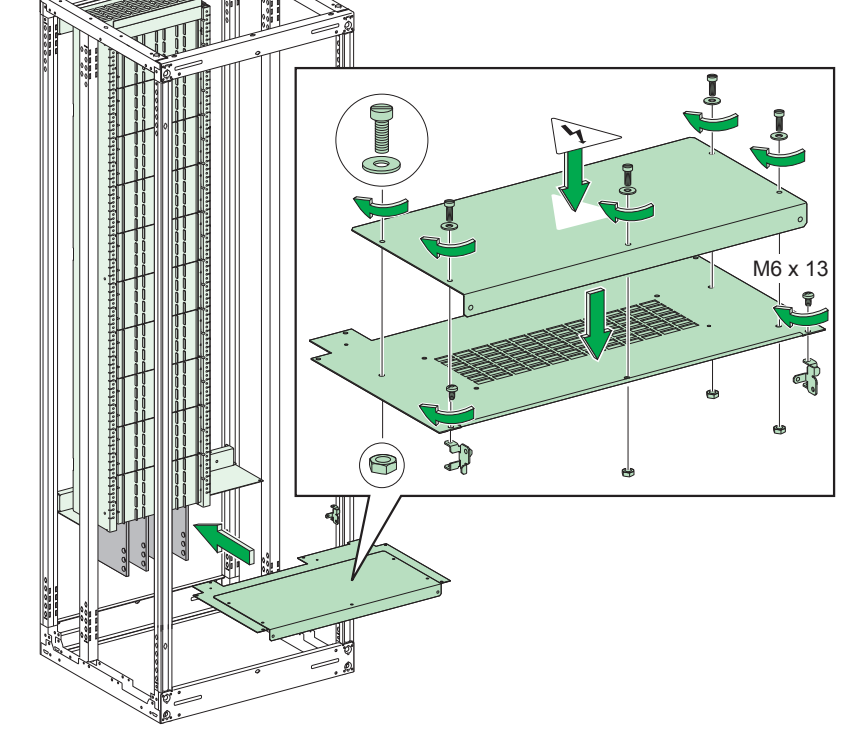
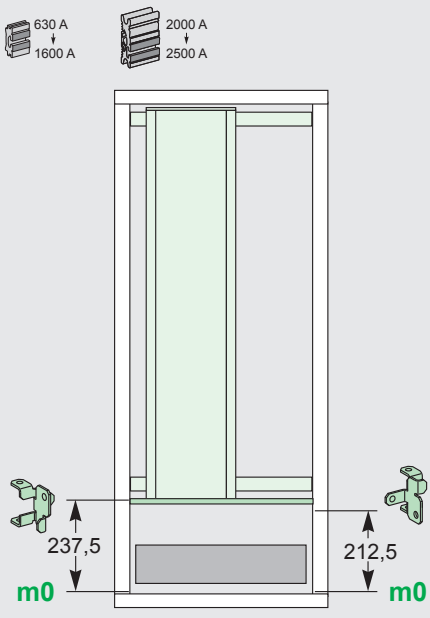
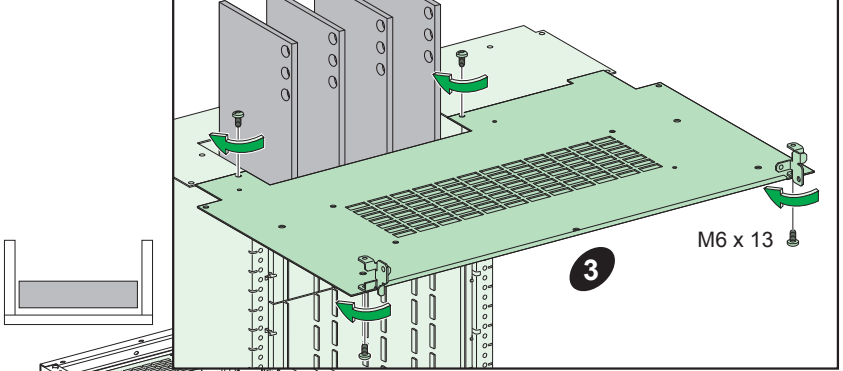
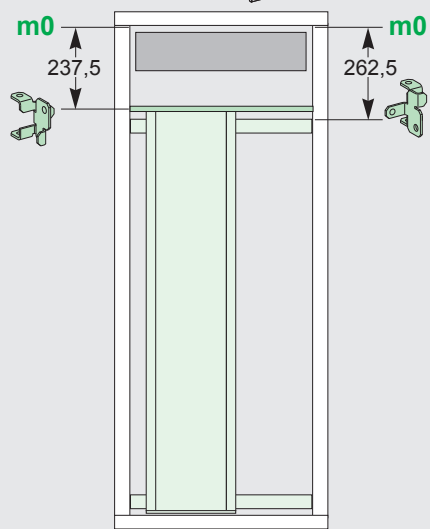
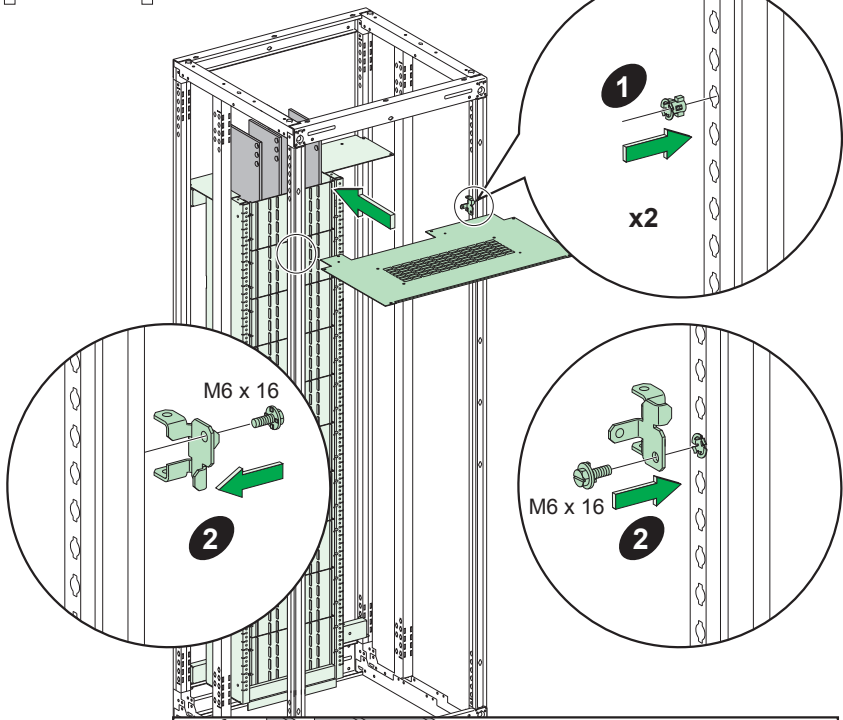



x12
M6 x 16

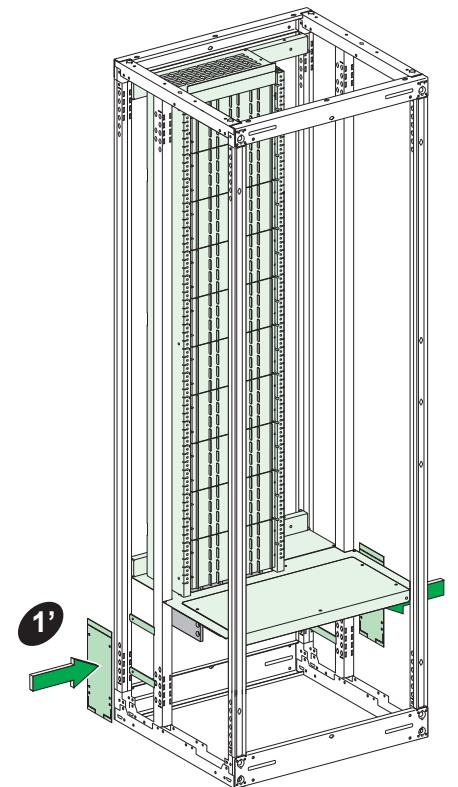
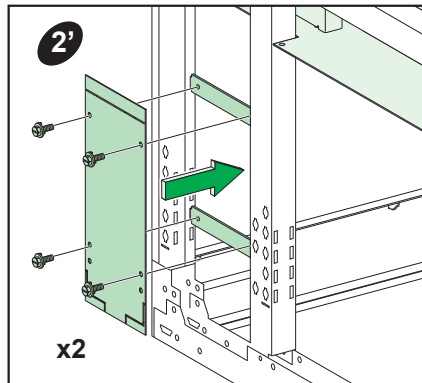
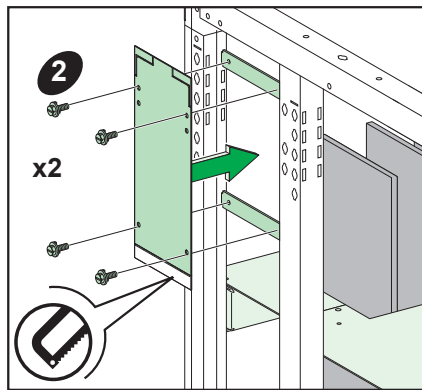
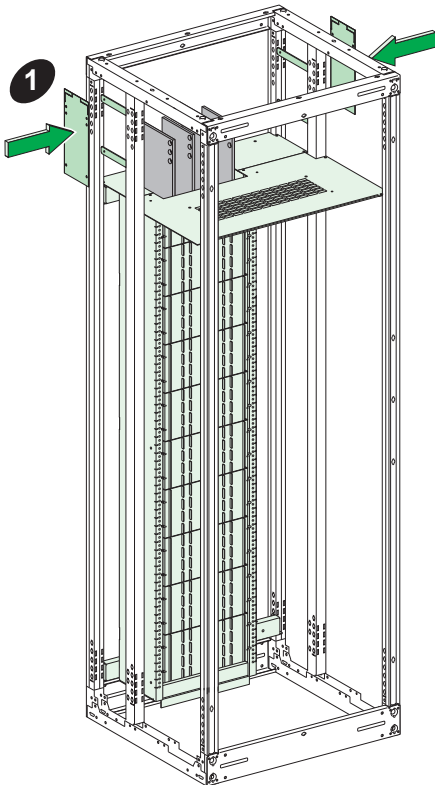
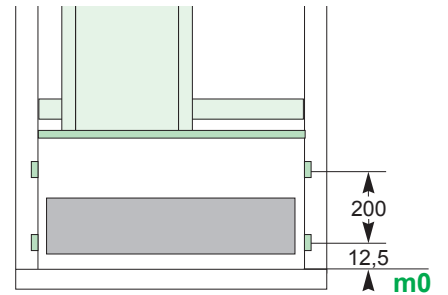
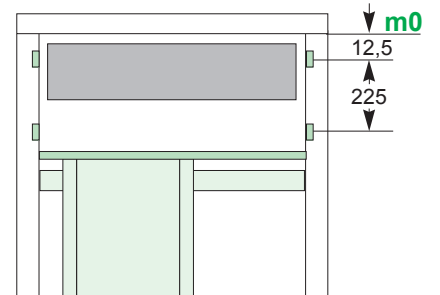
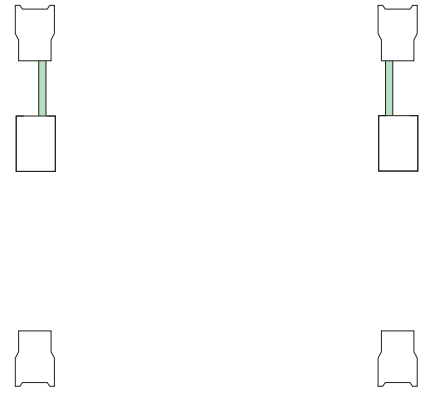
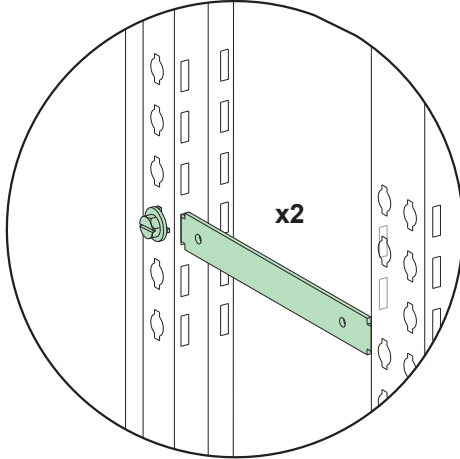
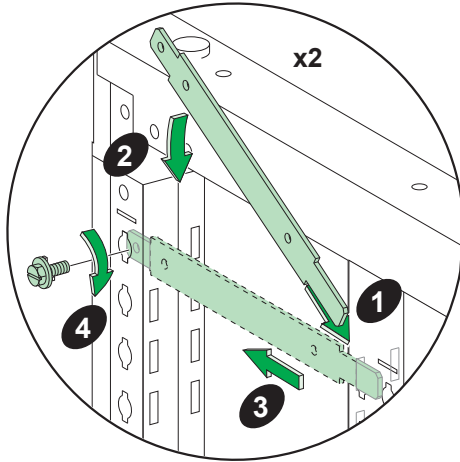
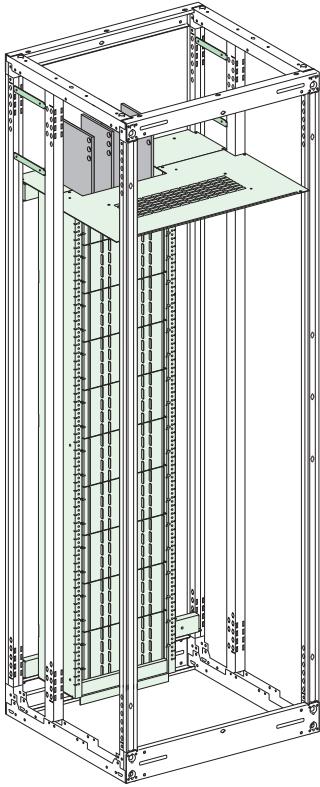

M

x4
M4 x 22

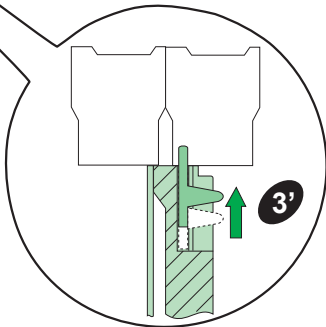
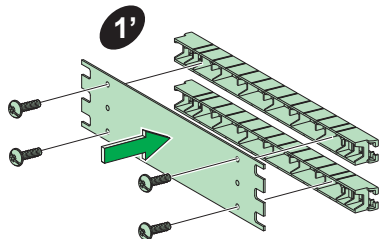
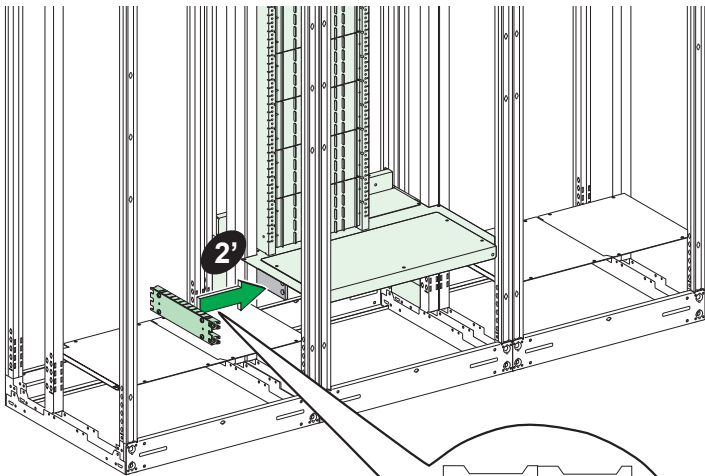
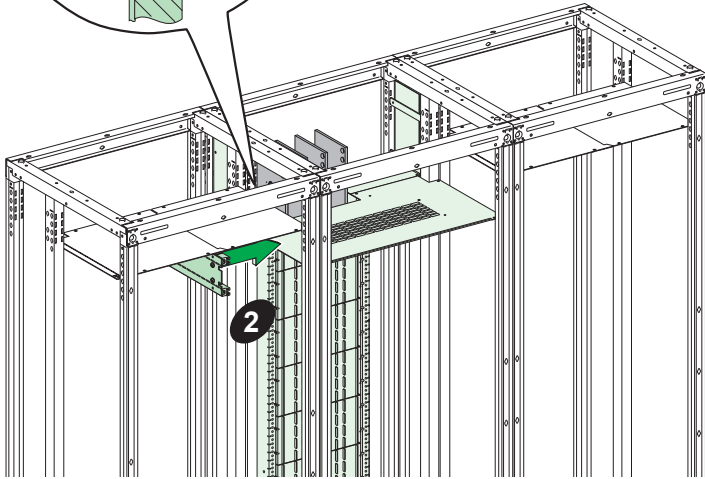
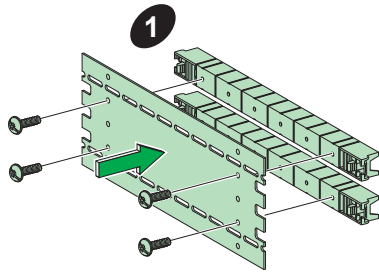
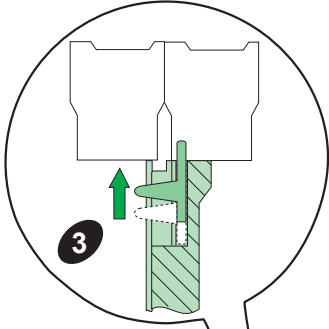

630 A + 1600 A 2000 A + 2500 A ≤ 100

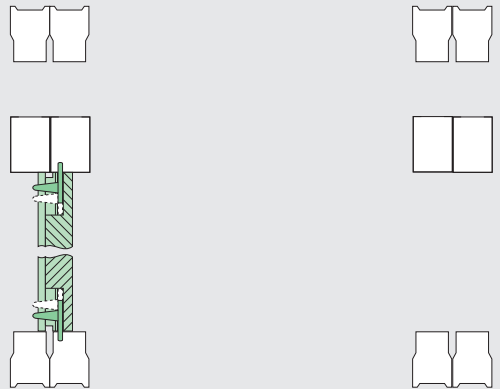
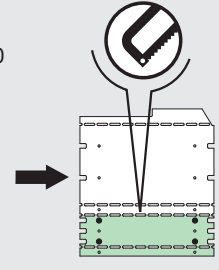
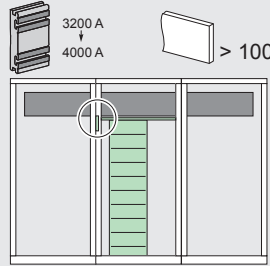
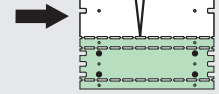
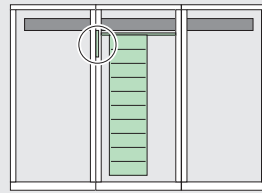

630 A + 1600 A 2000 A + 2500 A ≤ 100

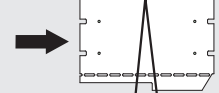
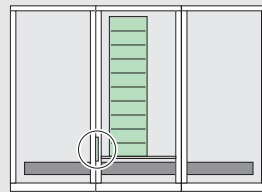

3200 A + 4000 A > 100

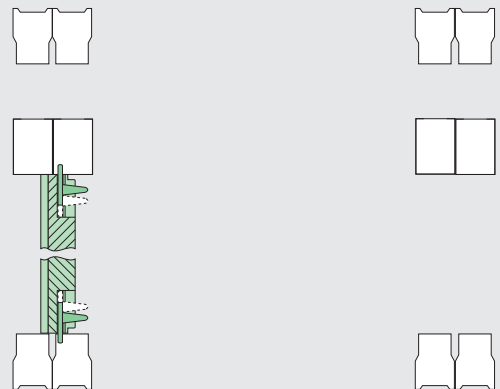
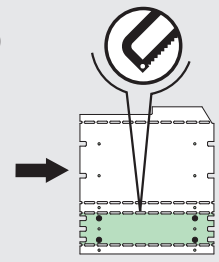
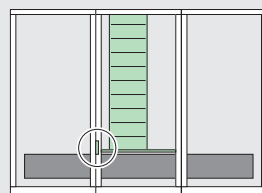

M'

x4
M4 x 22

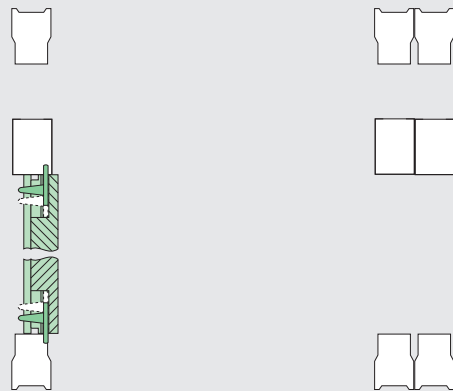
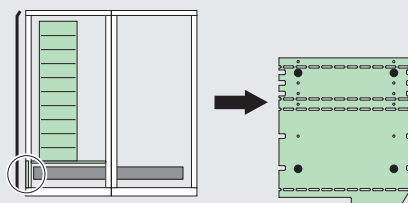
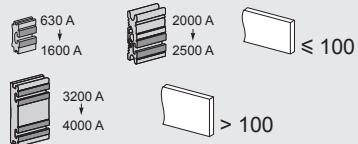
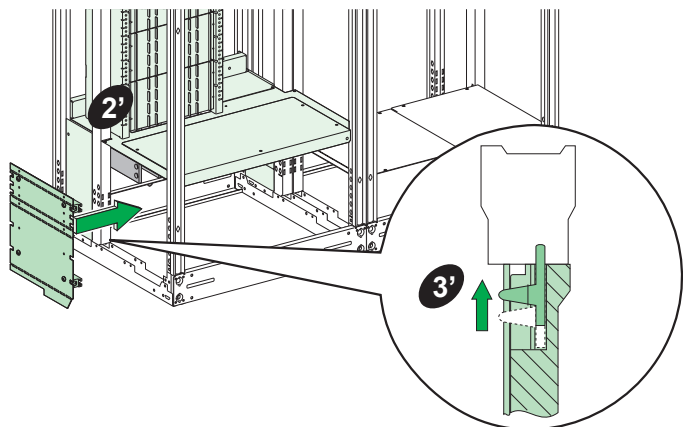
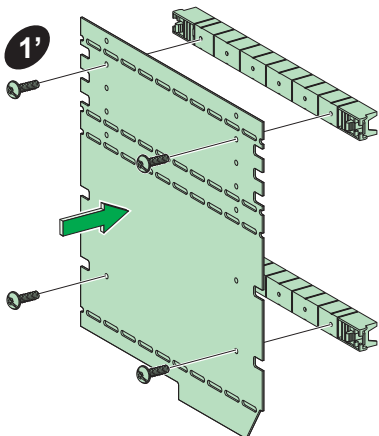
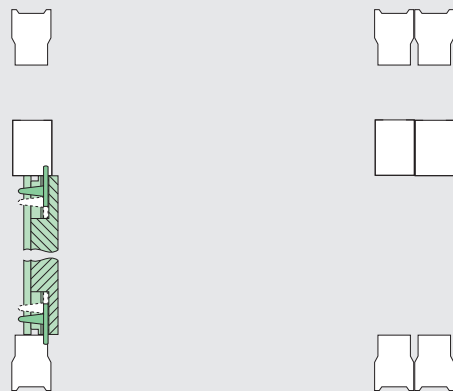
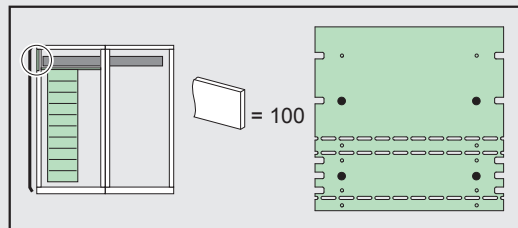
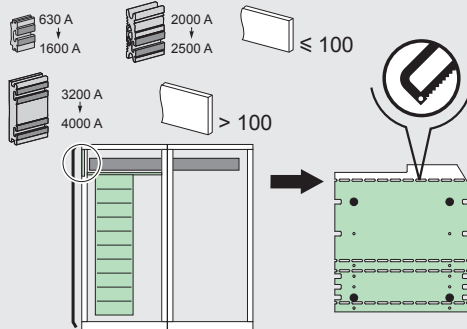
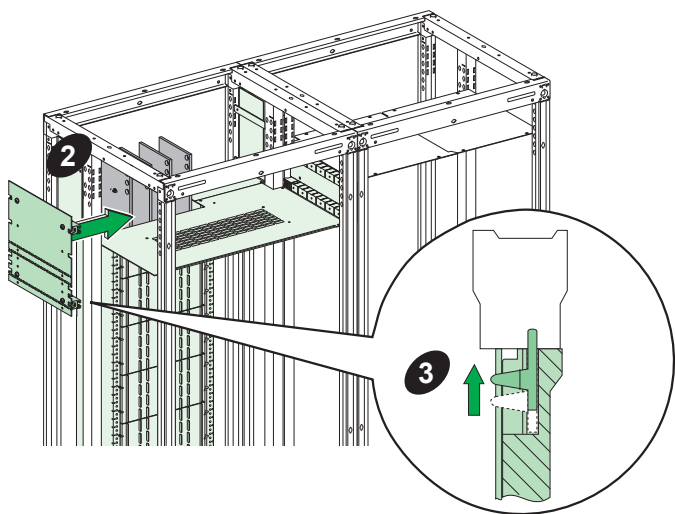
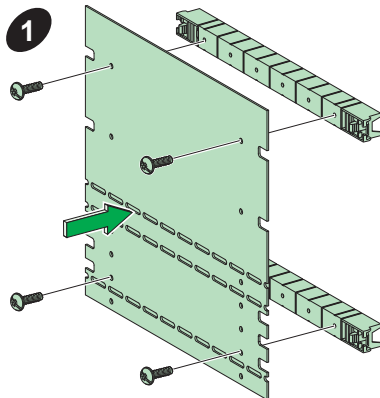

N

x4
M4 x 22

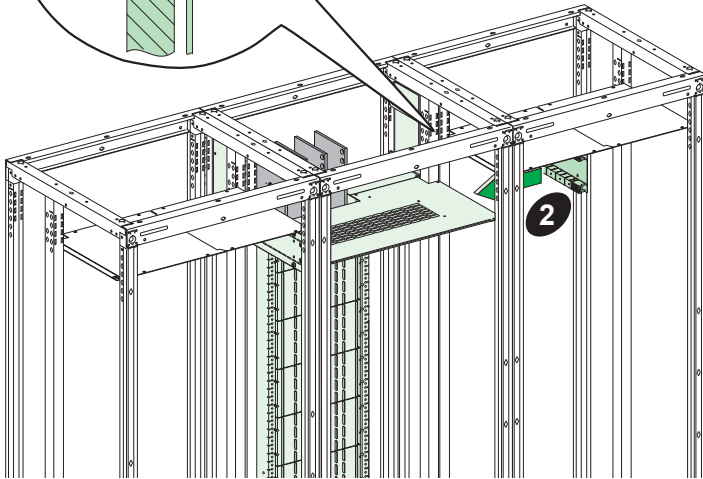
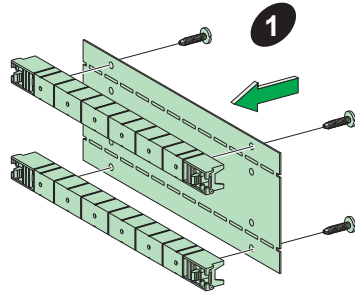
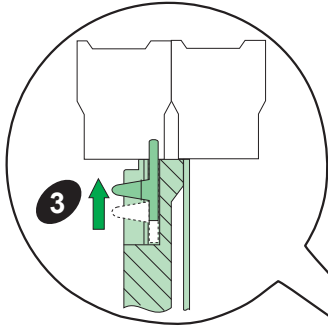

630 A + 1600 A 2000 A + 2500 A ≤ 100

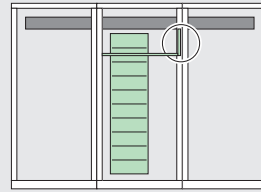

3200 A + 4000 A > 100

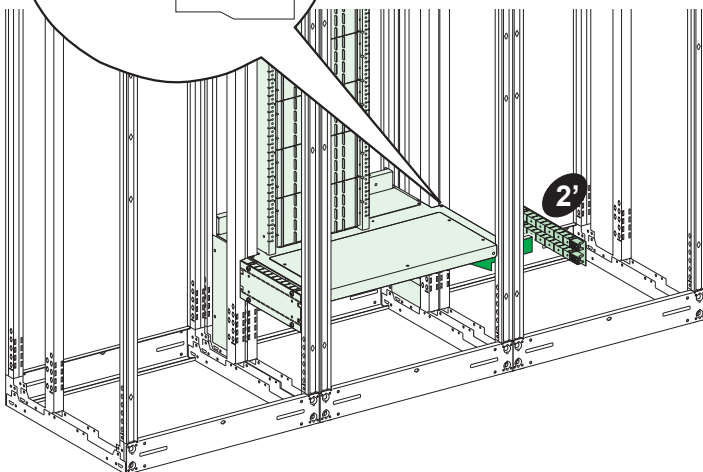
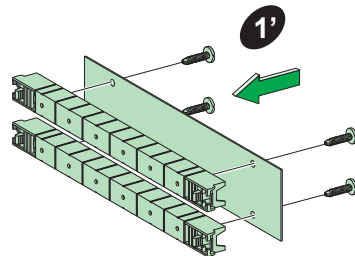
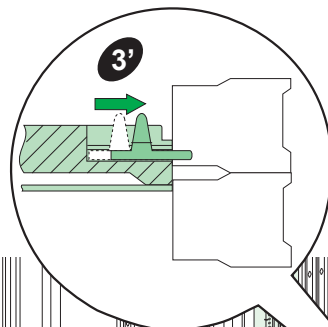
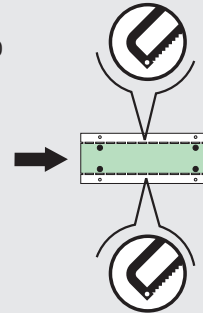
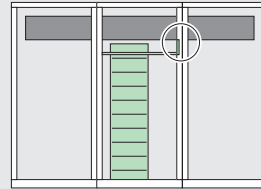

3200 A + 4000 A > 150

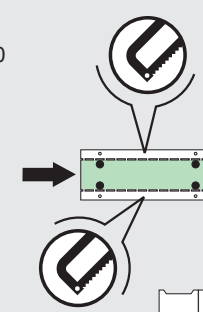
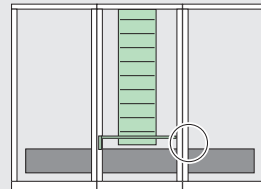



- x4
M6 x 16
- x4
- x4
M6 x 13

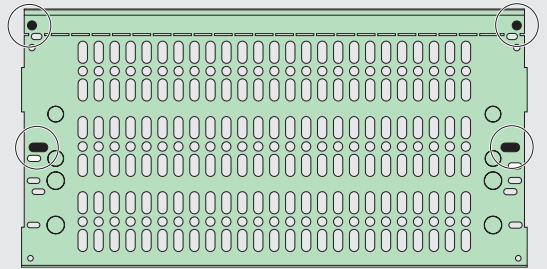
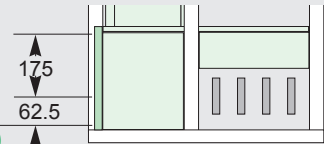
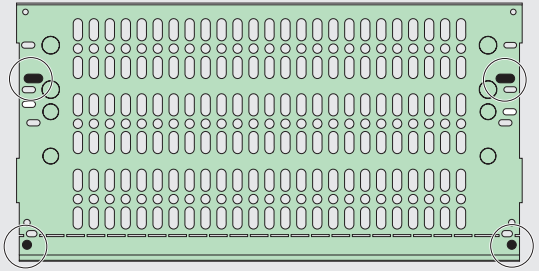
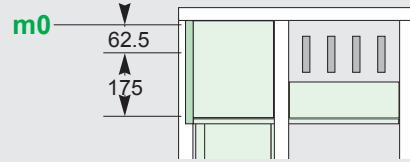
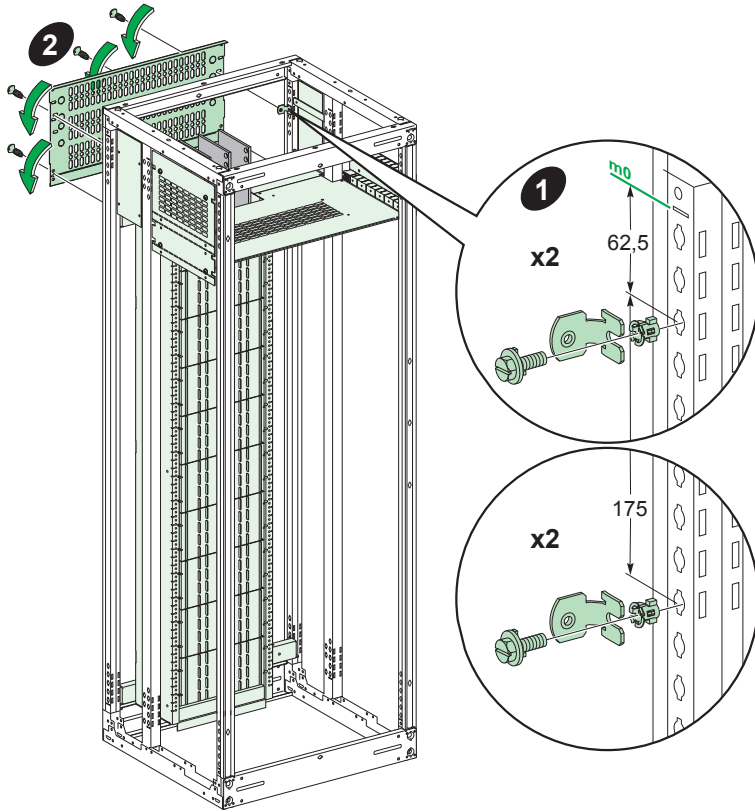

- x2
M6 x 13

- M6x10 PLASTIC
 x2

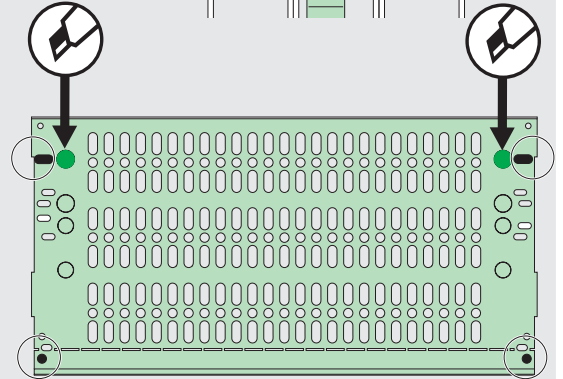
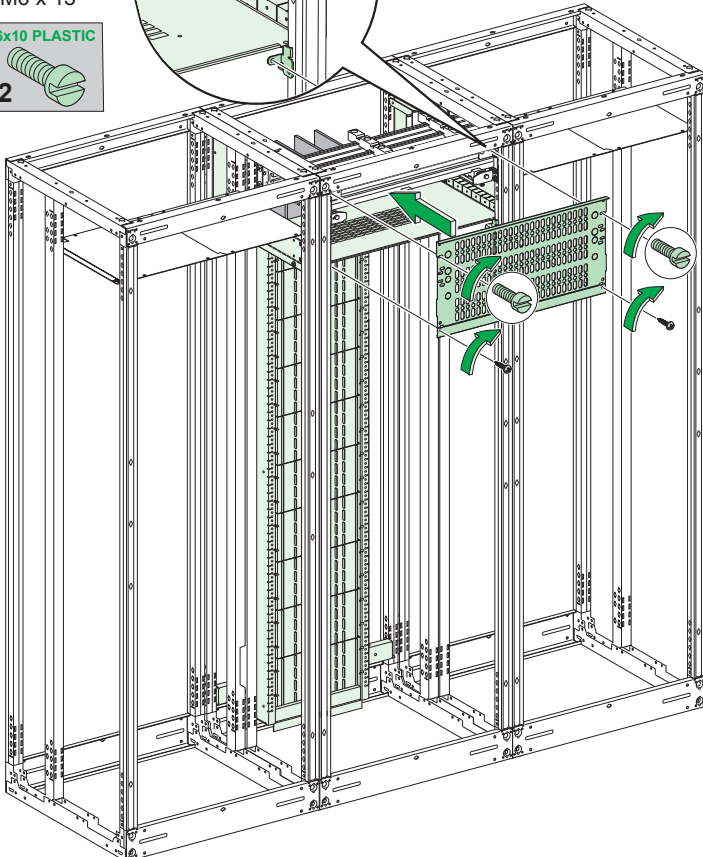
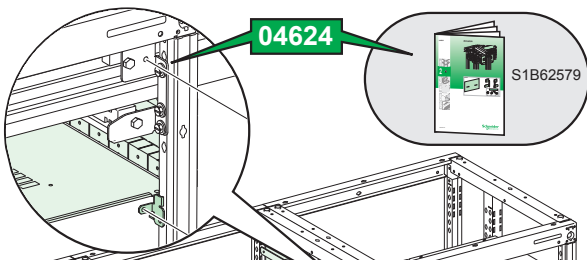

P'

x2
M6 x 13

M6x10 PLASTIC
x2

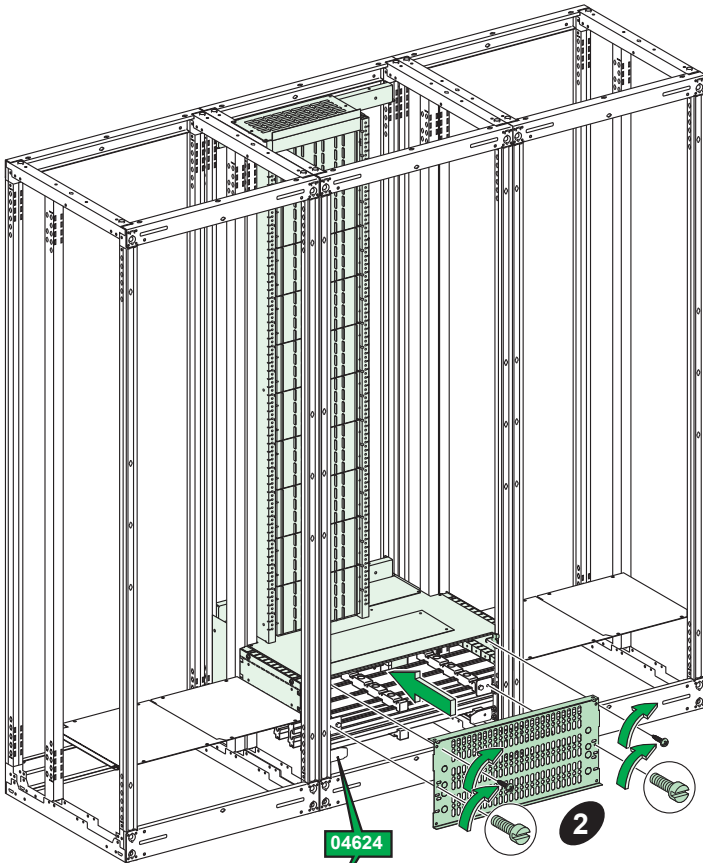
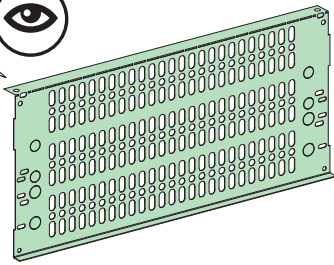
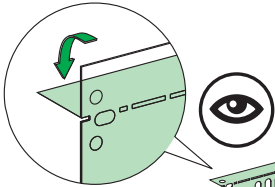

630 A
1600 A

2000 A
2500 A

3200 A
4000 A

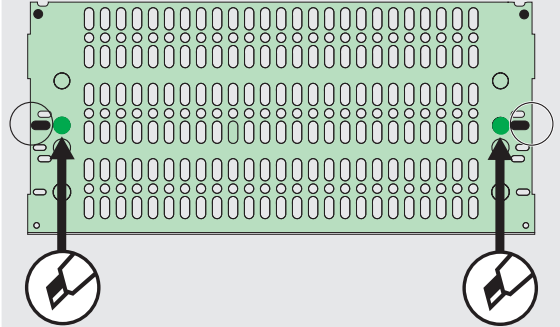
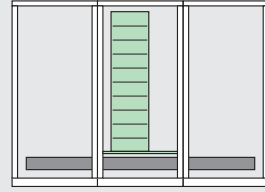

 x2
M6 x 13

M6x10 PLASTIC
 x2

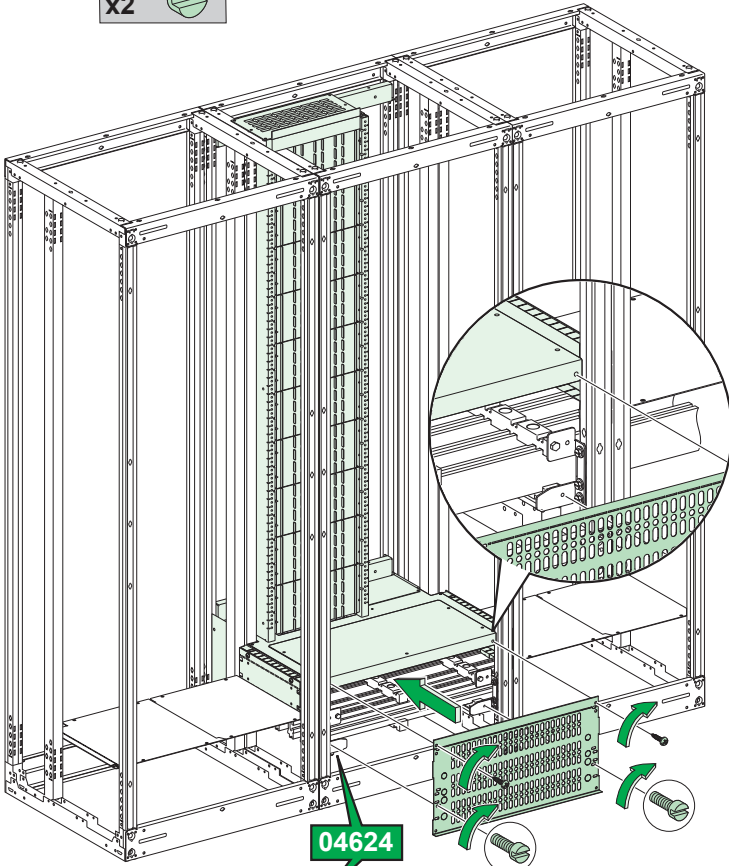

 3200 A
↓
4000 A

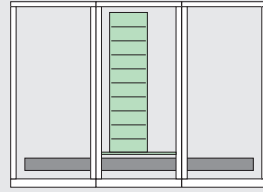



x4
M6 x 13

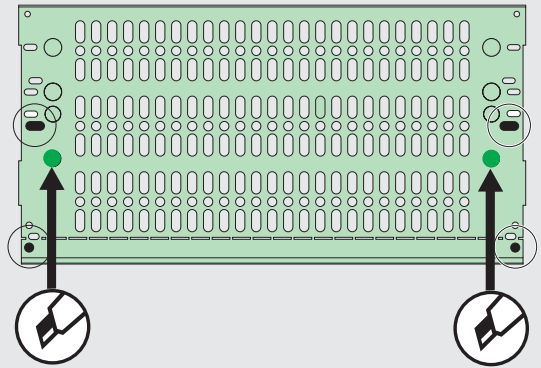
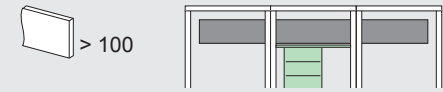
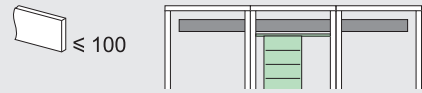
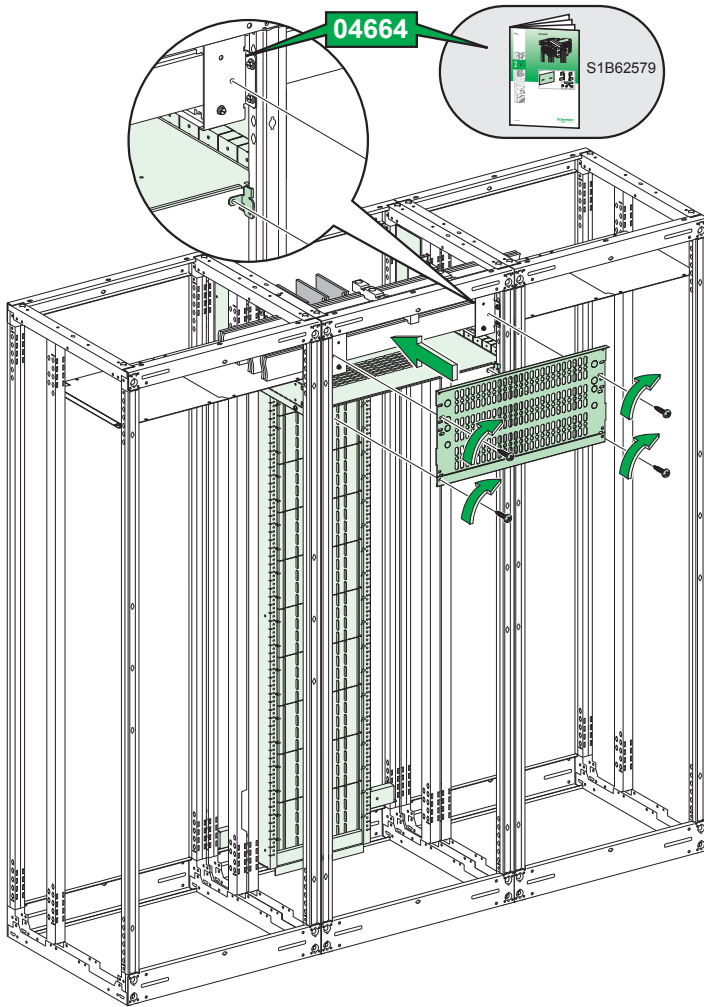

 **x4**
M6 x 13

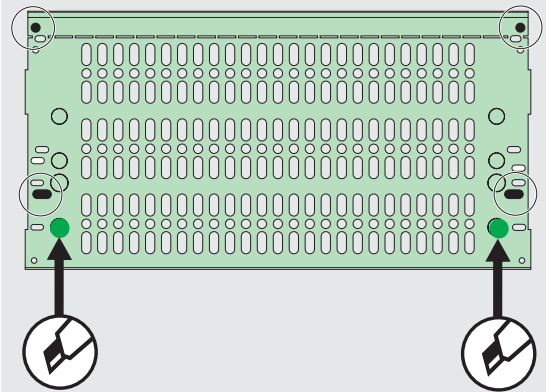
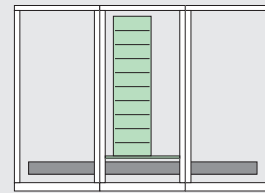
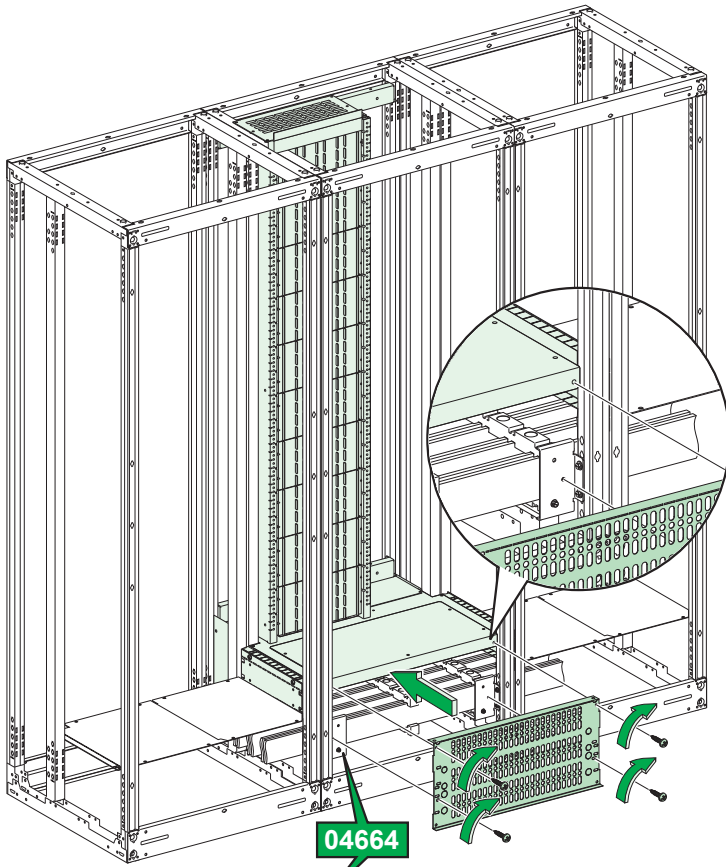

Schneider Electric Industries SAS

35, rue Joseph Monier
92506 Rueil Malmaison
France

<http://www.schneider-electric.com>

En raison de l'évolution des normes et du matériel, les caractéristiques indiquées par le texte et les images de ce document ne nous engagent qu'après confirmation par nos services.

As standards, specifications and designs change from time to time, please ask for confirmation of the information given in this publication.

Publication : Schneider Electric
Réalisation : Schneider Electric
Impression :
Format de pliage : 210 x 297 mm



Ce document a été imprimé sur du papier écologique.

This document has been printed on ecological paper