

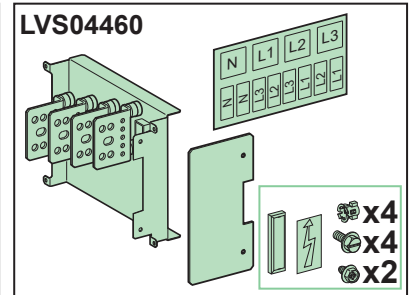

en fr es de it pt zh ru

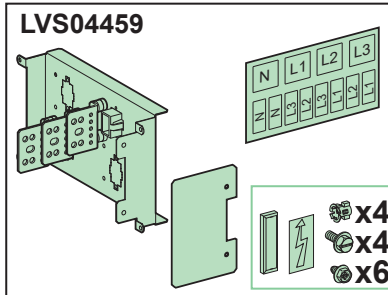
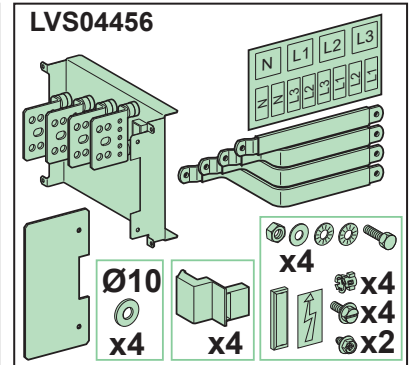
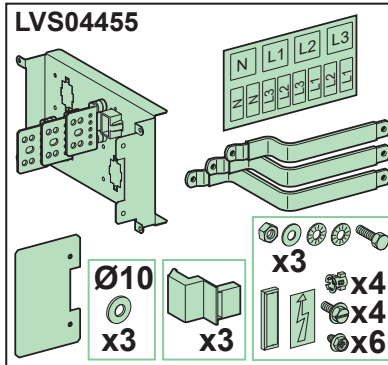
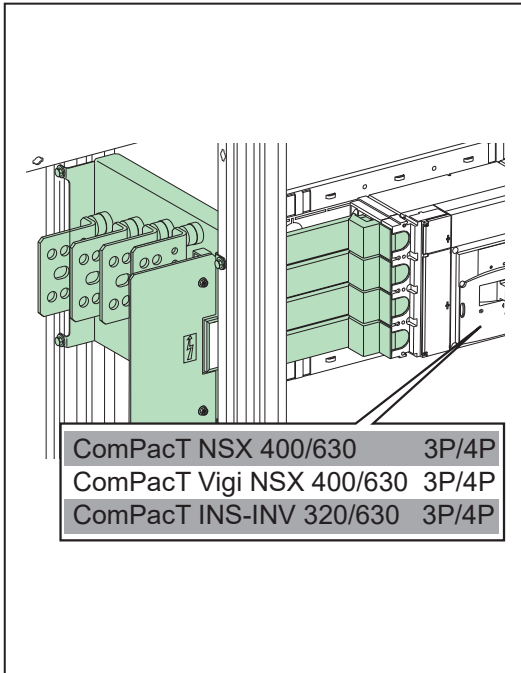

<p><b>PLEASE NOTE</b>          Electrical equipment should be installed, operated, serviced, and maintained only by qualified personnel. No responsibility is assumed by Schneider Electric for any consequences arising out of the use of this material.</p>	<p><b>REMARQUE IMPORTANTE</b>          L'installation, l'utilisation, la réparation et la maintenance des équipements électriques doivent être assurées uniquement par du personnel qualifié. Schneider Electric décline toute responsabilité quant aux conséquences de l'utilisation de ce matériel.</p>	<p><b>TENGA EN CUENTA</b>          La instalación, manejo, puesta en servicio y mantenimiento de equipos eléctricos deberán ser realizados sólo por personal cualificado. Schneider Electric no se hace responsable de ninguna de las consecuencias del uso de este material.</p>	<p><b>BITTE BEACHTEN</b>          Elektrische Geräte dürfen nur von Fachpersonal installiert, betrieben, bedient und gewartet werden. Schneider Electric haftet nicht für Schäden, die durch die Verwendung dieses Materials entstehen.</p>
<p><b>NOTA</b>          Manutenzione, riparazione, installazione e uso delle apparecchiature elettriche si devono affidare solo a personale qualificato. Schneider Electric non si assume alcuna responsabilità per qualsiasi conseguenza derivante dall'uso di questo materiale.</p>	<p><b>NOTA</b>          A instalação, utilização e manutenção do equipamento eléctrico devem ser efectuadas exclusivamente por pessoal qualificado. A Schneider Electric não assume qualquer responsabilidade pelas consequências resultantes da utilização deste material.</p>	<p><b>请注意</b>          电气设备的安装、操作、维修和维护工作仅限于合格人员执行。Schneider Electric 不承担由于使用本资料所引起的任何后果。</p>	<p><b>ОБРАТИТЕ ВНИМАНИЕ</b>          Установка, эксплуатация, ремонт и обслуживание электрического оборудования может выполняться только квалифицированными электриками. Компания Schneider Electric не несет никакой ответственности за любые возможные последствия использования данной документации.</p>

## ⚠️ DANGER / DANGER / PELIGRO / GEFAHR / PERICOLO / PERIGO / 危险 / ОПАСНО

<p><b>HAZARD OF ELECTRIC SHOCK, EXPLOSION, OR ARC FLASH</b></p> <ul style="list-style-type: none"> <li>Disconnect all power before servicing equipment.</li> <li>Always use a properly rated voltage sensing device to confirm that all power is off.</li> </ul> <p><b>Failure to follow these instructions will result in death or serious injury.</b></p>	<p><b>RISQUE D'ÉLECTROCUTION, D'EXPLOSION OU D'ARCS ÉLECTRIQUE</b></p> <ul style="list-style-type: none"> <li>Coupez toutes les alimentations avant de travailler sur ce produit</li> <li>Vérifiez toujours que toutes les alimentations sont coupées à l'aide d'un dispositif de détection de tension approprié.</li> </ul> <p><b>Le fait de ne pas suivre ces instructions entrainera des blessures graves, voire mortelles.</b></p>	<p><b>PELIGRO DE DESCARGA ELÉCTRICA, EXPLOSIÓN O ARCO ELÉCTRICO</b></p> <ul style="list-style-type: none"> <li>Desconecte todas las alimentaciones antes de manipular el producto.</li> <li>Per verificare che l'alimentazione sia isolata usare sempre un rilevatore di tensione correttamente tarato.</li> </ul> <p><b>El incumplimiento de estas instrucciones tendrá como resultado la muerte o lesiones graves.</b></p>	<p><b>GEFAHR VON ELEKTRISCHEM SCHLAG, EXPLOSION ODER LICHTBOGEN</b></p> <ul style="list-style-type: none"> <li>Vor dem Arbeiten am Gerät alle Spannungsversorgungen abschalten.</li> <li>Verwenden Sie stets ein Spannungsprüfgerät mit der korrekten Bemessungsspannung, um festzustellen, ob die Spannungsversorgung wirklich abgeschaltet ist.</li> </ul> <p><b>Eine Nichtbeachtung dieser Anweisungen hat Tod, schwere Verletzungen oder Schäden an der Ausrüstung zur Folge.</b></p>
<p><b>RISCHIO DI SCARICA ELETTRICA, ESPLOSIONE O ARCO ELETTRICO</b></p> <ul style="list-style-type: none"> <li>Scollegare l'appare cchio da tutti i circuiti di alimentazione prima di qualsiasi intervento.</li> <li>Per verificare che l'alimentazione sia isolata usare sempre un rilevatore di tensione correttamente tarato.</li> </ul> <p><b>Il mancato rispetto di queste istruzioni provocherà morte o gravi infortuni.</b></p>	<p><b>RISCO DE ELECTROCUSSÃO, DE EXPLOSIÃO, OU DE ARCO ELÉCTRICO</b></p> <ul style="list-style-type: none"> <li>Desconecte todas as alimentações antes de manipular o produto.</li> <li>Utilize sempre um dispositivo de detecção da tensão nominal adequada para confirmar se a alimentação está desligada.</li> </ul> <p><b>O não cumprimento destas instruções resultará em morte e lesões graves.</b></p>	<p><b>电击、爆炸或弧闪的危险</b></p> <ul style="list-style-type: none"> <li>在此电力设备上工作时,请先切断所有电源。</li> <li>确保使用合适的额定电压 传感器 确认电源已关闭。</li> </ul> <p><b>未按说明操作将导致人身伤亡等严重后果。</b></p>	<p><b>ОПАСНОСТЬ ПОРАЖЕНИЕМ ЭЛЕКТРИЧЕСКИМ ТОКОМ , ОПАСНОСТИ ВЗРЫВА ИЛИ ВСПЫШКИ ДУГИ</b></p> <ul style="list-style-type: none"> <li>Перед обслуживанием или ремонтом убедитесь, что питание отключено.</li> <li>Чтобы убедиться в отключении питания, обязательно используйте тестер надлежащего номинала.</li> </ul> <p><b>Несоблюдение данных инструкций приводит к смерти или серьезной травме.</b></p>

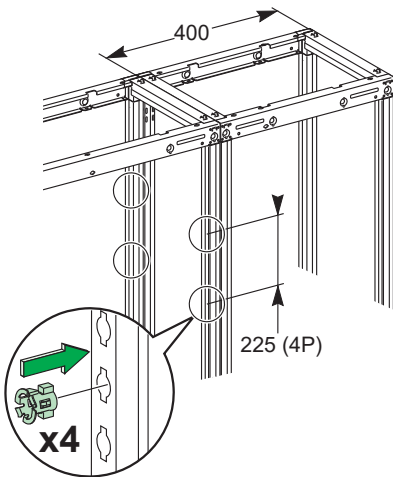
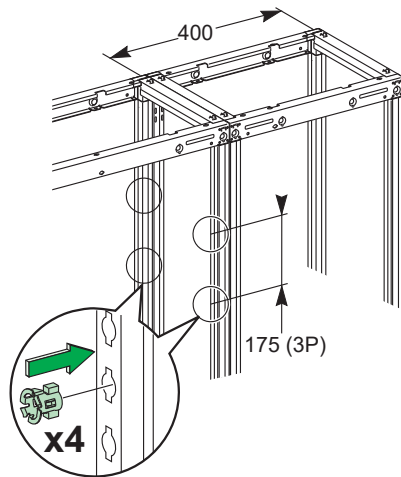
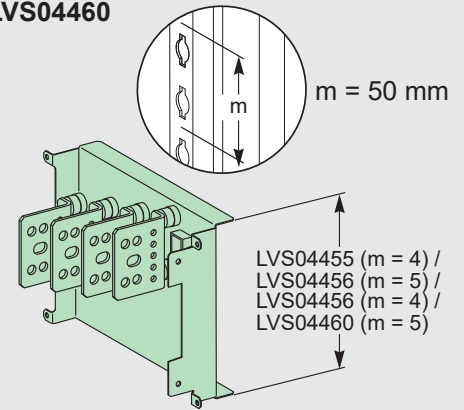
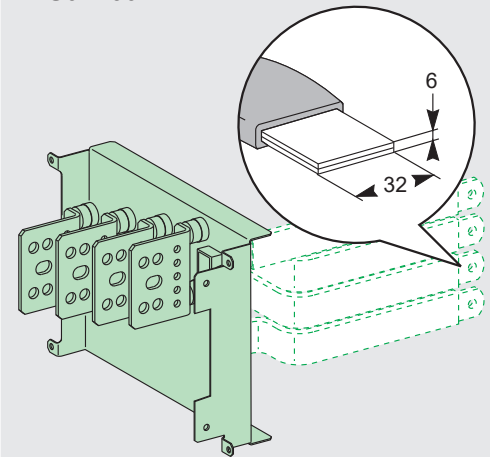
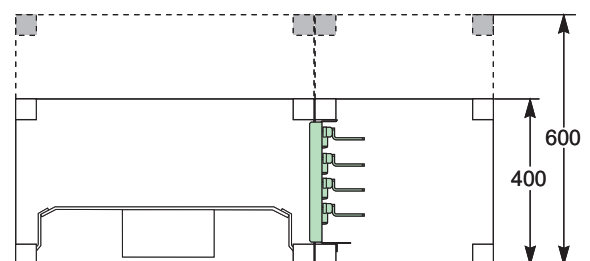
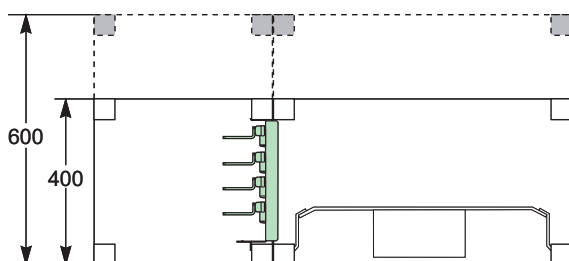
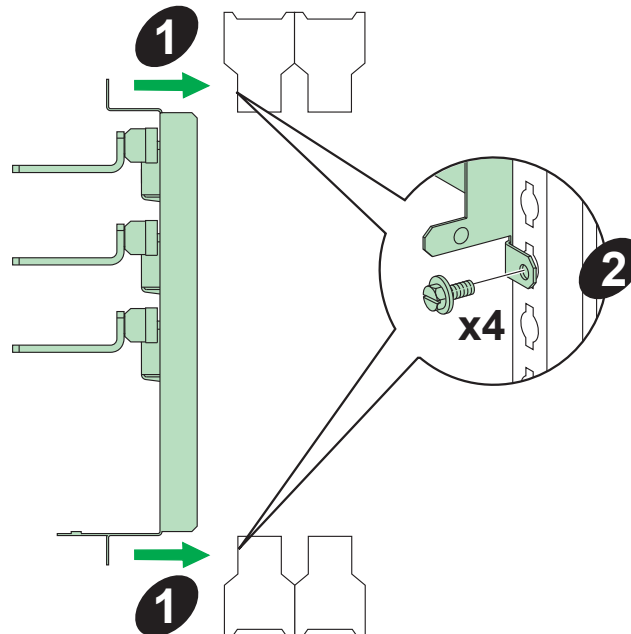
**A**LVS04456 /  
LVS04460LVS04455 /  
LVS04459LVS04455 / LVS04456 / LVS04459 /  
LVS04460LVS04459 /  
LVS04460Vigi NSX 400/630 3P/4P  
INS-INV 320/630 3P/4P**B**LVS04455 / LVS04456 /  
LVS04459 / LVS04460



LVS04455 /  
LVS04456

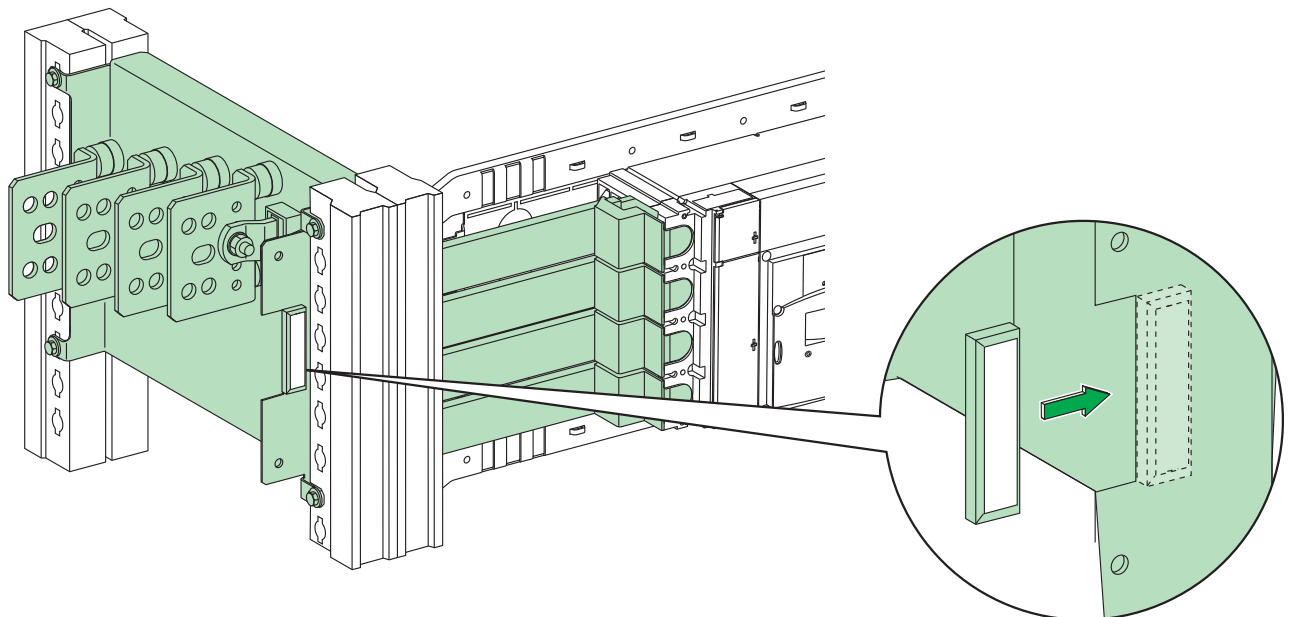
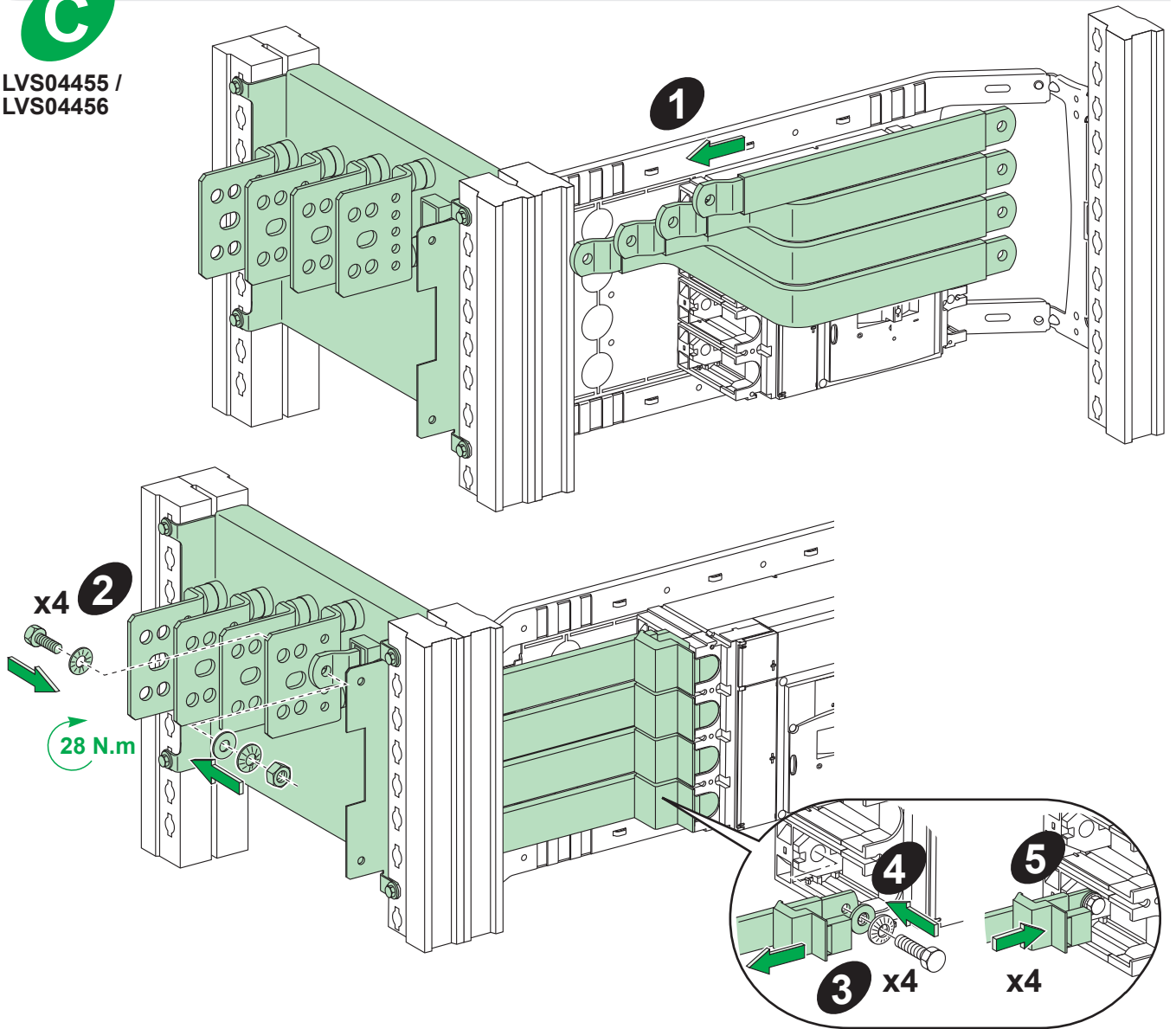

**E**

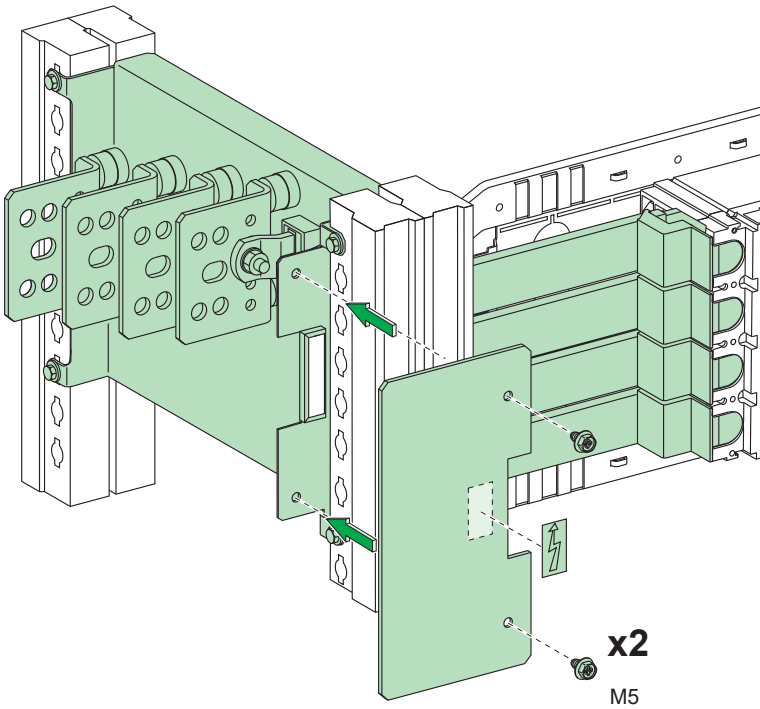

x2  
M5

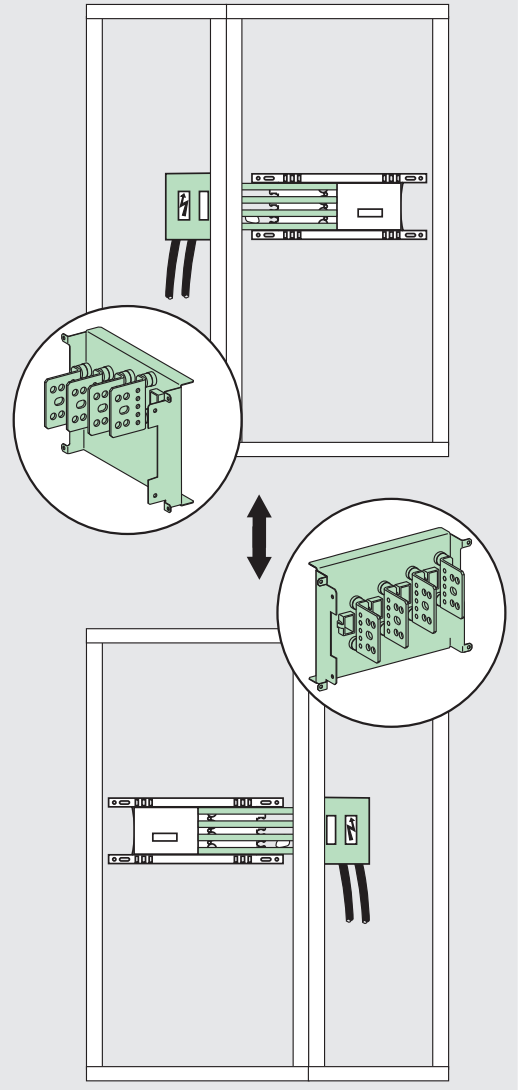

**F**

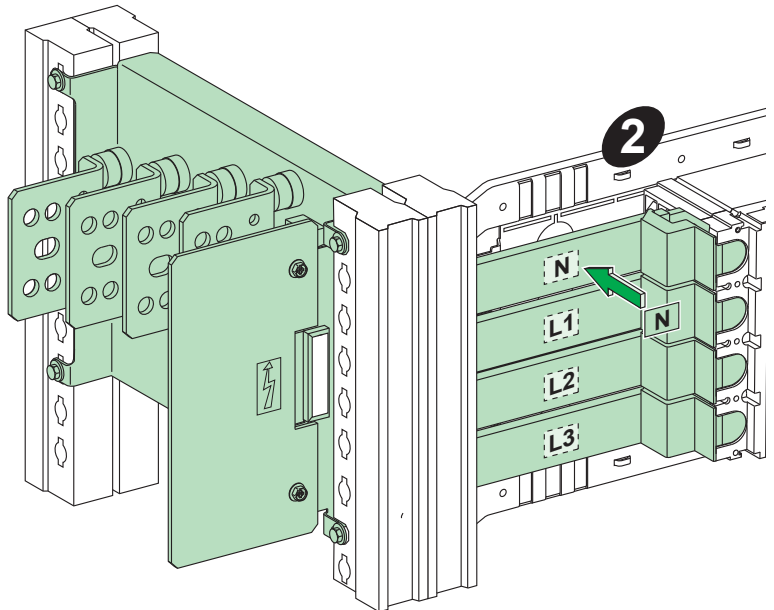
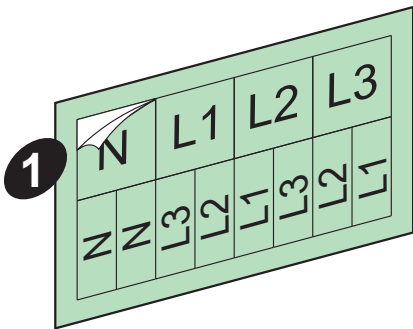

**Schneider Electric Industries SAS**  
35, rue Joseph Monier  
92500 Rueil-Malmaison  
France

[www.se.com](http://www.se.com)

En raison de l'évolution des normes et du matériel, les caractéristiques indiquées par le texte et les images de ce document ne nous engageant qu'après confirmation par nos services.

*As standards, specifications and designs change from time to time, please ask for confirmation of the information given in this publication.*

Publication : Schneider Electric  
Réalisation :  
Impression :  
format de pliage : 210 x 297 mm



Ce document a été imprimé sur du papier écologique.

*This document has been printed on ecological paper.*

**Schneider Electric Limited**  
Stafford Park 5  
Telford, TF3 3BL  
United Kingdom  
[www.se.com/uk](http://www.se.com/uk)

