

SpaceLogic IP-IO for Niagara Framework® Plant Room Controllers

I/A Series



Introduction

SpaceLogic™ IP-IO for Niagara Framework® provides I/O expansion to your HVAC application over BACnet/IP. The module can share its I/O resources across applications running in I/A Series servers, JACE controllers, BACnet/IP controllers, or third-party systems. With the support of local alarms and local trend logs, the IP-IO module avoids unnecessary traffic over the network while being able to log important information locally. The IP-IO module can be installed near facilities in the field, away from the I/A Series server or the BACnet/IP controller. All IP-IO models support an optional display that provides insight and control of the inputs and outputs.

The IP-IO module has the following features:

- IP enabled with dual-port Ethernet switch
- Versatile onboard I/O point mix
- Advanced monitoring
- Commission mobile application for commissioning of the IP-IO module before the BMS is in place
- Seamless integration with I/A Series Niagara software
- Upgrade with signed firmware

SpaceLogic IP-IO for Niagara Framework®

IP connectivity and flexible network topologies

The IP-IO module is based on open protocols that simplify interoperability, IP configuration, and device management:

- IP addressing
- BACnet/IP communications
- DHCP for easy network configuration

The IP-IO module has a dual-port Ethernet switch, which enables flexible network topologies:

- Star
- Daisy chain
- Rapid Spanning Tree Protocol (RSTP) ring

In a star topology, the IP-IO module and the parent Niagara or I/A Series Niagara server are individually connected to an Ethernet switch. Daisy-chain multiple IP-IO modules together to reduce installation time and cost. When using a ring network topology, in the event of a broken IP network or a non-operational IP-IO module, RSTP will enable rapid identification of the location of the detected error while maintaining communication with the IP-IO modules on either side of the break.

Models with a versatile mix of I/O points

The IP-IO module comes in three models with different I/O point count and a versatile mix of I/O point types that match a wide variety of applications. The universal inputs/outputs are highly flexible and can be configured as either inputs or outputs.

I/O Point Types by IP-IO Models

I/O Point Types	IP-IO-DI10	IP-IO-UIO10	IP-IO-UIO5DOFA4
Digital inputs	10	-	-
Universal I/O Type Ub	-	10	5
Relay outputs Form A	-	-	3
High power relay outputs Form A	-	-	1

Configurations by I/O Point Types

Configurations	Digital Inputs	Universal I/O Type Ub	Relay Outputs Form A	High Power Relay Outputs Form A
Digital inputs	yes	yes	-	-
Counter inputs	yes	yes	-	-
Supervised inputs	-	yes	-	-
Voltage inputs (0 to 10 VDC)	-	yes	-	-
Current inputs (0 to 20 mA)	-	yes	-	-
Temperature inputs	-	yes	-	-
Resistive inputs	-	yes	-	-
2-wire RTD temperature inputs	-	yes	-	-
Voltage outputs (0 to 10 VDC)	-	yes	-	-
Digital outputs	-	-	yes	yes
Digital pulsed outputs	-	-	yes	yes

SpaceLogic IP-IO for Niagara Framework®

Continued

Configurations	Digital Inputs	Universal I/O Type Ub	Relay Outputs Form A	High Power Relay Outputs Form A
PWM outputs	-	-	yes	yes
Tristate outputs	-	-	yes	-
Tristate pulsed outputs	-	-	yes	-

Digital inputs

The digital inputs can be used for cost effective sensing of multiple dry contact digital inputs in applications, such as equipment status monitoring or alarm point monitoring. As counter inputs, digital inputs are commonly used in energy metering applications.

Universal inputs/outputs

The universal inputs/outputs are ideal for any mix of temperature, pressure, flow, status points, and similar point types in a building control system.

As counter inputs, the universal inputs/outputs are commonly used in energy metering applications. As RTD inputs, they are ideal for temperature points in a building control system. As supervised inputs, they are used for security applications where it is critical to know whether or not a wire has been cut or shorted. These events provide a separate indication of alarms and events in the system.

For all analog inputs, maximum and minimum levels can be defined to automatically detect over-range and under-range values.

The universal inputs/outputs can also be used as voltage outputs, without the need for external bias resistors. Therefore, the universal inputs/outputs support a wide range of devices, such as actuators.

Relay outputs

The relay outputs support digital Form A point types. The Form A relays are designed for direct load applications.

High power relay output

The high power relay output is ideal for switching loads of up to 12 A, such as electrical heating elements.

Advanced monitoring

The I/O module supports local trends and alarms, enabling local operation when the I/O module is offline.

With user-defined fallback values, the I/O module outputs will be in a predictable state in cases of network disruption.

The battery-free power backup of the memory and real-time clock helps prevent data loss and allows seamless and quick recovery after a power disruption.

All IP-IO models can be equipped with a display add-on module (same module as used for the MP-C), which features an LCD display and five keys. With this module, you can manually override analog and digital outputs for testing, commissioning, and maintenance of equipment connected to the outputs. The display module's dedicated processing power ensures reliable override for maintenance applications. The override status can be viewed in I/A Series Niagara Workbench, enabling precise monitoring and reliable control.



Display module

Commission mobile application

The Commission mobile application is designed for local configuration, field deployment, and commissioning of IP-IO modules. The mobile application reduces the commissioning time, allows flexibility in project execution, and minimizes dependencies on network infrastructure.

The mobile application is designed for use with Android, Apple (iOS), and Microsoft Windows devices. For more information, see the EcoStruxure Building Commission Specification Sheet.

SpaceLogic IP-IO for Niagara Framework®

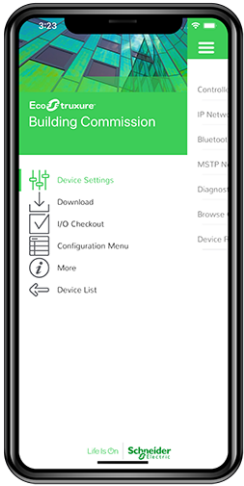

Commission mobile application

Using the Commission mobile application, you can connect to IP-IO modules and BACnet/IP controllers over the network. Using a wireless access point or a network switch, you can connect to a network of IP-IO modules and BACnet/IP controllers on the local IP network.

Device configuration

With the Commission mobile application, you can easily discover IP-IO modules and BACnet/IP controllers on the IP network. You can change the configuration of each module and controller, including the BACnet and IP network settings, location, and parent server. To save engineering time, you can save common device settings and then reuse them for devices of the same type and model.

Firmware management

The Commission mobile application enables you to update the firmware of IP-IO modules and BACnet/IP controllers. Using a wired or wireless connection, you can audit and update the firmware for each module and controller.

Field I/O checkout

The Commission mobile application does not require an I/A Series Niagara server or a network infrastructure to be in place. You can use the mobile application to browse objects and view device status information. You can also perform an I/O checkout to verify that the IP-IO module's I/O points are configured, wired, and operating correctly.

Seamless integration with I/A Series Niagara software

The power of the IP-IO module is fully realized when it is part of an I/A Series Niagara BMS, which provides the following benefits:

- Device discovery

- Full engineering capability from Workbench
- Graphical programming from a Wiresheet
- Engineering efficiency

Device discovery

The enhanced Device Discovery in Workbench enables you to easily identify IP-IO modules and BACnet/IP controllers on a BACnet network and to associate the modules and controllers with their parent server.

Full engineering capability from Workbench

Workbench provides a consistent user experience regardless of which I/A Series Niagara BMS server the user is logged on to. The user can log on to the parent Niagara BMS server to engineer, commission, supervise, and monitor the IP-IO module and its I/O.

Graphical programming from a Wiresheet

The IP-IO module can be engineered directly using the familiar Wiresheet interface and an extensive palette of graphical objects. Users can quickly drag, drop, and configure objects to create full applications and download them to the module.

Engineering efficiency

Workbench supports both online and offline engineering of IP-IO modules. You can create and engineer IP-IO modules offline and then associate with an online device when complete.

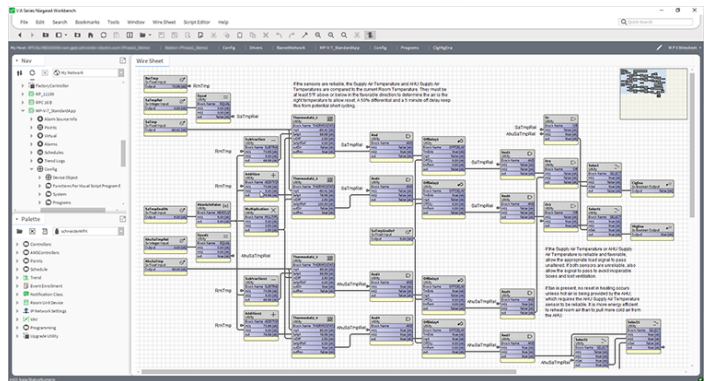

Workbench

Upgrade with signed firmware

Using digitally signed firmware provides more secure upgrading of the device. During an upgrade, the device verifies that the firmware is authentic and uncompromised. If the device detects discrepancies in the authenticity or integrity of the firmware, it will reject the upgrade. Once the device is upgraded with signed firmware, all upgrades thereafter must be with a signed firmware version.

SpaceLogic IP-IO for Niagara Framework®

Part Numbers for IP-IO

Product	Part number
IP-IO-DI10	SXWIPIOAA10001
IP-IO-UIO10	SXWIPIOBA10001
IP-IO-UIO5DOFA4	SXWIPIOCA10001

Part Numbers for IP-IO Accessories

Product	Part number
MP-C DISPLAY (MP-C override display module)	SXWMPCDSP10001
DIN-RAIL-CLIP, DIN-rail end clip package of 25 pieces	SXWDINEND10001

For more information on part numbers for Network Connectivity Accessories, see the Product Selection Guide - EcoStruxure Building.

Specifications

SpaceLogic IP-IO for Niagara Framework®	
AC input	
Nominal voltage	24 VAC
Operating voltage range	+/- 20 %
Frequency	50/60 Hz
Maximum power consumption	17 VA
Power input protection	MOV suppression and internal fuse
DC input	
Nominal voltage	24 to 30 VDC
Operating voltage range	21 to 33 VDC
Maximum power consumption	9 W
Power input protection	MOV suppression and internal fuse
Environment	
Ambient temperature, operating	0 to 50 °C (32 to 122 °F) at normal operation ^a -40 to +60 °C (-40 to +140 °F) for rooftop applications, horizontal installation only ^a
a) MP-C Display has an operating temperature range of -30 to +60 °C (-22 to +140 °F).	
Ambient temperature, storage	-40 to +70 °C (-40 to +158 °F)
Maximum humidity	95 % RH non-condensing

SpaceLogic IP-IO for Niagara Framework®

Material

Plastic flame rating UL94 V-0

Ingress protection rating IP 20

Mechanical

Dimensions 153 W x 110 H x 64 D mm (6.0 W x 4.3 H x 2.5 D in.)

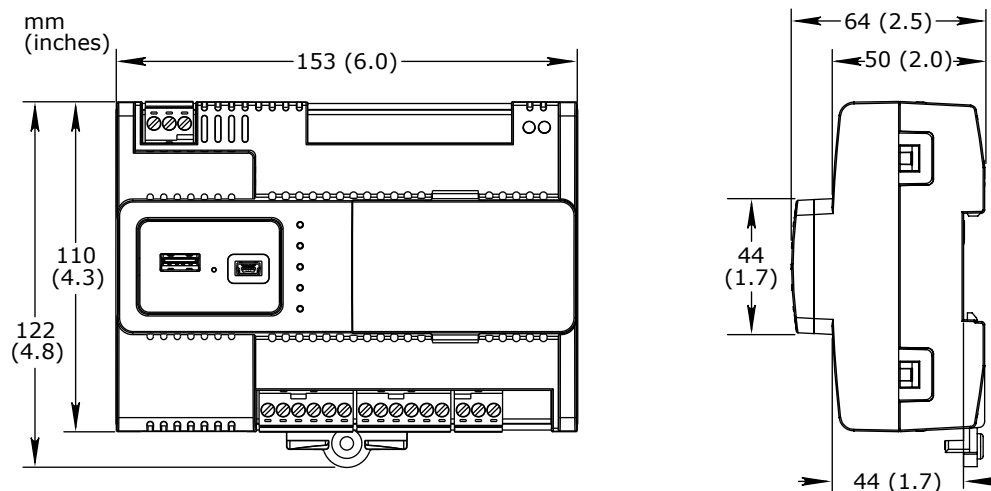

Weight, IP-IO-DI10 Including terminal blocks 0.337 kg (0.742 lb)

Weight, IP-IO-UIO10 Including terminal blocks 0.336 kg (0.740 lb)

Weight, IP-IO-UIO5DOFA4 Including terminal blocks 0.357 kg (0.787 lb)

Recommended installation DIN rail or flat surface in a cabinet[†]

a) It is recommended to install the device in an enclosure (cabinet), unless local regulations allow an exception.

Terminal blocks Removable

Software compatibility

I/A Series Niagara software version 4.10 and later

Agency compliances

Emission RCM; BS/EN 61000-6-3; BS/EN IEC 63044-5-2; FCC Part 15, Sub-part B, Class B

Immunity BS/EN 61000-6-2; BS/EN IEC 63044-5-3

Safety standards BS/EN 60730-1; BS/EN 60730-2-11; BS/EN IEC 63044-3; UL 916 C-UL US Listed

Real-time clock

Accuracy, at 25 °C (77 °F) +/-1 minute per month

Backup time, at 25 °C (77 °F) 7 days minimum

SpaceLogic IP-IO for Niagara Framework®

Communication ports	
Ethernet	Dual 10/100BASE-TX (RJ45), IEEE 802.3 compliant
USB	1 USB 2.0 device port (mini-B) 1 USB 2.0 host port (type-A), 5 VDC, 2.5 W
Communications	
BACnet	BACnet/IP, port configurable, default 47808 BTL B-ASC (BACnet Application Specific Controller) ^a
a) See the BTL Product Catalog for up-to-date details on BTL listed firmware revisions on BACnet International's home page.	
CPU	
Frequency	500 MHz
Type	ARM Cortex-A7 dual-core
DDR3 SDRAM	128 MB
NOR flash memory	32 MB
Memory backup	128 kB, FRAM, non-volatile
MP-C Display (Optional)	
Removable	No
Display size	36 W x 17 H mm (1.4 W x 0.7 H in.)
Display resolution	128 x 64 pixels
Display type	FSTN monochrome LCD, white color transfective backlight
Power consumption	max. 0.15 W (45 mA at 3.3 V)
Ambient temperature, operating	-30 to +60 °C (-22 to +140 °F)
Ambient temperature, storage	-40 to +70 °C (-40 to +158 °F)
Maximum humidity	95 % RH non-condensing
Weight	0.035 kg (0.077 lb)
Compliance with standards	EN ISO 16484-2
Digital inputs, DI	
Channels, IP-IO-DI10	10, DI1 to DI10
Channels, IP-IO-UIO10	0
Channels, IP-IO-UIO5DOFA4	0
Absolute maximum ratings	-0.5 to +24 VDC
Digital input protection	Transient voltage suppressor on each digital input
Digital inputs	
Range	Dry contact switch closure or open collector/open drain, 24 VDC, typical wetting current 2.4 mA
Minimum pulse width	150 ms

SpaceLogic IP-IO for Niagara Framework®

Counter inputs	
Range	Dry contact switch closure or open collector/open drain, 24 VDC, typical wetting current 2.4 mA
Minimum pulse width	20 ms
Maximum frequency	25 Hz
Universal inputs/outputs, Ub	
Channels, IP-IO-DI10	0
Channels, IP-IO-UIO10	10 Ub, Ub1 to Ub10
Channels, IP-IO-UIO5DOFA4	5 Ub, Ub1 to Ub5
Absolute maximum ratings	-0.5 to +24 VDC
A/D converter resolution	16 bits
Universal input/output protection	Transient voltage suppressor on each universal input/output
Digital inputs	
Range	Dry contact switch closure or open collector/open drain, 24 VDC, typical wetting current 2.4 mA
Minimum pulse width	150 ms
Counter inputs	
Range	Dry contact switch closure or open collector/open drain, 24 VDC, typical wetting current 2.4 mA
Minimum pulse width	20 ms
Maximum frequency	25 Hz
Supervised inputs	
5 V circuit, 1 or 2 resistors Monitored switch combinations	Series only, parallel only, and series and parallel
Resistor range For a 2-resistor configuration, each resistor must have the same value +/- 5 %	1 to 10 kohm
Voltage inputs	
Range	0 to 10 VDC
Accuracy	+/- (7 mV + 0.2 % of reading)
Resolution	1.0 mV
Impedance	100 kohm
Current inputs	
Range	0 to 20 mA
Accuracy	+/- (0.01 mA + 0.4 % of reading)
Resolution	1 µA
Impedance	47 ohm

SpaceLogic IP-IO for Niagara Framework®

Resistive inputs

10 ohm to 10 kohm accuracy +/- $(7 + 4 \times 10^{-3} \times R)$ ohm
 R = Resistance in ohm

10 kohm to 60 kohm accuracy +/- $(4 \times 10^{-3} \times R + 7 \times 10^{-8} \times R^2)$ ohm
 R = Resistance in ohm

Temperature inputs (thermistors)

Range -50 to +150 °C (-58 to +302 °F)

Supported thermistors

Honeywell	20 kohm
Type I (Continuum)	10 kohm
Type II (I/NET)	10 kohm
Type III (Satchwell)	10 kohm
Type IV (FD)	10 kohm
Type V (FD w/ 11k shunt)	Linearized 10 kohm
Satchwell D?T	Linearized 10 kohm
Johnson Controls	2.2 kohm
Xenta	1.8 kohm
Balco	1 kohm

Measurement accuracy

20 kohm -50 to -30 °C: +/-1.5 °C (-58 to -22 °F: +/-2.7 °F)
 -30 to 0 °C: +/-0.5 °C (-22 to +32 °F: +/-0.9 °F)
 0 to 100 °C: +/-0.2 °C (32 to 212 °F: +/-0.4 °F)
 100 to 150 °C: +/-0.5 °C (212 to 302 °F: +/-0.9 °F)

10 kohm, 2.2 kohm, and 1.8 kohm -50 to -30 °C: +/-0.75 °C (-58 to -22 °F: +/-1.35 °F)
 -30 to +100 °C: +/-0.2 °C (-22 to +212 °F: +/-0.4 °F)
 100 to 150 °C: +/-0.5 °C (212 to 302 °F: +/-0.9 °F)

Linearized 10 kohm -50 to -30 °C: +/-2.0 °C (-58 to -22 °F: +/-3.6 °F)
 -30 to 0 °C: +/-0.75 °C (-22 to +32 °F: +/-1.35 °F)
 0 to 100 °C: +/-0.2 °C (32 to 212 °F: +/-0.4 °F)
 100 to 150 °C: +/-0.5 °C (212 to 302 °F: +/-0.9 °F)

1 kohm -50 to +150 °C: +/-1.0 °C (-58 to +302° F: +/-1.8 °F)

RTD temperature inputs

Supported RTDs Pt1000, Ni1000, and LG-Ni1000

SpaceLogic IP-IO for Niagara Framework®

Pt1000

Sensor range	-50 to +150 °C (-58 to +302 °F)	
BACnet/IP device environment	Sensor range	Measurement accuracy
0 to 50 °C (32 to 122 °F)	-50 to +70 °C (-58 to +158 °F)	+/-0.5 °C (+/-0.9 °F)
0 to 50 °C (32 to 122 °F)	70 to 150 °C (158 to 302 °F)	+/-0.7 °C (+/-1.3 °F)
-40 to +60 °C (-40 to +140 °F)	-50 to +150 °C (-58 to +302 °F)	+/-1.0 °C (+/-1.8 °F)

Ni1000

Sensor range	-50 to +150 °C (-58 to +302 °F)	
BACnet/IP device environment	Sensor range	Measurement accuracy
0 to 50 °C (32 to 122 °F)	-50 to +150 °C (-58 to +302 °F)	+/-0.5 °C (+/-0.9 °F)
-40 to +60 °C (-40 to +140 °F)	-50 to +150 °C (-58 to +302 °F)	+/-0.5 °C (+/-0.9 °F)

LG-Ni1000

Sensor range	-50 to +150 °C (-58 to +302 °F)	
BACnet/IP device environment	Sensor range	Measurement accuracy
0 to 50 °C (32 to 122 °F)	-50 to +150 °C (-58 to +302 °F)	+/-0.5 °C (+/-0.9 °F)
-40 to +60 °C (-40 to +140 °F)	-50 to +150 °C (-58 to +302 °F)	+/-0.5 °C (+/-0.9 °F)

RTD temperature wiring

Maximum wire resistance	20 ohm/wire (40 ohm total)
Maximum wire capacitance	60 nF
The wire resistance and capacitance typically corresponds to a 200 m wire.	

Voltage outputs

Range	0 to 10 VDC
Accuracy	+/-60 mV
Resolution	10 mV
Minimum load resistance	5 kohm
Load range	-1 to +2 mA

Relay outputs, DO

Channels, IP-IO-DI10	0
Channels, IP-IO-UIO10	0
Channels, IP-IO-UIO5DOFA4	3, DO1 to DO3
Contact rating	250 VAC/30 VDC, 2 A, Pilot Duty (C300)
Switch type	Form A Relay Single Pole Single Throw Normally Open
Isolation contact to system ground	3000 VAC
Cycle life (Resistive load)	At least 100,000 cycles

SpaceLogic IP-IO for Niagara Framework®

Continued

Minimum pulse width	100 ms
High power relay outputs, DO	
Channels, IP-IO-DI10	0
Channels, IP-IO-UIO10	0
Channels, IP-IO-UIO5DOFA4	1, DO4
Contact rating	250 VAC/24 VDC, 12 A, Pilot Duty (B300)
Switch type	Form A Relay Single Pole Single Throw Normally Open
Isolation contact to system ground	5000 VAC
Cycle life (Resistive load)	At least 100,000 cycles
Minimum pulse width	100 ms

Terminals

For more information on wiring, see the SpaceLogic and EasyLogic - Hardware Installation System Guide.

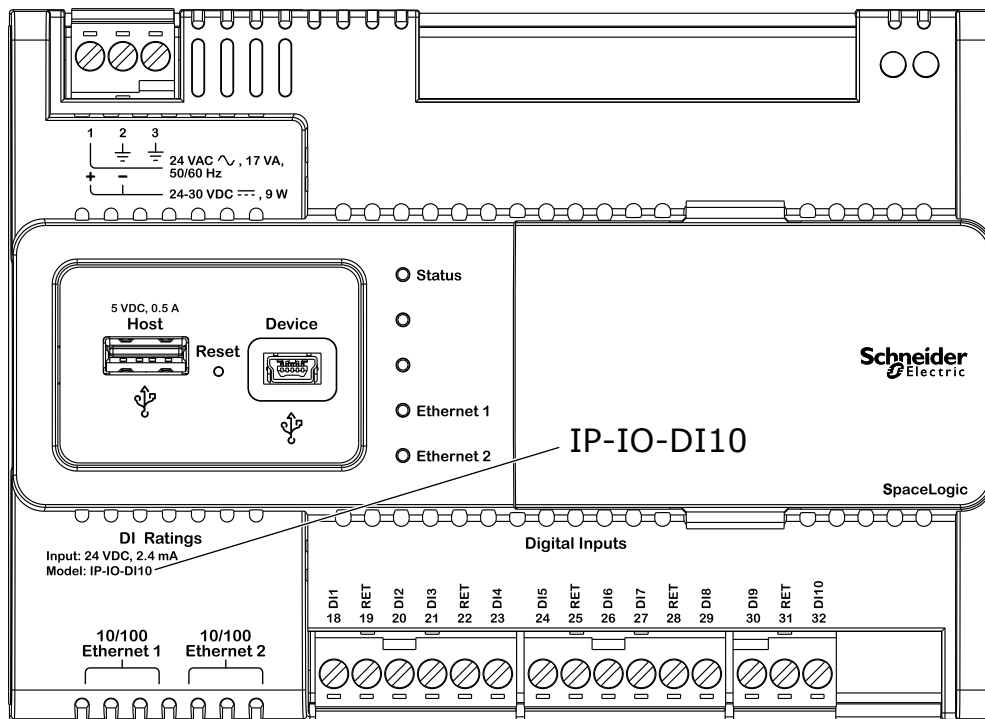

IP-IO-DI10

SpaceLogic IP-IO for Niagara Framework®

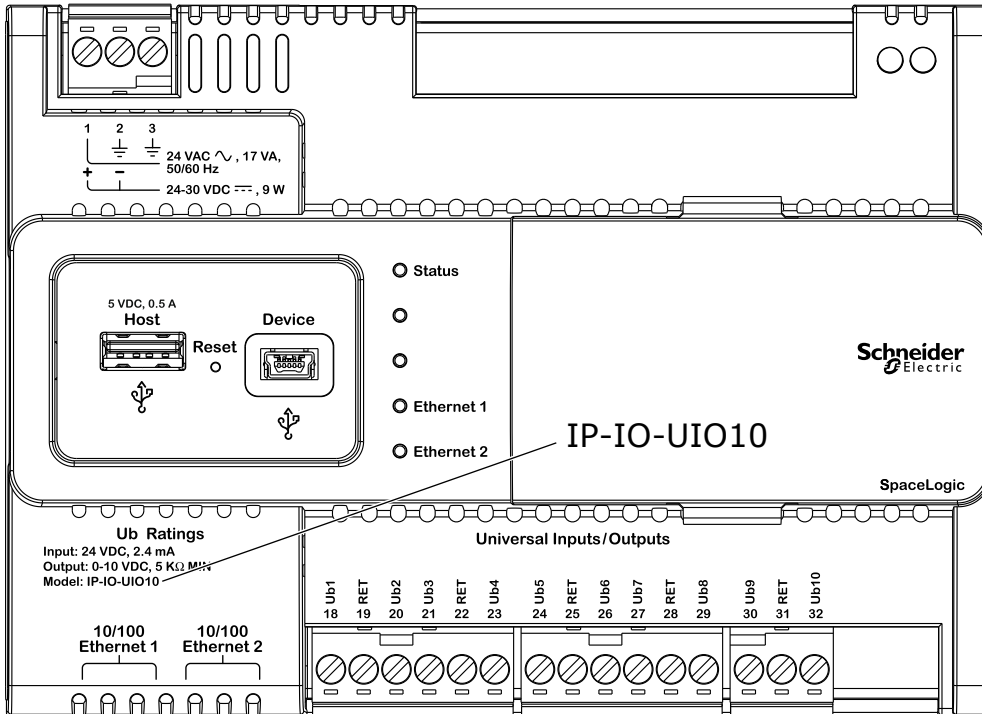

IP-IO-UIO10

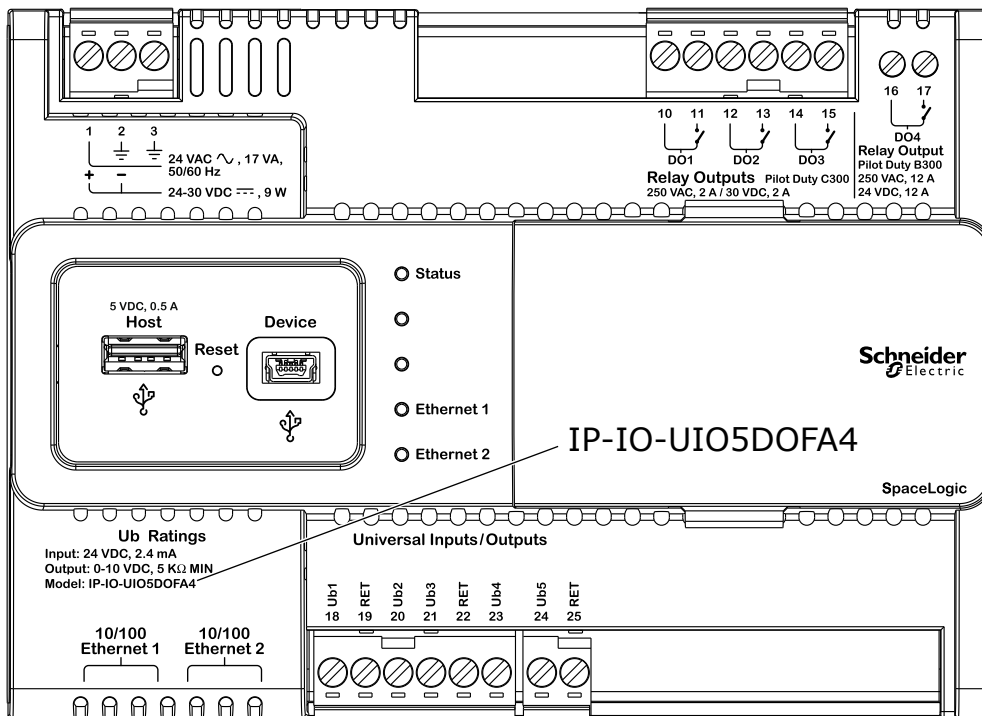

IP-IO-UIO5DOFA4

SpaceLogic IP-IO for Niagara Framework®

Regulatory Notices



Federal Communications Commission

FCC Rules and Regulations CFR 47, Part 15, Class B

This device complies with part 15 of the FCC Rules. Operation is subject to the following two conditions: (1) This device may not cause harmful interference. (2) This device must accept any interference received, including interference that may cause undesired operation.

Industry Canada

This Class B digital apparatus complies with Canadian ICES-003.

Cet appareil numérique de la classe B est conforme à la norme NMB-003 du Canada.



Regulatory Compliance Mark (RCM) - Australian Communications and Media Authority (ACMA)

This equipment complies with the requirements of the relevant ACMA standards made under the Radiocommunications Act 1992 and the Telecommunications Act 1997. These standards are referenced in notices made under section 182 of the Radiocommunications Act and 407 of the Telecommunications Act.



UK Conformity Assessed

S.I. 2016/1091 - Electromagnetic Compatibility Regulations 2016

S.I. 2016/1101 - Electrical Equipment (Safety) Regulations 2016

S.I. 2012/3032 - Restriction of the Use of Certain Hazardous Substances in Electrical and Electronic Equipment Regulations 2012

S.I. 2013/3113 - Waste Electrical and Electronic Equipment Regulations 2013

This equipment complies with the rules, of the UK regulations, for governing the UKCA Marking for the United Kingdom specified in the above directive(s).



CE - Compliance to European Union (EU)

2014/30/EU Electromagnetic Compatibility Directive

2014/35/EU Low Voltage Directive

2011/65/EU Restriction of Hazardous Substances (RoHS) Directive

2015/863/EU amending Annex II to Directive 2011/65/EU

This equipment complies with the rules, of the Official Journal of the European Union, for governing the Self Declaration of the CE Marking for the European Union as specified in the above directive(s).



WEEE - Directive of the European Union (EU)

This equipment and its packaging carry the waste of electrical and electronic equipment (WEEE) label, in compliance with European Union (EU) Directive 2012/19/EU, governing the disposal and recycling of electrical and electronic equipment in the European community.



UL 916 Listed products for the United States and Canada, Open Class Energy Management Equipment. UL file E80146.

www.se.com/buildings

Life Is On

Schneider
Electric