

SpaceLogic Operator Display HMIs

EcoStruxure™ Building



7-inch panel mounted touch-screen interface

Introduction

SpaceLogic™ Operator Display is a touch-screen Human Machine Interface (HMI) for SpaceLogic controllers and servers, designed for local monitoring of building controllers in small and medium-sized buildings, as well as in large buildings with comprehensive building management systems. Operator Display is specifically designed for equipment rooms and it simplifies operations, service, and troubleshooting for System Integrators and Service Engineers, as well as for non-technical users (notably Facility Managers and Janitors).

Features

The simplified user interface and the intuitive touch-screen navigation make it easy to operate and maintain the system. Operator Display communicates quickly over BACnet/IP open protocol with a direct connection to SpaceLogic MP or RP controllers, IP-IO modules, AS-B or AS-P servers. Only one Operator Display is required per cabinet in the equipment room, so there is no need for more displays when a controller is added. The operator can view and acknowledge alarms, edit schedules, and adjust setpoint temperatures. Authorized operators can also view and override inputs, outputs, and other virtual points.

SpaceLogic Operator Display

Fully integrated HMI solution

Operator Display offers a fully integrated HMI solution that provides benefits such as ease of use and installation.

Protective frame and ease of installation

Operator Display has an IP 65 rated frame that helps protect against dust and moisture. It is quick and easy to install.

It is important to note that this product is designed for indoor use only.

Touch-screen display

Operator Display features a large 7-inch, color touch-screen display.

Preinstalled software

Operator Display is delivered with the purpose-built application preloaded on the device so it is ready-to-use and commissioned quickly without the need for any programming or external tools.

Communication and power

Operator Display is powered by an external 24 VDC power supply (not included) through the DC power supply connector, and it communicates over BACnet/IP open protocol.

Part Number

Product	Part number
Operator Display 7-inch bundle (Includes HMI device, installation gasket, installation fasteners, screws, DC power supply connector, and installation sheet)	HMIST6400SL

Spare Parts (Not Included)

Product	Part number
Installation gasket (Provides dust and moisture resistance when this product is installed into a solid panel (1 piece))	HMIZS53W1
Installation fastener (2 pieces/set)	HMIZSFIXTF1
Power supply connector for small panels (10 pieces/set)	XBTZ3004

Other Required Parts (Not Included)

Product	Part number
24 VDC power supply (Typical examples)	ABLM1A24004, ABLM1A24006, ABLM1A24012, ABLM1A24025
Micro USB 2.0 OTG cable	–
USB stick (FAT formatted)	–

Specifications

SpaceLogic Operator Display	
System capacity	
Maximum number of controllers or servers per display	Up to 7
DC input	
Nominal voltage	24 VDC

SpaceLogic Operator Display

Operating voltage range	+/- 20 %
Inrush current	30 A or less
Maximum power consumption	9 W
Immunity to microbreaks	5 ms
Environment	
Physical environment	
Ambient temperature, operating	0 to 50 °C (32 to 122 °F)
Ambient temperature, storage	-20 to +60 °C (-4 to +140 °F)
Humidity	10 to 90 % RH non-condensing
Pollution degree	2
Operating altitude	800 to 1,114 hPa (2,000 m (6,561 ft) or lower)
Mechanical environment	
Vibration resistance	IEC/BS/EN 61131-2 compliant 5 to 9 Hz Single amplitude 3.5 mm (0.14 in) 9 to 150 Hz Fixed acceleration: 9.8 m/s ² X, Y, Z directions for 10 cycles (approximately 100 minutes)
Shock resistance	IEC/BS/EN 61131-2 compliant: 147 m/s ² , X, Y, Z directions for 3 times
Electrical environment	
Electrical fast transient/burst	IEC/BS/EN 61000-4-4, 2 kV: Power port (display unit), 1 kV: Signal ports
Electrostatic discharge immunity	IEC/BS/EN 61000-4-2 Level 3, Contact discharge method: 6 kV, Air discharge method: 8 kV
Material	
Enclosure	Polycarbonate (PC)
Front	Aluminum
Display	Polyethylene Terephthalate (PET)
Ingress protection rating	IP 65 (front of product that is exposed, on panel-mounted installation)
NEMA rating	NEMA 4 (front, indoor use) NEMA 13 (front, in enclosure)
Plastic flame rating	UL94 V-0
Mechanical	
Dimensions (W x H x D) See drawing below:	208 x 153 x 45 mm (8.19 x 6.02 x 1.77 in.)

SpaceLogic Operator Display

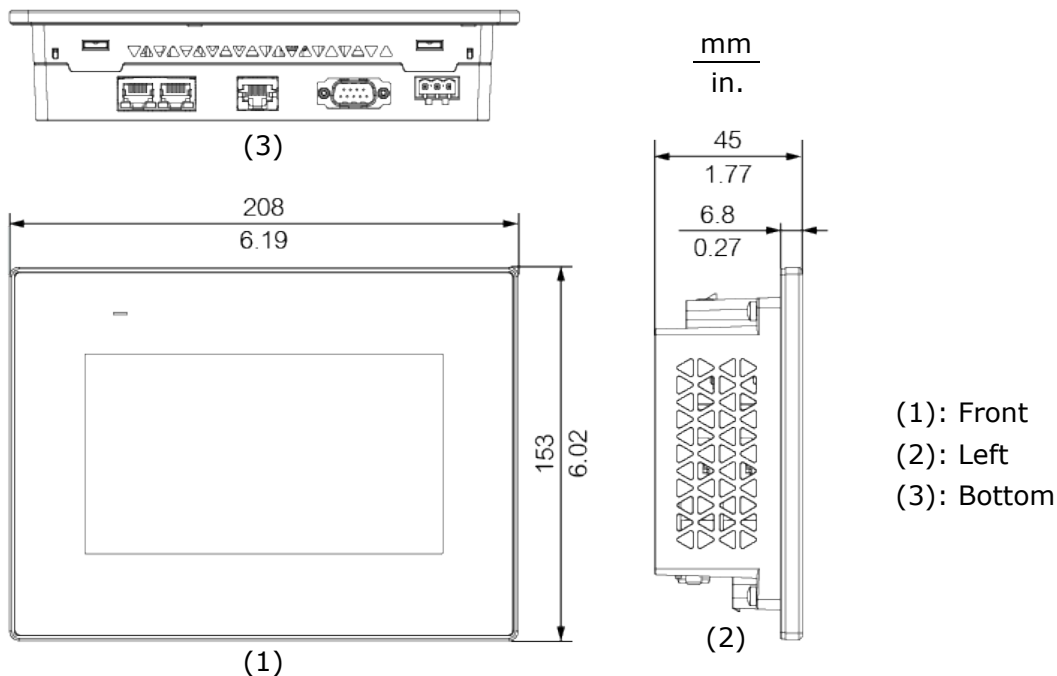

Weight 0.8 kg (1.8 lb)

Installation Mounted to the panel using 4 screws (included), conforming to UL 61010-1, CSA C22.2 No 61010-1, UL 61010-2-201, CSA C22.2 No 61010-2-201 (1.6 to 5 mm (0.1 to 0.2 in) thick panel), BS/EN 61131-2, and BS/EN 61000-6-2

Software compatibility

Customized alarm message support
EcoStruxure Building Operation software version 3.3.1 and later

Agency compliances

Emission BS/EN 61326-1, Class A; FCC Part 15, Sub-part B, Class A
BS/EN 61000-6-4

Immunity BS/EN 61000-6-2

Safety standards BS/EN 61131-2
UL 61010-1
CSA C22.2 No 61010-1
UL 61010-2-201
CSA C22.2 No 61010-2-201

Real-time clock

Power Battery (CR2032)

Accuracy +/- 20 ppm

Battery lifetime 5 years at room temperature^a

a) The lifetime of the battery may vary depending on different applications and environments.

Communication ports

Ethernet Dual 10/100BASE-TX (RJ45)^a

a) Only one port is used; the second one is inactive.

SpaceLogic Operator Display

USB	1 USB 2.0 host port (type-A), 5 VDC, 2.5 W 1 USB 2.0 device port (micro-B)
RS-232C	1 COM1 (D-Sub, 9-pin, female) - Inactive
RS-485	1 COM2 (RJ45, female) - Inactive
Hardware	
CPU type	ARM Cortex-A8 single-core
Frequency	800 MHz
Device memory (NAND Flash)	1 GB (including 180 MB for user data)
Backup memory (MRAM)	512 KB
Status indicator	LED (green, orange, and red) Buzzer (not used)
Display	
Display resolution	800 x 480 pixels (WVGA)
Display aspect ratio	16:10
Display size	7 inches (178 mm)
Display type	TFT LCD, touchscreen Single touch analog resistive panel
Color	16 million colors
Display languages	Czech, Danish, English, Finnish, French, German, Italian, Norwegian, Polish, Portuguese, Russian, Slovak, Spanish, Swedish
Brightness control	400 cd/m ² 16 levels
LED lifetime ^a	50,000 hours
<small>a) The LED lifetime is defined as the time when the LED continues to operate at the ambient temperature 25 °C +/-2 °C (77 °F +/- 3.6 °F) until the brightness is reduced to 25% of its original value.</small>	

SpaceLogic Operator Display

Regulatory Notices



Federal Communications Commission

FCC Rules and Regulations CFR 47, Part 15, Class A

This device complies with part 15 of the FCC Rules. Operation is subject to the following two conditions: (1) This device may not cause harmful interference. (2) This device must accept any interference received, including interference that may cause undesired operation.

Industry Canada

This Class A digital apparatus complies with Canadian ICES-003.

Cet appareil numérique de la classe A est conforme à la norme NMB-003 du Canada.



UL 61010-1 and 61010-2-201 Listed product for the United States and Canada. UL file E220851.



UK Conformity Assessed

S.I. 2016/1091 - Electromagnetic Compatibility Regulations 2016

S.I. 2016/1101 - Electrical Equipment (Safety) Regulations 2016

S.I. 2012/3032 - Restriction of the Use of Certain Hazardous Substances in Electrical and

Electronic Equipment Regulations 2012

This equipment complies with the rules, of the UK regulations, for governing the UKCA Marking for the United Kingdom specified in the above directive(s).



CE - Compliance to European Union (EU)

2014/30/EU Electromagnetic Compatibility Directive

2014/35/EU Low Voltage Directive

2011/65/EU Restriction of Hazardous Substances (RoHS) Directive

2015/863/EU amending Annex II to Directive 2011/65/EU

This equipment complies with the rules, of the Official Journal of the European Union, for governing the Self Declaration of the CE Marking for the European Union as specified in the above directive(s).



WEEE - Directive of the European Union (EU)

This equipment and its packaging carry the waste of electrical and electronic equipment (WEEE) label, in compliance with European Union (EU) Directive 2012/19/EU, governing the disposal and recycling of electrical and electronic equipment in the European community.

www.se.com/buildings

Life Is On

Schneider
Electric