

SpaceLogic MP-V for Niagara Framework® Room Controllers

I/A Series

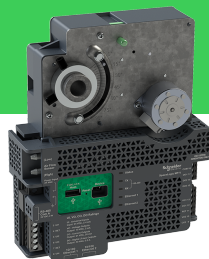

Introduction

SpaceLogic™ MP-V for Niagara Framework® is a multi-purpose, fully programmable, IP based field controller dedicated for VAV cooling and heating applications. MP-V integrates a controller, a damper actuator, and an air flow sensor in a single compact unit for ease of installation. MP-V can either be used as a standalone BACnet/IP controller or as part of an I/A Series Niagara BMS with a JACE or Niagara Supervisor as the parent server. MP-V comes in two models with different I/O count.

MP-V has the following features:

- IP enabled with dual-port Ethernet switch
- Versatile onboard I/O point mix

- Integrated damper actuator with feedback signal
- Factory-calibrated air flow sensor
- Advanced monitoring
- Sensor bus for living space sensors
- Commission mobile application for commissioning of the controller before the BMS is in place
- Seamless integration with I/A Series Niagara software
- Upgrade with signed firmware

www.se.com/buildings

Life Is On

Schneider
Electric

SpaceLogic MP-V for Niagara Framework®

IP connectivity and flexible network topologies

The BACnet/IP controllers are based on open protocols that simplify interoperability, IP configuration, and device management:

- IP addressing
- BACnet/IP communications
- DHCP for easy network configuration

The BACnet/IP controllers have a dual-port Ethernet switch, which enables flexible network topologies:

- Star
- Daisy chain

- Rapid Spanning Tree Protocol (RSTP) ring

In a star topology, the controller and the parent Niagara or I/A Series Niagara server are individually connected to an Ethernet switch. Daisy-chain multiple controllers together to reduce installation time and cost. When using a ring network topology, in the event of a broken IP network or a non-operational controller, RSTP will enable rapid identification of the location of the detected error while maintaining communication with the controllers on either side of the break.

Models with a versatile mix of I/O points

The MP-V range includes two models with different I/O point count and a versatile mix of I/O point types that match a wide variety of VAV applications.

I/O Point Types by MP-V Models

I/O Point Types	MP-V-7A	MP-V-9A
Universal inputs	3	4
Triac outputs	3	3
Analog outputs	1	2

Configurations by I/O Point Types

Configurations	Universal Inputs	Triac Outputs	Analog Outputs
Digital inputs	yes	-	-
Counter inputs	yes	-	-
Supervised inputs	yes	-	-
Voltage inputs (0 to 10 VDC)	yes	-	-
Current inputs (0 to 20 mA)	yes	-	-
Temperature inputs	yes	-	-
Resistive inputs	yes	-	-
2-wire RTD temperature inputs	yes	-	-
Digital outputs	-	yes	-
Digital pulsed outputs	-	yes	-
PWM outputs	-	yes	-
Tristate outputs	-	yes	-
Tristate pulsed outputs	-	yes	-

SpaceLogic MP-V for Niagara Framework®

Continued

Configurations	Universal Inputs	Triac Outputs	Analog Outputs
Voltage outputs (0 to 10 VDC)	-	-	yes
Current outputs (0 to 20 mA)	-	-	yes

Universal inputs

The universal inputs are ideal for any mix of temperature, pressure, flow, status points, and similar point types in a building control system.

As counter inputs, they are commonly used in energy metering applications. As RTD inputs, they are ideal for temperature points in a building control system. As supervised inputs, they are used for security applications where it is critical to know whether or not a wire has been cut or shorted. These events provide a separate indication of alarms and events in the system.

For all analog inputs, maximum and minimum levels can be defined to automatically detect over-range and under-range values.

Triac outputs

The triac outputs can be used in many applications to switch 24 VAC on or off for external loads such as actuators, relays, or indicators. The triac outputs are isolated from the controller. Triacs are silent and are not adversely affected by relay contact wear.

Analog outputs

The analog outputs are capable of supporting analog voltage or current point types, without the need for external bias resistors. Therefore, analog outputs support a wide range of devices, such as actuators.

I/O expansion

For applications that require more I/O resources, the SpaceLogic IP-IO modules provide a versatile mix of I/O points for any application. For more information, see the SpaceLogic IP-IO Specification Sheet.

Integrated damper actuator with feedback signal

The integrated damper actuator allows for simplified installation of MP-V directly over the damper shaft. This means that separate

installation, wiring, and positioning of the damper motor is not needed. MP-V uses the same actuator mechanics as many Schneider Electric VAV controller models including I/A series MNB and MNL product lines. The feedback signal from the actuator makes it possible to determine the exact position of the damper. The actuator also features a push button for manual positioning of the damper during commissioning.

Factory-calibrated air flow sensor

The factory-calibrated air flow sensor uses a micro-flow channel integrated with the sensor chip that requires only a small air flow from the velocity probe. The sensor requires no maintenance and a minimum of field adjustments.

Advanced monitoring

The BACnet/IP controllers support local trends, schedules, and alarms, enabling local operation when the controller is offline or used in standalone applications.

The battery-free power backup of the memory and real-time clock helps prevent data loss and allows seamless and quick recovery after a power disruption.

Sensor bus for living space sensors

The BACnet/IP controllers provide an interface designed for the SpaceLogic Sensor family of living space sensors. The SpaceLogic Sensor devices offer an efficient way to sense the temperature, humidity, CO₂, and occupancy in a room. The SpaceLogic Sensor devices are available with different combinations of sensor types and various covers and user interface options, such as touchscreen, setpoint and override buttons, and blank covers. For more information, see the SpaceLogic Sensors - SXWS Sensors for MP and RP IP Controllers - Specification Sheet.

SpaceLogic MP-V for Niagara Framework®



SpaceLogic Sensor devices

The sensor bus provides both power and communications for up to four sensors that are daisy-chained using standard Cat 5 (or higher) cables. The maximum number of sensors that can be connected to a controller varies depending on the sensor model and the combination of cover and sensor base type:

- Blank covers: Up to four sensors of any combination of sensor base types
- 3-button and touchscreen covers:
 - Up to two sensor bases with CO₂ option
 - Up to four sensor bases without CO₂ option
- SpaceLogic LCD temperature sensors: Up to four sensors are supported

The maximum total length of the sensor bus is 61 m (200 ft). For more information, see the SpaceLogic Sensors - SXWS Sensors for MP and RP IP Controllers - Specification Sheet.

The RS-485 Power Adapter can be used to supply 24 VDC power to the MP controller sensor bus so that the maximum number of sensor bases with CO₂ option can be increased from two to four sensor bases. The adapter can be ordered from Schneider Electric. For more information, see section the RS-485 Adapters Specification Sheet.

Commission mobile application

The Commission mobile application is designed for local configuration, field deployment, commissioning of BACnet/IP controllers, and air flow balancing of VAV units. The mobile application reduces the commissioning time, allows flexibility in project execution, and minimizes dependencies on network infrastructure.

The mobile application is designed for use with Android, Apple (iOS), and Microsoft Windows devices. For more information, see the EcoStruxure Building Commission Specification Sheet.

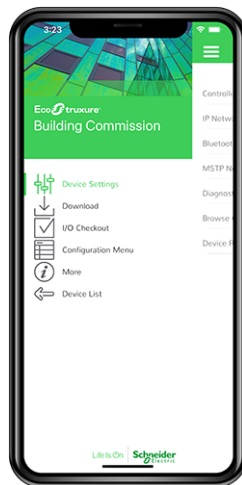

Commission mobile application

Using the Commission mobile application, you can connect to one or many BACnet/IP controllers. You can connect to a single BACnet/IP controller using the SpaceLogic Bluetooth Adapter connected to a SpaceLogic Sensor. Using a wireless access point or a network switch, you can connect to a network of BACnet/IP controllers on the local IP network.

Device configuration

With the Commission mobile application, you can easily discover BACnet/IP controllers on the IP network. You can change the configuration of each controller, including the BACnet and IP network settings, location, and parent server. To save engineering time, you can save common device settings and then reuse them for controllers of the same model.

Firmware management

The Commission mobile application enables you to update the firmware of BACnet/IP controllers. Using a wired or wireless connection, you can audit and update the firmware for each controller.

Field I/O checkout

The Commission mobile application does not require an I/A Series Niagara server or a network infrastructure to be in place. You can use the mobile application to browse objects and view device status information. You can also perform an I/O checkout to verify that the controller's I/O points are configured, wired, and operating correctly.

Air flow balancing

Using the Commission mobile application, you can perform air flow balancing of VAV units controlled by MP-Vs. An intuitive workflow automatically guides you through the process. After the

SpaceLogic MP-V for Niagara Framework®

flow balancing, you can generate a report in HTML format for one or more VAV units. The balancing parameters associated with each MP-V are stored in the parent server, which makes it easier to replace the controller if necessary.

Seamless integration with I/A Series Niagara software

The power of the BACnet/IP controller is fully realized when it is part of an I/A Series Niagara BMS, which provides the following benefits:

- Device discovery
- Full engineering capability from Workbench
- Graphical programming from a Wiresheet
- Support for custom Script programs
- Engineering efficiency

Device discovery

The enhanced Device Discovery in Workbench enables you to easily identify BACnet/IP controllers on a BACnet network and to associate the controllers with their parent server.

Full engineering capability from Workbench

Workbench provides a consistent user experience regardless of which I/A Series Niagara BMS server the user is logged on to. The user can log on to the parent Niagara BMS server to engineer, commission, supervise, and monitor the BACnet/IP controller and its I/O as well as its attached SpaceLogic Sensor devices.

Graphical programming from a Wiresheet

The BACnet/IP controllers can be programmed directly using the familiar Wiresheet interface and an extensive palette of graphical program objects. Users can quickly drag, drop, and configure program objects to create full applications and download to the controllers.

Part Numbers for MP-V

Product	Part number
MP-V-7A	SXWMPV7AX10002
MP-V-9A	SXWMPV9AX10002

Part Numbers for MP-V Accessories

Product	Part number
Spare terminal blocks for all MP-V models (1 x 2-pin, 2 x 3-pin, 2 x 4-pin, 1 x 5-pin, 1 x 6-pin terminal blocks)	SXWMPVCON10001
Adapter for damper shaft diameter 9.5 mm (0.375 inch)	AM-135
RS-485 power adapter	SXWNISORS485P10001

Support for custom Scripts programs

The BACnet/IP controllers also support custom Script programs. Users can write their own custom Script programs, compile, and download them to the controller. These custom Script programs will appear graphically on a Wiresheet where they can be bound with other objects.

Engineering efficiency

Workbench supports both online and offline engineering of BACnet/IP controllers. You can create and engineer controllers offline and then associate with an online controller when complete.

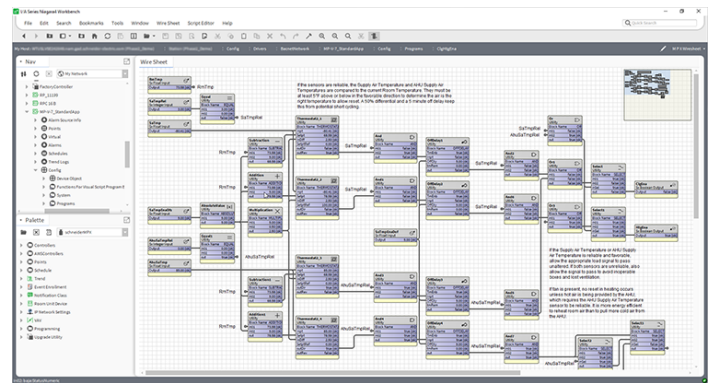

Workbench

Upgrade with signed firmware

Using digitally signed firmware provides more secure upgrading of the device. During an upgrade, the device verifies that the firmware is authentic and uncompromised. If the device detects discrepancies in the authenticity or integrity of the firmware, it will reject the upgrade. Once the device is upgraded with signed firmware, all upgrades thereafter must be with a signed firmware version.

SpaceLogic MP-V for Niagara Framework®

Continued

Product	Part number
SpaceLogic Bluetooth Adapter	SXWBTAECXX10001

For more information on part numbers for Network Connectivity Accessories, see the Product Selection Guide - EcoStruxure Building.

Specifications

SpaceLogic MP-V for Niagara Framework®	
AC input	
Nominal voltage	24 VAC
Operating voltage range	+/- 20 %
Frequency	50/60 Hz
Maximum power consumption (MP-V-7A)	21 VA
Maximum power consumption (MP-V-9A)	22 VA
Power input protection	MOV suppression and internal fuse
Environment	
Ambient temperature, operating	0 to 50 °C (32 to 122 °F)
Ambient temperature, storage	-40 to +70 °C (-40 to +158 °F)
Maximum humidity	95 % RH non-condensing
Material	
Plastic flame rating	UL94 V-0
Ingress protection rating	IP 20
Mechanical	
Dimensions	161 W x 198 H x 63 D mm (6.3 W x 7.8 H x 2.5 D in.)

SpaceLogic MP-V for Niagara Framework®

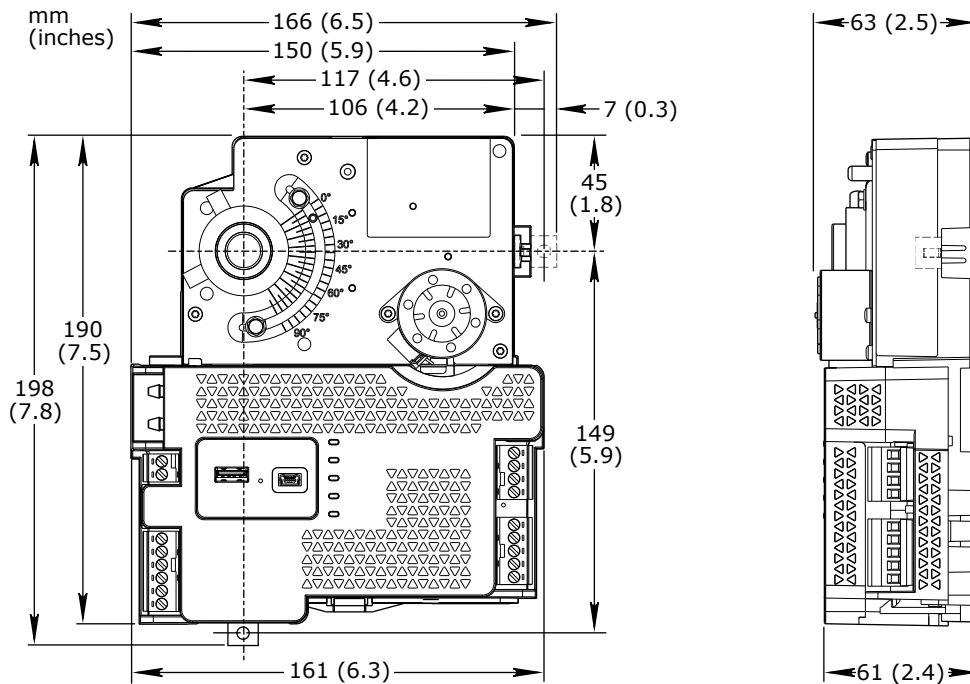

Weight	1.13 kg (2.5 lb)
Installation	Over the damper shaft
Terminal blocks	Removable
Software compatibility	
I/A Series Niagara software	version 4.10 and later
Agency compliances	
Emission	RCM; BS/EN 61000-6-3; BS/EN IEC 63044-5-2; FCC Part 15, Sub-part B, Class B
Immunity	BS/EN 61000-6-2; BS/EN IEC 63044-5-3
Safety standards	BS/EN 60730-1; BS/EN 60730-2-11; BS/EN IEC 63044-3; UL 916 C-UL US Listed
Fire performance in air-handling spaces ^a	UL 2043
a) The MP-V-7A and MP-V-9A models are approved for plenum applications.	
Real-time clock	
Accuracy, at 25 °C (77 °F)	+/-1 minute per month
Backup time, at 25 °C (77 °F)	7 days minimum
Communication ports	
Ethernet	Dual 10/100BASE-TX (RJ45), IEEE 802.3 compliant
USB	1 USB 2.0 device port (mini-B) 1 USB 2.0 host port (type-A), 5 VDC, 2.5 W
RS-485 port Com A	24 VDC, 2 W, RS-485 (RJ45) Transient voltage suppressors on communication and power signals

SpaceLogic MP-V for Niagara Framework®

RS-485 transceiver characteristics

Transceiver type	Failsafe Non-isolated
External biasing	None required
Total Unit Load (UL) per device	Maximum 0.5 UL

Communications

BACnet	BACnet/IP, port configurable, default 47808 BTL B-AAC (BACnet Advanced Application Controller), B-GW (BACnet Gateway) ^a
--------	---

a) See the BTL Product Catalog for up-to-date details on BTL listed firmware revisions on BACnet International's home page.

CPU

Frequency	500 MHz
Type	ARM Cortex-A7 dual-core
DDR3 SDRAM	128 MB
NOR flash memory	32 MB
Memory backup	128 kB, FRAM, non-volatile

Damper actuator

Torque rating	6 Nm (53 lbf.in)
Stroke	0° to 90°, fully adjustable
Timing	Approximately 2 seconds/degree at 60 Hz and 2.4 seconds/degree at 50 Hz for 90° rotation at 24 VAC
Position indication	Visual indication
Damper position feedback	Yes
Manual override	Push-button clutch release
Damper shaft diameter	12.7 mm (0.5 inch) or 9.5 mm (0.375 inch) Adapter kit AM-135 is required for 9.5 mm (0.375 inch) diameter shafts.

Damper shaft minimum length (from VAV box)	22.2 mm (0.875 inch)
--	----------------------

Air flow sensor

Range	0 to 249 Pa (0 to 1 inH ₂ O)
Resolution	0.0167 Pa (0.000067 inH ₂ O)
Accuracy	±5% of reading (typical) at 25°C (77°F)

Universal inputs, UI

Channels, MP-V-7A	3, UI1 to UI3
Channels, MP-V-9A	4, UI1 to UI4
Absolute maximum ratings	-0.5 to +24 VDC
A/D converter resolution	16 bits
Universal input protection	Transient voltage suppressor on each input

SpaceLogic MP-V for Niagara Framework®

Digital inputs	
Range	Dry contact switch closure or open collector/open drain, 24 VDC, typical wetting current 2.4 mA
Minimum pulse width	150 ms
Counter inputs	
Range	Dry contact switch closure or open collector/open drain, 24 VDC, typical wetting current 2.4 mA
Minimum pulse width	20 ms
Maximum frequency	25 Hz
Supervised inputs	
5 V circuit, 1 or 2 resistors Monitored switch combinations	Series only, parallel only, and series and parallel
Resistor range For a 2-resistor configuration, each resistor must have the same value +/- 5 %	1 to 10 kohm
Voltage inputs	
Range	0 to 10 VDC
Accuracy	+/- (7 mV + 0.2 % of reading)
Resolution	1.0 mV
Impedance	100 kohm
Current inputs	
Range	0 to 20 mA
Accuracy	+/- (0.01 mA + 0.4 % of reading)
Resolution	1 µA
Impedance	47 ohm
Resistive inputs	
10 ohm to 10 kohm accuracy R = Resistance in ohm	+/- (7 + 4 x 10 ⁻³ x R) ohm
10 kohm to 60 kohm accuracy R = Resistance in ohm	+/- (4 x 10 ⁻³ x R + 7 x 10 ⁻⁸ x R ²) ohm
Temperature inputs (thermistors)	
Range	-50 to +150 °C (-58 to +302 °F)
Supported thermistors	
Honeywell	20 kohm
Type I (Continuum)	10 kohm
Type II (I/NET)	10 kohm
Type III (Satchwell)	10 kohm

SpaceLogic MP-V for Niagara Framework®

Type IV (FD)	10 kohm
Type V (FD w/ 11k shunt)	Linearized 10 kohm
Satchwell D?T	Linearized 10 kohm
Johnson Controls	2.2 kohm
Xenta	1.8 kohm
Balco	1 kohm
Measurement accuracy	
20 kohm	-50 to -30 °C: +/-1.5 °C (-58 to -22 °F: +/-2.7 °F) -30 to 0 °C: +/-0.5 °C (-22 to +32 °F: +/-0.9 °F) 0 to 100 °C: +/-0.2 °C (32 to 212 °F: +/-0.4 °F) 100 to 150 °C: +/-0.5 °C (212 to 302 °F: +/-0.9 °F)
10 kohm, 2.2 kohm, and 1.8 kohm	-50 to -30 °C: +/-0.75 °C (-58 to -22 °F: +/-1.35 °F) -30 to +100 °C: +/-0.2 °C (-22 to +212 °F: +/-0.4 °F) 100 to 150 °C: +/-0.5 °C (212 to 302 °F: +/-0.9 °F)
Linearized 10 kohm	-50 to -30 °C: +/-2.0 °C (-58 to -22 °F: +/-3.6 °F) -30 to 0 °C: +/-0.75 °C (-22 to +32 °F: +/-1.35 °F) 0 to 100 °C: +/-0.2 °C (32 to 212 °F: +/-0.4 °F) 100 to 150 °C: +/-0.5 °C (212 to 302 °F: +/-0.9 °F)
1 kohm	-50 to +150 °C: +/-1.0 °C (-58 to +302° F: +/-1.8 °F)
RTD temperature inputs	
Supported RTDs	Pt1000, Ni1000, and LG-Ni1000
Pt1000	
Sensor range	-50 to +150 °C (-58 to +302 °F)
BACnet/IP Controller device environment	Sensor range
0 to 50 °C (32 to 122 °F)	-50 to +70 °C (-58 to +158 °F)
0 to 50 °C (32 to 122 °F)	70 to 150 °C (158 to 302 °F)
	Measurement accuracy
	+/-0.5 °C (+/-0.9 °F)
	+/-0.7 °C (+/-1.3 °F)
Ni1000	
Sensor range	-50 to +150 °C (-58 to +302 °F)
BACnet/IP Controller device environment	Sensor range
0 to 50 °C (32 to 122 °F)	-50 to +150 °C (-58 to +302 °F)
	Measurement accuracy
	+/-0.5 °C (+/-0.9 °F)
LG-Ni1000	
Sensor range	-50 to +150 °C (-58 to +302 °F)
BACnet/IP Controller device environment	Sensor range
0 to 50 °C (32 to 122 °F)	-50 to +150 °C (-58 to +302 °F)
	Measurement accuracy
	+/-0.5 °C (+/-0.9 °F)
RTD temperature wiring	
Maximum wire resistance	20 ohm/wire (40 ohm total)
Maximum wire capacitance	60 nF
The wire resistance and capacitance typically corresponds to a 200 m wire.	

SpaceLogic MP-V for Niagara Framework®

Continued

Triac outputs, DO	
Channels, MP-V-7A	3, DO1 to DO3
Channels, MP-V-9A	3, DO1 to DO3
Output rating (for each triac output)	Max. 0.5 A
Voltage	24 VAC +/-20 %
Commons	COM (terminal number 18)
The common terminal COM can be connected to 24 VAC or to ground.	
Common voltage, high side output	24 VAC
Common voltage, low side output	0 VAC (ground)
Minimum pulse width	100 ms
Triac output protection	MOV and snubber across each triac output MOV from triac COM to ground
Analog outputs, AO	
Channels, MP-V-7A	1, VO1/CO1
Channels, MP-V-9A	2, VO1/CO1 and VO2/CO2
Analog output protection	Transient voltage suppressor on each output
Voltage outputs	
Range	0 to 10 VDC
Accuracy	+/-60 mV
Resolution	10 mV
Minimum load resistance	5 kohm to ground
Load range	0 to +2 mA
Terminals	Voltage Output (VO), Return (RET)
Current outputs	
Range	0 to 20 mA
Accuracy	+/-0.2 mA
Resolution	21 µA
Load range	0 to 650 ohm
Terminals	Current Output (CO), Return (RET)

Terminals

For more information on wiring, see the SpaceLogic and EasyLogic - Hardware Installation System Guide.

SpaceLogic MP-V for Niagara Framework®

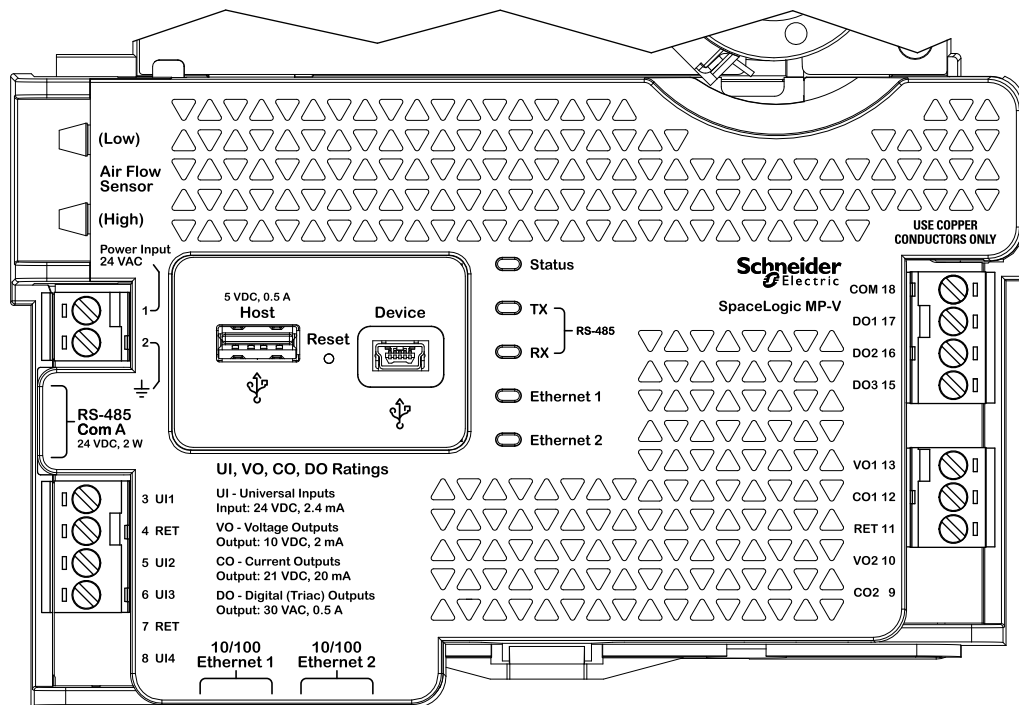

MP-V-7A

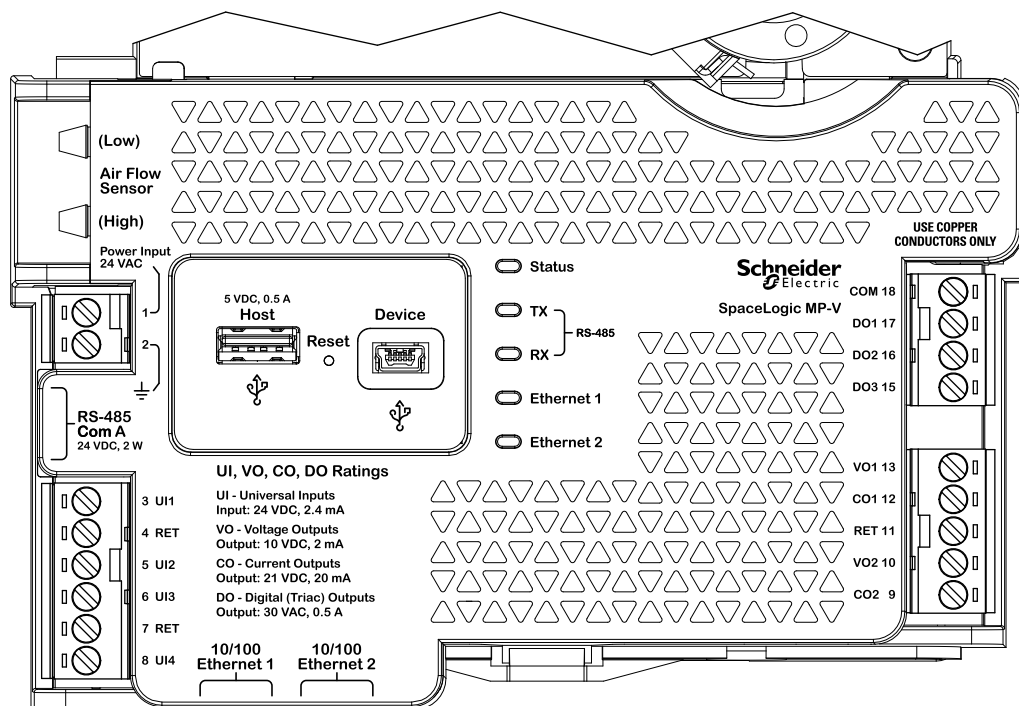

MP-V-9A

SpaceLogic MP-V for Niagara Framework®

Regulatory Notices



Federal Communications Commission

FCC Rules and Regulations CFR 47, Part 15, Class B

This device complies with part 15 of the FCC Rules. Operation is subject to the following two conditions: (1) This device may not cause harmful interference. (2) This device must accept any interference received, including interference that may cause undesired operation.

Industry Canada

This Class B digital apparatus complies with Canadian ICES-003.

Cet appareil numérique de la classe B est conforme à la norme NMB-003 du Canada.



Regulatory Compliance Mark (RCM) - Australian Communications and Media Authority (ACMA)

This equipment complies with the requirements of the relevant ACMA standards made under the Radiocommunications Act 1992 and the Telecommunications Act 1997. These standards are referenced in notices made under section 182 of the Radiocommunications Act and 407 of the Telecommunications Act.



UK Conformity Assessed

S.I. 2016/1091 - Electromagnetic Compatibility Regulations 2016

S.I. 2012/3032 - Restriction of the Use of Certain Hazardous Substances in Electrical and Electronic Equipment Regulations 2012

S.I. 2013/3113 - Waste Electrical and Electronic Equipment Regulations 2013

This equipment complies with the rules, of the UK regulations, for governing the UKCA Marking for the United Kingdom specified in the above directive(s).



CE - Compliance to European Union (EU)

2014/30/EU Electromagnetic Compatibility Directive

2011/65/EU Restriction of Hazardous Substances (RoHS) Directive

2015/863/EU amending Annex II to Directive 2011/65/EU

This equipment complies with the rules, of the Official Journal of the European Union, for governing the Self Declaration of the CE Marking for the European Union as specified in the above directive(s).



WEEE - Directive of the European Union (EU)

This equipment and its packaging carry the waste of electrical and electronic equipment (WEEE) label, in compliance with European Union (EU) Directive 2012/19/EU, governing the disposal and recycling of electrical and electronic equipment in the European community.



UL 916 Listed products for the United States and Canada, Enclosed Energy Management Equipment. UL file E80146.

www.se.com/buildings

Life Is On

Schneider
Electric