

SpaceLogic RP-C-EXT-0-10V-4-PD

RP Controller Expansion Modules

EcoStruxure™ Building



0-10V light module with power distribution

Introduction

SpaceLogic™ RP-C-EXT-0-10V-4-PD light module connects to the SpaceLogic RP room controllers and provides I/O expansion for 0-10V lighting control.

The 0-10V light module enables power supply and control of lights equipped with 0-10V ballasts.

Lighting can be controlled by the RP controller through motion detection and light intensity measurement provided by the Multi-sensor or Insight-Sensor, or by SpaceLogic Sensors connected to the RP controller.

The 0-10V light module is part of the RP controller expansion modules for connected room solution and can be combined with other modules from this product range.

Features

The 0-10V light module has the following features:

- Power and communications through the room bus
- Four light control outputs (the maximum number of lights per output is determined by the maximum inrush current)

SpaceLogic RP-C-EXT-0-10V-4-PD

- Four digital inputs for connection of light switches and window contacts. The digital inputs are SELV (Safety Extra-Low Voltage).
- Measurement of energy consumption per module
- Suitable for mounting in ceilings
- Wieland connectors for quick and easy installation
- Engage mobile application for room comfort settings
- Status LED for the device
- One status LED for each light output
- Rotary switch for address configuration

0-10V lighting control

The light outputs are connected to the power supply network through the 0-10V light module. For the 0-10 VDC control signal wires, you may use the standard installation equipment permitted for ELV (Extra-Low Voltage) installations. The 0-10 VDC control signal meets SELV (Safety Extra-Low Voltage) requirements.

The analog interface has the following features:

- Independent control of each of the four outputs.
- The lights on each output belong to the same group and are thus controlled simultaneously (same ON / OFF / Dimming setpoint).
- Power to the ballasts is cut off when the lights are switched off.

Room bus

The RP controller room bus allows RP controller expansion modules to be connected to the controller for people counting, motion detection, luminosity and sound pressure level measurements, Bluetooth Low Energy based applications, and control of electric lights and window blinds.

The RP-C Pro and RP-C Pro Plus controller room bus supports up to nine connected RP controller expansion modules with the following restrictions:

- Maximum of two DALI light modules
- Maximum of two SMI blind modules
- Maximum of seven Multi-sensor or Insight-Sensor devices

The RP-C Advanced controller room bus supports up to six connected RP controller expansion modules with the following restrictions:

- Maximum of two DALI light modules
- Maximum of two SMI blind modules
- Maximum of four Multi-sensor or Insight-Sensor devices

The RP-V Advanced controller room bus supports up to four connected RP controller expansion modules with the following restrictions:

- Maximum of one DALI light module
- Maximum of one SMI blind module
- Maximum of two Multi-sensor or Insight-Sensor devices

Maximum total length of the room bus is 72 m (236 ft).

Engage mobile application

The Engage mobile application enables control of room temperature, fan speed, lights, and blinds/shades directly from a smartphone. A user can manage these settings when the application is connected to the RP controller.

The Engage mobile application is free and available for download from Google Play and Apple App Store.

For more information, see the Engage Specification Sheet.

Part Numbers

Product	Part number
RP-C-EXT-0-10V-4-PD	SXWRE0104PD10001
DIN-RAIL-CLIP, DIN-rail end clip package of 25 pieces	SXWDINEND10001
Mounting plate - RP controller expansion modules package of 5 pieces	SXWREMPK510001

SpaceLogic RP-C-EXT-0-10V-4-PD

Specifications

SpaceLogic RP-C-EXT-0-10V-4-PD

Electrical

Nominal voltage	230 VAC
Operating voltage range	+/-10 %
Frequency	50/60 Hz
Maximum current consumption	10 A
Room bus power consumption	0.3 W (24 VDC)
Protection	Maximum 16 A external fuse (circuit breaker) is needed
Overvoltage category	III

Environment

Ambient temperature, operating	0 to 50 °C (32 to 122 °F)
Ambient temperature, storage	-20 to +70 °C (-4 to +158 °F)
Humidity	20 to 90 % RH non-condensing
Pollution degree	2

Material

Plastic flame rating	UL94 V-0
Ingress protection rating	IP 20

Mechanical

Dimensions 198 W x 110 H x 64 D mm (7.8 W x 4.3 H x 2.5 D in.)

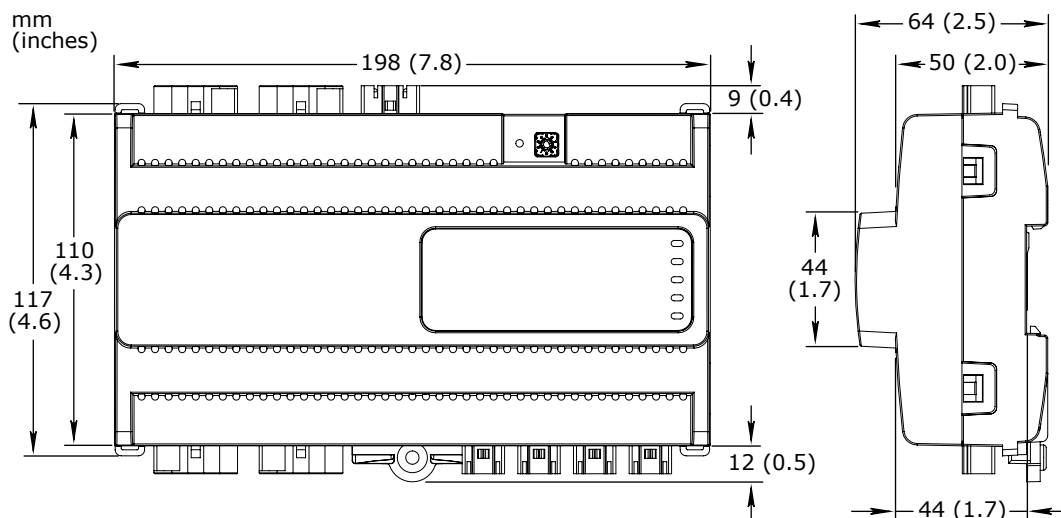

Weight

0.418 kg (0.922 lb)

SpaceLogic RP-C-EXT-0-10V-4-PD

Recommended installation

DIN rail or flat surface in a cabinet^a

a) It is recommended to install the device in an enclosure (cabinet), unless local regulations allow an exception.

Connectors

Power input: 1 x 3-pin Wieland GST15i3 connector
 Light outputs: 4 x 5-pin Wieland GST15i5 connector
 Digital inputs: 4 x 2-pin Wieland GST15i2 connector

Optional mounting plate

The mounting plate is used to facilitate mounting and cable management for the RP controller expansion module as well as to provide strain relief for the connectors.

Dimensions

202 W x 268.3 H x 17.8 D mm (8.0 W x 10.6 H x 0.7 D in.)

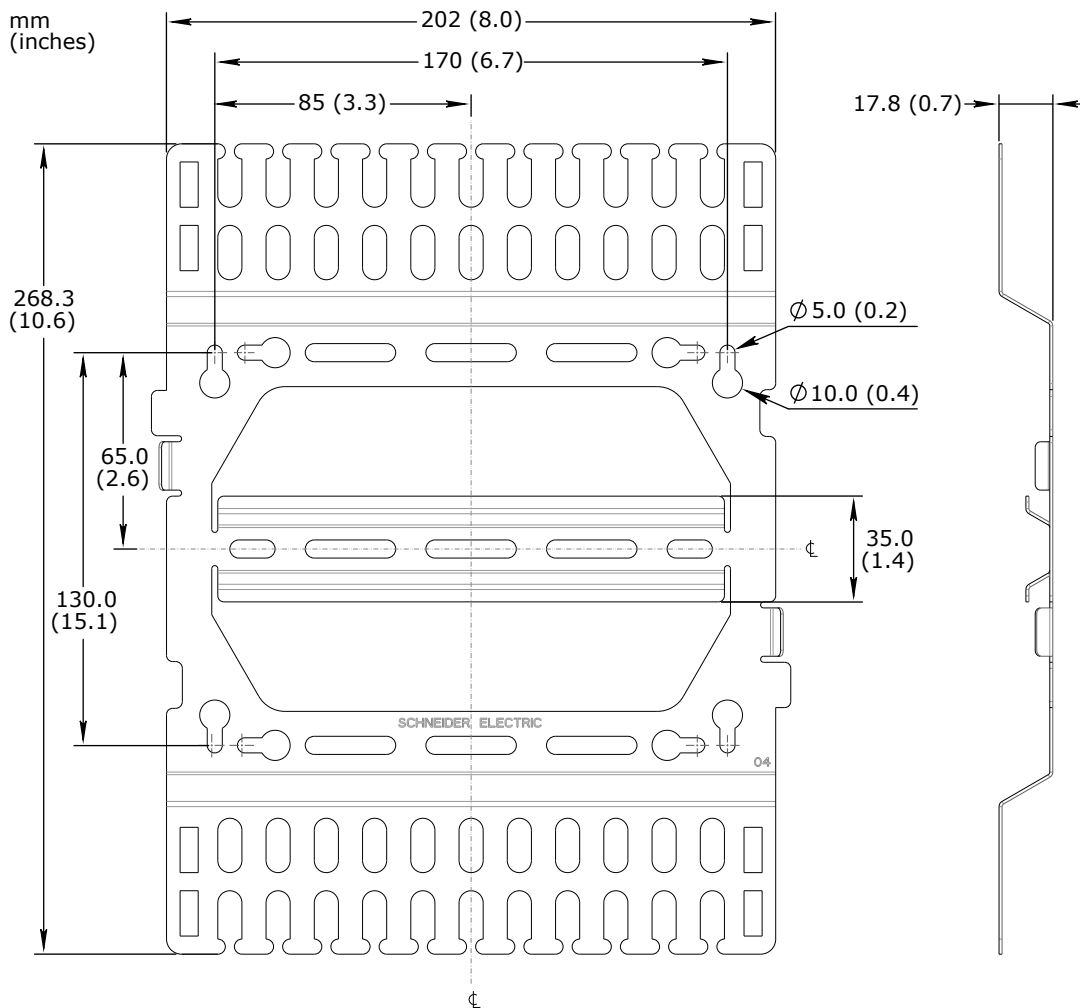

Weight

0.306 kg (0.675 lb)

Compatibility

EcoStruxure BMS server communication
 EcoStruxure Building Operation

version 3.1.1 and later

Energy metering support
 EcoStruxure Building Operation

version 3.3.1 and later

SpaceLogic RP-C-EXT-0-10V-4-PD

Agency compliances	
Emission	RCM; BS/EN 61000-6-3; BS/EN IEC 63044-5-2; FCC Part 15, Sub-part B, Class B
Immunity	BS/EN 61000-6-2; BS/EN IEC 63044-5-3
Safety standards	BS/EN 60730-1; BS/EN 60730-2-11; BS/EN IEC 63044-3
Communication ports	
Room bus	RS-485 Dual RJ45 ports for daisy-chain configurations Use a Cat 5 (or higher) cable Maximum total length of the room bus: 72 m (236 ft)
Room bus protection	Transient voltage suppressors on communication and power signals
Hardware	
CPU type	ARM Cortex-M4 single-core
Frequency	80 MHz
SRAM (embedded)	320 KB
Flash memory (embedded)	512 KB
NOR flash memory	16 MB
Status indicator	LED (green and red) that shows the status of the device
Light status indicator	One status LED (green) for each output
Address switch	Rotary switch 0 to 9
Set button	Push-button switch
Energy metering	
Energy consumption measurement	
The energy consumption is measured in Wh, shared by the four outputs.	
Accuracy class (according to IEC 61557-12)	Active energy measurement: Class 1
Typical measurement accuracy at room temperature	20 to 100 W: 5% 100 to 3000 W: 1%
0-10V light outputs	
Outputs	4, Light 1 to Light 4
Output terminals	N, PE, L, AOn (n: 1 to 4), and COM
Analog output voltage	0 to 10 VDC
Maximum source/sink current	10 mA per output
Power distribution	230 VAC (same voltage as power supply) Maximum 5 A load per output Maximum 10 A total load for the 4 outputs Maximum 165 A inrush current (<20 ms) per output Maximum 800 A inrush current (<200 μs) per output
Digital inputs	
Inputs	4, DI1 to DI4

SpaceLogic RP-C-EXT-0-10V-4-PD

Range

Dry contact, 0 to 5.0 VDC, 2.2 mA, SELV (Safety Extra-Low Voltage)

Connections

Follow proper installation wiring diagrams and instructions. For more information on wiring, see the SpaceLogic and EasyLogic - Hardware Installation System Guide.

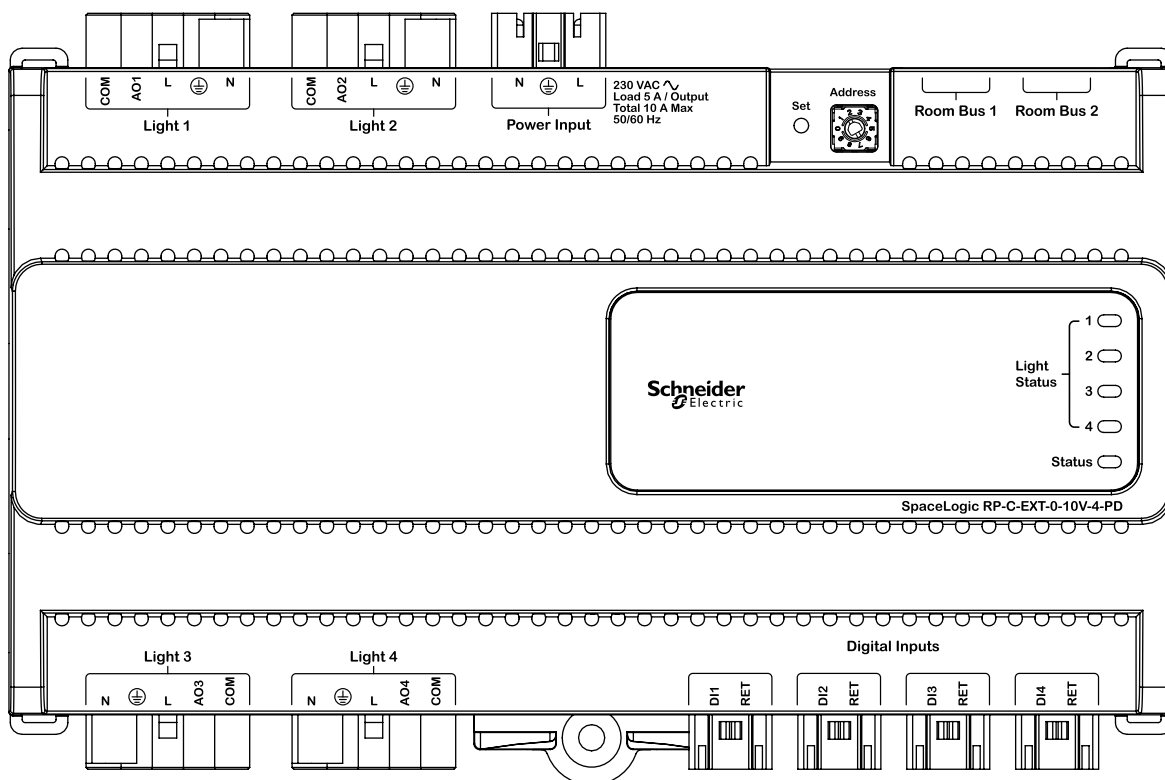

RP-C-EXT-0-10V-4-PD

Required External Connectors

Use	Part number	Reference	Connector type	Suitable for cable diameters mm (inches)	Marking	Color of coding /housing	Minimum order quantity
Power supply input	SXWRPCCON WWPOW	91.931.4053.1	Female	5.6–11 (0.22–0.43)	L, PE, N	Black /Black	100
Light outputs	SXWRPCCON WWLIGHTPD	91.952.4453.0	Male	8.5–12.5 (0.34–0.49)	N, PE, L, D2, D1 D2: AO1..4 D1: COM	Pastel blue /White	50
Digital inputs	SXWRPCCON WDI	91.921.2353.0	Female	3.4–5.5 (0.14–0.21)	1, 2 1: DI1..4 2: RET	Light blue /White	100

The external connectors need to be ordered separately. The connectors can be ordered in quantities of 50 or 100 from Schneider Electric using the above part numbers. The connectors can also be ordered directly from Wieland using the

above reference numbers. For more information, see the Wieland Electric web site.

SpaceLogic RP-C-EXT-0-10V-4-PD

Regulatory Notices



Federal Communications Commission

FCC Rules and Regulations CFR 47, Part 15, Class B

This device complies with part 15 of the FCC Rules. Operation is subject to the following two conditions: (1) This device may not cause harmful interference. (2) This device must accept any interference received, including interference that may cause undesired operation.

Industry Canada

This Class B digital apparatus complies with Canadian ICES-003.

Cet appareil numérique de la classe B est conforme à la norme NMB-003 du Canada.



Regulatory Compliance Mark (RCM) - Australian Communications and Media Authority (ACMA)

This equipment complies with the requirements of the relevant ACMA standards made under the Radiocommunications Act 1992 and the Telecommunications Act 1997. These standards are referenced in notices made under section 182 of the Radiocommunications Act and 407 of the Telecommunications Act.



CE - Compliance to European Union (EU)

2014/30/EU Electromagnetic Compatibility Directive

2014/35/EU Low Voltage Directive

2011/65/EU Restriction of Hazardous Substances (RoHS) Directive

2015/863/EU amending Annex II to Directive 2011/65/EU

This equipment complies with the rules, of the Official Journal of the European Union, for governing the Self Declaration of the CE Marking for the European Union as specified in the above directive(s).



WEEE - Directive of the European Union (EU)

This equipment and its packaging carry the waste of electrical and electronic equipment (WEEE) label, in compliance with European Union (EU) Directive 2012/19/EU, governing the disposal and recycling of electrical and electronic equipment in the European community.



UK Conformity Assessed

S.I. 2016/1091 - Electromagnetic Compatibility Regulations 2016

S.I. 2016/1101 - Electrical Equipment (Safety) Regulations 2016

S.I. 2012/3032 - Restriction of the Use of Certain Hazardous Substances in Electrical and Electronic Equipment Regulations 2012

S.I. 2013/3113 - Waste Electrical and Electronic Equipment Regulations 2013

This equipment complies with the rules, of the UK regulations, for governing the UKCA Marking for the United Kingdom specified in the above directive(s).

www.se.com/buildings

Life Is On

Schneider
Electric