

SpaceLogic MP-V Room Controllers

EcoStruxure™ Building



Introduction

SpaceLogic™ MP-V is a multi-purpose, fully programmable, IP based field controller dedicated for VAV cooling and heating applications. MP-V integrates a controller, a damper actuator, and an air flow sensor in a single compact unit for ease of installation. MP-V can either be used as a standalone BACnet/IP controller, BACnet/SC node, or as part of an EcoStruxure BMS with an automation server or an Enterprise Server as the parent server. MP-V can also be reconfigured through the EcoStruxure Building Operation software to use BACnet MS/TP, instead of BACnet/IP. MP-V comes in two models with different I/O count.

MP-V has the following features:

- IP enabled with dual-port Ethernet switch

- BACnet/SC node
- Versatile onboard I/O point mix
- Integrated damper actuator with feedback signal
- Factory-calibrated air flow sensor
- Advanced monitoring
- Configurable RS-485 port
- Sensor bus for living space sensors
- Modbus RTU subnetwork
- BACnet MS/TP support (adapter required)
- Commission mobile application for commissioning of the controller before the BMS is in place

SpaceLogic MP-V

- Full EcoStruxure Building Operation software support, providing efficient engineering tools
- Upgrade with signed firmware

IP connectivity, flexible network topologies, and support for BACnet/SC applications

The BACnet/IP controllers are based on open protocols that simplify interoperability, IP configuration, and device management, and can be enabled as BACnet/SC nodes for increased cybersecurity:

- IP addressing
- BACnet/IP or BACnet/SC communications
- DHCP for easy network configuration

The BACnet/IP controllers have a dual-port Ethernet switch, which enables flexible network topologies:

- Star
- Daisy chain
- Rapid Spanning Tree Protocol (RSTP) ring

In a star topology, the controller and the parent EcoStruxure BMS server are individually connected to an Ethernet switch. Daisy-

chain multiple controllers together to reduce installation time and cost. When using a ring network topology, in the event of a broken IP network or a non-operational controller, RSTP will enable rapid identification of the location of the detected error while maintaining communication with the controllers on either side of the break.

BACnet/SC (Secure Connect) support

The BACnet/IP controllers support BACnet/SC applications as a BACnet/SC node. This allows the controllers to be used in a BACnet/SC network, which allows secure transport of BACnet traffic and information between BACnet/SC devices over private and public networks without the need for BBMDs, VLANs, and VPNs, because the BACnet/SC protocol uses WebSocket technology and TLS 1.3 encryption. In addition, BACnet/SC uses certificate management to help ensure only those devices authorized to be on a BACnet/SC network can operate on that network.

Models with a versatile mix of I/O points

The MP-V range includes two models with different I/O point count and a versatile mix of I/O point types that match a wide variety of VAV applications.

I/O Point Types by MP-V Models

I/O Point Types	MP-V-7A	MP-V-9A
Universal inputs	3	4
Triac outputs	3	3
Analog outputs	1	2

Configurations by I/O Point Types

Configurations	Universal Inputs	Triac Outputs	Analog Outputs
Digital inputs	yes	-	-
Counter inputs	yes	-	-
Supervised inputs	yes	-	-
Voltage inputs (0 to 10 VDC)	yes	-	-
Current inputs (0 to 20 mA)	yes	-	-
Temperature inputs	yes	-	-
Resistive inputs	yes	-	-
2-wire RTD temperature inputs	yes	-	-

SpaceLogic MP-V

Continued

Configurations	Universal Inputs	Triac Outputs	Analog Outputs
Digital outputs	-	yes	-
Digital pulsed outputs	-	yes	-
PWM outputs	-	yes	-
Tristate outputs	-	yes	-
Tristate pulsed outputs	-	yes	-
Voltage outputs (0 to 10 VDC)	-	-	yes
Current outputs (0 to 20 mA)	-	-	yes

Universal inputs

The universal inputs are ideal for any mix of temperature, pressure, flow, status points, and similar point types in a building control system.

As counter inputs, they are commonly used in energy metering applications. As RTD inputs, they are ideal for temperature points in a building control system. As supervised inputs, they are used for security applications where it is critical to know whether or not a wire has been cut or shorted. These events provide a separate indication of alarms and events in the system.

For all analog inputs, maximum and minimum levels can be defined to automatically detect over-range and under-range values.

Triac outputs

The triac outputs can be used in many applications to switch 24 VAC on or off for external loads such as actuators, relays, or indicators. The triac outputs are isolated from the controller. Triacs are silent and are not adversely affected by relay contact wear.

Analog outputs

The analog outputs are capable of supporting analog voltage or current point types, without the need for external bias resistors. Therefore, analog outputs support a wide range of devices, such as actuators.

I/O expansion

For applications that require more I/O resources, the SpaceLogic IP-IO modules provide a versatile mix of I/O points for any application. For more information, see the SpaceLogic IP-IO Specification Sheet.

Integrated damper actuator with feedback signal

The integrated damper actuator allows for simplified installation of MP-V directly over the damper shaft. This means that separate installation, wiring, and positioning of the damper motor is not needed. MP-V uses the same actuator mechanics as many Schneider Electric VAV controller models from the Andover Continuum, TAC Vista, and TAC I/A Series product lines. The feedback signal from the actuator makes it possible to determine the exact position of the damper. The actuator also features a push button for manual positioning of the damper during commissioning.

Factory-calibrated air flow sensor

The factory-calibrated air flow sensor uses a micro-flow channel integrated with the sensor chip that requires only a small air flow from the velocity probe. The sensor requires no maintenance and a minimum of field adjustments.

Advanced monitoring

The BACnet/IP controllers support local trends, schedules, and alarms, enabling local operation when the controller is offline or used in standalone applications.

With user-defined fallback values, the I/O module outputs will be in a predictable state in cases of network disruption.

The battery-free power backup of the memory and real-time clock helps prevent data loss and allows seamless and quick recovery after a power disruption.

In WorkStation, you update the firmware of multiple BACnet/IP controllers at the same time and with minimum down time. The EcoStruxure BMS server keeps track of the installed firmware to support backup, restore, and replacement of the controllers and sensors. The server can host controllers of different firmware versions.

SpaceLogic MP-V

Configurable RS-485 port

The MP-V controller has one configurable RS-485 port, which can be configured to support two different types of networks:

- Sensor bus
- Modbus network

The controller can host one of the network types.

The RS-485 port can alternatively be configured to support BACnet MS/TP network communication with the automation server, instead of BACnet/IP. For more information, see section “BACnet MS/TP support”.

Sensor bus for living space sensors

The BACnet/IP controllers provide an interface designed for the SpaceLogic Sensor family of living space sensors. The SpaceLogic Sensor devices offer an efficient way to sense the temperature, humidity, CO₂, and occupancy in a room. The SpaceLogic Sensor devices are available with different combinations of sensor types and various covers and user interface options, such as touchscreen, setpoint and override buttons, and blank covers. For more information, see the SpaceLogic Sensors - SXWS Sensors for MP and RP IP Controllers - Specification Sheet.



SpaceLogic Sensor devices

The sensor bus provides both power and communications for up to four sensors that are daisy-chained using standard Cat 5 (or higher) cables. The maximum number of sensors that can be

connected to a controller varies depending on the sensor model and the combination of cover and sensor base type:

- Blank covers: Up to four sensors of any combination of sensor base types
- 3-button and touchscreen covers:
 - Up to two sensor bases with CO₂ option
 - Up to four sensor bases without CO₂ option
- SpaceLogic LCD temperature sensors: Up to four sensors are supported

The maximum total length of the sensor bus is 61 m (200 ft). For more information, see the SpaceLogic Sensors - SXWS Sensors for MP and RP IP Controllers - Specification Sheet.

The RS-485 Power Adapter can be used to supply 24 VDC power to the MP controller sensor bus so that the maximum number of sensor bases with CO₂ option can be increased from two to four sensor bases. The adapter can be ordered from Schneider Electric. For more information, see section the RS-485 Adapters Specification Sheet.

Modbus RTU subnetwork

The MP-V Modbus RTU (RS-485) subnetwork allows standard Modbus devices to be connected to the controller.

The Modbus RTU protocol is used for the communication. The MP controller acts as the Modbus client and the connected devices act as servers.

For connection to Modbus devices, it is recommended to use the non-isolated RS-485 adapter to provide screw termination. The adapter converts an RS-485 RJ45 interface to screw terminals. The adapter can be ordered from Schneider Electric. For more information, see the RS-485 Adapters Specification Sheet.

To connect the adapter, it is recommended that you use a Cat 5 (or higher) UTP cable with eight conductors and RJ45 connectors. The cable should be rated for the target environment and have a maximum length of 0.3 m (12 in.). The cable is not included and needs to be purchased separately.

The maximum number of Modbus devices that can be connected to an MP controller depends on the type of Modbus device and the number of Modbus registers.

The MP controller Modbus network supports up to 20 connected Modbus devices with the following restrictions:

- Maximum of 1,000 Modbus registers per network

64-bit Modbus registers are supported, which can be used in energy metering.

Maximum total length of the Modbus network is 72 m (236 ft).

SpaceLogic MP-V

The Modbus devices require a separate power supply unit.

Modbus device types

Modbus device types are pre-configured Modbus applications for quick and easy Modbus device integration in EcoStruxure Building Operation solutions. For information on the Modbus devices supported using Modbus device types, see the document EcoStruxure Building - Modbus Device Integration - Supported Device Brochure.

BACnet MS/TP support

The MP-V controller supports both BACnet IP and MS/TP protocols. The controller can be configured to use either protocol. This feature enables both retrofitting of MNB and b3 BACnet devices while reusing parts of the existing cabling and equipment, as well as a later transition from the BACnet MS/TP (RS-485) network to an IP based network.

An RJ45 to screw terminal block adapter is required to connect the MP-V controller to the BACnet MS/TP network of the SpaceLogic automation server. The adapter can be ordered from Schneider Electric. The adapter is available in two models, with an isolated or non-isolated RS-485 transceiver. For more information, see the RS-485 Adapters Specification Sheet.

To connect the adapter, it is recommended that you use a Cat 5 (or higher) UTP cable with eight conductors and RJ45 connectors. The cable should be rated for the target environment and have a maximum length of 0.3 m (12 in.). The cable is not included and needs to be purchased separately.

In retrofit projects with MNB devices, the MP-V controllers can be mixed with MNB devices on the BACnet MS/TP network. The isolated adapter is used for connection of a controller. The adapter is connected to the RS-485 Com A port on the controller.

In retrofit projects with b3 BACnet devices, the MP-V controllers can be mixed with b3 BACnet devices on the BACnet MS/TP network. The non-isolated adapter is used for connection of a controller. The adapter is connected to the RS-485 Com A port on the controller.

In retrofit projects with only MP-V controllers on the BACnet MS/TP network, the non-isolated adapter is used for connection of a controller. The adapter is connected to the RS-485 Com A port on the controller.

Commission mobile application

The Commission mobile application is designed for local configuration, field deployment, commissioning of BACnet/IP controllers, and air flow balancing of VAV units. The mobile application reduces the commissioning time, allows flexibility in project execution, and minimizes dependencies on network infrastructure.

The mobile application is designed for use with Android, Apple (iOS), and Microsoft Windows devices. For more information, see the EcoStruxure Building Commission Specification Sheet.

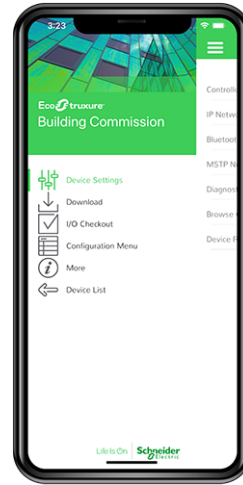

Commission mobile application

Using the Commission mobile application, you can connect to one or many BACnet/IP controllers. You can connect to a single BACnet/IP controller using the SpaceLogic Bluetooth Adapter connected to a SpaceLogic Sensor. Using a wireless access point or a network switch, you can connect to a network of BACnet/IP controllers on the local IP network.

Device configuration

With the Commission mobile application, you can easily discover BACnet/IP controllers on the IP network. You can change the configuration of each controller, including the BACnet and IP network settings, location, and parent server. To save engineering time, you can save common device settings and then reuse them for controllers of the same model.

Field deployment and I/O checkout

The Commission mobile application does not require an EcoStruxure BMS server or a network infrastructure to be in place. You can use the mobile application to load the controller application directly into the local BACnet/IP controller and deploy the controller. The controller application can be created offline using Project Configuration Tool or WorkStation. You can also perform an I/O checkout to verify that the controller's I/O points are configured, wired, and operating correctly.

Air flow balancing

Using the Commission mobile application, you can perform air flow balancing of VAV units controlled by MP-Vs. An intuitive workflow automatically guides you through the process. After the flow balancing, you can generate a report in HTML format for one or more VAV units. The balancing parameters associated with each MP-V are stored in the parent server, which makes it easier to replace the controller if necessary.

SpaceLogic MP-V

Full EcoStruxure Building Operation software support

The power of the BACnet/IP controller is fully realized when it is part of an EcoStruxure BMS, which provides the following benefits:

- WorkStation/WebStation interface
- Script and Function Block programming options
- Device discovery
- Engineering efficiency
- Preconfigured BMS applications for HVAC

WorkStation/WebStation interface

WorkStation and WebStation provide a consistent user experience regardless of which EcoStruxure BMS server the user is logged on to. The user can log on to the parent EcoStruxure BMS server to engineer, commission, supervise, and monitor the BACnet/IP controller and its I/O as well as its attached SpaceLogic Sensor devices. For more information, see the WorkStation and WebStation specification sheets.

Script and Function Block programming options

Unique to the industry, the BACnet/IP controllers have both Script and Function Block programming options. This flexibility assures that the best programming method can be selected for the application. Existing programs can easily be reused between the EcoStruxure BMS server and the controller.

Device discovery

The enhanced Device Discovery in WorkStation enables you to easily identify BACnet/IP controllers on a BACnet network and to associate the controllers with their parent server.

Engineering efficiency

The engineering and maintenance of BACnet/IP controllers can be done very efficiently using the EcoStruxure Building Operation reusability features. With these features, you can create library items (Custom Types) for a complete controller application that contains programs and all necessary objects such as trends, alarms, and schedules. The controller application in the Custom Types library is reusable across all controllers of the same model. You can use the controller application as a base for creating new controllers intended for similar applications. You can then edit the controller application, and the changes are automatically replicated to all controllers, while each controller keeps its local values.

WorkStation supports both online and offline engineering of BACnet/IP controllers. You can make the configuration changes online or use database mode to make the changes offline. In database mode, the changes are saved to the EcoStruxure

Building Operation database so that you can apply the changes to the controllers later.

Project Configuration Tool enables you to perform all the engineering off site, without the need for physical hardware, which minimizes the time you need to spend on site. You can run the EcoStruxure BMS servers virtually and engineer the BACnet/IP controllers before you deploy your server and controller applications to the servers and controllers on site. For more information, see the Project Configuration Tool specification sheet.

Preconfigured BMS applications for HVAC

To improve engineering efficiency and standardize engineering practices, fully designed and tested controller applications are available at bms-applications.schneider-electric.com for use with the MP controllers. This library contains applications for different MP controller models and application types, such as fan coil units, VAV, and ceiling solutions. These preconfigured controller applications are packages that include all software programs, and for example graphics, alarms, and documentation such as functional specifications and I/O wiring schedules, that are needed for your projects. The online repository can be accessed using common web browsers on Windows PCs as well as mobile devices running Apple iOS 11.3 (or later) and Android 6.0 Marshmallow (or later).

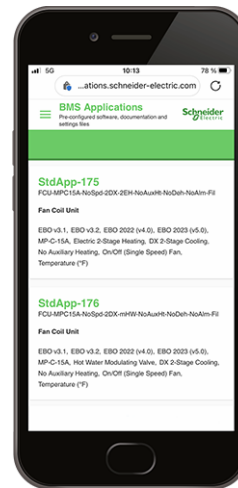

[Download page for preconfigured BMS applications](#)

Upgrade with signed firmware

Using digitally signed firmware provides more secure upgrading of the device. During an upgrade, the device verifies that the firmware is authentic and uncompromised Schneider Electric firmware. If the device detects discrepancies in the authenticity or integrity of the firmware, it will reject the upgrade. Once the device is upgraded with signed firmware, all upgrades thereafter must be with a signed firmware version.

SpaceLogic MP-V

Part Numbers for MP-V

Product	Part number
MP-V-7A	SXWMPV7AX10002
MP-V-9A	SXWMPV9AX10002
MP-V-7A-BAA ^a	SXWMPV7AX10A02
MP-V-9A-BAA ^a	SXWMPV9AX10A02
MP-V-7A-SMK ^b	SXWMPV7AX1S001
MP-V-9A-SMK ^b	SXWMPV9AX1S001

a) Buy American Act (BAA) compliant.

b) Approved for use in UL 864 smoke control systems. The smoke control (SMK) models are shipped with a validated UL 864 software version, which can differ from the latest released software. For information on the approved software revisions for the device when used in UL 864 smoke control systems, see the Smoke Control System Approved Software Revisions - EcoStruxure Building Management document, 01-16001-XX-en.

Part Numbers for MP-V accessories

Product	Part number
Spare terminal blocks for all MP-V models (1 x 2-pin, 2 x 3-pin, 2 x 4-pin, 1 x 5-pin, 1 x 6-pin terminal blocks)	SXWMPVCON10001
Adapter for damper shaft diameter 9.5 mm (0.375 inch)	AM-135
Isolated RS-485 adapter ^a	SXWISORS48510001
Non-isolated RS-485 adapter ^a	SXWNISORS48510001
RS-485 power adapter ^a	SXWNISORS485P10001
SpaceLogic Bluetooth Adapter ^a	SXWBTAECXX10001

a) The RS-485 adapters and the Bluetooth adapter are not available in Buy American Act (BAA) compliant variants.

For more information on part numbers for Network Connectivity Accessories, see the Product Selection Guide - EcoStruxure Building.

Specifications

SpaceLogic MP-V	
AC input	
Nominal voltage	24 VAC
Operating voltage range	+/- 20 %
Frequency	50/60 Hz
Maximum power consumption (MP-V-7A)	21 VA
Maximum power consumption (MP-V-9A)	22 VA
Power input protection	MOV suppression and internal fuse

SpaceLogic MP-V

Environment

Ambient temperature, operating	0 to 50 °C (32 to 122 °F)
Ambient temperature, storage	-40 to +70 °C (-40 to +158 °F)
Maximum humidity	95 % RH non-condensing

Material

Plastic flame rating	UL94 V-0
Ingress protection rating	IP 20

Mechanical

Dimensions

161 W x 198 H x 63 D mm (6.3 W x 7.8 H x 2.5 D in.)

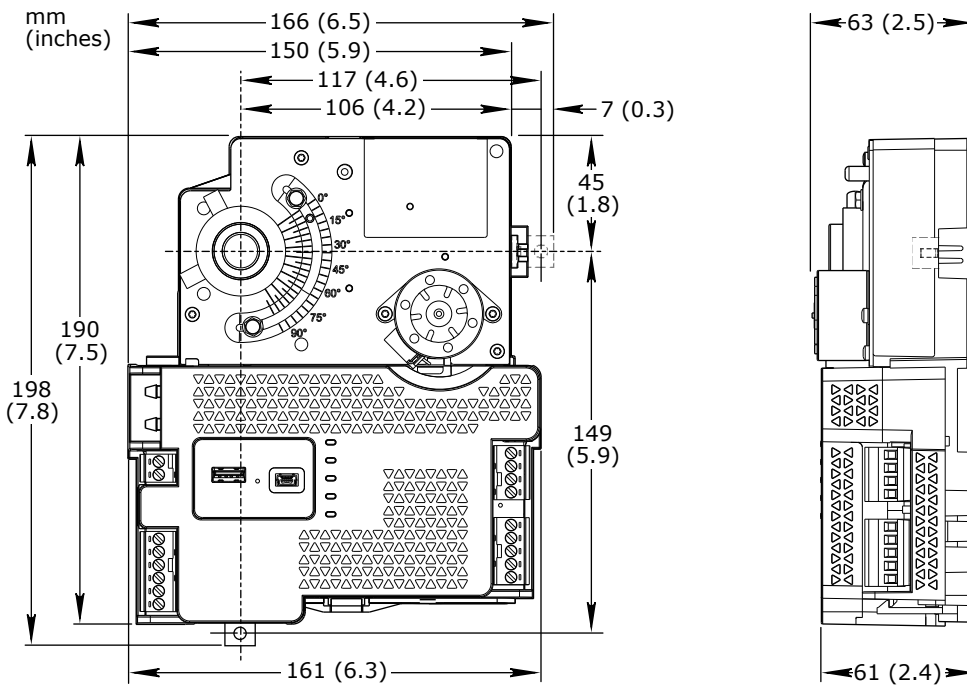

Weight

1.13 kg (2.5 lb)

Installation

Over the damper shaft

Terminal blocks

Removable

Compatibility

EcoStruxure BMS server communication
EcoStruxure Building Operation

version 3.x.x and later

BACnet MS/TP network support
EcoStruxure Building Operation

version 4.0.2 and later

Modbus RTU subnetwork support
EcoStruxure Building Operation

version 5.0.1 and later

BACnet/SC network support
EcoStruxure Building Operation

version 6.0.1 and later

SpaceLogic MP-V

NTP support
EcoStruxure Building Operation

version 7.0.3 and later

EcoStruxure Building Management Smoke Control System^a
EcoStruxure Building Operation For information, see the Smoke Control System Approved Software Revisions - EcoStruxure Building Management document, 01-16001-XX-en.

a) Applies to the Smoke Control (SMK) models.

Agency compliances

Emission RCM; BS/EN 61000-6-3; BS/EN IEC 63044-5-2; FCC Part 15, Sub-part B, Class B

Immunity BS/EN 61000-6-2; BS/EN IEC 63044-5-3

Safety standards BS/EN 60730-1; BS/EN 60730-2-11; BS/EN IEC 63044-3; UL 916 C-UL US Listed

Fire performance in air-handling spaces^a UL 2043

a) The MP-V-7A and MP-V-9A models are approved for plenum applications.

Smoke control product safety^a UL 864

a) Applies to the Smoke Control (SMK) models. For specifications and information on the restrictions that apply to the SMK models when used in UL 864 smoke control systems, see the EcoStruxure Building Management - Smoke Control System Design Guide, 04-16014-XX-en.

Real-time clock

Accuracy in backup mode, at 25 °C (77 °F) +/-1 minute per month

Backup time, at 25 °C (77 °F) 7 days minimum

Communication ports

Ethernet Dual 10/100BASE-TX (RJ45), IEEE 802.3 compliant

USB 1 USB 2.0 device port (mini-B)
1 USB 2.0 host port (type-A), 5 VDC, 2.5 W

RS-485 port Com A 24 VDC, 2 W, RS-485 (RJ45)
Transient voltage suppressors on communication and power signals

RS-485 transceiver characteristics

Transceiver type Failsafe
Non-isolated

External biasing None required

Total Unit Load (UL) per device Maximum 0.5 UL

Communications

BACnet BACnet/IP, port configurable, default 47808
BACnet/SC, port configurable, no default port
BACnet MS/TP, maximum bus length: 1200 m (4000 ft), maximum baud rate: 76800
BTL B-AAC (BACnet Advanced Application Controller), B-GW (BACnet Gateway)^a

a) See the BTL Product Catalog for up-to-date details on BTL listed firmware revisions on BACnet International's home page.

CPU

Frequency 500 MHz

Type ARM Cortex-A7 dual-core

DDR3 SDRAM 128 MB

SpaceLogic MP-V

NOR flash memory	32 MB
Memory backup	128 kB, FRAM, non-volatile
Damper actuator	
Torque rating	6 Nm (53 lbf.in)
Stroke	0° to 90°, fully adjustable
Timing	Approximately 2 seconds/degree at 60 Hz and 2.4 seconds/degree at 50 Hz for 90° rotation at 24 VAC
Position indication	Visual indication
Damper position feedback	Yes
Manual override	Push-button clutch release
Damper shaft diameter	12.7 mm (0.5 inch) or 9.5 mm (0.375 inch)
Damper shaft minimum length (from VAV box)	22.2 mm (0.875 inch)
Air flow sensor	
Range	0 to 249 Pa (0 to 1 inH ₂ O)
Resolution	0.0167 Pa (0.000067 inH ₂ O)
Accuracy	±5% of reading (typical) at 25°C (77°F)
Universal inputs, UI	
Channels, MP-V-7A	3, UI1 to UI3
Channels, MP-V-9A	4, UI1 to UI4
Absolute maximum ratings	-0.5 to +24 VDC
A/D converter resolution	16 bits
Universal input protection	Transient voltage suppressor on each input
Digital inputs	
Range	Dry contact switch closure or open collector/open drain, 24 VDC, typical wetting current 2.4 mA
Minimum pulse width	150 ms
Counter inputs	
Range	Dry contact switch closure or open collector/open drain, 24 VDC, typical wetting current 2.4 mA
Minimum pulse width	20 ms
Maximum frequency	25 Hz
Supervised inputs	
5 V circuit, 1 or 2 resistors Monitored switch combinations	Series only, parallel only, and series and parallel
Resistor range For a 2-resistor configuration, each resistor must have the same value +/- 5 %	1 to 10 kohm

SpaceLogic MP-V

Voltage inputs	
Range	0 to 10 VDC
Accuracy	+/- (7 mV + 0.2 % of reading)
Resolution	1.0 mV
Impedance	100 kohm
Current inputs	
Range	0 to 20 mA
Accuracy	+/- (0.01 mA + 0.4 % of reading)
Resolution	1 μ A
Impedance	47 ohm
Resistive inputs	
10 ohm to 10 kohm accuracy R = Resistance in ohm	+/- (7 + 4 x 10 ⁻³ x R) ohm
10 kohm to 60 kohm accuracy R = Resistance in ohm	+/- (4 x 10 ⁻³ x R + 7 x 10 ⁻⁸ x R ²) ohm
Temperature inputs (thermistors)	
Range	-50 to +150 °C (-58 to +302 °F)
Supported thermistors	
Honeywell	20 kohm
Type I (Continuum)	10 kohm
Type II (I/NET)	10 kohm
Type III (Satchwell)	10 kohm
Type IV (FD)	10 kohm
Type V (FD w/ 11k shunt)	Linearized 10 kohm
Satchwell D?T	Linearized 10 kohm
Johnson Controls	2.2 kohm
Xenta	1.8 kohm
Balco	1 kohm
Measurement accuracy	
20 kohm	-50 to -30 °C: +/-1.5 °C (-58 to -22 °F: +/-2.7 °F) -30 to 0 °C: +/-0.5 °C (-22 to +32 °F: +/-0.9 °F) 0 to 100 °C: +/-0.2 °C (32 to 212 °F: +/-0.4 °F) 100 to 150 °C: +/-0.5 °C (212 to 302 °F: +/-0.9 °F)
10 kohm, 2.2 kohm, and 1.8 kohm	-50 to -30 °C: +/-0.75 °C (-58 to -22 °F: +/-1.35 °F) -30 to +100 °C: +/-0.2 °C (-22 to +212 °F: +/-0.4 °F) 100 to 150 °C: +/-0.5 °C (212 to 302 °F: +/-0.9 °F)

SpaceLogic MP-V

Linearized 10 kohm

-50 to -30 °C: +/-2.0 °C (-58 to -22 °F: +/-3.6 °F)
 -30 to 0 °C: +/-0.75 °C (-22 to +32 °F: +/-1.35 °F)
 0 to 100 °C: +/-0.2 °C (32 to 212 °F: +/-0.4 °F)
 100 to 150 °C: +/-0.5 °C (212 to 302 °F: +/-0.9 °F)

1 kohm

-50 to +150 °C: +/-1.0 °C (-58 to +302° F: +/-1.8 °F)

RTD temperature inputs

Supported RTDs

Pt1000, Ni1000, and LG-Ni1000

Pt1000

Sensor range

-50 to +150 °C (-58 to +302 °F)

BACnet/IP Controller device environment

Sensor range

Measurement accuracy

0 to 50 °C (32 to 122 °F)

-50 to +70 °C (-58 to +158 °F)

+/-0.5 °C (+/-0.9 °F)

0 to 50 °C (32 to 122 °F)

70 to 150 °C (158 to 302 °F)

+/-0.7 °C (+/-1.3 °F)

Ni1000

Sensor range

-50 to +150 °C (-58 to +302 °F)

BACnet/IP Controller device environment

Sensor range

Measurement accuracy

0 to 50 °C (32 to 122 °F)

-50 to +150 °C (-58 to +302 °F)

+/-0.5 °C (+/-0.9 °F)

LG-Ni1000

Sensor range

-50 to +150 °C (-58 to +302 °F)

BACnet/IP Controller device environment

Sensor range

Measurement accuracy

0 to 50 °C (32 to 122 °F)

-50 to +150 °C (-58 to +302 °F)

+/-0.5 °C (+/-0.9 °F)

RTD temperature wiring

Maximum wire resistance

20 ohm/wire (40 ohm total)

Maximum wire capacitance

60 nF

The wire resistance and capacitance typically corresponds to a 200 m wire.

Triac outputs, DO

Channels, MP-V-7A

3, DO1 to DO3

Channels, MP-V-9A

3, DO1 to DO3

Output rating (for each triac output)

Max. 0.5 A

Voltage

24 VAC +/-20 %

Commons

COM (terminal number 18)

The common terminal COM can be connected to 24 VAC or to ground.

Common voltage, high side output

24 VAC

Common voltage, low side output

0 VAC (ground)

Minimum pulse width

100 ms

Triac output protection

MOV and snubber across each triac output
 MOV from triac COM to ground

SpaceLogic MP-V

Continued

Analog outputs, AO	
Channels, MP-V-7A	1, VO1/CO1
Channels, MP-V-9A	2, VO1/CO1 and VO2/CO2
Analog output protection	Transient voltage suppressor on each output
Voltage outputs	
Range	0 to 10 VDC
Accuracy	+/-60 mV
Resolution	10 mV
Minimum load resistance	5 kohm to ground
Load range	0 to +2 mA
Terminals	Voltage Output (VO), Return (RET)
Current outputs	
Range	0 to 20 mA
Accuracy	+/-0.2 mA
Resolution	21 µA
Load range	0 to 650 ohm
Terminals	Current Output (CO), Return (RET)

Terminals

For more information on wiring, see the SpaceLogic and EasyLogic - Hardware Installation System Guide.

SpaceLogic MP-V

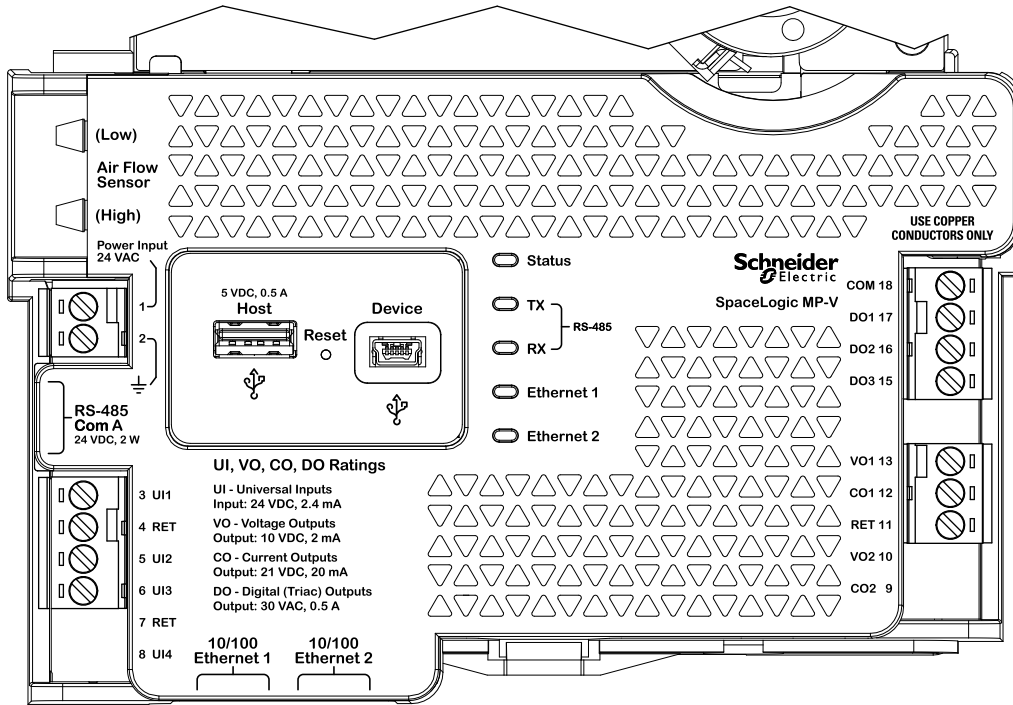

MP-V-7A

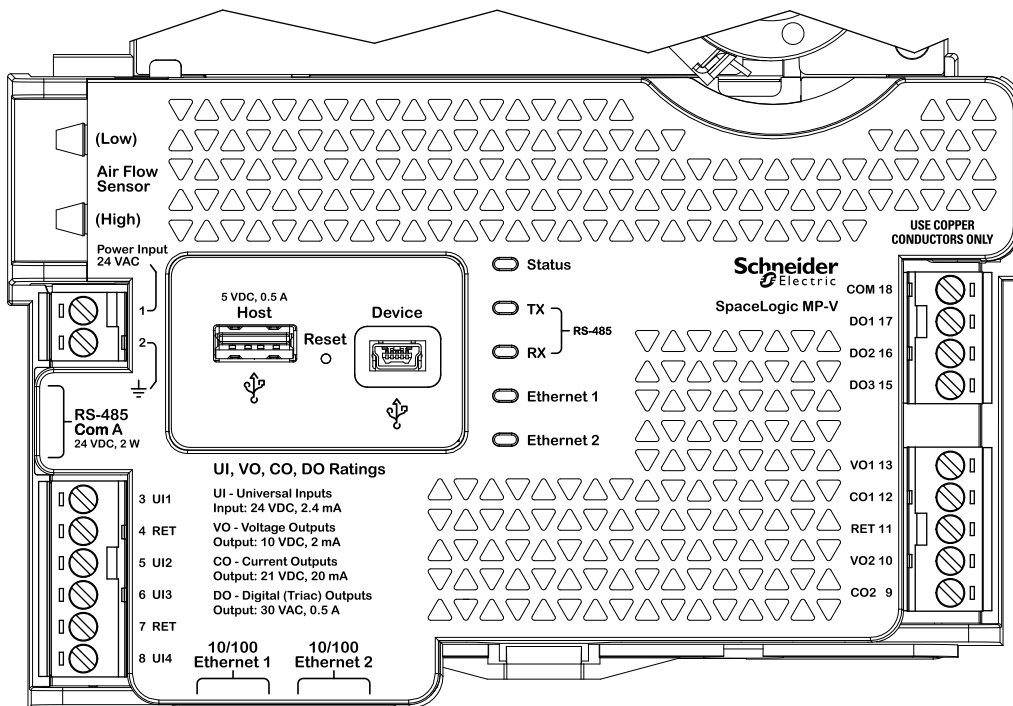

MP-V-9A

SpaceLogic MP-V

Regulatory Notices



Federal Communications Commission

FCC Rules and Regulations CFR 47, Part 15, Class B

This device complies with part 15 of the FCC Rules. Operation is subject to the following two conditions: (1) This device may not cause harmful interference. (2) This device must accept any interference received, including interference that may cause undesired operation.

Industry Canada

This Class B digital apparatus complies with Canadian ICES-003.

Cet appareil numérique de la classe B est conforme à la norme NMB-003 du Canada.



Regulatory Compliance Mark (RCM) - Australian Communications and Media Authority (ACMA)

This equipment complies with the requirements of the relevant ACMA standards made under the Radiocommunications Act 1992 and the Telecommunications Act 1997. These standards are referenced in notices made under section 182 of the Radiocommunications Act and 407 of the Telecommunications Act.



UK Conformity Assessed

S.I. 2016/1091 - Electromagnetic Compatibility Regulations 2016

S.I. 2012/3032 - Restriction of the Use of Certain Hazardous Substances in Electrical and Electronic Equipment Regulations 2012

S.I. 2013/3113 - Waste Electrical and Electronic Equipment Regulations 2013

This equipment complies with the rules, of the UK regulations, for governing the UKCA Marking for the United Kingdom specified in the above directive(s).



CE - Compliance to European Union (EU)

2014/30/EU Electromagnetic Compatibility Directive

2011/65/EU Restriction of Hazardous Substances (RoHS) Directive

2015/863/EU amending Annex II to Directive 2011/65/EU

This equipment complies with the rules, of the Official Journal of the European Union, for governing the Self Declaration of the CE Marking for the European Union as specified in the above directive(s).



WEEE - Directive of the European Union (EU)

This equipment and its packaging carry the waste of electrical and electronic equipment (WEEE) label, in compliance with European Union (EU) Directive 2012/19/EU, governing the disposal and recycling of electrical and electronic equipment in the European community.



UL 916 Listed products for the United States and Canada, Enclosed Energy Management Equipment. UL file E80146.



UL 864 Listed products for the United States. 10th Edition Smoke Control System. UL file S5527.

www.se.com/buildings

Life Is On

Schneider
Electric