

SpaceLogic RP-C Advanced Room Controllers

EcoStruxure™ Building



Introduction

SpaceLogic™ RP-C Advanced is a room-purpose, fully programmable, IP based field controller that suits a wide range of HVAC applications and offers a room connectivity hub for Connected Room Solutions.

RP-C Advanced comes either as a 24 VAC/DC controller with 12 I/O points or as a 230 VAC controller with 16 I/O points.

The controller can be integrated into Connected Room Solutions and EcoStruxure Building Operation and is positioned for room control as well as well-being and comfort of occupants in an energy-efficient way.

The RP-C Advanced controller can also be reconfigured through the EcoStruxure Building Operation software to support BACnet MS/TP, instead of BACnet/IP.

The controller can either be used as a standalone BACnet/IP field controller, BACnet/SC node, or as part of an EcoStruxure BMS with an automation server or an Enterprise Server as the parent server.

The controller features a wireless chip, which enables commissioning of the controller with the Commission mobile application and allows tenants to change the room comfort settings using their smartphones with the Engage mobile application.

SpaceLogic RP-C Advanced

Web services enable web access directly to the controller, making the controller an open IoT hub in the room or space area.

RP-C Advanced has the following features:

- IP enabled with dual-port Ethernet switch
- BACnet/SC node
- Full range of controller models
- Versatile onboard I/O point mix
- Optional covers
- Wireless connectivity
- Advanced monitoring
- Two configurable RS-485 ports
- Sensor bus for living space sensors
- Room bus for Connected Room Solutions
- Modbus RTU subnetwork
- KNX support (KNX Modbus gateway required)
- BACnet MS/TP support (adapter required)
- Engage mobile application for room comfort settings
- Commission mobile application for commissioning of the controller before the BMS is in place
- Full EcoStruxure Building Operation software support, providing efficient engineering tools
- Web services through RESTful API
- Upgrade with signed firmware

IP connectivity, flexible network topologies, and support for BACnet/SC applications

The BACnet/IP controllers are based on open protocols that simplify interoperability, IP configuration, and device management, and can be enabled as BACnet/SC nodes for increased cybersecurity:

- IP addressing
- BACnet/IP or BACnet/SC communications
- DHCP for easy network configuration

The BACnet/IP controllers have a dual-port Ethernet switch, which enables flexible network topologies:

- Star
- Daisy chain
- Rapid Spanning Tree Protocol (RSTP) ring

In a star topology, the controller and the parent EcoStruxure BMS server are individually connected to an Ethernet switch. Daisy-chain multiple controllers together to reduce installation time and cost. When using a ring network topology, in the event of a broken IP network or a non-operational controller, RSTP will enable rapid identification of the location of the detected error while maintaining communication with the controllers on either side of the break.

BACnet/SC (Secure Connect) support

The BACnet/IP controllers support BACnet/SC applications as a BACnet/SC node. This allows the controllers to be used in a BACnet/SC network, which allows secure transport of BACnet traffic and information between BACnet/SC devices over private and public networks without the need for BBMDs, VLANs, and VPNs, because the BACnet/SC protocol uses WebSocket technology and TLS 1.3 encryption. In addition, BACnet/SC uses certificate management to help ensure only those devices authorized to be on a BACnet/SC network can operate on that network.

Full range of controller models

The RP-C Advanced range includes four different models, which offer four different sets of I/O point types, named 12A, 12B, 12C, and 16A. The RP-C-12A, -12B, and -12C models support 24 VAC/DC power supply, whereas the RP-C-16A model is a 230 VAC model.

RP-C-12A-F-24V

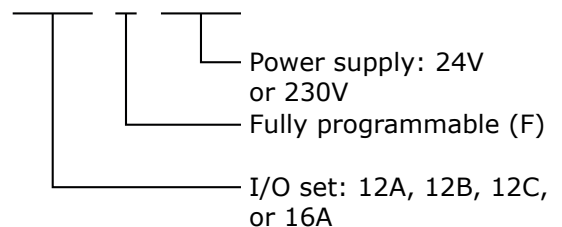

Fully programmable

The fully programmable RP-C models provide flexibility through support of both Script and Function Block programming options. The RP-C promotes efficiency and standardization through the use of standard controller applications.

Models with a versatile mix of I/O points

The RP-C-12A, -12B, -12C, and -16A models provide 12 or 16 I/O points, consisting of four different sets of I/O point types. The versatile mix of I/O point types match a wide variety of applications. The universal inputs/outputs are highly flexible and can be configured as either inputs or outputs.

SpaceLogic RP-C Advanced

I/O Point Types by RP-C Models

I/O Point Types	RP-C-12A model	RP-C-12B model	RP-C-12C model	RP-C-16A model
Universal I/O Type Ub	8	8	4	8
Solid-state relay outputs (MOSFET)	4	-	4	4
Relay outputs Form A	-	3	3	3
High power relay outputs Form C	-	1	1	1

Configurations by I/O Point Types

Configurations	Universal I/O Type Ub	Solid-state Relay Outputs (MOSFET)	Relay Outputs Form A	High Power Relay Outputs Form C
Digital inputs	yes	-	-	-
Counter inputs	yes	-	-	-
Supervised inputs	yes	-	-	-
Voltage inputs (0 to 10 VDC)	yes	-	-	-
Current inputs (0 to 20 mA)	yes	-	-	-
Temperature inputs	yes	-	-	-
Resistive inputs	yes	-	-	-
2-wire RTD temperature inputs	yes	-	-	-
Voltage outputs (0 to 10 VDC)	yes	-	-	-
Digital outputs	-	yes	yes	yes
Digital pulsed outputs	-	yes	yes	yes
PWM outputs	-	yes	yes	yes
Tristate outputs	-	yes	yes	-
Tristate pulsed outputs	-	yes	yes	-

Universal inputs/outputs

The universal inputs/outputs are ideal for any mix of temperature, pressure, flow, status points, and similar point types in a building control system.

As counter inputs, the universal inputs/outputs are commonly used in energy metering applications. As RTD inputs, they are ideal for temperature points in a building control system. As supervised inputs, they are used for security applications where it is critical to know whether or not a wire has been cut or shorted. These events provide a separate indication of alarms and events in the system.

For all analog inputs, maximum and minimum levels can be defined to automatically detect over-range and under-range values.

The universal inputs/outputs are capable of supporting analog outputs of type voltage outputs. Therefore, the universal inputs/outputs support a wide range of devices, such as actuators.

Only devices with safe extra low voltage equipment (SELV/PELV) inputs/outputs should be connected to the universal inputs/outputs.

SpaceLogic RP-C Advanced

Solid-state relay outputs

The solid-state relay (SSR) outputs can be used in many applications to switch 24 VAC or 24 VDC on or off for external loads such as actuators, relays, or indicators. SSRs are silent and are not adversely affected by relay contact wear.

Relay outputs

The relay outputs support digital Form A point types. The Form A relays are designed for direct load applications.

High power relay output

The high power relay output is of type Form C. The normally-open (NO) contact is ideal for switching resistive loads of up to 12 A, such as electrical heating elements. The normally-closed (NC) contact can be used to switch inductive loads of up to 3 A.

Optional covers

All RP-C models can be equipped with optional covers to reduce access to the screw terminals and wires.



RP-C with equipped with optional covers

Wireless connectivity

RP-C is a Bluetooth Low Energy (BLE) enabled product. You can use this wireless connectivity option to connect the RP-C with a smartphone or tablet running the Commission mobile application or the Engage mobile application for room comfort settings.

Through Wireless Adapter - Advanced connected to the host USB port, Zigbee™ wireless connectivity can be enabled for the RP controller. The controller can extend its point count through the Zigbee wireless network and bring flexibility in your

applications. The RP controller equipped with the adapter is a Zigbee Certified Product that is compliant with Zigbee 3.0. For more information on the adapter and supported wireless devices, see the Wireless Adapter - Advanced Specification Sheet.

Advanced monitoring

The BACnet/IP controllers support local trends, schedules, and alarms, enabling local operation when the controller is offline or used in standalone applications.

The battery-free power backup of the memory and real-time clock helps prevent data loss and allows seamless and quick recovery after a power disruption.

In WorkStation, you update the firmware of multiple BACnet/IP controllers at the same time and with minimum down time. The EcoStruxure BMS server keeps track of the installed firmware to support backup, restore, and replacement of the controllers and sensors. The server can host controllers of different firmware versions.

Two configurable RS-485 ports

The RP-C controller has two configurable RS-485 ports, which can be configured to support three different types of networks:

- Sensor bus
- Room bus
- Modbus network

The controller can host two networks, but only one of each network type.

One of the RS-485 ports can alternatively be configured to support BACnet MS/TP network communication with the automation server, instead of BACnet/IP. For more information, see section “BACnet MS/TP support”. The other RS-485 port can then be configured to support either sensor bus, room bus, or Modbus network.

Sensor bus for living space sensors

The BACnet/IP controllers provide an interface designed for the SpaceLogic Sensor family of living space sensors. The SpaceLogic Sensor devices offer an efficient way to sense the temperature, humidity, CO₂, and occupancy in a room. The SpaceLogic Sensor devices are available with different combinations of sensor types and various covers and user interface options, such as touchscreen, setpoint and override buttons, and blank covers. For more information, see the SpaceLogic Sensors - SXWS Sensors for MP and RP IP Controllers - Specification Sheet.

SpaceLogic RP-C Advanced



SpaceLogic Sensor devices

The RP controller sensor bus provides both power and communications for up to four sensors that are daisy-chained using standard Cat 5 (or higher) cables. This maximum number of sensors that can be connected to a controller is regardless of the sensor model and the combination of cover and sensor base type:

- Blank covers: Up to four sensors of any combination of sensor base types
- 3-button and touchscreen covers: Up to four sensors of any combination of sensor base types
- SpaceLogic LCD temperature sensors: Up to four sensors are supported

The maximum total length of the sensor bus is 61 m (200 ft). For more information, see the SpaceLogic Sensors - SXWS Sensors for MP and RP IP Controllers - Specification Sheet.

The RS-485 Power Adapter can be used for injecting 24 VDC from an external 24 VDC power supply to the bus. For more information, see the RS-485 Adapters Specification Sheet.

Room bus for Connected Room Solutions

The RP controller room bus allows RP controller expansion modules to be connected to the controller for people counting, motion detection, luminosity and sound pressure level measurements, Bluetooth Low Energy based applications, and control of electric lights and window blinds.

The RP-C Advanced controller room bus supports up to six connected RP controller expansion modules with the following restrictions:

- Maximum of two DALI light modules
- Maximum of two SMI blind modules

- Maximum of four Multi-sensor or Insight-Sensor devices

Maximum total length of the room bus is 72 m (236 ft).

The RS-485 Power Adapter can be used for injecting 24 VDC from an external 24 VDC power supply to the bus. For more information, see the RS-485 Adapters Specification Sheet.

For more information, see the Specification Sheets for the RP controller expansion modules.

Modbus RTU subnetwork

The RP controller Modbus network allows standard Modbus devices and the KNX Modbus gateway (RP-C-EXT-KNX) to be connected to the controller.

The Modbus RTU protocol is used for the communication. The RP controller acts as the Modbus client and the connected devices act as servers.

For connection to Modbus devices, it is recommended to use the non-isolated RS-485 adapter to provide screw termination. The adapter converts an RS-485 RJ45 interface to screw terminals. The adapter can be ordered from Schneider Electric. For more information, see the RS-485 Adapters Specification Sheet.

To connect the adapter, it is recommended that you use a Cat 5 (or higher) UTP cable with eight conductors and RJ45 connectors. The cable should be rated for the target environment and have a maximum length of 0.3 m (12 in.). The cable is not included and needs to be purchased separately.

The maximum number of Modbus devices that can be connected to an RP controller depends on the type of Modbus device and the number of Modbus registers.

The RP-C Advanced controller Modbus network supports up to 10 connected Modbus devices with the following restrictions:

- Maximum of one KNX Modbus gateway (RP-C-EXT-KNX)
- Maximum of 250 Modbus registers per network

64-bit Modbus registers are supported, which can be used in energy metering.

Modbus device types

Modbus device types are pre-configured Modbus applications for quick and easy Modbus device integration in EcoStruxure Building Operation solutions. For information on the Modbus devices supported using Modbus device types, see the document EcoStruxure Building - Modbus Device Integration - Supported Device Brochure.

SpaceLogic RP-C Advanced

KNX support

Through the KNX Modbus gateway (RP-C-EXT-KNX), the RP controller can communicate with KNX devices such as push-buttons and sensors.

The KNX Modbus gateway provides a KNX to Modbus interface that connects to one of the RP controller's configurable RS-485 ports.

For more information, see the RP-C-EXT-KNX Specification Sheet.

BACnet MS/TP support

The RP controllers support both BACnet IP and MS/TP protocols. The controller can be configured to use either protocol. This feature enables both retrofitting of MNB and b3 BACnet devices while reusing parts of the existing cabling and equipment, as well as a later transition from the BACnet MS/TP (RS-485) network to an IP based network.

An RJ45 to screw terminal block adapter is required to connect the RP controller to the BACnet MS/TP network of the SpaceLogic automation server. The adapter can be ordered from Schneider Electric. The adapter is available in two models, with an isolated or non-isolated RS-485 interface. For more information, see the RS-485 Adapters Specification Sheet.

To connect the adapter, it is recommended that you use a Cat 5 (or higher) UTP cable with eight conductors and RJ45 connectors. The cable should be rated for the target environment and have a maximum length of 0.3 m (12 in.). The cable is not included and needs to be purchased separately.

In retrofit projects with MNB devices, the RP controllers can be mixed with MNB devices on the BACnet MS/TP network. The isolated adapter is used for connection of a controller. The adapter is connected to the RS-485 Com B port on the controller.

In retrofit projects with b3 BACnet devices, the RP controllers can be mixed with b3 BACnet devices on the BACnet MS/TP network. The non-isolated adapter is used for connection of a controller. The adapter can be connected to either the RS-485 Com A or Com B port on the controller.

In retrofit projects with only RP controllers on the BACnet MS/TP network, the non-isolated adapter is used for connection of a controller. The adapter can be connected to either the RS-485 Com A or Com B port on the controller.

Engage mobile application

The Engage mobile application enables control of room temperature, fan speed, lights, and blinds/shades directly from a smartphone. A user can manage these settings when the application is connected to the RP controller.

The Engage mobile application is free and available for download from Google Play and Apple App Store.

For more information, see the Engage Specification Sheet.

Commission mobile application

The Commission mobile application is designed for local configuration, field deployment, and commissioning of BACnet/IP controllers. The mobile application reduces the commissioning time, allows flexibility in project execution, and minimizes dependencies on network infrastructure.

The mobile application is designed for use with Android, Apple (iOS), and Microsoft Windows devices. For more information, see the EcoStruxure Building Commission Specification Sheet.

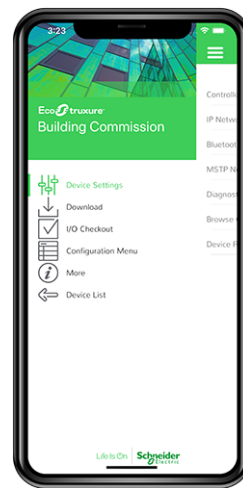

Commission mobile application

Using the Commission mobile application, you can connect to one or many RP controllers. You can connect to a single RP controller using the controller's built-in Bluetooth connectivity or using the SpaceLogic Bluetooth Adapter connected to a SpaceLogic Sensor. Using a wireless access point or a network switch, you can connect to a network of RP controllers on the local IP network.

Device configuration

With the Commission mobile application, you can easily discover BACnet/IP controllers on the IP network. You can change the configuration of each controller, including the BACnet and IP network settings, location, and parent server. To save engineering time, you can save common device settings and then reuse them for controllers of the same model.

Field deployment and I/O checkout

The Commission mobile application does not require an EcoStruxure BMS server or a network infrastructure to be in place. You can use the mobile application to load the controller application directly into the local BACnet/IP controller and deploy

SpaceLogic RP-C Advanced

the controller. The controller application can be created offline using Project Configuration Tool or WorkStation. You can use the mobile application to change the behavior of an installed standard controller application, such as configuring temperature setpoints. You can also perform an I/O checkout to verify that the controller's I/O points are configured, wired, and operating correctly.

You can perform I/O checkout on the RP controller room bus to verify proper communication over the room bus between the RP controller and the associated RP controller expansion modules. Module type mismatches or address mismatches can then be resolved. After wiring the physical inputs and outputs of the RP controller expansion modules, you can perform the following tasks on the different modules:

- DALI light modules: discover, wink, and associate DALI lights with the logical software points, and test individual lights
- 0-10V light modules: test individual lights
- Blind modules: calibrate and test blinds
- Relay module: test outputs

Full EcoStruxure Building Operation software support

The power of the RP controller is fully realized when it is part of an EcoStruxure BMS, which provides the following benefits:

- WorkStation/WebStation interface
- Script and Function Block programming options
- Device discovery
- Engineering efficiency
- Preconfigured BMS applications for HVAC and Connected Room Solutions
- Zoning option

WorkStation/WebStation interface

WorkStation and WebStation provide a consistent user experience regardless of which EcoStruxure BMS server the user is logged on to. The user can log on to the parent EcoStruxure BMS server to engineer, commission, supervise, and monitor the BACnet/IP controller and its I/O as well as its attached SpaceLogic Sensor devices. For more information, see the WorkStation and WebStation specification sheets.

Script and Function Block programming options

The fully programmable RP and MP controller models have both Script and Function Block programming options. Existing programs can easily be reused between the EcoStruxure BMS server and the controller.

Device discovery

The enhanced Device Discovery in WorkStation enables you to easily identify BACnet/IP controllers on a BACnet network and to associate the controllers with their parent server.

Engineering efficiency

The engineering and maintenance of BACnet/IP controllers can be done very efficiently using the EcoStruxure Building Operation reusability features. With these features, you can create library items (Custom Types) for a complete controller application that contains programs and all necessary objects such as trends, alarms, and schedules. The controller application in the Custom Types library is reusable across all controllers of the same model. You can use the controller application as a base for creating new controllers intended for similar applications. You can then edit the controller application, and the changes are automatically replicated to all controllers, while each controller keeps its local values.

WorkStation supports both online and offline engineering of BACnet/IP controllers. You can make the configuration changes online or use database mode to make the changes offline. In database mode, the changes are saved to the EcoStruxure Building Operation database so that you can apply the changes to the controllers later.

Project Configuration Tool enables you to perform all the engineering off site, without the need for physical hardware, which minimizes the time you need to spend on site. You can run the EcoStruxure BMS servers virtually and engineer the BACnet/IP controllers before you deploy your server and controller applications to the servers and controllers on site. For more information, see the Project Configuration Tool specification sheet.

Preconfigured BMS applications for HVAC and Connected Room Solutions

To improve engineering efficiency and standardize engineering practices, fully designed and tested controller applications are available at bms-applications.schneider-electric.com for use with the RP controllers. This library contains applications for different RP controller models and application types, such as fan coil units, ceiling solutions, lights and blinds. These preconfigured controller applications are packages that include all software programs, and for example graphics, alarms, and documentation such as functional specifications and I/O wiring schedules, that are needed for your projects. The online repository can be accessed using common web browsers on Windows PCs as well as mobile devices running Apple iOS 11.3 (or later) and Android 6.0 Marshmallow (or later).

SpaceLogic RP-C Advanced

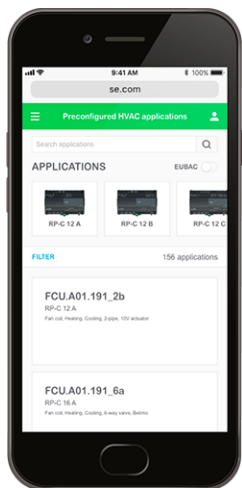

Download page for preconfigured BMS applications

Zoning option

The Zoning option for WorkStation and WebStation provides access to an interactive zoning tool that enables easy reconfiguration of Connected Room Solutions and flexibility when switching between zones. The WebStation zoning tool provides a graphical interface that enables quick editing of zones from any web browser device.

Part Numbers for RP-C Advanced

Product	Part number
RP-C-12A-F-24V	SXWRCF12A10002
RP-C-12B-F-24V	SXWRCF12B10002
RP-C-12C-F-24V	SXWRCF12C10002
RP-C-16A-F-230V	SXWRCF16A10003

Part Numbers for RP-C Accessories

Product	Part number
Optional covers	SXWRPCCOV10001
DIN-RAIL-CLIP, DIN-rail end clip package of 25 pieces	SXWDINEND10001
Isolated RS-485 adapter	SXWISORS48510001
Non-isolated RS-485 adapter	SXWNISORS48510001
RS-485 power adapter	SXWNISORS485P10001
SpaceLogic Wireless Adapter - Advanced	SXWZBAUSB10001
SpaceLogic Bluetooth Adapter	SXWBTAECXX10001

The RP-C-12A, -12B, -12C, and -16A models support up to four segments, which can be used to support rezoning in a building.

Web services

The RP controller uses the RESTful API, which allows IT web services to easily interact with software applications. The flexibility of the RESTful API allows the RP controller to handle multiple types of input and return different data formats. With Web services, clients can read/write data (BACnet values) directly from/to the controller. Web services use resource methods GET, PUT, POST, and DELETE to access and use the data. HTTPS is used for communication between the client and the controller.

The Web services function is disabled by default. When enabled, it requires approximately 200 kB of RP controller memory.

Upgrade with signed firmware

Using digitally signed firmware provides more secure upgrading of the device. During an upgrade, the device verifies that the firmware is authentic and uncompromised Schneider Electric firmware. If the device detects discrepancies in the authenticity or integrity of the firmware, it will reject the upgrade. Once the device is upgraded with signed firmware, all upgrades thereafter must be with a signed firmware version.

SpaceLogic RP-C Advanced

For more information on part numbers for Network Connectivity Accessories, see the Product Selection Guide - EcoStruxure Building.

Specifications

SpaceLogic RP-C Advanced	
AC input	
RP-C-12A-F-24V, RP-C-12B-F-24V, and RP-C-12C-F-24V	
Nominal voltage	24 VAC
Operating voltage range	+/-15 %
Frequency	50/60 Hz
Maximum power consumption	23 VA
Power input protection	MOV suppression and internal fuse
RP-C-16A-F-230V	
Nominal voltage	230 VAC
Operating voltage range	+/-10 %
Frequency	50/60 Hz
Maximum power consumption	65 VA
Power consumption without load	5 W
Power input protection	MOV suppression and internal fuse Separate PTC thermistor used as a resettable fuse for 24 VAC Out only
Overvoltage category	III
Pollution degree	2
DC input	
RP-C-12A-F-24V, RP-C-12B-F-24V, and RP-C-12C-F-24V	
Nominal voltage	24 to 30 VDC
Operating voltage range	23.5 to 33 VDC
Maximum power consumption	14 W
Power input protection	MOV suppression and internal fuse
AC output	
RP-C-16A-F-230V	
Type	Isolated Class 2 output
Nominal voltage	24.0 VAC ^a
a) Condition: 13 VA load and 230 VAC power supply voltage. The AC output voltage varies linearly with the load and the power supply voltage (230 VAC ± 10 %).	
Minimum voltage	19.8 VAC ^a
a) Condition: Maximum load (19 VA ± 10 %) and 230 VAC -10 % power supply voltage.	

SpaceLogic RP-C Advanced

Maximum voltage	30.8 VAC ^a
a) Condition: No load and 230 VAC +10 % power supply voltage.	

Frequency	Same frequency as the power supply (50/60 Hz)
-----------	---

Output power rating	19 VA
---------------------	-------

Environment

RP-C-12A-F-24V, RP-C-12B-F-24V, and RP-C-12C-F-24V	
--	--

Ambient temperature, operating	0 to 50 °C (32 to 122 °F) at normal operation -40 to +60 °C (-40 to +140 °F) for rooftop applications, horizontal installation only
--------------------------------	--

Ambient temperature, storage	-20 to +70 °C (-4 to +158 °F)
------------------------------	-------------------------------

Maximum humidity	95 % RH non-condensing
------------------	------------------------

RP-C-16A-F-230V

Ambient temperature, operating	0 to 50 °C (32 to 122 °F)
--------------------------------	---------------------------

Ambient temperature, storage	-20 to +70 °C (-4 to +158 °F)
------------------------------	-------------------------------

Maximum humidity	95 % RH non-condensing
------------------	------------------------

Material

Plastic flame rating	UL94 V-0
----------------------	----------

Ingress protection rating	IP 20
---------------------------	-------

Mechanical

Dimensions	180 W x 110 H x 64 D mm (7.1 W x 4.3 H x 2.5 D in.)
------------	---

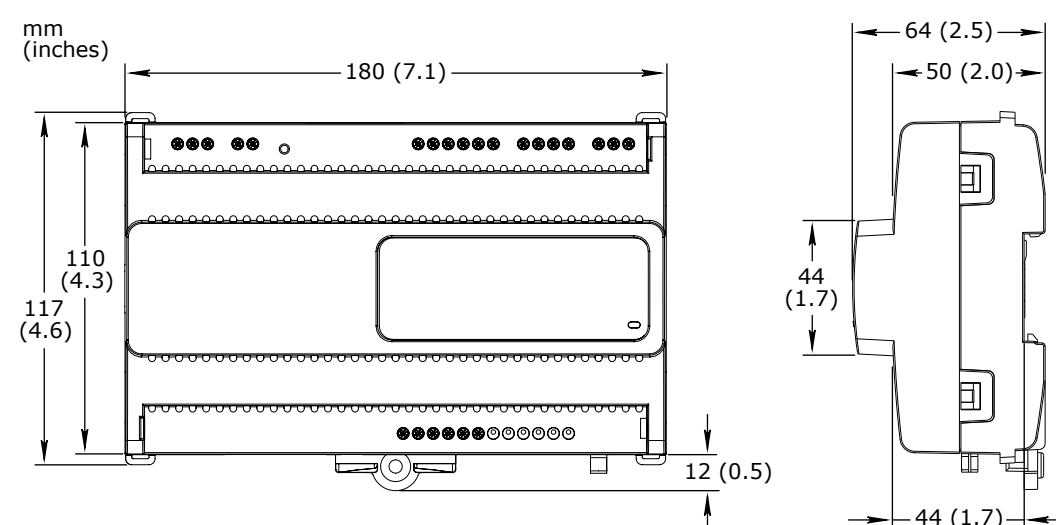

Weight, RP-C-12A-F-24V	0.370 kg (0.816 lb)
------------------------	---------------------

Weight, RP-C-12B-F-24V and RP-C-12C-F-24V	0.390 kg (0.860 lb)
---	---------------------

Weight, RP-C-16A-F-230V	0.720 kg (1.587 lb)
-------------------------	---------------------

Recommended installation	DIN rail or flat surface in a cabinet ^a
--------------------------	--

a) It is recommended to install the device in an enclosure (cabinet), unless local regulations allow an exception.

SpaceLogic RP-C Advanced

Terminal blocks

Fixed

Optional covers

Dimensions

181 W x 164 H x 64 D mm (7.1 W x 6.5 H x 2.5 D in.)

mm
(inches)

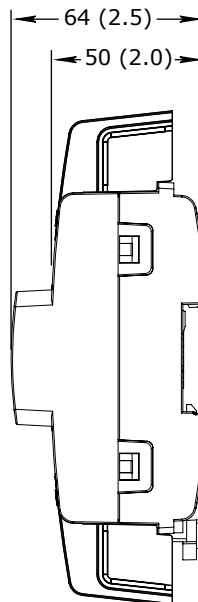
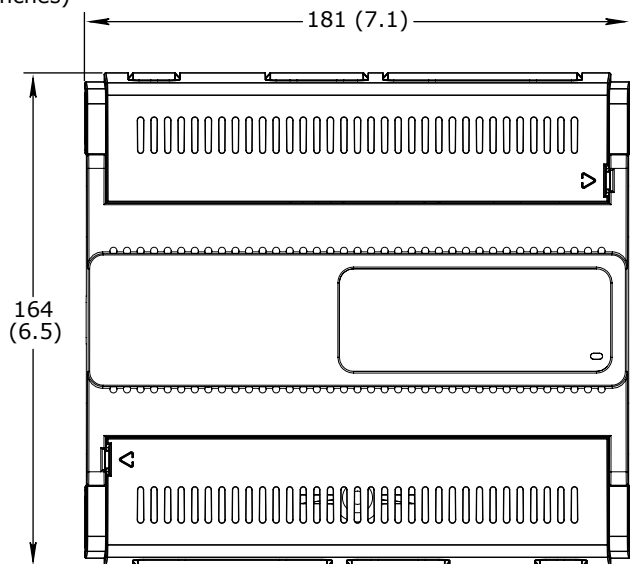

Weight, optional covers

0.070 kg (0.154 lb)

Compatibility

EcoStruxure BMS server communication
EcoStruxure Building Operation

version 3.0.1 and later

BACnet MS/TP network support
EcoStruxure Building Operation

version 4.0.2 and later

Modbus 64-bit register support
EcoStruxure Building Operation

version 5.0.1 and later

BACnet/SC network support
EcoStruxure Building Operation

version 6.0.1 and later

NTP support
EcoStruxure Building Operation

version 7.0.3 and later

Agency compliances

RP-C-12A-F-24V, RP-C-12B-F-24V, and RP-C-12C-F-24V

Emission

RCM; BS/EN 61000-6-3; BS/EN IEC 63044-5-2; FCC Part 15, Subparts B and C, Class B

Immunity

BS/EN 61000-6-2; BS/EN IEC 63044-5-3

Radio

ETSI EN 300 328 V2.2.2

Safety standards

BS/EN 60730-1; BS/EN 60730-2-11; BS/EN IEC 63044-3; UL 916 C-UL US Listed^a

a) RP-C-12A is marked "Energy Management Equipment". RP-C-12B and -12C are marked "Open Energy Management Equipment".

FCC ID

DVE-RPC24

ISED certification number

IC: 24775-RPC24

SpaceLogic RP-C Advanced

Fire performance in air-handling spaces^a

UL 2043

a) The RP-C-12A, -12B, and -12C models are approved for plenum applications.

RP-C-16A-F-230V

Emission RCM; BS/EN 61000-6-3; BS/EN IEC 63044-5-2

Immunity BS/EN 61000-6-2; BS/EN IEC 63044-5-3

Radio ETSI EN 300 328 V2.2.2

Safety standards BS/EN 60730-1; BS/EN 60730-2-11; BS/EN IEC 63044-3

Energy eu.bac Certified Product (Licence No. 219832); BS/EN 15500-1

Real-time clock

Accuracy in backup mode, at 25 °C (77 °F) +/-1 minute per month

Backup time, at 25 °C (77 °F) 7 days minimum

Communication ports

Ethernet Dual 10/100BASE-TX (RJ45), IEEE 802.3 compliant

USB 1 USB 2.0 device port (mini-B)
1 USB 2.0 host port (type-A), 5 VDC, 2.5 W

RS-485 port Com A 24 VDC, 3 W, RS-485 (RJ45)
Transient voltage suppressors on communication and power signals

RS-485 port Com B 24 VDC, 3 W, RS-485 (RJ45)
Transient voltage suppressors on communication and power signals

RS-485 transceiver characteristics

Transceiver type Failsafe
Non-isolated

External biasing None required

Total Unit Load (UL) per device Maximum 0.5 UL

Communications

BACnet BACnet/IP, port configurable, default 47808
BACnet/SC, port configurable, no default port
BACnet MS/TP, maximum bus length: 1200 m (4000 ft), maximum baud rate: 76800
BTL B-AAC (BACnet Advanced Application Controller), B-GW (BACnet Gateway)^a

a) See the BTL Product Catalog for up-to-date details on BTL listed firmware revisions on BACnet International's home page.

Wireless connectivity

Bluetooth Low Energy

Communication protocol Bluetooth® 5.1 Low Energy compliant

Frequency 2.402 to 2.480 GHz

Maximum output power 10 dBm

Maximum communication distance Line-of-sight: 100 m (328 ft)

Antenna Integrated antenna

SpaceLogic RP-C Advanced

RF connector for optional external antenna			SMA connector	
External antenna (optional)		Restricted to the approved antenna type listed below (used in certification)		
Manufacturer	Model (Part number)	Gain	Type	Impedance
Linx Technologies	ANT-2.4-WRT-MON-SMA	0.8 dBi	Monopole	50 ohm
CPU				
Frequency		500 MHz		
Type		ARM Cortex-A7 single-core		
Internal SRAM		6 MB		
NOR flash memory		48 MB		
Memory backup		128 kB, FRAM, non-volatile		
Universal inputs/outputs				
Channels, RP-C-12A-F-24V		8 Ub, Ub1 to Ub8		
Channels, RP-C-12B-F-24V		8 Ub, Ub1 to Ub8		
Channels, RP-C-12C-F-24V		4 Ub, Ub1 to Ub4		
Channels, RP-C-16A-F-230V		8 Ub, Ub1 to Ub8		
Absolute maximum ratings		-0.5 to +24 VDC		
A/D converter resolution		16 bits		
Universal input/output protection		Transient voltage suppressor on each universal input/output		
Digital inputs				
Range		Dry contact switch closure or open collector/open drain, 24 VDC, typical wetting current 2.4 mA		
Minimum pulse width		150 ms		
Counter inputs				
Range		Dry contact switch closure or open collector/open drain, 24 VDC, typical wetting current 2.4 mA		
Minimum pulse width		20 ms		
Maximum frequency		25 Hz		
Supervised inputs				
5 V circuit, 1 or 2 resistors Monitored switch combinations		Series only, parallel only, and series and parallel		
Resistor range For a 2-resistor configuration, each resistor must have the same value +/- 5 %		1 to 10 kohm		
Voltage inputs				
Range		0 to 10 VDC		
Accuracy		+/- (7 mV + 0.2 % of reading)		
Resolution		1.0 mV		

SpaceLogic RP-C Advanced

Continued

Impedance	1 Mohm
Current inputs	
Range	0 to 20 mA
Accuracy	+/(0.01 mA + 0.4 % of reading)
Resolution	1 μ A
Impedance	47 ohm
Resistive inputs	
10 ohm to 10 kohm accuracy R = Resistance in ohm	+/(7 + 4 x 10 ⁻³ x R) ohm
10 kohm to 60 kohm accuracy R = Resistance in ohm	+/(4 x 10 ⁻³ x R + 7 x 10 ⁻⁸ x R ²) ohm
Temperature inputs (thermistors)	
Range	-50 to +150 °C (-58 to +302 °F)
Supported thermistors	
Honeywell	20 kohm
Type I (Continuum)	10 kohm
Type II (I/NET)	10 kohm
Type III (Satchwell)	10 kohm
Type IV (FD)	10 kohm
Type V (FD w/ 11k shunt)	Linearized 10 kohm
Satchwell D?T	Linearized 10 kohm
Johnson Controls	2.2 kohm
Xenta	1.8 kohm
Balco	1 kohm
Measurement accuracy	
20 kohm	-50 to -30 °C: +/-1.5 °C (-58 to -22 °F: +/-2.7 °F) -30 to 0 °C: +/-0.5 °C (-22 to +32 °F: +/-0.9 °F) 0 to 100 °C: +/-0.2 °C (32 to 212 °F: +/-0.4 °F) 100 to 150 °C: +/-0.5 °C (212 to 302 °F: +/-0.9 °F)
10 kohm, 2.2 kohm, and 1.8 kohm	-50 to -30 °C: +/-0.75 °C (-58 to -22 °F: +/-1.35 °F) -30 to +100 °C: +/-0.2 °C (-22 to +212 °F: +/-0.4 °F) 100 to 150 °C: +/-0.5 °C (212 to 302 °F: +/-0.9 °F)
Linearized 10 kohm	-50 to -30 °C: +/-2.0 °C (-58 to -22 °F: +/-3.6 °F) -30 to 0 °C: +/-0.75 °C (-22 to +32 °F: +/-1.35 °F) 0 to 100 °C: +/-0.2 °C (32 to 212 °F: +/-0.4 °F) 100 to 150 °C: +/-0.5 °C (212 to 302 °F: +/-0.9 °F)
1 kohm	-50 to +150 °C: +/-1.0 °C (-58 to +302 °F: +/-1.8 °F)

SpaceLogic RP-C Advanced

Continued

RTD temperature inputs		
Supported RTDs		Pt1000, Ni1000, and LG-Ni1000
Pt1000		
Sensor range		-50 to +150 °C (-58 to +302 °F)
BACnet/IP device environment	Sensor range	Measurement accuracy
0 to 50 °C (32 to 122 °F)	-50 to +70 °C (-58 to +158 °F)	+/-0.5 °C (+/-0.9 °F)
0 to 50 °C (32 to 122 °F)	70 to 150 °C (158 to 302 °F)	+/-0.7 °C (+/-1.3 °F)
-40 to +60 °C (-40 to +140 °F)	-50 to +150 °C (-58 to +302 °F)	+/-1.0 °C (+/-1.8 °F)
Ni1000		
Sensor range		-50 to +150 °C (-58 to +302 °F)
BACnet/IP device environment	Sensor range	Measurement accuracy
0 to 50 °C (32 to 122 °F)	-50 to +150 °C (-58 to +302 °F)	+/-0.5 °C (+/-0.9 °F)
-40 to +60 °C (-40 to +140 °F)	-50 to +150 °C (-58 to +302 °F)	+/-0.5 °C (+/-0.9 °F)
LG-Ni1000		
Sensor range		-50 to +150 °C (-58 to +302 °F)
BACnet/IP device environment	Sensor range	Measurement accuracy
0 to 50 °C (32 to 122 °F)	-50 to +150 °C (-58 to +302 °F)	+/-0.5 °C (+/-0.9 °F)
-40 to +60 °C (-40 to +140 °F)	-50 to +150 °C (-58 to +302 °F)	+/-0.5 °C (+/-0.9 °F)
RTD temperature wiring		
Maximum wire resistance		20 ohm/wire (40 ohm total)
Maximum wire capacitance		60 nF
The wire resistance and capacitance typically corresponds to a 200 m wire.		
Voltage outputs		
Range		0 to 10 VDC
Accuracy		+/-60 mV
Resolution		10 mV
Minimum load resistance		2.4 kohm
Source current		+4.2 mA
Sink current		-1 mA (0 to 0.4 VDC) -4.2 mA (0.4 to 10 VDC)
Relay outputs, DO		
Channels, RP-C-12A-F-24V		0
Channels, RP-C-12B-F-24V		3, DO1 to DO3
Channels, RP-C-12C-F-24V		3, DO5 to DO7

SpaceLogic RP-C Advanced

Continued

Channels, RP-C-16A-F-230V	3, DO5 to DO7
Contact rating	Pilot Duty (C300) Resistive load: 250 VAC/30 VDC, 4 A (cos phi = 1) Inductive load: 250 VAC/30 VDC, 4 A (cos phi = 0.4)
Switch type	Form A Relay Single Pole Single Throw Normally Open
Commons	COM1 for DO1, DO2, and DO3 (on RP-C-12B model) COM3 for DO5, DO6, and DO7 (on RP-C-12C and RP-C-16A models)
Isolation contact to system ground	3,000 VAC
Cycle life	At least 100,000 cycles ^a
a) Actual relay life will vary depending on electrical load characteristics, switching conditions, environmental factors, and application usage.	
Minimum pulse width	100 ms
High power relay outputs, DO	
Channels, RP-C-12A-F-24V	0
Channels, RP-C-12B-F-24V	1, DO4
Channels, RP-C-12C-F-24V	1, DO8
Channels, RP-C-16A-F-230V	1, DO8
Contact rating	Pilot Duty (B300) Minimum current: 100 mA (5 VDC) Normally Open contact, resistive load: 250 VAC/24 VDC, 12 A (cos phi = 1) Normally Closed contact, inductive load: 250 VAC/24 VDC, 3 A (cos phi = 0.4)
Switch type	Form C Relay Single Pole Double Throw Normally Open and Normally Closed
Isolation contact to system ground	5,000 VAC
Cycle life	At least 100,000 cycles ^a
a) Actual relay life will vary depending on electrical load characteristics, switching conditions, environmental factors, and application usage.	
Minimum pulse width	100 ms
Solid-state relay outputs, DO	
Channels, RP-C-12A-F-24V	4, DO1 to DO4
Channels, RP-C-12B-F-24V	0
Channels, RP-C-12C-F-24V	4, DO1 to DO4
Channels, RP-C-16A-F-230V	4, DO1 to DO4
Output rating	Maximum 2 A load per output Maximum 4 A total load for the 4 outputs
AC voltage range	Maximum 30 VAC
DC voltage range	Maximum 30 VDC

SpaceLogic RP-C Advanced

Continued

Commons	COM1 for DO1 and DO2 (on RP-C-12A, -12C, and -16A models) COM2 for DO3 and DO4 (on RP-C-12A, -12C, and -16A models)
When the SSR outputs are used to switch AC, the common terminals can be connected to 0 to 30 VAC. When the SSR outputs are used to switch DC, the common terminals can be connected to -30 VDC to +30 VDC.	
Common voltage range (AC)	0 to 30 VAC
Common voltage range (DC)	-30 to +30 VDC
Minimum pulse width	100 ms
Solid-state relay output protection	Transient voltage suppressor across each solid-state relay (SSR) output

Terminals

For more information on wiring, see the SpaceLogic and EasyLogic - Hardware Installation System Guide.

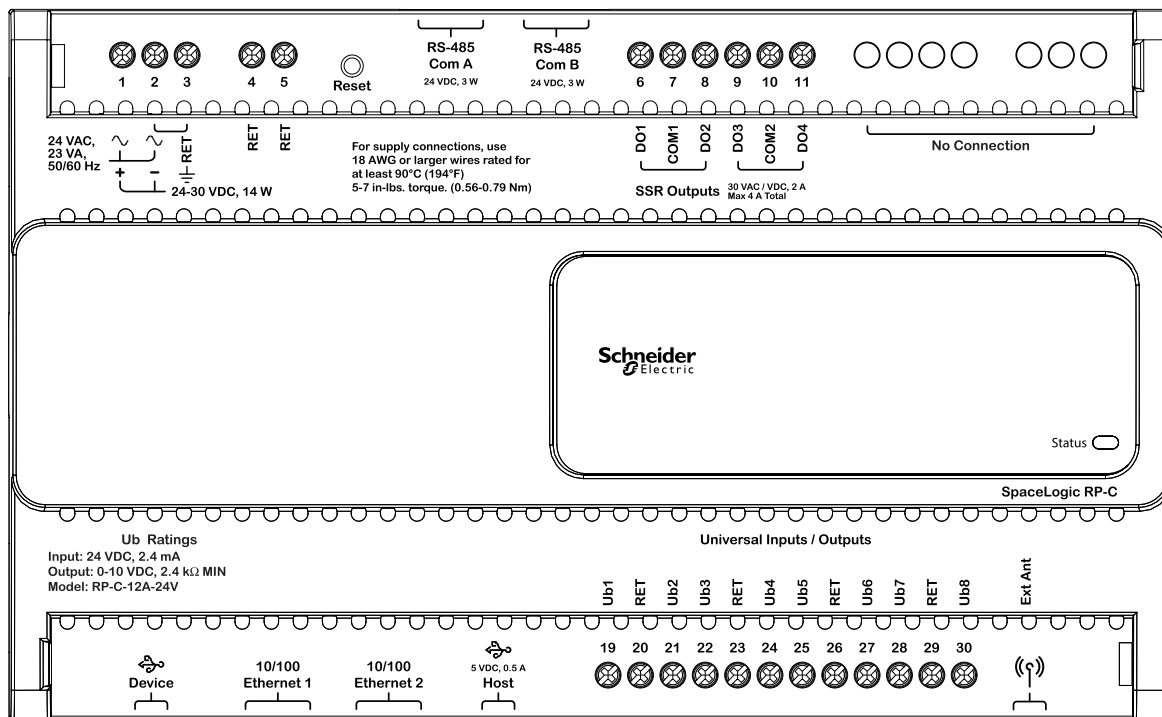

RP-C-12A model (24 VAC/DC)

SpaceLogic RP-C Advanced

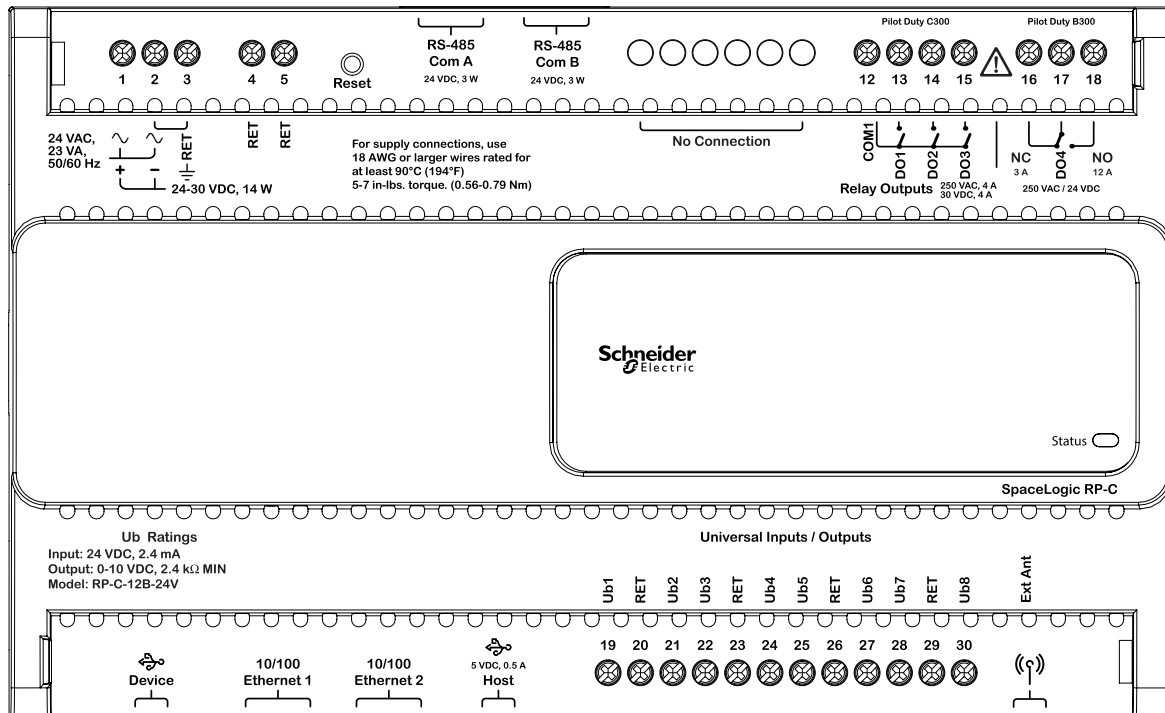

RP-C-12B model (24 VAC/DC)

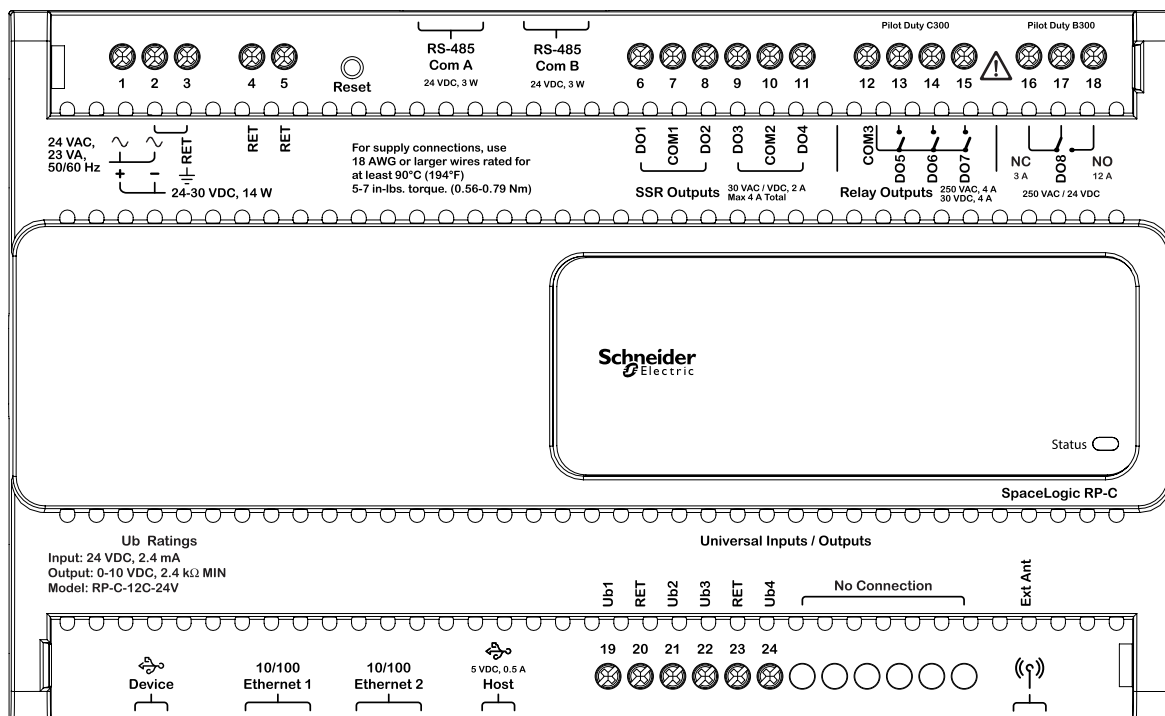

RP-C-12C model (24 VAC/DC)

SpaceLogic RP-C Advanced

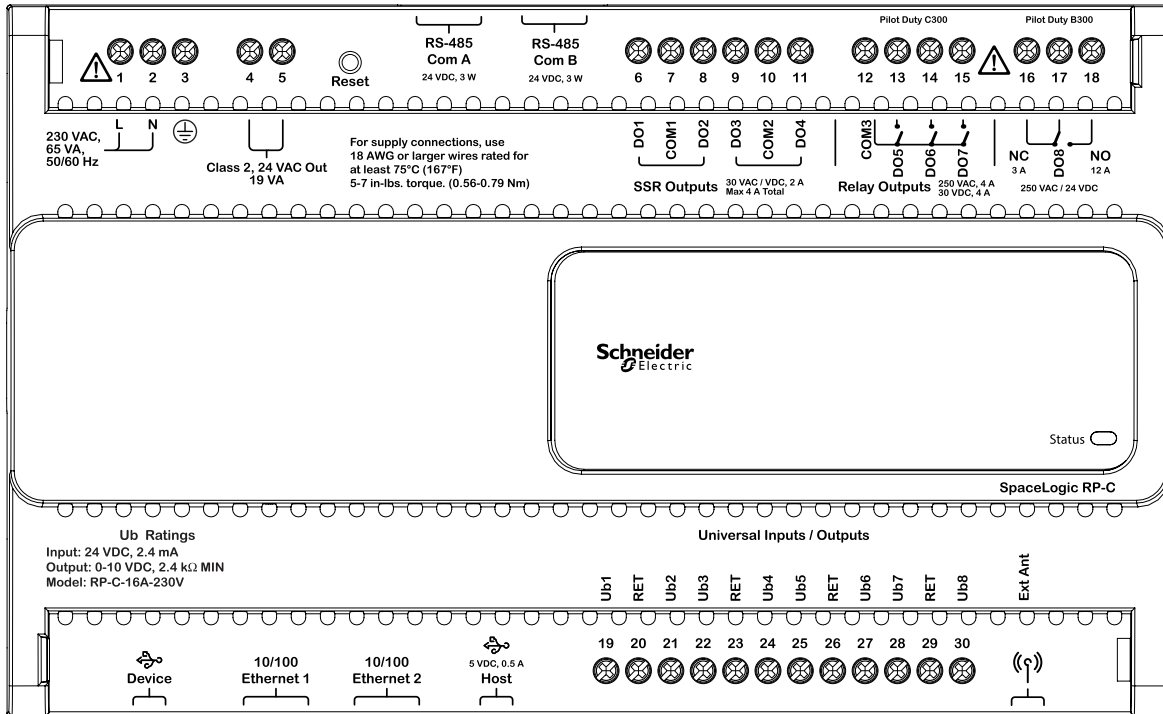

RP-C-16A model (230 VAC)

SpaceLogic RP-C Advanced

Regulatory Notices



Federal Communications Commission

FCC Rules and Regulations CFR 47, Part 15, Class B

This device complies with part 15 of the FCC Rules. Operation is subject to the following two conditions: (1) This device may not cause harmful interference. (2) This device must accept any interference received, including interference that may cause undesired operation.

FCC ID: DVE-RPC24

Industry Canada

This Class B digital apparatus complies with Canadian ICES-003.

Cet appareil numérique de la classe B est conforme à la norme NMB-003 du Canada.

IC: 24775-RPC24



Regulatory Compliance Mark (RCM) - Australian Communications and Media Authority (ACMA)

This equipment complies with the requirements of the relevant ACMA standards made under the Radiocommunications Act 1992 and the Telecommunications Act 1997. These standards are referenced in notices made under section 182 of the Radiocommunications Act and 407 of the Telecommunications Act.

eu.bac



eu.bac - European Building Automation and Controls Association. Certified Product (Licence No. 219832).

This product is certified by eu.bac and conforms to the quality and energy performance criteria outlined by the following European product standard: BS/EN 15500-1.

All eu.bac certified products are found on the eu.bac web site www.eubaccert.eu



CE - Compliance to European Union (EU)

2014/53/EU Radio Equipment Directive (RED)

2014/35/EU Low Voltage Directive

2011/65/EU Restriction of Hazardous Substances (RoHS) Directive

2015/863/EU amending Annex II to Directive 2011/65/EU

This equipment complies with the rules, of the Official Journal of the European Union, for governing the Self Declaration of the CE Marking for the European Union as specified in the above directive(s).



WEEE - Directive of the European Union (EU)

This equipment and its packaging carry the waste of electrical and electronic equipment (WEEE) label, in compliance with European Union (EU) Directive 2012/19/EU, governing the disposal and recycling of electrical and electronic equipment in the European community.



UK Conformity Assessed

S.I. 2017/1206 - Radio Equipment Regulations 2017

S.I. 2016/1101 - Electrical Equipment (Safety) Regulations 2016

S.I. 2012/3032 - Restriction of the Use of Certain Hazardous Substances in Electrical and Electronic Equipment Regulations 2012

S.I. 2013/3113 - Waste Electrical and Electronic Equipment Regulations 2013

This equipment complies with the rules, of the UK regulations, for governing the UKCA Marking for the United Kingdom specified in the above directive(s).



UL 916 Listed products for the United States and Canada. UL file E80146.

www.se.com/buildings

Life Is On

Schneider
Electric