

MH3

Servo motor

Motor manual

V1.01, 03.2026

0198441114042, V1.01, 03.2026

The information provided in this documentation contains general descriptions and/or technical characteristics of the performance of the products contained herein. This documentation is not intended as a substitute for and is not to be used for determining suitability or reliability of these products for specific user applications. It is the duty of any such user or integrator to perform the appropriate and complete risk analysis, evaluation and testing of the products with respect to the relevant specific application or use thereof. Neither Schneider Electric nor any of its affiliates or subsidiaries shall be responsible or liable for misuse of the information contained herein. If you have any suggestions for improvements or amendments or have found errors in this publication, please notify us.

No part of this document may be reproduced in any form or by any means, electronic or mechanical, including photocopying, without express written permission of Schneider Electric.

All pertinent state, regional, and local safety regulations must be observed when installing and using this product. For reasons of safety and to help ensure compliance with documented system data, only the manufacturer should perform repairs to components.

When devices are used for applications with technical safety requirements, the relevant instructions must be followed.

Failure to use Schneider Electric software or approved software with our hardware products may result in injury, harm, or improper operating results.

Failure to observe this information can result in injury or equipment damage.

© 2013 Schneider Electric. All rights reserved.

Table of contents



| | |
|--|-----------|
| Table of contents | 3 |
| Safety Information | 5 |
| Hazard categories | 5 |
| Qualification of personnel..... | 6 |
| Intended use | 6 |
| Basic information..... | 7 |
| Standards and terminology..... | 9 |
| About the book | 11 |
| 1 Introduction | 13 |
| 1.1 Motor family..... | 13 |
| 1.2 Options and accessories | 14 |
| 1.3 Nameplate..... | 15 |
| 1.4 Type code..... | 16 |
| 2 Technical Data | 17 |
| 2.1 General characteristics | 17 |
| 2.2 Motor-specific data..... | 20 |
| 2.2.1 MH3070..... | 20 |
| 2.2.2 MH3100..... | 22 |
| 2.2.3 MH3140..... | 24 |
| 2.2.4 MH3190..... | 26 |
| 2.3 Dimensions | 27 |
| 2.4 Shaft-specific data..... | 31 |
| 2.4.1 Force for pressing on..... | 31 |
| 2.4.2 Shaft load | 32 |
| 2.5 Options | 34 |
| 2.5.1 Holding brake..... | 34 |
| 2.5.2 Encoder..... | 35 |
| 2.6 Conditions for UL 1004-1, UL 1004-6 and CSA 22.2 No. 100 | 36 |
| 2.7 Certifications | 36 |
| 2.8 Declaration of conformity..... | 37 |
| 3 Installation | 39 |
| 3.1 Overview of procedure..... | 41 |
| 3.2 Electromagnetic compatibility (EMC)..... | 41 |
| 3.3 Before mounting | 44 |

| | | |
|----------|---|-----------|
| 3.4 | Mounting the motor | 48 |
| 3.4.1 | Compressed air connection..... | 52 |
| 3.5 | Electrical installation..... | 53 |
| 3.5.1 | Connectors and connector assignments..... | 53 |
| 3.5.2 | Power and encoder connection..... | 57 |
| 3.5.3 | Holding brake connection | 63 |
| 4 | Commissioning..... | 65 |
| 5 | Diagnostics and troubleshooting | 67 |
| 5.1 | Mechanical problems..... | 67 |
| 5.2 | Electrical problems..... | 67 |
| 6 | Accessories and spare parts..... | 69 |
| 6.1 | IP67 Kit..... | 69 |
| 6.2 | Connectors..... | 69 |
| 6.3 | Motor cables..... | 70 |
| 6.3.1 | Motor cables 1.5 mm ² | 70 |
| 6.3.2 | Motor cables 2.5 mm ² | 71 |
| 6.3.3 | Motor cables 4 mm ² | 72 |
| 6.3.4 | Motor cables 10 mm ² | 73 |
| 6.4 | Encoder cables..... | 74 |
| 7 | Service, maintenance and disposal..... | 75 |
| 7.1 | Service address..... | 75 |
| 7.2 | Maintenance..... | 75 |
| 7.3 | Changing the motor..... | 77 |
| 7.4 | Shipping, storage, disposal | 78 |
| | Glossary..... | 79 |
| | Units and conversion tables..... | 79 |
| | Length..... | 79 |
| | Mass..... | 79 |
| | Force..... | 79 |
| | Power..... | 79 |
| | Rotation..... | 80 |
| | Torque..... | 80 |
| | Moment of inertia..... | 80 |
| | Temperature..... | 80 |
| | Conductor cross section | 80 |
| | Terms and Abbreviations | 81 |
| | Table of figures..... | 83 |
| | Index..... | 85 |

Safety Information



Read these instructions carefully, and look at the equipment to become familiar with the device before trying to install, operate, or maintain it. The following special messages may appear throughout this documentation or on the equipment to warn of potential hazards or to call attention to information that clarifies or simplifies a procedure.



The addition of this symbol to a Danger safety label indicates that an electrical hazard exists, which will result in personal injury if the instructions are not followed.



This is the safety alert symbol. It is used to alert you to potential personal injury hazards. Obey all safety messages that follow this symbol to avoid possible injury or death.

Hazard categories

Safety instructions to the user are highlighted by safety alert symbols in the manual. In addition, labels with symbols and/or instructions are attached to the product that alert you to potential hazards.

Depending on the seriousness of the hazard, the safety instructions are divided into 4 hazard categories.

DANGER

DANGER indicates an imminently hazardous situation, which, if not avoided, **will result** in death or serious injury.

WARNING

WARNING indicates a potentially hazardous situation, which, if not avoided, **can result** in death, serious injury, or equipment damage.

CAUTION

CAUTION indicates a potentially hazardous situation, which, if not avoided, **can result** in injury or equipment damage.

NOTICE

NOTICE indicates a potentially hazardous situation, which, if not avoided, **can result** in equipment damage.

Qualification of personnel

Only appropriately trained persons who are familiar with and understand the contents of this manual and all other pertinent product documentation are authorized to work on and with this product. In addition, these persons must have received safety training to recognize and avoid hazards involved. These persons must have sufficient technical training, knowledge and experience and be able to foresee and detect potential hazards that may be caused by using the product, by changing the settings and by the mechanical, electrical and electronic equipment of the entire system in which the product is used.

All persons working on and with the product must be fully familiar with all applicable standards, directives, and accident prevention regulations when performing such work.

Intended use

This product is a motor and intended for industrial use according to this manual.

The product may only be used in compliance with all applicable safety regulations and directives, the specified requirements and the technical data.

Prior to using the product, you must perform a risk assessment in view of the planned application. Based on the results, the appropriate safety measures must be implemented.

Since the product is used as a component in an entire system, you must ensure the safety of persons by means of the design of this entire system (for example, machine design).

Operate the product only with the specified cables and accessories. Use only genuine accessories and spare parts.

Any use other than the use explicitly permitted is prohibited and can result in hazards.

Electrical equipment should be installed, operated, serviced, and maintained only by qualified personnel.

Basic information

DANGER

HAZARD OF ELECTRIC SHOCK, EXPLOSION OR ARC FLASH

- Supplement the motor cable grounding conductor with an additional protective ground conductor to the motor housing.
- Do not touch unshielded components or terminals with voltage present. Use only electrically insulated tools.
- Insulate both ends of unused conductors of the motor cable.
- Do not short across the DC bus terminals or the DC bus capacitors.
- Before performing work on the drive system:
 - Block the motor shaft to prevent generation of voltage by external driving forces (regeneration condition).
 - Disconnect all power, including external control power that may be present.
 - Place a "Do Not Turn On" label on all power switches.
 - Lock all power switches in the open position.
 - Verify that no voltage is present (for example, voltage from the DC bus capacitors of the drive).
- Install and close all covers before applying voltage.

Failure to follow these instructions will result in death or serious injury.

The product is not approved for use in hazardous areas (explosive atmospheres).

WARNING

EXPLOSION HAZARD

Only use this device outside of hazardous areas (explosive atmospheres).

Failure to follow these instructions can result in death, serious injury, or equipment damage.

NOTE: See the product manual of the servo drive for additional important safety information.

If the power stage is disabled unintentionally, for example as a result of power outage, errors or functions, the motor is no longer decelerated in a controlled way. Overload, errors or incorrect use may cause

the holding brake to no longer operate properly and may result in premature wear.

| |
|---|
| ▲ WARNING |
| MOVEMENT WITHOUT BRAKING EFFECT |
| <ul style="list-style-type: none">• Verify that movements without braking effect cannot cause injuries or equipment damage.• Verify the function of the holding brake at regular intervals.• Do not use the holding brake as a service brake. |
| Failure to follow these instructions can result in death, serious injury, or equipment damage. |

| |
|--|
| ▲ WARNING |
| LOSS OF CONTROL |
| <ul style="list-style-type: none">• The designer of any control scheme must consider the potential failure modes of control paths and, for certain critical functions, provide a means to achieve a safe state during and after a path failure. Examples of critical control functions are emergency stop, overtravel stop, power outage and restart.• Separate or redundant control paths must be provided for critical functions.• System control paths may include communication links. Consideration must be given to the implication of unanticipated transmission delays or failures of the link.• Observe all accident prevention regulations and local safety guidelines.¹⁾• Each implementation of the product must be individually and thoroughly tested for proper operation before being placed into service. |
| Failure to follow these instructions can result in death, serious injury, or equipment damage. |

1) For USA: Additional information, refer to NEMA ICS 1.1 (latest edition), "Safety Guidelines for the Application, Installation, and Maintenance of Solid State Control" and to NEMA ICS 7.1 (latest edition), "Safety Standards for Construction and Guide for Selection, Installation and Operation of Adjustable-Speed Drive Systems".

Standards and terminology

Technical terms, terminology and the corresponding descriptions in this manual are intended to use the terms or definitions of the pertinent standards.

In the area of drive systems, this includes, but is not limited to, terms such as "safety function", "safe state", "fault", "fault reset", "failure", "error", "error message", "warning", etc.

Among others, these standards include:

- IEC 61800 series: "Adjustable speed electrical power drive systems"
- IEC 61158 series: "Digital data communications for measurement and control – Fieldbus for use in industrial control systems"
- IEC 61784 series: "Industrial communication networks – Profiles"
- IEC 61508 series: "Functional safety of electrical/electronic/programmable electronic safety-related systems"

Also see the glossary at the end of this manual.

About the book



This manual is valid for the standard products listed in the type code, see chapter "1.4 Type code".

Source manuals The latest versions of the manuals can be downloaded from the Internet at:

<http://www.schneider-electric.com>

Work steps If work steps must be performed consecutively, this sequence of steps is represented as follows:

- Special prerequisites for the following work steps
- ▶ Step 1
- ◁ Specific response to this work step
- ▶ Step 2

If a response to a work step is indicated, this allows you to verify that the work step has been performed correctly.

Unless otherwise stated, the individual steps must be performed in the specified sequence.

Making work easier Information on making work easier is highlighted by this symbol:



Sections highlighted this way provide supplementary information on making work easier.

SI units Technical data are specified in SI units. Converted units are shown in parentheses behind the SI unit; they may be rounded.

Example:

Minimum conductor cross section: 1.5 mm² (AWG 14)

Glossary Explanations of special technical terms and abbreviations.

Index List of keywords with references to the corresponding page numbers.

1 Introduction

1.1 Motor family

The motors are AC synchronous servo motors with a very high power density. A drive system consists of the AC synchronous servo motor and the appropriate drive. Maximum performance requires the motor and drive to be adapted to each other.

Characteristics The AC synchronous servo motors excel with:

- High power density: the use of the latest magnetic materials and an optimized design result in motors with a shorter length at a comparable torque.
- High peak torque: the peak torque can be up to four times the continuous stall torque

1.2 Options and accessories

The motors are available with various options such as:

- Holding brake
- Various shaft versions
- Various lengths
- Various sizes

The options can be found in the type code section on page 16.

For accessories see chapter "6 Accessories and spare parts", page 69.

1.3 Nameplate

The nameplate contains the following data:

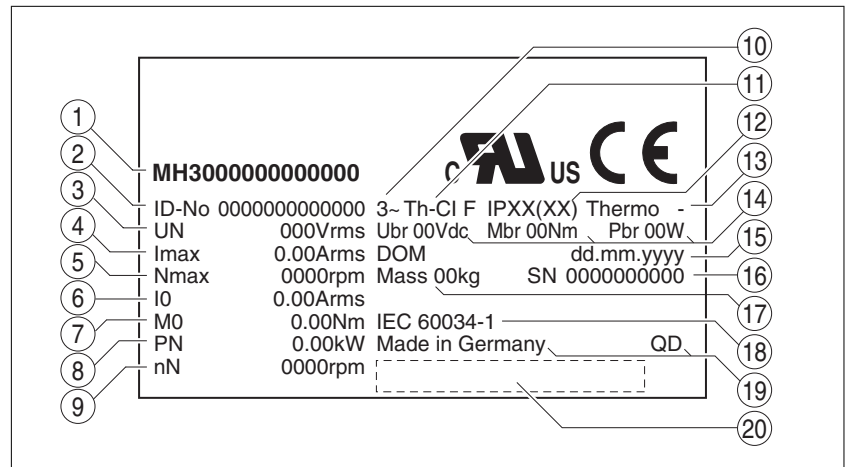

Figure 1: Nameplate

- (1) Motor type, see type code
- (2) Identification number
- (3) Maximum nominal value of supply voltage
- (4) Maximum current
- (5) Maximum speed of rotation
- (6) Continuous stall current
- (7) Continuous stall torque
- (8) Nominal power
- (9) Nominal speed of rotation
- (10) Number of motor phases
- (11) Thermal class
- (12) Degree of protection (housing without shaft bushing)
- (13) Temperature sensor
- (14) Holding brake data
- (15) Date of manufacture
- (16) Serial number
- (17) Mass of the motor
- (18) Applied standard
- (19) Country of manufacture, site
- (20) Barcode

1.4 Type code

| | | | | | | | | | | |
|---|-----|-----|---|---|---|---|---|---|---|----|
| | MH3 | 070 | 1 | P | 0 | 1 | A | 2 | 2 | 00 |
| Product family MH3 = Synchronous motor - medium moment of inertia | | | | | | | | | | |
| Size (housing) 070 = 70 mm flange 100 = 100 mm flange 140 = 140 mm flange 190 = 190 mm flange | | | | | | | | | | |
| Length 1 = 1 stack 2 = 2 stacks 3 = 3 stacks | | | | | | | | | | |
| Winding P = Optimized in terms of torque and speed of rotation | | | | | | | | | | |
| Shaft 0 = Smooth shaft 1 = Parallel key | | | | | | | | | | |
| Encoder system 1 = Absolute singleturn 128 Sin/Cos periods per revolution (SKS36) 2 = Absolute multiturn 128 Sin/Cos periods per revolution (SKM36) 6 = Absolute singleturn 16 Sin/Cos periods per revolution (SEK37) 7 = Absolute multiturn 16 Sin/Cos periods per revolution (SEL37) | | | | | | | | | | |
| Holding brake A = Without holding brake F = With holding brake | | | | | | | | | | |
| Connection version 2 = Angular connector 90°, can be rotated | | | | | | | | | | |
| Degree of protection shaft and housing - type of cooling ¹⁾ 2 = Shaft IP65 ^{2) 3)} with shaft sealing ring ⁴⁾ , housing IP65 ³⁾ , free convection | | | | | | | | | | |
| Versions 00 = Standard | | | | | | | | | | |

- 1) Versions not listed are not considered in this manual.
- 2) In the case of mounting position IM V3 (drive shaft vertical, shaft end upward), the motor only has degree of protection IP 50.
- 3) With connection possibility for compressed air to reach IP67. See chapter "3.4.1 Compressed air connection".
- 4) The maximum permissible speed of rotation is limited to 6000 min⁻¹ by the shaft sealing ring.

If you have questions concerning the type code, contact your Schneider Electric sales office.

Designation customized version

In the case of a customized version, position 8 of the type code is an "S". The subsequent number defines the customized version. Example: MH30551S01A00

Contact your machine vendor if you have questions concerning customized versions.

2 Technical Data

This chapter contains information on the ambient conditions and on the mechanical and electrical properties of the product family and the accessories.

2.1 General characteristics

| | | |
|--|----------------------------|-------------------------------|
| Motor type | AC synchronous servo motor | |
| Degree of protection motor housing | IP65 | As per IEC 60034-5 |
| Degree of protection shaft bushing with shaft sealing ring | IP65 ^{1) 2)} | As per IEC 60034-5 |
| Degree of protection with connected compressed air | Shaft IP67 Housing IP67 | As per IEC 60034-5 |
| Thermal class | F (155 C°) | As per IEC 60034-1 |
| Vibration grade | A | As per IEC 60034-14 |
| Test voltage | > 2400 Vac | As per IEC 60034-1 |
| Perpendicularity | normal class | As per IEC 60072-1, DIN 42955 |
| Housing color | Black RAL 9005 | |
| Overvoltage category | III | As per IEC 61800-5-1 |
| Protection class ³⁾ | I | As per IEC 61140, EN 50178 |

- 1) With shaft sealing ring: the maximum speed of rotation is limited to 6000 min⁻¹; shaft sealing ring with initial lubrication, if the seal runs dry, this increases friction and reduces service life.
- 2) In the case of mounting position IM V3 (drive shaft vertical, shaft end up), the motor only has degree of protection IP50. The degree of protection only relates to the motor itself, not to mounted components such as, for example, a gearbox.
- 3) The signals of the holding brake at CN1 and the signals at CN2 meet the PELV requirements.

The motor has been tested for compatibility with external substances according to the latest knowledge. However, it is impossible to follow up on all further developments of all substances such as lubricants or cleaning agents. Therefore, you must perform a compatibility test prior to using new substances.

Climatic environmental conditions transportation and storage

The environment during transportation and storage must be dry and free from dust.

The storage time is primarily limited by the service life of the lubricants in the bearings; do not store the product for more than 36 months. It is recommended to periodically operate the motor. Long storage periods may reduce the holding torque of the holding brake. See "Inspecting/braking in the holding brake" in chapter "7 Service, maintenance and disposal".

| | | |
|--|------------|-----------------------------|
| Temperature | °C (°F) | -40 ... 70 (-40 ... 158) |
| Relative humidity (non-condensing) | % | ≤75 |
| Set of class combinations as per IEC 60721-3-2 | | IE 21 |

Climatic environmental conditions operation

| | | |
|---|------------|----------------------------------|
| Ambient temperature ¹⁾ (no icing, non-condensing) | °C (°F) | -20 ... 40 (-4 ... 104) |
| Ambient temperature with current derating of 1% per °C (per 1.8 °F ¹⁾) | °C (°F) | 40 ... 60 (104 ... 140) |
| Relative humidity (non-condensing) | % | 5 ... 85 |
| Class as per IEC 60721-3-3 | | 3K3, 3Z12, 3Z2, 3B2, 3C1, 3M6 |
| Installation altitude ²⁾ | m (ft) | <1000 (<3281) |
| Installation altitude with current derating of 1% per 100 m (328 ft) at altitudes of more than 1000 m (3281 ft) ²⁾ | m (ft) | 1000 ... 3000 (3281 ... 9843) |

1) Limit values with flanged motor (steel plate, height and width = 2.5 * motor flange, 10 mm thickness, centered hole.).

2) The installation altitude is defined in terms of altitude above mean sea level.

Vibration and shock

| | |
|------------------------|--|
| Vibration, sinusoidal | Type test with 10 runs as per IEC 60068-2-6 0.15 mm (10 ... 60 Hz) 20 m/s ² (60 ... 500 Hz) |
| Shock, semi-sinusoidal | Type test with 3 shocks in each direction as per IEC 60068-2-27 150 m/s ² (11 ms) |

Service life

| | | |
|--|---|-------|
| Nominal bearing service life L_{10h} ¹⁾ | h | 20000 |
|--|---|-------|

1) Operating hours at a probability of failure of 10%

The service life of the motors when operated correctly is limited primarily by the service life of the rolling bearing.

The following operating conditions significantly reduce the service life:

- Installation altitude >1000 m (3281 ft) above mean sea level
- Rotary movements exclusively within a fixed angle of <100°
- Operation under vibration load >20 m/s²
- Allowing sealing rings to run dry
- Contact of the seals with aggressive substances

Shaft sealing ring / degree of protection

The motors are equipped with a shaft sealing ring. With a shaft sealing ring, they have degree of protection IP65. The shaft sealing ring limits the maximum speed of rotation to 6000 min⁻¹.

Note the following:

- The shaft sealing ring is factory-pre-lubricated.
- If the seals run dry, this increases friction and greatly reduces the service life of the sealing rings.

Compressed air connection The compressed air generates a permanent overpressure inside the motor. This overpressure inside the motor is used to obtain degree of protection IP67.

Compressed air must also be available when the system is switched off, for example to maintain the required degree of protection during cleaning work. When the compressed air is switched off, the degree of protection is decreased to IP65. The degree of protection only relates to the motor itself, not to mounted components such as, for example, a gearbox.

Special compressed air must be used:

| | | |
|--|-----------|-------------------------------|
| Nominal pressure | bar (psi) | 0.1 ... 0.3 (1.45 ... 4.35) |
| Maximum air pressure | bar (psi) | 0.4 (5.8) |
| Permissible humidity | % | 20 ... 30 |
| Other properties of the compressed air | | Free from dust, free from oil |

Tightening torque and property class of screws used

| | | |
|--|------------|--------------------------|
| Tightening torque of housing screws M3 | Nm (lb•in) | 1 (8.85) |
| Tightening torque of housing screws M4 | Nm (lb•in) | 1.5 (13.28) |
| Tightening torque of housing screws M5 | Nm (lb•in) | 5 (44.3) |
| Tightening torque protective ground conductor M4 (MH3070 ... 100) Tightening torque protective ground conductor M6 (MH3140 ... 190) | Nm (lb•in) | 2.9 (25.7) 9.9 (87.3) |
| Property class of the screws | H | 8.8 |

Approved drives You may use drives that are approved for the MH3 motor family (such as LXM52 and LXM62). When selecting, consider the type and amount of the mains voltage. Contact your local sales office for additional drives.

2.2 Motor-specific data

2.2.1 MH3070

| MH3... | | 0701 | 0702 | 0703 |
|--|-------------------|----------|----------|----------|
| Winding | | P | P | P |
| Technical data - general | | | | |
| Continuous stall torque ¹⁾ M ₀ ²⁾ | Nm | 1.40 | 2.48 | 3.40 |
| Peak torque M _{max} | Nm | 4.20 | 7.44 | 10.20 |
| With supply voltage U _n = 115 Vac ¹⁾ | | | | |
| Nominal speed of rotation n _N | min ⁻¹ | 1250 | 1250 | 1250 |
| Nominal torque M _N | Nm | 1.38 | 2.37 | 3.18 |
| Nominal current I _N | A _{rms} | 1.75 | 2.82 | 3.56 |
| Nominal power P _N | kW | 0.18 | 0.31 | 0.42 |
| With supply voltage U _n = 230 Vac ¹⁾ | | | | |
| Nominal speed of rotation n _N | min ⁻¹ | 3000 | 3000 | 2500 |
| Nominal torque M _N | Nm | 1.34 | 2.23 | 2.96 |
| Nominal current I _N | A _{rms} | 1.75 | 2.70 | 3.47 |
| Nominal power P _N | kW | 0.42 | 0.70 | 0.75 |
| With supply voltage U _n = 400 Vac ¹⁾ | | | | |
| Nominal speed of rotation n _N | min ⁻¹ | 5500 | 5500 | 5000 |
| Nominal torque M _N | Nm | 1.30 | 2.01 | 2.53 |
| Nominal current I _N | A _{rms} | 1.72 | 2.49 | 3.02 |
| Nominal power P _N | kW | 0.75 | 1.16 | 1.32 |
| With supply voltage U _n = 480 Vac ¹⁾ | | | | |
| Nominal speed of rotation ³⁾ n _N | min ⁻¹ | 7000 | 7000 | 6500 |
| Nominal torque M _N | Nm | 1.27 | 1.89 | 2.26 |
| Nominal current I _N | A _{rms} | 1.70 | 2.36 | 2.74 |
| Nominal power P _N | kW | 0.93 | 1.38 | 1.54 |

1) Conditions for performance data: Mounted to steel plate (2.5 * flange dimension)² area, 10 mm thickness, centered hole.

2) M₀= Continuous stall torque at low speed of rotation and 100% duty cycle; at speeds of rotation of < 20 min⁻¹ the continuous stall torque is reduced to 87%

3) With shaft sealing ring: the maximum speed of rotation is limited to 6000 min⁻¹; shaft sealing ring with initial lubrication, if the seals run dry, this increases friction and reduces the service life.

| MH3... | | 0701 | 0702 | 0703 |
|---|------------|----------|----------|----------|
| Winding | | P | P | P |
| Technical data - electrical | | | | |
| Maximum current I_{max} | A_{rms} | 5.97 | 9.68 | 12.57 |
| Continuous stall current I_0 | A_{rms} | 1.78 | 2.94 | 3.91 |
| Voltage constant ¹⁾ k_{EU-V} | V_{rms} | 50.72 | 54.08 | 55.00 |
| Torque constant ²⁾ k_t | Nm/A | 0.79 | 0.84 | 0.87 |
| Winding resistance R_{20U-V} | Ω | 8.28 | 3.84 | 2.65 |
| Winding inductance L_{qU-V} | mH | 23.40 | 12.19 | 8.64 |
| Winding inductance L_{dU-V} | mH | 24.15 | 12.54 | 8.91 |
| Technical data - mechanical | | | | |
| Maximum permissible speed of rotation n_{max} | min^{-1} | 6000 | 6000 | 6000 |
| Rotor inertia without holding brake J_M | $kgcm^2$ | 0.59 | 1.13 | 1.67 |
| Rotor inertia with holding brake J_M | $kgcm^2$ | 0.70 | 1.24 | 1.78 |
| Mass without holding brake m | kg | 1.60 | 2.30 | 3.00 |
| Mass with holding brake m | kg | 2.60 | 3.30 | 4.00 |

1) RMS value at 1000 min^{-1} and 20 °C

2) At $n = 20 min^{-1}$ and 120 °C

2.2.2 MH3100

| MH3... | | 1001 | 1002 | 1003 |
|--|-------------------|----------|----------|----------|
| Winding | | P | P | P |
| Technical data - general | | | | |
| Continuous stall torque ¹⁾ M ₀ ²⁾ | Nm | 3.40 | 6.00 | 9.00 |
| Peak torque M _{max} | Nm | 10.20 | 18.00 | 27.00 |
| With supply voltage U _n = 115 Vac ¹⁾ | | | | |
| Nominal speed of rotation n _N | min ⁻¹ | 1000 | 1000 | 1000 |
| Nominal torque M _N | Nm | 3.30 | 5.67 | 8.45 |
| Nominal current I _N | A _{rms} | 3.07 | 4.81 | 7.30 |
| Nominal power P _N | kW | 0.35 | 0.59 | 0.88 |
| With supply voltage U _n = 230 Vac ¹⁾ | | | | |
| Nominal speed of rotation n _N | min ⁻¹ | 2000 | 2000 | 2500 |
| Nominal torque M _N | Nm | 3.20 | 5.33 | 7.63 |
| Nominal current I _N | A _{rms} | 2.99 | 4.58 | 6.70 |
| Nominal power P _N | kW | 0.67 | 1.12 | 2.00 |
| With supply voltage U _n = 400 Vac ¹⁾ | | | | |
| Nominal speed of rotation n _N | min ⁻¹ | 4000 | 4000 | 4000 |
| Nominal torque M _N | Nm | 3.00 | 4.67 | 6.80 |
| Nominal current I _N | A _{rms} | 2.83 | 4.10 | 6.07 |
| Nominal power P _N | kW | 1.26 | 1.95 | 2.85 |
| With supply voltage U _n = 480 Vac ¹⁾ | | | | |
| Nominal speed of rotation n _N | min ⁻¹ | 5000 | 5000 | 5000 |
| Nominal torque M _N | Nm | 2.90 | 4.20 | 6.25 |
| Nominal current I _N | A _{rms} | 2.75 | 3.73 | 5.64 |
| Nominal power P _N | kW | 1.52 | 2.27 | 3.27 |

1) Conditions for performance data: Mounted to steel plate 300 * 300 mm area, 20 mm thickness, centered hole.

2) M₀= Continuous stall torque at low speed of rotation and 100% duty cycle; at speeds of rotation of < 20 min⁻¹ the continuous stall torque is reduced to 87%

| MH3... | | 1001 | 1002 | 1003 |
|---|------------|----------|----------|----------|
| Winding | | P | P | P |
| Technical data - electrical | | | | |
| Maximum current I_{max} | A_{rms} | 11.20 | 17.50 | 26.71 |
| Continuous stall current I_0 | A_{rms} | 3.15 | 5.04 | 7.69 |
| Voltage constant ¹⁾ k_{EU-V} | V_{rms} | 70.30 | 78.00 | 77.95 |
| Torque constant ²⁾ k_t | Nm/A | 1.09 | 1.19 | 1.17 |
| Winding resistance R_{20U-V} | Ω | 4.12 | 1.97 | 1.08 |
| Winding inductance L_{qU-V} | mH | 14.90 | 8.24 | 5.23 |
| Winding inductance L_{dU-V} | mH | 13.15 | 7.35 | 4.62 |
| Technical data - mechanical | | | | |
| Maximum permissible speed of rotation n_{max} | min^{-1} | 6000 | 6000 | 6000 |
| Rotor inertia without holding brake J_M | $kgcm^2$ | 3.19 | 6.28 | 9.37 |
| Rotor inertia with holding brake J_M | $kgcm^2$ | 3.68 | 6.77 | 10.30 |
| Mass without holding brake m | kg | 3.34 | 4.92 | 6.50 |
| Mass with holding brake m | kg | 4.80 | 6.38 | 8.15 |

1) RMS value at 1000 min^{-1} and 20 °C

2) At $n = 20 min^{-1}$ and 120 °C

2.2.3 MH3140

| MH3... | | 1401 | 1402 | 1403 |
|--|-------------------|-------|-------|-------|
| Winding | | P | P | P |
| Technical data - general | | | | |
| Continuous stall torque ¹⁾ M ₀ ²⁾ | Nm | 10.30 | 18.50 | 24.00 |
| Peak torque M _{max} | Nm | 39.90 | 55.50 | 75.00 |
| With supply voltage U _n = 115 Vac ¹⁾ | | | | |
| Nominal speed of rotation n _N | min ⁻¹ | 1000 | 1000 | 750 |
| Nominal torque M _N | Nm | 9.36 | 16.34 | 22.17 |
| Nominal current I _N | A _{rms} | 7.82 | 14.87 | 18.00 |
| Nominal power P _N | kW | 0.98 | 1.71 | 1.78 |
| With supply voltage U _n = 230 Vac ¹⁾ | | | | |
| Nominal speed of rotation n _N | min ⁻¹ | 2000 | 2000 | 1750 |
| Nominal torque M _N | Nm | 8.50 | 14.00 | 19.30 |
| Nominal current I _N | A _{rms} | 7.30 | 13.13 | 14.90 |
| Nominal power P _N | kW | 1.78 | 2.93 | 3.55 |
| With supply voltage U _n = 400 Vac ¹⁾ | | | | |
| Nominal speed of rotation n _N | min ⁻¹ | 3500 | 3500 | 3500 |
| Nominal torque M _N | Nm | 7.22 | 10.17 | 13.06 |
| Nominal current I _N | A _{rms} | 6.35 | 9.76 | 10.42 |
| Nominal power P _N | kW | 2.64 | 3.73 | 4.75 |
| With supply voltage U _n = 480 Vac ¹⁾ | | | | |
| Nominal speed of rotation n _N | min ⁻¹ | 3500 | 3500 | 3500 |
| Nominal torque M _N | Nm | 7.22 | 10.17 | 13.06 |
| Nominal current I _N | A _{rms} | 6.35 | 9.76 | 10.42 |
| Nominal power P _N | kW | 2.64 | 3.73 | 4.75 |

1) Conditions for performance data: Mounted to steel plate 400 * 400 mm area, 10 mm thickness, centered hole.

2) M₀= Continuous stall torque at low speed of rotation and 100% duty cycle; at speeds of rotation of < 20 min⁻¹ the continuous stall torque is reduced to 87%

| MH3... | | 1401 | 1402 | 1403 |
|---|------------|----------|----------|----------|
| Winding | | P | P | P |
| Technical data - electrical | | | | |
| Maximum current I_{max} | A_{rms} | 29.80 | 57.42 | 62.32 |
| Continuous stall current I_0 | A_{rms} | 8.58 | 16.83 | 18.00 |
| Voltage constant $^1)k_{EU-V}$ | V_{rms} | 77.41 | 70.70 | 85.89 |
| Torque constant $^2)k_t$ | Nm/A | 1.20 | 1.10 | 1.33 |
| Winding resistance R_{20U-V} | Ω | 0.69 | 0.23 | 0.22 |
| Winding inductance L_{qU-V} | mH | 6.72 | 2.99 | 3.00 |
| Winding inductance L_{dU-V} | mH | 6.72 | 2.99 | 2.80 |
| Technical data - mechanical | | | | |
| Maximum permissible speed of rotation n_{max} | min^{-1} | 4000 | 4000 | 4000 |
| Rotor inertia without holding brake J_M | $kgcm^2$ | 16.46 | 32.00 | 47.54 |
| Rotor inertia with holding brake J_M | $kgcm^2$ | 17.96 | 33.50 | 50.27 |
| Mass without holding brake m | kg | 8.00 | 12.00 | 16.00 |
| Mass with holding brake m | kg | 10.30 | 14.30 | 18.53 |

1) RMS value at 1000 min^{-1} and 20 °C

2) At $n = 20 min^{-1}$ and 120 °C

2.2.4 MH3190

| MH3... | | 1901 | 1902 | 1903 |
|--|-------------------|----------|----------|----------|
| Winding | | P | P | P |
| Technical data - general | | | | |
| Continuous stall torque ¹⁾ M ₀ ²⁾ | Nm | 30 | 48 | 65 |
| Peak torque M _{max} | Nm | 90 | 144 | 195 |
| With supply voltage U _n = 400 Vac ¹⁾ | | | | |
| Nominal speed of rotation n _N | min ⁻¹ | 3000 | 2000 | 2000 |
| Nominal torque M _N | Nm | 16.50 | 29.00 | 37.00 |
| Nominal current I _N | A _{rms} | 14.00 | 19.30 | 21.30 |
| Nominal power P _N | kW | 5.18 | 6.07 | 7.75 |
| With supply voltage U _n = 480 Vac ¹⁾ | | | | |
| Nominal speed of rotation n _N | min ⁻¹ | 3000 | 2000 | 2000 |
| Nominal torque M _N | Nm | 16.50 | 29.00 | 37.00 |
| Nominal current I _N | A _{rms} | 14.00 | 19.30 | 21.30 |
| Nominal power P _N | kW | 5.18 | 6.07 | 7.75 |

1) Conditions for performance data: Mounted to steel plate 550 * 550 mm area, 30 mm thickness, centered hole.

2) M₀= Continuous stall torque at low speed of rotation and 100% duty cycle; at speeds of rotation of < 20 min⁻¹ the continuous stall torque is reduced to 87%

| MH3... | | 1901 | 1902 | 1903 |
|--|-------------------|----------|----------|----------|
| Winding | | P | P | P |
| Technical data - electrical | | | | |
| Maximum current I _{max} | A _{rms} | 89.6 | 114 | 124.5 |
| Continuous stall current I ₀ | A _{rms} | 23.2 | 30.8 | 36.1 |
| Voltage constant ¹⁾ k _{EU-V} | V _{rms} | 87.6 | 108.3 | 129.2 |
| Torque constant ²⁾ k _t | Nm/A | 1.30 | 1.56 | 1.80 |
| Winding resistance R _{20U-V} | Ω | 0.24 | 0.15 | 0.13 |
| Winding inductance L _{qU-V} | mH | 5.08 | 3.86 | 3.62 |
| Winding inductance L _{dU-V} | mH | 5.23 | 3.73 | 3.43 |
| Technical data - mechanical | | | | |
| Maximum permissible speed of rotation n _{max} | min ⁻¹ | 4000 | 4000 | 3500 |
| Rotor inertia without holding brake J _M | kgcm ² | 67.7 | 130.1 | 194.1 |
| Rotor inertia with holding brake J _M | kgcm ² | 71.8 | 144.8 | 208.8 |
| Mass without holding brake m | kg | 19 | 31 | 43 |
| Mass with holding brake m | kg | 20.5 | 32.5 | 44.5 |

1) RMS value at 1000 min⁻¹ and 20 °C

2) At n = 20 min⁻¹ and 120 °C

2.3 Dimensions

Dimensions MH3070

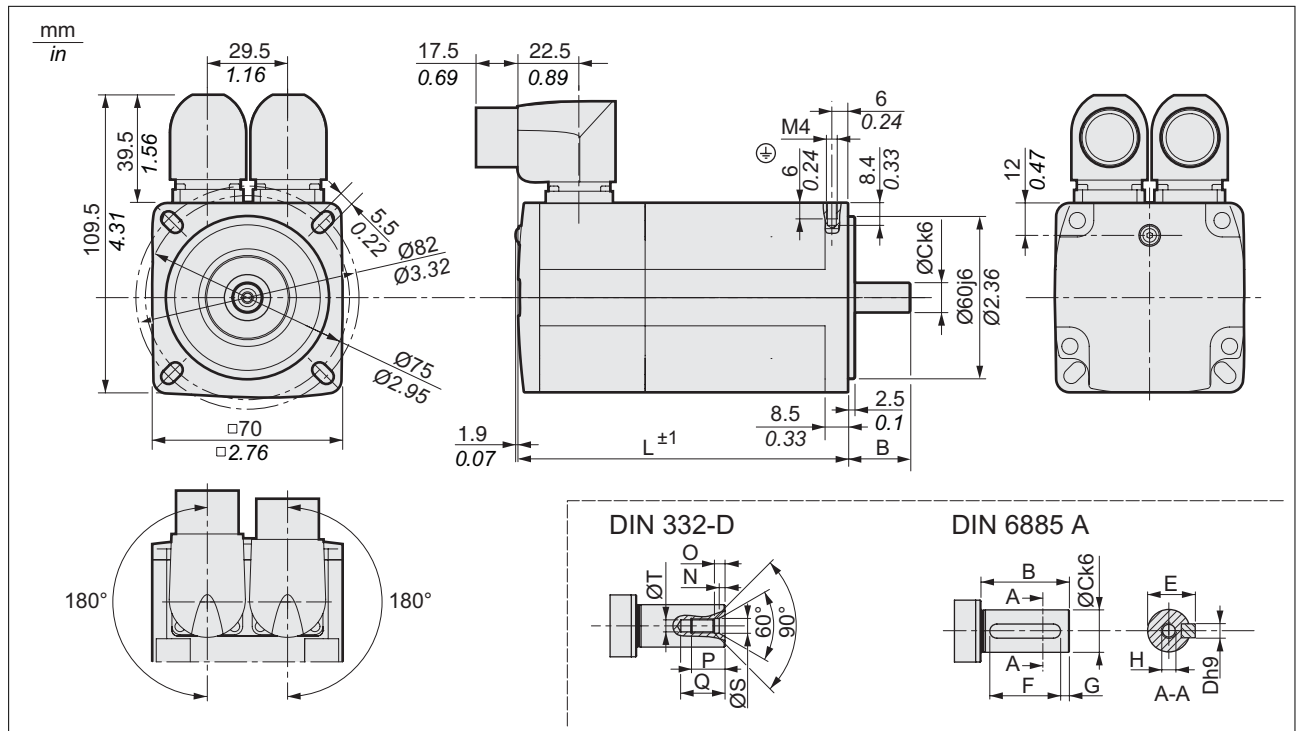

Figure 2: Dimensions MH3070

| MH3... | | | 0701 | 0702 | 0703 |
|--------|------------------------------------|---------|------------------|------------------|------------------|
| L | Length without holding brake | mm (in) | 122 (4.8) | 154 (6.06) | 186 (7.32) |
| L | Length with holding brake | mm (in) | 161(6.34) | 193 (7.6) | 225 (8.86) |
| B | Shaft length | mm (in) | 23 (0.91) | 23 (0.91) | 30 (1.18) |
| C | Shaft diameter | mm (in) | 11 (0.43) | 11 (0.43) | 14 (0.55) |
| D | Width of parallel key | mm (in) | 4 (0.16) | 4 (0.16) | 5 (0.2) |
| E | Shaft width with parallel key | mm (in) | 12.5 (0.49) | 12.5 (0.49) | 16 (0.63) |
| F | Length of parallel key | mm (in) | 18 (0.71) | 18 (0.71) | 20 (0.79) |
| G | Distance parallel key to shaft end | mm (in) | 2.5 (0.1) | 2.5 (0.1) | 5 (0.2) |
| | Parallel key | | DIN 6885-A4x4x18 | DIN 6885-A4x4x18 | DIN 6885-A4x4x20 |
| H | Female thread of shaft | | M4 | M4 | M5 |
| N | | mm (in) | 2.1 (0.08) | 2.1 (0.08) | 2.4 (0.09) |
| O | | mm (in) | 3.2 (0.13) | 3.2 (0.13) | 4 (0.16) |
| P | | mm (in) | 10 (0.39) | 10 (0.39) | 12.5 (0.49) |
| Q | | mm (in) | 14 (0.55) | 14 (0.55) | 17 (0.67) |
| S | | mm (in) | 4.3 (0.17) | 4.3 (0.17) | 5.3 (0.21) |
| T | | mm (in) | 3.3 (0.13) | 3.3 (0.13) | 4.2 (0.17) |

019844114042, V1.01, 03.2026

Dimensions MH3100

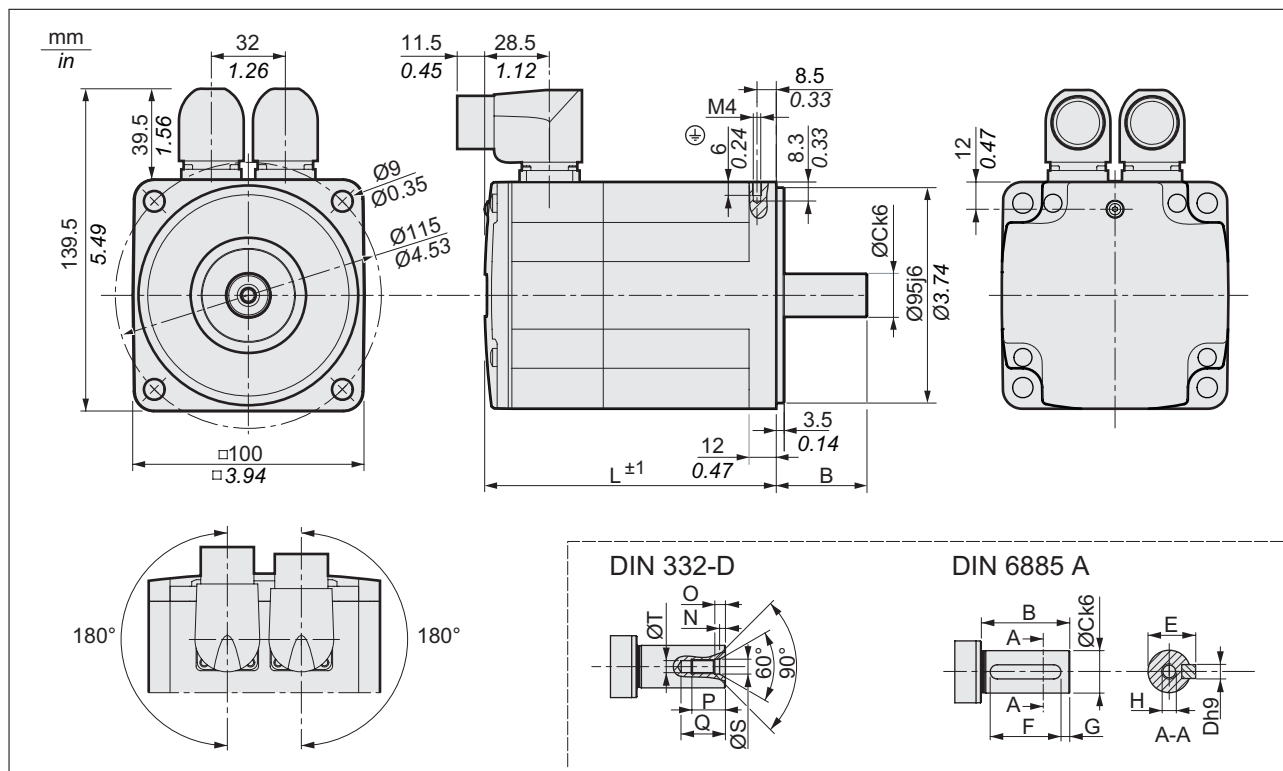

Figure 3: Dimensions MH3100

| MH3... | | | 1001 | 1002 | 1003 |
|--------|------------------------------------|---------|------------------|------------------|------------------|
| L | Length without holding brake | mm (in) | 128.6 (5.06) | 160.6 (6.32) | 192.6 (7.58) |
| L | Length with holding brake | mm (in) | 170.3 (6.7) | 202.3 (7.96) | 234.3 (9.22) |
| B | Shaft length | mm (in) | 40 (1.57) | 40 (1.57) | 40 (1.57) |
| C | Shaft diameter | mm (in) | 19 (0.75) | 19 (0.75) | 19 (0.75) |
| D | Width of parallel key | mm (in) | 6 (0.24) | 6 (0.24) | 6 (0.24) |
| E | Shaft width with parallel key | mm (in) | 21.5 (0.85) | 21.5 (0.85) | 21.5 (0.85) |
| F | Length of parallel key | mm (in) | 30 (1.18) | 30 (1.18) | 30 (1.18) |
| G | Distance parallel key to shaft end | mm (in) | 5 (0.2) | 5 (0.2) | 5 (0.2) |
| | Parallel key | | DIN 6885-A6x6x30 | DIN 6885-A6x6x30 | DIN 6885-A6x6x30 |
| H | Female thread of shaft | | M6 | M6 | M6 |
| N | | mm (in) | 2.8 (0.11) | 2.8 (0.11) | 2.8 (0.11) |
| O | | mm (in) | 5 (0.2) | 5 (0.2) | 5 (0.2) |
| P | | mm (in) | 16 (0.63) | 16 (0.63) | 16 (0.63) |
| Q | | mm (in) | 21 (0.83) | 21 (0.83) | 21 (0.83) |
| S | | mm (in) | 6.4 (0.25) | 6.4 (0.25) | 6.4 (0.25) |
| T | | mm (in) | 5 (0.2) | 5 (0.2) | 5 (0.2) |

Dimensions MH3140

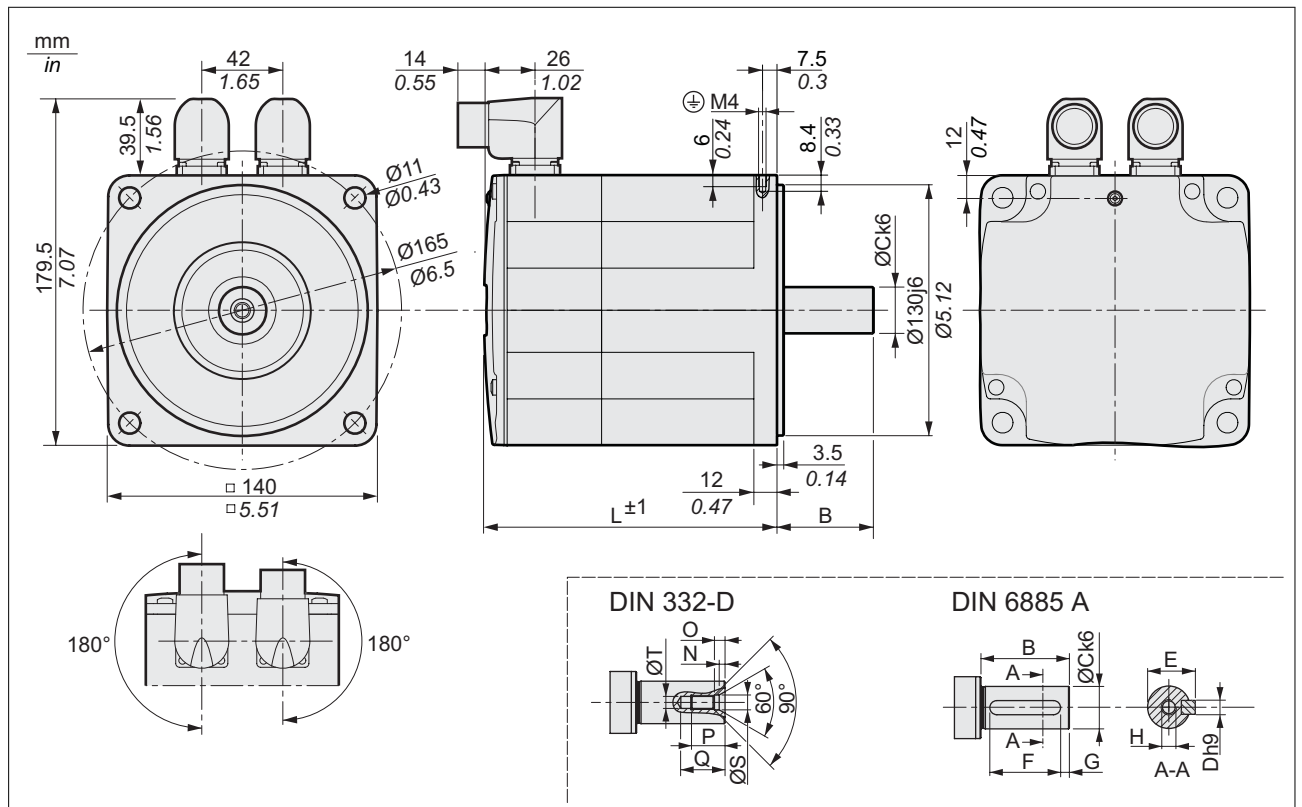

Figure 4: Dimensions MH3140

| MH3... | | | 1401 | 1402 | 1403 |
|--------|------------------------------------|---------|------------------|------------------|------------------|
| L | Length without holding brake | mm (in) | 152 (5.98) | 192 (7.56) | 232 (9.13) |
| L | Length with holding brake | mm (in) | 187 (7.36) | 227 (8.94) | 267 (10.51) |
| B | Shaft length | mm (in) | 50 (1.97) | 50 (1.97) | 50 (1.97) |
| C | Shaft diameter | mm (in) | 24 (0.94) | 24 (0.94) | 24 (0.94) |
| D | Width of parallel key | mm (in) | 8 (0.31) | 8 (0.31) | 8 (0.31) |
| E | Shaft width with parallel key | mm (in) | 27 (1.06) | 27 (1.06) | 27 (1.06) |
| F | Length of parallel key | mm (in) | 40 (1.57) | 40 (1.57) | 40 (1.57) |
| G | Distance parallel key to shaft end | mm (in) | 5 (0.2) | 5 (0.2) | 5 (0.2) |
| | Parallel key | | DIN 6885-A8x7x40 | DIN 6885-A8x7x40 | DIN 6885-A8x7x40 |
| H | Female thread of shaft | | M8 | M8 | M8 |
| N | | mm (in) | 3.3 (0.13) | 3.3 (0.13) | 3.3 (0.13) |
| O | | mm (in) | 6 (0.24) | 6 (0.24) | 6 (0.24) |
| P | | mm (in) | 19 (0.75) | 19 (0.75) | 19 (0.75) |
| Q | | mm (in) | 25 (0.98) | 25 (0.98) | 25 (0.98) |
| S | | mm (in) | 8.4 (0.33) | 8.4 (0.33) | 8.4 (0.33) |
| T | | mm (in) | 6.8 (0.27) | 6.8 (0.27) | 6.8 (0.27) |

019844114042, V1.01, 03.2026

Dimensions MH3190

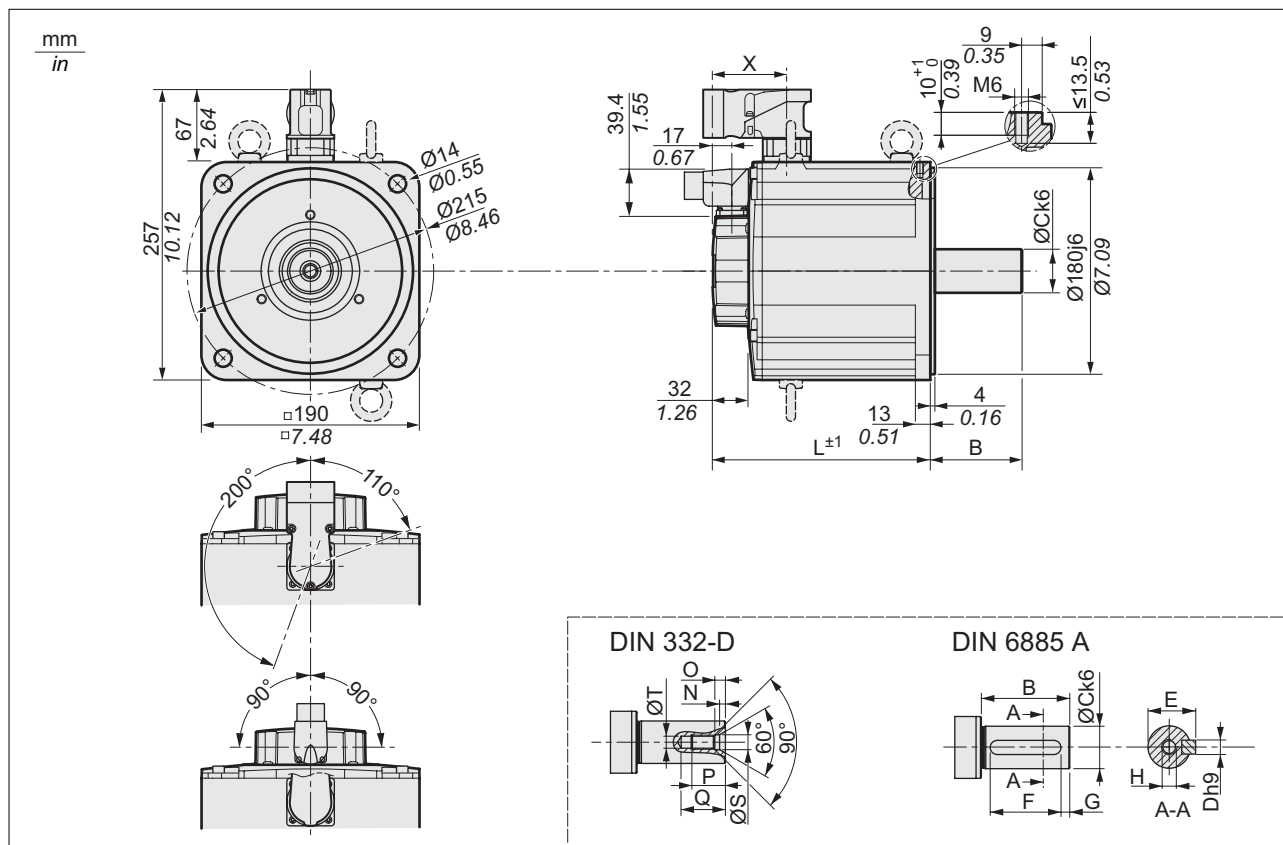

Figure 5: Dimensions MH3190

| MH3... | | | 1901 | 1902 | 1903 |
|--------|------------------------------------|---------|-------------------|-------------------|-------------------|
| L | Length without holding brake | mm (in) | 190 (7.48) | 250 (9.84) | 310 (12.2) |
| L | Length with holding brake | mm (in) | 248 (9.76) | 308 (12.13) | 368 (14.49) |
| X | Length without holding brake | mm (in) | 65 (2.56) | 65 (2.56) | 65 (2.56) |
| X | Length with holding brake | mm (in) | 123 (4.84) | 123 (4.84) | 123 (4.84) |
| B | Shaft length | mm (in) | 80 (3.15) | 80 (3.15) | 80 (3.15) |
| C | Shaft diameter | mm (in) | 38 (1.5) | 38 (1.5) | 38 (1.5) |
| D | Width of parallel key | mm (in) | 10 (0.39) | 10 (0.39) | 10 (0.39) |
| E | Shaft width with parallel key | mm (in) | 41 (1.61) | 41 (1.61) | 41 (1.61) |
| F | Length of parallel key | | 70 (2.76) | 70 (2.76) | 70 (2.76) |
| G | Distance parallel key to shaft end | | 5 (0.2) | 5 (0.2) | 5 (0.2) |
| | Parallel key | mm (in) | DIN 6885-A10x8x70 | DIN 6885-A10x8x70 | DIN 6885-A10x8x70 |
| H | Female thread of shaft | mm (in) | M12 | M12 | M12 |
| N | | mm (in) | 4.4 (0.17) | 4.4 (0.17) | 4.4 (0.17) |
| O | | mm (in) | 9.5 (0.37) | 9.5 (0.37) | 9.5 (0.37) |
| P | | mm (in) | 28 (1.1) | 28 (1.1) | 28 (1.1) |
| Q | | mm (in) | 37 (1.46) | 37 (1.46) | 37 (1.46) |
| S | | mm (in) | 13 (0.51) | 13 (0.51) | 13 (0.51) |
| T | | mm (in) | 10.2 (0.4) | 10.2 (0.4) | 10.2 (0.4) |

2.4 Shaft-specific data

If the maximum permissible forces at the motor shaft are exceeded, this will result in premature wear of the bearing or shaft breakage.

⚠ WARNING

UNINTENDED EQUIPMENT OPERATION DUE TO MECHANICAL DAMAGE TO THE MOTOR

- Do not exceed the maximum permissible axial and radial forces at the motor shaft.
- Protect the motor shaft from impact.
- Do not exceed the maximum permissible axial force when pressing components onto the motor shaft.

Failure to follow these instructions can result in death, serious injury, or equipment damage.

2.4.1 Force for pressing on

Maximum force during pressing on

The force applied during pressing on must not exceed the maximum permissible axial force, see chapter "2.4.2 Shaft load". Applying assembly paste (such as Klüberpaste 46 MR 401) to the shaft and the component to be mounted reduces friction and mechanical impact on the surfaces.

If the shaft has a thread, it is recommended to use it to press on the component to be mounted. This way there is no axial force acting on the rolling bearing.

It is also possible to shrink-fit, clamp or glue the component to be mounted.

The following table shows the maximum permissible axial force F_A at standstill.

| MH3... | | 070 | 100 | 140 | 190 |
|--------|-----------|------------|-------------|-------------|--------------|
| | N (lb) | 80 (18) | 160 (36) | 300 (65) | 500 (112) |

2.4.2 Shaft load

The following conditions apply:

- The permissible force applied during pressing on must not be exceed.
- Radial and axial limit loads must not be applied simultaneously
- Nominal bearing service life in operating hours at a probability of failure of 10% ($L_{10h} = 20000$ hours)
- Mean speed of rotation $n = 4000 \text{ min}^{-1}$
- Ambient temperature = $40 \text{ }^\circ\text{C}$
- Peak torque = Duty types S3 - S8, 10% duty cycle
- Nominal torque = Duty type S1, 100% duty cycle

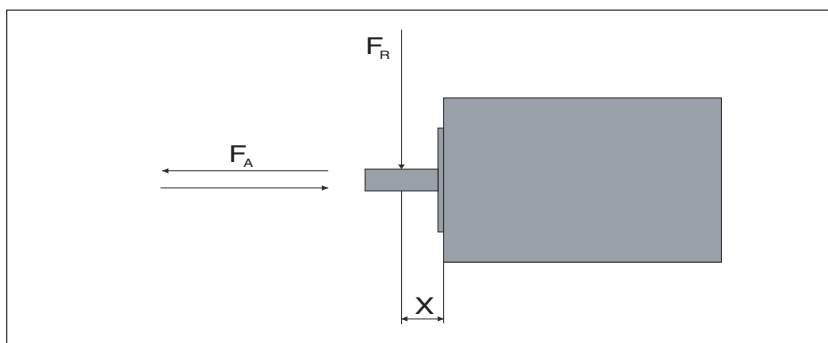

Figure 6: Shaft load

The point of application of the forces depends on the motor size:

| Motor version | | Values for "X" |
|---------------------|---------|----------------|
| MH30701 and MH30702 | mm (in) | 11.5 (0.45) |
| MH30703 | mm (in) | 15 (0.59) |
| MH3100 | mm (in) | 20 (0.76) |
| MH3140 | mm (in) | 25 (0.98) |
| MH3190 | mm (in) | 40 (1.57) |

The following table shows the maximum radial shaft load F_R .

| MH3... | | 070 1 | 070 2 | 070 3 | 100 1 | 100 2 | 100 3 | 140 1 | 140 2 | 140 3 | 190 1 | 190 2 | 190 3 |
|------------------------|-----------|--------------|--------------|--------------|--------------|--------------|---------------|---------------|---------------|---------------|---------------|---------------|---------------|
| 1000 min ⁻¹ | N (lb) | 660 (148) | 710 (160) | 730 (164) | 900 (202) | 990 (223) | 1050 (236) | 1930 (434) | 2240 (544) | 2420 (544) | 2900 (652) | 3200 (719) | 3300 (742) |
| 2000 min ⁻¹ | N (lb) | 520 (117) | 560 (126) | 580 (130) | 720 (162) | 790 (178) | 830 (187) | 1530 (344) | 1780 (400) | 1920 (432) | 2750 (618) | 3100 (697) | 3250 (731) |
| 3000 min ⁻¹ | N (lb) | 460 (103) | 490 (110) | 510 (115) | 630 (142) | 690 (155) | 730 (164) | 1340 (301) | 1550 (348) | 1670 (375) | 2650 (596) | 3000 (674) | 3150 (708) |
| 4000 min ⁻¹ | N (lb) | 410 (92) | 450 (101) | 460 (103) | 570 (128) | 620 (139) | 660 (148) | - | - | - | 2600 (585) | 2950 (663) | 3100 (697) |
| 5000 min ⁻¹ | N (lb) | 380 (85) | 410 (92) | 430 (97) | 530 (119) | 580 (130) | 610 (137) | - | - | - | - | - | - |
| 6000 min ⁻¹ | N (lb) | 360 (81) | 390 (88) | 400 (90) | - | - | - | - | - | - | - | - | - |

The following table shows the maximum axial shaft load F_A .

| MH3... | | 070 1 | 070 2 | 070 3 | 100 1 | 100 2 | 100 3 | 140 1 | 140 2 | 140 3 | 190 1 | 190 2 | 190 3 |
|------------------------|-----------|-------------|-------------|-------------|-------------|-------------|-------------|-------------|--------------|--------------|--------------|--------------|--------------|
| 1000 min ⁻¹ | N (lb) | 132 (30) | 142 (32) | 146 (lb) | 180 (40) | 198 (45) | 210 (47) | 386 (87) | 448 (109) | 484 (109) | 580 (130) | 640 (144) | 660 (148) |
| 2000 min ⁻¹ | N (lb) | 104 (23) | 112 (25) | 116 (lb) | 144 (32) | 158 (36) | 166 (37) | 306 (69) | 356 (86) | 384 (86) | 550 (124) | 620 (139) | 650 (146) |
| 3000 min ⁻¹ | N (lb) | 92 (21) | 98 (22) | 102 (lb) | 126 (28) | 138 (31) | 146 (33) | 268 (60) | 310 (75) | 334 (75) | 530 (119) | 600 (135) | 630 (142) |
| 4000 min ⁻¹ | N (lb) | 82 (18) | 90 (20) | 92 (lb) | 114 (26) | 124 (28) | 132 (30) | - | - | - | 520 (117) | 590 (133) | 620 (139) |
| 5000 min ⁻¹ | N (lb) | 76 (17) | 82 (18) | 86 (lb) | 106 (24) | 116 (26) | 122 (27) | - | - | - | - | - | - |
| 6000 min ⁻¹ | N (lb) | 72 (16) | 78 (18) | 80 (lb) | - | - | - | - | - | - | - | - | - |

2.5 Options

2.5.1 Holding brake

| MH3... | | 070 | 1001, 2 | 1003 | 1401 | 1402 | 1403 | 1901 | 1902, 3 |
|--|---------------|---------------|---------------|-------------|--------------|--------------|--------------|--------------|--------------|
| Holding torque ¹⁾ | Nm (lb•in) | 3.0 (0.12) | 5.5 (0.22) | 9 (0.35) | 18 (0.71) | 18 (0.71) | 23 (0.91) | 32 (1.26) | 60 (2.36) |
| Holding brake release time | ms | 80 | 70 | 90 | 100 | 100 | 100 | 200 | 220 |
| Holding brake application time | ms | 10 | 30 | 25 | 50 | 50 | 40 | 60 | 50 |
| Nominal voltage | Vdc | 24 +/-15% | | | | | | | |
| Nominal power (electrical pull-in power) | W | 7 | 12 | 18 | 18 | 18 | 19 | 22.5 | 25 |
| Maximum speed of rotation during braking of moving loads | | 3000 | | | | | | | |
| Maximum number of decelerations during braking of moving loads and 3000 min ⁻¹ | | 500 | | | | | | | |
| Maximum number of decelerations during braking of moving loads per hour (at even distribution) | | 20 | | | | | | | |
| Maximum kinetic energy that can be transformed into heat per deceleration during braking of moving loads | J | 130 | 150 | 150 | 550 | 550 | 550 | 850 | 850 |

1) The holding brake is factory-broken in. After longer storage periods, parts of the holding brake may corrode. See "Inspecting/braking in the holding brake" in chapter "7 Service, maintenance and disposal".

2.5.2 Encoder

The standard motor is equipped with a SinCos encoder. The drive can access the electronic nameplate via the Hiperface interface for easy commissioning.

The signals meet the PELV requirements.

SKS36 Singleturn

This motor encoder measures an absolute value within one revolution during switching on and continues to count incrementally from this point.

| | |
|--|----------------------------|
| Resolution in increments | Depending on evaluation |
| Resolution per revolution | 128 sin/cos periods |
| Measuring range absolute | 1 revolution |
| Accuracy of the digital absolute value ¹⁾ | ±0.0889° |
| Accuracy of the incremental position | ±0.0222° |
| Signal shape | Sinusoidal |
| Supply voltage | 7 ... 12 Vdc |
| Maximum supply current | 60 mA (without load) |
| Maximum angular acceleration | 200,000 rad/s ² |

1) Depending on the evaluation through the drive, the accuracy may be increased by including the incremental position in the calculation of the absolute value. In this case, the accuracy corresponds to the incremental position.

SKM36 Multiturn

This motor encoder measures an absolute value within 4096 revolutions during switching on and continues to count incrementally from this point.

| | |
|--|----------------------------|
| Resolution in increments | Depending on evaluation |
| Resolution per revolution | 128 sin/cos periods |
| Measuring range absolute | 4096 revolutions |
| Accuracy of the digital absolute value ¹⁾ | ±0.0889° |
| Accuracy of the incremental position | ±0.0222° |
| Signal shape | Sinusoidal |
| Supply voltage | 7 ... 12 Vdc |
| Maximum supply current | 60 mA (without load) |
| Maximum angular acceleration | 200,000 rad/s ² |

1) Depending on the evaluation through the drive, the accuracy may be increased by including the incremental position in the calculation of the absolute value. In this case, the accuracy corresponds to the incremental position.

SEK37 Singleturn This motor encoder measures an absolute value within one revolution during switching on and continues to count incrementally from this point.

| | |
|---------------------------|-------------------------|
| Resolution in increments | Depending on evaluation |
| Resolution per revolution | 16 sin/cos periods |
| Measuring range absolute | 1 revolution |
| Accuracy of position | $\pm 0.08^\circ$ |
| Signal shape | Sinusoidal |
| Supply voltage | 7 ... 12 Vdc |
| Maximum supply current | 50 mA (without load) |

SEL37 Multiturn This motor encoder measures an absolute value within 4096 revolutions during switching on and continues to count incrementally from this point.

| | |
|---------------------------|-------------------------|
| Resolution in increments | Depending on evaluation |
| Resolution per revolution | 16 sin/cos periods |
| Measuring range absolute | 4096 revolutions |
| Accuracy of position | $\pm 0.08^\circ$ |
| Signal shape | Sinusoidal |
| Supply voltage | 7 ... 12 Vdc |
| Maximum supply current | 50 mA (without load) |

2.6 Conditions for UL 1004-1, UL 1004-6 and CSA 22.2 No. 100

PELV power supply Use only power supply units that are approved for overvoltage category III.

Wiring Use at least 60/75 °C copper conductors.

2.7 Certifications

Product certifications:

| Certified by | Assigned number |
|--------------|-----------------|
| UL | File E 208613 |

2.8 Declaration of conformity

EC DECLARATION OF CONFORMITY

Dokumentnummer / Monat.Jahr: 100000152_00 / 11.2013
 - Translation of the German Version -



We: Schneider Electric Automation GmbH
 Schneiderplatz 1
 97828 Marktheidenfeld
 Germany

hereby declare that the product

| | |
|-----------------------|---|
| Trademark: | Schneider Electric |
| Product: | 3 phase servo motor |
| Models: | MH3070, MH3100, MH3140, MH3190 |
| Serial number: | ZZYYXXXXXXXXX |
| | ZZ: last two digits of year +10, YY: Manufacturer code; X: consecutive number |

x are numbers for different variations

are in conformity with the requirements of the following directives and conformity was checked in accordance with the following standards:

| Directive | Harmonized Standard |
|--|--|
| DIRECTIVE 2006/95/EC OF THE EUROPEAN PARLIAMENT AND OF THE COUNCIL of 12 December 2006 on the harmonization of the laws of the member states relating to electrical equipment designed for use within certain voltage limits | EN 60034-1:2004 Rotating electrical machines - Part 1: Rating and performance (IEC 60034-1:2010, modified) EN 60034-5:2001 Rotating electrical machines - Part 5: Degrees of protection provided by integral design of rotating electrical machines (IP code) - Classification (IEC 60034-5:2000 + Corrigendum 2001 + A1:2006) EN 61800-5-1:2007 Adjustable speed electrical power drive systems - Part 5-1: Safety requirements - Electrical, thermal and energy (IEC 61800-5-1:2007) |

And also the standards:
 UL 1004-1 and UL 1004-6
 CSA Standard C22.2, No. 100.

It is important that the component is subject to correct installation, maintenance and use conforming to its intended purpose, to the applicable regulations and standards, to the supplier's instructions, user manual and to the accepted rules of the art.

First year of affixing CE Marking: 2013

Issued at Marktheidenfeld, Germany November 4, 2013

i.V.
 Manager Motor Development

Authorized Signatory

i.A.
 Machine Solution Certification Manager

3 Installation

DANGER

ELECTRIC SHOCK OR UNINTENDED EQUIPMENT OPERATION

- Keep foreign objects from getting into the product.
- Verify correct seat of seals and cable entries in order to avoid deposits and humidity.

Failure to follow these instructions will result in death or serious injury.

DANGER

ELECTRIC SHOCK CAUSED BY INSUFFICIENT GROUNDING

- Verify compliance with all local and national electrical code requirements as well as all other applicable regulations with respect to grounding of the entire drive system.
- Ground the drive system before applying voltage.
- Do not use conduits as protective ground conductors; use a protective ground conductor inside the conduit.
- The cross section of the protective ground conductor must comply with the applicable standards.
- Do not consider cable shields to be protective ground conductors.

Failure to follow these instructions will result in death or serious injury.

Motors are very heavy relative to their size. The great mass of the motor can cause injuries and damage.

WARNING

GREAT MASS OR FALLING PARTS

- Use a suitable crane or other suitable lifting gear for mounting the motor if this is required by the mass of the motor.
- Use the necessary personal protective equipment (for example, safety shoes, safety glasses and protective gloves).
- Mount the motor in such a way (tightening torque, securing screws) that it cannot come loose, even in the case of fast acceleration or continuous vibration.

Failure to follow these instructions can result in death, serious injury, or equipment damage.

Motors can generate strong local electrical and magnetic fields. This can cause interference in sensitive devices.

⚠ WARNING

STRONG ELECTROMAGNETIC FIELDS

- Keep persons with electronic medical implants, such as pace-makers, away from the motor.
- Do not place any sensitive devices close to the motor.

Failure to follow these instructions can result in death, serious injury, or equipment damage.

The metal surfaces of the product may exceed 100 °C (212 °F) during operation.

⚠ WARNING

HOT SURFACES

- Avoid unprotected contact with hot surfaces.
- Do not allow flammable or heat-sensitive parts in the immediate vicinity of hot surfaces.
- Verify that the heat dissipation is sufficient by performing a test run under maximum load conditions.

Failure to follow these instructions can result in death, serious injury, or equipment damage.

⚠ CAUTION

DAMAGE CAUSED BY IMPROPER APPLICATION OF FORCES

- Do not use the motor as a step to climb into or onto the machine.
- Do not use the motor as a load-bearing part.
- Verify that the motor cannot be improperly used at the machine, for example, by means of design measures.

Failure to follow these instructions can result in injury or equipment damage.

3.1 Overview of procedure

| Chapter | Page |
|---|------|
| "3.2 Electromagnetic compatibility (EMC)" | 41 |
| "3.3 Before mounting" | 44 |
| "3.4 Mounting the motor " | 48 |
| "3.5.2 Power and encoder connection" | 57 |
| "3.5.3 Holding brake connection" | 63 |

3.2 Electromagnetic compatibility (EMC)

The measures for electromagnetic compatibility (EMC) are intended to minimize electromagnetic interference of the device and interference caused by the device that affects the environment. Such measures include measures to reduce interference and emission as well as to increase immunity.

Electromagnetic compatibility hinges to a great extent on the individual components used in the system. The EMC measures described in this manual may help to comply with the requirements of IEC 61800-3. You must always comply with all EMC regulations of the country in which the product is operated. Also, respect any special EMC regulations that may apply at the installation site (for example, residential environments or airports).

Signal interference can cause unexpected responses of the device and of other equipment in the vicinity of the device.

⚠ WARNING

SIGNAL AND DEVICE INTERFERENCE

- Install the wiring in accordance with the EMC requirements described.
- Verify compliance with the EMC requirements described.
- Verify compliance with all EMC regulations and requirements applicable in the country in which the product is to be operated and with all EMC regulations and requirements applicable at the installation site.

Failure to follow these instructions can result in death, serious injury, or equipment damage.

Motor and encoder cables

In terms of EMC, motor cables are especially critical since they are particularly prone to causing interference.

When planning the wiring, take into account the fact that the motor cable must be routed separately. The motor cable must be separate from mains cables or signal cables. Use only pre-assembled cables or cables that comply with the specifications and implement the EMC measures described below.

| EMC measures | Effect |
|---|--|
| Keep cables as short as possible. Do not install unnecessary cable loops, use short cables from the central grounding point in the control cabinet to the external ground connection. | Reduces capacitive and inductive interference. |
| Ground the product via the motor flange or with a ground strap to the ground connection at the cover of the connector housing. | Reduces emissions, increases immunity. |
| Connect large surface areas of cable shields, use cable clamps and ground straps. | Reduces emissions. |
| Do not install switching elements in motor cables or encoder cables. | Reduces interference. |
| Route the motor cable at a distance of at least 20 cm (5.08 in) from the signal cable or use shielding plates between the motor cable and signal cable. | Reduces mutual interference |
| Route the motor cable and encoder cable without cutting them. ¹⁾ | Reduces emission. |

1) If a cable is cut for the installation, take appropriate measures for uninterrupted shielding (such as a metal housing) at the point of the cut. Connect a large area of the cable shield to the metal housing at both ends of the cut.

| |
|---|
| <p>▲ WARNING</p> |
| <p>UNINTENDED EQUIPMENT OPERATION DUE TO ELECTROMAGNETIC INTERFERENCE</p> <ul style="list-style-type: none"> Route the motor cable separately from any power (mains) cabling and from all other signal wires. Maintain a minimum distance of 20 cm (5.08 in) between the motor cable routing and all other wiring, or install shielding plates between the motor cable and other wiring. Only use approved, pre-assembled motor and encoder cables. Use the shortest motor and encoder cable lengths between the motor and the drive. Do not install switching elements (power switches, contactors, etc.) in motor or encoder cables, nor otherwise compromise the integrity of a continuous, uninterrupted connection between the motor and the drive. <p>Failure to follow these instructions can result in death, serious injury, or equipment damage.</p> |

019844114042, V1.01, 03.2026

Pre-assembled connection cables (accessories)

Use pre-assembled cables to reduce the risk of wiring errors, see chapter "6 Accessories and spare parts".

Place the female connector of the motor cable onto the male connector and tighten the union nut. Proceed in the same manner with the connection cable of the encoder system. Connect the motor cable and the encoder cable to the drive according to the wiring diagram of the drive.



Pre-assembled motor cables and encoder cables in many different lengths are available for the drive solutions. Contact your local sales office.

Equipotential bonding conductors

Potential differences can result in excessive currents on the cable shields. Use equipotential bonding conductors to reduce currents on the cable shields.

The equipotential bonding conductor must be rated for the maximum current flowing. Practical experience has shown that the following conductor cross sections can be used:

- 16 mm² (AWG 4) for equipotential bonding conductors up to a length of 200 m (656 ft)
- 20 mm² (AWG 4) for equipotential bonding conductors with a length of more than 200 m (656 ft)

⚠ WARNING

IMPROPER GROUNDING CAN CAUSE UNINTENDED EQUIPMENT OPERATION

- Use cables with insulated shielded jackets for analog I/O, fast I/O and communication signals.
- Ground shielded cables for analog I/O, fast I/O and communication signals at a single point. ¹
- Always comply with local wiring requirements regarding grounding of cable shields.

Failure to follow these instructions can result in death, serious injury, or equipment damage.

1. Multipoint grounding is permissible if connections are made to an equipotential ground plane dimensioned to help avoid cable shield damage in the event of power system short circuit currents.

3.3 Before mounting

Inspecting the product

- ▶ Verify the product version by means of the type code on the nameplate. See chapter "1.3 Nameplate" and chapter "1.4 Type code".
- ▶ Prior to mounting, inspect the product for visible damage.

Damaged products may cause electric shock or unintended equipment operation.

| |
|---|
|  DANGER |
| <p>ELECTRIC SHOCK OR UNINTENDED EQUIPMENT OPERATION</p> <ul style="list-style-type: none"> • Do not use damaged products. • Keep foreign objects such as chips, screws or wire clippings from getting into the product. <p>Failure to follow these instructions will result in death or serious injury.</p> |

Contact your local Schneider Electric sales office if you detect any damage whatsoever.

Inspecting the holding brake (option)

See chapter "7.2 Maintenance", "Inspecting/braking in the holding brake".

Cleaning the shaft

The shaft extensions are factory-treated with an anti-corrosive. If output components are glued to the shaft, the anti-corrosive must be removed and the shaft cleaned. If required, use a grease removal agent as specified by the glue manufacturer. If the glue manufacturer does not provide information on grease removal, acetone may be used.

- ▶ Remove the anti-corrosive. Avoid direct contact of the skin and the sealing material with the anti-corrosive or the cleaning agent.

Mounting surface for flange

The mounting surface must be stable, clean, deburred and low-vibration.

- ▶ Verify that the mounting surface meets all requirements in terms of dimensions and tolerances.

Conductor cross sections according to method of installation

The following sections describe the conductor cross sections for two standard methods of installation:

- Method of installation B2:
Cables in conduits or cable trunking systems
- Method of installation E:
Cables on open cable trays

| Cross section in mm ² (AWG) ¹⁾ | Current carrying capacity with method of installation E in A ²⁾ | Current-carrying capacity with method of installation B2 in A ²⁾ |
|--|--|---|
| 0.75 (18) | 10.4 | 8.5 |
| 1 (16) | 12.4 | 10.1 |
| 1.5 (14) | 16.1 | 13.1 |
| 2.5 (12) | 22 | 17.4 |
| 4 (10) | 30 | 23 |
| 6 (8) | 37 | 30 |
| 10 (6) | 52 | 40 |
| 16 (4) | 70 | 54 |
| 25 (2) | 88 | 70 |

1) See chapter "6 Accessories and spare parts" for available cables.

2) Values as per IEC 60204-1 for continuous operation, copper conductors and ambient air temperature 40°C (104 °F); see IEC 60204-1 for additional information.

Note the derating factors for grouping of cables and correction factors for other ambient conditions (IEC 60204-1).

The conductors must have a sufficiently large cross section so that the upstream fuse can trip.

In the case of longer cables, it may be necessary to use a greater conductor cross section to reduce the energy losses.

Cable specifications Use pre-assembled cables to reduce the risk of wiring errors. See chapter "6 Accessories and spare parts".

The genuine accessories have the following properties:

| Cables with connectors | | VW3E1143R••• | VW3E1144R••• | VW3E1145R••• |
|---|--------------------|--|--|--|
| Cable jacket, insulation | | PUR matte green (similar to RAL 6018) | | |
| Capacitance Power wires Signal wires | pF/m | Approx. 120 (wire/wire) Approx. 208 (wire/shield) Approx. 170 (wire/wire) Approx. 335 (wire/shield) | - | - |
| Number of contacts (shielded) | | [(4 x 1.5 mm ²) + 2 x (2 x 0.75 mm ²)] | [(4 x 2.5 mm ²) + 2 x (2 x 1 mm ²)] | [(4 x 2.5 mm ²) + 2 x (2 x 1 mm ²)] |
| Connection version | | Motor end 8-pin circular connector M23, other cable end open | Motor end 8-pin circular connector M23, other cable end open | Motor end 8-pin circular connector M40, other cable end open |
| Cable diameter | mm (in) | 12.4 ± 0.4 (0.49 ± 0.1) | 14.4 ± 0.3 (0.57 ± 0.1) | 14.7 ± 0.3 (0.58 ± 0.1) |
| Minimum bend radius | | 5 times the cable diameter with permanently installed connection 12 times the cable diameter with flexible installation | | |
| Nominal voltage Power wires Signal wires | V | 1000 300 | 1000 300 | 1000 300 |
| Maximum orderable length | m (ft) | 75 ¹⁾ (246) | 50 ¹⁾ (164) | 75 ¹⁾ (246) |
| Permissible temperature range during operation fixed: moving: | °C (°F) °C (°F) | -40 ... 80 (-40 ... 176) -30 ... 80 (-22 ... 176) | -50 ... 80 (-58 ... 176) -40 ... 80 (-40 ... 176) | -50 ... 80 (-58 ... 176) -40 ... 80 (-40 ... 176) |
| Certifications / declaration of conformity | | UL, cUL / CE | | |

1) Contact your Schneider Electric sales office for longer cables.

| Cables with connectors | | VW3E1153R•• | VW3E1154R••• | VW3E2094R••• |
|--|------------|--|---|--|
| Cable jacket, insulation | | PUR matte green (similar to RAL 6018) | | |
| Number of contacts (shielded) | | [(4 x 4 mm ²) + (2 x 1 mm ²) + (2 x 1.5 mm ²)] | [(4 x 10 mm ²) + (2 x 1 mm ²) + (2 x 1.5 mm ²)] | [3 x (2 x 0.14 mm ²) + (2 x 0.34 mm ²)] |
| Connection version | | Motor end 8-pin circular connector M40, other cable end open | Motor end 8-pin circular connector M40, other cable end open | Motor end 12-pin circular connector M23, other cable end open |
| Cable diameter | mm (in) | 18.4 ± 0.3 (0.72 ± 0.1) | 22.7 ± 0.3 (0.89 ± 0.1) | 6.8 ± 0.2 (0.27 ± 0.1) |
| Minimum bend radius | | 5 times the cable diameter with permanently installed connection 12 times the cable diameter with flexible installation | | 5 times the cable diameter with permanently installed connection 10 times the cable diameter with flexible installation |
| Nominal voltage | V | | | |
| Power wires | | 1000 | 1000 | - |
| Signal wires | | 300 | 300 | 300 |
| Maximum orderable length | m (ft) | 75 ¹⁾ (246) | | |
| Permissible temperature range during operation | | | | |
| fixed: | °C (°F) | -40 ... 80 (-40 ... 176) | -50 ... 80 (-58 ... 176) | -40 ... 80 (-40 ... 176) |
| moving: | °C (°F) | -30 ... 80 (-22 ... 176) | -40 ... 80 (-40 ... 176) | - |
| Certifications / declaration of conformity | | UL, cUL / CE | | |

1) Contact your Schneider Electric sales office for longer cables.

3.4 Mounting the motor

In rare cases, electrostatic discharge to the shaft may cause incorrect operation of the encoder system and result in unanticipated motor movements and damage to the bearing.

| |
|---|
| ⚠ WARNING |
| UNINTENDED MOVEMENT CAUSED BY ELECTROSTATIC DISCHARGE |
| Use conductive components such as antistatic belts or other suitable measures to avoid static charge by motion. |
| Failure to follow these instructions can result in death, serious injury, or equipment damage. |

If the permissible ambient conditions are not respected, external substances from the environment may penetrate the product and cause unintended movement or equipment damage.

| |
|---|
| ⚠ WARNING |
| UNINTENDED MOVEMENT |
| <ul style="list-style-type: none">• Verify that the ambient conditions are respected.• Do not allow seals to run dry.• Keep liquids from getting to the shaft bushing (for example, in mounting position IM V3).• Do not expose the shaft sealing rings and cable entries of the motor to the direct spray of a pressure washer. |
| Failure to follow these instructions can result in death, serious injury, or equipment damage. |

The metal surfaces of the product may exceed 100 °C (212 °F) during operation.

| |
|---|
| ⚠ WARNING |
| HOT SURFACES |
| <ul style="list-style-type: none">• Avoid unprotected contact with hot surfaces.• Do not allow flammable or heat-sensitive parts in the immediate vicinity of hot surfaces.• Verify that the heat dissipation is sufficient by performing a test run under maximum load conditions. |
| Failure to follow these instructions can result in death, serious injury, or equipment damage. |

Mounting position The following mounting positions are defined and permissible as per IEC 60034-7:

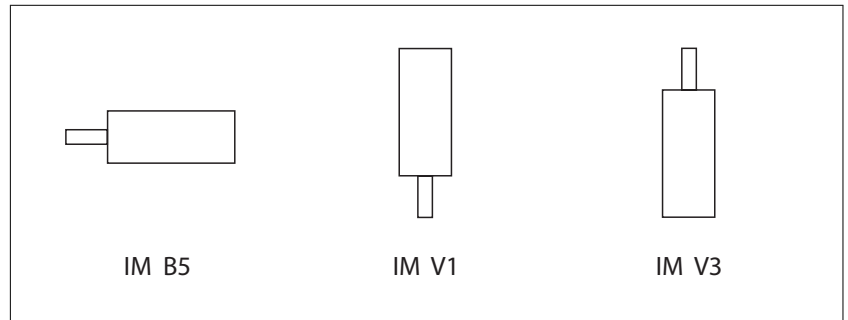

Mounting situation

NOTICE

DAMAGE TO THE MOTOR CAUSED BY FORCES ACTING ON THE REAR SIDE OF THE MOTOR

- Do not place the motor on the rear side.
- Protect the rear side of the motor from impact.
- Do not lift motors via the rear side.
- Only lift motors equipped with eyebolts via the eyebolts.

Failure to follow these instructions can result in equipment damage.

Special characteristics MH3190

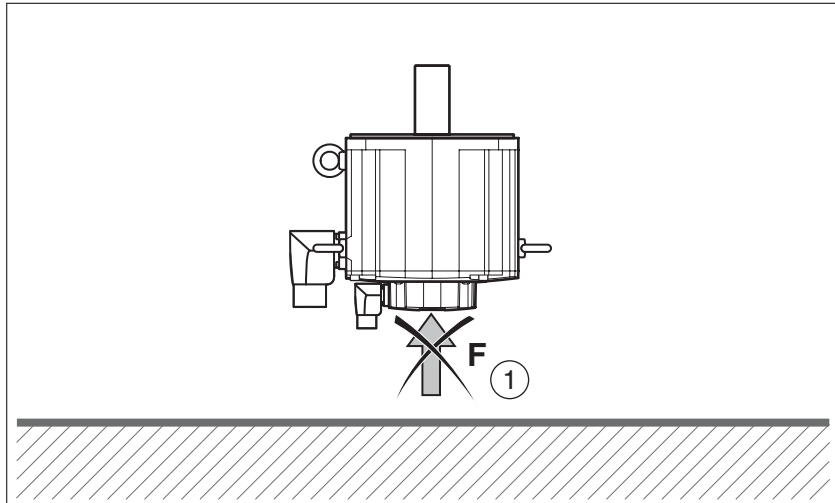
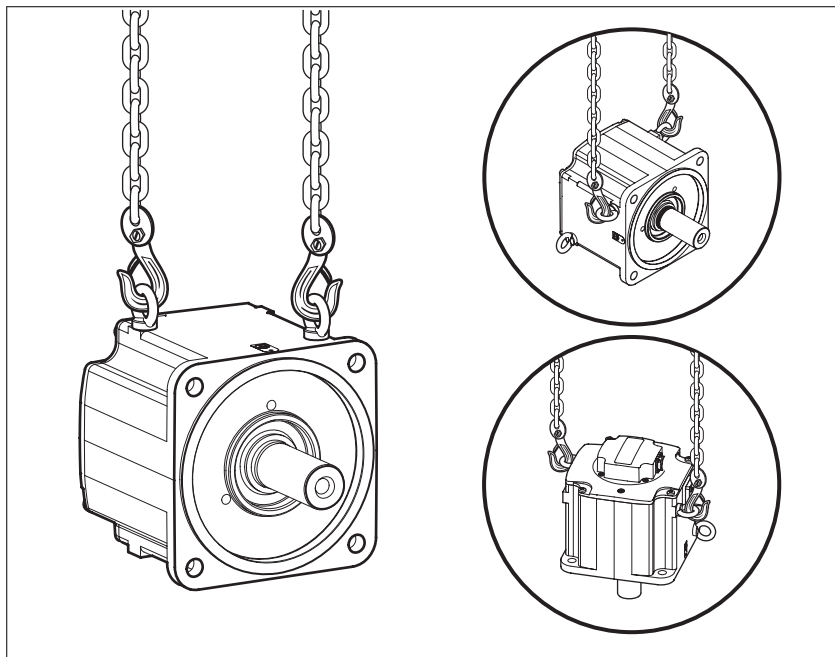

Figure 7: MH3190 rear side of motor

- (1) Protect the rear side of the motor from application of forces. Consider the mass of the product when mounting the motor. It may be necessary to use suitable lifting gear.



Mounting When the motor is mounted to the mounting surface, it must be accurately aligned axially and radially and make even contact with the mounting surface. All mounting screws must be tightened with the specified tightening torque. No uneven mechanical load must be applied when the mounting screws are tightened. See chapter "2 Technical Data" for data, dimensions and degrees of protection (IP).

Mounting output components Output components such as pulleys and couplings must be mounted with suitable equipment and tools. Motor and output component must be accurately aligned both axially and radially. If the motor and the output component are not accurately aligned, this will cause runout and premature wear.

The maximum axial and radial forces acting on the shaft must not exceed the maximum shaft load values specified, see chapter "2.4.2 Shaft load".

Mounting output components Output components such as pulleys and couplings must be mounted with suitable equipment and tools. Motor and output component must be accurately aligned both axially and radially. If the motor and the output component are not accurately aligned, this will cause runout and premature wear.

The maximum axial and radial forces acting on the shaft must not exceed the maximum shaft load values specified, see chapter "2.4.2 Shaft load".

If the maximum permissible forces at the motor shaft are exceeded, this will result in premature wear of the bearing, shaft breakage or damage to the encoder.

WARNING

UNINTENDED EQUIPMENT OPERATION DUE TO MECHANICAL DAMAGE TO THE MOTOR

- Do not exceed the maximum permissible axial and radial forces at the motor shaft.
- Protect the motor shaft from impact.
- Do not exceed the maximum permissible axial force when pressing components onto the motor shaft.

Failure to follow these instructions can result in death, serious injury, or equipment damage.

3.4.1 Compressed air connection

The compressed air generates a permanent overpressure inside the motor. This overpressure inside the motor is used to obtain degree of protection IP67.

Note the special requirements in terms of the compressed air in chapter "2 Technical Data".

For installation, the existing screw plug is replaced by an L-shaped push-in fitting. See page 69 for sources of supply of the L-shaped push-in fitting.

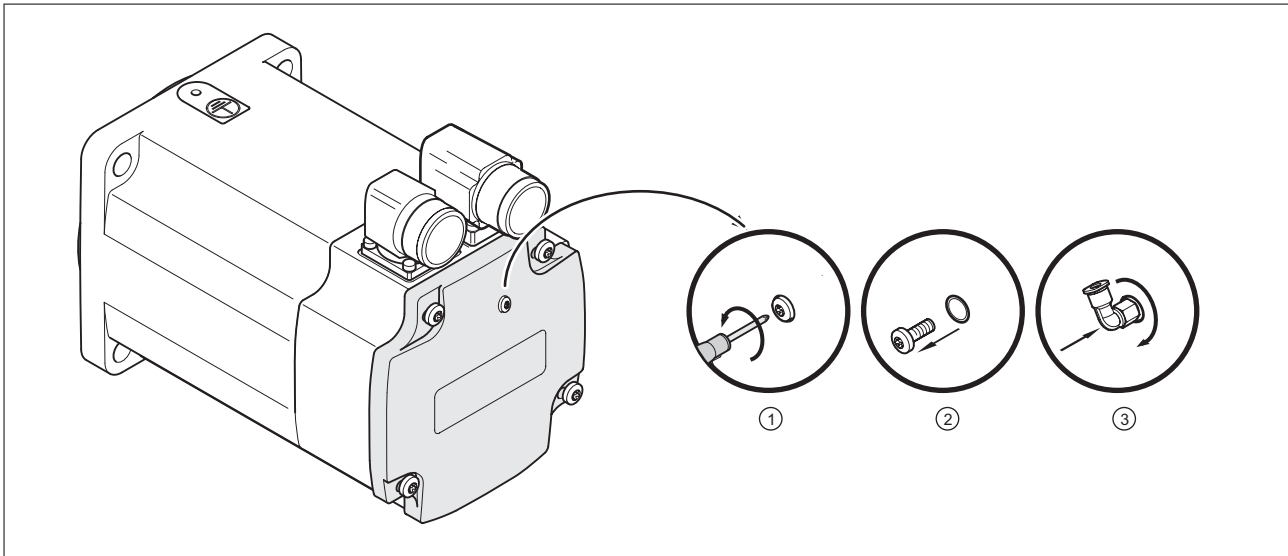

- ▶ (1) and (2): Remove the screw plug.
- ▶ (3) Screw the L-shaped push-in fitting into the thread.
- ▶ Verify proper seat of the L-shaped push-in fitting.
- ▶ Verify the tightening torque of the L-shaped push-in fitting:

| | | |
|--|------------|------------|
| Tightening torque L-shaped push-in fitting | Nm (lb•in) | 0.6 (5.31) |
|--|------------|------------|

Compressed air connection The compressed air connection of the L-shaped push-in fitting is designed for compressed air hoses made of standard plastic with a nominal diameter of 4 mm.

Compressed air monitoring It is recommended to use a compressed air monitor.

3.5 Electrical installation

3.5.1 Connectors and connector assignments

Connection overview

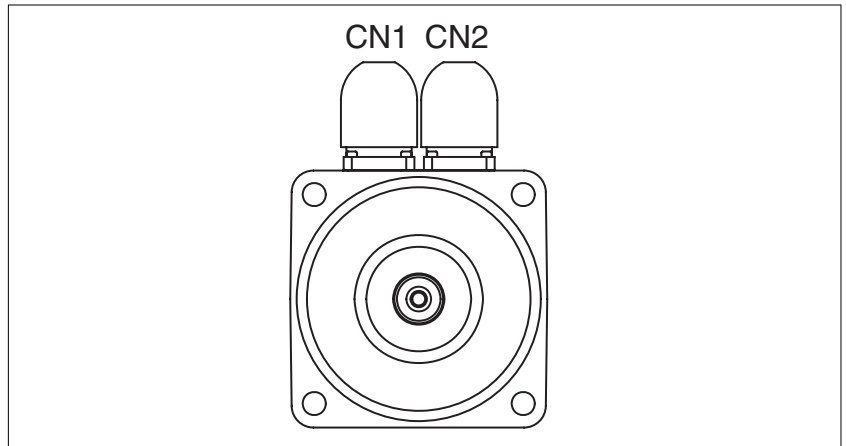

Figure 8: Connection overview

Depending on the motor size, different connector sizes are used for the motor connection CN1. MH3070, MH3100 and MH3140 have an M23 connection. MH3190 has an M40 connection. The encoder connection CN2 is identical irrespective of the motor size.

CN1 motor connection M23

Motor connector for connection of the motor phases and the holding brake.

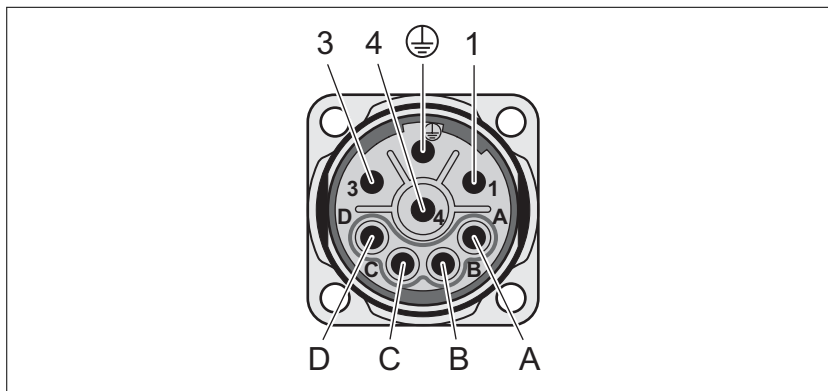

Figure 9: Pin assignment motor connection M23

See chapter "6.2 Connectors" for suitable mating connectors.

The signals of the holding brake meet the PELV requirements.

| Pin | Assignment | Meaning |
|-----|------------|---|
| 1 | W | Motor phase W |
| ⊕ | PE | Protective ground conductor |
| 3 | U | Motor phase U |
| 4 | V | Motor phase V |
| A | BR+ | Supply voltage holding brake 24 Vdc |
| B | BR- | Reference potential holding brake 0 Vdc |
| C | Reserved | Reserved |
| D | Reserved | Reserved |
| | SHLD | Shield (to connector housing) |

CN1 motor connection M40 Motor connector for connection of the motor phases and the holding brake.

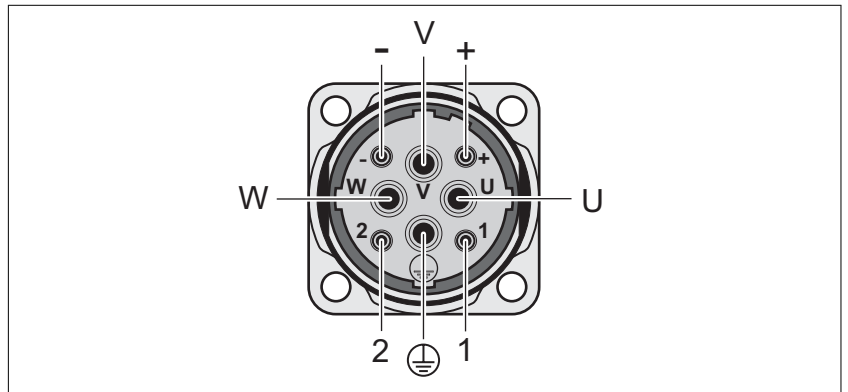

Figure 10: Pin assignment motor connection M40

See chapter "6.2 Connectors" for suitable mating connectors.

The signals of the holding brake meet the PELV requirements.

| Pin | Assignment | Meaning |
|-----|------------|---|
| U | U | Motor phase U |
| ⊕ | PE | Protective ground conductor |
| W | W | Motor phase W |
| V | V | Motor phase V |
| + | BR+ | Supply voltage holding brake 24 Vdc |
| - | BR- | Reference potential holding brake 0 Vdc |
| 1 | Reserved | Reserved |
| 2 | Reserved | Reserved |
| | SHLD | Shield (to connector housing) |

CN2 encoder connection M23

Encoder connector for connection of the SinCos encoder (singleturn and multiturn)

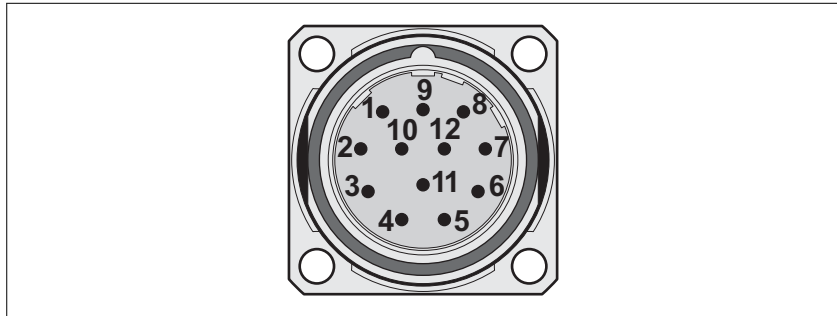

Figure 11: Pin assignment encoder connector

See chapter "6.2 Connectors" for suitable mating connectors.

The signals meet the PELV requirements.

| Pin | Signal | Meaning |
|-----|--------------------------|--|
| 1 | REFCOS_OUT | Reference for cosine signal, 2.5V |
| 2 | DATA | Receive data, transmit data |
| 3 | Reserved | Reserved |
| 4 | Reserved | Reserved |
| 5 | SIN_OUT | Sine signal |
| 6 | REFSIN_OUT | Reference for sine signal, 2.5 V |
| 7 | $\overline{\text{DATA}}$ | Receive data and transmit data, inverted |
| 8 | COS_OUT | Cosine signal |
| 9 | Reserved | Reserved |
| 10 | ENC_0V | Reference potential ¹⁾ |
| 11 | Reserved | Reserved |
| 12 | ENC+10V | 7 ... 12 V supply voltage |
| | SHLD | Shield (to connector housing) |

1) The ENC_0V connection of the supply voltage has no connection to the encoder housing.

3.5.2 Power and encoder connection

The motor is designed for operation via a drive. Connecting the motor directly to three-phase AC voltage will damage the motor and can cause fires.

DANGER

FIRE HAZARD DUE TO INCORRECT CONNECTION

Only connect the motor to an approved drive.

Failure to follow these instructions will result in death or serious injury.

High voltages may be present at the motor connection. The motor itself generates voltage when the motor shaft is rotated. AC voltage can couple voltage to unused conductors in the motor cable.

DANGER

ELECTRIC SHOCK

- Disconnect all power prior to performing any type of work on the drive system.
- Block the motor shaft to prevent rotation prior to performing any type of work on the drive system.
- Insulate both ends of unused conductors of the motor cable.
- Supplement the motor cable grounding conductor with an additional protective ground conductor to the motor housing.
- Verify compliance with all local and national electrical code requirements as well as all other applicable regulations with respect to grounding of all equipment.

Failure to follow these instructions will result in death or serious injury.

Drive systems may perform unanticipated movements because of incorrect connection or other errors.

WARNING

UNINTENDED MOVEMENT

- Operate the motor with approved power stages only. Even if the connectors of a different power stage match, this does not imply compatibility.
- Verify proper wiring.
- Only start the system if there are no persons or obstructions in the zone of operation.
- Perform the first test runs without coupled loads.
- Do not touch the motor shaft or the mounted output components.
- Only touch the motor shaft or the mounted output components if all power has been disconnected.

Failure to follow these instructions can result in death, serious injury, or equipment damage.

Protective ground conductor connection

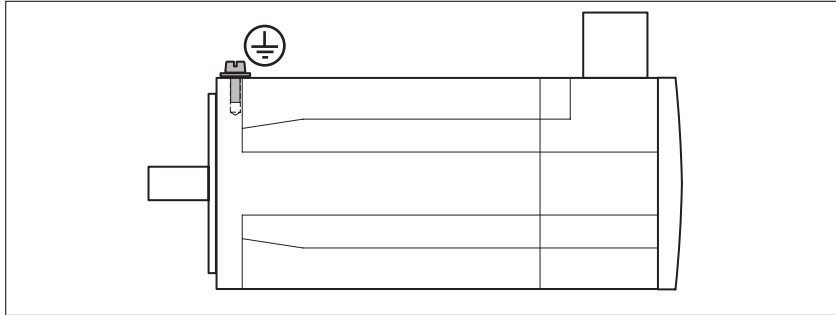

- ▶ Ground the motor via a grounding screw if grounding via the flange and the protective ground conductor of the motor cable is not sufficient. Use parts with suitable corrosion protection. Note the required tightening torque and the property class of the grounding screw, see page 19.

Assembling cables

Insulate unused wires individually.

- ▶ Note the EMC requirements for motor cables and encoder cables, page 42.
- ▶ Use equipotential bonding conductors for equipotential bonding.

Follow the procedure and note the dimensions in "Dimensions for crimping and assembling".

⚠ WARNING

IMPROPER GROUNDING CAN CAUSE UNINTENDED EQUIPMENT OPERATION

- Use cables with insulated shielded jackets for analog I/O, fast I/O and communication signals.
- Ground shielded cables for analog I/O, fast I/O and communication signals at a single point. 2
- Always comply with local wiring requirements regarding grounding of cable shields.

Failure to follow these instructions can result in death, serious injury, or equipment damage.

2. Multipoint grounding is permissible if connections are made to an equipotential ground plane dimensioned to help avoid cable shield damage in the event of power system short circuit currents.

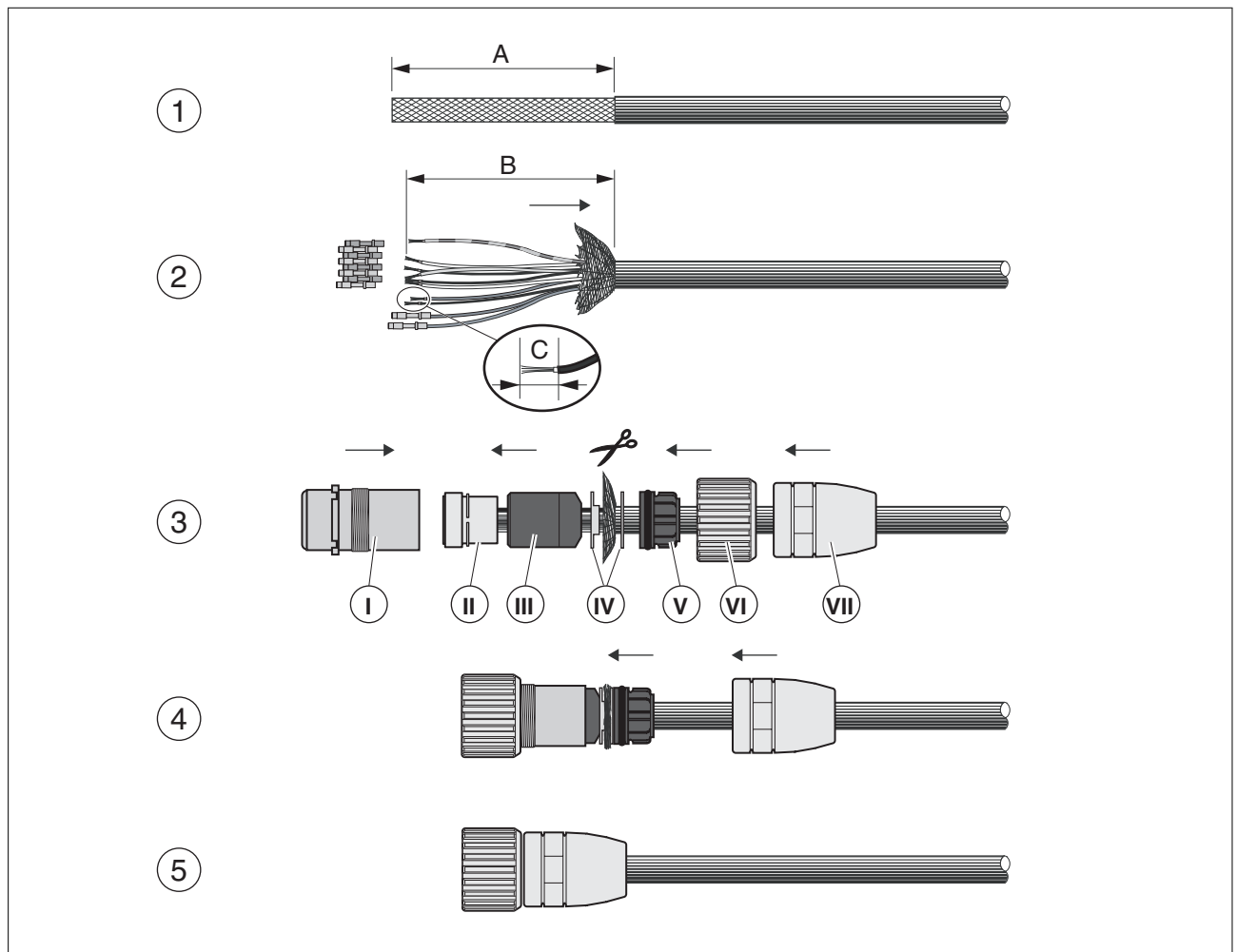

Figure 12: Assembling encoder cables with M23 encoder connector

- ▶ (1) Strip the cable jacket; length as specified (see table below).
- ▶ Open the shield braiding and slide it back over the outer cable jacket.
- ▶ Shorten the inner cable jacket.
- ▶ (2) Shorten the wires to the specified length (see table below) and crimp them to the connector.

If possible, also connect unused wires. This improves EMC. Wires that are not connected must be insulated at both ends.

- ▶ (3) Push part (IV) and part (III) onto the cable. The cable entry contains rubber seals of various sizes for different cable diameters. Use rubber seals matching the diameter of the cable. Enclose the shield with part (IV). Snap the contacts into part (II). Open part (III) at the side and enclose part (II) as well as the rear part of the contacts with it. Slide part (II) into part (I).
- ▶ (4) Slide part (IV) behind the shield braiding. Slide part (VI) over part (I).
- ▶ Screw part (IV) onto part (I) all the way to the stop.

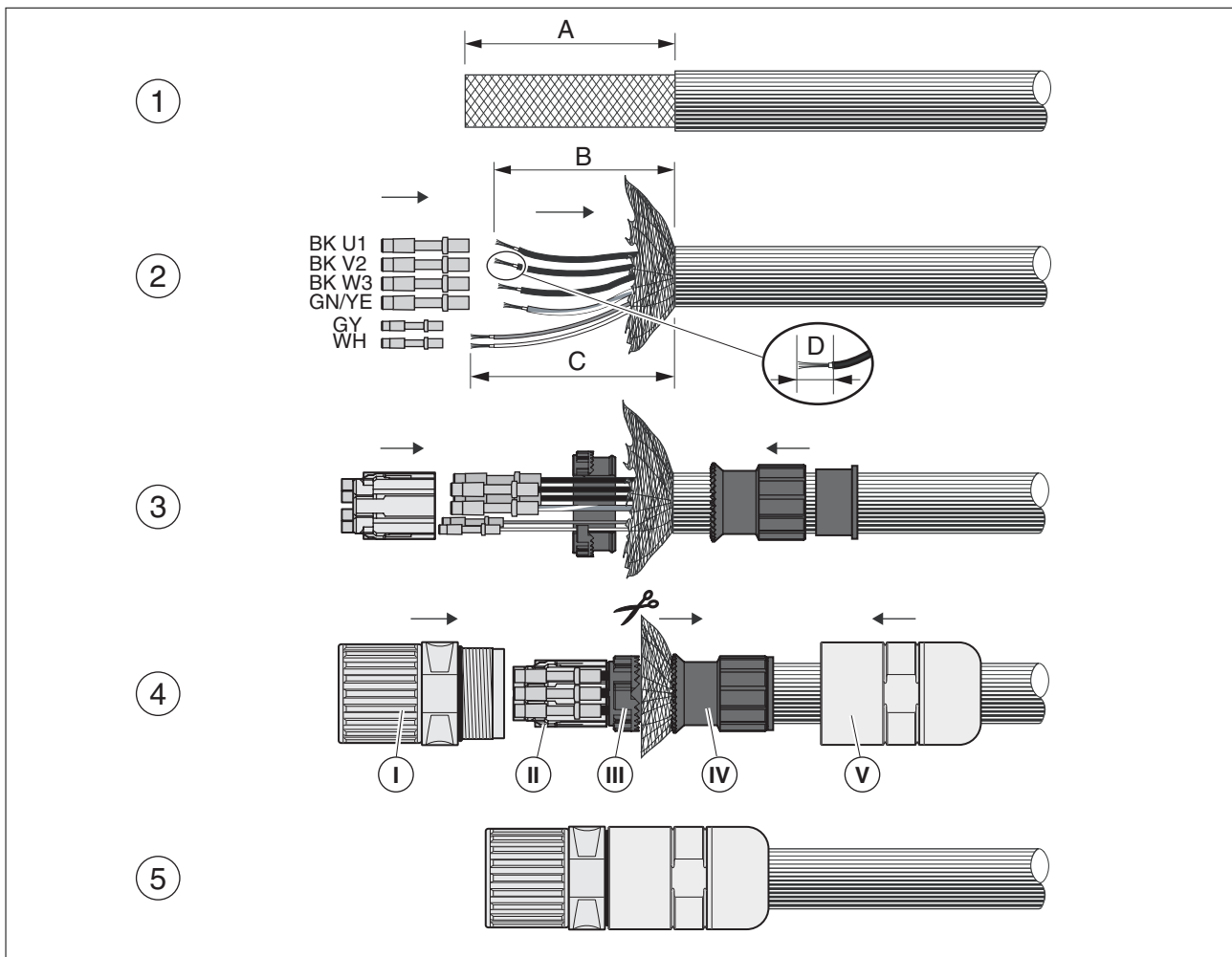

Figure 13: Assembling motor cables with M23 motor connector

- ▶ (1) Strip the cable jacket; length as specified (see table below).
- ▶ Open the shield braiding and slide it back over the outer cable jacket.
- ▶ Shorten the inner cable jacket.
- ▶ (2) Shorten the wires to the specified length (see table below) and crimp them to the connector.

If possible, also connect unused wires. This improves EMC. Wires that are not connected must be insulated at both ends.

- ▶ (3) Push part (IV) and part (III) onto the cable. Snap the contacts into part (II). Open the side of part (III) and enclose the wires using this part.
- ▶ (4) Slide part (III) behind the shield braiding and insert part (II) into part (I). Arrange the shield braiding as shown. Push part (I) and part (III) together and shorten the shield braiding.
- ▶ Screw part (IV) onto part (I) all the way to the stop.
- ▶ If your motor is equipped with a holding brake, follow the instructions in chapter "3.5.3 Holding brake connection".

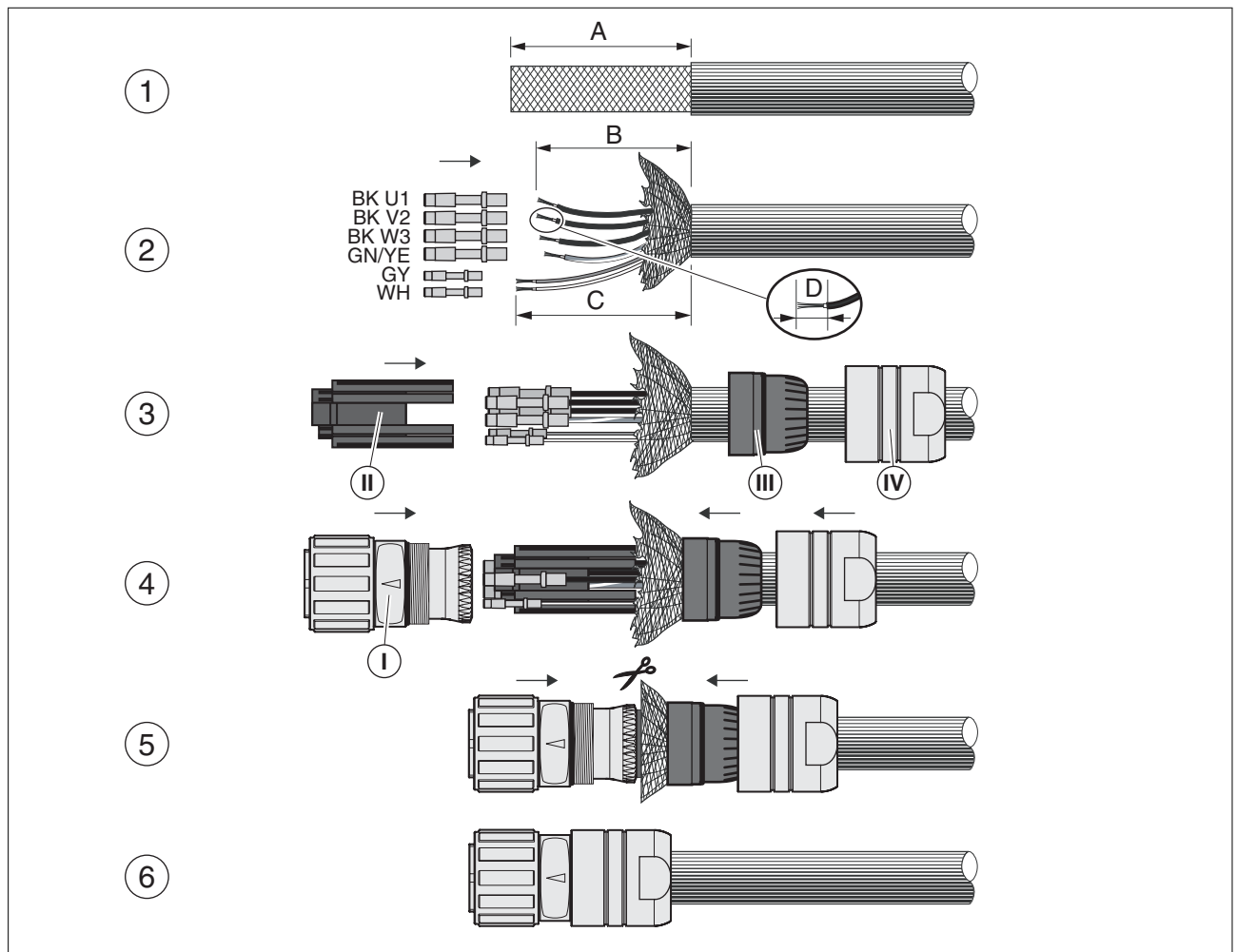

Figure 14: Assembling motor cables with M40 motor connector

- ▶ (1) Strip the cable jacket; length as specified (see table below).
- ▶ Open the shield braiding and slide it back over the outer cable jacket.
- ▶ Shorten the inner cable jacket.
- ▶ (2) Shorten the wires to the specified length (see table below) and crimp them to the connector.

If possible, also connect unused wires. This improves EMC. Wires that are not connected must be insulated at both ends.

- ▶ (3) Push part (IV) and part (III) onto the cable. Snap the contacts laterally into part (II).
- ▶ (4) Slide part (III) behind the shield braiding and insert part (II) into part (I).
- ▶ (5) Arrange the shield braiding as shown. Push part (I) and part (III) together and shorten the shield braiding.
- ▶ Screw part (IV) onto part (I) all the way to the stop.
- ▶ If your motor is equipped with a holding brake, follow the instructions in chapter "3.5.3 Holding brake connection".

Dimensions for crimping and assembling

| | Signal wires encoder 0.14 mm ² | Signal wires encoder 0.34 mm ² | Signal wires 1 mm ² | Power wire 1.5 mm ² | Power wire 2.5 mm ² | Power wire 4 mm ² | Power wire 10 mm ² |
|-----------------------|---|---|--------------------------------|--------------------------------|--------------------------------|------------------------------|-------------------------------|
| Stripping length A | 28 mm (1.1 in) | 28 mm (1.1 in) | 40 mm (1.57 in) | 40 mm (1.57 in) | 40 mm (1.57 in) | 40 mm (1.57 in) | 40 mm (1.57 in) |
| Stripping length B | 28 mm (1.1 in) | 28 mm (1.1 in) | - | 36 mm (1.42 in) | 36 mm (1.42 in) | 36 mm (1.42 in) | 36 mm (1.42 in) |
| Stripping length C | - | - | 40 mm (1.57 in) | - | - | - | - |
| Stripping length D | 4.5 mm (0.18 in) | 4.5 mm (0.18 in) | 4.5 mm (0.18 in) | 8 mm (0.31 in) | 8 mm (0.31 in) | 10 mm (0.39 in) | 10 mm (0.39 in) |
| Crimping tool | SF-Z0007 | SF-Z0007 | SF-Z0007 | SF-Z0008 | SF-Z0008 | SF-Z0008 | SF-Z0008 |
| Positioner type | SF-Z2002 | SF-Z2002 | SF-Z0012 | SF-Z0012 | SF-Z0012 | SF-Z0013 | SF-Z0013 |
| Parameters positioner | Fixed | Fixed | +2 | -2 | -2 | -2 | -2 |
| Parameters eccentric | 5 | 6 | 1 | 4 | 6 | 6 | 6 |

Connecting the cables Incorrect installation of the cable may destroy the insulation. Broken conductors in the cable or improperly connected connectors may be melted by arcs.

⚠ ⚠ DANGER

ELECTRIC SHOCK, ARC FLASH AND FIRE CAUSED BY INCORRECT INSTALLATION OF THE CABLE

- Disconnect all power before plugging in or unplugging the connectors.
- Verify correct pin assignment of the connectors according to the specifications in this chapter before connecting the cables.
- Verify that the connectors are properly plugged in and locked before applying power.
- Avoid impermissible movements of the cable.
- Avoid forces or movements of the cable at the cable entries.

Failure to follow these instructions will result in death or serious injury.

- ▶ Place the female connector of the motor cable onto the motor connector and tighten the union nut. Proceed in the same manner with the connection cable of the encoder system.
Keep the connection cables from being twisted when tightening the union nut.
- ▶ Connect the motor cable and the encoder cable to the drive according to the wiring diagram of the drive.
- ▶ Ground the shield to a large surface area. See the product manual of the drive for information on connecting the shield.
- ▶ If your motor is equipped with a holding brake, follow the instructions in chapter "3.5.3 Holding brake connection".

019844114042, V1.01, 03.2026

3.5.3 Holding brake connection

Applying the holding brake while the motor is running will cause excessive wear and loss of the braking force.

WARNING

LOSS OF BRAKING FORCE DUE TO WEAR OR HIGH TEMPERATURE

- Do not use the holding brake as a service brake.
- Do not exceed the maximum number of brake applications and the kinetic energy during braking of moving loads.

Failure to follow these instructions can result in death, serious injury, or equipment damage.

See chapter "2.5.1 Holding brake" for technical data on braking while the load moves.

Releasing the holding brake may cause an unintended movement in the system, for example, if vertical axes are used.

WARNING

UNINTENDED MOVEMENT

- Take appropriate measures to avoid damage caused by falling or lowering loads.
- Verify that there are no persons or obstacles in the danger zone when performing a test of the holding brake.

Failure to follow these instructions can result in death, serious injury, or equipment damage.

If the voltage is incorrect, the holding brake cannot be released which causes wear. If the voltage is higher than the specified voltage, the holding brake may be re-applied. If the voltage polarity is incorrect, the holding brake cannot be released.

WARNING

MISOPERATION OF THE HOLDING BRAKE CAUSED BY INCORRECT VOLTAGE

- Verify that the specified voltage is available at the holding brake connection.
- Use a properly rated voltage-sensing device for measuring.

Failure to follow these instructions can result in death, serious injury, or equipment damage.

A motor with a holding brake requires a suitable holding brake controller which releases the brake when the power stage is enabled and locks the motor shaft when the power stage is disabled.

Cable specifications

- Minimum wire cross section: 2 * 1.0 mm² (AWG 16)
- Maximum cable length: See product manual of the drive.

4 Commissioning

Drive systems may perform unanticipated movements because of incorrect connection or other errors.

WARNING

UNINTENDED MOVEMENT

- Operate the motor with approved power stages only. Even if the connectors of a different power stage match, this does not imply compatibility.
- Verify proper wiring.
- Only start the system if there are no persons or obstructions in the zone of operation.
- Perform the first test runs without coupled loads.
- Do not touch the motor shaft or the mounted output components.
- Only touch the motor shaft or the mounted output components if all power has been disconnected.

Failure to follow these instructions can result in death, serious injury, or equipment damage.

Rotating parts may cause injuries and may catch clothing or hair. Loose parts or parts that are out of balance may be ejected.

WARNING

MOVING UNGUARDED EQUIPMENT

Verify that rotating parts cannot cause injuries or equipment damage.

Failure to follow these instructions can result in death, serious injury, or equipment damage.

The motor may move, tip and crash down as a result of the reaction torque.

WARNING

FALLING PARTS

Mount the motor properly secured.

Failure to follow these instructions can result in death, serious injury, or equipment damage.

The metal surfaces of the product may exceed 100 °C (212 °F) during operation.

▲ WARNING

HOT SURFACES

- Avoid unprotected contact with hot surfaces.
- Do not allow flammable or heat-sensitive parts in the immediate vicinity of hot surfaces.
- Verify that the heat dissipation is sufficient by performing a test run under maximum load conditions.

Failure to follow these instructions can result in death, serious injury, or equipment damage.

Verifying correct installation

Prior to commissioning, verify correct installation.

- ▶ Verify proper mechanical installation.
- ▶ Verify proper electrical installation.
- Did you connect all protective ground conductors?
- Did you properly connect and install all cables and connectors?
- Did you tighten the cable glands properly?
- ▶ Verify that the ambient conditions are met.
- Does the installation meet the ambient conditions specified?
- ▶ Verify the output components.
- Have the installed output components been balanced and accurately aligned?
- ▶ Verify that the parallel key at the shaft end of the motor.
- If you have a motor with a parallel key groove and parallel key, the parallel key must not be inserted during commissioning without output component or it must be appropriately secured.
- ▶ Verify the function of the holding brake.
- Is the holding brake able to hold the maximum load?
- Is the holding brake released prior to the start of a movement?

5 Diagnostics and troubleshooting

5.1 Mechanical problems

| Problem | Cause | Troubleshooting |
|-----------------------------|---|--|
| Excessive heat | Overload Holding brake not released Heavy pollution | Reduce load Verify that the holding brake controller operates properly Clean the motor |
| Whistling or knocking noise | Rolling bearings | Contact service |
| Grinding noise | Rotating output component grinds | Align output component |
| Radial oscillation | Poor alignment of output component Output component out of balance Shaft bent Resonance with machine bed | Align output component Balance output component Contact service Suppress resonance |
| Axial oscillation | Poor alignment of output component Damage to the output component Resonance with machine bed | Align output component Repair/replace output component Suppress resonance |

5.2 Electrical problems

| Problem | Cause | Troubleshooting |
|---|--|---|
| Motor does not start or has difficulty starting | Overload Unsuitable settings for the drive Cable damaged | Reduce load Correct drive settings Replace damaged cables |
| Excessive heat | Overload | Reduce power |
| Heat at the terminals or connectors | Poor contact | Tighten the terminals / connectors with the specified tightening torque |

6 Accessories and spare parts

6.1 IP67 Kit

Degree of protection IP65 is a prerequisite for the use of the IP67 kit (shaft sealing ring).

| Description | Order no. |
|---|----------------|
| L-shaped push-in fitting, to be bought from Festo | QSML-B-M3-4-20 |

6.2 Connectors

| Description | Order no. |
|---|-----------|
| Connector kit motor / encoder to LXM62, 1.5 mm ² , M23 | VW3E6041 |
| Connector kit motor / encoder to LXM62, 2.5 mm ² , M23 | VW3E6042 |
| Connector kit motor / encoder to LXM62, 2.5 mm ² , M40 | VW3E6043 |
| Connector kit motor / encoder to LXM62, 4 mm ² , M40 | VW3E6044 |
| Connector kit motor / encoder to LXM62, 10 mm ² , M40 | VW3E6045 |

Tools The tools required for cable assembly can be ordered directly from the manufacturer.

- Crimping tool for encoder connector M23:
Coninvers SF-Z0007 www.coninvers.com
- Crimping tool for power connector M23/M40:
Coninvers SF-Z0008 www.coninvers.com
- Crimping tools for encoder connector RJ45 10 pins:
Yamaichi Y-ConTool-11, Y-ConTool-20, Y-ConTool-30
www.yamaichi.com

6.3 Motor cables

6.3.1 Motor cables 1.5 mm²

| Description | Order no. |
|---|--------------|
| Motor cable 5 m, [(4 x 1.5 mm ²) + 2 x (2 x 0.75 mm ²)] shielded; motor end 8-pin circular connector M23, other cable end open | VW3E1143R050 |
| Motor cable 10 m, [(4 x 1.5 mm ²) + 2 x (2 x 0.75 mm ²)] shielded; motor end 8-pin circular connector M23, other cable end open | VW3E1143R100 |
| Motor cable 15 m, [(4 x 1.5 mm ²) + 2 x (2 x 0.75 mm ²)] shielded; motor end 8-pin circular connector M23, other cable end open | VW3E1143R150 |
| Motor cable 20 m, [(4 x 1.5 mm ²) + 2 x (2 x 0.75 mm ²)] shielded; motor end 8-pin circular connector M23, other cable end open | VW3E1143R200 |
| Motor cable 25 m, [(4 x 1.5 mm ²) + 2 x (2 x 0.75 mm ²)] shielded; motor end 8-pin circular connector M23, other cable end open | VW3E1143R250 |
| Motor cable 30 m, [(4 x 1.5 mm ²) + 2 x (2 x 0.75 mm ²)] shielded; motor end 8-pin circular connector M23, other cable end open | VW3E1143R300 |
| Motor cable 40 m, [(4 x 1.5 mm ²) + 2 x (2 x 0.75 mm ²)] shielded; motor end 8-pin circular connector M23, other cable end open | VW3E1143R400 |
| Motor cable 50 m, [(4 x 1.5 mm ²) + 2 x (2 x 0.75 mm ²)] shielded; motor end 8-pin circular connector M23, other cable end open | VW3E1143R500 |

6.3.2 Motor cables 2.5 mm²

Circular connector M23:

| Description | Order no. |
|--|--------------|
| Motor cable 5 m, [(4 x 2.5 mm ²) + 2 x (2 x 1 mm ²)] shielded; motor end 8-pin circular connector M23, other cable end open | VW3E1144R050 |
| Motor cable 10 m, [(4 x 2.5 mm ²) + 2 x (2 x 1 mm ²)] shielded; motor end 8-pin circular connector M23, other cable end open | VW3E1144R100 |
| Motor cable 15 m, [(4 x 2.5 mm ²) + 2 x (2 x 1 mm ²)] shielded; motor end 8-pin circular connector M23, other cable end open | VW3E1144R150 |
| Motor cable 20 m, [(4 x 2.5 mm ²) + 2 x (2 x 1 mm ²)] shielded; motor end 8-pin circular connector M23, other cable end open | VW3E1144R200 |
| Motor cable 25 m, [(4 x 2.5 mm ²) + 2 x (2 x 1 mm ²)] shielded; motor end 8-pin circular connector M23, other cable end open | VW3E1144R250 |
| Motor cable 30 m, [(4 x 2.5 mm ²) + 2 x (2 x 1 mm ²)] shielded; motor end 8-pin circular connector M23, other cable end open | VW3E1144R300 |
| Motor cable 40 m, [(4 x 2.5 mm ²) + 2 x (2 x 1 mm ²)] shielded; motor end 8-pin circular connector M23, other cable end open | VW3E1144R400 |
| Motor cable 50 m, [(4 x 2.5 mm ²) + 2 x (2 x 1 mm ²)] shielded; motor end 8-pin circular connector M23, other cable end open | VW3E1144R500 |

Circular connector M40:

| Description | Order no. |
|--|--------------|
| Motor cable 5 m, [(4 x 2.5 mm ²) + 2 x (2 x 1 mm ²)] shielded; motor end 8-pin circular connector M40, other cable end open | VW3E1145R050 |
| Motor cable 10 m, [(4 x 2.5 mm ²) + 2 x (2 x 1 mm ²)] shielded; motor end 8-pin circular connector M40, other cable end open | VW3E1145R100 |
| Motor cable 15 m, [(4 x 2.5 mm ²) + 2 x (2 x 1 mm ²)] shielded; motor end 8-pin circular connector M40, other cable end open | VW3E1145R150 |
| Motor cable 20 m, [(4 x 2.5 mm ²) + 2 x (2 x 1 mm ²)] shielded; motor end 8-pin circular connector M40, other cable end open | VW3E1145R200 |
| Motor cable 25 m, [(4 x 2.5 mm ²) + 2 x (2 x 1 mm ²)] shielded; motor end 8-pin circular connector M40, other cable end open | VW3E1145R250 |
| Motor cable 30 m, [(4 x 2.5 mm ²) + 2 x (2 x 1 mm ²)] shielded; motor end 8-pin circular connector M40, other cable end open | VW3E1145R300 |
| Motor cable 40 m, [(4 x 2.5 mm ²) + 2 x (2 x 1 mm ²)] shielded; motor end 8-pin circular connector M40, other cable end open | VW3E1145R400 |
| Motor cable 50 m, [(4 x 2.5 mm ²) + 2 x (2 x 1 mm ²)] shielded; motor end 8-pin circular connector M40, other cable end open | VW3E1145R500 |

6.3.3 Motor cables 4 mm²

| Description | Order no. |
|---|--------------|
| Motor cable 5 m, [(4 x 4 mm ²) + (2 x 1 mm ²) + (2 x 1.5 mm ²)] shielded; motor end 8-pin circular connector M40, other cable end open | VW3E1153R050 |
| Motor cable 10 m, [(4 x 4 mm ²) + (2 x 1 mm ²) + (2 x 1.5 mm ²)] shielded; motor end 8-pin circular connector M40, other cable end open | VW3E1153R100 |
| Motor cable 15 m, [(4 x 4 mm ²) + (2 x 1 mm ²) + (2 x 1.5 mm ²)] shielded; motor end 8-pin circular connector M40, other cable end open | VW3E1153R150 |
| Motor cable 20 m, [(4 x 4 mm ²) + (2 x 1 mm ²) + (2 x 1.5 mm ²)] shielded; motor end 8-pin circular connector M40, other cable end open | VW3E1153R200 |
| Motor cable 25 m, [(4 x 4 mm ²) + (2 x 1 mm ²) + (2 x 1.5 mm ²)] shielded; motor end 8-pin circular connector M40, other cable end open | VW3E1153R250 |
| Motor cable 30 m, [(4 x 4 mm ²) + (2 x 1 mm ²) + (2 x 1.5 mm ²)] shielded; motor end 8-pin circular connector M40, other cable end open | VW3E1153R300 |
| Motor cable 40 m, [(4 x 4 mm ²) + (2 x 1 mm ²) + (2 x 1.5 mm ²)] shielded; motor end 8-pin circular connector M40, other cable end open | VW3E1153R400 |
| Motor cable 50 m, [(4 x 4 mm ²) + (2 x 1 mm ²) + (2 x 1.5 mm ²)] shielded; motor end 8-pin circular connector M40, other cable end open | VW3E1153R500 |
| Motor cable 75 m, [(4 x 4 mm ²) + (2 x 1 mm ²) + (2 x 1.5 mm ²)] shielded; motor end 8-pin circular connector M40, other cable end open | VW3E1153R750 |

6.3.4 Motor cables 10 mm²

| Description | Order no. |
|--|--------------|
| Motor cable 5 m, [(4 x 10 mm ²) + (2 x 1 mm ²) + (2 x 1.5 mm ²)] shielded; motor end 8-pin circular connector M40, other cable end open | VW3E1154R050 |
| Motor cable 10 m, [(4 x 10 mm ²) + (2 x 1 mm ²) + (2 x 1.5 mm ²)] shielded; motor end 8-pin circular connector M40, other cable end open | VW3E1154R100 |
| Motor cable 15 m, [(4 x 10 mm ²) + (2 x 1 mm ²) + (2 x 1.5 mm ²)] shielded; motor end 8-pin circular connector M40, other cable end open | VW3E1154R150 |
| Motor cable 20 m, [(4 x 10 mm ²) + (2 x 1 mm ²) + (2 x 1.5 mm ²)] shielded; motor end 8-pin circular connector M40, other cable end open | VW3E1154R200 |
| Motor cable 25 m, [(4 x 10 mm ²) + (2 x 1 mm ²) + (2 x 1.5 mm ²)] shielded; motor end 8-pin circular connector M40, other cable end open | VW3E1154R250 |
| Motor cable 30 m, [(4 x 10 mm ²) + (2 x 1 mm ²) + (2 x 1.5 mm ²)] shielded; motor end 8-pin circular connector M40, other cable end open | VW3E1154R300 |
| Motor cable 40 m, [(4 x 10 mm ²) + (2 x 1 mm ²) + (2 x 1.5 mm ²)] shielded; motor end 8-pin circular connector M40, other cable end open | VW3E1154R400 |
| Motor cable 50 m, [(4 x 10 mm ²) + (2 x 1 mm ²) + (2 x 1.5 mm ²)] shielded; motor end 8-pin circular connector M40, other cable end open | VW3E1154R500 |
| Motor cable 75 m, [(4 x 10 mm ²) + (2 x 1 mm ²) + (2 x 1.5 mm ²)] shielded; motor end 8-pin circular connector M40, other cable end open | VW3E1154R750 |

6.4 Encoder cables

| Description | Order no. |
|---|--------------|
| Encoder cable 5 m, [3 x (2 x 0.14 mm ²) + (2 x 0.34 mm ²)] shielded; motor end 12-pin circular connector M23, device end 10-pin connector RJ45 | VW3E2094R050 |
| Encoder cable 10 m, [3 x (2 x 0.14 mm ²) + (2 x 0.34 mm ²)] shielded; motor end 12-pin circular connector M23, device end 10-pin connector RJ45 | VW3E2094R100 |
| Encoder cable 15 m, [3 x (2 x 0.14 mm ²) + (2 x 0.34 mm ²)] shielded; motor end 12-pin circular connector M23, device end 10-pin connector RJ45 | VW3E2094R150 |
| Encoder cable 20 m, [3 x (2 x 0.14 mm ²) + (2 x 0.34 mm ²)] shielded; motor end 12-pin circular connector M23, device end 10-pin connector RJ45 | VW3E2094R200 |
| Encoder cable 25 m, [3 x (2 x 0.14 mm ²) + (2 x 0.34 mm ²)] shielded; motor end 12-pin circular connector M23, device end 10-pin connector RJ45 | VW3E2094R250 |
| Encoder cable 30 m, [3 x (2 x 0.14 mm ²) + (2 x 0.34 mm ²)] shielded; motor end 12-pin circular connector M23, device end 10-pin connector RJ45 | VW3E2094R300 |
| Encoder cable 40 m, [3 x (2 x 0.14 mm ²) + (2 x 0.34 mm ²)] shielded; motor end 12-pin circular connector M23, device end 10-pin connector RJ45 | VW3E2094R400 |
| Encoder cable 50 m, [3 x (2 x 0.14 mm ²) + (2 x 0.34 mm ²)] shielded; motor end 12-pin circular connector M23, device end 10-pin connector RJ45 | VW3E2094R500 |

7 Service, maintenance and disposal

7.1 Service address



If you have any questions please contact your sales office. Your sales office staff will be happy to give you the name of a customer service office in your area.

<http://www.schneider-electric.com>

Schneider Electric Automation GmbH
Schneiderplatz 1
97828 Marktheidenfeld
Germany

7.2 Maintenance

Repairs may only be made by the manufacturer. No warranty or liability is accepted for repairs made by unauthorized persons.

Repairs cannot be made with the device installed.

Include the following points in the maintenance plan of your machine.

Connections and fastening

- ▶ Inspect all connection cables and connectors regularly for damage. Replace damaged cables immediately.
- ▶ Verify that all output elements are firmly seated.
- ▶ Tighten all mechanical and electrical threaded connections to the specified torque.

Lubricating the shaft sealing ring

In the case of motors with shaft sealing ring, lubricant must be applied to the space between the sealing lip of the shaft sealing ring and the shaft with a suitable non-metallic tool. If the shaft sealing rings are allowed to run dry, the service life of the shaft sealing rings will be significantly reduced.

Cleaning

If the permissible ambient conditions are not respected, external substances from the environment may penetrate the product and cause unintended movement or equipment damage.

▲ WARNING

UNINTENDED MOVEMENT

- Verify that the ambient conditions are respected.
- Do not allow seals to run dry.
- Keep liquids from getting to the shaft bushing (for example, in mounting position IM V3).
- Do not expose the shaft sealing rings and cable entries of the motor to the direct spray of a pressure washer.

Failure to follow these instructions can result in death, serious injury, or equipment damage.

Clean dust and dirt off the product at regular intervals. Insufficient heat dissipation to the ambient air may excessively increase the temperature.

Motors are not suitable for cleaning with a pressure washer. The high pressure may force water into the motor.

When using solvents or cleaning agents, verify that the cables, cable entry seals, O-rings and motor paint are not damaged.

Inspecting/braking in the holding brake



Occasional braking while the load moves helps to maintain the holding torque of the holding brake. If the brake does not work mechanically for an extended period of time, parts of the holding brake may corrode. Corrosion reduces the holding torque.

The holding brake is factory-broken in. If the holding brake is not used for an extended period of time, parts of the holding brake may corrode. If the holding brake does not have the holding torque indicated in the technical data, it must be broken in again.

- The motor is dismounted. The holding brake is applied.
- ▶ Measure the holding torque of the holding brake using a torque wrench.
- ▶ Compare the value to the specified holding torque of the holding brake when it was delivered. See chapter "2.5.1 Holding brake".
- ▶ If the holding torque of the holding brake considerably differs from the specified values, manually rotate the motor shaft by 25 rotations in both directions.
- ▶ Repeat the process. Contact your sales office if you cannot restore the original holding torque by repeating the process 3 times.

Replacing the rolling bearing

When the rolling bearing is replaced, the motor is partially demagnetized and loses power.

NOTICE

DAMAGE TO MOTOR

Do not replace the rolling bearing.

Failure to follow these instructions can result in equipment damage.

7.3 Changing the motor

If you replace the motor, the absolute position of the encoder changes so that it is no longer valid.

⚠ WARNING

UNINTENDED MOVEMENT DUE TO CHANGED ABSOLUTE POSITION

Set the new absolute position of the encoder after having replaced the motor.

Failure to follow these instructions can result in death, serious injury, or equipment damage.

- ▶ Switch off all supply voltages. Verify that no voltages are present.
- ▶ Label all connections and uninstall the product.
- ▶ Note the identification number and the serial number shown on the product nameplate for later identification.
- ▶ Install the new product as per chapter "3 Installation".
- ▶ Commission the product as per chapter "4 Commissioning".

7.4 Shipping, storage, disposal

Note the ambient conditions in chapter "2.1 General characteristics".

Shipping The product must be protected against shocks during transportation. If possible, use the original packaging for shipping.

Storage Protect the product from dust and dirt.

The storage time is primarily limited by the service life of the lubricants in the bearings; do not store the product for more than 36 months. It is recommended to periodically operate the motor. Long storage periods may reduce the holding torque of the holding brake. See "Inspecting/braking in the holding brake".

Disposal The product consists of various materials that can be recycled. Dispose of the product in accordance with local regulations.

Visit <http://www.schneider-electric.com> for information and documents on environmental protection as per ISO 14025 such as:

- EoLi (Product End-of-Life Instructions)
- PEP (Product Environmental Profile)

Glossary



Units and conversion tables

The value in the specified unit (left column) is calculated for the desired unit (top row) with the formula (in the field).

Example: conversion of 5 meters (m) to yards (yd)
 $5 \text{ m} / 0.9144 = 5.468 \text{ yd}$

Length

| | in | ft | yd | m | cm | mm |
|-----------|-----------|-----------|-----------|-----------|-----------|-----------|
| in | - | / 12 | / 36 | * 0.0254 | * 2.54 | * 25.4 |
| ft | * 12 | - | / 3 | * 0.30479 | * 30.479 | * 304.79 |
| yd | * 36 | * 3 | - | * 0.9144 | * 91.44 | * 914.4 |
| m | / 0.0254 | / 0.30479 | / 0.9144 | - | * 100 | * 1000 |
| cm | / 2.54 | / 30.479 | / 91.44 | / 100 | - | * 10 |
| mm | / 25.4 | / 304.79 | / 914.4 | / 1000 | / 10 | - |

Mass

| | lb | oz | slug | kg | g |
|-------------|--------------|----------------------------|----------------------------|--------------|------------|
| lb | - | * 16 | * 0.03108095 | * 0.4535924 | * 453.5924 |
| oz | / 16 | - | * $1.942559 \cdot 10^{-3}$ | * 0.02834952 | * 28.34952 |
| slug | / 0.03108095 | / $1.942559 \cdot 10^{-3}$ | - | * 14.5939 | * 14593.9 |
| kg | / 0.45359237 | / 0.02834952 | / 14.5939 | - | * 1000 |
| g | / 453.59237 | / 28.34952 | / 14593.9 | / 1000 | - |

Force

| | lb | oz | p | N |
|-----------|-------------|-------------|-------------------------|-------------------------|
| lb | - | * 16 | * 453.55358 | * 4.448222 |
| oz | / 16 | - | * 28.349524 | * 0.27801 |
| p | / 453.55358 | / 28.349524 | - | * $9.807 \cdot 10^{-3}$ |
| N | / 4.448222 | / 0.27801 | / $9.807 \cdot 10^{-3}$ | - |

Power

| | HP | W |
|-----------|-----------|----------|
| HP | - | * 746 |
| W | / 746 | - |

Rotation

| | min ⁻¹ (RPM) | rad/s | deg./s |
|-------------------------|-------------------------|--------------|----------|
| min ⁻¹ (RPM) | - | * $\pi / 30$ | * 6 |
| rad/s | * $30 / \pi$ | - | * 57.295 |
| deg./s | / 6 | / 57.295 | - |

Torque

| | lb-in | lb-ft | oz-in | Nm | kp-m | kp-cm | dyne-cm |
|---------|----------------------|-----------------------|--------------------------|--------------------------|--------------------------|--------------------------|-----------------------|
| lb-in | - | / 12 | * 16 | * 0.112985 | * 0.011521 | * 1.1521 | * $1.129 \cdot 10^6$ |
| lb-ft | * 12 | - | * 192 | * 1.355822 | * 0.138255 | * 13.8255 | * $13.558 \cdot 10^6$ |
| oz-in | / 16 | / 192 | - | * $7.0616 \cdot 10^{-3}$ | * $720.07 \cdot 10^{-6}$ | * $72.007 \cdot 10^{-3}$ | * 70615.5 |
| Nm | / 0.112985 | / 1.355822 | / $7.0616 \cdot 10^{-3}$ | - | * 0.101972 | * 10.1972 | * $10 \cdot 10^6$ |
| kp-m | / 0.011521 | / 0.138255 | / $720.07 \cdot 10^{-6}$ | / 0.101972 | - | * 100 | * $98.066 \cdot 10^6$ |
| kp-cm | / 1.1521 | / 13.8255 | / $72.007 \cdot 10^{-3}$ | / 10.1972 | / 100 | - | * $0.9806 \cdot 10^6$ |
| dyne-cm | / $1.129 \cdot 10^6$ | / $13.558 \cdot 10^6$ | / 70615.5 | / $10 \cdot 10^6$ | / $98.066 \cdot 10^6$ | / $0.9806 \cdot 10^6$ | - |

Moment of inertia

| | lb-in ² | lb-ft ² | kg-m ² | kg-cm ² | kp-cm-s ² | oz-in ² |
|----------------------|--------------------|--------------------|-------------------|--------------------|----------------------|--------------------|
| lb-in ² | - | / 144 | / 3417.16 | / 0.341716 | / 335.109 | * 16 |
| lb-ft ² | * 144 | - | * 0.04214 | * 421.4 | * 0.429711 | * 2304 |
| kg-m ² | * 3417.16 | / 0.04214 | - | * $10 \cdot 10^3$ | * 10.1972 | * 54674 |
| kg-cm ² | * 0.341716 | / 421.4 | / $10 \cdot 10^3$ | - | / 980.665 | * 5.46 |
| kp-cm-s ² | * 335.109 | / 0.429711 | / 10.1972 | * 980.665 | - | * 5361.74 |
| oz-in ² | / 16 | / 2304 | / 54674 | / 5.46 | / 5361.74 | - |

Temperature

| | °F | °C | K |
|----|-------------------------|-----------------|--------------------------|
| °F | - | (°F - 32) * 5/9 | (°F - 32) * 5/9 + 273.15 |
| °C | °C * 9/5 + 32 | - | °C + 273.15 |
| K | (K - 273.15) * 9/5 + 32 | K - 273.15 | - |

Conductor cross section

| AWG | 1 | 2 | 3 | 4 | 5 | 6 | 7 | 8 | 9 | 10 | 11 | 12 | 13 |
|-----------------|------|------|------|------|------|------|------|-----|-----|-----|-----|-----|-----|
| mm ² | 42.4 | 33.6 | 26.7 | 21.2 | 16.8 | 13.3 | 10.5 | 8.4 | 6.6 | 5.3 | 4.2 | 3.3 | 2.6 |

| AWG | 14 | 15 | 16 | 17 | 18 | 19 | 20 | 21 | 22 | 23 | 24 | 25 | 26 |
|-----------------|-----|-----|-----|-----|------|------|------|------|------|------|------|------|------|
| mm ² | 2.1 | 1.7 | 1.3 | 1.0 | 0.82 | 0.65 | 0.52 | 0.41 | 0.33 | 0.26 | 0.20 | 0.16 | 0.13 |

Terms and Abbreviations

| | |
|-----------------------------|---|
| | See chapter " Standards and terminology" for information on the pertinent standards on which many terms are based. Some terms and abbreviations may have specific meanings with regard to the standards. |
| <i>Axial forces</i> | Tension or compression forces acting longitudinally on the shaft |
| <i>Centering collar</i> | Centering device at the motor flange that allows for accurate motor mounting. |
| <i>DOM</i> | Date of manufacturing: The nameplate of the product shows the date of manufacture in the format DD.MM.YY or in the format DD.MM.YYYY. For example: 31.12.11 corresponds to December 31, 2011 31.12.2011 corresponds to December 31, 2011 |
| <i>Degree of protection</i> | The degree of protection is a standardized specification for electrical equipment that describes the protection against the ingress of foreign objects and water (for example: IP 20). |
| <i>Drive system</i> | System consisting of controller, drive and motor. |
| <i>EMC</i> | Electromagnetic compatibility |
| <i>Encoder</i> | Sensor that converts a measured distance or angle into an electrical signal. This signal is evaluated by the drive to determine the actual position of a shaft (rotor) or a driving unit. |
| <i>Error</i> | Discrepancy between a detected (computed, measured or signaled) value or condition and the specified or theoretically correct value or condition. |
| <i>Error class</i> | Classification of errors into groups. The different error classes allow for specific responses to errors, for example by severity. |
| <i>Fault</i> | Fault is an operating state. If the monitoring functions detect an error, a transition to this operating state is triggered, depending on the error class. A "Fault Reset" is required to exit this operating state after the cause of the detected error has been removed. Further information can be found in the pertinent standards such as IEC 61800-7, ODVA Common Industrial Protocol (CIP). |
| <i>Fault Reset</i> | A function used to restore the drive to an operational state after a detected error is cleared by removing the cause of the error so that the error is no longer active. |
| <i>Length</i> | In the type code, the length is defined in terms of the number of stacks. |
| <i>PELV</i> | Protective Extra Low Voltage, low voltage with isolation. For more information: IEC 60364-4-41 |
| <i>Radial forces</i> | Forces that act radially on the shaft |
| <i>Size</i> | In the type code, the size is defined in terms of the flange size. |
| <i>Warning</i> | If the term is used outside the context of safety instructions, a warning alerts to a potential problem that was detected by a monitoring function. A warning does not cause a transition of the operating state. |

Table of figures



| | | |
|-----|--|----|
| 1) | Nameplate | 15 |
| 2) | Dimensions MH3070 | 27 |
| 3) | Dimensions MH3100 | 28 |
| 4) | Dimensions MH3140 | 29 |
| 5) | Dimensions MH3190 | 30 |
| 6) | Shaft load | 32 |
| 7) | MH3190 rear side of motor | 50 |
| 8) | Connection overview | 53 |
| 9) | Pin assignment motor connection M23 | 54 |
| 10) | Pin assignment motor connection M40 | 55 |
| 11) | Pin assignment encoder connector | 56 |
| 12) | Assembling encoder cables with M23 encoder connector | 59 |
| 13) | Assembling motor cables with M23 motor connector | 60 |
| 14) | Assembling motor cables with M40 motor connector | 61 |

Index



| | | | |
|----------|--------------------------------------|----------|---|
| A | | E | |
| | Abbreviations 81 | | EMC 41 |
| | Accessories and spare parts 69 | | Motor cable and encoder cable 42 |
| | Approved drives 19 | | Encoder 35 |
| C | | | Connection 57 |
| | Cable assembly | | Multiturn 35, 35, 36 |
| | Power 58 | | Singleturn 36 |
| | Cable specifications 46 | | Encoder cable |
| | Holding brake 63 | | EMC requirements 42 |
| | Certifications 36 | | Environmental conditions |
| | Changing the motor 77 | | Operation 18 |
| | Commissioning 65 | F | Equipotential bonding conductors 43 |
| | Connecting the motor cable 62 | | |
| | Connection | | Force for pressing on 31 |
| | Holding brake 63 | G | |
| | Motor 57 | | General characteristics 17 |
| | Power 57 | | Glossary 79 |
| | Connector | H | |
| | Installation 53 | | Hazard categories 5 |
| | Connector assignments 53 | | Holding brake 34 |
| D | | | Connection 63 |
| | Degree of protection 18 | I | |
| | Diagnostics 67 | | Installation 39 |
| | dimensional drawing, see dimensions | | Intended use 6 |
| | Dimensions 27 | | Introduction 13 |
| | Disposal 75, 78 | M | |
| | DOM 81 | | Maintenance 75 |

| | | | |
|--|------------|-----------------------------------|------------|
| Manuals | | S | |
| Source | 11 | Safety Information | 5 |
| Maximum force during pressing on | 31 | Sealing air | 52 |
| Motor | | Service | 75 |
| Connection | 57 | Service address | 75 |
| Motor cable | | Shaft sealing ring | 18 |
| Assembly | 58 | Shaft-specific data | 31 |
| EMC requirements | 42 | Shipping | 78 |
| motor connection CN1 | 54, 55 | SinCos Multiturn | 35, 35, 36 |
| Motor-specific data | 20 | SinCos Singleturn | 36 |
| Mounting position | 49 | Singleturn | 36 |
| Multiturn | 35, 35, 36 | Source | |
| N | | Manuals | 11 |
| Name plate | 15 | Storage | 78 |
| O | | T | |
| Options | 34 | Technical data | 17 |
| Overview | | Terms | 81 |
| Procedure for electrical installation | 41 | Tightening torques | |
| P | | Screws | 19 |
| PELV power supply UL | 36 | Troubleshooting | 67 |
| Power | | Type code | 16 |
| Connection | 57 | U | |
| Power connection CN1 | 54, 55 | UL, conditions for | |
| Pressing on | | PELV power supply | 36 |
| Maximum force | 31 | Wiring | 36 |
| Property class | | Units and conversion tables | 79 |
| Screws | 19 | W | |
| Q | | Wiring UL | 36 |
| Qualification of personnel | 6 | | |