

LXM32M

Safety Module eSM

User Guide

Original instructions

0198441113825.04
12/2021

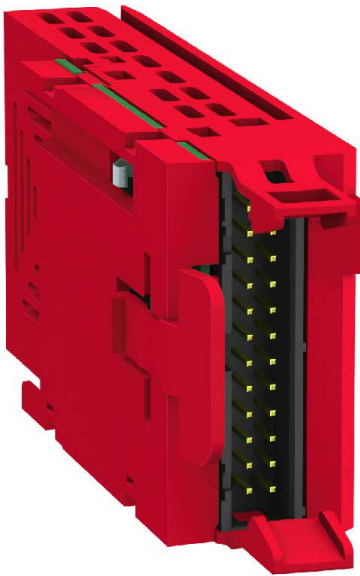

Legal Information

The Schneider Electric brand and any trademarks of Schneider Electric SE and its subsidiaries referred to in this guide are the property of Schneider Electric SE or its subsidiaries. All other brands may be trademarks of their respective owners.

This guide and its content are protected under applicable copyright laws and furnished for informational use only. No part of this guide may be reproduced or transmitted in any form or by any means (electronic, mechanical, photocopying, recording, or otherwise), for any purpose, without the prior written permission of Schneider Electric.

Schneider Electric does not grant any right or license for commercial use of the guide or its content, except for a non-exclusive and personal license to consult it on an "as is" basis. Schneider Electric products and equipment should be installed, operated, serviced, and maintained only by qualified personnel.

As standards, specifications, and designs change from time to time, information contained in this guide may be subject to change without notice.

To the extent permitted by applicable law, no responsibility or liability is assumed by Schneider Electric and its subsidiaries for any errors or omissions in the informational content of this material or consequences arising out of or resulting from the use of the information contained herein.

As part of a group of responsible, inclusive companies, we are updating our communications that contain non-inclusive terminology. Until we complete this process, however, our content may still contain standardized industry terms that may be deemed inappropriate by our customers.

© 2021 Schneider Electric. All Rights Reserved.

Table of Contents

Safety Information.....	5
Qualification of Personnel	5
Intended Use.....	6
Before You Begin.....	6
Start-up and Test	7
Operation and Adjustments	8
About the Book.....	9
Introduction	12
Introduction.....	12
Technical Data.....	13
Data Functional Safety.....	13
Technical Data Safety Module eSM.....	14
Technical Data eSM Terminal Adapter	17
Approved Motors	18
Engineering.....	19
General	19
Prerequisites and Requirements for Using the Safety-Related Functions	19
Safety-Related Functions	23
Overview.....	23
Safety-Related Function STO	23
Safety-Related Function SOS	24
Safety-Related Function SLS.....	25
Safety-Related Function SS1.....	30
Safety-Related Function SS2.....	31
Monitored Deceleration	32
Connected Equipment	35
Overview.....	35
Status Information via Non-Safety-Related Status Outputs.....	37
Wiring of Input Devices/Sensors	40
Selecting the Machine Operating Mode	41
Guard Door with Guard Locking	42
Enabling Device.....	44
Acknowledge/Reset Pushbutton	45
Installation.....	48
Installation of the Safety Module eSM.....	48
Wiring for Multi-Axis Systems	53
Installation of the eSM Terminal Adapter.....	55
Commissioning.....	57
Configuration with the Commissioning Software.....	57
Commissioning - Overview	57
Menu Item "Status"	58
Menu Item "Duplicate".....	58
Menu Item "Parameters".....	59
Menu Item "Change Password".....	60
Operation	62
Machine Operating Modes	62

- Machine Operating Modes - General 62
- Machine Operating Mode Automatic Mode..... 63
- Machine Operating Mode Setup Mode..... 65
- Start/Restart Signal 68
 - Start/Restart Signal - Overview 68
 - Manual Start/Restart 69
 - Automatic Start/Restart 69
- Emergency Stop..... 71
 - Emergency Stop - Overview 71
 - Integrated Emergency Stop 71
 - Emergency Stop with External Safety Relay..... 74
- Guard Door 76
 - Safety-Related Function SOS with Open Guard Door 76
 - Safety-Related Function SLS with Open Guard Door 77
 - Acknowledge/Reset Pushbutton 78
 - Guard Door with Guard Locking Device 79
- Monitoring Functions 81
 - Monitoring Functions..... 81
- Diagnostics and Troubleshooting 82**
 - Diagnostics and Troubleshooting 82
 - Operating States and State Transitions 83
 - Error Classes and Error Responses 84
- Parameters 86**
 - Representation of the Parameters..... 86
 - List of Parameters 89
- Accessories and Spare Parts..... 96**
 - Safety Module eSM 96
- Service, Maintenance, and Disposal 97**
 - Maintenance 97
 - Replacing Modules 97
 - Shipping, Storage, Disposal 99
- Index 101**

Safety Information

Important Information

Read these instructions carefully, and look at the equipment to become familiar with the device before trying to install, operate, service, or maintain it. The following special messages may appear throughout this documentation or on the equipment to warn of potential hazards or to call attention to information that clarifies or simplifies a procedure.



The addition of this symbol to a “Danger” or “Warning” safety label indicates that an electrical hazard exists which will result in personal injury if the instructions are not followed.



This is the safety alert symbol. It is used to alert you to potential personal injury hazards. Obey all safety messages that follow this symbol to avoid possible injury or death.

⚠ DANGER
DANGER indicates a hazardous situation which, if not avoided, will result in death or serious injury.
⚠ WARNING
WARNING indicates a hazardous situation which, if not avoided, could result in death or serious injury.
⚠ CAUTION
CAUTION indicates a hazardous situation which, if not avoided, could result in minor or moderate injury.
NOTICE
NOTICE is used to address practices not related to physical injury.

Please Note

Electrical equipment should be installed, operated, serviced, and maintained only by qualified personnel. No responsibility is assumed by Schneider Electric for any consequences arising out of the use of this material.

A qualified person is one who has skills and knowledge related to the construction and operation of electrical equipment and its installation, and has received safety training to recognize and avoid the hazards involved.

Qualification of Personnel

Only appropriately trained persons who are familiar with and understand the contents of this manual and all other pertinent product documentation are authorized to work on and with this product. These persons must have sufficient technical training, knowledge and experience and be able to foresee and detect potential hazards that may be caused by using the product, by modifying the settings and by the mechanical, electrical and electronic equipment of the entire system in which the product is used.

The qualified person must be a certified expert in functional safety.

The qualified person must be familiar with and understand the contents of the risk assessment as per ISO 12100-1 and/or any other equivalent assessment as well as all documents related to such risk assessment or equivalent assessments for the machine/process.

The qualified person must be able to detect possible hazards that may arise from parameterization, modifying parameter values and generally from mechanical, electrical, or electronic equipment.

The qualified person must be familiar with the standards, provisions, and regulations for the prevention of industrial accidents, which they must observe when designing and implementing the system.

The qualified person must be thoroughly familiar with the safety-related applications and the non-safety-related applications used to operate the machine/process.

Intended Use

The products described or affected by this document are, along with software, accessories and options, servo-drive systems for three-phase servo motors.

The products are intended for industrial use according to the instructions, directions, examples, and safety information contained in the present user guide and other supporting documentation.

The product may only be used in compliance with all applicable safety regulations and directives, the specified requirements and the technical data.

Prior to using the products, you must perform a risk assessment in view of the planned application. Based on the results, the appropriate safety-related measures must be implemented.

Since the products are used as components in an overall machine or process, you must ensure the safety of persons by means of the design of this overall machine or process.

Operate the products only with the specified cables and accessories. Use only genuine accessories and spare parts.

Any use other than the use explicitly permitted as described herein is prohibited and may result in unanticipated hazards.

Before You Begin

Do not use this product on machinery lacking effective point-of-operation guarding. Lack of effective point-of-operation guarding on a machine can result in serious injury to the operator of that machine.

▲ WARNING

UNGUARDED EQUIPMENT

- Do not use this software and related automation equipment on equipment which does not have point-of-operation protection.
- Do not reach into machinery during operation.

Failure to follow these instructions can result in death, serious injury, or equipment damage.

This automation equipment and related software is used to control a variety of industrial processes. The type or model of automation equipment suitable for each application will vary depending on factors such as the control function required, degree of protection required, production methods, unusual conditions, government regulations, etc. In some applications, more than one processor may be required, as when backup redundancy is needed.

Only you, the user, machine builder or system integrator can be aware of all the conditions and factors present during setup, operation, and maintenance of the machine and, therefore, can determine the automation equipment and the related safeties and interlocks which can be properly used. When selecting automation and control equipment and related software for a particular application, you should refer to the applicable local and national standards and regulations. The National Safety Council's Accident Prevention Manual (nationally recognized in the United States of America) also provides much useful information.

In some applications, such as packaging machinery, additional operator protection such as point-of-operation guarding must be provided. This is necessary if the operator's hands and other parts of the body are free to enter the pinch points or other hazardous areas and serious injury can occur. Software products alone cannot protect an operator from injury. For this reason the software cannot be substituted for or take the place of point-of-operation protection.

Ensure that appropriate safeties and mechanical/electrical interlocks related to point-of-operation protection have been installed and are operational before placing the equipment into service. All interlocks and safeties related to point-of-operation protection must be coordinated with the related automation equipment and software programming.

NOTE: Coordination of safeties and mechanical/electrical interlocks for point-of-operation protection is outside the scope of the Function Block Library, System User Guide, or other implementation referenced in this documentation.

Start-up and Test

Before using electrical control and automation equipment for regular operation after installation, the system should be given a start-up test by qualified personnel to verify correct operation of the equipment. It is important that arrangements for such a check are made and that enough time is allowed to perform complete and satisfactory testing.

▲ WARNING

EQUIPMENT OPERATION HAZARD

- Verify that all installation and set up procedures have been completed.
- Before operational tests are performed, remove all blocks or other temporary holding means used for shipment from all component devices.
- Remove tools, meters, and debris from equipment.

Failure to follow these instructions can result in death, serious injury, or equipment damage.

Follow all start-up tests recommended in the equipment documentation. Store all equipment documentation for future references.

Software testing must be done in both simulated and real environments.

Verify that the completed system is free from all short circuits and temporary grounds that are not installed according to local regulations (according to the National Electrical Code in the U.S.A, for instance). If high-potential voltage testing is necessary, follow recommendations in equipment documentation to prevent accidental equipment damage.

Before energizing equipment:

- Remove tools, meters, and debris from equipment.
- Close the equipment enclosure door.
- Remove all temporary grounds from incoming power lines.
- Perform all start-up tests recommended by the manufacturer.

Operation and Adjustments

The following precautions are from the NEMA Standards Publication ICS 7.1-1995 (English version prevails):

- Regardless of the care exercised in the design and manufacture of equipment or in the selection and ratings of components, there are hazards that can be encountered if such equipment is improperly operated.
- It is sometimes possible to misadjust the equipment and thus produce unsatisfactory or unsafe operation. Always use the manufacturer's instructions as a guide for functional adjustments. Personnel who have access to these adjustments should be familiar with the equipment manufacturer's instructions and the machinery used with the electrical equipment.
- Only those operational adjustments actually required by the operator should be accessible to the operator. Access to other controls should be restricted to prevent unauthorized changes in operating characteristics.

About the Book

Document Scope

The information provided in this user guide supplements the user guide of the servo drive LXM32M.

The functions described in this user guide are only intended for use with the servo drive LXM32M.

Fully read and understand the user guide of the servo drive that you use.

Validity Note

This user guide applies to the safety module eSM for the servo drive LXM32M, module identification eSM (VW3M3501).

For product compliance and environmental information (RoHS, REACH, PEP, EOL, etc.), go to www.se.com/ww/en/work/support/green-premium/.

The characteristics that are described in the present document, as well as those described in the documents included in the Related Documents section below, can be found online. To access the information online, go to the Schneider Electric home page www.se.com/ww/en/download/.

The characteristics that are described in the present document should be the same as those characteristics that appear online. In line with our policy of constant improvement, we may revise content over time to improve clarity and accuracy. If you see a difference between the document and online information, use the online information as your reference.

Related Documents

Title of documentation	Reference number
LXM32M - Safety module eSM - User Guide (this user guide)	0198441113825 (eng)
	0198441113826 (fre)
	0198441113824 (ger)
Lexium 32M - Servo Drive - User Guide	0198441113767 (eng)
	0198441113768 (fre)
	0198441113766 (ger)
	0198441113770 (spa)
	0198441113769 (ita)
	0198441113771 (chi)

Product Related Information

⚠ WARNING

LOSS OF CONTROL

- The designer of any control scheme must consider the potential failure modes of control paths and, for certain critical control functions, provide a means to achieve a safe state during and after a path failure. Examples of critical control functions are emergency stop and overtravel stop, power outage and restart.
- Separate or redundant control paths must be provided for critical control functions.
- System control paths may include communication links. Consideration must be given to the implications of unanticipated transmission delays or failures of the link.
- Observe all accident prevention regulations and local safety guidelines.¹
- Each implementation of this equipment must be individually and thoroughly tested for proper operation before being placed into service.

Failure to follow these instructions can result in death, serious injury, or equipment damage.

¹ For additional information, refer to NEMA ICS 1.1 (latest edition), "Safety Guidelines for the Application, Installation, and Maintenance of Solid State Control" and to NEMA ICS 7.1 (latest edition), "Safety Standards for Construction and Guide for Selection, Installation and Operation of Adjustable-Speed Drive Systems" or their equivalent governing your particular location.

⚠ WARNING

INSUFFICIENT AND/OR INEFFECTIVE SAFETY-RELATED FUNCTIONS

- Verify that a risk assessment as per ISO 12100 and/or other equivalent assessment has been performed before this product is used.
- Fully read and understand all pertinent manuals before performing any type of work on or with this product.
- Verify that modifications do not compromise or reduce the Safety Integrity Level (SIL), Performance Level (PL) and/or any other safety-related requirements and capabilities defined for your machine/process.
- After modifications of any type whatsoever, restart the machine/process and verify the correct operation and effectiveness of all functions by performing comprehensive tests for all operating states, the defined safe state, and all potential error situations.

Failure to follow these instructions can result in death, serious injury, or equipment damage.

Terminology Derived from Standards

The technical terms, terminology, symbols and the corresponding descriptions in this manual, or that appear in or on the products themselves, are generally derived from the terms or definitions of international standards.

In the area of functional safety systems, drives and general automation, this may include, but is not limited to, terms such as *safety*, *safety function*, *safe state*, *fault*, *fault reset*, *malfunxion*, *failure*, *error*, *error message*, *dangerous*, etc.

Among others, these standards include:

Standard	Description
IEC 61131-2:2007	Programmable controllers, part 2: Equipment requirements and tests.
ISO 13849-1:2015	Safety of machinery: Safety related parts of control systems. General principles for design.
EN 61496-1:2013	Safety of machinery: Electro-sensitive protective equipment. Part 1: General requirements and tests.
ISO 12100:2010	Safety of machinery - General principles for design - Risk assessment and risk reduction
EN 60204-1:2006	Safety of machinery - Electrical equipment of machines - Part 1: General requirements
ISO 14119:2013	Safety of machinery - Interlocking devices associated with guards - Principles for design and selection
ISO 13850:2015	Safety of machinery - Emergency stop - Principles for design
IEC 62061:2015	Safety of machinery - Functional safety of safety-related electrical, electronic, and electronic programmable control systems
IEC 61508-1:2010	Functional safety of electrical/electronic/programmable electronic safety-related systems: General requirements.
IEC 61508-2:2010	Functional safety of electrical/electronic/programmable electronic safety-related systems: Requirements for electrical/electronic/programmable electronic safety-related systems.
IEC 61508-3:2010	Functional safety of electrical/electronic/programmable electronic safety-related systems: Software requirements.
IEC 61784-3:2016	Industrial communication networks - Profiles - Part 3: Functional safety fieldbuses - General rules and profile definitions.
2006/42/EC	Machinery Directive
2014/30/EU	Electromagnetic Compatibility Directive
2014/35/EU	Low Voltage Directive

In addition, terms used in the present document may tangentially be used as they are derived from other standards such as:

Standard	Description
IEC 60034 series	Rotating electrical machines
IEC 61800 series	Adjustable speed electrical power drive systems
IEC 61158 series	Digital data communications for measurement and control – Fieldbus for use in industrial control systems

Finally, the term *zone of operation* may be used in conjunction with the description of specific hazards, and is defined as it is for a *hazard zone* or *danger zone* in the *Machinery Directive (2006/42/EC)* and *ISO 12100:2010*.

NOTE: The aforementioned standards may or may not apply to the specific products cited in the present documentation. For more information concerning the individual standards applicable to the products described herein, see the characteristics tables for those product references.

Introduction

Introduction

Overview

The safety module eSM is an optional module which allows you to implement additional safety-related functions with LXM32M drives.

The safety module eSM offers the following safety-related functions:

	Safety-related sub-functions as per IEC 61800-5-2:
STO	Safe Torque Off No power that can cause torque or force is supplied to the motor.
SS1	Safe Stop 1 , type SS1-r (ramp-monitored) SS1 consists of: <ul style="list-style-type: none"> • Monitored deceleration of the movement according a specified deceleration ramp. • STO (triggered after standstill has been reached).
SS2	Safe Stop 2 , type SS2-r (ramp-monitored) SS2 consists of: <ul style="list-style-type: none"> • Monitored deceleration of the movement according a specified deceleration ramp. • SOS (triggered after standstill has been reached).
SOS	Safe Operating Stop SOS monitors the standstill position. The power stage is enabled.
SLS	Safely Limited Speed SLS monitors speed limits.

The safety-related functions listed above correspond to the safety-related sub-functions as defined by IEC 61800-5-2. The term “safety-related function” in the present document corresponds to the term “safety-related sub-function” as defined by IEC 61800-5-2 for the above functions.

Technical Data

Data Functional Safety

Data Functional Safety Safety Module eSM

Characteristic	Unit	Value
Lifetime as per IEC 61508	Years	20
Safe Failure Fraction (SFF) as per IEC 61508	%	95
Hardware Fault Tolerance (HFT) as per IEC 61508 Hardware Fault Tolerance Type B subsystem	-	1
Safety Integrity Level (SIL) as per IEC 61508	-	3
Safety Integrity Level Claim Limit (SILCL) as per IEC 62061	-	3
Probability of Dangerous Hardware Failure per Hour (PFH) as per IEC 61508	1/h (FIT)	$7 \cdot 10^{-9}$ (7)
Performance Level (PL) and category as per ISO 13849-1	-	e, 3
Mean Time to Dangerous Failure (MTTF _d) as per ISO 13849-1	Years	170 (High)
Diagnostic Coverage (DC) as per ISO 13849-1	%	95
Demand mode of operation as per IEC-61508-1, IEC-62061	-	High

Data Functional Safety eSM Terminal Adapter (Accessory)

Characteristic	Unit	Value
Lifetime as per IEC 61508	Years	20
Safe Failure Fraction (SFF) as per IEC 61508	%	95
Hardware Fault Tolerance (HFT) as per IEC 61508 Hardware Fault Tolerance Type B subsystem	-	1
Safety Integrity Level (SIL) as per IEC 61508	-	3
Safety Integrity Level Claim Limit (SILCL) as per IEC 62061	-	3
Probability of Dangerous Hardware Failure per Hour (PFH) as per IEC 61508	1/h (FIT)	$2.5 \cdot 10^{-9}$ (2.5)
Performance Level (PL) and category as per ISO 13849-1	-	e, 3
Mean Time to Dangerous Failure (MTTF _d) as per ISO 13849-1	Years	1000 (High)
Diagnostic Coverage (DC) as per ISO 13849-1	%	95
Demand mode of operation as per IEC-61508-1, IEC-62061	-	High

Technical Data Safety Module eSM

Environmental Conditions

The environmental conditions for the safety module eSM are identical to those specified for the drive. Refer to the user guide of the drive (Related Documents, page 9) for the environmental conditions.

Degree of Protection

The safety module eSM must be installed and operated in a control cabinet, secured by a keyed or toolled locking mechanism, with degree of protection IP54 or higher as per IEC 60529.

Logic Type

The safety module eSM must be wired for positive logic.

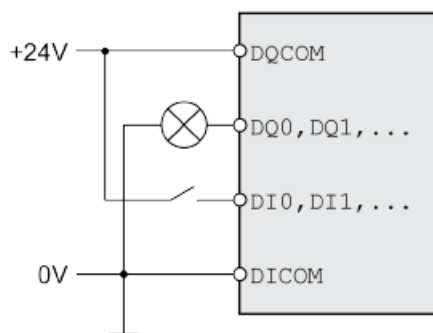

Logic type	Active state
Positive logic	Output supplies current (source output)
	Current flows to the input (sink input)

Refer to the user guide of the drive (Related Documents, page 9) for additional information on the logic type.

24 V Power Supply

The 24 Vdc supply must meet the requirements of IEC 61131-2 (PELV standard power supply unit).

Characteristic	Unit	Value
Input voltage	Vdc	24 (-15/+20%)
Nominal input current safety module eSM without load on outputs	A	≤0.02
Nominal input current eSM terminal adapter (accessory), without load on outputs	A	≤0.05
Residual ripple	%	<5

Digital Inputs

The digital signal inputs are protected against reverse polarity.

Characteristic	Unit	Value
Voltage at level 0	Vdc	-3 ... +5
Voltage at level 1	Vdc	+15 ... +30

Characteristic	Unit	Value
Nominal input current dual-channel input ⁽¹⁾	mA	2.5
Nominal input current single-channel input	mA	5
Debounce time	ms	≥1
Time window for simultaneous switching (both channels)	s	1
(1) Refer to <i>Wiring of Input Devices/Sensors</i> , page 40 for additional information on inputs with suffixes ..._A and ..._B.		

Digital Outputs

The digital signal outputs are short-circuit protected.

Characteristic	Unit	Value
Maximum inductive load	H	20 (at 100 mA) 0.8 (at 500 mA)
Maximum capacitive load	µF	≤ 1
Maximum switching current <i>RELAY_OUT_A, RELAY_OUT_B</i>	A	≤ 0.5
Maximum switching current <i>INTERLOCK_OUT</i>	A	≤ 0.5
Maximum switching current <i>CCM24V_OUT_A, CCM24V_OUT_B</i>	A	≤ 0.3
Maximum switching current <i>AUXOUT1, AUXOUT2</i>	A	≤ 0.1
Voltage drop at 0.5 A	V	≤ 1
Deactivation time for test	ms	≤ 1
Maximum time for detection of cross circuits at activated outputs	s	≤ 5

Signal Duration Start/Restart and Acknowledge/Reset

The duration of the signals provided by a manual start/restart push-button and an acknowledge/reset push-button must be within the following limits:

Characteristic	Unit	Value
Signal duration manual start/restart push-button	s	0.1 ... 2
Signal duration acknowledge/reset push-button	s	0.1 ... 2

Response Times, Maximum Movement SOS, Maximum Motor-Induced Movement STO

Characteristic	Unit	Value
Triggering of emergency stop until beginning of SS1	ms	≤ 20
Detection of invalid velocity (monitored velocity exceeded)	ms	≤ 20
Detection of invalid movement (monitored position value exceeded)	ms	≤ 20
Detection of invalid deceleration (monitored deceleration exceeded)	ms	≤ 10
Maximum movement with active SOS (trigger threshold for STO) ⁽¹⁾	inc	± 25
Maximum motor-induced movement with active STO	-	One half of motor pole pitch
(1) With reference to 1000 increments per revolution		

Monitoring for Periodic Movement

If the power stage is enabled, the motor must perform a movement of at least two increments (with reference to 1000 increments per revolution) every 36 hours. This periodic movement is used to verify that the encoder is operative. If this periodic movement is not detected, an error is detected. The periodic movement is also monitored in the machine operating mode Automatic Mode.

Safety Module eSM and Encoder Module

An additional encoder connected to the encoder module (encoder 2) can be used as a machine encoder or as a motor encoder. Refer to the user guide of the drive for additional information. The safety module eSM only monitors the signals of the encoder connected to connection CN3 of the drive. It does not monitor signals of encoders connected to the encoder module.

Technical Data eSM Terminal Adapter

Environmental Conditions

The environmental conditions for the eSM terminal adapter are identical to those specified for the drive. Refer to the user guide of the drive (Related Documents, page 9) for the environmental conditions.

Degree of Protection

The eSM terminal adapter may only be installed and operated in a control cabinet, secured by a keyed or tooled locking mechanism, with degree of protection IP54 or higher as per IEC 60529.

Mounting

The eSM terminal adapter can be mounted to standard DIN rails or G-type rails.

Dimensions eSM Terminal Adapter

Dimensions eSM terminal adapter:

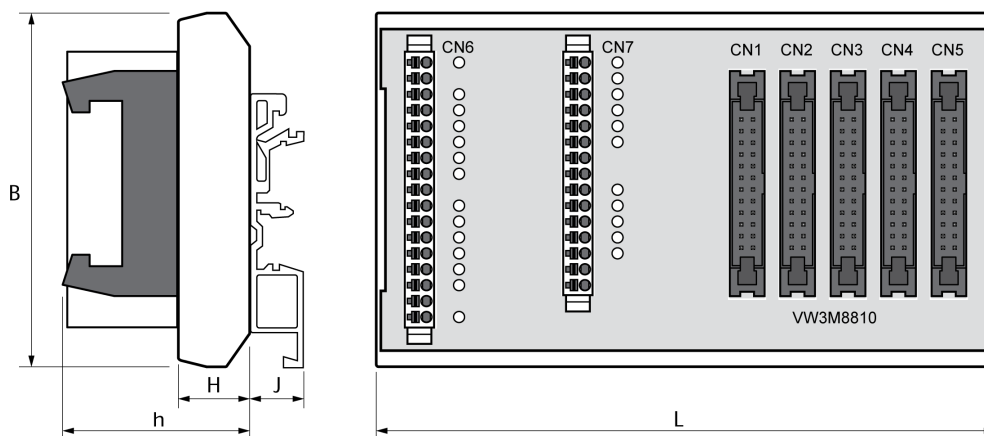

Characteristic	Unit	Value
Space requirements (h + J + cable)	mm	≥ 100
B	mm	78
L	mm	136
Available space for unlocking the DIN rail	mm	≥ 10

Approved Motors

Approved Motors

Drive systems may perform unintended movements if unapproved combinations of drive and motor are used. Though the connectors for motor connection and encoder connection may match mechanically, this does not imply that the motor is approved for use.

⚠ WARNING

UNINTENDED MOVEMENT

Only use approved combinations of drive and motor.

Failure to follow these instructions can result in death, serious injury, or equipment damage.

The safety module eSM may only be used with approved motors and encoders. The motor encoder must be connected to CN3 (encoder 1) of the servo drive.

Approved motors	With approved encoders
BMH	SEK37: Absolute singleturn 16 Sin/Cos periods SEL37: Absolute multiturn 16 Sin/Cos periods SKS36: Absolute singleturn 128 Sin/Cos periods SKM36: Absolute multiturn 128 Sin/Cos periods
BRH	SKS36: Absolute singleturn 128 Sin/Cos periods SKM36: Absolute multiturn 128 Sin/Cos periods
BSH	SKS36: Absolute singleturn 128 Sin/Cos periods SKM36: Absolute multiturn 128 Sin/Cos periods

Speed of Rotation of Motor

If the safety module eSM is used, a speed of rotation of the motor of 8000 RPM must not be exceeded.

Engineering

General

Prerequisites and Requirements for Using the Safety-Related Functions

General

The safety-related function STO (Safe Torque Off) does not remove power from the DC bus. The safety-related function STO only removes power to the motor. The DC bus voltage and the mains voltage to the drive are still present.

⚠️ DANGER

ELECTRIC SHOCK

- Do not use the safety-related function STO for any other purposes than its intended function.
- Use an appropriate switch, that is not part of the circuit of the safety-related function STO, to disconnect the drive from the mains power.

Failure to follow these instructions will result in death or serious injury.

After the safety-related function STO is triggered, the motor can no longer generate torque and coasts down without braking.

⚠️ WARNING

UNINTENDED EQUIPMENT OPERATION

Install a dedicated, external safety-related brake if coasting does not meet the deceleration requirements of your application.

Failure to follow these instructions can result in death, serious injury, or equipment damage.

Holding Brake and Safety-Related Function STO

When the safety-related function STO is triggered, the power stage is immediately disabled. Applying the holding brake requires a certain amount of time. In the case of vertical axes or external forces acting on the load, you may have to take additional measures to bring the load to a standstill and to keep it at a standstill when the safety-related function STO is used, for example, by using a service brake.

⚠️ WARNING

FALLING LOAD

Ensure that all loads come to a secure standstill when the safety-related function STO is used.

Failure to follow these instructions can result in death, serious injury, or equipment damage.

If the suspension of hanging / pulling loads is a safety objective for the machine, then you can only achieve this objective by using an appropriate external brake as a safety-related measure.

⚠ WARNING

UNINTENDED AXIS MOVEMENT

- Do not use the internal holding brake as a safety-related measure.
- Only use certified external brakes as safety-related measures.

Failure to follow these instructions can result in death, serious injury, or equipment damage.

NOTE: The drive does not provide its own safety-related output to connect an external brake to use as a safety-related measure.

Stops with Stop Category 0 and Stop Category 1

IEC 60204-1 defines several stop categories for stop functions. As opposed to a stop with stop category 1 which actively decelerates the motor to a standstill (power available to the motor to achieve the stop) before power is removed, a stop with stop category 0 immediately removes power to the motor. Consequently, the motor coasts down to a standstill. Coasting down is subject to the external forces interacting with the load, such as inertia and gravity. The safety-related function STO corresponds to a stop with stop category 0.

Depending on your application, a stop with stop category 0 may not be sufficient to remove the hazards. For example, the available rotational or axial distance required to come to a complete standstill by coasting down may not be sufficient at a specific load. This could result in collisions of machine parts. In addition, the distance between the guard and hazardous machine parts must be sufficiently great so that a machine operator can only reach such parts after the coasting period has finished. Such distances are specified, for example, in ISO 13855.

⚠ WARNING

UNINTENDED EQUIPMENT OPERATION

- Make certain that no hazards can arise for persons or material during the coast down period of the axis/machine.
- Do not enter the zone of operation during the coast down period.
- Ensure that no other persons can access the zone of operation during the coast down period.
- Use appropriate safety interlocks where personnel and/or equipment hazards exist.

Failure to follow these instructions can result in death, serious injury, or equipment damage.

Unintended Restart

⚠ WARNING

UNINTENDED EQUIPMENT OPERATION

- Verify that your risk assessment covers all potential effects of automatic or unintended enabling of the power stage, for example, after power outage.
- Implement all measures such as control functions, guards, or other safety-related functions, required to reliably protect against all hazards that may result from automatic or unintended enabling of the power stage.
- Verify that a master controller cannot enable the power stage in an unintended way.

Failure to follow these instructions can result in death, serious injury, or equipment damage.

▲ WARNING**UNINTENDED EQUIPMENT OPERATION**

Set the parameter *IO_AutoEnable* to "off" if the automatic enabling of the power stage presents hazards in your application.

Failure to follow these instructions can result in death, serious injury, or equipment damage.

▲ WARNING**UNINTENDED EQUIPMENT OPERATION**

Use Manual Start/Restart if unintended restart is a hazard according to your risk assessment.

Failure to follow these instructions can result in death, serious injury, or equipment damage.

Direction of Movement and Scaling

Movements are made in positive or in negative directions. In the case of rotary motors, direction of movement is defined in accordance with IEC 61800-7-204: Positive direction is when the motor shaft rotates clockwise as you look at the end of the protruding motor shaft.

Modifying the parameter *InvertDirOfMove* (inversion of the direction of movement) does not modify the limit values in the safety module eSM.

Modifying the scaling parameters *ScalePOSnum*, *ScalePOSdenom*, *ScaleVELnum*, *ScaleVELdenom*, *ScaleRAMPnum* and *ScaleRAMPdenom* does not modify the limit values in the safety module eSM.

Motor-Induced Movement With Active STO

In the case of a short circuit of the power stage transistors, a motor-induced movement is possible when the safety-related function STO is active. The maximum motor-induced movement in the case of active STO amounts to one half of the motor pole pitch.

▲ WARNING**INEFFECTIVE SAFETY-RELATED FUNCTION AND/OR UNINTENDED EQUIPMENT OPERATION**

- In your risk assessment, take into account the specified maximum motor-induced movement possible when the safety-related function STO is active.
- Implement all measures required to remove the hazards that can result from such movements.

Failure to follow these instructions can result in death, serious injury, or equipment damage.

Type of motor	Unit	Maximum possible motor-induced movement
Motors with 3 pairs of poles	°	60
Motors with 4 pairs of poles	°	45

Degree of Protection With Safety-Related Functions

You must ensure that conductive substances cannot get into the product (pollution degree 2). Moreover, conductive substances may cause the safety-related function to become inoperative.

▲ WARNING

INOPERABLE SAFETY-RELATED FUNCTION

Ensure that conductive substances (water, contaminated or impregnated oils, metal shavings, etc.) cannot get into the drive.

Failure to follow these instructions can result in death, serious injury, or equipment damage.

Protected Cable Installation

If short circuits and other wiring errors such as a cross circuit between the signals of the safety-related function STO can be expected in connection with safety-related signals, and if these short circuits and cross circuits are not detected by upstream devices, protected cable installation as per ISO 13849-2 is required.

In the case of an unprotected cable installation, the two signals (both channels) of a safety-related function may be connected to external voltage if a cable is damaged. If the two channels are connected to external voltage, the safety-related function is no longer operative.

ISO 13849-2 describes protected cable installation for cables for safety-related signals. The cables for the safety-related function STO must be protected against external voltage. A shield with ground connection helps to keep external voltage away from the cables for the signals of the safety-related function STO.

Ground loops can cause problems in machines. A shield connected at one end only is sufficient for grounding and does not create a ground loop.

- Use shielded cables for the signals of the safety-related function STO.
- Do not use the cable for the signals of the safety-related function STO for other signals.
- Connect one end of the shield.

Safety-Related Functions

Overview

General

Refer to Technical Data, page 13 for data for safety-related calculations and the maintenance plan.

Overview of the Safety-Related Functions

The safety module eSM offers the following safety-related functions:

	Safety-related sub-functions as per IEC 61800-5-2:
STO	Safe Torque Off No power that can cause torque or force is supplied to the motor.
SOS	Safe Operating Stop SOS monitors the standstill position. The power stage is enabled.
SLS	Safely Limited Speed SLS monitors speed limits.
SS1	Safe Stop 1, type SS1-r (ramp-monitored) SS1 consists of: <ul style="list-style-type: none"> • Monitored deceleration of the movement according a specified deceleration ramp. • STO (triggered after standstill has been reached).
SS2	Safe Stop 2, type SS2-r (ramp-monitored) SS2 consists of: <ul style="list-style-type: none"> • Monitored deceleration of the movement according a specified deceleration ramp. • SOS (triggered after standstill has been reached).

The safety-related functions listed above correspond to the safety-related sub-functions as defined by IEC 61800-5-2. The term “safety-related function” in the present document corresponds to the term “safety-related sub-function” as defined by IEC 61800-5-2 for the above functions.

Safety-Related Function STO

Overview

The safety-related function STO (Safe Torque Off) keeps torque-producing or force-producing power from being provided to the motor. STO does not monitor for standstill.

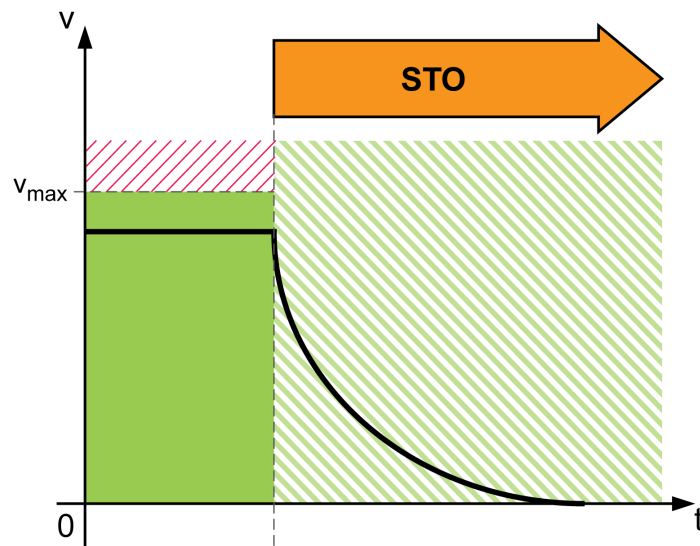

Safety-Related Function SOS

Overview

The safety-related function SOS (Safe Operating Stop) monitors the standstill position of the motor. If a movement of more than 25 increments with reference to 1000 increments per revolution is detected while SOS is active, the safety-related function STO is triggered.

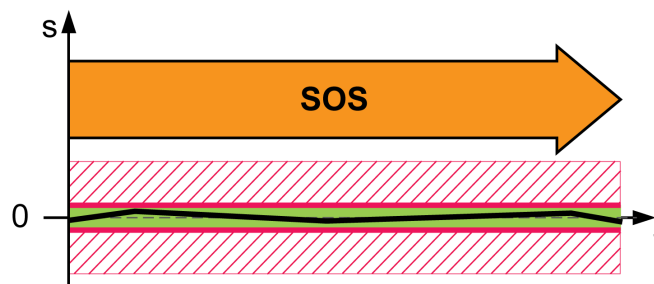

Response to Exceedance of Limit Value

If the monitored limit value is exceeded for the first time:

- An error is detected.
- The safety module eSM requests a Quick Stop from the drive and monitors the Quick Stop ramp.
 - If the Quick Stop is executed properly, the safety-related function SOS is triggered.
 - If the Quick Stop is not executed properly, the safety-related function STO is triggered.

If the monitored limit value is exceeded again:

- The safety-related function STO is triggered.

Parameter name	Description	Unit	Data type	Parameter address via fieldbus
HMI menu		Minimum value	R/W	
HMI name		Factory setting	Persistent	
		Maximum value	Expert	
<i>eSM_dec_Qstop</i>	<p>eSM deceleration ramp for Quick Stop.</p> <p>Deceleration ramp for monitored Quick Stop. This value must be greater than 0.</p> <p>Value 0: eSM module is not configured</p> <p>Value >0: Deceleration ramp in RPM/s</p> <p>Setting can only be modified if power stage is disabled.</p> <p>Available with firmware version ≥V01.01.</p>	<p>RPM/s</p> <p>0</p> <p>0</p> <p>32786009</p>	<p>UINT32</p> <p>R/W</p> <p>per.</p> <p>-</p>	-

Safety-Related Function SLS

Overview

The safety-related function SLS (Safely Limited Speed) monitors adjustable speed limits.

Machine operating mode	SLS monitors speed limits:
Automatic Mode	Independent of direction of movement
Setup Mode	Independent of direction of movement
Setup Mode	Dependent on direction of movement ⁽¹⁾
(1) Available as of firmware version ≥1.01. The firmware version of the drive and of the safety module eSM can be read determined with the commissioning software.	

NOTE: Inverting the direction of movement via the parameter *InvertDirOfMove* in the drive is not taken into account by the safety module eSM.

SLS Independent of Direction of Movement - General

The safety-related function SLS monitors the following speed limits independently of the direction of movement:

- Machine operating mode Automatic Mode: Value of the parameter *eSM_v_maxAuto*, parameter value >0.
- Machine operating mode Setup Mode: Value of the parameter *eSM_v_maxSetup* for speed limit in positive and negative directions of movement.

NOTE: Safety modules eSM with a firmware version ≥1.01 require the following parameter values to be set (factory setting):

- eSM_FuncSwitches*: Bit 0 = 0
- eSM_SLSnegDirS*: Parameter value = 0

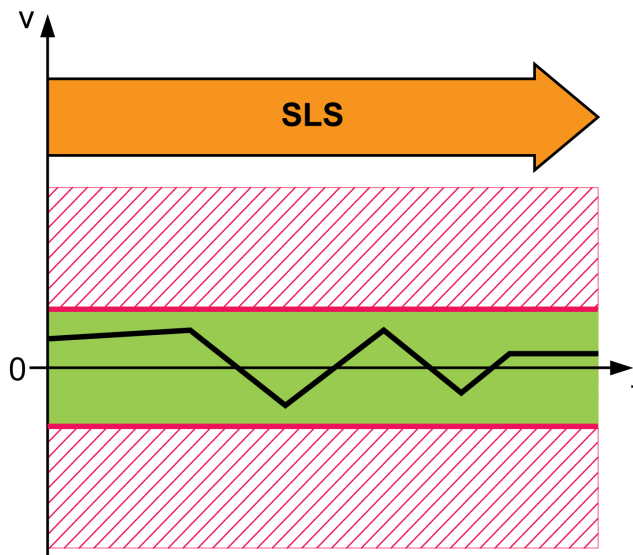

Parameter name HMI menu HMI name	Description	Unit Minimum value Factory setting Maximum value	Data type R/W Persistent Expert	Parameter address via fieldbus
<i>eSM_v_maxAuto</i>	<p>eSM speed limit for machine operating mode Automatic Mode.</p> <p>This value sets the speed limit for monitoring in machine operating mode Automatic Mode.</p> <p>Value 0: The speed limit is not monitored</p> <p>Value >0: Monitored speed limit</p> <p>Setting can only be modified if power stage is disabled.</p> <p>Available with firmware version \geqV01.01.</p>	<p>RPM</p> <p>0</p> <p>0</p> <p>8000</p>	<p>UINT16</p> <p>R/W</p> <p>per.</p> <p>-</p>	-
<i>eSM_v_maxSetup</i>	<p>eSM speed limit for machine operating mode Setup Mode.</p> <p>This value sets the speed limit for monitoring in machine operating mode Setup Mode.</p> <p>Firmware version safety module eSM \geqV01.01:</p> <p>Parameter eSM_FuncSwitches Bit 0 = 0: Value = Monitored speed limit for positive and negative directions of movement.</p> <p>Parameter eSM_FuncSwitches Bit 0 = 1: Value = Monitored speed limit for positive direction of movement.</p> <p>Setting can only be modified if power stage is disabled.</p> <p>Available with firmware version \geqV01.01.</p>	<p>RPM</p> <p>0</p> <p>0</p> <p>8000</p>	<p>UINT16</p> <p>R/W</p> <p>per.</p> <p>-</p>	-

Parameter name HMI menu HMI name	Description	Unit Minimum value Factory setting Maximum value	Data type R/W Persistent Expert	Parameter address via fieldbus
<i>eSM_FuncSwitches</i>	<p>eSM switches for functions.</p> <p>None: No function</p> <p>DirectionDependentSLS: SLS dependent on direction of movement</p> <p>Reserved (Bit 1): Reserved (bit 1)</p> <p>Reserved (Bit 2): Reserved (bit 2)</p> <p>Reserved (Bit 3): Reserved (bit 3)</p> <p>Reserved (Bit 4): Reserved (bit 4)</p> <p>Reserved (Bit 5): Reserved (bit 5)</p> <p>Available as of firmware version safety module eSM ≥V01.01.</p> <p>Bit 0 = 0: SLS independent of direction of movement</p> <p>Bit 0 = 1: SLS dependent on direction of movement</p> <p>Bits 1 ... 15: Reserved (must be set to 0)</p> <p>Setting can only be modified if power stage is disabled.</p> <p>Available with firmware version ≥V01.01.</p>	- 0 0 63	UINT16 R/W per. -	-
<i>eSM_SLSnegDirS</i>	<p>eSM speed limit negative direction machine operating mode Setup Mode.</p> <p>Firmware version safety module eSM ≥V01.01.</p> <p>Parameter eSM_FuncSwitches Bit 0 = 1: Value = Monitored speed limit for negative direction of movement.</p> <p>Setting can only be modified if power stage is disabled.</p> <p>Available with firmware version ≥V01.01.</p>	RPM 0 0 8000	UINT16 R/W per. -	-

SLS Independent of Direction of Movement - Response to Exceedance of Limit Value

If the monitored limit value is exceeded for the first time:

- An error is detected.
- The safety module eSM requests a Quick Stop from the drive and monitors the Quick Stop ramp.
 - If the Quick Stop is executed properly, the safety-related function SOS is triggered.
 - If the Quick Stop is not executed properly, the safety-related function STO is triggered.

If the monitored limit value is exceeded again:

- The safety-related function STO is triggered.

Parameter name	Description	Unit	Data type	Parameter address via fieldbus
HMI menu		Minimum value	R/W	
HMI name		Factory setting	Persistent	
		Maximum value	Expert	
<i>eSM_dec_Qstop</i>	<p>eSM deceleration ramp for Quick Stop.</p> <p>Deceleration ramp for monitored Quick Stop. This value must be greater than 0.</p> <p>Value 0: eSM module is not configured</p> <p>Value >0: Deceleration ramp in RPM/s</p> <p>Setting can only be modified if power stage is disabled.</p> <p>Available with firmware version \geqV01.01.</p>	<p>RPM/s</p> <p>0</p> <p>0</p> <p>32786009</p>	<p>UINT32</p> <p>R/W</p> <p>per.</p> <p>-</p>	-

SLS Dependent on Direction of Movement - General

In the machine operating mode Setup Mode, the limited speed can be monitored depending on the direction of movement. The limited speeds are set and monitored via one parameter each for positive and negative direction of movement. This requires a safety module eSM with a firmware version \geq 1.01.

- Machine operating mode Automatic Mode: refer to SLS Independent of Direction of Movement - General, page 25.
- Machine operating mode Setup Mode: Parameterizable speed limits for movements in positive and in negative directions of movement via the following parameters:
 - Parameter *eSM_FuncSwitches*: Activation of direction-dependent SLS, bit 0 = 1.
 - Parameter *eSM_v_maxSetup*: Setting the speed limit for movements in positive direction of movement, parameter value >0.
 - Parameter *eSM_SLSnegDirS*: Setting the speed limit for movements in negative direction of movement, parameter value >0.

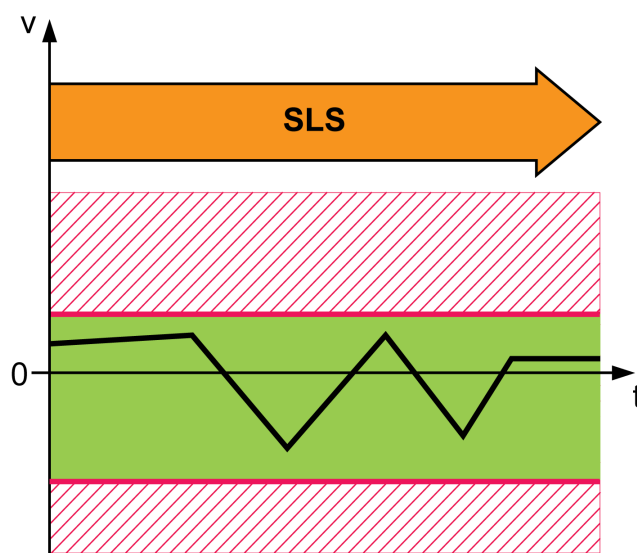

Parameter name	Description	Unit	Data type	Parameter address via fieldbus
HMI menu		Minimum value	R/W	
HMI name		Factory setting	Persistent	
		Maximum value	Expert	
<i>eSM_FuncSwitches</i>	<p>eSM switches for functions.</p> <p>None: No function</p> <p>DirectionDependentSLS: SLS dependent on direction of movement</p> <p>Reserved (Bit 1): Reserved (bit 1)</p> <p>Reserved (Bit 2): Reserved (bit 2)</p> <p>Reserved (Bit 3): Reserved (bit 3)</p> <p>Reserved (Bit 4): Reserved (bit 4)</p> <p>Reserved (Bit 5): Reserved (bit 5)</p> <p>Available as of firmware version safety module eSM ≥V01.01.</p> <p>Bit 0 = 0: SLS independent of direction of movement</p> <p>Bit 0 = 1: SLS dependent on direction of movement</p> <p>Bits 1 ... 15: Reserved (must be set to 0)</p> <p>Setting can only be modified if power stage is disabled.</p> <p>Available with firmware version ≥V01.01.</p>	- 0 0 63	UINT16 R/W per. -	-
<i>eSM_v_maxSetup</i>	<p>eSM speed limit for machine operating mode Setup Mode.</p> <p>This value sets the speed limit for monitoring in machine operating mode Setup Mode.</p> <p>Firmware version safety module eSM ≥V01.01:</p> <p>Parameter eSM_FuncSwitches Bit 0 = 0: Value = Monitored speed limit for positive and negative directions of movement.</p> <p>Parameter eSM_FuncSwitches Bit 0 = 1: Value = Monitored speed limit for positive direction of movement.</p> <p>Setting can only be modified if power stage is disabled.</p> <p>Available with firmware version ≥V01.01.</p>	RPM 0 0 8000	UINT16 R/W per. -	-
<i>eSM_SLSnegDirS</i>	<p>eSM speed limit negative direction machine operating mode Setup Mode.</p> <p>Firmware version safety module eSM ≥V01.01.</p> <p>Parameter eSM_FuncSwitches Bit 0 = 1: Value = Monitored speed limit for negative direction of movement.</p> <p>Setting can only be modified if power stage is disabled.</p> <p>Available with firmware version ≥V01.01.</p>	RPM 0 0 8000	UINT16 R/W per. -	-

In the case of rotary motors, direction of movement is defined in accordance with IEC 61800-7-204: Positive direction is when the motor shaft rotates clockwise as you look at the end of the protruding motor shaft.

NOTE: Inverting the direction of movement via the parameter *InvertDirOfMove* in the drive is not taken into account by the safety module eSM.

SLS Dependent on Direction of Movement - Response to Exceedance of Limit Value

If the monitored limit value is exceeded for the first time:

- An error is detected.
- The safety module eSM requests a Quick Stop from the drive and monitors the Quick Stop ramp.
 - If the Quick Stop is executed properly, the safety-related function SOS is triggered.
 - If the Quick Stop is not executed properly, the safety-related function STO is triggered.

If the monitored limit value is exceeded again:

- The safety-related function STO is triggered.

Parameter name	Description	Unit	Data type	Parameter address via fieldbus
HMI menu		Minimum value	R/W	
HMI name		Factory setting	Persistent	
		Maximum value	Expert	
<i>eSM_dec_Qstop</i>	<p>eSM deceleration ramp for Quick Stop.</p> <p>Deceleration ramp for monitored Quick Stop. This value must be greater than 0.</p> <p>Value 0: eSM module is not configured</p> <p>Value >0: Deceleration ramp in RPM/s</p> <p>Setting can only be modified if power stage is disabled.</p> <p>Available with firmware version \geqV01.01.</p>	<p>RPM/s</p> <p>0</p> <p>0</p> <p>32786009</p>	<p>UINT32</p> <p>R/W</p> <p>per.</p> <p>-</p>	-

Safety-Related Function SS1

Overview

The safety-related function SS1 (Safe Stop 1) monitors the deceleration and removes the motor torque once standstill has been reached (type SS1-r, ramp-monitored).

When the safety-related function is triggered:

- The deceleration of the movement is monitored with the specified monitoring ramp *eSM_dec_Qstop* until standstill is reached.
- After a standstill has been reached, the safety-related function STO is triggered.

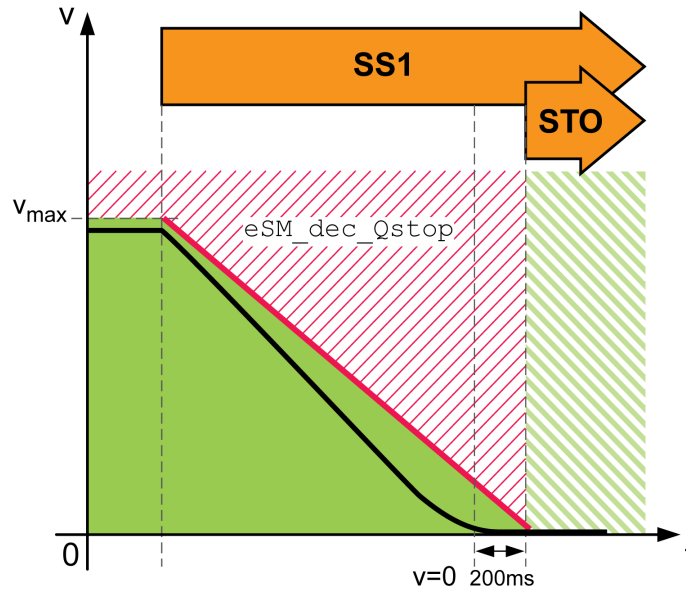

Parameter name	Description	Unit	Data type	Parameter address via fieldbus
HMI menu		Minimum value	R/W	
HMI name		Factory setting	Persistent	
		Maximum value	Expert	
<i>eSM_dec_Qstop</i>	eSM deceleration ramp for Quick Stop. Deceleration ramp for monitored Quick Stop. This value must be greater than 0. Value 0: eSM module is not configured Value >0: Deceleration ramp in RPM/s Setting can only be modified if power stage is disabled. Available with firmware version ≥V01.01.	RPM/s 0 0 32786009	UINT32 R/W per. -	-

Response to Exceedance of Limit Value

If the monitored limit value is exceeded (for a maximum of 4 times):

- An error is detected.
- The safety-related function STO is triggered.
- The number of times the limit value is exceeded is stored (1 ... 4).

If the monitored value is exceeded for the fifth time:

- The safety-related function STO is triggered.
- An error of error class 4 is detected.

Safety-Related Function SS2

Overview

The safety-related function SS2 (Safe Stop 2) monitors the deceleration and the standstill position (type SS2-r, ramp-monitored).

When the safety-related function is triggered:

- The deceleration of the movement is monitored with the specified monitoring ramp *eSM_dec_Qstop* until standstill is reached.
- Monitoring of the standstill position with the safety-related function SOS.

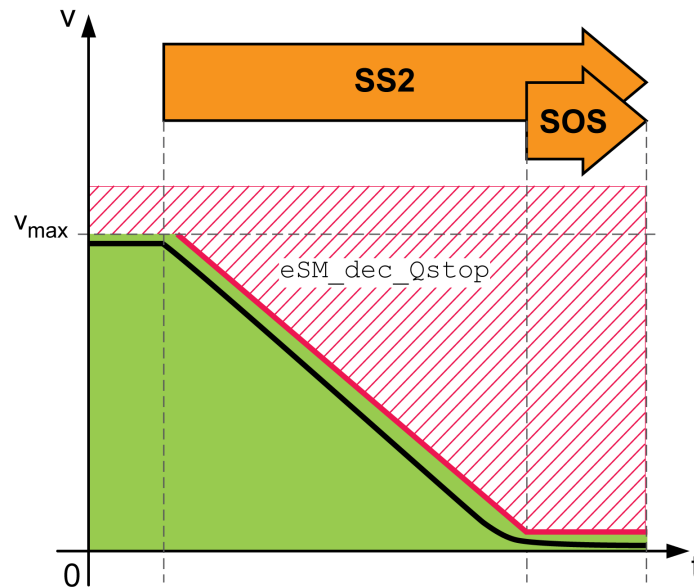

Parameter name	Description	Unit	Data type	Parameter address via fieldbus
HMI menu		Minimum value	R/W	
HMI name		Factory setting	Persistent	
		Maximum value	Expert	
<i>eSM_dec_Qstop</i>	eSM deceleration ramp for Quick Stop. Deceleration ramp for monitored Quick Stop. This value must be greater than 0. Value 0: eSM module is not configured Value >0: Deceleration ramp in RPM/s Setting can only be modified if power stage is disabled. Available with firmware version ≥V01.01.	RPM/s 0 0 32786009	UINT32 R/W per. -	-

Response to Exceedance of Limit Value

If the values for the monitored deceleration ramp *dec_Qstop* are not within range:

- An error is detected.
- The safety-related function STO is triggered.

If a movement from the monitored standstill position is detected for the first time:

- An error is detected
- The safety module eSM requests a Quick Stop from the drive and monitors the Quick Stop ramp.
 - If the Quick Stop is executed properly, the safety-related function SOS is triggered.
 - If the Quick Stop is not executed properly, the safety-related function STO is triggered.

If a movement from the monitored standstill position is again detected:

- The safety-related function STO is triggered.

Monitored Deceleration

General

If the velocity is greater than the permissible maximum velocity when the safety-related function SOS or the safety-related function SLS is requested, monitored

deceleration is used to reduce the velocity. Without monitored deceleration, this would result in an error response.

When a safety-related function with velocity monitoring is requested, the master controller must first trigger a deceleration of the movement.

After the delay time set with the parameter *eSM_t_NCDel* has elapsed, the safety module eSM monitors the deceleration of the movement on the basis of the deceleration ramp set by means of the parameter *eSM_dec_NC*. If the velocity value requested by the safety-related function is reached and if the monitored deceleration ramp remains within the permissible value range, the requested safety-related function continues to monitor further movement.

Parameter name HMI menu HMI name	Description	Unit Minimum value Factory setting Maximum value	Data type R/W Persistent Expert	Parameter address via fieldbus
<i>eSM_t_NCDel</i>	eSM time delay until start of monitored deceleration. This time can be adjusted to meet the requirements of a controller. Setting can only be modified if power stage is disabled. Available with firmware version ≥V01.01.	ms 0 0 10000	UINT16 R/W per. -	-
<i>eSM_dec_NC</i>	eSM deceleration ramp. Deceleration ramp for monitored deceleration Value 0: Disabled, no monitoring of deceleration ramp Value >0: Deceleration ramp in RPM/s Setting can only be modified if power stage is disabled. Available with firmware version ≥V01.01.	RPM/s 0 0 32786009	UINT32 R/W per. -	-

Response to Exceedance of Limit Value

If the monitored limit value is exceeded for the first time:

- An error is detected.
- The safety module eSM requests a Quick Stop from the drive and monitors the Quick Stop ramp.
 - If the Quick Stop is executed properly, the safety-related function SOS is triggered.
 - If the Quick Stop is not executed properly, the safety-related function STO is triggered.

If the monitored limit value is exceeded again:

- Safety-related function STO is triggered.

Parameter name	Description	Unit	Data type	Parameter address via fieldbus
HMI menu		Minimum value	R/W	
HMI name		Factory setting	Persistent	
		Maximum value	Expert	
<i>eSM_dec_Qstop</i>	<p>eSM deceleration ramp for Quick Stop.</p> <p>Deceleration ramp for monitored Quick Stop. This value must be greater than 0.</p> <p>Value 0: eSM module is not configured</p> <p>Value >0: Deceleration ramp in RPM/s</p> <p>Setting can only be modified if power stage is disabled.</p> <p>Available with firmware version \geqV01.01.</p>	<p>RPM/s</p> <p>0</p> <p>0</p> <p>32786009</p>	<p>UINT32</p> <p>R/W</p> <p>per.</p> <p>-</p>	-

Connected Equipment

Overview

Equipment

⚠ WARNING

INSUFFICIENT AND/OR INEFFECTIVE SAFETY-RELATED FUNCTIONS

Only connect equipment to the safety-related inputs and outputs that meets all requirements as per your risk assessment and that complies with all regulations, standards, and process definitions applicable to your machine/process.

Failure to follow these instructions can result in death, serious injury, or equipment damage.

The following equipment can be connected to the inputs and outputs of the safety module eSM:

Component	Detailed information
Emergency Stop actuator	Emergency Stop - General, page 71
Start/restart pushbutton	Start/Restart Signal - General, page 68
Selector switch for selecting the machine operating mode Setup Mode and the machine operating mode Automatic Mode	Selecting the Machine Operating Mode, page 41
Interlocking of the guard door, locking device	Guard Door with Locking Device, page 42
Guards such as guard doors or electro-sensitive protective equipment (for example, light curtains)	-
Enabling device for enabling movements in machine operating mode Setup Mode	Enabling Device, page 44
Acknowledge/reset pushbutton for guard door acknowledgement	Acknowledge/Reset Pushbutton, page 45
Contactors for switching of external loads (with forcibly guided contacts, if required)	-
Controller to request status and diagnostics information via the status outputs	Status Request via Status Outputs, page 37

NOTE: The term “guard” as used in the present document does not only refer to guard doors, but also to other guarding equipment such as light curtains, where applicable.

The following illustration shows the connection of the equipment mentioned above with an eSM terminal adapter. Depending on your application, less or different equipment may be connected. Wiring is also possible without an eSM terminal adapter.

Equipment connected via eSM terminal adapter:

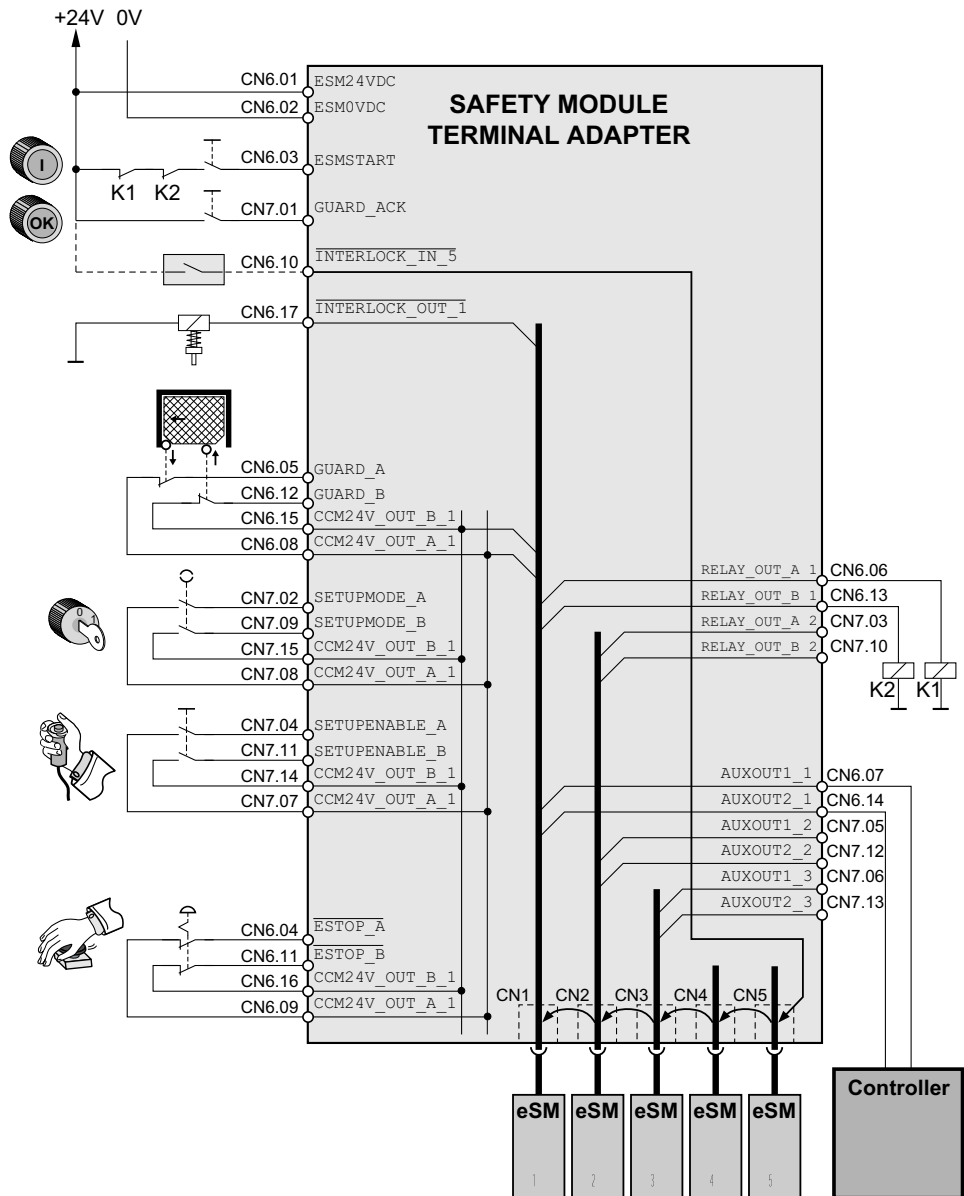

Multiple Safety Modules eSM in Multi-Axis System Via eSM Terminal Adapter

Information on wiring of several safety modules eSM in a multi-axis system using an eSM terminal adapter:

- Outputs *CCM24V_OUT_A* and *CCM24V_OUT_B*: These outputs (terminals CN6 and CN7) are internally connected to CN1.
- Outputs *RELAY_OUT_A_1* and *RELAY_OUT_B_1* (for switching of external loads): These outputs (terminal CN6) are internally connected to CN1.
- Outputs *RELAY_OUT_A_2* and *RELAY_OUT_B_2* (for switching of external loads): These outputs (terminal CN7) are internally connected to CN2.
- Outputs *AUXOUT1_1* and *AUXOUT2_1*: These outputs (terminal CN6) are internally connected to CN1.
- Outputs *AUXOUT1_2* and *AUXOUT2_2*: These outputs (terminal CN7) are internally connected to CN2.
- Outputs *AUXOUT1_3* and *AUXOUT2_3*: These outputs (terminal CN7) are internally connected to CN3.
- Inputs and supply voltages are internally connected to the connections CN1 ... CN5.

- Connect the first safety module eSM to CN1 of the eSM terminal adapter, the second safety module eSM to CN2, and so on.

If you want to chain the interlock signals ($\overline{INTERLOCK_OUT}$ connected to $INTERLOCK_IN$ of the next safety module eSM) and if you use less than five safety modules eSM, install a "Connector with wire jumper for INTERLOCK signal" (available as an accessory, refer to [Accessories and Spare Parts](#), page 96) in those slots in which no safety module eSM is connected. For example, if you use three safety modules eSM connected to CN1, CN2, and CN3, install the connectors at CN4 and CN5.

If you chain several safety modules eSM, set the parameter *eSM_BaseSetting* of the first (that is, the one connected to CN1) safety module eSM (input $INTERLOCK_IN$ not connected, output $INTERLOCK_OUT$ connected) to the value $INTERLOCK_IN$. If the output $INTERLOCK_OUT$ of a safety module eSM is not connected, do not set the parameter *eSM_BaseSetting* of this safety module eSM to the value $INTERLOCK_IN$.

Flyback Diodes

The outputs of the safety module eSM provide integrated protection against inductive voltage. Additional flyback diodes can slow down the switching behavior of contactors. Refer to [Digital Outputs](#), page 15 for information on the maximum inductive load on the outputs.

Status Information via Non-Safety-Related Status Outputs

Overview

⚠ WARNING
INCORRECT USE OF OUTPUTS
Do not use the outputs <i>AUXOUT1</i> and <i>AUXOUT2</i> for safety-related purposes.
Failure to follow these instructions can result in death, serious injury, or equipment damage.

The non-safety-related status outputs *AUXOUT1* and *AUXOUT2* provide the status of the safety module eSM (such as the states of the inputs and outputs). The information to be made available via a status output can be selected separately for each status output.

Parameter name HMI menu HMI name	Description	Unit Minimum value Factory setting Maximum value	Data type R/W Persistent Expert	Parameter address via fieldbus
eSM_FuncAUXOUT1	<p>eSM function of status output AUXOUT1.</p> <p>None: No function</p> <p>/ESTOP: Signal state /ESTOP</p> <p>GUARD: Signal state GUARD</p> <p>SETUPMODE: Signal state SETUPMODE</p> <p>SETUPENABLE: Signal state SETUPENABLE</p> <p>GUARD_ACK: Signal state GUARD_ACK</p> <p>/INTERLOCK_IN: Signal state /INTERLOCK_IN</p> <p>STO by eSM: Signal state of internal STO</p> <p>RELAY: Signal state RELAY</p> <p>/INTERLOCK_OUT: Signal state /INTERLOCK_OUT</p> <p>Standstill: Standstill (v = 0)</p> <p>SLS: SLS</p> <p>Error class 4: Error of error class 4 detected</p> <p>Error class 1 ... 4: Error of error classes 1 ... 4 detected</p> <p>/ESTOP inv.: Signal state /ESTOP, inverted</p> <p>GUARD inv.: Signal state GUARD, inverted</p> <p>SETUPMODE inv.: Signal state SETUPMODE, inverted</p> <p>SETUPENABLE inv.: Signal state SETUPENABLE, inverted</p> <p>GUARD_ACK inv.: Signal state GUARD_ACK, inverted</p> <p>/INTERLOCK_IN inv.: Signal state /INTERLOCK_IN, inverted</p> <p>STO by eSM inv.: Signal state of internal STO, inverted</p> <p>RELAY inv.: Signal state RELAY, inverted</p> <p>/INTERLOCK_OUT inv.: Signal state /INTERLOCK_OUT, inverted</p> <p>Standstill inv.: Standstill, inverted</p> <p>SLS inv.: SLS, inverted</p> <p>Error class 4 inv.: Error of error class 4 detected (inverted)</p> <p>Error class 1 ... 4 inv.: Error of error classes 1 ... 4 detected (inverted)</p> <p>Setting can only be modified if power stage is disabled.</p> <p>Available with firmware version ≥V01.01.</p>	- - - -	UINT32 R/W per. -	-

Parameter name HMI menu HMI name	Description	Unit Minimum value Factory setting Maximum value	Data type R/W Persistent Expert	Parameter address via fieldbus
eSM_FuncAUXOUT2	<p>eSM function of status output AUXOUT2.</p> <p>None: No function</p> <p>/ESTOP: Signal state /ESTOP</p> <p>GUARD: Signal state GUARD</p> <p>SETUPMODE: Signal state SETUPMODE</p> <p>SETUPENABLE: Signal state SETUPENABLE</p> <p>GUARD_ACK: Signal state GUARD_ACK</p> <p>/INTERLOCK_IN: Signal state /INTERLOCK_IN</p> <p>STO by eSM: Signal state of internal STO</p> <p>RELAY: Signal state RELAY</p> <p>/INTERLOCK_OUT: Signal state /INTERLOCK_OUT</p> <p>Standstill: Standstill (v = 0)</p> <p>SLS: SLS</p> <p>Error class 4: Error of error class 4 detected</p> <p>Error class 1 ... 4: Error of error classes 1 ... 4 occurred</p> <p>/ESTOP inv.: Signal state /ESTOP, inverted</p> <p>GUARD inv.: Signal state GUARD, inverted</p> <p>SETUPMODE inv.: Signal state SETUPMODE, inverted</p> <p>SETUPENABLE inv.: Signal state SETUPENABLE, inverted</p> <p>GUARD_ACK inv.: Signal state GUARD_ACK, inverted</p> <p>/INTERLOCK_IN inv.: Signal state /INTERLOCK_IN, inverted</p> <p>STO by eSM inv.: Signal state of internal STO, inverted</p> <p>RELAY inv.: Signal state RELAY, inverted</p> <p>/INTERLOCK_OUT inv.: Signal state /INTERLOCK_OUT, inverted</p> <p>Standstill inv.: Standstill, inverted</p> <p>SLS inv.: SLS, inverted</p> <p>Error class 4 inv.: Error of error class 4 detected (inverted)</p> <p>Error class 1 ... 4 inv.: Error of error classes 1 ... 4 detected (inverted)</p> <p>Setting can only be modified if power stage is disabled.</p> <p>Available with firmware version ≥V01.01.</p>	- - - -	UINT32 R/W per. -	-

Wiring of Input Devices/Sensors

Overview

The following graphic presents dual-channel wiring of safety-related input devices/sensors to the safety module eSM with and without cross-circuit detection:

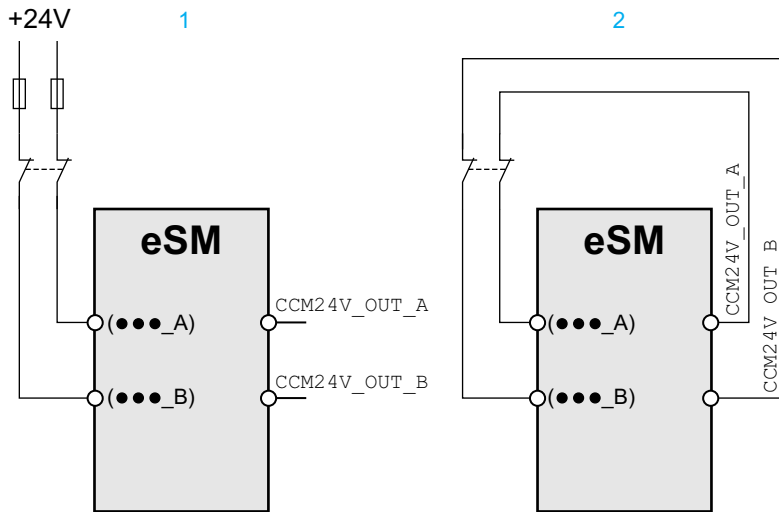

1	Dual-channel wiring without cross-circuit detection. Protected cable installation, page 22 as per ISO 13849-2 is required.
2	Dual-channel wiring with cross circuit detection. Dual-channel wiring with cross circuit detection allows for the detection of cross circuits between signals whose names have the suffix "_A" and signals of the same name with the suffix "_B". Protected cable installation, page 22 as per ISO 13849-2 is required.

Cross Circuit Detection

The outputs *CCM24V_OUT_A* and *CCM24V_OUT_B* of the safety module eSM provide 24 Vdc supply voltage with cross circuit detection for input devices/sensors with relay output contacts. In the case of dual-channel wiring and supply of the input devices/sensors via *CCM24V_OUT_A* and *CCM24V_OUT_B*, cross circuits between channels and short circuits to other conductors can be detected.

The maximum safety-related data, page 13 specified for the safety module eSM (SIL, PL) are reached with and without cross circuit detection.

Cross circuit detection:

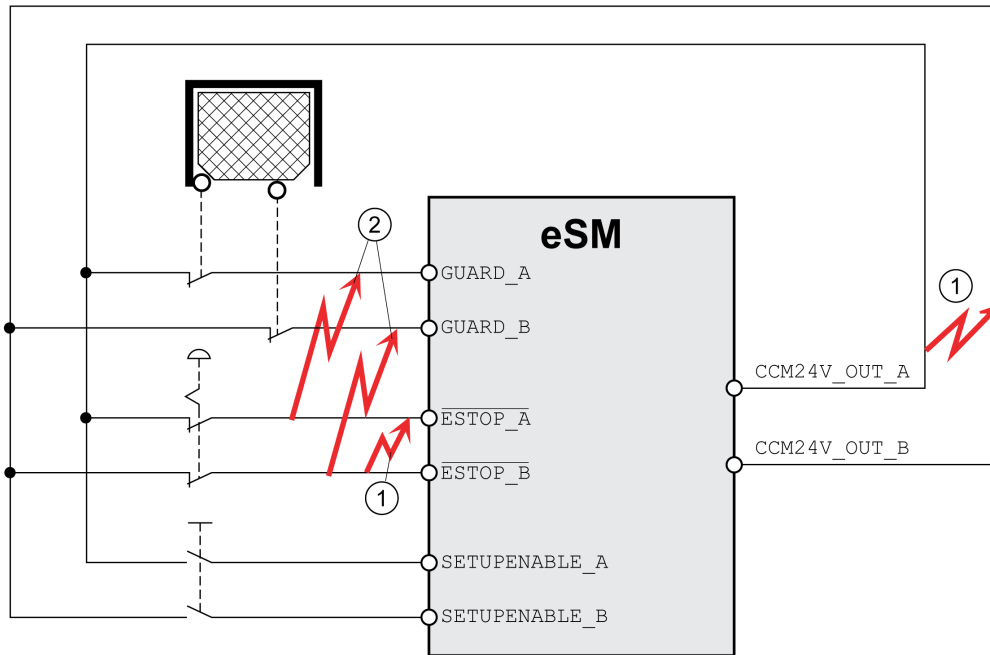

1	Cross circuit detection detects cross circuits between signals whose names have the suffix " <i>A</i> " and signals of the same name with the suffix " <i>B</i> " supplied via the 24 Vdc power supply, for example, between <i>ESTOP_A</i> and <i>ESTOP_B</i> .
2	Cross circuits between signals with different name, but with the same suffix are not detected, for example, cross circuits between <i>ESTOP_A</i> and <i>GUARD_A</i>

Selecting the Machine Operating Mode

Overview

The safety module eSM supports the two machine operating modes Automatic Mode and Setup Mode (refer to *Machine Operating Modes - General*, page 62 for details). The safety module eSM provides the inputs *SETUPMODE_A* and *SETUPMODE_B* for dual-channel connection of a selector switch for the machine operating modes.

Selecting a machine operating mode (Automatic Mode or Setup Mode):

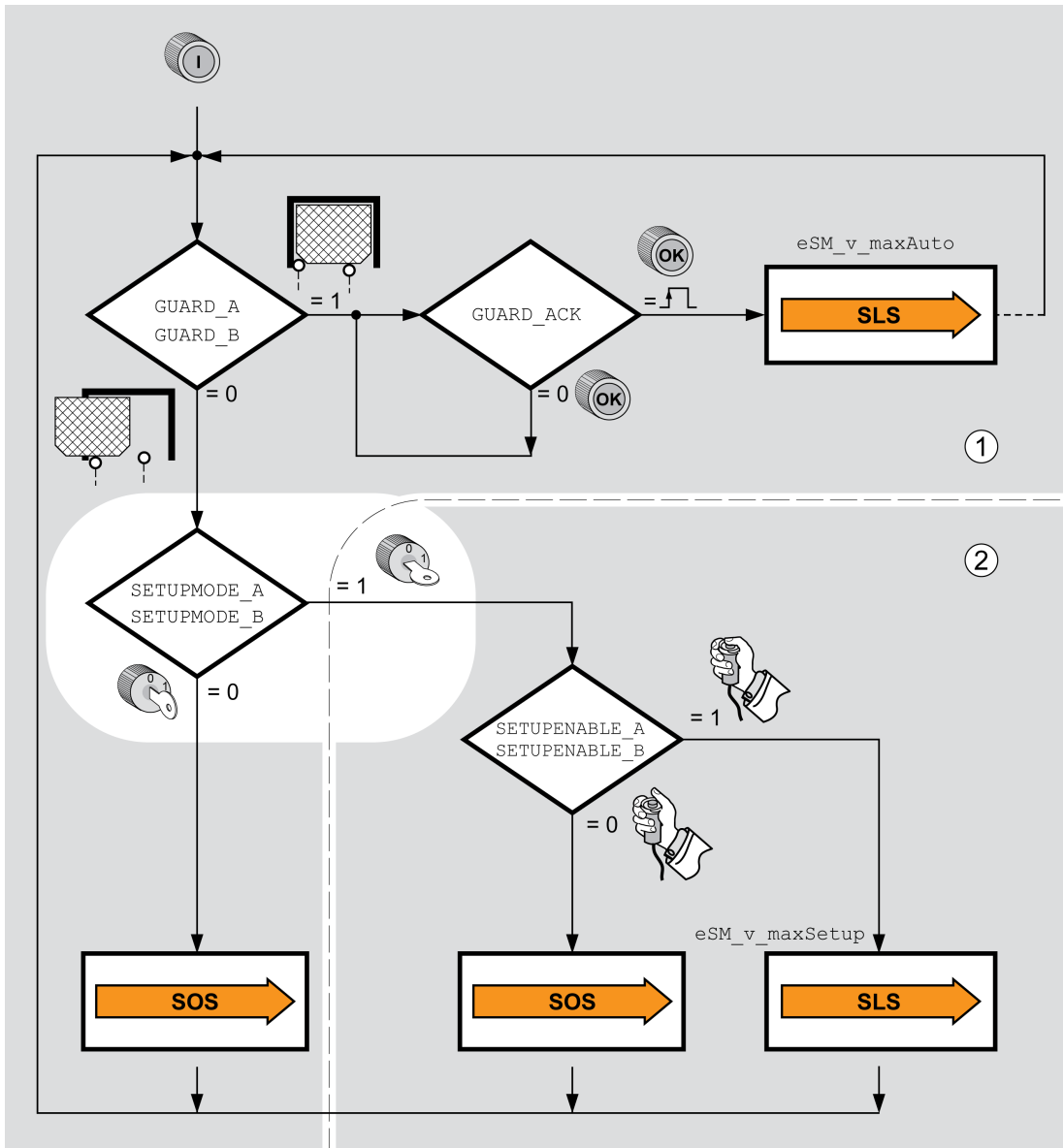

1 Automatic Mode

2 Setup Mode

Machine operating mode	Required inputs
Automatic Mode	GUARD_A and GUARD_B: Level 1
	GUARD_A and GUARD_B: Level 0
	SETUPMODE_A and SETUPMODE_B: Level 0
Setup Mode	GUARD_A and GUARD_B: Level 0 SETUPMODE_A and SETUPMODE_B: Level 1

Guard Door with Guard Locking

Overview

You can connect a guard locking device for a guard door to the output *INTERLOCK_OUT* of the safety module eSM.

If the velocity is 0, the level at the output $\overline{INTERLOCK_OUT}$ is 1. Several safety modules eSM modules can be interconnected by chaining the signal of output $\overline{INTERLOCK_OUT}$ and the input $\overline{INTERLOCK_IN}$ of the next safety module eSM.

Conditions	State of output $\overline{INTERLOCK_OUT}$ (interlocking of guard door)
Velocity is 0	Output $\overline{INTERLOCK_OUT}$ has level 1, guard door can be opened.
Velocity is greater than 0 and safety-related function STO is not active	Output $\overline{INTERLOCK_OUT}$ has level 0, guard door cannot be opened.
Velocity is greater than 0 and safety-related function STO is active	When the velocity is 0: Output $\overline{INTERLOCK_OUT}$ has level 1, guard door can be opened. If, after that, the velocity increases to a value greater than 0 and STO is active, the level of output $\overline{INTERLOCK_OUT}$ remains 1.

Guard door interlocking and locking device:

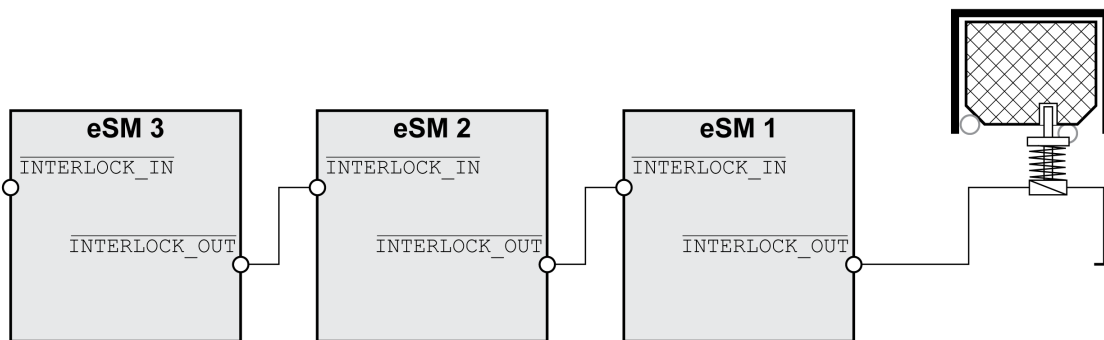

By connecting the output $\overline{INTERLOCK_OUT}$ of a safety module eSM to the input $\overline{INTERLOCK_IN}$ of the next safety module eSM, you can chain signals, for example, for a multi-axis system.

When all axes signal standstill, the level of the output $\overline{INTERLOCK_OUT}$ of the last safety module eSM in the chain is 1.

If the input $\overline{INTERLOCK_IN}$ of a safety module eSM is not used, use the parameter $eSM_BaseSetting$ to disable the corresponding input $\overline{INTERLOCK_IN}$. The signal chain starts with this safety module eSM.

The safety module eSM detects an error if the level at the disabled input is 1.

If you want to chain the interlock signals ($\overline{INTERLOCK_OUT}$ connected to $\overline{INTERLOCK_IN}$ of the next safety module eSM) and if you use less than five safety modules eSM, install a "Connector with wire jumper for INTERLOCK signal" (available as an accessory, refer to [Accessories and Spare Parts, page 96](#)) in those slots in which no safety module eSM is connected. For example, if you use three safety modules eSM connected to CN1, CN2, and CN3, install a "Connector with wire jumper for INTERLOCK signal" at CN4 and another one at CN5.

Refer to [Multiple Safety Modules eSM in Multi-Axis System Via eSM Terminal Adapter, page 36](#) for additional details.

If you chain several safety modules eSM, set the parameter $eSM_BaseSetting$ of the first (that is, the one connected to CN1) safety module eSM (input $\overline{INTERLOCK_IN}$ not connected, output $\overline{INTERLOCK_OUT}$ connected) to the value $\overline{INTERLOCK_IN}$. If the output $\overline{INTERLOCK_OUT}$ of a safety module eSM is not connected, do not set the parameter $eSM_BaseSetting$ of this safety module eSM to the value $\overline{INTERLOCK_IN}$.

Parameter name	Description	Unit	Data type	Parameter address via fieldbus
HMI menu		Minimum value	R/W	
HMI name		Factory setting	Persistent	
		Maximum value	Expert	
<i>eSM_BaseSetting</i>	<p>eSM basic settings.</p> <p>None: No function</p> <p>Auto Start: Automatic start (ESMSTART)</p> <p>Ignore GUARD_ACK: GUARD_ACK inactive</p> <p>Ignore /INTERLOCK_IN: INTERLOCK chain inactive</p> <p>Setting can only be modified if power stage is disabled.</p> <p>Available with firmware version \geqV01.01.</p>	- - - -	UINT16 R/W per. -	-

Enabling Device

Overview

An enabling device can be used if, for example, in machine operating mode Setup Mode, a movement with open guard door is required and possible as determined by your risk assessment. The velocity is monitored by the safety-related function SLS.

Monitored limited velocity with open guard door with the safety-related function SLS is only possible if the following conditions are met:

- The guard door is open, the level at *GUARD_A* and *GUARD_B* is 0.
- Machine operating mode Setup Mode is active, the level at the inputs *SETUPMODE_A* and *SETUPMODE_B* is 1.
- Enabling switch is activated (level at the inputs *SETUPENABLE_A* and *SETUPENABLE_B* is 1).

Enabling switch:

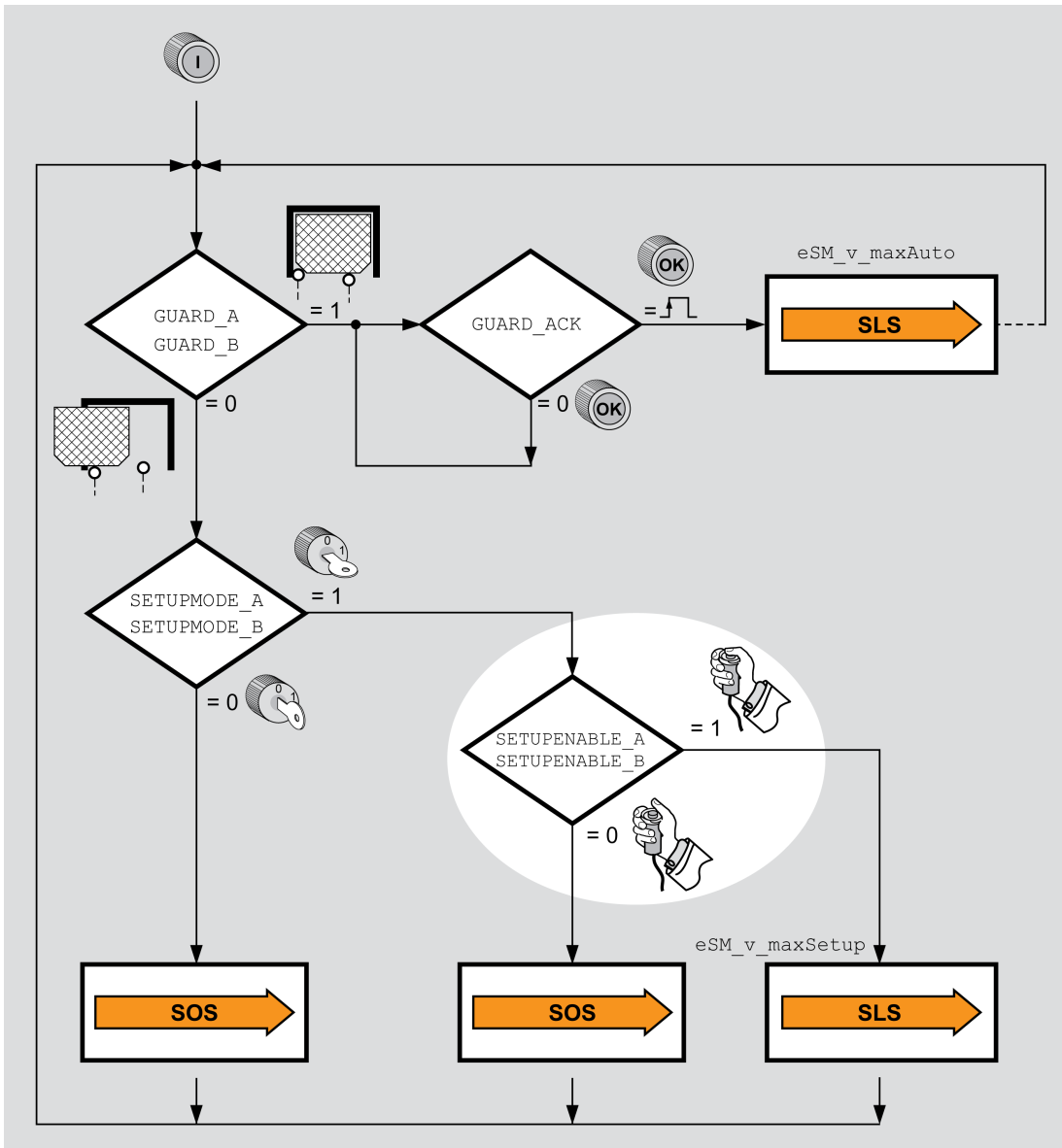

If the enabling switch is not activated, the safety-related function SOS is active in machine operating mode Setup Mode when the guard door is open.

Wiring:

- Connect the selector switch for the machine operating mode to the inputs *SETUPMODE_A* and *SETUPMODE_B* of the safety module eSM.
- Connect the enabling device to the inputs *SETUPENABLE_A* and *SETUPENABLE_B* of the safety module eSM.
- If you want to use cross circuit detection, use the outputs *CCM24V_OUT_A* and *CCM24V_OUT_B* to supply the enabling device.

Acknowledge/Reset Pushbutton

Overview

An acknowledge/reset pushbutton can be used for confirmation before a movement is started even if the level at the inputs *GUARD_A* and *GUARD_B* is 1 (for example, the guard door is closed or the light curtain is activated). Whether or not such confirmation is required depends on your application and the results of your risk assessment.

Acknowledge/reset pushbutton:

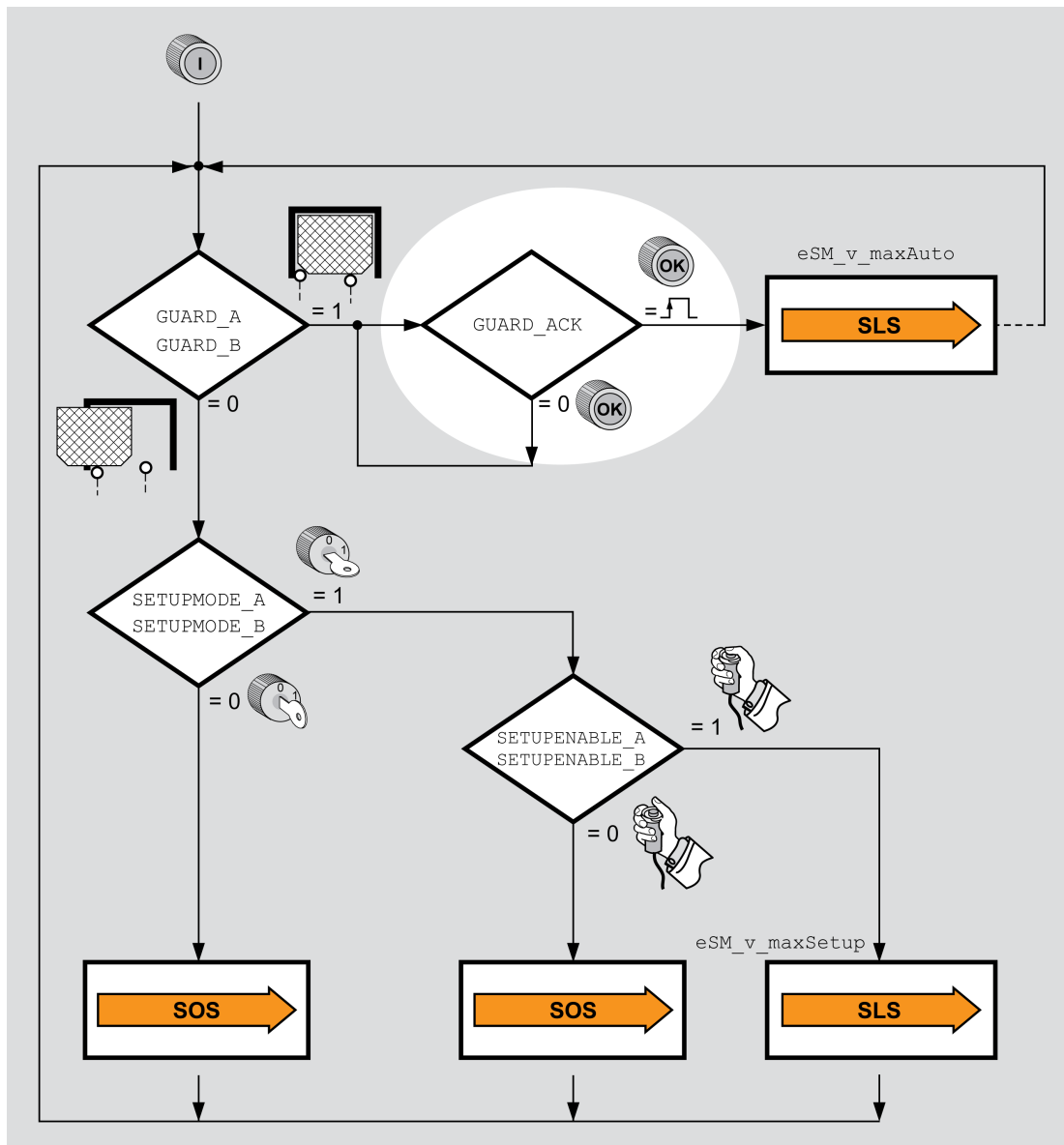

If the use of an acknowledge/reset pushbutton has been parameterized, the acknowledge/reset pushbutton must be pressed before a movement can be started in the machine operating mode Automatic Mode after the guard door has been closed.

The safety module eSM monitors the duration of the acknowledge/reset pulse at the input *GUARD_ACK* in order to detect contact welding at the acknowledge/reset pushbutton.

If the maximum duration of the acknowledge/reset signal is exceeded, the signal is ignored and an error of error class 2 is detected.

Wiring and setup:

- Activate the use of the acknowledge/reset pushbutton via the parameter *eSM_BaseSetting*.
- Connect the acknowledge/reset pushbutton to the input *GUARD_ACK* of the safety module eSM.
- Install the acknowledge/reset pushbutton outside the zone of operation at a suitable location as determined by your risk assessment.

Parameter name	Description	Unit	Data type	Parameter address via fieldbus
HMI menu		Minimum value	R/W	
HMI name		Factory setting	Persistent	
		Maximum value	Expert	
<i>eSM_BaseSetting</i>	<p>eSM basic settings.</p> <p>None: No function</p> <p>Auto Start: Automatic start (ESMSTART)</p> <p>Ignore GUARD_ACK: GUARD_ACK inactive</p> <p>Ignore /INTERLOCK_IN: INTERLOCK chain inactive</p> <p>Setting can only be modified if power stage is disabled.</p> <p>Available with firmware version \geqV01.01.</p>	- - - -	UINT16 R/W per. -	-

Installation

Installation of the Safety Module eSM

General

DANGER

ELECTRIC SHOCK, EXPLOSION, OR ARC FLASH

- Disconnect all power from all equipment including connected devices prior to removing any covers or doors, or installing or removing any accessories, hardware, cables, or wires.
- Place a "Do Not Turn On" or equivalent hazard label on all power switches and lock them in the non-energized position.
- Wait 15 minutes to allow the residual energy of the DC bus capacitors to discharge.
- Measure the voltage on the DC bus with a properly rated voltage sensing device and verify that the voltage is less than 42 Vdc.
- Do not assume that the DC bus is voltage-free when the DC bus LED is off.
- Block the motor shaft to prevent rotation prior to performing any type of work on the drive system.
- Do not create a short-circuit across the DC bus terminals or the DC bus capacitors.
- Replace and secure all covers, accessories, hardware, cables, and wires and confirm that a proper ground connection exists before applying power to the unit.
- Use only the specified voltage when operating this equipment and any associated products.

Failure to follow these instructions will result in death or serious injury.

DANGER

ELECTRIC SHOCK OR UNINTENDED EQUIPMENT OPERATION

- Keep foreign objects from getting into the product.
- Verify the correct seating of seals and cable entries in order to avoid contamination such as deposits and humidity.

Failure to follow these instructions will result in death or serious injury.

The safety-related function STO (Safe Torque Off) does not remove power from the DC bus. The safety-related function STO only removes power to the motor. The DC bus voltage and the mains voltage to the drive are still present.

DANGER

ELECTRIC SHOCK

- Do not use the safety-related function STO for any other purposes than its intended function.
- Use an appropriate switch, that is not part of the circuit of the safety-related function STO, to disconnect the drive from the mains power.

Failure to follow these instructions will result in death or serious injury.

Conductive foreign objects, dust or liquids may cause safety-related functions to become inoperative.

▲ WARNING

LOSS OF SAFETY-RELATED FUNCTION CAUSED BY FOREIGN OBJECTS

Protect the system against contamination by conductive substances.

Failure to follow these instructions can result in death, serious injury, or equipment damage.

Signal interference can cause unexpected responses of the drive system and of other equipment in the vicinity of the drive system.

▲ WARNING

SIGNAL AND EQUIPMENT INTERFERENCE

- Install the wiring in accordance with the EMC requirements described in the present document.
- Verify compliance with the EMC requirements described in the present document.
- Verify compliance with all EMC regulations and requirements applicable in the country in which the product is to be operated and with all EMC regulations and requirements applicable at the installation site.

Failure to follow these instructions can result in death, serious injury, or equipment damage.

Mechanical Installation

Electrostatic discharge (ESD) may permanently damage the module either immediately or over time.

NOTICE

EQUIPMENT DAMAGE DUE TO ESD

- Use suitable ESD measures (for example, ESD gloves) when handling the module.
- Do not touch internal components.

Failure to follow these instructions can result in equipment damage.

Commission the drive before installing the safety module eSM if your machine/process permits to do so.

Install the module according to the instructions in the user guide of the drive (Related Documents, page 9).

Electrical Installation - Interface

The safety module eSM is connected by means of a 24-pin connector.

Refer to *Accessories and Spare Parts*, page 96 for information on suitable cables and terminal adapters for the safety module.

Electrical Installation - Cable Specifications

Characteristic	Unit	Value
Shield	-	Not required
Shield connected at one end	-	Not required

Characteristic	Unit	Value
Protected cable installation, page 22 as per ISO 13849-2	-	Required
Minimum conductor cross section	mm ² (AWG)	0.34 (22)
Maximum cable length between safety module eSM and eSM terminal adapter	m (ft)	3 (9.84)
NOTE: Do not use ribbon cables.		

- Observe the EMC requirements specified in the user guide of the drive (Related Documents, page 9).
- Use pre-assembled cables.
- Verify that wiring, cables and connected interfaces meet the PELV requirements.

Electrical Installation - STO Inputs of the Drive

The safety-related function STO can be triggered directly via two inputs of the drive (refer to the user guide of the drive (Related Documents, page 9)). If you do not want to trigger the safety-related function STO via a signal at the inputs *STO_A* and *STO_B* of the safety module eSM, connect the inputs *STO_A* and *STO_B* to +24VDC.

Electrical Installation - Connecting the Inputs and Outputs

Pin assignment of the eSM connector:

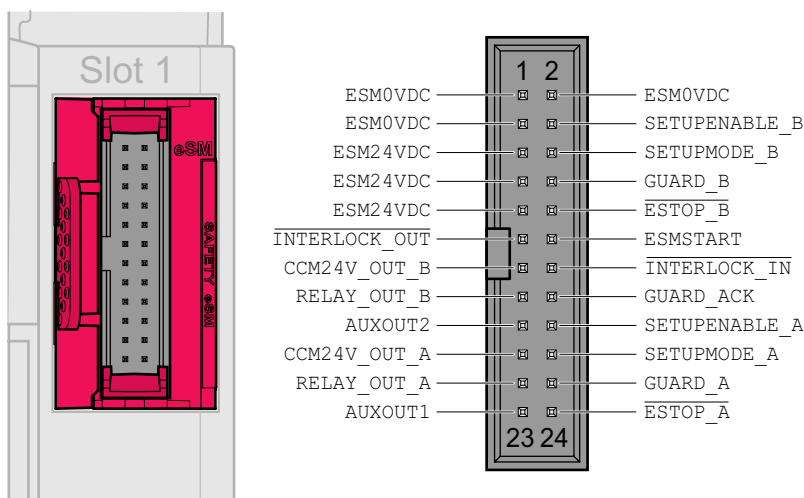

Pin	Signal	Active level	Explanation	Wire color ⁽¹⁾	I/O
1	<i>ESM0VDC</i>	-	Reference potential supply safety module eSM	White	-
2	<i>ESM0VDC</i>	-	Reference potential supply safety module eSM	Brown	-
3	<i>ESM0VDC</i>	-	Reference potential supply safety module eSM	Green	-
4	<i>SETUPENABLE_B</i>	1	Enabling device, channel B	Yellow	I
5	<i>ESM24VDC</i>	-	Supply safety module eSM	Gray	-
6	<i>SETUPMODE_B</i>	1	Activation of the machine operating mode Setup Mode, channel B	Pink	I
7	<i>ESM24VDC</i>	-	Supply safety module eSM	Blue	-
8	<i>GUARD_B</i>	1	Guard door, channel B	Red	I
9	<i>ESM24VDC</i>	-	Supply safety module eSM	Black	-
10	<i>ESTOP_B</i>	0	Emergency Stop request, channel B	Violet	I

Pin	Signal	Active level	Explanation	Wire color ⁽¹⁾	I/O
11	$\overline{INTERLOCK_OUT}$	0	Guard locking device of guard door	Pink, gray	O
12	ESMSTART	1	Start/restart signal	Blue, red	I
13	CCM24V_OUT_B	1	Supply for input device/sensor, channel B	White, green	O
14	$\overline{INTERLOCK_IN}$	0	Release input for interlock device of guard door	Brown, green	I
15	RELAY_OUT_B	1	Relay, channel B (for switching of external loads)	White, yellow	O
16	GUARD_ACK	1	Acknowledge/reset pushbutton	Yellow, brown	I
17	AUXOUT2	1	Non-safety-related status output 2	White, gray	O
18	SETUPENABLE_A	1	Enabling device, channel A	Gray, brown	I
19	CCM24V_OUT_A	1	Supply for input device/sensor, channel A	White, pink	O
20	SETUPMODE_A	1	Activation of machine operating mode Setup Mode, channel A	Pink, brown	I
21	RELAY_OUT_A	1	Relay, channel A (for switching of external loads)	White, blue	O
22	GUARD_A	1	Guard door, channel A	Brown, blue	I
23	AUXOUT1	1	Non-safety-related status output 1	White, red	O
24	$\overline{ESTOP_A}$	0	Emergency Stop request, channel A	Brown, red	I

(1) Colors of wires of cable VW3M8801R30, refer to Accessories and Spare Parts, page 96.

Electrical Installation - Connecting the 24 Vdc Supply

The 24 Vdc supply voltage is connected with many exposed signal connections in the drive system.

▲ WARNING

UNINTENDED EQUIPMENT OPERATION

- Use power supply units that meet the PELV (Protective Extra Low Voltage) requirements.
- Connect the 0 Vdc outputs of all power supply units to FE (functional earth/functional ground), for example, for the VDC supply voltage and for the 24 Vdc voltage for the safety-related function STO.
- Interconnect all 0 Vdc outputs (reference potentials) of all power supply units used for the drive.

Failure to follow these instructions can result in death, serious injury, or equipment damage.

Connection of the 24 Vdc supply of the safety module eSM:

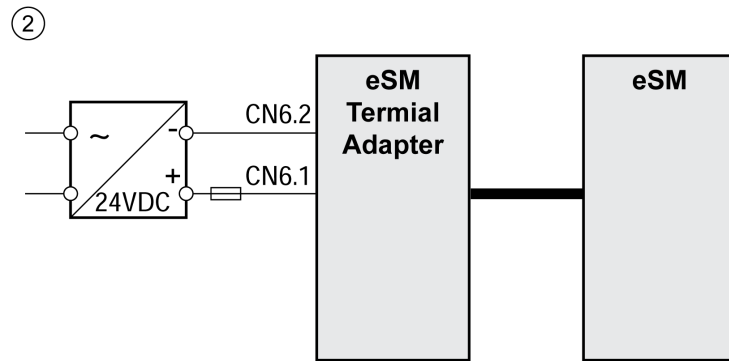
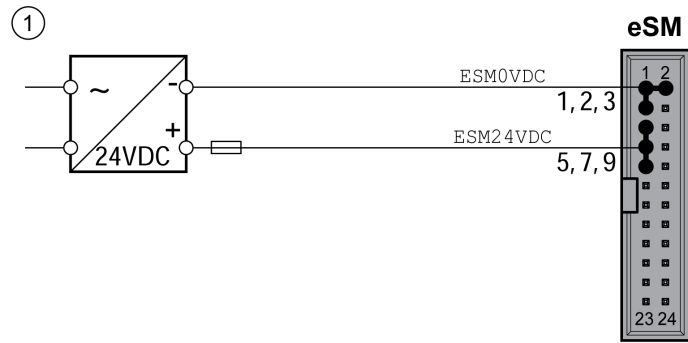

1 Without eSM terminal adapter

2 With eSM terminal adapter

Wiring for Multi-Axis Systems

Overview

If you use a single safety-related relay for several axes, connect the inputs of the safety modules eSM in parallel.

Do not connect the outputs of the safety module eSM in parallel.

Flyback Diodes

The outputs of the safety module eSM provide integrated protection against inductive voltage. Additional flyback diodes can slow down the switching behavior of contactors. Refer to *Electrical Data Module*, page 14 for information on the maximum inductive load on the outputs.

Wiring Without eSM Terminal Adapter

Wiring of several safety modules eSM without eSM terminal adapter

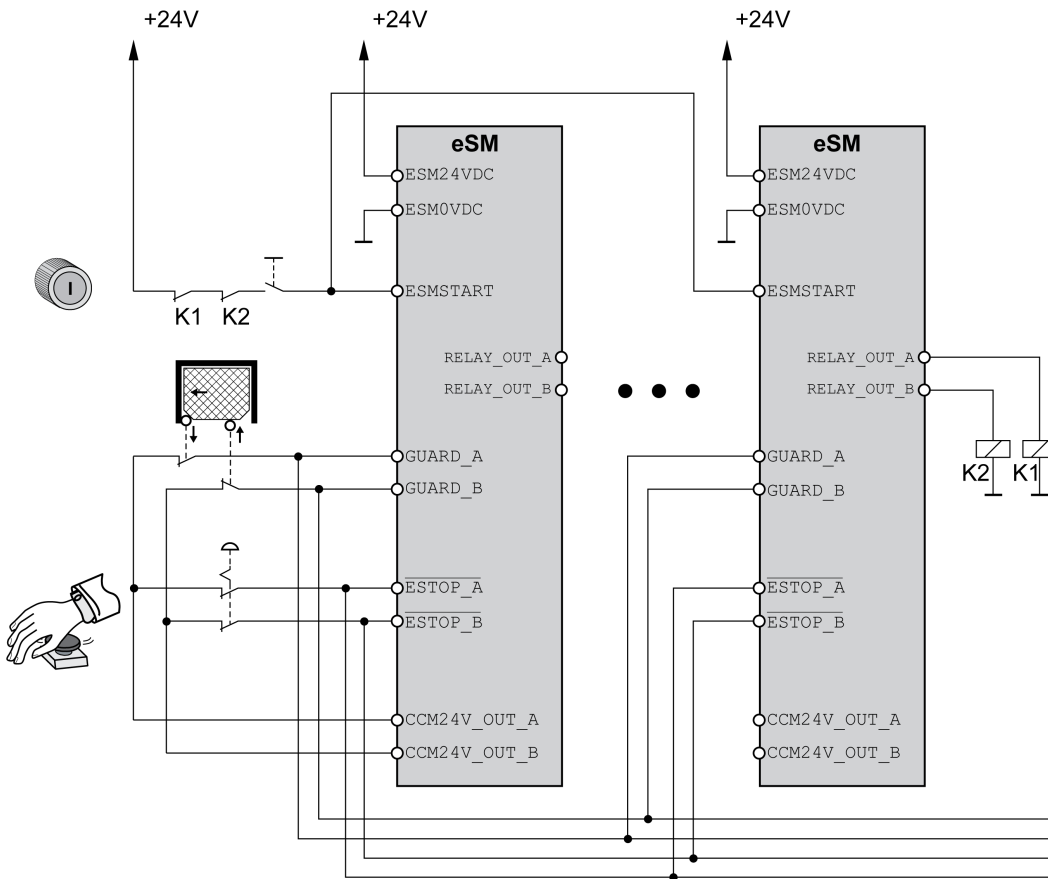

Wiring With eSM Terminal Adapter

The eSM terminal adapter available as an accessory, page 96 simplifies wiring of several safety modules eSM for multi-axis systems and chaining of the inputs and outputs for guard door interlocking.

Wiring of several safety modules eSM with eSM terminal adapter

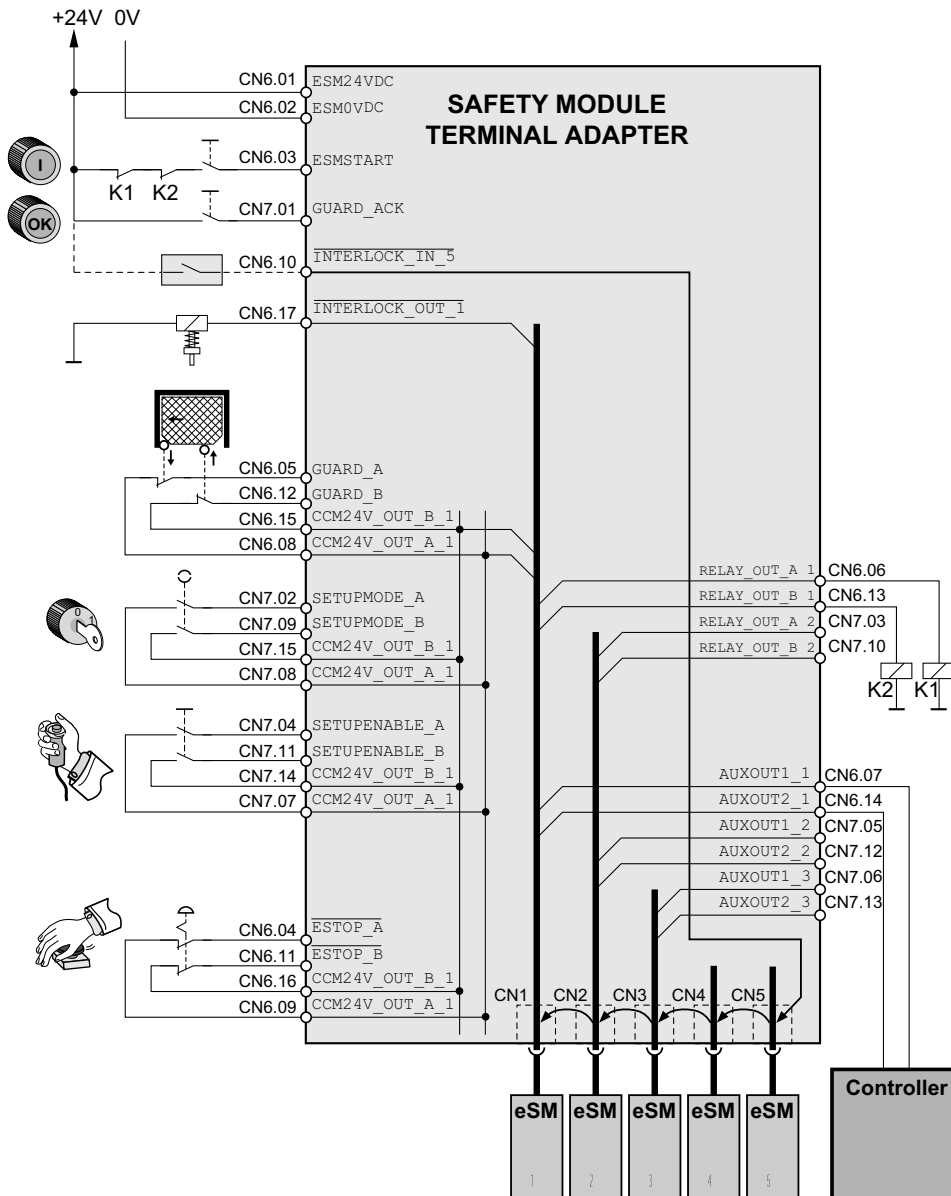

Refer to Multiple Safety Modules eSM in Multi-Axis System Via eSM Terminal Adapter, page 36 for additional details.

Installation of the eSM Terminal Adapter

General Information

The eSM terminal adapter distributes the input signals of a system to the safety modules eSM of up to five drives.

Refer to Multiple Safety Modules eSM in Multi-Axis System Via eSM Terminal Adapter, page 36 for additional details.

Interlocking of the guard door with the signal INTERLOCK: The input INTERLOCK_IN (terminal CN6) is internally connected to the input INTERLOCK_IN of CN5. The output INTERLOCK_OUT is connected to the input INTERLOCK_IN of the following connection. The output INTERLOCK_OUT (terminal CN1) is internally connected to terminal CN6.

Mounting

The eSM terminal adapter can be mounted to standard DIN rails or type G rails.
eSM terminal adapter:

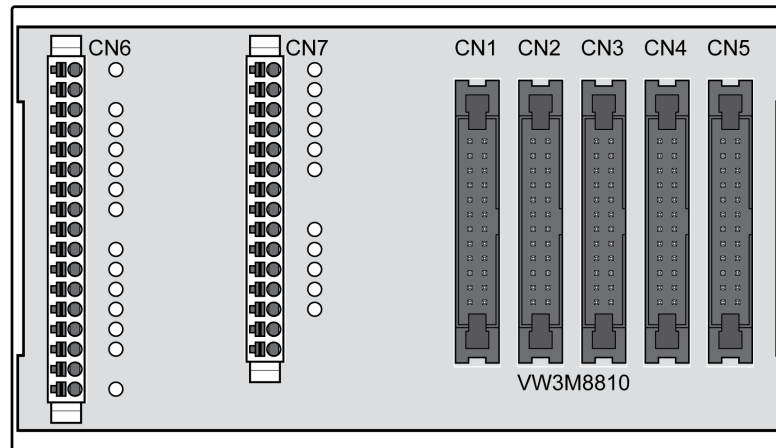

Spring Terminals CN6 ... CN7

Cross sections for the spring terminals:

Characteristic	Unit	Value
Wire cross section for rigid and flexible cables	[mm ²] (AWG)	0.2 ... 1.5 (AWG24 ... AWG16)
Connection cross section for flexible cable with wire ferrule without plastic collar	[mm ²] (AWG)	0.25 ... 1.5 (AWG22 ... AWG16)
Connection cross section for flexible cable with wire ferrule with plastic collar	[mm ²] (AWG)	0.25 ... 0.75 (AWG22 ... AWG20)

Connection CN6

Pin	Signal	Active level	Explanation	I/O
01	ESM24VDC	-	Supply safety module eSM	-
02	ESM0VDC	-	Reference potential supply safety module eSM	-
03	ESMSTART	1	Start/restart signal	I
04	ESTOP_A	0	Emergency Stop request, channel A	I
05	GUARD_A	1	Guard door, channel A	I

Pin	Signal	Active level	Explanation	I/O
06	RELAY_OUT_A_1	1	Relay, channel A (for switching of external loads), connected to CN1	O
07	AUXOUT1_1	1	Non-safety-related status output 1, internally connected to CN1	O
08	CCM24V_OUT_A_1	1	Supply input device/sensor, channel A, internally connected to CN1	O
09	CCM24V_OUT_A_1	1	Supply input device/sensor, channel A, internally connected to CN1	O
10	INTERLOCK_IN_5	0	Release input for interlock device of guard door, internally connected to CN5	I
11	ESTOP_B	0	Emergency Stop request, channel B	I
12	GUARD_B	1	Guard door, channel B	I
13	RELAY_OUT_B_1	1	Relay, channel B (for switching of external loads), internally connected to CN1	O
14	AUXOUT2_1	1	Non-safety-related status output 2, internally connected to CN1	O
15	CCM24V_OUT_B_1	1	Supply input device/sensor, channel B, internally connected to CN1	O
16	CCM24V_OUT_B_1	1	Supply input device/sensor, channel B, internally connected to CN1	O
17	INTERLOCK_OUT_1	0	Interlock device of guard door, internally connected to CN1	O

Connection CN7

Pin	Signal	Active level	Explanation	I/O
1	GUARD_ACK	1	Acknowledge/reset pushbutton	I
2	SETUPMODE_A	1	Activation of machine operating mode Setup Mode, channel A	I
3	RELAY_OUT_A_2	1	Relay, channel A (for switching of external loads), internally connected to CN2	O
4	SETUPENABLE_A	1	Enabling device, channel A	I
5	AUXOUT1_2	1	Non-safety-related status output 1, internally connected to CN2	O
6	AUXOUT1_3	1	Non-safety-related status 1, internally connected to CN3	O
7	CCM24V_OUT_A_1	1	Supply input device/sensor, channel A, internally connected to CN1	O
8	CCM24V_OUT_A_1	1	Supply input device/sensor, channel A, internally connected to CN1	O
9	SETUPMODE_B	1	Activation of the machine operating mode Setup Mode, channel B	I
10	RELAY_OUT_B_2	1	Relay, channel B (for switching of external loads), internally connected to CN2	O
11	SETUPENABLE_B	1	Enabling device, channel B	I
12	AUXOUT2_2	1	Non-safety-related status output 2, internally connected to CN2	O
13	AUXOUT2_3	1	Non-safety-related status output 2, internally connected to CN3	O
14	CCM24V_OUT_B_1	1	Supply input device/sensor, channel B, internally connected to CN1	O
15	CCM24V_OUT_B_1	1	Supply input device/sensor, channel B, internally connected to CN1	O

Connections CN1 ... CN5

The pin assignment of the 24-pin connectors corresponds to the pin assignment of the safety module eSM, refer to [Connecting the Inputs and Outputs](#), page 50.

Refer to [Accessories and Spare Parts](#), page 96 for information on cables and terminal adapters for the safety module eSM.

Commissioning

Configuration with the Commissioning Software

Commissioning - Overview

General information

▲ WARNING
<p>INEFFECTIVE SAFETY-RELATED FUNCTION AND/OR UNINTENDED EQUIPMENT OPERATION</p> <ul style="list-style-type: none"> • Commission the drive with the installed safety module before it is used for the first time and after each modification to the drive and/or the installed safety module according to the instructions in the present user guide and the user guide of the drive, and in compliance with all regulations, standards, and process definitions applicable to your machine/process. • Only start the machine/process if there are no persons or obstructions in the zone of operation. • Verify correct operation and effectiveness of all functions by performing comprehensive tests for all operating states, the defined safe state, and all potential error situations. • During commissioning, verify that your machine/process meets all requirements identified in your risk assessment. • Document all steps and the results of the commissioning procedure, including the checksum of the eSM parameters, in compliance with all regulations, standards, and process definitions applicable to your machine/process. <p>Failure to follow these instructions can result in death, serious injury, or equipment damage.</p>

Wire the safety module eSM for the intended application (refer to *Installation*, page 48) before commissioning it. Commission the drive before installing the safety module eSM.

Required Components

The following is required for commissioning:

- Commissioning software “Lexium32 DTM Library”
www.se.com/en/download/document/Lexium_DTM_Library/
- User guide of the drive (refer to *Related Documents*, page 9) and user guide of the safety module eSM (the present document)

Commissioning Software

The safety module eSM is configured with the commissioning software.

The commissioning software provides a menu with the following menu items for the safety module eSM:

- Status
- Duplicate
- Parameters
- Change password

To access the functions of the menu items “Duplicate” and “Parameters”, select Expert mode and enter your eSM parameter password. Refer to *Menu Item “Change Password”*, page 60 for information on passwords.

Menu Item “Status”

General

The menu item “Status” provides information on:

- Signal states of inputs and outputs
- eSM operating state in eSM state machine
- Selected machine operating mode
- Active safety-related function

No password is required to access the functions of the menu item “Status”. The states of the inputs and outputs cannot be modified via the commissioning software.

Menu Item “Duplicate”

General

The menu item “Duplicate” allows you to copy the eSM parameters and parameter values of a safety module eSM to another safety module eSM.

▲ WARNING

INEFFECTIVE SAFETY-RELATED FUNCTION AND/OR UNINTENDED EQUIPMENT OPERATION

- Verify that the duplicated configuration is only used for the same purposes as the original configuration and only with an identical machine.
- Document the results of the duplication procedure in compliance with all regulations, standards, and process definitions applicable to your machine/process.
- Commission or recommission a machine/process using a duplicated configuration pursuant to all regulations, standards, and process definitions applicable to your machine/process.
- Ensure that your overall machine/process in which a duplicated configuration is used is properly certified and/or approved according to all standards, regulations, and directives applicable at the installation site of the machine/process.

Failure to follow these instructions can result in death, serious injury, or equipment damage.

This function can be used, for example, in the following scenarios:

- Production of multiple, identical machines
- Replacement of a safety module eSM

The eSM parameters are transferred from a safety module eSM to a storage medium or from a storage medium to a safety module eSM in the form of a file.

It is not possible to modify individual parameter values with the “Duplicate” function.

Prerequisites for Duplication

eSM parameters can be duplicated under the following conditions:

- Expert mode must be active in the commissioning software.
- The eSM standard password must have been entered.

Refer to Menu Item “Change Password”, page 60 for information on passwords.

Password for “Duplicate”

Enter your eSM standard password to access the function “Duplicate”. The eSM standard password is verified by the safety module eSM. If the password is correct, you can duplicate the eSM parameters. Refer to Menu Item “Change Password”, page 60 for information on passwords.

When you duplicate the eSM parameters, the eSM parameter password that is used to modify the eSM parameter values is saved along with the parameters. You can only modify parameter values after having entered the eSM parameter password.

Transferring an eSM Parameter Set

eSM parameters are not stored on the memory card in the drive.

Verify correct commissioning before duplication.

A checksum is saved along with the configuration file to allow for identification of the duplicated eSM parameters. The checksum is displayed for verification purposes before an eSM parameter set is transferred to a safety module eSM.

Menu Item “Parameters”

General

The menu item “Parameters” provides access to functions for setting the values of eSM parameters.

▲ WARNING

INEFFECTIVE SAFETY-RELATED FUNCTION AND/OR UNINTENDED EQUIPMENT OPERATION

- Only modify the values of parameters if you are fully aware of all effects of such modifications.
- Verify that the values of parameters match the intended safety-related function and the corresponding wiring of the safety module.
- Verify that modifications do not compromise or reduce the Safety Integrity Level (SIL), Performance Level (PL), and/or any other safety-related requirements and capabilities defined for your machine/process.
- Commission the drive with the installed safety module before it is used for the first time and after each modification to the drive and/or the installed safety module according to the instructions in the present user guide and the user guide of the drive, and in compliance with all regulations, standards, and process definitions applicable to your machine/process.

Failure to follow these instructions can result in death, serious injury, or equipment damage.

Prerequisite

Before you can modify eSM parameter values, you need to disable the power stage of the drive (operating states 3, 4 or 9 of the state machine). Refer to the user guide of the drive (Related Documents, page 9) for additional information on operating states of the drive.

Password for Menu Item “Parameters”

Modify the default eSM parameter password before you modify the parameter values of a safety module eSM for the first time. Refer to Menu Item “Change Password”, page 60.

If you want to modify the eSM parameter values, enter the eSM parameter password for access to the menu item “Parameters”. The eSM parameter password is verified by the safety module eSM.

Menu Item “Change Password”

Overview

⚠ WARNING

UNAUTHORIZED DATA ACCESS

- Do not expose the device or device network to public networks and the Internet as much as possible.
- Immediately change the default password to a new secure password.
- Do not distribute passwords to unauthorized or otherwise unqualified personnel.
- Restrict access to unauthorized personnel.
- Use additional security layers like VPN for remote access and install firewall mechanisms.
- Validate the effectiveness of these measurements regularly and frequently.

Failure to follow these instructions can result in death, serious injury, or equipment damage.

NOTE: Choose a password that complies with all password requirements of your company and that follows best practices with regard to password strength.

This includes, but is not limited to:

- The password does not contain any personal or otherwise obvious information.
- The password consists of a mix of uppercase and lowercase letters, numbers, and special characters.
- The password length is at least ten characters.
- Follow all rules for keeping the password confidential.
- Do not disclose the password to any unauthorized persons.

The commissioning software distinguishes between two passwords:

- eSM standard password
- eSM parameter password

eSM Standard Password

The eSM standard password cannot be modified. Use the eSM standard password if you want to duplicate eSM parameters, page 58.

eSM standard password:	eSM4SAFE
------------------------	----------

The password is case-sensitive.

eSM Parameter Password

With the factory settings, the eSM standard password and the eSM parameter password are the same. Access to the eSM parameters is restricted via the eSM parameter password.

Use the menu item “Change password” to change the eSM parameter password.

Forgot your eSM Parameter Password?

If you have forgotten your eSM parameter password:

- Duplicate a file with eSM parameters, page 58 whose eSM parameter password you know, from a storage medium to the safety module eSM.
- Modify the eSM parameter password.
- Modify the eSM parameter values as required.
- Commission the drive with the safety module eSM.

Operation

Machine Operating Modes

Machine Operating Modes - General

Overview

The following machine operating modes are distinguished for the safety module eSM (see also EN 12417):

- Machine operating mode Automatic Mode for regular production
- Machine operating mode Setup Mode for setup work at the machine

Monitoring of Movements

The safety module eSM monitors the movements triggered by the drive. The safety module eSM does not modify reference values but intervenes if the active safety-related function detects that a limit value has been exceeded. If the movement cannot be stopped as required, the safety-related function STO (Safe Torque Off) is triggered.

Monitored movement with the safety-related function SLS while the guard is open is possible if the following conditions are met:

- Guard is open, the level at *GUARD_A* and *GUARD_B* is 0
- Machine operating mode Setup Mode is active, the level at the inputs *SETUPMODE_A* and *SETUPMODE_B* is 1.
- Enabling switch is activated (the level at the inputs *SETUPENABLE_A* and *SETUPENABLE_B* is 1)

Selecting a machine operating mode (Automatic Mode or Setup Mode):

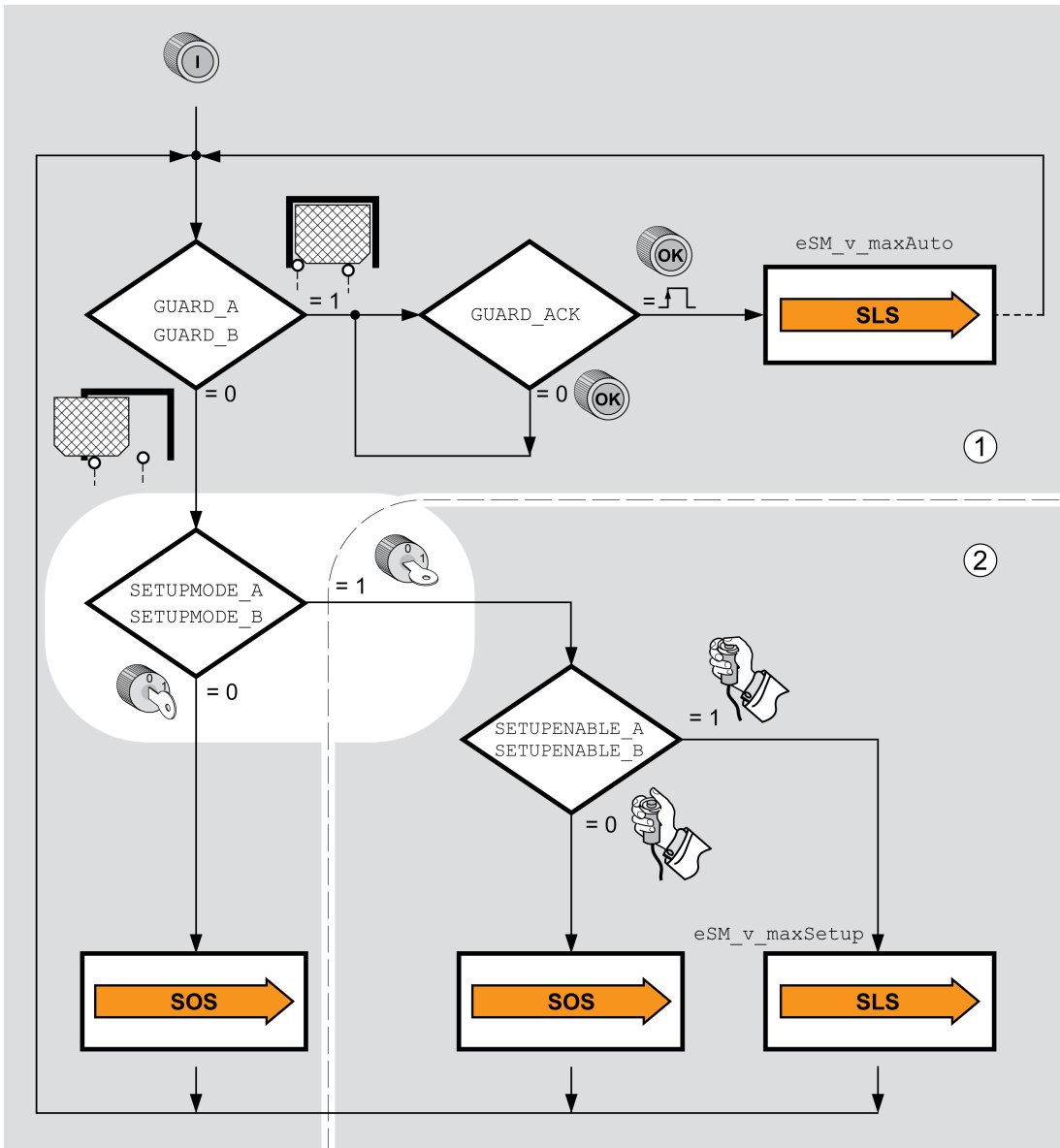

1 Automatic Mode

2 Setup Mode

Machine operating mode	Required inputs
Automatic Mode	<i>GUARD_A</i> and <i>GUARD_B</i> : level 1
	<i>GUARD_A</i> and <i>GUARD_B</i> : level 0
	<i>SETUPMODE_A</i> and <i>SETUPMODE_B</i> : level 0
Setup Mode	<i>GUARD_A</i> and <i>GUARD_B</i> : level 0 <i>SETUPMODE_A</i> and <i>SETUPMODE_B</i> : level 1

Machine Operating Mode Automatic Mode

Overview

The machine operating mode Automatic Mode is used for regular production.

When the guard is closed, movements can be made at the velocity for Automatic Mode that can be monitored with the safety-related function SLS.

When the guard is opened during the production process, the standstill position of the motor is monitored with the safety-related function SOS.

Conditions for Safety-Related Function SLS

In the machine operating mode Automatic Mode, the safety module eSM can monitor the speed limit set via the parameter *eSM_v_maxAuto* with the safety-related function SLS. The following conditions must be met:

- The safety module eSM must be in the eSM operating state 6 (Operation Enabled).
- The level at the safety-related inputs *GUARD_A* and *GUARD_B* is 1 (guard closed)

NOTE: If the parameter *eSM_v_maxAuto* is set to 0, the velocity is not monitored. Take into account that the velocity of a movement in a multi-axis system can be greater than the velocities of the individual axes.

Parameter name	Description	Unit	Data type	Parameter address via fieldbus
HMI menu		Minimum value	R/W	
HMI name		Factory setting	Persistent	
		Maximum value	Expert	
<i>eSM_v_maxAuto</i>	<p>eSM speed limit for machine operating mode Automatic Mode.</p> <p>This value sets the speed limit for monitoring in machine operating mode Automatic Mode.</p> <p>Value 0: The speed limit is not monitored</p> <p>Value >0: Monitored speed limit</p> <p>Setting can only be modified if power stage is disabled.</p> <p>Available with firmware version ≥V01.01.</p>	<p>RPM</p> <p>0</p> <p>0</p> <p>8000</p>	<p>UINT16</p> <p>R/W</p> <p>per.</p> <p>-</p>	-

Response to Exceedance of Limit Value

If the monitored limit value is exceeded for the first time:

- An error is detected
- The safety module eSM requests a Quick Stop from the drive and monitors the Quick Stop ramp.
 - If the Quick Stop is executed properly, the safety-related function SOS is triggered.
 - If the Quick Stop is not executed properly the safety-related function STO is triggered.

If the monitored limit value is exceeded again:

- The safety-related function STO is triggered.

Parameter name	Description	Unit	Data type	Parameter address via fieldbus
HMI menu		Minimum value	R/W	
HMI name		Factory setting	Persistent	
		Maximum value	Expert	
<i>eSM_dec_Qstop</i>	eSM deceleration ramp for Quick Stop. Deceleration ramp for monitored Quick Stop. This value must be greater than 0. Value 0: eSM module is not configured Value >0: Deceleration ramp in RPM/s Setting can only be modified if power stage is disabled. Available with firmware version ≥V01.01.	RPM/s 0 0 32786009	UINT32 R/W per. -	-

Machine Operating Mode Setup Mode

Overview

The machine operating mode Setup Mode is activated when the guard is opened and the level at the inputs *SETUPMODE_A* and *SETUPMODE_B* is 1.

Take into account that the velocity of a movement in a multi-axis system can be greater than the velocities of the individual axes.

Conditions for Safety-Related Function SLS

With the safety-related function SLS, the safety module eSM monitors set speed limits. The following conditions must be met:

- The safety module eSM is in the eSM operating state 6 (Operation Enabled).
- The level at the safety-related inputs *GUARD_A* and *GUARD_B* is 0 (guard open).
- The level at the safety-related inputs *SETUPMODE_A* and *SETUPMODE_B* is 1 (machine operating mode Setup Mode).
- The level at the safety-related inputs *SETUPENABLE_A* and *SETUPENABLE_B* is 1 (enabling device).

Monitoring of the Speed Limits

For SLS independent of the direction of movement, a common speed limit is set that applies to both positive and negative direction of movement.

For SLS dependent on the direction of movement, parameter values are set for the speed limits in positive direction and in negative direction of movement. This function is available for safety modules eSM with firmware version ≥1.01.

	SLS: Independent of direction of movement	SLS: Dependent on direction of movement ⁽¹⁾
Parameter <i>eSM_FuncSwitches</i> : Selection: SLS independent of or dependent on direction of movement	Bit 0 = "0"	Bit 0 = "1"
Parameter <i>eSM_v_maxSetup</i> :	Parameter value = Speed limit for positive and negative direction of movement	Parameter value = Speed limit for positive direction of movement (parameter value > 0)
Parameter <i>eSM_SLSnegDirS</i> :	Parameter value = "0"	Parameter value = Speed limit for movement in negative direction of movement (parameter value > 0)
(1) Prerequisite: Firmware version of safety module eSM ≥1.01		

NOTE: The parameter value of *eSM_v_maxAuto* (speed limit in machine operating mode Automatic Mode) must be greater than the parameter values of *eSM_v_maxSetup* and *eSM_SLSnegDirS*.

Parameter name HMI menu HMI name	Description	Unit Minimum value Factory setting Maximum value	Data type R/W Persistent Expert	Parameter address via fieldbus
<i>eSM_FuncSwitches</i>	<p>eSM switches for functions.</p> <p>None: No function</p> <p>DirectionDependentSLS: SLS dependent on direction of movement</p> <p>Reserved (Bit 1): Reserved (bit 1)</p> <p>Reserved (Bit 2): Reserved (bit 2)</p> <p>Reserved (Bit 3): Reserved (bit 3)</p> <p>Reserved (Bit 4): Reserved (bit 4)</p> <p>Reserved (Bit 5): Reserved (bit 5)</p> <p>Available as of firmware version safety module eSM ≥V01.01.</p> <p>Bit 0 = 0: SLS independent of direction of movement</p> <p>Bit 0 = 1: SLS dependent on direction of movement</p> <p>Bits 1 ... 15: Reserved (must be set to 0)</p> <p>Setting can only be modified if power stage is disabled.</p> <p>Available with firmware version ≥V01.01.</p>	- 0 0 63	UINT16 R/W per. -	-
<i>eSM_v_maxSetup</i>	<p>eSM speed limit for machine operating mode Setup Mode.</p> <p>This value sets the speed limit for monitoring in machine operating mode Setup Mode.</p> <p>Firmware version safety module eSM ≥V01.01:</p> <p>Parameter <i>eSM_FuncSwitches</i> Bit 0 = 0: Value = Monitored speed limit for positive and negative directions of movement.</p> <p>Parameter <i>eSM_FuncSwitches</i> Bit 0 = 1: Value = Monitored speed limit for positive direction of movement.</p> <p>Setting can only be modified if power stage is disabled.</p> <p>Available with firmware version ≥V01.01.</p>	RPM 0 0 8000	UINT16 R/W per. -	-
<i>eSM_SLSnegDirS</i>	<p>eSM speed limit negative direction machine operating mode Setup Mode.</p> <p>Firmware version safety module eSM ≥V01.01.</p> <p>Parameter <i>eSM_FuncSwitches</i> Bit 0 = 1: Value = Monitored speed limit for negative direction of movement.</p> <p>Setting can only be modified if power stage is disabled.</p> <p>Available with firmware version ≥V01.01.</p>	RPM 0 0 8000	UINT16 R/W per. -	-

Direction of Movement

Movements are made in positive or in negative directions.

In the case of a rotary motors, direction of movement is defined in accordance with IEC 61800-7-204: Positive direction is when the motor shaft rotates clockwise as you look at the end of the protruding motor shaft.

NOTE: Inverting the direction of movement via a parameter in the drive is not taken into account by the safety module eSM.

Response to Exceedance of Limit Value

If the monitored limit value is exceeded for the first time:

- An error is detected
- The safety module eSM requests a Quick Stop from the drive and monitors the Quick Stop ramp.
 - If the Quick Stop is executed properly, the safety-related function SOS is triggered.
 - If the Quick Stop is not executed properly, the safety-related function STO is triggered.

If the monitored limit value is exceeded again:

- The safety-related function STO is triggered.

Parameter name	Description	Unit	Data type	Parameter address via fieldbus
HMI menu		Minimum value	R/W	
HMI name		Factory setting	Persistent	
		Maximum value	Expert	
<i>eSM_dec_Qstop</i>	eSM deceleration ramp for Quick Stop. Deceleration ramp for monitored Quick Stop. This value must be greater than 0. Value 0: eSM module is not configured Value >0: Deceleration ramp in RPM/s Setting can only be modified if power stage is disabled. Available with firmware version ≥V01.01.	RPM/s 0 0 32786009	UINT32 R/W per. -	-

Start/Restart Signal

Start/Restart Signal - Overview

General Information

The safety module eSM provides for automatic start/restart and manual start/restart.

▲ WARNING
UNINTENDED EQUIPMENT OPERATION
Use Manual Start/Restart if unintended restart is a hazard according to your risk assessment.
Failure to follow these instructions can result in death, serious injury, or equipment damage.

The safety module eSM disables the power stage and inhibits enabling of the power stage after the following events:

- After the 24 V power supply is activated.
- After an Emergency Stop.
- After an error of classes 2, 3 or 4 has been detected.

When enabling of the power stage is inhibited by the safety module eSM, the drive remains in the operating state 3 (Switch On Disabled) of the state diagram.

The power stage can only be unlocked by a start/restart signal at the input *ESMSTART*. The following conditions must be fulfilled for the start/restart signal to be accepted:

- No Emergency Stop request (signals $\overline{ESTOP_A}$ and $\overline{ESTOP_B}$).
- Error messages of the safety module eSM have been acknowledged.

In the case of manual start/restart, the power stage is unlocked via a start pulse. In the case of automatic start/restart, it is unlocked via the level at the input *ESMSTART*. The type of start is selected via the parameter *eSM_BaseSetting*.

The parameters of the safety module eSM can only be modified via the commissioning software.

Parameter name	Description	Unit	Data type	Parameter address via fieldbus
HMI menu		Minimum value	R/W	
HMI name		Factory setting	Persistent	
		Maximum value	Expert	
<i>eSM_BaseSetting</i>	eSM basic settings. None: No function Auto Start: Automatic start (ESMSTART) Ignore GUARD_ACK: GUARD_ACK inactive Ignore /INTERLOCK_IN: INTERLOCK chain inactive Setting can only be modified if power stage is disabled. Available with firmware version $\geq V01.01$.	- - - -	UINT16 R/W per. -	-

The start/restart signal *ESMSTART* unlocks the power stage.

The power stage cannot be enabled by means of an Enable signal unless it is unlocked.

Manual Start/Restart

General

In the case of manual start/restart, the power stage is unlocked via a start/restart signal with a defined duration at the input *ESMSTART*.

Timing of start/restart signal for manual start/restart:

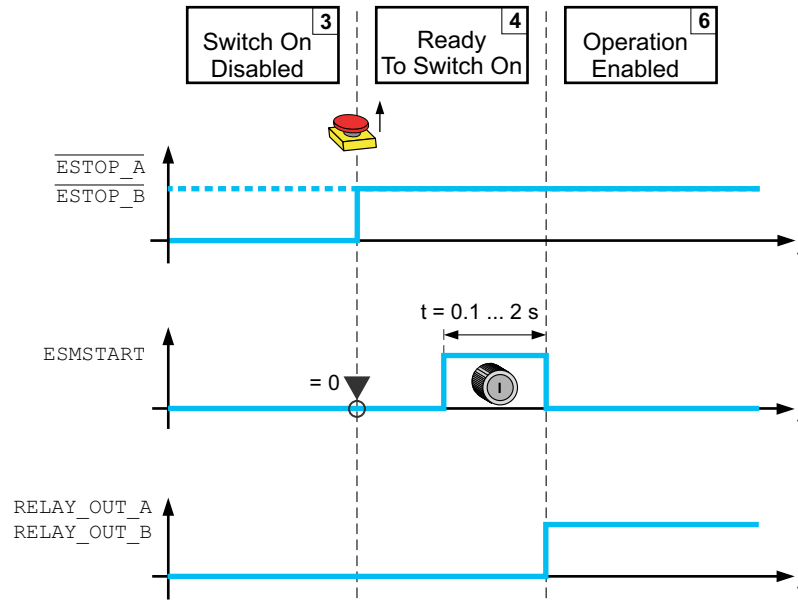

The safety module eSM monitors the duration of the start/restart pulse at the input *ESMSTART* in order to detect contact welding at the start/restart pushbutton.

If the maximum duration of the start/restart signal is exceeded, the start/restart signal is ignored and an error is detected.

Automatic Start/Restart

General

For automatic start/restart, the safety module eSM does not require a start pulse, but a static 24 Vdc signal at the input *ESMSTART*.

Start signal for automatic start/restart

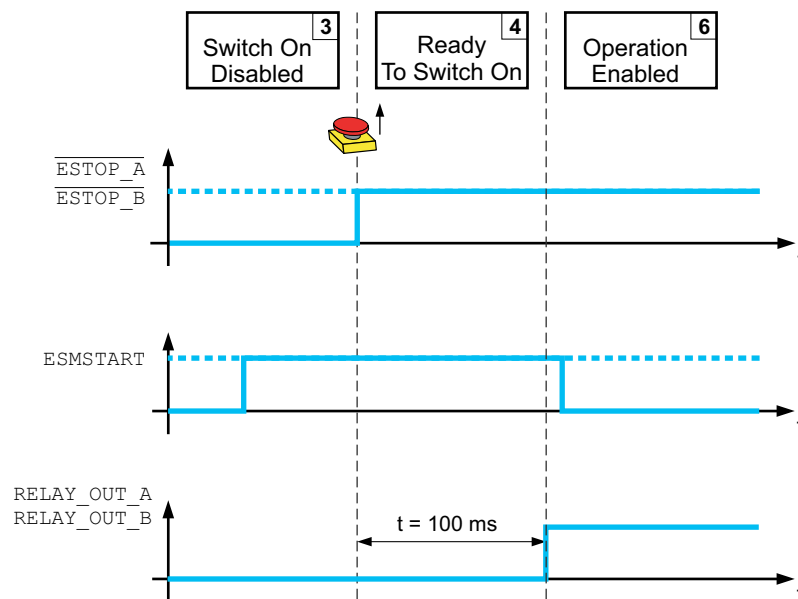

If automatic start/restart is configured, the safety module eSM verifies that the level at the input *ESMSTART* is 1.

If the forcibly guided normally closed contacts of the power contactors connected in series to the input *ESMSTART* are not closed, enabling of the power stage remains inhibited even if automatic start/restart is configured.

Delay Time for Automatic Start

The fixed delay time can be used to start several interconnected safety modules eSM together. The inputs *ESMSTART* of the safety modules eSM must be connected in parallel (for example, via the eSM terminal adapter).

One power contactor with forcibly guided normally closed contacts each is connected to the two inputs *RELAY_A* and *RELAY_B* of one of the interconnected safety modules eSM. The start/restart signal is supplied to the inputs *ESMSTART* of the other safety modules eSM via the forcibly guided normally closed contacts of the two power contactors connected in series.

Delay time for automatic start:

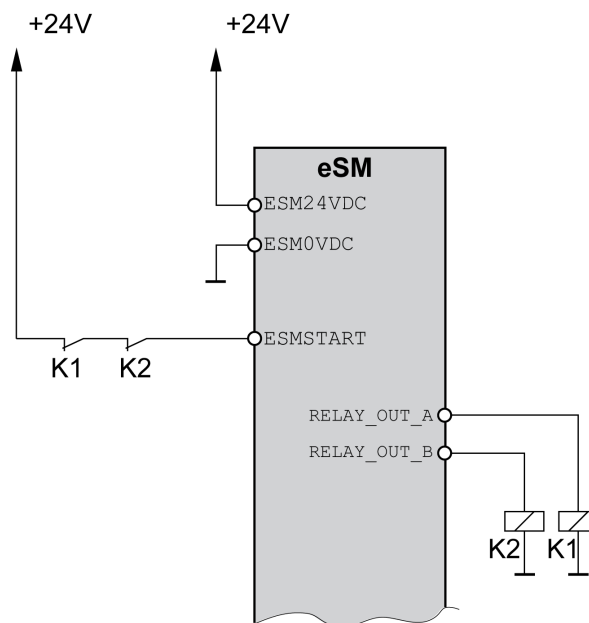

The start/restart signal is available at the inputs *ESMSTART* of the safety modules eSM for a period of 100 ms. During this time the connected safety modules eSM must recognize the start signal. When this time has passed, the two power contactors at the outputs *RELAY_A* and *RELAY_B* switch. The normally closed contacts interrupt the start/restart signal.

Error acknowledgement:

If errors cannot be acknowledged simultaneously for the interconnected safety modules eSM, the error must be acknowledged last at the safety module eSM that controls the power contactors.

Emergency Stop

Emergency Stop - Overview

General Information

The safety module eSM provides two ways of implementing an Emergency Stop

- Integrated Emergency Stop Without External Safety Relay, page 71
- Emergency Stop with External Safety Relay, page 74

The type of Emergency stop depends on the wiring.

Integrated Emergency Stop

Wiring

Wiring of the safety module eSM or the eSM terminal adapter for Emergency Stop:

- Connect the supply voltage to *ESM24VDC* and *ESM0VDC*.
- Connect the Emergency Stop pushbutton to $\overline{ESTOP_A}$ and $\overline{ESTOP_B}$.
- Connect the start/restart pushbutton to the input *ESMSTART*.

Emergency Stop: Category 1 Stop ($\overline{ESTOP_A}$ and $\overline{ESTOP_B}$)

If the inputs $\overline{ESTOP_A}$ and $\overline{ESTOP_B}$ are deactivated (level 0), a Quick Stop and the safety-related function SS1 are triggered. This corresponds to stop category 1 as per IEC 60204-1.

Triggering an Emergency Stop:

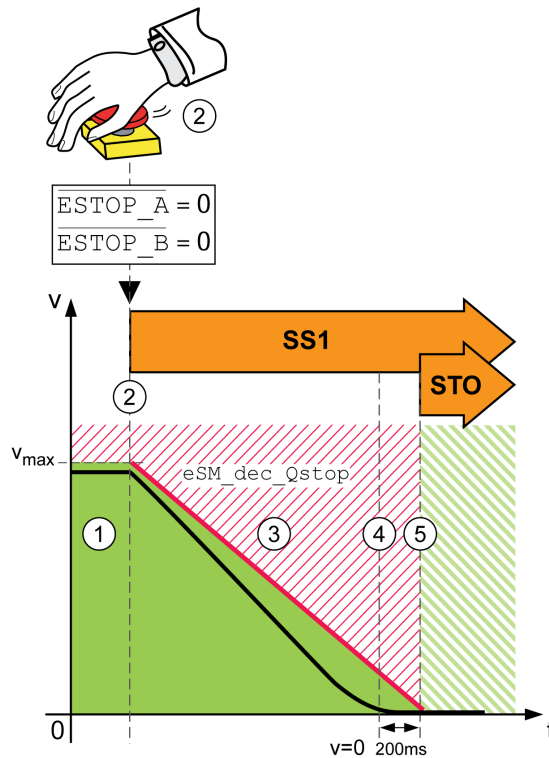

The following steps are performed in the case of an Emergency Stop:

1	No Emergency Stop triggered. The machine operating mode is Automatic Mode or Setup Mode.
2	An Emergency Stop is triggered via the inputs $\overline{ESTOP_A}$ and $\overline{ESTOP_B}$ (level 0) The safety module eSM request a Quick Stop. The safety-related function SS1 is triggered.
3	The deceleration ramp is monitored by the safety-related function SS1.
4	The velocity is zero. A delay time of 200 ms starts. If a holding brake is present, it can be applied.
5	The delay time has elapsed. The safety-related function STO is active.

Parameter name	Description	Unit	Data type	Parameter address via fieldbus
HMI menu		Minimum value	R/W	
HMI name		Factory setting	Persistent	
		Maximum value	Expert	
eSM_dec_Qstop	eSM deceleration ramp for Quick Stop. Deceleration ramp for monitored Quick Stop. This value must be greater than 0. Value 0: eSM module is not configured Value >0: Deceleration ramp in RPM/s Setting can only be modified if power stage is disabled. Available with firmware version \geq V01.01.	RPM/s 0 0 32786009	UINT32 R/W per. -	-

Integrated Emergency Stop: Wiring with eSM Terminal Adapter

Wiring of Emergency Stop with evaluation of the signal state of a start/restart pushbutton via eSM terminal adapter:

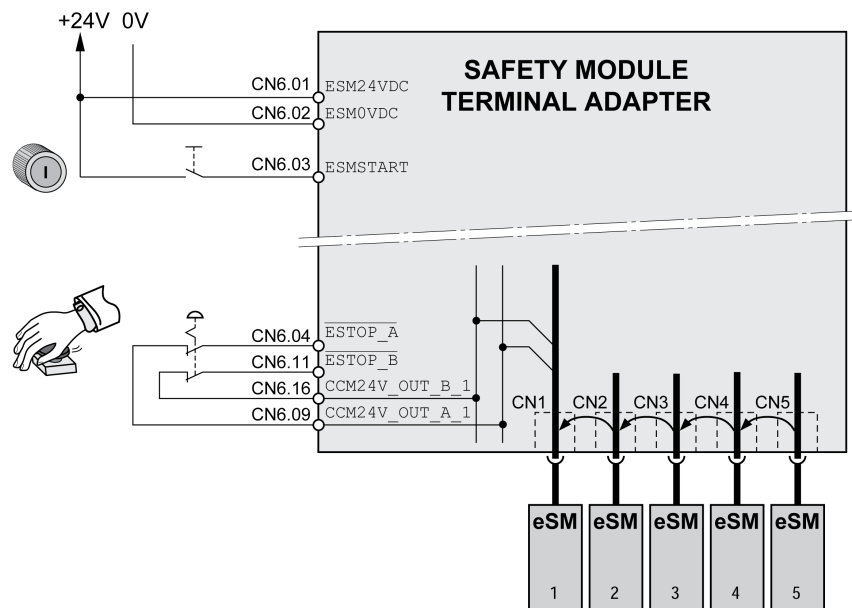

Refer to Multiple Safety Modules eSM in Multi-Axis System Via eSM Terminal Adapter, page 36 for additional details.

Deenergizing Other Consumers

If other consumers are to be deenergized via the safety module eSM or contact multiplication is to be implemented, power contactors with forcibly guided contacts can be connected to the outputs *RELAY_OUT_A* and *RELAY_OUT_B*. Connect one power contactor to each output of a pair of outputs, for example, K1 to *RELAY_OUT_A_1* and K2 to *RELAY_OUT_B_1*. The forcibly guided, normally closed contacts of the power contactors must be connected in series with the start/restart pushbutton (*ESMSTART*), refer to Evaluation of the Start/Restart Signal - General, page 68.

If the power contactors are used to apply or remove mains voltage, the power contactors must meet the requirement of protective separation.

If an error is detected, you can reset it by triggering an Emergency Stop.

Delay Time for Other Consumers

It is possible to deenergize other consumers after a delay time:

- After a fixed delay time
- When the movement has come to a standstill

Timing for deactivation of the *RELAY* output:

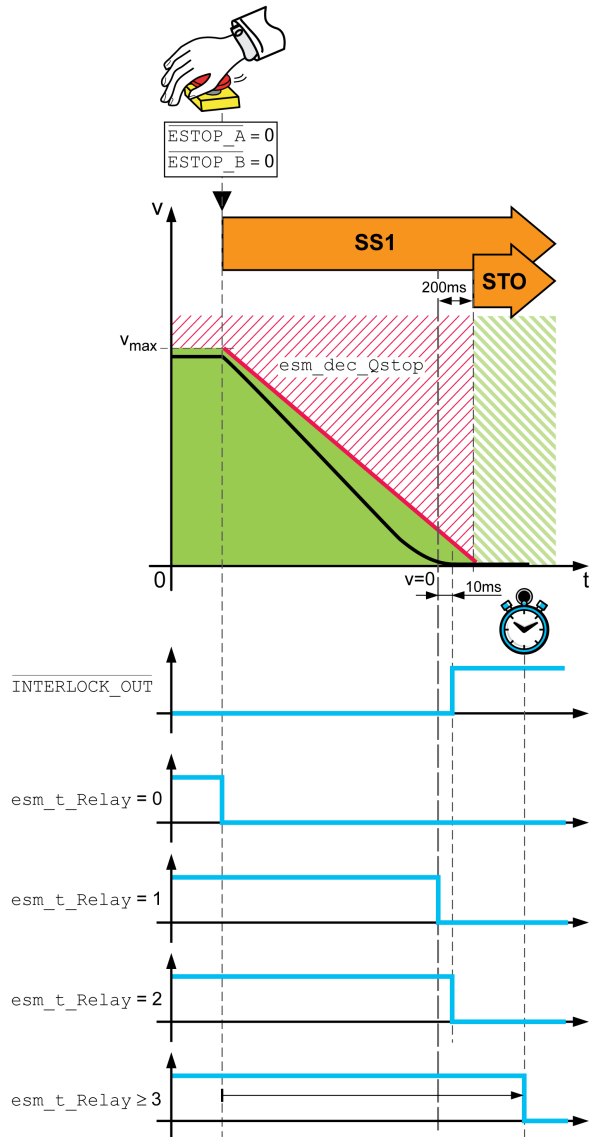

The parameter *eSM_t_Relay* lets you set the timing for deactivation.

Parameter name	Description	Unit	Data type	Parameter address via fieldbus
HMI menu		Minimum value	R/W	
HMI name		Factory setting	Persistent	
		Maximum value	Expert	
<i>eSM_t_Relay</i>	<p>eSM deactivation of output RELAY.</p> <p>Deactivation of the digital output RELAY:</p> <p>Value 0: Immediate, no time delay</p> <p>Value 1: At motor standstill ($v = 0$)</p> <p>Value 2: At motor standstill ($v = 0$) and $/INTERLOCK_OUT = 1$</p> <p>Value >2: Time delay in ms, deactivation of output after this time has passed</p> <p>Setting can only be modified if power stage is disabled.</p> <p>Available with firmware version $\geq V01.01$.</p>	<p>ms</p> <p>0</p> <p>0</p> <p>10000</p>	<p>UINT16</p> <p>R/W</p> <p>per.</p> <p>-</p>	-

The outputs of the safety module eSM provide integrated protection against inductive voltage. Additional flyback diodes can slow down the switching behavior of contactors. Refer to *Electrical Data Module*, page 14 for information on the maximum inductive load on the outputs.

Event	Value of parameter <i>eSM_t_Relay</i>	Outputs <i>RELAY_OUT</i>
Error of error class 1 detected	Any	The outputs <i>RELAY_OUT</i> are not deactivated.
Error of error class 2 detected (Emergency Stop)	0	Outputs <i>RELAY_OUT</i> are immediately deactivated (without time delay).
	1	The outputs <i>RELAY_OUT</i> are deactivated when the motor is at a standstill ($v = 0$).
	2	The outputs <i>RELAY_OUT</i> are deactivated when the motor is at a standstill ($v = 0$) and if the level at the output <i>INTERLOCK_OUT</i> is 1.
	≥ 3	The outputs <i>RELAY_OUT</i> are deactivated after the parameterizable delay time <i>eSM_t_Relay</i> [ms] has passed.
Error of classes 3 or 4 detected	Any	The outputs <i>RELAY_OUT</i> are deactivated immediately, irrespective of the settings in the parameter <i>eSM_t_Relay</i> .

Emergency Stop with External Safety Relay

Wiring

If the external safety relay requires a start signal, an additional start signal at the safety module eSM is not needed. Automatic Start needs to be activated via the parameter *eSM_BaseSetting*.

Emergency Stop with external safety relay (1) and Automatic Start:

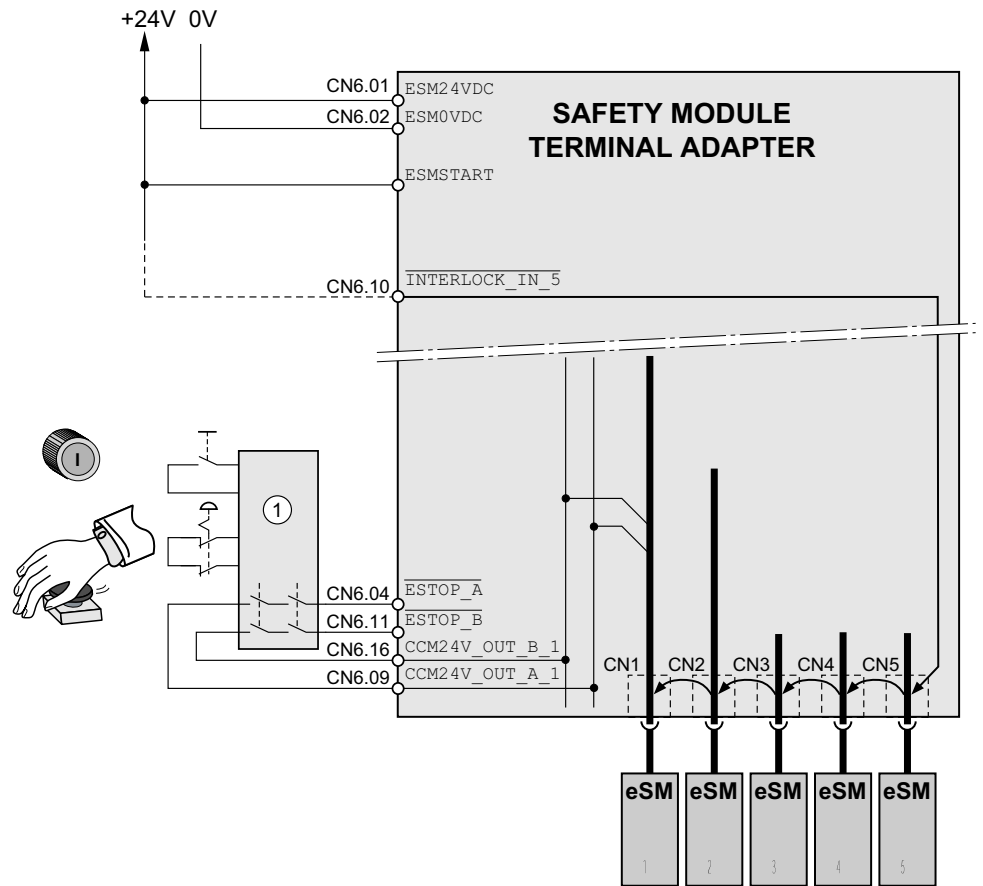

Parameter name HMI menu HMI name	Description	Unit Minimum value Factory setting Maximum value	Data type R/W Persistent Expert	Parameter address via fieldbus
<i>eSM_BaseSetting</i>	eSM basic settings. None: No function Auto Start: Automatic start (ESMSTART) Ignore GUARD_ACK: GUARD_ACK inactive Ignore /INTERLOCK_IN: INTERLOCK chain inactive Setting can only be modified if power stage is disabled. Available with firmware version \geq V01.01.	- - - -	UINT16 R/W per. -	-

Guard Door

Safety-Related Function SOS with Open Guard Door

General

A typical scenario for using the safety-related function SOS in the machine operating mode Automatic Mode includes opening of the guard door during operation of the machine. As long as the guard door is open and access to the zone of operation is possible, the standstill position is monitored with the safety-related function SOS. Regular operation is to be resumed when the guard door is closed again.

Safety-related function SOS with open guard door:

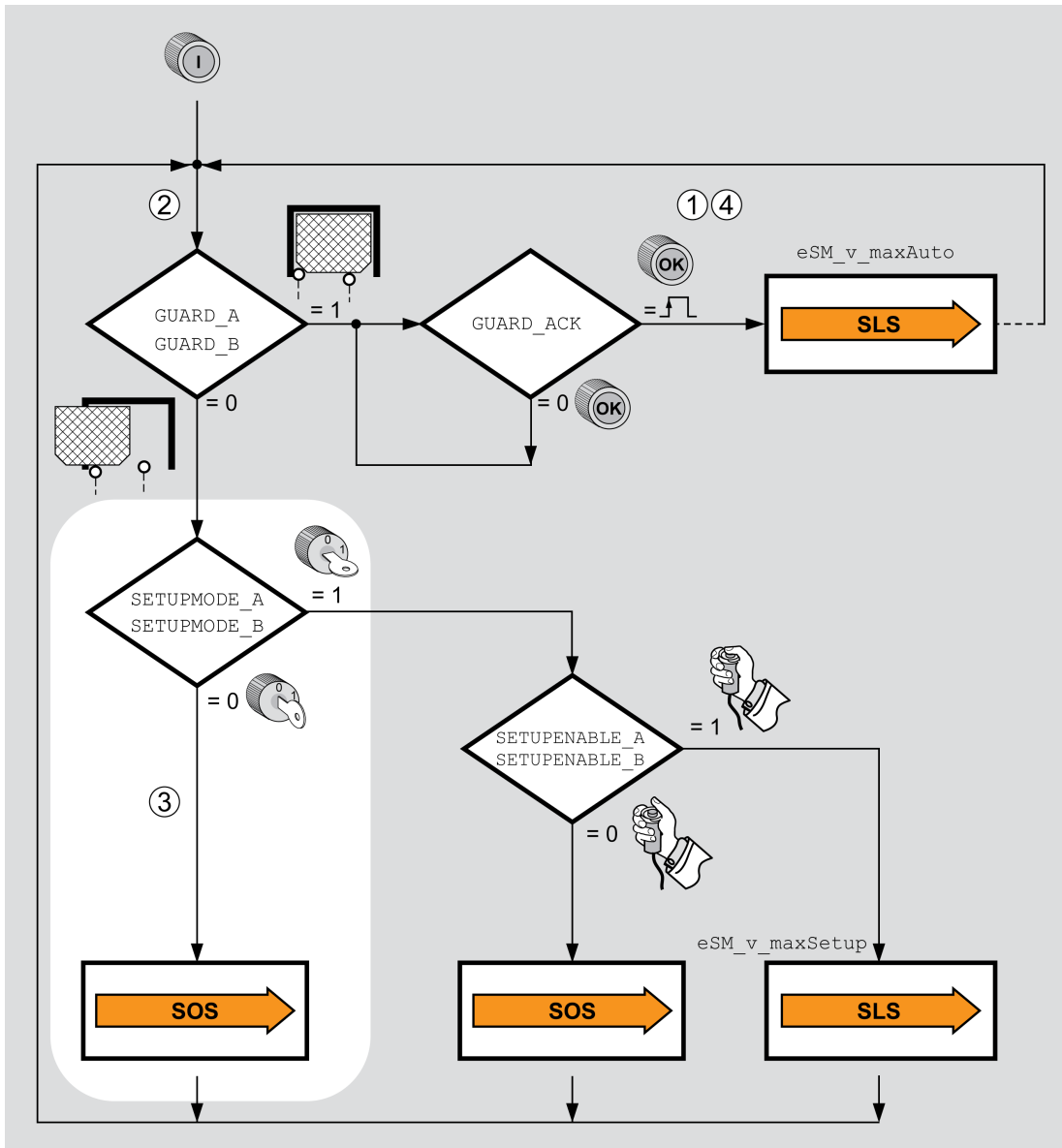

1	The level at the safety-related inputs <i>GUARD_A</i> and <i>GUARD_B</i> is 1 (guard door closed).
2	Opening of the guard door is requested. The controller must request a deceleration of the movement. The safety module eSM monitors the deceleration. The signal <i>INTERLOCK_OUT</i> releases guard locking of the guard door.

3	The guard door is open (<i>GUARD_A</i> , <i>GUARD_B</i> , <i>SETUPMODE_A</i> , <i>SETUPMODE_B</i> : level 0). The safety-related function SOS is active.
4	The guard door is closed again. After acknowledgement (<i>GUARD_ACK</i>), regular operation is resumed with the speed set for machine operating mode Automatic Mode.

Safety-Related Function SLS with Open Guard Door

General Information

A typical scenario for using the safety-related function SLS in the machine operating mode Automatic Mode includes opening of the guard door during operation. As long as the guard door is open and access to the zone of operation is possible, the speed is limited to a specified value with the safety-related function SLS. Regular operation is to be resumed when the guard door is closed again.

Use an enabling device if this is required according to your risk assessment,.

Safety-related function SLS with open guard door:

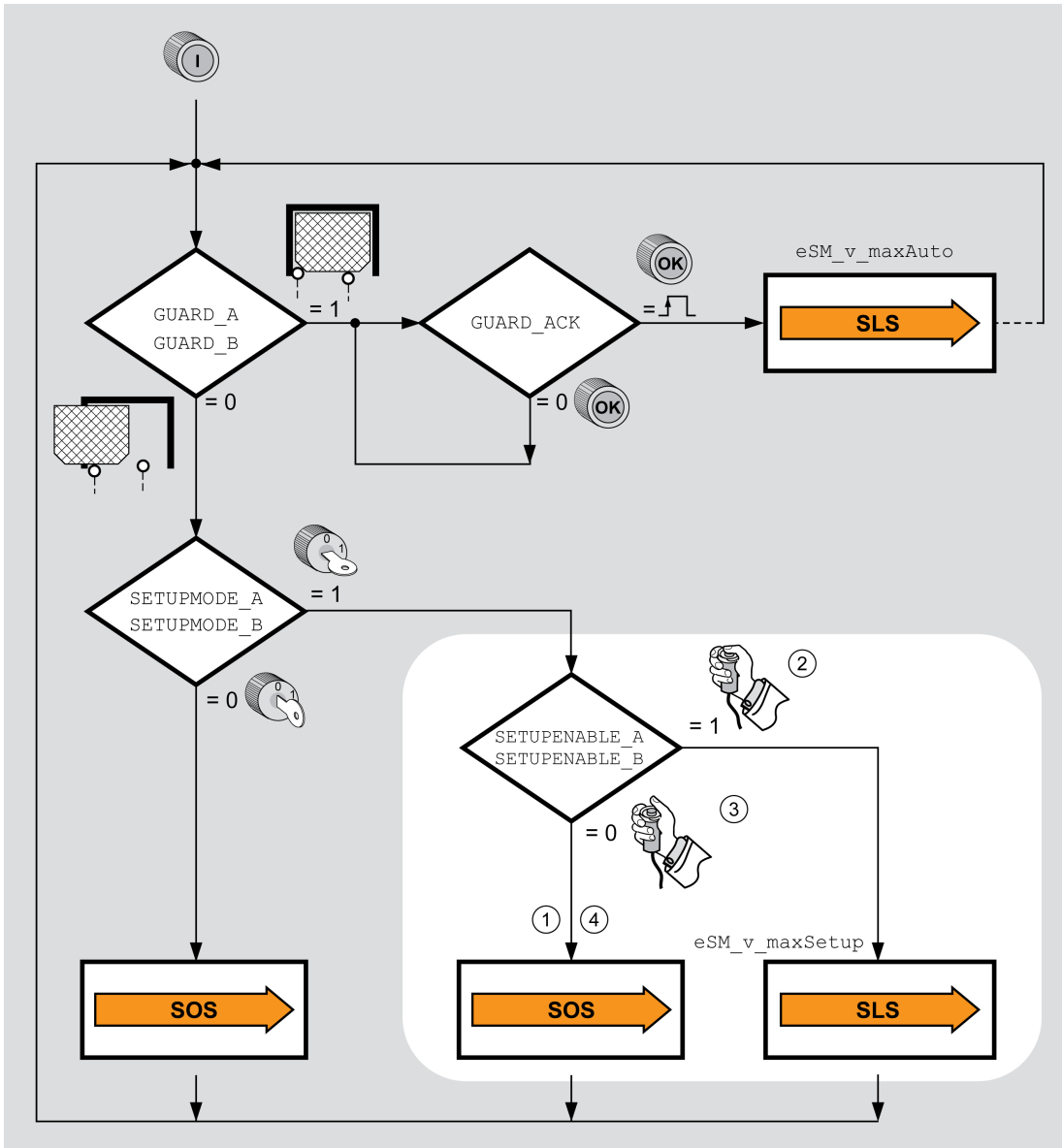

Safety-related inputs	Level
<i>GUARD_A</i> and <i>GUARD_B</i>	0, guard door open
<i>SETUPMODE_A</i> and <i>SETUPMODE_B</i>	1, machine operating mode Setup Mode

Safety-related inputs	Level
SETUPENABLEE_A and SETUPENABLEE_B (enabling device)	0, safety-related function SOS
	1, safety-related function SLS
1	The enabling device is not active. The safety-related function SOS is active.
2	The enabling device is active. Movement at reduced velocity, monitored by safety-related function SLS.
3	The enabling device is no longer active. The master controller must trigger a deceleration of the movement. The safety module eSM monitors the deceleration.
4	The enabling device is not active. The safety-related function SOS is active.

Acknowledge/Reset Pushbutton

General

The safety module eSM lets you connect an Acknowledge/Reset pushbutton installed outside the zone of operation according to your risk assessment. It acknowledges the safety-related function when the guard door is closed (the level at the inputs *Guard_A* and *GUARD_B* is 1).

Acknowledge/Reset pushutton:

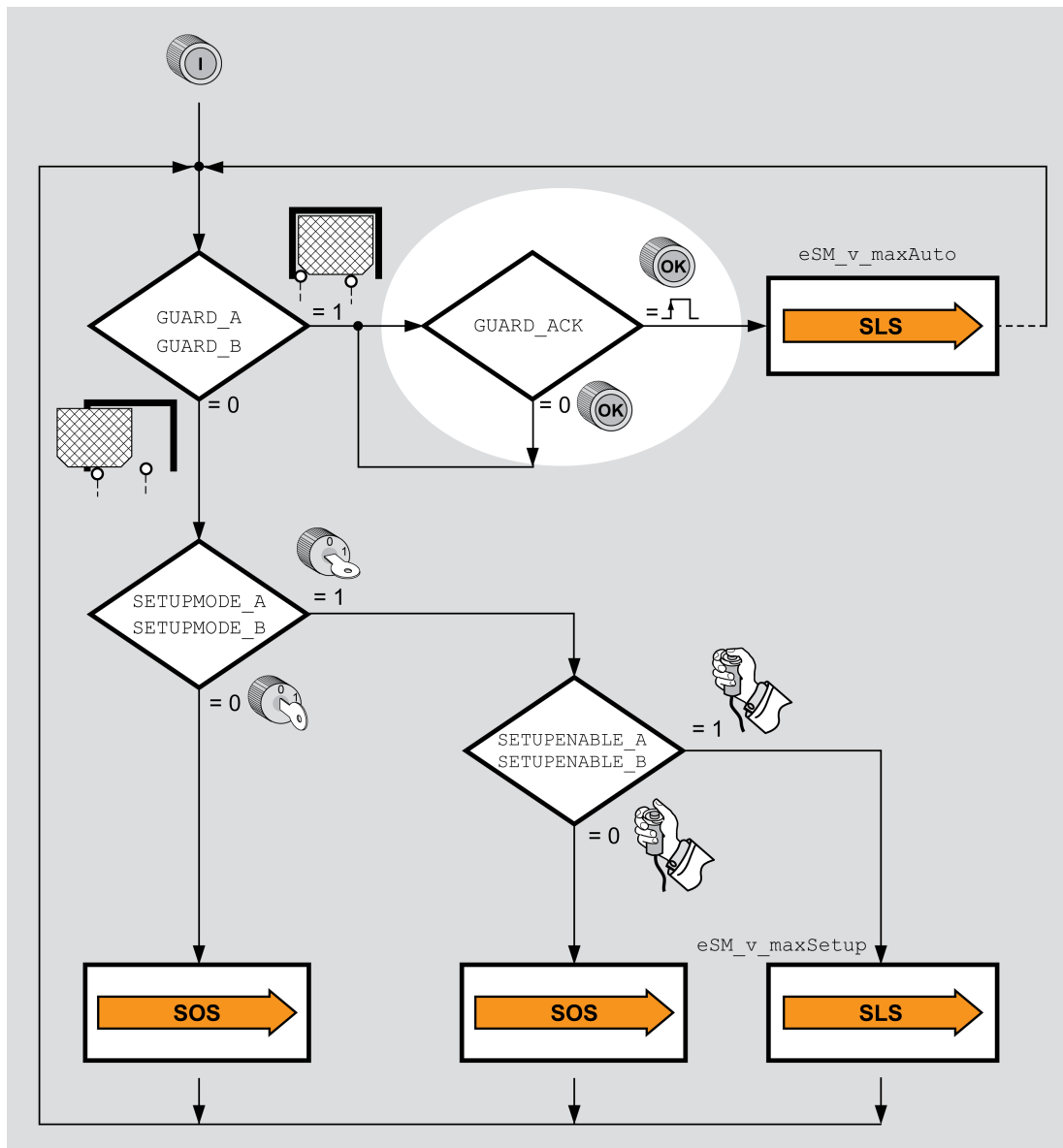

Guard Door with Guard Locking Device

General

A guard locking device can be connected to the output $\overline{INTERLOCK_OUT}$ of an eSM safety module.

If the velocity is zero, the level at the output $\overline{INTERLOCK_OUT}$ of the safety module eSM is 1. Multiple safety modules eSM can be interconnected by chaining the signal of output $\overline{INTERLOCK_OUT}$ and the input $\overline{INTERLOCK_IN}$ of the next safety module eSM.

Guard locking device and signal chaining:

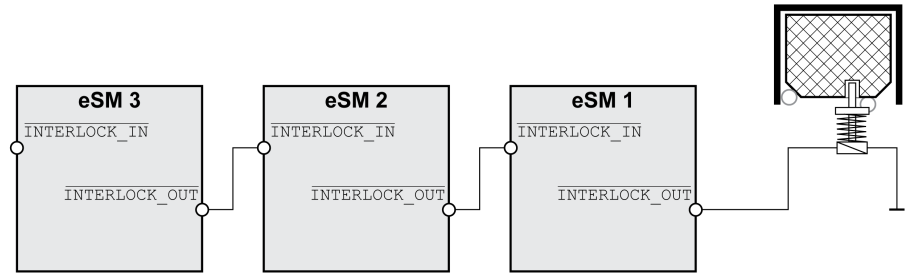

Monitoring Functions

Monitoring Functions

Simultaneous Switching

The safety module eSM monitors simultaneous switching of signal pairs (channel A and channel B). Both signals of a pair must change to the same state within one second. An error is detected if this is not the case. Contact welding, short circuits to other voltage-carrying conductors, or inoperative connected equipment can be the causes of such conditions.

Monitoring for Periodic Movement

If the safety module is in operating state 6 (Operation Enabled), the motor must perform a movement of at least two increments (with reference to 1000 increments per revolution) every 36 hours. This periodic movement is used to verify that the encoder is operative. If this periodic movement is not detected, an error of error class 2 is detected. The minimum movement is also monitored in the machine operating mode Automatic Mode.

Supply Voltage Monitoring

If the supply voltage of the safety module eSM leaves the permissible range, the safety-related function SS1 is triggered. The safety-related outputs are deactivated. An error of error class 2 is detected.

Temperature Monitoring

If the temperature of the safety module eSM leaves the permissible range, the safety-related function STO is triggered. The safety-related outputs are deactivated. An error is detected.

This error can only be reset by cycling the control power of the drive after the cause of the error has been remedied.

Test of the Outputs

The safety-related outputs are deactivated cyclically for a period of less than 1 ms.

Diagnostics and Troubleshooting

Diagnostics and Troubleshooting

Obtaining Diagnostics and Status Information

Diagnostics information and status information on the safety module eSM is provided by the drive. Refer to the user guide of the drive ([Related Documents](#), page 9) for additional information.

The states of the inputs and the outputs as well as the operating states of the eSM safety modules can be read via the fieldbus. The parameters are accessed in the same way as the parameters of the drive.

NOTE: Reading a status message via the fieldbus may be subject to a time delay due to the asynchronous access to the parameters of a safety module eSM.

The menu item "Status", page 58 in the commissioning software allows you to display the status of the safety module eSM.

Troubleshooting

Problem	Possible causes	Remedy
Machine operating mode Automatic Mode does not start even though the guard door is closed.	The acknowledge/reset pushbutton for the guard door is not connected or not activated.	Connect an acknowledge/reset pushbutton for the guard door to <i>GUARD_ACK</i> or activate a connected acknowledge/reset pushbutton.
	Guard door acknowledgement is not required, but configured.	Verify correct settings for the eSM parameter <i>MiscModes</i> .
The safety module eSM remains in the eSM operating state 2.	Supply not connected.	Connect <i>ESM24VDC</i> and <i>ESM0VDC</i> .
eSM parameter password forgotten.	eSM parameter password has been changed or forgotten.	Duplicate an eSM parameter set from a different safety module eSM with known eSM parameter password. Set the eSM parameters to the required values.

NOTE: Refer to the user guide of the drive ([Related Documents](#), page 9) for detailed information on specific error messages.

Operating States and State Transitions

eSM state diagram

The state diagram of the safety module eSM has the same operating states and state transitions as the state diagram of the drive.

eSM state diagram:

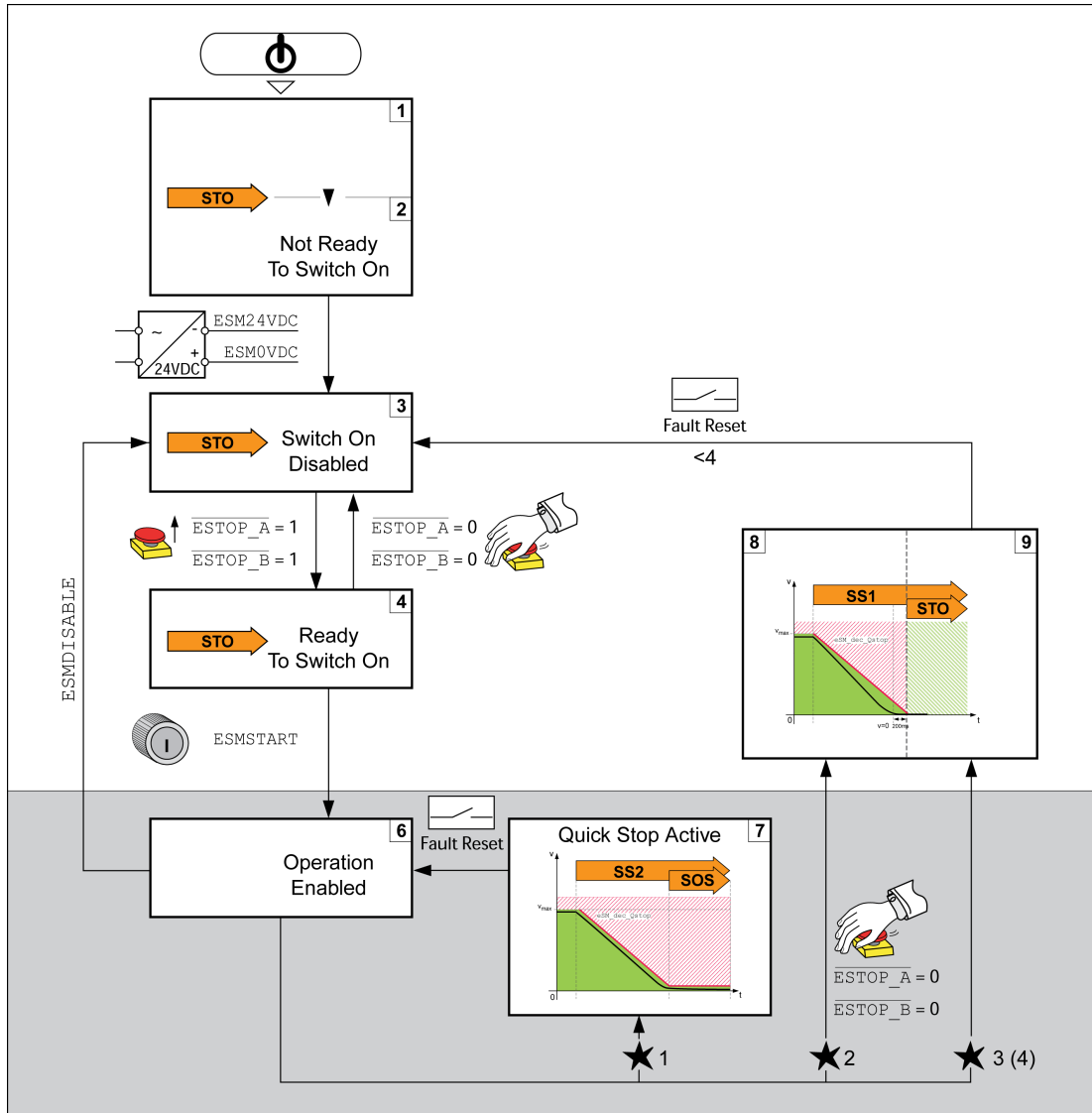

Error Classes and Error Responses

General

The safety module eSM monitors specified limit values. If a limit value is exceeded, the safety module eSM responds according to the corresponding error class as outlined in the following table:

Error class	Stop category (1)	Explanation
0	-	No interruption of the movement.
1	2	<p>The safety-related function SS2 is triggered. The power stage remains enabled.</p>
2	1	<p>The safety-related function SS1 is triggered. The power stage is disabled when STO is triggered.</p>
3.4	0	<p>The safety-related function STO is triggered. The power stage is immediately disabled.</p>
(1) Stop category as per IEC 60204		

Errors of classes 0, 1, 2, and 3 are reset with the function “Fault Reset” of the drive after the cause of the detected error has been removed. Errors of class 4 can only be reset with a power cycle of the drive. Refer to the user guide of the drive for details.

Parameters

Representation of the Parameters

Description

This section provides an overview of the parameters which can be used for operating the drive.

In addition, special parameters for communication via the fieldbus are described in the corresponding fieldbus user guide.

Unsuitable parameter values or unsuitable data may trigger unintended movements, trigger signals, damage parts and disable monitoring functions. Some parameter values or data do not become active until after a restart.

⚠ WARNING
<p>UNINTENDED EQUIPMENT OPERATION</p> <ul style="list-style-type: none"> Only start the system if there are no persons or obstructions in the zone of operation. Do not operate the drive system with undetermined parameter values or data. Never modify a parameter value unless you fully understand the parameter and all effects of the modification. Restart the drive and verify the saved operational data and/or parameter values after modifications. Carefully run tests for all operating states and potential error situations when commissioning, upgrading or otherwise modifying the operation of the drive. Verify the functions after replacing the product and also after making modifications to the parameter values and/or other operational data. <p>Failure to follow these instructions can result in death, serious injury, or equipment damage.</p>

Overview

The way parameters are shown provides information required for unique identification, the default values and the properties of a parameter.

Structure of the parameter representation:

Parameter name	Description	Unit	Data type	Parameter address via fieldbus
HMI menu HMI name		Minimum value Factory setting Maximum value	R/W Persistent Expert	
<i>ABCDE</i> <i>CONF → inf -</i> <i>Prn</i>	Short description Selection values 1 / Abc1 / <i>ABC 1</i> : Explanation 1 2 / Abc2 / <i>ABC 2</i> : Explanation 2 Description and details	A _{pk} 0.00 3.00 300.00	UINT32 R/W per. -	Fieldbus 1234

Field “Parameter Name”

The parameter name uniquely identifies a parameter.

Field “HMI menu” and “HMI name”

HMI menu shows the sequence of menus and commands to access the parameter via the HMI.

Field “Description”

Short description:

The short description contains information on the parameter and a cross reference to the page that describes the use of the parameter.

Selection values:

In the case of parameters which offer a selection of settings, the value to be entered via the fieldbus, the designation of the value for entry via the commissioning software and the designation of the value for entry via the HMI are specified.

1 = Value for input via fieldbus

Abc1 = Designation for entry via the commissioning software

Abc 1 = Designation for entry via the HMI

Description and details:

Provides further information on the parameter.

Field “Unit”

The unit of the value.

Field “Minimum Value”

The minimum value which can be entered.

Field “Factory Settings”

Settings when the product is shipped.

Field “Maximum Value”

The maximum value which can be entered.

Field “Data Type”

If the minimum and the maximum values are not explicitly indicated, the valid range of values is determined by the data type.

Data type	Mininum value	Maximum value
INT8	-128	127
UINT8	0	255
INT16	-32768	32767
UINT16	0	65535
INT32	-2147483648	2147483647
UINT32	0	4294967295

Field “R/W”

Indicates read and/or write values

"R/" values can only be read

"R/W" values can be read and written.

Field “Persistent”

“per.” indicates whether the value of the parameter is persistent, i.e. whether it remains in the memory after the device is powered off.

When a value of a persistent parameter is modified via the HMI, the drive stores the value automatically in the persistent memory.

When a value of a persistent parameter is modified via the commissioning software or the fieldbus, the user must explicitly store the modified value in the persistent memory.

Parameters for the safety module eSM are modified using the commissioning software. The parameter values are saved persistently after transfer. Explicit saving to the persistent memory is not required in the case of the eSM module.

Field “Parameter Address”

Each parameter has a unique parameter address.

Decimal Numbers Entered via the Fieldbus

Note that parameter values are entered via the fieldbus without a decimal point. All decimal places must be entered.

Input examples:

Value	Commissioning software	Fieldbus
20	20	20
5.0	5.0	50
23.57	23.57	2357
1.000	1.000	1000

List of Parameters

Parameter name HMI menu HMI name	Description	Unit Minimum value Factory setting Maximum value	Data type R/W Persistent Expert	Parameter address via fieldbus
<i>_eSM_funct</i> <i>Π ο η</i> <i>5 Π ο P</i>	<p>eSM function.</p> <p>Active eSM function</p> <p>Value 0: Safe Torque Off (STO)</p> <p>Value 1: No function active</p> <p>Value 2: Safe Operating Stop (SOS)</p> <p>Value 3: Safely Limited Speed (SLS)</p> <p>Value 4: Reserved</p> <p>Value 5: Safe Stop 1 (SS1)</p> <p>Value 6: Safe Stop 2 (SS2)</p> <p>Value 7: Safe Operating Stop (SOS) after error</p> <p>Value 8: Safely Limited Speed (SLS) in machine operating mode Automatic Mode</p> <p>If bit 15 of the value is set: GUARD_ACK was triggered</p> <p>Available with firmware version \geqV01.01.</p>	- - - -	UINT16 R/- - -	CANopen 304C:17 _h Modbus 19502 Profibus 19502 CIP 176.1.23 ModbusTCP 19502 EtherCAT 304C:17 _h PROFINET 19502
<i>_eSM_LL_act</i>	<p>eSM digital inputs channel B.</p> <p>Signal state:</p> <p>0: 0 level</p> <p>1: 1 level</p> <p>Bit assignments:</p> <p>Bit 0: /ESTOP_B</p> <p>Bit 1: GUARD_B</p> <p>Bit 3: SETUPMODE_B</p> <p>Bit 4: SETUPENABLE_B</p> <p>Bit 6: GUARD_ACK</p> <p>Bit 8: ESMSTART</p> <p>Bit 9: /INTERLOCK_IN</p> <p>Available with firmware version \geqV01.01.</p>	- - - -	UINT16 R/- - -	CANopen 304C:12 _h Modbus 19492 Profibus 19492 CIP 176.1.18 ModbusTCP 19492 EtherCAT 304C:12 _h PROFINET 19492
<i>_eSM_LL_mask</i>	<p>eSM digital inputs channel B mask.</p> <p>Mask of active digital inputs</p> <p>0: Digital input is not active</p> <p>1: Digital input is active</p> <p>Bit assignments:</p> <p>See digital inputs channel.</p> <p>Available with firmware version \geqV01.01.</p>	- - - -	UINT16 R/- - -	CANopen 304C:13 _h Modbus 19494 Profibus 19494 CIP 176.1.19 ModbusTCP 19494 EtherCAT 304C:13 _h PROFINET 19494

Parameter name HMI menu HMI name	Description	Unit Minimum value Factory setting Maximum value	Data type R/W Persistent Expert	Parameter address via fieldbus
<i>_eSM_LO_act</i>	eSM digital outputs channel B. Signal state: 0: 0 level 1: 1 level Bit assignments: Bit 0: CCM24V_OUT_B Bit 1: Drive operating state 6 Operation Enabled (B) Bit 2: RELAY_OUT_B Bit 3: AUXOUT2 Bit 4: /INTERLOCK_OUT Bits 5 ... 15: Reserved Available with firmware version ≥V01.01.	- - - -	UINT16 R/- - -	CANopen 304C:14 _h Modbus 19496 Profibus 19496 CIP 176.1.20 ModbusTCP 19496 EtherCAT 304C:14 _h PROFINET 19496
<i>_eSM_state</i> <i>Π ο η</i> <i>5 Π 5 ε</i>	eSM operating state. 0 / eSM module missing / Π , 5 5 : eSM module missing 1 / Start / 5 ε r ε : Start 2 / Not Ready To Switch On / η r d y : Not Ready To Switch On 3 / Switch On Disabled / d , 5 : Switch On Disabled 4 / Ready To Switch On / r d y : Ready To Switch On 6 / Operation Enabled / r u η : Operation Enabled 7 / Quick Stop / q 5 ε P : Quick Stop 8 / Fault Reaction Active / F L ε : Fault Reaction Active 9 / Fault / F L ε : Fault Status word of eSM state machine Available with firmware version ≥V01.01.	- - - -	UINT16 R/- - -	CANopen 304C:16 _h Modbus 19500 Profibus 19500 CIP 176.1.22 ModbusTCP 19500 EtherCAT 304C:16 _h PROFINET 19500
<i>_eSMVer</i>	eSM revision of firmware. Revision of firmware: Bits 0 ... 7: Firmware evolution (dec) Bits 8 ... 15: Firmware minor revision (dec) Bits 16 ... 23: Firmware major revision (dec) Bits 24 ... 31: Reserved Available with firmware version ≥V01.01.	- - - -	UINT32 R/- - -	CANopen 304C:F _h Modbus 19486 Profibus 19486 CIP 176.1.15 ModbusTCP 19486 EtherCAT 304C:F _h PROFINET 19486

Parameter name HMI menu HMI name	Description	Unit Minimum value Factory setting Maximum value	Data type R/W Persistent Expert	Parameter address via fieldbus
<i>eSM_BaseSetting</i>	eSM basic settings. None: No function Auto Start: Automatic start (ESMSTART) Ignore GUARD_ACK: GUARD_ACK inactive Ignore /INTERLOCK_IN: INTERLOCK chain inactive Setting can only be modified if power stage is disabled. Available with firmware version \geq V01.01.	- - - -	UINT16 R/W per. -	-
<i>eSM_dec_NC</i>	eSM deceleration ramp. Deceleration ramp for monitored deceleration Value 0: Disabled, no monitoring of deceleration ramp Value >0: Deceleration ramp in RPM/s Setting can only be modified if power stage is disabled. Available with firmware version \geq V01.01.	RPM/s 0 0 32786009	UINT32 R/W per. -	-
<i>eSM_dec_Qstop</i>	eSM deceleration ramp for Quick Stop. Deceleration ramp for monitored Quick Stop. This value must be greater than 0. Value 0: eSM module is not configured Value >0: Deceleration ramp in RPM/s Setting can only be modified if power stage is disabled. Available with firmware version \geq V01.01.	RPM/s 0 0 32786009	UINT32 R/W per. -	-
<i>eSM_disable</i>	eSM disable. Value 0: No action Value 1: Force a change of eSM state 6 to eSM state 3 Available with firmware version \geq V01.01.	- - - -	UINT16 R/W - -	CANopen 304C:1A _h Modbus 19508 Profibus 19508 CIP 176.1.26 ModbusTCP 19508 EtherCAT 304C:1A _h PROFINET 19508

Parameter name	Description	Unit	Data type	Parameter address via fieldbus
HMI menu		Minimum value	R/W	
HMI name		Factory setting	Persistent	
		Maximum value	Expert	
eSM_FuncAUXOUT1	<p>eSM function of status output AUXOUT1.</p> <p>None: No function</p> <p>/ESTOP: Signal state /ESTOP</p> <p>GUARD: Signal state GUARD</p> <p>SETUPMODE: Signal state SETUPMODE</p> <p>SETUPENABLE: Signal state SETUPENABLE</p> <p>GUARD_ACK: Signal state GUARD_ACK</p> <p>/INTERLOCK_IN: Signal state /INTERLOCK_IN</p> <p>STO by eSM: Signal state of internal STO</p> <p>RELAY: Signal state RELAY</p> <p>/INTERLOCK_OUT: Signal state /INTERLOCK_OUT</p> <p>Standstill: Standstill (v = 0)</p> <p>SLS: SLS</p> <p>Error class 4: Error of error class 4 detected</p> <p>Error class 1 ... 4: Error of error classes 1 ... 4 detected</p> <p>/ESTOP inv.: Signal state /ESTOP, inverted</p> <p>GUARD inv.: Signal state GUARD, inverted</p> <p>SETUPMODE inv.: Signal state SETUPMODE, inverted</p> <p>SETUPENABLE inv.: Signal state SETUPENABLE, inverted</p> <p>GUARD_ACK inv.: Signal state GUARD_ACK, inverted</p> <p>/INTERLOCK_IN inv.: Signal state /INTERLOCK_IN, inverted</p> <p>STO by eSM inv.: Signal state of internal STO, inverted</p> <p>RELAY inv.: Signal state RELAY, inverted</p> <p>/INTERLOCK_OUT inv.: Signal state /INTERLOCK_OUT, inverted</p> <p>Standstill inv.: Standstill, inverted</p> <p>SLS inv.: SLS, inverted</p> <p>Error class 4 inv.: Error of error class 4 detected (inverted)</p> <p>Error class 1 ... 4 inv.: Error of error classes 1 ... 4 detected (inverted)</p> <p>Setting can only be modified if power stage is disabled.</p> <p>Available with firmware version \geqV01.01.</p>	- - - -	UINT32 R/W per. -	-
eSM_FuncAUXOUT2	<p>eSM function of status output AUXOUT2.</p> <p>None: No function</p> <p>/ESTOP: Signal state /ESTOP</p> <p>GUARD: Signal state GUARD</p> <p>SETUPMODE: Signal state SETUPMODE</p>	- - - -	UINT32 R/W per. -	-

Parameter name HMI menu HMI name	Description	Unit Minimum value Factory setting Maximum value	Data type R/W Persistent Expert	Parameter address via fieldbus
	<p>SETUPENABLE: Signal state SETUPENABLE</p> <p>GUARD_ACK: Signal state GUARD_ACK</p> <p>/INTERLOCK_IN: Signal state /INTERLOCK_IN</p> <p>STO by eSM: Signal state of internal STO</p> <p>RELAY: Signal state RELAY</p> <p>/INTERLOCK_OUT: Signal state /INTERLOCK_OUT</p> <p>Standstill: Standstill (v = 0)</p> <p>SLS: SLS</p> <p>Error class 4: Error of error class 4 detected</p> <p>Error class 1 ... 4: Error of error classes 1 ... 4 occurred</p> <p>/ESTOP inv.: Signal state /ESTOP, inverted</p> <p>GUARD inv.: Signal state GUARD, inverted</p> <p>SETUPMODE inv.: Signal state SETUPMODE, inverted</p> <p>SETUPENABLE inv.: Signal state SETUPENABLE, inverted</p> <p>GUARD_ACK inv.: Signal state GUARD_ACK, inverted</p> <p>/INTERLOCK_IN inv.: Signal state /INTERLOCK_IN, inverted</p> <p>STO by eSM inv.: Signal state of internal STO, inverted</p> <p>RELAY inv.: Signal state RELAY, inverted</p> <p>/INTERLOCK_OUT inv.: Signal state /INTERLOCK_OUT, inverted</p> <p>Standstill inv.: Standstill, inverted</p> <p>SLS inv.: SLS, inverted</p> <p>Error class 4 inv.: Error of error class 4 detected (inverted)</p> <p>Error class 1 ... 4 inv.: Error of error classes 1 ... 4 detected (inverted)</p> <p>Setting can only be modified if power stage is disabled.</p> <p>Available with firmware version \geqV01.01.</p>			
<i>eSM_FuncSwitches</i>	<p>eSM switches for functions.</p> <p>None: No function</p> <p>DirectionDependentSLS: SLS dependent on direction of movement</p> <p>Reserved (Bit 1): Reserved (bit 1)</p> <p>Reserved (Bit 2): Reserved (bit 2)</p> <p>Reserved (Bit 3): Reserved (bit 3)</p> <p>Reserved (Bit 4): Reserved (bit 4)</p> <p>Reserved (Bit 5): Reserved (bit 5)</p> <p>Available as of firmware version safety module eSM \geqV01.01.</p>	<p>-</p> <p>0</p> <p>0</p> <p>63</p>	<p>UINT16</p> <p>R/W</p> <p>per.</p> <p>-</p>	-

Parameter name HMI menu HMI name	Description	Unit Minimum value Factory setting Maximum value	Data type R/W Persistent Expert	Parameter address via fieldbus
	<p>Bit 0 = 0: SLS independent of direction of movement</p> <p>Bit 0 = 1: SLS dependent on direction of movement</p> <p>Bits 1 ... 15: Reserved (must be set to 0)</p> <p>Setting can only be modified if power stage is disabled.</p> <p>Available with firmware version \geqV01.01.</p>			
<i>eSM_LO_mask</i>	<p>eSM digital outputs channel B mask.</p> <p>Mask of active digital outputs</p> <p>0: Digital output is not active</p> <p>1: Digital output is active</p> <p>Bit assignments:</p> <p>See digital outputs channel.</p> <p>Available with firmware version \geqV01.01.</p>	- - - -	UINT16 R/W - -	CANopen 304C:15 _h Modbus 19498 Profibus 19498 CIP 176.1.21 ModbusTCP 19498 EtherCAT 304C:15 _h PROFINET 19498
<i>eSM_SLSnegDirS</i>	<p>eSM speed limit negative direction machine operating mode Setup Mode.</p> <p>Firmware version safety module eSM \geqV01.01.</p> <p>Parameter eSM_FuncSwitches Bit 0 = 1: Value = Monitored speed limit for negative direction of movement.</p> <p>Setting can only be modified if power stage is disabled.</p> <p>Available with firmware version \geqV01.01.</p>	RPM 0 0 8000	UINT16 R/W per. -	-
<i>eSM_t_NCDel</i>	<p>eSM time delay until start of monitored deceleration.</p> <p>This time can be adjusted to meet the requirements of a controller.</p> <p>Setting can only be modified if power stage is disabled.</p> <p>Available with firmware version \geqV01.01.</p>	ms 0 0 10000	UINT16 R/W per. -	-
<i>eSM_t_Relay</i>	<p>eSM deactivation of output RELAY.</p> <p>Deactivation of the digital output RELAY:</p> <p>Value 0: Immediate, no time delay</p> <p>Value 1: At motor standstill ($v = 0$)</p> <p>Value 2: At motor standstill ($v = 0$) and /INTERLOCK_OUT = 1</p> <p>Value >2: Time delay in ms, deactivation of output after this time has passed</p> <p>Setting can only be modified if power stage is disabled.</p> <p>Available with firmware version \geqV01.01.</p>	ms 0 0 10000	UINT16 R/W per. -	-

Parameter name HMI menu HMI name	Description	Unit Minimum value Factory setting Maximum value	Data type R/W Persistent Expert	Parameter address via fieldbus
<i>eSM_v_maxAuto</i>	<p>eSM speed limit for machine operating mode Automatic Mode.</p> <p>This value sets the speed limit for monitoring in machine operating mode Automatic Mode.</p> <p>Value 0: The speed limit is not monitored</p> <p>Value >0: Monitored speed limit</p> <p>Setting can only be modified if power stage is disabled.</p> <p>Available with firmware version \geqV01.01.</p>	<p>RPM</p> <p>0</p> <p>0</p> <p>8000</p>	<p>UINT16</p> <p>R/W</p> <p>per.</p> <p>-</p>	-
<i>eSM_v_maxSetup</i>	<p>eSM speed limit for machine operating mode Setup Mode.</p> <p>This value sets the speed limit for monitoring in machine operating mode Setup Mode.</p> <p>Firmware version safety module eSM \geqV01.01:</p> <p>Parameter eSM_FuncSwitches Bit 0 = 0: Value = Monitored speed limit for positive and negative directions of movement.</p> <p>Parameter eSM_FuncSwitches Bit 0 = 1: Value = Monitored speed limit for positive direction of movement.</p> <p>Setting can only be modified if power stage is disabled.</p> <p>Available with firmware version \geqV01.01.</p>	<p>RPM</p> <p>0</p> <p>0</p> <p>8000</p>	<p>UINT16</p> <p>R/W</p> <p>per.</p> <p>-</p>	-

Accessories and Spare Parts

Safety Module eSM

Description	Reference
Safety module eSM with safety functions SOS, SLS, SS1, SS2 as per IEC/EN 61800-5-2	VW3M3501
Cable for safety module eSM, 3 m (9.84 ft); 24-pin connector, other cable end open	VW3M8801R30
Cable for safety module eSM, 1.5 m (4.92 ft); 2 x 24-pin connector	VW3M8802R15
Cable for safety module eSM, 3 m (9.84 ft); 2 x 24-pin connector	VW3M8802R30
Connection terminal adapter for eSM safety module, for wiring of several safety modules in the control cabinet	VW3M8810
Connector with wire jumper (for INTERLOCK signal) for eSM terminal adapter; 4 pieces	VW3M8820

Service, Maintenance, and Disposal

Maintenance

Service and Repairs

The safety module contains no user-serviceable parts. Do not attempt to open, service, or repair the safety module.

Maintenance

Add the following information specific to the safety module eSM to the maintenance plan of the drive:

- Ensure that a safety-related function implemented with the safety module eSM is triggered at the minimum intervals required by the regulations, standards, and process definitions applicable to your machine/process.
- Verify the wiring at regular intervals.
- To determine the end of the lifetime, add the specified lifetime to the date of manufacture indicated on the safety module in the format DD.MM.YY or in the format DD.MM.YYYY.

Example: If the date of manufacture indicated on the nameplate is 31.12.2019, do not use the safety module eSM after December 31, 2039

As a machine designer or system integrator, include this information in the maintenance plan for your customer.

Replacing Modules

General

⚠ DANGER

ELECTRIC SHOCK, EXPLOSION, OR ARC FLASH

- Disconnect all power from all equipment including connected devices prior to removing any covers or doors, or installing or removing any accessories, hardware, cables, or wires.
- Place a "Do Not Turn On" or equivalent hazard label on all power switches and lock them in the non-energized position.
- Wait 15 minutes to allow the residual energy of the DC bus capacitors to discharge.
- Measure the voltage on the DC bus with a properly rated voltage sensing device and verify that the voltage is less than 42 Vdc.
- Do not assume that the DC bus is voltage-free when the DC bus LED is off.
- Block the motor shaft to prevent rotation prior to performing any type of work on the drive system.
- Do not create a short-circuit across the DC bus terminals or the DC bus capacitors.
- Replace and secure all covers, accessories, hardware, cables, and wires and confirm that a proper ground connection exists before applying power to the unit.
- Use only the specified voltage when operating this equipment and any associated products.

Failure to follow these instructions will result in death or serious injury.

Unsuitable parameter values or unsuitable data may trigger unintended movements, trigger signals, damage parts and disable monitoring functions. Some parameter values or data do not become active until after a restart.

▲ WARNING

UNINTENDED EQUIPMENT OPERATION

- Only start the system if there are no persons or obstructions in the zone of operation.
- Do not operate the drive system with undetermined parameter values or data.
- Never modify a parameter value unless you fully understand the parameter and all effects of the modification.
- Restart the drive and verify the saved operational data and/or parameter values after modifications.
- Carefully run tests for all operating states and potential error situations when commissioning, upgrading or otherwise modifying the operation of the drive.
- Verify the functions after replacing the product and also after making modifications to the parameter values and/or other operational data.

Failure to follow these instructions can result in death, serious injury, or equipment damage.

Electrostatic discharge (ESD) may permanently damage the module either immediately or over time.

NOTICE

EQUIPMENT DAMAGE DUE TO ESD

- Use suitable ESD measures (for example, ESD gloves) when handling the module.
- Do not touch internal components.

Failure to follow these instructions can result in equipment damage.

Removing the Safety Module eSM

Procedure for removing the safety module eSM:

- Save the parameters of the safety module eSM (refer to Menu Item "Duplicate", page 58).
- Duplicate the drive device settings, refer to the user guide of the drive (Related Documents, page 9).
- Disconnect all power.
- Wait 15 minutes to allow the residual energy of the DC bus capacitors to discharge.
- Remove the safety module eSM according to the instructions in the user guide of the drive (Related Documents, page 9).
- The drive detects an error (restore factory settings) after the module is removed, refer to the user guide of the drive (Related Documents, page 9).

Installing a New Safety Module eSM

Procedure for installing the safety module eSM:

- Disconnect all power.
- Wait 15 minutes to allow the residual energy of the DC bus capacitors to discharge.
- Install the safety module eSM as described in Installation, page 48.

- Commission the safety module eSM as described in *Commissioning*, page 57. If you have stored an eSM parameter set, you can duplicate it, see Menu Item "Duplicate", page 58.

NOTE: If a safety module eSM is removed from one drive and installed in another drive, the eSM parameters are reset to their factory settings.

Shipping, Storage, Disposal

Shipping

The product must be protected against shocks during transportation. If possible, use the original packaging for shipping.

Storage

The product may only be stored in spaces where the specified permissible ambient conditions are met.

Protect the product from dust and dirt.

Disposal

The product consists of various materials that can be recycled. Dispose of the product in accordance with local regulations.

Visit <https://www.se.com/green-premium> for information and documents on environmental protection as per ISO 14025 such as:

- EoLi (Product End-of-Life Instructions)
- PEP (Product Environmental Profile)

Index

A

acknowledge/reset pushbutton	45
approved motors	18

C

cable specifications	49
connecting the 24 V supply	51
connecting the inputs and outputs.....	50
connections	35
cross circuit detection	40

D

degree of protection eSM terminal adapter	17
degree of protection safety module eSM	14
delay time for automatic start.....	70
disposal	99
dual-channel	40

E

enabling device	44
encoder module	16
environmental conditions eSM terminal adapter	17
environmental conditions safety module eSM	14
eSM parameter password	60
eSM standard password	60

F

flyback diodes	37, 53
----------------------	--------

G

guard door with guard locking.....	42
------------------------------------	----

I

installation	
24 Vdc supply	51
mechanical	49
pin assignments.....	50
intended use	6

M

machine operating modes	41
maximum speed of rotation of motor	18
mechanical installation.....	49
monitored deceleration	32
monitoring of movements.....	62

O

operating states and state transitions	83
--	----

P

parameter <i>_eSM_funct</i>	89
-----------------------------------	----

parameter <i>_eSM_LI_act</i>	89
parameter <i>_eSM_LI_mask</i>	89
parameter <i>_eSM_LO_act</i>	90
parameter <i>_eSM_state</i>	90
parameter <i>_eSMVer</i>	90
parameter <i>eSM_BaseSetting</i>	44, 47, 68, 75, 91
parameter <i>eSM_dec_NC</i>	33, 91
parameter <i>eSM_dec_Qstop</i>	25, 28, 30–32, 34, 65, 67, 72, 91
parameter <i>eSM_disable</i>	91
parameter <i>eSM_FuncAUXOUT1</i>	38, 92
parameter <i>eSM_FuncAUXOUT2</i>	39, 92
parameter <i>eSM_FuncSwitches</i>	27, 29, 66, 93
parameter <i>eSM_LO_mask</i>	94
parameter <i>eSM_SLSnegDirS</i>	27, 29, 66, 94
parameter <i>eSM_t_NCDel</i>	33, 94
parameter <i>eSM_t_Relay</i>	74, 94
parameter <i>eSM_v_maxAuto</i>	26, 64, 95
parameter <i>eSM_v_maxSetup</i>	26, 29, 66, 95
periodic movement	16
pin assignment eSM connector.....	50

R

representation of the parameters	86
requirements for using the safety-related function	19
response times.....	15

S

safety-related function SLS	25
safety-related function SOS	24
safety-related function SS1	30
safety-related function SS2	31
safety-related function STO.....	23
selecting the machine operating mode	41
shipping.....	99
signal duration	15
signal interface.....	14
single-channel.....	40
SLS	
overview.....	25
SOS	
overview.....	24
SS1	
overview.....	30
SS2	
overview.....	31
status information via status outputs	37
STO	
overview.....	23
storage	99
supply, 24 Vdc, connection.....	51

W

wiring for multi-axis systems.....	53
wiring of input devices/sensors	40

Schneider Electric
35 rue Joseph Monier
92500 Rueil Malmaison
France

+ 33 (0) 1 41 29 70 00

www.se.com

As standards, specifications, and design change from time to time,
please ask for confirmation of the information given in this publication.

© 2021 – Schneider Electric. All rights reserved.

0198441113825.04