

Section 16

Contactors and Starters



Electromechanical
Reduced Voltage Starter

Reversing Drum Switches	16-2
Electromechanical Reduced Voltage Starters	16-3
Multispeed Magnetic Starters	16-9
Lighting Contactors	16-15
Well-Guard™ Pump Panel	16-16
Factory Modifications (Forms)	16-18
Definite Purpose Contactors	16-21
Thermal Overload Relays—NEMA Style	16-22



Type AG2

NEMA 1, 3R, 4, and 13 Without Overload

Class 2601 reversing drum switches may be used for across-the-line starting and reversing of AC polyphase, AC single phase or DC motors, where overload protection is not required or is provided separately. They are compact and inexpensive but ruggedly constructed. Drum switches are field convertible from Maintained-On to Momentary-On operation. This conversion consists of removing the handle screw and handle, turning the shaft 180 degrees, then replacing the handle and handle screw.

Table 16.1: Reversing Drum Switches

Voltage	600 Vac Maximum Ratings			Class 2601		360 Vdc Maximum	
	Maximum Horsepower			NEMA Type 1 General Purpose Enclosure	NEMA Type 4 Watertight & Dusttight Enclosure	NEMA Type 1 Maintained & Momentary [1]	NEMA Type 13 Oiltight Flush Mounting
	AC Single Phase	AC Poly-Phase	DC	Type	Type	Type	Type
115-200/230	1-1/2	—	1/4	AG2	AW2	AG2S2	AF2
230	2	1/4					
460/575	—	2					
115-200/230	1-1/2	—	2	BG1	BW1	—	—
230	3	2					
460/575	5	7-1/2					



File E42243
CCN NLRV



File LR25490
Class 3211-05

Approximate Dimensions—Class 2601 Reversing Drum Switches

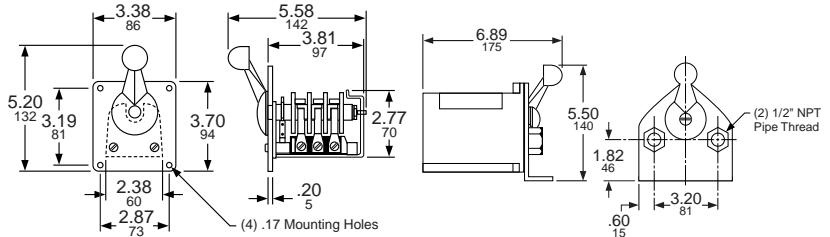

Type AW2

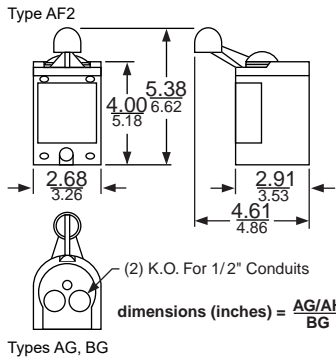

Types AW and BW

Dimensions: $\frac{\text{in.}}{\text{mm}}$

Table 16.2: How to Order

To Order Specify:	Catalog Number	
• Class Number	Class	Type
• Type Number	2601	AG2

[1] Maintained—Forward, Momentary—Reverse (not field convertible)

Reduced Voltage Starting of Squirrel Cage Motors

A squirrel cage motor draws high starting current (inrush) and produces high starting torque when started at full voltage. While these values differ for different motor designs, for a typical NEMA design B motor, the inrush will be approximately 600% of the motor full load amperage (FLA) rating, and the starting torque will be approximately 150% of full load torque at full voltage. High current inrush and starting torque can cause problems in the electrical and mechanical systems, or may even damage the materials being processed.

When a motor is started at reduced voltage, the current at the motor terminals is reduced in direct proportion to the voltage reduction, while the torque is reduced by the square of the voltage reduction. If the "typical" NEMA B motor is started at 70% of line voltage, the starting current would be 70% of the full voltage value (that is, $0.70 \times 600\% = 420\%$ FLA). The torque would then be $(0.70)^2$ or 49% of the normal starting torque (that is, $0.49 \times 150\% = 74\%$ full load torque). Therefore, reduced voltage starting provides an effective means of reducing both inrush current and starting torque.

If the motor has a high inertia or if the motor rating is marginal for the applied load, reducing the starting torque may prevent the motor from reaching full speed before the thermal overload relays trip. Applications that require high starting torque should be reviewed to determine if reduced voltage starting is suitable. Square D™ offers several types of electromechanical as well as solid-state reduced voltage starters that provide different starting characteristics. The following describes the 8600 series of reduced voltage starters.

Class 8606—Autotransformer Starter: Autotransformer starters provide reduced voltage to the motor terminals during starting through the use of a tapped, three phase autotransformer. Taps on the autotransformer allow for selection of the motor with 50%, 65%, or 80% of line voltage values supplying 50%, 65%, or 80% of the current inrush seen during a full voltage start. The resulting starting torque will be 25%, 42%, or 64% of full voltage values, as will be the current draw on the line. Thus, the autotransformer provides the maximum torque with minimum line current.

Class 8630—Wye-Delta Starter: Wye-delta starters can only be used on wye-delta motors which have six leads that allow for motor winding to be connected in either a wye or delta configuration. During start up, the windings are connected in the wye, resulting in 58% of line voltage applied across two windings. This reduces both inrush and starting torque to 33% of the delta connected values. After a set time delay, the motor leads are switched to the delta connection. The wye-delta starter is available in both open and closed transition configurations. Closed transition starters are supplied with an additional contactor and resistor bank used to keep the motor windings energized for a few cycles until the transition from wye to delta is complete.

Class 8640—Part Winding Starter: Part winding starters can be used only with part winding motors. During a part winding start, only one winding is energized, reducing the inrush current to 60–70% (depending on the motor design) and starting torque to 50% of normal starting values with both windings energized. Most (but not all) dual voltage 230/460 volt motors are suitable for part winding starts at 230 volts.

Electromechanical Reduced Voltage Starters

Specifications

Table 16.3: Starter Characteristics

Characteristic	Full Voltage	Autotransformer, Class 8606	Wye-Delta Class, 8630	Part Winding, Class 8640	Solid-State ATS46
Voltage at Motor	100%	50% / 65% / 80% (tap setting)	100%	100%	Ramped Up
Line Current (% Full Load Current)	600%	150% / 250% / 380%	200%	390%	150% to 700% (adjustable)
Starting Torque (% Rated Torque)	150%	40% / 60% / 100%	50%	70%	0% to 100% (adjustable)
Start Time (Factory Setting)	—	6–7 s	10 s / 15 s (open/closed transition)	1–1.5 s	10 s (adjustable 1–60 s)
Advantages	<ul style="list-style-type: none"> Simple Economical High Starting Torque 	<ul style="list-style-type: none"> High torque/amperage High inertial loads Flexibility 	<ul style="list-style-type: none"> High inertial loads Long acceleration loads Good torque/amperage 	<ul style="list-style-type: none"> Simple Small size 	<ul style="list-style-type: none"> Greatest flexibility Smooth ramp Solid-state overload relay Diagnostics
Disadvantages	<ul style="list-style-type: none"> Abrupt starts Large current inrush 	<ul style="list-style-type: none"> Large size 	<ul style="list-style-type: none"> Low torque No flexibility 	Not suitable for: <ul style="list-style-type: none"> High inertial loads Frequent starting 	<ul style="list-style-type: none"> SCR heat dissipation Ambient limitations
Motor	Standard	Standard	Special	Special	Standard

Table 16.4: Line Voltage Codes (60 Hz)

Line	Control	Code
208	208	V08
240	240	V03
380	380	V05
480	480	V06
600	600	V07

Table 16.5: Coil Voltage Codes (60 Hz)

Line	Control	Code
208	120	V84
240	24	V82
240	120	V80
480	24	V83
480	120	V81
480	240	V87
600	120	V86
380	110/50	V95
other	specify	V99

Table 16.6: Form Codes

Form Description	Form Code
Fused CPT for timing relay only	F4T
Fused CPT for all coils	F4T40
Separate control of timing relay only	S
Separate control for all coils	Y195

Table 16.8: Coil Voltage Codes (50 Hz)

Hz	V	Code	V	Code	V	Code	V	Code
60	120	V02	240	V03	480	V06	600	V07
50	110		220		440		550	

How to Order

NOTE: Table 16.4 and Table 16.5 are for 60 Hz; for 50 Hz codes, see Table 16.8.

- Specify the Class Number and the Type Number.
- If all coils are at the line voltage, and not Sizes 6 or 7, select the voltage code from Table 16.4 (Sizes 6 and 7 are supplied with a fused transformer with 120 Vac as standard).
- If the coils are at a different voltage than line supply, or Size 6 or 7, select a voltage code from Table 16.5 and also select a Form code from Table 16.6 (note that a Form code may be used with any voltage code, except as noted).

See Table 16.7 for sizing of 380 V starters.

24 V coils are not available on Sizes 4–7.

Factory Modifications (Forms): see [Factory Modifications \(Forms\)](#), page 16-18.

380 Vac, 50 Hz Starters

The Class 8600 starters are available for 380 Vac, 50 Hz applications. Table 16.7 provides maximum horsepower ratings. To determine the Type number, select the second digit based on the NEMA size. Select the fifth digit based on the horsepower requirement. Specify V05 voltage code.

Table 16.7: 380 Vac, 50 Hz Starters, Maximum Horsepower Rating

Autotransformer, Class 8606		Wye-Delta, Class 8630		Part Winding, Class 8640	
Max. hp	NEMA Size	Max. hp	NEMA Size	Max. hp	NEMA Size
—	—	15	1YD	15	1PW
25	2	40	2YD	40	2PW
50	3	75	3YD	75	3PW
75	4	150	4YD	125	4PW
150	5	250	5YD	250	5PW
300	6	500	6YD	500	6PW

50 Hz Control Voltage

The starters in this section can also be operated at 50 Hz at the coil voltages listed in Table 16.8. For additional coil voltage availability, contact the Customer Care Center (CCC) at 1-888-778-2733.

Selection, 3-Pole Polyphase

NOTE: Devices require 3 thermal units (Sizes 00–6). See Digest Section 16 for selection information.

Table 16.9: 3-Pole Polyphase, 600 Vac Maximum, 50–60 Hz

Motor Voltage (Starter Voltage)	Max. Hp	NEMA Size	NEMA Type 1 General Purpose Enclosure	NEMA Type 4 [1] Watertight and Dusttight Enclosure	NEMA Type 12/3R [2] Dusttight & Driptight Industrial Use Enclosure	Open Type	OEM Kit [3]
			Type [4]	Type [4]	Type [4]	Type [4]	Type [4]
200 (208)	10	2	SDG1C	SDW1C	SDA1C	SDO1C	SDK1C
	15	3	SEG1D	SEW1D	SEA1D	SEO1D	SEK1D
	20		SEG1E	SEW1E	SEA1E	SEO1E	SEK1E
	25		SEG1F	SEW1F	SEA1F	SEO1F	SEK1F
	30	4	SFG1G	SFW1G	SFA1G	SFO1G	SFK1G
	40		SFG1H	SFW1H	SFA1H	SFO1H	SFK1H
50	5	SGG1J	SGW1J	SGA1J	SGO1J	SGK1J	
75		SGG1L	SGW1L	SGA1L	SGO1L	SGK1L	
230 (240)	100	6	SHG1M	SHW1M	SHA1M	SHO1M	SHK1M
	125		SHG1N	SHW1N	SHA1N	SHO1N	SHK1N
	150		SHG1P	SHW1P	SHA1P	SHO1P	SHK1P
	10	2	SDG1C	SDW1C	SDA1C	SDO1C	SDK1C
	15		SDG1D	SDW1D	SDA1D	SDO1D	SDK1D
	20		SEG1E	SEW1E	SEA1E	SEO1E	SEK1E
25	3	SEG1F	SEW1F	SEA1F	SEO1F	SEK1F	
30		SEG1G	SEW1G	SEA1G	SEO1G	SEK1G	
40		SFG1H	SFW1H	SFA1H	SFO1H	SFK1H	
50	4	SFG1J	SFW1J	SFA1J	SFO1J	SFK1J	
75		SGG1L	SGW1L	SGA1L	SGO1L	SGK1L	
100		SGG1M	SGW1M	SGA1M	SGO1M	SGK1M	
125	6	SHG1N	SHW1N	SHA1N	SHO1N	SHK1N	
150		SHG1P	SHW1P	SHA1P	SHO1P	SHK1P	
200		SHG1Q	SHW1Q	SHA1Q	SHO1Q	SHK1Q	
250	7	SJG1R	SJW1R	SJA1R	—	—	
300		SJG1S	SJW1S	SJA1S	—	—	
460 (480) / 575 (600)	10	2	SDG1C	SDW1C	SDA1C	SDO1C	SDK1C
	15		SDG1D	SDW1D	SDA1D	SDO1D	SDK1D
	20		SDG1E	SDW1E	SDA1E	SDO1E	SDK1E
	25		SDG1F	SDW1F	SDA1F	SDO1F	SDK1F
	30	3	SEG1G	SEW1G	SEA1G	SEO1G	SEK1G
	40		SEG1H	SEW1H	SEA1H	SEO1H	SEK1H
	50		SEG1J	SEW1J	SEA1J	SEO1J	SEK1J
	60	4	SFG1K	SFW1K	SFA1K	SFO1K	SFK1K
	75		SFG1L	SFW1L	SFA1L	SFO1L	SFK1L
	100		SFG1M	SFW1M	SFA1M	SFO1M	SFK1M
	125	5	SGG1N	SGW1N	SGA1N	SGO1N	SGK1N
	150		SGG1P	SGW1P	SGA1P	SGO1P	SGK1P
200	SGG1Q		SGW1Q	SGA1Q	SGO1Q	SGK1Q	
250	6	SHG1R	SHW1R	SHA1R	SHO1R	SHK1R	
300		SHG1S	SHW1S	SHA1S	SHO1S	SHK1S	
400		SHG1T	SHW1T	SHA1T	SHO1T	SHK1T	
500	7	SJG1U	SJW1U	SJA1U	—	—	
600		SJG1W	SJW1W	SJA1W	—	—	

NOTE: Class 8606 starters come with a NEMA style medium-duty autotransformer. Medium-duty service includes applications to motors that drive loads such as fans, pumps, compressors, and line shafts.

NEMA Sizes 2–5: Autotransformer is rated for fifteen 15-second starts per hour. NEMA Sizes 6–7: Autotransformer is rated for three 30-second starts per hour. Contact the Customer Care Center (CCC) at 1-888-778-2733 for applications that require frequent starting or jogging, or have extremely high inertia.

Table 16.10: How to Order

To Order Specify:	Catalog Number			
• Class Number	8606	SFG1M	V81	S
• Type Number				
• Voltage Code	Description: 100 hp, 480 V line, 120 V separate control, 60 Hz			
• Form(s) [5]				

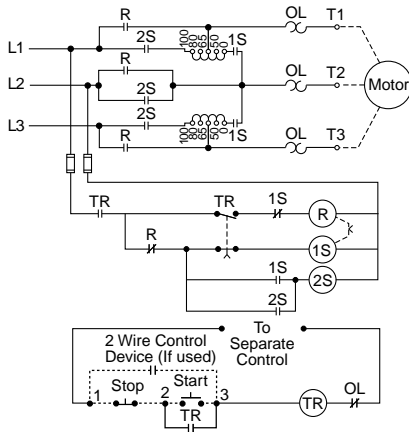

Typical Autotransformer Starter Sizes 2–5 Separate Control (Form S)

[1] NEMA 4 enclosures are painted sheet steel. Where required, stainless steel enclosures are available at extra cost. Specify as Form G17
 [2] NEMA Type 12 enclosures can be field modified for outdoor non-corrosive and non-service-entrance rated applications. See Digest Section 16 for more information.
 [3] No factory modifications (Forms) are available with the OEM kit.
 [4] Both the line and control voltage must be specified to order this product. See page 16-3 for the necessary codes and instructions for ordering.
 [5] Specify Forms only if any of the coils are at a different voltage than line supply (V8•). See page 16-3 for a fuller explanation of how to order; this page also provides the necessary coil voltage and Form codes as well as codes for 380 V starters and 50 Hz applications.

Selection, 3-Pole Polyphase

NOTE: Devices require 3 thermal units (Sizes 00–6). See Digest Section 16 for selection information.

Table 16.11: 3-Pole Polyphase, 600 Vac Maximum, 50–60 Hz

Motor Voltage (Starter Voltage)	Max. Hp	NEMA Size	NEMA Type 1 General Purpose Enclosure	NEMA Type 4 [6] Watertight and Dusttight Enclosure (Stainless Steel 1YD-4YD)	NEMA Type 12/3R [7] Dusttight & Driptight Industrial Use Enclosure	Open Type	OEM Kit [8]
			Type [9]	Type [9]	Type [9]		
200 (208)	10	1YD	SCG1C	SCW1C	SCA1C	SCO1C	—
	15	2YD	SDG1D	SDW1D	SDA1D	SDO1D	—
	20		SDG1E	SDW1E	SDA1E	SDO1E	—
	25		SDG1F	SDW1F	SDA1F	SDO1F	—
	30	3YD	SEG1G	SEW1G	SEA1G	SEO1G	SEK1G
	40		SEG1H	SEW1H	SEA1H	SEO1H	SEK1H
	50		SEG1J	SEW1J	SEA1J	SEO1J	SEK1J
	60	4YD	SFG1K	SFW1K	SFA1K	SFO1K	SFK1K
	75		SFG1L	SFW1L	SFA1L	SFO1L	SFK1L
	100		SFG1M	SFW1M	SFA1M	SFO1M	SFK1M
	125	5YD	SGG1N	SGW1N	SGA1N	SGO1N	SGK1N
	150		SGG1P	SGW1P	SGA1P	SGO1P	SGK1P
200	SGG1Q		SGW1Q	SGA1Q	SGO1Q	SGK1Q	
250	6YD	SHG1R	SHW1R	SHA1R	SHO1R	SHK1R	
300		SHG1S	SHW1S	SHA1S	SHO1S	SHK1S	
400		SHG1T	SHW1T	SHA1T	SHO1T	SHK1T	
500	7YD	SJG1U	SJW1U	SJA1U	SJO1U	—	
600		SJG1V	SJW1V	SJA1V	SJO1V	—	
800		SJG1W	SJW1W	SJA1W	SJO1W	—	
1000		SJG1Z	SJW1Z	SJA1Z	SJO1Z	—	

Table 16.12: How to Order

To Order Specify:	Catalog Number			
• Class Number	Class	Type	Voltage Code	Form(s)
• Type Number	8630	SFG1M	V06	
• Voltage Code	Description: 100 hp, 480 V line, 480 V common control, 60 Hz			
• Form(s) [10]				

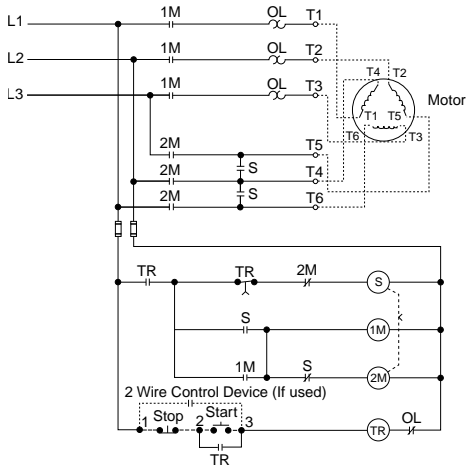

Typical Wye-Delta Starter Sizes 1–4 (Open Transition)
Common Control (Standard)

[6] NEMA 4 enclosures are painted sheet steel. Where required, stainless steel enclosures are available at extra cost. Specify as **Form G17**.
 [7] NEMA Type 12 enclosures can be field modified for outdoor non-corrosive and non-service-entrance rated applications. See Digest Section 16 for more information.
 [8] No factory modifications (Forms) are available with the OEM kit.
 [9] Both the line and control voltage must be specified to order this product. See page 16-3 for the necessary codes and instructions for ordering.
 [10] Specify Forms only if any of the coils are at a different voltage than line supply (V8*). See page 16-3 for a fuller explanation of how to order; this page also provides the necessary coil voltage and Form codes as well as codes for 380 V starters and 50 Hz applications.

Selection, 3-Pole Polyphase

NOTE: Devices require 3 thermal units (Sizes 00–6). See Digest Section 16 for selection information.

Table 16.13: 3-Pole Polyphase, 600 Vac Maximum, 50–60 Hz

Motor Voltage (Starter Voltage)	Max. Hp	NEMA Size	NEMA Type 1 General Purpose Enclosure	NEMA Type 4 [11] Watertight and Dusttight Enclosure (Stainless Steel 1YD-4YD)	NEMA Type 12/3R [12] Dusttight & Driptight Industrial Use Enclosure	Open Type	OEM Kit [13]
			Type [14]	Type [14]	Type [14]		
200 (208)	10	1YD	SCG2C	SCW2C	SCA2C	SCO2C	—
	15	2YD	SDG2D	SDW2D	SDA2D	SDO2D	—
	20		SDG2E	SDW2E	SDA2E	SDO2E	—
	25		SDG2F	SDW2F	SDA2F	SDO2F	—
	30	3YD	SEG2F	SEW2F	SEA2F	SEO2F	SEK2F
	40		SEG2G	SEW2G	SEA2G	SEO2G	SEK2G
	50		SEG2H	SEW2H	SEA2H	SEO2H	SEK2H
	60	4YD	SFG2J	SFW2J	SFA2J	SFO2J	SFK2J
	75		SFG2K	SFW2K	SFA2K	SFO2K	SFK2K
	100		SFG2L	SFW2L	SFA2L	SFO2L	SFK2L
	125	5YD	SGG2M	SGW2M	SGA2M	SGO2M	SGK2M
	150		SGG2N	SGW2N	SGA2N	SGO2N	SGK2N
200	SGG2P		SGW2P	SGA2P	SGO2P	SGK2P	
250	6YD	SHG2Q	SHW2Q	SHA2Q	SHO2Q	SHK2Q	
300		SHG2R	SHW2R	SHA2R	SHO2R	SHK2R	
400		SHG2S	SHW2S	SHA2S	SHO2S	SHK2S	
230 (240)	10	1YD	SCG2C	SCW2C	SCA2C	SCO2C	—
	15	2YD	SDG2D	SDW2D	SDA2D	SDO2D	—
	20		SDG2E	SDW2E	SDA2E	SDO2E	—
	25		SDG2F	SDW2F	SDA2F	SDO2F	—
	30	3YD	SEG2G	SEW2G	SEA2G	SEO2G	SEK2G
	40		SEG2H	SEW2H	SEA2H	SEO2H	SEK2H
	50		SEG2J	SEW2J	SEA2J	SEO2J	SEK2J
	60	4YD	SFG2K	SFW2K	SFA2K	SFO2K	SFK2K
	75		SFG2L	SFW2L	SFA2L	SFO2L	SFK2L
	100		SFG2M	SFW2M	SFA2M	SFO2M	SFK2M
	125	5YD	SGG2N	SGW2N	SGA2N	SGO2N	SGK2N
	150		SGG2P	SGW2P	SGA2P	SGO2P	SGK2P
200	SGG2Q		SGW2Q	SGA2Q	SGO2Q	SGK2Q	
250	6YD	SHG2R	SHW2R	SHA2R	SHO2R	SHK2R	
300		SHG2S	SHW2S	SHA2S	SHO2S	SHK2S	
400		SHG2T	SHW2T	SHA2T	SHO2T	SHK2T	
500	7YD	SJG2U	SJW2U	SJA2U	SJO2U	—	
600		SJG2V	SJW2V	SJA2V	SJO2V	—	
800		SJG2W	SJW2W	SJA2W	SJO2W	—	
460 (480) / 575 (600)	10	1YD	SCG2C	SCW2C	SCA2C	SCO2C	—
	15	2YD	SDG2D	SDW2D	SDA2D	SDO2D	—
	20		SDG2E	SDW2E	SDA2E	SDO2E	—
	25		SDG2F	SDW2F	SDA2F	SDO2F	—
	30	3YD	SDG2G	SDW2G	SDA2G	SDO2G	—
	40		SDG2H	SDW2H	SDA2H	SDO2H	—
	50		SDG2I	SDW2I	SDA2I	SDO2I	—
	60	4YD	SEG2J	SEW2J	SEA2J	SEO2J	SEK2J
	75		SEG2K	SEW2K	SEA2K	SEO2K	SEK2K
	100		SEG2L	SEW2L	SEA2L	SEO2L	SEK2L
	125	5YD	SFG2M	SFW2M	SFA2M	SFO2M	SFK2M
	150		SFG2N	SFW2N	SFA2N	SFO2N	SFK2N
200	SFG2P		SFW2P	SFA2P	SFO2P	SFK2P	
250	6YD	SGG2Q	SGW2Q	SGA2Q	SGO2Q	SGK2Q	
300		SGG2R	SGW2R	SGA2R	SGO2R	SGK2R	
400		SGG2S	SGW2S	SGA2S	SGO2S	SGK2S	
500	7YD	SHG2T	SHW2T	SHA2T	SHO2T	SHK2T	
700		SHG2U	SHW2U	SHA2U	SHO2U	SHK2U	
800		SHG2V	SHW2V	SHA2V	SHO2V	SHK2V	
1000	7YD	SJG2Z	SJW2Z	SJA2Z	SJO2Z	—	

Table 16.14: How to Order

To Order Specify:	Catalog Number			
• Class Number	Class	Type	Voltage Code	Form(s)
• Type Number	8630	SFG1M	V81	F4T40
• Voltage Code	Description: 100 hp, 480 V line, 120 V separate control, 60 Hz			
• Form(s) [15]				

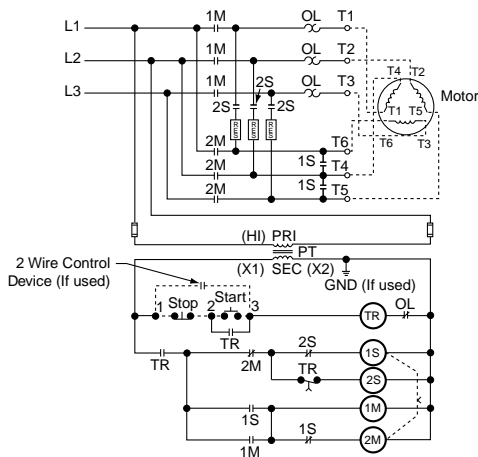

Typical Wye-Delta Starter Sizes 1–4 (Closed Transition) Fused Control Transformer (Form F4T40)

[11] NEMA 4 enclosures are painted sheet steel. Where required, stainless steel enclosures are available at extra cost. Specify as Form G17.
 [12] NEMA Type 12 enclosures can be field modified for outdoor non-corrosive and non-service-entrance rated applications. See Digest Section 16 for more information.
 [13] No factory modifications (Forms) are available with the OEM kit.
 [14] Both the line and control voltage must be specified to order this product. See page 16-3 for the necessary codes and instructions for ordering.
 [15] Specify Forms only if any of the coils are at a different voltage than line supply (V8*). See page 16-3 for a fuller explanation of how to order; this page also provides the necessary coil voltage and Form codes as well as codes for 380 V starters and 50 Hz applications.

Part Winding Starters, Selection

NOTE: Devices require 6 thermal units (Sizes 00–6). See Digest Section 16 for selection information.

Table 16.15: 3-Pole Polyphase—600 Vac Maximum—50–60 Hz

Motor Voltage (Starter Voltage)	Max. Hp	NEMA Size	NEMA Type 1 General Purpose Enclosure	NEMA Type 4 [16] Watertight and Dusttight Enclosure (Stainless Steel 1PW–4PW)	NEMA Type 12/3R [17] Dusttight & Driptight Industrial Use Enclosure	Open Type	OEM Kit [18]
			Type [19]	Type [19]	Type [19]	Type [19]	Type [19]
200 (208)	10	1PW	SCG1C	SCW1C	SCA1C	SCO1C	—
	15	2PW	SDG1D	SDW1D	SDA1D	SDO1D	SDK1D
	20		SDG1E	SDW1E	SDA1E	SDO1E	SDK1E
	25		SDG1F	SDW1F	SDA1F	SDO1F	SDK1F
	30	3PW	SEG1F	SEW1F	SEA1F	SEO1F	SEK1F
	40		SEG1G	SEW1G	SEA1G	SEO1G	SEK1G
	50		SEG1H	SEW1H	SEA1H	SEO1H	SEK1H
	60	4PW	SFG1J	SFW1J	SFA1J	SFO1J	SFK1J
	75		SFG1K	SFW1K	SFA1K	SFO1K	SFK1K
	100		SFG1L	SFW1L	SFA1L	SFO1L	SFK1L
	125	5PW	SGG1M	SGW1M	SGA1M	SGO1M	SGK1M
	150		SGG1N	SGW1N	SGA1N	SGO1N	SGK1N
200	SGG1P		SGW1P	SGA1P	SGO1P	SGK1P	
230 (240)	10	1PW	SCG1C	SCW1C	SCA1C	SCO1C	—
	15	2PW	SDG1D	SDW1D	SDA1D	SDO1D	SDK1D
	20		SDG1E	SDW1E	SDA1E	SDO1E	SDK1E
	25		SDG1F	SDW1F	SDA1F	SDO1F	SDK1F
	30	3PW	SEG1G	SEW1G	SEA1G	SEO1G	SEK1G
	40		SEG1H	SEW1H	SEA1H	SEO1H	SEK1H
	50		SEG1J	SEW1J	SEA1J	SEO1J	SEK1J
	60	4PW	SFG1K	SFW1K	SFA1K	SFO1K	SFK1K
	75		SFG1L	SFW1L	SFA1L	SFO1L	SFK1L
	100		SGG1M	SGW1M	SGA1M	SGO1M	SGK1M
	125	5PW	SGG1N	SGW1N	SGA1N	SGO1N	SGK1N
	150		SGG1P	SGW1P	SGA1P	SGO1P	SGK1P
200	SHG1Q		SHW1Q	SHA1Q	SHO1Q	—	
250	6PW	SHG1R	SHW1R	SHA1R	SHO1R	—	
300		SHG1S	SHW1S	SHA1S	SHO1S	—	
400		SJG1T	SJW1T	SJA1T	SJO1T	—	
460 (480) / 575 (600)	10	1PW	SCG1C	SCW1C	SCA1C	SCO1C	—
	15	2PW	SCG1D	SCW1D	SCA1D	SCO1D	—
	20		SDG1E	SDW1E	SDA1E	SDO1E	SDK1E
	25		SDG1F	SDW1F	SDA1F	SDO1F	SDK1F
	30	3PW	SDG1G	SDW1G	SDA1G	SDO1G	SDK1G
	40		SDG1H	SDW1H	SDA1H	SDO1H	SDK1H
	50		SEG1J	SEW1J	SEA1J	SEO1J	SEK1J
	60	4PW	SEG1K	SEW1K	SEA1K	SEO1K	SEK1K
	75		SEG1L	SEW1L	SEA1L	SEO1L	SEK1L
	100		SFG1M	SFW1M	SFA1M	SFO1M	SFK1M
	125	5PW	SFG1N	SFW1N	SFA1N	SFO1N	SFK1N
	150		SFG1P	SFW1P	SFA1P	SFO1P	SFK1P
200	SGG1Q		SGW1Q	SGA1Q	SGO1Q	SGK1Q	
250	6PW	SGG1R	SGW1R	SGA1R	SGO1R	SGK1R	
350		SGG1S	SGW1S	SGA1S	SGO1S	SGK1S	
400		SHG1T	SHW1T	SHA1T	SHO1T	—	
500	7PW	SHG1U	SHW1U	SHA1U	SHO1U	—	
600		SHG1W	SHW1W	SHA1W	SHO1W	—	
700		SJG1X	SJW1X	SJA1X	SJO1X	—	
800	SJG1Y	SJW1Y	SJA1Y	SJO1Y	—		

Table 16.16: How to Order

To Order Specify:	Catalog Number			
<ul style="list-style-type: none"> • Class Number • Type Number • Voltage Code • Form(s) [20] 	Class	Type	Voltage Code	Form(s)
	8640	SFG1M	V06	C
Description: 100 hp, 480 V line, 480 V common control, 60 Hz				

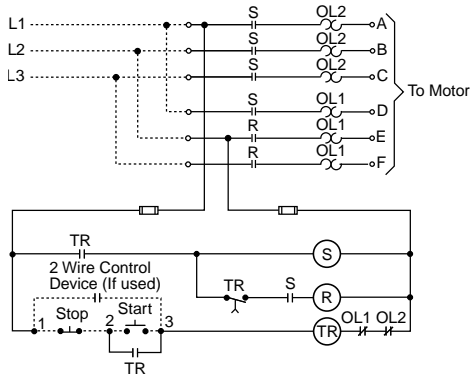

Typical Part Winding Sizes 1–4 Common Control (Standard)

[16] NEMA 4 enclosures are painted sheet steel. Where required, stainless steel enclosures are available at extra cost. Specify as Form G17.
 [17] NEMA Type 12 enclosures can be field modified for outdoor non-corrosive and non-service-entrance rated applications. See Digest Section 16 for more information.
 [18] No factory modifications (Forms) are available with the OEM. kit.
 [19] Both the line and control voltage must be specified to order this product. See page 16-3 for the necessary codes and instructions for ordering.
 [20] Specify Forms only if any of the coils are at a different voltage than line supply (V8*). See page 16-3 for a fuller explanation of how to order; this page also provides the necessary coil voltage and Form codes as well as codes for 380 V starters and 50 Hz applications.



Class 8606
Autotransformer



Class 8630
Wye-Delta



Class 8640
Part Winding

Approximate Dimensions—Not for Construction

NOTE: H = Height, W = Width, D = Depth

Table 16.17: Class 8606—Autotransformer

NEMA Size	Dim.	Open		NEMA Type 1 / 12 Enclosure				NEMA Type 4 Enclosure			
				Non-Combo or Combo, with Circuit Breaker		Combo, with Disconnect Switch		Non-Combo or Combo, with Circuit Breaker		Combo, with Disconnect Switch	
		in.	mm	in.	mm	in.	mm	in.	mm	in.	mm
2	H	43	1092	52	1320	52	1320	52	1320	52	1320
	W	22	559	25	635	25	635	25	635	25	635
	D	8	203	10	254	10	254	10	254	10	254
3 or 4	H	63	1600	70 [21]	1778	70 [21]	1778	75 [21]	1778	75 [21]	1778
	W	28	711	32	813	32	813	32	813	32	813
	D	9	229	16	406	16	406	16	406	16	406
5	H	63	1600	70 [21]	1778	90 [21]	2286	75 [21]	1778	95 [21]	2413
	W	28	711	32	813	36	914	32	813	36	914
	D	9	229	16	406	16	406	16	406	16	406
6	H	56	1422	90 [21]	2286	90 [21]	2286	98 [21]	2489	98 [21]	2489
	W	30	762	34	864	64	1626	34	864	64	1626
	D	14	354	20	508	24	610	20	508	24	610

Table 16.18: Class 8630—Wye-Delta, Open Transition

NEMA Size	Dim.	Open		NEMA Type 1 / 12 Enclosure				NEMA Type 4 Enclosure			
				Non-Combo		Combo		Non-Combo		Combo	
		in.	mm	in.	mm	in.	mm	in.	mm	in.	mm
1YD or 2YD	H	21	553	25	635	25	635	25	635	—	—
	W	21	553	23	584	23	584	23	584	—	—
	D	7	178	8	203	8	203	8	203	—	—
3YD or 4YD	H	42	1067	48	1219	49	1245	48	1219	49	1245
	W	25	635	28	712	30	762	28	712	30	762
	D	7	178	8	203	11	279	8	203	11	279
5YD or 6YD	H	62	1576	90 [21]	2286	90 [21]	2286	98 [21]	2489	98 [21]	2489
	W	29	737	36	914	36	914	36	914	36	914
	D	10	254	16	406	16	406	16	406	16	406

Table 16.19: Class 8630—Wye-Delta, Closed Transition

NEMA Size	Dim.	Open		NEMA Type 1 / 12 Enclosure				NEMA Type 4 Enclosure			
				Non-Combo		Combo		Non-Combo		Combo	
		in.	mm	in.	mm	in.	mm	in.	mm	in.	mm
1YD or 2YD	H	21	553	25	635	25	635	25	635	—	—
	W	21	553	23	584	23	584	23	584	—	—
	D	14	354	16	406	16	406	16	406	—	—
3YD or 4YD	H	42	1067	48	1219	49	1245	48	1219	49	1245
	W	25	635	28	712	30	762	28	712	30	762
	D	14	354	16	406	18	457	16	406	18	457
5YD or 6YD	H	80	2032	90 [21]	2286	90 [21]	2286	98 [21]	2489	98 [21]	2489
	W	30	762	36	914	36	914	36	914	36	914
	D	12	305	16	406	16	406	16	406	16	406

Table 16.20: Class 8640—Part Winding

NEMA Size	Dim.	Open		Enclosed—NEMA Type 1 / 4 / 12					
				Non-Combo		Combo, with Circuit Breaker		Combo, with Disconnect Switch	
		in.	mm	in.	mm	in.	mm	in.	mm
1PW or 2PW	H	21	553	25	635	34	853	25	635
	W	21	553	23	584	19	483	23	584
	D	6	152	8	203	11	279	8	203
3PW	H	42	1067	48	1219	44	1118	52	1321
	W	26	660	28	712	30	762	25	635
	D	7	178	8	203	12	305	11	279
4PW	H	42	1067	48	1219	44	1118	78 [21]	1981
	W	26	660	28	712	30	762	32	813
	D	7	178	8	203	12	305	16	406
5PW	H	35	889	44	1118	78 [21] [22]	1981	78 [21] [22]	1981
	W	22	559	24	610	36	914	36	914
	D	10	254	12	305	16	406	16	406
6PW	H	49	1245	64	1626	—	—	90 [21]	2286
	W	24	610	28	712	—	—	64	1626
	D	11	279	16	406	—	—	24	406

Combination Starter Form Reference

Circuit Breaker: Y791, Y7911
 Nonfusible Disconnect Switch: Y792, Y7910
 Fusible Disconnect Switch: Y793-Y799

Refer to page 16-18 for a complete listing of Forms for combination devices.

[21] Free-standing enclosure.
 [22] Subtract 8 in. from the height for a Type 1 or 12 enclosure.

Table 16.21: Typical Applications

Constant Hp	Constant Torque	Variable Torque
A. Spindles B. Cutting Tools 1. Lathes 2. Saws	A. Conveyors B. Mills C. Dough Mixers D. Reciprocating Pumps	A. Fans B. Centrifugal Pumps

Multispeed Magnetic Starters Application Data

Multispeed motors are available in two basic versions:

1) separate winding, and 2) consequent pole. A separate winding motor has a winding for each speed while a consequent pole motor has a winding for every two speeds (three-speed motors have two windings). The motor connections (and thus the types of controllers) for two speed starters are exemplified by the schematic diagrams shown in Table 16.22. Note that consequent pole two-speed controllers involve a 5-pole and a 3-pole starter, while separate winding controllers have two 3-pole starters.

Verify the type of motor before ordering. Field modification of starters to match the motor may not be possible.

Separate winding motors are usually chosen when flexibility is important, since the speeds of a consequent pole motor are usually limited to a 2/1 ratio; a broad range of speeds can be obtained on a separate winding motor.

Both separate winding and consequent pole motors are available in three types: 1) constant horsepower, 2) constant torque, and 3) variable torque. Table 16.21 shows typical applications for these different types of motors.

NOTE: For detailed information involving the technical aspects of flexibility of the starters used in the multispeed controllers, see Classes 8702, 8736, and 8810 application data.

Table 16.22: Typical Schematic Diagrams

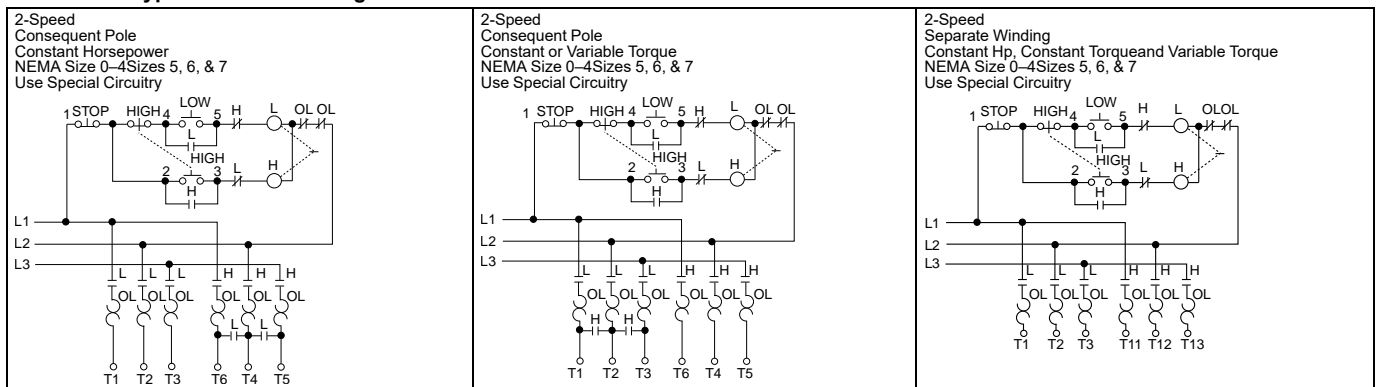

Additional Features—Special Relays for Non-Reversing and Reversing Multispeed Starters

General. Some applications require special relays to control the speed change and/or starting of the motor.

The descriptions that follow cover the four common relay schemes for these applications.

Form R1 Compelling Relay. This relay requires the motor to be started at low speed before any higher speed can be selected. This arrangement ensures that the motor will always start the load at low speed. The stop button must be pressed before it is possible to change from a higher to a lower speed. (Not available with Form R2.)

Form R2 Accelerating Relay/Timer. With Form R2 accelerating relays, the ultimate speed is determined by the button which is pressed, but the starter will start the motor at low speed and automatically accelerate it through successive steps until the selected speed is reached. Definite time intervals must elapse between each speed change. Individual adjustable timing relays are provided for each interval.

The stop button must be pressed before it is possible to change from a higher to a lower speed. (Not available with Form R1.)

Form R3 Decelerating Relay/Timer. This is similar in action to Form R2 accelerating relays, except that they function to prevent immediate transfer from a higher to a lower speed. A definite time interval, preset on the timer, must elapse between each speed change.

Form R10 Antiplugging Relays/Timers. This Form imposes a time delay when transferring from the forward to the reverse direction or reverse to forward, for reversing multispeed starters. This provides up to a 60 second delay in the transfer of the direction of the motor, and can help prevent damage which could result from plugging.

Form Y81 (Low Speed) Overload Relay Modification.

For NEMA size 3 and 4, when the low speed full load current does not appear on the appropriate thermal unit selection tables, include Form Y81 (low speed) (no charge for this Form). This Form modifies the overload relay block to accept Type B thermal units. For assistance on thermal unit selection, contact the Customer Care Center (CCC) at 1-888-778-2733.

Table 16.23: Special Pilot Lighting

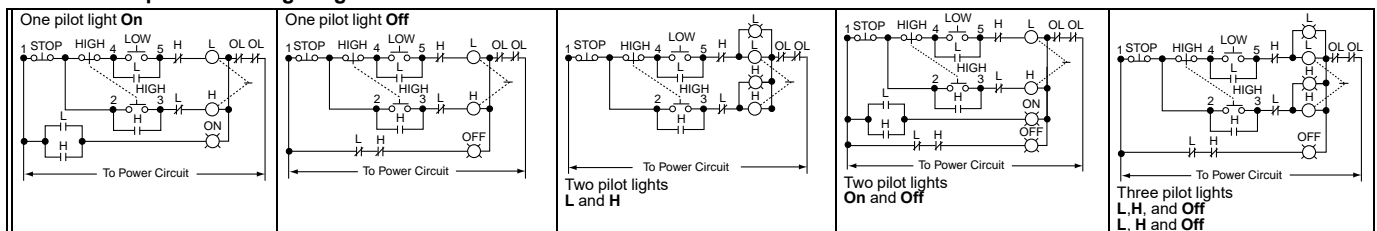

3-Pole Polyphase, 600 Vac Maximum, 50–60 Hz

Multispeed motors are available in two basic versions: 1) consequent pole, and 2) separate winding. A separate winding motor has a winding for each speed while a consequent pole motor has a winding for every two speeds (three-speed motors have two windings).

Devices require 6 thermal units (Sizes 0–6). See Digest Section 16 for selection information.

Table 16.24: Class 8810—Non-Combination Type

Type of Motor	NEMA Size	Maximum Polyphase Horsepower Ratings						NEMA 1 General Purpose Enclosure	NEMA 4 & 4X Watertight and Dusttight Enclosure (Stainless Steel) (304) (Sizes 0–5) Sheet Steel (Size 6)	NEMA 4X [1] Watertight, Dusttight and Corrosion Resistant Enclosure	NEMA 12 /3R [2] Dusttight and Driptight Industrial Use Enclosure	Open Type					
		Constant Horsepower Motors			Constant Torque or Variable Torque Motors								Type [3]	Type [3]	Type [3]	Type [3]	Type [3]
		200 V	230 V	460–575 V	200 V	230 V	460–575 V										
Single Winding (Consequent Pole) 5-Pole–3-Pole																	
Constant Hp	0	2	2	3	—	—	—	SBG1●●●	SBW1●●●	SBW51●●●	SBA1●●●	SBO1●●●					
	1	5	5	7-1/2	—	—	—	SCG1●●●	SCW1●●●	SCW51●●●	SCA1●●●	SCO1●●●					
	2	7-1/2	10	20	—	—	—	SDG1●●●	SDW1●●●	SDW51●●●	SDA1●●●	SDO1●●●					
	3	20	25	40	—	—	—	SEG1●●●	SEW1●●●	—	SEA1●●●	SEO1●●●					
	4	30	40	75	—	—	—	SFG1●●●	SFW1●●●	—	SFA1●●●	SFO1●●●					
	5	60	75	150	—	—	—	SGG1●●●	SGW1●●●	—	SGA1●●●	SGO1●●●					
Constant Torque or Variable Torque	0	—	—	—	3	3	5	SBG2●●●	SBW2●●●	SBW52●●●	SBA2●●●	SBO2●●●					
	1	—	—	—	7-1/2	7-1/2	10	SCG2●●●	SCW2●●●	SCW52●●●	SCA2●●●	SCO2●●●					
	2	—	—	—	10	15	25	SDG2●●●	SDW2●●●	SDW52●●●	SDA2●●●	SDO2●●●					
	3	—	—	—	25	30	50	SEG2●●●	SEW2●●●	—	SEA2●●●	SEO2●●●					
	4	—	—	—	40	50	100	SFG2●●●	SFW2●●●	—	SFA2●●●	SFO2●●●					
	5	—	—	—	75	100	200	SGG2●●●	SGW2●●●	—	SGA2●●●	SGO2●●●					
Two Winding (Separate Winding) 3-Pole–3-Pole [4]	0	2	2	3	—	—	—	SBG3●●●	SBW3●●●	SBW53●●●	SBA3●●●	SBO3●●●					
	1	5	5	7-1/2	—	—	—	SCG3●●●	SCW3●●●	SCW53●●●	SCA3●●●	SCO3●●●					
	2	7-1/2	10	20	—	—	—	SDG3●●●	SDW3●●●	SDW53●●●	SDA3●●●	SDO3●●●					
	3	20	25	40	—	—	—	SEG3●●●	SEW3●●●	—	SEA3●●●	SEO3●●●					
	4	30	40	75	—	—	—	SFG3●●●	SFW3●●●	—	SFA3●●●	SFO3●●●					
	5	60	75	150	—	—	—	SGG3●●●	SGW3●●●	—	SGA3●●●	SGO3●●●					
	6	100	150	300	—	—	—	SHG3●●●	SHW3●●●	—	SHA3●●●	SHO3●●●					
	7	—	225	450	—	—	—	SJG3●●●	—	—	SJA3●●●	SJO3●●●					
	Constant Torque or Variable Torque [4]	0	—	—	—	3	3	5	SBG4●●●	SBW4●●●	SBW54●●●	SBA4●●●	SBO4●●●				
		1	—	—	—	7-1/2	7-1/2	10	SCG4●●●	SCW4●●●	SCW54●●●	SCA4●●●	SCO4●●●				
		2	—	—	—	10	15	25	SDG4●●●	SDW4●●●	SDW54●●●	SDA4●●●	SDO4●●●				
		3	—	—	—	25	30	50	SEG4●●●	SEW4●●●	—	SEA4●●●	SEO4●●●				
		4	—	—	—	40	50	100	SFG4●●●	SFW4●●●	—	SFA4●●●	SFO4●●●				
5		—	—	—	75	100	200	SGG4●●●	SGW4●●●	—	SGA4●●●	SGO4●●●					
6		—	—	—	150	200	400	SHG4●●●	SHW4●●●	—	SHA4●●●	SHO4●●●					
7	—	—	—	—	300	600	SJG4●●●	—	—	SJA4●●●	SJO4●●●						

Table 16.25: Class 8810—Combination Circuit Breaker Type (Thermal Magnetic Circuit Breakers) [5][6]

Single Winding (Consequent Pole) 5-Pole–3-Pole																	
Type of Motor	NEMA Size	Maximum Polyphase Horsepower Ratings						NEMA 1 General Purpose Enclosure	NEMA 4 & 4X Watertight and Dusttight Enclosure (Stainless Steel) (304) (Sizes 0–5) Sheet Steel (Size 6)	NEMA 4X [1] Watertight, Dusttight and Corrosion Resistant Enclosure	NEMA 12 /3R [2] Dusttight and Driptight Industrial Use Enclosure	Open Type					
		Constant Horsepower Motors			Constant Torque or Variable Torque Motors								Type [3]	Type [3]	Type [3]	Type [3]	Type [3]
		200 V	230 V	460–575 V	200 V	230 V	460–575 V										
Constant Hp	0	2	2	3	—	—	—	CBG1●●●	CBW1●●●	CBW51●●●	CBA1●●●	—					
	1	5	5	7-1/2	—	—	—	CCG1●●●	CCW1●●●	CCW51●●●	CCA1●●●	—					
	2	7-1/2	10	20	—	—	—	CDG1●●●	CDW1●●●	CDW51●●●	CDA1●●●	—					
	3	20	25	40	—	—	—	CEG1●●●	CEW1●●●	—	CEA1●●●	—					
	4	30	40	75	—	—	—	CFG1●●●	CFW1●●●	—	CFA1●●●	—					
	5	60	75	150	—	—	—	CGG1●●●	CGW1●●●	—	CGA1●●●	—					
Constant Torque or Variable Torque	0	—	—	—	3	3	5	CBG2●●●	CBW2●●●	CBW52●●●	CBA2●●●	—					
	1	—	—	—	7-1/2	7-1/2	10	CCG2●●●	CCW2●●●	CCW52●●●	CCA2●●●	—					
	2	—	—	—	10	15	25	CDG2●●●	CDW2●●●	CDW52●●●	CDA2●●●	—					
	3	—	—	—	25	30	50	CEG2●●●	CEW2●●●	—	CEA2●●●	—					
	4	—	—	—	40	50	100	CFG2●●●	CFW2●●●	—	CFA2●●●	—					
	5	—	—	—	75	100	200	CGG2●●●	CGW2●●●	—	CGA2●●●	—					
Two Winding (Separate Winding) 3-Pole–3-Pole [4]	0	2	2	3	—	—	—	CBG3●●●	CBW3●●●	CBW53●●●	CBA3●●●	—					
	1	5	5	7-1/2	—	—	—	CCG3●●●	CCW3●●●	CCW53●●●	CCA3●●●	—					
	2	7-1/2	10	20	—	—	—	CDG3●●●	CDW3●●●	CDW53●●●	CDA3●●●	—					
	3	20	25	40	—	—	—	CEG3●●●	CEW3●●●	—	CEA3●●●	—					
	4	30	40	75	—	—	—	CFG3●●●	CFW3●●●	—	CFA3●●●	—					
	5	60	75	150	—	—	—	CGG3●●●	CGW3●●●	—	CGA3●●●	—					
	6	100	150	300	—	—	—	CHG3●●●	CHW3●●●	—	CHA3●●●	—					
	7	—	225	450	—	—	—	CJG3●●●	—	—	CJA3●●●	—					
	Constant Torque or Variable Torque [4]	0	—	—	—	3	3	5	CBG4●●●	CBW4●●●	CBW54●●●	CBA4●●●	—				
		1	—	—	—	7-1/2	7-1/2	10	CCG4●●●	CCW4●●●	CCW54●●●	CCA4●●●	—				
		2	—	—	—	10	15	25	CDG4●●●	CDW4●●●	CDW54●●●	CDA4●●●	—				
		3	—	—	—	25	30	50	CEG4●●●	CEW4●●●	—	CEA4●●●	—				
		4	—	—	—	40	50	100	CFG4●●●	CFW4●●●	—	CFA4●●●	—				
5		—	—	—	75	100	200	CGG4●●●	CGW4●●●	—	CGA4●●●	—					
6		—	—	—	150	200	400	CHG4●●●	CHW4●●●	—	CHA4●●●	—					
7	—	—	—	—	300	600	CJG4●●●	—	—	CJA4●●●	—						

[1] NEMA 4X hubs are included with each starter at no additional cost.

[2] NEMA Type 12 enclosures can be field modified for outdoor non-corrosive and non-service-entrance rated applications. See Digest Section 16 for more information.

[3] Replace the bullets (●●●) with the voltage code when ordering this product. Refer to the standard voltage codes shown on page 16-3.

[4] Type numbers shown for three-phase, separate-winding motor starters apply only when motor windings are wye connected.

When motor windings are connected open delta, prices for three-phase, consequent pole motor starters apply.

[5] The NEC 1300% maximum setting for instantaneous trip circuit breakers may be inadequate for multispeed motors.

[6] Not available in Mag-Gard versions.

3-Pole Polyphase, 600 Vac Max., 50–60 Hz

Devices require 6 thermal units (Sizes 0–6). See Digest Section 16 for selection information.

Table 16.26: Class 8810—Combination Disconnect Switch Type (Class H Fuse Clips)

Type of Motor	NEMA Size	Maximum Polyphase Horsepower Ratings						Fuse Clip Size A	NEMA 1 General Purpose Enclosure Type [8]	NEMA 4 & 4X Watertight and Dusttight Enclosure Stainless Steel (304) (Sizes 0–5) Sheet Steel (Size 6 not 4X) Type [8]	NEMA 12/3R [7] Dusttight and Driptight Industrial Use Enclosure Type [8]
		Constant Horsepower Motors			Constant Torque or Variable Torque Motors						
		200 V	230 V	460–575 V	200 V	230 V	460–575 V				
Single Winding (Consequent Pole) 5-Pole–3-Pole											
Constant Hp	0	2	2	3	—	—	—	None 30 [9]	UBG1●●● DBG1●●●	UBW1●●● DBW1●●●	UBA1●●● DBA1●●●
	1	5	5	7-1/2	—	—	—	None 30 [9]	UCG1●●● DCG1●●●	UCW1●●● DCW1●●●	UCA1●●● DCA1●●●
	2	7-1/2	10	20	—	—	—	None 60	UDG1●●● DDG1●●●	UDW1●●● DDW1●●●	UDA1●●● DDA1●●●
	3	20	25	40	—	—	—	None 100	UEG1●●● DEG1●●●	UEW1●●● DEW1●●●	UEA1●●● DEA1●●●
	4	30	40	75	—	—	—	None 200	UFG1●●● DFG1●●●	UFW1●●● DFW1●●●	UFA1●●● DFA1●●●
	5	60	75	150	—	—	—	None 400	UGG1●●● DGG1●●●	UGW1●●● DGW1●●●	UGA1●●● DGA1●●●
	6	100	150	300	—	—	—	None 600	UHG1●●● DHG1●●●	UHW1●●● DHW1●●●	UHA1●●● DHA1●●●
Constant Torque or Variable Torque	0	—	—	—	3	3	5	None 30 [9]	UBG2●●● DBG2●●●	UBW2●●● DBW2●●●	UBA2●●● DBA2●●●
	1	—	—	—	7-1/2	7-1/2	10	None 30 [9]	UCG2●●● DCG2●●●	UCW2●●● DCW2●●●	UCA2●●● DCA2●●●
	2	—	—	—	10	15	25	None 60	UDG2●●● DDG2●●●	UDW2●●● DDW2●●●	UDA2●●● DDA2●●●
	3	—	—	—	25	30	50	None 100	UEG2●●● DEG2●●●	UEW2●●● DEW2●●●	UEA2●●● DEA2●●●
	4	—	—	—	40	50	100	None 200	UFG2●●● DFG2●●●	UFW2●●● DFW2●●●	UFA2●●● DFA2●●●
	5	—	—	—	75	100	200	None 400	UGG2●●● DGG2●●●	UGW2●●● DGW2●●●	UGA2●●● DGA2●●●
	6	—	—	—	150	200	400	None 600	UHG2●●● DHG2●●●	UHW2●●● DHW2●●●	UHA2●●● DHA2●●●
Two Winding (Separate Winding) 3-Pole–3-Pole											
Constant Hp [10]	0	2	2	3	—	—	—	None 30 [9]	UBG3●●● DBG3●●●	UBW3●●● DBW3●●●	UBA3●●● DBA3●●●
	1	5	5	7-1/2	—	—	—	None 30 [9]	UCG3●●● DCG3●●●	UCW3●●● DCW3●●●	UCA3●●● DCA3●●●
	2	7-1/2	10	20	—	—	—	None 60	UDG3●●● DDG3●●●	UDW3●●● DDW3●●●	UDA3●●● DDA3●●●
	3	20	25	40	—	—	—	None 100	UEG3●●● DEG3●●●	UEW3●●● DEW3●●●	UEA3●●● DEA3●●●
	4	30	40	75	—	—	—	None 200	UFG3●●● DFG3●●●	UFW3●●● DFW3●●●	UFA3●●● DFA3●●●
	5	60	75	150	—	—	—	None 400	UGG3●●● DGG3●●●	UGW3●●● DGW3●●●	UGA3●●● DGA3●●●
	6	100	150	300	—	—	—	None 600	UHG3●●● DHG3●●●	UHW3●●● DHW3●●●	UHA3●●● DHA3●●●
Constant Torque or Variable Torque [10]	0	—	—	—	3	3	5	None 30 [9]	UBG4●●● DBG4●●●	UBW4●●● DBW4●●●	UBA4●●● DBA4●●●
	1	—	—	—	7-1/2	7-1/2	10	None 30 [9]	UCG4●●● DCG4●●●	UCW4●●● DCW4●●●	UCA4●●● DCA4●●●
	2	—	—	—	10	15	25	None 60	UDG4●●● DDG4●●●	UDW4●●● DDW4●●●	UDA4●●● DDA4●●●
	3	—	—	—	25	30	50	None 100	UEG4●●● DEG4●●●	UEW4●●● DEW4●●●	UEA4●●● DEA4●●●
	4	—	—	—	40	50	100	None 200	UFG4●●● DFG4●●●	UFW4●●● DFW4●●●	UFA4●●● DFA4●●●
	5	—	—	—	75	100	200	None 400	UGG4●●● DGG4●●●	UGW4●●● DGW4●●●	UGA4●●● DGA4●●●
	6	—	—	—	150	200	400	None 600	UHG4●●● DHG4●●●	UHW4●●● DHW4●●●	UHA4●●● DHA4●●●

Table 16.27: Coil Voltage Codes

Voltage		Code
60 Hz	50 Hz	
24 [11] [12]	—	V01
120 [12]	110	V02
208	—	V08
240	220	V03
—	380	V05
480	440	V06
600	550	V07
Specify	Specify	V99

NOTE: For voltage codes used with control transformers, see page 16-18. **Form S** (separate control) is used when a separate source of power is available for the control (coil) voltage. Form S is provided at no charge.

For dimensions, see page 16-13.

Refer to Digest Section 16 factory modifications (Forms), replacement parts (Class 9998), and Type S accessories (Class 9999).

[7] NEMA Type 12 enclosures can be field modified for outdoor non-corrosive and non-service-entrance rated applications. See Digest Section 16 for more information.

[8] Replace the bullets (●●●) with the voltage code when ordering this product. Refer to the standard voltage codes shown in Table 16.27.

[9] When separate control is specified, use V8x voltage codes (see Table 16.53) to specify motor and control voltages.

[10] Type numbers shown for three-phase, separate-winding motor starters apply only when motor windings are wye connected.

When motor windings are connected open delta, prices for three-phase, consequent pole motor starters apply.

[11] 24 V coils are not available on Sizes 4–7. On Sizes 00–3, 24 V coils are available using **Form S** (separate control) (for example, order as 8810UBG1V01S).

[12] These voltage codes must include **Form S** (provided at no charge) (for example, order as 8810UCG1V02S).

3-Pole Polyphase, 600 Vac Max., 50–60 Hz

Devices require 6 thermal units (Sizes 0–6). See Digest Section 16 for selection information.

Table 16.28: Class 8810—Reversing

Type of Motor	NEMA Size	Maximum Polyphase Ratings						Reversing In One Speed Only (Specify High or Low) [13]			Reversing In Both Speeds		
		Constant Hp Motors			Constant Torque or Variable Torque Motors			NEMA 1 General Purpose Enclosure	NEMA 12 Dusttight and Driptight Industrial Use Enclosure	Open Type	NEMA 1 General Purpose Enclosure	NEMA 12/3R [14] Dusttight and Driptight Industrial Use Enclosure	Open Type
		200 V	230 V	460–575 V	200 V	230 V	460–575 V	Type [15]	Type [15]	Type [15]	Type [15]	Type [15]	Type
Single Winding, Constant Hp	0	2	2	3	—	—	—	SBG21●●●	SBA21●●●	SBO21●●●	SBG31●●●	SBA31●●●	SBO31●●●
	1	5	5	7-1/2	—	—	—	SCG21●●●	SCA21●●●	SCO21●●●	SCG31●●●	SCA31●●●	SCO31●●●
	2	7-1/2	10	20	—	—	—	SDG21●●●	SDA21●●●	SDO21●●●	SDG31●●●	SDA31●●●	SDO31●●●
	3	20	25	40	—	—	—	SEG21●●●	SEA21●●●	SEO21●●●	SEG31●●●	SEA31●●●	SEO31●●●
	4	30	40	75	—	—	—	SFG21●●●	SFA21●●●	SFO21●●●	SFG31●●●	SFA31●●●	SFO31●●●
5	60	75	150	—	—	—	SGG21●●●	SGA21●●●	SGO21●●●	SGG31●●●	SGA31●●●	SGO31●●●	
Single Winding, Constant Torque or Variable Torque	0	—	—	—	3	3	5	SBG22●●●	SBA22●●●	SBO22●●●	SBG32●●●	SBA32●●●	SBO32●●●
	1	—	—	—	7-1/2	7-1/2	10	SCG22●●●	SCA22●●●	SCO22●●●	SCG32●●●	SCA32●●●	SCO32●●●
	2	—	—	—	10	15	25	SDG22●●●	SDA22●●●	SDO22●●●	SDG32●●●	SDA32●●●	SDO32●●●
	3	—	—	—	25	30	50	SEG22●●●	SEA22●●●	SEO22●●●	SEG32●●●	SEA32●●●	SEO32●●●
	4	—	—	—	40	50	100	SFG22●●●	SFA22●●●	SFO22●●●	SFG32●●●	SFA32●●●	SFO32●●●
5	—	—	—	75	100	200	SGG22●●●	SGA22●●●	SGO22●●●	SGG32●●●	SGA32●●●	SGO32●●●	
Two Winding, Constant Hp [16]	0	2	2	3	—	—	—	SBG23●●●	SBA23●●●	SBO23●●●	SBG33●●●	SBA33●●●	SBO33●●●
	1	5	5	7-1/2	—	—	—	SCG23●●●	SCA23●●●	SCO23●●●	SCG33●●●	SCA33●●●	SCO33●●●
	2	7-1/2	10	20	—	—	—	SDG23●●●	SDA23●●●	SDO23●●●	SDG33●●●	SDA33●●●	SDO33●●●
	3	20	25	40	—	—	—	SEG23●●●	SEA23●●●	SEO23●●●	SEG33●●●	SEA33●●●	SEO33●●●
	4	30	40	75	—	—	—	SFG23●●●	SFA23●●●	SFO23●●●	SFG33●●●	SFA33●●●	SFO33●●●
5	60	75	150	—	—	—	SGG23●●●	SGA23●●●	SGO23●●●	SGG33●●●	SGA33●●●	SGO33●●●	
Two Winding, Constant Torque or Variable Torque [16]	0	—	—	—	3	3	5	SBG24●●●	SBA24●●●	SBO24●●●	SBG34●●●	SBA34●●●	SBO34●●●
	1	—	—	—	7-1/2	7-1/2	10	SCG24●●●	SCA24●●●	SCO24●●●	SCG34●●●	SCA34●●●	SCO34●●●
	2	—	—	—	10	15	25	SDG24●●●	SDA24●●●	SDO24●●●	SDG34●●●	SDA34●●●	SDO34●●●
	3	—	—	—	25	30	50	SEG24●●●	SEA24●●●	SEO24●●●	SEG34●●●	SEA34●●●	SEO34●●●
	4	—	—	—	40	50	100	SFG24●●●	SFA24●●●	SFO24●●●	SFG34●●●	SFA34●●●	SFO34●●●
5	—	—	—	75	100	200	SGG24●●●	SGA24●●●	SGO24●●●	SGG34●●●	SGA34●●●	SGO34●●●	

3-Pole Polyphase, 600 Vac Max., 50–60 Hz

Devices require 6 thermal units (Sizes 0–6). See Digest Section 16 for selection information.

Table 16.29: Class 8810—Non-Reversing, Vertically Arranged, Open Type, Two-Speed Starters

Type of Motor	NEMA Size	Maximum Hp Ratings				For Consequent Pole Motors	For Separate Winding Motors
		200 V	230 V	380 V	460-575 V	Type [15]	Type [15]
Constant Hp	0	2	2	3	3	SBO11●●●	SBO13●●●
	1	5	5	7-1/2	7-1/2	SCO11●●●	SCO13●●●
	2	7-1/2	10	20	20	SDO11●●●	SDO13●●●
	3	20	25	40	40	SEO11●●●	SEO13●●●
4	30	40	60	75	SFO11●●●	SFO13●●●	
Constant Torque or Variable Torque	0	3	3	5	5	SBO12●●●	SBO14●●●
	1	7-1/2	7-1/2	10	10	SCO12●●●	SCO14●●●
	2	10	15	25	25	SDO12●●●	SDO14●●●
	3	25	30	50	50	SEO12●●●	SEO14●●●
4	40	50	75	100	SFO12●●●	SFO14●●●	

Table 16.30: Coil Voltage Codes

Voltage		Code
60 Hz	50 Hz	
24 [17] [18]	—	V01
120 [18]	110	V02
208	—	V08
240	220	V03
—	380	V05
480	440	V06
600	550	V07
Specify	Specify	V99

NOTE: For voltage codes used with control transformers, see page 16-18.

Form S (separate control) is used when a separate source of power is available for the control (coil) voltage.

Form S is provided at no charge.

For dimensions, see page 16-13.

Refer to Digest Section 16 for factory modifications (Forms), replacement parts (Class 9998), and Type S accessories (Class 9999).

[13] Specify the speed that requires reversing by adding an L (low) or an H (high) after the type number—for example, a Class 8810 Type SBG21 with reversing in low only would be ordered as a Class 8810 Type SBG21L.

[14] NEMA Type 12 enclosures can be field modified for outdoor non-corrosive and non-service-entrance rated applications. See Digest Section 16 for more information.

[15] Replace the bullets (●●●) with the voltage code when ordering this product. Refer to the standard voltage codes shown in Table 16.30.

[16] Type numbers shown for three-phase, separate-winding motor starters apply only when motor windings are wye connected.

When motor windings are connected open delta, prices for three-phase, consequent pole motor starters apply.

[17] 24 V coils are not available on Sizes 4–7. On Sizes 00–3, 24 V coils are available using Form S (separate control) (for example, order as 8810SCG21V01S).

[18] These voltage codes must include Form S (provided at no charge) (for example, order as 8810SDG21V02S).

Dimensions

Table 16.31: NEMA Type 1 Enclosure (see Figure 1)

Type	A	B	C	D	E	F	G	H
SBG and SCG	11-7/8	11-7/8	7-17/32	9-3/4	1-1/16	1-1/16	9-3/4	5/16
SDG	14-7/8	14-1/8	7-21/32	12-3/4	1-1/16	1-1/16	12	5/16
SEG3 & 4 and SFG3 & 4	18-5/32	29-5/32	9-15/64	15-1/2	1-11/32	1-11/32	26-1/2	7/16
SEG1 & 2 and SFG1 & 2	22-5/32	39-5/32	10-15/64	19-1/2	1-11/32	1-11/32	36-1/2	7/16
SGG1, 2, 3, 4	20-7/32	65-3/4	16-29/64	31	2-1/8	2-1/8	42	9/16
SHG1, 2, 3, 4	36-7/32	62-7/32	19-15/32					
SJG3 & 4	Consult Square D				Floor Mount			

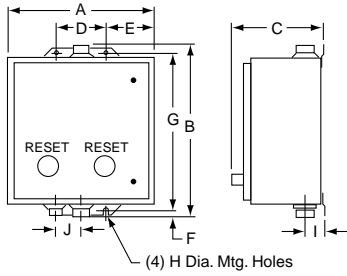

Figure 1: NEMA Type 1, 4, and 12 Enclosures

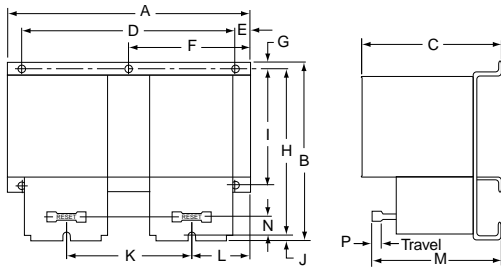

Figure 2: Class 8810 NEMA Sizes 0, 1, and 2

Table 16.32: NEMA Type 4 Enclosure (see Figure 1)

Type	A	B	C	D	E	F	G	H	I	J
SBW and SCW	12-5/8	14-11/16	7-13/16	4-1/4	4-3/16	19/32	13-1/2	5/16	1-21/32	2-5/16
SDW	14-7/8	15-3/4	8-1/4	4-1/4	5-5/16	3/8	15	5/16	2-1/32	2-5/8
SEW3 & 4 and SFW3 & 4	18-5/32	32-7/32	8-19/64	12	3-5/64	55/64	30-1/2	7/16	2-37/64	3-3/16
SEW1 & 2 and SFW1 & 2	22-5/32	42-7/32	9-49/64	16	3-5/64	55/64	40-1/2	7/16	2-21/64	2-57/64
SGW1, 2, 3, 4	35-7/32	49-7/32	12-1/8	27	4-3/32	39/64	48	9/16	2-63/64	3-1/2

Table 16.33: NEMA Type 12/3R Enclosure (see Figure 1)

Type	A	B	C	D	E	F	G	H
SBA and SCA	11-7/8	13-1/2	7-3/4	4-1/4	3-13/16	3/8	12-3/4	5/16
SDA	14-7/8	15-3/4	7-7/8	4-1/4	5-5/16	3/8	15	5/16
SEA3 & 4 and SFA3 & 4	18-5/32	31-1/2	9-19/32	16	3-3/32	1/2	30-1/2	7/16
SEA1 & 2 and SFA1 & 2	22-5/32	41-1/2	10-19/32	16	3-3/32	1/2	40-1/2	7/16
SGA1, 2, 3, 4	35-7/32	49	13-7/64	27	4-7/64	1/2	48	9/16
SHA1, 2, 3, 4	36-7/32	62-7/32	19-15/32					
SJA3 & 4	Consult Square D				Floor Mount			

Table 16.34: Non-Reversing, Open Type

Fig. No.	NEMA Size	Type	Mtg. Holes	A	B	C	D	E	F	G	H	I	J	K	L	M	N
2	0 and 1	SBO1, 2 SCO1, 2	4	9-5/8	7-11/32	5-5/16	8	5/8	—	7/32	6-29/32	—	7/32	4-3/4	2-1/4	5-1/16	19/32
		SBO3, 4 SCO3, 4	3	7-1/8	6-29/32	5-5/16	—	—	3-13/32	15/32	6-7/32	—	7/32	3-9/16	1-5/8	5-1/16	19/32
	2	SDO1, 2	6	12-1/32	8-17/32	6-1/32	10-3/8	1/2	—	1/4	8-1/8	6-1/4	5/32	5-3/4	2-13/16	5-5/32	25/32
3	3	SEO1, 2	4	18	14-7/16	17	12-1/4	1-1/2	11/16	1/2	6-7/16	7-3/8	1-21/32	2-5/32	—	—	—
		SEO3, 4	4	12-3/4	12-9/32	11-3/4	10-3/4	1-1/32	1/2	1/2	2-1/2	6-3/4	1-5/32	1-5/32	—	—	—
	4	SFO1, 2	4	18-5/8	15-19/32	17	12-1/4	1-27/32	1-1/2	1-1/8	6-7/16	7-21/32	1-21/32	1-21/32	—	—	—
		SFO3, 4	4	14-1/4	14-19/32	13-1/4	12-1/4	1-27/32	1/2	1/2	2-15/16	7-3/8	1-21/32	1-21/32	—	—	—
4	5	SGO1, 2 [19]	4	29-9/32	20-9/32	9-3/8	5-13/32	1-9/32	28	5/8	12-9/16	19	5/8	22-17/32	1/2	2-13/32	6-5/8
		SGO3, 4	4	19-9/32	20-9/32	9-3/8	5-13/32	1-9/32	18	5/8	2-5/8	19	5/8	12-17/32	1/2	2-13/32	6-5/8
4	6 [20]	SHO1, 2 [19]	4	29-17/32	22-7/16	9-17/32	6-31/32	3-13/16	28	3/4	11-5/8	21-3/16	5/8	9-7/8	9/16	3-1/32	9-5/16
		SHO3, 4	4	19-17/32	22-7/16	9-17/32	6-31/32	3-13/16	18	3/4	21-3/16	1-11/16	5/8	9-7/8	9/16	3-1/32	9-5/16
—	7 [21]	SJO3, 4	Consult the Customer Care Center (CCC) at 1-888-778-2733.														

NOTE: Illustrations are for dimensional information only and may not represent the actual enclosure. Dimension units are in. or in. (mm).

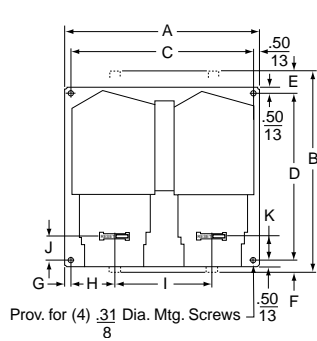

Figure 3: Class 8810 NEMA Sizes 3 and 4

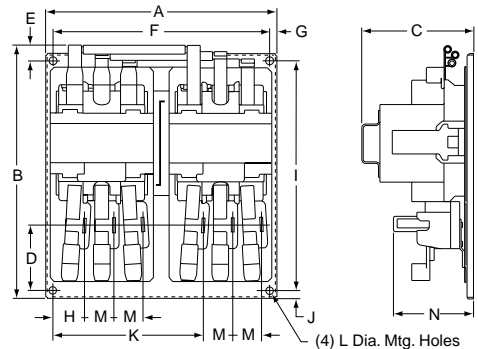

Figure 4: Class 8810 NEMA Size 5 and 6

[19] Consequent pole style starters consist of two 3-pole starters as pictured in Figure 4 and an additional 2-pole shorting contactor (not shown), all on a common baseplate, horizontally mounted.
 [20] Current transformers used with Size 1 overload relay blocks.
 [21] Solid-state overload relays and special current transformers.

Disconnect Switch or Circuit Breaker Type

Dimensions are for reference only. For precise measurements, contact the Customer Care Center (CCC) at 1-888-778-2733.

Table 16.35: Class 8810, NEMA 1 Enclosure, Figure 1

NEMA Size	Type	Dimensions (in.)—see Figure 1														Hubs			
		A	B	C	D	E	F	G	H	I	J	K	L	M	N	O	W	X	Y
0-1	CBG UBG DBG CCG UCG DCG	13.88	23.13	8.25	10.63	21	19.28	1.88	1.88	3.75	2.31	1.06	3.3	2.19	1.25	0.88	0.5-0.75-1	0.5-0.75-1	0.5
2	CDG UDG DDG	15.16	28.91	9.56	11.63	26.25	21.81	2.19	2	4	2.63	1.33	3.3	2.22	1.27	0.91	1-1.25	0.5-0.75	0.5
3 [22]	CEG UEG DEG	22.13	42.63	10.13	18.63	40	29.13	2.34	2.13	4.25	2.63	1.25	3.3	2.25	0.88	0.75	1-1.25-1.5	0.5-0.75	0.5
4 [22]	CFG UFG DFG	22.13	50.13	10.19	18.63	47.5	29.19	2.91	2.69	5.38	2.63	1.31	3.3	2.25	0.88	0.75	2.5	0.5-0.75	0.5

Table 16.36: Class 8810, NEMA 4 Enclosure, Figure 2

NEMA Size	Type	Dimensions (in.)—see Figure 2												Hubs	
		A	B	C	D	E	F	G	H	I	J	K	L	W	X
0-1	CBW UBW DBW UCW CCW DCW	13.88	8.33	25.19	3.3	2.56	8.75	24	0.59	3.95	1.63	2.31	18.53	0.75	1
2	CDW UDW DDW	15.13	9.58	30.94	3.3	2.56	10	29.75	0.59	3.95	2	2.63	21.34	0.75	1.5
3 [22]	CEW UEW DEW	22.13	10.13	46.25	3.3	3	16	44	0.63	3.94	1.75	2.63	29.13	0.75	2
4 [22]	CFW UFW DFW	22.13	10.19	53.75	3.3	3	16	51.5	0.63	3.94	2.28	3.19	29.19	0.75	2.5

Table 16.37: Class 8810, NEMA 12 Enclosure, Figure 3

NEMA Size	Type	Dimensions (in.)—see Figure 3									
		A	B	C	D	E	F	G	H	I	J
0-1	CBA UBA DBA CCA UCA DCA	13.88	10.09	24.75	3.3	2.56	8.75	24	0.38	3.95	20.28
2	CDA UDA DDA	15.16	10.97	31.25	3.3	3.08	9	30.25	0.5	4.83	23.44
3 [22]	CEA UEA DEA	22.13	10.13	45	3.3	3	16	44	0.63	3.94	29.13
4 [22]	CFA UFA DFA	22.13	10.19	52.5	3.3	3	16	51.5	0.63	3.94	29.19

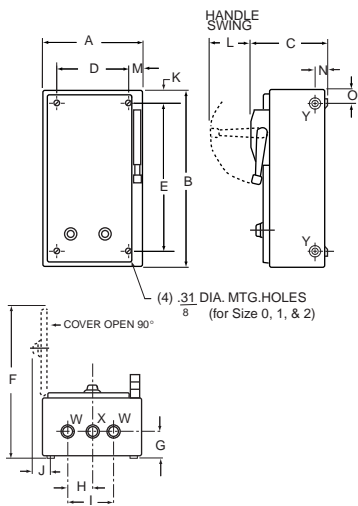

Figure 1:
NEMA Type 1 Enclosure

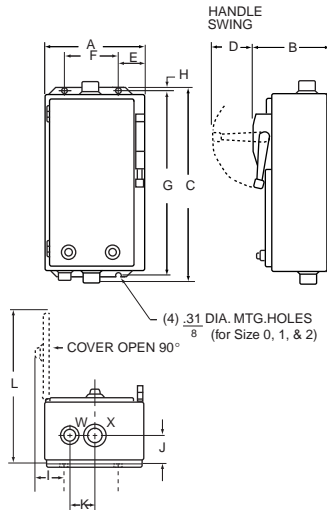

Figure 2:
NEMA Type 4 Enclosure

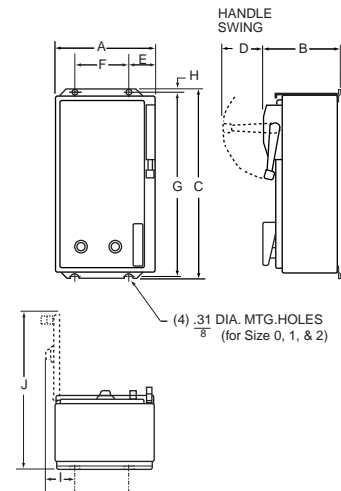

Figure 3:
NEMA Type 12 Enclosure

NOTE: Illustrations are intended for dimensional information only and may not represent the actual enclosure. Dimensions are shown in inches.

[22] Size 3 (5-Pole-3-Pole) with FA, KA circuit breaker or 100 A disconnect switch. Size 4 (5-Pole-3-Pole) with KA circuit breaker or 200 A disconnect switch. Size 3 & 4 (3-Pole-3-Pole) enclosures may be smaller. Consult the Customer Care Center (CCC) at 1-888-778-2733 for additional dimensional information.



Panel Mount



General Information

Panelboard lighting contactors, sometimes called remote control switches, are designed for use with lighting panelboards and motor control centers where either panel or bus mounting is desired. Type PB lighting contactors can be used in a retrofit or new project without increasing the panelboard depth. They can be used to directly replace many inoperative existing switches.

The features include: mechanically held; compatible with Square D panelboards; short-circuit ratings to 100 kA; compact arc suppression; bus or panel mounted; fits in standard-depth lighting panelboards; easy manual operation; standard coil clearing contacts; and operates in any position.

Table 16.38: Class 8903 Type PB Lighting Contactors

Description	Bus Mount	Panel Mount (Includes Lugs)	
		Type [1]	Type [1]
Size (A)	Poles	Type [1]	Type [1]
30	2	PBM10B●●●	PBM10●●●
	3	PBM11B●●●	PBM11●●●
60	2	PBP10B●●●	PBP10●●●
	3	PBP11B●●●	PBP11●●●
75	2	PBN10B●●●	PBN10●●●
	3	PBN11B●●●	PBN11●●●
100	2	PBQ10B●●●	PBQ10●●●
	3	PBQ11B●●●	PBQ11●●●
150	2	PBR10B●●●	PBR10●●●
	3	PBR11B●●●	PBR11●●●
200	2	PBV10B●●●	PBV10●●●
	3	PBV11B●●●	PBV11●●●
225	2	PBW10B●●●	PBW10●●●
	3	PBW11B●●●	PBW11●●●

Table 16.39: AC Coil Voltage Codes

60 Hz	Voltage Code
120	V02
208	V08
240/277	V39
480	V28

Table 16.40: Class 8903—Auxiliary Contacts

Type	Description
PBX1	(1) Auxiliary Contact SPDT
PBX2	(2) Auxiliary Contacts SPDT

Table 16.41: Factory Modifications

Form	Description
X11	(1) Auxiliary Contact SPDT
X22	(2) Auxiliary Contacts SPDT

Table 16.42: Maximum Wire Size (AWG)

Current Range	Power Wire (Cu/Al)	Control Wire (Cu Only)
30–100 A	#1/0 Max.	#18–#10
150–225 A	350 MCM Max.	#18–#10

Table 16.43: Control Distance

Wire Gauge AWG	Maximum Distance (feet)				
	120 V	208 V	240 V	277 V	480 V
14	550	1650	2200	2925	8800
12	900	2700	3600	4700	14400
10	1425	4275	5700	7550	22800

Table 16.44: Short-Circuit Ratings

RMS Sym. Current (A)	Max. Volts	Short Circuit Protection Device Recommended
100,000	600	Class J Fuses
22,000	600	Circuit Breaker—Square D—Type LHL
65,000	240	Circuit Breaker—Square D—Type LHL

Table 16.45: Dimensions (Panel Mount)

A	Dimensions													
	H		W		D		A		B		C		E	
	in.	mm	in.	mm	in.	mm	in.	mm	in.	mm	in.	mm	in.	mm
30–100	11.75	298	7.50	191	3.88	98	2.25	57	7.38	187	2.25	57	9.25	235
150–225	14.50	368	7.50	191	3.88	98	2.88	73	8.50	216	3.00	76	10.50	267

Table 16.46: Dimensions (Bus Mount)

A	Dimensions									
	H		W		D		A		B	
	in.	mm	in.	mm	in.	mm	in.	mm	in.	mm
30–100	8.31	211	7.50	191	3.38	86	2.25	57	7.38	187
150–225	9.50	241	7.50	191	3.38	86	2.88 [2]	73	8.50	216

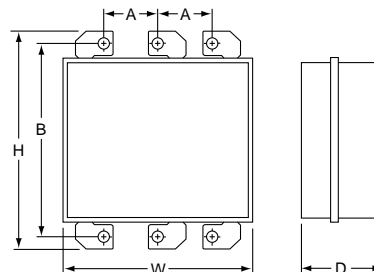
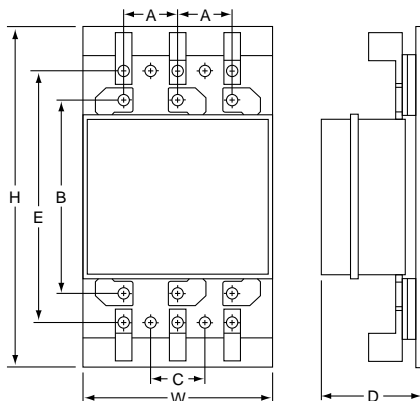

[1] Replace the bullets (●●●) with the voltage code when ordering this product. Refer to the standard voltage codes shown in Table 16.39.

[2] Slotted mounting holes are suitable for 2.88–3.19 in. mounting centers.

Table 16.47: Coil Voltage Codes

Voltage		Code
60 Hz	50 Hz	
24 [1]	—	V01
120 [2]	110	V02
208	—	V08
240	220	V03
—	380	V05
480	440	V06
600	550	V07
Specify	Specify	V99

For How to Order Information, see Digest Section 16 for selection information.

Well-Guard Reduced Voltage Pump Panels

Class 8940 reduced voltage panels in NEMA 3R enclosures are specifically designed for pumping applications. Extra space is provided for field installation of auxiliary equipment.

- Type S contactors/starters provided as standard
- All devices are UL Listed, and marked "SUITABLE ONLY FOR USE AS SERVICE EQUIPMENT"
- Includes a Hand-Off-Auto selector switch and a Start push button

NOTE: Illustrations may not represent the actual enclosure; they are intended for dimensional information only.



Type VG4V06K15

Table 16.48: Closed Transition Autotransformer Type, 3-Pole Polyphase—480 Vac Maximum (50–60 Hz)

Motor (Starter) Volts	Max. Hp Polyphase	Coil Voltage	NEMA Size	Fusible Disconnect Style		Circuit Breaker Style	
				Fuse Clip Amperes[3]	Type [4]	Circuit Breaker	Type [4]
230 (240)	15	240@ 60 Hz 220@ 50 Hz	2	60	RD4DV03	FAL36080	VD1DV03
	25		100	RE4FV03	FAL36100	VE1FV03	
	30		200	RE1GV03	KAL36100	VE2GV03	
	50		200	RF4JV03	KAL36200	VF1JV03	
	75		400	RG1LV03	LAL36250	VG2LV03	
	100		400	RG1MV03	LAL36350	VG2MV03	
460 (480)	25	480 @ 60 Hz 440 @ 50 Hz	2	60	RD2FV06	FAL36070	VD1FV06
	30		100	RE2GV06	FAL36080	VE1GV06	
	50		100	RE2JV06	FAL36100	VE1JV06	
	75		200	RF2LV06	KAL36125	VF1LV06	
	100		200	RF2MV06	KAL36200	VF1MV06	
	150		400	RG3PV06	LAL36250	VG4PV06	
	200		400	RG3QV06	LAL36350	VG4QV06	
	300		—	—	—	MAL36600	VH1SV06
	400		—	—	—	MAL36900	VH2TV06
	400		—	—	—	MAL361000	VJ1WV06
	600		—	—	—	—	—

Table 16.49: Autotransformer—Reduced Voltage Type

Type	Figure	A		B		C		D		E		F	
		in.	mm	in.	mm	in.	mm	in.	mm	in.	mm	in.	mm
RD, VD	3	25.00	635	52.50	1334	11.13	283	19.00	483	51.50	1308	0.44	11
RE, VE, RF, VF	4	32.00	813	72.50	1842	19.25	489	29.75	756	12.50	318	0.68	17
RG	4	36.00	914	93.00	2362	19.25	489	33.75	857	12.50	318	0.69	17
VG	4	32.00	813	72.50	1842	19.25	489	29.75	756	12.50	318	0.68	17
VH	4	34.00	864	93.00	2362	23.25	591	31.75	806	16.50	419	0.69	17
VJ[5]	4	64.00	1626	93.00	2362	27.25	692	61.75	1568	17.25	438	0.81	21

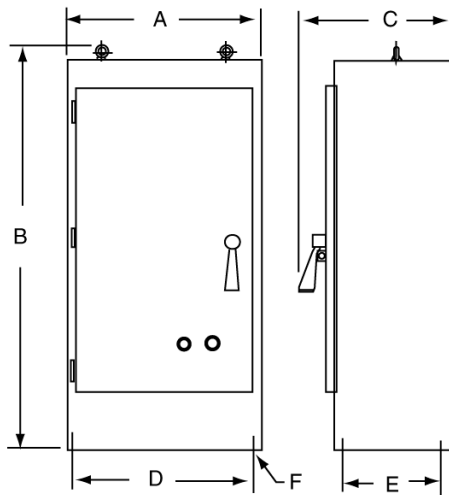

[1] 24 V coils are not available on Sizes 4–7. On Sizes 2–3, 24 V coils are available using Form S (separate control).

[2] This voltage code must include Form S (no charge).

[3] Fuse clips are sized for use with dual-element time-delay fuses.

[4] Specify the coil voltage code to order this product. Refer to the standard voltage codes shown in Table 16.47.

[5] The cabinet has double doors.

Table 16.50: Part Winding Type, 3-Pole Polyphase—480 Vac Maximum (50–60 Hz)—Obsolete December 31, 2015

Motor (Starter) Voltage	Max. Hp Polyphase	Coil Voltage	NEMA Size	Combination			
				Fusible Disconnect Style		Circuit Breaker Style	
				Fuse Clip (2 Sets) (A) [6]	Type [7]	Circuit Breaker (2 Breakers) Frame Size	Type [7]
230 (240)	25	240 @ 60 Hz 220 @ 50 Hz	2PW	60	MD4FV03	FAL36070	PD1FV03
	30			60	ME5GV03	FAL36080	PE3GV03
	50		3PW	100	ME6JV03	FAL36100	PE3JV03
	75			200	MF1LV03	KAL36150	PF3LV03
	100		4PW	200	MG3MV03	KAL36175	PG2MV03
	125			400	MG1NV03	LAL36250	PG3NV03
150	5PW	400	MG1PV03	LAL36250	PG3PV03		
30		30	MD5GV06	FAL36040	PD1GV06		
460 (480)	40	480 @ 60 Hz 440 @ 50 Hz	2PW	60	MD2HV06	FAL36050	PD1HV06
	60			60	ME7KV06	FAL36070	PE3KV06
	75		3PW	100	ME3LV06	FAL36090	PE3LV06
	100			200	MF3MV06	FAL36100	PF2MV06
	150		4PW	200	MF3PV06	KAL36125	PF3PV06
	200			200	MG4QV06	KAL36175	PG2QV06
	250		5PW	200	MG4RV06	KAL36225	PG3RV06
	350			400	MG2TV06	LAL36300	PG3TV06

Table 16.51: Part Winding, Reduced Voltage Type—Obsolete December 31, 2015

Type	Figure	A		B		C		D		E		F	
		in.	mm	in.	mm	in.	mm	in.	mm	in.	mm	in.	mm
PD	3	19.00	483	34.50	876	12.25	311	13.00	330	33.50	851	0.44	11
MD	3	23.00	584	25.50	648	10.60	269	17.00	432	24.50	622	0.44	11
PE, PF	3	30.00	762	47.00	1194	13.25	337	22.00	559	46.00	1168	0.56	14
ME	3	25.00	635	52.50	1334	12.13	308	19.00	483	51.50	1308	0.44	11
MF	4	36.00	914	93.00	2362	19.25	489	33.75	857	12.50	318	0.69	18
PG, MG	4	36.00	914	73.00	1854	19.25	489	33.75	857	12.50	318	0.69	18
PH	4	38.00	965	93.00	2362	19.25	489	35.75	908	12.50	318	0.69	18

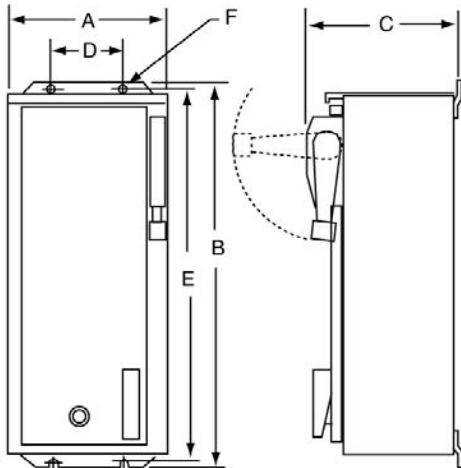

[6] Fuse clips are sized for use with dual-element time-delay fuses.
[7] Specify the coil voltage code to order this product. Refer to the standard voltage codes shown in Table 16.47.

Forms—Reduced Voltage Controllers Only

Table 16.52: Reduced Voltage Controllers Only—Classes 8606, 8630, 8640

Factory Modifications	Enclosure Type	Form	NEMA Size							
			1 1PW 1YD	2 2PW 2YD	3 3PW 3YD	4 4PW 4YD	5 5PW 5YD	6 6PW 6YD	7 7PW 7YD	
Push Buttons [1]										
Start-Stop	1, 4, 12	A	X	X	X	X	X	X	X	X
Selector Switches										
Hand-Off-Auto	1, 4, 12	C	X	X	X	X	X	X	X	X
On-Off	1, 4, 12	C6	X	X	X	X	X	X	X	X
Pilot Lights (specify color) [2]										
One light On	1, 4, 12	P	X	X	X	X	X	X	X	X
Separate Control Circuit [3] [4]										
TR coil only (at control voltage)	1, 4, 12	S	N/C	N/C	N/C	N/C	N/C	N/C	N/C	N/C
All coils (at control voltage)	1, 4, 12	Y195	N/C	N/C	N/C	N/C	N/C	N/C	N/C	N/C
Fused Control Circuit [3] [4] [5] [6]										
One fuse	1, 4, 12	F	X	X	X	X	X	X	N/C [7]	N/C [7]
Two fuses	1, 4, 12	F4	X	X	X	X	X	X	N/C [7]	N/C [7]
Control Circuit Transformer [3] [4] [5] Standard Capacity (50 or 60 Hz)										
Fuses										
Primary	Secondary									
2—	0—	1, 4, 12	F4T	X	X	X	X	X	N/C [7]	N/C [7]
2—	1—	1, 4, 12	FF4T	X	X	X	X	X	X	X
2—	0—	1, 4, 12	F4T40	X	X	X	X	X	X	X
2—	1—	1, 4, 12	FF4T40	X	X	X	X	X	X	X
Additional capacity (50 or 60 Hz) [8]										
100 VA additional capacity		1, 4, 12	T11	X	X	X	X	X	X	X
200 VA additional capacity		1, 4, 12	T12	X	X	X	X	X	X	X
300 VA additional capacity		1, 4, 12	T13	X	X	X	X	X	X	X
400 VA additional capacity		1, 4, 12	T14	X	X	X	X	X	X	X
500 VA additional capacity		1, 4, 12	T15	X	X	X	X	X	X	X
Substitute nonstandard single primary and/or single secondary										
Voltage rating on the control transformer [5]		1, 4, 12	T1[9]	X	X	X	X	X	—	—

Pilot Devices in Cover and Control Circuit Reduced Voltage Controllers Only
Classes
8606
8630
8640
8647
8650

16 CONTACTORS AND STARTERS

Table 16.53: Selection of Control Circuit Transformers

Voltage 60 Hz (Primary–Secondary)	Code
120–12	V88
120–24	V89
208–120	V84
240–24	V82
240–120	V80
277–120	V85
480–24	V83
480–120	V81
480–240	V87
600–120	V86
Specify	V99

Selection of Control Circuit Transformers

The standard primary and secondary voltages for control circuit transformers are indicated in Table 16.53.

To order, select the desired device with the appropriate transformer Form designation. Then convert the previously selected voltage code (V**) to reflect the desired primary/secondary voltage for the transformer. The secondary voltage should equal the previously selected coil voltage of the device. (24 Vac coils for NEMA Sizes 4–7 are not available).

Example:

You have a Class 8606SDG1V02S. The designation V02S means that you need a coil voltage of 120-60/110-50 wired for separate control. You want to add Form FF4T with the transformer voltages at 480 V primary, 120 V secondary. The new, complete Class, Type, Voltage Code, and Form are:

Class	Type	Voltage Code	Form [10]
8606	SDG1	V81	FF4T

[1] All push buttons are momentary contact.

[2] For pilot light details, refer to the pilot light table in Digest Section 16.

[3] As standard, reduced voltage controllers are supplied with common control. If Form S or T is specified, only the TR coil will be at control voltage. Specify Form Y195 or T40 (ex. Form FF4T40) if all coils must be at control voltage. Refer to page 16-3 for control circuit arrangements.

[4] Reduced voltage controllers include two control circuit fuses for conductors at line voltage. Additional fusing may be provided if a fused control circuit transformer or separate control is specified.

[5] See Table 16.53.

[6] Must be used with a Form specifying separate control (Ex. Form FS).

[7] Size 6 and 7 controllers come with Form FF4T as standard.

[8] Add Form letters to the standard control transformer (example: for Size 1, Form F4T plus 100 VA becomes F4T11; Form F4T40 plus 100 VA becomes F4T41.).

[9] Must be used in conjunction with a variation of Form F4T (ex.: standard capacity transformer required, 208–24 V; order as Form F4TT1, 208–24 V).

[10] Always list Form numbers in alphabetical order.

Class 8606 Reduced Voltage Starters

Table 16.54: Class 8606 Reduced Voltage Starters Only

Factory Modifications		Enclosure Type	Form	NEMA Size							
				1	2	3	4	5	6	7	
Circuit Breaker or Disconnect Switch	Molded case thermal magnetic circuit breaker [11]	1	Y791	X	X	X	X	X	X	X	
		4	Y791	X	X	X	X	X	X	X	
		12	Y791	X	X	X	X	X	X	X	
	Nonfusable disconnect switch	1	Y792	X	X	X	X	X	—	—	
		4	Y792	X	X	X	X	X	—	—	
		12	Y792	X	X	X	X	X	—	—	
	Automatic molded case switch	1	Y7910	—	—	—	—	—	X	X	
		4	Y7910	—	—	—	—	—	X	X	
		12	Y7910	—	—	—	—	—	X	X	
	Fusible Disconnect Switch with Fuse Clips [12]										
	30 A clips	1	Y793	X	X	—	—	—	—	—	—
		4	Y793	X	X	—	—	—	—	—	—
		12	Y793	X	X	—	—	—	—	—	—
	60 A clips	1	Y794	X	X	X	—	—	—	—	—
		4	Y794	X	X	X	—	—	—	—	—
		12	Y794	X	X	X	—	—	—	—	—
	100 A clips	1	Y795	—	—	X	X	—	—	—	—
		4	Y795	—	—	X	X	—	—	—	—
		12	Y795	—	—	X	X	—	—	—	—
	200 A clips	1	Y796	—	—	X	X	—	—	—	—
		4	Y796	—	—	X	X	—	—	—	—
		12	Y796	—	—	X	X	—	—	—	—
	400 A clips	1	Y797	—	—	—	—	X	X	—	—
		4	Y797	—	—	—	—	X	X	—	—
		12	Y797	—	—	—	—	X	X	—	—
	Automatic molded case switch with 600 A fuse clips	1	Y798	—	—	—	—	—	X	—	—
		4	Y798	—	—	—	—	—	X	—	—
12		Y798	—	—	—	—	—	X	—	—	
Automatic molded case switch with fuse clips 1200 A or less	1	Y799	—	—	—	—	—	—	X	—	
	4	Y799	—	—	—	—	—	—	X	—	
	12	Y799	—	—	—	—	—	—	X	—	

Table 16.55: Class 8630 Reduced Voltage Controllers Only [13]

Factory Modifications		Enclosure Type	Form	NEMA Size							
				1 YD	2 YD	3 YD	4 YD	5 YD	6 YD	7 YD	
Circuit Breaker or Disconnect Switch	Molded case thermal magnetic circuit breaker [11]	1	Y791	X	X	X	X	X	X	X	
		4	Y791	X	X	X	X	X	X	X	
		12	Y791	X	X	X	X	X	X	X	
	Nonfusable disconnect switch	1	Y792	X	X	X	X	—	—	—	
		4	Y792	X	X	X	X	—	—	—	
		12	Y792	X	X	X	X	—	—	—	
	Automatic molded case switch	1	Y7910	—	—	—	—	X	X	X	
		4	Y7910	—	—	—	—	X	X	X	
		12	Y7910	—	—	—	—	X	X	X	
	Fusible Disconnect Switch with Fuse Clips [12]										
	30 A clips	1	Y793	X	X	—	—	—	—	—	—
		4	Y793	X	X	—	—	—	—	—	—
		12	Y793	X	X	—	—	—	—	—	—
	60 A clips	1	Y794	X	X	—	—	—	—	—	—
		4	Y794	X	X	—	—	—	—	—	—
		12	Y794	X	X	—	—	—	—	—	—
	100 A clips	1	Y795	—	X	X	—	—	—	—	—
		4	Y795	—	X	X	—	—	—	—	—
		12	Y795	—	X	X	—	—	—	—	—
	200 A clips	1	Y796	—	—	X	X	—	—	—	—
		4	Y796	—	—	X	X	—	—	—	—
		12	Y796	—	—	X	X	—	—	—	—
	400 A clips	1	Y797	—	—	—	X	X	—	—	—
		4	Y797	—	—	—	X	X	—	—	—
		12	Y797	—	—	—	X	X	—	—	—
	Automatic molded case switch with 600 A fuse clips	1	Y798	—	—	—	—	X	X	—	—
		4	Y798	—	—	—	—	X	X	—	—
12		Y798	—	—	—	—	X	X	—	—	
Automatic molded case switch with fuse clips 1200 A or less	1	Y799	—	—	—	—	—	X	X	—	
	4	Y799	—	—	—	—	—	X	X	—	
	12	Y799	—	—	—	—	—	X	X	—	

[11] Mag-Gard™ circuit breakers are not supplied nor recommended.

[12] Fuses not included.

[13] Wye-Delta motor starters typically have higher current ratings per NEMA Size than full voltage motor starters. Care must be taken in selecting the appropriate short circuit protection. The table in Digest Section 7 will assist in selecting proper protection based on motor full-load current.

Class 8640 Reduced Voltage Starters

NOTE: To comply with Section 430-3 of the National Electrical Code®, combination part-winding starters come as follows:

- Circuit breaker: two thermal-magnetic, adjustable-trip circuit breakers—one for each motor winding. In the smaller controllers that use the FA and KA frames, a single external operating mechanism operates the two circuit breakers simultaneously. In the larger controllers that use the KA and LA frames, each circuit breaker has its own operating mechanism.
- Nonfusible disconnect switch: a single 3-pole unfused disconnect switch of the proper rating for both windings. The user must provide proper short-circuit protection external to the starter, using only Class J fuses.
- Fusible disconnect switch: a single unfused disconnect switch with two sets of fuse clips (each set of the rating indicated) to provide short-circuit protection for each winding.

Table 16.56: Class 8640 Reduced Voltage Starters Only

Factory Modifications		Enclosure Type	Form	NEMA Size						
				1 PW	2 PW	3 PW	4 PW	5 PW	6 PW	
Circuit Breaker or Disconnect Switch	Molded case thermal magnetic circuit breaker [14]	1	Y7911	X	X	X	X	X	—	
		4	Y7911	X	X	X	X	X	—	
		12	Y7911	X	X	X	X	X	—	
	Fusible Disconnect Switch with Fuse Clips [15]									
	30 A clips (two sets)	1	Y7931	X	X	—	—	—	—	—
		4	Y7931	X	X	—	—	—	—	—
		12	Y7931	X	X	—	—	—	—	—
	60 A clips (two sets)	1	Y7941	—	X	X	—	—	—	—
		4	Y7941	—	X	X	—	—	—	—
		12	Y7941	—	X	X	—	—	—	—
	100 A clips (two sets)	1	Y7951	—	X	X	X	—	—	—
		4	Y7951	—	X	X	X	—	—	—
		12	Y7951	—	X	X	X	—	—	—
	200 A clips (two sets)	1	Y7961	—	—	X	X	X	—	—
		4	Y7961	—	—	X	X	X	—	—
		12	Y7961	—	—	X	X	X	—	—
	400 A clips (two sets)	1	Y7971	—	—	—	X	X	[16]	[16]
		4	Y7971	—	—	—	X	X	[16]	[16]
		12	Y7971	—	—	—	X	X	[16]	[16]
	Automatic molded case switch with 600 A fuse clips (two sets)	1	Y7920	—	—	—	—	—	—	X
		4	Y7920	—	—	—	—	—	—	X
		12	Y7920	—	—	—	—	—	—	X
	Automatic molded case switch with fuse clips 601–1200 A or less (two sets)	1	Y7921	—	—	—	—	—	—	X
		4	Y7921	—	—	—	—	—	—	X
12		Y7921	—	—	—	—	—	—	X	

Table 16.57: Reduced Voltage Controllers Only—Classes 8606, 8630, 8640 [17]

Factory Modifications	Enclosure Type	Form	NEMA Size						
			1 PW 1 YD	2 PW 2 YD	3 PW 3 YD	4 PW 4 YD	5 PW 5 YD	6 PW 6 YD	7 PW 7 YD
Overload relays Substitute 9999SO4 isolated alarm contact on melting alloy overload relay Substitute 9999SO5 isolated alarm contact on melting alloy overload relay	Any Any	Y342 Y344	X X	X X	X X	X X	X X	X X	— — [18]
Motor Logic™ overload relays (Class 10/20 Selectable) [19] [20]	Any	H30	X	X	X	X	X	X	X
Add for thermal protector Class 8606 Coil transient suppressor, per coil Addition of terminal blocks (specify wired or unwired). —Wired, per terminal, each —Unwired, per terminal, each	1, 4, 12 Any	Y116 Y145	— X	X X	X X	X X	X X	X —	— —
	1, 4, 12 1, 4, 12	G56 [21] G50 [21]	X X	X X	X X	X X	X X	X X	X X

[14] Mag-Gard™ circuit breakers are not supplied nor recommended.

[15] Fuses not included.

[16] Consists of automatic molded case switch with two sets of 400 A fuse clips.

[17] NEMA 7 and 9 enclosures not available with Class 8600 devices.

[18] Size 7 uses a solid-state overload relay. See Class 8536 for complete details.

[19] Motor Logic overload relays are not available on Class 8640 Size 1PW to 4PW starters.

[20] See Motor Logic overload relays in the Full Voltage section in Digest Section 16 for additional Form options of Motor Logic overload relays.

[21] Addition of terminal block 9080CA or 9080GR6 only. The number of circuits is the same as the ending of the Form number. (Example: G505 is a 5-wire terminal block.) Available in groups of 5 only. Order in increments of 5. The number of circuits is the same as the ending of the Form number. (Example: G505 = 5 unwired terminals, G510 is 10 unwired terminals.)



Type RO10V02

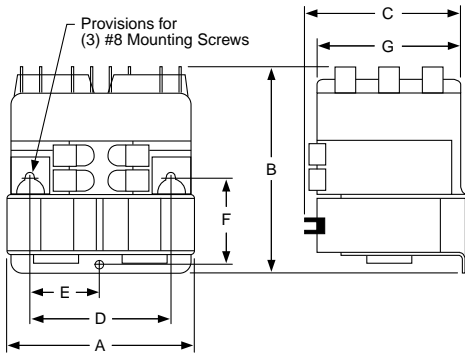

Table 16.58: Approximate Dimensions (3 Poles per Contactor)

Type	A	B	C	D	E	F	G
RO10, 11	3.31 84	3.31 84	3.03 77	2.69 68	1.34 34	1.56 40	2.66 68
RO12, 13	3.31 84	3.69 94	2.69 68	2.69 68	1.34 34	1.56 40	2.66 68

Table 16.64: Cross Reference—Obsolete Devices

Obsolete Device		Replacement Device		Auxiliary Contact Required		Obsolete Device		Replacement Device		Auxiliary Contact Required			
Class	Type	Class	Type	Class	Type	Class	Type	Class	Type	Class	Type		
8702 or 8965	HO3	8965	RO12	—	—	8965	RO2	8965	RO10	9999	R10		
	HO4		RO12	9999	R12		RO11		9999	R10			
	HO5		RO12	9999	R13		RO10		9999	R10			
	HO6		RO12	—	—		RO10		9999	R11			
	HO7		RO12	9999	R12		RO11		9999	R11			
HO8	RO12	9999	R13	RO12	9999		R11						
8965	RG2S1	8965	RO10	9999	R10		RO4		—	RO12	—	—	—
	RG5S1		RO12	9999	R12		RO4S1		—	RO13	—	—	—
	RG5S2		RO12	9999	R12		RO5		—	RO12	9999	R12	R12
	RO1		RO10	—	—		RO5S1		—	RO13	9999	R12	R12
	RO1S1		RO11	—	—	RO5S2	—	RO12	9999	R12	R12		
	RO1S2		RO10	—	—	RO6	—	RO12	9999	R13	R13		
	RO1S3		RO11	—	—	RO6S1	—	RO13	9999	R13	R13		
	RO1S4		RO10	—	—	RO6S2	—	RO12	9999	R13	R13		
RO1S5	RO10	—	—	—	—	—	—	—	—	—			
RO1S6	RO10	—	—	—	—	—	—	—	—	—			

Table 16.65: Application Data

Coils	Duty: Hoist Duty—H4 Intermittent Voltage Range: AC coils only; +10%, -15% of nominal
Burden	Inrush 76 VA, Sealed 27 VA

Table 16.66: Approvals

UL Component Recognized: File E78351, CCN NLDX2
CSA Certified: File LR60905, Class 3211 04

Selection—AC Reversing/Hoist Contactors

Class 8965 reversing hoist contactors meet the small space requirements found in electrical hoists, light duty cranes, door operators, and related products. They are designed to perform in the short periods of jogging experienced in hoist service. Note that these contactors must be mounted upright on the vertical plane; the contactors will not operate properly when mounted in any other position.

Table 16.59: AC Reversing/Hoist Contactors—600 Vac Maximum

No. of Poles	Horsepower Ratings				Power Terminals	With [1] Jumper Straps	Without [1] Jumper Straps
	115 V 1 Ø	230 V 1 Ø	230 V 3 Ø	460/575 V 3 Ø		Open Type	Open Type
3-Pole Poly-phase	1	1-1/2	3	3	Quick Connect	RO10 [2]	RO11 [2]
					Pressure Wire [3]	RO12 [2]	RO13 [2]

Table 16.60: Miscellaneous Hoist Contactor Kits For Use With Class 8965

Type	Series	Description	Class	Type	Series	Description	Class	Type
RO10 RO11 RO12 RO13	A & B	Armature Kit	9998	RP1 [4]	C	Armature Kit	9998	RP2 [4]
		Contact Carrier	Order as Part Number 3100206050				Contact Carrier	Order as Part Number 3100208150

Table 16.61: Class 8965 Replacement Contact Kits

Device Type	Device Series	Class 9998 Kit Type	Device Series	Class 9998 Kit Type
RO10	A & B	RA10	C	RA14
RO11		RA11		RA15
RO12		RA12		RA16
RO13		RA13		RA17

Table 16.62: Auxiliary Contacts Separate Module

Description	Terminals	Class 9999 Type
1 N.O. Each Side	Quick Connect	R10
	Screw	R12
1 N.C. Each Side	Quick Connect	R11
	Screw	R13

Table 16.63: Coil Table

Voltage 60 Hz	Voltage 50 Hz	Voltage Code	Replacement Part Number
24	—	V01	3100240319 [5]
120	110	V02	3100240340 [5]
208/220	—	V21	3100240047 [5]
240	220	V03	3100240049 [6]
480	440	V06	3100240058 [6][7]
600	550	V07	3100240060 [6]

Table 16.67: How to Order

To Order Specify:	Catalog Number		
• Class Number	Class	Type	Voltage and Frequency
• Type Number	8695	RO10	V02
• Voltage and Frequency			

[1] Jumper straps connect the line side power terminals of the same phase between the forward (up) and reverse (down) contactors in common—i.e., L1 to L1, L2 to L2, and L3 to L3.
 [2] Specify the voltage code to order this product. Refer to the standard voltage codes shown in Table 16.63.
 [3] Coils rated 120 Vac or less are provided with quick connect terminals only.
 [4] One armature per kit.
 [5] Tape wound coils, 2 per package.
 [6] Molded coil, 1 per package.
 [7] Suitable for 440 V 50 Hz applications.

Motor Logic Plus—Class 9065



Motor Logic Plus

The Motor Logic Plus solid-state overload relay is separately powered and fully programmable. It is designed to protect 3-phase AC motor applications, 200–480 Vac or 600 Vac. The SSOLR has one Form C relay output rated for 300 Vac maximum.

Table 16.68: Motor Logic Plus—Replacement Only

Class 9065 SP Solid-State Overload Relay		
200–480 V	600 V	Current Range
SPB4	SPB6	0.5–2.3 A
SPC4	SPC6	2.0–9.0 A
SP14	SP16	6.0–27.0 A
SP24	SP26	10.0–45.0 A
SP34	SP36	20.0–90.0 A
SP44 [1]	SP46 [1]	60.0–135.0 A
SP54 [2]	SP56 [2]	120.0–270.0 A
SP64 [3]	SP66 [3]	240.0–540.0 A

Lug-Lug Kit

This kit can be field installed on separately mounted Motor Logic Plus overload relays.

Table 16.69: Lug-Lug Kit

For Use With		Parts Kit Description	Class 9999 Type
Class & Type	NEMA Size		
8536 SA-SH	1–6	Lug-Lug Kit	MLPL
9065 SP	1–6		

Software Kit

Solutions software program allows an IBM PC compatible computer (with Windows 95 or greater) to communicate with a Motor Logic Plus overload relay connected to an RS-485 network using Modbus protocol.

Table 16.70: Software Kit

For Use With		Parts Kit Description	Class 9999 Type
Class & Type	NEMA Size		
8536 SA-SH	1–6	Software Kit	MLPS
9065 SP			

Communication Module

This module allows the Motor Logic Plus overload relay to support RS-485 electrical communications standards. Up to 99 Motor Logic Plus overload relays can be controlled and monitored from one remote personal computer.

Table 16.72: Communication Module

For Use With		Parts Kit Description	Class 9999 Type
Class & Type	NEMA Size		
8536 SA-SH	1–6	Modbus Communication Module	MB22
9065 SP			

Table 16.71: How to Order

To Order Specify:	Catalog Number	
	Class	Type
• Class Number	9999	AC04
• Type Number		

Table 16.73: Full Voltage Controllers Only—Classes 8502, 8536, 8538, 8539, 8702, 8736, 8738, 8739, 8810, 8811 and 8812

Factory Modifications	Enclosure Type	Form	NEMA Size									
			00	0	1	2	3	4	5	6	7	
Overload Relays—General Modify Size 3 Type SE starters with melting alloy overload relays to accept Type FB quick trip or SB slow trip thermal units	Any	Y81	—	—	—	—	N/C	—	—	—	—	—
Substitute 9999 SO4 isolated alarm contact (N.O.) on melting alloy overload relay	Any	Y342	X	X	X	X	X	X	X	[4]	X	[5]
Substitute 9999 SO5 isolated alarm contact (N.C.) on melting alloy overload relay	Any	Y344	X	X	X	X	X	X	X	[4]	X	[5]

[1] Must use 150:5 external current transformer, purchased separately.

[2] Must use 300:5 external current transformer, purchased separately.

[3] Must use 600:5 external current transformer, purchased separately.

[4] For Classes 8736, 8738, and 8739 Type SG, consult the Customer Care Center at 1-888-778-2733.

[5] Size 7 uses a solid-state overload relay as standard. See Digest Section 16 for complete details.