

Section 11

Obsolescent and Obsolete Circuit Breakers

Obsolescent and Obsolete Types	11-2
<hr/>	
Circuit Breaker Availability	11-2
Pictorial and Dimensions	11-4
Obsolescent Circuit Breakers	11-6
<hr/>	
Thermal-Magnetic Circuit Breakers	11-6
SF Circuit Breakers	11-6
Breaking Capacities	11-6
SF Circuit Breaker Dimensions	11-6
Photovoltaic Accessories	11-7
F-Frame Circuit Breakers Ending Production in 2018–2019	11-8
F-Frame Molded Case Circuit Breakers	11-8
F-Frame I-Line Circuit Breakers	11-9
Mag-Gard™ Motor Circuit Protector	11-10
Mag-Gard™ Motor Circuit Protector	11-10
GJL MCP Selection	11-10
GJL MCP Selection Table	11-11
Circuit Breaker Accessories	11-11
<hr/>	
PowerPact™ Circuit Breakers Miscellaneous Accessories	11-11
Neutral CTs and MicroLogic™ Series B Trip Unit Accessories	11-12
Factory-Installed Accessories	11-12
Field-Installable Accessories	11-13
Electrical Operators and Handle Accessories	11-15
Lug Information	11-16
Electronic Products	11-19
<hr/>	
MicroLogic™ Series 2/3/A/B Trip Unit Test Sets	11-19
Ground-Fault Protection	11-20
<hr/>	
MicroLogic™ Add-On Ground-Fault Module (GFM)	11-20
Obsolescent Circuit Breakers	11-20
<hr/>	
MasterPact™ M/MP/MC Circuit Breaker Control Units	11-21
MasterPact™ M/MP/MC Circuit Breaker Accessories	11-21
MasterPact™ M/MP/MC Circuit Breaker Spare Parts	11-22
Enclosures	11-23
<hr/>	

Circuit Breaker Availability

Table 11.1: Circuit Breaker Availability

Series of Cat. No.	Frame Size	Volts	Poles	Amperes	Availability	
					Obsolete No Longer Available	Obsolescent
115A-130A	MO-1 (Add-on)	120 Vac	1	15-30	X	
215A-250A	MO-2 (Add-on)	120/240 Vac	2	15-50	X	
215B-250B	MO-2B (Add-on)	120/240 Vac	2 S.P.	15-50	X	
70000	Multi-Breaker	120 Vac	4 S.P.	15-50	X	
111600	MO-2	120/240 Vac	2	15-30	X	
131600	MO-2	120/240 Vac	2	15-30	X	
151101	MO-1	120 Vac	1	15-30	X	
151600	MO-2	120/240 Vac	2	15-30	X	
161101	MO-1	120 Vac	1 With SN	15-30	X	
161600	MO-2	120/240 Vac	2 With SN	15-30	X	
161700	MO-2	120/240 Vac	2 S.P.	15-30	X	
260000	MB (Left-hand)	120 Vac	4 S.P.	15-50	X	
270000	MB (Right-hand)	120 Vac	4 S.P.	15-50	X	
460000	MO-8	120/240 Vac	4 S.P.	15-50	X	
470000	MO-4	120/240 Vac	4 S.P.	15-40	X	
480000	MO-4 (Plug-in)	120/240 Vac	4 S.P.	15-50	X	
940000	LM	600 Vac	2-3	125-800	X	
950000	50 A Form W	250 Vac	1, 2, 3	15-50	X	
951000	50 A Form W	250 Vac	2, 3	15-50	X	
952000	50 A Form W	250 Vac	2, 3	15-50	X	
953000	Flip-on Form W	230 Vac	1, 2, 3	15-50	X	
954000	100 A Form W (Trip Unit)	250 Vac	2, 3	50-100	X	
955000	100 A Form W	250 Vac	2, 3	50-100	X	
956000	225 A Form W	250 Vac	2, 3	70-225	X	
957000	400 A (KL) Form W	250 Vac	2, 3	125-400	X	
958000	600 A (WL) Form W	250 Vac	2, 3	225-600	X	
959000	KL Frame Only	600 Vac	2, 3	125-400	X	
961000	50 A Form W	600 Vac	2, 3	15-50	X	
962000	50 A Form W	600 Vac	2, 3	15-50	X	
964000	100 A Form W	600 Vac	2, 3	50-100	X	
965000	100 A Form W	600 Vac	2, 3	50-100	X	
966000	225 A Form W	600 Vac	2, 3	70-225	X	
967000	400 A (KL) Form W	600 Vac	2, 3	125-400	X	
968000	600 A (WL) Form W	600 Vac	2, 3	225-600	X	
970000	Type L Form W	240 Vac	1, 2, 3	10-50	X	
971000	Type L Form W (Flip-on)	240 Vac	1, 2, 3	10-50	X	
972000	M1 (Bolt-on)	240 Vac	2, 3	15-70	X	
973000	M2 (Bolt-on)	240 Vac	2, 3	50-100	X	
974000	MM (M) (Bolt-on)	120/240 Vac	2 S.P.	15-50	X	
975000	100 A Trip Unit	250 Vac	2, 3	50-100	X	
976000	225 A Trip Unit	250 Vac	2, 3	70-225	X	
977000	KL Trip Unit	600 Vac	2, 3	125-400	X	
978000	LM Trip Unit	600 Vac	2, 3	225-800	X	
979000	WL Frame	600 Vac	2, 3	225-600	X	
982000	50 A Form W (Flip-on)	125/250 Vac	1, 2, 3	15-50	X	
984000	ML-2	250 Vac	2, 3	50-100	X	
985000	100 A (G) Form W	600 Vac	2, 3	50-100	X	
986000	100 A (F) Form W	600 Vac	2, 3	10-100	X	
987000	ML-3	250 Vac	2, 3	125-225	X	
988000	ML-1	250 Vac	2, 3	15-100	X	
989000	ML-1	480 Vac	2, 3	15-100	X	
991000	QB	120/240 Vac	1	15-50	X	
992000	ML	120/240 Vac	1, 2, 3	10-50	X	
992900	ML Form Y	277 Vac	1	10-20	X	
994000	ML-2	600 Vac	2, 3	15-100	X	
995000	100 A (G) Form W	600 Vac	2, 3	15-100	X	
996000	100 A (F) Form W	600 Vac	2, 3	15-100	X	
997000	ML-3	600 Vac	2, 3	50-225	X	
998000	ML-1	600 Vac	2, 3	15-100	X	
999000	ML-1	600 Vac	2, 3	15-100	X	
A1B	100 A	120/240 Vac	1, 2, 3	15-100	X	
PowerPact D-Frame	600 A	600 Vac	3, 4	150-600	X	
EH, EHB	100 A	480Y/277 Vac	1, 2, 3	15-100	X	
FA, FH, FC	100 A	480 Vac	2, 3	15-100	X	X
FD, FG, FJ	100 A	480Y/277 Vac	1, 2, 3	15-100	X	
GJL / NENL	100 A	480 Vac	3	15-100	X	
KA, KH, KC	250 A	480 Vac	2, 3	70-250	X	
FI, FIL	100 A	480 Vac	2, 3	20-100	X	
KI, KIL	225 A	480 Vac	2, 3	110-225	X	
LI, LIL	400 A	480 Vac	2, 3	300-400	X	
KD, KG	250 A	240 Vac	2, 3	100-250	X	
LA(JKL) 0000	400 A	600 Vac	2, 3	125-400	X	
MA-0000	1000 A	600 Vac	2, 3	125-1000	X	
MasterPact M/MP/MC	6300 A	600 Vac	3, 4	800-6300	—	See page 11-22
MEC	225 A	600 Vac	2, 3	100-225	X	
MEC	400 A	600 Vac	2, 3	250-400	X	
MEC	800 A	600 Vac	2, 3	400-800	X	
MHAB, BC, CA	MM (Plug-on)	120/240 Vac	2 S.P.	15-50	X	

11 OBSOLESCENT AND OBSOLETE CIRCUIT BREAKERS

Table 11.1 Circuit Breaker Availability (cont'd.)

Series of Cat. No.	Frame Size	Volts	Poles	Amperes	Availability	
					Obsolete No Longer Available	Obsolescent
MHAB, BC, CA	M1 (Plug-on)	120/240 Vac	2, 3	15–70	X	
Q2, Q2-H, Q2H	225 A	240 Vac	2, 3	100–225	X	
QE	200 A	120/240 Vac	2, 3	70–200	X	
SE	4000 A	600 Vac	3	200–4000	X	
CK	1200 A	480 Vac	3	400–1200	X	
CM	2000 A	480 Vac	3	1250–2000	X	
XO	50 A	120/240 Vac	1, 2	15–50	X	
Y1B	100 A	277 Vac	1	15–100	X	
LXi	600 A	600 Vac	3	100–600	X	
ME, MEL	250 A, 400 A, 800 A	600 Vac	3	100–800	X	
MX, MXL	250 A, 400 A, 800 A	600 Vac	3	100–800	X	
NA, NAL	1200 A	600 Vac	3	600–1200	X	
NC, NCL	1200 A	600 Vac	3	600–1200	X	
NX, NXL	1200 A	600 Vac	3	600–1200	X	
NE, NEL	1200 A	600 Vac	3	600–1200	X	
PAF	2000 A	600 Vac	3	600–2000	X	
PHF	2000 A	600 Vac	2, 3	600–2000	X	
PCF	2500 A	600 Vac	2, 3	1600–2500	X	
PXF	2500 A	600 Vac	2, 3	600–2500	X	
PEF	2500 A	600 Vac	3	600–2500	X	

Contact your local Sales Office for availability.

Dimensions



LIL



LA (W)



MA (W)

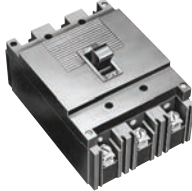

MIL-1



MIL-2

Table 11.2: Circuit Breaker Dimensions

Circuit Breaker Type	Cat. No. Prefix	Number Poles	Dimensions															
			A		B		C		D		E		F		G		H	
			in.	mm	in.	mm	in.	mm	in.	mm	in.	mm	in.	mm	in.	mm		
QB	991	1	3.75	95	1.00	25	2.50	63	3.06	78	—	—	—	—	—	—	—	—
ML	992	1	6.00	152	1.00	25	3.09	78	3.91	99	.88	22	4.25	108	—	—	.33	8
	992	2	6.00	152	2.00	51	3.09	78	3.91	99	.88	22	4.25	108	—	—	.19	5
	992	3	6.00	152	3.00	76	3.09	78	3.91	99	.88	22	4.25	108	—	—	1.83	46
ML-1	999	2, 3	6.50	165	4.47	113	3.06	78	3.94	100	.94	24	4.25	108	1.50	38	.75	19
ML-2	994	2, 3	9.56	243	4.47	113	3.75	95	4.88	124	1.69	43	6.50	165	1.50	38	.75	19
ML-3	997	2, 3	10.38	264	5.97	152	3.88	98	5.31	135	1.69	43	6.63	168	2.00	51	1.00	25
LA (W)	LA	2, 3	10.75	273	8.25	209	4.31	109	5.50	140	.63	16	9.50	241	2.75	70	1.38	35
MA (W)	MA	2, 3	16.00	406	8.25	209	4.06	103	6.06	154	.88	22	14.25	362	2.75	70	1.38	35
KL	967	2, 3	22.00	559	8.25	209	5.50	140	7.00	178	.63	16	20.75	527	2.75	70	1.38	35
LM	940	2, 3	22.00	559	8.25	209	5.50	140	7.00	178	.63	16	20.75	527	2.75	70	1.38	35
FIL (4)	IFL	2, 3	8.29	210	4.46	113	3.67	93	4.70	119	.44	11	7.41	188	1.50	38	.75	19
KIL (4)	IKL	2, 3	11.00	279	6.00	152	4.02	102	5.51	140	.88	22	9.25	235	2.00	51	1.00	25
LIL	ILL	2, 3	11.00	279	12.00	305	4.05	103	6.11	155	.88	22	9.25	235	4.00	102	2.00	51
NHL	NHL	2, 3	20.00	508	12.00	305	5.75	146	8.12	206	5.87	149	7.76	197	4.00	102	2.00	51

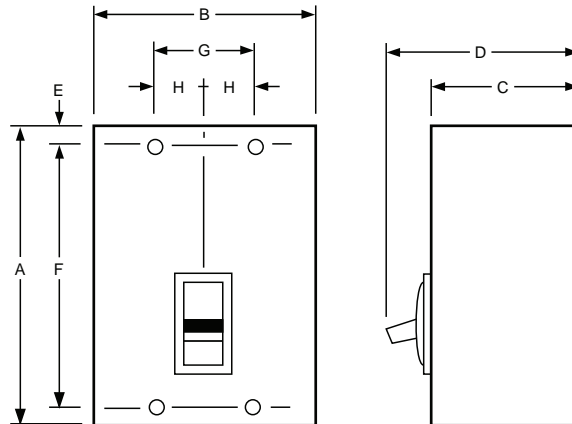

11 OBSOLESCENT AND OBSOLETE CIRCUIT BREAKERS

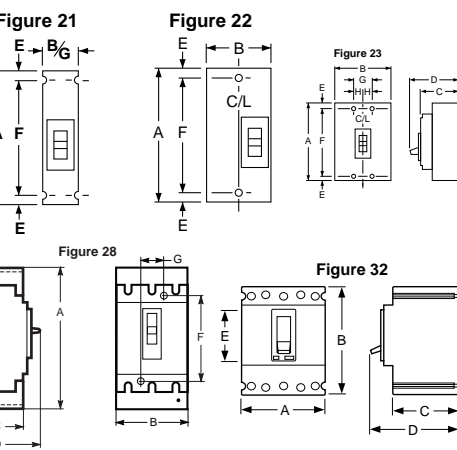
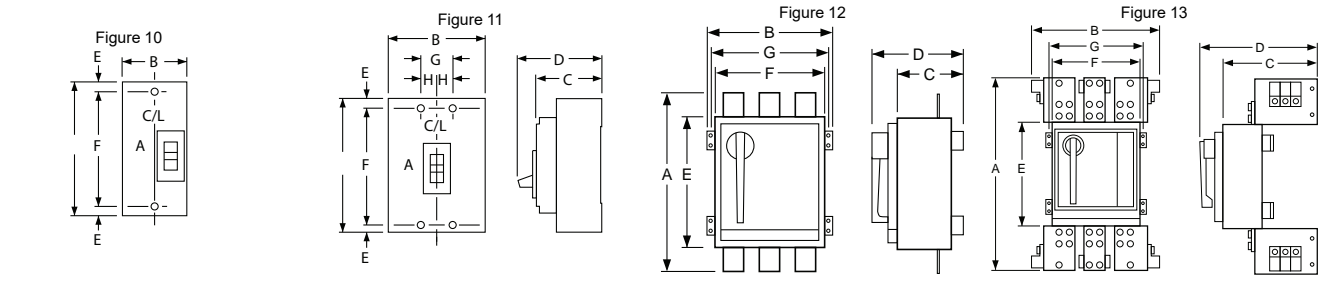
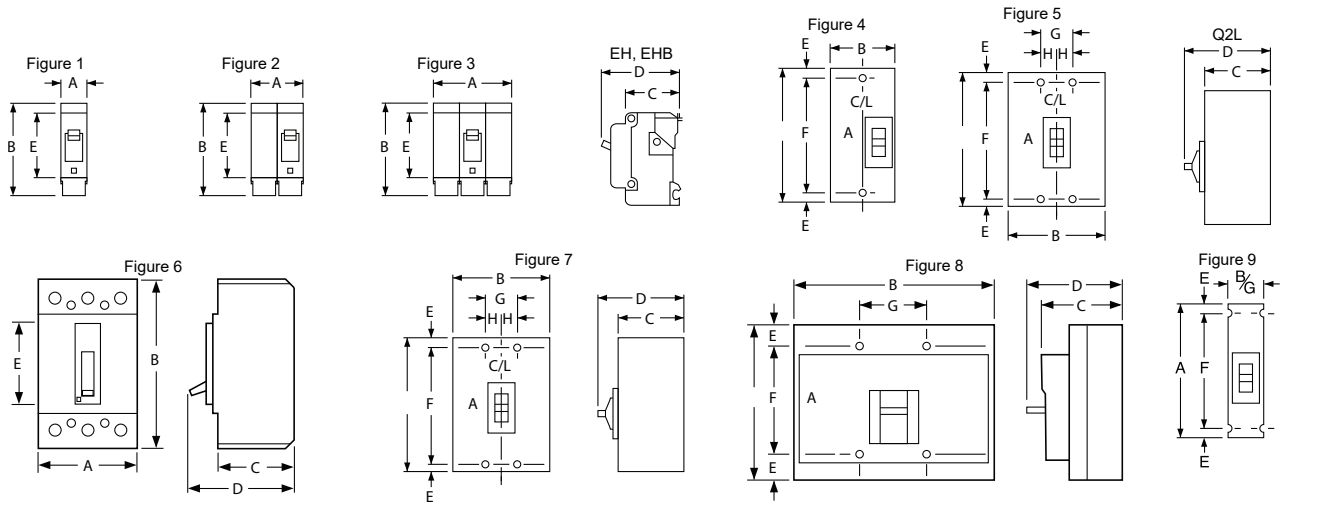

Table 11.4: Circuit Breaker Dimensions

Circuit Breaker Cat. No. Prefix	No. Poles	Fig. No.	Dimensions—In.							
			A	B	C	D	E	F	G	H
EH, EHB	1	1	1.00	3.50	2.00	2.97	2.44	—	—	—
	2	2	2.00	3.50 [1]	2.00	2.97	2.44	—	—	—
	3	3	3.00	3.50 [1]	2.00	2.97	2.44	—	—	—
FDA, FGA, FJA	1	Width 1.50								
	2, 3	Width 3.00								
FAL, FHL	1	21	6.00	1.50	3.16	4.13	0.44	5.13	1.50	—
	2	22	6.00	3.00	3.16	4.13	0.44	5.13	—	—
	3	23	6.00	4.50	3.16	4.13	0.44	5.13	1.50	0.75
FIL, KIL	2, 3	11	8.00	4.50	3.66	4.75	0.44	7.13	1.50	0.75
DG, DJ, DL	3	28	13.38	5.51	3.75	6.61	2.22	8.93	1.77	—
GJ	3	32	3.54	4.72	2.76	3.94	2.20	—	—	—
KAL, KCL, KHL	2, 3	23	8.00	4.50	3.66	4.75	0.44	7.13	1.50	0.75
KIL	2, 3	23	8.00	4.50	3.66	4.75	0.44	7.13	1.50	0.75
KD, KG	2, 3	6	4.12	7.35	3.20	4.17	3.34	—	—	—
LC, LI, LE, LX, LXI	2, 3	11	11.86	7.50	5.48	6.74	0.55	10.75	2.50	—
LIL, LXIL	2, 3	11	11.86	7.50	5.48	6.74	0.55	10.75	2.50	—
Q4L, LAL, LHL	2, 3	11	11.00	6.00	4.06	5.84	0.88	9.25	2.00	1.00
Q2L, Q2L-H	2	4	6.44	3.00	3.16	3.92	[2]	4.25	—	—
	3	5	6.44	4.50	3.16	3.92	[2]	4.25	1.50	0.75
MXL, MEL	2, 3	7	14.75	9.00	4.37	6.50	1.66	11.43	3.00	1.50
NAL, NCL, NEL, NXL	2, 3	8	12.12	14.98	6.40	8.07	1.69	8.75	5.00	—
FCL	1	9	6.00	1.50	3.16	4.13	0.44	5.13	1.50	—
	2	10	6.00	3.00 [3]	3.16	4.13	0.44	5.13	—	—
	3	11	6.00	4.50	3.16	4.13	0.44	5.13	1.50	0.75
MAL, MHL	2, 3	23	14.00	9.00	4.53	6.50	1.66	10.69	3.00	1.50
NA, NC, NX, NE	2, 3	8	12.12	14.98	6.40	8.07	1.69	8.75	5.00	—
PA, PH, PX, PE	2, 3	12	20.06	13.70	7.25	10.47	14.00	12.00	12.75	—
PC, PX-25, PE-20, PE-25	2, 3	13	26.10	23.30	13.33	16.55	14.10	12.00	—	—

Table 11.3: Shipping Weights

Frame Size	Approx. Shipping Weight (Lbs.)
FAL, FHL 2-pole FCL	3
FAL, FHL 3-pole	5
FIL	8
GJ	3
KAL, KHL	7
MAL, MHL	34
PAF, PHF	69
PXF, PEF	80

[1] 70–100 A is 4.00 in.
 [2] Dimensions E are 1.59 in at ON end and 0.63 in at OFF end.
 [3] FCL 2-pole circuit breaker dimension B is 4.50 as in Fig. 23.

SF Circuit Breakers

- CE marking.
- S-frame circuit breakers are CCC Certified.
- International products—for export use only.
- MCCBs in I-Line™ plug-on construction and a complete line of accessories are available. Contact your local Field Sales office.
- Order entry point is Cedar Rapids, Iowa.

Table 11.5: SFAL, Individually-Mounted, IEC Rated Circuit Breakers, 415/240 Vac Max., 50/60 Hz, 1P, 2P, and 3P

Ampere Rating	Cat. No.		
	1P	2P	3P
SFAL [1]			
16 A	SFAL1016	SFAL2016	SFAL3016
20 A	SFAL1020	SFAL2020	SFAL3020
32 A	SFAL1032	SFAL2032	SFAL3032
40 A	SFAL1040	SFAL2040	SFAL3040
50 A	SFAL1050	SFAL2050	SFAL3050
63 A	SFAL1063	SFAL2063	SFAL3063
80 A	SFAL1080	SFAL2080	SFAL3080
100 A	SFAL1100	SFAL2100	SFAL3100
125 A	—	SFAL2125	SFAL3125
160 A	—	SFAL2160	SFAL3160

Breaking Capacities

- CE Marking
- International products—IEC 60947-2 rated. North American products are dual rated, UL 489 and IEC 60947-2.
- MCCBs in I-Line™ plug-on construction and a complete line of accessories are available. Contact your nearest Field Sales office.
- Order entry point is Cedar Rapids, Iowa.

Table 11.6: Circuit Breaker Breaking Capacities

Circuit Breaker Cat. Prefix		Current Rating (Amps)	Short-circuit Ratings (415 Vac)			Isolator Rating	Impulse Rating U _{imp} (kV)	Insulation Rating U _i (Vac)
International	North America		Ultimate I _{cu}	Service I _{cs}	Withstand I _{cw}			
—	FA, FH	15–100 A	10 kA	2.5 kA	N/A	Yes	6	750
—	FA, FH (1 pole) [2]	15–100 A	18 kA	9 kA	N/A	Yes	6	750
SFA (1 pole) [2]	—	16–100 A	25 kA	12.5 kA	N/A	Yes	6	750
SFA [3]	—	16–160 A	25 kA	12.5 kA	N/A	Yes	6	750
—	FC	15–100 A	10 kA	2.5 kA	N/A	Yes	6	750
SFH	—	16–63 A	65 kA	50 kA	N/A	Yes	6	750
		80–100 A	65 kA	33 kA	N/A	Yes	6	750

SF Circuit Breaker Dimensions

- CE Marking
- International products—IEC 60947-2 rated. North American products are dual rated, UL 489 and IEC 60947-2.
- MCCBs in I-Line™ plug-on construction and a complete line of accessories are available. Contact your nearest Field Sales office.
- Order entry point is Cedar Rapids, Iowa.

Table 11.7: Dimensions

Circuit Breaker	No. Poles	Fig. No.	Dimensions – mm							
			A	B	C	D	E	F	G	H
SFA, FA, FH	3	1	152	114	80	105	11	130	38	19

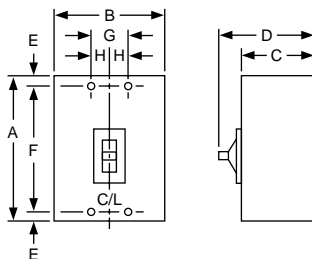

Figure 1

[1] Add suffix K for CCC label
 [2] Single pole ratings are 240 V.
 [3] SFA 2 & 3 pole marked Line and Load.

Photovoltaic Accessories

NOTE: Photovoltaic circuit breakers and related accessories are obsolete. Limited service stock is available for replacement or fill purposes. Contact the nearest sales office for product availability.

Table 11.8: Auxiliary Switches

Contacts	Factory-Installed Suffix	Field-Installable Kit No.	Kit Qty.
1A/1B Standard	AA	S29450	1
2A/2B Standard	AB	S29450	2
3A/3B Standard [4]	AC	S29450	3
1A/1B Low-Level (Gold)	AE	S29452	1
2A/2B Low-Level (Gold)	AF	S29452	2
3A/3B Low-Level (Gold) [4]	AG	S29452	3

Table 11.9: Alarm/Overcurrent Trip Switches

Suffix	Switch	Kit No.	Kit Qty.
PowerPact T-Frame			
BC	Alarm Switch	S29450	1
BD	Overcurrent Trip Switch, Standard	S29450	1
BE	Alarm Switch and Overcurrent Trip Switch, Standard	S29450	2
PowerPact U-Frame			
BC	Alarm Switch	S29450	1
BD	Overcurrent Trip Switch, Standard	S29450	1
BE	Alarm Switch and Overcurrent Trip Switch, Standard	S29450	2

Table 11.10: Shunt Trips and Undervoltage Trips

Voltage	Shunt Trip (MX)		Undervoltage Trip (MN) Field-Installable Kit No.	Adjustable and Fixed Time Delay Units for Undervoltage Trip Field-Installable Kit No.
	Suffix	Field-Installable Kit No.		
120 Vac	SA	P29386	—	—

[4] U-Frame only.

F-Frame Circuit Breakers Ending Production in 2018–2019

PowerPact B-Frame 15–125 A molded case circuit breakers are the designated replacement for F-frame applications. The PowerPact™ B-frame features increased capacity, a smaller size in unit mount, same size in I-Line applications to ease retrofit, and a flexible range of field-installable accessories, auxiliaries and operators.

F-Frame Molded Case Circuit Breakers

Thermal-magnetic molded case circuit breakers shown here are permanent trip UL Listed, CSA Certified, IEC rated, and also meet the requirements of Federal Specification W–C–375B/GEN as indicated in Digest Section 7.

NOTE: Consider using PowerPact™ circuit breakers for situations requiring circuit breaker accessories. See Digest Section 7 for more information.



Table 11.12: F-Frame—100 A, Thermal-Magnetic, Individually-Mounted, Standard Interrupting, 240 Vac

Ampere Rating	Fixed AC Magnetic Trip		Cat. No.			Terminal Wire Range (AWG)
	Hold	Trip	1 P 120 Vac	2 P 240 Vac	3 P 240 Vac	
15 A	275 A	600 A	FAL12015	FAL22015	FAL32015	AL50FA 14–4 Cu or 12–4 Al
20 A	275 A	600 A	FAL12020	FAL22020	FAL32020	
25 A	275 A	600 A	FAL12025	FAL22025	FAL32025	
30 A	275 A	600 A	FAL12030	FAL22030	FAL32030	
35 A	400 A	850 A	FAL12035	FAL22035	FAL32035	
40 A	400 A	850 A	FAL12040	FAL22040	FAL32040	AL100FA 14–1/0 Cu or 12–1/0 Al
45 A	400 A	850 A	FAL12045	FAL22045	FAL32045	
50 A	400 A	850 A	FAL12050	FAL22050	FAL32050	
60 A	800 A	1450 A	FAL12060	FAL22060	FAL32060	
70 A	800 A	1450 A	FAL12070	FAL22070	FAL32070	
80 A	800 A	1450 A	FAL12080	FAL22080	FAL32080	
90 A	900 A	1700 A	FAL12090	FAL22090	FAL32090	
100 A	900 A	1700 A	FAL12100	FAL22100	FAL32100	

Table 11.11: Termination Option

Termination Letter
F = No Lugs
L = Lugs both ends
P with MT Suffix = Lugs ON end
P = Lugs OFF end
F A L 3 6 1 0 0
For factory-installed termination, place termination letter in the third block of the circuit breaker catalog number.

Table 11.13: F-Frame—100 A, Thermal-Magnetic, Individually-Mounted, 480 Vac

Ampere Rating	Fixed AC Magnetic Trip		Standard Interrupting Cat. No.			Terminal
	Hold	Trip	1P 277 Vac, 125 Vdc	2P 480 Vac, 250 Vdc	3P 480 Vac, 250 Vdc	
15 A	275 A	600 A	FAL14015	FAL24015	FAL34015	AL50FA (1) 14–4 Cu or (1) 12–4 Al
20 A	275 A	600 A	FAL14020	FAL24020	FAL34020	
25 A	275 A	600 A	FAL14025	FAL24025	FAL34025	
30 A	275 A	600 A	FAL14030	FAL24030	FAL34030	
35 A	400 A	850 A	FAL14035	FAL24035	FAL34035	
40 A	400 A	850 A	FAL14040	FAL24040	FAL34040	AL100FA (1) 14–1/0 Cu or (1) 12–1/0 Al
45 A	400 A	850 A	FAL14045	FAL24045	FAL34045	
50 A	400 A	850 A	FAL14050	FAL24050	FAL34050	
60 A	800 A	1450 A	FAL14060	FAL24060	FAL34060	
70 A	800 A	1450 A	FAL14070	FAL24070	FAL34070	
80 A	800 A	1450 A	FAL14080	FAL24080	FAL34080	
90 A	900 A	1700 A	FAL14090	FAL24090	FAL34090	
100 A	900 A	1700 A	FAL14100	FAL24100	FAL34100	

Table 11.14: F-Frame—100 A, Thermal-Magnetic, Individually-Mounted, 600 Vac

Ampere Rating	Fixed AC Magnetic Trip		Cat. No.							Terminal Wire Range (AWG)
	Hold	Trip	Standard Interrupting		High Interrupting			Current Limiting		
			2P 600 Vac, 250 Vdc	3P 600 Vac, 250 Vdc	1P 277 Vac, 125 Vdc	2P 600 Vac, 250 Vdc	3P 600 Vac, 250 Vdc	2P 600 Vac, 250 Vdc	3P 600 Vac, 250 Vdc	
15 A	275 A	600 A	FAL26015	FAL36015	FHL16015	FHL26015	FHL36015	—	—	AL50FA 14–4 Cu or 12–4 Al
20 A	275 A	600 A	FAL26020	FAL36020	FHL16020	FHL26020	FHL36020	FIL26020	FIL36020	
25 A	275 A	600 A	FAL26025	FAL36025	FHL16025	FHL26025	FHL36025	FIL26025	FIL36025	
30 A	275 A	600 A	FAL26030	FAL36030	FHL16030	FHL26030	FHL36030	FIL26030	FIL36030	
35 A	400 A	850 A	FAL26035	FAL36035	FHL16035	FHL26035	FHL36035	FIL26035	FIL36035	
40 A	400 A	850 A	FAL26040	FAL36040	FHL16040	FHL26040	FHL36040	FIL26040	FIL36040	AL100FA 14–1/0 Cu or 12–1/0 Al
45 A	400 A	850 A	FAL26045	FAL36045	FHL16045	FHL26045	FHL36045	FIL26045	FIL36045	
50 A	400 A	850 A	FAL26050	FAL36050	FHL16050	FHL26050	FHL36050	FIL26050	FIL36050	
60 A	800 A	1450 A	FAL26060	FAL36060	FHL16060	FHL26060	FHL36060	FIL26060	FIL36060	
70 A	800 A	1450 A	FAL26070	FAL36070	FHL16070	FHL26070	FHL36070	FIL26070	FIL36070	
80 A	800 A	1450 A	FAL26080	FAL36080	FHL16080	FHL26080	FHL36080	FIL26080	FIL36080	
90 A	900 A	1700 A	FAL26090	FAL36090	FHL16090	FHL26090	FHL36090	FIL26090	FIL36090	
100 A	900 A	1700 A	FAL26100	FAL36100	FHL16100	FHL26100	FHL36100	FIL26100	FIL36100	

Table 11.15: Interrupting Ratings

Voltage	FAL			FHL	FCL [5]	FIL
	240 Vac	480 Vac	600 Vac			
240 Vac	10 kA	18 kA (1P) 25 kA (2P, 3P)	25 kA	25 kA (1P) 65 kA (2P, 3P)	100 kA	200 kA
480 Vac	—	18 kA	18 kA	25 kA (2P, 3P)	65 kA	200 kA
600 Vac	—	—	14 kA	18 kA (2P, 3P)	—	100 kA

Accessories see page 11-14 through page 11-18

Optional Lugs see page 11-16

Enclosures see page 11-23

[5] See Section 11.

F-Frame I-Line Circuit Breakers

NOTE: Consider using PowerPact™ circuit breakers for situations requiring circuit breaker accessories. See Digest Section 7 for more information.



Table 11.16: F-Frame—100 A, Thermal-Magnetic, I-Line™ Construction, 240 Vac, Standard Interrupting

Ampere Rating	Fixed AC Magnetic Trip		Cat. No.		Terminal Wire Range (AWG)
	Hold	Trip	2P [6]	3P 240 Vac	
15 A	275 A	600 A	FA22015()	FA32015	AL50FA 14–4 Cu or 12–4 Al
20 A	275 A	600 A	FA22020()	FA32020	
25 A	275 A	600 A	FA22025()	FA32025	
30 A	275 A	600 A	FA22030()	FA32030	
35 A	400 A	850 A	FA22035()	FA32035	
40 A	400 A	850 A	FA22040()	FA32040	AL100FA 14–1/0 Cu or 12–1/0 Al
45 A	400 A	850 A	FA22045()	FA32045	
50 A	400 A	850 A	FA22050()	FA32050	
60 A	800 A	1450 A	FA22060()	FA32060	
70 A	800 A	1450 A	FA22070()	FA32070	
80 A	800 A	1450 A	FA22080()	FA32080	
90 A	900 A	1700 A	FA22090()	FA32090	
100 A	900 A	1700 A	FA22100()	FA32100	

Table 11.17: F-Frame—100 A, Thermal-Magnetic, I-Line Construction, 480 Vac

Ampere Rating	Fixed AC Magnetic Trip		Standard Interrupting			Terminal Wire Range (AWG)
	Hold	Trip	1P [6] [7] 277 Vac, 125 Vdc	2P [6] 480 Vac, 250 Vdc	3P 480 Vac, 250 Vdc	
15 A	275 A	600 A	—	FA24015()	FA34015	AL50FA (1) 14–4 Cu or (1) 12–4 Al
20 A	275 A	600 A	—	FA24020()	FA34020	
25 A	275 A	600 A	—	FA24025()	FA34025	
30 A	275 A	600 A	—	FA24030()	FA34030	
35 A	400 A	850 A	FA14035()	FA24035()	FA34035	
40 A	400 A	850 A	FA14040()	FA24040()	FA34040	AL100FA (1) 14–1/0 Cu or (1) 12–1/0 Al
45 A	400 A	850 A	FA14045()	FA24045()	FA34045	
50 A	400 A	850 A	FA14050()	FA24050()	FA34050	
60 A	800 A	1450 A	FA14060()	FA24060()	FA34060	
70 A	800 A	1450 A	FA14070()	FA24070()	FA34070	
80 A	800 A	1450 A	FA14080()	FA24080()	FA34080	
90 A	900 A	1700 A	FA14090()	FA24090()	FA34090	
100 A	900 A	1700 A	FA14100()	FA24100()	FA34100	

Table 11.18: F-Frame—100 A, Thermal-Magnetic, I-Line™ Construction, 600 Vac

Ampere Rating	Fixed AC Magnetic Trip		Cat. No.						Terminal Wire Range (AWG)	
	Hold	Trip	Standard Interrupting			High Interrupting		Current Limiting		
			2P [6] 600 Vac, 250 Vdc	3P 600 Vac, 250 Vdc	1P [6] [7] 277 Vac, 125 Vdc	2P [6] 600 Vac, 250 Vdc	3P 600 Vac, 250 Vdc	2P [6] 600 Vac, 250 Vdc		3P 600 Vac, 250 Vdc
15 A	275 A	600 A	FA26015()	FA36015	FH16015()	FH26015()	FH36015	—	—	AL50FA 14–4 Cu or 12–4 Al
20 A	275 A	600 A	FA26020()	FA36020	FH16020()	FH26020()	FH36020	FI26020()	FI36020	
25 A	275 A	600 A	FA26025()	FA36025	FH16025()	FH26025()	FH36025	—	—	
30 A	275 A	600 A	FA26030()	FA36030	FH16030()	FH26030()	FH36030	FI26030()	FI36030	
35 A	400 A	850 A	FA26035()	FA36035	FH16035()	FH26035()	FH36035	—	—	
40 A	400 A	850 A	FA26040()	FA36040	FH16040()	FH26040()	FH36040	FI26040()	FI36040	AL100FA 14–1/0 Cu or 12–1/0 Al
45 A	400 A	850 A	FA26045()	FA36045	FH16045()	FH26045()	FH36045	—	—	
50 A	400 A	850 A	FA26050()	FA36050	FH16050()	FH26050()	FH36050	FI26050()	FI36050	
60 A	800 A	1450 A	FA26060()	FA36060	FH16060()	FH26060()	FH36060	FI26060()	FI36060	
70 A	800 A	1450 A	FA26070()	FA36070	FH16070()	FH26070()	FH36070	FI26070()	FI36070	
80 A	800 A	1450 A	FA26080()	FA36080	FH16080()	FH26080()	FH36080	FI26080()	FI36080	
90 A	900 A	1700 A	FA26090()	FA36090	FH16090()	FH26090()	FH36090	FI26090()	FI36090	
100 A	900 A	1700 A	FA26100()	FA36100	FH16100()	FH26100()	FH36100	FI26100()	FI36100	

Table 11.19: Phase Options

Phase Option Letter	1P	2P	3P
A	FA14035A	—	—
B	FA14035B	—	—
C	FA14035C	—	—
AB	—	FA24030AB	—
AC	—	FA24030AC	—
BC	—	FA24030BC	—
ABC	—	—	FA34030
CBA	—	—	FA34030CBA

Table 11.20: Interrupting Ratings

Voltage	FA			FH	FC[8]	FI
	240 Vac	480 Vac	600 Vac			
240 Vac	10 kA	18 kA (1P), 25 kA (2P, 3P)	25 kA	25 kA (1P) 65 kA (2P, 3P)	100 kA	200 kA
277 Vac	—	18 kA	—	—	65 kA	—
480 Vac	—	18 kA	18 kA	25 kA (2P, 3P)	65 kA	200 kA
600 Vac	—	—	14 kA	18 kA (2P, 3P)	—	100 kA

Accessories see page 11-14 through page 11-18

Optional Lugs see page 11-16

Enclosures see page 11-23

[6] 1P and 2P circuit breaker catalog numbers are completed by adding the required phase connection letters as a suffix. See Phase Option Table.

[7] Rated 277 Vac, 125 Vdc, 15–30 A circuit breaker suitable for use with 60°C or 75°C conductors. 35–100 A circuit breakers are suitable for use with 75°C conductors.

[8] See Section 11.

Mag-Gard™ Motor Circuit Protector

Instantaneous trip magnetic only circuit breakers have a single adjustment which simultaneously sets the magnetic trip level of each individual pole. Mag-Gard circuit breakers comply with NEC® requirements for providing motor circuit protection when installed as part of a UL Listed combination controller having motor overload protection. Interrupting ratings are established for these UL Recognized Components only when they are used in combination with motor starters with properly sized overload relays and contactors.

Mag-Gard circuit breakers will accept the same lugs and accessories as equivalent thermal-magnetic circuit breakers.

Table 11.21: Magnetic-Only GJL Circuit Breakers, 400 A, 600 Vac, 50/60 Hz [9]

Ampere Rating	Adjustable [10] Trip Range	Cat. No. 3P Only
GJL [11]	3	9–33 A GJL36003M01
	7	21–77 A GJL36007M02
	15	45–165 A GJL36015M03
	30	90–330 A GJL36030M04
	50	150–550 A GJL36050M05
	75	225–825 A GJL36075M06

NOTE: Each ampere rating can be ordered with any designated trip range for the frame by adding the proper suffix to the catalog numbers.

GJL MCP Selection

Adjustable instantaneous-trip circuit breakers are intended for use in combination with motor starters with overload relays for the protection of motor circuits from short circuits. Other specific applications include rectifiers and resistance welders. These circuit breakers contain a magnetic trip element in each pole with the trip point adjustable from the front. Interrupting ratings are determined by testing the instantaneous-trip circuit breakers in combination with a contactor and overload relay.

Select instantaneous-trip circuit breakers using the selection table below.

This selection table is suitable for motors, other than NEMA Design E, with locked-rotor indicating code letters per NEC® Table 430.7 (b).

Table 11.22: Locked-Rotor Indicating Codes

Horsepower	Motor Code letter
1/2 or less	A–L
3/4 to 1-1/2	A–K
2 to 3	A–J
5 to 25	A–H
30 to 125	A–G
150 or more	A–F

- For other motors order a special thermal-magnetic circuit breaker with magnetic trip settings for the specific motor— specify motor horsepower, voltage, frequency, full-load current and code letter or locked rotor current.
- Determine motor hp rating from the motor nameplate.
- Refer to the tables and select an instantaneous-trip circuit breaker with an ampere rating recommended for the hp and voltage involved.
- Select an adjustable trip setting of at least 800%, not to exceed 1300%, of the motor full-load amperes (FLA) for other than Design E motors. For Design E motors, select an adjustable trip setting of at least 1100% not to exceed 1700% of FLA.
- The NEC 1300% maximum setting may be inadequate for instantaneous-trip circuit breakers to withstand current surges typical of the magnetization current of autotransformer type reduced voltage starters, or open transition wye-delta starters during transfer from “start” to “run”, constant hp multi-speed motors, and motors labeled “high efficiency”. Select thermal-magnetic circuit breakers from Digest Section 7 for those applications.
- Part-winding motors, per NEC 430.3, should have two circuit breakers selected from the above at not more than one half the allowable trip setting for the horsepower rating. The two circuit breakers should operate simultaneously as a disconnecting means per NEC 430.103.
- Based on NEC 430.52 and NEC Table 430.150. See Digest Section 7 for a available Adjustable Instantaneous-Trip Circuit Breakers.



[9] 250 Vdc ratings are available. No UL component recognition.

[10] UL magnetic trip setting tolerances are -20%/+30% from the nominal values shown.

[11] No GJL I-Line available.

GJL MCP Selection Table

Table 11.23: GJL Adjustable Instantaneous-Trip Circuit Breakers for Single Motor Circuit Protection

Hp Ratings of Induction Type Squirrel-Cage and Wound Rotor Motors 3Ø 60 Hz				Full Load Amperes [12]	GJL Family Mag-Gard Circuit Breaker Cat. No.	Magnetic Trip Settings [13]	
200 Vac	230 Vac	460 Vac	575 Vac			MIN	MAX
—	—	—	1/2	0.8	GJL36003M01 [14]	1100%	4100%
—	—	1/2	—	1	GJL36003M01 [14]	900%	3300%
—	—	—	3/4	1.1	GJL36003M01 [14]	800%	3000%
—	—	3/4	—	1.4	GJL36003M01	600%	2400%
—	—	1	—	1.8	GJL36003M01	500%	1800%
—	1/2	—	—	2	GJL36003M01	500%	1700%
—	—	—	1-1/2	2.1	GJL36003M01	400%	1600%
1/2	—	—	—	2.3	GJL36003M01	400%	1400%
—	—	1-1/2	—	2.6	GJL36003M01	300%	1300%
—	—	—	2	2.7	GJL36003M01 [15]	300%	1200%
—	3/4	—	—	2.8	GJL36003M01 [15]	300%	1200%
3/4	—	—	—	3.2	GJL36007M02	700%	2400%
—	—	2	—	3.4	GJL36007M02	600%	2300%
—	1	—	—	3.6	GJL36007M02	600%	2100%
—	—	—	3	3.9	GJL36007M02	500%	2000%
1	—	—	—	4.1	GJL36007M02	500%	1900%
—	—	3	—	4.8	GJL36007M02	400%	1600%
—	1-1/2	—	—	5.2	GJL36007M02	400%	1500%
1-1/2	—	—	—	6	GJL36007M02	400%	1300%
—	—	—	5	6.1	GJL36015M03	700%	2700%
—	2	—	—	6.8	GJL36015M03	700%	2400%
—	—	5	—	7.6	GJL36015M03	600%	2200%
2	—	—	—	7.8	GJL36015M03	600%	2100%
—	—	—	7-1/2	9	GJL36015M03	500%	1800%
—	3	—	—	9.6	GJL36015M03	500%	1700%
3	—	7-1/2	10	11	GJL36015M03	400%	1500%
—	—	10	—	14	GJL36030M04	600%	2400%
—	5	—	—	15.2	GJL36030M04	600%	2200%
—	—	—	1	17	GJL36030M04	500%	1900%
5	—	—	—	17.5	GJL36030M04	500%	1900%
—	—	15	—	21	GJL36030M04	400%	1600%
—	7-1/2	—	20	22	GJL36030M04	400%	1500%
7-1/2	—	—	—	25.3	GJL36030M04	400%	1300%
—	—	20	25	27	GJL36050M05	600%	2000%
—	10	—	—	28	GJL36050M05	500%	2000%
—	—	—	30	32	GJL36050M05	500%	1700%
10	—	—	—	32.2	GJL36050M05	500%	1700%
—	—	25	—	34	GJL36050M05	400%	1600%
—	—	30	—	40	GJL36050M05	400%	1400%
—	—	—	40	41	GJL36050M05	400%	1300%
—	15	—	—	42	GJL36075M06	400%	1300%
15	—	—	—	48.3	GJL36075M06	500%	1700%
—	—	40	50	52	GJL36075M06	400%	1600%
—	20	—	—	54	GJL36075M06	400%	1500%
20	—	—	60	62	GJL36075M06	400%	1300%
—	—	50	—	65	GJL36075M06	300%	1300%

11 OBSOLETE AND OBSOLETE CIRCUIT BREAKERS

[12] Motor full-load currents are taken from NEC Table 430.150. Select wire and circuit breakers on basis of horsepower rather than nameplate full-load current per NEC 430.6 (A) for general motor applications. Do not use these values to select overload relay thermal units. See Digest Section 14 for selection of thermal units when actual full load current is not known. The voltages listed are rated motor voltages. Corresponding nominal system voltages are 200–208, 220–240, 440–480 and 550–600 V.

[13] Only MIN and MAX settings are shown, intermediate settings are available on all circuit breakers.

[14] See NEC 430.52(A) for circuit breaker settings above 800%.

[15] If due to motor starting characteristics, trip settings at the 1300% maximum permitted level are needed, the next size Mag-Gard circuit breaker should be chosen.

Locks, Installation Accessories, and Rear Connections

Table 11.24: Locks, Interlocking

Device	Description	D-Frame Field-Installable Cat. No.
Handle Padlocking Device	Removable (lock OFF only)	S29370
	Fixed (lock OFF or ON)	S32631
	Fixed (lock OFF only)	NJPAF
Interlocking (Not UL listed)	Mechanical for circuit breakers with rotary handles	32621
	Mechanical for circuit breakers with toggles	32614
Key Locking	Ronix	41950
	Profalux	42878

Provision and 2 locks keyed alike

Table 11.25: Installation Accessories for G- and D-Frame Circuit Breakers

Description	D-Frame Field-Installable Cat. No.
Front Panel Escutcheon for Toggle Breakers	32556
Front Panel Escutcheon for Rotary Handle, Motor Operator, or extended escutcheon	32558
Phase Barriers (set of 6)	32570
Handle Rubber Boot	32560
Sealing Accessories	29375
DIN rail adapter	—
Toggle Extensions (set of 10)	32553

Table 11.26: Rear Connections

Device	D-Frame		
	Poles	Factory-Installed Termination No.	Field-Installed Cat. No.
Mixed Rear Connection Kit	3	S	32477
	4	S	32478
Consisting of:	Short rear connections (set of 2)	3	2x 32475
	Long rear connections (set of 2)	3	32476
	Short terminal cover (3P)	3	32562

Neutral Current Transformers and MicroLogic™ Series B Trip Unit Accessories

Table 11.27: Test Equipment for Circuit Breakers with MicroLogic Series B Trip Systems

Description	Cat. No.
Test Module for Full-function and Standard-function LEL, LXL, LXIL. (For use with existing CBTU1 or UTS3 test set.)	CBTMB
Replacement ribbon cable and rating plug adapter for CBTMB	CBTMBRK

LA and Q-Frame Factory-Installed Electrical Accessories

Electrical accessories are available on all molded case circuit breakers except QOM1 circuit breakers.

- All AC electrical accessories shown below are rated for 50/60 Hz.
- See [Field-Installable Electrical Accessories](#), page 11-13 for field-installable accessories. See Digest Section 7 for PowerPact™ circuit breaker accessories.

Table 11.28: Factory-Installed Accessories for Thermal-Magnetic LA and Q-Frame Circuit Breakers

Accessory	Description	Rated Voltage	Coil Burden	Suffix
Time Delay Unit	Provides adjustable time delay for UVR of 0.1 to 0.6 second before circuit breaker trips. Application <ul style="list-style-type: none"> For use only with -1121 UV trip Adjustable time delay (0.1 to 0.6 second) I-Line unit requires 1.5 in. (38 mm) of mounting space Leads: (2) Brown 18 AWG Cu and (2) Black/White 18 AWG Cu 	120 Vac	Cat. No.	
			690UVTD	690UVTDI

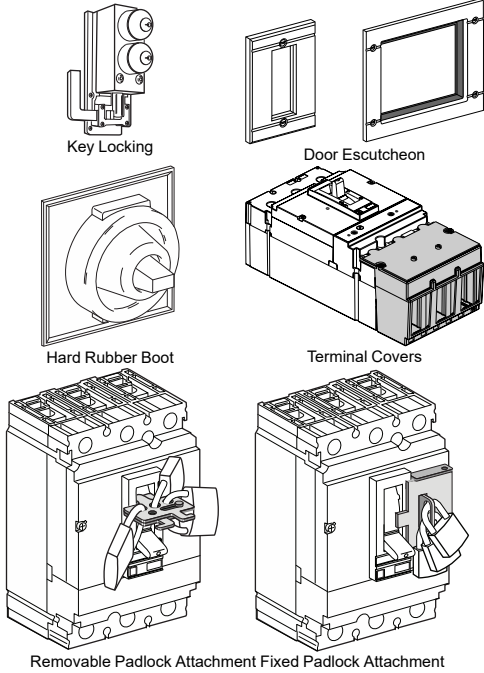

11 OBSOLETE AND OBSOLETE CIRCUIT BREAKERS

Auxiliary Switch Contact Configuration

Color Code:
"A" Contact - Yellow Leads
"B" Contact - Blue Leads
Common-Striped Leads

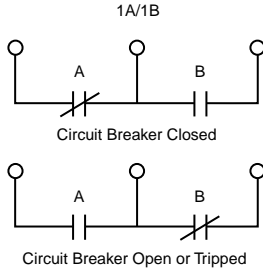

1A Alarm Switch Configuration

Color Code: Red Leads

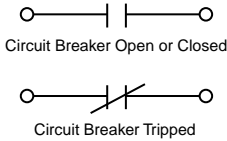

1B Alarm Switch Configuration

Color Code: Red Leads

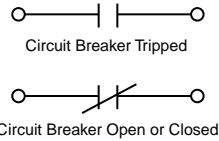

Undervoltage Trip Wiring Diagram

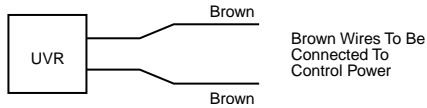

Shunt Trip Wiring Diagram

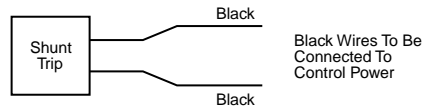

Field-Installable Electrical Accessories

Complete field-installable accessory catalog number by inserting suffix from Digest Section 7 between the parentheses in the catalog numbers shown in the table below. (Example: LA11212)

Table 11.29: Field-Installable Accessories for Thermal-Magnetic and Electronic Trip Circuit Breakers

Circuit Breaker	Shunt Trip	Ground-Fault Shunt Trip [1]	Undervoltage Trip	Auxiliary Switches	Alarm Switch
FI, KI	Factory-Installed Only	Factory-Installed Only	Factory-Installed Only	Factory-Installed Only	Factory-Installed Only
LC, LI, LE, LX, LXI	LC1 ()	LC1G	LC1 ()	LC1 ()	Factory-Installed Only
MA, MH	MA1 ()	MA1G	MA1 ()	MA1 ()	Factory-Installed Only
ME, MX	Factory-Installed Only	Factory-Installed Only	Factory-Installed Only	Factory-Installed Only	Factory-Installed Only
NA, NC, NE, NX Series 1, 2, 3	NA1 ()	NA1 ()	NA1 ()	NA1 ()	NA1 ()
PA, PH, PC Series 4	PA1 ()	Factory-Installed Only	PA1121	PA1 ()	Factory-Installed Only
PE, PX Series 4, 5, 6	PA1 ()	Factory-Installed Only	PA1121	PA1 ()	Factory-Installed Only

Table 11.30: Accessory Mounting Locations

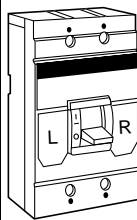

MA, MH Series 2 circuit breakers or newer = Field-installable accessories
ME/MX circuit breakers = Not field-installable accessories

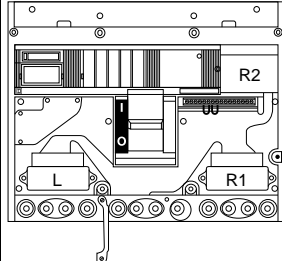

NA, NC, NE, NX circuit breakers - Field-installable accessories
"L" port and "R" port will accept shunt trips, alarm switches and UVRs;
"R2" port will accept auxiliary switches. Maximum of one device per port.

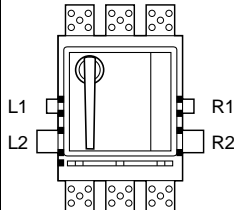



PA, PH, PC, PE, PX Series 4 circuit breakers or newer = Field-installable accessories.
"L1" and "L2" or "R1" and "R2" port combinations are required to mount a single shunt trip. Both "L2" and "R2" ports will accept a UVR. Both "L1" and "R1" ports will accept auxiliary switches. If alarm switch is factory installed in PA or PC circuit breaker, it will be installed in "R2" port. For a PE or PX circuit breaker, the alarm switch will be factory installed in "L2" port.

11 OBSOLETE AND OBSOLETE CIRCUIT BREAKERS

[1] Used with obsolete GP Ground-Censor™ system or add-on ground-fault modules.

GJL Electrical Accessories

Table 11.31: Electrical Accessories

Accessory	Description	Rated Voltage	G-Frame Field-Installable Cat. No.	
<p>Auxiliary and Alarm Switches (OF, SD, SDE)</p>  <p>G-Frame</p>	<p>Provides circuit breaker contact status. NOTE: The location of the accessory in the circuit breaker determines its function.</p>	Standard Min Load = 10mA with 24V	1 auxiliary switch (OF) 1a1b AAC	
		2 auxiliary switch (OF) 2a2b —		
		3 auxiliary switch (OF) 3a3b —		
		Alarm Switch (SD) 1a1b AAC		
		Overcurrent Trip Switch (SDE) 1a1b —		
		Consisting of: OF Switch SDE Adapter —		
		Alarm Switch and Overcurrent Trip Switch —		
		Consisting of: OF Switch SDE Adapter —		
		Auxiliary Switch/Alarm Switch/Adapter (OF/SD/SDE) Kit —		
		Low Level Min Load = 1mA with 24V	One auxiliary switch (OF) 1a1b —	
		Two auxiliary switches (OF) 2a2b —		
		3 auxiliary switches (OF) 3a3b —		
		Alarm Switch (SD) 1a1b —		
		Overcurrent Trip Switch (SDE) 1a1b —		
Consisting of: OF Switch SDE Adapter —				
Consisting of: OF Switch SDE Adapter [2] —				
<p>Shunt Trip (MX)</p>  <p>G-Frame</p>	<p>Trips the circuit breaker from a remote location by means of a trip coil energized from a separate supply voltage circuit.</p>	AC	24 —	
			48 —	
			120 GSA	
			110/130 —	
			208 GSB	
			240 GSC	
			200/250 —	
			277 GSD	
			208/277 —	
			480 GSH	
			380/480 —	
			525/600 —	
			DC	12 —
				24 GSO
30 —				
48 GSP				
60 —				
125 GSR				
250 GSS				
<p>Undervoltage Trip</p>  <p>G-Frame</p>	<p>Instantaneously opens the circuit breaker when the undervoltage trip supply voltage drops to a value between 35% and 70% of its rated voltage. Closing is allowed when the supply voltage of the undervoltage trip reaches 85% of rated voltage.</p>	AC	24 —	
			48 —	
			120 GUA	
			110/130 —	
			208 GUB	
			240 GUC	
			200/250 —	
			277 GUD	
			208/277 —	
			480 GUH	
			380/480 —	
			525/600 —	
			DC	12 —
				24 GUO
30 —				
48 GUP				
60 —				
125 GUR				
250 GUS				

11 OBSOLETE AND OBSOLETE CIRCUIT BREAKERS

[2] SDE Adapter used for H- and J-frame only.



KAMO2120AC with KIL Circuit Breaker



FAMO1 and FAMOP with FAL Circuit Breaker

Electrical Operators

Provides remote ON, OFF/RESET control of molded case circuit breakers.

- A complete line of field-installable electrical operators.
- Not applicable on LC/LI/LE/LX/LXI circuit breakers.
- Installing side mounted motor operators on non I-Line™ circuit breakers requires the use of a separate mounting pan.
- Side mounted electrical operators require an additional 4-1/2 in. (114 mm) of mounting space in I-Line installations.

When remote indication of circuit breaker status is required, order circuit breaker with 1A-1B auxilliary switch for ON-OFF Indication and alarm switch for TRIP Indication. Electrical operators require SPDT maintained contact switch. Refer to Class 9001 control unit listing for operators and pilot lights.

NOTE: Not available on Mag-Gard™ circuit breakers and molded case switches.

Table 11.32: Electrical Operators

Circuit Breaker Prefix	Top Mount		Side Mount		Mounting Pan Cat. No.
	Voltage	Cat. No.	Voltage	Cat. No.	
FI, KI	—	—	120 Vac	KAMO1	—
FIL, KIL	120 Vac	KAMO2120AC	120 Vac	KAMO1	KAMOP
	240 Vac	KAMO2240AC			
	24 Vdc	KAMO224DC			
	125 Vdc	KAMO2125DC			
LAL, LHL, Q4L	120 Vac	LAMO2120AC	—	—	—
	240 Vac	LAMO2240AC			
	24 Vdc	LAMO224DC			
	125 Vdc	LAMO2125DC			
MAL, MHL	120 Vac	MAMO2120AC	120 Vac	MAMO1	MAMOP
	240 Vac	MAMO2240AC			
	24 Vdc	MAMO224DC			
	125 Vdc	MAMO2125DC			
PA, PH, PC, PE, PX	120 Vac	PAMO2	—	—	—

Handle Accessories

Table 11.33: Handle Accessories

Circuit Breaker Prefix	Poles	Cat. No.
Handle Tie		
2 FI, 2 KI, or 1 FI + 1 KI	2, 3	FKHT
California Title 24 Comb. Handle Tie and Lock Off		
Handle Extension		
LE, LI, LX, LXI	2, 3	AHEXLI
Handle Padlock Attachment (locks ON or OFF)		
FI	1, 2, 3	HPAFK
FY Series 1	1	HPAFYQ
FA, FH	1, 2, 3	HPAFK
FY Series 2	2, 3	HPAFK
KI	2, 3	HPAFK ^[3]
LC, LE, LI, LX, LXI	2, 3	AHPALI

[3] Locks OFF only.

Mechanical Lugs

Table 11.34: Mechanical Lug Kit Information



Circuit Breaker Application				(Number of Wires Per Lug) Wire Range [4]	Cat. No.	Lugs Per Kit	Availability
Standard	Ampere Rating	Optional	Ampere Rating				
Al Lugs for Use with Al or Cu Wire							
FA, FH	15–30 A	FA, FH	35–100 A	(1) 14–4 AWG Cu or (1) 12–4 AWG Al	AL50FA	3	Not Available
FC	35–100 A	FC	15–30 A	(1) 14–3 AWG Cu or (1) 12–1 AWG Al	AL100FA4	3	—
FA, FH	35–100 A	FA, FH	15–30 A	(1) 14–1/0 AWG Cu or (1) 12–1/0 AWG Al	AL100FA	3	—
—	—	FA, FH, FC	15–100 A	(1) 12–3 AWG Cu	AL100TF[5]	3	Not Available
—	—	FA	150 A (only)	(1) 2–3/0 AWG	AL150FA	3	—
FI	15–30 A	FI	35–100 A	(1) 14–4 AWG Cu or (1) 12–4 AWG Al	AL50FA	3	Not Available
FI	35–100 A	FI	15–30 A	(1) 14–1/0 AWG Cu or (1) 12–1/0 AWG Al	AL100FA	3	—
KI	110–175 A	—	—	(1) 4 AWG–350 kcmil	AL250KA	3	—
KI	200–250 A	KI	110–175 A	(1) 1/0 AWG–350 kcmil	AL250KI	3	Not Available
LE, LX, LXI	100–250 A	LI, LE, LX, LXI	300–600 A	(2) 1 AWG–350 kcmil	AL600LI35	1	—
LI, LE, LX, LXI	300–600 A	LE, LX, LXI	100–250 A	(2) 4/0 AWG–500 kcmil	AL600LI5	1	—
—	—	LC, LI, LE, LX, LXI	—	(1) 500–750 kcmil	AL600LI7	1	—
—	—	LC, LI, LE, LX, LXI	—	(1) 500–750 kcmil	AL600LI7	1	—
MA, MH	300–1000 A	—	—	(3) 3/0 AWG–500 kcmil	AL900MA	1	—
—	—	MA, MH	300–1000 A	(2) 500–750 kcmil	AL800MA7	1	—
—	—	MA, MH	300–1200 A	(4) 1/0 AWG–350 kcmil	AL1000MA	1	Not Available
ME, MX	100–250 A	—	—	(1) 6 AWG–350 kcmil	AL250ME	3	Not Available
—	—	ME, MX	250–400 A	(1) 350–750 kcmil	AL400ME7	1	Not Available
—	—	ME, MX	100–800 A	(2) 500–750 kcmil	AL800MA7	1	—
ME, MX	300–800 A	ME, MX	100–250 A	(3) 3/0 AWG–500 kcmil	AL900MA	1	—
—	—	ME, MX	300–1200 A	(4) 1/0 AWG–350 kcmil	AL1000MA	1	Not Available
NA, NC, NE, NX	600–1200 A	—	—	(4) 3/0 AWG–600 kcmil	AL1200NE6	1	Not Available
—	—	PAF, PHF, PEF, PXF, PCF	600–2500 A	(1) 1/0 AWG–750 kcmil	AL2500PA	2	Not Available
Cu Lugs for Use with Cu Wire Only [6]							
FC	15–30 A	—	—	(1) 14–10 AWG Cu	CU30FA4	3	—
—	—	FA, FH, FC	15–100 A	(1) 12–3 AWG Cu	CU100TF[5]	3	Not Available
—	—	FA, FH, FC	15–100 A	(1) 14–1 AWG Cu	CU100FA	3	—
—	—	FI	15–100 A	(1) 14–1 AWG Cu	CU100FA	3	—
—	—	FI	15–100 A	(1) 14–1 AWG Cu	CU100FA	3	—
—	—	KI	110–250 A	(1) 4 AWG–250 kcmil Cu	CU250KA	3	Not Available
—	—	LI, LE, LX, LXI	—	(2) 1 AWG–350 kcmil Cu	CU600LI35	1	—
—	—	LI, LE, LX, LXI	—	(2) 4/0 AWG–500 kcmil Cu	CU600LI5	1	—
—	—	LI, LE, LX, LXI	—	(1) 500–750 kcmil Cu	CU600LI7	1	Not Available
—	—	MA, MH	300–1000 A	(3) 3/0 AWG–500 kcmil Cu	CU1000MA	1	Not Available
—	—	ME, MX	125–250 A	(1) 4 AWG–250 kcmil Cu	CU250ME	3	Not Available
—	—	ME, MX	100–800 A	(3) 3/0 AWG–500 kcmil Cu	CU1000MA	1	Not Available
—	—	NA, NC, NE, NX	600–1200 A	(4) 3/0 AWG–600 kcmil Cu	CU1200NE6	1	Not Available

11 OBSOLETE AND OBSOLETE CIRCUIT BREAKERS

[4] Unless otherwise specified, wire sizes apply to both aluminum and copper conductors.

[5] For use in the OFF end only, when the OFF end is the load end.

[6] Use suffix 8002 for factory-installed Cu lugs.

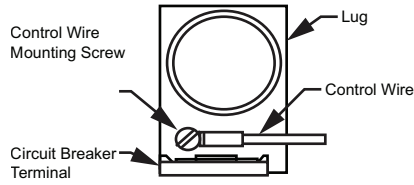

Control Wire Tap Lugs

Control wire tap lugs are used in applications requiring connection to a small wire (22-14 AWG) for control circuits. This is accomplished by crimping the wire to a standard wire crimp terminal (not included) and fastening the terminal to the circuit breaker lug. **Note:** To order as a factory-installed device on FI, KI, LC, LI, LXI, LX or LC circuit breakers, add suffix number 8041 to circuit breaker catalog number, e.g., KIL362258041.

Table 11.35: Control Wire Terminations for Circuit Breakers

Circuit Breaker	Control Wire Termination Kits	
	Cat. No.	Standard Package Quantity
FA, FH	FAT [7]	1
FI	FAT [7]	1
KI	AL250KIT	1
LC, LI, LXI, LX, LE	AL600L35T	1
	AL600L15T	1
MA, MH, MX, ME	AL900MAT	1
	AL1000MAT	1
NA, NC, NX, NE	AL1200NE6T	1

Compression Lug Kits

Table 11.36: Field-Installable Compression Lug Kits



Circuit Breaker Type	Wire Range [8]	Dimension A (In)	Max. Lugs Per Terminal	Cat. No. [9]	Lugs Per Kit	Availability
Aluminum Compression Lug Kits						
FA, FH, FC	8-1/0 AWG	1.3	1	VC100FA	3	—
FI	8-1/0 AWG	1.3	1	VC100FA	3	—
KI	4 AWG-300 kcmil	1.5	1	VC250KA3	3	Not Available
	250-350 kcmil	1.5	1	VC250KA35	3	Not Available
LI, LE, LX, LXI [10]	4 AWG-300 kcmil	1.05	2	VC600LI3	2	Not Available
	2/0 AWG-500 kcmil	3.20	2	VC600LI5	2	Not Available
	500-750 kcmil	3.45	1	VC600LI7	1	Not Available
MA, MH	2/0 AWG-500 kcmil	1.9	2	VC600MA5	2	Not Available
	500-750 kcmil	2.1	2	VC800MA7	2	Not Available
ME2, MX2	4 AWG-300 kcmil	1.5	1	VC250ME3	3	Not Available
	250-350 kcmil	1.5	1	VC250ME35	3	Not Available
ME4, MX4	2/0 AWG-500 kcmil	2.2	1	VC400ME5	1	Not Available
	500-750 kcmil Al or 500 kcmil Cu	2.5	1	VC400ME7	1	Not Available
ME, MX, MA, MH	2/0 AWG-500 kcmil	1.9	2	VC600MA5	2	Not Available
	500-750 kcmil Al or 500 kcmil Cu	2.1	2	VC800MA7	2	Not Available
NA, NC, NE, NX	2/0 AWG-500 kcmil	3.3	4	VC1200NE5	4	Not Available
	500-750 kcmil Al or 500 kcmil Cu	3.6	4	VC1200NE7	4	—
PAF, PHF, PCF, PEF	2/0 AWG-500 kcmil	[11]	6-8	VC2000PA5	4	Not Available
	2/0 AWG-500 kcmil	[11]	6-8	VC2500PA7	4	Not Available
Copper Compression Lug Kits						
FA, FH, FC	6-1/0 AWG Cu	1.4	1	CVC100FA	3	—
FI	6-1/0 AWG Cu	1.4	1	CVC100FA	3	—
KI	2/0 AWG-300 kcmil Cu	1.5	1	CVC250KA3	3	Not Available
LI, LE, LX, LXI [10]	250-500 kcmil Cu	3.20	2	CVC600LI5	2	Not Available
ME4, MX4	250-500 kcmil Cu	2.6	1	CVC400ME5	1	Not Available
ME, MX	250-500 kcmil Cu	2.4	2	CVC600MA5	2	Not Available
NA, NC, NE, NX	250-500 kcmil Cu	3.3	4	CVC1200NE5	4	Not Available
	500-750 kcmil Cu	3.6	4	CVC1200NE7	4	—

11 OBSOLETE AND OBSOLETE CIRCUIT BREAKERS

[7] Use fully-insulated 0.250 inch slip-on connectors.
 [8] Unless otherwise specified, wire sizes apply to both aluminum and copper conductors.
 [9] See instruction bulletins for recommended tools.
 [10] These lug kits cannot be used on I-Line™ circuit breakers.
 [11] All P-frame circuit breakers require terminal pads for mounting lugs of any type.

Power Distribution Connectors (PDC) for Circuit Breakers—for Field Replacement of Mechanical Lugs

Can be used for multiple load connections on one circuit breaker. Use in place of standard distribution blocks to save space and time.

Field-installable kits, including tin-plated aluminum connectors and all necessary mounting hardware are available for Square D FA, LA and Q4-frame molded case circuit breakers.

Connectors are UL Listed:

- For use on load end of circuit breaker only.
- For use in UL508 Industrial Control applications only.
- For use in UL 1995/CSA C22.2 No. 236 heating and cooling equipment.
- For copper wire only.

Table 11.37: Power Distribution Connectors for FAL/FHL/FCL Circuit Breakers

Use With Circuit Breaker [12]	Circuit Breaker Ampere Rating	Wires Per Terminal & Wire Range [13] Cu	Cat. No.	Lug Quantity Per Kit	Dimension A (in.)
FAL, FHL, FCL [14]	15–100 A	(6) 14–6 AWG	PDC6FA6	3	1.0
		(3) 14–2 AWG	PDC3FA2	3	1.2

Table 11.38: Power Distribution Connectors for M- and P-Frame Circuit Breakers

Use With Circuit Breaker [12]	Circuit Breaker Ampere Rating	Wires Per Terminal & Wire Range [13] Cu	Cat. No.	Lug Quantity Per Kit	Dimension A (in.)	Availability
MAL, MHL, MEL, MXL	125–1000 A	(6) 12–2/0 AWG Cu	PDC6MA20	1	0.0	Not Available
		(12) 14–4 AWG Cu	PDC12MA4	1	0.0	Not Available

11

OBSCURE AND OBSOLETE
CIRCUIT BREAKERS

[12] Not for use with I-Line circuit breakers.

[13] When using fine stranded wire, increased cross sectional area may cause maximum wire size to be reduced.

[14] OFF end only when OFF end is the load end.

Test Information

Universal Test Sets and related accessories are obsolete. Limited service stock is available for replacement or fill purposes. Contact the nearest sales office for product availability.

Table 11.39: Test Equipment for Circuit Breakers with MicroLogic Series B Trip Systems

Description	Cat. No.
For those customers who already own the Universal Test Set and want to test the latest standard and full-function (Series B) trip systems, all that is needed is the MicroLogic Series B module (CBTMB). Included is the rating plug adapter and instruction manual.	CBTMB
Replacement ribbon cable and rating plug adapter for CBTMB	CBTMBRK



GFM250

GFM Ground Fault Module

The MicroLogic ground-fault module (GFM) is a UL Listed circuit breaker accessory for equipment protection. It is a combination ground-fault relay and ground-fault sensing device.

MicroLogic Add-On Ground-Fault Module features:

- Used in combination with the FA, KA, FC, KC, FI, and KI type circuit breakers with a ground-fault shunt trip factory installed (add the suffix "G" to the circuit breaker)
- Adjustable ground-fault pickup levels
- Adjustable ground-fault time delays
- Integral ground fault push-to-test feature and ground-fault indicator
- All GFMs supplied for I-Line™ mounting, easily convertible to unit mount by removing the I-Line brackets
- Neutral current transformer is supplied for 3-phase 4-wire applications. Refer to instructions for proper installation
- Zone-selective interlocking capability is standard with upstream MicroLogic trip system circuit breakers. The GFM can also be zone interlocked with the GC ground-fault system by using a restraint interface module. See page 11-20.
- 120 Vac control power is required for integral test feature. Meets NEC 230-95(c)

NOTE: Ground-fault modules cannot be reverse fed.

Table 11.40: Module/Enclosure Selection Chart

Companion Circuit Breaker Prefix	Cat. No.	Enclosure Space Required		Ground-Fault Pickup Adjustment Range	Availability
		I-Line Switchboard	Individual Enclosure [1]		
FAL, FHL, FCL, FA, FH, FC	GFM100FA	LA	KA	20–100 A	—
FI	GFM100FI	LA	—	20–100 A	Not Available
KAL, KHL, KI, KA, KH, KC	GFM250	LA	LA	40–200 A	—

RIM32 Restraint Interface Module

The RIM32 Restraint Interface Module is used to interface the restraint signals between various Square D MicroLogic™ circuit breakers, MicroLogic ground-fault modules, and GC-100 ground-fault protection systems.

The restraint interface module operates on either 120 or 240 Vac, 50/60 Hz. The module is protected by a 1/4 A fuse.

Allowable ZSI combinations are shown in the table below. (Series numbers for current design circuit breakers end in B, for example NE Series 3B.) For double-ended or larger systems, or systems which contain devices from different columns in the table below, contact your local Sales Office for combination information.

If more inputs or outputs are needed, another restraint interface module is necessary. Contact your local Sales Office for information on multiple module installations.

NOTE: The maximum distance between devices is 1000 ft. (305 m).

Table 11.42: ZSI Combination (Where All Inputs Driven are Same Columns)

Circuit Breaker Series Outputs	Circuit Breaker Series Inputs							
	SE 2 (Ground Fault)	SE 2 (Short Time)	ME 3, NE 1, PE 4	ME 4, 5, NE 2 & 3, P 5 & 6A, SE 3A	ME 5A, NE 3A, PE 6A, SE 3A	LE 1B, ME 5B, NE 3B, PE 6B, SE 3B	GC100	Rim32
SE 2 (Ground Fault)	50	—	R	R	R	R	R	50
SE 2 (Short Time)	—	1	R	R	R	R	R	50
ME 3, NE 1, PE 4	50	R	15	2	13	47	R	50
ME 4, 5 & 5A, NE 2, 3 & 3A, PE 5, 6 & 6A, SE 3 & 3A	50	R	R	1	1	7	R	14
LE 1B, ME 5B, NE 3B, PE 6B, SE 3B	50	R	10	1	R	26	R	44
GC100	R	R	R	R	R	R	R	7
GFM [2]	50	—	2	1	1	5	R	1
RIM32	50	6	50	7	37	50	15	50

= Maximum inputs without RIM32. Self-restraint counts as one input.
R = RIM32(s) required to restrain any device.
— = Invalid combination.

11 OBSOLETE AND OBSOLETE CIRCUIT BREAKERS

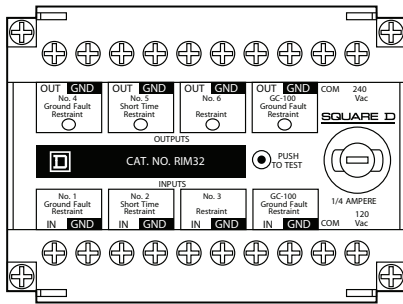

RIM32

Table 11.41: RIM32

Cat. No.
RIM32

[1] Use NEMA 1 or 3R enclosures only.

[2] GFM is an output device only.

MasterPact™ M/MP/MC Circuit Breaker Control Units

NOTE: MasterPact M/MP/MC circuit breakers and related accessories are obsolete. Use MasterPact NT/NW for new applications. See Digest Section 7. Limited service stock is available for replacement or fill purposes. Contact the nearest sales office for product availability.

Table 11.43: Control Units

	Control Unit	Ground-Fault Protection [1]	Without Ground-Fault Protection [1]
	STR 58U (long-time, short-time and instantaneous protection)	Includes Residual Type T — and Ammeter — I	
	STR58U (long-time = 0.4x1 sensor rating)	External neutral sensor (TCE) [2]— see page 11-21	
	—	M10H2	M10H2NG
	—	M16H2	M16H2NG
	—	M20H2	M20H2NG
	—	M25H2	M25H2NG
	—	M32H2	M32H2NG
	—	M63H2	M63H2NG

MasterPact™ M/MP/MC Circuit Breaker Accessories

NOTE: MasterPact M/MP/MC circuit breakers and related accessories are obsolete. Use MasterPact NT/NW for new applications. See Digest Section 7. Limited service stock is available for replacement or fill purposes. Contact the nearest sales office for product availability.

Table 11.44: Neutral Sensor for 3ØH4W Systems (TCE)

	Rating	Cat. No.
	800 A	54422
	1250 A	54426
	2000 A	54427

Table 11.45: Accessories (Must be ordered as separate items)

	Accessory	Description	Cat. No.
	For STR 18M to STR 58U control units Output voltage: 24 Vdc	Input voltage	
		24/30 Vdc	54440
		48/60 Vdc	54441
		10 Vac 50/60 Hz	54443
		220 Vac 50/60 Hz	54444
	Battery back-up power supply for AD module	380 Vac 50/60 Hz	54446
			54446

Table 11.46: Accessories for Cradle

	Accessory	Cat. No.
Position Switches		
	Four SPDT connected position switches (CE)	54590
	Two SPDT disconnected position switches (CD)	54591
Door Escutcheon		
	Can be used with fixed or drawout circuit breakers	54594

[1] External neutral sensor not included.
[2] External AD module (see page 11-21) is required if load is below 20% or if setting is red zone.

Class 931, 940, 960

MasterPact M/MP/MC Frame Accessories

NOTE: MasterPact M/MP/MC circuit breakers and related accessories are obsolete. Use MasterPact NT/NW for new applications. See Digest Section 7. Limited service stock is available for replacement or fill purposes. Contact the nearest sales office for product availability.

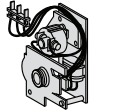

Table 11.47: Accessories for Circuit Breaker Frame

	Volts (V)	Cat. No. (XF)	Cat. No. (MX)
Spring Charging Motor (MCH) — Includes Spring Charged Switch			
	AC 50/60 Hz	100/127	— 54512

MasterPact™ M/MP/MC Circuit Breaker Spare Parts

NOTE: MasterPact M/MP/MC circuit breakers and related accessories are obsolete. Use MasterPact NT/NW for new applications. See Digest Section 7. Limited service stock is available for replacement or fill purposes. Contact the nearest sales office for product availability.

Table 11.48: Spare Parts

Spare Parts	Cat. No.		
Clusters for Cradle (Set of 2)			
	MP25–MP30 3P	M20–M25L 3P	54063 (3)
	MP25–MP30 4P	M20–M25L 4P	54063 (4)
	—	M32H 3P	54063 (3)
	—	M32H 4P	54063 (4)
	MP40–MP50 3P	M50H 3P	54063 (6)
	—	M50H 4P	54063 (7)
Charging Handle			
	One piece		685713
Racking Handle			
	One piece		685631
Vertical UL 489—UL 1066 Connectors			
	MP25–MP30 3P (set of three top or bottom connectors)		54107 (2)

F-Frame Circuit Breaker Enclosures

F-Frame Thermal-Magnetic Circuit Breaker Enclosures

The enclosures for the F-Frame thermal-magnetic circuit breakers are UL listed and CSA certified. The enclosures are suitable for service entrance equipment when neutral assembly is installed. The short circuit ratings of these enclosed circuit breakers are equal to the interrupter rating, at the supply voltage marked on the circuit breaker installed.

The FA100RB enclosure has a provision of 3/4 through 2 1/2 inch B-Type bolt-on hubs in the top end wall. For details and hub catalog numbers see Section 3 of the Digest.



FA100S



FA100RB



FA100DS

Table 11.49: F-Frame Thermal-Magnetic Circuit Breaker Enclosures

Circuit Breaker			Cat. No.				
Cat. No. Prefix	Rating	Poles	Enclosure			Neutral Assembly Kit	Service Ground Kit
			NEMA 1 Flush	NEMA 1 Surface	NEMA 3R		
FAL, FHL, FCL	15–100 A	1, 2, 3	FA100F	FA100S	FA100RB	SN100FA	PKOGTA2
			NEMA 4, 4X, 5 [1] Type 304 Stainless Steel [2]	NEMA 12K With Knockouts	NEMA 12/3R Without Knockouts [2]		
FAL, FHL, FCL	15–100 A	1, 2, 3	FA100DS	FA100A	FA100AWK	SN100FA	PKOGTA2

[1] Complete rating is NEMA 3, 3R, 4, 4X, 5, and 12.
[2] For NEMA 3R applications, remove drain screw from bottom endwall.

Enclosures for Special Applications

Hazardous Locations: NEMA 7 And NEMA 9 Circuit Breaker Enclosures

The NEMA 7 and 9 enclosures are cULus listed unless otherwise noted. They are rated for use in hazardous locations as defined in NEC Article 500. The short circuit current rating of the enclosed circuit breakers is equal to the rating of the circuit breaker installed unless otherwise noted. They are suitable for use as service entrance equipment when neutral is installed. Enclosures require the use of 75°C copper wire only. The NEMA 7 enclosures are suitable for rainproof applications when the included PKDB1 breather and drain kit is installed.

Table 11.50: NEMA 7 and NEMA 9 Circuit Breaker Enclosures; Thermal-Magnetic F-Frame Circuit Breakers

Circuit Breaker Cat. No. Prefix	Rating	Poles	Enclosure Catalog Number		Neutral Assembly Kit Cat. No.	Service Ground Kit Cat. No.	Threaded Conduit Provisions, Inches
			NEMA 7 Cast Aluminum [3]	NEMA 9 Cast Aluminum [4]			
FAL, FHL	15–60 A	1, 2, 3	FA060X	FA060Y	100SNA	Included	3/4 in.
FAL, FHL	15–100 A	1, 2, 3	FA100X	FA100Y	100SNA	Included	1 1/4 in.

Stainless Steel Front Enclosure

The FA100F NEMA Type 1, flush-mount circuit breaker enclosure is available with a stainless steel front. This modification is desirable in food handling areas such as cafeterias and restaurants. Not UL Listed.

Table 11.51: Stainless Steel Front Enclosure

Cat. No.
FA100FSS

Enclosure Dimensions

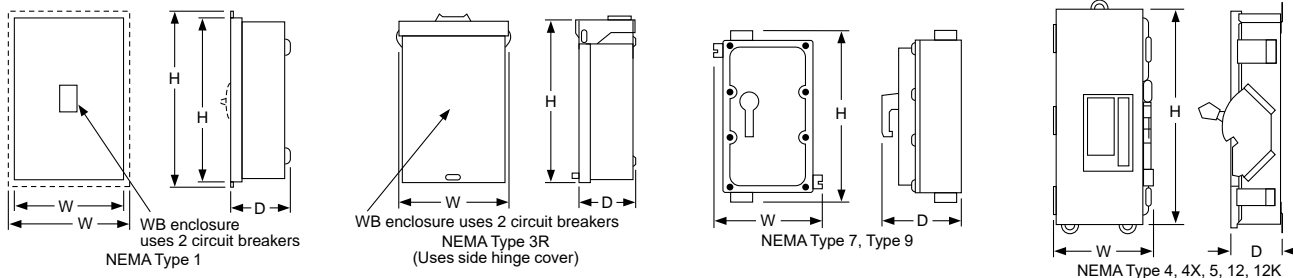

Table 11.52: Dimensions

Cat. No.	Series	Approximate Dimension					
		H		W		D	
		in.	mm	in.	mm	in.	mm
FA100A, AWK	E05	19.5	495	9.13	232	4.88	124
FA100DS	E05	19.5	495	9.13	232	4.88	124
FA100F	E2	19.5	495	9.88	251	4.13	105
FA100RB	E2	18.0	457	8.88	226	4.88	124
FA100S	E2	18.13	461	8.63	219	4.13	105
FA060X	E2	16.00	406	9.88	251	7.00	178
FA060Y	E2	16.00	406	9.88	251	7.00	178
FA100X	E2	16.00	406	9.88	251	7.00	178
FA100Y	E2	16.00	406	9.88	251	7.00	178

11 OBSOLETE AND OBSOLETE CIRCUIT BREAKERS

[3] NEMA 7 — Indoor Hazardous Locations — Division 1 and 2, Class I, Groups C and D; Class II, Groups E, F and G; Class III.

[4] NEMA 9 — Indoor Hazardous Locations — Division 1 and 2, Class II, Groups E, F and G; Class III.