



# Digest 179

## Supplemental and Obsolescence Digest

Document Number 0100CT2402

[se.com/us/digestplus](https://se.com/us/digestplus)

**Schneider**  
Electric

<b>Section 1</b>	<b>Load Centers</b>
<b>Section 2</b>	<b>Heavy Duty Safety Switches</b>
<b>Section 3</b>	<b>Molded Case Circuit Breakers and Enclosures</b>
<b>Section 4</b>	<b>Panelboards</b>
<b>Section 5</b>	<b>Switchboards</b>
<b>Section 6</b>	<b>Transformers</b>
<b>Section 7</b>	<b>International Load Centers</b>
<b>Section 8</b>	<b>International Safety Switches</b>
<b>Section 9</b>	<b>International Circuit Breakers</b>
<b>Section 10</b>	<b>International Panelboards</b>
<b>Section 11</b>	<b>Obsolescent and Obsolete Circuit Breakers</b>
<b>Section 12</b>	<b>Obsolete Motor Control Centers</b>
<b>Section 13</b>	<b>Obsolescent Panelboards</b>
<b>Section 14</b>	<b>Busway</b>
<b>Section 15</b>	<b>Operating Mechanisms and Disconnect Switches</b>
<b>Section 16</b>	<b>Contactors and Starters</b>
<b>Section 17</b>	<b>Medical Products</b>

# Section 1

## Load Centers

LOAD CENTERS  
1

<b>QO™ Load Centers</b>	<b>1-3</b>
<hr/>	
Plug-on Neutral Load Center Main Breaker, Convertible Mains	1-3
QO Plug-On Neutral Load Center with Qwik-Grip™	1-3
QO Load Centers with Included Cover	1-4
Backup Power Solutions, Single Phase	1-5
Backup Power Solutions	1-5
QO Special Constructions, Single Phase	1-6
QO Standard Load Center Main Lugs and Main Breaker, Fixed Mains	1-6
QO Riser Panels	1-7
Panelboard-style Covers for Riser Panels	1-7
<b>Fusible Pullouts and Circuit Breaker Covers</b>	<b>1-9</b>
<hr/>	
Class T Fusible Pullouts	1-9
Circuit Breaker Covers	1-9
<b>Servicepak™ Power Outlet Panels</b>	<b>1-10</b>
<hr/>	
Power Outlet Panels for Construction Sites	1-10
Power Outlet Panels for Recreational Vehicle Parks	1-11



**Plug-on Neutral Load Center Main Breaker, Convertible Mains**  
**1Ø3W—120/240 Vac Indoor—UL Listed**

QO Plug-on Neutral Load Centers and CAFI Breakers are engineered for a quick Plug-on Neutral connection on every unit.

**Table 1.1: Convertible Main Breaker Plug-on Neutral Load Centers (Compatible with QO Plug-on Circuit Breakers and QO Plug-on Neutral Circuit Breakers)**

	Mains Rating	Space-s	Max. 1P Circuits	Max. Tandem Breakers	Load Center Box and Interior	Load Center Covers		AI	Cu	Bus Rating	Equipment Ground Bar Kit (Order Separately)	Box No. [1]
						Flush/Surface	Mono-Flat					
 QO154M200P	Convertible Mains—Factory-Installed Main Circuit Breaker—22 kA Short Circuit Current Rating Convertible to Main Lugs (see below) or Lower Amperage Main Circuit Breaker (see "QO Standard Plug-On Circuit Breakers" in Section 1 of the Digest) [2], QOM2 Main Circuit Breaker Frame Size—Copper Bus											
	150 A	20	30	10	QO120M150P	QOC30UF [3] QOC30US	QOCMF30UCW [4]	4-250	225	PK15GTA	9	
	200 A	20	30	10	QO120M200P	QOC30UF [3] QOC30US	QOCMF30UCW [3]	4-300	4-250	225	PK15GTA	9
	225 A	40	60	20	QO140M225P	QOC42UF [3] QOC42US	QOCMF42UCW [3]	4-300	225	PK23GTA	11	

Above listings through 200 A mains rating meet Federal Specification W-P-115c as Type 1, Class 2.

**QO Plug-On Neutral Load Center with Qwik-Grip™**  
**1Ø3W—120/240 Vac Indoor—UL Listed**



QO Plug-on Neutral Load Center with Qwik-Grip™

The Square D QO plug-on neutral load centers with Qwik-Grip simplify rough-in by eliminating the need to remove knockouts, install wire connectors, and blindly pull wire into the load center. A quick bend of the wire using the wire bend guide on the Qwik-Grip insert and the wire slides into the slot. Once inserted, the Qwik-Grip shield snaps on to keep the wire behind the router for a secure, code-compliant installation.

**Table 1.2: Plug-on Neutral Load Centers with Qwik-Grip (Compatible with QO Plug-on Circuit Breakers and QO Plug-on Neutral Circuit Breakers)**

	Mains Rating	Space-s	Max. Single Pole Circuits	Max. Tandem Circuit Breakers	Load Center Box and Interior	Indoor Cover with Door (Order Separately)		Main Wire Size AWG/kcmil		Bus Rating	Equipment Ground Bar Kit	Box No.
						Flush/Surface	Mono-Flat	AI	Cu			
INDOOR	Convertible Mains—Factory-Installed Main Lugs, 65 kA Short Circuit Current Rating—Copper Bus, QOM1 Main Frame Size, Convertible to Main Circuit Breaker											
	125 A	30	34	4	QO130L125PQG	QOC30U125C	—	6-2/0	125	PK23GTAL Included	9Q	
	Convertible Mains—Factory—Installed Main Lugs, 65 kA Short Circuit Current Rating—Copper Bus, QOM2 Main Frame Size, Convertible to Main Circuit Breaker											
	225 A	54	72	18	QO154L225PQG	QOC54UF [3]	—	6-300	225	PK23GTAL	9Q	
INDOOR	Convertible Mains—Factory-Installed Main Circuit Breaker, 22 kA Short Circuit Current Rating—Copper Bus, QOM2 Main Frame Size, Convertible to Main Lugs or Main Circuit Breaker											
	200 A	54	72	18	QO154M200PQ	QOC54UF [3]	—	4-250	225	PK23GTA (Order separately)	12Q	

[1] See Indoor Enclosure Dimensions and Knockout Information in the Digest.

[2] 22 k AIR main circuit breaker UL Listed for use ahead of QO, QOT and QO-PL 10 k AIR branch circuit breakers to permit their application on systems with up to 22 kA available fault current.

[3] Available in gray and white. For white equivalencies, add the "W" suffix to the reference, or see QO Load Center Accessories in Section 1 of the Digest.

[4] Available in gray and white. For white equivalencies, add the "W" suffix to the reference, or see QO Load Center Accessories in Section 1 of the Digest.

**QO Load Centers with Included Cover**  
**1Ø3W—120/240 Vac Indoor—UL Listed**

**Table 1.3: Load Centers with Included Cover (Compatible with QO Plug-on Circuit Breakers and QO Plug-on Neutral Circuit Breakers)**

Mains Rating	Short Circuit Current Rating	Spaces	Max. 1P Circuits [5]	Max. Tandem Circuit Breakers	Load Center [6] Box, Interior, and Cover	AI	Cu	Bus Rating	Equipment Ground Bar Kit	Box No. [7]
125 A	65 kA	20	24	4	QO120L125PGC	6-2/0		125	PKGTALP1 Included	6
Convertible Mains—Factory-Installed Main Lugs [8]—QOM2 Main Frame Size—Convertible to Main Circuit Breaker (See “QO Standard Plug-On Circuit Breakers” in Section 1 of the Digest)—Copper Bus										
225 A	65 kA	54	72	18	QO154L225PGC	4-300		225	PK23GTA, LK100AN Included	12
Convertible Mains—Factory-Installed Main Circuit Breaker—QOM1 Main Frame Size—Convertible to Main Lugs (See “1Ø, Field-Installed Mains Kits” in Section 1 of the Digest) or Lower Amperage Main Circuit Breaker (See QO Standard Plug-On Circuit Breakers in the Digest)—Copper Bus [9]										
100 A	22 kA	16	24	8	QO116M100PC	6-2/0	6-1	125	PK9GTA	6

[5] Maximum single pole branch circuits utilizing QO and/or QOT circuit breakers.

[6] Order F for flush device or S for surface device.

[7] See Indoor Enclosure Dimensions and Knockout Information in the Digest.

[8] UL Listed 5000 A short circuit current rating for corner grounded Delta systems. Use QO-H circuit breakers only.

[9] 22 k AIR main circuit breaker UL Listed for use ahead of QO, QOT and QO-PL 10 k AIR branch circuit breakers to permit their application on systems with up to 22 kA available fault current.

**Backup Power Solutions**  
**1Ø3W—120/240 Vac Backup Power—UL Listed**

**Table 1.4: Backup Power Solutions**

	Mains Rating (A)	Spaces	Max. Single Pole Circuits [10]	Max. Tandem Circuit Breakers	Load Center Box, Interior and Cover	Equipment Grounding Bar Kit (Order Separately)	Main Wire Size AWG/kcmil		Bus Rating	Box No. [11]
							Al	Cu		
INDOOR	Split Bus Plug-On Neutral Load Centers—Manual Transfer for use with Temporary Backup Power Source Applications NEMA 1 (Indoor)									
	200	48	48	0	QO122X26M200PC	PK23GTA	4–250	4–250	—	12
		36	69	34	HOM1427X2242M200PC	PK27GTA	4–250	4–250	—	12
RAINFREE	Generator Panels—Manual Transfer with Generator Power Inlet Plug for Sub-Feed Applications NEMA 3R (Outdoor)									
	Factory-Installed Main Circuit Breakers with Mechanical Interlock—10 kA Short Circuit Current Rating									
	100	4	8	4	QO1DM10020TRBR	Factory-Installed	—	8–2	100	17R
RAINFREE	Split Bus Plug-On Neutral Load Centers—Manual Transfer for use with Temporary Backup Power Source Applications NEMA 1 (Indoor)									
	200	48	48	0	QO122X26M200PC	PK23GTA	—	4–250	—	12

LOAD CENTERS 1

[10] Maximum single pole branch circuits utilizing QO and/or QOT circuit breakers.

[11] See QO/Homeline Load Center Dimensions in Section 1 of the Digest.

### QO Standard Load Center Main Lugs and Main Breaker, Fixed Mains

1Ø3W—120/240 Vac Special Applications—UL Listed

**Table 1.5: Low Amperage Fixed Main Lugs Indoor Load Centers (Accepts Only QO Plug-on Circuit Breakers - Not compatible with QO Plug-on Neutral Circuit Breakers)**

	Mains Rating	Spaces	Max. 1P Circuits [12]	Max. Tandem Circuit Breakers	Load Center Box and Interior	Indoor Cover with Door		Main Wire Size AWG/kcmil		Bus Rating	Equipment Ground Bar Kit (Order Separately)	Box No. [13]
						Flush	Surface	Al	Cu			
INDOOR	Fixed Mains—Factory-Installed Main Lugs—10 kA Short Circuit Current Rating [14]											
	100 A	6	12	6	QO612L100DFCU	Cover Included—With Door		8-1	100	PK7GTA	4	
		8	16	8	QO816L100DFCU	Cover Included—With Door						

**Table 1.6: Low Amperage Fixed Mains Indoor Load Centers with Factory Installed Ground Bar (Accepts Only QO Plug-On Circuit Breakers - Not compatible with QO Plug-on Neutral Circuit Breakers)**

	Mains Rating	Short Circuit Current Rating	Spaces	Max. 1P Circuits [12]	Max. Tandem Circuit Breakers	Load Center [15] Box, Interior, and Cover	Equipment Ground Bar Kit (Order Separately)	Main Wire Size AWG/kcmil		Bus Rating	Box No. [13]
								Al	Cu		
INDOOR	Manufactured Housing: 1Ø2W 120 Vac—Main Lugs Only—CSA Certified										
	30 A [16]	10 kA	2	2	0	QO2L30TTS [17]	Factory-installed	12-10	14-10	30	1
	50 A	10 kA	2	4	2	QO24L50TTS [18]	Factory-installed	—	14-6	70	2
	1Ø2W 120 Vac—Main Circuit Breakers—CSA Certified										
	30 A	10 kA	3	5	2	QO35FM30TTF	Factory-installed	[19]	—	—	3
	1Ø3W 120/240 Vac—Main Lugs Only—CSA Certified										
	100 A	10 kA	6	12	6	QO612L100TF	Factory-installed	4-1	100	100	4
			6	12	6	QO612L100DTF [20]					
			8	16	8	QO816L100TF					

[12] Maximum single pole branch circuits utilizing QO and/or QOT circuit breakers.

[13] See Indoor Enclosure Dimensions and Knockout Information in the Digest..

[14] UL short circuit current rating depends on lowest interrupting rating of circuit breaker installed.

[15] Order F for flush device or S for surface device.

[16] Mains rated 25 A when Al wire is used.

[17] Will not accept Qwik-Gard™ QO-GFI or QO-AFI circuit breaker.

[18] Use 10 AWG maximum size wire for GFI and AFI circuit breakers.

[19] Main circuit breaker is a field-installed standard QO single pole circuit breaker. Order separately from page 1-2 and 1-3.

[20] 70 A max. branch circuit breaker and 70 A max. back fed main circuit breaker.

**QO Riser Panels**  
**1Ø3W—120/240 Vac Special Applications—UL Listed**

**Table 1.7: Riser Panels for Offset Interior for Wide Gutter—30 A Maximum Branch Circuit Breaker on Left Side of Interior [21], [22]**  
**(Compatible with QO Plug-on Circuit Breakers and QO Plug-on Neutral Circuit Breakers)**

	Mains Rating	Spaces	Max. Single Pole Circuits [23]	Max. Tandem Circuit Breakers	Load Center Box and Interior	Load Center Cover		Equipment Ground Bar Kit (Order Separately)	Main Wire Size AWG/kcmil		Bus Ratings	Box No. [24]
						Flush	Mono-Flat		Al	Cu		
INDOOR	Convertible Mains—Factory-Installed Main Lugs, 65 kA Short Circuit Current Rating Convertible to QOM1 22 kA Short Circuit Current Rating Main Circuit Breaker (See page ) when used with QOC cover below—Copper Bus											
	125 A	12	24	12	QO112L125PWG	QOC20JFWG [25]	NQC20FWGW [25]	PK15GTA	6–2/0	125	14	
	Convertible Mains—Factory-Installed Main Circuit Breaker, 22 kA Short Circuit Current Rating Convertible to Main Lugs (See "Indoor, 1Ø, Main Circuit Breaker" or "Lower Amperage QOM2 Main Circuit Breaker" in Section 1 of the Digest) when used with QOC cover below—Copper Bus											
	200 A	24	36	12	QO124M200PWG125 [26]	QOC30JFWG [25]	NQC30FWGW [25]	PK23GTA	4–250	225	23	

Above listings through 200 A mains rating meet Federal Specification W-P-115c as Type 1, Class 2.

**Panelboard-style Covers for Riser Panels**

Mono-Flat™ Front available for riser panels as an alternative to standard load center cover. Provides a low-profile, aesthetically pleasing solution for high-traffic areas in upscale multi-family applications. Deadfront included. Lock kit not provided. [27]

Main Rating of Load Center	Catalog No.
125 A	NQC20FWG
200 A	NQC30FWG

**Table 1.8: Tap Kits for Use with Auxiliary Gutter**

Cat. No.	Use with Auxiliary Gutter Cat. No.	Riser Wire		Tap Off Wire	
		Lug Type	Al/Cu Wire Size	Lug Type	Al/Cu Wire Size
SDGT300C10C	SDAG26	Anderson VCEL030516H1 (Not included)	(2) 4 AWG–300 kcmil	Anderson VCEL02114S1 (Not Included)	(1) 8–1/0 AWG
SDGT300C300C	SDAG26	Anderson VCEL030516H1 (Not included)	(2) 4 AWG–300 kcmil	Anderson VCEL030516H1 (Not included)	(1) 4 AWG–300 kcmil

[21] UL short circuit current rating depends on lowest interrupting rating of circuit breaker installed.  
 [22] UL Listed 5000 A short circuit current rating for corner grounded Delta systems. Use QO-H circuit breakers only.  
 [23] Maximum single pole branch circuits utilizing QO and/or QOT circuit breakers.  
 [24] See Indoor Enclosure Dimensions and Knockout Information in the Digest..  
 [25] Available in gray and white. For white equivalencies, add the "W" suffix to the reference, or see QO Load Center Accessories in Section 1 of the Digest..  
 [26] Comes with 125 A main circuit breaker factory installed.  
 [27] Order catalog number PK4FL for field-installed lock kit.



Refer to Catalog **1100CT0501**

**Class T Fusible Pullouts**

- 2- or 3-pole fusible pullouts
- 200 A maximum 300 V Class T fuses (not included)
- 1Ø3W 120/240 V
- 1Ø2W 240 V
- 3Ø3W 240 V delta
- 3Ø4W 240/120 V delta
- 3Ø4W 208Y/120 V
- UL Listed 100 kA short circuit current rating

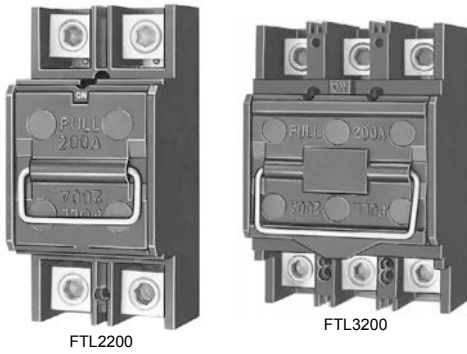

**Table 1.9: Fusible Pullouts**

Mains		Cat. No.		Main Wire Size AWG/kcmil	Fuse Pullout Only
System	Rating	Two Pole	Three Pole		
1Ø3W 120/240 V	100 A	FTL2100 [1]	—	4–250 Al/Cu	4050704950 [1]
1Ø2W 240 V	200 A	FTL2200 [1]	—		4050703850 [1]
3Ø3W 240 V delta	100 A	—	FTL3100	4–250 Al/Cu	4050707050 [1]
3Ø4W 240/120 V delta	200 A	—	FTL3200		4050705950 [1]

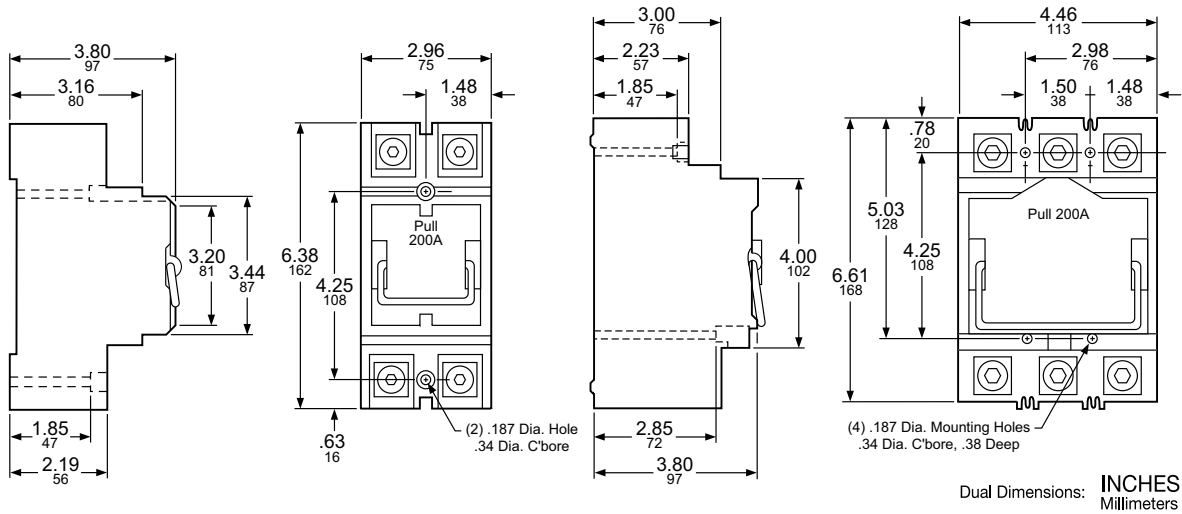

**Table 1.10: Covers**

Quantity	Cat. No.
1	BCH
1	BCV

**Circuit Breaker Covers**

Available now from Square D™ / Schneider Electric™ are two different versions of rainproof circuit breaker covers which are UL component recognized as being suitable for use as circuit breaker handle covers.

They are constructed of durable impact-resistant material and are intended for use by OEMs where a rainproof cover is needed (e.g. on heat pumps and air conditioners with built-in disconnects). Both models have a built-in latch with padlock provisions.

The BCH covers are for use on a horizontally-mounted circuit breaker and fit over Square D two-pole QO™, QOU, Q2, EH and three-pole Q2 and EH circuit breakers.

The BCV covers are for use on vertically-mounted circuit breakers and will fit over Square D two- and three-pole QO, QOU, Q2, EH, FA and KA circuit breakers.

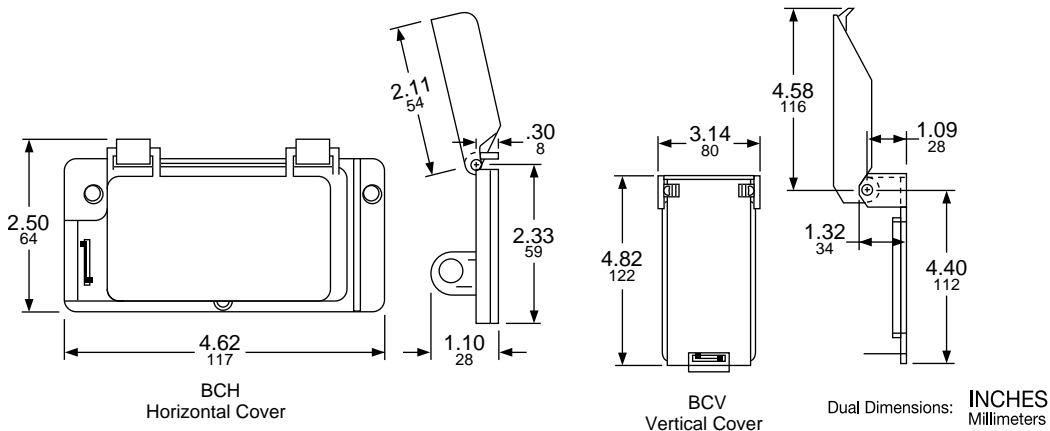

[1] Not stocked in PDS. Order point Lexington.

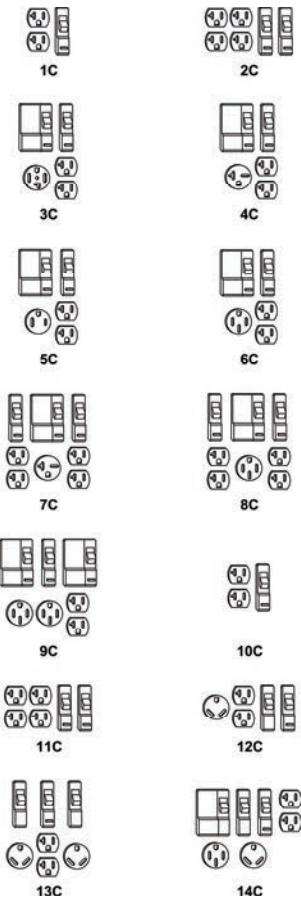

**Power Outlet Panels for Construction Sites**

- Provide temporary power at construction sites.
- Each receptacle protected by QO-GFI circuit breaker in compliance with NEC® requirements.
- Each enclosure is rainproof.
- 10 kA short circuit current rating.
- UL Listed as suitable for use as temporary site service equipment.
- Provided with neutral bonding provisions.
- Boxes have provisions for type “B” hubs to be field-installed.

**Table 1.11: Construction Site Panels**

Power Outlet Configuration	Service [1]	Mains Ampere Rating	Circuit Breaker (Included)	Receptacles (Included)						Cat. No. [2]	Main Wire Size AWG [3]	
				A	C	D	E	F	Cu		Al	
1C	1Ø2W	40 A	(1) QO120GFI	1					PAK10C1 OBS	14-6	12-6	
2C	1Ø2W	40 A	(2) QO120GFI	2					PAK11C [4]	14-6	12-6	
3C	1Ø3W	70 A	(1) QO120GFI (1) QO230GFI	1			1		PAK31CGFI	8-1	8-1	
4C	1Ø3W	70 A	(1) QO120GFI (1) QO220GFI	1		1			PAK36C1GFI	8-1	8-1	
5C	1Ø3W	70 A	(1) QO120GFI (1) QO250GFI	1				1	PAK51CGFI	8-1	8-1	
6C	1Ø3W	70 A	(1) QO120GFI (1) QO250GFI	1	1				PAK55CGFI	8-1	8-1	
7C	1Ø3W	70 A	(2) QO120GFI (1) QO220GFI	2		1			PAK72CGFI	8-1	8-1	
8C	1Ø3W	70 A	(2) QO120GFI (1) QO250GFI	2	1				PAK76CGFI	8-1	8-1	
9C	1Ø3W	100 A	(1) QO120GFI (2) QO250GFI	1	2				PAK1004CGFI	14-1	12-1	

OBS This product is obsolete.

[1] (1Ø2W 120 Vac) (1Ø3W 120/240 Vac)

[2] Devices have a bolt-on factory-installed closing cap. Order type “B” bolt-on hub separately from page 1-18.

[3] Equipment ground terminal suitable for (2) 14 or 12 AWG Cu or (2) 12 or 10 AWG Al.

[4] Receptacles in this device are in bottom endwall and are accessible with outer door padlocked. “Order Only” from Lexington—Minimum order quantity is 50 devices.

<b>A</b>		20 A 125 V 2W and Grd. NEMA 5-20R
<b>B</b>		30 A 125 V 2W and Grd. ANSI 73.13
<b>C</b>		50 A 125/250 V 3W and Grd. NEMA 14-50R
<b>D</b>		20 A 250 V 2W and Grd. NEMA 6-20R
<b>E</b>		30 A 125/250 V 3W and Grd. NEMA 14-30R
<b>F</b>		50 A 250 V 2W and Grd. NEMA 6-50R

All non-pedestal devices have provisions to field-install a Type "B" hub on the bottom endwall for bottom feed from a conduit riser. Order Type "B" bolt-on hub (B250 Max.) and two mounting screws (Cat. No. 8002505501) and two hex nuts (Cat. No. 2340102000).

**Power Outlet Panels for Recreational Vehicle Parks**

- Provide electrical power to individual recreational vehicle park sites.
- Each receptacle protected by appropriate GFI or Standard QO™ circuit breaker.
- All receptacles and circuit breakers included.
- 10 kA short circuit current rating.
- UL Listed.
- All enclosures are rainproof.
- No neutral bonding provisions.
- Loop-feed provisions.

**Table 1.12: Recreational Vehicle Park Panels**

Power Outlet Configuration	Service [5]	Mains Am-pere Rating	Circuit Breaker (Included)	Receptacles (Included) [6]			Cat. No.	Main Wire Size AWG/kcmil [7]	
				A	B	C		Phase and Neutral	
Underground or Overhead Loop-Feed Terminals—Non-Pedestal [8] [9]									
11C	1Ø2W	40 A	(2) QO120GFI	2			PAK11CTG	14–6	12–6
12C	1Ø2W	50 A	(1) QO120GFI (1) QO130	1	1		PAK41CTGFI		12–1
			(2) QO130	1	1		PAK41CTG		
14C	1Ø3W	100 A	(1) QO120GFI (1) QO250 (1) QO130	1	1	1	PAK75CTGFI (Not Loop Feed)	14–1	12–1
			(1) QO250 (1) QO130 (1) QO120GFI	1	1	1	PAK75CTG (Not Loop Feed)		
Pedestal Mounted—Underground Loop-Feed Terminals [10]									
11C	1Ø2W	40 A	(2) QO120GFI	2			PAK11PG	(2) 6–250	
12C	1Ø2W	50 A	(1) QO120GFI (1) QO130	1	1		PAK41PGFI		
			(2) QO130	1	1		PAK41PG		
13C	1Ø2W	75 A	(1) QO120GFI (2) QO130	1	2		PAK61PGFI <sup>OBS</sup>		
			(3) QO130	1	2		PAK61PG <sup>OBS</sup>		
14C	1Ø3W	100 A	(1) QO120GFI (1) QO250 (1) QO130	1	1	1	PAK75PG FI		
			(1) QO250 (1) QO130 (1) QO120GFI	1	1	1	PAK75PG		

<sup>OBS</sup> This product is obsolete.

[5] (1Ø2W 120 Vac) (1Ø3W 120/240 Vac)

[6] 20 A receptacles protected by 20 A GFI circuit breaker.

[7] Two wires each per phase, neutral, and equipment ground—for loop feed (except PAK75CTG).

[8] Devices have a bolt-on factory-installed closing cap. Order type "B" bolt-on hub separately from page 1-18.

[9] Equipment ground terminal suitable for (2) 14–12 AWG Cu or (2) 12–10 Al.

[10] Equipment ground terminals suitable for (2) 10–2/0 AWG Cu or (2) 6–2/0 AWG Al.

# Section 2

## Safety Switches

<b>Heavy Duty Safety Switches</b>	<b>2-2</b>
Bonded Neutral Safety Switches	2-2
240 Volt Single-Throw Fusible Switches	2-2
600 Volt Single-Throw Fusible Switches	2-2
Neutral Safety Switches	2-3
NEMA 7 and 9	2-3
Receptacle Switches	2-4
Interlocked Receptacle Switches	2-4
Appleton Powertite Receptacle	2-4
Crouse-Hinds Arktite Receptacle	2-5
Hubbell Receptacle	2-5
Key Interlock Systems	2-6
240 Volt Single-Throw Fusible Switches Obsolete – April 28, 2023	2-8
600 Volt Single-Throw Fusible Switches	2-9
600 Volt Single-Throw Non-Fusible Switches Obsolete – April 28, 2023	2-10
Special Applications	2-11
316 Grade Stainless Steel - NEMA Type 3, 3R, 4, 4X, 5, 12 Obsolete – April 28, 2023	2-11
Dimensions for Heavy Duty Safety Switches	2-12
NEMA Type 4, 4X, 5, 7, 9, and 12 Obsolete – April 28, 2023	2-12
Electrical Interlocks	2-13

240 Volt Single-Throw Fusible Switches

Table 2.1: 240 Volt Single-Throw Fusible Safety Switches

Ampere	Type 1	Type 3R	Equipment Ground Kit	Type 12	Type 4X 304 SS	Class R Fuse Kits	Line Side Barriers	Horsepower Ratings				250 Vdc
								Std (Fast Acting One-Time Fuses)		Max (Dual Element Time-Delay Fuses)		
								1Ø	3Ø	1Ø	3Ø	
<b>3 Wire (2 Blade and Fuseholder, 1 neutral) –240 Vac 250 Vdc</b>												
30	VH221BGL	VH221BRBGL	GTK03	VH221BAWKGL	VH221BDSGL	RFK03L	Factory Included	1-1/2	3	3	7-1/2	5
60	VH222BGL	VH222BRBGL	GTK03	VH222BAWKGL	VH222BDSGL	RFK03H	Factory Included	3	7-1/2	10	15	10
100	VH223BGL	VH223BRBGL	GTK0610	VH223BAWKGL	VH223BDSGL	RFK10	Factory Included	7-1/2	15	15	30	20
200	VH224BGL	VH224BRBGL	PKOGTA2	VH224BAWKGL	VH224BDSGL	HRK1020	Factory Included	15	25	—	60	40
400	CH225N	CH225NR	PKOGTA2	CH225NAWK	CH225NDS	HRK4060	LSBG202	—	50	—	125	50
600	CH226N	CH226NR	PKOGTA2	CH226NAWK	CH226NDS	HRK4060	LSBG202	—	75	—	200	50
800	CH227N	CH227NR	PKOGTA7	CH227NAWK	—	—	LSBF202	50	—	—	—	50
1200	CH228N	CH228NR	PKOGTA8	CH228NAWK	—	—	LSBF202	50	—	—	—	50
<b>4 Wire (3 Blade and Fuseholder, 1 neutral) –240 Vac 250 Vdc</b>												
30	VH321BGL	VH321BRBGL	GTK03	VH321BAWKGL	VH321BDSGL	RFK03L	Factory Included	1-1/2	3	3	7-1/2	5
60	VH322BGL	VH322BRBGL	GTK03	VH322BAWKGL	VH322BDSGL	RFK03H	Factory Included	3	7-1/2	10	15	10
100	VH323BGL	VH323BRBGL	GTK0610	VH323BAWKGL	VH323BDSGL	RFK10	Factory Included	7-1/2	15	15	30	20
200	VH324BGL	VH324BRBGL	PKOGTA2	VH324BAWKGL	VH324BDSGL	HRK1020	Factory Included	15	25	—	60	40
400	CH325N	CH325NR	PKOGTA2	CH325NAWK	CH325NDS	HRK4060	LSBG203	—	50	—	125	50
600	CH326N	CH326NR	PKOGTA2	CH326NAWK	CH326NDS	HRK4060	LSBG203	—	75	—	200	50
800	CH327N	CH327NR	PKOGTA7	CH327NAWK	—	—	LSBF203	50	—	—	—	50
1200	CH328N	CH328NR	PKOGTA8	CH328NAWK	—	—	LSBF203	50	—	—	—	50

600 Volt Single-Throw Fusible Switches

Table 2.2: 600 Volt Single-Throw Fusible Safety Switches

Ampere	Type 1	Type 3R	Equipment Ground Kit	Type 12	Type 4X 304 SS	Class R Fuse Kits	Line Side Barriers	Horsepower Ratings				600 Vdc
								Std (Fast acting one-time fuses)		Max (Dual element time-delay fuses)		
								1Ø	3Ø	1Ø	3Ø	
<b>4 Wire (3 Blade and Fuseholder, 1 neutral) –600 Vac 600Vdc</b>												
30	VH361BGL	VH361BRBGL	GTK03	VH361BAWKGL	VH361BDSGL	RFK03L	Factory Included	5	15	7-1/2	20	15
60	VH362BGL	VH362BRBGL	GTK03	VH362BAWKGL	VH362BDSGL	RFK03H	Factory Included	15	30	15	50	30
100	VH363BGL	VH363BRBGL	GTK0610	VH363BAWKGL	VH363BDSGL	RFK10	Factory Included	25	60	30	100	50
200	VH364BGL	VH364BRBGL	PKOGTA2	VH364BAWKGL	VH364BDSGL	HRK1020	Factory Included	50	125	60	150	50
400	CH365N	CH365NR	PKOGTA2	CH365NAWK	CH365NDS	HRK4060	LSBG203	100	250	125	350	50
600	CH366N	CH366NR	PKOGTA2	CH366NAWK	CH366NDS	HRK4060	LSBG203	150	400	200	500	50
800	CH367N	CH367NR	PKOGTA7	CH367NAWK	—	—	LSBF203	200	500	250	500	50
1200	CH368N	CH368NR	PKOGTA8	CH368NAWK	—	—	LSBF203	200	500	250	500	50

SAFETY SWITCHES



**NEMA 7 and 9**

An enclosed automatic molded case switch for use in Divisions 1 and 2 of the following: Class I, Groups C and D; Class II, Groups E, F and G; or Class III, Hazardous Locations as defined in NEC Article 500. Furnished with threaded conduit openings in both top and bottom endwall. Suitable for use as service equipment and listed as “Raintight” for outdoor applications. cULus Listed. Equipment grounding lugs supplied as standard. See CAD drawing of the switch to verify the UL listed short circuit current rating or the enclosed safety switch catalog.

Amperes	Enclosed Molded Case Switch	Solid Neutral Assembly	Horsepower Ratings 3Ø			Size of Threaded Conduit Openings
	Cat. No.	Cat. No.	240 V	480 V	600 V	
60	H60XBD	100SNA	15	15	50	3/4 in.
60	H60XBDAA					
100	H100XBD		30	60	75	
100	H100XBDAA					
225	H225XJG	225SNA	60	125	150	2-1/2 in.
225	H225XJGAA					

**Table 2.3: Conduit Provisions**

Amperes	Top and Bottom Endwall
	NEMA Type 7 and 9 [1]
30	—
60	3/4 in.
100	1-1/4 in.
200	2-1/2 in.

[1] Threaded conduit opening

**Interlocked Receptacle Switches**

**Interlocked Receptacle Switches** are furnished with a factory-installed three-phase four-wire Appleton Powertite<sup>TM</sup>, Crouse-Hinds Style 2 Arkrite<sup>TM</sup>, or Hubbelock<sup>TM</sup> receptacle. The fourth wire is connected to the switch equipment grounding terminal and is not a solid neutral termination. Interlocking linkage between the receptacle and switch mechanism protects against insertion or removal of the plug while the switch is in the “ON” position or insertion of any plug other than specified. Grounding lugs are included. See wiring diagram of the switch to verify the UL listed short circuit current rating or the Square D Enclosed Safety Switches catalog.



H362AWA  
Interlocked Receptacle  
Switch with Appleton  
Powertite Receptacle



H362AWC  
Interlocked Receptacle  
Switch with Crouse-Hinds  
Arkrite Receptacle



H362AWH  
Interlocked Receptacle  
Switch with Hubbell  
Hubbelock Receptacle

**Appleton Powertite Receptacle**

- UL Listed and CSA Certified
- Available in 30–100 A, 600 Vac / 250 Vdc, fused or non-fused, NEMA Type 1, NEMA Type 4 / 4X / 5 stainless steel and NEMA Type 12 / 3R
- Suitable for use as service equipment (USA only)
- Receptacles are epoxy powder coated over copper-free cast aluminum

**Table 2.4: Appleton Powertite Receptacle Switches**

Amperes	NEMA Type 1	NEMA Types 3, 3R, 4, 4X, 5, 12 304 Stainless Steel Enclosure	NEMA Types 12, 3R	Use with Plug [2]	Horsepower Ratings—3Ø					
					480 Vac [3]		600 Vac [3]		250 Vdc [4]	
					Std.	Max.	Std.	Max.	Std.	Max.
<b>Fusible—3P, 600 Vac, 250 Vdc</b>										
30	H361WA	H361DSWA	H361AWA	ACP3034BC	5	15	7-1/2	20	5	—
60	H362WA	H362DSWA	H362AWA	ACP6034BC	15	30	15	50	10	—
100	H363WA	H363DSWA	H363AWA	ACP1034CD	25	60	30	75	20	—
<b>Non-Fusible—3P, 600 Vac, 250 Vdc</b>										
30	HU361WA	HU361DSWA	HU361AWA	ACP3034BC	—	20	—	30	—	5
60	HU362WA	HU362DSWA	HU362AWA	ACP6034BC	—	50	—	60	—	10
100	HU363WA	HU363DSWA	HU363AWA	ACP1034CD	—	75	—	100	—	20

**Table 2.5: Appleton Powertite Receptacle Switches Fuses and Circuit Breakers**

Ampere	10 kAIR Fuse	100 kAIR Fuses	200 kAIR Fuses	14 kAIR Circuit Breaker	18kAIR Circuit Breaker
<b>Fusible—3P, 600 Vac, 250 Vdc</b>					
30	H, K	—	J, R	—	—
60	H, K	—	J, R	—	—
100	H, K	—	J, R	—	—
<b>Non-Fusible—3P, 600 Vac, 250 Vdc</b>					
30	H, K	J, R, T [5]	J, R, T	FA	FH
60	H, K	—	J, R, T	FA	FH
100	H, K	—	J, R, T	FA	FH

[2] Receptacle UL listed for use with Appleton ACP or CPH plugs; UL Classified for use with Crouse-Hinds APJ Arkrite plugs. (see Table 2.6).  
 [3] Std.—Using fast acting one time fuses. Max.—Using dual element time delay fuses.  
 [4] For switching dc, use two outside switching poles.  
 [5] SCCR when using 60 A Max fuse.

**Crouse-Hinds Arktite Receptacle**

- UL Listed
- Available in 30–100 A, 600 Vac / 250 Vdc, fused or non-fused, NEMA Type 1, NEMA Types 4/4X/5 stainless steel and NEMA Types 12/3R
- Suitable for use as service equipment
- Receptacles are cast aluminum, copper free for NEMA Type 1 and NEMA Types 12/3R safety switches
- Receptacles are epoxy powder coated, copper free cast aluminum for NEMA Types 4/4X/5 stainless steel safety switches

**Table 2.6: Crouse-Hinds Arktite Safety Switches**

Amperes	NEMA Type 1	NEMA Types 4, 4X, 5 304 Stainless Steel Enclosure	NEMA Types 12, 3R	Use with Plug	Horsepower Ratings—3Ø					
					480 Vac [6]		600 Vac [6]		250 Vdc [7]	
					Std.	Max.	Std.	Max.	Std.	Max.
<b>Fusible—3P, 600 Vac, 250 Vd</b>										
30	H361WC	H361DSWC	H361AWC	APJ3485	5	15	7-1/2	20	5	—
60	H362WC	H361DSWC	H361AWC	APJ6485	15	30	15	50	10	—
100	H363WC	H363DSWC	H362AWC	APJ10487	25	60	30	75	20	—
<b>Non-Fusible—3P, 600 Vac, 250 Vdc</b>										
30	HU361WC	HU361DSWC	HU361AWC	APJ3485	—	20	—	30	—	5
60	HU362WC	HU362DSWC	HU362AWC	APJ6485	—	50	—	60	—	10
100	HU363WC	HU363DSWC	HU363AWC	APJ10487	—	60	—	100	—	20

**Table 2.7: Crouse-Hinds Arktite Safety Switches Fuses and Circuit Breakers**

Amperes	10 kAIR Fuses	100 kAIR Fuses	200 kAIR Fuses	14 kAIR Circuit Breaker	18 kAIR Circuit Breaker
<b>Fusible—3P, 600 Vac, 250 Vd</b>					
30	H, K	—	J, R	—	—
60	H, K	—	J, R	—	—
100	H, K	—	J, R	—	—
<b>Non-Fusible—3P, 600 Vac, 250 Vdc</b>					
30	H, K	J, R, T [8]	J, R, T	FA	FH
60	H, K	—	J, R, T	FA	FH
100	H, K	—	J, R, T	FA	FH

**Hubbelock Receptacle**

- UL Listed
- Available in 30–100 A, 600 Vac / 250 Vdc, fused or non-fused, NEMA Type 1, and NEMA Type 12
- Suitable for use as service equipment [9]
- Receptacles are zinc plated steel for NEMA Types 1 and 12 safety switches
- Short Circuit Current Rating for fusible switches is 10 kAIR maximum when used with Class H, K, J or R fuses
- Short Circuit Current Rating for non-fusible switches is 10 kAIR maximum when using Class H, K, J, R or T fuses

**Table 2.8: Hubbelock Receptacle Safety Switch**

Amperes	NEMA Type 1	NEMA Type 12	Use with Plug [10]	Horsepower Ratings—3Ø			
				480 Vac [11]		600 Vac [11]	
				Std.	Max.	Std.	Max.
<b>Fusible—3P, 600 Vac</b>							
60	H362WH	H362AWH	SD12781	15	30	15	50
<b>Non-Fusible—3P, 600 Vac</b>							
60	HU362WH	HU362AWH	SD12781	—	50	—	60

[6] Std.—Using fast acting one time fuses. Max.—Using dual element time delay fuses.

[7] For switching dc, use two outside switching poles.

[8] SCCR when using 60 A Max fuse.

[9] Receptacle only rated for NEMA Type 1 and 12 applications.

[10] Hubbell plug is furnished with a Kellems grip for 1-1/2 in. to 1-21/64 in. cable diameter.

[11] Std.—Using fast acting one time fuses. Max.—Using dual element time delay fuses.



## Key Interlock Systems and Sample Applications

**Factory-installed only** on heavy duty and double throw safety switches.

Interlocks help protect against unauthorized operation. Not available on hazardous location devices (NEMA 7/9) or fiberglass reinforced polyester (NEMA 4X).

The key interlock system is a simple and easy method of applying individual key interlock units and assemblies to the above equipment so as to require operation in a predetermined sequence. UL Listed.

**Quoting:** Contact Schneider Electric for catalog number, availability and pricing prior to quoting a job.

**Ordering:** Order cannot be released for production until the following information has been provided:

- End User—Company name, address.
- Function of each lock (e.g., switch to be locked open with key removed, key held when switch is closed).
- Existing Equipment—if switch is to be interlocked with equipment already on site, provide brand of existing lock and key number.
- Other New Equipment—if switch is to be interlocked with new equipment not yet installed at the site, then provide contact person and phone number so that locks may be coordinated.
- Additional information may be required upon order entry.

**Use these suffixes on switch catalog numbers:**

- KI = 1 lock per switch
- KI2 = 1 lock with 2 cylinders per switch
- KIKI = 2 separate locks per switch

### Key Interlock Sample Applications

**Sample Application—1** (see Figure 1)

To protect against two devices from being closed simultaneously.

Two devices are shown in Figure 1. In operation they are not closed at the same time. With the interlocks arranged as shown only one key is required in the interlocking system. Both devices are shown open, therefore, the key is free. To close any one device the key is inserted and turned in that particular lock, the key is held in this lock until the device is again locked open. This simple interlocking sequence lends itself to a multitude of applications. The procedure is the same for two devices, neither of which is to be opened at the same time.

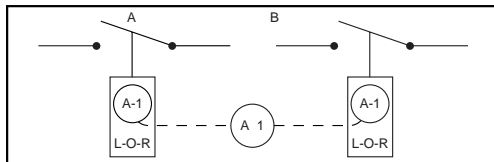

Figure 1

**Sample Application—2** (see Figure 2)

To protect against opening of switch A when circuit breaker B is closed.

Switch A and circuit breaker B are in closed position. Key A-1 is held in circuit breaker B interlock.

- Open circuit breaker.
- Turn key A-1 in L-O-R interlock on circuit breaker B to lock open. Key A-1 is now free.
- Insert key A-1 in L-C-R interlock on switch A and turn to unlock.
- Open switch A. Key A-1 is now held. Reverse sequence to restore service.

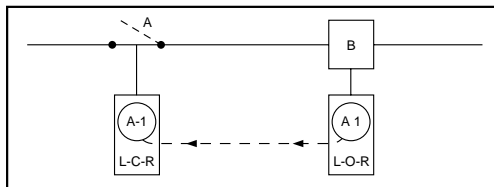

Figure 2

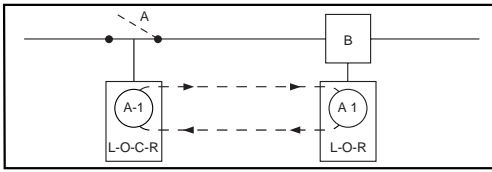

Figure 3

**Sample Application—3** (see Figure 3)

To protect against operation of switch A when circuit breaker B is closed. Permits re-closing of circuit breaker for servicing when switch is locked open.

Switch A and circuit breaker B are in closed position. Key A-1 is held in circuit breaker interlock.

- Open circuit breaker.
- Turn key A-1 in L-O-R interlock on circuit breaker B to lock open. Key A-1 is now free.
- Insert key A-1 in L-O-C-R interlock on switch A and turn to unlock.
- Open switch A.
- Turn key A-1 in L-O-C-R interlock on switch A to lock open. Key A-1 is now free.
- Return key A-1 to circuit breaker interlock and unlock for operation during servicing period.

Reverse sequence to restore service.

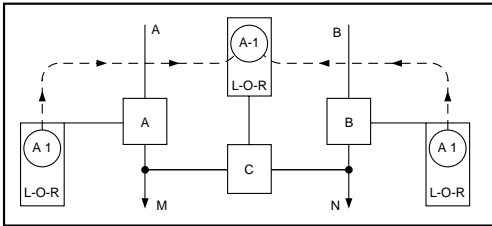

Figure 4

**Sample Application—4 (Main-Tie-Main)** (See Figure 4)

To protect against paralleling of lines A and B; two loads, fed from either source.

Circuit breaker A is closed to supply load M. Circuit breaker B is closed to supply load N. Tie-circuit breaker C is open. Keys A-1 are held in interlocks on both circuit breakers A and B. Tie-circuit breaker C cannot be closed unless either A or B is locked open.

To transfer load N to circuit breaker A, proceed as follows:

- Open circuit breaker B.
- Turn key A-1 in L-O-R interlock on circuit breaker B to lock open. Key A-1 is now free.
- Insert Key A-1 in L-O-R interlock on tie-circuit breaker C and turn to unlock. Key A-1 is now held.
- Close tie-circuit breaker C.
- Reverse sequence to restore service.
- Load M can be supplied through circuit breaker B in a similar manner.

**Locking Position—Designations**

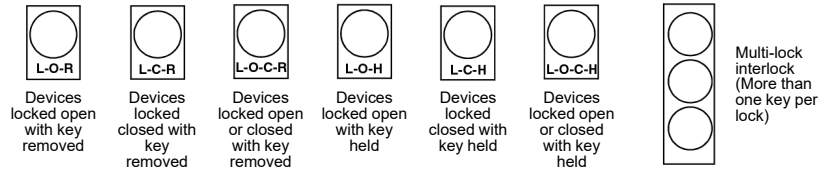

**Diagram Symbols**

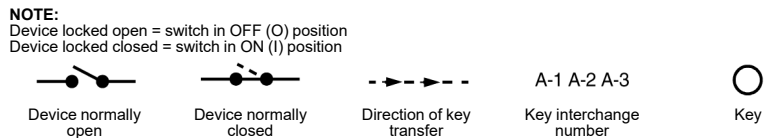

240 Volt Single-Throw Fusible Switches Obsolete – April 28, 2023

Table 2.9: 240 V Single-Throw Fusible Safety Switches

Amperes	NEMA Type 1 Indoor	NEMA Type 3R Rainproof (Bolt-on Hubs [12])	NEMA Type 4, 4X, 5, [13] 304 Stainless Steel [14] Dust Resistant, Water Resistant, Corrosion Resistant (Water Resistant Hubs [12])	NEMA Type 12K With Knockouts (Water Resistant Hubs [12])	NEMA Type 3R, 5 or 12 [15] Without Knockouts (Water Resistant Hubs [12])	Line Side Barriers Factory Included [16]	Horsepower Ratings				
							240 Vac				250 Vdc [17]
							Std. (Using Fast Acting, One Time Fuses)		Max. (Using Dual Element, Time Delay Fuses)		
Cat. No.	Cat. No.	Cat. No.	Cat. No.	Cat. No.	1Ø	3Ø	1Ø	3Ø			
<b>2-Wire (2 Blades and Fuseholders)—240 Vac, 250 Vdc</b>											
30	Use three-wire devices for two-wire applications		H221DS	H221A	H221AWK	Factory Included	1-1/2	3 [18]	3	7-1/2 [18]	5
30			—	—	H2212AWK [19]	Factory Included	1-1/2	—	3	—	5
60			H222DS	—	H222AWK	Factory Included	3	7-1/2 [18]	10	15 [18]	10
100			H223DS	H223A	H223AWK	Factory Included	7-1/2	15 [18]	15	30 [20]	20
200			H224DS	H224A	H224AWK	Factory Included	15	25 [18]	—	60 [18]	40
<b>3-Wire (2 Blades and Fuseholders, 1 Neutral)—240 Vac, 250 Vdc</b>											
30	H221N	H221NRB	Use two-wire devices.			Factory Included	1-1/2	3 [18]	3	7-1/2 [20]	5
60	H222N	H222NRB				Factory Included	3	7-1/2 [18]	10	15 [18]	10
100	H223N	H223NRB				Factory Included	7-1/2	15 [18]	15	30 [18]	20
200	H224N	H224NRB				Factory Included	15	25 [18]	—	60 [18]	40
<b>3-Wire (3 Blades and Fuseholders)—240 Vac, 250 Vdc</b>											
30	Use four-wire devices For three-wire applications		H321DS	H321A	H321AWK	Factory Included	1-1/2	3	3	7-1/2	5
60			H322DS	H322A	H322AWK	Factory Included	3	7-1/2	10	15	10
100			H323DS	H323A	H323AWK	Factory Included	7-1/2	15	15	30	20
200			H324DS	H324A	H324AWK	Factory Included	15	25	—	60	40
<b>4-Wire (3 Blades and Fuseholders, 1 Neutral)—240 Vac, 250 Vdc</b>											
30	H321N	H321NRB	Use three-wire devices. See Digest section 3.			Factory Included	1-1/2	3	3	7-1/2	5
60	H322N	H322NRB				Factory Included	3	7-1/2	10	15	10
100	H323N	H323NRB				Factory Included	7-1/2	15	15	30	20
200	H324N	H324NRB				Factory Included	15	25	—	60	40

SAFETY SWITCHES

[12] For Rainproof Bolt-On Hubs and Water Resistant Hubs see Digest section 3.  
 [13] Complete rating is NEMA Type 3, 3R, 4, 4X, 5 and 12. For NEMA Type 3R applications, remove drain screw from bottom endwall.  
 [14] See 316 Grade Stainless Steel-NEMA Type 3, 3R, 4, 4X, 5, 12, in Digest section 3.  
 [15] Also suitable for NEMA Type 3R application by removing drain screw from bottom endwall.  
 [16] Factory included to prevent inadvertent contact with live parts per UL 869A and NEC Service entrance barrier requirements.  
 [17] For switching dc, use two outside switching poles.  
 [18] For corner grounded delta systems, use switching poles for ungrounded conductors. See data bulletin 2700D60202 for additional information.  
 [19] 60 A switch with 30 A fuse spacing and clips. Must use 60 A enclosure accessories including electrical interlocks.  
 [20] For corner grounded delta systems, use switching poles for ungrounded conductors.

**600 Volt Single-Throw Fusible Switches**
**Table 2.10: 600 Volt Single-Throw Fusible Safety Switches**

Amperes	NEMA Type 1 Indoor	NEMA Type 3R Rainproof (Bolt-on Hubs [21])	NEMA Type 4, 4X, 5 [22] 304 Stainless Steel (316 stainless steel [23]) Dust Resistant, Water Resistant, Corrosion Resistant (Water Resistant Hubs [21])	NEMA Type 12K With Knockouts (Water Resistant Hubs [21])	NEMA Type 3R, 5 or 12 Without Knockouts (Water Resistant Hubs [21])	Line Side Barriers Factory Included	Horsepower Ratings					
							480 Vac		600 Vac		DC	
							Std. (Using Fast Acting, One Time Fuses)	Max. (Using Dual Element, Time Delay Fuses)	Std. (Using Fast Acting, One Time Fuses)	Max. (Using Dual Element, Time Delay Fuses)		
Cat. No.	Cat. No.	Cat. No.	Cat. No.	Cat. No.		3Ø	3Ø	3Ø	3Ø	250	600	
<b>3-Wire (3 Blades and Fuseholders)—600 Vac, 600 Vdc</b>												
30	H361	H361RB	H361DS	H361A	H361AWK	Factory included	5	15	7-1/2	20	5	15
30	H3612	H3612RB	—	H3612A	H3612AWK	Factory included	5	15	7-1/2	20	—	15
60	H362	H362RB	H362DS	H362A	H362AWK	Factory included	15	30	15	50	—	30
100	H363	H363RB	H363DS	H363A	H363AWK	Factory included	25	60	30	100	—	50
200	H364	H364RB	H364DS	H364A	H364AWK	Factory included	50	125	60	150	40	50
<b>4-Wire (3 Blades and Fuseholders, 1 Neutral)—600 Vac, 600 Vdc</b>												
30	H361N	H361NRB	—			Factory included	5	15	7-1/2	20	—	15
60	H362N	H362NRB	—			Factory included	15	30	15	50	—	30
100	H363N	H363NRB	—			Factory included	25	60	30	75	—	50
200	H364N	H364NRB	H364NDS	H364NA	H364NAWK	Factory included	50	125	60	150	40	50
<b>4-Wire (4 Blades and Fuseholders)—600 Vac, 600 Vdc</b>												
30	H461	—	—	—	—	Factory included	7-1/2	20	10	25	5	15
60	H462	—	—	—	—	Factory included	15	40	20	50	10	30
100	H463	—	—	—	—	Factory included	25	60	30	75	20	30
200	H464	—	—	—	—	Factory included	50	125	60	150	40	50
400	H465	—	—	—	—	QTY (2): LSBG602	100	250	125	350	50	50
600	H466	—	—	—	—	QTY (2): LSBG602	150	400	200	500	50	50

[21] For Rainproof Bolt-On Hubs and Water Resistant Hubs see Digest section 3.

[22] Complete rating is NEMA Type 3, 3R, 4, 4X, 5 and 12. For NEMA Type 3R applications, remove drain screw from bottom endwall.

[23] See 316 Grade Stainless Steel-NEMA Type 3, 3R, 4, 4X, 5, 12, in Digest section 3.

600 Volt Single-Throw Non-Fusible Obsolete – April 28, 2023

Table 2.11: 600 Volt Single-Throw Non-Fusible Switches

Amperes	NEMA Type 1 Indoor	NEMA Type 3R Rainproof (Bolt-on Hubs [24])	NEMA Type 4, 4X, 5 [25] 304 Stainless Steel [26] Dust Resistant, Water Resistant, Corrosion Resistant (Water Resistant Hubs [24])	NEMA Type 12K With Knockouts [24]	NEMA Type 3R, 5 or 12 [27] Without Knockouts [24]	Line Side Barriers	Horsepower Ratings (Max.)							
							Volts AC						Volts DC [28]	
							240		Line 480		600			
Cat. No.	Cat. No.	Cat. No.	Cat. No.	Cat. No.	1Ø	3Ø	1Ø	3Ø	1Ø	3Ø	250	600		
<b>3-Wire (3 Blades)—600 Vac, 600 Vdc</b>														
30	HU361	HU361RB	HU361DS	HU361A	HU361AWK	[29]	5	10	7-1/2	20	10	30	5	15
39	HU361EI [30]	HU361RBEI [30]	HU361DSEI [30]	HU361AEI [30]	HU361AWKEI [30]	[29]	5	10	7-1/2	20	10	30	5	15
30	—	HU3612RB [31]	—	HU3612A [31]	HU3612AWK [31]	[29]	5	10	7-1/2	20	10	30	5	15
60	HU362	HU362RB	HU362DS	HU362A	HU362AWK	[29]	10	20	25	50	30	60	10	30
60	—	—	HU362DSEI [30]	—	—	[29]	10	20	25	50	30	60	10	30
100	HU363	HU363RB	HU363DS	HU363A	HU363AWK	[29]	20	40	40	75	40	100	20	50
200	HU364	HU364RB	HU364DS	HU364A	HU364AWK	[29]	15	60	50	125	50	150	40	50

SAFETY SWITCHES

[24] For Rainproof Bolt-On Hubs and Water Resistant Hubs see Digest section 3.

[25] Complete rating is NEMA Type 3, 3R, 4, 4X, 5 and 12. For NEMA Type 3R applications, remove drain screw from bottom endwall.

[26] See 316 Grade Stainless Steel-NEMA Type 3, 3R, 4, 4X, 5, 12, in Digest section 3.

[27] Also suitable for NEMA Type 3R application by removing drain screw from bottom endwall.

[28] or switching dc use two switching poles.

[29] Factory Included to help avoid inadvertent contact with live parts per UL 869A and NEC service entrance barrier requirements.

[30] Switches with EI suffix are stocked with factory-installed electrical interlocks with one normally-open and one normally-closed contact.

[31] Use 60 A enclosure accessories, including electrical interlocks.

### 316 Grade Stainless Steel - NEMA Type 3, 3R, 4, 4X, 5, 12 Obsolete – April 28, 2023

316 stainless steel enclosure safety switches offer superior corrosion resistance to a wider range of chemicals than 304 stainless switches. 316 better resists chloride and is often used in marine, waste treatment, and transportation applications. Use water resistant hubs, see Hubs in Digest Section 3.

Equipment grounding lugs are supplied as standard through 200 A. See Terminal Lug Data in Digest Section 3 for wire termination data for grounding lugs.

**Table 2.12: 316 Grade Stainless Steel Three-pole 600 Vac, 600 Vdc**

Amperes	Cat. No.	Line Side Barriers [32]	Horsepower Ratings– 3Ø				
			480 Vac [33]		600 Vac [33]		600 Vdc [34]
			Std.	Max.	Std.	Max.	Max.
<b>Fusible—3P, 600 Vac, 600 Vdc</b>							
30	H361SS	Factory Included	5	15	7-1/2	20	15
60	H362SS	Factory Included	15	30	15	50	30
100	H363SS	Factory Included	25	60	30	75	50
200	H364SS	Factory Included	50	125	60	150	50
<b>Non-Fusible—3P, 600 Vac, 600 Vdc</b>							
30	HU361SS	Factory Included	—	20	—	30	15
60	HU362SS	Factory Included	—	50	—	60	30
100	HU363SS	Factory Included	—	75	—	100	50
200	HU364SS	Factory Included	—	125	—	150	50

[32] Factory-included to help avoid inadvertent contact with live parts per UL 869A and NEC service entrance barrier requirements.

[33] Std.—Using fast acting, one time fuses. Max.—Using dual element time delay fuses.

[34] For switching dc use two switching poles.

NEMA Type 4, 4X, 5, 7, 9, and 12 Obsolete – April 28, 2023  
Terminal lug data can be found in Digest Section 3.

Table 2.13: Approximate Dimensions for NEMA Type 4, 4X, 5, 7, 9, and 12 Safety Switches

Cat. No.	Series	H		W		D		W/H		Cat. No.	Series	H		W		D		W/H	
		in.	mm	in.	mm	in.	mm	in.	mm			in.	mm	in.	mm	in.	mm	in.	mm
H221A	F6	14.60	371	6.63	168	4.96	125	7.55	192	H362SS	F6	16.87	428	8.92	227	6.97	177	10.81	275
H221AWK	F6	14.60	371	6.63	168	4.96	125	7.55	192	H363AWA	F7	20.50	521	9.00	229	7.00	178	10.50	267
H221DS	F6	14.93	379	7.22	183	5.11	130	8.67	220	H363AWC	F7	20.50	521	9.00	229	7.00	178	10.50	267
H2212AWK	F6	16.50	419	9.00	229	7.00	178	10.50	267	H363A	F6	20.50	521	9.00	229	7.00	178	10.50	267
H222A	F6	14.60	371	6.63	168	4.96	125	7.55	192	H363AWK	F6	20.50	521	9.00	229	7.00	178	10.50	267
H222AWK	F6	14.60	371	6.63	168	4.96	125	7.55	192	H363DS	F6	20.82	529	9.36	238	6.97	177	11.25	286
H222DS	F6	14.93	379	7.22	183	5.11	130	8.67	220	H363DSWA	F7	20.82	529	9.36	238	6.97	177	11.25	286
H223A	F6	20.50	521	9.00	229	7.00	178	10.50	267	H363DSWC	F7	20.82	529	9.36	238	6.97	177	11.25	286
H223AWK	F6	20.50	521	9.00	229	7.00	178	10.50	267	H363SS	F7	20.82	529	9.36	238	6.97	177	11.25	286
H223DS	F6	20.82	529	9.36	238	6.97	177	11.25	286	H364A	F6	29.00	737	17.25	438	8.75	216	18.63	473
H224A	F6	29.00	737	17.25	438	8.75	216	18.63	473	H36AWK	F6	29.00	737	17.25	438	8.75	216	18.63	473
H224AWK	F6	29.00	737	17.25	438	8.75	216	18.63	473	H364DS	F6	29.00	737	17.75	451	8.88	226	19.25	489
H224DS	F6	29.00	737	17.25	451	8.88	226	19.25	489	H364NDS	F6	29.00	737	17.75	451	8.88	226	19.25	489
H321AWK	F6	14.60	371	6.63	168	4.96	125	7.55	192	H364NA	F6	29.00	737	17.25	438	8.75	216	18.63	473
H321A	F6	14.60	371	6.63	168	4.96	125	7.55	192	H364NAWK	F6	29.00	737	17.25	438	8.75	216	18.63	473
H321DS	F6	14.93	379	7.22	183	5.11	130	8.67	220	H364SS	F6	29.00	737	17.25	451	8.88	226	19.25	489
H321AWK	F6	14.60	371	6.63	168	4.96	125	7.55	192	HU361AWA	F7	16.50	419	9.00	229	7.00	178	10.50	267
H322A	F6	14.60	371	6.63	168	4.96	125	7.55	192	HU361AWC	F7	16.50	419	9.00	229	7.00	178	10.50	267
H322DS	F6	14.93	379	7.22	183	5.11	130	8.67	220	HU361A	F6	14.60	371	6.63	168	4.96	125	7.55	192
H323AWK	F6	20.50	521	9.00	229	7.00	178	10.50	267	HU361AWK	F6	14.60	371	6.63	168	4.96	125	7.55	192
H323A	F6	20.50	521	9.00	229	7.00	178	10.50	267	HU361DS	F6	14.93	379	7.22	183	5.11	130	8.67	220
H323DS	F6	20.82	529	9.36	238	6.97	177	11.25	286	HU361DSWA	F7	16.87	428	8.92	227	5.11	130	10.81	275
H324A	F6	29.00	737	17.25	438	8.75	216	18.63	473	HU361DSWC	F7	16.87	428	8.92	227	5.11	130	10.79	274
H324AWK	F6	29.00	737	17.25	438	8.75	216	18.63	473	HU361SS	F6	14.93	379	7.22	183	5.11	130	8.67	220
H324DS	F6	29.00	737	17.75	451	8.88	226	19.25	489	HU362DSWA	F7	16.87	428	8.92	227	5.11	130	10.81	275
H326DS	E5	46.25	1175	26.25	667	10.13	259	26.25	667	HU362DSWC	F7	16.87	428	8.92	227	5.11	130	10.79	274
H326NAWK	E5	46.25	1175	26.25	667	10.13	259	26.25	667	HU362SS	F6	16.87	428	8.92	227	6.97	177	10.81	275
H326DS	E5	46.25	1175	26.25	667	10.13	259	26.25	667	HU363AWA	F7	20.50	521	9.00	229	7.00	178	10.50	267
H326NAWK	E5	46.25	1175	26.25	667	10.13	259	26.25	667	HU363AWC	F7	20.50	521	9.00	229	7.00	178	10.50	267
H326NDS	E5	46.25	1175	26.25	667	10.13	259	26.25	667	HU363A	F6	20.50	521	9.00	229	7.00	178	10.50	267
H361AWA	F7	16.5	419	10.50	267	7.0	178	10.50	267	HU363AWK	F6	20.50	521	9.00	229	7.00	178	10.50	267
H361AWC	F7	16.5	419	10.50	267	7.0	178	10.50	267	HU363DS	F6	20.82	529	9.36	238	6.97	177	11.25	286
H361AWK	F7	14.60	371	7.55	192	4.96	125	7.55	192	HU363DSWA	F7	20.82	529	9.36	238	6.97	177	11.25	286
H361A	F7	14.60	371	7.55	192	4.96	125	7.55	192	HU363DSWC	F7	20.82	529	9.36	238	6.97	177	11.25	286
H361DS	F6	14.93	379	8.67	220	5.11	130	8.67	220	HU363SS	F6	20.82	529	9.36	238	6.97	177	11.25	286
H361DSWA	F7	16.87	428	8.92	227	5.11	130	10.81	275	HU364A	F6	29.00	737	17.25	438	8.75	216	18.63	473
H361DSWC	F7	16.87	428	8.92	227	5.11	130	10.79	274	HU364AWK	F6	29.00	737	17.25	438	8.75	216	18.63	473
H361SS	F6	14.93	379	7.22	183	5.11	130	8.67	220	HU364DF	E1	31.30	795	26.30	668	11.80	300	26.30	668
H3612A	F6	16.50	419	9.00	229	7.00	178	10.50	267	HU364DS	F6	29.00	737	17.75	451	8.88	226	19.25	489
H3612AWK	F6	16.50	419	9.00	229	7.00	178	10.50	267	HU364SS	F6	29.00	737	17.75	451	8.88	226	19.25	489
H362AWA	F7	16.50	419	9.00	229	7.00	178	10.50	267	HU365AWK	E5	46.25	1175	26.25	667	10.13	259	26.25	667
H362AWC	F7	16.50	419	9.00	229	7.00	178	10.50	267	HU365DS	E5	46.25	1175	26.25	667	10.13	259	26.25	667
H362AWH	F6	16.50	419	9.00	229	7.00	178	10.50	267	HU365SS	E5	46.25	1175	26.25	667	10.13	259	26.25	667
H362A	F6	16.50	419	9.00	229	7.00	178	10.50	267	HU366AWK	E5	46.25	1175	26.25	667	10.13	259	26.25	667
H362AWK	F6	16.50	419	9.00	229	7.00	178	10.50	267	HU366DS	E5	46.25	1175	26.25	667	10.13	259	26.25	667
H362DS	F6	16.87	428	8.92	227	6.97	177	10.81	275	HU366SS	E5	46.25	1175	26.25	667	10.13	259	26.25	667
H362DSWA	F7	16.87	428	8.92	227	5.11	130	10.81	275	HU367AWK	E4	69.13	1756	36.62	930	17.75	451	36.62	930
H362DSWC	F7	16.87	428	8.92	227	5.11	130	10.79	274	HU368AWK	E4	69.13	1756	36.62	930	17.75	451	36.62	930

SAFETY SWITCHES

**Electrical Interlock Kits**

Electrical interlocks for heavy duty 30–1200 A safety switches are available factory-installed or in kit form for field installation. Each kit contains instructions for proper field mounting. A pivot arm operates from switch mechanism, breaking the control circuit before the main switch blades break. Switches with electrical interlocks installed are UL Listed. For factory-installed electrical interlocks add EI (for one contact) or EI2 (for two contacts) suffix to catalog number.

**Table 2.14: Electrical Interlock Kit** [35] [36]

Switch Amperes Rating	Series Number [37]	Electrical Interlock Kit Cat. No. [38]
30	F5–F6	EIK031
		EIK032
60 (600 V)	F5–F6	EIK1
		EIK2
60 (240 V)	F5–F6	EIK031
		EIK032
100–200	F5–F6	EIK1
		EIK2
30–100 Receptacle Switches	F5–F7	EIK1
		EIK2
30–200 4 and 6 Pole Switches	F5–F6	EIK1
		EIK2
400–1200	E4–E5	EIK40601
		EIK40602

**Table 2.15: Electrical Interlock Contact Ratings** [39]

Interlock Type	AC - 50 or 60 Hz				DC		
	Volts	Make	Break	Cont.	Volts	Make & Break	Cont.
<b>Cat. no. ending with a 1 utilize a 9007A01 limit switch.</b>							
1 NO/1 NC Contact	120	40 A	15 A	15 A	115	0.50 A	15 A
	240	20 A	10 A	15 A	230	0.25 A	15 A
	480	10 A	6 A	15 A	—	—	—
	600	8 A	5 A	15 A	600	0.05 A	15 A
<b>Cat. no. ending with a 2 utilize a 9007C03 limit switch.</b>							
2 NO/2 NC Contacts	120	30 A	3.0 A	10 A	115	1.0 A	10 A
	240	15 A	1.5 A	10 A	230	0.30 A	10 A
	480	7.5 A	0.75 A	10 A	—	—	—
	600	6.0 A	0.60 A	10 A	600	0.10 A	10 A

[35] For series not shown in table refer to the switch wiring diagram.

[36] Electrical interlocks for Type 4X fiberglass reinforced polyester and Krydon™ see Digest Section 3.

[37] See Digest Section 3 for safety switch series.

[38] Electrical interlock kit catalog numbers ending in 1 indicates one normally open and one normally closed contact. These kits use a 9007A01 industrial snap switch. Electrical interlock kit catalog numbers ending in 2 indicates two normally open and two normally closed contacts. These kits use a 9007C03 industrial snap switch.

[39] Single pole single throw interlock kits are rated 1/2 hp @ 110 and 220 Vac.

## Section 3

**Molded Case Circuit Breakers and Enclosures**

<b>PowerPacT™ Circuit Breakers</b>	<b>3-2</b>
PowerPacT H- and J-Frame Circuit Breakers	3-2
PowerPacT L-Frame Circuit Breakers	3-4
<b>PowerPacT™ Automatic Switches</b>	<b>3-5</b>
PowerPacT™ Automatic Switches	3-5
<b>Molded Case Circuit Breakers</b>	<b>3-6</b>
Mag-Gard™ Motor Circuit Protector	3-6
<b>Special Construction Circuit Breakers</b>	<b>3-8</b>
Special Terminal Connectors and Lugs	3-8
Special Calibration and Accessories	3-9
Special Terminations	3-11
Grounded BØ Systems	3-12
UL Marine Listed Circuit Breakers	3-13
<b>Circuit Breaker Accessories</b>	<b>3-13</b>
Factory-Installed Accessories	3-14
Field-Installable Accessories	3-15
Electrical Operators, Handle Accessories and Walking Beam Interlocks	3-16
Mechanical Lug Information	3-17
Compression Lug and Power Distribution Connectors	3-17
<b>Circuit Breaker Dimensions</b>	<b>3-18</b>
Circuit Breaker Dimensions and Shipping Weights	3-18
<b>Enclosures</b>	<b>3-19</b>
Enclosed Switches, Dimensions, and Accessories	3-19
Accessories	3-20
Key Interlock Systems—Factory Installed Only	3-21

PowerPac™ H- and J-Frame Circuit Breakers

Table 3.1: H-Frame 150 A UL Current-Limiting Circuit Breaker Frame with Field-Interchangeable Thermal-Magnetic Trip Units [1]

Ampere Rating	Fixed AC Magnetic Trip		Cat. No.					Terminal Wire Range
	Hold	Trip	D Interrupting	G Interrupting	J Interrupting [2]	L Interrupting [2]	R Interrupting [2]	
3P, 600 Vac 50/60 Hz								
15 A	350 A	750 A	HDL36015T	HGL36015T	HJL36015T	HLL36015T	HRL36015T	AL150HD 14-3/0 AWG Al or Cu
20 A	350 A	750 A	HDL36020T	HGL36020T	HJL36020T	HLL36020T	HRL36020T	
25 A	350 A	750 A	HDL36025T	HGL36025T	HJL36025T	HLL36025T	HRL36025T	
30 A	350 A	750 A	HDL36030T	HGL36030T	HJL36030T	HLL36030T	HRL36030T	
35 A	400 A	850 A	HDL36035T	HGL36035T	HJL36035T	HLL36035T	HRL36035T	
40 A	400 A	850 A	HDL36040T	HGL36040T	HJL36040T	HLL36040T	HRL36040T	
45 A	400 A	850 A	HDL36045T	HGL36045T	HJL36045T	HLL36045T	HRL36045T	
50 A	400 A	850 A	HDL36050T	HGL36050T	HJL36050T	HLL36050T	HRL36050T	
60 A	800 A	1450 A	HDL36060T	HGL36060T	HJL36060T	HLL36060T	HRL36060T	
70 A	800 A	1450 A	HDL36070T	HGL36070T	HJL36070T	HLL36070T	HRL36070T	
80 A	800 A	1450 A	HDL36080T	HGL36080T	HJL36080T	HLL36080T	HRL36080T	
90 A	800 A	1450 A	HDL36090T	HGL36090T	HJL36090T	HLL36090T	HRL36090T	
100 A	900 A	1700 A	HDL36100T	HGL36100T	HJL36100T	HLL36100T	HRL36100T	
110 A	900 A	1700 A	HDL36110T	HGL36110T	HJL36110T	HLL36110T	HRL36110T	
125 A	900 A	1700 A	HDL36125T	HGL36125T	HJL36125T	HLL36125T	HRL36125T	
150 A	900 A	1700 A	HDL36150T	HGL36150T	HJL36150T	HLL36150T	HRL36150T	

Table 3.2: J-Frame 250 A UL Current-Limiting Circuit Breaker Frame with Field-Interchangeable Thermal-Magnetic Trip Units [1]

Ampere Rating	Adjustable AC Magnetic Trip		Cat. No.					Terminal Wire Range
	Low	High	D Interrupting	G Interrupting	J Interrupting [2]	L Interrupting [2]	R Interrupting [2]	
3P, 600 Vac 50/60 Hz								
150 A	750 A	1500 A	JDL36150T	JGL36150T	JJL36150T	JLL36150T	JRL36150T	AL175JD 4-4/0 AWG Al or Cu
175 A	875 A	1750 A	JDL36175T	JGL36175T	JJL36175T	JLL36175T	JRL36175T	AL250JD 3/0 AWG-350 kcmil Al or Cu
200 A	1000 A	2000 A	JDL36200T	JGL36200T	JJL36200T	JLL36200T	JRL36200T	
225 A	1125 A	2250 A	JDL36225T	JGL36225T	JJL36225T	JLL36225T	JRL36225T	
250 A	1250 A	2500 A	JDL36250T	JGL36250T	JJL36250T	JLL36250T	JRL36250T	

Table 3.3: H-Frame 150 A and J-Frame 250 A 3P Basic UL Current-Limiting Circuit Breaker Frame Without Terminations [3] or Trip Unit

Circuit Breaker Frame	Ampere Rating	Cat. No.				
		D Interrupting	G Interrupting	J Interrupting [2]	L Interrupting [2]	R Interrupting [2]
H-Frame	15-60 A	HDF36000F06	HGF36000F06	HJF36000F06	HLF36000F06	HRF36000F06
	70-150 A	HDF36000F15	HGF36000F15	HJF36000F15	HLF36000F15	HRF36000F15
J-Frame	150-250 A	JDF36000F25	JGF36000F25	JJF36000F25	JLF36000F25	JRF36000F25

Table 3.4: H-Frame and J-Frame 3P Field-Installable Thermal-Magnetic Trip Unit

15-60 A H-Frame		70-150 A H-Frame		150-250 A J-Frame	
Amperage	Cat. No.	Amperage	Cat. No.	Amperage	Cat. No.
15 A	HT3015	70 A	HT3070	150 A	JT3150
20 A	HT3020	80 A	HT3080	175 A	JT3175
25 A	HT3025	90 A	HT3090	200 A	JT3200
30 A	HT3030	100 A	HT3100	225 A	JT3225
35 A	HT3035	110 A	HT3110	250 A	JT3250
40 A	HT3040	125 A	HT3125	—	—
45 A	HT3045	150 A	HT3150	—	—
50 A	HT3050	—	—	—	—
60 A	HT3060	—	—	—	—

Table 3.5: H- and J-Frame Interrupting Ratings

Voltage	Interrupting Rating				
	D	G	J	L	R
240 Vac	25 kA	65 kA	100 kA	125 kA	200 kA
480 Vac	18 kA	35 kA	65 kA	100 kA	200 kA
600 Vac	14 kA	18 kA	25 kA	50 kA	100 kA

Table 3.6: H- and J-Frame Termination Options

Termination Letter
F = No Lugs (includes terminal nut kit on both ends) [4]
L = Lugs both ends
M = Lugs ON end Terminal Nut Kit OFF end
P = Lugs OFF end Terminal Nut Kit ON end
N = Plug-in
D = Drawout
S = Rear Connected
For factory-installed termination, place termination letter in the third block of the circuit breaker catalog number. H D L 3 6 0 1 5 T



H-Frame and Trip Unit

Accessories see Digest Section 7  
Optional Lugs see Digest Section 7  
Dimensions see Digest Section 7  
Enclosures see Digest Section 7

[1] Circuit breakers will be labeled with Line and Load markings and are not suitable for reverse connections. Available on 3P circuit breakers; not available on I-Line™ constructions. For 100% rated circuit breakers replace the "T" suffix with an "R" suffix. 100% rated is not available in I-Line, plug-in, or drawout constructions.  
[2] Circuit breakers with J, L, and R interrupting ratings are UL Certified as current limiting.  
[3] See Digest Section 7 for lug and termination kits.  
[4] Add TS suffix for circuit breaker without terminal nut kit.

**PowerPacT H- and J-Frame Circuit Breakers**

**Table 3.7: H-Frame 150 A and J-Frame 250 A Current-Limiting Circuit Breakers with Lugs and Field-Interchangeable Electronic Trip Units [5] (600 Vac, 50/60 Hz, 3P)**

Electronic Trip Unit			Sensor Rating	Cat. No.					Terminal Wire Range
Type	Function	Trip Unit		D Interrupting	G Interrupting	J Interrupting [6]	L Interrupting [6]	R Interrupting [6]	
MicroLogic Standard	LI	3.2	60 A	HDL36060TU31X	HGL36060TU31X	HJL36060TU31X	HLL36060TU31X	HRL36060TU31X	AL150HD 14-3/0 AWG Al or Cu
			100 A	HDL36100TU31X	HGL36100TU31X	HJL36100TU31X	HLL36100TU31X	HRL36100TU31X	
			150 A	HDL36150TU31X	HGL36150TU31X	HJL36150TU31X	HLL36150TU31X	HRL36150TU31X	
			250 A	JDL36250TU31X	JGL36250TU31X	JJL36250TU31X	JLL36250TU31X	JRL36250TU31X	AL250JD 3/0 AWG-350 kcmil Al or Cu [7]
MicroLogic Standard	LSI	3.2S	60 A	HDL36060TU33X	HGL36060TU33X	HJL36060TU33X	HLL36060TU33X	HRL36060TU33X	AL150HD 14-3/0 AWG Al or Cu
			100 A	HDL36100TU33X	HGL36100TU33X	HJL36100TU33X	HLL36100TU33X	HRL36100TU33X	
			150 A	HDL36150TU33X	HGL36150TU33X	HJL36150TU33X	HLL36150TU33X	HRL36150TU33X	
			250 A	JDL36250TU33X	JGL36250TU33X	JJL36250TU33X	JLL36250TU33X	JRL36250TU33X	AL250JD 3/0 AWG-350 kcmil Al or Cu [7]
MicroLogic Ammeter	LSI	5.2A	60 A	HDL36060TU43X	HGL36060TU43X	HJL36060TU43X	HLL36060TU43X	HRL36060TU43X	AL150HD 14-3/0 AWG Al or Cu
			100 A	HDL36100TU43X	HGL36100TU43X	HJL36100TU43X	HLL36100TU43X	HRL36100TU43X	
			150 A	HDL36150TU43X	HGL36150TU43X	HJL36150TU43X	HLL36150TU43X	HRL36150TU43X	
			250 A	JDL36250TU43X	JGL36250TU43X	JJL36250TU43X	JLL36250TU43X	JRL36250TU43X	AL250JD 3/0 AWG-350 kcmil Al or Cu [7]
MicroLogic Energy	LSI	5.2E	60 A	HDL36060TU53X	HGL36060TU53X	HJL36060TU53X	HLL36060TU53X	HRL36060TU53X	AL150HD 14-3/0 AWG Al or Cu
			100 A	HDL36100TU53X	HGL36100TU53X	HJL36100TU53X	HLL36100TU53X	HRL36100TU53X	
			150 A	HDL36150TU53X	HGL36150TU53X	HJL36150TU53X	HLL36150TU53X	HRL36150TU53X	
			250 A	JDL36250TU53X	JGL36250TU53X	JJL36250TU53X	JLL36250TU53X	JRL36250TU53X	AL250JD 3/0 AWG-350 kcmil Al or Cu [7]
MicroLogic Ammeter	LSIG	6.2A	60 A	HDL36060TU44X	HGL36060TU44X	HJL36060TU44X	HLL36060TU44X	HRL36060TU44X	AL150HD 14-3/0 AWG Al or Cu
			100 A	HDL36100TU44X	HGL36100TU44X	HJL36100TU44X	HLL36100TU44X	HRL36100TU44X	
			150 A	HDL36150TU44X	HGL36150TU44X	HJL36150TU44X	HLL36150TU44X	HRL36150TU44X	
			250 A	JDL36250TU44X	JGL36250TU44X	JJL36250TU44X	JLL36250TU44X	JRL36250TU44X	AL250JD 3/0 AWG-350 kcmil Al or Cu [7]
MicroLogic Energy	LSIG	6.2E	60 A	HDL36060TU54X	HGL36060TU54X	HJL36060TU54X	HLL36060TU54X	HRL36060TU54X	AL150HD 14-3/0 AWG Al or Cu
			100 A	HDL36100TU54X	HGL36100TU54X	HJL36100TU54X	HLL36100TU54X	HRL36100TU54X	
			150 A	HDL36150TU54X	HGL36150TU54X	HJL36150TU54X	HLL36150TU54X	HRL36150TU54X	
			250 A	JDL36250TU54X	JGL36250TU54X	JJL36250TU54X	JLL36250TU54X	JRL36250TU54X	AL250JD 3/0 AWG-350 kcmil Al or Cu [7]

MOLDED CASE CIRCUIT BREAKERS AND ENCLOSURES

3

**Table 3.8: H-Frame 150 A and J-Frame 250 A 3P Basic UL Current-Limiting Circuit Breaker Frame Without Terminations [8] or Trip Unit (600 Vac, 250 Vdc)**

Circuit Breaker Frame	Ampere Rating	Cat. No.				
		D Interrupting	G Interrupting	J Interrupting [6]	L Interrupting [6]	R Interrupting [6]
H-Frame	15-60 A	HDF36000F06	HGF36000F06	HJF36000F06	HLF36000F06	HRF36000F06
	70-150 A	HDF36000F15	HGF36000F15	HJF36000F15	HLF36000F15	HRF36000F15
J-Frame	150-250 A	JDF36000F25	JGF36000F25	JJF36000F25	JLF36000F25	JRF36000F25

**Table 3.9: H- and J-Frame Interrupting Ratings**

Voltage	Interrupting Rating				
	D	G	J	L	R
240 Vac	25 kA	65 kA	100 kA	125 kA	200 kA
480 Vac	18 kA	35 kA	65 kA	100 kA	200 kA
600 Vac	14 kA	18 kA	25 kA	50 kA	100 kA

**Table 3.10: Termination Letter**

Termination Letter
F = No Lugs (includes terminal nut kit on both ends) [9]
L = Lugs both ends
M = Lugs ON end Terminal Nut Kit OFF end
P = Lugs OFF end Terminal Nut Kit ON end
N = Plug-in
D = Drawout
S = Rear Connected
H D L 3 6 0 1 5 T
For factory-installed termination, place termination letter in the third block of the circuit breaker catalog number.

Accessories see Digest Section 7  
 Optional Lugs see Digest Section 7  
 Dimensions see Digest Section 7  
 Enclosures see Digest Section 7

**Table 3.11: MicroLogic Field-Installable Trip Unit**

Model	Trip Function	Trip Unit	Continuous Current	Trip Unit Cat. No.
MicroLogic Standard	LI	3.2	15-20-25-30-35-40-45-50-60	HE3060U31X
			35-40-45-50-60-70-80-90-100	HE3100U31X
	LSI	3.2S	50-60-70-80-90-100-110-125-150	HE3150U31X
			70-80-100-125-150-175-200-225-250	JE3250U31X
MicroLogic Ammeter	LSI	5.2A	15-20-25-30-35-40-45-50-60	HE3060U33X
			35-40-45-50-60-70-80-90-100	HE3100U33X
	LSIG	6.2A	50-60-70-80-90-100-110-125-150	HE3150U33X
			70-80-100-125-150-175-200-225-250	JE3250U33X
MicroLogic Energy	LSI	5.2E	15-60	HE3060U43X
			35-100	HE3100U43X
	LSIG	6.2A	50-150	HE3150U43X
			70-250	JE3250U43X
MicroLogic Energy	LSI	5.2E	15-60	HE3060U44X
			35-100	HE3100U44X
	LSIG	6.2E	50-150	HE3150U44X
			70-250	JE3250U44X
MicroLogic Energy	LSI	5.2E	15-60	HE3060U53X
			35-100	HE3100U53X
	LSIG	6.2E	50-150	HE3150U53X
			70-250	JE3250U53X
MicroLogic Energy	LSI	5.2E	15-60	HE3060U54X
			35-100	HE3100U54X
	LSIG	6.2E	50-150	HE3150U54X
			70-250	JE3250U54X

[5] Circuit breakers will be labeled with Line and Load markings and are not suitable for reverse connections. Available on 3P circuit breakers; not available on I-Line™ constructions. For 100% rated circuit breakers replace the "T" suffix with an "R" suffix. 100% rated is not available in I-Line, plug-in, or drawout constructions.  
 [6] Circuit breakers with J, L, and R interrupting ratings are UL Certified as current limiting.  
 [7] For smaller wire (4-4/0 AWG Al or Cu), replace the lug wire binding screws with longer binding screws provided.  
 [8] See Digest Section 7 for lug and termination kits.  
 [9] Add TS suffix for circuit breaker without terminal nut kit.

**PowerPac™ L-Frame Molded Case Circuit Breakers**

**Table 3.12: L-Frame 3 Pole, 600 A Current-Limiting [10] Circuit Breakers with Lugs and Field-Interchangeable Electronic Trip Units (600 Vac, 50/60 Hz) [11][12]**

Electronic Trip Unit			Sensor Rating	Cat. No.				Terminal Wire Range
Type	Function	Trip Unit		D Interrupting	G Interrupting	J Interrupting [10]	L Interrupting [10]	
MicroLogic Standard	LI	3.3	250 A	LDL36250TU31X	LGL36250TU31X	LJL36250TU31X	LLL36250TU31X	AL400L61K3D (1) 2 AWG–600 kcmil Cu (1) 2 AWG–500 kcmil Al
			400 A	LDL36400TU31X	LGL36400TU31X	LJL36400TU31X	LLL36400TU31X	
			600 A	LDL36600TU31X	LGL36600TU31X	LJL36600TU31X	LLL36600TU31X	
MicroLogic Standard	LSI	3.3S	250 A	LDL36250TU33X	LGL36250TU33X	LJL36250TU33X	LLL36250TU33X	AL400L61K3D (1) 2 AWG–600 kcmil Cu (1) 2 AWG–500 kcmil Al
			400 A	LDL36400TU33X	LGL36400TU33X	LJL36400TU33X	LLL36400TU33X	
			600 A	LDL36600TU33X	LGL36600TU33X	LJL36600TU33X	LLL36600TU33X	
MicroLogic Ammeter	LSI	5.3A	400 A	LDL36400TU43X	LGL36400TU43X	LJL36400TU43X	LLL36400TU43X	AL600S52K3 (2) 2/0 AWG–500 kcmil Al/Cu
MicroLogic Energy	LSI	5.3E	600 A	LDL36600TU43X	LGL36600TU43X	LJL36600TU43X	LLL36600TU43X	
			400 A	LDL36400TU53X	LGL36400TU53X	LJL36400TU53X	LLL36400TU53X	
MicroLogic Ammeter	LSIG	6.3A	600 A	LDL36600TU44X	LGL36600TU44X	LJL36600TU44X	LLL36600TU44X	AL600S52K3 (2) 2/0 AWG–500 kcmil Al/Cu
			400 A	LDL36400TU44X	LGL36400TU44X	LJL36400TU44X	LLL36400TU44X	
MicroLogic Energy	LSIG	6.3E	400 A	LDL36400TU54X	LGL36400TU54X	LJL36400TU54X	LLL36400TU54X	
			600 A	LDL36600TU54X	LGL36600TU54X	LJL36600TU54X	LLL36600TU54X	

**Table 3.13: L-Frame 3 Pole, 600 A Circuit Breaker Frame without Terminations or Trip Unit (600 Vac, 50/60 Hz) [13]**

Ampere Rating	Interrupting Rating			
	D	G	J	L
250 A (70–250 A)	LDF36000F25	LGF36000F25	LJF36000F25	LLF36000F25
400 A (125–400 A)	LDF36000F40	LGF36000F40	LJF36000F40	LLF36000F40
600 A (200–600 A)	LDF36000F60	LGF36000F60	LJF36000F60	LLF36000F60

**Table 3.14: Termination Options**

Termination Letter	Termination Option
A	I-Line (See Section 9)
F	No lugs (includes terminal nut kit on both ends)
L	Lugs both ends
M	Lugs ON end, terminal nut kit OFF end
P	Lugs OFF end, terminal nut kit ON end
N	Plug In
D	Drawout
S	Rear Connected

For factory-installed termination, place termination letter in the third block of the circuit breaker catalog number.  
J G L 3 6 2 5 0 or L G L 3 6 6 0 0 U 4 4 X

Accessories see Digest Section 7  
Optional Lugs see Digest Section 7  
Dimensions see Digest Section 7

**Table 3.15: L-Frame 3P Field-Installable MicroLogic Electronic Trip Units**

Electronic Trip Unit			Continuous Current	Trip Unit Cat. No.
Type	Function	Code		
MicroLogic Standard	LI	3.3	70-80-100-125-150-175-200-225-250	LE3250U31X
			125-150-175-200-225-250-300-350-400	LE3400U31X
			200-225-250-300-350-400-450-500-600	LE3600U31X
MicroLogic Standard	LSI	3.3S	70-80-100-125-150-175-200-225-250	LE3250U33X
			125-150-175-200-225-250-300-350-400	LE3400U33X
			200-225-250-300-350-400-450-500-600	LE3600U33X
MicroLogic Ammeter	LSI	5.3A	125–400	LE3400U43X
	LSIG	6.3A	125–400 200–600	LE3400U44X LE3600U44X
MicroLogic Energy	LSI	5.3E	125–400	LE3400U53X
			200–600	LE3600U53X
	LSIG	6.3E	125–400	LE3400U54X
			200–600	LE3600U54X

**Table 3.16: L-Frame Interrupting Ratings**

Voltage	Interrupting Rating			
	D	G	J	L
240 Vac	25 kA	65 kA	100 kA	125 kA
480 Vac	18 kA	35 kA	65 kA	100 kA
600 Vac	14 kA	18 kA	25 kA	50 kA

[10] J and L interrupts are UL Certified as current limiting.

[11] Circuit breakers will be labeled with Line and Load markings and are not suitable for reverse connections.

[12] Only available on 3P unit-mount circuit breakers. Not allowed on I-Line constructions. For 100% rated field-interchangeable circuit breakers, replace the “T” suffix with an “R”. 100% field-interchangeable circuit breakers are not allowed on 600 A I-Line, Plug-In, or Drawout constructions.

[13] See Digest Section 7 for lug and termination kits.

3 MOLDED CASE CIRCUIT BREAKERS AND ENCLOSURES

### Automatic Switches

Automatic molded case switches open instantaneously at a factory preset magnetic trip point, calibrated to protect only the molded case switch itself, when it is subjected to high fault currents. The trip point is nonadjustable and provides no overload or low level fault protection.

Molded case switches open when the handle is switched to the OFF position or in response to an auxiliary tripping device such as a shunt trip.

All molded case switches will accept the same lugs and accessories as equivalent thermal-magnetic circuit breakers, with the exception of Q-frame switches which do not have electrical accessories available.

Automatic molded case switches are UL Listed per UL 489 and are CSA Certified.

**Table 3.17: Q-Frame (240 Vac) PowerPacT™ Automatic Molded Case Switches**

Circuit Breaker	Poles	Ampere Rating	J Interrupting Rating		Wire Range
			Cat. No.	Trip Point	
Q-Frame <sup>[1]</sup>	2	225 A	<a href="#">QBL22000S22</a>	4500 A	4 AWG–300 kcmil
	3	225 A	<a href="#">QBL32000S22</a>	4500 A	

[1] Withstand rating of 10 kA at 240 Vac.

### Mag-Gard Motor Circuit Protector

Instantaneous trip magnetic only circuit breakers have a single adjustment which simultaneously sets the magnetic trip level of each individual pole. Mag-Gard circuit breakers comply with NEC® requirements for providing motor circuit protection when installed as part of a UL Listed combination controller having motor overload protection. Interrupting ratings are established for these UL Recognized Components only when they are used in combination with motor starters with properly sized overload relays and contactors.

Mag-Gard circuit breakers will accept the same lugs and accessories as equivalent thermal-magnetic circuit breakers.

**Table 3.18: Special Low-Magnetic Trip Settings for PowerPac™ H- and J-Frame Thermal Magnetic Circuit Breakers 70–125 A**

Amps	Special Low Mags		I <sub>n</sub> on Label	Mag Suffix	Interrupting Rating				
	Hold [1]	Trip [1]			D	G	J	L	R
70	400	850	625	H83	HDL36070H83	HGL36070H83	HJL36070H83	HLL36070H83	HRL36070H83
80	400	850	625	H83	HDL36080H83	HGL36080H83	HJL36080H83	HLL36080H83	HRL36080H83
90	400	850	625	H83	HDL36090H83	HGL36090H83	HJL36090H83	HLL36090H83	HRL36090H83
100	400	850	625	H83	HDL36100H83	HGL36100H83	HJL36100H83	HLL36100H83	HRL36100H83
110	400	850	625	H83	HDL36110H83	HGL36110H83	HJL36110H83	HLL36110H83	HRL36110H83
125	800	1450	1125	H84	HDL36125H84	HGL36125H84	HJL36125H84	HLL36125H84	HRL36125H84

**Table 3.19: Special High-Magnetic Trip Settings for PowerPac H- and J-Frame Thermal Magnetic Circuit Breakers**

Amps	Special High Mags		I <sub>n</sub> on Label	Mag Suffix	Interrupting Rating				
	Hold [1]	Trip [1]			D	G	J	L	R
90	900	1700	1300	H85	HDL36090H85	HGL36090H85	HJL36090H85	HLL36090H85	HRL36090H85

**Table 3.20: Special Low-Magnetic Trip Settings for PowerPac H- and J-Frame Thermal Magnetic Circuit Breakers 150–200 A**

Amps	Special Low Mags		I <sub>n</sub> on Label	Mag Suffix	Interrupting Rating				
	Low [2]	High [2]			D	G	J	L	R
150	875L	1750H		H29	JDL36150H29	JGL36150H29	JJL36150H29	JLL36150H29	JRL36150H29
200	1250L	2500H		H32	JDL36200H32	JGL36200H32	JJL36200H32	JLL36200H32	JRL36200H32

**Table 3.21: H- and J-Frame Interrupting Ratings**

Voltage	Interrupting Rating				
	D	G	J	L	R
240 Vac	25 kA	65 kA	100 kA	125 kA	200 kA
480 Vac	18 kA	35 kA	65 kA	100 kA	200 kA
600 Vac	14 kA	18 kA	25 kA	50 kA	100 kA

Accessories see [Circuit Breaker Accessories](#), page 3-13 through page 3-17

Optional Lugs see [page 3-17](#)

Dimensions see [page 3-18](#)

3 MOLDED CASE CIRCUIT BREAKERS AND ENCLOSURES

[1] Hold and Trip indicate fixed magnetic trip levels.  
 [2] Low and High refer to adjustable mag level setting.



LAL3640031M  
Motor Circuit Protector



LAL3640036M  
Motor Circuit Protector

**LA/LH Motor Circuit Protectors**

Mag-Gard™ Motor Circuit Protectors (MCP) are instantaneous-trip magnetic-only circuit breakers. They have a single adjustment which simultaneously sets the magnetic trip level of each individual pole. Mag-Gard™ circuit breakers comply with NEC requirements for providing motor circuit protection when installed as part of a UL Listed combination controller having motor overload protection. Interrupting ratings are established for these UL Recognized Components only when they are used in combination with motor starters with properly sized overload relays and contactors.

LA/LH-Frame Mag-Gard™ Motor Circuit Protectors (MCP):

- 400 A rating at up to 600 Vac
- Instantaneous-trip magnetic-only circuit breakers available in unit mount and I-Line 3-pole constructions
- Accept the same lugs and accessories as equivalent LA/LH-Frame circuit breakers
- Available in unit mount and I-Line construction<sup>[3]</sup>
- High-interruption (LHL) are also available

Complies with NEC requirements for providing motor circuit protection when installed as part of a UL Listed combination controller having motor overload protection.

**Table 3.22: LA/LH Frame Magnetic Only 3 Pole, 600 Vac, 50/60 Hz <sup>[3]</sup>—Three Device Solutions <sup>[4]</sup>**

Ampere Rating	Trip Unit	Adjustable <sup>[5]</sup> Trip Range (A)	250 Vdc Multiplier	Cat. No.
LAL	400	—	High = 1.2 Low = 1.4	LAL3640022M LAL3640028M LAL3640030M LAL3640031M LAL3640032M LAL3640033M LAL3640035M LAL3640036M

**Table 3.23: LAL Adjustable Instantaneous-Trip Circuit Breakers for Single Motor Circuit Protection**

Hp Ratings of Induction Type Squirrel-Cage and Wound Rotor Motors 3Ø 60 Hz				Full Load Amperes <sup>[6]</sup>	Mag-Gard Circuit Breaker Cat. No.	Magnetic Trip Settings <sup>[7]</sup>	
200 Vac	230 Vac	460 Vac	575 Vac			MIN	MAX
75	—	—	—	221	LAL3640033M	700%	1400%
—	—	200	—	240	LAL3640035M	700%	1500%
—	—	—	250	242	LAL3640035M	700%	1400%
—	100	—	—	248	LAL3640035M	700%	1400%
100	—	—	—	285	LAL3640036M	700%	1400%
—	—	—	300	289	LAL3640036M	700%	1400%
—	—	250	—	302	LAL3640036M	700%	1300%
—	125	—	—	312	LAL3640036M	600%	1300%

MOLDED CASE CIRCUIT BREAKERS AND ENCLOSURES 3

<sup>[3]</sup> These electronic magnetic-only motor circuit protectors are available with I-Line constructions. Consult the factory.

<sup>[4]</sup> Three-device solutions are the traditional solutions: motor circuit protector plus motor starter plus overload relay.

<sup>[5]</sup> UL magnetic trip tolerances are -20%/+30% from the nominal values shown.

<sup>[6]</sup> [7] Motor full-load currents are taken from NEC Table 430.250. Select wire and circuit breakers on basis of horsepower rather than nameplate full-load current per NEC 430.6 (A) for general motor applications. Do not use these values to select overload relay thermal units. See Digest Section 14 for selection of thermal units when actual full load current is not known. The voltages listed are rated motor voltages. Corresponding nominal system voltages are 200–208, 220–240, 440–480 and 550–600 V.

<sup>[7]</sup> Only MIN and MAX settings are shown, intermediate settings are available on all circuit breakers.

**I-Line™ Special Terminal Connectors**

**Bolt-On I-Line Circuit Breakers**

**NOTE:** Bolt-on I-Line connectors are not available on Powerpact™ circuit breakers.

The standard I-Line circuit breaker is designed to provide a high quality, secure connection between the distribution bus and circuit breaker. I-Line circuit breakers use plug-on type line-side connectors. The parallel line-side connectors “clamp” around the bus bars. In case of a short circuit, the increased magnetic flux causes the connectors to grasp the bus bars even tighter. I-Line circuit breakers with bolted connections have clamp-on jaws that are bolted around the main bus, as shown. The bolt-on I-Line design is offered as an alternative in order to meet specifications requiring a bolted connection. Bolt-on I-Line construction is available on FY, QB, QD, QG, QJ, Q4, LA, and LH frame circuit breakers and molded case switches, and SL225 and SL400 sub-feed lugs.

To order on all products except QB, QD, QG and QJ, simply add the letter “B” in the catalog number prefix of the circuit breaker, e.g., LA36100 becomes LAB36100. For QB, QD, QG and QJ, insert the letter “E” in the third position, e.g., QBE, QDE, etc.

**Top-Feed I-Line Circuit Breakers**

I-Line panelboards may require the use of a top-feed I-Line circuit breaker in applications where a top-feed main circuit breaker is required. This involves having the I-Line jaw connectors on the OFF end of the circuit breaker, as opposed to the standard location on the ON end of the circuit breaker. To designate this construction, simply place the suffix “MT” at the end of the circuit breaker catalog number, e.g., FA36100 becomes FA36100MT. On LA or LH top-feed I-Line circuit breakers, accessories must be factory installed. This option is available in PowerPact™ H and J-frame by placing a “K” in the 4th position (termination indicator) of the circuit breaker catalog number, e.g., HGA36125 becomes HGK36125. This option is not available on 600 A LA or LH circuit breakers, or Powerpact M-, P- and R-frame circuit breakers.

**“CBA” I-Line Jaw Configuration (Non-PowerPact Circuit Breaker)**

Standard 1- and 2-pole I-Line circuit breakers are ordered by designating the required phase connection letters as a suffix to the circuit breaker catalog number. 3-pole circuit breakers do not require this phase designation and are supplied with an “ABC” phase jaw configuration as standard. In most applications this is acceptable since the phase loading is evenly distributed. In applications where the phases must be reversed it is possible to order a “CBA” jaw configuration by simply placing the letters “CBA” at the end of the standard catalog number, e.g., LA36100 becomes LA36100CBA.

**Control Wire Tap Lugs**

Control wire tap lugs are used in applications requiring connection to a small wire (22-14 AWG) for control circuits. This is accomplished by crimping the wire to a standard wire crimp terminal (not included) and fastening the terminal to the circuit breaker lug. On LA lugs, the lug is drilled to accept a 6-32 screw (included) to secure the crimp connector. On FA lugs, a flat slip-on crimp connector is used to attach to a shim-like connector placed under the circuit breaker lug.

**Note:** To order as a factory-installed device on Q4, LA, or LH circuit breakers, add suffix number 8041 to circuit breaker catalog number, e.g., LAL364008041. To order as a factory-installed device on MG, MJ, PG, PJ, PL RG, RJ and RL use the product selector or the respective PowerPact catalog. Tapped lugs will be installed on the “ON” and “OFF” ends of the circuit breaker.

**Table 3.24: Control Wire Terminations for Circuit Breakers**

Circuit Breaker	Cat. No.	Standard Package Qty.
Q4, LA, LH	AL400LAT	1

**Table 3.25: Tapped Lugs for PowerPacT™ Circuit Breakers**

Circuit Breaker	Amperes Max.	Kit Cat. No.	Standard Package Qty.
MG, MJ, PG, PJ, PL	800 A	AL800M23TK	3
		AL800P6TK	3
PG, PJ, PL	800 A	AL800M23TK4	4
		AL800P6TK4	4
		AL1200P24TK	1
	1200 A	AL1200P25TK	3
		AL1200P25TK4	4
RG, RJ, RL	1200 A	AL1200R53TK [1]	1

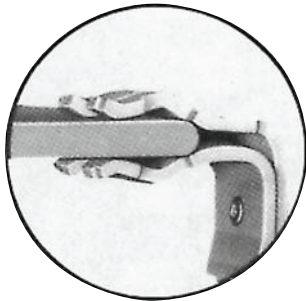

Plug-On Connector

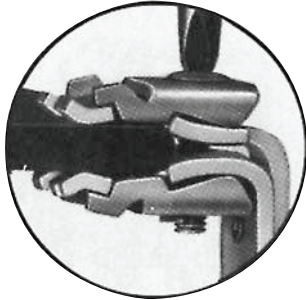

Bolted Connector

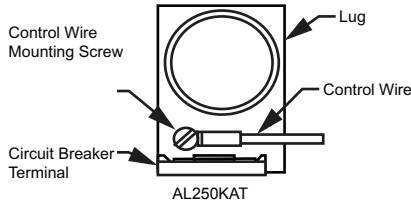

3 MOLDED CASE CIRCUIT BREAKERS AND ENCLOSURES

[1] I-Line only.

**Special Magnetic or Thermal Calibration**

**Magnetic**

The magnetic trip ranges for standard circuit breakers are listed in the Square D Digest. Requirements outside this range are best accommodated by selecting another standard circuit breaker. In some cases where this is not practical, a circuit breaker may be ordered with special magnetic calibration. Special magnetic calibration is not possible in all cases. Circuit breakers with special magnetic calibration and an **adjustable** magnetic trip range are **not** UL Listed; those with a **fixed** magnetic trip setting are UL Listed. Consult Schneider Electric local sales office for more information.

**50 Degrees C**

UL 489 Listed molded case circuit breakers are calibrated for 40°C ambient temperature. To meet requirements of higher ambient conditions, circuit breakers can be factory calibrated for a 50°C ambient temperature. Circuit breakers with special thermal calibration are not UL Listed. To order 50°C calibration, add “35” suffix to LA/LH or “CA” to H or J thermal magnetic circuit breaker. Consult local sales office for more information.

**Rear-Connected Studs**

Rear-connected studs are designed to allow rear termination in applications such as control panels where wire gutter space may be limited. The studs may be bolted directly to the bus or lugs may be attached to the studs.

**NOTE:** Long and short studs must be alternated on adjacent poles to assure proper electrical clearance.

**Table 3.26: Rear-Connected Studs—Not UL Listed**

Circuit Breaker Cat. No. Prefix	Ampere Ratings	Stud Cat. No.	Dimensions			
			Overall Length	To Back of Circuit Breaker	Diameter	Threads/Inch
LAL, LHL	125–400 A	LAS114	12-3/16 in.	11-1/2 in.	3/4 in.	16

**NOTE:** Use alternate size studs on adjacent poles to obtain proper electrical clearance.



Rear-Connected Studs

**Visi-Blade™ Circuit Breakers**

Visi-blade construction is a modification to the cover of a thermal-magnetic circuit breaker, a molded case switch, or a Mag-Gard™ circuit breaker which provides a “window” through which the position of the movable contacts can be verified. Luminescent paint is applied to the movable contact arms to clearly indicate their position. Gases produced during high level interruption may cause clouding of the Visi-blade window. Visi-Blade construction is not available on circuit breakers not included in table below.

Add suffix letter “V” to the circuit breaker catalog number, i.e., LAL36400V.

**Table 3.27: Available Visi-Blade Circuit Breakers**

Circuit Breaker Prefix	Amperes
LA, LH	125–400 A

### Moisture and Fungus Resistant Treatment for Circuit Breakers

This treatment covers the application of moisture and fungus resistant varnish to circuit breakers and molded case switches.

- The varnish meets Military Specification MIL-V-173C VARNISH, MOISTURE AND FUNGUS RESISTANT.
- The treatment meets military Specification MIL-T-152E TREATMENT, MOISTURE AND FUNGUS-RESISTANT, OF COMMUNICATIONS, ELECTRONIC, AND ASSOCIATED ELECTRICAL EQUIPMENT.

The treatment of circuit breakers in accordance with said specifications is intended to protect them against the moisture and fungus condition encountered in service by retarding the absorption of moisture and inhibiting the growth of fungi.

To order for L-frame circuit breakers, place the suffix "FT" at the end of the circuit breaker catalog number, e.g., LAL36100 becomes LAL36100FT. To order for QB, QD, and QG circuit breakers, place the suffix "YF" at the end of the circuit breaker catalog number, e.g., QDL32150 becomes QDL32150YF. ED, EG, EF, PowerPact™ B-, D-, H-, J-, L, M-, P- and R-frame circuit breakers are inherently fungus resistant and need no further treatment.

### Short Handle for LA/LH Circuit Breakers

Certain applications of the LA/LH circuit breakers (as mains in particular panelboards) require the use of a slightly shorter operating handle. For ordering information refer to the chart below.

**Table 3.28: Catalog Numbers for Short Handle LA/LH Circuit Breakers**

Lug Configuration Desired		Catalog "Prefix Indication"	Catalog "Suffix Indication"	Circuit Breaker Cat. No.
ON End	OFF End			
Lugs	Lugs	"L"	"MB"	LAL36400MB
No Lugs	Lugs	"P"	"MB"	LAP36400MB
Lugs	No Lugs	"P"	"MT"	LAP36400MT
No Lugs	No Lugs	"F"	"MB"	LAF36400MB

**Lug Deletion**

In some applications, the circuit breaker does not require lugs on one or both ends. To meet this requirement, the circuit breaker should be ordered with the desired lug configuration as indicated below. If necessary, lugs may be removed in the field. However, if lugs are removed in the field, circuit breaker **Types** Q4, LA and LH must be secured with pan-mounting screws, or have "P" screws (cover screws and nuts) installed securing the base to the cover.

**Table 3.29: Lug Configuration [2]**

ON End	OFF End	Circuit Breaker Prefix – Suffix
Lugs	Lugs	"L" (e.g., LAL36100)
No Lugs	No Lugs	"F" (e.g., LAF36100)
No Lugs	Lugs	"P" (e.g., LAP36100)
Lugs	No Lugs	"P – MT" [3] (e.g., LAP36100MT)

**Termination Insert Kits**

The standard lugs supplied with EDB, EGB, EJB, and FJA circuit breakers and molded case switches are secured by means of a screw fastened through the circuit breaker terminal into the lug body. If the standard lug is removed and a bolted connection to the circuit breaker terminal pad is desired, a threaded insert kit is required. The insert is installed below the terminal pad. For ordering information see chart below.

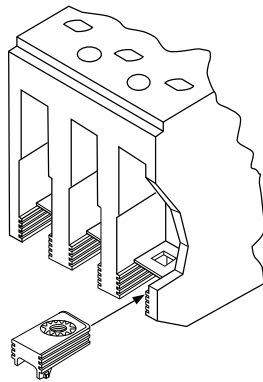

EDB, EGB,  
EJB, FJA

**Table 3.30: Termination Kit Inserts**

Kit Cat. No.	Inserts Per Kit	Circuit Breakers
TIKFD	3	EDB, EGB, EJB, FJA

**Electric Joint Compound**

I-Line™ circuit breakers, I-Line busway plug-on units, I-Line panelboards and switchboards, QMB plug-on switches and motor control center plug-on units are supplied with factory applied joint compound on the plug-on connectors. The compound should not be removed because it contributes to the overall performance of the connection. Whenever one of these units is removed and reinstalled, the joint compound should be reapplied. Catalog number PJC 7201 is a two-ounce container of compound specially formulated for the I-Line, QMB and motor control center connections. No other type of commercially available joint compound should be used.



Joint Compound

**Table 3.31: Electric Joint Compound**

Use With	Cat. No.
I-Line Circuit Breakers, QMB Plug-On Units, or Model-V MCC Units	PJC7201
SED Drawout Circuit Breakers	PJC8311

[2] See information on termination kits below  
 [3] MT suffix also required (except for PowerPact™).

### Circuit Breakers for Grounded B-Phase (BØ) (Corner-Grounded Delta) Systems

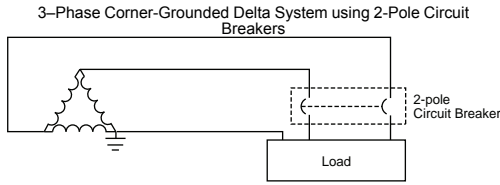

- For use on 480 V systems, LH type circuit breakers must be ordered as 600 V versions and with a 5861 suffix (i.e. LHL361005861).
- For use on 240 V systems, circuit breakers may be ordered as 480 V versions with a 5861 suffix (i.e. LHL341005861).
- LA type circuit breakers are not available with grounded B phase markings.
- Two-pole 240 V grounded B-phase circuit breakers (except EDB, EGB, EJB, QB, QD, QG, QJ, BD, BG, and BJ) will be built using three-pole modules.
- Two-pole grounded BØ circuit breakers will be labeled with 240 Vac interrupting ratings.
- No self-certification is available for interrupting ratings greater than shown in the tables below.

**Table 3.32: Application Data for 240 Vac 3Ø Corner-Grounded Delta System**

Cat. No. Prefix	Poles	UL Listed Interrupting Rating	
		Ampere Rating	240 Vac Interrupting Rating
QO-H, QOB-H	2	15–100 A	5 kA
QB, QD, QG, QJ	2 [4]	70–250 A	10 kA
EDB, EGB, EJB	2 [4]	15–125 A	18 kA, 35 kA, 65 kA
BD, BG, BJ	2 [4]	15–125 A	18 kA, 35 kA, 65 kA
HD, HG	2 [4]	15–150 A	42 kA
HJ, HL	2 [5]	15–150 A	65 kA, 100 kA
JD, JG, JJ, JL	2 [5]	150–250 A	42 kA, 65 kA, 100 kA
LH, LHL	2 [5]	125–400 A	30 kA
MG, MJ Electronic Trip Unit	2 [5][6]	300–800 A	65 kA
PG, PJ, PK, PL Electronic Trip Unit	2 [5][6]	600–1200 A	65 kA
RG, RK Electronic Trip Unit	2 [5][6]	1200–2500 A	35 kA, 65 kA
RJ Electronic Trip Unit	2 [5][6]	1200–2500 A	100 kA
RL Electronic Trip Unit	2 [5][6]	1200–2500 A	100 kA

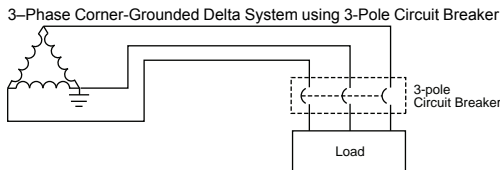

**NOTE:** Three-pole circuit breakers may be used on three-phase corner-grounded delta systems. The outside poles are to be connected to the ungrounded phase and the grounded conductor connected to the center pole. Connecting the circuit breaker in a manner other than that described or shown may result in an unsafe application of the circuit breaker.

**Table 3.33: 480 Vac 3Ø Corner-Grounded Delta System [7]**

Cat. No. Prefix	Poles [8]	UL Listed Interrupting Rating [8]	
		Ampere Rating	480 Vac 3Ø Interrupting Rating
HD, HG, HJ, HL	3	15–150 A	18 kA, 35 kA, 65 kA, 100 kA
JD, JG, JJ, JL	3	150–250 A	
LH, LHL	3	125–400 A	14 kA
LD, LG, LJ, LL Electronic Trip Unit	3	250–600 A	18 kA, 35 kA, 65 kA, 100 kA
MG, MJ Electronic Trip Unit	3 [6]	300–800 A	35 kA
PG, PK Electronic Trip Unit	3 [6]	600–1200 A	35 kA, 50 kA
PG, PK MicroLogic Trip Unit	3 [6]	250–1200 A	
PJ, PL Electronic Trip Unit	3 [6]	600–1200 A	65 kA, 100 kA
PJ, PL MicroLogic Trip Unit	3 [6]	250–1200 A	
RG, RJ, RK RL Electronic Trip Unit	3 [6]	1200–2500 A	35 kA, 65 kA, 65 kA, 100 kA
RG, RJ, RK, RL MicroLogic Trip Unit	3 [6]	600–2500 A	
NT	3	800–1200 A	100 kA
NW	3	800–6000 A	150 kA

[4] Standard labeling includes grounded B phase.

[5] Built using 3P module.

[6] Electronic = ET1.0 Electronic Trip System  
MicroLogic = 3.0, 5.0, 3.0A, 5.0A, 6.0A, 5.0P, 6.0P, 5.0H and 6.0 H MicroLogic Trip System.

[7] Refer to NEC 240.85 for application guidance.

[8] The grounded phase must be connected through the center pole only.

**UL Marine Listed/CSA Certified Circuit Breakers (UL 489 Supplement SA)**

PowerPacT™ H and J circuit breakers with thermal magnetic trip units meet the UL 489 SA requirements on vessels of any length under or over 65 ft. (19.8 m). PowerPacT H, J, and L circuit breakers with MicroLogic™ trip units meet the UL 489 Supplement SA requirements for use on vessels over 65 ft. (19.8 m) in length. Marine circuit breakers must not use aluminum or aluminum alloys for terminal connections and must be calibrated at an ambient temperature of 104°F (40°C). Standard circuit breakers should not be specified or used in place of marine rated circuit breakers.



For use on vessels over 65 ft. (19.8 m) in length.

Circuit breakers can be ordered with the Marine SA listing by adding the suffix "YA" (marine) to the catalog number.

**Table 3.34: Circuit Breakers for Marine Applications**

Cat. No. Prefix	Poles	Ampere Rating	Application	Cat. No.
LA, LAL	2, 3	125–400 A	For use only on vessels over 65 feet (19.8 m) in length.	Add the number "9" after the catalog number prefix of the standard circuit breaker catalog number. Example: Standard FAL36100 Marine FAL936100
LH, LHL	2, 3	125–400 A		
PowerPacT™ HD, HG, HJ, HL [9]	2, 3	15–150 A	For use on vessels over and under 65 feet (19.8 m) in length.	Add suffix "YA" after the standard circuit breaker catalog number. Example: Standard HGL36100 Marine HGL36100YA
PowerPacT JD, JG, JJ, JL [9]	2, 3	150–250 A		
PowerPacT HD, HG, HJ, HL, HR [10]	2, 3	15–150 A	For use on vessels over 65 feet (19.8m) in length.	
PowerPacT JD, JG, JJ, JL, JR [10]	2, 3	150–250 A		
PowerPacT LD, LG, LJ, LL, LR	3, 4	250–600 A	For use only on vessels over 65 feet (19.8 m) in length.	
PowerPacT MG, MJ	2, 3	300–800 A		
PowerPacT PG, PJ, PL	2, 3, 4	100–1200 A		
PowerPacT RG, RJ, RL	2, 3, 4	600–2500 A		

**UL Naval Listed/CSA Certified Circuit Breakers (UL 489 Supplement SB)**

PowerPacT™ H, J, and L circuit breakers with MicroLogic™ trip units meet the UL 489 Supplement SB requirements for naval vessels. These circuit breakers are subject to various vibration testing as described in UL 489 Supplement SB. Naval circuit breakers must not use aluminum or aluminum alloys for terminal connections and are calibrated at an ambient temperature of 122°F (50°C). Standard circuit breakers should not be specified or used in the place of naval rated circuit breakers.

Circuit breakers can be ordered with the Naval SB listing by adding the suffix "YA1" (naval) to the catalog number.

**Table 3.35: Circuit Breakers for Naval Applications**

Cat. No. Prefix	Poles	Ampere Rating	Application	Cat. No.
HD, HG, HJ, HL [11]	2, 3	15–150 A	For use on non-combat and auxiliary navalships of any length.	Add suffix "YA1" after the standard circuit breaker catalog number. Example: Standard HGL36100 Marine HGL36100YA1
JD, JG, JJ, JL [11]	2, 3	150–250 A		
LD, LG, LH, LL	3, 4	250–600 A		

[9] Thermal-Magnetic trip units only.

[10] MicroLogic trip units only.

[11] With MicroLogic trip units only thermal-magnetic circuit breakers not approved.

### Factory-Installed LA and Q-Frame Electrical Accessories

Electrical accessories are available on all molded case circuit breakers except QOM1 circuit breakers.

- Combination accessories may be ordered by description, i.e., 1021 and 1212.
- All AC electrical accessories shown below are rated for 50/60 Hz.
- See page 3-15 for field-installable accessories. See Digest Section 7 for PowerPac™ circuit breaker accessories.

**Table 3.36: Factory-Installed Accessories for Thermal-Magnetic LA and Q-Frame Circuit Breakers**

Accessory	Description	Rated Voltage	Coil Burden	Suffix
Shunt Trip	Trips the circuit breaker from a remote location by means of a trip coil energized from a separate circuit. A 120 V shunt trip will operate at 55% or more of rated voltage. All other shunt trips will operate at 75% or more of rated voltage. <b>Application</b> <ul style="list-style-type: none"> <li>• For use with momentary or maintained push button</li> <li>• Sure Trip Capacitor Unit requires 48 Vdc shunt trip</li> <li>• Leads: (2) Black, 18 AWG Cu</li> </ul>	24 Vac	21 VA	-1042
		120 Vac	24 VA	-1021
		208 Vac	107 VA	-1021
		240 Vac	154 VA	-1021
		277 Vac	14 VA	-1037
		480 Vac	45 VA	-1037
		24 Vdc	36 VA	-1027
		48 Vdc	36 VA	-1028
		125 Vdc	44 VA	-1029
		250 Vdc	15 VA	-1030
Ground-Fault Shunt Trip	Trips the circuit breaker electrically using the signal from a MicroLogic™ Ground-Fault Module. <b>Application</b> <ul style="list-style-type: none"> <li>• For use only with obsolete GP Ground-Censor™ system or add on ground-fault module</li> <li>• Leads: (2) Orange 18 AWG Cu</li> </ul>	—	—	-G
Undervoltage Trip (UVR)	Trips the circuit breaker electrically when a control circuit falls below 35 to 70% of nominal (not field adjustable). Picks up at 35–85% of nominal voltage. <b>Application</b> <ul style="list-style-type: none"> <li>• UVR must be energized in order to close the circuit breaker</li> <li>• Leads: (2) Brown 18 AWG Cu leads</li> </ul>	24 Vac 120 Vac 240 Vac 24 Vdc 48 Vdc	5 VA 8 VA 8 VA 2 VA 3 VA	-1143 -1121 -1124 -1127 -1128
Auxiliary Switches	Monitors circuit breaker contact status and provides a remote signal indicating the circuit breaker contacts are OPEN or CLOSED. <b>Application</b> <ul style="list-style-type: none"> <li>• Max. Load = 10 A @ 125–250 Vac, ¼ hp @ 125–250 Vac, 5 A @ 30 Vdc</li> <li>• Leads: Yellow for "A", Blue for "B", Striped for common 18 AWG Cu</li> </ul>	See load info. in App. text at left	See load info. in App. text at left	1A/1B
				2A/2B
				3A/3B
Alarm Switches	Used with control circuits and actuated only when the circuit breaker has tripped. Standard construction includes a normally-open contact. <b>Application</b> <ul style="list-style-type: none"> <li>• Max. Load = 10 A @ 125–250 Vac</li> <li>• Max. Load = 15 A @ 30 Vdc</li> <li>• Leads: (2) Red 18 AWG Cu</li> </ul>	250 Vac 28 Vdc 250 Vac 48 Vdc	See load info. in App. text at left	1A
				1A
				1B
				1B

**Auxiliary Switch Contact Configuration**  
Color Code:  
"A" Contact - Yellow Leads  
"B" Contact - Blue Leads  
Common-Striped Leads

1A/1B

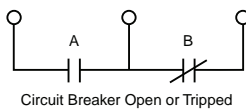
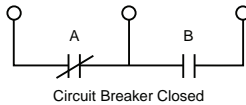

**1A Alarm Switch Configuration**  
Color Code: Red Leads

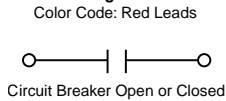

**1B Alarm Switch Configuration**  
Color Code: Red Leads



3 MOLDED CASE CIRCUIT BREAKERS AND ENCLOSURES

**Undervoltage Trip Wiring Diagram**

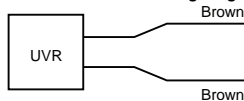

Brown Wires To Be Connected To Control Power

**Shunt Trip Wiring Diagram**

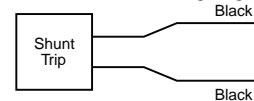

Black Wires To Be Connected To Control Power

690UVTD Wiring Diagram

**Auxiliary Switch Contact Configuration**  
Color Code:  
"A" Contact - Yellow Leads  
"B" Contact - Blue Leads  
Common-Striped Leads

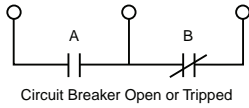
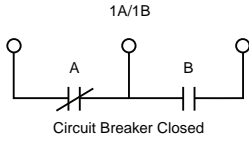

**1A Alarm Switch Configuration**  
Color Code: Red Leads



**1B Alarm Switch Configuration**  
Color Code: Red Leads



**Undervoltage Trip Wiring Diagram**

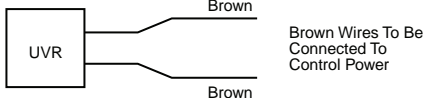

**Shunt Trip Wiring Diagram**

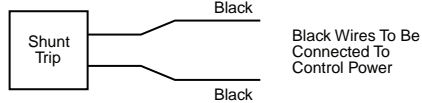

**Field-Installable Electrical Accessories**

Complete field-installable accessory catalog number by inserting suffix from page 3-14 between the parentheses in the catalog numbers shown in the table below. (Example: LA11212)

**Table 3.37: Field-Installable Accessories for Thermal-Magnetic and Electronic Trip Circuit Breakers**

Circuit Breaker	Shunt Trip	Ground-Fault Shunt Trip [1]	Undervoltage Trip	Auxiliary Switches	Alarm Switch
Miniature Circuit Breakers EH and EH-PL	Factory-Installed Only	Not Available	Not Available	Factory-Installed Only	Factory-Installed Only
LA, LH Series 4 [2]	LA1( )	LA1G	LA1 ( )	LA1( )	Factory-Installed Only Right Pole
Q4	LA1( )	LA1G	LA1 ( )	LA1( )	Factory-Installed Only Right Pole

**Table 3.38: Accessory Mounting Locations**

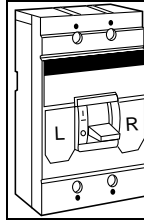

LA, LH, Q4 Series 4 circuit breakers or newer = Field-installable accessories  
Both accessory ports will accept shunt trips, UVRs and auxiliary switches. Alarm switches are factory installable **only** (right pole). Maximum of one device per port.

[1] Used with obsolete GP Ground-Censor™ system or add-on ground-fault modules.  
[2] With LA and LH top-feed circuit breakers (suffix MT, I-Line jaws on OFF end) all accessories must be factory installed.

### Electrical Operators

Provides remote ON, OFF/RESET control of molded case circuit breakers.

- A complete line of field-installable electrical operators.
- Installing side mounted motor operators on non I-Line™ circuit breakers requires the use of a separate mounting pan.
- Side mounted electrical operators require an additional 4-1/2 in. (114 mm) of mounting space in I-Line installations.

When remote indication of circuit breaker status is required, order circuit breaker with 1A-1B auxilliary switch for ON-OFF Indication and alarm switch for TRIP Indication. Electrical operators require SPDT maintained contact switch. Refer to Class 9001 control unit listing for operators and pilot lights.

**NOTE:** Not available on Mag-Gard™ circuit breakers and molded case switches.

**Table 3.39: Electrical Operators**

Circuit Breaker Prefix	Top Mount		Side Mount		Mounting Pan Cat. No.
	Voltage	Cat. No.	Voltage	Cat. No.	
LA, LH, Q4	—	—	120 Vac	LAMO1	—
LAL, LHL, Q4L	—	—	120 Vac	LAMO1	LAMOP

### Handle Accessories

**Table 3.40: Handle Accessories**

Circuit Breaker Prefix	Poles	Cat. No.
Handle Tie		
2 LA or 2 Q4	2, 3	LAHT
Handle Extension		
Q4	2, 3	AHEXLI
Handle Padlock Attachment (locks ON or OFF)		
LA, LH, Q4	2, 3	HPALM HPAXLM

### Cylinder Lock

Used to lock the circuit breaker in the OFF position. Circuit breaker cannot be reset when locked OFF.

**Table 3.41: Cylinder Lock**

Circuit Breaker Prefix	Factory Installed Suffix	Field-Installable Cat. No.
LA, LAL, LH, LHL, Q4	Field-installable only	LA1CL

### Interlocks

**Table 3.42: Walking Beam Mechanical Interlock Components [3]**

Circuit Breaker Prefix	Manually Operated			Electrically Operated		
	Operator Suffix	Walking Beam Ass'y.	Mounting Pan	Operator Suffix	Walking Beam Ass'y.	Mounting Pan
		Cat. No.	Cat. No.		Cat. No.	Cat. No.
LAL, LHL	WB	LA6WB	LAWBP6	WBMO	LA10WB	LAWBP10



Walking Beam Mechanical Interlock  
Requires 2 circuit breakers with WB suffix,  
1 walking beam assembly and 1 mounting pan.

[3] Fully enclosed interlocked units are available in Type 1 and Type 3R enclosures, with two neutrals provided in each enclosure. The completely enclosed assembly is not UL Listed. Please consult your nearest Schneider Electric sales office for more information.

**Mechanical Lug Kits**

**Table 3.43: Mechanical Lug Kit Information**



Circuit Breaker Application				(Number of Wires Per Lug) Wire Range [4]	Cat. No.	Lugs Per Kit
Standard	Ampere Rating	Optional	Ampere Rating			
<b>Al Lugs for Use with Al or Cu Wire</b>						
Q4, LA, LH	125–400 A	—	—	(1) 1 AWG–600 kcmil or (2) 1 AWG–250 kcmil	AL400LA	1
—	—	Q4, LA, LH	125–400 A	(1) 350–750 kcmil	AL400LH7	1
<b>Cu Lugs for Use with Cu Wire Only [5]</b>						
—	—	Q4, LA, LH	125–400 A	(1) 1 AWG–600 kcmil Cu or (2) 1 AWG–250 kcmil Cu	CU400LA	1

**Compression Lug Kits**

**Table 3.44: Field-installable Compression Lug Kits [6]**

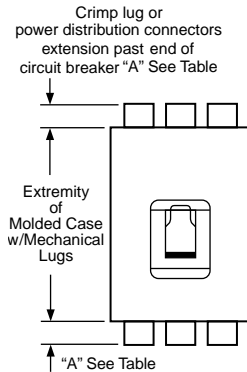

Circuit Breaker Type	Wire Range [4]	Dimension A (In)	Max. Lugs Per Terminal	Cat. No.	Lug Qty. Per Kit
<b>Aluminum Compression Lug Kits</b>					
LA, LH, Q4	250–350 kcmil	1.25	2	VC400LA35	2
	4 AWG–300 kcmil	1.0	2	VC400LA3	2
	2/0 AWG–500 kcmil	2.2	1	VC400LA5	1
	500–750 kcmil	2.5	1	VC400LA7	1
<b>Copper Compression Lug Kits</b>					
LA, LH, Q4	2/0 AWG–300 kcmil Cu	1.3	2	CVC400LA3	2
	250–500 kcmil Cu	2.3	1	CVC400LA5	1



**Power Distribution Connectors (PDC) for Circuit Breakers—for Field Replacement of Mechanical Lugs**

Can be used for multiple load connections on one circuit breaker. Use in place of standard distribution blocks to save space and time.

Field-installable kits, including tin-plated aluminum connectors and all necessary mounting hardware are available for Square D LA and Q4-frame molded case circuit breakers.

Connectors are UL Listed:

- For use on load end of circuit breaker only
- For use in UL508 Industrial Control applications only
- For use in UL 1995/CSA C22.2 No. 236 heating and cooling equipment
- For copper wire only

**Table 3.45: Power Distribution Connectors for LAL, LHL, and Q4L Circuit Breakers**



Use With Circuit Breaker [7]	Circuit Breaker Ampere Rating	Wires Per Terminal & Wire Range [8] Cu	Cat. No.	Lug Quantity Per Kit	Dimension A (in.)
LAL, LHL, Q4L	125–400 A	(6) 12–2/0 AWG	PDC6LA20	1	2.25
		(12) 14–4 AWG	PDC12LA4	1	1.25
		(3) 14–2 AWG (1) 2 AWG–250 kcmil	PDC4LA250	1	2.0

[4] Unless otherwise specified, wire sizes apply to both aluminum and copper conductors.  
 [5] Use suffix 8002 for factory-installed Cu lugs.  
 [6] See instruction bulletins for recommended tools.  
 [7] Not for use with I-Line circuit breakers.  
 [8] When using fine stranded wire, increased cross sectional area may cause maximum wire size to be reduced.

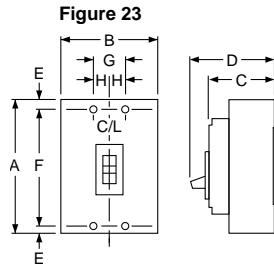

**Dimensions and Weights**

**Table 3.46: Circuit Breakers Dimensions**

Circuit Breaker Catalog No. Prefix	No. Poles	Fig. No.	Dimensions—Inches							
			A	B	C	D	E	F	G	H
Q4L, LAL, LHL	2, 3	23	11.00	6.00	4.06	5.84	0.88	9.25	2.00	1.00

**Table 3.47: Shipping Weights**

Frame Size	Approx. Shipping Weight (Lbs.)
Q4L	15
LAL LHL	15

**Enclosed Molded Case Switches**

Enclosed molded case switches are UL Listed devices supplied with factory-installed automatic molded case switch. Use the Cat. No. listed below and add the enclosure NEMA™ type suffix as noted in footnote in Table 3.48. An insulated groundable neutral, if required, must be ordered separately from Digest Section 7. Enclosed molded case switches are manufactured on order only.

**Table 3.48: Enclosed Molded Case Switches**

System	Ampere Rating	Cat. No. Add Suffix [1]	600 Vac Short Circuit Withstand Ratings
LH—400 A Frame, 3P, 600 Vac Max.			
2P	400	LHE26000( )	25 kA
3P	400	LHE36000( )	25 kA

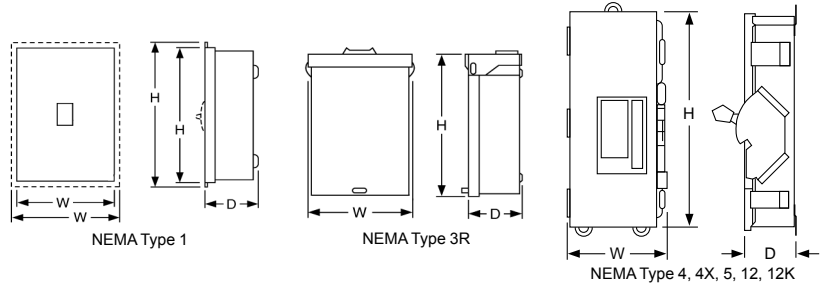

**Table 3.49: Enclosed Molded Case Switch Dimensions**

Cat. No. Prefix—Suffix	Series	Approximate Dimension					
		H		W		D	
		in.	mm	in.	mm	in.	mm
LHE—AWK	E05	42.25	1073	13.75	349	7.25	184
LHE—DS	E05	42.25	1073	13.75	349	7.25	184
LHE—F	A03	45.63	1159	16.50	419	6.50	165
LHE—R	A03	44.00	1118	15.38	391	7.88	200
LHE—S	E03	44.50	1130	15.38	391	6.50	165

**3 MOLDED CASE CIRCUIT BREAKERS AND ENCLOSURES**

**3**

[1] Add suffix S or F for NEMA 1 surface mounted or NEMA 1 flush mounted, respectively. Add suffix RB for NEMA 3R with bolt-on hub provision (FHE prefix only) or suffix R for NEMA 3R with a blank top endwall (LHE prefix only), respectively. Add suffix AWK for NEMA 12. Add suffix DS for NEMA 4/4X/5 stainless steel.

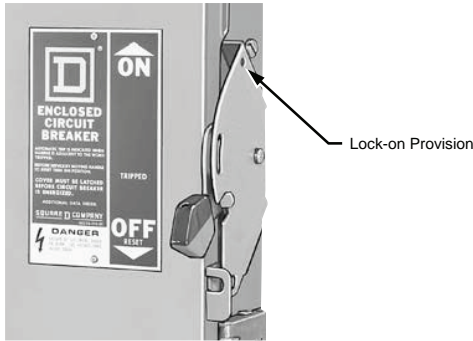

Lock-On Provision

### Lock-On Provisions

Lock-off provisions are standard on all NEMA Type 4, 4X, 5 stainless steel and NEMA Type 12, 12K circuit breaker enclosures. Provision for one inch hasp padlock is available factory installed. This modification will allow the circuit breaker to be locked in the ON position. When locked in the ON position, the external operator will not indicate if circuit breaker is tripped. UL Listed.

**Table 3.50: Enclosure**

Enclosure Prefix	Suffix for Lock-On Provision
FA, J, LA, L, M, P	SPLO

### Pilot Light—Selector Switch—Push Button

Pilot lights, push buttons or selector switches are available factory installed in the cover of NEMA Type 4, 4X, 5 stainless steel or NEMA Type 12, 12K circuit breaker enclosures. Wiring to contact blocks is not available. Customer must furnish catalog number of device desired. Price = circuit breaker + enclosure + neutral + ground + pilot light, push button and/or selector switch + factory-installed adder. Order by description. L600 enclosures are UL Listed, other enclosures are not UL Listed.

### Phenolic Legend Plate

Available engraved and mounted on most circuit breaker enclosures. Legend engraved in 1/4-inch high white letters on black background. Customer must provide legend. UL Listed. Not available on NEMA Type 7 or 9 enclosures.

To order, add suffix NP to standard catalog number (i.e. LA400SNP).



**Key Interlock Systems for Circuit Breaker Enclosures**

(Factory installed only.)

Interlocks are used to prevent the authorized operator from making an unauthorized operation. Available only on NEMA 4, 4X, 5, 12K, and 12/3R circuit breaker enclosures. The key interlock system is a simple and easy method of applying individual key interlock units and assemblies to the above equipment so as to require operation in a predetermined sequence. UL Listed.

**Quoting**

Contact local Field Sales office for catalog number, availability and pricing prior to quoting a job.

**Ordering**

Order cannot be released for production until the following information has been provided:

- End User—Company name, address
- Function of each lock (e.g., circuit breaker to be locked open with key removed, key held when circuit breaker is closed)
- Existing Equipment—if circuit breaker is to be interlocked with equipment already on site, provide brand of existing lock and key number
- Other New Equipment—if circuit breaker is to be interlocked with new equipment not yet installed at the site, then provide contact person and phone number so that locks may be coordinated
- Additional information may be required upon order entry

**Diagram Symbols**

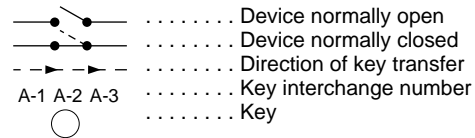

**Sample Application—1 (See Figure 1)**

To prevent two devices from being closed simultaneously.

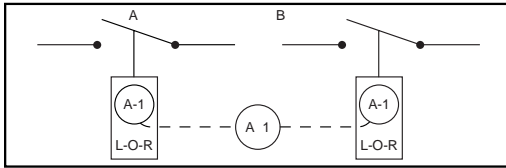

Figure 1

Two devices are shown in Figure 1. In operation they are not closed at the same time. With the interlocks arranged as shown only one key is required in the interlocking system. Both devices are shown open, therefore, the key is free. To close any one device the key is inserted and turned in that particular lock, the key is held in this lock until the device is again locked open. This simple interlocking sequence lends itself to a multitude of applications. The procedure is the same for two devices, neither of which is to be opened at the same time.

**Sample Application—2 (See Figure 2)**

To prevent opening of switch A when circuit breaker B is closed.

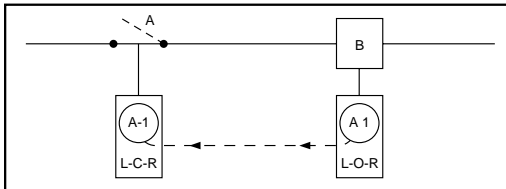

Figure 2

Switch A and circuit breaker B are in closed position. Key A-1 is held in circuit breaker B interlock.

- Open circuit breaker.
- Turn key A-1 in L-O-R interlock on circuit breaker B to lock open. Key A-1 is now free.
- Insert key A-1 in L-C-R interlock on switch A and turn to unlock.
- Open switch A. Key A-1 is now held. Reverse sequence to restore service.

**Sample Application—3 (See Figure 3)**

To prevent operation of switch A when circuit breaker B is closed. Permits reclosing of circuit breaker for servicing when switch is locked open.

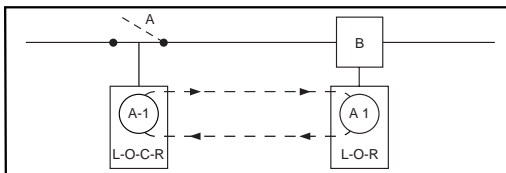

Figure 3

Switch A and circuit breaker B are in closed position. Key A-1 is held in circuit breaker interlock.

- Open circuit breaker.
- Turn key A-1 in L-O-R interlock on circuit breaker B to lock open. Key A-1 is now free.
- Insert key A-1 in L-O-C-R interlock on switch A and turn to unlock.
- Open switch A.
- Turn key A-1 in L-O-C-R interlock on switch A to lock open. Key A-1 is now free.
- Return key A-1 to circuit breaker interlock and unlock for operation during servicing period.

Reverse sequence to restore service.

**Sample Application—4 (Main-Tie-Main) (See Figure 4)**

To prevent paralleling of lines A and B.—Two loads, fed from either source.

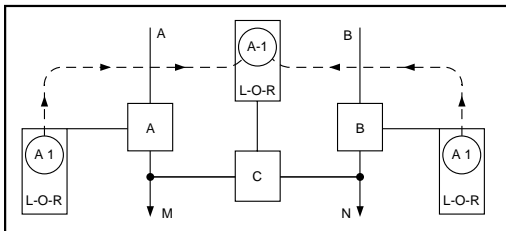

Figure 4

Circuit breaker A is closed to supply load M. Circuit breaker B is closed to supply load N. Tie-circuit breaker C is open. Keys A-1 are held in interlocks on both circuit breakers A and B. Tie-circuit breaker C cannot be closed unless either A or B is locked open.

To transfer load N to circuit breaker A, proceed as follows:

- Open circuit breaker B.
- Turn key A-1 in L-O-R interlock on circuit breaker B to lock open. Key A-1 is now free.
- Insert Key A-1 in L-O-R interlock on tie-circuit breaker C and turn to unlock. Key A-1 is now held.
- Close tie-circuit breaker C.

Reverse sequence to restore service.

Load M can be supplied through circuit breaker B in a similar manner.

# Section 4

## Panelboards



NQ Panelboard with Door-in-Door (Hinged) Trim



MH38 Enclosure with 12-inch Wireway and Mono-Flat™ Trim with 12-inch Wireway Cover

<b>Panelboards</b>	<b>4-2</b>
General Information	4-2
General Instructions	4-2
<b>Special Features</b>	<b>4-2</b>
Mains and Branches	4-2
Mains	4-2
Branches	4-2
Cabinets	4-3
Special Features	4-3
<b>Surge Protection Devices (SPD) in Panelboards</b>	<b>4-8</b>
NQ Panelboard with SPD	4-8
NF Merchandised Interiors with SPD - 480Y/277 Vac	4-8
<b>Ready-to-Install (RTI) Merchandise</b>	<b>4-9</b>
Miscellaneous Panelboard Accessories	4-9
Copper Equipment Ground Bars	4-9
NF and NQ Panelboard Replacement Part Kits	4-9
Type 1 Door-in-Door (Hinged) Trim Fronts	4-14
<b>Replacement Parts for Standard Panelboards</b>	<b>4-15</b>
Trim Clamps and Screws	4-15
Trim Clamps and Screws	4-15
Locks and Keys	4-16
Locks	4-16
Keys	4-16
NQ IP2X "Fingersafe" Panelboard Replacement Parts	4-16
<b>CTC Cabinets</b>	<b>4-17</b>
Wall Mounted Metering Equipment	4-17
Main Circuit Breaker and Current Transformer Compartment	4-17
<b>Retrofit Information</b>	<b>4-17</b>
Retrofit Existing Enclosure Data Sheet	4-17
Data Sheet for Panelboards to Retrofit Existing Enclosures	4-17

### FAQs

Visit the online FAQs page to find additional technical information covering all products including discontinued and obsolete products.  
<https://www.se.com/us/en/faqs/home/>

### General Instructions

The special feature options covered in this Panelboard estimating procedure are applicable to factory-assembled panelboards only. Do not apply this pricing to ready-to-assemble panelboards.

Special features are listed in three major categories:

- Mains
- Branches
- Cabinets

### Metric Conversion

Inches (in.) x 25.4 = millimeters (mm).

### I-Line™ Panelboards Factory Assembled

Panel Type	No. Poles	Main Circuit Breaker					
		400 A			600 A		
		LX <sup>[1]</sup>	LE <sup>[1]</sup>	LXI <sup>[1]</sup>	LX <sup>[1]</sup>	LE <sup>[1]</sup>	LXI <sup>[1]</sup>
HCP, HCP-SU	2						
	3						

### Mains

#### NEMA Type 1 Enclosures Only (1200 A Maximum)

Enclosures and Interiors are shipped fully assembled.

NQ, NF and Powerlink™ require a 7-inch left side gutter extension and a 6-inch main end extension for PowerLogic Power Meter applications.

I-Line™ and QMB require a 14-inch side gutter extension for PowerLogic Circuit Monitor and Power Meter applications.

#### Current Transformers In Mains (ac only and line side only)<sup>[1]</sup>

Prices listed are based on transformers having a 5 A secondary and mounted under a separate cover. Apply appropriate charge from the table below

Table 4.1: Current Transformers

Primary Amperes (5 A—Secondary)	Additional Enclosure Height Required <sup>[2]</sup>
100–1200	6 inches

#### Customer Equipment Space<sup>[1]</sup>

**NOTE:** End user must specify end use equipment to be installed.

Available with NQ, and NF lighting panelboards only. Must be opposite the mains end, both main breaker and main lug, to prevent interference with incoming cables. Customer equipment space is not available with thru-feed lugs or sub-feed breakers.

A barrier exists between the equipment space and the panelboard compartment; a separate door is provided as standard (requires 18-inch additional enclosure height).

**NOTE:** A separate door is not supplied in NEMA 3R/12 construction.

### Branches

#### Keyed Interlocks

**NOTE:** Not available for use in NQ, NF or I-Line™ HCN panelboards with door. Not available on I-Line™ with door when key interlocked MG/MJ/P/R frame branch-mounted circuit breakers are installed. Must use 4-piece trim or NEMA 3R/12.

Keyed mechanical interlocking of two or more circuits is available on request. Individual locks are furnished for each circuit. All locks operate by one key, which can be removed only when the circuit is locked in the desired position.

I-Line Circuit Breakers — A 3-inch filler adjacent to the circuit is necessary for mounting the interlock; contact your nearest Schneider Electric sales office for assistance with power distribution panelboards with doors. Feature not available on vertically mounted main circuit breaker.

QMB Fusible Switches — Available on 100 A singles (100 A single QMB requires 9 inches of mounting space) through 800 A switches plus LA circuit breaker adapters. Requires 3 inches of branch mounting space per switch for interlock installation.

#### Motor Operators—I-Line Circuit Breakers Only

Motor operators provide remote *open*, *close*, and *reset* control of molded case circuit breakers. Price panelboard from the latest Digest, and, for each motor operator, add per table below. In I-Line panelboards, motor operators require 4.5 inches of circuit breaker mounting space. This can be provided on I-Line main circuit breaker only when the main is branch-mounted and back-fed.

**NOTE:** Not available in I-Line HCN Panelboards



[1] Std. construction back-fed main.  
 [1] Feature supported by product selectors in Q2C and SE Advantage.  
 [2] For NQ, and NF panelboards.

**Table 4.2: Motor Operators**

Circuit Breaker Type	Motor Operator Voltage
F-frame	120 Vac
H-frame (3P modules only)	48/60, 110/130, 208/277, 380/480 Vac; 24/30, 48/60, 110/130, 250 Vdc
J-frame	48/60, 110/130, 208/277, 380/480 Vac; 24/30, 48/60, 110/130, 250 Vdc
LA, LH	120 Vac
PG, PJ, PL	48, 110/130, 220/240, 380/480 Vac; 24/30, 48/60, 110/130, 200/250 Vdc

**NOTE:** If the customer is not supplying the motor operator voltage, a control transformer can be supplied.

**Special Features**

**Cabinets**

**Increased Enclosure Depth**

**NEMA Type 1 Enclosure** [3]

8-inch depth (HC26)  
12-inch depth (HC32, 42, 44-12-inch only)

**NEMA Type 3R, 5, or 12 Enclosure** [3]

8-inch or 12-inch depth  
**NOTE:** No other depths are available.

**Increased Side Gutters (Type 1 Enclosures Only)**

**NOTE:** Available on MH enclosures (right or left) in 3, 6 and 12-inch added widths, 26-inch wide HC enclosures up to a maximum of 14 additional inches and 32-inch wide HC enclosures up to a maximum of 10 additional inches.

Not available on 42-inch wide HC enclosures.

No barrier will be supplied unless specified.

Includes one-piece trim.

Provide extended side gutters.

**Steel Barrier in Enclosure**

**NOTE:** The enclosure will be extended on one side only. If extension is required on both sides, contact your nearest Schneider Electric sales office for assistance.

**Extended Top and Bottom End Gutters**

**NOTE:** Available for Type 1 enclosures only

**Type MH Enclosures**

6-inch, 12-inch, 18-inch or 24-inch extension. Includes one-piece trim.

**Type, HCM Enclosures**

9-inch extension. Includes standard panel trim and enclosure extension cover.

**Type HCP, HCR-U Enclosures**

12-inch extension. Includes standard panel trim and enclosure extension cover.

**Type QMB Enclosures**

38-inch W x 11.5-inch D may have a 6-inch maximum increased end gutter. This is the only QMB enclosure with an increased end gutter option. Available only with a four-piece trim.

For lengths other than those listed above, refer to the Wireway section on page 4-8.

**Drip Hoods** [3]

Surface-mounted-only panelboard

**Special Finishes**

**NOTE:** The standard finish of the enclosure fronts is ANSI 49. The enclosures are galvanized steel.

**ANSI 49 Enclosure** [3]

**ANSI 61 Front or Enclosure** [3]

**Front and Enclosure with Polyester Acrylic Powder Paint Finish**

Provides increased salt spray performance in coastal areas and increased resistance to UV fading

**Special or Custom Paint for Trim and/or Enclosure**

**Free-standing Enclosures (welded base channels)** [4]

Supports extending out front and back, welded to bottom of enclosure



MH38 Enclosure with 6-inch Increased Left-side Gutter



MH38 Enclosure with 12-inch Extended Bottom End Gutter and One-Piece Trim

[3] Feature supported by product selectors in Q2C and SE Advantage.

[4] Base channels are available only for indoor applications.



Hinged Trim

**Special Trims****Hinged Trim****Hinged Trim with Outer Door Lock<sup>[5]</sup>**

**NOTE:** Outer door lock, must be priced with hinged trim. For door-in-door trim, use hinged trim with outer door lock. "ODL" suffix is added to trim front part number.

**Stainless Steel Trim Fronts<sup>[5]</sup>**

NF & NQ 20 inch-wide Mono-flat or Hinged right surface or flush trim fronts for panelboard heights up to 92 inches.

Mono-flat vented and three point latch trim fronts for 400A and 600A panelboards available in heights from 50 to 92 inches.

NF & NQ 26 inch-wide Mono-flat vented surface or flush trim fronts available for panelboard heights from 50 to 92 inches.

I-Line HCM—Standard trim with door

I-Line HCP—Standard trim with door

**Special Locks<sup>[5]</sup>****Padlock Hasp<sup>[5]</sup>**

For hasp, staple and standard lock (padlock not included) "PH" suffix is added to trim front part number.

**Special Locks**

On trim with a 3-point latch, special locks will be installed as a secondary latch. Special locks include Corbin 60, Corbin 15767, GE 75, Yale® 511S and Best 5L7RL2-626. For all other locks, contact your nearest Schneider Electric sales office for assistance.

Standard key change, Corbin 60, Corbin 15767 or GE 75<sup>[5]</sup>

Standard key change, Yale 511S<sup>[5]</sup>

Standard key change, Best 5L7RL2-626<sup>[5]</sup>

Quarter turn fasteners

**NOTE:** Special locks for all HC trims and NF panelboards with three-point latches, will be installed as secondary locks. Special locks are not available on I-Line™ 42-inch and 44-inch wide panelboards or QMB type panelboards.

Many key configurations can be accommodated with our standard Square D™ brand lock. Contact your nearest Schneider Electric sales office for assistance.

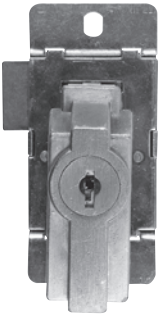
NC38S  
Padlock Hasp

Corbin 15767 Lock

NC38S with  
Yale Lock Installed

<sup>[5]</sup> Feature supported by product selectors in Q2C and SE Advantage.



Common Trim Front for Use with Multiple-Section Panelboards Mounted Side-By-Side

**Multi-Section Panels**

**Equal-Height Enclosures<sup>[6]</sup>**

NQ, and NF  
I-Line or QMB

**Common Trim in Place of Two Individual Fronts<sup>[6]</sup>**

Used to cover two equal-height enclosures mounted side-by-side.

**Sheared on Inside Edges**

Allows enclosures to be butted together.

**Panel Skirt for Standard Width Panelboards<sup>[6]</sup>**

Panel skirts are intended for cosmetic purposes only; they are meant to hide cables which are enclosed in conduit.

Do not use a panel skirt as a wireway; see the Wireway section below.

**NOTE:** Panel skirts are for Type 1 surface-mounted applications with standard depth and width, Square D™ brand enclosures only.

**Table 4.3: Panel Skirts**

Skirt Length	NQ, NF	I-Line™, QMB
	4–60 inches	PSxx <sup>[7]</sup>
61–92 inches	N/A	



Panel skirt framework to be bolted to the wall.



Panel skirt bolted in place below an MH26 enclosure.



Panel skirt completely installed.

[6] Feature supported by product selectors in Q2C and SE Advantage.

[7] Panel Skirts supplied as a Commercial Reference has a PSxx part number, where xx is the length in inches.



MH38 enclosure with 12-inch wireway and Mono-Flat™ trim with 12-inch wireway cover.

**Wireway**

Allows for terminating conduit in the wireway endwall. Only the cable passes through the wireway into the NEMA Type 1 panelboard enclosure. Includes trim and wireway cover.

**NOTE:** Wireway is for Type 1, surface-mounted applications with standard depth and width, Square D™ brand enclosures only.

**Table 4.4: Wireway**

Wireway Length	NQ, NF	I-Line™, QMB
4–60 inches	WWxx <sup>[8]</sup>	
61–92 inches	N/A	

**Panels to Fit Existing Enclosures**

Panelboard interiors and special fronts can be furnished to fit existing enclosures. First, price the complete panel along with the appropriate price adder from below. Next, photocopy the Retrofit Existing Enclosure data sheet found on page 4-17, record the required dimensions on the photocopy and forward it with your order to the nearest Schneider Electric sales office. For interiors requiring vented enclosures, contact your nearest Schneider Electric sales office for assistance.

**NOTE:** Existing enclosure depth on flush installations must be measured from inside surface of enclosure to outer wall or plaster surface.

**Special Fronts**

Existing enclosure the same depth as or deeper than our standard.

**NOTE:** Elevating brackets to be supplied by customer for existing enclosures deeper than our standard.

Existing enclosure shallower than our standard. Requires an enclosure extension (surface applications) or a formed front (flush applications). A hinged trim front option is not available for these applications.

**NOTE:** A formed front is available on NQ (225 A max.) and, NF (250 A max.). When a flush front is required for an existing enclosure that is shallower than our standard, be sure to indicate the position of the enclosure with respect to the wall in which it is mounted. This is required in order to determine whether an enclosure extension with a flat front should be supplied, or whether a flush formed front is more applicable. The interior must be centered in the enclosure and, if the enclosure is deeper than our standard, the interior must be leveled within the enclosure. The existing enclosure for NQ and, NF panels cannot be more than 3.0 inches shorter than the standard enclosure. Minimum width is 17 inches. Special trims that are manufactured to fit an existing enclosure will be within ± 0.25 inches of the specification. Refer to the table below for standard enclosure depths and for the maximum depth for which no special mounting brackets are required.

**Table 4.5: Panelboard Enclosure Depths**

Panelboard Type	Standard Enclosure Depth	Maximum Enclosure Depth for which No Special Mounting Brackets Required
NQ standard width—main lugs only	5.75 inches	5.75 inches
NQ standard width—main circuit breaker <sup>[9]</sup>	5.75 inches	5.75 inches
NF <sup>[9]</sup>	5.75 inches	5.75 inches
I-Line™—Maximum F, H or Q-frame branch circuit breaker	6.5 inches	7.25 inches
I-Line™—Maximum J-frame branch circuit breaker	8.25 inches	9.0 inches
I-Line™—Maximum P or R-frame branch circuit breaker	9.25 inches	10.25 inches

**Space Heater**

**NOTE:** Enclosure, interior and trim ship fully assembled. 120 V is standard. Top feed applications only.

NQ and NF require 18 inches equipment space in NEMA 3R/12 constructions.

NQ and NF require 6 inch bottom end gutter in NEMA 1 construction.

Unwired (provisions for wiring to external source)

Wired (with overcurrent device, thermostat)

<sup>[8]</sup> Wireway supplied as a Commercial Reference has a WWxx part number, where xx is the length in inches.

<sup>[9]</sup> Panelboards with PowerPac T L main or sub-feed circuit breakers require 8.75 inch deep MHxxD9 enclosures, which are shipped with all required mounting brackets.



I-Line Door-in-Door Enclosure



Access to Circuit Breaker Handles



Access to Wiring Gutters

**Special Enclosures**

**Type 1 Gasketed Enclosure (gasketing between front and enclosure)**

20-inch maximum panel width

Over 20-inch panel width

**NOTE:** For 250 A and below enclosures only.

**Stainless Steel Enclosure (Type 3R, 4, 4X, 5 and 12; UL Listed)**

**NOTE:** For #316 stainless steel, add 15% to the prices shown below.

NF and NQ for panelboard heights up to 86 inches

For panelboard heights up to 41 inches

For panelboard heights of 44–56 inches

For panelboard heights of 59–80 inches

I-Line™

HCM

HCP

**NOTE:** 304 stainless, standard

QMB [10]

**Fiberglass Enclosures (Type 4X, Non-Vented; UL Listed)**

NF and NQ for panelboard heights up to 50 inches

28-inch height

33-inch, 40-inch and 50-inch height

I-Line and QMB

**Type 12 Door-In-Door Enclosures**

**Table 4.6: Available Enclosures**

Interior Type	Enclosure Size		
	Height	Width	Depth
NQ [11]	56 inches	20 inches	6.5 inches
NF [12]	56 inches	20 inches	6.5 inches
I-Line (HCM)	91 inches	32 inches	11.5 inches
I-Line (HCP)	68 inches	42 inches	12.7 inches
I-Line (HCP)	86 inches	42 inches	12.7 inches

**Table 4.7: I-Line Door Kits**

Panel Type	Catalog No. [13]
HCN	HCN52D ( )
	HCN65D ( )
	HCN74D ( )
	HCN83D ( )
	HCN92D ( )
HCM	HCM48D ( )
	HCM64D ( )
	HCM73D ( )
	HCM91D ( )
HCP	HCW50D
	HCW59D
	HCW68D
	HCW86D
HCRU	HCW86D
HCN/HCM Latch Bracket	80104-908-50

• NOTE: HCRU door covers circuit breakers only, not entire box

[10] Not available for QMB interiors over 800 A.

[11] Not available for NQ interiors over 225 A.

[12] Not available for NF interiors over 250 A.

[13] Add "S" for surface or "F" for flush in place of the parentheses.

**NQ Panelboard with SPD**

**Table 4.8: OBSOLETE NQ SurgeLogic SurgeLoc Plug-on SPD (occupies 12-pole spaces) [1] [2]**

Voltage	Surge Current Rating	Part Number
120 / 240 V	80 kA	SSP01BIA08PBQ1
	100 kA	SSP01BIA10PBQ1
	120 kA	SSP01BIA12PBQ1
	160 kA	SSP01BIA16PBQ1
	200 kA	SSP01BIA20PBQ1
	240 kA	SSP01BIA24PBQ1
208 Y / 120 V	80 kA	SSP02BIA08PBQ1
	100 kA	SSP02BIA10PBQ1
	120 kA	SSP02BIA12PBQ1
	160 kA	SSP02BIA16PBQ1
	200 kA	SSP02BIA20PBQ1
	240 kA	SSP02BIA24PBQ1
240 / 120 High Leg Delta	80 kA	SSP03BIA08PBQ1
	100 kA	SSP03BIA10PBQ1
	120 kA	SSP03BIA12PBQ1
	160 kA	SSP03BIA16PBQ1
	200 kA	SSP03BIA20PBQ1
	240 kA	SSP03BIA24PBQ1

**NF Merchandised Interiors with SPD - 480Y/277 Vac**

**NOTE:** For selecting SurgeLoc SPD for RTI NQ Panelboard application, please refer to Section 9 of the Digest.

**Table 4.9: NF Merchandised Interiors with SPD—Use I-Line Panelboards on 480 V 3Ø3W Delta Applications**

Mains Rating	Max. Breaker Spaces	SPD Ratings		Interior Catalog No.	Components for adding Vertical Main Circuit Breaker	
		Voltage	Surge Rating		MCB Kit Catalog No.	Main Circuit Breaker Frame Select the appropriate MCB and price from the tables starting on Digest page 7-22
250 A	42	480Y/277 3P4W	120	NF442L2TVS412	N250MJ	PowerPacT J
			160	NF442L2TVS416		PowerPacT J
400 A	42	480Y/277 3P4W	120	NF442L4TVS412	N400M	LAL/LHL (PowerPacT L F/A only)
			160	NF442L4TVS416	N400M	

**NOTE:** Dry contacts standard.

[1] When selecting a panelboard with SurgeLoc SPD, an additional 12 circuit positions (6 adjacent mounting spaces per side) are occupied. For example, if the desired number of circuits is 30, refer to "NQ Main Lug Interiors" and "NQ Main Circuit Breaker Interiors" in Digest section 9 to select the NQ442L2/NQ442L2C interior and corresponding Box and Trim.

[2] 96 space interiors are available factory assembled when SurgeLoc SPDs are to be installed in 84 circuit NQ panelboards.

**Copper Equipment Ground Bars**

Copper equivalents of our aluminum PK-GTA equipment ground bars are available. These copper ground bars accept #14-4 Cu only.

**Table 4.10: Copper Ground Bars for NF Panelboards (see the Digest, Section 9 for NQ copper ground bar kits)**

Maximum Interior Circuit Count	Maximum Ampere Rating	Catalog No.
18	250	8010302651
30	250	8010302652
54	250	8010302653
84	400/600/800	PK27GTACU

**NF and NQ Panelboard Replacement Part Kits**

**Table 4.11: TBPANEL NF and NQ Spare PartsTackle Box Replacement Kits**

Catalog Number	Description	Contents	Qty
NF102OETB	NF Number Strips TB Replacement Kit	NF102OE Circuit Strips	10
NQ102OETB	NQ Number Strips TB Replacement Kit	NQ102OE Circuit Strips	10
PANELDCTB	Directory Card & Pouch Replacement Kit	Directory Cards with Pouches	10
PAN-ELDCWMD54TB	Directory Card WMD # 1 TB Replacement Kit	Directory Cards #1 WMD	10
PAN-ELDCWMD96TB	Directory Card WMD # 2 TB Replacement Kit	Directory Cards #2 WMD	10
PANELDGTB	Danger Label TB Replacement Kit	Danger Labels	10
PANELLSTB	Label Sheet TB Replacement Kit	Label Sheets	10
PANELMBTB	Main Breaker Label TB Replacement Kit	MB Labels	10
PANELSMCTB	Seismic Label TB Replacement Kit	Seismic Labels	10
PANELWGTB	Warning Label TB Replacement Kit	Warning Labels	10
PANELKSTB	Kit Screw TB Replacement Kit	10-32 x 5/8" Kit Screws	50
PANELKEYTB	NSR251 Key TB Replacement Kit	NSR251 Keys	25
PANEL-TRIMSCSTB	Trim Screw Mono-Flat TB Replacement Kit	10-32 x 19/32" Trim Front Screws	30
PANEL-TRIMHSCSTB	Trim Screw Hinged TB Replacement Kit	1/4"-20 x 1" Trim Front Screws	30
PANEL-TRIMHNTB	Tinnerman Clips TB Replacement Kit	1/4"-20 Spring Nut Clips	30
NQFP15	NQ Filler Plate Kit (15 per Pkg)	NQ Filler Plates	15
NFELVTB	NF Elevating Nut TB Replacement Kit	NF Elevating Nuts	25
PANELDFSTB	Deadfront Screw TB Replacement Kit	10-32 x 7/16" Deadfront Screws	50
PANELBOX-NUTTB	Enclosure Nut TB Replacement Kit	Enclosure Nuts	30
NQELVTB	NQ Elevating Screw TB Replacement Kit	NQ Elevating Screws	50
NFFP15	NF Filler Plate Kit (15 per Pkg)	NF Filler Plates	15

**Table 4.12: NQ and NF Replacement Deadfront Kits**

NQ and NF Replacement Deadfront Kits	Commercial Reference
NQ and NF Replacement Deadfront Cover 1.65" Long	NQNFRL05601
NQ and NF Replacement Deadfront Cover 4.59" Long	NQNFRL05602
NQ and NF Replacement Deadfront Cover 7.58" Long	NQNFRL05603
NQ and NF Replacement Deadfront 7.58" Long w/ Label	NQNFRL05603L
NQ and NF Replacement Deadfront Cover 10.59" Long	NQNFRL05604
NQ and NF Replacement Deadfront 10.59" Long w/ Label	NQNFRL05604L
NQ and NF Replacement Deadfront Cover 12.08" Long	NQNFRL05605
NQ and NF Replacement Deadfront 12.08" Long w/ Label	NQNFRL05605L
NQ and NF Replacement Deadfront Cover 13.58" Long	NQNFRL05606
NQ and NF Replacement Deadfront 13.58" Long w/ Label	NQNFRL05606L
NQ and NF Replacement Deadfront Cover 19.58" Long	NQNFRL05607
NQ and NF Replacement Deadfront 19.58" Long w/ Label	NQNFRL05607L
NQ and NF Replacement Deadfront Cover 25.58" Long	NQNFRL05608
NQ and NF Replacement Deadfront 25.58" Long w/ Label	NQNFRL05608L
NQ and NF Replacement Deadfront Cover 30.08" Long	NQNFRL05609
NQ and NF Replacement Deadfront 30.08" Long w/ Label	NQNFRL05609L
NQ and NF Replacement Deadfront Cover 31.58" Long	NQNFRL05610
NQ and NF Replacement Deadfront 31.58" Long w/ Label	NQNFRL05610L
NQ and NF Replacement Deadfront Cover 8.53" Long	NQNFRL08902
NQ and NF Replacement Deadfront 8.53" Long w/ Label	NQNFRL08902L
NQ and NF Replacement Deadfront Cover 12.05" Long FTL	NQNFRL08903
NQ and NF Replacement Deadfront 12.05" Long FTL w/ Label	NQNFRL08903L
NQ and NF Replacement Deadfront Cover 12.05" Long	NQNFRL08906
NQ and NF Replacement Deadfront 12.05" Long w/ Label	NQNFRL08906L
NQ and NF Replacement Deadfront Cover 14.53" Long	NQNFRL08909
NQ and NF Replacement Deadfront 14.53" Long w/ Label	NQNFRL08909L
NQ and NF Replacement Deadfront Cover 18.05" Long	NQNFRL08910
NQ and NF Replacement Deadfront 18.05" Long w/ Label	NQNFRL08910L
NQ and NF Replacement Deadfront Cover 18.05" Long	NQNFRL08912
NQ and NF Replacement Deadfront 18.05" Long w/ Label	NQNFRL08912L
NQ and NF Replacement Deadfront Cover 3.05" Long	NQNFRL33001
NQ and NF Replacement Deadfront Cover 6.08" Long	NQNFRL33002
NQ and NF Replacement Deadfront 6.08" Long w/ Label	NQNFRL33002L
NQ and NF Replacement Deadfront Cover 9.05" Long	NQNFRL33003
NQ and NF Replacement Deadfront 9.05" Long w/ Label	NQNFRL33003L

**Table 4.12 NQ and NF Replacement Deadfront Kits (cont'd.)**

NQ and NF Replacement Deadfront Kits	Commercial Reference
NQ and NF Replacement Deadfront Cover 18.05" Long	NQNFRL33004
NQ and NF Replacement Deadfront 18.05" Long w/ Label	NQNFRL33004L
NQ and NF Replacement Deadfront Cover 24.05" Long	NQNFRL33005
NQ and NF Replacement Deadfront 24.05" Long w/ Label	NQNFRL33005L
NQ and NF Replacement Deadfront End	NQNFRL33301
NQ and NF ASCO Contactor Replacement Cover Kit	NQNFRLCASC0

**Table 4.13: NQ and NF Replacement Lug Kits**

NQ and NF Replacement Lug Kits	Commercial Reference
NQ and NF 400 A / 600 A Al Neutral Replacement Mech Lug	NQNFRLALMN46
NQ and NF 100 A / 125 A Al Replacement Mechanical Lug	NQNFRLALM1
NQ and NF 100 A / 125 A Al Dual Replacement Mechanical Lug	NQNFRLALM1D
NQ and NF 225 A / 250 A Al Replacement Mechanical Lug	NQNFRLALM2
NQ and NF 400 A Al Replacement Mechanical Lug	NQNFRLALM4
NQ and NF 600 A Al Replacement Mechanical Lug	NQNFRLALM6
NQ and NF 400 A / 600 A Al Replacement Crimp Lug	NQNFRLALVN46
NQ and NF 400 A / 600 A Al Replacement Crimp Lug w/ Label	NQNFRLALV46
NQ and NF 400 A / 600 A Cu Replacement Mech Lug	NQNFRLCUM46
NQ and NF 100 A / 125 A Cu Replacement Mech Lug	NQNFRLCUM1
NQ and NF 225 A / 250 A Cu Replacement Mech Lug	NQNFRLCUM2
NQ and NF 400 A Cu Replacement Mech Lug	NQNFRLCUM4
NQ and NF 600 A Cu Replacement Mech Lug	NQNFRLCUM6
NQ and NF 400 A / 600 A Cu Replacement Crimp Lug	NQNFRLCUMVN46
NQ and NF 100 A / 125 A Cu Replacement Crimp Lug	NQNFRLCUMV
NQ and NF 400 A Al Neutral Exp Mechanical Lug	NQRPLSFBALN

**Table 4.14: NQ and NF Replacement Parts**

NQ and NF Replacement Parts	Commercial Reference
ANSI 49 Gray Touch-up Paint (Aerosol)	PK49SP

**Table 4.15: NQ Replacement Parts Kits**

NQ Replacement Parts Kits	Commercial Reference
NQ 600 A Al ACC Replacement Mech Lug	NQRPLALM6A
NQ 100 A Al Replacement Crimp Lug	NQRPLALV1
NQ 225 A Al Replacement Crimp Lug	NQRPLALV2
NQ (KI) 225 A Main Breaker Replacement Deadfront	NQRPLMB2KI
NQ (H, J) 100 A / 225 A Main Breaker Replacement Deadfront	NQRPLMB2HJ
NQ (Q) 225 A Main Breaker Replacement Deadfront	NQRPLMB2Q
NQ (LA/LH) 400 A Main Breaker Replacement Deadfront	NQRPLMB4LA
NQ (LC) 400 A / 600 A Main Breaker Replacement Deadfront	NQRPLMB6LC
NQ (PPL) 400 A / 600 A Main Breaker Replacement Deadfront	NQRPLMB6PPL
NQ (PPL) NEMA 3R 400 A / 600 A Main Breaker Replacement Deadfront	NQRPLMB63PPL
NQ Low Amp Cover Kit	NQRPLML2
NQ High Amp Cover Kit	NQRPLML6
NQ SFB (H,J) 225A Replacement Deadfront	NQRPLSFB2HJ
NQ SFB (Q) 225A Replacement Deadfront	NQRPLSFB2Q
NQ SFB (LA/LH) Replacement Deadfront	NQRPLSFB4LA
NQ Dual PP-Q SFB Replacement Deadfront	NQRPLSFB4Q
NQ SFB (H,J) 400 A / 600 A Replacement Deadfront	NQRPLSFB6HJ
NQ SFB (Q) 400 A / 600 A Replacement Deadfront	NQRPLSFB6Q
NQ Column Width MB Branch Repl Deadfront Kit	NQRPL20MB100CW
NQ Column Width MB Branch Repl Deadfront Kit	NQRPL30MB100CW
NQ Column Width Branch 100 A Repl Deadfront Kit	NQRPL30ML100CW
NQ Column Width Branch 225 A Repl Deadfront Kit	NQRPL30ML225CW
NQ Column Width MB Branch 225 A Repl Deadfront Kit	NQRPL42MB225CW
NQ Column Width Branch 225 A Repl Deadfront Kit	NQRPL42ML225CW
NQ Branch Repl Deadfront Kit 100 A 18 Circuits 1 Phase	NQRPL18L1
NQ Branch Repl Deadfront Kit 100 A 30 Circuits 1 Phase	NQRPL30L1
NQ Branch Repl Deadfront Kit 225 A 30 Circuits 1 Phase	NQRPL30L2
NQ Branch Repl Deadfront Kit 225 A 30 Circuits MB 1 Ph	NQRPL30L2M250
NQ Branch Repl Deadfront Kit 225 A 30 Circuits MB 3 Ph	NQRPL430L2M250
NQ MB Branch Repl Deadfront Kit 250 A 1 Ph	NQRPL30M250
NQ MB Branch Repl Deadfront Kit 250 A 3 Ph	NQRPL430M250
NQ Branch Repl Deadfront Kit 400 A 30 Circuits 1 Phase	NQRPL30L4
NQ Branch Repl Deadfront Kit 600 A 30 Circuits 1 Phase	NQRPL30L6
NQ LC MB Branch Repl Deadfront Kit 1 Ph	NQRPL30MB6LC
NQ LC MB Branch Repl Deadfront Kit 3 Ph	NQRPL430MB6LC
NQ Branch Repl Deadfront Kit 225 A 42 Circuits 1 Phase	NQRPL42L2
NQ Branch Repl Deadfront Kit 225 A 42 Circuits MB 1 Ph	NQRPL42L2M250
NQ Branch Repl Deadfront Kit 225 A 42 Circuits MB 3 Ph	NQRPL442L2M250
NQ MB Branch Repl Deadfront Kit 250 A 1 Ph	NQRPL42M250
NQ MB Branch Repl Deadfront Kit 250 A 3 Ph	NQRPL442M250
NQ Branch Repl Deadfront Kit 400 A 42 Circuits 1 Phase	NQRPL42L4
NQ Branch Repl Deadfront Kit 600 A 42 Circuits 1 Phase	NQRPL42L6
NQ LC MB Branch Repl Deadfront Kit 1 Ph	NQRPL42MB6LC
NQ LC MB Branch Repl Deadfront Kit 3 Ph	NQRPL442MB6LC
NQ Branch Repl Deadfront Kit 225 A 54 Circuits 1 Phase	NQRPL54L2
NQ Branch Repl Deadfront Kit 400 A 54 Circuits 1 Phase	NQRPL54L4

4

PANEL BOARDS

**Table 4.15 NQ Replacement Parts Kits (cont'd.)**

NQ Replacement Parts Kits	Commercial Reference
NQ Branch Repl Deadfront Kit 600 A 54 Circuits 1 Phase	NQRPL54L6
NQ MB Branch Repl Deadfront Kit 250 A 1 Ph	NQRPL54M250
NQ LC MB Branch Repl Deadfront Kit 1 Ph	NQRPL54MB6LC
NQ Branch Repl Deadfront Kit 225 A 72 Circuits 1 Phase	NQRPL72L2
NQ Branch Repl Deadfront Kit 400 A 72 Circuits 1 Phase	NQRPL72L4
NQ Branch Repl Deadfront Kit 600 A 72 Circuits 1 Phase	NQRPL72L6
NQ MB Branch Repl Deadfront Kit 250 A 1 Ph	NQRPL72M250
NQ LC MB Branch Repl Deadfront Kit 1 Ph	NQRPL72MB6LC
NQ Branch Repl Deadfront Kit 225 A 84 Circuits 1 Phase	NQRPL84L2
NQ Branch Repl Deadfront Kit 400 A 84 Circuits 1 Phase	NQRPL84L4
NQ Branch Repl Deadfront Kit 600 A 84 Circuits 1 Phase	NQRPL84L6
NQ MB Branch Repl Deadfront Kit 250 A 1 Ph	NQRPL84M250
NQ LC MB Branch Repl Deadfront Kit 1 Ph	NQRPL84MB6LC
NQ Branch Repl Deadfront Kit 100 A 18 Circuits 3 Phase	NQRPL18L1
NQ Branch Repl Deadfront Kit 100 A 30 Circuits 3 Phase	NQRPL430L1
NQ Branch Repl Deadfront Kit 225 A 30 Circuits 3 Phase	NQRPL430L2
NQ Branch Repl Deadfront Kit 400 A 30 Circuits 3 Phase	NQRPL430L4
NQ Branch Repl Deadfront Kit 600 A 30 Circuits 3 Phase	NQRPL430L6
NQ Branch Repl Deadfront Kit 225 A 42 Circuits 3 Phase	NQRPL442L2
NQ Branch Repl Deadfront Kit 400 A 42 Circuits 3 Phase	NQRPL442L4
NQ Branch Repl Deadfront Kit 600 A 42 Circuits 3 Phase	NQRPL442L6
NQ Branch Repl Deadfront Kit 225 A 54 Circuits 3 Phase	NQRPL454L2
NQ Branch Repl Deadfront Kit 400 A 54 Circuits 3 Phase	NQRPL454L4
NQ Branch Repl Deadfront Kit 600 A 54 Circuits 3 Phase	NQRPL454L6
NQ Branch Repl Deadfront Kit 225 A 54 Circuits MB 3 Ph	NQRPL454L2M250
NQ LC MB Branch Repl Deadfront Kit 3 Ph	NQRPL454MB6LC
NQ Branch Repl Deadfront Kit 225 A 72 Circuits 3 Phase	NQRPL472L2
NQ Branch Repl Deadfront Kit 400 A 72 Circuits 3 Phase	NQRPL472L4
NQ Branch Repl Deadfront Kit 600 A 72 Circuits 3 Phase	NQRPL472L6
NQ MB Branch Repl Deadfront Kit 250 A 3 Ph	NQRPL472M250
NQ Branch Repl Deadfront Kit 225 A 82 Circuits MB 3 Ph	NQRPL472L2M250
NQ LC MB Branch Repl Deadfront Kit 3 Ph	NQRPL472MB6LC
NQ Branch Repl Deadfront Kit 225 A 84 Circuits 3 Phase	NQRPL484L2
NQ Branch Repl Deadfront Kit 400 A 84 Circuits 3 Phase	NQRPL484L4
NQ Branch Repl Deadfront Kit 600 A 84 Circuits 3 Phase	NQRPL484L6
NQ MB Branch Repl Deadfront Kit 250 A 3 Ph	NQRPL484M250
NQ Branch Repl Deadfront Kit 225 A 84 Circuits MB 3 Ph	NQRPL484L2M250
NQ LC MB Branch Repl Deadfront Kit 3 Ph	NQRPL484MB6LC
NQ Bonding Strap 100 / 225 AMP	NQBOND12
NQ Bonding Strap 400 / 600 AMP	NQBOND46
NQ 400 A & 600 A Condo Riser Neutral Bonding Kit	NFNQCRBOND46

**Table 4.16: NF Replacement Parts Kits**

NF Replacement Parts Kits	Commercial Reference
NF 800 A Al Neutral Replacement Mech Lug	NFRPLALM8
NF Al Neutral Branch Lug Adder	NFRPLALNADD
NF 125 A Al Replacement Crimp Lug	NFRPLALV1
NF 250 A Al Replacement Crimp Lug	NFRPLALV2
NF 800 A Cu Neutral Replacement Mech Lug	NFRPLCUM8
NF Cu Neutral Branch Lug Adder	NFRPLCUNADD
NF (F) 125 A Main Breaker Replacement Deadfront	NFRPLMB1F
NF (H) 125 A Main Breaker Replacement Deadfront	NFRPLMB1H
NF (J) 250 A Main Breaker Replacement Deadfront	NFRPLMB2J
NF (KI) 250 A Main Breaker Replacement Deadfront	NFRPLMB2KI
NF (LA/LH) 400 A Main Breaker Replacement Deadfront	NFRPLMB4LA
NF (LC) 400 A / 600 A Main Breaker Replacement Deadfront	NFRPLMB6LC
NF PowerPacT L MB or SFB Deadfront Replacement Kit	NFRPLM6PPL
NF PowerPacT L NEMA 3R MB or SFB Deadfront Replacement Kit	NFRPLM63PPL
NF PowerPacT M MB Deadfront Replacement Kit	NFRPLM8PPM
NF PowerPacT P MB Deadfront Replacement Kit	NFRPLM8PPP
NF 125 Amp Repl Cover Kit	NFRPLML1
NF 250 Amp Repl Cover Kit	NFRPLML2
NF 125/250/400/600 Amp Repl Cover Kit	NFRPLML6
NF SFB (H) 250A Replacement Deadfront	NFRPLSFB2H
NF SFB (J) 250A Replacement Deadfront	NFRPLSFB2J
NF SFB (H) 400A Replacement Deadfront	NFRPLSFB4H
NF SFB (J) 400A Replacement Deadfront	NFRPLSFB4J
NF SFB (LA/LH) Replacement Deadfront	NFRPLSFB4LA
NF SFB (LA & H) Replacement Deadfront	NFRPLSFB4LAH
NF SFB (LA & J) Replacement Deadfront	NFRPLSFB4LAJ
NF Column Width Branch 100 A Repl Deadfront Kit	NFRPL30L100CW
NF Column Width Branch 100 A Repl Deadfront Kit	NFRPL30M100CW
NF Column Width Branch 125 A Repl Deadfront Kit	NFRPL30L125CW
NF Column Width 30 Circuit MB Branch Repl Deadfront Kit	NFRPL30MBCW
NF Column Width Branch 100 A MB Repl Deadfront Kit	NFRPL42M100CW
NF Column Width Branch 150 A MB Repl Deadfront Kit	NFRPL42M150CW
NF Column Width Branch 225 A Repl Deadfront Kit	NFRPL42L225CW
NF Column Width Branch 225 A MB Repl Deadfront Kit	NFRPL42M225CW
NF Column Width 42 Circuit MB Branch Repl Deadfront Kit	NFRPL42MBCW

Table 4.16 NF Replacement Parts Kits (cont'd.)

NF Replacement Parts Kits	Commercial Reference
NF Branch Repl Deadfront Kit 125 A 18 Circuits 1 Phase	NFRPL18L1
NF Branch Repl Deadfront Kit 125 A 30 Circuits 1 Phase	NFRPL30L1
NF Branch Repl Deadfront Kit 125 A TFL 30 Circuits 1 Phase	NFRPL30L1TFL
NF Branch Repl Deadfront Kit 250 A 30 Circuits 1 Phase	NFRPL30L2
NF Branch Repl Deadfront Kit 250 A TFL 30 Circuits 1 Phase	NFRPL30L2TFL
NF Branch Repl Deadfront Kit 400 A 30 Circuits 1 Phase	NFRPL30L4
NF Branch Repl Deadfront Kit 400 A TFL 30 Circuits 1 Phase	NFRPL30L4TFL
NF Branch Repl Deadfront Kit 600 A 30 Circuits 1 Phase	NFRPL30L6
NF Branch Repl Deadfront Kit 600 A TFL 30 Circuits 1 Phase	NFRPL30L6TFL
NF Branch Repl Deadfront Kit 800 A 30 Circuits 1 Phase	NFRPL30L8
NF Branch Repl Deadfront Kit 800 A TFL 30 Circuits 1 Phase	NFRPL30L8TFL
NF Branch Repl Deadfront Kit 125 A 42 Circuits 1 Phase	NFRPL42L1
NF Branch Repl Deadfront Kit 125 A TFL 42 Circuits 1 Phase	NFRPL42L1TFL
NF Branch Repl Deadfront Kit 250 A 42 Circuits 1 Phase	NFRPL42L2
NF Branch Repl Deadfront Kit 250 A TFL 42 Circuits 1 Phase	NFRPL42L2TFL
NF Branch Repl Deadfront Kit 400 A 42 Circuits 1 Phase	NFRPL42L4
NF Branch Repl Deadfront Kit 400 A TFL 42 Circuits 1 Phase	NFRPL42L4TFL
NF Branch Repl Deadfront Kit 600 A 42 Circuits 1 Phase	NFRPL42L6
NF Branch Repl Deadfront Kit 600 A TFL 42 Circuits 1 Phase	NFRPL42L6TFL
NF Branch Repl Deadfront Kit 800 A 42 Circuits 1 Phase	NFRPL42L8
NF Branch Repl Deadfront Kit 800 A TFL 42 Circuits 1 Phase	NFRPL42L8TFL
NF Branch Repl Deadfront Kit 125 A 54 Circuits 1 Phase	NFRPL54L1
NF Branch Repl Deadfront Kit 125 A TFL 54 Circuits 1 Phase	NFRPL54L1TFL
NF Branch Repl Deadfront Kit 250 A 54 Circuits 1 Phase	NFRPL54L2
NF Branch Repl Deadfront Kit 250 A TFL 54 Circuits 1 Phase	NFRPL54L2TFL
NF Branch Repl Deadfront Kit 400 A 54 Circuits 1 Phase	NFRPL54L4
NF Branch Repl Deadfront Kit 400 A TFL 54 Circuits 1 Phase	NFRPL54L4TFL
NF Branch Repl Deadfront Kit 600 A 54 Circuits 1 Phase	NFRPL54L6
NF Branch Repl Deadfront Kit 600 A TFL 54 Circuits 1 Phase	NFRPL54L6TFL
NF Branch Repl Deadfront Kit 800 A 54 Circuits 1 Phase	NFRPL54L8
NF Branch Repl Deadfront Kit 800 A TFL 54 Circuits 1 Phase	NFRPL54L8TFL
NF Branch Repl Deadfront Kit 250 A 66 Circuits 1 Phase	NFRPL66L2
NF Branch Repl Deadfront Kit 250 A TFL 66 Circuits 1 Phase	NFRPL66L2TFL
NF Branch Repl Deadfront Kit 400 A 66 Circuits 1 Phase	NFRPL66L4
NF Branch Repl Deadfront Kit 400 A TFL 66 Circuits 1 Phase	NFRPL66L4TFL
NF Branch Repl Deadfront Kit 600 A 66 Circuits 1 Phase	NFRPL66L6
NF Branch Repl Deadfront Kit 600 A TFL 66 Circuits 1 Phase	NFRPL66L6TFL
NF Branch Repl Deadfront Kit 250 A 84 Circuits 1 Phase	NFRPL84L2
NF Branch Repl Deadfront Kit 400 A 84 Circuits 1 Phase	NFRPL84L4
NF Branch Repl Deadfront Kit 600 A 84 Circuits 1 Phase	NFRPL84L6
NF Branch Repl Deadfront Kit 125 A 12 Circuits 3 Phase	NFRPL412L1
NF Branch Repl Deadfront Kit 125 A 18 Circuits 3 Phase	NFRPL418L1
NF Branch Repl Deadfront Kit 125 A 30 Circuits 3 Phase	NFRPL430L1
NF Branch Repl Deadfront Kit 125 A TFL 30 Circuits 3 Phase	NFRPL430L1TFL
NF Branch Repl Deadfront Kit 250 A 30 Circuits 3 Phase	NFRPL430L2
NF Branch Repl Deadfront Kit 250 A TFL 30 Circuits 3 Phase	NFRPL430L2TFL
NF Branch Repl Deadfront Kit 400 A 30 Circuits 3 Phase	NFRPL430L4
NF Branch Repl Deadfront Kit 400 A TFL 30 Circuits 3 Phase	NFRPL430L4TFL
NF Branch Repl Deadfront Kit 600 A 30 Circuits 3 Phase	NFRPL430L6
NF Branch Repl Deadfront Kit 600 A TFL 30 Circuits 3 Phase	NFRPL430L6TFL
NF Branch Repl Deadfront Kit 800 A 30 Circuits 3 Phase	NFRPL430L8
NF Branch Repl Deadfront Kit 800 A TFL 30 Circuits 3 Phase	NFRPL430L8TFL
NF Branch Repl Deadfront Kit 125 A 42 Circuits 3 Phase	NFRPL442L1
NF Branch Repl Deadfront Kit 125 A TFL 42 Circuits 3 Phase	NFRPL442L1TFL
NF Branch Repl Deadfront Kit 250 A 42 Circuits 3 Phase	NFRPL442L2
NF Branch Repl Deadfront Kit 250 A TFL 42 Circuits 3 Phase	NFRPL442L2TFL
NF Branch Repl Deadfront Kit 400 A 42 Circuits 3 Phase	NFRPL442L4
NF Branch Repl Deadfront Kit 400 A TFL 42 Circuits 3 Phase	NFRPL442L4TFL
NF Branch Repl Deadfront Kit 600 A 42 Circuits 3 Phase	NFRPL442L6
NF Branch Repl Deadfront Kit 600 A TFL 42 Circuits 3 Phase	NFRPL442L6TFL
NF Branch Repl Deadfront Kit 800 A 42 Circuits 3 Phase	NFRPL442L8
NF Branch Repl Deadfront Kit 800 A TFL 42 Circuits 3 Phase	NFRPL442L8TFL
NF Branch Repl Deadfront Kit 125 A 54 Circuits 3 Phase	NFRPL454L1
NF Branch Repl Deadfront Kit 125 A TFL 54 Circuits 3 Phase	NFRPL454L1TFL
NF Branch Repl Deadfront Kit 250 A 54 Circuits 3 Phase	NFRPL454L2
NF Branch Repl Deadfront Kit 250 A TFL 54 Circuits 3 Phase	NFRPL454L2TFL
NF Branch Repl Deadfront Kit 400 A 54 Circuits 3 Phase	NFRPL454L4
NF Branch Repl Deadfront Kit 400 A TFL 54 Circuits 3 Phase	NFRPL454L4TFL
NF Branch Repl Deadfront Kit 600 A 54 Circuits 3 Phase	NFRPL454L6
NF Branch Repl Deadfront Kit 600 A TFL 54 Circuits 3 Phase	NFRPL454L6TFL
NF Branch Repl Deadfront Kit 800 A 54 Circuits 3 Phase	NFRPL454L8
NF Branch Repl Deadfront Kit 800 A TFL 54 Circuits 3 Phase	NFRPL454L8TFL
NF Branch Repl Deadfront Kit 250 A 66 Circuits 3 Phase	NFRPL466L2
NF Branch Repl Deadfront Kit 250 A TFL 66 Circuits 3 Phase	NFRPL466L2TFL
NF Branch Repl Deadfront Kit 400 A 66 Circuits 3 Phase	NFRPL466L4
NF Branch Repl Deadfront Kit 400 A TFL 66 Circuits 3 Phase	NFRPL466L4TFL
NF Branch Repl Deadfront Kit 600 A 66 Circuits 3 Phase	NFRPL466L6
NF Branch Repl Deadfront Kit 600 A TFL 66 Circuits 3 Phase	NFRPL466L6TFL
NF Branch Repl Deadfront Kit 250 A 84 Circuits 3 Phase	NFRPL484L2

4

PANEL BOARDS

**Table 4.16 NF Replacement Parts Kits (cont'd.)**

NF Replacement Parts Kits	Commercial Reference
NF Branch Repl Deadfront Kit 250 A TFL 84 Circuits 3 Phase	NFRPL484L2TFL
NF Branch Repl Deadfront Kit 400 A 84 Circuits 3 Phase	NFRPL484L4
NF Branch Repl Deadfront Kit 400 A TFL 84 Circuits 3 Phase	NFRPL484L4TFL
NF Branch Repl Deadfront Kit 600 A 84 Circuits 3 Phase	NFRPL484L6
NF Branch Repl Deadfront Kit 600 A TFL 84 Circuits 3 Phase	NFRPL484L6TFL
NF 125 A / 250 A Bonding Strap Kit	NFBOND12
NF 400 A / 600 A / 800 A Bonding Strap Kit	NFBOND468
NF Gutter Mounted Bonding Strap Kit	NFBONDGUTTER

**Type 1 Door-in-Door (Hinged) Trim Fronts**

**Features**

- Meets door-in-door specifications
- Provides continuous piano hinge
- Permits one-person maintenance



Catalog No.  
NC44SHR

**Table 4.17: Interiors, Boxes and Fronts (PENDING OBSOLESCENCE)**

Note: HCM pending obsolescence and replaced by HCJ

Total Circuit Breaker Mounting Space (In.)	Mains Ampere Rating	Front [1]		Box [2]		Box Height (In.)
		4 Piece Trim Without Door	Trim With Door[3]	Type 1	NEMA 3R/5/12 [4] (Includes Front)	
		Catalog Number	Catalog Number	Catalog Number	Catalog Number	
<b>HCM Main Lugs Only</b>						
<b>3-pole—Suitable for use as service equipment when provided with a main circuit breaker. [5]</b>						
27	225 A	HCM48T ( )	HCM48T( )D	HC3248B	HC3248WP	48
	400 A					
	600 A					
	800 A					
45	225 A	HCM64T ( )	HCM64T( )D	HC3264B	HC3264WP	64
	400 A					
	600 A					
	800 A					
63	225 A	HCM73T ( )	HCM73T( )D	HC3273B	HC3273WP	73
	400 A					
	600 A					
	800 A					
99	225 A	HCM91T ( )	HCM91T( )D	HC3291B	HC3291WP	91
	400 A					
	600 A					
	800 A					
<b>HCM Main Circuit Breaker [6]</b>						
<b>Includes 3-pole, vertically mounted main circuit breaker—Suitable for use as service equipment.</b>						
27	400 A	HCM64T ( )	HCM64T( )D	HC3264B	HC3264WP	64
36	225 A	HCM73T( )	HCM73T( )D	HC3273DB9[7]	Use HCP	—
	600 A					
	800 A					
45	400 A	HCM73T( )	HCM73T( )D	HC3273B	HC3273WP	73
54	225 A	HCM91T( )	HCM91T( )D	HC3291DB9[7]	Use HCP	—
600 A						
800 A						
81	400 A	HCM91T( )	HCM91T( )D	HC3291B	HC3291WP	91

**Table 4.18: Hinged Trim**

I-Line Fronts	NQ and NF Fronts
Catalog No. [8]	Catalog No. [8]/[9]
HC2652T( )HR	NC26( )HR
HC2665T( )HR	NC32( )HR
HC2674T( )HR	NC38( )HR
HC2683T( )HR	NC44( )HR
HC2692T( )HR	NC50( )HR

[1] Add "F" for flush mount, "S" for surface mount for panelboards with bus rated 250A or less. Add "VS" for vented surface or "VF" for vented flush in place of the parentheses for panelboards with bus rated 400A or greater.  
 [2] For Type 1 applications, order interior, front, and box. For Type 3R/5/12 applications, order interior and box only. The front is included with the box.  
 [3] For Type 1 applications order interior, trim and box. For type 3R/5/12, order interior and box only.  
 [4] Remove drain screws for Type 3R rating.  
 [5] Suitable for use as service equipment if equipped with an integral main circuit breaker or when not more than six main disconnecting means are provided and the panelboard is not used as a lighting and appliance branch circuit panelboard. (Not applicable in Canada)  
 [6] Bottom feed standard.  
 [7] DB9 box is 9.5 inches deep.  
 [8] Add "S" for surface or "F" for flush in place of the parentheses.  
 [9] For welded metal directory, add "WMD" suffix to the end of the catalog number.

**Table 4.18 Hinged Trim (cont'd.)**

I-Line Fronts	NQ and NF Fronts
Catalog No. [10]	Catalog No. [10][11]
HC3248T( )HR	NC56( )HR
HC3264T( )HR	NC62( )HR
HC3273T( )HR	NC68( )HR
HC3291T( )HR	NC74( )HR
HC4250T( )HR	NC80( )HR
HC4259T( )HR	NC86( )HR
HC4268T( )HR	NC50V( )HR
HC4286T( )HR	NC56V( )HR
HC4486T( )HR	NC62V( )HR
—	NC68V( )HR
—	NC74V( )HR
—	NC80V( )HR
—	NC86V( )HR

**NF Merchandised and Factory Assembled Accessories**

**Table 4.19: NF Merchandised Interiors with Surge Protection Devices (SPD)**

Available Pole Spaces	Main Rating	Main Circuit Breaker Adapter Kit	Main Circuit Breaker Frame	Interior Only Catalog No. [12]	Surge Current Rating	NEMA 1 Enclosure			NEMA 3R, 5, 12 Enclosure
						Box	Mono-Flat Front	Hinged Front	
42	250 A	Main Lug Only		NF442L2TVS416C	160 kA	MH56	NC56( )	NC56( )HR	MHWP56
		N250MJ [13]	JD/JG/JJ/JL			MH68	NC68( )	NC68( )HR	MHWP68
	Main Lug Only		MH68			NC68V( )	NC68V( )HR	MHWP68	
	400 A	Main Lug Only				MH80	NC80V( )	NC80V( )HR	MHWP80
N400M [14]		LA/LH							

**Trim Clamps and Screws**

**Table 4.20: Trim Clamps and Screws**

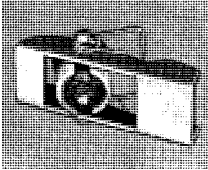

Catalog No LP9501

Application	Catalog No.
NQOD Panelboards: Series E1 [1] 400 A and 600 A fronts NEHB Panelboards: Series E1 [1] 600 A fronts I-Line Panelboards: All Series E1 [1] fronts	LP9501
NQOD Panelboards: All Series E1 [1] vented fronts and hinged fronts manufactured after July 1994. NF Panelboards: All vented fronts and hinged fronts. NEHB Panelboards: All Series E1 [1] hinged fronts manufactured after July 1994. I-Line and QMB Panelboards: I-Line front with door manufactured after July 1994 but before August 1997; and I-Line hinged fronts and QMB front with door manufactured after July 1994.	LP9502 (includes 8 trim screws and captive hardware)
NQ and NQOD Panelboards: Screws for all fronts through 225 A. NF Panelboards: Screws for all fronts through 250 A. I-Line Panelboards: 4-piece trim and trim with door manufactured after July 1997. QMB Panelboards: Screws for 4-piece covers.	PANELTRIMSCTB (package of 30)
I-Line Panelboards: Panelboard deadfront screws for 4-piece trim manufactured after July 1994 but before August 1997.	8002506701

PANELBOARDS

4

[10] Add "S" for surface or "F" for flush in place of the parentheses.  
 [11] For welded metal directory, add "WMD" suffix to the end of the catalog number.  
 [12] Order branch circuit breakers separately.  
 [13] Select the appropriate PowerPacT main circuit breaker from Section 7.  
 [14] Select an appropriate LA or LH Thermal-Magnetic Circuit Breaker from Section 7.  
 [1] Panelboards that meet 1984 NEC® Wire Bending Space are Series E1.

Locks

Table 4.21: Locks—Type 1 Enclosures<sup>[2]</sup>

Application	Catalog No.
<b>NQOD, NQO, and NQOB Panelboards</b>	
All trim fronts on enclosures up to and including 50-inch high and 53-inch through 68-inch high vented trims	PK4FL (Before 01/06/97)
	PK22FL (After 01/06/97 NQ or NQOD only)
All trim fronts on enclosures 56 inches high or higher, excluding 53-inch through 68-inch high vented fronts	PK5FL (Before 11/01/99)
	PK22FL (After 11/01/99 NQOD only)
<b>NQ and NF Panelboards</b>	
Flush lock and key for all NC trim fronts <sup>[3]</sup> <sup>[4]</sup> (except panels using LC or LI main circuit breakers.)	PK22FL
Vault lock handle for trim fronts on enclosures 68 inches high or higher for panels using LC or LI main circuit breakers	PK5FL
<b>I-Line Panelboards</b>	
HCN: Series 1 and 2 fronts on enclosures up to 54 inches high	PK4FL
HCN: Series 1 and 2 fronts on enclosures 63 inches high or higher	PK5FL
HCM: Series 1 and 2 fronts on 38-inch high enclosures	PK4FL
HCM: Series 1 and 2 fronts on enclosures 47 inches high or higher	PK5FL
<b>I-Line Panelboards</b>	
HCW, HCWM: Series 1 and 2 fronts	PK4FL
HCN: Series E1 <sup>[2]</sup> fronts on enclosures up to and including 74-inches high	PK4FL (Before 11/14/97)
	PK22FL (After 11/14/97)
HCN: Series E1 <sup>[2]</sup> fronts on enclosures 83 inches high or higher	PK5FL (Before 04/05/02)
	PK22FL (After 04/05/02) <sup>[5]</sup>
HCM: Series E1 <sup>[2]</sup> fronts on enclosures 64 inches high or higher	PK5FL (Before 11/14/97)
HCW, HCWM, HCWM-U, HCR-U: Series E1 <sup>[2]</sup> Front	PK22FL (After 11/14/97) <sup>[5]</sup>
	PK5FL
<b>I-Line Panelboards (4-piece trim with door kit)</b>	
HCN: Series E1 <sup>[2]</sup> fronts on enclosures up to and including 74 inches high	PK22FL
HCN: Series E1 <sup>[2]</sup> fronts on enclosures 83 inches high or higher	PK5FL (Before 02/22/02)
	PK22FL (After 02/22/02) <sup>[5]</sup>
HCM: Series E1 <sup>[2]</sup> fronts on enclosures 73 inches high or higher	PK22FL
HCP, HCR-U: Series E1 <sup>[2]</sup> Front	PK5FL
HCP-SU: Series E1 <sup>[2]</sup> Front and HCP-SU Hinged Front	PK22FL <sup>[5]</sup>

• One NSR-251 key is included with each lock.



Catalog No. PK4FL and PD22FL



Catalog No. PK5FL



Catalog No. PK4NVL

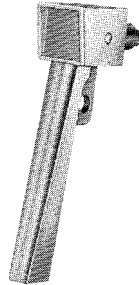

Catalog No. 30007 11851

Table 4.22: Locks—Type 3R/12 Enclosures

Application	Catalog No.
NQOD, NQO, NQOB, NF all enclosures Series E1	PK4NVL
NQ, NQOD, NF Series E2	8011604350 (one handle)
	8011604350 (two handles)
I-Line and QMB Series E1	PK4NVL
I-Line and QMB Series E2	8012106350
I-Line—Handle for padlocking Series 1 and 2	3000711851
Stainless steel enclosures	HSEM3PLH

Keys

Table 4.23: Replacement Keys

Application	Catalog No.
For use on all locks except those on stainless steel enclosures	PANELKEYTB (package of 25 keys)
Locks on stainless steel enclosures	8010645601



Catalog No. LP9618

Replacement Parts		
Catalog Number	Quantity Per Package	Description
QOFSBF12	12	NQ IP2X Bus Finger Filler <sup>[6]</sup>
QOFSLALB12	12	NQ IP2X QO(B) Lug Cover Low Amp
QOFSHALB12	12	NQ IP2X QO(B) Lug Cover High Amp
HJQLLC	1	HJQ Main Breaker IP2X Line Lug Cover
LALLC	1	LA/LH Main Breaker IP2X Line Lug Cover
NQHJLSC	1	HJ Main Breaker IP2X Load Side Cover

<sup>[2]</sup> Panelboards that meet 1984 NEC® Wire Bending Space are Series E1.  
<sup>[3]</sup> Fronts 56 inches or higher on 250 A maximum interior require two locks.  
<sup>[4]</sup> Front 74 inches or higher on 600 A maximum interior require two locks.  
<sup>[5]</sup> Fronts require two locks.  
<sup>[6]</sup> Used only with Standard IP2X design.



Standard Unit

Inverted Unit

**Cold Sequence Metering**

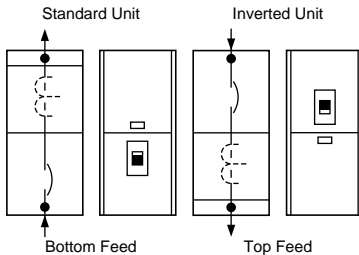

**Hot Sequence Metering**

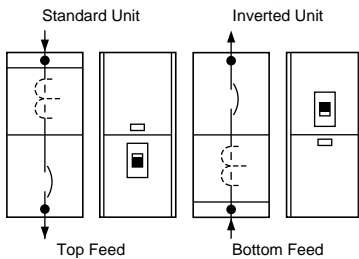

Replacement Parts		
NQQLSC	1	Q Main Breaker IP2x Load Side Cover
NQLALHLSC	1	LA/LH Main Breaker IP2X Load Side Cover
NQMLLSC	1	Main Lugs IP2X Cover
NQNCC	1	NQ IP2X Neutral Cover
QO1PJ15	15	QOB Jaw Kit <sup>[7]</sup>

**Main Circuit Breaker and Current Transformer Compartment**  
**Service Entrance Equipment Hot or Cold Sequence Metering, Top or Bottom Feed, Indoor Construction at 600 Volts**

**General:** Suitable for use as service entrance equipment on AC systems. Listed by Underwriters' Laboratories.

**Service:** 1Ø3W, 3Ø3W, 3Ø4W, rated up to 600 Vac maximum.

**Metering:** <sup>[1]</sup> Current transformer compartment with provisions for installing bar type current transformers. For window type current transformers, order bus link kit from Table 4.24 Product Selection Table, page 4-17.

Standard unit is factory assembled for bottom feed cold sequence or top feed hot sequence metering applications. The unit is field convertible for bottom feed hot sequence or top feed cold sequence metering. Refer to instruction bulletin 80105-113-0x, *CTC Wall-Mounted Metering Equipment*, for field conversion details.

**Mains:** Main disconnects provided. 400-800 A: MJP. 1000-1200 A: PJP. Handle lock-off attachment provided for main circuit breaker as standard.

Refer to the Digest for field installable accessories.

**Enclosure:** Front accessible, totally enclosed, gray baked enamel finish. Available as indoor construction only. **Dimensions**—78 in. H x 26 in. W x 14.3 in. D.

- NOTE: Not EUSERC approved.

**Table 4.24: Product Selection Table<sup>[2]</sup>**

System	Service Voltage (AC)	Ampere Rating of Main	Catalog Number
1Ø3W, 3Ø3W, 3Ø4W	600 V Max.	400 A	CTC364CU
		600 A	CTC366CU
		800 A	CTC368CU
		1000 A	CTC3610CU
		1200 A	CTC3612CU
Bus link kit—used when installing window-type current transformers <sup>[3]</sup>			SS4BLC

**Table 4.25: Lug Table**

Ampere Rating	Main Circuit Breaker Lug Wire Range <sup>[4]</sup>	Ground Lug
400 A	(3) 3/0–500 kcmil Al or Cu	#6 AWG–300 kcmil Al or Cu
600 A	(3) 3/0–500 kcmil Al or Cu	
800 A	(3) 3/0–500 kcmil Al or Cu	
1000 A	(4) 3/0–500 kcmil Al or Cu	
1200 A	(4) 3/0–500 kcmil Al or Cu	

**Data Sheet for Panelboards to Retrofit Existing Enclosures**

Distributor: \_\_\_\_\_  
 Job Name: \_\_\_\_\_  
 Contractor: \_\_\_\_\_  
 Panel Marking: \_\_\_\_\_

<sup>[7]</sup> Used only with Enhanced IP2X design.  
<sup>[1]</sup> Field conversion is the customer's responsibility, only the standard configuration is built by the factory.  
<sup>[2]</sup> Must specify feed (top or bottom) and sequence (hot or cold) at the time of order.  
<sup>[3]</sup> Kits required per 3Ø application:  
 400–600 A—Order one kit  
 800–1200 A—Order two kits  
<sup>[4]</sup> CT bus lugs and neutral lugs are identical to the main circuit breaker lugs.

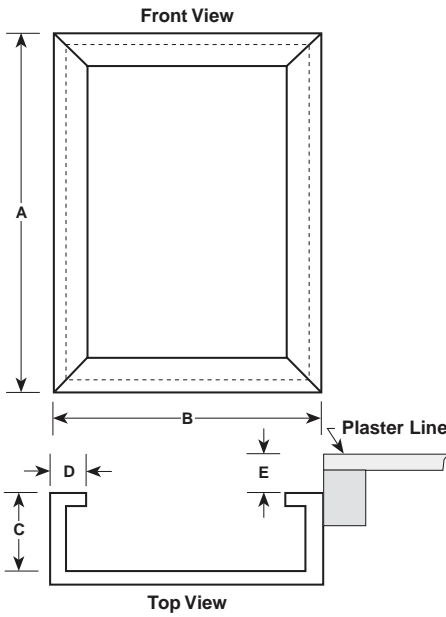

The following dimensions are necessary for quotation and production of a panel to fit an existing enclosure. Provide dimensions in inches only.

**Existing Flush-Mounted Enclosures**

- Height dimension "A":
- Width dimension "B":
- Depth dimension "C":
- Flange width dimension "D":
- If enclosure is not flush with Plaster Line, dimension "E":

**Existing Surface-Mounted Enclosures**

- Height dimension "A":
- Width dimension "B":
- Depth dimension "C":
- Flange dimension may be either dimension "D" or "F" (select one)
  - Dimension "D":
  - Dimension "F": NOTE: Trims are furnished so that the interior must be centered within the enclosure.

If the enclosure is deeper than the standard panelboard enclosure for the required type of panelboard, *customer-supplied mounting brackets may be necessary to bring the interior out to the front of the enclosure.*

If interior requires a vented enclosure, contact your nearest Schneider Electric sales office for assistance.

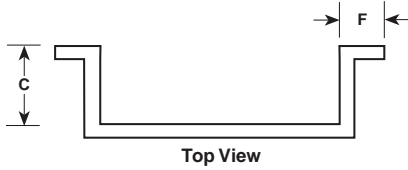

# Section 5

## Switchboards



Power-Style™ Commercial Multi-Metering Switchboard Lineup

### Power-Style™ Commercial Multi-Metering (CMM) Switchboards

CMM (UL Listed)	5-2
Power-Style Commercial Multi-Metering Switchboards (UL Listed)	5-2
CMM Replacement Parts	5-3
Meter Sockets, Covers, Hardware Kits	5-3
Tenant Main Disconnects	5-4
Class T Fusible Pullouts, CMM Pullout Heads	5-4

### Speed-D™ Switchboards

Service Selection	5-5
Merchandised Speed-D Switchboards	5-5
Speed-D SB/SF (UL Listed)	5-6
Speed-D SB/SF Switchboards (UL Listed)	5-6

### Air-Insulated Switchgear for Primary Distribution

Masterclad™ Medium Voltage Metalclad Switchgear (UL Listed)	5-10
---	------

### Frequently Asked Questions

#### FAQs

Visit the online FAQs page to find additional technical information covering all products including discontinued and obsolete products.  
<https://www.se.com/us/en/faqs/home/>



EUSERC UCT,  
Single Main Circuit Breaker  
with I-Line Distribution Panel



EUSERC UCT,  
Fusible Multiple Mains

Speed-D™ Switchboards

### Power-Style Commercial Multi-Metering Switchboards (UL Listed)

- Designed, built, and listed to UL 891
- Lever bypass and EUSERC non-lever bypass
- Hot or cold sequence metering—EUSERC, NEMA, LOCAL
- Front and rear alignment standard
- Switchboard ratings through 4000 A, 100 kA
- Meter sections in either three- or six-socket section configuration
- Tenant mains either circuit breaker or fusible
- 60–200 A without lever bypass with self-contained meter sockets, 5- or 7-jaw, ring type and test block where required
- 60–200 A lever bypass with self-contained meter sockets, 7-jaw, ringless
- Factory-installed devices with completely wired from meter socket to disconnect
- Provisions for adding future tenants available, as well as future sections
- Sections in either NEMA 1 or NEMA 3R construction
- For use on 120/240 V, 120/208 V, and 277/480 V systems
- Integrated, front-accessible wireway for top exiting load cables
- Customer access area for top exiting load cables



Lever Bypass  
Class 2755



EUSERC  
Class 2756

Class **2755, 2756** / Refer to Catalog **2756CT9601**

**Meter Sockets, Covers, Hardware Kits**

Meter socket kits include meter socket (ringless type or ring type—see tables below) and instruction bulletin. The connection cables from the line bus to the meter socket and from the meter socket to the tenant main disconnect are not included. These should be provided by the contractor.

**Table 5.1: EUSERC Meter Socket with Test Block Kit (Ring Type; Class 2756)**

Voltage System	Poles	Description	Catalog No.	
			Single-Phase	Phase
120/240 V, 208Y/120 V, or 240/120 V Delta	AB	Old design: plug on to line side bus	CM522ABE	—
	AC		CM522ACE	—
	BC		CM522BCE	—
208Y/120 V, 240/120 V Delta, or 480Y/277 V	AC	New design: lugs on line side	CMLL522E	—
	ABC	Old design: plug on to line side bus	—	CM732E
		New design: lugs on line side	—	CMLL732E

**Table 5.2: Lever Bypass Meter Socket (Ringless Type; Class 2755)**

Voltage System	Poles	Description	Catalog No.	
			Single-Phase	Phase
480Y/277 V	ABC	Old design: plug on to line side bus	—	8024878850
		New design: lugs on line side	—	CMLL732

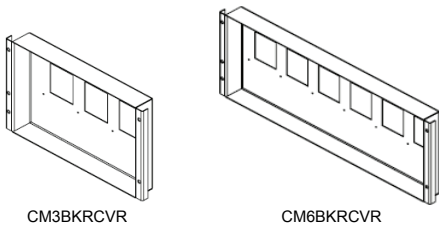

**Table 5.3: Cover and Hardware Kits**

Description	Tenant Main Structure	Catalog No.
<b>CMM Circuit Breaker Cover Kit [1]</b>		
Allows PowerPact™ H, J, and Q circuit breakers to be installed in legacy design CMM structures.	3-Socket	CM3BKRCVR
	6-Socket	CM6BKRCVR
<b>CMM Meter Cover Kit for EUSERC Applications</b>		
Includes meter cover, test block cover, and hardware.	3-Socket	CM7CR20ER
	6-Socket	CM7CR32ER
<b>CMM Meter Cover Kit for Lever Bypass Applications</b>		
Meter socket cover		CM7CR20R [2]
Blank cover		CM20BLK [2]
<b>CMM Universal Hardware Kit</b>		
Required to add any tenant main disconnect.		CMUHWKIT
For additional information or for custom applications, please contact your local Schneider Electric representative. Or, visit us on the web at <a href="http://www.se.com/us/en/">www.se.com/us/en/</a> .		

[1] A new circuit breaker cover is required when adding a PowerPact Q, H, or J circuit breaker to a legacy design tenant metering structure. The new cover has larger openings to accommodate the padlock attachment for these circuit breakers.  
 [2] Order point: PDS

Class 2755, 2756 / Refer to Catalog 2756CT9601

Tenant Main Disconnects

Table 5.4: Circuit Breakers

Ampacity	Catalog No.	SCCR		Load Lug Information
		240 V	480 V	
<b>100 A F-frame Circuit Breaker</b>				
60 A	FAL34060	25 kA	18 kA	#12 - 1/0 AWG Al or Cu
70–100 A	FAL34___[3]			
60 A	FHL36060	65 kA	25 kA	
70–100 A	FHL36___[3]			
Padlock Attachment	HPAFK	—	—	—
<b>PowerPact™ Q-frame 250 A Circuit Breaker (240 Vac) [4] [5]</b>				
110–200 A	QDL32___[6]	25 kA	N/A	#4 - 300 kcmil Al or Cu
110–200 A	QGL32___[6]	65 kA	N/A	
110–200 A	QJL32___[6]	100 kA	N/A	
Padlock Attachment	QBPAF	—	—	—
<b>PowerPact H-frame 150 A Circuit Breaker (600 Vac, 250 Vdc)</b>				
60 A	HDL36060	25 kA	18 kA	#4 - 3/0 kcmil Al or Cu
70–100 A	HDL36___[7]			
110–150 A	HDL36___[7]			
60 A	HGL36060	65 kA	35 kA	
70–100 A	HGL36___[7]			
110–150 A	HGL36___[7]			
60 A	HJL36060	100 kA	65 kA	
70–100 A	HJL36___[7]			
110–150 A	HJL36___[7]			
60 A	HLL36060	100 kA	100 kA	
70–100 A	HLL36___[7]			
110–150 A	HLL36___[7]			
Padlock Attachment	S37422	—	—	—
<b>PowerPact J-frame 250 A Circuit Breaker (600 Vac, 250 Vdc)</b>				
175–200 A	JDL36___[8]	25 kA	18 kA	#4 - 300 kcmil Al or Cu
175–200 A	JGL36___[8]	65 kA	35 kA	
175–200 A	JLL36___[8]	100 kA	65 kA	
175–200 A	JLL36___[8]	100 kA	100 kA	
Padlock Attachment	S37422	—	—	—

Class T Fusible Pullouts, CMM Pullout Heads

Table 5.5: Class T Fusible Pullouts (Universal Hardware Kit CMUHWKIT Required)

Ampacity	Catalog No. [9]	SCCR		Wire Size Al or Cu
		240 V [10]	480 V	
100 A	FTL3100	100 kA	N/A	#14 - 1/0 AWG
200 A	FTL3200	100 kA	N/A	#4 - 250 kcmil
60 A	FTL43060	N/A	100 kA	#14 - #2
100 A	FTL43100	N/A	100 kA	#14 - 1/0 AWG
200 A	FTL43200	N/A	100 kA	1/0 AWG - 300 kcmil

Table 5.6: CMM Pullout Heads

Voltage System	Mains		Catalog No. [11] (Pullout Head — No Base)
	Rating (A)	Poles	
1Ø3W 120/240 V 3Ø4W 240/120 V Delta 3Ø4W 208Y/120 V	100	3	4050707050 [12]
	200	3	4050705950 [12]
3Ø4W 480Y/277 V	60	3	—
	100	3	—
	200	3	—

[3] To complete the catalog number for these PowerPact F-frame circuit breakers, replace \_\_\_ with the required ampacity (070, 080, 090, or 100).

[4] A shunt trip is not available on PowerPact Q-frame circuit breakers.

[5] A new circuit breaker cover is required when adding a PowerPact Q-, H-, or J-frame circuit breaker to an old-design tenant metering structure. This new cover has larger openings to accommodate the padlock attachment for these circuit breakers. See Table 5.3 Cover and Hardware Kits, page 5-3 for ordering information.

[6] To complete the catalog number for PowerPact Q-frame circuit breakers, replace \_\_\_ with the required ampacity (110, 125, 150, 175, or 200).

[7] To complete the catalog number for PowerPact H-frame circuit breakers, replace \_\_\_ with the required ampacity (070, 080, 090, 100, 110, 125, or 150).

[8] To complete the catalog number for PowerPact J-frame circuit breakers, replace \_\_\_ with the required ampacity (175 or 200)

[9] Discount schedules: FTL3100 and FTL3200 = DE5; FTL43060, FTL43100, and FTL43200 = PE1A.

[10] 240 V fusible pullouts cannot be used on a Lever Bypass CMM. Only 480 V pullouts can be used.

[11] Discount schedule: DE5.

[12] Order point: Lexington, KY.

**Merchandised Speed-D Switchboards**
**Table 5.7: Subfeed Circuit Breakers** [1] [2]

Description	Rating (A)	2-Pole [3]		3-Pole	
		Catalog No.		Catalog No.	
		Left	Right	Left	Right
<b>Subfeed Circuit Breaker Kits—</b> Includes circuit breaker, connectors and mounting hardware.	100	SASFB100L()	SASFB100R()	SASFB100L	SASFB100R
	110	SASFB110L()	SASFB110R()	SASFB110L	SASFB110R
	125	SASFB125L()	SASFB100R()	SASFB125L	SASFB125R
	150	SASFB150L()	SASFB150R()	SASFB150L	SASFB150R
	175	SASFB175L()	SASFB175R()	SASFB175L	SASFB175R
	200	SASFB200L()	SASFB200R()	SASFB200L	SASFB200R
	225	SASFB225L()	SASFB225R()	SASFB225L	SASFB225R

[1] Cannot use subfeed circuit breaker kit with multiple mains service section switchboards.

[2] For use on all Speed-D switchboards except Series E4.

[3] Two pole circuit breaker catalog numbers are completed by adding required phase connection letters as suffix (for example, SASFB100LAC).



Speed-D Switchboard shown with optional underground pull section

## Speed-D SB/SF Switchboards (UL Listed)

- UL Listed
- California Energy Commission (CEC) Title 24 compliant configurations available for California installations
- Hot sequence utility compartment per EUSERC requirements
- Single service disconnect rated 400, 600, or 800 A with either type of distribution interiors, NQ up to 240 Vac, I-Line™ through 480 Vac
- Meter doors can be 15 inches high with one meter socket and test block, or 30 inches high with two meter sockets and test block
- Meter sockets can be 6-, 8-, 13-, or 15-jaw meter sockets with test block, based on application
- Solar ready configurations are now available, using a back-fed circuit breaker on the I-Line stack
- Accessories include:
  - Underground pull sections with and without lug landing
  - Loadside wireway
  - Bus links for donut-type current transformers
  - Double padlock hasp attachments
  - Plug-on distribution panel
  - Subfeed circuit breakers
- Full height add-on I-Line distribution section
- Stand-alone I-Line distribution section

### Application

Suitable for use as service entrance equipment on ac systems. Sections contain metering compartment, barriers, main disconnects, distribution panel, neutral bus, and grounding provisions.

### Metering

C/T compartment with two 15-inch blank meter doors. (Order doors with meter socket from [Table 5.12 Meter Door Selection, page 5-8.](#)) Incoming cable lugs are for top feed with one twin conductor 2 AWG–600 kcmil lug per phase and neutral, suitable for aluminum or copper cables. Optional single conductor lug is available. Refer to [Table 5.13 Accessories, page 5-8.](#)

### Mains

Main breaker can be LH, MJ, PowerPact L, or PowerPact P. Standard and advanced electronic trip units available for PowerPact breakers. Main breakers with Energy or Power trip units comply with CEC Title 24 metering requirements.

### Branches

NQ distribution bus is rated 400 A and provides mounting space for QO™/QOB Type (150 A maximum) circuit breakers. Panel provides space for mounting 42 single pole circuit breakers. One or two individually mounted 225 A maximum circuit breakers can be added with bus connectors. (Order subfeed circuit breakers from [Table 5.14 Subfeed Circuit Breakers \(Series E4\), page 5-9.](#))

I-Line™ distribution bus is rated 400, 600, or 800 A and will accept 27 inches of I-Line circuit breakers on the left side with a maximum frame size of “J”. The right side will accept either a QO plug-on distribution panel (240 V only) or LA or LH I-Line circuit breaker, which allows for a back-fed solar power source.

### Enclosure

Totally enclosed front accessible with ANSI 49 gray baked enamel finish. Dimensions are 90 in. (H) x 36 in. (W) x 14 in. (D) for indoor and 90 in. (H) x 36 in. (W) x 24.5 in. (D) for outdoor enclosures.

**EUSERC Utility Metering, Main Disconnects and Distribution Panel (UL Listed)**

**Table 5.8: Single Main Circuit Breaker with Distribution (Series E4)**

System	Service Voltage	Mains Ratings (A)	Main Breaker Trip Unit	SCCR 240 V Max.	SCCR 480 V Max.	Distribution Interior	Circuit Breaker Catalog No.					
							Indoor	Outdoor				
1Ø3W	120/240	400	Thermal Magnetic	65	—	None	NQ	SB124QS	SB124QR			
							I-Line	SB124IS	SB124IR			
							None	SB124WS	SB124WR			
			LSI Standard Electronic	100			NQ	SB124QSJS	SB124QRJS			
							I-Line	SB124ISJS	SB124IRJS			
							None	SB124WSJS	SB124WRJS			
	LSI Energy Electronic	100	NQ	SB124QSJE	SB124QRJE							
			I-Line	SB124ISJE	SB124IRJE							
			None	SB124WSJE	SB124WRJE							
	600	400	LI Basic Electronic	65	—	None	I-Line	SB126IS	SB126IR			
							None	SB126WS	SB126WR			
							NQ	SB324QS	SB324QR			
LSI Standard Electronic			100	NQ			SB324QSJS	SB324QRJS				
				I-Line			SB324ISJS	SB324IRJS				
				None			SB324WSJS	SB324WRJS				
LSI Energy Electronic	100	NQ	SB324QSJE	SB324QRJE								
		I-Line	SB324ISJE	SB324IRJE								
		None	SB324WSJE	SB324WRJE								
3Ø4W [4]	208Y/120 240/120	400	Thermal Magnetic	65	—	None	NQ	SB324QS	SB324QR			
							I-Line	SB344IS	SB344IR			
							None	SB344WS	SB344WR			
			LSI Standard Electronic				100	NQ	SB324QSJS	SB324QRJS		
								I-Line	SB324ISJS	SB324IRJS		
								None	SB324WSJS	SB324WRJS		
		LSI Energy Electronic	100	NQ			SB324QSJE	SB324QRJE				
				I-Line			SB324ISJE	SB324IRJE				
				None			SB324WSJE	SB324WRJE				
		600	400	LI Basic Electronic			65	35	None	I-Line	SB344IS	SB344IR
										None	SB344WS	SB344WR
										NQ	SB344QS	SB344QR
	LSI Standard Electronic			100	I-Line	SB344ISJS				SB344IRJS		
					None	SB344WSJS				SB344WRJS		
					NQ	SB344QSJS				SB344QRJS		
	LSI Energy Electronic	100	I-Line	SB344ISJE	SB344IRJE							
			None	SB344WSJE	SB344WRJE							
			NQ	SB344QSJE	SB344QRJE							
	800	400	LI Basic Electronic	65	65	None	I-Line			SB346IS	SB346IR	
							None			SB346WS	SB346WR	
							NQ			SB346QS	SB346QR	
			LSI Standard Electronic				100	I-Line	SB346ISJS	SB346IRJS		
								None	SB346WSJS	SB346WRJS		
								NQ	SB346QSJS	SB346QRJS		
LSI Energy Electronic	100	I-Line	SB346ISJE	SB346IRJE								
		None	SB346WSJE	SB346WRJE								
		NQ	SB346QSJE	SB346QRJE								
208Y/120 240/120 480Y/277	600	LI Basic Electronic	65	50			None	I-Line	SB346IS	SB346IR		
								None	SB346WS	SB346WR		
								NQ	SB346QS	SB346QR		
		LSI Standard Electronic			100	I-Line		SB346ISJS	SB346IRJS			
						None		SB346WSJS	SB346WRJS			
						NQ		SB346QSJS	SB346QRJS			
	LSI Energy Electronic	100	I-Line		SB346ISJE	SB346IRJE						
			None		SB346WSJE	SB346WRJE						
			NQ		SB346QSJE	SB346QRJE						
	800	LI Basic Electronic	65		65	65		None	I-Line	SB348IS	SB348IR	
									None	SB348WS	SB348WR	
									NQ	SB348QS	SB348QR	
LSI Standard Electronic		100		I-Line			SB348ISJS		SB348IRJS			
				None			SB348WSJS		SB348WRJS			
				NQ			SB348QSJS		SB348QRJS			
LSI Power Electronic	100	I-Line	SB348ISJP	SB348IRJP								
		None	SB348WSJP	SB348WRJP								
		NQ	SB348QSJP	SB348QRJP								

**Table 5.9: Single Main Circuit Breaker with Solar Feed**

System	Service Voltage	I-Line Bus Rating (A)	Mains Ratings (A)	Main Breaker Trip Unit	Solar Feed Maximum (A)	SCCR 240 V Max.	SCCR 480 V Max.	Circuit Breaker Catalog No.				
								Indoor	Outdoor			
1Ø3W	120/240	1200	400	Thermal Magnetic	800	800	—	65	SB124IS8S	SB124IR8S		
								100	SB124ISJS8S	SB124IRJS8S		
								100	SB124ISJE8S	SB124IRJE8S		
			LI Basic Electronic	600				65	SB126IS6S	SB126IR6S		
400	800				35	65	NQ	SB344IS8S	SB344IR8S			
							I-Line	SB344ISJS8S	SB344IRJS8S			
			None	SB344WS8S			SB344WR8S					
LSI Standard Electronic	100		NQ	SB344IS8SJS			SB344IR8SJS					
			I-Line	SB344IS8SJE			SB344IR8SJE					
			None	SB344WS8SJS			SB344WR8SJS					
LSI Energy Electronic	100		NQ	SB344IS8SJE	SB344IR8SJE							
			I-Line	SB344IS8SJE	SB344IR8SJE							
		None	SB344WS8SJE	SB344WR8SJE								
3Ø4W [4]	208Y/120 240/120 480Y/277	600	LI Basic Electronic	400	400	65	50	I-Line	SB346IS6S	SB346IR6S		
								None	SB346WS6S	SB346WR6S		
								NQ	SB346QS6S	SB346QR6S		
		LI Basic Electronic	65					50	65	I-Line	SB348IS4S	SB348IR4S
										None	SB348WS4S	SB348WR4S
										NQ	SB348QS4S	SB348QR4S
LSI Standard Electronic	100	I-Line	SB348IS4SJS	SB348IR4SJS								
		None	SB348WS4SJS	SB348WR4SJS								
		NQ	SB348QS4SJS	SB348QR4SJS								
LSI Power Electronic	100	I-Line	SB348IS4SJP	SB348IR4SJP								
		None	SB348WS4SJP	SB348WR4SJP								
		NQ	SB348QS4SJP	SB348QR4SJP								

[4] Can be used on 3Ø3W Delta voltage systems (for example, 240 V Delta or 480 V Delta).

**Table 5.10: Single Main Fusible Disconnect with Distribution (Series E4)**

System	Service Voltage	Mains Ratings (A)	Distribution Interior	SCCR 240 V Max.	SCCR 480 V Max.	Fusible Disconnect Catalog No.	
						Indoor	Outdoor
1Ø3W	120/240	400	NQ	65	—	SF124QS	SF124QR
			I-Line	100	—	SF124IS	SF124IR
			None	200	—	SF124WS	SF124WR
		600	I-Line	100	—	SF126IS	SF126IR
			None	200	—	SF126WS	SF126WR
3Ø4W [5]	208Y/120 240/120	400	NQ	65	—	SF324QS	SF324QR
3Ø4W [5]	208Y/120 240/120	400	None	200	—	SF324WS	SF324WR
3Ø4W [5]	208Y/120 240/120	400	I-Line	100	65	SF344IS	SF344IR
	480Y/277						
3Ø4W [5]	208Y/120 240/120	400	None	200	200	SF344WS	SF344WR
	480Y/277						
	208Y/120 240/120						
3Ø4W [5]	208Y/120 240/120	600	I-Line	100	65	SF346IS	SF346IR
	480Y/277						
	208Y/120 240/120						
3Ø4W [5]	208Y/120 240/120	600	None	200	200	SF346WS	SF346WR
	480Y/277						
	208Y/120 240/120						
3Ø4W [5]	208Y/120 240/120	800	I-Line	100	65	SF348IS	SF348IR
	480Y/277						
	208Y/120 240/120						
3Ø4W [5]	208Y/120 240/120	800	None	200	200	SF348WS	SF348WR
	480Y/277						
	208Y/120 240/120						

**Merchandised Options**

**Table 5.11: I-Line Distribution Section (Series E4)**

System	Service Voltage	Mains Ratings (A)	Distribution Interior	SCCR 240 V Max.	SCCR 480 V Max.	Distribution Type	Catalog No.	
							Indoor	Outdoor
3Ø4W	208Y/120 240/120 480Y/277	800	I-Line	65 k	65 k	Add-on distribution section, must be connected to an SB UCT and main section without distribution panel, such as SB348WS. <b>An I-Line plug-on subfeed lug kit must be ordered to terminate the distribution section.</b>	SBAD800	SBAD800R
3Ø4W	208Y/120 240/120 480Y/277	800	I-Line	125 k	100 k	Stand-alone distribution section not connected to an SB section. <b>A back-fed main circuit breaker or I-Line plug-on subfeed lug kit must be ordered to terminate the distribution section.</b> (Non-ULSE)	SBSAD800	SBSAD800R

**Table 5.12: Meter Door Selection**

Meter Socket Jaws	15-inch High Door With One Meter Socket and Test Block	30-inch High Door With Two Meter Sockets and Test Blocks
	Catalog No.	Catalog No.
6 [6]	SBA15D6MS	—
8	SBA15D8MS	—
13	SBA15D13MS	SBA30D13MS
15	SBA15D15MS	SBA30D15MS
Blank	SBA15DBC	—
[7]	SBA15DMS	—

**NOTE:** To order structure with meter door factory-installed, add door catalog number as suffix to structure (for example, SF344IS-15D13MS).

**Table 5.13: Accessories**

Description	Catalog No.
<b>Indoor underground pull section</b> (w/o lug landing)—26-in. (W) Order separate SA8LL lug kit below if required.	SA26PS
<b>Outdoor (3R) underground pull section</b> (w/o lug landing)—26 in. (W) x 24.5 in. (D) Order separate SA8LL lug landing kit below when required.	SA26PSR
<b>Lug landing kit</b> —800 A max. For terminating utility service cables in indoor or outdoor underground pull sections.	SA8LL
<b>Single barrel lug kit</b> —Kit provides single barrel lugs and pad in lieu of twin barrel lug provided with service section. Mechanical lugs provided are sized to fit 1-3/0–750 kcmil cable. Two lugs per phase are supplied.	SA7PL
<b>Loadside wireway</b> —11.5 in. (W) x 14 in. (D)—indoor only	SA10LW
<b>Bus link kit</b> —800 A max.—Order one kit per phase for 400, 600, and 800 A.	SA10BL
<b>Double padlock hasp attachment</b> —For mounting two padlocks on door handle of rainproof enclosure. Padlocks not included.	SS2PL
<b>Plug-On Distribution Panel</b> —mounts on right side of I-Line interior. Cannot be used with LA/LH branch circuit breaker. Panel rated 225 A for 240 V applications. For QO™ type plug-on circuit breakers only.	System
	Phase
	Pole Spaces
	1Ø AC 3Ø ABC 3Ø AB
	12
	SS212AC SS312 SS212AB [8]

[5] Can be used on 3Ø3W Delta voltage systems (for example, 240 V Delta or 480 V Delta).

[6] 6-jaw meter socket can also be used on 4- and 5-jaw applications.

[7] Door with provisions for mounting meter socket.

[8] To be used on 120/240 V, 3Ø4W delta applications.

**Table 5.14: Subfeed Circuit Breakers (Series E4)**

Description	Rating (A)	2-Pole Catalog No. [9]		3-Pole Catalog No.	
		Left	Right	Left	Right
<b>Subfeed Circuit Breaker Kit [10]</b> Includes circuit breaker, connectors and mounting hardware. The complete kit, mounting hardware, circuit breaker and connectors will be shipped direct from plant. Delivery is stock to three days.	100	SASFBH100L( )	SASFBH100R( )	SASFBH100L	SASFBH100R
	110	SASFBH110L( )	SASFBH110R( )	SASFBH110L	SASFBH110R
	125	SASFBH125L( )	SASFBH125R( )	SASFBH125L	SASFBH125R
	150	SASFBH150L( )	SASFBH150R( )	SASFBH150L	SASFBH150R
	175	SASFBJ175L( )	SASFBJ175R( )	SASFBJ175L	SASFBJ175R
	200	SASFBJ200L( )	SASFBJ200R( )	SASFBJ200L	SASFBJ200R
	225	SASFBJ225L( )	SASFBJ225R( )	SASFBJ225L	SASFBJ225R

**Ordering Information**

1. **Service section:** Order service section from Table 5.9 Single Main Circuit Breaker with Distribution (Series E4), page 5-7, Table 5.10 Single Main Fusible Disconnect with Distribution (Series E4), page 5-8, as determined by mains rating, voltage, and system.
2. **Meter doors:** Order meter door from Table 5.12 Meter Door Selection, page 5-8 as determined by the height and utility metering requirements.
3. **Accessories and subfeeds:** Order as required from Table 5.13 Accessories, page 5-8 and/or Table 5.14 Subfeed Circuit Breakers (Series E4), page 5-9.
4. **Circuit breakers:** Order devices as determined by voltage, trip rating, AIR, and mounting space.
  - QO, QOB, QO-VH, QOB-VH: See Digest Section 1 or Section 7.
  - I-Line: See Digest Section 9.

[9] Two pole circuit breaker catalog numbers are completed by adding required phase connection letters as suffix (for example, SASFBH100LAC).

[10] Cannot use subfeed circuit breaker kit with multiple mains service section switchboards.

**Masterclad™ Medium Voltage Metalclad Switchgear (UL Listed)  
The Reliability of a Quality Design**

Masterclad™ offers a customizable solution for demanding medium voltage applications. Rugged construction is coupled with low maintenance 3-cycle vacuum circuit breaker.

A comprehensive design testing program has been performed by Schneider Electric. The switchgear and breakers are designed and tested in accordance with all applicable ANSI Standards C37.04, C37.06, C37.09, and C37.20.2. The switchgear and breakers meet the requirements of ANSI, IEEE, NEMA, and exceeds most IEC standards.



Two-high Masterclad 5–27 kV Indoor, Metalclad Switchgear



Vacuum VR Circuit Breaker for Masterclad Switchgear



Masterclad 27 kV, Outdoor Non Walk-in, Metalclad Switchgear

**Table 5.15: Ratings**

Nominal voltage (kV)	4.16	7.2	13.8	24.9						
Maximum voltage (kV)	4.76	8.25	15.0	27.0						
BIL (kV)	60	95	95	125						
Frequency (Hz)	50/60									
Continuous amperes (A)	1200–4000			1200–2000						
MVA (reference only)	250	350	500	500	500	750	1000	1500	1250	2000
Short-time rating (kA) 3 seconds	40	50	63	50	25	40	50	63	25	40
Close and latch rating (kA) (peak)	104	130	164	130	65	104	130	164	68	108

**Type VR Vacuum Circuit Breaker**

The VR breaker is a horizontal drawout type designed to provide long life, reduced maintenance, and ease of handling. The Type RI advanced design motor-charged stored energy mechanism is a model of reliability with simplicity-with an operating life exceeding ANSI requirements. The VR circuit breaker is UL labeled and includes a permanently mounted manual charging handle.

Standard features include:

- 3-cycle interrupting rating
- Rated per ANSI/IEEE C37.06, C37.09, C37.013, C37.54
- UL Listed
- Motor operated, spring-charged, stored-energy operating mechanism
- Permanently mounted manual charging handle
- Five normally open and normally closed auxiliary contacts
- Wheels that roll directly to floor level from lower cell

**Switchgear Construction**

- High-speed operation—3–cycles
- Removable (draw-out) circuit breaker
- Grounded metal barriers enclose all live parts
- Automatic shutters driven by breaker racking mechanism
- Closed door breaker position indication
- Closed door breaker racking mechanism
- Insulated main bus—aluminum or copper
- Standard glass polyester insulators or optional epoxy and porcelain insulators
- Mechanical interlocks
- Disconnect type CPT and VT trucks
- Grounded breaker truck in and between test/disconnected and connected positions
- Low voltage instrument/control compartment isolated from primary voltage areas
- Compliance to ANSI/IEEE standards C37.20.2 and C37.55 (designed and tested to comply with or exceed ANSI and IEEE standards)
- ISO 9001 Certification (Designed and manufactured in a facility that is Quality Systems Certified by Underwriters Laboratories, Inc.® to ISO 9001)
- Indoor NEMA 1 enclosure
- Outdoor NEMA 3R enclosure
  - Walk-in enclosure
  - Non walk-in enclosure

# Section 6

## Transformers

<b>Miscellaneous</b>	<b>6-1</b>
Class 7400	6-2
<b>General Purpose Dry Type 600 Volts and Below</b>	<b>6-3</b>
Drive Isolation Transformers	6-3
Open Core and Coil Transformers	6-4
<b>Industrial Control</b>	<b>6-5</b>
Type EO Transformers	6-5
Type T and MultiTap™ Transformers	6-5
<b>Instrument 600 Volt Class</b>	<b>6-7</b>
Voltage and Current Transformers	6-7
Toroidal Current Transformers	6-8
Obsolete—January 1, 2023Toroidal Current Transformers (64R, 74R, 66R, 76R)	6-8
Obsolete—January 1, 2023Toroidal Current Transformers (110R, 110R, 120R, 140R)	6-8
Obsolete—January 1, 2023Toroidal Current Transformers (152R, 170R, 180R, 210R)	6-9
Obsolete—January 1, 2023Toroidal Current Transformers (200R, 201R, 202R, 203R)	6-10
Obsolete—January 1, 2023Shorting Terminal Blocks	6-10
Current Transformers: Multi-Ratio, Rectangular, Split-Core	6-10
Obsolete—January 1, 2023Multi-Ratio Current Transformers	6-10
Obsolete—January 1, 2023Rectangular Window Current Transformers	6-11
Obsolete—January 1, 2023Split-Core Current Transformers	6-11
Current Transformers: Bushing, Auxiliary	6-12
Obsolete—January 1, 2023Bushing Current Transformers 50–400 Hz	6-12
Obsolete—January 1, 2023Auxiliary Current Transformers	6-12

Enclosure Dimensions and Accessories [1]

Enclosure Number/Style	Height		Width		Depth		Mounting	Weather-shield	Wall Mounting Bracket	Ceiling Mounting Bracket	Insulation Class °C																																																																											
	In.	mm	In.	mm	In.	mm																																																																																
1	A	5.00	127	4.47	114	3.44	87	Wall	[2]	[3]	—	105																																																																										
2		5.50	140										8.68	220	6.56	167	—	—																																																																				
3		5.00	127																4.85	123	3.75	95	—	—																																																														
4		5.50	140	5.23	133	4.06	103				—	—																																																																										
5		6.19	157	6.19	157	4.69	119												—	—																																																																		
6		6.69	170	8.62	219	6.50	165														—	—																																																																
7		8.13	270																						6.94	176	5.31	135	—	—																																																								
8		8.25	210																						14.75	375	9.00	229			—	—																																																						
9		9.56	243																														19.10	485	12.25	311	—	—																																																
10		10.50	267																																				15.00	381	13.50	343	—	—																																										
11		12.56	319																																										25.00	635	13.50	343	—	—																																				
12	C	13.50	343																																																20.00	508	16.00	406	—	—																														
13	B	14.75	375										30.00	762	20.00	508	WMB361362	CMB363																																																																				
14	C	14.75	375																				30.00	762																																	20.00	508	WS363	—																										
15	B	20.00	508								30.00	762																																																	20.00	508	WS363	—																						
16	C	22.00	559																30.00	762																																													20.00	508	WS364	—																		
17	D	27.00	686	32.00	813	27.00	686	WS364	—																																																																													
	E									30.00											940	20.00							508	WS364																																							—																	
H	30.00	940	20.00																						508	WS364	—																																																											
D																												30.00			762	20.00	508	WS364	—																																																			
E																																				30.00	762	20.00	508	WS364	—																																													
H																																										30.00	762	20.00	508	WS364	—																																							
D																																																30.00	762	20.00	508	WS364	—																																	
E													30.00	762	20.00	508	WS364	—																																																																				
H																							30.00	762																														20.00	508	WS364	—																													
D											30.00	762																																														20.00	508	WS364	—																									
E																			30.00	762																																										20.00	508	WS364	—																					
H				30.00	762	20.00	508	WS364	—																																																																													
D										37.00											940	24.00							610	WS380																																				—																				
E	37.00	940	24.00																						610	WS380	—																																																											
H																												37.00			940	24.00	610	WS380	—																																																			
D																																				43.75	1111	27.00	686	WS381	—																																													
E																																										43.75	1111	27.00	686	WS381	—																																							
H																																																43.75	1111	27.00	686	WS381	—																																	
D													48	1219	35	889	28.5	724																																																	WS382	—																		
E																							48	1219																														35	889	28.5	724												WS382	—																
H											48	1219																																														35	889	28.5	724										WS382	—														
D																			49.5	1257																																										41	1041	32	813								WS382	—												
E				49.5	1257	41	1041	32	813																																																																		WS382	—										
H										49.5											1257	41							1041	32																																				813											WS382	—								
D	57.5	1461	56																						1422	36	914																																																				WS382	—						
E																												57.5			1461	56	1422	36	914																																														WS382	—				
H																																				57.5	1461	56	1422	36	914																																										WS382	—		
D																																										60	1524	48	1219	40.5	1029																																						WS370A	—
E																																																60	1524	48	1219	40.5	1029																																	
H													60	1524	48	1219	40.5	1029																																																	WS370A	—																		
D																							68	1727																														56	1422	40.5	1029												WS370A	—																
E											68	1727																																														56	1422	40.5	1029										WS370A	—														
H																			68	1727																																										56	1422	40.5	1029								WS370A	—												
D				71	1803	56	1422	40.5	1029																																																																		WS383	—										
E										71											1803	56							1422	40.5																																				1029											WS383	—								
H	71	1803	56																						1422	40.5	1029																																																				WS383	—						
D																												74			1880	72	1832	50	1272																																														WS384	—				
E																																				74	1880	72	1832	50	1272																																										WS384	—		
H																																										74	1880	72	1832	50	1272																																						WS384	—
D																																																91.5	2388	72	1829	54	1372																																	
E													91.5	2388	72	1829	54	1372																																																	WS384	—																		
H																							91.5	2388																														72	1829	54	1372												WS384	—																
D											94	2388																																														84	2134	54	1372										WS384	—														
E																			94	2388																																										84	2134	54	1372								WS384	—												
H				94	2388	84	2134	54	1372																																																																		WS384	—										
D										96											2438	96							2438	54																																				1372											WS384	—								
E	96	2438	96																						2438	54	1372																																																				WS384	—						
H																												96			2438	96	2438	54	1372																																														WS384	—				
D																																				40.5	1031	36.5	916	21.75	553																																										WS384	—		
E																																										40.5	1031	36.5	916	21.75	553																																						WS384	—
H																																																40.5	1031	36.5	916	21.75	553																																	
D													51.5	1310	40.5	1031	26.5	674																																																	WS384	—																		
E																							51.5	1310																														40.5	1031	26.5	674												WS384	—																
H											51.5	1310																																														40.5	1031	26.5	674										WS384	—														
D																			66	1679																																										50.5	1285	32	814								WS384	—												
E				66	1679	50.5	1285	32	814																																																																		WS384	—										
H										66											1679	50.5							1285	32																																				814											WS384	—								
D	90	2290	80																						2036	50	1272																																																				WS384	—						
E																												90			2290	80	2036	50	1272																																														WS384	—				
H																																				90	2290	80	2036	50	1272																																										WS384	—		
D																																										100	2545	100	2545	60	1527																																						WS384	—
E																																																100	2545	100	2545	60	1527																																	
H													100	2545	100	2545	60	1527																																																	WS384	—																		
D																							108	2748																														108	2748	64	1628												44	1120																
E											108	2748																																														108	2748	64	1628										44	1120														
H																			108	2748																																										108	2748	64	1628								44	1120												
D				90	2290	72	1832	50	1272																																																																		WS384	—										
E										90											2290	72							1832	50																																				1272											WS384	—								
H	90	2290	72																						1832	50	1272																																																				WS384	—						
D																												80			2036	64	1628	44	1120																																														WS384	—				
E																																				80	2036	64	1628	44	1120																																										WS384	—		
H																																										80	2036	64	1628	44	1120																																						WS384	—
D																																																9.5	24	10	25	7.75	20																																	
E													9.5	24	10	25	7.75	20																																																	WS384	—																		
H																							9.5	24																														10	25	7.75	20												WS384	—																
D											12	30																																														13.75	35	13.75	35										WS384	—														
E																			12	30																																										13.75	35	13.75	35								WS384	—												
H				12	30	13.75	35	13.75	35																																																																		WS384	—										
D										24											61	21.5							55	16.38																																				42											WS384	—								
E	24	61	21.5																						55	16.38	42																																																				WS384	—						
H																												24			61	21.5	55	16.38	42																																														WS384	—				
D																																				23	58	25.5	65	13.75	35																																										WS384	—		
E																																										23	58	25.5	65	13.75	35																																						WS384	—
H																																																23	58	25.5	65	13.75	35																																	
D													31.5	80	31.5	80	16.25	41																																																	WS384	—																		
E																							31.5	80																														31.5	80	16.25	41												WS384	—																
H											31.5	80																																														31.5	80	16.25	41										WS384	—														
D																			9.5	24																																										10	25	7.75	20								WS384	—												
E				9.5	24	10	25	7.75	20																																																																		WS384	—										
H										9.5											24	10							25	7.75																																				20											WS384	—								
D	12	30	13.75																						35	13.75	35																																																				WS384	—						
E																												12			30	13.75	35	13.75	35																																														WS384	—				
H																																				12	30	13.75	35	13.75	35																																										WS384	—		
D																																										24	61	21.5	55	16.38	42																																						WS384	—
E																																																24	61	21.5	55	16.38	42																																	
H													24	61	21.5	55	16.38	42																																																	WS384	—																		
D																							23	58																														25.5	65	13.75	35												WS384	—																
E											23	58																																														25.5	65	13.75	35										WS384	—														
H																			23	58																																										25.5	65	13.75	35								WS384	—												
D				31.5	80	31.5	80	16.25	41																																																																		WS384	—										
E										31.5											80	31.5							80	16.25																																																								

**Drive Isolation Transformers**

Special design considerations must be made for the requirements of both adjustable frequency and dc motor drive power isolation. Allowance for high surge, harmonic and offset currents are taken into account in the design of Square D™ brand drive isolation transformers. Drive isolation transformers are not shielded isolation transformers, but act to lessen transient generation into the supply power and act as a buffer for SCR current surges.

**Table 6.1: Three-Phase 60 Hz; Class B (IEEE Standard 597-1983); 460 V Delta Primary**

kVA	Catalog No.	Full Capacity Taps	Weight (lbs) [1]	Enclosure [1][2]
<b>460 V Delta Primary, 460Y/265 V Secondary, 150°C Rise</b>				
7.5	7T145HDIT	2-5%1 + 1-	180	17D
11	11T145HDIT		190	
15	15T145HDIT		210	
20	20T145HDIT		250	18D
27	27T145HDIT		295	
34	34T145HDIT		350	
40	40T145HDIT		445	20D
51	51T145HDIT		465	
63	63T145HDIT		550	
75	75T145HDIT		845	22D
93	93T145HDIT	920		
118	118T145HDIT	1025		
145	145T145HDIT	1120	25D	
175	175T145HDIT	1200		
220	220T145HDIT	1500		
275	275T145HDIT	1390	30D	
330	330T145HDIT	2700		
440	440T145HDIT	3800		
550	550T145HDIT			
<b>460 V Delta Primary, 230Y/132 V Secondary, 150°C Rise</b>				
7.5	7T144HDIT	2-5%1 + 1-	180	17D
11	11T144HDIT		190	
15	15T144HDIT		210	
20	20T144HDIT		250	18D
27	27T144HDIT		295	
34	34T144HDIT		350	
40	40T144HDIT		445	20D
51	51T144HDIT		465	
63	63T144HDIT		550	
75	75T144HDIT		845	22D
93	93T144HDIT	920		
118	118T144HDIT	1025		
145	145T144HDIT	1120	25D	
175	175T144HDIT	1200		
220	220T144HDIT	1500		
275	275T144HDIT	1390	30D	
330	330T144HDIT	2700		
440	440T144HDIT	3800		
550	550T144HDIT			

**Table 6.2: Three-Phase 60 Hz; Class B (IEEE Standard 597-1983); 230 V Delta Primary**

kVA	Catalog No.	Full Capacity Taps	Weight (lbs) [1]	Enclosure [1][2]
<b>230 V Delta Primary, 460Y/265 V Secondary, 150°C Rise</b>				
7.5	7T143HDIT	2-5%1 + 1-	180	17D
11	11T143HDIT		190	
15	15T143HDIT		210	
20	20T143HDIT		250	18D
27	27T143HDIT		295	
34	34T143HDIT		350	
40	40T143HDIT		445	20D
51	51T143HDIT		465	
63	63T143HDIT		550	
75	75T143HDIT		845	22D
93	93T143HDIT	920		
118	118T143HDIT	1025		
145	145T143HDIT	1120	25D	
175	175T143HDIT	1200		
220	220T143HDIT	1500		
275	275T143HDIT	1390	30D	
330	330T143HDIT	2700		
440	440T143HDIT	3800		
550	550T143HDIT			
<b>230 V Delta Primary, 230Y/132 V Secondary, 150°C Rise</b>				
7.5	7T142HDIT	2-5%1 + 1-	180	17D
11	11T142HDIT		190	
15	15T142HDIT		210	
20	20T142HDIT		250	18D
27	27T142HDIT		295	
34	34T142HDIT		350	
40	40T142HDIT		445	20D
51	51T142HDIT		465	
63	63T142HDIT		550	
75	75T142HDIT		845	22D
93	93T142HDIT	920		
118	118T142HDIT	1025		
145	145T142HDIT	1120	25D	
175	175T142HDIT	1200		
220	220T142HDIT	1500		
275	275T142HDIT	1390	30D	
330	330T142HDIT	2700		
440	440T142HDIT	3800		
550	550T142HDIT			

**NOTE:** Lugs are furnished by customer.

[1] Not for construction. Contact your nearest Schneider Electric sales office for certified prints.  
 [2] For enclosure styles, see the dimensions table in Digest Section for Transformers.

### Open Core and Coil Transformers Designed for General Applications for 600 V and Below

Units are designed with 220 °C insulation, aluminum windings, top terminations, compact design to save space, and are UL component recognized for:

- Non-energy efficiency (less than 15 kVA)  
Single-phase 5–10 VA  
Three-phase 3–9 VA
- Energy efficiency (meets Table 4-2 of NEMA TP1–2002)  
Single-phase 15–75 kVA  
Three-phase 15–112.5 kVA

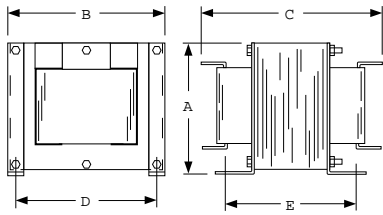

Figure 1

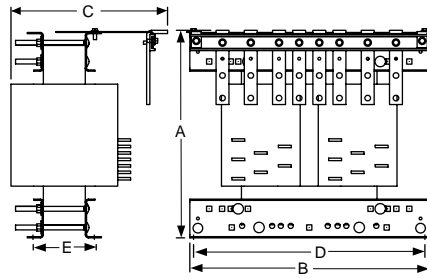

Figure 2

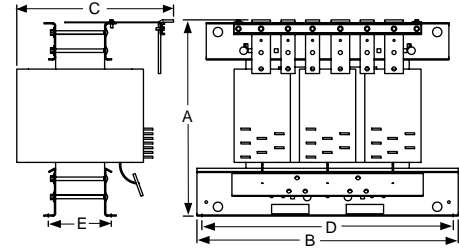

Figure 3

**Table 6.3: Single-Phase Open Core and Coil Transformers—240 X 480 V Primary, 120/240 V Secondary, 60 Hz**

kVA	Catalog No.	Deg. C Temp. Rise	Full Capacity Taps	Dimensions [3]										Weight (lbs)	Figure						
				A		B		C		D		E[4]									
				in	mm	in	mm	in	mm	in	mm	in	mm								
5	5S1HFOC	115	—	8.00	203	9.00	229	11.00	279	8.00	203	8.00	203	66	1						
7.5	7S1HFOC		14.25					362	8.00			203	80								
10	10S1HFOC		20.50					521	18.5			470	14.00	356		17.0	432	4.25	108	140	
15	EE15S3HOC	150	6–2.5% 2+4–[5]	20.25	514	18.5	470	14.00	356	17.0	432	5.00	127	200							
25	EE25S3HOC							18.00	457			5.50	140	255							
37.5	EE37S3HOC							22.00	559			6.50	165	310							
50	EE50S3HOC							22.25	565			28.0	711	22.00		559	27.0	686	8.50	216	460
75	EE75S3HOC																				

[3] Not for construction. Contact your nearest Schneider Electric sales office for certified prints.

[4] Dimensions may vary due to manufacturing process.

[5] When 240 V tap is used, there will be 3–5% taps, 1 above and 2 below.



**Table 6.4: Regulation Chart for Type EO Transformers**

VA (60 Hz)	Secondary Voltage					
	Inrush UL VA at 20% Power Factor			Inrush UL VA at 40% Power Factor		
	95%	90%	85%	95%	90%	85%
25	95	—	146	60	—	119
50	164	213	277	123	168	225
75	387	487	622	284	375	798
100	479	606	770	346	463	613
150	755	1177	1532	567	930	1252
200	1260	1883	2419	910	1462	1950
250	1530	2327	2995	1115	1811	2419
300	2030	2981	3800	1455	2290	3038
350	2920	4586	5981	2180	3637	4903
500	4230	5984	7707	3120	4661	6229
750	7430	11460	14736	5380	8907	11891
1000	10300	16873	21734	7450	13145	17571
1500	19200	30042	39217	14500	23859	32179
2000	27750	45194	60022	21750	36901	50994
3000	31800	82333	108205	26750	66072	89509
5000	86100	148768	202077	72600	126887	175552

**Type EO Transformers**

Type EO units are designed with exceptional voltage regulation. These control transformers are constructed using traditional materials and manufacturing techniques, and are designed for 25–5000 VA with a 55°C temperature rise. When exceptional regulation and very low temperature rise are an absolute necessity, choose Type EO units.

**Table 6.5: Type EO Transformer Dimensions**

VA (60 Hz)	Catalog Number Class 9070	A		B		C		Weight	
		IN	mm	IN	mm	IN	mm	lbs	kg
<b>220x440 V Primary, 110 V Secondary; 230x460 V Primary, 115 V Secondary; or 240x480 V Primary, 120 V Secondary</b>									
25	9070EO17D1	3.31	84	3.00	76	2.50	64	1.9	0.9
50	9070EO1D1							2.2	1.0
75	9070EO18D1	3.78	96	3.38	86	2.81	71	3.5	1.6
100	9070EO2D1							3.8	1.7
150	9070EO3D1	4.44	113	3.75	95	3.13	80	6.0	2.7
200	9070EO19D1	4.81	122	4.50	114	3.75	95	10.5	4.8
250	9070EO15D1	5.19	132					13.2	6.0
300	9070EO4D1	5.56	141					17.2	7.8
500	9070EO51D1	6.56	167	5.25	133	4.38	111	24.5	11.1
750	9070EO61D1	7.94	202					30.5	13.8
1000	9070EO71D1	7.94	202	6.00	152	5.00	127	45.0	20.4
1500	9070EO81D1	8.59	218	7.06	179	6.03	153	56.0	25.4
2000	9070EO91D1	9.22	234					72.0	32.7
3000	9070EO10D1	9.44	239	9.00	229	7.50	191	115.0	52.2
<b>240x480 V Primary, 24 V Secondary</b>									
25	9070EO17D2	3.31	84	3.00	76	2.50	64	1.9	0.9
50	9070EO10D2							2.2	1.0
75	9070EO18D2	3.78	96	3.38	86	2.81	71	3.5	1.6
100	9070EO2D2							3.8	1.7
250	9070EO16D2	6.19	157	4.50	114	3.75	95	13.2	6.0
<b>550 V Primary, 110 V Secondary; 575 V Primary, 115 V Secondary; or 600 V Primary, 120 V Secondary</b>									
200	9070EO19D5	5.56	141	122	4.50	114	3.75	10.5	4.8
300	9070EO04D5			4.50	114	3.75	95	17.2	7.8
500	9070EO51D5	6.56	167	5.25	133	4.38	111	24.5	11.1
750	9070EO61D5	7.94	202					30.5	13.8

**Table 6.6: Regulation Chart for Type T Transformers**

VA (60 Hz)	Secondary Voltage					
	Inrush UL VA at 20% Power Factor			Inrush UL VA at 40% Power Factor		
	95%	90%	85%	95%	90%	85%
50	193	266	339	151	215	282
75	271	396	20	210	318	430
100	339	499	659	266	404	549
150	666	893	1120	529	731	942
200	588	815	1041	459	659	866
250	1416	1910	2388	1057	1494	1936
300	1634	2184	2709	1194	1681	2169
350	1894	2592	3261	1392	2005	621
500	3197	4104	4981	2374	3195	4019
750	3770	5515	7231	2887	4391	5945
1000	6587	9079	11430	4706	6886	9051
1500	19324	23983	28607	15066	19361	23756
2000	31384	38777	6161	24794	31630	38667
3000	26539	39934	52713	19355	30721	42216
5000	53111	85265	116277	39368	66309	93882

**Type T and MultiTap™ Transformers**

Type T transformers are designed with low impedance windings for excellent voltage regulation and can accommodate the high inrush current associated with contactors, starters, solenoids, and relays. As the most popular and complete line of control transformers with unmatched design innovations for top performance, Type Ts are manufactured using the most advanced insulating materials and are the best choice if size and cost are of concern. It is available in the MultiTap version, designed to respond to the increased need for voltage and stock flexibility. It combines multiple primary voltages with one or more secondary voltages, all in a single transformer.

**Selection Guide**

1. Determine the inrush and sealed VA of each coil in the control circuit, and the VA of all other components.
2. Total the sealed VA of all operating coils and the VA of all other loads. (This determines the minimal VA size required for the circuit.)
3. Total the inrush VA of all coils that are starting at the same time, and all loads and coils that are running. (Use the regulation chart to give possible units to be used.)
4. Taking the VA size from step 2, go to the standard VA size in the chart. Make sure the inrush VA from the chart is greater than the total VA from step 3. (If not, go to the next larger VA size and repeat.)

If your supply voltage is stable and fluctuates less than 5%, we recommend you use the 90% secondary voltage column. If your supply voltage is not stable and fluctuates more than 10%, we recommend you use the 95% secondary voltage column. We recommend that you never use the 85% secondary voltage column since magnetic devices lose life expectancy if they are continuously started at 85% of rated voltage.

**Table 6.7: Type T Transformer Selection**

VA		Catalog No.	H	W	D	Weight (lbs)
UL/CSA/NOM	CE		in (mm)	in (mm)	in (mm)	
<b>120 V Primary, 120 V Secondary; 115 V Primary, 115 V Secondary; or 110 V Primary, 110 V Secondary</b>						
50	50	9070T50D24	2.58 (65.5)	3.00 (76.2)	3.09 (78.5)	2.5
75	75	9070T75D24	2.89 (73.4)	3.38 (85.8)	3.34 (84.8)	3.8
100	100	9070T100D24				3.8
150	150	9070T150D24	3.20 (81.3)	3.75 (95.3)	3.59 (91.2)	5.5
200	200	9070T200D24				5.5
250	160	9070T250D24	3.25 (82.6)	3.75 (95.3)	5.25 (133.4)	7.1
300	200	9070T300D24	3.80 (96.5)	4.50 (114.3)	4.70 (119.4)	8.5
350	250	9070T350D24			5.09 (129.3)	10.5
500	300	9070T500D24			5.46 (138.7)	11.9
750	500	9070T750D24			5.66 (143.8)	11.0
1000	630	9070T1000D24	4.43 (112.5)	5.25 (133.4)	6.04 (153.4)	20.6
1500	1000	9070T1500D24	6.16 (156.5)	7.06 (179.3)	5.81 (147.6)	34.0
2000	1500	9070T2000D24			7.04 (178.8)	47.0
3000	2000	9070T3000D24			8.46 (214.9)	9.00 (228.6)

**Table 6.7 Type T Transformer Selection (cont'd.)**

VA		Catalog No.	H	W	D	Weight (lbs)
UL/CSA/NOM	CE		in (mm)	in (mm)	in (mm)	
5000	3000	9070T5000D24			8.73 (221.7)	89.0
<b>120 V x 240 V Primary, 120/240 V Secondary; 115 V x 230 V Primary, 115/230 V Secondary; or 110 V x 220 V Primary, 110/220 V Secondary</b>						
50	50	9070T50D55	2.58 (65.5)	3.00 (76.2)	3.09 (78.5)	2.5
75	75	9070T75D55	2.89 (73.4)	3.38 (85.8)	3.34 (84.8)	3.8
100	100	9070T100D55				
150	150	9070T150D55	3.20 (81.3)	3.75 (95.3)	3.59 (91.2)	5.5
200	200	9070T200D55				
250	160	9070T250D55	3.25 (82.6)	3.75 (95.3)	5.25 (133.4)	7.1
300	200	9070T300D55			4.70 (119.4)	8.5
350	250	9070T350D55	3.80 (96.5)	4.50 (114.3)	5.09 (129.3)	10.5
500	300	9070T500D55			5.46 (138.7)	11.9
750	500	9070T750D55	4.43 (112.5)	5.25 (133.4)	5.66 (143.8)	11.0
1000	630	9070T1000D55			6.04 (153.4)	20.6
1500	1000	9070T1500D55	6.16 (156.5)	7.06 (179.3)	5.81 (147.6)	34.0
2000	1500	9070T2000D55			7.04 (178.8)	47.0
3000	2000	9070T3000D55	8.46 (214.9)	9.00 (228.6)	6.86 (174.2)	60.0
5000	3000	9070T5000D55			8.73 (221.7)	89.0
<b>277 V Primary, 24 V Secondary</b>						
50	50	9070T50D25	2.58 (65.5)	3.00 (76.2)	3.09 (78.5)	2.5
75	75	9070T75D25	2.89 (73.4)	3.38 (85.8)	3.34 (84.8)	3.8
100	100	9070T100D25				
150	150	9070T150D25	3.20 (81.3)	3.75 (95.3)	3.59 (91.2)	5.5
200	200	9070T200D25				
250	160	9070T250D25	3.25 (82.6)	3.75 (95.3)	5.25 (133.4)	7.1
300	200	9070T300D25			4.70 (119.4)	8.5
350	250	9070T350D25	3.80 (96.5)	4.50 (114.3)	5.09 (129.3)	10.5
500	300	9070T500D25			5.46 (138.7)	11.9
750	500	9070T750D25	4.43 (112.5)	5.25 (133.4)	5.66 (143.8)	11.0
1000	630	9070T1000D25			6.04 (153.4)	20.6
<b>600 V Primary, 12/24 V Secondary</b>						
50	50	9070T50D36	2.58 (65.5)	3.00 (76.2)	3.09 (78.5)	2.5
75	75	9070T75D36	2.89 (73.4)	3.38 (85.8)	3.34 (84.8)	3.8
100	100	9070T100D36				
150	150	9070T150D36	3.20 (81.3)	3.75 (95.3)	3.59 (91.2)	5.5
200	200	9070T200D36				
250	160	9070T250D36	3.25 (82.6)	3.75 (95.3)	5.25 (133.4)	7.1
300	200	9070T300D36			4.70 (119.4)	8.5
350	250	9070T350D36	3.80 (96.5)	4.50 (114.3)	5.09 (129.3)	10.5
500	300	9070T500D36			5.46 (138.7)	11.9
750	500	9070T750D36	4.43 (112.5)	5.25 (133.4)	5.66 (143.8)	11.0
1000	630	9070T1000D36			6.04 (153.4)	20.6
<b>480 V Primary, 240 V Secondary; 460 V Primary, 230 V Secondary; or 440 V Primary, 220 V Secondary</b>						
50	50	9070T50D12	2.58 (65.5)	3.00 (76.2)	3.09 (78.5)	2.5
75	75	9070T75D12	2.89 (73.4)	3.38 (85.8)	3.34 (84.8)	3.8
100	100	9070T100D12				
150	150	9070T150D12	3.20 (81.3)	3.75 (95.3)	3.59 (91.2)	5.5
200	200	9070T200D12				
250	160	9070T250D12	3.25 (82.6)	3.75 (95.3)	5.25 (133.4)	7.1
300	200	9070T300D12			4.70 (119.4)	8.5
350	250	9070T350D12	3.80 (96.5)	4.50 (114.3)	5.09 (129.3)	10.5
500	300	9070T500D12			5.46 (138.7)	11.9
750	500	9070T750D12	4.43 (112.5)	5.25 (133.4)	5.66 (143.8)	11.0
1000	630	9070T1000D12			6.04 (153.4)	20.6
1500	1000	9070T1500D12	6.16 (156.5)	7.06 (179.3)	5.81 (147.6)	34.0
2000	1500	9070T2000D12			7.04 (178.8)	47.0
3000	2000	9070T3000D12	8.46 (214.9)	9.00 (228.6)	6.86 (174.2)	60.0
5000	3000	9070T5000D12			8.73 (221.7)	89.0



Model 450R

Model 460R  
Model 470R

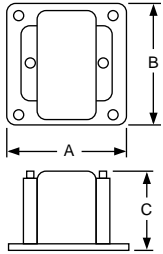

**Voltage Transformers: Obsolete—January 1, 2023**

These voltage transformers are designed for line-to-line or line-to-ground connection on the primary voltage indicated. See [Table 6.8 Voltage Transformers, UR/cUR Recognized, 60 Hz, page 6-7](#) to determine the applicable configuration for proper system voltage indication.

- **Model 450R**—designed for switchboard use. This model features high accuracy and burden capacity for excellent performance in metering and indication.
- **Model 460R**—a compact, lightweight design, providing exceptional performance in indicating applications.
- **Model 470R**—a compact, low cost design optimized for maximum accuracy and performance when used with PowerLogic™ circuit monitors.

**Table 6.8: Voltage Transformers, UR/cUR Recognized, 60 Hz**

Model 450R Thermal Rating: 500 VA @ 30 °C; 300 VA @ 55 °C; Accuracy 0.3W, X, M & Y; 1.2 Z	Model 460R Thermal Rating: 150 VA @ 30 °C; 100 VA @ 55 °C; Accuracy 0.6W, 1.2 X	Model 470R Thermal Rating: 150 VA @ 30 °C; 100 VA @ 55 °C; Accuracy 0.3W, 1.2 X	System Voltage	Winding Ratio
Catalog Number	Catalog Number	Catalog Number		
450R069	460R069	470R069	69/120Y	0.58:1
450R120	460R120	470R120	120/208Y	1:1
450R208	460R208	470R208	120/208Y	1.73:1
450R240	460R240	470R240	240/416Y	2:1
450R288	460R288	470R288	288/500Y <sup>[1]</sup>	2.4:1
450R300	460R300	470R300	300/520Y	2.5:1
450R380	460R380	470R380	220/380Y	3.17:1
450R480	460R480	470R480	480/480Y <sup>[2]</sup>	4:1
450R600	460R600	470R600	600/600Y	5:1

Model	Dimensions (inches)		
	A	B	C
450R	6	7-1/8	5-7/8
460R	4-3/4	4-1/2	3-7/8
470R	4-3/4	4-1/2	3-7/8

**Obsolete—January 1, 2023**

**Current Transformers**

**Table 6.10: General Purpose Compact Units, UR/cUR Recognized**

Window Size (inches)	Catalog Number (without brackets)	Current Rating (Amperes)	VA 60 Hz	VA 400 Hz	Accuracy (At Rated Current)	Rating Factor 30 °C Ambient
1-1/8	2NR500	50:5	1.0	2.0	= 2%	1.0
	2NR600	60:5	1.0	2.0	= 2%	
	2NR750	75:5	1.5	3.0	= 2%	
	2NR800	80:5	1.5	3.0	= 2%	
	2NR101	100:5	2.0	4.0	= 1%	
	2NR121	120:5	2.5	5.0	= 1%	
	2NR1250	125:5	2.5	5.0	= 1%	
	2NR151	150:5	2.5	5.0	= 1%	
	2NR201	200:5	2.5	5.0	= 1%	
	2NR251	250:5	2.5	5.0	= 1%	
	2NR301	300:5	2.5	5.0	= 1%	
	1-9/16	5NR101	100:5	2.0	4.0	
5NR151		150:5	2.5	5.0		
5NR201		200:5	5.0	12.5		
5NR251		250:5	5.0	12.5		
5NR301		300:5	5.0	12.5		
5NR401		400:5	12.5	25.0		
5NR501		500:5	12.5	25.0		
5NR601		600:5	25.0	50.0		
1-9/16	54R101	100:5	2.0	4.0	= 1%	1.0
	54R151	150:5	2.5	5.0		
	54R201	200:5	5.0	12.5		
	54R251	250:5	5.0	12.5		
	54R301	300:5	5.0	12.5		
	54R401	400:5	12.5	25.0		
	54R501	500:5	12.5	25.0		
	54R601	600:5	25.0	50.0		
2-1/4	7RL500	50:5	2.5	5.0	= 1%	1.5
	7RL101	100:5	2.5	5.0		
	7RL151	150:5	2.5	5.0		
	7RL201	200:5	5.0	10.0		
	7RL251	250:5	5.0	10.0		
	7RL301	300:5	5.0	10.0		
	7RL401	400:5	12.5	25.0		
	7RL501	500:5	12.5	25.0		
	7RL601	600:5	12.5	25.0		
	7RL751	750:5	12.5	25.0		
	7RL801	800:5	12.5	25.0		
	7RL102	1000:5	25.0	50.0		
	7RL122	1200:5	25.0	50.0		
	7RL152	1500:5	25.0	50.0		

**Table 6.9: Dimensions for Models 2NR, 5NR, 54R, and 7RL**

Model	Dimensions (inches)				
	A	B	C	D	E
2NR	1.13	2.38	—	.94	—
5NR	1.56	3.50	—	1.06	—
54R	1.56	3.50	4.56	1.06	4.00
7RL	2.25	4.38	—	1.38	—

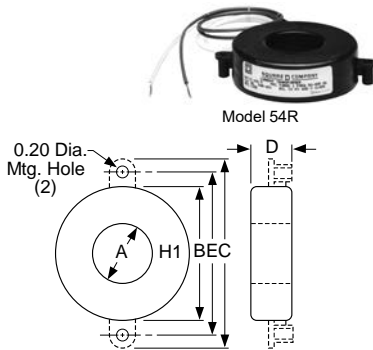

Model 54R

[1] For use on 277/480 Wye systems.  
[2] For use on 480 V Delta systems.

**Obsolete—January 1, 2023**  
**Toroidal Current Transformers (64R, 74R, 66R, 76R)**

Table 6.12: Toroidal Current Transformers, UR/cUR Recognized, 25–400 Hz

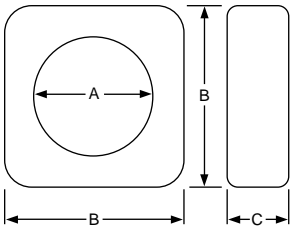

Models 64R, 66R, 74R, 76R,  
Table 6.11: Dimensions for 64R, 66R, 74R, and 76R

Model	Dimensions (inches)		
	A	B	C
64R	1-15/16	4-3/16	1-1/2
66R	1-15/16	4-3/16	31/16
74R	2-11/32	4-11/16	1-5/8
76R	2-11/32	4-11/16	3-1/4

Window Size (inches)	Catalog Number (without brackets) [3]	Current Rating (Amperes)	Relay Class	ANSI Accuracy Classification—60 Hz Metering Class					Rating Factor 30 °C Ambient
				B-0.1	B-0.2	B-0.5	B-0.9	B-1.8	
1-15/16	64R101	100:5	—	1.2	2.4	—	—	—	1.33
	64R151	150:0	—	1.2	1.2	—	—	—	
	64R201	200:5	—	1.2	1.2	2.4	—	—	
	64R251	250:5	—	0.6	0.6	1.2	—	—	
	64R301	300:5	—	0.6	0.6	1.2	2.4	—	
	64R401	400:5	—	0.3	0.6	0.6	1.2	—	
	64R501	500:5	—	0.3	0.3	0.6	0.6	—	
	64R601	600:5	—	0.3	0.3	0.3	0.6	1.2	
64R751	750:5	—	0.3	0.3	0.3	0.6	0.6		
1-15/16	66R101	100:5	—	1.2	2.4	—	—	—	1.33
	66R151	150:0	—	0.6	1.2	2.4	2.4	—	
	66R201	200:5	C10	0.6	0.6	1.2	2.4	—	
	66R251	250:5	C10	0.3	0.6	0.6	1.2	2.4	
	66R301	300:5	C10	0.3	0.3	0.6	1.2	2.4	
	66R401	400:5	C10	0.3	0.3	0.3	0.6	1.2	
	66R501	500:5	C20	0.3	0.3	0.3	0.6	0.6	
	66R601	600:5	C20	0.3	0.3	0.3	0.3	0.6	
66R751	750:5	C20	0.3	0.3	0.3	0.3	0.3		
2-11/32	74R201	200:5	—	1.2	1.2	0.6	—	—	1.33
	74R251	250:5	—	1.2	1.2	0.6	1.2	—	
	74R301	300:5	—	0.6	0.6	1.2	2.4	—	
	74R401	400:5	—	0.3	0.3	0.6	1.2	—	
	74R501	500:5	—	0.3	0.3	0.6	0.6	1.2	
	74R601	600:5	—	0.3	0.3	0.3	0.6	1.2	
	74R751	750:5	—	0.3	0.3	0.6	0.6	1.2	
	74R801	800:5	—	0.3	0.3	0.3	0.6	1.2	
	74R102	1000:5	—	0.3	0.3	0.3	0.3	0.6	
	74R122	1200:5	—	0.3	0.3	0.3	0.3	0.6	
	74R152	1500:5	—	0.3	0.3	0.3	0.3	0.6	
	74R152	1500:5	C20	0.3	0.3	0.3	0.3	0.3	
2-11/32	76R201	200:5	C10	0.6	0.6	1.2	2.4	2.4	1.33
	76R251	250:5	C10	0.3	0.6	1.2	1.2	2.4	
	76R301	300:5	C10	0.3	0.3	0.6	1.2	1.2	
	76R401	400:5	C10	0.3	0.3	0.3	0.6	1.2	
	76R501	500:5	C10	0.3	0.3	0.3	0.3	0.6	
	76R601	600:5	C20	0.3	0.3	0.3	0.3	0.6	
	76R751	750:5	C20	0.3	0.3	0.3	0.3	0.6	
	76R801	800:5	C20	0.3	0.3	0.3	0.3	0.3	
	76R102	1000:5	C20	0.3	0.3	0.3	0.3	0.3	
	76R122	1200:5	C20	0.3	0.3	0.3	0.3	0.3	
	76R152	1500:5	C20	0.3	0.3	0.3	0.3	0.3	
	76R152	1500:5	C20	0.3	0.3	0.3	0.3	0.3	

**Obsolete—January 1, 2023**  
**Toroidal Current Transformers (110R, 110R, 120R, 140R)**

Table 6.14: Toroidal Current Transformers, UR/cUR Recognized, 25–400 Hz



Models 100R, 110R, 120R, 140R

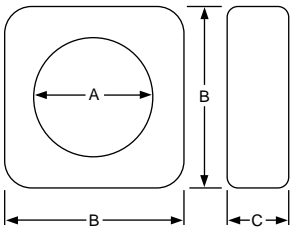

100R, 110R, 120R, and 140R

Table 6.13: Dimensions for 100R, 110R, 120R, and 140R

Model	Dimensions (inches)		
	A	B	C
100R	4	7	2-1/8
110R	4	7	2-7/8
120R	5-3/4	8-1/2	2-1/8
140R	8-1/8	11	3

Window Size (inches)	Catalog Number (without brackets) [3]	Current Rating (Amperes)	Relay Class	ANSI Accuracy Classification—60 Hz Metering Class					Rating Factor 30 °C Ambient
				B-0.1	B-0.2	B-0.5	B-0.9	B-1.8	
4	100R201	200:5	C10	0.6	1.2	2.4	—	—	1.33
	100R301	300:5	C10	0.3	0.6	1.2	1.2	2.4	
	100R401	400:5	C20	0.3	0.3	0.6	1.2	1.2	
	100R501	500:5	C20	0.3	0.3	0.6	0.6	1.2	
	100R601	600:5	C20	0.3	0.3	0.3	0.6	0.6	
	100R801	800:5	C20	0.3	0.3	0.3	0.3	0.6	
	100R102	1000:5	C50	0.3	0.3	0.3	0.3	0.3	
	100R122	1200:5	C50	0.3	0.3	0.3	0.3	0.3	
	100R152	1500:5	C50	0.3	0.3	0.3	0.3	0.3	
	100R162	1600:5	C50	0.3	0.3	0.3	0.3	0.3	
	100R202	2000:5	C50	0.3	0.3	0.3	0.3	0.3	
	4	110R201	200:5	C20	0.6	0.6	1.2	2.4	
110R301		300:5	C20	0.3	0.3	0.6	1.2	2.4	
110R401		400:5	C20	0.3	0.3	0.3	0.6	1.2	
110R501		500:5	C50	0.3	0.3	0.3	0.6	0.6	
110R601		600:5	C50	0.3	0.3	0.3	0.3	0.6	
110R801		800:5	C50	0.3	0.3	0.3	0.3	0.3	
110R102		1000:5	C100	0.3	0.3	0.3	0.3	0.3	
110R122		1200:5	C100	0.3	0.3	0.3	0.3	0.3	
110R152		1500:5	C100	0.3	0.3	0.3	0.3	0.3	
110R162		1600:5	C100	0.3	0.3	0.3	0.3	0.3	
110R202		2000:5	C100	0.3	0.3	0.3	0.3	0.3	
5-3/4		120R201	200:5	C10	1.2	2.4	2.4	—	—
	120R301	300:5	C10	0.6	1.2	2.4	—	—	
	120R401	400:5	C20	0.3	0.6	1.2	2.4	2.4	
	120R501	500:5	C20	0.3	0.3	0.6	1.2	2.4	
	120R601	600:5	C20	0.3	0.3	0.6	1.2	2.4	
	120R801	800:5	C20	0.3	0.3	0.6	0.6	1.2	
	120R102	1000:5	C50	0.3	0.3	0.3	0.6	0.6	
	120R122	1200:5	C50	0.3	0.3	0.3	0.3	0.6	
	120R152	1500:5	C50	0.3	0.3	0.3	0.3	0.3	
	120R162	1600:5	C50	0.3	0.3	0.3	0.3	0.3	
	120R202	2000:5	C50	0.3	0.3	0.3	0.3	0.3	
	120R252	2500:5	C50	0.3	0.3	0.3	0.3	0.3	
120R302	3000:5	C50	0.3	0.3	0.3	0.3	0.3		
120R402	4000:5	—	0.3	0.3	0.3	0.3	0.3		

[3] For mounting brackets, refer to Bushing Current Transformers 50–400 Hz, page 6-12

**Table 6.14 Toroidal Current Transformers, UR/cUR Recognized, 25–400 Hz (cont'd.)**

Window Size (inches)	Catalog Number (without brackets) [4]	Current Rating (Amperes)	Relay Class	ANSI Accuracy Classification—60 Hz Metering Class					Rating Factor 30 °C Ambient
				B-0.1	B-0.2	B-0.5	B-0.9	B-1.8	
8-1/8	140R500	50:5	—	For Ground Fault Sensing					1.33
	140R101	100:5	—						
8-1/8	140R401	400:5	C20	0.6	0.6	1.2	1.2	2.4	1.33
	140R501	500:5	C20	0.3	0.3	0.6	1.2	1.2	1.33
	140R601	600:5	C20	0.3	0.3	0.6	0.6	1.2	1.33
	140R801	800:5	C50	0.3	0.3	0.3	0.6	0.6	1.33
	140R102	1000:5	C50	0.3	0.3	0.3	0.3	0.6	1.33
	140R122	1200:5	C100	0.3	0.3	0.3	0.3	0.3	1.33
	140R152	1500:5	C100	0.3	0.3	0.3	0.3	0.3	1.33
	140R202	2000:5	C100	0.3	0.3	0.3	0.3	0.3	1.33
	140R252	2500:5	C100	0.3	0.3	0.3	0.3	0.3	1.33
	140R302	3000:5	C100	0.3	0.3	0.3	0.3	0.3	1.33
	140R402	4000:5	C100	0.3	0.3	0.3	0.3	0.3	1.33
	140R502	5000:5	C100	0.3	0.3	0.3	0.3	0.3	1.00
140R602	6000:5	C100	0.3	0.3	0.3	0.3	0.3	1.00	

**Obsolete—January 1, 2023**

**Toroidal Current Transformers (152R, 170R, 180R, 210R)**

**Table 6.16: Toroidal Current Transformers, UR/cUR Recognized, 25–400 Hz**

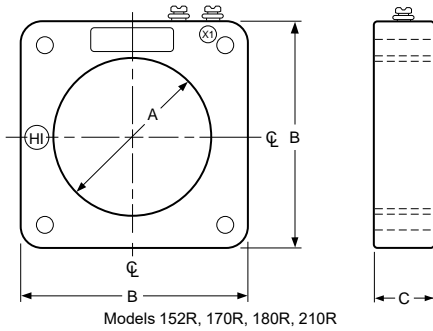

**Table 6.15: Dimensions for Models 152R, 170R, 180R, and 210R**

Model	Dimensions (inches)		
	A	B	C
152R	6.88	12.25	4.12
170R	4.25	6.75	1.31
180R	2.50	4.50	2.12
210R	6.25	9.50	2.87

Window Size (inches)	Catalog Number (without brackets) [4]	Current Rating (Amperes)	Relay Class	ANSI Accuracy Classification—60 Hz Metering Class					Rating Factor 30 °C Ambient
				B-0.1	B-0.2	B-0.5	B-0.9	B-1.8	
6-7/8	152R500	50:5	C10	1.2	—	—	—	—	1.33
	152R101	100:5	C20	1.2	2.4	—	—	—	
	152R151	150:5	C50	0.6	1.2	2.4	—	—	
	152R201	200:5	C50	0.6	0.6	1.2	2.4	2.4	
	152R251	250:5	C50	—	0.6	0.6	1.2	2.4	1.33
	152R301	300:5	C100	0.3	0.3	0.6	1.2	1.2	
	152R401	400:5	C100	—	0.3	0.3	0.6	1.2	
	152R501	500:5	C100	—	0.3	0.3	0.3	0.6	
	152R601	600:5	C200	—	—	—	—	—	1.33
	152R801	800:5	C200	0.3	0.3	0.3	0.3	0.3	
	152R102	1000:5	C200	—	—	—	—	—	
	152R122	1200:5	C400	—	—	—	—	—	
152R152	1500:5	—	—	—	—	—	—	1.33	
152R162	1600:5	—	—	—	—	—	—		
152R202	2000:5	C400	0.3	0.3	0.3	0.3	0.3		
152R252	2500:5	—	—	—	—	—	—		
152R302	3000:5	C400	0.3	0.3	0.3	0.3	0.3	1.33	
152R402	4000:5	C800	0.3	0.3	0.3	0.3	0.3		
4-1/4	170R201	200:5	—	1.2	—	2.4	—	—	1.33
	170R251	250:5	—	0.6	0.6	2.4	—	—	
	170R301	300:5	—	0.6	—	1.2	2.4	—	
	170R401	400:5	—	0.6	0.6	—	—	—	
	170R501	500:5	—	0.3	0.6	0.6	1.2	—	1.33
	170R601	600:5	—	0.3	0.3	0.6	1.2	2.4	
	170R751	750:5	C10	0.3	0.3	0.6	0.6	1.2	
	170R801	800:5	—	—	—	0.3	0.6	1.2	
	170R102	1000:5	—	—	—	0.3	0.3	0.6	1.33
	170R122	1200:5	C10	—	—	—	—	—	
	170R152	1500:5	—	—	—	—	—	—	
	170R162	1600:5	—	0.3	0.3	0.3	0.3	0.6	
170R202	2000:5	—	—	—	—	—	0.3	1.33	
170R252	2500:5	—	—	—	—	—	0.3		
2-1/2	180R101	100:5	—	2.4	2.4	—	—	—	1.33
	180R151	150:5	—	1.2	2.4	—	—	—	
	180R201	200:5	—	1.2	1.2	2.4	—	—	
	180R251	250:5	—	0.6	1.2	2.4	2.4	—	
	180R301	300:5	—	0.6	0.6	1.2	2.4	—	1.33
	180R401	400:5	—	0.3	0.3	0.6	1.2	2.4	
	180R501	500:5	—	—	—	0.6	0.6	1.2	
	180R601	600:5	—	0.3	0.3	0.3	0.6	1.2	
	180R751	750:5	—	—	—	0.3	0.3	0.6	1.33
	180R801	800:5	—	—	—	—	—	—	
	180R102	1000:5	—	—	—	—	—	—	
	180R122	1200:5	—	0.3	0.3	0.3	0.3	0.6	
180R152	1500:5	—	—	—	—	—	0.3	1.33	
210R122	1200:5	C100	—	—	—	—	—		
210R162	1600:5	C100	—	—	—	—	—	1.33	
210R202	2000:5	C100	—	—	—	—	—		
210R252	2500:5	C200	0.3	0.3	0.3	0.3	0.3		
210R302	3000:5	C200	—	—	—	—	—		
210R402	4000:5	C200	—	—	—	—	—	1.0	

[4] For mounting brackets, refer to Bushing Current Transformers 50–400 Hz, page 6-12

Obsolete—January 1, 2023  
Toroidal Current Transformers (200R, 201R, 202R, 203R)

Table 6.18: Toroidal Current Transformers, UR/cUR Recognized, 25–400 Hz

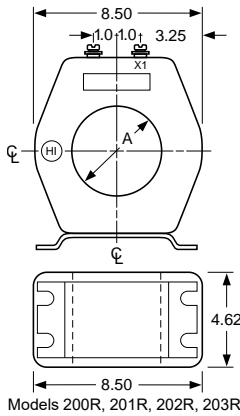

Table 6.17: Dimensions for Models 200R, 201R, 202R, and 203R

Model [5]	Dimensions A (Inches)
200R	2.50
201R	3.50
202R	4.50
203R	5.25

Window Size (Inches)	Catalog Number (without brackets) [6]	Current Rating (Amperes)	Relay Class	ANSI Accuracy Classification—60 Hz Metering Class					Rating Factor 30 °C Ambient	
				B-0.1	B-0.2	B-0.5	B-0.9	B-1.8		
2-1/2	200R101	100:5	C50	0.6	1.2	1.2	—	—	1.5	
	200R151	150:5	C50	0.3	0.6	0.6	1.2	2.4		
	200R201	200:5	C100	0.3	0.3	0.6	1.2	1.2		
	200R251	250:5	C100	0.3	0.3	0.3	0.6	1.2		
	200R301	300:5	C100	0.3	0.3	0.3	0.3	0.3	0.6	
	200R401	400:5	C200						0.3	
200R501	500:5	C200	0.3							
3-1/2	201R101	100:5	C20	1.2	1.2	2.4	2.4	—	1.5	
	201R151	150:5	C50	0.3	0.6	1.2	2.4	2.4		
	201R201	200:5	C50	0.3	0.3	0.6	1.2	2.4		
	201R251	250:5	C100	0.3	0.3	0.6	1.2	1.2	0.6	
	201R301	300:5	C100						0.6	
	201R401	400:5	C100						0.6	
201R501	500:5	C200	0.3	0.3	0.3	0.3	0.6	1.5		
201R601	600:5	C200	0.3	0.3	0.3	0.3	0.3		0.3	
201R751	750:5									
201R801	800:5									
4-1/2	202R101	100:5	C20	1.2	2.4	2.4	—	—	1.5	
	202R151	150:5	C20	1.2	1.2	2.4	2.4	—		
	202R201	200:5	C50	0.3	0.6	1.2	1.2	2.4		
	202R251	250:5	C50	0.3	0.3	0.6	1.2	1.2	0.6	
	202R301	300:5	C50						0.6	
	202R401	400:5	C100						0.3	
202R501	500:5	C100	0.3	0.3	0.3	0.3	0.8	1.5		
202R601	600:5	C100	0.3	0.3	0.3	0.3	0.3		0.3	
202R751	750:5	C200								
202R801	800:5	C200								
202R102	1000:5	C200	0.3	0.3	0.3	0.3	0.3	1.5		
5-1/4	203R101	100:5	C20	1.2	2.4	—	—	—	1.5	
	203R151	150:5		0.6	1.2	2.4	2.4	—		
	203R201	200:5		0.3	0.6	1.2	2.4	2.4		
	203R251	250:5	C20	0.3	0.6	1.2	1.2	2.4	0.6	
	203R301	300:5							C50	0.6
	203R401	400:5							C50	0.6
	203R501	500:5	C100	0.3	0.3	0.3	0.3	0.3	0.6	
	203R601	600:5							0.6	
	203R751	750:5							0.3	
	203R801	800:5	0.3	0.3	0.3	0.3	0.3	0.3	1.5	
	203R102	1000:5	C200	0.3	0.3	0.3	0.3	0.3		1.5
	203R122	1200:5								1.5
203R152	1500:5	1.5								
203R162	1600:5	1.33								
203R202	2000:5	C200	0.3	0.3	0.3	0.3	0.3	1.33		
203R252	2500:5									
203R302	3000:5									

Obsolete—January 1, 2023  
Shorting Terminal Blocks

Table 6.19: Shorting Terminal Blocks

Catalog No.	Description
3090TB4	Shorting terminal block (4-pole)
3090TB6	Shorting terminal block (6-pole)

Obsolete—January 1, 2023  
Multi-Ratio Current Transformers

Table 6.21: Multi-Ratio Transformers, UR/cUR Recognized 60 Hz-Model 312R, 25–400 Hz-Model 151R

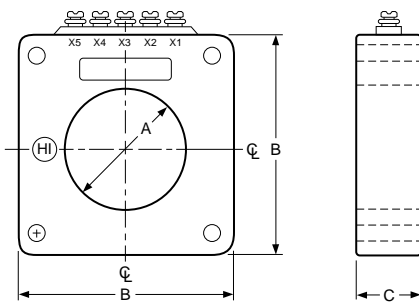

Models 151R, 312R

Table 6.20: Dimensions for Models 151R and 312R

Model	Dimensions (Inches)		
	A	B	C
151R	6.88	12.25	4.12
312R	4.50	11.00	2.38

Window Size (Inches)	Catalog Number (without brackets) [6]	Current Rating [7] (Amperes)	Relay Class [8]	ANSI Accuracy Classification – 60 Hz Metering Class					Rating Factor 30 °C Ambient
				B-0.1	B-0.2	B-0.5	B-0.9	B-1.8	
4-1/2	312R601	600:5MR	C100	—	—	—	—	—	1.5
	312R122	1200:5MR	C200	—	—	—	—	—	1.5
	312R202	2000:5MR	C400	—	—	—	—	—	1.5
	312R302	3000:5MR	C400	—	—	—	—	—	1.5
	312R402	4000:5MR	C400	—	—	—	—	—	1.33
6-7/8	151R601	600:5MR	C200	—	—	—	—	—	1.33
	151R122	1200:5MR	C400	—	—	—	—	—	
	151R202	2000:5MR	C400	—	—	—	—	—	
	151R302	3000:5MR	C400	—	—	—	—	—	
	151R402	4000:5MR	C800	—	—	—	—	—	

Table 6.22: Multi-Ratio Taps (Models 151R, 312R, 781R, 786R)

Nominal Ratio	Current Ratio [9] (Amperes)
600:5	600/500/450/400/300/250/200/150/100/50:5
1200:5	1200/1000/900/800/600/500/400/300/200/100:5
2000:5	2000/1600/1500/1200/1100/800/500/400/300:5
3000:5	3000/2500/2200/2000/1500/1200/1000/800/500/300:5
4000:5	4000/3500/3000/2500/2000/1500/1000/500

[5] Base is included.  
 [6] For mounting brackets, refer to Bushing Current Transformers 50–400 Hz, page 6-12  
 [7] For multi-ratio (MR) taps, refer to the Multi-Ratio Taps table.  
 [8] Relay class applies to nominal ratio only.  
 [9] Taps in accordance with ANSI C57.13 and NEMA SG-4.

**Obsolete—January 1, 2023  
Rectangular Window Current Transformers**

**Table 6.24: Rectangular Window Transformers, UR/cUR Recognized, 50–400 Hz**

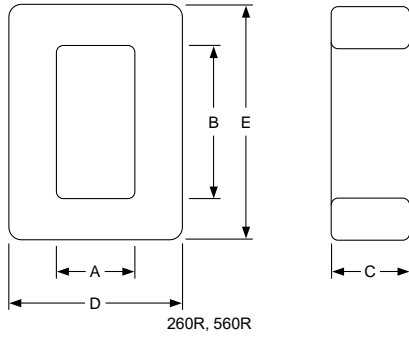

**Table 6.23: Dimensions for Models 260R, and 560R**

Model	Dimensions (inches)				
	A	B	C	D	E
260R	2.13	4.25	2.12	4.88	7.25
560R	3.75	7.45	1.13	5.53	11.19

Window Size (inches)	Catalog Number (without brackets) [10]	Current Rating (Amperes)	ANSI Accuracy Classification—60 Hz Metering Class					Rating Factor 30 °C Ambient
			B-0.1	B-0.2	B-0.5	B-0.9	B-1.8	
2-1/8 x 4-1/4	260R101	100:5	—	2.4	—	—	—	1.33
	260R151	150:5	1.2	2.4	—	—	—	
	260R201	200:5	—	1.2	—	—	—	
	260R301	300:5	0.6	0.6	—	—	—	1.33
	260R401	400:5	0.6	0.6	—	—	—	
	260R601	600:5	0.3	0.3	—	—	—	
	260R801	800:5	0.3	0.3	—	—	—	1.33
	260R122	1200:5	—	—	—	—	—	
	260R162	1600:5	—	—	—	—	—	
	260R202	2000:5	0.3	0.3	—	—	—	1.33
	260R252	2500:5	—	—	—	—	—	
	260R302	3000:5	—	—	—	—	—	
260R402	4000:5	—	—	—	—	—		
3-3/4 x 7-7/16	560R401	400:5	1.2	1.2	2.4	—	—	1.33
	560R501	500:5	0.6	1.2	2.4	—	—	
	560R601	600:5	0.6	0.6	1.2	2.4	2.4	
	560R751	750:5	0.6	0.6	1.2	1.2	2.4	
	560R801	800:5	0.6	0.6	1.2	1.2	2.4	
	560R102	1000:5	0.3	—	0.6	1.2	1.2	1.33
	560R122	1200:5	—	—	0.6	0.6	1.2	
	560R152	1500:5	—	—	0.3	0.6	0.6	
	560R162	1600:5	—	—	0.3	0.6	0.6	1.33
	560R202	2000:5	—	—	0.3	0.6	0.6	
	560R252	2500:5	—	—	—	—	—	
	560R302	3000:5	0.3	0.3	0.3	0.3	0.6	1.33
560R322	3200:5	—	—	—	—	—		
560R402	4000:5	—	—	—	—	—		
560R502	5000:5	—	—	—	—	—		

**Obsolete—January 1, 2023  
Split-Core Current Transformers**

**Table 6.26: Split-Core Transformers, Model 270R is UR/cUR Recognized, 60 Hz**

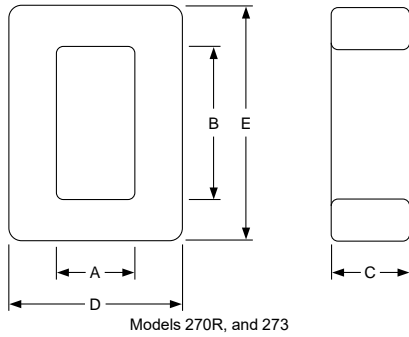

**Table 6.25: Dimensions for Models 270R, and 273**

Model	Dimensions (inches)				
	A	B	C	D	E
270R	3.56	8.81	3.00	9.25	13.06
273	3.50	6.25	3.27	9.25	11.28

Window Size (inches)	Catalog Number (without brackets) [10]	Current Rating (Amperes)	ANSI Accuracy Classification — 60 Hz Metering Class					Rating Factor 30 °C Ambient
			B-0.1	B-0.2	B-0.5	B-0.9	B-1.8	
3-9/16 x 8-3/16	270R401	400:5	—	—	—	—	—	1.33
	270R501	500:5	—	—	—	—	—	
	270R601	600:5	—	—	—	—	—	
3-9/16 x 8-3/16	270R801	800:5	—	2.4	—	—	—	1.33
	270R102	1000:5	1.2	1.2	2.4	—	—	
	270R122	1200:5	—	1.2	2.4	—	—	
	270R152	1500:5	—	1.2	2.4	—	—	
	270R162	1600:5	—	1.2	2.4	—	—	
	270R202	2000:5	1.2	1.2	1.2	2.4	—	1.33
	270R252	2500:5	—	—	—	2.4	—	
270R302	3000:5	—	—	—	1.2	2.4		
3-1/2 x 6-1/4	270R402	4000:5	—	—	—	1.2	1.2	1.0
	270R502	5000:5	—	—	—	1.2	1.2	
	273201	200:5	—	—	—	—	—	
	273251	250:5	—	—	—	—	—	1.33
	273301	300:5	2.4	—	—	—	—	
	273401	400:5	2.4	—	—	—	—	
	273501	500:5	2.4	—	—	—	—	
	273601	600:5	2.4	2.4	—	—	—	1.33
	273801	800:5	1.2	2.4	—	—	—	
	273102	1000:5	1.2	1.2	2.4	—	—	
	273122	1200:5	1.2	1.2	2.4	—	—	
	273162	1600:5	1.2	1.2	2.4	—	—	
273202	2000:5	1.2	1.2	1.2	2.4	—	1.33	
273252	2500:5	—	—	—	2.4	—		
273302	3000:5	—	—	—	1.2	2.4		
273402	4000:5	—	—	—	1.2	1.2		

[10] For mounting brackets, refer to [Bushings Current Transformers 50–400 Hz](#), page 6-12

Obsolete—January 1, 2023  
Bushings Current Transformers 50–400 Hz

Table 6.29: Bushing Current Transformers

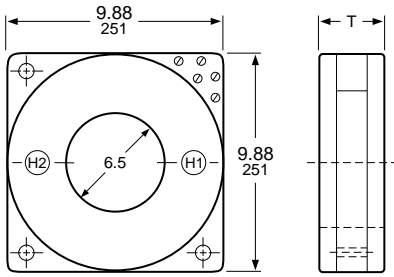

Models 780 R, 781R, 785R, and 786R

Table 6.27: Dimensions for Models 780R, 781R, 785R, and 786R

Model	T (inches)
780R	3.38
781R	3.38
785R	6.75
786R	6.75

Table 6.28: Mounting Brackets

Model	Bracket
2NR	MB1
5NR	
7RL	MB7
54R	Included
64R	MB10
66R	MB12
74R	MB16
76R	MB18
81X	MB81
100R	MB31
110R	MB32
120R	MB31
140R	MB32
151R	MB30
152R	
170R	MB9
180R	
200R	Included
201R	
202R	
203R	
210R	MB32
260R	Not Available
270R	
273	

Window Size (inches)	Catalog Number	Current Rating [11] (Amperes)	Relay Class	ANSI Accuracy Classification—60 Hz Metering Class					Rating Factor 30°C Ambient
				B-0.1	B-0.2	B-0.5	B-0.9	B-1.8	
6-1/2	780R500	50:5	—	—	—	—	—	—	2.0
	780R750	75:5	—	1.2	—	—	—	—	
	780R101	100:5	C10	2.4	2.4	—	—	—	
	780R151	150:5	—	—	—	—	—	—	
	780R201	200:5	C20	0.6	1.2	—	—	—	
	780R251	250:5	—	—	—	—	2.4	—	
	780R301	300:5	—	—	0.6	1.2	—	2.4	
	780R401	400:5	C50	—	—	0.6	—	1.2	
	780R501	500:5	—	—	—	—	—	—	
	780R601	600:5	—	—	—	—	0.6	—	
	780R751	750:5	C100	—	—	—	—	0.6	
	780R801	800:5	—	—	—	—	—	—	
	780R102	1000:5	—	—	—	—	—	—	
	780R122	1200:5	—	—	—	—	—	—	
	780R152	1500:5	—	—	—	—	—	—	
	780R162	1600:5	—	—	—	—	—	—	
	780R202	2000:5	C200	0.3	0.3	0.3	0.3	0.3	
	780R252	2500:5	—	—	—	—	—	—	
780R302	3000:5	—	—	—	—	—	—		
780R402	4000:5	—	—	—	—	—	—		
6-1/2	781R601	600:5 MR	C100	—	—	—	0.6	0.6	1.5
	781R122	1200:5 MR	—	—	—	—	—	—	—
	781R202	2000:5 MR	C200	—	—	—	0.3	0.3	2.0
	781R302	3000:5 MR	—	—	—	—	—	—	—
	781R402	4000:5 MR	—	—	—	—	—	—	1.5
6-1/2	785R500	50:5	C10	2.4	2.4	—	—	—	2.0
	785R750	75:5	—	—	—	—	—	—	
	785R101	100:5	C20	1.2	1.2	—	—	—	
	785R151	150:5	—	—	—	—	—	—	
	785R201	200:5	C50	0.6	0.6	1.2	2.4	—	
	785R251	250:5	—	—	—	—	1.2	2.4	
	785R301	300:5	—	—	—	—	—	—	
	785R401	400:5	C100	—	—	0.6	—	1.2	
	785R501	500:5	—	—	—	—	—	—	
	785R601	600:5	—	—	—	—	0.6	—	
	785R751	750:5	C200	—	—	—	—	—	
	785R801	800:5	—	—	—	—	—	—	
	785R102	1000:5	—	—	—	—	—	—	
	785R122	1200:5	—	—	—	—	—	—	
	785R152	1500:5	—	—	—	—	—	—	
	785R162	1600:5	—	—	—	—	—	—	
	785R202	2000:5	C400	0.3	0.3	0.3	0.3	0.3	
	785R252	2500:5	—	—	—	—	—	—	
785R302	3000:5	—	—	—	—	—	—		
785R402	4000:5	—	—	—	—	—	—		
6-1/2	786R601	600:5 MR	C200	—	—	—	—	—	1.5
	786R122	1200:5 MR	—	—	—	—	—	—	—
	786R202	2000:5 MR	C400	—	—	—	—	—	2.0
	786R302	3000:5 MR	—	—	—	—	—	—	—
	786R402	4000:5 MR	—	—	—	—	—	—	1.5

Obsolete—January 1, 2023  
Auxiliary Current Transformers

Table 6.30: Auxiliary Current Transformers

Catalog Number (without brackets)	Ratio
81X05000100	5:1
81X05000200	5:2
81X05000250	5:2.5
81X05000500	5:5
81X07500500	7.5:5
81X10000500	10:5
81X12500500	12.5:5
81X15000500	15:5

NOTE: Model 81X Accuracy 0.3B0.1, B0.2, B0.5@60 Hz, RF=1.5@30 °C

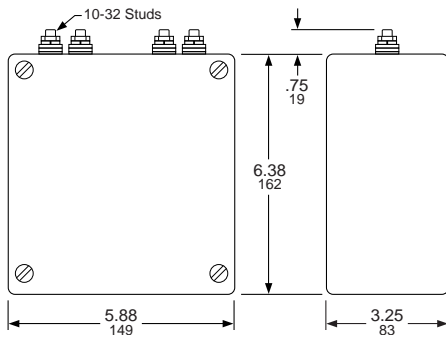

Model 81X

[11] For multi-ratio (MR) taps, refer to Table 6.22 Multi-Ratio Taps (Models 151R, 312R, 781R, 786R), page 6-10

# Section 7

## International Load Centers

<b>International Miniature Circuit Breakers</b>	<b>7-2</b>
QO™ Plug-On and Bolt-On Circuit Breakers and Switches	7-2
Plug-On QOXD and Bolt-On QOBXD	7-2
<b>Load Centers</b>	<b>7-4</b>
IEC Certified QO™ Load Centers, Type 1 (Indoor)	7-4

## QO™ Plug-On and Bolt-On Circuit Breakers and Switches

### General Description

In 1955 Square D Company introduced the QO™ Plug-on System and revolutionized the way electrical contractors install miniature circuit breakers in the United States. Today as part of Schneider Electric™ we offer the same Plug-on System technology around the world. IEC certified QO products are available for residential, commercial and industrial applications.

**Table 7.1: International Miniature Circuit Breaker Description**

Circuit Breaker	Description	1Ø Consumer Units	3Ø Distribution Boards
QOXD	Branch circuit breaker	X	X

### Characteristics

- Circuit breakers are rated 240 Vac single phase and 415 Vac three phase, 50/60 Hz.
- Circuit breakers are available in 1-, 2- or 3-pole construction.
- Thermal trip elements are factory calibrated to 40°C (IEC 947-2) and 30°C (IEC 898) ambient temperature.
- Trip-free handle ensures tripping even when the circuit breaker is held or locked in the ON position.
- Circuit breakers are in compliance with international standards set by the International Electrotechnical Commission (IEC).
- The CE marking is located on each circuit breaker in accordance with the low voltage directive of the European Union.
- The entire QO circuit breaker family provides the advantage of a plug-on connection. (Bolt-on connections also available)

### Accessories

**Table 7.2: Accessories**

Accessory	Description	Cat. No.	QOXD
Handle Tie	Ties two 1P circuit breakers together	QO1HT	X
Handle Lock-Off (Clamp)	Attaches to 1P circuit breaker handles	QO1LO	X
	Attaches to 1P, 2P, 3P circuit breaker handles	HLO1	X
Handle Padlock Attachment	Attaches to 1P, 2P, 3P circuit breaker handles	QOEPLA	—
	Attaches to 1P circuit breaker handles	QOE1PL	—
	Attaches to 1P circuit breaker escutcheon (fixed)	QO1PA	X
	Attaches to 1P circuit breaker handles (removable)	QOHPL	X
	Attaches to 2P, 3P circuit breaker handles (removable)	QO1HPL	X
	Attaches to 2P circuit breaker handles (removable)	GFI2PA	—

### Circuit Breaker Operating Characteristics

**Table 7.3: Branch Circuit Breakers**

Cat. No. Prefix		Number of Poles	Continuous Ampere Rating	IEC 898 Service Rating I <sub>cn</sub>		Tripping Characteristics
Plug-on	Bolt-on			240 V	415 V	
QOXD	QOBXD	1, 2, 3	10–32 A	3000	3000	Type D (10–20 I <sub>n</sub> )
Cat. No. Prefix		Number of Poles	Continuous Ampere Rating	IEC 947-2 Service Rating I <sub>cu</sub> (I <sub>cs</sub> )		—
Plug-on	Bolt-on			240 V	415 V	
QOXD	QOBXD	1, 2, 3	10–32 A	3000 (100%)	3000 (100%)	—
		1	40–63 A	3000 (50%)	—	—
		2, 3	40–100 A	—	3000 (50%)	—

### Main Switches

**Table 7.4: QO-M Plug-On Main Incomer Switch**  
240 V Certified to IEC 947-3

Ampere Rating	1P Cat. No.	2P Cat. No.	3P and 4P Cat. No.
100 A	N/A	N/A	N/A
125 A	N/A	N/A	QO3100M
125 A–4P	N/A	N/A	QO4100M

### Plug-On QOXD and Bolt-On QOBXD

**Table 7.5: QOXD Thermal-Magnetic, Plug-On Miniature Circuit Breakers**  
240/415 V 10–32 A Certified to IEC 898 at 3 kA,  
40–100 A Certified to IEC 947-2 at 3 kA

Ampere Rating	1P		2P		3P		Terminal Capacity Range
	Cat. No.	Cat. No.	Cat. No.	Cat. No.	Cat. No.	Cat. No.	
10 A	QOXD110	QOXD210	QOXD310	QOXD310	QOXD310	QOXD310	2.5–6 mm <sup>2</sup>
16 A	QOXD116	QOXD216	QOXD316	QOXD316	QOXD316	QOXD316	2.5–6 mm <sup>2</sup>
20 A	QOXD120	QOXD220	QOXD320	QOXD320	QOXD320	QOXD320	2.5–6 mm <sup>2</sup>
25 A	QOXD125	QOXD225	QOXD325	QOXD325	QOXD325	QOXD325	2.5–6 mm <sup>2</sup>
32 A	QOXD132	QOXD232	QOXD332	QOXD332	QOXD332	QOXD332	2.5–6 mm <sup>2</sup>
40 A	QOXD140	QOXD240	QOXD340	QOXD340	QOXD340	QOXD340	10–25 mm <sup>2</sup>
45 A	QOXD145	QOXD245	QOXD345	QOXD345	QOXD345	QOXD345	10–25 mm <sup>2</sup>
50 A	QOXD150	QOXD250	QOXD350	QOXD350	QOXD350	QOXD350	10–25 mm <sup>2</sup>
63 A	QOXD163	QOXD263	QOXD363	QOXD363	QOXD363	QOXD363	10–25 mm <sup>2</sup>
80 A	N/A	QOXD280	QOXD380	QOXD380	QOXD380	QOXD380	25–50 mm <sup>2</sup>
100 A	N/A	QOXD2100	QOXD3100	QOXD3100	QOXD3100	QOXD3100	25–50 mm <sup>2</sup>

**Table 7.6: QOBXD Thermal-Magnetic, Bolt-On Miniature Circuit Breakers  
240/415 V 10–32 A Certified to IEC 898 at 3 kA,  
40–100 A Certified to IEC 947-2 at 3 kA**

Ampere Rating	1P	2P	3P	Terminal Capacity Range
	Cat. No.	Cat. No.	Cat. No.	
10 A	QOBXD110	QOBXD210	QOBXD310	2.5–6 mm <sup>2</sup>
16 A	QOBXD116	QOBXD216	QOBXD316	2.5–6 mm <sup>2</sup>
20 A	QOBXD120	QOBXD220	QOBXD320	2.5–6 mm <sup>2</sup>
25 A	QOBXD125	QOBXD225	QOBXD325	2.5–6 mm <sup>2</sup>
32 A	QOBXD132	QOBXD232	QOBXD332	2.5–6 mm <sup>2</sup>
40 A	QOBXD140	QOBXD240	QOBXD340	10–25 mm <sup>2</sup>
45 A	QOBXD145	QOBXD245	QOBXD345	1–25 mm <sup>2</sup>
50 A	QOBXD150	QOBXD250	QOBXD350	10–25 mm <sup>2</sup>
63 A	QOBXD163	QOBXD263	QOBXD363	10–25 mm <sup>2</sup>
80 A	N/A	QOBXD280	QOBXD380	25–50 mm <sup>2</sup>
100 A	N/A	QOBXD2100	QOBXD3100	25–50 mm <sup>2</sup>

For Accessories, see Table 7.2 Accessories, page 7-2  
For short circuit ratings, see Table 7.3 Branch Circuit Breakers, page 7-2

## IEC Certified QO™ Load Centers, Type 1 (Indoor)

### Application Data

Square D™ QO™ Three-Phase Circuit Breaker Load Centers can be certified to IEC 60439-1 and 60439-3. Contact your local Field Sales office for more information. They are designed to meet residential, commercial, and industrial requirements to protect electrical systems and equipment.

### Features

- Three phase construction
- 125, 150, 200 and 225 A mains ratings with main lugs or main circuit breaker
- 12-42 circuit indoor version
- Flush or surface mounting
- Straight-in wiring to minimize service cable installation
- Top or bottom feed
- Automatic flush adjustment cover to speed installation
- Covers sold separately
- Products are stocked in USA
- Bus on 12-42 circuit load centers is one piece; bus on 12–42 circuit load centers is a one-piece copper bus.
- Order entry point is Lexington
- For more information, contact your local Field Sales office.

**Table 7.7: Load Centers**

Mains Rating Ampere	Spaces/ Max. Poles	Type 1	
		Box and Interior Cat. No.	Cover With Door Cat. No. [1]
<b>Main Lugs 240/415 Vac 3Ø4W</b>			
125 A	12	QO312L125G	QOC16UF/S
	20	QO320L125G	QOC24UF/S
	24	QO324L125G	QOC24UF/S
200	18	QO318L200G	QOC30UF/S
	30	QO330L200G	QOC30UF/S
225	42	QO342L225G	QOC42UF/S
<b>Main Circuit Breaker 240/415 Vac 3Ø4W</b>			
125	30	QO330MQ125	QOC342MQF/S
150	30	QO330MQ150	QOC342MQF/S
	42	QO342MQ150	QOC342MQF/S
200	30	QO330MQ200	QOC342MQF/S
	42	QO342MQ200	QOC342MQF/S
225	42	QO342MQ225	QOC342MQF/S

[1] F/S at end of catalog number indicates to order F for flush device or S for surface device.

# Section 8

## International Safety Switches

<b>General Duty Safety Switches</b>	<b>8-2</b>
<hr/>	
CSA Certified General Duty—Fusible 240 Vac	8-2
<b>Heavy Duty Safety Switches</b>	<b>8-3</b>
<hr/>	
CSA Certified Heavy Duty—Fusible 240 Vac	8-3
CSA Certified Heavy Duty—Fusible 600 Vac	8-3
CSA Certified Heavy Duty—Special Applications	8-4
<b>Double-Throw Safety Switches</b>	<b>8-5</b>
<hr/>	
CSA Certified Double-Throw	8-5
CSA Certified Switch Accessories	8-6

**CSA Certified General Duty—Fusible 240 Vac**

- Switches have factory-installed ground bars.
- For optional accessories, see *CSA Certified Switch Accessories*, page 8-6.

**Table 8.1: General Duty Single-Throw 120/240 Vac (Plug); 240 Vac (Cartridge)**

Ampere	Fuse	Type 1	Type 3R	Field Installable Class R Fuse Kits
		Cat. No.	Cat. No.	Cat. No.
<b>2-Pole + S/N (2 Blades and Fuseholders, 1 S/N)—Suitable For Service Entrance Use</b>				
30	Plug	CD211N [1]	—	—
30	Cartridge	CD221N [1]	—	DRK30
60	—	CD222N	CD222NRB	RFK03H
100	—	CD223N	CD223NRB	RFK10
200	—	CD224N	CD224NRB	HRK1020
400	—	CD225N	CD225NR	DRK40
600	—	CD226N	CD226NR	DRK600
<b>3-Pole + S/N (3 Blades and Fuseholders, 1 S/N)—Suitable For Service Entrance Use</b>				
30	Cartridge	CD321N [1]	CD321NRB [1]	DRK30
60	—	CD322N	CD322NRB	RFK03H
100	—	CD323N	CD323NRB	RFK10
200	—	CD324N	CD324NRB	HRK1020
400	—	CD325N	CD325NR	DRK40
600	—	CD326N	CD326NR	DRK600

**Table 8.2: Light Duty Single-Throw 120 Vac Plug**

Ampere	Fuse	Type 1
		Cat. No.
30	Plug	L111N [2]

**NOTE:** For more information on International Safety Switches, please see: <http://www.schneider-electric.com/products/ca/en/80377-safety-switches/>.

[1] Not suitable for use as service entrance equipment.  
[2] Not suitable for use as service equipment.

**CSA Certified Heavy Duty—Fusible 240 Vac**

- Switches have factory-installed ground bars.
- Switches 30–200 A Type 4/4X and 3R/12 have viewing windows.
- For optional accessories, see [CSA Certified Switch Accessories](#), page 8-6.

**Table 8.3: Single-Throw 240 Vac, 250 Vdc**

Ampere	Type 1	Type 3R	Type 4/4X	Type 3R/12
	Cat. No.	Cat. No.	Cat. No.	Cat. No.
<b>2P + S/N (2 Blades and Fuseholders, 1 S/N)—Suitable For Service Entrance Use</b>				
30 A	CH221N	CH221NRB	Use 3P devices listed below.	CH221NAWK
60 A	CH222N	CH222NRB		CH222NAWK
100 A	CH223N	CH223NRB		CH223NAWK
200 A	CH224N	CH224NRB		CH224NAWK
400 A	CH225N	CH225NR		CH225NAWK
600 A	CH226N	CH226NR		CH226NAWK
800 A	H227N [1]	H227NR [1]	—	H227NAWK [1]
1200 A	H228N [1]	H228NR [1]	—	H228NAWK [1]
<b>3P + S/N (3 Blades and Fuseholders, 1 S/N)—Suitable For Service Entrance Use</b>				
30 A	CH321N	CH321NRB	CH321NDS	CH321NAWK
60 A	CH322N	CH322NRB	CH322NDS	CH322NAWK
100 A	CH323N	CH323NRB	CH323NDS	CH323NAWK
200 A	CH324N	CH324NRB	CH324NDS	CH324NAWK
400 A	CH325N	CH325NR	CH325NDS	CH325NAWK
600 A	CH326N	CH326NR	CH326NDS	CH326NAWK
800 A	H327N [1]	H327NR [1]	—	H327NAWK [1]
1200 A	H328N [1]	H328NR [1]	—	H328NAWK [1]

**NOTE:** For more information on International Safety Switches, please see: <http://www.schneider-electric.com/products/ca/en/80377-safety-switches/>.

**CSA Certified Heavy Duty—Fusible 600 Vac**

- Switches have factory-installed ground bars.
- Switches 30–200 A Type 4/4X and 3R/12 have viewing windows.
- For optional accessories, see [CSA Certified Switch Accessories](#), page 8-6.

**Table 8.4: Single-Throw 600 Vac, 600 Vdc**

Ampere	Type 1	Type 3R	Type 4/4X	Type 3R/12
	Cat. No.	Cat. No.	Cat. No.	Cat. No.
<b>3-Pole (3 Blades and Fuseholders)</b>				
30 A	CH361	CH361RB	CH361DS	CH361AWK
60 A	CH362	CH362RB	CH362DS	CH362AWK
100 A	CH363	CH363RB	CH363DS	CH363AWK
200 A	CH364	CH364RB	CH364DS	CH364AWK
400 A	CH365	CH365R	CH365DS	CH365AWK
600 A	CH366	CH366R	CH366DS	CH366AWK
800 A	H367 [1]	H367R [1]	—	H367AWK [1]
1200 A	H368 [1]	H368R [1]	—	H368AWK [1]
<b>3-Pole + S/N (3 Blades and Fuseholders, 1 S/N)—Suitable For Service Entrance Use</b>				
30 A	For 3 pole switches 30 A–1200 A with solid neutral attachment, select switch from 3-Pole table above and add the Solid Neutral Assembly Kit from Table 8.12 Solid Neutral Assembly Kits Not Stocked—Order Only., page 8-6			
60 A				
100 A				
200 A				
400 A				
600 A				
800 A				
1200 A				
<b>4-Pole (4 Blades and Fuseholders)—Not Suitable For Service Entrance Use</b>				
30 A	H461 [1]	—	H461DS	H461AWK [1] [2]
60 A	H462 [1]	—	H462DS	H462AWK [1] [2]
100 A	H463 [1]	—	H463DS	H463AWK [1] [2]
200 A	H464 [1]	—	H464DS	H464AWK [1] [2]
400 A	CH465	—	—	CH465AWK [2]
600 A	CH466	—	—	—

**NOTE:** For more information on International Safety Switches, please see: <http://www.schneider-electric.com/products/ca/en/80377-safety-switches/>.

[1] Dual UL Listed and CSA Certified device.  
[2] Type 3R/12 switches are suitable for Type 3R application by removing the drainscrew from bottom endwall.

**CSA Certified Heavy Duty—Special Applications**

- Switches have factory-installed ground bars.
- For optional accessories, see [CSA Certified Switch Accessories](#), page 8-6.

**Table 8.5: Fiberglass Reinforced Polyester NEMA 4X Enclosures  
Single-Throw 600 Vac, 600 Vdc**

Amperes	Type 4X	Type 7/9
	Cat. No.	Cat. No.
<b>3P Fusible</b>		
30 A	H361DF [3] [4]	—
60 A	H362DF [3] [4]	—
100 A	H363DF [3] [4]	—
200 A	H364DF [3]	—
<b>3P Non-Fusible</b>		
30 A	HU361DF [3] [4]	—
60 A	HU362DF [3] [4]	H60XFA [3]
100 A	HU363DF [3] [4]	H100XFA [3]
200 A	HU364DF [3]	—

**Table 8.6: Receptacle Switches with Crouse Hinds Receptacles—Single-Throw 600 Vac**

Ampere	Stainless Steel Type 4/4X [5]	Type 12 [5]	Use With Plug
	Cat. No.	Cat. No.	Cat. No.
<b>3P Fusible</b>			
30 A	CH361DSWC	CH361AWC	APJ3485
60 A	CH362DSWC	CH362AWC	APJ6485
100 A	CH363DSWC	CH363AWC	APJ10487
<b>3P Non-Fusible</b>			
30 A	CHU361DSWC	CHU361AWC	APJ3485
60 A	CHU362DSWC	CHU362AWC	APJ6485
100 A	CHU363DSWC	CHU363AWC	APJ10487

**NOTE:** For more information on International Safety Switches, please see: <http://www.schneider-electric.com/products/ca/en/80377-safety-switches/>.

**Table 8.7: Single-Throw 600 Vac, 600 Vdc**

Ampere	Type 1	Type 3R	Type 4/4X	Type 3R/12
	Cat. No.	Cat. No.	Cat. No.	Cat. No.
<b>3P</b>				
30 A	CHU361	CHU361RB	CHU361DS	CHU361AWK
60 A	CHU362	CHU362RB	CHU362DS	CHU362AWK
100 A	CHU363	CHU363RB	CHU363DS	CHU363AWK
200 A	CHU364	CHU364RB	CHU364DS	CHU364AWK
400 A	CHU365	CHU365RB	CHU365DS	CHU365AWK
600 A	CHU366	CHU366R	CHU366DS	CHU366AWK
800 A	HU367 [6]	HU367R [3]	—	HU367AWK [6]
1200 A	HU368 [6]	HU368R [6]	—	HU368AWK [6]
<b>4P, 600 Vac, 600 Vdc</b>				
30 A	HU461 [3] [4]	—	—	HU461AWK [3] [4]
60 A	HU462 [3] [4]	—	—	HU462AWK [3] [4]
100 A	HU463 [3] [4]	—	—	HU463AWK [3] [4]
200 A	HU464 [6]	—	—	HU464AWK
400 A	CHU465	—	—	CHU465AWK
600 A	CHU466	—	—	CHU466AWK
<b>6P, 600 Vac</b>				
30 A	—	—	—	HU661AWK [6]
60 A	—	—	—	HU662AWK [3]
100 A	—	—	—	HU663AWK [6]
200 A	—	—	—	HU664AWK

**NOTE:** For more information on International Safety Switches, please see: <http://www.schneider-electric.com/products/ca/en/80377-safety-switches/>.

[3] Dual UL Listed and CSA Listed device.  
 [4] F Series devices.  
 [5] Supplied with viewing window.  
 [6] Dual UL Listed and CSA Listed device.

**CSA Certified Double-Throw**

- Switches have factory-installed ground bars.
- For optional accessories, see [CSA Certified Switch Accessories](#), page 8-6.

**Table 8.8: Double-Throw**

Ampere	Type 1	Type 3R	Type 4/4X	Type 12
	Cat. No.	Cat. No.	Cat. No.	Cat. No.
<b>2P 240 Vac—250 Vdc</b>				
30 A	C92251	—	—	—
60 A	For 2P switch applications, select 3P switch 60–600 A from 3P table below.			
100 A				
200 A				
400 A				
<b>3P 600 Vac—250 Vdc</b>				
30 A	C92351 [1]	—	—	—
60 A	For 60–100 A, use US devices.			
100 A				
200 A	C82344 [2]	C82344RB [2]	C82344DS [2]	CH82344 [2]
<b>4P 240 Vac</b>				
30 A	C92451 [1]	—	—	—
60 A	DTU462 [3]	DTU462AWK [3]	DTU462DS [3]	DTU462AWK [3]
100 A	DTU463 [3]	DTU463AWK [3]	DTU463DS [3]	DTU463AWK [3]

**NOTE:** For more information on International Safety Switches, please see: <http://www.schneider-electric.com/products/ca/en/80377-safety-switches/>.

[1] 240 Vac Maximum  
 [2] For isolation only, not Load-Make/Load-Break.  
 [3] 600 Vac rated.

**CSA Certified Switch Accessories**  
Optional Accessories

**Table 8.9: Electrical Interlock Kits**

Ampere	Single-Throw	Double-Throw Type 1 Only
	Cat. No.	Cat. No.
30–100 A	EIK-1 or -2	EIK-1 or -2 [4]
200 A-3P	EIK-1 or -2 [5]	EK200DTU2
200 A-4P	EIK-1 or -2 [5]	EK100DTU2
400 A	EIK4060-1 or -2	EK400DTU2
600 A	EIK4060-1 or -2	—
800 A	EIK4060-1 or -2	—
1200 A	EIK4060-1 or -2	—

**Table 8.10: Fuse Puller Kits [6]**

Ampere	Cat. No.
30 A	FPK03
60 A	FPK0610
100 A	FPK0610

**Table 8.11: Class R Fuse Kits**

Voltage	Ampere	Cat. No.
240 Vac	30 A	RFK03L
	60 A	RFK03H
	100 A	RFK10
	200 A	HRK1020
	400 A	HRK4060
	600 A	HRK4060
600 Vac	30 A	RFK03H
	60 A	RFK06H
	100 A	RFK10
	200 A	HRK1020
	400 A	HRK4060
	600 A	HRK4060

**Table 8.12: Solid Neutral Assembly Kits [6][7]**

Ampere	Single-Throw Type 1, 3R	Single-Throw (Copper) Type 4, 4X	Double-Throw Type 1
	Cat. No.	Cat. No.	Cat. No.
30 A	CSN03	CSN03C	SN0310 [8]
60 A	CSN0610	CSN0610C	SN0310
100 A	CSN0610	CSN0610C	SN0310
200 A	CSN20	CSN20C	225SNA
400 A	CH600SN	CH600SNC	DT400N
600 A	CH600SN	CH600SNC	—
800 A	H800SNE4	—	—
1200 A	H1200SNE4	—	—

**Table 8.13: Hubs**

Size	Type 3R	Type 4/4X/12	
		Standard Zinc	Chrome Plated Zinc
Inches	Cat. No.	Cat. No.	Cat. No.
0.50	—	H050	H050CP
0.75	B075	H075	H075CP
1.00	B100	H100	H100CP
1.25	B125	H125	H125CP
1.50	B150	H150	H150CP
2.00	B200	H200	H200CP
2.50	B250	H250	—
3.00	B300	H300	—
3.50	B350	H350	—
4.00	B400	H400	—
CAP	BCAP	—	—

**NOTE:** For more information on International Safety Switches, please see: <http://www.schneider-electric.com/products/ca/en/80377-safety-switches/>.

[4] Not for C92251, C92351, C92451.

[5] E-series uses EK1020-1 or -2. Requires 2.

[6] Not Stocked—Order Only.

[7] Non-fusible 600 V switches do not come with Neutral factory-installed. The solid neutral kit must be ordered separately.

[8] C92251, C92351, C92451 uses DT30SN.

# Section 9

## International Circuit Breakers

<b>Thermal-Magnetic Circuit Breakers</b>	<b>9-2</b>
SF and SL Circuit Breakers, IEC Rated 415/240 Vac Max.	9-2
<b>Electronic Trip Circuit Breakers</b>	<b>9-3</b>
P-frame, 3P, MicroLogic™ Electronic-Trip Unit, IEC Rated	9-3
R-frame, 3P, MicroLogic™ Electronic-Trip Unit, IEC Rated	9-4
P-frame, 4P, MicroLogic™ Electronic-Trip Unit, IEC Rated	9-5
R-frame, 4P, MicroLogic™ Electronic-Trip Unit, IEC Rated	9-6
<b>Breaking Capacities</b>	<b>9-7</b>
<b>Circuit Breaker Dimensions</b>	<b>9-8</b>

### SL Individually Mounted Circuit Breakers

- CE marking.
- S-frame circuit breakers are CCC Certified.
- International products—for export use only.
- MCCBs in I-Line™ plug-on construction and a complete line of accessories are available. Contact your local Field Sales office.
- Order entry point is Cedar Rapids, Iowa.

**Table 9.1: SLAL Individually-Mounted, IEC Rated Circuit Breakers, 415/240 Vac Max., 50/60 Hz, 2P and 3P**

Frame Size	Circuit Breaker Type	Ampere Rating	Cat. No.	
			2P	3P
400 A	SLAL [1]	250 A	SLAL2250	SLAL3250
		300 A	SLAL2300	SLAL3300
		350 A	SLAL2350	SLAL3350
		400 A	SLAL2400	SLAL3400

[1] Add suffix K for CCC label



**P-frame, 3P, MicroLogic Electronic-Trip Unit, IEC Rated**

**Table 9.2: P-frame—1600 A, Individually-Mounted, MicroLogic Electronic Trip Unit, IEC Rated**

Sensor Rating	Cat. No.			Terminal Wire Range (AWG–kcmil)
	N Interrupting [1]	H Interrupting [1]	L Interrupting [1]	
<b>3P, 690 Vac 50/60 Hz with LS0 Trip Functions</b>				
630 A	NPNLE36063U32R	NPHLE36063U32R	NPLLE34063U32R	(4) 3/0–500 Al/Cu
800 A	NPNLE36080U32R	NPHLE36080U32R	NPLLE34080U32R	
1000 A	NPNLE36100U32R	NPHLE36100U32R	NPLLE34100U32R	
1250 A	NPNLE36125U32R	NPHLE36125U32R	—	
1600 A	NPNLE36160U32R	NPHLE36160U32R	—	
<b>3P, 690 Vac 50/60 Hz with LSI Trip Functions</b>				
630 A	NPNLE36063U33R	NPHLE36063U33R	NPLLE34063U33R	(4) 3/0–500 Al/Cu
800 A	NPNLE36080U33R	NPHLE36080U33R	NPLLE34080U33R	
1000 A	NPNLE36100U33R	NPHLE36100U33R	NPLLE34100U33R	
1250A	NPNLE36125U33R	NPHLE36125U33R	—	
1600A	NPNLE36160U33R	NPHLE36160U33R	—	
<b>MicroLogic Ammeter Trip Unit</b>				
<b>3P, 690 Vac 50/60 Hz with LS0 Trip Functions</b>				
630 A	NPNLE36063U42R	NPHLE36063U42R	NPLLE34063U42R	(4) 3/0–500 Al/Cu
800 A	NPNLE36080U42R	NPHLE36080U42R	NPLLE34080U42R	
1000 A	NPNLE36100U42R	NPHLE36100U42R	NPLLE34100U42R	
1250 A	NPNLE36125U42R	NPHLE36125U42R	—	
1600 A	NPNLE36160U42R	NPHLE36160U42R	—	
<b>3P, 690 Vac 50/60 Hz with LSI Trip Functions</b>				
630 A	NPNLE36063U43R	NPHLE36063U43R	NPLLE34063U43R	(4) 3/0–500 Al/Cu
800 A	NPNLE36080U43R	NPHLE36080U43R	NPLLE34080U43R	
1000 A	NPNLE36100U43R	NPHLE36100U43R	NPLLE34100U43R	
1250 A	NPNLE36125U43R	NPHLE36125U43R	—	
1600 A	NPNLE36160U43R	NPHLE36160U43R	—	
<b>3P, 690 Vac 50/60 Hz with LSIg Trip Functions</b>				
630 A	NPNLE36063U44R	NPHLE36063U44R	NPLLE34063U44R	(4) 3/0–500 Al/Cu
800 A	NPNLE36080U44R	NPHLE36080U44R	NPLLE34080U44R	
1000 A	NPNLE36100U44R	NPHLE36100U44R	NPLLE34100U44R	
1250 A	NPNLE36125U44R	NPHLE36125U44R	—	
1600 A	NPNLE36160U44R	NPHLE36160U44R	—	
<b>MicroLogic Power Trip Unit</b>				
<b>3P, 690 Vac 50/60 Hz with LSI Trip Functions</b>				
630 A	NPNLE36063U63RE1	NPHLE36063U63RE1	NPLLE34063U63RE1	(4) 3/0–500 Al/Cu
800 A	NPNLE36080U63RE1	NPHLE36080U63RE1	NPLLE34080U63RE1	
1000 A	NPNLE36100U63RE1	NPHLE36100U63RE1	NPLLE34100U63RE1	
1250 A	NPNLE36125U63RE1	NPHLE36125U63RE1	—	
1600 A	NPNLE36160U63RE1	NPHLE36160U63RE1	—	
<b>3P, 690 Vac 50/60 Hz with LSIg Trip Functions</b>				
630 A	NPNLE36063U64RE1	NPHLE36063U64RE1	NPLLE34063U64RE1	(4) 3/0–500 Al/Cu
800 A	NPNLE36080U64RE1	NPHLE36080U64RE1	NPLLE34080U64RE1	
1000 A	NPNLE36100U64RE1	NPHLE36100U64RE1	NPLLE34100U64RE1	
1250 A	NPNLE36125U64RE1	NPHLE36125U64RE1	—	
1600 A	NPNLE36160U64RE1	NPHLE36160U64RE1	—	

**NOTE:** See Digest for accessories and other information.

**Table 9.3: Interrupting Ratings**

	N		H		L	
	Icu	Ics (%Icu)	Icu	Ics (%Icu)	Icu	Ics (%Icu)
220/240 V	50 kA	75%	70 kA	50%	150 kA	100%
380/415 V	50 kA		70 kA		150 kA	
440 V	50 kA		65 kA		130 kA	
500/525 V	40 kA		50 kA		100 kA	
660/690 V	30 kA		42 kA		25 kA	

[1] New for P frame IEC only.



R-frame, 3P, MicroLogic™ Electronic-Trip Unit, IEC Rated

Table 9.4: R-frame—3200 A, Individually-Mounted, MicroLogic Electronic Trip Unit, IEC Rated

Sensor Rating	Cat. No.	
	N Interrupting	H Interrupting
<b>3P, 690 Vac 50/60 Hz with LS0 Trip Functions</b>		
1600 A	RNFE36160U32R	RHFE34160U32R
2000 A	RNFE36200U32R	RHFE34200U32R
2500 A	RNFE36250U32R	RHFE34250U32R
3200 A	RNFE36320U32R	RHFE34320U32R
<b>3P, 690 Vac 50/60 Hz with LSI Trip Functions</b>		
1600 A	RNFE36160U33R	RHFE34160U33R
2000 A	RNFE36200U33R	RHFE34200U33R
2500 A	RNFE36250U33R	RHFE34250U33R
3200 A	RNFE36320U33R	RHFE34320U33R
<b>MicroLogic Ammeter Trip Unit</b>		
<b>3P, 690 Vac 50/60 Hz with LS0 Trip Functions</b>		
1600 A	RNFE36160U42R	RHFE34160U42R
2000 A	RNFE36200U42R	RHFE34200U42R
2500 A	RNFE36250U42R	RHFE34250U42R
3200 A	RNFE36320U42R	RHFE34320U42R
<b>3P, 690 Vac 50/60 Hz with LSI Trip Functions</b>		
1600 A	RNFE36160U43R	RHFE34160U43R
2000 A	RNFE36200U43R	RHFE34300U43R
2500 A	RNFE36250U43R	RHFE34350U43R
3200 A	RNFE36320U43R	RHFE34320U43R
<b>3P, 690 Vac 50/60 Hz with LSIG Trip Functions</b>		
1600 A	RNFE36160U44R	RHFE34160U44R
2000 A	RNFE36200U44R	RHFE34200U44R
2500 A	RNFE36250U44R	RHFE34250U44R
3200 A	RNFE36320U44R	RHFE34320U44R
<b>MicroLogic Power Trip Unit</b>		
<b>3P, 690 Vac 50/60 Hz with LSI Trip Functions</b>		
1600 A	RNFE36160U63RE1	RHFE34160U63RE1
2000 A	RNFE36200U63RE1	RHFE34200U63RE1
2500 A	RNFE36250U63RE1	RHFE34250U63RE1
3200 A	RNFE36320U63RE1	RHFE34320U63RE1
<b>3P, 690 Vac 50/60 Hz with LSIG Trip Functions</b>		
1600 A	RNFE36160U64RE1	RHFE34160U64RE1
2000 A	RNFE36200U64RE1	RHFE34200U64RE1
2500 A	RNFE36250U64RE1	RHFE34250U64RE1
3200 A	RNFE36320U64RE1	RHFE34320U64RE1

NOTE: See Digest for accessories and other information.

Table 9.5: Interrupting Ratings

	N		H	
	Icu	Ics	Icu	Ics (%Icu)
220/240 V	85 kA	75%	125 kA	75%
380/415 V	70 kA		85 kA	
440 V	65 kA		85 kA	
500/525 V	65 kA	100%	—	
660/690 V	65 kA	—	—	



**P-frame, 4P, MicroLogic™ Electronic-Trip Unit, IEC Rated**

**Table 9.6: P-frame—1600 A, Individually-Mounted, MicroLogic Electronic Trip Unit, IEC Rated**

Sensor Rating	Cat. No.			Terminal Wire Range (AWG—kcmil)
	N Interrupting [2]	H Interrupting [2]	L Interrupting [2]	
<b>4P, 690 Vac 50/60 Hz with LS0 Trip Functions</b>				
630 A	NPNLE46063U32R	NPHLE46063U32R	NPLLE44063U32R	(4) 3/0–500 Al/Cu
800 A	NPNLE46080U32R	NPHLE46080U32R	NPLLE44080U32R	
1000 A	NPNLE46100U32R	NPHLE46100U32R	NPLLE44100U32R	
1250 A	NPNLE46125U32R	NPHLE46125U32R	—	
1600 A	NPNLE46160U32R	NPHLE46160U32R	—	
<b>4P, 690 Vac 50/60 Hz with LSI Trip Functions</b>				
630 A	NPNLE46063U33R	NPHLE46063U33R	NPLLE44063U33R	(4) 3/0–500 Al/Cu
800 A	NPNLE46080U33R	NPHLE46080U33R	NPLLE44080U33R	
1000 A	NPNLE46100U33R	NPHLE46100U33R	NPLLE44100U33R	
1250 A	NPNLE46125U33R	NPHLE46125U33R	—	
1600 A	NPNLE46160U33R	NPHLE46160U33R	—	
<b>MicroLogic Ammeter Trip Unit</b>				
<b>4P, 690 Vac 50/60 Hz with LS0 Trip Functions</b>				
630 A	NPNLE46063U42R	NPHLE46063U42R	NPLLE44063U42R	(4) 3/0–500 Al/Cu
800 A	NPNLE46080U42R	NPHLE46080U42R	NPLLE44080U42R	
1000 A	NPNLE46100U42R	NPHLE46100U42R	NPLLE44100U42R	
1250 A	NPNLE46125U42R	NPHLE46125U42R	—	
1600 A	NPNLE46160U42R	NPHLE46160U42R	—	
<b>4P, 690 Vac 50/60 Hz with LSI Trip Functions</b>				
630 A	NPNLE46063U43R	NPHLE46063U43R	NPLLE44063U43R	(4) 3/0–500 Al/Cu
800 A	NPNLE46080U43R	NPHLE46080U43R	NPLLE44080U43R	
1000 A	NPNLE46100U43R	NPHLE46100U43R	NPLLE44100U43R	
1250 A	NPNLE46125U43R	NPHLE46125U43R	—	
1600 A	NPNLE46160U43R	NPHLE46160U43R	—	
<b>4P, 690 Vac 50/60 Hz with LSIG Trip Functions</b>				
630 A	NPNLE46063U44R	NPHLE46063U44R	NPLLE44063U44R	(4) 3/0–500 Al/Cu
800 A	NPNLE46080U44R	NPHLE46080U44R	NPLLE44080U44R	
1000 A	NPNLE46100U44R	NPHLE46100U44R	NPLLE44100U44R	
1250 A	NPNLE46125U44R	NPHLE46125U44R	—	
1600 A	NPNLE46160U44R	NPHLE46160U44R	—	
<b>MicroLogic Power Trip Unit</b>				
<b>4P, 690 Vac 50/60 Hz with LSI Trip Functions</b>				
630 A	NPNLE46063U63RE1	NPHLE46063U63RE1	NPLLE44063U63RE1	(4) 3/0–500 Al/Cu
800 A	NPNLE46080U63RE1	NPHLE46080U63RE1	NPLLE44080U63RE1	
1000 A	NPNLE46100U63RE1	NPHLE46100U63RE1	NPLLE44100U63RE1	
1250 A	NPNLE46125U63RE1	NPHLE46125U63RE1	—	
1600 A	NPNLE46160U63RE1	NPHLE46160U63RE1	—	
<b>4P, 690 Vac 50/60 Hz with LSIG Trip Functions</b>				
630 A	NPNLE46063U64RE1	NPHLE46063U64RE1	NPLLE44063U64RE1	(4) 3/0–500 Al/Cu
800 A	NPNLE46080U64RE1	NPHLE46080U64RE1	NPLLE44080U64RE1	
1000 A	NPNLE46100U64RE1	NPHLE46100U64RE1	NPLLE44100U64RE1	
1250 A	NPNLE46125U64RE1	NPHLE46125U64RE1	—	
1600 A	NPNLE46160U64RE1	NPHLE46160U64RE1	—	

**NOTE:** See Digest for accessories and other information.

**Table 9.7: Interrupting Ratings**

	N		H		L	
	Icu	Ics (%Icu)	Icu	Ics (%Icu)	Icu	Ics (%Icu)
220/240 V	50 kA	75%	70 kA	50%	150 kA	100%
380/415 V	50 kA		70 kA		150 kA	
440 V	50 kA		65 kA		130 kA	
500/525 V	40 kA		50 kA		100 kA	
660/690 V	30 kA		42 kA		25 kA	

[2] New for P frame IEC only.

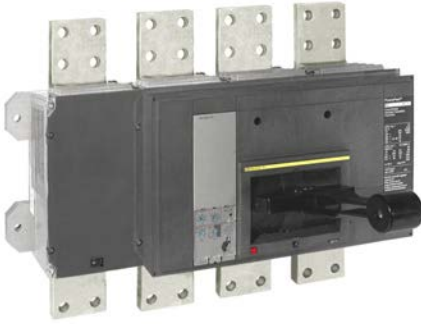

**R-frame, 4P, MicroLogic Electronic-Trip Unit, IEC Rated**

**Table 9.8: R-frame—3200 A, Individually-Mounted, MicroLogic Electronic Trip Unit, IEC Rated**

Sensor Rating	Cat. No.	
	N Interrupting	H Interrupting
<b>4P, 690 Vac 50/60 Hz with LS0 Trip Functions</b>		
1600 A	RNFE46160U32R	RHFE44160U32R
2000 A	RNFE46200U32R	RHFE44200U32R
2500 A	RNFE46250U32R	RHFE44250U32R
3200 A	RNFE46320U32R	RHFE44320U32R
<b>4P, 690 Vac 50/60 Hz with LSI Trip Functions</b>		
1600 A	RNFE46160U33R	RHFE44160U33R
2000 A	RNFE46200U33R	RHFE44200U33R
2500 A	RNFE46250U33R	RHFE44250U33R
3200 A	RNFE46320U33R	RHFE44320U33R
<b>MicroLogic Ammeter Trip Unit</b>		
<b>4P, 690 Vac 50/60 Hz with LS0 Trip Functions</b>		
1600 A	RNFE46160U42R	RHFE44160U42R
2000 A	RNFE46200U42R	RHFE44200U42R
2500 A	RNFE46250U42R	RHFE44250U42R
3200 A	RNFE46320U42R	RHFE44320U42R
<b>4P, 690 Vac 50/60 Hz with LSI Trip Functions</b>		
1600 A	RNFE46160U43R	RHFE44160U43R
2000 A	RNFE46200U43R	RHFE44300U43R
2500 A	RNFE46250U43R	RHFE44350U43R
3200 A	RNFE46320U43R	RHFE44320U43R
<b>4P, 690 Vac 50/60 Hz with LSIG Trip Functions</b>		
1600 A	RNFE46160U44R	RHFE44160U44R
2000 A	RNFE46200U44R	RHFE44200U44R
2500 A	RNFE46250U44R	RHFE44250U44R
3200 A	RNFE46320U44R	RHFE44320U44R
<b>MicroLogic Power Trip Unit</b>		
<b>4P, 690 Vac 50/60 Hz with LSI Trip Functions</b>		
1600 A	RNFE46160U63RE1	RHFE44160U63RE1
2000 A	RNFE46200U63RE1	RHFE44200U63RE1
2500 A	RNFE46250U63RE1	RHFE44250U63RE1
3200 A	RNFE46320U63RE1	RHFE44320U63RE1
<b>4P, 690 Vac 50/60 Hz with LSIG Trip Functions</b>		
1600 A	RNFE46160U64RE1	RHFE44160U64RE1
2000 A	RNFE46200U64RE1	RHFE44200U64RE1
2500 A	RNFE46250U64RE1	RHFE44250U64RE1
3200 A	RNFE46320U64RE1	RHFE44320U64RE1

**NOTE:** See Digest for accessories and other information.

**Table 9.9: Interrupting Ratings**

	N		H	
	Icu	Ics	Icu	Ics (%Icu)
220/240 V	85 kA	75%	125 kA	75%
380/415 V	70 kA		85 kA	
440 V	65 kA		85 kA	
500/525 V	65 kA	—		
660/690 V	65 kA	100%	—	

**Breaking Capacities**

- CE Marking
- International products—IEC 60947-2 rated. North American products are dual rated, UL 489 and IEC 60947-2.
- MCCBs in I-Line™ plug-on construction and a complete line of accessories are available. Contact your nearest Field Sales office.
- Order entry point is Cedar Rapids, Iowa.

**Table 9.10: Circuit Breaker Breaking Capacities**

Circuit Breaker Cat. Prefix		Current Rating (Amps)	Short-circuit Ratings (415 Vac)			Isolator Rating	Impulse Rating $U_{imp}$ (kV)	Insulation Rating $U_i$ (Vac)
International	North America		Ultimate $I_{cu}$	Service $I_{cs}$	Withstand $I_{cw}$			
—	QB [1]	70–250 A [2]	10 kA	5 kA	N/A	Yes	6	750
—	LA	125–400 A	20 kA	5 kA	N/A	Yes	6	750
SLA	—	250–400 A	36 kA	18 kA	N/A	Yes	6	750
—	LH	125–400 A	20 kA	5 kA	N/A	Yes	6	750
—	PG	250–1200 A	35 kA	17.5 kA	25 kA	Yes	6	750
	PJ		50 kA	25 kA	10 kA			
	PL		85 kA	42.5 kA	10 kA			
	PK		50 kA	25 kA	25 kA			
—	RG	600–2500 A	35 kA	17.5 kA	32 kA	Yes	6	750
	RJ		50 kA	25 kA	32 kA			
	RL		85 kA	42.5 kA	32 kA			
	RK		70 kA	52.5 kA	32 kA			
—	PA	600–2000 A	50 kA	38 kA	N/A	No	6	750
—	PC, PH	600–2500 A	70 kA	53 kA	N/A	No	6	750
PE, PX	PE, PX	600–2500 A	70 kA	53 kA	12.5	No	6	750

[1] IEC rating 415Y/240 Vac; NEMA/UL rating 240 Vac.  
 [2] 250 A lugs are suitable for copper conductors only.

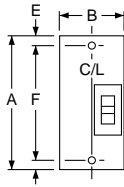

Figure 2

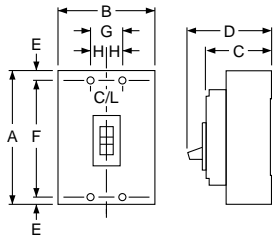

Figure 3

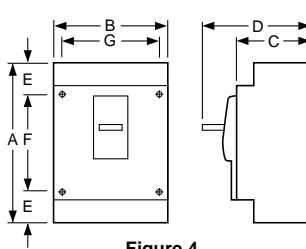

Figure 4

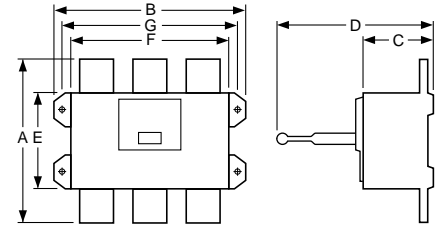

Figure 5

**Dimensions**

- CE Marking
- International products—IEC 60947-2 rated. North American products are dual rated, UL 489 and IEC 60947-2.
- MCCBs in I-Line™ plug-on construction and a complete line of accessories are available. Contact your nearest Field Sales office.
- Order entry point is Cedar Rapids, Iowa.

**Table 9.11: Dimensions**

Circuit Breaker	No. Poles	Fig. No.	Dimensions – mm							
			A	B	C	D	E	F	G	H
SLA/LA, LH	3	1	279	152	103	148	22	235	51	25
QB	2	2	164	76	77	100	[1]	108		—
	3	3	164	114	77	100	[1]	108	38	19
PG, PJ, PL	2, 3	4	414	210	140	204	106	200	200	—
RG, RJ, RL	2, 3	5	381	420	160	365	222	362	390	—

[1] Dimensions E are 40 mm at ON end and 16 mm at OFF end.

# Section 10

## International Panelboards



NQX Panelboard

<b>NQX Panelboards</b>	<b>10-2</b>
Factory Assembled Circuit Breaker Panelboard	10-2
Factory Assembled NQX Circuit Breaker Panelboards	10-2

**Factory Assembled NQX Circuit Breaker Panelboards**

NOTE: For export application only. Not UL Listed

**Table 10.1: Panelboard Information**

<b>Service</b>	1Ø3W 110/220, 127/220, 115/230/ Vac 50 Hz, 60 Hz 3Ø4W 220/110, 220/127, 230/115, 380/220, 415Y/240, 400/230 Vac 50 Hz, 60 Hz
<b>Branches</b>	Plug-on QOXD and Bolt-on QOBXD 10–100 A QOXD and QOBXD 1-, 2-, and 3-pole (3000 AIR)
<b>Boxes</b>	Galvanized steel with removable endwalls with knockouts on one end. Two sizes: • NQB — 14 in. W x 5.75 in. D — 225 A interior maximum (availability to be announced) • MH — 20 in. W x 5.75 in. D — 600 A main lug interior maximum
<b>Fronts</b>	<ul style="list-style-type: none"> <li>• Gray baked enamel finish (ANSI49)</li> <li>• Door with flush lock</li> <li>• Mono-Flat™ fronts on 100–225 A. Front mounts to the interior with trim screws. (Both trim screws and door hinges are concealed.)</li> <li>• Fronts for 400A–600 A interiors are louvered and mount to the enclosure with trim screws. (Door hinges are concealed.)</li> </ul>
<b>Common Features</b>	Sub-Feed Lugs, Sub-Feed Circuit Breaker, Split Bus, Feed-Through Lugs
<b>Bus Bars</b>	<ul style="list-style-type: none"> <li>• Aluminum bus, standard — 100 A, 225 A, and 400 A interiors</li> <li>• Copper bus, optional — 100 A, 225 A, and 400 A interiors</li> <li>• Copper bus, standard — 600 A interiors</li> </ul>
<b>Neutrals</b>	<ul style="list-style-type: none"> <li>• 100% Aluminum neutral, standard</li> <li>• 100% Copper neutral, optional</li> <li>• 200% Neutral, optional</li> </ul>
<b>Enclosures</b>	<ul style="list-style-type: none"> <li>• Type 1, standard</li> <li>• Type 3R, 5, and 12, optional</li> <li>• Type 3R, 4, 4X, and 12 Stainless Steel, optional</li> </ul> <p>NOTE: Price factory assembled NQX panelboard in the Quote to Cash Product Selector. Select "NQ" panelboard, then select the appropriate "International Voltage".</p>
<b>Order Point</b>	Peru, IN

**Table 10.2: Mains**

Mains Rating	Main Lugs	Main Circuit Breaker
70 A	—	QOBXD [1], QB, HD
100 A	Yes	QOBXD [1], QB, HD
150 A	—	QB, HD
225 A	Yes	QB
250 A	—	JD
400 A	Yes	LA
600 A	Yes	—

**Table 10.3: Distributed Phase Bussing**

	Main Lugs		Main Circuit Breaker	
100 A	(1) #6-2/0 Al or Cu	100 A	QOXD/QOBXD	(1) #4-2/0 Al or Cu
225 A	(1) #6-350 kcmil Al or Cu	150 A	HD	(1) #14-3/0 Al or Cu
400 A	(1) 1/0-750 kcmil, or	225 A	QB	(1) #4-300 kcmil Al or Cu, or
	(2) 1/0-350 kcmil Al or Cu		JD	(1) #3/0-350 kcmil Al or Cu
600 A	(2) 1/0-750 kcmil Al or Cu	250 A	JD	(1) #3/0-350 kcmil Al or Cu
			400 A	LA

[1] Available at 240 Vac maximum.

## Section 11

## Obsolescent and Obsolete Circuit Breakers

<b>Obsolescent and Obsolete Types</b>	<b>11-2</b>
Circuit Breaker Availability	11-2
Pictorial and Dimensions	11-4
<b>Obsolescent Circuit Breakers</b>	<b>11-6</b>
Thermal-Magnetic Circuit Breakers	11-6
SF Circuit Breakers	11-6
Breaking Capacities	11-6
SF Circuit Breaker Dimensions	11-6
Photovoltaic Accessories	11-7
F-Frame Circuit Breakers Ending Production in 2018–2019	11-8
F-Frame Molded Case Circuit Breakers	11-8
F-Frame I-Line Circuit Breakers	11-9
Mag-Gard™ Motor Circuit Protector	11-10
Mag-Gard™ Motor Circuit Protector	11-10
GJL MCP Selection	11-10
GJL MCP Selection Table	11-11
<b>Circuit Breaker Accessories</b>	<b>11-11</b>
PowerPact™ Circuit Breakers Miscellaneous Accessories	11-11
Neutral CTs and MicroLogic™ Series B Trip Unit Accessories	11-12
Factory-Installed Accessories	11-12
Field-Installable Accessories	11-13
Electrical Operators and Handle Accessories	11-15
Lug Information	11-16
<b>Electronic Products</b>	<b>11-19</b>
MicroLogic™ Series 2/3/A/B Trip Unit Test Sets	11-19
<b>Ground-Fault Protection</b>	<b>11-20</b>
MicroLogic™ Add-On Ground-Fault Module (GFM)	11-20
<b>Obsolescent Circuit Breakers</b>	<b>11-20</b>
MasterPact™ M/MP/MC Circuit Breaker Control Units	11-21
MasterPact™ M/MP/MC Circuit Breaker Accessories	11-21
MasterPact™ M/MP/MC Circuit Breaker Spare Parts	11-22
<b>Enclosures</b>	<b>11-23</b>

Circuit Breaker Availability

Table 11.1: Circuit Breaker Availability

Series of Cat. No.	Frame Size	Volts	Poles	Amperes	Availability	
					Obsolete No Longer Available	Obsolescent
115A-130A	MO-1 (Add-on)	120 Vac	1	15-30	X	
215A-250A	MO-2 (Add-on)	120/240 Vac	2	15-50	X	
215B-250B	MO-2B (Add-on)	120/240 Vac	2 S.P.	15-50	X	
70000	Multi-Breaker	120 Vac	4 S.P.	15-50	X	
111600	MO-2	120/240 Vac	2	15-30	X	
131600	MO-2	120/240 Vac	2	15-30	X	
151101	MO-1	120 Vac	1	15-30	X	
151600	MO-2	120/240 Vac	2	15-30	X	
161101	MO-1	120 Vac	1 With SN	15-30	X	
161600	MO-2	120/240 Vac	2 With SN	15-30	X	
161700	MO-2	120/240 Vac	2 S.P.	15-30	X	
260000	MB (Left-hand)	120 Vac	4 S.P.	15-50	X	
270000	MB (Right-hand)	120 Vac	4 S.P.	15-50	X	
460000	MO-8	120/240 Vac	4 S.P.	15-50	X	
470000	MO-4	120/240 Vac	4 S.P.	15-40	X	
480000	MO-4 (Plug-in)	120/240 Vac	4 S.P.	15-50	X	
940000	LM	600 Vac	2-3	125-800	X	
950000	50 A Form W	250 Vac	1, 2, 3	15-50	X	
951000	50 A Form W	250 Vac	2, 3	15-50	X	
952000	50 A Form W	250 Vac	2, 3	15-50	X	
953000	Flip-on Form W	230 Vac	1, 2, 3	15-50	X	
954000	100 A Form W (Trip Unit)	250 Vac	2, 3	50-100	X	
955000	100 A Form W	250 Vac	2, 3	50-100	X	
956000	225 A Form W	250 Vac	2, 3	70-225	X	
957000	400 A (KL) Form W	250 Vac	2, 3	125-400	X	
958000	600 A (WL) Form W	250 Vac	2, 3	225-600	X	
959000	KL Frame Only	600 Vac	2, 3	125-400	X	
961000	50 A Form W	600 Vac	2, 3	15-50	X	
962000	50 A Form W	600 Vac	2, 3	15-50	X	
964000	100 A Form W	600 Vac	2, 3	50-100	X	
965000	100 A Form W	600 Vac	2, 3	50-100	X	
966000	225 A Form W	600 Vac	2, 3	70-225	X	
967000	400 A (KL) Form W	600 Vac	2, 3	125-400	X	
968000	600 A (WL) Form W	600 Vac	2, 3	225-600	X	
970000	Type L Form W	240 Vac	1, 2, 3	10-50	X	
971000	Type L Form W (Flip-on)	240 Vac	1, 2, 3	10-50	X	
972000	M1 (Bolt-on)	240 Vac	2, 3	15-70	X	
973000	M2 (Bolt-on)	240 Vac	2, 3	50-100	X	
974000	MM (M) (Bolt-on)	120/240 Vac	2 S.P.	15-50	X	
975000	100 A Trip Unit	250 Vac	2, 3	50-100	X	
976000	225 A Trip Unit	250 Vac	2, 3	70-225	X	
977000	KL Trip Unit	600 Vac	2, 3	125-400	X	
978000	LM Trip Unit	600 Vac	2, 3	225-800	X	
979000	WL Frame	600 Vac	2, 3	225-600	X	
982000	50 A Form W (Flip-on)	125/250 Vac	1, 2, 3	15-50	X	
984000	ML-2	250 Vac	2, 3	50-100	X	
985000	100 A (G) Form W	600 Vac	2, 3	50-100	X	
986000	100 A (F) Form W	600 Vac	2, 3	10-100	X	
987000	ML-3	250 Vac	2, 3	125-225	X	
988000	ML-1	250 Vac	2, 3	15-100	X	
989000	ML-1	480 Vac	2, 3	15-100	X	
991000	QB	120/240 Vac	1	15-50	X	
992000	ML	120/240 Vac	1, 2, 3	10-50	X	
992900	ML Form Y	277 Vac	1	10-20	X	
994000	ML-2	600 Vac	2, 3	15-100	X	
995000	100 A (G) Form W	600 Vac	2, 3	15-100	X	
996000	100 A (F) Form W	600 Vac	2, 3	15-100	X	
997000	ML-3	600 Vac	2, 3	50-225	X	
998000	ML-1	600 Vac	2, 3	15-100	X	
999000	ML-1	600 Vac	2, 3	15-100	X	
A1B	100 A	120/240 Vac	1, 2, 3	15-100	X	
PowerPact D-Frame	600 A	600 Vac	3, 4	150-600	X	
EH, EHB	100 A	480Y/277 Vac	1, 2, 3	15-100	X	
FA, FH, FC	100 A	480 Vac	2, 3	15-100	X	X
FD, FG, FJ	100 A	480Y/277 Vac	1, 2, 3	15-100	X	
GJL / NENL	100 A	480 Vac	3	15-100	X	
KA, KH, KC	250 A	480 Vac	2, 3	70-250	X	
FI, FIL	100 A	480 Vac	2, 3	20-100	X	
KI, KIL	225 A	480 Vac	2, 3	110-225	X	
LI, LIL	400 A	480 Vac	2, 3	300-400	X	
KD, KG	250 A	240 Vac	2, 3	100-250	X	
LA(JKL) 0000	400 A	600 Vac	2, 3	125-400	X	
MA-0000	1000 A	600 Vac	2, 3	125-1000	X	
MasterPact M/MP/MC	6300 A	600 Vac	3, 4	800-6300	—	See page 11-22
MEC	225 A	600 Vac	2, 3	100-225	X	
MEC	400 A	600 Vac	2, 3	250-400	X	
MEC	800 A	600 Vac	2, 3	400-800	X	
MHAB, BC, CA	MM (Plug-on)	120/240 Vac	2 S.P.	15-50	X	

11 OBSOLESCENT AND OBSOLETE CIRCUIT BREAKERS

**Table 11.1 Circuit Breaker Availability (cont'd.)**

Series of Cat. No.	Frame Size	Volts	Poles	Amperes	Availability	
					Obsolete No Longer Available	Obsolescent
MHAB, BC, CA	M1 (Plug-on)	120/240 Vac	2, 3	15–70	X	
Q2, Q2-H, Q2H	225 A	240 Vac	2, 3	100–225	X	
QE	200 A	120/240 Vac	2, 3	70–200	X	
SE	4000 A	600 Vac	3	200–4000	X	
CK	1200 A	480 Vac	3	400–1200	X	
CM	2000 A	480 Vac	3	1250–2000	X	
XO	50 A	120/240 Vac	1, 2	15–50	X	
Y1B	100 A	277 Vac	1	15–100	X	
LXi	600 A	600 Vac	3	100–600	X	
ME, MEL	250 A, 400 A, 800 A	600 Vac	3	100–800	X	
MX, MXL	250 A, 400 A, 800 A	600 Vac	3	100–800	X	
NA, NAL	1200 A	600 Vac	3	600–1200	X	
NC, NCL	1200 A	600 Vac	3	600–1200	X	
NX, NXL	1200 A	600 Vac	3	600–1200	X	
NE, NEL	1200 A	600 Vac	3	600–1200	X	
PAF	2000 A	600 Vac	3	600–2000	X	
PHF	2000 A	600 Vac	2, 3	600–2000	X	
PCF	2500 A	600 Vac	2, 3	1600–2500	X	
PXF	2500 A	600 Vac	2, 3	600–2500	X	
PEF	2500 A	600 Vac	3	600–2500	X	

Contact your local Sales Office for availability.

Dimensions



LIL



LA (W)



MA (W)

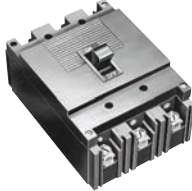

MIL-1



MIL-2

Table 11.2: Circuit Breaker Dimensions

Circuit Breaker Type	Cat. No. Prefix	Number Poles	Dimensions															
			A		B		C		D		E		F		G		H	
			in.	mm	in.	mm	in.	mm	in.	mm	in.	mm	in.	mm	in.	mm		
QB	991	1	3.75	95	1.00	25	2.50	63	3.06	78	—	—	—	—	—	—	—	—
ML	992	1	6.00	152	1.00	25	3.09	78	3.91	99	.88	22	4.25	108	—	—	.33	8
	992	2	6.00	152	2.00	51	3.09	78	3.91	99	.88	22	4.25	108	—	—	.19	5
	992	3	6.00	152	3.00	76	3.09	78	3.91	99	.88	22	4.25	108	—	—	1.83	46
ML-1	999	2, 3	6.50	165	4.47	113	3.06	78	3.94	100	.94	24	4.25	108	1.50	38	.75	19
ML-2	994	2, 3	9.56	243	4.47	113	3.75	95	4.88	124	1.69	43	6.50	165	1.50	38	.75	19
ML-3	997	2, 3	10.38	264	5.97	152	3.88	98	5.31	135	1.69	43	6.63	168	2.00	51	1.00	25
LA (W)	LA	2, 3	10.75	273	8.25	209	4.31	109	5.50	140	.63	16	9.50	241	2.75	70	1.38	35
MA (W)	MA	2, 3	16.00	406	8.25	209	4.06	103	6.06	154	.88	22	14.25	362	2.75	70	1.38	35
KL	967	2, 3	22.00	559	8.25	209	5.50	140	7.00	178	.63	16	20.75	527	2.75	70	1.38	35
LM	940	2, 3	22.00	559	8.25	209	5.50	140	7.00	178	.63	16	20.75	527	2.75	70	1.38	35
FIL (4)	IFL	2, 3	8.29	210	4.46	113	3.67	93	4.70	119	.44	11	7.41	188	1.50	38	.75	19
KIL (4)	IKL	2, 3	11.00	279	6.00	152	4.02	102	5.51	140	.88	22	9.25	235	2.00	51	1.00	25
LIL	ILL	2, 3	11.00	279	12.00	305	4.05	103	6.11	155	.88	22	9.25	235	4.00	102	2.00	51
NHL	NHL	2, 3	20.00	508	12.00	305	5.75	146	8.12	206	5.87	149	7.76	197	4.00	102	2.00	51

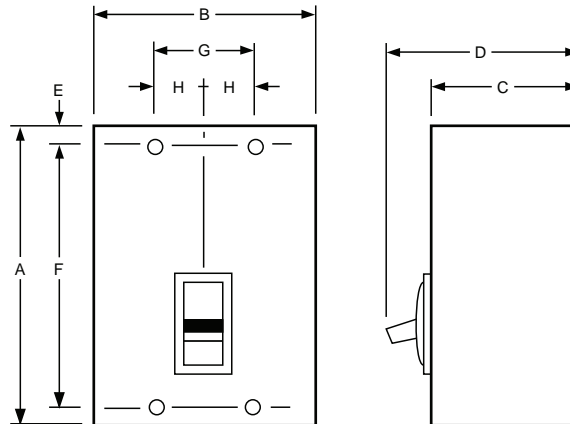

11 OBSOLESCENT AND OBSOLETE CIRCUIT BREAKERS

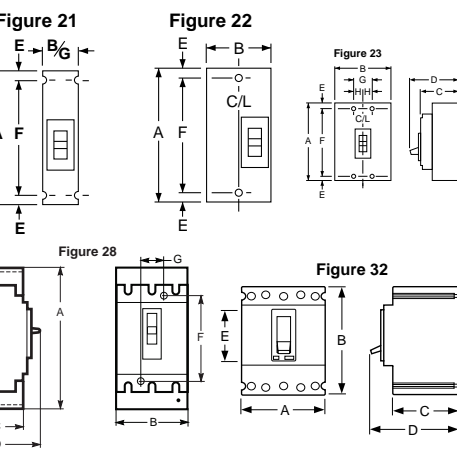
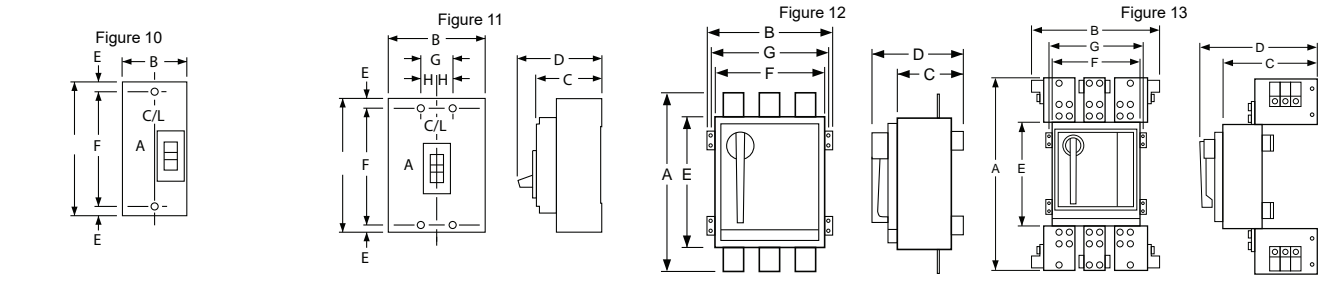
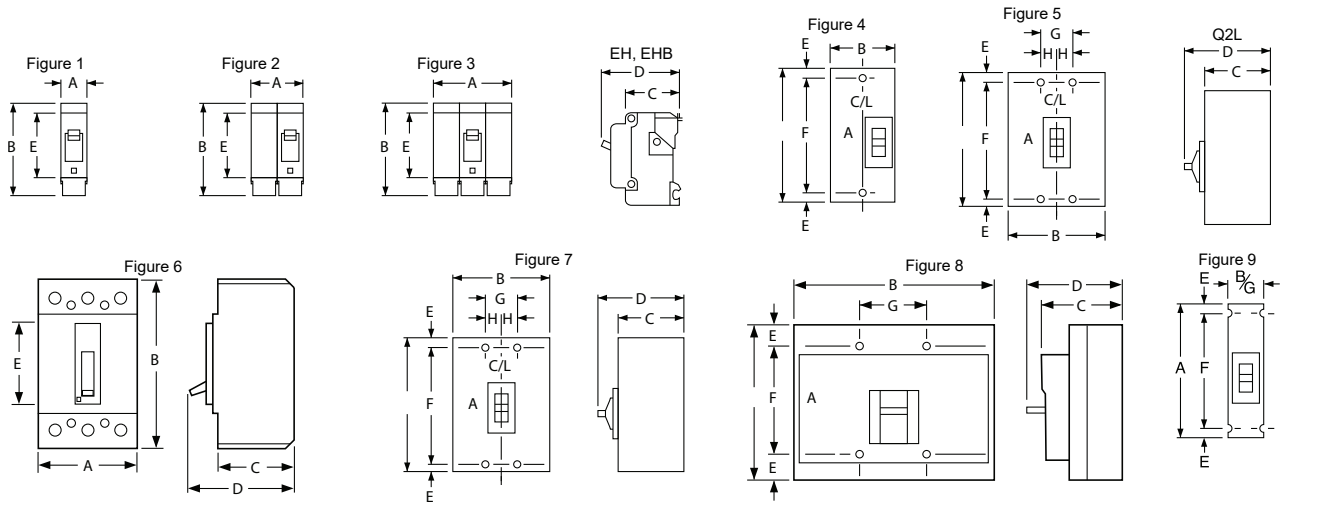

**Table 11.4: Circuit Breaker Dimensions**

Circuit Breaker Cat. No. Prefix	No. Poles	Fig. No.	Dimensions—In.							
			A	B	C	D	E	F	G	H
EH, EHB	1	1	1.00	3.50	2.00	2.97	2.44	—	—	—
	2	2	2.00	3.50 [1]	2.00	2.97	2.44	—	—	—
	3	3	3.00	3.50 [1]	2.00	2.97	2.44	—	—	—
FDA, FGA, FJA	1	Width 1.50								
	2, 3	Width 3.00								
FAL, FHL	1	21	6.00	1.50	3.16	4.13	0.44	5.13	1.50	—
	2	22	6.00	3.00	3.16	4.13	0.44	5.13	—	—
	3	23	6.00	4.50	3.16	4.13	0.44	5.13	1.50	0.75
FIL, KIL	2, 3	11	8.00	4.50	3.66	4.75	0.44	7.13	1.50	0.75
DG, DJ, DL	3	28	13.38	5.51	3.75	6.61	2.22	8.93	1.77	—
GJ	3	32	3.54	4.72	2.76	3.94	2.20	—	—	—
KAL, KCL, KHL	2, 3	23	8.00	4.50	3.66	4.75	0.44	7.13	1.50	0.75
KIL	2, 3	23	8.00	4.50	3.66	4.75	0.44	7.13	1.50	0.75
KD, KG	2, 3	6	4.12	7.35	3.20	4.17	3.34	—	—	—
LC, LI, LE, LX, LXI	2, 3	11	11.86	7.50	5.48	6.74	0.55	10.75	2.50	—
LIL, LXIL	2, 3	11	11.86	7.50	5.48	6.74	0.55	10.75	2.50	—
Q4L, LAL, LHL	2, 3	11	11.00	6.00	4.06	5.84	0.88	9.25	2.00	1.00
Q2L, Q2L-H	2	4	6.44	3.00	3.16	3.92	[2]	4.25	—	—
	3	5	6.44	4.50	3.16	3.92	[2]	4.25	1.50	0.75
MXL, MEL	2, 3	7	14.75	9.00	4.37	6.50	1.66	11.43	3.00	1.50
NAL, NCL, NEL, NXL	2, 3	8	12.12	14.98	6.40	8.07	1.69	8.75	5.00	—
FCL	1	9	6.00	1.50	3.16	4.13	0.44	5.13	1.50	—
	2	10	6.00	3.00 [3]	3.16	4.13	0.44	5.13	—	—
	3	11	6.00	4.50	3.16	4.13	0.44	5.13	1.50	0.75
MAL, MHL	2, 3	23	14.00	9.00	4.53	6.50	1.66	10.69	3.00	1.50
NA, NC, NX, NE	2, 3	8	12.12	14.98	6.40	8.07	1.69	8.75	5.00	—
PA, PH, PX, PE	2, 3	12	20.06	13.70	7.25	10.47	14.00	12.00	12.75	—
PC, PX-25, PE-20, PE-25	2, 3	13	26.10	23.30	13.33	16.55	14.10	12.00	—	—

**Table 11.3: Shipping Weights**

Frame Size	Approx. Shipping Weight (Lbs.)
FAL, FHL 2-pole FCL	3
FAL, FHL 3-pole	5
FIL	8
GJ	3
KAL, KHL	7
MAL, MHL	34
PAF, PHF	69
PXF, PEF	80

[1] 70–100 A is 4.00 in.  
 [2] Dimensions E are 1.59 in at ON end and 0.63 in at OFF end.  
 [3] FCL 2-pole circuit breaker dimension B is 4.50 as in Fig. 23.

**SF Circuit Breakers**

- CE marking.
- S-frame circuit breakers are CCC Certified.
- International products—for export use only.
- MCCBs in I-Line™ plug-on construction and a complete line of accessories are available. Contact your local Field Sales office.
- Order entry point is Cedar Rapids, Iowa.

**Table 11.5: SFAL, Individually-Mounted, IEC Rated Circuit Breakers, 415/240 Vac Max., 50/60 Hz, 1P, 2P, and 3P**

Ampere Rating	Cat. No.		
	1P	2P	3P
SFAL [1]			
16 A	SFAL1016	SFAL2016	SFAL3016
20 A	SFAL1020	SFAL2020	SFAL3020
32 A	SFAL1032	SFAL2032	SFAL3032
40 A	SFAL1040	SFAL2040	SFAL3040
50 A	SFAL1050	SFAL2050	SFAL3050
63 A	SFAL1063	SFAL2063	SFAL3063
80 A	SFAL1080	SFAL2080	SFAL3080
100 A	SFAL1100	SFAL2100	SFAL3100
125 A	—	SFAL2125	SFAL3125
160 A	—	SFAL2160	SFAL3160

**Breaking Capacities**

- CE Marking
- International products—IEC 60947-2 rated. North American products are dual rated, UL 489 and IEC 60947-2.
- MCCBs in I-Line™ plug-on construction and a complete line of accessories are available. Contact your nearest Field Sales office.
- Order entry point is Cedar Rapids, Iowa.

**Table 11.6: Circuit Breaker Breaking Capacities**

Circuit Breaker Cat. Prefix		Current Rating (Amps)	Short-circuit Ratings (415 Vac)			Isolator Rating	Impulse Rating U <sub>imp</sub> (kV)	Insulation Rating U <sub>i</sub> (Vac)
International	North America		Ultimate I <sub>cu</sub>	Service I <sub>cs</sub>	Withstand I <sub>cw</sub>			
—	FA, FH	15–100 A	10 kA	2.5 kA	N/A	Yes	6	750
—	FA, FH (1 pole) [2]	15–100 A	18 kA	9 kA	N/A	Yes	6	750
SFA (1 pole) [2]	—	16–100 A	25 kA	12.5 kA	N/A	Yes	6	750
SFA [3]	—	16–160 A	25 kA	12.5 kA	N/A	Yes	6	750
—	FC	15–100 A	10 kA	2.5 kA	N/A	Yes	6	750
SFH	—	16–63 A	65 kA	50 kA	N/A	Yes	6	750
		80–100 A	65 kA	33 kA	N/A	Yes	6	750

**SF Circuit Breaker Dimensions**

- CE Marking
- International products—IEC 60947-2 rated. North American products are dual rated, UL 489 and IEC 60947-2.
- MCCBs in I-Line™ plug-on construction and a complete line of accessories are available. Contact your nearest Field Sales office.
- Order entry point is Cedar Rapids, Iowa.

**Table 11.7: Dimensions**

Circuit Breaker	No. Poles	Fig. No.	Dimensions – mm							
			A	B	C	D	E	F	G	H
SFA, FA, FH	3	1	152	114	80	105	11	130	38	19

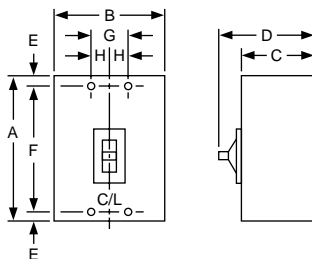

Figure 1

[1] Add suffix K for CCC label  
 [2] Single pole ratings are 240 V.  
 [3] SFA 2 & 3 pole marked Line and Load.

**Photovoltaic Accessories**

**NOTE:** Photovoltaic circuit breakers and related accessories are obsolete. Limited service stock is available for replacement or fill purposes. Contact the nearest sales office for product availability.

**Table 11.8: Auxiliary Switches**

Contacts	Factory-Installed Suffix	Field-Installable Kit No.	Kit Qty.
1A/1B Standard	AA	S29450	1
2A/2B Standard	AB	S29450	2
3A/3B Standard [4]	AC	S29450	3
1A/1B Low-Level (Gold)	AE	S29452	1
2A/2B Low-Level (Gold)	AF	S29452	2
3A/3B Low-Level (Gold) [4]	AG	S29452	3

**Table 11.9: Alarm/Overcurrent Trip Switches**

Suffix	Switch	Kit No.	Kit Qty.
<b>PowerPact T-Frame</b>			
BC	Alarm Switch	S29450	1
BD	Overcurrent Trip Switch, Standard	S29450	1
BE	Alarm Switch and Overcurrent Trip Switch, Standard	S29450	2
<b>PowerPact U-Frame</b>			
BC	Alarm Switch	S29450	1
BD	Overcurrent Trip Switch, Standard	S29450	1
BE	Alarm Switch and Overcurrent Trip Switch, Standard	S29450	2

**Table 11.10: Shunt Trips and Undervoltage Trips**

Voltage	Shunt Trip (MX)		Undervoltage Trip (MN) Field-Installable Kit No.	Adjustable and Fixed Time Delay Units for Undervoltage Trip Field-Installable Kit No.
	Suffix	Field-Installable Kit No.		
120 Vac	SA	P29386	—	—

[4] U-Frame only.

**F-Frame Circuit Breakers Ending Production in 2018–2019**

PowerPact B-Frame 15–125 A molded case circuit breakers are the designated replacement for F-frame applications. The PowerPact™ B-frame features increased capacity, a smaller size in unit mount, same size in I-Line applications to ease retrofit, and a flexible range of field-installable accessories, auxiliaries and operators.

**F-Frame Molded Case Circuit Breakers**

Thermal-magnetic molded case circuit breakers shown here are permanent trip UL Listed, CSA Certified, IEC rated, and also meet the requirements of Federal Specification W–C–375B/GEN as indicated in Digest Section 7.

**NOTE:** Consider using PowerPact™ circuit breakers for situations requiring circuit breaker accessories. See Digest Section 7 for more information.



**Table 11.12: F-Frame—100 A, Thermal-Magnetic, Individually-Mounted, Standard Interrupting, 240 Vac**

Ampere Rating	Fixed AC Magnetic Trip		Cat. No.			Terminal Wire Range (AWG)
	Hold	Trip	1 P 120 Vac	2 P 240 Vac	3 P 240 Vac	
15 A	275 A	600 A	FAL12015	FAL22015	FAL32015	AL50FA 14–4 Cu or 12–4 Al
20 A	275 A	600 A	FAL12020	FAL22020	FAL32020	
25 A	275 A	600 A	FAL12025	FAL22025	FAL32025	
30 A	275 A	600 A	FAL12030	FAL22030	FAL32030	
35 A	400 A	850 A	FAL12035	FAL22035	FAL32035	
40 A	400 A	850 A	FAL12040	FAL22040	FAL32040	AL100FA 14–1/0 Cu or 12–1/0 Al
45 A	400 A	850 A	FAL12045	FAL22045	FAL32045	
50 A	400 A	850 A	FAL12050	FAL22050	FAL32050	
60 A	800 A	1450 A	FAL12060	FAL22060	FAL32060	
70 A	800 A	1450 A	FAL12070	FAL22070	FAL32070	
80 A	800 A	1450 A	FAL12080	FAL22080	FAL32080	
90 A	900 A	1700 A	FAL12090	FAL22090	FAL32090	
100 A	900 A	1700 A	FAL12100	FAL22100	FAL32100	

**Table 11.11: Termination Option**

Termination Letter
F = No Lugs
L = Lugs both ends
P with MT Suffix = Lugs ON end
P = Lugs OFF end
F A L 3 6 1 0 0
For factory-installed termination, place termination letter in the third block of the circuit breaker catalog number.

**Table 11.13: F-Frame—100 A, Thermal-Magnetic, Individually-Mounted, 480 Vac**

Ampere Rating	Fixed AC Magnetic Trip		Standard Interrupting Cat. No.			Terminal
	Hold	Trip	1P 277 Vac, 125 Vdc	2P 480 Vac, 250 Vdc	3P 480 Vac, 250 Vdc	
15 A	275 A	600 A	FAL14015	FAL24015	FAL34015	AL50FA (1) 14–4 Cu or (1) 12–4 Al
20 A	275 A	600 A	FAL14020	FAL24020	FAL34020	
25 A	275 A	600 A	FAL14025	FAL24025	FAL34025	
30 A	275 A	600 A	FAL14030	FAL24030	FAL34030	
35 A	400 A	850 A	FAL14035	FAL24035	FAL34035	
40 A	400 A	850 A	FAL14040	FAL24040	FAL34040	AL100FA (1) 14–1/0 Cu or (1) 12–1/0 Al
45 A	400 A	850 A	FAL14045	FAL24045	FAL34045	
50 A	400 A	850 A	FAL14050	FAL24050	FAL34050	
60 A	800 A	1450 A	FAL14060	FAL24060	FAL34060	
70 A	800 A	1450 A	FAL14070	FAL24070	FAL34070	
80 A	800 A	1450 A	FAL14080	FAL24080	FAL34080	
90 A	900 A	1700 A	FAL14090	FAL24090	FAL34090	
100 A	900 A	1700 A	FAL14100	FAL24100	FAL34100	

**Table 11.14: F-Frame—100 A, Thermal-Magnetic, Individually-Mounted, 600 Vac**

Ampere Rating	Fixed AC Magnetic Trip		Cat. No.							Terminal Wire Range (AWG)
	Hold	Trip	Standard Interrupting		High Interrupting			Current Limiting		
			2P 600 Vac, 250 Vdc	3P 600 Vac, 250 Vdc	1P 277 Vac, 125 Vdc	2P 600 Vac, 250 Vdc	3P 600 Vac, 250 Vdc	2P 600 Vac, 250 Vdc	3P 600 Vac, 250 Vdc	
15 A	275 A	600 A	FAL26015	FAL36015	FHL16015	FHL26015	FHL36015	—	—	AL50FA 14–4 Cu or 12–4 Al
20 A	275 A	600 A	FAL26020	FAL36020	FHL16020	FHL26020	FHL36020	FIL26020	FIL36020	
25 A	275 A	600 A	FAL26025	FAL36025	FHL16025	FHL26025	FHL36025	FIL26025	FIL36025	
30 A	275 A	600 A	FAL26030	FAL36030	FHL16030	FHL26030	FHL36030	FIL26030	FIL36030	
35 A	400 A	850 A	FAL26035	FAL36035	FHL16035	FHL26035	FHL36035	FIL26035	FIL36035	
40 A	400 A	850 A	FAL26040	FAL36040	FHL16040	FHL26040	FHL36040	FIL26040	FIL36040	AL100FA 14–1/0 Cu or 12–1/0 Al
45 A	400 A	850 A	FAL26045	FAL36045	FHL16045	FHL26045	FHL36045	FIL26045	FIL36045	
50 A	400 A	850 A	FAL26050	FAL36050	FHL16050	FHL26050	FHL36050	FIL26050	FIL36050	
60 A	800 A	1450 A	FAL26060	FAL36060	FHL16060	FHL26060	FHL36060	FIL26060	FIL36060	
70 A	800 A	1450 A	FAL26070	FAL36070	FHL16070	FHL26070	FHL36070	FIL26070	FIL36070	
80 A	800 A	1450 A	FAL26080	FAL36080	FHL16080	FHL26080	FHL36080	FIL26080	FIL36080	
90 A	900 A	1700 A	FAL26090	FAL36090	FHL16090	FHL26090	FHL36090	FIL26090	FIL36090	
100 A	900 A	1700 A	FAL26100	FAL36100	FHL16100	FHL26100	FHL36100	FIL26100	FIL36100	

**Table 11.15: Interrupting Ratings**

Voltage	FAL			FHL	FCL [5]	FIL
	240 Vac	480 Vac	600 Vac			
240 Vac	10 kA	18 kA (1P) 25 kA (2P, 3P)	25 kA	25 kA (1P) 65 kA (2P, 3P)	100 kA	200 kA
480 Vac	—	18 kA	18 kA	25 kA (2P, 3P)	65 kA	200 kA
600 Vac	—	—	14 kA	18 kA (2P, 3P)	—	100 kA

Accessories see page 11-14 through page 11-18

Optional Lugs see page 11-16

Enclosures see page 11-23

[5] See Section 11.

**F-Frame I-Line Circuit Breakers**

**NOTE:** Consider using PowerPact™ circuit breakers for situations requiring circuit breaker accessories. See Digest Section 7 for more information.



**Table 11.16: F-Frame—100 A, Thermal-Magnetic, I-Line™ Construction, 240 Vac, Standard Interrupting**

Ampere Rating	Fixed AC Magnetic Trip		Cat. No.		Terminal Wire Range (AWG)
	Hold	Trip	2P [6]	3P 240 Vac	
15 A	275 A	600 A	FA22015()	FA32015	AL50FA 14–4 Cu or 12–4 Al
20 A	275 A	600 A	FA22020()	FA32020	
25 A	275 A	600 A	FA22025()	FA32025	
30 A	275 A	600 A	FA22030()	FA32030	
35 A	400 A	850 A	FA22035()	FA32035	
40 A	400 A	850 A	FA22040()	FA32040	AL100FA 14–1/0 Cu or 12–1/0 Al
45 A	400 A	850 A	FA22045()	FA32045	
50 A	400 A	850 A	FA22050()	FA32050	
60 A	800 A	1450 A	FA22060()	FA32060	
70 A	800 A	1450 A	FA22070()	FA32070	
80 A	800 A	1450 A	FA22080()	FA32080	
90 A	900 A	1700 A	FA22090()	FA32090	
100 A	900 A	1700 A	FA22100()	FA32100	

**Table 11.17: F-Frame—100 A, Thermal-Magnetic, I-Line Construction, 480 Vac**

Ampere Rating	Fixed AC Magnetic Trip		Standard Interrupting			Terminal Wire Range (AWG)
	Hold	Trip	1P [6] [7] 277 Vac, 125 Vdc	2P [6] 480 Vac, 250 Vdc	3P 480 Vac, 250 Vdc	
15 A	275 A	600 A	—	FA24015()	FA34015	AL50FA (1) 14–4 Cu or (1) 12–4 Al
20 A	275 A	600 A	—	FA24020()	FA34020	
25 A	275 A	600 A	—	FA24025()	FA34025	
30 A	275 A	600 A	—	FA24030()	FA34030	
35 A	400 A	850 A	FA14035()	FA24035()	FA34035	
40 A	400 A	850 A	FA14040()	FA24040()	FA34040	AL100FA (1) 14–1/0 Cu or (1) 12–1/0 Al
45 A	400 A	850 A	FA14045()	FA24045()	FA34045	
50 A	400 A	850 A	FA14050()	FA24050()	FA34050	
60 A	800 A	1450 A	FA14060()	FA24060()	FA34060	
70 A	800 A	1450 A	FA14070()	FA24070()	FA34070	
80 A	800 A	1450 A	FA14080()	FA24080()	FA34080	
90 A	900 A	1700 A	FA14090()	FA24090()	FA34090	
100 A	900 A	1700 A	FA14100()	FA24100()	FA34100	

**Table 11.18: F-Frame—100 A, Thermal-Magnetic, I-Line™ Construction, 600 Vac**

Ampere Rating	Fixed AC Magnetic Trip		Cat. No.						Terminal Wire Range (AWG)	
	Hold	Trip	Standard Interrupting		High Interrupting		Current Limiting			
			2P [6] 600 Vac, 250 Vdc	3P 600 Vac, 250 Vdc	1P [6] [7] 277 Vac, 125 Vdc	2P [6] 600 Vac, 250 Vdc	3P 600 Vac, 250 Vdc	2P [6] 600 Vac, 250 Vdc		3P 600 Vac, 250 Vdc
15 A	275 A	600 A	FA26015()	FA36015	FH16015()	FH26015()	FH36015	—	—	AL50FA 14–4 Cu or 12–4 Al
20 A	275 A	600 A	FA26020()	FA36020	FH16020()	FH26020()	FH36020	FI26020()	FI36020	
25 A	275 A	600 A	FA26025()	FA36025	FH16025()	FH26025()	FH36025	—	—	
30 A	275 A	600 A	FA26030()	FA36030	FH16030()	FH26030()	FH36030	FI26030()	FI36030	
35 A	400 A	850 A	FA26035()	FA36035	FH16035()	FH26035()	FH36035	—	—	
40 A	400 A	850 A	FA26040()	FA36040	FH16040()	FH26040()	FH36040	FI26040()	FI36040	AL100FA 14–1/0 Cu or 12–1/0 Al
45 A	400 A	850 A	FA26045()	FA36045	FH16045()	FH26045()	FH36045	—	—	
50 A	400 A	850 A	FA26050()	FA36050	FH16050()	FH26050()	FH36050	FI26050()	FI36050	
60 A	800 A	1450 A	FA26060()	FA36060	FH16060()	FH26060()	FH36060	FI26060()	FI36060	
70 A	800 A	1450 A	FA26070()	FA36070	FH16070()	FH26070()	FH36070	FI26070()	FI36070	
80 A	800 A	1450 A	FA26080()	FA36080	FH16080()	FH26080()	FH36080	FI26080()	FI36080	
90 A	900 A	1700 A	FA26090()	FA36090	FH16090()	FH26090()	FH36090	FI26090()	FI36090	
100 A	900 A	1700 A	FA26100()	FA36100	FH16100()	FH26100()	FH36100	FI26100()	FI36100	

**Table 11.19: Phase Options**

Phase Option Letter	1P	2P	3P
A	FA14035A	—	—
B	FA14035B	—	—
C	FA14035C	—	—
AB	—	FA24030AB	—
AC	—	FA24030AC	—
BC	—	FA24030BC	—
ABC	—	—	FA34030
CBA	—	—	FA34030CBA

**Table 11.20: Interrupting Ratings**

Voltage	FA			FH	FC[8]	FI
	240 Vac	480 Vac	600 Vac			
240 Vac	10 kA	18 kA (1P), 25 kA (2P, 3P)	25 kA	25 kA (1P) 65 kA (2P, 3P)	100 kA	200 kA
277 Vac	—	18 kA	—	—	65 kA	—
480 Vac	—	18 kA	18 kA	25 kA (2P, 3P)	65 kA	200 kA
600 Vac	—	—	14 kA	18 kA (2P, 3P)	—	100 kA

Accessories see page 11-14 through page 11-18

Optional Lugs see page 11-16

Enclosures see page 11-23

[6] 1P and 2P circuit breaker catalog numbers are completed by adding the required phase connection letters as a suffix. See Phase Option Table.

[7] Rated 277 Vac, 125 Vdc, 15–30 A circuit breaker suitable for use with 60°C or 75°C conductors. 35–100 A circuit breakers are suitable for use with 75°C conductors.

[8] See Section 11.

### Mag-Gard™ Motor Circuit Protector

Instantaneous trip magnetic only circuit breakers have a single adjustment which simultaneously sets the magnetic trip level of each individual pole. Mag-Gard circuit breakers comply with NEC® requirements for providing motor circuit protection when installed as part of a UL Listed combination controller having motor overload protection. Interrupting ratings are established for these UL Recognized Components only when they are used in combination with motor starters with properly sized overload relays and contactors.

Mag-Gard circuit breakers will accept the same lugs and accessories as equivalent thermal-magnetic circuit breakers.

**Table 11.21: Magnetic-Only GJL Circuit Breakers, 400 A, 600 Vac, 50/60 Hz [9]**

Ampere Rating	Adjustable [10] Trip Range	Cat. No. 3P Only
GJL [11]	3	9–33 A GJL36003M01
	7	21–77 A GJL36007M02
	15	45–165 A GJL36015M03
	30	90–330 A GJL36030M04
	50	150–550 A GJL36050M05
	75	225–825 A GJL36075M06

**NOTE:** Each ampere rating can be ordered with any designated trip range for the frame by adding the proper suffix to the catalog numbers.

### GJL MCP Selection

Adjustable instantaneous-trip circuit breakers are intended for use in combination with motor starters with overload relays for the protection of motor circuits from short circuits. Other specific applications include rectifiers and resistance welders. These circuit breakers contain a magnetic trip element in each pole with the trip point adjustable from the front. Interrupting ratings are determined by testing the instantaneous-trip circuit breakers in combination with a contactor and overload relay.

Select instantaneous-trip circuit breakers using the selection table below.

This selection table is suitable for motors, other than NEMA Design E, with locked-rotor indicating code letters per NEC® Table 430.7 (b).

**Table 11.22: Locked-Rotor Indicating Codes**

Horsepower	Motor Code letter
1/2 or less	A–L
3/4 to 1-1/2	A–K
2 to 3	A–J
5 to 25	A–H
30 to 125	A–G
150 or more	A–F

- For other motors order a special thermal-magnetic circuit breaker with magnetic trip settings for the specific motor— specify motor horsepower, voltage, frequency, full-load current and code letter or locked rotor current.
- Determine motor hp rating from the motor nameplate.
- Refer to the tables and select an instantaneous-trip circuit breaker with an ampere rating recommended for the hp and voltage involved.
- Select an adjustable trip setting of at least 800%, not to exceed 1300%, of the motor full-load amperes (FLA) for other than Design E motors. For Design E motors, select an adjustable trip setting of at least 1100% not to exceed 1700% of FLA.
- The NEC 1300% maximum setting may be inadequate for instantaneous-trip circuit breakers to withstand current surges typical of the magnetization current of autotransformer type reduced voltage starters, or open transition wye-delta starters during transfer from “start” to “run”, constant hp multi-speed motors, and motors labeled “high efficiency”. Select thermal-magnetic circuit breakers from Digest Section 7 for those applications.
- Part-winding motors, per NEC 430.3, should have two circuit breakers selected from the above at not more than one half the allowable trip setting for the horsepower rating. The two circuit breakers should operate simultaneously as a disconnecting means per NEC 430.103.
- Based on NEC 430.52 and NEC Table 430.150. See Digest Section 7 for a available Adjustable Instantaneous-Trip Circuit Breakers.



[9] 250 Vdc ratings are available. No UL component recognition.

[10] UL magnetic trip setting tolerances are -20%/+30% from the nominal values shown.

[11] No GJL I-Line available.

**GJL MCP Selection Table**

**Table 11.23: GJL Adjustable Instantaneous-Trip Circuit Breakers for Single Motor Circuit Protection**

Hp Ratings of Induction Type Squirrel-Cage and Wound Rotor Motors 3Ø 60 Hz				Full Load Amperes [12]	GJL Family Mag-Gard Circuit Breaker Cat. No.	Magnetic Trip Settings [13]	
200 Vac	230 Vac	460 Vac	575 Vac			MIN	MAX
—	—	—	1/2	0.8	GJL36003M01 [14]	1100%	4100%
—	—	1/2	—	1	GJL36003M01 [14]	900%	3300%
—	—	—	3/4	1.1	GJL36003M01 [14]	800%	3000%
—	—	3/4	—	1.4	GJL36003M01	600%	2400%
—	—	1	—	1.8	GJL36003M01	500%	1800%
—	1/2	—	—	2	GJL36003M01	500%	1700%
—	—	—	1-1/2	2.1	GJL36003M01	400%	1600%
1/2	—	—	—	2.3	GJL36003M01	400%	1400%
—	—	1-1/2	—	2.6	GJL36003M01	300%	1300%
—	—	—	2	2.7	GJL36003M01 [15]	300%	1200%
—	3/4	—	—	2.8	GJL36003M01 [15]	300%	1200%
3/4	—	—	—	3.2	GJL36007M02	700%	2400%
—	—	2	—	3.4	GJL36007M02	600%	2300%
—	1	—	—	3.6	GJL36007M02	600%	2100%
—	—	—	3	3.9	GJL36007M02	500%	2000%
1	—	—	—	4.1	GJL36007M02	500%	1900%
—	—	3	—	4.8	GJL36007M02	400%	1600%
—	1-1/2	—	—	5.2	GJL36007M02	400%	1500%
1-1/2	—	—	—	6	GJL36007M02	400%	1300%
—	—	—	5	6.1	GJL36015M03	700%	2700%
—	2	—	—	6.8	GJL36015M03	700%	2400%
—	—	5	—	7.6	GJL36015M03	600%	2200%
2	—	—	—	7.8	GJL36015M03	600%	2100%
—	—	—	7-1/2	9	GJL36015M03	500%	1800%
—	3	—	—	9.6	GJL36015M03	500%	1700%
3	—	7-1/2	10	11	GJL36015M03	400%	1500%
—	—	10	—	14	GJL36030M04	600%	2400%
—	5	—	—	15.2	GJL36030M04	600%	2200%
—	—	—	1	17	GJL36030M04	500%	1900%
5	—	—	—	17.5	GJL36030M04	500%	1900%
—	—	15	—	21	GJL36030M04	400%	1600%
—	7-1/2	—	20	22	GJL36030M04	400%	1500%
7-1/2	—	—	—	25.3	GJL36030M04	400%	1300%
—	—	20	25	27	GJL36050M05	600%	2000%
—	10	—	—	28	GJL36050M05	500%	2000%
—	—	—	30	32	GJL36050M05	500%	1700%
10	—	—	—	32.2	GJL36050M05	500%	1700%
—	—	25	—	34	GJL36050M05	400%	1600%
—	—	30	—	40	GJL36050M05	400%	1400%
—	—	—	40	41	GJL36050M05	400%	1300%
—	15	—	—	42	GJL36075M06	400%	1300%
15	—	—	—	48.3	GJL36075M06	500%	1700%
—	—	40	50	52	GJL36075M06	400%	1600%
—	20	—	—	54	GJL36075M06	400%	1500%
20	—	—	60	62	GJL36075M06	400%	1300%
—	—	50	—	65	GJL36075M06	300%	1300%

**11** OBSOLETE AND OBSOLETE CIRCUIT BREAKERS

[12] Motor full-load currents are taken from NEC Table 430.150. Select wire and circuit breakers on basis of horsepower rather than nameplate full-load current per NEC 430.6 (A) for general motor applications. Do not use these values to select overload relay thermal units. See Digest Section 14 for selection of thermal units when actual full load current is not known. The voltages listed are rated motor voltages. Corresponding nominal system voltages are 200–208, 220–240, 440–480 and 550–600 V.

[13] Only MIN and MAX settings are shown, intermediate settings are available on all circuit breakers.

[14] See NEC 430.52(A) for circuit breaker settings above 800%.

[15] If due to motor starting characteristics, trip settings at the 1300% maximum permitted level are needed, the next size Mag-Gard circuit breaker should be chosen.

Locks, Installation Accessories, and Rear Connections

Table 11.24: Locks, Interlocking

Device	Description	D-Frame Field-Installable Cat. No.
Handle Padlocking Device	Removable (lock OFF only)	S29370
	Fixed (lock OFF or ON)	S32631
	Fixed (lock OFF only)	NJPAF
Interlocking (Not UL listed)	Mechanical for circuit breakers with rotary handles	32621
	Mechanical for circuit breakers with toggles	32614
Key Locking	Ronis	41950
	Profalux	42878

Provision and 2 locks keyed alike

Table 11.25: Installation Accessories for G- and D-Frame Circuit Breakers

Description	D-Frame Field-Installable Cat. No.
Front Panel Escutcheon for Toggle Breakers	32556
Front Panel Escutcheon for Rotary Handle, Motor Operator, or extended escutcheon	32558
Phase Barriers (set of 6)	32570
Handle Rubber Boot	32560
Sealing Accessories	29375
DIN rail adapter	—
Toggle Extensions (set of 10)	32553

Table 11.26: Rear Connections

Device	D-Frame		
	Poles	Factory-Installed Termination No.	Field-Installed Cat. No.
Mixed Rear Connection Kit	3	S	32477
	4	S	32478
Consisting of:	Short rear connections (set of 2)	3	2x 32475
	Long rear connections (set of 2)	3	32476
	Short terminal cover (3P)	3	32562

Neutral Current Transformers and MicroLogic™ Series B Trip Unit Accessories

Table 11.27: Test Equipment for Circuit Breakers with MicroLogic Series B Trip Systems

Description	Cat. No.
Test Module for Full-function and Standard-function LEL, LXL, LXIL. (For use with existing CBTU1 or UTS3 test set.)	CBTMB
Replacement ribbon cable and rating plug adapter for CBTMB	CBTMBRK

LA and Q-Frame Factory-Installed Electrical Accessories

Electrical accessories are available on all molded case circuit breakers except QOM1 circuit breakers.

- All AC electrical accessories shown below are rated for 50/60 Hz.
- See [Field-Installable Electrical Accessories](#), page 11-13 for field-installable accessories. See Digest Section 7 for PowerPact™ circuit breaker accessories.

Table 11.28: Factory-Installed Accessories for Thermal-Magnetic LA and Q-Frame Circuit Breakers

Accessory	Description	Rated Voltage	Coil Burden	Suffix
Time Delay Unit	Provides adjustable time delay for UVR of 0.1 to 0.6 second before circuit breaker trips. <b>Application</b> <ul style="list-style-type: none"> <li>For use only with -1121 UV trip</li> <li>Adjustable time delay (0.1 to 0.6 second)</li> <li>I-Line unit requires 1.5 in. (38 mm) of mounting space</li> <li>Leads: (2) Brown 18 AWG Cu and (2) Black/White 18 AWG Cu</li> </ul>	120 Vac	Cat. No.	
			690UVTD	690UVTDI

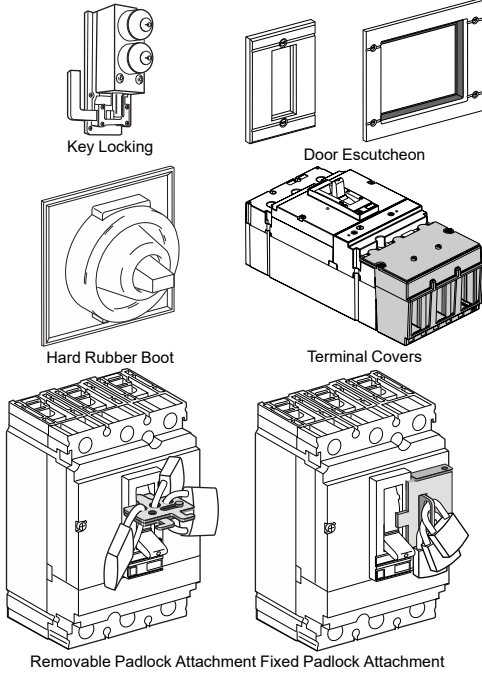

11 OBSOLETE AND OBSOLETE CIRCUIT BREAKERS

**Auxiliary Switch Contact Configuration**

Color Code:  
"A" Contact - Yellow Leads  
"B" Contact - Blue Leads  
Common-Striped Leads

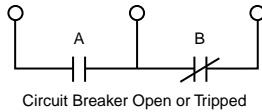
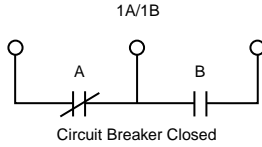

**1A Alarm Switch Configuration**

Color Code: Red Leads



**1B Alarm Switch Configuration**

Color Code: Red Leads



**Undervoltage Trip Wiring Diagram**

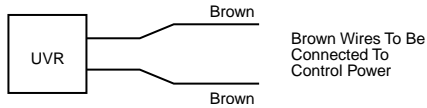

**Shunt Trip Wiring Diagram**

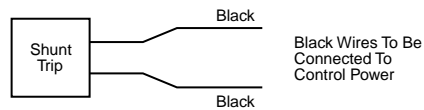

**Field-Installable Electrical Accessories**

Complete field-installable accessory catalog number by inserting suffix from Digest Section 7 between the parentheses in the catalog numbers shown in the table below. (Example: LA11212)

**Table 11.29: Field-Installable Accessories for Thermal-Magnetic and Electronic Trip Circuit Breakers**

Circuit Breaker	Shunt Trip	Ground-Fault Shunt Trip [1]	Undervoltage Trip	Auxiliary Switches	Alarm Switch
FI, KI	Factory-Installed Only	Factory-Installed Only	Factory-Installed Only	Factory-Installed Only	Factory-Installed Only
LC, LI, LE, LX, LXI	LC1 ( )	LC1G	LC1 ( )	LC1 ( )	Factory-Installed Only
MA, MH	MA1 ( )	MA1G	MA1 ( )	MA1 ( )	Factory-Installed Only
ME, MX	Factory-Installed Only	Factory-Installed Only	Factory-Installed Only	Factory-Installed Only	Factory-Installed Only
NA, NC, NE, NX Series 1, 2, 3	NA1 ( )	NA1 ( )	NA1 ( )	NA1 ( )	NA1 ( )
PA, PH, PC Series 4	PA1 ( )	Factory-Installed Only	PA1121	PA1 ( )	Factory-Installed Only
PE, PX Series 4, 5, 6	PA1 ( )	Factory-Installed Only	PA1121	PA1 ( )	Factory-Installed Only

**Table 11.30: Accessory Mounting Locations**

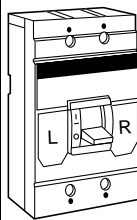

MA, MH Series 2 circuit breakers or newer = Field-installable accessories  
ME/MX circuit breakers = Not field-installable accessories

---

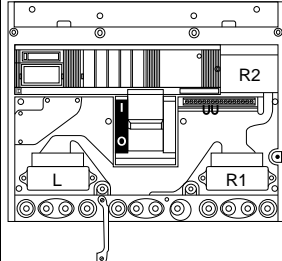

NA, NC, NE, NX circuit breakers - Field-installable accessories  
"L" port and "R" port will accept shunt trips, alarm switches and UVRs;  
"R2" port will accept auxiliary switches. Maximum of one device per port.

---

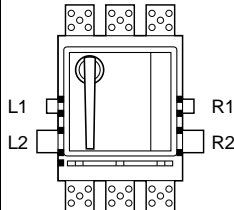



PA, PH, PC, PE, PX Series 4 circuit breakers or newer = Field-installable accessories.  
"L1" and "L2" or "R1" and "R2" port combinations are required to mount a single shunt trip. Both "L2" and "R2" ports will accept a UVR. Both "L1" and "R1" ports will accept auxiliary switches. If alarm switch is factory installed in PA or PC circuit breaker, it will be installed in "R2" port. For a PE or PX circuit breaker, the alarm switch will be factory installed in "L2" port.

**11** OBSOLETE AND OBSOLETE CIRCUIT BREAKERS

[1] Used with obsolete GP Ground-Censor™ system or add-on ground-fault modules.

GJL Electrical Accessories

Table 11.31: Electrical Accessories

Accessory	Description	Rated Voltage	G-Frame Field-Installable Cat. No.	
<p>Auxiliary and Alarm Switches (OF, SD, SDE)</p>  <p>G-Frame</p>	<p>Provides circuit breaker contact status. NOTE: The location of the accessory in the circuit breaker determines its function.</p>	Standard Min Load = 10mA with 24V	1 auxiliary switch (OF) 1a1b AAC	
		2 auxiliary switch (OF) 2a2b —		
		3 auxiliary switch (OF) 3a3b —		
		Alarm Switch (SD) 1a1b AAC		
		Overcurrent Trip Switch (SDE) 1a1b —		
		Consisting of: OF Switch SDE Adapter —		
		Alarm Switch and Overcurrent Trip Switch —		
		Consisting of: OF Switch SDE Adapter —		
		Auxiliary Switch/Alarm Switch/Adapter (OF/SD/SDE) Kit —		
		Low Level Min Load = 1mA with 24V	One auxiliary switch (OF) 1a1b —	
		Two auxiliary switches (OF) 2a2b —		
		3 auxiliary switches (OF) 3a3b —		
		Alarm Switch (SD) 1a1b —		
		Overcurrent Trip Switch (SDE) 1a1b —		
Consisting of: OF Switch SDE Adapter —				
Consisting of: OF Switch SDE Adapter [2] —				
<p>Shunt Trip (MX)</p>  <p>G-Frame</p>	<p>Trips the circuit breaker from a remote location by means of a trip coil energized from a separate supply voltage circuit.</p>	AC	24 —	
			48 —	
			120 GSA	
			110/130 —	
			208 GSB	
			240 GSC	
			200/250 —	
			277 GSD	
			208/277 —	
			480 GSH	
			380/480 —	
			525/600 —	
			DC	12 —
				24 GSO
30 —				
48 GSP				
60 —				
125 GSR				
250 GSS				
<p>Undervoltage Trip</p>  <p>G-Frame</p>	<p>Instantaneously opens the circuit breaker when the undervoltage trip supply voltage drops to a value between 35% and 70% of its rated voltage. Closing is allowed when the supply voltage of the undervoltage trip reaches 85% of rated voltage.</p>	AC	24 —	
			48 —	
			120 GUA	
			110/130 —	
			208 GUB	
			240 GUC	
			200/250 —	
			277 GUD	
			208/277 —	
			480 GUH	
			380/480 —	
			525/600 —	
			DC	12 —
				24 GUO
30 —				
48 GUP				
60 —				
125 GUR				
250 GUS				

11 OBSOLETE AND OBSOLETE CIRCUIT BREAKERS

[2] SDE Adapter used for H- and J-frame only.



KAMO2120AC with KIL Circuit Breaker



FAMO1 and FAMOP with FAL Circuit Breaker

**Electrical Operators**

Provides remote ON, OFF/RESET control of molded case circuit breakers.

- A complete line of field-installable electrical operators.
- Not applicable on LC/LI/LE/LX/LXI circuit breakers.
- Installing side mounted motor operators on non I-Line™ circuit breakers requires the use of a separate mounting pan.
- Side mounted electrical operators require an additional 4-1/2 in. (114 mm) of mounting space in I-Line installations.

When remote indication of circuit breaker status is required, order circuit breaker with 1A-1B auxilliary switch for ON-OFF Indication and alarm switch for TRIP Indication. Electrical operators require SPDT maintained contact switch. Refer to Class 9001 control unit listing for operators and pilot lights.

**NOTE:** Not available on Mag-Gard™ circuit breakers and molded case switches.

**Table 11.32: Electrical Operators**

Circuit Breaker Prefix	Top Mount		Side Mount		Mounting Pan Cat. No.
	Voltage	Cat. No.	Voltage	Cat. No.	
FI, KI	—	—	120 Vac	KAMO1	—
FIL, KIL	120 Vac	KAMO2120AC	120 Vac	KAMO1	KAMOP
	240 Vac	KAMO2240AC			
	24 Vdc	KAMO224DC			
	125 Vdc	KAMO2125DC			
LAL, LHL, Q4L	120 Vac	LAMO2120AC	—	—	—
	240 Vac	LAMO2240AC			
	24 Vdc	LAMO224DC			
	125 Vdc	LAMO2125DC			
MAL, MHL	120 Vac	MAMO2120AC	120 Vac	MAMO1	MAMOP
	240 Vac	MAMO2240AC			
	24 Vdc	MAMO224DC			
	125 Vdc	MAMO2125DC			
PA, PH, PC, PE, PX	120 Vac	PAMO2	—	—	—

**Handle Accessories**

**Table 11.33: Handle Accessories**

Circuit Breaker Prefix	Poles	Cat. No.
<b>Handle Tie</b>		
2 FI, 2 KI, or 1 FI + 1 KI	2, 3	FKHT
California Title 24 Comb. Handle Tie and Lock Off		
<b>Handle Extension</b>		
LE, LI, LX, LXI	2, 3	AHEXLI
<b>Handle Padlock Attachment (locks ON or OFF)</b>		
FI	1, 2, 3	HPAFK
FY Series 1	1	HPAFYQ
FA, FH	1, 2, 3	HPAFK
FY Series 2	2, 3	HPAFK
KI	2, 3	HPAFK <sup>[3]</sup>
LC, LE, LI, LX, LXI	2, 3	AHPALI

[3] Locks OFF only.

Mechanical Lugs

Table 11.34: Mechanical Lug Kit Information



Circuit Breaker Application				(Number of Wires Per Lug) Wire Range [4]	Cat. No.	Lugs Per Kit	Availability
Standard	Ampere Rating	Optional	Ampere Rating				
<b>Al Lugs for Use with Al or Cu Wire</b>							
FA, FH	15–30 A	FA, FH	35–100 A	(1) 14–4 AWG Cu or (1) 12–4 AWG Al	AL50FA	3	Not Available
FC	35–100 A	FC	15–30 A	(1) 14–3 AWG Cu or (1) 12–1 AWG Al	AL100FA4	3	—
FA, FH	35–100 A	FA, FH	15–30 A	(1) 14–1/0 AWG Cu or (1) 12–1/0 AWG Al	AL100FA	3	—
—	—	FA, FH, FC	15–100 A	(1) 12–3 AWG Cu	AL100TF[5]	3	Not Available
—	—	FA	150 A (only)	(1) 2–3/0 AWG	AL150FA	3	—
FI	15–30 A	FI	35–100 A	(1) 14–4 AWG Cu or (1) 12–4 AWG Al	AL50FA	3	Not Available
FI	35–100 A	FI	15–30 A	(1) 14–1/0 AWG Cu or (1) 12–1/0 AWG Al	AL100FA	3	—
KI	110–175 A	—	—	(1) 4 AWG–350 kcmil	AL250KA	3	—
KI	200–250 A	KI	110–175 A	(1) 1/0 AWG–350 kcmil	AL250KI	3	Not Available
LE, LX, LXI	100–250 A	LI, LE, LX, LXI	300–600 A	(2) 1 AWG–350 kcmil	AL600LI35	1	—
LI, LE, LX, LXI	300–600 A	LE, LX, LXI	100–250 A	(2) 4/0 AWG–500 kcmil	AL600LI5	1	—
—	—	LC, LI, LE, LX, LXI	—	(1) 500–750 kcmil	AL600LI7	1	—
—	—	LC, LI, LE, LX, LXI	—	(1) 500–750 kcmil	AL600LI7	1	—
MA, MH	300–1000 A	—	—	(3) 3/0 AWG–500 kcmil	AL900MA	1	—
—	—	MA, MH	300–1000 A	(2) 500–750 kcmil	AL800MA7	1	—
—	—	MA, MH	300–1200 A	(4) 1/0 AWG–350 kcmil	AL1000MA	1	Not Available
ME, MX	100–250 A	—	—	(1) 6 AWG–350 kcmil	AL250ME	3	Not Available
—	—	ME, MX	250–400 A	(1) 350–750 kcmil	AL400ME7	1	Not Available
—	—	ME, MX	100–800 A	(2) 500–750 kcmil	AL800MA7	1	—
ME, MX	300–800 A	ME, MX	100–250 A	(3) 3/0 AWG–500 kcmil	AL900MA	1	—
—	—	ME, MX	300–1200 A	(4) 1/0 AWG–350 kcmil	AL1000MA	1	Not Available
NA, NC, NE, NX	600–1200 A	—	—	(4) 3/0 AWG–600 kcmil	AL1200NE6	1	Not Available
—	—	PAF, PHF, PEF, PXF, PCF	600–2500 A	(1) 1/0 AWG–750 kcmil	AL2500PA	2	Not Available
<b>Cu Lugs for Use with Cu Wire Only [6]</b>							
FC	15–30 A	—	—	(1) 14–10 AWG Cu	CU30FA4	3	—
—	—	FA, FH, FC	15–100 A	(1) 12–3 AWG Cu	CU100TF[5]	3	Not Available
—	—	FA, FH, FC	15–100 A	(1) 14–1 AWG Cu	CU100FA	3	—
—	—	FI	15–100 A	(1) 14–1 AWG Cu	CU100FA	3	—
—	—	FI	15–100 A	(1) 14–1 AWG Cu	CU100FA	3	—
—	—	KI	110–250 A	(1) 4 AWG–250 kcmil Cu	CU250KA	3	Not Available
—	—	LI, LE, LX, LXI	—	(2) 1 AWG–350 kcmil Cu	CU600LI35	1	—
—	—	LI, LE, LX, LXI	—	(2) 4/0 AWG–500 kcmil Cu	CU600LI5	1	—
—	—	LI, LE, LX, LXI	—	(1) 500–750 kcmil Cu	CU600LI7	1	Not Available
—	—	MA, MH	300–1000 A	(3) 3/0 AWG–500 kcmil Cu	CU1000MA	1	Not Available
—	—	ME, MX	125–250 A	(1) 4 AWG–250 kcmil Cu	CU250ME	3	Not Available
—	—	ME, MX	100–800 A	(3) 3/0 AWG–500 kcmil Cu	CU1000MA	1	Not Available
—	—	NA, NC, NE, NX	600–1200 A	(4) 3/0 AWG–600 kcmil Cu	CU1200NE6	1	Not Available

11 OBSOLETE AND OBSOLETE CIRCUIT BREAKERS

[4] Unless otherwise specified, wire sizes apply to both aluminum and copper conductors.

[5] For use in the OFF end only, when the OFF end is the load end.

[6] Use suffix 8002 for factory-installed Cu lugs.

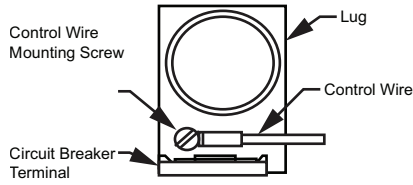

**Control Wire Tap Lugs**

Control wire tap lugs are used in applications requiring connection to a small wire (22-14 AWG) for control circuits. This is accomplished by crimping the wire to a standard wire crimp terminal (not included) and fastening the terminal to the circuit breaker lug.  
**Note:** To order as a factory-installed device on FI, KI, LC, LI, LXI, LX or LC circuit breakers, add suffix number 8041 to circuit breaker catalog number, e.g., KIL362258041.

**Table 11.35: Control Wire Terminations for Circuit Breakers**

Circuit Breaker	Control Wire Termination Kits	
	Cat. No.	Standard Package Quantity
FA, FH	FAT [7]	1
FI	FAT [7]	1
KI	AL250KIT	1
LC, LI, LXI, LX, LE	AL600L35T	1
	AL600L15T	1
MA, MH, MX, ME	AL900MAT	1
	AL1000MAT	1
NA, NC, NX, NE	AL1200NE6T	1

**Compression Lug Kits**

**Table 11.36: Field-Installable Compression Lug Kits**



Circuit Breaker Type	Wire Range [8]	Dimension A (In)	Max. Lugs Per Terminal	Cat. No. [9]	Lugs Per Kit	Availability
<b>Aluminum Compression Lug Kits</b>						
FA, FH, FC	8-1/0 AWG	1.3	1	VC100FA	3	—
FI	8-1/0 AWG	1.3	1	VC100FA	3	—
KI	4 AWG-300 kcmil	1.5	1	VC250KA3	3	Not Available
	250-350 kcmil	1.5	1	VC250KA35	3	Not Available
LI, LE, LX, LXI [10]	4 AWG-300 kcmil	1.05	2	VC600LI3	2	Not Available
	2/0 AWG-500 kcmil	3.20	2	VC600LI5	2	Not Available
	500-750 kcmil	3.45	1	VC600LI7	1	Not Available
MA, MH	2/0 AWG-500 kcmil	1.9	2	VC600MA5	2	Not Available
	500-750 kcmil	2.1	2	VC800MA7	2	Not Available
ME2, MX2	4 AWG-300 kcmil	1.5	1	VC250ME3	3	Not Available
	250-350 kcmil	1.5	1	VC250ME35	3	Not Available
ME4, MX4	2/0 AWG-500 kcmil	2.2	1	VC400ME5	1	Not Available
	500-750 kcmil Al or 500 kcmil Cu	2.5	1	VC400ME7	1	Not Available
ME, MX, MA, MH	2/0 AWG-500 kcmil	1.9	2	VC600MA5	2	Not Available
	500-750 kcmil Al or 500 kcmil Cu	2.1	2	VC800MA7	2	Not Available
NA, NC, NE, NX	2/0 AWG-500 kcmil	3.3	4	VC1200NE5	4	Not Available
	500-750 kcmil Al or 500 kcmil Cu	3.6	4	VC1200NE7	4	—
PAF, PHF, PCF, PEF	2/0 AWG-500 kcmil	[11]	6-8	VC2000PA5	4	Not Available
	2/0 AWG-500 kcmil	[11]	6-8	VC2500PA7	4	Not Available
<b>Copper Compression Lug Kits</b>						
FA, FH, FC	6-1/0 AWG Cu	1.4	1	CVC100FA	3	—
FI	6-1/0 AWG Cu	1.4	1	CVC100FA	3	—
KI	2/0 AWG-300 kcmil Cu	1.5	1	CVC250KA3	3	Not Available
LI, LE, LX, LXI [10]	250-500 kcmil Cu	3.20	2	CVC600LI5	2	Not Available
ME4, MX4	250-500 kcmil Cu	2.6	1	CVC400ME5	1	Not Available
ME, MX	250-500 kcmil Cu	2.4	2	CVC600MA5	2	Not Available
NA, NC, NE, NX	250-500 kcmil Cu	3.3	4	CVC1200NE5	4	Not Available
	500-750 kcmil Cu	3.6	4	CVC1200NE7	4	—

11 OBSOLETE AND OBSOLETE CIRCUIT BREAKERS

[7] Use fully-insulated 0.250 inch slip-on connectors.  
 [8] Unless otherwise specified, wire sizes apply to both aluminum and copper conductors.  
 [9] See instruction bulletins for recommended tools.  
 [10] These lug kits cannot be used on I-Line™ circuit breakers.  
 [11] All P-frame circuit breakers require terminal pads for mounting lugs of any type.

### Power Distribution Connectors (PDC) for Circuit Breakers—for Field Replacement of Mechanical Lugs

Can be used for multiple load connections on one circuit breaker. Use in place of standard distribution blocks to save space and time.

Field-installable kits, including tin-plated aluminum connectors and all necessary mounting hardware are available for Square D FA, LA and Q4-frame molded case circuit breakers.

Connectors are UL Listed:

- For use on load end of circuit breaker only.
- For use in UL508 Industrial Control applications only.
- For use in UL 1995/CSA C22.2 No. 236 heating and cooling equipment.
- For copper wire only.

**Table 11.37: Power Distribution Connectors for FAL/FHL/FCL Circuit Breakers**

Use With Circuit Breaker [12]	Circuit Breaker Ampere Rating	Wires Per Terminal & Wire Range [13] Cu	Cat. No.	Lug Quantity Per Kit	Dimension A (in.)
FAL, FHL, FCL [14]	15–100 A	(6) 14–6 AWG	PDC6FA6	3	1.0
		(3) 14–2 AWG	PDC3FA2	3	1.2

**Table 11.38: Power Distribution Connectors for M- and P-Frame Circuit Breakers**

Use With Circuit Breaker [12]	Circuit Breaker Ampere Rating	Wires Per Terminal & Wire Range [13] Cu	Cat. No.	Lug Quantity Per Kit	Dimension A (in.)	Availability
MAL, MHL, MEL, MXL	125–1000 A	(6) 12–2/0 AWG Cu	PDC6MA20	1	0.0	Not Available
		(12) 14–4 AWG Cu	PDC12MA4	1	0.0	Not Available

11

OBSCURE AND OBSOLETE  
CIRCUIT BREAKERS

[12] Not for use with I-Line circuit breakers.

[13] When using fine stranded wire, increased cross sectional area may cause maximum wire size to be reduced.

[14] OFF end only when OFF end is the load end.

**Test Information**

Universal Test Sets and related accessories are obsolete. Limited service stock is available for replacement or fill purposes. Contact the nearest sales office for product availability.

**Table 11.39: Test Equipment for Circuit Breakers with MicroLogic Series B Trip Systems**

Description	Cat. No.
For those customers who already own the Universal Test Set and want to test the latest standard and full-function (Series B) trip systems, all that is needed is the MicroLogic Series B module (CBTMB). Included is the rating plug adapter and instruction manual.	CBTMB
Replacement ribbon cable and rating plug adapter for CBTMB	CBTMBRK



GFM250

### GFM Ground Fault Module

The MicroLogic ground-fault module (GFM) is a UL Listed circuit breaker accessory for equipment protection. It is a combination ground-fault relay and ground-fault sensing device.

MicroLogic Add-On Ground-Fault Module features:

- Used in combination with the FA, KA, FC, KC, FI, and KI type circuit breakers with a ground-fault shunt trip factory installed (add the suffix "G" to the circuit breaker)
- Adjustable ground-fault pickup levels
- Adjustable ground-fault time delays
- Integral ground fault push-to-test feature and ground-fault indicator
- All GFMs supplied for I-Line™ mounting, easily convertible to unit mount by removing the I-Line brackets
- Neutral current transformer is supplied for 3-phase 4-wire applications. Refer to instructions for proper installation
- Zone-selective interlocking capability is standard with upstream MicroLogic trip system circuit breakers. The GFM can also be zone interlocked with the GC ground-fault system by using a restraint interface module. See page 11-20.
- 120 Vac control power is required for integral test feature. Meets NEC 230-95(c)

**NOTE:** Ground-fault modules cannot be reverse fed.

**Table 11.40: Module/Enclosure Selection Chart**

Companion Circuit Breaker Prefix	Cat. No.	Enclosure Space Required		Ground-Fault Pickup Adjustment Range	Availability
		I-Line Switchboard	Individual Enclosure [1]		
FAL, FHL, FCL, FA, FH, FC	GFM100FA	LA	KA	20–100 A	—
FI	GFM100FI	LA	—	20–100 A	Not Available
KAL, KHL, KI, KA, KH, KC	GFM250	LA	LA	40–200 A	—

### RIM32 Restraint Interface Module

The RIM32 Restraint Interface Module is used to interface the restraint signals between various Square D MicroLogic™ circuit breakers, MicroLogic ground-fault modules, and GC-100 ground-fault protection systems.

The restraint interface module operates on either 120 or 240 Vac, 50/60 Hz. The module is protected by a 1/4 A fuse.

Allowable ZSI combinations are shown in the table below. (Series numbers for current design circuit breakers end in B, for example NE Series 3B.) For double-ended or larger systems, or systems which contain devices from different columns in the table below, contact your local Sales Office for combination information.

If more inputs or outputs are needed, another restraint interface module is necessary. Contact your local Sales Office for information on multiple module installations.

**NOTE:** The maximum distance between devices is 1000 ft. (305 m).

**Table 11.42: ZSI Combination (Where All Inputs Driven are Same Columns)**

Circuit Breaker Series Outputs	Circuit Breaker Series Inputs							
	SE 2 (Ground Fault)	SE 2 (Short Time)	ME 3, NE 1, PE 4	ME 4, 5, NE 2 & 3, P 5 & 6A, SE 3A	ME 5A, NE 3A, PE 6A, SE 3A	LE 1B, ME 5B, NE 3B, PE 6B, SE 3B	GC100	Rim32
SE 2 (Ground Fault)	50	—	R	R	R	R	R	50
SE 2 (Short Time)	—	1	R	R	R	R	R	50
ME 3, NE 1, PE 4	50	R	15	2	13	47	R	50
ME 4, 5 & 5A, NE 2, 3 & 3A, PE 5, 6 & 6A, SE 3 & 3A	50	R	R	1	1	7	R	14
LE 1B, ME 5B, NE 3B, PE 6B, SE 3B	50	R	10	1	R	26	R	44
GC100	R	R	R	R	R	R	R	7
GFM [2]	50	—	2	1	1	5	R	1
RIM32	50	6	50	7	37	50	15	50

# = Maximum inputs without RIM32. Self-restraint counts as one input.  
R = RIM32(s) required to restrain any device.  
— = Invalid combination.

11 OBSOLETE AND OBSOLETE CIRCUIT BREAKERS

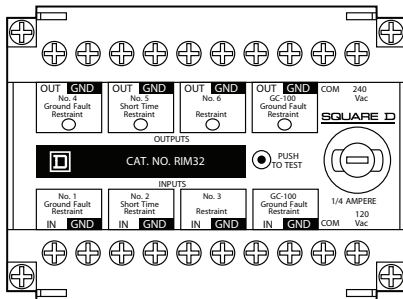

RIM32

**Table 11.41: RIM32**

Cat. No.
RIM32

[1] Use NEMA 1 or 3R enclosures only.

[2] GFM is an output device only.

**MasterPact™ M/MP/MC Circuit Breaker Control Units**

**NOTE:** MasterPact M/MP/MC circuit breakers and related accessories are obsolete. Use MasterPact NT/NW for new applications. See Digest Section 7. Limited service stock is available for replacement or fill purposes. Contact the nearest sales office for product availability.

**Table 11.43: Control Units**

Control Unit	Ground-Fault Protection [1]	Without Ground-Fault Protection [1]
	STR 58U (long-time, short-time and instantaneous protection)	
	Includes Residual Type T — and Ammeter — I	
	STR58U (long-time = 0.4x1 sensor rating)	
	External neutral sensor (TCE) [2]— see page 11-21	
	M10H2	M10H2NG
	M16H2	M16H2NG
	M20H2	M20H2NG
	M25H2	M25H2NG
M32H2	M32H2NG	
M63H2	M63H2NG	



**MasterPact™ M/MP/MC Circuit Breaker Accessories**

**NOTE:** MasterPact M/MP/MC circuit breakers and related accessories are obsolete. Use MasterPact NT/NW for new applications. See Digest Section 7. Limited service stock is available for replacement or fill purposes. Contact the nearest sales office for product availability.



**Table 11.44: Neutral Sensor for 3ØH4W Systems (TCE)**

	Rating	Cat. No.
	800 A	54422
	1250 A	54426
	2000 A	54427

**Table 11.45: Accessories (Must be ordered as separate items)**

	Accessory	Description	Cat. No.
	For STR 18M to STR 58U control units <b>Output voltage:</b> 24 Vdc	Input voltage	
		24/30 Vdc	54440
		48/60 Vdc	54441
		10 Vac 50/60 Hz	54443
		220 Vac 50/60 Hz	54444
	Battery back-up power supply for AD module	380 Vac 50/60 Hz	54446
			54446

**Table 11.46: Accessories for Cradle**

	Accessory	Cat. No.
<b>Position Switches</b>		
	Four SPDT connected position switches (CE)	54590
	Two SPDT disconnected position switches (CD)	54591
<b>Door Escutcheon</b>		
	Can be used with fixed or drawout circuit breakers	54594

[1] External neutral sensor not included.

[2] External AD module (see page 11-21) is required if load is below 20% or if setting is red zone.

Class 931, 940, 960

**MasterPact M/MP/MC Frame Accessories**

**NOTE:** MasterPact M/MP/MC circuit breakers and related accessories are obsolete. Use MasterPact NT/NW for new applications. See Digest Section 7. Limited service stock is available for replacement or fill purposes. Contact the nearest sales office for product availability.

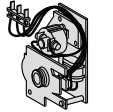

**Table 11.47: Accessories for Circuit Breaker Frame**

	Volts (V)	Cat. No. (XF)	Cat. No. (MX)
Spring Charging Motor (MCH) — Includes Spring Charged Switch			
	AC 50/60 Hz	100/127	—
			54512

**MasterPact™ M/MP/MC Circuit Breaker Spare Parts**

**NOTE:** MasterPact M/MP/MC circuit breakers and related accessories are obsolete. Use MasterPact NT/NW for new applications. See Digest Section 7. Limited service stock is available for replacement or fill purposes. Contact the nearest sales office for product availability.

**Table 11.48: Spare Parts**

Spare Parts	Cat. No.		
Clusters for Cradle (Set of 2)			
	MP25–MP30 3P	M20–M25L 3P	54063 (3)
	MP25–MP30 4P	M20–M25L 4P	54063 (4)
	—	M32H 3P	54063 (3)
	—	M32H 4P	54063 (4)
	MP40–MP50 3P	M50H 3P	54063 (6)
	—	M50H 4P	54063 (7)
Charging Handle			
	One piece		685713
Racking Handle			
	One piece		685631
Vertical UL 489—UL 1066 Connectors			
	MP25–MP30 3P (set of three top or bottom connectors)		54107 (2)

**F-Frame Circuit Breaker Enclosures**

**F-Frame Thermal-Magnetic Circuit Breaker Enclosures**

The enclosures for the F-Frame thermal-magnetic circuit breakers are UL listed and CSA certified. The enclosures are suitable for service entrance equipment when neutral assembly is installed. The short circuit ratings of these enclosed circuit breakers are equal to the interrupter rating, at the supply voltage marked on the circuit breaker installed.

The FA100RB enclosure has a provision of 3/4 through 2 1/2 inch B-Type bolt-on hubs in the top end wall. For details and hub catalog numbers see Section 3 of the Digest.



FA100S



FA100RB



FA100DS

**Table 11.49: F-Frame Thermal-Magnetic Circuit Breaker Enclosures**

Circuit Breaker			Cat. No.				
Cat. No. Prefix	Rating	Poles	Enclosure			Neutral Assembly Kit	Service Ground Kit
			NEMA 1 Flush	NEMA 1 Surface	NEMA 3R		
FAL, FHL, FCL	15–100 A	1, 2, 3	FA100F	FA100S	FA100RB	SN100FA	PKOGTA2
			NEMA 4, 4X, 5 [1] Type 304 Stainless Steel [2]	NEMA 12K With Knockouts	NEMA 12/3R Without Knockouts [2]		
FAL, FHL, FCL	15–100 A	1, 2, 3	FA100DS	FA100A	FA100AWK	SN100FA	PKOGTA2

[1] Complete rating is NEMA 3, 3R, 4, 4X, 5, and 12.  
[2] For NEMA 3R applications, remove drain screw from bottom endwall.

Enclosures for Special Applications

Hazardous Locations: NEMA 7 And NEMA 9 Circuit Breaker Enclosures

The NEMA 7 and 9 enclosures are cULus listed unless otherwise noted. They are rated for use in hazardous locations as defined in NEC Article 500. The short circuit current rating of the enclosed circuit breakers is equal to the rating of the circuit breaker installed unless otherwise noted. They are suitable for use as service entrance equipment when neutral is installed. Enclosures require the use of 75°C copper wire only. The NEMA 7 enclosures are suitable for rainproof applications when the included PKDB1 breather and drain kit is installed.

Table 11.50: NEMA 7 and NEMA 9 Circuit Breaker Enclosures; Thermal-Magnetic F-Frame Circuit Breakers

Circuit Breaker	Enclosure Catalog Number		Neutral Assembly Kit Cat. No.	Service Ground Kit Cat. No.	Threaded Conduit Provisions, Inches		
	Cat. No. Prefix	Rating				Poles	NEMA 7 Cast Aluminum [3]
FAL, FHL	15-60 A	1, 2, 3	FA060X	FA060Y	100SNA	Included	3/4 in.
FAL, FHL	15-100 A	1, 2, 3	FA100X	FA100Y	100SNA	Included	1 1/4 in.

Stainless Steel Front Enclosure

The FA100F NEMA Type 1, flush-mount circuit breaker enclosure is available with a stainless steel front. This modification is desirable in food handling areas such as cafeterias and restaurants. Not UL Listed.

Table 11.51: Stainless Steel Front Enclosure

Cat. No.
FA100FSS

Enclosure Dimensions

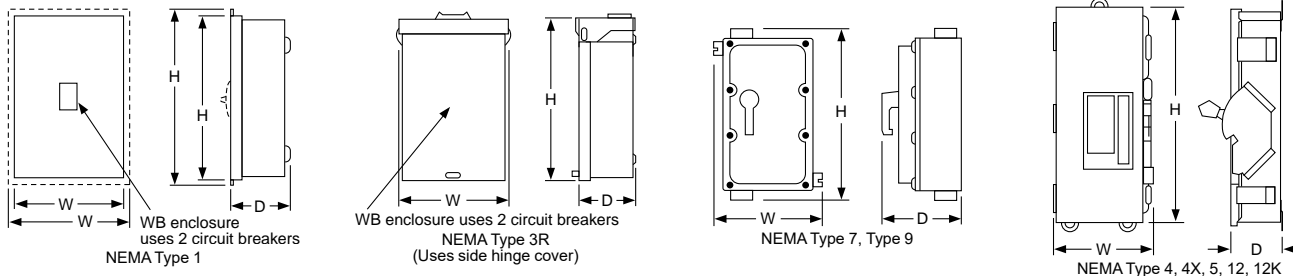

Table 11.52: Dimensions

Cat. No.	Series	Approximate Dimension					
		H		W		D	
		in.	mm	in.	mm	in.	mm
FA100A, AWK	E05	19.5	495	9.13	232	4.88	124
FA100DS	E05	19.5	495	9.13	232	4.88	124
FA100F	E2	19.5	495	9.88	251	4.13	105
FA100RB	E2	18.0	457	8.88	226	4.88	124
FA100S	E2	18.13	461	8.63	219	4.13	105
FA060X	E2	16.00	406	9.88	251	7.00	178
FA060Y	E2	16.00	406	9.88	251	7.00	178
FA100X	E2	16.00	406	9.88	251	7.00	178
FA100Y	E2	16.00	406	9.88	251	7.00	178

11 OBSOLETE AND OBSOLETE CIRCUIT BREAKERS

[3] NEMA 7 — Indoor Hazardous Locations — Division 1 and 2, Class I, Groups C and D; Class II, Groups E, F and G; Class III.

[4] NEMA 9 — Indoor Hazardous Locations — Division 1 and 2, Class II, Groups E, F and G; Class III.

# Section 12

## Obsolete Motor Control Centers

<b>Model 4</b>	<b>12-2</b>
Branch Feeder Units	12-2
Circuit Breaker Type Combination Starters	12-3
Fusible Switch Combination Starter Units	12-4
<b>Series 5600</b>	<b>12-5</b>
General Information	12-5
Branch Feeder and Circuit Breaker Type Combination Starter Units	12-6

**Overview**

This section covers Model 4 Motor Control Center (MCC) unit availability during product obsolescence. All Model 4 orders can be completely defined by catalog type and modifications. Layout sheets and data sheets are not required for order entry.

Note the standard features of the unit. Please refer to footnotes for important information.

Model 4 structures are no longer available. Transition sections can be provided to match an existing Model 4 MCC to a Model 6 MCC.

**Model 4 to Model 6 Transition**

Provides transition from a Model 4 to a Model 6 MCC. The transition requires a 12-inch extension on the first section of the Model 6 lineup. The transition section must be ordered with at least one Model 6 section and cannot ship separately. **The Model 6 bus must be of equal or greater ampacity than the Model 4 bus.** The transition section includes all required splice bars. (Reference the Model 6 Motor Control Center Pricing Guide.)

Please supply original Model 4 factory order number, basic configuration, and Model 4 bus amperage, material, and plating at time of order.

Compatible structure depths include:

- 15-inch deep Model 6 to 14-inch deep Model 4
- 20-inch deep Model 6 to 20-inch deep Model 4

**Branch Feeder Units and Modifications**

**Table 12.1: Circuit Breaker Branch Feeder Units [1]**

No. of Poles	Trip Rating	Breaker Frame Type	Unit Type No.	Space Factor
3	15	FH	BW423	1
	20		BW424	
	30		BW425	
	40		BW429	
	50		BW428	
	60	FH	BW426	
	70		BW450	
	80		BW451	
	90		BW452	
	100		BW427	

**Table 12.2: Dual Mounted Units**

No. of Poles	Trip Rating	Breaker Frame Type	Unit Type No.	Space Factor
3	15/15	FH/FH	BW453	1-1/2
	20/20		BW454	
	30/30		BW455	
	50/50		BW456	
	60/60	FH/FH	BW457	
	100/100		BW458	

**Table 12.3: Miscellaneous Items**

Unit	Description
K401[2]	1/2 S.F. Blank Plate
K402[2]	1 S.F. Blank Plate
K404[2]	2 S.F. Blank Plate

**Table 12.4: Fusible Switch Branch Feeder Units—3-pole [3]**

Voltage	Max. Fuse Size	Unit Type No.	Space Factor
250	30	KW408	1
	60	KX409	1
	100	KY409	1
	200	KZ409	2-1/2
600	30	KW409	1
	60	KX410	1
	100	KY410	1
	200	KZ410	2-1/2

**NOTE:** Fusible branch feeders 30-200 amp using Class H fuse clips have a short circuit rating of 10,000 AIR @ 600 V. If Class R fuse clips are required, order field install kit from Digest.

**Table 12.5: Starter Unit Options**

Description	Form No.
Start-Stop PB with 1 Pilot light — Red (On)[4]	AP
Forward-Reverse-Stop PB with 2 Pilot Lights[5]	A1PP
High-Low-Stop PB with 2 Pilot Lights [6]	A2PP
Hand-Off-Auto SS with 1 Pilot Light — Red (On)[4]	CP
1 Pilot Light only — Red (On)[4]	P
2 Pilot Lights — Red (On)[5]	PP

**Table 12.6: Miscellaneous Units**

MT Units (Undrilled Panel and Hinged Door)		
Unit Type No.	Space Factors	Panel Dimensions[7]
MT414	1	11-3/4 in. H x 13-5/8 in. W
MT415	2	22-1/3 in. H x 13-5/8 in. W

[1] All branch circuit breakers are thermal magnetic with high interrupting Form Y532.  
 [2] Unit support pan included.  
 [3] Fuses not included.  
 [4] Full Voltage Non-Reversing units only.  
 [5] Reversing units only.  
 [6] Two-Speed units only.  
 [7] Dimensions are in inches — Depth from door to panel is 7.50 inches.

**1B Wiring and 1 N.O. and 1 N.C. Auxiliary Interlock (Standard)**

**Table 12.7: Full Voltage Non-Reversing**

Maximum Horsepower At				NEMA Starter Size	C/B Amp	Unit Type No.	Space Factor	No. of Thermal Units Required <sup>[8]</sup>
208 V	240 V	480 V	600 V					
1/4-1/3	1/3	1	1/4-1	1	3	EC403	1	3
1/2-1	1	3	1-1/2-3		7	EC404		
1-1/2-3	3	7-1/2	5-10		15	EC405		
5	7-1/2	10	—		30	EC406		
1-1/2-3	3	7-1/2	5-10	1	15	EC409	1-1/2 <sup>[9]</sup>	3
5	7-1/2	10	—		30	EC410		
5	7-1/2	15	15-20	2	30	ED402	1	3
7-1/2-10	10	25	25		50	ED403		
—	15	—	—		100	ED404		
5	7-1/2	15	15-20		30	ED405		
7-1/2-10	10	25	25	2	50	ED406	1-1/2 <sup>[9]</sup>	3
—	15	—	—		100	ED407		
10	10	25	25-30	3	50	EE404	1-1/2	3
15-25	30	50	40-50		100	EE405		
30	40	—	—	4	225	EF406	2	3
40	—	75	100		225	EF407		
—	50	100	—		225	EF408		
—	—	—	—		—	—		

**Table 12.8: Full Voltage Reversing**

Maximum Horsepower At				NEMA Starter Size	C/B Amp	Unit Type No.	Space Factor	No. of Thermal Units Required <sup>[8]</sup>
208 V	240 V	480 V	600 V					
1/4-1/3	1/3	1	1/4-1	1	3	FC408	1-1/2	3
1/2-1	1	3	1-1/2-3		7	FC409		
1-1/2-3	3	7-1/2	5-10		15	FC410		
5	7-1/2	10	—		30	FC411		
5	7-1/2	15	15-20	2	30	FD402	2	3
7-1/2-10	10	25	25		50	FD403		
—	15	—	—		100	FD404		

**Table 12.9: Two-Speed, Constant Hp, Full Voltage Non-Reversing**

Maximum Horsepower At				NEMA Starter Size	C/B Amp	One Winding (Consequent Pole)		Two Winding (Separate Winding)		No. of Thermal Units Required <sup>[8]</sup>
208 V	240 V	480 V	600 V			Unit Type No.	Space Factor	Unit Type No.	Space Factor	
—	—	1/2	1/4-3/4	1	3	HC415	2	HC419	2	6
1/4-3/4	3/4	2	1-2		7	HC416		HC420		
1-2	2	5	3-5		15	HC417		HC421		
3-5	5	7-1/2	7-1/2		30	HC418		HC422		
—	—	10	10-15	2	30	HC411	2	HD413	2	6
7-1/2	10	20	20		50	HC412		HD414		

**Table 12.10: Two-Speed, Constant or Variable Torque, Full Voltage Non-Reversing**

Maximum Horsepower At				NEMA Starter Size	C/B Amp	One Winding (Consequent Pole)		Two Winding (Separate Winding)		No. of Thermal Units Required <sup>[8]</sup>
208 V	240 V	480 V	600 V			Unit Type No.	Space Factor	Unit Type No.	Space Factor	
1/4-1/3	1/3	1	1/4-1	1	3	HC407	2	HC411	2	6
1/2-1	1	3	1-1/2-3		7	HC408		HC412		
1-1/2-3	3	7-1/2	5-10		15	HC409		HC413		
5	7-1/2	10	—		30	HC410		HC414		
5	7-1/2	15	15-20	2	30	HD405	2	HD408	2	6
7-1/2-10	10	25	25		50	HD406		HD409		
—	15	—	—		100	HD407		HD410		

**NOTE:** Units are wired for 480 V unless 240 V is stated on order. The 480 V control circuit transformer is reconnectable for 240 V. For 240 V and 480 V, form FT is used. For other voltages, form SY74 must be used.

To get NEMA 12, add form N12 to unit.

Mag-Gard™ circuit breaker combination starter units through Size 4 are UL Listed for 22,000 AIR @ 600 V.

[8] Melting alloy overload relay included; thermal units must be ordered separately.  
 [9] Includes extra 1/2 space factor (additional space only).

1B Wiring and 1 N.O. and 1 N.C. Auxiliary Interlock (Standard)

Table 12.11: Full Voltage Non-Reversing

Maximum Horsepower At				NEMA Starter Size	Switch Amp Rating	Unit Type No.	Space Factor	No. of Thermal Units Required <sup>[10]</sup>
208 V	240 V	480 V	600 V					
5	5	—	—	1	30	NC413	1	3
—	—	10	10		30	NC414		
7-1/2	7-1/2	—	—		60	NC415		
—	—	10	10	1	60	NC416	1-1/2 <sup>[11]</sup>	3
7-1/2	7-1/2	—	—		30	NC417		
10	15	—	—	2	60	ND411	1	3
—	—	25	25		60	ND412		
10	15	—	—	2	60	ND413	1-1/2 <sup>[11]</sup>	3
—	—	25	25		60	ND414		
20	25	—	—	3	100	NE416	1-1/2	3
25	30	—	—		200	NE417	3	
—	—	50	50		100	NE418	1-1/2	
40	50	—	—	4	200	NF409	3-1/2	3
—	—	100	100		200	NF410		

Table 12.12: Full Voltage Reversing

Maximum Horsepower At				NEMA Starter Size	Switch Ampere Rating	Unit Type No.	Space Factor	No. of Thermal Units Required <sup>[10]</sup>
208 V	240 V	480 V	600 V					
5	5	—	—	1	30	OC417	1-1/2	3
7-1/2	7-1/2	—	—		60	OC418		
—	—	10	10		30	OC419		
10	10	—	—	2	60	OD409	2	3
—	—	25	25		60	OD410		

Table 12.13: Two-Speed, Constant Hp, Full Voltage Non-Reversing

Maximum Horsepower At				NEMA Starter Size	Switch Amp Rating	One Winding (Consequent Pole)		Two Winding (Separate Winding)		No. of Thermal Units Required <sup>[10]</sup>
208 V	240 V	480 V	600 V			Unit Type No.	Space Factor	Unit Type No.	Space Factor	
5	5	—	—	1	30	QC447	2	QC450	2	6
5	5	—	—		60	QC448		QC450		
—	—	7-1/2	7-1/2		30	QC449		QC452		
7-1/2	10	—	—	2	60	QD437	2	QD439	2	6
—	—	20	20		60	QD438		QD440		

Table 12.14: Two-Speed, Constant or Variable Torque, Full Voltage Non-Reversing

Maximum Horsepower At				NEMA Starter Size	Switch Amp Rating	One Winding (Consequent Pole)		Two Winding (Separate Winding)		No. of Thermal Units Required <sup>[10]</sup>
208 V	240 V	480 V	600 V			Unit Type No.	Space Factor	Unit Type No.	Space Factor	
7-1/2	7-1/2	—	—	1	30	QC441	2	QC444	2	6
7-1/2	7-1/2	—	—		60	QC442		QC445		
—	—	10	10		30	QC443		QC446		
10	15	—	—	2	60	QD433	2	QD435	2	6
—	—	25	25		60	QD434		QD436		

**NOTE:** Units are wired for 480 V unless 240 V is stated on order. The 480 V control circuit transformer is reconnectable for 240 V. For 240 V and 480 V, form FT is used. For other voltages, form SY74 must be used.

Refer to catalog to get NEMA 12, add form N12 to unit.

Fusible starters Sizes 1–3 using Class H fuse clips have a short circuit rating of 5,000 AIR @ 600 V. Size 4 starters using Class H are rated 10 kAIR @ 600 V. If Class R fuse clips are required, order field installable kit from Digest. Fuses are not included.

[10] Melting alloy overload relay included; thermal units must be ordered separately.

[11] Includes extra 1/2 space factor (additional space only).

## Overview

This section covers Series 5600 Motor Control Center availability during product obsolescence. All Series 5600 orders can be completely defined by price, catalog type, and modifications. Layout sheets and data sheets are not required for order entry.

All unit prices are shown as NEMA 1. Note the standard features of the unit. Please refer to footnotes for important information.

### Notes:

1. All units are circuit breaker type.
2. All starter units use Square D™ brand Type S starters and contactors.

## Telemecanique™ Series 5600 History

The Series 5600 MCC was in production for more than 20 years. In 1970 it was first sold under the ITE Circuit Breaker/ITE Imperial name. In 1976 ITE Imperial merged with Gould Inc. The MCC was then sold with the Gould ITE name and later the Gould name. In 1985 the Industrial Controls Division of Gould Inc. was sold to Telemecanique Inc., and the MCC was renamed the Telemecanique Series 5600 MCC. Telemecanique, Inc., was acquired by Groupe Schneider in 1988, and in 1991 Square D Company was purchased by Groupe Schneider.

## Transition Sections From Telemecanique Series 5600 To Square D™ Brand Model 6

Provides transition from Telemecanique Series 5600 MCC to Square D™ brand Model 6 MCC. The transition requires an extension on the first section of the Model 6 lineup. The transition section must be ordered with at least one Model 6 section, and cannot ship separately. **The ampacity of the Model 6 bus will be equal to or greater than that of the Series 5600 bus.** 20 in. deep Model 6 can be spliced to 20 in. deep Series 5600. 15 in. deep Model 6 can be spliced to 15 in. deep Series 5600. 20 in. deep Model 6 can be spliced to 20 in. deep back-to-back Series 5600 (units mounted both front and back), with front only unit mounting on the Model 6 section(s). The transition section includes all required splice bars. (Reference Model 6 Motor Control Center Pricing Guide.)

**NOTE:** Not Available In NEMA Type 3R Construction.

The Model 6 to Series 5600 transition section is available in two basic configurations:

1. Model 6 on right spliced to Series 5600 on left
2. Model 6 on left spliced to Series 5600 on right

The following information must be provided when ordering a Model 6 to Series 5600 transition section:

1. Basic configuration (Model 6 Right/Series 5600 Left or Model 6 Left/Series 5600 Right)
2. Series 5600 bus amperage, material, plating, and dimensions
3. Model 6 bus amperage, material, and plating
4. Original Series 5600 factory order number

Please contact your local Schneider Electric sales office for price and availability of transition sections.

Branch Feeder and Circuit Breaker Type Combination Starter Units

Notes:

1. On starter units, the last digits of the unit catalog number represent the horsepower.
2. All units are NEMA 1 enclosure.
3. All units include a control power transformer and are wired for 120 V control.
4. All starter units are rated for 100 k AIR at 480 V.
5. All starter units are supplied with 1B wiring, 1 N.O. auxiliary interlock, and 1 N.C. auxiliary interlock.

Table 12.15: Full Voltage Non-Reversing Starters

Unit Catalog No.				NEMA Size	C/B Amps	Space Factor
208 V	240 V	480 V	600 V			
1TA.33	2TA.33	TA1	6TA1	1	3	1
1TA1	2TA1	TA3	6TA3		7	
1TA3	2TA3	TA7.5	6TA10		15	
1TA5	2TA7.5	TA10	—		30	
1TA10	2TA10	TA25	6TA25	2	50	1
1TA25	2TA30	TA50	6TA50	3	100	2

Table 12.16: Full Voltage Reversing Starters

Unit Catalog No.				NEMA Size	C/B Amps	Space Factor
208 V	240 V	480 V	600 V			
1TC.33	2TC.33	TC1	6TC1	1	3	1.5
1TC1	2TC1	TC3	6TC3		7	
1TC3	2TC3	TC7.5	6TC7.5		15	
1TC5	2TC7.5	TC10	6TC10		30	
1TC10	2TC10	TC25	6TC25	2	50	1.5

Table 12.19: Single Branch Circuit Breaker Feeder Units

Unit Type	Trip Rating	Frame Type	Space Factor
TW15	15	FD	1
TW20	20		
TW30	30		
TW40	40		
TW50	50		
TW60	60		
TW70	70		
TW80	80		
TW90	90		
TW100	100	FD	1.5
TW125	125		
TW150	150		
TW175	175	JD	1.5
TW200	200		
TW225	225		
TW250	250		

Table 12.17: 2 Speed 1 Winding Starters

Constant Hp				Constant or Variable Torque				NEMA Size	C/B Amps	Space Factor
Unit Catalog No.				Unit Catalog No.						
208 V	240 V	480 V	600 V	208 V	240 V	480 V	600 V	1	3	2
—	—	TH.5	6TH.75	1TE.33	2TE.33	TE1	6TE1			
1TH.75	2TH.75	TH2	6TH2	1TE1	2TE1	TE3	6TE3			
1TH2	2TH2	TH5	6TH5	1TE3	2TE3	TE7.5	6TE7.5			
1TH5	2TH5	TH7.5	6TH7.5	1TE5	2TE7.5	TE10	6TE10	2	50	2
1TH7.5	2TH10	TH20	6TH20	1TE10	2TE10	TE25	6TE25			

Table 12.18: 2 Speed 2 Winding Starters

Constant Hp				Constant or Variable Torque				NEMA Size	C/B Amps	Space Factor
Unit Catalog No.				Unit Catalog No.						
208 V	240 V	480 V	600 V	208 V	240 V	480 V	600 V	1	3	2
—	—	TI.5	6TI.75	1TG.33	2TG.33	TG1	6TG1			
1TI.75	2TI.75	TI2	6TI2	1TG1	2TG1	TG3	6TG3			
1TI2	2TI2	TI5	6TI5	1TG3	2TG3	TG7.5	6TG7.5			
1TI5	2TI5	TI7.5	6TI7.5	1TG5	2TG7.5	TG10	6TG10	2	50	2
1TI7.5	2TI10	TI20	6TI20	1TG10	2TG10	TG25	6TG25			

Table 12.20: Dual Mounted Branch Circuit Breaker Feeder Units

Unit Type	Trip Rating	Frame Type	Space Factor
TW415	15/15	FD/FD	1
TW420	20/20		
TW430	30/30		
TW450	50/50		
TW460	60/60		
TW4100	100/100		

NOTE: All circuit breaker branch feeder units are rated for 25 k AIR at 480 V.

Table 12.21: Starter Unit Options

Description <sup>[1]</sup>	Form No.
Start-Stop PB with 1 Pilot Light—Red (On) <sup>[2]</sup>	AP
Forward-Reverse-Stop PB with 2 Pilot Lights <sup>[3]</sup>	A1PP
High-Low-Stop PB with 2 Pilot Lights <sup>[4]</sup>	A2PP
Hand-Off-Auto SS with 1 Pilot Light—Red (On) <sup>[2]</sup>	CP
1 Pilot Light Only—Red (On) <sup>[2]</sup>	P
2 Pilot Lights—Red (On) <sup>[3][4]</sup>	PP

Table 12.22: Misc. Units—Empty Mounting Units

Description	Unit Type
1 Space Factor	TMT1
2 Space Factor	TMT2

NOTE: Undrilled panel and hinged door.

Table 12.23: Miscellaneous Items

Description	Unit Type
½ Space Factor Blank Door	TBD.5
1 Space Factor Blank Door	TBD1
2 Space Factor Blank Door	TBD2
Ground Stab Kit	TGSK
1 Space Factor Unit Gasketing Kit	TGAS12
1.5 Space Factor Unit Gasketing Kit	TGAS18
2 Space Factor Unit Gasketing Kit	TGAS24

- All units are NEMA 1 enclosure.
- All operators and pilot lights are 22 mm.
- 1 space factor = 12 inches.
- The ground stab kit is field installed and available for all units.

[1] To order a unit with any of the options listed, add the form number as a suffix to the unit type number. Only listed combinations of options are available. Choose only one form number option per starter unit.  
 [2] Full Voltage Non-Reversing units only.  
 [3] Reversing units only.  
 [4] Two-speed units only.

## Section 13

## Obsolescent Panelboards

<b>QMB Fusible Panelboards</b>	<b>13-2</b>
Ready-to-Install (RTI)—600 Vac, 250 Vdc	13-2
QMB Main Lugs and Main Switch Interiors and Accessories	13-2
QMB Layout Information	13-2
Main Switch Replacement Units	13-3
Main Switch Replacement Units	13-3
Branch Switch Replacement	13-4
Guidelines	13-4
Obsolescent Branch Switch Replacement Units	13-5
30–200 A Obsolescent Switch Units—Series D2	13-5
Series E1 Motor Starter Replacement Units	13-6
Application	13-6
Starters	13-6
Selection of Components	13-7
Starter Data	13-7
Accessories	13-7
<b>Replacement Parts</b>	<b>13-7</b>
Trim Clamps and Screws; Circuit I.D. Numbers; Locks	13-7
Trim Clamps and Screws, Circuit I.D. Numbers, Locks	13-7
<b>NQOD Lighting and Appliance Panelboards</b>	<b>13-8</b>
Series Ratings	13-8
Pricing Procedure Examples	13-9
NQOD Merchandised Pricing Procedure	13-9
NQOD 20–inch Wide Main Lug Interiors and NQOD Accessories	13-10
NQOD 20–inch Wide Main Circuit Breaker Interiors and Adapter Kits	13-11
NQOD 14–inch Wide Main Lug and Circuit Breaker Interiors	13-11
For Non-Linear Loads (200% Rated Neutral)	13-12
<b>I-Line Merchandised Panelboards</b>	<b>13-14</b>
I-Line HCN	13-14
<b>Circuit Breakers for I-Line Panelboards and Switchboards</b>	<b>13-16</b>
2 KI, 2 LC, and LI Breakers	13-16
<b>QMB/QMJ Fusible Panelboards Switch Units</b>	<b>13-16</b>
QMB/QMJ Fusible Panelboards Switch Units—600 Vac, 250 Vac	13-16
For QMB/QMJ Panelboards and Switchboards	13-16
Fusible—600 Vac, 250 Vdc	13-17
QMB Layout Information	13-18
<b>Special Features, Modifications, and Terminal Data</b>	<b>13-18</b>
Terminal Data for I-Line Panelboards	13-18

**QMB Main Lugs and Main Switch Interiors and Accessories**

**Table 13.1: QMB Main Lugs Interiors, Boxes and Fronts**

Total Branch Unit Mounting Space (Inches)	Ampere Rating of Mains	Component Selection			Box Height (inches)	Box Width (inches)
		Interior Assembly—3-pole with Main Lugs	Front (4-piece Standard)	Box		
		Catalog No.	Catalog No.	Catalog No.		
60	225	QMB60902	QM38902TS	QM3890B	90	38
45	400	QMB45754	QM38756TS	QM3875B	75	
45	600	QMB45756	QM38756TS	QM3875B	75	
45	800	QMB45908	QM38908TS	QM3890B	90	38
45	1200	QMB459012	QM389012TS	QM3890B		
60	600	QMB60906	QM38906TS	QM3890B		

**Table 13.2: QMB Main Switch Interiors, Boxes and Fronts**

Total Branch Unit Mounting Space (inches)	Ampere Rating of Mains	Maximum Voltage (ac)	Component Selection			Box Height (inches)	Box Width (inches)
			Interior Assembly—3-pole with Main Switch	Front (4-Piece Standard)	Box		
			Catalog No.	Catalog No.	Catalog No.		
51	200	240	QMB5190324M	QM38902TS	QM3890B	90	38
45	400		QMB4590325M	QM38906TS	QM3890B		
	600		QMB4590326M				
51	200	600	QMB5190364M	QM38902TS	QM3890B	90	38
45	400		QMB4590365M	QM38906TS	QM3890B		
	600		QMB4590366M				

**Table 13.3: Accessories [1]**

Blanks		Solid Neutral Assembly	
Height	Catalog No.	Ampere Rating	Catalog No.
1.5	QMB1BLW	225	QMB2SN
3	QMB3BLW	400	QMB4SN2
6	QMB6BLW	600	QMB6SN
15	QMB15BLW	800	QMB8SN
—	—	1200	QMB12SN

**Table 13.4: QMB Branch Circuit Breaker Units 600 Vac**

Unit Ampere Rating	Unit Height (Inches)	Catalog No. [2]	Description
15 –150	6	QMBHW[3]	Mounts (1) or (2) 3-pole HDL circuit breakers
150 –225	6	QMBJW[4]	Mounts (1) 3-Pole JDL circuit breaker
400	7.5	QMB3400LAW[5]	Includes (1) 3-Pole LAL circuit breaker

**QMB Layout Information**

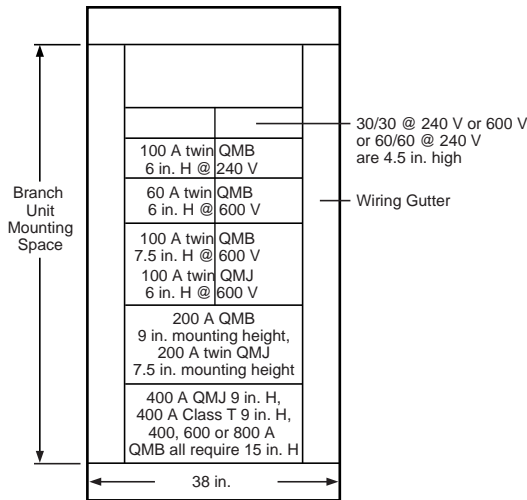

13 OBSOLETE PANELBOARDS

[1] Equipment Ground Bar—PK32DGTA  
 [2] Circuit breakers not included. Order HDL or JDL circuit breakers from Digest.  
 [3] Order one catalog number S37444 for each circuit breaker.  
 [4] Order catalog number S37445 with QMBJW.  
 [5] For trip ratings above 400A, contact your local Schneider Electric sales office.

**Main Switch Replacement Units**

**Table 13.5: Main Switch Replacement Units (Replaces Series E1)**

Ampere Rating	Standard—Class H, R, K Fuse Spacing	Class T Fuse Spacing		Class J Fuse Spacing	
	Catalog No.	Catalog No.		Catalog No.	
<b>3-Pole, 240 Vac</b>					
100	QMB323MW	—	—	—	—
200	QMB324MW	—	—	—	—
400	QMB325MW	—	—	—	—
600	QMB326MW	—	—	—	—
800	—	—	—	—	—
<b>3-Pole, 600 Vac</b>					
100	QMB363MW	—	—	—	—
200	QMB364MW	—	—	—	—
400	QMB365MW	{	QMB365MW[6]	{	QMB365MW[6]
			QMB400T6		QMB400J
600	QMB366MW	{	QMB366MW	{	QMB366MW
			QMB600T6		QMB600J
800	QMB367MW	{	QMB367MW[6]	{	—
			QMB800T6		—
Example:	{	QMB365MW QMB400T6	constitutes a complete device.		

**Table 13.6: Main Switch Interior Lug Data**

Mains Ampere Rating	Conductors Per Phase	Mechanical Lugs		VCEL Compression Lugs			
		Wire Range Wire Bending Space per NEC Table 373-6	Lug Wire Range	Conductors Per Phase	Wire Range Wire Bending Space per NEC Table 373-6	Catalog No.	Lug Wire Range
200	(1)	#6–300 kcmil Al or Cu	#6–300 kcmil Al or Cu	(1)	#4–300 kcmil Al or Cu	VCEL030516H1	#4–300 kcmil Al or Cu
400	(2)	3/0–500 kcmil Al or Cu	3/0–600 kcmil Al or Cu	(2)	2/0–600 kcmil Al or Cu	VCEL05012H1	2/0–500 kcmil Al or Cu
						VCEL07512H1	500–750 kcmil Al
600	(2)	3/0–500 kcmil Al or Cu	3/0–600 kcmil Al or Cu	(2)	2/0–500 kcmil Al or Cu	VCEL05012H1	3/0–500 kcmil Al or Cu
800	(3)	3/0–500 kcmil Al or Cu	3/0–600 kcmil Al or Cu	(3)	2/0–500 kcmil Al or Cu	VCEL05012H1	3/0–500 kcmil Al or Cu

[6] Both catalog numbers are required for a complete device.

**Guidelines**

**STEP 1:** Determine the panelboard interior type. If the date of manufacture is not known, compare your switch with the pictures below to determine the mounting rail direction. Only mounting rails that face outward will accept the Series D2 switch and its required mounting rail extension bracket.

**STEP 2:** Order a replacement switch from 30–200 A Obsolete Switch Units—Series D2, page 13-5.

**Table 13.7: Panelboard Interiors**

Illustration No.	Interior Catalog No. Prefix	Designed For Switch Type	Switch Availability/Order Information
1	Type QM in 31-inch wide box built before 1961.	Series 1-4 30–200 A Maximum	NOT AVAILABLE Series D2 switches are not compatible replacements for this application.
2	Type QM in 31-inch wide box built after 1961 and before 1984.	Series 1-4 30–200 A Maximum	NOT AVAILABLE Order Series D2 switch from page 13-5.
		Series D2 30–200 A Maximum	Order Series D2 switch from page 13-5. (Many still stocked in DS.)
3	Type QW in 38-inch wide box built before 1984.	Series 1-4 30–200 A Maximum	NOT AVAILABLE Order Series D2 switch and plug-on extension assembly from page 13-5.
		Series 1-4 400–600 A	NOT AVAILABLE QMB3400LA available order only from Lexington.
		Series D2 30–200 A Maximum	Order Series D2 switch and plug-on extension assembly from page 13-5.
4	Type QMB in 35-inch or 38-inch wide box built after 1984.	Series E1 or E2 30–800 A	Order from Digest Section 9.

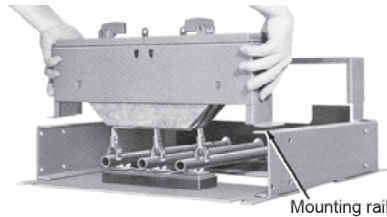

Type QM (31-inch Wide)  
Manufactured Before 1961  
Panelboards manufactured before 1961 have the interior mounting rails facing inward (toward the bus). Switches and circuit breakers that fit in this interior type are obsolete.

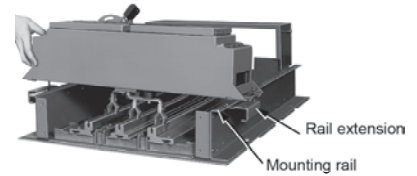

Type QM (31-inch Wide)  
Manufactured After 1961 But Before October 1984  
Panelboards manufactured after 1961 have the interior mounting rails facing outward (away from the bus). This interior accepts Series 1-4 switches and Series D2 switches (shown above with required rail extensions). Order the Series D2 switch (includes mounting rail extensions) from page 13-5.

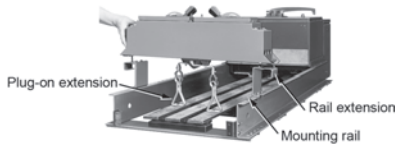

Type QW (38-inch Wide)  
Manufactured Before 1984  
Type QW panelboards were built to accept bolt-on 400 A and 600 A Series 1-4 switches. 30-200 A Series D2 switches may be installed as shown using the plug-on extension assembly from page 13-5.

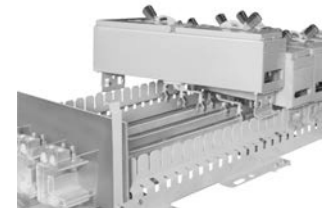

Type QMB  
Manufactured After October 1984  
Series E1 panelboards will accept only Series E1 or E2 switches. Order from Digest Section 9.

**30–200 A Obsolescent Switch Units—Series D2**  
Available In DS Stock, except where noted.

All Series D2 switches require that rail extension assemblies be attached to the interior side rails in order to mount the switch. These rail extension assemblies are packaged with every Series D2 switch. If a rail extension is lost or missing, contact the nearest Schneider Electric™ sales office to order a replacement.

Plug-on extension assemblies must also be ordered when installing 30–200 A plug-on units in blank spaces of a QW interior in the 38-inch wide box. These plug-on extension assemblies (which extend the bus) are NOT the same as the rail extension assemblies packaged with every Series D2 switch (which extend only the mounting rails).

**Table 13.8: Branch Units—Three Pole**

Ampere Rating	Unit Height (inches)	Obsolescent [7]/Series 1–4 Catalog No.	Replaced By Series D2 Catalog No.	Class R Fuse Kits	
				No. Kits Req'd.	Catalog No.
<b>240 Vac</b>					
30-30	4.50	QMB3203T	QMB321T <sup>[8]</sup>	2	HRK30
60-60	4.50	QMB306T	QMB322TD	1	QMB36R
100-100	6.00	QMB310T	QMB323TD	1	QMB100R
200	9.00	QMB3220	QMB324	1	HRK1020
<b>600 Vac</b>					
30-30	4.50	QMB3603T	QMB361T <sup>[8]</sup>	1	QMB36R
30-30	6.00		QMB362T1		
60-60	6.00	QMB3606T	QMB362T	1	QMB60R
100-100	7.50	QMB3610T	QMB363T	2	HRK1020
200	9.00	QMB3620	QMB364	1	

**Table 13.9: Obsolescent Circuit Breaker Units [9]**

Catalog No.
QMB3400LA <sup>[10]</sup>

**Table 13.10: Plug-On Extension Assemblies [11]**

Ampere Rating	Switch Mounting Height (inches)	Catalog No.
30-30 Switch	3	QMB303LEX
30-30 Switch	4.5	QMB306LEX
30-30 Switch	6	QMB306EX
60-60 Switch	4.5	QMB306LEX
60-60 Switch	6	QMB306EX
100-100 Switch	6	QMB310LEX
100-100 Switch	7.5	QMB310EX
200 Switch	9	QMB320EX
LA Circuit Breaker	7.5	QMB310EX

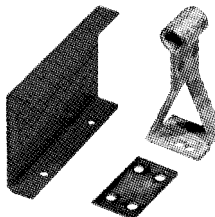

Plug-On Extension Assembly

**Table 13.11: Obsolescent Main Switch Units [12]**

Ampere Rating	Unit Height (inches)	Catalog No.	Replaces Series 4 Unit Catalog No.
<b>3-pole 240 Vac</b>			
100	9	QMB323M <sup>[13]</sup>	QMB3210M
200		QMB324M	QMB3220M
<b>3-pole 600 Vac</b>			
100	9	QMB363M <sup>[13]</sup>	QMB3610M
		QMB363MJ	QMB3610MJ
200	9	QMB364M	QMB3620M
		QMB364MJ	QMB3620MJ

[7] These switch units are no longer available; the catalog number is provided only for cross referencing to Series D2 units.

[8] When this Series D2 switch is used as a replacement for a Series 1-4 3-inch switch, a blank filler plate is also required. Purchase the blank filler plate from a local sheet-metal fabricator.

[9] Circuit breaker units are designed for use in all QMB interior types manufactured between 1961 and October 1984.

[10] Includes a 3-pole, LA type circuit breaker. For other ampere ratings, contact the Schneider Electric Customer Information Center.

[11] Bus extensions are required on all 30–200 A switches. They are also required on all circuit breaker units used in switchboards or in QW type panelboards with a 38-inch wide box.

[12] Replace Series 4 Units

[13] Order only from the Lexington plant.

**Application**

For use on three-phase ac systems—208, 240, or 480 volts. UL® Listed.

**Starters**

Line Voltage Type

- Non-Reversing—Twin Units: Sizes 0 through 3—Class 8536, Types SB, SC, SD and SE.
- Reversing—Single Units: Sizes 0 through 3—Class 8736, Types SB, SC, SD and SE



QMB Motor Starter Panelboard

**Table 13.12: Starter Units—Not stocked in DS. Order only from the Peru plant.**

NEMA Size	Coil Voltage [14]	Class 8536—Types SB, SC, SD and SEq Type S—Non-Reversing (see Digest page 16-16)		Class 8736—Types SB, SC, SD and SE [15] Reversing (see Digest page 16-51)	
		Unit Height (Inches)	Twin-Starter Unit (Two Non-Reversing Starters)	Unit Height (Inches)	Single-Starter Unit (One Reversing Starter)
			Catalog No. [16]		Catalog No. [16]
0	120	9	QMBS8536100120W	9	QMBS873610120W
	208		QMBS8536100208W		QMBS873610208W
	240		QMBS8536100240W		QMBS873610240W
	480		QMBS8536100480W		QMBS873610480W
1	120	9	QMBS8536111120W	9	QMBS873611120W
	208		QMBS8536111208W		QMBS873611208W
	240		QMBS8536111240W		QMBS873611240W
	480		QMBS8536111480W		QMBS873611480W
2	120	10-1/2	QMBS8536222120W	10-1/2	QMBS873622120W
	208		QMBS8536222208W		QMBS873622208W
	240		QMBS8536222240W		QMBS873622240W
	480		QMBS8536222480W		QMBS873622480W
3	120	18	QMBS8536333120W	18	QMBS873633120W
	208		QMBS8536333208W		QMBS873633208W
	240		QMBS8536333240W		QMBS873633240W
	480		QMBS8536333480W		QMBS873633480W

**Table 13.13: UL Listed Short Circuit Ratings @ 600 V Maximum**

Starter Size	Fusible Switch (with Class R or J fuse) RMS Sym. Amperes	Thermal-Magnetic Circuit Breaker RMS Sym. Amperes
0	100,000	5,000
1		
2		
3		

[14] See motor starter section of the current Digest for complete ratings.  
 [15] Space and drilling are provided for field addition of control voltage transformer and fuse base.  
 [16] Catalog numbers include starters, but do not include overload relay thermal units.

**Selection of Components**

1. List required motor starter units (reversing or non-reversing) from the tables above.
2. Specify the HP, voltage, phase, frequency and full load current rating of the motor.
3. Specify the unit mounting space.
4. Determine the circuit breaker or fusible switch rating for motor branch circuits from the selection tables on Digest page 13-16.
5. For motor starter voltages other than standard voltages of 120, 208, 240 and 480 volts, contact the nearest Schneider Electric sales office.

**Starter Data**

- Line voltage coils are furnished as standard on all starters.
- Twistouts are provided in starter covers for start-stop push buttons, selector switches and pilot lights. See accessories table below.
- Starter door interlocks are furnished with motor starter enclosures.
- Type S starter enclosures include drillings for the next smaller size.
- All Type S starters have provisions for three overload relay thermal units, as required by NEC® Table 430.37 for three phase ac motor circuits.

**Accessories**

Accessories listed below are available for field installation on all units. Go to the sections shown for prices.

**Table 13.14: Field Installable Accessories**

Description	Digest Section
Push Buttons and Selector Switches: Class 9001, Type K	Push Buttons and Operator Interface
Pilot Lights: Class 9001, Type KP	
Electrical Interlocks: Class 9999, Types SX6, SX7	NEMA-Definite Purpose Type Contactors and Starters
Industrial Control Transformers: Class 9070	Supplemental Digest, Transformers
Type EO1; Starter Size: 0 and 1, Non-Reversing	
Type EO2; Starter Size: 0, 1 and 2, Reversing	
Type EO3; Starter Size: 3	
Type EO4; Starter Size: 4	
Control Circuit Fuse Block: Class 9080, Type PF1	Terminal Blocks

**Trim Clamps and Screws, Circuit I.D. Numbers, Locks**

**Table 13.15: Trim Clamps and Screws**

Application	Catalog No.
NEHB Panelboards: All fronts up through 400 A	PK3TC

**Table 13.16: Circuit I.D. Numbers**

Circuit Number Description	NEHB and NEHB Column Width Catalog No.
1 through 54	8004332501

**Table 13.17: Locks—Type 1 Enclosures**

Application	Catalog No.
<b>NEHB Panelboards</b>	
All main lug fronts and all main circuit breaker fronts up to 225 A	
Lock only	PK4FL
Complete assembly	PK7FL
All 400 A main circuit breaker fronts	PK5FL
<b>Telephone Cabinets</b>	
Fronts on boxes up to 30 inches wide	PK4FL (Before November 1997) PK22FL (After November 1997)
Fronts on boxes 36 inches or wider	PK5FL



Catalog No. PK3TC



Catalog No. PK4FL



Catalog No. PK5L

**Series Ratings**

This page contains UL Tested and Certified series combination ratings for panelboards. These ratings apply to either an integral main located in the same enclosure or a remote main located in a separate enclosure. NOTE: Where QO(B) GFI circuit breakers are shown above, QO (B) EPD circuit breakers may also be used.

**Table 13.18: NQOD Series Ratings**

Maximum System Voltage AC [1]	Maximum Short Circuit Current Rating (RMS Sym.)	Integral or Remote Main Circuit Breakers and Remote Main Fuses	Branch Circuit Breaker Designations and Allowable Ampere Ranges [2] [3]						
			Type	1-pole	2-pole	3-pole			
120/240 1Ø	22k	MG	QO (B)	15-30 A	—	—			
	42k	HD, JD	QO (B) PL	15-30 A	15-60 A	15-30 A			
	65k	HG, JG							
	100k	HJ, JJ							
	125k	HL, JL							
120/240 1Ø 208Y/120	100k	DJ 400 A	QO (B)	15-70 A	15-125 A	—			
			QO (B) GFI	15-30 A	40-60 A	—			
			QO (B) VH	—	150 A	15-150 A			
			QO (B) AFI	15-20 A	—	—			
		QJ	QO (B)	15-70 A	15-125 A	15-30 A			
			QO (B) AS	15-30 A	15-30 A	15-30 A			
			QO (B) GFI	15-30 A	15-60 A	—			
			QO (B) PL	15-30 A	15-60 A	15-30 A			
			QO (B) VH	—	150 A	35-150 A			
			QO (B) AFI	15-20 A	—	—			
208Y/120	18k	LA/LH (L) 34200MC, LA/LH (L) 34225MC, LA/LH (L) 34250MC, LA/LH (L) 34400MC	QO (B)	15-30 A	15-30 A	15-30 A			
240	22k	QO (B) VH	QO (B)	15-70 A	15-125 A	15-100 A			
			QO (B) AS	15-30 A	15-30 A	15-30 A			
			QO (B) GFI	15-30 A	15-60 A	—			
			QO (B) PL	15-30 A	15-30 A	—			
			QO (B) AFI	15-20 A	—	—			
		Q2-H[4]	QO (B)	15-70 A	15-100 A	15-30 A			
			QO (B) GFI	15-30 A	15-30 A	—			
			QO (B) AFI	15-20 A	—	—			
			240	25k	QD	QO (B)	15-70 A	15-125 A	15-30 A
						QO (B) AS	15-30 A	15-30 A	15-30 A
QO (B) GFI	15-30 A	15-60 A				—			
QO (B) PL	15-30 A	15-60 A				15-30 A			
QO (B) VH	—	150 A				35-150 A			
QO (B) AFI	15-20 A	—			—				
ED, FD[4]	QO (B)	15-70 A			15-125 A	15-100 A			
	QO (B) GFI	15-30 A			15-60 A	—			
	QO (B) AFI	15-20 A			—	—			
	KD[4]	QO (B)			15-70 A	15-125 A	15-100 A		
		QO (B) AS	15-30 A	15-30 A	15-30 A				
QO (B) GFI		15-30 A	15-60 A	—					
QO (B) AFI		15-20 A	—	—					
HD, JD		QO (B)	15-70 A	15-125 A	15-100 A				
	QO (B) VH	—	—	35-150 A					
	QO (B) GFI	15-30 A	15-60 A	—					
	QO (B) AFI	15-20 A	—	—					
	QO (B) H	—	15-100 A	—					
	QOB2150VH	—	150 A	—					
	240	42k	LA, MA	Q2L-H[4]	—	110-225 A	110-225 A		
				QDL	—	70-225 A	70-225 A		
			MG	QO (B) VH	15-30 A	15-30 A	15-30 A		
				QO (B) PL	15-30 A	15-60 A	15-30 A		
LC 600 A Maximum			QO (B)	15-70 A[5]	—	—			
			QO (B) VH	15-30 A	15-125 A	15-100 A (3P 208 V Max.)			
			QO (B) GFI	15-30 A[6]	15-60 A	—			
			QO (B) AFI	15-20 A	—	—			
			QO (B) VH	15-30 A	15-125 A	15-100 A (3P 208 V Max.)			
			QO (B) GFI	15-30 A[6]	—	—			
240	65k	LC 600 A Maximum	QO (B) AFI	15-20 A	—	—			
			QO (B) VH	15-30 A	15-125 A	15-100 A (3P 208 V Max.)			
			QO (B) GFI	15-30 A[6]	—	—			
		DJ 400 A	QO (B) AFI	15-20 A	—	—			
			QO (B)	15-70 A	15-125 A	—			
			QO (B) VH	—	150 A	15-150 A			
			QO (B) H	—	15-100 A	—			
			EG, FG[4], KG[4]	QO (B)	15-70 A	15-125 A	15-100 A		

[1] For shown circuit breakers rated less than this maximum voltage, the indicated short circuit current rating also applies, but at the voltage rating of the circuit breaker.  
 [2] Suffixes HID, SWD and SWN may also be applied to the applicable branch circuit breakers shown above, except suffix SWN may NOT be applied in combination with LC main circuit breakers.  
 [3] Where QO (B) circuit breakers are shown above, QO (B) H, QO (B) VH, and QH (B) circuit breakers may also be used.  
 [4] Obsolete. Contact the Schneider Electric local Field Sales Office for the replacement circuit breaker. One-pole FJ circuit breakers are still available.  
 [5] Only 15-30 A circuit breakers may be used when the LC circuit breaker is rated 450, 500 or 600 A.  
 [6] Circuit breakers may not be used when the LC circuit breaker is rated 450, 500 or 600 A.

**Table 13.18 NQOD Series Ratings (cont'd.)**

Maximum System Voltage AC [7]	Maximum Short Circuit Current Rating (RMS Sym.)	Integral or Remote Main Circuit Breakers and Remote Main Fuses	Branch Circuit Breaker Designations and Allowable Ampere Ranges [8] [9]			
			Type	1-pole	2-pole	3-pole
		QG	QO (B) GFI	15–30 A	15–60 A	—
			QO (B) AFI	15–20 A	—	—
			QO (B)	15–70 A	15–125 A	15–30 A
			QO (B) AS	15–30 A	15–30 A	15–30 A
		QG, HG, JG	QO (B) VH	—	—	35–150 A
			QO (B) GFI	15–30 A	15–60 A	—
			QO (B) PL	15–30 A	15–60 A	15–30 A
			QO (B) AFI	15–30 A	—	—
		HG, JG	QO (B)	15–70 A	15–125 A	15–100 A
			QO (B) VH	—	—	35–150 A
			QO (B) H	—	15–100 A	—
		400 A Max. Class J or T6 Fuses	QOB2150VH	—	150 A	—
			QO (B)	15–70 A	15–100 A	15–100 A
			QO (B) AS	15–30 A	15–30 A	15–30 A
			QO (B) GFI	15–30 A	15–30 A	—
			QO (B) AFI	15–20 A	—	—
QO (B) VH	15–30 A		15–125 A	15–100 A		
QOB-VH	—		150 A	—		
QO (B) AFI	15–20 A		—	—		
240	100k	FC24	QO (B)	15–70 A	15–100 A	15–100 A
		KC24	QO (B) AS	15–30 A	15–30 A	15–30 A
		FC34	QO (B) GFI	15–30 A	15–30 A	—
		KC34	QO (B) AFI	15–20 A	—	—
		200 A Max. Class T3 Fuses	QO (B) AFI	15–20 A	—	—
			QO (B)	15–70 A	15–125 A	15–100 A
		EJ, FJ[7]	QO (B) GFI	15–30 A	15–60 A	—
			QO (B) AFI	15–20 A	—	—
			QO (B)	15–70 A	15–125 A	15–100 A
			QO (B) VH	—	—	35–150 A
240	125k	HL, JL	QO (B) GFI	15–30 A	15–60 A	—
			QO (B) PL	15–30 A	15–60 A	15–30 A
			QO (B) AFI	15–20 A	—	—
			QO (B) H	—	15–100 A	—
240	200k	FI, KI	QOB2150VH	—	150 A	—
			QO (B)	15–70 A	15–125 A	15–100 A
			QO (B) AS	15–30 A	15–30 A	15–30 A
			QO (B) GFI	15–30 A	15–60 A	—
		Maximum Fuses 200 A Class J or T6 400 A Class T3	QO (B) AFI	15–20 A	—	—
			QO (B)	15–70 A	15–125 A	15–100 A
			QO (B) AS	15–30 A	15–30 A	15–30 A
			QO (B) GFI	15–30 A	15–60 A	—

**NQOD Merchandised Pricing Procedure**

1. List circuit breakers required, either plug-on or bolt-on. See appropriate pages for catalog numbers.
2. Determine equivalent number of pole spaces required.
3. Select proper main lugs interior or main lugs exterior and main circuit breaker adapter kit based on equivalent number of poles and ampere rating from appropriate page. Interiors include solid neutral and are field convertible to top feed.
4. Select enclosure from appropriate page.  
Type 1—Select box and front catalog number corresponding to interior catalog number. Types 3R, 5, 12—Select enclosure, front included.
5. For complete price, add the component prices. Include panelboard accessories.
6. Apply appropriate discount schedule.

**NQOD Merchandised Example**

**Table 13.19: 208Y/120 Vac, 3Ø4W, 10 kAIR, 225 A, MLO, Type 1 surface mount, bolt-on branch circuit breakers, main sub-feed lugs**

Branches	Page No.	Catalog Number	Spaces
225 A MLO Interior	NQOD 20-inch Wide Enclosures—240 Vac, 48 Vdc, page 13-10	NQOD430L225CU	30
Box	NQOD 20-inch Wide Enclosures—240 Vac, 48 Vdc, page 13-10	MH32	—
Cover	NQOD 20-inch Wide Enclosures—240 Vac, 48 Vdc, page 13-10	MHC32S	—
Main Sub-Feed Lugs	NQOD 20-inch Wide Enclosures—240 Vac, 48 Vdc, page 13-10	NQOD225SFL	—

[7] For shown circuit breakers rated less than this maximum voltage, the indicated short circuit current rating also applies, but at the voltage rating of the circuit breaker.  
 [8] Suffixes HID, SWD and SWN may also be applied to the applicable branch circuit breakers shown above, except suffix SWN may NOT be applied in combination with LC main circuit breakers.  
 [9] Where QO (B) circuit breakers are shown above, QO (B) H, QO (B) VH, and QH (B) circuit breakers may also be used.  
 [7] Obsolescent. Contact the Schneider Electric local Field Sales Office for the replacement circuit breaker. One-pole FJ circuit breakers are still available.

**NQOD 20-inch Wide Main Lug Interiors and NQOD Accessories**

**Table 13.20: Main Lug Interiors—Accepts plug-on and bolt-on circuit breakers**

Max. No. of Single Pole QO™/QOB Circuit Breakers	Mains Rating	Interior Only (Order Branch Circuit Breakers Separately) Catalog No. [9][10]	Type 1 Enclosure			Types 3R, 5, 12 Enclosures	
			Box 20"W x 5.75"D [8]	Mono-Flat™ Front [8]	Enclosure 20"W x 6.5"D	Height (In.)	
<b>20" Wide Cabinet—Single Phase 3-Wire</b>							
20	100	NQOD20L100CU	MH23	MHC23 ( )	MH23WP	23	
30	225	NQOD30L225CU	MH32	MHC32 ( )	MH32WP	32	
42		NQOD42L225CU	MH35	MHC35 ( )	MH35WP	35	
42		NQOD42L225CUTF [11]	MH41	MHC41 ( )	MH41WP	41	
54		NQOD54L225CU	MH41	MHC41 ( )	MH41WP	41	
30	400	NQOD30L400CU	MH50	MHC50V ( )	MH50WP	50	
42		NQOD42L400CU	MH53	MHC53V ( )	MH53WP	53	
54		NQOD54L400CU	MH59	MHC59V ( )	MH59WP	59	
30	600 [12]	NQOD30L600	MH53	MHC53V ( )	MH656WP	53/65	
42		NQOD42L600	MH56	MHC56V ( )	MH686WP	56/68	
42		NQOD42L600TFL [11]	MH62	MHC62V ( )	MH746WP	62/74	
54		NQOD54L600	MH62	MHC62V ( )	MH746WP	62/74	
<b>20" Wide Cabinet—Three Phase 4-Wire</b>							
24	100	NQOD424L100CU	MH23	MHC23 ( )	MH23WP	23	
30	225	NQOD430L100CU	MH26	MHC26 ( )	MH26WP	26	
30		NQOD430L225CU	MH23	MHC32 ( )	MH32WP	32	
42		NQOD442L225CU	MH35	MHC35 ( )	MH35WP	35	
42		NQOD442L225CUTF [11]	MH41	MHC41 ( )	MH41WP	41	
54	400	NQOD454L225CU	MH41	MHC41 ( )	MH41WP	41	
30		NQOD430L400CU	MH50	MHC50V ( )	MH50WP	50	
42		NQOD442L400CU	MH53	MHC53V ( )	MH53WP	53	
54	600 [12]	NQOD454L400CU	MH59	MHC59V ( )	MH59WP	59	
30		NQOD430L600	MH53	MHC53V ( )	MH656WP	53/65	
42		NQOD442L600	MH56	MHC56V ( )	MH686WP	56/68	
42		NQOD442L600TFL [11]	MH62	MHC62V ( )	MH746WP	62/74	
54	NQOD454L600	MH62	MHC62V ( )	MH746WP	62/74		

**Table 13.21: NQOD Accessories [13]**

Description	Catalog No.
<b>Sub-feed lug kits—main lugs only—1Ø or 3Ø [14]</b>	
100 A	NQOD100SFL
225 A	NQOD225SFL
Sub-feed: Bolt-on: 2-pole	QOB2125SL
3-pole	QOB3125SL
Equipment ground bars: 12 circuit 225 A max.	PK9GTA
20 circuit 225 A max.	PK12GTA
24 circuit 225 A max.	PK15GTA
30 circuit 225 A max.	PK18GTA
54 circuit 225 A max.	PK23GTA
54 circuit 600 A max.	PK27GTA
PK15GTA with #1 to 4/0 Al/Cu lug	PK15GTAL
PK18GTA with #1 to 4/0 Al/Cu lug	PK18GTAL
PK23GTA with #1 to 4/0 Al/Cu lug	PK23GTAL
<b>Ground bar insulator kit</b>	PKGTAB
<b>Filler plate</b>	QOFP
<b>Circuit I.D. number strips</b>	
1-102 odd/even (left side numbered 1,3,5 ... 101)	NQ102OE
103-204 odd/even (left side numbered 103,105,107 ... 203)	NQ204OE
1-102 sequential (left side numbered 1,2,3 ... 102)	NQ102S
103-204 sequential (left side numbered 103,104,105 ... 204)	NQ204S
Directory cards	8003115801
Plastic stick-on directory pouch	8003115901
Lock—for Mono-Flat fronts	PK22FL
Key—NSR-251 (for all locks)	LP9618
Touch-up paint USAS #49 Gray (Aerosol can)	PK49SP
<b>Handle attachments—branch circuit breakers:</b>	
Handle lock-off	HLO1
Handle tie - (QO and QOB only)	QO1HT
Handle padlock attachment - 1-pole	QO1PA
2- and 3-pole	QO1PL
Combination handle tie and lock-off for three 1-pole (QO, QOB)	QO3HT
<b>Neutral or Ground Lugs: #10 to #2 Al or #14 to #4 Cu</b>	
#4 to #1/0 Al/Cu	QO70AN
#1 to #4/0 Al/Cu	Q1100AN
#1 to #4/0 Al/Cu	Q1150AN
<b>Endwalls for MH Boxes</b>	
Blank	8011010501

[8] Embossed mounting holes add a 0.25 inch standoff to back of MH box.  
 [9] "CU" suffix indicates copper bussing. NQOD RTI interiors with aluminum bus are no longer available. Order copper bussed equivalent with a "CU" suffix when ordering replacement interior.  
 [10] Add "F" for flush, "S" for surface.  
 [11] Feed-thru lug interior.  
 [12] Copper bus standard on 600 A interiors.  
 [13] For Door-in-door (hinged) trim see the Supplemental & Obsolescence Digest, Section 4.  
 [14] 42 circuit MLO panelboard requires MH38 box, 54 circuit panelboard requires MH44 box.

**Table 13.21 NQOD Accessories<sup>[13.21]</sup> (cont'd.)**

Description	Catalog No.
With Knockouts	8011010401
Elevating Nuts (4 required)	2322000003

**NQOD 20–inch Wide Main Circuit Breaker Interiors and Adapter Kits**

**Table 13.22: Main Circuit Breaker Interiors—Accepts plug-on and bolt-on circuit breakers**

Max. No. of One-pole QO™/QOB Circuit Breakers	Mains Rating	Main Circuit Breaker Adapter Kit	Interior Only (Order Branch Circuit Breakers Separately)	Type 1 Enclosure		Types 3R, 5, 12 Enclosures <sup>[15]</sup>	
				Box 20"W x 5.75"D <sup>[16]</sup>	Mono-Flat™ Front <sup>[16]</sup>	Enclosure 20"W x 6.5"D	Height (In.)
		Catalog No.	Catalog No. <sup>[17]</sup>	Catalog No.	Catalog No.	Catalog No.	
<b>20" Wide Cabinet—Single Phase 3-Wire</b>							
20	100	Factory Installed Backfed QOB Main Circuit Breaker	NQOD20M100CU	MH26	MHC26 ( )	MH26WP	26
30	225	NQODQB or NQODJK	NQOD30L225CU	MH44	MHC44 ( )	MH44WP	44
42			NQOD42L225CU	MH50	MHC50 ( )	MH50WP	50
42			NQOD42L225CUTF <sup>[18]</sup>	MH56	MHC56 ( )	MH56WP	56
54			NQOD54L225CU	MH56	MHC56 ( )	MH56WP	56
30	400	NQOD4	NQOD30L400CU	MH65	MHC65V ( )	MH65WP	65
42			NQOD42L400CU	MH68	MHC68V ( )	MH68WP	68
42			NQOD42L600TFL <sup>[18]</sup>	MH77	MHC77V ( )	MH77WP	77
54			NQOD54L400CU	MH74	MHC74V ( )	MH74WP	74
<b>20" Wide Cabinet—Three Phase 4-Wire</b>							
24	100	Factory Installed Backfed QOB Main Circuit Breaker	NQOD424M100CU	MH26	MHC26 ( )	MH26WP	26
30	225	NQODQB or NQODJK	NQOD430M100CU	MH29	MHC29 ( )	MH29WP	29
30			NQOD430L225CU	MH44	MHC44 ( )	MH44WP	44
42			NQOD442L225CU	MH50	MHC50 ( )	MH50WP	50
42			NQOD442L225CUTF <sup>[18]</sup>	MH56	MHC56 ( )	MH56WP	56
54	400	NQOD4	NQOD454L225CU	MH56	MHC56 ( )	MH56WP	56
30			NQOD430L400CU	MH65	MHC65V ( )	MH65WP	65
42			NQOD442L400CU	MH68	MHC68V ( )	MH68WP	68
42			NQOD442L600TFL <sup>[18]</sup>	MH77	MHC77V ( )	MH77WP	77
54	NQOD454L400CU	MH74	MHC74V ( )	MH74WP	74		

**Table 13.23: Main Circuit Breaker Adapter Kits (Less Circuit Breaker)**

Amperes	Catalog Number	Circuit Breaker Frame <sup>[19]</sup>
225	NQODQB	QBL, QDL, QGL, QJL
225	NQODJK	JDL, JGL, JJL, JLL, KIL
400	NQOD4	LAL, LHL, Q4L

**NQOD 14–inch Wide Main Lug and Circuit Breaker Interiors**

**Table 13.24: Main Lug Interiors—Accepts plug-on and bolt-on circuit breakers**

Max. No. of Single Pole QO™/QOB Circuit Breakers	Mains Rating	Interior Only (Order Branch Circuit Breakers Separately)	Type 1 Enclosure		Types 3R, 5, 12 Enclosures	
			Box 14 in. W x 5.75 in. D <sup>[20]</sup>	Mono-Flat™ Front <sup>[21]</sup>	Enclosure 20 in. W x 6.5 in. D	Height (In.)
		Catalog No. <sup>[17]</sup>	Catalog No.	Catalog No.	Catalog No.	
<b>14-inch Wide Cabinet—Single Phase 3-Wire</b>						
12	100	NQOD12L100CU	NQB520	NQC20 ( )	Use 20-inch Wide Enclosure for Types 3R, 5, 12	20
20		NQOD20L100CU	NQB523	NQC23 ( )		23
30	225	NQOD30L225CU	NQB532	NQC32 ( )	Use 20-inch Wide Enclosure for Types 3R, 5, 12	32
42		NQOD42L225CU	NQB535	NQC35 ( )		35
54		NQOD54L225CU	NQB541	NQC41 ( )		41
<b>14-inch Wide Cabinet—Three Phase 4-Wire</b>						
12	100	NQOD412L100CU	NQB520	NQC20 ( )	Use 20-inch Wide Enclosure for Types 3R, 5, 12	20
24		NQOD424L100CU	NQB523	NQC23 ( )		23
30		NQOD430L100CU	NQB526	NQC26 ( )		26
30	225	NQOD430L225CU	NQB532	NQC32 ( )	Use 20-inch Wide Enclosure for Types 3R, 5, 12	32
42		NQOD442L225CU	NQB535	NQC35 ( )		35
54		NQOD454L225CU	NQB541	NQC41 ( )		41

<sup>[15]</sup> Enclosure includes trim kit.

<sup>[16]</sup> Embossed mounting holes add a 0.25 inch standoff to back of MH box.

<sup>[17]</sup> "CU" suffix indicates copper bussing. NQOD RT1 interiors with aluminum bus are no longer available. Order copper bussed equivalent with a "CU" suffix when ordering replacement interior.

<sup>[18]</sup> Feed-thru lug interior.

<sup>[19]</sup> Circuit breaker interrupting ratings, see Digest Section 7 under The PowerPact Advantage.

<sup>[20]</sup> 14-inch wide cabinets accept 100 A max. branch circuit breakers.

<sup>[21]</sup> Add "F" for flush, "S" for surface.

**Table 13.25: Main Circuit Breaker Interiors—Accepts Plug-On and Bolt-On Circuit Breakers**

Max. No. of One Pole QO/QOB Circuit Breakers	Mains Rating	Main Circuit Breaker Adapter Kit	Interior Only (Order Branch Circuit Breakers Separately)	Type 1 Enclosure		Types 3R, 5, 12 Enclosure	
				Box 14 in. W x 5.75 in. D <sup>[22]</sup>	Mono-Flat Front <sup>[23]</sup>	Enclosure 20 in. W x 6.5 in. D	Height (In.)
				Catalog No.	Catalog No. <sup>[24]</sup>	Catalog No.	
<b>14-inch Wide Cabinet—Single Phase 3-Wire</b>							
12	100	Factory Installed QOB Main Circuit Breaker	NQOD12M100CU	NQB523	NQC23 ( )	Use 20-inch Wide Enclosure for Types 3R, 5, 12	23
20			NQOD20M100CU	NQB526	NQC26 ( )		26
30	225	NQODJK or NQODQB	NQOD30L225CU	NQB544	NQC44 ( )	Use 20-inch Wide Enclosure for Types 3R, 5, 12	44
42			NQOD42L225CU	NQB550	NQC50 ( )		50
54			NQOD54L225CU	NQB556	NQC56 ( )		56
<b>14-inch Wide Cabinet—Three Phase 4-Wire</b>							
12	100	Factory Installed QOB Main Circuit Breaker	NQOD412M100CU	NQB523	NQC23 ( )	Use 20-inch Wide Enclosure for Types 3R, 5, 12	23
24			NQOD424M100CU	NQB526	NQC26 ( )		26
30			NQOD430M100CU	NQB529	NQC29 ( )		29
30	225	NQODJK or NQODQB	NQOD430L225CU	NQB544	NQC44 ( )	Use 20-inch Wide Enclosure for Types 3R, 5, 12	44
42			NQOD442L225CU	NQB550	NQC50 ( )		50
54			NQOD454L225CU	NQB556	NQC56 ( )		56

**Table 13.26: Main Circuit Breaker Adapter Kits (Less Circuit Breaker)**

Amperes	Catalog No.	Circuit Breaker Frame <sup>[25]</sup>
225	NQODQB	QBL, QDL, QGL, QJL
225	NQODJK	JDL, JGL, JLL, JLL, KIL

**For Non-Linear Loads (200% Rated Neutral)**

**Table 13.27: Main Lug Interiors—Accepts plug-on and bolt-on circuit breakers**

Max. No. of Single Pole QO/QOB Circuit Breakers	Mains Rating	Main Lugs Interior Only (Order Branch Circuit Breakers Separately)	Type 1 Enclosure		Types 3R, 5, 12 Enclosures <sup>[26]</sup>	
			Box 20"W x 5.75"D <sup>[27]</sup>	MONO-FLAT <sup>®</sup> Front <sup>[23]</sup>	Enclosure 20"W x 6.5"D	Height (In.)
			Catalog No. <sup>[24]</sup>	Catalog No.	Catalog No.	
<b>20" Wide Cabinet—3 Phase 4-Wire</b>						
30	100	NQOD430L100CUNL	MH29	MHC29 ( )	MH29WP	29
42	225	NQOD442L225CUNL	MH38	MHC38 ( )	MH38WP	38
42	400	NQOD442L400CUNL	MH53	MHC53V ( )	MH53WP	53

[22] 14-inch wide cabinets accept 100 A max. branch circuit breakers.

[23] Add "F" for flush, "S" for surface.

[24] "CU" suffix indicates copper bussing. NQOD RTI interiors with aluminum bus are no longer available. Order copper bussed equivalent with a "CU" suffix when ordering replacement interior.

[25] Circuit breaker interrupting ratings, see Digest Section 7 under The PowerPact Advantage.

[26] Enclosure includes trim kit.

[27] Embossed mounting holes add a 0.25 inch standoff to back of MH box.

**Table 13.28: Main Circuit Breaker Interiors**

Max. No. of Single Pole QO/QOB Circuit Breakers	Mains Rating	Main Circuit Breaker Adapter Kit [28]	Main Lugs Interior Only (Order Branch Circuit Breakers Separately)	Type 1 Enclosure		Types 3R, 5, 12 Enclosures [29]	
				Box 20"W x 5.75"D	MONO-FLAT Front [30]	Enclosure 20"W x 6.5"D	Height (In.)
		Catalog No.	Catalog No. [31]	Catalog No.	Catalog No.	Catalog No.	
<b>20" Wide Cabinet—3 Phase 4-Wire</b>							
30	100	QOB Main Circuit Breaker	NQOD430M100CUNL	MH32	MHC32 ( )	MH32WP	32
42	225	NQODJK NQODQB	NQOD442L225CUNL	MH50	MHC50 ( )	MH50WP	50
42	400	NQOD4	NQOD442L400CUNL	MH68	MHC68V ( )	MH68WP	68

**Table 13.29: Main Circuit Breaker Adapter Kits (Less Circuit Breaker) [28]**

Amperes	Catalog Number	Circuit Breaker Frame [32]
225	NQODQB	QBL, QDL, QGL, QJL
225	NQODJK	JDL, JGL, JLL, JLL, KIL
400	NQOD4	LAL, LHL

**Table 13.30: NQOD Main Neutral Conductors—Required Size and Quantity [33]**

Panelboard Ampacity	Neutral Conductors Required [34]	Actual Lug Wire Range
100/125	(2) 1/0 Cu or Al	(2) #4–300 kcmil
225	(2) 4/0 Cu or (2) 300 kcmil Al	(2) #4–300 kcmil
400	(4) 3/0 Cu or (4) 250 kcmil Al (2) 600 kcmil Cu (2) 750 kcmil Al	(2) 1/0–300 kcmil or (1) 750 kcmil

[28] Order main circuit breaker separately

[29] Enclosure includes trim kit.

[30] Add "F" for flush, "S" for surface.

[31] "CU" suffix indicates copper bussing. NQOD RT1 interiors with aluminum bus are no longer available. Order copper bussed equivalent with a "CU" suffix when ordering replacement interior.

[32] Main neutral conductors must be copper or aluminum conductors of minimum size and quantity shown to maintain UL Listing. Requirement is based on heat rise testing.

[33] Neutral conductors must be of size and quantity per table above.

[34] Main neutral conductors must be copper or aluminum conductors of minimum size and quantity shown to maintain UL Listing. Requirement is based on heat rise testing.

I-Line HCN

Table 13.31: Interiors, Boxes and Fronts

Total Circuit Breaker Mounting Space (In.)	Mains Ampere Rating	Interior Assembly (Less Branch Circuit Breakers)	Front [1]		Box [2]		Box Height (In.)
			4 Piece Trim Without Door	Trim With Door[3]	Type 1	NEMA 3R/5/12 [4] (Includes Front)	
			Catalog Number	Catalog Number	Catalog Number	Catalog Number	
HCN Main Lugs Only 3-pole—Suitable for use as service equipment when provided with a main circuit breaker. [5]							
27	225 A	HCN14522N	HCN52T( )	HCN52T( )D	HC2652B	HC2652WP	52
	400 A	HCN14524					
	600 A	HCN14526					
45	225 A	HCN23652N	HCN65T( )	HCN65T( )D	HC2665B	HC2665WP	65
	400 A	HCN23654					
	600 A	HCN23656					
63	225 A	HCN32742N	HCN74T( )	HCN74T( )D	HC2674B	HC2674WP	74
	400 A	HCN32744					
	600 A	HCN32746					
81	225 A	HCN41832N	HCN83T( )	HCN83T( )D	HC2683B	HC2683WP	83
	400 A	HCN41834					
	600 A	HCN41836					
99	225 A	HCN50922N	HCN92T( )	HCN92T( )D	HC2692B	HC2692WP	92
	400 A	HCN50924					
	600 A	HCN50926					
HCN Main Circuit Breaker [6] [7] Includes 3-pole, vertically mounted main circuit breaker—Suitable for use as service equipment							
27	400 A	HCN14654M	HCN65T( )	HCN65T( )D	HC2665B	HC2665WP	65
36	100 A	HCN18651MN	HCN65T( )	HCN65T( )D	HC2665B	HC2665WP	65
	225 A	HCN18652MN					
45	400 A	HCN23744M	HCN74T( )	HCN74T( )D	HC2674B	HC2674WP	74
54	100 A	HCN27741MN					
	225 A	HCN27742MN	HCN83T( )	HCN83T( )D	HC2683B	HC2683WP	83
63	225 A	HCN32832MN					
	400 A	HCN32834M	HCN92T( )	HCN92T( )D	HC2692B	HC2692WP	92
81	400 A	HCN41924M					
90	225 A	HCN45922MN					

**TYPE HCM**

250 A max. branch circuit breaker  
BD, BG, BJ, FA, FH, FY, QB, QD, QG, QJ, QH, HD, HG, HJ, HL, HR, JD, JG, JJ, JL, JR

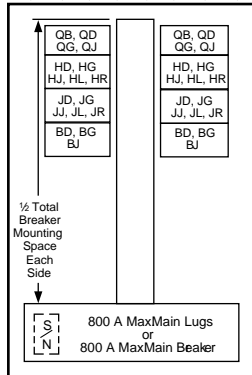

Box Size:  
32 in. Wide, 8.25 in. Deep

**TYPE HCP-SU [8]**

800 A max. main circuit breaker  
600 A max. branch circuit breaker  
BD, BG, BJ, FY, FA, FH, LA, LD, LG, LJ, LL, LH, LR, MG, MJ, PG, PJ, PL, PGC, PJC, PLC [9], QB, QD, QG, QJ, HD, HG, HJ, HL, JD, JG, JJ, JL

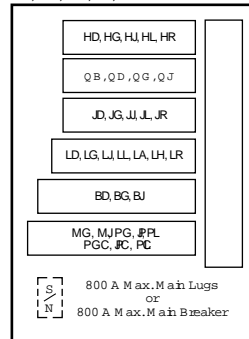

Box Size:  
26 in. Wide, 9.5 in. Deep

13

OBSCURE PANELBOARDS

[1] Add "F" for flush mount, "S" for surface mount.  
 [2] For Type 1 applications, order interior, front, and box. For Type 3R/5/12 applications, order interior and box only. The front is included with the box.  
 [3] For Type 1 applications order interior, trim and box. For type 3R/5/12, order interior and box only.  
 [4] Remove drain screws for Type 3R rating.  
 [5] Suitable for use as service equipment if equipped with an integral main circuit breaker or when not more than six main disconnecting means are provided and the panelboard is not used as a lighting and appliance branch circuit panelboard.  
 [6] Bottom feed standard.  
 [7] Circuit breaker interrupting ratings, see Digest Section 7 under The PowerPact Advantage.  
 [8] For main circuit breaker panel, order plug-on I-Line type PG, PJ, PL, MG, or MJ circuit breakers from 9-47 through 9-48 and backfeed as the main breaker (order solid neutral from 9-37).  
 [9] PG, PJ, PL circuit breakers are available with both thermal-magnetic equivalent and MicroLogic trip. The MicroLogic circuit breakers are available 80% and 100% rated. "C" suffix denotes a 100% rating.

**TYPE HCP**

800 A max. branch circuit breaker  
FA [10], BD, BG, BJ, FA, FH, QB, QD, QG, QJ, HD, HG, HJ, HL, HR, JD, JG, JJ, JL, JR, LA, LH, LD, LG, LJ, LL, LR, MG, MJ, PG, PJ, PL, PGC, PJC, PLC [11]

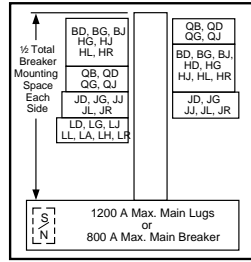

Box Size: 42 in. Wide, 9.5 in. Deep

**TYPE HCR-U Universal Mains**

1200 A max. branch circuit breaker  
FA [10], BD, BG, BJ, FA, FH, QB, QD, QG, QJ, HD, HG, HJ, HL, HR, JD, JG, JJ, JL, JR, LA, LH, LD, LG, LJ, LL, LR, MG, MJ, PG, PJ, PK, PL, RG, RJ, RK, RL, PGC, PJC, PKC, PLC, RGC, RJC, RKC, RLC [12] [11]

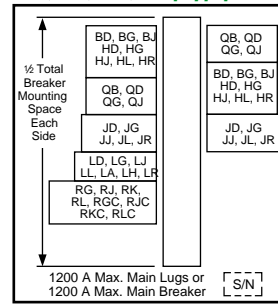

Box Size: 44 in. Wide, 9.5 in. Deep

**Table 13.32: Circuit Breaker / Sub-feed Lug Kit Mounting Space Requirement**

Type of Circuit Breaker	Maximum Ampacity	No. of Poles	Inch Mounting Requirements
FY	30	1	1.5
FA, FH	100	1	1.5
FA, FH		2	3
FA, FH, SL-100		3	4.5
FI		2, 3	4.5
LC, LI, LXI	600	2, 3	7.5

**Accessories**

**Table 13.33: Sub-feed Lug Kits [13][14][15]**

Ampere Rating	Height		Catalog Number	Max. Short Circuit System Ratings RMS Symmetrical Amperes			Protected by Circuit Breaker	For Use in I-Line Panelboard Types
	In.	(mm)		240 Vac	480 Vac	600 Vac		
100 A	4.5	114	SL100	100,000	65,000	18,000	FA, FH, FD, FG, FJ	HCM, HCP, HCP-SU, HCR-U

**Table 13.34: Sub-feed Lug kit terminal data**

Catalog No. (Prefix)	No. Poles	Ampere Rating	Standard Lug Wire Size [16]
SL100	3	100	#14–1/0 AWG Cu or #12–1/0 AWG Al

[10] FA and JDA circuit breakers with field installable ground fault kits may be mounted in type HCP, HCP-SU, and HCR-U panelboards as shown, and require L-frame mounting space.  
 [11] PG, PJ, and PL circuit breakers are available with both thermal-magnetic equivalent and MicroLogic trip. The MicroLogic circuit breakers are available 80% and 100% rated. "C" suffix denotes a 100% rating.  
 [12] When RL main circuit breakers with equipment ground fault are applied on a 3Ø4W system, order solid neutral catalog number HCR12SNCT. The HCR12SNCT includes a neutral current transformer.  
 [13] Plug-on in same manner as a branch circuit breaker  
 [14] For other ratings, see the latest edition of I-Line Information Manual, #80043-309-xx.  
 [15] SL400 cannot be used in HCJ panelboards due to inadequate wire bending space.  
 [16] Unless otherwise specified, wire sizes apply to both aluminum and copper conductors.



KI362502- and 3-pole  
4.5 in. (114 mm) Mounting Height

2 KI breakers

Table 13.35: K-frame—250 A, Thermal-magnetic, Current Limiting (600 Vac)

Ampere Rating	AC Magnetic Trip Settings		Current Limiting Catalog Number	Terminal Wire Range
	Low	High		
2-pole, 600 Vac, 250 Vdc [1]				
110 A	550	1100	KI26110( )	AL250KA one #4 AWG– 350 kcmil Al or Cu
125 A	625	1250	KI26125( )	
150 A	750	1500	KI26150( )	
175 A	875	1750	KI26175( )	
200 A	1000	2000	KI26200( )	
225 A	1125	2250	KI26225( )	AL250KI one #1/0 AWG– 350 kcmil Al or Cu
250 A	1250	2500	KI26250( )	
3-pole, 600 Vac, 250 Vdc				
110 A	550	1100	KI36110	AL250KA one #4 AWG– 350 kcmil Al or Cu
125 A	625	1250	KI36125	
150 A	750	1500	KI36150	
175 A	875	1750	KI36175	
200 A	1000	2000	KI36200	
225 A	1125	2250	KI36225	AL250KI one #1/0 AWG– 350 kcmil Al or Cu
250 A	1250	2500	KI36250	

2 LC, LI

Table 13.36: L-frame—600 A, Thermal-magnetic (600 Vac)[2]



LC  
2- and 3-pole  
7.5 in. (190 mm)  
Mounting Height

Ampere Rating	AC Magnetic Trip Settings		Extra High Interrupting Catalog Number	Current Limiting Catalog Number	Terminal Wire Range
	Low	High			
2-pole, 600 Vac [1]					
300 A	1500	3200	LC26300( )	LI26300( )	AL600LI5 two #4/0 AWG–500 kcmil AL or Cu
350 A	1750		LC26350( )	LI26350( )	
400 A	2000	LC26400( )	LI26400( )		
450 A	2250	LC26450( )	LI26450( )		
500 A	2500	LC26500( )	LI26500( )		
600 A	3000	4200	LC26600( )	LI26600( )	
3-pole, 600 Vac					
300 A	1500	3200	LC36300	LI36300	AL600LI5 two #4/0 AWG–500 kcmil AL or Cu
350 A	1750		LC36350	LI36350	
400 A	2000	LC36400	LI36400		
450 A	2250	LC36450	LI36450		
500 A	2500	4200	LC36500	LI36500	
600 A	3000	LC36600	LI36600		

For QMB/QMJ Panelboards and Switchboards

Table 13.37: QMB Branch Switch Units

Unit Ampere Rating	Unit Height (in.)	Catalog Number	Class R Fuse Kits		Electrical Interlock Kit Catalog Number [2]	Horsepower Ratings [1]													
			No. Kits Req'd.	Catalog Number		240 Vac				480 Vac				600 Vac				250 Vdc	
						Std.	Max.	Std.	Max.	Std.	Max.	Std.	Max.						
2-pole, 240 Vac, 250 Vdc																			
30 A-30 A	4.5	QMB221TW	2	HRK30	QMB300EK (1 or 2)	1.5	3	3	7.5	—	—	—	—	—	—	5			
30 A-Blank		QMB221HW [3]				—	—	—	—	—	—	—	—	—	—	—	5		
60 A-60 A		QMB222TW				1	QMB36R	QMB300EK (1 or 2)	3	7.5	10	15	—	—	—	—	—	—	10
60 A-Blank		QMB222HW [3]							—	—	—	—	—	—	—	—	—	—	—
100 A-100 A	6	QMB223TW	1	QMB100R	QMB610EK (1 or 2)	7.5	15	15	30	—	—	—	—	—	—	20			
100 A-Blank		QMB223HW [3]				—	—	—	—	—	—	—	—	—	—	—	20		
200 A	9	QMB224W	1	HRK1020	QMB200EK (1 or 2)	—	25	15	60	—	—	—	—	—	—	40			
400 A	15	QMB225W		QMB4060R	—	—	—	—	—	—	—	—	—	—	—	—			
	9	QMB225WT3 [4]		—	—	—	—	—	—	—	—	—	—	—	—	—			
600 A	Use 3-pole devices for 2-pole application.												—	—	—	—			
3-pole, 240 Vac																			
30 A-30 A	4.5	QMB321TW	2	HRK30	QMB300EK (1 or 2)	—	3	—	7.5	—	—	—	—	—	—	—			
30 A-Blank		QMB321HW [3]				—	—	—	—	—	—	—	—	—	—	—	—		
60 A-60 A		QMB322TW				1	QMB36R	QMB300EK (1 or 2)	—	7.5	—	15	—	—	—	—	—	—	
60 A-Blank		QMB322HW [3]							—	—	—	—	—	—	—	—	—	—	—
100 A-100 A	6	QMB323TW	1	QMB100R	QMB610EK (1 or 2)	—	15	—	30	—	—	—	—	—	—				
100 A-Blank		QMB323HW [3]				—	—	—	—	—	—	—	—	—	—	—			
200 A	9	QMB324W	1	HRK1020	QMB200EK (1 or 2)	—	25	—	60	—	—	—	—	—	—				
400 A	15	QMB325W		QMB4060R	—	—	—	—	—	125	—	—	—	—	—				
	9	QMB325WT3 [4]		—	—	—	—	—	—	—	—	—	—	—	—				
600 A	15	QMB326W	1	QMB4060R	—	—	—	—	150	—	—	—	—	—	—				
	9	QMB326WT3 [4]				—	—	—	—	—	—	—	—	—	—	—			

[1] 2-pole circuit breaker catalog numbers are completed by adding required phase connection letters as suffix to catalog number. See Digest Section 9.  
 [2] Type LC and LI circuit breakers are NOT recommended for use on single-motor branch circuits.  
 [1] Horsepower rating applicable to 480Y/277 V system only.  
 [2] "1" indicates one normally open and one normally closed contact.  
 "2" indicates two normally open and two normally closed contacts.  
 [3] Blank units cannot be modified to accept a switch interior.  
 [4] Use 300 Vac Class T fuses only.

**Table 13.37 QMB Branch Switch Units (cont'd.)**

Unit Ampere Rating	Unit Height (In.)	Catalog Number	Class R Fuse Kits		Electrical Interlock Kit	Horsepower Ratings [5]															
			No. Kits Req'd.	Catalog Number		Catalog Number [6]	240 Vac				480 Vac				600 Vac				250 Vdc		
					Std.		Max.		Std.		Max.		Std.		Max.						
					1Ø		3Ø	1Ø	3Ø	1Ø	3Ø	1Ø	3Ø	1Ø	3Ø	1Ø	3Ø				
800 A		QMB327WT3 [5]	—	—	—	—	—	—	—	—	—	—	—	—	—	—	—				
<b>2-pole, 600 Vac, 250 Vdc[6]</b>																					
30 A-30 A	4.5	QMB261TW	1	QMB36R	QMB300EK (1 or 2)	1.5	—	3	—	3	5	7.5	15	3	—	10	—	5			
30 A-Blank		QMB261HW [7]				—	—	—	—	—	—	—	—	—	—	—	—	—	—	—	
60 A-60 A		QMB262TW				—	QMB60R	QMB610EK (1 or 2)	3	—	10	—	5	15	20	30	10	—	25	—	10
60 A-Blank		QMB262HW [7]				—			—	—	—	—	—	—	—	—	—	—	—	—	—
100 A-100 A	6	QMB263TW	2	HRK1020	QMB610EK (1 or 2)	7.5	—	15	—	10	25	30	60	15	—	40	—	20			
100 A-Blank		QMB263HW [7]																	—	—	—
200 A	9	QMB264W	1	HRK1020	QMB200EK (1 or 2)	15	—	—	—	25	50	50	125	30	—	50	—	40			
400 A	Use 3-pole devices for 2-pole application.			—	—	—	—	—	—	—	—	—	—	—	—	—	—	—			
600 A				—	—	—	—	—	—	—	—	—	—	—	—	—	—	—			
<b>3-pole, 600 Vac, 250 Vdc[6]</b>																					
30 A-30 A	4.5	QMB361TW	1	QMB36R	QMB300EK (1 or 2)	—	3	—	7.5	—	5	—	15	—	7.5	—	20	—			
30 A-Blank		QMJ361T	—	—		—	—	—	—	—	—	—	—	—	—	—	—	20	5		
60 A-60 A	6	QMB361HW [7]	1	QMB36R	QMB610EK (1 or 2)	—	3	—	7.5	—	5	—	15	—	7.5	—	20	—			
60 A-Blank		QMB362TW				—	QMB60R	—	7.5	—	15	—	15	—	30	—	15	—	50	—	
60 A-Blank		QMJ362T	—	—		—	—	—	—	—	—	—	—	—	—	—	—	—	10		
60 A-30 A		QMB362HW [7]	1	QMB60R and QMB36R		—	7.5	—	15	—	15	—	30	—	15	—	50	—	—		
100 A-100 A	7.5	QMB363TW	2	HRK1020	QMB610EK (1 or 2)	—	15	—	30	—	25	—	60	—	30	—	75	—			
100 A-Blank		QMJ363T				—	—	—	—	—	—	—	—	—	—	—	—	—	—	20	
100 A-Blank	6	QMB363HW [7]	1	HRK1020	QMB610EK (1 or 2)	—	15	—	30	—	25	—	60	—	30	—	75	—			
100 A-30 A		QMJ363H [7]				—	—	—	—	—	—	—	—	—	—	—	—	—	—	20	
100 A-60 A	7.5	QMB363T31W	1	QMB36R and QMB60R	QMB610EK (1 or 2)	—	—	—	—	—	—	—	—	—	—	—	—	—			
100 A-60 A		QMB363T32W				—	—	—	—	—	—	—	—	—	—	—	—	—	—	—	
200 A	9	QMB364W	1	HRK1020	QMB200EK (1 or 2)	—	25	—	60	—	50	—	125	—	60	—	150	—			
200 A-200 A	7.5	QMJ364T	—	—	QMB610EK (1 or 2)	—	25	—	60	—	50	—	125	—	60	—	150	40			
200 A-Blank		QMJ364H [7]				—	—	—	—	—	—	—	—	—	—	—	—	—	—	—	
400 A [8]	15	QMB365W	1	QMB4060R	—	—	—	—	—	100	—	250	—	125	—	350	50				
400 A	9	QMJ365	—	—	QMB200EK (1 or 2)	—	50	—	125	—	100	—	250	—	125	—	350	50			
400 A [8]		QMB365WT6 [9]				—	—	—	—	—	—	—	—	—	—	—	—	—	—	—	
600 A [8]	15	QMB366W	1	QMB4060R	—	—	—	—	—	150	—	400	—	250	—	500	—				
600 A		QMJ366				—	—	—	—	75	—	150	—	—	—	—	—	—	—		
800 A		QMB367W				—	—	—	—	—	—	—	150	—	400	—	250	—	500	—	

**NOTE:** See the Supplemental Digest for merchandised motor starter units, QMB RTI panelboards, and replacement switches for Series 1–4 and D2 QMB panelboards.

**NOTE:** For series E1 and E2, QMJ switches may be used in 400 A–1200 A interiors in a NEMA 1 without door only. QMJ switches cannot be used in series E1 and E2, 225 A panelboards. QMJ switches cannot be used in NEMA 1 with door or any NEMA 3R/12 enclosure.

**Fusible—600 Vac, 250 Vdc**

**Table 13.38: Available QMB Accessories**

Electrical Interlocks		
1NO and 1NC Electrical Interlocks on Main Switches		
2NO and 2NC Electrical Interlocks on Main Switches		
Equipment Ground Bars		
Standard Ground Bar		
Copper Ground Bar		
Insulated/Isolated Ground Bar		
Name Plates		
Copper Neutral		
Copper Neutral		
125–400A		
600A		
800A		
Enclosure Modifications		
Hinged Trim		
Weatherproof - NEMA 3R		
Lugs		
Mechanical Lugs - Standard		
Copper Mechanical Lugs		
Copper Compression Lugs		
Aluminum Compression Lugs		
VCEL Lugs		
UL Listed Short Circuit Ratings for QMB Starters		
Starter Size	Fusible switch-600V Max. (with Class R or J Fuses) RMS Sym. Amps	Thermal-Magnetic Bircuit Breaker 600V Max. Rms Sym. Amps
0	100,000	5,000

OBSOLETE PANELBOARDS 13

[5] Horsepower rating applicable to 480Y/277 V system only.

[6] "1" indicates one normally open and one normally closed contact.

"2" indicates two normally open and two normally closed contacts.

[5] Use 300 Vac Class T fuses only.

[6] Class J fuse provisions—to field modify switch, move load side fuse base to position indicated in switch. Not available on 100-30, 100-60, or 800 A switch units.

[7] Blank units cannot be modified to accept a switch interior.

[8] 250 Vdc rating.

[9] Use 600 Vac Class T fuses only.

Table 13.38 Available QMB Accessories (cont'd.)

1	100,000	5,000
2	100,000	5,000
3	100,000	5,000

**QMB Layout Information**

To maximize the quantity of branch switches, use QMJ switches from page 13-16. Class J fuses are available in time delay construction suitable for motor and transformer loads.

Table 13.39: I-Line™ Panelboard Split Bus Bars

Ampacity MLO	Additional Mounting Height Required On Split Bus Section [10]	
	Split Bus	
225 A	7.5 in.	
400 A	9 in.	
600 A	12 in.	
800 A	12 in.	
1200 A	18 in.	

**NOTE:** For applications with main circuit breaker panelboards, contact your local Schneider Electric representative or distributor.

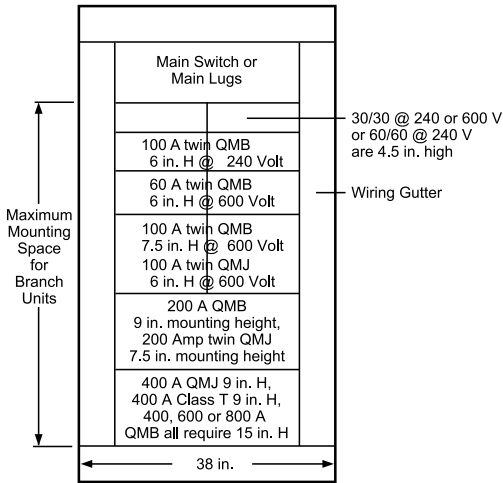

**I-Line Terminal Data**

Table 13.40: Standard Mechanical Lugs—Main Lugs

Panel Type	Ampere Rating	Wire Range Wire Bending Space per NEC Table 312-6 [1]
I-Line	100 A	—
	225 A	(1) #6–300 kcmil Al or Cu
	400 A	(1) #2–600 kcmil Al or Cu (2) #2–500 kcmil Al or Cu
	600 A	(2) #2–500 kcmil Al or Cu
	800 A	(3) 3/0–500 kcmil Al or Cu
	1200 A	(4) 3/0–500 kcmil Al or Cu

Table 13.41: Standard Mechanical Lugs—Main Circuit Breaker

Panel Type	Ampere Rating	Circuit Breaker Type	Wire Range Wire Bending Space per NEC Table 312-6 [1]
I-Line	125 A	BD, BG, BJ	(1) #14–#2/0 AWG Al or Cu
	150 A	HD, HG, HJ, HL	(1) #14–3/0 Al or Cu
	250 A	JD, JG, JJ, JL	(1) #1/0–300 kcmil Al or Cu
	400 A	LA, LH	(1) #1–600 kcmil Al or Cu
	800 A	MG, MJ, PG, PJ, PL	(3) 3/0–500 kcmil Al or Cu
	1200 A	PG, PJ, PL, RGC, RJC, RLC	(4) 3/0–500 kcmil Al or Cu

[10] For I-Line panelboards, dimension includes height of "SL" sub-feed lug kit from Digest, plus 3 in. from available branch mounting space.

[1] (#) = Number of conductors per phase.

# Section 14

## Busway

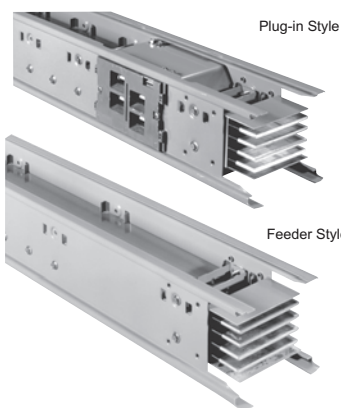

I-Line II Busway 800-5000 A



Powerbus 100-400 A

<b>I-Line™ Busway</b>	<b>14-2</b>
Special Purpose Plug-In Units	14-2
APD and SD Busway Plug-In Units (Not I-Line™ Busway)	14-2
Capacitor and Transformer Units	14-2
Combination Switches and Contactors (For I-Line Busway)	14-2
Ground Indicator and Neutralizer Plugs	14-2
<b>Powerbus™ Busway</b>	<b>14-3</b>
Powerbus™ Busway	14-3
Powerbus 225 (240 V) Ampere	14-3
Powerbus 100 (600 V) Ampere	14-3
Busbar Configurations	14-4

APD and SD Busway Plug-In Units (Not I-Line™ Busway)

Table 14.1: Circuit Breaker Plug-In Units

Breaker Frame	Trip Rating Amps	600 Vac 3Ø4W for use on both 3-Pole and 3Ø4W Busway	Breaker Frame	Trip Rating Amps	600 Vac 3Ø4W for use on both 3-Pole and 3Ø4W Busway
		Catalog Number			Catalog Number
FA	15	SD75415	LA	125	SD78417LA
	20	SD75420		150	SD78418LA
	30	SD75430		175	SD78419LA
	40	SD75440		200	SD78426LA
	50	SD75450		225	SD78427LA
	60	SD75460		250	SD67428
	70	SD75470		300	SD67436
	100	SD75416		350	SD67438
			400	SD67446	

Table 14.2: 100 A Busway Plug-In Unit Circuit Breaker Enclosures and Accessories

Enclosure Only (Price Circuit Breaker Separately)	1Ø3W & 3Ø4W [1]	Ground Kit	Floor Operator Attachment
	Catalog No.	Catalog No.	Catalog No.
QO Breaker—70 A Enclosure	PINQO	PGKQO2	P11QO
QO Breaker/Recpt.—70 A Enclosure [2]	PINQOR	PGKQOR	P11QO
FA Breaker—15-100 A Enclosure	PIN100FA	PGKFA2	P11FA

Capacitor and Transformer Units

Table 14.3: 3Ø Capacitor Units (Order plug-in units separately) [3]

3Ø kVAR	240 Vac	480 Vac
	Catalog Number	Catalog Number
2.5	—	PC3402
5	PC3205	PC3405
7.5	PC3207	PC3407
10	PC3210	PC3410
15	PC3215	PC3415
20	—	PC3420
25	—	PC3425
30	—	PC3430

Table 14.4: 1Ø Transformer Units (Order plug-in units separately) [4]

1Ø kVA	Primary Voltage	
	240 Vac	480 Vac
	Catalog Number	Catalog Number
1	PT2200	PT2400
1.5	PT2201	PT2401
2	PT2202	PT2402
3	PT2203	PT2403
5	PT2205	PT2405
7.5	PT2207	PT2407
10	PT2210	PT2410

Combination Switches and Contactors (For I-Line Busway)

Refer to Catalog 5600CT9101.

Ground Indicator and Neutralizer Plugs

Table 14.5: Ground Indicator and Neutralizer Plugs

240 Vac—3-Pole	600 Vac—3-Pole
Catalog Number	Catalog Number
PGD3200G	PGD3600G

[1] With PIN-QO, use circuit breakers QO215H, QO220H, and QO230H. For higher ratings, use FA enclosures and circuit breakers.

[2] Enclosure with space for three QO circuit breaker poles and provisions for three duplex receptacles.

[3] Capacitor units do not plug into busway and must be used with plug-in switch or circuit breaker.

[4] Transformer units do not plug into busway and must be used with plug-in switch, circuit breaker or cable tap box. Standard secondary voltage terminals are provided for 120 V or 240 V 1Ø2W, or 120/240, 1Ø3W connection. Specify secondary voltage if other than standard.

**Powerbus 225 (240 V) Ampere**

**Table 14.6: 1Ø Systems—Powerbus Straight Lengths and Fittings [1]**

Component	Configuration 3E 1Ø3W	Configuration 3B 1Ø2W Isolated Ground
	Catalog No.	Catalog No.
Straight 10 ft.	PBCP3E225ST120	PBCP3B225ST120
Straight 4 ft.	PBCP3E225ST048	PBCP3B225ST048
Elbow – Left	PBCF3E225LL	PBCF3B225LL
Elbow – Right	PBCF3E225LR	PBCF3B225LR
Cross Fitting	PBCF3E225CR	PBCF3B225CR
Tap Box	PBCF3E225TB	PBCF3B225TB

**Table 14.7: 3Ø3W—Straight Lengths and Fittings**

Component	Configuration 3A	Configuration 4B Isolated Ground
	Catalog No.	Catalog No.
Straight 10 ft.	PBCP3A225ST120	PBCP4B225ST120
Straight 4 ft.	PBCP3A225ST048	PBCP4B225ST048
Elbow – Left	PBCF3A225LL	PBCF4B225LL
Elbow – Right	PBCF3A225LR	PBCF4B225LR
Cross Fitting	PBCF3A225CR	PBCF4B225CR
Tap Box	PBCF3A225TB	PBCF4B225TB

**Table 14.8: 3Ø4W—Straight Lengths and Fittings**

Component	Configuration 4A 100% Neutral	Configuration 5A 100% Neutral Plus Isolated Ground; or 200% Neutral
	Catalog No.	Catalog No.
Straight 10 ft.	PBCP4A225ST120	PBCP5A225ST120
Straight 4 ft.	PBCP4A225ST048	PBCP5A225ST048
Elbow – Left	PBCF4A225LL	PBCF5A225LL
Elbow – Right	PBCF4A225LR	PBCF5A225LR
Cross Fitting	PBCF4A225CR	PBCF5A225CR
Tap Box	PBCF4A225TB	PBCF5A225TB

**Powerbus 100 (600 V) Ampere**

**Table 14.9: 1Ø Systems—Powerbus Straight Lengths and Fittings [1]**

Component	Configuration 3E 1Ø3W	Configuration 3B 1Ø2W Isolated Ground
	Catalog No.	Catalog No.
Straight 10 ft.	PBCP3E100ST120	PBCP3B100ST120
Straight 4 ft.	PBCP3E100ST048	PBCP3B100ST048
Elbow – Left	PBCF3E100LL	PBCF3B100LL
Elbow – Right	PBCF3E100LR	PBCF3B100LR
Cross Fitting	PBCF3E100CR	PBCF3B100CR
Tap Box	PBCF3E100TB	PBCF3B100TB

**Table 14.10: 3Ø3W—Straight Lengths and Fittings**

Component	Configuration 3A	Configuration 4B Isolated Ground
	Catalog No.	Catalog No.
Straight 10 ft.	PBCP3A100ST120	PBCP4B100ST120
Straight 4 ft.	PBCP3A100ST048	PBCP4B100ST048
Elbow – Left	PBCF3A100LL	PBCF4B100LL
Elbow – Right	PBCF3A100LR	PBCF4B100LR
Cross Fitting	PBCF3A100CR	PBCF4B100CR
Tap Box	PBCF3A100TB	PBCF4B100TB

**Table 14.11: 3Ø4W—Straight Lengths and Fittings**

Component	Configuration 4A 100% Neutral	Configuration 5A 100% Neutral Plus Isolated Ground; or 200% Neutral
	Catalog No.	Catalog No.
Straight 10 ft.	PBCP4A100ST120	PBCP5A100ST120
Straight 4 ft.	PBCP4A100ST048	PBCP5A100ST048
Elbow – Left	PBCF4A100LL	PBCF5A100LL
Elbow – Right	PBCF4A100LR	PBCF5A100LR
Cross Fitting	PBCF4A100CR	PBCF5A100CR
Tap Box	PBCF4A100TB	PBCF5A100TB

[1] Also suitable for DC applications.

**Busbar Configurations**

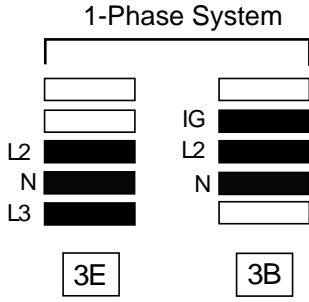

NOTE: Integral ground is standard.

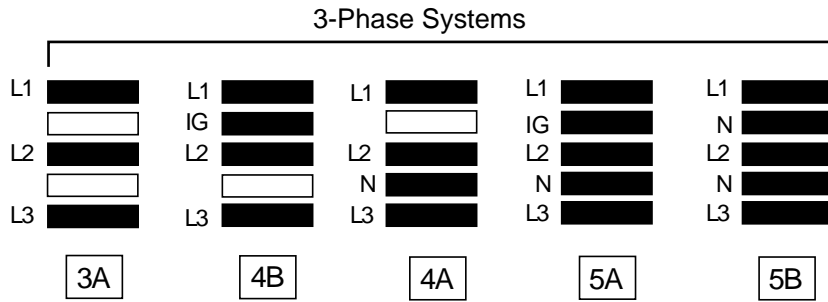

# Section 15

## Operating Mechanisms and Disconnect Switches



Electromechanical  
Reduced Voltage Starter

<b>IEC Style Disconnect Switches</b>	<b>15-2</b>
<b>UL508 Motor Disconnect Switches</b>	<b>15-8</b>
<b>NEMA Style Disconnect Switches</b>	<b>15-9</b>
<b>Door-Mounted Operating Mechanisms</b>	<b>15-10</b>
<b>Door Closing Mechanisms</b>	<b>15-13</b>
Introduction	15-13
Types M5, M6, M1, and M8	15-14
Single and Multi-Door Enclosures	15-15
Types M5, M6, M1, and M8	15-16
<b>Operating Mechanisms, Accessories</b>	<b>15-17</b>
Disconnect Switches and Circuit Breakers	15-17
<b>Bracket-Mounted Disconnect Devices</b>	<b>15-18</b>
<b>Disconnect Switch Accessories</b>	<b>15-19</b>



200 A Switch

30 A Side Handle  
GS1EERU30

Compact 30 A Switch

**Table 15.3: Fusible Switches with Direct Mount  
Side Handle**

Catalog No.	Description
GS1EERU20	30 A, 2-pole, Class CC
GS1EERU30	30 A, 3-pole, Class CC
GS1AH01	Right-side handle for GS1EERU20 and GS1EERU30

**For example:**

LK3SU3 (600 A nonfusible switch, use 15x15 shaft)  
 + GS1AE6 (15x15 200 mm Type H shaft)  
 + LK3AH150 (black/black, lockable)

**To add auxiliary contacts:**

For front-mounted contacts order  
 GS1AD30 (front-mounted auxiliary contact holder)  
 + GS1AM110 (NO contact for GS1AD10, 20, 30)

**Catalog Number Identification System**

The GS1 part numbers can be identified as shown in Table 15.1.  
 See Catalog 9421CT0301 for specific applications.

**Table 15.1: Identification System**

GS1		D	U	3
Model GS1 Fusible (Class J fuse unless noted), LK3 Nonfusible				
Current Range, Operator Type (front operator unless noted), Accessory Type				
D	30 A front and side operation	T	800 A (Class L if fused)	
DD	30 A Class CC front and side operation	U	1000 A	
E	30 A	W	1200 A	
EE	30 A Class CC	AH	handle	
G	60 A	AHT	handle with test	
J	100 A	AE	extension shaft	
M	200 A	AD	auxiliary contact holder	
Q	400 A	AM	auxiliary contact	
S	600 A			
UL Certification				
Poles—Number of Poles, 2 or 3				

**NOTE:** All fusible switches through 400 A, and nonfused switches through 200 A, are equipped with a feature to test the optional auxiliary contacts without energizing the load, when the appropriate GS1AHT\*\*\* handle is used.

**Table 15.2: Fusible Switches, 3-pole**

Catalog No.	Rating	Fuses	Shaft to Use
Compact GS1 Fusible IEC Style Disconnect Switches			
GS1DDU3	30 A	Class CC	5x5 shaft
GS1DU3	30 A	Class J	5x5 shaft
GS1 Fusible IEC Style Disconnect Switches			
GS1EEU3	30 A	Class CC	10x10 shaft
GS1EU3	30 A	Class J	10x10 shaft
GS1GU3	60 A	Class J	10x10 shaft
GS1JU3 [1] [2]	100 A	Class J	10x10 shaft
GS1MU3 [1] [2]	200 A	Class J	10x10 shaft
GS1QU3 [1]	400 A	Class J	10x10 shaft
GS1SU3 [1] [2]	600 A	Class J	15x15 shaft
GS1TU3 [1]	800 A	Class L	15x15 shaft

**Table 15.4: Nonfusible Switches, 3-pole**

Catalog No.	Rating	Shaft to Use
Compact LK3 Nonfusible IEC Style Disconnect Switches		
LK3DU3 [2]	30 A	5x5 shaft
LK3 Nonfusible IEC Style Disconnect Switches		
LK3GU3	60 A	10x10 shaft
LK3JU3 [2]	100 A	10x10 shaft
LK3MU3 [1]	200 A	10x10 shaft
LK3QU3 [1]	400 A	15x15 shaft
LK3SU3 [1]	600 A	15x15 shaft
LK3TU3 [1]	800 A	15x15 shaft
LK3UU3 [1]	1000 A	15x15 shaft
LK3WU3 [1]	1200 A	15x15 shaft

**Example of the parts to order to build a complete GS or LK switch:**

Choose a Switch	+	Shaft	+	Handle Assembly	+	Lugs, if needed
600 A, LK3SU3		Shaft 200 mm, GS1AE6		Black Handle, LK3AH150		Lugs Kit, GS1AW503



[1] Shipped with line side terminal shrouds—for additional shrouds, see Table 15.12. Terminal lug must be ordered separately—see Table 15.11.

[2] Obsolete.

**Handles**

**Table 15.5: Operating Handles for Compact GS1 and LK3 for Use with Shaft Type D**

Type		Defeatable	Padlockable	Color	Operation	Catalog Number
NEMA/UL	IEC					
1, 12	IP54	Yes	Yes	Black	Off/On (O/I)	GS1AH101
				Red/Yellow		GS1AH102



GS1AH101 GS1AH102  
Type D—alternate handles for compact switches only



GS1AE7/AE71 Shafts  
5 mm x 5 mm  
Compact Shaft Kits

**Table 15.6: Operating Handles for Compact GS1 and LK3 for Use with Shaft Type G**

Type		Defeatable	Padlockable	Color	Operation	Catalog Number
NEMA/UL	IEC					
1, 3R, 12	IP54	Yes	Yes	Black	Off/On (O/I)	GS1AH110
				Red/Yellow	Off/On (O/I)	GS1AH120
				Black	Test/Off/On (T/O/I)	GS1AHT110
				Red/Yellow	Test/Off/On (T/O/I)	GS1AHT120
1, 3R, 4, 4X, 12	IP65	Yes	Yes	Black	Off/On (O/I)	GS1AH410 <sup>[3]</sup>
				Red/Yellow	Off/On (O/I)	GS1AH420
				Black	Test/Off/On (T/O/I)	GS1AHT410
				Red/Yellow	Test/Off/On (T/O/I)	GS1AHT420

**Table 15.7: Operating Handles for Standard GS1 and LK3**

Type		Defeatable	Padlockable	Color	Operation	Catalog Number
NEMA/UL	IEC					
GS1 30–100 A and LK3 60–100 A (3 in. handles)						
1, 3R, 12	IP54	Yes	Yes	Black	Off/On (O/I)	GS1AH110
				Red/Yellow	Off/On (O/I)	GS1AH120
				Black	Test/Off/On (T/O/I)	GS1AHT110
				Red/Yellow	Test/Off/On (T/O/I)	GS1AHT120
1, 3R, 4, 4X, 12	IP65	Yes	Yes	Black	Off/On (O/I)	GS1AH410
				Red/Yellow	Off/On (O/I)	GS1AH420
				Black	Test/Off/On (T/O/I)	GS1AHT410
				Red/Yellow	Test/Off/On (T/O/I)	GS1AHT420
GS1 200–400 A and LK3 200 A (5 in. handles)						
1, 3R, 12	IP54	Yes	Yes	Black	Off/On (O/I)	GS1AH130
				Red/Yellow	Off/On (O/I)	GS1AH140
				Black	Test/Off/On (T/O/I)	GS1AHT130
				Red/Yellow	Test/Off/On (T/O/I)	GS1AHT140
1, 3R, 4, 4X, 12	IP65	Yes	Yes	Black	Off/On (O/I)	GS1AH430
				Red/Yellow	Off/On (O/I)	GS1AH440



GS1AH110 GS1AH120  
Type G—Standard Handle Design

Use these shaft kits when using compact switches:



GS1AE8/AE81 Shafts  
5 mm x 5 mm

**Table 15.8: Operating Handles for Use with Shaft Type H**

Type		Defeatable	Padlockable	Color	Operation	Catalog Number
NEMA/UL	IEC					
For LK3 400–1200 A						
1, 3R, 4, 4X, 12	IP65	No	Yes	Black	Off/On (O/I)	LK3AH150 <sup>[3]</sup>
		No		Red/Yellow		LK3AH160 <sup>[3]</sup>
		Yes		Black		LK3AH170
		Yes		Red/Yellow		LK3AH180
For GS1 600–800 A						
1, 3R, 4, 4X, 12	IP65	No	Yes	Black	Off/On (O/I)	LK3AH150 <sup>[3]</sup>
		No		Red/Yellow		LK3AH160 <sup>[3]</sup>
		Yes		Black		GS1AH170
		Yes		Red/Yellow		GS1AH180 <sup>[3]</sup>

**NOTE:** UL approved for indoor or outdoor applications.

**Table 15.9: Shafts**

Length	Length		Catalog No.
	in.	mm	
Shaft 5 mm x 5 mm—For use with Operating Handles, Type D			
12.6		320	GS1AE7
15.7		400	GS1AE71 <sup>[3]</sup>
Shaft 5 mm x 5 mm—For use with Operating Handles, Type G			
12.6		320	GS1AE8 <sup>[3]</sup>
15.7		400	GS1AE81
Shaft 10 mm x 10 mm—For Standard GS1 and LK3			
12.6		320	GS1AE2
15.7		400	GS1AE21
Shaft 15 mm x 15 mm—For use with Operating Handles, Type H			
7.9		200	GS1AE6 <sup>[3]</sup>
15.7		400	GS1AE61 <sup>[3]</sup>



LK3AH160 GS1AE6



GS1AE2/AE21 Shafts

<sup>[3]</sup> Obsolete.

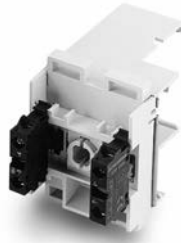
GS1AD10 +  
GS1AM110GS1AD20 +  
GS1AM110GS1AD30 +  
GS1AM110

Terminal Lugs



Terminal Shrouds



Shorting Links

## Accessories

Table 15.10: Auxiliary Contacts

Type	Description	Catalog No.
For Compact LK3 / GS1		
U = Upper or Top mounted	Standard products allow up to 4 auxiliary contacts without any extra contact holders. Contact holder (for 5 to 8 auxiliary contacts)	GS1AD10
10 A	1 N.O. Contact Block	GS1AM110
600 Vac	1 N.C. Contact Block	GS1AM101
For LK3 60–200 A, GS1 30–400 A		
U = Upper or Top mounted	Contact holder required (for 1 to 8 upper auxiliary contacts)	GS1AD20
10 A	1 N.O. Contact Block	GS1AM110
600 Vac	1 N.C. Contact Block	GS1AM101
S = Side mounted [4]	1 N.O. & N.C. Contact Block (max of two blocks—any mix)	GS1AN11
	2 N.O. & N.C. Contact Block (max of two blocks—any mix)	GS1AN22
S = Side mounted [4]	1 N.O. & N.C. Contact Block w/ Test (max of two blocks—any mix)	GS1ANT11 [5]
	2 N.O. & N.C. Contact Block w/ Test (max of two blocks—any mix)	GS1ANT22 [5]
For LK3 400–1200 A		
U = Upper or Top mounted	Contact holder (for 1 to 4 auxiliary contacts)	LK3AD30
10 A	1 N.O. Contact Block	GS1AM110
600 Vac	1 N.C. Contact Block	GS1AM101
For GS1 600–800 A		
Micro-switch (top mounted)	1 N.O./N.C. Contact	GS1AMU3[5]
	2 N.O./N.C. Contact	GS1AMU4[5]

Table 15.11: Terminal Lugs

For Use On	Wire Size (AWG)	No. of Wires per Lug	Wire Type	Lugs per Kit	Catalog No.
Compact GS1/LK3	14–10	1	Cu	—	Standard
GS1 30 A CC	14–10	1	Cu	—	Standard
GS1 30 A J	14–10	1	Cu	—	Standard
GS1/LK3 60 A J	10–3	1	Cu	—	Standard
LK3 100 A	14–2/0	1	Cu	—	Standard
GS1 100 A	14–2/0	1	Cu/Al	6	GS1AW303
GS1/LK3 200 A	6–3/0	1	Cu/Al	6	GS1AW403
GS1/LK3 400–600 A [6]	2 x 2–2 x 600	2	Cu/Al	6	GS1AW503
GS1/LK3 800 A / LK3 1000 A [6]	3 x 2–3 x 600	3	Cu/Al	6	GS1AW803 [5] GS1AW803
LK3 1250 A [6]	4 x 2–4 x 600	2	Cu/Al	12	GS1AW903

Table 15.12: Terminal Shrouds

For Use On	Catalog No.
For Line or Load Side [7]	
Compact GS1/LK3	Standard
All GS1/LK3 30 A	Standard
All GS1/LK3 60 A	Standard
LK3 100 A	Standard
GS1 100 A [8]	GS1AP33
GS1/LK3 200 A [8]	GS1AP43
GS1 400 A	GS1AP63
LK3 400–600 A	LK3AP63
GS1 600–800 A	GS1AP83
LK3 800–1250 A	LK3AP83

Table 15.13: Shorting Links

For Use On	Shorting Links per Kit	Catalog No.
GS1 60 A	3	GS1AU203
GS1 100 A		GS1AU303
GS1 200 A		GS1AU403
GS1 400 A		GS1AU503
GS1 600–800 A		GS1AU803

Table 15.14: Shaft Padlocking Kit

For Use On	Catalog No.
Compact GS1/LK3	Standard
LK3 60–200 A	
GS1 30–400 A	
LK3 400–1250 A	

[4] A GS1AN\*\* contact block may not be used on the same switch as a GS1ANT\*\*. A single switch must use all GS1AN11/GS1AN22 contact blocks or all GS1ANT11/GS1ANT22 contact blocks.

[5] Obsolete.

[6] GS1 600–800 A and LK3 800–1250 A can receive 1 lug for 3 cables per terminal or 2 lugs for 2 cables per terminal.

[7] All GS1 and LK3 switches are provided with line side shrouding.

[8] Three-piece kit for either the line or load side.

**GS1DDU3**  
Compact  
30 A rating  
Class CC fuses

**Dimensions**

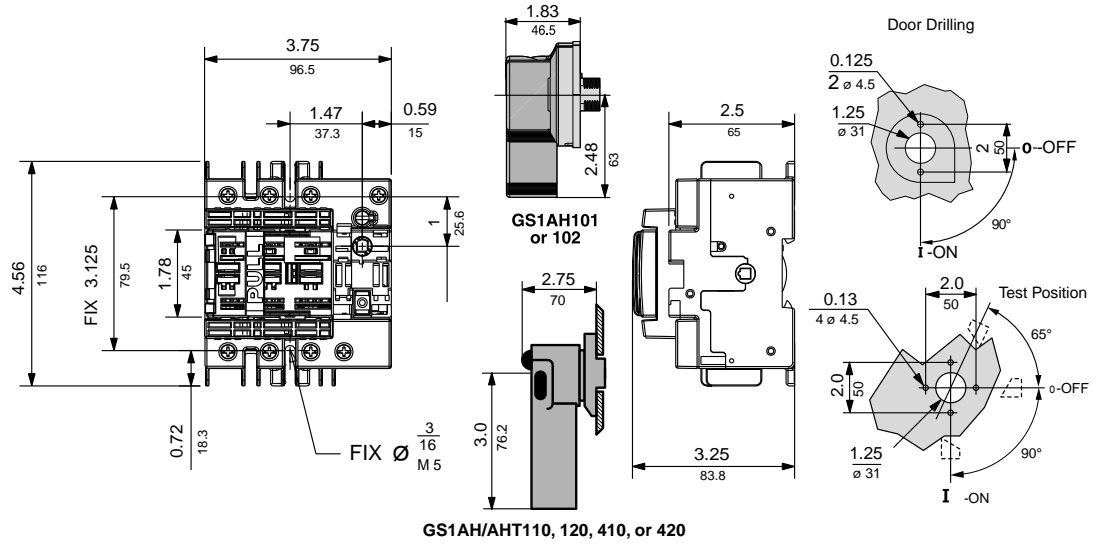

**GS1DU3**  
Compact  
30 A rating  
Class J fuses

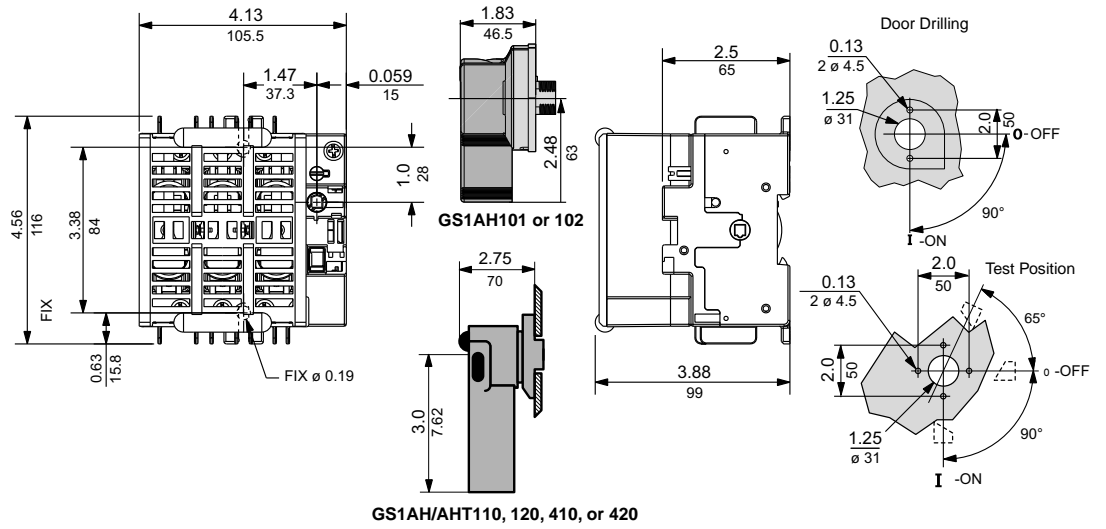

**GS1EEU3**  
30 A rating  
Class CC fuses

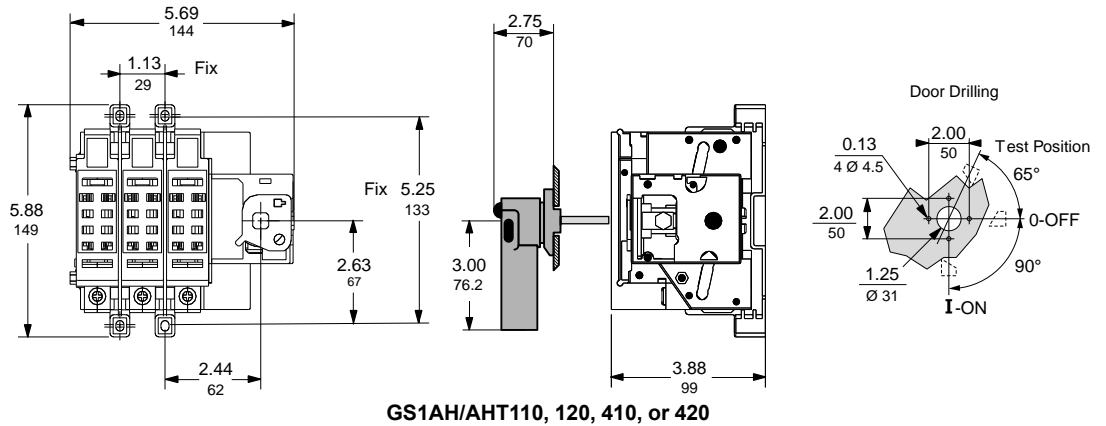

GS1 Dimensions

GS1EU3/GS1GU3,  
30 and 60 A (Class J)

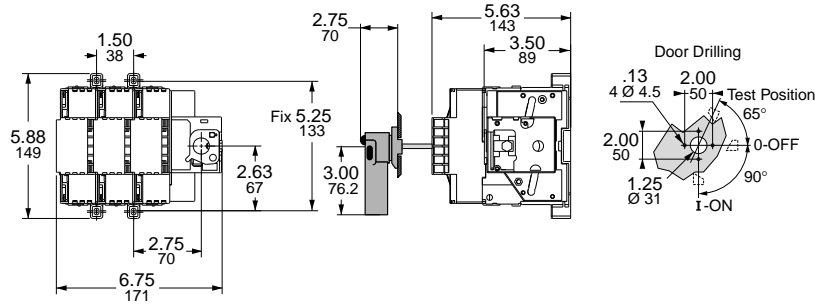

Mounting Hole  
Dimension:  
0.19 in. (4.8 mm)

GS1JU3,  
100 A (Class J)

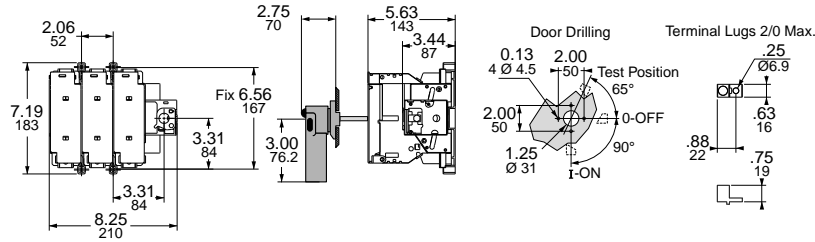

Mounting Hole  
Dimension:  
0.19 in. (4.8 mm)

GS1MU3,  
200 A (Class J)

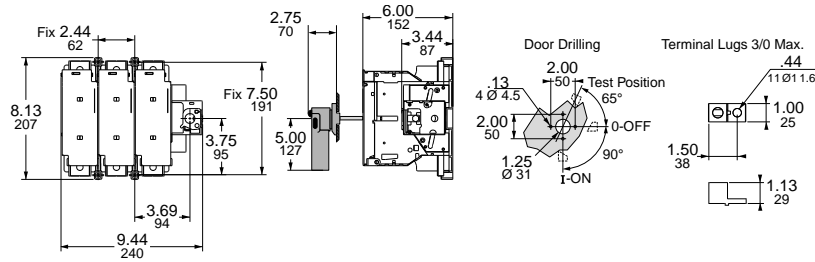

Mounting Hole  
Dimension:  
0.19 in. (4.8 mm)

GS1QU3,  
400 A (Class J)

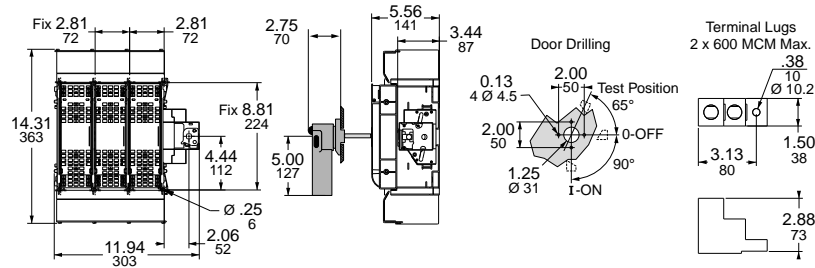

Mounting Hole  
Dimension:  
0.25 in. (6.3 mm)

GS1SU3/GS1TU3,  
600 A (Class J) and  
800 A (Class L)

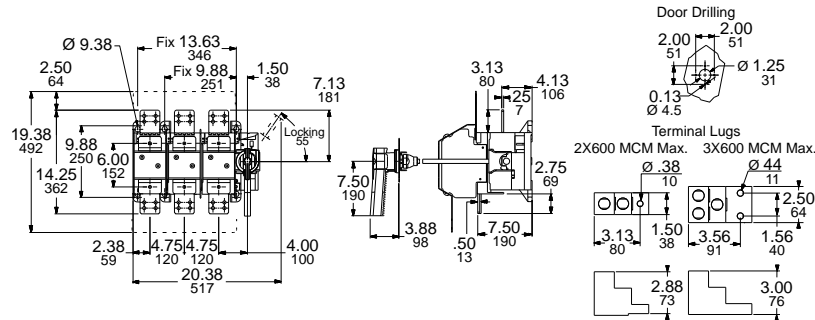

Mounting Hole  
Dimension:  
0.38 in. (9.6 mm)

**LK3DU3,  
Compact LK3  
30 A**

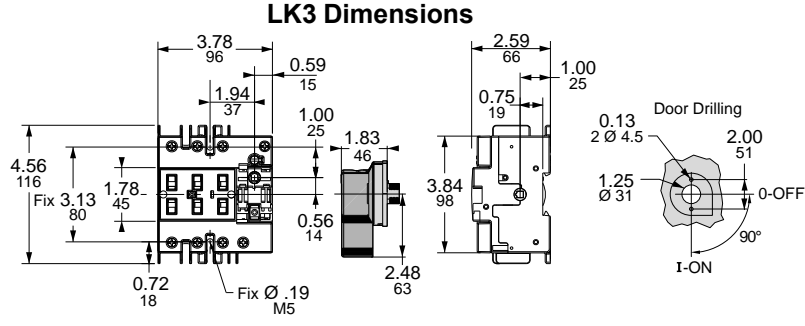

Mounting Hole  
Dimension:  
0.19 in. (4.8 mm)

**LK3GU3/LK3JU3,  
60 and 100 A**

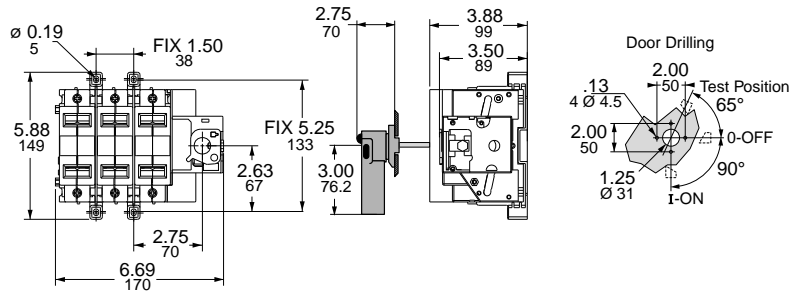

Mounting Hole  
Dimension:  
0.19 in. (4.8 mm)

**LK3MU3,  
200 A**

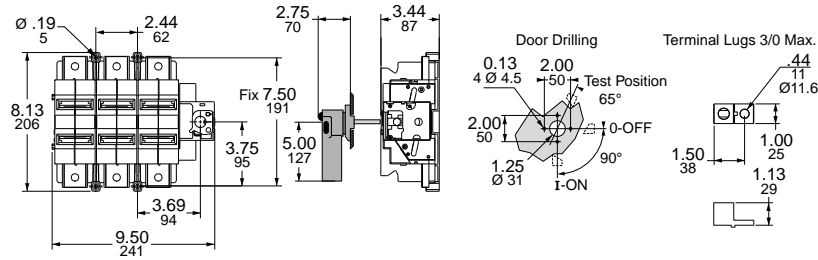

Mounting Hole  
Dimension:  
0.19 in. (4.8 mm)

**LK3QU3/LK3SU3,  
400 and 600 A**

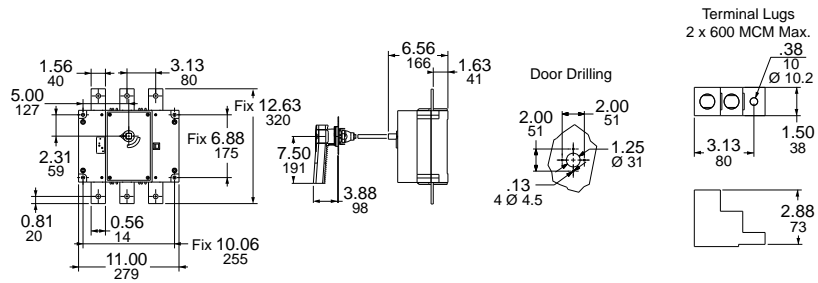

Mounting Hole  
Dimension:  
0.25 in. (6.3 mm)

**LK3TU3/LK3UU3/  
LK3WU3,  
800, 1000, and 1250 A**

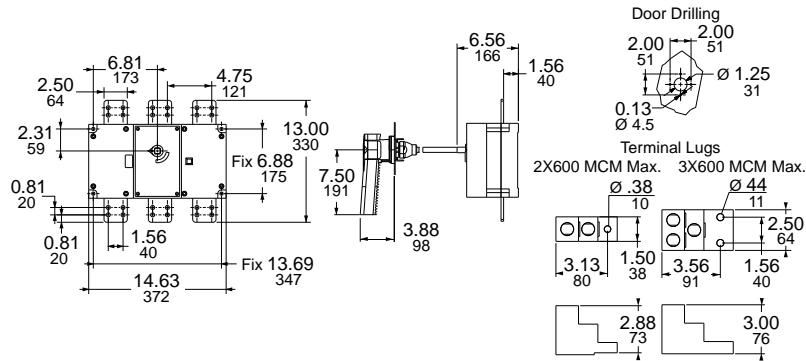

Mounting Hole  
Dimension:  
0.38 in. (9.6 mm)



Non-Metallic Enclosure

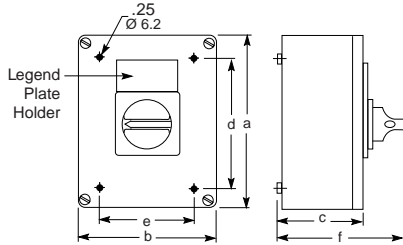

VC1GU-VC6GU

**Vario**

The Vario motor disconnect switch is also offered as an enclosed switch made of corrosion resistant material. The 3-pole version makes the Vario switch ideal for manual motor control applications. The switches are compact, easy to wire and connect, and come undrilled to allow variable cable entry positions.

**NOTE:** VCGUN enclosures are UL approved.

**Table 15.15: Non-Metallic Enclosed Switches [1]**

Ampere Size		IP55-PVC 3-Pole, NEMA Type 1 & 12
UL	IEC	Catalog No.
20	32	VC1GUN
25	40	VC2GUN
45	63	VC3GUN
63	80	VC4GUN
100	125	VC5GUN
115	175	VC6GUN

**Table 15.16: Non-Metallic Enclosed Switch Dimensions**

Catalog No. [2]	No. of Poles	Dimensions											
		a		b		c		d		e		f	
		in.	mm	in.	mm	in.	mm	in.	mm	in.	mm	in.	mm
VC1GU-VC2GU	3	6.7	170	4.1	105	3.2	82	4.8	122	2.1	53	5.0	128
VC3GU-VC4GU		6.7	170	5.3	135	3.3	85	5.1	130	3.7	95	5.2	131
VC5GU-VC6GU		11.0	280	8.6	220	5.0	126	7.9	201	7.5	190	8.6	203

**Table 15.17: Vario Manual Motor Control Switches, IEC**

Rating (A) IEC	kW Rating				3-Pole Switch Body	
	230 V	240 V	400 V	415 V	500 V	690 V
20	4	4	5.5	5.5	7.5	11
25	5.5	5.5	7.5	7.5	11	15
32	5.5	5.5	11	11	11	15
40	7.5	7.5	15	15	18.5	15
63	15	15	22	22	30	22
80	18.5	18.5	30	30	37	30
125	22	22	37	37	45	37
175	30	30	45	45	55	45

[1] Assembled, includes switches mounted in an enclosure with a handle.

[2] UL Rated, NEMA Type 1, 12, IP55.

**File D10**

The D10 disconnect switch features high I<sup>2</sup>T rating, longer contact life, visible contact indication, fuse-mounting flexibility, dead-front construction, and auxiliary interlocks.

A complete installation includes a D10 disconnect switch, D11 handle operator, and D12 fuse clip kit. The D10 accepts Class H, K, J, or R fuses, or can be used for nonfusible applications. The D10 disconnect switch is operated by a cast metal handle operator that is lockable in the Off position and defeatable in the On position.

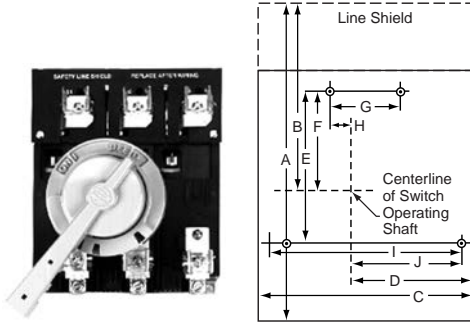

**Table 15.18: Lug Data**

Rating (A)	Number Per Pole	Wire Range [1]	Wire Type
30	1	14-8 AWG	Cu
60		14-4 AWG	Cu
100		14-1/0 AWG	Al-Cu
200		6 AWG - 250 kcmil	Al-Cu

**Table 15.19: Fuse Clip Kits**

D10 Switch Size	Fuse Clip Rating [2]			Catalog Number
	Amperes	AC Volts	Type	
30 A	No Fuse			D12C01
	0-30	250	H, K	D12C21 [3]
	0-30	250	R	D12CR21
	0-30	600	H, K	D12C61
	0-30	600	R	D12CR61
	0-30	600	J	D12CJ1
	31-60	250	H, K	D12C22 [3]
	31-60	600	H, K	D12C62
	31-60	600	R	D12CR62
	31-60	600	J	D12CJ2 [3]
	61-100	250	H, K	D12C23
	60 A	No Fuse		
0-30		250	R	D12DR21 [4]
0-30		600	H, K	D12D61
0-30		600	R	D12DR61
31-60		250	H, K	D12D22
31-60		250	R	D12DR22
31-60		600	H, K	D12D62
31-60		600	R	D12DR62
31-60		600	J	D12DJ2
61-100		250	H, K	D12D23 [3]
61-100		600	H, K	D12D63 [3]
61-100		600	J	D12DJ3 [3]
100 A	No Fuse			D12E03
	31-60	250	H, K	D12E22 [3]
	31-60	600	H, K	D12E62
	61-100	250	H, K	D12E23
	61-100	250	R	D12ER23
	61-100	600	H, K	D12F63
	61-100	600	R	D12FR63
	61-100	600	J	D12EJ3
	101-200	250	H, K	D12F24
	101-200	600	H, K	D12F64
	101-200	600	J	D12FJ4
	200 A	No Fuse		
61-100		600	H, K	D12F63
101-200		250	H, K	D12F24
101-200		250	R	D12FR24
101-200		600	H, K	D12F64
101-200		600	R	D12FR64

**Table 15.20: Disconnect Switches (without fuse clips or shorting straps)**

600 V—Without Service Entrance Rating						
Starter NEMA Size	Rating (A)	Max. Horsepower Rating [5]				Catalog Number
		120 V	200-240 V	480 V	600 V	
0-1	30	5	10	20	25	D10S1
2	60	10	20	40	50	D10S2
3	100	15	30	60	75	D10S3
4	200	25	50	100	100	D10S4
600 V—With Service Entrance Rating						
Starter NEMA Size	Rating (A)	Max. Horsepower Rating [5]				Catalog Number
		120 V	200-240 V	480 V	600 V	
0-1	30	5	10	20	25	D10S1H
2	60	10	20	40	50	D10S2H
3	100	15	30	60	75	D10S3H
4	200	25	50	100	100	D10S4H

**Table 15.21: Rotary Handle Operator Kits and Shafts**

Kits include: Handle, Shaft, and Actuator NEMA Type 1, 3, 3R, 4, and 12			
Description	Rating (A)	Enclosure Interior Depth (in.)	Catalog Number
Complete Kit with Handle, Shaft, and Actuator	30, 60, 100, 200	5-6	D11SF4
		6-10	D11SF10
		10-16	D11SF16
Shaft only		6	D11SH10 [4]
		12	D11SH16

**Table 15.22: Auxiliary Electrical Interlock (for mounting on a 30-200 A disconnect switch) [6]**

Block Description (with switch contacts open)	Catalog Number
1 N.O.	D11N0 [3]
1 N.C.	D11NC
1 N.O. and 1 N.C.	D11N0C
2 N.O.	D11N00 [3]
2 N.O. and 2 N.C.	D11N00C2

**Table 15.23: Interrupting and Withstandability Ratings**

Rating (A)	Interrupting Rating Amperes Symmetrical 600 Vac, 3Ø	Withstandability I <sup>2</sup> T (Amperes <sup>2</sup> seconds)
30	1,200	0.38 x 10 <sup>6</sup>
60	1,800	1.28 x 10 <sup>6</sup>
100	2,000	2.62 x 10 <sup>6</sup>
200	3,600	5.25 x 10 <sup>6</sup>

**NOTE:** These switches are for motor circuit applications.

**Table 15.24: Switch Dimensions (in.)**

Rating (A)	Length		Width		Mounting Hole Dimensions						Depth	
	A	B	C	D	E	F	G	H	I	J	K [7]	L [8]
30	7-5/16	4-15/32	5-7/8	3-15/32	6	3-15/32	1-7/8	13/32	5-7/16	3-1/4	4-3/32	4-11/32
60	7-5/16	4-15/32	5-7/8	3-15/32	6	3-15/32	1-7/8	13/32	5-7/16	3-1/4	4-11/32	4-11/32
100	9-27/32	5-11/32	8-3/16	4-5/8	5-13/16	3-13/16	2-11/16	51/64	7-5/16	4-3/16	5-23/32	4-27/32
200	12-3/16	7-7/32	8-3/16	4-5/8	5-13/16	3-13/16	2-11/16	51/64	7-5/16	4-3/16	5-23/32	4-27/32

[1] One conductor per lug.  
 [2] Continuous current should not exceed switch rating (size). Fuse clip kits should be sized to accommodate inrush.  
 [3] Obsolete.  
 [4] Obsolete.  
 [5] Nonfused ratings.  
 [6] One block per switch.  
 [7] Maximum depth with largest fuse.  
 [8] Depth including insulating barrier on service entrance switches.

### Type L Circuit Breaker Mechanisms

Type L door-mounted, variable-depth operating mechanisms feature heavy duty, all metal construction with trip indication. All can be padlocked in the Off position when the enclosure door is open. Further, the handle assemblies can be locked Off with up to three padlocks, which also locks the enclosure when the door is closed. (The 3" handle accepts one padlock.) Complete kits are rated for NEMA Type 1, 3R, and 12 enclosures. They include a handle assembly, operating mechanism, and shaft assembly.

**Table 15.25: Electrical Interlock Kits—Class 9999**

Description	Class	Type
Single-Pole, Double-Throw	9999	R47
Double-Pole, Double-Throw	9999	R48

**Table 15.26: Complete Kits**

For Use With Circuit Breakers (Not Included in the Complete Kit)			Operating Mechanism Standard 6 in. Handle				Operating Mechanism Short 3 in. Handle	
Circuit Breaker or Interrupter Type	No. of Poles	Frame Size (A)	Standard Shaft Kit		Long Shaft Kit		Long Shaft Kit	
			Type	Mounting Depth [2] Range	Type	Mounting Depth [2] Range	Type	Mounting Depth [2] Range
GJL	3	75, 100	LG1	5-1/2 to 10-1/4	LG4	5-1/2 to 20-7/8	LG3	5-1/2 to 20-7/8
FAL, FCL, FHL	2-3	100	LN1	5-1/2 to 10-7/16	LN4	5-1/2 to 21	LN3	5-1/2 to 21
KAL, KCL, KHL	2-3	250	LP1	6-1/4 to 11-3/16	LP4	6-1/4 to 21-3/4	LP3	6-1/4 to 21-3/4
LAL [3], LHL [3], Q4L	2-3	400	LR1	6-5/16 to 10-7/8	LR4	6-5/16 to 21-1/2	LJ3	5-1/2 to 21-3/8
MEL, MXL	2-3	800	LT1 [4]	7-3/16 to 11-5/8	LT4 [4]	7-3/16 to 22-1/4	Not recommended.	
MAL, MHL	2-3	1200	LT1 [4]	7-3/16 to 11-5/8	LT4 [4]	7-3/16 to 22-1/4		
NAL, NCL, NEL, NXL	2-3	1200	LX1 [4]	8-1/4 to 12-3/4	LX4 [4]	8-1/4 to 23-3/8		
NSF	2-3	250	9421LJ1	5.50-10.75	9421LJ4	5.50-21.38	9421LJ3	5.50-21.38
PowerPac™ D	2-3	600	9421LD1	7.25-12.06	9421LD4	7.25-22.63	3 in. handles are not recommended for use with these circuit breakers.	

**Table 15.27: Component Parts**

Use With			Handle Assemblies NEMA 1, 3R, 12		Operating Mechanism (Lockout Included)	Standard Shaft (Support Bracket Not Required)		Long Shaft (Support Bracket Included)	
Circuit Breaker or Interrupter Type	No. of Poles	Frame Size (A)	3 in.			Type	Mounting Depth [2] Range	Type	Mounting Depth [2] Range
			Type	Type					
GJL	3	75, 100	LH3	LH6	LG7	5-1/2 to 10-7/16	LS8	5-1/2 to 21	LS13
FAL, FCL, FHL	2-3	100	LH3	LH6	LF1	5-1/2 to 10-7/16	LS8	5-1/2 to 21	LS12
KAL, KCL, KHL	2-3	250	LH3	LH6	LK1	6-1/4 to 11-3/16	LS8	6-1/4 to 21-3/4	LS12
LAL [3], LHL [3], Q4L	2-3	400	Not recommended	LH6	LL1	6-5/16 to 10-7/8	LS8	6-5/16 to 21-1/2	LS10
MEL, MXL	2-3	800		LH8	LM1	7-3/16 to 11-5/8	LS8	7-3/16 to 22-1/4	LS10
MAL, MHL	2-3	1200		LH8	LM1	7-3/16 to 11-5/8	LS8	7-3/16 to 22-1/4	LS10
NAL, NCL, NEL, NXL	2-3	1200		LH8	LM1	8-1/4 to 12-3/4	LS8	8-1/4 to 23-3/8	LS10
NSF	2-3	250	9421LH3 [5]	9421LH6 [5]	9421LJ7	5.50-10.25	9421LS8	5.50-21.38	9421LS13

**Table 15.28: NEMA Type 4 and 4X Handle Assemblies [6]**

Use With			Standard Handle Assemblies		3 in. Handle Version	
Circuit Breaker or Interrupter Type	No. of Poles	Frame Size (A)	NEMA 1, 3R, 4, 12 (Painted)	NEMA 1, 3R, 4, 4X, 12 (Chrome Plated)	NEMA 1, 3R, 4, 12 (Painted)	NEMA 1, 3R, 4, 4X, 12 (Chrome Plated)
			Type	Type	Type	Type
GJL	3	75	LH46	LC46	LH43	LC43
FAL, FCL, FHL	2-3	100	LH46	LC46	LH43	LC43
KAL, KCL, KHL	2-3	250	LH46	LC46	LH43	LC43
LAL, LHL, Q4L	2-3	400	LH46	LC46	Not recommended	
MEL, MXL	2-3	800	LH48	LC48		
MAL, MHL	2-3	1000	LH48	LC48		
NAL, NCL, NEL, NXL	2-3	1200	LH48	LC48		

**Table 15.29: IEC Style Operating Mechanisms**

Circuit Breaker or Interrupter Type	Handle Type 1, 4, 4X, 12		Operating Mechanism (Lockout Included)	Extension Shafts		
	Color	Type		Mounting Depth		Type
			Min.	Max.		
GJL	Red/Yellow	NW3 [7]	LG8	6-1/8	10-3/4	NS16
	Black	NW3B		6-1/8	17-7/8	NS36 [8]



Operating Mechanism



Operating Mechanism (includes lockout)



3 in. Handle Assembly



Standard Handle Assembly

[1] Optional accessory for use with 9421L operating mechanisms. Not used with GJL, NAL, NCL, NEL, NXL, NSF, NSJ, PowerPac™ C, D, H, and J circuit breakers; use field-installed circuit breaker interlocks instead.

[2] Mounting depth in inches, measured from the circuit breaker mounting surface (control panel) to the outside of the enclosure door.

[3] These operating mechanisms cannot be used with any LAL/LHL circuit breakers with an MB or MT suffix.

[4] Types LT1, LT4, LX1, and LX4 include an 8 in. handle rather than a 6 in. handle.

[5] For a red handle and yellow bezel, add suffix RY to catalog number, e.g., 9421LH6RY.

[6] Due to gasketing, NEMA Type 3 and 4 handle assemblies are **not** trip indicating.

[7] Obsolete.

[8] Contains support bracket.

Panel Drilling, Types G, F, and K

Refer to Table 15.30 for the shaft cutting dimensions.

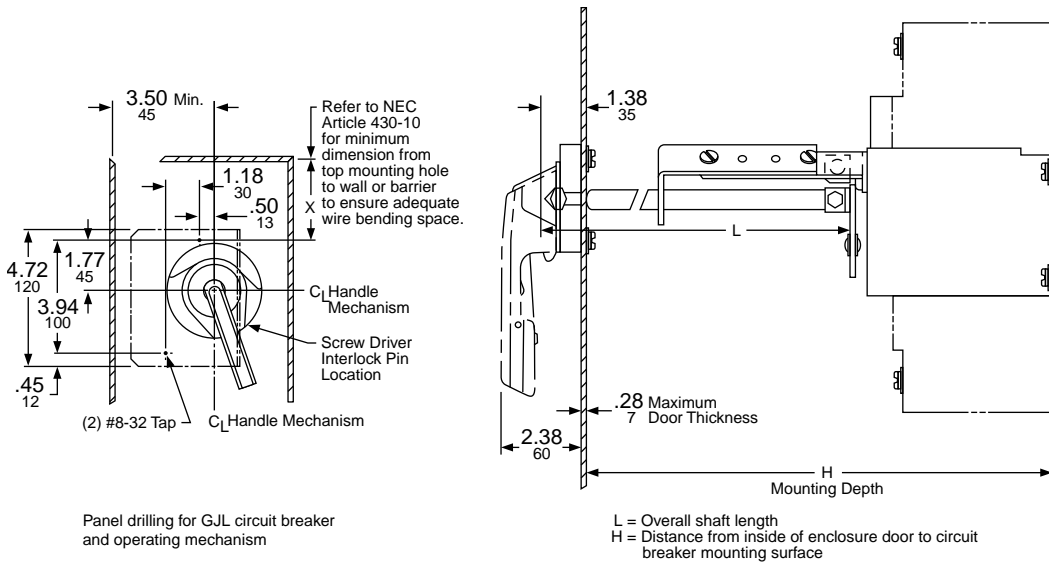

**NOTE:** The mounting depth is measured from the circuit breaker mounting surface (control panel) to the outside of the enclosure door.

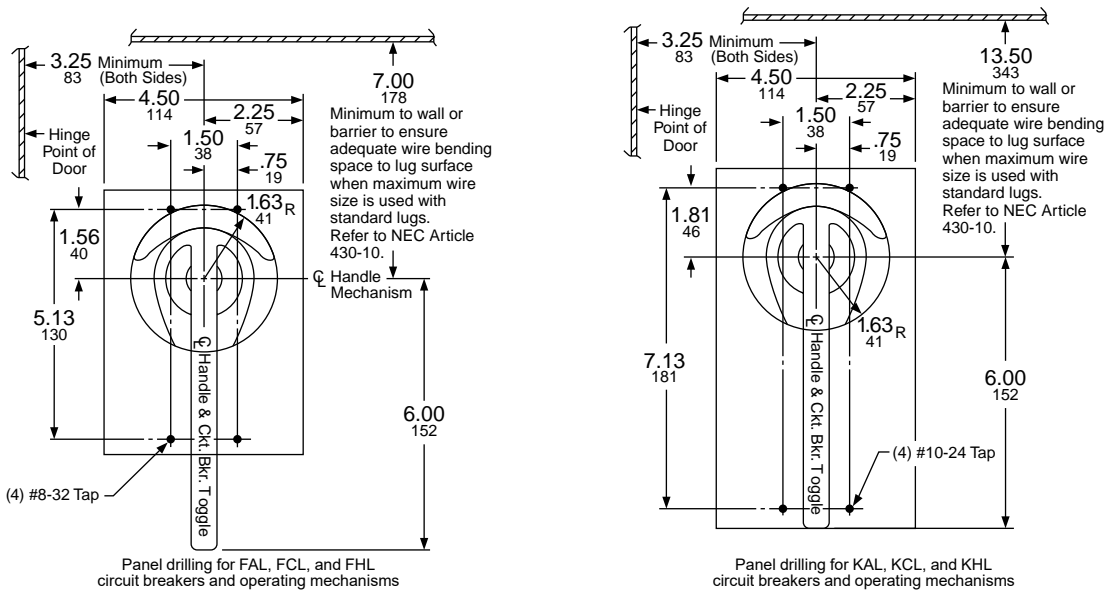

Dimensions:  $\frac{\text{in.}}{\text{mm}}$

Table 15.30: Shaft Cutting Dimensions, in. (mm)

Class	Type	Shaft Length Formula	H = Standard Shaft		H = Long Shaft	
			Min.	Max.	Min.	Max.
9421	LG7, LG1, LG4, LG3	$L = H - 2.50$ (64)	5.50 (140)	10.25 (260)	5.50 (140)	20.85 (530)
9421	LF1, LN1, LN3, LN4	$L = H - 2.88$ (73)	5.50 (140)	10.44 (265)	5.50 (140)	21.00 (533)
9421	LK1, LP1, LP3, LP4	$L = H - 3.63$ (92)	6.25 (159)	11.19 (284)	6.25 (159)	21.75 (552)
9421	LL1, LR1, LR4	$L = H - 3.13$ (79)	6.31 (160)	10.88 (276)	6.31 (160)	21.50 (546)
9421	LM1, LT1, LT4	$L = H - 4.00$ (102)	7.18 (182)	11.63 (295)	7.18 (182)	22.25 (565)
9421	LX7, LX1, LX4	$L = H - 5.17$ (131)	8.25 (210)	12.75 (324)	8.25 (210)	23.38 (594)

Panel Drilling, Types L, M, and N

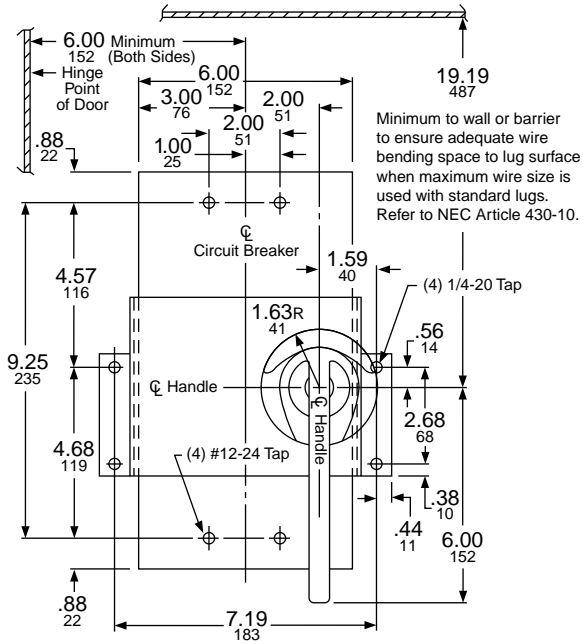

Panel drilling for LAL, LHL, and Q4L circuit breakers and operating mechanisms

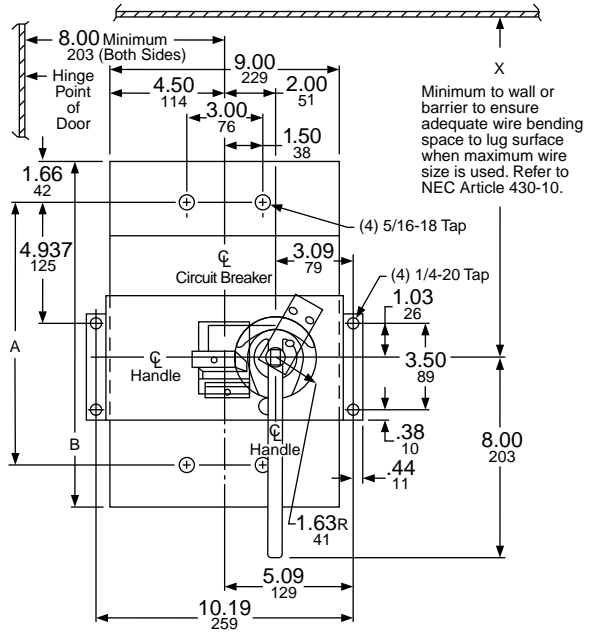

Panel drilling for MAL, MEL, MHL, and MXL circuit breakers and operating mechanisms

Circuit Breaker Type	Dimensions = in. (mm)	
	A	B
MAL, MHL	10.69 (272)	14.00 (356)
MEL, MXL	11.47 (291)	14.75 (375)

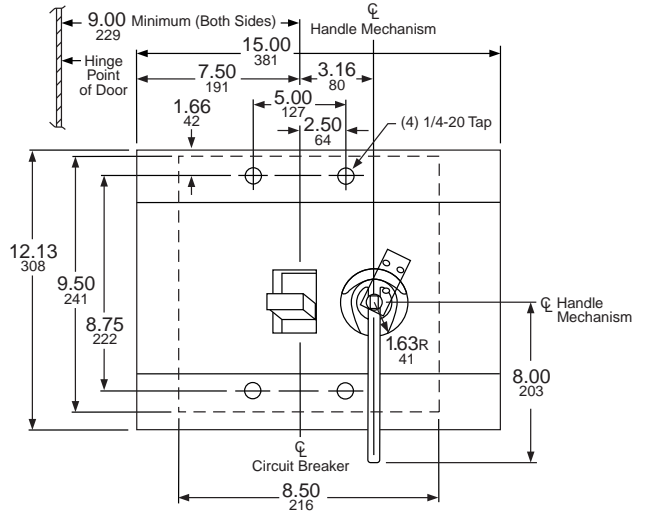

Panel drilling for NAL, NCL, NEL, and NXL circuit breakers and operating mechanisms

Dimensions:  $\frac{\text{in.}}{\text{mm}}$

**Door Closing Mechanisms**

Class 9423 door closing mechanisms cover a range of enclosures with door openings up to a maximum of 91 in. high. The door closing mechanisms are designed to be used on control enclosures and interlocked with a Class 9422 disconnect device, although they all can be used independently. Three different systems are available, and their use is as recommended below. A complete system is available for interlocking all the doors of a multi-door enclosure with the master door when using the 6 in. or 8 in. vault handle mechanism.

Note that the “Master Door” is defined to be the door of a single or multi-door enclosure which is interlocked directly with the disconnect device. The master door can be hinged on either the right or left hand side. It can be located in any position on a multi-door enclosure. An “Auxiliary Door” is defined to be any remaining doors of a multi-door enclosure which are interlocked with the master door by means of the overhead interlocking system as illustrated on [page 15-13](#) and [page 15-14](#).



**Selection Procedure**

1. Determine enclosure construction (no. of doors, door height, hinge location, etc.).
2. Determine Class 9422 disconnect device to be used—either a disconnect switch or a circuit breaker mechanism.
3. Determine the location of the disconnect device and handle mechanism (right- or left-hand flange or center channel).
4. Select the door closing mechanism required.
5. Select the auxiliary door closing mechanisms and multi-door interlocking hardware, if required. (A complete system for interlocking all auxiliary doors of a multi-door enclosure with center channel is available for the medium and large enclosures.)

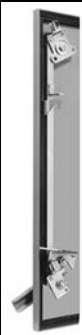

Type M4 Latch bar not included, but most prepunched enclosures that accept Square D™ operating mechanisms supply a pre-drilled latch bar.

**Table 15.31: Door Closing Mechanism**

60 in. Maximum Door Opening (Recommended)	46–60 in. Door Opening (Recommended)	61–91 in. Door Opening (Recommended)
 <ul style="list-style-type: none"> <li>• 2 Point Locking is Standard</li> <li>• A Third Roller Latch Kit is Available for 3 Point Locking</li> <li>• For 3/4 in. Door Depths</li> </ul>	 <ul style="list-style-type: none"> <li>• For use on Single or Multi-Door Enclosures</li> <li>• For use with Doors Hinged on Right or Left Side</li> <li>• Referred to as the 6 in. Vault Handle Mechanism</li> <li>• For 3/4 in. Door Depths</li> </ul>	 <ul style="list-style-type: none"> <li>• For use on Single or Multi-Door Enclosures</li> <li>• For use with Doors Hinged on Right or Left Side</li> <li>• Referred to as the 8 in. Vault Handle Mechanism</li> <li>• For 1-1/8 in. Door Depths</li> </ul>

The door closing mechanisms listed below are for use on small to medium size single door control enclosures. They are designed to be used in conjunction with Class 9422 flange-mounted disconnect switches and circuit breaker operating mechanisms; however, they can be used independently as well. When used on properly designed and gasketed NEMA Type 12 enclosures, they meet NFPA 79 standards.



Circuit Breaker Operating Mechanism

**Table 15.32: Single Door Enclosures—NEMA Type 4 or 12 with 60 in. High Maximum Opening**

Description	For Use On: (Enclosure Type)	Use in Conjunction With:	Door Latch Handle Length	Suggested Maximum Door Opening	Door Depth	Cat. No.
Two point, roller latch, door closing mechanism for use on enclosures with doors hinged on the <b>left</b> side.	NEMA Type 4 and 12 Sheet Steel	Class 9422 Types A1, A3, A9	4 in.	Less than 39 in.	3/4 in.	9423M4
			4 in.	Less than 39 in.	[1]	9423M10
			6 in.	60 in.	3/4 in.	9423M9
Two point, roller latch, door closing mechanism for use on enclosures with doors hinged on the <b>right</b> side.	NEMA Type 4 and 12 Stainless Steel	Class 9422 Types A2, A4, A10	4 in.	Less than 39 in.	3/4 in.	9423M24
			4 in.	Less than 39 in.	[1]	9423M4L
			6 in.	60 in.	3/4 in.	9423M9L
Third roller latch kit for 3 point locking; for use where 3 point locking is desired or where the door opening is ≥39 in.	NEMA Type 4 and 12 Sheet Steel	Class 9423 Types M4, M9, M4L, M9L	—	—	3/4 in.	9423M3
			NEMA Type 4 and 12 Stainless Steel	Class 9423 Types M24, M24L	—	—

[1] Suitable for door depths of 1-1/8 in., 1-1/4 in., 1-3/8 in. and 1-1/2 in.

**Vault Type for Single and Multi-Door Enclosures**

Table 15.33 shows the requirements for the door closing mechanism, the locking bar kit, and the mechanical interlock kit, if used.

**Table 15.33: Single or Multi-Door Enclosures—NEMA Type 12 with 40 in. to 60 in. Door Opening**

Single-Door Enclosure		Multi-Door Enclosure		
Without Interlocking	With Interlocking	Without Interlocking	With Interlocking	
1—M6 door closing mechanism 1—Type M660 locking bar kit	1—M6 door closing mechanism 1—Type M660 locking bar kit 1—Type M5 (use with 9422A handles)	For <i>each</i> door: 1—M6 door closing mechanism 1—Type M660 locking bar kit	For <i>Master</i> door: 1—M6 door closing mechanism 1—Type M660 locking bar kit 1—Type M5 (for use with 9422A handles)	For <i>each Auxiliary</i> door: 1—M6 door closing mechanism 1—Type M660 locking bar kit Necessary quantities of Types M2 and M7 for each door (see below)

**NOTE:** All mechanisms listed on this page are suitable for either left or right hand mounting.

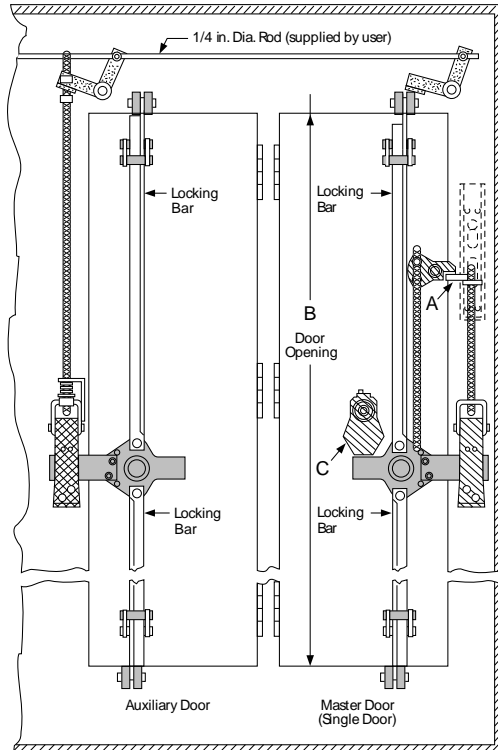

**Table 15.34: Door Interlocks**

Type	Description
<b>Type M6 Door Closing Mechanism</b>	The Class 9423 Type M6 door closing mechanism is designed to close and seal 0.75 in. deep doors of single or multi-door NEMA Type 12 enclosures. The Type M6 can be used on doors hinged on either the left or right hand side. Recommended door openings are from 40–60 in. Vault type handle length is 6 in.
<b>Type M660 Locking Bar Kits</b>	The lock bar kit for the Type M6 door closing mechanism contains two lock bars and is available from stock. The bars can be cut to fit door openings through 60 in. One lock bar kit is required for each Type M6 ordered.
<b>Type M5</b>	The Class 9423 Type M5 mechanical interlock kit is designed to interlock a Class 9422 handle mechanism with the Type M6 door closing mechanism. This kit prevents the opening of the master door (or single door) with the disconnect handle in the "ON" position, making it mandatory to use a screwdriver to gain entry to the enclosure at any time, regardless of the disconnect handle position.

**Table 15.35: Required Accessories for Auxiliary Doors**

Type	Description
<b>Type M2</b>	One Type M2 kit is required for each auxiliary door. This kit is required to interlock any auxiliary door(s) with the master door.
<b>Type M7</b>	The first auxiliary door requires 2 Type M7 kits. Additional auxiliary doors require only 1 Type M7 kit. The 0.25 in. diameter rod used to interconnect the M7 kits is furnished by the user. If the distance between any two Type M7 kits exceeds 36 in., an additional Type M7 kit should be installed to prevent the rod from buckling.



**NOTE:** A - Interlocking lever extension of the flange-mounted handle mechanism.

**NOTE:** B - Actual enclosure opening—not door height.

**NOTE:** C - Screwdriver interlock assembly can be ordered separately. Class 9423 Type CEQ2493.

**Vault Type for Single and Multi-Door Enclosures**

Table 15.36 shows the requirements for the door closing mechanism, the locking bar kit, and the mechanical interlock kit, if used.

**Table 15.36: Single Or Multi-Door Enclosures—NEMA Type 12 with 61 in. to 91 in. Door Openings**

Single-Door Enclosure		Multi-Door Enclosure		
Without Interlocking	With Interlocking	Without Interlocking	With Interlocking	
1—M8 door closing mechanism 1—Type M891 locking bar kit	1—M8 door closing mechanism 1—Type M891 locking bar kit 1—Type M1 (for use with 9422A handles)	For each door: 1—M8 door closing mechanism 1—Type M891 locking bar kit	For Master door: 1—M8 door closing mechanism 1—Type M891 locking bar kit 1—Type M1 (for use with 9422A handles)	For each Auxiliary door: 1—M8 door closing mechanism 1—Type M891 locking bar kit Necessary quantities of Types M2 and M7 for each door (see below)

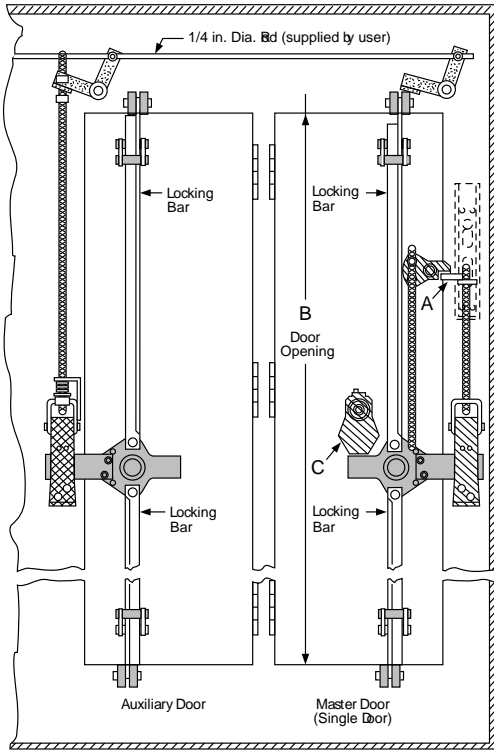

**NOTE:** A - Interlocking lever extension of the flange-mounted handle mechanism.

**NOTE:** B - Actual enclosure opening—not door height.

**NOTE:** C - Screwdriver interlock assembly can be ordered separately. Class 9423 Type CEQ2493.

**NOTE:** All mechanisms listed on this page are suitable for either left or right hand mounting.

**Table 15.37: Door Interlocks**

Type	Description
<b>Type M8 Door Closing Mechanism</b>	The Class 9423 Type M8 door closing mechanism is designed to close and seal 1.125 in. deep doors of single or multi-door NEMA Type 12 enclosures. The Type M8 can be used on doors hinged on either the left or right hand side. Recommended door openings are from 61–91 in. Vault type handle length is 8 in.
<b>Type M891 Locking Bar Kits</b>	The lock bar kit for the Type M8 door closing mechanism contains two lock bars and is available from stock. The bars can be cut to fit door openings through 91 in.. One lock bar kit is required for each Type M8 ordered.
<b>Type M1</b>	The Class 9423 Type M1 mechanical interlock kit is designed to interlock a Class 9422 handle mechanism with the Type M8 door closing mechanism. This kit prevents the opening of the master door (or single door) with the disconnect handle in the "ON" position, making it mandatory to use a screwdriver to gain entry to the enclosure at any time, regardless of the disconnect handle position.

**Table 15.38: Required Accessories for Auxiliary Doors**

Type	Description
<b>Type M2</b>	One Type M2 kit is required for each auxiliary door. This kit is required to interlock any auxiliary door(s) with the master door.
<b>Type M7</b>	The first auxiliary door requires 2 Type M7 kits. Additional auxiliary doors require only 1 Type M7 kit. The 0.25 in. diameter rod used to interconnect the M7 kits is furnished by the user. If the distance between any two Type M7 kits exceeds 36 in., an additional Type M7 kit should be installed to prevent the rod from buckling.

### Enclosure Construction and General Location Information For Types M5 and M6

Drilling and location information below is complete for a single door enclosure with door hinged on left side, incorporating a Type M6, M5, and Class 9422 handle mechanism. Transpose all horizontal dimensions for doors hinged on right side.

#### Dimension A

- Single door enclosures: A minimum = 1 in.
- Multi-door enclosures without overhead interlocking system: A minimum = 1 in.
- Multi-door enclosures with overhead interlocking system: A minimum = 4-1/2 in.

**NOTE:** Overhead interlocking system consists of the required number of Class 9423 Type M2 and M7 kits for interlocking the auxiliary doors with the master door. See page 15-14.

Table 15.39: Dimension B (Minimum)

Type	Disconnect Device	If A = 1 Minimum B =	If A = 4-1/2 Minimum B =	C
TCF, TCN, TDF, TDN, TD	60 A Disconnect Switch	3-1/16	2-1/2	3-3/16
TE, TEF, TEN	100 A Disconnect Switch	5-1/4	2-1/2	3-3/16
TF	200 A Disconnect Switch	11-5/8	8-1/8	3-3/16
TG	400 A Disconnect Switch	15-1/16	11-9/16	6-3/4
RN1	FAL, FHL, Circuit Breaker	4-27/32	2-1/2	3-3/16
RP1	KAL, KHL Circuit Breaker	11-5/32	7-21/32	3-3/16
RR2	ILL Circuit Breaker	17-31/32	14-15/32	3-3/16
RT1	MAL, MHL, MEL, MXL Circuit Breaker	18-5/8	15-1/8	3-3/16

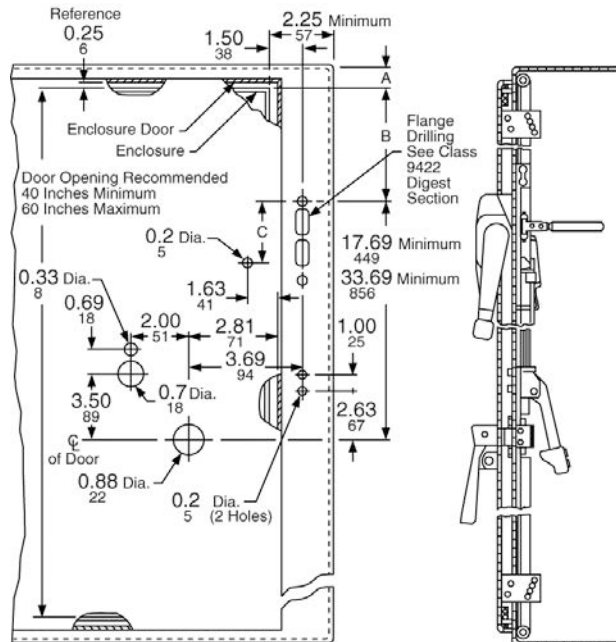

**Enclosure Construction and General Location Information For Types M1 and M8**

Drilling and location information below is complete for a single door enclosure with the door hinged on the left side, incorporating a Type M8, M1, and Class 9422 handle mechanism. Transpose all horizontal dimensions for doors hinged on the right side.

**Dimension A**

- Single door enclosures: A minimum = 1-1/2 in.
- Multi-door enclosures without overhead interlocking system: A minimum = 1-1/2 in.
- Multi-door enclosures with overhead interlocking system: A minimum = 4-1/2 in.

**NOTE:** Overhead interlocking system consists of the required number of Class 9423 Type M2 and M7 kits for interlocking the auxiliary doors with the master door. See page 15-14.

**Table 15.40: Dimension B (Minimum)**

Type	Disconnect Device	If A = 1-1/2 Minimum B =	If A = 4-1/2 Minimum B =	C
TCF, TCN, TDF, TDN, TD	60 A Disconnect Switch	2-15/16	2-1/2	3-3/16
TE, TEF, TEN	100 A Disconnect Switch	4-3/4	2-1/2	3-3/16
TF	200 A Disconnect Switch	11-1/8	8-1/8	3-3/16
TG	400 A Disconnect Switch	14-9/16	11-9/16	5-7/8
RN1	FAL, FHL Circuit Breaker	4-11/32	2-1/2	3-3/16
RP1	KAL, KHL Circuit Breaker	10-21/32	7-21/32	3-3/16
RR2	ILL Circuit Breaker	17-15/32	14-15/32	3-3/16
RT1	MAL, MHL, MEL, MXL Circuit Breaker	18-1/8	15-1/8	3-3/16

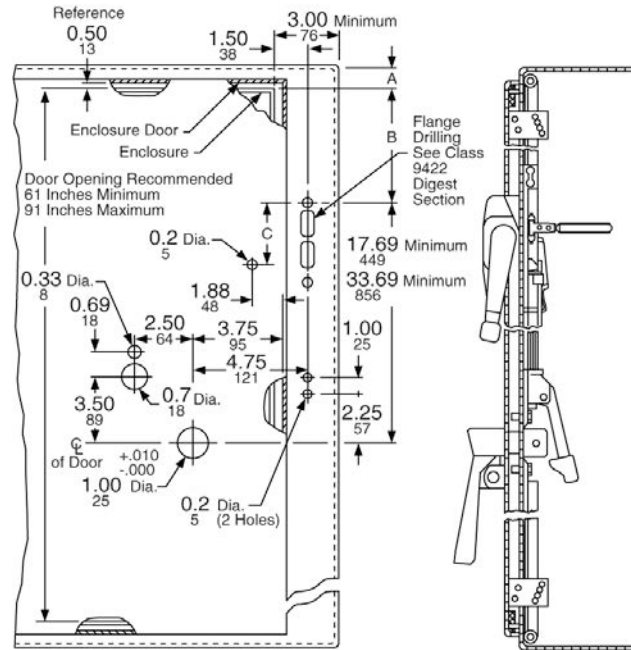

**Additional Accessories**

**Table 15.41: Additional Accessories**

Accessory	Description	Cat. No.
Alternate Mounting Kit	Permits mounting Class 9422 Type A1 or A2 handle mechanisms in enclosures with flange thickness of 16 gauge to 0.5 in.	9422AM2
Auxiliary Lock Plate	Auxiliary kit recommended for use with the Class 9422 Type A-1 flange handle to facilitate padlocking the handle in the "OFF" position. Primarily used when the handle is mounted on the center channel of a multi-door enclosure. Also in any case where the enclosure doors interfere with the normal padlock slot in the flange handle. Meets both the Automotive and NFPA 79 specifications.	9422L1
Special Lugs for Disconnect Switches	Copper Lugs only—Specify Form Y157 Tin Plated Aluminum Lugs for 400 A Type TG Switch—Specify Form Y1572 (000–750 kcmil Cu/Al wire)	—
Operating Rods	Anderson Type VCEL Compression Lugs—Specify Form Y1574 <b>Exceptions:</b> None of the 30 A or 60 A disconnect switches are available with compression lugs.	—
	Standard operating rod for use with Class 9422 variable depth mechanisms. Included as standard in each kit.	9422R1
	Extra long operating rod for use with Class 9422 variable depth mechanisms. Can be used as a substitute for the standard rod included in each kit to increase the maximum mounting depth 7 in. (Two are required for Types ARR, RR, ART, RT, ATE, TE, ATF, TF).	9422R2

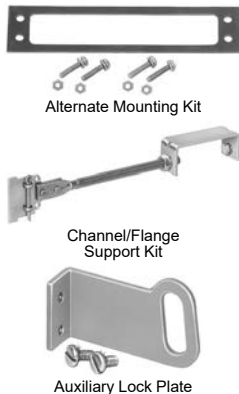

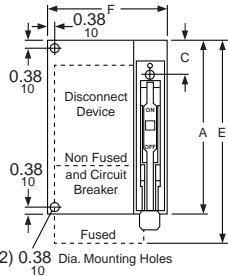
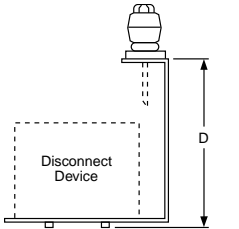

(2) 0.38 Dia. Mounting Holes  
(For back panel support if necessary.)



**NOTE:** No external auxiliary contacts are available for the following circuit breakers: GJL circuit breakers must use internal auxiliary contacts, catalog number AAC. PowerPacT D circuit breakers must use internal auxiliary contacts, catalog number AAC.

**NOTE:** For additional variations, contact the Customer Care Center (CCC) at 1-888-778-2733.

### Bracket-Mounted Operating Mechanisms for Use With Square D™ Circuit Breakers

The circuit breaker operating mechanisms listed below are shipped with the external operating handle assembled to a bracket. Circuit breakers are not included and must be ordered separately. A trim plate is provided with each kit to prevent any mounting screws from being accessible from the front and also to provide an attractive installation. The operating handle is Type A1. These switches can be used with Class 9423 door closing mechanisms.

**Table 15.42: Bracket-Mounted Operating Mechanisms for Use With Square D™ Circuit Breakers**

Circuit Breaker or Interrupter Type	Use With		Operating Mechanism	
	No. of Poles	Frame Size (A)	Right Hand, Flange Mounting	
			Cat. No.	
FAL, FHL	2-3	100	BN1	
KAL, KHL	2-3	250	BP1	
LAL [1], LHL [1], Q4L	2-3	400	BR1	

**NOTE:** Some enclosures may not accept the listed bracket-mounted operating mechanisms; contact the enclosure manufacturer.

**Table 15.43: Electrical Interlock Kits—Class 9999**

Optional accessory for use with circuit breaker operating mechanisms listed to the left and the flexible cable mechanisms listed below, except GJL

Description	Class	Type
Single Pole, Double Throw	9999	R26
Double Pole, Double Throw	9999	R27

**NOTE:** Not used with GJL; use field installed circuit breaker interlocks.

**Table 15.44: Dimensions, in. (mm)**

Type	A	C	D	Min. Enclosure Depth [2] in. (mm)	F
BG1, BN1	8.75 (222)	1.13 (29)	6.50 (165)	8.00 (203)	7.13 (181)
BP1	9.13 (232)				7.38 (187)

**NOTE:** Back panel support is recommended for Types TFB1, 2, and 3. Other devices may also require support if the flange is not sufficiently rigid.

**Table 15.45: Class 9422—Flexible Cable Mechanisms for Use with Square D Circuit Breakers**

For use with Square D circuit breakers and Class 9422 A handle operators. Especially designed for tall, deep enclosures where placement flexibility is required. See Digest, Section 8 for dimensions.

Circuit Breaker Type	No. of Poles	Frame Size (A)	Cable Mechanism		Cable Mechanisms with A1 Handle For Types 1, 3, 3R, 4, 12
			Cable Length	Catalog No.	Catalog No.
GJL	3	100	36 in.	CGJ30	CGJ31
			48 in.	CGJ40	CGJ41
			60 in.	CGJ50	CGJ51
			120 in.	CGJ10	CGJ11 [3]
FAL, FHL	2, 3	100	36 in.	CFA30	CFA31
			60 in.	CFA50	CFA51
			120 in.	CFA10	CFA11
KAL, KHL	2, 3	250	36 in.	CKA30	CKA31
			60 in.	CKA50	CKA51
			120 in.	CKA10	CKA11
LAL [1], LHL [1], Q4L	2, 3	400	36 in.	CLA30	CLA31
			60 in.	CLA50	CLA51
			120 in.	CLA10 [3]	CLA11

**Table 15.46: Class 9999 Auxiliary Contact Kits for Disconnect Switches and Circuit Breakers**

Class	Type	SPDT	DPDT
		Type	Type
<b>Disconnect Switches</b>			
9422	TF	R8	R9
<b>Circuit Breaker Operating Mechanisms</b>			
9421	LF, LK, LL, LM, LN, LP, LR, LT	R47	R48
9422	RM, RN, RP, RR, RT	R26	R27
9422	CFA, CKA, CLA, CSF	R26	R27

[1] These operating mechanisms cannot be used with any LA/LH circuit breakers with an MB or MT suffix.  
 [2] The minimum enclosure depth is greater than Dimension D, since additional space is needed when mounting the mechanism.  
 [3] Obsolete.

**Variable-Depth Mechanisms**

Designed for installation in custom built control enclosures where main or branch circuit protective devices are required. All circuit breaker operating mechanisms are suitable for either right- or left-hand flange mounting, convertible on the job.

**Table 15.47: Variable-Depth Mechanisms for Use with Square D™ Circuit Breakers and Schneider Electric™ (formerly Merlin Gerin™) Circuit Breakers**

Circuit Breaker Frame Size	Use With			Operating Mechanism		
	No. of Poles	Frame Size A	Variable-Depth Mounting, Range [1] (in.)	Operating Mechanism Only— Does Not Include Handle Mechanism	Operating Mechanism and Handle Mechanism	
					Includes Type A1 Handle Mechanism	Includes Type A2 Handle Mechanism
				Type	Type	Type
<b>Square D Circuit Breakers</b>						
GJL	3	100	6.00–17.75	RG1	ARG11	ARG21
FAL, FHL	2–3	100	5.38–17.75	RN1	ARN11	ARN21
KAL, KHL	2–3	250	6.38–17.88	RP1	ARP11	ARP21
LAL [2], LHL [2], Q4L	2–3	400	7.44–18.25	RR1	ARR11	ARR21
MEL, MXL	2–3	800	9.00–18.38	RT1	ART11	ART21
MAL, MHL	2–3	1200	9.00–18.38	RT1	ART11	ART21
NAL, NCL, NEL, NXL	2–3	1200	11.00–18.37	RX1	—	—

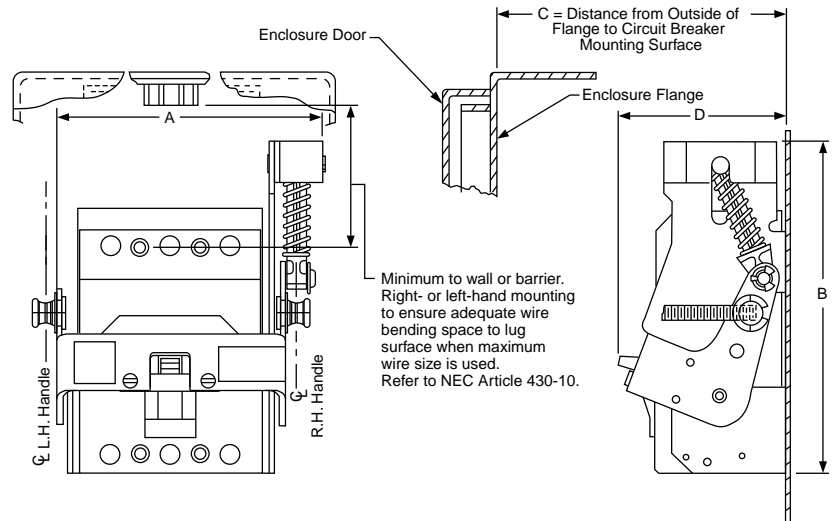

**Table 15.48: Electrical Interlocks—Class 9999**

Description	Class	Type
Single Pole, Double Throw	9999	R26 [3]
Double Pole, Double Throw	9999	R27 [3]

**Table 15.49: Dimensions**

Circuit Breaker Frame Size	Type	Width (A)		Height (B)		Distance to Enclosure Flange [4] (C)				Bracket Depth (D)	
						Minimum		Maximum			
		in.	mm	in.	mm	in.	mm	in.	mm	in.	mm
GJL	RG1	5.00	127	4.75	121	6.00	152	17.75	451	4.00	102
FAL, FHL	RN1	6.75	171	8.50	216	5.51	140	17.75	451	4.26	108
KAL, KHL	RP1	7.13	181	10.13	257	6.51	165	17.88	454	4.94	125
LAL [2], LHL [2], Q4L	RR1	10.19	259	11.00	279	7.44	189	18.25	464	6.00	152
MEL, MXL	RT1	13.38	340	14.00	356	9.00	229	18.38	467	9.69	246
MAL, MHL [5]	RT1	13.38	340	14.00	356	9.00	229	18.38	467	9.69	246
NAL, NCL, NEL, NXL	RX1	19.63	499	13.50	343	11.00	279	18.37	467	9.00	229



[1] Class 9422 Type R2 extends the mounting depth by 7 in.

[2] These operating mechanisms cannot be used with any LA/LH circuit breakers with an MB or MT suffix.

[3] Not for use with the GJL operating mechanism.

[4] 9422R2 extends the dimension by 7 in. Two are required.

[5] The minimum mounting depth when using MAL or MHL circuit breakers can be decreased to 7.63 in. by using the Class 9422 Type RT1B conversion kit.

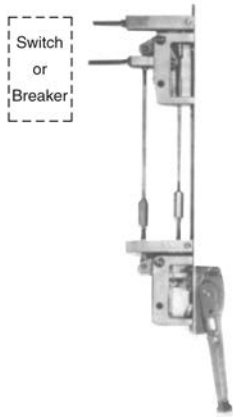

Remote operation shown (the handle mechanism is not included in the kit)



Air valve interlock mounted on the enclosure



Channel/Flange Support Kit



Alternate Mounting Kit



Auxiliary Lock Plate

### Remote or Dual Adapter Kit

For the remote or dual operation of GJL, FAL, FHL, KAL, KHL, LAL, LHL, Q4L, MAL, MHL, MEL, and MXL circuit breakers.

**Remote Operation**—permits mounting the Class 9422 Type A9 or A10 handle mechanism at a lower level than the disconnect device it controls. This arrangement is often required where the disconnect device is mounted too high for personnel to easily reach a conventional operator.

**Dual Operation**—permits controlling two disconnect devices, one in line with, and one remote from, a single Class 9422 Type A9 or A10 handle mechanism.

**NOTE:** A Class 9422 Type A9 or A10 handle (see Digest, Section 8) and the preferred mounting method **must** be used.

Table 15.50: Disconnect Device

Disconnect Device	Enclosure Mounting Depth		Type
	Min.	Max.	
<b>Circuit Breaker</b>			
GJL	10.50	19.50	D2
FAL, FHL	10.66	19.50	
KAL, KHL	11.13	19.50	
LAL, LHL, Q4L	12.13	19.88	
MAL, MHL, MEL, MXL	13.75	20.25	

Table 15.51: Air Valve Interlock

**NOTE:** Air valve interlocks only accept the specific three-way air valves, manufactured by Parker, listed in the table below.

Air Valve Size	Parker Valve Model Number [6]	Class 9422 Air Valve Interlock Type
	Knob Operated	
0.50 in. NPT (13)	M04841885	G1
	M08541848	
0.75 in. NPT (19)	M04861885	G2
	M08561848	
1.00 in. NPT (25)	M00080004	G1

Table 15.52: Other Accessories

Accessory	Description	Class	Type
Channel/Flange Support Kit	Auxiliary kit recommended for use with 30 A and 60 A disconnect switches and FAL, FCL, FHL, KAL, KHL, NSF, and NSJ circuit breaker mechanisms when these devices are to be mounted on the center channel of a multi-door enclosure or when extra rigidity for the flange is required. Supplied as standard with 100 A and 200 A disconnect switches and LAL, LHL, Q4L, MAL, MHL, MEL, and MXL circuit breaker mechanisms.	9422	C1

[6] Prices do not include air valves or the handle mechanism. For more information on the air valves listed, contact Parker at c-parker@parker.com, or call 1-800-272-7537.

# Section 16

## Contactors and Starters



Electromechanical  
Reduced Voltage Starter

Reversing Drum Switches	16-2
Electromechanical Reduced Voltage Starters	16-3
Multispeed Magnetic Starters	16-9
Lighting Contactors	16-15
Well-Guard™ Pump Panel	16-16
Factory Modifications (Forms)	16-18
Definite Purpose Contactors	16-21
Thermal Overload Relays—NEMA Style	16-22



Type AG2

**NEMA 1, 3R, 4, and 13 Without Overload**

Class 2601 reversing drum switches may be used for across-the-line starting and reversing of AC polyphase, AC single phase or DC motors, where overload protection is not required or is provided separately. They are compact and inexpensive but ruggedly constructed. Drum switches are field convertible from Maintained-On to Momentary-On operation. This conversion consists of removing the handle screw and handle, turning the shaft 180 degrees, then replacing the handle and handle screw.

**Table 16.1: Reversing Drum Switches**

Voltage	600 Vac Maximum Ratings			Class 2601		360 Vdc Maximum	
	Maximum Horsepower			NEMA Type 1 General Purpose Enclosure	NEMA Type 4 Watertight & Dusttight Enclosure	NEMA Type 1 Maintained & Momentary [1]	NEMA Type 13 Oiltight Flush Mounting
	AC Single Phase	AC Poly-Phase	DC	Type	Type	Type	Type
115-200/230	1-1/2	—	1/4	AG2	AW2	AG2S2	AF2
230	2	1/4					
460/575	—	2					
115-200/230	1-1/2	—	2	BG1	BW1	—	—
230	3	2					
460/575	5	7-1/2					



File E42243  
CCN NLRV



File LR25490  
Class 3211-05

**Approximate Dimensions—Class 2601 Reversing Drum Switches**

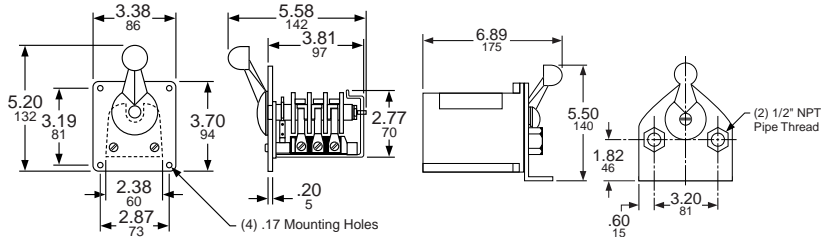

Type AW2

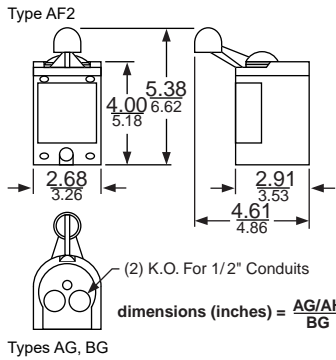

Types AG, BG

Dimensions:  $\frac{\text{in.}}{\text{mm}}$

**Table 16.2: How to Order**

To Order Specify:	Catalog Number	
• Class Number	Class	Type
• Type Number	2601	AG2

[1] Maintained—Forward, Momentary—Reverse (not field convertible)

### Reduced Voltage Starting of Squirrel Cage Motors

A squirrel cage motor draws high starting current (inrush) and produces high starting torque when started at full voltage. While these values differ for different motor designs, for a typical NEMA design B motor, the inrush will be approximately 600% of the motor full load amperage (FLA) rating, and the starting torque will be approximately 150% of full load torque at full voltage. High current inrush and starting torque can cause problems in the electrical and mechanical systems, or may even damage the materials being processed.

When a motor is started at reduced voltage, the current at the motor terminals is reduced in direct proportion to the voltage reduction, while the torque is reduced by the square of the voltage reduction. If the "typical" NEMA B motor is started at 70% of line voltage, the starting current would be 70% of the full voltage value (that is,  $0.70 \times 600\% = 420\%$  FLA). The torque would then be  $(0.70)^2$  or 49% of the normal starting torque (that is,  $0.49 \times 150\% = 74\%$  full load torque). Therefore, reduced voltage starting provides an effective means of reducing both inrush current and starting torque.

If the motor has a high inertia or if the motor rating is marginal for the applied load, reducing the starting torque may prevent the motor from reaching full speed before the thermal overload relays trip. Applications that require high starting torque should be reviewed to determine if reduced voltage starting is suitable. Square D™ offers several types of electromechanical as well as solid-state reduced voltage starters that provide different starting characteristics. The following describes the 8600 series of reduced voltage starters.

**Class 8606—Autotransformer Starter:** Autotransformer starters provide reduced voltage to the motor terminals during starting through the use of a tapped, three phase autotransformer. Taps on the autotransformer allow for selection of the motor with 50%, 65%, or 80% of line voltage values supplying 50%, 65%, or 80% of the current inrush seen during a full voltage start. The resulting starting torque will be 25%, 42%, or 64% of full voltage values, as will be the current draw on the line. Thus, the autotransformer provides the maximum torque with minimum line current.

**Class 8630—Wye-Delta Starter:** Wye-delta starters can only be used on wye-delta motors which have six leads that allow for motor winding to be connected in either a wye or delta configuration. During start up, the windings are connected in the wye, resulting in 58% of line voltage applied across two windings. This reduces both inrush and starting torque to 33% of the delta connected values. After a set time delay, the motor leads are switched to the delta connection. The wye-delta starter is available in both open and closed transition configurations. Closed transition starters are supplied with an additional contactor and resistor bank used to keep the motor windings energized for a few cycles until the transition from wye to delta is complete.

**Class 8640—Part Winding Starter:** Part winding starters can be used only with part winding motors. During a part winding start, only one winding is energized, reducing the inrush current to 60–70% (depending on the motor design) and starting torque to 50% of normal starting values with both windings energized. Most (but not all) dual voltage 230/460 volt motors are suitable for part winding starts at 230 volts.

### Electromechanical Reduced Voltage Starters

### Specifications

Table 16.3: Starter Characteristics

Characteristic	Full Voltage	Autotransformer, Class 8606	Wye-Delta Class, 8630	Part Winding, Class 8640	Solid-State ATS46
Voltage at Motor	100%	50% / 65% / 80% (tap setting)	100%	100%	Ramped Up
Line Current (% Full Load Current)	600%	150% / 250% / 380%	200%	390%	150% to 700% (adjustable)
Starting Torque (% Rated Torque)	150%	40% / 60% / 100%	50%	70%	0% to 100% (adjustable)
Start Time (Factory Setting)	—	6–7 s	10 s / 15 s (open/closed transition)	1–1.5 s	10 s (adjustable 1–60 s)
Advantages	<ul style="list-style-type: none"> <li>Simple</li> <li>Economical</li> <li>High Starting Torque</li> </ul>	<ul style="list-style-type: none"> <li>High torque/amperage</li> <li>High inertial loads</li> <li>Flexibility</li> </ul>	<ul style="list-style-type: none"> <li>High inertial loads</li> <li>Long acceleration loads</li> <li>Good torque/amperage</li> </ul>	<ul style="list-style-type: none"> <li>Simple</li> <li>Small size</li> </ul>	<ul style="list-style-type: none"> <li>Greatest flexibility</li> <li>Smooth ramp</li> <li>Solid-state overload relay</li> <li>Diagnostics</li> </ul>
Disadvantages	<ul style="list-style-type: none"> <li>Abrupt starts</li> <li>Large current inrush</li> </ul>	<ul style="list-style-type: none"> <li>Large size</li> </ul>	<ul style="list-style-type: none"> <li>Low torque</li> <li>No flexibility</li> </ul>	Not suitable for: <ul style="list-style-type: none"> <li>High inertial loads</li> <li>Frequent starting</li> </ul>	<ul style="list-style-type: none"> <li>SCR heat dissipation</li> <li>Ambient limitations</li> </ul>
Motor	Standard	Standard	Special	Special	Standard

Table 16.4: Line Voltage Codes (60 Hz)

Line	Control	Code
208	208	V08
240	240	V03
380	380	V05
480	480	V06
600	600	V07

Table 16.5: Coil Voltage Codes (60 Hz)

Line	Control	Code
208	120	V84
240	24	V82
240	120	V80
480	24	V83
480	120	V81
480	240	V87
600	120	V86
380	110/50	V95
other	specify	V99

Table 16.6: Form Codes

Form Description	Form Code
Fused CPT for timing relay only	F4T
Fused CPT for all coils	F4T40
Separate control of timing relay only	S
Separate control for all coils	Y195

Table 16.8: Coil Voltage Codes (50 Hz)

Hz	V	Code	V	Code	V	Code	V	Code
60	120	V02	240	V03	480	V06	600	V07
50	110		220		440		550	

### How to Order

**NOTE:** Table 16.4 and Table 16.5 are for 60 Hz; for 50 Hz codes, see Table 16.8.

- Specify the Class Number and the Type Number.
- If all coils are at the line voltage, and not Sizes 6 or 7, select the voltage code from Table 16.4 (Sizes 6 and 7 are supplied with a fused transformer with 120 Vac as standard).
- If the coils are at a different voltage than line supply, or Size 6 or 7, select a voltage code from Table 16.5 and also select a Form code from Table 16.6 (note that a Form code may be used with any voltage code, except as noted).

See Table 16.7 for sizing of 380 V starters.

24 V coils are not available on Sizes 4–7.

**Factory Modifications (Forms):** see [Factory Modifications \(Forms\)](#), page 16-18.

### 380 Vac, 50 Hz Starters

The Class 8600 starters are available for 380 Vac, 50 Hz applications. Table 16.7 provides maximum horsepower ratings. To determine the Type number, select the second digit based on the NEMA size. Select the fifth digit based on the horsepower requirement. Specify V05 voltage code.

Table 16.7: 380 Vac, 50 Hz Starters, Maximum Horsepower Rating

Autotransformer, Class 8606		Wye-Delta, Class 8630		Part Winding, Class 8640	
Max. hp	NEMA Size	Max. hp	NEMA Size	Max. hp	NEMA Size
—	—	15	1YD	15	1PW
25	2	40	2YD	40	2PW
50	3	75	3YD	75	3PW
75	4	150	4YD	125	4PW
150	5	250	5YD	250	5PW
300	6	500	6YD	500	6PW

### 50 Hz Control Voltage

The starters in this section can also be operated at 50 Hz at the coil voltages listed in Table 16.8. For additional coil voltage availability, contact the Customer Care Center (CCC) at 1-888-778-2733.

Selection, 3-Pole Polyphase

NOTE: Devices require 3 thermal units (Sizes 00–6). See Digest Section 16 for selection information.

Table 16.9: 3-Pole Polyphase, 600 Vac Maximum, 50–60 Hz

Motor Voltage (Starter Voltage)	Max. Hp	NEMA Size	NEMA Type 1 General Purpose Enclosure	NEMA Type 4 [1] Watertight and Dusttight Enclosure	NEMA Type 12/3R [2] Dusttight & Driptight Industrial Use Enclosure	Open Type	OEM Kit [3]
			Type [4]	Type [4]	Type [4]	Type [4]	Type [4]
200 (208)	10	2	SDG1C	SDW1C	SDA1C	SDO1C	SDK1C
	15	3	SEG1D	SEW1D	SEA1D	SEO1D	SEK1D
	20		SEG1E	SEW1E	SEA1E	SEO1E	SEK1E
	25		SEG1F	SEW1F	SEA1F	SEO1F	SEK1F
	30	4	SFG1G	SFW1G	SFA1G	SFO1G	SFK1G
	40		SFG1H	SFW1H	SFA1H	SFO1H	SFK1H
50	5	SGG1J	SGW1J	SGA1J	SGO1J	SGK1J	
75		SGG1L	SGW1L	SGA1L	SGO1L	SGK1L	
230 (240)	100	6	SHG1M	SHW1M	SHA1M	SHO1M	SHK1M
	125		SHG1N	SHW1N	SHA1N	SHO1N	SHK1N
	150		SHG1P	SHW1P	SHA1P	SHO1P	SHK1P
	10	2	SDG1C	SDW1C	SDA1C	SDO1C	SDK1C
	15		SDG1D	SDW1D	SDA1D	SDO1D	SDK1D
	20		SEG1E	SEW1E	SEA1E	SEO1E	SEK1E
25	3	SEG1F	SEW1F	SEA1F	SEO1F	SEK1F	
30		SEG1G	SEW1G	SEA1G	SEO1G	SEK1G	
40		SFG1H	SFW1H	SFA1H	SFO1H	SFK1H	
50	4	SFG1J	SFW1J	SFA1J	SFO1J	SFK1J	
75		SGG1L	SGW1L	SGA1L	SGO1L	SGK1L	
100		SGG1M	SGW1M	SGA1M	SGO1M	SGK1M	
125	6	SHG1N	SHW1N	SHA1N	SHO1N	SHK1N	
150		SHG1P	SHW1P	SHA1P	SHO1P	SHK1P	
200		SHG1Q	SHW1Q	SHA1Q	SHO1Q	SHK1Q	
250	7	SJG1R	SJW1R	SJA1R	—	—	
300		SJG1S	SJW1S	SJA1S	—	—	
460 (480) / 575 (600)	10	2	SDG1C	SDW1C	SDA1C	SDO1C	SDK1C
	15		SDG1D	SDW1D	SDA1D	SDO1D	SDK1D
	20		SDG1E	SDW1E	SDA1E	SDO1E	SDK1E
	25	SDG1F	SDW1F	SDA1F	SDO1F	SDK1F	
	30	3	SEG1G	SEW1G	SEA1G	SEO1G	SEK1G
	40		SEG1H	SEW1H	SEA1H	SEO1H	SEK1H
	50		SEG1J	SEW1J	SEA1J	SEO1J	SEK1J
	60	4	SFG1K	SFW1K	SFA1K	SFO1K	SFK1K
	75		SFG1L	SFW1L	SFA1L	SFO1L	SFK1L
	100		SFG1M	SFW1M	SFA1M	SFO1M	SFK1M
	125	5	SGG1N	SGW1N	SGA1N	SGO1N	SGK1N
	150		SGG1P	SGW1P	SGA1P	SGO1P	SGK1P
200	SGG1Q		SGW1Q	SGA1Q	SGO1Q	SGK1Q	
250	6	SHG1R	SHW1R	SHA1R	SHO1R	SHK1R	
300		SHG1S	SHW1S	SHA1S	SHO1S	SHK1S	
400		SHG1T	SHW1T	SHA1T	SHO1T	SHK1T	
500	7	SJG1U	SJW1U	SJA1U	—	—	
600		SJG1W	SJW1W	SJA1W	—	—	

NOTE: Class 8606 starters come with a NEMA style medium-duty autotransformer. Medium-duty service includes applications to motors that drive loads such as fans, pumps, compressors, and line shafts.

NEMA Sizes 2–5: Autotransformer is rated for fifteen 15-second starts per hour.  
NEMA Sizes 6–7: Autotransformer is rated for three 30-second starts per hour.  
Contact the Customer Care Center (CCC) at 1-888-778-2733 for applications that require frequent starting or jogging, or have extremely high inertia.

Table 16.10: How to Order

To Order Specify:	Catalog Number			
• Class Number	8606	SFG1M	V81	S
• Type Number				
• Voltage Code	Description: 100 hp, 480 V line, 120 V separate control, 60 Hz			
• Form(s) [5]				

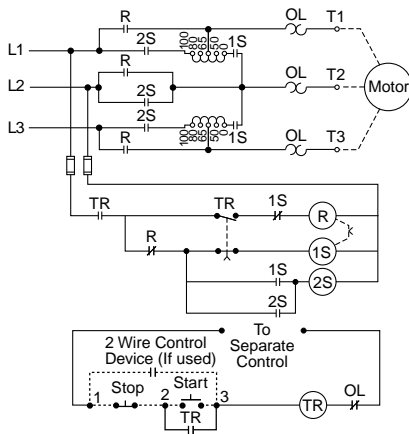

Typical Autotransformer Starter  
Sizes 2–5  
Separate Control (Form S)

[1] NEMA 4 enclosures are painted sheet steel. Where required, stainless steel enclosures are available at extra cost. Specify as Form G17  
[2] NEMA Type 12 enclosures can be field modified for outdoor non-corrosive and non-service-entrance rated applications. See Digest Section 16 for more information.  
[3] No factory modifications (Forms) are available with the OEM kit.  
[4] Both the line and control voltage must be specified to order this product. See page 16-3 for the necessary codes and instructions for ordering.  
[5] Specify Forms only if any of the coils are at a different voltage than line supply (V8•). See page 16-3 for a fuller explanation of how to order; this page also provides the necessary coil voltage and Form codes as well as codes for 380 V starters and 50 Hz applications.

**Selection, 3-Pole Polyphase**

**NOTE:** Devices require 3 thermal units (Sizes 00–6). See Digest Section 16 for selection information.

**Table 16.11: 3-Pole Polyphase, 600 Vac Maximum, 50–60 Hz**

Motor Voltage (Starter Voltage)	Max. Hp	NEMA Size	NEMA Type 1 General Purpose Enclosure	NEMA Type 4 [6] Watertight and Dusttight Enclosure (Stainless Steel 1YD-4YD)	NEMA Type 12/3R [7] Dusttight & Driptight Industrial Use Enclosure	Open Type	OEM Kit [8]
			Type [9]	Type [9]	Type [9]		
200 (208)	10	1YD	SCG1C	SCW1C	SCA1C	SCO1C	—
	15	2YD	SDG1D	SDW1D	SDA1D	SDO1D	—
	20		SDG1E	SDW1E	SDA1E	SDO1E	—
	25		SDG1F	SDW1F	SDA1F	SDO1F	—
	30	3YD	SEG1G	SEW1G	SEA1G	SEO1G	SEK1G
	40		SEG1H	SEW1H	SEA1H	SEO1H	SEK1H
	50		SEG1J	SEW1J	SEA1J	SEO1J	SEK1J
	60	4YD	SFG1K	SFW1K	SFA1K	SFO1K	SFK1K
	75		SFG1L	SFW1L	SFA1L	SFO1L	SFK1L
	100		SFG1M	SFW1M	SFA1M	SFO1M	SFK1M
	125	5YD	SGG1N	SGW1N	SGA1N	SGO1N	SGK1N
	150		SGG1P	SGW1P	SGA1P	SGO1P	SGK1P
200	SGG1Q		SGW1Q	SGA1Q	SGO1Q	SGK1Q	
250	6YD	SHG1R	SHW1R	SHA1R	SHO1R	SHK1R	
300		SHG1S	SHW1S	SHA1S	SHO1S	SHK1S	
400		SHG1T	SHW1T	SHA1T	SHO1T	SHK1T	
500	7YD	SJG1U	SJW1U	SJA1U	SJO1U	—	
600		SJG1V	SJW1V	SJA1V	SJO1V	—	
800		SJG1W	SJW1W	SJA1W	SJO1W	—	
1000	—	—	—	—	—	—	—

**Table 16.12: How to Order**

To Order Specify:	Catalog Number			
• Class Number	Class	Type	Voltage Code	Form(s)
• Type Number	8630	SFG1M	V06	
• Voltage Code	Description: 100 hp, 480 V line, 480 V common control, 60 Hz			
• Form(s) [10]				

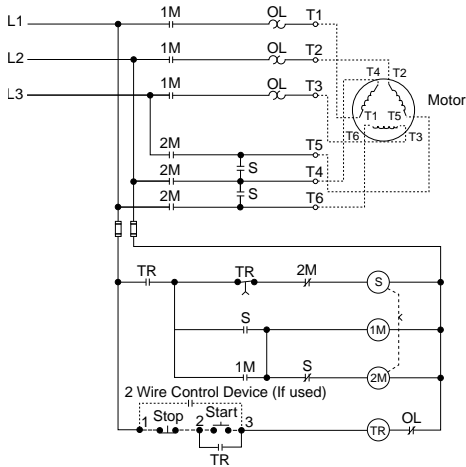

Typical Wye-Delta Starter Sizes 1–4 (Open Transition)  
Common Control (Standard)

[6] NEMA 4 enclosures are painted sheet steel. Where required, stainless steel enclosures are available at extra cost. Specify as **Form G17**.  
 [7] NEMA Type 12 enclosures can be field modified for outdoor non-corrosive and non-service-entrance rated applications. See Digest Section 16 for more information.  
 [8] No factory modifications (Forms) are available with the OEM kit.  
 [9] Both the line and control voltage must be specified to order this product. See page 16-3 for the necessary codes and instructions for ordering.  
 [10] Specify Forms only if any of the coils are at a different voltage than line supply (V8\*). See page 16-3 for a fuller explanation of how to order; this page also provides the necessary coil voltage and Form codes as well as codes for 380 V starters and 50 Hz applications.

Selection, 3-Pole Polyphase

NOTE: Devices require 3 thermal units (Sizes 00–6). See Digest Section 16 for selection information.

Table 16.13: 3-Pole Polyphase, 600 Vac Maximum, 50–60 Hz

Motor Voltage (Starter Voltage)	Max. Hp	NEMA Size	NEMA Type 1 General Purpose Enclosure	NEMA Type 4 [11] Watertight and Dusttight Enclosure (Stainless Steel 1YD-4YD)	NEMA Type 12/3R [12] Dusttight & Driptight Industrial Use Enclosure	Open Type	OEM Kit [13]
			Type [14]	Type [14]	Type [14]	Type [14]	Type [14]
200 (208)	10	1YD	SCG2C	SCW2C	SCA2C	SCO2C	—
	15	2YD	SDG2D	SDW2D	SDA2D	SDO2D	—
	20		SDG2E	SDW2E	SDA2E	SDO2E	—
	25		SDG2F	SDW2F	SDA2F	SDO2F	—
	25	3YD	SEG2F	SEW2F	SEA2F	SEO2F	SEK2F
	30		SEG2G	SEW2G	SEA2G	SEO2G	SEK2G
	40		SEG2H	SEW2H	SEA2H	SEO2H	SEK2H
	50	4YD	SFG2J	SFW2J	SFA2J	SFO2J	SFK2J
	60		SFG2K	SFW2K	SFA2K	SFO2K	SFK2K
	75	5YD	SGG2L	SGW2L	SGA2L	SGO2L	SGK2L
	100		SGG2M	SGW2M	SGA2M	SGO2M	SGK2M
	125		SGG2N	SGW2N	SGA2N	SGO2N	SGK2N
150	SGG2P		SGW2P	SGA2P	SGO2P	SGK2P	
200	6YD	SHG2Q	SHW2Q	SHA2Q	SHO2Q	SHK2Q	
250		SHG2R	SHW2R	SHA2R	SHO2R	SHK2R	
300		SHG2S	SHW2S	SHA2S	SHO2S	SHK2S	
230 (240)	10	1YD	SCG2C	SCW2C	SCA2C	SCO2C	—
	15	2YD	SDG2D	SDW2D	SDA2D	SDO2D	—
	20		SDG2E	SDW2E	SDA2E	SDO2E	—
	25		SDG2F	SDW2F	SDA2F	SDO2F	—
	30	3YD	SEG2G	SEW2G	SEA2G	SEO2G	SEK2G
	40		SEG2H	SEW2H	SEA2H	SEO2H	SEK2H
	50		SEG2J	SEW2J	SEA2J	SEO2J	SEK2J
	60	4YD	SFG2K	SFW2K	SFA2K	SFO2K	SFK2K
	75		SFG2L	SFW2L	SFA2L	SFO2L	SFK2L
	100	5YD	SGG2M	SGW2M	SGA2M	SGO2M	SGK2M
	125		SGG2N	SGW2N	SGA2N	SGO2N	SGK2N
	150		SGG2P	SGW2P	SGA2P	SGO2P	SGK2P
200	6YD	SHG2Q	SHW2Q	SHA2Q	SHO2Q	SHK2Q	
250		SHG2R	SHW2R	SHA2R	SHO2R	SHK2R	
300		SHG2S	SHW2S	SHA2S	SHO2S	SHK2S	
400	7YD	SJG2T	SJW2T	SJA2T	SJO2T	—	
500		SJG2U	SJW2U	SJA2U	SJO2U	—	
460 (480) / 575 (600)	10	1YD	SCG2C	SCW2C	SCA2C	SCO2C	—
	15	2YD	SDG2D	SDW2D	SDA2D	SDO2D	—
	20		SDG2E	SDW2E	SDA2E	SDO2E	—
	25		SDG2F	SDW2F	SDA2F	SDO2F	—
	30		SDG2G	SDW2G	SDA2G	SDO2G	—
	40		SDG2H	SDW2H	SDA2H	SDO2H	—
	50	3YD	SEG2J	SEW2J	SEA2J	SEO2J	SEK2J
	60		SEG2K	SEW2K	SEA2K	SEO2K	SEK2K
	75		SEG2L	SEW2L	SEA2L	SEO2L	SEK2L
	100	4YD	SFG2M	SFW2M	SFA2M	SFO2M	SFK2M
	125		SFG2N	SFW2N	SFA2N	SFO2N	SFK2N
	150		SFG2P	SFW2P	SFA2P	SFO2P	SFK2P
200	5YD	SGG2Q	SGW2Q	SGA2Q	SGO2Q	SGK2Q	
250		SGG2R	SGW2R	SGA2R	SGO2R	SGK2R	
300		SGG2S	SGW2S	SGA2S	SGO2S	SGK2S	
400	6YD	SHG2T	SHW2T	SHA2T	SHO2T	SHK2T	
500		SHG2U	SHW2U	SHA2U	SHO2U	SHK2U	
700		SHG2W	SHW2W	SHA2W	SHO2W	SHK2W	
800	7YD	SJG2Y	SJW2Y	SJA2Y	SJO2Y	—	
1000		SJG2Z	SJW2Z	SJA2Z	SJO2Z	—	

Table 16.14: How to Order

To Order Specify:	Catalog Number			
• Class Number	Class	Type	Voltage Code	Form(s)
• Type Number	8630	SFG1M	V81	F4T40
• Voltage Code	Description: 100 hp, 480 V line, 120 V separate control, 60 Hz			
• Form(s) [15]				

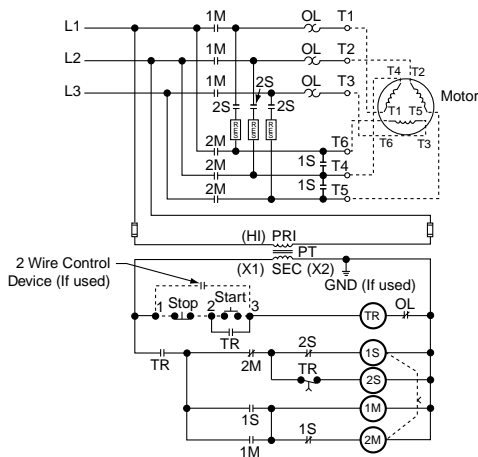

Typical Wye-Delta Starter Sizes 1–4 (Closed Transition) Fused Control Transformer (Form F4T40)

[11] NEMA 4 enclosures are painted sheet steel. Where required, stainless steel enclosures are available at extra cost. Specify as Form G17.  
 [12] NEMA Type 12 enclosures can be field modified for outdoor non-corrosive and non-service-entrance rated applications. See Digest Section 16 for more information.  
 [13] No factory modifications (Forms) are available with the OEM kit.  
 [14] Both the line and control voltage must be specified to order this product. See page 16-3 for the necessary codes and instructions for ordering.  
 [15] Specify Forms only if any of the coils are at a different voltage than line supply (V8\*). See page 16-3 for a fuller explanation of how to order; this page also provides the necessary coil voltage and Form codes as well as codes for 380 V starters and 50 Hz applications.

**Part Winding Starters, Selection**

**NOTE:** Devices require 6 thermal units (Sizes 00–6). See Digest Section 16 for selection information.

**Table 16.15: 3-Pole Polyphase—600 Vac Maximum—50–60 Hz**

Motor Voltage (Starter Voltage)	Max. Hp	NEMA Size	NEMA Type 1 General Purpose Enclosure	NEMA Type 4 [16] Watertight and Dusttight Enclosure (Stainless Steel 1PW–4PW)	NEMA Type 12/3R [17] Dusttight & Driptight Industrial Use Enclosure	Open Type	OEM Kit [18]
			Type [19]	Type [19]	Type [19]	Type [19]	Type [19]
200 (208)	10	1PW	SCG1C	SCW1C	SCA1C	SCO1C	—
	15	2PW	SDG1D	SDW1D	SDA1D	SDO1D	SDK1D
	20		SDG1E	SDW1E	SDA1E	SDO1E	SDK1E
	25		SDG1F	SDW1F	SDA1F	SDO1F	SDK1F
	30	3PW	SEG1F	SEW1F	SEA1F	SEO1F	SEK1F
	40		SEG1G	SEW1G	SEA1G	SEO1G	SEK1G
50	4PW	SEG1H	SEW1H	SEA1H	SEO1H	SEK1H	
60		SFG1J	SFW1J	SFA1J	SFO1J	SFK1J	
75		SFG1K	SFW1K	SFA1K	SFO1K	SFK1K	
100	5PW	SFG1L	SFW1L	SFA1L	SFO1L	SFK1L	
125		SGG1M	SGW1M	SGA1M	SGO1M	SGK1M	
150		SGG1N	SGW1N	SGA1N	SGO1N	SGK1N	
230 (240)	10	1PW	SCG1C	SCW1C	SCA1C	SCO1C	—
	15	2PW	SDG1D	SDW1D	SDA1D	SDO1D	SDK1D
	20		SDG1E	SDW1E	SDA1E	SDO1E	SDK1E
	25		SDG1F	SDW1F	SDA1F	SDO1F	SDK1F
	30	3PW	SEG1G	SEW1G	SEA1G	SEO1G	SEK1G
	40		SEG1H	SEW1H	SEA1H	SEO1H	SEK1H
	50	4PW	SEG1J	SEW1J	SEA1J	SEO1J	SEK1J
	60		SFG1K	SFW1K	SFA1K	SFO1K	SFK1K
	75		SFG1L	SFW1L	SFA1L	SFO1L	SFK1L
	100	5PW	SGG1M	SGW1M	SGA1M	SGO1M	SGK1M
125	SGG1N		SGW1N	SGA1N	SGO1N	SGK1N	
150	SGG1P		SGW1P	SGA1P	SGO1P	SGK1P	
200	6PW	SHG1Q	SHW1Q	SHA1Q	SHO1Q	—	
250		SHG1R	SHW1R	SHA1R	SHO1R	—	
300		SHG1S	SHW1S	SHA1S	SHO1S	—	
400	7PW	SJG1T	SJW1T	SJA1T	SJO1T	—	
460 (480) / 575 (600)	10	1PW	SCG1C	SCW1C	SCA1C	SCO1C	—
	15	2PW	SCG1D	SCW1D	SCA1D	SCO1D	—
	20		SDG1E	SDW1E	SDA1E	SDO1E	SDK1E
	25		SDG1F	SDW1F	SDA1F	SDO1F	SDK1F
	30		SDG1G	SDW1G	SDA1G	SDO1G	SDK1G
	40	3PW	SDG1H	SDW1H	SDA1H	SDO1H	SDK1H
	50		SEG1J	SEW1J	SEA1J	SEO1J	SEK1J
	60		SEG1K	SEW1K	SEA1K	SEO1K	SEK1K
	75	4PW	SEG1L	SEW1L	SEA1L	SEO1L	SEK1L
	100		SFG1M	SFW1M	SFA1M	SFO1M	SFK1M
	125		SFG1N	SFW1N	SFA1N	SFO1N	SFK1N
	150	5PW	SFG1P	SFW1P	SFA1P	SFO1P	SFK1P
200	SGG1Q		SGW1Q	SGA1Q	SGO1Q	SGK1Q	
250	SGG1R		SGW1R	SGA1R	SGO1R	SGK1R	
350	SGG1S	SGW1S	SGA1S	SGO1S	SGK1S		
460 (480) / 575 (600)	400	6PW	SHG1T	SHW1T	SHA1T	SHO1T	—
	500		SHG1U	SHW1U	SHA1U	SHO1U	—
	600		SHG1W	SHW1W	SHA1W	SHO1W	—
700	7PW	SJG1X	SJW1X	SJA1X	SJO1X	—	
800		SJG1Y	SJW1Y	SJA1Y	SJO1Y	—	

**Table 16.16: How to Order**

To Order Specify:	Catalog Number			
	Class	Type	Voltage Code	Form(s)
<ul style="list-style-type: none"> <li>• Class Number</li> <li>• Type Number</li> <li>• Voltage Code</li> <li>• Form(s) [20]</li> </ul>	8640	SFG1M	V06	C
Description: 100 hp, 480 V line, 480 V common control, 60 Hz				

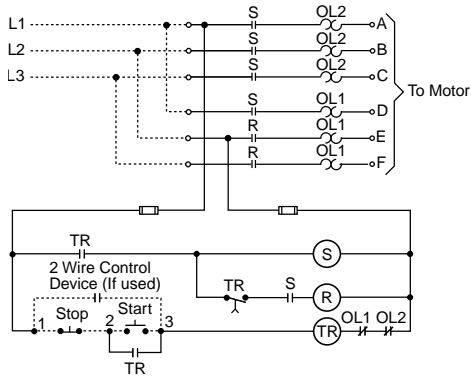

Typical Part Winding Sizes 1–4 Common Control (Standard)

[16] NEMA 4 enclosures are painted sheet steel. Where required, stainless steel enclosures are available at extra cost. Specify as Form G17.  
 [17] NEMA Type 12 enclosures can be field modified for outdoor non-corrosive and non-service-entrance rated applications. See Digest Section 16 for more information.  
 [18] No factory modifications (Forms) are available with the OEM. kit.  
 [19] Both the line and control voltage must be specified to order this product. See page 16-3 for the necessary codes and instructions for ordering.  
 [20] Specify Forms only if any of the coils are at a different voltage than line supply (V8\*). See page 16-3 for a fuller explanation of how to order; this page also provides the necessary coil voltage and Form codes as well as codes for 380 V starters and 50 Hz applications.



Class 8606  
Autotransformer



Class 8630  
Wye-Delta



Class 8640  
Part Winding

Approximate Dimensions—Not for Construction

NOTE: H = Height, W = Width, D = Depth

Table 16.17: Class 8606—Autotransformer

NEMA Size	Dim.	Open		NEMA Type 1 / 12 Enclosure				NEMA Type 4 Enclosure			
				Non-Combo or Combo, with Circuit Breaker		Combo, with Disconnect Switch		Non-Combo or Combo, with Circuit Breaker		Combo, with Disconnect Switch	
		in.	mm	in.	mm	in.	mm	in.	mm	in.	mm
2	H	43	1092	52	1320	52	1320	52	1320	52	1320
	W	22	559	25	635	25	635	25	635	25	635
	D	8	203	10	254	10	254	10	254	10	254
3 or 4	H	63	1600	70 [21]	1778	70 [21]	1778	75 [21]	1778	75 [21]	1778
	W	28	711	32	813	32	813	32	813	32	813
	D	9	229	16	406	16	406	16	406	16	406
5	H	63	1600	70 [21]	1778	90 [21]	2286	75 [21]	1778	95 [21]	2413
	W	28	711	32	813	36	914	32	813	36	914
	D	9	229	16	406	16	406	16	406	16	406
6	H	56	1422	90 [21]	2286	90 [21]	2286	98 [21]	2489	98 [21]	2489
	W	30	762	34	864	64	1626	34	864	64	1626
	D	14	354	20	508	24	610	20	508	24	610

Table 16.18: Class 8630—Wye-Delta, Open Transition

NEMA Size	Dim.	Open		NEMA Type 1 / 12 Enclosure				NEMA Type 4 Enclosure			
				Non-Combo		Combo		Non-Combo		Combo	
		in.	mm	in.	mm	in.	mm	in.	mm	in.	mm
1YD or 2YD	H	21	553	25	635	25	635	25	635	—	—
	W	21	553	23	584	23	584	23	584	—	—
	D	7	178	8	203	8	203	8	203	—	—
3YD or 4YD	H	42	1067	48	1219	49	1245	48	1219	49	1245
	W	25	635	28	712	30	762	28	712	30	762
	D	7	178	8	203	11	279	8	203	11	279
5YD or 6YD	H	62	1576	90 [21]	2286	90 [21]	2286	98 [21]	2489	98 [21]	2489
	W	29	737	36	914	36	914	36	914	36	914
	D	10	254	16	406	16	406	16	406	16	406

Table 16.19: Class 8630—Wye-Delta, Closed Transition

NEMA Size	Dim.	Open		NEMA Type 1 / 12 Enclosure				NEMA Type 4 Enclosure			
				Non-Combo		Combo		Non-Combo		Combo	
		in.	mm	in.	mm	in.	mm	in.	mm	in.	mm
1YD or 2YD	H	21	553	25	635	25	635	25	635	—	—
	W	21	553	23	584	23	584	23	584	—	—
	D	14	354	16	406	16	406	16	406	—	—
3YD or 4YD	H	42	1067	48	1219	49	1245	48	1219	49	1245
	W	25	635	28	712	30	762	28	712	30	762
	D	14	354	16	406	18	457	16	406	18	457
5YD or 6YD	H	80	2032	90 [21]	2286	90 [21]	2286	98 [21]	2489	98 [21]	2489
	W	30	762	36	914	36	914	36	914	36	914
	D	12	305	16	406	16	406	16	406	16	406

Table 16.20: Class 8640—Part Winding

NEMA Size	Dim.	Open		Enclosed—NEMA Type 1 / 4 / 12					
				Non-Combo		Combo, with Circuit Breaker		Combo, with Disconnect Switch	
		in.	mm	in.	mm	in.	mm	in.	mm
1PW or 2PW	H	21	553	25	635	34	853	25	635
	W	21	553	23	584	19	483	23	584
	D	6	152	8	203	11	279	8	203
3PW	H	42	1067	48	1219	44	1118	52	1321
	W	26	660	28	712	30	762	25	635
	D	7	178	8	203	12	305	11	279
4PW	H	42	1067	48	1219	44	1118	78 [21]	1981
	W	26	660	28	712	30	762	32	813
	D	7	178	8	203	12	305	16	406
5PW	H	35	889	44	1118	78 [21] [22]	1981	78 [21] [22]	1981
	W	22	559	24	610	36	914	36	914
	D	10	254	12	305	16	406	16	406
6PW	H	49	1245	64	1626	—	—	90 [21]	2286
	W	24	610	28	712	—	—	64	1626
	D	11	279	16	406	—	—	24	406

Combination Starter Form Reference

Circuit Breaker: Y791, Y7911  
 Nonfusible Disconnect Switch: Y792, Y7910  
 Fusible Disconnect Switch: Y793-Y799

Refer to page 16-18 for a complete listing of Forms for combination devices.

[21] Free-standing enclosure.  
 [22] Subtract 8 in. from the height for a Type 1 or 12 enclosure.

Table 16.21: Typical Applications

Constant Hp	Constant Torque	Variable Torque
A. Spindles B. Cutting Tools 1. Lathes 2. Saws	A. Conveyors B. Mills C. Dough Mixers D. Reciprocating Pumps	A. Fans B. Centrifugal Pumps

### Multispeed Magnetic Starters Application Data

Multispeed motors are available in two basic versions:

1) separate winding, and 2) consequent pole. A separate winding motor has a winding for each speed while a consequent pole motor has a winding for every two speeds (three-speed motors have two windings). The motor connections (and thus the types of controllers) for two speed starters are exemplified by the schematic diagrams shown in Table 16.22. Note that consequent pole two-speed controllers involve a 5-pole and a 3-pole starter, while separate winding controllers have two 3-pole starters.

**Verify the type of motor before ordering.** Field modification of starters to match the motor may not be possible.

Separate winding motors are usually chosen when flexibility is important, since the speeds of a consequent pole motor are usually limited to a 2/1 ratio; a broad range of speeds can be obtained on a separate winding motor.

Both separate winding and consequent pole motors are available in three types: 1) constant horsepower, 2) constant torque, and 3) variable torque. Table 16.21 shows typical applications for these different types of motors.

**NOTE:** For detailed information involving the technical aspects of flexibility of the starters used in the multispeed controllers, see Classes 8702, 8736, and 8810 application data.

Table 16.22: Typical Schematic Diagrams

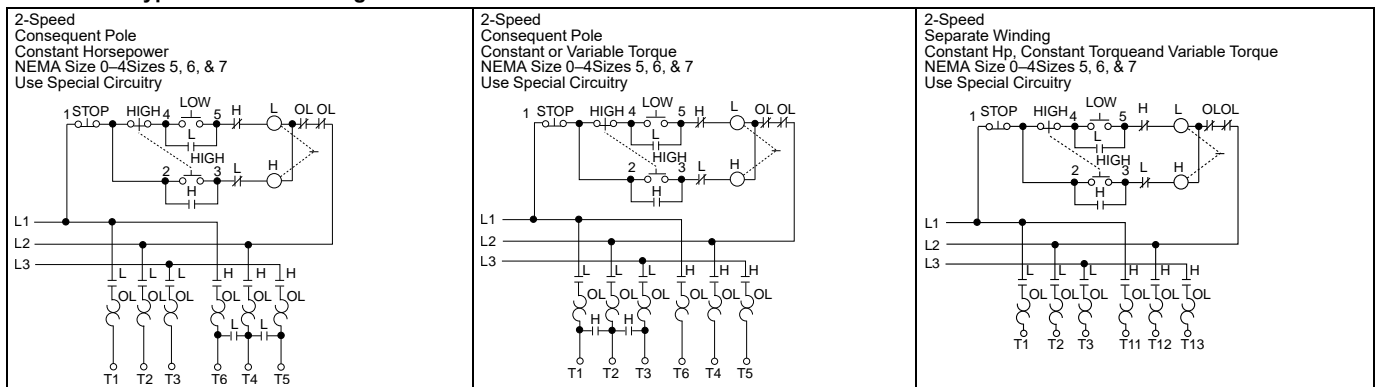

### Additional Features—Special Relays for Non-Reversing and Reversing Multispeed Starters

**General.** Some applications require special relays to control the speed change and/or starting of the motor.

The descriptions that follow cover the four common relay schemes for these applications.

**Form R1 Compelling Relay.** This relay requires the motor to be started at low speed before any higher speed can be selected. This arrangement ensures that the motor will always start the load at low speed. The stop button must be pressed before it is possible to change from a higher to a lower speed. (Not available with Form R2.)

**Form R2 Accelerating Relay/Timer.** With Form R2 accelerating relays, the ultimate speed is determined by the button which is pressed, but the starter will start the motor at low speed and automatically accelerate it through successive steps until the selected speed is reached. Definite time intervals must elapse between each speed change. Individual adjustable timing relays are provided for each interval.

The stop button must be pressed before it is possible to change from a higher to a lower speed.

(Not available with Form R1.)

**Form R3 Decelerating Relay/Timer.** This is similar in action to Form R2 accelerating relays, except that they function to prevent immediate transfer from a higher to a lower speed. A definite time interval, preset on the timer, must elapse between each speed change.

**Form R10 Antiplugging Relays/Timers.** This Form imposes a time delay when transferring from the forward to the reverse direction or reverse to forward, for reversing multispeed starters. This provides up to a 60 second delay in the transfer of the direction of the motor, and can help prevent damage which could result from plugging.

**Form Y81 (Low Speed) Overload Relay Modification.**

For NEMA size 3 and 4, when the low speed full load current does not appear on the appropriate thermal unit selection tables, include Form Y81 (low speed) (no charge for this Form). This Form modifies the overload relay block to accept Type B thermal units. For assistance on thermal unit selection, contact the Customer Care Center (CCC) at 1-888-778-2733.

Table 16.23: Special Pilot Lighting

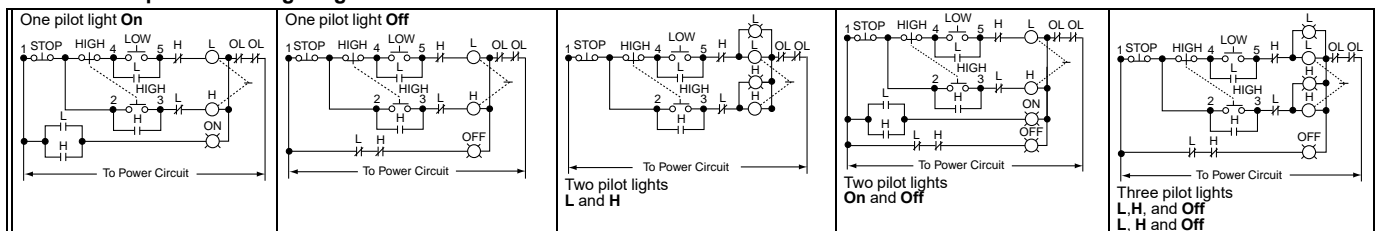

### 3-Pole Polyphase, 600 Vac Maximum, 50–60 Hz

Multispeed motors are available in two basic versions: 1) consequent pole, and 2) separate winding. A separate winding motor has a winding for each speed while a consequent pole motor has a winding for every two speeds (three-speed motors have two windings).

Devices require 6 thermal units (Sizes 0–6). See Digest Section 16 for selection information.

**Table 16.24: Class 8810—Non-Combination Type**

Type of Motor	NEMA Size	Maximum Polyphase Horsepower Ratings						NEMA 1 General Purpose Enclosure	NEMA 4 & 4X Watertight and Dusttight Enclosure (Stainless Steel) (304) (Sizes 0–5) Sheet Steel (Size 6)	NEMA 4X [1] Watertight, Dusttight and Corrosion Resistant Enclosure	NEMA 12 /3R [2] Dusttight and Driptight Industrial Use Enclosure	Open Type					
		Constant Horsepower Motors			Constant Torque or Variable Torque Motors								Type [3]	Type [3]	Type [3]	Type [3]	Type [3]
		200 V	230 V	460–575 V	200 V	230 V	460–575 V										
Single Winding (Consequent Pole) 5-Pole–3-Pole																	
Constant Hp	0	2	2	3	—	—	—	SBG1●●●	SBW1●●●	SBW51●●●	SBA1●●●	SBO1●●●					
	1	5	5	7-1/2	—	—	—	SCG1●●●	SCW1●●●	SCW51●●●	SCA1●●●	SCO1●●●					
	2	7-1/2	10	20	—	—	—	SDG1●●●	SDW1●●●	SDW51●●●	SDA1●●●	SDO1●●●					
	3	20	25	40	—	—	—	SEG1●●●	SEW1●●●	—	SEA1●●●	SEO1●●●					
	4	30	40	75	—	—	—	SFG1●●●	SFW1●●●	—	SFA1●●●	SFO1●●●					
	5	60	75	150	—	—	—	SGG1●●●	SGW1●●●	—	SGA1●●●	SGO1●●●					
Constant Torque or Variable Torque	0	—	—	—	3	3	5	SHG1●●●	SHW1●●●	—	SHA1●●●	SHO1●●●					
	1	—	—	—	7-1/2	7-1/2	10	SBG2●●●	SBW2●●●	SBW52●●●	SBA2●●●	SBO2●●●					
	2	—	—	—	10	15	25	SCG2●●●	SCW2●●●	SCW52●●●	SCA2●●●	SCO2●●●					
	3	—	—	—	25	30	50	SDG2●●●	SDW2●●●	SDW52●●●	SDA2●●●	SDO2●●●					
	4	—	—	—	40	50	100	SEG2●●●	SEW2●●●	—	SEA2●●●	SEO2●●●					
	5	—	—	—	75	100	200	SFG2●●●	SFW2●●●	—	SFA2●●●	SFO2●●●					
Constant Hp [4]	0	—	—	—	150	200	400	SHG2●●●	SHW2●●●	—	SHA2●●●	SHO2●●●					
	1	—	—	—	—	—	—	SBG3●●●	SBW3●●●	SBW53●●●	SBA3●●●	SBO3●●●					
	2	—	—	—	—	—	—	SCG3●●●	SCW3●●●	SCW53●●●	SCA3●●●	SCO3●●●					
	3	—	—	—	—	—	—	SDG3●●●	SDW3●●●	SDW53●●●	SDA3●●●	SDO3●●●					
	4	—	—	—	—	—	—	SEG3●●●	SEW3●●●	—	SEA3●●●	SEO3●●●					
	5	—	—	—	—	—	—	SFG3●●●	SFW3●●●	—	SFA3●●●	SFO3●●●					
	6	—	—	—	—	—	—	SGG3●●●	SGW3●●●	—	SGA3●●●	SGO3●●●					
Constant Torque or Variable Torque [4]	0	—	—	—	—	—	—	SHG3●●●	SHW3●●●	—	SHA3●●●	SHO3●●●					
	1	—	—	—	3	3	5	SJG3●●●	—	—	SJA3●●●	SJO3●●●					
	2	—	—	—	7-1/2	7-1/2	10	SBG4●●●	SBW4●●●	SBW54●●●	SBA4●●●	SBO4●●●					
	3	—	—	—	10	15	25	SCG4●●●	SCW4●●●	SCW54●●●	SCA4●●●	SCO4●●●					
	4	—	—	—	25	30	50	SDG4●●●	SDW4●●●	SDW54●●●	SDA4●●●	SDO4●●●					
	5	—	—	—	40	50	100	SEG4●●●	SEW4●●●	—	SEA4●●●	SEO4●●●					
	6	—	—	—	75	100	200	SFG4●●●	SFW4●●●	—	SFA4●●●	SFO4●●●					
Constant Hp [4]	0	—	—	—	150	200	400	SHG4●●●	SHW4●●●	—	SHA4●●●	SHO4●●●					
	1	—	—	—	—	—	—	SJG4●●●	—	—	SJA4●●●	SJO4●●●					
	2	—	—	—	—	—	—	—	—	—	—	—					
	3	—	—	—	—	—	—	—	—	—	—	—					
	4	—	—	—	—	—	—	—	—	—	—	—					
	5	—	—	—	—	—	—	—	—	—	—	—					
	6	—	—	—	—	—	—	—	—	—	—	—					

**Table 16.25: Class 8810—Combination Circuit Breaker Type (Thermal Magnetic Circuit Breakers) [5][6]**

Single Winding (Consequent Pole) 5-Pole–3-Pole																
Type of Motor	NEMA Size	Maximum Polyphase Horsepower Ratings						NEMA 1 General Purpose Enclosure	NEMA 4 & 4X Watertight and Dusttight Enclosure (Stainless Steel) (304) (Sizes 0–5) Sheet Steel (Size 6)	NEMA 4X [1] Watertight, Dusttight and Corrosion Resistant Enclosure	NEMA 12 /3R [2] Dusttight and Driptight Industrial Use Enclosure	Open Type				
		Constant Horsepower Motors			Constant Torque or Variable Torque Motors								Type [3]	Type [3]	Type [3]	Type [3]
		200 V	230 V	460–575 V	200 V	230 V	460–575 V									
Constant Hp	0	2	2	3	—	—	—	CBG1●●●	CBW1●●●	CBW51●●●	CBA1●●●	—				
	1	5	5	7-1/2	—	—	—	CCG1●●●	CCW1●●●	CCW51●●●	CCA1●●●	—				
	2	7-1/2	10	20	—	—	—	CDG1●●●	CDW1●●●	CDW51●●●	CDA1●●●	—				
	3	20	25	40	—	—	—	CEG1●●●	CEW1●●●	—	CEA1●●●	—				
	4	30	40	75	—	—	—	CFG1●●●	CFW1●●●	—	CFA1●●●	—				
	5	60	75	150	—	—	—	CGG1●●●	CGW1●●●	—	CGA1●●●	—				
Constant Torque or Variable Torque	0	—	—	—	—	—	—	CHG1●●●	CHW1●●●	—	CHA1●●●	—				
	1	—	—	—	3	3	5	CBG2●●●	CBW2●●●	CBW52●●●	CBA2●●●	—				
	2	—	—	—	7-1/2	7-1/2	10	CCG2●●●	CCW2●●●	CCW52●●●	CCA2●●●	—				
	3	—	—	—	10	15	25	CDG2●●●	CDW2●●●	CDW52●●●	CDA2●●●	—				
	4	—	—	—	25	30	50	CEG2●●●	CEW2●●●	—	CEA2●●●	—				
	5	—	—	—	40	50	100	CFG2●●●	CFW2●●●	—	CFA2●●●	—				
Constant Hp [4]	0	—	—	—	75	100	200	CGG2●●●	CGW2●●●	—	CGA2●●●	—				
	1	—	—	—	150	200	400	CHG2●●●	CHW2●●●	—	CHA2●●●	—				
	2	—	—	—	—	—	—	CBG3●●●	CBW3●●●	CBW53●●●	CBA3●●●	—				
	3	—	—	—	—	—	—	CCG3●●●	CCW3●●●	CCW53●●●	CCA3●●●	—				
	4	—	—	—	—	—	—	CDG3●●●	CDW3●●●	CDW53●●●	CDA3●●●	—				
	5	—	—	—	—	—	—	CEG3●●●	CEW3●●●	—	CEA3●●●	—				
	6	—	—	—	—	—	—	CFG3●●●	CFW3●●●	—	CFA3●●●	—				
Constant Torque or Variable Torque [4]	0	—	—	—	—	—	—	CGG3●●●	CGW3●●●	—	CGA3●●●	—				
	1	—	—	—	—	—	—	CHG3●●●	CHW3●●●	—	CHA3●●●	—				
	2	—	—	—	—	—	—	CJG3●●●	—	—	CJA3●●●	—				
	3	—	—	—	3	3	5	CBG4●●●	CBW4●●●	CBW54●●●	CBA4●●●	—				
	4	—	—	—	7-1/2	7-1/2	10	CCG4●●●	CCW4●●●	CCW54●●●	CCA4●●●	—				
	5	—	—	—	10	15	25	CDG4●●●	CDW4●●●	CDW54●●●	CDA4●●●	—				
	6	—	—	—	25	30	50	CEG4●●●	CEW4●●●	—	CEA4●●●	—				
Constant Hp [4]	0	—	—	—	40	50	100	CFG4●●●	CFW4●●●	—	CFA4●●●	—				
	1	—	—	—	75	100	200	CGG4●●●	CGW4●●●	—	CGA4●●●	—				
	2	—	—	—	150	200	400	CHG4●●●	CHW4●●●	—	CHA4●●●	—				
	3	—	—	—	—	—	—	CJG4●●●	—	—	CJA4●●●	—				
	4	—	—	—	—	—	—	—	—	—	—	—				
	5	—	—	—	—	—	—	—	—	—	—	—				
	6	—	—	—	—	—	—	—	—	—	—	—				

[1] NEMA 4X hubs are included with each starter at no additional cost.

[2] NEMA Type 12 enclosures can be field modified for outdoor non-corrosive and non-service-entrance rated applications. See Digest Section 16 for more information.

[3] Replace the bullets (●●●) with the voltage code when ordering this product. Refer to the standard voltage codes shown on page 16-3.

[4] Type numbers shown for three-phase, separate-winding motor starters apply only when motor windings are wye connected.

When motor windings are connected open delta, prices for three-phase, consequent pole motor starters apply.

[5] The NEC 1300% maximum setting for instantaneous trip circuit breakers may be inadequate for multispeed motors.

[6] Not available in Mag-Gard versions.

### 3-Pole Polyphase, 600 Vac Max., 50–60 Hz

Devices require 6 thermal units (Sizes 0–6). See Digest Section 16 for selection information.

**Table 16.26: Class 8810—Combination Disconnect Switch Type (Class H Fuse Clips)**

Type of Motor	NEMA Size	Maximum Polyphase Horsepower Ratings						Fuse Clip Size A	NEMA 1 General Purpose Enclosure Type [8]	NEMA 4 & 4X Watertight and Dusttight Enclosure Stainless Steel (304) (Sizes 0–5) Sheet Steel (Size 6 not 4X) Type [8]	NEMA 12/3R [7] Dusttight and Driptight Industrial Use Enclosure Type [8]
		Constant Horsepower Motors			Constant Torque or Variable Torque Motors						
		200 V	230 V	460–575 V	200 V	230 V	460–575 V				
Single Winding (Consequent Pole) 5-Pole–3-Pole											
Constant Hp	0	2	2	3	—	—	—	None 30 [9]	UBG1●●● DBG1●●●	UBW1●●● DBW1●●●	UBA1●●● DBA1●●●
	1	5	5	7-1/2	—	—	—	None 30 [9]	UCG1●●● DCG1●●●	UCW1●●● DCW1●●●	UCA1●●● DCA1●●●
	2	7-1/2	10	20	—	—	—	None 60	UDG1●●● DDG1●●●	UDW1●●● DDW1●●●	UDA1●●● DDA1●●●
	3	20	25	40	—	—	—	None 100	UEG1●●● DEG1●●●	UEW1●●● DEW1●●●	UEA1●●● DEA1●●●
	4	30	40	75	—	—	—	None 200	UFG1●●● DFG1●●●	UFW1●●● DFW1●●●	UFA1●●● DFA1●●●
	5	60	75	150	—	—	—	None 400	UGG1●●● DGG1●●●	UGW1●●● DGW1●●●	UGA1●●● DGA1●●●
	6	100	150	300	—	—	—	None 600	UHG1●●● DHG1●●●	UHW1●●● DHW1●●●	UHA1●●● DHA1●●●
Constant Torque or Variable Torque	0	—	—	—	3	3	5	None 30 [9]	UBG2●●● DBG2●●●	UBW2●●● DBW2●●●	UBA2●●● DBA2●●●
	1	—	—	—	7-1/2	7-1/2	10	None 30 [9]	UCG2●●● DCG2●●●	UCW2●●● DCW2●●●	UCA2●●● DCA2●●●
	2	—	—	—	10	15	25	None 60	UDG2●●● DDG2●●●	UDW2●●● DDW2●●●	UDA2●●● DDA2●●●
	3	—	—	—	25	30	50	None 100	UEG2●●● DEG2●●●	UEW2●●● DEW2●●●	UEA2●●● DEA2●●●
	4	—	—	—	40	50	100	None 200	UFG2●●● DFG2●●●	UFW2●●● DFW2●●●	UFA2●●● DFA2●●●
	5	—	—	—	75	100	200	None 400	UGG2●●● DGG2●●●	UGW2●●● DGW2●●●	UGA2●●● DGA2●●●
	6	—	—	—	150	200	400	None 600	UHG2●●● DHG2●●●	UHW2●●● DHW2●●●	UHA2●●● DHA2●●●
Two Winding (Separate Winding) 3-Pole–3-Pole											
Constant Hp [10]	0	2	2	3	—	—	—	None 30 [9]	UBG3●●● DBG3●●●	UBW3●●● DBW3●●●	UBA3●●● DBA3●●●
	1	5	5	7-1/2	—	—	—	None 30 [9]	UCG3●●● DCG3●●●	UCW3●●● DCW3●●●	UCA3●●● DCA3●●●
	2	7-1/2	10	20	—	—	—	None 60	UDG3●●● DDG3●●●	UDW3●●● DDW3●●●	UDA3●●● DDA3●●●
	3	20	25	40	—	—	—	None 100	UEG3●●● DEG3●●●	UEW3●●● DEW3●●●	UEA3●●● DEA3●●●
	4	30	40	75	—	—	—	None 200	UFG3●●● DFG3●●●	UFW3●●● DFW3●●●	UFA3●●● DFA3●●●
	5	60	75	150	—	—	—	None 400	UGG3●●● DGG3●●●	UGW3●●● DGW3●●●	UGA3●●● DGA3●●●
	6	100	150	300	—	—	—	None 600	UHG3●●● DHG3●●●	UHW3●●● DHW3●●●	UHA3●●● DHA3●●●
Constant Torque or Variable Torque [10]	0	—	—	—	3	3	5	None 30 [9]	UBG4●●● DBG4●●●	UBW4●●● DBW4●●●	UBA4●●● DBA4●●●
	1	—	—	—	7-1/2	7-1/2	10	None 30 [9]	UCG4●●● DCG4●●●	UCW4●●● DCW4●●●	UCA4●●● DCA4●●●
	2	—	—	—	10	15	25	None 60	UDG4●●● DDG4●●●	UDW4●●● DDW4●●●	UDA4●●● DDA4●●●
	3	—	—	—	25	30	50	None 100	UEG4●●● DEG4●●●	UEW4●●● DEW4●●●	UEA4●●● DEA4●●●
	4	—	—	—	40	50	100	None 200	UFG4●●● DFG4●●●	UFW4●●● DFW4●●●	UFA4●●● DFA4●●●
	5	—	—	—	75	100	200	None 400	UGG4●●● DGG4●●●	UGW4●●● DGW4●●●	UGA4●●● DGA4●●●
	6	—	—	—	150	200	400	None 600	UHG4●●● DHG4●●●	UHW4●●● DHW4●●●	UHA4●●● DHA4●●●

**Table 16.27: Coil Voltage Codes**

Voltage		Code
60 Hz	50 Hz	
24 [11][12]	—	V01
120 [12]	110	V02
208	—	V08
240	220	V03
—	380	V05
480	440	V06
600	550	V07
Specify	Specify	V99

**NOTE:** For voltage codes used with control transformers, see page 16-18. **Form S** (separate control) is used when a separate source of power is available for the control (coil) voltage. Form S is provided at no charge.

For dimensions, see page 16-13.

Refer to Digest Section 16 factory modifications (Forms), replacement parts (Class 9998), and Type S accessories (Class 9999).

[7] NEMA Type 12 enclosures can be field modified for outdoor non-corrosive and non-service-entrance rated applications. See Digest Section 16 for more information.

[8] Replace the bullets (●●●) with the voltage code when ordering this product. Refer to the standard voltage codes shown in Table 16.27.

[9] When separate control is specified, use V8x voltage codes (see Table 16.53) to specify motor and control voltages.

[10] Type numbers shown for three-phase, separate-winding motor starters apply only when motor windings are wye connected.

When motor windings are connected open delta, prices for three-phase, consequent pole motor starters apply.

[11] 24 V coils are not available on Sizes 4–7. On Sizes 00–3, 24 V coils are available using **Form S** (separate control) (for example, order as 8810UBG1V01S).

[12] These voltage codes must include **Form S** (provided at no charge) (for example, order as 8810UCG1V02S).

3-Pole Polyphase, 600 Vac Max., 50–60 Hz

Devices require 6 thermal units (Sizes 0–6). See Digest Section 16 for selection information.

Table 16.28: Class 8810—Reversing

Type of Motor	NEMA Size	Maximum Polyphase Ratings						Reversing In One Speed Only (Specify High or Low) [13]			Reversing In Both Speeds		
		Constant Hp Motors			Constant Torque or Variable Torque Motors			NEMA 1 General Purpose Enclosure	NEMA 12 Dusttight and Driptight Industrial Use Enclosure	Open Type	NEMA 1 General Purpose Enclosure	NEMA 12/3R [14] Dusttight and Driptight Industrial Use Enclosure	Open Type
		200 V	230 V	460–575 V	200 V	230 V	460–575 V	Type [15]	Type [15]	Type [15]	Type [15]	Type [15]	Type
Single Winding, Constant Hp	0	2	2	3	—	—	—	SBG21●●●	SBA21●●●	SBO21●●●	SBG31●●●	SBA31●●●	SBO31●●●
	1	5	5	7-1/2	—	—	—	SCG21●●●	SCA21●●●	SCO21●●●	SCG31●●●	SCA31●●●	SCO31●●●
	2	7-1/2	10	20	—	—	—	SDG21●●●	SDA21●●●	SDO21●●●	SDG31●●●	SDA31●●●	SDO31●●●
	3	20	25	40	—	—	—	SEG21●●●	SEA21●●●	SEO21●●●	SEG31●●●	SEA31●●●	SEO31●●●
	4	30	40	75	—	—	—	SFG21●●●	SFA21●●●	SFO21●●●	SFG31●●●	SFA31●●●	SFO31●●●
5	60	75	150	—	—	—	SGG21●●●	SGA21●●●	SGO21●●●	SGG31●●●	SGA31●●●	SGO31●●●	
Single Winding, Constant Torque or Variable Torque	0	—	—	—	3	3	5	SBG22●●●	SBA22●●●	SBO22●●●	SBG32●●●	SBA32●●●	SBO32●●●
	1	—	—	—	7-1/2	7-1/2	10	SCG22●●●	SCA22●●●	SCO22●●●	SCG32●●●	SCA32●●●	SCO32●●●
	2	—	—	—	10	15	25	SDG22●●●	SDA22●●●	SDO22●●●	SDG32●●●	SDA32●●●	SDO32●●●
	3	—	—	—	25	30	50	SEG22●●●	SEA22●●●	SEO22●●●	SEG32●●●	SEA32●●●	SEO32●●●
	4	—	—	—	40	50	100	SFG22●●●	SFA22●●●	SFO22●●●	SFG32●●●	SFA32●●●	SFO32●●●
5	—	—	—	75	100	200	SGG22●●●	SGA22●●●	SGO22●●●	SGG32●●●	SGA32●●●	SGO32●●●	
Two Winding, Constant Hp [16]	0	2	2	3	—	—	—	SBG23●●●	SBA23●●●	SBO23●●●	SBG33●●●	SBA33●●●	SBO33●●●
	1	5	5	7-1/2	—	—	—	SCG23●●●	SCA23●●●	SCO23●●●	SCG33●●●	SCA33●●●	SCO33●●●
	2	7-1/2	10	20	—	—	—	SDG23●●●	SDA23●●●	SDO23●●●	SDG33●●●	SDA33●●●	SDO33●●●
	3	20	25	40	—	—	—	SEG23●●●	SEA23●●●	SEO23●●●	SEG33●●●	SEA33●●●	SEO33●●●
	4	30	40	75	—	—	—	SFG23●●●	SFA23●●●	SFO23●●●	SFG33●●●	SFA33●●●	SFO33●●●
5	60	75	150	—	—	—	SGG23●●●	SGA23●●●	SGO23●●●	SGG33●●●	SGA33●●●	SGO33●●●	
Two Winding, Constant Torque or Variable Torque [16]	0	—	—	—	3	3	5	SBG24●●●	SBA24●●●	SBO24●●●	SBG34●●●	SBA34●●●	SBO34●●●
	1	—	—	—	7-1/2	7-1/2	10	SCG24●●●	SCA24●●●	SCO24●●●	SCG34●●●	SCA34●●●	SCO34●●●
	2	—	—	—	10	15	25	SDG24●●●	SDA24●●●	SDO24●●●	SDG34●●●	SDA34●●●	SDO34●●●
	3	—	—	—	25	30	50	SEG24●●●	SEA24●●●	SEO24●●●	SEG34●●●	SEA34●●●	SEO34●●●
	4	—	—	—	40	50	100	SFG24●●●	SFA24●●●	SFO24●●●	SFG34●●●	SFA34●●●	SFO34●●●
5	—	—	—	75	100	200	SGG24●●●	SGA24●●●	SGO24●●●	SGG34●●●	SGA34●●●	SGO34●●●	

3-Pole Polyphase, 600 Vac Max., 50–60 Hz

Devices require 6 thermal units (Sizes 0–6). See Digest Section 16 for selection information.

Table 16.29: Class 8810—Non-Reversing, Vertically Arranged, Open Type, Two-Speed Starters

Type of Motor	NEMA Size	Maximum Hp Ratings				For Consequent Pole Motors	For Separate Winding Motors
		200 V	230 V	380 V	460-575 V	Type [15]	Type [15]
Constant Hp	0	2	2	3	3	SBO11●●●	SBO13●●●
	1	5	5	7-1/2	7-1/2	SCO11●●●	SCO13●●●
	2	7-1/2	10	20	20	SDO11●●●	SDO13●●●
	3	20	25	40	40	SEO11●●●	SEO13●●●
4	30	40	60	75	SFO11●●●	SFO13●●●	
Constant Torque or Variable Torque	0	3	3	5	5	SBO12●●●	SBO14●●●
	1	7-1/2	7-1/2	10	10	SCO12●●●	SCO14●●●
	2	10	15	25	25	SDO12●●●	SDO14●●●
	3	25	30	50	50	SEO12●●●	SEO14●●●
4	40	50	75	100	SFO12●●●	SFO14●●●	

Table 16.30: Coil Voltage Codes

Voltage		Code
60 Hz	50 Hz	
24 [17] [18]	—	V01
120 [18]	110	V02
—	208	V08
—	240	V03
—	380	V05
—	440	V06
—	600	V07
Specify	Specify	V99

NOTE: For voltage codes used with control transformers, see page 16-18.

Form S (separate control) is used when a separate source of power is available for the control (coil) voltage.

Form S is provided at no charge.

For dimensions, see page 16-13.

Refer to Digest Section 16 for factory modifications (Forms), replacement parts (Class 9998), and Type S accessories (Class 9999).

[13] Specify the speed that requires reversing by adding an L (low) or an H (high) after the type number—for example, a Class 8810 Type SBG21 with reversing in low only would be ordered as a Class 8810 Type SBG21L.

[14] NEMA Type 12 enclosures can be field modified for outdoor non-corrosive and non-service-entrance rated applications. See Digest Section 16 for more information.

[15] Replace the bullets (●●●) with the voltage code when ordering this product. Refer to the standard voltage codes shown in Table 16.30.

[16] Type numbers shown for three-phase, separate-winding motor starters apply only when motor windings are wye connected.

When motor windings are connected open delta, prices for three-phase, consequent pole motor starters apply.

[17] 24 V coils are not available on Sizes 4–7. On Sizes 00–3, 24 V coils are available using Form S (separate control) (for example, order as 8810SCG21V01S).

[18] These voltage codes must include Form S (provided at no charge) (for example, order as 8810SDG21V02S).

**Dimensions**

**Table 16.31: NEMA Type 1 Enclosure (see Figure 1)**

Type	A	B	C	D	E	F	G	H
SBG and SCG	11-7/8	11-7/8	7-17/32	9-3/4	1-1/16	1-1/16	9-3/4	5/16
SDG	14-7/8	14-1/8	7-21/32	12-3/4	1-1/16	1-1/16	12	5/16
SEG3 & 4 and SFG3 & 4	18-5/32	29-5/32	9-15/64	15-1/2	1-11/32	1-11/32	26-1/2	7/16
SEG1 & 2 and SFG1 & 2	22-5/32	39-5/32	10-15/64	19-1/2	1-11/32	1-11/32	36-1/2	7/16
SGG1, 2, 3, 4	20-7/32	65-3/4	16-29/64	31	2-1/8	2-1/8	42	9/16
SHG1, 2, 3, 4	36-7/32	62-7/32	19-15/32					
SJG3 & 4	Consult Square D				Floor Mount			

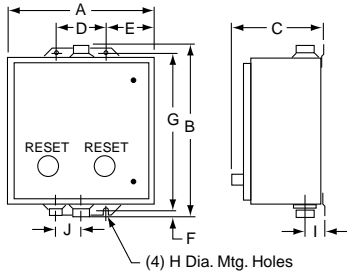

Figure 1: NEMA Type 1, 4, and 12 Enclosures

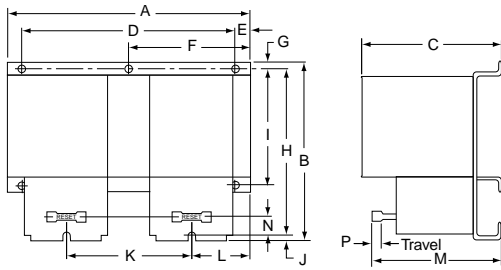

Figure 2: Class 8810 NEMA Sizes 0, 1, and 2

**Table 16.32: NEMA Type 4 Enclosure (see Figure 1)**

Type	A	B	C	D	E	F	G	H	I	J
SBW and SCW	12-5/8	14-11/16	7-13/16	4-1/4	4-3/16	19/32	13-1/2	5/16	1-21/32	2-5/16
SDW	14-7/8	15-3/4	8-1/4	4-1/4	5-5/16	3/8	15	5/16	2-1/32	2-5/8
SEW3 & 4 and SFW3 & 4	18-5/32	32-7/32	8-19/64	12	3-5/64	55/64	30-1/2	7/16	2-37/64	3-3/16
SEW1 & 2 and SFW1 & 2	22-5/32	42-7/32	9-49/64	16	3-5/64	55/64	40-1/2	7/16	2-21/64	2-57/64
SGW1, 2, 3, 4	35-7/32	49-7/32	12-1/8	27	4-3/32	39/64	48	9/16	2-63/64	3-1/2

**Table 16.33: NEMA Type 12/3R Enclosure (see Figure 1)**

Type	A	B	C	D	E	F	G	H
SBA and SCA	11-7/8	13-1/2	7-3/4	4-1/4	3-13/16	3/8	12-3/4	5/16
SDA	14-7/8	15-3/4	7-7/8	4-1/4	5-5/16	3/8	15	5/16
SEA3 & 4 and SFA3 & 4	18-5/32	31-1/2	9-19/32	16	3-3/32	1/2	30-1/2	7/16
SEA1 & 2 and SFA1 & 2	22-5/32	41-1/2	10-19/32	16	3-3/32	1/2	40-1/2	7/16
SGA1, 2, 3, 4	35-7/32	49	13-7/64	27	4-7/64	1/2	48	9/16
SHA1, 2, 3, 4	36-7/32	62-7/32	19-15/32					
SJA3 & 4	Consult Square D				Floor Mount			

**Table 16.34: Non-Reversing, Open Type**

Fig. No.	NEMA Size	Type	Mtg. Holes	A	B	C	D	E	F	G	H	I	J	K	L	M	N
2	0 and 1	SBO1, 2 SCO1, 2	4	9-5/8	7-11/32	5-5/16	8	5/8	—	7/32	6-29/32	—	7/32	4-3/4	2-1/4	5-1/16	19/32
		SBO3, 4 SCO3, 4	3	7-1/8	6-29/32	5-5/16	—	—	3-13/32	15/32	6-7/32	—	7/32	3-9/16	1-5/8	5-1/16	19/32
	2	SDO1, 2	6	12-1/32	8-17/32	6-1/32	10-3/8	1/2	—	1/4	8-1/8	6-1/4	5/32	5-3/4	2-13/16	5-5/32	25/32
3	3	SEO1, 2	4	18	14-7/16	17	12-1/4	1-1/2	11/16	1/2	6-7/16	7-3/8	1-21/32	2-5/32	—	—	—
		SEO3, 4	4	12-3/4	12-9/32	11-3/4	10-3/4	1-1/32	1/2	1/2	2-1/2	6-3/4	1-5/32	1-5/32	—	—	—
	4	SFO1, 2	4	18-5/8	15-19/32	17	12-1/4	1-27/32	1-1/2	1-1/8	6-7/16	7-21/32	1-21/32	1-21/32	—	—	—
		SFO3, 4	4	14-1/4	14-19/32	13-1/4	12-1/4	1-27/32	1/2	1/2	2-15/16	7-3/8	1-21/32	1-21/32	—	—	—
4	5	SGO1, 2 [19]	4	29-9/32	20-9/32	9-3/8	5-13/32	1-9/32	28	5/8	12-9/16	19	5/8	22-17/32	1/2	2-13/32	6-5/8
		SGO3, 4	4	19-9/32	20-9/32	9-3/8	5-13/32	1-9/32	18	5/8	2-5/8	19	5/8	12-17/32	1/2	2-13/32	6-5/8
4	6 [20]	SHO1, 2 [19]	4	29-17/32	22-7/16	9-17/32	6-31/32	3-13/16	28	3/4	11-5/8	21-3/16	5/8	9-7/8	9/16	3-1/32	9-5/16
		SHO3, 4	4	19-17/32	22-7/16	9-17/32	6-31/32	3-13/16	18	3/4	21-3/16	1-11/16	5/8	9-7/8	9/16	3-1/32	9-5/16
—	7 [21]	SJO3, 4	Consult the Customer Care Center (CCC) at 1-888-778-2733.														

**NOTE:** Illustrations are for dimensional information only and may not represent the actual enclosure. Dimension units are in. or in. (mm).

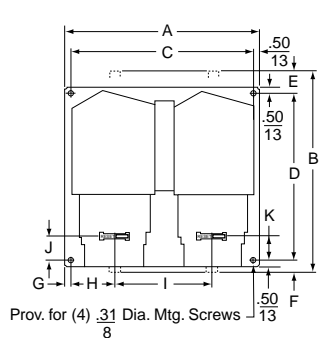

Figure 3: Class 8810 NEMA Sizes 3 and 4

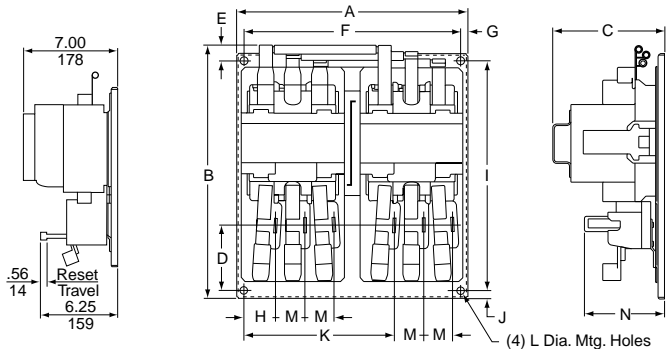

Figure 4: Class 8810 NEMA Size 5 and 6

[19] Consequent pole style starters consist of two 3-pole starters as pictured in Figure 4 and an additional 2-pole shorting contactor (not shown), all on a common baseplate, horizontally mounted.  
 [20] Current transformers used with Size 1 overload relay blocks.  
 [21] Solid-state overload relays and special current transformers.

Disconnect Switch or Circuit Breaker Type

Dimensions are for reference only. For precise measurements, contact the Customer Care Center (CCC) at 1-888-778-2733.

Table 16.35: Class 8810, NEMA 1 Enclosure, Figure 1

NEMA Size	Type	Dimensions (in.)—see Figure 1														Hubs			
		A	B	C	D	E	F	G	H	I	J	K	L	M	N	O	W	X	Y
0-1	CBG UBG DBG CCG UCG DCG	13.88	23.13	8.25	10.63	21	19.28	1.88	1.88	3.75	2.31	1.06	3.3	2.19	1.25	0.88	0.5-0.75-1	0.5-0.75-1	0.5
2	CDG UDG DDG	15.16	28.91	9.56	11.63	26.25	21.81	2.19	2	4	2.63	1.33	3.3	2.22	1.27	0.91	1-1.25	0.5-0.75	0.5
3 [22]	CEG UEG DEG	22.13	42.63	10.13	18.63	40	29.13	2.34	2.13	4.25	2.63	1.25	3.3	2.25	0.88	0.75	1-1.25-1.5	0.5-0.75	0.5
4 [22]	CFG UFG DFG	22.13	50.13	10.19	18.63	47.5	29.19	2.91	2.69	5.38	2.63	1.31	3.3	2.25	0.88	0.75	2.5	0.5-0.75	0.5

Table 16.36: Class 8810, NEMA 4 Enclosure, Figure 2

NEMA Size	Type	Dimensions (in.)—see Figure 2												Hubs	
		A	B	C	D	E	F	G	H	I	J	K	L	W	X
0-1	CBW UBW DBW UCW CCW DCW	13.88	8.33	25.19	3.3	2.56	8.75	24	0.59	3.95	1.63	2.31	18.53	0.75	1
2	CDW UDW DDW	15.13	9.58	30.94	3.3	2.56	10	29.75	0.59	3.95	2	2.63	21.34	0.75	1.5
3 [22]	CEW UEW DEW	22.13	10.13	46.25	3.3	3	16	44	0.63	3.94	1.75	2.63	29.13	0.75	2
4 [22]	CFW UFW DFW	22.13	10.19	53.75	3.3	3	16	51.5	0.63	3.94	2.28	3.19	29.19	0.75	2.5

Table 16.37: Class 8810, NEMA 12 Enclosure, Figure 3

NEMA Size	Type	Dimensions (in.)—see Figure 3									
		A	B	C	D	E	F	G	H	I	J
0-1	CBA UBA DBA CCA UCA DCA	13.88	10.09	24.75	3.3	2.56	8.75	24	0.38	3.95	20.28
2	CDA UDA DDA	15.16	10.97	31.25	3.3	3.08	9	30.25	0.5	4.83	23.44
3 [22]	CEA UEA DEA	22.13	10.13	45	3.3	3	16	44	0.63	3.94	29.13
4 [22]	CFA UFA DFA	22.13	10.19	52.5	3.3	3	16	51.5	0.63	3.94	29.19

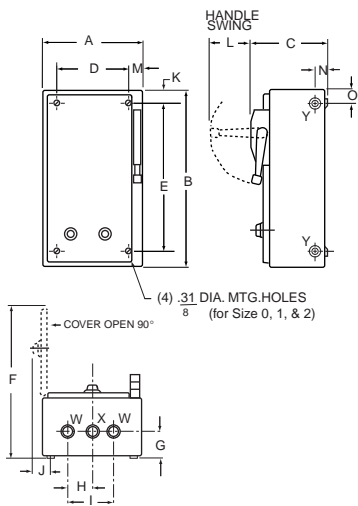

Figure 1:  
NEMA Type 1 Enclosure

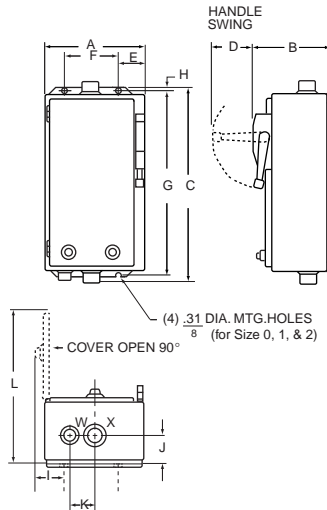

Figure 2:  
NEMA Type 4 Enclosure

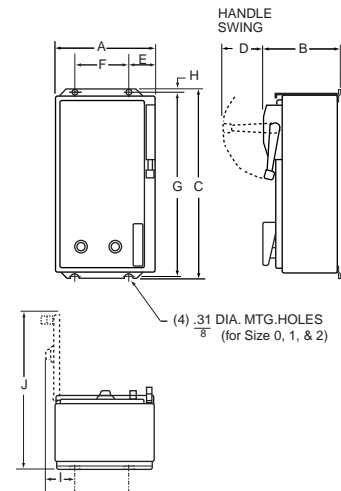

Figure 3:  
NEMA Type 12 Enclosure

NOTE: Illustrations are intended for dimensional information only and may not represent the actual enclosure. Dimensions are shown in inches.

[22] Size 3 (5-Pole-3-Pole) with FA, KA circuit breaker or 100 A disconnect switch. Size 4 (5-Pole-3-Pole) with KA circuit breaker or 200 A disconnect switch. Size 3 & 4 (3-Pole-3-Pole) enclosures may be smaller. Consult the Customer Care Center (CCC) at 1-888-778-2733 for additional dimensional information.



Panel Mount



**General Information**

Panelboard lighting contactors, sometimes called remote control switches, are designed for use with lighting panelboards and motor control centers where either panel or bus mounting is desired. Type PB lighting contactors can be used in a retrofit or new project without increasing the panelboard depth. They can be used to directly replace many inoperative existing switches.

The features include: mechanically held; compatible with Square D panelboards; short-circuit ratings to 100 kA; compact arc suppression; bus or panel mounted; fits in standard-depth lighting panelboards; easy manual operation; standard coil clearing contacts; and operates in any position.

**Table 16.38: Class 8903 Type PB Lighting Contactors**

Description	Bus Mount	Panel Mount (Includes Lugs)	
		Type [1]	Type [1]
30	2	PBM10B●●●	PBM10●●●
	3	PBM11B●●●	PBM11●●●
60	2	PBP10B●●●	PBP10●●●
	3	PBP11B●●●	PBP11●●●
75	2	PBN10B●●●	PBN10●●●
	3	PBN11B●●●	PBN11●●●
100	2	PBQ10B●●●	PBQ10●●●
	3	PBQ11B●●●	PBQ11●●●
150	2	PBR10B●●●	PBR10●●●
	3	PBR11B●●●	PBR11●●●
200	2	PBV10B●●●	PBV10●●●
	3	PBV11B●●●	PBV11●●●
225	2	PBW10B●●●	PBW10●●●
	3	PBW11B●●●	PBW11●●●

**Table 16.39: AC Coil Voltage Codes**

60 Hz	Voltage Code
120	V02
208	V08
240/277	V39
480	V28

**Table 16.40: Class 8903—Auxiliary Contacts**

Type	Description
PBX1	(1) Auxiliary Contact SPDT
PBX2	(2) Auxiliary Contacts SPDT

**Table 16.41: Factory Modifications**

Form	Description
X11	(1) Auxiliary Contact SPDT
X22	(2) Auxiliary Contacts SPDT

**Table 16.42: Maximum Wire Size (AWG)**

Current Range	Power Wire (Cu/Al)	Control Wire (Cu Only)
30–100 A	#1/0 Max.	#18–#10
150–225 A	350 MCM Max.	#18–#10

**Table 16.43: Control Distance**

Wire Gauge AWG	Maximum Distance (feet)				
	120 V	208 V	240 V	277 V	480 V
14	550	1650	2200	2925	8800
12	900	2700	3600	4700	14400
10	1425	4275	5700	7550	22800

**Table 16.44: Short-Circuit Ratings**

RMS Sym. Current (A)	Max. Volts	Short Circuit Protection Device Recommended
100,000	600	Class J Fuses
22,000	600	Circuit Breaker—Square D—Type LHL
65,000	240	Circuit Breaker—Square D—Type LHL

**Table 16.45: Dimensions (Panel Mount)**

A	Dimensions													
	H		W		D		A		B		C		E	
	in.	mm	in.	mm	in.	mm	in.	mm	in.	mm	in.	mm	in.	mm
30–100	11.75	298	7.50	191	3.88	98	2.25	57	7.38	187	2.25	57	9.25	235
150–225	14.50	368	7.50	191	3.88	98	2.88	73	8.50	216	3.00	76	10.50	267

**Table 16.46: Dimensions (Bus Mount)**

A	Dimensions									
	H		W		D		A		B	
	in.	mm	in.	mm	in.	mm	in.	mm	in.	mm
30–100	8.31	211	7.50	191	3.38	86	2.25	57	7.38	187
150–225	9.50	241	7.50	191	3.38	86	2.88 [2]	73	8.50	216

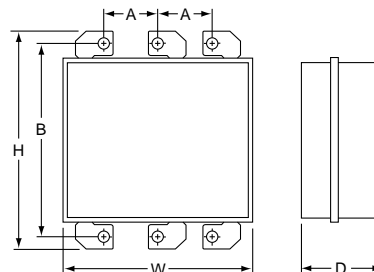
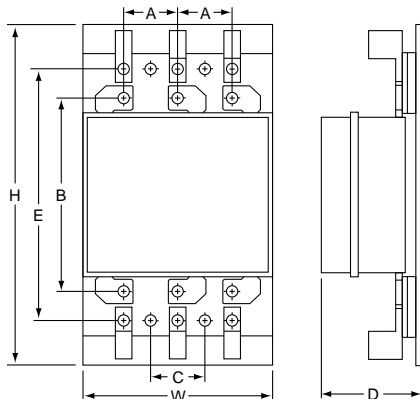

[1] Replace the bullets (●●●) with the voltage code when ordering this product. Refer to the standard voltage codes shown in Table 16.39.

[2] Slotted mounting holes are suitable for 2.88–3.19 in. mounting centers.

Table 16.47: Coil Voltage Codes

Voltage		Code
60 Hz	50 Hz	
24 [1]	—	V01
120 [2]	110	V02
208	—	V08
240	220	V03
—	380	V05
480	440	V06
600	550	V07
Specify	Specify	V99

For How to Order Information, see Digest Section 16 for selection information.

Well-Guard Reduced Voltage Pump Panels

Class 8940 reduced voltage panels in NEMA 3R enclosures are specifically designed for pumping applications. Extra space is provided for field installation of auxiliary equipment.

- Type S contactors/starters provided as standard
- All devices are UL Listed, and marked "SUITABLE ONLY FOR USE AS SERVICE EQUIPMENT"
- Includes a Hand-Off-Auto selector switch and a Start push button

**NOTE:** Illustrations may not represent the actual enclosure; they are intended for dimensional information only.



Type VG4V06K15

Table 16.48: Closed Transition Autotransformer Type, 3-Pole Polyphase—480 Vac Maximum (50–60 Hz)

Motor (Starter) Volts	Max. Hp Polyphase	Coil Voltage	NEMA Size	Fusible Disconnect Style		Circuit Breaker Style	
				Fuse Clip Amperes[3]	Type [4]	Circuit Breaker	Type [4]
230 (240)	15	240@ 60 Hz 220@ 50 Hz	2	60	RD4DV03	FAL36080	VD1DV03
	25		100	RE4FV03	FAL36100	VE1FV03	
	30		200	RE1GV03	KAL36100	VE2GV03	
	50		200	RF4JV03	KAL36200	VF1JV03	
	75		400	RG1LV03	LAL36250	VG2LV03	
	100		400	RG1MV03	LAL36350	VG2MV03	
460 (480)	25	480 @ 60 Hz 440 @ 50 Hz	2	60	RD2FV06	FAL36070	VD1FV06
	30		100	RE2GV06	FAL36080	VE1GV06	
	50		100	RE2JV06	FAL36100	VE1JV06	
	75		200	RF2LV06	KAL36125	VF1LV06	
	100		200	RF2MV06	KAL36200	VF1MV06	
	150		400	RG3PV06	LAL36250	VG4PV06	
	200		400	RG3QV06	LAL36350	VG4QV06	
	300		—	—	—	MAL36600	VH1SV06
	400		—	—	—	MAL36900	VH2TV06
	400		—	—	—	MAL361000	VJ1WV06
	600		—	—	—	—	—

Table 16.49: Autotransformer—Reduced Voltage Type

Type	Figure	A		B		C		D		E		F	
		in.	mm	in.	mm	in.	mm	in.	mm	in.	mm	in.	mm
RD, VD	3	25.00	635	52.50	1334	11.13	283	19.00	483	51.50	1308	0.44	11
RE, VE, RF, VF	4	32.00	813	72.50	1842	19.25	489	29.75	756	12.50	318	0.68	17
RG	4	36.00	914	93.00	2362	19.25	489	33.75	857	12.50	318	0.69	17
VG	4	32.00	813	72.50	1842	19.25	489	29.75	756	12.50	318	0.68	17
VH	4	34.00	864	93.00	2362	23.25	591	31.75	806	16.50	419	0.69	17
VJ[5]	4	64.00	1626	93.00	2362	27.25	692	61.75	1568	17.25	438	0.81	21

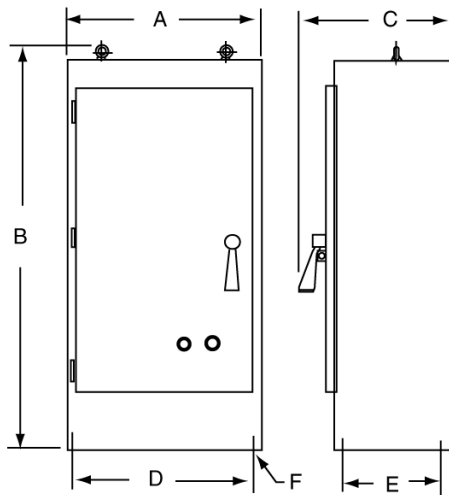

[1] 24 V coils are not available on Sizes 4–7. On Sizes 2–3, 24 V coils are available using Form S (separate control).

[2] This voltage code must include Form S (no charge).

[3] Fuse clips are sized for use with dual-element time-delay fuses.

[4] Specify the coil voltage code to order this product. Refer to the standard voltage codes shown in Table 16.47.

[5] The cabinet has double doors.

**Table 16.50: Part Winding Type, 3-Pole Polyphase—480 Vac Maximum (50–60 Hz)—Obsolete December 31, 2015**

Motor (Starter) Voltage	Max. Hp Polyphase	Coil Voltage	NEMA Size	Combination			
				Fusible Disconnect Style		Circuit Breaker Style	
				Fuse Clip (2 Sets) (A) [6]	Type [7]	Circuit Breaker (2 Breakers) Frame Size	Type [7]
230 (240)	25	240 @ 60 Hz 220 @ 50 Hz	2PW	60	MD4FV03	FAL36070	PD1FV03
	30			60	ME5GV03	FAL36080	PE3GV03
	50		3PW	100	ME6JV03	FAL36100	PE3JV03
	75			200	MF1LV03	KAL36150	PF3LV03
	100		4PW	200	MG3MV03	KAL36175	PG2MV03
	125			400	MG1NV03	LAL36250	PG3NV03
150	5PW	400	MG1PV03	LAL36250	PG3PV03		
460 (480)	30	480 @ 60 Hz 440 @ 50 Hz	2PW	30	MD5GV06	FAL36040	PD1GV06
	40			60	MD2HV06	FAL36050	PD1HV06
	60		3PW	60	ME7KV06	FAL36070	PE3KV06
	75			100	ME3LV06	FAL36090	PE3LV06
	100		4PW	200	MF3MV06	FAL36100	PF2MV06
	150			200	MF3PV06	KAL36125	PF3PV06
	200		5PW	200	MG4QV06	KAL36175	PG2QV06
	250			200	MG4RV06	KAL36225	PG3RV06
	350		400	MG2TV06	LAL36300	PG3TV06	

**Table 16.51: Part Winding, Reduced Voltage Type—Obsolete December 31, 2015**

Type	Figure	A		B		C		D		E		F	
		in.	mm	in.	mm	in.	mm	in.	mm	in.	mm	in.	mm
PD	3	19.00	483	34.50	876	12.25	311	13.00	330	33.50	851	0.44	11
MD	3	23.00	584	25.50	648	10.60	269	17.00	432	24.50	622	0.44	11
PE, PF	3	30.00	762	47.00	1194	13.25	337	22.00	559	46.00	1168	0.56	14
ME	3	25.00	635	52.50	1334	12.13	308	19.00	483	51.50	1308	0.44	11
MF	4	36.00	914	93.00	2362	19.25	489	33.75	857	12.50	318	0.69	18
PG, MG	4	36.00	914	73.00	1854	19.25	489	33.75	857	12.50	318	0.69	18
PH	4	38.00	965	93.00	2362	19.25	489	35.75	908	12.50	318	0.69	18

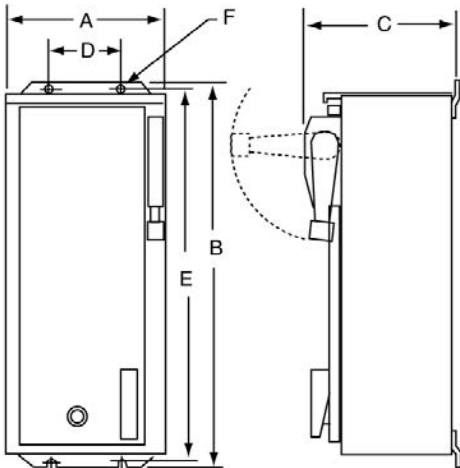

[6] Fuse clips are sized for use with dual-element time-delay fuses.  
[7] Specify the coil voltage code to order this product. Refer to the standard voltage codes shown in Table 16.47.

Forms—Reduced Voltage Controllers Only

Table 16.52: Reduced Voltage Controllers Only—Classes 8606, 8630, 8640

Factory Modifications	Enclosure Type	Form	NEMA Size							
			1 1PW 1YD	2 2PW 2YD	3 3PW 3YD	4 4PW 4YD	5 5PW 5YD	6 6PW 6YD	7 7PW 7YD	
<b>Push Buttons [1]</b>										
Start-Stop	1, 4, 12	A	X	X	X	X	X	X	X	X
<b>Selector Switches</b>										
Hand-Off-Auto	1, 4, 12	C	X	X	X	X	X	X	X	X
On-Off	1, 4, 12	C6	X	X	X	X	X	X	X	X
<b>Pilot Lights (specify color) [2]</b>										
One light On	1, 4, 12	P	X	X	X	X	X	X	X	X
<b>Separate Control Circuit [3] [4]</b>										
TR coil only (at control voltage)	1, 4, 12	S	N/C	N/C	N/C	N/C	N/C	N/C	N/C	N/C
All coils (at control voltage)	1, 4, 12	Y195	N/C	N/C	N/C	N/C	N/C	N/C	N/C	N/C
<b>Fused Control Circuit [3] [4] [5] [6]</b>										
One fuse	1, 4, 12	F	X	X	X	X	X	X	N/C [7]	N/C [7]
Two fuses	1, 4, 12	F4	X	X	X	X	X	X	N/C [7]	N/C [7]
<b>Control Circuit Transformer [3] [4] [5] Standard Capacity (50 or 60 Hz)</b>										
Fuses										
Primary	Secondary									
2—	0—	1, 4, 12	F4T	X	X	X	X	X	N/C [7]	N/C [7]
2—	1—	1, 4, 12	FF4T	X	X	X	X	X	X	X
2—	0—	1, 4, 12	F4T40	X	X	X	X	X	X	X
2—	1—	1, 4, 12	FF4T40	X	X	X	X	X	X	X
<b>Additional capacity (50 or 60 Hz) [8]</b>										
100 VA additional capacity		1, 4, 12	T11	X	X	X	X	X	X	X
200 VA additional capacity		1, 4, 12	T12	X	X	X	X	X	X	X
300 VA additional capacity		1, 4, 12	T13	X	X	X	X	X	X	X
400 VA additional capacity		1, 4, 12	T14	X	X	X	X	X	X	X
500 VA additional capacity		1, 4, 12	T15	X	X	X	X	X	X	X
Substitute nonstandard single primary and/or single secondary										
Voltage rating on the control transformer [5]		1, 4, 12	T1[9]	X	X	X	X	X	—	—

Pilot Devices in Cover and Control Circuit Reduced Voltage Controllers Only  
Classes  
8606  
8630  
8640  
8647  
8650

16 CONTACTORS AND STARTERS

Table 16.53: Selection of Control Circuit Transformers

Voltage 60 Hz (Primary–Secondary)	Code
120–12	V88
120–24	V89
208–120	V84
240–24	V82
240–120	V80
277–120	V85
480–24	V83
480–120	V81
480–240	V87
600–120	V86
Specify	V99

Selection of Control Circuit Transformers

The standard primary and secondary voltages for control circuit transformers are indicated in Table 16.53.

To order, select the desired device with the appropriate transformer Form designation. Then convert the previously selected voltage code (V\*\*) to reflect the desired primary/secondary voltage for the transformer. The secondary voltage should equal the previously selected coil voltage of the device. (24 Vac coils for NEMA Sizes 4–7 are not available).

Example:

You have a Class 8606SDG1V02S. The designation V02S means that you need a coil voltage of 120-60/110-50 wired for separate control. You want to add Form FF4T with the transformer voltages at 480 V primary, 120 V secondary. The new, complete Class, Type, Voltage Code, and Form are:

Class	Type	Voltage Code	Form [10]
8606	SDG1	V81	FF4T

[1] All push buttons are momentary contact.

[2] For pilot light details, refer to the pilot light table in Digest Section 16.

[3] As standard, reduced voltage controllers are supplied with common control. If Form S or T is specified, only the TR coil will be at control voltage. Specify Form Y195 or T40 (ex. Form FF4T40) if all coils must be at control voltage. Refer to page 16-3 for control circuit arrangements.

[4] Reduced voltage controllers include two control circuit fuses for conductors at line voltage. Additional fusing may be provided if a fused control circuit transformer or separate control is specified.

[5] See Table 16.53.

[6] Must be used with a Form specifying separate control (Ex. Form FS).

[7] Size 6 and 7 controllers come with Form FF4T as standard.

[8] Add Form letters to the standard control transformer (example: for Size 1, Form F4T plus 100 VA becomes F4T11; Form F4T40 plus 100 VA becomes F4T41.).

[9] Must be used in conjunction with a variation of Form F4T (ex.: standard capacity transformer required, 208–24 V; order as Form F4TT1, 208–24 V).

[10] Always list Form numbers in alphabetical order.

**Class 8606 Reduced Voltage Starters**

**Table 16.54: Class 8606 Reduced Voltage Starters Only**

Factory Modifications		Enclosure Type	Form	NEMA Size							
				1	2	3	4	5	6	7	
Circuit Breaker or Disconnect Switch	Molded case thermal magnetic circuit breaker [11]	1	Y791	X	X	X	X	X	X	X	
		4	Y791	X	X	X	X	X	X	X	
		12	Y791	X	X	X	X	X	X	X	
	Nonfusable disconnect switch	1	Y792	X	X	X	X	X	—	—	
		4	Y792	X	X	X	X	X	—	—	
		12	Y792	X	X	X	X	X	—	—	
	Automatic molded case switch	1	Y7910	—	—	—	—	—	X	X	
		4	Y7910	—	—	—	—	—	X	X	
		12	Y7910	—	—	—	—	—	X	X	
	<b>Fusible Disconnect Switch with Fuse Clips [12]</b>										
	30 A clips	1	Y793	X	X	—	—	—	—	—	
		4	Y793	X	X	—	—	—	—	—	
		12	Y793	X	X	—	—	—	—	—	
	60 A clips	1	Y794	X	X	X	—	—	—	—	
		4	Y794	X	X	X	—	—	—	—	
		12	Y794	X	X	X	—	—	—	—	
	100 A clips	1	Y795	—	—	X	X	—	—	—	
		4	Y795	—	—	X	X	—	—	—	
		12	Y795	—	—	X	X	—	—	—	
	200 A clips	1	Y796	—	—	X	X	—	—	—	
		4	Y796	—	—	X	X	—	—	—	
		12	Y796	—	—	X	X	—	—	—	
	400 A clips	1	Y797	—	—	—	—	X	X	—	
		4	Y797	—	—	—	—	X	X	—	
		12	Y797	—	—	—	—	X	X	—	
	Automatic molded case switch with 600 A fuse clips	1	Y798	—	—	—	—	—	X	—	
		4	Y798	—	—	—	—	—	X	—	
		12	Y798	—	—	—	—	—	X	—	
Automatic molded case switch with fuse clips 1200 A or less	1	Y799	—	—	—	—	—	—	X		
	4	Y799	—	—	—	—	—	—	X		
	12	Y799	—	—	—	—	—	—	X		

**Table 16.55: Class 8630 Reduced Voltage Controllers Only [13]**

Factory Modifications		Enclosure Type	Form	NEMA Size							
				1 YD	2 YD	3 YD	4 YD	5 YD	6 YD	7 YD	
Circuit Breaker or Disconnect Switch	Molded case thermal magnetic circuit breaker [11]	1	Y791	X	X	X	X	X	X	X	
		4	Y791	X	X	X	X	X	X	X	
		12	Y791	X	X	X	X	X	X	X	
	Nonfusable disconnect switch	1	Y792	X	X	X	X	—	—	—	
		4	Y792	X	X	X	X	—	—	—	
		12	Y792	X	X	X	X	—	—	—	
	Automatic molded case switch	1	Y7910	—	—	—	—	X	X	X	
		4	Y7910	—	—	—	—	X	X	X	
		12	Y7910	—	—	—	—	X	X	X	
	<b>Fusible Disconnect Switch with Fuse Clips [12]</b>										
	30 A clips	1	Y793	X	X	—	—	—	—	—	
		4	Y793	X	X	—	—	—	—	—	
		12	Y793	X	X	—	—	—	—	—	
	60 A clips	1	Y794	X	X	—	—	—	—	—	
		4	Y794	X	X	—	—	—	—	—	
		12	Y794	X	X	—	—	—	—	—	
	100 A clips	1	Y795	—	X	X	—	—	—	—	
		4	Y795	—	X	X	—	—	—	—	
		12	Y795	—	X	X	—	—	—	—	
	200 A clips	1	Y796	—	—	X	X	—	—	—	
		4	Y796	—	—	X	X	—	—	—	
		12	Y796	—	—	X	X	—	—	—	
	400 A clips	1	Y797	—	—	—	X	X	—	—	
		4	Y797	—	—	—	X	X	—	—	
		12	Y797	—	—	—	X	X	—	—	
	Automatic molded case switch with 600 A fuse clips	1	Y798	—	—	—	—	X	X	—	
		4	Y798	—	—	—	—	X	X	—	
		12	Y798	—	—	—	—	X	X	—	
Automatic molded case switch with fuse clips 1200 A or less	1	Y799	—	—	—	—	—	X	X		
	4	Y799	—	—	—	—	—	X	X		
	12	Y799	—	—	—	—	—	X	X		

[11] Mag-Gard™ circuit breakers are not supplied nor recommended.

[12] Fuses not included.

[13] Wye-Delta motor starters typically have higher current ratings per NEMA Size than full voltage motor starters. Care must be taken in selecting the appropriate short circuit protection. The table in Digest Section 7 will assist in selecting proper protection based on motor full-load current.

### Class 8640 Reduced Voltage Starters

**NOTE:** To comply with Section 430-3 of the National Electrical Code®, combination part-winding starters come as follows:

- Circuit breaker: two thermal-magnetic, adjustable-trip circuit breakers—one for each motor winding. In the smaller controllers that use the FA and KA frames, a single external operating mechanism operates the two circuit breakers simultaneously. In the larger controllers that use the KA and LA frames, each circuit breaker has its own operating mechanism.
- Nonfusible disconnect switch: a single 3-pole unfused disconnect switch of the proper rating for both windings. The user must provide proper short-circuit protection external to the starter, using only Class J fuses.
- Fusible disconnect switch: a single unfused disconnect switch with two sets of fuse clips (each set of the rating indicated) to provide short-circuit protection for each winding.

**Table 16.56: Class 8640 Reduced Voltage Starters Only**

Factory Modifications		Enclosure Type	Form	NEMA Size						
				1 PW	2 PW	3 PW	4 PW	5 PW	6 PW	
Circuit Breaker or Disconnect Switch	Molded case thermal magnetic circuit breaker [14]	1	Y7911	X	X	X	X	X	—	
		4	Y7911	X	X	X	X	X	—	
		12	Y7911	X	X	X	X	X	—	
	Fusible Disconnect Switch with Fuse Clips [15]									
	30 A clips (two sets)	1	Y7931	X	X	—	—	—	—	—
		4	Y7931	X	X	—	—	—	—	—
		12	Y7931	X	X	—	—	—	—	—
	60 A clips (two sets)	1	Y7941	—	X	X	—	—	—	—
		4	Y7941	—	X	X	—	—	—	—
		12	Y7941	—	X	X	—	—	—	—
	100 A clips (two sets)	1	Y7951	—	X	X	X	—	—	—
		4	Y7951	—	X	X	X	—	—	—
		12	Y7951	—	X	X	X	—	—	—
	200 A clips (two sets)	1	Y7961	—	—	X	X	X	—	—
		4	Y7961	—	—	X	X	X	—	—
		12	Y7961	—	—	X	X	X	—	—
	400 A clips (two sets)	1	Y7971	—	—	—	X	X	[16]	[16]
		4	Y7971	—	—	—	X	X	[16]	[16]
		12	Y7971	—	—	—	X	X	[16]	[16]
	Automatic molded case switch with 600 A fuse clips (two sets)	1	Y7920	—	—	—	—	—	—	X
		4	Y7920	—	—	—	—	—	—	X
		12	Y7920	—	—	—	—	—	—	X
	Automatic molded case switch with fuse clips 601–1200 A or less (two sets)	1	Y7921	—	—	—	—	—	—	X
		4	Y7921	—	—	—	—	—	—	X
12		Y7921	—	—	—	—	—	—	X	

**Table 16.57: Reduced Voltage Controllers Only—Classes 8606, 8630, 8640 [17]**

Factory Modifications	Enclosure Type	Form	NEMA Size							
			1 PW 1 YD	2 PW 2 YD	3 PW 3 YD	4 PW 4 YD	5 PW 5 YD	6 PW 6 YD	7 PW 7 YD	
<b>Overload relays</b> Substitute 9999SO4 isolated alarm contact on melting alloy overload relay Substitute 9999SO5 isolated alarm contact on melting alloy overload relay	Any Any	Y342 Y344	X X	X X	X X	X X	X X	X X	X X	— [18] — [18]
<b>Motor Logic™ overload relays</b> (Class 10/20 Selectable) [19] [20]	Any	H30	X	X	X	X	X	X	X	X
<b>Add for thermal protector Class 8606</b> <b>Coil transient suppressor, per coil</b> <b>Addition of terminal blocks</b> (specify wired or unwired). —Wired, per terminal, each —Unwired, per terminal, each	1, 4, 12 Any	Y116 Y145	— X	X X	X X	X X	X X	X X	X —	— —
	1, 4, 12 1, 4, 12	G56 [21] G50 [21]	X X	X X	X X	X X	X X	X X	X X	X X

[14] Mag-Gard™ circuit breakers are not supplied nor recommended.

[15] Fuses not included.

[16] Consists of automatic molded case switch with two sets of 400 A fuse clips.

[17] NEMA 7 and 9 enclosures not available with Class 8600 devices.

[18] Size 7 uses a solid-state overload relay. See Class 8536 for complete details.

[19] Motor Logic overload relays are not available on Class 8640 Size 1PW to 4PW starters.

[20] See Motor Logic overload relays in the Full Voltage section in Digest Section 16 for additional Form options of Motor Logic overload relays.

[21] Addition of terminal block 9080CA or 9080GR6 only. The number of circuits is the same as the ending of the Form number. (Example: G505 is a 5-wire terminal block.) Available in groups of 5 only. Order in increments of 5. The number of circuits is the same as the ending of the Form number. (Example: G505 = 5 unwired terminals, G510 is 10 unwired terminals.)



Type RO10V02

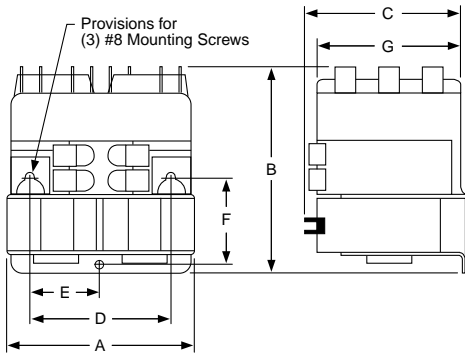

**Table 16.58: Approximate Dimensions (3 Poles per Contactor)**

Type	A	B	C	D	E	F	G
RO10, 11	3.31 84	3.31 84	3.03 77	2.69 68	1.34 34	1.56 40	2.66 68
RO12, 13	3.31 84	3.69 94	2.69 68	2.69 68	1.34 34	1.56 40	2.66 68

**Table 16.64: Cross Reference—Obsolete Devices**

Obsolete Device		Replacement Device		Auxiliary Contact Required		Obsolete Device		Replacement Device		Auxiliary Contact Required			
Class	Type	Class	Type	Class	Type	Class	Type	Class	Type	Class	Type		
8702 or 8965	HO3	8965	RO12	—	—	8965	RO2	8965	RO10	9999	R10		
	HO4		RO12	9999	R12		RO11		9999	R10			
	HO5		RO12	9999	R13		RO10		9999	R10			
	HO6		RO12	—	—		RO10		9999	R11			
	HO7		RO12	9999	R12		RO11		9999	R11			
HO8	RO12	9999	R13	RO12	9999		R11						
8965	RG2S1	8965	RO10	9999	R10		RO4		—	RO12	—	—	—
	RG5S1		RO12	9999	R12		RO4S1		—	RO13	—	—	—
	RG5S2		RO12	9999	R12		RO5		—	RO12	9999	R12	R12
	RO1		RO10	—	—		RO5S1		—	RO13	9999	R12	R12
	RO1S1		RO11	—	—	RO5S2	—	RO12	9999	R12	R12		
	RO1S2		RO10	—	—	RO6	—	RO12	9999	R13	R13		
	RO1S3		RO11	—	—	RO6S1	—	RO13	9999	R13	R13		
	RO1S4		RO10	—	—	RO6S2	—	RO12	9999	R13	R13		
RO1S5	RO10	—	—										
RO1S6	RO10	—	—										

**Table 16.65: Application Data**

<b>Coils</b>	Duty: Hoist Duty—H4 Intermittent Voltage Range: AC coils only; +10%, -15% of nominal
<b>Burden</b>	Inrush 76 VA, Sealed 27 VA

**Table 16.66: Approvals**

UL Component Recognized: File E78351, CCN NLDX2  
CSA Certified: File LR60905, Class 3211 04

**Selection—AC Reversing/Hoist Contactors**

Class 8965 reversing hoist contactors meet the small space requirements found in electrical hoists, light duty cranes, door operators, and related products. They are designed to perform in the short periods of jogging experienced in hoist service. Note that these contactors must be mounted upright on the vertical plane; the contactors will not operate properly when mounted in any other position.

**Table 16.59: AC Reversing/Hoist Contactors—600 Vac Maximum**

No. of Poles	Horsepower Ratings				Power Terminals	With [1] Jumper Straps	Without [1] Jumper Straps
	115 V 1 Ø	230 V 1 Ø	230 V 3 Ø	460/575 V 3 Ø		Open Type	Open Type
3-Pole Poly-phase	1	1-1/2	3	3	Quick Connect	RO10 [2]	RO11 [2]
					Pressure Wire [3]	RO12 [2]	RO13 [2]

**Table 16.60: Miscellaneous Hoist Contactor Kits For Use With Class 8965**

Type	Series	Description	Class	Type	Series	Description	Class	Type
RO10 RO11 RO12 RO13	A & B	Armature Kit	9998	RP1 [4]	C	Armature Kit	9998	RP2 [4]
		Contact Carrier	Order as Part Number 3100206050				Contact Carrier	Order as Part Number 3100208150

**Table 16.61: Class 8965 Replacement Contact Kits**

Device Type	Device Series	Class 9998 Kit Type	Device Series	Class 9998 Kit Type
RO10	A & B	RA10	C	RA14
RO11		RA11		RA15
RO12		RA12		RA16
RO13		RA13		RA17

**Table 16.62: Auxiliary Contacts Separate Module**

Description	Terminals	Class 9999 Type
1 N.O. Each Side	Quick Connect	R10
	Screw	R12
1 N.C. Each Side	Quick Connect	R11
	Screw	R13

**Table 16.63: Coil Table**

Voltage 60 Hz	Voltage 50 Hz	Voltage Code	Replacement Part Number
24	—	V01	3100240319 [5]
120	110	V02	3100240340 [5]
208/220	—	V21	3100240047 [5]
240	220	V03	3100240049 [6]
480	440	V06	3100240058 [6][7]
600	550	V07	3100240060 [6]

**Table 16.67: How to Order**

To Order Specify:	Catalog Number		
• Class Number	Class	Type	Voltage and Frequency
• Type Number	8695	RO10	V02
• Voltage and Frequency			

[1] Jumper straps connect the line side power terminals of the same phase between the forward (up) and reverse (down) contactors in common—i.e., L1 to L1, L2 to L2, and L3 to L3.  
 [2] Specify the voltage code to order this product. Refer to the standard voltage codes shown in Table 16.63.  
 [3] Coils rated 120 Vac or less are provided with quick connect terminals only.  
 [4] One armature per kit.  
 [5] Tape wound coils, 2 per package.  
 [6] Molded coil, 1 per package.  
 [7] Suitable for 440 V 50 Hz applications.

Motor Logic Plus—Class 9065



Motor Logic Plus

The Motor Logic Plus solid-state overload relay is separately powered and fully programmable. It is designed to protect 3-phase AC motor applications, 200–480 Vac or 600 Vac. The SSOLR has one Form C relay output rated for 300 Vac maximum.

Table 16.68: Motor Logic Plus—Replacement Only

Class 9065 SP Solid-State Overload Relay		
200–480 V	600 V	Current Range
SPB4	SPB6	0.5–2.3 A
SPC4	SPC6	2.0–9.0 A
SP14	SP16	6.0–27.0 A
SP24	SP26	10.0–45.0 A
SP34	SP36	20.0–90.0 A
SP44 [1]	SP46 [1]	60.0–135.0 A
SP54 [2]	SP56 [2]	120.0–270.0 A
SP64 [3]	SP66 [3]	240.0–540.0 A

Lug-Lug Kit

This kit can be field installed on separately mounted Motor Logic Plus overload relays.

Table 16.69: Lug-Lug Kit

For Use With		Parts Kit Description	Class 9999 Type
Class & Type	NEMA Size		
8536 SA-SH	1–6	Lug-Lug Kit	MLPL
9065 SP	1–6		

Software Kit

Solutions software program allows an IBM PC compatible computer (with Windows 95 or greater) to communicate with a Motor Logic Plus overload relay connected to an RS-485 network using Modbus protocol.

Table 16.70: Software Kit

For Use With		Parts Kit Description	Class 9999 Type
Class & Type	NEMA Size		
8536 SA-SH	1–6	Software Kit	MLPS
9065 SP			

Communication Module

This module allows the Motor Logic Plus overload relay to support RS-485 electrical communications standards. Up to 99 Motor Logic Plus overload relays can be controlled and monitored from one remote personal computer.

Table 16.72: Communication Module

For Use With		Parts Kit Description	Class 9999 Type
Class & Type	NEMA Size		
8536 SA-SH	1–6	Modbus Communication Module	MB22
9065 SP			

Table 16.71: How to Order

To Order Specify:	Catalog Number	
	Class	Type
• Class Number	9999	AC04
• Type Number		

Table 16.73: Full Voltage Controllers Only—Classes 8502, 8536, 8538, 8539, 8702, 8736, 8738, 8739, 8810, 8811 and 8812

Factory Modifications	Enclosure Type	Form	NEMA Size									
			00	0	1	2	3	4	5	6	7	
Overload Relays—General Modify Size 3 Type SE starters with melting alloy overload relays to accept Type FB quick trip or SB slow trip thermal units	Any	Y81	—	—	—	—	N/C	—	—	—	—	—
Substitute 9999 SO4 isolated alarm contact (N.O.) on melting alloy overload relay	Any	Y342	X	X	X	X	X	X	X	[4]	X	[5]
Substitute 9999 SO5 isolated alarm contact (N.C.) on melting alloy overload relay	Any	Y344	X	X	X	X	X	X	X	[4]	X	[5]

[1] Must use 150:5 external current transformer, purchased separately.

[2] Must use 300:5 external current transformer, purchased separately.

[3] Must use 600:5 external current transformer, purchased separately.

[4] For Classes 8736, 8738, and 8739 Type SG, consult the Customer Care Center at 1-888-778-2733.

[5] Size 7 uses a solid-state overload relay as standard. See Digest Section 16 for complete details.

# Section 17

## Medical Products

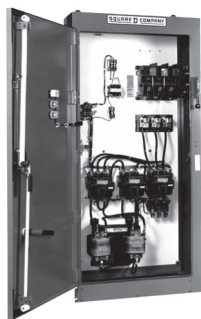

Electromechanical  
Reduced Voltage Starter

<b>Isolated Power Panels and Systems</b>	<b>17-2</b>
Isolated Power Systems Overview	17-2
Isolated Power Systems: Multiple Configurations	17-3
Line Isolation Monitor (LIM)	17-8
<b>Remote Indicator for LIM</b>	<b>17-8</b>
IG2000 Series Remote Alarm Indicator	17-8
Requirements for Line Isolation Monitors (LIM)	17-8
LIM Remote Alarm Indicator	17-8
<b>Isolated Power System Accessories</b>	<b>17-9</b>
Hospital Power and Ground Modules	17-9
Hospital Ground Cords and Jacks	17-9
Hospital X-ray / Laser Power Receptacle Modules	17-10
Hospital Power Panel Kits and Options	17-11

### Overview of Isolated Power Systems

An isolated power system provides a critical safety advantage in medical environments by functioning as a predictive, rather than reactive, solution. It enables early detection of potentially hazardous current before a fault causes system failure. Through a line isolation monitor (LIM), hospital staff receive visual indications of leakage current and audible and visual alarms when current exceeds a preset threshold. This early warning capability allows personnel to take timely corrective actions, helping ensure continuous operation of critical medical systems and enhanced patient safety. Additional information can be found in the [Iso-Gard Series 6 Line Isolation Monitor \(LIM\) Catalog](#), Document Number 4805CT1301.

An isolated, ungrounded, electrical distribution system contains the following components:

1	<b>Isolation Transformer</b> —specifically designed with low leakage current per UL 1047. Includes electrostatic shielding for noise attenuation in the ungrounded system.
2	<b>PowerPacT™ Circuit Breaker</b> —used for main equipment disconnect; can be coordinated with QOB branch circuit breakers
3	<b>NQ Interior</b> —provides space for up to 16 branch circuit breakers
4	<b>Iso-Gard™ Line Isolation Monitor (LIM)</b> —shipped with interior (not shown below)
5	<b>Hinged Back Box/Trim System</b> —this system houses all other components
6	Ground Bus—ALCU

17 MEDICAL PRODUCTS

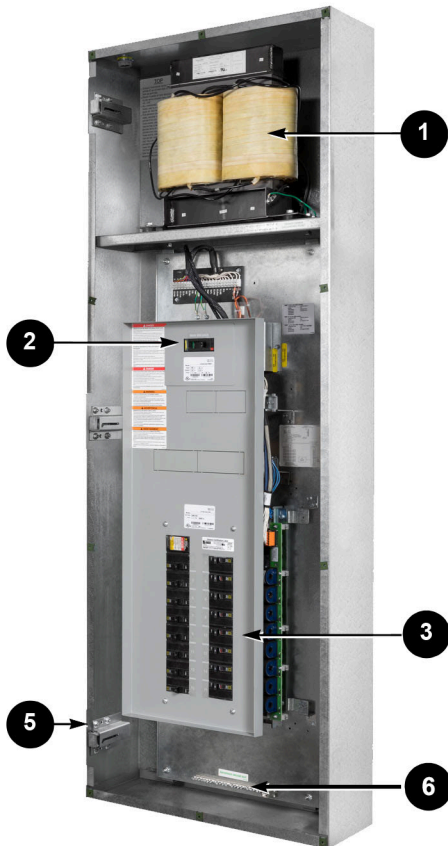

Isolated Power System Components

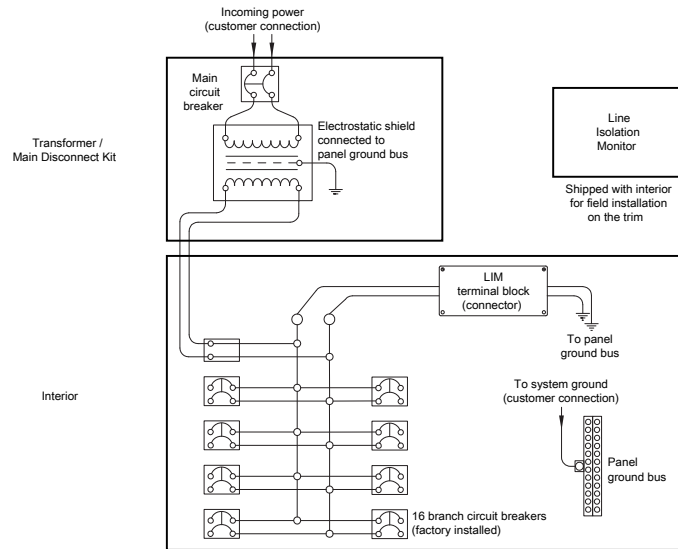

Typical Isolated Power System Wiring Diagram

Schneider Electric has been involved in the design and manufacture of isolated power systems since 1944. Our isolated power systems have evolved over the years and will continue to do so to meet the ever-changing needs of the health care industry.

**Isolation Power System Configurations**

Isolation power systems support safe, NEC-compliant operating room power distribution. Standard systems serve single ORs, duplex systems provide dual capacity and future expansion, dual voltage systems deliver 120V and 208V from one feed, and controlled systems centrally manage 208V power to multiple locations using PLC-controlled, modular designs. Additional information can be found in the [Iso-Gard Series 6 Line Isolation Monitor \(LIM\) Catalog](#), Document Number 4805CT1301.

**Standard Isolation System**

Standard System offer the most compact solution for a single isolated power system feeding one operating room.

- Designed to support either 120 or 208 V power requirements in the operating room
- 120 V Systems are available in 3, 5, 7.5, and 10 kVA designs
  - Space for 16 branch circuits
- 208 V Systems are available in 7.5, 10, 15, and 25 kVA designs
  - Space for 16 branch circuits

**Duplex Isolation Systems**

Duplex Systems allow for two standard systems to be mounted in a common backbox and use a common trim. Backbox is barrier to keep the two-system separate. Requires two unique feeds. Solution also offers one side to be design for future space.

- Designed to support either 120 or 208 V power requirements in the operating room
- 120 V Systems are available in 3, 5, 7.5, and 10 kVA designs
  - Space for 16 branch circuits
- 208 V Systems are available in 7.5 and 10 kVA designs
  - Space for 16 branch circuits

**Dual Voltage Isolation System**

Dual Voltage System are designed to feed both 120 and 208 V power via one Isolation System. Incorporate a transformer with one primary winding and two secondary windings. Supply via One Feed.

- Designed to support both 120 and 208 V power requirements in the operating room
- 120 V Systems are available in 5, 7.5 and 10 kVA
  - Space for 16 branch circuits
- 208 V Systems are available in 7.5 and 15 kVA
  - Space for four branch circuits

**Controlled Isolation System**

Controlled Systems are designed to provide 208 V of isolated power to multiple areas from one central location. A programmable logic controller (PLC) lets the system be designed to feed multiple load location, but only provide power to specific power modules. This helps prevent overloading of the system, and compliance with 200,000 resistance requirements of NEC, since the PLC limits number of circuits. (Default is one circuit energized)

- Designed to support 208 V power requirements for multiple locations
  - Options for 4, 8, or 12 branch circuits – preconfigured at the factory
- Modular Design provides maximum flexibility and easy for upgrading and changing the system

**Interiors:** Line Isolation Monitor, Line Isolation connector terminal, 125 Amp 250 V NQ panelboard with copper bus, Dead front, Space for Main Breaker (field installed), allocated space for field installed accessory.

**Table 17.1: Interiors Standard and Duplex Systems**

Catalog Number	Branch Breakers Factory Installed	Spaces	Line Isolation Monitor	LIM Connector terminals	Ground Bus	Fit into BackBox
SMIPB	(16) QOB220	(0)	IG6M	4800IG6C	PK23GTA/Q1100AN	SB662408F SB662408S SB803608F SB803608S
SMIPBA212	(12) QOB220	(4)	IG6M	4800IG6C	PK23GTA/Q1100AN	
SMIPAN	None	(16)	IG6M	4800IG6C	PK23GTA/Q1100AN	
SMIE	None	(16)	IG6M	4800IG6C	PK23GTA/Q1100AN	SB723014F SB723014S

Allocated space for field installed power modules require TRIM with removal blank plate, **example: ST8238R**

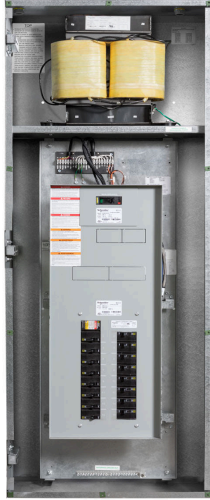

**Standard**  
Isolated Power System



**Duplex**  
Isolated Power System

**Interiors:** Line Isolation Monitor, Line Isolation connector terminal, 120 V Side: 125 Amp 250 V NQ panelboard with copper bus, 208 V Side: terminal block and allocated space for FOUR QOU branch breakers, Dead front, Space for Main Breaker (field installed), Space for Secondary Main Breakers.

**Table 17.2: Interiors Dual Voltage Systems**

Catalog Number	120 V Side		208 V Side		Line Isolation Monitor	LIM Connector terminals	Ground Bus
	Branch Breakers Factory Installed	Space	Branch Breakers Factory Installed	Space			
SMIDBA216A31A51	(16) QOB220	(0)	(1) QOU230 (1) QOU250	(2)	IG6M	4800IG6C	PK23GTA/Q1100AN
SMIDBA216A32	(16) QOB220	(0)	(2) QOU230	(2)	IG6M	4800IG6C	PK23GTA/Q1100AN
SMIDBA216A52	(16) QOB220	(0)	(2) QOU250	(2)	IG6M	4800IG6C	PK23GTA/Q1100AN
SMIDBA216AN	(16) QOB220	(0)	none	(4)	IG6M	4800IG6C	PK23GTA/Q1100AN
SMIDBA212A31A51	(12) QOB220	(4)	(1) QOU230 (1) QOU250	(2)	IG6M	4800IG6C	PK23GTA/Q1100AN
SMIDBA212A32	(12) QOB220	(4)	(2) QOU230	(2)	IG6M	4800IG6C	PK23GTA/Q1100AN
SMIDBA212AN	(12) QOB220	(4)	none	(4)	IG6M	4800IG6C	PK23GTA/Q1100AN
SMIDANAN	none	(16)	none	(4)	IG6M	4800IG6C	PK23GTA/Q1100AN

All dual voltage interiors go into Backbox SB723014F or SB723014S.

**Interiors:** Line Isolation Monitor, Line Isolation connector terminal, 125 Amp 250 V NQ panelboard with copper bus, Dead front, Space for Main Breaker (field installed), Programmable Controller (PLC), N/C Relays for each circuit, terminal board for remotes, terminal board for "IN USE LIGHT".

**Table 17.3: Interiors Controlled System**

Catalog Number	Branch Breakers Factory Installed	N/C Relays Factory Installed	PLC Programmed to allow energized circuits	Line Isolation Monitor	LIM Connector terminals	Ground Bus
SMICBP UA24H1	(4) QOB220	(4) 30 A	(1)	IG6M	4800IG6C	PK23GTA/Q1100AN
SMICBP UA34H1	(4) QOB230	(4) 30 A	(1)	IG6M	4800IG6C	PK23GTA/Q1100AN
SMICBP UA54H1	(4) QOB250	(4) 60 A	(1)	IG6M	4800IG6C	PK23GTA/Q1100AN
SMICBP UA32A52H1	(2) QOB230	(2) 30 A	(1)	IG6M	4800IG6C	PK23GTA/Q1100AN
	(2) QOB250	(2) 60 A				
SMICBP UA28H1	(8) QOB220	(8) 30 A	(1)	IG6M	4800IG6C	PK23GTA/Q1100AN
SMICBP UA38H1	(8) QOB230	(8) 30 A	(1)	IG6M	4800IG6C	PK23GTA/Q1100AN
SMICBP UA58H1	(8) QOB250	(8) 60 A	(1)	IG6M	4800IG6C	PK23GTA/Q1100AN
SMICBP UA68H1	(8) QOB260	(8) 60 A	(1)	IG6M	4800IG6C	PK23GTA/Q1100AN
SMICBP UA212H1	(12) QOB220	(12) 30 A	(1)	IG6M	4800IG6C	PK23GTA/Q1100AN
SMICBP UA312H1	(12) QOB230	(12) 30 A	(1)	IG6M	4800IG6C	PK23GTA/Q1100AN
SMICBP UA512H1	(12) QOB250	(12) 60 A	(1)	IG6M	4800IG6C	PK23GTA/Q1100AN
SMICBP UA36A56H1	(6) QOB230	(6) 30 A	(1)	IG6M	4800IG6C	PK23GTA/Q1100AN
	(6) QOB250	(6) 60 A				

All dual voltage interiors go into Backbox SB723014F or SB723014S.

In use Light terminal: PLC will turn on all terminals that are not energized causing optional light on Power Module to be energized, that informs the hospital staff that POWER IS NOT AVAILABLE at this time. communicates: POWER IS IN USE AT OTHER LOCATION.

**Transformer Disconnect Kits**

The transformer type is determined by the source voltage and the load capacity requirements. The main disconnect type is determined by the transformer choice. Schneider Electric packages these two components together for field installation into the isolated power system. The advantages of this installation method are:

- Flexibility in the job schedule—the interior can be shipped without fixed voltage and kVA capacity
- Job changes can be made without impacting the interior
- Future expansion since the capacity of the system can be upgraded without changing the interior
- NEC requires Isolation Power Systems to UL Listed Equipment - Labeling comes on Dead Front as part of Transformer Disconnect Kit.

Main disconnect sizing per UL 1047 to allow for full capacity of the isolated power system, PowerPacT H circuit breakers, coordinated with the branch circuit breakers for 0.1 seconds.

Transformer Disconnect Kit includes: One Transformer, Terminal (Lead wire) to connect to breaker and NQ panelboard, Main Disconnect, mounting bracket, Dead Front with System characteristics and UL Label.

**Table 17.4: Standard/Duplex/Control**

Kit Catalog Number	KVA	Primary Voltage	Main Disconnect (breaker)	Amp Rating Breaker	Sec Voltage	Transformer Part Number	Isolation Power System
SXMK03DASC	3	277	HDL26015	15	120	SXM03DA	Standard / Duplex
SXMK03CASC	3	240	HDL36060U31X	20	120	SXM03CA	Standard / Duplex
SXMK03BASC	3	208	HDL36060U31X	20	120	SXM03BA	Standard / Duplex
SXMK03AASC	3	120	HDL36100U31X	35	120	SXM03AA	Standard / Duplex
SXMK05EASC	5	480	HDL26015	15	120	SXM05EA	Standard / Duplex
SXMK05DASC	5	277	HDL26025	25	120	SXM05DA	Standard / Duplex
SXMK05CASC	5	240	HDL36060U31X	30	120	SXM05CA	Standard / Duplex
SXMK05BASC	5	208	HDL36060U31X	30	120	SXM05BA	Standard / Duplex
SXMK05AASC	5	120	HDL26060	60	120	SXM05AA	Standard / Duplex
SXMK07EASC	7.5	480	HDL26020	20	120	SXM07EA	Standard / Duplex
SXMK07DASC	7.5	277	HDL26035	35	120	SXM07DA	Standard / Duplex
SXMK07CASC	7.5	240	HDL26040	40	120	SXM07CA	Standard / Duplex
SXMK07BASC	7.5	208	HDL36060U31X	45	120	SXM07BA	Standard / Duplex
SXMK07AASC	7.5	120	HDL26080	80	120	SXM07AA	Standard / Duplex
SXMK10EASC	10	480	HDL26030	30	120	SXM10EA	Standard / Duplex
SXMK10DASC	10	277	HDL26045	45	120	SXM10DA	Standard / Duplex
SXMK10CASC	10	240	QOU260	60	120	SXM10CA	Standard / Duplex
SXMK10BASC	10	208	HDL26060	60	120	SXM10BA	Standard / Duplex
SXMK10AASC	10	120	HDL26100	100	120	SXM10AA	Standard / Duplex
SXMK05EBSC	5	480	HDL26015	15	208	SXM05EB	Standard / Duplex/Control
SXMK05DB	5	277	HDL26025	25	208	SXM05DB	Standard / Duplex/Control
SXMK05CB	5	240	QOU230	30	208	SXM05CB	Standard / Duplex/Control
SXMK05BB	5	208	QOU230	30	208	SXM05BB	Standard / Duplex/Control
SXMK07EBSC	7.5	480	HDL36060U31X	20	208	SXM07EB	Standard / Duplex/Control
SXMK07DBSC	7.5	277	HDL36100U31X	35	208	SXM07DB	Standard / Duplex/Control
SXMK07CBSC	7.5	240	HDL36100U31X	40	208	SXM07CB	Standard / Duplex/Control
SXMK07BBSC	7.5	208	HDL36100U31X	45	208	SXM07BB	Standard / Duplex/Control
SXMK10EBSC	10	480	HDL36060U31X	30	208	SXM10EB	Standard / Duplex/Control
SXMK10DBSC	10	277	HDL36100U31X	45	208	SXM10DB	Standard / Duplex/Control
SXMK10CBSC	10	240	HDL36100U31X	60	208	SXM10CB	Standard / Duplex/Control
SXMK10BBSC	10	208	HDL36100U31X	60	208	SXM10BB	Standard / Duplex/Control
SXMK15EBSC	15	480	HDL36060U31X	40	208	SXM15EB	Standard/Control
SXMK15DBSC	15	277	HDL36100U31X	70	208	SXM15DB	Standard/Control
SXMK15CBSC	15	240	HDL36100U31X	80	208	SXM15CB	Standard/Control
SXMK15BBSC	15	208	HDL36100U31X	90	208	SXM15BB	Standard/Control
SXMK25EBSC	25	480	HDL26070	70	208	SXM25EB	Standard/Control
SXMK25DBSC	25	277	HDL26125	125	208	SXM25DB	Standard/Control
SXMK25CBSC	25	240	QOU2150	150	208	SXM25CB	Standard/Control
SXMK25BBSC	25	208	QOU2150	150	208	SXM25BB	Standard/Control

Transformer Disconnect Kit includes: One Transformer, Terminal (Lead wire) to connect to breaker and NQ panelboard, Main Breaker, 120 V Secondary Main Breaker, 208 V Secondary Main Breaker, mounting brackets, Dead Front with System characteristics and UL Label, Dead Front for Secondary Breakers.

**Table 17.5: Dual Voltage**

Kit Catalog Number	System kVA	Pri V	Main Disconnect (Breaker)	Amp Rating Breaker	Sec V	Sec kVA	Sec Main Breaker	Sec Amp Rating	Transformer Part Number
SXMK15EB07	15	480	HDL26040	40	120	7.5	HDL26070	70	SXM15EB07
					208	7.5	QOU240	40	
SXMK15DB07	15	277	HDL26070	70	120	7.5	HDL26070	70	SXM15DB07
					208	7.5	QOU240	40	
SXMK15CB07	15	240	QOU280	80	120	7.5	HDL26070	70	SXM15CB07
					208	7.5	QOU240	40	
SXMK15BB07	15	208	QOU290	90	120	7.5	HDL26070	70	SXM15BB07
					208	7.5	QOU240	40	
SXMK22EB07	22.5	480	HDL26060	60	120	7.5	HDL26070	70	SXM25EB10
					208	15	QOU280	80	
SXMK22DB07	22.5	277	HDL26100	100	120	7.5	HDL26070	70	SXM25DB10
					208	15	QOU280	80	
SXMK22CB07	22.5	240	HDL26125	125	120	7.5	HDL26070	70	SXM25CB10
					208	15	QOU280	80	
SXMK22BB07	22.5	208	HDL26150	150	120	7.5	HDL26070	70	SXM25BB10
					208	15	QOU280	80	
SXMK25EB10SC	25	480	HDL26070	70	120	10	QOU2100	100	SXM25EB10
					208	15	QOU280	80	
SXMK25DB10SC	25	277	HDL26125	125	120	10	QOU2100	100	SXM25DB10
					208	15	QOU280	80	
SXMK25CB10SC	25	240	HDL36150U31X	150	120	10	QOU2100	100	SXM25CB10
					208	15	QOU280	80	
SXMK25BB10SC	25	480	HDL36150U31X	150	120	10	QOU2100	100	SXM25BB10
					208	15	QOU280	80	

Dual Voltage Transformer kits only work on Dual Voltage system.

**Hinged Back Box Trim System**

The trim/back box system incorporates a new barrel hinge design that hides the hinge when the trim piece is closed and fastened to the back box. This design helps facilitate ease of cleaning by keeping debris from accumulating in the hinge system. The hinge pins are factory-mounted on the trim piece. The sliding support mechanisms are factory-mounted on the inside of the back box.

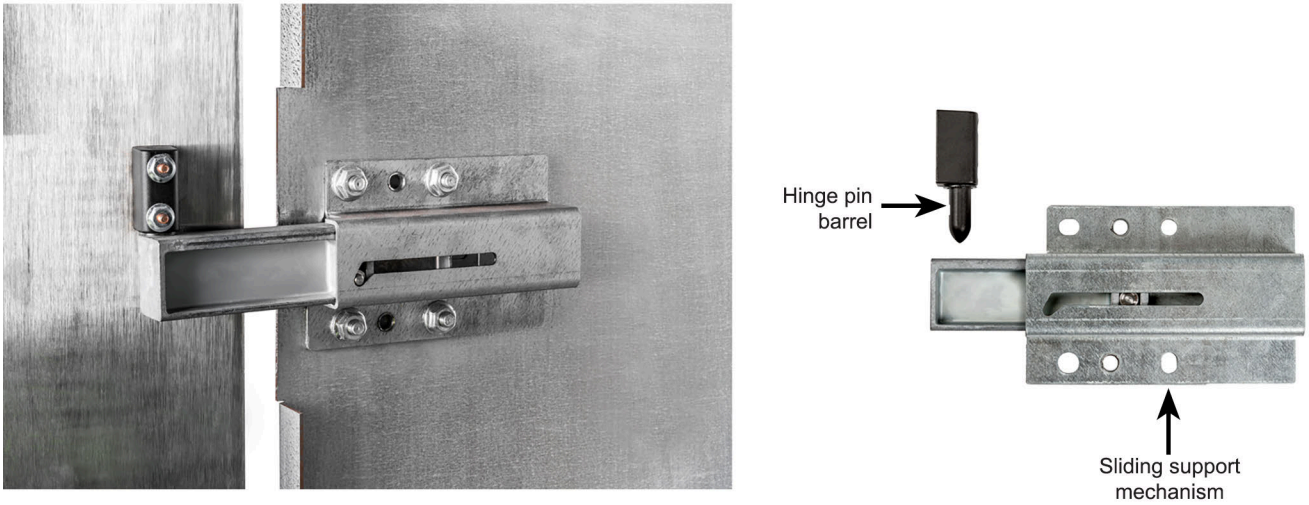

**Hinged Trim/Back Box System Design**

Back box is constructed of 14-gauge (minimum), galvanized steel. Flush mounting is standard. Surface-mounted back boxes are finished with a coat of hospital-ivory colored baked enamel.

**Table 17.6: Back Box**

System	Catalog Number	H	W	D	Mounting	kVA
Standard	SB662408F	66	24	8	Flush	3, 5, 7.5, or 10
Standard	SB662408S	66	24	8	Surface	3, 5, 7.5, or 10
Standard	SB723014F	72	30	14	Flush	15 or 25
Standard	SB723014S	72	30	14	Surface	15 or 25
Controlled	SB723014F	72	30	14	Flush	5, 7.5, 10, 15 or 25
Controlled	SB723014S	72	30	14	Surface	5, 7.5, 10, 15 or 25
Dual	SB723014F	72	30	14	Flush	15 or 25
Dual	SB723014S	72	30	14	Surface	15 or 25
Duplex	SB803608F	80	36	8	Flush	3, 5, 7.5, or 10
Duplex	SB803608F	80	36	8	Surface	3, 5, 7.5, or 10

Table Trim is constructed of 14-gauge (minimum) 304 Stainless steel, brush finished, door with hidden hinge, flush-mounted key lock, allocated hole for Line Isolation Mounting.

**Table 17.7: Table Trim**

Catalog Number	Used with	H	W	
ST6826	SB662408F	68	26	
ST6826R	SB662408F	68	26	Removal blank plate for field accessories {1}
ST6624	SB662408S	66	24	
ST6624R	SB662408S	66	24	Removal blank plate for field accessories {1}
ST8238	SB803608F	82	38	
ST8238R	SB803608F	82	38	Removal blank plates for field accessories {2}
ST8036	SB803608S	80	36	
ST8036R	SB803608S	80	36	Removal blank plates for field accessories {2}
ST7432	SB723014F	74	32	
ST7230	SB723014S	72	30	
ST7432D	SB723014F	74	32	
ST7432DR	SB723014F	74	32	Removal blank plate for field accessories {1}
ST7230D	SB723014S	72	30	
ST7230DR	SB723014S	72	30	Removal blank plate for field accessories {1}
ST7432C	SB723014F	74	32	
ST7230C	SB723014S	72	30	



Iso-Gard Series 6 LIM

### Iso-Gard™ Series 6 Line Isolation Monitor (LIM)

The Iso-Gard Series 6, microprocessor-controlled, Line Isolation Monitor (LIM) is included as standard equipment in all Schneider Electric hospital isolation panels. The Iso-Gard Series 6 LIM incorporates automatic and manual self-test and self-calibration to reduce the frequency of required periodic testing. Microprocessor controlled circuitry for highest accuracy and stability. UL Component Recognized and CSA Classified.

Additional information can be found in the [Iso-Gard Series 6 Line Isolation Monitor \(LIM\) Catalog](#), Document Number 4805CT1301.

Catalog Number	Description	Additional Detail
IG6M	Series 6 Line Isolation Monitor	Included with each interior, mounted on TRIM
4800IG6C	Connector terminal	Included with each interior, factory mounted
4800IG6CBKTVM	Connector terminal	Required when installing IG6M into older Square D Isolation Power Systems
	Mounting Bracket	

### Requirements for Line Isolation Monitors (LIM)

NEC® Requirement: The National Electrical Code® (NEC) requires audible and visual alarm indication where isolation power is used (NEC 517-160). Schneider Electric offers the IG2000CBM remote alarm indicators for this purpose when line isolation monitor (LIM) is located outside the area.

### LIM Remote Alarm Indicator

The Iso-Gard™ IG2000CBM remote indicator from Schneider Electric provides remote indication of the visible and audible alarms and digital mA reading from an Iso-Gard Series 6 (IG6) line isolation monitor (LIM). Additional information can be found in the [Medical Products: Isolated Power Systems Catalog](#), Document Number 4800CT2001.

- Green LED—stays illuminated while the system is in normal condition
- Red LED—illuminates when the Total Hazard Current (THC) exceeds the preset alarm level
- Audible hazard alarm—sounds when the THC exceeds the preset alarm level  
Mute button with yellow LED—silences the audible alarm on the remote indicator (local muting), or silences all audible alarms in the system (system muting)
- Test button—remotely performs a functional test of the LIM

IG2000CBM remote indicator is available in different mounting configurations.

Catalog Number	QTY	Description	Box Requirements
IG2000CBMG2	1	Mounted on two gang plate	Customer supplied two gang box
IG2000CBMG4	1	Mounted on four gang plate	Customer supplied four gang box
IG2000CBM2G4	2	Mounted on four gang plate	Customer supplied four gang box
IG2000CBMST0614	1	Mounted on Trim 14 x 6	Existing backbox 53008BB
IG2000CBMPM	1	Mounted on Bracket	Existing Square D Isolation Power System



Iso-Gard IG2000CBM Remote Indicator

Schneider Electric offers 208 V or 240 V modules designed to complete the control circuit of a controlled power panel. Additional information can be found in the [Medical Products: Isolated Power Systems Catalog](#), Document Number 4800CT2001.

**Medical Power Receptacle and Ground Modules**

**Power Modules:** When both ground jacks and power receptacles are required, these UL Listed modules offer convenience and save labor in field wiring. The units include four power receptacles, four twist-to-lock ground jacks, and a ground bus with a generous number of lugs for external ground connections. The main ground connection in the module accommodates up to a #1/0 cable. The units are completely factory wired; only field power connections and ground connections are necessary. They are furnished with Type 304, brushed stainless steel face plates.

Multiple mounting options for the product:

- Backbox 12 x 8 x 4
- Bottom of Standard or Duplex Isolation Power System
- Standard Gang Box supplied by customer



**Power Modules**  
4 Red Duplex Receptacles and 4 Ground Jacks

**Table 17.8: Power Modules**

Catalog Number	Hospital Grade Ground Jacks	Power Receptacles	Mounting
SGPMF4DR4	(4) 30 A, 250 V, Green	(4) 20 A, Duplex Red	Backbox SB120804
SGPMF4DI4		(4) 20 A, Duplex Ivory	
SGPMF4TB4		(4) 20 A, Single Twist Lock	
SGPMP4DR4		(4) 20 A, Duplex Red	Duplex or Standard Isolation Power System <sup>[1]</sup>
SGPMP4DI4		(4) 20 A, Duplex Ivory	
SGPMG4DR4		(4) 20 A, Duplex Red	Customer supplied eight gang box
SGPMG4TB4		(4) 20 A, Single Twist Lock	

**Master Ground Station:** These modules can be used as a collection point for grounds in a large area, such as a coronary care unit or intensive care ward. The primary application is where the equipment ground bus in the isolated power panel is not conveniently located or cannot accept the large number of connections required for the area. This unit can be connected to the ground point by a single conductor and located in a more convenient area. The module contains a bus bar with 18 lugs for field connections and has a Type #304 brushed stainless steel cover plate. It is designed for installation into a 12 in. x 8 in. x 4 in. back box.

**Table 17.9: Master Ground Station – Ground Modules**

Catalog Number	Description	Mounting
SGPMF0NNO	Master ground station, *****	Backbox SB120804
SGPMF4NNO	(4) 30 A, 250 V, Green Hospital Grade ground jacks	
SGPMP4NNO	(4) 30 A, 250 V, Green Hospital Grade ground jacks	Duplex or Standard Isolation Power System
SGPMG4NNO	(4) 30 A, 250 V, Green Hospital Grade ground jacks	Customer supplied four Gang Box



Medical Ground Station Module

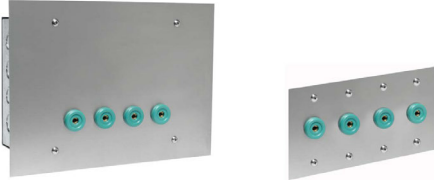

Medical Ground Station Module with Four Ground Jacks



Ground Cord with Lug End

Ground Cord with Clip End



Ground Jack

**Hospital Ground Cords and Jacks**

- Highly flexible wire with a heavy-duty lug or clip end
- Ground cord with lug end is UL Listed (UL 467)
- Various lengths available

Catalog Number	Description
SHGC15L	15 foot, with plug and lug for #10 stud
SHGC15C	15 foot, with plug and heavy duty clip
SHGJ1R	Hospital grade ground jack, 30 A, 250 V green

[1] Must have TRIM with Removal blank plate for field accessories example: ST8238R.







**X-Ray/Laser Power Receptacle Module**

Optional "IN USE LIGHT" – used with Control Panel to inform customer that power is not available at this Laser Module – it is IN USE AT ANOTHER LOCATION.

**X-ray / Laser Power Receptacle Modules for Controlled Panels**

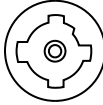
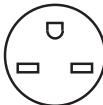
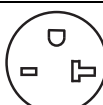
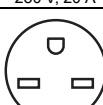
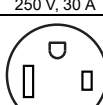
X-ray/laser power receptacle modules provide a convenient source of power for portable X-ray and laser equipment. The receptacle provided in each module is matched to the NEMA plug configuration of the equipment with which it will be used and is mounted behind the door on the stainless steel face plate. The door features a concealed hinge and a touch latch. Additional information can be found in the [Medical Products: Isolated Power Systems Catalog](#), Document Number 4800CT2001.

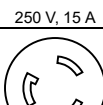
**Table 17.10: Laser Power Modules**

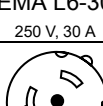
Catalog Number	Factory installed remote	Outlet Configuration	"In Use Light"	Required backbox
SXRM1A1F	IG2000P	 IN16494 250 V, 60 A	NO	SB120804
SXRM1E1F	IG2000CBM		NO	SB120804
SXRM1A2F	IG2000P		YES	SB120804
SXRM1E2F	IG2000CBM		YES	SB120804
SXRM2A1F	IG2000P	 NEMA 6-15R 250 V, 15 A	NO	SB120804
SXRM2E1F	IG2000CBM		NO	SB120804
SXRM2A2F	IG2000P		YES	SB120804
SXRM2E2F	IG2000CBM		YES	SB120804
SXRM3A1F	IG2000P	 NEMA 6-20R 250 V, 20 A	NO	SB120804
SXRM3E1F	IG2000CBM		NO	SB120804
SXRM3A2F	IG2000P		YES	SB120804
SXRM3E2F	IG2000CBM		YES	SB120804
SXRM4A1F	IG2000P	 NEMA 6-30R 250 V, 30 A	NO	SB120804
SXRM4E1F	IG2000CBM		NO	SB120804
SXRM4A2F	IG2000P		YES	SB120804
SXRM4E2F	IG2000CBM		YES	SB120804
SXRM5A1F	IG2000P	 NEMA 6-50R 250 V, 50 A	NO	SB120804
SXRM5E1F	IG2000CBM		NO	SB120804
SXRM5A2F	IG2000P		YES	SB120804
SXRM5E2F	IG2000CBM		YES	SB120804
SXRM6A1F	IG2000P	 NEMA L6-15R 250 V, 15 A	NO	SB120804
SXRM6E1F	IG2000CBM		NO	SB120804
SXRM6A2F	IG2000P		YES	SB120804
SXRM6E2F	IG2000CBM		YES	SB120804
SXRM7A1F	IG2000P	 NEMA L6-20R 250 V, 20 A	NO	SB120804
SXRM7E1F	IG2000CBM		NO	SB120804
SXRM7A2F	IG2000P		YES	SB120804
SXRM7E2F	IG2000CBM		YES	SB120804
SXRM8A1F	IG2000P	 NEMA L6-30R 250 V, 30 A	NO	SB120804
SXRM8E1F	IG2000CBM		NO	SB120804
SXRM8A2F	IG2000P		YES	SB120804
SXRM8E2F	IG2000CBM		YES	SB120804
SXRM9A1F	IG2000P	 CS8269 250 V, 50 A	NO	SB120804
SXRM9E1F	IG2000CBM		NO	SB120804
SXRM9A2F	IG2000P		YES	SB120804
SXRM9E2F	IG2000CBM		YES	SB120804

## Medical Power Panel Kits and Options

### Seismic Kit

The Schneider Electric Medical Panels, Standard Isolation Panels, Dual Isolation Panels, have been qualified to the seismic limits with the installation of special hardware for trim installation and use of bolt on breakers.

Catalog Number	Description
4800S10200015	Trim hardware to replace hardware shipped with device. OSP label for where required

**Table 17.11: Replacement Parts / Kits**

Catalog Number	Description
4800S10200000	Transformer Mounting hardware and isolation pads
4800S10200002	Mounting hardware, Power and Ground Modules
4800S10200004	Mounting hardware, Power and Ground Modules
4800S10200009	Mounting hardware Fault locator system
4800S10200306	Mounting hardware Isolation Power System Trim
4800S10200705	Line Isolation Monitor – rear mounted hardware
4800KEY	Replacement KEY for Isolation Power System
4800IG6BKTVM	Mounting bracket to mount IG6M in Square D branded Isolation Power Systems
4800IG6C	Line Isolation Monitor connector cord and terminal block
4800IG6CBKTVM	4800IG6C and 4800IG6BKTVM shipped together

**Table 17.12: Ground Kit options**

Description	Catalog Number
Installed in every Isolation Panel System Accepting AL/CU wire	PK23GTA
	Q1100AN
Field installable Copper Ground Kit	PK27GTACU
Field installable Chicago Code Ground Bus Copper	4800B521301722

# Product Selection made EASY.

Our online product selector tools are designed to assist you through the product selection process with the click of a button.



#### Save Time

Click-to-answer questions guide you through selecting the right product for your application!



#### Dive Deeper

Direct links to detailed product information at your fingertips.



#### Share your Projects

Email data sheets directly from product selectors.



#### Manage Large Projects

Create a project list online to keep you organized.



#### Efficient

Distributors can add product selector results directly to their cart and checkout.



## Join the Movement

Try our online product selectors and other tools and see why thousands of customers are using them to make their jobs easier.

[se.com/us/en/work/support/resources-and-tools/calculators-and-online-tools/](https://se.com/us/en/work/support/resources-and-tools/calculators-and-online-tools/)

### Other Digital Self-Service Tools:

#### mySchneider App

Access tailored services, 24/7 self-service and expert help. Anywhere, anytime, any project.

#### Digest Plus

Find the latest product information including catalogs, trip curves and more.

#### Technical FAQs

Find the answers you need from our online database of frequently asked questions.

#### Product Competitor Cross Reference Tool

Find the replacement for competitor and obsolete part numbers.

0100CT2402

Schneider Electric USA, Inc.

800 Federal Street  
Andover, MA 01810 USA  
888-778-2733

[se.com/us](https://se.com/us)

Life Is On

**Schneider**  
Electric