

V241

Two-way Globe Valve, Bronze, PN 16

Product Description

The V241 is a precision flow control valve with polished stainless steel seats for a strong close off and a low leakage rate for all heating, cooling, air handling and domestic hot water systems.

The patented crown plug design provides an excellent low flow control and is self-cleaning when used in media with a high concentration of dirt particulates.

Resilient construction materials allow the valve to be used at high differential pressures and with the following types of media.

- Hot and chilled water.
- Water containing phosphate or hydrazine additives.
- Water with antifreeze additives such as glycol (at 50% glycol concentration).

Specifications

Design	Two-way globe valve
Pressure class	PN 16
Flow characteristic	EQM
Stroke	20 mm
Rangeability Kvs/Kv _{min}	see table
Leakage	Up to 0,02% of Kvs
ΔPm	600 kPa, water
Max. temperature of medium	150 °C
Min. temperature of medium ^a	-20 °C
End Connections	External pipe thread according to ISO 228-1
Connection sets	see tables
Materials	
Body	Bronze Rg5
Plug and seat	Stainless steel SS 2346
Stem	Stainless steel SS 2346
Pressure Equipment Directive	PED 2014/68/EU, Article 4 (3)

Note: It is the responsibility of the installer or product specifier to verify media compatibility of the valves construction materials with the supplier of water treatment/heat transfer solution.



Available Part Numbers

Size		Valve Connection Thread	Kvs m ³ /h	Part number (excluding connection)	Rangeability
DN	in.				
15	½"	G1B	0.25	7214106000	> 50
15	½"		0.40	7214110000	
15	½"		0.63	7214114000	
15	½"		1.0	7214118000	
15	½"		1.6	7214122000	
15	½"		2.5	7214126000	
15	½"		4.0	7214130000	
20	¾"	G1-1/4B	6.3	7214134000	> 100
25	1"	G1-1/2B	10	7214138000	
32	1¼"	G2B	16	7214142000	
40	1½"	G2-1/4B	25	7214146000	
50	2"	G2-3/4B	38	7214150000	

End Connection Accessories ordered separately, pg. 5.

- Rangeability is the ratio of Kvs and Kv_{min}
- Kvs is the flow through the valve in m³/h at the specified valve lift and at a pressure drop of 100 kPa across the valve.
- Kv_{min} is the minimum controllable flow (m³/h) at a pressure drop of 100 kPa within the range in which the valve characteristics conform to the slope requirements of EN60534-1.

Recommendations

- If the valve is used for media at temperatures below 0 °C, it should be equipped with a stem heater in order to prevent ice formation on the valve stem.

Spare Parts

Description	Part No.
Stuffing box Standard type S max 150 °C	100108000

Design and Characteristics

The patented plug design of the V241 gives good resistance against solid particles in the fluid.

The plug is guided throughout the lift, which reduces the risk for vibrations. The valve closes with the stem up.

The V241 has a metal to metal seat constructed from polished Stainless steel for a resilient and low leakage close off performance.

The flow characteristics of the V241 is equal percentage modified. This characteristic makes it possible to control low flow rates down to almost closed position. This is particularly important for achieving good control performance in systems with wide load variations.

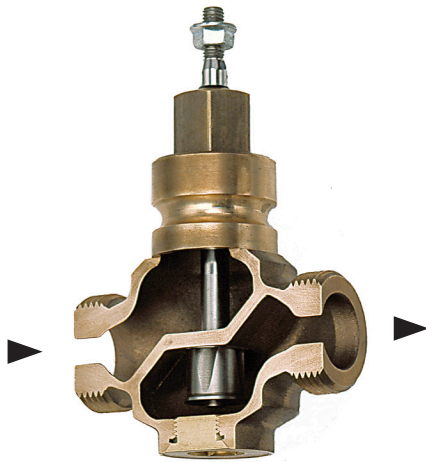

Flow Characteristics Chart

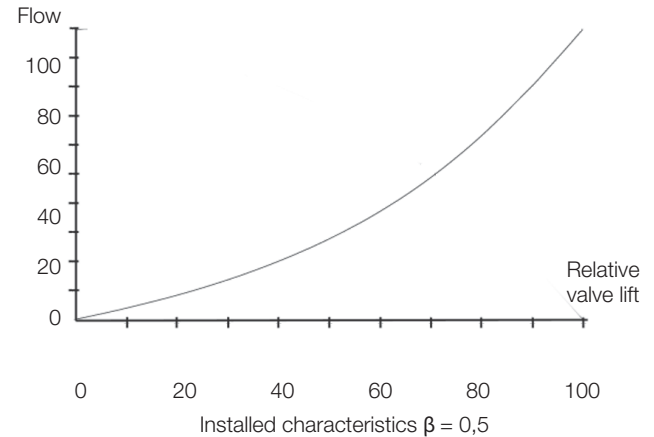

Cavitation

Cavitation takes place in a valve when the velocity of the fluid media over the plug and seat increases to such an extent that gas bubbles are created.

As the fluid passes over the seat and the velocity decreases, these gas bubbles collapse (implode), generating considerable noise and erosion to the valve trim.

The cavitation diagram provides guidance as to the cavitation zone where this phenomae will exist.

Chart usage:

- Using the static pressure before the valve (e.g. 1000 kPa), plot the horizontal line to the line for the temperature of the liquid (e.g. 120 °C).
- From the intersection point, plot a vertical line downwards and read off the max.permissible pressure drop across the valve.
- If the computed pressure drop exceeds the value from the diagram there is risk for cavitation.

Pressure drop chart at the beginning of Cavitation

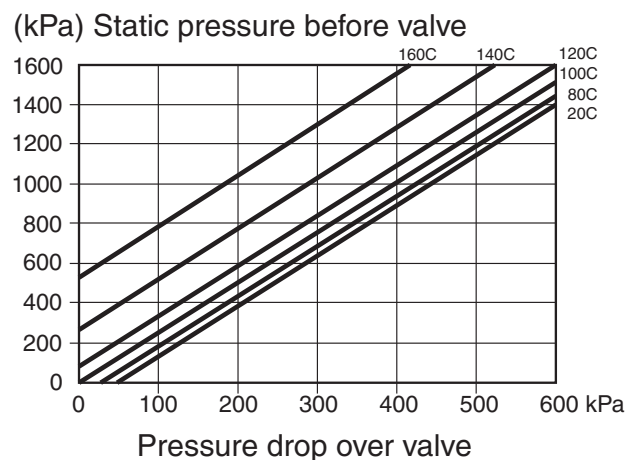

Actuator Selection

Use the table below to select actuator for the V241 to close against the required ΔP_c .

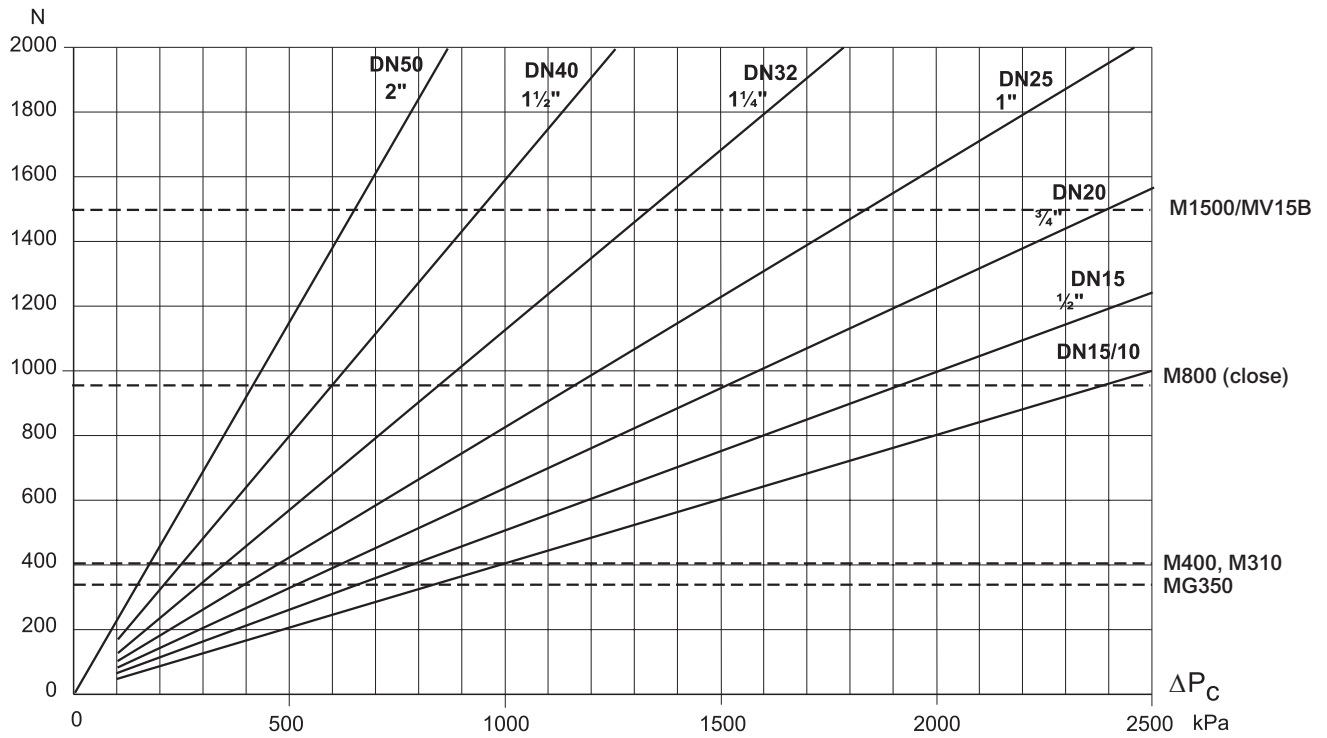

V241			Max Close-off Pressure (kPa)							
			Non-spring Return Actuators					Spring Return		
Part Number	DN	Kvs	M310	MG350	M400	M800	M1500	MV15B (1500N)	M700	MG900 SR
7214106000	15	0.25	800	800	1000	1600	1600	1600	1600	1600
7214110000		0.40								
7214114000		0.63								
7214118000		1.0			800	1600				
7214122000		1.6								
7214126000		2.5								
7214130000		4.0								
7214134000	20	6.3	650	650	650	1500		1100	1510	
7214138000	25	10	400	400	500	1150		850	1160	
7214142000	32	16	300	300	350	850	1350	1350	650	855
7214146000	40	25	150	150	250	600	950	950	450	605
7214150000	50	38	50	50	150	400	650	650	300	415

Service kit:

Replacement stem packing: 100108000

Installation

The valve should be mounted with flow direction in accordance with the valve marking. It is recommended to install the valve in the return pipe, in order to avoid exposing the actuator to high temperatures. The valve must not be installed with the actuator mounted below the valve. To ensure that suspended solids will not become jammed between the valve plug and seat, a filter should be installed upstream of the valve, and the pipe system should be flushed before the valve is installed.

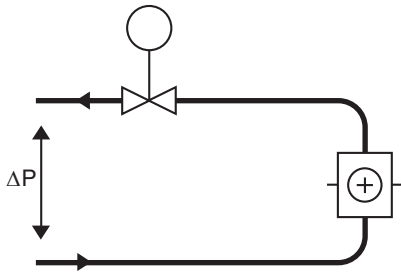

A. Typical installation without local circulating pump.

To provide a good function, the pressure drop across the valve should be no less than half of the available pressure (ΔP). This corresponds to a valve authority of 50%.

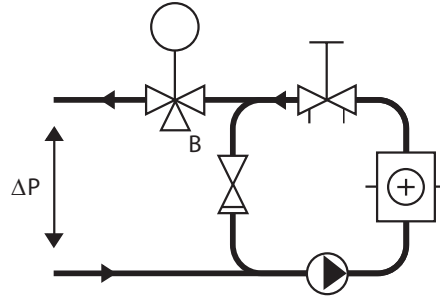

B. Typical installation with local circulating pump.

To provide a good function, the Kvs value of the valve is to be selected so that the entire available pressure drop (ΔP) falls across the control valve.

Flow and Pressure Drop Chart

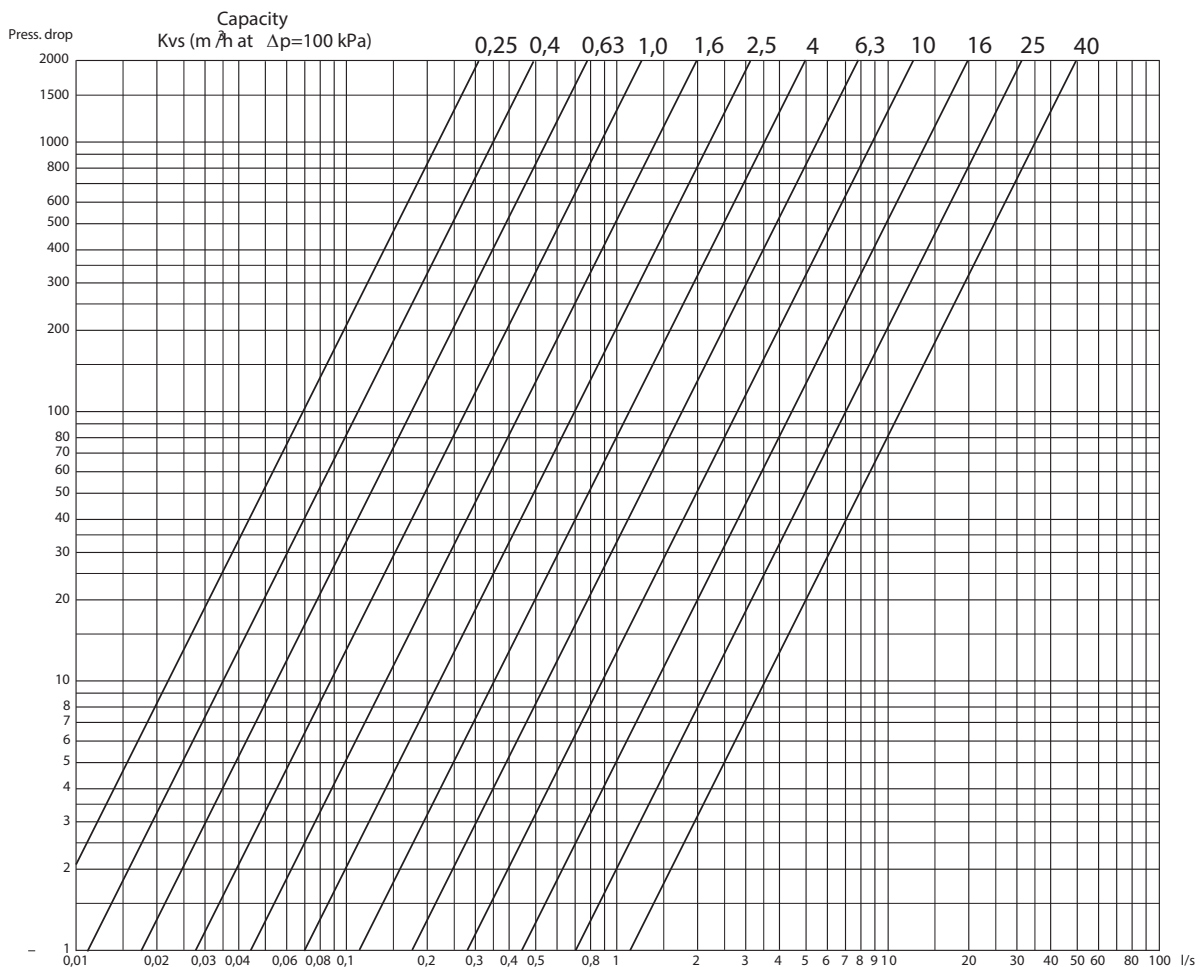

End Connection Accessories

Internal Thread Connection

Valve Size DN	Valve Thread Connection	Int. thread $\varnothing d1^*$	AA1	Part No. for Connection (1 piece per port, i.e. 2 needed)	
		mm		w/Packing, std	w/Packing, spec.**
15	G1B	R 1/2	146	9112100015	9112103015
20	G1-1/4B	R 3/4	146	9112100020	9112103020
25	G1-1/2B	R 1	159	9112100025	9112103025
32	G2B	R 1 1/4	169	9112100032	9112103032
40	G2-1/4B	R 1 1/2	197	9112100040	9112103040
50	G2-3/4B	R 2	222	9112100050	9112103050

* Thread according to ISO 7/1

** The accessory combination "w/Packing, special" is intended for the primary circuit of district heating connections.

Materials		Packing, standard	Klingersil C4400
Union nut	malleable iron casting, galv.	or Packing, spec	Klingersil Top chem
Union end	malleable iron casting, galv.		1,5 mm

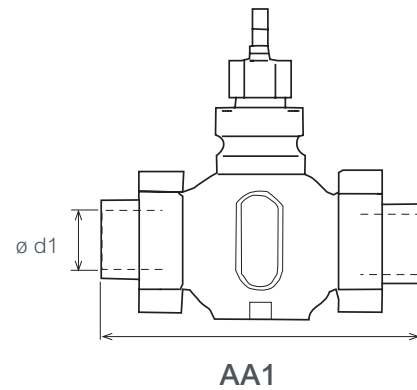

Soldering Type Connection

Valve Size DN	Valve Thread Connection	$\varnothing d2$	AA2	Part No. for Connection (1 piece per port, i.e. 2 needed)	
		mm		w/Packing, std	w/Packing, spec.*
15	G1B	15	136	9112101015	9112104015
20	G1-1/4B	22	146	9112101020	9112104020
25	G1-1/2B	28	155	9112101025	9112104025
32	G2B	35	163	9112101032	9112104032
40	G2-1/4B	42	200	9112101040	9112104040
50	G2-3/4B	54	232	9112101050	9112104050

* The accessory combination "w/Packing, special" is intended for the primary circuit of district heating connections.

Materials		
Union nut	malleable iron casting, galv.	
Union end	Bronze, Stainless steel SS 5204	
Packing, standard		Klingersil C4400
or Packing, spec		Klingersil Top chem
		1,5 mm

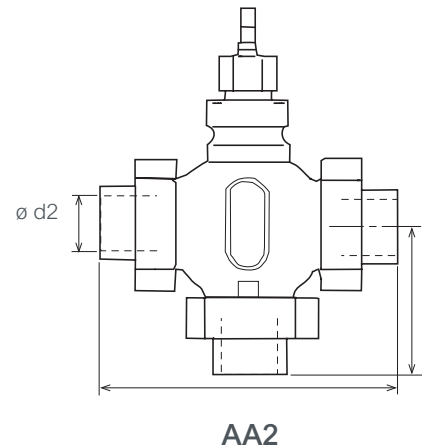

Welded Type Connection

Valve Size DN	Valve Thread Connection	$\varnothing d3$	AA3	Part No. for Connection (1 piece per port, i.e. 2 needed)	
		mm		w/Packing, std	w/Packing, spec.*
15	G1B	21.3	182	9112102015	9112105015 1)
20	G1-1/4B	26.9	182	9112102020	9112105020 1)
25	G1-1/2B	33.7	187	9112102025	9112105025 1)
32	G2B	42.4	197	9112102032	9112105032 1)
40	G2-1/4B	48.3	232	9112102040	9112105040
50	G2-3/4B	60.3	262	9112102050	9112105050

1) Material Union nut: Brass SS 5252

* The accessory combination "w/Packing, special" is intended for the primary circuit of district heating connections.

Materials	
Union nut	malleable iron casting, galv. (except 1)
Union end	Stainless Steel SS 2172, SS 2174
Packing, standard	Klingersil C4400
or Packing, spec	Klingersil Top chem
	1,5 mm

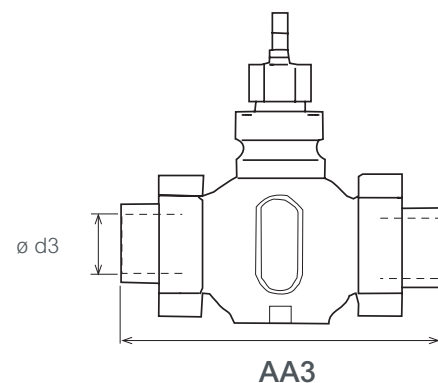

Dimensions And Weight

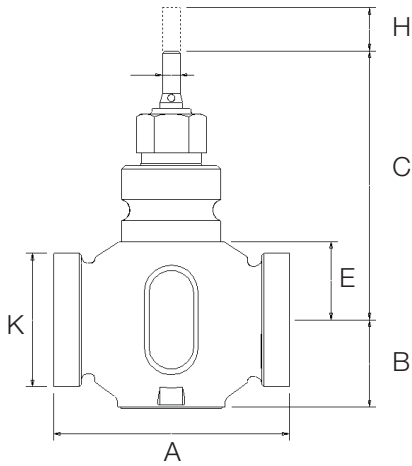

Valve Size DN	Dimensions (mm)					K (ISO 228-1)	Weight kg
	A	B	C	E	H		
15	100	36	109.5	23.5	20	G1B	1.0
20	100	38	116	30	20	G1-1/4B	1.2
25	105	39	120	34	20	G1-1/2B	1.4
32	105	39	121	35	20	G2B	1.8
40	130	48.5	128.5	42.5	20	G2-1/4B	2.6
50	150	58	139	53	20	G2-3/4B	4.3