

OUTLINE FOR ASCO® 300 SERIES 600-1200 AMPERE "H" FRAME (H3ATS,H3NTS,H3ADTS,H3NDTS) FRONT CONNECTED TRANSFER SWITCHES OPEN TYPE

MAXIMUM BUS BAR BOLTING SURFACE (PER PHASE) 3.25" [82,6mm] x 2.50" [63,5mm]

BUS TERMINATION DETAIL

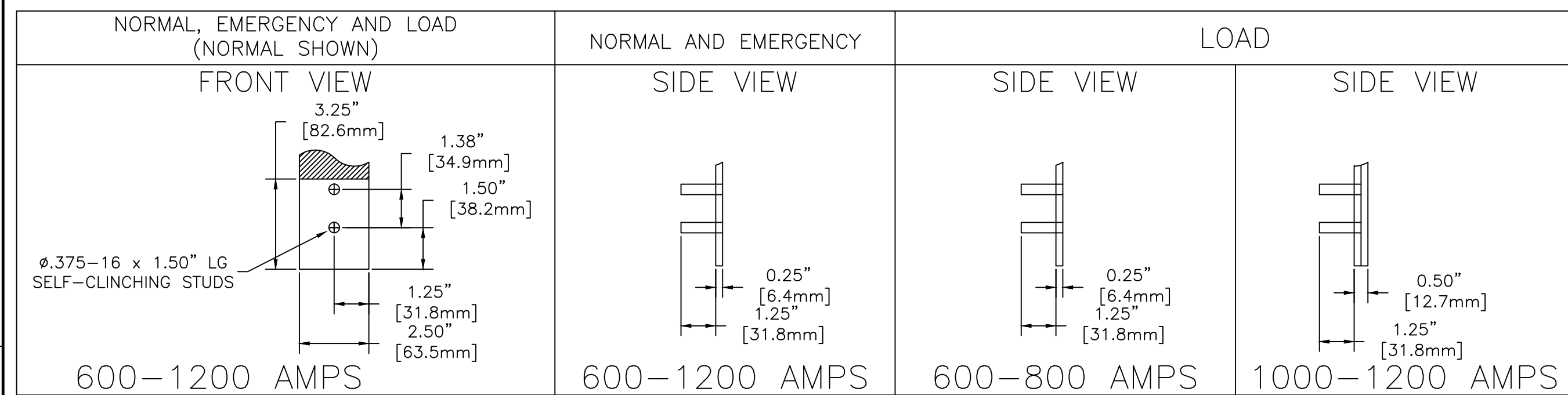

APPROXIMATE SHIPPING WEIGHT, LBS (KG)

SWITCH RATING (AMPS)	POLES	WEIGHTS LB (KG)
600, 800	2	119 (54)
600, 800	3	142 (64)
600, 800	4	165 (75)
1000, 1200	2	131 (59)
1000, 1200	3	160 (73)
1000, 1200	4	189 (86)

GENERAL NOTES

- THE STANDARD SWITCH CONFIGURATION IS FOR EMERGENCY & LOAD OUT THE TOP AND NORMAL OUT THE BOTTOM. OPTIONAL SWITCH CONFIGURATION LOAD OUT THE BOTTOM. CONSULT FACTORY FOR OTHER SWITCH CONFIGURATION.
- NEUTRAL CONFIGURATIONS:
AN OPTIONAL FULL RATED NEUTRAL CONFIGURATION FOR EACH SOURCE AND THE LOAD MAY BE PROVIDED. WHEN EQUIPPED IT IS IN ONE OF THE FOLLOWING FORMATS AS SPECIFIED BY THE CATALOG NUMBER NEUTRAL TYPE:
(A) SOLID (COPPER BUS) NEUTRAL
(B) SWITCHED NEUTRAL POLE
- THE STANDARD MECHANICAL (SCREW TYPE) AL/CU TERMINAL LUGS ARE SHOWN FOR REFERENCE (800-1200).
- SWITCH NEUTRAL POLE IS SHOWN FOR REFERENCE.
- WHEN INSTALLING CONDUCTORS, CONNECT TO SIMILARLY MARKED PHASES OF NORMAL, EMERGENCY & LOAD.
- ALL INTERNAL CONNECTIONS ARE MADE AT FACTORY.
- MAINTAIN ELECTRICAL CLEARANCE OF 1.00" [25.4mm] BETWEEN LIVE METAL PARTS AND GROUNDED METAL.
- WHEN MOUNTING THE TRANSFER SWITCH IN THE ENCLOSURE, THE CONTROL PANEL(S) AND OPERATOR CONTROLS SHOULD BE MOUNTED ON THE INSIDE, REAR SURFACE OF THE DOOR. 6.00" [152.4mm] MIN. DEPTH TO TRANSFER SWITCH FOR CONTROLS IS REQUIRED.
- THE CONTROL PANEL(S) IS CONNECTED TO THE TRANSFER SWITCH BY A HARNESS WITH A QUICK DISCONNECT PLUG(S). THE HARNESS EXITS THE TRANSFER SWITCH ON THE RIGHT SIDE. CONSULT FACTORY FOR EXTENSION HARNESSES.
- OPTIONAL ACCESSORY ADD-ON PANELS. (SEE PAGE 2 FOR TYPICAL MOUNTING)
- FOR TYPE 1 ENCLOSURE SEE DETAIL A -1 AND DETAIL B -1 FOR CUTOUT DATA. FOR TYPE 3R, 4, & 12 ENCLOSURE SEE DETAIL A -2 & DETAIL B -2 FOR CUTOUT DATA. GASKETS AND BEZELS ARE PROVIDED FOR TYPE 3R, 4, & 12 ENCLOSURE.
- CUSTOMER TERMINAL BLOCKS (SEE SHEET 2):
FOR ADTS AND NDTs THE TB WILL BE MOUNTED ON THE UPPER RIGHT INSIDE OF THE ENCLOSURE. FOR ATS AND NTS THE TB WILL BE MOUNTED ON THE TRANSFER SWITCH.

SIZE	CABLE ACCOMMODATIONS (PER PHASE & NEUTRAL)
600	SCREW TYPE (STANDARD)- (2) #2 - 600 MCM AL/CU
800-1200	SCREW TYPE (STANDARD)- (4) 1/0 - 750 MCM AL/CU (SHOWN)

CABLING NOTES

- ALL SIZES SUPPLIED STANDARD WITH MECHANICAL (SCREW TYPE) LUGS. (SEE AMP SIZE BELOW)
- LUG MATERIAL: ALUMINUM ALLOY 6061-T6 WITH ELECTRO TIN PLATED FINISH.
- SCREW MATERIAL: ALUMINUM ALLOY 6262-T9 WITH ELECTRO TIN PLATED FINISH.
- UL LISTED, CSA CERTIFIED.
- LUG SCREW TIGHTENING TORQUE PER UL 486B: 19 FT-LBS.

NOTES 600 AMP SWITCHES

- SUPPLIED WITH STANDARD MECHANICAL (SCREW TYPE) LUGS ON THE NORMAL, EMERGENCY & LOAD BUS STABS. ONE (1) LUG PER PHASE AND NEUTRAL EACH SUITABLE FOR CONNECTION OF TWO (2) #2 -600MCM CU/AL CABLE

NOTES 800-1200 AMP SWITCHES

- SUPPLIED WITH STANDARD MECHANICAL (SCREW TYPE) LUGS ON THE NORMAL, EMERGENCY & LOAD BUS STABS. ONE (1) LUG PER PHASE AND NEUTRAL EACH SUITABLE FOR CONNECTION OF FOUR (4) 1/0 -750MCM CU/AL CABLE.

MINIMUM REQUIRED ENCLOSURE SIZE INCH (mm)

SWITCH RATING (AMPS)	HEIGHT	WIDTH	DEPTH
600, 800, 1000	72.00" (1828.8mm)	34.00" (863.6mm)*	20.00" (508mm)
1200	87.00" (2209.8mm)	38.00" (965.2mm)	23.00" (584.2mm)

NOTE: *WIDTH MAY BE 30.00" (762mm) IF NO CABLES ARE TO BE RUN ALONG THE SIDE OF TRANSFER SWITCH, "1200 AMPS" NEEDS VENTILATION TOP AND BOTTOM.

NOTE: 1200 AMP T/S REQUIRES MIN. 96.00" OF VENTILATION. 48.00" TOP AND BOTTOM. VENTILATION SHOULD BE PLACED ON FRONT AND REAR OF ENCLOSURE UNLESS VENTILATION IS IMPEDED ON THE REAR, THEN ALL VENTILATION MUST BE PROVIDED ON FRONT OF ENCLOSURE.

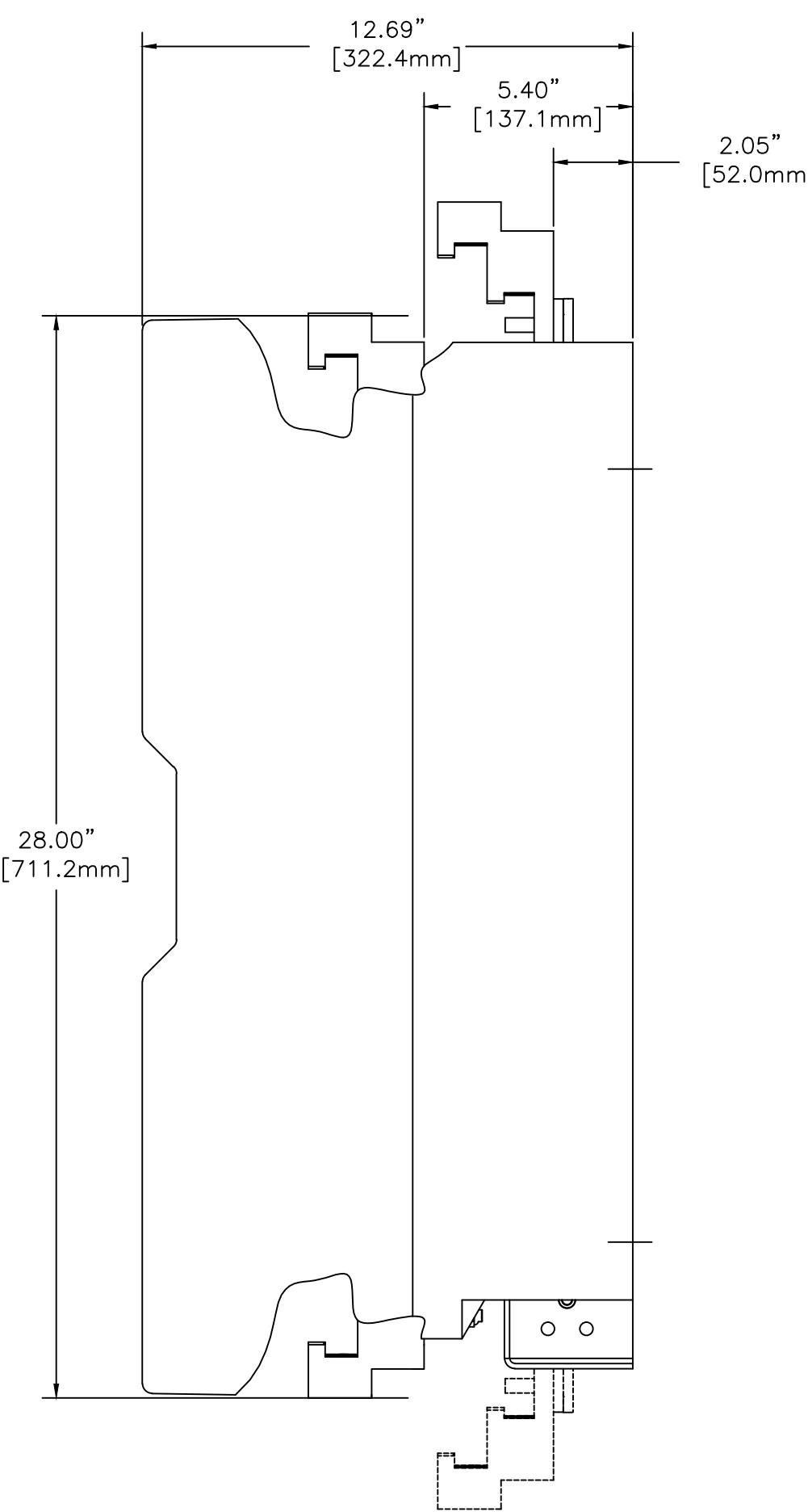
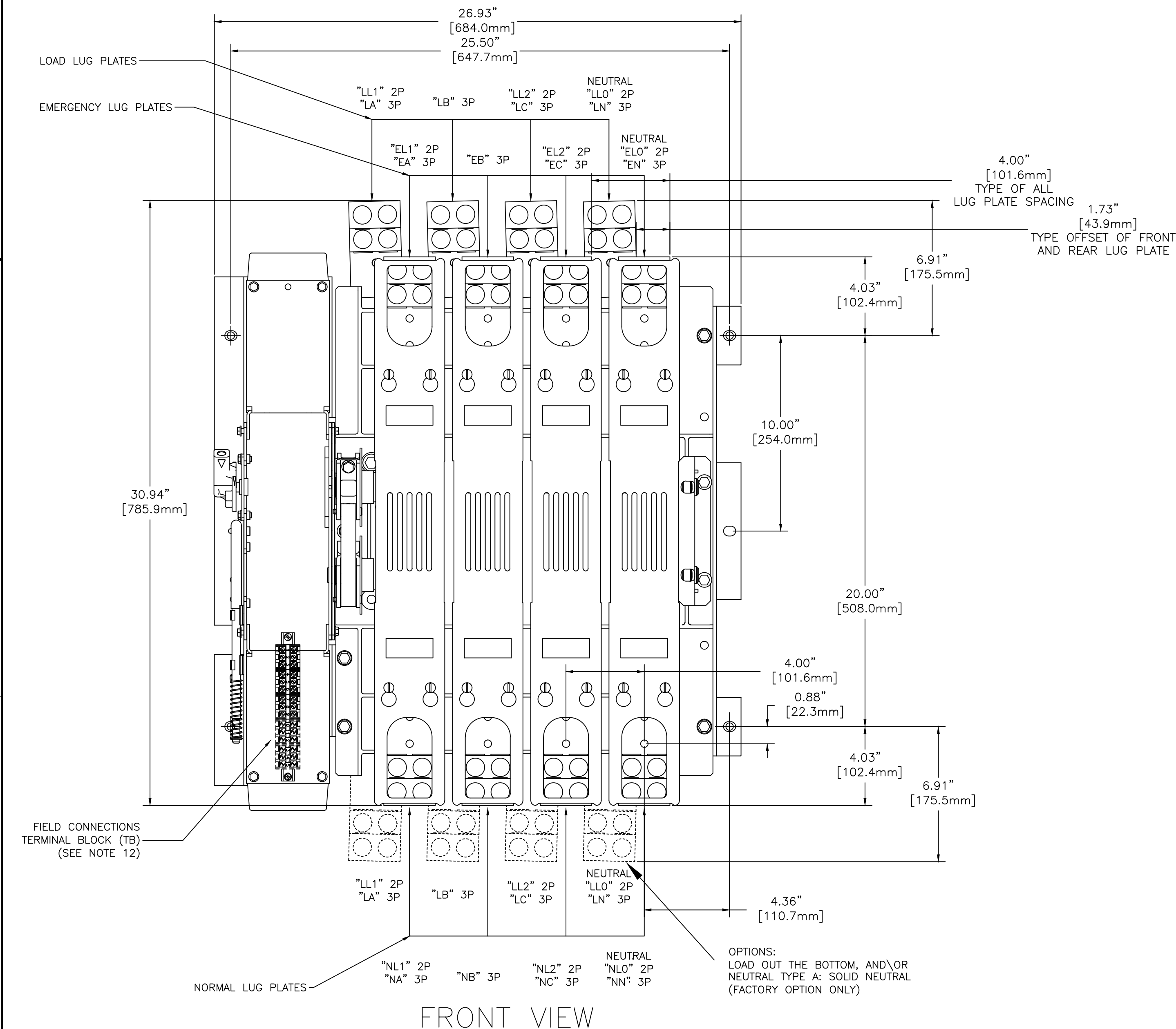

SIDE VIEW

REV.	BY	DATE	DESCRIPTION
C	265708	TR BK	03/21/17
B	264276	WK BK	11/18/16
A	252726	TR BK	1/21/15
-	248804	TR BK	
-			ISSUE

PROJECT NAME:		REV. TO SHEET	ECN NO.	BY	APP.	DATE
OUTLINE 300 SERIES TS "H" 600-1200 AMP OPEN TYPE						
DRAWN BY	BWM	DATE	12/11/13	MANUFACTURING TOLERANCES TO BE IN ACCORDANCE WITH ASCO PROCEDURE MP-1-003. FOR PLASTIC PARTS SEE MP-1-005	ASSEM. REF. NO.	COMPUTER GENERATED DRAWING
CHECKED	BWM	DATE	12/11/13	PROPERTY OF ASCO POWER TECHNOLOGIES. USE PERMITTED FOR OUR WORK ONLY. ALL RIGHTS OF DESIGN OR INVENTION ARE RESERVED.	SCALE	1/4" = 1" SIZE DS
PROJECT APPROVAL	BK	DATE	12/11/13			DWG. NO. 1001394-004
FINAL APPROVAL						REV. C ECN NO. 265708 SHEET 1 OF 3

ASCO® ASCO POWER TECHNOLOGIES, L.P.
FLORHAM PARK, NEW JERSEY 07932 U.S.A.

8 7 6 5 4 3 2 1

OUTLINE FOR ASCO® 300 SERIES 600-1200 AMPERE "H" FRAME (H3ATS,H3NTS,H3ADTS,H3NDTS) FRONT CONNECTED TRANSFER SWITCHES OPEN TYPE

MOUNTING OF FIELD TERMINAL BLOCK ASSEMBLY (TB) (SEE NOTE 12)

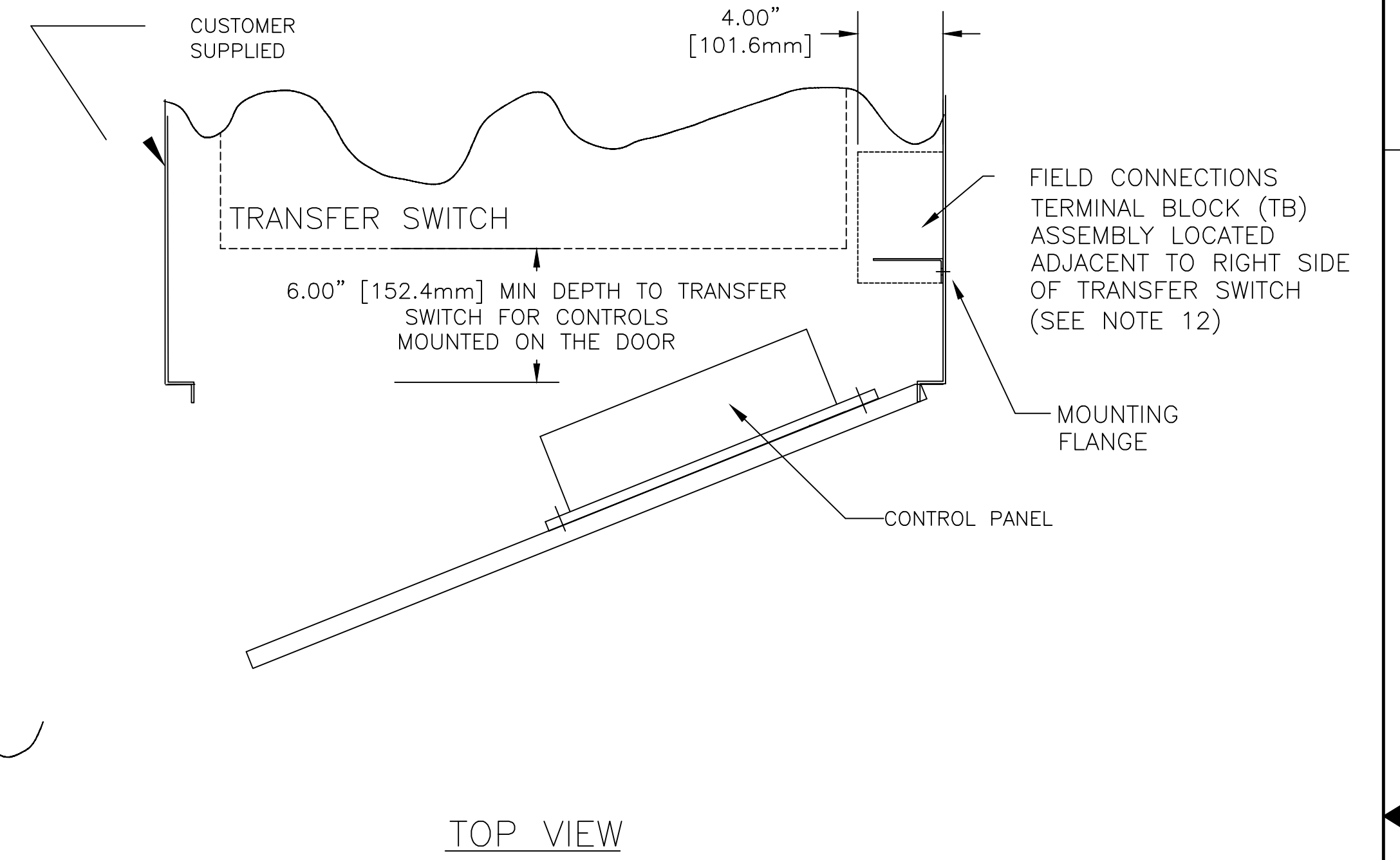
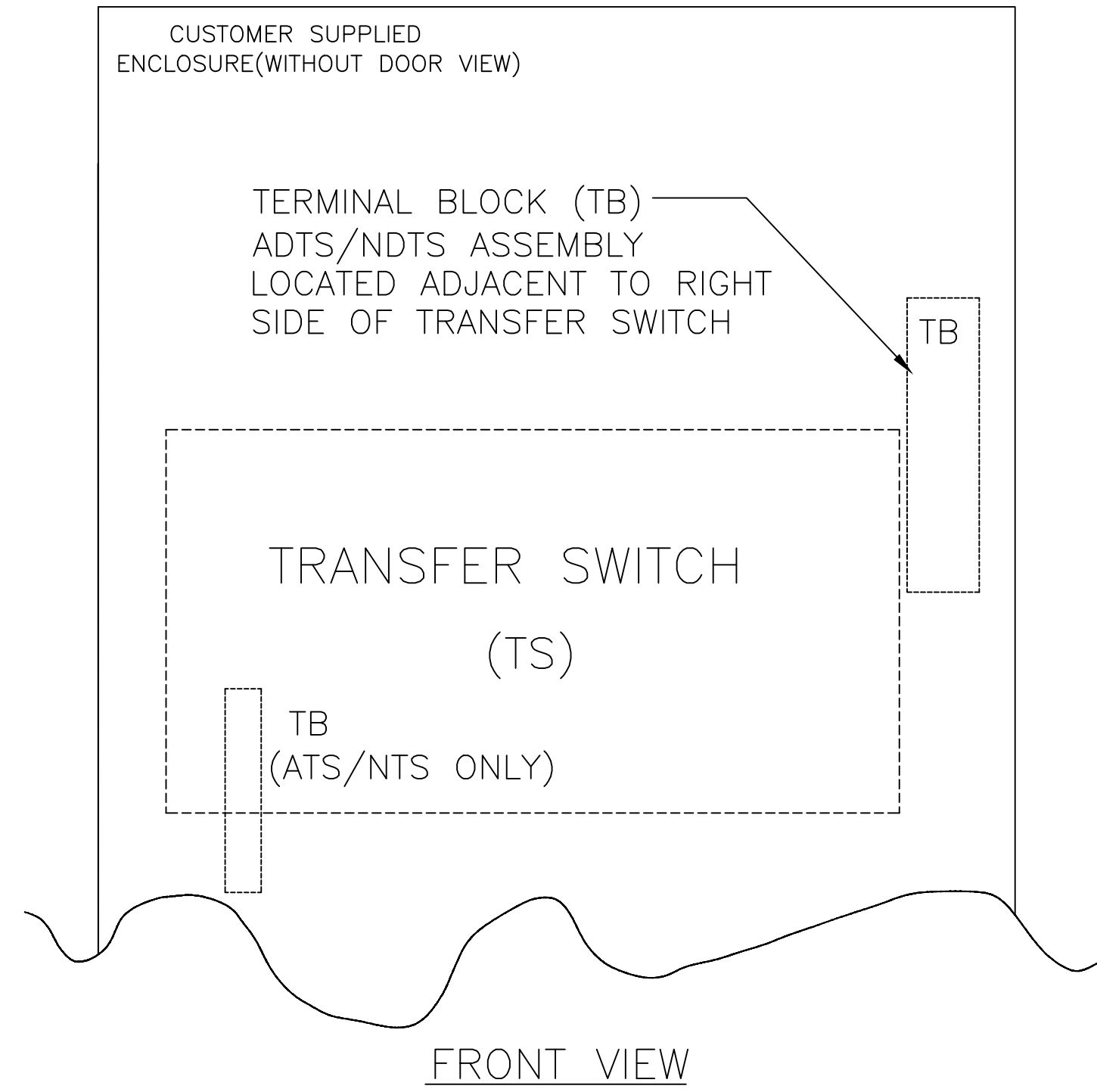
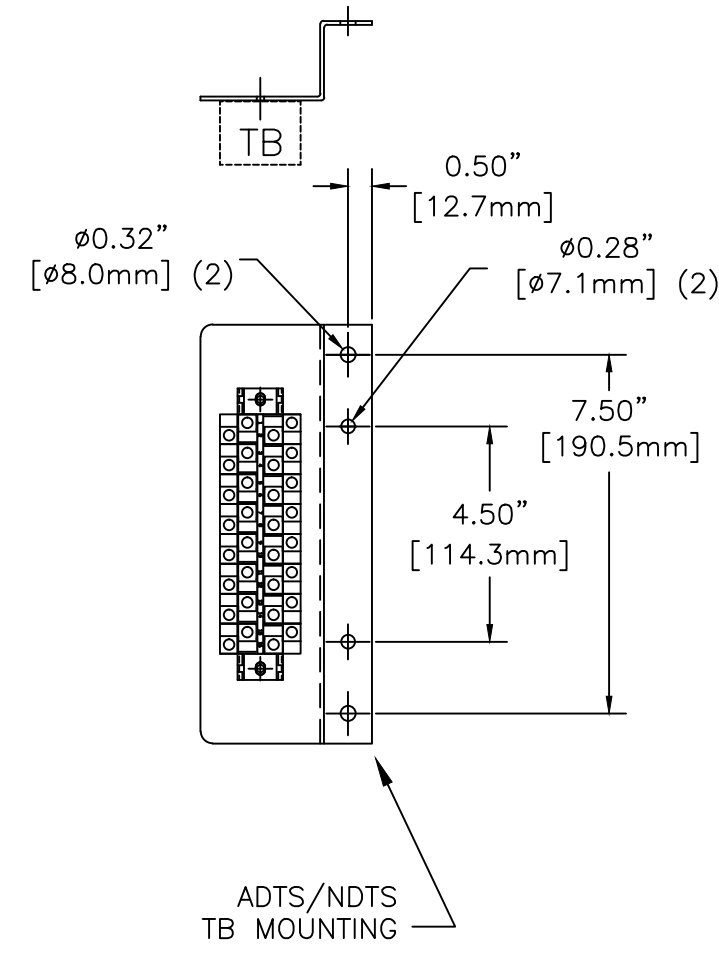
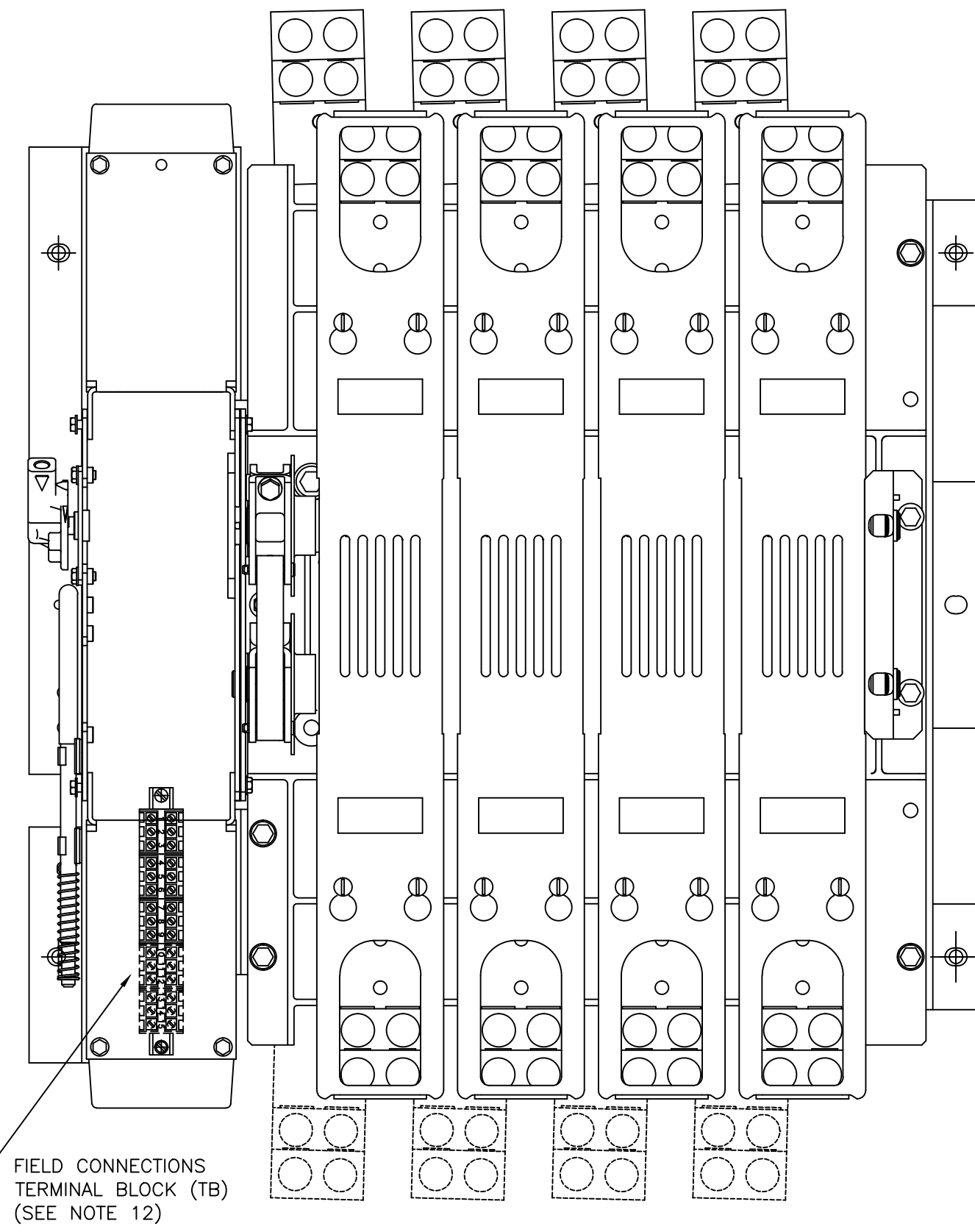

C	265708	TR	BK	03/21/17
	SEE ECN			
B	264276	WK	BK	11/18/16
	SEE ECN			
A	252726	TR	BK	1/21/15
	SEE ECN			
-	248804	TR	BK	
	ISSUE			

PROJECT NAME:		REV. TO SHEET	ECN NO.	BY	APP.	DATE
OUTLINE						
300 SERIES TS "H"						
600-1200 AMP OPEN TYPE						
BY	DATE	MANUFACTURING TOLERANCES TO BE IN ACCORDANCE WITH ASCO PROCEDURE MP-1-003. FOR PLASTIC PARTS SEE MP-1-055		ASSEM. REF. NO.	COMPUTER GENERATED DRAWING	
DRAWN BY	BWM	12/11/13			SCALE 1/4" = 1"	SIZE DS
CHECKED	BWM	12/11/13	PROPERTY OF ASCO POWER TECHNOLOGIES. USE PERMITTED FOR OUR WORK ONLY. ALL RIGHTS OF DESIGN OR INVENTION ARE RESERVED.		DWG. NO.	
PROJECT APPROVAL	BK	12/11/13			1001394-004	
FINAL APPROVAL					DRAWING C	ECN NO. 265708 SHEET 2 OF 3
					REV.	

ASCO ASCO POWER TECHNOLOGIES, L.P.
 FLORHAM PARK, NEW JERSEY 07932 U.S.A.

OUTLINE FOR ASCO® 300 SERIES 600-1200 AMPERE "H" FRAME (H3ATS,H3NTS,H3ADTS,H3NDTS) FRONT CONNECTED TRANSFER SWITCHES OPEN TYPE

CONTROL PANEL & CONTROLS MOUNTING DATA

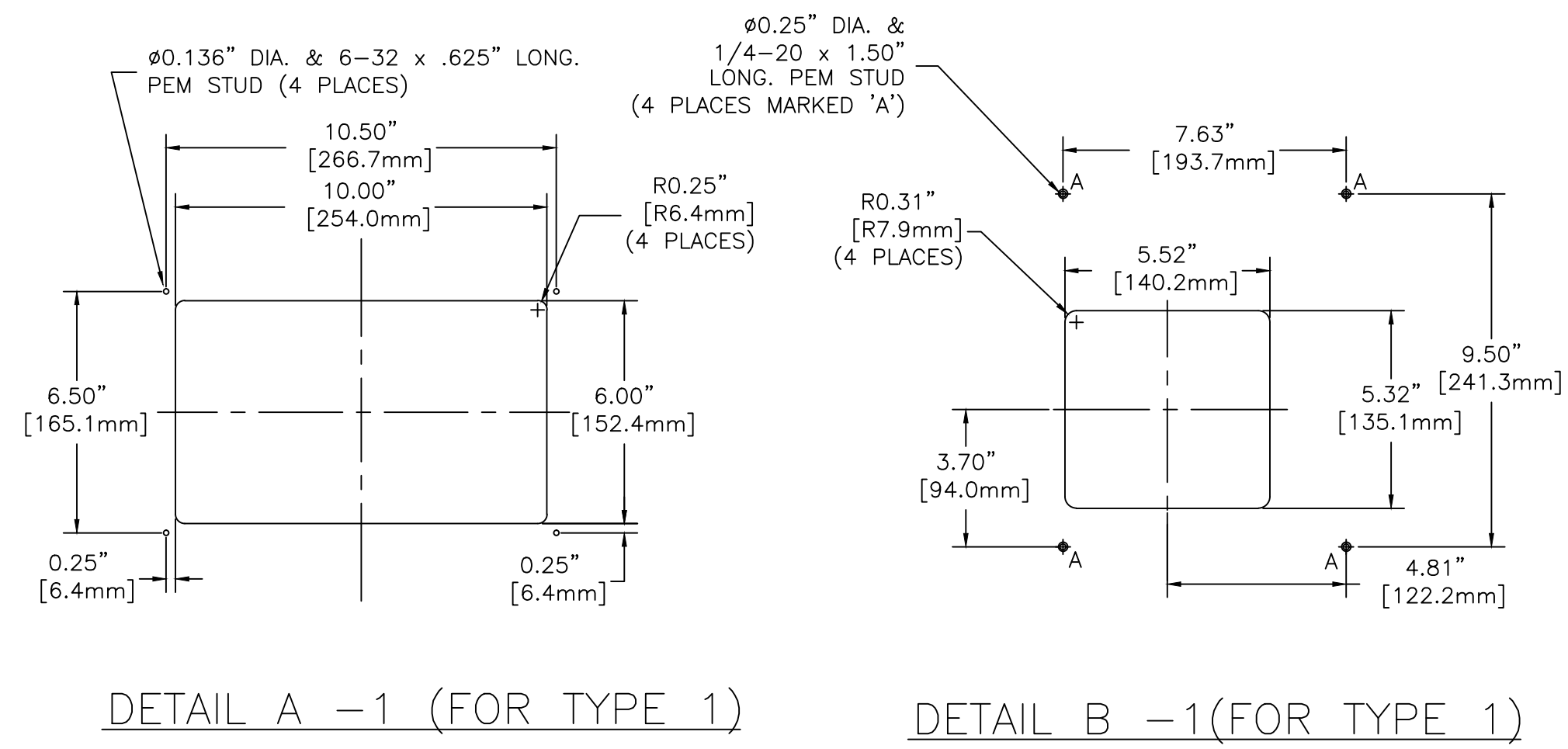

CONTROL PANEL & CONTROLS MOUNTING

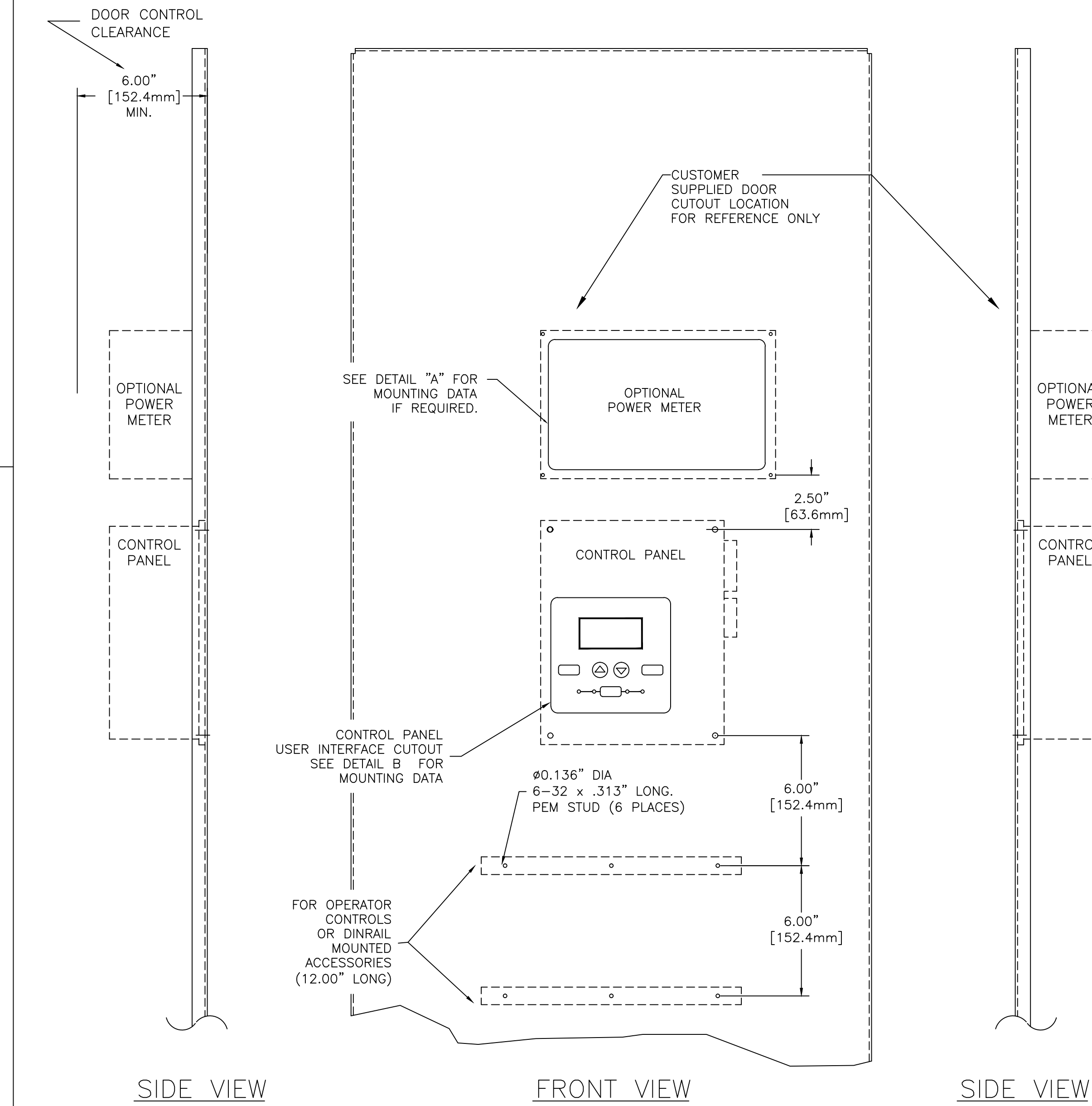

DEVICES ON MOUNTING RAILS FOR SHIPMENT ONLY

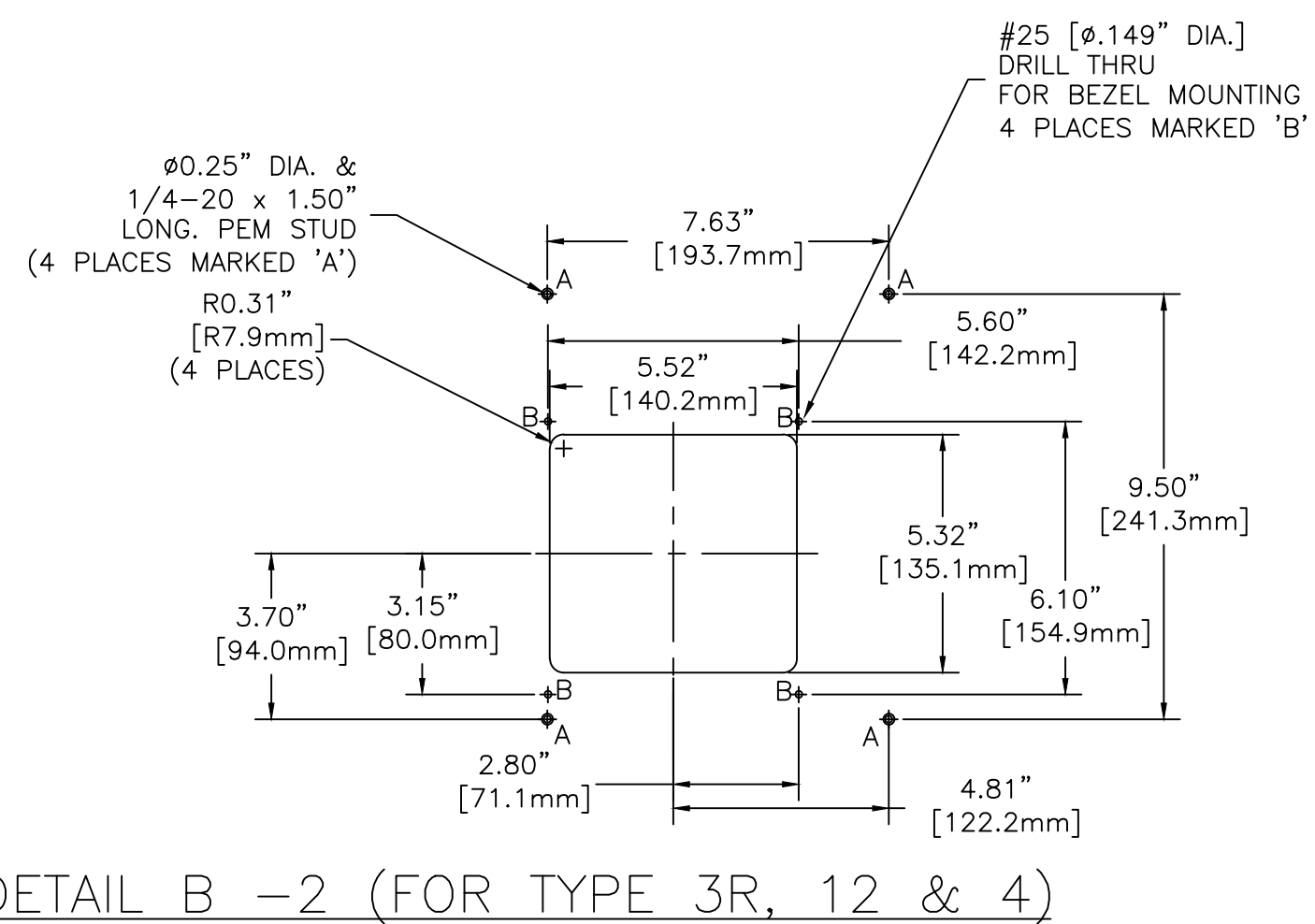
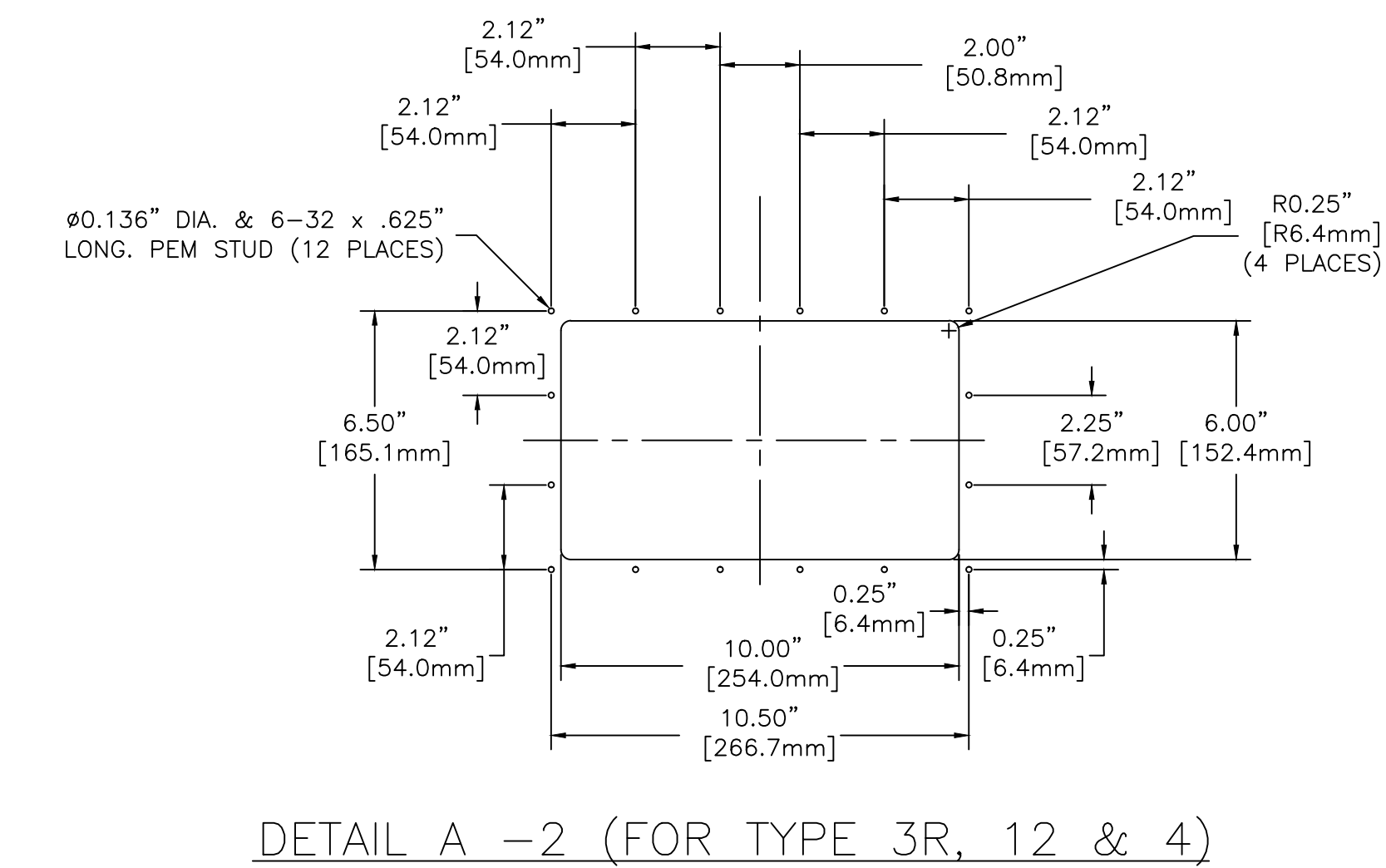
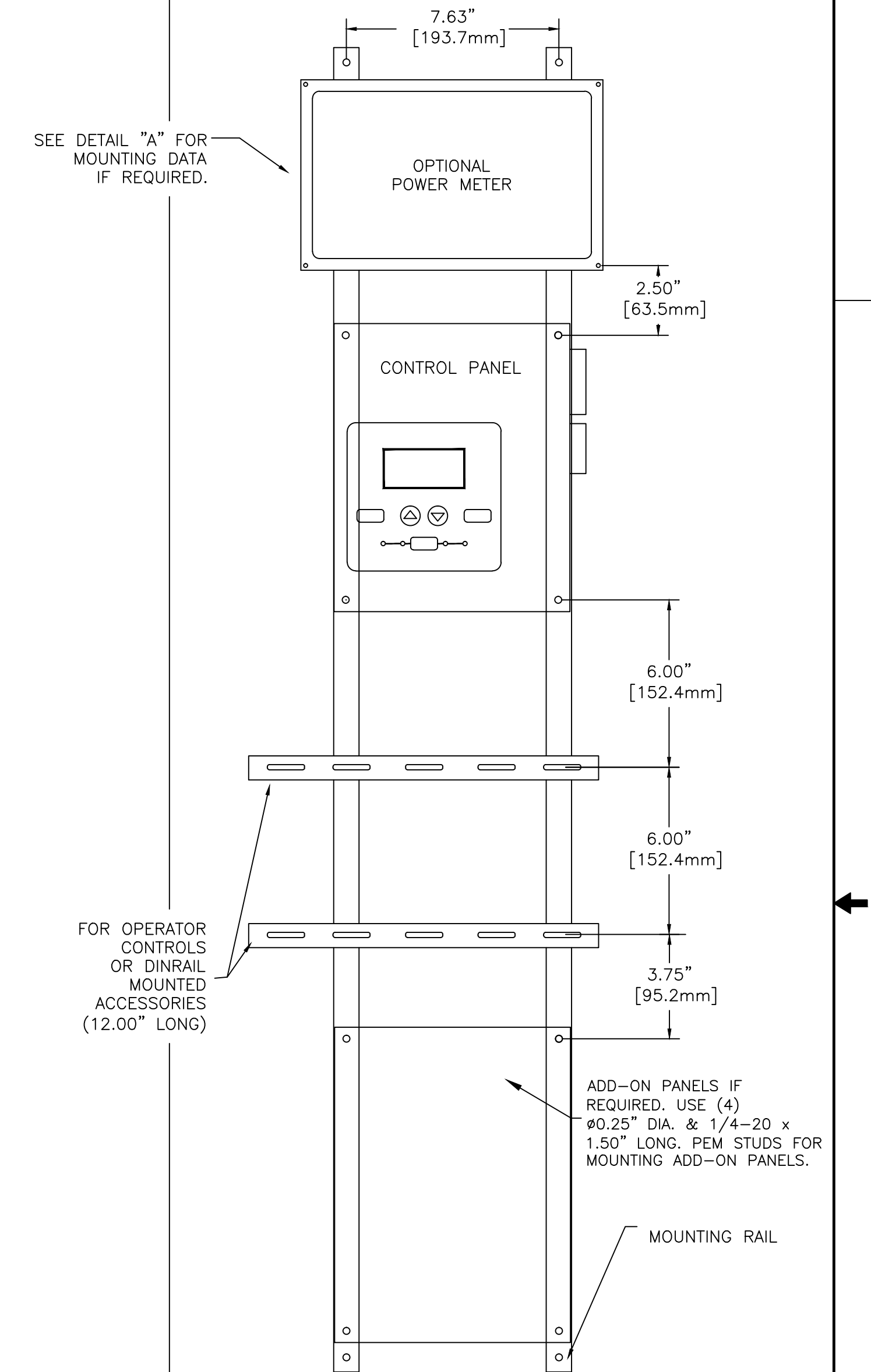

C	265708	TR	BK	03/21/17
	SEE ECN			
B	264276	WK	BK	11/18/16
	SEE ECN			
A	252726	TR	BK	1/21/15
	SEE ECN			
	248804	TR	BK	
	ISSUE			

PROJECT NAME:		REV. TO SHEET	ECN NO.	BY	APP.	DATE
OUTLINE 300 SERIES TS "H" 600-1200 AMP OPEN TYPE						
BY	DATE	MANUFACTURING TOLERANCES TO BE IN ACCORDANCE WITH ASCO PROCEDURE MP-1-003. FOR PLASTIC PARTS SEE MP-1-005		ASSEM. REF. NO.	COMPUTER GENERATED DRAWING	
DRAWN BY	BWM	12/11/13			SCALE	1/4" = 1" SIZE DS
CHECKED	BWM	12/11/13	PROPERTY OF ASCO POWER TECHNOLOGIES. USE PERMITTED FOR OUR WORK ONLY. ALL RIGHTS OF DESIGN OR INVENTION ARE RESERVED.		DWG. NO.	1001394-004
PROJECT APPROVAL	BK	12/11/13			DRAWING C	REV. NO. 265708
FINAL APPROVAL					ASCO	ASCO POWER TECHNOLOGIES, L.P. FLORHAM PARK, NEW JERSEY 07932 U.S.A.
						SHEET 3 OF 3