

# OUTLINE FOR ASCO® 300 SERIES 1000-2000 AMPERE "G" FRAME (G3ATS,G3NTS,G3ADTS,G3NDTS) FRONT CONNECTED TRANSFER SWITCHES TYPE 1 ENCLOSURE

## GENERAL NOTES

- TYPE 1 ENCLOSURE. FREE STANDING. FLOOR MOUNTED. CODE GAUGE FORMED FRAME CONSTRUCTION.
- NEC STANDARD GAUGE PAN TYPE DOOR WITH LOCKABLE HANDLE.
- FINISH: ANSI 61 GRAY, POLYESTER POWDER STANDARD. OTHER ANSI COLORS AVAILABLE CONSULT FACTORY. UL RECOGNIZED.
- CONSTRUCTION IS IN ACCORDANCE WITH APPLICABLE REQUIREMENTS OF UL 1008.
- RECOMMENDED CLEARANCES:  
FRONT: 36.00" [914mm].
- A 20% RATED GROUND BUS IS PROVIDED.
- UNIT IS DESIGNED FOR COMBINATION TOP AND BOTTOM CABLE ENTRY. THE STANDARD SWITCH CONFIGURATION IS FOR TOP ENTRY EMERGENCY & LOAD AND BOTTOM ENTRY NORMAL. OPTIONALLY, THE SWITCH MAY BE SUPPLIED WITH BOTTOM ENTRY LOAD. (REFER TO THE WIRING DIAGRAM FURNISHED WITH EACH TRANSFER SWITCH TO DETERMINE TERMINATION POSITIONS).

**IMPORTANT NOTE:**  
UNDER NO CIRCUMSTANCES SHOULD POWER CABLES BE ROUTED ALONG THE SIDES OF THE TRANSFER SWITCH. AN OPTIONAL CABLE PULL BOX WHICH MOUNTS ON THE LEFT SIDE OF THE ENCLOSURE IS AVAILABLE WHEN CONDITIONS EXIST FOR WHICH CABLES MUST RUN BETWEEN THE TOP AND BOTTOM OF THE UNIT. GROUND CONDUCTORS ONLY MAY BE RUN ALONG THE LEFT SIDEWALL OF THE ENCLOSURE.

**NEUTRAL CONFIGURATIONS:**  
AN OPTIONAL FULL RATED NEUTRAL CONFIGURATION FOR EACH SOURCE AND THE LOAD MAY BE PROVIDED. WHEN EQUIPPED IT IS IN ONE OF THE FOLLOWING FORMATS AS SPECIFIED BY THE CATALOG NUMBER NO. NEUTRAL TYPE:  
(A) SOLID (COPPER BUS) NEUTRAL.  
(B) SWITCHED NEUTRAL POLE.

- NO KNOCKOUTS ARE PROVIDED.
- 2000 AMP TRANSFER SWITCH ONLY.
- (OPTIONAL) LEFT SIDE PULL BOX AVAILABLE FOR TOP AND BOTTOM CABLE ACCESS WHEN REQUIRED. CONTACT FACTORY FOR DETAILS AND SHIPPED SEPARATELY.  
A. TO ATTACH PULL BOX TO THE LEFT SIDE OF THE ENCLOSURE. REMOVE CONDUIT SIDE COVERS FROM ENCLOSURE. MOVE PULL-BOX INTO POSITION. USE HARDWARE FROM CONDUIT SIDE COVERS TO ATTACH THE PULL-BOX TO ENCLOSURE.

## CABLING NOTES

- ALL SIZES SUPPLIED STANDARD WITH MECHANICAL (SCREW TYPE) LUGS. (SEE AMP SIZE BELOW)  
A. LUG MATERIAL: ALUMINUM ALLOY 6061-T6 WITH ELECTRO TIN PLATED FINISH.  
B. SCREW MATERIAL: ALUMINUM ALLOY 6262-T9 WITH ELECTRO TIN PLATED FINISH.  
C. UL LISTED, CSA CERTIFIED.  
D. LUG SCREW TIGHTENING TORQUE PER UL 486B: 19 FT-LBS.  
E. SUITABLE WIRE BENDING SPACE IS PROVIDED. (SEE AMP SIZE BELOW)
- GROUND LUGS ARE PROVIDED STANDARD AS FOLLOWS. (SEE AMP SIZE BELOW)

## NOTES 1000-1200 AMPS

- SUPPLIED WITH STANDARD MECHANICAL (SCREW TYPE) LUGS ON THE NORMAL, EMERGENCY & LOAD BUS STABS. ONE (1) LUG PER PHASE AND NEUTRAL EACH SUITABLE FOR CONNECTION OF FOUR (4) 1/0 - 750MCM CU/AL CABLE (SEE NOTE "E" BELOW).  
E. SUITABLE WIRE BENDING SPACE IS PROVIDED FOR UP TO FOUR (4) 600MCM CABLES PER TERMINAL PER NEC.
- GROUND LUGS ARE PROVIDED STANDARD AS FOLLOWS;  
(12) 1/0 - 750MCM CU/AL CABLE

## NOTES 1600-2000 AMPS

- SUPPLIED WITH STANDARD MECHANICAL (SCREW TYPE) LUGS ON THE NORMAL, EMERGENCY & LOAD BUS STABS. ONE (1) LUG PER PHASE AND NEUTRAL EACH SUITABLE FOR CONNECTION OF SIX (6) 1/0 - 750MCM CU/AL CABLE (SEE NOTE "E" BELOW).  
E. SUITABLE WIRE BENDING SPACE IS PROVIDED FOR UP TO SIX (6) 750MCM CABLES PER TERMINAL PER NEC.
- GROUND LUGS ARE PROVIDED STANDARD AS FOLLOWS;  
(12) 1/0 - 750MCM CU/AL CABLE

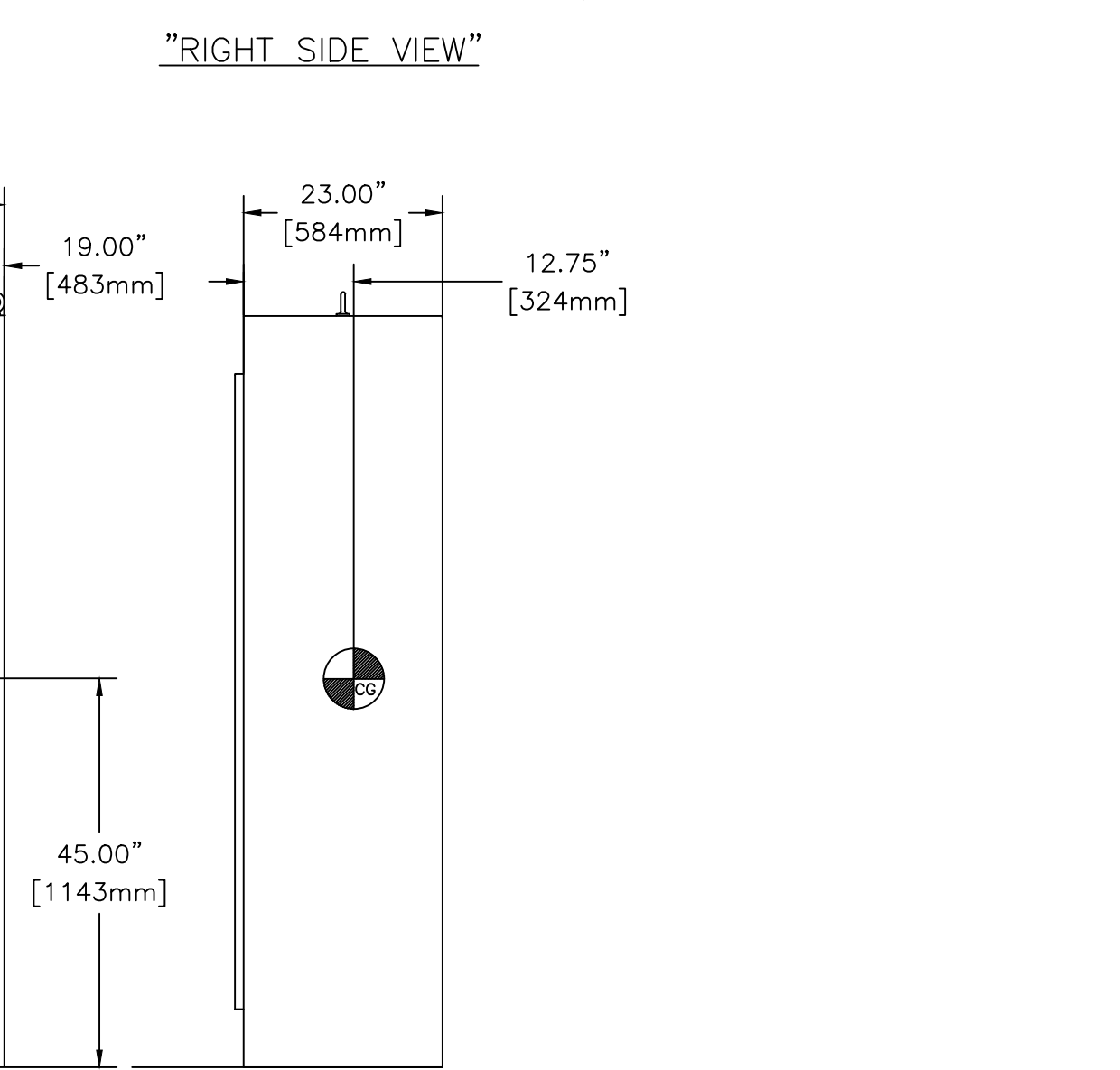
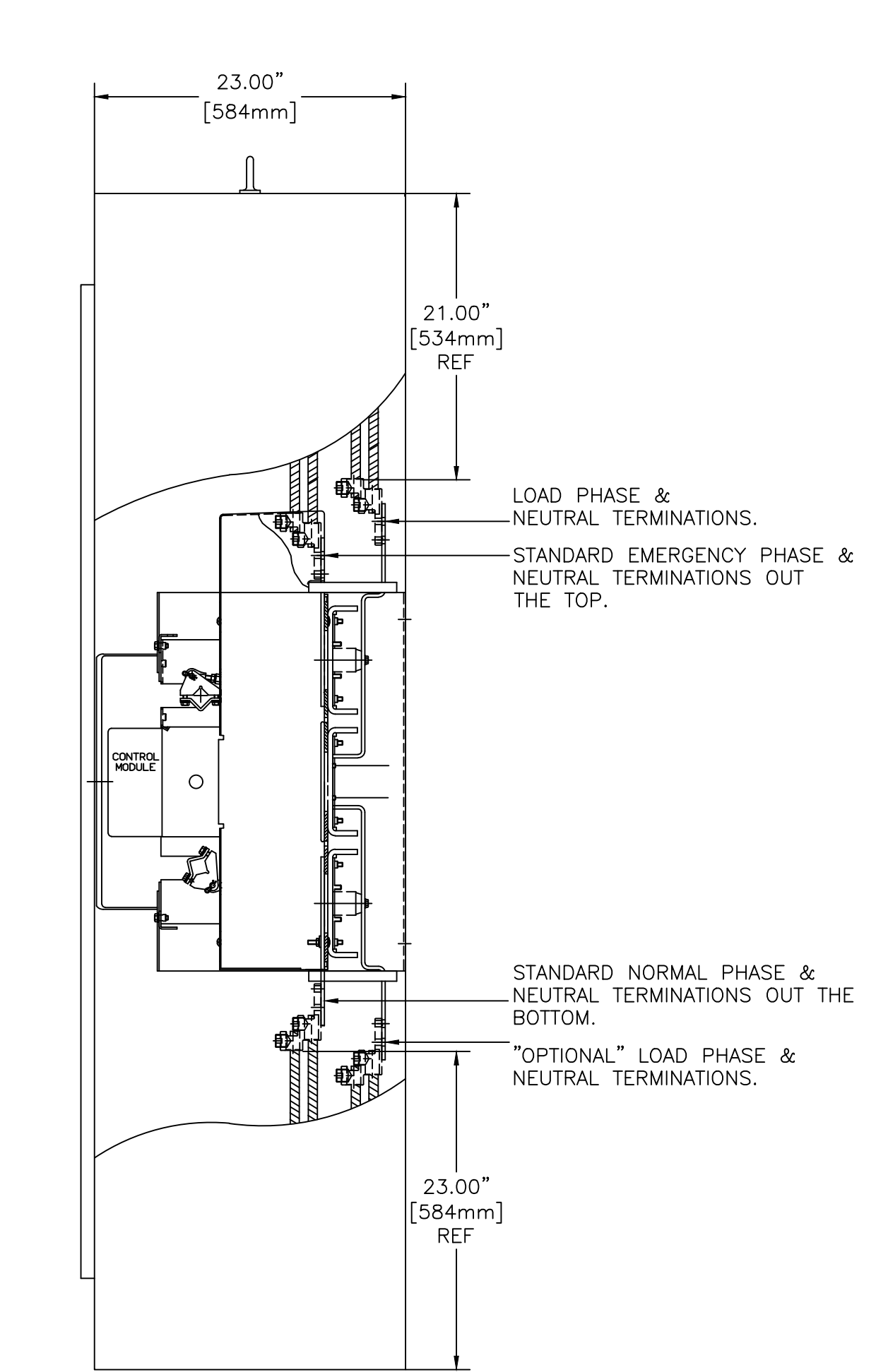
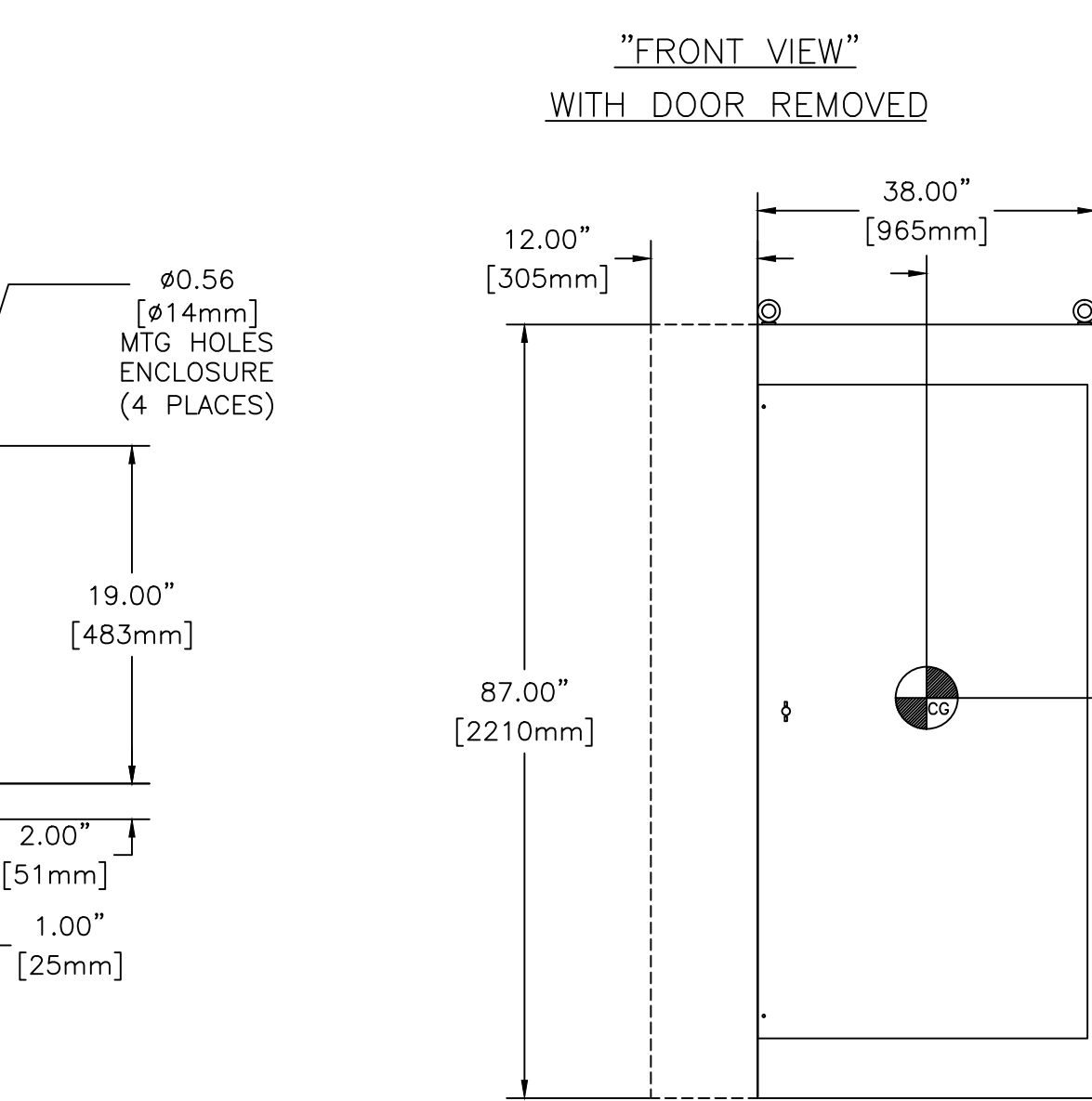
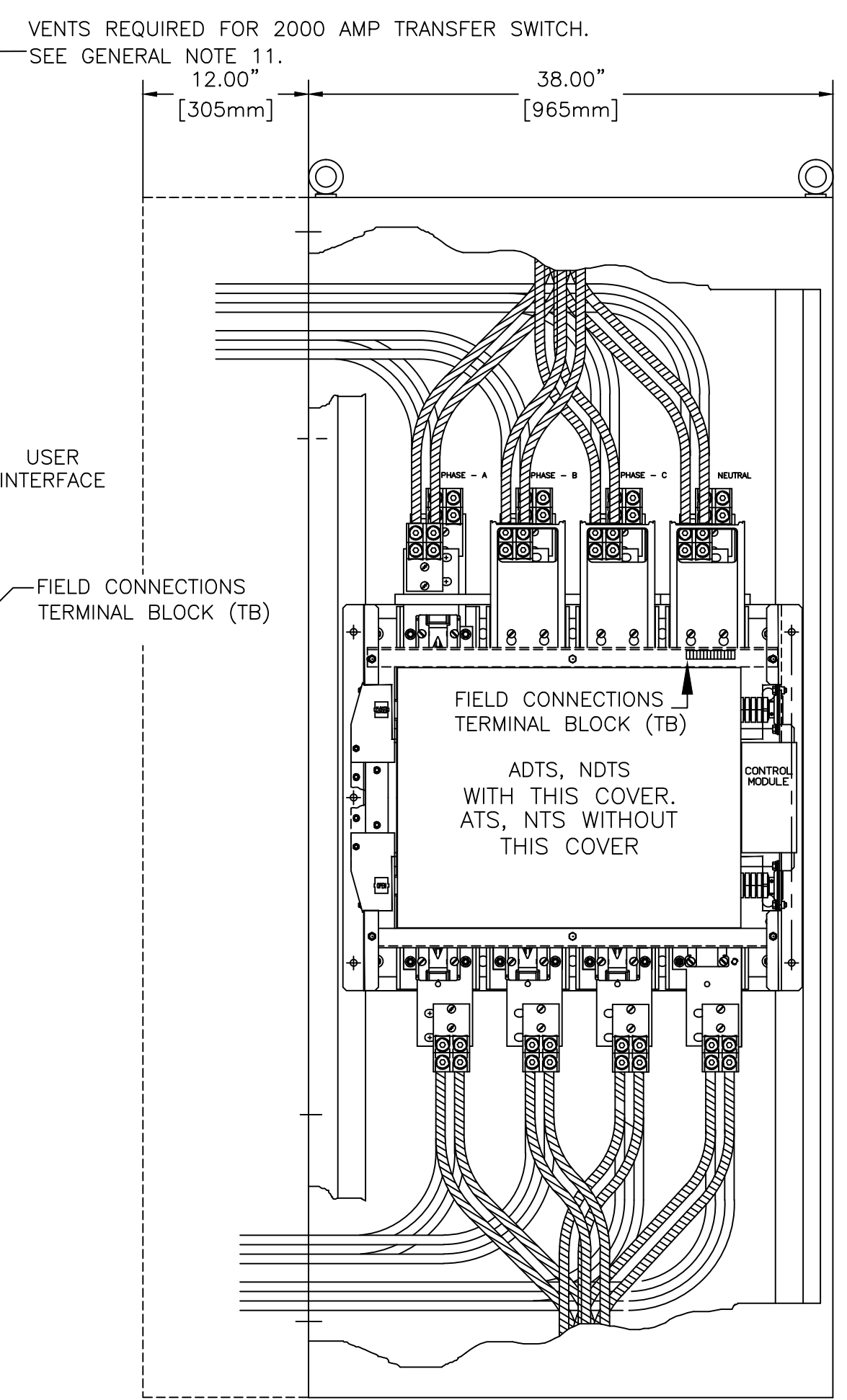
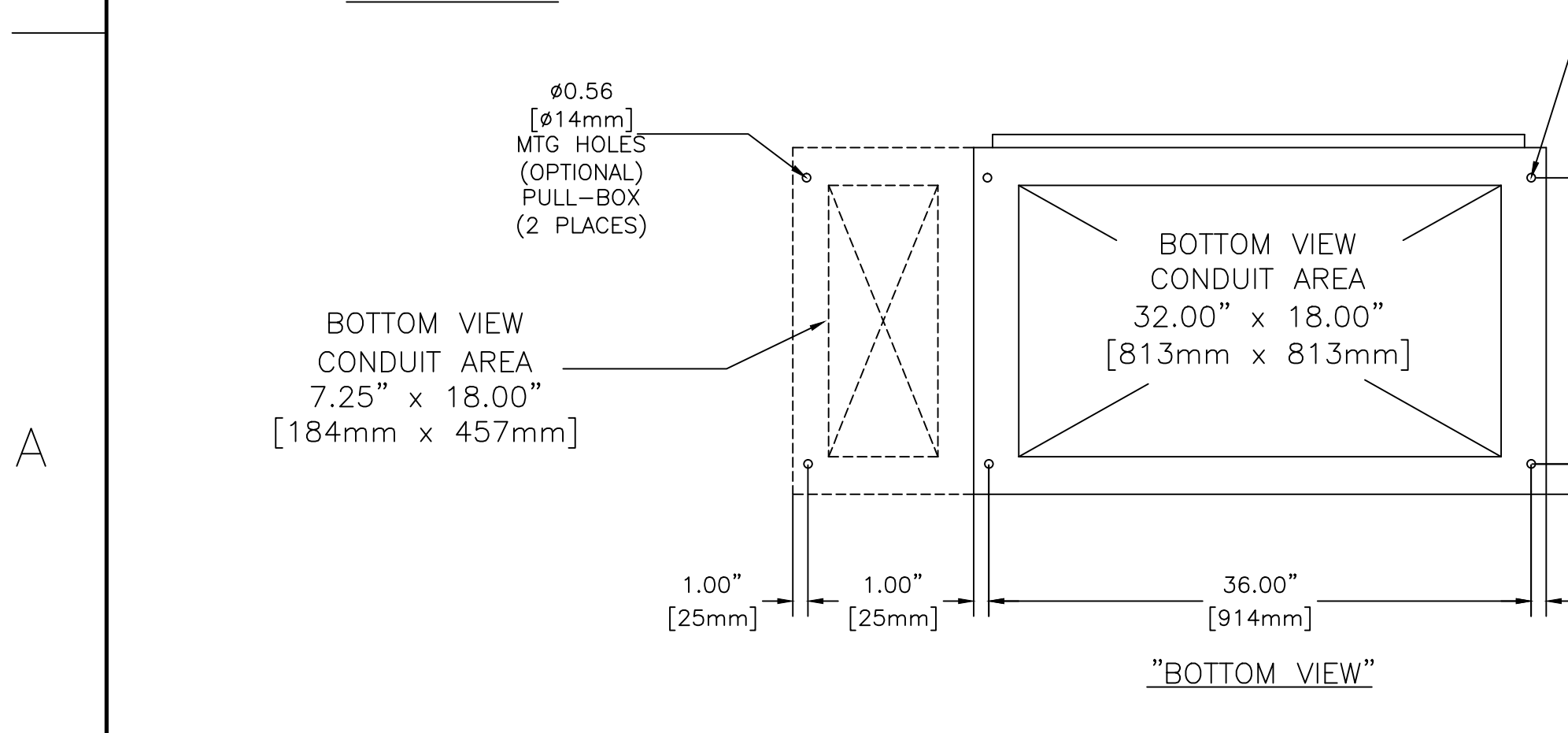
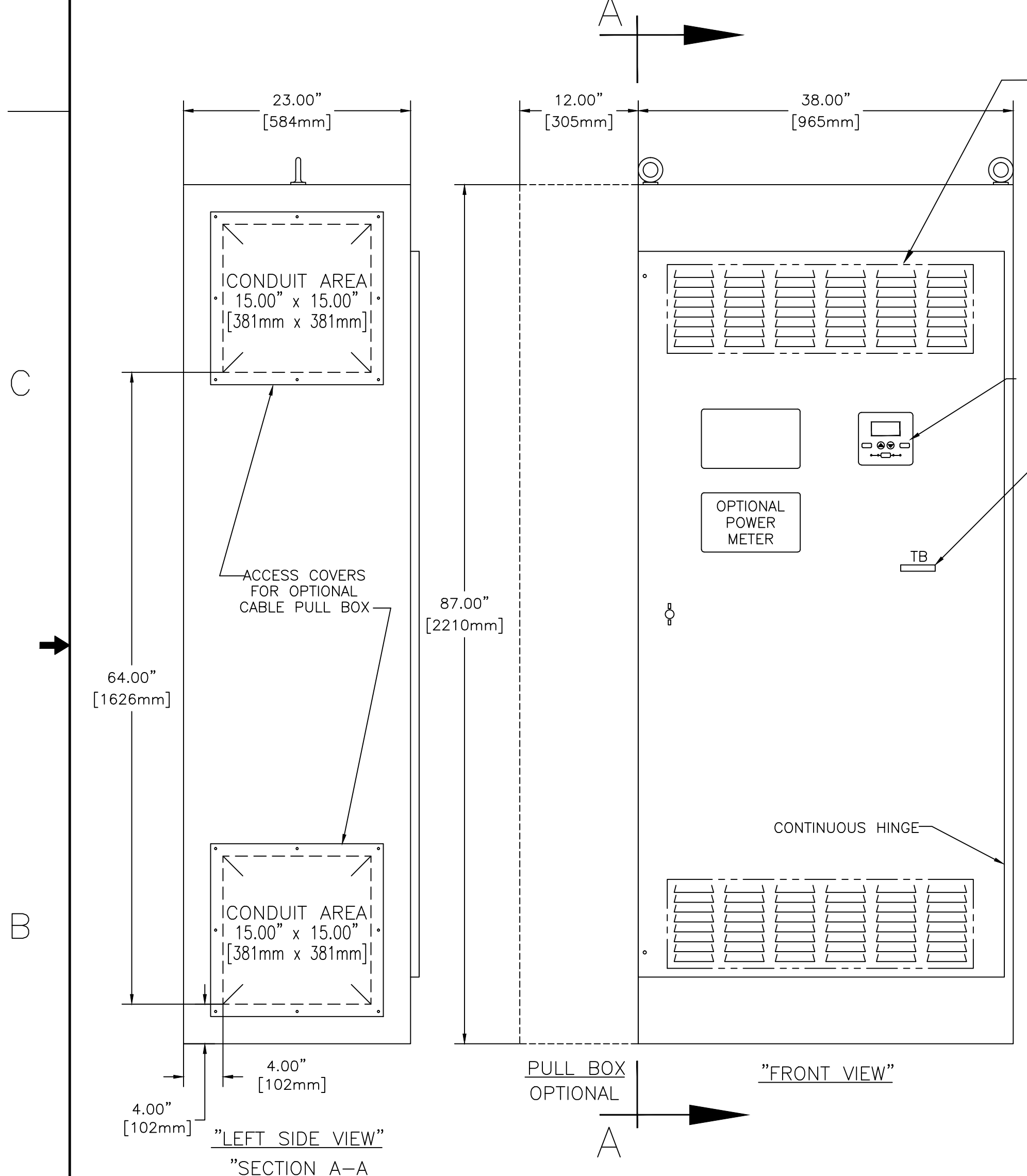
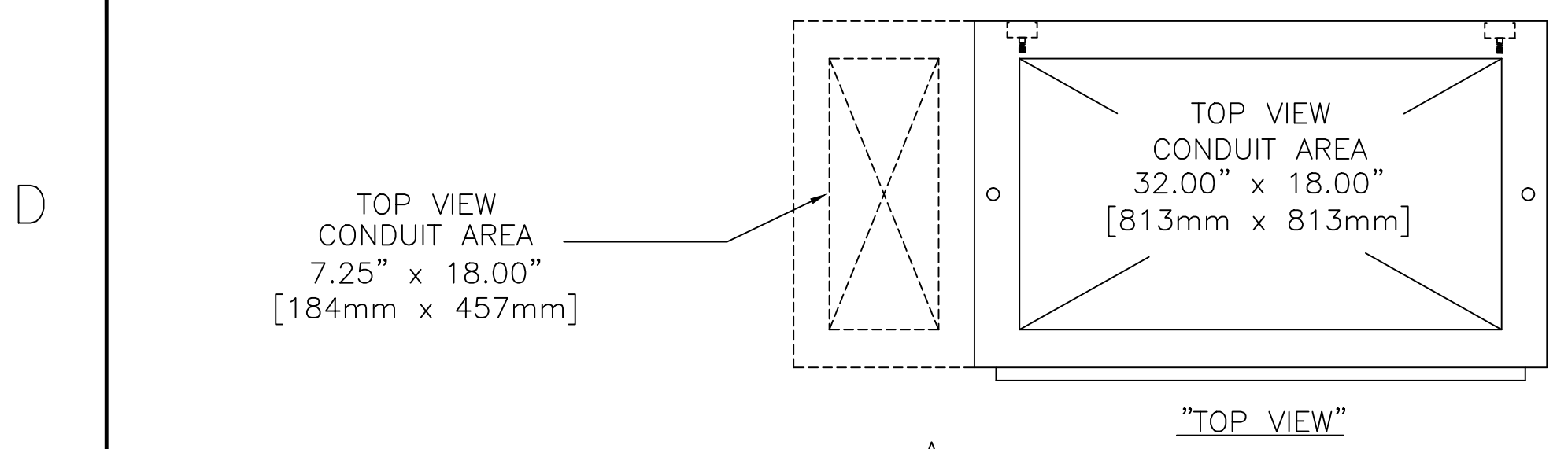

B	289440	TR	MM	05/19/21
SEE ECN				
A	248253	TR	BK	5/7/14
SEE ECN				
-	245058	BWM	SDH	10/25/13
ISSUED				

PROJECT NAME:		REV. TO SHEET		ECN NO.	BY	APP.	DATE
OUTLINE							
300 SERIES							
1000-2000 AMP (F/C ONLY)							
DRAWN BY	DATE	MANUFACTURING TOLERANCES TO BE IN ACCORDANCE WITH ASCO PROCEDURE MP-1-003. FOR PLASTIC PARTS SEE MP-1-035.		ASSEM. REF. NO.	COMPUTER GENERATED DRAWING		
CHECKED	DATE	PROPERTY OF ASCO POWER TECHNOLOGIES. USE PERMITTED FOR OUR WORK ONLY. ALL RIGHTS OF DESIGN OR INVENTION ARE RESERVED.			SCALE	SIZE	DS
PROJECT APPROVAL	DATE				DWG. NO.		
FINAL APPROVAL	DATE				1001395		
		ASCO® ASCO POWER TECHNOLOGIES, L.P. FLORHAM PARK, NEW JERSEY 07932 U.S.A.		DRAWING B	ECN NO.	SHEET	
				289440	1 OF 1		