

# 5.2 MW, Pod-based build, Chilled Water, 85000 ft<sup>2</sup>

## DESIGN OVERVIEW

### Data Center IT Capacity

5.2 MW

### Target Availability

Tier III with 2N power distribution and less-redundant generator configuration

### Annualized PUE at 100% Load

1.43 in Miami, FL USA  
1.24 in Montreal, Canada  
1.31 in St. Louis, MO USA

### Total Racks and Average Density

864 traditional racks at 6 kW/rack

### Data Center Overall Space

Min. 85000 ft<sup>2</sup>

### Regional Voltage and Frequency

480V, 60Hz

## ABOUT THIS DESIGN

- IT Space and power distribution designed to enable pod-by-pod deployment
- *HyperPod* containment system allows for fully populated and/or hyper-converged racks to be rolled in place
- *Galaxy VX* UPS with Li-Ion batteries
- Battery backup on one power path only allows for cost savings (optional)
- 6 kW density racks with hot aisle containment
- Chilled water heat removal system

## INTRODUCTION

The planning process of most projects can be iterative and thereby expensive. Data center projects are burdened with these challenges and can benefit greatly from simplification and time savings. Schneider Electric's data center reference designs help optimize the planning process by providing validated, proven, and documented data center physical infrastructure plans. The use of these designs has a positive impact on not just the project itself, but also on the performance, reliability, and efficiency of the data center over its lifetime.

This reference design was developed for colocation customers planning medium to large data centers, with a focus on increased speed and lower cost of deploying a pod-based architecture, avoiding the need to modify the data center ceiling infrastructure to accommodate cabling and piping, by using the *HyperPod* containment system instead. For scalability and lower-cost, IT rooms can be built in stages and an alternative UPS redundancy scheme is proposed. This data center includes four rooms with 1296 kW of IT capability, along with a chilled water perimeter cooling system serving each room. Together these rooms and systems constitute the building blocks for the data center. Each expansion, therefore, can occur in increments of 1296 kW of IT load.

Reference Design 65 includes information for three areas: facility power, facility cooling, and IT space. Combined together, they comprise the integrated power, cooling and structural systems required to meet the design's specifications in this overview document.

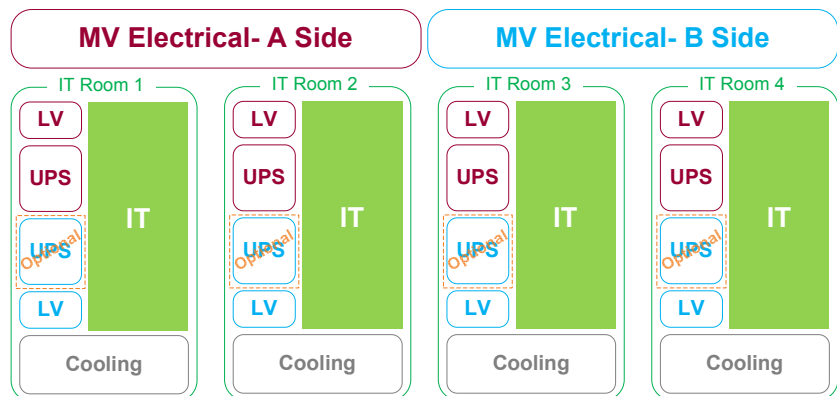

### FACILITY POWER BLOCK DIAGRAM

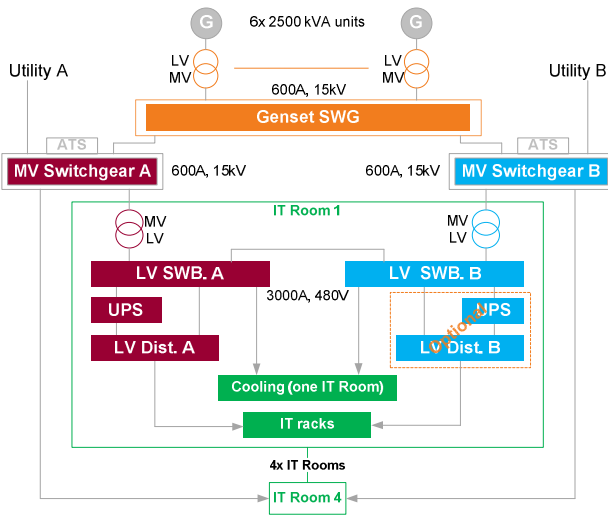

### DESIGN OPTIONS

This reference design can be modified as follows without a significant effect on the design's performance attributes:

- Add a UPS to alternate power path
- Change UPS batteries
  - Location
  - Type (VRLA or Li-Ion)

### FACILITY POWER ATTRIBUTES

Name	Value	Unit
Total bus amps (MV bus)	600	A
Input voltage (MV bus)	15	kV
MV Switchboard kAIC	25	kA
Generator Redundancy	N+1	
Total amps (main LV bus)	3000	A
Input voltage (main LV bus)	480	V
LV Switchboard kAIC	85	kA
Power path	Double	
IT space UPS capacity	6000	kW
IT space UPS redundancy	N (Optional 2N)	
IT space UPS runtime @ rated load	5	minutes
Facility cooling UPS capacity	None	kW
Facility cooling UPS redundancy	N/A	
Facility cooling UPS runtime @ rated load	N/A	minutes

## Facility Power

### Medium Voltage (MV) Distribution

The facility power system supplies energy to the critical and non-critical components within the data center, with high reliability levels. Two *Premset* switchboards, each rated at 15 kV, 600 A and 25 kA (2s), make up the MV distribution, providing A and B side power downstream to IT and cooling equipment. Backup power is provided by six diesel generators in an N+1 redundant arrangement, where each generator is paired with an LV/MV step up 2500 kVA *Power Dry II VPI* cast resin transformer (5.75% short circuit impedance) and a *Premset* switchboard rated at 15 kV, 600 A and 25 kA (2s), with automatic transfer built into the design. This generator plant is shared across the facility, allowing capital costs savings from additional switchgear and over-sizing.

### Low Voltage (LV) Distribution

Downstream from the MV distribution, the 2N redundant distribution is separated into 8 LV sections for the four IT rooms, cooling systems, and auxiliaries. The LV distribution for each IT room is made up of two *Power Dry II* 2500 kVA transformers (5.75% impedance), each coupled with an *QED6* LV lineup, rated at 480 V and 85 kA (1s) with a 3000 A bus, providing power to the main and alternate power paths. One of these *QED6* lineups feeds two 750 kVA *Galaxy VX* UPSs with Li-Ion batteries on side A, while the second *QED6* lineup directly feeds the IT load from side B, to guarantee 2N LV power distribution. This arrangement allows for cost, footprint and weight savings, while still maintaining a high level of reliability. As an option, another set of *Galaxy VX* UPSs can be placed on the alternate path to provide the IT load with both A and B-side UPS backup.

Cooling systems and auxiliary loads for all IT rooms also receive power from the LV section, provided by A and B-side distribution from two additional *QED6* lineups, rated at 480V, 85 kA (1s), with a 1200 A bus, which is designed to automatically switch between feeds.

The facility power system is designed to also support integrated peripheral devices like fire panels, access control systems, and environmental monitoring and control devices. Additionally, power meters in the electrical path monitor power quality and allow for predictive maintenance & diagnostics of the system. These meters also integrate with *EcoStruxure Power Monitoring Expert*.

Every component in this Reference Design is built and tested to the applicable ANSI standards. Further design details and schematics are available in the engineering package available upon request.

# Facility Cooling

## FACILITY COOLING BLOCK DIAGRAM

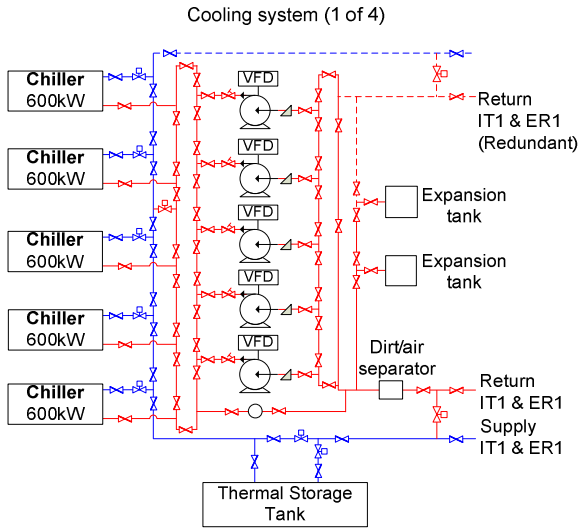

The facility cooling design is comprised of four identical stand-alone cooling systems, each with a dual-path piping system, five packaged chillers with free cooling capabilities and 14 *Uniflair* chilled water room-based computer room air handlers (CRAHs) that deliver clean and conditioned supply air to the IT and electrical rooms, in an N+1 configuration. The redundant piping system across the IT and electrical distribution rooms provides an alternate path for chilled water, in case of cooling equipment failure. In addition, thermal storage systems are offered to provide continuous cooling after a power outage or chiller restart. Thermal storage tanks should be sized to accommodate the ramp-up time of the chillers and building topology. Additional air handling units are added to supply fresh air in the building.

Warm return air from the IT equipment is ducted to a common ceiling plenum, from which each *Uniflair* cooling unit draws air and supplies the data center with a flood of cool air at the perimeter of the IT and electrical rooms.

This design is instrumented to work with *EcoStruxure Building Operation* software.

Further design details such as dimensions, equipment placement, temperature set points, pipe sizing, flow rates, and pressure drops are available in the engineering package.

Piping inside electrical and IT rooms (1 of 4)

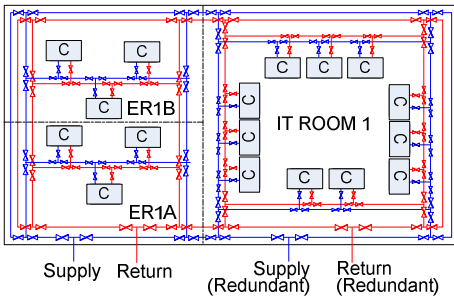

## FACILITY COOLING ATTRIBUTES

Name	Value	Unit
Total cooling capacity	7500	kW
Input voltage	480	V
Heat rejection medium	Chilled water	
Mechanical redundancy	N+1	
Outdoor heat exchange	Packaged chiller with free-cooling	
Coolant supply temperature	59	F
Coolant return temperature	69	F
Storage tank size per cooling system	7750	gallons
Ride through time	5	mins
Economizer type	Water-side	

## DESIGN OPTIONS

This reference design can be modified as follows without a significant effect on the design's performance attributes:

- Reduce redundancy to the module, not frame, level
- Eliminate secondary water supply tank size, or change its size
- Use water-saver mode to rely more on direct expansion and reduce water consumption

# IT Space

## IT ROOM LAYOUT

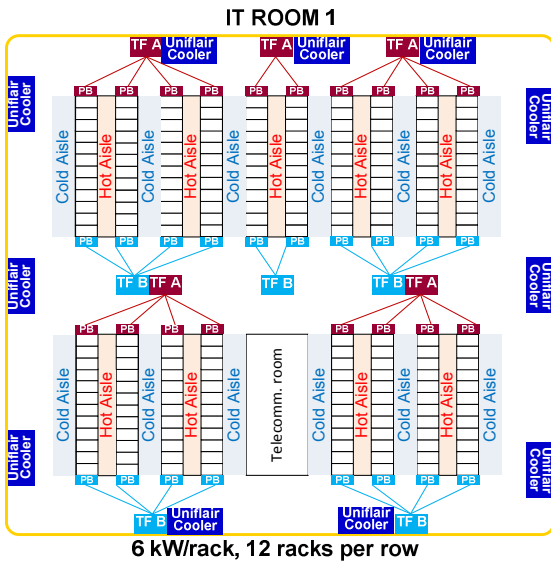

Four IT rooms make up the entire IT space of this design. Each of the rooms is comprised of 9 pods, or 18 rows, housing 24 racks each, for a total of 216 racks per IT room. Each rack is capable of an average of 6 kW for a total of 1.3 MW per room, with 5.2 MW worth of IT capacity in aggregate.

The IT rooms are designed to allow for pod-by-pod deployment, since the supporting system and hot aisle containment is provisioned for each pod by the *HyperPod* containment system, allowing racks to be fully populated and rolled in place. Deploying *HyperPod* increases the cooling efficiency of the N+1 perimeter cooling units while it also provides a robust structural system to support power cabling and equipment, including end-of-pod power distribution through distribution cabinets, among other advantages.

In this design, power from the UPS systems in the electrical room is stepped down from 480 V to 208 V by 300 and 150 kVA *SquareD* dry-type transformers located in the perimeter of the IT pods. Four 225 A *SquareD* standard panelboards, located inside the distribution cabinets at the end of the *HyperPod*, and distribute power from the transformers to each rack, in a 2N configuration, through a power raceway that integrates seamlessly to the frame. Every rack is configured with two metered rack-mount power distribution units (rPDU), to enable remote monitoring of the units for efficiency and capacity management.

## HYPERPOD CONTAINMENT SYSTEM

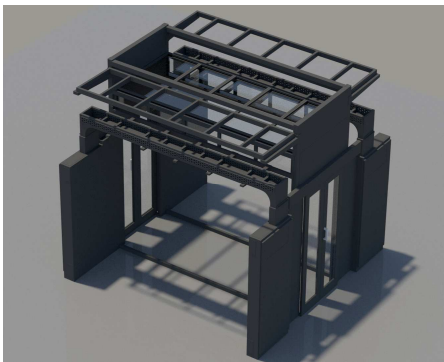

The security of the room can be maintained at multiple points with *NetBotz* systems installed on the *HyperPod* frames. At the rack level, access is controlled by a door lock and sensor and at the room level, security cameras are utilized for monitoring.

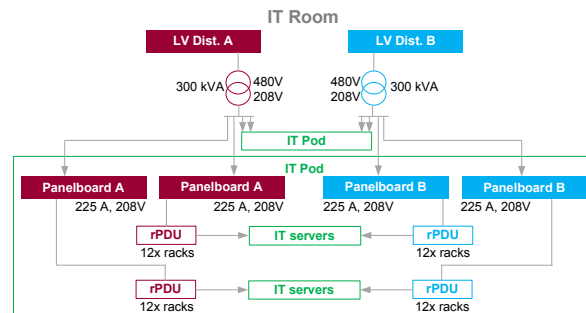

## IT SPACE ATTRIBUTES

### DESIGN OPTIONS

This reference design can be modified as follows without a significant effect on the design's performance attributes:

- Change voltage to the IT equipment
- Add environmental and security management
- Change rack options (tall, wide, deep)
- Change power distribution options
- Add *EcoStruxure IT Expert*

Name	Value	Unit
IT load (total – per room)	5.2 – 1.3	MW
Input voltage	480	V
Supply voltage to IT	208	V
Average density	6	kW/rack
Number of IT racks (total – per room)	864 – 216	racks
IT floor space (total – per room)	34172 – 8543	ft <sup>2</sup>
Single or dual cord	Dual	
Heat rejection medium	Chilled water	
CRAC/CRAH type	Perimeter	
CRAC/CRAH redundancy	N+1	
Containment type	Hot Aisle	

© 2018 Schneider Electric. All rights reserved.

## Design Attributes

Overview	Value	
Annualized PUE at 100% load	1.43 / 1.24 / 1.31	
Data center overall space	85000 ft <sup>2</sup>	
Facility Power	Value	Unit
Total bus amps (MV bus)	600	A
Input voltage (MV bus)	15	kV
MV Switchboard kAIC	25	kA
Generator Redundancy	N+1	
Total amps (main LV bus)	3000	A
Input voltage (main LV bus)	480	V
LV Switchboard kAIC	65	kA
Power path	Double	
IT space UPS capacity	1500	kW
IT space UPS redundancy	N (Optional 2N)	
IT space UPS runtime @ rated load	5	minutes
Facility cooling UPS capacity	None	kW
Facility cooling UPS redundancy	None	
Facility cooling UPS runtime @ rated load	None	minutes
Facility cooling		
Total cooling capacity	7500	kW
Input voltage	480	V
Heat rejection medium	Chilled water	
Mechanical redundancy	N+1	
Outdoor heat exchange	Packaged chiller with free-cooling	
Coolant supply temperature	59	F
Coolant return temperature	69	F
Storage tank size per cooling system	7750	gallons
Ride through time	5	mins
Economizer type	Water-side	
IT Space		
IT load (total – per room)	5.2 – 1.3	MW
Input voltage	480	V
Supply voltage to IT	208	V
Average density	6	kW/rack
Number of IT racks (total – per room)	864 – 216	racks
IT floor space (total – per room)	34172 – 8543	ft <sup>2</sup>
Single or dual cord	Dual	
Heat rejection medium	Chilled water	
CRAC/CRAH type	Perimeter	
CRAC/CRAH redundancy	N+1	
Containment type	Hot Aisle	

# EcoStruxure Data Center

*EcoStruxure™* is Schneider Electric’s open, interoperable, integrated Internet of Things (IOT)-enabled system architecture and platform. *EcoStruxure* delivers enhanced value around safety, reliability, efficiency, sustainability, and connectivity for our customers. *EcoStruxure* leverages advancements in IoT, mobility, sensing, cloud, analytics, and cybersecurity to deliver Innovation at Every Level. It consists of three layers: connected products, edge control, and applications, analytics, and services. This includes Connected Products, Edge Control, and Apps, Analytics & Services. *EcoStruxure™* has been deployed in 480,000+ sites, with the support of 20,000+ system integrators and developers, connecting over 1.6 million assets under management through 40+ digital services.

The connected products layer communicates with the edge control layer, which allows users to remotely monitor and control the connected products in real time. The edge control layer communicates with the application, analytics, and services, which will translate data into actionable intelligence and better business decisions. All three layers are secured with end-to-end cybersecurity. *EcoStruxure* can either be located on-premise (this will only consist of the connected products and edge control layers) or the cloud.

*EcoStruxure Data Center* is a combination of three domains of *EcoStruxure*: Power, Building, and IT. Each domain is focused on a subsystem of the data center: power, cooling, and IT. These three domains combined will reduce risks, increase efficiencies, and speed operations across the entire facility.

- *EcoStruxure Power* monitors power quality, generates alerts, while protecting and controlling the electrical distribution the electrical distribution system of the data center from the MV level to the LV level. It uses any device for monitoring and alerting, uses predictive analytics for increased safety, availability, and efficiency, while lowering maintenance costs.
- *EcoStruxure Building* controls cooling effectively while driving reliability, efficiency, and safety of building management, security, and fire systems. It performs data analytics on assets, energy use, and operational performance.
- *EcoStruxure IT* makes IT infrastructure more reliable and efficient while simplifying management by offering complete visibility, alerting and modelling tools. It receives data, generates alerts, predictive analytics, and system advice on any device to optimize availability and efficiency in the IT space.

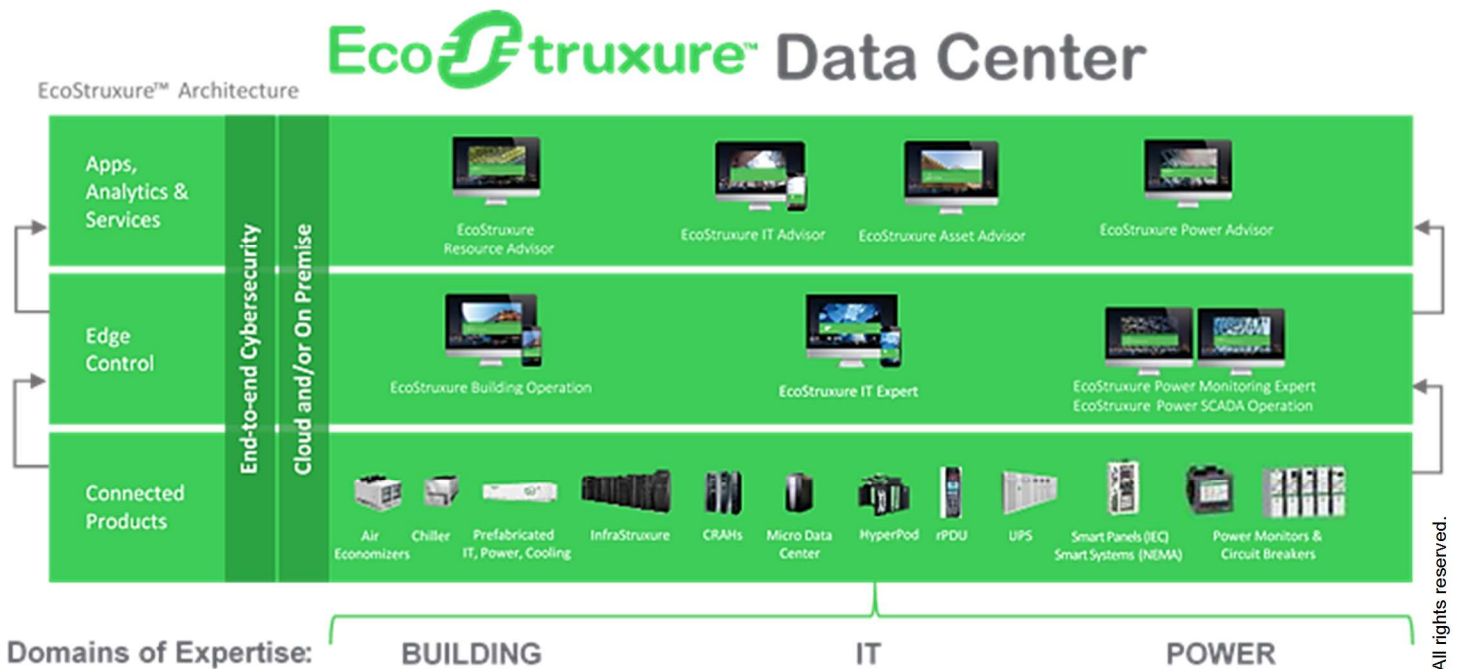

➤ Visit [EcoStruxure for Data Center](#) for more details.

# Schneider Electric Life-Cycle Services

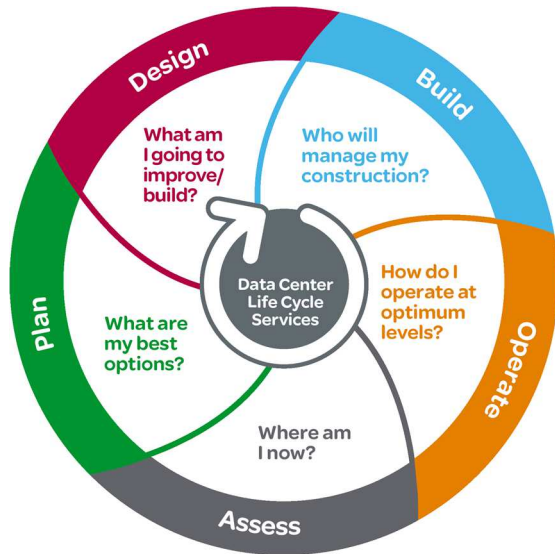

- 1** Team of **over 7,000 trained specialists** covering every phase and system in the data center
- 2** Standardized, documented, and validated **methodology** leveraging automation tools and repeatable processes **developed over 45 years**
- 3** **Complete portfolio of services** to solve your technical or business challenge, simplify your life, and reduce costs

## Get more information for this design:

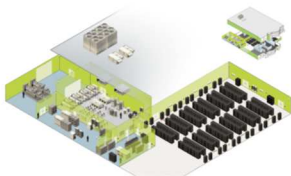

**3D spatial views**



**Floor layouts**

### Engineering Package

Every reference design is built with technical documentation for engineers and project managers. This includes engineering schematics (CAD, PDF), floor layouts, equipment lists containing all the components used in the design and 3D images showing real world illustrations of our reference designs.

Documentation is available in multiple formats to suit the needs of both engineers and managers working on data center projects.

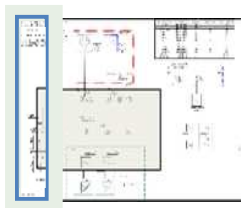

**One-line schematics**

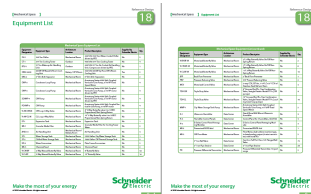

**Bill of materials**

➤

Click here to register to receive the Engineering Package for this design, or email [ReferenceDesigns@Schneider-Electric.com](mailto:ReferenceDesigns@Schneider-Electric.com).