

Altivar Process Variable Speed Drives

Modbus Serial Link Manual (Embedded)

11/2014



The information provided in this documentation contains general descriptions and/or technical characteristics of the performance of the products contained herein. This documentation is not intended as a substitute for and is not to be used for determining suitability or reliability of these products for specific user applications. It is the duty of any such user or integrator to perform the appropriate and complete risk analysis, evaluation and testing of the products with respect to the relevant specific application or use thereof. Neither Schneider Electric nor any of its affiliates or subsidiaries shall be responsible or liable for misuse of the information contained herein. If you have any suggestions for improvements or amendments or have found errors in this publication, please notify us.

No part of this document may be reproduced in any form or by any means, electronic or mechanical, including photocopying, without express written permission of Schneider Electric.

All pertinent state, regional, and local safety regulations must be observed when installing and using this product. For reasons of safety and to help ensure compliance with documented system data, only the manufacturer should perform repairs to components.

When devices are used for applications with technical safety requirements, the relevant instructions must be followed.

Failure to use Schneider Electric software or approved software with our hardware products may result in injury, harm, or improper operating results.

Failure to observe this information can result in injury or equipment damage.

© 2014 Schneider Electric. All rights reserved.

Table of Contents



	Safety Information	5
	About the Book	9
Chapter 1	Presentation	11
	Hardware Overview	12
	Software Overview	13
Chapter 2	Basics	15
2.1	Profile	16
	Definition of a Profile	17
	Functional Profiles Supported by the Drive	18
	Functional Description	19
	CIA402 Operating State Diagram	20
	Description of Operating States	21
	Summary	23
	Control Word (<i>C P d</i>)	24
	Stop Commands	25
	Assigning Control Word Bits	26
	Status Word (<i>E L R</i>)	27
	Starting Sequence	28
	Sequence for a Drive Powered by the Power Stage Supply	29
	Sequence for a Drive with Separate Control Stage	31
	Sequence for a Drive with Mains Contactor Control	33
2.2	Modbus Functions	34
	Modbus Protocol	35
	Supported Modbus Functions	36
Chapter 3	Hardware Setup	41
	Hardware Presentation	42
	Firmware Version	43
	Connection to the Adapter	44
	Electrical Installation	45
	Cable Routing Practices	47
	Accessories Presentation	48
Chapter 4	Software Setup	49
4.1	Basic Settings	50
	Configuring the Communication Parameters	51
	[Modbus Address] (<i>R d d</i>)	52
	[Modbus baud rate] (<i>L b r</i>)	53
	[Modbus format] (<i>L F o</i>)	54
	[Modbus Time Out] (<i>L t o</i>)	55
4.2	Additional Settings	56
	Local Configuration of the Communication Scanner	57
	[Scan.IN1 address] (<i>n P R 1</i>)	58
	[Scan.IN2 address] (<i>n P R 2</i>)	59
	[Scan.IN3 address] (<i>n P R 3</i>)	60
	[Scan.IN4 address] (<i>n P R 4</i>)	61
	[Scan.IN5 address] (<i>n P R 5</i>)	62
	[Scan.IN6 address] (<i>n P R 6</i>)	63
	[Scan.IN7 address] (<i>n P R 7</i>)	64
	[Scan.IN8 address] (<i>n P R 8</i>)	65
	[Scan.Out1 address] (<i>n C R 1</i>)	66
	[Scan.Out2 address] (<i>n C R 2</i>)	67
	[Scan.Out3 address] (<i>n C R 3</i>)	68

	[Scan.Out4 address] (н С А 4)	69
	[Scan.Out5 address] (н С А 5)	70
	[Scan.Out6 address] (н С А 6)	71
	[Scan.Out7 address] (н С А 7)	72
	[Scan.Out8 address] (н С А 8)	73
4.3	Monitoring the Communication Scanner	74
	Introduction	75
	[Com Scan.In1 val.] (н П 1)	76
	[Com Scan.In2 val.] (н П 2)	77
	[Com Scan.In3 val.] (н П 3)	78
	[Com Scan.In4 val.] (н П 4)	79
	[Com Scan.In5 val.] (н П 5)	80
	[Com Scan.In6 val.] (н П 6)	81
	[Com Scan.In7 val.] (н П 7)	82
	[Com Scan.In8 val.] (н П 8)	83
	[Com Scan.Out1 val.] (н С 1)	84
	[Com Scan.Out2 val.] (н С 2)	85
	[Com Scan.Out3 val.] (н С 3)	86
	[Com Scan.Out4 val.] (н С 4)	87
	[Com Scan.Out5 val.] (н С 5)	88
	[Com Scan.Out6 val.] (н С 6)	89
	[Com Scan.Out7 val.] (н С 7)	90
	[Com Scan.Out8 val.] (н С 8)	91
4.4	Fieldbus Integration Using Unity	92
	Introduction	93
	Drive Configuration	94
	Modbus Master Configuration	95
Chapter 5	Operations	99
5.1	Operating States	100
	Configuring Communication Detected Error Response	100
5.2	Operating Modes	101
	Configuring the Control Channel	102
	Configuration of the Drive for Operation in I/O Profile	103
	Configuration of the Drive for Operation with CiA 402 Profile in Combined Mode	104
	Configuration of the Drive for Operation with CiA 402 Profile in Separate Mode	105
Chapter 6	Diagnostics and Troubleshooting	107
	Fieldbus Status LEDs	108
	Checking Connections	110
	Fieldbus Function Test	111
	Communication Interruption Message	112
Glossary	113

Safety Information



Important Information

NOTICE

Read these instructions carefully, and look at the equipment to become familiar with the device before trying to install, operate, or maintain it. The following special messages may appear throughout this documentation or on the equipment to warn of potential hazards or to call attention to information that clarifies or simplifies a procedure.



The addition of this symbol to a “Danger” or “Warning” safety label indicates that an electrical hazard exists which will result in personal injury if the instructions are not followed.



This is the safety alert symbol. It is used to alert you to potential personal injury hazards. Obey all safety messages that follow this symbol to avoid possible injury or death.

DANGER

DANGER indicates a hazardous situation which, if not avoided, **will result in death or serious injury**.

WARNING

WARNING indicates a hazardous situation which, if not avoided, **could result in death or serious injury**.

CAUTION

CAUTION indicates a hazardous situation which, if not avoided, **could result in minor or moderate injury**.

NOTICE

NOTICE is used to address practices not related to physical injury.

PLEASE NOTE

Electrical equipment should be installed, operated, serviced, and maintained only by qualified personnel. No responsibility is assumed by Schneider Electric for any consequences arising out of the use of this material.

A qualified person is one who has skills and knowledge related to the construction and operation of electrical equipment and its installation, and has received safety training to recognize and avoid the hazards involved.

Qualification Of Personnel

Only appropriately trained persons who are familiar with and understand the contents of this manual and all other pertinent product documentation are authorized to work on and with this product. In addition, these persons must have received safety training to recognize and avoid hazards involved. These persons must have sufficient technical training, knowledge and experience and be able to foresee and detect potential hazards that may be caused by using the product, by changing the settings and by the mechanical, electrical and electronic equipment of the entire system in which the product is used. All persons working on and with the product must be fully familiar with all applicable standards, directives, and accident prevention regulations when performing such work.

Intended Use

This product is a drive for three-phase synchronous and asynchronous motors and intended for industrial use according to this manual. The product may only be used in compliance with all applicable safety regulations and directives, the specified requirements and the technical data. Prior to using the product, you must perform a risk assessment in view of the planned application. Based on the results, the appropriate safety measures must be implemented. Since the product is used as a component in an entire system, you must ensure the safety of persons by means of the design of this entire system (for example, machine design). Any use other than the use explicitly permitted is prohibited and can result in hazards. Electrical equipment should be installed, operated, serviced, and maintained only by qualified personnel.

Product Related Information

Read and understand these instructions before performing any procedure with this drive.

DANGER

HAZARD OF ELECTRIC SHOCK, EXPLOSION OR ARC FLASH

- Only appropriately trained persons who are familiar with and understand the contents of this manual and all other pertinent product documentation and who have received safety training to recognize and avoid hazards involved are authorized to work on and with this drive system. Installation, adjustment, repair and maintenance must be performed by qualified personnel.
- The system integrator is responsible for compliance with all local and national electrical code requirements as well as all other applicable regulations with respect to grounding of all equipment.
- Many components of the product, including the printed circuit boards, operate with mains voltage. Do not touch. Use only electrically insulated tools.
- Do not touch unshielded components or terminals with voltage present.
- Motors can generate voltage when the shaft is rotated. Prior to performing any type of work on the drive system, block the motor shaft to prevent rotation.
- AC voltage can couple voltage to unused conductors in the motor cable. Insulate both ends of unused conductors of the motor cable.
- Do not short across the DC bus terminals or the DC bus capacitors or the braking resistor terminals.
- Before performing work on the drive system:
 - Disconnect all power, including external control power that may be present.
 - Place a **Do Not Turn On** label on all power switches.
 - Lock all power switches in the open position.
 - Wait 15 minutes to allow the DC bus capacitors to discharge. The DC bus LED is not an indicator of the absence of DC bus voltage that can exceed 800 Vdc. Measure the voltage on the DC bus between the DC bus terminals (PA/+, PC/-) using a properly rated voltmeter to verify that the voltage is <42 Vdc
 - If the DC bus capacitors do not discharge properly, contact your local Schneider Electric representative. Do not repair or operate the product.
- Install and close all covers before applying voltage.

Failure to follow these instructions will result in death or serious injury.

WARNING

UNEXPECTED MOVEMENT

Drive systems may perform unexpected movements because of incorrect wiring, incorrect settings, incorrect data or other errors.

- Carefully install the wiring in accordance with the EMC requirements.
- Do not operate the product with unknown or unsuitable settings or data.
- Perform a comprehensive commissioning test.

Failure to follow these instructions can result in death, serious injury, or equipment damage.

Damaged products or accessories may cause electric shock or unanticipated equipment operation.

DANGER

ELECTRIC SHOCK OR UNANTICIPATED EQUIPMENT OPERATION

Do not use damaged products or accessories.

Failure to follow these instructions will result in death or serious injury.

Contact your local Schneider Electric sales office if you detect any damage whatsoever.

WARNING

LOSS OF CONTROL

- The designer of any control scheme must consider the potential failure modes of control paths and, for critical control functions, provide a means to achieve a safe state during and after a path failure. Examples of critical control functions are emergency stop, overtravel stop, power outage and restart.
- Separate or redundant control paths must be provided for critical control functions.
- System control paths may include communication links. Consideration must be given to the implications of unanticipated transmission delays or failures of the link.
- Observe all accident prevention regulations and local safety guidelines (1).
- Each implementation of the product must be individually and thoroughly tested for proper operation before being placed into service.

Failure to follow these instructions can result in death, serious injury, or equipment damage.

(1) For USA: Additional information, refer to NEMA ICS 1.1 (latest edition), Safety Guidelines for the Application, Installation, and Maintenance of Solid State Control and to NEMA ICS 7.1 (latest edition), Safety Standards for Construction and Guide for Selection, Installation and Operation of Adjustable-Speed Drive Systems.

NOTICE

DESTRUCTION DUE TO INCORRECT MAINS VOLTAGE

Before switching on and configuring the product, verify that it is approved for the mains voltage

Failure to follow these instructions can result in equipment damage.

About the Book



At a Glance

Document Scope

The purpose of this document is to:

- Show you how to install the Modbus fieldbus on your drive.
- Show you how to configure drive to use Modbus for monitoring and control.
- Provide examples of setup using Unity

NOTE: Read and understand this document and all related documents (see below) before installing, operating, or maintaining your drive.

Validity Note

This documentation is valid for the drive Modbus fieldbus.

The technical characteristics of the devices described in this document also appear online. To access this information online:

Step	Action
1	Go to the Schneider Electric home page www.schneider-electric.com .
2	In the Search box type the reference of a product or the name of a product range. <ul style="list-style-type: none">• Do not include blank spaces in the model number/product range.• To get information on grouping similar modules, use asterisks (*).
3	If you entered a reference, go to the Product Datasheets search results and click on the reference that interests you. If you entered the name of a product range, go to the Product Ranges search results and click on the product range that interests you.
4	If more than one reference appears in the Products search results, click on the reference that interests you.
5	Depending on the size of your screen, you may need to scroll down to see the data sheet.
6	To save or print a data sheet as a .pdf file, click Download XXX product datasheet .

The characteristics that are presented in this manual should be the same as those characteristics that appear online. In line with our policy of constant improvement, we may revise content over time to improve clarity and accuracy. If you see a difference between the manual and online information, use the online information as your reference.

Related Documents

Use your tablet or your PC to quickly access detailed and comprehensive information on all our products on www.schneider-electric.com

The Internet site provides the information you need for products and solutions

- The whole catalog for detailed characteristics and selection guides
- The CAD files to help design your installation, available in over 20 different file formats
- All software and firmware to maintain your installation up to date
- A large quantity of White papers, environment documents, application solutions, specifications... To gain a better understanding of electrical systems and equipment or automation
- All the user guides related to your drive, listed below:

Title of Documentation	Reference Number
Altivar Process Getting Started	EAV63253
Altivar Process Installation Manual	EAV64301
Altivar Process Programming Manual	EAV64318
Altivar Process Modbus Serial Link Manual (Embedded)	EAV64325
Altivar Process Ethernet Manual (Embedded)	EAV64327
Altivar Process EtherNet/IP - Modbus TCP Manual (VW3A3720)	EAV64328
Altivar Process PROFIBUS DP manual (VW3A3607)	EAV64329
Altivar Process DeviceNet manual (VW3A3609)	EAV64330
Altivar Process PROFINET manual (VW3A3627)	EAV64333
Altivar Process CANopen Serial Link Manual (VW3A3608, 618, 628)	EAV64331
Altivar Process Communication Parameters	EAV64332
Altivar Process Safety Function Manual	EAV64334

You can download these technical publications and other technical information from our website at www.schneider-electric.com.

Standards and Terminology

The technical terms, terminology, and the corresponding descriptions in this manual normally use the terms or definitions in the relevant standards.

In the area of drive systems this includes, but is not limited to, terms such as **error, error message, failure, fault, fault reset, protection, safe state, safety function, warning, warning message**, and so on.

Among others, these standards include:

- IEC 61800 series: Adjustable speed electrical power drive systems
- IEC 61508 Ed.2 series: Functional safety of electrical/electronic/programmable electronic safety-related
- EN 954-1 safety of machinery - Safety related parts of control systems
- EN ISO 13849-1 & 2 safety of machinery - Safety related parts of control systems.
- IEC 61158 series: Industrial communication networks - Fieldbus specifications
- IEC 61784 series: Industrial communication networks - Profiles
- IEC 60204-1: Safety of machinery - Electrical equipment of machines – Part 1: General requirements

Chapter 1

Presentation

What Is in This Chapter?

This chapter contains the following topics:

Topic	Page
Hardware Overview	12
Software Overview	13

Hardware Overview

General

The following figure shows the Modbus serial communication port:

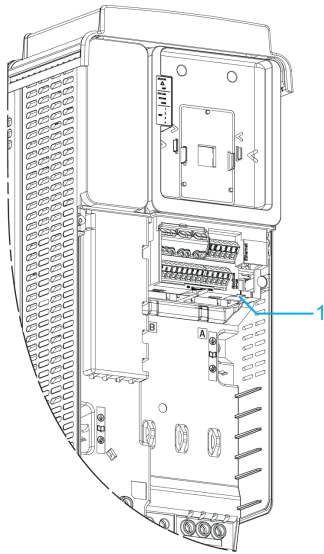

1 Modbus serial communication port

Software Overview

Supported Modbus Functions

The drive supports the following Modbus functions:

Function Name	Code		Description	Remarks
	Dec.	Hex		
Read Holding Registers	03	03 hex	Read N output words	Maximum PDU length: 63 words
Write One Output Word	06	06 hex	Write 1 output word	–
Write Multiple Registers	16	10 hex	Write N output word	Maximum PDU length: 61 words
Read/write Multiple Registers	23	17 hex	Read/write multiple registers	Maximum PDU length: 20 words (W), 20 words (R)
(Subfunction) Read Device Identification	43/14	2B hex/ 0E hex	Encapsulated interface transport/Read device identification	–
Diagnostics	08	08 hex	Diagnostics	–

Chapter 2

Basics

What Is in This Chapter?

This chapter contains the following sections:

Section	Topic	Page
2.1	Profile	16
2.2	Modbus Functions	34

Section 2.1

Profile

What Is in This Section?

This section contains the following topics:

Topic	Page
Definition of a Profile	17
Functional Profiles Supported by the Drive	18
Functional Description	19
CIA402 Operating State Diagram	20
Description of Operating States	21
Summary	23
Control Word (<i>C P d</i>)	24
Stop Commands	25
Assigning Control Word Bits	26
Status Word (<i>E L R</i>)	27
Starting Sequence	28
Sequence for a Drive Powered by the Power Stage Supply	29
Sequence for a Drive with Separate Control Stage	31
Sequence for a Drive with Mains Contactor Control	33

Definition of a Profile

Types of Profiles

There are 3 types of profile:

- Communication profiles
- Functional profiles
- Application profiles

Communication Profile

A communication profile describes the characteristics of the bus or network:

- Cables
- Connectors
- Electrical characteristics
- Access protocol
- Addressing system
- Periodic exchange service
- Messaging service
- ...

A communication profile is unique to a type of fieldbus (such as Modbus, PROFIBUS DP, and so on) and is used by various different types of device.

Functional Profile

A functional profile describes the behavior of a type of device:

- Functions
- Parameters (such as name, format, unit, type, and so on.)
- Periodic I/O variables
- State chart
- ...

A functional profile is common to all members of a device family (such as variable speed drives, encoders, I/O modules, displays, and so on).

They can feature common or similar parts. The standardized (IEC 61800-7) functional profiles of variable speed drives are:

- CiA402
- PROFIDRIVE
- CIP

DRIVECOM has been available since 1991.

CiA402 device profile for drives and motion control represents the next stage of this standard development and is now part of the IEC 61800-7 standard.

Some protocols also support the Open DeviceNet Vendor Association profile (ODVA).

Application Profile

Application profile defines the services to be provided by the devices on a machine. For example, CiA DSP 417-2 V 1.01 part 2: CANopen application profile for lift control systems - virtual device definitions.

Interchangeability

The aim of communication and functional profiles is to achieve interchangeability of the devices connected via the fieldbus.

Functional Profiles Supported by the Drive

I/O Profile

Using the I/O profile simplifies PLC programming.

The I/O profile mirrors the use of the terminal strip for control by utilizing 1 bit to control a function.

The I/O profile for the drive can also be used when controlling via a fieldbus. The drive starts up as soon as the `run` command is sent. 15 bits of the control word (bits 1...15) can be assigned to a specific function.

This profile can be developed for simultaneous control of the drive via:

- The terminals
- The Modbus control word
- The CANopen control word
- Ethernet Modbus TCP embedded
- The fieldbus module control word

The I/O profile is supported by the drive itself and therefore in turn by all the communication ports (integrated Modbus, CANopen, Ethernet, PROFIBUS DP, PROFINET, and DeviceNet fieldbus modules).

CiA402 Profile

The drive only starts up following a command sequence.

The control word is standardized.

5 bits of the control word (bits 11...15) can be assigned to a function.

The CiA402 profile is supported by the drive itself and therefore by all the communication ports (Modbus, CANopen, Ethernet, PROFIBUS DP, PROFINET, and DeviceNet).

The drive supports the `velocity` mode of CiA402 profile.

In the CiA402 profile, there are two modes that are specific to the drive and characterize commands and references value management:

- Separate [**Separate**] (*S E P*)
- Not separate [**Not separ.**] (*S I N*),

Functional Description

Introduction

Drive operation involves two main functions, which are illustrated in the diagrams below.

CiA402

The main parameters are shown with their CiA402 name and their CiA402/Drivecom index (the values in brackets are the CANopen addresses of the parameter).

The following figure shows the control diagram for drive operation:

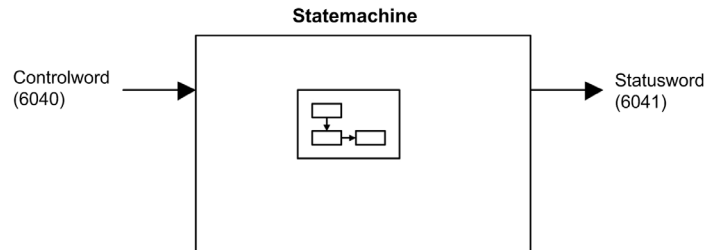

Simplified diagram for speed control in Velocity mode:

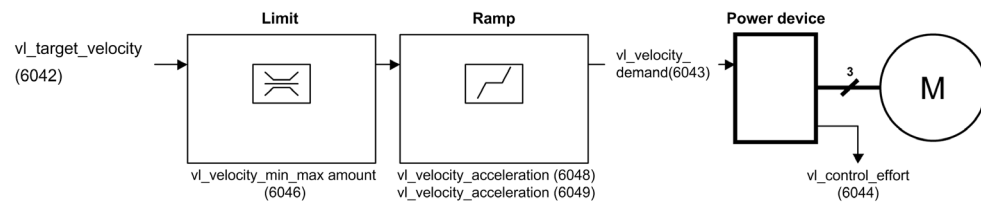

Altivar Drive

These diagrams translate as follows for the Altivar drive.

The following figure shows the control diagram for drive operation:

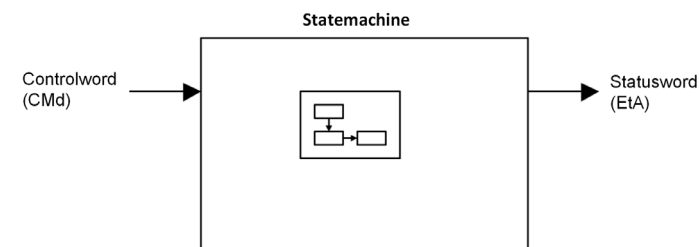

Simplified diagram for speed control in Velocity mode:

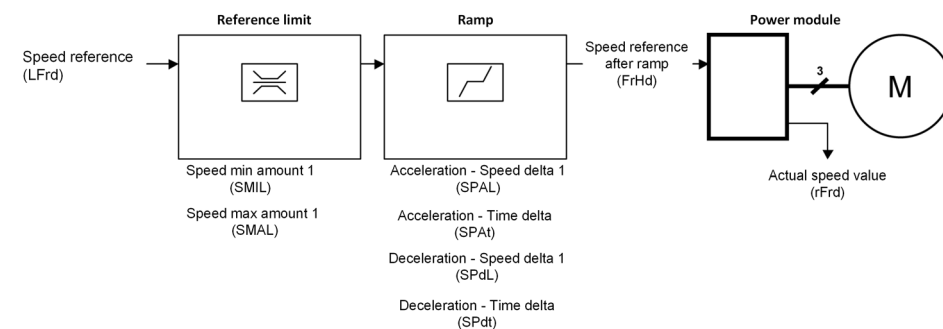

CIA402 Operating State Diagram

State Diagram

After switching on and when an operating mode is started, the product goes through a number of operating states.

The state diagram (state machine) shows the relationships between the operating states and the state transitions. The operating states are internally monitored and influenced by monitoring functions.

The following figure shows the CIA402 state diagram:

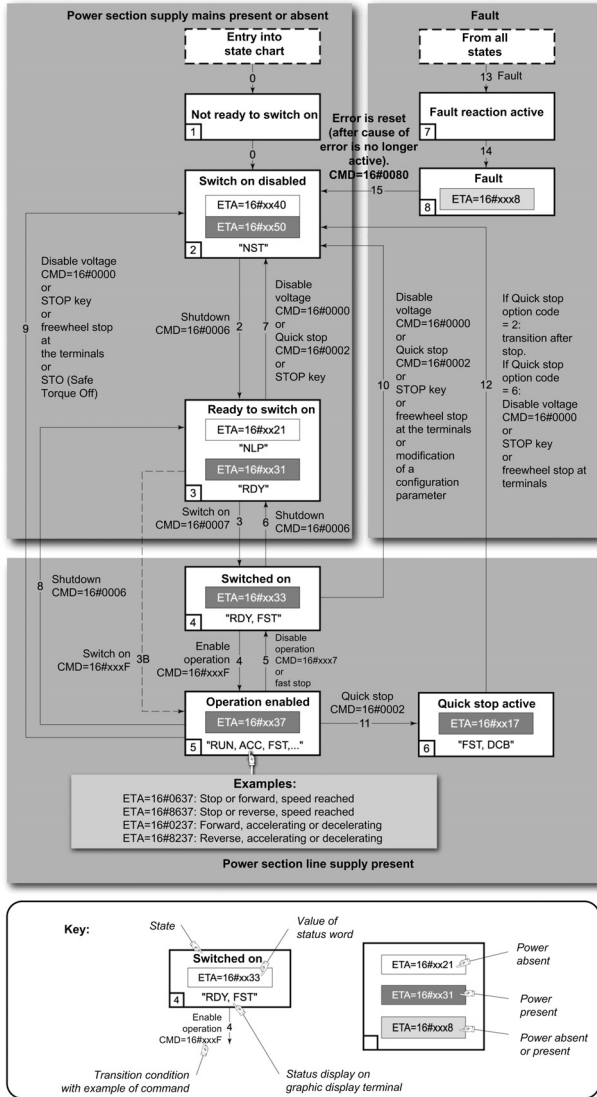

Description of Operating States

Drive Operating State

The operating state of the drive changes depending on whether the control word is sent ($C P d$) or an event occurs (an error detection, for example).

The drive operating state can be identified by the value of the status word ($E L R$).

Operating State	Description
1 - Not ready to switch on	Initialization starts. This is a transient state invisible to the communication network.
2 - Switch on disabled	The power stage is not ready to switch on. The drive is locked, no power is supplied to the motor. For a separate control stage, it is not necessary to supply the power. For a separate control stage with mains contactor, the contactor is not closed. The configuration and adjustment parameters can be modified.
3 - Ready to switch on	The power stage is ready to switch on and awaiting power stage supply mains. For a separate control stage, it is not necessary to supply the power stage, but the system expects it in order to change to state 4 - Switched on. For a separate control stage with mains contactor, the contactor is not closed. The drive is locked, no power is supplied to the motor. The configuration and adjustment parameters can be modified.
4 - Switched on	Power stage is switched on. For a separate control stage, the power stage must be supplied. For a separate control stage with mains contactor, the contactor is closed. The drive is locked, no power is supplied to the motor. The power stage of the drive is ready to operate, but voltage has not yet been applied to the output. The adjustment parameters can be modified. If a configuration parameter is modified, the drive returns to the state 2 - Switch on disable.

Operating State	Description
5 - Operation enabled	<p>Power stage is enabled. The drive is in running state For a separate control stage, the power stage must be supplied. For a separate control stage with mains contactor, the contactor is closed. The drive is unlocked, power is supplied to the motor. The drive functions are activated and voltage is applied to the motor terminals. If the reference value is zero or the <code>Halt</code> command is applied, no power is supplied to the motor and no torque is applied. To perform [Auto tuning] (t u n) , the drive must be in state 5 - Operation enabled. The adjustment parameters can be modified. The configuration parameters cannot be modified.</p> <p>NOTE: The command <code>4 - Enable operation</code> must be taken into consideration only if the channel is valid. In particular, if the channel is involved in the command and the reference value, transition 4 is possible only after the reference value has been received once.</p> <p>The reaction of the drive to a <code>Disable operation</code> command depends on the value of the [Dis. operat opt code] (d o k d) parameter:</p> <ul style="list-style-type: none"> ● If the [Dis. operat opt code] (d o k d) parameter is set to 0, the drive changes to operating state <code>4 - Switched on</code> and stops in freewheel stop. ● If the [Dis. operat opt code] (d o k d) parameter is set to 1, the drive stops on ramp and then changes to operating state <code>4 - Switched on</code>.
6 - Quick stop active	<p>The drive performs a fast stop and remains locked in the operating state <code>6-Quick stop active</code>. Before restarting the motor, it is required to go to the operating state <code>2-switch on disabled</code>. During fast stop, the drive is unlocked and power is supplied to the motor. The configuration parameters cannot be modified. The condition for transition <code>12 to state 2 - Switch on disabled</code> depends on the value of the parameter <code>Quick stop mode (QStd)</code>:</p> <p>If the <code>Quick stop mode</code> parameter has the value <code>FST2</code>, the drive stops according to the fast stop ramp and then changes to state <code>2 - Switch on disabled</code>. If the <code>Quick stop mode</code> parameter has the value <code>FST6</code>, the drive stops according to the fast stop ramp and then remains in state <code>6 - Quick stop active</code> until:</p> <ul style="list-style-type: none"> ● A <code>Disable voltage</code> command is received or ● The STOP key is pressed or ● A <code>freewheel stop</code> command via the digital input of the terminal.
7 - Fault reaction active	<p>Transient state during which the drive performs an action corresponding to the selected error response.</p>
8 - Fault	<p>Error response terminated. Power stage is disabled. The drive is locked, no power is supplied to the motor.</p>

Summary

Device Status Summary

Operating State	Power Stage Supply for Separate Control Stage	Power Supplied to Motor	Modification of Configuration Parameters
1 - Not ready to switch on	Not required	No	Yes
2 - Switch on disabled	Not required	No	Yes
3 - Ready to switch on	Not required	No	Yes
4 - Switched on	Required	No	Yes, return to 2 - Switch on disabled operating state
5 - Operation enabled	Required	Yes	No
6 - Quick stop active	Required	Yes, during fast stop	No
7 - Fault reaction active	Depends on error response configuration	Depends on error response configuration	–
8 - Fault	Not required	No	Yes

Control Word (CND)

Bit Mapping

Bit 7	Bit 6	Bit 5	Bit 4	Bit 3	Bit 2	Bit 1	Bit 0
Fault reset	Reserved (=0)	Reserved (=0)	Reserved (=0)	Enable operation	Quick stop	Enable voltage	Switch on
0 to 1 transition = Error is reset (after cause of error is no longer active)				1 = Run command	0 = Quick stop active	Authorization to supply AC power	Mains contactor control

Bit 15	Bit 14	Bit 13	Bit 12	Bit 11	Bit 10	Bit 9	Bit 8
Manufacturer specific assignable	Manufacturer specific assignable	Manufacturer specific assignable	Manufacturer specific assignable	Manufacturer specific	Reserved (=0)	Reserved (=0)	Halt
				0 = Forward direction asked 1 = Reverse direction asked			Halt

Command	State Transition	Final Operating State	Bit 4	Bit 3	Bit 2	Bit 1	Bit 0	Example Value
			Fault Reset	Enable Operation	Quick Stop	Enable Voltage	Switch On	
Shutdown	2, 6, 8	3 - Ready to switch on	X	X	1	1	0	0006 hex
Switch on	3	4 - Switched on	X	X	1	1	1	0007 hex
Enable operation	4	5 - Operation enabled	X	1	1	1	1	000F hex
Disable operation	5	4 - Switched on	X	0	1	1	1	0007 hex
Disable voltage	7, 9, 10, 12	2 - Switch on disabled	X	X	X	0	X	0000 hex
Quick stop	11	6 - Quick stop active	X	X	0	1	X	0002 hex
	7, 10	2 - Switch on disabled						
Fault reset	15	2 - Switch on disabled	0 [gs56] 1	X	X	X	X	0080 hex

X: Value is of no significance for this command.
0[gs56] 1: Command on rising edge.

Stop Commands

Halt Command

The `Halt` command enables movement to be interrupted without having to leave the `5 - Operation enabled state`. The stop is performed in accordance with the **[Type of stop] (SLE)** parameter.

If the `Halt` command is active, no power is supplied to the motor and no torque is applied.

Regardless of the assignment of the **[Type of stop] (SLE)** parameter **[Fast stop assign] (FSE)**, **[Ramp stop] (RPP)**, **[Freewheel] (NSE)**, or **[DC injection assign.] (DCI)**, the drive remains in the `5 - Operation enabled state`.

Fast Stop Command

A `Fast Stop` command at the terminals or using a bit of the control word assigned to `Fast Stop` causes a change to the `4 - Switched on`

Freewheel Command

A `Freewheel Stop` command using a digital input of the terminal or a bit of the control word assigned to `Freewheel Stop` causes a change to operating state `2 - Switch on disabled`.

Assigning Control Word Bits

Function Codes

In the CiA402 profile, fixed assignment of a function input is possible using the following codes:

Bit	Integrated Modbus Serial
Bit 11	C111
Bit 12	C112
Bit 13	C113
Bit 14	C114
Bit 15	C115

For example, to assign the DC injection braking to bit13 of Modbus serial, simply configure the **[DC injection assign.]** (*d C i*) parameter with the **[C113]** (*C 1 1 3*) value.

Bit 11 is assigned by default to the operating direction command **[Reverse assign.]** (*r r 5*).

Status Word (E L R)

Bit Mapping

Bit 7	Bit 6	Bit 5	Bit 4	Bit 3	Bit 2	Bit 1	Bit 0
Warning	Switch on disabled	Quick stop	Voltage enabled	Detected error	Operation enabled	Switched on	Ready to switch on
A warning is active	Power stage supply disabled	0 = Quick stop is active	Power stage supply present	Detected error	Running	Ready	1 = Awaiting power Stage supply

Bit 15	Bit 14	Bit 13	Bit 12	Bit 11	Bit 10	Bit 9	Bit 8
Manufacturer-specific Direction of rotation	Manufacturer-specific Stop via STOP key	Reserved (=0)	Reserved (=0)	Internal limit active	Target reached	Remote	Reserved (=0)
				Reference value outside limits	Reference value reached	Command or reference value via fieldbus	

Operating State	Bit 6	Bit 5	Bit 4	Bit 3	Bit 2	Bit 1	Bit 0	ETA Masked by 006F H ⁽¹⁾
	Switch On Disabled	Quick Stop	Voltage Enabled	Fault	Operation Enabled	Switched On	Ready to Switch On	
1 -Not ready to switch on	0	X	X	0	0	0	0	-
2 -Switch on disabled	1	X	X	0	0	0	0	0040 hex
3 -Ready to switch on	0	1	X	0	0	0	1	0021 hex
4 - Switched on	0	1	1	0	0	1	1	0023 hex
5 - Operation enabled	0	1	11	0	1	1	1	0027 hex
6 -Quick stop active	0	0		0	1	1	1	0007 hex
7 -Fault reaction active	0	X	X	1	1	1	1	-
8 -Fault	0	X	X	1	0	0	0	0008 hex ⁽²⁾ .. .0028 hex

⁽¹⁾ This mask can be used by the PLC program to test the diagram state.

⁽²⁾ detected error following operating state 6 - Quick stop active.

X: In this state, the value of the bit can be 0 or 1.

Starting Sequence

Description

The command sequence in the state diagram depends on how power is being supplied to the drive.

There are 3 possible scenarios:

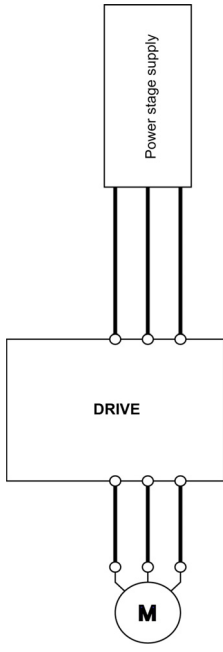
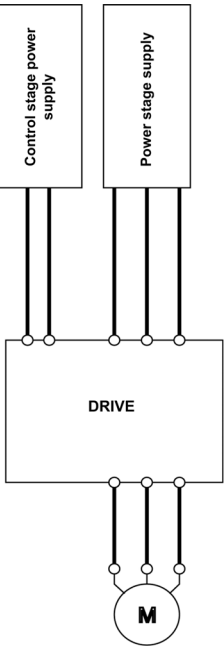
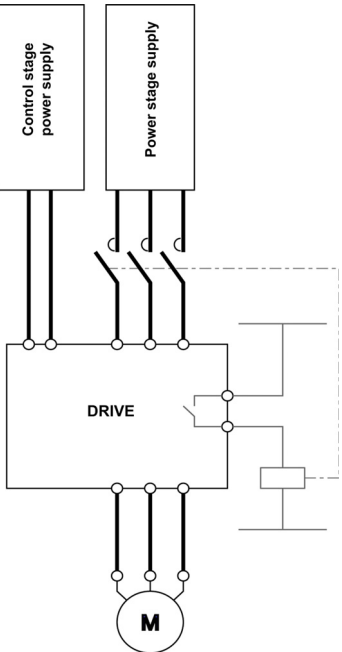
			
Power stage supply	Direct	Direct	Mains contactor controlled by the drive
Control stage supply	Not separate ⁽¹⁾	Separate	Separate
⁽¹⁾ The power stage supplies the control stage.			

Sequence for a Drive Powered by the Power Stage Supply

Description

Both the power and control stages are powered by the power stage supply.
 If power is supplied to the control stage, it has to be supplied to the power stage as well.
 The following sequence must be applied:

Step 1

Apply the 2 - Shut down command

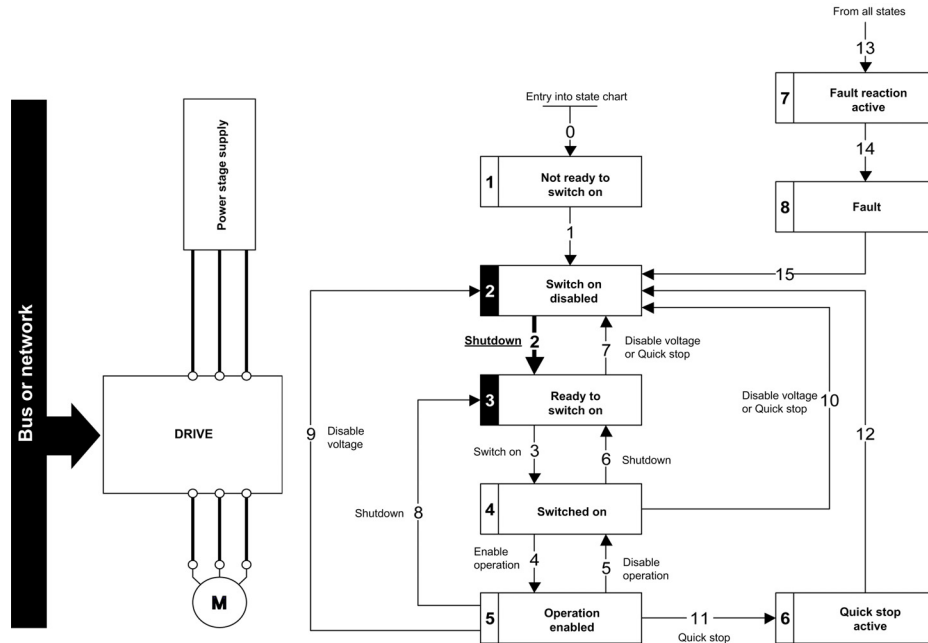

Step 2

- Check that the drive is in the operating state 3 - Ready to switch on.
- Then apply the 4 - Enable operation command.
- The motor can be controlled (send a reference value not equal to zero).

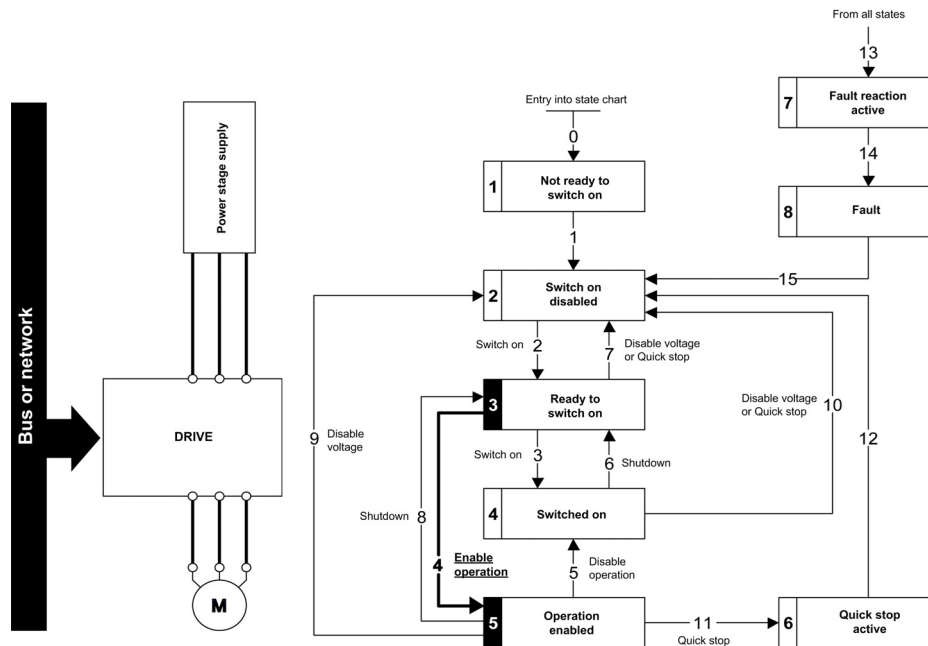

NOTE: It is possible, but not necessary to apply the 3 - Switch on command followed by the 4 - Enable Operation command to switch successively into the operating states 3 - Ready to Switch on, 4 - Switched on and then 5 - Operation Enabled. The 4 - Enable operation command is sufficient.

Sequence for a Drive with Separate Control Stage

Description

Power is supplied separately to the power and control stages.

If power is supplied to the control stage, it does not have to be supplied to the power stage as well.

The following sequence must be applied:

Step 1

- The power stage supply is not necessarily present.
- Apply the 2 - Shut down command

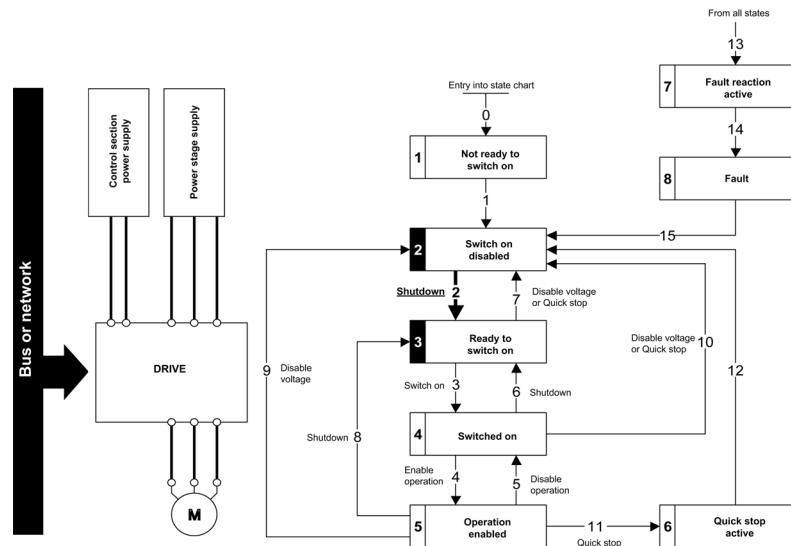

Step 2

- Check that the drive is in the operating state 3 - Ready to switch on.
- Check that the power stage supply is present (Voltage enabled of the status word).

Power Stage Supply	Terminal Display	Status Word
Absent	<i>r L P</i>	21 hex
Present	<i>r d Y</i>	31 hex

- Apply the 3 - Switch on command

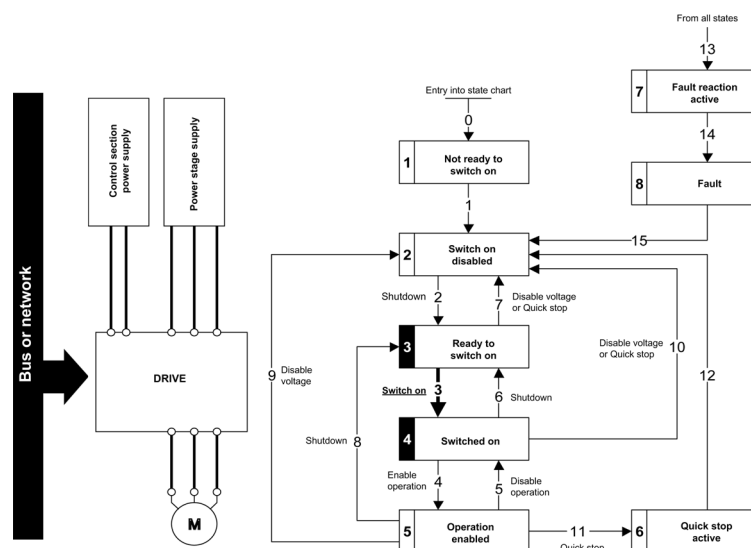

Step 3

- Check that the drive is in the operating state 4 - Switched on.
- Then apply the 4 - Enable operation command.
- The motor can be controlled (send a reference value not equal to zero).
- If the power stage supply is still not present in the operating state 4 - Switched on after a time delay [Mains V. time out] (L C E), the drive triggers an error [input contactor] (L C F).

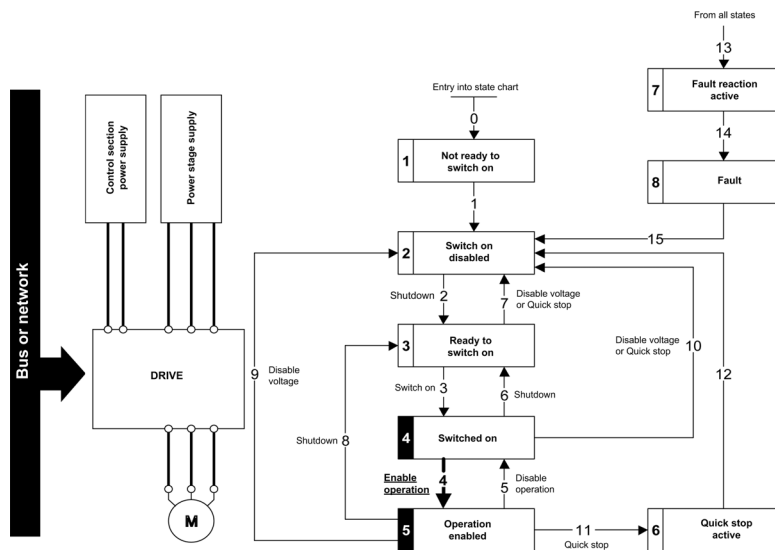

Sequence for a Drive with Mains Contactor Control

Description

Power is supplied separately to the power and control stages.

If power is supplied to the control stage, it does not have to be supplied to the power stage as well. The drive controls the mains contactor.

The following sequence must be applied:

Step 1

- The power stage supply is not present as the mains contactor is not being controlled.
- Apply the 2 - Shutdown command.

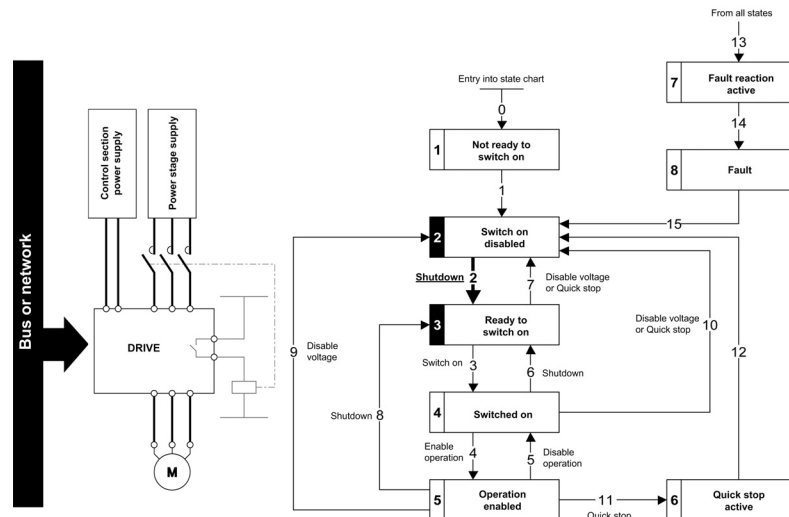

Step 2

- Check that the drive is in the operating state 3 - Ready to switch on.
- Apply the 3 - Switch on command, which closes the mains contactor and switch on the power stage supply.

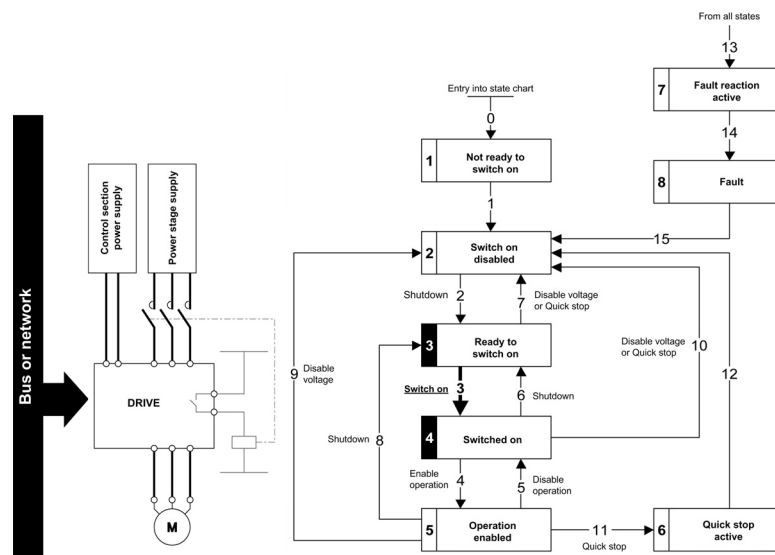

Section 2.2

Modbus Functions

What Is in This Section?

This section contains the following topics:

Topic	Page
Modbus Protocol	35
Supported Modbus Functions	36

Modbus Protocol

Introduction

The transmission mode used is RTU. The frame does not contain message header and end of message bytes.

Slave address	Request code	Data	CRC16
---------------	--------------	------	-------

The data is transmitted in binary code.

CRC16: cyclical redundancy check.

The end of the frame is detected on a silence greater than or equal to three characters.

Principle

The Modbus protocol is a master/slave protocol

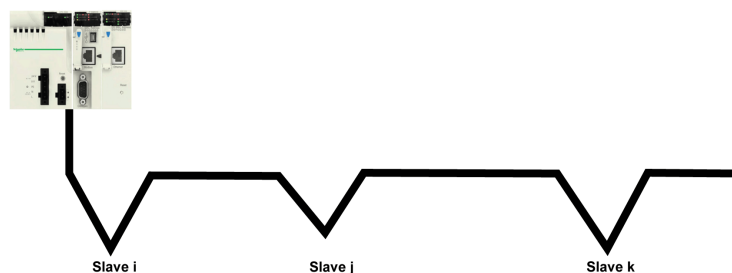

Only one device can transmit on the line at any time.

The master manages the exchanges and only it can take the initiative.

It interrogates each of the slaves in succession

No slave can send a message unless it is invited to do so.

The master repeats the question when there is an incorrect exchange, and declares the interrogated slave absent if no response is received within a given time period.

If a slave does not understand a message, it sends an exception response to the master. The master may or may not repeat the request.

Direct slave-to-slave communications are not possible.

For slave-to-slave communication, the application software must therefore be designed to interrogate a slave and send back data received to the other slave.

The 2 types of dialogue are possible between master and slaves:

- The master sends a request to a slave and waits for its response
- The master sends a request to all slaves without waiting for a response (broadcasting principle)

Addresses

Address specification:

- The drive Modbus address can be configured from 1 to 247.
- Address 0 coded in a request sent by the master is reserved for broadcasting. Drives take account of the request, but do not respond to it.

Supported Modbus Functions

Introduction

The drive supports the following Modbus functions:

Function Name	Code		Description	Remarks
	Dec.	Hex		
Read Holding Registers	03	03 hex	Read N output words	Maximum PDU length: 63 words
Write One Output Word	06	06 hex	Write 1 output word	–
Write Multiple Registers	16	10 hex	Write N output word	Maximum PDU length: 61 words
Read/write Multiple Registers	23	17 hex	Read/write multiple registers	Maximum PDU length: 20 words (W), 20 words (R)
(Subfunction) Read Device Identification	43/14	2B hex/ 0E hex	Encapsulated interface transport/Read device identification	–
Diagnostics	08	08 hex	Diagnostics	–

Read Holding Registers

Request

Function code	1 byte	03 hex
Starting address	2 bytes	0000 hex...FFFF hex
Quantity of registers	2 bytes	1...63 (3F hex)

Response

Function code	1 byte	03 hex
Byte count	1 byte	2 x N ⁽¹⁾
Register value	N ⁽¹⁾ x 2 bytes	–
⁽¹⁾ N: Quantity of registers		

Request

Detected error code	1 byte	83 hex
Exception code	1 bytes	01...04

For example:

This function can be used to read all drive words, both input words and output words.

Request

Slave no.	03	No. of first word		No. of words		CRC16	
		Hi	Lo	Hi	Lo	Lo	Hi
1 byte	1 byte	2 bytes		2 bytes		2 bytes	
Hi = high-order byte, Lo = low-order byte.							

Response

Slave no.	03	Number of bytes read	First word value		Last word value		CRC16	
			Hi	Lo	Hi	Lo	Lo	Hi
1 byte	1 byte	1 byte	2 bytes		2 bytes		2 bytes	
Hi = high-order byte, Lo = low-order byte.								

For example: read 4 words W3102...W3105 (0C1E...0C21 hex) in slave 2, using function 3, where:

- SFr = Switching frequency = 4 kHz (W3102 = 0028 hex)
- tFr = Maximum output frequency = 60 Hz (W3103 = 0258 hex)
- HSP = High speed = 50 Hz (W3104 = 01F4 hex)
- LSP = Low speed = 0 Hz (W3105 = 0000 hex)

Request

02	03	0C1E	004	276C
----	----	------	-----	------

Response

02	03	08	0028	0258	01F4	0000	52B0
	Value of:	–	W3102	W3103	W3104	W3105	–
	Parameters:	–	SFr	tFr	HSP	LSP	–

Write 1 Output Word

Request

Function code	1 byte	06 hex
Register address	2 bytes	0000 hex...FFFF hex
Register value	2 bytes	0000 hex...FFFF hex

Response

Function code	1 byte	06 hex
Register address	2 bytes	0000 H...FFFF hex
Register value	2 bytes	0000 H...FFFF hex

Detected error

Detected error code	1 byte	06 hex
Exception code	1 bytes	01...04

For example

Request and response(the frame format is identical)

Slave no.	06	Word number		Value of word		CRC16	
		Hi	Lo	Hi	Lo	Lo	Hi
1 byte	1 byte	2 bytes		2 bytes		2 bytes	

For example: write value 000D hex in word W9001 (2329 hex) in slave 2 (ACC = 1.3 s).

Request and response	02	06	2329	000D	9270
----------------------	----	----	------	------	------

Write Multiple Register

Request

Slave no.	10	No. of first word		Number of words		Number of bytes	Value of first word		CRC16	
		Hi	Lo	Hi	Lo		Hi	Lo	Lo	Hi
1 byte	1 byte	2 bytes		2 bytes		1 byte	2 bytes		2 bytes	

Response

Slave no.	10	No. of first word				No. of words		CRC16	
		Hi		Lo		Hi	Lo	Lo	Hi
1 byte	1 byte	2 bytes				2 bytes		2 bytes	

For example

Write values 20 and 30 to words W9001 and W9002 on slave 2 (acceleration time = 2 s and deceleration time = 3 s)

Request

Slave no.	Request code	No. of first word		Number of words		Number of bytes	Value of first word		Value of Second word		CRC16	
		Hi	Lo	Hi	Lo		Hi	Lo	Hi	Lo	Lo	Hi
02 hex	10 hex	23 hex	29 hex	00 hex	02 hex	04 hex	00 hex	14 hex	00 hex	1E hex	73 hex	A4 hex

Response

Slave no.	Response code	No. of first word				No. of words		CRC16	
		Hi		Lo		Hi	Lo	Lo	Hi
02 hex	10 hex	23 hex		29 hex		00 hex	02 hex	9B hex	B7 hex

Read/Write Multiple Registers

Description	Length in Byte	Value	Comment
Function code	1	17 hex	-
Read starting address	2	XXXX hex	Always Modbus address
Quantity	2	03 hex	Contain number of holding registers to be read
Write starting address	2	XXXX hex	Always Modbus address
Quantity	2	03 hex	Contain number of holding registers to be written
Write byte count	1	06 hex	The byte count specifies the number of bytes to follow in the field write register value
Write registers value	6	XXXXXX XXXXXX hex	Value to be written respectively in NCA1 to NCA3, so the configured For example: CMD, LFRD, CMI

For example

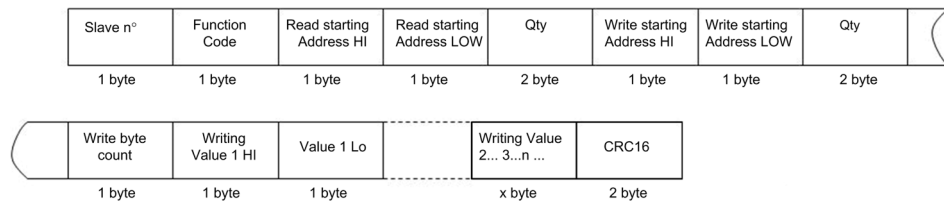

Read Device Identification

The table provides the device identification details:

ID	Name / Description	Type
00 hex	VendorName	ASCII String
01 hex	ProductCode	ASCII String
02 hex	MajorMinorRevision	ASCII String
03 hex	ProductName	ASCII String

For example

Default value to be detailed

Request

Slave no.	2B	Type of MEI 0E	Read Device Id 01	Object Id 00	CRC16	
					Lo	Hi
1 byte	1 byte	1 byte	1 byte	1 byte	2 bytes	

Response

Slave no.	2B	Type of MEI 0E	Read Device Id 01	Degree of conformity 02
1 byte	1 byte	1 byte	1 byte	1 byte

Number of additional frames 00	Next object Id 00	Number of objects 03
1 byte	1 byte	1 byte

Id of object number 1 00	Length of object number 1 12	Value of object number 1 Schneider Electric
1 byte	1 byte	18 bytes

Id of object number 2 01	Length of object number 2 0B	Value of object number 2 ATV6xxxxxxx
1 byte	1 byte	11 bytes

Id of object number 2 02	Length of object number 2 04	Value of object number 2 0201
1 byte	1 byte	4 bytes

CRC16	
Lo	Hi
1 byte	1 byte

The total response size equals 49 bytes

The three objects contained in the response correspond to the following objects:

- Object number 1: Manufacturer name (always **Schneider Electric**, that is. 18 bytes).
- Object number 2: Device reference (ASCII string; for example, **ATV6xxxxxxx**, that is. 11 bytes).
- Object number 3: Device version, in **MMmm** format where **MM** represents the determinant and **mm** the subdeterminant (4-bytes ASCII string; for example.: **0201** for version 2.1).

NOTE: The response to function 43 may be negative; in this case, the response located at the top of the next page is sent by the rather than the response described above.

Diagnostics

Subcode 00 hex: Echo

This function asks the slave being interrogated to echo (return) the message sent by the master in its entirety.

Subcode 0A hex: Counter reset

This function resets all the counters responsible for monitoring a slave exchanges.

Subcode 0C hex: Read message counter responsible for counting messages received with checksum errors.

Subcode 0E hex: Read message counter responsible for counting messages addressed to slave. Read a word indicating the total number of messages addressed to the slave, regardless of type (excluding broadcast messages).

Request and response

Slave no.	08	Subcode		Data		CRC16	
		Hi	Lo	Hi	Lo	Lo	Hi
1 byte	1 byte	2 bytes		N bytes		2 bytes	

Subcode	Request Data	Response Data	Function Executed
00	XX YY	XX YY	Echo
0A	00 00	00 00	Counter reset
0C	00 00	XX YY (= counter value)	Read message counter responsible for counting messages received with checksum errors
0E	00 00	XX YY (= counter value)	Read message counter responsible for counting messages addressed to slave

For example: values 31 hex and 32 hex echoed by slave 4.

Request and response

Slave no.	Request code or response code	Subcode		Value of first byte	Value of second byte	CRC16	
		Hi	Lo			Lo	Hi
02 hex	08 hex	00 hex	00 hex	31 hex	32 hex	74 hex	1B hex

Chapter 3

Hardware Setup

What Is in This Chapter?

This chapter contains the following topics:

Topic	Page
Hardware Presentation	42
Firmware Version	43
Connection to the Adapter	44
Electrical Installation	45
Cable Routing Practices	47
Accessories Presentation	48

Hardware Presentation

Modbus Serial Communication Port

The following figure shows the terminal view of the drive:

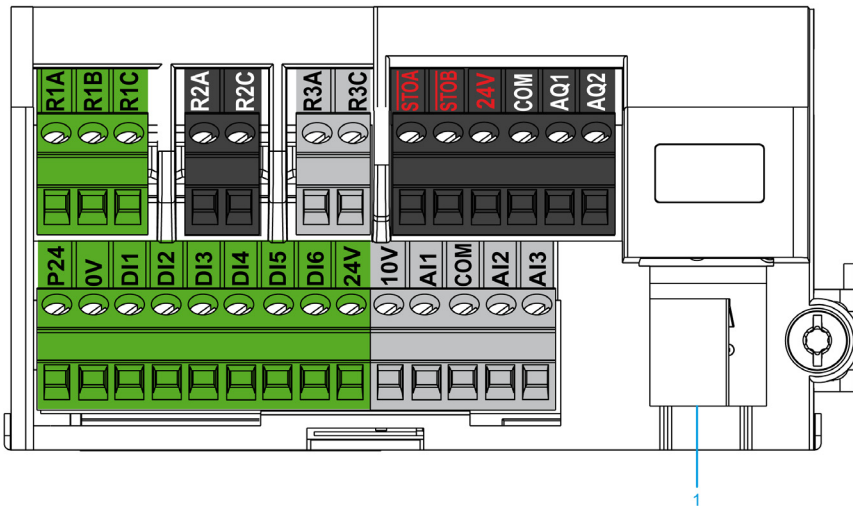

- 1 Modbus serial communication port

Firmware Version

Compatibility

There is no specific firmware for Modbus serial communication. The drive firmware embeds the Modbus serial firmware.

Connection to the Adapter

Procedure to Remove the Front Cover of the Drive

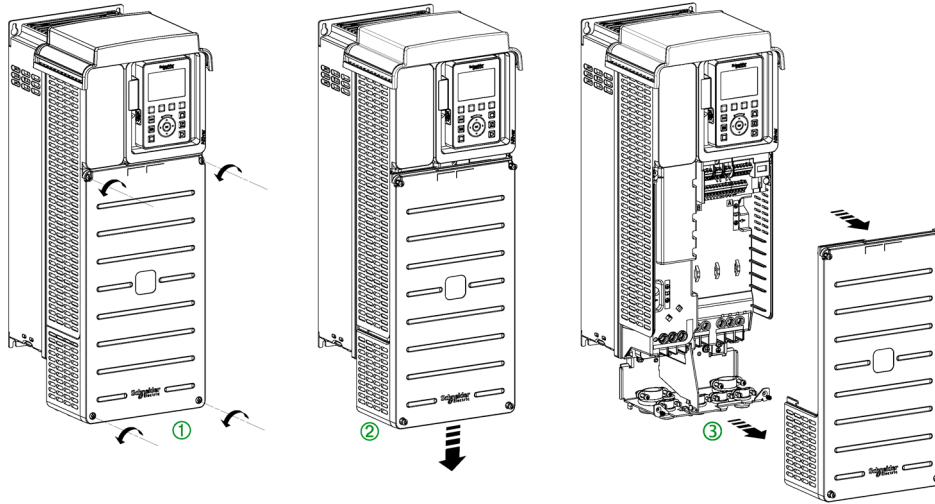

Apply the following instructions to remove the front cover of the drive:

Step	Action
1	Unscrew the four screws attaching the front cover
2	Slide down the front cover
3	Remove the front cover
4	Plug the Modbus serial cable in the Modbus serial port

Electrical Installation

Connection to Drive

Connection accessories should be ordered separately (See the catalog for more details).

Connect the RJ45 cable connector to the drive connector.

The following figure shows the pin layout for RJ45 connector:

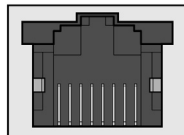

8 7 6 5 4 3 2 1

The table describes the pin out of the RJ45 connector of the drive:

Pin	Signal
1	Reserved
2	
3	
4	D1 ⁽¹⁾
5	D0 ⁽¹⁾
6	–
7	VP, 10 Vdc ⁽²⁾
8	Common
⁽¹⁾ Modbus signals	
⁽²⁾ Supply for RS232 / RS485 converter or a remote terminal	

RS485 Bus Schematic

The RS485 standard allows variants of different characteristics:

- Polarization
- Line terminator
- Distribution of a reference potential
- Number of slaves
- Length of bus

The new Modbus specification published on the Modbus.org site in 2006 contains precise details of all these characteristics. They are also summarized in standard schematic section. The new Schneider Electric devices conform to this specification.

Schematic Diagram

The following is the RS485 bus schematic diagram:

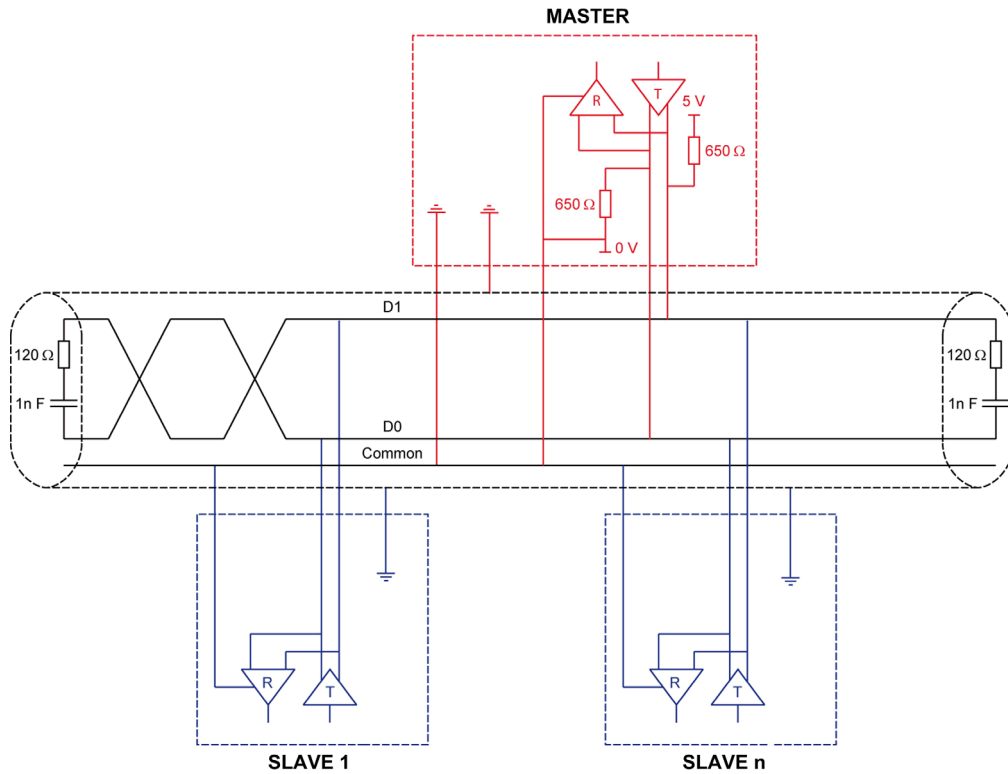

Characteristic	Definition
Type of trunk cable	Shielded cable with 1 twisted pair and at least a third conductor
Maximum length of bus	1000 m at 19200 bps with the Schneider Electric TSX CSA... cable
Maximum number of stations (without repeater)	32 stations that are 31 slaves
Maximum length of tap links	<ul style="list-style-type: none"> • 20 m for 1 tape link • 40 m divided by the number of tape links on a multiple junction box
Bus polarization	<ul style="list-style-type: none"> • One 450...650 Ω pull-down resistor at 5 V (650 Ω recommended) • One 450...650 Ω pull-down resistor at the common (650 Ω recommended) This polarization is recommended for the master.
Line terminator	One 120 Ω 0.25 W resistor in series with 1 nF 10 V capacitor
Common polarity	Yes (Common), connected to the protective earth ground at one or more points of the bus

Cable Routing Practices

Protection Against Interference

- Use the Schneider Electric cable with 2 pairs of shielded twisted conductors (reference: TSXCSA100, TSXCSA200, and TSXCSA500).
- Keep the Modbus cable separated from the power cables (30 cm (11.8 in.) minimum).
- Make any crossovers of the Modbus cable and the power cables at right-angles, if necessary.

Accessories Presentation

Introduction

Connection accessories should be ordered separately (See the catalogs).

Chapter 4

Software Setup

What Is in This Chapter?

This chapter contains the following sections:

Section	Topic	Page
4.1	Basic Settings	50
4.2	Additional Settings	56
4.3	Monitoring the Communication Scanner	74
4.4	Fieldbus Integration Using Unity	92

Section 4.1

Basic Settings

What Is in This Section?

This section contains the following topics:

Topic	Page
Configuring the Communication Parameters	51
[Modbus Address] (<i>A d d</i>)	52
[Modbus baud rate] (<i>t b r</i>)	53
[Modbus format] (<i>t F o</i>)	54
[Modbus Time Out] (<i>t t o</i>)	55

Configuring the Communication Parameters

Overview

Configuration of the Modbus communication functions of the drive can be accessed from the **[Communication]** (C 0 P -) / **[Comm parameters]** (C P P -) / **[Modbus SL]** (P 5 L -) menu.

[Modbus Address] (R d d)

About This Parameter

This parameter defines the address of the drive on the network.

Access

This is a read/write parameter.

The parameter Modbus address is 6001

Possible Settings

The table presents the parameter settings:

Settings	Code	Value	Description
[OFF]	(0 F F)	0	Modbus address is not assigned.
[1 to 247]	(1 ... 2 4 7)	1...247	Modbus address is assigned. Factory setting: OFF

[Modbus baud rate] (*l b r*)

About This Parameter

This parameter defines the baud rate at which data is transferred.

Access

This is a read/write parameter.

The parameter Modbus address is 6003

Possible Settings

The table presents the parameter settings:

Settings	Code	Value	Description
[4K8]	(<i>4 K 8</i>)	24	Baud rate is set to 4.8 Kbps.
[9K6]	(<i>9 K 6</i>)	28	Baud rate is set to 9.6 Kbps.
[19K2]	(<i>1 9 K 2</i>)	32	Baud rate is set to 19.2 Kbps.
[38K4]	(<i>3 8 K 4</i>)	36	Baud rate is set to 38.4 Kbps. Factory setting: 19.2 Kbps

[Modbus format] (LF0)

About This Parameter

This parameter is used to define the data format.

Access

This is a read/write parameter.

The parameter Modbus address is 6004

Possible Settings

This table presents the parameter settings:

Settings	Code	Value	Description
[8O1]	(B o 1)	2	8 data bits, odd parity, 1 stop bit
[8E1]	(B E 1)	3	8 data bits, even parity, 1 stop bit
[8N1]	(B n 1)	4	8 data bits, no parity, 1 stop bit
[8N2]	(B n 2)	5	8 data bits, no parity, 2 stop bits Factory setting: 8E1

[Modbus Time Out] (t t o)

About This Parameter

This parameter defines.

Access

This is a read/write parameter.

The parameter Modbus address is 6005

Possible Settings

The table presents the parameter settings:

Settings	Code	Value	Description
[0.1...30.0]	(0. 1... 30.0)	1...300	Adjustable from 0.1 to 30 s Factory setting: 10 s

Section 4.2

Additional Settings

What Is in This Section?

This section contains the following topics:

Topic	Page
Local Configuration of the Communication Scanner	57
[Scan.IN1 address] (n P A 1)	58
[Scan.IN2 address] (n P A 2)	59
[Scan.IN3 address] (n P A 3)	60
[Scan.IN4 address] (n P A 4)	61
[Scan.IN5 address] (n P A 5)	62
[Scan.IN6 address] (n P A 6)	63
[Scan.IN7 address] (n P A 7)	64
[Scan.IN8 address] (n P A 8)	65
[Scan.Out1 address] (n C A 1)	66
[Scan.Out2 address] (n C A 2)	67
[Scan.Out3 address] (n C A 3)	68
[Scan.Out4 address] (n C A 4)	69
[Scan.Out5 address] (n C A 5)	70
[Scan.Out6 address] (n C A 6)	71
[Scan.Out7 address] (n C A 7)	72
[Scan.Out8 address] (n C A 8)	73

Local Configuration of the Communication Scanner

Overview

The communication scanner is useful when used in combination by the Modbus client device with the function `Read/Write Multiple registers: 23 (17 hex)`, which provides in a single telegram a read multiple registers and a write multiple registers. The detail of the function 23 is described in the supported Modbus functions.

The communication scanner is accessible via the following menus: **Communication (C 0 0 -) / Comm parameters (C 0 0 -) / Modbus SL (0 5 L -) / Modbus Fieldbus (0 0 1 -)** and **[COM. SCANNER INPUT] (, C 5 -)**, **[COM. SCANNER OUTPUT] (0 C 5 -)** submenus.

The eight output variables and the eight input variables are assigned to parameter nCA1 to nCA8 and nMA1 to nMA8. An nCAx or nMAx parameter with a value of zero is not linked to a parameter in the drive.

[Scan.IN1 address] (r P R I)

About This Parameter

This parameter displays the source drive address of the first input word.

Access

This is a read/write parameter.

The parameter Modbus address is 12701

Possible Settings

The table presents the parameter settings:

Settings	Code	Value	Description
[Scan.IN1 address]	(r P R I)	–	Source drive address of the first input word. Factory settings: Status (ETA)

[Scan.IN2 address] (r P R 2)

About This Parameter

This parameter displays the source drive address of the second input word.

Access

This is a read/write parameter.

The parameter Modbus address is 12702

Possible Settings

The table presents the parameter settings:

Settings	Code	Value	Description
[Scan.IN2 address]	(r P R 2)	–	Source drive address of the second input word. Factory settings: Output speed (RFRD)

[Scan.IN3 address] (P P A 3)

About This Parameter

This parameter displays the source drive address of the third input word.

Access

This is a read/write parameter.

The parameter Modbus address is 12703

Possible Settings

The table presents the parameter settings:

Settings	Code	Value	Description
[Scan.IN3 address]	(P P A 3)	–	Source drive address of the third input word. Factory settings: 0

[Scan.IN4 address] (P P 4)

About This Parameter

This parameter displays the source drive address of the fourth input word.

Access

This is a read/write parameter.

The parameter Modbus address is 12704

Possible Settings

The table presents the parameter settings:

Settings	Code	Value	Description
[Scan.IN4 address]	(P P 4)	–	Source drive address of the fourth input word. Factory settings: 0

[Scan.IN5 address] (P P A 5)

About This Parameter

This parameter displays the source drive address of the fifth input word.

Access

This is a read/write parameter.

The parameter Modbus address is 12705

Possible Settings

The table presents the parameter settings:

Settings	Code	Value	Description
[Scan.IN5 address]	(P P A 5)	–	Source drive address of the fifth input word. Factory settings: 0

[Scan.IN6 address] (H P R B)

About This Parameter

This parameter displays the source drive address of the sixth input word.

Access

This is a read/write parameter.

The parameter Modbus address is 12706.

Possible Settings

The table presents the parameter settings:

Settings	Code	Value	Description
[Scan.IN6 address]	(H P R B)	–	Source drive address of the sixth input word. Factory settings: 0

[Scan.IN7 address] (n P R 7)

About This Parameter

This parameter displays the source drive address of the seventh input word.

Access

This is a read/write parameter.

The parameter Modbus address is 12707

Possible Settings

The table presents the parameter settings:

Settings	Code	Value	Description
[Scan.IN7 address]	(n P R 7)	–	Source drive address of the seventh input word. Factory settings: 0

[Scan.IN8 address] (n P R B)

About This Parameter

This parameter displays the source drive address of the eighth input word.

Access

This is a read/write parameter.

The parameter Modbus address is 12708.

Possible Settings

The table presents the parameter settings:

Settings	Code	Value	Description
[Scan.IN8 address]	(n P R B)	–	Source drive address of the eighth input word. Factory settings: 0

[Scan.Out1 address] (n L R I)

About This Parameter

This parameter displays the destination drive address of the first output word.

Access

This is a read/write parameter.

The parameter Modbus address is 12721.

Possible Settings

The table presents the parameter settings:

Settings	Code	Value	Description
[Scan.Out1 address]	(n L R I)	–	Destination drive address of the first output word. Factory settings: Command (CMD)

[Scan.Out2 address] (r L R 2)

About This Parameter

This parameter displays the destination drive address of the second output word.

Access

This is a read/write parameter.

The parameter Modbus address is 12722.

Possible Settings

The table presents the parameter settings:

Settings	Code	Value	Description
[Scan.Out2 address]	(r L R 2)	–	Destination drive address of the second output word. Factory settings: Speed target (LFRD)

[Scan.Out3 address] (r L R E)**About This Parameter**

This parameter displays the destination drive address of the third output word.

Access

This is a read/write parameter.

The parameter Modbus address is 12723.

Possible Settings

The table presents the parameter settings:

Settings	Code	Value	Description
[Scan.Out3 address]	(r L R E)	–	Destination drive address of the third output word. Factory settings: 0

[Scan.Out4 address] (n L R 4)

About This Parameter

This parameter displays the destination drive address of the fourth output word.

Access

This is a read/write parameter.

The parameter Modbus address is 12724.

Possible Settings

The table presents the parameter settings:

Settings	Code	Value	Description
[Scan.Out4 address]	(n L R 4)	–	Destination drive address of the fourth output word. Factory settings: 0

[Scan.Out5 address] (n L R 5)

About This Parameter

This parameter displays the destination drive address of the fifth output word.

Access

This is a read/write parameter.

The parameter Modbus address is 12725.

Possible Settings

The table presents the parameter settings:

Settings	Code	Value	Description
[Scan.Out5 address]	(n L R 5)	–	Destination drive address of the fifth output word. Factory settings: 0

[Scan.Out6 address] (rLB)

About This Parameter

This parameter displays the destination drive address of the sixth output word.

Access

This is a read/write parameter.

The parameter Modbus address is 12726.

Possible Settings

The table presents the parameter settings:

Settings	Code	Value	Description
[Scan.Out6 address]	(rLB)	–	Destination drive address of the sixth output word. Factory settings: 0

[Scan.Out7 address] (r L R 7)**About This Parameter**

This parameter displays the destination drive address of the seventh output word.

Access

This is a read/write parameter.

The parameter Modbus address is 12727.

Possible Settings

The table presents the parameter settings:

Settings	Code	Value	Description
[Scan.Out7 address]	(r L R 7)	–	Destination drive address of the seventh output word. Factory settings: 0

[Scan.Out8 address] (r L RB)

About This Parameter

This parameter displays the destination drive address of the eight output word.

Access

This is a read/write parameter.

The parameter Modbus address is 12728.

Possible Settings

The table presents the parameter settings:

Settings	Code	Value	Description
[Scan.Out8 address]	(r L RB)	–	Destination drive address of the 8 output word. Factory settings: 0

Section 4.3

Monitoring the Communication Scanner

What Is in This Section?

This section contains the following topics:

Topic	Page
Introduction	75
[Com Scan.In1 val.] (n П 1)	76
[Com Scan.In2 val.] (n П 2)	77
[Com Scan.In3 val.] (n П 3)	78
[Com Scan.In4 val.] (n П 4)	79
[Com Scan.In5 val.] (n П 5)	80
[Com Scan.In6 val.] (n П 6)	81
[Com Scan.In7 val.] (n П 7)	82
[Com Scan.In8 val.] (n П 8)	83
[Com Scan.Out1 val.] (n C 1)	84
[Com Scan.Out2 val.] (n C 2)	85
[Com Scan.Out3 val.] (n C 3)	86
[Com Scan.Out4 val.] (n C 4)	87
[Com Scan.Out5 val.] (n C 5)	88
[Com Scan.Out6 val.] (n C 6)	89
[Com Scan.Out7 val.] (n C 7)	90
[Com Scan.Out8 val.] (n C 8)	91

Introduction

Overview

It is also possible to monitor the value of the parameters which has been configured in the communication scanner. This monitored values are accessible via the following menus: **[Display]** (П о н -)/**[Communication map]** (С П П -)/**[Modbus network diag]** (П н д -) and **[COM. SCANNER INPUT MAP]** (, 5 H -), **[COM SCANNER OUTPUT MAP]** (о 5 H -) submenu.

The 8 output variable values and the 8 input variable values are located into parameters **[Com Scan Out1 val.]** (н С 1) to **[Com Scan Out8 val.]** (н С 8) and **[Com Scan In1 val.]** (н П 1) to **[Com Scan In8 val.]** (н П 8).

[Com Scan.In1 val.] (r r l)

About This Parameter

This parameter displays the source drive value of the first input word.

Access

This is a read/write parameter.

The parameter Modbus address is 12741.

Possible Settings

The table presents the parameter settings:

Settings	Code	Value	Description
[Com Scan.In1 Val.]	(r r l)	–	Source drive value of the first input word. Factory settings: ETA value

[Com Scan.In2 val.] (r r 2)

About This Parameter

This parameter displays the source drive value of the second input word.

Access

This is a read/write parameter.

The parameter Modbus address is 12742.

Possible Settings

The table presents the parameter settings:

Settings	Code	Value	Description
[Com Scan.In2 Val.]	(r r 2)	–	Source drive value of the second input word Factory settings: RFRD value

[Com Scan.In3 val.] (r r 3)

About This Parameter

This parameter displays the source drive value of the third input word.

Access

This is a read/write parameter.

The parameter Modbus address is 12743 .

Possible Settings

The table presents the parameter settings:

Settings	Code	Value	Description
[Com Scan.In3 Val.]	(r r 3)	–	Source drive value of the third input word Factory settings: 0

[Com Scan.In4 val.] (r r 4)

About This Parameter

This parameter displays the source drive value of the fourth input word.

Access

This is a read/write parameter.

The parameter Modbus address is 12744.

Possible Settings

The table presents the parameter settings:

Settings	Code	Value	Description
[Com Scan.In4 Val.]	(r r 4)	–	Source drive value of the fourth input word. Factory settings: 0

[Com Scan.In5 val.] (r r 5)

About This Parameter

This parameter displays the source drive value of the fifth input word.

Access

This is a read/write parameter.

The parameter Modbus address is 12745.

Possible Settings

The table presents the parameter settings:

Settings	Code	Value	Description
[Com Scan.In5 Val.]	(r r 5)	–	Source drive value of the fifth input word. Factory settings: 0

[Com Scan.In6 val.] (r/w)

About This Parameter

This parameter displays the source drive value of the sixth input word.

Access

This is a read/write parameter.

The parameter Modbus address is 12746.

Possible Settings

The table presents the parameter settings:

Settings	Code	Value	Description
[Com Scan.In6 Val.]	(r/w)	–	Source drive value of the sixth input word Factory settings: 0

[Com Scan.In7 val.] (r r 7)

About This Parameter

This parameter displays the source drive value of the seventh input word.

Access

This is a read/write parameter.

The parameter Modbus address is 12747.

Possible Settings

The table presents the parameter settings:

Settings	Code	Value	Description
[Com Scan.In7 Val.]	(r r 7)	–	Source drive value of the seventh input word. Factory settings: 0

[Com Scan.In8 val.] (r B)

About This Parameter

This parameter displays the source drive value of the eighth input word.

Access

This is a read/write parameter.

The parameter Modbus address is 12748.

Possible Settings

The table presents the parameter settings:

Settings	Code	Value	Description
[Com Scan.In8 Val.]	(r B)	–	Source drive value of the eighth input word. Factory settings: 0

[Com Scan.Out1 val.] (r L I)

About This Parameter

This parameter displays the destination drive value of the first output word.

Access

This is a read/write parameter.

The parameter Modbus address is 12761.

Possible Settings

The table presents the parameter settings:

Settings	Code	Value	Description
[Com Scan.Out1 Val.]	(r L I)	–	Destination drive value of the first output word. Factory settings: CMD value

[Com Scan.Out2 val.] (n L 2)

About This Parameter

This parameter displays the destination drive value of the second output word.

Access

This is a read/write parameter.

The parameter Modbus address is 12762.

Possible Settings

The table presents the parameter settings:

Settings	Code	Value	Description
[Com Scan.Out2 Val.]	(n L 2)	–	Destination drive value of the second output word Factory settings: LFRD value

[Com Scan.Out3 val.] (r L 3)

About This Parameter

This parameter displays the destination drive value of the third output word.

Access

This is a read/write parameter.

The parameter Modbus address is 12763.

Possible Settings

The table presents the parameter settings:

Settings	Code	Value	Description
[Com Scan.Out3 Val.]	(r L 3)	–	Destination drive value of the third output word. Factory settings: 0

[Com Scan.Out4 val.] (n L 4)

About This Parameter

This parameter displays the destination drive value of the fourth output word.

Access

This is a read/write parameter.

The parameter Modbus address is 12764.

Possible Settings

The table presents the parameter settings:

Settings	Code	Value	Description
[Com Scan.Out4 Val.]	(n L 4)	–	Destination drive value of the fourth output word. Factory settings: 0

[Com Scan.Out5 val.] (n L 5)

About This Parameter

This parameter displays the destination drive value of the fifth output word.

Access

This is a read/write parameter.

The parameter Modbus address is 12765.

Possible Settings

The table presents the parameter settings:

Settings	Code	Value	Description
[Com Scan.Out5 Val.]	(n L 5)	–	Destination drive value of the fifth output word. Factory settings: 0

[Com Scan.Out6 val.] (r L B)

About This Parameter

This parameter displays the destination drive value of the sixth output word.

Access

This is a read/write parameter.

The parameter Modbus address is 12766.

Possible Settings

The table presents the parameter settings:

Settings	Code	Value	Description
[Com Scan.Out6 Val.]	(r L B)	–	Destination drive value of the sixth output word. Factory settings: 0

[Com Scan.Out7 val.] (r L 7)

About This Parameter

This parameter displays the destination drive value of the seventh output word.

Access

This is a read/write parameter.

The parameter Modbus address is 12767.

Possible Settings

The table presents the parameter settings:

Settings	Code	Value	Description
[Com Scan.Out7 Val.]	(r L 7)	–	Destination drive value of the seventh output word. Factory settings: 0

[Com Scan.Out8 val.] (r L B)

About This Parameter

This parameter displays the destination drive value of the eighth output word.

Access

This is a read/write parameter.

The parameter Modbus address is 12768.

Possible Settings

The table presents the parameter settings:

Settings	Code	Value	Description
[Com Scan.Out8 Val.]	(r L B)	–	Destination drive value of the eighth output word. Factory settings: 0

Section 4.4

Fieldbus Integration Using Unity

What Is in This Section?

This section contains the following topics:

Topic	Page
Introduction	93
Drive Configuration	94
Modbus Master Configuration	95

Introduction

Overview

Here is an example of an application that shows how to control a drive with a M340 PLC equipped with a Modbus master serial port. The operator can control the drive directly from Unity. The version of Unity used here is Unity Pro XL

In the example, the communication scanner of the drive is used. The PLC sends the command and the reference speed to the drive and read the status word and the actual speed of the drive.

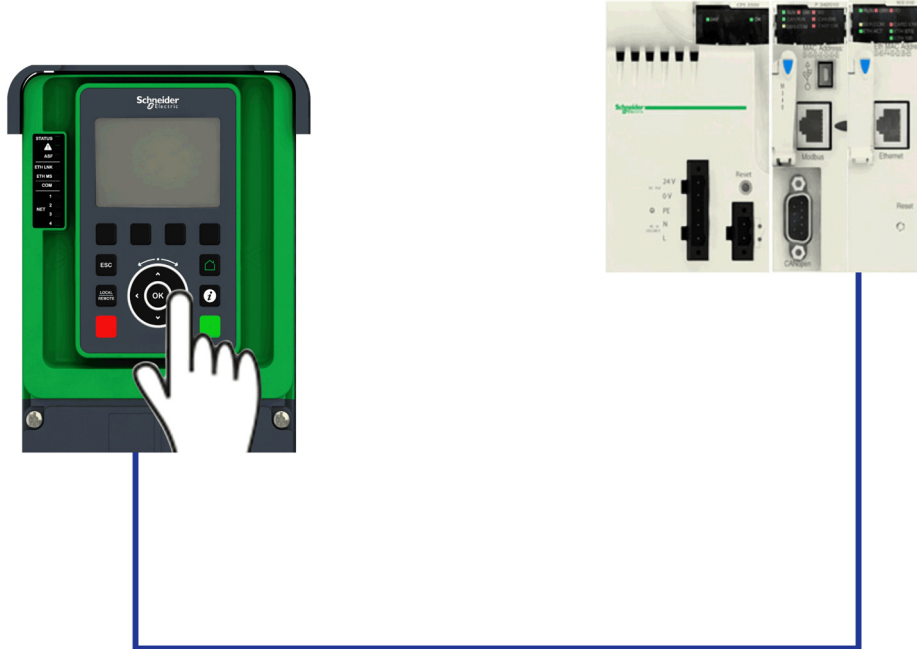

Drive Configuration

Factory Setting

Before configuring the drive, it is advised to make a factory setting. Go to:

- **[File management]** (F P E -) menu,
- **[Factory settings]** (F C S -) submenu.

Then configure the following parameters:

- **[Parameter group list]** (F r Y -) = **[All]** (A L L)
- **[Go to Factory Settings]** (G F S) = OK

Command Configuration

To control the drive with a Modbus master, it is necessary to select Modbus as command channel active.

Goto to:

- **[Complete Settings]** (C S E -)
- **[Command and Reference]** (C r P -) menu

Then configure:

- **[Ref.1 channel]** (F r I) parameter to **[Ref. Freq-Modbus]** (P d b) value.

Communication Configuration

Select the Modbus address in the menu:

- **[Communication]** (C o m -)
- **[Comm parameters]** (C P P -)
- **[Modbus SL]** (P S L -)
- **[Modbus Fieldbus]** (P d I -)
- **[Modbus Address]** (A d d)

The drive must be restarted in order to take into account the Modbus address.

Modbus Master Configuration

Overview

In this example, Modbus master configuration is done with unity.

Serial Port Configuration

Configure the serial port as master. The other default settings are compliant with the default settings of the drive.

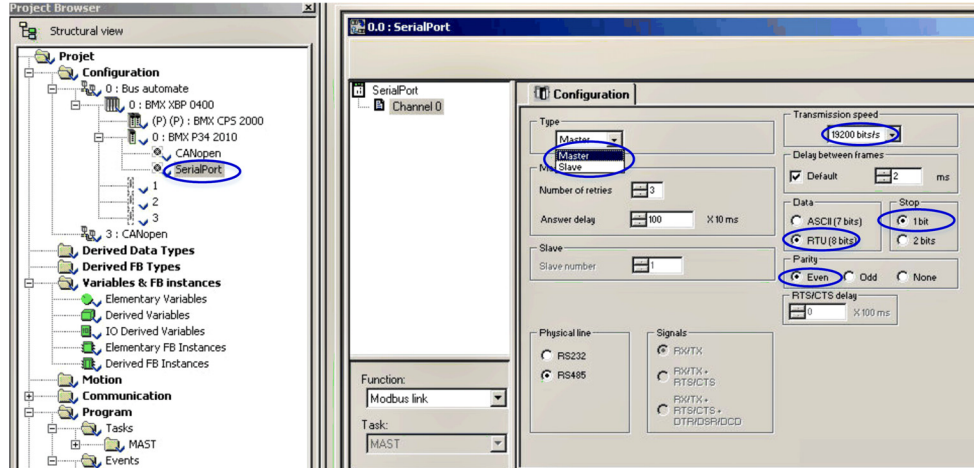

Data Structure Declaration

Create the following table (DevicePath). DevicePath describes the path to the device including its slave address.

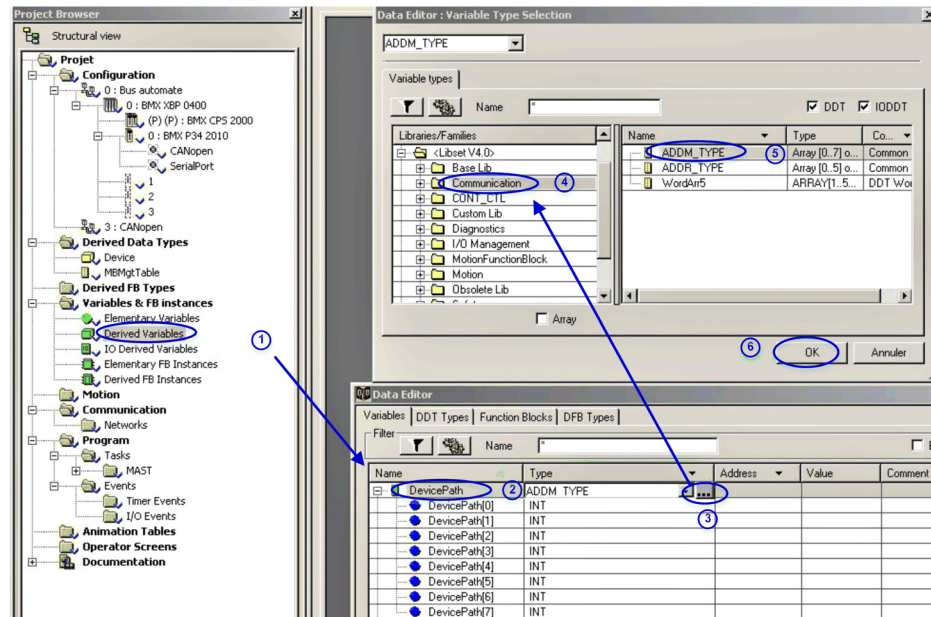

Then create the four other tables as arrays from 0 to 3 of integer.

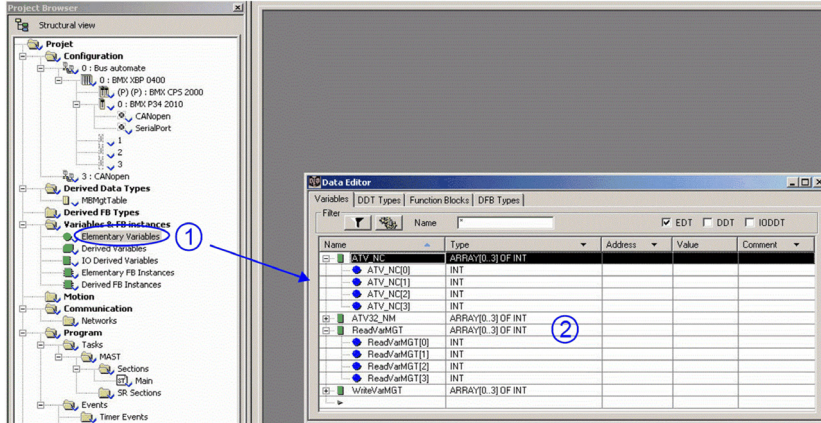

As all the tables declared are dynamic (no fixed address), it is necessary in the project setting to «Allows dynamic array» and to «Directly represented array variables». The parameterization must be done in the menu «Tool», «Project settings», «Language extensions» window.

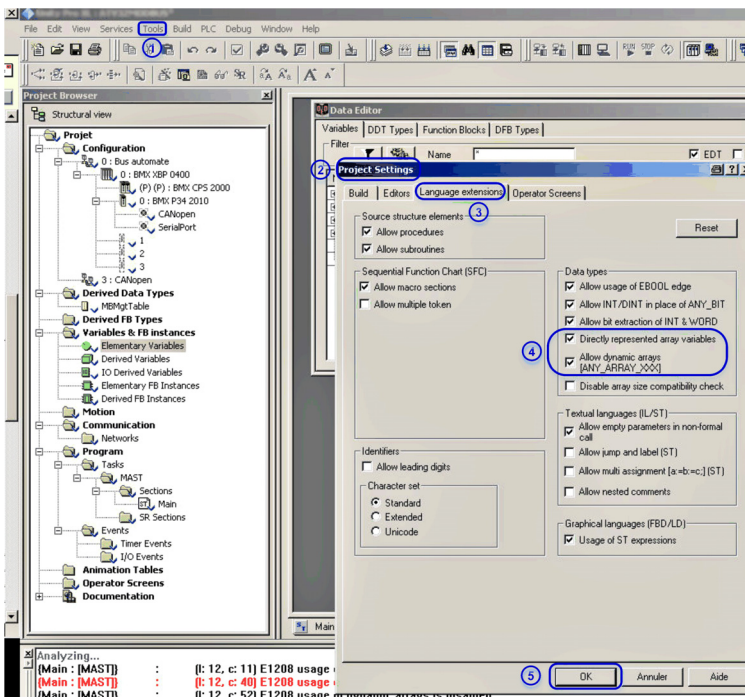

Program

Create a program in MAST section.

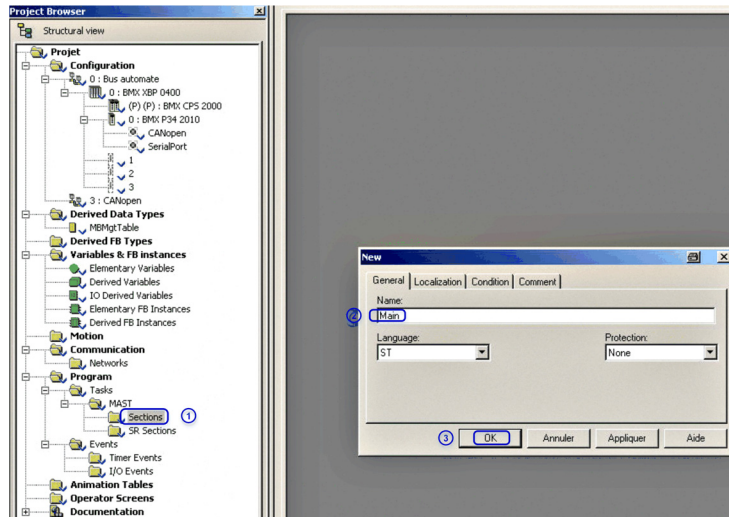

The communication is based on the `READ_VAR`, `WRITE_VAR` functions. During the first execution of the MAST task, you can initialize the data structure used by these two functions.

`ReadVarMgt` and `WriteVarMgt` are arrays used respectively by `READ_VAR` and `WRITE_VAR`. Only the third element of these arrays is modifiable, you can define the timeout duration of the requests.

In the example, the application manages two requests:

- A read request of four words starting at Modbus address 12741 (31C5 hex). It is the address of the first word of the input scanner of the drive **[Com Scan In1 val.]** (r r l). Modbus function. The information is sent from the PLC to the drive. The table `ATV_NM` is used. The 2 first words are mapped by default.

Name	Address	Comment
ATV_NM(0)	12741	Default: ETA (status word)
ATV_NM(1)	12742	Default: RFRD (output speed)
ATV_NM(2)	12743	–
ATV_NM(3)	12744	–

- A write request of four words starting at Modbus address 12761 (31D9 hex). It is the address of the first word of the input scanner of the drive **[Com Scan Out1 val.]** (r l l). Modbus function #16. The information is sent from the drive to the PLC. The table `ATV_NC` is used. The 2 first words are mapped by default.

Name	Address	Comment
ATV_NC(0)	12761	Default: CMD (command word)
ATV_NC(1)	12762	Default: LFRD (speed referenced)
ATV_NC(2)	12763	–
ATV_NC(3)	12764	–

```

Main:[MAST]
IF NOT init THEN
  (* ADDM has to be used to add the slave at address 2 *)
  DevicePath := ADDM("0.0.0.2");

  (* Timeout duration *)
  ReadVarMGT[2] := 50;
  WriteVarMGT[2] := 50;

  (* the configuration has to be done only once *)
  init := TRUE;
END_IF;

IF NOT ReadVarMGT[0].0 THEN (* bit 0 is set when READ_VAR is busy *)
  (* read data is stored in ATV_NM array *)
  READ_VAR(DevicePath, "%MM", 12741, 4, ReadVarMGT, ATV_NM);
END_IF;

IF NOT WriteVarMGT[0].0 THEN (* bit 0 is set when WRITE_VAR is busy *)
  (* data to be written is stored in ATV_NC array *)
  WRITE_VAR(DevicePath, "%MM", 12761, 4, ATV_NC, WriteVarMGT);
END_IF;

```

Chapter 5

Operations

What Is in This Chapter?

This chapter contains the following sections:

Section	Topic	Page
5.1	Operating States	100
5.2	Operating Modes	101

Section 5.1

Operating States

Configuring Communication Detected Error Response

Description

The response of the drive in the event of a Modbus serial communication interruption can be configured. Configuration can be performed using the display terminal from the **[Complete settings]** (*C 5 E -*), **[Error/warning handling]** (*C 5 W Π*) menu, **[Fieldbus monitoring]** (*C L L -*) submenu, via the **[Modbus Error Resp]** (*S L L*) .

The values of the **[Modbus Error Resp]** (*S L L*) parameter, which triggers a drive detected error **[Modbus Com Interruption]** (*S L F I*), are:

Value	Meaning
[Freewheel] (<i>Y E 5</i>)	Freewheel stop (factory setting)
[Ramp stop] (<i>r Π P</i>)	Stop on ramp
[Fast stop] (<i>F 5 E</i>)	Fast stop
[DC injection] (<i>d C i</i>)	DC injection stop

The values of the **[Modbus Error Resp]** (*S L L*) parameter, which does not trigger a drive detected error, are:

Value	Meaning
[Ignore] (<i>n o</i>)	Detected error ignored
[Per STT] (<i>S E E</i>)	Stop according to configuration of [Type of stop] (<i>S E E</i>)
[fallback spd] (<i>L F F</i>)	Change to fallback speed, maintained as long as the detected error persists and the run command has not been removed. The fallback speed can be configured in the [Complete settings] (<i>C 5 E -</i>), [Error/warning handling] (<i>C 5 W Π</i>) menu, [Fallback speed] (<i>L F F -</i>) submenu, using the [Fallback speed] (<i>L F F</i>) parameter.
[Spd maint.] (<i>r L 5</i>)	The drive maintains the speed at the time the detected error occurred, as long as the detected error persists, and the run command has not been removed

WARNING

LOSS OF CONTROL

If this parameter is set to *n o*, Modbus communication monitoring is disabled.

- Only use this setting after a thorough risk assessment in compliance with all regulations and standards that apply to the device and to the application.
- Only use this setting for tests during commissioning.
- Verify that communication monitoring has been re-enabled before completing the commissioning procedure and performing the final commissioning test.

Failure to follow these instructions can result in death, serious injury, or equipment damage.

Section 5.2

Operating Modes

What Is in This Section?

This section contains the following topics:

Topic	Page
Configuring the Control Channel	102
Configuration of the Drive for Operation in I/O Profile	103
Configuration of the Drive for Operation with CiA 402 Profile in Combined Mode	104
Configuration of the Drive for Operation with CiA 402 Profile in Separate Mode	105

Configuring the Control Channel

Overview

This chapter explains how to configure the drive for operation from communication network through three following examples.

- I/O mode - a simple command word (based on forward, reverse, and reset binary commands).
- Combined mode (with native profile CiA 402) - Both reference value and command word come from the communication network.
- Separate (with native profile CiA 402) - reference value and command come from separate sources: for example, the command (in CiA 402) comes from the communication network and the reference value from the HMI.

Configuration of the Drive for Operation in I/O Profile

Description

The I/O profile, here is a simple example, which can be extended with additional features. The command word is made of run forward (bit 0 of CMd), run reverse (bit 1 of CMd), and the function fault reset (bit 7 of CMd).

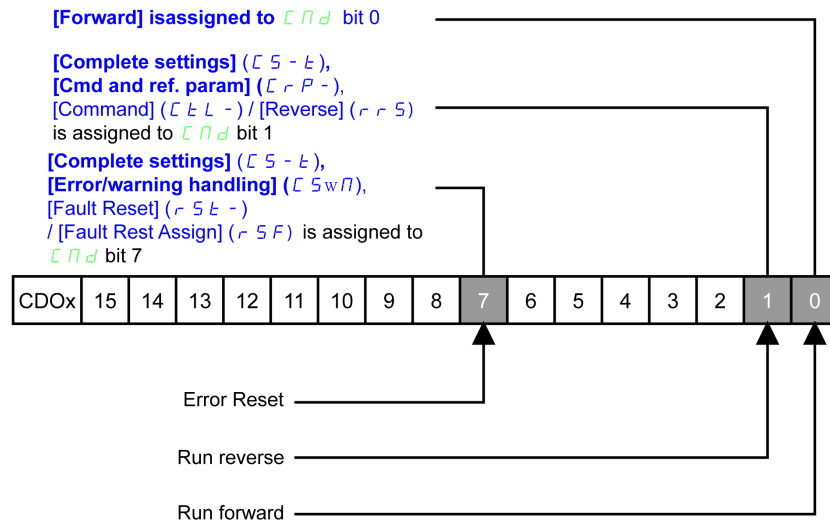

The settings are the following:

[Ref.1 channel] (F r l)	[HMI] (H Π i)
[Reverse Disable] (r i n)	Default
[Stop Key Enable] (P S t)	Default
[Profile] (CHCF)	[I/O profile] i o
[Cmd switching] (CL S)	Default
[Cmd channel 1] (CD I)	[Modbus] (Π d b)

The bits of the command word can now be configured.

In the **[Command and Reference]** (**CrP -**) menu configure:

[Reverse assign.] (r r S)	[Cd01] (CD 0 1)
-------------------------------------------	---------------------------------

In the **[Error/warning handling]** (**CSwΠ**) menu, **[Fault Reset]** (**r S t -**) submenu, configure:

[Fault Reset Assign] (r S F)	[Cd07] (CD 0 7)
----------------------------------------------	---------------------------------

Configuration of the Drive for Operation with CiA 402 Profile in Combined Mode

Description

This section describes how to configure the settings of the drive if it is controlled in CiA 402 mode. The example focuses on the not separate mode. Additional modes are detailed in the drive programming manual.

In the **[Complete settings]** (*C S L -*) menu, **[Command and reference]** (*C r P -*) submenu:)

- **[Ref.1 Channel]** (*F r 1*): is set on according to the communication source you can choose in the following table:

Origin of the Control	Ref1 Channel Setting
Modbus serial	[Modbus] (<i>M d b</i>)

- **[Profile]** (*C H C F*): defines if the drive operates in combined mode (reference value and command from the same channel).

Configuration of the Drive for Operation with CiA 402 Profile in Separate Mode

Description

Alternate combinations are possible, see the drive programming manual for the list of possible settings.
For example:



The drive is controlled from the communication (Modbus serial) but the reference value is adjusted on display terminal. The control word comes from the controller and is written according to CiA 402 profile.
The settings are as shown in the table:

[Ref.1 channel] (<i>F r 1</i>)	[HMI] (<i>L C C</i>)
[Reverse Disable] (<i>r i n</i>)	Default
[Stop Key Enable] (<i>P S E</i>)	Default
[Profile] (<i>C H C F</i>)	[Separate] (<i>S E P</i>)
[Cmd switching] (<i>C C S</i>)	Default
[Cmd channel 1] (<i>C d 1</i>)	[Modbus] <i>n b d</i>

Chapter 6

Diagnostics and Troubleshooting

What Is in This Chapter?

This chapter contains the following topics:

Topic	Page
Fieldbus Status LEDs	108
Checking Connections	110
Fieldbus Function Test	111
Communication Interruption Message	112

Fieldbus Status LEDs

LED Indicators

The following figure describes the LEDs status for fieldbus monitoring:

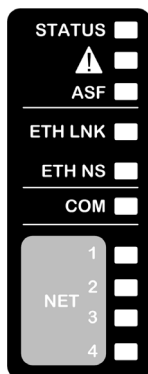

LED Description

Item	LED	Description
1	COM	Indicates the Modbus serial link connection status

LED COM : Link Activity

The table provides the LED status for Modbus serial connection

Color & Status	Description
OFF	No link
Yellow flashing	Fieldbus active

Communication Diagnostics

These parameters are visible only with the graphic display terminal.

On the terminal, in the **[Display]** (П о н -) menu (**[COMMUNICATION MAP]** (С П П -) **[Modbus network diag]** (П о д -) submenu):

RUN	+50.0 Hz	30.5 A	MDB
-15:21-			
Modbus network diag			
COM LED	:		⊗
Mdb Frame Nb	:	45115	
Mb NET CRC errors	:	0	
Com. Scanner input m..	:		
Com. Scan output map	:		

⊗ Indicates a LED, which is not lit

Modbus Counters

- **[Mdb Frame Nb.]** (Π I C E) indicate the number of Modbus frames received. The counter counts both correct and incorrect frames.
- **[Mb NET CRC errors]** (Π I E C) indicate the number of Modbus frames containing checksum errors.

In the case of these two counters, only frames that are destined for the drive and whose Modbus address is supplied by the **[Modbus Address]** (Π d d) parameter are counted. Broadcast frames are not counted.

[Mdb Frame Nb.] (Π I C E) is modulo 65 536 counters, that is, the value is reset to zero once the value of 65 535 is reached.

By contrast, the **[Mb NET CRC errors]** (Π I E C) remain at 65 535 once this value is reached.

Each Modbus counter corresponds to a drive parameter:

Menu	Parameter Name	Code	Logical Address
[Modbus network diag] (Π n d -)	[Mdb Frame Nb.]	(Π I C E)	6011
	[Mb NET CRC errors]	(Π I E C)	6010

Modbus Communication State

This can be accessed from the menu:

[Communication] (Γ o Π -) / **[Comm parameters]** (Γ Π P -) / **[Modbus SL]** (Π 5 L -) / **[Modbus Fieldbus]** (Π d l -) / **[Mdb com stat]** (Γ o Π l)

(r \square E \square) : Modbus no reception, no transmission = communication idle

(r \square E l) : Modbus no reception, transmission

(r l E \square) : Modbus reception, no transmission

(r l E l) : Modbus reception and transmission

Checking Connections

Description

If the product cannot be addressed using the fieldbus, verify that

- The connector is plugged in correctly.
- The wires are correctly connected to connector(if possible).
- The ends of line resistors are connected on both sides of the complete network.
- The ends of line resistors have the good values.
- The wiring of the all devices on the network is consistent.

Fieldbus Function Test

Command and Reference Channels

All the drive command and reference parameters are managed on a channel-by-channel basis.

Parameter Name	Parameter Code				
	Taken Into Account by the Drive	Modbus Serial	CANopen	Fieldbus Module	Ethernet Embedded
Control word	(<i>CNd</i>)	(<i>CNd1</i>)	(<i>CNd2</i>)	(<i>CNd3</i>)	(<i>CNd5</i>)
Extended control word	(<i>CNi</i>)	(<i>CNi1</i>)	(<i>CNi2</i>)	(<i>CNi3</i>)	(<i>CNi5</i>)
Reference speed (rpm)	(<i>LFr d</i>)	(<i>LFr d1</i>)	(<i>LFr d2</i>)	(<i>LFr d3</i>)	(<i>LFr d5</i>)
Reference frequency (0.1 Hz)	(<i>LFr</i>)	(<i>LFr1</i>)	(<i>LFr2</i>)	(<i>LFr3</i>)	(<i>LFr5</i>)
Reference value supplied by PI controller	(<i>PiSP</i>)	(<i>Pir1</i>)	(<i>Pir2</i>)	(<i>Pir3</i>)	(<i>Pir5</i>)
Reference value supplied by analog multiplier function	(<i>PFr</i>)	(<i>PFr1</i>)	(<i>PFr2</i>)	(<i>PFr3</i>)	(<i>PFr5</i>)

Communication Interruption Message

Description

If the drive does not receive any Modbus request sent to its address for a predefined time **[Modbus Timeout]** (*E E 0*), a **[Modbus Com Interruption]** (*S L F I*) is triggered.



A

Abbreviations

Req. = Required

Opt. = Optional

D

Display terminal

The display terminal menus are shown in square brackets.

For example: **[Communication]**

The codes are shown in round brackets.

For example: (C o n -)

Parameter names are displayed on the display terminal in square brackets.

For example: **[fallback spd]**

Parameter codes are displayed in round brackets.

For example: (L F F)

E

Error

Discrepancy between a detected (computed, measured, or signaled) value or condition and the specified or theoretically correct value or condition.

F

Factory setting

Factory settings when the product is shipped

Fault

Fault is an operating state. If the monitoring functions detect an error, a transition to this operating state is triggered, depending on the error class. A "Fault reset" is required to exit this operating state after the cause of the detected error has been removed. Further information can be found in the pertinent standards such as IEC 61800-7, ODVA Common Industrial Protocol (CIP).

Fault Reset

A function used to restore the drive to an operational state after a detected error is cleared by removing the cause of the error so that the error is no longer active.

M

Monitoring function

Monitoring functions acquire a value continuously or cyclically (for example, by measuring) in order to check whether it is within permissible limits. Monitoring functions are used for error detection.

P

Parameter

Device data and values that can be read and set (to a certain extent) by the user.

PELV

Protective Extra Low Voltage, low voltage with isolation. For more information: IEC 60364-4-41

PLC

Programmable logic controller

Power stage

The power stage controls the motor. The power stage generates current for controlling the motor.

Q

Quick Stop

The Quick Stop function can be used for fast deceleration of a movement as a response to a detected error or via a command.

W

Warning

If the term is used outside the context of safety instructions, a warning alerts to a potential problem that was detected by a monitoring function. A warning does not cause a transition of the operating state.

