

APPLICATION

For proportional temperature control of pneumatic actuated valves and damper actuators to maintain room air temperatures in heating, ventilating and air conditioning systems.

SPECIFICATIONS

Thermostat: Proportional two pipe type. Two pressure Heating/Cooling or Day/Night thermostats switch between two bimetal sensors.

Sensing Elements: Two bimetals.

Control Dial Ranges: Two independent with stops, see Table 1.

Throttling Range: Independently adjustable for each setpoint dial 2 to 10F°/10 psi (1 to 5.5 C°/69 kPa) change in branch line pressure, factory set at 4F°/10 psi (2.2 C°/69 kPa).

Output Air Signal: 0.5 psig (3.4 kPa) to supply air -0.5 psig (-3.4 kPa).

Action: See Table 1.

Ambient Limits: Shipping, -40 to 150°F (-40 to 65°C). 0 to 98% R. H. non-condensing.

Operating, 20 to 115°F (-7 to 46°C). 10 to 98% R. H. non-condensing.

Supply Air Pressure: Clean, oil free, dry air required (reference EN-123).

Requires, 15 and 22 psig (103 and 152 kPa) dual pressure, see Table 1.

Maximum, 30 psig (207 kPa).

Air Connections: Main (Black), 5/32" dia. Spring reinforced plastic tube.

Branch (white), 5/32" dia. spring reinforced plastic tube.

Air Consumption for Sizing Air Compressor: TK-17XX, 0.008 scfm (3.8 ml/s).

Air Capacity for Sizing Air Mains: TK-17XX, 80 scfm (21.8 ml/s).

Cover: Beige plastic with brushed bronze metal inserts as standard.

Mounting: Upright position on wall.

Dimensions: TK-17XX, 4-3/8" high x 2-3/4" wide x 1-5/8" deep (111 mm x 7 mm x 43 mm).

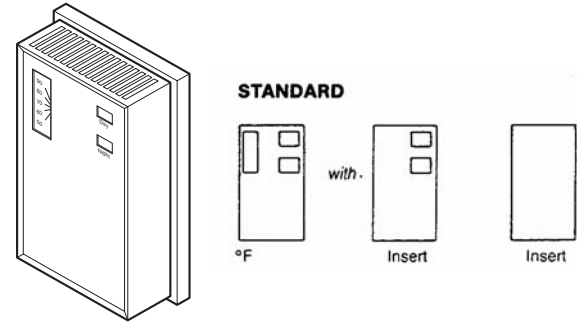

ACCESSORIES

| | |
|----------------|---|
| AT-65 Series | Cover inserts |
| AT-504 | Plaster hole cover |
| AT-505 | Surface mounting base |
| AT-536 | Pneumatic wall thermostat conversion kit |
| AT-546 | Auxiliary mounting base |
| AT-1100 Series | Thermostat guards |
| AT-533-101 | Adapter 1/4" plastic to 5/32" plastic |
| AT-533-127 | Adapter 3/16" copper or 1/4" copper with 1/4" solder coupling (not included) to 5/32" plastic |
| TOOL-15 | Spanner head driver for #6 spanner head screws |
| TOOL-80-1 | Calibration tool |
| TOOL-95-1 | Pneumatic calibration tool kit |

PRE-INSTALLATION

The thermostats are shipped with mounting screws. Wall fittings must be ordered separately.

Inspect the carton for damage. If damaged, notify the appropriate carrier immediately. Inspect the device for obvious damage due to shipping. Return damaged parts.

Air Connections: Two plastic tubes reinforced with a coil spring are coded M and B. The M (black) designates the supply main and the B (white) designates the controlled branch line. See Figure 1.

INSTALLATION

Requirements

Locate the thermostat where it will be exposed to unrestricted circulation of air which represents the average temperature of the controlled space. Do not locate the thermostat near sources of heat or cold, such as lamps, motors, sunlight or concealed ducts or pipes.

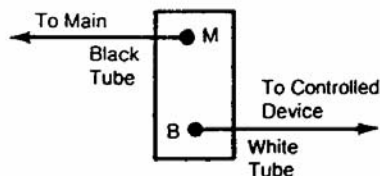

Figure-1

Table-1 SPECIFICATIONS.

| Application | Controlled Device Action | 15 psig (103 kPa) Supply Pressure | | | 20 psig (138 kPa) Supply Pressure ^a | | | Part Number | |
|------------------------|--------------------------|-----------------------------------|-----------------------------|-------------------|--|----------------|--------------|---------------------------------|--------------------|
| | | Dial Range ^b | Control Action ^c | Cover Legend | Dial Range | Control Action | Cover Legend | Dial Markings °F | |
| Heating and Cooling | N. O. Heat, N. C. Cool | 55 to 85°F (13 to 29°C) | Direct | Heat ^d | 55 to 85°F (13 to 29°C) | Direct | Cool | TK-1717 | |
| | N.C. Heat, N. O. Cool | | Reverse | | | Reverse | | TK-1727 | |
| | N.C. Heat, N.C. Cool | | Reverse | | | Direct | | TK-1731 | |
| | N. O. Heat, N. O. Cool | | Direct | | | Reverse | | TK-1741 | |
| Heating with Day/Night | Normally Open | | Direct | Day | | Direct | Night | TK-1711 TK-1751 ^e | |
| | Normally Closed | | Reverse | | | Reverse | | TK-1721 TK-1761 | |
| Cooling with Day/Night | Normally Open | | Reverse | | | Reverse | | Reverse | TK-1721 TK-1761 |
| | Normally Closed | | Direct | | | Direct | | Direct | TK-1711 TK-1751 |

- ^a 22 psi required if setpoints are more than 20F° (11C°) apart.
- ^b Control dial is marked in °F on one side and °C on the other side. Units have built-in stops that can limit high and/or low setting of each dial.
- ^c Direct Acting (D.A) - Increase output pressure on temperature rise.
Reverse Acting (R.A.) - Decrease output pressure on temperature rise.
- ^d Use AT-67 series cover plate to reverse heat/cool legends.
- ^e Units include a manual override lever for overriding 22 psig (152 kPa) operation and placing control into 15 psig (103 kPa) control mode when unit is supplied with 22 psig (152 kPa) Lever automatically resets when supply pressure is reduced to 15 psig (103 kPa).

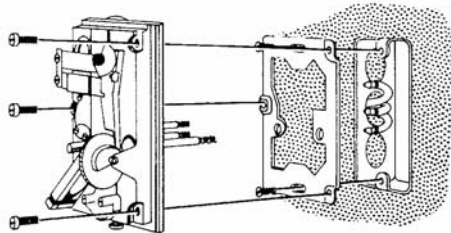

Figure-2 Mounting Thermostat to Electrical Box.

Installation of external setpoint, refer to Figure 4.

1. Insert the knob through hole in cover. The knob should rest on the calibration screw with the slots aligned with the dial clamp screws.
2. Insert screw supplied with the knob into the center of the knob and tighten (with TOOL-082, 5/64" Allen wrench), being careful not to disturb the setting of the calibration screw.

Note: The knob must be removed in order to remove thermostat cover or recalibrate thermostat.

Procedure

To mount a thermostat on an electrical switch box, refer to Figure 2.

1. Attach the mounting plate to the switch box with the two flathead screws provided. Be sure the mounting plate is vertical.
2. Slightly rotate the tubes back and forth, and push firmly onto the fittings. See Figure 3.
3. Fasten the thermostat to the mounting plate with the Allen head screws provided and tighten evenly.

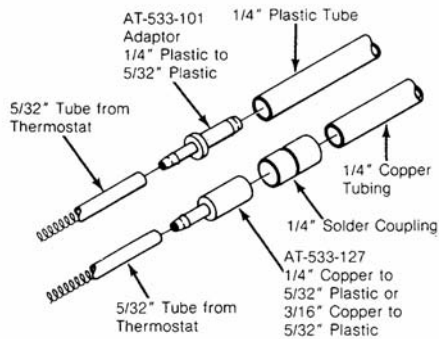

Figure-3

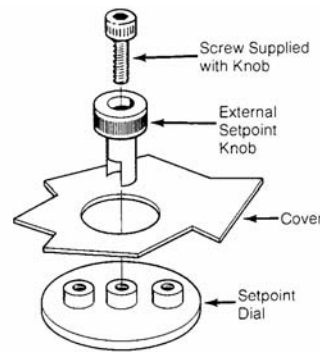

Figure-4

CHECKOUT

After installing the thermostat, verify proper operation as follows:

1. With 15 psig (103 kPa) supply pressure, check the nozzle and/or restriction. Turn the upper setpoint dial to maximum value. If the thermostat is direct-acting at 15 psig (103 kPa), the output pressure will drop. If the thermostat is reverse-acting, the output pressure will rise. Turn the setpoint dial to minimum value. If the thermostat is direct-acting the output pressure will rise. If the thermostat is reverse-acting, the output pressure will drop.

Note: The amount of rise or drop in the output pressure may vary depending on the ambient temperature in the test area. If output is always 0 psig, the restriction may be plugged. If output is always equal to supply or unable to decrease below 3 psig (20.6 kPa), the nozzle may be plugged.

2. To check for active thermal element, adjust the setpoint knob to obtain approximately 8 psig (55 kPa) branch output. Slightly warm the element with your hand or breath. A direct-acting thermostat will increase output pressure. A reverse-acting thermostat will decrease output pressure. If the thermostat fails to function properly, refer to REPAIR.

ADJUSTMENTS

Note: The TOOL-095 calibration kit should be available for calibration.

Throttling Ranges: The throttling ranges are set at 4F° per 10 psi (2.2 C° per 69 kPa) control pressure change. They should be set at the lowest value which will allow the thermostat to control the system without cycling under the normal load conditions. The most satisfactory setting will vary with the type of system being controlled. The throttling range is independently adjustable for each bimetal.

If the throttling range of the thermostat as shipped is not satisfactory, proceed as follows:

1. Measure temperature at sensing element. This should be a stable temperature.
2. With 15 psig (103 kPa) supplied to thermostat, adjust calibration screw until 3 psig (20.6 kPa) is read on branch test gauge.
3. Rotate upper setpoint dial to this temperature.
4. Rotate the upper setpoint dial in a direction which raises the output until 13 psig (89.6 kPa) is read on the branch gauge.
5. The difference between the setpoint dial readings in step 2 and 4 is the throttling range of the thermostat.
6. If the throttling range in step 5 is not that desired, move the throttling range slider (Figure 5) in the appropriate direction and repeat steps 2 through 5 until the desired throttling range is obtained.
7. Change supply pressure to 22 psig (151 kPa) and repeat steps 2 through 6. On day/night applications, both throttling ranges should have the same setting.

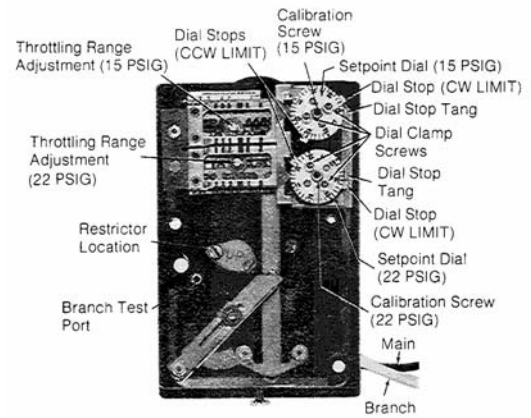

Figure-5

The calibration of the thermostat should be checked after the throttling range has been changed. See CALIBRATION.

Adjustment of Dial Stops: To set the setpoint dial stops, proceed as follows:

1. Using the TOOL-082, 5/64" Allen wrench, loosen the two dial clamp screws approximately 1/2 turn.
2. Separate the two dial stop tabs if not already separated.
3. Using the TOOL-082, 5/64" Allen wrench, turn the setpoint dial to the desired clockwise dial limit. While holding the dial with the Allen wrench, slide the one stop tab in a clockwise direction until it touches the top side of the stop tang.
4. Rotate the setpoint dial to the counterclockwise limit. While holding the dial with the 5/64" Allen wrench, rotate the other stop tab counterclockwise to touch the bottom of the stop tang.
5. Carefully tighten the dial screws with the TOOL-082, 5/64" Allen wrench.
6. Rotate setpoint dial from counterclockwise stop to clockwise stop to check stop settings. Repeat adjustment steps if necessary.

Note: Stops can be rotated to lock setpoint dial in one place if desired.

Converting Dials to °C:

1. Rotate setpoint dial clockwise to end of dial scale.
2. Hold dial. Use the TOOL-082, 5/64" Allen wrench to remove the dial screws. Remove dial plate and turn over. Make sure stop tab plates and clamp ring are in place.
3. Align dial plate to read clockwise end of °C scale.
4. Carefully re-install dial screws. Do not tighten.
5. Readjust stop tabs. See "Adjustment of Dial Stops".

CALIBRATION

As a nominal calibration, the branch line control pressure should be 8 psig (55 kPa) when the setpoint is equal to the room temperature indicated by an accurate thermometer. On some applications, a value other than 8 psig (55 kPa) will be required to get the desired control results. In this case, change the 8 psig (55 kPa) designation used in the calibration procedure.

Caution: The thermal element of the room thermostat is very sensitive to temperature change. Do not affect its temperature by touching the bimetal or breathing on the thermostat. When calibrating the instrument, observe the room temperature frequently and reset the setpoint dial if required.

1. Remove the thermostat cover by loosening the cover screw.
2. Using the TOOL-082, 5/64" Allen wrench, unscrew (counterclockwise rotation) the branch test port screw one full turn (Figure 4).
3. Attach the test gauge rubber seal to the boss, as shown. Using a rotary motion, push the gauge on as far as it will go (1/4" minimum). The tubing will support the test gauge in a position where it will be easily read. The supply pressure to the thermostat should be 15 psig (103 kPa).
4. Adjust the upper setpoint dial to the room temperature as indicated on the test thermometer.
5. With the TOOL-082 0.048" six spline wrench, turn the calibration screw clockwise if the controlled pressure is above 8 psig (55 kPa) and counterclockwise if it is below 8 psig (55 kPa). Adjust the screw until the controlled pressure is 8 ± 1 psi (55 ± 7 kPa).

Note: The hex nuts on the calibration screws are tension devices only. They should not be loosened to make an adjustment.

The 15 psig bimetal is calibrated. To calibrate the 22 psig (151 kPa) bimetal, proceed as follows using a special tool (TOOL-080). Refer to Figure 5.

1. Adjust the lower setpoint dial to the room temperature as indicated on the test thermometer.
2. Insert the blade of the tool between the switchover plunger and the switchover lever shown in Figure 5. The top bimetal should be approximately 1/32" off the lever and the bottom bimetal should be in contact with the lever.
3. Adjust the lower bimetal with the TOOL-082, 0.048" six spline wrench. Turn the calibration screw clockwise if the controlled pressure is above 8 psig (55 kPa) and counterclockwise if the controlled pressure is below 8 psig (55 kPa). Adjust the screw until the pressure is ± 1 psi (7 kPa).

4. Manually switch the thermostat several times by removing and reinserting the TOOL-080 or screwdriver and observing the branch line pressure. If it varies beyond desired limits, repeat the calibration.
5. Remove the test gauge.
6. Turn the branch test port screw clockwise to tighten.
7. Replace cover.

MAINTENANCE

The pneumatic thermostat requires no routine maintenance.

REPAIR

Field repair of pneumatic thermostats is not recommended. However, if the thermostat output pressure is 0 and it cannot be corrected by calibration, the restriction should be checked. Hold the restriction plate up to the light and check the 0.0045 hole. If the hole is blocked, the restriction plate must be replaced. The filter should be replaced at the same time. If the hole is not blocked, then the thermostat should be replaced.

On October 1st, 2009, TAC became the Buildings business of its parent company Schneider Electric. This document reflects the visual identity of Schneider Electric, however there remains references to TAC as a corporate brand in the body copy. As each document is updated, the body copy will be changed to reflect appropriate corporate brand changes.

Copyright 2010, Schneider Electric
All brand names, trademarks and registered trademarks are the property of their respective owners. Information contained within this document is subject to change without notice.

Schneider Electric
1354 Clifford Avenue
P.O. Box 2940
Loves Park, IL 61132-2940

www.schneider-electric.com/buildings

Schneider
 **Electric**