

ConneXium

TCSESSU Switch Installation Manual

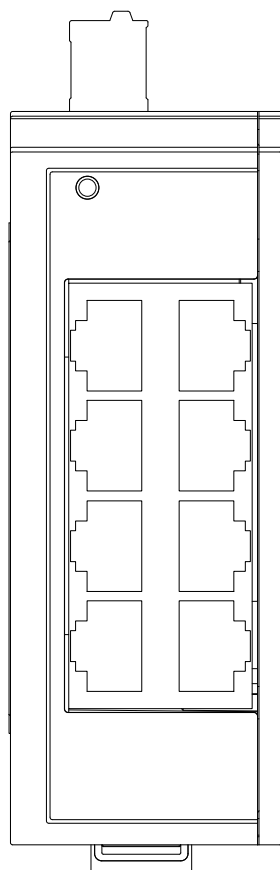

TCSESSU083FN0

The information provided in this documentation contains general descriptions and/or technical characteristics of the performance of the products contained herein. This documentation is not intended as a substitute for and is not to be used for determining suitability or reliability of these products for specific user applications. It is the duty of any such user or integrator to perform the appropriate and complete risk analysis, evaluation and testing of the products with respect to the relevant specific application or use thereof. Neither Schneider Electric nor any of its affiliates or subsidiaries shall be responsible or liable for misuse of the information contained herein. If you have any suggestions for improvements or amendments or have found errors in this publication, please notify us.

You agree not to reproduce, other than for your own personal, noncommercial use, all or part of this document on any medium whatsoever without permission of Schneider Electric, given in writing. You also agree not to establish any hypertext links to this document or its content. Schneider Electric does not grant any right or license for the personal and noncommercial use of the document or its content, except for a non-exclusive license to consult it on an "as is" basis, at your own risk. All other rights are reserved.

All pertinent state, regional, and local safety regulations must be observed when installing and using this product. For reasons of safety and to help ensure compliance with documented system data, only the manufacturer must perform repairs to components.

When devices are used for applications with technical safety requirements, the relevant instructions must be followed.

Failure to use Schneider Electric software or approved software with our hardware products may result in injury, harm, or improper operating results.

Failure to observe this information can result in injury or equipment damage.

© 2017 Schneider Electric. All Rights Reserved.

Contents

	About this Manual	4
	Key	5
	Safety instructions	6
1	Description	14
1.1	General device description	14
2	Assembly and start-up	15
2.1	Installing the device	15
2.1.1	Overview of installation	15
2.1.2	Unpacking and checking	15
2.1.3	Connecting the terminal block for supply voltage and grounding	15
2.1.4	Connecting the terminal block, start-up procedure	17
2.1.5	Installing the device on the DIN rail, grounding	17
2.2	Connecting the data lines	18
2.2.1	10/100 Mbit/s twisted pair port	18
2.3	Display elements	19
2.3.1	Device state	19
2.3.2	Port status	20
3	Monitoring the ambient air temperature	21
4	Maintenance	22
5	Disassembly	23
6	Technical data	24

About this Manual

Validity Note

The technical characteristics of the devices described in this document also appear online. To access this information online:

Step	Action
1	Go to the Schneider Electric home page www.schneider-electric.com .
2	In the Search box type the reference of a product or the name of a product range. <input type="checkbox"/> Do not include blank spaces in the reference or product range. <input type="checkbox"/> To get information on grouping similar modules, use asterisks (*).
3	If you entered a reference, go to the Product Datasheets search results and click on the reference that interests you. If you entered the name of a product range, go to the Product Ranges search results and click on the product range that interests you.
4	If more than one reference appears in the Products search results, click on the reference that interests you.
5	Depending on the size of your screen, you may need to scroll down to see the data sheet.
6	To save or print a data sheet as a .pdf file, click Download XXX product datasheet.

The characteristics that are presented in this manual should be the same as those characteristics that appear online. In line with our policy of constant improvement, we may revise content over time to improve clarity and accuracy. If you see a difference between the manual and online information, use the online information as your reference.

Related Documents

Title	Reference Number
ConneXium TCSESSU Switch Installation Manual	QGH59100

You can download these technical publications and other technical information from our website at <http://www.schneider-electric.com/ww/en/download>.

The Installation Manual contains a device description, safety instructions, a description of the display, and the other information that you need to install the device.

Key

The symbols used in this manual have the following meanings:

▶	Listing
□	Work step
■	Subheading

Safety instructions

Important Information

Notice: Read these instructions carefully, and look at the equipment to become familiar with the device before trying to install, operate, or maintain it. The following special messages may appear throughout this documentation or on the equipment to warn of potential hazards or to call attention to information that clarifies or simplifies a procedure.



The additional of this symbol to a "Danger" or "Warning" safety label indicates that an electrical hazard exists, which will result in personal injury if the instructions are not followed.



This is the safety alert symbol. It is used to alert you to potential personal injury hazards. Obey all safety messages that follow this symbol to avoid possible injury or death.



DANGER

DANGER indicates an imminently hazardous situation which, if not avoided, **will result in** death or serious injury.



WARNING

WARNING indicates a potentially hazardous situation which, if not avoided, **can result in** death or serious injury.



CAUTION

CAUTION indicates a potentially hazardous situation which, if not avoided, **can result in** minor or moderate injury.

NOTICE

NOTICE is used to address practices not related to physical injury.

PLEASE NOTE: Electrical equipment must be installed, operated, serviced, and maintained only by qualified personnel.

No responsibility is assumed by Schneider Electric for any consequences arising out of the use of this material.

A qualified person is one who has skills and knowledge related to the construction and operation of electrical equipment and its installation, and has received safety training to recognize and avoid the hazards involved.

■ **Before you begin**

Do not use this product on machinery lacking effective point-of-operation guarding. Lack of effective point-of-operation guarding on a machine can result in serious injury to the operator of that machine.



WARNING

UNGUARDED EQUIPMENT

- Do not use this software and related automation equipment on equipment which does not have point-of-operation protection.
- Do not reach into machinery during operation.

Failure to follow these instructions can result in death, serious injury, or equipment damage.

This automation equipment and related software is used to control a variety of industrial processes. The type or model of automation equipment suitable for each application will vary depending on factors such as the control function required, degree of protection required, production methods, unusual conditions, government regulations, etc. In some applications, more than one processor may be required, as when backup redundancy is needed.

Only you, the user, machine builder or system integrator can be aware of all the conditions and factors present during setup, operation, and maintenance of the machine and, therefore, can determine the automation equipment and the related safeties and interlocks which can be properly used. When selecting automation and control equipment and related software for a particular application, you should refer to the applicable local and national standards and regulations. The National Safety Council's Accident Prevention Manual (nationally recognized in the United States of America) also provides much useful information.

In some applications, such as packaging machinery, additional operator protection such as point-of-operation guarding must be provided. This is necessary if the operator's hands and other parts of the body are free to enter the pinch points or other hazardous areas and serious injury can occur. Software products alone cannot protect an operator from injury. For this reason the software cannot be substituted for or take the place of point-of-operation protection.

Ensure that appropriate safeties and mechanical/electrical interlocks related to point-of-operation protection have been installed and are operational before placing the equipment into service. All interlocks and safeties related to point-of-operation protection must be coordinated with the related automation equipment and software programming.

Note: Coordination of safeties and mechanical/electrical interlocks for point-of-operation protection is outside the scope of the Function Block Library, System User Guide, or other implementation referenced in this documentation.

■ **Start-up and test**

Before using electrical control and automation equipment for regular operation after installation, the system should be given a start-up test by qualified personnel to verify correct operation of the equipment. It is important that arrangements for such a check be made and that enough time is allowed to perform complete and satisfactory testing.



CAUTION

EQUIPMENT OPERATION HAZARD

- Verify that all installation and set up procedures have been completed.
- Before operational tests are performed, remove all blocks or other temporary holding means used for shipment from all component devices.
- Remove tools, meters, and debris from equipment.

Failure to follow these instructions can result in injury or equipment damage.

Follow all start-up tests recommended in the equipment documentation. Store all equipment documentation for future references.

Software testing must be done in both simulated and real environments.

Verify that the completed system is free from all short circuits and temporary grounds that are not installed according to local regulations (according to the National Electrical Code in the U.S.A, for instance). If high-potential voltage testing is necessary, follow recommendations in equipment documentation to help prevent accidental equipment damage.

Before energizing equipment:

- Remove tools, meters, and debris from equipment.
- Close the equipment enclosure door.
- Remove all temporary grounds from incoming power lines.
- Perform all start-up tests recommended by the manufacturer.

■ **Operation and adjustments**

The following precautions are from the NEMA Standards Publication ICS 7.1-1995 (English version prevails):

- ▶ Regardless of the care exercised in the design and manufacture of equipment or in the selection and ratings of components, there are hazards that can be encountered if such equipment is improperly operated.
- ▶ It is sometimes possible to misadjust the equipment and thus produce unsatisfactory or unsafe operation. Always use the manufacturer's instructions as a guide for functional adjustments. Personnel who have access to these adjustments should be familiar with the equipment manufacturer's instructions and the machinery used with the electrical equipment.
- ▶ Only those operational adjustments actually required by the operator should be accessible to the operator. Access to other controls should be restricted to help prevent unauthorized changes in operating characteristics.

■ **General safety instructions**

Electricity is used to operate this equipment. Comply with every detail of the safety requirements specified in the operating instructions regarding the voltages to apply (see ["Supply voltage" on page 10](#)).

- Only appropriately qualified personnel should work on this device or in its vicinity. These personnel must be thoroughly familiar with the hazard messages and maintenance procedures in accordance with this operating manual.
- The proper and safe operation of this device depends on proper handling during transport, proper storage and assembly, and conscientious operation and maintenance procedures.
- Never start operation with damaged components.
- Only use the devices in accordance with this manual. In particular, observe the hazard messages and safety-related information.
- Any work that may be required on the electrical installation may only be carried out by personnel trained for this purpose.

■ **Staff qualification requirements**

Only appropriately qualified staff should work on or near this equipment. Such staff must be thoroughly acquainted with all the hazard messages and maintenance measures contained in these operating instructions. The proper and safe operation of this equipment assumes proper transport, appropriate storage and assembly, and careful operation and maintenance.

Qualified staff are persons familiar with setting up, assembling, installation, starting up, and operating this product, and who have appropriate qualifications to cover their activities, such as:

- ▶ knowledge of how to switch circuits and equipment/systems on and off, ground them, and identify them in accordance with current safety standards
- ▶ training or instruction in accordance with current safety standards of using and maintaining appropriate safety equipment
- ▶ first aid training

■ **Usage**

The device may only be employed for the purposes described in the catalog, technical description, and manuals.

■ **Supply voltage**

For safety reasons the devices have been designed to operate at low voltages. Thus, they may only be connected to the supply voltage connections and to the signal contact with SELV circuits with the voltage restrictions in accordance with IEC/EN 60950-1.

- Relevant for North America:

The device may only be connected to a Class 2 supply voltage that fulfills the requirements of the National Electrical Code, Table 11(b). If the voltage is being supplied redundantly (two different voltage sources), the combined supply voltages must fulfill the requirements of the National Electrical Code, Table 11(b).

- Relevant for North America: For use in Class 2 circuits.

Only use copper wire/conductors of class 1, 140/167 °F (60/75 °C) or 167 °F (75 °C).

■ **Shielding ground**

The shielding ground of the connectable twisted pair cables is connected to the ground connection as a conductor.

■ Housing



DANGER

HAZARD OF ELECTRIC SHOCK

Never insert sharp objects (small screwdrivers, wires, etc.) into the inside of the product.

Failure to follow these instructions will result in death, serious injury, or equipment damage.



WARNING

FIRE HAZARD

Install the device in a fire protected enclosure according to EN 60950-1.

Failure to follow these instructions can result in death, serious injury, or equipment damage.



CAUTION

EQUIPMENT OVERHEATING

When installing the device, make sure any ventilation slots remain free. Maintain a clearance of at least 3.94 in (10 cm).

Failure to follow these instructions can result in injury or equipment damage.

Only technicians authorized by the manufacturer are permitted to open the casing.

- Verify that the electrical installation meets locally or nationally applicable safety regulations.
- Mount the device per instructions on page [17](#).

■ **Environment**

Operate the device at the specified ambient temperature (temperature of the ambient air at a distance of 2 inches (5 cm) from the device) and at the specified relative humidity exclusively.

- Install the device in a location where the climatic threshold values specified in the technical data will be observed.
- Use the device only in an environment within the pollution degree specified in the technical data.

■ **CE marking**

The labeled devices comply with the regulations contained in the following European directive(s):

2011/65/EU (RoHS)

Directive of the European Parliament and of the Council on the restriction of the use of certain hazardous substances in electrical and electronic equipment.

2014/30/EU (EMC)

Directive of the European Parliament and the council for standardizing the regulations of member states with regard to electromagnetic compatibility.

In accordance with the above-named EU directive(s), the EU conformity declaration will be available to the relevant authorities at the following address:

Schneider Electric Systems USA, Inc.
38 Neponset Avenue
Foxboro, Massachusetts 02035-2037
United States of America

The device can be used in the industrial sector.

- ▶ Interference immunity: EN 61000-6-2:2005
- ▶ Emitted interference: EN 55032

■ **FCC note:**

This device complies with part 15 of the FCC rules. Operation is subject to the following two conditions: (1) this device may not cause harmful interference; (2) this device must accept any interference received, including interference that may cause undesired operation. Appropriate testing has established that this device fulfills the requirements of a class A digital device in line with part 15 of the FCC regulations.

These requirements are designed to provide sufficient protection against interference when the device is being used in a business environment. The device creates and uses high frequencies and can also radiate these frequencies. If it is not installed and used in accordance with this operating manual, it can cause radio transmission interference. The use of this device in a residential area can also cause interference, and in this case the user is obliged to cover the costs of removing the interference.

■ **Recycling note**

After usage, this device must be disposed of properly as electronic waste, in accordance with the current disposal regulations of your county, state, and country.

1 Description

1.1 General device description

The TCSESSU devices are designed for the special requirements of industrial automation. They meet the relevant industry standards, provide very high operational reliability, even under extreme conditions, and also long-term reliability and flexibility.

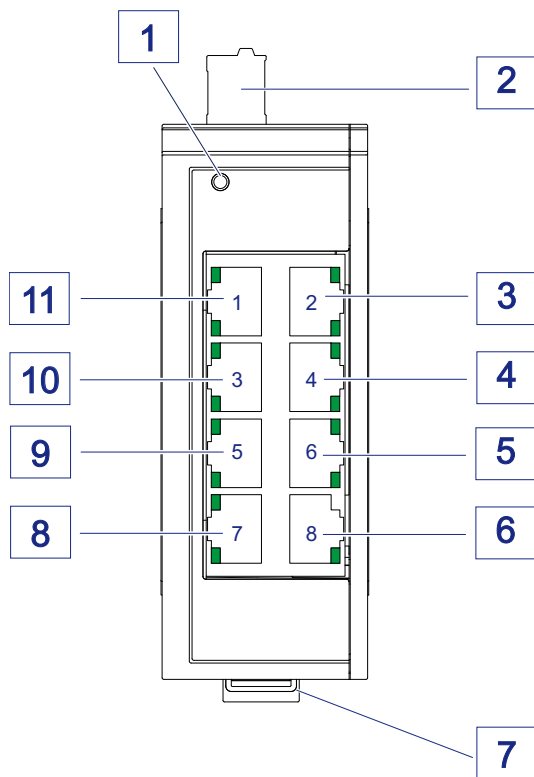

1	LED display element for device status
2	3-pin, pluggable terminal block for power supply
3 ... 6	4 × RJ45 socket for 10/100 Mbit/s twisted pair connections
7	Rail lock gate for DIN rail mounting
8 ... 11	4 × RJ45 socket for 10/100 Mbit/s twisted pair connections

Table 1: Front view TCSESSU083FN0

2 Assembly and start-up

2.1 Installing the device



WARNING

FIRE HAZARD

Install the device in a fire protected enclosure according to EN 60950-1.

Failure to follow these instructions can result in death, serious injury, or equipment damage.

Before installing and starting up the device, note the safety instructions (see [“Safety instructions” on page 6](#)).

2.1.1 Overview of installation

The devices have been developed for practical application in a harsh industrial environment.

On delivery, the device is ready for operation.

The following steps should be performed to install a ConneXium TCSESSU product:

- ▶ Unpacking and checking
- ▶ Connect the terminal block for voltage supply and grounding
- ▶ Install the device on the DIN rail, grounding
- ▶ Connect the data lines

2.1.2 Unpacking and checking

- Check that the contents of the package are complete ([see on page 27 “Scope of delivery”](#)).
- Check the individual parts for transport damage.

2.1.3 Connecting the terminal block for supply voltage and grounding

A 3-pin terminal block is used for the grounding and for connecting the supply voltage.

■ Supply voltage



DANGER

HAZARD OF ELECTRIC SHOCK OR BURN

When the module is operated with direct plug-in power units, use only:

- SELV supply units that comply with IEC 60950/EN 60950 and
- (in USA and Canada) Class 2 power units that comply with applicable national or regional electrical codes

Connect the ground wire to the PE terminal (where applicable) before you establish any further connections. When you remove connections, disconnect the ground wire last.

Failure to follow these instructions will result in death, serious injury, or equipment damage.

The supply voltage is only connected with the ground connection via protective elements.

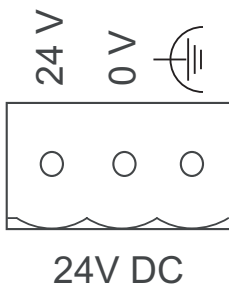

Figure 1: 3-pin, pluggable terminal block for power supply and grounding

Type of the voltages that can be connected	Specification of the supply voltage	Connections
DC voltage	Rated voltage range DC 12 V ... 24 V	24 V Plus terminal of the supply voltage
	Voltage range DC incl. maximum tolerances 9.6 V ... 32 V	0 V Minus terminal of the supply voltage
		Functional ground connection

Table 2: Type and specification of the supply voltage and pin assignment on the device

2.1.4 Connecting the terminal block, start-up procedure

■ Connecting the terminal block

- Verify the required conditions for connecting the voltage supply.
[See “Supply voltage” on page 10.](#)
- Pull the terminal block off the device.
- Connect the ground connection.
- Connect the power supply cables.
- Plug the terminal block into the connection on the housing.

■ Startup procedure

By connecting the supply voltage via the terminal block, you start the operation of the device.

2.1.5 Installing the device on the DIN rail, grounding

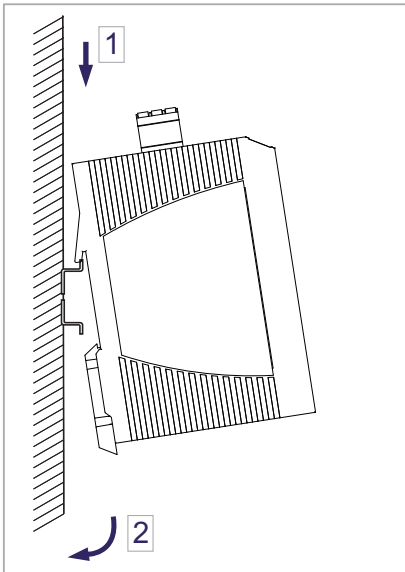

Figure 2: Mounting the device on the DIN rail

- Mount the device in a vertical position on a 35 mm DIN rail in accordance with DIN EN 60715.
- Slide the upper snap-in guide of the device into the DIN rail.
- Use a screwdriver to pull the rail lock gate downwards.
- Snap in the device by releasing the rail lock slide.

Note: The shielding ground of the connectable twisted pair cables is connected to the ground connection as a conductor.

■ Grounding

Use a wire diameter for the ground conductor that is no smaller than the diameter of the supply voltage connection, however of at least 0.5 mm² (AWG20).

The device is grounded by a 3-pin terminal block.

2.2 Connecting the data lines

You can connect end devices and other segments to the device ports using twisted pair cables.

2.2.1 10/100 Mbit/s twisted pair port

This port is an RJ45 socket.

The 10/100 Mbit/s twisted pair port allows you to connect network components according to the IEEE 802.3 10BASE-T/100BASE-TX standard.

This port supports:

- ▶ Autonegotiation
- ▶ Autopolarity
- ▶ Autocrossing
- ▶ 100 Mbit/s half-duplex mode, 100 Mbit/s full duplex mode
- ▶ 10 Mbit/s half-duplex mode, 10 Mbit/s full duplex mode

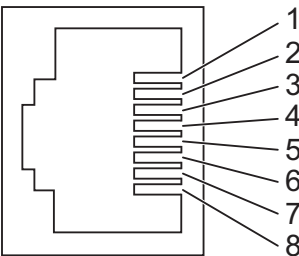
RJ45	Pin	10/100 Mbit/s
	MDI mode	
	1	TX+
	2	TX-
	3	RX+
	4	—
	5	—
	6	RX-
	7	—
8	—	
MDI-X mode		
1	RX+	
2	RX-	
3	TX+	
4	—	
5	—	
6	TX-	
7	—	
8	—	

2.3 Display elements

After the supply voltage is switched on, the device performs a self-test. During this process, various LEDs light up.

2.3.1 Device state

This LED provides information on the status of the power supply.

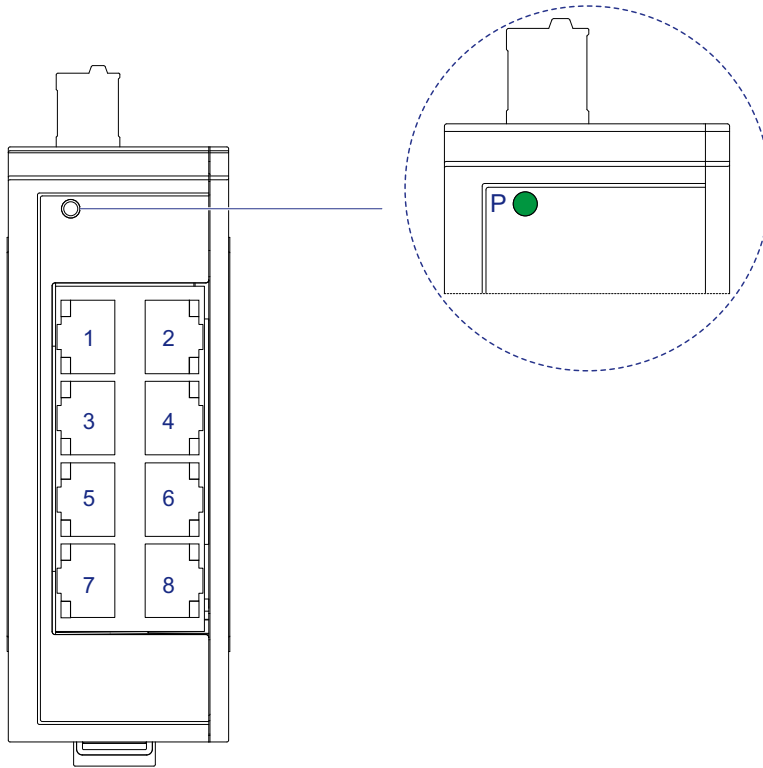

LED	Display	Color	Activity	Meaning
P	Supply voltage	Green	Lights up	Supply voltage is on Device is ready for operation
			None	Supply voltage is too low Device is not ready for operation

2.3.2 Port status

These LEDs provide port-related information.

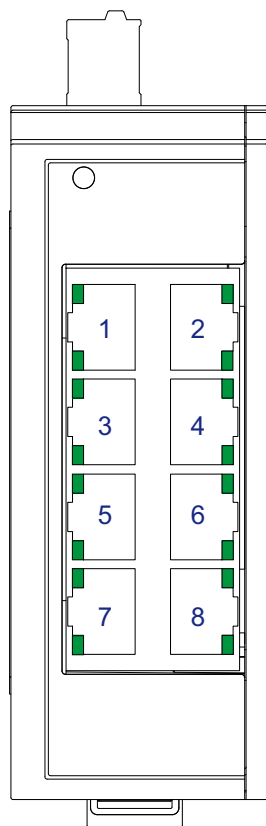

Color	Activity	Meaning
Green	Lights up	Device detects a valid link
	Flashing	Device is transmitting and/or receiving data
	None	Device detects an invalid or missing link

3 Monitoring the ambient air temperature

Operate the device below the specified maximum ambient air temperature exclusively.

See [“General technical data” on page 24.](#)

The ambient air temperature is the temperature of the air at a distance of 2 in (5 cm) from the device. It depends on the installation conditions of the device, e.g. the distance from other devices or other objects, and the output of neighboring devices.

4 Maintenance

- Depending on the degree of pollution in the operating environment, check at regular intervals that the ventilation slots in the device are not obstructed.
- Operate this device according to the specifications (see [“General technical data”](#)).

5 Disassembly

■ Removing the device from the DIN rail

- In order to remove the device from the DIN rail, insert the screwdriver horizontally under the chassis in the locking slide, pull this down – without tilting the screwdriver – and lift the device upwards.

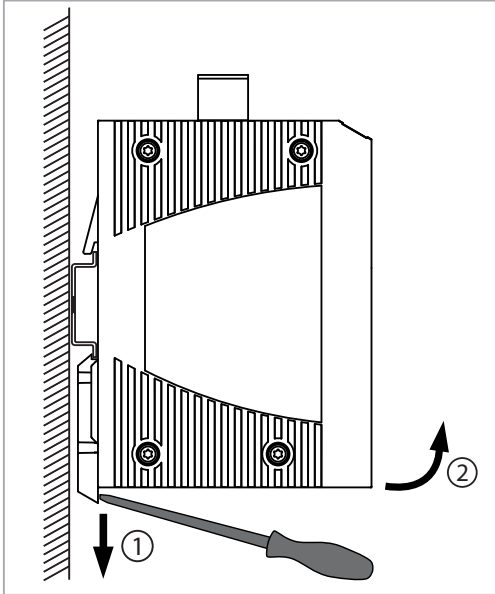

Figure 3: Removing the device from the DIN rail

6 Technical data

■ General technical data

Dimensions W × H × D	TCSESSU083FN0	See "Dimension drawings" on page 25.
Weight		5.3 oz (150 g)
Power supply	<ul style="list-style-type: none"> ▶ 1 voltage input ▶ 3-pin terminal block ▶ Safety extra-low voltage (SELV) 	
	Rated voltage range DC	12 V ... 24 V Class 2
	Voltage range DC incl. maximum tolerances	9.6 V ... 32 V
	Power failure bypass	10 ms at 20.4 V DC
	Back-up fuse	≤ 4 A, slow blow
	Peak inrush current	4 A
Potential difference between input voltage and ground connection	Potential difference from incoming voltage +24 V DC	+32 V DC
	Potential difference from incoming voltage, ground	-32 V DC
Climatic conditions during operation	Ambient air temperature ^a	+32 °F ... +140 °F (0 °C ... +60 °C)
	Humidity	10 % ... 95 % (non-condensing)
	Air pressure	minimum 795 hPa (+6562 ft; +2000 m)
Climatic conditions during storage	Ambient air temperature ^a	-40 °F ... +158 °F (-40 °C ... +70 °C)
	Humidity	10 % ... 95 % (non-condensing)
	Air pressure	minimum 700 hPa (+9842 ft; +3000 m)
Pollution degree		2
Protection classes	Degree of protection	IP30

a. Temperature of the ambient air at a distance of 2 in (5 cm) from the device

■ Dimension drawings

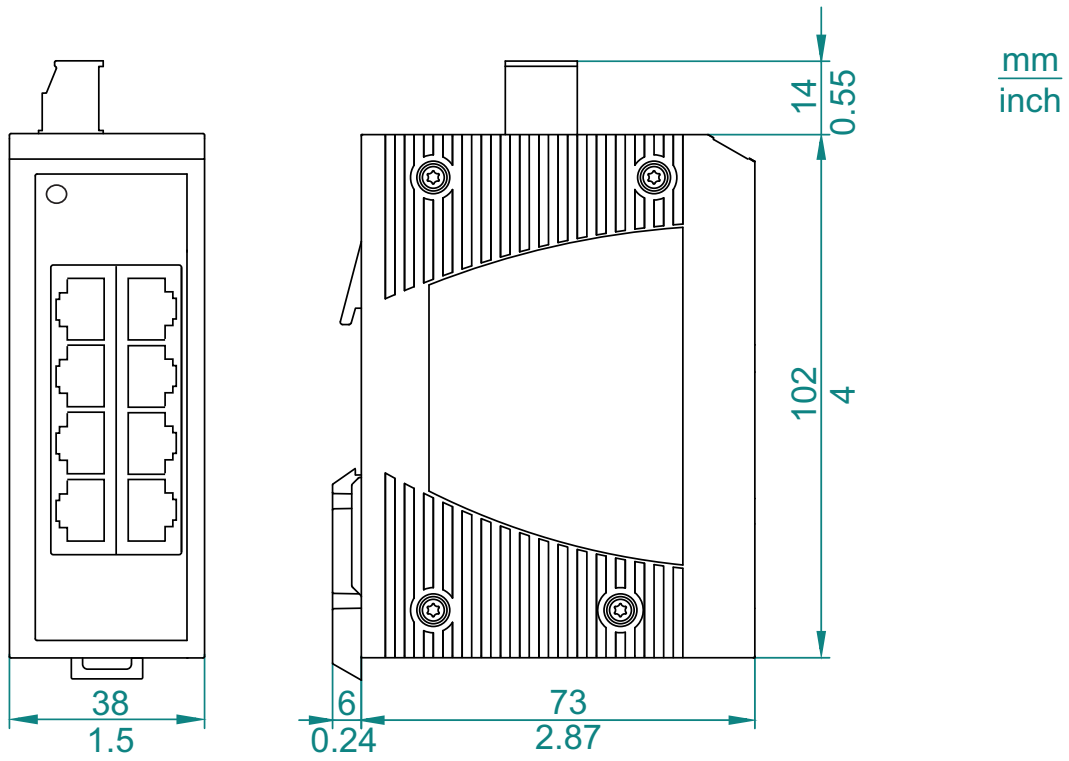

Figure 4: Device variant: TCSESSU083FN0

■ EMC and immunity

EMC interference emission		
Radiated emission		
FCC 47 CFR Part 15		Class A
EN 55032		Class A
Conducted emission		
FCC 47 CFR Part 15		Class A
EN 55032		Class A
EMC interference immunity		
Electrostatic discharge		
EN 61000-4-2 IEEE C37.90.3	Contact discharge	± 4 kV
EN 61000-4-2 IEEE C37.90.3	Air discharge	± 8 kV
Electromagnetic field		
EN 61000-4-3	80 MHz ... 1000 MHz	10 V/m
Fast transients (burst)		
EN 61000-4-4 IEEE C37.90.1	DC supply connection	2 kV
EN 61000-4-4 IEEE C37.90.1	Data line	4 kV
Voltage surges - DC supply connection		
EN 61000-4-5	line/ground	2 kV
EN 61000-4-5	line/line	1 kV
Voltage surges - data line		
EN 61000-4-5	line/ground	1 kV
Conducted disturbances		
EN 61000-4-6	150 kHz ... 80 MHz	10 V
Stability		
IEC 60068-2-6, test Fc	Vibration	5 Hz ... 8.4 Hz with 3.5 mm amplitude 8.4 Hz ... 150 Hz with 1 g
IEC 60068-2-27, test Ea	Shock	15 g at 11 ms

■ Network range

TP port	
Length of a twisted pair segment	max. 100 m

Table 3: TP port 10BASE-T / 100BASE-TX

■ Power consumption/power output

Maximum power consumption	Power output
1.5 W	5.3 Btu (IT)/h

■ Interfaces

TCSESSU083FN0	8 × 10/100 Mbit/s twisted pair with RJ45 sockets, 3-pin terminal block for power supply and grounding
---------------	---

■ Scope of delivery

Number	Article
1 ×	Device
1 ×	3-pin, pluggable terminal block for power supply
1 ×	Read Me document with attached licence activation key

■ Product/product code/product description

Product	Product code	Product description
TCSESSU with 8 ports	TCSESSU083FN0	8 × 10/100 TX

■ Underlying norms and standards

Name	
RCM	Australian Regulatory Compliance Mark (RCM) Australian Radiocommunications Standard 2008, Radiocommunications Act 1992
UL/IEC 61010-1, UL/IEC 61010-2-201	Safety for Control Equipment

Table 4: List of norms and standards

The device has an approval based on a specific standard or de facto standard only if the approval indicator appears on the housing.