

MG600C



The Forta MG600C is an electro-mechanical actuator for the control of two and three-way globe valves in:

- Heating and Cooling systems
- Air Handling systems

The MG600C has a compact yoke which is designed to fit directly onto VG210.. and VG310.. threaded globe valves without any linkage kits providing a quick and simple connection to the valves U brace bonnet and slotted stem connection.

The Forta Family of actuators utilise brushless DC motors with a high resolution control board to allow very fine fluid control in the VG210/VG310 globe valves.

The MG600C actuator is extremely flexible and allows for field configuration to either 3 point increase/decrease signals or various modulating control signals including sequencing. Feedback position is standard on all models.

The Manual override on the Forta can be operated without disconnecting the power to the board. Stroke Indicators on the yoke of the actuator provide clear visual indication to the valves opening position.

Specifications

Supply voltage	24 V AC +25%/-35%, 50–60 Hz
Power Consumption	
running	4W
rest	3W
Transformer sizing	30 VA

Running time

Modulating	60 s
Increase/decrease	300 s/60 s
Stroke range	9–30 mm
Factory set stroke	11 mm
Thrust, nominal	600 N
Duty cycle	20% Full load (80% half load, amb. temp.)

Analogue input (modulating control)

Voltage range	0–10 V
Impedance	min 100 k Ohm
Selectable input signals	0-10V / 2-10V, 0-5V / 2-6V
.....	5-10V, 6-10V

Digital inputs VH-VC (increase/decrease floating control)

Voltage across open input	24 V AC
Current through closed input	5 mA
Pulse time, min	20 ms

Output G1

Voltage	16 V DC
Load	25 mA, short-circuit proof

Output Y (Position feedback signal)

Voltage	2-10 V (0-100%)
Load	2 mA

Environmental

Operation temperature	-10 – +50 °C
Storage temperature	20 – +60 °C
Ambient humidity	max. 90% RH
Enclosure rating	IP 54
Sound power level	max. 32 dBA

S2-Auxillary Switch (Optional Accessory)

2 x SPDT	24V ac 4A AC1
----------------	---------------

(contacts made at 5% and 95% of end stroke)

Standards

Emission/Immunity	EMC 2004/108/CE
.....	according to EN 61326-1:2006
Heat	IEC-68-2-2
Humidity	IEC-68-2-3
Cold	IEC-68-2-1
Vibration	IEC-68-2-6
IP54 Housing Protection	EN60529

Materials

Housing	aluminium
Cover	ABS/PC plastic
Colour	aluminium/Red
Weight	1.8 kg

Ordering Table

Part number	Description	Type Designation
MG600C	Forta 600N; Compact Yoke; Universal control	MG600C-24FM T54 00
MG600C-S	Forta 600N; Compact yoke; Universal control with S2 end switches	MG600C-24FMS T54 00

Type designation and part number construction

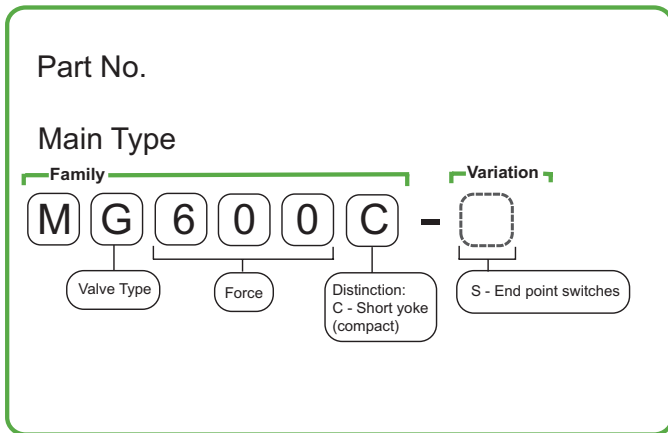
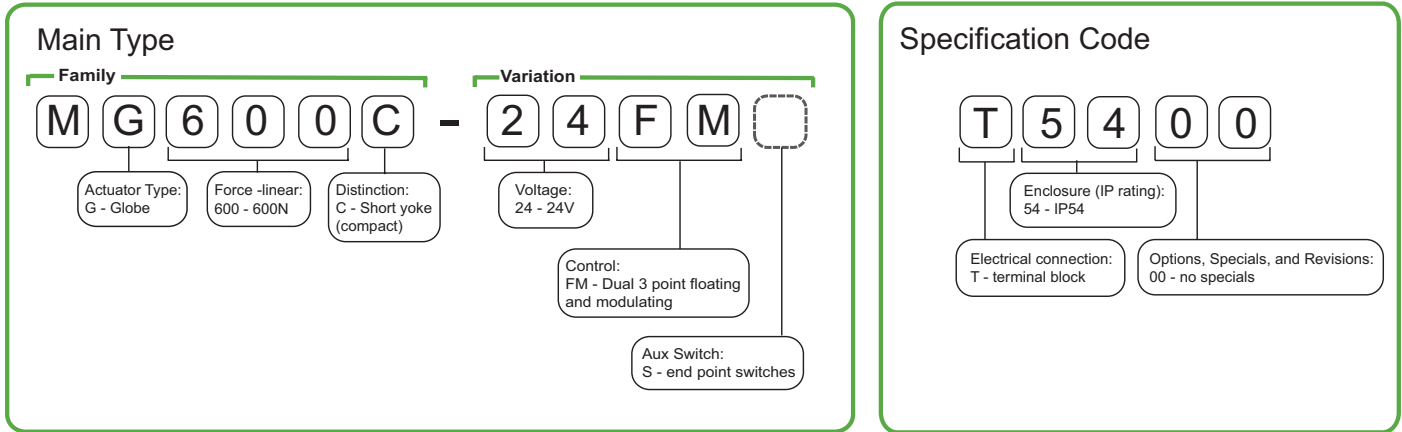

Accessories

Part number	Description
880 0104 000	S2 auxiliary end point switches
880 0109 000	FYH050 Forta Yoke Heater for fluid temperatures below 0°C

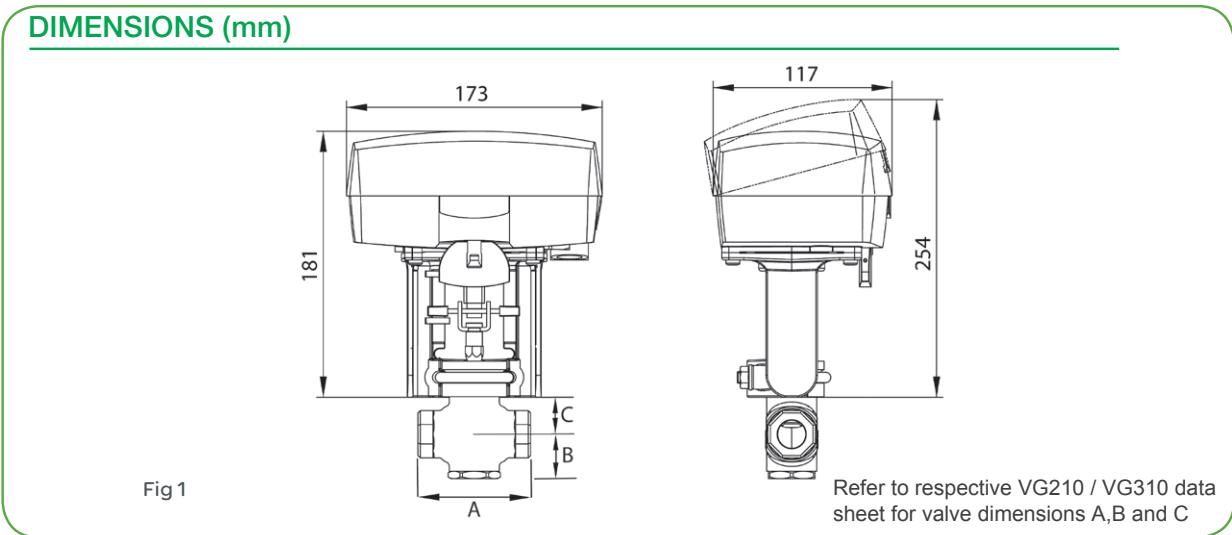

Function

Actuator

The actuator utilises a brushless DC motor to accurately position the main spindle via a gearbox in accordance to the control signal received from the controller.

Upon initial power up and activation of end stroke calibration switch 9 the actuator undertakes a full stroke cycle to learn the valve end stop positions and to program the S2 Auxiliary switch points.

Control signal

Forta MG600C actuator can either be controlled by an increase/decrease signal or by a range of proportional dc voltage signals.

The actuator is very flexible regarding the configuration of input signal selection and a direct or inverse actuation. Normally for an increase/decrease the actuator moves inwards (up) on an increase signal and outwards (down) on a decrease signal, see Settings.

Manual operation

The actuator can be manually overridden by operation of the manual override lever without disconnecting the power to the actuator. See figure 2. When the lever is lowered into the (MAN) position the power to the board is cut, by rotating the lever the actuator spindle can be raised or lowered.

Position feedback

Forta actuators are equipped with a 2 -10 V DC position feedback signal. 2V corresponds to the closed position and 10V to the open position.

End point switches

When fitted, the end point switches are calibrated during initial stroke learning procedure. The end switch points are made at 5% and 95% of calibrated stroke position. When actuators are controlled in normal or sequence control it is possible to use the end point switches to toggle when the valve is in the effective open or closed state.

Calibration

When the actuator is first installed on a valve and/or the valve is later maintained or serviced, calibration by Dipswitch No. 9 is mandatory. If calibration is not performed the actuator may not be able to properly modulate within the actual stroke range of the valve.

Maintenance

The actuator is maintenance-free.

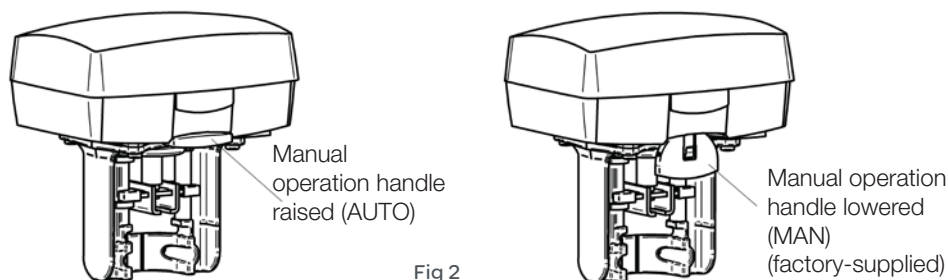

Mounting

The actuator may be mounted horizontally, vertically and in any position in between, but not upside down, see figure 3.

To mount the actuator on a VG210.. or VG310.. valve, slide the actuator onto the valve neck, aligning the slot on the valve stem adaptor fit into the groove on the cross bar. Then slide the 'U' brace over the groove on the valve neck and into the actuator yoke and secure the flanged nuts. It may be necessary to operate the manual override lever to align the actuator cross bar with the valve stem.

When installed with 3 conductors, where the control signal reference is connected to G0, the motor current of the actuator can cause varying voltage loss in the cable and thus in the reference level. Forta, which has a highly sensitive control signal input, can detect this varying signal and try to follow it, making it difficult for the actuator to find a stable position.

This variation may be accepted in simplified installations on the following conditions: the cables between the controller and actuator are shorter than 100 m, the cross-sectional area is larger than 1.5 mm² (AWG 16) and the cables are only connected to one actuator. Please refer to the section labelled "Wiring Examples" for wiring instructions.

Cable lengths

The power cables connected to G, G0 and G1 should be max. 100 m and have a cross-sectional area of min. 1.5 mm² (AWG 16).

Other control cables should be max. 200 m and have a cross-sectional area of min. 0.5 mm² (AWG 20).

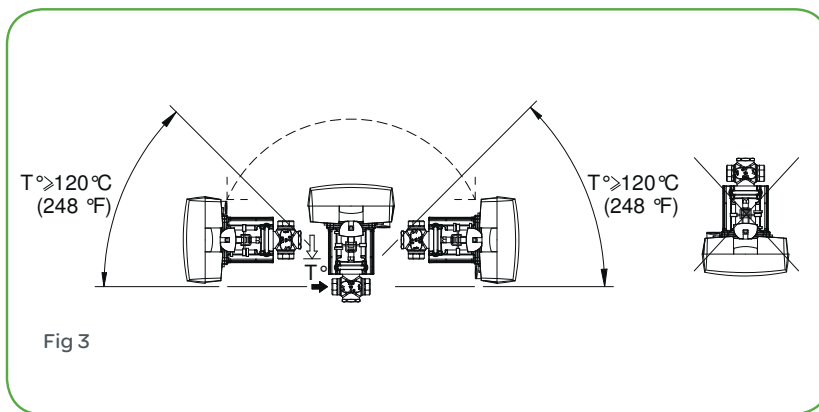

Fig 3

Electrical connections

Block	Function	Description
G	24 V AC	Supply voltage
G0	24 V AC return (Ground)	
X1	Input	Control Signal, proportional
MX	Input, neutral	
VH	Increase	Control Signal, Inc/Dec, 3 point floating (VH, VC short circuited to G0)
VC	Decrease	
G1	16 V DC	External Supply, 25mA max.
Y	0-100%	Feedback signal (2-10V)

ELECTRICAL CONNECTIONS / PCB layout

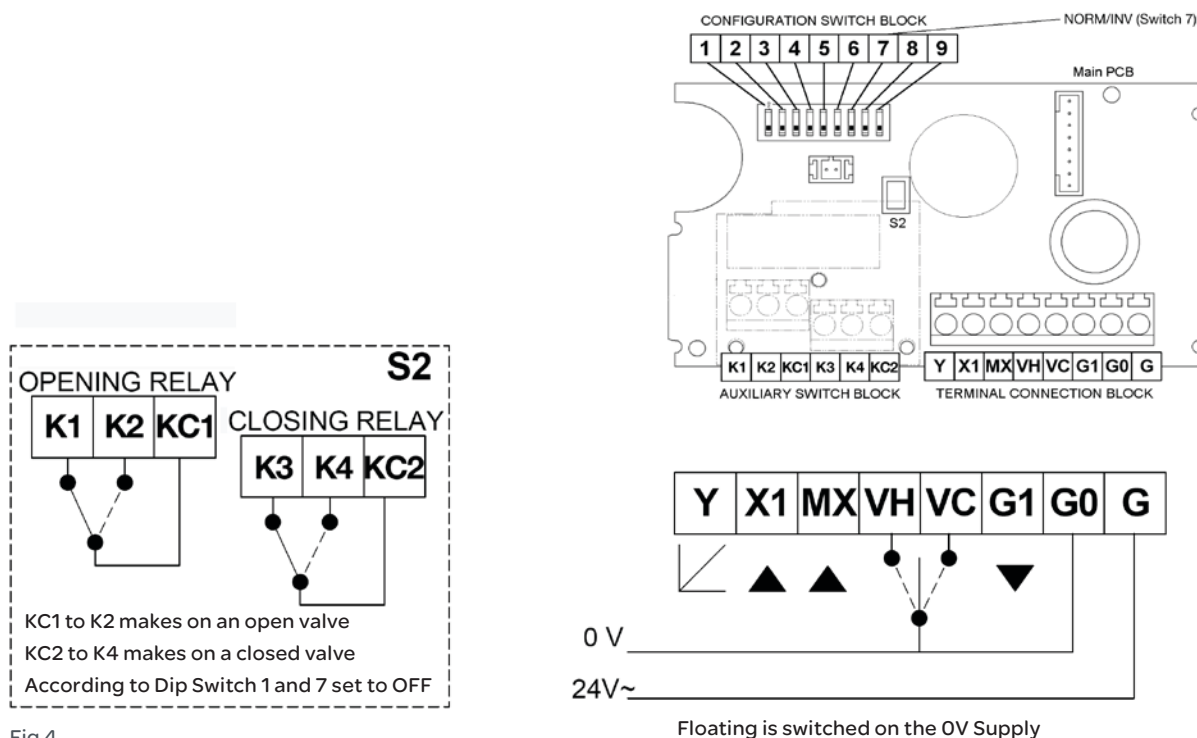
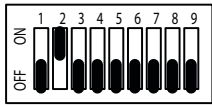

Fig 4

Wiring examples

FLOATING



50 VA transformer required per actuator

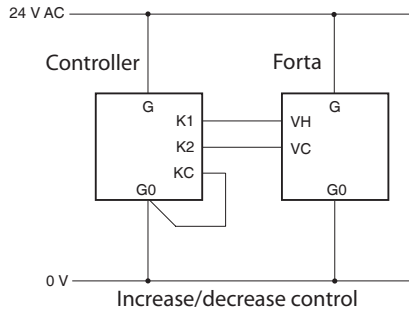

PROPORTIONAL

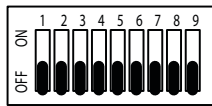

0-10 V



2-10 V

50 VA transformer required per actuator

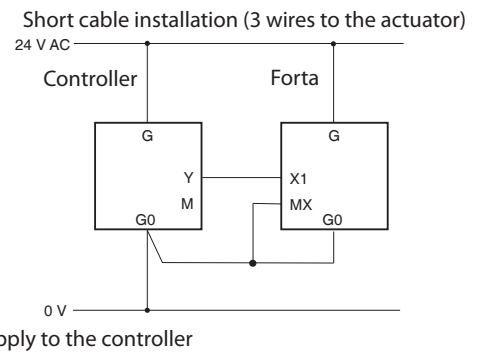
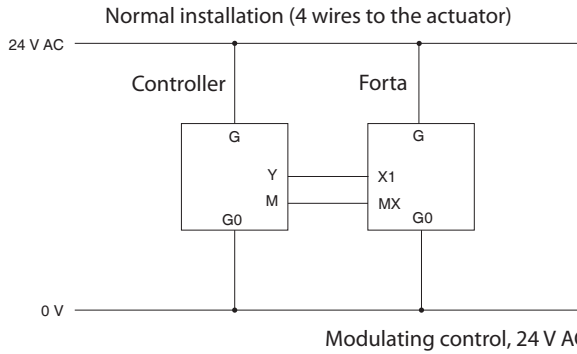

Program switch settings

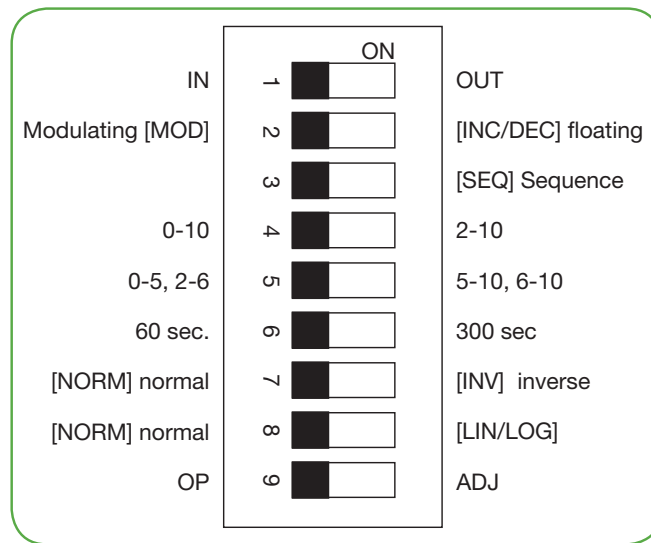

Switch Number	Description	Off Position ¹	On Position
1	Valve closing screw direction NB. Switch influences the feedback signal and end point relay switch	IN - Actuator retracts to 'close' the valve	OUT - Actuator extends to 'close' the valve This setting should not selected with the VG210../VG310.. valves
2	Control mode	Modulating (proportional) signal	Increase/Decrease (Floating) signal
3	Sequence operation (modulating control only)	Normal operation.	Sequence control [SEQ]
4	Input voltage range	0 to 10 Vdc.	2 to 10 Vdc.
5	Working voltage range (modulating sequence control)	0 to 5 Vdc (switch 4 off) or 2 to 6 Vdc (switch 4 on)	5 to 10 Vdc (switch 4 off) or 6 to 10 Vdc (switch 4 on)
6	Running time (floating Control) or Safety function (2-10V control)	60 sec. / safety Off	300 sec. / safety On
7	Direction of movement	Normal [NORM] - (Direct action) High voltage signal = 100% flow	Inverse [INV] - (Reverse Action) High Voltage signal = 0% flow
8	Valve characteristic	Normal	Linear / Logarithmic [LIN / LOG] (changes an EQ% valve to Linear or changes a Linear valve to quick opening)
9	Input signal/ Stroke Calibration	Operation (OP)	Stroke Callibration [ADJ] (monetary switch to undertake end position adjustment)

¹ Units are shipped with all nine switches in the default "off" position.

Notes for Dipswitch settings

Sequence (or parallel) control (switch 3 [SEQ]): allows two actuators (and valves) to be controlled by one control signal. Input voltage range (switch 4) and working voltage range (switch 5) define which part of the control signal the actuator will respond to.

Running Time / Safety Function (switch 6 [60s/300s]), Dual function :

- a) Defines full running time under floating control. Running time under modulation control is fixed at 60 seconds
- b) Selects security function in the event of a loss in control signal X1 (2-10V only). In this mode the valve will move to mid position if the control signal =0V. (e.g. to ensure the heating plant is providing some heat for occupants in the event of local BMS failure)

N.B.

For the actuator to register new settings of the switches, the supply voltage must first be removed by cutting power to the actuator or lowering the manual override lever, adjustment to switches 1-8 may then be made. Restoring the power or raising the manual override level will then initiate a zero point check prior to being operational under the new program settings.

Auxiliary End Switch Contacts

Auxiliary End Switch chart applicable when Switch 1 and Switch 7 is set to OFF.
(Stem up closed valve, Normal Function.)

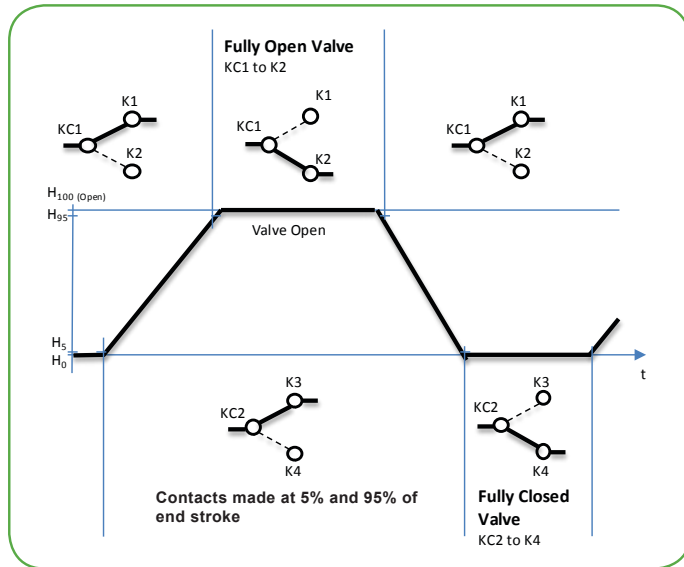

Normal / Inverse signal Control

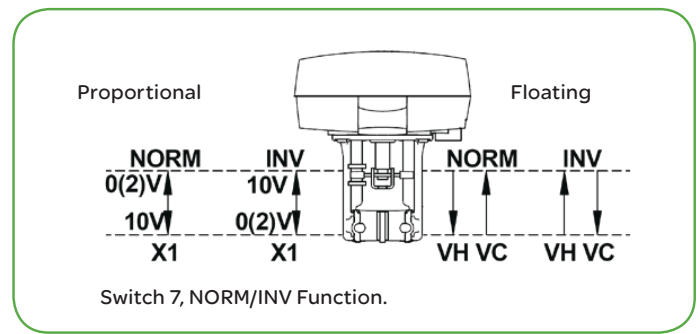

Switch 7 should be used to control the actuator direction of travel according to the signal input.
Switch 1, IN/OUT must be left OFF when connected to the VG210/VG310 valves to avoid conflict with the open and close relays

Actuator installation

The switches on the circuit board should be set before the actuator is installed. There are no other switches or potentiometers that can be set or adjusted.

To make an end position adjustment stroke calibration, momentary latch switch 9, »OP/ADJ« into its ADJ position and then back to its OP position. The supply voltage must be applied to the actuator and the manual operation lever

raised to initiate the calibration process. When an end position adjustment is made, Forta closes the valve and opens it fully.

The adjustment is finished by the actuator closing the valve again; the electronic circuitry then adjusts the stroke and the running time to the valve. The set values are stored in the EEPROM of the actuator so that they will remain after a loss of voltage.

When the end position adjustment is complete, the actuator starts to control the valve according to the control signal.

Hot media hazard. Before removing actuator from valve or opening the valve, ensure that the valve control medium is isolated and relieve the pressure. Work should only be carried out by a competent engineer.

