

# SKU DETAILS

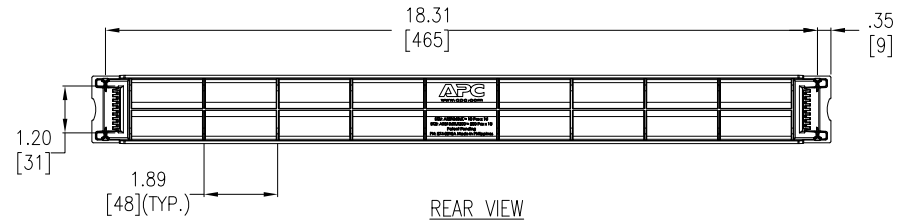

## APPLICATION DETAILS (10 UNITS PER SKU)

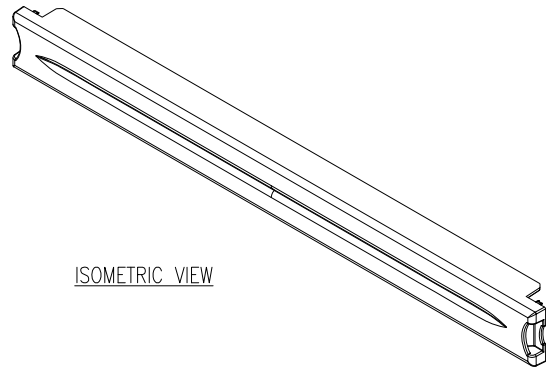
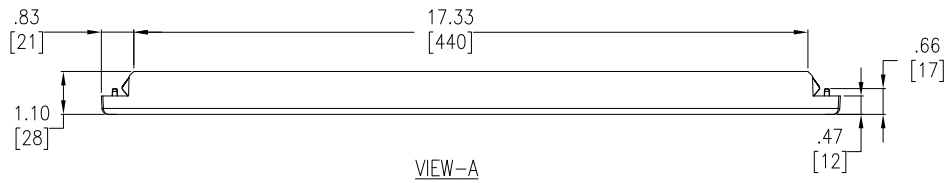
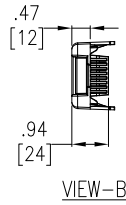
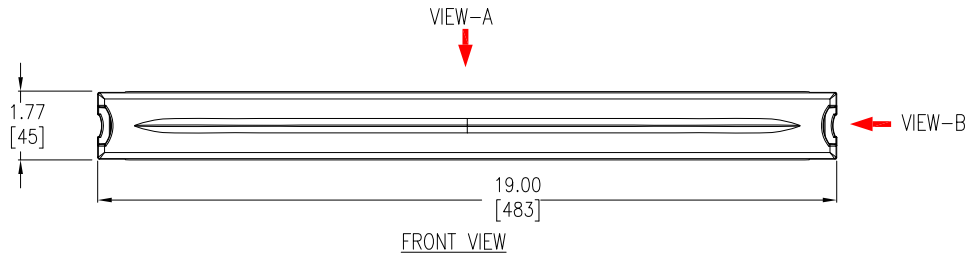
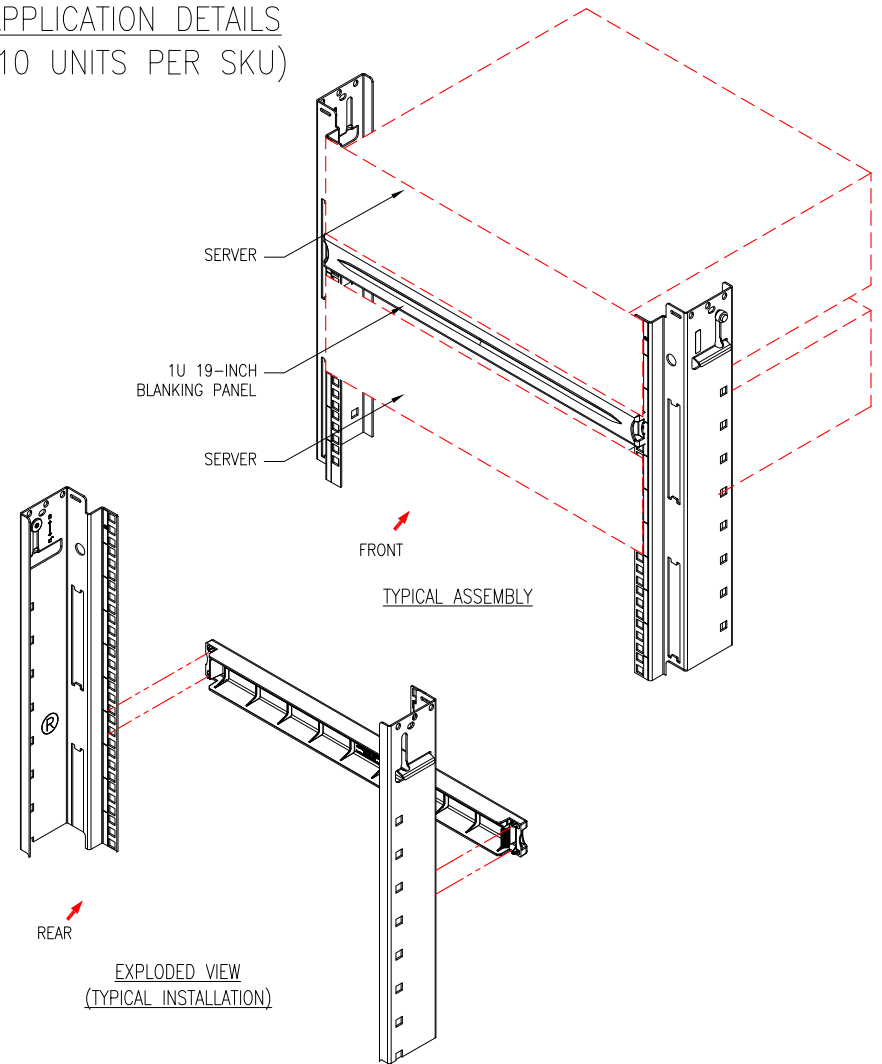

### NOTES:

1. INSTALLATION SHALL COMPLY WITH ALL APPLICABLE NATIONAL AND LOCAL CODES.
2. SEE PRODUCT DOCUMENTATION FOR FURTHER INFORMATION.
3. UNLESS OTHERWISE SPECIFIED, ALL DIMENSIONS ARE IN INCHES [MILLIMETERS].
4. WEIGHT OF UNIT IS 0.20 LBS. [0.09 kg].

THIS DRAWING AND SPECIFICATIONS HEREIN ARE THE PROPERTY OF SCHNEIDER ELECTRIC AND SHALL NOT BE COPIED, REPRODUCED OR USED IN WHOLE OR IN PART, AS THE BASIS FOR THE MANUFACTURE OR SALE OF ITEMS WITHOUT WRITTEN PERMISSION FROM SCHNEIDER ELECTRIC. THIS DRAWING IS BASED UPON LATEST AVAILABLE INFORMATION AND IS SUBJECT TO CHANGE WITHOUT NOTICE.



TITLE:  
1U 19-INCH BLACK MODULAR TOOLLESS  
AIRFLOW MANAGEMENT BLANKING PANEL  
MAIN MECHANICAL

PROJECT: STD SUBMITTAL DRAWINGS SHEET 1 OF 1

DWG NO: **AR8136ABLK**

DRAWN BY: K NAGENDRA 03-JAN-08

ENGINEER: M UHRHAN/B OLIVER 03-JAN-08

APPROVED BY: SHERIDANE SIVAK LARSENIS 03-JAN-08

REV **0**

PROJ  
ANGLE  
N/A