

TRANSFORMER SPECIFICATIONS:
 30KVA 3Ø 60 HZ
 PRIMARY VOLTAGE 480
 SECONDARY VOLTAGE 280/120
 115°C RISE
 185°C INSULATION SYSTEM
 APPROXIMATE WEIGHT: 755 LBS
 GUARANTEED SOUND LEVEL: 45 dB

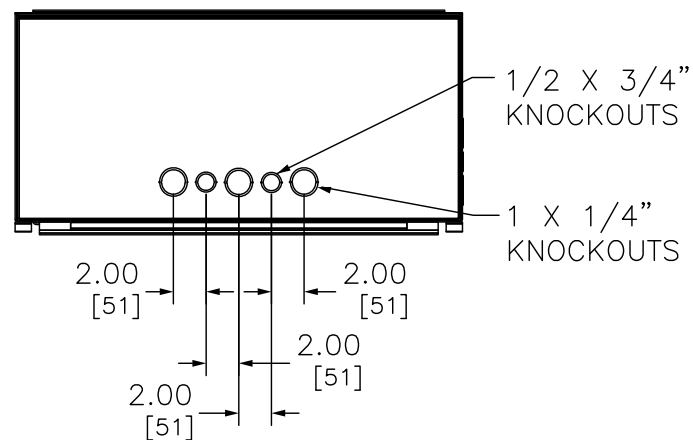

SEISMIC QUALIFICATION:
 TO BE COMPLIANT WITH THE SEISMIC REQUIREMENTS OF ASCE/SEI 7, THIS UNIT HAS BEEN QUALIFIED BY SHAKE TABLE TESTING THROUGH SELF CERTIFICATION TO ICC ES AC156. CONTACT YOUR LOCAL SQUARE D / SCHNEIDER ELECTRIC REPRESENTATIVE FOR RELATED QUESTIONS.

DUAL DIMENSIONS: INCHES / MILLIMETERS

- NOTES:
- 1) UL LISTED (MEETING UL 1062)
 - 2) NEMA 3R ENCLOSURE
 - 3) MINIMUM FIELD CLEARANCES: 13.00/[330] SIDE AND 21.00/[533] VERTICAL
 - 4) CENTER OF GRAVITY (CG) LOCATED AS SHOWN.

SEALED MINI POWER-ZONE
 TRANSFORMER
 CATALOG NO MPZB30T2F
 3 PHASE, 30 kVA
 PRIMARY 480, SECONDARY 120/240



DWG# PWEQP-TRFBC-0026
 NO.