

MiCOM Pxxx

PRP

Pxxx/EN PR/B11

Version	Software Version	See Table 2
	Hardware Suffix	See Table 2

Update Documentation

Note

The technical manual for this device gives instructions for its installation, commissioning, and operation. However, the manual cannot cover all conceivable circumstances or include detailed information on all topics. In the event of questions or specific problems, do not take any action without proper authorization. Contact the appropriate Schneider Electric technical sales office and request the necessary information.

Any agreements, commitments, and legal relationships and any obligations on the part of Schneider Electric including settlements of warranties, result solely from the applicable purchase contract, which is not affected by the contents of the technical manual.

This device **MUST NOT** be modified. If any modification is made without the express permission of Schneider Electric, it will invalidate the warranty, and may render the product unsafe.

The Schneider Electric logo and any alternative version thereof are trademarks and service marks of Schneider Electric.

All trade names or trademarks mentioned herein whether registered or not, are the property of their owners.

This manual is provided for informational use only and is subject to change without notice.

© 2013, Schneider Electric. All rights reserved.

PRP NOTES

CHAPTER 1

Date (month/year):	04/2013
Hardware suffix:	See Table 2 for details
Software version:	See Table 2 for details

CONTENTS

Page (AD) 1-

1	Parallel Redundancy Protocol (PRP) Notes	5
1.1	Introduction to PRP	5
1.2	Protocols	5
1.3	PRP Summary (IEC 62439-3 Clause 4)	5
1.4	Example of a PRP Network	6
1.5	Structure of a DAN	7
1.6	Communication between SANs and DANs	8
1.7	PRP Technical Data	10
2	PRP and MiCOM Functions	11
2.1	MiCOM Products and PRP	11
2.2	Planned PRP Product Releases	11
2.3	MiCOM S1 Studio Software	12
2.4	MiCOM Relay Configuration	12
2.5	Firmware Changes	12
2.5.1	Main Card	12
2.5.2	Ethernet Card	13
2.6	Hardware Changes	13
2.7	PRP Parameters	13
2.8	Product Requirements	14
2.8.1	Abbreviations and Acronyms	15

TABLES

Page (AD) 1-

Table 1 - MiCOM model numbers for PRP options	11
Table 2 - MiCOM relay/IED Models which will support PRP	12
Table 3 - PRP parameter values (for PRP Protocol Version 1)	13

FIGURES

	Page (AD) 1-
Figure 1 - PRP Redundancy Network	6
Figure 2 - Communication between two DANs	7
Figure 3 - Frames without and with RCT and padding	9

1 PARALLEL REDUNDANCY PROTOCOL (PRP) NOTES

1.1 Introduction to PRP

This section gives an introduction to the Parallel Redundancy Protocol (PRP); and how it is implemented on MiCOM-based products manufactured by Schneider Electric.

1.2 Protocols

Industrial real-time Ethernets typically need much better levels of availability and uninterrupted operation than normal office-type Ethernet solutions. For power networks, even a short loss of connectivity may result in a significant loss of functionality or impaired safety. To recover from a network failure, various redundancy schemes have been considered, including: Rapid Spanning Tree Protocol (RSTP), Media Redundancy Protocol (MRP) and Parallel Redundancy Protocol (PRP). The key properties of these are as follows:

- | | |
|-------------|--|
| RSTP | this uses mesh-based topologies and computes a tree, based on path costs and priorities. In case of network failure, a typical reset time for RSTP-based system is normally a few seconds. |
| MRP | this uses ring-based topologies. In case of network failure, the network is broken into two separate lines, which are reconnected by de-blocking the previously blocked part. The guaranteed reset time for MRP protocol-based systems is typically around 100ms. |
| PRP | this does not change the active topology as it uses two independent networks. Each message is replicated and sent over both networks. The first network node to receive it acts on it, with all later copies of the message being discarded. Importantly, these details are controlled by the low-level PRP layer of the network architecture, with the two networks being hidden from the higher level layers. Consequently, PRP-based networks are continuously available. |

Power networks need to be able to respond to problems very quickly (typically in less than 10ms), and PRP is the only available protocol which is quick enough to achieve this. The PRP protocol used in the MiCOM relay/IEDs is defined in the IEC62439-3 (2012) standard and is configured using the existing redundant Ethernet card(s).

1.3 PRP Summary (IEC 62439-3 Clause 4)

A summary of the main PRP features is given below:

- Ethernet redundancy method independent of any industrial Ethernet protocol or topology (tree, ring or mesh).
- Seamless switchover and recovery in case of failure, which supports real-time communication.
- Supervises redundancy continuously for better management of network devices.
- Suitable for hot swap - 24 hour/365 day operation in substations.
- Allows the mixing of devices with single and double network attached nodes on the same Local Area Network (LAN).
- Allows laptops and workstations to be connected to the network with standard Ethernet adapters (on double or single attached nodes).
- Particularly suited for substation automation, high-speed drives and transportation.

1.4 Example of a PRP Network

Essentially a PRP network is a pair of similar Local Area Networks (LANs) which can be any topology (tree, ring or mesh). An example of a PRP network is shown in Figure 1:

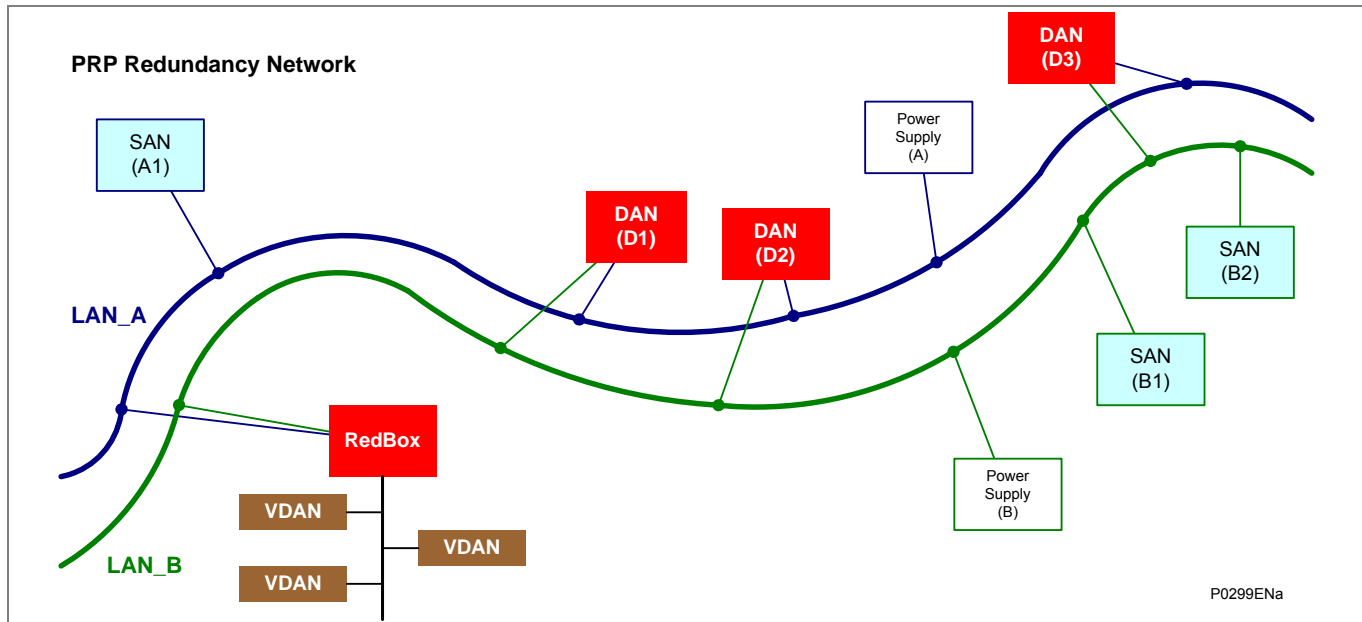

Figure 1 - PRP Redundancy Network

Figure 1 shows two similar Local Area Networks (LANs) which have various Nodes in common. The key features of these networks include:

- With the exception of a RedBox (see below), no direct cable connections can be made between the two LANs.
- Each of these LANs can have one or more Single Attached Nodes (SANs). These are normally non-critical devices that are attached only to a single network. SANs can talk to one another, but only if they are on the same LAN.
- Matched pairs of devices which are critical to the operation of the overall scheme are connected one to each network at single Dual Attached Nodes (DANs).
- To be sure that network messages (also known as frames) are transferred correctly to each device at the DAN, each device must have the same Media Access Control (MAC) code and Internet Protocol (IP) address. This will also mean that TCP/IP traffic will automatically communicate with both of the paired devices, so it will be unaware of any two-layer redundancy or frame duplication issues.
- A Redundancy Box (RedBox) is used when a single interface node has to be connected to both networks. The RedBox can talk to all other nodes. So far as other nodes are concerned, the RedBox behaves like a DAN, so a RedBox is also called a Virtual Doubly Attached Node (VDAN). The RedBox must have its own unique IP address.
- Transmission delays can also be different between related Nodes of the two LANs.
- Each LAN (i.e. LAN_A and LAN_B) must be powered from a different power source and must be failure independent.
- The two LANs can differ in terms of performance and topology, but the Ethernet interface to the relay must be made using an optical fibre connection with an ST connector type. There is no need for an optical interface away from the relay.

1.5 Structure of a DAN

Each DAN has two ports that operate in parallel. They are attached to the upper layers of the communications stack through the Link Redundancy Entity (LRE) as in Figure 2:

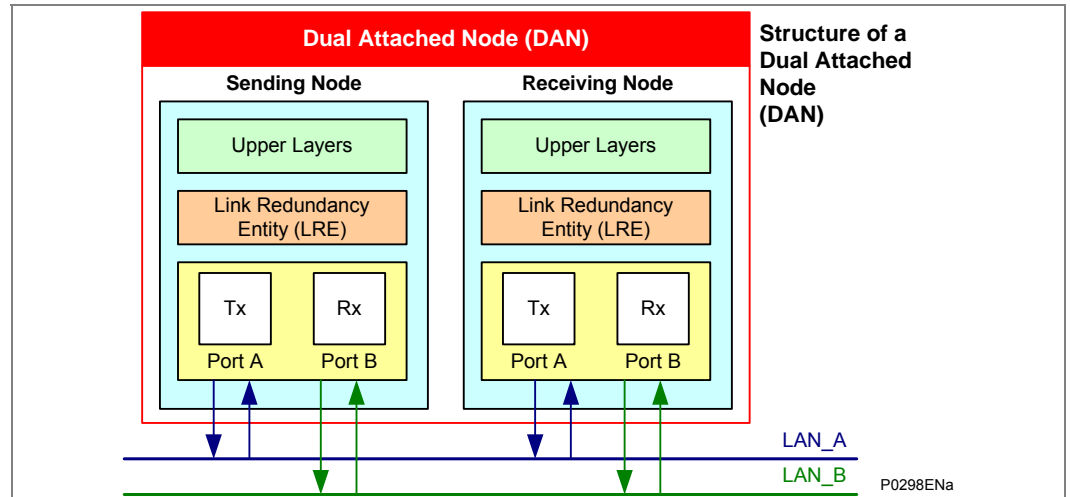

Figure 2 - Communication between two DANs

The LRE has two main tasks:

- handling message frames and
- management of redundancy

When an upper layer sends a frame to the LRE, the LRE replicates the frame and sends it through both its ports at nearly the same time. The two frames move through the two LANs with slightly different delays, ideally arriving at the destination node within a small time window.

When receiving frames, the LRE forwards the first frame it received to its upper layers and then discards the duplicate.

As both DAN nodes have the same MAC and IP addresses, this makes redundancy transparent to the upper layers. This allows the Address Resolution Protocol (ARP) to work in the same way as with a SAN. Accordingly, to the upper layers of a DAN, the LRE layer shows the same interface as the network adapter of a non-redundant adapter.

To manage redundancy, the LRE:

- Adds a 32-bit Redundancy Check Tag (RCT) to each frame it sends and
- Removes the RCT from each frame it receives

1.6 Communication between SANs and DANs

A SAN can be connected to any LAN and can communicate with any other SAN or DAN on the same LAN. However, a SAN which connected to one LAN can not communicate directly to a SAN which is connected to the other LAN.

A DAN is connected to both LANs and can communicate with the RedBox or any other DANs or any SANs on either network. For communication purposes, a DAN views the RedBox as a VDAN.

When a SAN generates a basic frame, it sends the frame only onto the LAN to which it is connected.

Originating at the SAN, a typical frame contains these parameters:

- dest_addr Destination Address
- src_addr Source Address
- type Type
- data
- fcs Frame Check Sequence (i.e. extra checksum characters added to allow error detection and correction)

The frame from the SAN is then received by the DAN; which sends the frame to its upper layers, which act accordingly.

When a DAN generates a frame, it needs to send the frame onto both of the LANs to which it is connected. When it does this, it extends the frame by adding the 32-bit Redundancy Control Trailer (RCT) into the frame.

The RCT consists of these parameters:

- 16-bit Sequence Number
- 4-bit LAN identifier, 1010 (0xA) for LAN_A and 1011 (0xB) for LAN_B
- 12-bit frame size
- PRP suffix

Note The Sequence number is a measure of the number of messages which have been sent since the last system reset. Each time the link layer sends a frame to a particular destination the sender increases the sequence number corresponding to that destination and sends the (nearly) identical frames over both LANs.

Accordingly, originating at the DAN, a typical frame then contains these parameters:

- dest_addr Destination Address
- src_addr Source Address
- type Type
- lsdu Link Service Data Unit
- Padding if needed
- RCT data:
 - 16-bit sequence number:
 - 4-bit LAN identifier

- 12-bit frame size
 - 16-bit PRP suffix (0X88 0XFB)
 - fcs Frame Check Sequence

<i>LSDU</i>	<i>The Link Service Data Unit (LSDU) data allows PRP frames to be distinguished from none-PRP frames.</i>
<i>Padding</i>	<i>After the LSDU data, there may be some data padding. This is added to frames which would otherwise be too short for conventional network traffic (minimum frame size is 64 octets).</i>
<i>Size</i>	<i>The frame size will vary depending on the contents of the frame and how it has been tagged by the various SANs and DANs. In VLANs, frame tags may be added or removed during transit through a switch. To make the length field independent of tagging, only the LSDU and the RCT are considered in the size.</i>

Figure 3 shows the frame types with different types of data.

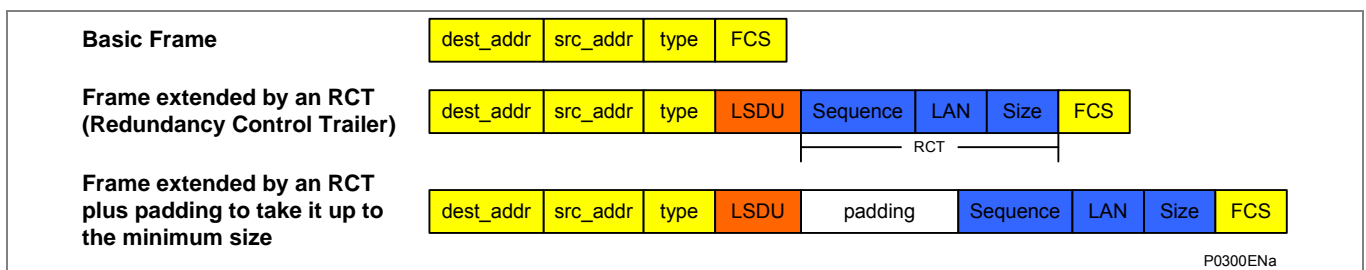

Figure 3 - Frames without and with RCT and padding

The key points about these differing frame structures is that:

- SANs do not implement any redundancy features, so they generate basic frames which SANs and DANs can understand.
- SANs can still understand the frames that come from DANs, as SANs ignore the RCT components in frames which come from DANs (a SAN can not distinguish the RCT from the IEEE802.3 padding)
- If a DAN receives a frame which does not include the RCT component, it sends a single copy of the frame to its upper layers.
- If a DAN receives a frame which does include the RCT component, it does not send a duplicate copy of the frame to its upper layers.
- If a DANP can not identify that the remote Node is a DAN, it inserts no RCT.

Rejection Algorithm

A Nodes table maintains a list of all the Nodes (SANs and DANs) on each network. This table is used by the rejection algorithm to assess the possibility of frames being duplicates and for network integrity monitoring. The table maintains a list of all the sequence numbers so it can keep track of the frames which have been sent.

For every node on BOTH networks, the table also maintains:

- The expected next sequence number (so it can establish whether messages are not being received or are being received in an incorrect order)
- Message counts to show how many messages have been received
- Error counts to show whether frames were received out-of-order or were not received or were sent/received on the incorrect LAN

- A time field to keep track of when a frame was last received from the node
- An indicator to track whether the node is a SAN or not

The receiver scans the frames starting from the end and uses the algorithm to analyse the frames it has already received and the various data included in the current frame. The algorithm then combines the frame data with the information in the Nodes table to decide whether the frame is the first one it has received, or whether it is a candidate for rejection.

1.7**PRP Technical Data**

- One VLAN tag supported.
- 128 VDANs supported.
- Up to 100Mbit/s full duplex Ethernet.
- Dynamic frame memory allocation (page manager).
- Configurable duplicate detection.
- Wishbone interface for configuration and status registers.
- CPU port interface - Ethernet or Wishbone.
- Support for link-local protocols - CPU may send to specific ports only - CPU knows receive port.
- Configurable frame memory and queue length.
- Duplicate detection with configurable size and aging time.
- MAC address filtering (8 filter masks for interlink, 6 for CPU).
- Support for interfaces with or without Ethernet preamble.

2 PRP AND MICOM FUNCTIONS

2.1 MiCOM Products and PRP

The PRP functions being introduced as part of the overall MiCOM product range provide additional functionality, which is backwards compatible with existing Schneider Electric MiCOM equipment. This means that existing MiCOM relays/IEDs can be used on networks which use PRP functions, with no changes being made to those relays/IEDs.

The new MiCOM products that use the PRP, will interrogate other equipment to determine the equipment model number, and then use the model number to decide (at runtime), whether that particular item of equipment can support PRP or not.

The model number to denote PRP functionality uses the Digit 7 Hardware option. This is shown in Table 1:

Hardware Option	Type	Example Model Number
"N" at digit number 7	Modulated PRP board	P14221 <u>N</u> A6M0440J
"P" at digit number 7	Unmodulated PRP board	P14221 <u>P</u> A6M0440J

Table 1 - MiCOM model numbers for PRP options

The MiCOM relay/IED firmware has been modified to allow the PRP options to be accepted for the power-up tests in addition to the implementation of the supervision frame transmission.

2.2 Planned PRP Product Releases

To clarify the dependency between the new firmware and the hardware option for PRP, the PRP feature is normally associated with a major firmware release. The planned releases are shown in Table 2 below:

Relay	SW	HW	Previous Platform	Released Platform
P141	46 (cyber)	J	M2.3	M2.5
P142 *	46 (cyber)	J	M2.3	M2.5
P143 *	46 (cyber)	J	M2.3	M2.5
P144	46 (cyber)	J	M2.3	M2.5
P145	46 (cyber)	J	M2.3	M2.5
P741 P743	51	K	L4.6	L4.10 without Lx_NO_ctse10045
P742	51	J	L4.6	L4.10 without Lx_NO_ctse10045
P746	02	K	K4.8	L4.10
P642	04 (cyber)		L6.4	L6.5
P643 *	04 (cyber)		L6.4	L6.5
P645	04 (cyber)		L6.4	L6.5
P543 *	C0/D0 (cyber)		M4.x	M4.2
P544	C0/D0 (cyber)		M4.x	M4.2
P545	C0/D0 (cyber)		M4.x	M4.2
P546 *	C0/D0 (cyber)		M4.x	M4.2
P547	D0 (cyber)		M4.x	M4.2
P443	D0 (cyber)		M4.x	M4.2

Relay	SW	HW	Previous Platform	Released Platform
P445	F0 (cyber)		M4.x	M4.2
P446	D0 (cyber)		M4.x	M4.2
P841A	C0/D0 (cyber)		M4.x	M4.2
P841B	C0/D0 (cyber)		M4.x	M4.2
P441 P442 P444	C7	J	M3.1	M3.2
P442 P444	D6	K	L5.4 + NCIT	L5.7 + NCIT
P34x				
P443	B0		L7.x	
P445	E0		L7.x	
P446	B0		L7.x	
P543	A0/B0		L7.x	
P544	A0/B0		L7.x	
P545	A0/B0		L7.x	
P546	A0/B0		L7.x	
P547	B0		L7.x	
P642	04		L6.4	L6.5
P643	04		L6.4	L6.5
P645	04		L6.4	L6.5
P841A	A0		L7.x	
P841B	B0		L7.x	
P849	A0A			
P241	C7	J	L3.1_a	L4.10
P242 P243	C7	K	L3.1_a	L4.10

Table 2 - MiCOM relay/IED Models which will support PRP

The MiCOM relay/IED cortecc shows that the Hardware options identified in Table 1 are only available with the new firmware version.

2.3 MiCOM S1 Studio Software

The addition of the PRP feature has no impact of the MiCOM S1 Studio support files so there is no need to upgrade any MiCOM S1 Studio software.

2.4 MiCOM Relay Configuration

There is no need to change the configuration of any relay (as relays which include support for PRP will be able to recognize other devices which support PRP).

2.5 Firmware Changes

2.5.1 Main Card

The relay main card has only a minimal change for the implementation of the PRP Protocol. The change required is to recognize the two new hardware options (see Table 1) during the power up tests. For the two new options, the relay firmware will verify the presence of the Ethernet card. The relay firmware will not be able to differentiate between the PRP and non-PRP variants of the Ethernet card; as the only difference between them is a different FPGA.

2.5.2 Ethernet Card

An extension to the Ethernet board software is needed to support the transmission of the PRP supervision frame. To keep the same number of released software executables this feature is integrated into the standard software with the transmission of the supervision frame being controlled by the IED/relay model number.

2.6 Hardware Changes

The PRP protocol is implemented using the existing dual redundant Ethernet card as a starting point. The PRP Frame management is achieved by re-programming the Field-Programmable Gate Array (FPGA).

The low-level management of the redundant frames is performed within the FPGA; this being defined as the Link Redundancy Entity (LRE). This will involve the addition of the Redundancy Check Tag (RCT) to a frame to be transmitted; this identifies the LAN and the sequence number of the message over the two networks. The FPGA is also responsible for the stripping of the RCT from received frames and discarding the duplicated messages such that only a single application frame is received by the Ethernet processor.

The LRE functionality of the supervision frame transmission is performed by the Ethernet processor card.

The new version of the dual redundant Ethernet card is based on the ZN0071 part 007, but has a new part number of 2072082 (Part 9 for the modulated IRIG-B option and Part 10 for the Unmodulated IRIG-B option).

Warning

The main feature of PRP is a high level of network availability due to the presence of two LANs. The dual redundant Ethernet card provides watchdog contacts to show a link failure on either of the dual redundant Ethernet interfaces. To use this feature effectively, it is very strongly recommended that the watchdog contacts are connected to the supervision system.

2.7 PRP Parameters

The Redundant Ethernet standard (IEC 62439-3:2011/FDIS A) defines several parameters for the PRP protocol; these being fixed at a default value within this release. The following values are set:

Parameter	Value	Description
Supervision Frame Multicast Address	01-15-4E-00-01-00	Target MAC Address for multicast supervision frame
Life Check Interval	2 seconds	Period between transmission of supervision frames
PRP Mode	Duplicate Discard	This is normal PRP mode, Duplicate address will not be supported.
Node Forget Time	60 s	
Entry Forget Time	400 ms	Duration that the received message Sequence number will be held to discard a duplicate message.
Node Reboot Interval	500ms	Duration following reboot for which no PRP frames should be transmitted.

Table 3 - PRP parameter values (for PRP Protocol Version 1)

2.8 Product Requirements

Here is a list of the main Product Requirements for MiCOM products which support PRP:

- The MiCOM relay/IED provides two redundant Ethernet ports using PRP.
- Redundancy protocols other than PRP (e.g. RSTP and MRP) are not implemented within this project.
- The MiCOM relay/IED must be connected to the redundant Ethernet network as a Double Attached Node (DAN) using PRP (DAN using PRP is known as DANP)
- The redundant Ethernet interface must be made using an optical fibre connection with an ST connector type.
- The management of the PRP redundancy is transparent to the application data provided via the Ethernet interface.
- The PRP option is available with any of the existing protocol options via the Ethernet Interface (IEC61850, DNP3.0)
- Loss of one of the LAN connections to the device does not cause any loss or degradation to the Application data over the Ethernet interface.
- The redundant Ethernet card provides watchdog contacts to show a link failure on either of the redundant Ethernet interfaces.
- The link fail alarm within the MiCOM relay/IED firmware can not detect the failure of the link on the redundant Ethernet interface.
- The MiCOM relay/IED supports the transmission of the PRP Supervision frame at a fixed time period (LifeCheckInterval) of 2s (+/- 100ms)
- The Media Access (MAC) Address for the two physical Ethernet interfaces must be the same and is defined by the MAC address for the Ethernet card (this is set during manufacturing).
- Each supervision frame includes a sequence number as defined in the IEC 62439-3:2011/FDIS specification. This will be incremented for each supervision message and the value will start from zero following a system restart.
- The IP address for the two physical Ethernet interfaces must be the same and will normally be defined using the MiCOM S1 Studio tool.
- The MiCOM relay/IED will not process received supervision frames to provide supervision of the redundant network.
- The MiCOM relay/IED does not provide for the PRP management to be configured (via either the MiCOM relay/IED HMI or the Ethernet interface). Accordingly, the default values (as defined within this document) are used for all PRP parameters.
- The performance of the Ethernet Interface is not degraded by using the PRP interface.
- We are stating that the PRP interface of the Px40 relay will support up to 32 connected DANP nodes. Note that the maximum number of connected DANP nodes is dependent on the memory size inside the FPGA which is used to manage the messages from each DANP mode and reject duplicates.

2.8.1

Abbreviations and Acronyms

Abbreviations / Acronyms	Meaning
CRC	Cyclic Redundancy Check
DAN	Dual Attached Nodes
DANP	Double Attached Node implementing PRP
FPGA	Field-Programmable Gate Array
HMI	Human Machine Interface
IED	Intelligent Electronic Devices
IP	Internet Protocol
LAN	Local Area Network
LRE	Link Redundancy Entity
MAC	Media Access Control
MRP	Media Redundancy Protocol
PRP	Parallel Redundancy Protocol
RCT	Redundancy Check Tag
RedBox	Redundancy Box
RSTP	Rapid Spanning Tree Protocol
SAN	Singly Attached Node
TCP	Transmission Control Protocol
VDAN	Virtual Doubly Attached Node

Notes:



Customer Care Centre

<http://www.schneider-electric.com/cc>

Schneider Electric

35 rue Joseph Monier
92506 Rueil-Malmaison
FRANCE

Phone: +33 (0) 1 41 29 70 00

Fax: +33 (0) 1 41 29 71 00

www.schneider-electric.com

Publication: Pxxx/EN PR/B11 Software Version: See Inside Hardware Suffix: See Inside

Publisher: Schneider Electric

04/2013