

871CR Series Contacting Conductivity and Resistivity Sensors and Accessories



The Schneider Electric® brand 871CR Series contacting conductivity and resistivity sensors are suitable for ionic measurements in most clean water applications found in power, semiconductor, pharmaceutical, and other process industries. Application flexibility is enhanced by the choice of insulator materials and numerous mounting hardware accessories. These sensors conform to all applicable European Union Directives when used with Models 876CR and 870ITCR Intelligent Transmitters, or a Model 875CR Intelligent Analyzer.

INTRODUCTION

The 871CR Series Sensors measure the conductivity or resistivity of a solution. These sensors, together with 876CR or 870ITCR Intelligent Electrochemical Transmitter, or an 875CR Intelligent Electrochemical Analyzer, are used in a broad range of applications including critical ultrapure water resistivity measurements found in the semiconductor industry, and conductivity measurements used in power and pharmaceutical water measurements.

APPLICATION FLEXIBILITY

Two cell factors, 0.1 cm^{-1} and 10 cm^{-1} , are available for ionic measurements. The cell factor used is dictated by the measurement range desired. The sensors are constructed of different materials, standard and extended insertion lengths, and many mounting options. The sliding bore piece design provides easy installation and reduces replacement costs since normally the mounting hardware is permanently installed in the process system.

*Equipment should be installed, operated, serviced, and maintained only by qualified personnel.
No responsibility is assumed by Schneider Electric for any consequences arising from the use of this material.*

NUMEROUS MATERIAL SELECTIONS

The 0.1 cm⁻¹ cell factor sensors are concentric cylinders constructed with titanium or Monel electrodes. Titanium is highly corrosion resistant and is compatible with most fluids except acidic fluorides. For applications involving acidic fluorides, Monel electrodes are recommended. The 10 cm⁻¹ cell factor sensors use graphite electrodes. A choice of insulator and process connection materials permits chemical compatibility and helps ensure measurement integrity at elevated temperatures and pressures.

QUALITY AND UNIFORMITY

871CR sensors are manufactured under strict guidelines of quality and uniformity. All 0.1 cm⁻¹ sensors are built and tested to be within 1% of their nominal cell factor. Actual cell factors are stamped on the sensor housing or cable. A choice of cell factor determination and certification is available. Ultrapure water resistivity applications benefit from the -R option, ultrapure water cell factor determination.

Conductivity measurements and applications requiring USP23/24 compliance can specify the -S option, NIST traceable conductivity calibration and calibration certificate.

Simply enter the geometrical cell factor and temperature cell factor into a calibrated 876CR or 870ITCR Transmitter, or 875CR Analyzer, and you have a fully calibrated measurement system.

MEASUREMENT RANGES

Figure 1 depicts the Conductivity/Resistivity Ranges of common aqueous solutions at 25°C. Table 1 lists the supported measurement ranges with different Cell Factors and with Models 876CR, 870ITCR, or 875CR.

Figure 1. Conductivity/Resistivity Ranges of Common Aqueous Solutions at 25°C

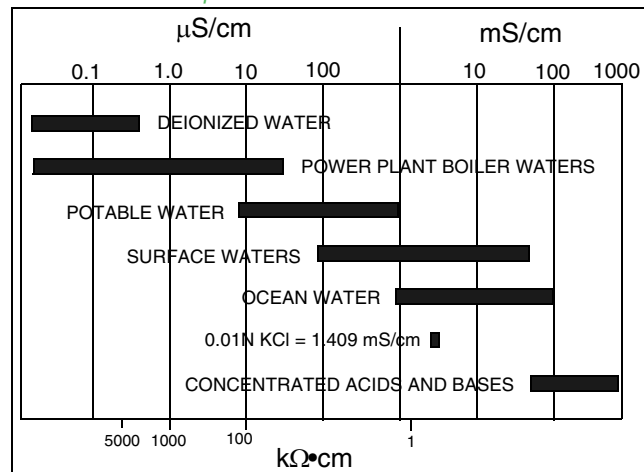

Table 1. Measurement Ranges with 876CR or 870ITCR Transmitter, or 875CR Analyzer

Supported Measurement Ranges			
871CR Cell Factor	Unit of Measure	With Model 876CR, 870ITCR	With Model 875CR
		Upper Range Settings (a)	Upper Range Settings (a)
0.1 cm ⁻¹	MΩ•cm	2, 5, 10, 15, 20	0.1, 0.2, 0.5, 2, 5, 10, 20
	kΩ•cm	50, 100, 500, 1000, 5000	50, 100, 200, 500, 1000, 2000, 5000
	mS/m	0.2, 0.5, 1, 2, 5, 10, 20	0.1, 0.2, 0.5, 1, 2, 5, 10, 20
	μS/cm	1, 2, 5, 10, 20, 50, 100, 200	1, 2, 5, 10, 20, 50, 100, 200
10.0 cm ⁻¹	kΩ•cm	10, 50	10, 50
	mS/m	50, 100, 200, 500	10, 20, 50, 100, 200, 500, 1000, 2000
	S/m	0.2, 0.5, 1, 2	0.1, 0.2, 0.5, 1, 2
	μS/cm	200, 500, 1000, 2000, 5000	200, 500, 1000, 2000, 5000
	mS/cm	0.2, 0.5, 1, 2, 5, 10, 20	0.2, 0.5, 1, 2, 5, 10, 20

a. Absolute (without temperature compensation) measurements exceed the range setting by approximately five times.

SENSOR APPLICATIONS

1000 OHM RTD FOR ACCURATE TEMPERATURE COMPENSATION

All 871CR sensors incorporate a 1000 Ω, 3-wire RTD integral temperature transducer whose signal is used by the transmitter for temperature compensation and measurement.

The 0.1 cm⁻¹ sensors offer a choice of accuracy associated with this device. The -A cell factor selection utilizes a standard Class B, 1000 Ω RTD. This RTD meets DIN 43760 requirements for Class B accuracy; ±[0.30+0.005 (T)] (where T = temperature in °C). This selection can be used for conductivity and noncritical resistivity measurements. The -B Cell factor selection utilizes a Class A, 1000 Ω RTD. This selection is recommended for all resistivity measurements and is required to obtain optimum system accuracy.





This RTD meets DIN 43760 requirements for Class A accuracy; ±[0.15±0.002 (T)] (where T = temperature in °C). Optimum positioning of these RTDs within the inner electrode helps ensure close thermal contact with the process and minimal influence from ambient temperatures.

Temperature cell factors (tCF) are determined utilizing NIST traceable techniques and are stamped on each 0.1 cm⁻¹ cell factor sensor housing or cable.





EASY TO INSTALL

The sliding bore piece design permits installation without twisted cables. A large selection of mounting hardware and accessories is offered to meet virtually all process requirements. This includes bushings in varying materials and sizes, flanges, sanitary fittings, flowcells, and ball valve assemblies.

SENSOR APPLICATIONS

Sensor Mounting Code	Description	Sensor
A, B, C	0.1 cm ⁻¹ universal bore piece sensor with 3/4 NPT bushing. Use directly in Tee and flowcell installations.	
D, E	10 cm ⁻¹ universal bore piece sensor with 3/4 NPT bushing. Use directly in Tee and flowcell installations.	
A, B, C, D, E, J, K (0.1 cm ⁻¹ sensor shown)	Extended length universal bore piece sensor with 3/4 NPT bushing. Use when installing in larger Tee (with reducer) or at elbow to help ensure adequate flow through sensor.	
F	0.1 or 10 cm ⁻¹ universal bore piece sensor with 1 1/2-inch Tri-Clamp fitting. (2-inch Tri-Clamp fitting is available by purchasing a universal bore piece sensor and 2-inch Tri-Clamp accessory separately.)	

SENSOR APPLICATIONS (CONTINUED)

Sensor Mounting Code	Description	Sensor
G	0.1 cm ⁻¹ insertion sensor for use with PVDF ball valve assembly. Available in standard and 4-inch insertion lengths. Electrode is replaceable.	
H	0.1 or 10 cm ⁻¹ insertion sensor for use with stainless steel ball valve assembly. Available in standard and 4-inch insertion lengths.	
J (0.1 cm ⁻¹ sensor shown)	Universal bore piece designed to use Schneider Electric flanges, Tri-Clamp fittings, 3/4 NPT, 1 NPT, and metric bushings.	
K (0.1 cm ⁻¹ sensor shown)	Universal bore piece with 3/8 NPT conduit connector. Designed to use Schneider Electric flanges, Tri-Clamp fittings, 3/4 NPT, 1 NPT, and metric bushings.	

STANDARD SPECIFICATIONS

Accuracy

0.1 cm⁻¹ cell factor sensors manufactured to within 1% of nominal value.

- ▶ NIST traceable CF determinations are tagged with actual CF value with ±0.2537% accuracy.
- ▶ Ultrapure water CF determinations are tagged with actual CF values with ±0.000101 accuracy.
- ▶ Temperature cell factors (tCF) are determined with ±0.03°C accuracy.

10 cm⁻¹ cell factor sensors manufactured to within 5% of nominal value. Calibration in standards or solutions is recommended if greater accuracy is desired.

Temperature Compensator (Integral)

-A and -C Cell Factor Selection:

Class B 1000 Ω RTD 3-wire device.
Meets DIN 43760 Class B requirements.

-B Cell Factor Selection:

Class A 1000 Ω RTD 3-wire device.

Conductivity/Resistivity Ranges

See Table 1.

Wetted Parts

See Table 2 for process wetted parts, and see Table 3 for wetted material compatibility in common solutions.

Table 2. Process Wetted Parts

Cell Factor	Mounting Code	Mounting	Insulator	Electrodes	Seals/O-ring	Sheath
0.1 cm ⁻¹	A, B, C, F, J, K	CPVC, Virgin PVDF, Virgin PEEK, or Titanium Bushings; Titanium or 316 ss Tri-Clamp Fittings; or 316 ss Flanges	CPVC or Virgin PVDF or Virgin PEEK	Titanium or Monel	Teflon-Impregnated EPDM	–
	G	PVDF Insertion Shaft	Virgin PVDF	Titanium or Monel		
	H	316 ss Insertion Shaft	CPVC or Virgin PVDF or Virgin PEEK	Titanium		
10 cm ⁻¹	D, E, F, J, K	Glass-Filled PEEK, Glass-Filled Noryl, 316 ss Bushings, or 316 ss Tri-Clamp Fittings; or 316 ss Flanges	Glass-Filled PEEK or Glass-Filled Noryl	Graphite/Titanium Cup	EPDM and Teflon-Impregnated EPDM	Teflon and Titanium (a)
	H	316 ss Insertion Shaft	Glass-Filled PEEK or Glass-Filled Noryl	Graphite/Titanium Cup		

a. Sheath must be in place for measurement.

Table 3. Wetted Material Compatibility in Common Solutions

Solution	Titanium	Monel	CPVC	Virgin PEEK	Virgin PDMF	Glass-Filled PEEK	Glass-Filled Noryl	EPDM	Teflon Coating
Dilute Ammonium Hydroxide	----	U	R 93°C (199°F)	R 26°C (79°F)	R 138°C (280°F)	R 26°C (79°F)	R 70°C (158°F)	R 116°C (240°F)	R 238°C (460°F)
Dilute Hydrochloric Acid	G 26°C (79°F)	G 26°C (79°F)	R 85°C (185°F)	R 100°C (212°F)	R 138°C (280°F)	R 100°C (212°F)	R 82°C (180°F)	R 149°C (300°F)	R 238°C (460°F)
Dilute Hydrofluoric Acid	U	E 210°C (410°F)	U	U	R 138°C (280°F)	U	R 26°C (79°F)	R 15°C (59°F)	R 238°C (460°F)
Dilute Hydrogen Peroxide	E 93°C (199°F)	G 49°C (120°F)	U	R 93°C (199°F)	R 116°C (241°F)	R 104°C (219°F)	R 26°C (79°F)	R 38°C (100°F)	R 238°C (460°F)
Dilute Nitric Acid	E/G 193°C (379°F)	U	R 82°C (180°F)	R 93°C (199°F)	R 93°C (199°F)	R 93°C (199°F)	R 60°C (140°F)	R 150°C (302°F)	R 238°C (460°F)
Dilute Phosphoric Acid	E 26°C (79°F)	E/G 26°C (79°F)	R 93°C (199°F)	R 93°C (199°F)	R 138°C (280°F)	R 93°C (199°F)	----	R 149°C (300°F)	R 238°C (460°F)
Salt Solution	E 93°C (199°F)	E/G 26°/93°C) (79°/199°F)	R 93°C (199°F)	R 100°C (212°F)	R 150°C (302°F)	R 100°C (212°F)	R 38°C (100°F)	R 150°C (302°F)	R 238°C (460°F)
Dilute Sodium Hydroxide	E 93°C (199°F)	E/G 93°/171°C) (199°/340°F)	R 82°C (180°F)	R 104°C (219°F)	R 93°C (199°F)	R 104°C (219°F)	R 60°C (140°F)	R 104°C (219°F)	R 238°C (460°F)
Sulfuric Acid	U	U	R 82°C (180°F)	R 100°C (212°F)	R 120°C (248°F)	R 100°C (212°F)	R 60°C (140°F)	R 60°C (140°F)	R 238°C (460°F)
Ozone	----	G 38°C (100°F)	R 82°C (180°F)	R 100°C (212°F)	R 138°C (280°F)	R 100°C (212°F)	----	R 149°C (300°F)	R 204°C (399°F)

Metals:

U = Unacceptable; G =<20 mills penetration/year; E =< 2 mills penetration/year

Plastics and Elastomers:

U = Unsatisfactory; R = Resistant

Response Time

Cell Factor	Measurement	Temperature
0.1 cm ⁻¹	Instantaneous	17.5 seconds
10 cm ⁻¹	Instantaneous	140 seconds

Transportation and Storage Temperature Limits

-40 to + 70°C (-40 to 158°F)

Operating Temperature and Pressure Limits

See Tables 5 to 9.

Sensor Mounting

See “Sensor Applications” on page 3.

Cable

Standard Temperature Cable:

PVC-insulated cable rated to 80°C (176°F)

High Temperature Cable:

Teflon-insulated cable rated to 200°C (392°F).

Since both cable and insulation extend into the sensor body, specify the cable that is rated for the process temperature used.

See Figure 2 and “Sensor Wiring Table”.

Figure 2. Sensor Wiring

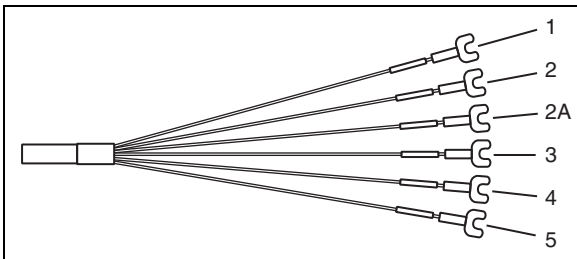

Sensor Wiring Table

Sensor Terminal	Wire Color	Signal Description
1	Clear	Outer Electrode
2	Thick White (a)	Inner Electrode
2A	Clear (a)	Shield
3	White	RTD Drive
4	Black	RTD Return
5	Red	RTD 3-Wire Return (b)

- a. For standard temperature cable, inside brown jacket and for high temperature cable, inside grey jacket.
- b. 3-wire return for RTD cable compensation.

ELECTRICAL SAFETY SPECIFICATIONS

The 871CR Series Sensors have been designed to meet the electrical safety specifications shown in the table below. Contact Global Customer Support for status of testing laboratory approval or certification.

Testing Laboratory, Types of Protection, and Area Classification	Application Conditions	Electrical Certification Specification
ATEX Intrinsically Safe for II 1 G, EEx ia, IIC, Zone 0.	Connect to certified 876CR or 870ITCR Transmitter, or 875CR Analyzer per MI 611-208. Temperature Class T3 - T6.	CS-E/EAA
CSA Intrinsically Safe for Class I, Division 1, Groups A, B, C, and D; Class II, Division 1, Groups E, F, and G; Class III, Division 1 hazardous locations.	Connect to certified 876CR or 870ITCR Transmitter, or 875CR Analyzer per MI 611-206. Temperature Class T6.	CS-E/CAA
CSA Nonincendive Class I, Division 2, Groups A, B, C, and D; Suitable for Class I, Division 2, Groups A, B, C, and D; Class II, Division 2, Groups F and G; Class III, Division 2 hazardous locations.	Connect to certified 876CR or 870ITCR Transmitter, or 875CR Analyzer per MI 611-206. Temperature Class T6. Class II and III, Division 2 only applicable to Sensor Mounting "K."	CS-E/CNN
FM Intrinsically Safe for Class I, Division 1, Groups A, B, C, and D; Class II, Division 1, Groups E, F, and G; Class III, Division 1.	Connect to certified 876CR or 870ITCR Transmitter, or 875CR Analyzer per MI 611-206. Temperature Class T6.	CS-E/FAA
FM nonincendive Class I, Division 2, Groups A, B, C, and D; Class II, Division 2, Groups F and G; Class III, Division 2.	Connect to certified 876CR or 870ITCR Transmitter, or 875CR Analyzer per MI 611-206. Temperature Class T6.	CS-E/FNN

SYSTEM ACCURACY OF THE 876CR OR 870ITCR TRANSMITTER, OR 875CR ANALYZER WITH AN 871CR-B2***-R SENSOR FOR RESISTIVITY MEASUREMENT**

The 876CR or 870ITCR Transmitter, or the 875CR Analyzer, along with an 871CR-B2*****-R Sensor, provide an advanced resistivity measurement system with significantly enhanced performance. The transmitter, or analyzer, and sensor provide exceptional stability and performance during measurement in pure and ultrapure water. Temperature compensated system accuracy has been found to be better than or equal to $\pm 1.06\%$ RMS throughout the 20 to 60°C temperature range. All variables – cell factor calibration, design for increased transmitter and sensor accuracy – and calibration procedures have been refined for optimum performance.

The premium resistivity sensors are manufactured of materials accepted in industries utilizing ultrapure water. They are available with increased insertion lengths and a larger profile to optimize representative measurement sampling. The 0.1 cm^{-1} cell factor sensors are manufactured to 1% tolerances and are precalibrated with an ultrapure water calibration factor determined to $\pm 0.000101 \text{ cm}^{-1}$ accuracy. The cell factor accuracy of 0.101% assumes published data for ultrapure water introduces negligible detected error. If experimental uncertainty in the published data is considered, the effective cell factor accuracy changes to $\pm 0.270\%$, thereby impacting the system accuracy stated above.

Figure 3 shows absolute resistivity vs. temperature curves for a range of water samples with salt to ultrapure water ($18.16 \text{ M}\Omega\cdot\text{cm}$). It should be noted that, as the temperature of water with trace impurities increases, the absolute resistivity of that water starts to converge to similar values for the various samples. Also, as the temperature increases, the relationship between resistivity and salt concentration becomes smaller; and calculation of the temperature-compensated value at 25°C becomes more demanding.

To improve the temperature corrected resistivity measurement over an extended temperature range, the most important parameter to control is the accuracy of the temperature measurement. The 871CR-B Sensor incorporates a Class A 1000Ω Pt RTD 3-wire temperature transducer for temperature measurement optimization. Platinum RTDs are

known to be mechanically and electrically steady with accurately known thermal curves. In addition to an accurate transducer, highly accurate temperature measurements must also provide lead wire resistance compensation. The 871CR Sensor family incorporates a 3-wire resistance measurement (instead of a 2-wire) to minimize lead wire effects. The actual temperature calibration (tCF) of each cell's RTD is known with an accuracy of $\pm 0.03^\circ\text{C}$.

The 876CR Intelligent Transmitter and 875CR Intelligent Analyzer are the newest members of the family of 876/875 Series of high performance intelligent transmitters and analyzers. A factory default calibration is available for every measurement range selected and the transmitter has a choice of two pre-engineered resistivity specific temperature compensations available for ultrapure water (based upon published research). The measurement method used to make the absolute resistivity measurement is extremely important to achieve optimum results. The 876CR, 870ITCR and 875CR use ac frequency and voltage drive for each to optimize the measurement range chosen. All instruments have high accuracy (either 0.1% of full scale or 0.5% of reading) and the temperature circuit has an accuracy of $\pm 0.03^\circ\text{C}$.

The two factory calibrations on the sensor (CF and tCF) are easily entered into the calibration menu of the transmitter for a total system calibration.

Figure 3. Absolute Resistivity versus Temperature Curves

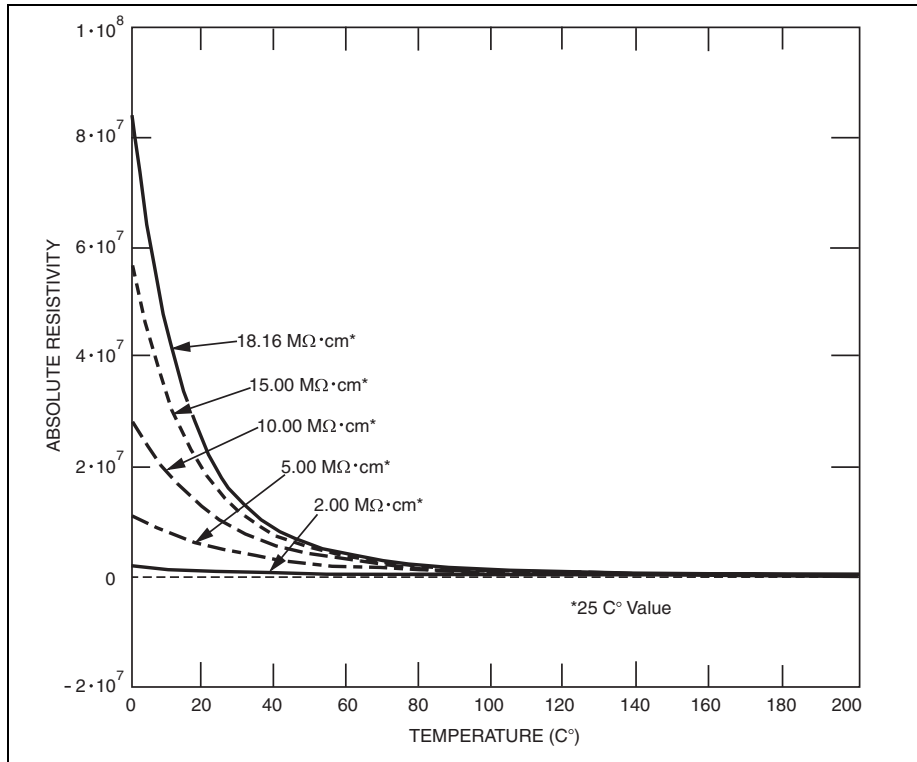

Figure 4. 871CR Sensor

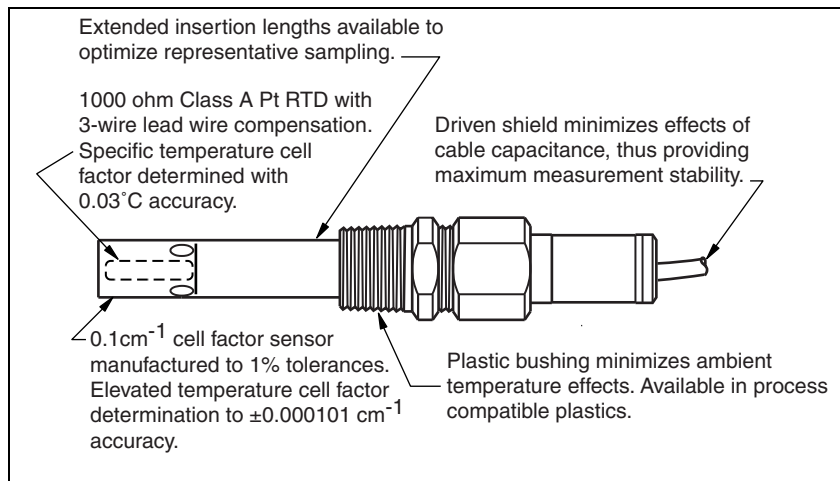

Table 4. Accessory Selection Table (Continued)
 (for Additional Accessory Specifications, see pages that follow)

Sensor Mountings	Models 871CR-A and 871CR-B Materials Relevant to:					Model 871CR-C Materials Relevant to:		
	CPVC	Virgin PVDF	Virgin PEEK	CP2 Titanium	316 ss	Glass-Filled Noryl	Glass-Filled PEEK	316 ss
Ball Valves and Ball Valve Part Numbers								
1-Inch Valve Insertion Assembly	n/a	n/a	n/a	n/a	BS809NJ	n/a	n/a	BS809NJ BS811EN (c)
1 1/4-Inch Valve Insertion Assembly	n/a	BS809DH	n/a	n/a	n/a	n/a	n/a	n/a

- a. All flow chambers accommodate 0.1 cm⁻¹ and 10 cm⁻¹ standard length sensors.
- b. Note that the Flow Chamber with 3/4 NPT x 1/4 NPT is PVC material, and not CPVC.
- c. BS809NJ has a standard 7.06-in retraction chamber for standard length sensors, including 871CR-C.G1. BS811EN has an extended 8.18-in retraction chamber that is compatible with Standard and 4-Inch length sensors, whether 0.1 cm⁻¹ cell factor or 10 cm⁻¹ cell factor; e.g., with 10 cm⁻¹ sensor 871CR-C.G4. BS811EN is not compatible with 6-Inch length sensors; e.g., with 10 cm⁻¹ sensor 871CR-C.G6 or 871CR-A.T6.

Figure 5. Bushings

Bushings

Bushings are used with a Universal Bore Piece (J sensor mounting selection) and a Universal Bore Piece with Integral Conduit Fitting (K sensor mounting selection) to provide a mounting mechanism for the sensor. All bushings require the use of a locking cap to fix the sensor to the bushing (see DIMENSIONS-NOMINAL section for assembly relationship). Bushings are available in 3/4 NPT and 1 NPT as well as metric ISO 7/1-R 1 1/2 and ISO 7/1-R 2. To order a bushing or locking cap separately, specify the applicable part number per Table 5.

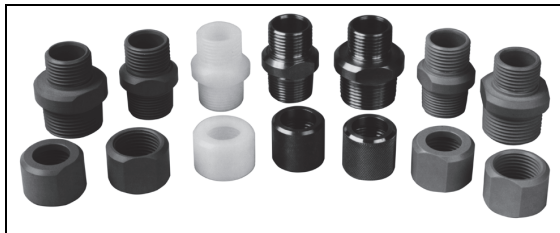

Table 5. Maximum Pressure/Temperature Ratings for Sensors in Bushing Mounts (a)

Bushing	Sensor Model	Bushing Material/ Insulator Material	Maximum Pressure/ Temperature Rating	Bushing Part No.	Locking Cap Part No.
3/4 NPT	871CR-A1	CPVC/CPVC	250 psig at 27 °C (80°F) (b)	BS809HR	BS809HP
	871CR-A2	Virgin PVDF/Virgin PVDF	250 psig at 24 °C (75°F) (c)	BS809ES	BS809EZ
	871CR-A3	Virgin PEEK/Virgin PEEK	250 psig at 175 °C (350°F)	BS809EQ	BS809EY
	871CR-A or 871CR-B	Titanium/Virgin PVDF	250 psig at 121 °C (250°F)	BS809ER	BS808KB
		Titanium/Virgin PEEK	250 psig at 175 °C (350°F)		
	871CR-C5	Glass-Filled Noryl/Glass-Filled Noryl	150 psig at 121 °C (250°F)	BS809HU	BS809HV
	871CR-C4	Glass-Filled PEEK/Glass-Filled PEEK	250 psig at 175 °C (350°F)	BS809DW	BS809EJ
	871CR-A or 871CR-B	316 SS/Virgin PVDF	250 psig at 121 °C (250°F)	BS809DX	BS809AJ
316 SS/Virgin PEEK		250 psig at 175 °C (350°F)			
1 NPT	871CR-A or 871CR-B	CPVC/CPVC	250 psig at 27 °C (80°F) (b)	BS809HQ	BS809HP
		Virgin PVDF/Virgin PVDF	250 psig at 24 °C (75°F) (c)	BS809EW	BS809EZ
		Virgin PEEK/Virgin PEEK	250 psig at 175 °C (350°F)	BS809EU	BS809EY
		Titanium/Virgin PVDF	250 psig at 121 °C (250°F)	BS809EV	BS808KB
		Titanium/Virgin PEEK	250 psig at 175 °C (350°F)		
	871CR-C	Glass-Filled Noryl/Glass-Filled Noryl	150 psig at 121 °C (250°F)	BS809QV	BS809HV
		Glass-Filled PEEK/Glass-Filled PEEK	250 psig at 175 °C (350°F)	BS809DY	BS809EJ
		316 SS/Glass-Filled Noryl	250 psig at 121 °C (250°F)	BS809DZ	BS809AJ
316 SS/Glass Filled PEEK		250 psig at 175 °C (350°F)			
ISO 7/1-R-1 1/2	871CR-A or 871CR-B	CPVC/CPVC	250 psig at 27 °C (80°F) (b)	BS809FE	BS809HP
		Virgin PVDF/Virgin PVDF	250 psig at 24 °C (75°F) (c)	BS809FD	BS809EZ
		Virgin PEEK/Virgin PEEK	250 psig at 175 °C (350°F)	BS809FB	BS809EY
		Titanium/Virgin PVDF	250 psig at 121 °C (250°F)	BS809FC	BS808KB
		Titanium/Virgin PEEK	250 psig at 175 °C (350°F)		
	871CR-C	Glass-Filled Noryl/Glass-Filled Noryl	150 psig at 121 °C (250°F)	BS809QW	BS809HV
		Glass-Filled PEEK/Glass-Filled PEEK	250 psig at 175 °C (350°F)	BS809EA	BS809EJ
		316 SS/Glass-Filled Noryl	250 psig at 121 °C (250°F)	BS809EB	BS809AJ
316 SS/Glass-Filled PEEK		250 psig at 175 °C (350°F)			

Table 5. Maximum Pressure/Temperature Ratings for Sensors in Bushing Mounts (a) (Continued)

Bushing	Sensor Model	Bushing Material/ Insulator Material	Maximum Pressure/ Temperature Rating	Bushing Part No.	Locking Cap Part No.
ISO 7/1-R 2	871CR-A or 871CR-B	CPVC/CPVC	250 psig at 27°C (80°F) (b)	BS809FJ	BS809HP
		Virgin PVDF/Virgin PVDF	250 psig at 24°C (75°F) (c)	BS809FH	BS809EZ
		Virgin PEEK/Virgin PEEK	250 psig at 175°C (350°F)	BS809FF	BS809EY
		Titanium/Virgin PVDF	250 psig at 121°C (250°F)	BS809FG	BS808KB
		Titanium/Virgin PEEK	250 psig at 175°C (350°F)		
	871CR-C	Glass-Filled Noryl/Glass-Filled Noryl	150 psig at 121°C (250°F)	BS809QX	BS809HV
		Glass-Filled PEEK/Glass-Filled PEEK	250 psig at 175°C (350°F)	BS809EC	BS809EJ
		316 SS/Glass-Filled Noryl	250 psig at 121°C (250°F)	BS809ED	BS809AJ
		316 SS/Glass-Filled PEEK	250 psig at 175°C (350°F)		

- a. Part numbers listed are for bushing and locking caps if ordered separately.
- b. Linearly derated to 50 psig at 88°C (190°F).
- c. Linearly derated to 42 psig at 121°C (250°F).

Tri-Clamp Fittings

Tri-Clamp fittings are used with a Universal Bore Piece (J sensor mounting selection) and a Universal Bore Piece with Integral Conduit Fitting (K sensor mounting selection) to provide a mounting mechanism for the sensor. All Tri-Clamp fittings require the use of a locking cap (ordered separately) to lock the sensor to the fitting. See “Dimensions - Nominal” on page 22 for assembly relationship between sensor, Tri-Clamp fittings, and locking cap. Tri-Clamp fittings are available in 1 1/2-inch, 2-inch, and 2 1/2-inch sizes. Titanium fittings have an RA3 mirror finish on the wetted side. Stainless steel fittings have an RA3 mirror finish for Models 871CR-A and 871CR-B and a 32 microinch finish for Model 871CR-C (finish applies to process wetted surface only). To order a Tri-Clamp or locking cap separately, specify applicable part number per Table 6.

Figure 6. Tri-Clamp Fittings



Table 6. Maximum Pressure/Temperature Ratings for Sensors in Tri-Clamp Mountings (a)

Tri-Clamp Fitting	Sensor Model	Material	Insulator Material	Maximum Pressure/Temperature Rating	Fitting Part No.	Locking Cap Part No.
1-1/2 inch	871CR-A or 871CR-B	Titanium	Virgin PVDF	250 psig at 121 °C (250°F)	BS809AA	BS808KB
			Virgin PEEK	250 psig at 175 °C (350°F)		
		316 ss	Virgin PVDF	250 psig at 121 °C (250°F)	BS808KD	BS809AJ
			Virgin PEEK	250 psig at 175 °C (350°F)		
	871CR-C	316 ss	Glass-Filled PEEK	250 psig at 175 °C (350°F)	BS809DS	BS809AJ
			Glass-Filled Noryl	250 psig at 121 °C (250°F)		
2 inch	871CR-A or 871CR-B	Titanium	Virgin PVDF	250 psig at 121 °C (250°F)	BS809AB	BS808KB
			Virgin PEEK	250 psig at 175 °C (350°F)		
		316 ss	Virgin PVDF	250 psig at 121 °C (250°F)	BS808KC	BS809AJ
			Virgin PEEK	250 psig at 175 °C (350°F)		
	871CR-C	316 ss	Glass-Filled PEEK	250 psig at 175 °C (350°F)	BS809DU	BS809AJ
			Glass-Filled Noryl	250 psig at 121 °C (250°F)		
2-1/2 inch	871CR-A or 871CR-B	316 ss	Virgin PVDF	250 psig at 121 °C (250°F)	BS811FK	BS809AJ
			Virgin PEEK	250 psig at 175 °C (350°F)		

a. Part numbers listed are for Tri-Clamp fitting and locking cap if ordered separately.

Flanges

Flanges are used with a Universal Bore Piece (J sensor mounting selection) and a Universal Bore Piece with Integral Conduit Fitting (K sensor mounting selection) to provide a mounting mechanism for the sensor. All flanges are 316 stainless steel and require the use of a locking cap (ordered separately) to fix the sensor to the flange. See “Dimensions - Nominal” on page 22 for assembly relationship between sensor, flange, and locking cap. Flanges are available in 2-, 2 1/2-, and 4-inch ANSI Class 150, and metric DN 50 and DN 100. To order a flange or locking cap separately, specify the applicable part number listed in Table 7.

Table 7. Maximum Pressure/Temperature Ratings for Sensors in Flange Mounts (a)

Flange Description	Linear Rating	Sensor Model	Flange Part No.	Locking Cap Part No.
2 inch ANSI Class 150 316 ss	198 psi at 88 °C (190°F) 184 psi at 121 °C (250°F) 167 psi at 175 °C (350°F)	871CR-*1**J 871CR-*2**J 871CR-*3**J	BS809LT	BS809AJ
	167 psi at 175 °C (350°F) 184 psi at 121 °C (250°F)	871CR-*4**J 871CR-*5**J	BS809UQ	BS809AJ
2 1/2 inch ANSI Class 150 316 ss	198 psi at 88 °C (190°F) 184 psi at 121 °C (250°F) 167 psi at 175 °C (350°F)	871CR-*1**J 871CR-*2**J 871CR-*3**J	BS809LU	BS809AJ
	167 psi at 175 °C (350°F) 184 psi at 121 °C (250°F)	871CR-*4**J 871CR-*5**J	BS809UR	BS809AJ
4 inch ANSI Class 150 316 ss	198 psi at 88 °C (190°F) 184 psi at 121 °C (250°F) 167 psi at 175 °C (350°F)	871CR-*1**J 871CR-*2**J 871CR-*3**J	BS808MN	BS809AJ
	167 psi at 175 °C (350°F) 184 psi at 121 °C (250°F)	871CR-*4**J 871CR-*5**J	BS809US	BS809AJ
DN 50 DIN2501, 10 Bar 316 ss	198 psi at 88 °C (190°F) 184 psi at 121 °C (250°F) 167 psi at 175 °C (350°F)	871CR-*1**J 871CR-*2**J 871CR-*3**J	BS809PC	BS809AJ
	167 psi at 175 °C (350°F) 184 psi at 121 °C (250°F)	871CR-*4**J 871CR-*5**J	BS809UT	BS809AJ
DN 100 DIN 2501, 10 Bar	198 psi at 88 °C (190°F) 184 psi at 121 °C (250°F) 167 psi at 175 °C (350°F)	871CR-*1**J 871CR-*2**J 871CR-*3**J	BS809PD	BS809AJ
	167 psi at 175 °C (350°F) 184 psi at 121 °C (250°F)	871CR-*4**J 871CR-*5**J	BS809UU	BS809AJ

a. Part numbers listed are for flanges and locking caps ordered separately.

Flow Chambers

Flow chambers offer a convenient way of mounting standard length sensors with bushing mounting into a system where the sample is provided by a small diameter sample line. The flow chamber connects to the system via a user-supplied NPT fitting (see size of fitting associated with part number). The 3/4 NPT and 1 NPT at the bottom of the flow chamber are the inlet connections, while the 1/4 NPT and 1/2 NPT ports on the side of the flow chamber are the outlet connections. See Figure 7 and Table 8. To order, specify the applicable part number.

Figure 7. Flow Chambers



Table 8. Maximum Pressure/Temperature Ratings for Sensors in Flow Chambers

Flow Chamber	Sensor Model Code	Maximum Pressure/Temperature Rating (a)	Material	Flow Chamber Part Number
3/4 NPT x 1/4 NPT Ports	871CR-A or 871CR-B	60 psig at 50°C (122°F)	PVC	0051182
		60 psig at 50°C (122°F)	Virgin PVDF	BS805GR
		250 psig at 175°C (350°F)	Virgin PEEK	BS809SG
		500 psig at 175°C (350°F)	316 ss	0051180
	871CR-C	500 psig at 175°C (350°F)	316 ss	0051180
PVC	0051182			
1 NPT x 1/2 NPT Ports	871CR-A or 871CR-B	60 psig at 50°C (122°F)	CPVC	BS809SF

a. Actual sensor rating may derate pressure-temperature ratings listed.

Ball Valve Assemblies

Ball valves enable the user to install and withdraw an insertion sensor (Sensor Mounting Code G) easily for cleaning, recalibration, or replacement while the process is operating and pressurized. The ball valve permits withdrawal of the standard or 4-inch insertion length sensor into its isolation chamber. This 316 ss Ball Valve has a 1-inch process connection. Sensors must be purchased separately. To order a ball valve, specify the applicable part numbers listed in Table 9.

Figure 8. 316 ss Ball Valve Assembly

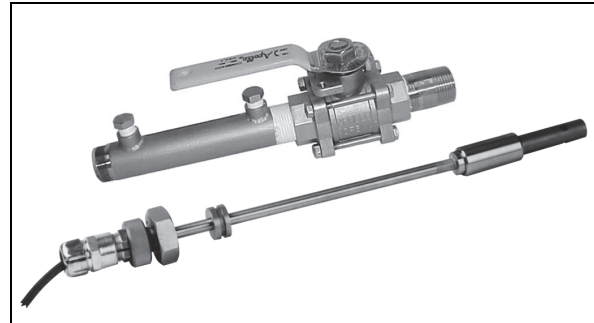

Table 9. Maximum Pressure/Temperature Ratings for Ball Valves and Insertion Sensor

Ball Valve Assembly			Insertion Sensor		
Size and Mat'l	Press./Temp. Rating	Ball Valve Assy. Part Number	Sensor Model (a)	Sensor Insulation Material	Sensor with TFE Cable Press./Temp. Rating
1-inch 316 ss	500 psig at 143°C (290°F) (b)	BS809NJ (c)	871CR-A1T1H (c) 871CR-B1T1H 871CR-A1T4H 871CR-B1T4H	CPVC	250 psig at 82°C (180°F)
			871CR-A2T1H (c) 871CR-B2T1H 871CR-A2T4H 871CR-B2T4H	Virgin PVDF	250 psig at 121°C (250°F)
			871CR-A3T1H (c) 871CR-B3T1H 871CR-A3T4H 871CR-B3T4H	Virgin PEEK	500 psig at 143°C (290°F)
1-inch 316 ss	500 psig at 143°C (290°F) (b)	BS809NJ (d)	871CR-C4G1H	Glass-Filled PEEK	500 psig at 175°C (347°F)
		BS811EN (d)	871CR-C4G4H	Glass-Filled Noryl	250 psig at 175°C (347°F)
		BS809NJ (d)	871CR-C5G1H	Glass-Filled PEEK	500 psig at 175°C (347°F)
		BS811EN (d)	871CR-C5G4H	Glass-Filled Noryl	250 psig at 175°C (347°F)

- a. Insertion sensors must be selected with the high temperature cable only.
- b. Linearly derated to 275 psig at 175°C (350°F).
- c. Insertion style sensors 871CR-A1T1H/A2T1H/A3T1H with 0.1 cm⁻¹ cell constants and standard lengths may also be used with Gate Valve Assembly Part Numbers 0051351 or 0051356.
- d. BS809NJ has a standard 7.06-in retraction chamber for standard length sensors, including 871CR-C.G1. BS811EN has an extended 8.18-in retraction chamber that is compatible with Standard and 4-Inch length sensors, whether 0.1 cm⁻¹ cell factor or 10 cm⁻¹ cell factor; e.g., with 10 cm⁻¹ sensor 871CR-C.G4. BS811EN is not compatible with 6-Inch length sensors; e.g., with 10 cm⁻¹ sensor 871CR-C.G6 or 871CR-A.T6.

Junction Box (Not recommended for resistivity measurement)

The junction box mounts to a surface and provides a convenient means of connecting the sensor cable to the extension cable assembly (see “Extension Cable Assembly (Not recommended for resistivity measurement)” on page 19). The junction box has the dusttight and weatherproof rating of IP65 as defined by IEC 60529, and provides the weatherproof protection rating of NEMA 4. Specify Part Number 0051052.

Figure 9. Junction Box

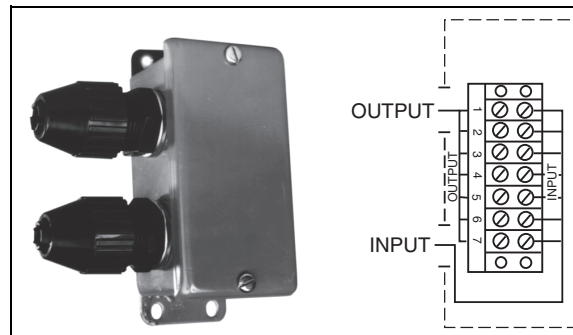

Patch Cord (Not recommended for resistivity measurement)

Patch cords provide connections between sensors and a transmitter or junction box. One end of the patch cord has a connector socket for connection to the sensor; the other end has numbered leads. The cord is available in lengths of 10, 20, 40, 60, and 80 feet. See Table 10 for part numbers.

Figure 10. Patch Cord

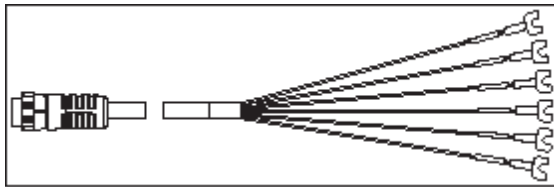

Extension Cable Assembly (Not recommended for resistivity measurement)

The extension cable is a PVC-jacketed multi-conductor cable with numbered leads and is terminated with spade lugs on both ends allowing it to be connected to terminals in the transmitter or a junction box. The cable is available in lengths of 10, 20, 40, 60, and 80 feet. See Table 10 for part numbers.

Figure 11. Extension Cable Assembly

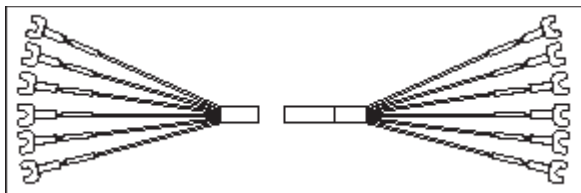

Extension Cable (Not recommended for resistivity measurement)

The standard extension cable is a PVC-jacketed multi-conductor cable. The high temperature extension cable is an FEP-jacketed multi-conductor cable. The cable is not dressed and has no terminations. The cable accepts spade lugs and is available in custom lengths up to 24 m (80 feet). Specify Part Number P0170LF for standard cable or P0170TJ for high temperature cable, and give the length in feet.

Table 10. Patch Cords and Extension Cable Assemblies

Length (feet)	Patch Cord Part Number	Extension Cable Ass'y Part Number
10	BS809GA	BS809TF
20	BS809GB	BS809TG
40	BS809GC	BS809TH
60	BS809GD	BS809TJ
80	BS809GF	BS809TK
Variable (a)	BS811LN	BS811LP

a. Variable length patch cords and extension cable assemblies may be ordered up to a maximum length of 100 ft (30 m). Specify required length on sales order.

MODEL CODE

<u>Description</u>	<u>Model</u>
Conductivity/Resistivity Sensor	871CR
<u>Cell Factor Selection</u>	
0.1 cm ⁻¹ Conductivity/Resistivity Sensor with Class B 1000 Ω RTD	-A
0.1 cm ⁻¹ Resistivity Sensor with Class A 1000 Ω RTD (a)	-B
10 cm ⁻¹ Conductivity Sensor with Class B 1000 Ω RTD	-C
<u>Insulator Material</u>	
CPVC (b)	1
Virgin PVDF (c)	2
Virgin PEEK (c)	3
Glass-Filled PEEK (d)	4
Glass-Filled Noryl (d)	5
<u>Electrode Material</u>	
Graphite (d)	G
Monel (c)	M
Titanium (c)	T
<u>Insertion Length</u>	
Standard	1
4-Inch	4
6-Inch	6
<u>Sensor Mounting</u>	
Universal Bore Piece with 3/4 NPT CPVC Bushing (b) (e)	A
Universal Bore Piece with 3/4 NPT Virgin PVDF Bushing (c) (f)	B
Universal Bore Piece with 3/4 NPT Virgin PEEK Bushing (c) (g)	C
Universal Bore Piece with 3/4 NPT Glass-filled PEEK Bushing (d) (h)	D
Universal Bore Piece with 3/4 NPT Glass-filled Noryl Bushing (d) (i)	E
Universal Bore Piece with 1 1/2-Inch Tri-Clamp Fitting (j) (k)	F
Insertion Sensor for use with 1-Inch ss. Ball Valve Assembly (l) (m) (n) (o)	H
Universal Bore Piece (p)	J
Universal Bore Piece with Integral Conduit Fitting (p) (q)	K
<u>Temperature Compensation</u>	
1000 Ohm RTD	1
<u>Cable Selection</u>	
Standard 20 ft (6 m) Length, Standard Temperature Cable	A
Standard 20 ft (6 m) Length, High Temperature Cable	B
30 ft (9 m) Length, Standard Temperature Cable	C
30 ft (9 m) Length, High Temperature Cable	D
40 ft (12 m) Length, Standard Temperature Cable	E
40 ft (12 m) Length, High Temperature Cable	F
<u>Cable Selection (Cont.)</u>	
80 ft (24 m) Length, Standard Temperature Cable	J
80 ft (24 m) Length, High Temperature Cable	K
No Cable (Integral Connector on Sensor (r) (s) (t) (u)	L
Variable Length, Standard Temperature Cable (v)	M
Variable Length, High Temperature Cable (v)	N

MODEL CODE

MODEL CODE

Description	Model
Termination	
Cable with #6 Spade Lugs (r) (u) (w)	1
Cable with Connector at End (r) (u) (s) (x)	2
Integral Connector on Sensor	3
Options	
Calibration Cert/Cell Factor determined in Schneider Electric Pure Water Loop (a) (y)	-R
Calibration Cert/Cell Factor/Cert NIST Traceable (Use for USP23/24) (c)	-S

- a. Recommended for optimum resistivity measurements.
- b. -A Cell Factor only.
- c. -A and -B Cell Factor only.
- d. -C Cell Factor only.
- e. Insulator Material Code 1 only.
- f. Insulator Material Code 2 only.
- g. Insulator Material Code 3 only.
- h. Insulator Material Code 4 only.
- i. Insulator Material Code 5 only.
- j. Insertion Length Codes 4 and 6 only.
- k. -A and -B Cell Factors use titanium Tri-Clamp fitting; -C Cell Factor uses 316 ss Tri-Clamp fitting.
- l. Insertion Length Codes 1 and 4 only.
- m. Electrode material Codes G or T only.
- n. Ball valve assembly required for new installations. Specify separately.
- o. Insertion sensors must be selected with high temperature cable only.
- p. No mounting accessories included.
- q. Not available with Cable Selection Code L.
- r. Not recommended for optimum resistivity accuracy.
- s. Not available with Sensor Mounting Codes H or K.
- t. Termination Selection Code 3 only.
- u. Patch cable required. Specify separately.
- v. Variable length offered up to 100 ft (30 m) maximum. Specify length on sales order.
- w. Not available with high temp Cable Selections.
- x. Cable Selection Code L only.
- y. Option -R is for use with Virgin PVDF insulator sensors only. For this option with Virgin PEEK insulator sensors, contact Global Customer Support.

DIMENSIONS - NOMINAL

Figure 12. Universal Bore Piece

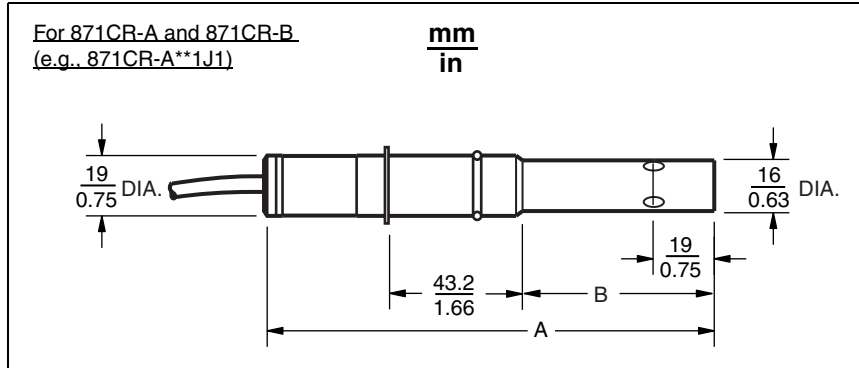

Insertion Length	Dimensions	
	A	B
50 mm (2 in) (a)	$\frac{142}{5.59}$	$\frac{60.5}{2.38}$
100 mm (4 in)	$\frac{193}{7.59}$	$\frac{111}{4.38}$
150 mm (6 in)	$\frac{244}{9.59}$	$\frac{162}{6.38}$

a. Standard length.

Figure 13. Universal Bore Piece

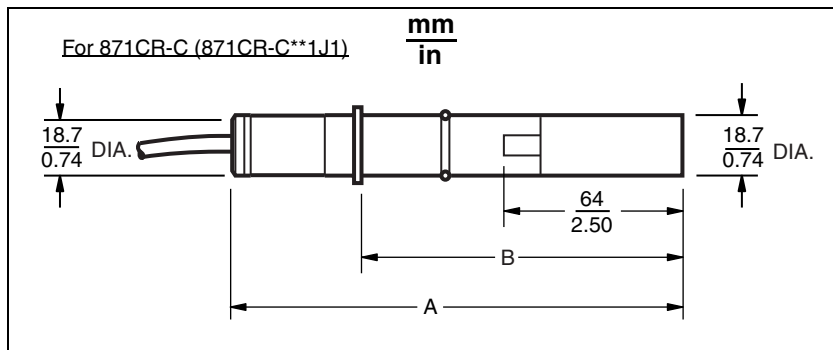

Insertion Length	Dimensions	
	A	B
50 mm (2 in) (a)	$\frac{155}{6.10}$	$\frac{115}{4.54}$

Insertion Length	Dimensions	
	A	B
100 mm (4 in)	$\frac{187}{7.37}$	$\frac{148}{5.83}$
150 mm (6 in)	$\frac{238}{9.37}$	$\frac{199}{7.84}$

a. Standard length.

Figure 14. Universal Bore Piece with Cable Connector or Conduit Fitting

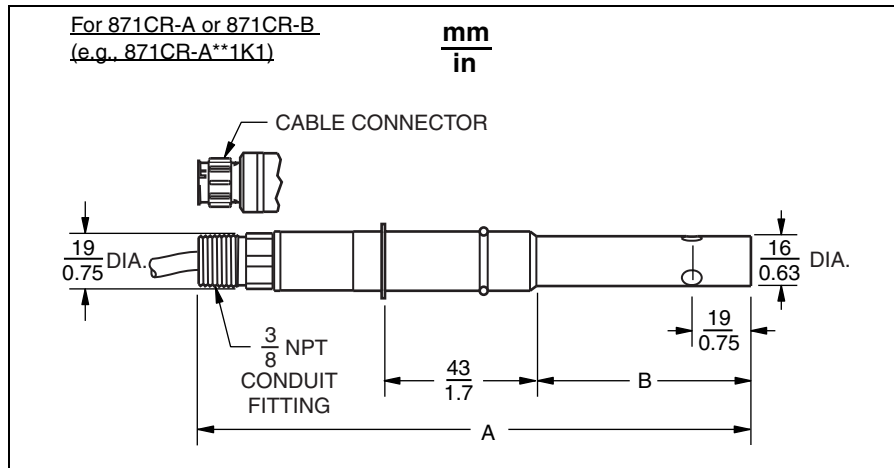

Insertion Length	Dimensions		
	A		B
	With Cable Connector	With Conduit Fitting	
50 mm (2 in) (a)	$\frac{156}{6.15}$	$\frac{158}{6.23}$	$\frac{60.5}{2.38}$
100 mm (4 in)	$\frac{207}{8.15}$	$\frac{209}{8.23}$	$\frac{111}{4.38}$
150 mm (6 in)	$\frac{258}{10.2}$	$\frac{260}{10.2}$	$\frac{162}{6.38}$

a. Standard length.

Figure 15. Universal Bore Piece with Cable Connector or Conduit Fitting

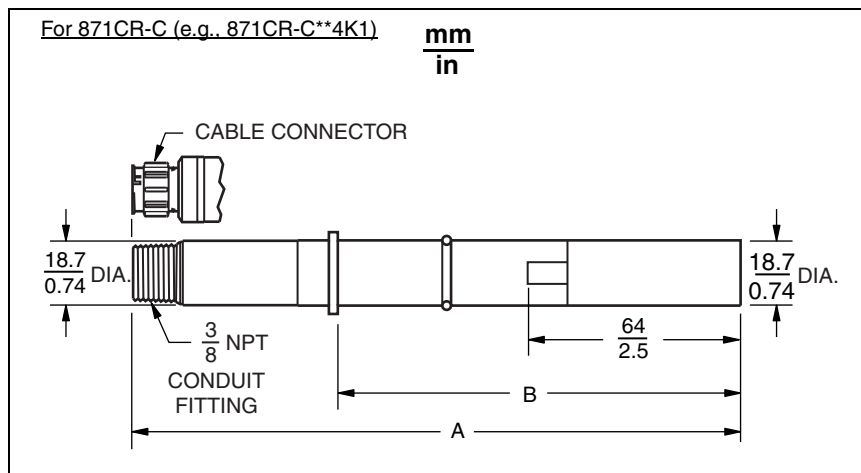

Insertion Length	Dimensions		
	A		B
	With Cable Connector	With Conduit Fitting	
50 mm (2 in) (a)	131 5.14	155 6.10	115 4.54
100 mm (4 in)	163 6.43	187 7.37	148 5.83
150 mm (6 in)	214 8.44	238 9.37	199 7.84

a. Standard length.

Figure 16. 871CR-A and 871CR-B Bushing Mounting Sensor

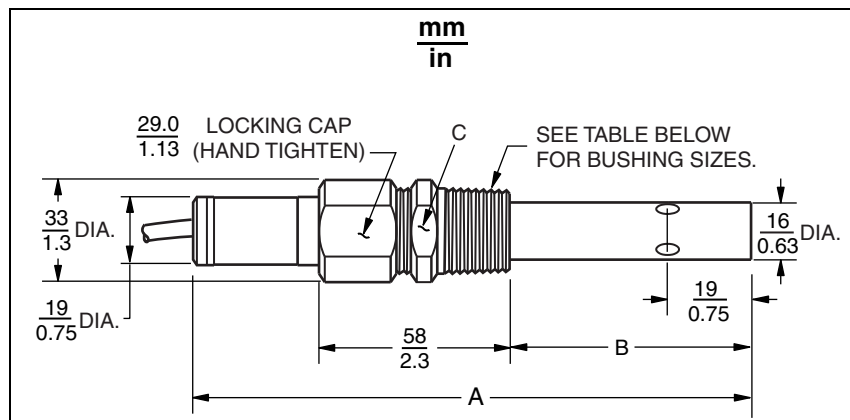

Cell Insertion Length	Dimensions					
	A	B	C (Wrench Opening)			
			3/4 NPT (a)	1 NPT (b)	R 1 1/2 (b)	R 2 (b)
50 mm (2 in) (c)	$\frac{142}{5.59}$	$\frac{51}{2.00}$				
100 mm (4 in)	$\frac{193}{7.59}$	$\frac{102}{4.00}$				
150 mm (6 in)	$\frac{244}{9.59}$	$\frac{152}{6.00}$				

- a. Standard bushing.
- b. Available accessory.
- c. Standard length.

Figure 17. 871CR-C Bushing Mounting Sensor

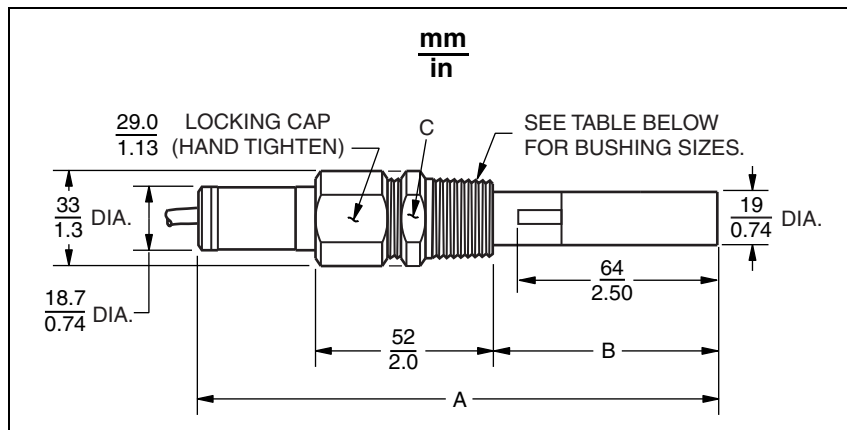

Cell Insertion Length	Dimensions					
	A	B	C (Wrench Opening)			
			3/4 NPT (a)	1 NPT (b)	R 1 1/2 (b)	R 2 (b)
50 mm (2 in) (c)	$\frac{155}{6.10}$	$\frac{70.4}{2.77}$				
100 mm (4 in)	$\frac{187}{7.37}$	$\frac{102}{4.00}$				
150 mm (6 in)	$\frac{238}{9.37}$	$\frac{154}{6.01}$				

- a. Standard bushing.
- b. Available accessory.
- c. Standard length.

Figure 18. 871CR-A and 871CR-B Sensor with Tri-Clamp Fitting

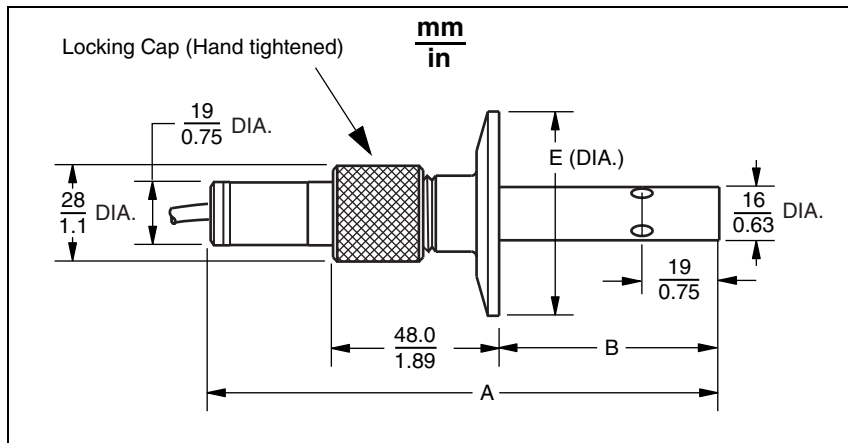
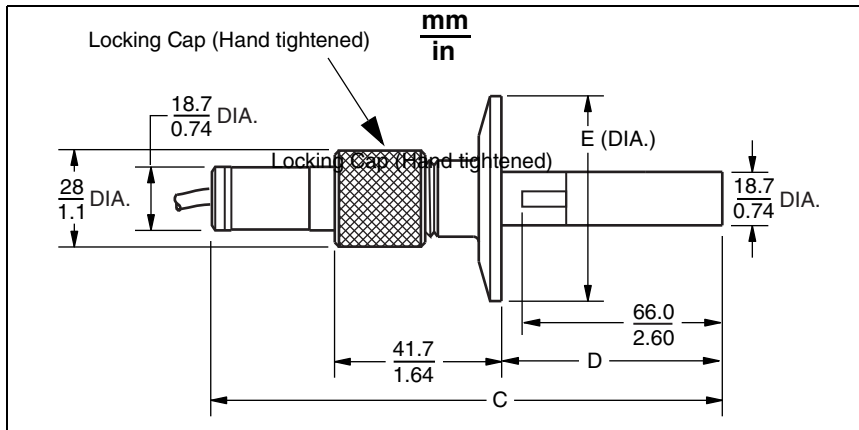

Figure 19. 871CR-C Sensor with Tri-Clamp Fitting



Cell Insertion Length	Nominal Dimensions						
	A	B	C	D	E (Diameter)		
					1 1/2-in Tri-Clamp (a)	2-in Tri-Clamp (b)	2 1/2-in Tri-Clamp (b)
100 mm (4 in)	$\frac{193}{7.59}$	$\frac{111}{4.38}$	$\frac{187}{7.37}$	$\frac{112}{4.40}$	$\frac{50}{2.0}$	$\frac{64}{2.5}$	$\frac{75}{3.0}$
150 mm (6 in)	$\frac{244}{9.59}$	$\frac{162}{6.38}$	$\frac{238}{9.37}$	$\frac{163}{6.41}$			

- a. Standard Tri-Clamp.
- b. Available accessory.

Figure 20. 871CR-A, 871CR-B, and 871CR-C Sensor

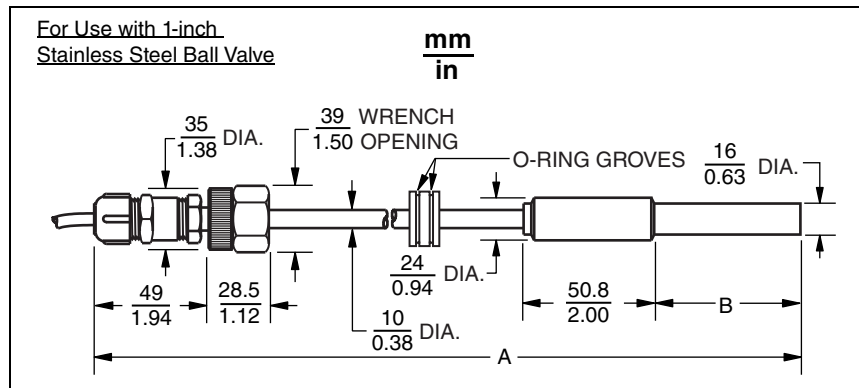

Cell Insertion Length	Dimensions			
	871CR-A and -B (0.1 cm ⁻¹ Cell Factor)		871CR-C (0.1 cm ⁻¹ Cell Factor)	
	A	B	A	B
50 mm (2 in) (a)	$\frac{431}{17.0}$	$\frac{60.5}{2.38}$	$\frac{486}{19.1}$	$\frac{115}{4.50}$
100 mm (4 in)	$\frac{482}{19.0}$	$\frac{111}{4.38}$	$\frac{519}{20.4}$	$\frac{148}{5.80}$

a. Standard length.

Figure 21. ANSI Class 150 Flanges or Metric DN50 and DN100 Flanges

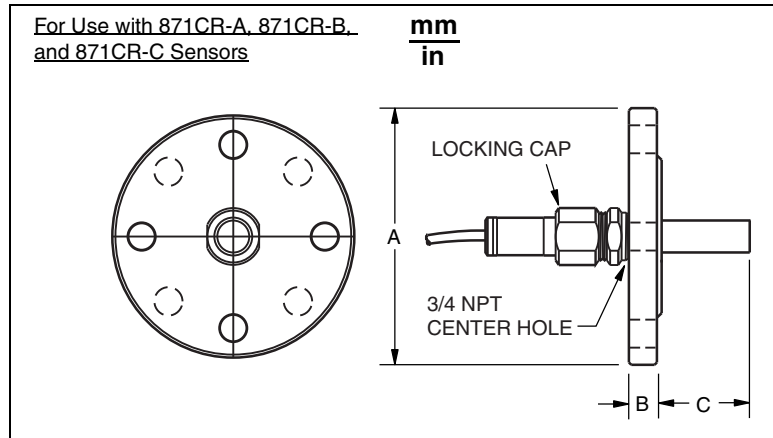

Nominal Flange Size	Dimensions for ANSI Class 150 Flanges								
	A (Dia.)	B	C						Number of Bolt Holes
			871CR-A and -B (0.1 cm ⁻¹ Cell Factor)			871CR-C (10 cm ⁻¹ Cell Factor)			
			50 mm (2 in) (a) Insertion Length	100 mm (4 in) Insertion Length	150 mm (6 in) Insertion Length	50 mm (2 in) (a) Insertion Length	100 mm (4 in) Insertion Length	150 mm (6 in) Insertion Length	
2 in	$\frac{152}{6.00}$	$\frac{19}{0.75}$	$\frac{51}{2.0}$	$\frac{102}{4.0}$	$\frac{153}{6.0}$	$\frac{64}{2.5}$	$\frac{97}{3.8}$	$\frac{150}{5.9}$	4
2 1/2 in	$\frac{178}{7.00}$	$\frac{22}{0.88}$	$\frac{48}{1.9}$	$\frac{99}{3.9}$	$\frac{150}{5.9}$	$\frac{61}{2.4}$	$\frac{94}{3.7}$	$\frac{147}{5.8}$	4
4 in	$\frac{229}{9.00}$	$\frac{24}{0.94}$	$\frac{47}{1.8}$	$\frac{97}{3.8}$	$\frac{148}{5.8}$	$\frac{59}{2.3}$	$\frac{92}{3.6}$	$\frac{145}{5.7}$	8

a. Standard length.

Nominal Flange Size	Dimensions for Metric DN50 and DN100 Flanges								
	A (Dia.)	B	C						Number of Bolt Holes
			871CR-A and -B (0.1 cm ⁻¹ Cell Factor)			871CR-C (10 cm ⁻¹ Cell Factor)			
			50 mm (2 in) (a) Insertion Length	100 mm (4 in) Insertion Length	150 mm (6 in) Insertion Length	50 mm (2 in) (a) Insertion Length	100 mm (4 in) Insertion Length	150 mm (6 in) Insertion Length	
2 in	$\frac{152}{6.00}$	$\frac{19}{0.75}$	$\frac{51}{2.0}$	$\frac{102}{4.0}$	$\frac{153}{6.0}$	$\frac{64}{2.5}$	$\frac{97}{3.8}$	$\frac{150}{5.9}$	4
2 1/2 in	$\frac{178}{7.00}$	$\frac{22}{0.88}$	$\frac{48}{1.9}$	$\frac{99}{3.9}$	$\frac{150}{5.9}$	$\frac{61}{2.4}$	$\frac{94}{3.7}$	$\frac{147}{5.8}$	4
4 in	$\frac{229}{9.00}$	$\frac{24}{0.94}$	$\frac{47}{1.8}$	$\frac{97}{3.8}$	$\frac{148}{5.8}$	$\frac{59}{2.3}$	$\frac{92}{3.6}$	$\frac{145}{5.7}$	8

a. Standard length.

Figure 22. Ball Valve Assemblies

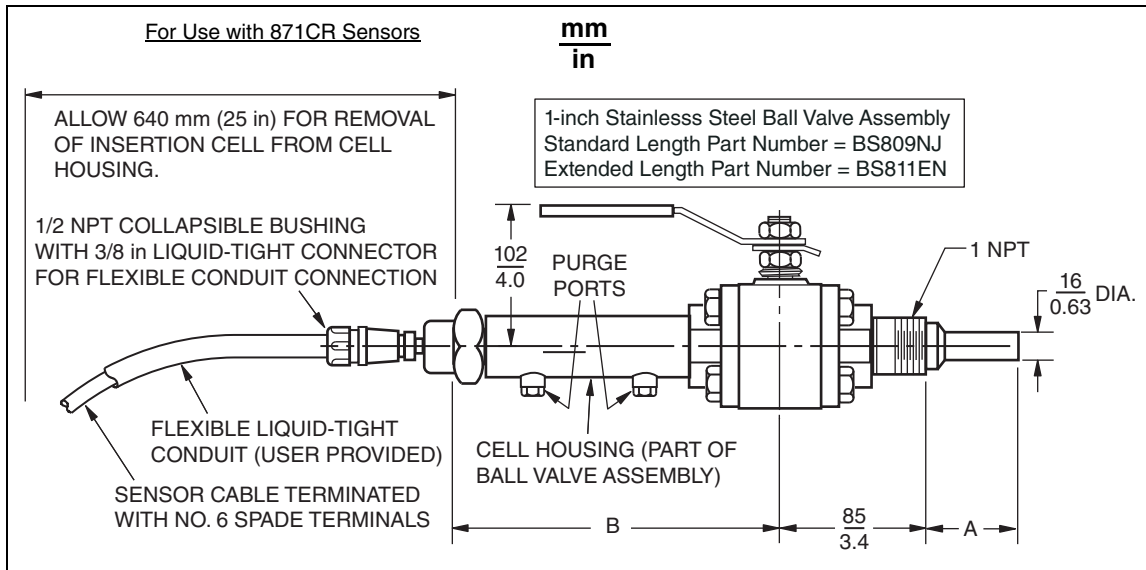

Dimension A			Dimension B		
Cell Insertion Length	1-inch ss Valve (a)		Valve Part Number	Standard Length	Extended Length
	871CR-A or -B (0.1 cm ⁻¹ C.F.)	871CR-C (10 cm ⁻¹ C.F.)			
50 mm (2 in)	$\frac{56}{2.2}$ (b)	$\frac{86}{3.8}$ (b)	BS809NJ	$\frac{215}{8.5}$	-
100 mm (4 in)	$\frac{107}{4.2}$ (c)	$\frac{118}{4.7}$ (c)	BS811EN	-	$\frac{244}{9.6}$

- a. Valve can be used with indicated models. Cell Factors (C.F.) are shown in parentheses.
- b. 1-in ss Valve; Standard Insertion Length; Valve Assembly P. N. BS809NJ.
- c. 1-in ss Valve; Extended Insertion Length; Valve Assembly P. N. BS811EN.

Figure 23. Flow Chambers

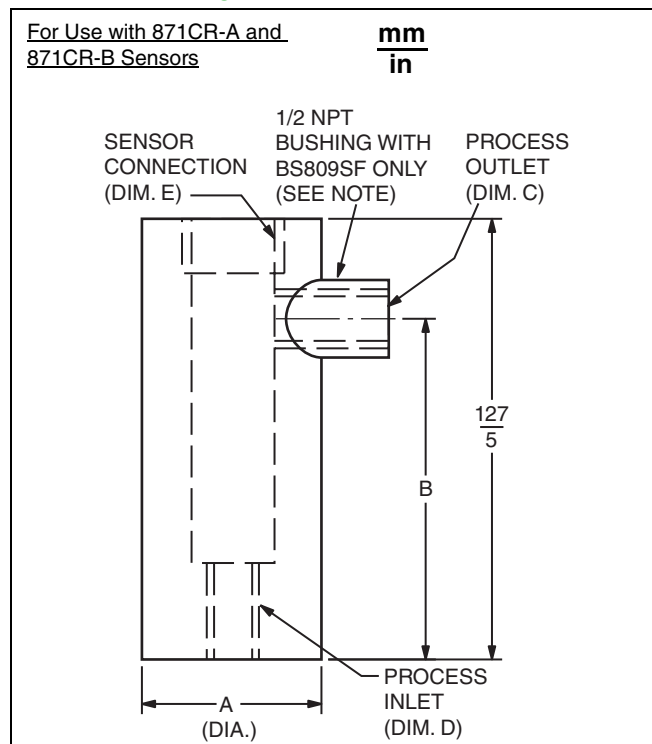

Part Numbers	Material	Dimensions				
		A	B	C (a)	D	E
BS809SG	VIRGIN PEEK	$\frac{38}{1.5}$	$\frac{98}{3.8}$	1/4 NPT	1/4 NPT	3/4 NPT
0051182	PVC	$\frac{38}{1.5}$	$\frac{105}{4.1}$	1/4 NPT	1/4 NPT	3/4 NPT
BS809SF	CPVC	$\frac{44}{1.8}$	$\frac{94}{3.7}$	1/2 NPT	1/2 NPT	1 NPT
0051180	316 SS	$\frac{38}{1.5}$	$\frac{105}{4.1}$	1/4 NPT	1/4 NPT	3/4 NPT
BS805GR	VIRGIN PVDF	$\frac{41}{1.6}$	$\frac{104}{4.1}$	1/4 NPT	1/4 NPT	3/4 NPT

- a. The figure above depicts a 1/2 NPT bushing at the process outlet. This bushing is only offered with the BS809SF Flow Chamber. The BS809SG, BS805GR, 0051182, and 0051180 Flow Chambers are provided with a 1/4 NPT process outlet tapped into the surface of the chamber in lieu of a bushing.

INSTALLATION CRITERIA

- 1 Check measurement range to select cell factor.
 - 0.1 C.F. = 0 to 18.16 megohm, resistivity version (specify resistivity sensor); 871CR-A, -B only
0 to 200 microSiemens/cm, conductivity version; 871CR-A only.
 - 10.0 C.F. = ~ 200 to 20 000 microSiemens/cm (~ 0.2 to 20 milliSiemens/cm); 871CR-C only.
- 2 Check material compatibility and pressure/temperature limits to choose material.
- 3 Since horizontal installation with flow entering from electrode end of sensor is preferred, choose insertion length to help ensure adequate sampling of measurement solution.
- 4 Choose installation mounting from standard model code selection or by ordering accessories and bore pieces.
- 5 Choose cable selection based upon length required and process temperature.

NOTES

ORDERING INSTRUCTIONS

When ordering a variable length sensor cable, patch cord, or extension cable assembly, specify the desired length on the sales order up to a maximum length of 100 ft (30 m).

For high conductivity, fouling applications, or applications damaging to the electrode, etc., it is recommended that electrodeless conductivity sensors be used. Refer to PSS 6-3C4 A for the 871EC Series Electrodeless Conductivity Sensors, or PSS 6-3Q1 A for the 871FT Flowthrough Electrode Conductivity sensors.

1. Model Number
2. Mounting Hardware
3. Electrical Certification Specification
4. Accessories
5. User Tag Data

ADDITIONAL PRODUCTS

These product lines offer a broad range of measurement and instrument products, including solutions for pressure, flow, analytical, temperature, positioning, controlling, and recording.

For a list of these offerings, visit our web site at:

www.schneider-electric.com

Schneider Electric Systems USA, Inc.
38 Neponset Avenue
Foxboro, MA 02035
United States of America
<http://www.schneider-electric.com>

Global Customer Support
Inside U.S.: 1-866-746-6477
Outside U.S.: 1-508-549-2424
<https://pasupport.schneider-electric.com>

Copyright 1998-2018 Schneider Electric Systems USA, Inc. All rights reserved.

ISchneider Electric is a trademark of Schneider Electric Systems USA, Inc., its subsidiaries, and affiliates. All other trademarks are the property of their respective owners.

