

Wibe Cable Support Systems

# Cable ladders

Wibe  
is becoming

**Schneider**  
Electric

## Index

	page		page		page		page
<b>Bends</b>							
90° Bend 15	94	Insert piece EM	100	Joint 9	125	Screw set M12	102
90° Bend 55	106	Profile clamp 41	135	Pendant joint 2J, 2FJ, 20J	85	(joint KHZV/KHZPV)	
S-bend 67	97	Profile clamp 42	61	Reducer 31	124	Screw set W34	88
		Profile clamp 43	61	Screw set M12	51	Screw set W37	88
				(KHZV/KHZPV)		Spring nut M8, M10	87
						T-bolt 26F	89
<b>Brackets</b>		<b>Couplings</b>		<b>Junctions</b>		<b>Steel wire installation</b>	
Angle bracket 5L, 5LS	128	Angle plate 33/1, 33/2	125	T-junction 16	95	<b>system HT</b>	
Bracket 60/40	86	Coupling 22	51	T-junction 56	106	Angle bracket 5L	115
Clamp 12	130	Coupling 44	103	X-junction 17	95	Carrying bracket HT-152	117
Combi bracket 53	131	Coupling 51	104			Carrying bracket HT-31	116
End bracket HT-11	136	Fixed take-off hook 4	129			Carrying bracket HT-33/34	116
End connection 10	129	Junction coupling 14	124	<b>Junction box plates</b>		Carrying sling HT-51	119
Lighting bracket 200	107	Take-off hook 47	105	Earth clamp W79	93	End bracket HT-11	117
Pendant bar 1	86			Junction box plate 35P	92	Pipe HT-68, HTR-68	118
Profile support piece 46	107			Junction box plate 35S	92	Steel wire	114
Rail fixing support 24/20F,		<b>Covers</b>				Tightening loop HT	118
24/20FS	143	Cover W5	108			Wall bracket HT-14	115
Rod bracket 82	130	Cover 90° bend	111	<b>Lashing wires</b>			
Wall bracket 11/25, 11/75	73	Cover clamp	110	Lashing wire	100		
Wall bracket 20	133	Cover joint	109				
Wall bracket 20F	133	Cover T-junction	112	<b>Marking plates</b>			
		Profile support piece 37	110	Marking plate 93	139	<b>Support brackets</b>	
						Support bracket 3	57
<b>Cable ladders</b>		<b>Cover plates</b>		<b>Mesh trays</b>		Support bracket 6	60
Cable ladder KHZ	32	Cover 64	144	Fixing tray N for casting-in	145	Support bracket HSO	59
Cable ladder KHZP	34	Cover plate 65	144				
Cable ladder KHZPS	30	Junction box cover	145	<b>Mounting rails</b>		<b>Surface treatment</b>	
Cable ladder KHZPV	38	Protecting cover	113	Mounting rail 40	142	Corrosion classes	4
Cable ladder KHZSP	26			Mounting rail WMS15	142	Current load of cables	6
Cable ladder KHZSPZ	28			Mounting rail WMS25	143	EMC	10
Cable ladder KHZV	36	<b>Dividers</b>				Environment/Quality	11
Thermoplastic coated		Distance piece W39	90	<b>Paint</b>		Installation regulations	6
KHZSP & accessories	40-49	Dividing strip 39	90	Anti-corrosive paint		Make the right choice	2-3
				"Galvafruid"	146	Potential balancing	7-9
				Repair paint	146	Product certificates	11-13
						Surface treatments	5
<b>Cable rollers</b>		<b>End plugs</b>		<b>Pendant/Fixing rails</b>		<b>Tele-conduits</b>	
Cable roller 38 Rig'n roll	138	Cross member plug 27	127	Fixing rail 24/26x53		Tele-conduit 36	91
Cable roller S	137	End plug 28, 28i	126	for casting-in	84		
Cable roller set 66	138	End plug 28C,D,E,F	126	Pendant/Fixing rail 24/20	81	<b>Vertical pieces</b>	
		Profile protection 28P	141	Pendant/Fixing rail 24/20F	82	Threaded rod W76 M10	140
				Pendant/Fixing rail 24/20FS	83	Vertical piece 2	62
				Pendant/Fixing rail 24/34	79	Vertical piece 2F	64
				Pendant/Fixing rail 24/48	80	Vertical piece 2Fi	66
<b>Cantilever arms</b>		<b>Fixings</b>		<b>Risers</b>		Vertical piece 20	67
Cantilever arm 30	52	Concrete screws	318	Riser 18	96	Vertical piece 20F	69
Cantilever arm 50L, 50, 50F	55	Expansion bolts	316	Riser coupling 49	105	Vertical piece 20FS	71
Cantilever arm 50i	53						
Cantilever arm 81	54	<b>Installation examples</b>		<b>Round bar fixings</b>			
		Cable ladders	147	Clamp set M6	122		
<b>Accessories</b>		Frame installations	24	Round bar fixing for ceilings	120		
Back plate 40	141			Round bar fixing for floors	121		
Mounting rail 40	142	<b>Installation summeries</b>		Round bar fixing for walls	121		
		KHZ	18-19	View Round bar fixings	120		
<b>Ceiling brackets</b>		KHZP	18-19			<b>Screw sets</b>	
Beam clamp 5BK	78	KHZPS	18-19	<b>Screw sets</b>		Back nut M8	88
Ceiling bracket 2Fi	74	KHZPV	20-21	Expansion bolts	134	Joint nut M10	140
Ceiling bracket 5	75	KHZSP, KHZSPZ	18-19	Joint nut M10	140	Nut M10	140
Ceiling bracket 5TP	77	KHZV	20-21	Screw M10x20	88	Screw set 2S	87
Ceiling bracket 5TPA	76	Suspension components	22-23	Screw set 2S	87	Screw set 20S	87
Ceiling bracket TF-10, TF-16	132			Screw set 22S	87		
Pendant base plate 520	77						
		<b>Installation plates</b>					
<b>Ceiling plates</b>		Installation plate 61	93				
Ceiling plate 20F	134						
Ceiling plate 20FS	134	<b>Joints</b>					
		Dropper joint 32	123				
<b>Clamps</b>		Intermediate connection					
Cable clamp A	98	bolt 29	123				
Cable clamp ER	101	Joint 21	50				
Cable clamp R	99	Joint 45	102				
Hook 8	132						

Installation summary KHZSP, KHZSPZ, KHZPS, KHZ, KHZP		18-19
Installation summary KHZV, KHZPV		20-21
Installation summary Suspension components		22-23
Frame installations		24
Cable ladders KHZSP, KHZSPZ, KHZPS, KHZ, KHZP, KHZV/KHZPV		26-39
Thermoplastic coating - KHZSP & accessories		40-49
Joints, Couplings		50-51
Cantilever arms, Support brackets		52-61
Vertical pieces		62-72
Wall bracket, Ceiling brackets		73-78
Pendant/Fixing rails, joints, bars		79-86
Screw sets		87-89
Tele-conduit, Dividers, Junction box plates, Installation plates		90-93
Bends, Junctions, Cable clamps		94-101
Details for KHZV, KHZPV		102-107
Covers & Accessories		108-113
Steel wire system HT		114-119
Round bar fixings		120-122
<b>Common parts</b>		
Joints, Couplings, Endplugs, Brackets, Cable rollers, Marking plates		123-139
<b>Accessories</b>		
Threaded rod W76 M10, Profile protection, Mounting rails, Rail fixing support, Repair paint etc		140-146
Installation examples		147

# Installation summary

KHZSP, KHZSPZ, KHZPS, KHZ, KHZP

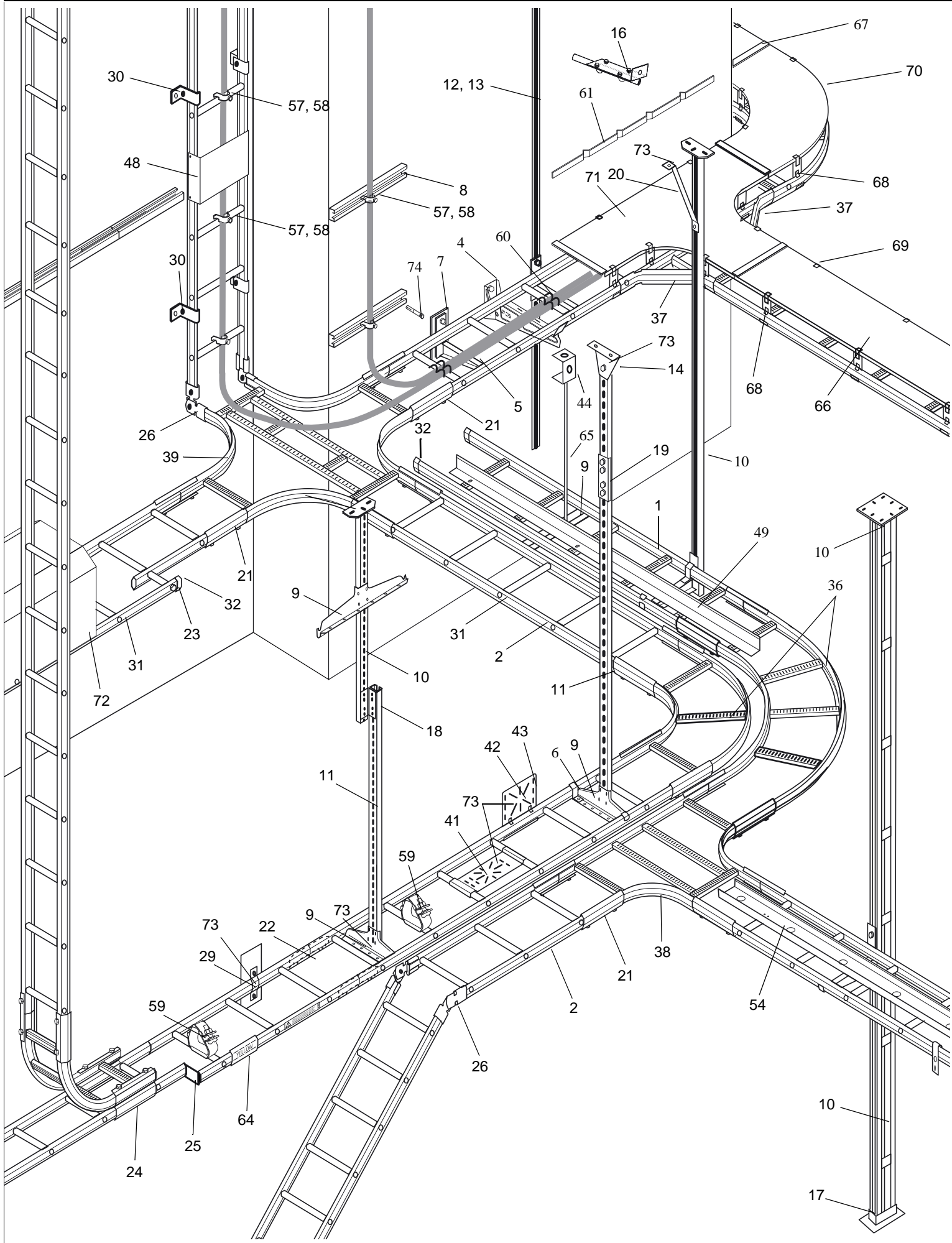

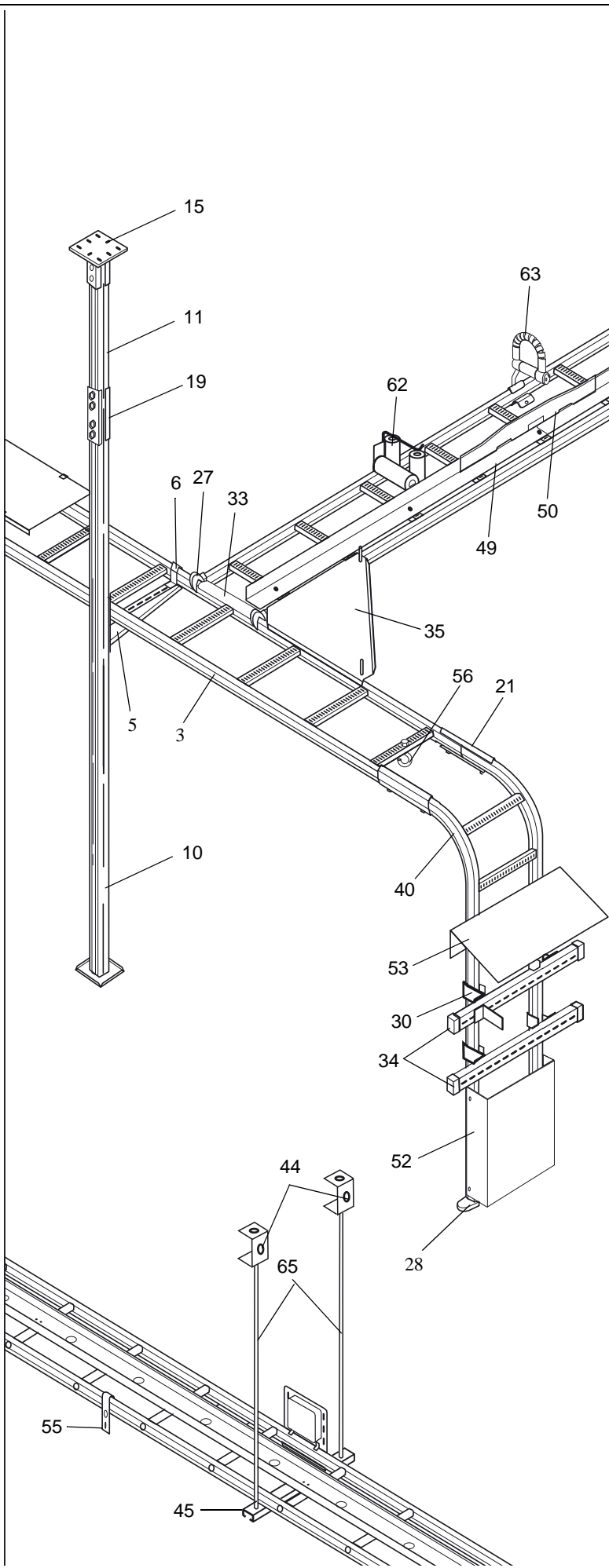

**Components**

	<b>Page</b>
1 Cable ladder KHZSP, KHZSPZ	26,28
2 Cable ladder KHZ	32
3 Cable ladder KHZPS, KHZP	30,34
4 Cantilever arm 50i	53
5 Cantilever arm 50, 50L, 50F	55
6 Profile clamp 42	61
7 Back plate 40	141
8 Mounting rail 40	142
9 Support bracket 3, Support bracket 6	57,60
10 Vertical pieces	62-71
11 Pendant/Fixing rails	79-83
12 Fixing rail 24/26x53 for casting-in	84
14 Ceiling bracket 5	75
15 Pendant base plate 520	77
16 Round bar fixings(ceiling,wall,floor)	120-122
17 Rail fixing support 24/20F, 24/20FS	143
18 End bracket HT-11	136
19 Pendant joint 2J, 2FJ, 20J	85
20 Pendant bar 1	86
21 Joint 21	50
22 Joint 9	125
23 Intermediate connection bolt 29	123
24 Dropper joint 32	123
25 Reducer 31	124
26 Coupling 22	51
27 Fixed take-off hook 4	129
28 End connection 10	129
29 Profile clamp 41	135
30 Wall bracket 11/25, 11/75	73
31 Cross member plug 27	127
32 End plug 28, 28i	126
33 Profile protection 28P	141
34 End plug 28E, 28D, 28C, 28F	126
35 Angle plate 33/1, 33/2	125
36 90° bend 15	94
37 Junction coupling 14	124
38 T-junction 16	95
39 X-junction 17	95
40 Riser 18	96
41 Junction box plate 35P	92
42 Junction box plate 35S	92
43 Earth clamp W79	93
44 Ceiling bracket TF10 and TF16	132
45 Support bracket HSO	59
48 Installation plate 61	93
49 Dividing strip 39	90
50 Distance piece W39	90
52 Cover plate 65	144
53 Junction box cover	145
54 Tele-conduit 36	91
55 Clamp 12	130
56 Hook 8	132
57 Cable clamp A and R	98-99
58 Insert piece EM	100
59 Cable clamp ER	101
60 Lashing wire	100
61 Mounting rail WMS15, WMS25	142-143
62 Cable roller S	137
63 Cable roller 38 Rig'n roll/Cable roller set 66	138
64 Marking plate 93	139
65 Threaded rod W76 M10	140
66 Cover W5	108
67 Cover joint	109
68 Profile support piece 37	110
69 Cover clamp	110
70 Cover 90° bend	111
71 Cover T-junction	112
72 Protecting cover	113
73 Screw sets	87-89
74 Expansion bolts	316
Fixings-concrete screws	318
Fixing tray N for casting-in	145

# Installation summary

KHZV, KHZPV

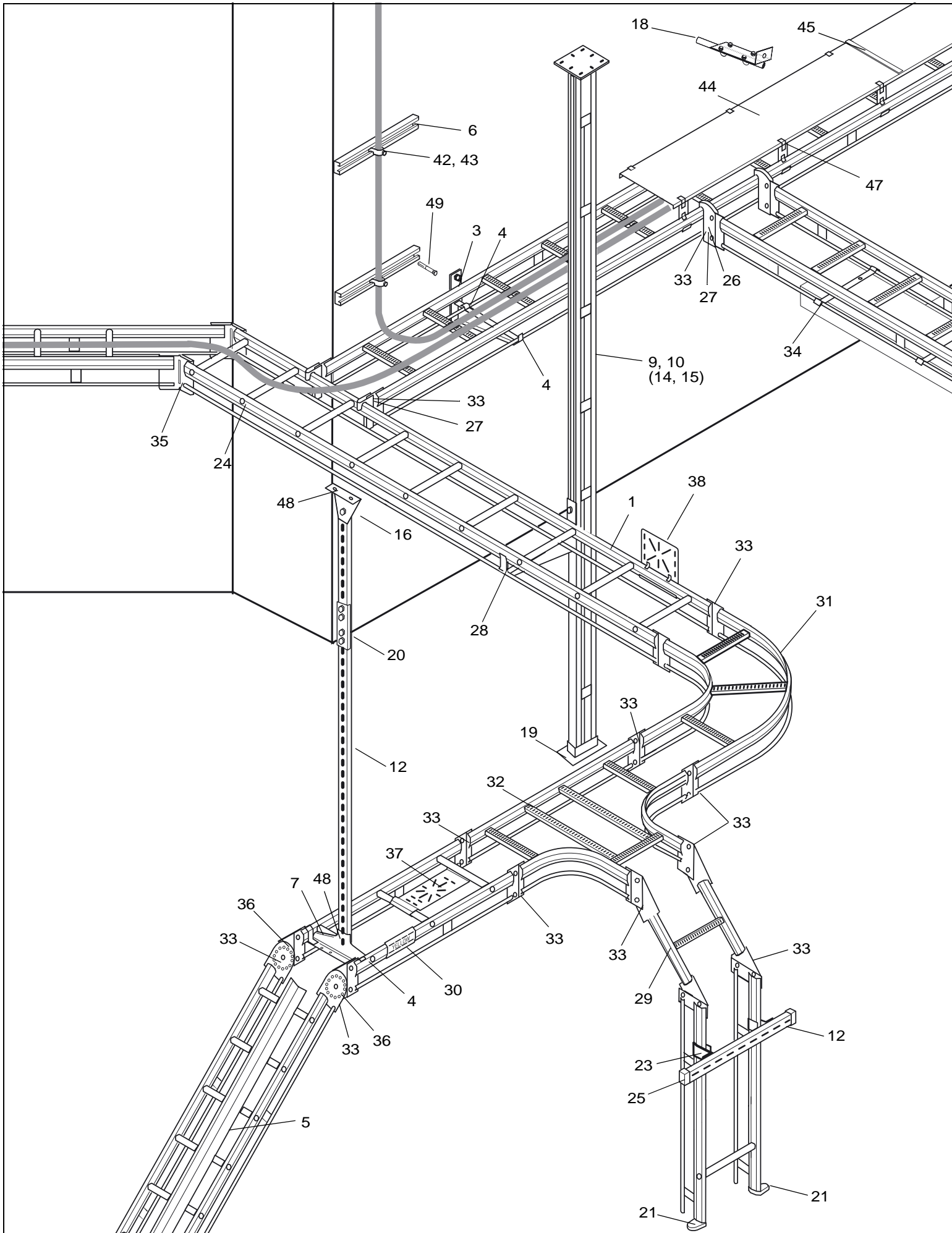

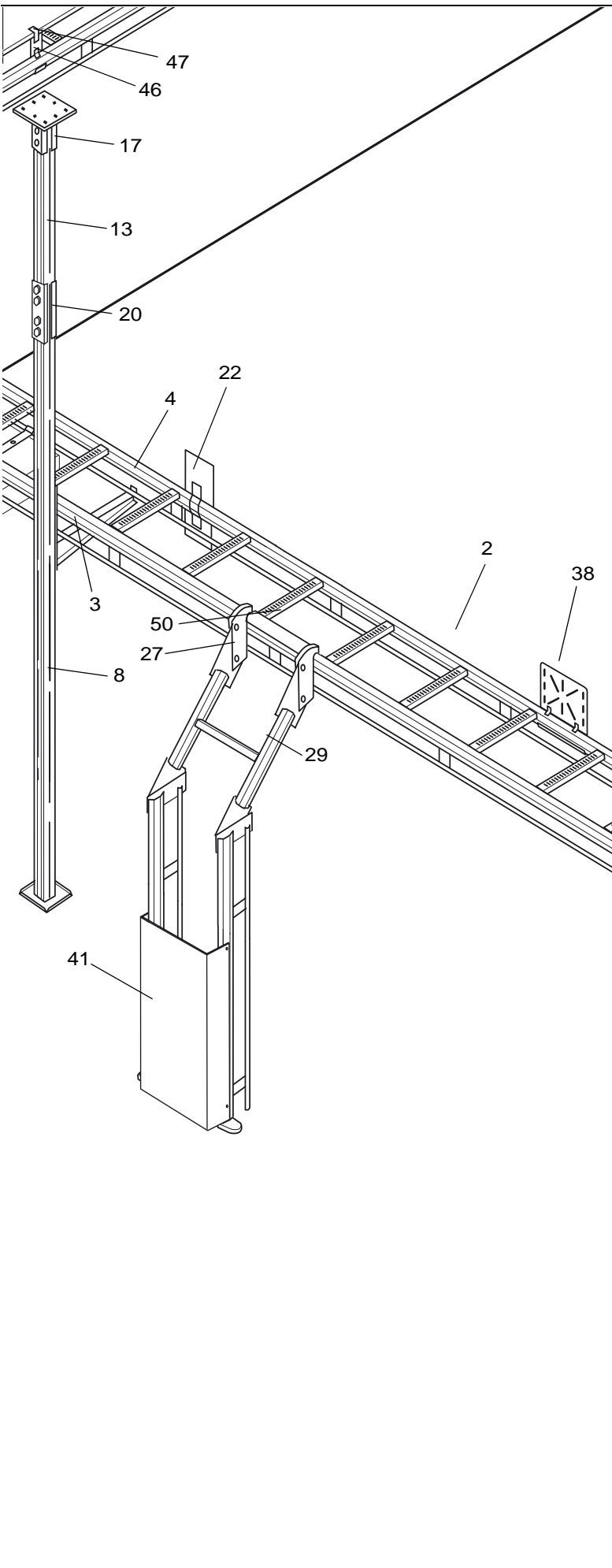

Components		Page
1	Cable ladder KHZV	36
2	Cable ladder KHZPV	38
3	Cantilever arm 50F	55
4	Profile clamp 43	61
5	Dividing strip 39	90
6	Mounting rail 40	142
7	Support bracket 3	57
8	Vertical piece 20	67
9	Vertical piece 20F	69
10	Vertical piece 20FS	71
12	Pendant/Fixing rail 24/48	80
13	Pendant/Fixing rail 24/20	81
14	Pendant/Fixing rail 24/20F	82
15	Pendant/Fixing rail 24/20FS	83
16	Ceiling bracket 5	75
17	Pendant base plate 520	77
18	Round bar fixings (ceiling, wall, floor)	120-122
19	Rail fixing support 24/20F, 24/20FS	143
20	Pendant joint 2J, 2 FJ, 20J	85
21	End connection 10	129
22	Profile clamp 41	135
23	Wall bracket 11/25, 11/75	73
24	Cross member plug 27	127
25	End plug 28E, 28D, 28C, 28F	126
26	Joint 45	102
27	Take-off hook 47	105
28	Profile support piece 46	107
29	Riser coupling 49	105
30	Marking plate 93	139
31	90° bend 55	106
32	T-junction 56	106
33	Screw set M12	51,102
34	Lighting bracket 200	107
35	Coupling 44	103
36	Coupling 51	104
37	Junction box plate 35P	92
38	Junction box plate 35S	92
41	Cover plate 65	144
42	Cable clamp A and R	98-99
43	Insert piece EM	100
44	Cover W5	108
45	Cover joint	109
46	Profile support piece 37	110
47	Cover clamp	110
48	Screw sets	87-89
49	Expansion bolts	316
50	Profile protection 28P	141
	Fixings - concrete screws	318

# Suspension components

KHZSP, KHZSPZ, KHZPS, KHZ, KHZP, KHZV, KHZPV

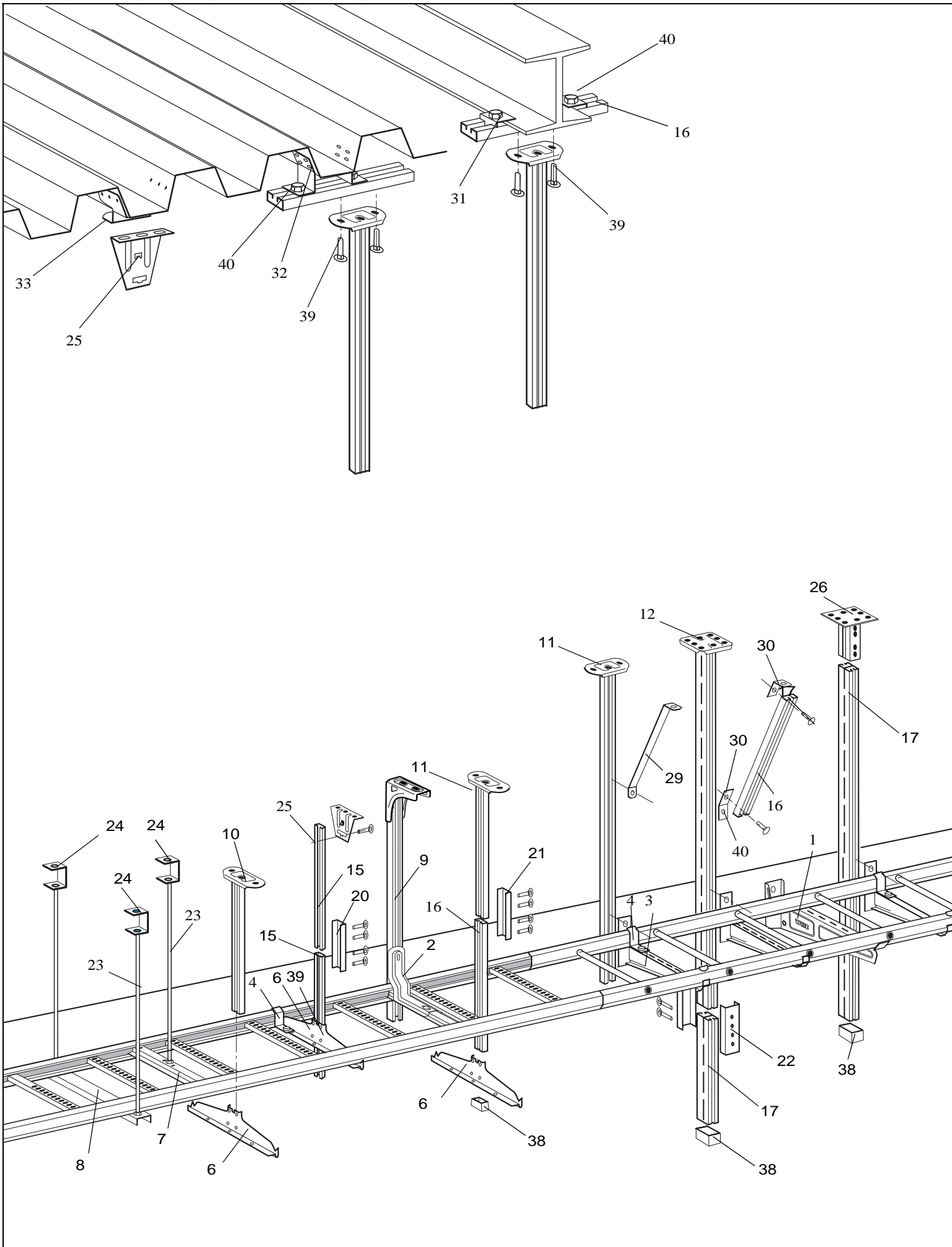



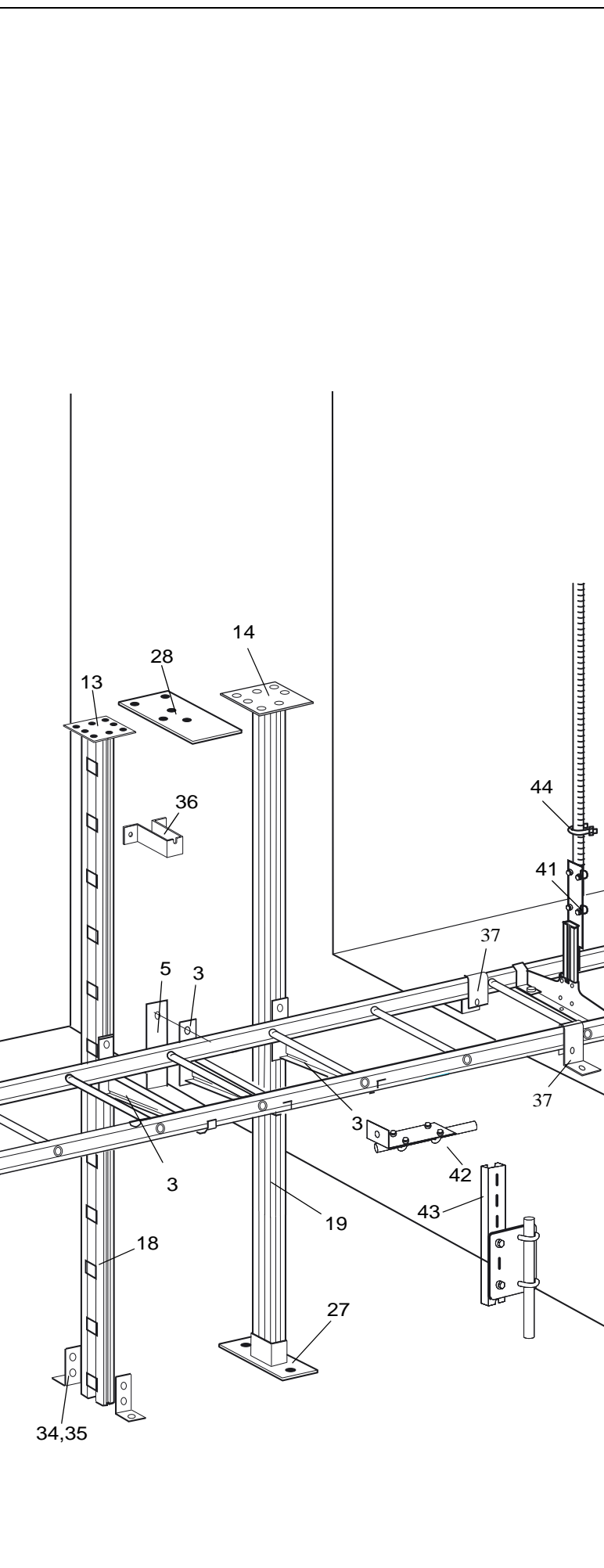

Suspension components _____	Page
1 Cantilever arm 50i _____	53
2 Cantilever arm 30 _____	52
3 Cantilever arm 50L, 50, 50F _____	55
4 Profile clamp 42 _____	61
5 Back plate 40 _____	141
6 Support bracket 3 _____	57
7 Support bracket 6 _____	60
8 Support bracket HSO _____	59
9 Vertical piece 2Fi _____	66
10 Vertical piece 2 _____	62
11 Vertical piece 2F _____	64
12 Vertical piece 20 _____	67
13 Vertical piece 20F _____	69
14 Vertical piece 20FS _____	71
15 Pendant/Fixing rail 24/34 _____	79
16 Pendant/Fixing rail 24/48 _____	80
17 Pendant/Fixing rail 24/20 _____	81
18 Pendant/Fixing rail 24/20F _____	82
19 Pendant/Fixing rail 24/20FS _____	83
20 Pendant joint 2J _____	85
21 Pendant joint 2FJ _____	85
22 Pendant joint 20J _____	85
23 Threaded rod W76 M10 _____	140
24 Ceiling bracket TF-10, TF-16 _____	132
25 Ceiling bracket 5 _____	75
26 Pendant base plate 520 _____	77
27 Rail fixing support 24/20F, 24/20FS _____	143
28 Ceiling plate 20F, 20FS _____	134
29 Pendant bar 1 _____	86
30 Bracket 60/40 _____	86
31 Beam clamp 5BK _____	78
32 Ceiling bracket 5TP _____	77
33 Ceiling bracket 5TPA _____	76
34 Angle bracket 5L _____	128
35 Angle bracket 5LS _____	128
36 Wall bracket 20, 20F _____	133
37 Wall bracket 11/25, 11/75 _____	73
38 End plug 28E, 28D, 28C, 28F _____	126
39 Screw sets _____	87-88
40 T-bolts _____	89
41 Round bar fixing for ceilings _____	120
42 Round bar fixing for walls _____	121
43 Round bar fixing for floors _____	121
44 Clamp set M6 _____	122
Fixings - expansion bolts, concrete screws _____	316-332

## Selfsupporting frame

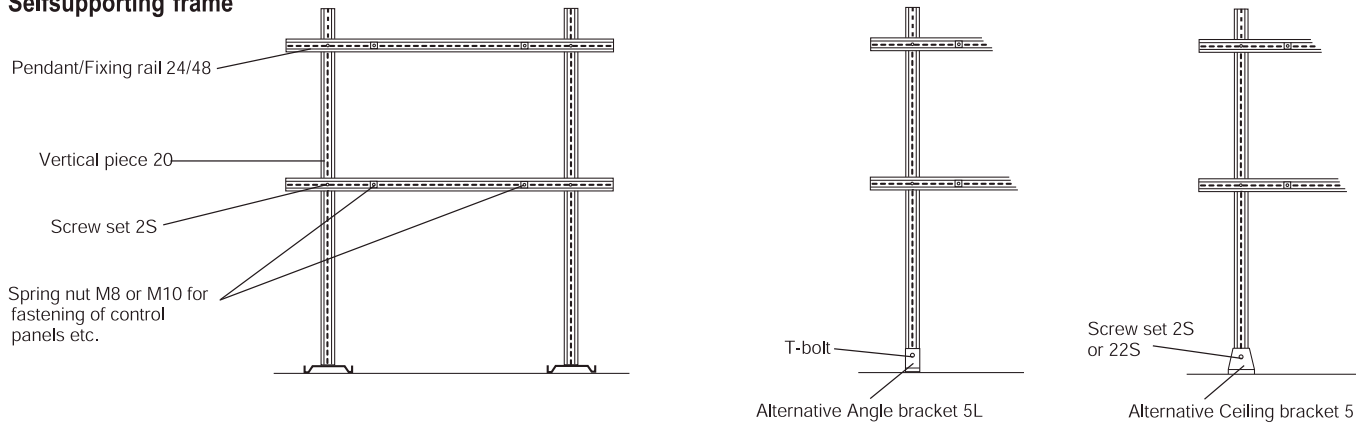

## Ladder as a selfsupporting frame

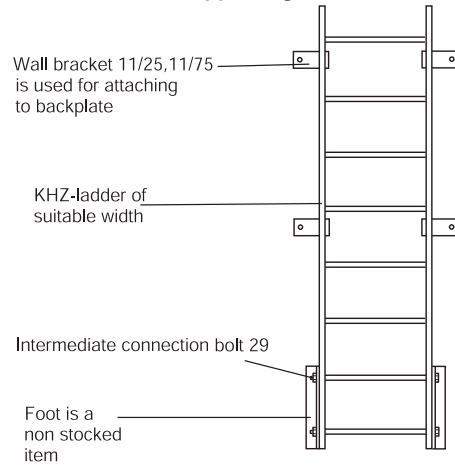

## Frame mounted on cable ladders

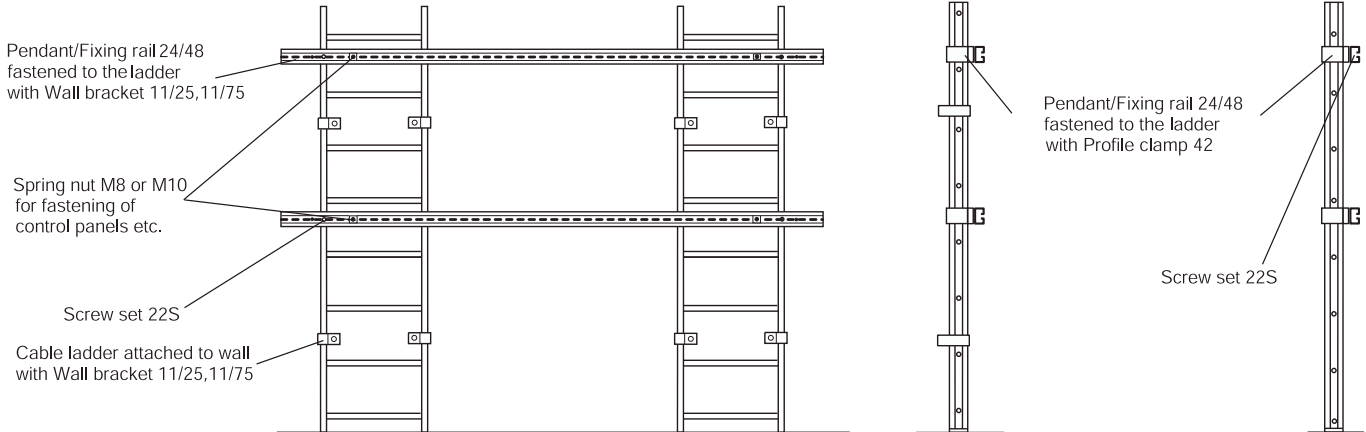

## Wall mounted frame

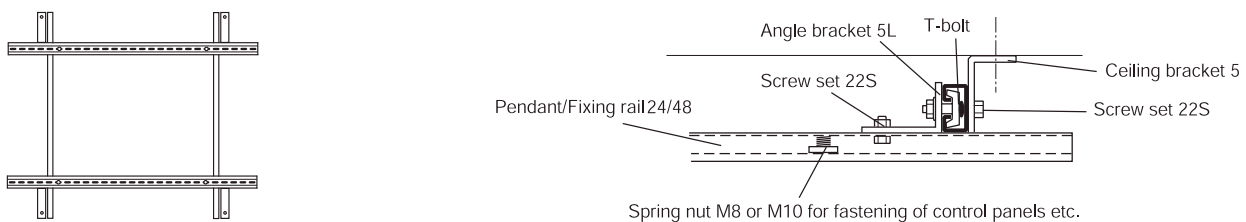



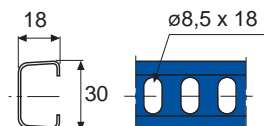

Length	3, 4, 6 m	Corrosion class
Width	200-600 mm	
Pre-galvanized	X	C2
Hot dip galvanized		
Zinkpox® coated white		
Stainless steel AISI 316L		

#### Applications

Hospitals, public buildings, schools, storage buildings, small industries, department stores, offices... wherever there are dry environments.

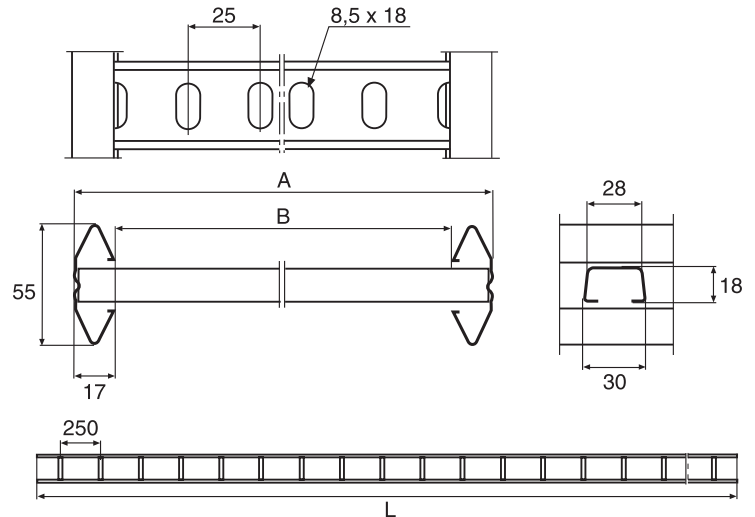
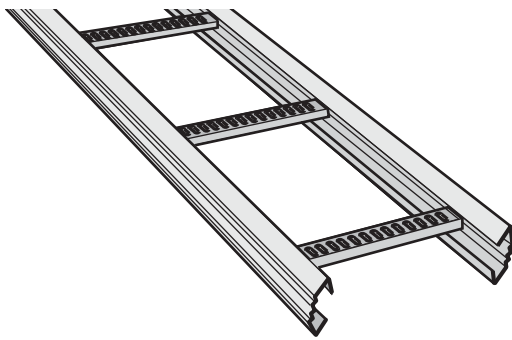

	A	B	L=6 m Pre-galv. Part.No. C*	L=4 m Pre-galv. Part.No. C*	L=3 m Pre-galv. Part.No. C*	Weight kg 100 m
	mm	mm				
KHZSP-200	198	164	734488 8	718572 6	783155 5	198
KHZSP-300	298	264	734489 5	718573 3	783156 2	217
KHZSP-400	398	364	734490 1	718574 0	783157 9	237
KHZSP-500	498	464	734491 8	718575 7	783158 6	257
KHZSP-600	598	564	734492 5	718576 4	783159 3	277

\*EAN-code=732167+Part.no+C (control figure)

### Going through a fire wall

When passing through a fire wall, the ladder must be cut on either side of the fire barrier.

### Loadings

The ladders are tested according to IEC 61537, test model II - a joint in the intermediate span (F2).

### Guaranteed load

Guaranteed uniformly distributed load supported by Wibe includes a minimum safety factor of 1.7 towards rupture. The diagram shows the deflection with Joint 21 for ladder widths up to 600 mm.

The cable ladders must not be used as walkways.

Test model II

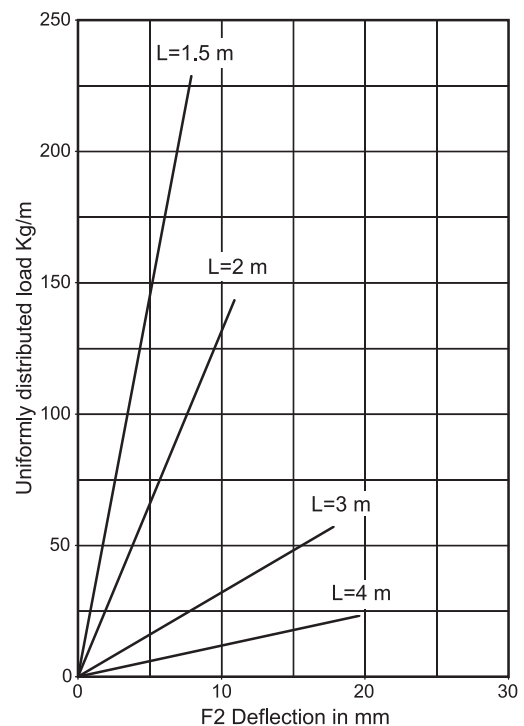
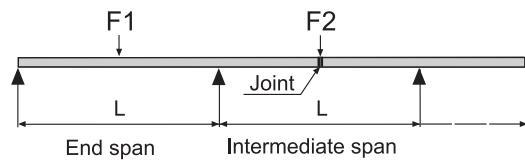

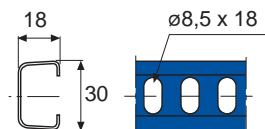

Length	6 m	Corrosion class
Width	200-600 mm	
Pre-galvanized		
Hot dip galvanized	X	C3,C4
Zinkpox® coated white		
Stainless steel AISI 316L		

#### Applications

Industrial installations both indoors and outdoors.

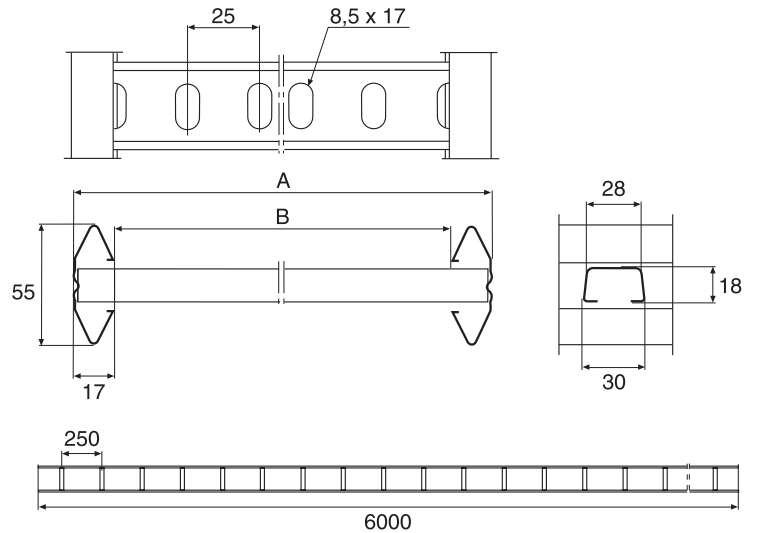
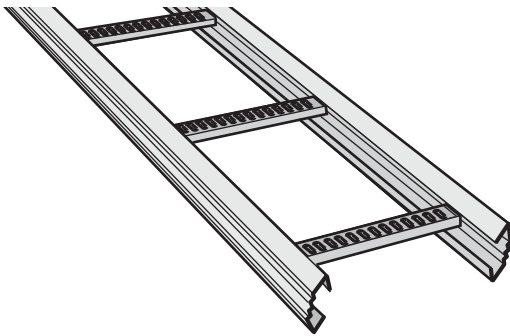

	A	B	Hot dip galv. Part.No. C*	Weight kg 100 m
KHZSPZ-200	198	164	734494 9	200
KHZSPZ-300	298	264	734495 6	220
KHZSPZ-400	398	364	734496 3	240
KHZSPZ-500	498	464	734497 0	260
KHZSPZ-600	598	564	734498 7	280

\*EAN-code=732167+Part.no+C (control figure)

### Going through a fire wall

When passing through a fire wall, the ladder must be cut on either side of the fire barrier.

### Loadings

The ladders are tested according to IEC 61537, test model II - a joint in the intermediate span (F2).

### Guaranteed load

Guaranteed uniformly distributed load supported by Wibe includes a minimum safety factor of 1.7 towards rupture. The diagram shows the deflection with Joint 21 for ladder widths up to 600 mm.

The cable ladders must not be used as walkways.

Test model II

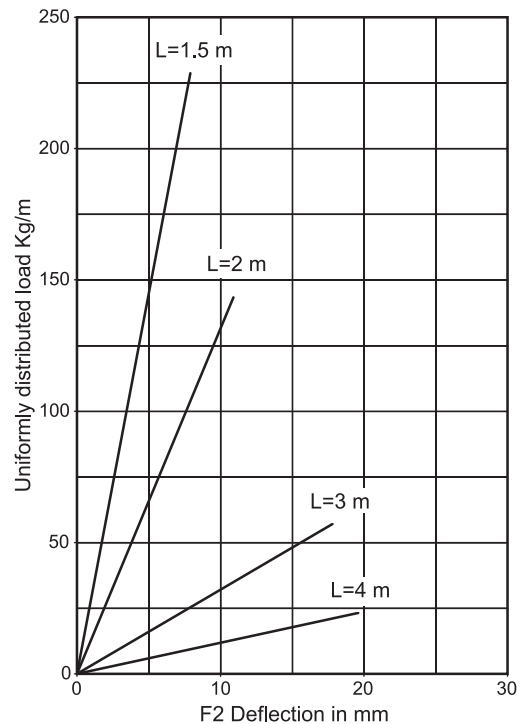
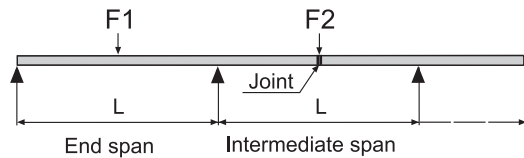

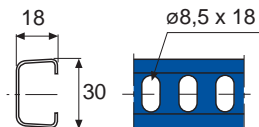

Length	6 m	Corrosion class
Width	150-1000 mm	
Pre-galvanized	X	C2
Hot dip galvanized		
Zinkpox® coated white		
Stainless steel AISI 316L		

**Applications**

Hospitals, public buildings, schools, storage buildings, small industries, department stores, offices... wherever there are dry environments.



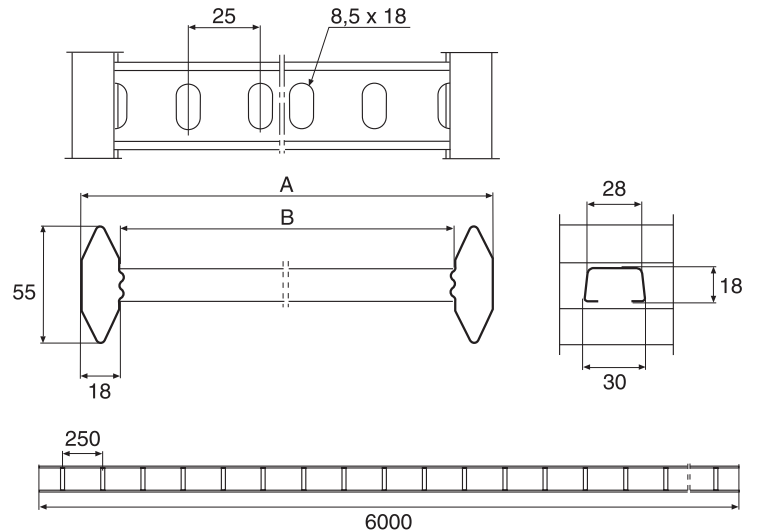
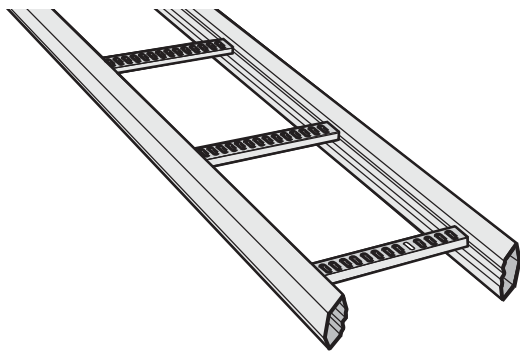

	A mm	B mm	Pre-galv. Part.No. C*	Weight kg 100 m
KHZPS-150	147	111	725350 0	225
KHZPS-200	197	161	725351 7	235
KHZPS-300	297	261	725352 4	255
KHZPS-400	397	361	725353 1	275
KHZPS-500	497	461	725354 8	300
KHZPS-600	597	561	725355 5	315
KHZPS-800	797	761	781099 4**	410
KHZPS-1000	997	961	725356 2	490

\*EAN-code=732167+Part.no+C (control figure) \*\*Produced to order

### Going through a fire wall

When passing through a fire wall, the ladder must be cut on either side of the fire barrier.

### Loadings

The ladders are tested according to IEC 61537, test model II - a joint in the intermediate span (F2).

### Guaranteed load

Guaranteed uniformly distributed load supported by Wibe includes a minimum safety factor of 1.7 towards rupture. The diagram shows the deflection with Joint 21 for ladder widths up to 600 mm. For widths greater than 600 mm contact Wibe or distributor.

The cable ladders must not be used as walkways.

Test model II

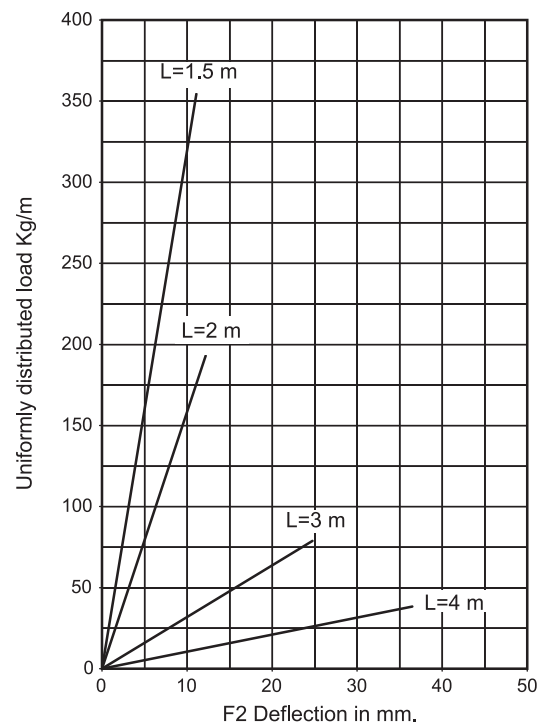
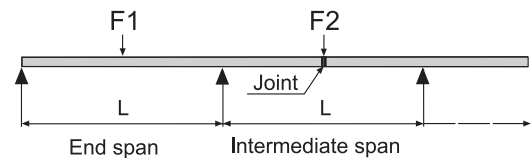



Length	6 m	Corrosion class
Width	150-600 mm	
Pre-galvanized		
Hot dip galvanized	X	C3,C4
Zinkpox® coated white	X	C5-I
Stainless steel AISI 316L	X	C5-M

### Applications

Industrial installations both indoors and outdoors.  
KHZ AISI 316L for installations e.g. in food industries,  
coastal and offshore areas.

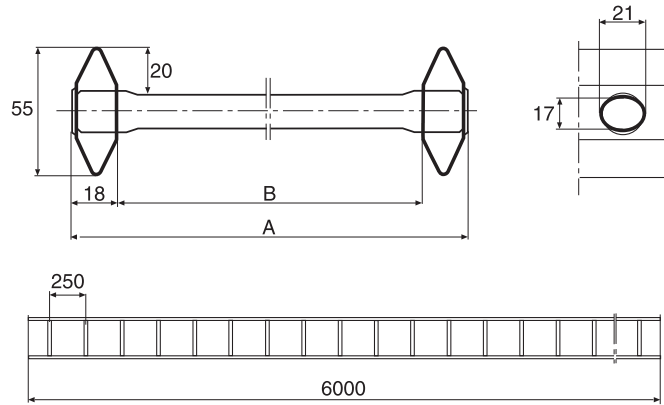
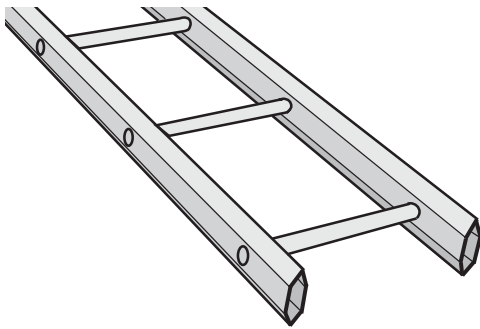

KHZ closed

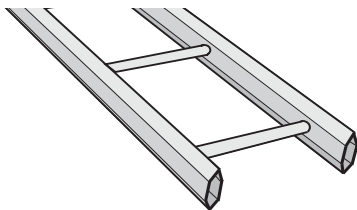

	Closed		Hot dip galv. Part. No. C*	Hot dip galv. Part. No. C*	Closed Stainl. steel (AISI316L) Part. No. C*	ZINKPOX® White Part. No. C*	Weight kg 100 m
	A mm	B mm					
KHZ-150	147	111	768001 6	726416 2**	727376 8**	714058 9	270
KHZ-200	197	161	768002 3	726417 9**	727377 5**	714059 6	280
KHZ-300	297	261	768004 7	726419 3**	727378 2**	714061 9	300
KHZ-400	397	361	768005 4	726420 9**	727379 9**	714062 6	320
KHZ-500	497	461	768006 1	726421 6**	727380 5**	714063 3	340
KHZ-600	597	561	768007 8	726422 3**	727381 2**	714064 0	360

\*EAN-code=732167+Part.no+C (control figure) \*\*Produced to order

### Going through a fire wall

When going through a fire wall one shall always cut the cable ladders just before and right after the opening in the wall.

### Loadings

The ladders are tested according to IEC 61537, test model II - a joint in the intermediate span (F2).

### Guaranteed load

Guaranteed uniformly distributed load supported by Wibe includes a minimum safety factor of 1.7 towards rupture. The diagram shows the deflection with Joint 21 for ladder widths up to 600 mm.

The cable ladders must not be used as walkways.

Test model II

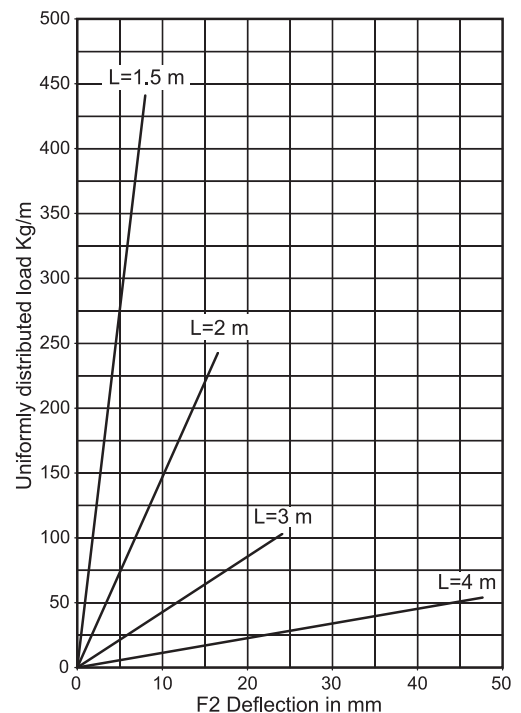
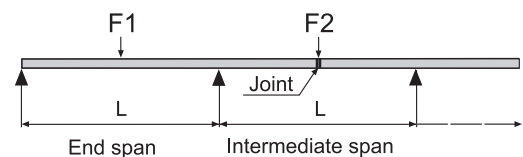

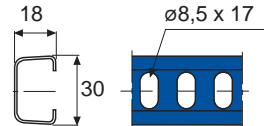

Length	3, 6 m	Corrosion class
Width	150-1000 mm	
Pre-galvanized		
Hot dip galvanized	X	C3,C4
Zinkpox® coated white	X	C5-I
Stainless steel AISI 316L	X	C5-M

**Applications**

Industrial installations both indoors and outdoors. Coastal and offshore areas.

**Going through a fire wall**

When passing through a fire wall, the ladder must be cut on either side of the fire barrier.

**Loadings**

The ladders are tested according to IEC 61537, test model II - a joint in the intermediate span (F2).

**Guaranteed load**

Guaranteed uniformly distributed load supported by Wibe includes a minimum safety factor of 1.7 towards rupture. The diagram shows the deflection with Joint 21 for ladder widths up to 600 mm. For widths greater than 600 mm contact Wibe or distributor.

The cable ladders must not be used as walkways.

Test model II

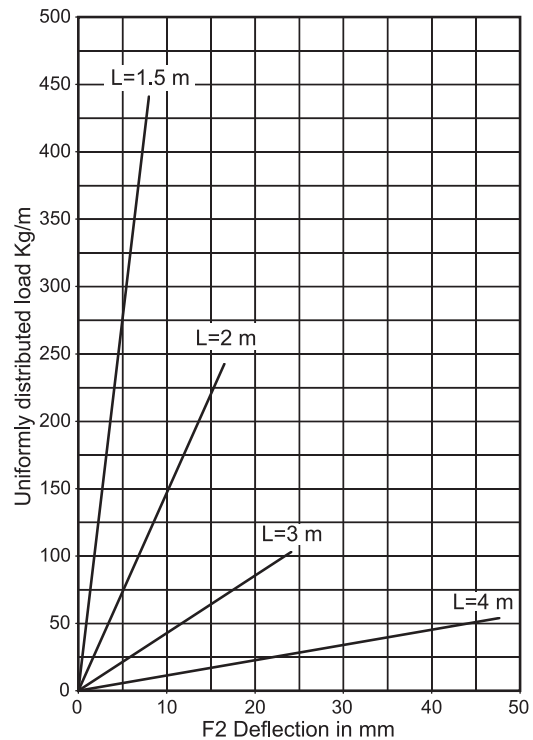
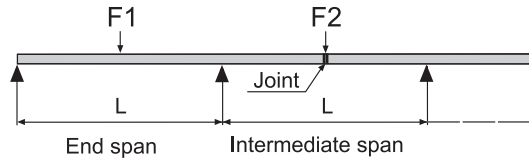

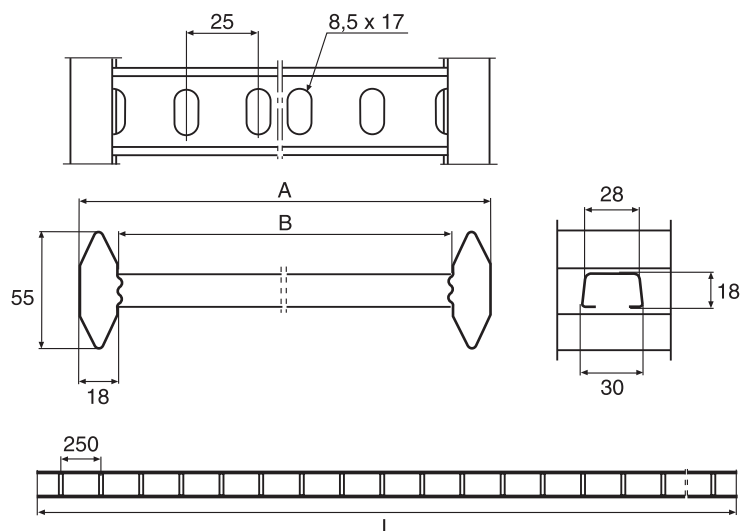
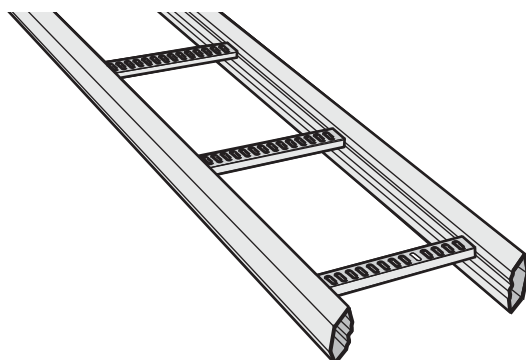

	L	A	B	Hot dip galv.	Stainl. steel (AISI316L)	ZINKPOX® White	Weight kg
	mm	mm	mm	Part. No. C*	Part. No. C*	Part. No. C*	100 m
KHZP-150	6000	147	111	718562 7	727382 9	718591 7	260
KHZP-200	6000	197	161	718563 4	727383 6	718592 4	270
KHZP-300	6000	297	261	718564 1	727384 3	718593 1	290
KHZP-400	6000	397	361	718565 8	727385 0	718594 8	315
KHZP-500	6000	497	461	718566 5	727386 7	718595 5	340
KHZP-600	6000	597	561	718567 2	727387 4	718596 2	360
KHZP-800	6000	797	761	721960 5	782128 0**	728033 9**	490
KHZP-1000	6000	997	961	718568 9	782129 7**	718597 9**	560
KHZP-150	3000	147	111	783516 4**		783524 9**	260
KHZP-200	3000	197	161	783517 1**		783525 6**	270
KHZP-300	3000	297	261	783518 8**		783526 3**	290
KHZP-400	3000	397	361	783519 5**		783527 0**	315
KHZP-500	3000	497	461	783520 1**		783528 7**	340
KHZP-600	3000	597	561	783521 8**		783529 4**	360
KHZP-800	3000	797	761	783522 5**		783530 0**	490
KHZP-1000	3000	997	961	783523 2**		783531 7**	560

\*EAN-code=732167+Part.no+C (control figure) \*\*Produced to order



Length	6 m	Corrosion class
Width	200-600 mm	
Pre-galvanized		
Hot dip galvanized	X	C3,C4
Zinkpox® coated white	X	C5-I
Stainless steel AISI 316L		

#### Applications

Coastal areas, industrial installations both indoors and outdoors.  
The ladder is designed for extreme support distances and loadings.

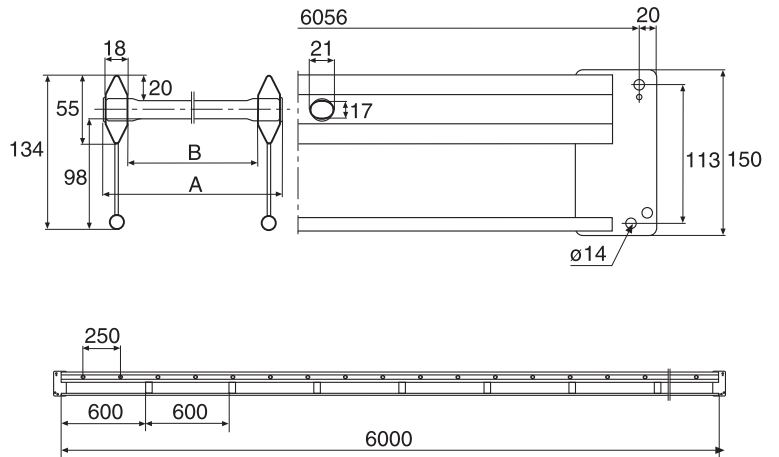
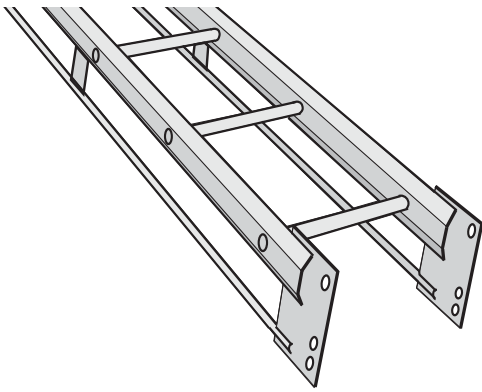

	A	B	Hot dip galv.	ZINKPOX® White	Weight kg
	mm	mm	Part. No. C*	Part. No. C*	100 m
KHZV-200	197	161	712015 4	714198 2	440
KHZV-300	297	261	712017 8	714200 2	460
KHZV-400	397	361	712019 2	714202 6	480
KHZV-500	497	461	712018 5	714201 9	500
KHZV-600	597	561	712020 8	714203 3	530

\*EAN-code=732167+Part.no+C (control figure)

### Going through a fire wall

When passing through a fire wall, the ladder must be cut on either side on the fire barrier.

### Loadings

The ladders are tested according to IEC 61537, test model II for bracket distance up to and including 4 m, test type V for bracket distance more than 4 m.

### Guaranteed load

Guaranteed uniformly distributed load supported by Wibe includes a minimum safety factor of 1.7 towards rupture. The diagram shows the deflection for ladder widths up to 600 mm.

The cable ladders must not be used as walkways.

Test model V

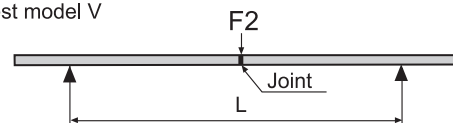

Test model II

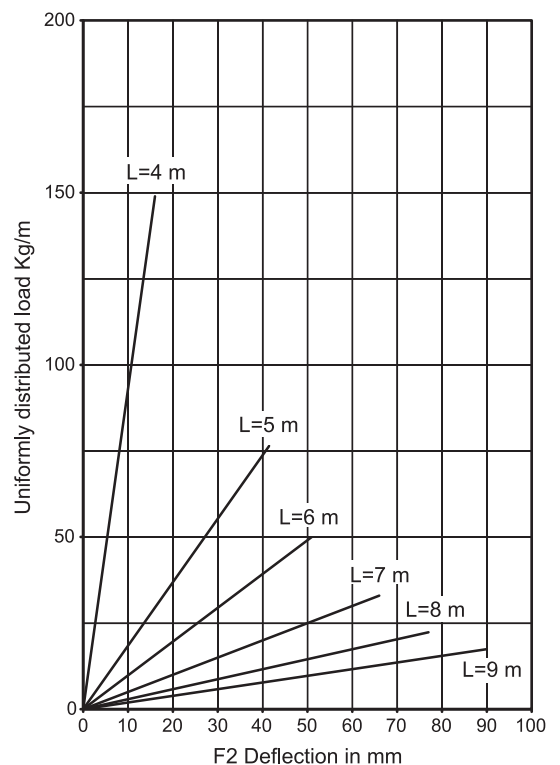
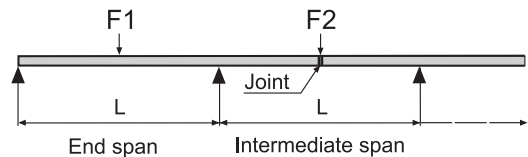

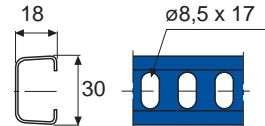

Length	6 m	Corrosion class
Width	200-1000 mm	
Pre-galvanized		
Hot dip galvanized	X	C3,C4
Zinkpox® coated white	X	C5-I
Stainless steel AISI 316L	X	C5-M

#### Applications

Coastal and offshore areas, industrial installations both indoors and outdoors.  
The ladder is designed for extreme support distances and loadings.



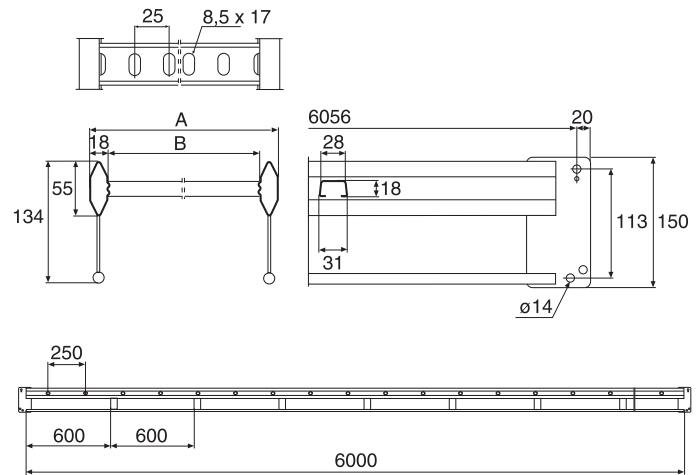
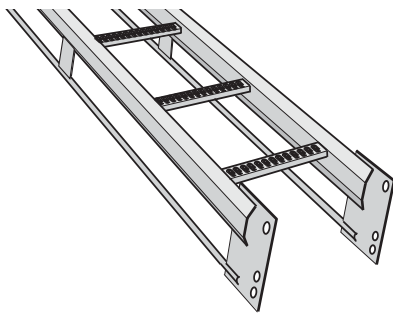

	A	B	Hot dip galv.	Stainl. steel (AISI316L)	ZINKPOX® White	Weight kg
	mm	mm	Part. No. C*	Part. No. C*	Part. No. C*	100 m
KHZPV-200	197	161	717982 4	784066 3**	723390 8**	426
KHZPV-300	297	261	717983 1	784067 0**	723391 5**	448
KHZPV-400	397	361	717984 8	784068 7**	723392 2**	470
KHZPV-500	497	461	717985 5	784069 4**	723393 9**	493
KHZPV-600	597	561	717986 2	784070 0**	723394 6**	515
KHZPV-800	797	761		784071 7**		587
KHZPV-1000	997	961	716400 4	784072 4**	716401 1**	703

\*EAN-code=732167+Part.no+C (control figure) \*\*Produced to order

## Going through a fire wall

When passing through a fire wall, the ladder must be cut on either side on the fire barrier.

## Loadings

The ladders are tested according to IEC 61537, test model II for bracket distance up to and including 4 m, test type V for bracket distance more than 4 m.

## Guaranteed load

Guaranteed uniformly distributed load supported by Wibe includes a minimum safety factor of 1.7 towards rupture. The diagram shows the deflection for ladder widths up to 600 mm. For widths greater than 600 mm contact Wibe or distributor.

The cable ladders must not be used as walkways.

Test model V

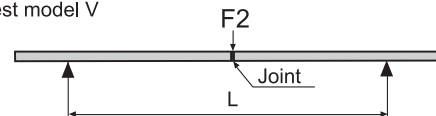

Test model II

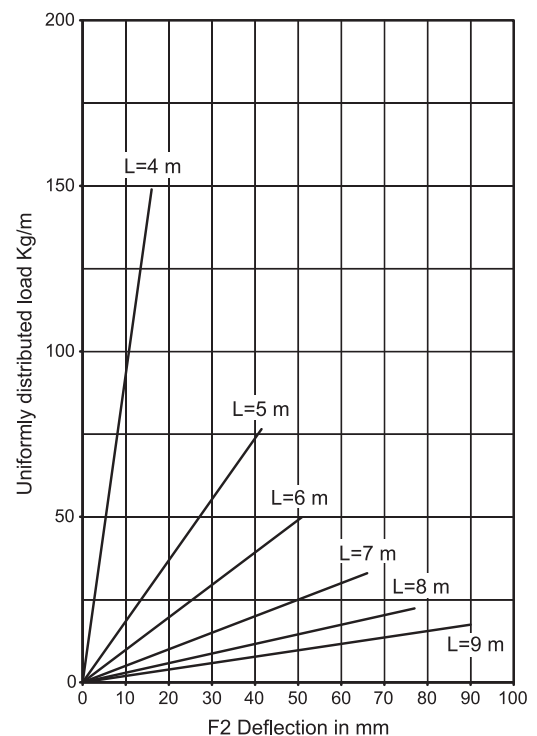
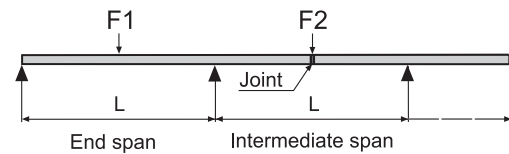

## An option for corrosive environments

The base is provided by our KHZSP range, i.e. ladders that are easy to handle and can be quickly installed with a minimum of tools. Coated with a halogen-free thermoplastic, the range offers high corrosion protection. For a complete system, simply add acid-resistant components!



## Thermoplastic coating - brief details

Thermoplastic coating is a thermal process in which a plastic powder is melted to give a component, most usually metal, a special coat. The beneficial properties brought by this coat depend on the coating material that is used. Thermoplastics are predominantly employed in aggressive environments. Here, they provide hardwearing, long-lasting and environment-friendly protection against, amongst other things, corrosion. Because the coating process is thermal with no solvents, it has minimal impact on the environment. Thermoplastic coatings meet the requirements of the most aggressive environments, e.g. wet, humid environments and those with large temperature variations and concentrations of chemicals. Besides durability, the coatings also have high impact resistance. As the coating provides complete cover, is pore-free and strong, it is also hygienic and dirt repellent.

## Distinctive properties

- Hardwearing/scratch-resistant coating
- High corrosion resistance in environments up to and including class C5-M (ISO 12944-6)
- Very good resistance to chemicals
- Low toxicity in the event of fire
- VO fire rating (UL 94), UV resistant
- EMC neutral
- Can be used in environments from -40C° to +65C°
- Easy to assemble
- All accessories can be assembled using M8 screws
- Provision for equipotential bonding

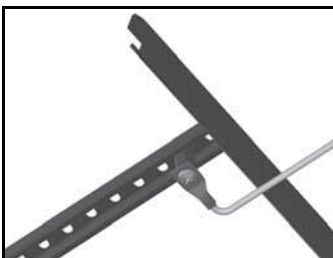

The cable ladder has provision for equipotential bonding, threaded M8 at both ends.

# Cable ladder KHZSP

Thermoplastic coated cable ladder.

WEF-0033

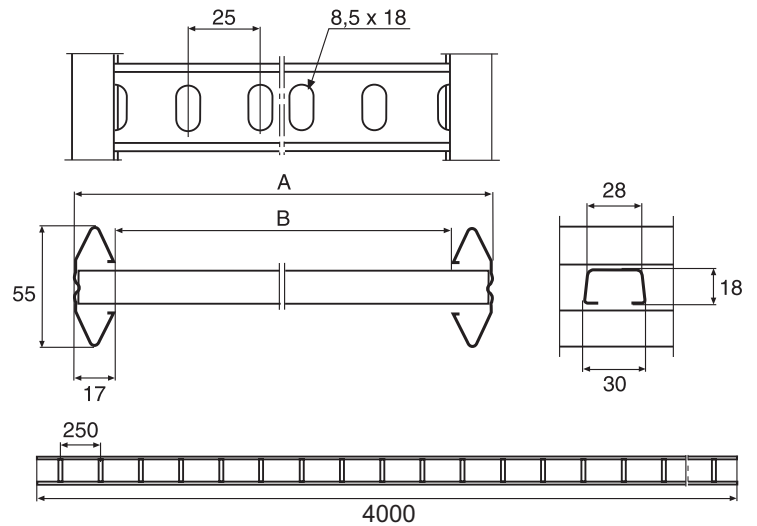

	A	B	Thermoplastic Part.No. C*	Weight kg 100 m
KHZSP-200	200	166	783383 2**	210
KHZSP-300	300	266	783384 9**	230
KHZSP-400	400	366	783385 6**	253
KHZSP-500	500	466	783386 3**	273
KHZSP-600	600	566	783387 0**	295

\*EAN-code=732167+Part.no+C (control figure)

\*\*Produced to order

## Going through a fire wall

When passing through a fire wall, the ladder must be cut on either side of the fire barrier.

## Loadings

The ladders are tested according to IEC 61537, test model II - a joint in the intermediate span (F2).

## Guaranteed load

Guaranteed uniformly distributed load supported by Wibe includes a minimum safety factor of 1.7 towards rupture. The diagram shows the deflection with Joint 21 for ladder widths up to 600 mm.

The cable ladders must not be used as walkways.

Test model II

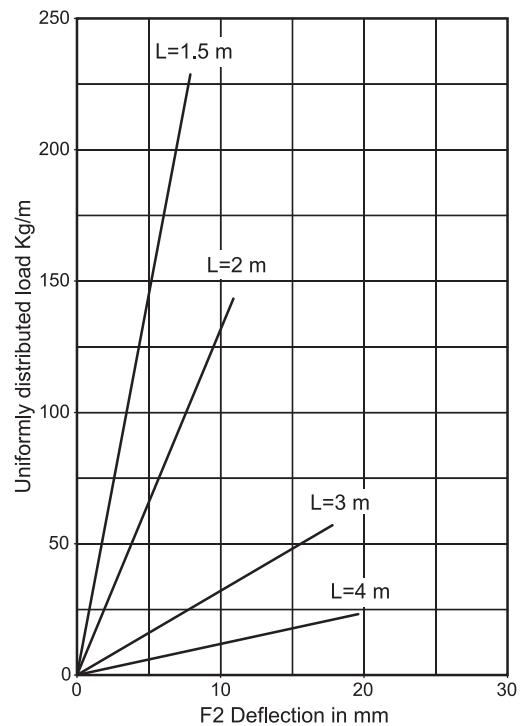
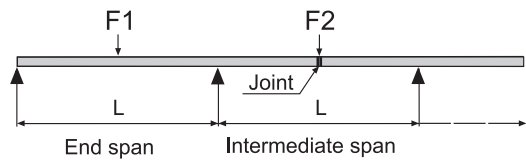

## Joint 21P

**WIBE**

Thermoplastic coated joint, used for straight, rigid joining of cable ladders KHZSP.

WEF-0033

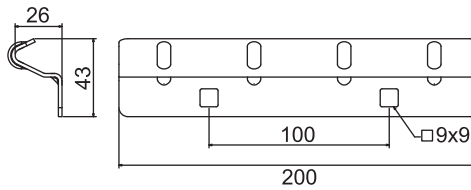

	Thermoplastic Part. No. C*	Weight kg 100 pcs
Joint 21P (Screw and nut included)	783449 5**	47
*EAN-code=732167+Part.no+C (control figure) **Produced to order		

### Use and installation

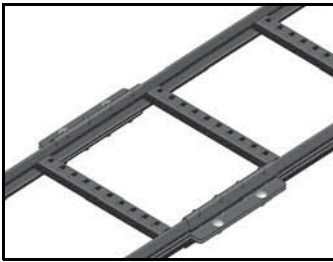

Joint 21P is used for straight joining of thermoplastic coated cable ladders without affecting the surface treatment.

## Coupling 22P

**WIBE**

Thermoplastic coated, used for horizontal or vertical branching to the required angle.

WEF-0033

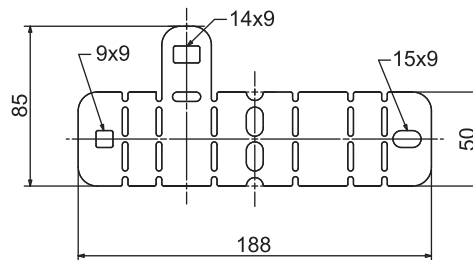
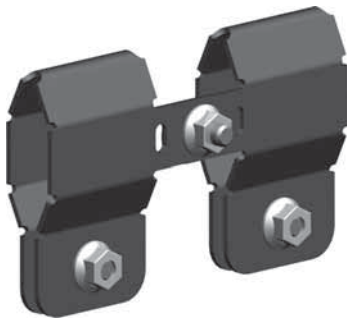

	Thermoplastic Part. No. C*	Weight kg 100 pcs
Coupling 22P (Screw and nut included)	783772 4**	33
*EAN-code=732167+Part.no+C (control figure) **Produced to order		

### Use and installation



Coupling 22P is mounted by forming the coupling around the side profile.



Coupling 22P is used for horizontal or vertical branching to the required angle.



Coupling 22P can also be used as a connection vertically against floors or horizontally against walls.

## Cantilever arm 50

Thermoplastic coated, used for mounting on walls, pendant/fixing rails or vertical pieces.

WEF-0033

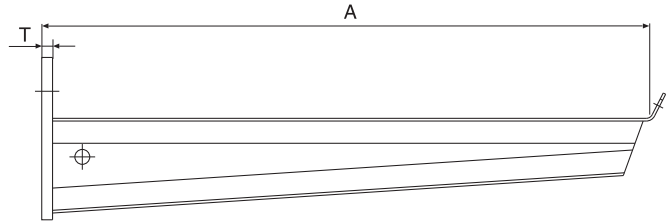
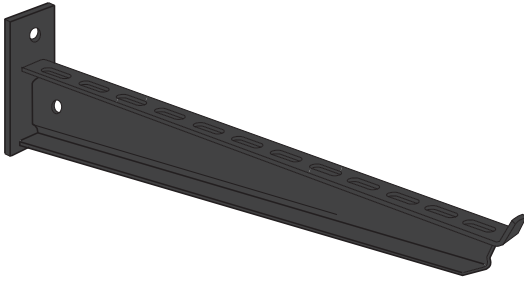

	A mm	T mm	Thermoplastic Part. No. C*	Weight kg 100 pcs
50-200	250	4	783389 4**	40
50-300	350	6	783390 0**	70
50-400	450	8	783391 7**	130
50-500	550	8	783392 4**	180
50-600	650	10	783393 1**	230

\*EAN-code=732167+Part.no+C (control figure) \*\*Produced to order

### Use and installation

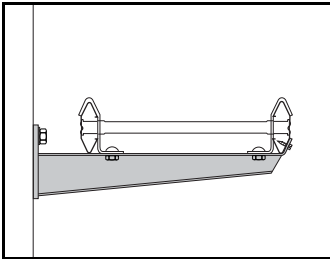

Cantilever arm 50 is mounted on vertical piece or pendant/fixing rail by using T-bolt 26F. Profile clamp 42 is used for attaching a cable ladder to Cantilever arm 50.

# Support bracket 3

Thermoplastic coated, used for centre installation of cable ladders on pendant/fixing rails and vertical pieces.

WEF-0033

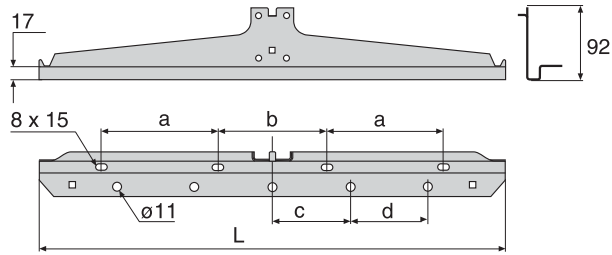
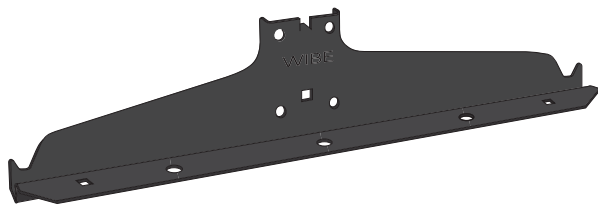

	L mm	a	b	c	d	Thermoplastic Part. No. C*	Weight kg 100 pcs
Support bracket 3-200	200	-	100	-	-	783404 4**	30
Support bracket 3-300	300	70	100	-	-	783405 1**	50
Support bracket 3-400	400	70	100	100	-	783406 8**	70
Support bracket 3-500	500	100	140	100	-	783407 5**	120
Support bracket 3-600	600	150	140	100	100	783408 2**	140

\*EAN-code=732167+Part.no+C (control figure) \*\*Produced to order

## Use and installation

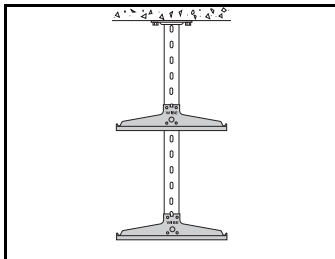

Mount Support bracket 3 on Vertical piece 2F with Screw set 22S.

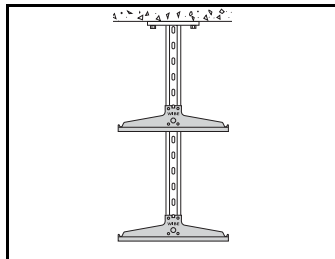

Mount Support bracket 3 on Vertical piece 20F with Screw set W37.

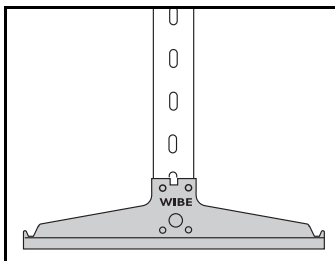

Mount Support bracket 3 on Pendant/Fixing rail 24/48 with Screw set 22S.

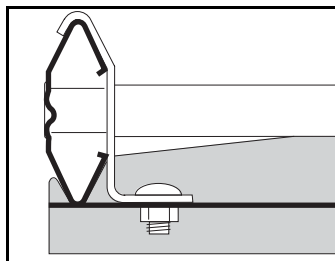

Mount the cable ladder on Support bracket 3 by using Profile clamp 42.

## Breaking load-symmetrical loading

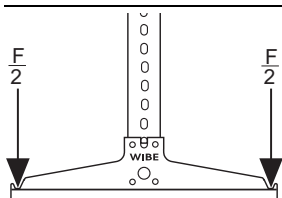

	Breaking load F	
	kN	kg
Support bracket 3-200	16	1600
Support bracket 3-300	16	1600
Support bracket 3-400	12	1200
Support bracket 3-500	12	1200
Support bracket 3-600	10	1000

## Profile clamp 42

Thermoplastic coated, used for installations where the cable ladder is to be fixed to cantilever arms, support brackets etc.

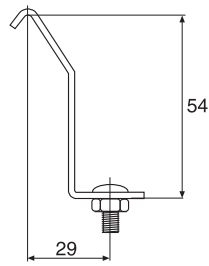
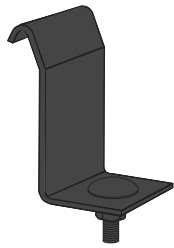

	Thermoplastic Part. No. C*	Weight kg 100 pcs
Profile clamp 42 (Screw and nut included)	783388 7**	8
*EAN-code=732167+Part.no+C (control figure) **Produced to order		

### Use and installation

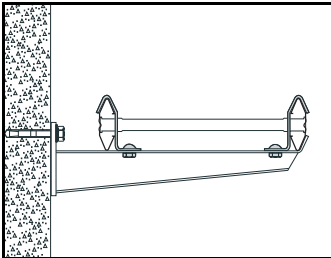

Use Profile clamp 42 for attaching KHZSP to Cantilever arm 50. For small loads, mount the ladder with a clamp on each cantilever arm, alternately right side and left side.

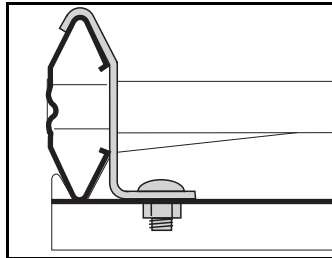

Profile clamp 42 is used for installation of KHZSP on Support bracket 3.

# Vertical piece 2F

Thermoplastic coated, used for installation of Support bracket 3 or Cantilever arm 50.

WEF-0033

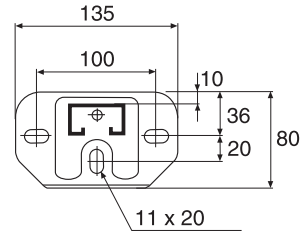
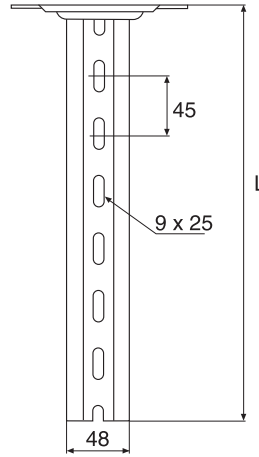
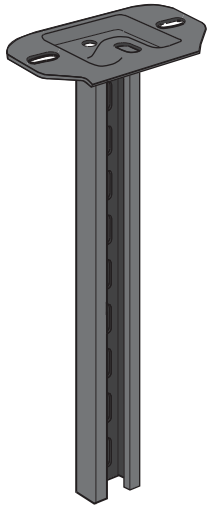

	L mm	Thermoplastic Part. No. C*	Weight kg 100 pcs
Vertical piece 2F-280	280	783394 8**	90
Vertical piece 2F-370	370	783395 5**	110
Vertical piece 2F-505	505	783396 2**	140
Vertical piece 2F-730	730	783397 9**	180
Vertical piece 2F-1000	1000	783398 6**	230
Vertical piece 2F-1500	1500	783399 3**	310

\*EAN=732167+Part.no+C (control figure) \*\*Produced to order

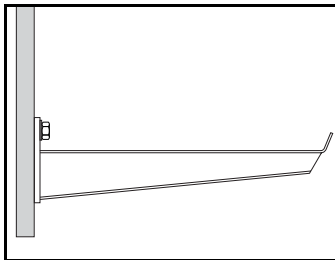

Mount Cantilever arm 50 using T-bolt 26F.

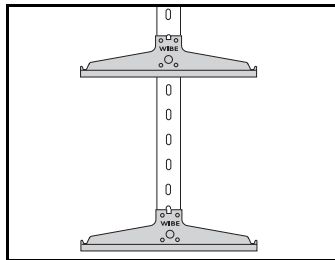

Mount Support bracket 3 using Screw set 22S.

## Breaking load

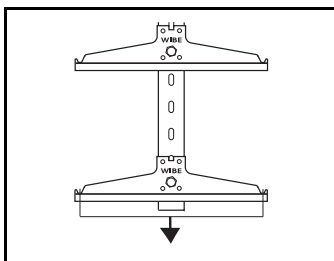

Breaking load for Vertical piece 2F = 2300 kg (23 kN) at symmetrical loading.



# Vertical piece 20F

Thermoplastic coated, used for mounting in ceiling or on floor.  
 Suitable for rather heavy loadings.

WEF-0033

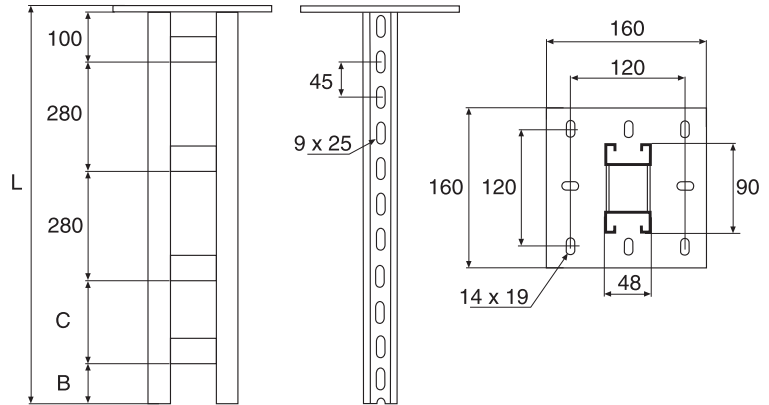
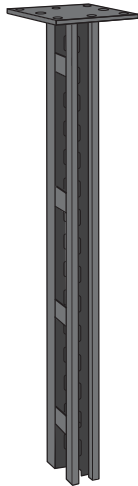

	L mm	Thermoplastic Part. No. C*	Weight kg 100 pcs
Vertical piece 20F-1000	1000	783400 6**	630
Vertical piece 20F-1500	1500	783401 3**	840
Vertical piece 20F-2000	2000	783402 0**	1050
Vertical piece 20F-3000	3000	783403 7**	1320

\*EAN-code=732167+Part.no+C (control figure) \*\*Produced to order

## Use and installation

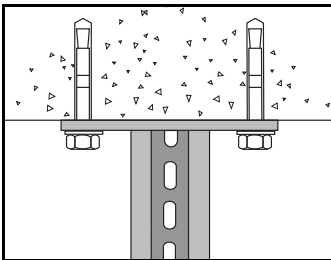

Mount Vertical piece 20F using Expansion bolt.

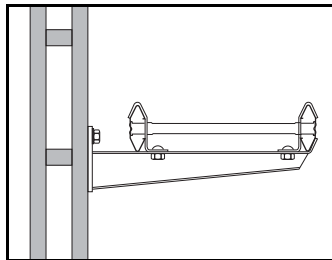

Cantilever arm 50 is mounted on Vertical piece 20F with T-bolt 26F.

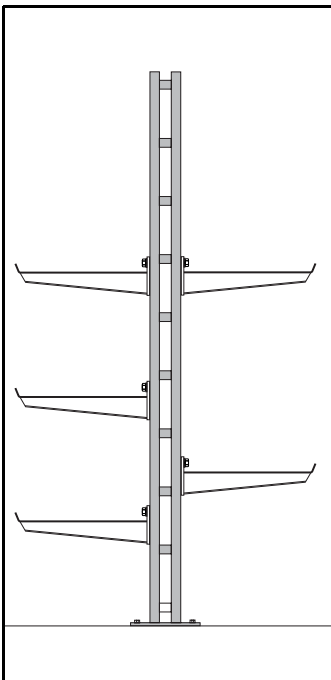

Floor mounting example.

# Pendant/Fixing rail 24/48

**WIBE**

Thermoplastic coated, used for mounting of support brackets, cantilever arms etc.

WEF-0033

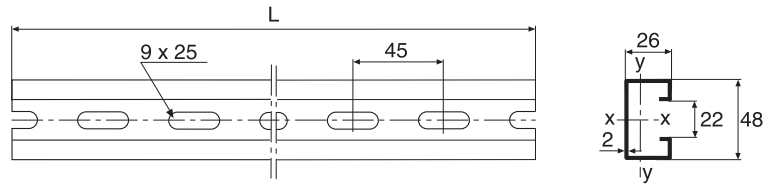

	L mm	Thermoplastic Part. No. C*	Weight kg 100 pcs
P/F-rail 24/48	2970	783773 1**	550

\*EAN-code=732167+Part.no+C (control figure) \*\*Produced to order

## Use and installation

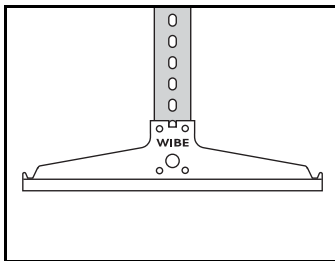

Mount Support bracket 3 using  
Screw set 22S.

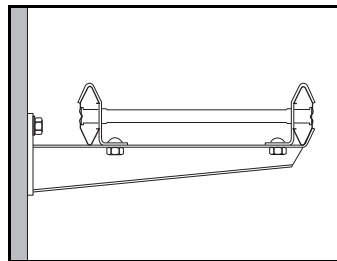

Mount Cantilever arm 50 using  
T-bolt 26F.

## Screw set 22S

**WIBE**

For installation of Support bracket 3 on Vertical piece 2F and Pendant/fixing rail 24/48.

WEF-0001

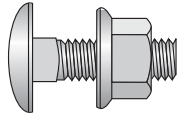

	Stainl. steel (AISI316) Part. No. C*	Weight kg 100 pcs
Screw set 22S (screw MVBF 8x16+nut M6MF 8)	725582 5	1.9
*EAN-code=732167+Part.no+C (control figure)		

## Screw set W37

**WIBE**

For installation of Support bracket 3 on Vertical piece 20F.

WEF-0001

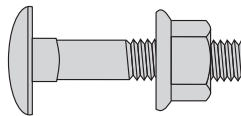

	Stainl. steel (AISI316) Part. No. C*	Weight kg 100 pcs
Screw set W37 (bolt MVBF 8x35+nut M6MF 8)	725586 3	2.8
*EAN-code=732167+Part.no+C (control figure)		

## T-bolt 26F

**WIBE**

Used for mounting Cantilever arm 50 on Pendant/Fixing rail 24/48, Vertical piece 2F and Vertical piece 20F.

WEF-0002

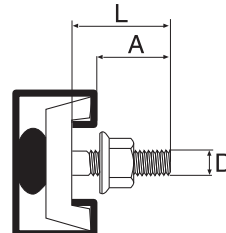
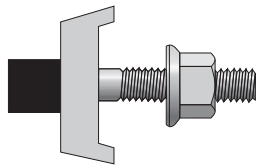

T-bolt 26F/M8  
T-bolt 26F/M10

	D	L mm	A mm	Stainl. steel (AISI316) Part. No. C*	Weight kg 100 pcs
T-bolt 26F	M8	30	24	734986 9	4.5
T-bolt 26F	M10	30	24	728596 9	7
T-bolt 26F	M10	50	44	728598 3	8
*EAN-code=732167+Part.no+C (control figure)					

## Repair kit

**WIBE**

Used for repair of clean metal areas e.g. from cutting.

WEF-0033

	Part. No. C*
Repair kit	783774 8
*EAN-code=732167+Part.no+C (control figure)	

## Joint 21

**WIBE**

For straight, rigid joining of cable ladders, bends, junctions and risers. See also values for potential balancing.

WEF-0001

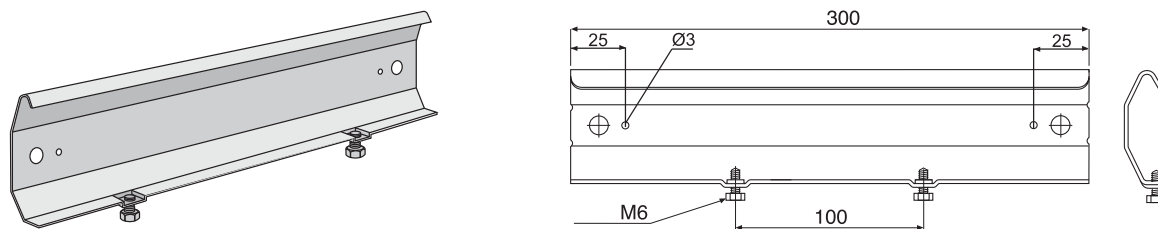

	Pre-galv. Part. No. C*	Hot dip galv. Part. No. C*	Pre-galv. White Part. No. C*	ZINKPOX® White Part. No. C*	Weight kg 100 pcs
Joint 21	791196 7	791199 8	791197 4**	791200 1	46

(M6 screw included)

\*EAN-code=732167+Part.no+C (control figure) \*\*Produced to order

### Stainless steel AISI316L

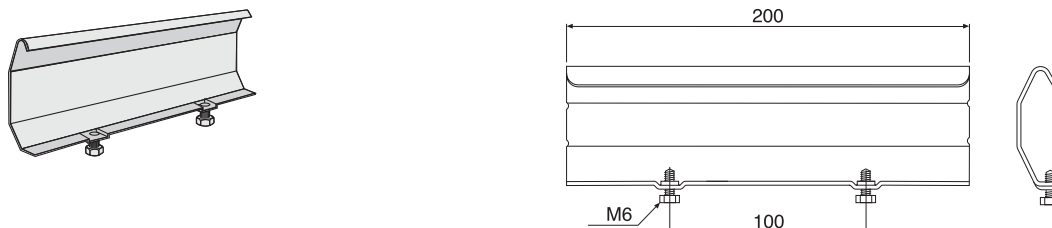

	Stainl. steel (AISI316L) Part. No. C*	Weight kg 100 pcs
Joint 21	725751 5	37

(M6 screw included)

\*EAN-code=732167+Part.no+C (control figure)

### Use and installation

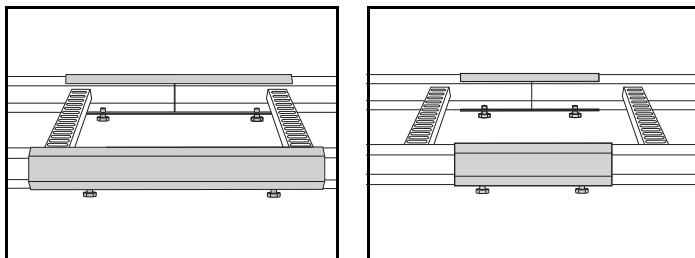

Joint 21 is used for straight, robust joining of cable ladders and when fitting 90° bends, T- and X-branches, vertical bends and for vertical ladder mounting. It also reduces the transition resistance and prevents the ladders from slipping apart.

## Screw set M12

**WIBE**

Used for all joints with KHZV and KHZPV.

See also Details for KHZV, KHZPV, page 102.

WEF-0001

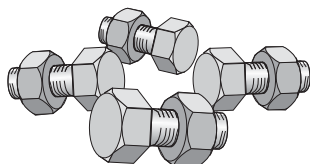

	Hot dip galv. Part. No. C*	Stainl. steel (AISI316L) Part. No. C*	Weight kg 100 pcs
Screw set M12 (4 bolts M6S 12x25 and 4 nuts M6M 12)	706415 1	728767 3	20

\*EAN-code=732167+Part.no+C (control figure)

# Coupling 22

Used for horizontal or vertical branches at any desired angle.

WEF-0001

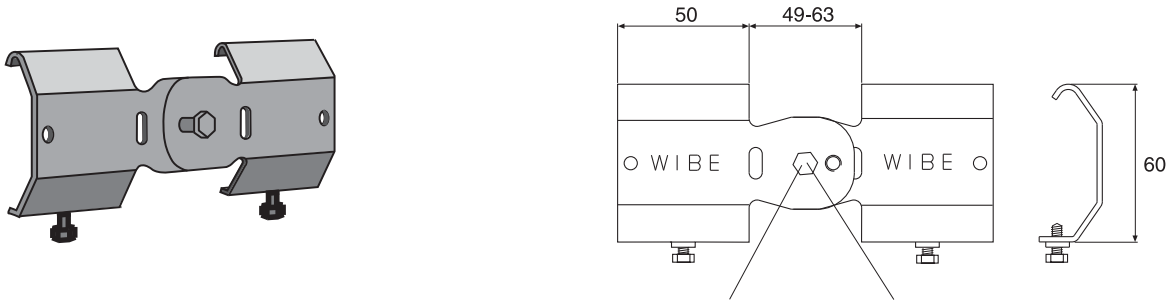

	Pre-galv. Part. No. C*	Hot dip galv. Part. No. C*	ZINKPOX® White** Part. No. C*	Stainl. steel (AISI316L) Part. No. C*	Weight kg 100 pcs
Coupling 22	721122 7	718409 5	718410 1	725760 7	21

\*EAN-code=732167+Part.no+C (control figure)  
\*\*Stainless steel screws and nuts are used

## Use and installation

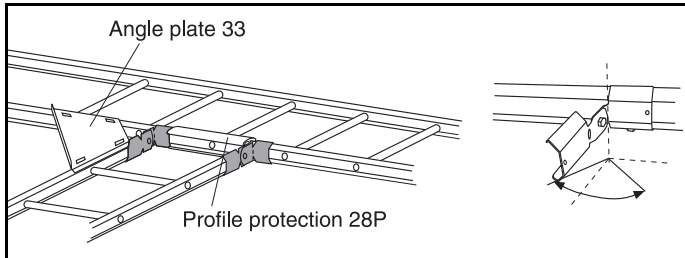

Coupling 22 is used for horizontal branching to the required angle. The cut length of the ladder ends determines the angle. Angle plate 33 is always recommended for horizontal branches. Mount Profile protection 28P. To be cut when required.

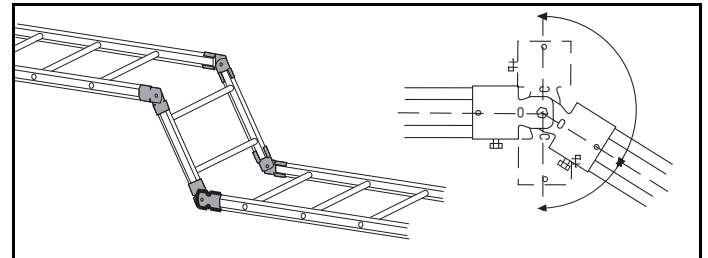

Coupling 22 is used to form vertical angles of the required size.

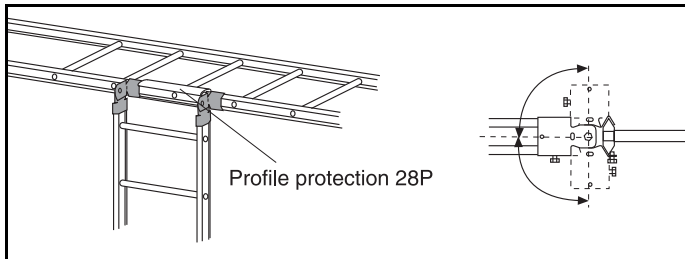

Coupling 22 is used to form vertical branches of the required angle. Mount Profile protection 28P. To be cut when required.

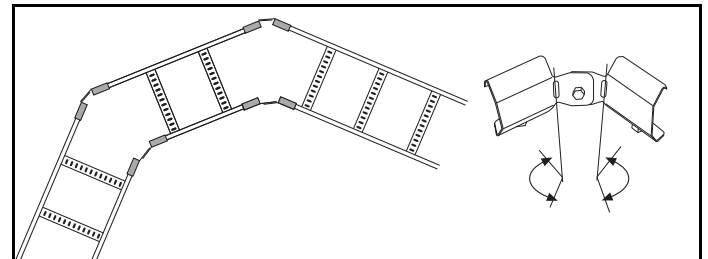

Use 4 Couplings 22 to form a horizontal bend in different angles. The cut lengths of the ladder ends determine the angle.

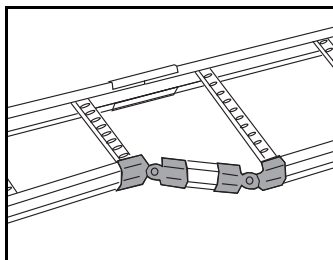

As an alternative at transition joining of KHZSP, KHZPS, KHZ and KHZP use 1 Joint 21 and 2 Couplings 22.

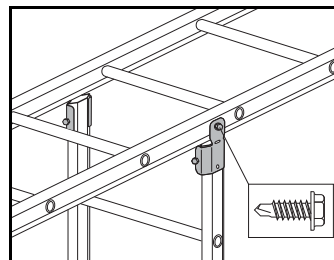

Vertical branching under the cable ladder with one part of Coupling 22 and plate screw.

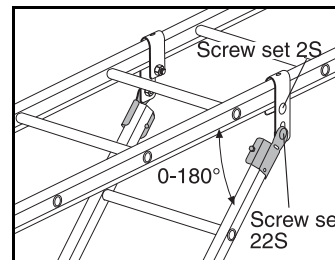

Clamp 12 and one part of Coupling 22 can be used for branching under the cable ladder allowing angles from 0-180°.

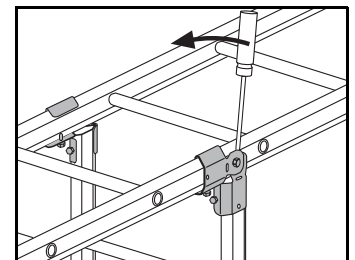

Use 2 Coupling 22 for vertical branching under the cable ladder. Note! The screw of Coupling 22 must be turned so that its head will be placed against the side profile of the cable ladder. Bend the coupling with a screwdriver according to the above.

# Cantilever arm 30

For installation inside cable ladder KHZSP

WEF-0001

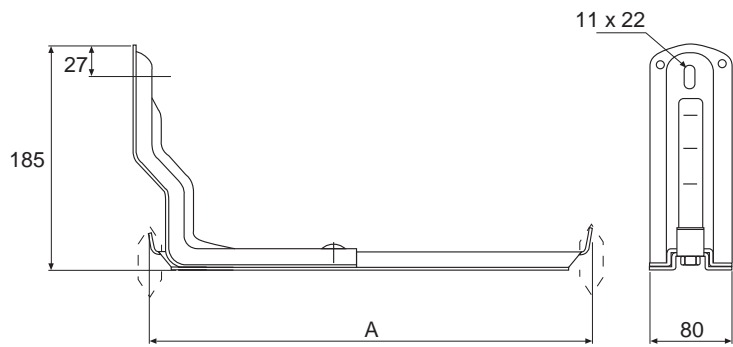
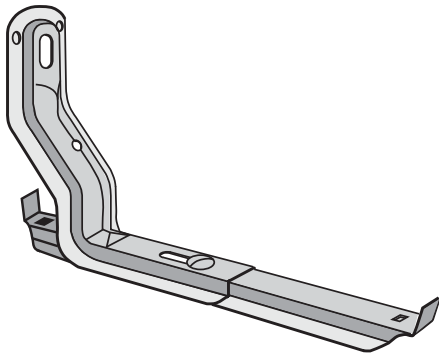

	A mm	Pre-galv. Part. No. C*	Weight kg 100 pcs
Cantilever arm 30-200	184	727777 3	90
Cantilever arm 30-300	284	727778 0	110
Cantilever arm 30-400	384	727779 7	120
Cantilever arm 30-500	484	727780 3	140
Cantilever arm 30-600	584	727781 0	160

\*EAN-code=732167+Part.no+C (control figure)

## Use and installation

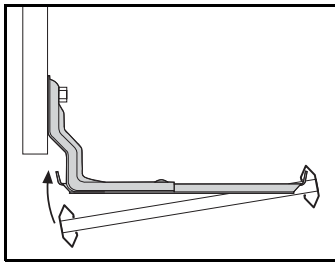

Installation of cable ladder KHZSP. Place the ladder on the outer tab and press it over the inner tab. When necessary, the ladder can be locked with a Profile clamp 43.

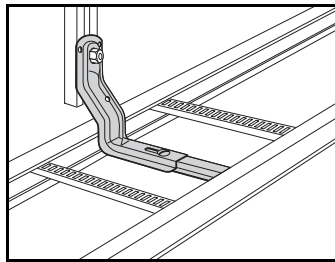

Installation on Vertical piece 2F. Cable ladder KHZSP can be adjusted max 40 mm.

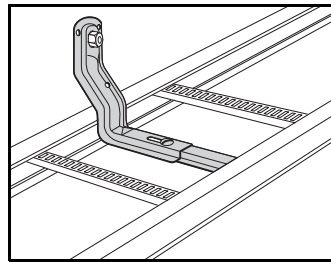

Installation direct on wall. Cable ladder KHZSP is adjustable from 0-15 mm to the wall.

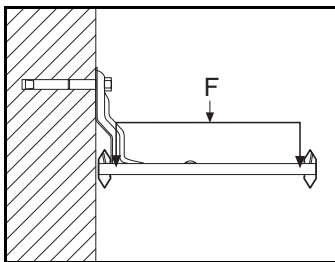

Breaking load for cantilever arm on wall, see table below.

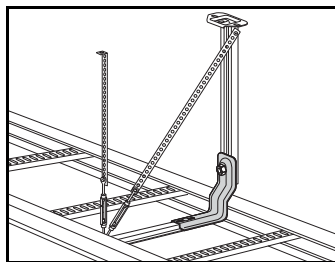

When you mount cable ladders that are 500-600 mm wide it might be necessary with a reinforcement of the outer edge of the cantilever arm. Installation band and stretching screw can be used for mounting in the ceiling or on a vertical piece.

## Loading table

Cantilever arm type	Max load F on cantilever arm at a deflection of 3°		Deflection at 3° deflection of cantilever arm	Breaking load	
	kN	kg		mm	kN
30-200	2.0	200	10	2.3	230
30-300	1.9	190	15	3.5	350
30-400	1.2	120	20	3.0	300
30-500	0.8	80	26	2.4	240
30-600	0.6	60	31	2.0	200

# Cantilever arm 50i

Used for lighter mountings on walls, vertical pieces or pendant/fixing rails.  
 Cantilever arm 81 is used for widths 500-600 mm.

WEF-0001

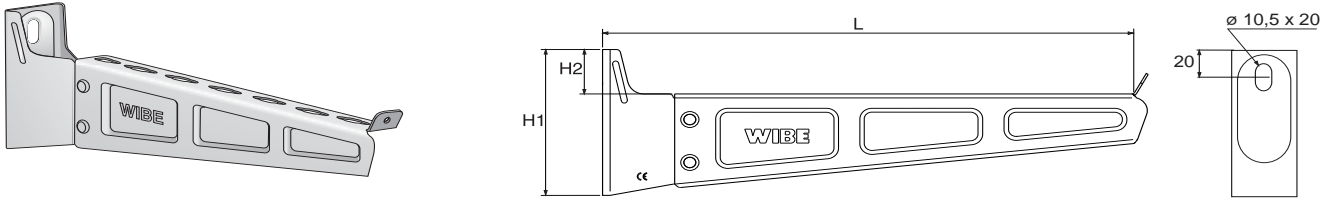

**W=100**

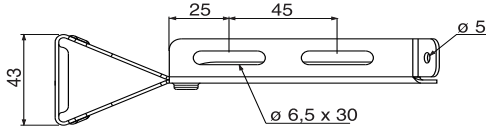

**W=200**

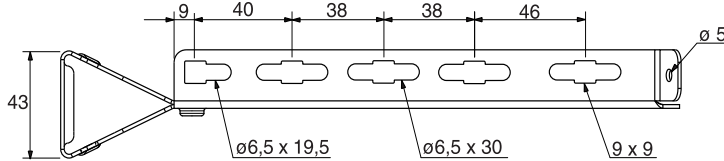

**W=300**

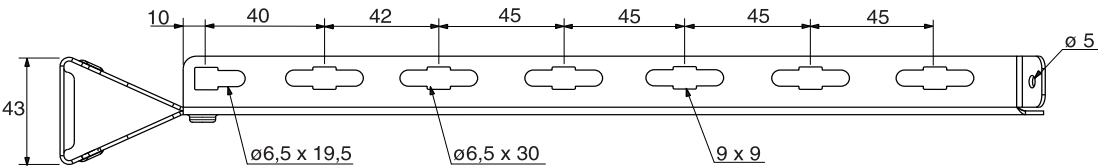

**W=400**

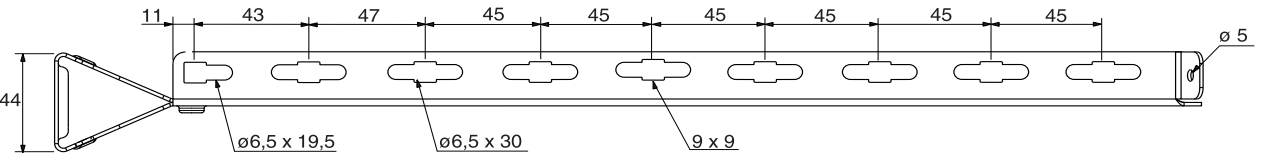

	For ladder width mm	L mm	H1 mm	H2 mm	Pre-galv. Part. No. C*	Pre-galv. White Part. No. C*	Weight kg 100 pcs
Cantilever arm 50i-100	100	150	80	32	791412 8	791416 6**	19
Cantilever arm 50i-200	200	250	85	28.5	791413 5	791417 3**	29
Cantilever arm 50i-300	300	350	110	33.5	791414 2	791418 0**	46
Cantilever arm 50i-400	400	450	115	31	791415 9	791419 7**	83

\*EAN-code=732167+Part.no+C (control figure) \*\*Produced to order

**Use and installation**

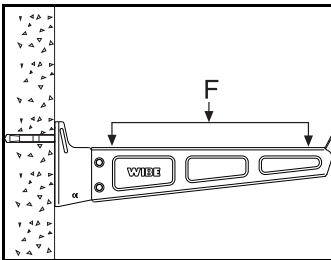

Installation of cantilever arm mounted to wall using Expansion bolt M8.  
 Breaking load - see below.

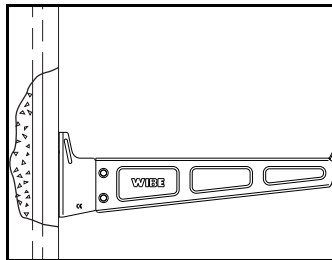

Installation of cantilever arm using T-bolt M8 on Fixing rail 24/26 x 53 for casting-in or Pendant/ Fixing rail mounted on the wall.

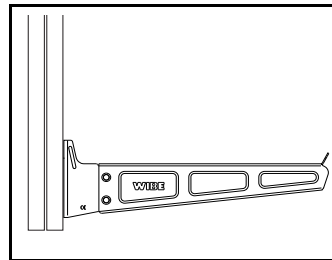

Installation of cantilever arm using T-bolt M8 on vertical piece. Check breaking load of the vertical piece.

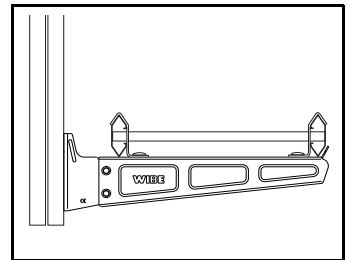

Cable ladder KHZSP mounted on Cantilever arm 50i, Profile clamp 42 is used.

**Breaking load F**

	Mounted on wall kg
Cantilever arm 50i-100	230
Cantilever arm 50i-200	215
Cantilever arm 50i-300	220
Cantilever arm 50i-400	335

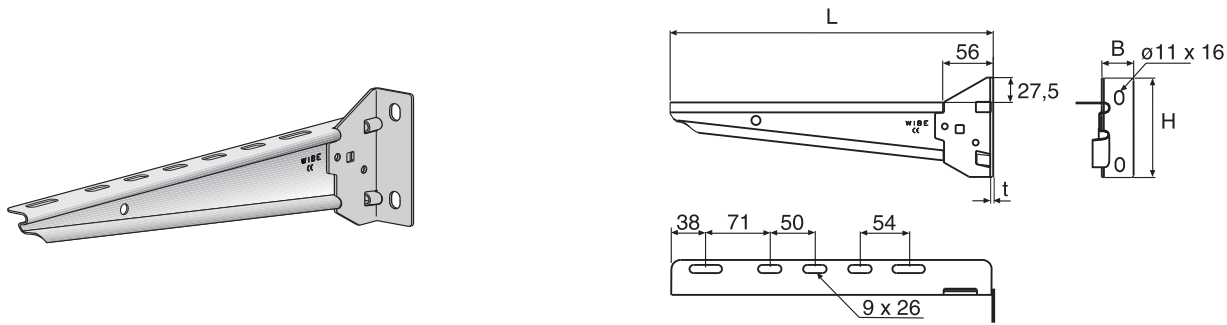

	L mm	B mm	H mm	Pre-galv. Part. No. C*	Pre-galv. White Part. No. C*	Weight kg 100 pcs
Cantilever arm 81-500	568	40	150	780162 6	780855 7**	100
Cantilever arm 81-600	658	40	150	780163 3	780856 4**	140

\*EAN-code=732167+Part.no+C (control figure) \*\*Produced to order

## Use and installation

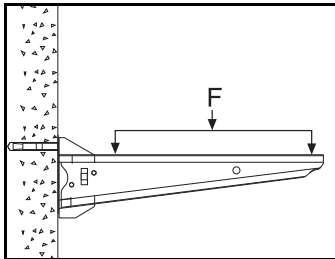

Installation of a cantilever arm to a wall using an Expansion bolt. Breaking load - see below.

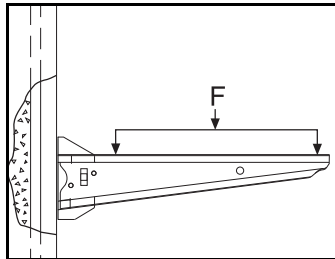

Installation of a cantilever arm using a T-bolt on a Fixing rail 24/26 x 53 for casting-in or Pendant/Fixing rails mounted on the wall.

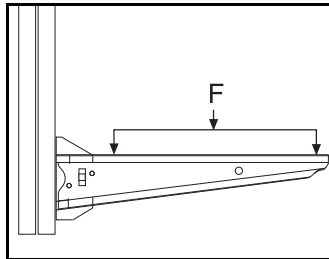

Installation of cantilever arm using T-bolt with vertical pieces. Breaking load - see below. Also check breaking load of the vertical piece.

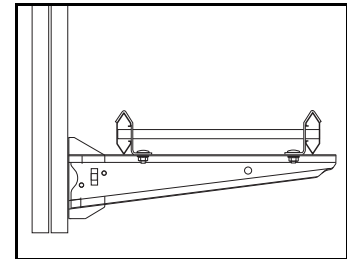

Cable ladder KHZSP mounted on Cantilever arm 81, Profile clamp 42 is used.

## Breaking load F

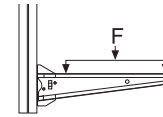
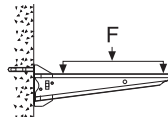

Type of Cantilever arm	Mounted on wall		Mounted on P/F rail 24/48 with T-bolt 26F	
	kN	kg	kN	kg
81-500	1.9	190	1.9	190
81-600	1.9	190	1.9	190



# Cantilever arm 50L,50 and 50F

For mounting on walls, pendant/fixing rails or vertical pieces.

WEF-0001

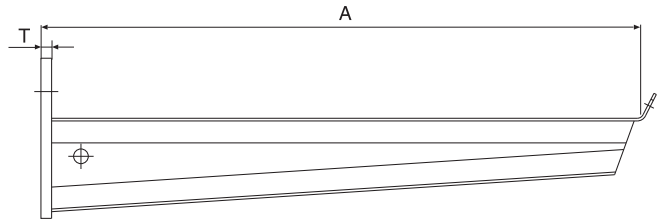
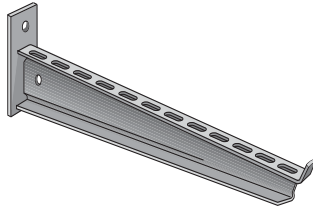

## Cantilever arm 50L and 50

50L,50/100-300 50L,50/400-600 50/700-1000

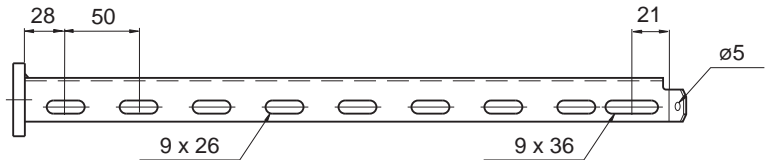
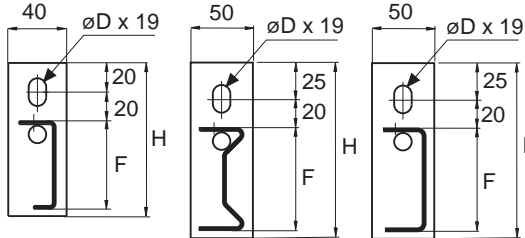

## Cantilever arm 50F

50F/200-600

50F/1000

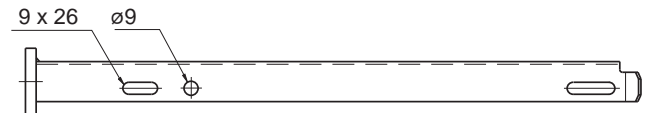
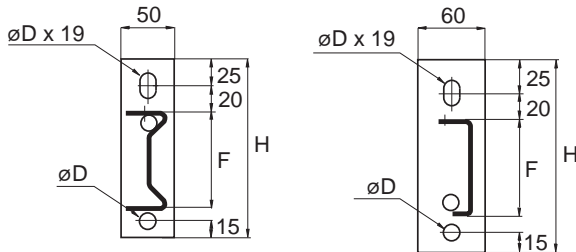

	A	D	F	H	T	Hot dip galv. Part. No. C*	Stainl. steel (AISI316L) Part. No. C*	ZINKPOX® White Part. No. C*	Weight kg 100 pcs
50L-100	150	12	34	85	4	725105 6		725113 1**	24
50L-150	200	12	36	85	4	725106 3		725114 8**	28
50L-200	250	12	39	85	4	725107 0		725115 5**	34
50L-250	298	12	56	105	4	725108 7		725116 2**	46
50L-300	348	12	60	105	4	725109 4		725117 9**	54
50L-400	447	12	70	120	5	725110 0		725118 6**	103
50L-500	548	12	77	140	6	725111 7		725119 3**	160
50L-600	646	12	84	150	6	725112 4		725120 9**	191
50-100	150	12	34	85	4	723432 5	725618 1	723440 0	24
50-150	200	12	36	85	4	723433 2	725619 8	723441 7	28
50-200	250	12	39	85	4	723434 9	725620 4	723442 4	34
50-250	300	12	56	105	6***	723435 6	725621 1	723443 1	52
50-300	350	12	60	105	6***	723436 3	725622 8	723444 8	60
50-400	450	12	70	120	8***	723437 0	725623 5	723445 5	118
50-500	550	12	77	140	8***	723438 7	725624 2	723446 2	172
50-600	650	12	84	150	10***	723439 4	725625 9	723447 9	215
50-700	750	12	90	150	10	727125 2		727782 7**	270
50-800	850	12	95	160	10	727126 9		727783 4**	310
50-900	950	12	100	160	10	727127 6		727784 1**	350
50-1000	1050	12	105	170	10	727128 3		727785 8**	390
50F-200	245	12	72	148	8	718624 2		714021 3	95
50F-300	345	12	79	175	8	718625 9		714700 7	125
50F-400	445	12	86	175	8	718626 6		714022 0	170
50F-500	547	14	93	180	10	718627 3		718793 5	220
50F-600	647	14	100	180	10	718628 0		714023 7	250
50F-1000	1052	14	160	240	12	712465 7		714024 4	770

\*EAN-code=732167+Part.no+C (control figure) \*\*Produced to order

\*\*\*Stainl. steel: 50/250-300 T=4 mm, 50/400-600 T=5 mm

## Use and installation

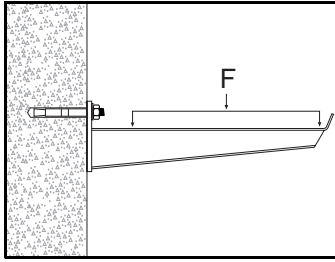

Installation of a cantilever arm to a wall using an Expansion bolt. Breaking load – see below.

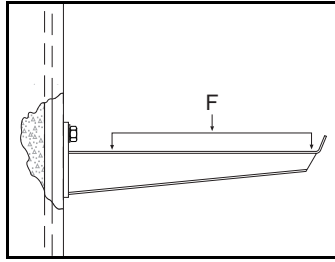

Installation of a cantilever arm using a T-bolt on a Fixing rail 24/26 x 53 rail for casting-in or Pendant/Fixing rails mounted on the wall. Breaking load – see below.

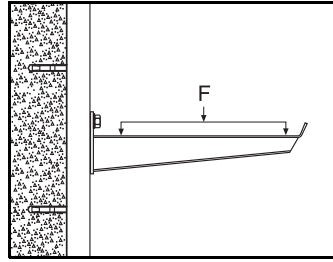

Mounting of a cantilever arm using a T-bolt on a Pendant-/Fixing rail mounted on a wall.

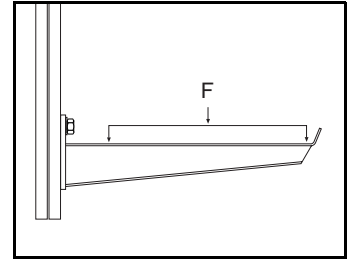

Installation of a cantilever arm using T-bolt with vertical pieces. Breaking load - see below. Also check breaking load of the vertical piece.

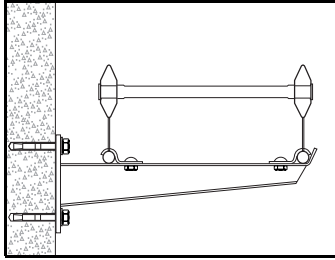

Profile clamp 43 is used for attaching a KHZV onto a Cantilever arm 50F.

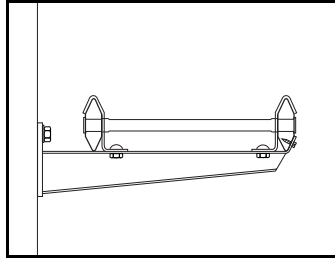

For attaching a KHZSP, KHZ, KHZPS or KHZP cable ladder, mount Profile clamp 42. If it is only necessary to fix the cable ladder at the outer end of the bracket, use selftapping sheet screws or suchlike with 5 mm dia. holes in the bracket and in the side section.

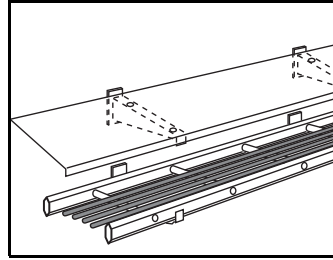

Cantilever arm 50F mounted upside down can be used for installation of tilted protective roofs.

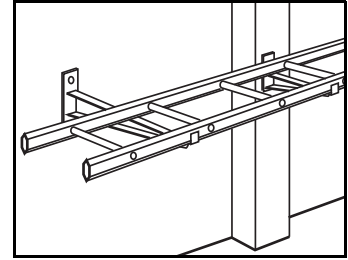

Use Cantilever arm 50/700-1000 as support when cable ladders have to pass columns etc.

## Breaking load F

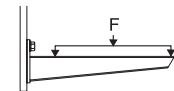
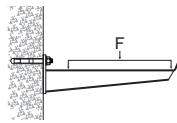
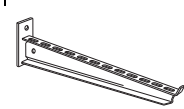

Type of cantilever arm	Mounted on wall		Mounted on P/F rail 24/48 with T-bolt 26F	
	kN	kg	kN	kg
50L-100	1.5	150	1.5	150
50L-150	1.5	150	1.5	150
50L-200	1.5	150	1.5	150
50L-250	2.0	200	2.0	200
50L-300	2.0	200	2.0	200
50L-400	3.0	300	3.0	300
50L-500	3.0	300	3.0	300
50L-600	3.0	300	3.0	300
50-100	3.0	300	3.0	300
50-150	3.0	300	3.0	300
50-200	2.5	250	2.5	250
50-250	4.0	400	4.0	400
50-300	4.0	400	4.0	400
50-400	6.5	650	6.5	650
50-500	7.0	700	7.0	700
50-600	7.0	700	7.0	700
50-700	6.0	600	5.5	550
50-800	5.5	550	5.2	520
50-900	5.3	530	4.8	480
50-1000	5.0	500	4.2	420
50F-200	10.0	1000	10.0	1000
50F-300	10.0	1000	10.0	1000
50F-400	11.0	1100	9.0	900
50F-500	10.0	1000	8.0	800
50F-600	10.0	1000	8.0	800
50F-1000	11.0	1100	8.0	800

# Support bracket 3

Used for centre installation of cable ladders on pendant/fixing rails and vertical pieces.

WEF-0001

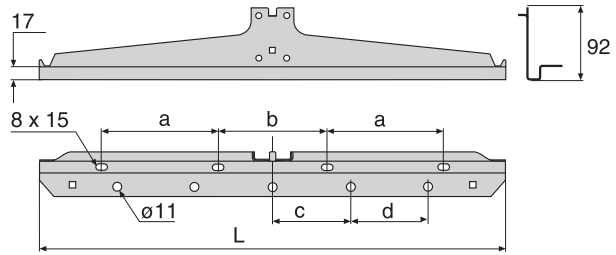
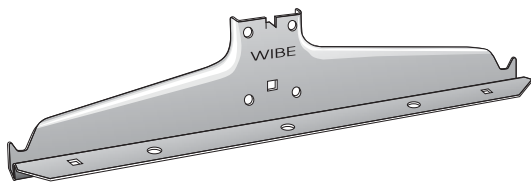

	Pre-galv. Part. No. C*	Hot dip galv. Part. No. C*	Stainl. steel (AISI316L) Part. No. C*	ZINKPOX® White Part. No. C*	Weight kg 100 pcs
Support bracket 3-150		720761 9	726433 9**	721862 2	26
Support bracket 3-200	721869 1	720762 6	726434 6	721863 9	33
Support bracket 3-300	721870 7	720763 3	726435 3	721864 6	58
Support bracket 3-400	721871 4	720764 0	726436 0	721865 3	78
Support bracket 3-500	721872 1	720765 7	726437 7**	721866 0**	120
Support bracket 3-600	721873 8	720766 4	726438 4	721867 7	145

\*EAN-code=732167+Part.no+C (control figure) \*\*Produced to order

## Stainless steel AISI 316L

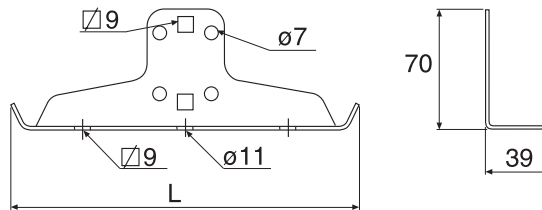
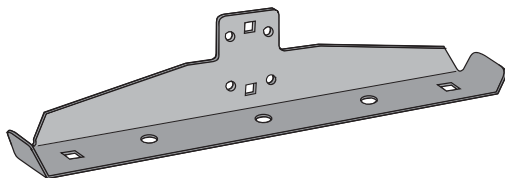

3/150-200

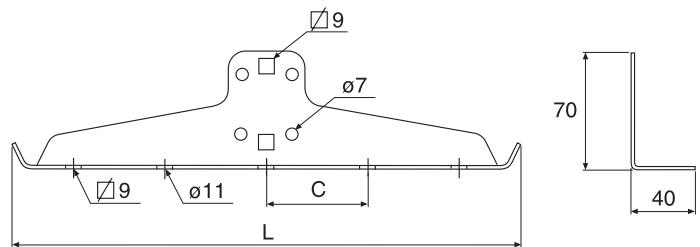

3/300-600

	Stainl. steel					
	L	L	a	b	c	d
Support bracket 3-150	150	154	—	100	—	—
Support bracket 3-200	200	204	—	100	—	—
Support bracket 3-300	300	306	70	100	—	—
Support bracket 3-400	400	406	70	100	100	—
Support bracket 3-500	500	506	100	140	100	—
Support bracket 3-600	600	606	150	140	100	100

## Breaking load-symmetrical loading

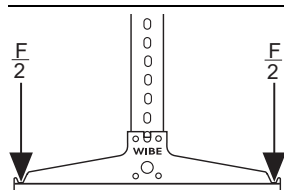

	Breaking load F	
	kN	kg
Support bracket 3-150	16	1600
Support bracket 3-200	16	1600
Support bracket 3-300	16	1600
Support bracket 3-400	12	1200
Support bracket 3-500	12	1200
Support bracket 3-600	10	1000

## Use and installation

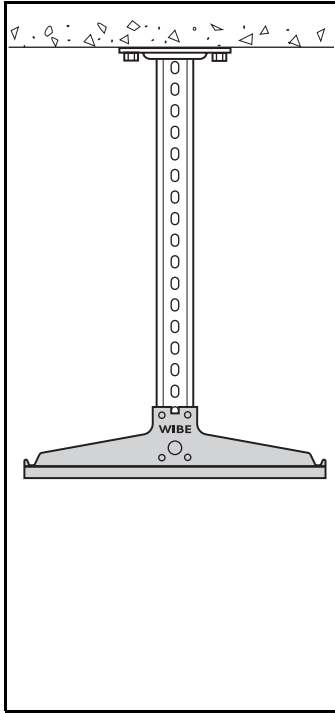

Mount Support bracket 3 on Vertical piece 2 with Screw set 22S.

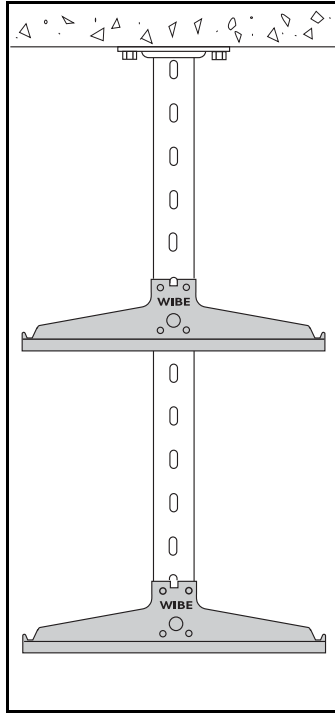

Mount Support bracket 3 on Vertical piece 2F with Screw set 22S.

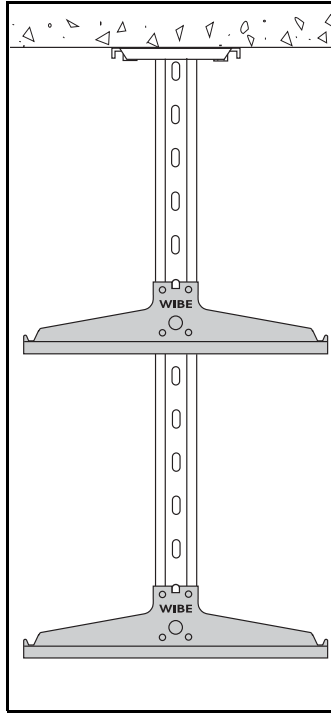

Mount Support bracket 3 on Vertical piece 20 with Screw set 20S.

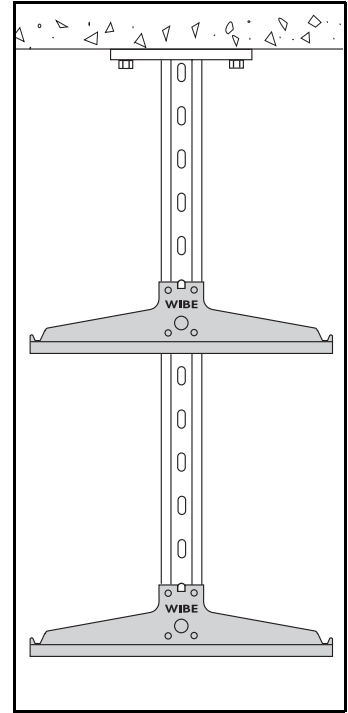

Mount Support bracket 3 on Vertical piece 20F with Screw set 2S.

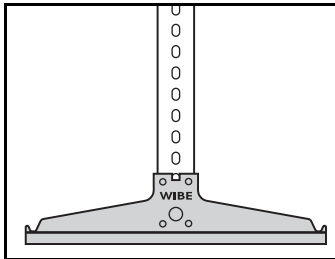

Mount Support bracket 3 on Pendant/Fixing rail 24/34 with Screw set 22S.

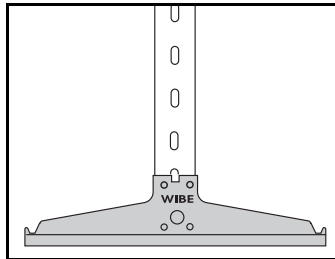

Mount Support bracket 3 on Pendant/Fixing rail 24/20 or 24/48 with Screw set 22S.

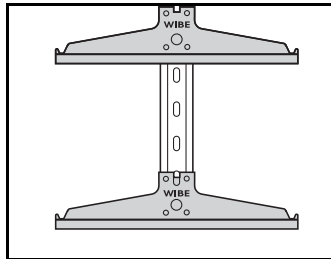

Support bracket 3 installed on Pendant/Fixing rail 24/20F with Screw set 2S.

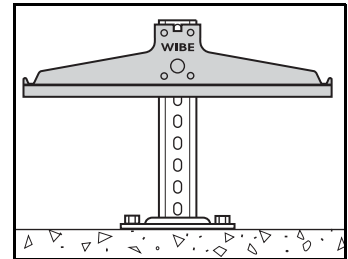

Support bracket 3 can be mounted on floor or under data floor with a suitable vertical piece.

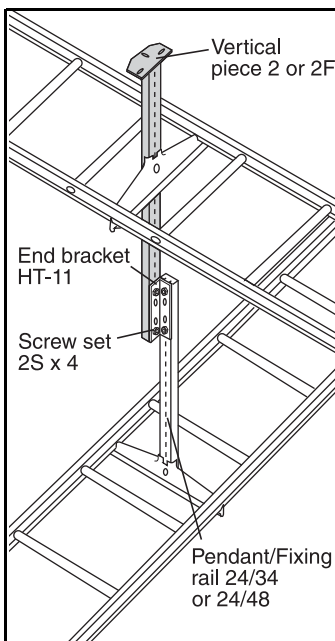

End bracket HT-11 permits the mounting of crossing cable ladders at different levels on the same pendant/fixing rail.

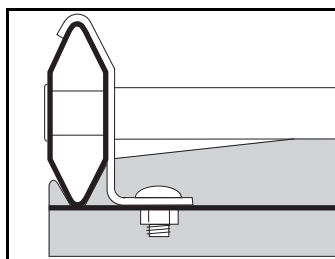

.For installation of KHZSP, KHZ, KHZP and KHZPS on Support bracket 3 Profile clamp 42 is used.

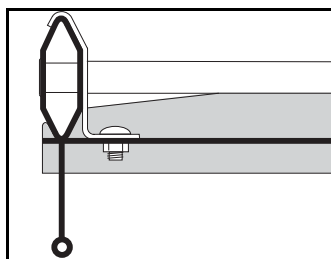

When attaching KHZV/KHZPV to Support bracket 3, use Profile clamp 42.

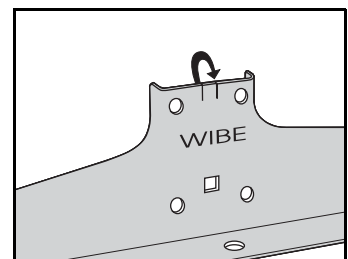

When attaching Support bracket 3 using clamp set M6 the tab must be bent up using a hammer or pair of pliers.

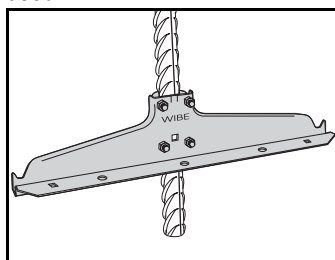

Support bracket 3 mounted on a rock bolt with Clamp set M6.

# Support bracket HSO

Support bracket HSO mounted with Threaded rod M10 or M16 is used for installation of cable ladders.

WEF-0001

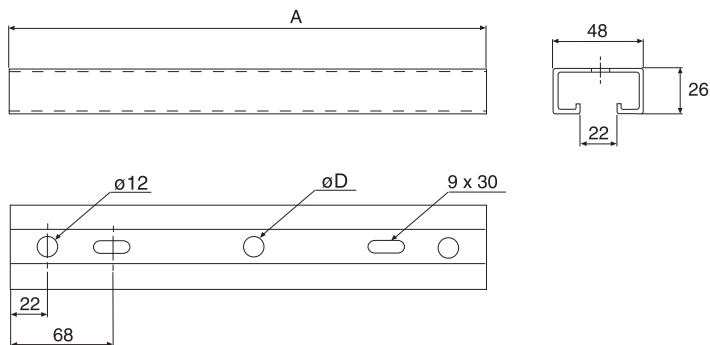
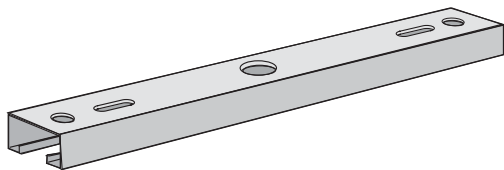

	A mm	D mm	Hot dip galv. Part. No. C*	Weight kg 100 pcs
Support bracket HSO-150 M10	210	12	791063 2	39
Support bracket HSO-200 M10	260	12	791064 9	48
Support bracket HSO-300 M10	360	12	791065 6	66
Support bracket HSO-400 M16	460	18	791066 3	84
Support bracket HSO-500 M16	560	18	791067 0	103
Support bracket HSO-600 M16	660	18	791068 7	121

(Nuts M10, M16 and Washer HSO M16 not included)

\*EAN-code=732167+Part.no+C (control figure)

Washer HSO M16 is used for centered mounting with Support bracket HSO M16 and Threaded rod M16.

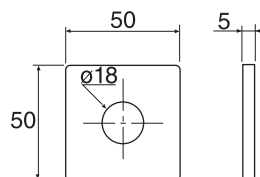
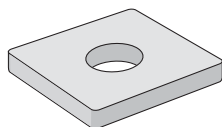

	Hot dip galv. Part. No. C*	Weight kg 100 pcs
Washer HSO M16	791092 2	8.7

\*EAN-code=732167+Part.no+C (control figure)

## Use and installation

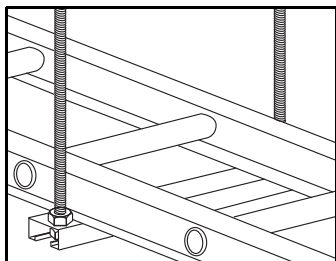

Support bracket HSO M10 installed with Threaded rod W76 M10.

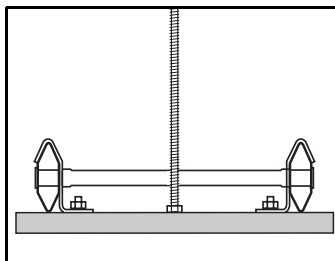

Centered installation with Support bracket HSO M10, widths 150-300, Threaded rod W76 M10 and 2 Nuts M10.

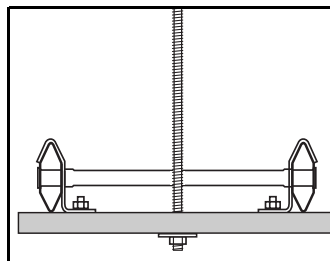

Centered installation with Support bracket HSO M16, widths 400-600, Threaded rod M16, 2 Nuts M16 and Washer HSO M16.

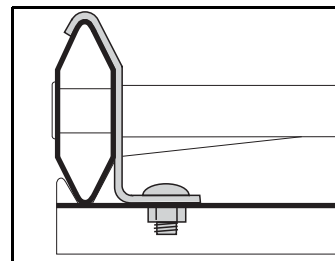

Profile clamp 42 is used to attach the cable ladder to the support bracket.

# Support bracket 6

For centre installation of cable ladder KHZSP.

WEF-0001

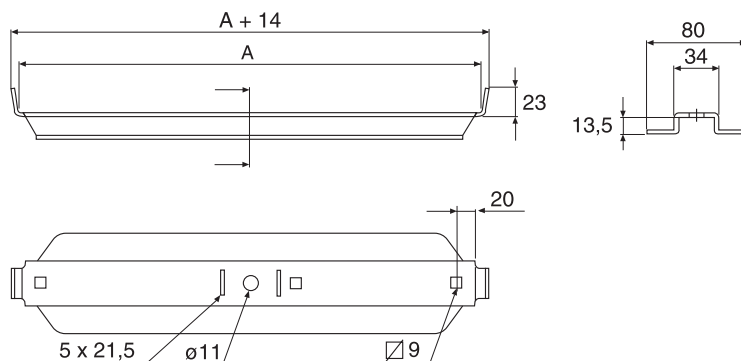
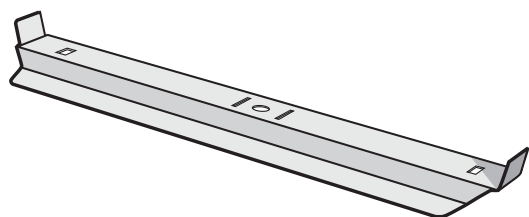

	A	Pre-galv. Part. No. C*	Weight kg 100 pcs
Support bracket 6-200	170	727582 3	27
Support bracket 6-300	270	727583 0	45
Support bracket 6-400	370	727584 7	63
Support bracket 6-500	470	727585 4	81
Support bracket 6-600	570	727586 1	99

\*EAN-code=732167+Part.no+C (control figure)

## Use and installation

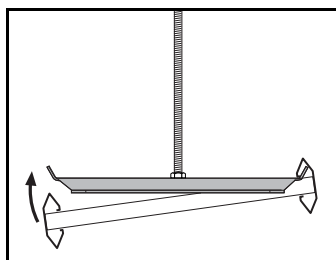

Support bracket 6 must be mounted inside cable ladder KHZSP.

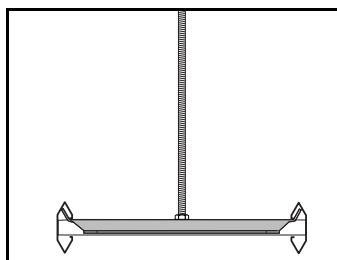

Support bracket 6 mounted with Threaded rod W76 M10. Nut M10 must be used.

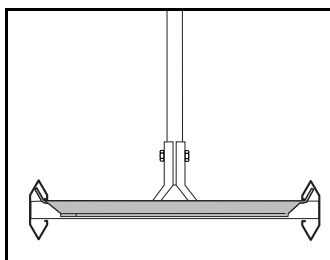

Support bracket 6 mounted with Pendant rail W32, Pendant attachment W21 and Screw set W37.

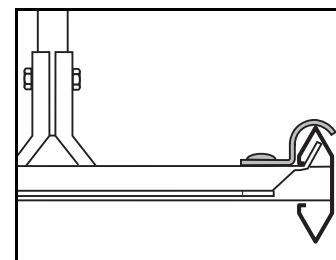

Profile clamp 43 can be used to fix the cable ladder to the support bracket.

## Breaking load-symmetrical loading

	Breaking load with Threaded rod W76 M10		Breaking load with Pendant attachment W21	
	kN	kg	kN	kg
Support bracket 6-200	5.0	500	3.4	340
Support bracket 6-300	4.8	480	3.4	340
Support bracket 6-400	3.0	300	3.0	300
Support bracket 6-500	2.2	220	2.2	220
Support bracket 6-600	1.7	170	1.7	170

## Profile clamp 42

**WIBE**

For installation where the cable ladder is to be fixed to cantilever arms, support brackets etc.

WEF-0001

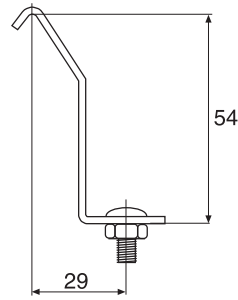

	Pre-galv. Part. No. C*	Hot dip galv. Part. No. C*	Stainl. steel (AISI316L) Part. No. C*	ZINKPOX® White Part. No. C*	Weight kg 100 pcs
Profile clamp 42	721121 0	705611 8	725763 8	714164 7	11

(screw M8 + nut supplied)

\*EAN-code=732167+Part.no+C (control figure)

### Use and installation

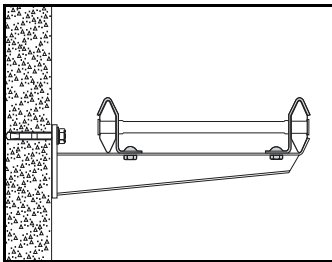

Use Profile clamp 42 for attaching KHZSP, KHZPS, KHZ and KHZP to Cantilever arm 50 and Support bracket 3. For small loads, mount the ladder with a clamp on each cantilever arm, alternately right and left side.

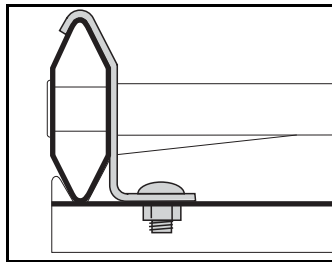

For installation of KHZSP, KHZPS, KHZ and KHZP on Support bracket 3, Profile clamp 42 is used.

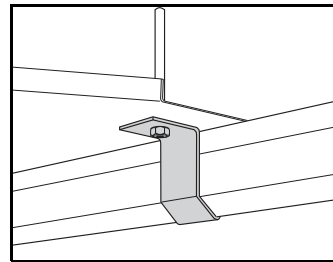

To lock Angle plate 33/2, fit 2 Profile clamps 42.

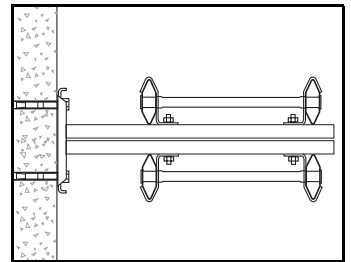

Cable ladders can be mounted directly on Vertical piece 20 or 20F with Profile clamp 42. Use T-bolt for mounting. Convenient at vertical installations in shafts.

## Profile clamp 43

**WIBE**

For installation where cable ladder KHZV and KHZPV is to be fixed to cantilever arms, support brackets etc.

WEF-0001

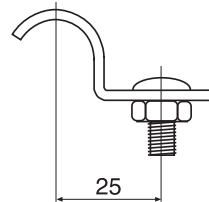
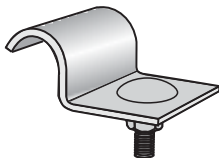

	Hot dip galv. Part. No. C*	ZINKPOX® White Part. No. C*	Weight kg 100 pcs
Profile clamp 43 (screw M8+nut supplied)	707511 9	714165 4	5

\*EAN-code=732167+Part.no+C (control figure)

### Use and installation

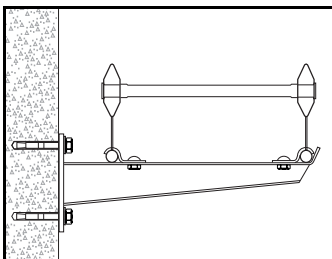

Use Profile clamp 43 to attach KHZV/KHZPV to Cantilever arm 50. For small loads, mount the ladder with a clamp on each cantilever arm, alternating right side and left side.

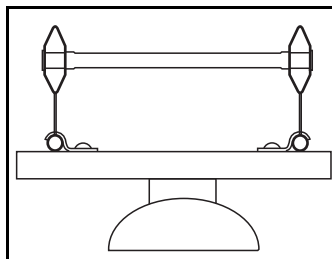

Pendant/Fixing rail 24/48, mounted under Cable ladder KHZV with Profile clamp 43, here used as carrier of lighting fittings.

## Vertical piece 2

Used for installation of Support bracket 3. Symmetrical loading.

Not suitable for KHZV and KHZPV.

Can be joined to Pendant/Fixing rail 24/34 with Pendant joint 2J.

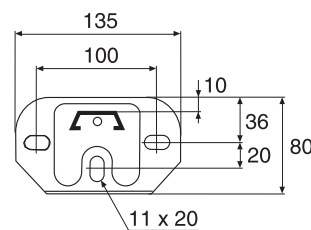
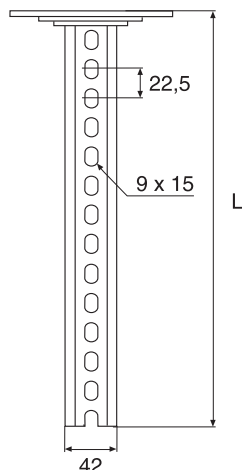
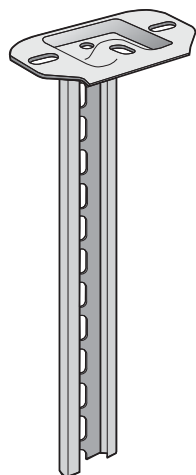

	L mm	Hot dip galv. Part. No. C*	Stainl. steel (AISI316L) Part. No. C*	ZINKPOX® White Part. No. C*	Weight kg 100 pcs
Vertical piece 2-300	279	717191 0	725557 3	716283 3	52
Vertical piece 2-400	392	717192 7	725558 0	716284 0	62
Vertical piece 2-500	504	717193 4	725559 7	716285 7	72
Vertical piece 2-700	729	717194 1	725560 3	716286 4	93
Vertical piece 2-1000	1022	717195 8	725561 0	716287 1	120

\*EAN-code=732167+Part.no+C (control figure)

### Use and installation

At asymmetrical loading of KHZ, KHZP, KHZSP or KHZPS width 600, Vertical piece 2F or 20 must be used.

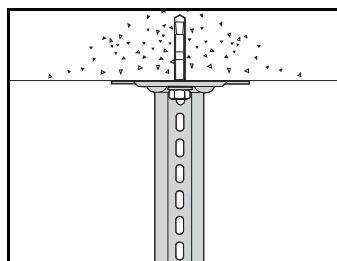

Mount Vertical piece 2 using an Expansion bolt or a concrete screw.

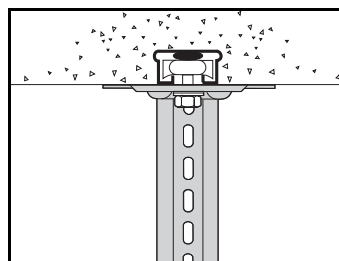

Mount Vertical piece 2 on a Fixing rail 24/26x53 for casting-in using T-bolt 26F.

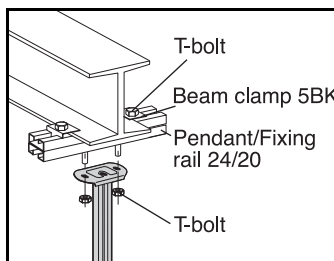

On beams in ceilings, mount Vertical piece 2 as in the figure above. When the beam flange thickness does not exceed 13 mm, use Beam clamp 5BK-10 and T-bolt 26F/40. For flange thicknesses not exceeding 30 mm use Beam clamp 5BK-30 and T-bolt 26F/50.

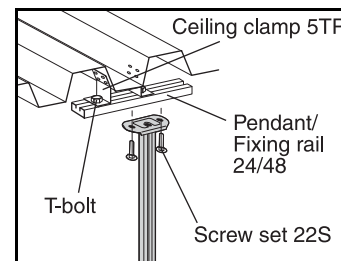

In ceilings with trapezoidal profile sheeting, mount Vertical piece 2 as shown above.



# Vertical piece 2

## Use and installation

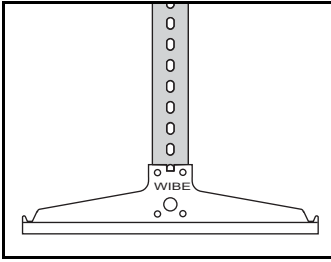

On Vertical piece 2, mount Support bracket 3 using Screw set 22S.

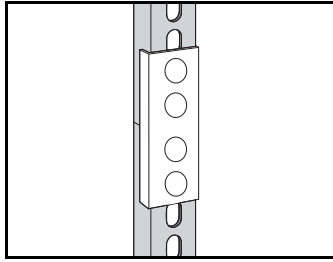

Vertical piece 2 can be joined to achieve the required length using Pendant/Fixing rail 24/34 and Pendant joint 2J.

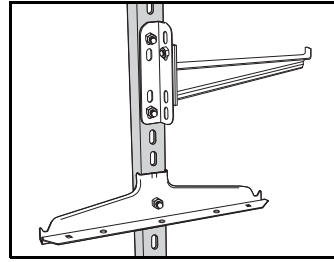

Cantilever arm 50 can, using End bracket HT-11, be mounted at 90° to the pendant/fixing rail. Only for lightweight mounting, such as data cables.

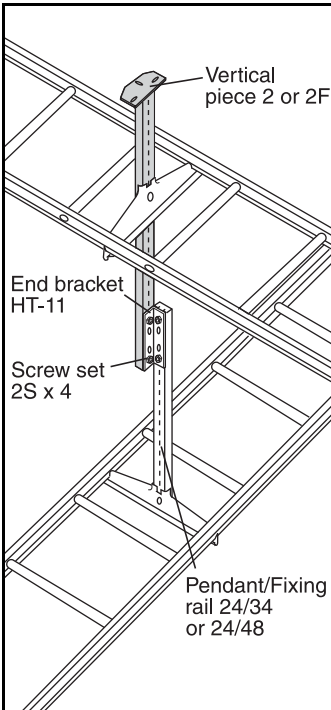

End bracket HT-11 permits the mounting of crossing cable ladders at different levels on the same pendant/fixing rail.

## Breaking load

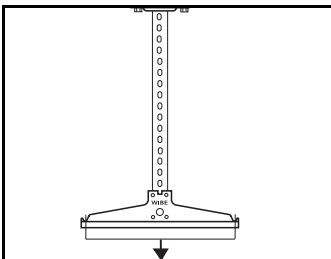

Breaking load for Vertical piece 2 with a symmetrical loading = 1400 kg (14 kN). See also Breaking load for Support bracket 3.

# Vertical piece 2F

Used for installation of Support bracket 3 or Cantilever arm 50.  
Can be joined to Pendant/Fixing rail 24/48 with Pendant joint 2FJ.

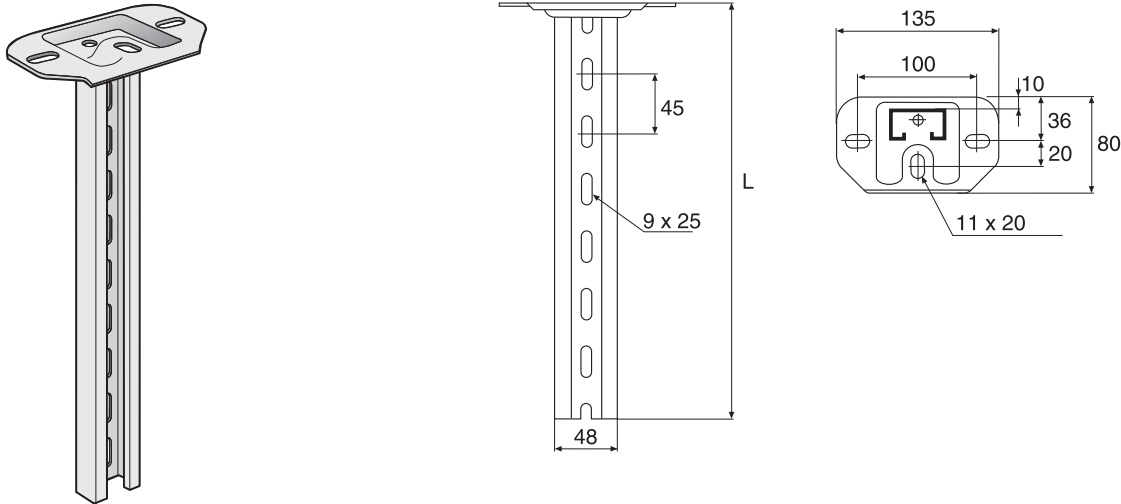

	L mm	Hot dip galv. Part. No. C*	Stainl. steel (AISI316L) Part. No. C*	ZINKPOX® White Part. No. C*	Weight kg 100 pcs
Vertical piece 2F-280	280	717196 5	725562 7	717201 6	80
Vertical piece 2F-370	370	717197 2	725563 4	717202 3	100
Vertical piece 2F-505	505	717198 9	725564 1	717203 0	130
Vertical piece 2F-730	730	717199 6	725565 8	717204 7	170
Vertical piece 2F-1000	1000	717200 9	725566 5	717205 4	220
Vertical piece 2F-1500	1495	787276 3	787278 7	787277 0	290

\*EAN-code=732167+Part.no+C (control figure)

## Use and installation

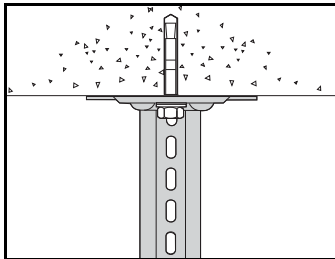

Mount Vertical piece 2F using Expansion bolt alt. Concrete screw.

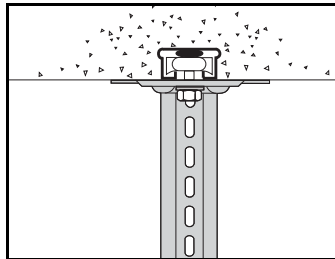

On Fixing rail for casting-in, mount Vertical piece 2F using T-bolt.

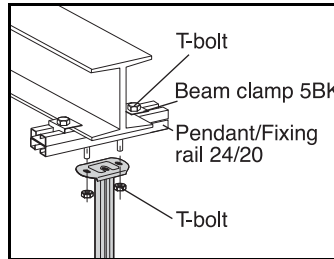

On beams in ceilings, mount Vertical piece 2F as shown in the figure above. When the beam flange thickness does not exceed 13 mm, use Beam clamp 5BK-10 and T-bolt 26F/40. For flange thicknesses not exceeding 30 mm use Beam clamp 5BK-30 and T-bolt 26F/50.

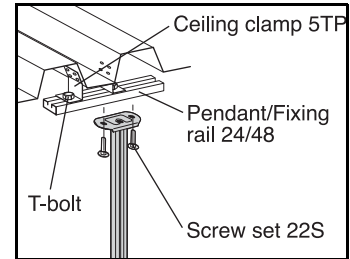

In ceilings with trapezoidal sheeting, mount Vertical piece 2F as shown above.

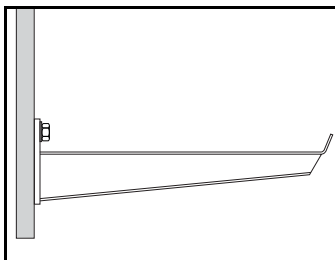

On Vertical piece 2F, mount Cantilever arm 50 using T-bolt.

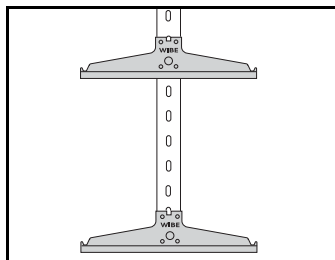

On Vertical piece 2F, mount Support bracket 3 using Screw set 22S.

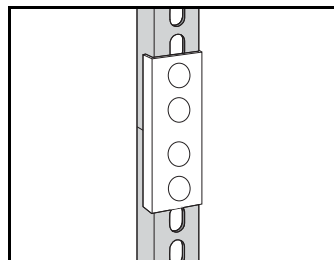

Vertical piece 2F can be joined to achieve the required length using Pendant/Fixing rail 24/48 and Pendant joint 2FJ.

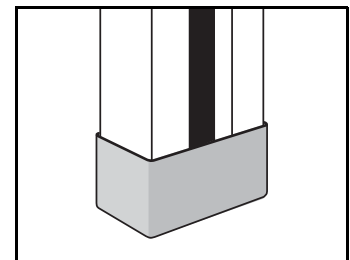

Vertical piece 2F may be equipped with a protective orange End plug 28E.

## Use and installation

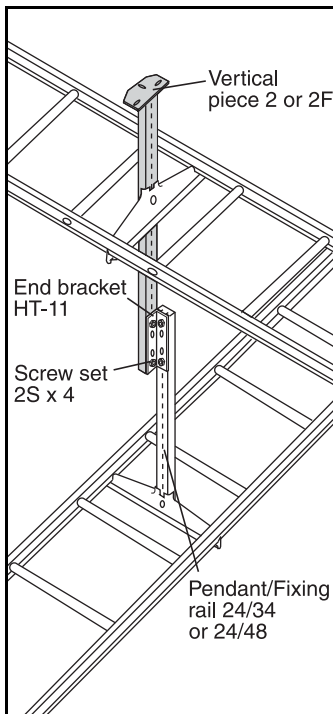

End bracket HT-11 permits mounting of crossing cable ladders on different levels on the same pendant/fixing rail.

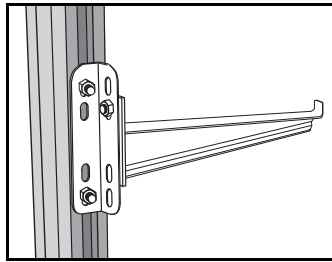

Cantilever arm 50 can, using End bracket HT-11, be mounted at 90° to the pendant/fixing rail. Only for lightweight installation of data cable type and suchlike.

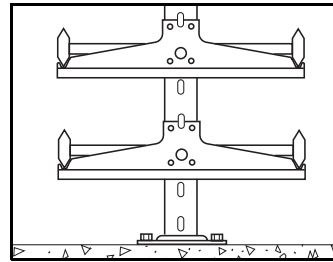

Cable ladders mounted on Vertical piece 2F and Support bracket 3 can be used for cable installations in raised access floors.

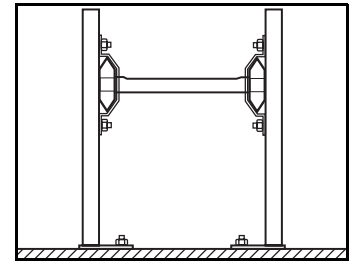

For installation on floor the cable ladders can be mounted with Vertical piece 2F, Profile clamp 41 and T-bolt.

## Breaking load

## Loading table

Vertical piece 2F installed as a cantilever arm

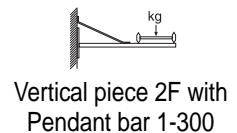
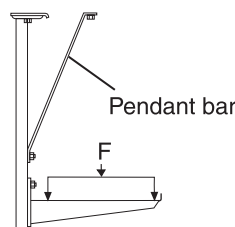
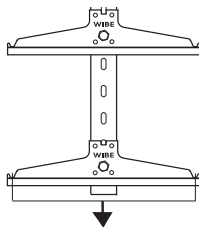

		Pendant type	2F-730		2F-1000	
		Ladder width	3° defl.	Break. load	3° defl.	Break. load
Breaking load for Vertical piece 2F = 2300 kg (23 kN) at symmetrical loading.	Deflection of Vertical piece 2F is reduced by installing Pendant bar 1 alt. Pendant/Fixing rail and Bracket 60/40. Loadings in accordance with table below.	150	90	120	60	75
		200	95	125	65	80
		300	100	135	70	90
		400	105	140	75	100
		600	—	—	100	120

## Max. loading F at 3° deflection of cantilever arm

Cantilever arm		2F-280		2F-370		2F-505		2F-730		2F-1000		2F-1500	
type		kN	kg	kN	kg	kN	kg	kN	kg	kN	kg	kN	kg
Without bar	50-200	1.15	115	1.1	110	1.0	100	0.9	90	0.8	80	0.38	38
	50-400	1.4	140	1.35	135	1.25	125	0.85	85	0.6	60	0.35	35
	50-600	1.25	125	1.1	110	0.9	90	0.7	70	0.55	55	0.30	30
With bar 1-300	50-200					1.2	120	1.0	100	0.85	85		
	50-400					1.5	150	1.1	110	0.65	65		
	50-600					1.3	130	1.0	100	0.6	60		
With bar 1-500	50-200							1.2	120	0.95	95	0.71	71
	50-400							1.4	140	0.8	80	0.57	57
	50-600							1.25	125	0.7	70	0.49	49
With bar 1-800	50-200									1.35	135	0.72	72
	50-400									1.25	125	0.75	75
	50-600									1.2	120	0.66	66

# Vertical piece 2Fi

Used for lighter mountings with Cantilever arm 50i and Cable ladder KHZSP.

WEF-0001

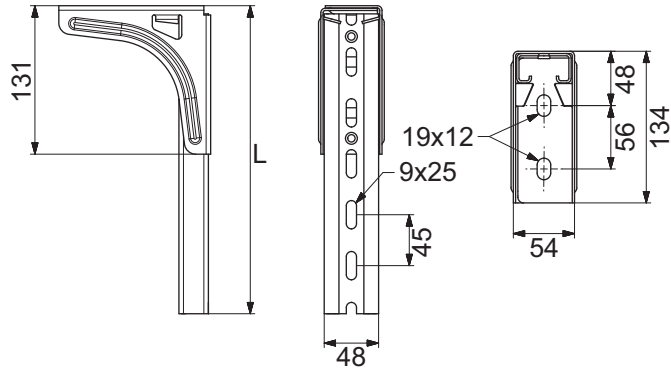
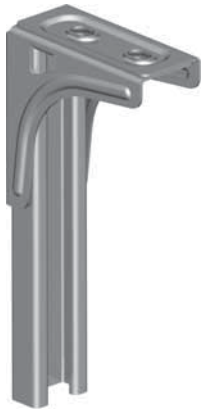

	L mm	Pre-galv. Part.No. C*	Weight kg 100 pcs
Vertical piece 2Fi-300	272	792723 4	97
Vertical piece 2Fi-500	497	792724 1	137
Vertical piece 2Fi-750	722	792725 8	177
Vertical piece 2Fi-1000	992	792726 5	225

\*EAN-code=732167+Part.no+C (control figure)

## Use and installation

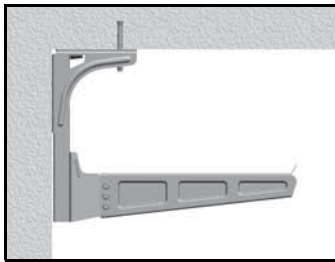

Vertical piece 2Fi can be mounted in ceiling close to wall.

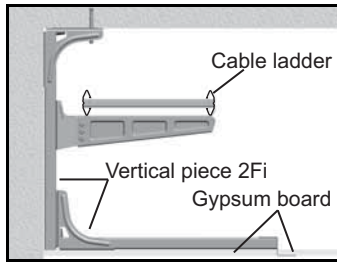

Vertical piece 2Fi can be mounted horizontally on wall and on vertical piece as carrier of gypsum board.

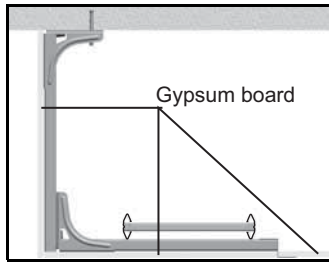

Vertical piece 2Fi can be used as carrier of gypsum boards in order to build in cable ladder passages.

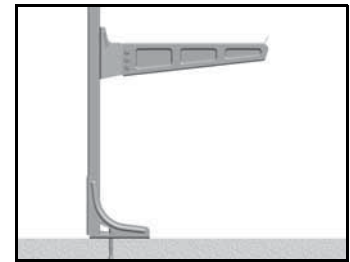

Vertical piece 2Fi is suitable for floor mounting.

## Loadings

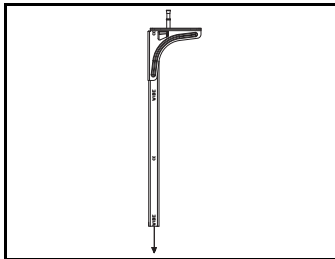

Vertical piece 2Fi mounted in the inner hole.  
Breaking load=500 kg  
(5 kN) at symmetrical loading.

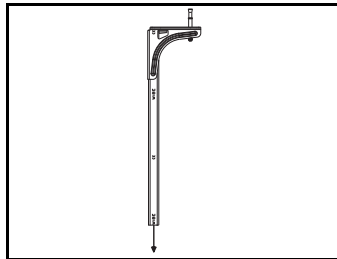

Vertical piece 2Fi mounted in the outer hole.  
Breaking load=100 kg  
(1 kN) at symmetrical loading

# Vertical piece 20

Used for vertical installation with Cantilever arm 50 from a ceiling or on a floor.  
Can also be installed as a cantilever arm on a wall. Cable ladders are fixed with profile clamps.

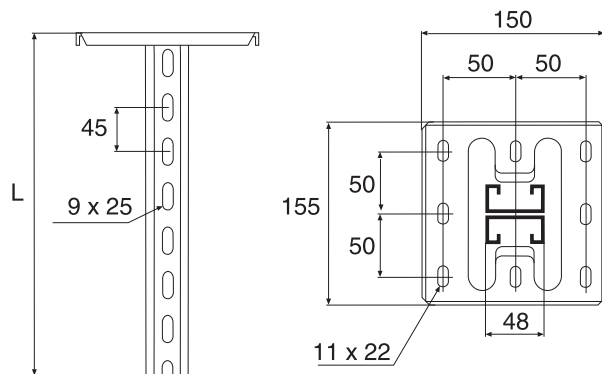
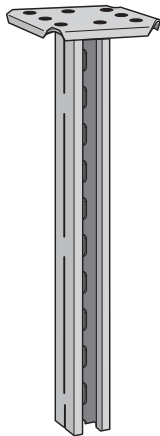

	L mm	Hot dip galv. Part. No. C*	Stainl. steel (AISI316L) Part. No. C*	ZINKPOX® White Part. No. C*	Weight kg 100 pcs
Vertical piece 20-500	500	715723 5	725567 2	716276 5	250
Vertical piece 20-700	725	715724 2	725568 9	716277 2	330
Vertical piece 20-1000	995	715725 9	725569 6	716278 9	440
Vertical piece 20-1500	1490	715726 6	725570 2	716279 6	620
Vertical piece 20-2000	1985	715727 3	725571 9	716280 2	800
Vertical piece 20-3000	2975	715728 0	725572 6	716281 9	1180

\*EAN-code=732167+Part.no+C (control figure)

## Use and installation

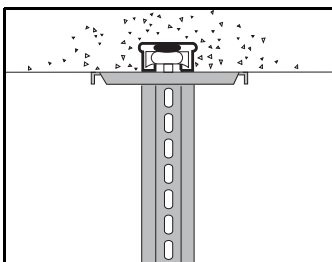

On fixing rail for casting-in, mount Vertical piece 20 using T-bolts.

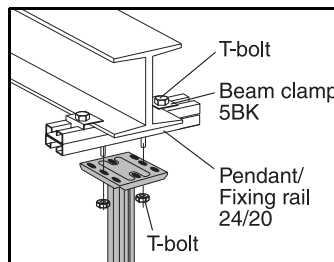

On beams in ceilings, mount Vertical piece 20 as shown in the figure above. When the beam flange thickness does not exceed 13 mm, use Beam clamp 5BK-10 and T-bolt 26F/40. For flange thicknesses not exceeding 30 mm use Beam clamp 5BK-30 and T-bolt 26F/50.

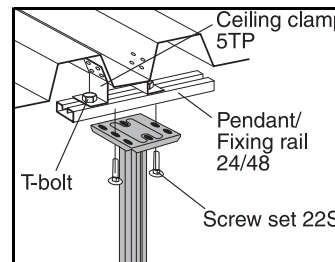

In ceilings with trapezoidal profile sheeting, mount Vertical piece 20 as shown above.

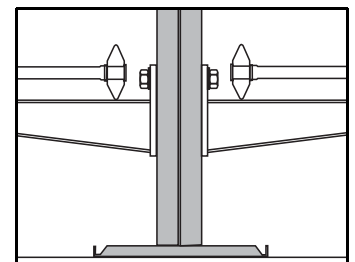

Vertical piece 20 is also suitable for floor mounting.

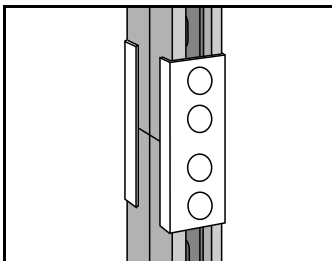

Vertical piece 20 can be joined to achieve the required length using Pendant/Fixing rail 24/20 and Pendant joint 20J.

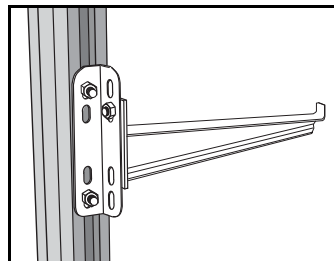

Using End bracket HT-11, Cantilever arm 50 can be mounted at 90° to the pendant/fixing rail. Only for lightweight mounting of data cable type and suchlike.

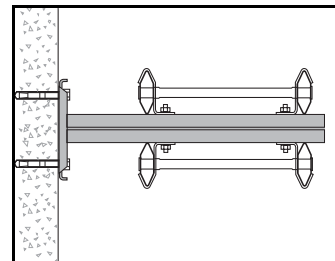

Vertical piece 20 may be used for vertical mounting in a shaft, for example. Mount Wall bracket 11 or Profile clamp 42 using T-bolts. The vertical piece may also be mounted horizontally as a cantilever arm, such as when passing columns.

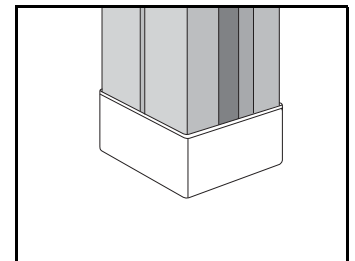

Vertical piece 20 may be equipped with a protective orange End plug 28D.

## Use and installation

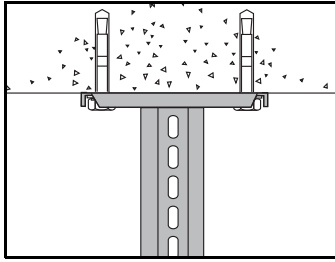

Mount Vertical piece 20 using Expansion bolt.

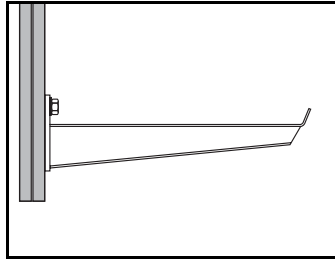

On vertical piece, mount Cantilever arm 50 using T-bolt. For loadings see Cantilever arm 50.

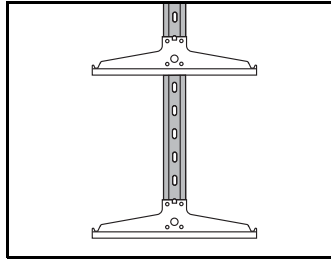

On Vertical piece 20, mount Support bracket 3 using Screw set 20S.

## Breaking load

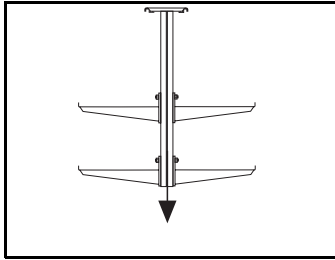

**Symmetrical loading:**  
Breaking load for vertical piece = 3000 kg (30 kN).

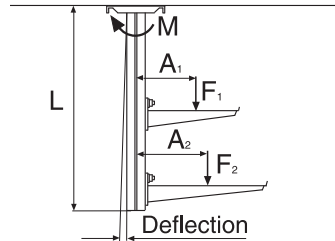

## Asymmetrical loading:

$M = \sum F \times A$   
See also max loading for Cantilever arm 50 installed on pendant/fixing rail, page Cantilever arm 50L, 50 and 50F.

For values outside diagram please contact Wibe.  
Bending torque M is total sum of  $F \times A$  (kgcm).  
F = Cantilever arm loading (kg)  
F = Loading (kg/m) x arm distance (m).  
A = Distance between loading and pendant centre line (cm)  
 $A = \frac{\text{Ladder width} + 7.7}{2}$

Break load torque 19 000 (kgcm)  
L=Pendant length

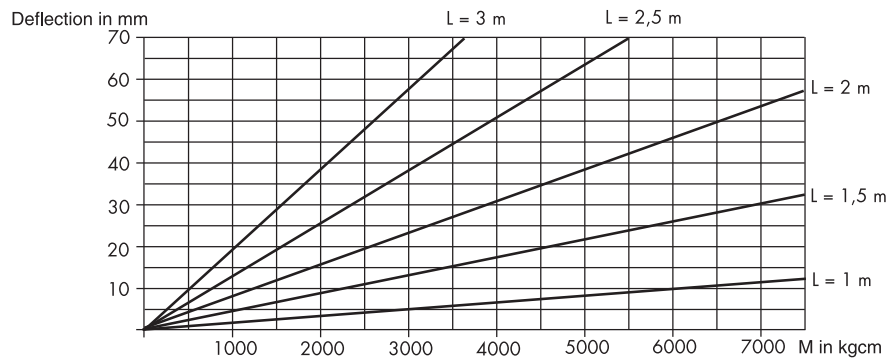

## Example:

Conditions:  
- 2 m bracket distance  
- 30 kg/m ladder  
- Two ladders, 400 and 600 mm  
- One-side loading  
- Pendant 20-1000  
- Bending?  
 $M = \sum F \times A$  (kgcm)  
 $M = 30 \times 2 \times \frac{(40 + 7.7)}{2} + 30 \times 2 \times \frac{(60 + 7.7)}{2}$   
 $(F_1) \quad (A_1) \quad (F_2) \quad (A_2)$

M = 3 924 kgcm — bending as per diagram, about 6 mm.

## Loading table for Vertical piece 20 installed as a cantilever arm

Pendant type	Vertical piece 20 with Pendant bar 1-300						Vertical piece 20 without Pendant bar 1					
	20-700		20-1000		20-1500		20-700		20-1000		20-1500	
Width Ladder type	3° defl.	Break. load	3° defl.	Break. load	3° defl.	Break. load	3° defl.	Break. load	3° defl.	Break. load	3° defl.	Break. load
150	330	380	180	210	105	155	190	230	130	165	70	115
200	350	400	200	240	110	160	200	250	140	170	70	115
300	375	425	225	270	115	165	215	280	150	175	75	120
400	400	450	250	300	120	170	230	310	160	180	80	125
600	—	—	280	320	130	180	280	370	170	190	90	130

# Vertical piece 20F

Vertical piece 20F can be mounted from the ceiling or on the floor.  
Suitable for rather heavy loadings.

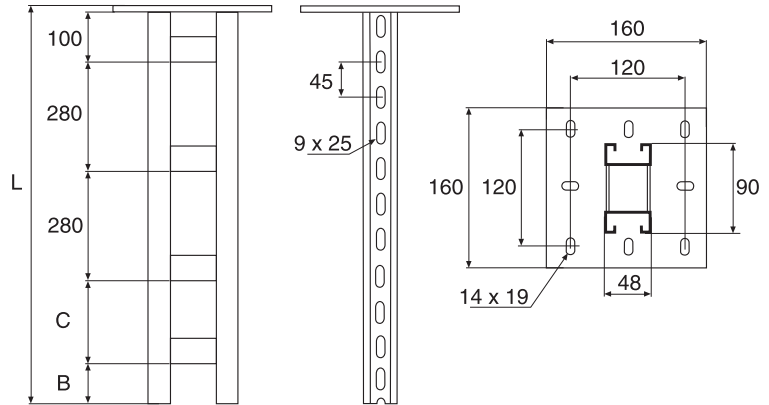
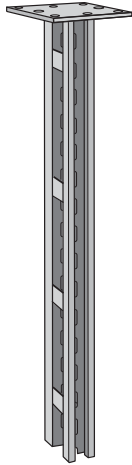

	B mm	C mm	L mm	Hot dip galv. Part. No. C*	ZINKPOX® White Part. No. C*	Weight kg 100 pcs
Vertical piece 20F-1000	50	280	995	718249 7	718484 2	590
Vertical piece 20F-1500	70	195	1490	718250 3	718485 9	790
Vertical piece 20F-2000	5	195	1985	718251 0	718486 6	990
Vertical piece 20F-3000	70	280	2980	709799 9	716282 6	1240

\*EAN-code=732167+Part.no+C (control figure)

## Use and installation

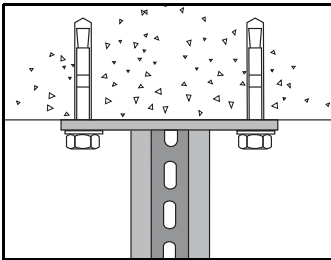

Mount Vertical piece 20F using Expansion bolt alt. Concrete screw.

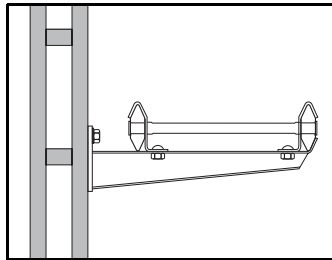

Cantilever arm 50 can be mounted using T-bolt. For loads on Cantilever arm 50, see Cantilever arm 50L, 50 and 50F.

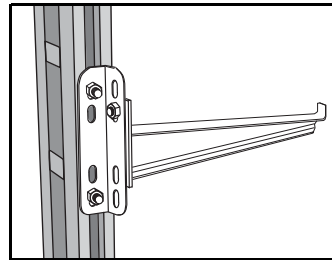

Using End bracket HT-11, Cantilever arm 50 can be mounted at 90° to the vertical piece. Only for lightweight mounting of data cable type or suchlike.

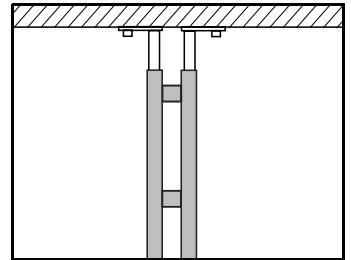

Vertical piece 20F mounted on floor can be fixed using Vertical piece 2 as ceiling bracket, adjustable in the pendant.

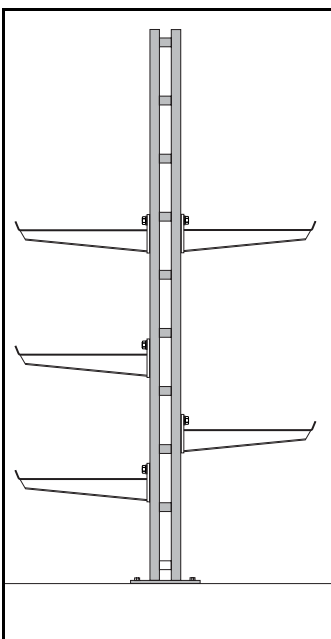

Floor mounting example.

## Loading table

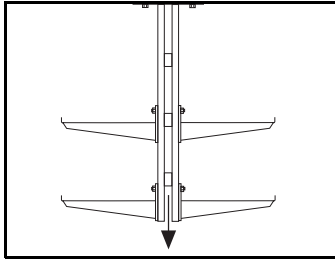

### Symmetrical loading

Breaking load for Vertical piece 20F  
= 5000 kg (50kN)

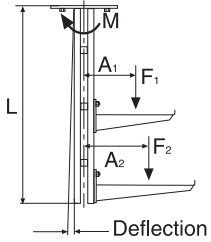

### Asymmetrical loading

Vertical piece 20F mounted in ceiling, see diagram.

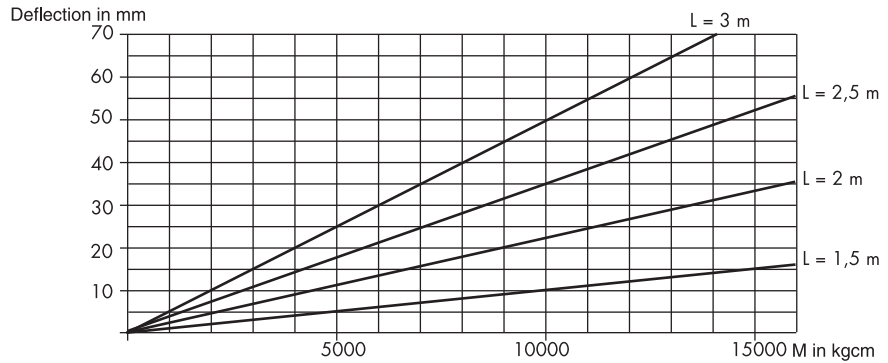

For values outside diagram please contact Wibe.

Bending torque M is total sum of  $F \times A$  (kgcm).

$F$  = Cantilever arm loading (kg)

$F$  = Loading (kg/m) x arm distance (m).

$A$  = Distance between loading and pendant centre line (cm)

$A = \frac{\text{Ladder width} + 9.4}{2}$

Break load torque 30 000 (kgcm)

$L$  = Pendant length

### Example:

Conditions:

- 2 m arm distance
- 50 kg/m ladder
- Two ladders, 400 and 600 mm
- One-side loading
- Pendant 20F-1500
- Bending?

$M = \sum F \times A$  (kgcm)

$$M = 50 \times 2 \times \left( \frac{40}{2} + 9.4 \right) + 50 \times 2 \times \left( \frac{60}{2} + 9.4 \right)$$

$$(F_1) \quad (A_1) \quad (F_2) \quad (A_2)$$

$M = 6\,880$  kgcm — bending as diagram, about 6 mm.



# Vertical piece 20FS

The Vertical piece 20FS can be mounted from the ceiling or on the floor.  
Suitable for very heavy loadings.

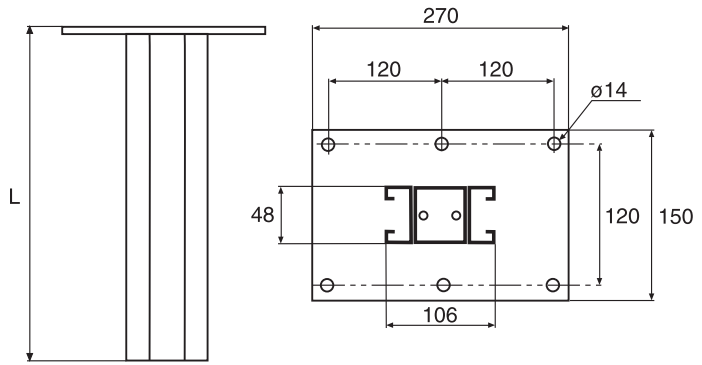
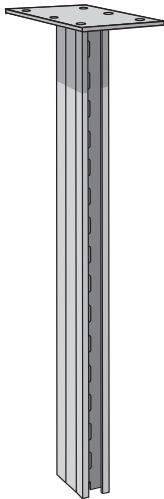

	L mm	Hot dip galv. Part. No. C*	ZINKPOX® White Part. No. C*	Weight kg 100 pcs
Vertical piece 20FS-1500	1495	718718 8	720521 9**	1460
Vertical piece 20FS-2000	1990	718719 5	720522 6**	1810
Vertical piece 20FS-2500	2485	718720 1	720523 3**	2160
Vertical piece 20FS-3000	2980	718721 8	720524 0**	2520

\*EAN-code=732167+Part.no+C (control figure) \*\*Produced to order

## Use and installation

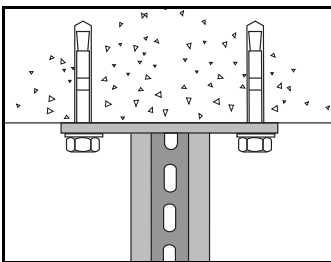

Mount Vertical piece 20FS using Expansion bolt alt. Concrete screw.

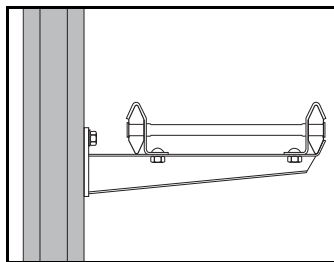

Mount Cantilever arm 50 using T-bolt. For loads on Cantilever arm 50, see Cantilever arm 50L, 50 and 50F.

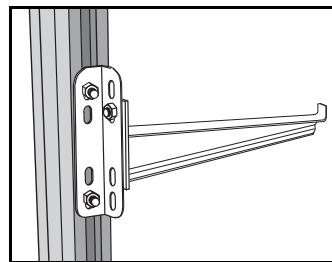

Using End bracket HT-11, Cantilever arm 50 can be mounted at 90° to the vertical piece. Only for lightweight mounting of data cable type or suchlike.

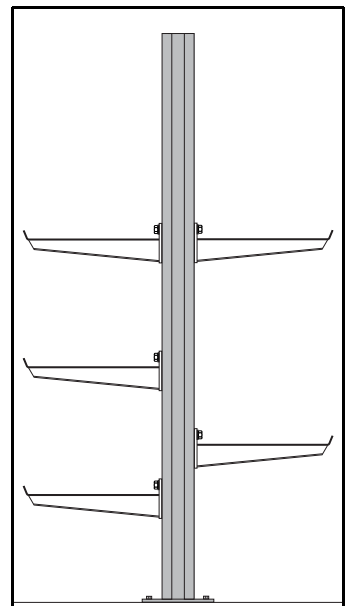

Vertical piece 20FS is suitable for floor mounting.

## Loading table

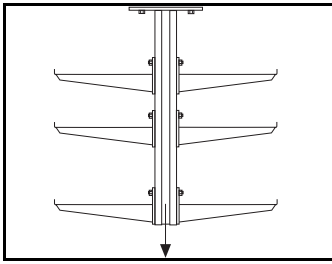

### Symmetrical loading

Breaking load for Vertical piece 20FS  
= 5000 kg (50 kN)

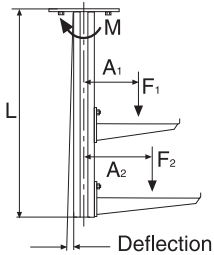

### Asymmetrical loading

Vertical piece 20FS mounted in ceiling, see diagram.

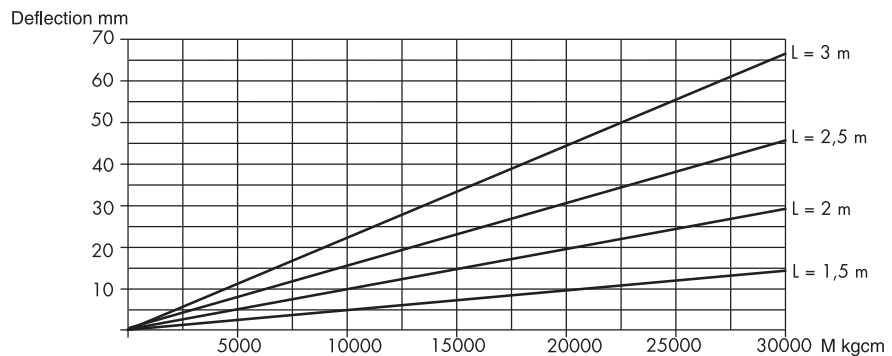

For values outside diagram please contact Wibe.

Bending torque M is total sum of  $F \times A$  (kgcm)

F = Cantilever arm loading (kg)

F = Loading (kg/m) x arm distance (m).

A = Distance between loading and pendant centre line (cm)

$A = \frac{\text{Ladder width} + 10.4}{2}$  cm

Break load torque 60 000 (kgcm)

L = Pendant length

### Example:

Conditions:

- 2 m arm distance
- 75 kg/m ladder
- Two ladders, 400 and 600 mm
- One-side loading
- Pendant 20FS-1500
- Bending?

$M = \Sigma F \times A$  (kgcm)

$$M = 75 \times 2 \times \frac{(40 + 10.4)}{2} + 75 \times 2 \times \frac{(60 + 10.4)}{2}$$

(F<sub>1</sub>)    (A<sub>1</sub>)    (F<sub>2</sub>)    (A<sub>2</sub>)

M = 10 620 kgcm — bending as per diagram, about 5 mm.

## T-bolt 26F

Used for mounting with all vertical pieces except Vertical piece 2.

WEF-0002

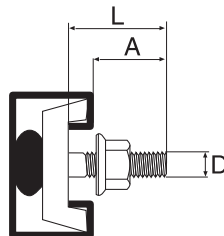
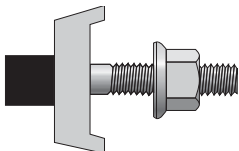

	D	L	A	Electro-galv. Part. No. C*	Hot dip galv. Part. No. C*	Stainl. steel (AISI316) Part. No. C*	Weight kg 100 pcs
T-bolt 26F	M8	30	24	734983 8	734744 5	734986 9	4.5
T-bolt 26F	M10	30	24	734864 0	716794 4	728596 9	7
T-bolt 26F	M10	40	34		716795 1		7.5
T-bolt 26F	M10	50	44		716796 8	728598 3	8

\*EAN-code=732167+Part.no+C (control figure)

# Wall bracket 11/25 and 11/75

For vertical or horizontal installation of cable ladders against a wall.

WEF-0001

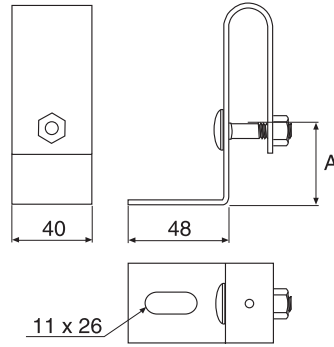
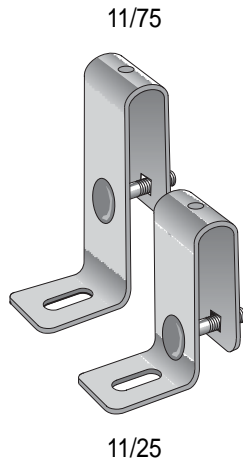

	A mm	Pre-galv. Part. No. C*	Hot dip galv. Part. No. C*	Stainl. steel (AISI316L) Part. No. C*	ZINKPOX® White** Part. No. C*	Weight kg 100 pcs
Wall bracket 11/25	25	721105 0	713204 1	725774 4	713208 9	24
Wall bracket 11/75	75	721106 7	713203 4	725775 1	713207 2	30

(Screw MVBF 8x40+nut incl) \*\*Screw+nut in AISI316L

\*EAN-code=732167+Part.no+C (control figure)

## Use and installation

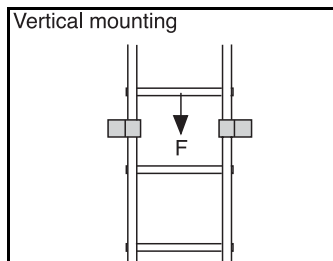

**Vertical mounting** (max load-F)  
 Wall bracket 11/25: 300 kg (3 kN)  
 Wall bracket 11/75: 300 kg (3 kN)  
 When mounting against a rung  
 the max load is 500 kg (5 kN)  
 for wall bracket 11/25.

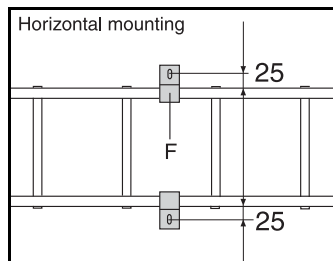

**Horizontal mounting** (max load-F)  
 Wall bracket 11/25: 250 kg (2.5 kN)  
 Wall bracket 11/75: 100 kg (1.0 kN)

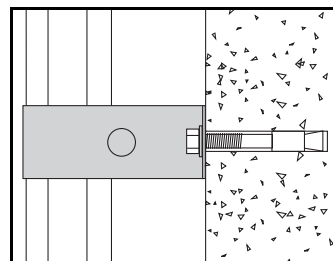

Mount wall brackets against walls using Expansion bolts.

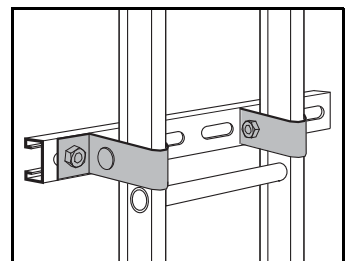

Pendant/fixing rails can be mounted on cable ladders using wall brackets for mounting equipment cubicles etc.  
 Mount wall brackets on Pendant/fixing rails using Screw set 22S.

## Ceiling bracket 2Fi

**WIBE**

WEF-0001

To be used mounted on Pendant/Fixing rail 24/48 Pre-galv. to achieve the desired length of vertical pieces.

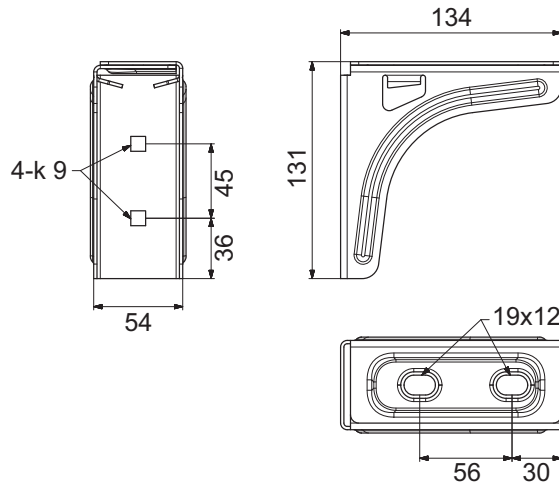

	Pre-galv. Part. No. C*	Weight kg 100 pcs
Ceiling bracket 2Fi	792554 4	50

\*EAN-code=732167+Part.no+C (control figure)

### Use and installation



Ceiling bracket 2Fi and Pendant/Fixing rail 24/48 Pre-galv., mounted together with 2 Screw sets 22S, are used when other lengths are required than those available for Vertical piece 2Fi.

# Ceiling bracket 5

For installation with Pendant/Fixing rails 24/34 and 24/48.

WEF-0001

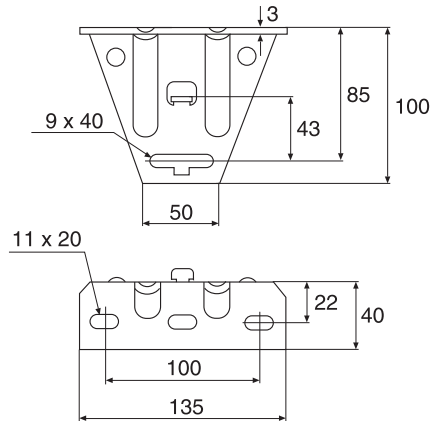
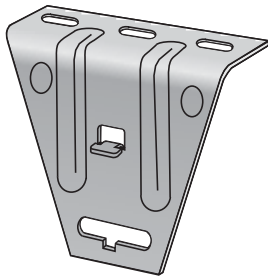

	Pre-galv. Part. No. C*	Hot dip galv. Part. No. C*	Stainl. steel (AISI316L) Part. No. C*	ZINKPOX® White Part. No. C*	Weight kg 100 pcs
Ceiling bracket 5 (screw excl.)	721101 2	718640 2	725573 3	716293 2	35

\* EAN-code=732167+Part.no+C (control figure)

## Use and installation

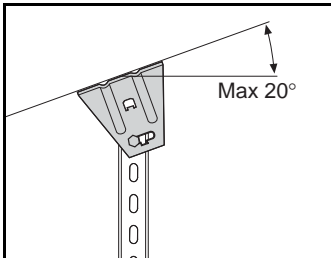

Using Pendant/Fixing rail 24/34 or 24/48, 1 Ceiling bracket 5 and 1 Screw set 22S it is possible to make a vertical piece that can be installed at an angle of up to 20°.  
 Breaking load for rail 34 = 1000 kg (10 kN).  
 Breaking load for rail 48 = 1200 kg (12 kN).

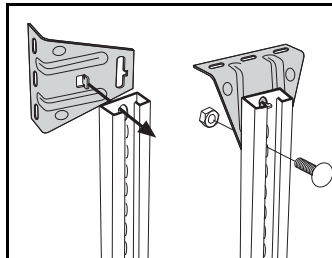

Mount Ceiling bracket 5 to the back of the pendant/fixing rail by turning the ceiling bracket 90° and inserting the tab into the hole in the rail. Then turn the ceiling bracket back and lock it in the required position using 1 Screw set 22S.  
 When mounting it at a horizontal ceiling, lock the screw in the slot recess for better lateral stability. Ceiling bracket 5 can be tilted max. 20°.

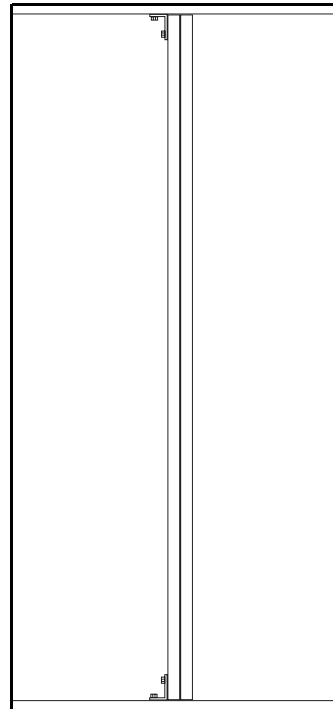

Pendant/Fixing rail 24/20 can, using 2 Ceiling brackets 5 and 2 T-bolts, be mounted between floor and ceiling (see also Angle bracket 5L).

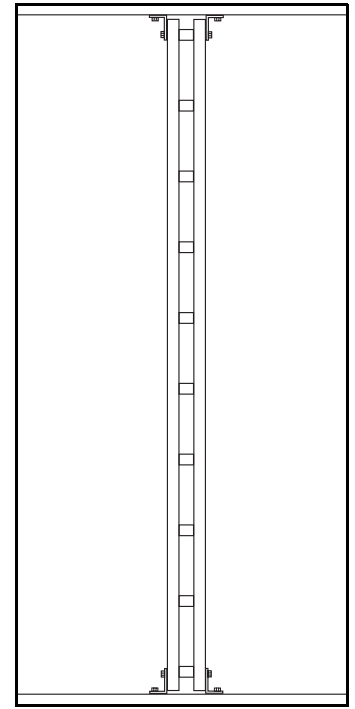

Pendant/Fixing rail 24/20F can, using 4 Ceiling brackets 5 and 4 T-bolts, be mounted between floor and ceiling (see also Angle bracket 5L).

# Ceiling bracket 5TPA

Used for mounting in trapezoid plate.

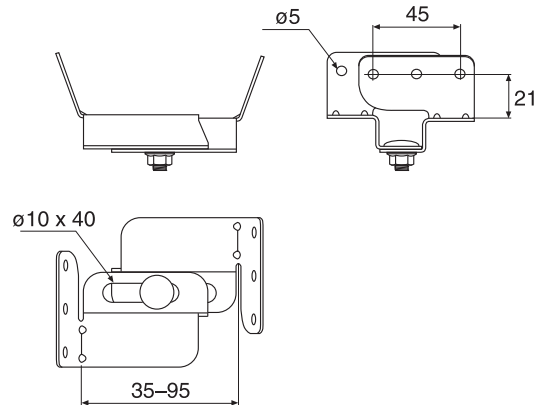
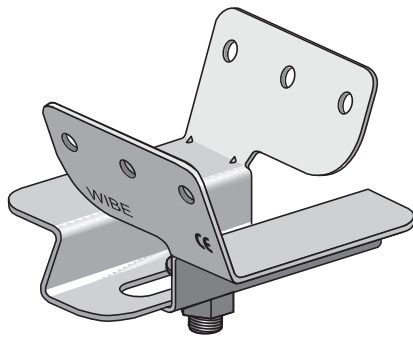

	Pre-galv. Part. No. C*	Hot dip galv. Part. No. C*	Pre-galv. White Part. No. C*	Weight kg 100 pcs
Ceiling bracket 5TPA (screw MVBF 8x16 + nut M6MF8 incl.)	732177 3	733487 2	733486 5	14

\*EAN-code=732167+Part.no+C (control figure)

## Use and installation

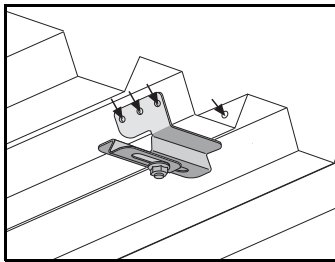

Ceiling bracket 5TPA can be mounted in trapezoid plate with blind rivets or suitable screws. The bracket is adjustable from 35 to 95 mm.

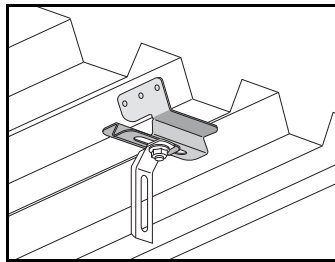

Pendant attachment W21 or Tube pendant attachment W73 can be mounted in Ceiling bracket 5TPA with the existing screw.

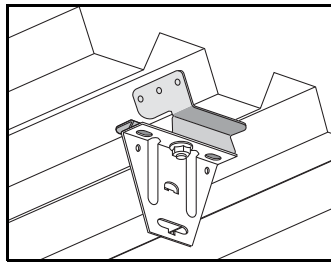

Ceiling bracket 5 or Ceiling attachment W31 can be mounted with the existing screw.

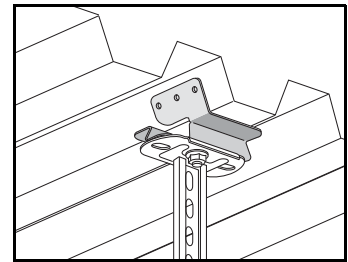

Vertical piece 2 or 2F can be mounted with the existing screw.

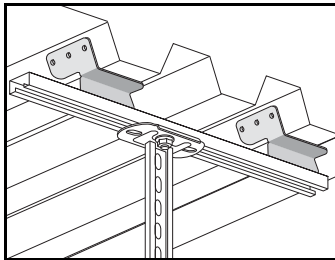

Install Mounting rail 40 between 2 Ceiling brackets 5TPA if the vertical piece must be adjusted sideways.

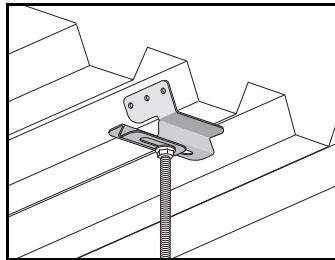

Pendant W76 M8 or M10 installed in Ceiling bracket 5TPA.

## Breaking load

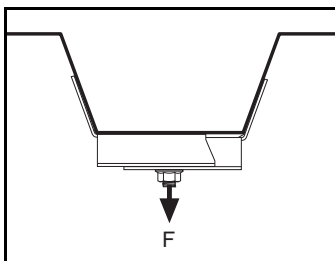

Ceiling bracket 5TPA can be loaded with  $F=150$  kgs without deformation. As to loading figures for thin plate or fixing elements, please follow the supplier's recommendations.

# Ceiling bracket 5TP

For installation of Vertical pieces 2, 2F and 20 in ceilings with a trapezoidal sheet profile.

WEF-0001

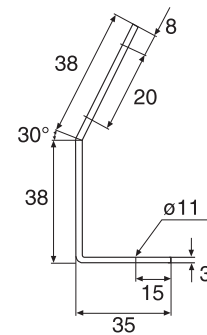
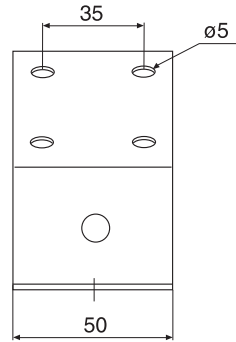
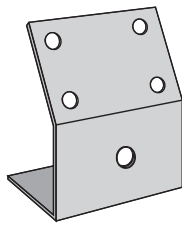

	Pre-galv. Part. No. C*	Hot dip galv. Part. No. C*	ZINKPOX® White Part. No. C*	Weight kg 100 pcs
Ceiling bracket 5TP	725362 3	713153 2	716295 6	12
*EAN-code=732167+Part.no+C (control figure)				

## Use and installation

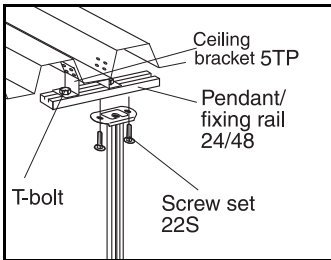

In ceilings with trapezoidal sheeting, mount Vertical piece 2, 2F or 20 using 2 Ceiling brackets 5TP, Pendant/Fixing rail 24/48, 2 T-bolts and Screw set 22S.

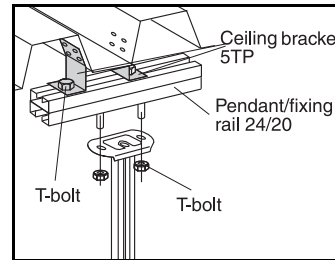

Alternatively Pendant/ Fixing rail 24/20 may be used. This will require the use of 4 T-bolts.

# Pendant base plate 520

Used as a ceiling or floor base plate for Pendant/Fixing rail 24/20 in any desired length.

WEF-0001

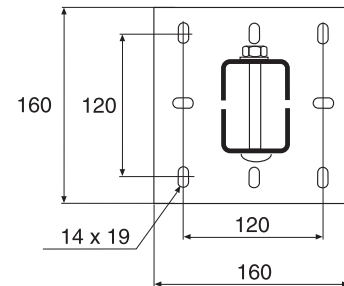
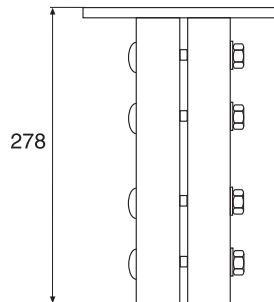
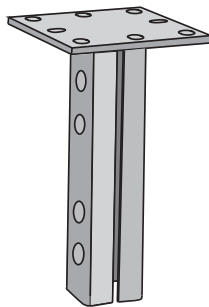

	Hot dip galv. Part. No. C*	ZINKPOX® White Part. No. C*	Weight kg 100 pcs
Pendant base plate 520 (4 Screws MVBF 8x80 and nuts incl.)	718253 4	718488 0**	400
*EAN-code=732167+Part.no+C (control figure) **Produced to order			

## Use and installation

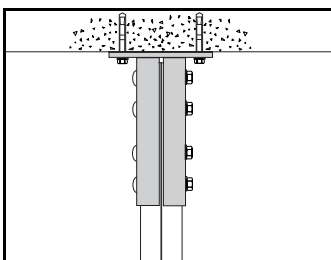

Vertical pieces of the required length can be mounted using Pendant base plate 520 and Pendant/Fixing rail 24/20. Screws and nuts are included.

# Beam clamp 5BK

For installation of Vertical pieces 2, 2F or 20 on I-beams.

WEF-0001

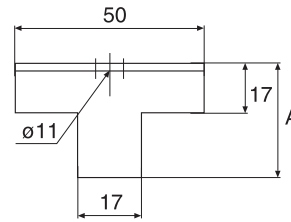
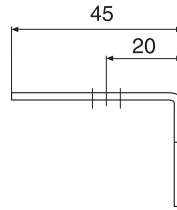
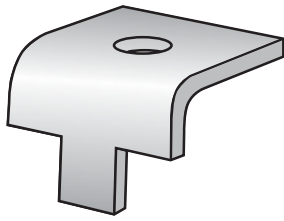

	A mm	Hot dip galv. Part. No. C*	ZINKPOX® White Part. No. C*	Weight kg 100 pcs
Beam clamp 5BK-10 (for flange thickness max 13 mm)	30	715675 7	716294 9	15
Beam clamp 5BK-30 (for flange thickness 14-30 mm)	50	718243 5	718487 3	18

\*EAN-code=732167+Part.no+C (control figure)

## Use and installation

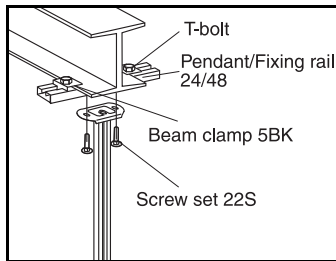

On ceiling beams, mount Vertical piece 2, 2F or 20 using 2 Beam clamps 5BK, Pendant/Fixing rail 24/48 and Screw set 22S. For Beam clamp 5BK-10, use T-bolt 26F/40. For Beam clamp 5BK-30, use T-bolt 26F/50.

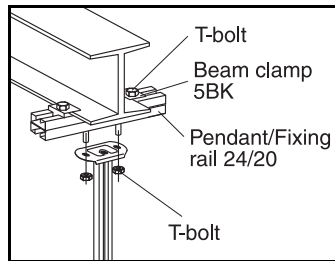

Alternatively, a Pendant/Fixing rail 24/20 may be used. This will require 4 T-bolts.



# Pendant/Fixing rail 24/34

For mounting of support brackets, cantilever arms etc.

WEF-0001

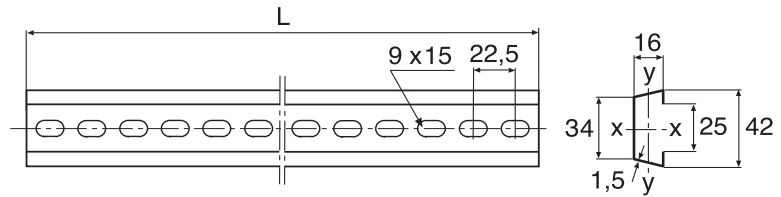

	L mm	Pre-galv. Part. No. C*	Hot dip galv. Part. No. C*	Stainl. steel (AISI316L) Part. No. C*	ZINKPOX® White Part. No. C*	Weight kg 100 st
P/F-rail 24/34	292.5	725357 9		725574 0		23
P/F-rail 24/34	382.5	725358 6		725575 7		31
P/F-rail 24/34	495	725359 3		725576 4		40
P/F-rail 24/34	697.5	725360 9		725577 1		56
P/F-rail 24/34	990	725361 6		725578 8		80
P/F-rail 24/34	2970	721102 9	715879 9	725579 5	716309 0	240

\*EAN-code=732167+Part.no+C (control figure)

## Use and installation

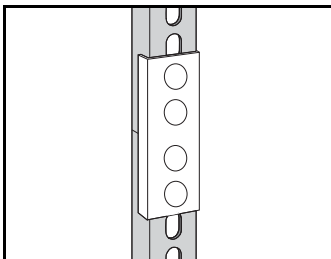

Vertical piece 2 may be joined to Pendant/Fixing rail 24/34 and Pendant joint 2J to achieve a suitable length.

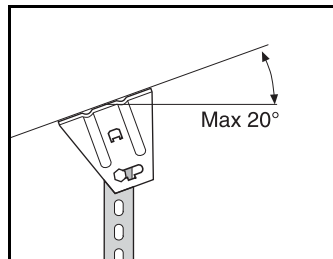

Ceiling bracket 5 and 1 Screw set 22S together provide a vertical piece that can be mounted with up to 20° slope.

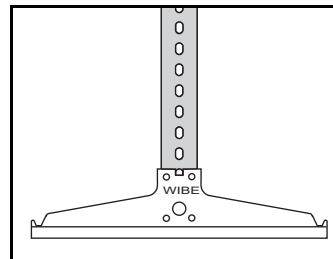

Mount Support bracket 3 using Screw set 22S.

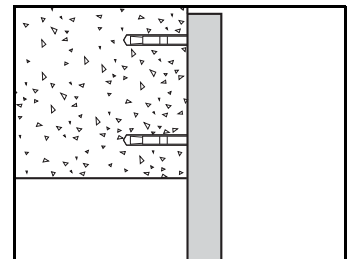

Side mounting of pendant/fixing rails may be done using 2 Expansion bolts alt. 2 Concrete screws.

# Pendant/Fixing rail 24/48

For mounting of support brackets, cantilever arms etc.

WEF-0001

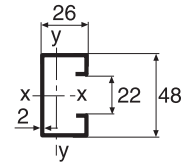
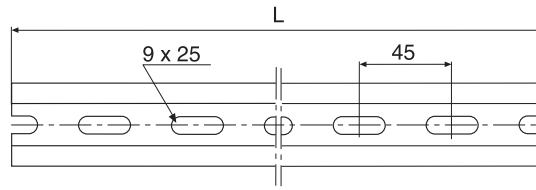

	L mm	Pre-galv. Part. No. C*	Hot dip galv. Part. No. C*	Stainl. steel (AISI316L) Part. No. C*	ZINKPOX® White Part. No. C*	Weight kg 100 pcs
P/F-rail 24/48	2970	731717 2	705093 2	728595 2	716306 9	520
P/F-rail 24/48	5940	731721 9	731719 6	731727 1**	731724 0**	1120

\*EAN-code=732167+Part.no+C (control figure) \*\*Produced to order

## Use and installations

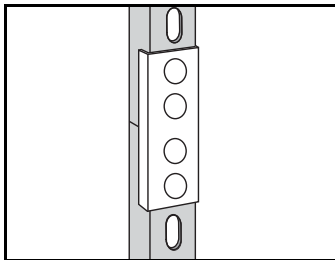

Vertical piece 2F may be joined using Pendant/Fixing rail 24/48 and Pendant joint 2FJ to achieve the required length.

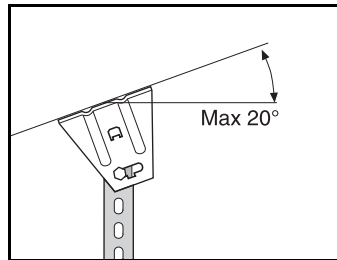

Ceiling bracket 5 and 1 Screw set 22S together provide a vertical piece that can be mounted with up to 20° slope. Only for mounting support brackets.

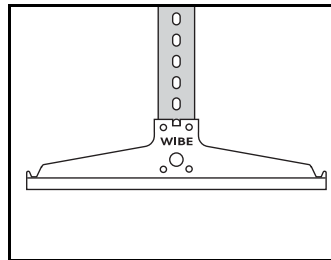

Mount Support bracket 3 using Screw set 22S.

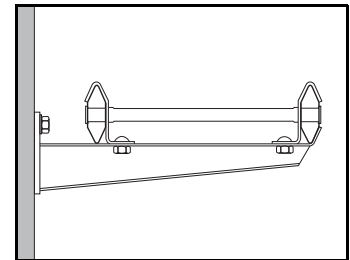

Mount Cantilever arm 50 using T-bolt.

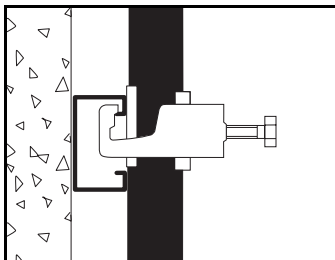

Cables are mounted on a Pendant/Fixing rail 24/48 using cable clamps of type A.

# Pendant/Fixing rail 24/20

For mounting of support brackets, cantilever arms etc.

WEF-0001

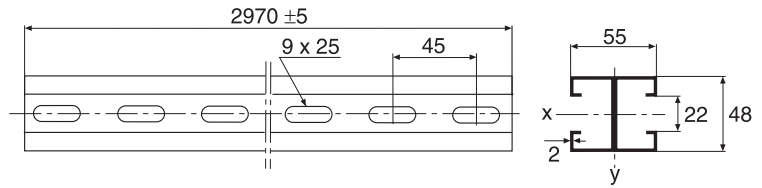

	Hot dip galv. Part. No. C*	ZINKPOX® White Part. No. C*	Weight kg 100 pcs
Pendant/Fixing rail 24/20	709795 1	716307 6	1130
*EAN-code=732167+Part.no+C (control figure)			

## Use and installation

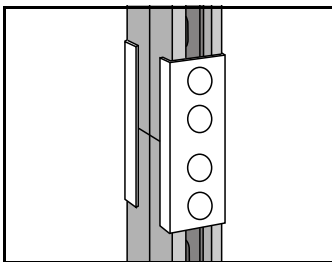

Vertical piece 20 may be joined using Pendant/Fixing rail 24/20 and Pendant joint 20J. Only for symmetrical loading.

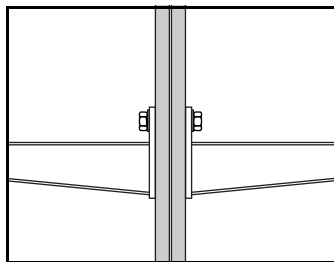

Mount Cantilever arm 50 using T-bolts.

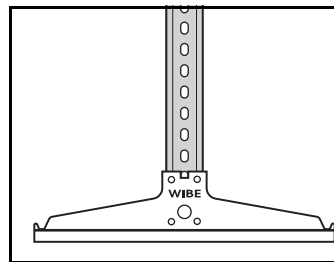

Mount Support bracket 3 using Screw set 20S.

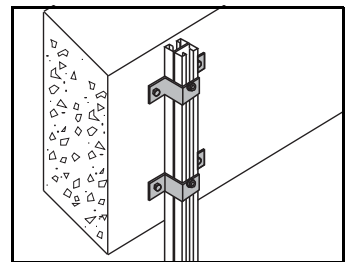

Pendant/Fixing rail can be mounted on beam or wall with Wall bracket 20.

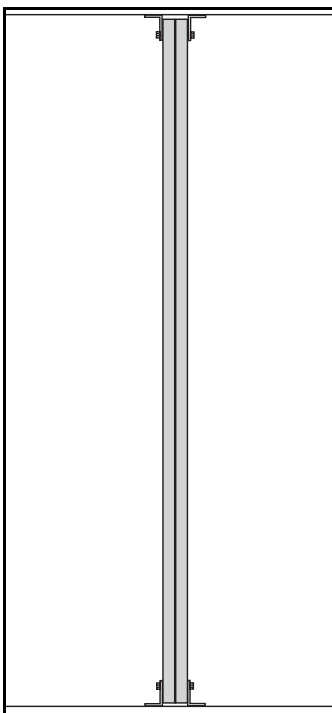

Pendant/Fixing rail 24/20 may be mounted as a riser between the floor and ceiling using 4 Angle brackets 5L and 4 T-bolts.

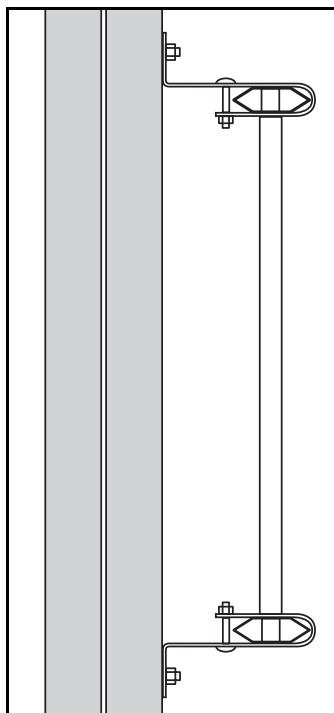

Cable ladder may be mounted vertically or horizontally on Pendant/Fixing rail 24/20 using Wall bracket 11/25 or 11/75 and T-bolt.

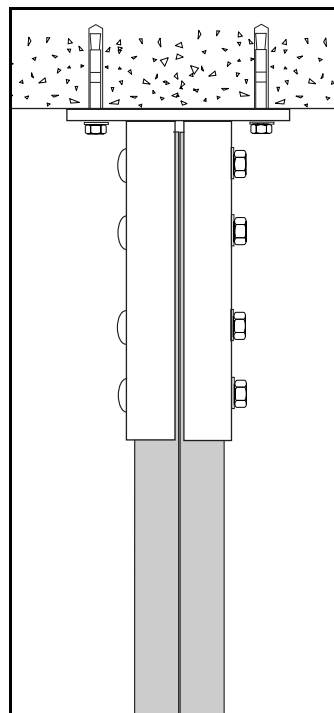

Pendant base plate 520 can be mounted as a ceiling or floor attachment.

# Pendant/Fixing rail 24/20F

For mounting of support brackets, cantilever arms etc.

WEF-0001

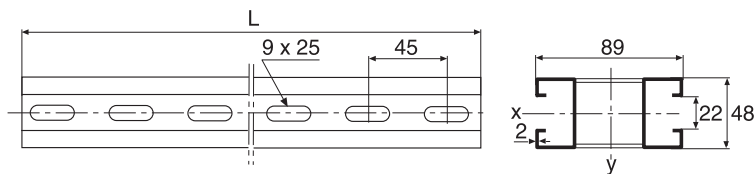
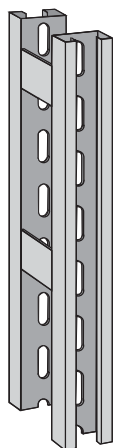

	L mm	Hot dip galv. Part. No. C*	ZINKPOX® White Part. No. C*	Weight kg 100 pcs
Pendant/Fixing rail 24/20F-3000	2970	709798 2	716308 3**	1160
Pendant/Fixing rail 24/20F-6000	5940	718808 6	720525 7**	2370

\*EAN-code=732167+Part.no+C (control figure) \*\*Produced to order

## Use and installation

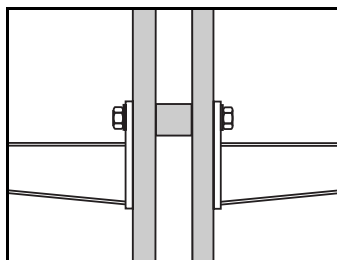

Mount Cantilever arm 50 using T-bolts.

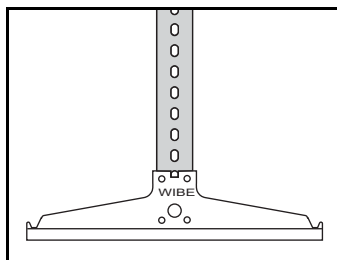

Mount Support bracket 3 using Screw set 2S.

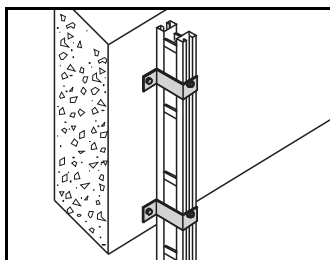

Pendant/Fixing rail 24/20F can be mounted on beam or wall with Wall bracket 20F.

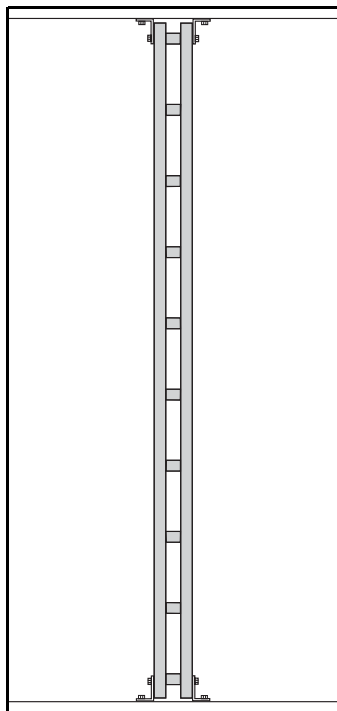

Pendant/Fixing rail 24/20F can be mounted as a riser between the ceiling and floor using 4 Angle brackets 5L and 4 T-bolts.

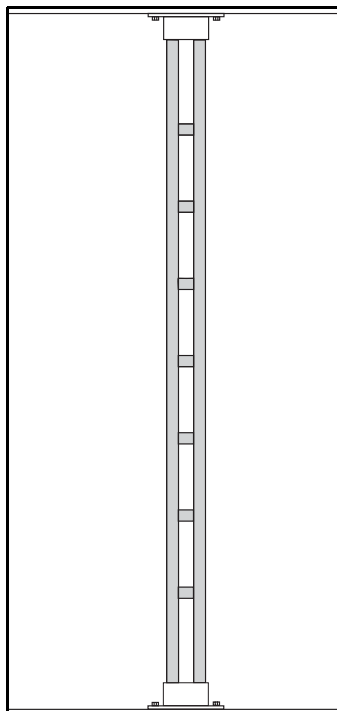

Mount Pendant/Fixing rail 24/20F between a floor and ceiling using 2 Rail fixing supports.

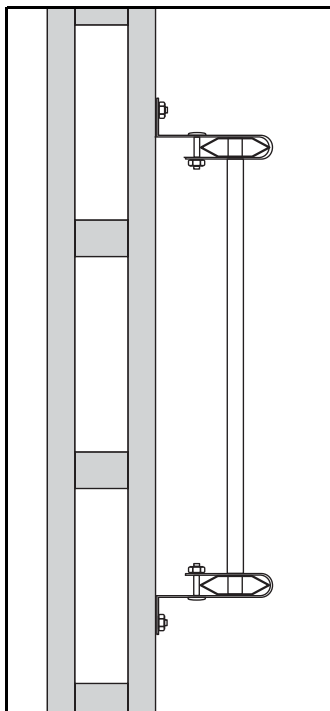

Cable ladder can be mounted vertically or horizontally on Pendant/Fixing rail 24/20F using Wall bracket 11/25 or 11/75.

# Pendant/Fixing rail 24/20FS

For mounting of cantilever arm etc.

WEF-0001

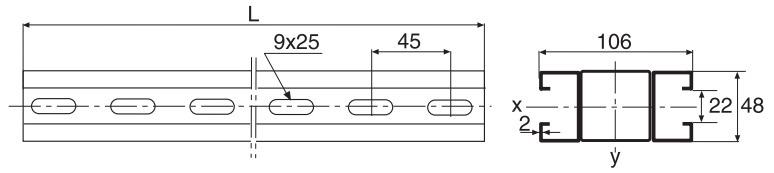
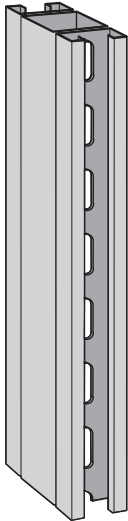

	L mm	Hot dip galv. Part. No. C*	ZINKPOX® White Part. No. C*	Weight kg 100 pcs
Pendant/Fixing rail 24/20FS	5940	709031 0	720526 4**	4200

\*EAN-code=732167+Part.no+C (control figure) \*\*Produced to order

## Use and installation

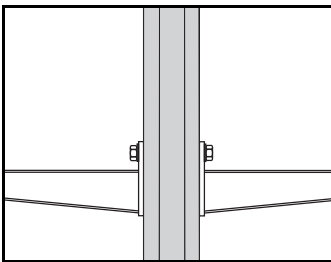

Mount Cantilever arm 50 using T-bolts.

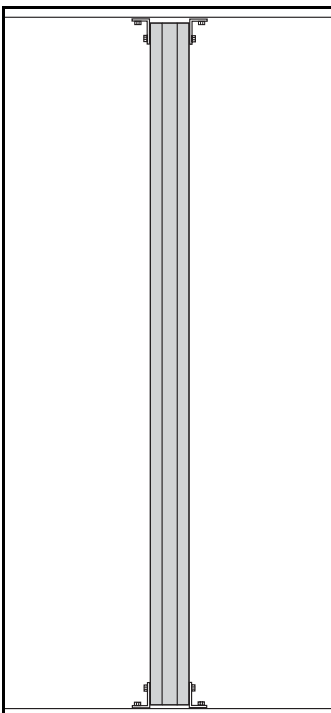

Pendant/Fixing rail 24/20FS can be mounted as a riser between the ceiling and floor using 4 Angle brackets 5L and 4 T-bolts.

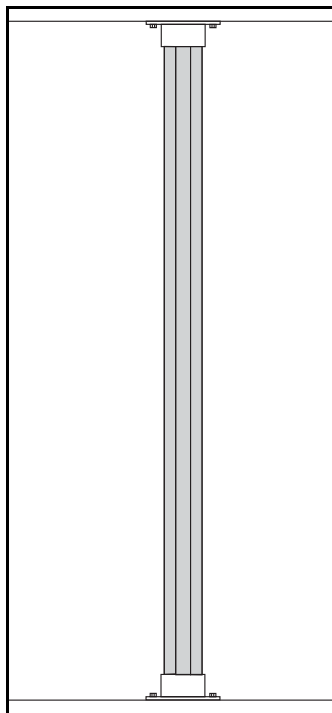

Mount Pendant/Fixing rail 24/20FS between floor and ceiling using 2 Rail fixing supports.

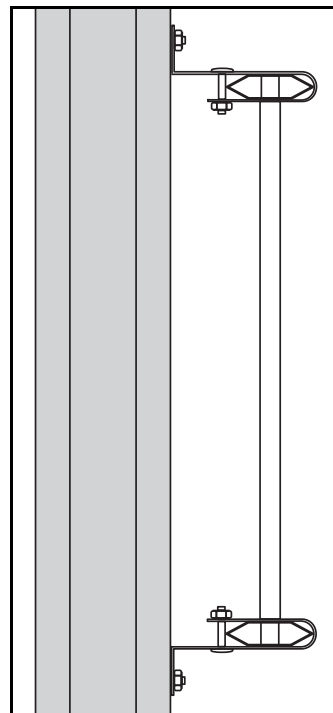

Cable ladders can be mounted vertically or horizontally on Pendant/Fixing rail 24/20FS using Wall bracket 11/25 or 11/75 and T-bolt.

# Fixing rail 24/26x53 for casting-in

For casting-in in walls and ceilings.

WEF-0001

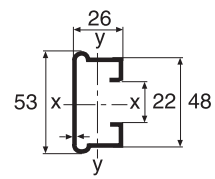
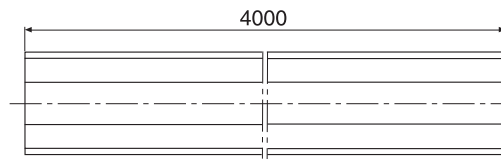
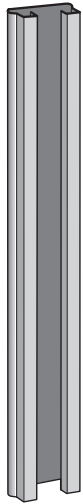

	Hot dip galv. Part. No. C*	Weight kg 100 pcs
Fixing rail 24/26 x 53 for casting-in	768063 4	970
*EAN-code=732167+Part.no+C (control figure)		

## Use and installation

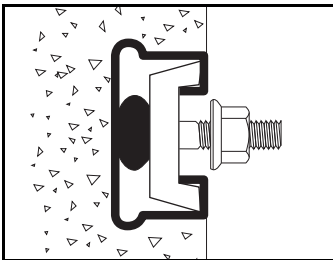

Fixing rail 24/26 x 53 for casting-in in walls and ceilings. Mount cantilever arms with T-bolt 26F.

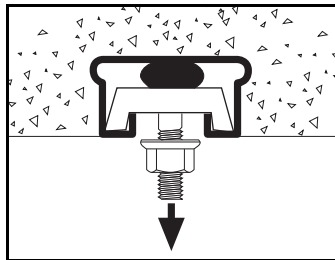

Max. pull-out load: 1000 kg/0.5 m of casting-in fixing rail (Concrete class K200).

# Pendant joint 2J, 2FJ and 20J

Used for joining pendant/fixing rails and vertical pieces.

WEF-0001

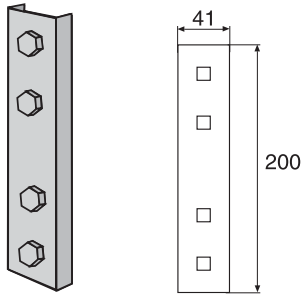

Pendant joint 2J

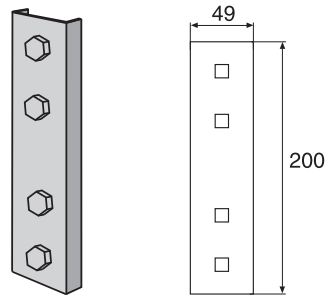

Pendant joint 2FJ

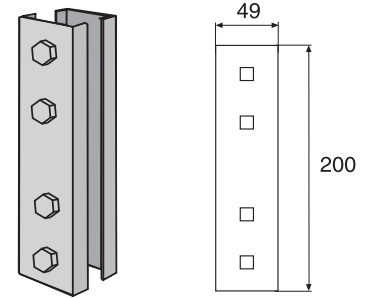

Pendant joint 20J

	Pre-galv Part. No. C*	Hot dip galv. Part. No. C*	Stainl. steel (AISI316L) Part. No. C*	ZINKPOX® White Part. No. C*	Weight kg 100 pcs
Pendant joint 2J	721119 7	713177 8	726484 1	716303 8	43
Pendant joint 2FJ		713178 5	726485 8	716304 5	46
Pendant joint 20J		713173 0		716302 1	94

2J and 2FJ: 4 screw M8x16 + nuts incl,

20J: 4 screw M8x70 + nuts incl.

Powder coated joints have screws+nuts of stainless steel (AISI 316L)

\*EAN-code=732167+Part.no+C (control figure)

## Use and installation

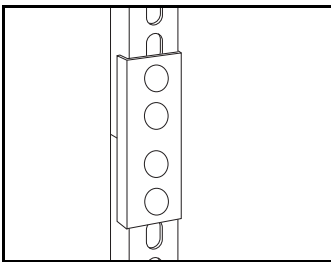

Pendant joint 2J, used for joining of Vertical piece 2 and Pendant/ Fixing rail 24/34.

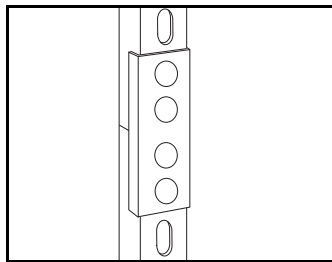

Pendant joint 2FJ, used for joining of Vertical piece 2F and Pendant/ Fixing rail 24/48.

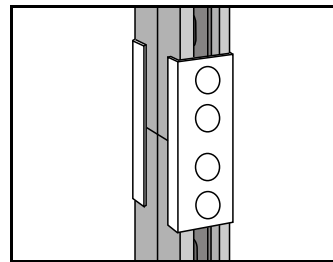

Pendant joint 20J, used for joining of Vertical piece 20 and Pendant/ Fixing rail 24/20. Only for symmetrical loading.

# Pendant bar 1

**WIBE**

Installed in order to reduce the deflection of heavy loaded vertical pieces.

WEF-0001

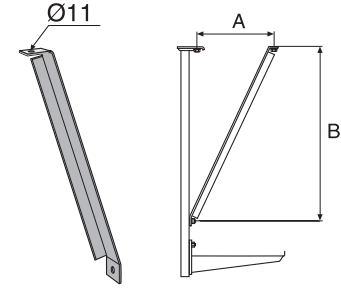
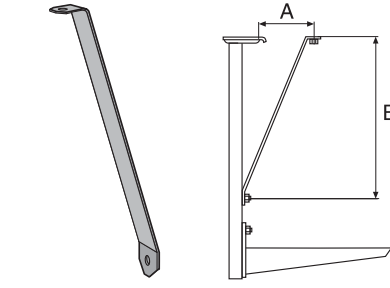
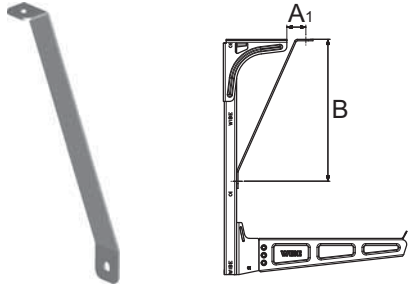

Pendant bar 1/300-800 Pre-galv.

Pendant bar 1/300-800 Hdg

Pendant bar 1-1500 Hdg

	A <sub>1</sub> mm	A mm	B mm	Pre-galv. Part. No. C*	Hot dip galv. Part. No. C*	ZINKPOX® White Part. No. C*	Weight kg 100 pcs
Pendant bar 1-300	40	80	300	792727 2	717640 3	717643 4**	35/50
Pendant bar 1-500	40	130	500	792728 9	717641 0	717644 1**	53/80
Pendant bar 1-800	125	215	800	792729 6	717642 7	717645 8**	82/125
Pendant bar 1-1500	May vary				718903 8	720530 1**	560

\*EAN-code=732167+Part.no+C (control figure) \*\*Produced to order

## Use and installation

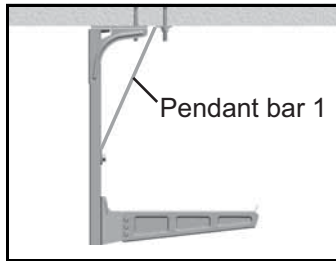

To reduce deflection of Vertical piece 2Fi at heavy loads on Cantilever arm 50i the Pendant bar 1 can be used. Install with T-bolt and Expansion bolt.

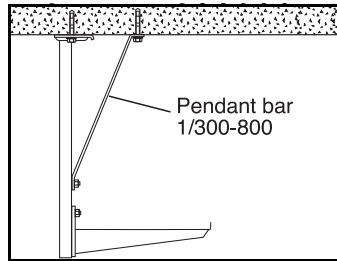

To reduce deflection of Vertical piece 2F at heavy loads on Cantilever arm 50 the Pendant bar 1 can be used. Install with T-bolt and Expansion bolt.

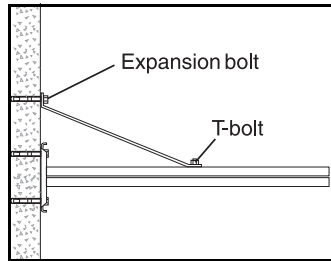

To be mounted to strengthen Vertical piece 20 when mounted horizontally. Use T-bolt and Expansion bolt.

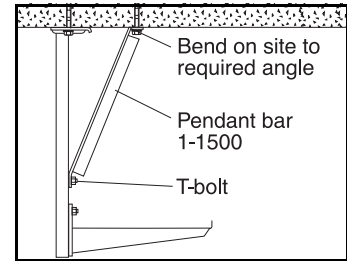

Mount this stay to reduce deflection of long Vertical pieces 2F, 20 and 20F.

# Bracket 60/40

**WIBE**

To be used with Pendant/Fixing rail 24/48 to reduce deflection of long vertical pieces.

WEF-0001

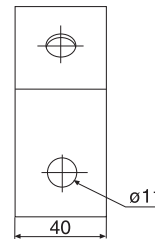
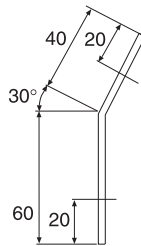
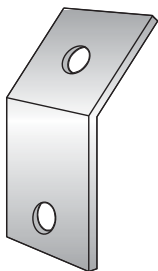

	Hot dip galv. Part. No. C*	ZINKPOX® White Part. No. C*	Weight kg 100 pcs
Bracket 60/40	718904 5	720531 8**	10

\*EAN-code=732167+Part.no+C (control figure) \*\*Produced to order

## Use and installation

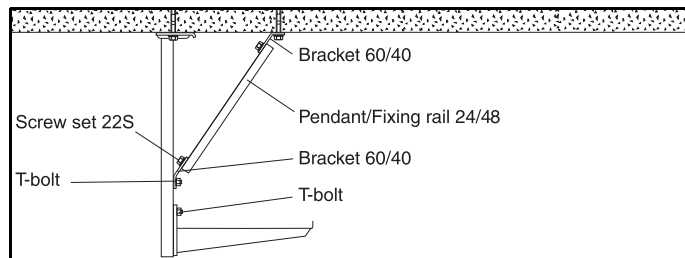

Use Bracket 60/40 together with Pendant/Fixing rail 24/48 to reduce the deflection of long Vertical pieces 2F, 20, 20F or 20FS. Cut the pendant/fixing rail to a suitable length on site.



## Screw set 2S

**WIBE**

For fastening of Support bracket 3 on Pendant/Fixing rail 24/20F and Angle bracket 5L to the opening on Pendant rail 24/34 and 24/48.

WEF-0001

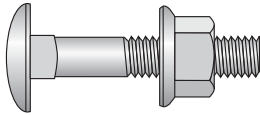

	Hot dip galv. Part. No. C*	Weight kg 100 pcs
Screw set 2S (screw MVBF 8x40 + nut M6MF8)	715735 8	2.9
*EAN-code=732167+Part.no+C (control figure)		

## Screw set 20S

**WIBE**

For installation of Support bracket 3 on Pendant/Fixing rail 24/20 and Vertical piece 20, Angle bracket 5L to the opening on Pendant/Fixing rail 24/48 and 24/20.

WEF-0001

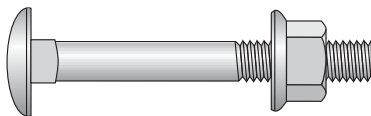

	Hot dip galv. Part. No. C*	Weight kg 100 pcs
Screw set 20S (screw MVBF 8x60+nut M6MF8)	715736 5	3.7
*EAN-code=732167+Part.no+C (control figure)		

## Screw set 22S

**WIBE**

For installation of Support bracket 3 on Vertical piece 2 and 2F, Support bracket 3 and Ceiling bracket 5 on Pendant/fixing rails 24/34 and 24/48, Angle bracket 5L against the back of pendant/fixing rail, Pendant/fixing rails back to back.  
Thermoplastic coated: Support bracket 3 mounted on Vertical piece 2F and Pendant/Fixing rail 24/48.

WEF-0001

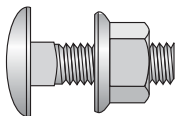

	Hot dip galv. Part. No. C*	Stainl. steel (AISI316) Part. No. C*	Weight kg 100 pcs
Screw set 22S (screw MVBF 8x16+nut M6MF8)	713694 0	725582 5	1.9
*EAN-code=732167+Part.no+C (control figure)			

## Spring nut M8/M10

**WIBE**

For fastening of accessories (control panels etc.) on Pendant/Fixing rail 24/48.

WEF-0001

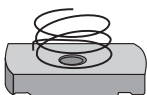

	Hot dip galv. Part. No. C*	Stainl. steel (AISI316) Part. No. C*	Weight kg 100 pcs
Spring nut M8	716407 3	—	2.7
Spring nut M10	—	728622 5	3.9
*EAN-code=732167+Part.no+C (control figure)			

## Back nut M8

**WIBE**

For fastening of vertical pieces etc. in the rungs of KHZSP, KHZSPZ, KHZP, KHZPS and KHZPV.

WEF-0001

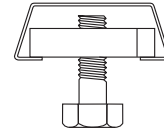
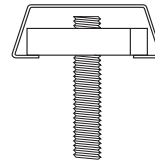
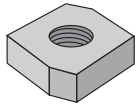

Mounting with Threaded rod M8 and Backnut M8 in the cable ladder rungs.

Pendants etc. are mounted with Bolt M8 and Back nut M8 in the rungs.

	Dim mm	Hot dip galv. Part. No. C*	Weight kg 100 pcs
Back nut M8	M8	718632 7	2.5
*EAN-code=732167+Part.no+C (control figure)			

## Screw set W34

**WIBE**

For fastening of dividing strips on KHZSP, KHZSPZ, KHZPS and KHZP.

WEF-0001



	Electro-galv. Part. No. C*	Stainl. steel (AISI316) Part. No. C*	Weight kg 100 pcs
Screw set W34 (screw MSCS 6x12 + nut M6MF 6)	718473 6	725589 4	0.8
*EAN-code=732167+Part.no+C (control figure)			

## Screw set W37

**WIBE**

For fastening of Support bracket 3 Thermoplastic on Vertical piece 20F Thermoplastic.

WEF-0001

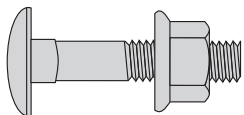

		Stainl. steel (AISI316) Part. No. C*	Weight kg 100 pcs
Screw set W37 (bolt MVBF 8x35+nut M6MF 8)		725586 3	2.8
*EAN-code=732167+Part.no+C (control figure)			

## Screw M10 x 20

**WIBE**

Used with Spring nut M10 (AISI 316) for installation of Cantilever arm 50 (AISI 316L) on Pendant/Fixing rail 24/48.

WEF-0001

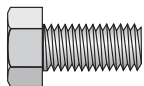

		Stainl. steel (AISI316) Part. No. C*	Weight kg 100 pcs
Screw M6S 10x20		728649 2	2.2
*EAN-code=732167+Part.no+C (control figure)			

# T-bolt 26F

Used for mounting with Pendant/Fixing rail 24/48.

WEF-0002

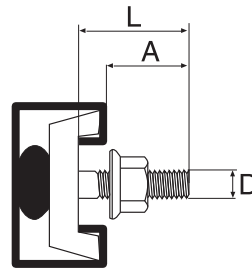
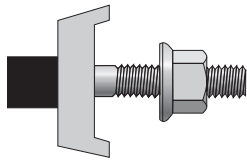

T-bolt 26F/M8  
T-bolt 26F/M10

	D	L mm	A mm	Electro-galv. Part. No. C*	Hot dip galv. Part. No. C*	Stainl. steel (AISI316) Part. No. C*	Weight kg 100 pcs
T-bolt 26F	M8	30	24	734983 8	734744 5	734986 9	4.5
T-bolt 26F	M10	30	24	734864 0	716794 4	728596 9	7
T-bolt 26F	M10	40	34		716795 1		7.5
T-bolt 26F	M10	50	44		716796 8	728598 3	8

\*EAN-code=732167+Part.no+C (control figure)

### Max permitted extraction force

T-bolt 26F M8/M10 + P/F-rail 24/48 + Washer 8,4x19x1,5

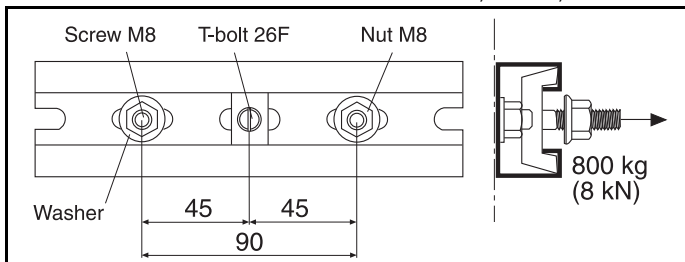

T-bolt 26F M8 + P/F-rail 24/48 + Washer 9x35x2

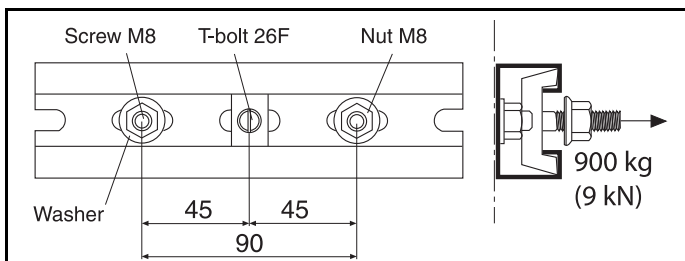

T-bolt 26F M10 + P/F-rail 24/48 + Washer 9x35x2

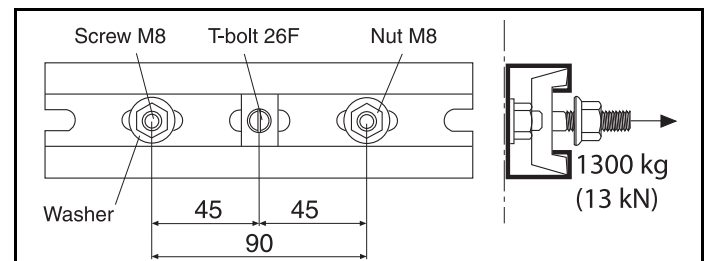

# Dividing strip 39

Used to separate low-tension and high-tension cables.

WEF-0001

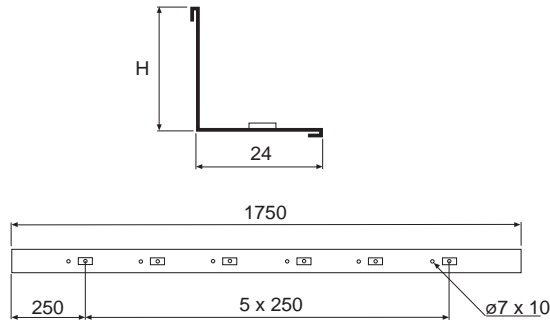
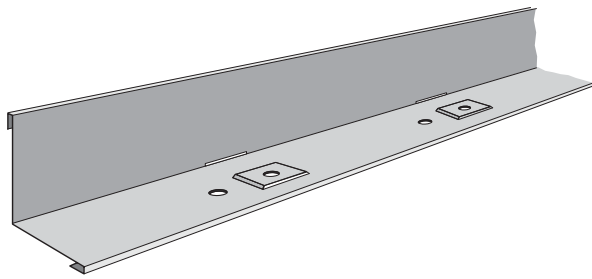

	H mm	Pre-galv. Part. No. C*	Hot dip galv. Part. No. C*	Stainl. steel (AISI316L) Part. No. C*	Pre-galv. White Part. No. C*	Weight kg 100 pcs
Dividing strip 39/24	24	718835 2	731747 9	725593 1	717950 3	46
Dividing strip 39/55	55	725785 0	732983 0	725594 8	725786 7**	73

\*EAN-code=732167+Part.no+C (control figure) \*\*Produced to order

## Use and installation

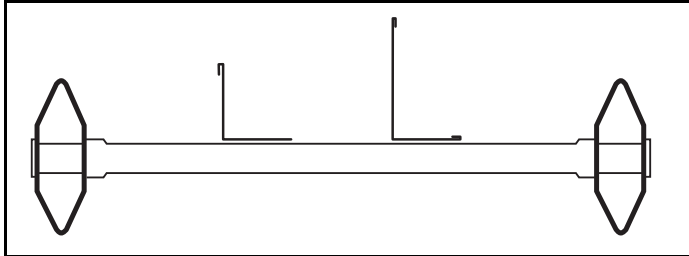

Mount one or more Dividing strips 39 to separate low and high tension cables.

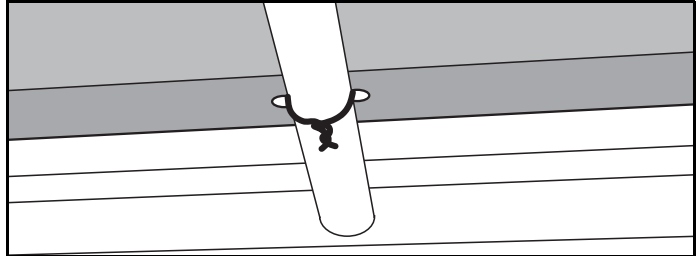

Attach Dividing strip 39 to KHZ and KHZV by lashing around the rungs.

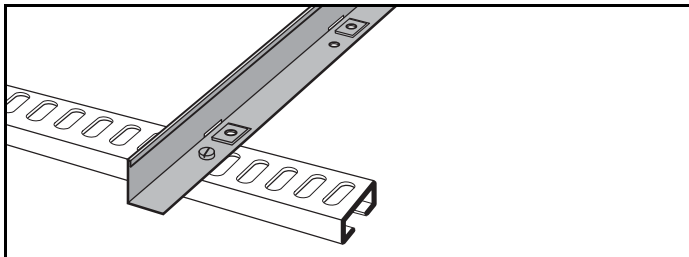

Attach Dividing strip 39 to KHZSP, KHZSPZ, KHZPS, KHZP and KHZPV using Screw set W34 through the rung perforations.

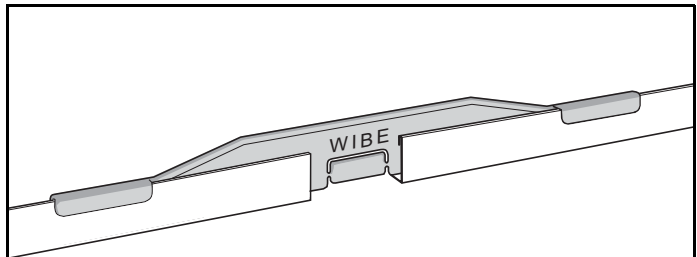

It is advisable to join dividing strips using Distance piece W39.

# Distance piece W39

Distance piece W39 is used for joining Dividing strips 39.

WEF-0021

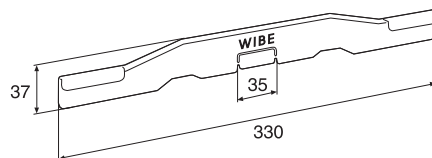
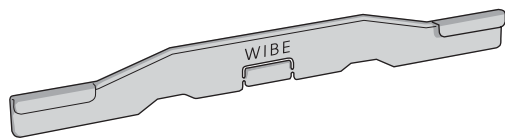

	Natural coloured plastic Part. No. C*	Weight kg 100 pcs
Distance piece W39	716824 8	3

\*EAN-code=732167+Part.no+C (control figure)

## Use and installation

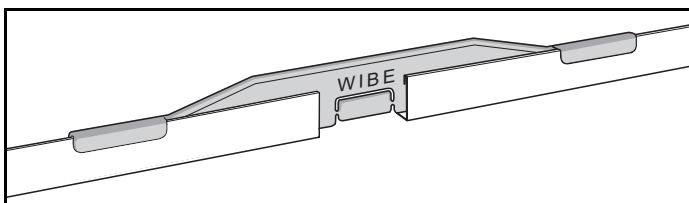

Mount one or more Dividing strips 39 to separate low and high tension cables.

## Tele-conduit 36 with knock-out holes

**WIBE**

WEF-0001

Tele-conduit is installed where a separate tray is required for low-tension cables. Knock-out holes in the bottom of the channel permit the cable to pass through.

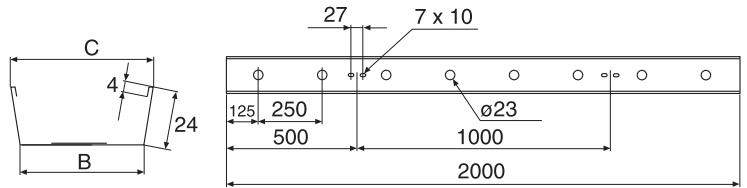
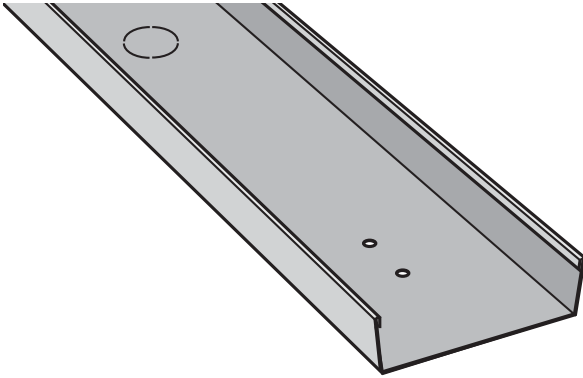

	B mm	C mm	Pre-galv. Part. No. C*	Hot dip galv. Part. No. C*	Stainl. steel*** (AISI316L) Part. No. C*	Pre-galv. White Part. No. C*	Weight kg 100 pcs
Teleconduit 36-50	42	50	725065 3	731748 6	725590 0	725068 4	94
Teleconduit 36-100	92	100	725066 0	731749 3	725591 7**	725069 1	142
Teleconduit 36-200	192	200	725067 7	731750 9	725592 4**	725070 7**	238

\*\*\*Without knock-out holes

\*EAN-code=732167+Part.no+C (control figure) \*\*Produced to order

### Use and installation

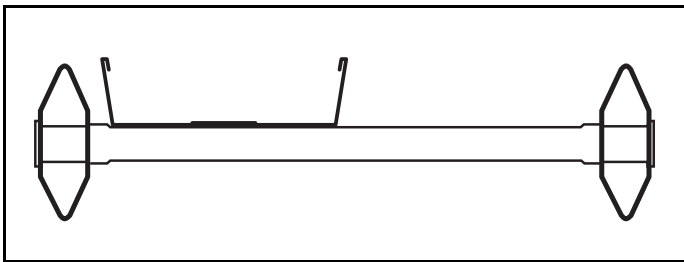

Mount Tele-conduit 36 whenever a special channel is required for low tension lines.

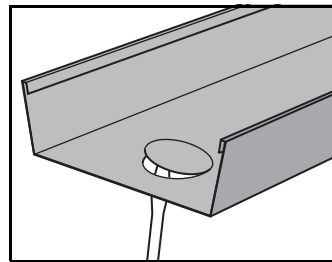

Whenever you wish to make a hole to let a cable through, press the knock-out piece from below using a screwdriver or suchlike.

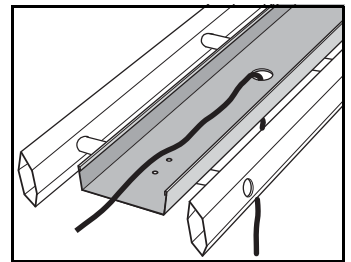

In the event of special needs, a sealing sleeve 22.5 or corresponding may be mounted in the hole.

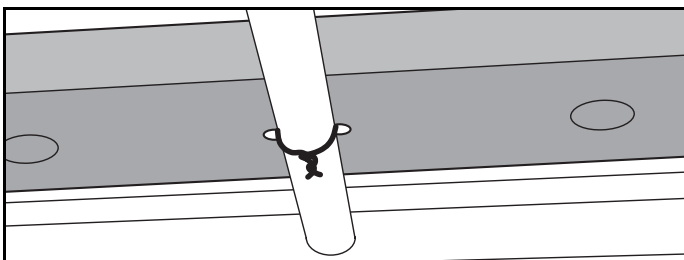

Attach Tele-conduit 36 onto KHZ and KHZV by tying with wire round rungs.

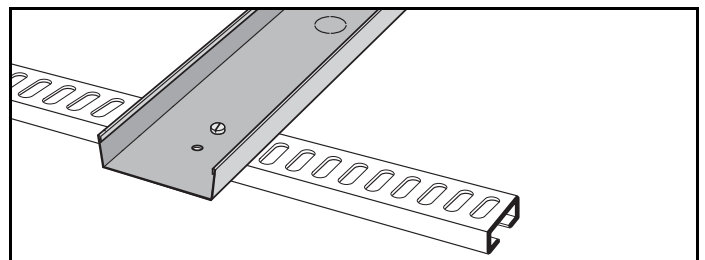

Attach Tele-conduit 36 to KHZSP, KHZSPZ, KHZPS, KHZP and KHZPV using Screw set W34 through the rung perforations.

### Screw set W34

**WIBE**

For fastening of dividing strips on KHZSP, KHZSPZ, KHZPS, KHZP and KHZPV.

WEF-0001



	Electro-galv. Part. No. C*	Stainl. steel (AISI316) Part. No. C*	Weight kg 100 pcs
Screw set W34 (screw MSCS 6x12 + nut M6MF 6)	718473 6	725589 4	0.8

\*EAN-code=732167+Part.no+C (control figure)

## Junction box plate 35P

**WIBE**

Installed between rungs. Locked with appropriate locking tabs for each ladder.

WEF-0001

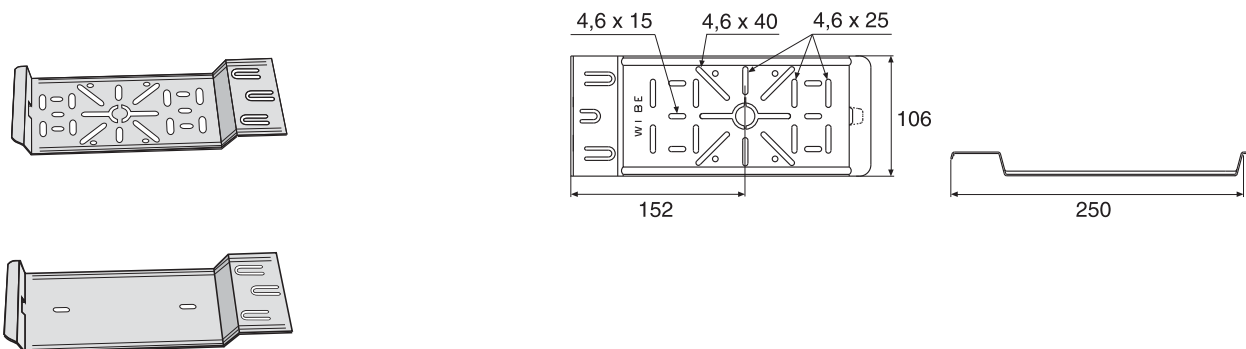

Unholed

	Pre-galv. Part. No. C*	Hot dip galv. Part. No. C*	Stainl. steel (AISI316L) Part. No. C*	Pre-galv. White Part. No. C*	Weight kg 100 pcs
Junction box plate 35P	718618 1	731745 5		714510 2	28
Junction box plate 35P unholed			725777 5		24

\*EAN-code=732167+Part.no+C (control figure)

### Use and installation

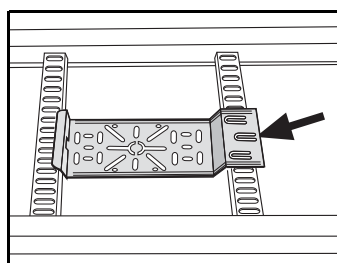

Mount junction box plates between the ladder rungs. On KHZSP, KHZSPZ, KHZPS, KHZP and KHZPV attach junction box plates by bending the central tab into the rung perforation using a screwdriver or such-like.

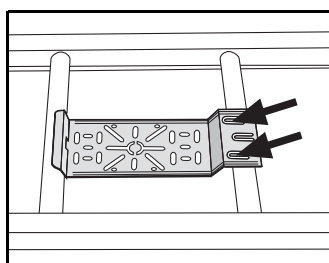

Mount junction box plates on KHZ and KHZV by bending the two outer tabs towards the round rung using a screwdriver or such-like

## Junction box plate 35S

**WIBE**

Installed upright or hanging from the profile. Locked with locking tabs.

WEF-0001

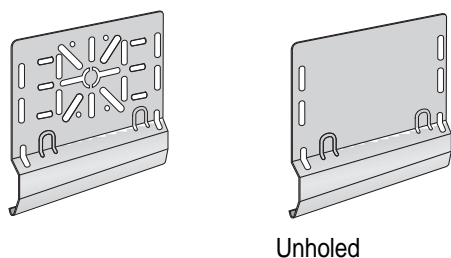

Unholed

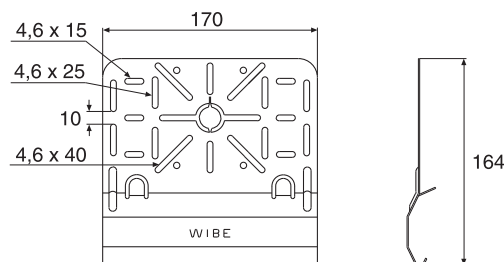

	Pre-galv. Part. No. C*	Hot dip galv. Part. No. C*	Stainl. steel (AISI316L) Part. No. C*	Pre-galv. White Part. No. C*	Weight kg 100 pcs
Junction box plate 35S	711205 0	731746 2	725776 8	716318 2	22
35S unholed	730245 1			730246 8	23

\*EAN-code=732167+Part.no+C (control figure)

### Use and installation

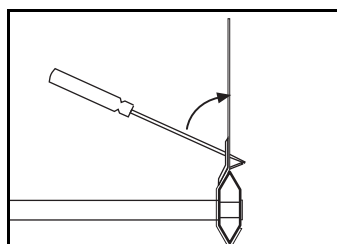

Bend the tab towards the ladder section by using a screwdriver as a lever for mounting junction box plates.

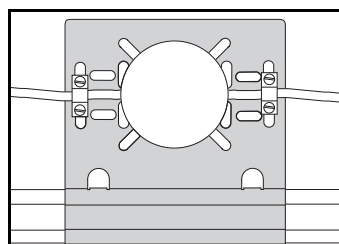

Junction box plates can be mounted in standing or hanging positions on the side sections. Strain-relief may be provided using the outermost holes and clamps or strips.

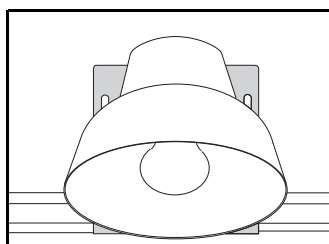

Light fittings can also be mounted on junction box plates.

## Installation plate 61

**WIBE**

Used on vertical cable ladder installations for mounting of terminal boxes, contact breakers etc.

WEF-0001

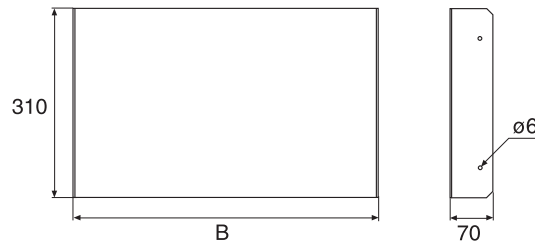
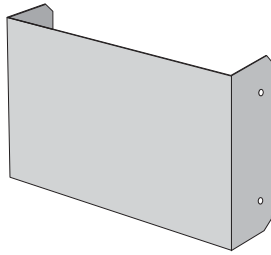

	B mm	Pre-galv. Part. No. C*	Hot dip galv. Part. No. C*	Weight kg 100 pcs
Installation plate 61-200	200	732486 6	732491 0	100
Installation plate 61-300	300	732487 3	732492 7	140
Installation plate 61-400	400	732488 0	732493 4	170
Installation plate 61-500	500	732489 7**	732494 1**	240
Installation plate 61-600	600	732490 3**	732495 8**	270

\*EAN-code=732167+Part.no+C (control figure) \*\*Produced to order

### Use and installation

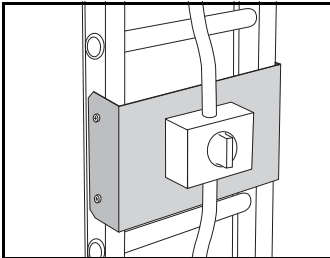

Used on vertical cable ladder installations for mounting of terminal boxes, contact breakers etc. Mount with selftapping screw ST4.2 in the side profile.

## Earth clamp W79

**WIBE**

The earth clamp is used when protective earthing of the junction box plate is required.

WEF-0001

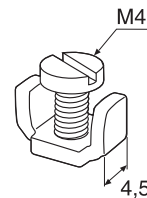
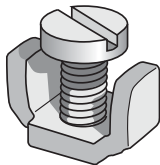

	Electro-galv. Part. No. C*	Weight kg 100 pcs
Earth clamp W79	716640 4	0.2

\*EAN-code=732167+Part.no+C (control figure)

### Use and installation

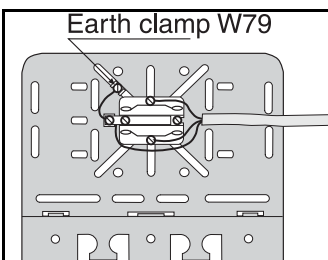

Earth clamps are designed for use when protective earthing of the mounting plate is required for mounting apparatuses as per relevant heavy current directives. The oblong holes in the junction box plate (mounting plate) permit movement of the earth clamp so that it always comes under the casing of the apparatus. If the apparatus's earth clamp is not approved for joining protective earth conductors, it must pass unbroken through the apparatus's earth clamp to the junction box earth clamp (see the fig.).

## 90° bend 15

The cable ladders are joined to the bend with Joint 21.

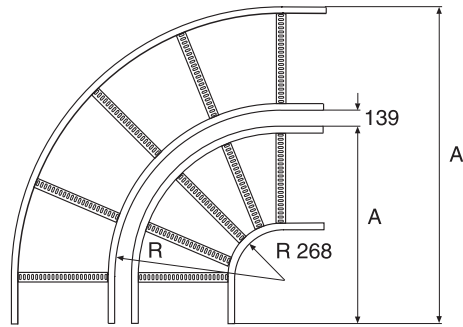
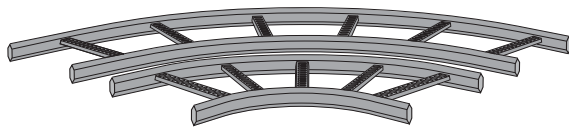

### Interior

	R mm	A mm	Pre-galv*** Part. No. C*	Hot dip galv. Part. No. C*	Stainl. steel (AISI316L) Part. No. C*	ZINKPOX® White Part. No. C*	Weight kg 100 pcs
90°bend 15-150	268	547		716066 2	727346 1	716074 7**	220
90°bend 15-200	268	597	723061 7	716067 9	727347 8	716075 4**	240
90°bend 15-300	268	697	723062 4	716069 3	727348 5	716077 8**	290
90°bend 15-400	268	797	723063 1	716070 9	727349 2	716078 5**	340
90°bend 15-500	268	897	723064 8	716071 6	727350 8	716079 2**	390
90°bend 15-600	268	997	723065 5	716072 3	727351 5	716080 8**	440
90°bend 15-800	268	1197		721961 2		728043 8**	640
90°bend 15-1000	268	1397		716073 0		716081 5**	760

### Exterior

	R mm	A mm	Pre-galv. Part. No. C*	Hot dip galv. Part. No. C*	Stainl. steel (AISI316L) Part. No. C*	ZINKPOX® White Part. No. C*	Weight kg 100 pcs
90°bend 15-150	554	703		716179 9**	727352 2**	716186 7**	320
90°bend 15-200	604	933		716180 5	727353 9**	716187 4**	370
90°bend 15-300	704	1133		716182 9	727354 6**	716189 8**	460
90°bend 15-400	804	1333		716183 6	727355 3**	716190 4**	550
90°bend 15-500	904	1533		716184 3	727356 0**	716191 1**	640
90°bend 15-600	1004	1733		716185 0	727357 7**	716192 8**	760
90°bend 15-800	1204	2133		723057 0		728052 0**	1060
90°bend 15-1000	1404	2533		723260 4		728053 7**	1280

\*EAN-code=732167+Part.no+C (control figure) \*\*Produced to order

\*\*\*Pre-galv. bends have open side profiles.

Note! R and A must be reduced with 5 mm for bends of stainless steel.

### Use and installation

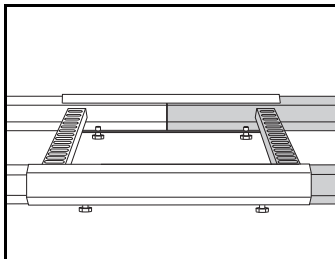

Join cable ladders to 90° bend using Joint 21.



## T-junction 16

The cable ladders are joined to the T-junction with Joint 21.

WEF-0001

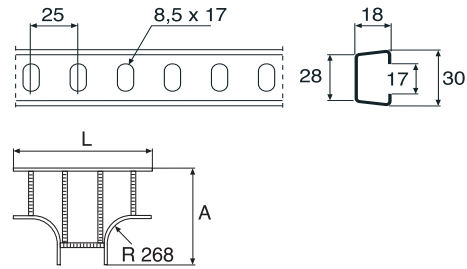
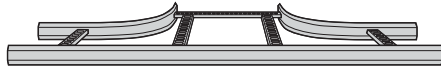

	A mm	L mm	Hot dip galv. Part. No. C*	Stainl. steel (AISI316L) Part. No. C*	ZINKPOX® White Part. No. C*	Weight kg 100 pcs
T-junction 16-150	547	944	716193 5	727358 4**	716201 7**	300
T-junction 16-200	597	997	716194 2	727359 1	716202 4**	320
T-junction 16-300	697	1097	716196 6	727360 7	716204 8**	390
T-junction 16-400	797	1197	716197 3	727361 4	716205 5**	440
T-junction 16-500	897	1297	716198 0	727362 1	716206 2**	530
T-junction 16-600	997	1397	716199 7	727363 8	716207 9**	600
T-junction 16-800	1197	1597	721962 9**			750
T-junction 16-1000	1397	1797	716200 0		716208 6**	860

\*EAN-code=732167+Part.no+C (control figure) \*\*Produced to order

### Use and installation

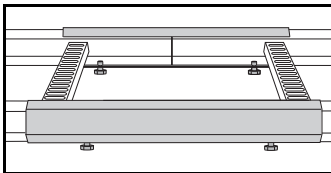

Join the cable ladders to T-junction 16 using Joint 21.

## X-junction 17

The cable ladders are joined to the X-junction with Joint 21.

WEF-0001

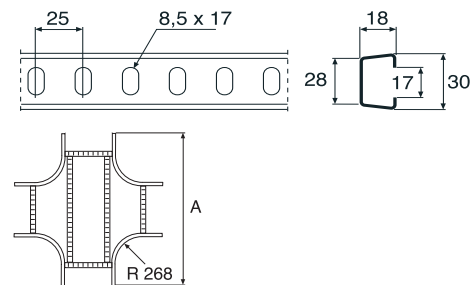
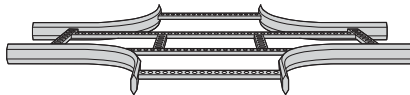

	A mm	Hot dip galv. Part. No. C*	Stainl. steel (AISI316L) Part. No. C*	ZINKPOX® White Part. No. C*	Weight kg 100 pcs
X-junction 17-150	547	716209 3	727364 5	716217 8**	380
X-junction 17-200	997	716210 9	727365 2	716218 5**	400
X-junction 17-300	1097	716212 3	727366 9	716220 8**	500
X-junction 17-400	1197	716213 0	727367 6	716221 5**	550
X-junction 17-500	1297	716214 7	727368 3	716222 2**	600
X-junction 17-600	1397	716215 4	727369 0	716223 9**	860
X-junction 17-800	1597	721963 6**			1070
X-junction 17-1000	1797	716216 1		716224 6**	1220

\*EAN-code=732167+Part.no+C (control figure) \*\*Produced to order

### Use and installation

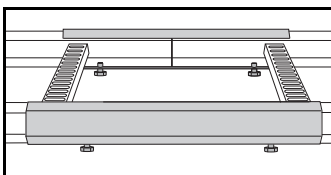

Join the cable ladders to X-junction 17 using Joint 21.

# Riser 18

The cable ladders are joined to the riser with Joint 21.

WEF-0001

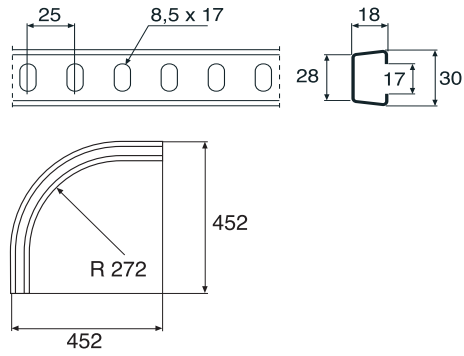
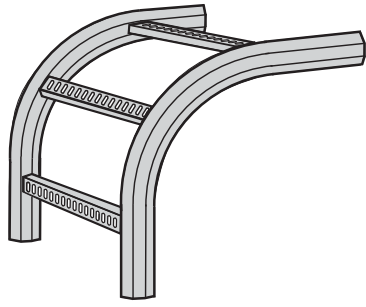

	Hot dip galv. Part. No. C*	Stainl. steel (AISI316L) Part. No. C*	ZINKPOX® White Part. No. C*	Weight kg 100 pcs
Riser 18-150	718176 6	727370 6	718184 1**	180
Riser 18-200	718177 3	727371 3	718185 8**	190
Riser 18-300	718179 7	727372 0	718187 2**	210
Riser 18-400	718180 3	727373 7	718188 9**	230
Riser 18-500	718181 0	727374 4**	718189 6**	250
Riser 18-600	718182 7	727375 1	718190 2**	270
Riser 18-800	721964 3		728034 6**	310
Riser 18-1000	718183 4		718191 9**	350

\*EAN-code=732167+Part.no+C (control figure) \*\*Produced to order

## Use and installation

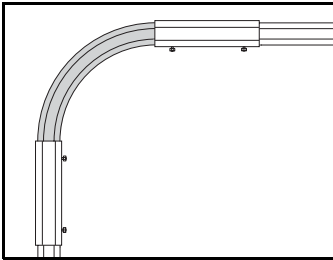

Join the cable ladders to Riser 18 using Joint 21.

## S-bend 67

To be used as a transition between cable ladders mounted on different levels.

WEF-0001

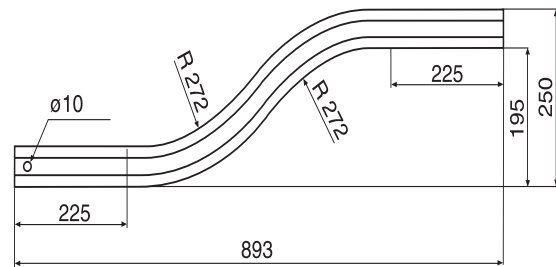
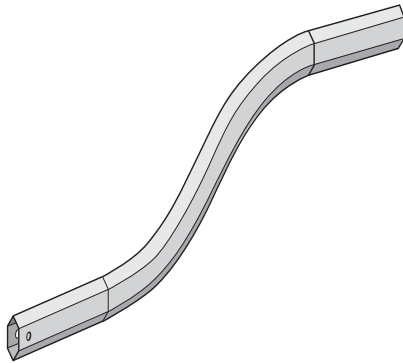

	Hot dip galv.	Weight kg
S-bend 67	Part. No. C*	100 pcs
*EAN-code=732167+Part.no+C (control figure) **Produced to order	788638 8**	90

### Use and installation

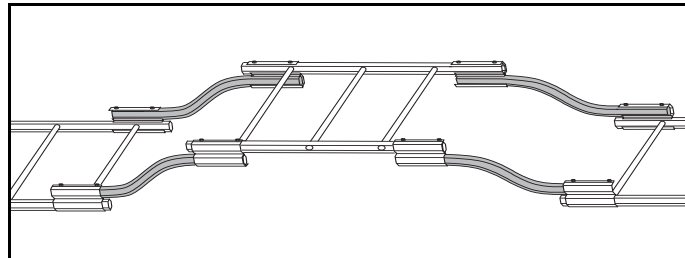
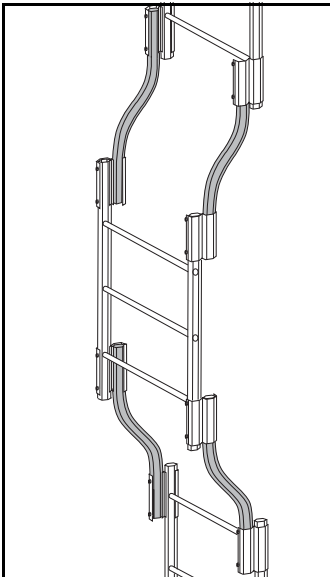

S-bend 67 can be mounted vertically or horizontally between cable ladders by using Dropper joint 32 or Joint 21.

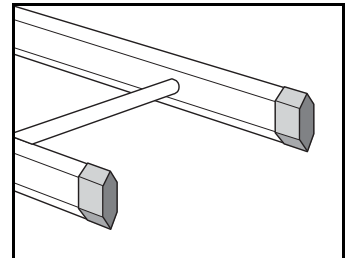

If necessary, mount End plug 28 at the end of the ladder profiles.

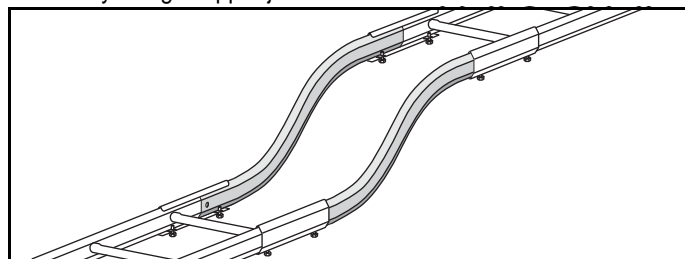

# Cable clamp type A

For fastening of cables on Pendant/Fixing rail 24/48,  
Cable ladders KHZSP, KHZSPZ, KHZPS, KHZPV and KHZPV.

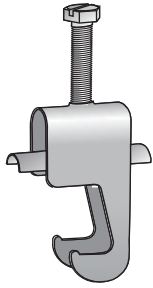

Cabel clamp for 1 cable

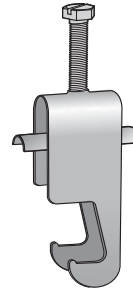

Cable clamp for 2 cables

## Cable clamp A for 1 cable

	For cable mm	Pre-galv. Part. No. C*	Weight kg 100 pcs
Cable clamp A1-12	-12	718507 8	3.4
Cable clamp A1-16	13-16	718508 5	3.7
Cable clamp A1-22	17-22	718509 2	4.6
Cable clamp A1-28	23-28	718510 8	5.3
Cable clamp A1-36	29-36	718511 5	8.8
Cable clamp A1-44	37-44	718512 2	9.9
Cable clamp A1-52	45-52	718513 9	11.0
Cable clamp A1-60	53-60	718514 6	12.5
Cable clamp A1-70	61-70	718515 3	15.4

## Cable clamp A for 2 cables

	For cable mm	Pre-galv. Part. No. C*	Weight kg 100 pcs
Cable clamp A2-12	-12	718516 0	4.0
Cable clamp A2-16	13-16	718517 7	4.6
Cable clamp A2-22	17-22	718518 4	5.9
Cable clamp A2-28	23-28	718519 1	7.0
Cable clamp A2-36	29-36	718520 7	11.2
Cable clamp A2-44	37-44	718521 4	13.3

\*EAN-code = 732167 + Part.no + C (control figure)

## Use and installation

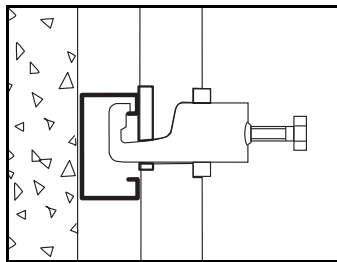

Use Cable clamp type A to attach cables to Pendant/Fixing rail 24/48. Use Insert piece EM.

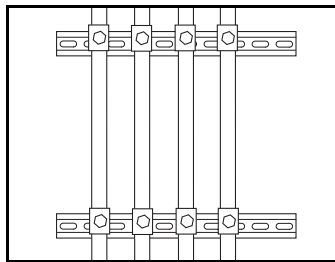

Mounting rail 40 with Cable clamp type A.

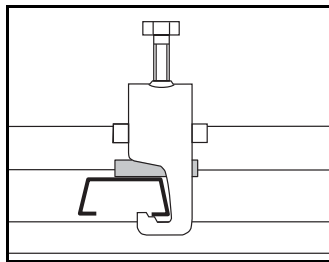

Use Cable clamp type A to attach cables to cable ladders KHZSP, KHZSPZ, KHZPS, KHZPV and KHZP. Use Insert piece EM.

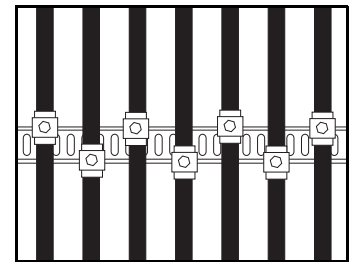

In order to avoid torsion of the rung, cable clamps can be mounted opposite each other on the rung.

## Tightening moment

When mounting, Insert piece EM is to be used.

It is important that the clamp is not tightened too hard.

The installer must watch out for deformations when tightening.

Suitable tightening moment for clamps with M6-screw is 0.5-1.0 Nm and for clamps with M8-screw 1.0-1.5 Nm.

# Cable clamp type R

For fastening of cables on Cable ladders KHZ and KHZV.

WEF-0001

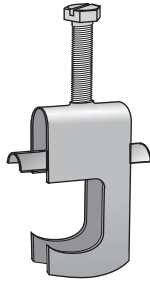

Cable clamp for 1 cable

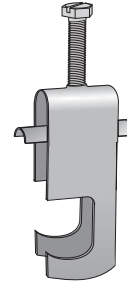

Cable clamp for 2 cables

## Cable clamp R for 1 cable

	For cable mm	Pre-galv. Part. No. C*	Weight kg 100 pcs
Cable clamp R1-12	-12	769000 8	5.5
Cable clamp R1-16	13-16	769001 5	6.3
Cable clamp R1-22	17-22	769002 2	7.4
Cable clamp R1-28	23-28	769003 9	8.5
Cable clamp R1-36	29-36	769004 6	11.1
Cable clamp R1-44	37-44	769005 3	12.7
Cable clamp R1-52	45-52	769006 0	14.2
Cable clamp R1-60	53-60	769007 7	15.5
Cable clamp R1-70	61-70	769008 4	18.4

## Cable clamp R for 2 cables

	For cable mm	Pre-galv. Part. No. C*	Weight kg 100 pcs
Cable clamp R2-12	-12	769009 1	6.8
Cable clamp R2-16	13-16	769010 7	7.9
Cable clamp R2-22	17-22	769011 4	9.6
Cable clamp R2-28	23-28	769012 1	11.3
Cable clamp R2-36	29-36	769013 8	14.5
Cable clamp R2-44	37-44	769014 5	17.0
Cable clamp R2-52	45-52	769015 2	19.2
Cable clamp R2-60	53-60	769016 9	21.4

\*EAN-code = 732167 + Part.no + C (control figure)

## Use and installation

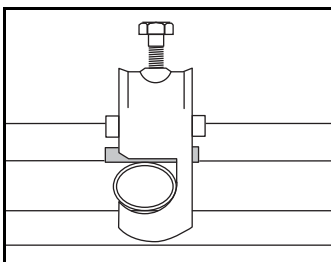

Cable clamp Type R is used for fastening cables on the cable ladders KHZ and KHZV. Insert piece EM must be installed.

## Tightening moment

When mounting, Insert piece EM is to be used. It is important that the clamp is not tightened too hard. The installer must watch out for deformations when tightening. Suitable tightening moment for clamps with M6-screw is 0.5-1.0 Nm and for clamps with M8-screw 1.0-1.5 Nm.

## Insert piece EM

**WIBE**

WEF-0006

Insert pieces are to be used in order to prevent pressure on the cable. The insert piece is placed between the cable and the rung from the same side whereas the clamp has been fastened to the rung.

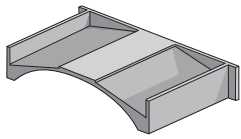

	For cable mm	Plastic, grey Part. No. C*	Weight kg 100 pcs
Insert piece EM-12	-12	709050 1	0.2
Insert piece EM-16	13-16	709051 8	0.2
Insert piece EM-22	17-22	709052 5	0.3
Insert piece EM-28	23-28	709053 2	0.3
Insert piece EM-36	29-36	709054 9	0.5
Insert piece EM-44	37-44	709055 6	0.7
Insert piece EM-52	45-52	709056 3	0.8
Insert piece EM-60	53-60	709057 0	0.9
Insert piece EM-70	61-70	709058 7	1.0

\*EAN-code=732167+Part.no+C (control figure)

### Use and installation

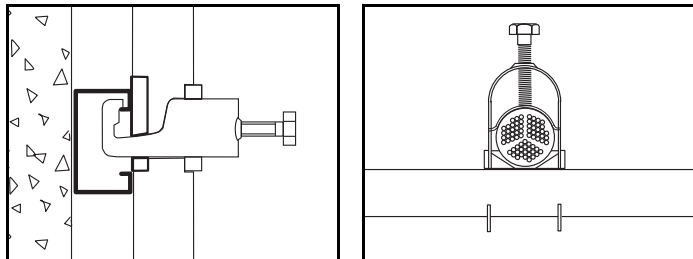

Insert pieces EM increase the contact area of the cables.

## Lashing wire

**WIBE**

WEF-0011

For lashing of wires on cable ladders.

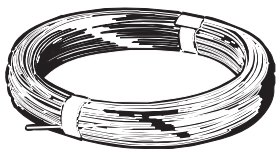

	Diam mm	Breaking load kg	Part. No. C*	Weight kg 100 m
HTR-2303 Lashing wire, stainless steel, white PVC	1.25	92	713686 5	1.3
HTR-2313 Lashing wire, stainless steel, black PVC	1.25	92	713687 2	1.3
HT-2304 Lashing wire, white PVC	1.5	25	713684 1	1.8
HT-2314 Lashing wire, black PVC	1.5	25	713685 8	1.8

\*EAN-code=732167+Part.no+C (control figure)

### Use and installation

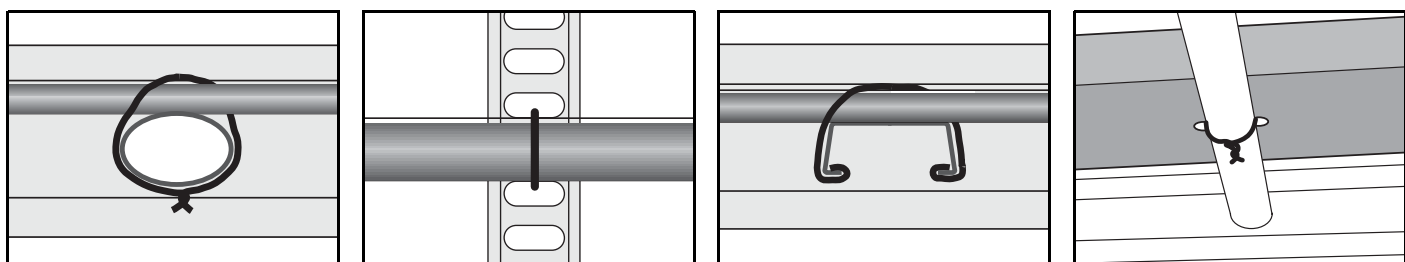

Cables are easily installed by lashing around the rungs of KHZ and KHZV.

Cables are easily installed by lashing through the perforations of the rungs or around the rungs of KHZSP, KHZSPZ, KHZPS, KHZP and KHZPV.

Cables are easily installed on KHZSP, KHZSPZ, KHZPS, KHZP and KHZPV by lashing in such a way that the lashing wire is pinched around the rung as shown.

Dividing strips and tele-conduits are attached to the ladder by lashing around the rungs of KHZ and KHZV.

# Cable clamp ER

For installation of cables on cable ladders with round or perforated rungs.

WEF-0001

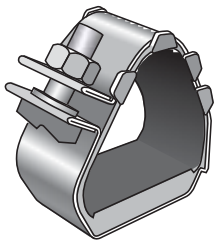

Cable clamp ER

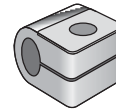
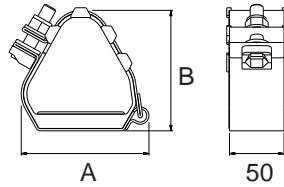

Oval rung adapter

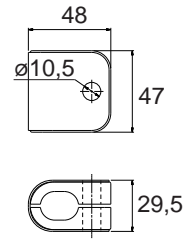

	For cable mm	A mm	B mm	Stainl. steel (AISI316) Part. No. C*	Weight kg 100 pcs
Cable clamp ER	23-28	80	74	736440 4	44
Cable clamp ER	27-32	82	81	736441 1	45
Cable clamp ER	30-35	82	88	736442 8	46
Cable clamp ER	33-38	85	94	736443 5	47
Cable clamp ER	36-42	113	101	736444 2	60
Cable clamp ER	40-46	115	108	736445 9	62
Cable clamp ER	44-50	117	115	736446 6	63
Cable clamp ER	48-55	120	129	736447 3	64
Cable clamp ER	51-58	121	130	736448 0	66
Cable clamp ER	55-62	156	138	736449 7	78
Cable clamp ER	59-66	158	146	736450 3	79
Cable clamp ER	63-70	160	150	736451 0	80
Cable clamp ER	67-74	163	161	736452 7	81
Cable clamp ER	71-78	165	168	736453 4	85
Cable clamp ER	74-82	167	176	736454 1	86
Cable clamp ER	77-85	169	181	736455 8	87
Oval rung adapter (screw set incl.)				736456 5	12
Screw set 74S (2 pcs are required for installation on perforated rungs)				737198 5	2

\*EAN-code=732167+Part.no+C (control figure)

## Use and installation

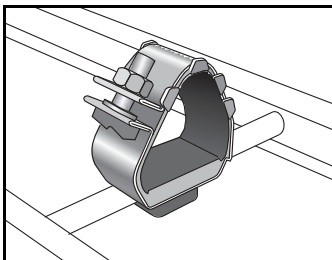

Remove the bottom plate of the clamp and mount it with Oval rung adapter on cable ladders with round rungs - KHZ and KHZV.

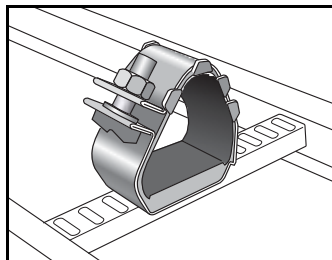

Remove the bottom plate of the clamp and mount it with 2 screw sets 74S on cable ladders with perforated rungs - KHZP, KHZPS, KHZSP, KHZSPZ and KHZPV.

Tested at British short-circuit testing station.

### Test report no. BS/F 1265

- Wibe cable ladder KHZ-600, KHZP-300 and KHZP-600  
Cable clamp ER mounted on every rung
- Wibe cable ladder KHZ-300  
Cable clamp ER mounted on every other rung

### Condition after test

400 volt 58 kA symmetrical current (Peak 140 kA) during 0.1 second:

- All clamps remained secure
- Some slight distortion of the ladder rungs
- The cables were splayed out between the clamps but otherwise in good order

### Test report no. BS/F 1268

- Wibe cable ladder KHZ-600 and KHZP-600  
Cable clamp ER mounted on every other rung

### Condition after test

352 volt 64 kA symmetrical current (Peak 140 kA) during 0.1 second:

- All clamps remained secure
- There was distortion of a number of the ladder rungs
- The cables were splayed out between the clamps but otherwise in good order

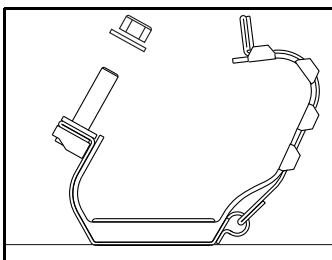

Remove the locking nut. Open the clamp.

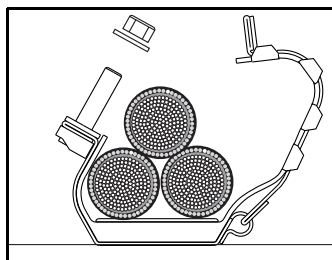

Mount the cables.

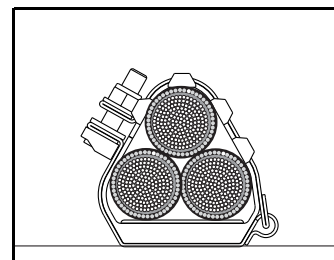

Lock the clamp with the locking nut. Turn the nut to max. 4-5 Nm. The rubber lining must touch the cables but not so tight that the cables will be deformed.

## Screw set M12

Used for all joints with KHZV and KHZPV.

WEF-0001

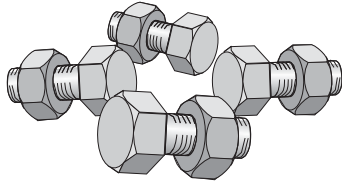

	Hot dip galv. Part. No. C*	Stainl. steel (AISI316L) Part. No. C*	Weight kg 100 pcs
Screw set M12 (4 bolts M6S 12x25 and 4 nuts M6M 12)	706415 1	728767 3	20

\*EAN-code=732167+Part.no+C (control figure)

### Use and installation

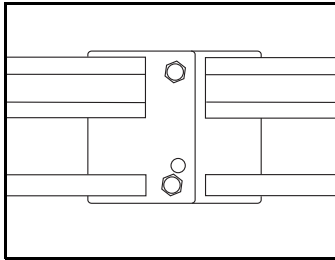

For joining ladders.

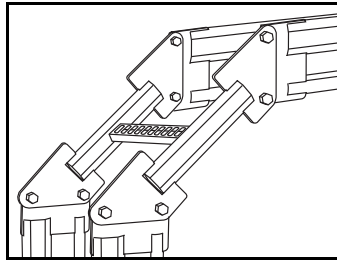

For joints with Riser coupling 49.

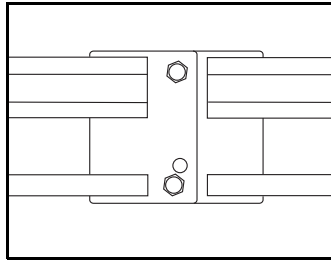

For joints with 90° bend 55 and T-junctions 56.

## Joint 45

Fitted as a joining plate in a cut KHZV/KHZPV ladder.

WEF-0001

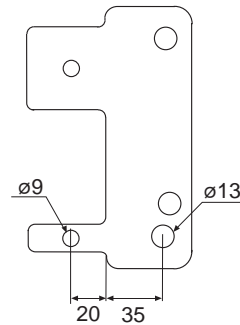
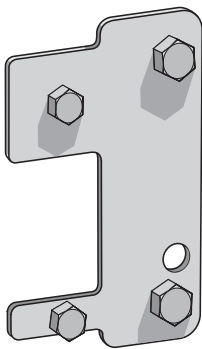

	Hot dip galv. Part. No. C*	Stainl. steel (AISI316L) Part. No. C*	ZINKPOX® White Part. No. C*	Weight kg 100 pcs
Joint 45 (screws M8 och M12 + nuts are supplied)	707609 3	792873 6**	714227 9	50

\*EAN-code=732167+Part.no+C (control figure) \*\*Produced to order

### Use and installation

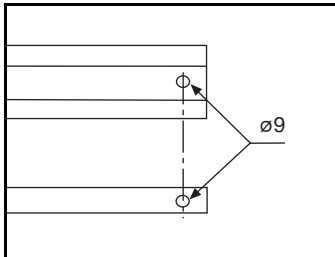

Cable ladders can be joined using separate joints.  
 - Cut the ends clean.  
 - Place the joints outside the ladders and mark where the holes shall be drilled.  
 - Drill 9 mm dia. holes.

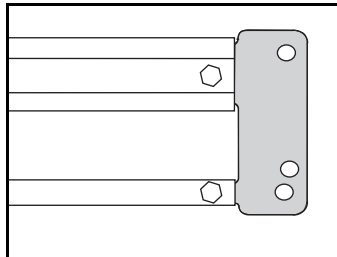

- Insert the joint plates into the ladders and bolt them fast.

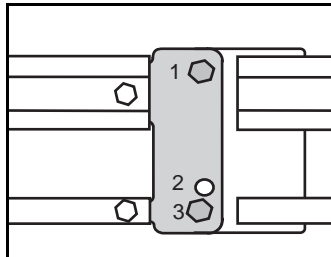

The holes are laterally displaced to avoid play in joints.  
 If the ladders are mounted with arch pipes facing downwards, use holes 1 and 3.

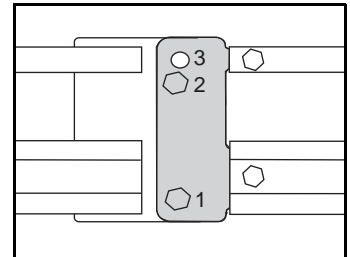

If the ladders are mounted with arch pipes facing upwards, use holes 1 and 2.



# Coupling 44

For horizontal coupling of KHZV/KHZPV. Also used for branches and as an end connection against a wall.

WEF-0001

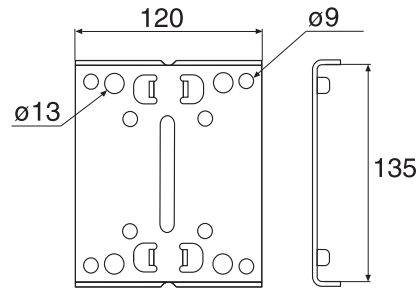
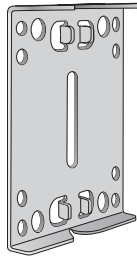

	Hot dip galv. Part. No. C*	Stainl. steel (AISI316L) Part. No. C*	ZINKPOX® White Part. No. C*	Weight kg 100 pcs
Coupling 44 (4 screws M8x30+nuts incl)	720815 9	792888 0**	720816 6**	50

\*EAN-code=732167+Part.no+C (control figure) \*\*Produced to order

## Use and installation

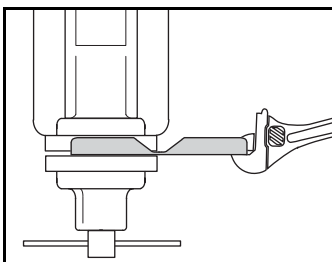

Coupling 44 may be bent to the required angle in a vice, using an adjustable spanner or suchlike.

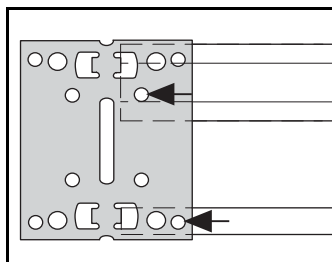

Use Coupling 44 as a drilling pattern on the cut ladder. Drill 9 mm dia. holes.

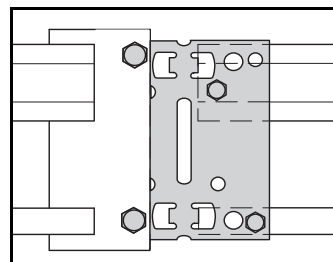

Assemble the cut and drilled ladders using M8x30 mm bolts. If the angle unit is mounted against a fixed joint plate use Screw set M12.

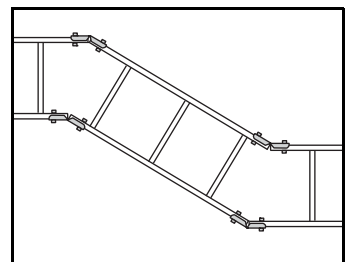

Horizontal angle formation. Angled cutting of the ladder ends determines the angle.

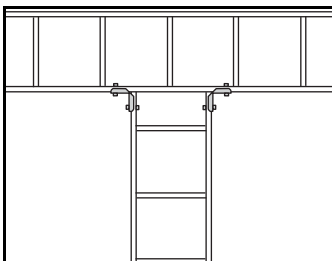

Straight branch.

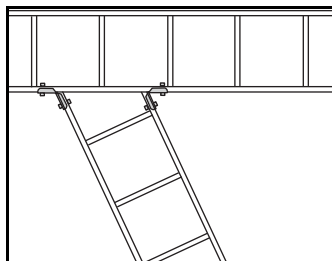

Angled branch.

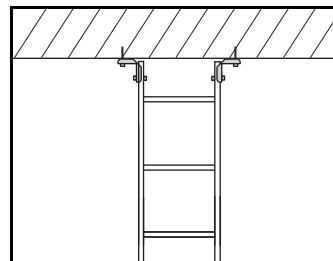

Use Coupling 44 as an end attachment for mounting ladders against walls or floors.

# Coupling 51

Used as self-supporting vertical coupling of KHZV/KHZPV.

WEF-0001

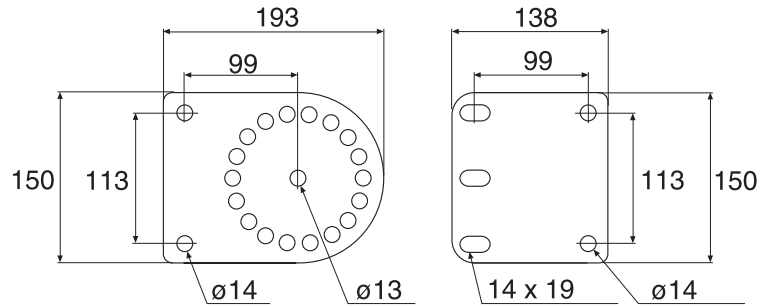
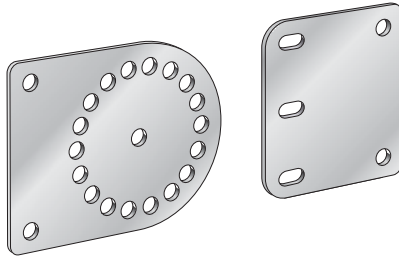

Screw set M12 for installation on the cable ladder is to be ordered separately.

	Hot dip galv. Part. No. C*	Stainl. steel (AISI316L) Part. No. C*	ZINKPOX® White*** Part. No. C*	Weight kg 100 st
Coupling 51	731837 7	731914 5**	731911 4	150
2 screws M12+nuts incl. ***Screws+nuts of stainless steel AISI 316L				
*EAN-code=732167+Part.no+C (control figure) **Produced to order				

## Use and installation

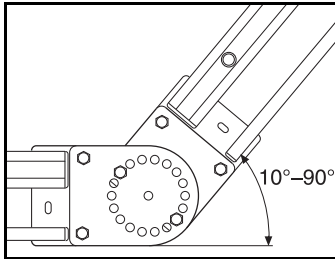

Coupling 51. Used as self-supporting vertical coupling of KHZV/KHZPV. Rising. Adjustable from 10° to 90° gradually in steps of 20°.

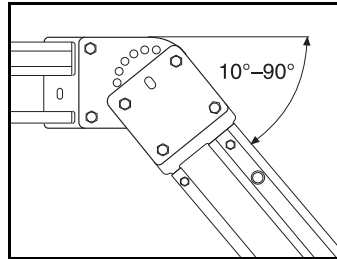

Coupling 51. Used as self-supporting vertical coupling of KHZV/KHZPV. Sloping. Adjustable from 10° to 90° gradually in steps of 20°.

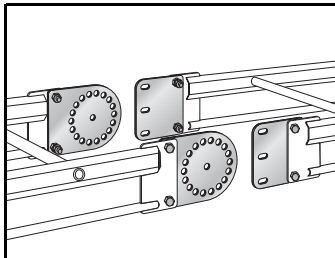

1. Install the plates on the ladder with Screw set M12.

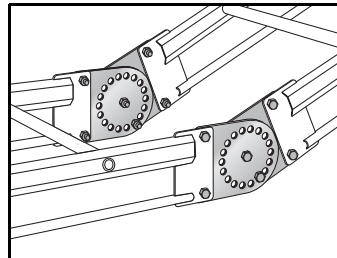

2. Assemble the ladders in the centre hole with one of the included screws/nuts. Adjust to desired angle and fix the installation in one of the outer holes with screw/nut.

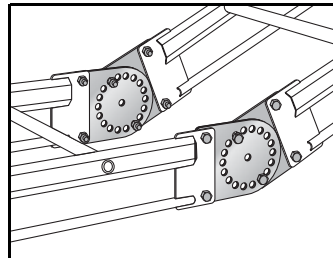

3. Move the nut in the centre hole to the opposite outer hole and tighten.

## Riser coupling 49

**WIBE**

Fitted at a 90° vertical coupling.

WEF-0001

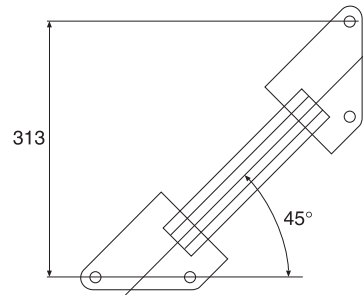
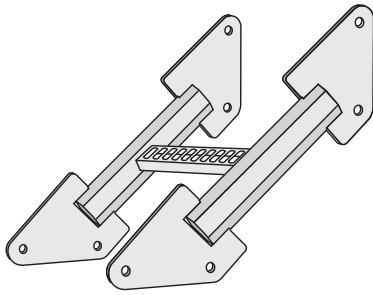

	Hot dip galv. Part. No. C*	Stainl. steel (AISI316L) Part. No. C*	ZINKPOX® White Part. No. C*	Weight kg 100 pcs
Riser coupling 49-200	716389 2	792880 4**	716395 3**	220
Riser coupling 49-300	716390 8	792881 1**	716396 0**	230
Riser coupling 49-400	716391 5	792882 8**	716397 7**	240
Riser coupling 49-500	720517 2	792883 5**	720518 9**	245
Riser coupling 49-600	716392 2	792884 2**	716398 4**	250
Riser coupling 49-800		792885 9**		265
Riser coupling 49-1000	716393 9**	792886 6**	716399 1**	280

\*EAN-code=732167+Part.no+C (control figure) \*\*Produced to order

### Use and installation

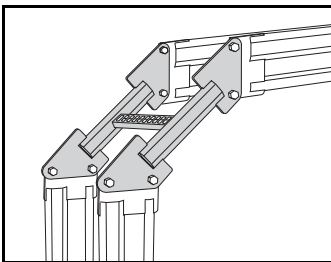

Mount Riser coupling 49 to form a 90° branch on KHZV/KHZPV using 2 Screw sets M12. This provides a large radius for cables.

## Take-off hook 47

**WIBE**

Used on KHZV/KHZPV ladders to make 90° branches.

WEF-0001

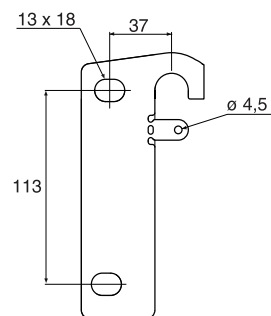
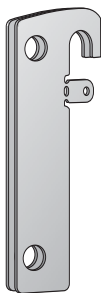

	Hot dip galv. Part. No. C*	Stainl. steel (AISI316L) Part. No. C*	ZINKPOX® White Part. No. C*	Weight kg 100 pcs
Take-off hook 47 (screw M12 + nuts are supplied)	791350 3	792875 0**	791401 2	27

\*EAN-code=732167+Part.no+C (control figure) \*\*Produced to order

### Use and installation

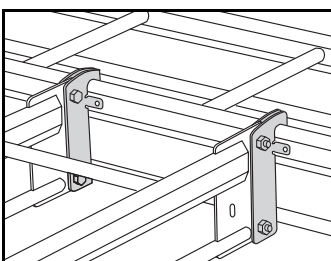

Use Take-off hook 47 to make 90° branches.

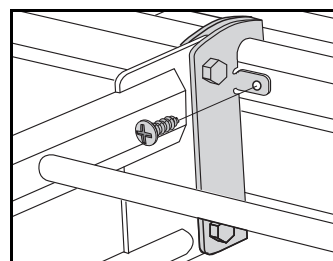

The extra hole, Ø 4.5, is to be used when earthing is demanded or if vertical locking of the ladder is needed. A self-drilling screw must be used.

## 90° bend 55

**WIBE**

Fitted at a 90° horizontal coupling of KHZV and KHZPV.

WEF-0001

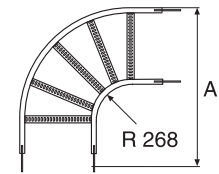
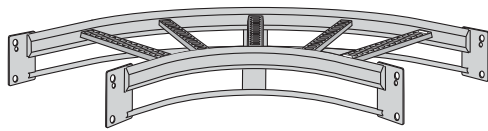

	A mm	Hot dip galv. Part. No. C*	Stainl. steel (AISI316L) Part. No. C*	ZINKPOX® White80 Part. No. C*	Weight kg 100 pcs
90° bend 55-200	625	716241 3	792903 0**	716248 2**	510
90° bend 55-300	725	716243 7	792904 7**	716250 5**	560
90° bend 55-400	825	716244 4	792905 4**	716251 2**	620
90° bend 55-500	925	716245 1	792906 1**	716252 9**	680
90° bend 55-600	1025	716246 8	792907 8**	716253 6**	750
90° bend 55-800	1225		792908 5**		830
90° bend 55-1000	1425	716247 5	792909 2**	716254 3**	1110

\*EAN-code=732167+Part.no+C (control figure) \*\*Produced to order

### Use and installation

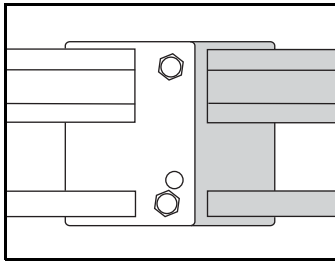

For joining to KHZV and KHZPV,  
use Screw set M12.

## T-junction 56

**WIBE**

Fitted at a T-junction of KHZV and KHZPV.

WEF-0001

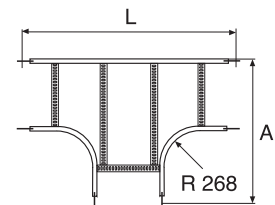
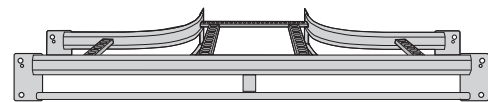

	A mm	L mm	Hot dip galv. Part. No. C*	Stainl. steel (AISI316L) Part. No. C*	ZINKPOX® White80 Part. No. C*	Weight kg 100 pcs
T-junction 56-200	625	1050	716255 0	792920 7**	716262 8**	710
T-junction 56-300	725	1150	716257 4	792921 4**	716264 2**	790
T-junction 56-400	825	1250	716258 1	792922 1**	716265 9**	840
T-junction 56-500	925	1350	716259 8	792923 8**	716266 6**	940
T-junction 56-600	1025	1450	716260 4	792924 5**	716267 3**	1010
T-junction 56-800	1225	1650		792925 2**		960
T-junction 56-1000	1425	1850	716261 1	783484 6**	716268 0**	1300

\*EAN-code=732167+Part.no+C (control figure) \*\*Produced to order

### Use and installation

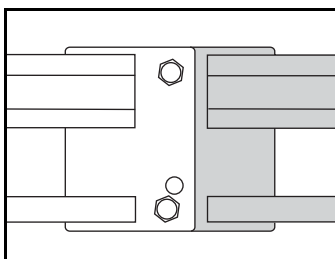

For joining to KHZV and KHZPV,  
use Screw set M12.

## Profile support piece 46

WIBE

Fitted between the ladder and the vault pipe when a support bracket is positioned between existing profile support pieces.

WEF-0001

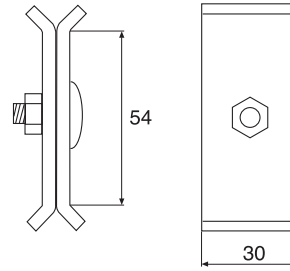
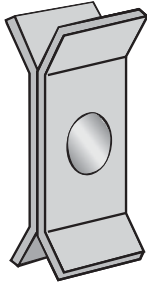

	Hot dip galv. Part. No. C*	Stainl. steel (AISI316L) Part. No. C*	ZINKPOX® White Part. No. C*	Weight kg 100 pcs
Profile support piece 46 (screw MVBF8x16+nut are supplied)	708001 4	792877 4**	714179 1	15
*EAN-code=732167+Part.no+C (control figure) **Produced to order				

### Use and installation

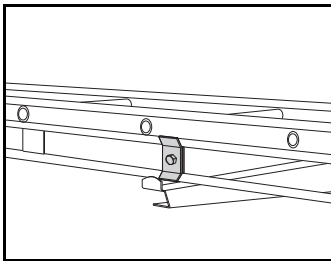

If a support bracket is placed between two profile support pieces, a Profile support piece 46 must be mounted between the arch pipes and the ladder. If the load amounts to half the permitted load, Profile support piece 46 may be excluded.

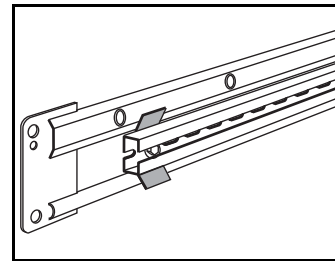

Profile support piece 46 can be installed as a fixing for different applications.

## Lighting bracket 200

WIBE

Used for the installation of lighting fittings beneath KHZV/KHZPV 200.

WEF-0001

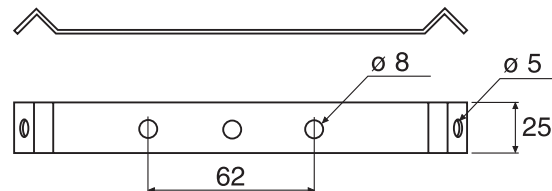
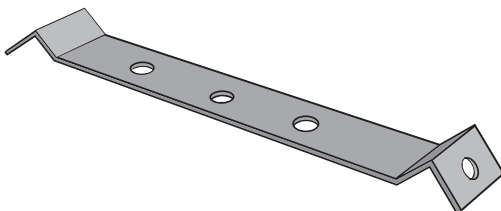

	Hot dip galv. Part. No. C*	ZINKPOX® White Part. No. C*	Weight kg 100 pcs
Lighting bracket 200	718643 3	718644 0**	16
*EAN-code=732167+Part.no+C (control figure) **Produced to order			

### Use and installation

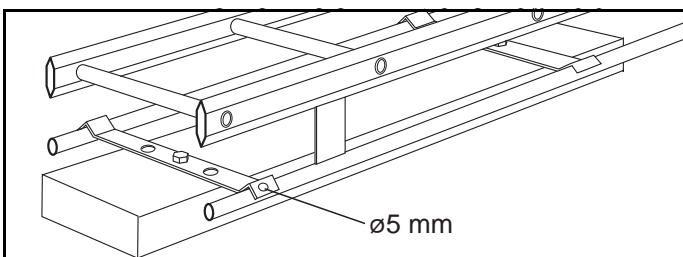

Mount Lighting bracket 200 for KHZV/KHZPV between the two lower tubes. If necessary, 5 mm dia. holes can be used for locking against the arch tube by means of blind rivets or sheet screws.

Covers are installed to protect the cable runs from dust, dirt and liquids etc. Outdoors, the covers protect against rain and sun. All Wibe cable ladders and cable trays can be fitted with covers.

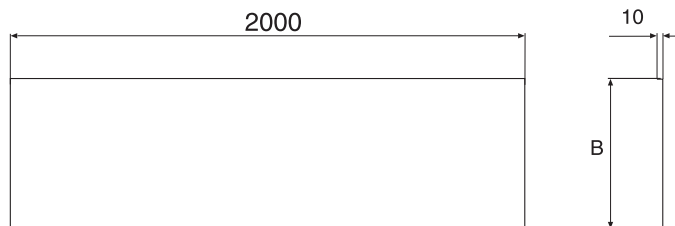
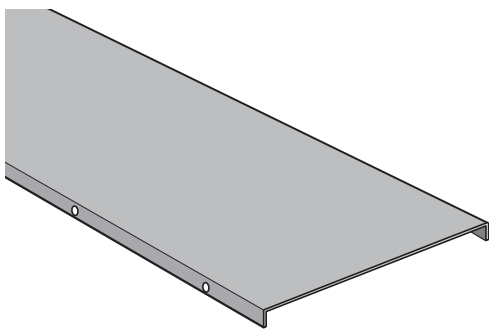
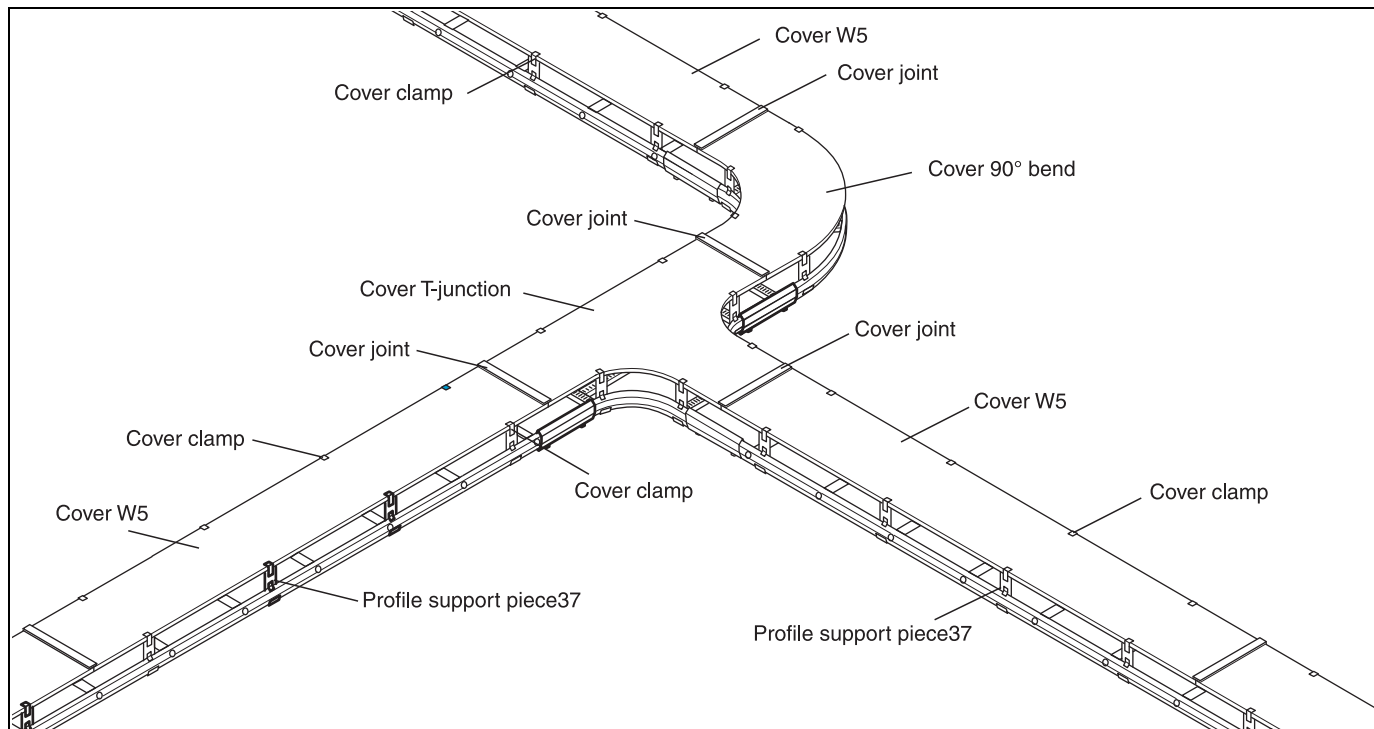

	Ladder width mm	B mm	Pre-galv. Part. No. C*	Hot dip galv. Part. No. C*	Stainl. steel (AISI316L) Part. No. C*	Pre-galv. White Part. No. C*	ZINKPOX® White Part. No. C*	Weight kg 100 pcs
Cover W5-150	150	151	732216 9	732264 0	732291 6**	734134 5**	782365 9**	190
Cover W5-200	200	201	732217 6	732265 7	732292 3**	729017 8**	782366 6**	250
Cover W5-300	300	301	732218 3	732266 4	732293 0**	729018 5**	782367 3**	360
Cover W5-400	400	401	732219 0	732267 1	732294 7**	729019 2**	782368 0**	680
Cover W5-500	500	501	732220 6	732268 8	732295 4**	729020 8**	782369 7**	840
Cover W5-600	600	601	732221 3	732269 5	732296 1**	729021 5**	782370 3**	700
Cover W5-800	800	801		782213 3**	783375 7**		782214 0**	1420
Cover W5-1000	1000	1001	732222 0	732270 1	732297 8**	729022 2**	782371 0**	1150

\*EAN-code=732167+Part.no+C (control figure) \*\*Produced to order

## Use and installation

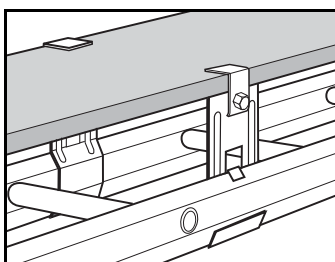

Mount covers to protect the cable routes from dust, waste, liquids, etc. Outdoors, covers protect against rain and sun. All Wibe cable ladders can be fitted with covers. Mount covers using Profile support piece 37 and Cover clamp.

# Cover joint

Inserted between the covers.

WEF-0001

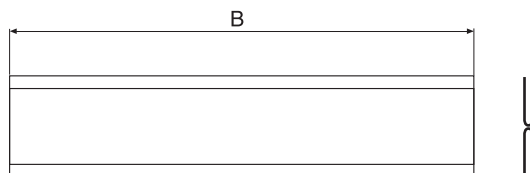
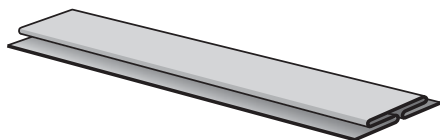

	For ladder width mm	B mm	Pre-galv. Part. No. C*	Hot dip galv. Part. No. C*	Pre-galv. White Part. No. C*	Weight kg 100 pcs
Cover joint-150	150	125	712639 2	780452 8	714710 6**	10
Cover joint-200	200	175	712640 8	780453 5	714711 3**	20
Cover joint-300	300	275	712642 2	780454 2	714713 7**	30
Cover joint-400	400	375	712643 9	780455 9	714714 4**	40
Cover joint-500	500	475	712644 6	780456 6	714715 1**	50
Cover joint-600	600	575	712645 3	780457 3	714716 8**	60

\*EAN-code=732167+Part.no+C (control figure) \*\*Produced to order

## Use and installation

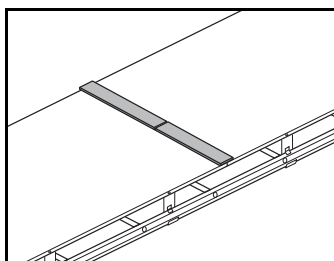

For width 800 or 1000 mm, use a combination of two smaller joints (e.g. 400+600 mm). Insert joints between covers.

## Profile support piece 37

**WIBE**

WEF-0001

When installing covers, the profile support pieces are mounted approx. every 0.5 m along both sides of the ladder.

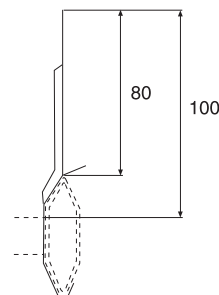
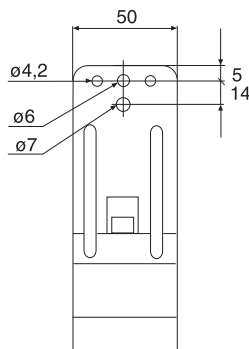
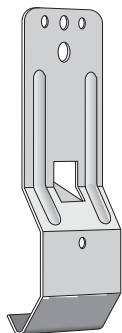

	Pre-galv. Part. No. C*	Hot dip galv. Part. No. C*	Stainl. steel (AISI316L) Part. No. C*	Pre-galv. White Part. No. C*	ZINKPOX® White Part. No. C*	Weight kg 100 pcs
Profile support piece 37	729217 2	730188 1	730190 4	730189 8	782382 6**	6

\*EAN-code=732167+Part.no+C (control figure) \*\*Produced to order

### Use and installation

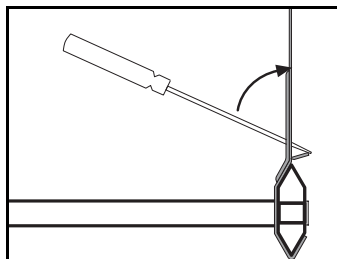

Mount Profile support piece 37 on the inside of the hexagonal section. Bend the tab towards the ladder section using a screwdriver as a lever.

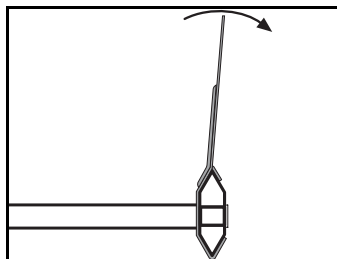

Profile support piece 37 can be bent to fit the cover width.

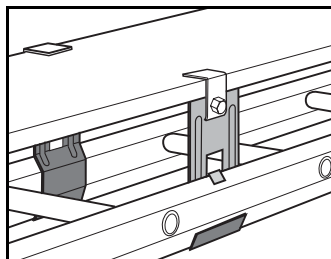

Lock the cover on the Profile support piece 37 using Cover clamps.

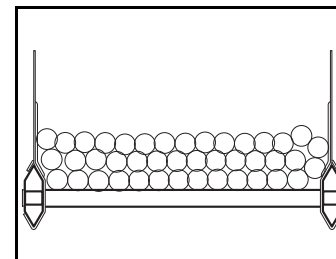

Profile support pieces 37 can be mounted as cable supports. Mount the attachments at about 0.5 m centres on both sides of the ladder.

## Cover clamp

**WIBE**

WEF-0001

Cover clamps are required when installing a cover on a Profile support piece 37.

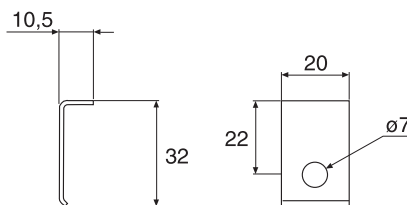
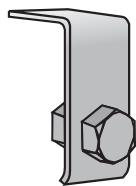

	Pre-galv. Part. No. C*	Hot dip galv. Part. No. C*	Stainl. steel (AISI316L) Part. No. C*	Pre-galv. White Part. No. C*	Zinkpox® White Part. No. C*	Weight kg 100 pcs
Cover clamp	712668 2	728584 6	728586 0	714709 0	782384 0**	1.5

\*EAN-code=732167+Part.no+C (control figure) \*\*Produced to order

### Use and installation

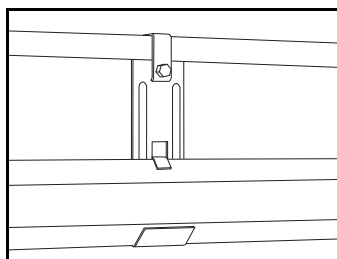

Cover clamps are required for mounting covers on Profile support piece 37.



## Cover 90° bend

Fits 90° interior bends. Installed with a Profile support piece 37, Cover clamp and Cover joint.

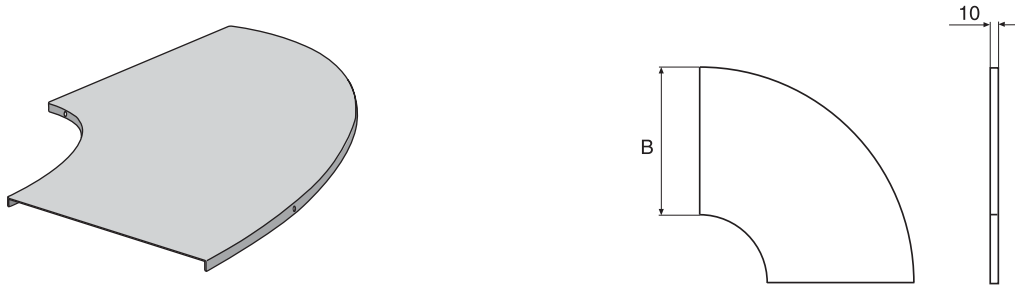

	For ladder width mm	B mm	Pre-galv. Part. No. C*	Hot dip galv. Part. No. C*	Pre-galv. White Part. No. C*	ZINKPOX® White Part. No. C*	Weight kg 100 pcs
Cover 90° bend-150	150	151	732322 7	781433 6	781804 4**	781751 1**	65
Cover 90° bend-200	200	201	732323 4	781434 3	781805 1**	781752 8**	91
Cover 90° bend-300	300	301	732324 1	781435 0	781806 8**	781753 5**	143
Cover 90° bend-400	400	401	732325 8	781436 7	781807 5**	781754 2**	221
Cover 90° bend-500	500	501	732326 5	781437 4	781808 2**	781755 9**	299
Cover 90° bend-600	600	601	732327 2	781438 1	781809 9**	781756 6**	390
Cover 90° bend-800	800	801	781802 0**	781793 1**	781810 5**	781794 8**	460
Cover 90° bend-1000	1000	1001	732328 9**	781439 8**	781811 2**	781757 3**	871

\*EAN-code=732167+Part.no+C (control figure) \*\*Produced to order

## Stainless steel (AISI316L)



	For ladder width mm	B mm	Stainl. steel (AISI316L) Part. No. C*	Weight kg 100 st
Cover 90° bend-150	150	147	788639 5**	44
Cover 90° bend-200	200	197	788640 1**	62
Cover 90° bend-300	300	297	788641 8**	105
Cover 90° bend-400	400	397	788642 5**	223
Cover 90° bend-500	500	497	788643 2**	310
Cover 90° bend-600	600	597	788644 9**	408
Cover 90° bend-800	800	797	788645 6**	643
Cover 90° bend-1000	1000	997	788646 3**	926

\*EAN-code=732167+Part.no+C (control figure) \*\*Produced to order

## Use and installation

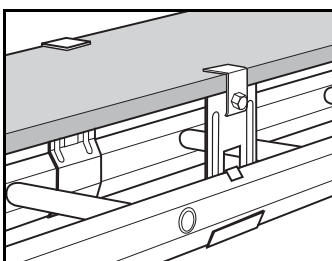

Fasten cover to Profile support piece 37 using Cover clamp.

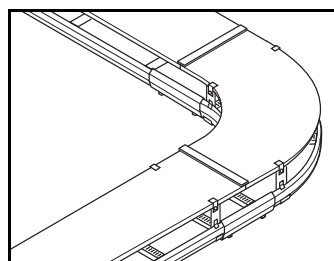

Mount with Profile support pieces 37, Cover clamps and Cover joints.

# Cover T-junction

Fits T-junctions. Installed with a Profile support piece 37, Cover clamp and Cover joint.

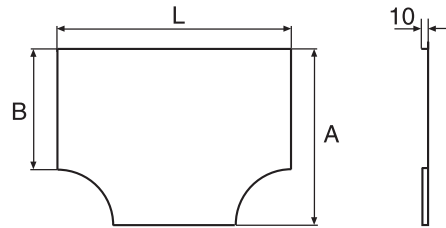
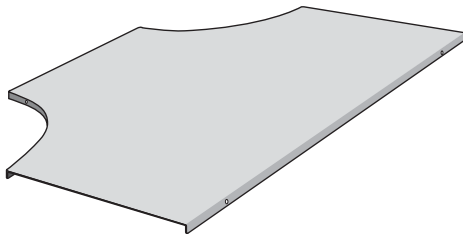

Cover	For ladder width mm	A mm	B mm	L mm	Pre-galv. Part. No. C*	Hot dip galv. Part. No. C*	Pre-galv. White Part. No. C*	ZINKPOX® White Part. No. C*	Weight kg 100 pcs
T-junction-150	150	400	151	651	732345 9**	781440 4**	781812 9**	781765 8**	182
T-junction-200	200	450	201	701	732346 3**	781441 1**	781813 6**	781766 5**	221
T-junction-300	300	550	301	801	732347 0**	781442 8**	781814 3**	781767 2**	312
T-junction-400	400	650	401	901	732348 7**	781443 5**	781815 0**	781768 9**	416
T-junction-500	500	750	501	1001	732349 4**	781444 2**	781816 7**	781769 6**	533
T-junction-600	600	850	601	1101	732350 0**	781445 9**	781817 4**	781770 2**	676
T-junction-800	800	1050	801	1301	781803 7**	781796 2**	781818 1**	781797 9**	710
T-junction-1000	1000	1240	1001	1501	732351 7**	781446 6**	781819 8**	781771 9**	1352

\*EAN-code=732167+Part.no+C (control figure) \*\*Produced to order

## Stainless steel (AISI316L)

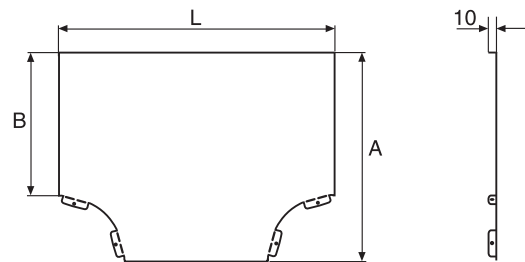
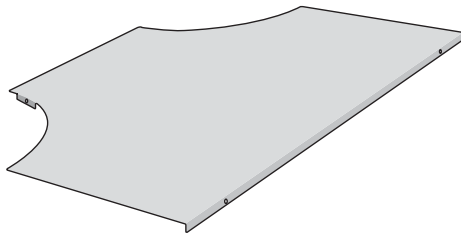

	For ladder width mm	A mm	B mm	L mm	Stainl. steel (AISI316L) Part. No. C*	Weight kg 100 pcs
Cover T-junction-150	150	402	147	657	788647 0**	95
Cover T-junction-200	200	452	197	707	788648 7**	126
Cover T-junction-300	300	552	297	807	788649 4**	196
Cover T-junction-400	400	652	397	907	788650 0**	394
Cover T-junction-500	500	752	497	1007	788651 7**	525
Cover T-junction-600	600	852	597	1107	788652 4**	672
Cover T-junction-800	800	1052	797	1307	788653 1**	1011
Cover T-junction-1000	1000	1242	997	1507	788654 8**	1414

\*EAN-code=732167+Part.no+C (control figure)

## Use and installation

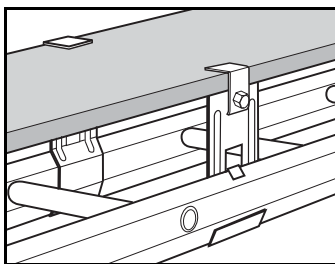

Fasten cover to Profile support piece 37 using Cover clamp.

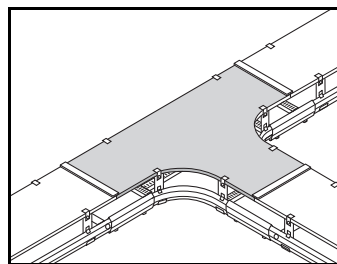

Mount with Profile support pieces 37, Cover clamps and Cover joints.

## Protecting cover

To be used as protection against ice and snow.  
Meant for cable ladder widths 300-400.

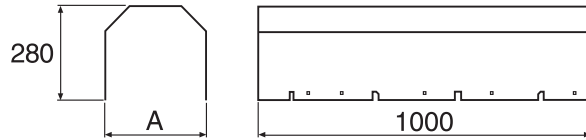
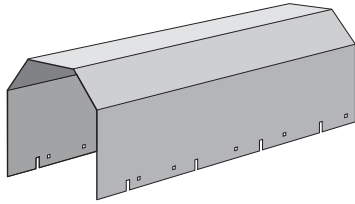

	A mm	Pre-galv. Part. No. C*	Hot dip galv. Part. No. C*	Weight kg 100 st
Protecting cover 300	300	786738 7	786746 2	880
Protecting cover 400	400	786739 4	786747 9	990

\*EAN-code=732167+Part.no+C (control figure)

### Use and installation

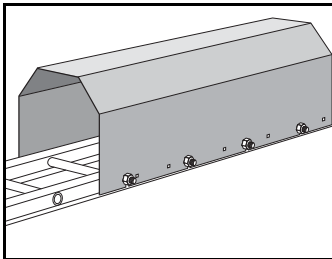

To be mounted on ladder KHZ with Intermediate connection bolt 29. When mounted on other ladders or when needed, drilling screw  $\text{Æ} 4.2$  is used.

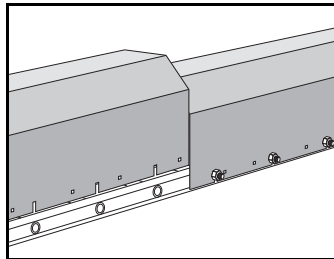

The covers can be mounted edge to edge.

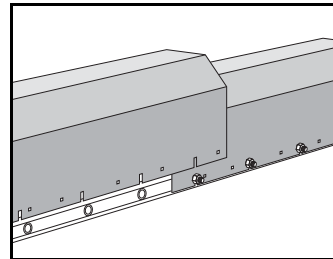

The covers can be mounted with overlap. The asymmetric hole pattern can be used to achieve a good fit.

# Steel wire

The steel wire is available in several qualities. To be installed as carrier of one or more cables.

WEF-0001,0011



	Dim mm	Breaking load kg	Part. No. C*	Weight kg 100 m
HT-2309 Steel wire galvanized, soft	5.0	700	713679 7	15.5
HT-2311 Steel wire 7 x diam 1.71=16 mm <sup>2</sup> coated, grey	6.15	970	713688 9	13.5
HTR-2322 Steel wire stainless, hard	2.5	450	713681 0	3.9
HTR-2323 Steel wire stainless, hard	3.0	700	713682 7	5.6
HTR-2324 Steel wire stainless, hard	4.0	1200	713683 4	10.0

\*EAN-code=732167+Part.no+C (control figure)

## Use and installation

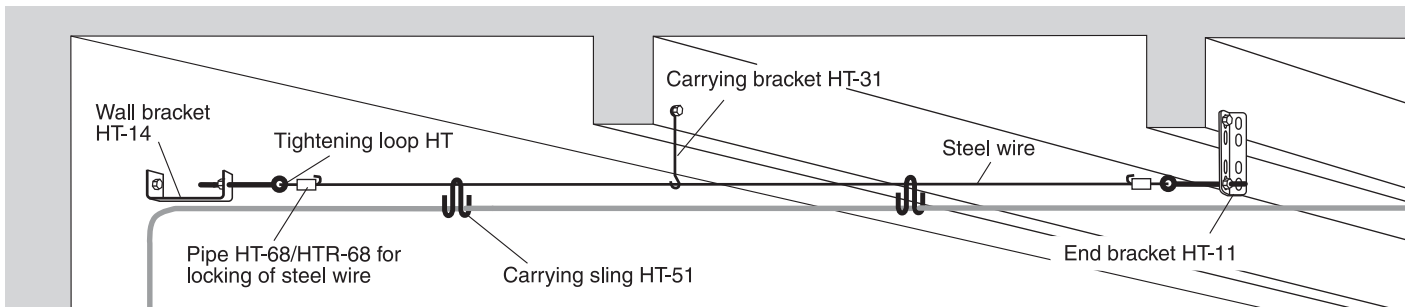

Steel wire installed in ceiling with beams.

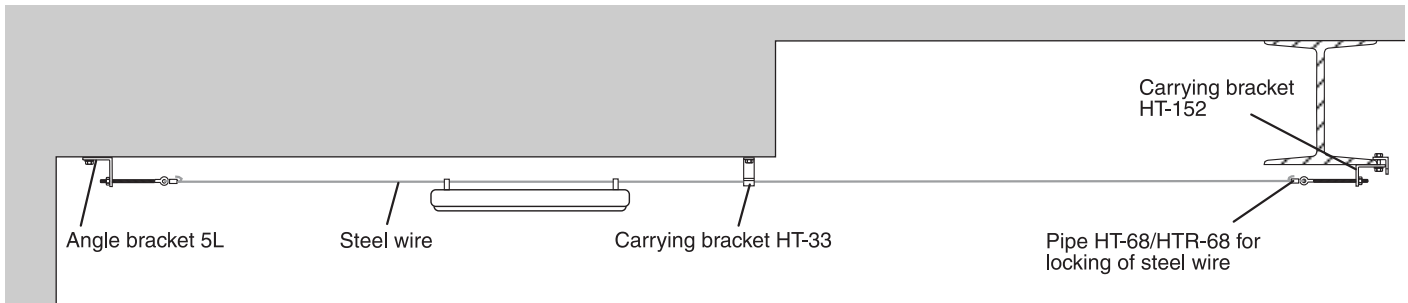

Steel wire installed in ceiling.

## Angle bracket 5L

**WIBE**

For steel wire installation in ceilings.

WEF-0001

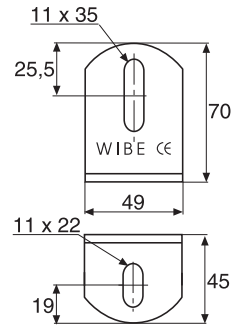

	Hot dip galv. Part. No. C*	Stainl. steel (AISI316L) Part. No. C*	ZINKPOX® White Part. No. C*	Weight kg 100 pcs
Angle bracket 5L	731791 2	731793 6	731792 9	15
*EAN-code=732167+Part.no+C (control figure)				

### Use and installation

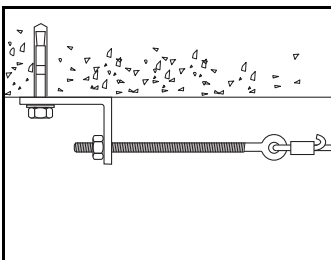

Angle bracket 5L is installed in ceiling with Expansion bolt or concrete screw.

Max. permitted loading  
600 kg (6 kN).

## Wall bracket HT-14

**WIBE**

Bracket for wall installation.

WEF-0001

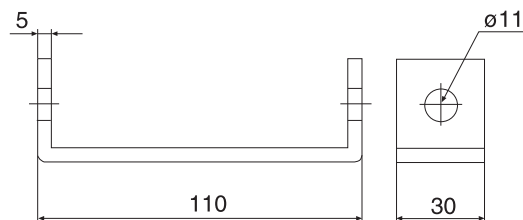
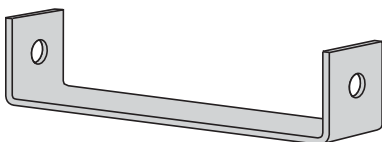

	Hot dip galv. Part. No. C*	Weight kg 100 pcs
Wall bracket HT-14	713671 1	18
*EAN-code=732167+Part.no+C (control figure)		

### Use and installation

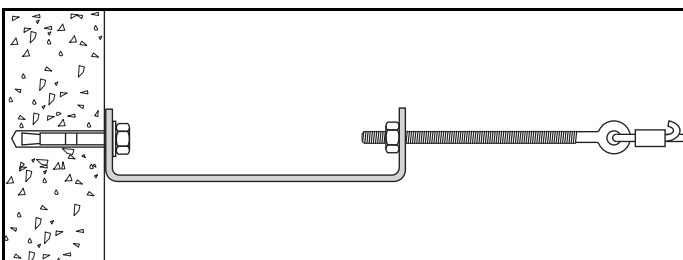

Wall bracket HT-14 is installed on wall with Expansion bolt or concrete screw.

## Carrying bracket HT-31

**WIBE**

Carrying bracket for ceiling installation.

WEF-0001

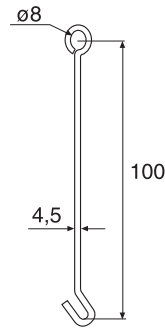
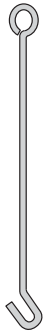

	Hot dip galv.	Weight kg
	Part. No. C*	100 pcs
Carrying bracket HT-31	713672 8	2
*EAN-code=732167+Part.no+C (control figure)		

### Use and installation

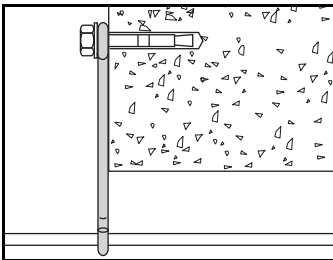

Carrying bracket HT-31 is installed on ceiling beam with Expansion bolt or concrete screw .

## Carrying bracket HT-33/34

**WIBE**

Carrying bracket for ceiling installation

WEF-0001

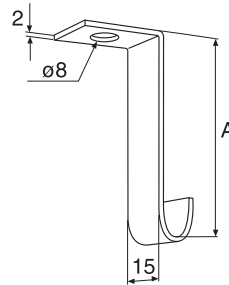
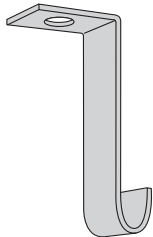

	A	Pre-galv.	Weight kg
	mm	Part. No. C*	100 pcs
Carrying bracket HT-33	14	713674 2	1
Carrying bracket HT-34	38	713675 9	2
*EAN-code=732167+Part.no+C (control figure)			

### Use and installation

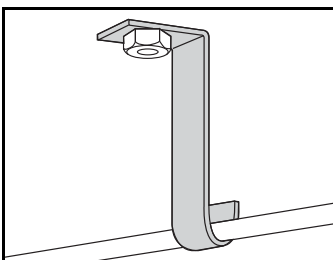

Carrying bracket is installed in ceiling with Expansion bolt or concrete screw.

## End bracket HT-11

**WIBE**

End bracket for ceiling beam installation.

WEF-0001

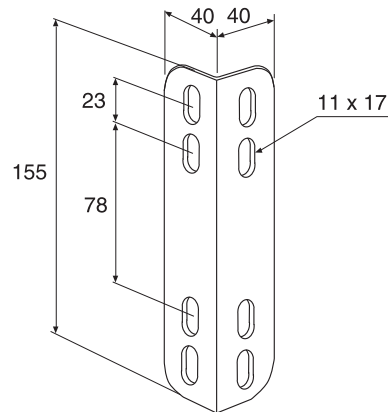
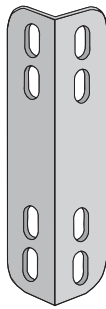

	Hot dip galv. Part. No. C*	Weight kg 100 pcs
End bracket HT-11	717618 2	41
*EAN-code=732167+Part.no+C (control figure)		

### Use and installation

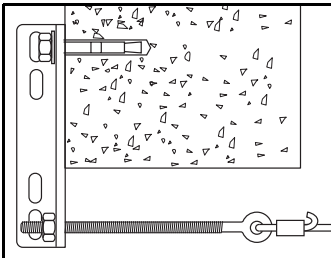

End bracket HT-11 is installed on ceiling beam with Expansion bolt or concrete screw.

## Carrying bracket HT-152

**WIBE**

Carrying bracket for I-beam installation.

WEF-0001

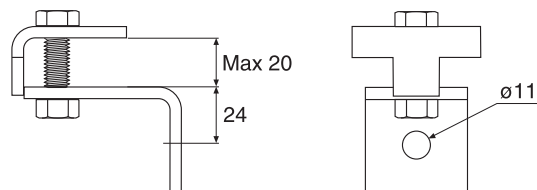
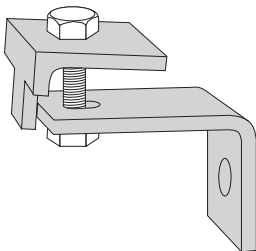

	Hot dip galv. Part. No. C*	Weight kg 100 pcs
Carrying bracket HT-152	717636 6	38
*EAN-code=732167+Part.no+C (control figure)		

### Use and installation

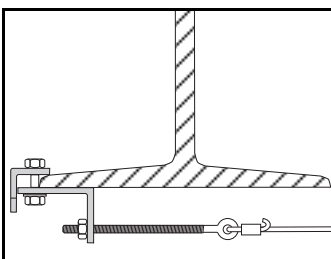

Carrying bracket is easily installed on I-beam.

## Tightening loop HT

**WIBE**

To be installed at the ends of steel wires.

WEF-0001

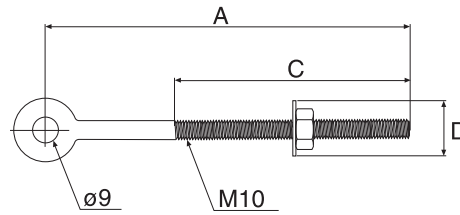
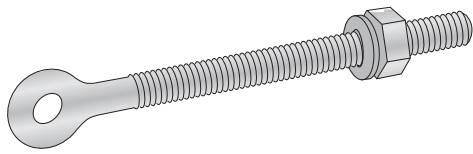

	A mm	C mm	D mm	Hot dip galv. Part. No. C*	Weight kg 100 pcs
Tightening loop HT-611	125	100	22	713689 6	10
Tightening loop HT-621	270	100	50	713690 2	18
Tightening loop HT-631	400	150	50	713691 9	29

\*EAN-code=732167+Part.no+C (control figure)

### Use and installation

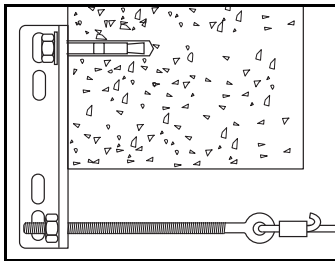

Tightening loop is installed in End bracket HT-11 for installation on ceiling beam.

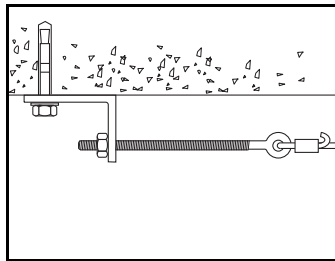

Tightening loop is installed in Angle bracket 5L for installation in ceiling.

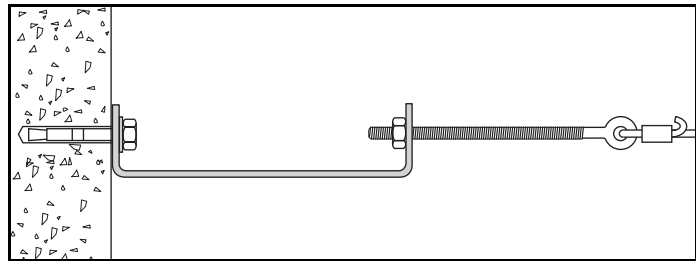

Tightening loop is installed in Wall bracket HT-14 for installation on wall.

## Pipe HT-68, HTR-68

**WIBE**

Pipe for locking of wire.

WEF-0001

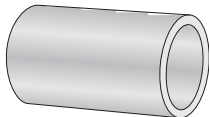

	Hot dip galv. Part. No. C*	Stainl. steel (AISI316L) Part. No. C*	Weight kg 100 pcs
Lock HT-68	713677 3		1
Lock HTR-68		713678 0	1

\*EAN-code=732167+Part.no+C (control figure)

### Use and installation

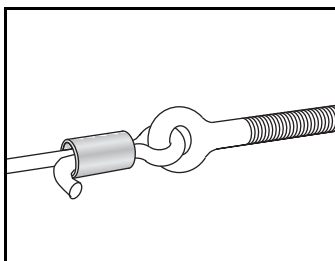

The steel cable is easily locked with the pipe.



# Carrying sling HT-51

Carrying slings for cables.

WEF-0001

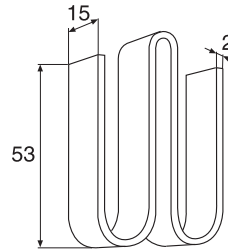
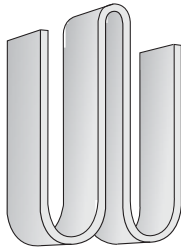

	Pre-galv. Part. No. C*	Weight kg 100 pcs
Carrying sling HT-51	713676 6	6
*EAN-code=732167+Part.no+C (control figure)		

## Use and installation

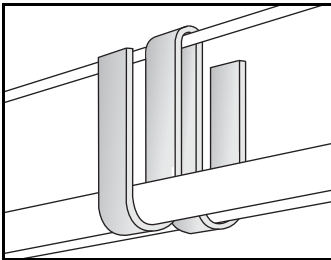

Carrying sling with space for  
6 cables max. diam. 16 mm.

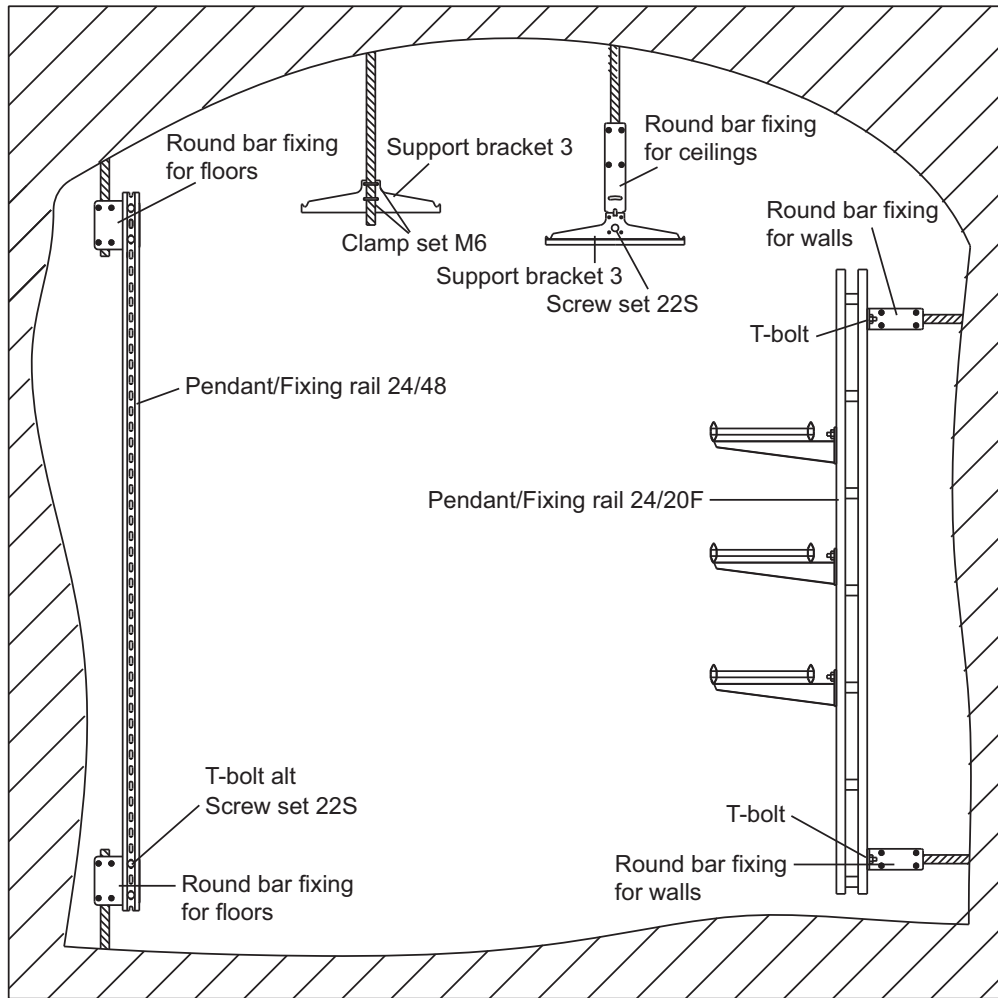

Round bar fixing for ceilings

Used for mounting in underground cavities and tunnels.

WEF-0001

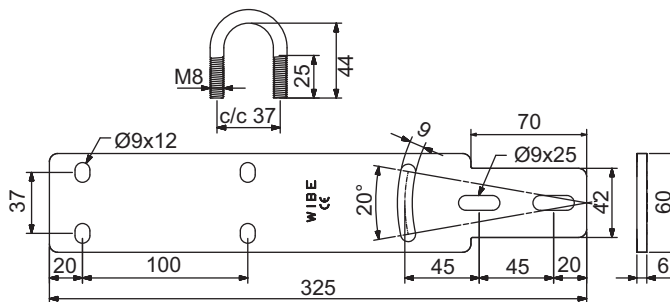

	Hot dip galv. Part. No. C*	Stainl. steel (AISI316L) Part. No. C*	Weight kg 100 pcs
Round bar fixing for ceilings	792863 7	792864 4**	90

\*EAN-code=732167+Part.no+C (control figure) \*\*Produced to order

Use and installation

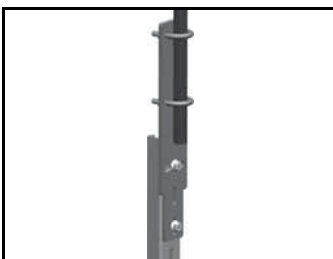

Round bar fixing for ceilings is mounted on pendant/fixing rail 24/48 with screw set 22S. Support bracket 3 is mounted directly on the fixing with Screw set 22S.

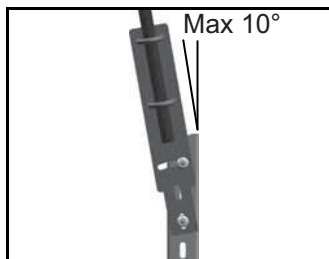

Using round bar fixing for ceilings, pendant/fixing rail 24/48 and screw set 22S it is possible to make a vertical piece that can be installed at an angle of up to 10°.

## Round bar fixing for floors

WIBE

Used for mounting in underground cavities and tunnels.

WEF-0001

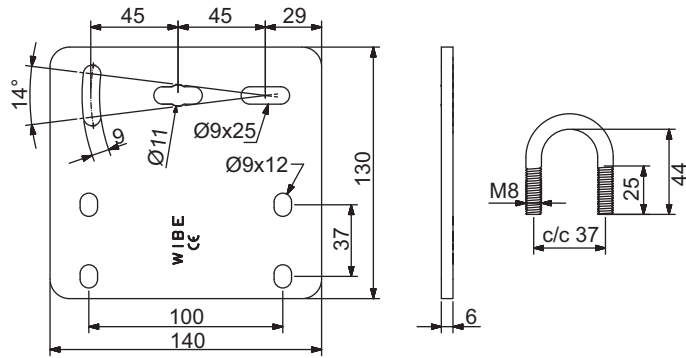
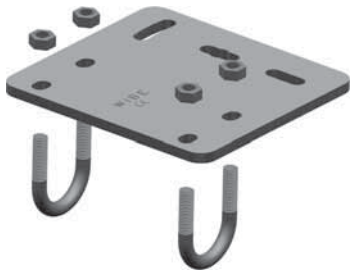

	Hot dip galv. Part. No. C*	Stainl. steel (AISI316L) Part. No. C*	Weight kg 100 pcs
Round bar fixing for floors	792865 1	792866 8**	91

\*EAN-code=732167+Part.no+C (control figure) \*\*Produced to order

### Use and installation



Round bar fixing for floors mounted on Pendant/fixing rail 24/48 with Screw set 22S.



Round bar fixing for floors mounted on Pendant/fixing rail 24/48 with T-bolt 26F.

## Round bar fixing for walls

WIBE

Used for mounting in underground cavities and tunnels.

WEF-0001

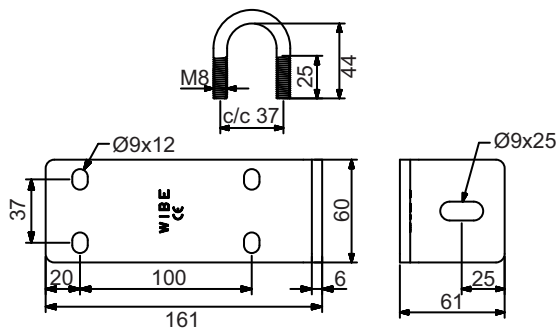

	Hot dip galv. Part. No. C*	Stainl. steel (AISI316L) Part. No. C*	Weight kg 100 pcs
Round bar fixing for walls	792867 5	792868 2	68

\*EAN-code=732167+Part.no+C (control figure) \*\*Produced to order

### Use and installation



Round bar fixing for walls mounted on Pendant/fixing rail 24/20F with T-bolt 26F.

## Clamp set M6

**WIBE**

Used for installation of Support bracket 3 directly on roof bolt.

WEF-0001

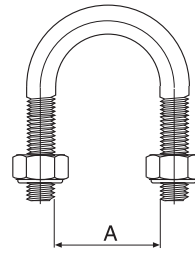
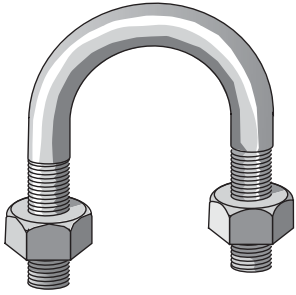

	A mm	Stainl. steel (AISI316L) Part. No. C*	Weight kg 100 pcs
Clamp set M6-25** (2 clamps and 4 locking nuts)	ø29	720786 2	5
Clamp set M6-20*** (2 clamps and 4 locking nuts)	ø24	725587 0	4

\*EAN-code=732167+Part.no+C (control figure)

\*\* Clamp set M6-25 must be used for Support bracket 3, hot dip and pre-galvanized.

\*\*\* Clamp set M6-20 must be used for Support bracket 3, stainless steel AISI316L and Installation plate 60, all surface treatments.

### Use and installation

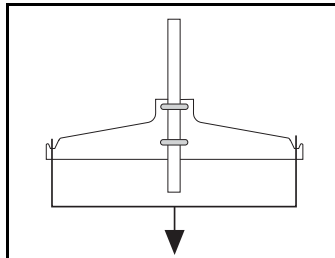
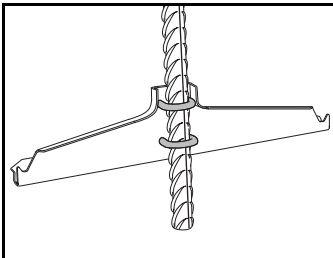

For installation of Support bracket 3 directly on ribbed bar 16-25 or fully threaded bar M16-M27.

Max. symmetrical loading 300 kg. Make sure the clamps grip the bar in a correct manner.

## Intermediate connection bolt 29

**WIBE**

Used at the transition from a broad to a narrower KHZ.

WEF-0001



	Bolt diam x length mm	Hot dip galv. Part. No. C*	Weight kg 100 pcs
Intermediate connection bolt 29-200	M10 x 235	705392 6	14
Intermediate connection bolt 29-300	M10 x 335	705394 0	19
Intermediate connection bolt 29-400	M10 x 435	705395 7	24
Intermediate connection bolt 29-500	M10 x 535	705396 4	29
Intermediate connection bolt 29-600	M10 x 635	705397 1	34

\*EAN-code=732167+Part.no+C (control figure)

### Use and installation

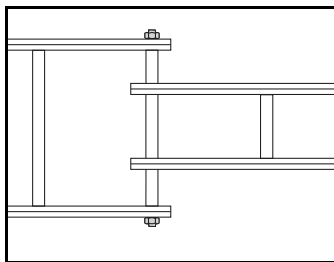

Intermediate connection bolts are used for changing from a broad to a narrower ladder. The broader ladder's last rung is cut to permit the narrower ladder to fit in. The intermediate connection bolt is mounted through the rungs of the KHZ ladder.

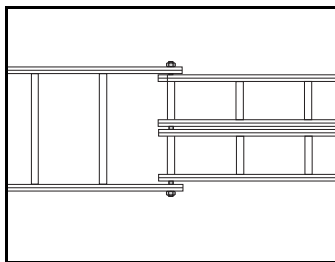

Intermediate connection bolts can also be used for transition from one wide ladder to two narrower ones.

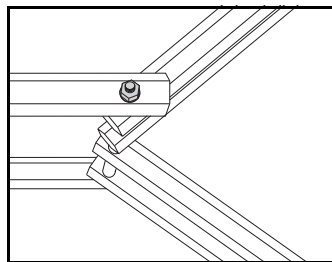

Intermediate connection bolt also permits formation of angles.

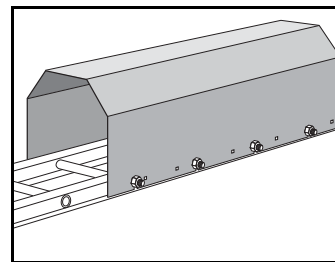

Intermediate connection bolt 29 is used for mounting protecting covers on KHZ ladders.

## Dropper joint 32

**WIBE**

A dropper joint to form vertical branches in centre position under/on top of cable ladders.

WEF-0001

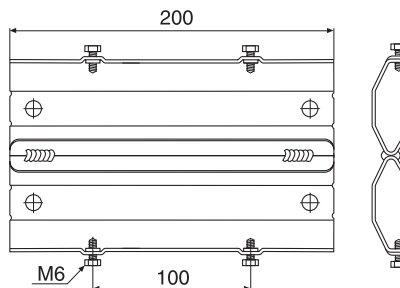
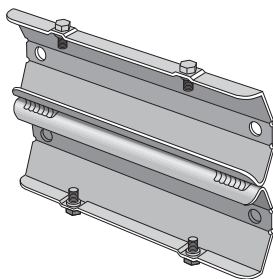

	Hot dip galv. Part No. C*	ZINKPOX® White Part. No. C*	Weight kg 100 pcs
Dropper joint 32 (screw M6 incl)	734713 1	780874 8**	75

\*EAN-code=732167+Part.no+C (control figure) \*\*Produced to order

### Use and installation

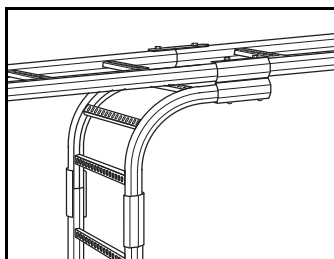

To be used together with Riser 18 to form vertical branches under Cable ladder KHZ, KHZP, KHZSP, KHZSPZ and KHZPS.

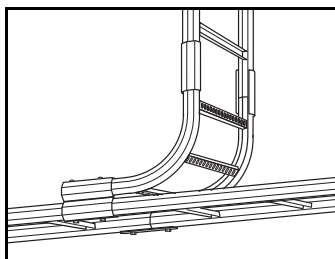

May also be used together with Riser 18 to form vertical branches on top of Cable ladder KHZ, KHZP, KHZSP, KHZSPZ and KHZPS.

## Reducer 31

**WIBE**

For transition joining from a wide to a narrower cable ladder.

WEF-0001

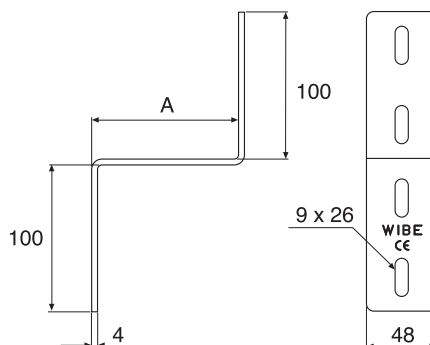
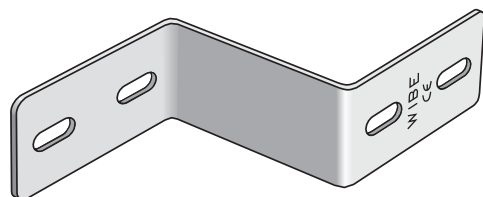

	A mm	Hot dip galv. Part. No. C*	ZINKPOX® White Part. No. C*	Weight kg 100 pcs
Reducer 31-100	100	734171 9	735433 7**	43
Reducer 31-200	200	734172 6	735434 4**	59
Reducer 31-300	300	734173 3	735435 1**	74
Reducer 31-400	400	734174 0	735436 8**	89

\*EAN-code=732167+Part.no+C (control figure) \*\*Produced to order

### Use and installation

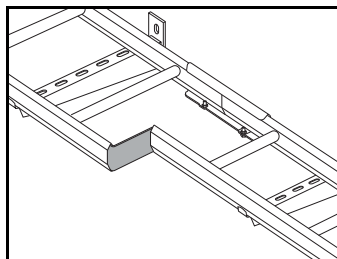

To be installed in the ladder profile and used together with Joint 21 at one-side transition joining of KHZ, KHZP, KHZSP, KHZSPZ and KHZPS.

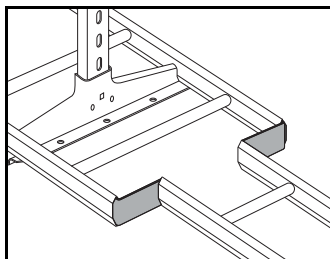

May also be used at centred transition joining.

## Junction coupling 14

**WIBE**

For T-and X-junctions. Suits cable ladder KHZ, KHZP, KHZSP, KHZSPZ and KHZPS all ladder widths.

WEF-0001

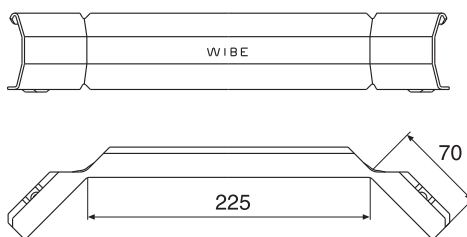
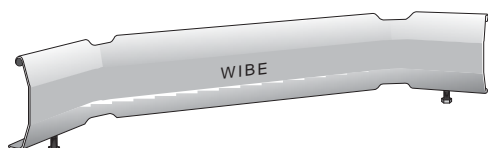

	Pre-galv. Part. No. C*	Hot dip galv. Part. No. C*	Stainl. steel (AISI316L) Part. No. C*	Pre-galv. White Part. No. C*	ZINKPOX® White Part. No. C*	Weight kg 100 pcs
Junction coupling 14	723212 3	725096 7	727195 5	723213 0**	790906 3	49

\*EAN-code= 732167+Part.no+C (control figure) \*\*Produced to order

### Use and installation

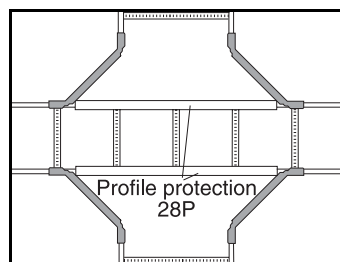
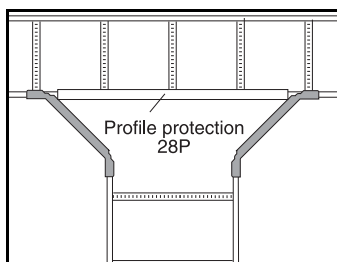

For T-junctions, use 2 Junction couplings 14.

For X-junctions, use 4 Junction couplings 14.

A bracket should be placed under the connecting ladder close to the connection. Profile protection 28P is recommended. To be cut to required length.

## Angle plate 33

**WIBE**

Angle plates are always recommended with 90° horizontal T-junctions. Suitable for all Wibe cable ladders.

WEF-0001

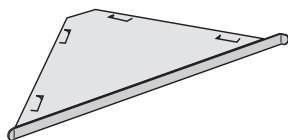

Angle plate 33/1

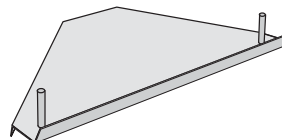
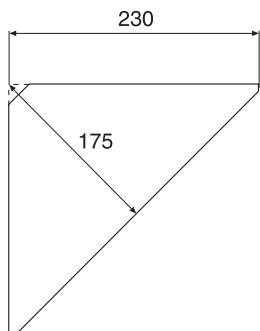

Angle plate 33/2

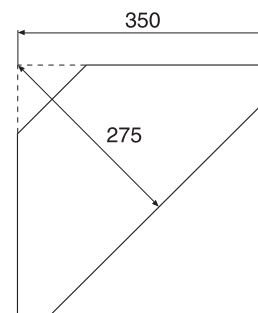

	Pre-galv. Part. No. C*	Hot dip galv. Part. No. C*	Stainl. steel (AISI316L) Part. No. C*	Pre-galv. White Part. No. C*	ZINKPOX® White Part. No. C*	Weight kg 100 pcs
Angle plate 33/1	768733 6		727340 9	714030 5**		50
Angle plate 33/2	721114 2	707748 9	727197 9		714168 5**	90

\*EAN-code=732167+Part.no+C (control figure) \*\*Produced to order

### Use and installation

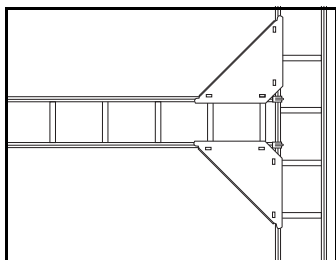

Angle plates are always recommended at 90° horizontal junctions.

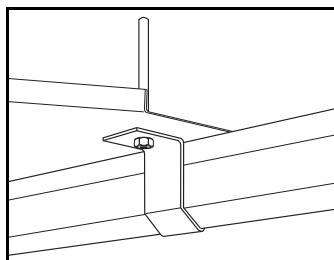

To lock Angle plate 33/2, fit Profile clamp 42.

## Joint 9

**WIBE**

For straight joining of KHZ, KHZP and KHZPS.

WEF-0001

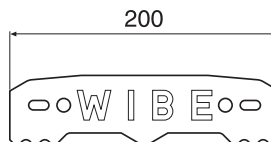

	Pre-galv. Part. No. C*	Hot dip galv. Part. No. C*	ZINKPOX® White Part. No. C*	Weight kg 100 pcs
Joint 9	721115 9	705304 9	714066 4	16

\*EAN-code=732167+Part.no+C (control figure)

### Use and installation

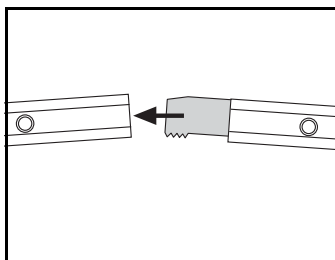

Joint 9 is used in straight joints of KHZ, KHZP and KHZPS.

NOTE! The teeth shall face downwards as shown in the figure.

Under load, the ladders are prevented from slipping apart. If the joint is above a bracket, the teeth should face upwards.

## End plug 28/28i

**WIBE**

Mount in ladder ends for sealing or protection.

WEF-0003,-0024

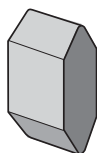

End plug 28



End plug 28i

	White plastic Part. No. C*	Red plastic Part. No. C*	Weight kg 100 st
End plug 28		709019 8	0.8
End plug 28i	735446 7	731994 7	0.4

\*EAN-code=732167+Part.no+C (control figure)

### Use and installation

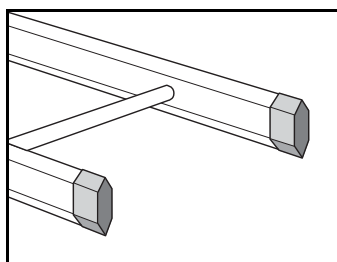

Mount End plug 28 in ladder ends as protection.

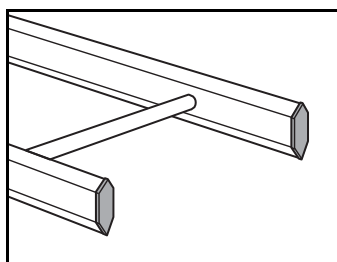

Mount End plug 28i inside the ladder ends for sealing. Joining with Joint 19 or 21 can be made with End plug 28i left in the ladders ends.

## End plug 28C,D,E and F

**WIBE**

Used for mounting in pendant ends to provide protection against personal injury.

WEF-0003

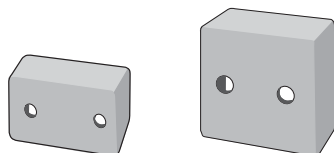

	Orange plastic Part. No. C*	Weight kg 100 pcs
End plug 28C	789875 6	0.5
End plug 28D	709020 4	1
End plug 28E	709021 1	0.5
End plug 28F	789876 3	4

\*EAN-code=732167+Part.no+C (control figure)

### Use and installation

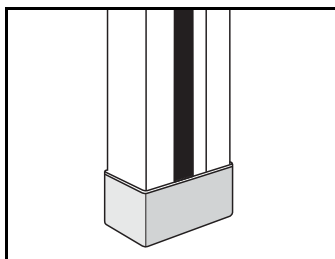

End plug 28C fits Vertical piece 2 and Pendant/ Fixing rail 24/34.  
End plug 28E fits Vertical piece 2F and Pendant/ Fixing rail 24/48.

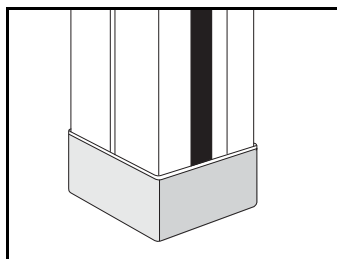

End plug 28F fits Vertical piece 20FS and Pendant/ Fixing rail 24/20FS.  
End plug 28D fits Vertical piece 20 and Pendant/ Fixing rail 24/20.



## Cross member plug 27

Cross member plugs are installed in the ends of the rungs of KHZ and KHZV .  
Used in premises with a high corrosion risk.

WEF-0018

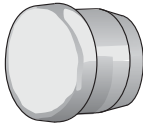

	Grey plastic Part. No. C*	Weight kg 100 pcs
Cross member plug 27	726668 5	0.15
*EAN-code=732167+Part.no+C (control figure)		

### Use and installation

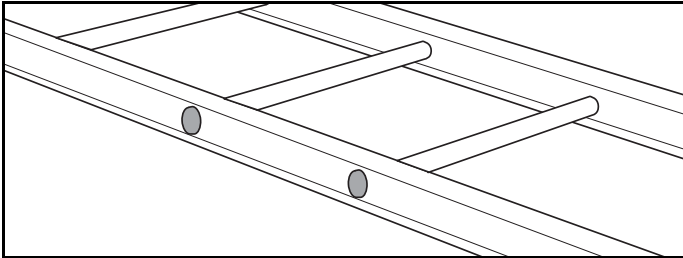

Mount Cross member plug 27 in KHZ and KHZV rung tube ends in pre-  
mises with high relative humidity where the risk of corrosion is high.

# Angle bracket 5L and 5LS

Used when assembling pendant/fixing rails to frames for switching cabinets and electrical control centres.  
For fixing an upright between floor and ceiling. Assembled with a T-bolt.

WEF-0001



Angle bracket 5L

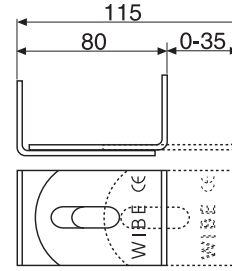
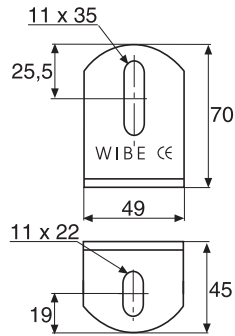

Adjustability 5L

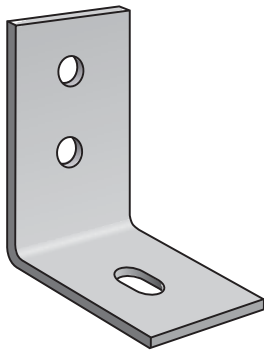

Angle bracket 5LS

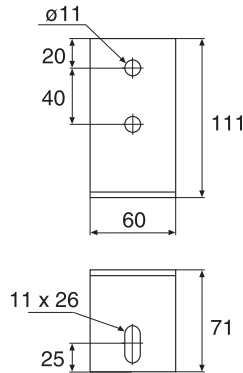
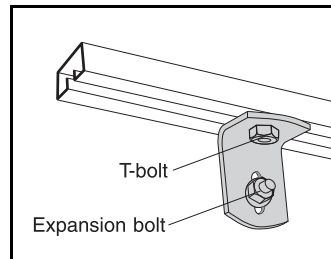
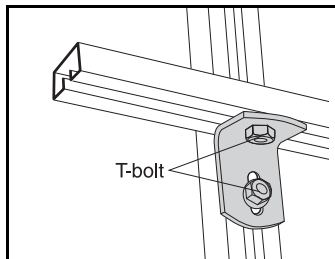
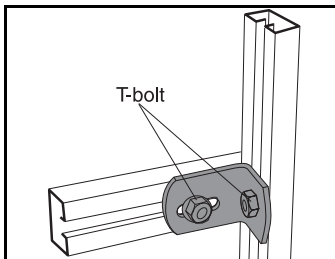

	Plate thickness mm	Hot dip galv. Part. No. C*	Stainl. steel (AISI316L) Part. No. C*	ZINKPOX® White Part. No. C*	Weight kg 100 pcs
Angle bracket 5L	4.0	731791 2	731793 6	731792 9	15
Angle bracket 5LS	6.0**	709801 9	725636 5	720529 5	50

\*EAN-code=732167+Part.no+C (control figure)

\*\*Plate thickness for Stainl. steel (AISI316L) is 5 mm.

## Use and installation



Installation examples for installation of pendant/fixing rails to different frameworks for installation of control panels, electric distribution boards, etc. Angle bracket 5L is used.

Mounting of a pendant/ fixing rail on a wall. Use Angle bracket 5L or 5LS.

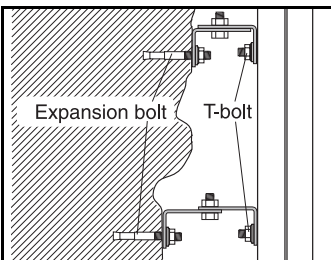
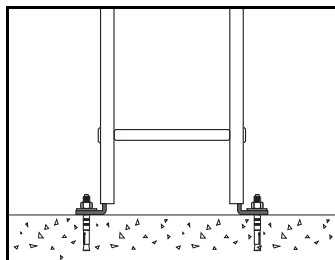
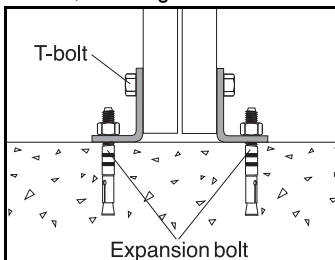

Mounting of a pendant/ fixing rail against floor with Angle bracket 5L or 5LS.

Angle bracket 5L can be mounted inside the ladder profile and thus be used as an end connection against wall or floor.

Can also be mounted as support behind pendant/ fixing rails to compensate for irregularities in, for example, concrete or mountain walls.

## Fixed take-off hook 4

**WIBE**

Used for 90° horizontal branches.

WEF-0001

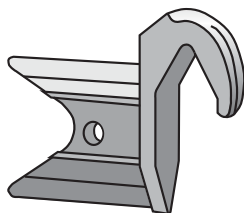

5 mm dia. hole for any locking against the ladder profile using sheet screws or blind rivets

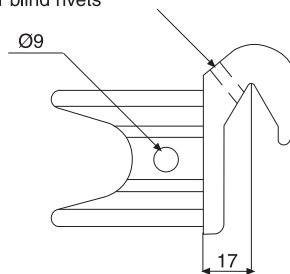

	Alum. Part. No. C*	Alum. White Part. No. C*	Weight kg 100 pcs
Fixed take-off hook 4	709017 4	714067 1	8

\*EAN-code=732167+Part.no+C (control figure)

### Use and installation

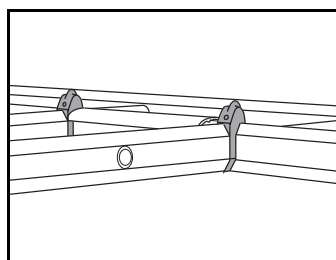

Fixed take-off hook 4 is used at 90° horizontal branches. Coupling 22 can also be used for straight angle formation.

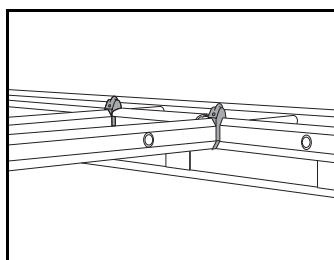

KHZSP, KHZSPZ, KHZPS, KHZ and KHZP can also be used to form 90° angles from KHZV/KHZPV using Fixed take-off hook 4. Mount Profile protection 28P.

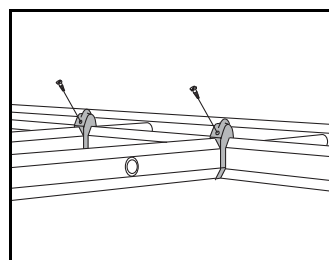

5 mm dia. hole for any locking against the section using sheet screws or blind rivets.

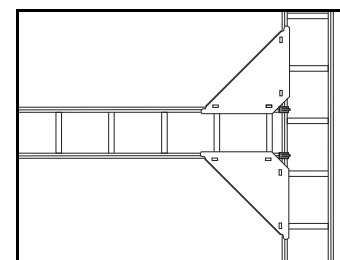

Angle plate 33 is always recommended at horizontal branches.

## End connection 10

**WIBE**

Used for the connection of a ladder vertically to a floor, or horizontally to a wall.

WEF-0001

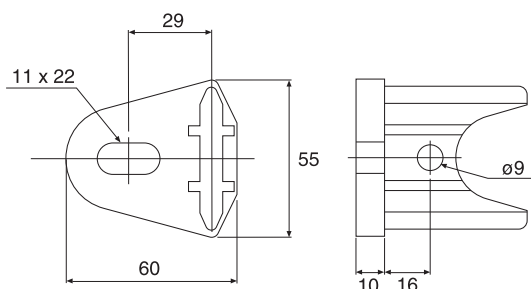
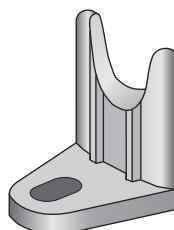

	Alum. Part. No. C*	Alum. White Part. No. C*	Weight kg 100 pcs
End connection 10	709018 1	714085 5	8

\*EAN-code=732167+Part.no+C (control figure)

### Use and installation

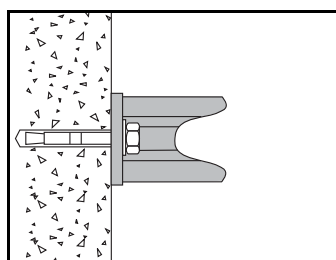

The End connection 10 is mounted at the ladder end vertically against floors or horizontally against walls.

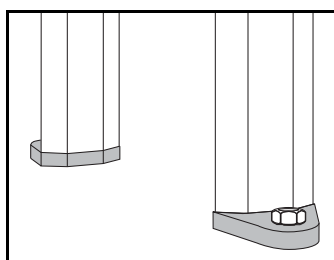

Mount the End connection 10 using Expansion bolts.

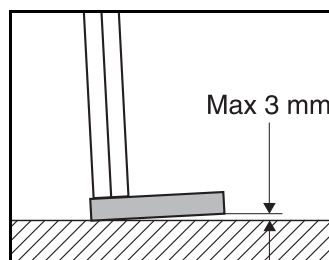

Max. tilt permitted=3 mm before tightening the screw.

## Clamp 12

**WIBE**

Used on the Cable ladder side profile for installation of accessories.

WEF-0001

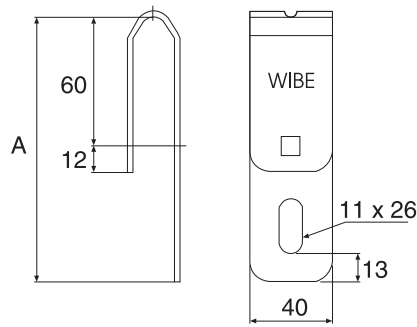
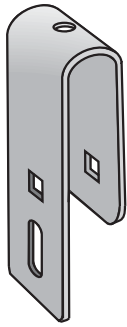

	A mm	Hot dip galv. Part. No. C*	Stainl. steel (AISI316L) Part. No. C*	ZINKPOX® White Part. No. C*	Weight kg 100 pcs
Clamp 12/70	125	728653 9	728651 5	732977 9**	19
Clamp 12/120	175	728654 6	728652 2	732978 6**	24

(screw not included)

\*EAN-code=732167+Part.no+C (control figure) \*\*Produced to order

### Use and installation

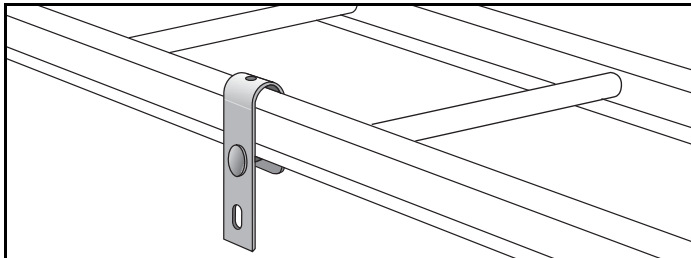

When mounted over the cable ladder side profile, Clamp 12 can be used for installation of antenna brackets, junction boxes and so on. Use Screw set 2S (for hot dip clamp) or Screw set W37 (for stainless steel clamp).

## Rod bracket 82

**WIBE**

Rod bracket 82 is adapted to fit both on Cantilever arm 50.

WEF-0001

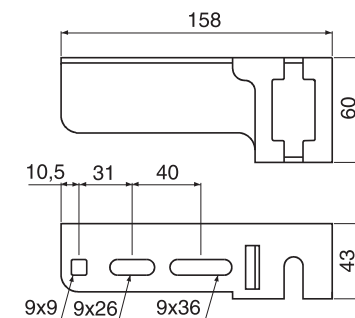
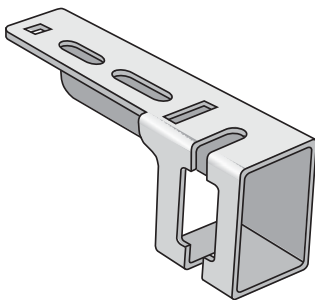

	Hot dip galv. Part. No. C*	Weight kg 100 pcs
Rod bracket 82	786768 4	360

\*EAN-code=732167+Part.no+C (control figure)

### Use and installation

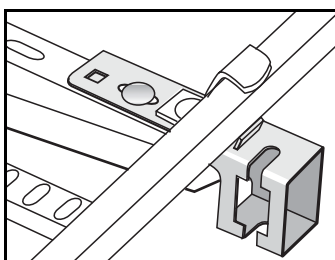

Rod bracket 82 mounted on Cantilever arm 50. Screw set 22S and Profile clamp 42 are to be used.

# Combi bracket 53

Used for mounting cable ladders and trays on seamed roofing sheet etc.

WEF-0001,-0031

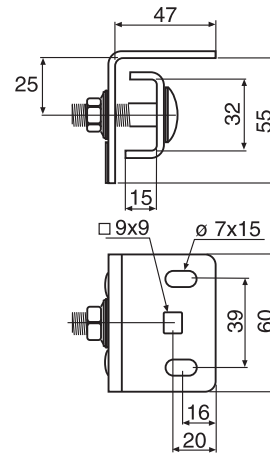
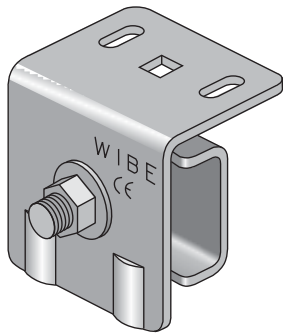

	Hot dip galv. Part. No. C*	Plastic Part. No. C*	Weight kg 100 pcs
Combi bracket 53	782353 6		26
Insulating plate 54		787223 7	2

\*EAN-code=732167+Part.no+C (control figure)

### Breaking load\*

Type of roofing sheet	Insulating plate	Permitted load
 F 1 F 2	No	F1=100 kg
 F 3 F 4	Yes	F2=50 kg
 F 3 F 4	No	F3=100 kg
 F 3 F 4	Yes	F4=50 kg

\* Loading values and fixing of roof sheet - follow the supplier's recommendations  
 Test have been made of:  
 Bandsheet Prelac BLX t=0.6 SSAB tunnplåt  
 Copper sheeting annealed SS 5015-80 t=0.6  
 Tightening torque at test=60Nm

### Use and installation

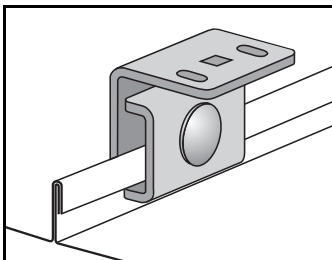

Combi bracket 53 mounted on seamed roofing sheet.

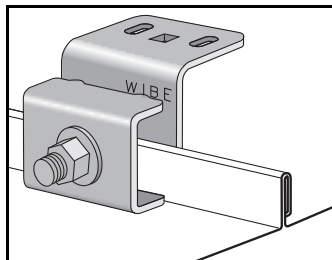

Alternative mounting of Combi bracket 53.

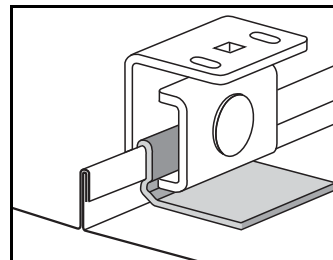

In order to avoid contact between Combi bracket 53 and copper sheeting, Insulating plate 54 must be used.

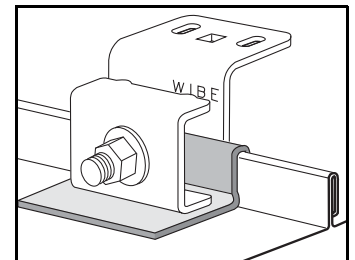

Alternative mounting of Combi bracket 53 and Insulating plate 54.

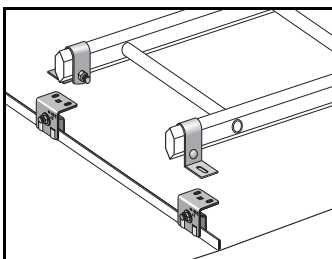

Cable ladder mounted across the seams of the roofing sheets with Combi bracket 53, Wall bracket 11/25 and Screw set 22S.

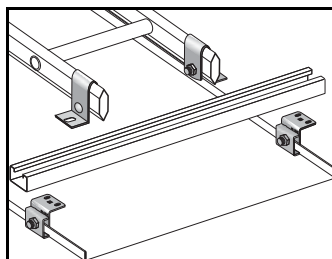

Cable ladder mounted along the seams of the roofing sheets with Combi bracket 53, Wall bracket 11/25, Screw set 22S, Pendant/Fixing rail 24/48 and T-bolt 26F.

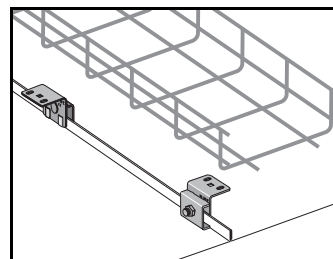

Wire tray mounted along the seams of the roofing sheets with Combi bracket 53 and accessories from the Wire tray programme.

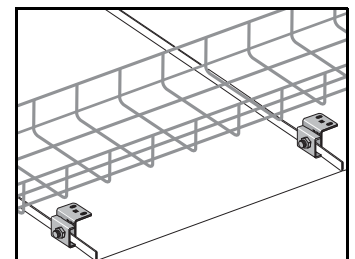

Wire tray mounted across the seams of the roofing sheets with Combi bracket 53 and accessories from the Wire tray programme.

# Hook 8

For installation of cables beneath Support bracket 3. Hooks can also be installed in perforated rungs.

WEF-0001



Hot dip galv.

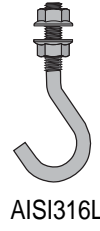
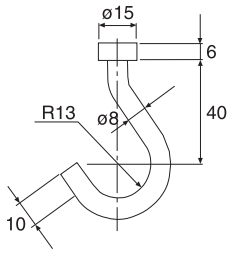

AISI316L

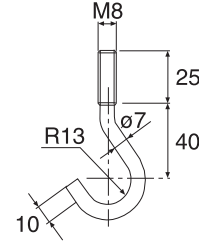

	Hot dip galv. Part. No. C*	Stainl. steel** (AISI316L) Part. No. C*	Weight kg 100 pcs
Hook 8	728642 3	728643 0	5
**2 nut M6MF8 included			
*EAN-code=732167+Part.no+C (control figure)			

## Use and installation

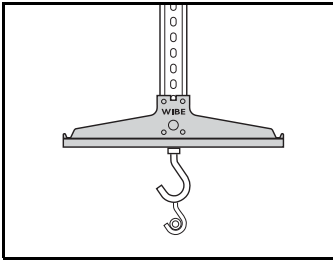

Hook 8 mounted beneath Support bracket 3 for installation of cables.

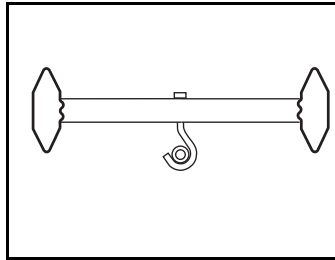

Hook 8 installed in a perforated rung.

# Ceiling bracket TF-10 and TF-16

For installation with Threaded rods.

WEF-0001

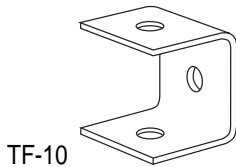

TF-10

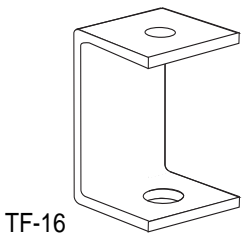

TF-16

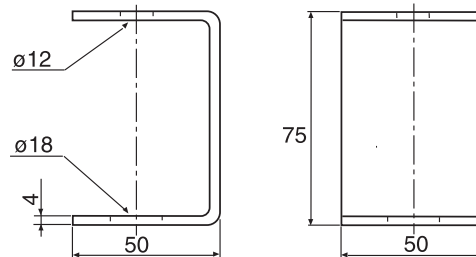
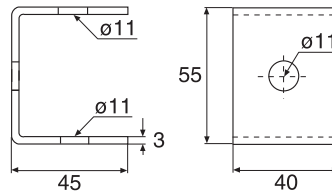

	Hot dip galv. Part. No. C*	Weight kg 100 pcs
Ceiling bracket TF-10 (nut M10 incl.)	788164 2	15
Ceiling bracket TF-16 (nut M16 incl.)	788165 9	30
*EAN-code=732167+Part.no+C (control figure)		

## Use and installation

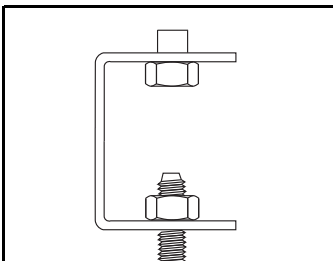

Ceiling bracket TF-10 or TF-16 installed with Threaded rod M10 or M16.

## Wall bracket 20

**WIBE**

To be used at installation of Pendant/Fixing rail 24/20 to ceiling beam or wall.

WEF-0001

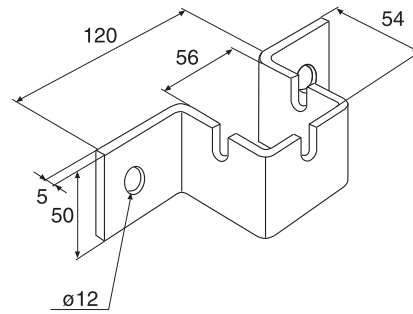
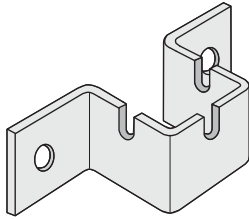

	Hot dip galv. Part. No. C*	Weight kg 100 pcs
Wall bracket 20	723450 9	47

\*EAN-code=732167+Part.no+C (control figure)

### Use and installation

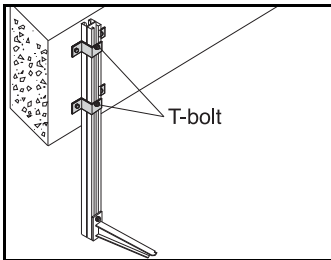

For cable ladder installations along a beam. Pendant/Fixing rail 24/20 must be mounted with 2 Wall brackets 20 and 2 T-bolts 26F-30 placed in the centre outlet. This installation is also used for fixing to wall. Max vertical load 700 kg (7 kN).

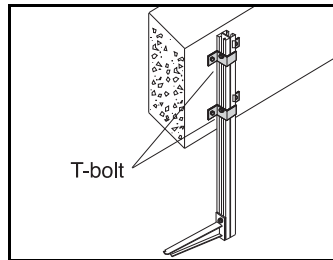

For cable ladder installations across a beam. Pendant/Fixing rail 24/20 shall be mounted with 2 Wall brackets 20 and 2 T-bolts 26F-30 in the side-outlets.

## Wall bracket 20F

**WIBE**

To be used at installation of Pendant/Fixing rail 20F to ceiling beam or wall.

WEF-0001

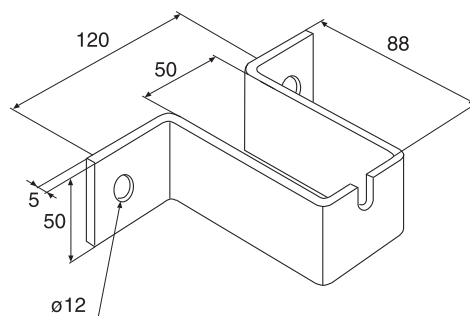
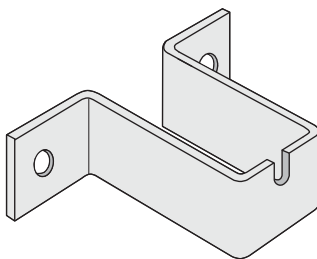

	Hot dip galv. Part. No. C*	Weight kg 100 pcs
Wall bracket 20F	723451 6	69

\*EAN-code=732167+Part.no+C (control figure)

### Use and installation

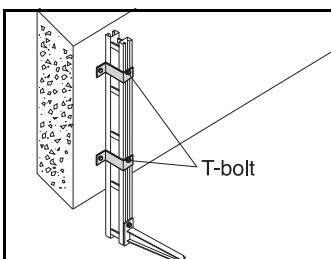

Pendant/Fixing rail 24/20F must be mounted with 2 Wall brackets 20F and 2 T-bolts 26F-30 for cable ladders along beams. This installation is also used for fixing to wall. Max. vertical load 700 kg (7 kN).

## Ceiling plate 20F

**WIBE**

Ceiling plate 20F is used as a pre-drilled attachment for Vertical piece 20F to a steel member.  
The ceiling plate is welded in position.

WEF-0001

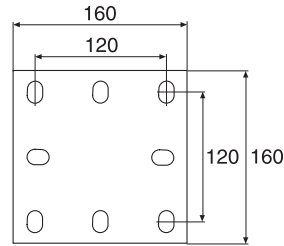
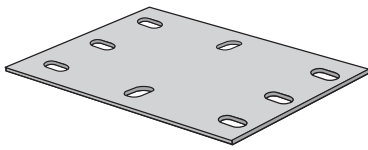

	Hot dip galv. Part. No. C*	Weight kg 100 pcs
Ceiling plate 20F	718849 9	200

\*EAN-code=732167+Part.no+C (control figure)

### Use and installation

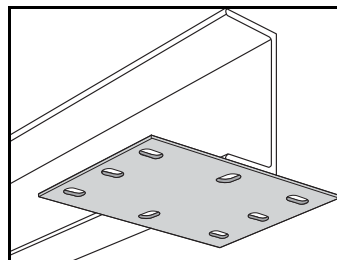
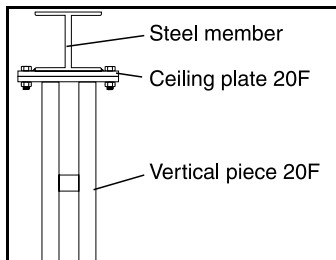

The ceiling plate is welded to the steel member. Permission to weld on the steel member is required. Remove all zinc at the weld. Post-treat using Galvafröid.

Use Ceiling plate 20F as a fully drilled attachment for Vertical piece 20F against a steel member. Secure the ceiling plate by welding. Remove all zinc at the weld. Post-treat using Galvafröid.

## Ceiling plate 20FS

**WIBE**

Ceiling plate 20FS is used as a pre-drilled attachment for Vertical piece 20FS to a steel member.  
The ceiling plate is welded in position.

WEF-0001

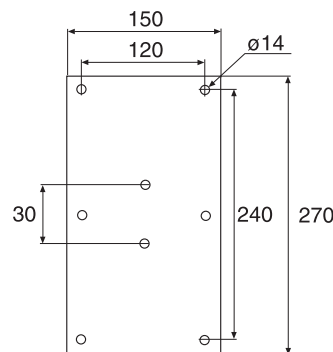
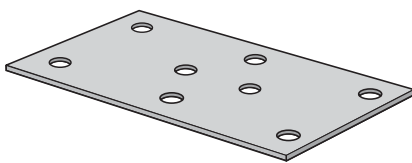

	Hot dip galv. Part. No. C*	Weight kg 100 pcs
Ceiling plate 20FS	720536 3	310

\*EAN-code=732167+Part.no+C (control figure)

### Use and installation

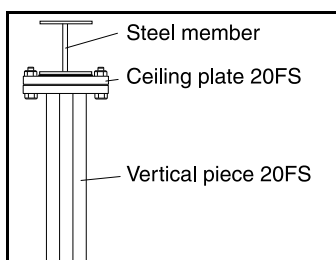

The ceiling plate is welded to the steel member. Permission to weld on the steel member is required. Remove all zinc at the weld. Post-treat using Galvafröid.

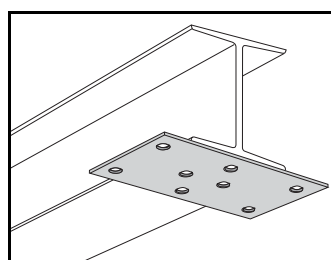

Use Ceiling plate 20FS as a fully drilled attachment for Vertical piece 20FS against a steel member. Secure the ceiling plate by welding. Remove all zinc at the weld. Post-treat using Galvafröid.



# Profile clamp 41

Profile clamp 41 is used to install a pendant/fixing rail or mounting plate etc. on the cable ladder profile.

WEF-0001

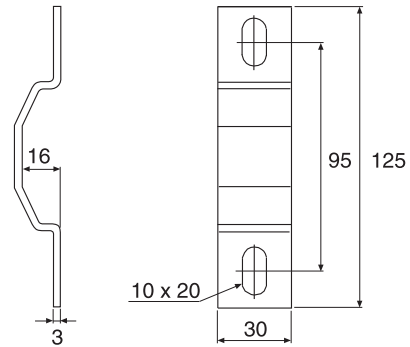
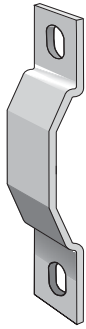

	Pre-galv. Part. No. C*	Hot dip galv. Part. No. C*	Stainl. steel (AISI316L) Part. No. C*	ZINKPOX® White Part. No. C*	Weight kg 100 pcs
Profile clamp 41	725363 0	720824 1	783374 0	721945 2	10

\*EAN-code=732167+Part.no+C (control figure)

## Use and installation

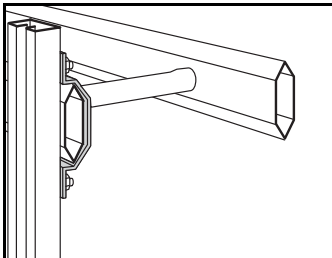

Mounting of pendant/fixing rail on cable ladder profile.  
Use Screw set 22S.

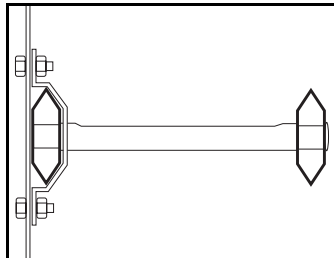

Installation of mounting plate for apparatuses.  
Use Screw set 22S.

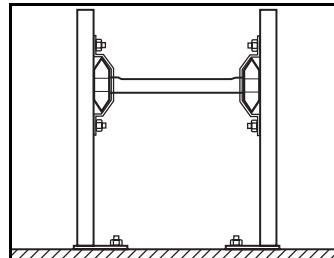

Mounting cable ladder on floor pendants. Use T-bolts against the opening of the fixing rail.

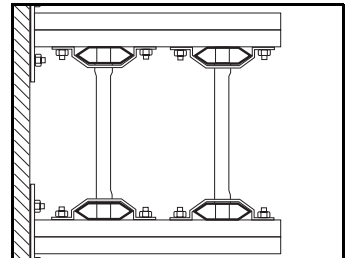

Mounting of cable ladders on wall pendants, such as in shafts. Use T-bolts against the opening of the fixing rail.

# End bracket HT-11

Used for assembling pendant/fixing rails to frames for switching cabinets and electrical control centres.  
Also suitable for assembling pendant rails for crossing cable runs.

WEF-0001

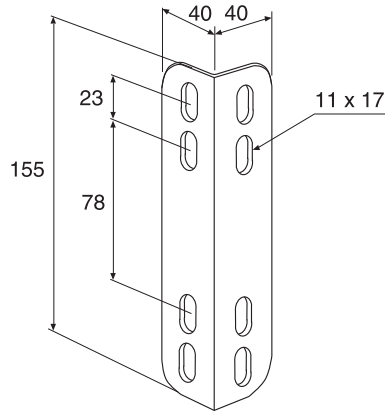
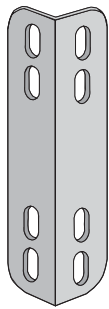

	Hot dip galv. Part. No. C*	Weight kg 100 pcs
End bracket HT-11	717618 2	41
*EAN-code=732167+Part.no+C (control figure)		

## Use and installation

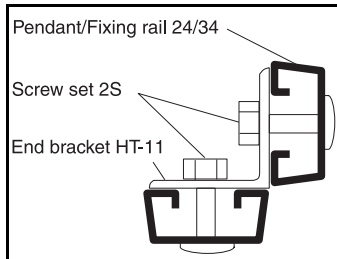

The HT-11 can be used when mounting together 2 Pendant/Fixing rail 24/34, for example when assembling a stand.

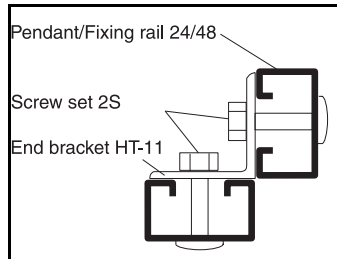

The HT-11 can be used when mounting together 2 Pendant/Fixing rail 24/48 with the opening towards the attachment, for example when assembling a stand.

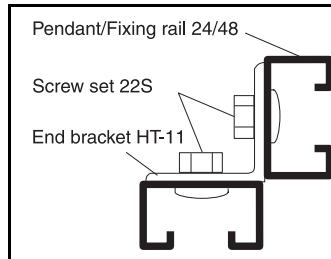

The HT-11 can be used when mounting together 2 Pendant/Fixing rail 24/48, with the rear towards the attachment.

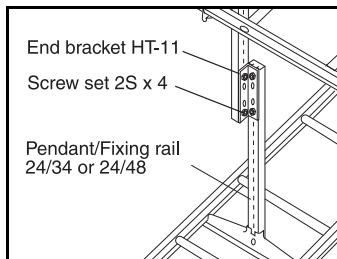

End bracket HT-11 permits mounting of crossing cable ladders in various planes on the same vertical piece.

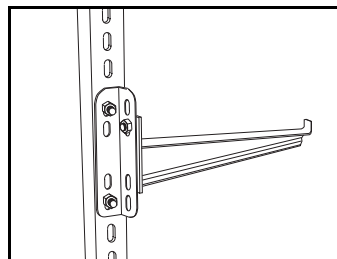

Cantilever arm 50 may, using End bracket HT-11, be mounted at 90° to the vertical piece. Only for lightweight mounting of data cable type or suchlike.

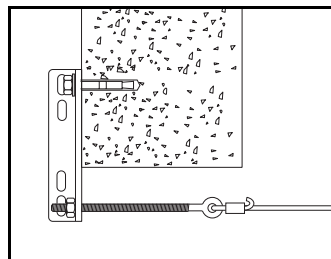

End bracket HT-11 must be installed on ceiling beams with Expansion bolts.

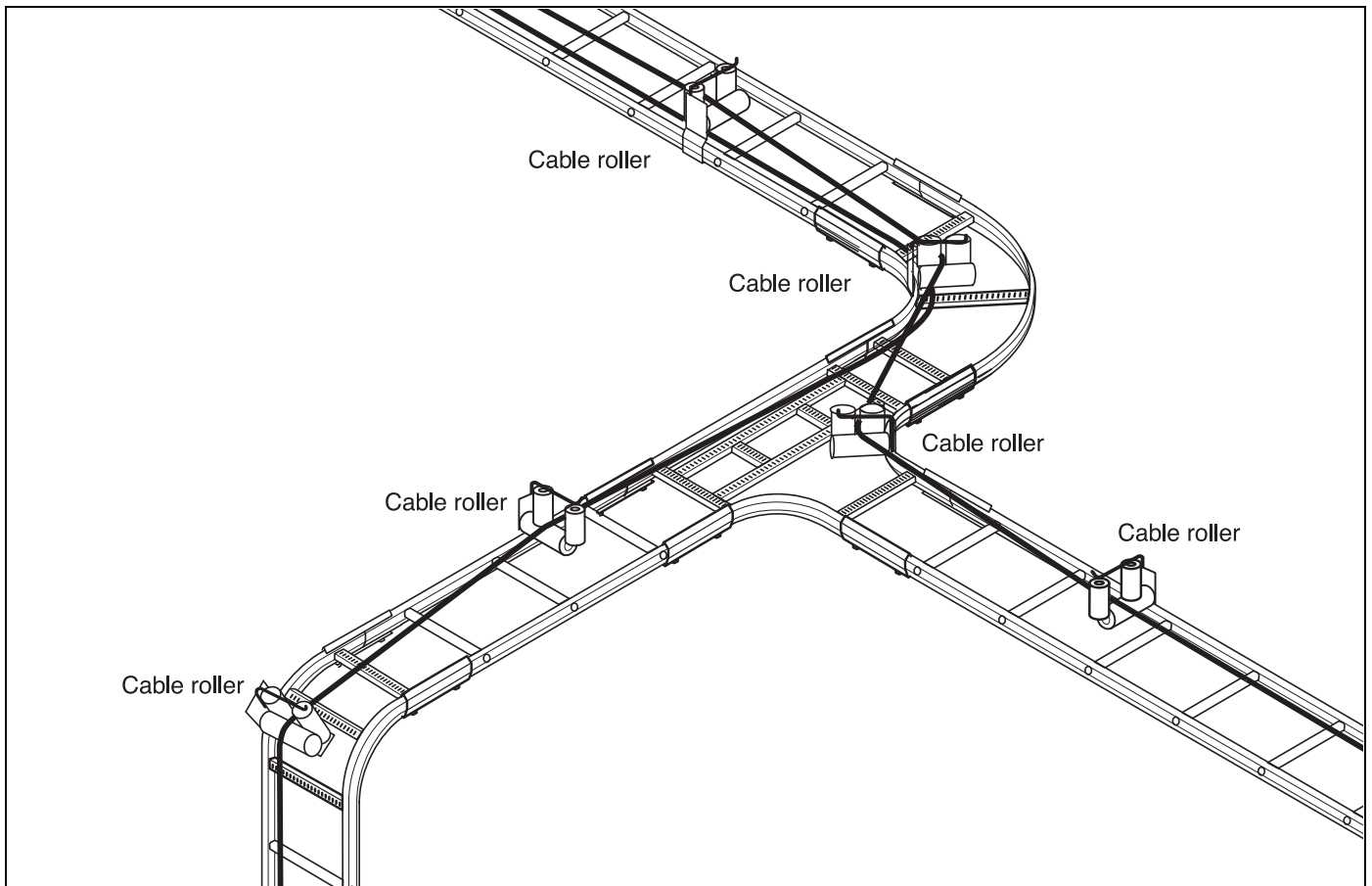

Wibe cable rollers facilitate the pulling of cables and lines. Cable rollers are easily installed on all Wibe cable ladders except the WHS-ladders (high sided). Also fits the external/internal profile of all 90° bends, T-junctions, X-junctions and risers. The cable roller has a height adjustment of 45 mm to leave room for cables to pass under the roller.

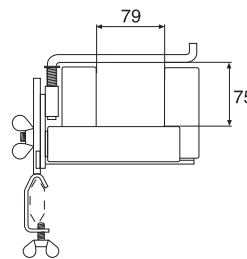
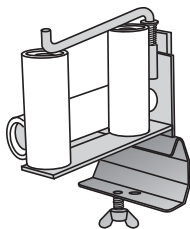

	Electro-galv. Part. No. C*	Weight kg 100 pcs
Cable roller S	718660 0	230

\*EAN-code=732167+Part.no+C (control figure)

### Loadings

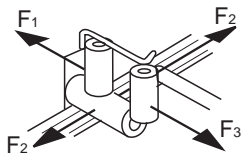

Permitted loading  $F_1=100$  kg (KHZ, KHZP, KHZV) 35 kg (KHZSP)  
 Permitted loading  $F_2=125$  kg (KHZ, KHZP, KHZV) 35 kg (KHZSP)  
 Permitted loading  $F_3=100$  kg (KHZ, KHZP, KHZV) 35 kg (KHZSP)

### Use and installation

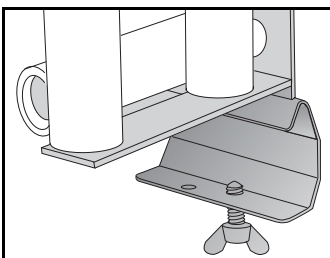

For fitting on 90°, T- and X-junctions, use the inner mounting hole.

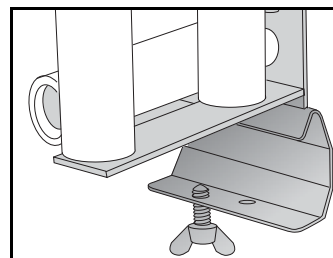

For mounting on ladders, use the outer mounting hole.

# Cable roller 38 Rig´n roll

Used for mounting on Wibe cable ladders with belonging junctions and branches.

WEF-0001

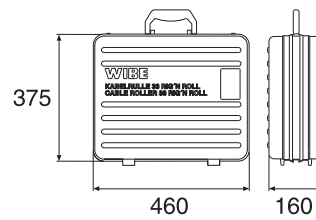
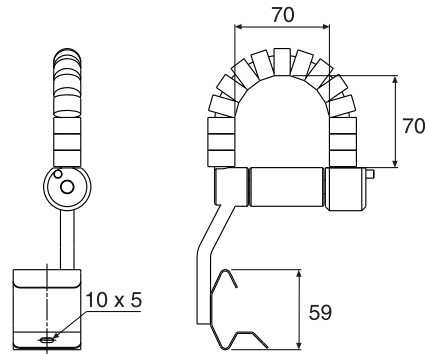
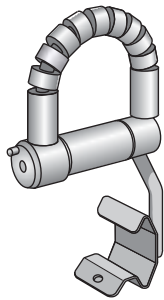

	Part. No. C*	Stainl. steel (AISI316L) Part. No. C*	Weight kg 100 pcs
Cable roller 38 Rig´n roll		735998 1	48
Bag	780186 2		230
Cable roller set 66 (1 bag+10 pcs Cable roller 38 Rig´n roll)	780187 9		710

\*EAN-code=732167+Part.no+C (control figure)

## Loadings

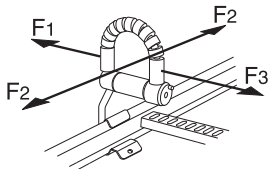

Permitted loading  $F_1=20$  kg (KHZ, KHZP, KHZV, KHZSP)  
 Permitted loading  $F_2=50$  kg (KHZ, KHZP, KHZV, KHZSP)  
 Permitted loading  $F_3=50$  kg (KHZ, KHZP, KHZV) 25 kg (KHZSP)

## Use and installation

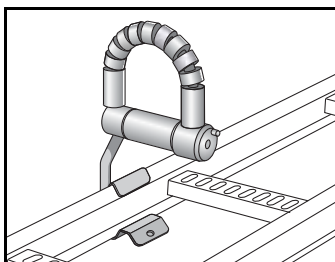

Cable roller 38 is to be mounted on the cable ladder profile.

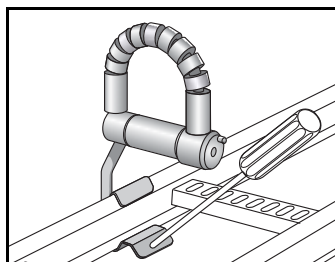

Use a screw driver when dismantling the cable roller.

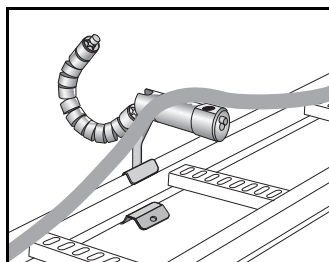

Open the cable roller by pressing the locking button and turn the loop aside.

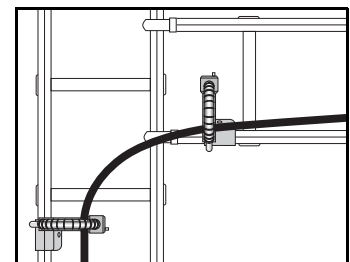

The loop has rollers which make cable pulling over bends and junctions very easy.

## Marking plate 93

A colour marking system that is easy to use when you want to mark out which type of cable that is placed on the cable ladder. 5 different colours are available.

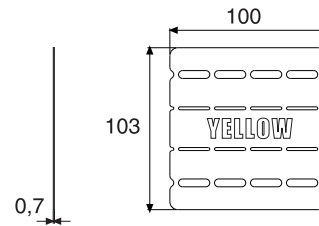
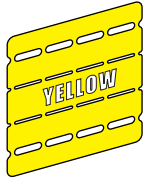
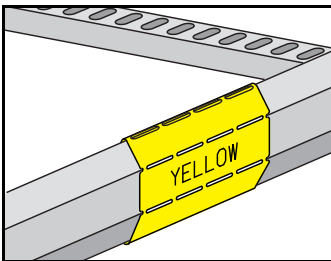

	Plate Part. No. C*	Weight kg 100 pcs
Marking plate 93, Yellow	737704 6	5
Marking plate 93, Orange	737705 3	5
Marking plate 93, Blue	737706 0	5
Marking plate 93, Green	737707 7	5
Marking plate 93, Black	737708 4	5

\*EAN-code=732167+Part.no+C (control figure)

### Use and installation



The Marking plate can be bent around the side profile on all Wibe cable ladders.

## Threaded rod W76 M10

**WIBE**

Threaded rod W76 M10 is used for installations of cable ladders KHZSP.  
Joint nut M10 is used for joining of Threaded rods W76 M10.

WEF-0001



	L mm	Electro-galv. Part. No. C*	Stainl. steel (AISI316) Part. No. C*	Electro-galv. White Part. No. C*	Weight kg 100 pcs
Threaded rod W76 M10-2000	2000	716792 0	723925 2**	718795 9**	100
Threaded rod W76 M10-3000	3000	716793 7	723926 9**	718797 3**	150
Joint nut M10		724806 3**	724807 0**		7.2

\*EAN-code=732167+Part.no+C (control figure) \*\*Produced to order

**Nut M10** for assembling of Threaded rod M10 W76 on Support bracket 6.



	Hot dip galv. Part. No. C*	Stainl. steel (AISI316) Part. No. C*	Weight kg 100 pcs
Nut M10	723938 2	723939 9	1.1

\*EAN-code=732167+Part.no+C (control figure)

### Use and installation

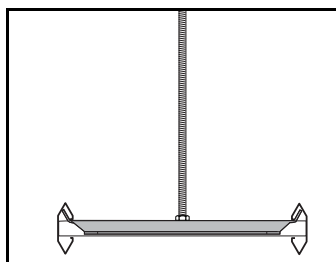

Support bracket 6 mounted with Threaded rod W76 M10.  
Nut M10 must be used.

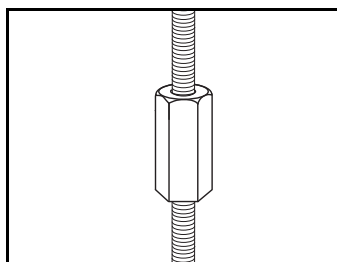

When joining two pieces of Threaded rod W76 M10 use Joint nut M10.

## Profile protection 28P

**WIBE**

Increases the contact surface of the cables, when pulled over the side profile of the ladder.

WEF-0012

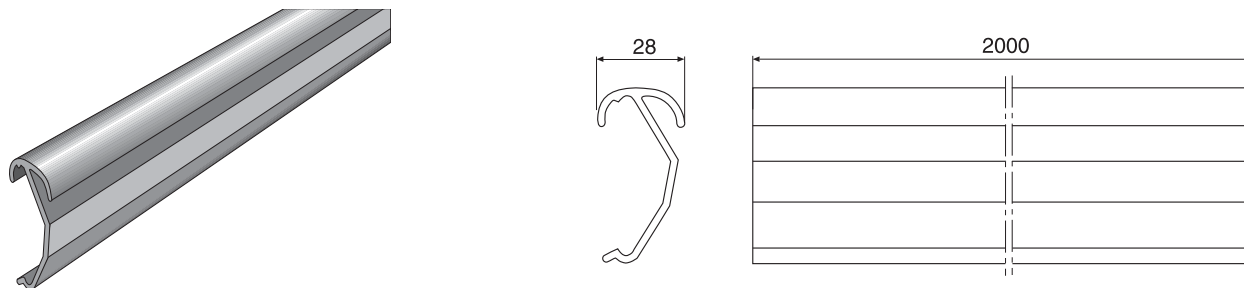

	Grey plastic Part. No. C*	Weight kg 100 pcs
Profile protection 28P	732151 3	80

\*EAN-code=732167+Part.no+C (control figure)

### Use and installation

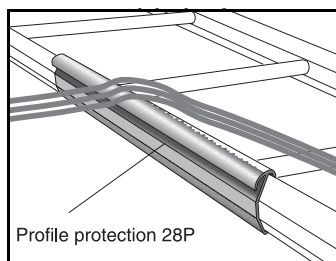

Mount Profile protection 28P in order to increase the contact surface of the cable, when pulled over the side profile of the ladder. Cut when required.

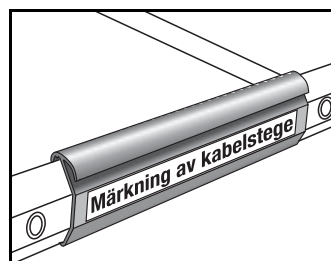
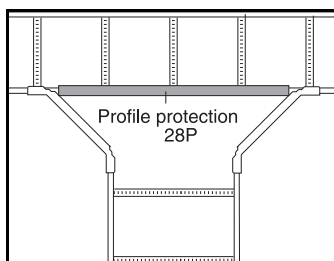

Profile protection 28P can be cut in suitable lengths and equipped with an information label. Easy to mount on the ladder side profile.

## Back plate 40

**WIBE**

For installation behind Cantilever arm 50 to reduce the surface pressure on porous walls.

WEF-0001

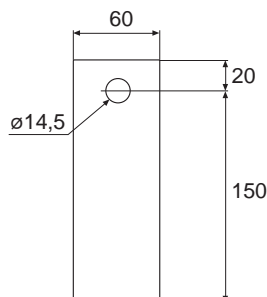

	Hot dip galv. Part. No. C*	ZINKPOX® White Part. No. C*	Weight kg 100 pcs
Back plate 40	768738 1	714029 9	55

\*EAN-code=732167+Part.no+C (control figure)

### Use and installation

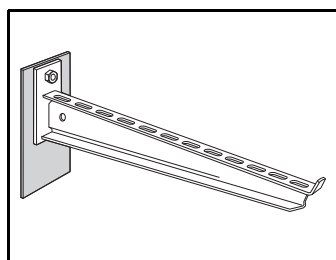

Mount Back plate 40 as shown in the illustration to reduce the surface stress on porous walls.

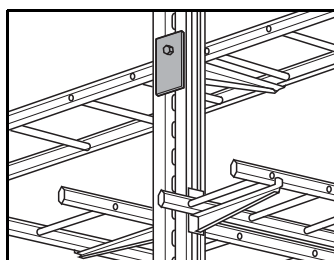

By using Back plate 40, a cantilever arm can be mounted on the side of Vertical piece 20F.

## Mounting rail 40

**WIBE**

For installation behind Cantilever arm 50 to reduce the surface pressure on porous walls.  
The rail permits vertical adjustment of the cantilever arm.

WEF-0001

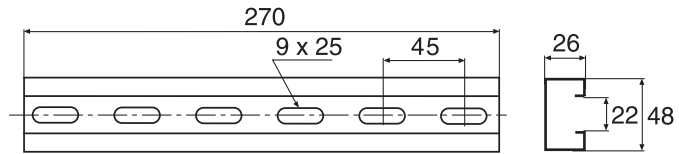
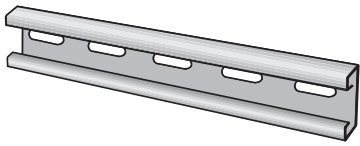

Hot dip galv.  
Part. No. C\*

ZINKPOX®  
White  
Part. No. C\*

Weight kg  
100 pcs

Mounting rail 40

717001 2

729045 1

56

\*EAN-code=732167+Part.no+C (control figure)

### Use and installation

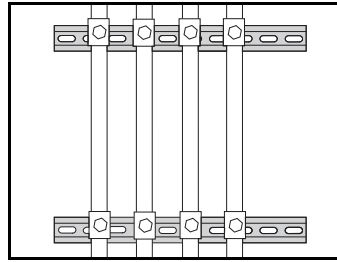
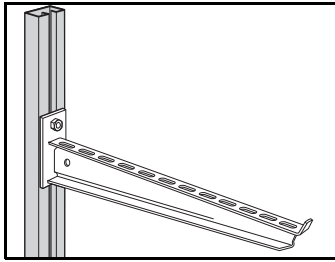

Mounting rails reduce the surface stress on porous walls. Mount the cantilever arm using T- bolt, which permits height adjustment.

Cables may be mounted on walls using Mounting rail 40 and a suitable Cable clamp Type A.

## Mounting rail WMS15

For installation directly on wall for lashing of cables.

WEF-0001

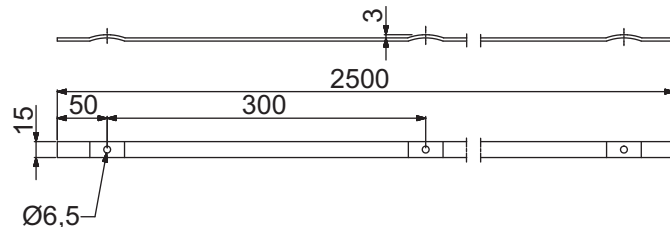
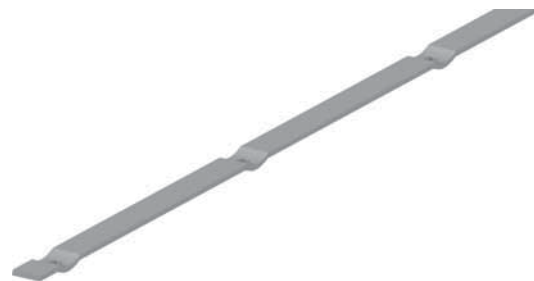

Pre-galv.  
Part. No. C\*

Hot dip galv.  
Part. No. C\*

Weight kg  
100 pcs

Mounting rail WMS15

792896 5

792895 8

88

\*EAN-code=732167+Part.no+C (control figure)

### Use and installation

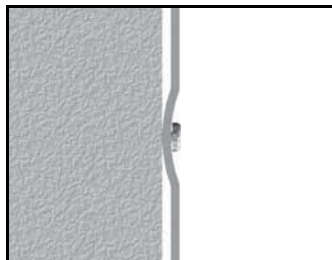
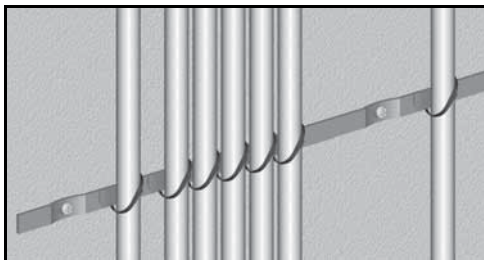

Mounting of cables with lashing wire, strips etc.

The mounting rail installed directly onto wall.



## Mounting rail WMS25

WIBE

For installation directly on wall for lashing of cables.

WEF-0001

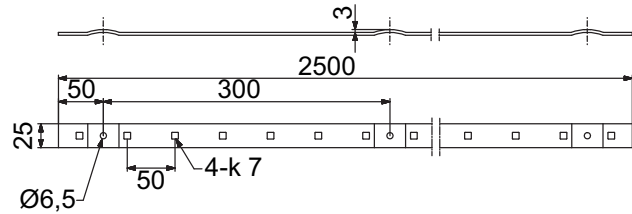

	Pre-galv. Part. No. C*	Hot dip galv. Part. No. C*	Weight kg 100 pcs
Mounting rail WMS25	792869 9	725000 4	141
*EAN-code=732167+Part.no+C (control figure)			

### Use and installation

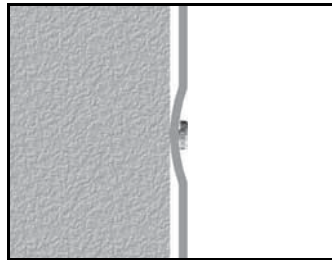
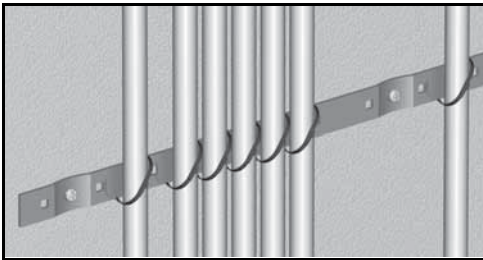

The mounting rail installed directly onto wall.

Mounting of cables with lashing wire, strips etc.

## Rail fixing support 24/20F, 24/20FS

WIBE

Used with Pendant/Fixing rails 24/20F and 24/20FS for mounting between floor and ceiling.

WEF-0001

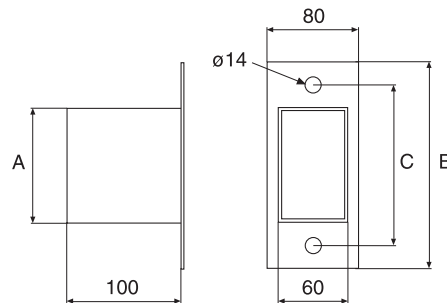
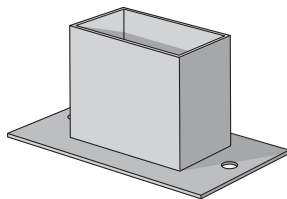

	A mm	B mm	C mm	Hot dip galv. Part. No. C*	ZINKPOX® White Part. No. C*	Weight kg 100 pcs
Rail fixing support 24/20F	100	165	135	718850 5	720527 1**	167
Rail fixing support 24/20FS	120	185	155	718851 2	720528 8**	190

\*EAN-code=732167+Part.no+C (control figure) \*\*Produced to order

### Use and installation

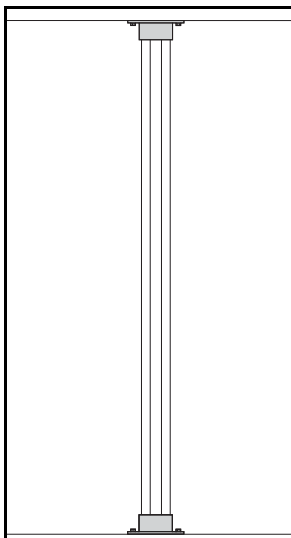

Simple mounting between floor and ceiling using 2 Rail fixing supports 20F or 20FS.

1. Mount one of the rail fixing supports in the ceiling.
2. Adjust the pendant length.
3. Mount the rail fixing support for floor mounting on the pendant.
4. Insert the pendant in the rail fixing support in the ceiling.
5. Attach the bottom rail fixing support securely to the floor.

## Cover 64

**WIBE**

Used for vertically mounted cable ladders.

WEF-0001

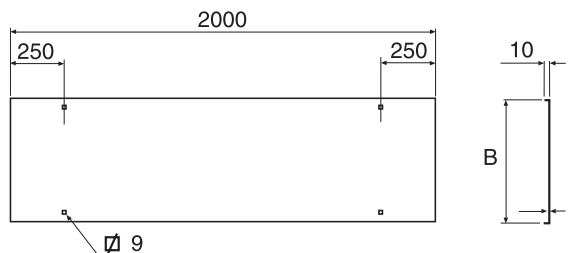
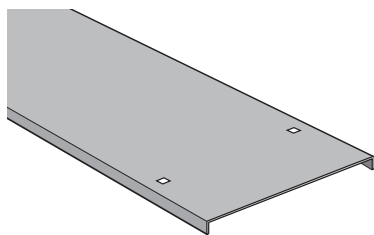

	B mm	Hot dip galv. Part. No. C*	Stainl. steel (AISI316L) Part. No. C*	ZINKPOX® White Part. No. C*	Weight kg 100 pcs
Cover 64-150	151	782561 5**	782585 1**	782569 1**	290
Cover 64-200	201	782562 2**	782586 8**	782570 7**	370
Cover 64-300	301	782563 9**	782587 5**	782571 4**	540
Cover 64-400	401	782564 6**	782588 2**	782572 1**	710
Cover 64-500	501	782565 3**	782589 9**	782573 8**	1020
Cover 64-600	601	782566 0**	782590 5**	782574 5**	1210
Cover 64-800	801	782567 7**	782591 2**	782575 2**	1660
Cover 64-1000	1001	782568 4**	782592 9**	782576 9**	2000

\*EAN-code=732167+Part.no+C (control figure) \*\*Produced to order

### Use and installation

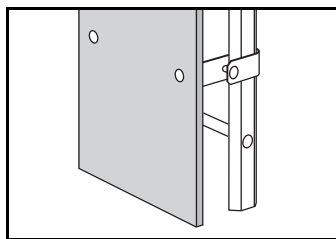

Cover 64 is to be mounted on the cable ladder with Wall bracket 11/25 or Wall bracket 11/75 and Screw set 22S. The covers are to be joined with Cover joints.

## Cover plate 65

**WIBE**

Used on vertical cable ladder installations as protection of cables near the floor.

WEF-0001

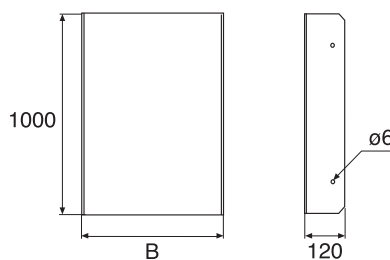
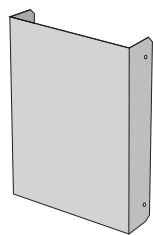

	B mm	Pre-galv. Part. No. C*	Hot dip galv. Part. No. C*	Stainl. steel (AISI316L) Part. No. C*	Pre-galv. White Part. No. C*	Weight kg 100 pcs
Cover plate 65-200	200	732475 0	730192 8	732481 1**	718909 0**	930
Cover plate 65-300	300	732476 7	730193 5	732482 8**	718910 6**	1140
Cover plate 65-400	400	732477 4	730194 2	732483 5**	718911 3**	1350
Cover plate 65-500	500	732478 1	730195 9**	732484 2**	718912 0**	1560
Cover plate 65-600	600	732479 8	730196 6	732485 9**	718913 7**	1780

\*EAN-code=732167+Part.no+C (control figure) \*\*Produced to order

### Use and installation

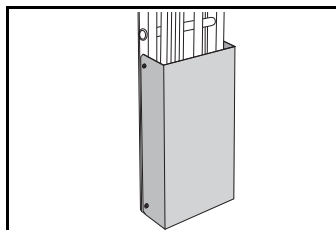

Used on vertical cable ladder installations as protection of cables near the floor. Mounted in the side profile with selftapping screw ST4.2.

## Junction box cover

**WIBE**

For mounting on cable ladder, hot dip galvanized.  
Not in stock, only on request.

WEF-0001

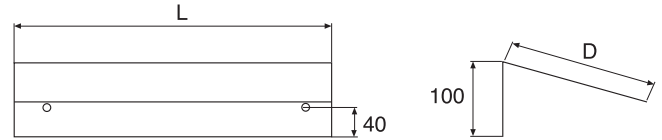
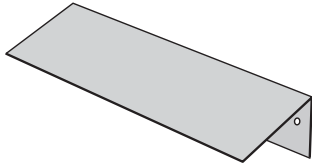

Hot dip galvanized, when ordering, please specify:  
Ladder width and the dimensions D and L

### Use and installation

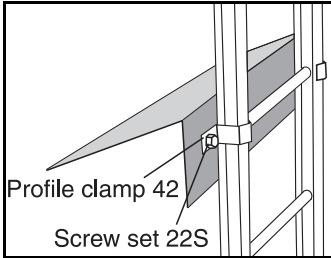

When installing Junction box cover on cable ladder use Profile clamp 42.

## Fixing tray N for casting-in

**WIBE**

A tray for casting-in with a mesh tray mounted on the inside of the tray for quick and easy lashing of cables.  
Pieces of Polystyrene at both ends makes it possible to adjust the height of the tray.  
2 fixing brackets and sealing strips are included.

WEF-0001

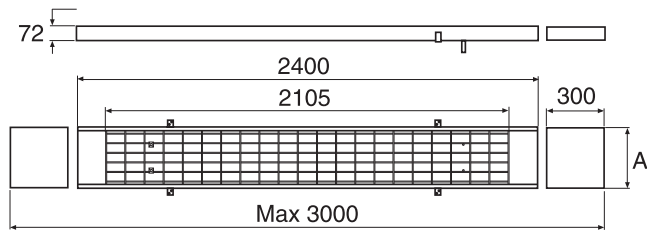
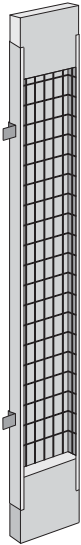

	A mm	Pre-galv. Part. No. C*	Weight kg 100 pcs
Fixing tray N-300 for casting-in	330	782695 7**	1800
Fixing tray N-400 for casting-in	430	782696 4**	2200

\*EAN-code=732167+Part.no+C (control figure) \*\*Produced to order

### Use and installation

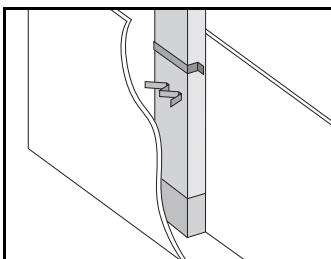

Fixing tray N for casting-in mounted in the mould.

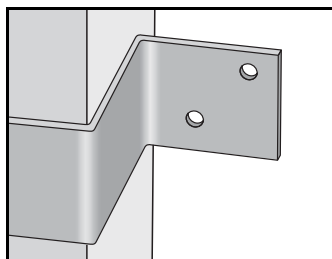

Fixing tray N adjusted onto the mould (from out- or inside) with fixing brackets.

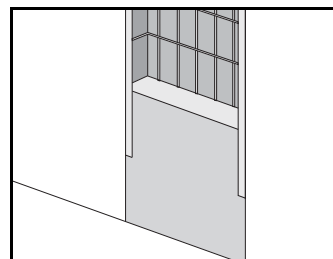

The length is adjustable to ceiling and floor by moving the pieces of Polystyrene, total height min 2400-max 3000 mm.

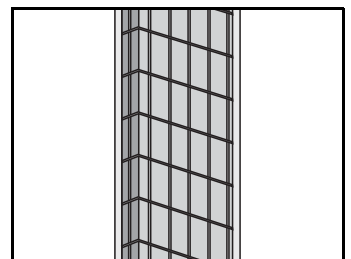

The mesh tray mounted into the Fixing tray N is used for lashing of cables.

## Repair paint

**WIBE**

Galvafröid for repair of damaged places on pre-galvanized or hot dip galvanized ladders and accessories.  
Repair paint for minor damages of powder coated products.

WEF-0013, -0016

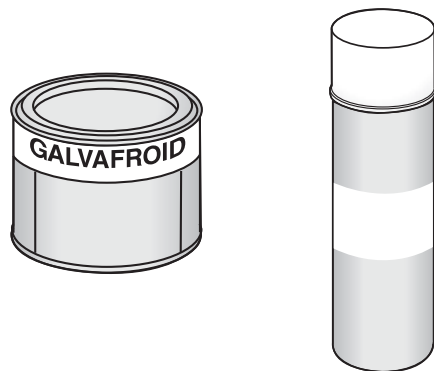

	Volume l	Part. No. C*	Weight kg 100 pcs
Anti-corrosive paint "Galvafröid", tin	0.4	717637 3	104
Repair paint White RAL 9003 Gloss 30, spray bottle	0.4	739713 6	60

\* EAN-code=732167+Part.no+C (control figure)

### Use and installation

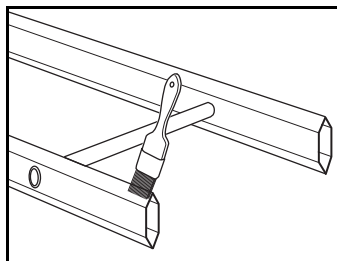

Galvafröid used to increase the protection of cut or damaged places. Applied with a colour brush.

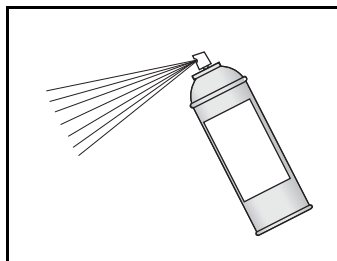

Repair paint in spray bottle for repainting of minor paint damages.

# Installation examples

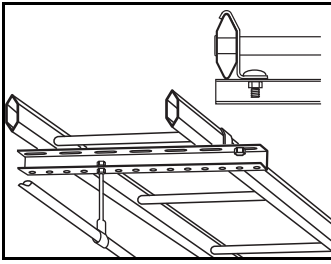

Water pipes, gas and sprinkler installations mounted on U-profile fixed with Profile clamp 42 under the ladder.

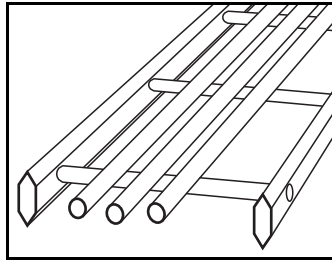

Hydraulic and pneumatic pipes are easily placed on cable ladders.

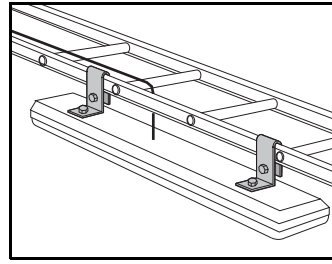

Installation of neon light fittings can easily be made with Wall bracket 11/25 or 11/75.

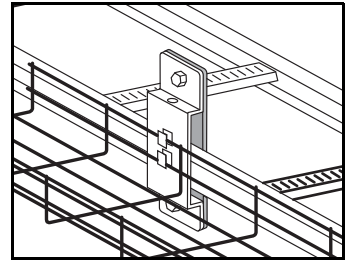

A Wire tray can easily be mounted along a cable ladder with accessories from the Wire tray program.

## Floor installations

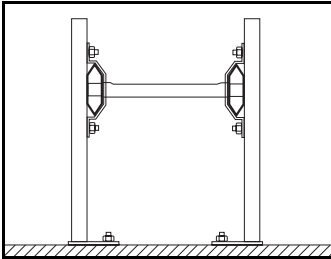

One or more cable ladders can be mounted with Vertical piece 2F, Profile clamp 41 and T-bolt.

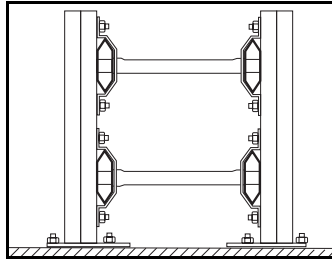

At heavy loadings several cable ladders can be mounted with Vertical piece 20, Profile clamp 41 and T-bolt.

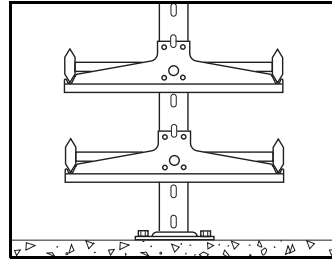

Cable ladders mounted on Vertical piece 2F and Support bracket 3.

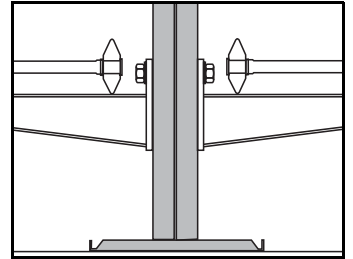

Cable ladders mounted on Vertical piece 20 and cantilever arms.

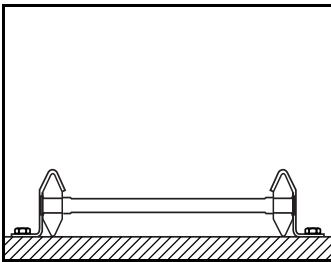

Installation of neon light fittings can easily be made with Wall bracket 11/25 or 11/75.

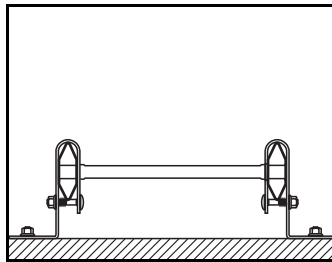

Cable ladders mounted with Wall bracket 11/25 or 11/75.

## Other installation examples

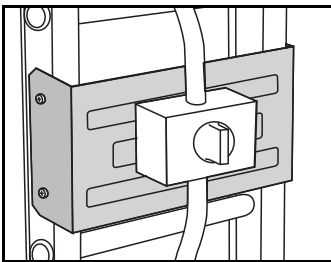

The Support bracket/joint for Wibe cable trays may very well be used as a mounting plate.

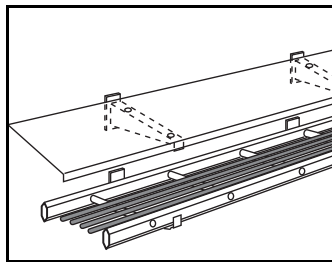

Tilted protective roofs can easily be mounted with a Cantilever arm 50F placed upside down.

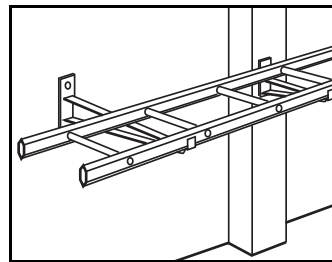

Use Cantilever arm 50/700-1000 as support when cable ladders have to pass columns etc.

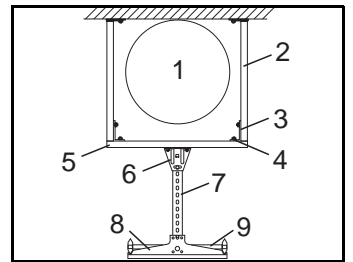

Installations under ventilation pipes and ducts:  
 1. Ventilating pipe  
 2. Vertical piece 2F  
 3. Angle bracket 5L  
 4. T-bolt  
 5. P/F-rail 24/48  
 6. Ceiling bracket 5  
 7. P/F-rail 24/34 or 24/48  
 8. Support bracket 3  
 9. Cable ladder