

Easergy MiCOM P54x (P543, P544, P545 & P546)

Current Differential Protection Relay

P54x/EN M/Yn5

Software Version	K6
Hardware Suffix	M
Date	02/2024

Technical Manual

Note The technical manual for this device gives instructions for its installation, commissioning, and operation. However, the manual cannot cover all conceivable circumstances or include detailed information on all topics. In the event of questions or specific problems, do not take any action without proper authorization. Contact the appropriate Schneider Electric technical sales office and request the necessary information.

Any agreements, commitments, and legal relationships and any obligations on the part of Schneider Electric including settlements of warranties, result solely from the applicable purchase contract, which is not affected by the contents of the technical manual.

This device **MUST NOT** be modified. If any modification is made without the express permission of Schneider Electric, it will invalidate the warranty, and may render the product unsafe.

Easergy MiCOM and the Schneider Electric logo and any alternative version thereof are trademarks and service marks of Schneider Electric.

All trade names or trademarks mentioned herein whether registered or not, are the property of their owners.

This manual is provided for informational use only and is subject to change without notice.

© 2024, Schneider Electric. All rights reserved.

CONTENTS

Chapter	Description	Document ID
SI	Safety Information	Px4x/EN SI/R14
Chapter 1	Introduction	P54x/EN IT/Yn5
Chapter 2	Technical Data	P54x/EN TD/Yn5
Chapter 3	Getting Started	P54x/EN GS/Yn5
Chapter 4	Settings	P54x/EN ST/Yn5
Chapter 5	Operation	P54x/EN OP/Yn5
Chapter 6	Application Notes	P54x/EN AP/Yn5
Chapter 7	Using the PSL Editor	Px4x/EN SE/I22
Chapter 8	Programmable Logic	P54x/EN PL/Yn5
Chapter 9	Measurements and Recording	P54x/EN MR/Yn5
Chapter 10	Product Design	Px4x/EN PD/C24
Chapter 11	Commissioning	P54x/EN CM/Yn5
Chapter 12	Test and Setting Records	P54x/EN RC/Yn5
Chapter 13	Maintenance	Px4x/EN MT/H53
Chapter 14	Troubleshooting	Px4x/EN TS/If9
Chapter 15	SCADA Communications	P54x/EN SC/Yn5
Chapter 16	Installation	Px4x/EN IN/A05
Chapter 17	Connection Diagrams	P54x/EN CD/Yn5
Chapter 18	Cyber Security	Px4x/EN CS/F34
Chapter 19	Dual Redundant Ethernet Board	Px4x/EN REB/K56
Chapter 20	Parallel Redundancy Protocol (PRP) Notes	Px4x/EN PR/F34
Chapter 21	High-availability Seamless Redundancy (HSR)	Px4x/EN HS/C33
Chapter 22	Rapid Spanning Tree Protocol (RSTP) Notes	Px4x/EN TP/B23
Chapter 23	Process Bus Notes	Px4x/EN PB/B24
Chapter 24	Firmware and Service Manual Version History	P54x/EN VH/Yn5
SG	Symbols and Glossary	Px4x/EN SG/E51

Date:	10/2022
Products covered by this chapter:	This chapter covers the specific versions of the MiCOM products listed below. This includes only the following combinations of Software Version and Hardware Suffix.
Hardware suffix:	M
Software version:	K6
Connection diagrams:	10P54302 (SH 1 to 2) 10P54303 (SH 1 to 2) 10P54304 (SH 1 to 2) 10P54400 10P54404 (SH 1 to 2) 10P54405 (SH 1 to 2) 10P54502 (SH 1 to 2) 10P54503 (SH 1 to 2) 10P54504 (SH 1 to 2) 10P54600 10P54604 (SH 1 to 2) 10P54605 (SH 1 to 2) 10P54606 (SH 1 to 2)

SAFETY INFORMATION

Chapter Applicability	
Date:	02/2024
Products covered by this chapter:	
This chapter covers the specific versions of the Easergy MiCOM products listed below. This includes only the following combinations of Software Version and Hardware Suffix.	
Hardware Suffix:	All PowerLogic P1, Easergy MiCOM P10, P20, P30, P40, P90 and C264 products
Software Version:	All PowerLogic P1, Easergy MiCOM P10, P20, P30, P40, P90 and C264 products
Connection Diagrams:	This chapter may use any of these connection diagrams:
P14x (P141, P142, P143 & P145):	10P141xx (xx = 01 to 02) 10P142xx (xx = 01 to 05) 10P143xx (xx = 01 to 11) 10P145xx (xx = 01 to 11)
P24x (P241, P242 & P243):	10P241xx (xx = 01 to 02) 10P242xx (xx = 01) 10P243xx (xx = 01)
P445:	10P445xx (xx = 01 to 04)
P34x (P342, P343, P344, P345 & P391):	10P342xx (xx = 01 to 17) 10P343xx (xx = 01 to 19) 10P344xx (xx = 01 to 12) 10P345xx (xx = 01 to 07) 10P391xx (xx = 01 to 02)
P44x (P442 & P444):	10P44101 (SH 1 & 2) 10P44201 (SH 1 & 2) 10P44202 (SH 1) 10P44203 (SH 1 & 2) 10P44401 (SH 1) 10P44402 (SH 1) 10P44403 (SH 1 & 2) 10P44404 (SH 1) 10P44405 (SH 1) 10P44407 (SH 1 & 2)
P44y (P443 & P446):	10P44303 (SH 01 and 03) 10P44304 (SH 01 and 03) 10P44305 (SH 01 and 03) 10P44306 (SH 01 and 03) 10P44600 10P44601 (SH 1 to 2) 10P44602 (SH 1 to 2) 10P44603 (SH 1 to 2)
P54x (P543, P544, P545 & P546):	10P54302 (SH 1 to 2) 10P54303 (SH 1 to 2) 10P54400 10P54404 (SH 1 to 2) 10P54405 (SH 1 to 2) 10P54502 (SH 1 to 2) 10P54503 (SH 1 to 2) 10P54600 10P54604 (SH 1 to 2)

	10P54605 (SH 1 to 2) 10P54606 (SH 1 to 2)
P547:	10P54702xx (xx = 01 to 02) 10P54703xx (xx = 01 to 02) 10P54704xx (xx = 01 to 02) 10P54705xx (xx = 01 to 02)
P64x (P642, P643 & P645):	10P642xx (xx = 1 to 10) 10P643xx (xx = 1 to 6) 10P645xx (xx = 1 to 9)
P74x (P741, P742 & P743):	10P740xx (xx = 01 to 07)
P746:	10P746xx (xx = 00 to 21)
P841:	10P84100 10P84101 (SH 1 to 2) 10P84102 (SH 1 to 2) 10P84103 (SH 1 to 2) 10P84104 (SH 1 to 2) 10P84105 (SH 1 to 2)
P849:	10P849xx (xx = 01 to 06)

Notes:

CONTENTS

	Page-
1. Safety Information	7
2. Introduction	8
3. Health and Safety	9
4. Symbols and Labels on the Equipment	11
4.1 Symbols.....	11
4.2 Labels.....	11
5. Installing, Commissioning and Servicing	12
5.1 Risk of Electric Shock using RJ45 Cables.....	15
6. De-Commissioning and Disposal	17
7. Equipment which includes Electromechanical Elements	18
8. Technical Specifications for Safety	19
8.1 Protective Fuse Rating.....	19
8.2 Protective Class.....	19
8.3 Installation Category.....	19
8.4 Environment.....	19
8.5 Humidity During Storage.....	19
9. Technical Specification for Functional Safety	21
9.1 Technical Specification for Functional Safety.....	21
9.2 General Conditions or Restrictions for use in SIL Applications.....	21
9.3 Proof Testing.....	21
9.4 Functional Safety Parameters.....	21
9.5 Random Hardware Failures (h-1).....	22
9.6 Parameters Common to All Products in Scope.....	23
9.7 Maintaining Systemic Safety Integrity.....	23
9.8 Safety Function End of Life.....	24
9.9 Fault Reporting.....	24
10. Compliance Marking for Applicable European Directives and UK Regulations	25
11. Requirements for the USA and Canada	27
11.1 Recognized and Listed Marks for North America.....	27
11.2 Information for MiCOM Relays Complying with USA & Canadian.....	27

Requirements	
11.2.1 Typical Equipment Marking.....	27
11.2.2 Rack and Panel Mounted Equipment.....	27
11.2.3 Operating Temperature.....	27
11.2.4 External Branch Circuit Protection.....	27
11.2.5 Wire Terminations (Field Wiring) - Power and Signal Circuits.....	27
11.2.6 M4 Terminal Screw Torque.....	28
11.2.7 Output Relay Ratings.....	28
11.2.8 Output Relay Contact Symbols.....	28

12. Typical Labels	29
12.1 Typical Compliance Label	29

1. SAFETY INFORMATION

Important Information

Read these instructions carefully and look at the equipment to become familiar with the device before trying to install, operate, service, or maintain it. The following special messages may appear throughout this documentation or on the equipment to warn of potential hazards or to call attention to information that clarifies or simplifies a procedure.



The addition of this symbol to a Danger or Warning safety label indicates that an electrical hazard exists, which will result in death or serious injury if the instructions are not followed.



This is the safety alert symbol. It is used to alert you to potential personal injury hazards. Obey all safety messages that follow this symbol to avoid possible injury or death.

DANGER

DANGER indicates a hazardous situation which, if not avoided, **will result in** death or serious injury.

WARNING

WARNING indicates a hazardous situation which, if not avoided, **could result in** death or serious injury.

CAUTION

CAUTION indicates a hazardous situation which, if not avoided, **could result in** minor or moderate injury.

NOTICE

NOTICE is used to address practices not related to physical injury.

Please Note

Electrical equipment should be installed, operated, serviced, and maintained only by qualified personnel. No responsibility is assumed by Schneider Electric for any consequences arising out of the use of this material.

A qualified person is one who has skills and knowledge related to the construction, installation, and operation of electrical equipment and has received safety training to recognize and avoid the hazards involved.

2. INTRODUCTION

This document and the relevant equipment documentation provide full information on safe handling, installation, testing, commissioning and operation of this equipment. This document also includes reference to typical equipment label markings.

Documentation for equipment ordered from Schneider Electric is dispatched separately from manufactured goods and may not be received at the same time as the equipment. Therefore this guide is provided to ensure that printed information which may be present on the equipment is fully understood by the recipient.

The technical data in this document provides typical information and advice, which covers a variety of different products. You must also refer to the Technical Data section of the relevant product publication(s) as this includes additional information which is specific to particular equipment.

DANGER

HAZARD OF ELECTRIC SHOCK, EXPLOSION, OR ARC FLASH

- Only qualified personnel, trained, authorized and familiar with the contents of the latest issue of the Safety Guide, Safety Information, Technical Data chapters and the equipment rating label(s) shall work on installation, connection, commissioning, maintenance or servicing of the equipment.

Failure to follow these instructions will result in death or serious injury.

You also need to make reference to the external connection diagram(s) before the equipment is installed, commissioned or serviced.

Language-specific, self-adhesive User Interface labels are provided in a bag for some equipment.

3. HEALTH AND SAFETY

The information in this part of the equipment documentation is intended to ensure that equipment is properly installed and handled in order to maintain it in a safe condition.

People

Receipt, Handling, Storage and Unpacking Relays

Although relays are of a robust construction, we recommend that you become familiar with the Installation chapter, as this describes important issues associated with receiving, handling, storage and unpacking relays.

Planning

Live and Stored Voltages

When electrical equipment is in operation, dangerous voltages will be present in certain parts of the equipment. Even if electrical power is no longer being supplied, some items of equipment may retain enough electrical energy inside them to pose a potentially serious risk of electrocution or damage to other equipment.

NOTICE

HAZARD OF EQUIPMENT DAMAGE

- Remember that placing equipment in a “test” position does not normally isolate it from the power supply or discharge any stored electrical energy.

Failure to follow these instructions could result in equipment damage.

Warnings and Barricades

Everyone must observe all warning notices. This is because the incorrect use of equipment, or improper use may endanger personnel and equipment and also cause personal injury or physical damage.

Unauthorized entry should also be prevented with suitably marked fixed barricades which will notify people of any dangers and screen off work areas.

People should not enter electrical equipment cubicles or cable troughs until it has been confirmed that all equipment/cables have been isolated and de-energised.

Electrical Isolation

Before working in the terminal strip area, all equipment which has the potential to provide damaging or unsafe levels of electrical energy must be isolated. You will need to isolate and de-energize the specific item of equipment which is being worked on.

Depending on the location, you may also need to isolate and de-energize other items which are electrically connected to it as well as those which are close enough to pose a risk of electrocution in the event of accidental physical or electrical contact.

Remember too that, where necessary, both load and line sides should be de-energized.

Before you make contact with any equipment use an approved voltage detection device to reduce the risk of electric shock.

Risk of Accidental Contact or Arc Flash

Be aware of the risk of accidental contact with hands, long hair, tools or other equipment; and be aware of the possibility of the increased risk of arc flash from areas of high voltage.

Always wear appropriate shock and arc flash personal protective equipment while isolating and de-energizing electrical equipment and until a de-energized state is confirmed.

Temporary Protection

Consider the use of temporary protective Earthing Clamps. This is required to establish and maintain de-energization when electrical equipment operates at greater than 1000 volts or there is potential for back-feed at any voltage.

Temporary protective earthing can be accomplished by installing cables designed for that purpose or by the use of intrinsic earthing clamp equipment. Temporary protective earthing clamp equipment must be able to carry maximum fault current available and have an impedance low enough to cause the applicable protective device to operate.

Restoring Power

To reduce the risks, the work plan should have a check list of things which must be completed and checks made before electrical power can be restored.

Be aware of the risk that electrical systems may have power restored to them at a remote location (possibly by the customer or a utility company). You should consider the use of lockouts so that the electrical system can be restored only when you unlock it. In any event, you should be aware of and be part of the process which determines when electrical power can be restored; and that people working on the system have control over when power is restored.

Inspect and test the electrical equipment to ensure it has been restored to a "safe" condition prior re-energizing. Replace all devices, doors and covers before turning on the power to any device.

Qualified Personnel

Proper and safe operation of the equipment depends on appropriate shipping and handling, proper storage, installation and commissioning, and on careful operation, maintenance and servicing. For this reason only qualified personnel may work on or operate the equipment.

Qualified personnel are individuals who:

- Are familiar with the installation, commissioning, and operation of the equipment and of the system to which it is being connected
- Are able to safely perform switching operations in accordance with accepted safety engineering practices and are authorized to energize and de-energize equipment and to isolate, ground, and label it
- Are trained in the care and use of safety apparatus in accordance with safety engineering practices
- Are trained in emergency procedures (first aid)

Documentation

The equipment documentation gives instructions for its installation, commissioning, and operation. However, the manuals cannot cover all conceivable circumstances or include detailed information on all topics. In the event of questions or specific problems, do not take any action without proper authorization. Contact the appropriate Schneider Electric technical sales office and request the necessary information.

4. SYMBOLS AND LABELS ON THE EQUIPMENT

For safety reasons the following symbols and external labels, which may be used on the equipment or referred to in the equipment documentation, should be understood before the equipment is installed or commissioned.

4.1 Symbols



Caution

Refer to equipment documentation



Caution

Risk of electric shock



Protective Conductor (*Earth) terminal



Functional/Protective Conductor (*Earth) terminal

Note

This symbol may also be used for a Protective Conductor (Earth) Terminal if that terminal is part of a terminal block or sub-assembly e.g. power supply.

CAUTION

HAZARD OF INJURY OR EQUIPMENT DAMAGE

- The term "Earth" used throughout this technical manual is the direct equivalent of the North American term "Ground".

Failure to follow these instructions could result in injury or equipment damage.

4.2 Labels

See the Typical Labels section for equipment labelling information.

5. INSTALLING, COMMISSIONING AND SERVICING



Manual Handling

Plan carefully, identify any possible hazards and determine whether the load needs to be moved at all. Look at other ways of moving the load to avoid manual handling. Use the correct lifting techniques and Personal Protective Equipment to reduce the risk of injury.

Many injuries are caused by:

- Lifting heavy objects
- Lifting things incorrectly
- Pushing or pulling heavy objects
- Using the same muscles repetitively

Follow European directives 89/654 EU, 89/655 EU, 89/656 EU, 90/269 EU and 90/270 EU for safety and health at work (EU-OSHA), the Health and Safety at Work, etc Act 1974, and the Management of Health and Safety at Work Regulations 1999.



Equipment Connections

Personnel undertaking installation, commissioning or servicing work for this equipment should be aware of the correct working procedures to ensure safety.

The equipment documentation should be consulted before installing, commissioning, or servicing the equipment.

Terminals exposed during installation, commissioning and maintenance may present a hazardous voltage unless the equipment is electrically isolated.

The clamping screws of all terminal block connectors, for field wiring, using M4 screws shall be tightened to a nominal torque of 1.3 Nm.

Equipment intended for rack or panel mounting is for use on a flat surface of a Type 1 enclosure, as defined by Underwriters Laboratories (UL).

Any disassembly of the equipment may expose parts at hazardous voltage, also electronic parts may be damaged if suitable ElectroStatic voltage Discharge (ESD) precautions are not taken.

If there is unlocked access to the rear of the equipment, care should be taken by all personnel to avoid electric shock or energy hazards.

! CAUTION

HAZARD OF INJURY OR EQUIPMENT DAMAGE

- Voltage and current connections shall be made using insulated crimp terminations to ensure that terminal block insulation requirements are maintained for safety.

Failure to follow these instructions could result in injury or equipment damage.

Watchdog (self-monitoring) contacts are provided in numerical relays to indicate the health of the device. Schneider Electric strongly recommends that these contacts are hardwired into the substation's automation system, for alarm purposes.

To ensure that wires are correctly terminated the correct crimp terminal and tool for the wire size should be used.

This equipment must be connected in accordance with the appropriate connection diagram.



Protection Class I Equipment

- Before energizing the equipment it must be earthed using the protective conductor terminal, if provided, or the appropriate termination of the supply plug in the case of plug connected equipment.

- The protective conductor (earth) connection must not be removed since the protection against electric shock provided by the equipment would be lost.
- When the protective (earth) conductor terminal (PCT) is also used to terminate cable screens, etc., it is essential that the integrity of the protective (earth) conductor is checked after the addition or removal of such functional earth connections. For M4 stud PCTs the integrity of the protective (earth) connections should be ensured by use of a locknut or similar.

The recommended minimum protective conductor (earth) wire size is 2.5 mm² (AWG 14) (3.3 mm² (AWG 12) for North America) unless otherwise stated in the technical data section of the equipment documentation, or otherwise required by local or country wiring regulations.

The protective conductor (earth) connection must be low-inductance and as short as possible.

All connections to the equipment must have a defined potential. Connections that are pre-wired, but not used, should preferably be grounded when binary inputs and output relays are isolated. When binary inputs and output relays are connected to common potential, the pre-wired but unused connections should be connected to the common potential of the grouped connections.



Pre-Energization Checklist

Before energizing the equipment, the following should be checked:

- Voltage rating/polarity (rating label/equipment documentation)
- Current Transformer (CT) circuit rating (rating label) and integrity of connections
- Protective fuse rating
- Integrity of the protective conductor (earth) connection (where applicable)
- Voltage and current rating of external wiring, applicable to the application



Accidental Touching of Exposed Terminals

If working in an area of restricted space, such as a cubicle, where there is a risk of electric shock due to accidental touching of terminals which do not comply with IP20 rating, then a suitable protective barrier should be provided.



Equipment Use

If the equipment is used in a manner not specified by the manufacturer, the protection provided by the equipment may be impaired.



Removal of the Equipment Front Panel/Cover

Removal of the equipment front panel/cover may expose hazardous live parts, which must not be touched until the electrical power is removed.



UL and CSA/CUL Listed or Recognized Equipment

To maintain UL and CSA/CUL Listing/Recognized status for North America the equipment should be installed using UL or CSA Listed or Recognized parts for the following items: connection cables, protective fuses/fuseholders or circuit breakers, insulation crimp terminals and replacement internal battery, as specified in the equipment documentation.

For external protective fuses a UL or CSA Listed fuse shall be used. The Listed type shall be a Class J time delay fuse, with a maximum current rating of 15 A and a minimum DC rating of 250 V DC, for example type AJT15.

Where UL or CSA Listing of the equipment is not required, a high rupture capacity (HRC) fuse type with a maximum current rating of 16 A and a minimum DC rating of 250 V DC may be used, for example Red Spot type NIT or TIA.



Equipment Operating Conditions

The equipment should be operated within the specified electrical and environmental limits. This includes humidity as well as temperature limits.

**Current Transformer (CT) Circuits**

Do not open the secondary circuit of a live CT since the high voltage produced may be lethal to personnel and could damage insulation. Generally, for safety, the secondary of the line CT must be shorted before opening any connections to it.

For most equipment with ring-terminal connections, the threaded terminal block for current transformer termination has automatic CT shorting on removal of the module. Therefore external shorting of the CTs may not be required, the equipment documentation should be checked to see if this applies.

For equipment with pin-terminal connections, the threaded terminal block for current transformer termination does NOT have automatic CT shorting on removal of the module.

**External Resistors, including Voltage Dependent Resistors (VDRs)**

Where external resistors, including Voltage Dependent Resistors (VDRs), are fitted to the equipment, these may present a risk of electric shock or burns, if touched.

**Battery Replacement**

Where internal batteries are fitted they should be replaced with the recommended type and be installed with the correct polarity to avoid possible damage to the equipment, buildings and persons.

**Insulation and Dielectric Strength Testing**

Insulation testing may leave capacitors charged up to a hazardous voltage. At the end of each part of the test, the voltage should be gradually reduced to zero, to discharge capacitors, before the test leads are disconnected.

**Insertion of Modules and PCB Cards**

Modules and PCB cards must not be inserted into or withdrawn from the equipment whilst it is energized, since this may result in damage.

**Insertion and Withdrawal of Extender Cards**

Extender cards are available for some equipment. If an extender card is used, this should not be inserted or withdrawn from the equipment whilst it is energized. This is to avoid possible shock or damage hazards. Hazardous live voltages may be accessible on the extender card.

**External Test Blocks and Test Plugs**

Great care should be taken when using external test blocks and test plugs such as the Easergy Test Block, Easergy Test Plug and MiCOM P99x types, as hazardous voltages may be accessible when using these. CT shorting links must be in place before the insertion or removal of Easergy test plugs, to avoid potentially lethal voltages.

NOTICE**HAZARD OF EQUIPMENT DAMAGE**

- When a MiCOM P992 Test Plug is inserted into the MiCOM P991 Test Block, the secondaries of the line CTs are automatically shorted.

Failure to follow these instructions could result in equipment damage.

**Fiber Optic Communication**

Where fiber optic communication devices are fitted, these use laser light. These laser-light sources should not be viewed directly, as they can cause permanent damage to eyesight. Optical power meters should be used to determine the operation or signal level of the device.



RJ45 Cable – Electric Shock Risk / Maximum Cable Length

Do not use an RJ45 cable which is longer than 10 m (32.8 ft).

This is because the ground potential may be different for the equipment at each end of the RJ45 cable. If someone was touching a conductive part of the sleeve at the other end of the cable, they could be electrocuted (which could result in death or serious injury). It is recommended that you use optical fiber cables instead of RJ45.



Product Configuration

After any modifications or download of any of the configuration files, it is the user's duty to define the list of tests to be performed before putting the relay back in service. These tests should be comprehensive enough to ensure the application of the product will not result in any unexpected behavior.

The tests to be performed will be dependent on the nature of the changes but could range from:

- A simple file comparison between application-specific settings applied to the relay and the original written application-specific setting record.

to

- Commissioning tests of the complete protection relay and functions.



Cleaning

The equipment may be cleaned using a lint free cloth dampened with clean water, when no connections are energized. Contact fingers of test plugs are normally protected by petroleum jelly, which should not be removed.

5.1 Risk of Electric Shock using RJ45 Cables

This diagram shows how a MiCOM P40 protection relay could be connected to a Stand Alone Merging Unit (SAMU), using either an optical or an RJ45 cable. When connecting devices using RJ45 wired network cables, precautions for cabling must be taken to avoid any risk of electrical shock.

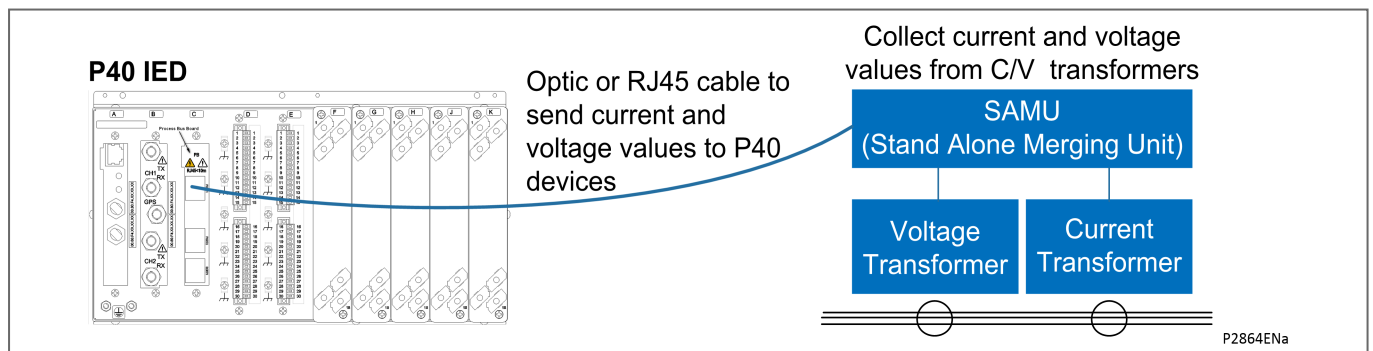

Figure 1 - Connecting a MiCOM P40 device to a SAMU

The risk arises due to the widely separated equipment having a different earth potential; and/or faults being propagated on the RJ45 cable. This diagram shows the possible risk:

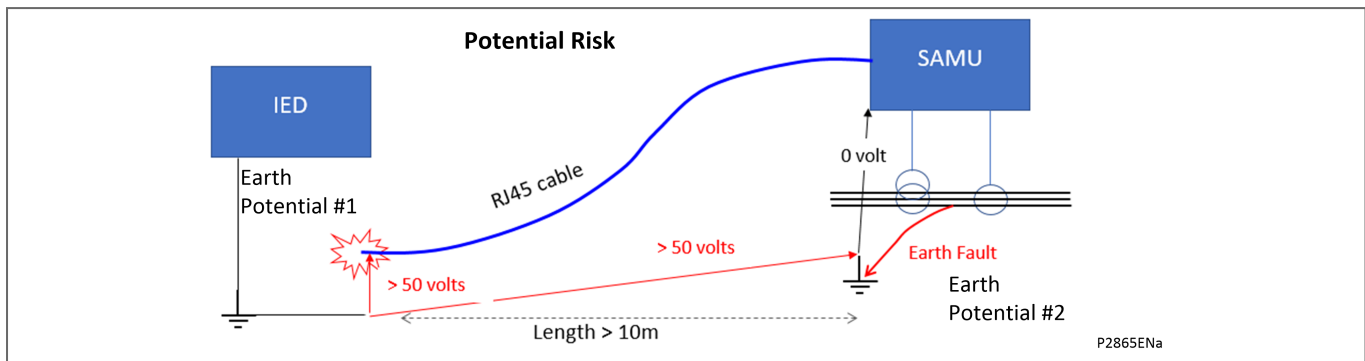

Figure 2 - RJ45 connection electric shock risk

The connection between the device and the SAMU is done using a RJ45 cable. An electric shock could occur if:

- A fault occurs on SAMU/Voltage Transformer/Current Transformer side
- There is an earth potential difference between the two locations
- An RJ45 cable is used instead of an optical cable, so that the earth potential difference and/or the fault is propagated along the RJ45 cable
- The distance from the MiCOM P40 protection relay (or a switch) to the SAMU is greater than 10 m (32.8 ft), so that there is a risk of electrical shock for someone who comes into electrical contact with the other end of the RJ45 cable (when it is disconnected from MiCOM P40 protection relay)

The latest advice for connecting a Low Power Instrument Transformer (LPIT) or a Stand Alone Merging Unit (SAMU) to an protection relay/switch is, if the distance from the protection relay/switch is:

- greater than 10 m: you must only use a fiber optic cable
- less than 10 m: you can use fiber optic or RJ45 cable

When a connection to a LPIT or SAMU is made with the RJ45 cable, this RJ45 cable must not be longer than 10 m (32.8 ft).

The reason is that, during a ground fault, the ground potential of the LPIT or the SAMU rises and is transmitted by the RJ45 cable. If someone was touching the conductive sleeve at the other end of the cable, they could be electrocuted or seriously injured.

⚡ ⚠ DANGER

HAZARD OF ELECTRIC SHOCK, EXPLOSION, OR ARC FLASH

- Do not connect items of equipment with different earth potentials with an RJ45 cable.
- Do not use RJ45 cable longer than 10 m (32.8 ft).

Failure to follow these instructions will result in death or serious injury.

6. DE-COMMISSIONING AND DISPOSAL



De-Commissioning

The supply input (auxiliary) for the equipment may include capacitors across the supply or to earth. To avoid electric shock or energy hazards, after completely isolating the supplies to the equipment (both poles of any DC supply), the capacitors should be safely discharged via the external terminals prior to de-commissioning.



Disposal

It is recommended that incineration and disposal to water courses is avoided. The equipment should be disposed of in a safe manner. Any equipment containing batteries should have them removed before disposal, taking precautions to avoid short circuits. Particular regulations within the country of operation, may apply to the disposal of the equipment.

7. EQUIPMENT WHICH INCLUDES ELECTROMECHANICAL ELEMENTS



Electrical Adjustments

It is possible to change current or voltage settings on some equipment by direct physical adjustment e.g. adjustment of a plug-bridge setting. The electrical power should be removed before making any change, to avoid the risk of electric shock.



Exposure of Live Parts

Removal of the cover may expose hazardous live parts such as relay contacts, these should not be touched before removing the electrical power.

8. TECHNICAL SPECIFICATIONS FOR SAFETY

Unless otherwise stated in the equipment technical manual, the following data is applicable.

8.1 Protective Fuse Rating

The recommended maximum rating of the external protective fuse for equipments is 16A, High Rupture Capacity (HRC) Red Spot type NIT, or TIA, or equivalent. Unless otherwise stated in equipment technical manual, the following data is applicable. The protective fuse should be located as close to the unit as possible.



HAZARD OF ELECTRIC SHOCK, EXPLOSION, OR ARC FLASH

- CTs must NOT be fused since open circuiting them may produce lethal hazardous voltages.

Failure to follow these instructions will result in death or serious injury.

8.2 Protective Class

IEC 60255-27: 2013	Class I (unless otherwise specified in the equipment
EN 60255-27: 2014	documentation). This equipment requires a protective conductor
BS EN 60255-27: 2014	(earth) connection to ensure user safety.

8.3 Installation Category

IEC 60255-27: 2013	Installation Category III (Overvoltage Category III)
EN 60255-27: 2014	Distribution level, fixed installation.
BS EN 60255-27: 2014	

Equipment in this category is qualification tested at 5 kV peak, 1.2/50 μ s, 500 Ω , 0.5 J, between all supply circuits and earth and also between independent circuits.

8.4 Environment

The equipment is intended for indoor installation and use only. If it is required for use in an outdoor environment then it must be mounted in a specific cabinet or housing which will enable it to meet the requirements of IEC 60529 with the classification of degree of protection IP54 (dust and splashing water protected).

Pollution Degree Pollution Degree 2 Compliance is demonstrated by reference to safety standards.

Altitude Operation up to 2000 m (6561 ft)

IEC 60255-27: 2013

EN 60255-27: 2014

BS EN 60255-27: 2014

8.5 Humidity During Storage

Sustained exposure to high humidity during storage may cause damage to electronics and reduce the lifetime of the equipment.

We recommend that storage humidity shall not exceed 50% relative humidity.

Once the MiCOM products have been unpacked, we recommend that they are energized within the three following months.

Where electrical equipment is being installed, sufficient time should be allowed for acclimatization to the ambient temperature of the environment, before energization.

9. TECHNICAL SPECIFICATION FOR FUNCTIONAL SAFETY

9.1 Technical Specification for Functional Safety

The following information is applicable when the MiCOM P130C, P132, P139, P141, P142, P143, P144, P145, P241, P242, P243, P341, P342, P343, P344 and P345 is used as an element in an automated safety function that is specified to achieve a Safety Integrity Level (SIL).

The reliability of the MiCOM P130C, P132, P139, P14x, P24x, P34x has been analysed in accordance with IEC 61508 for use in SIL applications.

The information in this Safety Guide is intended to support the safety system integration phase in accordance with IEC 61508 (and to be available to those performing the system 'lifecycle phases' that follow) to enable the safety function(s) achieve the specified SIL. The information only applies to the specified products; the actual SIL achieved will depend on many system considerations that are outside the scope of this safety manual.

9.2 General Conditions or Restrictions for use in SIL Applications

1. Safety functions are intended to be automated. Any non-specified manual interaction that could interfere with the safety function during operation should be protected from inadvertent use.
2. The MiCOM P130C, P132, P139, P14x, P24x, P34x are not to be used in environments beyond claimed specification.
3. The instructions contained in this Safety Guide (or referred to in associated user documentation) should be strictly complied with to provide the correct level of systematic safety integrity.
4. Failure modes of the MiCOM P130C, P132, P139, P14x, P24x, P34x that are classified as 'dangerous detected' (quantified by the value λ_{DD}) shall result in a safe action with respect to the hazard(s) being controlled or be repaired within the time assumed in the PFD calculations.

9.3 Proof Testing

The MiCOM P130C, P132, P139, P14x, P24x, P34x shall be periodically proof tested, preferably in the installation, by a qualified person familiar with the operation of the device, to verify all aspects of the functional specification required for the application when it is used in 'low demand' safety functions. Low demand is defined in IEC 61508-4 as a demand to act less frequently than once a year.

A suitable proof test interval (T_i) should be used to achieve the required average probability of failure on demand (PFD_{AVG}). A nominal interval of 8,760 hrs (1 year) and Mean Time To Repair (MTTR) of 8 hours has been used in the calculations for PFD_{AVG} illustration purposes.

9.4 Functional Safety Parameters

The MiCOM P130C, P132, P139, P14x, P24x, P34x have been assessed by CML B.V. (Notified Body number 2776) and by CMLEx (approved body number 2503) and found to comply with the functional safety requirements of IEC 61508-2:2010 clause 7.4.4.1.3 (Route 2H) and 7.4.10 (Route 2S / 'proven in use') for use in SIL 1 safety functions. This was done in accordance with the article 1(b) of ATEX Directive 2014/34/EU and with the Article 3 (b) part I of the UK regulation SI 2016 No. 1107 (as amended by UKSI 2019:696) for an intended use outside potentially explosive atmospheres. These are required for, or contributing to, the safe functioning of equipment and protective systems with respect to the risks of explosion, when used in accordance with the user documentation and subject to special conditions for safe

use specified in Section 14 of EU Type Examination Certificate CML 18ATEX3008X and in the Section 14 of UK Type Examination Certificate CML 21UKEX31194X.

Feeder management and Bay Control relays:	P130C, P132, P139	All versions since 2011
Feeder management relays:	P141, P142, P143, P144, P145	All versions since 2011
Motor protection relays:	P241, P242, P243 All versions since 2011	All versions since 2011
Generator protection relays:	P341, P342, P343, P344, P345	All versions since 2011

Element safety function (common to all relays):	To monitor the current supplied to electrical equipment in a hazardous area and isolate the equipment if a fault condition occurs that may lead to an ignition source.
--	--

Product specification:	Refer to Technical Manual for each product type.
-------------------------------	--

Random hardware failures:	The assessment confirms the following quantitative reliability data (failure rates in h^{-1})
----------------------------------	--

9.5 Random Hardware Failures (h^{-1})

Product [Note 1]	Dangerous failure rate λ_D [Note 2]	Diagnostic coverage [Note 3]	Dangerous Undetected failure rate λ_{DU}	Dangerous Detected failure rate λ_{DD}	PFD _{AVG} [Note 4]	PFD _{AVG} [Note 5]	ATEX	SIL1
P130C	$7.87 E^{-07}$	60%	$3.15 E^{-07}$	$4.72 E^{-07}$	$4.00 E^{-03}$	$6.48 E^{-03}$	Yes	Yes
P132	$6.67 E^{-07}$	60%	$2.67 E^{-07}$	$4.00 E^{-07}$	$3.39 E^{-03}$	$5.50 E^{-03}$	Yes	Yes
P139	$1.18 E^{-06}$	60%	$4.74 E^{-07}$	$7.10 E^{-07}$	$6.02 E^{-03}$	$9.75 E^{-03}$	Yes	Yes
P14x	$4.28 E^{-07}$	60%	$1.71 E^{-07}$	$2.57 E^{-07}$	$2.18 E^{-03}$	$3.53 E^{-03}$	Yes	Yes
P24x	$4.82 E^{-07}$	60%	$1.93 E^{-07}$	$2.89 E^{-07}$	$2.45 E^{-03}$	$3.97 E^{-03}$	Yes	Yes
P34x	$5.31 E^{-07}$	60%	$2.12 E^{-07}$	$3.18 E^{-07}$	$2.70 E^{-03}$	$4.37 E^{-03}$	Yes	Yes

Note 1
Refer to full list of products ('Product Identification' above) in scope where "x" appears

Note 2
Worst case assumptions have been used to classify a "dangerous failure"

Note 3
Diagnostic coverage is conservatively estimated by analysis of the design

Note 4
Calculated assuming proof test interval 8,760 hours and MTTR 8 hours

Note 5
Calculated assuming proof test interval 8,760 hours and MTTR 8 hours and proof test coverage factor of 90%, mission time 20 years

9.6 Parameters Common to All Products in Scope

Safe failure fraction (SFF):	Not assessed. The SFF parameter is not required for the 'Route 2H' compliance option in IEC 61508-2
Diagnostic coverage (DC):	60% (proportion of dangerous failures in the product that are self-diagnosed)
Type classification (A/B):	'Type B' in accordance with IEC 61508-2, 7.4.4.1.3 (contains some complex components whose fault behavior cannot be completely determined)
Architectural constraints:	SIL 1 in accordance with the Route 2H method with a hardware fault tolerance (HFT) = 0
Systematic capability:	SC 1 which limits an application that uses this product to no higher than SIL 1
Demand mode:	Safety function applications are expected to be low demand (greater than 1 year between demands)
Restrictions, conditions and general information:	<ul style="list-style-type: none"> Refer to information in this Safety Guide and the relevant product Technical Manual for all conditions, restrictions in use, installation, maintenance, test and all other functional safety related information. It is the responsibility of the system designer, installer and end user to ensure a specified safety integrity level (SIL) is achieved by reference to the data in this document and adhering to all the conditions and restrictions herein. Use of this data to ensure safety functions meet a specified SIL should only be made by persons who are competent in the functional safety activities they are performing. Cyclic diagnostic test intervals assume the process safety time is 50ms (although in some cases trip time can increase due to intentional time delays within the protection function). The watchdog relay is energized during normal operation and is de-energized with its contacts closed (for monitoring by the SCADA system) in the event of a fault.
Restrictions when using the MiCOM P30 and P40 in hazardous area applications:	<ul style="list-style-type: none"> No use shall be made of binary inputs to ensure the safety function is not interfered with. No reliance of data from communication interfaces shall be made to perform the safety function. Tripping of the circuit breaker shall be made directly using an output contact from the protection relay. (As contact allocation is configurable it is possible to assign multiple contacts to this tripping function to mitigate risk of contact failure as the external contact operation is not directly able to be monitored). Unauthorised access to the device configuration shall be prevented through the use of physical protection and/or password control. Protection functions using data from thermal or other sensors are not considered as safety functions. (RTD or CLIO inputs).

9.7 Maintaining Systemic Safety Integrity

The systematic safety integrity of MiCOM products listed in this section meet the requirements of SIL1 when the products are installed, used and maintained in accordance with the product and safety manuals.

To maintain functional safety and systematic safety integrity a suitable proof testing interval; 8,760 operational hours has been used for calculation, should be used. In view of the critical nature of protective and control equipment, and their infrequent operation, it is desirable to confirm that the equipment is operating correctly at regular interval periods following installation. Although MiCOM relays are self-supervising and therefore require less maintenance than earlier designs, periodic checks are necessary to ensure the equipment is functioning correctly and to ensure external wiring to the equipment remains intact. It is

particularly important to check the equipment for alarms, the functionality of opto-isolated inputs and relay outputs and measurement accuracy to prove the product calibration is maintained.

The product specific commissioning and maintenance guides should be followed to confirm that equipment is operating within specification. The maintenance results should be assessed against the original commissioning results (or previous maintenance results), any deviation outside tolerance should result in appropriate corrective action being taken.

Equipment repair or replacement should follow the recommendation of the maintenance chapter found in the specific product manual.

9.8 Safety Function End of Life

When a product has reached the end of its useful service life, a mission time of 20 years has been used for the purposes of calculation, the product must be disposed according to the legislation of the local country. MiCOM products are in the scope of European Union Directive 2012/19/EU on Waste Electrical and Electronic Equipment (WEEE) Regulations 2013. For Product End of Life Instructions, the documentation found on the Schneider Electric web site should be followed.

9.9 Fault Reporting

Any goods returned to Schneider Electric will require an RMA number which can be initiated by contacting a Technical Support Representative or the local country Sales Representative.

If a fault has been determined with a product the following details are required by Technical Support

- Contact name, email address and phone number
- Company name
- Serial number of unit(s)
- Model number of unit(s)
- Brief description of the problem(s)
- Invoice address
- Shipping address (if it is not the same as above)

A form with the assigned RMA number, along with details of the problem will be emailed to the contact email provided. All information on the form should be verified, the form should be included with the product(s) being returned. The RMA number must be marked on the outside of the box.

Schneider Electric warranty does not cover failures due to incorrect installation, misuse, abnormal operating conditions or lack of routine maintenance.

10. COMPLIANCE MARKING FOR APPLICABLE EUROPEAN DIRECTIVES AND UK REGULATIONS

The following European directives may be applicable to the equipment, if so it will carry the relevant marking(s) shown below:



For the Low Voltage Directive (LVD) 2014/35/EU, the following product specific harmonized standard was used to establish product safety compliance:

EN 60255-27:2014

For the Electromagnetic Compatibility Directive (EMCD) 2014/30/EU, the following product specific harmonized standard was used to establish the EMC compliance:

EN 60255-26:2013

For the restriction of the use of certain hazardous substances in electrical and electronic equipment (ROHS) Directive 2015/863/EU, the following harmonized standard was used to establish ROHS compliance:

EN IEC 63000:2018

The compliance is demonstrated via Technical Files, with reference to product safety and EMC standards.

Where applicable:

Equipment and protective systems intended for use in potentially explosive atmospheres European directive 2014/34/EU and UK regulations SI 2016 No. 1107 (as amended by SI 2019:696)

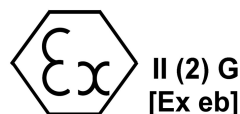

The equipment is compliant with Article 1(b) of ATEX Directive 2014/34/EU and with Article 3 (b) part I of the UK regulation SI 2016 No. 1107, amended by SI 2019 No. 696. It is approved for use outside potentially explosive atmospheres. It is required for the safe operation of 'Increased Safety - Ex eb' protected electrical machines, when used in accordance with the user documentation and subject to special conditions for safe use specified in Section 14 of EU Type Examination Certificate CML 18ATEX3008X and in the Section 14 of UK Type Examination Certificate CML 21UKEX31194X.

The following UK regulations may be applicable to the equipment, if so it will carry the relevant marking(s) shown below:



For the electrical equipment (safety) regulations SI 2016 No. 1101, the following product specific designated standards were used to establish product safety compliance:

BS EN 60255-27:2014

For the Electromagnetic Compatibility regulations SI 2016 No. 1091, the following product specific designated standard was used to establish the EMC compliance:

BS EN 60255-26:2013

For the restriction of the use of certain hazardous substances in electrical and electronic equipment (ROHS) regulations, SI 2012 No. 3032, the following standard was used to establish ROHS compliance:

BS EN IEC 63000:2018



HAZARD OF INJURY OR EQUIPMENT DAMAGE

- Equipment with this marking is not itself suitable for operation within a potentially explosive atmosphere.

Failure to follow these instructions could result in injury or equipment damage.

Compliance demonstrated through the following documents:

- EN 50495:2010 / BS EN 50495:2010
- EN 60079-7:2015 / BS EN 60079-7:2015+A1:2018
- EN 60079-14:2003 / BS EN 60079-14:2014
- EN ISO/IEC 80079-34:2018 / BS EN ISO/IEC 80079-34:2020
- EU Type Examination Certificate CML 18ATEX3008X
- UK Type Examination Certificate CML 21UKEX31194X

Equipment and Protective Systems Intended for Use in Potentially Explosive Atmospheres Classification:

Group II - equipment intended for use in potentially explosive atmospheres, except in mines.

(2) - Category 2 equipment intended for use in areas in which potentially explosive atmospheres are likely to occur. The number shown in brackets means that the equipment is approved for use outside potentially explosive atmospheres but are required for or contributing to the safe functioning of equipment and protective systems with respect to the risks of explosion.

G - equipment contributing to the safe functioning of equipment and protective systems with respect to the risks of explosion in gas zones 1 and 2.

[Ex eb] – Increased Safety electrical machines - additional measures are applied and employed so as to give increased security against the possibility of excessive temperatures and of the occurrence of arcs and sparks in normal service or under specified abnormal conditions.

For more information regarding CE documentation, please contact:



Schneider Electric Industries SAS

35 rue Joseph Monier
92500 Rueil-Malmaison
FRANCE

For more information regarding UKCA documentation, please contact:



Schneider Electric Limited

Stafford Park 5
Telford, TF3 3BL
UNITED KINGDOM

11. REQUIREMENTS FOR THE USA AND CANADA

11.1 Recognized and Listed Marks for North America

CSA	Canadian Standards Association
UL	Underwriters Laboratory of America

If applicable, the following marks will be present on the equipment:



UL Recognized to UL (USA) requirements



UL Recognized to UL (USA) and CSA (Canada) requirements



UL Listed to UL (USA) requirements



UL Listed to UL (USA) and CSA (Canada) requirements



Certified to CSA (Canada) requirements

11.2 Information for MiCOM Relays Complying with USA & Canadian Requirements

11.2.1 Typical Equipment Marking



Listed by UL for compliance with USA and Canadian requirements.
UL = Underwriters Laboratories Inc.

11.2.2 Rack and Panel Mounted Equipment

The MiCOM protection relay ranges are intended for use on a flat surface of a Type 1 enclosure, as defined by Underwriters Laboratories Inc. (UL).

11.2.3 Operating Temperature

The maximum rated continuous operating temperature, in surrounding air, of the equipment is 55 °C (131 °F).

Pollution Degree – Pollution Degree 2

11.2.4 External Branch Circuit Protection

For external protective fuses a UL or CSA Listed or Recognized fuse and fuseholder shall be used. The fuse type shall be a Class J time delay fuse, with a maximum current rating of 15 A and a minimum rating of 250 V DC and 250 V AC, for example type AJT15.

Where UL or CSA Listing of the equipment is not required, a high rupture capacity (HRC) fuse type with a maximum current rating of 16 A and a minimum DC rating of 250 V DC and 250 V AC may be used, for example Red Spot type NIT or TIA.

11.2.5 Wire Terminations (Field Wiring) - Power and Signal Circuits

Equipment wire terminations for power circuits shall be made using UL/CSA Listed wire and suitable insulated pressure/crimp terminals or terminal kits only.

These shall have a minimum temperature rating of 75 °C (167 °F).

The minimum wire size used shall be:

Relay Protective Ground/Earth Conductor:	AWG 12 (3.3 mm ²) for North America, AWG 14 (2.5 mm ²) elsewhere
Current Transformers (CTs):	AWG 12 (3.3 mm ²) for North America, AWG 14 (2.5 mm ²) elsewhere
Auxiliary Supply, Vx:	AWG 16 (1.5 mm ²)
EIA (RS) 485 Port (See Note 1):	AWG 22 (0.25 mm ²)
Low voltage signal circuits (e.g. RTD) (See Note 2)	AWG 22 (0.25 mm ²) using screw clamp connectors
Other Circuits (See Note 3):	AWG 18 (1.0 mm ²)

Note 1
Pressure/crimp push-on or ring or pin terminals may be used for communication circuit connections.

Note 2
Low voltage signal circuits using screw clamp connectors, wire may be clamped directly or terminated in a pressure/crimp pin terminal and clamped.

Note 3
Only insulated pressure/crimp ring terminals shall be used for connections to other circuits.

11.2.6 M4 Terminal Screw Torque

The terminal screws of all connector blocks, for field wiring, using M4 screws shall be tightened to a nominal torque of 1.3 Nm.

11.2.7 Output Relay Ratings

MiCOM Px4x relays:

Standard output relay (Make and carry):	5 A, 250 Vac
High Break - Make 30 A, carry 30 A for 0.2 s, 250Vac/Vdc, 15 s cycle as per ANSI C37.90 including break 30 A.	Continuous 10A, 250 Vac.

11.2.8 Output Relay Contact Symbols



12. TYPICAL LABELS

12.1 Typical Compliance Label

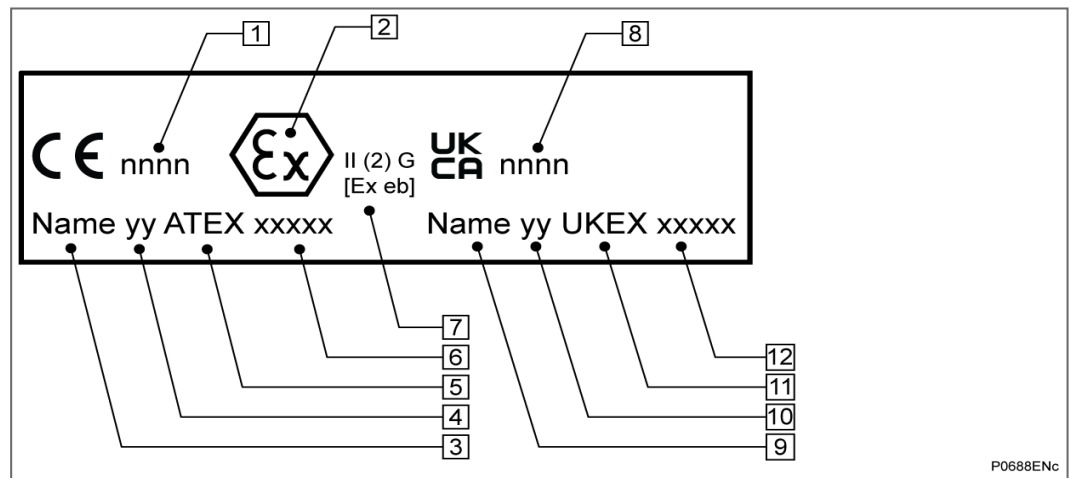

- [1] nnnn - identifying number of the Notified Body which demonstrated manufacturing Quality Assurance compliance to EN 80079-34:2018, e.g. 0891.
- [2] Ex logo - signifies compliance with the European directive 2014/34/EU and with the UK regulation SI 2016 No. 1107, amended by SI 2019 No. 696.
- [3] Name - Notified Body which carried out the EU Type Examination of the equipment design and construction, e.g. CML.
- [4] yy - year certificate issued e.g. 18 for 2018.
- [5] Compliance with European ATEX directive 2014/34/EU.
- [6] xxxxx - approval number given by the Notified Body for the Type Examination of the equipment, e.g. 3008X.
- [7] The equipment is compliant with Article 1(b) of ATEX Directive 2014/34/EU and with Article 3 (b) part I of the UK regulation SI 2016 No. 1107, amended by SI 2019 No. 696. It is approved for use outside potentially explosive atmospheres. It is required for the safe operation of 'Increased Safety - Ex eb' protected electrical machines, when used in accordance with the user documentation and subject to special conditions for safe use specified in Section 14 of EU Type Examination Certificate CML 18ATEX3008X and in the Section 14 of UK Type Examination Certificate CML 21UKEX31194X.
- [8] nnnn - identifying number of the Approval Body which demonstrated manufacturing Quality Assurance compliance to BS EN ISO/IEC 80079-34:2018, e.g. 0891.
- [9] Name - Approval Body which carried out the UK Type Examination of the equipment design and construction, e.g. CML.
- [10] yy - year certificate issued for compliance with UK regulation SI 2016 No. 1107, e.g. 21 for 2021.
- [11] Compliance with UK regulation SI 2016 No. 1107.
- [12] xxxxx - approval number given by the Approval Body for the UK Type Examination of the equipment, e.g. 31194X.

Notes:

INTRODUCTION

CHAPTER 1

Date:	10/2022
Products covered by this chapter:	This chapter covers the specific versions of the MiCOM products listed below. This includes only the following combinations of Software Version and Hardware Suffix.
Hardware suffix:	M
Software version:	K6
Connection diagrams:	10P54302 (SH 1 to 2) 10P54303 (SH 1 to 2) 10P54304 (SH 1 to 2) 10P54400 10P54404 (SH 1 to 2) 10P54405 (SH 1 to 2) 10P54502 (SH 1 to 2) 10P54503 (SH 1 to 2) 10P54504 (SH 1 to 2) 10P54600 10P54604 (SH 1 to 2) 10P54605 (SH 1 to 2) 10P54606 (SH 1 to 2)

CONTENTS

Page (IT) 1-

1	Documentation Structure	5
2	Introduction to MiCOM	7
3	Product Scope	8
3.1	Functional Overview	8
3.2	Process Bus	10
3.3	Application Overview	12
4	Ordering Options	13
4.1	MiCOM P543	14
4.2	MiCOM P544	16
4.3	MiCOM P545	18
4.4	MiCOM P546	20

FIGURES

Page (IT) 1-

Figure 1 - Process Bus principle	11
Figure 2 - Functional diagram	12

TABLES

Page (IT) 1-

Table 1 - Functional overview	10
--------------------------------------	-----------

Notes:

1 DOCUMENTATION STRUCTURE

This manual provides a functional and technical description of this MiCOM device, and gives a comprehensive set of instructions for its use and application. A summary of the different chapters of this manual is given here:

	Description	Chapter Code
SI	Safety Information A guide to the safe handling, commissioning and testing of equipment. This provides typical information and advice which covers a range of MiCOM Px4x products. It explains how to work with equipment safely.	Px4x/EN SI
1	Introduction A guide to the MiCOM range of relays and the documentation structure. General safety aspects of handling Electronic Equipment are discussed with particular reference to relay safety symbols. Also a general functional overview of the relay and brief application summary is given.	P54x/EN IT
2	Technical Data Technical data including setting ranges, accuracy limits, recommended operating conditions, ratings and performance data. Compliance with norms and international standards is quoted where appropriate.	P54x/EN TD
3	Getting Started A guide to the different user interfaces of the IED describing how to start using it. This chapter provides detailed information regarding the communication interfaces of the IED, including a detailed description of how to access the settings database stored within the IED.	P54x/EN GS
4	Settings List of all relay settings, including ranges, step sizes and defaults, together with a brief explanation of each setting.	P54x/EN ST
5	Operation A comprehensive and detailed functional description of all protection and non-protection functions.	P54x/EN OP
6	Application Notes This section includes a description of common power system applications of the relay, calculation of suitable settings, some typical worked examples, and how to apply the settings to the relay.	P54x/EN AP
7	Using the PSL Editor This provides a short introduction to using the PSL Editor application.	Px4x/EN SE
8	Programmable Logic Overview of the Programmable Scheme Logic (PSL) and a description of each logical node. This chapter includes the factory default and an explanation of typical applications.	P54x/EN PL
9	Measurements and Recording Detailed description of the relays recording and measurements functions including the configuration of the event and disturbance recorder and measurement functions.	P54x/EN MR
10	Product Design Overview of the operation of the relay's hardware and software. This chapter includes information on the self-checking features and diagnostics of the relay.	P540d/EN PD
11	Commissioning Instructions on how to commission the relay, comprising checks on the calibration and functionality of the relay.	P54x/EN CM
12	Test and Setting Records This is a list of the tests made and the settings stored on the MiCOM IED.	P54x/EN RC
13	Maintenance A general maintenance policy for the relay is outlined.	Px4x/EN MT

	Description	Chapter Code
14	Troubleshooting Advice on how to recognize failure modes and the recommended course of action. Includes guidance on whom within Schneider Electric to contact for advice.	Px4x/EN TS
15	SCADA Communications This chapter provides an overview regarding the SCADA communication interfaces of the relay. Detailed protocol mappings, semantics, profiles and interoperability tables are not provided within this manual. Separate documents are available per protocol, available for download from our website.	P540d/EN SC
16	Installation Recommendations on unpacking, handling, inspection and storage of the relay. A guide to the mechanical and electrical installation of the relay is provided, incorporating earthing recommendations.	Px4x/EN IN
17	Connection Diagrams A list of connection diagrams, which show the relevant wiring details for this relay.	P54x/EN CD
18	Cyber Security An overview of cyber security protection (to secure communication and equipment within a substation environment). Relevant cyber security standards and implementation are described too.	Px4x/EN CS
19	Dual Redundant Ethernet Board Information about how MiCOM products can be equipped with Dual Redundant Ethernet Boards (DREBs) and the different protocols which are available. Also covers how to configure and commission these types of boards.	Px4x/EN REB
20	Parallel Redundancy Protocol (PRP) Notes Includes an introduction to Parallel Redundancy Protocols (PRP) and the different networks PRP can be used with. Also includes details of PRP and MiCOM functions.	Px4x/EN PR
21	High-availability Seamless Redundancy (HSR) Introduction to the High-availability Seamless Redundancy (HSR); and how it is implemented on MiCOM-based products manufactured by Schneider Electric.	Px4x/EN HS
22	Rapid Spanning Tree Protocol (RSTP) This section gives an introduction to the Rapid Spanning Tree Protocol (RSTP); and how it is implemented on MiCOM-based products manufactured by Schneider Electric.	Px4x/EN TP
23	Process Bus Notes (PB) This section gives an introduction to the Process Bus Board (PB); and how it is implemented on MiCOM-based products manufactured by Schneider Electric.	Px4x/EN PB
24	Version History (of Firmware and Service Manual) This is a history of all hardware and software releases for this product.	P54x/EN VH
SG	Symbols and Glossary List of common technical terms, abbreviations and symbols found in this documentation.	P54x/EN SG

Some of these chapters are *Specific* to a particular MiCOM product. Others are *Generic* – meaning that they cover more than one MiCOM product. The generic chapters have a Chapter Code which starts with Px4x.

2 INTRODUCTION TO MICOM

About MiCOM Range

MiCOM is a comprehensive solution capable of meeting all electricity supply requirements. It comprises a range of components, systems and services from Schneider Electric.

Central to the MiCOM concept is flexibility. MiCOM provides the ability to define an application solution and, through extensive communication capabilities, integrate it with your power supply control system.

The components within MiCOM are:

- P range protection relays
- C range control products
- M range measurement products for accurate metering and monitoring
- S range versatile PC support and substation control packages

MiCOM products include extensive facilities for recording information on the state and behaviour of the power system using disturbance and fault records. They can also provide measurements of the system at regular intervals to a control centre enabling remote monitoring and control to take place.

For up-to-date information, please see:

www.schneider-electric.com

<i>Note</i>	<i>During 2011, the International Electrotechnical Commission classified the voltages into different levels (IEC 60038). The IEC defined LV, MV, HV and EHV as follows: LV is up to 1000V. MV is from 1000V up to 35 kV. HV is from 110 kV or 230 kV. EHV is above 230 KV. There is still ambiguity about where each band starts and ends. A voltage level defined as LV in one country or sector, may be described as MV in a different country or sector. Accordingly, LV, MV, HV and EHV suggests a possible range, rather than a fixed band. Please refer to your local Schneider Electric office for more guidance.</i>
-------------	--

3 PRODUCT SCOPE

All the P54x relays are designed for all overhead line and cable applications, as they interface readily with the longitudinal (end-end) communications channel between line terminals. They also include a high-speed **current** differential unit protection. They all have optional high-performance sub-cycle distance protection including phase-segregated aided Directional Earth Fault (DEF).

Four P54x (P543, P544, P545 & P546) models are offered:

P543 and P545:

- Features included only in the P543 and P545 models are: Differential for Plain and Transformer Feeders.
- P543 in (60TE /12") with 16 inputs and 14 standard outputs (or 7 standard and 4 high break outputs option or 24 standard outputs).
- P543 in (60TE /12") with 8 standard inputs and 8 standard outputs or 16 standard inputs and 16 standard output on process bus models.
- P545 in (80TE /19") with 24 inputs and 32 standard outputs (or 16 standard and 8 high break outputs option) or 32 inputs and 32 standard outputs.

Note The distance option is independent of the hardware configuration and is specified by means of the software number (refer to the ordering options in the Ordering Options section).

P544 and P546:

- Features included only in the P544 and P546 models are Differential for Mesh Corner.
- P544 in (60TE /12") with 16 inputs and 14 standard outputs (or 7 standard and 4 high break outputs option)
- P546 in (80TE /19") with 24 inputs and 32 standard outputs (or 16 standard and 8 high break outputs, or 8 standard and 12 high break outputs options).
- P546 in (80TE /19") with 8 standard inputs and 8 standard outputs or 16 standard inputs and 16 standard output on process bus models.

Note The distance option is independent of the hardware configuration and is specified by means of the software number (refer to the ordering options in Ordering Options section).

3.1 Functional Overview

The P54x current differential protection relay contains a wide variety of protection functions which are summarized below:

ANSI	FEATURE	Models			
		P543	P544	P545	P546
87	Phase segregated current differential	Yes	Yes	Yes	Yes
	2 and 3 terminal lines/cables	Yes	Yes	Yes	Yes
	Feeders with in-zone transformers	Yes	Yes	Yes	Yes
	Control of dual circuit breakers (one and a half breaker applications)		Yes		Yes
	Suitable for use with SDH/SONET networks (using GPS synchronization device)	Yes	Yes	Yes	Yes
	InterMiCOM64 teleprotection for direct relay-relay communication	Yes	Yes	Yes	Yes
21P/21G	Distance zones, full-scheme protection	6	6	6	6
	Mho or Quadrilateral Phase elements	Yes	Yes	Yes	Yes
	Mho or Quadrilateral Ground elements	Yes	Yes	Yes	Yes
	CVT transient overreach elimination	Yes	Yes	Yes	Yes
	Load blinder	Yes	Yes	Yes	Yes

ANSI	FEATURE	Models			
		P543	P544	P545	P546
	Easy setting mode	Yes	Yes	Yes	Yes
	Mutual compensation (for fault locator and distance zones)	Yes	Yes	Yes	Yes
85	Communication-aided schemes, PUTT, POTT, Blocking, Weak Infeed	Yes	Yes	Yes	Yes
	Accelerated tripping - loss of load and Z1 extension	Yes	Yes	Yes	Yes
50/27	Switch on to fault and trip on reclose - elements for fast fault clearance upon breaker closure	Yes	Yes	Yes	Yes
68	Power swing blocking	Yes	Yes	Yes	Yes
78	Out of step	Yes	Yes	Yes	Yes
67N/85	Directional Earth Fault (DEF) unit protection	Yes	Yes	Yes	Yes
50/51/67	Phase overcurrent stages, with optional directionality	4	4	4	4
50N/51N/67N	Earth/ground overcurrent stages, with optional directionality	4	4	4	4
51N/67N	Sensitive Earth Fault (SEF), with optional directionality	4	4	4	4
64	High-impedance Restricted Earth Fault (REF)	Yes	Yes	Yes	Yes
46/67	Negative sequence overcurrent stages, with optional directionality	4	4	4	4
46BC	46BC Broken conductor (open jumper), used to detect open circuit faults	Yes	Yes	Yes	Yes
49	Thermal overload protection	Yes	Yes	Yes	Yes
27	Undervoltage protection stages	2	2	2	2
59	Overvoltage protection stages	2	2	2	2
59	Remote overvoltage protection stages	2	2	2	2
59N	Residual overvoltage stages (neutral displacement)	2	2	2	2
81U	Underfrequency stages	4	4	4	4
81O	Overfrequency stages	2	2	2	2
81R	Advanced rate of change of frequency stages	4	4	4	4
50BF	2-stage circuit breaker failure with 1 or 3 pole operation.	Yes	Yes	Yes	Yes
CTS	CT supervision (including differential CTS, patent pending)	Yes	Yes	Yes	Yes
VTS	Voltage Transformer Supervision (VTS)	Yes	Yes	Yes	Yes
79	Auto-reclose - 4 shot	Yes	Yes	Yes	Yes
25	Check synchronism, 2 stages with additional split detection	Yes		Yes	
25	Check synchronism, 2 stages for 1.5 breaker applications		Yes		Yes
FL	Fault locator	Yes	Yes	Yes	Yes
	SOE event records	1024	1024	1024	1024
	Dual rated 1A and 5A CT inputs	Yes	Yes	Yes	Yes
	Tripping Mode - single or three pole	Yes	Yes	Yes	Yes
	ABC and ACB phase rotation	Yes	Yes	Yes	Yes
	Optocoupled digital inputs	16	16	24 to 32	24
	Standard relay output contacts	14 to 24	14	32	32
	Standard and high speed, high break (HB) output contacts	7/4HB	7/4HB	16/8HB	16/8HB or 8/12HB
	Rear communication port (EIA(RS)485) with order option of Courier, IEC870-5-103 (VDEW)&DNP3.0. Courier also supports Kbus interface	Yes	Yes	Yes	Yes
	Function keys	10	10	10	10

ANSI	FEATURE	Models			
		P543	P544	P545	P546
	Programmable tri-colour LEDs	18	18	18	18
	Front communication port (EIA(RS)232)	Yes	Yes	Yes	Yes
IRIG	IRIG-B time synchronism	Option	Option	Option	Option
	Second rear communication port EIA(RS)232, EIA(RS)485 or KBus and InterMiCOM teleprotection for direct relay-relay communication. EIA(RS)232 for MODEM links up to 19.2 kbit/s.	Option	Option	Option	Option
	Fibre optic serial communications	Option	Option	Option	Option
	Rear Ethernet communication port.	Option	Option	Option	Option
	Rear Redundant Ethernet port (RJ45 or optical).	Option	Option	Option	Option

Table 1 - Functional overview

The relay supports these relay management functions as well as the ones shown above.

- Measurement of all instantaneous & integrated values
- Circuit breaker, status & condition monitoring
- Programmable Scheme Logic (PSL)
- Trip circuit and coil supervision (using PSL)
- Alternative setting groups
- Control inputs
- Programmable allocation of digital inputs and outputs
- Sequence of event recording
- Comprehensive disturbance recording (waveform capture)
- Fault recording
- Fully customizable menu texts
- Power-up diagnostics and continuous self-monitoring of relay
- Commissioning test facilities
- Real time clock/time synchronization - time synchronization possible from IRIG-B input, opto input or communications
- Simple password management:
CSL0 - No Security Administration Tool (SAT) required
- Advanced Cyber Security:
CSL1 - Security Administration Tool (SAT) required
- Read only mode

3.2

Process Bus

The Process Bus board interfaces to IEC 61850-9-2LE and IEC61869-9 compliant Merging Units (MU). The Process Bus board replaces the conventional analogue inputs (analogue module) and is available in these Easergy protection relays:

- P145 (feeder protection)
- P442, P443 and P446 (distance protection)
- P543 and P546 (line differential protection)
- P643 and P645 (transformer protection)
- P746 (busbar protection)
- P841 (multifunction line terminal IED)

Process bus is mainly used to communicate the primary values of current and voltage to a protection relay via an Ethernet network. Merging Units form the data acquisition layer in the network. They connect to the primary sensor, determining the instantaneous primary measurements and publishing them on the process bus.

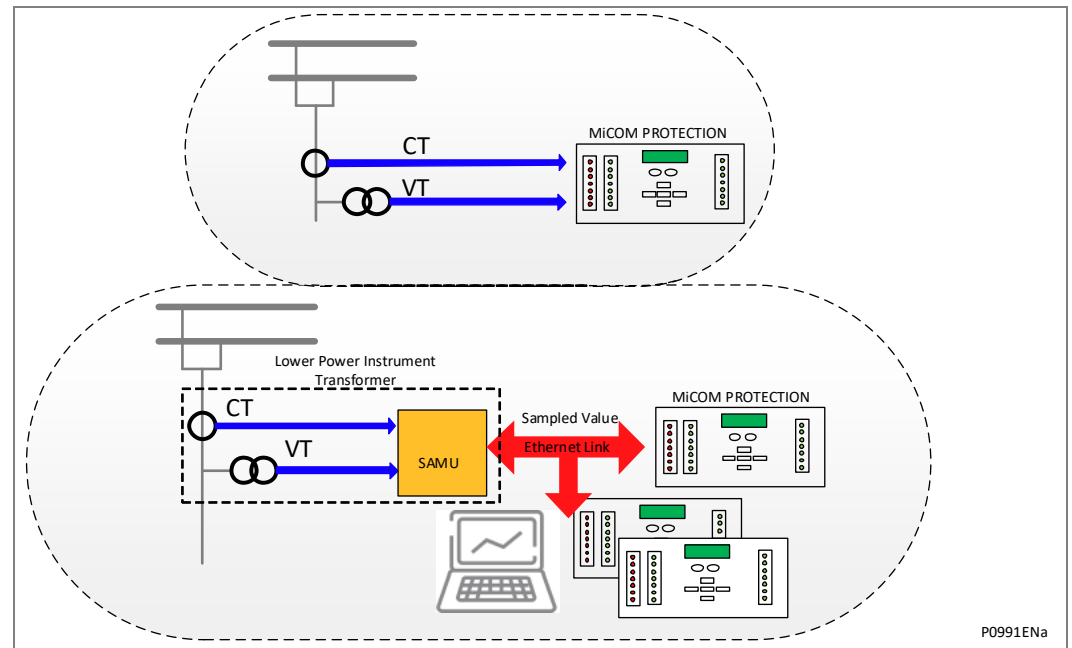

Figure 1 - Process Bus principle

The Process Bus philosophy is to enable isolating the primary interfaces (CTs or VTs) from the secondary system such as protection or control IEDs. The principle consists of interposing new primary equipment called Low Power Instrument Transformers (LPIT) or Stand Alone Merging Units (SAMU). Note that LPIT was previously known as Non-Conventional Instrument Transformers (NCIT)

The Stand Alone Merging Unit (SAMU) converts 1/5A and 100/110V signals to process bus measurements (called Sampled Values). One feature that is mandatory for the Merging Unit is a very accurate clock source. Time is unique and common in the "analogue world" but is not in the digital world. Sampled values must be synchronized via IEC61850-9-3 (refer to IEC 61588/IEEE1588 Precision Time Protocol) or 1 Pulse Per Second (PPS) signal. The measurement values provided must be suitable for the protection application. This performance is ensured by the selection of primary sensors meeting the CT requirements of the protection application. These requirements must now be met by both the primary CT and the Merging Unit.

An IMU can embed other digital functionality, sending information such as position of breaker and isolators and receiving digital information such as close, open, trip or reclose commands over the process bus.

The process bus links allow multiple measurement streams as well as the digital information to be sent over common Ethernet link which potentially could reduce the need to install secondary wiring. Also, the same stream can be used by multiple relays reducing the number of primary sensors required. This does, however, expose the system to a greater outage due to a link or switch failure. In most cases, redundancy such as IEC62439 PRP will be required to ensure system availability.

The protection tripping time in a Process Bus scheme is 4ms plus the MU delay offset setting, up to 7ms slower than in conventional one.

3.3 Application Overview

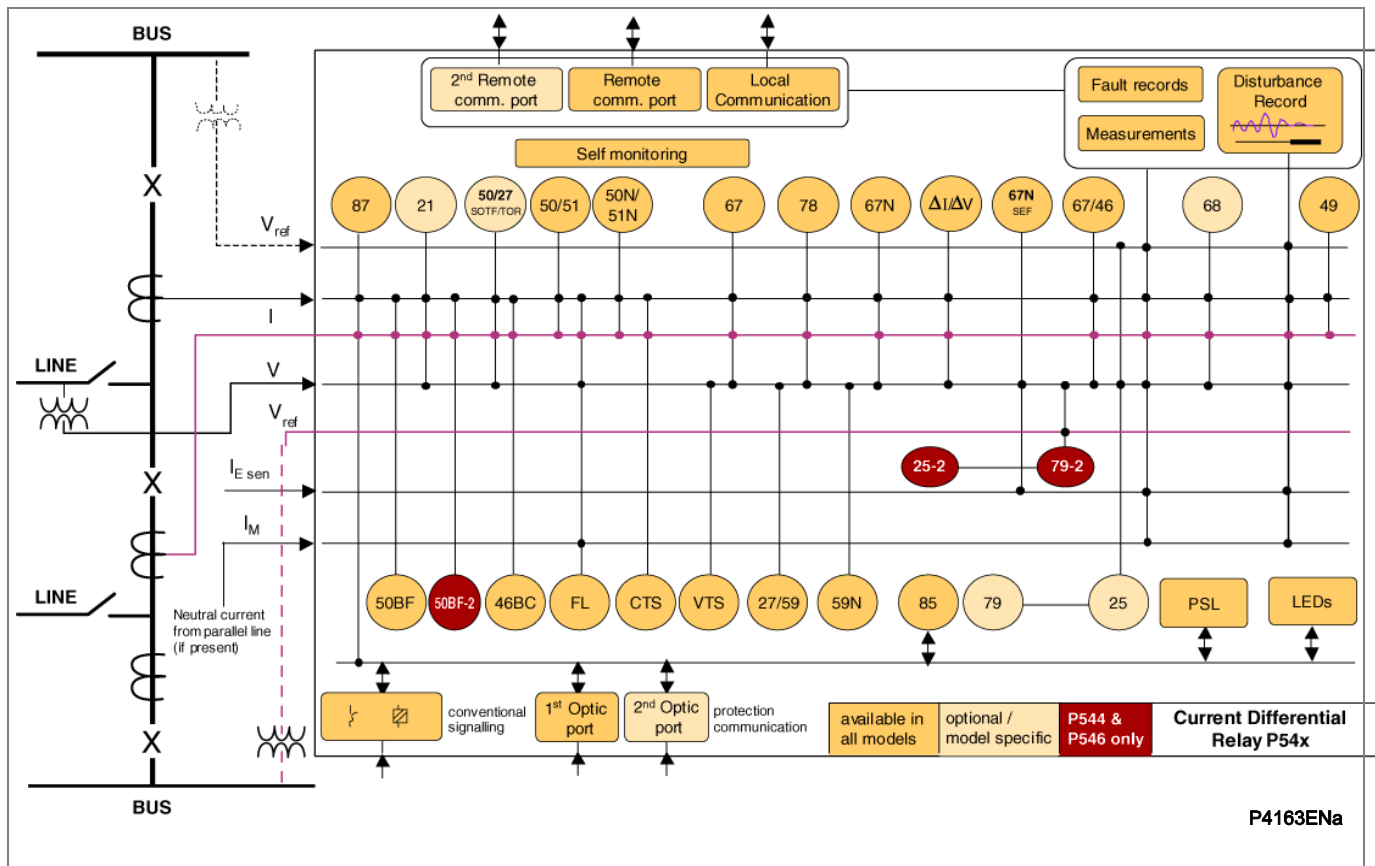

Figure 2 - Functional diagram

4 ORDERING OPTIONS

For each product there are range of ordering options. The options vary from one product to another, and from one Software Version to another.

The information required with your order is given in these sections:

- MiCOM P543
- MiCOM P544
- MiCOM P545
- MiCOM P546

Note *The Cortec table(s) list the options available as of the date of this documentation. The most up-to-date versions of these tables can be found on our web site (www.schneider-electric.com). It may not be possible to select ALL of the options shown here within a single item of equipment.*

4.1 MiCOM P543

Order form	MiCOM P543									
Current differential - With distance backup, 1/3 pole autoreclose and check synchronising	P543						M			
Nominal auxiliary voltage										
24 - 32 Vdc		9								
48 - 110 Vdc		2								
110 - 250 Vdc (100 - 240 Vac)		3								
In/Vn rating										
In = 1A/5A ; Vn = 100-120Vac			1							
Hardware options										
Standard - None				1						
IRIG-B Only (Modulated)				2						
Fibre optic serial communications				3						
IRIG-B + fibre optic serial communications				4						
LPIT (9-2LE or IEC 61869-9) with redundant Ethernet 2LC ports + 1 RJ45 port				B						
LPIT (9-2LE or IEC 61869-9) with redundant Ethernet 3 RJ45 ports				C						
InterMiCOM + Courier Rear Port				E						
InterMiCOM + Courier Rear Port + IRIG-B modulated				F						
Redundant Ethernet (100Mbit/s) PRP or HSR or RSTP and Dual IP, 2 LC ports + 1 RJ45 port + Modulated/Un-modulated IRIG-B + IEEE1588				Q						
Redundant Ethernet (100Mbit/s) PRP or HSR or RSTP and Dual IP, 3 RJ45 ports + Modulated/Un-modulated IRIG-B + IEEE1588				R						
Ethernet (100Mbit/s), 1 RJ45 port + Modulated/Un-modulated IRIG-B + IEEE1588				S						
Product Options (Conventional CT/VT models)										
Ch1=850nm multi-mode, Ch2=850nm multi-mode, 16inputs & 14stn outputs				A						
Ch1=1310nm single-mode, Ch2=not fitted (2 Terminal only), 16inputs & 14stn outputs				B						
Ch1=1310nm single-mode, Ch2=1310nm single-mode, 16inputs & 14stn outputs				C						
Ch1=1300nm multi-mode, Ch2=1300nm multi-mode, 16inputs & 14stn outputs				E						
Ch1=1550nm single-mode, Ch2=1550nm single-mode, 16inputs & 14stn outputs				G						
Ch1=850nm multi-mode, Ch2=1310nm single-mode, 16inputs & 14stn outputs				H						
Ch1=1310nm single-mode, Ch2=850nm multi-mode, 16inputs & 14stn outputs				L						
Ch1=1550nm single-mode, Ch2=850nm multi-mode, 16inputs & 14stn outputs				R						
Ch1=850nm multi-mode, Ch2=850nm multi-mode, 16 inputs & 7stn+4hb outputs				S						
Ch1=1310nm single-mode, Ch2=not fitted (2 Terminal only), 16 inputs & 7stn+4hb outputs				T						
Ch1=1310nm single-mode, Ch2=1310nm single-mode, 16 inputs & 7stn+4hb outputs				U						
Ch1=1300nm multi-mode, Ch2=1300nm multi-mode, 16 inputs & 7stn+4hb outputs				W						
Ch1=1550nm single-mode, Ch2=1550nm single-mode, 16 inputs & 7stn+4hb outputs				Z						
Ch1=850nm multi-mode, Ch2=1310nm single-mode, 16 inputs & 7stn+4hb outputs				0						
Ch1=1310nm single-mode, Ch2=850nm multi-mode, 16 inputs & 7stn+4hb outputs				3						
Ch1=1550nm single-mode, Ch2=850nm multi-mode, 16 inputs & 7stn+4hb outputs				5						
Ch1=850nm multi-mode, Ch2=850nm multi-mode, 16inputs & 24stn outputs				I						
Ch1=1310nm single-mode, Ch2=not fitted (2 Terminal only), 16inputs & 24stn outputs				N						
Ch1=1310nm single-mode, Ch2=1310nm single-mode, 16inputs & 24stn outputs				O						

Order form	MiCOM P543									
Current differential - With distance backup, 1/3 pole autoreclose and check synchronising	P543						M			
Ch1=1550nm single-mode, Ch2=1550nm single-mode, 16inputs & 24stn outputs						Q				
Ch1=850nm multi-mode, Ch2=1310nm single-mode, 16inputs & 24stn outputs						6				
Ch1=1310nm single-mode, Ch2=850nm multi-mode, 16inputs & 24stn outputs						7				
Product Options (Process Bus versions)										
Details to follow later										
Protocol options										
K-Bus with simple password management - CSL0							1			
IEC 60870-5-103 (VDEW) with simple password management - CSL0							3			
DNP3.0 with simple password management - CSL0							4			
IEC61850 Edition 1 / 2 and Courier via rear K-Bus/RS485 with simple password management - CSL0							6			
IEC 61850 Edition 1 / 2 and CS103 via rear port RS485 with simple password management - CSL0							7			
IEC61850 Edition 1 / 2 and DNP3 over Ethernet and DNP3.0 via rear RS485 with simple password management - CSL0							B			
IEC61850 Edition 1 / 2 and Courier via rear K-Bus/RS485 with advanced Cyber Security - CSL1 - Security Administration Tool (SAT) Required							G			
IEC61850 Edition 1 / 2 and CS103 via rear port RS485 with advanced Cyber Security - CSL1 - Security Administration Tool (SAT) Required							H			
IEC61850 Edition 1 / 2 and DNP3 serial with advanced Cyber Security - CSL1 - Security Administration Tool (SAT) Required							J			
IEC61850 Edition 1 / 2 and DNP3 over Ethernet and DNP3.0 via rear RS485 with advanced Cyber Security - CSL1 - Security Administration Tool (SAT) Required							L			
Mounting										
Flush / Panel mounting							M			
Language										
English, French, German, Spanish								0		
English, French, German, Russian								5		
Chinese, English or French via HMI, with English or French only via Communications port								C		
Software version										
With Distance									**	
Customer specific options										
Standard version										8
Customer specific										9
Hardware version										
CPU3/XCPU3										M

4.2 MiCOM P544

Order form	MiCOM P544							
	P544	1			M			
Current differential - With distance backup, suitable for 2 breaker configurations								
Nominal auxiliary voltage								
24 - 32 Vdc		9						
48 - 110 Vdc		2						
110 - 250 Vdc (100 - 240 Vac)		3						
In/Vn rating								
In = 1A/5A ; Vn = 100-120Vac		1						
Hardware options								
Standard - None					1			
IRIG-B Only (Modulated)					2			
Second Rear Comms					7			
Ethernet (100Mbit/s) plus IRIG-B (De-modulated)					B			
InterMiCOM + Courier Rear Port					E			
InterMiCOM + Courier Rear Port + IRIG-B modulated					F			
Redundant Ethernet RSTP, 2 multi-mode ST fibre ports + Modulated IRIG-B					J			
Redundant Ethernet RSTP, 2 multi-mode ST fibre ports + Un-modulated IRIG-B					K			
Redundant Ethernet (100Mbit/s) PRP or HSR or RSTP and Dual IP, 2 LC ports + 1 RJ45 port + Modulated/Un-modulated IRIG-B + IEEE1588					Q			
Redundant Ethernet (100Mbit/s) PRP or HSR or RSTP and Dual IP, 3 RJ45 ports + Modulated/Un-modulated IRIG-B + IEEE1588					R			
Ethernet (100Mbit/s), 1 RJ45 port + Modulated/Un-modulated IRIG-B + IEEE1588					S			
Product Options								
Ch1=850nm multi-mode, Ch2=850nm multi-mode					A			
Ch1=1310nm single-mode, Ch2=not fitted (2 Terminal only)					B			
Ch1=1310nm single-mode, Ch2=1310nm single-mode					C			
Ch1=1300nm multi-mode, Ch2=1300nm multi-mode					E			
Ch1=1550nm single-mode, Ch2=1550nm single-mode					G			
Ch1=850nm multi-mode, Ch2=1310nm single-mode					H			
Ch1=1310nm single-mode, Ch2=850nm multi-mode					L			
Ch1 1550nm single-mode, Ch2 850nm multi-mode					R			
Ch1=850nm multi-mode, Ch2=850nm multi-mode + High Break					S			
Ch1=1310nm single-mode, Ch2=not fitted (2 Terminal only) + High Break					T			
Ch1=1310nm single-mode , Ch2=1310nm single-mode + High Break					U			
Ch1=1300nm multi-mode, Ch2=1300nm multi-mode + High Break					W			
Ch1=1550nm single-mode, Ch2=1550nm single-mode + High Break					Z			
Ch1=850nm multi-mode, Ch2=1310nm single-mode + High Break					0			
Ch1=1310nm single-mode, Ch2=850nm multi-mode + High Break					3			
Ch1 1550nm single-mode, Ch2 850nm multi-mode + High Break					5			
Protocol options								
K-Bus with simple password management - CSL0						1		
IEC 60870-5-103 (VDEW) with simple password management - CSL0						3		

Order form	MiCOM P544									
Current differential - With distance backup, suitable for 2 breaker configurations	P544	1				M				
DNP3.0 with simple password management - CSL0						4				
IEC61850 Edition 1 / 2 and Courier via rear K-Bus/RS485 with simple password management - CSL0						6				
IEC61850 Edition 1 / 2 and CS103 via rear port RS485 with simple password management - CSL0						7				
DNP3 over Ethernet with Courier rear port K-Bus/RS485 protocol with simple password management - CSL0						8				
IEC61850 Edition 1 / 2 and DNP3 serial with simple password management - CSL0						9				
IEC61850 Edition 1 / 2 and DNP3 over Ethernet and DNP3.0 via rear RS485 with simple password management - CSL0						B				
IEC61850 Edition 1 / 2 and Courier via rear K-Bus/RS485 with advanced Cyber Security - CSL1 - Security Administration Tool (SAT) Required						G				
IEC61850 Edition 1 / 2 and CS103 via rear port RS485 with advanced Cyber Security - CSL1 - Security Administration Tool (SAT) Required						H				
IEC61850 Edition 1 / 2 and DNP3 serial with advanced Cyber Security - CSL1 - Security Administration Tool (SAT) Required						J				
IEC61850 Edition 1 / 2 and DNP3 over Ethernet and DNP3.0 via rear RS485 with advanced Cyber Security - CSL1 - Security Administration Tool (SAT) Required						L				
Mounting										
Flush/Panel mounting							M			
Language										
English, French, German, Spanish							0			
English, French, German, Russian							5			
Chinese, English or French via HMI, with English or French only via Communications port							C			
Software version										
Without Distance									**	
With Distance									**	
Customer specific options										
Standard version										8
Customer version										9
Hardware version										
CPU3/XCPU3										M
XCPU2										K

4.3 MiCOM P545

Order form	MiCOM P545									
	P545	1								
Current differential - With distance backup, 1/3 pole autoreclose and check synchronising, with 24 or 32 inputs, 32 outputs, GPS input.										
Nominal auxiliary voltage										
24 - 32 Vdc		9								
48 - 110 Vdc		2								
110 - 250 Vdc (100 - 240 Vac)		3								
In/Vn rating										
In = 1A/5A ; Vn = 100-120Vac		1								
Hardware options										
Standard - None			1							
IRIG-B Only (Modulated)			2							
Ethernet (100Mbit/s) plus IRIG-B (De-modulated)			B							
InterMiCOM + Courier Rear Port			E							
InterMiCOM + Courier Rear Port + IRIG-B modulated			F							
Redundant Ethernet RSTP, 2 multi-mode ST fibre ports + Modulated IRIG-B			J							
Redundant Ethernet RSTP, 2 multi-mode ST fibre ports + Un-modulated IRIG-B			K							
Redundant Ethernet (100Mbit/s) PRP or HSR or RSTP and Dual IP, 2 LC ports + 1 RJ45 port + Modulated/Un-modulated IRIG-B + IEEE1588			Q							
Redundant Ethernet (100Mbit/s) PRP or HSR or RSTP and Dual IP, 3 RJ45 ports + Modulated/Un-modulated IRIG-B + IEEE1588			R							
Ethernet (100Mbit/s), 1 RJ45 port + Modulated/Un-modulated IRIG-B + IEEE1588			S							
Product Options: Basic Configuration of										
Ch1=850nm multi-mode, Ch2=850nm multi-mode, 24inputs & 32stn outputs				A						
Ch1=1310nm single-mode, Ch2=not fitted (2 Terminal only), 24inputs & 32stn outputs				B						
Ch1=1310nm single-mode, Ch2=1310nm single-mode, 24inputs & 32stn outputs				C						
Ch1=1300nm multi-mode, Ch2=1300nm multi-mode, 24inputs & 32stn outputs				E						
Ch1=1550nm single-mode, Ch2=1550nm single-mode, 24inputs & 32stn outputs				G						
Ch1=850nm multi-mode, Ch2=1310nm single-mode, 24inputs & 32stn outputs				H						
Ch1=850nm multi-mode, Ch2=850nm multi-mode, 32inputs & 32stn outputs				I						
Ch1=1310nm single-mode, Ch2=850nm multi-mode, 24inputs & 32stn outputs				L						
Ch1=1310nm single-mode, Ch2=not fitted (2 Terminal only), 32inputs & 32stn outputs				N						
Ch1=1310nm single-mode, Ch2=1310nm single-mode, 32inputs & 32stn outputs				O						
Ch1=1300nm multi-mode, Ch2=1300nm multi-mode, 32inputs & 32stn outputs				Q						
Ch1=1550nm single-mode, Ch2=850nm multi-mode, 24inputs & 32stn outputs				R						
Ch1=850nm multi-mode, Ch2=850nm multi-mode, 24inputs & 16stn+8hb outputs				S						
Ch1=1310nm single-mode, Ch2=not fitted (2 Terminal only), 24inputs & 16stn+8hb outputs				T						
Ch1=1310nm single-mode, Ch2=1310nm single-mode, 24inputs & 16stn+8hb outputs				U						
Ch1=1300nm multi-mode, Ch2=1300nm multi-mode, 24inputs & 16stn+8hb outputs				W						
Ch1=1550nm single-mode, Ch2=1550nm single-mode, 24inputs & 16stn+8hb outputs				Z						
Ch1=850nm multi-mode, Ch2=1310nm single-mode, 24inputs & 16stn+8hb outputs				0						
Ch1=1310nm single-mode, Ch2=850nm multi-mode, 24inputs & 16stn+8hb outputs				3						
Ch1=1550nm single-mode, Ch2=850nm multi-mode, 24inputs & 16stn+8hb outputs				5						

Order form	MiCOM P545									
Current differential - With distance backup, 1/3 pole autoreclose and check synchronising, with 24 or 32 inputs, 32 outputs, GPS input.	P545	1								
Ch1=1550nm single-mode, Ch2=1550nm single-mode, 32inputs & 32stn outputs				9						
Protocol options										
K-Bus with simple password management - CSL0				1						
IEC 60870-5-103 (VDEW) with simple password management - CSL0				3						
DNP3.0 with simple password management - CSL0				4						
IEC61850 Edition 1 / 2 and Courier via rear K-Bus/RS485 with simple password management - CSL0				6						
IEC 61850 Edition 1 / 2 and CS103 via rear port RS485 with simple password management - CSL0				7						
DNP3 over Ethernet with Courier rear port K-Bus/RS485 protocol with simple password management - CSL0				8						
IEC61850 Edition 1 / 2 and DNP3 serial with simple password management - CSL0				9						
IEC61850 Edition 1 / 2 and DNP3 over Ethernet and DNP3.0 via rear RS485 with simple password management - CSL0				B						
IEC61850 Edition 1 / 2 and Courier via rear K-Bus/RS485 with advanced Cyber Security - CSL1 - Security Administration Tool (SAT) Required				G						
IEC61850 Edition 1 / 2 and CS103 via rear port RS485 with advanced Cyber Security - CSL1 - Security Administration Tool (SAT) Required				H						
IEC61850 Edition 1 / 2 and DNP3 serial with advanced Cyber Security - CSL1 - Security Administration Tool (SAT) Required				J						
IEC61850 Edition 1 / 2 and DNP3 over Ethernet and DNP3.0 via rear RS485 with advanced Cyber Security - CSL1 - Security Administration Tool (SAT) Required				L						
Mounting										
Flush/panel mounting							M			
Rack mounting							N			
Language										
English, French, German, Spanish							0			
English, French, German, Russian							5			
Chinese, English or French via HMI, with English or French only via Communications port							C			
Software version										
Without Distance									**	
With Distance									**	
Customer specific options										
Standard version									8	
Customer version									9	
Hardware version										
XCPU3										M
XCPU2										K

4.4 MiCOM P546

Order form	MiCOM P546							
Current differential - With distance backup, suitable for 2 breaker configurations	P546	1			M			
Nominal auxiliary voltage								
24 - 32 Vdc		9						
48 - 110 Vdc		2						
110 - 250 Vdc (100 - 240 Vac)		3						
In/Vn rating								
In = 1A/5A ; Vn = 100-120Vac		1						
Hardware options								
Standard - None					1			
IRIG-B Only (Modulated)					2			
Second Rear Comms					7			
IRIG-B (Modulated) + Second Rear Comms					8			
LPIT (9-2LE or IEC 61869-9) with redundant Ethernet 2LC ports + 1 RJ45 port					B			
LPIT (9-2LE or IEC 61869-9) with redundant Ethernet 3 RJ45 ports					C			
InterMiCOM + Courier Rear Port					E			
InterMiCOM + Courier Rear Port + IRIG-B modulated					F			
Redundant Ethernet RSTP, 2 multi-mode ST fibre ports + Modulated IRIG-B					J			
Redundant Ethernet RSTP, 2 multi-mode ST fibre ports + Un-modulated IRIG-B					K			
Redundant Ethernet (100Mbit/s) PRP or HSR or RSTP and Dual IP, 2 LC ports + 1 RJ45 port + Modulated/Un-modulated IRIG-B + IEEE1588					Q			
Redundant Ethernet (100Mbit/s) PRP or HSR or RSTP and Dual IP, 3 RJ45 ports + Modulated/Un-modulated IRIG-B + IEEE1588					R			
Ethernet (100Mbit/s), 1 RJ45 port + Modulated/Un-modulated IRIG-B + IEEE1588					S			
Product Options (Conventional CT/VT models)								
Ch1=850nm multi-mode, Ch2=850nm multi-mode, 24 Inputs 32 Standard Outputs					A			
Ch1=1310nm single-mode, Ch2=not fitted (2 Terminal only), 24 Inputs & 32 Standard outputs					B			
Ch1=1310nm single-mode, Ch2=1310nm single-mode, 24 inputs & 32 Standard Outputs					C			
Ch1=1300nm multi-mode, Ch2=1300nm multi-mode 24 Inputs & 32 Standard Outputs					E			
Ch1=1550nm single-mode, Ch2=1550nm single-mode, 24 Inputs & 32 Standard Outputs					G			
Ch1=850nm multi-mode, Ch2=1310nm single-mode, 24 Inputs & 32 Standard Outputs					H			
Ch1=850nm multi-mode, Ch2=850nm multi-mode, 24 Inputs & 8 Standard + 12 High Break Outputs					I			
Ch1=1310nm single-mode, Ch2=850nm multi-mode 24 Inputs & 32 Standard Outputs					L			
Ch1=1310nm single-mode, Ch2=not fitted (2 Terminal only) 24 Inputs & 8 Standard + 12 High Break Outputs					N			
Ch1=1310nm single-mode, Ch2=1310nm single-mode + 24 Inputs & 8 Standard + 12 High Break Outputs					O			
Ch1=1300nm multi-mode, Ch2=1300nm multi-mode + 24 Inputs & 8 Standard + 12 High Break Outputs					Q			
Ch1=1550nm single-mode, Ch2=850nm multi-mode, 24 Inputs & 32 Standard Outputs					R			
Ch1=850nm multi-mode, Ch2=850nm multi-mode, 24 Inputs & 16 Standard + 8 High Break Outputs					S			
Ch1=1310nm single-mode, Ch2=not fitted (2 Terminal only), 24 Inputs & 16 Standard + 8 High Break Outputs					T			

Order form	MiCOM P546						
	P546	1			M		
Current differential - With distance backup, suitable for 2 breaker configurations							
Ch1=1310nm single-mode, Ch2=1310nm single-mode, 24 Inputs & 16 Standard + 8 High Break Outputs				U			
Ch1=1300nm multi-mode, Ch2=1300nm multi-mode, 24 Inputs & 16 Standard + 8 High Break Outputs				W			
Ch1=1550nm single-mode, Ch2=1550nm single-mode, 24 Inputs & 16 Standard + 8 High Break Outputs				Z			
Ch1=850nm multi-mode, Ch2=1310nm single-mode, 24 Inputs & 16 Standard + 8 High Break Outputs				0			
Ch1=1310nm single-mode, Ch2=850nm multi-mode, 24 Inputs & 16 Standard + 8 High Break Outputs				3			
Ch1 1550nm single-mode, Ch2 850nm multi-mode, 24 Inputs & 16 Standard + 8 High Break Outputs				5			
Ch1=1550nm single-mode, Ch2=1550nm single-mode, 24 Inputs & 8 Standard + 12 High Break Outputs				9			
Product Options (Process Bus Versions)							
Details to follow later							
Protocol options							
K-Bus with simple password management - CSL0					1		
IEC 60870-5-103 (VDEW) with simple password management - CSL0					3		
DNP3.0 with simple password management - CSL0					4		
IEC61850 Edition 1 / 2 and Courier via rear K-Bus/RS485 with simple password management - CSL0					6		
IEC 61850 Edition 1 / 2 and CS103 via rear port RS485 with simple password management - CSL0					7		
DNP3 over Ethernet with Courier rear port K-Bus/RS485 protocol with simple password management - CSL0					8		
IEC61850 Edition 1 / 2 and DNP3 serial with simple password management - CSL0					9		
IEC61850 Edition 1 / 2 and DNP3 over Ethernet and DNP3.0 via rear RS485 with simple password management - CSL0					B		
IEC61850 Edition 1 / 2 and Courier via rear K-Bus/RS485 with advanced Cyber Security - CSL1 - Security Administration Tool (SAT) Required					G		
IEC61850 Edition 1 / 2 and CS103 via rear port RS485 with advanced Cyber Security - CSL1 - Security Administration Tool (SAT) Required					H		
IEC61850 Edition 1 / 2 and DNP3 serial with advanced Cyber Security - CSL1 - Security Administration Tool (SAT) Required					J		
IEC61850 Edition 1 / 2 and DNP3 over Ethernet and DNP3.0 via rear RS485 with advanced Cyber Security - CSL1 - Security Administration Tool (SAT) Required					L		
Mounting							
Flush / Panel mounting					M		
Language							
English, French, German, Spanish					0		
English, French, German, Russian					5		
Chinese, English or French via HMI, with English or French only via Communications port					C		
Software version							
Without Distance							**
With Distance							**
Customer specific options							
Standard version							8
Customer version							9
Hardware version							
XCPU3							M

Order form	MiCOM P546										
Current differential - With distance backup, suitable for 2 breaker configurations	P546	1					M				
XCPU2											K

TECHNICAL DATA

CHAPTER 2

Date:	02/2024
Products covered by this chapter:	This chapter covers the specific versions of the MiCOM products listed below. This includes only the following combinations of Software Version and Hardware Suffix.
Hardware suffix:	M
Software version:	K6
Connection diagrams:	10P54302 (SH 1 to 2) 10P54303 (SH 1 to 2) 10P54304 (SH 1 to 2) 10P54400 10P54404 (SH 1 to 2) 10P54405 (SH 1 to 2) 10P54502 (SH 1 to 2) 10P54503 (SH 1 to 2) 10P54504 (SH 1 to 2) 10P54600 10P54604 (SH 1 to 2) 10P54605 (SH 1 to 2) 10P54606 (SH 1 to 2)

CONTENTS

Page (TD) 2-

1	Mechanical Specifications	11
1.1	Design	11
1.2	Enclosure Protection	11
1.3	Weight	11
2	Terminals	12
2.1	AC Current and Voltage Measuring inputs	12
2.2	General Input/Output Terminals	12
2.3	Case Protective Earth Connection	12
2.4	Front Port Serial PC Interface	12
2.5	Front Download/Monitor Port	12
2.6	Rear Serial Communications Port	12
2.7	Optional Second Rear Communications Port	12
2.8	Optional Rear IRIG-B Interface Modulated or Un-modulated	12
2.9	IRIG-B Interface	13
2.9.1	IRIG-B 12X Interface (Modulated)	13
2.9.2	IRIG-B 00X Interface (Unmodulated)	13
2.10	Optional Rear Fiber Connection for SCADA/DCS	13
2.11	Optional Rear Ethernet Connection for IEC 61850 or DNP3.0	13
2.11.1	Optional Redundant Rear Ethernet Connection	13
3	Ratings	14
3.1	AC Measuring Inputs	14
3.2	AC Current	14
3.3	AC Voltage	14
4	Power Supply	15
4.1	Auxiliary Voltage (Vx)	15
4.2	Operating Range	15
4.3	Nominal Burden	15
4.4	Power-Up Time	15
4.5	Power Supply Interruption	15
4.6	Battery Backup	15
4.7	Field Voltage Output	15
4.8	Digital (“Opto”) Inputs	16
5	Output Contacts	17

5.1	Standard Contacts	17
5.2	High Break Contacts (Option)	17
5.3	Watchdog Contacts	18
6	Environmental Conditions	19
6.1	Ambient Temperature Range	19
6.2	Ambient Humidity Range	19
6.3	Corrosive Environments	19
7	Type Tests	20
7.1	Insulation	20
7.2	Creepage Distances and Clearances	20
7.3	High Voltage (Dielectric) Withstand	20
7.4	Impulse Voltage Withstand Test	20
8	Electromagnetic Compatibility (EMC)	21
8.1	1 MHz Burst High Frequency Disturbance Test	21
8.2	100kHz Damped Oscillatory Test	21
8.3	Immunity to Electrostatic Discharge	21
8.4	Electrical Fast Transient or Burst Requirements	21
8.5	Surge Withstand Capability	21
8.6	Surge Immunity Test	21
8.7	Immunity to Radiated Electromagnetic Energy	21
8.8	Radiated Immunity from Digital Communications	22
8.9	Radiated Immunity from Digital Radio Telephones	22
8.10	Immunity to Conducted Disturbances Induced by Radio Frequency Fields	22
8.11	Power Frequency Magnetic Field Immunity	22
8.12	Conducted Emissions	22
8.13	Radiated Emissions	22
9	EU Directives	23
9.1	EMC Compliance	23
9.2	Product Safety	23
9.3	ATEX Compliance	23
9.4	UKCA Compliance	23
10	Mechanical Robustness	24
10.1	Vibration Test	24
10.2	Shock and Bump	24
10.3	Seismic Test	24
11	Px40 Third Party Compliances	25

11.1	Underwriters Laboratory (UL)	25
11.2	Energy Networks Association (ENA)	25
<hr/>		
12	Protection Functions	26
12.1	Phase Current Differential Protection	26
12.2	Distance Protection	26
12.3	Three-Phase Overcurrent Protection	27
12.4	Phase and Ground (Earth) Overcurrent	27
12.4.1	Sensitive Earth Fault (SEF)	28
12.4.2	Wattmetric SEF	28
12.4.3	Polarizing quantities	28
12.5	Inverse Time Characteristic	28
12.6	Earth Fault/Sensitive Earth Fault Protection	29
12.6.1	Earth Fault	29
12.6.2	Sensitive Earth Fault (SEF)	29
12.6.3	Restricted EF	29
12.6.4	Wattmetric SEF	29
12.6.5	Polarizing Quantities	29
12.7	Negative Sequence Overcurrent	29
12.8	Undervoltage	30
12.9	Overvoltage	30
12.10	Neutral Displacement/Residual Overvoltage	30
12.11	Underfrequency Protection	30
12.12	Overfrequency Protection	30
12.13	Circuit Breaker Fail and Undercurrent	31
12.14	Broken Conductor Logic	31
12.15	Thermal Overload	31
12.16	Voltage Transformer Supervision (VTS)	31
12.17	Current Transformer Supervision (CTS)	31
12.17.1	Standard CTS	31
12.17.2	Differential CTS	31
12.18	CB State Monitoring and Condition Monitoring	32
12.19	Programmable Scheme Logic (PSL)	32
12.20	Auto-Reclose and Check Synchronism	32
12.21	Measurements and Recording Facilities	32
12.22	Real Time Clock	32
12.23	Enhanced Disturbance Records	33
12.24	Fault Locator	33
12.25	Event, Fault & Maintenance Records	33
12.26	Plant Supervision	33

12.27	InterMiCOM⁶⁴ Fiber Optic Teleprotection	33
12.28	Ethernet Data (where applicable)	34
12.28.1	100 Base FX Interface	34
<hr/>		
13	Settings List	35
13.1	Global Settings (System Data)	35
13.2	Circuit Breaker Control (CB Control)	35
13.2.1	P543 and P545 Specific CB Control Settings	35
13.2.2	P544 and P546 Specific CB Control Settings	35
13.3	Date and Time	36
13.4	Configuration	36
13.5	CT and VT Ratios	37
13.5.1	P543 and P545 CT and VT Ratio Settings	37
13.5.2	P544 and P546 CT and VT Ratio Settings	38
13.6	Sequence of Event Recorder (Record Control)	38
13.7	Oscillography (Disturb Recorder)	38
13.7.1	For Software Release 47/57 V/W/X and Earlier	38
13.7.2	For Software Release A0/B0 and Later	39
13.8	Measured Operating Data (Measure't Setup)	39
13.9	Communications	39
13.9.1	Courier Protocol	39
13.9.2	IEC60870-5-103 Protocol	39
13.9.3	DNP3.0 Protocol (Serial)	40
13.9.4	Ethernet Port, IEC61850 Protocol	40
13.9.5	Ethernet Port, DNP3.0 Protocol	40
13.10	Optional Additional Second Rear Communication (Rear Port2 (RP2))	40
13.11	Commission Tests	40
13.12	Circuit Breaker Condition Monitoring (CB Monitor Setup)	41
13.12.1	P543 and P545 CB Monitor Setup:	41
13.12.2	P544 and P546 CB Monitor Setup:	41
13.13	Optocoupled Binary Inputs (Opto Config.)	42
13.14	Settable Control Inputs (Control Inputs)	42
13.15	PSL Signal Grouping Nodes	42
13.16	EIA(RS)232 Teleprotection (INTERMiCOM Comms.)	42
13.17	INTERMiCOM Conf.	42
13.18	Function Keys	42
13.19	IED Configurator	43
13.20	Prot Comms/IM⁶⁴	43
13.21	Security Config	43
13.22	Control Input User Labels (Ctrl. I/P Labels)	43
13.23	Settings in Multiple Groups	44

14	Protection Functions	45
14.1	Line Parameters	45
14.2	Distance Setup	45
14.2.1	Phase Distance	45
14.2.2	Ground Distance	45
14.2.3	Delta Directional	46
14.3	Distance Elements	46
14.3.1	Phase Distance	46
14.3.2	Ground Distance	47
14.4	Phase Current Differential Protection	48
14.5	Scheme Logic	49
14.5.1	Basic Scheme	49
14.5.2	Aided Scheme 1	49
14.5.3	Aided Scheme 2	50
14.5.4	Trip On Close	50
14.5.5	Z1 Extension	50
14.5.6	Loss Of Load	50
14.6	Phase Overcurrent (Overcurrent)	50
14.7	Negative Sequence Overcurrent (Neg Seq O/C)	51
14.8	Broken Conductor	51
14.9	Ground Overcurrent (Earth Fault)	52
14.10	Directional Aided Schemes - DEF Settings	52
14.11	Sensitive Earth Fault Protection/ Restricted Earth Fault Protection	53
14.11.1	Wattmetric Sensitive Earth Fault (SEF)	53
14.11.2	Restricted Earth Fault (REF)	53
14.12	Neutral Voltage Displacement (Residual O/V NVD)	53
14.13	Thermal Overload	53
14.14	Power Swing/Out of Step	54
14.14.1	Power Swing	54
14.14.2	Out-Of-Step	54
14.15	Undervoltage Protection	54
14.16	Overvoltage Protection	55
14.17	Underfrequency Protection	55
14.18	Overfrequency Protection	55
14.19	Rate-of-Change of Frequency Protection ($\Delta f/\Delta t$ Protection)	55
14.20	Circuit Breaker Fail and Pole Dead Logic (CB Fail and P.Dead)	55
15	Supervision Functions (in Multiple Groups)	57
15.1	Voltage Transformer Supervision (VTS)	57
15.1.1	Inrush Detection	57
15.1.2	Weak Infeed Blk	57

15.2	Current Transformer Supervision (CTS)	57
15.3	Trip Supervision (TS) or Fault Detector	58
15.4	Bus-Line Synchronism and Voltage Checks (System Checks)	58
15.4.1	System Checks for P543 and P545	58
15.4.2	System Checks for P544 and P546	59
15.4.2.1	Manual System Checks	59
15.5	Auto-Reclose	60
15.5.1	P543 and P545 Auto-Reclose	60
15.5.2	P544 and P546 Auto-Reclose	61
<hr/>		
16	Function Keys and Labels	63
16.1	Function Keys	63
16.2	Opto Input Labels	63
16.3	Opto Output Labels	63
16.4	Disturbance Recorder Channel Labels (DR Chan Labels)	63
16.5	Virtual Input Labels (VIR I/P Labels)	63
16.6	Virtual Output Labels (VIR O/P Labels)	63
16.7	SR/MR User Alarm Labels (USR Alarm Labels)	63
16.8	Control Input Labels	63
<hr/>		
17	Measurements List	64
17.1	Measurements 1	64
17.2	Measurements 2	65
17.3	Measurements 3	65
17.4	Measurements 4	66
17.5	Circuit Breaker Monitoring Statistics	66
17.6	Fault Record Proforma	67

FIGURES

	Page (TD) 2-
Figure 1 - Operating Time vs Reach % at 50 Hz	26
Figure 2 - Operating Time vs Reach % at 60 Hz	27

TABLES

	Page (TD) 2-
Table 1 - MOV protection: Max Voltage 330 V dc	18
Table 2 - Minimum and maximum transfer time for InterMiCOM⁶⁴.	33
Table 3 - Transmitter optical characteristics	34
Table 4 - Receiver optical characteristics	34

Notes:

1 MECHANICAL SPECIFICATIONS

1.1 Design

Modular MiCOM Px40 platform relay, available in two different case sizes:

- P543 and P544: 60TE, front of panel flush mounting, or 19" rack mounted (ordering options).
- P545 and P546: 80TE, front of panel flush mounting, or 19" rack mounted (ordering options).

1.2 Enclosure Protection

Per IEC 60529:

- IP 52 Protection (front panel) against dust and dripping water.
- IP 50 Protection for the rear and sides of the case against dust.
- IP 10 Product safety protection for the rear due to live connections on the terminal block.

1.3 Weight

P543 approx.	9.2 kg
P544 approx.	11.5 kg
P545 approx.	11 kg
P546 approx.	13.1 kg

2 TERMINALS

2.1 AC Current and Voltage Measuring inputs

Located on heavy duty (black) terminal block:
Threaded M4 terminals, for ring terminal connection.
CT inputs have integral safety shorting, upon removal of the terminal block.

2.2 General Input/Output Terminals

For power supply, opto inputs, output contacts and RP1, COM1 and optional COM2 rear communications.
Located on general purpose (grey) blocks:
Threaded M4 terminals, for ring lug/terminal connection.

2.3 Case Protective Earth Connection

Two rear stud connections, threaded M4.
Must be earthed (grounded) using the protective (earth) conductor for safety, minimum earth wire size 2.5mm².

2.4 Front Port Serial PC Interface

EIA(RS)-232 DCE, 9 pin D-type female connector Socket SK1.
Courier protocol for interface to MiCOM S1 Studio software.
Isolation to SELV/ELV (Safety/Extra Low Voltage) level / PEB (Protective Equipotential Bonded).
Maximum cable length 15m.

2.5 Front Download/Monitor Port

EIA(RS)-232, 25 pin D-type female connector Socket SK2.
For firmware and menu text downloads.
Isolation to SELV/PEB level.

2.6 Rear Serial Communications Port

EIA(RS)-485 signal levels, two wire connections located on general purpose block, M4 screw.
For screened twisted pair cable, multidrop, 1000 m max.
For Courier (K-Bus), IEC-60870-5-103 or DNP3.0 protocol (ordering option).
Isolation to SELV (Safety Extra Low Voltage) level.

2.7 Optional Second Rear Communications Port

EIA(RS)-232, 9 pin D-type female connector, socket SK4.
Courier protocol: K-Bus, EIA(RS)-232, or EIA(RS)485 connection.
Isolation to SELV level.
Maximum cable length 15m.

2.8 Optional Rear IRIG-B Interface Modulated or Un-modulated

BNC plug
Isolation to SELV level.
50 Ohm coaxial cable.

2.9 IRIG-B Interface**2.9.1 IRIG-B 12X Interface (Modulated)**

External clock synchronization to IRIG standard 200-98, format B12x
Input impedance 6 k Ω at 1000 Hz
Modulation ratio: 3:1 to 6:1
Input signal, peak-peak: 200 mV to 20 V
A DDB point is available to indicate the IRIG-B signal is valid.

2.9.2 IRIG-B 00X Interface (Unmodulated)

External clock synchronization to IRIG standard 200-98, format B00X.
Input signal TTL level
Input impedance at dc 10 k Ω
A DDB point is available to indicate the IRIG-B signal is valid.

2.10 Optional Rear Fiber Connection for SCADA/DCS

BFOC 2.5 -(ST)-interface for multi-mode glass fiber type 62.5/125 μm , as for IEC 874-10.
850nm short-haul fibers, one Tx and one Rx. For Courier, IEC-60870-5-103 or DNP3.0
(see different ordering options for each model).

2.11 Optional Rear Ethernet Connection for IEC 61850 or DNP3.0**100Base-TX Communications**

Interface in accordance with IEEE802.3 and IEC 61850
Isolation: 1.5 kV
Connector type: RJ45
Cable type: Screened Twisted Pair (STP)
Max. cable length: 100 m

2.11.1 Optional Redundant Rear Ethernet Connection

Above copper port plus two copper or two fiber ports.

100Base-TX Communications

Interface in accordance with IEEE802.3 and IEC 61850
Isolation: 1.5 kV
Connector type: RJ45
Cable type: Screened Twisted Pair (STP)
Max. cable length: 100 m

100Base-FX Interface

Interface in accordance with IEEE802.3 and IEC 61850
Wavelength: 1300 nm
Fiber: multi-mode 50/125 μm or 62.5/125 μm
Connector type: LC Connector Optical Interface

3 RATINGS

3.1 AC Measuring Inputs

Nominal frequency: 50 and 60 Hz (settable)
Operating range: 45 to 66.3 Hz
Phase rotation: ABC or ACB

3.2 AC Current

Nominal current (In): 1 and 5 A dual rated. (1A and 5A inputs use different transformer tap Connections, check correct terminals are wired).

Nominal burden per phase: < 0.2 VA at In

Thermal withstand: continuous 4 In for 10 s: 30 In
for 1 s; 100 In

Linear to 64 In (non-offset AC current).

3.3 AC Voltage

Nominal voltage (Vn): 100 to 120 V phase-phase.

Nominal burden per phase: < 0.02 VA at Vn.

Thermal withstand: continuous 2 Vn for 10 s: 2.6 Vn

4 POWER SUPPLY

4.1 Auxiliary Voltage (Vx)

Three ordering options:

- (i) Vx: 24 to 32 Vdc
- (ii) Vx: 48 to 110 Vdc,
- (iii) Vx: 110 to 250 Vdc, and 100 to 240 Vac (rms).

4.2 Operating Range

- (i) 19 to 38V (dc only for this variant)
- (ii) 37 to 150V (dc only for this variant) for classic relay
43 to 150V (dc only for this variant) for Process Bus relay
- (iii) 87 to 300V (dc), 80 to 265V (ac).

With a tolerable ac ripple of up to 15% for a dc supply, per EN/IEC 60255-11, EN/IEC 60255-26.

4.3 Nominal Burden

Quiescent burden (DC): 15 W (Extra 1.25 W when fitted with second rear Courier)
Quiescent burden (AC): 28 VA (Extra 1.25 W when fitted with second rear Courier)

Additions for energized binary inputs/outputs:

Per opto input:	0.09 W	(24 to 54 V)
	0.12 W	(110/125 V)
	0.19 W	(220/250 V)

Per energized output relay: 0.13 W

4.4 Power-Up Time

Main Processor including User Interface and front access port < 25 s.
Ethernet Communications <120 s.

4.5 Power Supply Interruption

Per IEC60255-26: 2013

The relay will withstand a 20 ms interruption in the DC auxiliary supply, without deenergizing except process bus relays operating between 37 and 43V which have a 10 ms withstand.

The relay will withstand a 20 ms interruption in an AC auxiliary supply, without deenergizing.

4.6 Battery Backup

Front panel mounted.

Type ½ AA, 3.6 V Lithium Thionyl Chloride (SAFT advanced battery reference LS14250).
Battery life (assuming relay energized for 90% time) >10 years.

4.7 Field Voltage* Output

Regulated 48 Vdc

Current limited at 112 mA maximum output

*** Note**

It is compulsory to add an EMC Filter to use the field voltage outputs to prevent any noise or high frequency disturbance.

The EMC Filter must be connected to the protection relay with a **three-wires cable** of appr. 1m length.

The earth port of the EMC filter must **only** be connected to the earth terminal of Px4x; the metal housing of the filter **should** not be connected to the ground plane.

Proposal:

Schaffner EMC Filter (FN2010-1-06, 1A max - 250V), or equivalent

**4.8****Digital (“Opto”) Inputs**

Universal opto inputs with programmable voltage thresholds (24/27, 30/34, 48/54, 110/125, 220/250 V). May be energized from the 48 V field voltage, or the external battery supply.

Rated nominal voltage: 24 to 250 Vdc

Operating range: 19 to 265 Vdc

Withstand: 300 Vdc, 300 Vrms.

Peak current of opto input when energized is 3.5 mA (0-300 V)

Nominal pick-up and reset thresholds:

Nominal battery 24/27:	60 - 80% DO/PU
(logic 0) <16.2	(logic 1) >19.2

Nominal battery 24/27:	50 - 70% DO/PU
(logic 0) <12.0	(logic 1) >16.8

Nominal battery 30/34:	60 - 80% DO/PU
(logic 0) <20.4	(logic 1) >24.0

Nominal battery 30/34:	50 - 70% DO/PU
(logic 0) <15.0	(logic 1) >21.0

Nominal battery 48/54:	60 - 80% DO/PU
(logic 0) <32.4	(logic 1) >38.4

Nominal battery 48/54:	50 - 70% DO/PU
(logic 0) <24.0	(logic 1) >33.6

Nominal battery 110/125:	60 - 80% DO/PU
(logic 0) <75.0	(logic 1) >88.0

Nominal battery 110/125:	50 - 70% DO/PU
(logic 0) <55.0	(logic 1) >77.0

Nominal battery 220/250:	60 - 80% DO/PU
(logic 0) <150.0	(logic 1) >176.0

Nominal battery 220/250:	50 - 70% DO/PU
(logic 0) <110	(logic 1) >154

Recognition time:

<2 ms with filter removed.

<12 ms with half cycle ac immunity filter on.

5 OUTPUT CONTACTS

5.1

Standard Contacts

General purpose relay outputs for signaling, tripping and alarming:

Continuous Carry Ratings (Not Switched):

Maximum continuous current:	10 A (UL: 8 A)
Short duration withstand carry:	30 A for 3 s or 250A for 30ms
Rated voltage:	300 V

Make & Break Capacity:

DC:	50 W resistive	
DC:	62.5 W inductive	(L/R = 50 ms)
AC:	2500 VA resistive	(cos ϕ = unity)
AC:	2500 VA inductive	(cos ϕ = 0.7)

Make, Carry:

30 A for 3 secs, dc resistive.

10,000 operations (subject to the above limits of make/break capacity and rated voltage).

Make, Carry & Break:

30 A for 200 ms, ac resistive.

2,000 operations (subject to the above limits of make/break capacity & rated voltage).

4A for 1.5 secs, dc resistive.

10,000 operations (subject to the above limits of make/break capacity & rated voltage).

0.5 A for 1 sec, dc inductive.

10,000 operations (subject to the above limits of make/break capacity & rated voltage).

10 A for 1.5 secs, ac resistive/inductive.

10,000 operations (subject to the above limits of make/break capacity & rated voltage).

Durability:

Loaded contact:	10,000 operations minimum
Unloaded contact:	100,000 operations minimum
Operate Time	Less than 5 ms
Reset Time	Less than 5 ms

5.2

High Break Contacts (Option)

Continuous Carry Ratings (Not Switched):

Maximum continuous current:	10 A dc
Short duration withstand carry:	30 A dc for 3 s 250A dc for 30ms
Rated voltage:	300 V

Make & Break Capacity:

DC:	7500 W resistive	
DC:	2500 W inductive	(L/R = 50 ms)

Make, Carry:

30 A for 3 secs, dc resistive.

10,000 operations (subject to the above limits of make/break capacity & rated voltage).

Make, Carry & Break:

30 A for 3 secs, dc resistive.

5,000 operations (subject to the above limits of make/break capacity & rated voltage).

30 A for 200 ms, dc resistive.

10,000 operations (subject to the above limits of make/break capacity & rated voltage).

10 A (*), dc inductive.

10,000 operations (subject to the above limits of make/break capacity & rated voltage).

*Typical for repetitive shots - 2 minutes idle for thermal dissipation

Voltage	Current	L/R	No. of Shots in 1 sec
65 V	10 A	40 ms	5
150 V	10 A	40 ms	4
250 V	10 A	40 ms	2
250 V	10 A	20 ms	4

MOV protection: Max Voltage 330 V dc

Table 1 - MOV protection: Max Voltage 330 V dc

Durability:

Loaded contact: 10,000 operations minimum

Unloaded contact: 100,000 operations minimum

Operate Time: Less than 0.2 ms

Reset Time: Less than 8 ms

5.3**Watchdog Contacts**

Non-programmable contacts for relay healthy or relay fail indication:

Breaking capacity: DC: 30 W resistive
 DC: 15 W inductive (L/R = 40 ms)
 AC: 375 VA inductive ($\cos \phi = 0.7$)

6 ENVIRONMENTAL CONDITIONS

6.1 Ambient Temperature Range

Per IEC 60255-1: 2009

Operating temperature range: -25°C to +55°C (or -13°F to +131°F).

Storage and transit: -25°C to +70°C (or -13°F to +158°F).

6.2 Ambient Humidity Range

Per IEC 60068-2-78: 2012:

56 days at 93% relative humidity and +40°C

Per IEC 60068-2-30: 2009:

Damp heat cyclic, six (12 + 12) hour cycles, 93% RH, +25 to +55°C

6.3 Corrosive Environments

Per IEC 60068-2-60: 1995, Part 2, Test Ke, Method (class) 3

Industrial corrosive environment/poor environmental control, mixed gas flow test.

21 days at 75% relative humidity and +30°C

Exposure to elevated concentrations of H₂S, NO₂, Cl₂ and SO₂.

8 ELECTROMAGNETIC COMPATIBILITY (EMC)

8.1 1 MHz Burst High Frequency Disturbance Test

As for EN / IEC 60255-22-1, Class III,
 Common-mode test voltage: 2.5 kV,
 Differential test voltage: 1.0 kV,
 Test duration: 2 s,
 Source impedance: 200 Ω
 (EIA(RS)-232 ports excepted).

8.2 100kHz Damped Oscillatory Test

EN 61000-4-18: 2007: Level 3
 Common mode test voltage: 2.5 kV
 Differential mode test voltage: 1 kV

8.3 Immunity to Electrostatic Discharge

Per IEC 60255-22-2: 1997, Class 4,
 15kV discharge in air to user interface, display, and exposed metalwork.
 Per IEC 60255-22-2: 1997, Class 3,
 8kV discharge in air to all communication ports.
 6kV point contact discharge to any part of the front of the product.

8.4 Electrical Fast Transient or Burst Requirements

Per IEC 60255-22-4: 2002.
 Test severity: Class III and IV:
 Amplitude: 2 kV, burst frequency 5 kHz (Class III),
 Amplitude: 4 kV, burst frequency 2.5 kHz (Class IV).
 Applied directly to auxiliary supply, and applied to all other inputs. EIA(RS)232 ports excepted.

8.5 Surge Withstand Capability

IEEE/ANSI C37.90.1:2002:
 4 kV fast transient and 2.5 kV oscillatory applied common mode and differential mode to opto inputs (filtered), output relays, CTs, VTs, power supply, field voltage.
 4 kV fast transient and 2.5 kV oscillatory applied common mode to communications, IRIG- B.

8.6 Surge Immunity Test

EIA(RS)232 ports excepted.
 Per IEC 61000-4-5: 2005 Level 4.
 Time to half-value: 1.2/50 μ s.
 Amplitude: 4 kV between all groups and protective (earth) conductor terminal.
 Amplitude: 2 kV between terminals of each group.

8.7 Immunity to Radiated Electromagnetic Energy

IEC 60255-22-3: 2000, Class III:
 Test field strength, frequency band 80 to 1000 MHz: 10 V/m,
 Test using AM: 1 kHz / 80%,
 Spot tests at: 80, 160, 450, 900 MHz
 IEEE/ANSI C37.90.2: 1995:
 25 MHz to 1000 MHz, zero and 100% square wave modulated.
 Field strength of 35 V/m.

9 EU DIRECTIVES

9.1 EMC Compliance

2004/30/EU:

Compliance to the European Commission Directive on EMC is claimed via the Technical Construction File route. Product Specific Standards were used to establish conformity: EN 60255-26

9.2 Product Safety

2014/35/EU:

Compliance to the European Commission Low Voltage Directive (LVD) is demonstrated using a Technical File. A product-specific standard was used to establish conformity.



EN 60255-27

9.3 ATEX Compliance

ATEX Potentially Explosive Atmospheres directive 2014/34/EU, for equipment.

The equipment is compliant with Article 1 of European directive 2014/34/EU.

It is approved for operation outside an ATEX hazardous area. It is however approved for connection to Increased Safety, "Ex e", motors with rated ATEX protection, Equipment Category 2, to ensure their safe operation in gas Zones 1 and 2 hazardous areas.

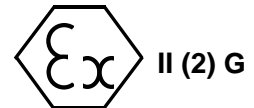

Caution

Equipment with this marking is not itself suitable for operation within a potentially explosive atmosphere.

Compliance demonstrated by Notified Body certificates of compliance.

9.4 UKCA Compliance

SI 2016 No.1107:

UK Type Examination regulation of the equipment.

The equipment is compliant with Article 3 (b) part I of the UK regulation SI 2016 No. 1107, amended by SI 2019 No. 696.



BS EN 60255-27

10 MECHANICAL ROBUSTNESS

10.1	Vibration Test	
	Per EN / IEC 60255-21-1	Response Class 2 Endurance Class 2
10.2	Shock and Bump	
	Per EN / IEC 60255-21-2	Shock response Class 2 Shock withstand Class 1 Bump Class 1
10.3	Seismic Test	
	Per EN / IEC 60255-21-3:	Class 2

11 PX40 THIRD PARTY COMPLIANCES

11.1 Underwriters Laboratory (UL)

File Number: E202519
(Complies with Canadian and US requirements).

11.2 Energy Networks Association (ENA)

Certificate Number: 116 Issue 2
Assessment Date: 18-04-2007

12 PROTECTION FUNCTIONS

12.1 Phase Current Differential Protection

Accuracy

Pick-up:	Formula $\pm 10\%$
Drop-off:	$0.75 \times \text{Formula} \pm 10\%$
IDMT characteristic shape:	$\pm 5\%$ or 40 ms whichever is greater
DT operation:	$\pm 2\%$ or 20 ms whichever is greater
Instantaneous Operation:	<30 ms
Reset time:	<60 ms
Repeatability:	$\pm 2.5\%$
Characteristic:	UK curves IEC 60255-3 – 1998 US curves IEEE C37.112 – 1996
Vector compensation:	No effect on accuracy
Current transformer ratio Compensation:	No effect on accuracy
High set characteristic setting:	No effect on accuracy
Two ended scheme operation:	No effect on accuracy
Three ended scheme operation:	No effect on accuracy

12.2 Distance Protection

From version H4 the operating times for off-angle faults have been improved to an average of 30-35ms in all zone 1 (for $f = 50\text{Hz}$). Faults at the zone boundary will be cleared in higher times (10-20% of zone 1 area). Sub cycle operation is maintained for faults close to the relay characteristic up to 75% of zone reach setting.

All quoted operating times include the closure of the trip output contact (standard output contacts used).

The *Operating Time v Reach % at 50 Hz* diagram and the *Operating Time v Reach % at 60 Hz* diagram shows Operating Time versus Reach Percentage, for faults close to line angle.

50 Hz Operation

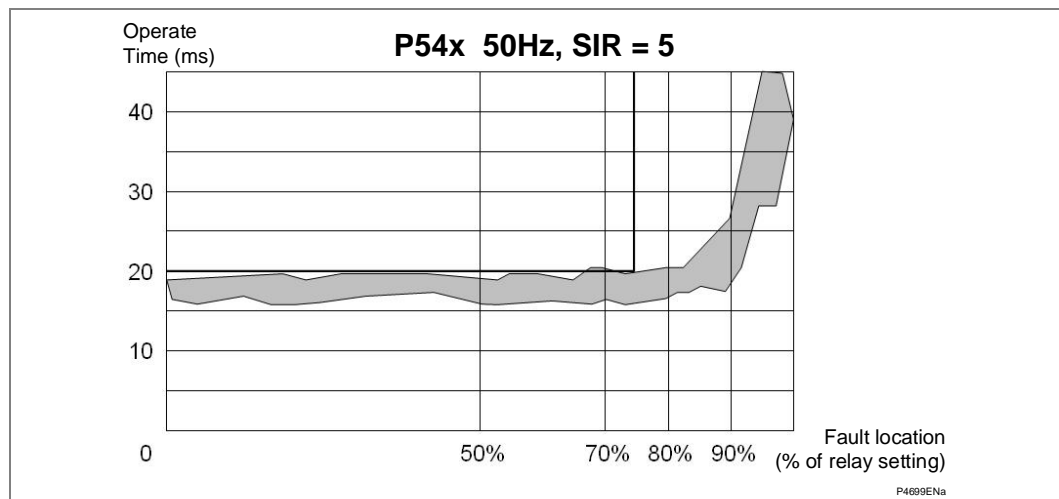
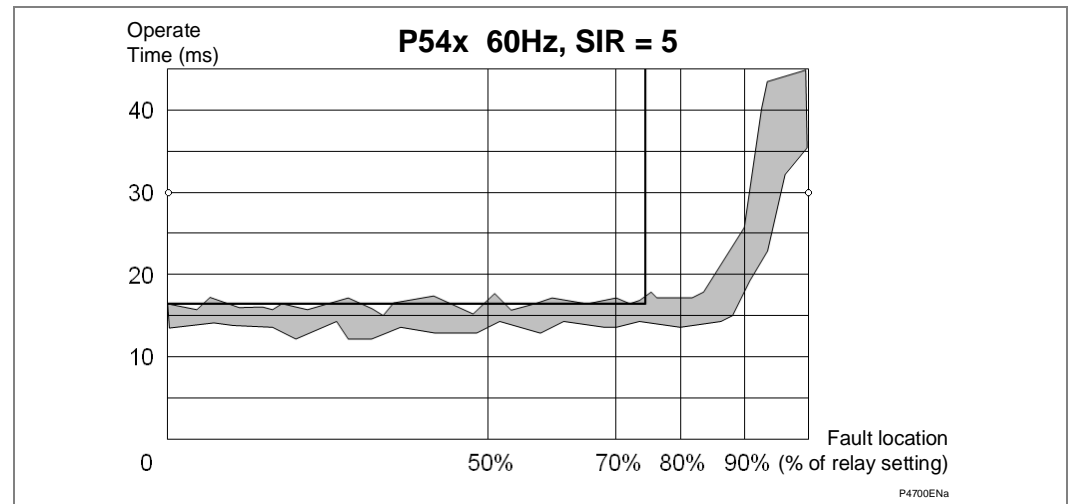

Figure 1 - Operating Time vs Reach % at 50 Hz

60 Hz Operation**Figure 2 - Operating Time vs Reach % at 60 Hz****Accuracy**

Characteristic shape, up to SIR = 30: $\pm 5\%$ for on-angle fault (the set line angle)
 $\pm 10\%$ off-angle

(Example: For a 70 degree set line angle, injection testing at 40 degrees would be referred to as "off-angle").

Zone time delay deviations: ± 20 ms or 2%, whichever is greater.

Sensitivity

Settings $< 5/\ln \Omega$: $(0.05 \ln^*5 / (\text{setting} * \ln)) \pm 5\%$

Settings $> 5/\ln \Omega$: $0.05 \ln \pm 5\%$

Out-Of-Step

Accuracy of zones and timers as per distance

Operating range: up to 7 Hz

12.3**Three-Phase Overcurrent Protection****Accuracy**

DT Pick-up:	Setting $\pm 5\%$
Minimum IDMT trip level:	1.05 x setting $\pm 5\%$
Drop-off:	0.95 x setting $\pm 5\%$
IDMT shape:	$\pm 5\%$ or 40 ms whichever is greater
IEEE reset:	$\pm 5\%$ or 50 ms whichever is greater
DT operation:	$\pm 2\%$ or 50 ms, whichever is greater
DT reset:	$\pm 5\%$
Directional boundary (RCA $\pm 90\%$):	$\pm 2^\circ$ hysteresis $< 3^\circ$
Characteristic:	UK curves IEC 60255-3 ... 1998
US curves:	IEEE C37.112... 1996
Reference conditions TMS = 1, TD = 1 and I > setting of 1 A operating range 2-20 In	

12.4**Phase and Ground (Earth) Overcurrent****Accuracy**

Pick-up:	Setting $\pm 5\%$
Drop-off:	0.95 x setting $\pm 5\%$
Minimum trip level for IDMT elements:	1.05 x Setting $\pm 5\%$
Inverse time stages:	± 40 ms or 5%, whichever is greater
Definite time stages:	± 40 ms or 2%, whichever is greater
Repeatability:	5%
Directional boundary accuracy:	$\pm 2^\circ$ with hysteresis $< 3^\circ$

Additional tolerance due to increasing X/R ratios: $\pm 5\%$ over the X/R ratio from 1 to 90
 Overshoot of overcurrent elements: < 30 ms

12.4.1 Sensitive Earth Fault (SEF)

Pick-up: Setting $\pm 5\%$
 Minimum IDMT Trip level: $1.05 \times$ Setting $\pm 5\%$
 Drop-off: $0.95 \times$ Setting $\pm 5\%$
 IDMT shape: $\pm 5\%$ or 40 ms whichever is greater
 IEEE reset: $\pm 17.5\%$ or 60 ms whichever is greater
 DT operation: $\pm 2\%$ or 50 ms whichever is greater
 DT reset: $\pm 5\%$
 Repeatability: $\pm 5\%$
 Reference conditions TMS = 1, TD = 1 and IN > setting of 100 mA, operating range 2-0 In
 Stages 1 and 2, Range: 5mA to 100mA
 Stages 3 and 4, Range: 5mA to 0.8A (Software Versions prior to D1)
 Stages 3 and 4, Range: 5mA to 2.0A (Software Version D1 and later)

12.4.2 Wattmetric SEF

Pick-up P=0W: ISEF > $\pm 5\%$ or 5 mA
 Pick-up P>0W: P > $\pm 5\%$
 Drop-off P=0W: $(0.95 \times \text{ISEF} >)$ $\pm 5\%$ or 5 mA
 Drop-off P>0W: $0.9 \times$ P > $\pm 5\%$
 Boundary accuracy: $\pm 5^\circ$ with 1° hysteresis
 Repeatability: 1%

12.4.3 Polarizing quantities

VN> and V2> Level detectors: Pick-up: $\pm 10\%$
 Resetting ratio: 0.9
 I2> Level detector: Pick-up: $\pm 10\%$
 Resetting ratio: 0.9

12.5 Inverse Time Characteristic

Accuracy

Pick-up: Setting $\pm 5\%$
 Drop-off: $0.95 \times$ setting $\pm 5\%$
 Minimum trip level for IDMT elements: $1.05 \times$ Setting $\pm 5\%$
 Inverse time stages: ± 40 ms or 5%, whichever is greater
 Definite time stages: ± 40 ms or 2%, whichever is greater
 Repeatability: 5%
 Directional boundary accuracy: $\pm 2^\circ$ with hysteresis $< 3^\circ$
 Additional tolerance due to increasing X/R ratios: $\pm 5\%$ over the X/R ratio from 1 to 90
 Overshoot of overcurrent elements: < 30 ms

12.6 Earth Fault/Sensitive Earth Fault Protection

12.6.1 Earth Fault

DT Pick-up:	Setting $\pm 5\%$
Minimum IDMT Trip level:	1.05 x Setting $\pm 5\%$
Drop-off:	0.90 x Setting $\pm 5\%$
IDMT shape:	$\pm 5\%$ or 40 ms whichever is greater
IEEE reset:	$\pm 10\%$ or 40 ms whichever is greater
DT operation:	$\pm 2\%$ or 50 ms whichever is greater
DT reset:	$\pm 2\%$ or 50 ms whichever is greater
Repeatability:	$\pm 5\%$
Reference conditions TMS = 1, TD = 1 and IN > setting of 1A, operating range 2-20 In	

12.6.2 Sensitive Earth Fault (SEF)

Pick-up:	Setting $\pm 5\%$
Minimum IDMT Trip level:	1.05 x Setting $\pm 5\%$
Drop-off:	0.95 x Setting $\pm 5\%$
IDMT shape:	$\pm 5\%$ or 40 ms whichever is greater
IEEE reset:	$\pm 17.5\%$ or 60 ms whichever is greater
DT operation:	$\pm 2\%$ or 50 ms whichever is greater
DT reset:	$\pm 5\%$
Repeatability:	$\pm 5\%$
Reference conditions TMS = 1, TD = 1 and ISEF > setting of 1A, operating range 2-0 In	

12.6.3 Restricted EF

Pick-up:	Setting formula $\pm 5\%$
Drop-off:	0.80 x setting formula $\pm 5\%$
Operating time:	<60 ms
High pick up:	Setting $\pm 5\%$
High operating time:	<30 ms
Repeatability:	<15%

12.6.4 Wattmetric SEF

Pick-up P=0W:	ISEF > $\pm 5\%$ or 5 mA
Pick-up P>0W:	P > $\pm 5\%$
Drop-off P=0W:	(0.95 x ISEF >) $\pm 5\%$ or 5 mA
Drop-off P>0W:	0.9 x P > $\pm 5\%$
Boundary accuracy:	$\pm 5^\circ$ with 1° hysteresis
Repeatability:	1%

12.6.5 Polarizing Quantities

VN> and V2> Level detectors:	Pick-up: $\pm 10\%$ Resetting ratio: 0.9
I2> Level detector:	Pick-up: $\pm 10\%$ Resetting ratio: 0.9

12.7 Negative Sequence Overcurrent

Accuracy

Pick-up:	Setting $\pm 5\%$
Drop-off:	0.95 x setting
Definite time operation:	± 60 ms or 2%, whichever is greater
Repeatability:	1%
Directional boundary accuracy:	$\pm 2^\circ$ with hysteresis $< 1^\circ$
Reset:	<35 ms

12.8 Undervoltage**Accuracy**

DT Pick-up:	Setting $\pm 2\%$
IDMT Pick-up:	0.98 x setting $\pm 2\%$
Drop-off:	1.02 x setting $\pm 2\%$
Definite time operation:	± 40 ms or 2%, whichever is greater
Repeatability:	1%
IDMT characteristic shape:	± 40 ms or 2%, whichever is greater
Reset:	<75 ms

12.9 Overvoltage**Accuracy**

DT Pick-up:	Setting $\pm 1\%$
IDMT Pick-up:	1.02 x setting $\pm 2\%$
Drop-off:	0.98 x setting $\pm 2\%$
Definite time operation:	± 40 ms or 2%, whichever is greater
Repeatability:	1%
IDMT characteristic shape:	± 40 ms or 2%, whichever is greater
Reset:	<75 ms

12.10 Neutral Displacement/Residual Overvoltage**Accuracy**

DT Pick-up:	Setting $\pm 5\%$
IDMT Pick-up:	1.05 x setting $\pm 5\%$
Drop-off:	0.95 x setting $\pm 5\%$
Definite time operation:	± 20 ms or 2%, whichever is greater
Instantaneous operation:	<50 ms
Repeatability:	10%
IDMT characteristic shape:	± 60 ms or 5%, whichever is greater
Reset:	<35 ms

12.11 Underfrequency Protection**Accuracy**

Pick-up:	Setting ± 0.025 Hz
Drop-off:	1.05 x Setting ± 0.025 Hz
DT operation:	$\pm 2\%$ or 50 ms whichever is greater *

* The operating time will also include a time for the relay to frequency tracking (20 Hz/second)

12.12 Overfrequency Protection**Accuracy**

Pick-up:	Setting ± 0.025 Hz
Drop-off:	0.95 x Setting ± 0.025 Hz
DT operation:	$\pm 2\%$ or 50 ms whichever is greater *

* The operating will also include a time for the relay to frequency tracking (20 Hz/ second)

12.13 Circuit Breaker Fail and Undercurrent

Pick-up:	$\pm 10\%$ or $0.025 I_n$, whichever is greater
Operating time:	< 12 ms
Timers:	2 ms or 2%, whichever is greater
Reset:	< 15 ms

12.14 Broken Conductor Logic**Accuracy**

Pick-up:	Setting $\pm 2.5\%$
Drop-off:	$0.95 \times$ setting $\pm 2.5\%$
Definite time operation:	± 50 ms or 2%, whichever is greater
Reset:	< 25 ms

12.15 Thermal Overload**Accuracy**

Thermal alarm pick-up:	Calculated trip time	$\pm 10\%$
Thermal overload pick-up:	Calculated trip time	$\pm 10\%$
Cooling time accuracy	$\pm 15\%$ of theoretical	
Repeatability:	$< 5\%$	
Operating time measured with applied current of 20% above thermal setting.		

12.16 Voltage Transformer Supervision (VTS)**Accuracy**

Fast block operation:	< 1 cycle
Fast block reset:	< 1.5 cycles
Time delay:	± 20 ms or 2%, whichever is greater

12.17 Current Transformer Supervision (CTS)**12.17.1 Standard CTS****Accuracy**

In $>$ Pick-up:	Setting $\pm 5\%$
VN $<$ Pick-up:	Setting $\pm 5\%$
In $>$ Drop-off:	$0.9 \times$ Setting $\pm 5\%$
VN $<$ Drop-off:	$1.05 \times$ Setting $\pm 5\%$ or 1 V whichever is greater
Time delay operation:	Setting $\pm 2\%$ or 20 ms whichever is greater
CTS block operation:	< 1 cycle
CTS reset:	< 35 ms

12.17.2 Differential CTS**Accuracy**

I1 Pick-up:	Setting 5%
I1 Drop-off:	$(0.9 \times$ setting) 5%
I2/I1 $>$ Pick-up:	Setting 5%
I2/I1 $>$ Drop-off:	$(0.9 \times$ setting) 5%
I2/I1 $>>$ Pick-up:	Setting 5%
I2/I1 $>>$ Drop-off:	$(0.9 \times$ setting) 5%
Time delay operation:	Setting 2% or 20 ms whichever is greater
CTS block operation:	< 1 cycle
CTS block diff operation:	< 1 cycle
CTS reset:	< 35 ms

12.18 CB State Monitoring and Condition Monitoring**Accuracy**

Timers:	$\pm 2\%$ or 20 ms whichever is greater
Broken current accuracy:	$\pm 5\%$

12.19 Programmable Scheme Logic (PSL)

Output conditioner timer:	Setting $\pm 2\%$ or 20 ms whichever is greater
Dwell conditioner timer:	Setting $\pm 2\%$ or 20 ms whichever is greater
Pulse conditioner timer:	Setting $\pm 2\%$ or 20 ms whichever is greater
No of PSL Timers:	32

Control Inputs into PSL (Ctrl. I/P Config.)

Hotkey Enabled:	Binary function link string, selecting which of the control inputs are driven from Hotkeys.
Control Input 1: (up to):	Latched/Pulsed
Control Input 32:	
Ctrl Command 1: (up to):	ON/OFF / SET/RESET / IN/OUT / ENALBED/DISABLED
Ctrl Command 32:	

12.20 Auto-Reclose and Check Synchronism**Accuracy**

Timers:	Setting ± 20 ms or 2%, whichever is greater
---------	---

12.21 Measurements and Recording Facilities**Accuracy**

Typically $\pm 1\%$, but $\pm 0.5\%$ between 0.2-2 In/Vn

Current:	0.05... 3 In
Accuracy:	$\pm 1.0\%$ of reading
Voltage:	0.05...2 Vn
Accuracy:	$\pm 1.0\%$ of reading
Power (W):	0.2...2 Vn 0.05...3 In
Accuracy:	$\pm 5.0\%$ of reading at unity power factor
Reactive Power (Vars):	0.2...2 Vn, 0.05...3 In
Accuracy:	$\pm 5.0\%$ of reading at zero power factor
Apparent Power (VA):	0.2...2 Vn 0.05...3 In
Accuracy:	$\pm 5\%$ of reading
Energy (Wh):	0.2...2 Vn 0.2...3 In
Accuracy:	$\pm 5\%$ of reading at unity power factor
Energy (Varh):	0.2...2 Vn 0.2...3 In
Accuracy:	$\pm 5\%$ of reading at zero power factor
Phase accuracy:	$0^\circ \dots 360^\circ$
Accuracy:	$\pm 0.5^\circ$
Frequency:	45...65 Hz
Accuracy:	± 0.025 Hz

12.22 Real Time Clock

Real time clock accuracy:	$< \pm 2$ seconds/day
---------------------------	-----------------------

12.23 Enhanced Disturbance Records

Maximum record duration: 3 seconds
 Maximum pre-trigger time 500 ms (see Note below)
 Extracted over: CS103, IEC61850 and COURIER

Note As from Software Version H4, in DNP3 the maximum DR pre-trigger time is around 140 ms (50Hz) and 120 ms (60 Hz).

Note As from Software Version H6, in DNP3 and CS103 the maximum DR pre-trigger time is around 500 ms (50Hz) and 420 ms (60 Hz).

Accuracy

Magnitude and relative phases: $\pm 5\%$ of applied quantities
 Duration: $\pm 2\%$
 Trigger position: $\pm 2\%$ (minimum Trigger 100 ms)

12.24 Fault Locator

Accuracy

Fault location: $\pm 2\%$ of line length
 Reference conditions solid fault applied on line

12.25 Event, Fault & Maintenance Records

The most recent records are stored in battery-backed memory, and can be extracted via the communication port or be viewed on the front panel display.

No of Event Records: Up to 1024 time tagged event records
 No of Fault Records: Up to 15
 No of Maintenance Records: Up to 10

12.26 Plant Supervision

Accuracy

Broken current accuracy: $\pm 5\%$

Timer Accuracy

Timers: $\pm 2\%$ or 40 ms whichever is greater
 Reset time: <30 ms
 Pick-up: $\pm 10\%$ or 25 mA whichever is greater
 Operating time: <20 ms
 Reset: <25 ms

12.27 InterMiCOM⁶⁴ Fiber Optic Teleprotection

End-end operation. The table below shows minimum and maximum transfer time for InterMiCOM⁶⁴ (IM64).

The times are measured from opto initialization (with no opto filtering) to relay standard output and include a small propagation delay for back-back test (2.7 ms for 64 kbits/s and 3.2 ms for 56 kbits/s).

IDiff IM64 indicates InterMiCOM⁶⁴ signals working in conjunction with the differential protection fiber optic communications channel. IM64 indicates InterMiCOM⁶⁴ signals working as a standalone feature.

Configuration	Permissive op times (ms)	Direct op times (ms)
IM64 at 64 k	13 - 18	17 - 20
IM64 at 56 k	15 - 20	19 - 22
IDiff IM64 at 64 k	22 - 24	23 - 25
IDiff IM64 at 56 k	24 - 26	25 - 27

Table 2 - Minimum and maximum transfer time for InterMiCOM⁶⁴.

12.28 Ethernet Data (where applicable)**12.28.1 100 Base FX Interface****Transmitter Optical Characteristics**

Parameter	Sym	Min.	Typ.	Max	Unit
Output Optical Power BOL: 62.5/125 μm , NA = 0.275 Fiber EOL	P _{OUT}	-19 -20	-16.8	-14	dBm avg.
Output Optical Power BOL: 50/125 μm , NA = 0.20 Fiber EOL	P _{OUT}	-22.5 -23.5	-20.3	-14	dBm avg.
Optical Extinction Ratio				10 -10	% dB
Output Optical Power at Logic "0" State	P _{OUT} ("0")			-45	dBm avg.

BOL – Beginning of life EOL – End of life NA – Numerical Aperture

Table 3 - Transmitter optical characteristics**Receiver Optical Characteristics**

Parameter	Sym	Min.	Typ.	Max.	Unit
Input Optical Power Minimum at Window Edge	P _{IN} Min. (W)		-33.5	-31	dBm avg.
Input Optical Power Minimum at Eye Center	P _{IN} Min. (C)		-34.5	-31.8	dBm avg.
Input Optical Power Maximum	P _{IN} Max.	-14	-11.8		dBm avg.

Table 4 - Receiver optical characteristics

13 SETTINGS LIST

13.1 Global Settings (System Data)

Language:	English/French/German/Spanish English/French/German/Russian Chinese/English/French
Frequency:	50/60 Hz
IEC61850 Edition	1 or 2
ETH COMM Mode	Dual IP, PRP, HSR or RSTP

13.2 Circuit Breaker Control (CB Control)

13.2.1 P543 and P545 Specific CB Control Settings

CB Control by:	Disabled, Local, Remote, Local+remote, Opto, Opto+local, Opto+Remote, Opto+Rem+Local
Close pulse time:	0.10...10.00s
Trip pulse time:	0.10...5.00s
Man close t max:	0.01...9999.00s
Man close delay:	0.01...600.00s
CB healthy time:	0.01...9999.00s
Check sync time:	0.01...9999.00s
Reset lockout by:	User interface/CB close
Man close RstDly:	0.10...600.00s
Single pole A/R:	Disabled/Enabled
Three pole A/R:	Disabled/Enabled
CB Status Input:	None, 52A 3 pole, 52B 3 pole, 52A & 52B 3 pole, 52A 1 pole, 52B 1 pole, 52A & 52B 1 pole

13.2.2 P544 and P546 Specific CB Control Settings

CB Control by:	Disabled, Local, Remote, Local+remote, Opto, Opto+local, Opto+remote, Opto+rem+local
Man close delay:	0.01...600.00s
CB healthy time:	0.01...9999.00s
Check sync time:	0.01...9999.00s
Rst CB mon LO By:	User Interface/CB Close
CB mon LO RstDly:	0.1...600s
CB1 Status Input:	None, 52A 3 pole, 52B 3 pole, 52A & 52B 3 pole, 52A 1 pole, 52B 1 pole, 52A & 52B 1 pole
CB Status Time	0.1 ... 5s
CB2 Status Input:	None, 52A 3 pole, 52B 3 pole, 52A & 52B 3 pole, 52A 1 pole, 52B 1 pole, 52A & 52B 1 pole
Res AROK by UI:	Enabled/Disabled
Res AROK by NoAR:	Enabled/Disabled
Res AROK by Ext:	Enabled/Disabled
Res AROK by TDly:	Enabled/Disabled
Res AROK by TDly:	1.0...9999 s
Res LO by CB IS:	Enabled/Disabled
Res LO by UI:	Enabled/Disabled
Res LO by NoAR:	Enabled/Disabled
Res LO by ExtDDB:	Enabled/Disabled
Res LO by TDelay:	Enabled/Disabled
LO Reset Time:	1...9999 s

13.3 Date and Time

IRIG-B Sync:	Disabled/Enabled
Battery Alarm:	Disabled/Enabled
LocalTime Enable:	Disabled/Fixed/Flexible
LocalTime Offset:	-720 min...720 min
DST Enable:	Disabled/Enabled
DST Offset:	30 min...60 min
DST Start:	First/Second/Third/Fourth/Last
DST Start Day:	Sun/Mon/Tues/Wed/Thurs/Fri/Sat
DST Start Month:	Jan/Feb/Mar/Apr/May/June/Jul/Aug/Sept/Oct/Nov/Dec
DST Start Mins:	0 min...1425 min
DST End:	First/Second/Third/Fourth/Last
DST End Day:	Sun/Mon/Tues/Wed/Thurs/Fri/Sat
DST End Month:	Jan/Feb/Mar/Apr/May/June/Jul/Aug/Sept/Oct/Nov/Dec
DST End Mins:	0 min...1425 min
RP1 Time Zone:	UTC/Local
RP2 Time Zone:	UTC/Local
Tunnel Time Zone:	UTC/Local
DNPOE Time Zone:	UTC or Local

13.4 Configuration

Setting Group:	Select via Menu	or	Select via PSL
Active Settings:	Group 1/2/3/4		
Setting Group 1:	Disabled/Enabled		
Setting Group 2:	Disabled/Enabled		
Setting Group 3:	Disabled/Enabled		
Setting Group 4:	Disabled/Enabled		
Distance:	Disabled/Enabled		
Directional E/F:	Disabled/Enabled		
Phase Diff:	Disabled/Enabled		
Overcurrent:	Disabled/Enabled		
Neg Sequence O/C:	Disabled/Enabled		
Broken Conductor:	Disabled/Enabled		
Earth Fault:	Disabled/Enabled		
SEF/REF Prot'n:	Disabled/Enabled		
Residual O/V NVD:	Disabled/Enabled		
Thermal Overload:	Disabled/Enabled		
Power Swing Block:	Disabled/Enabled		
Volt Protection:	Disabled/Enabled		
Freq Protection:	Disabled/Enabled		
df/dt Protection:	Disabled/Enabled		
CB Fail:	Disabled/Enabled		
Supervision:	Disabled/Enabled		
System Checks:	Disabled/Enabled		
Auto-Reclose:	Disabled/Enabled		
Input Labels:	Invisible/Visible		
Output Labels:	Invisible/Visible		
CT & VT Ratios:	Invisible/Visible		

Record Control:	Invisible/Visible
Disturb Recorder:	Invisible/Visible
Measure't Setup:	Invisible/Visible
Comms Settings:	Invisible/Visible
Commission Tests:	Invisible/Visible
Setting Values:	Primary/Secondary
Control Inputs:	Invisible/Visible
Ctrl I/P Config:	Invisible/Visible
Ctrl I/P Labels:	Invisible/Visible
Direct Access:	Disabled/Enabled/Hotkey Only/CB Ctrl Only
Function Key:	Invisible/Visible
VIR I/P Labels:	Invisible/Visible
VIR O/P Labels:	Invisible/Visible
Usr Alarm Labels:	Invisible/Visible
RP1 Read Only:	Disabled/Enabled
RP2 Read Only:	Disabled/Enabled
NIC Read Only:	Disabled/Enabled
LCD Contrast:	0...31

13.5**CT and VT Ratios****13.5.1****P543 and P545 CT and VT Ratio Settings**

Main VT Primary:	100 V...1000 kV
Main VT Sec'y:	80...140 V
CS VT Prim'y:	100 V...1000 kV
CS VT Sec'y:	80...140 V
Phase CT Primary:	1A...30 kA
Phase CT Sec'y:	1...5 A
SEF CT Primary:	1 A...30 kA
SEF CT Secondary:	1...5 A
MComp CT Primary:	1...30 k
MComp CT Sec'y:	1...5 A
CS Input:	A-N, B-N, C-N, A-B, B-C, C-A
Main VT Location:	Line/Bus
CT Polarity:	Standard/Inverted
SEF CT Polarity:	Standard/Inverted
M CT Polarity:	Standard/Inverted
VT Connected:	Yes/No
CS VT PhShft:	-180...+180 deg
CS VT Mag:	0.2...3

13.5.2 P544 and P546 CT and VT Ratio Settings

Main VT Primary:	100 V...1000 kV
Main VT Sec'y:	80...140 V
CB1 CS VT Prim'y:	100 V...1000 kV
CB1 CS VT Sec'y:	80...140 V
CB2 CS VT Prim'y:	100 V...1000 kV
CB2 CS VT Sec'y:	80...140 V
Phase CT Primary:	1A...30 kA
Phase CT Sec'y:	1...5 A
Phase CT2 Primary:	1A...30 kA
Phase CT2 Sec'y:	1...5 A
SEF CT Primary:	1 A...30 kA
SEF CT Secondary:	1...5 A
MComp CT Primary:	1...30 k
MComp CT Sec'y:	1...5 A
CS Input:	A-N, B-N, C-N, A-B, B-C, C-A
Main VT Location:	Line/Bus1
CT1 Polarity:	Standard/Inverted
CT2 Polarity:	Standard/Inverted
SEF CT Polarity:	Standard/Inverted
M CT Polarity:	Standard/Inverted
VT Connected:	Yes/No
CB1 CS VT PhShft:	-180...+180 deg
CB1 CS VT Mag:	0.2...3
CB2 CS VT PhShft:	-180...+180 deg
CB2 CS VT Mag:	0.2...3

13.6 Sequence of Event Recorder (Record Control)

Alarm Event:	Disabled/Enabled
Relay O/P Event:	Disabled/Enabled
Opto Input Event:	Disabled/Enabled
General Event:	Disabled/Enabled
Fault Rec Event:	Disabled/Enabled
Maint Rec Event:	Disabled/Enabled
Protection Event:	Disabled/Enabled
Security Event:	Disabled/Enabled
Flt Rec Extended:	Disabled/Enabled (where available)
DDB 31 - 0:	(up to):
DDB 1791 - 1760:	Binary function link strings, selecting which DDB signals will be stored as events, and which will be filtered out.

13.7 Oscillography (Disturb Recorder)**13.7.1 For Software Release 47/57 V/W/X and Earlier**

Duration:	0.10...10.50s
Trigger Position:	0.0...100.0%
Trigger Mode:	Single/Extended
Analog Channel 1:	(up to): Analog Channel 12:
Disturbance channels selected from:	IA, IB, IC, IN, IN Sensitive, VA, VB, VC, IM, V CheckSync (P443, P446, P543 and P545) and IA2, IB2, IC2 and VCheckSync2 (P446, P544 and P546 only)
Digital Input 1:	(up to): Digital Input 32:
	Selected binary channel assignment from any DDB status point within the relay (opto input, output contact, alarms, starts, trips, controls, logic...).

Input 1 Trigger: (up to): No Trigger or
 Input 32 Trigger: Trigger L/H (Low to High) or
 Trigger H/L (High to Low)

13.7.2**For Software Release A0/B0 and Later**

Duration: 0.10...3.00s
 Trigger Position: 0.0...16.7% (A0-A and B0-A and later versions)
 0.0...50.0% (A0-B and B0-B and later versions)
 Trigger Mode: Single/Extended
 Analog Channel 1 (up to) 20:
 Disturbance channels selected from:
 IA, IB, IC, IN, IN Sensitive, VA, VB, VC, V CheckSync, Idiff, Ibias, 2nd Harmonic.
 Digital Input 1: (up to): Digital Input 128:
 Selected binary channel assignment from any DDB status point within the relay
 (opto input, output contact, alarms, starts, trips, controls, logic...)
 Input 1 Trigger: (up to):
 Input 32 Trigger: No Trigger/Trigger

13.8**Measured Operating Data (Measure't Setup)**

Default Display: Banner / 3Ph + N Current / 3Ph Voltage / Power /
 Date and Time / Description / Plant Reference /
 Frequency / Access Level
 Local Values: Primary/Secondary
 Remote Values: Primary/Secondary
 Measurement Ref: VA/VB/VC/IA/IB/IC
 Measurement Mode: 0/1/2/3
 Fix Dem. Period: 1...99 mins
 Roll Sub Period: 1...99 mins
 Num. Sub Periods: 1...15
 Distance Unit: Miles/Kilometers
 Fault Location: Distance Ohms % of Line
 Remote2 Values: Primary/Secondary

13.9**Communications****13.9.1****Courier Protocol**

Courier protocol: Protocol and RP1 Card Status indicated
 RP1 Address: 0 to 255 (step 1)
 RP1 Inactiv timer: 1min to 30 mins (step 1min)
 RP1 Physical link: Copper/Fibre optic
 RP1 Port configuration: K-Bus/EIA485 (RS485)
 RP1 comms mode: IEC60870 FT1.2/10-Bit No Parity
 RP1 Baud Rate: 9600/19200/38400 bits/s

13.9.2**IEC60870-5-103 Protocol**

IEC60870-5-103 protocol: Protocol indicated
 RP1 Address: 1 to 254 (step 1)
 RP1 Inactiv timer: 1min to 30 mins (step 1min)
 RP1 Baud Rate: 9600/19200 bits/s
 RP1 Measurement period: 1s to 60s (step 1s)
 RP1 Physical link: Copper/Fibre optic
 CS103 blocking: Disabled/Monitor blocking/Command blocking

13.9.3 DNP3.0 Protocol (Serial)

DNP3.0 protocol:	Protocol indicated
RP1 Address:	1 to 65519 (step 1)
RP1 Baud Rate:	1200/2400/4800/9600/19200/38400 bits/s
RP1 Parity:	Odd/Even/None
RP1 Physical link:	RS485/Fibre optic
DNP Time Sync:	Disabled/Enabled
Meas scaling:	Primary/Secondary/Normalised
Message gap:	0ms to 50ms (step 1ms)
DNP Need Time:	1min to 30mins (step 1min)
DNP Application fragment size:	100 to 2048 (step 1)
DNP Application fragment timeout:	1s to 120s (step 1s)
DNP SBO timeout:	1s to 10s (step 1s)
DNP link timeout:	0s to 120s (step 1s)

13.9.4 Ethernet Port, IEC61850 Protocol

Ethernet port, IEC61850 Protocol:	Protocol, NIC MAC address(es), Redundancy IP address, Subnet mask and Gateway address indicated
ETH tunnel timeout:	1min to 30min (step 1min)

13.9.5 Ethernet Port, DNP3.0 Protocol

Ethernet port, DNP3.0 protocol:	Protocol, NIC MAC address(es), Redundancy IP address, Subnet mask and Gateway address indicated
DNP Time Sync:	Disabled/Enabled
Meas scaling:	Primary/Secondary/Normalised
DNP need time:	1min to 30mins (step 1min)
DNP Application Fragment size:	100 to 2048 (step 1)
DNP Application fragment timeout:	1s to 120s (step 1s)
DNP SBO timeout:	1s to 10s (step 1s)
DNP Link timeout:	0s to 120s (step 1s)
ETH tunnel timeout:	1min to 30mins (step 1min)

13.10 Optional Additional Second Rear Communication (Rear Port2 (RP2))

RP2 Protocol:	Courier (fixed)
RP2 Port Config:	Courier over EIA(RS)232 or Courier over EIA(RS)485 or K-Bus
RP2 Comms. Mode:	IEC60870 FT1.2 Frame 10-Bit NoParity
RP2 Address:	0...255
RP2 InactivTimer:	1...30mins
RP2 Baud Rate:	9600 or 19200 or 38400 bits/s

13.11 Commission Tests

Monitor bit 1: (up to):	Selects which DDB signals have their status visible in the Test Port Status.
Monitor bit 8:	
Test Mode:	Disabled / Enabled / Contacts Blocked
Test Pattern:	Configuration of which output contacts are to be energized when the contact test is applied
Contact test:	No operation/Apply test/Remove test
Test LEDs:	No operation/Apply test
Test Autoreclose:	No operation/Trip 3-pole/ Trip Pole A/Trip Pole B/Trip Pole C
Static Test:	Disabled/Enabled

Test Loopback:	Disabled, External, Internal
Loopback Mode:	Disabled, External, Internal
IM64 TestPattern:	Configuration of which InterMiCOM64 commands are to be set high or low for a loopback test.
IM64 Test Mode	Enabled/Disabled

13.12 Circuit Breaker Condition Monitoring (CB Monitor Setup)

13.12.1 P543 and P545 CB Monitor Setup:

Broken I [^] :	1.0...2.0
I [^] Maintenance:	Alarm Disabled/Enabled
I [^] Maintenance:	1...25000
I [^] Lockout:	Alarm Disabled/Enabled
I [^] Lockout:	1...25000
No. CB Ops Maint:	Alarm Disabled/Enabled
No. CB Ops Maint:	1...10000
No. CB Ops Lock:	Alarm Disabled/Enabled
No. CB Ops Lock:	1...10000
CB Time Maint:	Alarm Disabled/Enabled
CB Time Maint:	0.005...0.500s
CB Time Lockout:	Alarm Disabled/Enabled
CB Time Lockout:	0.005...0.500s
Fault Freq. Lock:	Alarm Disabled/Enabled
Fault Freq. Count:	1...9999
Fault Freq. Time:	0...9999s

13.12.2 P544 and P546 CB Monitor Setup:

CB1 Broken I [^] :	1...2
CB1 I [^] Maintenance:	Alarm Disabled/Alarm Enabled
CB1 I [^] Maintenance:	1...25000 In [^]
CB1 I [^] Lockout:	Alarm Disabled/Alarm Enabled
CB1 I [^] Lockout:	1...25000 In [^]
No. CB1 Ops. Maint.:	Alarm Disabled/Alarm Enabled
No. CB1 Ops. Maint.:	1...10000
No. CB1 Ops. Lock:	Alarm Disabled/Alarm Enabled
No. CB1 Ops. Lock:	1...10000
CB1 Time Maint.:	Alarm Disabled/Alarm Enabled
CB1 Time Maint.:	0.005...0.5 s
CB1 Time Lockout:	Alarm Disabled/Alarm Enabled
CB1 Time Lockout:	0.005...0.5 s
CB1 Fault Freq. Lock:	Alarm Disabled/Alarm Enabled
CB1 Flt Freq. Count:	1...9999
CB1 Flt Freq. Time:	0...9999 s
CB2 Broken I [^] :	(up to)
CB2 Flt Freq. Time:	All settings selected from the same ranges as per the first controlled circuit breaker, CB1.

13.13	Optocoupled Binary Inputs (Opto Config.)
Global Nominal V:	24 – 27 V / 30 – 34 V / 48 – 54 V / 110 – 125 V / 220 – 250 V / Custom
Opto Input 1 (up to):	
Opto Input #. (# = max. opto no. fitted):	Custom options allow independent thresholds to be set for each opto, from the same range as above.
Opto Filter Control:	Binary function link string, selecting which optos have an extra 1/2 cycle noise filter, and which do not.
Characteristics:	Standard 60% - 80% / 50% - 70%
Time stamping accuracy:	±1 msec

13.14	Settable Control Inputs (Control Inputs)
--------------	---

Ctrl Setg I/P 33:	Disabled/Enabled
(up to)	
Ctrl Steg I/P 48:	Disabled/Enabled

13.15	PSL Signal Grouping Nodes
--------------	----------------------------------

PSL Signal Grouping Nodes

For Software Version D1a and later, these DDB “Group” Nodes can be mapped to individual or multiple DDBs in the PSL:

PSL Group Sig 1
 PSL Group Sig 2
 PSL Group Sig 3
 PSL Group Sig 4

13.16	EIA(RS)232 Teleprotection (INTERMiCOM Comms.)
--------------	--

Source Address:	1...10
Received Address:	1...10
Data Rate:	600 / 1200 / 2400 / 4800 / 9600 / 19200 baud
Loopback Mode:	Disabled/Internal/External
Test Pattern:	Configuration of which InterMiCOM signals are to be energized when the loopback test is applied.

13.17	INTERMiCOM Conf.
--------------	-------------------------

IM Msg Alarm Lvl:	0.1...100.0%
IM1 Cmd Type:	(up to):
IM8 Cmd Type:	Disabled/Direct/Blocking, Permissive
IM1 FallBackMode:	(up to):
IM8 FallBackMode:	Default/Latched
IM1 DefaultValue:	(up to):
IM8 DefaultValue:	0/1
IM1 FrameSyncTim:	(up to):
IM8 FrameSyncTim:	1ms...1.5 s

13.18	Function Keys
--------------	----------------------

Fn. Key Status 1 (up to):	Disabled / Unlocked / Locked
Fn. Key Status 10	
Fn. Key 1 Mode (up to):	Toggled/Normal
Fn. Key 10 Mode:	
Fn. Key 1 Label (up to):	User defined text string to describe the function of the particular function key
Fn. Key 10 Label:	

13.19 IED Configurator

Switch Conf. Bank: No Action / Switch Banks

13.20 Prot Comms/IM⁶⁴

Scheme Setup: 2 Terminal/Dual Redundant/3 Terminal
 Address: 0-0, 1-A...20-A, 1-B...20-B
 Address: 0-0, 1-A...20-A, 1-B...20-B, 1-C...20-C
 Comm Mode: Standard/IEEE C37.94
 Baud Rate Ch 1: 56kbits/s or 64kbits/s
 Baud Rate Ch 2: 56kbits/s or 64kbits/s
 Clock Source Ch1: Internal or External
 Clock Source Ch2: Internal or External
 Ch1 N*64kbits/s: Auto, 1, 2, 3... 12
 Ch2 N*64kbits/s: Auto, 1, 2, 3... 12
 Comm Delay Tol: 0.001 s...0.00005 s
 Comm Fail Timer: 0.1 s...600 s
 Comm Fail Mode: Ch 1 Failure/Ch 2 Failure/Ch 1 or Ch 2 Fail/Ch 1 and Ch 2 Fail
 GPS Sync: GPS Disabled, GPS→Standard, GPS→Inhibit, GPS→Restrain
 Prop Delay Equal: No operation/Restore CDiff
 Re-Configuration: Three Ended/Two Ended (R1&R2)/
 Two Ended (L&R2)/Two Ended (L&R1)
 Alarm Level: 0%...100%
 Prop Delay Stats: Disabled or Enabled
 MaxCh 1 PropDelay: 1 m...50 ms
 MaxCh 2 PropDelay: 1 m...50 ms
 TxRx Delay Stats: Disabled or Enabled
 MaxCh1 Tx-RxTime: 1 m...50 ms
 MaxCh2 Tx-RxTime: 1 m...50 ms
 GPS Fail Timer: 0...9999 s
 GPS Trans Fail: Disabled or Enabled
 GPS Trans Count: 1...100 s
 GPS Trans Timer: 0...9999 s
 GPS Sync los Dly: 0...100s
 IMx Cmd Type: Direct or Permissive
 IMx FallBackMode: Default or Latched
 IMxDefaultValue: 0 or 1
 (x=1 to 8). The IM1 – IM8 settings are common to both Ch1 and Ch2 (i.e. if IM1
 DefaultValue is set to 0, it will be 0 on Ch1 and on Ch2)

13.21 Security Config

Front Port: Disabled/Enabled
 Rear Port 1: Disabled/Enabled
 Rear Port 2: Disabled/Enabled
 ETH Port 1: Disabled/Enabled
 ETH Port 1/2: Disabled/Enabled
 ETH Port 2/3: Disabled/Enabled
 ETH Port 3: Disabled/Enabled

13.22 Control Input User Labels (Ctrl. I/P Labels)

Control Input 1 (up to): User defined text string to describe the function
 Control Input 32: of the particular control input.
 Settable Control Input 33 (up to): User defined text string to describe the function
 Settable Control Input 48: of the particular settable control input.

13.23

Settings in Multiple Groups

Note *All settings here onwards apply for setting groups # = 1 to 4.*

14 PROTECTION FUNCTIONS

14.1

Line Parameters

Line Length (km):	0.30...1000.00 km
Line Length (miles):	0.20...625.00 mi
Line Impedance:	0.05...500.00/ln Ω
Line Angle:	20...90°
kZN Res Comp.:	0.00...10.00
kZN Res Angle:	-180...90°
Mutual Comp:	Disabled/Enabled
KZm Mutual Set:	0.00...10.00
KZm Mutual Angle:	-180...90°
Mutual Cut Off:	0...2.0
Phase Sequence:	Standard ABC or Reverse ACB
CB Tripping Mode:	3 Pole or 1 and 3 Pole
CB2 Tripping Mode:	3 Pole or 1 and 3 Pole
Line Charging Y:	0.00...10.00 ms

14.2

Distance Setup

Setting Mode:	Simple/Advanced
Distance Setup:	Zone Starting/Gen Starting
Digital Filter:	Standard / Special Applies
CVT Filters:	Disabled / Passive / Active
SIR Setting (for Passive CVT):	5...60
Load Blinders:	Disabled/Enabled
Load/B Impedance:	0.10...500.00/ln Ω
Load/B Angle:	15...65°
Load Blinder V<:	1.0...70.0V (ph-g)
Distance Polarizing:	0.2...5.0

14.2.1

Phase Distance

Phase Chars.:	Disabled/Mho/Quadrilateral
Quad Resistance:	Common/Proportional
Fault Resistance:	0.05...500.00/ln Ω
Zone 1 Ph Status:	Disabled/Enabled/Enabled Ch Fail
Zone 1 Ph Reach:	10...1000% of line
Zone 2 Ph Status:	Disabled/Enabled/Enabled Ch Fail
Zone 2 Ph Reach:	10...1000% of line
Zone 3 Ph Status:	Disabled/Enabled/Enabled Ch Fail
Zone 3 Ph Reach:	10...1000% of line
Zone 3 Ph Offset:	Disabled/Enabled
Zone 3 Ph Rev Reach:	10...1000% of line
Zone P Ph Status:	Disabled/Enabled/Enabled Ch Fail
Zone P Ph Dir.:	Forward/Reverse
Zone P Ph Reach:	10...1000% of line
Zone 4 Ph Status:	Disabled/Enabled/Enabled Ch Fail
Zone 4 Ph Reach:	10...1000% of line
Zone Q Ph Status:	Disabled/Enabled/Enabled Ch Fail
Zone Q Ph Reach:	0.05...500.00/ln Ω

14.2.2

Ground Distance

Ground Chars.:	Disabled/Mho/Quadrilateral
Quad Resistance:	Common/Proportional
Fault Resistance:	0.05...500.00/ln Ω

Zone1 Gnd Status:	Disabled/Enabled
Zone1 Gnd Reach:	10...1000% of line
Zone2 Gnd Status:	Disabled/Enabled
Zone2 Gnd Reach:	10...1000% of line
Zone3 Gnd Status:	Disabled/Enabled
Zone3 Gnd Reach:	10...1000% of line
Zone3 Gnd Offset:	Disabled/Enabled
Z3Gnd Rev Reach:	10...1000% of line
ZoneP Gnd Status:	Disabled/Enabled
ZoneP Gnd Direction:	Forward/Reverse
ZoneP Gnd Reach:	10...1000% of line
Zone4 Gnd Status:	Disabled/Enabled
Zone4 Gnd Reach:	10...1000% of line
Zone Q Ph Status:	Disabled/Enabled
Zone Q Ph Reach:	0.05...500.00/In Ω

For P546 all zone status should be:

Zone 1 Ph Status:	Disabled/Enabled/Enabled Ch Fail
-------------------	----------------------------------

14.2.3**Delta Directional**

Dir. Status:	Disabled/Enabled
AidedDeltaStatus:	Disabled/Phase Only/Ground Only/Phase and Ground
Dir. Char Angle:	0°...90°
Dir. V Fwd:	1.0...30.0 V
Dir. V Rev:	0.5...30.0 V
Dir. I Fwd:	0.10...10.00 In
Dir. I Rev:	0.05...10.00 In

14.3**Distance Elements****14.3.1****Phase Distance**

Z1 Ph. Reach:	0.05...500.00/In Ω
Z1 Ph. Angle:	20...90°
R1 Ph. Resistive:	0.05...500.00/In Ω
Z1 Tilt Top Line:	-30...30°
Z1 Ph. Sensit. Iph>1:	0.050...2.000 In
Z2 Ph. Reach:	0.05...500.00/In Ω
Z2 Ph. Angle:	20...90°
Z2 Ph Resistive:	0.05...500.00/In Ω
Z2 Tilt Top Line:	-30...30°
Z2 Ph. Sensit. Iph>2:	0.050...2.000 In
Z3 Ph. Reach:	0.05...500.00/In Ω
Z3 Ph. Angle:	20...90°
Z3' Ph Rev Reach:	0.05...500.00/In Ω
R3 Ph Res. Fwd.:	0.05...500.00/In Ω
R3' Ph Res. Rev.:	0.05...500.00/In Ω
Z3 Tilt Top Line:	-30...30°
Z3 Ph. Sensit. Iph>3:	0.050...2.000 In
ZP Ph. Reach:	0.05...500.00/In Ω
ZP Ph. Angle:	20...90°
ZP Ph Resistive:	0.05...500.00/In Ω
ZP Tilt Top line:	-30...30°
ZP Ph. Sensit. Iph>P:	0.050...2.000In

Z4 Ph. Reach:	0.05...500.00/ln Ω
Z4 Ph. Angle:	20...90°
Z4 Ph Resistive:	0.05...500.00/ln Ω
Z4 Tilt Top line:	-30...30°
Z4 Ph. Sensit. I _{ph} >4:	0.050...2.000 ln
Zone Q Ph Status:	Disabled/Enabled
Zone Q Ph Reach:	0.05...500.00/ln Ω
ZQ Ph Resistive:	0.05...500.00/ln Ω
ZQ Tilt Top line:	-30...30°
ZQ Sensit. I _{ph} >Q:	0.050...2.000ln

14.3.2

Ground Distance

Z1 Gnd. Reach:	0.05...500.00/ln Ω
Z1 Gnd. Angle:	20...90°
Z1 Dynamic Tilt:	Disabled or Enabled
Z1 Tilt top line:	-30°...30°
kZN1 Res. Comp.:	0.00...10.00
kZN1 Res. Angle:	-180...90°
kZm1 Mut. Comp.:	0.00...10.00
kZm1 Mut. Angle:	-180...90°
R1 Gnd. Resistive:	0.05...500.00/ln Ω
Z1 Sensit I _{gnd} >1:	0.050...2.000 ln
Z2 Gnd. Reach:	0.05...500.00/ln Ω
Z2 Gnd. Angle:	20...90°
Z2 Dynamic Tilt:	Disabled or Enabled
Z2 Tilt top line:	-30°...30°
kZN2 Res. Comp.:	0.00...10.00
kZN2 Res. Angle:	-180...90°
kZm2 Mut. Comp.:	0.00...10.00
kZm2 Mut. Angle:	-180...90°
R2 Gnd Resistive:	0.05...500.00/ln Ω
Z2 Sensit I _{gnd} >2:	0.050...2.000 ln
Z3 Gnd. Reach:	0.05...500.00/ln Ω
Z3 Gnd. Angle:	20...90°
Z3' Gnd Rev Rch:	0.05...500.00/ln Ω
Z3 Dynamic Tilt:	Disabled or Enabled
Z3 Tilt top line:	-30°...30°
kZN3 Res. Comp.:	0.00...10.00
kZN3 Res. Angle:	-180...90°
kZm3 Mut. Comp.:	0.00...10.00
kZm3 Mut. Angle:	-180...90°
R3 Gnd Res. Fwd:	0.05...500.00/ln Ω
R3 Gnd Res. Rev:	0.05...500.00/ln Ω
Z3 Sensit I _{gnd} >3:	0.050...2.000 ln
ZP Ground Reach:	0.05...500.00/ln Ω
ZP Ground Angle:	20...90°
ZP Dynamic Tilt:	Disabled or Enabled
ZP Tilt top line:	-30°...30°
kZNP Res. Comp.:	0.00...10.00
kZNP Res. Angle:	-180...90°
kZmP Mut. Comp.:	0.00...10.00
kZmP Mut. Angle:	-180...90°
RP Gnd Resistive:	0.05...500.00/ln Ω
ZP Sensit I _{gnd} >P:	0.050...2.000 ln

Z4 Gnd. Reach:	0.05...500.00/In Ω
Z4 Gnd. Angle:	20...90°
Z4 Dynamic Tilt:	Disabled or Enabled
Z4 Tilt top line:	-30°...30°
kZN4 Res. Comp.:	0.00...10.00
kZN4 Res. Angle:	-180...90°
kZm4 Mut. Comp.:	0.00...10.00
kZm4 Mut. Angle:	-180...90°
R4 Gnd. Resistive:	0.05...500.00/In Ω
Z4 Gnd Sensitivity:	0.050...2.000 In
ZQ Gnd. Reach:	0.05...500.00/In Ω
ZQ Gnd. Angle:	20...90°
ZQ Dynamic Tilt:	Disabled or Enabled
ZQ Tilt Top Line:	-30°...30°
kZnQ Res. Comp.:	0.00...10.00
kZnQ Res. Angle:	-180...90°
kZmQ Mut. Comp.:	0.00...10.00
kZmQ Mut. Angle:	-180...90°
RQ Gnd Resistive:	0.05...500.00/In Ω
ZQ Sensit Ignd>Q:	0.050...2.000 In

14.4 Phase Current Differential Protection

Phase Diff:	Enabled or Disabled
Phase Is1:	0.2 In...2 In
Phase Is2:	1 In...30 In
Phase k1:	10%...150%
Phase k2:	30%...150%
Phase Char:	DT/IEC S Inverse/IEC V Inverse/IEC E Inverse/ UK LT Inverse/IEEE M Inverse/IEEE V Inverse/IEEE E Inverse/ US Inverse/US ST Inverse
Phase Time Delay:	0 s...100 s
Phase TMS:	0.025...1.2
Phase Time Dial:	0.01...100
PIT Time:	0 s...0.2 s
Ph CT Corr'tion:	1...8
Compensation:	None/Cap Charging/Transformer
Susceptance:	1E-8*In...10*In
Inrush Restraint:	Restraint/Blocking/Disabled
Ih(2) CrossBlock:	Disabled/Enabled
Ih(2) Multiplier:	1..20
Ih(2) %>:	5% ..50%
Ih(5) CrossBlock:	Disabled/Enabled
Ih(5) Blocking:	Disabled/Enabled
Ih(5) %>:	5% ..100%
Highset Status:	Disabled/Enabled
Id High Set:	4*In...32*In
Vectorial Comp:	Yy0 (0 deg)/Yd1 (-30 deg)/ Yy2 (-60 deg)/Yd3 (-90 deg)/ Yy4 (-120 deg)/ Yd5 (-150 deg)/Yy6 (180 deg)/Yd7 (+150 deg)/ Yy8 (+120 deg)/Yd9 (+90 deg)/Yy10 (+60 deg)/ Yd11 (+30 deg)/Ydy0 (0 deg)/Ydy6 (180 deg)
Phase Is1 CTS:	0.2*In...4*In
PIT I Selection:	Local or Remote

Intertrip CH1:	Disabled/Enabled
Intertrip CH2:	Disabled/Enabled
OC Rel Status:	Disabled/Enabled
I> Release:	0.08...4.00 In
Diff CT Sat Stab:	Disabled/Enabled
Max I load/Inom:	0.50...4.00

14.5 Scheme Logic

14.5.1 Basic Scheme

Zone 1 Tripping:	Disabled/Phase only/Ground only/Phase and Ground
tZ1 Ph. Delay:	s...10s
tZ1 Gnd. Delay:	0s...10s
Zone 2 Tripping:	Disabled/Phase only/Ground only/Phase and Ground
tZ2 Ph. Delay:	s...10s
tZ2 Gnd. Delay:	0s...10s
Zone 3 Tripping:	Disabled/Phase only/Ground only/Phase and Ground
tZ3 Ph. Delay:	s...10s
tZ2 Gnd. Delay:	0s...10s
Zone P Tripping:	Disabled/Phase only/Ground only/Phase and Ground
tZP Ph. Delay:	0s...10s
tZP Gnd. Delay:	0s...10s
Zone 4 Tripping:	Disabled/Phase only/Ground only/Phase and Ground
tZ4 Ph. Delay:	s...10s
tZ4 Gnd. Delay:	0s...10s
Zone Q Tripping:	Disabled/Phase only/Ground only/Phase and Ground
tZQ Ph. Delay:	0s...10s
tZQ Gnd. Delay:	0s...10s
Dist tEnd Dir:	Non-Directional/Directional Fwd/Directional Rev
ZDir tEnd:	0...10.00
ZNonDir tEnd:	0...10.00

14.5.2 Aided Scheme 1

Aid 1 Selection:	Disabled / PUR / PUR Unblocking / POR / POR Unblocking / Blocking 1 / Blocking 2 / Prog Unblocking / Programmable
Aid 1 Distance:	Disabled / Phase Only / Ground only / Phase and Ground
Aid 1 Dist. Dly:	0s...1s
Unblocking Delay:	0s...0.1s
Aid 1 DEF:	Disabled/Enabled
Aid 1 DEF Dly:	0s...1s
Aid 1 DEF Trip:	1/3 Pole
Aided 1 Delta:	Disabled/Enabled
Aided1 Delta dly:	0s...1s
Aided1 DeltaTrip:	1 / 3 Pole
tREV Guard:	0s...0.15s
Unblocking Delay:	0s...0.1s
Send on Trip:	Aided/Z1, Any Trip or None
Weak Infeed:	Disabled / Echo / Echo and Trip
WI Sngl Pole Trp:	Disabled / Enabled
WI V< Thresh:	10V...70V
WI Trip Delay:	0s...1s
Custom Time PU:	0s...1s
Custom Time DO:	0s...1s

14.5.3	Aided Scheme 2 (As per aided scheme 1)
14.5.4	Trip On Close SOTF Status: Disabled/Enabled Pole Dead/Enabled ExtPulse/En Pdead + Pulse SOTF Delay: 0.2s...1000s SOTF Tripping: Bit 00 = Zone 1 / Bit 01 = Zone 2 / Bit 02 = Zone 3 / Bit 03 = Zone P / Bit 04 = Zone 4 / Bit 05 = Zone Q / Bit 06 = Current No Volts TOR Status Disabled/Enabled TOR Tripping: Bit 00 = Zone 1 / Bit 01 = Zone 2 / Bit 02 = Zone 3 / Bit 03 = Zone P / Bit 04 = Zone 4 / Bit 05 = Zone Q / Bit 06 = Current No Volts TOC Reset Delay: 0.1s...2s TOC Delay 0.05s...0.2s SOTF Pulse: 0.1s...10s
14.5.5	Z1 Extension Z1 Ext Scheme: Disabled/Enabled/En. On Ch1 Fail/En. On Ch2 Fail/ En All Ch Fail/En. anyCh Fail Z1 Ext Ph: 100%...200% Z1 Ext Gnd: 100%...200%
14.5.6	Loss Of Load LOL Scheme: Disabled/Enabled/En. On Ch1 Fail/En. On Ch2 Fail/ En All Ch Fail/En. Any Ch Fail LOL <l: 0.05 x In...1 x In LOL Window: 0.01s 0.1s Phase
14.6	Phase Overcurrent (Overcurrent) I>1 Status: Disabled / Enabled / Enabled VTS / Enabled Ch Fail / En VTS or Ch Fail / En VTS and Ch Fail / Enabled CTS / En VTSorCTS / En Ch FailorCTS / En VTSorCHForCTS / En VTSandCTS / En Ch FailandCTS / En VTS CHF CTS I>1 Function: DT / IEC S Inverse/IEC V Inverse / IEC E Inverse/UK LT Inverse / IEEE M Inverse/IEEE V Inverse/IEEE E Inverse/US Inverse / US ST Inverse I>1 Directional: Non-Directional/Directional Fwd /Directional Rev I>1 Current Set: 0.08...4.00 In I>1 Time Delay: 0.00...100.00 s I>1 TMS: 0.025...1.200 I>1 Time Dial: 0.01...100.00 I>1 Reset Char: DT/Inverse I>1 tRESET: 0.00...100.00 s I>2 Status (up to): I>2 tRESET All settings and options chosen from the same ranges as per the first stage overcurrent, I>1 I>3 Status: Disabled / Enabled / Enabled VTS / Enabled Ch Fail / En VTSorCh Fail / En VTSandCh Fail / Enabled CTS / En VTSorCTS / En Ch FailorCTS / En VTSorCHForCTS / En VTSandCTS / En Ch FailandCTS / En VTS CHF CTS I>3 Directional: Non-Directional/Directional Fwd/Directional Rev I>3 Current Set: 0.08...32.00 In I>3 Time Delay: 0.00...100.00 s I>4 Status (up to): I>4 Time Delay All settings and options chosen from the same ranges as per the third stage overcurrent, I>3

I> Char Angle: -95...95°
 I> Blocking: Binary function link string, selecting which overcurrent elements (stages 1 to 4) will be blocked if VTS detection of fuse failure occurs.

14.7 Negative Sequence Overcurrent (Neg Seq O/C)

I2>1 Status: Enabled/Disabled
 I2>1 Function: Disabled / DT / IEC S Inverse / IEC V Inverse / IEC E Inverse / UK LT Inverse / IEEE M Inverse / IEEE V Inverse / IEEE E Inverse / US Inverse / US ST Inverse
 I2>1 Direction: Non-Directional / Directional Fwd / Directional Rev
 I2>1 Current Set: 0.08...4.00 In
 I2>1 Time Delay: 0.00...100.00 s
 I2>1 TMS: 0.025...1.200
 I2>1 Time Dial: 0.01...100.00
 I2>1 Reset Char.: DT/Inverse
 I2>1 tRESET: 0.00...100.00 s
 I2>2 Status (up to):
 I2>2 tRESET All settings and options chosen from the same ranges as per the first stage overcurrent, I2>1.
 I2>3 Status: Disabled or Enabled
 I2>3 Direction: Non-Directional / Directional Fwd / Directional Rev
 I2>3 Current Set: 0.08...32.00 In
 I2>3 Time Delay: 0.00...100.00 s
 I2>4 Status (up to):
 I2>4 Time Delay All settings and options chosen from the same ranges as per the third stage overcurrent, I2>3.
 I2> VTS Blocking: Binary function link string, selecting which Neg. Seq. O/C elements (stages 1 to 4) will be blocked if VTS detection of fuse failure occurs
 I2> Char Angle: -95...95°
 I2> V2pol Set: 0.5...25.0

14.8 Broken Conductor

Broken Conductor: Disabled/Enabled
 I2/I1 Setting: 0.20...1.00
 I2/I1 Time Delay: 0.0...100.0 s

14.9 Ground Overcurrent (Earth Fault)

IN>1 Status:	Disabled / Enabled / Enabled VTS / Enabled Ch Fail / En VTSorCh Fail / En VTSandCh Fail / Enabled CTS / En VTSorCTS / En Ch FailorCTS / En VTSorCHForCTS / En VTSandCTS / En Ch FailandCTS / En VTS CHF CTS
IN>1 Function:	DT / IEC S Inverse/IEC V Inverse/IEC E Inverse/ UK LT Inverse/IEEE M Inverse/IEEE V Inverse/IEEE E Inverse/ US Inverse/US ST Inverse / IDG
IN>1 Directional:	Non-Directional/Directional Fwd/Directional Rev
IN>1 Current Set:	0.08...4.00 In
IN>1 IDG Is:	1...4
IN>1 IDG Time:	1...2
IN>1 Time Delay:	0.00...200.00 s
IN>1 TMS:	0.025...1.200
IN>1 Time Dial:	0.01...100.00
IN>1 Reset Char:	DT/Inverse
IN>1 tRESET:	0.00...100.00 s
IN>2 Status	<i>(up to):</i>
IN>2 tRESET	All settings and options chosen from the same ranges as per the first stage ground overcurrent, IN>1.
IN>3 Status:	Disabled / Enabled / Enabled VTS / Enabled Ch Fail / En VTSorCh Fail / En VTSandCh Fail / Enabled CTS / En VTSorCTS / En Ch FailorCTS / En VTSorCHForCTS / En VTSandCTS / En Ch FailandCTS / En VTS CHF CTS
IN>3 Directional:	Non-Directional/Directional Fwd /Directional Rev
IN>3 Current Set:	0.08...32.00 In
IN>3 Time Delay:	0.00...200.00 s
IN>4 Status	<i>(up to):</i>
IN>4 Time Delay	All settings and options chosen from the same ranges as per the third stage ground overcurrent, IN>3.
IN> Blocking:	Binary function link string, selecting which ground overcurrent elements (stages 1 to 4) will be blocked if VTS detection of fuse failure occurs.
IN> DIRECTIONAL	
IN> Char Angle:	-95...95°
IN> Polarization:	Zero or Neg Sequence
IN> VNpol Set:	0.5...40.0 V
IN> V2pol Set:	0.5...25.0 V
IN> I2pol Set:	0.02...1.00 In

14.10 Directional Aided Schemes - DEF Settings

DEF Status:	Disabled/Enabled
DEF Polarizing:	Zero Sequence (virtual current pol) or Neg Sequence
DEF Char Angle:	-95...95°
DEF VNpol Set:	0.5...40.0V
DEF V2pol Set:	0.5...25.0V
DEF Fwd Set:	0.08...1.00 In
DEF Rev Set:	0.04...1.00 In

14.11 Sensitive Earth Fault Protection/ Restricted Earth Fault Protection

SEF/REF Options:	SEF Enabled / Wattmetric SEF, HI Z REF
SEF>1 Function:	Disabled / DT / IEC S Inverse / IEC V Inverse / IEC E Inverse / UK LT Inverse / IEEE M Inverse / IEEE V Inverse / IEEE E Inverse / US Inverse / US ST Inverse / IDG
ISEF>1 Directional:	Non-Directional / Directional Fwd / Directional Rev
ISEF>1 Current Set:	0.005...0.1 In _{SEF}
ISEF>1 IDG Is:	1...4
ISEF>1 IDG Time:	1...2 s
ISEF>1 Time Delay:	0 s.....200 s
ISEF>1 TMS:	0.025...1.2
ISEF>1 Time Dial:	0.01...100
ISEF>1 Reset Char:	DT/Inverse
ISEF>1 tRESET:	0 s-100 s
ISEF>2 as ISEF>1	
ISEF>3 Status:	Disabled / Enabled
ISEF>3 Directional:	Non-Directional / Directional Fwd / Directional Rev
ISEF>3 Current Set:	0.05...2.00 In _{SEF}
ISEF>3 Time Delay:	0 s...200s
ISEF>3 Intertrip:	Enabled/Disabled
ISEF>4 as ISEF>3	
ISEF> Blocking	Bit 00 VTS Blks ISEF>1 Bit 01 VTS Blks ISEF>2 Bit 02 VTS Blks ISEF>3 Bit 03 VTS Blks ISEF>4 Bit 04 Not Used Bit 05 Not Used
ISEF> Directional	
ISEF> Char Angle:	-95°...95° deg
ISEF> VNpol Set:	0.5...80 V

14.11.1 Wattmetric Sensitive Earth Fault (SEF)

PN> Setting: 0...20 In_{SEF} W

14.11.2 Restricted Earth Fault (REF)

IREF>Is: 0.05 In .. 1.0 In

14.12 Neutral Voltage Displacement (Residual O/V NVD)

VN>1 Function:	Disabled / DT / IDMT
VN>1 Voltage Set:	1...200 V
VN>1 Time Delay:	0.00...100.00 s
VN>1 TMS:	0.5...100.0
VN>1 tReset:	0.00...100.00 s
VN>2 Status:	Disabled/Enabled
VN>2 Voltage Set:	1...200 V
VN>2 Time Delay:	0.00...100.00 s

14.13 Thermal Overload

Characteristic:	Disabled / Single / Dual
Thermal Trip:	0.08...4.00 In
Thermal Alarm:	50...100%
Time Constant 1:	1...200 mins
Time Constant 2:	1...200 mins

14.14 Power Swing/Out of Step**14.14.1 Power Swing**

PSB Status:	Blocking / Indication
Zone 1 Ph PSB:	(up to):
Zone Q Ph PSB:	Allow Trip / Blocking / Delayed Unblock
Zone 1 Gnd PSB:	(up to):
Zone Q Gnd PSB:	Allow Trip / Blocking / Delayed Unblock
Slow PSB:	Disabled / Enabled
PSB Unblocking:	Disabled / Enabled
PSB Unblock Dly:	0.1...20.0s
PSB Reset Delay:	0.05...2.00s

14.14.2 Out-Of-Step

OST (Out of Step Tripping) Mode:	Disabled, Predictive and OST Trip, OST Trip, Predictive OST
Z5 Fwd Reach:	0.1...500.00/In Ω
Z6 Fwd Reach:	0.1...500.00/In Ω
Z5' Rev Reach:	0.1...500.00/In Ω
Z6' Rev Reach:	0.1...500.00/In Ω
R5 Res. Fwd:	0.1...500.00/In Ω
R6 Res. Fwd:	0.1...500.00/In Ω
R5' Res. Rev:	0.1...500.00/In Ω
R6' Res. Rev:	0.1...500.00/In Ω
α Blinder Angle:	20...90°
Delta t Time Setting:	0.02s...1s
Tost Time Delay Setting:	0s...1s

14.15 Undervoltage Protection

V< Measur't Mode:	V<1 & V<2 Ph-Ph / V<1 & V<2 Ph-N / V<1Ph-Ph V<2Ph-N / V<1Ph-N V<2Ph-Ph
V< Operate Mode:	V<1 & V<2 Any Ph / V<1 & V<2 3Phase / V<1AnyPh V<2 3Ph / V<1 3Ph V<2AnyPh
V<1 Function:	Disabled / DT / IDMT
V<1 Voltage Set:	10...120 V
V<1 Time Delay:	0.00...100.00 s
V<1 TMS:	0.5...100.0
V<1 Poledead Inh:	Disabled/Enabled
V<2 Status:	Disabled/Enabled
V<2 Voltage Set:	10...120 V
V<2 Time Delay:	0.00...100.00 s
V<2 Poledead Inh:	Disabled/Enabled

14.16 Overvoltage Protection

V> Measur't Mode:	V>1 & V>2 Ph-Ph / V>1 & V>2 Ph-N /
	V>1Ph-Ph V>2Ph-N / V>1Ph-N V>2Ph-Ph
V> Operate Mode:	V>1 & V>2 Any Ph / V>1 & V>2 3Phase /
	V>1AnyPh V>2 3Ph / V>1 3Ph V>2AnyPh
V>1 Function:	Disabled / DT / IDMT
V>1 Voltage Set:	60...185 V
V>1 Time Delay:	0.00...100.00 s
V>1 TMS:	0.5...100.0
V>2 Status:	Disabled/Enabled
V>2 Voltage Set:	60...185 V
V>2 Time Delay:	0.00...100.00 s
V1>1 Cmp Funct:	Disabled / DT / IDMT
V1>1 Cmp Vlt Set:	60...110 V
V1>1 Cmp Tim Dly:	0.00...100.00 s
V1>1 CmpTMS:	0.5...100.0
V1>2 Cmp Status:	Disabled/Enabled
V1>2 Vlt Set:	60...110 V
V1>2 CmpTim Dly:	0.00...100.00 s

14.17 Underfrequency Protection

F<1 Status:	Disabled/Enabled
F<1 Setting:	45.00...65.00 Hz
F<1 Time Delay:	0.00...100.00 s
F<2 Status (up to):	F<4 Time Delay
All settings and options chosen from the same ranges as per the 1st stage.	
F> Blocking:	Binary function link string, selecting which frequency elements (stages 1 to 4) will be blocked by the pole-dead logic.

14.18 Overfrequency Protection

F>1 Status:	Disabled/Enabled
F>1 Setting:	45.00...65.00 Hz
F>1 Time Delay:	0.00...100.00 s
F>2 Status (up to):	All settings and options chosen from the same ranges as per the 1st stage.
F>2 Time Delay:	as per the 1st stage.

14.19 Rate-of-Change of Frequency Protection ($\Delta f/\Delta t$ Protection)

$\Delta f/\Delta t$ Avg. Cycles:	6...12
$\Delta f/\Delta t > 1$ Status:	Disabled/Enabled
$\Delta f/\Delta t > 1$ Setting:	0.1...10.0 Hz
$\Delta f/\Delta t > 1$ Dir'n.:	Negative/Positive/Both
$\Delta f/\Delta t > 1$ Time:	0.00...100.00 s
$\Delta f/\Delta t > 2$ Status: (up to):	
$\Delta f/\Delta t > 4$ Time	All settings and options chosen from the same ranges as per the 1st stage.

14.20 Circuit Breaker Fail and Pole Dead Logic (CB Fail and P.Dead)

CB Fail 1 Status:	Disabled/Enabled
CB Fail 1 Timer:	0.00...10.00 s
CB Fail 2 Status:	Disabled/Enabled
CB Fail 2 Timer:	0.00...10.00 s
Volt Prot. Reset:	I< Only / CB Open & I< / Prot. Reset & I<
Ext Prot. Reset:	I< Only / CB Open & I< / Prot. Reset & I<
WI Prot Reset:	Disabled / Enabled

CB1 I< Current Set: 0.02...3.20 In
CB2 I<Current: 0.02...3.20 In
ISEF< Current Set: 0.001...0.8 In_{SEF}
Poleddead V<: 10...40 V
Poleddead I<: 0.02...3.20 In
I< Current Set: 0.02...3.20 In
I_{SEF}< Current Set: 0.001...0.8 In_{SEF}
CB2 CB Fail1 Status: All settings and options chosen from the same ranges as per
(up to) the first CB above
CB2 Ext Prot Rst:

Note

I< Current Set and **I_{SEF}< Current Set** are applicable for 1CB product P443/P445/P543/P545/P841A; **CB1 I< Current Set**, **CB2 I<Current Set** and **I_{SEF}< Current Set** are applicable for 2CB product P446/P544/P546/P841B.

15 SUPERVISION FUNCTIONS (IN MULTIPLE GROUPS)

15.1 Voltage Transformer Supervision (VTS)

VTS Mode:	Measured + MCB, Measured Only or MCB Only
VTS Status:	Disabled/Blocking/Indication
VTS Reset Mode:	Manual/Auto
VTS Time Delay:	1 s...10 s
VTS I> Inhibit:	0.08...32 x In
VTS I2> Inhibit:	0.05...0.5 x In

15.1.1 Inrush Detection

Inrush Detection:	Disabled/Enabled
I> 2nd Harmonic:	10%...100%

15.1.2 Weak Infeed Blk

WI Inhibit:	Disabled/Enabled
I0/I2 Setting:	2...3

15.2 Current Transformer Supervision (CTS)

CTS Mode:	Disabled / Standard / I Diff / Idiff + Std
CTS Status:	Restrain / Indication
CTS Reset Mode:	Manual / Auto
CTS Time Delay:	0...10 s
CTS VN< Inhibit:	0.5...22 V
CTS IN> Set:	0.08...4.00 In
CTS i1>:	0.05...4.0 In
CTS i2/i1>:	0.05...1
CTS i2/i1>>:	0.05...1

15.3 Trip Supervision (TS) or Fault Detector

Stage 1 Trip Supervision (TS):

Stage 1 TS:	Enabled / Disabled
I>Threshold:	0.08... 4In,
I>TS Elements	Bit 00 Zone 1 Bit 01 Zone 2 Bit 02 Zone 3 Bit 03 Zone P Bit 04 Zone 4 Bit 05 Zone Q Bit 06 Aided Dist Bit 07 Current Diff
IN>Threshold:	0.08... 4In,
IN>TS Elements:	same as I> TS Elements
OCD>Threshold:	0.05... 0.2In,
OCD>TS Elements:	same as I> TS Elements
Vpp<Threshold:	10... 120 V
Vpp<TS Elements:	same as I> TS Elements
Vpn<Threshold:	10... 120 V
Vpn<TS Elements:	same as I> TS Elements
UVD>Threshold:	1... 20 V
UVD>TS Elements:	same as I> TS Elements
OCD>Hold Timer:	0... 10 s
UVD>Hold Timer:	0... 10 s

Stage 2 Trip Supervision (TS)

same as Stage 1 TS

Stage 3 Trip Supervision (TS)

same as Stage 1 TS

15.4 Bus-Line Synchronism and Voltage Checks (System Checks)

15.4.1 System Checks for P543 and P545

Voltage Monitors:

Live Line:	5... 132 V
Dead Line:	5... 132 V
Live Bus:	5... 132 V
Dead Bus:	5... 132 V
CS UV:	5... 120 V
CS OV:	60... 200 V

Synchrocheck (Check Synch)

CS1 Status:	Enabled/Disabled
CS1 Angle:	0... 90°
CS1 Vdiff:	1... 120 V
CS1 SlipCtrl:	None, Timer, Frequency, Both
CS1 Slip Freq:	5 mHz... 2 Hz
CS1 Slip Timer:	0.00... 99.00 s
CS2 Status:	Enabled/Disabled
CS2 Angle:	0... 90°
CS2 Vdiff:	1... 120 V
CS2 SlipCtrl:	None, Timer, Frequency, Timer+Freq, Freq+CB Comp
CS2 Slip Freq:	5 mHz... 2 Hz
CS2 Slip Timer:	0.0... 99.0 s
CI Time:	10.0 ms... 0.5 s
CS Voltage Block:	V< / V> / Vdiff.> / V< and V> / V< and Vdiff> / V> and Vdiff> / V< V> and Vdiff> / None

15.4.2 System Checks for P544 and P546

Voltage Monitors:

Live Line:	5...132 V
Dead Line:	5...132 V
Live Bus 1:	5...132 V
Dead Bus 1:	5...132 V
Live Bus 2:	5...132 V
Dead Bus 2:	5...132 V
CS UV:	5...120 V
CS OV:	60...200 V

System Checks

Sys Checks CB1:	Enabled/Disabled
CB1 CS Volt. Blk:	V< / V> / Vdiff.> / V< and V> / V< and Vdiff> / V> and Vdiff> / V< V> and Vdiff> / None
CB1 CS1 Status:	Enabled or Disabled
CB1 CS1 Angle:	0...90°
CB1 CS1 Vdiff:	1...120 V
CB1 CS1 SlipCtrl:	None, Timer, Frequency, Both
CB1 CS1 SlipFreq:	5 mHz...2 Hz
CB1 CS1 SlipTimer:	0...99 s
CB1 CS2 Status:	Enabled/Disabled
CB1 CS2 Angle:	0...90°
CB1 CS2 Vdiff:	1...120 V
CB1 CS2 SlipCtrl:	None, Timer, Frequency, Timer+Freq, Freq+CB Comp
CB1 CS2 SlipFreq:	5 mHz...2 Hz
CB1 CS2 SlipTimer:	0...99 s
CB1 CI Time:	10.0 ms...0.5 s
Sys Checks CB2:	(up to):
CB2 CI Time:	All settings and options chosen from the same ranges as per the first controlled circuit breaker, CB1.

15.4.2.1

Manual System Checks

Num CBs:	CB1 Only, CB2 Only, CB1 & CB2.
CB1M SC required:	Enabled/Disabled
CB1M SC CS1:	Enabled/Disabled
CB1M SC CS2:	Enabled/Disabled
CB1M SC DLLB:	Enabled/Disabled
CB1M SC LLDB:	Enabled/Disabled
CB1M SC DLDB:	Enabled/Disabled
CB2M SC required:	(up to):
CB2M SC DLDB:	All settings and options chosen from the same ranges as per the first controlled circuit breaker, CB1.

15.5 Auto-Reclose

15.5.1 P543 and P545 Auto-Reclose

Single Pole Shot:	1/2/3/4
Three Pole Shot:	1/2/3/4
1 Pole Dead Time:	0.05...5.00s
Dead Time 1:	0.05...100.00s
Dead Time 2:	1...1800s
Dead Time 3:	1...3600s
Dead Time 4:	1...3600s
CB Healthy Time:	1...3600s
Reclaim Time:	1...600s
AR Inhibit Time:	0.01...600.00s
Check Sync Time:	0.01...9999.00s
Z2T AR:	(up to):
Z4T AR:	No Action, Initiate AR or Block AR

All time-delayed distance zones can be independently set not to act upon AR logic, to initiate a cycle, or to block.

DEF Aided AR: No Action or Initiate AR or Block AR

TOR: No Action or Initiate AR or Block AR

I>1 AR to I>4 AR: No action, Block AR, Initiate AR

All overcurrent stages can be independently set not to act upon AR logic, to initiate a cycle, or to block.

IN>1 AR to IN>4 AR: No action, Block AR, Initiate AR

All ground/earth overcurrent stages can be independently set not to act upon AR logic, to initiate a cycle, or to block.

ISEF>1 AR to ISEF>4 AR: No action, Block AR, Initiate AR

All ground/earth overcurrent stages can be independently set not to act upon AR logic, to initiate a cycle, or to block.

Mult Phase AR: Allow Autoclose, BAR 2 and 3Ph or BAR 3 Phase

Dead Time Start: Protection Op or Protection Reset

Discrim Time: 0.10...5.00s

Auto-Reclose System Checks

CheckSync1 Close:	Disabled/Enabled
CheckSync2 Close:	Disabled/Enabled
LiveLine/DeadBus:	Disabled/Enabled
DeadLine/LiveBus:	Disabled/Enabled
DeadLine/DeadBus:	Disabled/Enabled
CS AR Immediate:	Disabled/Enabled
SysChk on Shot 1:	Disabled/Enabled
SPDT Ext Time:	0...300.00 s
CB1 Pole Dis. Tm:	0...10.00s
CB2 Pole Dis. Tm:	0...10.00s

15.5.2

P544 and P546 Auto-Reclose

Num CBs:	CB1 only / CB2 only / Both CB1 & CB2
No BF if L No CS:	Disabled / Enabled
Lead/Foll AR Mode:	L1P F1P / L1P F3P / L3P F3P / L1/3P F1/3P / L1/3P F3P / Opto
AR Mode:	AR 1P / AR 1/3P / AR 3P / AR Opto
Leader Select By:	Leader by Menu / Leader by Opto / Leader by Ctrl
Select Leader:	Sel Leader CB1 / Sel Leader CB2
BF if LFail CIs:	Enabled / Disabled
Dynamic F/L:	Enabled / Disabled
AR Shots:	1...4
AR Skip Shot 1:	Disabled / Enabled
Multi Phase AR:	Allow Autoclose / BAR 2 and 3 ph / BAR 3 phase
Ind Follower AR:	Allow Autoclose / BAR 2 and 3 ph / BAR 3 phase
Discrim Time:	20 ms...5 s
CB IS LL Check:	Disabled / Enabled
CB L Memory Time:	0.01...10.00 s
CB IS Time:	5...200 s
CB IS MemoryTime:	10 ms...1 s
DT Start by Prot:	Protection Reset / Protection Op / Disabled
3PDTStart WhenLD:	Enabled/Disabled
DTStart by CB Op:	Enabled/Disabled
Dead Line Time:	1...9999 s
SP AR Dead Time:	0...10 s
3P AR DT Shot 1:	10 ms...300 s
3P AR DT Shot 2:	1...9999 s
3P AR DT Shot 3:	1...9999 s
3P AR DT Shot 4:	1...9999 s
Follower Time:	100 ms...300 s
SPAR ReclaimTime:	1...600 s
3PAR ReclaimTime:	1...600 s
AR CBHealthy Time:	0.01...9999 s
AR CheckSync Time:	0.01...9999 s
Z1 AR:	Initiate AR / Block AR
Diff AR:	Initiate AR / Block AR
Dist. Aided AR:	Initiate AR / Block AR
Z2T AR:	(up to):
ZQT AR:	No Action / Initiate AR / Lock AR

All time-delayed distance zones can be independently set not to act upon AR logic, to initiate a cycle, or to block.

DEF Aided AR:	Initiate AR, Block AR
Dir. Comp AR:	Initiate AR, Block AR
TOR:	Initiate AR, Block AR

I>1 AR to I>4 AR: No action, Block AR, Initiate AR

All ground/earth overcurrent stages can be independently set not to act upon AR logic, to initiate a cycle, or to block.

IN>1 AR to IN>4 AR: No action, Block AR, Initiate AR

All ground/earth overcurrent stages can be independently set not to act upon AR logic, to initiate a cycle, or to block.

ISEF>1 AR to ISEF>4 AR: No action, Block AR, Initiate AR

All ground/earth overcurrent stages can be independently set not to act upon AR logic, to initiate a cycle, or to block.

Auto-Reclose System Checks

CB1L SC All:	Enabled/Disabled
CB1L SC Shot 1:	Enabled/Disabled
CB1L SC ClsNoDly:	Enabled/Disabled
CB1L SC CS1:	Enabled/Disabled
CB1L SC CS2:	Enabled/Disabled
CB1L SC DLLB:	Enabled/Disabled
CB1L SC LLDB:	Enabled/Disabled
CB1L SC DLDB:	Enabled/Disabled
CB2L SC all:	Enabled/Disabled
CB2L SC Shot 1:	Enabled/Disabled
CB2L SC ClsNoDly:	Enabled/Disabled
CB2L SC CS1:	Enabled/Disabled
CB2L SC CS2:	Enabled/Disabled
CB2L SC DLLB:	Enabled/Disabled
CB2L SC LLDB:	Enabled/Disabled
CB2L SC DLDB:	Enabled/Disabled
CB1F SC all:	Enabled/Disabled
CB1F SC Shot 1:	Enabled/Disabled
CB1F SC CS1:	Enabled/Disabled
CB1F SC CS2:	Enabled/Disabled
CB1F SC DLLB:	Enabled/Disabled
CB1F SC LLDB:	Enabled/Disabled
CB1F SC DLDB:	Enabled/Disabled
CB2F SC all:	Enabled/Disabled
CB2F SC Shot 1:	Enabled/Disabled
CB2F SC CS1:	Enabled/Disabled
CB2F SC CS2:	Enabled/Disabled
CB2F SC DLLB:	Enabled/Disabled
CB2F SC LLDB:	Enabled/Disabled
CB2F SC DLDB:	Enabled/Disabled
SPDT Ext Time:	0...300.00 s
CB1 Pole Dis. Tm:	0...10.00s
CB2 Pole Dis. Tm:	0...10.00s
Auto-Reclose Skip Shot 1 = Enabled/Disabled (using DDB No 1384)	

16 FUNCTION KEYS AND LABELS

16.1 Function Keys

Fn. Key Status 1 (up to) 10: Disable / Lock / Unlock / Enable
 Fn. Key 1 Mode (up to) 10: Toggled/Normal
 Fn. Key 1 Label (up to) 10: User defined text string to describe the function of the particular function key.

16.2 Opto Input Labels

Opto Input 1: (up to): Opto Input 24:
 User defined text string to describe the function of the particular opto input.

16.3 Opto Output Labels

Relay 1 to 32: Output R1 to Output R32
 User-defined text string to describe the function of the particular relay output contact.

16.4 Disturbance Recorder Channel Labels (DR Chan Labels)

If the first character of the label is a space the default DDB naming is used.
 Digital Input 1: (up to): Digital Input 128:
 User defined text string to describe the function of the particular digital input.

16.5 Virtual Input Labels (VIR I/P Labels)

Virtual Input 1 to Virtual Input 32.
 User-defined text string to describe the function of the particular virtual input.

16.6 Virtual Output Labels (VIR O/P Labels)

Virtual Output 1 to Virtual Output 32.
 User-defined text string to describe the function of the particular virtual output.

16.7 SR/MR User Alarm Labels (USR Alarm Labels)

SR User Alarm 1 to SR User Alarm 4:
 User-defined text string to describe the function of the particular self-reset user alarm.
 MR User Alarm 5 to MR User Alarm 8:
 User-defined text string to describe the function of the particular manual reset user alarm.

16.8 Control Input Labels

Control Input 1 (up to): User defined text string to describe the function of the particular control input.
 Control Input 32:
 Settable Control Input 33 (up to): User defined text string to describe the function of the particular settable control input.
 Settable Control Input 48:

17 MEASUREMENTS LIST

17.1	Measurements 1
	I ϕ Magnitude
	I ϕ Phase Angle Per phase ($\phi = A, B, C$)
	Current Measurements
	IN derived Mag
	IN derived Angle
	ISEF Mag
	ISEF Angle
	I1 Magnitude
	I2 Magnitude
	I0 Magnitude
	I ϕ RMS Per phase ($\phi = A, B, C$)
	RMS Current Measurements
	IN RMS
	V ϕ - ϕ Magnitude
	V ϕ - ϕ Phase Angle
	V ϕ Magnitude
	V ϕ Phase Angle All phase-phase and phase-neutral voltages ($\phi = A, B, C$).
	V1 Magnitude
	V2 Magnitude
	V0 Magnitude
	V ϕ RMS
	V ϕ - ϕ RMS All phase-phase and phase-neutral voltages ($\phi = A, B, C$).
	Frequency
	CB1 CS Volt Mag
	CB1 CS Voltage Ang
	CB1 Bus-Line Ang
	CB1 CS Slip Freq
	I1 Magnitude
	I1 Phase Angle
	I2 Magnitude
	I2 Phase Angle
	I0 Magnitude
	I0 Phase Angle
	V1 Magnitude
	V1 Phase Angle
	V2 Magnitude
	V2 Phase Angle
	V0 Magnitude
	V0 Phase Angle
	CB2 CS Voltage Mag (P446, P544, P546 and P841 only)
	CB2 CS Voltage Ang (P446, P544, P546 and P841 only)
	CB2 Bus-Line Ang (P446, P544, P546 and P841 only)
	CB2 CS Slip Freq (P446, P544, P546 and P841 only)
	V1 Rem Magnitude V1 Rem Phase Ang
	IA CT1 Magnitude (P446, P544, P546 and P841B only)
	IA CT1 Phase Ang (P446, P544, P546 and P841B only)
	IB CT1 Magnitude (P446, P544, P546 and P841B only)
	IB CT1 Phase Ang (P446, P544, P546 and P841B only)
	IC CT1 Magnitude (P446, P544, P546 and P841B only)
	IC CT1 Phase Ang (P446, P544, P546 and P841B only)

IA CT2 Magnitude	(P446, P544, P546 and P841B only)
IA CT2 Phase Ang	(P446, P544, P546 and P841B only)
IB CT2 Magnitude	(P446, P544, P546 and P841B only)
IB CT2 Phase Ang	(P446, P544, P546 and P841B only)
IC CT2 Magnitude	(P446, P544, P546 and P841B only)
IC CT2 Phase Ang	(P446, P544, P546 and P841B only)

17.2**Measurements 2**

φ Phase Watts	
φ Phase VArS	
φ Phase VA	All phase segregated power measurements, real, reactive and apparent (φ = A, B, C).
3 Phase Watts	
3 Phase VArS	
3 Phase VA	
Zero Seq Power	
3Ph Power Factor	
φPh Power Factor	Independent power factor measurements for all three phases (φ = A, B, C).
3Ph WHours Fwd	
3Ph WHours Rev	
3Ph VArHours Fwd	
3Ph VArHours Rev	
3Ph W Fix Demand	
3Ph VArS Fix Dem	
Iφ Fixed Demand	Maximum demand currents measured on a per phase basis (φ = A, B, C).
3Ph W Roll Dem	
3Ph VArS Roll Dem	
Iφ Roll Demand	Maximum demand currents measured on a per phase basis (φ = A, B, C).
3Ph W Peak Dem	
3Ph VAr Peak Dem	
Iφ Peak Demand	Maximum demand currents measured on a per phase basis (φ = A, B, C).
Thermal State	

17.3**Measurements 3**

IA Local	IA Angle Local	
IB Local	IB Angle Local	
IC Local	IC Angle Local	
IA Remote 1	IA Ang Remote 1	
IB Remote 1	IB Ang Remote 1	
IC Remote 1	IC Ang Remote 1	
IA Remote 2	IA Ang Remote 2	
IB Remote 2	IB Ang Remote 2	
IC Remote 2	IC Ang Remote 2	
IA Differential	IB Differential	IC Differential
IA Bias	IB Bias	IC Bias

17.4**Measurements 4**

Ch 1 Prop Delay	Ch 2 Prop Delay
Ch1 Rx Prop Delay	Ch1 Tx Prop Delay
Ch2 Rx Prop Delay	Ch2 Tx Prop Delay
Channel 1 Status	Channel 2 Status

Channel Status:

- Bit 0= Rx
- Bit 1= Tx
- Bit 2= Local GPS
- Bit 3= Remote GPS
- Bit 4= Mux Clk F Error
- Bit 5= Signal Lost
- Bit 6= Path Yellow
- Bit 7= Mismatch RxN
- Bit 8= Timeout
- Bit 9= Message Level
- Bit 10= Passthrough
- Bit 11= Hardware B to J model
- Bit 12= Max Prop Delay
- Bit 13= Max Tx-Rx Time

Binary function link strings denoting channel errors, and when self-healing has been initiated in 3-terminal applications.

IM64 Rx Status

Statistics

Last Reset on

Date/Time

Ch1 No. Vald Mess

Ch1 No. Err Mess

Ch1 No. Errored s

Ch1 No. Sev Err s

Ch1 No. Dgraded m

Ch2 No. Vald Mess

Ch2 No. Err Mess

Ch2 No. Errored s

Ch2 No. Sev Err s

Ch2 No. Dgraded m

Max Ch 1 Prop Delay

Max Ch 2 Prop Delay

Max Ch1 TxRx Time

Max Ch2 TxRx Time

Clear Statistics

17.5**Circuit Breaker Monitoring Statistics****CB Operations:**CB φ OperationsCircuit breaker operation counters on a per phase basis ($\varphi = A, B, C$).Total I_{φ} BrokenCumulative breaker interruption duty on a per phase basis ($\varphi = A, B, C$).

CB Operate Time

For a second circuit breaker (P446, P544, P546 and P841 B only)

CB2 Operations:CB2 φ OperationsCircuit breaker operation counters on a per phase basis ($\varphi = A, B, C$).CB2 I_{φ} BrokenCumulative breaker interruption duty on a per phase basis ($\varphi = A, B, C$).

CB2 Operate Time

17.6

Fault Record Proforma

The following data is recorded for any relevant elements that operated during a fault, and can be viewed in each fault record.

Time & Date		
Model Number:		
Address:		
Event Type:	Fault record	
Event Value		
Faulted Phase:	Binary data strings for fast polling of which phase elements started or tripped for the fault recorded.	
Start Elements		
Trip Elements	Binary data strings for fast polling of which protection elements started or tripped for the fault recorded.	
Fault Alarms	Binary data strings for fast polling of alarms for the fault recorded.	
Fault Time		
Active Group:	1/2/3/4	
System Frequency:	Hz	
Fault Duration:	s	
CB Operate Time:	s	
Relay Trip Time:	s	
Fault Location:	km/miles/Ω/%	
I _φ Pre Flt		
I _φ Angle Pre Flt	Per phase record of the current magnitudes and phase angles stored before the fault inception.	
IN Prefault Mag		
IN Prefault Ang		
IM Prefault Mag		
IM Prefault Ang		
V _φ Prefault Mag		
V _φ Prefault Ang	Per phase record of the voltage magnitudes and phase angles stored before the fault inception.	
VN Prefault Mag		
VN Prefault Ang		
I _φ Fault Mag		
I _φ Fault Ang	Per phase record of the current magnitudes and phase angles during the fault.	
IN Fault Mag		
IN Fault Ang		
IM Fault Mag		
IM Fault Ang		
V _φ Fault Mag		
V _φ Fault Ang	Per phase record of the voltage magnitudes and phase angles during the fault.	
VN Fault Mag		
VN Fault Ang		
IA Local	IB Local	IC Local
IA Remote 1	IB Remote 1	IC Remote 1
IA Remote 2	IB Remote 2	IC Remote 2
IA Differential	IB Differential	IC Differential
IA Bias	IB Bias	IC Bias
Ch1 Prop Delay	Ch 2 Prop Delay	
Ch1 Rx Prop Delay	Ch1 Tx Prop Delay	
Ch2 Rx Prop Delay	Ch2 Tx Prop Delay	
V1 Rem Magnitude	V1 Rem Phase Ang	

Fault IA Local
Fault IA Rem 1
Fault IA Rem 2
Fault IA Diff
Fault IA Bias

Fault IB Local
Fault IB Rem 1
Fault IB Rem 2
Fault IB Diff
Fault IB Bias

Fault IC Local
Fault IC Rem 1
Fault IC Rem 2
Fault IC Diff
Fault IC Bias

GETTING STARTED

CHAPTER 3

Date:	10/2022
Products covered by this chapter:	This chapter covers the specific versions of the MiCOM products listed below. This includes only the following combinations of Software Version and Hardware Suffix.
Hardware suffix:	M
Software version:	K6
Connection diagrams:	10P54302 (SH 1 to 2) 10P54303 (SH 1 to 2) 10P54304 (SH 1 to 2) 10P54400 10P54404 (SH 1 to 2) 10P54405 (SH 1 to 2) 10P54502 (SH 1 to 2) 10P54503 (SH 1 to 2) 10P54504 (SH 1 to 2) 10P54600 10P54604 (SH 1 to 2) 10P54605 (SH 1 to 2) 10P54606 (SH 1 to 2)

CONTENTS

Page (GS) 3-

1	Introduction to the Relay	5
1.1	User Interfaces and Menu Structure	5
1.2	Front Panel	5
1.3	LED Indications	6
1.3.1	Fixed Function	6
1.3.2	Programmable LEDs	6
1.4	Relay Rear Panel	8
1.4.1	Relay without Process Bus	8
1.4.2	Relay with Process Bus	9
1.5	Relay Connection and Power-Up	10
2	User Interfaces and Settings Options	11
3	Menu Structure	12
3.1	Protection Settings	13
3.2	Disturbance Recorder Settings	13
3.3	Control and Support Settings	13
4	Cyber Security	14
4.1	Cyber Security Settings	14
4.2	Role Based Access Control (RBAC)	14
4.3	User Roles and Rights	15
5	Relay Configuration	16
6	Front Panel User Interface (Keypad and LCD)	17
6.1	Default Display and Menu Time-Out	17
6.2	Navigating Menu and Browsing the Settings	18
6.3	Navigating the Hotkey Menu	18
6.3.1	Setting Group Selection	19
6.3.2	Control Inputs - User Assignable Functions	19
6.3.3	CB Control	19
6.4	How to Login	20
6.4.1	Local Default Access	20
6.4.2	Auto Login	20
6.4.3	Login with Prompt User List	20
6.5	Reading and Clearing of Alarm Messages and Fault Records	21
6.6	Setting Changes	21
6.7	How to Logout	22

6.7.1	How to Logout at the IED	22
6.7.2	How to Logout at MiCOM S1 Studio	22
7	Front Communication Port User Interface	23
7.1	Relay Front Port Settings	24
7.2	Front Courier Port	25
8	Easergy Studio Communications Basics	26
8.1	PC Requirements	26
8.2	Connecting to the Relay using Easergy Studio	28
8.3	Off-Line Use of Easergy Studio	28

TABLES

	Page (GS) 3-
Table 1 - Default LED mappings for P543/P544/P545/P546	7
Table 2 - Nominal and Operative dc and ac Ranges	10
Table 3 - User interfaces and settings	11
Table 4 - Auto Login process	20
Table 5 - Front port DCE pin connections	23
Table 6 - DTE devices serial port pin connections	23
Table 7 - Communication settings	24

FIGURES

	Page (GS) 3-
Figure 1 - Relay front view	5
Figure 2 - P543 relay rear view (60TE)	8
Figure 3 - Rear view of the process bus device	9
Figure 4 - Menu structure	12
Figure 5 - RBAC Role structure	14
Figure 6 - Front panel user interface	17
Figure 7 - Hotkey menu navigation	19
Figure 8 - Front port connection	23
Figure 9 - PC relay signal connection	24

1 INTRODUCTION TO THE RELAY



Warning Before carrying out any work on the equipment, you should be familiar with the contents of the latest issue of the Safety Guide, Safety Information and Technical Data chapters and the equipment rating label(s).

1.1 User Interfaces and Menu Structure

The settings and functions of the MiCOM protection relay can be accessed both from the front panel keypad and LCD, and via the front and rear communication ports. Information on each of these methods is given in this section to describe how to start using the relay.

1.2 Front Panel

The following figure shows the front panel of the relay; the hinged covers at the top and bottom of the front panel are shown open. An optional transparent front cover physically protects the front panel. With the cover in place, access to the user interface is read-only. Removing the cover allows access to the relay settings and does not compromise the protection of the product from the environment.

When editing relay settings, full access to the relay keypad is needed. To remove the front cover:

1. Open the top and bottom covers, then unclip and remove the transparent cover. If the lower cover is secured with a wire seal, remove the seal.
2. Using the side flanges of the transparent cover, pull the bottom edge away from the relay front panel until it is clear of the seal tab.
3. Move the cover vertically down to release the two fixing lugs from their recesses in the front panel.

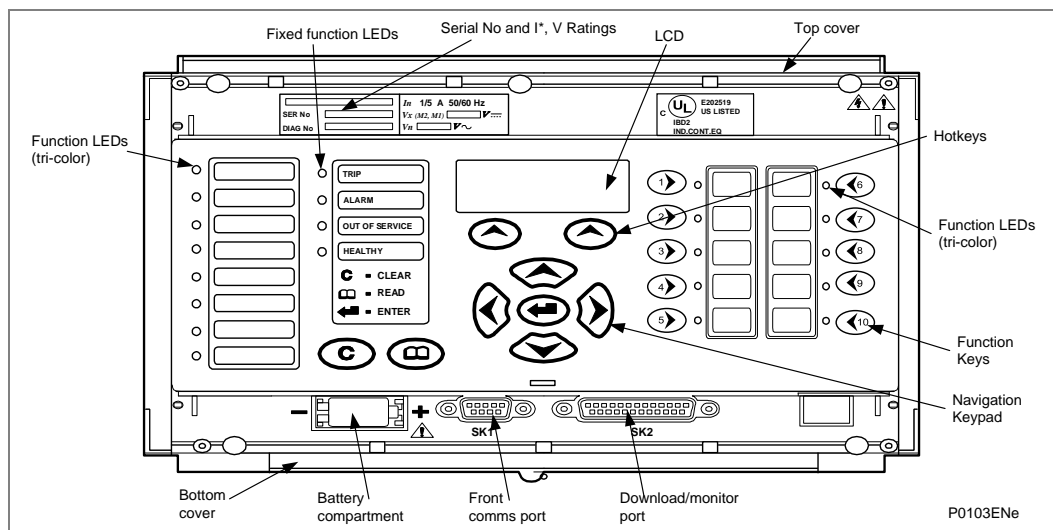

Figure 1 - Relay front view

The front panel of the relay includes the following, as shown in the previous figure:

- a 16-character by 3-line alphanumeric Liquid Crystal Display (LCD)
- a 19-key keypad comprising:
 - 4 arrow keys (⬅️ ⬆️ ⬇️ ⬇️), an enter key (⏎), a clear key (⏏), a read key (📖), 2 hot keys (⬠) and 10 (⏏ - ☒) programmable function keys

- The relay front panel has control keys with programmable LEDs for local control. Factory default settings associate specific relay functions with these 10 direct-action keys and LEDs, e.g. Enable or Disable the auto-recloser function. Using programmable scheme logic, the user can change the default functions of the keys and LEDs to fit specific needs.
- Hotkey functionality:
 - **SCROLL** starts scrolling through the various default displays.
 - **STOP** stops scrolling the default display.
 - **Control** of setting groups, control inputs and circuit breaker operation
- LED indicators (normally either 22 or 12 LEDs depending on the model):
 - four fixed function LEDs,
 - programmable function LEDs on the left hand side of the front panel
 - user programmable function LEDs on the right hand side associated with the function keys

Under the top hinged cover:

- The relay serial number, and the relay's current and voltage rating information

Under the bottom hinged cover:

- Battery compartment to hold the 1/2 AA size battery which is used for memory back-up for the real time clock, event, fault and disturbance records
- A 9-pin female D-type front port for communication with a PC locally to the relay (up to 15m distance) via an EIA(RS)232 serial data connection
- A 25-pin female D-type port providing internal signal monitoring and high speed local downloading of software and language text via a parallel data connection

1.3 LED Indications

1.3.1 Fixed Function

The Fixed Function LEDs on the left-hand side of the front panel show these conditions:

- **Trip (Red)** indicates that the relay has issued a trip signal. It is reset when the associated fault record is cleared from the front display.
- **Alarm (Yellow)** flashes when the relay has registered an alarm. This may be triggered by a fault, event or maintenance record. The LED will flash until the alarms have been accepted (read), after which the LED will change to constant illumination, and will extinguish, when the alarms have been cleared.
- **Out of Service (Yellow)** is ON when the relay is not fully operational.
- **Healthy (Green)** indicates that the relay is in correct working order, and should be on at all times. It will be extinguished if the relay's self-test facilities show that there is an error with the relay's hardware or software. The state of the healthy LED is reflected by the watchdog contact at the back of the relay.

To improve the visibility of the settings via the front panel, the LCD contrast can be adjusted using the "LCD Contrast" setting in the CONFIGURATION column. This should only be necessary in very hot or cold ambient temperatures.

1.3.2 Programmable LEDs

All the programmable LEDs are tri-colour and can be programmed to show red, yellow or green depending on the requirements. The eight programmable LEDs on the left are suitable for programming alarm indications. The 10 programmable LEDs associated with the function keys, are used to show the status of the key's function. The default behaviour and mappings for each of the programmable LEDs are as shown in this table:

LED No	Default Color	P543	P544	P545	P546
1	Red	Diff Trip	Diff Trip	Diff Trip	Diff Trip

LED No	Default Color	P543	P544	P545	P546
2	Red	Dist Inst Trip	Dist Inst Trip	Dist Inst Trip	Dist Inst Trip
3	Red	Dist Delay Trip	Dist Delay Trip	Dist Delay Trip	Dist Delay Trip
4	Red	Signaling Fail	Signaling Fail	Signaling Fail	Signaling Fail
5	Red	Any Start	Any Start	Any Start	Any Start
6	Red	AR in Progress	Not Used	AR in Progress	Not Used
6	Yellow	Not Used	Not Used	Not Used	Not Used
7	Green	AR Lockout	Not Used	AR Lockout	Not Used
7	Yellow	Not Used	Test Loopback	Not Used	Test Loopback
8	Yellow	Test Loopback	AR in Service	Test Loopback	AR in Service
8	Green	Not Used	Not Used	Not Used	Not Used
F1	Red	Not Used	CB1 A Open	Not Used	CB1 A Open
F1	Green	Not Used	CB1 A Closed	Not Used	CB1 A Closed
F2	Red	Not Used	CB1 B Open	Not Used	CB1 B Open
F2	Green	Not Used	CB1 B Closed	Not Used	CB1 B Closed
F3	Red	Not Used	CB1 C Open	Not Used	CB1 C Open
F3	Green	Not Used	CB1 C Closed	Not Used	CB1 C Closed
F4	Red	Not Used	CB1 AR Lockout	Not Used	CB1 AR Lockout
F5	Green	Not Used	CB1 AR Successful	Not Used	CB1 AR Successful
F5	Yellow	Not Used	CB1 ARIP	Not Used	CB1 ARIP
F6	Red	Not Used	CB2 A Open	Not Used	CB2 A Open
F6	Green	Not Used	CB2 A Closed	Not Used	CB2 A Closed
F7	Red	Not Used	CB2 B Open	Not Used	CB2 B Open
F7	Green	Not Used	CB2 B Closed	Not Used	CB2 B Closed
F8	Red	Not Used	CB2 C Open	Not Used	CB2 C Open
F8	Green	Not Used	CB2 C Closed	Not Used	CB2 C Closed
F9	Red	Not Used	CB2 AR Lockout	Not Used	CB2 AR Lockout
F10	Green	Not Used	CB2 AR Successful	Not Used	CB2 AR Successful
F10	Yellow	Not Used	CB2 ARIP	Not Used	CB2 ARIP

Table 1 - Default LED mappings for P543/P544/P545/P546

1.4 Relay Rear Panel

1.4.1 Relay without Process Bus

All the programmable LEDs are tri-colour and can be programmed to show red, yellow or green depending on the requirements. The eight programmable LEDs on the left are suitable for programming alarm indications. The 10 programmable LEDs associated with the function keys, are used to show the status of the key's function. The default behaviour and mappings for each of the programmable LEDs are as shown in this table:

Slot	Description
Slot A:	Optional IRIG-B and/or Communications board
Slot B:	Fiber communication board for differential teleprotection including GPS sampling synchronization
Slot C:	Analogue (CT& VT) Input Board
Slot D and F:	Opto-isolated inputs boards
Slot G and H:	Relay output contacts boards
Slot J:	Power Supply/EIA(RS)485 Communications board

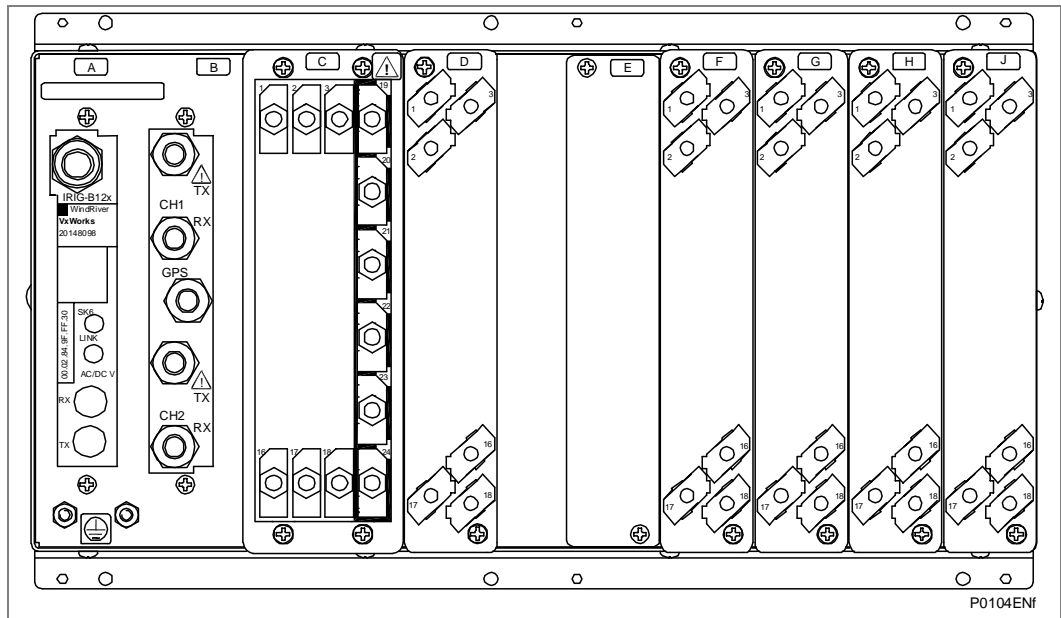

Figure 2 - P543 relay rear view (60TE)

Note This is one example of a case layout. The exact layout will vary depending on model configuration and case size. Refer to the wiring diagrams in the Connection Diagrams chapter for complete connection details.

1.4.2

Relay with Process Bus

The Process Bus board provides a IEC61850-9-2LE (80 samples/cycle) or IEC61869 (F4800S2liUu where $i+u < 24$) Ethernet link and IEC61850-8-1 (GOOSE).

The board fits into a dedicated slot of the Easergy P40 protection. The board can be connected to the network using:

- For the 3 RJ45 connectors board, either the top or both the bottom RJ45 connectors or
- For the 1 RJ45 connector and two optical fibre connectors board, either the top RJ45 connector or both the bottom LC connectors

Optical fiber connectors

- 1300nm multimode 100BaseFx LC® connectors

RJ45 connection

- 100BaseTx RJ45 connector

Case size

- The case size of all Easergy MiCOM P40 Process Bus relays is fixed at 60TE

Board Location

- The Process Bus board is fitted in slot C

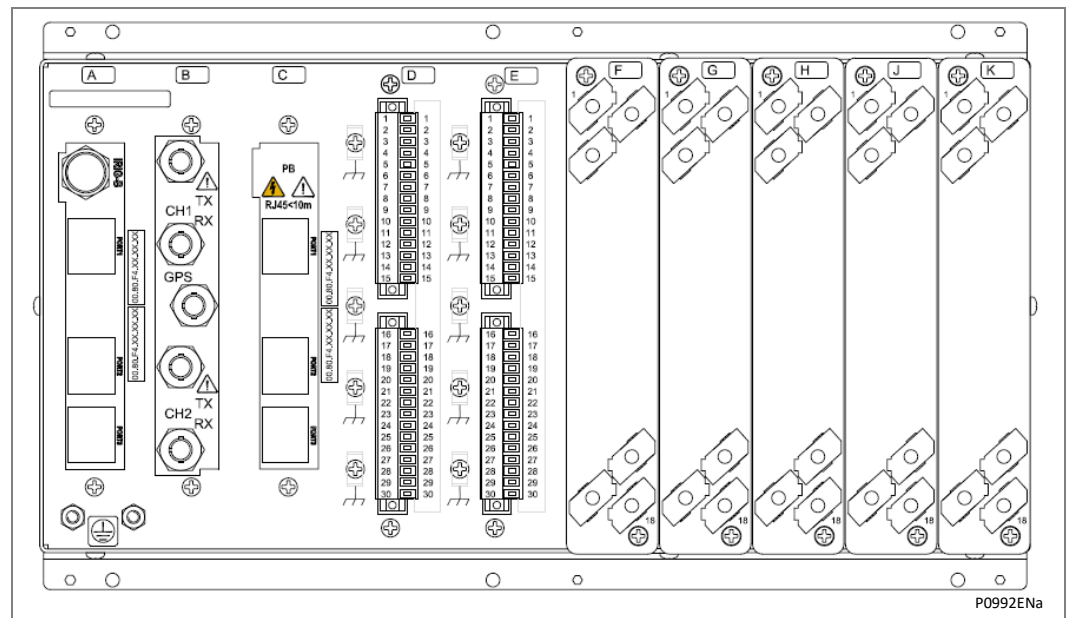

Figure 3 - Rear view of the process bus device

1.5

Relay Connection and Power-Up

Before powering-up the relay, confirm that the relay power supply voltage and nominal ac signal magnitudes are appropriate for your application. The relay serial number, and the relay's current and voltage rating, power rating information can be viewed under the top hinged cover. The relay is available in the auxiliary voltage versions shown in this table:

Nominal Ranges		Operative Ranges	
dc	ac	dc	ac
24 – 32 V dc	-	19 - 38 V dc	-
48 – 110 V dc	-	37 - 150 V dc	-
110 – 250 V dc **	100 – 240 V ac rms **	87 - 300 V dc	80 - 265 V ac

** rated for ac or dc operation

Table 2 - Nominal and Operative dc and ac Ranges

Please note that the label does not specify the logic input ratings. These relays are fitted with universal opto isolated logic inputs that can be programmed for the nominal battery voltage of the circuit of which they are a part. See 'Universal Opto input' in the Product Design (Firmware) section for more information on logic input specifications.

<i>Note</i>	<i>The opto inputs have a maximum input voltage rating of 300V dc at any setting.</i>
-------------	---

Once the ratings have been verified for the application, connect external power capable of delivering the power requirements specified on the label to perform the relay familiarization procedures. Previous diagrams show the location of the power supply terminals - please refer to the **Installation** and **Connection Diagrams** chapters for all the details, ensuring that the correct polarities are observed in the case of dc supply.

2 USER INTERFACES AND SETTINGS OPTIONS

The IED has three user interfaces:

- The front panel using the LCD and keypad.
- The front port which supports Courier communication.
- The rear port which supports
 - K-Bus or
 - DNP3.0 or
 - IEC 60870-5-103 or
 - IEC 61850 + Courier through the rear EIA(RS)485 port or
 - IEC 61850 + IEC 60870-5-103 through the rear EIA(RS)485 port.

The protocol for the rear port must be specified when the IED is ordered.

	Keypad / LCD	Courier	MODBUS	IEC870-5-103	DNP3.0	IEC 61850
Display and modification of all settings	Yes	Yes				
Digital I/O signal status	Yes	Yes		Yes	Yes	Yes
Display/extraction of measurements	Yes	Yes		Yes	Yes	Yes
Display/extraction of fault records	Yes	Yes		Yes	Yes	Yes
Extraction of disturbance records		Yes		Yes		Yes
Programmable scheme logic settings		Yes				
Reset of fault and alarm records	Yes	Yes		Yes	Yes	Yes
Clear event and fault records	Yes	Yes			Yes	
Time synchronization		Yes		Yes	Yes	Yes
Control commands	Yes	Yes		Yes	Yes	Yes

Table 3 - User interfaces and settings

3 MENU STRUCTURE

The relay’s menu is arranged in a table. Each setting in the menu is referred to as a cell, and each cell in the menu may be accessed using a row and column address. The settings are arranged so that each column contains related settings, for example all the disturbance recorder settings are contained within the same column. As shown in the following diagram, the top row of each column contains the heading that describes the settings contained within that column. Movement between the columns of the menu can only be made at the column heading level.

For a complete list of all of the menu settings see the *Settings* chapter and the *Menu Database* document.

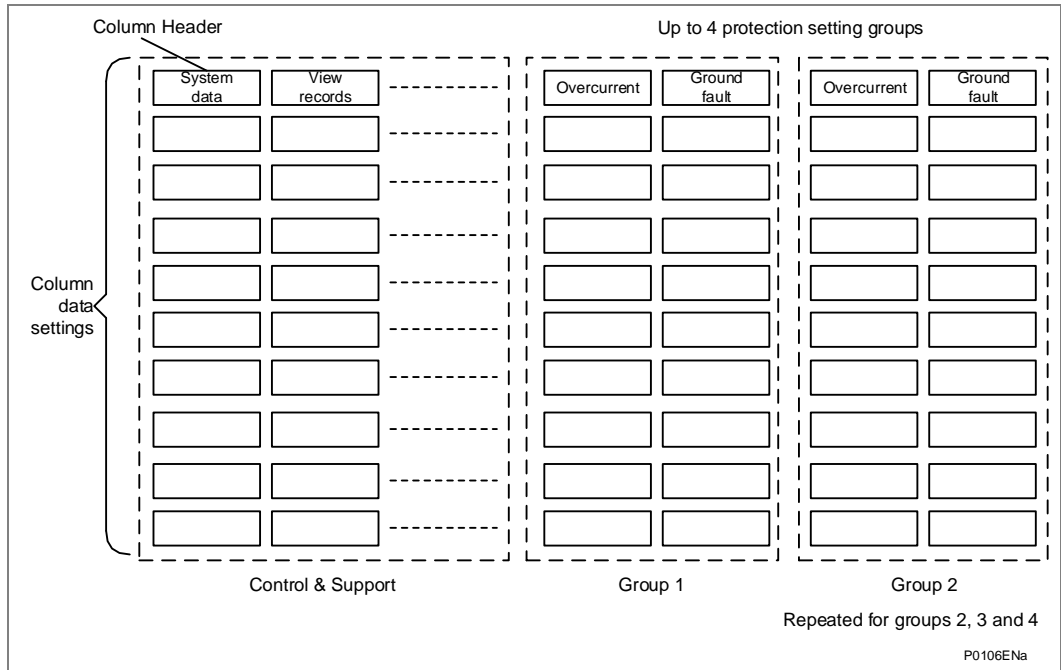

Figure 4 - Menu structure

The settings in the menu fall into one of these categories:

- Protection Settings
- Disturbance Recorder settings
- Control and Support (C&S) settings.

Different methods are used to change a setting depending on which category the setting falls into.

- C&S settings are stored and used by the relay immediately after they are entered.
- For either protection settings or disturbance recorder settings, the relay stores the new setting values in a temporary 'scratchpad'. It activates all the new settings together, but only after it has been confirmed that the new settings are to be adopted. This technique is employed to provide extra security, and so that several setting changes that are made within a group of protection settings will all take effect at the same time.

Additional security settings can now be gained by using Cyber Security. This is now an option for Software Releases C0/D0/F0 and later.

3.1 Protection Settings

The protection settings include the following items:

- Protection element settings
- Scheme logic settings

There are four groups of protection settings, with each group containing the same setting cells. One group of protection settings is selected as the active group, and is used by the protection elements.

3.2 Disturbance Recorder Settings

The Disturbance Recorder (DR) settings include the record duration and trigger position, selection of analogue and digital signals to record, and the signal sources that trigger the recording.

The number of digital channels varies depending on the product and the software version.

For Software Version numbers A0 and B0, the disturbance recorder was enhanced so that the maximum number of digital channels was increased to 128.

There are now four additional **DDB Group Sig x** Nodes that can be mapped to individual or multiple DDBs in the PSL. These can then be set to trigger the DR via the DISTURBANCE RECORD menu.

These "Nodes" are general and can also be used to group signals together in the PSL for any other reason. These four nodes are available in each of the four PSL setting groups.

1. For a control input, the DR can be triggered directly by triggering directly from the Individual Control Input (e.g. Low to High (L to H) change)
2. For an input that cannot be triggered directly, or where any one of a number of DDBs are required to trigger a DR, map the DDBs to the new PSL Group sig n and then trigger the DR on this.

e.g. in the PSL:

In the DR Settings:

- Digital Input 1 is triggered by the PSL Group Sig 1 (L to H)
- Digital Input 2 is triggered by Control Input 1 (L to H)

If triggering on both edges is required map another DR channel to the H/L as well

Digital Input 4 is triggered by the PSL Group Sig 1 (H to L)

Digital Input 5 is triggered by Control Input 1 (H to L)

3.3 Control and Support Settings

The control and support settings include:

- IED configuration settings
- VT ratio settings
- Reset LEDs
- Active setting group
- Password & language settings
- Communications settings
- Measurement settings
- Event and fault record settings
- User interface settings
- Commissioning settings

4 CYBER SECURITY

4.1 Cyber Security Settings

A detailed description of Schneider Electric Cyber Security features is provided in the *Cyber Security* chapter.

Important *We would strongly recommend that you understand the contents of the Cyber Security chapter before you use any cyber security features or make any changes to the settings.*

Each MiCOM P40 IED includes a large number of possible settings. These settings are very important in determining how the device works.

4.2 Role Based Access Control (RBAC)

The Role Based Access Control (RBAC) is a method to restrict resource access to authorized users. RBAC is an alternative to traditional Mandatory Access Control (MAC) and Discretionary Access Control (DAC).

A key feature of RBAC model is that all access is through roles. A role is essentially a collection of permissions, and all users receive permissions only through the roles to which they are assigned, or through roles they inherit through the role hierarchy.

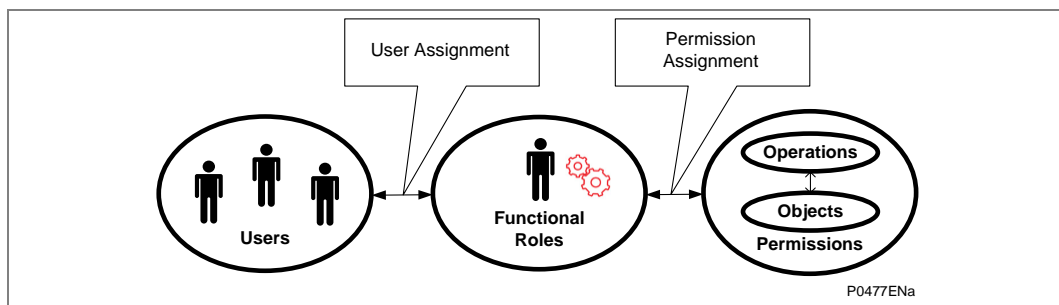

Figure 5 - RBAC Role structure

Roles are created for various job activities. The **Permissions**, to perform certain operations, are assigned to specific roles. **Users** are assigned particular roles, and through those role assignments acquire the computer permissions to perform particular computer-system functions. Since **users** are not assigned permissions directly, but only acquire them through their role (or roles), management of individual user rights becomes a matter of simply assigning appropriate roles to the user's account; this simplifies common operations, such as adding a user, or changing user's account.

4.3**User Roles and Rights**

Different named roles are associated with different access rights. Roles and Rights are setup in a pre-defined arrangement, according to the IEC62351 standard, but customized to the MiCOM Px4x equipment.

When the user tries to access an IED, they need to login using their own username and their own password. The username/password combination is then checked against the records stored on the IED. If they are allowed to login, a message appears which shows them what Role they have been assigned to. It is the role that defines their access to the relevant parts of the system.

In a similar way in which a set of pre-defined Roles have been created, a pre-defined set of Rights have been created.

These Rights give different permissions to look at what devices may be present, what those devices may contain, manage data within those devices (directly or by using files) and configure rights for other people.

5 RELAY CONFIGURATION

The relay is a multi-function device that supports numerous different protection, control and communication features. To simplify the setting of the relay, there is a configuration settings column which can be used to enable or disable many of the functions of the relay. The settings associated with any function that is disabled are made invisible, i.e. they are not shown in the menu. To disable a function change the relevant cell in the '**Configuration**' column from '**Enabled**' to '**Disabled**'.

The configuration column controls which of the protection settings groups is selected as active through the '**Active settings**' cell. A protection setting group can also be disabled in the configuration column, provided it is not the present active group. Similarly, a disabled setting group cannot be set as the active group.





The column also allows all of the setting values in one group of protection settings to be copied to another group.

To do this firstly set the 'Copy from' cell to the protection setting group to be copied, then set the 'Copy to' cell to the protection group where the copy is to be placed. The copied settings are initially placed in the temporary scratchpad and will only be used by the relay following confirmation.

To restore the default values to the settings in any protection settings group, set the 'Restore defaults' cell to the relevant group number. Alternatively, it is possible to set the 'Restore defaults' cell to 'All settings' to restore the default values to all of the relay's settings, not just the protection groups' settings. The default settings will initially be placed in the scratchpad and will only be used by the relay after they have been confirmed. Note that restoring defaults to all settings includes the rear communication port settings, which may result in communication via the rear port being disrupted if the new (default) settings do not match those of the master station.

6 FRONT PANEL USER INTERFACE (KEYPAD AND LCD)

When the keypad is exposed it provides full access to the menu options of the relay, with the information displayed on the LCD.

The , ,  and  keys which are used for menu navigation and setting value changes include an auto-repeat function that comes into operation if any of these keys are held continually pressed. This can speed up both setting value changes and menu navigation; the longer the key is held depressed, the faster the rate of change or movement becomes.

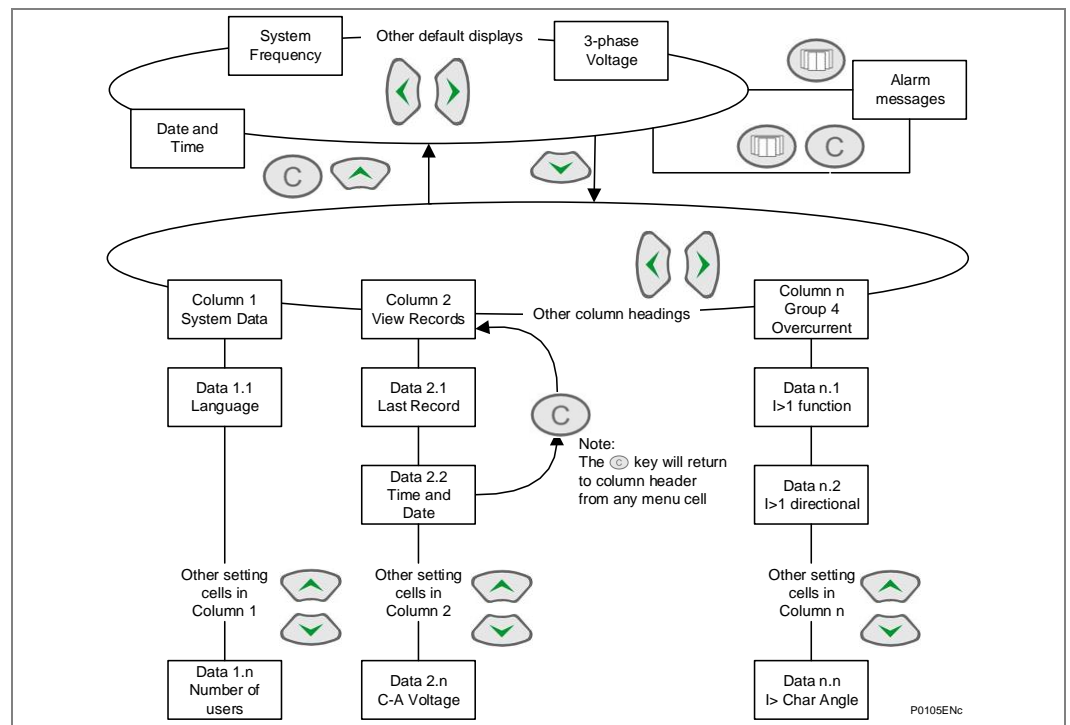



Figure 6 - Front panel user interface

6.1

Default Display and Menu Time-Out

The front panel menu has a default display. To change it, the Engineer Role will be required and the following items can be selected:

- Banner
- 3-phase and neutral current
- 3-phase voltage
- Power
- Date and time
- Description (user defined)
- Plant Reference (user defined)
- Frequency
- Access level

From the default display, the user can switch the default display to other default display items using the  and  keys. The default display will be saved as the last viewed items automatically. If the user tries to change the default display, Engineer Role will be requested (if the current access role is not that of an Engineer).

When user is browsing the relay menu structure with default access right, if there is no keypad activity for the 15 minutes (i.e. the timeout period), the default display will revert from the last viewed menu structure (can be any location from the menu structure) and the LCD backlight will turn off.

When user is logged in with Engineer Role, the menu timeout time may be shorter than 15 minutes. This depends on the value of inactive timer (e.g. if the inactive timer is set to shorter than 15 minutes). If menu timeout happens, any setting changes that have not been confirmed will be lost and the original setting values maintained.











Whenever there is an uncleared alarm present in the relay (e.g. fault record, protection alarm, control alarm etc.) the default display will be replaced by:

Alarms/Faults Present

Entry to the menu structure of the relay is made from the default display and is not affected if the display is showing the Alarms/Faults present message.





6.2**Navigating Menu and Browsing the Settings**

Use the four arrow keys to browse the menu, following the menu structure shown above.

1. Starting at the default display, press the  key to show the first column heading.
2. Use the  and  keys to select the required column heading.
3. Use the  and  keys to view the setting data in the column.
4. To return to the column header, either hold the  key down or press the clear key  once. It is only possible to move across columns at the column heading level.
5. To return to the default display, press the  key or the clear key  from any of the column headings. If you use the auto-repeat function of the  key, you cannot go straight to the default display from one of the column cells because the auto-repeat stops at the column heading.
6. Press the  key again to go to the default display.

6.3**Navigating the Hotkey Menu**

To access the hotkey menu from the default display:

1. Press the key directly below the **HOTKEY** text on the LCD.
2. Once in the hotkey menu, use the  and  keys to scroll between the available options, then use the hotkeys to control the function currently displayed. If neither the  or  keys are pressed within 20 seconds of entering a hotkey sub menu, the relay reverts to the default display.
3. Press the clear key  to return to the default menu from any page of the hotkey menu.

The layout of a typical page of the hotkey menu is as follows:

- The top line shows the contents of the previous and next cells for easy menu navigation
- The center line shows the function
- The bottom line shows the options assigned to the direct access keys

The functions available in the hotkey menu are listed in the following sections.

6.3.1 Setting Group Selection

The user can either scroll using <<NXT GRP>> through the available setting groups or <<SELECT>> the setting group that is currently displayed.

When the SELECT button is pressed a screen confirming the current setting group is displayed for 2 seconds before the user is prompted with the <<NXT GRP>> or <<SELECT>> options again. The user can exit the sub menu by using the left and right arrow keys.

For more information on setting group selection refer to “Setting group selection” section in the Operation chapter.

6.3.2 Control Inputs - User Assignable Functions

The number of control inputs represented in the hotkey menu is user configurable in the “CTRL I/P CONFIG” column. The chosen inputs can be SET/RESET using the hotkey menu.

For more information refer to the “Control Inputs” section in the Operation chapter.

6.3.3 CB Control

The CB control functionality varies from one Px40 relay to another. For a detailed description of the CB control via the hotkey menu refer to the “Circuit Breaker Control” section of the Setting chapter.

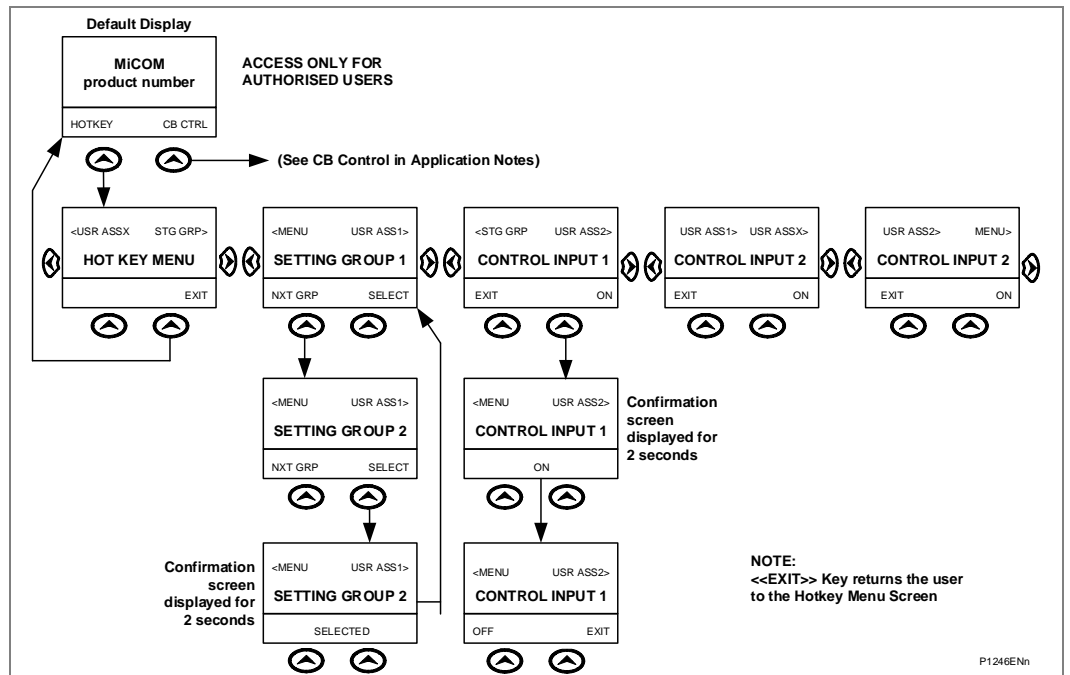

Figure 7 - Hotkey menu navigation

6.4 How to Login

The password entry method varies slightly between CSL0 and CSL1 Versions.

6.4.1 Local Default Access

In CSL0 models the user can access the relay menu without the need to login. In CSL1 models this can be enabled/disabled using Cybersecurity Admin Expert (CAE). If the Local Default Access is enabled, the user may login to the front panel with associated roles.

See Table 4 for the applied cases.

6.4.2 Auto Login

Auto login means the user will login the IED automatically and no need to select the user name and enter the password. In this case, the user will be authorized with relevant rights. The auto login will be applied in these cases:

CS Version	Interface	RBAC/PW Cases	Login Process
CSL1	Front panel	Factory RBAC	Auto login with EngineerLevel
		Customized RBAC	Local Default Access Enabled: Login with Local Default Access Local Default Access Disabled: Login with Prompt User List
	Courier Interface	All cases	Login with Prompt User List
CSL0	Front panel	Factory RBAC	Auto login with EngineerLevel
		Password changed	EngineerLevel password is "AAAA" or is disabled/blank: Auto login with EngineerLevel OperatorLevel password is "AAAA" or is disabled/blank: Auto login with OperatorLevel EngineerLevel and OperatorLevel password changed: Auto login with ViewerLevel Access
	Courier Interface	Factory RBAC	Auto login with EngineerLevel
		Password changed	EngineerLevel password is "AAAA" or is disabled/blank: Auto login with EngineerLevel OperatorLevel password is "AAAA" or is disabled/blank: Auto login with OperatorLevel EngineerLevel and OperatorLevel password changed: Login with Prompt User List

Table 4 - Auto Login process

For more details about the Factory RBAC, please refer to the Cyber Security chapter.

6.4.3 Login with Prompt User List



This login process will happen if:

- The Auto login process is not applied.
- Or high authorization is required for the current operation.







In this case, the IED will prompt the user list, and the user needs to select proper user name and enter the password to login.

6.5 Reading and Clearing of Alarm Messages and Fault Records









One or more alarm messages appear on the default display and the yellow alarm LED flashes. The alarm messages can either be self-resetting or latched, in which case they must be cleared manually.

1. To view the alarm messages, press the read key . When all alarms have been viewed but not cleared, the alarm LED change from flashing to constantly ON and the latest fault record appears (if there is one).
2. Scroll through the pages of the latest fault record, using the  key. When all pages of the fault record have been viewed, the following prompt appears.



Press clear to
reset alarms

3. To clear all alarm messages, press . To return to the display showing alarms or faults present, and leave the alarms uncleared, press .
4. Depending on the password configuration settings, you may need to enter a password before the alarm messages can be cleared. See the **How to Access the IED/Relay** section.
5. When all alarms are cleared, the yellow alarm LED switches OFF; also the red trip LED switches OFF if it was switched ON after a trip.
6. To speed up the procedure, enter the alarm viewer using the  key, then press the  key. This goes straight to the fault record display. Press  again to move straight to the alarm reset prompt, then press  again to clear all alarms.

6.6 Setting Changes

1. To change the value of a setting, go to the relevant cell in the menu, then press the enter key  to change the cell value. A flashing cursor on the LCD shows the value can be changed. If a password is required to edit the cell value, a password prompt appears.
2. To change the setting value, press the  or  keys. If the setting to be changed is a binary value or a text string, select the required bit or character to be changed using the  and  keys.
3. Press  to confirm the new setting value or the clear key  to discard it. The new setting is automatically discarded if it is not confirmed in 15 minutes.
4. For protection group settings and disturbance recorder settings, the changes must be confirmed before they are used by the relay.
5. To do this, when all required changes have been entered, return to the column heading level and press the  key. Before returning to the default display, the following prompt appears.

Update settings?
Enter or clear

6. Press  to accept the new settings or press  to discard the new settings.

Note *If the menu time-out occurs before the setting changes have been confirmed, the setting values are also discarded.*

Control and support settings are updated immediately after they are entered, without the **Update settings?** prompt.

6.7 How to Logout

6.7.1 How to Logout at the IED

For security consideration, it would be better to "logout" the IED once the configuration done. You can do this by going up to the default display. When you are at the default display and you press the 'Cancel' button, you may be prompted to log out with the following display:

ENTER TO LOGOUT
CLEAR TO CANCEL

You will be asked this question if you are logged in.

If you confirm, the following message is displayed for 2 seconds:

LOGGED OUT
User Name

If you decide not to log out (i.e. you cancel), the following message is displayed for 2 seconds.

LOGOUT CANCELLED
User Name

Note *The MiCOM IED runs a timer, which logs the user out after a period of inactivity. For more details, refer to the [Inactivity Timer](#) section.*

6.7.2 How to Logout at MiCOM S1 Studio

- Right-click on the device name and select Log Off.
- In the Log Off confirmation dialog click Yes.

7 FRONT COMMUNICATION PORT USER INTERFACE

The front communication port is provided by a 9-pin female D-type connector located under the bottom hinged cover. It provides EIA(RS)232 serial data communication and is intended for use with a PC locally to the relay (up to 15m distance) as shown in the following diagram. This port supports the Courier communication protocol only. Courier is the communication language developed by Schneider Electric to allow communication with its range of protection relays. The front port is particularly designed for use with the relay settings program Easergy Studio.

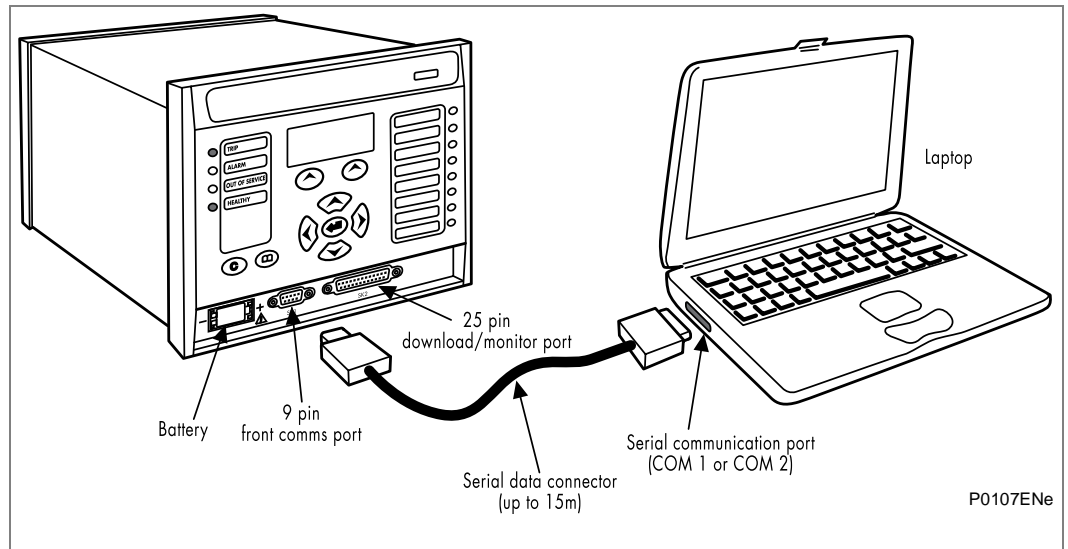

Figure 8 - Front port connection

The IED is a Data Communication Equipment (DCE) device. The pin connections of the 9-pin front port are as follows:

Pin no.	Description
2	Tx Transmit data
3	Rx Receive data
5	0V Zero volts common

Table 5 - Front port DCE pin connections

None of the other pins are connected in the relay. The relay should be connected to the serial port of a PC, usually called COM1 or COM2. PCs are normally Data Terminal Equipment (DTE) devices which have a serial port pin connection as below (if in doubt check your PC manual):

Pin	25 Way	9 Way	Description
Pin no. 2	3	2	Rx Receive data
Pin no. 3	2	3	Tx Transmit data
Pin no. 5	7	5	0V Zero volts common

Table 6 - DTE devices serial port pin connections

For successful data communication, the Tx pin on the relay must be connected to the Rx pin on the PC, and the Rx pin on the relay must be connected to the Tx pin on the PC, as shown in the diagram. Therefore, providing that the PC is a DTE with pin connections as given above, a 'straight through' serial connector is required, i.e. one that connects pin 2 to pin 2, pin 3 to pin 3, and pin 5 to pin 5.

Note A common cause of difficulty with serial data communication is connecting Tx to Tx and Rx to Rx. This could happen if a 'cross-over' serial connector is used, i.e. one that connects pin 2 to pin 3, and pin 3 to pin 2, or if the PC has the same pin configuration as the relay.

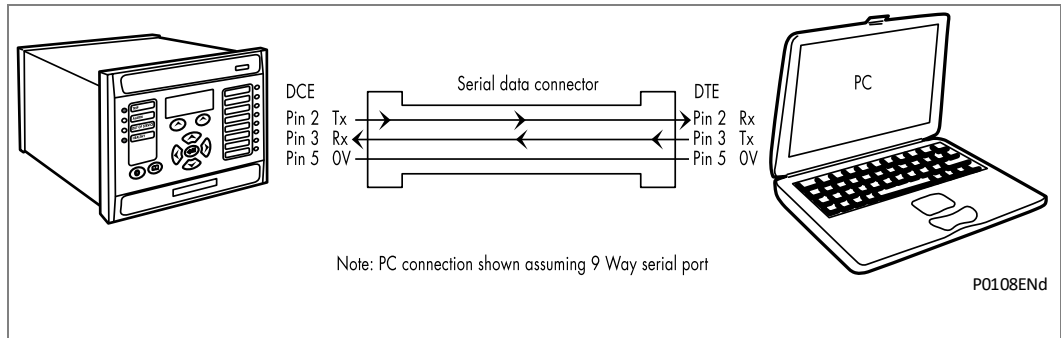

Figure 9 - PC relay signal connection

Having made the physical connection from the relay to the PC, the PC's communication settings must be configured to match those of the relay. The relay's communication settings for the front port are fixed as shown below:

Protocol	Baud rate	Courier address	Message format
Courier	19,200 bits/s	1	11 bit - 1 start bit, 8 data bits, 1 parity bit (even parity), 1 stop bit

Table 7 - Communication settings

7.1

Relay Front Port Settings

The inactivity timer for the front port is set at 15 minutes. This controls how long the relay will maintain its password access on the front port. If no messages are received on the front port for 15 minutes then any password access that has been enabled will be revoked.

7.2

Front Courier Port

The front EIA(RS)232 9-pin port supports the Courier protocol for one to one communication.

Note *The front port is actually compliant to EIA(RS)574; the 9-pin version of EIA(RS)232, see www.tiaonline.org.*

The front port is designed for use during installation and commissioning/maintenance and is not suitable for permanent connection. Since this interface will not be used to link the relay to a substation communication system, some of the features of Courier are not implemented. These are as follows:

- Automatic Extraction of Event Records:
 - Courier Status byte does not support the Event flag
 - Send Event/Accept Event commands are not implemented
- Automatic Extraction of Disturbance Records:
 - Courier Status byte does not support the Disturbance flag
- Busy Response Layer: Courier Status byte does not support the Busy flag, the only response to a request will be the final data
- Fixed Address: The address of the front courier port is always 1, the Change Device address command is not supported.
- Fixed Baud Rate: 19200 bps

Note *Although automatic extraction of event and disturbance records is not supported, this data can be manually accessed using the front port.*

8 EASERGY STUDIO COMMUNICATIONS BASICS

Note *MiCOM S1 Studio has been renamed as Easergy Studio.*

The EIA(RS)232 front communication port is particularly designed for use with the relay settings program Easergy Studio. This is our universal MiCOM IED Support Software and provide users a direct and convenient access to all stored data in any MiCOM IED using the EIA(RS)232 front communication port.

Easergy Studio provides full access to MiCOM Px10, Px20, Px30, Px40 and Mx20 measurements units.

The Easergy Studio product is updated periodically. These updates provide support for new features (such as allowing you to manage new MiCOM products, as well as using new software releases and hardware suffixes). The updates may also include fixes.

Accordingly, we strongly advise customers to use the latest Schneider Electric version of Easergy Studio.

If you need more information regarding bug fixes, please contact your **Schneider Electric** local support.

8.1

PC Requirements

The minimum and recommended hardware requirements for Easergy Studio (v9.0.0) are shown below. These include the Studio application and other tools which are included: UPCT, P746 RHMI, P74x Topology Tool:

Minimum requirements:				
Platform	Processor	RAM	HDD (Note 1 & 3)	HDD (Note 2 & 3)
Windows XP x86	1 GHz	512 MB	900 MB	1.5 GB
Windows 7 x86	1 GHz	1 GB	900 MB	1.9 GB
Windows 7 x64	1 GHz	2 GB	900 MB	2.1 GB
Windows Server 2008 x86 Sp1	1 GHz	512 MB	900 MB	1.7 GB

Recommended requirements:				
Platform	Processor	RAM	HDD (Note 1 & 3)	HDD (Note 2 & 3)
Windows XP x86	1 GHz	1 GB	900 MB	1.5 GB
Windows 7 x86	1 GHz	2 GB	900 MB	1.9 GB
Windows 7 x64	1 GHz	4 GB	900 MB	2.1 GB
Windows Server 2008 x86 Sp1	1 GHz	4 GB	900 MB	1.7 GB

Note 1 *Operating system with Windows Updates updated on 2015/05.*

Note 2 *Operating system without Windows Updates installed.*

Note 3 *Both configurations do not include Data Models HDD requirements. Data Models typically need from 1 GB to 15 GB of hard disk space.*

Screen resolution for minimum requirements: Super VGA (800 x 600).

Screen resolution for recommended requirements: XGA (1024x768) and higher.

Easergy Studio must be started with Administrator privileges.

Easergy Studio Additional components

The following components are required to run Easergy Studio and are installed by its installation package.

Component Type	Component
Package	.NET Framework 2.0 SP 1 (x64)
Package	.NET Framework 2.0 SP 1 (x86)
Package	.NET Framework 4.0 Client (x64)
Package	.NET Framework 4.0 Client (x86)
Package	Visual C++ 2005 SP1 Redistributable Package (x86)
Package	Visual C++ 2008 SP1 Redistributable Package (x86)
Merge modules	DAO 3.50
Merge modules	MFC 6.0
Merge modules	MFC Unicode 6.0
Merge modules	Microsoft C Runtime Library 6.0
Merge modules	Microsoft C++ Runtime Library 6.0
Merge modules	Microsoft Component Category Manager Library
Merge modules	Microsoft Data Access Components 2.8 (English)
Merge modules	Microsoft Jet Database Engine 3.51 (English)
Merge modules	Microsoft OLE 2.40 for Windows NT and Windows 95
Merge modules	Microsoft Visual Basic Virtual Machine 6.0
Merge modules	MSXML 4.0 - Windows 9x and later
Merge modules	MSXML 4.0 - Windows XP and later
Merge modules	Visual C++ 8.0 MFC (x86) WinSXS MSM
Merge modules	Visual C++ 8.0 MFC.Policy (x86) WinSXS MSM

8.2 Connecting to the Relay using Easergy Studio

This section is a quick start guide to using Easergy Studio and assumes this is installed on your PC. See the Easergy Studio online help for more detailed information.

1. Make sure the EIA(RS)232 serial cable is properly connected between the port on the front panel of the relay and the PC.
2. To start Easergy Studio, select **Start > All apps > Schneider Electric > Easergy Studio**.
3. Click the **Quick Connect** tab and select **Create a New System**.
4. Check the **Path to System file** is correct, then enter the name of the system in the **Name** field. To add a description of the system, use the **Comment** field.
5. Click **OK**.
6. Select the device type.
7. Select the communications port, and open a connection with the device.
8. Once connected, select the language for the settings file, the device name, then click **Finish**. The configuration is updated.
9. In the **Studio Explorer** window, select **Device > Supervise Device...** to control the relay directly. (User Login necessary)

8.3 Off-Line Use of Easergy Studio

Easergy Studio can also be used as an off-line tool to prepare settings, without access to the relay.

1. If creating a new system, in the Studio Explorer, select **create new system**. Then right-click the new system and select **New substation**.
2. Right-click the new substation and select **New voltage level**.
3. Then right-click the new voltage level and select **New bay**.
4. Then right-click the new bay and select **New device**.
You can add a device at any level, whether it is a system, substation, voltage or bay.
5. Select a device type from the list, then enter the relay type. Click **Next**.
6. Enter the full model number and click **Next**.
7. Select the **Language** and **Model**, then click **Next**.
8. If the IEC61850 protocol is selected, and an Ethernet board with hardware option Q, R or S is selected, select IEC 61850 Edition:
IEC 61850 Edition 2 Mode or
IEC 61850 Edition 1 Compatible Mode.
9. Enter a unique device name, then click **Finish**.
10. Right-click the **Settings** folder and select **New File**. A default file **000** is added.
11. Right-click file **000** and select click **Open**. You can then edit the settings. See the Easergy Studio online help for more information.

SETTINGS

CHAPTER 4

Date:	08/2023
Products covered by this chapter:	This chapter covers the specific versions of the MiCOM products listed below. This includes only the following combinations of Software Version and Hardware Suffix.
Hardware suffix:	M
Software version:	K6
Connection diagrams:	10P54302 (SH 1 to 2) 10P54303 (SH 1 to 2) 10P54304 (SH 1 to 2) 10P54400 10P54404 (SH 1 to 2) 10P54405 (SH 1 to 2) 10P54502 (SH 1 to 2) 10P54503 (SH 1 to 2) 10P54504 (SH 1 to 2) 10P54600 10P54604 (SH 1 to 2) 10P54605 (SH 1 to 2) 10P54606 (SH 1 to 2)

CONTENTS

Page (ST) 4-

1	Introduction	7
1.1	Making Changes to the Settings	7
1.2	Relay Settings	7
1.3	Default Settings Restore	7
2	Configuration Settings	8
3	Group Settings	14
3.1	Line Parameters	14
3.2	Distance Setup (only for Models with Distance Option)	17
3.3	Distance Elements (only for Models with Distance Option)	23
3.4	Phase Differential	31
3.5	Scheme Logic (Basic and Aided Scheme Logic). Only in Models with Distance Option	34
3.6	Power Swing Blocking (Only in Models with Distance Option)	42
3.7	Phase Overcurrent Protection	46
3.8	Negative Sequence Overcurrent	50
3.9	Broken Conductor	52
3.10	Earth Fault	52
3.11	Aided DEF (only in Models with Distance Option)	56
3.12	Sensitive Earth Fault (SEF)	57
3.13	Residual Overvoltage (Neutral Voltage Displacement)	59
3.14	Thermal Overload	60
3.15	Voltage Protection	61
3.16	Frequency Protection	63
3.17	Independent Rate of Change of Frequency Protection	65
3.18	Circuit Breaker (CB) Fail and Pole Dead Detection Function	66
3.19	Supervision (VTS, CTS, Inrush Detection, Special Weak Infeed Blocking and Trip Supervision)	68
3.20	System Checks (Check Sync. Function)	78
3.21	Auto-Reclose Function	84
3.22	Input Labels	96
3.23	Virtual Input Labels	98
3.24	Output Labels	100
3.25	Virtual Output Labels	102
3.26	DR Chan Labels	104

3.27	SR/MR User Alarm Labels	112
3.28	EIA(RS)232 InterMiCOM Communications	113
3.29	EIA(RS)232 InterMiCOM Conf 56/64 kbit/s Fiber Teleprotection – InterMiCOM 64	115
<hr/>		
4	Control and Support Settings	118
4.1	System Data	118
4.2	Circuit Breaker Control	121
4.3	Date and Time	125
4.4	CT/VT Ratios	128
4.5	Record Control	131
4.6	Disturbance Recorder Settings (Oscillography)	145
4.7	Measurement Setup	164
4.8	Communications Settings	165
4.9	Commissioning Tests	169
4.10	Circuit Breaker Condition Monitor Setup	171
4.11	Opto Configuration	174
4.12	Control Inputs	177
4.13	Control Input Configuration	180
4.14	Function Keys	185
4.15	PB Config	187
4.16	IED Configurator (for IEC 61850 Configuration)	189
4.17	56/64 kbit/s Fiber Teleprotection - InterMiCOM ⁶⁴	191
4.18	Control Input Labels	198
4.19	Direct Access (Breaker Control and Hotkeys)	202

TABLES

	Page (ST) 4-
Table 1 - Configuration settings	12
Table 2 - Line parameters	17
Table 3 - Group x distance setup	23
Table 4 - Group x distance elements	30
Table 5 - Group x phase diff	34
Table 6 - Group x scheme logic	42
Table 7 - Group x power swing blk	46
Table 8 - Phase overcurrent protection	49
Table 9 - Negative sequence overcurrent	51
Table 10 - Broken conductor	52
Table 11 - Earth fault	56

Table 12 - Group x aided DEF	57
Table 13 - Sensitive earth fault	59
Table 14 - Residual overvoltage (neutral voltage displacement)	60
Table 15 - Thermal overload	61
Table 16 - Voltage protection	63
Table 17 - Frequency protection	64
Table 18 - DF/DT protection	66
Table 19 - Circuit breaker fail and pole dead detection function	68
Table 20 - Supervision	77
Table 21 - System checks (check sync. function)	84
Table 22 - Auto-reclose function	96
Table 23 - Input labels	98
Table 24 - Virtual Input labels	100
Table 25 - Output labels	102
Table 26 - Virtual Output labels	104
Table 27 - DR Chan labels	112
Table 28 - SR/MR User Alarm labels	113
Table 29 - InterMiCOM comms	115
Table 30 - INTERMiCOM conf	117
Table 31 - System data	121
Table 32 - Circuit breaker control	125
Table 33 - Date and time	128
Table 34 - CT/VT ratios	131
Table 35 - Record control	145
Table 36 - Disturbance recorder	164
Table 37 - Measurement setup	165
Table 39 - Communications settings	169
Table 40 - Commissioning tests	171
Table 41 - Circuit breaker condition monitor setup	174
Table 42 - Opto configuration	177
Table 43 - Control inputs	180
Table 44 - Control input configuration	185
Table 45 - Function keys	187
Table 46 - PB Config	189
Table 47 - IED configurator (for IEC 61850 configuration)	191
Table 48 - Prot comms/IM64	198
Table 49 - Control input labels	201
Table 50 - Direct access (breaker control and “hotkeys”)	206

Notes:

1 INTRODUCTION

1.1 Making Changes to the Settings

The relay is supplied with a factory-set configuration of default settings. Before being put into service, it must be configured to the system and the application by means of appropriate settings.

Because of the complex functionality of the device, it contains a large number of settings. These settings are arranged in a menu structure to facilitate clarity of presentation. The ways in which individual settings can be changed is described in the Getting Started section of this manual.

When configuring the functionality to the system application, the structure of the settings can be considered in three parts:

- Configuration Settings
- Group Settings
- Control and Support Settings

The sequence in which the settings are listed and described in this chapter reflects this structure.

1.2 Relay Settings

The IED is a multi-function device that supports numerous different control and communication features. The settings associated with any function that is disabled are made invisible; i.e. they are not shown in the menu. To disable a function change the relevant cell in the **'Configuration'** column from **'Enabled'** to **'Disabled'**.

To simplify the setting of the IED, there is a configuration settings column, used to enable or disable many of the IED functions. The aim of the configuration column is to allow general configuration from a single point in the menu.

The configuration column controls which of the four settings groups is selected as active through the **'Active settings'** cell. A setting group can also be disabled in the configuration column, provided it is not the present active group. Similarly, a disabled setting group cannot be set as the active group.

The column also allows all of the setting values in one group of settings to be copied to another group.

To do this firstly set the **'Copy from'** cell to the setting group to be copied, then set the **'Copy to'** cell to the group where the copy is to be placed. The copied settings are initially placed in the temporary scratchpad, and will only be used by the IED following confirmation.

1.3 Default Settings Restore

To restore the default values to the settings in any protection settings group, set the 'restore defaults' cell to the relevant group number. Alternatively, it is possible to set the 'restore defaults' cell to 'all settings' to restore the default values to all of the IEDs settings, not just the protection groups' settings. The default settings will initially be placed in the scratchpad and will only be used by the IED after they have been confirmed.

Important

Restoring defaults to all settings includes the rear communication port settings, which may result in communication via the rear port being disrupted if the new (default) settings do not match those of the master station.

2 CONFIGURATION SETTINGS

To simplify the setting of the relay, there is a configuration settings column which is used to enable or disable many of the functions. If a function is disabled, the settings associated with that function are not shown in the menu. To disable a function, change the relevant cell in the Configuration column from Enabled to Disabled.

The **Active settings** cell of the configuration column controls which of the application setting groups is used by the relay.

The configuration column can also be used to copy the contents of one of the setting Groups to that of another Group.

To do this, firstly set the **Copy from** cell to the protection setting group to be copied, then set the **copy to** cell to the protection group where the copy is to be placed. The copied settings are initially placed in the temporary scratchpad, and will only be used by the IED following confirmation.

The settings of the configuration column are detailed below.

Col	Row	Menu Text	Default Setting	Available Setting	P543 / P545 No Distance	P544 / P546 No Distance	P543 / P545	P544 / P546
Description								
09	00	CONFIGURATION			*	*	*	*
This column contains all the general configuration options								
09	01	Restore Defaults	No Operation	0 = No Operation, 1 = All Settings, 2 = Setting Group 1, 3 = Setting Group 2, 4 = Setting Group 3, 5 = Setting Group 4	*	*	*	*
Setting to restore a setting group to factory default settings. To restore the default values to the settings in any Group settings, set the 'restore defaults' cell to the relevant Group number. Alternatively it is possible to set the 'restore defaults' cell to 'all settings' to restore the default values to all of the IED's settings, not just the Group settings. The default settings will initially be placed in the scratchpad and will only be used by the relay after they have been confirmed by the user. Note: Restoring defaults to all settings includes the rear communication port settings, which may result in communication via the rear port being disrupted if the new (default) settings do not match those of the master station.								
09	02	Setting Group	Select via Menu	0 = Select via Menu or 1 = Select via PSL	*	*	*	*
Allows setting group changes to be initiated via Opto Input or via Menu								
09	03	Active Settings	Group 1	0 = Group 1, 1 = Group 2, 2 = Group 3, 3 = Group 4	*	*	*	*
Selects the active setting group.								
09	04	Save Changes	No Operation	0 = No Operation, 1 = Save, 2 = Abort	*	*	*	*
Saves all relay settings.								
09	05	Copy From	Group 1	0 = Group 1, 1 = Group 2, 2 = Group 3, 3 = Group 4	*	*	*	*
Allows displayed settings to be copied from a selected setting group								
09	06	Copy To	No Operation	0 = No Operation, 1 = Group 1, 2 = Group 2, 3 = Group 3	*	*	*	*
Allows displayed settings to be copied to a selected setting group (ready to paste).								
09	07	Setting Group 1	Enabled	0 = Disabled or 1 = Enabled	*	*	*	*

Col	Row	Menu Text	Default Setting	Available Setting	P543 / P545 No Distance	P544 / P546 No Distance	P543 / P545	P544 / P546
Description								
Settings Group 1. If the setting group is disabled from the configuration, then all associated settings and signals are hidden, with the exception of this setting (paste).								
09	08	Setting Group 2	Disabled	0 = Disabled or 1 = Enabled	*	*	*	*
Settings Group 2. If the setting group is disabled from the configuration, then all associated settings and signals are hidden, with the exception of this setting (paste).								
09	09	Setting Group 3	Disabled	0 = Disabled or 1 = Enabled	*	*	*	*
Settings Group 3. If the setting group is disabled from the configuration, then all associated settings and signals are hidden, with the exception of this setting (paste).								
09	0A	Setting Group 4	Disabled	0 = Disabled or 1 = Enabled	*	*	*	*
Settings Group 4. If the setting group is disabled from the configuration, then all associated settings and signals are hidden, with the exception of this setting (paste).								
09	0B	Distance	Enabled	0 = Disabled or 1 = Enabled			*	*
Only in models with Distance option. To enable (activate) or disable (turn off) the Distance Protection: ANSI 21P/21G.								
09	0C	Directional E/F	Enabled	0 = Disabled or 1 = Enabled			*	*
Only in models with Distance option. To enable (activate) or disable (turn off) the Directional Earth Fault (DEF) Protection used in a pilot aided scheme: ANSI 67N. This protection is independent from back up Earth fault protection described below.								
09	0E	Tripping Mode	3 Pole	0 = 3 Pole, 1 = 1 and 3 Pole				
09	0F	Phase Diff	Enabled	0 = Disabled or 1 = Enabled	*	*	*	*
To enable (activate) or disable (turn off) the Differential Protection: ANSI 87. To get the differential protection fully active, it is necessary also to enable the differential protection in the group. Note that Phase Diff setting and InterMiCOM64 Fiber setting are mutually exclusive as with Phase Diff enabled, the digital message exchanged has the structure of the differential message (i.e. currents are sent to the remote end, etc) and with interMiCOM64 Fiber the digital message exchanged has the structure and properties of the InterMiCOM64 Fiber.								
09	0F	Phase Comparison	Enabled	0 = Disabled or 1 = Enabled				
To enable (activate) or disable (turn off) the Phase Comparison Protection function: ANSI 87								
09	10	Overcurrent	Disabled	0 = Disabled or 1 = Enabled	*	*	*	*
To enable (activate) or disable (turn off) the Phase Overcurrent Protection function. I> stages: ANSI 50/51/67P								
09	10	Overcurrent	Enabled	0 = Disabled or 1 = Enabled				
To enable (activate) or disable (turn off) the Phase Overcurrent Protection function. I2> stages: ANSI 50/51/67P								
09	11	Neg Sequence O/C	Disabled	0 = Disabled or 1 = Enabled	*	*	*	*
To enable (activate) or disable (turn off) the Negative Sequence Overcurrent Protection function. I2> stages: ANSI 46/67								
09	12	Broken Conductor	Disabled	0 = Disabled or 1 = Enabled	*	*	*	*
To enable (activate) or disable (turn off) the Broken Conductor function. I2/I1> stage: ANSI 46BC								
09	13	Earth Fault	Disabled	0 = Disabled or 1 = Enabled	*	*	*	*

Col	Row	Menu Text	Default Setting	Available Setting	P543 / P545 No Distance	P544 / P546 No Distance	P543 / P545	P544 / P546
Description								
To enable (activate) or disable (turn off) the back up Earth Fault Protection function. IN >stages: ANSI 50/51/67N								
09	13	Earth Fault	Enabled	0 = Disabled or 1 = Enabled				
To enable (activate) or disable (turn off) the back up Earth Fault Protection function. IN >stages: ANSI 50/51/67N								
09	15	SEF/REF Prot'n	Disabled	0 = Disabled or 1 = Enabled	*	*	*	*
To enable (activate) or disable (turn off) the Sensitive Earth Fault/Restricted Earth fault Protection function. ISEF >stages: ANSI 50/51/67N. IREF>stage: ANSI 64.								
09	16	Residual O/V NVD	Disabled	0 = Disabled or 1 = Enabled	*	*	*	*
To enable (activate) or disable (turn off) the Residual Overvoltage Protection function. VN>stages: ANSI 59N								
09	17	Thermal Overload	Disabled	0 = Disabled or 1 = Enabled	*	*	*	*
To enable (activate) or disable (turn off) the Thermal Overload Protection function. ANSI 49.								
09	18	PowerSwing Block	Enabled	0 = Disabled or 1 = Enabled			*	*
Only in models with Distance option. To enable (activate) or disable (turn off) the power swing blocking/out of step: ANSI 68/78.								
09	19	Cold Load Pickup	Disabled	0 = Disabled or 1 = Enabled				
To enable (activate) or disable (turn off) the Cold Load Pickup protection: ANSI CLP								
09	1D	Volt Protection	Disabled	0 = Disabled or 1 = Enabled	*	*	*	*
To enable (activate) or disable (turn off) the Voltage Protection (under/overvoltage) function. V<, V> stages: ANSI 27/59.								
09	1E	Freq Protection	Disabled	0 = Disabled or 1 = Enabled	*	*	*	*
To enable (activate) or disable (turn off) the Frequency Protection (under/over frequency) function. F<, F> stages: ANSI 81O/U.								
09	1F	df/dt Protection	Disabled	0 = Disabled or 1 = Enabled	*	*	*	*
To enable (activate) or disable (turn off) the Rate of change of Frequency Protection function. df/dt> stages: ANSI 81R.								
09	20	CB Fail	Disabled	0 = Disabled or 1 = Enabled	*	*	*	*
To enable (activate) or disable (turn off) the Circuit Breaker Fail Protection function. ANSI 50BF.								
09	21	Supervision	Enabled	0 = Disabled or 1 = Enabled	*	*	*	*
To enable (activate) or disable (turn off) the Supervision (VTS & CTS) functions. ANSI VTS/CTS.								
09	23	System Checks	Disabled	0 = Disabled or 1 = Enabled	*	*	*	*
To enable (activate) or disable (turn off) the System Checks (Check Sync. and Voltage Monitor) function: ANSI 25.								
09	23	System Checks	Enabled	0 = Disabled or 1 = Enabled				
To enable (activate) or disable (turn off) the System Checks (Check Sync. and Voltage Monitor) function: ANSI 25.								
09	24	Auto-Reclose	Disabled	0 = Disabled or 1 = Enabled	*	*	*	*
To enable (activate) or disable (turn off) the Auto-reclose function. ANSI 79.								
09	24	Auto-Reclose	Enabled	0 = Disabled or 1 = Enabled				
To enable (activate) or disable (turn off) the Auto-reclose function. ANSI 79.								

Col	Row	Menu Text	Default Setting	Available Setting	P543 / P545 No Distance	P544 / P546 No Distance	P543 / P545	P544 / P546
Description								
09	25	Input Labels	Visible	0 = Invisible or 1 = Visible	*	*	*	*
Sets the Input Labels menu visible further on in the relay settings menu.								
09	26	Output Labels	Visible	0 = Invisible or 1 = Visible	*	*	*	*
Sets the Output Labels menu visible further on in the relay settings menu.								
09	28	CT & VT Ratios	Visible	0 = Invisible or 1 = Visible	*	*	*	*
Sets the Current & Voltage Transformer Ratios menu visible further on in the relay settings menu.								
09	29	Record Control	Visible	0 = Invisible or 1 = Visible	*	*	*	*
Sets the Record Control menu visible further on in the relay settings menu.								
09	2A	Disturb Recorder	Visible	0 = Invisible or 1 = Visible	*	*	*	*
Sets the Disturbance Recorder menu visible further on in the relay settings menu.								
09	2B	Measure't Setup	Visible	0 = Invisible or 1 = Visible	*	*	*	*
Sets the Measurement Setup menu visible further on in the relay settings menu.								
09	2C	Comms Settings	Visible	0 = Invisible or 1 = Visible	*	*	*	*
Sets the Communications Settings menu visible further on in the relay settings menu. These are the settings associated with the 2nd rear communications ports.								
09	2D	Commission Tests	Visible	0 = Invisible or 1 = Visible	*	*	*	*
Sets the Commissioning Tests menu visible further on in the relay settings menu.								
09	2E	Setting Values	Primary	0 = Primary or 1 = Secondary	*	*	*	*
This affects all protection settings that are dependent upon CT and VT ratios. All subsequent settings input must be based in terms of this reference.								
09	2F	Control Inputs	Visible	0 = Invisible or 1 = Visible	*	*	*	*
Activates the Control Input status and operation menu further on in the relay setting menu.								
09	35	Control I/P Config	Visible	0 = Invisible or 1 = Visible	*	*	*	*
Sets the Control Input Configuration menu visible further on in the relay setting menu.								
09	36	Ctrl I/P Labels	Visible	0 = Invisible or 1 = Visible	*	*	*	*
Sets the Control Input Labels menu visible further on in the relay setting menu.								
09	39	Direct Access	Enabled	0= Disabled, 1 = Enabled, 2 = Hotkey Only, or 3 = CB Ctrl Only	*	*	*	*
Defines what CB control direct access is allowed. The front direct access keys that are used as a short cut function of the menu may be: Disabled – No function visible on the LCD. Enabled – All control functions mapped to the Hotkeys and Control Trip/Close are available. Hotkey Only – Only control functions mapped to the Hotkeys are available on the LCD. CB Ctrl Only – Only Control Trip/Control Close command will appear on the relay's LCD. Not available on Chinese version relays (P54??????C???)								

Col	Row	Menu Text	Default Setting	Available Setting	P543 / P545 No Distance	P544 / P546 No Distance	P543 / P545	P544 / P546
Description								
09	40	InterMiCOM	Disabled	0 = Disabled or 1 = Enabled				
To enable (activate) or disable (turn off) EIA (RS) 232 InterMiCOM (integrated teleprotection).								
09	41	InterMiCOM 64	Disabled	0 = Disabled or 1 = Enabled	*	*	*	*
To enable (activate) or disable (turn off) InterMiCOM64 (integrated 56/64kbit/s teleprotection). Note that Phase Diff setting and InterMiCOM64 Fiber setting are mutually exclusive as with Phase Diff enabled, the digital message exchanged has the structure of the differential message (i.e. currents are sent to the remote end, etc) and with InterMiCOM64 Fiber the digital message exchanged has the structure and properties of the InterMiCOM64 Fiber.								
9	48	PB CONFIG	Visible	0 = Invisible or 1 = Visible	*	*	*	*
Sets the PB CONFIG menu visible in the relay setting menu.								
09	50	Function Key	Visible	0 = Invisible or 1 = Visible	*	*	*	*
Sets the Function Key menu visible further on in the relay setting menu.								
09	70	VIR I/P Labels	Invisible	0 = Invisible or 1 = Visible	*	*	*	*
VIR I/P Labels Visible/Invisible								
09	80	VIR O/P Labels	Invisible	0 = Invisible or 1 = Visible	*	*	*	*
VIR O/P Labels Visible/Invisible								
09	90	Usr Alarm Labels	Invisible	0 = Invisible or 1 = Visible	*	*	*	*
USR Alarm Labels Visible/Invisible								
09	FB	RP1 Read Only	Disabled	0 = Disabled or 1 = Enabled	*	*	*	*
To enable (activate) or disable (turn off) Read Only Mode of Rear Port 1.								
09	FC	RP2 Read Only	Disabled	0 = Disabled or 1 = Enabled	*	*	*	*
To enable (activate) or disable (turn off) Read Only Mode of Rear Port 2.								
09	FD	NIC Read Only	Disabled	0 = Disabled or 1 = Enabled	*	*	*	*
Ethernet versions only. To enable (activate) or disable (turn off) Read Only Mode of Network Interface Card.								
9	FE	SettingValueBeh.	Independent	0 = Independent or 1 = Locked Mode	*	*	*	*
Independent: cell [092E] Setting Values will be independent in each interfaces Locked Mode: cell [092E] Setting Values are locked to the same value for all interfaces								
09	FF	LCD Contrast	11	0 to 31 step 1	*	*	*	*
Sets the LCD contrast.								

Table 1 - Configuration settings

“SettingValue” and “SettingValueBeh.” (09FE) Notes

A new setting [09FE] SettingValueBeh has been added:

Cell	Menu Text	Data Type	Strings	Default Setting	Available Setting
09FE	SettingValueBeh.	Indexed string	G263	Independent	0 = Independent 1 = Locked Mode

When [09FE] = Independent, the IED will behave as the original design. That means the [092E] Setting Values are independent for each interface. For example:

Interface	[092E]	Protect Setting Display as
Local	Primary	Primary
Remote 1	Secondary	Secondary
Remote 2	Secondary	Secondary
LPM	Primary	Primary

When [09FE] = Locked Mode, the IED will behave this way, [092E] Setting Values are locked to the same value for each interface:

- When the [092E] Setting Value = Primary, the protection settings are entered in Primary terms on all interfaces; and the value of this cell is equal to Primary on all interfaces.
- When the [092E] Setting Value = Secondary, the protection settings are entered in Secondary terms on all interfaces; and the value of this cell is equal to Secondary on all interfaces.

Note When [09FE] is changed to Locked Mode, all interfaces will apply to the current selection for the interface that is changing this setting.

For example, the Front Port is Secondary and Rear Port 1 is Primary. When [09FE] is changed to Locked Mode on the HMI, all interfaces should apply Secondary to [092E]; if it is changed from the Rear Port then we should apply Primary.

3 GROUP SETTINGS

The relay has four application settings groups to enable adaptive behaviour to changing system conditions. The Group settings contain the settings associated with the main application functions and include the following items that become active once enabled in the configuration column of the relay menu database:

- Protection element settings
- Programmable Scheme Logic (PSL) settings
- Auto-reclose and check synchronization settings
- Fault locator settings.

Those setting cells that are enabled in the configuration column are visible in each Group setting. One group of settings is selected as the active group, and those Group settings are then used by the appropriate application elements.

The settings for group 1 are described below. The settings are discussed in the same order in which they are displayed in the menu.

3.1 Line Parameters

The column **GROUP x LINE PARAMETERS** is used to enter the characteristics of the protected line or cable. These settings are used by the fault locator as the base data for input to the distance to fault algorithm, and also as the reference for all distance zones when the Distance set up is preferred in the 'Simple' setting mode. It also accommodates the system phase rotation (phase sequence) and defines the single or three pole tripping mode.

Col	Row	MENU TEXT	Default Setting	Available Setting	P543/P545 No Distance	P544/P546 No Distance	P543/P545	P544/P546
Description								
30	00	GROUP 1 LINE PARAMETERS			*	*	*	*
This column contains settings for Line Parameters								
30	01	Line Length (metres)	100000m	From 300m to 1000Km step 10m	*	*	*	*
Setting of the protected line/cable length in km. This setting is available if MEASURE'T SETUP column is selected as 'Visible' in the CONFIGURATION column and if 'Distance unit' in the MEASURE'T SETUP column is selected as 'kilometers'.								
30	02	Line Length (miles)	62.1mi	From 0.005mi to 621mi step 0.005mi	*	*	*	*
Setting of the protected line/cable length in miles. This setting is available if MEASURE'T SETUP column is selected as 'Visible' in the CONFIGURATION column and if 'Distance unit' in the MEASURE'T SETUP column is selected as 'miles'. Dual step size is provided, for cables/short lines up to 10 miles the step size is 0.005 miles, 0.01 miles otherwise.								
30	03	Line Impedance	10*V1/I1Ω	From 0.05*V1/I1Ω to 500*V1/I1Ω step 0.01*V1/I1Ω	*	*	*	*
Setting for protected line/cable positive sequence impedance in either primary or secondary terms, depending on the Setting Values reference chosen in the CONFIGURATION column. The set value is used for Fault locator, and for all distance zone reaches calculation if 'Simple' setting mode under GROUP x DISTANCE SETUP is selected.								
30	04	Line Angle	70°	From 20° to 90° step 1°	*	*	*	*
Setting of the line angle (line positive sequence impedance angle).								
30	05	Residual Comp	1	0 to 10 step 0.01	*	*	*	*

Col	Row	MENU TEXT	Default Setting	Available Setting	P543/P545 No Distance	P544/P546 No Distance	P543/P545	P544/P546
Description								
<p>Setting of the residual compensation factor magnitude, used to extend the ground loop reach by a multiplication factor of (1+kZN), is calculated as ratio: $kZN = (Z0 - Z1)/3Z1$ where, Z1 = positive sequence impedance for the protected line or cable. Z0 = zero sequence impedance for the protected line or cable. Setting of the residual compensation factor magnitude, used to extend the ground loop reach by a multiplication factor of (1+kZN), is calculated as ratio: $kZN = (Z0 - Z1)/3Z1$ where, Z1 = positive sequence impedance for the protected line or cable. Z0 = zero sequence impedance for the protected line or cable. This setting is a used for Distance protection (when set to simple mode) . If Distance protection is set to Advanced mode, there are individual settings per Zone in the GROUP x DISTANCE ELEMENTS settings.</p>								
30	06	kZN Res Angle	0°	From -180° to 90° step 1°	*	*	*	*
<p>Setting of the residual compensation factor angle (in degrees) is calculated as: $\angle kZN = \angle (Z0 - Z1)/3Z1$ where, Z1 = positive sequence impedance for the protected line or cable. Z0 = zero sequence impedance for the protected line or cable. This setting is a used for Distance protection (when set to simple mode) . If Distance protection is set to Advanced mode, there are individual settings per Zone in the GROUP x DISTANCE ELEMENTS settings.</p>								
30	07	Mutual Comp	Disabled	0 = Disabled or 1 = Enabled	*	*	*	*
To enable (activate) or disable (turn off) the Mutual compensation replica used in both, Distance and Fault locator ground fault loops.								
30	08	KZm Mutual Set.	1	0 to 10 step 0.01	*	*	*	*
<p>Setting of the mutual compensation factor kZm magnitude is calculated as a ratio: $kZm = ZM0/3Z1$ where, ZM0 = zero sequence mutual impedance for the protected line or cable. Z1 = positive sequence impedance for the protected line or cable. Setting kZm is visible if 'Mutual Comp' is enabled. This setting is a used for fault locator and Distance protection (when set to simple mode) . If Distance protection is set to Advanced mode, there are individual settings per Zone in the GROUP x DISTANCE ELEMENTS settings.</p>								
30	09	kZm Mutual Angle	0°	From -180° to 90° step 1°	*	*	*	*
<p>Setting of the mutual compensation angle (in degrees) is calculated as: $\angle kZm = \angle ZM0/3Z1$ Angle setting $\angle kZm$ is visible if 'Mutual Comp' is enabled. This setting is a used for fault locator and Distance protection (when set to simple mode) . If Distance protection is set to Advanced mode, there are individual settings per Zone in the GROUP x DISTANCE ELEMENTS settings.</p>								
30	0A	Mutual cut-off (k)	0	0 to 2 step 0.1			*	*
Only in models with Distance option. Setting used to eliminate the mutual compensation replica in case when the ratio of neutral current of the parallel line to the neutral current of the protective line (IMUTUAL/IN) exceeds the setting. This setting is visible only if 'Mutual Comp' is enabled.								
30	0B	Phase Sequence	Standard ABC	0 = Standard ABC or 1 = Reverse ACB	*	*	*	*
This setting is used to select whether the 3 phase quantities (V and I) are rotating in the standard ABC sequence, or whether the rotation is in reverse ACB order. The appropriate selection is required to ensure that all derived sequence components and faulted phase flagging/targeting are correct.								
30	0C	Tripping Mode	3 Pole	0 = 3 Pole, 1 = 1 and 3 Pole	*		*	
This setting is used to select the tripping mode. The selection 1 and 3 pole allows single pole tripping for single phase to ground faults, whilst selection 3 pole converts any trip command(s) to three pole tripping.								
30	0C	CB1Tripping Mode	3 Pole	0 = 3 Pole, 1 = 1 and 3 Pole		*		*

Col	Row	MENU TEXT	Default Setting	Available Setting	P543/P545 No Distance	P544/P546 No Distance	P543/P545	P544/P546
Description								
This setting is used to select the tripping mode. The selection 1 and 3 pole allows single pole tripping for single phase to ground faults, whilst selection 3 pole converts any trip command(s) to three pole tripping.								
30	0E	CB2Tripping Mode	3 Pole	0 = 3 Pole, 1 = 1 and 3 Pole		*		*
This setting is used to select the tripping mode. The selection 1 and 3 pole allows single pole tripping for single phase to ground faults, whilst selection 3 pole converts any trip command(s) to three pole tripping.								
30	10	Line Charging Y	0.002*11/V1 S	From 0 S to 0.01*11/V1 S step 0.0001*11/V1 S	*	*	*	*
Setting for protected lines' total susceptance in either primary or secondary terms, depending on the Setting Values reference chosen in the CONFIGURATION column. The set value is used to calculate the compensated overvoltage if 'V1>1 Cmp Funct' setting is enabled under GROUP x VOLT PROTECTION.								
30	12	Z1 Tripping Mode	3 Pole	0 = 3 Pole, 1 = 1 and 3 Pole	*		*	
This setting is used to select the tripping mode for zone 1. The selection 1 and 3 pole allows single pole tripping for single phase to ground faults, whilst selection 3 pole converts any trip command(s) to three pole tripping.								
30	12	CB1Z1 Trip Mode	3 Pole	0 = 3 Pole, 1 = 1 and 3 Pole		*		*
This setting is used to select the tripping mode for zone1 CB1. The selection 1 and 3 pole allows single pole tripping for single phase to ground faults, whilst selection 3 pole converts any trip command(s) to three pole tripping.								
30	13	Z2 Tripping Mode	3 Pole	0 = 3 Pole, 1 = 1 and 3 Pole	*		*	
This setting is used to select the tripping mode for zone 2. The selection 1 and 3 pole allows single pole tripping for single phase to ground faults, whilst selection 3 pole converts any trip command(s) to three pole tripping.								
30	13	CB1Z2 Trip Mode	3 Pole	0 = 3 Pole, 1 = 1 and 3 Pole		*		*
This setting is used to select the tripping mode for zone2 CB1. The selection 1 and 3 pole allows single pole tripping for single phase to ground faults, whilst selection 3 pole converts any trip command(s) to three pole tripping.								
30	14	Z3 Tripping Mode	3 Pole	0 = 3 Pole, 1 = 1 and 3 Pole	*		*	
This setting is used to select the tripping mode for zone 2. The selection 1 and 3 pole allows single pole tripping for single phase to ground faults, whilst selection 3 pole converts any trip command(s) to three pole tripping.								
30	14	CB1Z3 Trip Mode	3 Pole	0 = 3 Pole, 1 = 1 and 3 Pole		*		*
This setting is used to select the tripping mode for zone3 CB1. The selection 1 and 3 pole allows single pole tripping for single phase to ground faults, whilst selection 3 pole converts any trip command(s) to three pole tripping.								
30	15	Z4 Tripping Mode	3 Pole	0 = 3 Pole, 1 = 1 and 3 Pole	*		*	
This setting is used to select the tripping mode for zone 4. The selection 1 and 3 pole allows single pole tripping for single phase to ground faults, whilst selection 3 pole converts any trip command(s) to three pole tripping.								
30	15	CB1Z4 Trip Mode	3 Pole	0 = 3 Pole, 1 = 1 and 3 Pole		*		*
This setting is used to select the tripping mode for zone4 CB1. The selection 1 and 3 pole allows single pole tripping for single phase to ground faults, whilst selection 3 pole converts any trip command(s) to three pole tripping.								
30	16	ZP Tripping Mode	3 Pole	0 = 3 Pole, 1 = 1 and 3 Pole	*		*	
This setting is used to select the tripping mode for zone P. The selection 1 and 3 pole allows single pole tripping for single phase to ground faults, whilst selection 3 pole converts any trip command(s) to three pole tripping.								
30	16	CB1ZP Trip Mode	3 Pole	0 = 3 Pole, 1 = 1 and 3 Pole		*		*

Col	Row	MENU TEXT	Default Setting	Available Setting	P543/P545 No Distance	P544/P546 No Distance	P543/P545	P544/P546
Description								
This setting is used to select the tripping mode for zoneP CB1. The selection 1 and 3 pole allows single pole tripping for single phase to ground faults, whilst selection 3 pole converts any trip command(s) to three pole tripping.								
30	17	ZQ Tripping Mode	3 Pole	0 = 3 Pole, 1 = 1 and 3 Pole	*		*	
This setting is used to select the tripping mode for zoneQ. The selection 1 and 3 pole allows single pole tripping for single phase to ground faults, whilst selection 3 pole converts any trip command(s) to three pole tripping.								
30	17	CB1ZQ Trip Mode	3 Pole	0 = 3 Pole, 1 = 1 and 3 Pole		*		*
This setting is used to select the tripping mode for zoneQ CB1. The selection 1 and 3 pole allows single pole tripping for single phase to ground faults, whilst selection 3 pole converts any trip command(s) to three pole tripping.								
30	20	CB2Z1 Trip Mode	3 Pole	0 = 3 Pole, 1 = 1 and 3 Pole		*		*
This setting is used to select the tripping mode for zone1 CB2. The selection 1 and 3 pole allows single pole tripping for single phase to ground faults, whilst selection 3 pole converts any trip command(s) to three pole tripping.								
30	21	CB2Z2 Trip Mode	3 Pole	0 = 3 Pole, 1 = 1 and 3 Pole		*		*
This setting is used to select the tripping mode for zone2 CB2. The selection 1 and 3 pole allows single pole tripping for single phase to ground faults, whilst selection 3 pole converts any trip command(s) to three pole tripping.								
30	22	CB2Z3 Trip Mode	3 Pole	0 = 3 Pole, 1 = 1 and 3 Pole		*		*
This setting is used to select the tripping mode for zone2 CB2. The selection 1 and 3 pole allows single pole tripping for single phase to ground faults, whilst selection 3 pole converts any trip command(s) to three pole tripping.								
30	23	CB2Z4 Trip Mode	3 Pole	0 = 3 Pole, 1 = 1 and 3 Pole		*		*
This setting is used to select the tripping mode for zone4 CB2. The selection 1 and 3 pole allows single pole tripping for single phase to ground faults, whilst selection 3 pole converts any trip command(s) to three pole tripping.								
30	24	CB2ZP Trip Mode	3 Pole	0 = 3 Pole, 1 = 1 and 3 Pole		*		*
This setting is used to select the tripping mode for zone P CB2. The selection 1 and 3 pole allows single pole tripping for single phase to ground faults, whilst selection 3 pole converts any trip command(s) to three pole tripping.								
30	25	CB2ZQ Trip Mode	3 Pole	0 = 3 Pole, 1 = 1 and 3 Pole		*		*
This setting is used to select the tripping mode for zone Q CB2. The selection 1 and 3 pole allows single pole tripping for single phase to ground faults, whilst selection 3 pole converts any trip command(s) to three pole tripping.								

Table 2 - Line parameters**3.2****Distance Setup (only for Models with Distance Option)**

The column **GROUP x DISTANCE SETUP** is used to:

- Select the Distance setting mode (Simple or Advanced)
- Select the operating characteristic (Mho or Quad) for phase and ground measuring loops independently
- Enable or Disable each phase and ground zone independently
- Define the reach (in Ohms) for each phase and ground zone independently by simply setting the percentage required reach with reference to the line impedance (taken as the 100% reference basis)
- Other settings related to application of the "Basic" distance scheme

Col	Row	MENU TEXT	Default Setting	Available Setting	P543/P545 No Distance	P544/P546 No Distance	P543/P545	P544/P546
Description								
31	00	GROUP 1 DISTANCE SETUP					*	*
This column contains settings for Distance Setup								
31	0C	Setting Mode	Simple	0 = Simple or 1 = Advanced			*	*
<p>Setting to select setting mode for Distance protection, depending on type of application and user preferences.</p> <p>'Simple' mode: 'Simple' setting mode is the default setting mode, suitable for the majority of applications. Instead of entering distance zone impedance reaches in ohms, zone settings are simply entered in terms of percentage of the protected line data specified in the 'GROUP x LINE PARAMETERS/Line Impedance' setting. The setting assumes that the residual compensation factor is equal for all zones. The relay auto calculates the required reaches from the percentages. The calculated zone reaches are available for viewing but a user can not alter/change the value as long as 'Simple' mode setting remains active.</p> <p>Advanced setting mode: 'Advanced' setting mode allows individual distance ohmic reaches and residual compensation factors to be entered for each zone. When 'Advanced' mode is selected, all 'percentage' settings that are associated to 'Simple' setting mode in the column GROUP x DISTANCE SETUP will be hidden and the Distance zone settings need to be entered for each zone in the 'GROUP x DIST. ELEMENTS' column.</p>								
31	0D	Distance Setup	Zone Starting	0 = Zone Starting or 1 = Gen Starting			*	*
<p>Setting to select distance timers start option after fault finding. 'Zone Start' setting is default setting configure the device functionality comparable with existing solution where zone timers starts individually in which zone, the fault found. 'Gen Start' setting configures the device to start all distance zone timers irrespective of the fault finding zone. this triggers quick trip.</p>								
31	10	PHASE DISTANCE					*	*
31	11	Phase Chars.	Mho	0 = Disabled, 1 = Mho, 2 = Quadrilateral			*	*
<p>Setting to disable (turn off) phase distance protection or to set Mho or Quad operating characteristic: ANSI 21P. The chosen setting is applicable to all phase distance zones.</p>								
31	12	Quad Resistance	Proportional	0 = Common or 1 = Proportional			*	*
<p>Setting to define the mode of resistive reach coverage. If 'Common' mode is selected, all phase distance zones will have the equal resistive coverage. If 'Proportional' mode is selected, the zones will have resistive coverage according to the % reach set for the zone, multiplied by the 'Fault Resistance' RPH setting. This setting is visible only when 'Simple' setting mode and quad characteristic are set.</p>								
31	13	Fault Resistance	10*V1/I1Ω	From 0.1*V1/I1Ω to 500*V1/I1Ω step 0.01*V1/I1Ω			*	*
<p>Setting used to specify the fault arc resistance that can be detected for faults between phases. The set value determines the right hand side of the quadrilaterals. This setting is visible only when 'Simple' setting mode and quad characteristic are set.</p>								
31	20	Zone 1 Ph Status	Enabled	0 = Disabled or 1 = Enabled, 2 = Enabled on Ch Fail			*	*
<p>To enable (activate) or disable (turn off) or enable (only in the case that differential protection communication channel is lost) Z1 for phase faults. This setting is invisible if 'Phase Char.' is disabled.</p>								
31	21	Zone 1 Ph Reach	0.8	From 10% to 1000% step 1%			*	*
Setting entry as percentage of the line impedance that sets Zone 1 reach in ohms.								
31	30	Zone 2 Ph Status	Enabled	0 = Disabled or 1 = Enabled, 2 = Enabled on Ch Fail			*	*

Col	Row	MENU TEXT	Default Setting	Available Setting	P543/P545 No Distance	P544/P546 No Distance	P543/P545	P544/P546
Description								
To enable (activate) or disable (turn off) or enable (only in the case that differential protection communication channel is lost) Z2 for phase faults. This setting is invisible if 'Phase Char.' is disabled.								
31	31	Zone 2 Ph Reach	1.5	From 10% to 1000% step 1%			*	*
Setting entry as percentage of the line impedance that sets Zone 2 reach in ohms.								
31	40	Zone 3 Ph Status	Enabled	0 = Disabled or 1 = Enabled, 2 = Enabled on Ch Fail			*	*
To enable (activate) or disable (turn off) or enable (only in the case that differential protection communication channel is lost) Z3 for phase faults. This setting is invisible if 'Phase Char.' is disabled.								
31	41	Zone 3 Ph Reach	2.5	From 10% to 1000% step 1%			*	*
Setting entry as percentage of the line impedance that sets Zone 3 forward reach in ohms.								
31	42	Zone 3 Ph Offset	Enabled	0 = Disabled or 1 = Enabled			*	*
To enable (activate) or disable (turn off) or enable (only in the case that differential protection communication channel is lost) Zone 3 offset reach for phase faults. By default, Z3 Mho phase characteristic is offset (partly reverse directional), thus not memory/cross polarized. 'If Z3 Gnd Offset' is disabled, Z3 Mho characteristic becomes memory/cross polarized like all other zones.								
31	43	Z3Ph Rev Reach	0.1	From 10% to 1000% step 1%			*	*
Setting entry as percentage of the line impedance that sets Zone 3 reverse reach in ohms.								
31	50	Zone P Ph Status	Disabled	0 = Disabled or 1 = Enabled, 2 = Enabled on Ch Fail			*	*
To enable (activate) or disable (turn off) or enable (only in the case that differential protection communication channel is lost) ZP for phase faults. This setting is invisible if 'Phase Char.' is disabled.								
31	51	Zone P Ph Dir.	Forward	0 = Forward or 1 = Reverse			*	*
To directionalize Zone P forward or reverse.								
31	52	Zone P Ph Reach	2	From 10% to 1000% step 1%			*	*
Setting entry as percentage of the line impedance that sets Zone P forward or reverse reach in ohms.								
31	60	Zone 4 Ph Status	Enabled	0 = Disabled or 1 = Enabled, 2 = Enabled on Ch Fail			*	*
To enable (activate) or disable (turn off) or enable (only in the case that differential protection communication channel is lost) Z4 for phase faults. This setting is invisible if 'Phase Char.' is disabled.								
31	61	Zone 4 Ph Reach	1.5	From 10% to 1000% step 1%			*	*
Setting entry as percentage of the line impedance that sets reverse Zone 4 reach in ohms.								
31	65	Zone Q Ph Status	Enabled	0 = Disabled or 1 = Enabled, 2 = Enabled on Ch Fail			*	*
To enable (activate) or disable (turn off) or enable (only in the case that differential protection communication channel is lost) ZQ for phase faults. This setting is invisible if 'Phase Char.' is disabled.								

Col	Row	MENU TEXT	Default Setting	Available Setting	P543/P545 No Distance	P544/P546 No Distance	P543/P545	P544/P546
Description								
31	66	Zone Q Ph Dir.	Reverse	0 = Forward or 1 = Reverse			*	*
To directionalize Zone Q forward or reverse.								
31	67	Zone Q Ph Reach	2	From 10% to 1000% step 1%			*	*
Setting entry as percentage of the line impedance that sets reverse Zone Q reach in ohms.								
31	70	GROUND DISTANCE					*	*
31	71	Ground Chars.	Mho	0 = Disabled, 1 = Mho, 2 = Quadrilateral			*	*
Setting to disable (turn off) ground distance protection or to set Mho or Quad operating characteristic: ANSI 21G. The chosen setting is applicable to all ground distance zones.								
31	72	Quad Resistance	Proportional	0 = Common or 1 = Proportional			*	*
Setting to define the mode of resistive reach coverage. If 'Common' mode is selected, all ground distance zones will have the equal resistive coverage. If 'Proportional' mode is selected, the zones will have resistive coverage according to the % reach set for the zone, multiplied by the 'Fault Resistance' RG setting. This setting is visible only when 'Simple' setting mode and quad characteristic are set.								
31	73	Fault Resistance	10*V1/I1Ω	From 0.1*V1/I1Ω to 500*V1/I1Ω step 0.01*V1/I1Ω			*	*
Setting used to specify the fault arc resistance that can be detected for faults phase - ground. The set value determines the right hand side of the quadrilaterals. This setting is visible only when 'Simple' setting mode and quad characteristic are set.								
31	75	Dynamic Top Tilt	45	From 5° to 45° step 1°			*	*
Maximum tilt angle limit during dynamical tilting of phase - ground quadrilateral characteristic. This setting is visible when 'Advanced' setting mode and Quad characteristic are set								
31	80	Zone 1 Gnd Stat.	Enabled	0 = Disabled or 1 = Enabled, 2 = Enabled on Ch Fail			*	*
To enable (activate) or disable (turn off) or enable (only in the case that differential protection communication channel is lost) Zone 1 for ground faults. This setting is invisible if 'Ground Char.' is disabled.								
31	81	Zone 1 Gnd Reach	0.8	From 10% to 1000% step 1%			*	*
Setting entry as percentage of the line impedance that sets Zone 1 reach in ohms.								
31	90	Zone 2 Gnd Stat.	Enabled	0 = Disabled or 1 = Enabled, 2 = Enabled on Ch Fail			*	*
To enable (activate) or disable (turn off) or enable (only in the case that differential protection communication channel is lost) Zone 2 for ground faults. This setting is invisible if 'Ground Char.' is disabled.								
31	91	Zone 2 Gnd Reach	1.5	From 10% to 1000% step 1%			*	*
Setting entry as percentage of the line impedance that sets Zone 2 reach in ohms.								
31	A0	Zone 3 Gnd Stat.	Enabled	0 = Disabled or 1 = Enabled, 2 = Enabled on Ch Fail			*	*

Col	Row	MENU TEXT	Default Setting	Available Setting	P543/P545 No Distance	P544/P546 No Distance	P543/P545	P544/P546
Description								
To enable (activate) or disable (turn off) or enable (only in the case that differential protection communication channel is lost) Zone 3 for ground faults. This setting is invisible if 'Ground Char.' is disabled.								
31	A1	Zone 3 Gnd Reach	2.5	From 10% to 1000% step 1%			*	*
Setting entry as percentage of the line impedance that sets Zone 3 forward reach in ohms.								
31	A2	Zone3 Gnd Offset	Enabled	0 = Disabled or 1 = Enabled			*	*
To enable (activate) or disable (turn off) or enable (only in the case that differential protection communication channel is lost) Zone 3 offset reach for ground faults. By default, Z3 Mho ground characteristic is offset (partly reverse directional), thus not memory/cross polarized. 'If Z3 Gnd Offset' is disabled, Z3 Mho characteristic becomes memory/cross polarized like all other zones.								
31	A3	Z3Gnd Rev Reach	0.1	From 10% to 1000% step 1%			*	*
Setting entry as percentage of the line impedance that sets Zone 3 reverse reach in ohms.								
31	B0	Zone P Gnd Stat.	Disabled	0 = Disabled or 1 = Enabled, 2 = Enabled on Ch Fail			*	*
To enable (activate) or disable (turn off) or enable (only in the case that differential protection communication channel is lost) Zone P for ground faults. This setting is invisible if 'Ground Char.' is disabled.								
31	B1	Zone P Gnd Dir.	Forward	0 = Forward or 1 = Reverse			*	*
To directionalize ZP forward or reverse.								
31	B2	Zone P Gnd Reach	2	From 10% to 1000% step 1%			*	*
Setting entry as percentage of the line impedance that sets Zone P forward or reverse reach in ohms.								
31	C0	Zone 4 Gnd Stat.	Enabled	0 = Disabled or 1 = Enabled, 2 = Enabled on Ch Fail			*	*
To enable (activate) or disable (turn off) or enable (only in the case that differential protection communication channel is lost) Zone 4 for ground faults. This setting is invisible if 'Ground Char.' is disabled.								
31	C1	Zone 4 Gnd Reach	1.5	From 10% to 1000% step 1%			*	*
Setting entry as percentage of the line impedance that sets reverse Zone 4 reach in ohms.								
31	C5	Zone Q Gnd Stat.	Enabled	0 = Disabled or 1 = Enabled, 2 = Enabled on Ch Fail			*	*
To enable (activate) or disable (turn off) or enable (only in the case that differential protection communication channel is lost) Zone Q for ground faults. This setting is invisible if 'Ground Char.' is disabled.								
31	C6	Zone Q Gnd Dir.	Reverse	0 = Forward or 1 = Reverse			*	*
To directionalize ZQ forward or reverse.								
31	C7	Zone Q Gnd Reach	2	From 10% to 1000% step 1%			*	*
Setting entry as percentage of the line impedance that sets reverse Zone Q reach in ohms.								
31	D0	Digital Filter	Standard	0 = Standard or 1 = Special Applies.			*	*

Col	Row	MENU TEXT	Default Setting	Available Setting	P543/P545 No Distance	P544/P546 No Distance	P543/P545	P544/P546
Description								
Setting to enable (activate) 'Standard' or 'Special Application' filters. 'Standard' filters are the default setting and should be applied in the majority of applications. It is only the case when the fault currents and voltages may become very distorted by non-fundamental harmonics that extra filtering is necessary to avoid transient over-reach. In such system conditions the 'Special Applications' setting should be applied.								
31	D1	CVT Filters	Disabled	0 = Disabled, 1 = Passive, 2 = Active			*	*
Setting that accommodates the type of voltage transformer being used to prevent transient over-reach and preserve sub-cycle operating time whenever possible. In case of conventional wound VTs, the transients due to voltage collapse during faults are very small and no extra filtering is required, therefore the setting should be 'Disabled' as per default. For a CVT with active Ferro resonance damping, the voltage distortions may be severe and risk transient over-reach. For that reason, the 'CVT Filters' should be set to 'Active'. Trip times increase proportionally (subcycle up to SIR = 2, gradually lengthening for SIR up to 30). For a CVT with passive Ferro resonance damping, the voltage distortions are generally small up to SIR of 30. For such applications, 'CVT Filters' should be set 'Passive'. The relay calculates the SIR and will take marginally longer to trip if the infeed is weak (exceeds the relay's SIR setting).								
31	D2	SIR Setting	30	5 to 60 step 1			*	*
Setting that determines when extra filtering will be applied. If on fault inception the calculated SIR exceeds the 'SIR Setting' the relay will marginally slow down, as otherwise there would be a risk of over-reach. This setting is visible only when 'CVT Filters' is set to 'Passive'.								
31	D3	Load Blinders	Disabled	0 = Disabled or 1 = Enabled			*	*
Setting used to activate (enable) or turn off (disable) load blinders. Load blinders, when enabled, have two main purposes: to prevent tripping due to load encroachment under heavy load condition and detect very slow moving power swings.								
31	D4	Z< Blinder Imp	15*V1/I1Ω	From 0.1*V1/I1Ω to 500*V1/I1Ω step 0.01*V1/I1Ω			*	*
Setting of radius of under-impedance circle.								
31	D5	Load/B Angle	45	From 15° to 65° step 1°			*	*
Angle setting for the two blinder lines boundary with the gradient of the rise or fall with respect to the resistive axis.								
31	D6	Load Blinder V<	15*V1	From 1*V1 to 70*V1 step 0.5*V1			*	*
Load blinder phase to ground under-voltage setting that overrides the blinder if the measured voltage in the affected phase falls below setting. Also overrides blinding of phase-phase loops where the phase-phase voltage falls below $\sqrt{3} \times (V< \text{setting})$.								
31	D7	Distance Polarising	1	0.2 to 5 step 0.1			*	*
The setting defines the composition of polarizing voltage as a mixture of 'Self' and 'Memory' polarizing voltage. 'Self' polarized voltage is fixed to 1pu and could be mixed with 'Memory' polarizing voltage ranging from 0.2pu up to 5pu. The default setting of 1 means that half of the polarizing voltage is made up from 'Self' and the other half from clean 'Memory' voltage. Adding more 'Memory' voltage will enhance the resistive coverage of Mho characteristics, whose expansion is defined as: Mho expansion = [(Dist. Polarizing) / (Dist. Polarizing + 1)] x Zs Where Zs is the source impedance.								
31	E0	DELTADIRECTIONAL					*	*
31	E1	Dir. Status	Enabled	0 = Disabled or 1 = Enabled			*	*
Setting used to enable or disable Delta Direction ($\Delta I/\Delta V$). To enable or disable the delta direction decision used by distance elements. If disabled, the relay uses conventional (non delta) directional lines.								

Col	Row	MENU TEXT	Default Setting	Available Setting	P543/P545 No Distance	P544/P546 No Distance	P543/P545	P544/P546
Description								
31	E2	AidedDeltaStatus	Disabled	0 = Disabled, 1 = Phase only, 2 = Ground only, 3 = Phase And Ground			*	*
This setting is only used for channel aided schemes, and is used to select which types of fault Delta Directional Comparison protection to apply. When this setting is disabled, Delta V Fwd, Delta V Rev, Delta I Fwd and Delta I Rev are invisible. This setting is invisible if the Delta Status setting is disabled.								
31	E3	Dir. Char Angle	60	From 0° to 90° step 1°			*	*
Setting for the relay characteristic angle used for the delta directional decision.								
31	E4	Dir. V Fwd	5*V1	From 1.0*V1 to 30*V1 step 0.1*V1			*	*
Setting for the minimum delta voltage change to permit the directional forward decision.								
31	E5	Dir. V Rev	4*V1	From 0.5*V1 to 30*V1 step 0.1*V1			*	*
Setting for the minimum delta voltage change to permit the directional reverse decision.								
31	E6	Dir. I Fwd	0.1*I1 A	From 0.1*I1 A to 10*I1 A step 0.01*I1 A			*	*
Setting for the minimum delta current change to permit the directional forward decision.								
31	E7	Dir. I Rev	0.08*I1 A	From 0.05*I1 A to 10*I1 A step 0.01*I1 A			*	*
Setting for the minimum delta current change to permit the directional reverse decision.								

Table 3 - Group x distance setup

3.3 Distance Elements (only for Models with Distance Option)

The column **GROUP x DISTANCE ELEMENTS** is used to individually set reaches, line angles, neutral compensation factors, minimum current operating levels and line tilting for resistive phase faults for each zone if the setting mode is set to 'Advanced'. In 'Simple' setting mode, 'Distance Elements' setting can be **viewed**, but not edited here.

Col	Row	MENU TEXT	Default Setting	Available Setting	P543/P545 No Distance	P544/P546 No Distance	P543/P545	P544/P546
Description								
32	00	GROUP 1 DIST. ELEMENTS					*	*
This column contains settings for Distance Elements								
32	01	PHASE DISTANCE					*	*
Setting for Z1 reach.								
32	02	Z1 Ph. Reach	8*V1/I1Ω	From 0.05*V1/I1Ω to 500*V1/I1Ω step 0.01*V1/I1Ω			*	*
Setting for Z1 reach.								
32	03	Z1 Ph. Angle	70	From 20° to 90° step 1°			*	*
Setting of line angle for zone 1.								

Col	Row	MENU TEXT	Default Setting	Available Setting	P543/P545 No Distance	P544/P546 No Distance	P543/P545	P544/P546
Description								
32	07	R1 Ph. Resistive	8*V1/I1Ω	From 0.05*V1/I1Ω to 500*V1/I1Ω step 0.01*V1/I1Ω			*	*
Setting for Z1 resistive reach. This setting is only visible if Quad is selected.								
32	08	Z1 Tilt Top Line	-3	From -30° to 30° step 1°			*	*
Setting of Z1 top reactance line gradient to avoid over-reach for resistive phase faults under heavy load. Minus angle tilts the reactance line downwards.								
32	09	Z1 Sensit. Iph>1	0.075*I1 A	From 0.05*I1 A to 2*I1 A step 0.005*I1 A			*	*
Current sensitivity setting for Z1 that must be exceeded in faulted phases if Z1 is to operate.								
32	10	Z2 Ph. Reach	15*V1/I1Ω	From 0.05*V1/I1Ω to 500*V1/I1Ω step 0.01*V1/I1Ω			*	*
Setting for Z2 reach.								
32	11	Z2 Ph. Angle	70	From 20° to 90° step 1°			*	*
Setting of line angle for zone 2.								
32	15	R2 Ph. Resistive	15*V1/I1Ω	From 0.05*V1/I1Ω to 500*V1/I1Ω step 0.01*V1/I1Ω			*	*
Setting for Z2 resistive reach.								
32	16	Z2 Tilt Top Line	-3	From -30° to 30° step 1°			*	*
Setting of Z2 top reactance line gradient.								
32	17	Z2 Sensit. Iph>2	0.075*I1 A	From 0.05*I1 A to 2*I1 A step 0.005*I1 A			*	*
Zone 2 current sensitivity.								
32	20	Z3 Ph. Reach	25*V1/I1Ω	From 0.05*V1/I1Ω to 500*V1/I1Ω step 0.01*V1/I1Ω			*	*
Setting for Z3 reach.								
32	21	Z3 Ph. Angle	70	From 20° to 90° step 1°			*	*
Setting of line angle for zone 3.								
32	22	Z3' Ph Rev Reach	1*V1/I1Ω	From 0.05*V1/I1Ω to 500*V1/I1Ω step 0.01*V1/I1Ω			*	*
Setting for Z3 offset (reverse) reach. This setting is only visible if 'Z3 Offset' is enabled in 'GROUP x DISTANCE SETUP'.								
32	25	R3 Ph. Res. Fwd.	25*V1/I1Ω	From 0.05*V1/I1Ω to 500*V1/I1Ω step 0.01*V1/I1Ω			*	*
Setting for Z3 resistive reach that defines Quad's right hand line.								
32	26	R3' Ph. Res. Rev	1*V1/I1Ω	From 0.05*V1/I1Ω to 500*V1/I1Ω step 0.01*V1/I1Ω			*	*
Setting for Z3 resistive reach that defines Quad's left hand line. This is settable only if Phase Chars. is Quad and Z3 offset is enabled otherwise is fixed to 25% of the right hand blinder.								

Col	Row	MENU TEXT	Default Setting	Available Setting	P543/P545 No Distance	P544/P546 No Distance	P543/P545	P544/P546
Description								
32	27	Z3 Tilt Top Line	-3	From -30° to 30° step 1°			*	*
Setting of Z3 top reactance line gradient.								
32	28	Z3 Sensit. Iph>3	0.05*I1 A	From 0.05*I1 A to 2*I1 A step 0.005*I1 A			*	*
Zone 3 current sensitivity.								
32	30	ZP Ph. Reach	20*V1/I1Ω	From 0.05*V1/I1Ω to 500*V1/I1Ω step 0.01*V1/I1Ω			*	*
Setting for ZP reach.								
32	31	ZP Ph. Angle	70	From 20° to 90° step 1°			*	*
Setting of line angle for zone P.								
32	35	RP Ph Resistive	20*V1/I1Ω	From 0.05*V1/I1Ω to 500*V1/I1Ω step 0.01*V1/I1Ω			*	*
Setting for ZP resistive reach.								
32	36	ZP Tilt Top Line	-3	From -30° to 30° step 1°			*	*
Setting of ZP top reactance line gradient.								
32	37	ZP Sensit. Iph>P	0.05*I1 A	From 0.05*I1 A to 2*I1 A step 0.005*I1 A			*	*
Zone P current sensitivity.								
32	40	Z4 Ph. Reach	15*V1/I1Ω	From 0.05*V1/I1Ω to 500*V1/I1Ω step 0.01*V1/I1Ω			*	*
Setting for Z4 reach. This is a common setting for Z4 time delayed and Z4 high speed elements used in blocking schemes and for current reversal guard.								
32	41	Z4 Ph. Angle	70	From 20° to 90° step 1°			*	*
Setting of line angle for zone 4.								
32	42	R4 Ph. Resistive	15*V1/I1Ω	From 0.05*V1/I1Ω to 500*V1/I1Ω step 0.01*V1/I1Ω			*	*
Setting for ZP resistive reach.								
32	45	Z4 Tilt Top Line	-3	From -30° to 30° step 1°			*	*
Setting of Z4 top reactance line gradient.								
32	46	Z4 Sensit. Iph>4	0.05*I1 A	From 0.05*I1 A to 2*I1 A step 0.005*I1 A			*	*
Zone P current sensitivity.								
32	49	ZQ Ph. Reach	20*V1/I1Ω	From 0.05*V1/I1Ω to 500*V1/I1Ω step 0.01*V1/I1Ω			*	*
Setting for ZQ reach. This is a common setting for ZQ time delayed and ZQ high speed elements used in blocking schemes and for current reversal guard.								

Col	Row	MENU TEXT	Default Setting	Available Setting	P543/P545 No Distance	P544/P546 No Distance	P543/P545	P544/P546
Description								
32	4A	ZQ Ph. Angle	70	From 20° to 90° step 1°			*	*
Setting of line angle for zone Q.								
32	4B	RQ Ph. Resistive	20*V1/I1Ω	From 0.05*V1/I1Ω to 500*V1/I1Ω step 0.01*V1/I1Ω			*	*
Setting for ZQ resistive reach.								
32	4C	ZQ Tilt Top Line	-3	From -30° to 30° step 1°			*	*
Setting of ZQ top reactance line gradient.								
32	4D	ZQ Sensit. Iph>Q	0.05*11 A	From 0.05*11 A to 2*11 A step 0.005*11 A			*	*
Zone Q current sensitivity.								
32	50	GROUND DISTANCE					*	*
32	51	Z1 Gnd. Reach	8*V1/I1Ω	From 0.05*V1/I1Ω to 500*V1/I1Ω step 0.01*V1/I1Ω			*	*
Setting for Z1 reach.								
32	52	Z1 Gnd. Angle	70	From 20° to 90° step 1°			*	*
Setting of line angle (positive sequence) for zone 1.								
32	53	Z1 Dynamic Tilt	Enabled	0 = Disabled or 1 = Enabled			*	*
Setting that enables or disables zone 1 top reactance line dynamic tilting. If set enabled, the top line angle will be automatically shifted by the angle difference between the fault current and negative sequence current, starting from the 'Z1 Tilt top line' angle setting – see the next cell. The zone 1 is allowed only to tilt down. If Dynamic tilting is disabled, the top line will be shifted by the 'Z1 Tilt top line' setting (Predetermined tilting by fixed angle). This setting is visible only when ground characteristic is set to 'Quad'.								
32	54	Z1 Tilt Top Line	-3	From -30° to 30° step 1°			*	*
Setting of the zone 1 tilt angle. Minus angle tilts the reactance line downwards This setting is visible only when the above setting is visible.								
32	55	kZN1 Res. Comp.	1	0 to 10 step 0.01			*	*
Setting of Z1 residual compensation magnitude.								
32	56	kZN1 Res. Angle	0	From -180° to 90° step 0.1°			*	*
Setting of Z1 residual compensation angle.								
32	57	kZm1 Mut. Comp.	1	0 to 10 step 0.01			*	*
Setting of Z1 mutual compensation magnitude.								
32	58	kZm1 Mut. Angle	0	From -180° to 90° step 0.1°			*	*
Setting of Z1 mutual compensation angle.								
32	59	R1 Gnd Resistive	8*V1/I1Ω	From 0.05*V1/I1Ω to 500*V1/I1Ω step 0.01*V1/I1Ω			*	*
Setting for Z1 ground resistive reach. This setting is only visible if Quad is selected.								

Col	Row	MENU TEXT	Default Setting	Available Setting	P543/P545 No Distance	P544/P546 No Distance	P543/P545	P544/P546
Description								
32	5B	Z1 Sensit Ignd>1	0.075*I1 A	From 0.05*I1 A to 2*I1 A step 0.005*I1 A			*	*
Current sensitivity setting for Z1 that must be exceeded in faulted phase and the neutral if Z1 is to operate.								
32	60	Z2 Gnd. Reach	15*V1/I1Ω	From 0.05*V1/I1Ω to 500*V1/I1Ω step 0.01*V1/I1Ω			*	*
Setting for Z2 reach.								
32	61	Z2 Gnd. Angle	70	From 20° to 90° step 1°			*	*
Setting of line angle (positive sequence) for zone 2.								
32	63	Z2 Dynamic Tilt	Enabled	0 = Disabled or 1 = Enabled			*	*
Setting that enables or disables zone 2 top reactance line dynamic tilting. If set enabled, the top line angle will be automatically shifted by the angle difference between the fault current and negative sequence current, starting from the 'Z2 Tilt top line' angle setting – see the next cell. The zone 2, as over-reaching zone, is allowed only to tilt up. If Dynamic tilting is disabled, the top line will be shifted by the 'Z2 Tilt top line' setting (Predetermined tilting by fixed angle). This setting is visible only when ground characteristic is set to 'Quad'.								
32	64	Z2 Tilt Top Line	-3	From -30° to 30° step 1°			*	*
Setting of the zone 2 tilt angle. Minus angle tilts the reactance line downwards This setting is visible only when the above setting is visible.								
32	65	kZN2 Res. Comp.	1	0 to 10 step 0.01			*	*
Setting of Z2 residual compensation magnitude.								
32	66	kZN2 Res. Angle	0	From -180° to 90° step 0.1°			*	*
Setting of Z2 residual compensation angle.								
32	67	kZm2 Mut. Comp.	1	0 to 10 step 0.01			*	*
Setting of Z2 mutual compensation magnitude.								
32	68	kZm2 Mut. Angle	0	From -180° to 90° step 0.1°			*	*
Setting of Z2 mutual compensation angle.								
32	69	R2 Gnd Resistive	15*V1/I1Ω	From 0.05*V1/I1Ω to 500*V1/I1Ω step 0.01*V1/I1Ω			*	*
Setting for Z2 ground resistive reach.								
32	6B	Z2 Sensit Ignd>2	0.075*I1 A	From 0.05*I1 A to 2*I1 A step 0.005*I1 A			*	*
Zone 2 current sensitivity.								
32	70	Z3 Gnd. Reach	25*V1/I1Ω	From 0.05*V1/I1Ω to 500*V1/I1Ω step 0.01*V1/I1Ω			*	*
Setting for Z3 reach.								
32	71	Z3 Gnd. Angle	70	From 20° to 90° step 1°			*	*
Setting of line angle (positive sequence) for zone 3.								
32	72	Z3' Gnd Rev Rch	1*V1/I1Ω	From 0.05*V1/I1Ω to 500*V1/I1Ω step 0.01*V1/I1Ω			*	*

Col	Row	MENU TEXT	Default Setting	Available Setting	P543/P545 No Distance	P544/P546 No Distance	P543/P545	P544/P546
Description								
Setting for Z3 offset (reverse) reach. This setting is only visible if 'Z3 Offset' is enabled in 'GROUP x DISTANCE SETUP'.								
32	73	Z3 Dynamic Tilt	Enabled	0 = Disabled or 1 = Enabled			*	*
Setting that enables or disables Z3 top reactance line dynamic tilting. If set enabled, the top line angle will be automatically shifted by the angle difference between the fault current and negative sequence current, starting from the 'Z3 Tilt top line' angle setting – see the next cell. The ZP, as over-reaching zone, is allowed only to tilt up. If Dynamic tilting is disabled, the top line will be shifted by the 'ZP Tilt top line' setting (Predetermined tilting by fixed angle). This setting is visible only when ground characteristic is set to 'Quad' and Z3 offset disabled.								
32	74	Z3 Tilt Top Line	-3	From -30° to 30° step 1°			*	*
Setting of the Z3 tilt angle. Minus angle tilts the reactance line downwards This setting is visible only when the above setting is visible.								
32	75	kZN3 Res. Comp.	1	0 to 10 step 0.01			*	*
Setting of Z3 residual compensation magnitude.								
32	76	kZN3 Res. Angle	0	From -180° to 90° step 0.1°			*	*
Setting of Z3 residual compensation angle.								
32	77	kZm3 Mut. Comp.	1	0 to 10 step 0.01			*	*
Setting of Z3 mutual compensation magnitude.								
32	78	kZm3 Mut. Angle	0	From -180° to 90° step 0.1°			*	*
Setting of Z3 mutual compensation angle.								
32	79	R3 Gnd. Res. Fwd	25*V1/I1Ω	From 0.05*V1/I1Ω to 500*V1/I1Ω step 0.01*V1/I1Ω			*	*
Setting for Z3 resistive reach that defines Quad's right hand line.								
32	7A	R3' Gnd Res. Rev	1*V1/I1Ω	From 0.05*V1/I1Ω to 500*V1/I1Ω step 0.01*V1/I1Ω			*	*
Setting for Z3 resistive reach that defines Quad's left hand line. This is settable only if Ground Chars. is Quad and Z3 offset is enabled otherwise is fixed to 25% of the right hand blinder.								
32	7C	Z3 Sensit Ignd>3	0.05*11 A	From 0.05*11 A to 2*11 A step 0.005*11 A			*	*
Zone 3 current sensitivity.								
32	80	ZP Gnd. Reach	20*V1/I1Ω	From 0.05*V1/I1Ω to 500*V1/I1Ω step 0.01*V1/I1Ω			*	*
Setting for ZP reach.								
32	81	ZP Gnd. Angle	70	From 20° to 90° step 1°			*	*
Setting of line angle (positive sequence) for zone P.								
32	83	ZP Dynamic Tilt	Enabled	0 = Disabled or 1 = Enabled			*	*
Setting that enables or disables ZP top reactance line dynamic tilting. If set enabled, the top line angle will be automatically shifted by the angle difference between the fault current and negative sequence current, starting from the 'ZP Tilt top line' angle setting – see the next cell. The ZP, as over-reaching zone, is allowed only to tilt up. If Dynamic tilting is disabled, the top line will be shifted by the 'ZP Tilt top line' setting (Predetermined tilting by fixed angle). This setting is visible only when ground characteristic is set to 'Quad'.								

Col	Row	MENU TEXT	Default Setting	Available Setting	P543/P545 No Distance	P544/P546 No Distance	P543/P545	P544/P546
Description								
32	84	ZP Tilt Top Line	-3	From -30° to 30° step 1°			*	*
Setting of the ZP tilt angle. Minus angle tilts the reactance line downwards This setting is visible only when the above setting is visible.								
32	85	kZNP Res. Comp.	1	0 to 10 step 0.01			*	*
Setting of ZP residual compensation magnitude.								
32	86	kZNP Res. Angle	0	From -180° to 90° step 0.1°			*	*
Setting of ZP residual compensation angle.								
32	87	kZmP Mut. Comp.	1	0 to 10 step 0.01			*	*
Setting of ZP mutual compensation magnitude.								
32	88	kZmP Mut. Angle	0	From -180° to 90° step 0.1°			*	*
Setting of ZP mutual compensation angle.								
32	89	RP Gnd Resistive	20*V1/I1Ω	From 0.05*V1/I1Ω to 500*V1/I1Ω step 0.01*V1/I1Ω			*	*
Setting for ZP ground resistive reach.								
32	8B	ZP Sensit Ignd>P	0.05*I1 A	From 0.05*I1 A to 2*I1 A step 0.005*I1 A			*	*
Zone P current sensitivity.								
32	90	Z4 Gnd. Reach	15*V1/I1Ω	From 0.05*V1/I1Ω to 500*V1/I1Ω step 0.01*V1/I1Ω			*	*
Setting for Z4 reach. This is a common setting for Z4 time delayed and Z4 high speed elements used in blocking schemes and for current reversal guard.								
32	91	Z4 Gnd. Angle	70	From 20° to 90° step 1°			*	*
Setting of line angle (positive sequence) for zone 4.								
32	93	Z4 Dynamic Tilt	Enabled	0 = Disabled or 1 = Enabled			*	*
Setting that enables or disables Z4 top reactance line dynamic tilting. If set enabled, the top line angle will be automatically shifted by the angle difference between the fault current and negative sequence current, starting from the 'Z4 Tilt top line' angle setting – see the next cell. The Z4, as over-reaching zone, is allowed only to tilt up. If Dynamic tilting is disabled, the top line will be shifted by the 'Z4 Tilt top line' setting (Predetermined tilting by fixed angle). This setting is visible only when ground characteristic is set to 'Quad'.								
32	94	Z4 Tilt Top Line	-3	From -30° to 30° step 1°			*	*
Setting of the Z4 tilt angle. Minus angle tilts the reactance line downwards This setting is visible only when the above setting is visible.								
32	95	kZN4 Res. Comp.	1	0 to 10 step 0.01			*	*
Setting of Z4 residual compensation magnitude.								
32	96	kZN4 Res. Angle	0	From -180° to 90° step 0.1°			*	*
Setting of Z4 residual compensation angle.								
32	97	kZm4 Mut. Comp.	1	0 to 10 step 0.01			*	*
Setting of Z4 mutual compensation magnitude.								

Col	Row	MENU TEXT	Default Setting	Available Setting	P543/P545 No Distance	P544/P546 No Distance	P543/P545	P544/P546
Description								
32	98	kZm4 Mut. Angle	0	From -180° to 90° step 0.1°			*	*
Setting of Z4 mutual compensation angle.								
32	99	R4 Gnd Resistive	15*V1/I1Ω	From 0.05*V1/I1Ω to 500*V1/I1Ω step 0.01*V1/I1Ω			*	*
Setting for Z4 ground resistive reach.								
32	9B	Z4 Sensit Ignd>4	0.05*11 A	From 0.05*11 A to 2*11 A step 0.005*11 A			*	*
Zone 4 current sensitivity.								
32	A0	ZQ Gnd. Reach	20*V1/I1Ω	From 0.05*V1/I1Ω to 500*V1/I1Ω step 0.01*V1/I1Ω			*	*
Setting for ZQ reach. This is a common setting for ZQ time delayed and ZQ high speed elements used in blocking schemes and for current reversal guard.								
32	A1	ZQ Gnd. Angle	70	From 20° to 90° step 1°			*	*
Setting of line angle (positive sequence) for zone Q.								
32	A3	ZQ Dynamic Tilt	Enabled	0 = Disabled or 1 = Enabled			*	*
Setting that enables or disables ZQ top reactance line dynamic tilting. If set enabled, the top line angle will be automatically shifted by the angle difference between the fault current and negative sequence current, starting from the 'ZQ Tilt top line' angle setting – see the next cell. The ZQ, as over-reaching zone, is allowed only to tilt up. If Dynamic tilting is disabled, the top line will be shifted by the 'ZQ Tilt top line' setting (Predetermined tilting by fixed angle). This setting is visible only when ground characteristic is set to 'Quad'.								
32	A4	ZQ Tilt Top Line	-3	From -30° to 30° step 1°			*	*
Setting of the ZQ tilt angle. Minus angle tilts the reactance line downwards This setting is visible only when the above setting is visible.								
32	A5	kZNQ Res. Comp.	1	0 to 10 step 0.01			*	*
Setting of ZQ residual compensation magnitude.								
32	A6	kZNQ Res. Angle	0	From -180° to 90° step 0.1°			*	*
Setting of ZQ residual compensation angle.								
32	A7	kZmQ Mut. Comp.	1	0 to 10 step 0.01			*	*
Setting of ZQ mutual compensation magnitude.								
32	A8	kZmQ Mut. Angle	0	From -180° to 90° step 0.1°			*	*
Setting of ZQ mutual compensation angle.								
32	A9	RQ Gnd Resistive	20*V1/I1Ω	From 0.05*V1/I1Ω to 500*V1/I1Ω step 0.01*V1/I1Ω			*	*
Setting for ZQ ground resistive reach.								
32	AB	ZQ Sensit Ignd>Q	0.05*11 A	From 0.05*11 A to 2*11 A step 0.005*11 A			*	*
Zone Q current sensitivity.								

Table 4 - Group x distance elements

3.4 Phase Differential

The column "GROUP x PHASE DIFF" is used to:

- Select the settings of the phase differential characteristic
- Define CT correction factors
- Define type of compensation (Capacitive Charging current or phase shift compensation). If charging current is selected, to set the value of susceptance and if phase shift is chosen, to set the value of vector compensation (only models P543, P544 (H1 software or later), P545 and P546 (H1 software or later))
- Enable or Disable inrush restrain in the case of transformers in zone (only models P543, P544 (H1 software or later), P545 and P546 (H1 software or later))
- Set the amount of positive sequence current required for Differential current transformer supervision

The column "GROUP x PHASE DIFF" is invisible if disabled in 'CONFIGURATION' column.

Col	Row	MENU TEXT	Default Setting	Available Setting	P543/P545 No Distance	P544/P546 No Distance	P543/P545	P544/P546
Description								
33	00	GROUP 1 PHASE DIFF			*	*	*	*
This column contains settings for Current Differential								
33	01	Phase Diff	Enabled	0 = Disabled or 1 = Enabled	*	*	*	*
To enable (activate) or disable (turn off) the Differential protection function in the group.								
33	02	Phase Is1	0.2*I1 A	From 0.2*I1 A to 2*I1 A step 0.01*I1 A	*	*	*	*
Setting Visible when Scheme Setup is set to 3 Terminal. Setting that defines the minimum pick-up level of the relay.								
33	03	Phase Is2	2*I1 A	From 1*I1 A to 30*I1 A step 0.05*I1 A	*	*	*	*
Setting Visible when Scheme Setup is set to 3 Terminal. This setting defines the bias current threshold, above which the higher percentage bias k2 is used.								
33	04	Phase k1	0.3	From 10% to 150% step 5%	*	*	*	*
Setting Visible when Scheme Setup is set to 3 Terminal. The lower percentage bias setting used when the bias current is below Is2. This provides stability for small CT mismatches, whilst ensuring good sensitivity to resistive faults under heavy load conditions.								
33	05	Phase k2	1	From 30% to 150% step 5%	*	*	*	*
Setting Visible when Scheme Setup is set to 3 Terminal. The higher percentage bias setting used to improve relay stability under heavy through fault current conditions.								
33	06	Phase Is1	0.2*I1 A	From 0.2*I1 A to 2*I1 A step 0.01*I1 A	*	*	*	*
Setting Visible when Scheme Setup is set to 2 Terminal or Dual Redundant. Setting that defines the minimum pick-up level of the relay.								
33	07	Phase Is2	2*I1 A	From 1*I1 A to 30*I1 A step 0.05*I1 A	*	*	*	*
Setting Visible when Scheme Setup is set to 2 Terminal or Dual Redundant. This setting defines the bias current threshold, above which the higher percentage bias k2 is used.								
33	08	Phase k1	0.3	From 10% to 150% step 5%	*	*	*	*

Col	Row	MENU TEXT	Default Setting	Available Setting	P543/P545 No Distance	P544/P546 No Distance	P543/P545	P544/P546
Description								
Setting Visible when Scheme Setup is set to 2 Terminal or Dual Redundant. The lower percentage bias setting used when the bias current is below Is2. This provides stability for small CT mismatches, whilst ensuring good sensitivity to resistive faults under heavy load conditions.								
33	09	Phase k2	1.5	From 30% to 150% step 5%	*	*	*	*
Setting Visible when Scheme Setup is set to 2 Terminal or Dual Redundant. The higher percentage bias setting used to improve relay stability under heavy through fault current conditions.								
33	0A	Phase Char	DT	0 = DT, 1 = IEC S Inverse, 2 = IEC V Inverse, 3 = IEC E Inverse, 4 = UK LT Inverse, 5 = IEEE M Inverse, 6 = IEEE V Inverse, 7 = IEEE E Inverse, 8 = US Inverse or 9 = US ST Inverse	*	*	*	*
Setting for the tripping characteristic for differential protection element.								
33	0B	Phase Time Delay	0s	From 0s to 100s step 10ms	*	*	*	*
Setting for the time-delay for the definite time setting if selected. The setting is visible only when DT function is selected.								
33	0C	Phase TMS	1	0.025 to 1.2 step 0.005	*	*	*	*
Setting for the time multiplier setting to adjust the operating time of the IEC IDMT characteristic.								
33	0D	Phase Time Dial	1	0.01 to 100 step 0.01	*	*	*	*
Setting for the time multiplier setting to adjust the operating time of the IEEE/US IDMT curves. The Time Dial (TD) is a multiplier on the standard curve equation, in order to achieve the required tripping time. The reference curve is based on TD = 1. Care: Certain manufacturer's use a mid-range value of TD = 5 or 7, so it may be necessary to divide by 5 or 7 to achieve parity.								
33	0E	PIT Time	200ms	From 0s to 0.2s step 5ms	*	*	*	*
This timer is initiated upon receipt of PIT flag in the message. Once this timer elapses, and as long as the current is above of Is1 setting, the relay closes its three phase differential trip contacts.								
33	0F	Ph CT Corr'tion	1	1 to 8 step 0.01	*	*	*	*
Setting used to compensate CT ratios mismatch between terminals.								
33	10	Compensation	None	0 = None, 1 = Cap Charging, 2 = Transformer	*	*	*	*
Setting to define type of compensation. If set to None, Susceptance, Inrush Restraint and Transformer are invisible. If set to Cap Charging, Susceptance setting becomes visible and Inrush Restraint and Transformer are invisible. If set to Transformer, Inrush Restraint and Vectorial Comp settings become visible while Susceptance setting is invisible. Inrush Restraint, Id High Set and Vectorial Comp are only applicable in relay models P543 and P545.								
33	11	Susceptance	0.00000001*11/V1 S	From 0.00000001*11/V1 S to 10*11/V1S step 0.00000001*11/V1 S	*	*	*	*
Visible when Compensation is set to Cap Charging. Setting to define the positive sequence susceptance value of the circuit for capacitive charging current compensation								

Col	Row	MENU TEXT	Default Setting	Available Setting	P543/P545 No Distance	P544/P546 No Distance	P543/P545	P544/P546
Description								
33	12	Inrush Restraint	Disabled	0 = Disabled, 1 = Restraint, 2 = Blocking	*	*	*	*
Setting Restraint (activate), Blocking (Inrush blocking) or Disable (turn off) the additional bias inrush restrain. If set to Restraint, Ih(2) Multiplier setting becomes visible. If set to Blocking, Ih(2) %>, Ih(2) CrossBlock and Ih(5) Blocking settings becomes visible and Ih(2) Multiplier setting becomes invisible. Note: It must be ensure that this function is enabling at each end to avoid maloperation.								
33	14	Ih(2) Multiplier	4	1 to 20 step 0.1	*	*	*	*
Additional bias = Ih(2) Multiplier * $\sqrt{2}$ * Ih(2).								
33	15	Vectorial Comp	Yy0 (0 deg)	0 = Yy0 (0°), 1 = Yd1 (-30°), 2 = Yy2 (-60°), 3 = Yd3 (-90°), 4 = Yy4 (-120°), 5 = Yd5 (-150°), 6 = Yy6 (180°), 7 = Yd7 (+150°), 8 = Yy8 (+120°), 9 = Yd9 (+90°), 10 = Yy10 (+60°), 11 = Yd11 (+30°), 12 = Ydy0 (0°), 13 = Ydy6 (180°)	*	*	*	*
To define the vector compensation to account for phase shift correction and zero sequence current filtering (for transformer applications)								
33	16	Phase Is1 CTS	1.2*I1 A	From 0.2*I1 A to 4*I1 A step 0.05*I1 A	*	*	*	*
Setting that defines the minimum pick-up level of the relay when a current transformer supervision CTS is declared								
33	17	PIT I selection	Remote	0 = Remote or 1 = Local	*	*	*	*
Setting that defines the current to be used for the Permissive Intertrip								
33	20	Ih(2)%>	0.15	From 5% to 50% step 1%	*	*	*	*
If the % of 2nd harmonic in any phase is greater than Ih(2) %> setting, then inrush conditions shall be detected.								
33	21	Ih(2) CrossBlocking	Disabled	0 = Disabled or 1 = Enabled	*	*	*	*
If Ih(2) CrossBlock is set Disabled then independent blocking is used. If enabled then Cross blocking is used.								
33	27	Ih(5) Blocking	Disabled	0 = Disabled or 1 = Enabled	*	*	*	*
Setting to enable 5th harmonic Blocking element. This shall be used to detect overfluxing conditions.								
33	28	Ih(5)%>	0.35	From 5% to 100% step 1%	*	*	*	*
If the % of 5th harmonic in any phase is greater than Ih(5) %> setting, then overfluxing conditions shall be detected.								
33	29	Ih(5) CrossBlocking	Disabled	0 = Disabled or 1 = Enabled	*	*	*	*
If Ih(5) CrossBlock is set Disabled then independent blocking is used. If enabled then Cross blocking is used.								
33	30	Highset Status	Disabled	0 = Disabled or 1 = Enabled	*	*	*	*
Setting to enable highset differential element. HighSet Status only models P543 and P545 when Compensation is set to Transformer and Inrush Restraint is set to Restraint or Blocking.								

Col	Row	MENU TEXT	Default Setting	Available Setting	P543/P545 No Distance	P544/P546 No Distance	P543/P545	P544/P546
Description								
33	31	Id High Set	4.0*11 A	From 4*11 A to 32*11 A step 0.01*11 A	*	*	*	*
Only in models P543 and P545 when Inrush Restraint is set to Restrain or Blocking Pick-up setting for high set differential protection								
33	32	Intertrip CH1	Enabled	0 = Disabled or 1 = Enabled	*	*	*	*
To enable (activate) or disable (turn off) the Intertrip Channel 1 for sending intertrip signal.								
33	33	Intertrip CH2	Enabled	0 = Disabled or 1 = Enabled	*	*	*	*
To enable (activate) or disable (turn off) the Intertrip Channel 2 for sending intertrip signal.								
33	34	OC Rel Status	Disabled	0 = Disabled or 1 = Enabled	*	*	*	*
Setting to enable the conditioning of overcurrent protection								
33	35	I> Release	1*11 A	From 0.08*11 A to 4*11 A step 0.01*11 A	*	*	*	*
Setting visible when O/C release status enabled. Shows the threshold value of overcurrent. Trip done only when current exceeds this threshold								
33	40	Diff CT Sat Stab	Disabled	0 = Disabled or 1 = Enabled	*	*	*	*
Setting to enable Current Transformer Saturation Stabilisation								
33	41	Max I load/Inom	1.3	From 0.5 to 4 step 0.05	*	*	*	*
Setting visible when Current Transformer Saturation Stabilisation enabled. This setting specifies the "Maximum load current" / "nominal rated current". The Current Transformer Saturation Stabilisation feature is active when the measured load current is greater than or equal to this setting, i.e. 0.5 to 4.0 In.								

Table 5 - Group x phase diff

3.5 Scheme Logic (Basic and Aided Scheme Logic). Only in Models with Distance Option

The column **GROUP x SCHEME LOGIC** is used to:

- Set operating mode and associated timers for each distance zone when distance operates in the Basic scheme
- Select aided schemes via one or two available signaling channels
- Define operating zones during Trip On Close (TOC)

Col	Row	MENU TEXT	Default Setting	Available Setting	P543/P545 No Distance	P544/P546 No Distance	P543/P545	P544/P546
Description								
34	00	GROUP 1 SCHEME LOGIC					*	*
This column contains settings for Distance and Aided DEF Scheme Logic								
34	01	BASIC SCHEME					*	*
34	08	Zone 1 Tripping	Phase And Ground	0 = Disabled, 1 = Phase only, 2 = Ground only, 3 = Phase And Ground			*	*

Col	Row	MENU TEXT	Default Setting	Available Setting	P543/P545 No Distance	P544/P546 No Distance	P543/P545	P544/P546
Description								
Setting to select for which types of fault Zone 1 elements will be applied.								
34	09	tZ1 Ph. Delay	0s	From 0s to 10s step 10ms			*	*
Time delay for Z1 phase element.								
34	0A	tZ1 Gnd. Delay	0s	From 0s to 10s step 10ms			*	*
Time delay for Z1 ground element.								
34	10	Zone 2 Tripping	Phase And Ground	0 = Disabled, 1 = Phase only, 2 = Ground only, 3 = Phase And Ground			*	*
Setting to select for which types of fault Zone 2 elements will be applied.								
34	11	tZ2 Ph. Delay	200ms	From 0s to 10s step 10ms			*	*
Time delay for Z2 phase element.								
34	12	tZ2 Gnd. Delay	200ms	From 0s to 10s step 10ms			*	*
Time delay for Z2 ground element.								
34	18	Zone 3 Tripping	Phase And Ground	0 = Disabled, 1 = Phase only, 2 = Ground only, 3 = Phase And Ground			*	*
Setting to select for which types of fault Zone 3 elements will be applied.								
34	19	tZ3 Ph. Delay	600ms	From 0s to 10s step 10ms			*	*
Time delay for Z3 phase element.								
34	1A	tZ3 Gnd. Delay	600ms	From 0s to 10s step 10ms			*	*
Time delay for Z3 ground element.								
34	20	Zone P Tripping	Phase And Ground	0 = Disabled, 1 = Phase only, 2 = Ground only, 3 = Phase And Ground			*	*
Setting to select for which types of fault Zone P elements will be applied.								
34	21	tZP Ph. Delay	400ms	From 0s to 10s step 10ms			*	*
Time delay for ZP phase element.								
34	22	tZP Gnd. Delay	400ms	From 0s to 10s step 10ms			*	*
Time delay for ZP ground element.								
34	28	Zone 4 Tripping	Phase And Ground	0 = Disabled, 1 = Phase only, 2 = Ground only, 3 = Phase And Ground			*	*
Setting to select for which types of fault Zone 4 elements will be applied.								
34	29	tZ4 Ph. Delay	1s	From 0s to 10s step 10ms			*	*
Time delay for Z4 phase element.								

Col	Row	MENU TEXT	Default Setting	Available Setting	P543/P545 No Distance	P544/P546 No Distance	P543/P545	P544/P546
Description								
34	2A	tZ4 Gnd. Delay	1s	From 0s to 10s step 10ms			*	*
Time delay for Z4 ground element.								
34	30	Zone Q Tripping	Phase And Ground	0 = Disabled, 1 = Phase only, 2 = Ground only, 3 = Phase And Ground			*	*
Setting to select for which types of fault Zone Q elements will be applied.								
34	31	tZQ Ph. Delay	1s	From 0s to 10s step 10ms			*	*
Time delay for ZQ phase element.								
34	32	tZQ Gnd. Delay	1s	From 0s to 10s step 10ms			*	*
Time delay for ZQ ground element.								
34	35	Dist tEnd Dir	Non Directional	0 = Non-Directional, 1 = Directional Fwd, 2 = Directional Rev			*	*
Setting to select the direction that directional end timer should elapse								
34	36	ZDir tEnd	1s	From 0s to 10s step 10ms			*	*
Time delay for distance directional end timer								
34	37	ZNonDir tEnd	1s	From 0s to 10s step 10ms			*	*
Time delay for distance non directional end timer								
34	40	AIDED SCHEME 1					*	*
34	41	Aid. 1 Selection	Disabled	0 = Disabled, 1 = PUR, 2 = PUR Unblocking, 3 = POR, 4 = POR Unblocking, 5 = Blocking 1, 6 = Blocking 2, 7 = Prog. Unblocking, 8 = Programmable			*	*
Selection of the generic scheme type for aided channel 1. Note: POR is equivalent to POTT (permissive overreach transfer trip), PUR is equivalent to PUTT (permissive underreach transfer trip).								
34	42	Aid 1 Distance	Phase And Ground	0 = Disabled, 1 = Phase only, 2 = Ground only, 3 = Phase And Ground			*	*
Setting to select whether distance elements should key the scheme selected as per the previous setting. If set to Disabled, no distance zones interact with this aided scheme, and basic scheme tripping only applies.								
34	43	Aid.1 Dist. Dly	0s	From 0s to 1s step 2ms			*	*
Trip time delay for Aided 1 Distance schemes.								
34	44	Aid. 1 DEF	Disabled	0 = Disabled or 1 = Enabled			*	*

Col	Row	MENU TEXT	Default Setting	Available Setting	P543/P545 No Distance	P544/P546 No Distance	P543/P545	P544/P546
Description								
Setting to select whether a DEF scheme should be mapped to Aided scheme 1. (Not applicable where a Permissive Underreaching scheme selection has been made).								
34	45	Aid. 1 DEF Dly.	0s	From 0s to 1s step 2ms			*	*
Time delay for Aided 1 DEF tripping.								
34	46	Aid. 1 DEF Trip	3 Pole	0 = 3 Pole, 1 = 1 and 3 Pole			*	*
Setting that defines the tripping mode for Aided 1 DEF. This setting is visible only if tripping mode under GROUP x LINE PARAMETERS/Trip Mode is set to 1 and 3 pole.								
34	47	Aid. 1 Delta	Disabled	0 = Disabled or 1 = Enabled			*	*
Setting to select whether a Delta directional comparison scheme should be mapped to Aided scheme 1. (Not applicable where a Permissive Underreaching scheme selection has been made).								
34	48	Aid. 1 Delta Dly	0s	From 0s to 1s step 2ms			*	*
Time delay for Aided 1 Delta tripping.								
34	49	Aid. 1 Delta Trip	3 Pole	0 = 3 Pole, 1 = 1 and 3 Pole			*	*
Setting that defines tripping mode for Aided 1 Delta. This setting is visible only if tripping mode under GROUP x LINE PARAMETERS/ Trip Mode is set to 1 and 3 pole.								
34	4A	tRev. Guard	20ms	From 0s to 150ms step 2ms			*	*
Setting for the current reversal guard timer. Intended to keep stability on a healthy line, whilst breakers open on a faulted parallel line to clear the fault. This setting is visible only when over-reaching or Blocking schemes are selected.								
34	4B	Unblocking Delay	50ms	From 0s to 100ms step 2ms			*	*
Time delay after Loss of Guard until unblocking occurs. After the set delay, the relay will respond as though an aided signal has been received from the remote end. This setting is visible only when PUR Unblocking, POR Unblocking or Programmable Unblocking schemes are chosen.								
34	4C	Send On Trip	Aided / Z1	0 = Aided / Z1, 1 = Any Trip, 2 = None			*	*
Setting that defines the reinforced trip signal for POR Aided 1 scheme. If selected to: None: No reinforced signal is issued Aided/Z1: The reinforced signal is issued with aided trip or with Z1 if aided distance scheme is enabled Any Trip: Signal is reinforced with Any trip (DDB 522)								
34	50	Weak Infeed	Disabled	0 = Disabled, 1 = Echo, 2 = Echo and Trip			*	*
Setting that defines Aided 1 scheme operation in case of weak infeed conditions, where no protection elements detect the fault at the local end, but an aided channel has been received from the remote end. Setting "Echo" will allow the received signal to be returned to the remote relay, "Trip" will allow local end tripping after a set delay.								
34	51	WI Sngl Pole Trip	Disabled	0 = Disabled or 1 = Enabled			*	*
Setting that defines the Weak Infeed tripping mode. When disabled, any WI trip will be converted to a 3 phase trip.								
34	52	WI V< Threshold	45*V1	From 10*V1 to 70*V1 step 5*V1			*	*
Setting of Weak Infeed level detector. If phase - ground voltage in any phase drops below the threshold and with insufficient phase current for the protection to operate, the end is declared as a weak infeed terminal.								
34	53	WI Trip Delay	60ms	From 0s to 1s step 2ms			*	*

Col	Row	MENU TEXT	Default Setting	Available Setting	P543/P545 No Distance	P544/P546 No Distance	P543/P545	P544/P546
Description								
Setting for the weak infeed trip time delay.								
34	58	Custom Send Mask	000000001(bin)	Bit 00 = Z1 Gnd., Bit 01 = Z2 Gnd., Bit 02 = Z4 Gnd., Bit 03 = Z1 Ph., Bit 04 = Z2 Ph., Bit 05 = Z4 Ph., Bit 06 = DEF Fwd., Bit 07 = DEF Rev., Bit 08 = Dir Comp Fwd., Bit 09 = Dir Comp Rev.			*	*
Logic Settings that determine the element or group of elements that are sending a permissive signal to the other line end. For the signal to be sent, the element must operate and a corresponding bit in the matrix must be set to 1 (High). The above mapping is part of a custom made Aided 1 scheme, and unlike all other schemes that are factory tested, the customer must take the responsibility for testing and the operation of the scheme. This setting is visible only if a Programmable or Prog. Unblocking scheme is selected.								
34	59	Custom Time PU 0s					*	*
Pick up time delay of DDB signal 'Aid1 CustomT in', available in the PSL logic. Once the time delay elapses, the DDB signal 'Aid1 CustomT out' will become high.								
34	5A	Custom Time DO 0s		DEF Fwd., Bit 07 = DEF Rev., Bit 08 = Dir Comp Fwd., Bit 09 = Dir Comp Rev.			*	*
Drop off time delay of DDB signal 'Aid1 CustomT in'. Once the time delay elapses, the DDB signal 'Aid1 CustomT out' will become low. Note: The timer is a combined hard coded PU/DO timer for Custom Aided scheme 1.								
34	60	AIDED SCHEME 2					*	*
34	61	Aid. 2 Selection	Disabled	0 = Disabled, 1 = PUR, 2 = PUR Unblocking, 3 = POR, 4 = POR Unblocking, 5 = Blocking 1, 6 = Blocking 2, 7 = Prog. Unblocking, 8 = Programmable			*	*
Selection of the generic scheme type for aided channel 2. Note: POR is equivalent to POTT (permissive overreach transfer trip), PUR is equivalent to PUTT (permissive underreach transfer trip).								
34	62	Aid 2 Distance	Disabled	0 = Disabled, 1 = Phase only, 2 = Ground only, 3 = Phase And Ground			*	*
Setting to select whether distance elements should key the scheme selected as per the previous setting. If set to Disabled, no distance zones interact with this aided scheme, and basic scheme tripping only applies.								
34	63	Aid.2 Dist. Dly	20ms	From 0s to 1s step 2ms			*	*
Trip time delay for Aided 2 Distance schemes.								
34	64	Aid. 2 DEF	Enabled	0 = Disabled or 1 = Enabled			*	*
Setting to select whether a DEF scheme should be mapped to Aided scheme 2. (Not applicable where a Permissive Underreaching scheme selection has been made).								

Col	Row	MENU TEXT	Default Setting	Available Setting	P543/P545 No Distance	P544/P546 No Distance	P543/P545	P544/P546
Description								
34	65	Aid. 2 DEF Dly.	20ms	From 0s to 1s step 2ms			*	*
Time delay for Aided 2 DEF tripping.								
34	66	Aid. 2 DEF Trip	3 Pole	0 = 3 Pole, 1 = 1 and 3 Pole			*	*
Setting that defines the tripping mode for Aided 2 DEF. This setting is visible only if tripping mode under GROUP x LINE PARAMETERS/Trip Mode is set to 1 and 3 pole.								
34	67	Aid. 2 Delta	Enabled	0 = Disabled or 1 = Enabled			*	*
Setting to select whether a Delta directional comparison scheme should be mapped to Aided scheme 2. (Not applicable where a Permissive Underreaching scheme selection has been made).								
34	68	Aid. 2 Delta Dly	20ms	From 0s to 1s step 2ms			*	*
Time delay for Aided 2 Delta tripping.								
34	69	Aid. 2 Delta Trip	3 Pole	0 = 3 Pole, 1 = 1 and 3 Pole			*	*
Setting that defines tripping mode for Aided 2 Delta. This setting is visible only if tripping mode under GROUP x LINE PARAMETERS/ Trip Mode is set to 1 and 3 pole.								
34	6A	tRev. Guard	20ms	From 0s to 150ms step 2ms			*	*
Setting for the current reversal guard timer. Intended to keep stability on a healthy line, whilst breakers open on a faulted parallel line to clear the fault. This setting is visible only when over-reaching or Blocking schemes are selected.								
34	6B	Unblocking Delay	50ms	From 0s to 100ms step 2ms			*	*
Time delay after Loss of Guard until unblocking occurs. After the set delay, the relay will respond as though an aided signal has been received from the remote end. This setting is visible only when PUR Unblocking, POR Unblocking or Programmable Unblocking schemes are chosen.								
34	6C	Send On Trip	Aided / Z1	0 = Aided / Z1, 1 = Any Trip, 2 = None			*	*
Setting that defines the reinforced trip signal for POR Aided 2 scheme. If selected to: None: No reinforced signal is issued Aided/Z1: The reinforced signal is issued with aided trip or with Z1 if aided distance scheme is enabled Any Trip: Signal is reinforced with Any trip (DDB 522)								
34	70	Weak Infeed	Disabled	0 = Disabled, 1 = Echo, 2 = Echo and Trip			*	*
Setting that defines Aided 2 scheme operation in case of weak infeed conditions, where no protection elements detect the fault at the local end, but an aided channel has been received from the remote end. Setting "Echo" will allow the received signal to be returned to the remote relay, "Trip" will allow local end tripping after a set delay.								
34	71	WI Sngl Pole Trp	Disabled	0 = Disabled or 1 = Enabled			*	*
Setting that defines the Weak Infeed tripping mode. When disabled, any WI trip will be converted to a 3 phase trip.								
34	72	WI V< Threshold	45*V1	From 10*V1 to 70*V1 step 5*V1			*	*
Setting of Weak Infeed level detector. If phase - ground voltage in any phase drops below the threshold and with insufficient phase current for the protection to operate, the end is declared as a weak infeed terminal.								
34	73	WI Trip Delay	60ms	From 0s to 1s step 2ms			*	*
Setting for the weak infeed trip time delay.								

Col	Row	MENU TEXT	Default Setting	Available Setting	P543/P545 No Distance	P544/P546 No Distance	P543/P545	P544/P546
Description								
34	78	Custom Send Mask	0000000001(bin)	Bit 00 = Z1 Gnd., Bit 01 = Z2 Gnd., Bit 02 = Z4 Gnd., Bit 03 = Z1 Ph., Bit 04 = Z2 Ph., Bit 05 = Z4 Ph., Bit 06 = DEF Fwd., Bit 07 = DEF Rev., Bit 08 = Dir Comp Fwd., Bit 09 = Dir Comp Rev.			*	*
Logic Settings that determine the element or group of elements that are sending a permissive signal to the other line end. For the signal to be sent, the element must operate and a corresponding bit in the matrix must be set to 1 (High). The above mapping is part of a custom made Aided 2 scheme, and unlike all other schemes that are factory tested, the customer must take the responsibility for testing and the operation of the scheme. This setting is visible only if a Programmable or Prog. Unlocking scheme is selected.								
34	79	Custom Time PU	0s	From 0s to 1s step 2ms			*	*
Pick up time delay of DDB signal 'Aid2 CustomT in', available in the PSL logic. Once the time delay elapses, the DDB signal 'Aid2 CustomT out' will become high.								
34	7A	Custom Time DO	0s	From 0s to 1s step 2ms			*	*
Drop off time delay of DDB signal 'Aid2 CustomT in'. Once the time delay elapses, the DDB signal 'Aid2 CustomT out' will become low. Note: The timer is a combined hard coded PU/DO timer for Custom Aided scheme 2.								
34	80	Trip on Close					*	*
34	81	SOTF Status	Enabled PoleDead	0 = Disabled, 1 = Enabled PoleDead, 2 = Enabled ExtPulse, 3 = En Pdead + Pulse			*	*
Setting that enables note (turns on) or disables (turns off) a special protection logic which can apply upon line energization. SOTF = Switch on to Fault. Note: SOTF can be enabled in three different manners: 1. Enabled Pole Dead. By using pole dead logic detection logic 2. Enabled ExtPulse. By using an external pulse 3. En Pdead + Pulse. By using both								
34	82	SOTF Delay	110s	From 0.2s to 1000s step 0.2s			*	*
The SOTF Delay is a pick up time delay that starts after opening all 3 poles of a CB. If the CB is then closed after the set time delay has expired, SOTF protection will be active. SOTF provides enhanced protection for manual closure of the breaker (not for auto-reclosure). This setting is visible only if Pole Dead or Pdead + Pulse are selected to enable SOTF.								
34	83	SOTF Tripping	0000001(bin)	Bit 00 = Zone 1, Bit 01 = Zone 2, Bit 02 = Zone 3, Bit 03 = Zone P, Bit 04 = Zone 4, Bit 05 = Zone Q or Bit 06 = Current No Volts			*	*
Logic Settings that determine the Distance zones that are allowed to operate instantaneously upon line energization. If, for example, Bit 1 is set to 1 (High), Z2 will operate without waiting for the usual tZ2 time delay should a fault lie within Z2 upon CB closure. It also allows a user to map 'Currents No Volt' option for fast fault clearance upon line energization. SOTF tripping is 3 phase and auto-reclose will be blocked.								

Col	Row	MENU TEXT	Default Setting	Available Setting	P543/P545 No Distance	P544/P546 No Distance	P543/P545	P544/P546
Description								
34	84	TOR Status	Enabled	0 = Disabled or 1 = Enabled			*	*
Setting that enables (turns on) or disables (turns off) special protection following auto-reclosure. When set Enabled, TOR will be activated after the 'TOC Delay' has expired, ready for application when an auto-reclose shot occurs. TOR = Trip on (auto)Reclose.								
34	85	TOR Tripping	0000001(bin)	Bit 00 = Zone 1, Bit 01 = Zone 2, Bit 02 = Zone 3, Bit 03 = Zone P, Bit 04 = Zone 4, Bit 05 = Zone Q or Bit 06 = Current No Volts			*	*
Logic Settings that determine the Distance zones that are allowed to operate instantaneously upon line energization. If, for example, Bit 1 is set to 1 (High), Z2 will operate without waiting for the usual tZ2 time delay should a fault lie within Z2 upon CB closure. It also allows a user to map 'Currents No Volt' option for fast fault clearance upon line reclosure on a permanent fault. TOR tripping is 3 phase and auto-reclose will be blocked.								
34	86	TOC Reset Delay	500ms	From 100ms to 2s step 100ms			*	*
The TOC Reset Delay is a user settable time window during which TOC protection is available. The time window starts timing upon CB closure and it is common for SOTF and TOR protection. Once this timer expires after a successful (re)closure, all protection reverts to normal.								
34	87	SOTF Pulse	500ms	From 100ms to 10s step 10ms			*	*
The SOTF Pulse is a user settable time window during which the SOTF protection is available. This setting is visible only if ExtPulse or Pdead + Pulse are selected to enable SOTF								
34	88	TOC Delay	200ms	From 50ms to 200ms step 10ms			*	*
The TOC Delay is a user settable time delay following the CB opening after which the TOR becomes active (enabled). The time must be set in conjunction with the Dead Time setting of the Auto-reclose so that the setting must not exceed the minimum Dead Time setting since both timers start instantaneously.								
34	B0	Zone 1 Extension					*	*
34	B1	Z1 Ext Scheme	Disabled	0 = Disabled, 1 = Enabled, 2 = En. on Ch1 Fail, 3 = En. on Ch2 Fail, 4 = En. All Ch Fail, 5 = En. Any Ch Fail			*	*
Setting that enables (turns on) or disables (turns off) the Zone 1 Extension scheme. When Enabled, extended Zone 1 will apply unless the Reset Zone 1 Extension DDB signal is energized. Otherwise, it is possible to enable Z1X when aided scheme channel(s) fail.								
34	B2	Z1 Ext Ph	1.5	From 100% to 200% step 1%			*	*
Extended Z1X phase reach as a percentage of the Z1 phase reach. (Phase resistive reach for Z1X is the same as for Zone 1.)								
34	B3	Z1 Ext Gnd	1.5	From 100% to 200% step 1%			*	*
Extended Z1X ground reach as a percentage of Z1 ground reach. (Ground resistive reach and residual compensation for Z1X is the same as for Zone 1.)								
34	C0	Loss of Load					*	*

Col	Row	MENU TEXT	Default Setting	Available Setting	P543/P545 No Distance	P544/P546 No Distance	P543/P545	P544/P546
Description								
34	C1	LOL Scheme	Disabled	0 = Disabled, 1 = Enabled, 2 = En. on Ch1 Fail, 3 = En. on Ch2 Fail, 4 = En. All Ch Fail, 5 = En. Any Ch Fail			*	*
Setting that enables (turns on) or disables (turns off) the Loss of Load scheme. When Enabled, accelerated tripping can apply as the remote end opens (3-pole trip applications only). Otherwise, it is possible to enable Z1X when aided scheme channel(s) fail.								
34	C3	LOL <I	0.5*11 A	From 0.05*11 A to 1*11 A step 0.05*11 A			*	*
LOL undercurrent detector that indicates a loss of load condition on the unfaulted phases, indicating that the remote end has just opened.								
34	C4	LOL Window	40ms	From 10ms to 100s step 10ms			*	*
Length of LOL window - the time window in which Zone 2 accelerated tripping can occur following LOL undercurrent detector operation.								

Table 6 - Group x scheme logic

3.6 Power Swing Blocking (Only in Models with Distance Option)

The column **GROUP x POWER SWING BLK.** is used to set either blocking or indication for out of step conditions. If blocking mode is selected, a user can individually select for each zone to be either blocked or allow tripping.

The power swing detection is based on superimposed current, and is essentially “settings free”.

Col	Row	MENU TEXT	Default Setting	Available Setting	P543/P545 No Distance	P544/P546 No Distance	P543/P545	P544/P546
Description								
3D	00	GROUP 1 POWER SWING BLK.					*	*
This column contains settings for Power Swing Blocking/Out of Step Tripping								
3D	01	PSB Status	Blocking	0 = Blocking or 1 = Indication			*	*
To enable (activate) Indication or Blocking mode. This setting is invisible if disabled in 'CONFIGURATION' column. If Indication status is selected, the alarm will be issued but tripping by distance protection will be unaffected. When Blocking status is selected, the user is presented with further options as to which zones do/do not require blocking.								
3D	03	Zone 1 Ph. PSB	Blocking	0 = Allow Trip, 1 = Blocking, 2 = Delayed Unblock			*	*
Setting that defines the Z1 phase element operation should any swing impedance enter and remains inside the Z1 phase characteristic for more than 'tZ1 Ph. Delay'. If Blocking is selected, the Z1 phase element operation will be disabled for the duration of the swing. If Unblocking is chosen, the Z1 phase element block will be removed after drop off timer 'PSB Unblocking Dly' has expired, even if the swing is still present. This allows system separation when swings fail to stabilize. In 'Allow trip' mode, the Z1 phase element is unaffected by PSB detection.								

Col	Row	MENU TEXT	Default Setting	Available Setting	P543/P545 No Distance	P544/P546 No Distance	P543/P545	P544/P546
Description								
3D	05	Zone 2 Ph. PSB	Blocking	1 = Allow Trip, 1 = Blocking, 2 = Delayed Unblock			*	*
Setting that defines the Z2 phase element operation should any swing impedance enter and remains inside the Z2 phase characteristic for more then 'tZ2 Ph. Delay'. If Blocking is selected, the Z2 phase element operation will be disabled for the duration of the swing. If Unlocking is chosen, the Z2 phase element block will be removed after drop off timer 'PSB Unlocking Dly' has expired, even if the swing is still present. This allows system separation when swings fail to stabilize. In 'Allow trip' mode, the Z2 phase element is unaffected by PSB detection.								
3D	07	Zone 3 Ph. PSB	Blocking	2 = Allow Trip, 1 = Blocking, 2 = Delayed Unblock			*	*
Setting that defines the Z3 phase element operation should any swing impedance enter and remains inside the Z3 phase characteristic for more then 'tZ3 Ph. Delay'. If Blocking is selected, the Z3 phase element operation will be disabled for the duration of the swing. If Unlocking is chosen, the Z3 phase element block will be removed after drop off timer 'PSB Unlocking Dly' has expired, even if the swing is still present. This allows system separation when swings fail to stabilize. In 'Allow trip' mode, the Z3 phase element is unaffected by PSB detection.								
3D	09	Zone P Ph. PSB	Blocking	3 = Allow Trip, 1 = Blocking, 2 = Delayed Unblock			*	*
Setting that defines the ZP phase element operation should any swing impedance enter and remains inside the ZP phase characteristic for more then 'tZP Ph. Delay'. If Blocking is selected, the ZP phase element operation will be disabled for the duration of the swing. If Unlocking is chosen, the ZP phase element block will be removed after drop off timer 'PSB Unlocking Dly' has expired, even if the swing is still present. This allows system separation when swings fail to stabilize. In 'Allow trip' mode, the ZP phase element is unaffected by PSB detection.								
3D	0B	Zone 4 Ph. PSB	Blocking	4 = Allow Trip, 1 = Blocking, 2 = Delayed Unblock			*	*
Setting that defines the Z4 phase element operation should any swing impedance enter and remains inside the Z4 phase characteristic for more then 'tZ4 Ph. Delay'. If Blocking is selected, the Z4 phase element operation will be disabled for the duration of the swing. If Unlocking is chosen, the Z4 phase element block will be removed after drop off timer 'PSB Unlocking Dly' has expired, even if the swing is still present. This allows system separation when swings fail to stabilize. In 'Allow trip' mode, the Z4 phase element is unaffected by PSB detection.								
3D	0C	Zone Q Ph. PSB	Blocking	4 = Allow Trip, 1 = Blocking, 2 = Delayed Unblock			*	*
Setting that defines the ZQ phase element operation should any swing impedance enter and remains inside the ZQ phase characteristic for more then 'tZQ Ph. Delay'. If Blocking is selected, the ZQ phase element operation will be disabled for the duration of the swing. If Unlocking is chosen, the Z4 phase element block will be removed after drop off timer 'PSB Unlocking Dly' has expired, even if the swing is still present. This allows system separation when swings fail to stabilize. In 'Allow trip' mode, the Z4 phase element is unaffected by PSB detection.								
3D	0D	Zone 1 Gnd. PSB	Blocking	5 = Allow Trip, 1 = Blocking, 2 = Delayed Unblock			*	*
Setting that defines the Z1 ground element operation should any swing impedance enter and remains inside the Z1 ground characteristic for more then 'tZ1 Gnd. Delay'. If Blocking is selected, the Z1 ground element operation will be disabled for the duration of the swing. If Unlocking is chosen, the Z1 ground element block will be removed after drop off timer 'PSB Unlocking Dly' has expired, even if the swing is still present. This allows system separation when swings fail to stabilize. In 'Allow trip' mode, the Z1 ground element is unaffected by PSB detection.								

Col	Row	MENU TEXT	Default Setting	Available Setting	P543/P545 No Distance	P544/P546 No Distance	P543/P545	P544/P546
Description								
3D	0F	Zone 2 Gnd. PSB	Blocking	6 = Allow Trip, 1 = Blocking, 2 = Delayed Unblock			*	*
Setting that defines the Z2 ground element operation should any swing impedance enter and remains inside the Z2 ground characteristic for more then 'tZ2 Gnd. Delay'. If Blocking is selected, the Z2 ground element operation will be disabled for the duration of the swing. If Unblocking is chosen, the Z2 ground element block will be removed after drop off timer 'PSB Unblocking Dly' has expired, even if the swing is still present. This allows system separation when swings fail to stabilize. In 'Allow trip' mode, the Z2 ground element is unaffected by PSB detection.								
3D	11	Zone 3 Gnd. PSB	Blocking	7 = Allow Trip, 1 = Blocking, 2 = Delayed Unblock			*	*
Setting that defines the Z3 ground element operation should any swing impedance enter and remains inside the Z3 ground characteristic for more then 'tZ3 Gnd. Delay'. If Blocking is selected, the Z3 ground element operation will be disabled for the duration of the swing. If Unblocking is chosen, the Z3 ground element block will be removed after drop off timer 'PSB Unblocking Dly' has expired, even if the swing is still present. This allows system separation when swings fail to stabilize. In 'Allow trip' mode, the Z3 ground element is unaffected by PSB detection.								
3D	13	Zone P Gnd. PSB	Blocking	8 = Allow Trip, 1 = Blocking, 2 = Delayed Unblock			*	*
Setting that defines the ZP ground element operation should any swing impedance enter and remains inside the ZP ground characteristic for more then 'tZP Gnd. Delay'. If Blocking is selected, the ZP ground element operation will be disabled for the duration of the swing. If Unblocking is chosen, the ZP ground element block will be removed after drop off timer 'PSB Unblocking Dly' has expired, even if the swing is still present. This allows system separation when swings fail to stabilize. In 'Allow trip' mode, the ZP ground element is unaffected by PSB detection.								
3D	15	Zone 4 Gnd. PSB	Blocking	9 = Allow Trip, 1 = Blocking, 2 = Delayed Unblock			*	*
Setting that defines the Z4 ground element operation should any swing impedance enter and remains inside the Z4 ground characteristic for more then 'tZ4 Gnd. Delay'. If Blocking is selected, the Z4 ground element operation will be disabled for the duration of the swing. If Unblocking is chosen, the Z4 ground element block will be removed after drop off timer 'PSB Unblocking Dly' has expired, even if the swing is still present. This allows system separation when swings fail to stabilize. In 'Allow trip' mode, the Z4 ground element is unaffected by PSB detection.								
3D	17	Zone Q Gnd. PSB	Blocking	9 = Allow Trip, 1 = Blocking, 2 = Delayed Unblock			*	*
Setting that defines the ZQ ground element operation should any swing impedance enter and remains inside the ZQ ground characteristic for more then 'tZQ Gnd. Delay'. If Blocking is selected, the ZQ ground element operation will be disabled for the duration of the swing. If Unblocking is chosen, the Z4 ground element block will be removed after drop off timer 'PSB Unblocking Dly' has expired, even if the swing is still present. This allows system separation when swings fail to stabilize. In 'Allow trip' mode, the Z4 ground element is unaffected by PSB detection.								
3D	1A	Slow PSB	Enabled	0 = Disabled or 1 = Enabled			*	*
Enables slow swing power swing blocking in parallel with automatic swing detection. The slow swing condition will be declared if positive sequence impedance is detected inside zone 5 for more than a cycle without phase selection operation.								
3D	20	PSB Unblocking	Disabled	0 = Disabled or 1 = Enabled			*	*
To enable (activate) or disable (turn off) the PSB Unblocking delay timer. This setting is common to all zones and it is visible if any distance zone is set to 'PSB Unblocking Dly'. For swing durations longer than this setting, blocking can be selectively removed.								

Col	Row	MENU TEXT	Default Setting	Available Setting	P543/P545 No Distance	P544/P546 No Distance	P543/P545	P544/P546
Description								
3D	21	PSB Unblock dly	2s	From 100ms to 20s step 100ms			*	*
Unblock timer setting - on expiry, power swing blocking can optionally be removed.								
3D	22	PSB Reset Delay	200ms	From 50ms to 2s step 50ms			*	*
Setting to maintain the power swing detection for a period after the delta current detection has reset. ΔI will naturally reset momentarily twice in each swing cycle, and a short setting ensures continued PSB pick-up, to ride through the gaps.								
3D	23	OST Mode	OST Disabled	0 = OST Disabled, 1 = OST Predictive Trip, 2 = OST Trip			*	*
To enable (activate) or disable (turn off) Out of Step protection. This setting (and all related settings below) is invisible if PowerSwing Block is disabled in 'CONFIGURATION' column. If 'OST Trip' is selected, relay will operate after Tost time delay if the measured positive sequence impedance has passed the Z6-Z5 region slower than 25 ms (@ 50 or 60 Hz) and if the polarity of the resistive component has changed between entering and exiting zone 5. If 'Predictive OST Trip' is selected, relay will operate after Tost time delay if the positive sequence impedance has passed the Z6-Z5 region faster than 25ms but slower than 'Delta t' set time. If 'Predictive & OST Trip' is selected, it will operate if any of two above criteria is satisfied.								
3D	24	Z5	30*V1/I1Ω	From 0.1*V1/I1Ω to 500*V1/I1Ω step 0.01*V1/I1Ω			*	*
Setting for Z5 forward reactance reach.								
3D	25	Z6	32*V1/I1Ω	From 0.1*V1/I1Ω to 500*V1/I1Ω step 0.01*V1/I1Ω			*	*
Setting for Z6 forward reactance reach.								
3D	26	Z5'	-30*V1/I1Ω	From -500*V1/I1Ω to -0.1*V1/I1Ω step 0.01*V1/I1Ω			*	*
Setting for Z5 reverse reactance reach.								
3D	27	Z6'	-32*V1/I1Ω	From -500*V1/I1Ω to -0.1*V1/I1Ω step 0.01*V1/I1Ω			*	*
Setting for Z6 reverse reactance reach.								
3D	28	R5	20*V1/I1Ω	From 0.1*V1/I1Ω to 500*V1/I1Ω step 0.01*V1/I1Ω			*	*
Setting for Z5 positive resistive reach.								
3D	29	R6	22*V1/I1Ω	From 0.1*V1/I1Ω to 500*V1/I1Ω step 0.01*V1/I1Ω			*	*
Setting for Z6 positive resistive reach.								
3D	2A	R5'	-20*V1/I1Ω	From -0.1*V1/I1Ω to -500*V1/I1Ω step 0.01*V1/I1Ω			*	*
Setting for Z5 negative resistive reach.								
3D	2B	R6'	-22*V1/I1Ω	From -0.1*V1/I1Ω to -500*V1/I1Ω step 0.01*V1/I1Ω			*	*
Setting for Z6 negative resistive reach.								

Col	Row	MENU TEXT	Default Setting	Available Setting	P543/P545 No Distance	P544/P546 No Distance	P543/P545	P544/P546
Description								
3D	2C	Blinder Angle	80	From 20° to 90° step 1°			*	*
Setting of blinder angle, common for both Z5 and Z6.								
3D	2D	delta T	40ms	From 40ms to 1s step 1ms			*	*
Time setting that is compared with the measured time between positive sequence impedance entering Z6 and entering Z5.								
3D	2E	Tost	0s	From 0s to 1s step 10ms			*	*
Tripping time delay common for any OST setting option.								

Table 7 - Group x power swing blk

3.7 Phase Overcurrent Protection

The phase overcurrent protection included in the relay provides four-stage non-directional/directional phase-segregated overcurrent protection with independent time delay characteristics. All overcurrent and directional settings apply to each phase but are independent for each of the four stages. To arrange a single pole tripping by overcurrent protection, the default PSL needs to be checked (and possibly modified).

The first two stages of overcurrent protection have time-delayed characteristics which are selectable between Inverse Definite Minimum Time (IDMT), or Definite Time (DT). The third and fourth stages have DT characteristics only.

Col	Row	MENU TEXT	Default Setting	Available Setting	P543/P545 No Distance	P544/P546 No Distance	P543/P545	P544/P546
Description								
35	00	GROUP 1 OVERCURRENT			*	*	*	*
This column contains settings for Overcurrent								
35	01	I>1 Status	Enabled	0 = Disabled, 1 = Enabled, 2 = Enabled VTS, 3 = Enabled Ch Fail, 4 = En VTSorCh Fail, 5 = En VTSandCh Fail, 6 = Enabled CTS, 7 = En VTSorCTS, 8 = En Ch FailorCTS, 9 = En VTSorCHForCTS, 10 = En VTSandCTS, 11 = En Ch FailandCTS, 12 = En VTS CHF CTS	*	*	*	*
Setting that defines first stage overcurrent operating status. I>1 can be disabled or enabled permanently or in case of Voltage Transformer Supervision (VTS) operation, or in case of Communication Channel Fail (CH Fail or CHF), or in case of Current Transformer Supervision (CTS) operation, or a combination of VTS or CHF, VTS or CTS, CHF or CTS, VTS or CHF or CTS, VTS and CHF, VTS and CTS, CHF and CTS, CTS and CHF and CTS.								

Col	Row	MENU TEXT	Default Setting	Available Setting	P543/P545 No Distance	P544/P546 No Distance	P543/P545	P544/P546
Description								
35	02	I>1 Function	IEC S Inverse	0 = DT, 1 = IEC S Inverse, 2 = IEC V Inverse, 3 = IEC E Inverse, 4 = UK LT Inverse, 5 = IEEE M Inverse, 6 = IEEE V Inverse, 7 = IEEE E Inverse, 8 = US Inverse, 9 = US ST Inverse	*	*	*	*
Setting for the tripping characteristic for the first stage overcurrent element.								
35	03	I>1 Directional	Non-Directional	0 = Non-Directional, 1 = Directional Fwd, 2 = Directional Rev	*	*	*	*
This setting determines the direction of measurement for first stage element.								
35	04	I>1 Current Set	1*I1 A	From 0.08*I1 A to 4.0*I1 A step 0.01*I1 A	*	*	*	*
Pick-up setting for first stage overcurrent element.								
35	05	I>1 Time Delay	1s	From 0s to 100s step 10ms	*	*	*	*
Setting for the time-delay for the definite time setting if selected for first stage element. The setting is visible only when DT function is selected.								
35	06	I>1 TMS	1	0.025 to 1.2 step 0.005	*	*	*	*
Setting for the time multiplier setting to adjust the operating time of the IEC IDMT characteristic.								
35	07	I>1 Time Dial	1	0.01 to 100 step 0.01	*	*	*	*
Setting for the time multiplier setting to adjust the operating time of the IEEE/US IDMT curves. The Time Dial (TD) is a multiplier on the standard curve equation, in order to achieve the required tripping time. The reference curve is based on TD = 1. Care: Certain manufacturer's use a mid-range value of TD = 5 or 7, so it may be necessary to divide by 5 or 7 to achieve parity.								
35	08	I>1 Reset Char	DT	0 = DT or 1 = Inverse	*	*	*	*
Setting to determine the type of reset/release characteristic of the IEEE/US curves.								
35	09	I>1 tRESET	0s	From 0s to 100s step 10ms	*	*	*	*
Setting that determines the reset/release time for definite time reset characteristic								
35	10	I>2 Status	Disabled	0 = Disabled, 1 = Enabled, 2 = Enabled VTS, 3 = Enabled Ch Fail, 4 = En VTSorCh Fail, 5 = En VTSandCh Fail, 6 = Enabled CTS, 7 = En VTSorCTS, 8 = En Ch FailorCTS, 9 = En VTSorCHForCTS, 10 = En VTSandCTS, 11 = En Ch FailandCTS, 12 = En VTS CHF CTS	*	*	*	*
Setting that defines first stage overcurrent operating status. I>2 can be disabled or enabled permanently or in case of Voltage Transformer Supervision (VTS) operation, or in case of Communication Channel Fail (CH Fail or CHF), or in case of Current Transformer Supervision (CTS) operation, or a combination of VTS or CHF, VTS or CTS, CHF or CTS, VTS or CHF or CTS, VTS and CHF, VTS and CTS, CHF and CTS, CTS and CHF and CTS.								

Col	Row	MENU TEXT	Default Setting	Available Setting	P543/P545 No Distance	P544/P546 No Distance	P543/P545	P544/P546
Description								
35	11	I>2 Function	IEC S Inverse	0 = DT, 1 = IEC S Inverse, 2 = IEC V Inverse, 3 = IEC E Inverse, 4 = UK LT Inverse, 5 = IEEE M Inverse, 6 = IEEE V Inverse, 7 = IEEE E Inverse, 8 = US Inverse, 9 = US ST Inverse	*	*	*	*
Setting for the tripping characteristic for the second stage overcurrent element.								
35	12	I>2 Directional	Non-Directional	0 = Non-Directional, 1 = Directional Fwd, 2 = Directional Rev	*	*	*	*
This setting determines the direction of measurement for second stage element.								
35	13	I>2 Current Set	1*I1 A	From 0.08*I1 A to 4.0*I1 A step 0.01*I1 A	*	*	*	*
Pick-up setting for second stage overcurrent element.								
35	14	I>2 Time Delay	1s	From 0s to 100s step 10ms	*	*	*	*
Setting for the time-delay for the definite time setting if selected for second stage element. The setting is visible only when DT function is selected.								
35	15	I>2 TMS	1	0.025 to 1.2 step 0.005	*	*	*	*
Setting for the time multiplier setting to adjust the operating time of the IEC IDMT characteristic.								
35	16	I>2 Time Dial	1	0.01 to 100 step 0.01	*	*	*	*
Setting for the time multiplier setting to adjust the operating time of the IEEE/US IDMT curves. The Time Dial (TD) is a multiplier on the standard curve equation, in order to achieve the required tripping time. The reference curve is based on TD = 1. Care: Certain manufacturer's use a mid-range value of TD = 5 or 7, so it may be necessary to divide by 5 or 7 to achieve parity.								
35	17	I>2 Reset Char	DT	0 = DT or 1 = Inverse	*	*	*	*
Setting to determine the type of reset/release characteristic of the IEEE/US curves.								
35	18	I>2 tRESET	0s	From 0s to 100s step 10ms	*	*	*	*
Setting that determines the reset/release time for definite time reset characteristic								
35	20	I>3 Status	Disabled	0 = Disabled, 1 = Enabled, 2 = Enabled VTS, 3 = Enabled Ch Fail, 4 = En VTSorCh Fail, 5 = En VTSandCh Fail, 6 = Enabled CTS, 7 = En VTSorCTS, 8 = En Ch FailorCTS, 9 = En VTSorCHForCTS, 10 = En VTSandCTS, 11 = En Ch FailandCTS, 12 = En VTS CHF CTS	*	*	*	*
Setting that defines first stage overcurrent operating status. I>3 can be disabled or enabled permanently or in case of Voltage Transformer Supervision (VTS) operation, or in case of Communication Channel Fail (CH Fail or CHF), or in case of Current Transformer Supervision (CTS) operation, or a combination of VTS or CHF, VTS or CTS, CHF or CTS, VTS or CHF or CTS, VTS and CHF, VTS and CTS, CHF and CTS, CTS and CHF and CTS.								
35	21	I>3 Directional	Directional Fwd	0 = Non-Directional, 1 = Directional Fwd, 2 = Directional Rev	*	*	*	*
This setting determines the direction of measurement for the third stage overcurrent element.								

Col	Row	MENU TEXT	Default Setting	Available Setting	P543/P545 No Distance	P544/P546 No Distance	P543/P545	P544/P546
Description								
35	22	I>3 Current Set	10*I1 A	From 0.08*I1 A to 32*I1 A step 0.01*I1 A	*	*	*	*
Pick-up setting for third stage overcurrent element.								
35	23	I>3 Time Delay	0s	From 0s to 100s step 10ms	*	*	*	*
Setting for the operating time-delay for third stage overcurrent element.								
35	24	I>3 CT Select	CT1+2 Magnitude	0 = CT1 Magnitude, 1 = CT2 Magnitude, 2 = CT1+2 Magnitude		*		*
Allows Selection of the measured CT for two CT models								
35	30	I>4 Status	Disabled	0 = Disabled, 1 = Enabled, 2 = Enabled VTS, 3 = Enabled Ch Fail, 4 = En VTSorCh Fail, 5 = En VTSandCh Fail, 6 = Enabled CTS, 7 = En VTSorCTS, 8 = En Ch FailorCTS, 9 = En VTSorCHForCTS, 10 = En VTSandCTS, 11 = En Ch FailandCTS, 12 = En VTS CHF CTS	*	*	*	*
Setting that defines first stage overcurrent operating status. I>4 can be disabled or enabled permanently or in case of Voltage Transformer Supervision (VTS) operation, or in case of Communication Channel Fail (CH Fail or CHF), or in case of Current Transformer Supervision (CTS) operation, or a combination of VTS or CHF, VTS or CTS, CHF or CTS, VTS or CHF or CTS, VTS and CHF, VTS and CTS, CHF and CTS, CTS and CHF and CTS.								
35	31	I>4 Directional	Non-Directional	0 = Non-Directional, 1 = Directional Fwd, 2 = Directional Rev	*	*	*	*
This setting determines the direction of measurement for the fourth stage overcurrent element.								
35	32	I>4 Current Set	10*I1 A	From 0.08*I1 A to 32*I1 A step 0.01*I1 A	*	*	*	*
Pick-up setting for fourth stage overcurrent element.								
35	33	I>4 Time Delay	0s	From 0s to 100s step 10ms	*	*	*	*
Setting for the operating time-delay for fourth stage overcurrent element.								
35	34	I>4 CT Select	CT1+2 Magnitude	0 = CT1 Magnitude, 1 = CT2 Magnitude, 2 = CT1+2 Magnitude		*		*
Allows Selection of the measured CT for two CT models								
35	40	I> Char Angle	30	From -95° to 95° step 1°	*	*	*	*
Setting for the relay characteristic angle used for the directional decision. The setting is visible only when 'Directional Fwd' or 'Directional Rev' is set.								
35	41	I> Blocking	001111(bin)	Bit 00 = VTS Blocks I>1, Bit 01 = VTS Blocks I>2, Bit 02 = VTS Blocks I>3, Bit 03 = VTS Blocks I>4, Bit 04 = Not Used, Bit 05 = Not Used	*	*	*	*
Logic Settings that determine whether blocking signals from VT supervision affect certain overcurrent stages. VTS Block – only affects directional overcurrent protection. With the relevant bit set to 1, operation of the Voltage Transformer Supervision (VTS), will block the stage. When set to 0, the stage will revert to Non-directional upon operation of the VTS. If I> Status is set 'Enabled VTS', no blocking should be selected in order to provide fault clearance by overcurrent protection during the VTS condition.								

Table 8 - Phase overcurrent protection

3.8 Negative Sequence Overcurrent

The negative sequence overcurrent protection included in the relay provides four-stage non-directional/directional phase segregated negative sequence overcurrent protection with independent time delay characteristics.

The first two stages of negative sequence overcurrent protection have time-delayed characteristics which are selectable between Inverse Definite Minimum Time (IDMT), or Definite Time (DT). The third and fourth stages have DT characteristics only.

Col	Row	MENU TEXT	Default Setting	Available Setting
Description				
36	00	GROUP 1 NEG SEQ O/C	0	
This column contains settings for Negative Sequence Overcurrent				
36	10	I2>1 Status	Disabled	0 = Disabled or 1 = Enabled
Setting to enable or disable the first stage negative sequence element.				
36	11	I2>1 Function	DT	0 = DT, 1 = IEC S Inverse, 2 = IEC V Inverse, 3 = IEC E Inverse, 4 = UK LT Inverse, 5 = IEEE M Inverse, 6 = IEEE V Inverse, 7 = IEEE E Inverse, 8 = US Inverse or 9 = US ST Inverse
Setting for the tripping characteristic for the first stage negative sequence overcurrent element.				
36	12	I2>1 Directional	Non-Directional	0 = Non-Directional, 1 = Directional Fwd, 2 = Directional Rev
This setting determines the direction of measurement for this element.				
36	15	I2>1 Current Set	0.2*I1 A	From 0.08*I1 A to 4.0*I1 A step 0.01*I1 A
Pick-up setting for the first stage negative sequence overcurrent element.				
36	17	I2>1 Time Delay	10s	From 0s to 100s step 10ms
Setting for the operating time-delay for the first stage negative sequence overcurrent element.				
36	18	I2>1 TMS	1	From 0.025 to 1.2 step 0.005
Setting for the time multiplier setting to adjust the operating time of the IEC IDMT characteristic.				
36	19	I2>1 Time Dial	1	0.01 to 100 step 0.01
Setting for the time multiplier setting to adjust the operating time of the IEEE/US IDMT curves.				
36	1C	I2>1 Reset Char	DT	0 = DT or 1 = Inverse
Setting to determine the type of reset/release characteristic of the IEEE/US curves.				
36	1D	I2>1 tRESET	0s	From 0s to 100s step 10ms
Setting that determines the reset/release time for definite time reset characteristic.				
36	20	I2>2 Status	Disabled	0 = Disabled or 1 = Enabled
Setting to enable or disable the second stage negative sequence element.				
36	21	I2>2 Function	DT	0 = DT, 1 = IEC S Inverse, 2 = IEC V Inverse, 3 = IEC E Inverse, 4 = UK LT Inverse, 5 = IEEE M Inverse, 6 = IEEE V Inverse, 7 = IEEE E Inverse, 8 = US Inverse or 9 = US ST Inverse
Setting for the tripping characteristic for the second stage negative sequence overcurrent element.				
36	22	I2>2 Directional	Non-Directional	0 = Non-Directional, 1 = Directional Fwd, 2 = Directional Rev
This setting determines the direction of measurement for this element.				

Col	Row	MENU TEXT	Default Setting	Available Setting
Description				
36	25	I2>2 Current Set	0.2*I1 A	From 0.08*I1 A to 4.0*I1 A step 0.01*I1 A
Pick-up setting for the second stage negative sequence overcurrent element.				
36	27	I2>2 Time Delay	10s	From 0s to 100s step 10ms
Setting for the operating time-delay for the second stage negative sequence overcurrent element.				
36	28	I2>2 TMS	1	From 0.025 to 1.2 step 0.005
Setting for the time multiplier setting to adjust the operating time of the IEC IDMT characteristic.				
36	29	I2>2 Time Dial	1	0.01 to 100 step 0.01
Setting for the time multiplier setting to adjust the operating time of the IEEE/US IDMT curves.				
36	2C	I2>2 Reset Char	DT	0 = DT or 1 = Inverse
Setting to determine the type of reset/release characteristic of the IEEE/US curves.				
36	2D	I2>2 tRESET	0s	From 0s to 100s step 10ms
Setting that determines the reset/release time for definite time reset characteristic.				
36	30	I2>3 Status	Disabled	0 = Disabled or 1 = Enabled
Setting to enable or disable the third stage negative sequence element.				
36	32	I2>3 Directional	Non-Directional	0 = Non-Directional, 1 = Directional Fwd, 2 = Directional Rev
This setting determines the direction of measurement for this element.				
36	35	I2>3 Current Set	0.2*I1 A	From 0.08*I1 A to 32*I1 A step 0.01*I1 A
Pick-up setting for the third stage negative sequence overcurrent element.				
36	37	I2>3 Time Delay	10s	From 0s to 100s step 10ms
Setting for the operating time-delay for the third stage negative sequence overcurrent element.				
36	40	I2>4 Status	Disabled	0 = Disabled or 1 = Enabled
Setting to enable or disable the fourth stage negative sequence element.				
36	42	I2>4 Directional	Non-Directional	0 = Non-Directional, 1 = Directional Fwd, 2 = Directional Rev
This setting determines the direction of measurement for this element.				
36	45	I2>4 Current Set	0.2*I1 A	From 0.08*I1 A to 32*I1 A step 0.01*I1 A
Pick-up setting for the fourth stage negative sequence overcurrent element.				
36	47	I2>4 Time Delay	10s	From 0s to 100s step 10ms
Setting for the operating time-delay for the fourth stage negative sequence overcurrent element.				
36	50	I2> VTS Blocking	1111(bin)	0 = VTS Blocks I2>1, 1 = VTS Blocks I2>2, 2 = VTS Blocks I2>3, 3 = VTS Blocks I2>4
Logic settings that determine whether VT supervision blocks selected negative sequence overcurrent stages. Setting '0' will permit continued non-directional operation.				
36	51	I2> Char Angle	-60	From -95° to 95° step 1°
Setting for the relay characteristic angle used for the directional decision.				
36	52	I2> V2pol Set	5*V1	From 0.5*V1 to 25*V1 step 0.5*V1
Setting determines the minimum negative sequence voltage threshold that must be present to determine directionality.				

Table 9 - Negative sequence overcurrent

3.9 Broken Conductor

Col	Row	MENU TEXT	Default Setting	Available Setting
Description				
37	00	GROUP 1 BROKEN CONDUCTOR	0	
This column contains settings for Broken Conductor				
37	01	Broken Conductor	Disabled	0 = Disabled or 1 = Enabled
Enables or disables the broken conductor function.				
37	02	I2/I1 Setting	0.2	0.2 to 1 step 0.01
Setting to determine the pick-up level of the negative to positive sequence current ratio.				
37	03	I2/I1 Time Delay	60s	From 0s to 100s step 100ms
Setting for the function operating time delay.				

Table 10 - Broken conductor

3.10 Earth Fault

The back-up earth fault overcurrent protection included in the relay provides four-stage non-directional/directional three-phase overcurrent protection with independent time delay characteristics. All earth fault overcurrent and directional settings apply to all three phases but are independent for each of the four stages.

The first two stages of earth fault overcurrent protection have time-delayed characteristics which are selectable between Inverse Definite Minimum Time (IDMT), or Definite Time (DT). The third and fourth stages have DT characteristics only.

Col	Row	MENU TEXT	Default Setting	Available Setting	P543/P545 No Distance	P544/P546 No Distance	P543/P545	P544/P546
Description								
38	00	GROUP 1 EARTH FAULT			*	*	*	*
This column contains settings for Earth Fault								
38	01	IN>1 Status	Enabled	0 = Disabled, 1 = Enabled, 2 = Enabled VTS, 3 = Enabled Ch Fail, 4 = En VTSorCh Fail, 5 = En VTSandCh Fail, 6 = Enabled CTS, 7 = En VTSorCTS, 8 = En Ch FailorCTS, 9 = En VTSorCHForCTS, 10 = En VTSandCTS, 11 = En Ch FailandCTS, 12 = En VTS CHF CTS	*	*	*	*
Setting that defines first stage overcurrent operating status. IN>1 can be disabled or enabled permanently or in case of Voltage Transformer Supervision (VTS) operation, or in case of Communication Channel Fail (CH Fail or CHF), or in case of Current Transformer Supervision (CTS) operation, or a combination of VTS or CHF, VTS or CTS, CHF or CTS, VTS or CHF or CTS, VTS and CHF, VTS and CTS, CHF and CTS, CTS and CHF and CTS.								
38	25	IN>1 Function	IEC S Inverse	0 = DT, 1 = IEC S Inverse, 2 = IEC V Inverse, 3 = IEC E Inverse, 4 = UK LT Inverse, 5 = IEEE M Inverse, 6 = IEEE V Inverse, 7 = IEEE E Inverse, 8 = US Inverse, 9 = US ST Inverse or 10 = IDG	*	*	*	*

Col	Row	MENU TEXT	Default Setting	Available Setting	P543/P545 No Distance	P544/P546 No Distance	P543/P545	P544/P546
Description								
Setting for the tripping characteristic for the first stage earth fault overcurrent element.								
38	26	IN>1 Directional	Non-Directional	0 = Non-Directional, 1 = Directional Fwd, 2 = Directional Rev	*	*	*	*
This setting determines the direction of measurement for first stage element.								
38	29	IN>1 Current Set	0.2*11 A	From 0.08*11 A to 4.0*11 A step 0.01*11 A	*	*	*	*
Pick-up setting for first stage overcurrent element								
38	2A	IN1>1 IDG Is	1.5	1 to 4 step 0.1	*	*	*	*
This setting is set as a multiple of "IN>" setting for the IDG curve (Scandinavian) and determines the actual relay current threshold at which the element starts.								
38	2C	IN>1 Time Delay	1s	From 0s to 100s step 10ms	*	*	*	*
Setting for the time-delay for the definite time setting if selected for first stage element. The setting is available only when DT function is selected.								
38	2D	IN>1 TMS	1	From 0.025 to 1.2 step 0.005	*	*	*	*
Setting for the time multiplier setting to adjust the operating time of the IEC IDMT characteristic.								
38	2E	IN>1 Time Dial	1	0.01 to 100 step 0.01	*	*	*	*
Setting for the time multiplier setting to adjust the operating time of the IEEE/US IDMT curves. The Time Dial (TD) is a multiplier on the standard curve equation, in order to achieve the required tripping time. The reference curve is based on TD = 1. Care: Certain manufacturer's use a mid-range value of TD = 5 or 7, so it may be necessary to divide by 5 or 7 to achieve parity.								
38	30	IN1>1 IDG Time	1.2s	From 1s to 2s step 10ms	*	*	*	*
Setting for the IDG curve used to set the minimum operating time at high levels of fault current.								
38	32	IN>1 Reset Char	DT	0 = DT or 1 = Inverse	*	*	*	*
Setting to determine the type of reset/release characteristic of the IEEE/US curves.								
38	33	IN>1 tRESET	0s	From 10ms to 100s step 10ms	*	*	*	*
Setting that determines the reset/release time for definite time reset characteristic.								
38	35	IN>2 Status	Disabled	0 = Disabled, 1 = Enabled, 2 = Enabled VTS, 3 = Enabled Ch Fail, 4 = En VTSorCh Fail, 5 = En VTSandCh Fail, 6 = Enabled CTS, 7 = En VTSorCTS, 8 = En Ch FailorCTS, 9 = En VTSorCHForCTS, 10 = En VTSandCTS, 11 = En Ch FailandCTS, 12 = En VTS CHF CTS	*	*	*	*
Setting that defines first stage overcurrent operating status. IN>2 can be disabled or enabled permanently or in case of Voltage Transformer Supervision (VTS) operation, or in case of Communication Channel Fail (CH Fail or CHF), or in case of Current Transformer Supervision (CTS) operation, or a combination of VTS or CHF, VTS or CTS, CHF or CTS, VTS or CHF or CTS, VTS and CHF, VTS and CTS, CHF and CTS, CTS and CHF and CTS.								
38	36	IN>2 Function	IEC S Inverse	0 = DT, 1 = IEC S Inverse, 2 = IEC V Inverse, 3 = IEC E Inverse, 4 = UK LT Inverse, 5 = IEEE M Inverse, 6 = IEEE V Inverse, 7 = IEEE E Inverse, 8 = US Inverse, 9 = US ST Inverse or 10 = IDG	*	*	*	*
Setting for the tripping characteristic for the second stage earth fault overcurrent element.								

Col	Row	MENU TEXT	Default Setting	Available Setting	P543/P545 No Distance	P544/P546 No Distance	P543/P545	P544/P546
Description								
38	37	IN>2 Directional	Non-Directional	0 = Non-Directional, 1 = Directional Fwd, 2 = Directional Rev	*	*	*	*
This setting determines the direction of measurement for first stage element.								
38	3A	IN>2 Current Set	0.2*I1 A	From 0.08*I1 A to 4.0*I1 A step 0.01*I1 A	*	*	*	*
Pick-up setting for second stage overcurrent element								
38	3B	IN2>1 IDG Is	1.5	1 to 4 step 0.1	*	*	*	*
This setting is set as a multiple of "IN>" setting for the IDG curve (Scandinavian) and determines the actual relay current threshold at which the element starts.								
38	3D	IN>2 Time Delay	1s	From 0s to 200s step 10ms	*	*	*	*
Setting for the time-delay for the definite time setting if selected for second stage element. The setting is available only when DT function is selected.								
38	3E	IN>2 TMS	1	From 0.025 to 1.2 step 0.005	*	*	*	*
Setting for the time multiplier setting to adjust the operating time of the IEC IDMT characteristic.								
38	3F	IN>2 Time Dial	1	0.01 to 100 step 0.01	*	*	*	*
Setting for the time multiplier setting to adjust the operating time of the IEEE/US IDMT curves. The Time Dial (TD) is a multiplier on the standard curve equation, in order to achieve the required tripping time. The reference curve is based on TD = 1. Care: Certain manufacturer's use a mid-range value of TD = 5 or 7, so it may be necessary to divide by 5 or 7 to achieve parity.								
38	41	IN2>1 IDG Time	1.2s	From 1s to 2s step 10ms	*	*	*	*
Setting for the IDG curve used to set the minimum operating time at high levels of fault current.								
38	43	IN>2 Reset Char	DT	0 = DT or 1 = Inverse	*	*	*	*
Setting to determine the type of reset/release characteristic of the IEEE/US curves.								
38	44	IN>2 tRESET	0s	From 0s to 100s step 10ms	*	*	*	*
Setting that determines the reset/release time for definite time reset characteristic.								
38	46	IN>3 Status	Disabled	0 = Disabled, 1 = Enabled, 2 = Enabled VTS, 3 = Enabled Ch Fail, 4 = En VTSorCh Fail, 5 = En VTSandCh Fail, 6 = Enabled CTS, 7 = En VTSorCTS, 8 = En Ch FailorCTS, 9 = En VTSorCHForCTS, 10 = En VTSandCTS, 11 = En Ch FailandCTS, 12 = En VTS CHF CTS	*	*	*	*
Setting that defines first stage overcurrent operating status. IN>3can be disabled or enabled permanently or in case of Voltage Transformer Supervision (VTS) operation, or in case of Communication Channel Fail (CH Fail or CHF), or in case of Current Transformer Supervision (CTS) operation, or a combination of VTS or CHF, VTS or CTS, CHF or CTS, VTS or CHF or CTS, VTS and CHF, VTS and CTS, CHF and CTS, CTS and CHF and CTS.								
38	47	IN>3 Directional	Directional Fwd	0 = Non-Directional, 1 = Directional Fwd, 2 = Directional Rev	*	*	*	*
This setting determines the direction of measurement for the earth fault overcurrent element.								
38	4A	IN>3 Current Set	10*I1 A	From 0.08*I1 A to 32*I1 A step 0.01*I1 A	*	*	*	*
Pick-up setting for third stage earth fault overcurrent element.								
38	4B	IN>3 Time Delay	0s	From 0s to 200s step 10ms	*	*	*	*
Setting for the operating time-delay for third stage earth fault overcurrent element.								

Col	Row	MENU TEXT	Default Setting	Available Setting	P543/P545 No Distance	P544/P546 No Distance	P543/P545	P544/P546
Description								
38	4C	IN>3 CT Select	CT1+2 Magnitude	0 = CT1 Magnitude, 1 = CT2 Magnitude, 2 = CT1+2 Magnitude		*		*
Allows Selection of the measured CT for two CT models								
38	4D	IN>4 Status	Disabled	0 = Disabled, 1 = Enabled, 2 = Enabled VTS, 3 = Enabled Ch Fail, 4 = En VTSorCh Fail, 5 = En VTSandCh Fail, 6 = Enabled CTS, 7 = En VTSorCTS, 8 = En Ch FailorCTS, 9 = En VTSorCHForCTS, 10 = En VTSandCTS, 11 = En Ch FailandCTS, 12 = En VTS CHF CTS	*	*	*	*
Setting that defines fourth stage overcurrent operating status. IN>4 can be disabled or enabled permanently or in case of Voltage Transformer Supervision (VTS) operation, or in case of Communication Channel Fail (CH Fail or CHF), or in case of Current Transformer Supervision (CTS) operation, or a combination of VTS or CHF, VTS or CTS, CHF or CTS, VTS or CHF or CTS, VTS and CHF, VTS and CTS, CHF and CTS, CTS and CHF and CTS.								
38	4E	IN>4 Directional	Non-Directional	0 = Non-Directional, 1 = Directional Fwd, 2 = Directional Rev	*	*	*	*
This setting determines the direction of measurement for the earth fault overcurrent element.								
38	51	IN>4 Current Set	10*11 A	From 0.08*11 A to 32*11 A step 0.01*11 A	*	*	*	*
Pick-up setting for fourth stage earth fault overcurrent element.								
38	52	IN>4 Time Delay	0s	From 0s to 200s step 10ms	*	*	*	*
Setting for the operating time-delay for fourth stage earth fault overcurrent element.								
38	53	IN>4 CT Select	CT1+2 Magnitude	0 = CT1 Magnitude, 1 = CT2 Magnitude, 2 = CT1+2 Magnitude		*		*
Allows Selection of the measured CT for two CT models								
38	54	IN> Blocking	001111(bin)	Bit 00 = VTS Blocks IN>1, Bit 01 = VTS Blocks IN>2, Bit 02 = VTS Blocks IN>3, Bit 03 = VTS Blocks IN>4, Bit 04 = Not Used, Bit 05 = Not Used	*	*	*	*
Logic Settings that determine whether blocking signals from VT supervision affect certain earth fault overcurrent stages. VTS Block - only affects directional earth fault overcurrent protection. With the relevant bit set to 1, operation of the Voltage Transformer Supervision (VTS), will block the stage. When set to 0, the stage will revert to Non-directional upon operation of the VTS. If IN> Status is set 'Enabled VTS', no blocking should be selected in order to provide earth fault clearance by earth fault overcurrent protection during VTS condition.								
38	55	IN> DIRECTIONAL			*	*	*	*
38	56	IN> Char Angle	-60	From -95° to 95° step 1°	*	*	*	*
Setting for the relay characteristic angle used for the directional decision. The setting is visible only when 'Directional Fwd' or 'Directional Rev' is set.								
38	57	IN> Polarisation	Zero Sequence	0 = Zero Sequence or 1 = Neg Sequence	*	*	*	*
Setting that determines whether the directional function uses zero sequence or negative sequence voltage polarizing.								

Col	Row	MENU TEXT	Default Setting	Available Setting	P543/P545 No Distance	P544/P546 No Distance	P543/P545	P544/P546
Description								
38	59	IN> VNpol Set	1*V1	From 0.5*V1 to 40*V1 step 0.5*V1	*	*	*	*
Setting for the minimum zero sequence voltage polarizing quantity for directional decision. Setting is visible only when 'Zero Sequence' polarization is set.								
38	5A	IN> V2pol Set	1*V1	From 0.5*V1 to 25*V1 step 0.5*V1	*	*	*	*
Setting for the minimum negative sequence voltage polarizing quantity for directional decision. Setting is visible only when 'Negative Sequence' polarization is set.								
38	5B	IN> I2pol Set	0.08*I1 A	From 0.08*I1 A to 1.0*I1 A step 0.01*I1 A	*	*	*	*
Setting for the minimum negative sequence current polarizing quantity for directional decision. Setting is visible only when 'Negative Sequence' polarization is set.								

Table 11 - Earth fault

3.11 Aided DEF (only in Models with Distance Option)

The column **GROUP x AIDED DEF** is used to set all parameters for operation of DEF (Directional Earth Fault aided scheme thresholds). As this configuration merely assigns pick up at the local end only, they need to be further configured to a selected Aided channel scheme under **GROUP x SCHEME LOGIC** to provide unit protection.

Col	Row	Menu Text	Default Setting	Available Setting	P543 / P545 No Distance	P544 / P546 No Distance	P543 / P545	P544 / P546
Description								
39	00	GROUP 1 AIDED DEF					*	*
This column contains settings for Aided DEF								
39	02	DEF Status	Enabled	0 = Disabled or 1 = Enabled			*	*
To enable (activate) or disable (turn off) the Directional Earth Fault element that is used in an aided scheme (= ground overcurrent pilot scheme). This setting is invisible if disabled in 'CONFIGURATION' column.								
39	03	DEF Polarizing	Zero Sequence	0 = Zero Sequence or 1 = Neg Sequence			*	*
Setting that defines the method of DEF polarization. Either zero, or negative sequence voltage can be taken as the directional reference. When Zero Sequence is selected, this arms the Virtual Current Polarizing.								
39	04	DEF Char Angle	-60	From -95° to 95° step 1°			*	*
Setting for the relay characteristic angle used for the directional decision.								
39	05	DEF VNpol Set	1*V1	From 0.5*V1 to 40*V1 step 0.5*V1			*	*
Setting that must be exceeded by generated neutral displacement voltage VN (= 3.Vo) in order for the DEF function to be operational. As Virtual Current Polarizing will be in force when Zero sequence polarizing is used, this setting will normally have no relevance. If the relay phase selector (delta sensitivity typically 4% In) detects the faulted phase, this will artificially generate a large VNpol, typically equal to Vn (phase-ground). Only if the phase selector cannot phase select will this setting be relevant, as VNpol will then measure true VN. The setting is invisible if 'Neg. Sequence' polarization is set.								
39	06	DEF V2pol Set	1*V1	From 0.5*V1 to 25*V1 step 0.5*V1			*	*

Col	Row	Menu Text	Default Setting	Available Setting	P543 / P545 No Distance	P544 / P546 No Distance	P543 / P545	P544 / P546
Description								
Setting that must be exceeded by generated negative sequence voltage V2 in order for the DEF function to be operational. The setting is invisible if 'Zero Sequence' polarization is set.								
39	07	DEF FWD Set	0.08*11 A	From 0.05*11 A to 1.0*11 A step 0.01*11 A			*	*
Setting the forward pickup current sensitivity for residual current (= 3.Io).								
39	08	DEF REV Set	0.04*11 A	From 0.03*11 A to 1.0*11 A step 0.01*11 A			*	*
Setting the reverse pickup current sensitivity for residual current (= 3.Io).								
39	09	Virtual I Pol	Enabled	0 = Disabled or 1 = Enabled			*	*
Setting to Enable/Disable virtual current polarizing								

Table 12 - Group x aided DEF

3.12 Sensitive Earth Fault (SEF)

If a system is earthed through a high impedance, or is subject to high ground fault resistance, the earth fault level will be severely limited. Consequently, the applied earth fault protection requires both an appropriate characteristic and a suitably sensitive setting range in order to be effective. A separate four-stage sensitive earth fault element is provided within the relay for this purpose, which has a dedicated input.

Col	Row	MENU TEXT	Default Setting	Available Setting
Description				
3A	00	GROUP 1 SEF/REF PROT'N	0	
This column contains settings for SEF/REF				
3A	01	SEF/REF Options	SEF Enabled	0 = SEF Enabled, 1 = Wattmetric SEF, 2 = Hi Z REF
Setting to select the type of sensitive earth fault protection function and the type of high-impedance function to be used.				
3A	2A	ISEF>1 Function	DT	0 = Disabled, 1 = DT, 2 = IEC S Inverse, 3 = IEC V Inverse, 4 = IEC E Inverse, 5 = UK LT Inverse, 6 = IEEE M Inverse, 7 = IEEE V Inverse, 8 = IEEE E Inverse, 9 = US Inverse, 10 = US ST Inverse or 11 = IDG
Setting for the tripping characteristic for the first stage sensitive earth fault element.				
3A	2B	ISEF>1 Direction	Non-Directional	0 = Non-Directional, 1 = Directional Fwd, 2 = Directional Rev
This setting determines the direction of measurement for the first stage sensitive earth fault element.				
3A	2E	ISEF>1 Current	0.05*13 A	From 0.005*13 A to 0.1*13 A step 0.00025*13 A
Pick-up setting for the first stage sensitive earth fault element.				
3A	2F	ISEF>1 IDG Is	1.5	1 to 4 step 0.1
This setting is set as a multiple of ISEF> setting for the IDG curve (Scandinavian) and determines the actual relay current threshold at which the element starts.				
3A	31	ISEF>1 Delay	1s	From 0s to 200s step 10ms
Setting for the time delay for the first stage definite time element.				
3A	32	ISEF>1 TMS	1	From 0.025 to 1.2 step 0.005

Col	Row	MENU TEXT	Default Setting	Available Setting
Description				
Setting for the time multiplier to adjust the operating time of the IEC IDMT characteristic.				
3A	33	ISEF>1 Time Dial	1	From 0.01 to 100 step 0.01
Setting for the time multiplier to adjust the operating time of the IEEE/US IDMT curves.				
3A	34	ISEF>1 IDG Time	1.2s	From 1s to 2s step 10ms
Setting for the IDG curve used to set the minimum operating time at high levels of fault current.				
3A	36	ISEF>1 Reset Chr	DT	0 = DT or 1 = Inverse
Setting to determine the type of reset/release characteristic of the IEEE/US curves.				
3A	37	ISEF>1 tRESET	0s	From 10ms to 100s step 10ms
Setting to determine the reset/release time for definite time reset characteristic.				
3A	3A	ISEF>2 Function	Disabled	0 = Disabled, 1 = DT, 2 = IEC S Inverse, 3 = IEC V Inverse, 4 = IEC E Inverse, 5 = UK LT Inverse, 6 = IEEE M Inverse, 7 = IEEE V Inverse, 8 = IEEE E Inverse, 9 = US Inverse, 10 = US ST Inverse or 11 = IDG
Setting for the tripping characteristic for the second stage sensitive earth fault element.				
3A	3B	ISEF>2 Direction	Non-Directional	0 = Non-Directional, 1 = Directional Fwd, 2 = Directional Rev
This setting determines the direction of measurement for the second stage sensitive earth fault element.				
3A	3E	ISEF>2 Current	0.05*I3 A	From 0.005*I3 A to 0.1*I3 A step 0.00025*I3 A
Pick-up setting for the second stage sensitive earth fault element.				
3A	3F	ISEF>2 IDG Is	1.5	From 1 to 4 step 0.1
This setting is set as a multiple of ISEF> setting for the IDG curve (Scandinavian) and determines the actual relay current threshold at which the element starts.				
3A	41	ISEF>2 Delay	1s	From 0s to 200s step 10ms
Setting for the time delay for the second stage definite time element.				
3A	42	ISEF>2 TMS	1	From 0.025 to 1.2 step 0.005
Setting for the time multiplier to adjust the operating time of the IEC IDMT characteristic.				
3A	43	ISEF>2 Time Dial	1	From 0.01 to 100 step 0.01
Setting for the time multiplier to adjust the operating time of the IEEE/US IDMT curves.				
3A	44	ISEF>2 IDG Time	1.2s	From 1s to 2s step 10ms
Setting for the IDG curve used to set the minimum operating time at high levels of fault current.				
3A	46	ISEF>2 Reset Chr	DT	0 = DT or 1 = Inverse
Setting to determine the type of reset/release characteristic of the IEEE/US curves.				
3A	47	ISEF>2 tRESET	0s	From 10ms to 100s step 10ms
Setting to determine the reset/release time for definite time reset characteristic.				
3A	49	ISEF>3 Status	Disabled	0 = Disabled or 1 = Enabled
Setting to enable or disable the third stage definite time sensitive earth fault element.				
3A	4A	ISEF>3 Direction	Non-Directional	0 = Non-Directional, 1 = Directional Fwd, 2 = Directional Rev
This setting determines the direction of measurement for the third stage element.				
3A	4D	ISEF>3 Current	0.4*I3 A	From 0.005*I3 A to 2.0*I3 A step 0.001*I3 A
Pick-up setting for the third stage sensitive earth fault element.				
3A	4E	ISEF>3 Delay	500ms	From 0s to 200s step 10ms
Setting for the operating time delay for third stage sensitive earth fault element.				
3A	50	ISEF>4 Status	Disabled	0 = Disabled or 1 = Enabled

Col	Row	MENU TEXT	Default Setting	Available Setting
Description				
Setting to enable or disable the fourth stage definite time sensitive earth fault element.				
3A	51	ISEF>4 Direction	Non-Directional	0 = Non-Directional, 1 = Directional Fwd, 2 = Directional Rev
This setting determines the direction of measurement for the fourth stage element.				
3A	54	ISEF>4 Current	0.6*I3 A	From 0.005*I3 A to 2.0*I3 A step 0.001*I3 A
Pick-up setting for the fourth stage sensitive earth fault element.				
3A	55	ISEF>4 Delay	250ms	From 0s to 200s step 10ms
Setting for the operating time delay for fourth stage sensitive earth fault element.				
3A	57	ISEF> Blocking	001111(bin)	Bit 00 = VTS Blks ISEF>1, Bit 01 = VTS Blks ISEF>2, Bit 02 = VTS Blks ISEF>3, Bit 03 = VTS Blks ISEF>4, Bit 04 = Not Used, Bit 05 = Not Used
Logic Settings that determine whether blocking signals from VT supervision affect certain earth fault overcurrent stages. VTS Block - only affects sensitive earth fault protection. With the relevant bit set to 1, operation of the Voltage Transformer Supervision (VTS), will block the stage. When set to 0, the stage will revert to Non-directional upon operation of the VTS.				
3A	58	ISEF DIRECTIONAL	0	
0				
3A	59	ISEF> Char Angle	90	From -95° to 95° step 1°
Setting for the relay characteristic angle used for the directional decision.				
3A	5B	ISEF> VNpol Set	5*V1	From 0.5*V1 to 88*V1 step 0.5*V1
Setting for the minimum zero sequence voltage polarizing quantity required for directional decision.				
3A	5D	Wattmetric SEF	0	0
0				
3A	5E	PN> Setting	9*V1*I3	From 0.0*V1*I3 to 20*V1*I3 step 0.05*V1*I3
Setting for the threshold for the wattmetric component of zero sequence power. The power calculation is as follows: The PN> setting corresponds to: $V_{res} \times I_{res} \times \cos(\varphi - \varphi_c) = 9 \times V_0 \times I_0 \times \cos(\varphi - \varphi_c)$ Where; φ = Angle between the Polarizing Voltage (-Vres) and the Residual Current φ_c = Relay Characteristic Angle (RCA) Setting (ISEF> Char Angle) Vres = Residual Voltage Ires = Residual Current V0 = Zero Sequence Voltage I0 = Zero Sequence Current				
3A	60	RESTRICTED E/F	0	0
0				
3A	65	IREF> Is	0.2*I3 A	From 0.05*I1 A to 1.0*I3 A step 0.01*I3 A
Pick-up setting for the High Impedance restricted earth fault element.				

Table 13 - Sensitive earth fault

3.13

Residual Overvoltage (Neutral Voltage Displacement)

The Neutral Voltage Displacement (NVD) element within the relay is of two-stage design, each stage having separate voltage and time delay settings. Stage 1 may be set to operate on either an IDMT or DT characteristic, whilst stage 2 may be set to DT only.

Col	Row	MENU TEXT	Default Setting	Available Setting
Description				
3B	00	GROUP 1 RESIDUAL O/V NVD	0	
This column contains settings for Residual Overcurrent				
3B	01	VN Input	Derived	Not Settable
Data cell indicating the VN Input is always derived from the 3 phase voltages				
3B	02	VN>1 Function	DT	0 = Disabled, 1 = DT or 2 = IDMT
Setting for the tripping characteristic of the first stage residual overvoltage element.				
3B	03	VN>1 Voltage Set	5*V1	From 1*V1 to 200*V1 step 1*V1
Pick-up setting for the first stage residual overvoltage characteristic.				
3B	04	VN>1 Time Delay	5s	From 0s to 100s step 10ms
Operating time delay setting for the first stage definite time residual overvoltage element.				
3B	05	VN>1 TMS	1	0.5 to 100 step 0.5
Setting for the time multiplier setting to adjust the operating time of the IDMT characteristic. The characteristic is defined as follows: $t = K / (M - 1)$ Where: K = Time multiplier setting t = Operating time in seconds M = Derived residual voltage/relay setting voltage (VN> Voltage Set)				
3B	06	VN>1 tReset	0s	From 0s to 100s step 10ms
Setting to determine the reset/release definite time for the first stage characteristic				
3B	07	VN>2 Status	Disabled	0 = Disabled or 1 = Enabled
Setting to enable or disable the second stage definite time residual overvoltage element.				
3B	08	VN>2 Voltage Set	10*V1	From 1*V1 to 200*V1 step 1*V1
Pick-up setting for the second stage residual overvoltage element.				
3B	09	VN>2 Time Delay	10s	From 0s to 100s step 10ms
Operating time delay for the second stage residual overvoltage element.				

Table 14 - Residual overvoltage (neutral voltage displacement)

3.14 Thermal Overload

The thermal overload function within the relay can be selected as a single time constant or dual time constant characteristic, dependent on the type of plant to be protected.

Col	Row	MENU TEXT	Default Setting	Available Setting
Description				
3C	00	GROUP 1 THERMAL OVERLOAD	0	
This column contains settings for Thermal Overload				
3C	01	Characteristic	Single	0 = Disabled, 1 = Single, 2 = Dual
Setting for the operating characteristic of the thermal overload element.				
3C	02	Thermal Trip	1*11 A	From 0.08*11 A to 4.0*11 A step 0.01*11 A
Sets the maximum full load current allowed and the pick-up threshold of the thermal characteristic.				

Col	Row	MENU TEXT	Default Setting	Available Setting
Description				
3C	03	Thermal Alarm	0.7	From 50% to 100% step 1%
Setting for the thermal state threshold corresponding to a percentage of the trip threshold at which an alarm will be generated.				
3C	04	Time Constant 1	10min	From 1min to 200min step 1min
Setting for the thermal time constant for a single time constant characteristic or the first time constant for the dual time constant characteristic.				
3C	05	Time Constant 2	5min	From 1min to 200min step 1min
Setting for the second thermal time constant for the dual time constant characteristic.				

Table 15 - Thermal overload

3.15 Voltage Protection

Under and overvoltage protection included within the relay consists of two independent stages. The measuring mode (ph-N or ph-ph) and operating mode (any phase or 3 phase) are configurable as a combination between Stage 1 and Stage 2, therefore allowing completely independent operation for each stage.

Stage 1 may be selected as IDMT, DT or Disabled, within the **V<1 function** cell.

Stage 2 is DT only and is enabled/disabled in the **V<2 status** cell.

Two stages are included to provide both alarm and trip stages, where required.

Col	Row	MENU TEXT	Default Setting	Available Setting
Description				
42	00	GROUP 1 VOLT PROTECTION	0	
This column contains settings for Voltage Protection				
42	01	UNDER VOLTAGE	0	
0				
42	02	V< Measur't Mode	V<1 & V<2 Ph-Ph	0 = V<1 & V<2 Ph-Ph, 1 = V<1 & V<2 Ph-N, 2 = V<1Ph-Ph V<2Ph-N, 3 = V<1Ph-N V<2Ph-Ph
Sets the combination of measured input voltage that will be used for the undervoltage elements. Note: If any stage is disabled, the associated text in the setting menu cell setting will remain visible but will not affect the operation of the stage that is enabled.				
42	03	V< Operate Mode	V<1 & V<2 Any Ph	0 = V<1 & V<2 Any Ph, 1 = V<1 & V<2 3Phase, 2 = V<1AnyPh V<2 3Ph, 3 = V<1 3Ph V<2AnyPh
Setting that determines whether any phase or all three phases has to satisfy the undervoltage criteria before a decision is made. Note: If any stage is disabled, the associated text in the setting menu cell setting will remain visible but will not affect the operation of the stage that is enabled.				
42	04	V<1 Function	DT	0 = Disabled, 1 = DT or 2 = IDMT
Tripping characteristic for the first stage undervoltage function. The IDMT characteristic available on the first stage is defined by the following formula: $t = K / (1 - M)$ Where: K = Time multiplier setting t = Operating time in seconds M = Measured voltage/relay setting voltage (V< Voltage Set)				

Col	Row	MENU TEXT	Default Setting	Available Setting
Description				
42	05	V<1 Voltage Set	80*V1	From 10*V1 to 120*V1 step 0.1*V1
Sets the pick-up setting for first stage undervoltage element.				
42	06	V<1 Time Delay	10s	From 0s to 100s step 10ms
Setting for the operating time-delay for the first stage definite time undervoltage element.				
42	07	V<1 TMS	1	0.5 to 100 step 0.5
Setting for the time multiplier setting to adjust the operating time of the IDMT characteristic.				
42	08	V<1 Poledead Inh	Enabled	0 = Disabled or 1 = Enabled
If the cell is enabled, the relevant stage will become inhibited by the pole dead logic. This logic produces an output when it detects either an open circuit breaker via auxiliary contacts feeding the relay opto inputs or it detects a combination of both undercurrent and undervoltage on any one phase. It allows the undervoltage protection to reset when the circuit breaker opens to cater for line or bus side VT applications.				
42	09	V<2 Status	Disabled	0 = Disabled or 1 = Enabled
Setting to enable or disable the second stage undervoltage element.				
42	0A	V<2 Voltage Set	60*V1	From 10*V1 to 120*V1 step 0.1*V1
This setting determines the pick-up setting for second stage undervoltage element.				
42	0B	V<2 Time Delay	5s	From 0s to 100s step 10ms
Setting for the operating time-delay for the second stage definite time undervoltage element.				
42	0C	V<2 Poledead Inh	Enabled	0 = Disabled or 1 = Enabled
Similar function to V<1 Poledead Inhibit.				
42	0D	OVERVOLTAGE	0	
0				
42	0E	V> Measur't Mode	V>1 & V>2 Ph-Ph	0 = V>1 & V>2 Ph-Ph, 1 = V>1 & V>2 Ph-N, 2 = V>1Ph-Ph V>2Ph-N, 3 = V>1Ph-N V>2Ph-Ph
Sets the combination of measured input voltage that will be used for the overvoltage elements. Note: If any stage is disabled, the associated text in the setting menu cell setting will remain visible but will not affect the operation of the stage that is enabled.				
42	0F	V> Operate Mode	V>1 & V>2 Any Ph	0 = V>1 & V>2 Any Ph, 1 = V>1 & V>2 3Phase, 2 = V>1AnyPh V>2 3Ph, 3 = V>1 3Ph V>2AnyPh
Setting that determines whether any phase or all three phases has to satisfy the overvoltage criteria before a decision is made. Note: If any stage is disabled, the associated text in the setting menu cell setting will remain visible but will not affect the operation of the stage that is enabled.				
42	10	V>1 Function	DT	0 = Disabled, 1 = DT or 2 = IDMT
Tripping characteristic setting for the first stage overvoltage element. The IDMT characteristic available on the first stage is defined by the following formula: $t = K/(M - 1)$ Where: K = Time multiplier setting t = Operating time in seconds M = Measured voltage/relay setting voltage (V<>Voltage Set)				
42	11	V>1 Voltage Set	130*V1	From 60*V1 to 185*V1 step 0.1*V1
Sets the pick-up setting for first stage overvoltage element.				
42	12	V>1 Time Delay	10s	From 0s to 100s step 10ms
Setting for the operating time-delay for the first stage definite time overvoltage element.				
42	13	V>1 TMS	1	0.5 to 100 step 0.5
Setting for the time multiplier setting to adjust the operating time of the IDMT characteristic.				

Col	Row	MENU TEXT	Default Setting	Available Setting
Description				
42	14	V>2 Status	Disabled	0 = Disabled or 1 = Enabled
Setting to enable or disable the second stage overvoltage element.				
42	15	V>2 Voltage Set	150*V1	From 60*V1 to 185*V1 step 0.1*V1
This setting determines the pick-up setting for the second stage overvoltage element.				
42	16	V>2 Time Delay	500ms	From 0s to 100s step 10ms
Setting for the operating time-delay for the second stage definite time overvoltage element.				
42	20	COMP OVERVOLTAGE	0	0
0				
42	23	V1>1 Cmp Funct	Disabled	0 = Disabled, 1 = DT or 2 = IDMT
Tripping characteristic setting for the first stage compensated overvoltage element. The IDMT characteristic available on the first stage is defined by the following formula: $t = K/(M - 1)$ Where: K = Time multiplier setting t = Operating time in seconds M = Remote calculated voltage/relay setting voltage (V<>Voltage Set)				
42	24	V1>1 Cmp Vlt Set	75*V1	From 60*V1 to 110*V1 step 0.1*V1
Sets the pick-up setting for first stage overvoltage element. This is set in terms of the phase to neutral voltage.				
42	25	V1>1 Cmp Tim Dly	10s	From 0s to 100s step 10ms
Setting for the operating time-delay for the first stage definite time compensated overvoltage element.				
42	26	V1>1 Cmp TMS	1	0.5 to 100 step 0.5
Setting for the time multiplier setting to adjust the operating time of the IDMT characteristic.				
42	27	V1>2 Cmp Status	Disabled	0 = Disabled or 1 = Enabled
Setting to enable or disable the second stage compensated overvoltage element.				
42	28	V1>2 Cmp Vlt Set	85*V1	From 60*V1 to 110*V1 step 0.1*V1
This setting determines the pick-up setting for the second stage overvoltage element.				
42	29	V1>2 Cmp Tim Dly	500ms	From 0s to 100s step 10ms
Setting for the operating time-delay for the second stage definite time compensated overvoltage element.				

Table 16 - Voltage protection

3.16 Frequency Protection

The relay includes four stages of underfrequency and two stages of overfrequency protection to facilitate load shedding and subsequent restoration. The underfrequency stages may be optionally blocked by a pole dead (CB Open) condition.

Col	Row	MENU TEXT	Default Setting	Available Setting
Description				
43	00	GROUP 1 FREQ PROTECTION	0	
This column contains settings for Frequency				
43	01	UNDER FREQUENCY	0	0
0				
43	02	F<1 Status	Enabled	0 = Disabled or 1 = Enabled

Col	Row	MENU TEXT	Default Setting	Available Setting
Description				
Setting to enable or disable the first stage underfrequency element.				
43	03	F<1 Setting	49.5Hz	From 45Hz to 66.3Hz step 0.01Hz
Setting that determines the pick-up threshold for the first stage underfrequency element.				
43	04	F<1 Time Delay	4s	From 0s to 100s step 10ms
Setting that determines the minimum operating time-delay for the first stage underfrequency element.				
43	05	F<2 Status	Disabled	0 = Disabled or 1 = Enabled
Setting to enable or disable the second stage underfrequency element.				
43	06	F<2 Setting	49Hz	From 45Hz to 66.3Hz step 0.01Hz
Setting that determines the pick-up threshold for the second stage underfrequency element.				
43	07	F<2 Time Delay	3s	From 0s to 100s step 10ms
Setting that determines the minimum operating time-delay for the second stage underfrequency element.				
43	08	F<3 Status	Disabled	0 = Disabled or 1 = Enabled
Setting to enable or disable the third stage underfrequency element.				
43	09	F<3 Setting	48.5Hz	From 45Hz to 66.3Hz step 0.01Hz
Setting that determines the pick-up threshold for the third stage underfrequency element.				
43	0A	F<3 Time Delay	2s	From 0s to 100s step 10ms
Setting that determines the minimum operating time-delay for the third stage underfrequency element.				
43	0B	F<4 Status	Disabled	0 = Disabled or 1 = Enabled
Setting to enable or disable the fourth stage underfrequency element.				
43	0C	F<4 Setting	48Hz	From 45Hz to 66.3Hz step 0.01Hz
Setting that determines the pick-up threshold for the fourth stage underfrequency element.				
43	0D	F<4 Time Delay	1s	From 0s to 100s step 10ms
Setting that determines the minimum operating time-delay for the fourth stage underfrequency element.				
43	0E	F< Function Link	0000(bin)	Bit 00 = F<1 Poledead Blk, Bit 01 = F<2 Poledead Blk, Bit 02 = F<3 Poledead Blk, Bit 03 = F<4 Poledead Blk
Settings that determines whether undervoltage level (setting CB FAIL & P.DEAD/POLEDEAD VOLTAGE/V<) signal block the underfrequency elements.				
43	0F	OVER FREQUENCY	0	0
0				
43	10	F>1 Status	Enabled	0 = Disabled or 1 = Enabled
Setting to enable or disable the first stage overfrequency element.				
43	11	F>1 Setting	50.5Hz	From 45Hz to 66.3Hz step 0.01Hz
Setting that determines the pick-up threshold for the first stage overfrequency element.				
43	12	F>1 Time Delay	2s	From 0s to 100s step 10ms
Setting that determines the minimum operating time-delay for the first stage overfrequency element.				
43	13	F>2 Status	Disabled	0 = Disabled or 1 = Enabled
Setting to enable or disable the second stage overfrequency element.				
43	14	F>2 Setting	51Hz	From 45Hz to 66.3Hz step 0.01Hz
Setting that determines the pick-up threshold for the second stage overfrequency element.				
43	15	F>2 Time Delay	1s	From 0s to 100s step 10ms
Setting that determines the minimum operating time-delay for the second stage overfrequency element.				

Table 17 - Frequency protection

3.17 Independent Rate of Change of Frequency Protection

The relay provides four independent stages of rate of change of frequency protection (df/dt+t). Depending upon whether the rate of change of frequency setting is set positive or negative, the element will react to rising or falling frequency conditions respectively, with an incorrect setting being indicated if the threshold is set to zero.

Col	Row	MENU TEXT	Default Setting	Available Setting
Description				
44	00	GROUP 1 DF/DT PROTECTION	0	
This column contains settings for DF/DT Protection				
44	01	df/dt Avg.Cycles	6	6 to 12 step 6
This setting is available for calculating the rate of change of frequency measurement over a fixed period of either 6 or 12 cycles.				
44	04	df/dt>1 Status	Enabled	0 = Disabled or 1 = Enabled
Setting to enable or disable the first stage df/dt element.				
44	05	df/dt>1 Setting	2Hz/s	From 0.1Hz/s to 10Hz/s step 0.1Hz/s
Pick-up setting for the first stage df/dt element.				
44	06	df/dt>1 Dir'n	Negative	0 = Negative, 1 = Positive, 2 = Both
This setting determines whether the element will react to rising or falling frequency conditions respectively, with an incorrect setting being indicated if the threshold is set to zero.				
44	07	df/dt>1 Time	500ms	From 0s to 100s step 10ms
Minimum operating time-delay setting for the first stage df/dt element.				
44	0B	df/dt>2 Status	Enabled	0 = Disabled or 1 = Enabled
Setting to enable or disable the second stage df/dt element.				
44	0C	df/dt>2 Setting	2Hz/s	From 0.1Hz/s to 10Hz/s step 0.1Hz/s
Pick-up setting for the second stage df/dt element.				
44	0D	df/dt>2 Dir'n	Negative	0 = Negative, 1 = Positive, 2 = Both
This setting determines whether the element will react to rising or falling frequency conditions respectively, with an incorrect setting being indicated if the threshold is set to zero.				
44	0E	df/dt>2 Time	1s	From 0s to 100s step 10ms
Minimum operating time-delay setting for the second stage df/dt element.				
44	12	df/dt>3 Status	Enabled	0 = Disabled or 1 = Enabled
Setting to enable or disable the third stage df/dt element.				
44	13	df/dt>3 Setting	2Hz/s	From 0.1Hz/s to 10Hz/s step 0.1Hz/s
Pick-up setting for the third stage df/dt element.				
44	14	df/dt>3 Dir'n	Negative	0 = Negative, 1 = Positive, 2 = Both
This setting determines whether the element will react to rising or falling frequency conditions respectively, with an incorrect setting being indicated if the threshold is set to zero.				
44	15	df/dt>3 Time	2s	From 0s to 100s step 10ms
Minimum operating time-delay setting for the third stage df/dt element.				
44	19	df/dt>4 Status	Enabled	0 = Disabled or 1 = Enabled
Setting to enable or disable the fourth stage df/dt element.				
44	1A	df/dt>4 Setting	2Hz/s	From 0.1Hz/s to 10Hz/s step 0.1Hz/s
Pick-up setting for the fourth stage df/dt element.				
44	1B	df/dt>4 Dir'n	Negative	0 = Negative, 1 = Positive, 2 = Both

Col	Row	MENU TEXT	Default Setting	Available Setting
Description				
This setting determines whether the element will react to rising or falling frequency conditions respectively, with an incorrect setting being indicated if the threshold is set to zero.				
44	1C	df/dt>4 Time	3s	From 0s to 100s step 10ms
Minimum operating time-delay setting for the fourth stage df/dt element.				

Table 18 - DF/DT protection

3.18 Circuit Breaker (CB) Fail and Pole Dead Detection Function

CB Fail Function

This function consists of a two-stage Circuit Breaker (CB) fail function initiated by:

- Current-based or Voltage-based protection elements
- External protection elements.

For current-based protection, the reset condition is based on undercurrent operation to determine that the CB has opened. For the non-current based protection, the reset criteria may be selected by means of a setting for determining a CB Failure condition.

It is common practice to use low set undercurrent elements in protection relays to indicate that circuit breaker poles have interrupted the fault or load current, as required.

Pole Dead Function

The Pole Dead Detection consists of a two user-settable level detectors:

- Undercurrent
- Undervoltage

Both, undercurrent and undervoltage settings are also used for CNV (Current No Volt) function in TOC protection.

Col	Row	MENU TEXT	Default Setting	Available Setting	P543/P545 No Distance	P544/P546 No Distance	P543/P545	P544/P546
Description								
45	00	GROUP1 CB FAIL & P.DEAD			*	*	*	*
This column contains settings for Circuit Breaker Fail and Pole Dead detection								
45	01	BREAKER FAIL			*		*	
45	01	CB1 BREAKER FAIL				*		*
45	02	CB Fail 1 Status	Enabled	0 = Disabled or 1 = Enabled	*		*	
Setting to enable or disable the first stage of the circuit breaker function.								
45	02	CB1 Fail1 Status	Enabled	0 = Disabled or 1 = Enabled		*		*
Setting to enable or disable the first stage of the circuit breaker function for CB1.								
45	03	CB Fail 1 Timer	200ms	From 0s to 100s step 10ms	*		*	
Setting for the circuit breaker fail timer stage 1, during which breaker opening must be detected. There are timers per phase to cope with evolving faults, but the timer setting is common.								
45	03	CB1 Fail1 Timer	200ms	From 0s to 100s step 10ms		*		*

Col	Row	MENU TEXT	Default Setting	Available Setting	P543/P545 No Distance	P544/P546 No Distance	P543/P545	P544/P546
Description								
Setting for the circuit breaker fail timer stage 1, during which breaker opening must be detected. There are timers per phase to cope with evolving faults, but the timer setting is common.								
45	04	CB Fail 2 Status	Disabled	0 = Disabled or 1 = Enabled	*		*	
Setting to enable or disable the second stage of the circuit breaker function.								
45	04	CB1 Fail2 Status	Disabled	0 = Disabled or 1 = Enabled		*		*
Setting to enable or disable the first stage of the circuit breaker function for CB1.								
45	05	CB Fail 2 Timer	400ms	From 0s to 100s step 10ms	*		*	
Setting for the circuit breaker fail timer stage 2, during which breaker opening must be detected.								
45	05	CB1 Fail2 Timer	400ms	From 0s to 100s step 10ms		*		*
Setting for the circuit breaker fail timer stage 2, during which breaker opening must be detected.								
45	06	Volt Prot Reset	Prot Reset & I<	0 = I< Only, 1 = CB Open & I<, 2 = Prot Reset & I<	*		*	
Setting which determines the elements that will reset the circuit breaker fail time for voltage protection function initiated circuit breaker fail conditions.								
45	06	CB1 Volt Prot Rst	Prot Reset & I<	0 = I< Only, 1 = CB Open & I<, 2 = Prot Reset & I<		*		*
Setting which determines the elements that will reset the circuit breaker fail time for voltage protection function initiated circuit breaker fail conditions.								
45	07	Ext Prot Reset	Prot Reset & I<	0 = I< Only, 1 = CB Open & I<, 2 = Prot Reset & I<	*		*	
Setting which determines the elements that will reset the circuit breaker fail time for external protection function initiated circuit breaker fail conditions.								
45	07	CB1 Ext Prot Rst	Prot Reset & I<	0 = I< Only, 1 = CB Open & I<, 2 = Prot Reset & I<		*		*
Setting which determines the elements that will reset the circuit breaker fail time for external protection function initiated circuit breaker fail conditions.								
45	08	WI Prot Reset	Disabled	0 = Disabled or 1 = Enabled	*	*	*	*
When Enabled, CB Fail timers will be reset by drop off of a weak infeed trip condition, providing that WI trip logic is activated.								
45	0A	UNDER CURRENT			*	*	*	*
Setting that determines the circuit breaker fail timer reset current for overcurrent based protection circuit breaker fail initiation.								
45	0B	I< Current Set	0.05*11 A	From 0.02*11 A to 3.2*11 A step 0.01*11 A	*		*	
Setting that determines the circuit breaker fail timer reset current for overcurrent based protection circuit breaker fail initiation.								
45	0B	CB1 I< Current Set	0.05*11 A	From 0.02*11 A to 3.2*11 A step 0.01*11 A		*		*
Setting that determines the circuit breaker fail timer reset current for overcurrent based protection circuit breaker fail initiation.								

Col	Row	MENU TEXT	Default Setting	Available Setting	P543/P545 No Distance	P544/P546 No Distance	P543/P545	P544/P546
Description								
45	0C	CB2 I< Current Set	0.05*I2 A	From 0.02*I2 A to 3.2*I2 A step 0.01*I2 A		*		*
Setting that determines the circuit breaker fail timer reset current for overcurrent based protection circuit breaker fail initiation.								
45	0D	ISEF< Current	0.02*I3 A	From 0.001*I3 A to 0.8*I3 A step 0.0005*I3 A	*	*	*	*
Setting that determines the circuit breaker fail timer reset current for Sensitive earth fault (SEF) protection circuit breaker fail initiation.								
45	0E	POLEDEAD			*	*	*	*
Under voltage level detector for pole dead detection								
45	10	V<	38.1*V1	From 10*V1 to 40*V1 step 0.1*V1	*	*	*	*
Under current level detector for pole dead detection								
45	11	I<	0.05*I1 A	From 0.02*I1 A to 3.2*I1 A step 0.01*I1 A	*	*	*	*
Under current level detector for pole dead detection								
45	21	CB2 BREAKER FAIL				*		*
Setting to enable or disable the first stage of the circuit breaker function for CB2.								
45	22	CB2 Fail 1 Status	Enabled			*		*
Setting for the circuit breaker fail timer stage 1, during which breaker opening must be detected. There are timers per phase to cope with evolving faults, but the timer setting is common.								
45	23	CB2 Fail1 Timer	200ms	From 0s to 10s step 10ms		*		*
Setting to enable or disable the second stage of the circuit breaker function for CB2.								
45	24	CB2 Fail 2 Status	Disabled			*		*
Setting for the circuit breaker fail timer stage 2, during which breaker opening must be detected.								
45	25	CB2 Fail2 Timer	400ms	From 0s to 10 step 10ms		*		*
Setting which determines the elements that will reset the circuit breaker fail time for voltage protection function initiated circuit breaker fail conditions.								
45	26	CB2 Volt Prot Reset	Prot Reset & I<			*		*
Setting which determines the elements that will reset the circuit breaker fail time for external protection function initiated circuit breaker fail conditions.								
45	27	CB2 Ext Prot Reset	Prot Reset & I<			*		*

Table 19 - Circuit breaker fail and pole dead detection function

3.19 Supervision (VTS, CTS, Inrush Detection, Special Weak Infeed Blocking and Trip Supervision)

The Trip Supervision feature is used to provide to the Differential and Distance protection functions a confirmation of the presence of a fault, based on overcurrent, undervoltage or/and delta current/delta voltage criteria.

The VTS feature within the relay operates on detection of Negative Phase Sequence (NPS) voltage without the presence of NPS current.

The CT Supervision (CTS) feature operates on detection of derived zero sequence current, in the absence of corresponding derived zero sequence voltage that would normally accompany it.

The Trip supervision (TS) feature relates to using fault detectors to supervise the trip signals.

The Special Weak Infeed Blocking is not normally applied, and is described in detail later in this service manual.

Col	Row	MENU TEXT	Default Setting	Available Setting	P543/P545 No Distance	P544/P546 No Distance	P543/P545	P544/P546
Description								
46	00	GROUP 1 SUPERVISION			*	*	*	*
This column contains settings for Voltage and Current Transformer Supervision								
46	01	VTS Mode	Measured + MCB	0 = Measured + MCB, 1 = Measured Only, 2 = MCB Only	*	*	*	*
Setting that determines the method to be used to declare VT failure.								
46	02	VTS Status	Blocking	0 = Disabled, 1 = Blocking, 2 = Indication	*	*	*	*
This setting determines whether the following operations will occur upon detection of VTS. <ul style="list-style-type: none"> • VTS set to provide alarm indication only. • Optional blocking of voltage dependent protection elements. • Optional conversion of directional overcurrent elements to non-directional protection (available when set to blocking mode only). These settings are found in the function links cell of the relevant protection element columns in the menu. 								
46	03	VTS Reset Mode	Auto	0 = Manual or 1 = Auto	*	*	*	*
The VTS block will be latched after a user settable time delay 'VTS Time Delay'. Once the signal has latched then two methods of resetting are available. The first is manually via the front panel interface (or remote communications) and secondly, when in 'Auto' mode, provided the VTS condition has been removed and the 3 phase voltages have been restored above the phase level detector settings for more than 240 ms.								
46	04	VTS Time Delay	5s	From 1s to 10s step 100ms	*	*	*	*
Setting that determines the operating time-delay of the element upon detection of a voltage supervision condition.								
46	05	VTS I> Inhibit	10*I1 A	From 0.08*I1 A to 32*I1 A step 0.01*I1 A	*	*	*	*
The setting is used to override a voltage supervision block in the event of a phase fault occurring on the system that could trigger the voltage supervision logic.								
46	06	VTS I2> Inhibit	0.05*I1 A	From 0.05*I1 A to 0.5*I1 A step 0.01*I1 A	*	*	*	*
The setting is used to override a voltage supervision block in the event of a fault occurring on the system with negative sequence current above this setting which could trigger the voltage supervision logic.								
46	0E	Inrush Detection	Disabled	0 = Disabled or 1 = Enabled		*		*
This setting is to enable/disable the Inrush Detection used for the Distance protection.								
46	0E	Inrush Detection	Disabled	0 = Disabled or 1 = Enabled	*		*	

Col	Row	MENU TEXT	Default Setting	Available Setting	P543/P545 No Distance	P544/P546 No Distance	P543/P545	P544/P546
Description								
This setting is to enable/disable the Inrush Detection used for the Distance protection if Phase Differential Protection is disabled or set Compensation is not set to Transformer.								
46	0F	I>2nd Harmonic	0.35	From 10% to 100% step 5%		*		*
If the level of second harmonic in any phase current or neutral current exceeds the setting, inrush conditions will be recognized by changing the status of four DDB signals from low to high in the Programmable Scheme Logic (PSL). The user then has a choice to use them further in the PSL in accordance with the application.								
46	0F	I>2nd Harmonic	0.2	From 10% to 100% step 5%	*		*	
If the level of second harmonic in any phase current or neutral current exceeds the setting, inrush conditions will be recognized by changing the status of four DDB signals from low to high in the Programmable Scheme Logic (PSL). The user then has a choice to use them further in the PSL in accordance with the application.								
46	10	WEAK INFEED BLK					*	*
46	11	WI Inhibit	Enabled	0 = Disabled or 1 = Enabled			*	*
This setting enables (turns on) or disables (turns off) a special feature to cover scenarios when there is a very weak positive or negative sequence source behind the relay, but the zero sequence infeed is large. Special to stub-end transformer feeding, where the stub end has no generation, but has solid earthing at a Yd transformer neutral.								
46	12	I0/I2 Setting	3	2 to 3 step 0.2			*	*
If the ratio of zero sequence current to negative sequence current exceeds the setting, all protection elements such as Distance, DEF and Delta that could potentially operate during a genuine weak infeed condition will be inhibited. This setting will be visible only if 'WI Inhibit' is enabled.								
46	30	CT SUPERVISION			*	*	*	*
46	31	CTS Mode	Disabled	0 = Disabled, 1 = Standard / Enabled, 2 = I Diff, 3 = IDiff + Std	*	*	*	*
Setting to disable, enable the standard (voltage dependant) CTS or enable the Differential (current based, communication dependant) CTS or allow both CTS algorithms to work simultaneously								
46	32	CTS Status	Restrain	0 = Restrain or 1 = Indication	*	*	*	*
This setting determines whether the following operations will occur upon detection of CTS. <ul style="list-style-type: none"> • CTS set to provide alarm indication only. • CTS set to restrain local protection Note: The setting applies to both CTS algorithms. The settings are visible if CTS Mode is not disabled.								
46	33	CTS Reset Mode	Manual	0 = Manual or 1 = Auto	*	*	*	*
The CTS block will be latched after a user settable time delay 'CTS Time Delay'. Once the signal has latched then two methods of resetting are available. The first is manually via the front panel interface (or remote communications) and secondly, when in 'Auto' mode, provided the CTS condition has been removed. The setting is common for both CTS algorithms. The setting is visible if CTS Mode is not disabled.								
46	34	CTS Time Delay	5s	From 0s to 10s step 10ms	*	*	*	*
Setting that determines the operating time-delay of the element upon detection of a current transformer supervision condition. The setting is common for both CTS algorithms. The setting is visible if CTS Mode is not disabled								

Col	Row	MENU TEXT	Default Setting	Available Setting	P543/P545 No Distance	P544/P546 No Distance	P543/P545	P544/P546
Description								
46	35	CTS VN< Inhibit	5*V1	From 0.5*V1 to 22*V1 step 0.5*V1	*	*	*	*
This setting is used to inhibit the current transformer supervision element should the zero sequence voltage exceed this setting. The setting is visible if 'Standard' or 'Standard' + 'I Diff' CTS Mode is chosen.								
46	36	CTS IN> Set	0.1*I1 A	From 0.08*I1 A to 4*I1 A step 0.01*I1 A	*	*	*	*
This setting determines the level of zero sequence current that must be present for a valid current transformer supervision condition. The setting is visible if 'Standard' or 'Standard' + 'I Diff' CTS Mode is chosen.								
46	37	CTS i1 >	0.1*I1 A	From 0.05*I1 A to 4.0*I1 A step 0.01*I1 A	*	*	*	*
Setting that determines if the circuit is loaded. If the positive sequence current calculated by the relay exceed this value, the relay declares load condition at relay end. The setting is visible if 'I Diff' or 'Standard' + 'I Diff' CTS Mode is set.								
46	38	CTS i2/i1>	0.05	0.05 to 1 step 0.01	*	*	*	*
Setting above which an asymmetrical fault condition or a CT problem is declared. The setting is visible if 'I Diff' or 'Standard' + 'I Diff' CTS Mode is set								
46	39	CTS i2/i1>>	0.4	0.05 to 1 step 0.01	*	*	*	*
Setting above which a CT failure is declared providing that CTS i2/i1> threshold at any other CT set connected to the differential zone relay has not been exceed. The setting is visible if 'I Diff' or 'Standard' + 'I Diff' CTS Mode is set.								
46	60	Trip Supervision					*	*
Setting to enable/disable the first stage of supervision								
46	61	Stage 1 TS	Disabled	0 = Disabled or 1 = Enabled			*	*
Threshold of Over-current supervision element								
46	62	I> Threshold	1*I1 A	From 0.08*I1 A to 4*I1 A step 0.01*I1 A			*	*
Threshold of Over-current supervision element								
46	63	I> TS Elements	00000000(bin)	Bit 00 = Zone 1, Bit 01 = Zone 2, Bit 02 = Zone 3, Bit 03 = Zone P, Bit 04 = Zone 4, Bit 05 = Zone Q, Bit 06 = Aided Dist, Bit 07 = Current Diff			*	*
A binary flag cell with bits for each of the distance zone functions, one bit for the Aided Scheme trip and one bit for Line Differential function. If the flag is set to 1, the function will be allowed to trip if the current is above the threshold. If set to 0, the element will have no influence on the function								
46	64	IN> Threshold	0.2*I1 A	From 0.008*I1 A to 4*I1 A step 0.001*I1 A			*	*
Threshold of Earth Fault over-current supervision element								

Col	Row	MENU TEXT	Default Setting	Available Setting	P543/P545 No Distance	P544/P546 No Distance	P543/P545	P544/P546
Description								
46	65	IN> TS Elements	00000000(bin)	Bit 00 = Zone 1, Bit 01 = Zone 2, Bit 02 = Zone 3, Bit 03 = Zone P, Bit 04 = Zone 4, Bit 05 = Zone Q, Bit 06 = Aided Dist, Bit 07 = Current Diff			*	*
A binary flag cell with bits for each of the distance zone functions, one bit for the Aided Scheme trip and one bit for Line Differential function. If the flag is set to 1, the function will be allowed to trip if the neutral current is above the threshold. If set to 0, the element will have no influence on the function								
46	66	OCD> Threshold	0.08*I1 A	From 0.005*I1 A to 0.2*I1 A step 0.001*I1 A			*	*
Threshold for the delta over-current supervision element.								
46	67	OCD> TS Elements	00000000(bin)	Bit 00 = Zone 1, Bit 01 = Zone 2, Bit 02 = Zone 3, Bit 03 = Zone P, Bit 04 = Zone 4, Bit 05 = Zone Q, Bit 06 = Aided Dist, Bit 07 = Current Diff			*	*
A binary flag cell with bits for each of the distance zone functions, one bit for the Aided Scheme trip and one bit for Line Differential function. If the flag is set to 1, the function will be allowed to trip if the delta current is above the threshold. If set to 0, the element will have no influence on the function								
46	68	Vpp< Threshold	80.00V	From 10*V1 to 120*V1 step 1*V1			*	*
Threshold for the under phase-to-phase voltage supervision element.								
46	69	Vpp< TS Elements	00000000(bin)	Bit 00 = Zone 1, Bit 01 = Zone 2, Bit 02 = Zone 3, Bit 03 = Zone P, Bit 04 = Zone 4, Bit 05 = Zone Q, Bit 06 = Aided Dist, Bit 07 = Current Diff			*	*
A binary flag cell with bits for each of the distance zone functions, one bit for the Aided Scheme trip and one bit for Line Differential function. If the flag is set to 1, the function will be allowed to trip if the phase-to-phase voltage is below the threshold. If set to 0, the element will have no influence on the function								
46	6A	Vpn< Threshold	80.00V	From 10*V1 to 120*V1 step 1*V1			*	*
Threshold for the under phase-neutral voltage supervision element.								

Col	Row	MENU TEXT	Default Setting	Available Setting	P543/P545 No Distance	P544/P546 No Distance	P543/P545	P544/P546
Description								
46	6B	Vpn< TS Elements	00000000(bin)	Bit 00 = Zone 1, Bit 01 = Zone 2, Bit 02 = Zone 3, Bit 03 = Zone P, Bit 04 = Zone 4, Bit 05 = Zone Q, Bit 06 = Aided Dist, Bit 07 = Current Diff			*	*
A binary flag cell with bits for each of the distance zone functions, one bit for the Aided Scheme trip and one bit for Line Differential function. If the flag is set to 1, the function will be allowed to trip if the phase-neutral voltage is below the threshold. If set to 0, the element will have no influence on the function								
46	6C	UVD< Threshold	5.00V	From 1*V1 to 20*V1 step 0.1*V1			*	*
Threshold for the delta phase-neutral voltage supervision element.								
46	6D	UVD< TS Elements	00000000(bin)	Bit 00 = Zone 1, Bit 01 = Zone 2, Bit 02 = Zone 3, Bit 03 = Zone P, Bit 04 = Zone 4, Bit 05 = Zone Q, Bit 06 = Aided Dist, Bit 07 = Current Diff			*	*
A binary flag cell with bits for each of the distance zone functions, one bit for the Aided Scheme trip and one bit for Line Differential function. If the flag is set to 1, the function will be allowed to trip if the delta phase-neutral voltage is over the threshold. If set to 0, the element will have no influence on the function								
46	6E	UVD>Hold Timer	0s	From 0s to 10s step 10ms			*	*
Setting that determines the operating time-delay of the trip supervision element upon detection of a UVD drop-off.								
46	6F	OCD>Hold Timer	0s	From 0s to 10s step 10ms			*	*
Setting that determines the operating time-delay of the trip supervision element upon detection of a OCD drop-off.								
46	70	Stage 2 TS	Disabled	0 = Disabled or 1 = Enabled			*	*
Setting to enable/disable the second stage of supervision								
46	71	I> Threshold	1*11 A	From 0.008*11 A to 4*11 A step 0.001*11 A			*	*
Threshold of Over-current supervision element								
46	72	I> TS Elements	00000000(bin)	Bit 00 = Zone 1, Bit 01 = Zone 2, Bit 02 = Zone 3, Bit 03 = Zone P, Bit 04 = Zone 4, Bit 05 = Zone Q, Bit 06 = Aided Dist, Bit 07 = Current Diff			*	*

Col	Row	MENU TEXT	Default Setting	Available Setting	P543/P545 No Distance	P544/P546 No Distance	P543/P545	P544/P546
Description								
A binary flag cell with bits for each of the distance zone functions, one bit for the Aided Scheme trip and one bit for Line Differential function. If the flag is set to 1, the function will be allowed to trip if the current is above the threshold. If set to 0, the element will have no influence on the function								
46	73	IN> Threshold	0.2*I1 A	From 0.008*I1 A to 4*I1 A step 0.001*I1 A			*	*
Threshold of Earth Fault over-current supervision element								
46	74	IN> TS Elements	00000000(bin)	Bit 00 = Zone 1, Bit 01 = Zone 2, Bit 02 = Zone 3, Bit 03 = Zone P, Bit 04 = Zone 4, Bit 05 = Zone Q, Bit 06 = Aided Dist, Bit 07 = Current Diff			*	*
A binary flag cell with bits for each of the distance zone functions, one bit for the Aided Scheme trip and one bit for Line Differential function. If the flag is set to 1, the function will be allowed to trip if the neutral current is above the threshold. If set to 0, the element will have no influence on the function								
46	75	OCD> Threshold	0.08*I1 A	From 0.005*I1 A to 0.2*I1 A step 0.001*I1 A			*	*
Threshold for the delta over-current supervision element.								
46	76	OCD> TS Elements	00000000(bin)	Bit 00 = Zone 1, Bit 01 = Zone 2, Bit 02 = Zone 3, Bit 03 = Zone P, Bit 04 = Zone 4, Bit 05 = Zone Q, Bit 06 = Aided Dist, Bit 07 = Current Diff			*	*
A binary flag cell with bits for each of the distance zone functions, one bit for the Aided Scheme trip and one bit for Line Differential function. If the flag is set to 1, the function will be allowed to trip if the delta current is above the threshold. If set to 0, the element will have no influence on the function								
46	77	Vpp< Threshold	80.00V	From 10*V1 to 120*V1 step 1*V1			*	*
Threshold for the under phase-to-phase voltage supervision element.								
46	78	Vpp< TS Elements	00000000(bin)	Bit 00 = Zone 1, Bit 01 = Zone 2, Bit 02 = Zone 3, Bit 03 = Zone P, Bit 04 = Zone 4, Bit 05 = Zone Q, Bit 06 = Aided Dist, Bit 07 = Current Diff			*	*
A binary flag cell with bits for each of the distance zone functions, one bit for the Aided Scheme trip and one bit for Line Differential function. If the flag is set to 1, the function will be allowed to trip if the phase-to-phase voltage is below the threshold. If set to 0, the element will have no influence on the function								

Col	Row	MENU TEXT	Default Setting	Available Setting	P543/P545 No Distance	P544/P546 No Distance	P543/P545	P544/P546
Description								
46	79	Vpn< Threshold	80.00V	From 10*V1 to 120*V1 step 1*V1			*	*
Threshold for the under phase-neutral voltage supervision element.								
46	7A	Vpn< TS Elements	00000000(bin)	Bit 00 = Zone 1, Bit 01 = Zone 2, Bit 02 = Zone 3, Bit 03 = Zone P, Bit 04 = Zone 4, Bit 05 = Zone Q, Bit 06 = Aided Dist, Bit 07 = Current Diff			*	*
A binary flag cell with bits for each of the distance zone functions, one bit for the Aided Scheme trip and one bit for Line Differential function. If the flag is set to 1, the function will be allowed to trip if the phase-neutral voltage is below the threshold. If set to 0, the element will have no influence on the function								
46	7B	UVD> Threshold	5.00V	From 1*V1 to 20*V1 step 0.1*V1			*	*
Threshold for the delta phase-neutral voltage supervision element.								
46	7C	UVD> TS Elements	00000000(bin)	Bit 00 = Zone 1, Bit 01 = Zone 2, Bit 02 = Zone 3, Bit 03 = Zone P, Bit 04 = Zone 4, Bit 05 = Zone Q, Bit 06 = Aided Dist, Bit 07 = Current Diff			*	*
A binary flag cell with bits for each of the distance zone functions, one bit for the Aided Scheme trip and one bit for Line Differential function. If the flag is set to 1, the function will be allowed to trip if the delta phase-neutral voltage is over the threshold. If set to 0, the element will have no influence on the function								
46	7D	UVD>Hold Timer	0s	From 0s to 10s step 10ms			*	*
Setting that determines the operating time-delay of the trip supervision element upon detection of a UVD> drop-off.								
46	7E	OCD>Hold Timer	0s	From 0s to 10s step 10ms			*	*
Setting that determines the operating time-delay of the trip supervision element upon detection of an OCD> drop-off.								
46	80	Stage 3 TS	Disabled	0 = Disabled or 1 = Enabled			*	*
Setting to enable/disable the third stage of supervision								
46	81	I> Threshold	1*I1 A	From 0.008*I1 A to 4*I1 A step 0.001*I1 A			*	*
Threshold of Over-current supervision element								

Col	Row	MENU TEXT	Default Setting	Available Setting	P543/P545 No Distance	P544/P546 No Distance	P543/P545	P544/P546
Description								
46	82	I> TS Elements	00000000(bin)	Bit 00 = Zone 1, Bit 01 = Zone 2, Bit 02 = Zone 3, Bit 03 = Zone P, Bit 04 = Zone 4, Bit 05 = Zone Q, Bit 06 = Aided Dist, Bit 07 = Current Diff			*	*
A binary flag cell with bits for each of the distance zone functions, one bit for the Aided Scheme trip and one bit for Line Differential function. If the flag is set to 1, the function will be allowed to trip if the current is above the threshold. If set to 0, the element will have no influence on the function								
46	83	IN> Threshold	0.2*I1 A	From 0.008*I1 A to 4*I1 A step 0.001*I1 A			*	*
Threshold of Earth Fault over-current supervision element								
46	84	IN> TS Elements	00000000(bin)	Bit 00 = Zone 1, Bit 01 = Zone 2, Bit 02 = Zone 3, Bit 03 = Zone P, Bit 04 = Zone 4, Bit 05 = Zone Q, Bit 06 = Aided Dist, Bit 07 = Current Diff			*	*
A binary flag cell with bits for each of the distance zone functions, one bit for the Aided Scheme trip and one bit for Line Differential function. If the flag is set to 1, the function will be allowed to trip if the neutral current is above the threshold. If set to 0, the element will have no influence on the function								
46	85	OCD> Threshold	0.08*I1 A	From 0.005*I1 A to 0.2*I1 A step 0.001*I1 A			*	*
Threshold for the delta over-current supervision element.								
46	86	OCD> TS Elements	00000000(bin)	Bit 00 = Zone 1, Bit 01 = Zone 2, Bit 02 = Zone 3, Bit 03 = Zone P, Bit 04 = Zone 4, Bit 05 = Zone Q, Bit 06 = Aided Dist, Bit 07 = Current Diff			*	*
A binary flag cell with bits for each of the distance zone functions, one bit for the Aided Scheme trip and one bit for Line Differential function. If the flag is set to 1, the function will be allowed to trip if the delta current is above the threshold. If set to 0, the element will have no influence on the function								
46	87	Vpp< Threshold	80.00V	From 10*V1 to 120*V1 step 1*V1			*	*
Threshold for the under phase-to-phase voltage supervision element.								

Col	Row	MENU TEXT	Default Setting	Available Setting	P543/P545 No Distance	P544/P546 No Distance	P543/P545	P544/P546
Description								
46	88	Vpp< TS Elements	00000000(bin)	Bit 00 = Zone 1, Bit 01 = Zone 2, Bit 02 = Zone 3, Bit 03 = Zone P, Bit 04 = Zone 4, Bit 05 = Zone Q, Bit 06 = Aided Dist, Bit 07 = Current Diff			*	*
A binary flag cell with bits for each of the distance zone functions, one bit for the Aided Scheme trip and one bit for Line Differential function. If the flag is set to 1, the function will be allowed to trip if the phase-to-phase voltage is below the threshold. If set to 0, the element will have no influence on the function								
46	89	Vpn< Threshold	80.00V	From 10*V1 to 120*V1 step 1*V1			*	*
Threshold for the under phase-neutral voltage supervision element.								
46	8A	Vpn< TS Elements	00000000(bin)	Bit 00 = Zone 1, Bit 01 = Zone 2, Bit 02 = Zone 3, Bit 03 = Zone P, Bit 04 = Zone 4, Bit 05 = Zone Q, Bit 06 = Aided Dist, Bit 07 = Current Diff			*	*
A binary flag cell with bits for each of the distance zone functions, one bit for the Aided Scheme trip and one bit for Line Differential function. If the flag is set to 1, the function will be allowed to trip if the phase-neutral voltage is below the threshold. If set to 0, the element will have no influence on the function								
46	8B	UVD> Threshold	5.00V	From 1*V1 to 20*V1 step 0.1*V1			*	*
Threshold for the delta phase-neutral voltage supervision element.								
46	8C	UVD> TS Elements	00000000(bin)	Bit 00 = Zone 1, Bit 01 = Zone 2, Bit 02 = Zone 3, Bit 03 = Zone P, Bit 04 = Zone 4, Bit 05 = Zone Q, Bit 06 = Aided Dist, Bit 07 = Current Diff			*	*
A binary flag cell with bits for each of the distance zone functions, one bit for the Aided Scheme trip and one bit for Line Differential function. If the flag is set to 1, the function will be allowed to trip if the delta phase-neutral voltage is over the threshold. If set to 0, the element will have no influence on the function								
46	8D	UVD>Hold Timer	0s	From 0s to 10s step 10ms			*	*
Setting that determines the operating time-delay of the trip supervision element upon detection of a UVD> drop-off.								
46	8E	OCD>Hold Timer	0s	From 0s to 10s step 10ms			*	*
Setting that determines the operating time-delay of the trip supervision element upon detection of an OCD> drop-off.								

Table 20 - Supervision

3.20 System Checks (Check Sync. Function)

The relay has a two-stage Check Synchronization function that can be set independently.

System Checks (Check Sync. Function) for P543/P545

The MiCOM P543/P545 has a two stage Check Synchronization function that can be set independently.

System Checks (Check Sync. Function) for P544/P546

The MiCOM P544/P546 has a two-stage Check Synchronization function that can be set independently for each circuit breaker.

Col	Row	MENU TEXT	Default Setting	Available Setting	P543/P545 No Distance	P544/P546 No Distance	P543/P545	P544/P546
Description								
48	00	GROUP 1 SYSTEM CHECKS			*	*	*	*
This column contains settings for System Checks								
48	14	VOLTAGE MONITORS			*	*	*	*
48	85	Live Line	32	From 5 to 132 step 0.5	*	*	*	*
Line is considered Live with voltage above this setting.								
48	86	Dead Line	13	From 5 to 132 step 0.5	*	*	*	*
Line is considered Dead with voltage below this setting.								
48	87	Live Bus 1	32	From 5 to 132 step 0.5	*	*	*	*
Bus 1 is considered Live with voltage above this setting.								
48	88	Dead Bus 1	13	From 5 to 132 step 0.5	*	*	*	*
Bus 1 is considered Dead with voltage below this setting.								
48	89	Live Bus 2	32	From 5 to 132 step 0.5		*		*
Bus 2 is considered Live with voltage above this setting.								
48	8A	Dead Bus 2	13	From 5 to 132 step 0.5		*		*
Bus 2 is considered Dead with voltage below this setting.								
48	8B	CS UV	54	From 5 to 120 step 0.5	*	*	*	*
Check Synch Undervoltage setting decides that System Check Synchronism logic for CB1 will be blocked if V< is one of the selected options in setting CB1 CS Volt.Blk (48 8 E), and either line or bus voltage is below this setting. System Check Synchronism for CB2 will be blocked if V< is one of the selected options in setting CB2 CS Volt. Blk (48 9 C), and either line or bus voltage is below this setting.								
48	8C	CS OV	130	From 60 to 200 step 0.5	*	*	*	*
Check Synch Overvoltage setting decides that System Check Synchronism logic for CB1 is blocked if V> is one of the selected options in setting CB1 CS Volt.Blk (48 8 E), and either line or bus voltage is above this setting. System Check Synchronism for CB2 is blocked if V> is one of the selected options in setting CB2 CS Volt. Blk (48 9 C), and either line or bus voltage is above this setting.								

Col	Row	MENU TEXT	Default Setting	Available Setting	P543/P545 No Distance	P544/P546 No Distance	P543/P545	P544/P546
Description								
48	8D	System Checks	Disabled	0 = Disabled or 1 = Enabled	*		*	
Setting to enable or disable both stages of system checks for reclosing. If System Checks is set to Disabled, all other menu settings associated with synchronism checks become invisible, and a DDB (880) signal SysChks Inactive is set.								
48	8D	Sys Checks CB1	Disabled	0 = Disabled or 1 = Enabled		*		*
Setting to enable or disable both stages of system checks for reclosing CB1 If Sys Checks CB1 is set to Disabled, all other menu settings associated with synchronism checks for CB1 become invisible, and a DDB (880) signal SChksInactiveCB1 is set.								
48	8E	CS Voltage Block	V<	0 = None, 1 = V<, 2 = V>, 3 = Vdiff>, 4 = V< and V>, 5 = V< and Vdiff>, 6 = V> and Vdiff>, 7 = V< V> and Vdiff>	*		*	
Setting to determine which, if any, conditions should block synchronism check (undervoltage V<, overvoltage V>, and/or voltage differential Vdiff etc) for the line and bus voltages.								
48	8E	CB1 CS Volt. Blk	V<	0 = None, 1 = V<, 2 = V>, 3 = Vdiff>, 4 = V< and V>, 5 = V< and Vdiff>, 6 = V> and Vdiff>, 7 = V< V> and Vdiff>		*		*
Setting to determine which, if any, conditions should block synchronism check for CB1 (undervoltage V<, overvoltage V>, and/or voltage differential Vdiff etc) for the line and bus voltages.								
48	8F	CS1 Status	Enabled	0 = Disabled or 1 = Enabled	*		*	
Setting to enable or disable the stage 1 synchronism check elements for auto-reclosing and manual closing of CB.								
48	8F	CB1 CS1 Status	Enabled	0 = Disabled or 1 = Enabled		*		*
Setting to enable or disable the stage 1 synchronism check elements for auto-reclosing and manual closing CB1.								
48	90	CS1 Angle	20	From 0° to 90° step 1°	*		*	
Maximum permitted phase angle between Line and Bus 1 voltages for first stage synchronism check element to reclose CB.								
48	90	CB1 CS1 Angle	20	From 0° to 90° step 1°		*		*
Maximum permitted phase angle between Line and Bus 1 voltages for first stage synchronism check element to reclose CB1.								
48	91	CS1 VDiff	6.5	From 1 to 120 step 0.5	*		*	
Check Synch Voltage differential setting decides that stage 1 System Check Synchronism logic is blocked if Vdiff> is one of the selected options in setting CS Voltage Block (48 8 E), and voltage magnitude difference between line and bus 1 voltage is above this setting.								
48	91	CB1 CS1 VDiff	6.5	From 1 to 120 step 0.5		*		*

Col	Row	MENU TEXT	Default Setting	Available Setting	P543/P545 No Distance	P544/P546 No Distance	P543/P545	P544/P546
Description								
Check Synch Voltage differential setting decides that stage 1 System Check Synchronism logic for CB1 is blocked if Vdiff> is one of the selected options in setting CB1 CS Volt. Blk (48 8 E), and voltage magnitude difference between line and bus 1 voltage is above this setting.								
48	92	CS1 Slip Ctrl	Frequency	From None to Both step 1	*		*	
Setting to enable or disable blocking of synchronism check stage 1 for reclosing CB by excessive frequency difference or inadequate time slip.								
48	92	CB1 CS1 SlipCtrl	Frequency	From None to Both step 1		*		*
Setting to enable or disable blocking of synchronism check stage 1 for reclosing CB1 by excessive frequency difference or inadequate time slip.								
48	93	CS1 Slip Freq	50mHz	From 5mHz to 2Hz step 5mHz	*		*	
If CS1 Slip Ctrl is enabled for frequency, synchronism check stage 1 is blocked for reclosing CB if measured frequency difference between line and bus voltages is greater than this setting.								
48	93	CB1 CS1 SlipFreq	50mHz	From 5mHz to 2Hz step 5mHz		*		*
If CB1 CS1 SlipCtrl is enabled for frequency, synchronism check stage 1 is blocked for reclosing CB1 if measured frequency difference between line and bus voltages is greater than this setting.								
48	94	CS1 Slip Timer	1s	From 0 to 99s step 10ms	*		*	
If CS1 Slip Ctrl is enabled for timer, synchronism check stage 1 is blocked for reclosing CB if time slip is smaller than this setting.								
48	94	CB1 CS1 SlipTimer	1s	From 0 to 99s step 10ms		*		*
If CB1 CS1 SlipCtrl is enabled for timer, synchronism check stage 1 is blocked for reclosing CB1 if time slip is smaller than this setting.								
48	95	CS2 Status	Disabled	0 = Disabled or 1 = Enabled	*		*	
Setting to enable or disable the stage 2 synchronism check elements for auto-reclosing and manual closing CB.								
48	95	CB1 CS2 Status	Disabled	0 = Disabled or 1 = Enabled		*		*
Setting to enable or disable the stage 2 synchronism check elements for auto-reclosing and manual closing CB1.								
48	96	CS2 Angle	20	From 0° to 90° step 1°	*		*	
Maximum permitted phase angle between Line and Bus 1 voltages for second stage synchronism check element to reclose CB								
48	96	CB1 CS2 Angle	20	From 0° to 90° step 1°		*		*
Maximum permitted phase angle between Line and Bus 1 voltages for second stage synchronism check element to reclose CB1								
48	97	CS2 VDiff	6.5V	From 1 to 120 step 0.5	*		*	
Check Synch Voltage differential setting decides that stage 2 System Check Synchronism logic is blocked if Vdiff> is one of the selected options in setting CS Voltage Block (48 8 E), and voltage magnitude difference between line and bus 1 voltage is above this setting.								
48	97	CB1 CS2 VDiff	6.5V	From 1 to 120 step 0.5		*		*

Col	Row	MENU TEXT	Default Setting	Available Setting	P543/P545 No Distance	P544/P546 No Distance	P543/P545	P544/P546
Description								
Check Synch Voltage differential setting decides that stage 2 System Check Synchronism logic for CB1 is blocked if Vdiff> is one of the selected options in setting CB1 CS Volt.Blk (48 8 E), and voltage magnitude difference between line and bus 1 voltage is above this setting.								
48	98	CS2 Slip Ctrl	Frequency	From None to Both step 1	*		*	
Setting to enable or disable blocking of synchronism check stage 2 for reclosing CB by excessive frequency difference or inadequate time slip.								
48	98	CB1 CS2 SlipCtrl	Frequency	From None to Freq+CB Comp step 1		*		*
Setting to enable or disable blocking of synchronism check stage 2 for reclosing CB1 by excessive frequency difference or inadequate time slip.								
48	99	CS2 Slip Freq	50mHz	From 5mHz to 2Hz step 5mHz	*		*	
If CS2 Slip Ctrl is enabled for frequency, synchronism check stage 2 is blocked for reclosing CB if measured frequency difference between line and bus voltages is greater than this setting.								
48	99	CB1 CS2 SlipFreq	50mHz	From 5mHz to 2Hz step 5mHz		*		*
If CB1 CS2 SlipCtrl is enabled for frequency, synchronism check stage 2 is blocked for reclosing CB1 if measured frequency difference between line and bus voltages is greater than this setting.								
48	9A	CS2 Slip Timer	1s	From 0 to 99s step 10ms	*		*	
If CS2 Slip Ctrl is enabled for timer, synchronism check stage 2 is blocked for reclosing CB if time slip is smaller than this setting.								
48	9A	CB1 CS2 SlipTimer	1s	From 0 to 99s step 10ms		*		*
If CB1 CS2 SlipCtrl is enabled for timer, synchronism check stage 2 is blocked for reclosing CB1 if time slip is smaller than this setting.								
48	9B	CB1 CI Time	50ms	From 10ms to 500ms step 1ms	*	*	*	*
This sets CB1 closing time, from receipt of CB1 close command until main contacts touch								
48	9C	Sys Checks CB2	Disabled	0 = Disabled or 1 = Enabled		*		*
Setting to enable or disable both stages of system checks for reclosing CB2. If Sys Checks CB2 is set to Disabled, all other menu settings associated with synchronism checks for CB2 become invisible, and a DDB (1484) signal SChksInactiveCB2 is set.								
48	9D	CB2 CS Volt. Blk	V<	0 = None, 1 = V<, 2 = V>, 3 = Vdiff>, 4 = V< and V>, 5 = V< and Vdiff>, 6 = V> and Vdiff>, 7 = V< V> and Vdiff>		*		*
Setting to determine which, if any, conditions should block synchronism check for CB2 (undervoltage V<, overvoltage V>, and/or voltage differential Vdiff etc) for the line and bus voltages.								
48	9E	CB2 CS1 Status	Enabled	0 = Disabled or 1 = Enabled		*		*
Setting to enable or disable the stage 1 synchronism check elements for auto-reclosing and manual closing CB2.								

Col	Row	MENU TEXT	Default Setting	Available Setting	P543/P545 No Distance	P544/P546 No Distance	P543/P545	P544/P546
Description								
48	9F	CB2 CS1 Angle	20	From 0° to 90° step 1°		*		*
Maximum permitted phase angle between Line and Bus 2 voltages for first stage synchronism check element to reclose CB2.								
48	A0	CB2 CS1 VDiff	6.5V	From 1 to 120 step 0.5		*		*
Check Synch Voltage differential setting decides that stage 1 System Check Synchronism logic for CB2 is blocked if Vdiff> is one of the selected options in setting CB2 CS Volt. Blk (48 9C), and voltage magnitude difference between line and bus 2 voltage is above this setting.								
48	A1	CB2 CS1 SlipCtrl	Frequency	From None to Both step 1		*		*
Setting to enable or disable blocking of synchronism check stage 1 for reclosing CB2 by excessive frequency difference or inadequate time slip.								
48	A2	CB2 CS1 SlipFreq	50mHz	From 5mHz to 2Hz step 5mHz		*		*
If CB2 CS1 SlipCtrl is enabled for frequency, synchronism check stage 1 is blocked for reclosing CB2 if measured frequency difference between line and bus voltages is greater than this setting.								
48	A3	CB2 CS1 SlipTimer	1s	From 0 to 99s step 10ms		*		*
If CB2 CS1 SlipCtrl is enabled for timer, synchronism check stage 1 is blocked for reclosing CB1 if time slip is smaller than this setting.								
48	A4	CB2 CS2 Status	Disabled	0 = Disabled or 1 = Enabled		*		*
Setting to enable or disable the stage 2 synchronism check elements for auto-reclosing and manual closing CB2.								
48	A5	CB2 CS2 Angle	20	From 0° to 90° step 1°		*		*
Maximum permitted phase angle between Line and Bus 2 voltages for second stage synchronism check element to reclose CB2.								
48	A6	CB2 CS2 VDiff	6.5	From 1 to 120 step 0.5		*		*
Check Synch Voltage differential setting decides that stage 2 System Check Synchronism logic for CB2 is blocked if Vdiff> is one of the selected options in setting CB2 CS Volt. Blk (48 9C), and voltage magnitude difference between line and bus 2 voltage is above this setting.								
48	A7	CB2 CS2 SlipCtrl	Frequency	From None to Freq+CB Comp step 1		*		*
Setting to enable or disable blocking of synchronism check stage 2 for reclosing CB2 by excessive frequency difference or inadequate time slip.								
48	A9	CB2 CS2 SlipFreq	50mHz	From 5mHz to 2Hz step 5mHz		*		*
If CB2 CS2 SlipCtrl is enabled for frequency, synchronism check stage 2 is blocked for reclosing CB2 if measured frequency difference between line and bus voltages is greater than this setting.								
48	A9	CB2 CS2 SlipTimer	1s	From 0 to 99s step 10ms		*		*
If CB2 CS2 SlipCtrl is enabled for timer, synchronism check stage 2 is blocked for reclosing CB2 if time slip is smaller than this setting.								
48	AA	CB2 CI Time	50ms	From 10ms to 500ms step 1ms		*		*
This sets CB2 closing time, from receipt of CB2 close command until main contacts touch								

Col	Row	MENU TEXT	Default Setting	Available Setting	P543/P545 No Distance	P544/P546 No Distance	P543/P545	P544/P546
Description								
48	B0	MAN SYS CHECKS			*	*	*	*
48	B1	Num CBs	CB1 Only	0 = CB1 Only, 1 = CB2 Only or 2 = Both CB1 & CB2		*		*
This setting is only visible if the CB Control by cell (Cell 0701 under CB CONTROL column) is 'Enabled'. If visible, the setting dictates which of the circuit breakers (CB1 only, CB2 only, or both CB1 & CB2) can be manually closed.								
48	B2	CBM SC required	Disabled	0 = Disabled or 1 = Enabled	*		*	
This setting determines whether a system check (e.g. live bus / dead line etc) is required for any manual (operator-controlled) closure of CB. If Enabled, system check is required for closure. If Disabled, system check is not required.								
48	B2	CB1M SC required	Disabled	0 = Disabled or 1 = Enabled		*		*
This setting determines whether a system check (e.g. live bus / dead line etc) is required for any manual (operator-controlled) closure of CB1. If Enabled, system check is required for closure. If Disabled, system check is not required.								
48	B3	CBM SC CS1	Disabled	0 = Disabled or 1 = Enabled	*		*	
This setting enables CB to close by manual control when the system satisfies all the System Check Synchronism Stage 1 conditions as listed under the setting CS1 Status in the SYSTEM CHECKS column.								
48	B3	CB1M SC CS1	Disabled	0 = Disabled or 1 = Enabled		*		*
This setting enables CB1 to close by manual control when the system satisfies all the System Check Synchronism Stage 1 conditions as listed under the setting CB1 CS1 Status in the SYSTEM CHECKS column.								
48	B4	CBM SC CS2	Disabled	0 = Disabled or 1 = Enabled	*		*	
This setting enables CB1 to close by manual control when the system satisfies all the System Check Synchronism Stage 2 conditions as listed under the setting CS2 Status in the SYSTEM CHECKS column.								
48	B4	CB1M SC CS2	Disabled	0 = Disabled or 1 = Enabled		*		*
This setting enables CB1 to close by manual control when the system satisfies all the System Check Synchronism Stage 2 conditions as listed under the setting CB1 CS2 Status in the SYSTEM CHECKS column.								
48	B5	CBM SC DLLB	Disabled	0 = Disabled or 1 = Enabled	*		*	
This setting enables CB to close by manual control when the dead line & live bus1 conditions are satisfied as set in the SYSTEM CHECKS column.								
48	B5	CB1M SC DLLB	Disabled	0 = Disabled or 1 = Enabled		*		*
This setting enables CB1 to close by manual control when the dead line & live bus1 conditions are satisfied as set in the SYSTEM CHECKS column.								
48	B6	CBM SC LLDB	Disabled	0 = Disabled or 1 = Enabled	*		*	
This setting enables CB to close by manual control when the live line & dead bus1 conditions are satisfied as set in the SYSTEM CHECKS column.								
48	B6	CB1M SC LLDB	Disabled	0 = Disabled or 1 = Enabled		*		*
This setting enables CB1 to close by manual control when the live line & dead bus1 conditions are satisfied as set in the SYSTEM CHECKS column.								

Col	Row	MENU TEXT	Default Setting	Available Setting	P543/P545 No Distance	P544/P546 No Distance	P543/P545	P544/P546
Description								
48	B7	CBM SC DLDB	Disabled	0 = Disabled or 1 = Enabled	*		*	
This setting enables CB to close by manual control when the dead line & dead bus1 conditions are satisfied as set in the SYSTEM CHECKS column.								
48	B7	CB1M SC DLDB	Disabled	0 = Disabled or 1 = Enabled		*		*
This setting enables CB1 to close by manual control when the dead line & dead bus1 conditions are satisfied as set in the SYSTEM CHECKS column.								
48	B8	CB2M SC required	Disabled	0 = Disabled or 1 = Enabled		*		*
This setting determines whether a system check (e.g. live bus / dead line etc) is required for any manual (operator-controlled) closure of CB2. If Enabled, system check is required for closure. If Disabled, system check is not required.								
48	B9	CB2M SC CS1	Disabled	0 = Disabled or 1 = Enabled		*		*
This setting enables CB2 to close by manual control when system satisfies all the System Check Synchronism Stage 1 conditions as listed under the setting CB2 CS1 Status in the SYSTEM CHECKS column.								
48	BA	CB2M SC CS2	Disabled	0 = Disabled or 1 = Enabled		*		*
This setting enables CB2 to close by manual control when the system satisfies all the System Check Synchronism Stage 2 conditions as listed under setting CB2 CS2 status in the SYSTEM CHECKS column.								
48	BB	CB2M SC DLLB	Disabled	0 = Disabled or 1 = Enabled		*		*
This setting enables CB2 to close by manual control when the dead line & live bus2 conditions are satisfied as set in the SYSTEM CHECKS column.								
48	BC	CB2M SC LLDB	Disabled	0 = Disabled or 1 = Enabled		*		*
This setting enables CB2 to close by manual control when the live line & dead bus2 conditions are satisfied as set in the SYSTEM CHECKS column.								
48	BD	CB2M SC DLDB	Disabled	0 = Disabled or 1 = Enabled		*		*
This setting enables CB2 to close by manual control when the dead line & dead bus2 conditions are satisfied as set in the SYSTEM CHECKS column.								

Table 21 - System checks (check sync. function)

3.21

Auto-Reclose Function

The auto-reclose functionality differs between the P543/P545 and the P544/P546 since the P543/P545 can only control one circuit breaker, whereas the P544/P546 can control two. Accordingly, therefore, the settings are different for the two.

As from Software Version D1a, the Auto-Reclose can now be configured so that it skips the first shot. This means that the first AR cycle is skipped (missed), and so starts Dead Time 2 at the first reclose attempt.

This is done by changing DDB No 1384 (Skip Shot 1 = Enabled/Disabled) as required. This means that this signal can now be mapped from an opto to a comms input.

Auto-Reclose Function (P543/P545)

The MiCOM P543/P545 will initiate auto-reclose for fault clearances by any instantaneous trip allocated in the PSL to DDB Trip Inputs A,B or C (DDB 530,531 or 532 respectively). The default PSL includes differential trip, Zone 1 trip and aided trips. In addition, other distance zones, Aided DEF, Directional comparison, phase and earth overcurrent protection and Trip On Reclose (TOR) may be set to initiate auto-reclose, when required. This is done in the settings (shown here after). Protection such as voltage, frequency, thermal etc. will block auto-reclose.

The following shows the relay settings for the auto-reclose function, which must be set in conjunction with the Circuit Breaker Control settings under main Menu. The available setting ranges and factory defaults are shown.

Auto-Reclose Function (P544/P546)

The MiCOM P544/P546 can be set to initiate auto-reclose for fault clearances by Zone 1 trips, phase differential trips, distance aided trips, other distance zones, Aided DEF, Directional comparison, phase and earth overcurrent protection and Trip On Reclose (TOR). This is configured in the settings (shown here after). Other protection functions such as voltage, frequency, thermal etc. will block auto-reclose.

The following shows the relay settings for the auto-reclose function, which must be set in conjunction with the Circuit Breaker Control settings under main Menu. The available setting ranges and factory defaults are shown.

Col	Row	MENU TEXT	Default Setting	Available Setting	P543/P545 No Distance	P544/P546 No Distance	P543/P545	P544/P546
Description								
49	00	GROUP 1 AUTORECLOSE			*	*	*	*
This column contains settings for Autoreclose								
49	50	Num CBs	CB1 Only	0 = CB1 Only, 1 = CB2 Only or 2 = CB1 & CB2		*		*
Setting defines which CB(s) are active for the specific installation: CB1 only, CB2 only or both CB1 & CB2.								
49	51	AR Mode	AR 3P	0 = 1P, 1 = 1/3P, 2 = 3P or 3 = AR Opto		*		*
If the Num CBs setting (cell 4950 {above} in the AUTORECLOSE column) is set to CB1 Only, or CB2 Only, then this setting determines which auto-reclose modes are permitted for the circuit breaker : single phase (AR 1P) only, both single phase and three phase (AR 1/3P), three phase only (AR 3P), or the auto-reclosing mode is controlled by opto input signals (AR Opto) mapped via DDBs (1497) AR Mode 1P and (1498) AR Mode 3P.								
49	51	AR Mode	AR 3P	0 = 1P, 1 = 1/3P, 2 = 3P or 3 = AR Opto	*		*	
This setting determines which auto-reclose modes are permitted for the circuit breaker : single phase (AR 1P) only, both single phase and three phase (AR 1/3P), three phase only (AR 3P), or the auto-reclosing mode is controlled by opto input signals (AR Opto) mapped via DDBs (1497) AR Mode 1P and (1498) AR Mode 3P.								
49	53	Lead/Foll ARMode	L 3P, F 3P	0 = L 1P, F 1P, 1 = L 1P, F 3P, 2 = L 3P, F 3P, 3 = L 1/3P, F 1/3P, 4 = L 1/3P, F 3P, 5 = AR Opto		*		*

Col	Row	MENU TEXT	Default Setting	Available Setting	P543/P545 No Distance	P544/P546 No Distance	P543/P545	P544/P546
Description								
<p>Setting determines which auto-reclose modes are permitted for leader /follower circuit breakers. The auto-reclose scheme provides single phase or three phase auto-reclosing of a feeder switched by two circuit breakers. The two circuit breakers are normally arranged to reclose sequentially with one, designated the 'Leader' circuit breaker, reclosing after a set dead time followed, if the leader CB remains closed, by the second circuit breaker, designated the 'Follower' circuit breaker after a further delay (follower time).</p> <p>L1P F1P : both leader and follower are configured for single phase auto-reclosing. L1P F3P : the leader is configured for single phase auto-reclosing, whilst the follower is configured for three phase auto-reclosing. L3P F3P : both leader and follower are configured for three phase auto-reclosing. L1/3P F1/3P : both leader and follower are configured for either single phase or three phase auto-reclosing. L1/3P F3P : the leader is configured for single phase or three phase auto-reclosing, while the follower is configured for three phase auto-reclosing only. AR Opto : the auto-reclosing mode of the leader and follower are controlled by opto input signals (Opto) mapped via DDBs (1497) Lead AR 1P, (1498) Lead AR 3P, (1409) Follower AR 1P, and (1410) Follower AR 3P.</p>								
49	54	No BF if L No CS	Disabled	0 = Disabled or 1 = Enabled		*		*
<p>No BF if L No CS = No Block Follower reclose if Leader has No Check Sync conditions. This setting determines whether a follower CB should lock out without reclosing, or continue to reclose, if the leader CB can not reclose because check sync conditions are not met. If No BF if L No CS is set to Enable, follower CB can continue its reclose cycle, no matter if the leader CB can not reclose due to check sync conditions not met. If No BF if L No CS is set to Disable, follower CB is locked out due to the fact that leader CB can not reclose due to Check Sync conditions not being met.</p>								
49	55	Leader Select By	Menu	0 = Menu, 1 = Opto, 2 = Control		*		*
<p>Setting which determines how the preferred leader CB is selected - can be by menu setting, HMI command or by designated opto input.</p> <p>If Leader Select By: is set to Leader by Opto, then preferred leader CB is :-</p> <ul style="list-style-type: none"> • CB1 if input DDB(1408) CB2 Lead is low, or • CB2 if input DDB (1408) CB2 Lead is high. <p>If Leader Select By: is set to Leader by Control, then user control setting CTRL CB2 Lead under CB CONTROL in the IED menu determines the preferred leader by applying set/reset commands (If Set then CB2 is leader ,If Reset then CB1 is leader).</p>								
49	56	Select Leader	CB1	0 = CB1 or 1 = CB2		*		*
<p>If Leader Select By is set to Leader by Menu in the previous cell, then setting Select Leader becomes visible, and determines which CB is the preferred leader.</p>								
49	57	BF if LFail CIs	Enabled	0 = Disabled or 1 = Enabled		*		*
<p>BF if L Fail CIs = Block Follower reclose if Leader CB Fails to close. This setting determines whether a follower CB should lock out without reclosing, or continue to reclose, if the leader CB fails to reclose when the leader CB close command is given. If BF if L Fail CIs is set to Enable, follower CB reclosing is locked out if the leader fails to close. If BF if L Fail CIs is set to Disable, the follower CB can continue its reclose cycle if the leader CB fails to close. (See also setting Dynamic F/L).</p>								
49	58	Dynamic F/L	Disabled	0 = Disabled or 1 = Enabled		*		*
<p>Dynamic F/L = Dynamic change from follower to leader status during an auto-reclose cycle if the leader CB fails to close. If setting BF if Lfail CIs is set to Disabled, then setting Dynamic F/L becomes visible and determines whether the follower CB should assume leader status and reclose immediately if the leader CB should fail to close, or whether it should continue as follower and reclose after the Follower Time delay. Dynamic F/L set to Enabled selects immediate follower reclose if the leader CB fails to close; Dynamic F/L set to Disabled selects the follower to reclose after the Follower Time if leader CB fails to close.</p>								
49	59	AR Shots	1	1 to 4 step 1		*		*
<p>This setting determines how many reclose attempts (shots) are permitted for any single fault incident before it is treated as persistent and auto-reclosing is locked out. For example if AR Shots = 2, a second reclose attempt is initiated if the protection retrips during the reclaim time following one reclose attempt, but locks out if the protection retrips during the reclaim time after a second reclose attempt.</p>								
49	59	AR Shots	1	1 to 4 step 1	*		*	

Col	Row	MENU TEXT	Default Setting	Available Setting	P543/P545 No Distance	P544/P546 No Distance	P543/P545	P544/P546
Description								
This setting determines how many reclose attempts (shots) are permitted for any single fault incident before it is treated as persistent and auto-reclosing is locked out. For example if AR Shots = 2, a second reclose attempt is initiated if the protection retrips during the reclaim time following one reclose attempt, but locks out if the protection retrips during the reclaim time after a second reclose attempt.								
49	5A	AR Skip Shot 1	Disable	0 = Disabled or 1 = Enabled		*		*
If Enabled then the first shot can be skipped by setting the AR Skip Shot1 DDB high in the PSL								
49	5A	AR Skip Shot 1	Disable	0 = Disabled or 1 = Enabled	*		*	
If Enabled then the first shot can be skipped by setting the AR Skip Shot1 DDB high in the PSL								
49	5B	Ind Follower AR	Disable	0 = Disabled or 1 = Enabled		*		*
Enables Independent Follower mode. Visible when Autoreclose is for both CBs.								
49	5C	Multi Phase AR	Allow AR	0 = Allow Autoclose, 1 = BAR 2 and 3Ph, 2 = BAR 3 Phase		*		*
This setting determines whether auto-reclosing is permitted or blocked for two phase or three phase faults.								
49	5C	Multi Phase AR	Allow AR	0 = Allow Autoclose, 1 = BAR 2 and 3Ph, 2 = BAR 3 Phase	*		*	
This setting determines whether auto-reclosing is permitted or blocked for two phase or three phase faults.								
49	5D	Discrim Time	100ms	From 5ms to 5s step 5ms		*		*
Discrim Time = Discriminating Time. This is a setting which determines whether a fault on another phase (evolving or developing fault) after single phase trip and auto-reclose has been initiated by a single phase fault stops the single phase cycle and starts a three phase auto-reclose cycle provided this second fault (evolving fault) occurs BEFORE the Discrimination Time elapsed. It forces a lockout if second fault (evolving fault) occurs AFTER Discrimination Time has elapsed but before Single Phase Dead Time elapses.								
49	5D	Discrim Time	100ms	From 5ms to 5s step 5ms	*		*	
Discrim Time = Discriminating Time. This is a setting which determines whether a fault on another phase (evolving or developing fault) after single phase trip and auto-reclose has been initiated by a single phase fault stops the single phase cycle and starts a three phase auto-reclose cycle provided this second fault (evolving fault) occurs BEFORE the Discrimination Time elapsed. It forces a lockout if second fault (evolving fault) occurs AFTER Discrimination Time has elapsed but before Single Phase Dead Time elapses.								
49	5E	CB IS LL Check	Disabled	0 = Disabled or 1 = Enabled	*	*	*	*
CB IS LL Check = CB In Service Live Line Check. If Enabled the Live Line status is held for a selectable memory time.								
49	5F	CB L Memory Time	200ms	From 10ms to 10s step 10ms	*	*	*	*
CB L Memory Time is a timer setting which allows the Live Line state to be remembered for a short period. Visible if CB IS LL Check is Enabled								
49	60	CB IS Time	5s	From 10ms to 200s step 100ms	*	*	*	*
CB IS Time = CB In Service Time. This is a timer setting for which a CB must remain closed (and optionally the line be live) before it is considered to be In Service.								
49	61	CB IS MemoryTime	500ms	From 10ms to 1s step 10ms	*	*	*	*
CB IS Memory Time is a timer setting which allows a CB In Service state to be remembered for a short period following changeover of the CB auxiliary switch contacts to a CB Open state. This may occasionally be necessary for a few types of CB with exceptionally fast acting auxiliary switch contacts which allow the auto-reclose scheme logic to detect the CB opening before it detects an associated protection operation.								

Col	Row	MENU TEXT	Default Setting	Available Setting	P543/P545 No Distance	P544/P546 No Distance	P543/P545	P544/P546
Description								
49	62	DT Start by Prot	Prot Res	0 = Prot Res, 1 = Prot Op or 2 = Disabled	*	*	*	*
DT Start by Prot = Dead Time Start By Protection action. If DT Start by Prot is set to Disable, a dead time start is not directly affected by protection operation or reset, but is enabled by other conditions or events (see settings: 3PDTStart WhenLD and DTStart by CB Op). If DT Start by Prot is set to Protection Op, the dead time starting is enabled when the auto-reclose initiation signal is received from the protection. If DT Start by Prot is set to Protection Reset, the dead time starting is inhibited until the auto-reclose initiation signal from the protection resets.								
49	63	3PDTStart WhenLD	Disabled	0 = Disabled or 1 = Enabled		*		*
3PDTStart When LD = three phase auto-reclose dead time starts when the line has gone dead. If Enabled, the line is required to go dead before a 3 phase auto-reclose dead time can start. If Disabled, dead time can start when other selected conditions are satisfied, irrespective of line volts.								
49	63	3PDTStart WhenLD	Disabled	0 = Disabled or 1 = Enabled	*		*	
3PDTStart When LD = three phase auto-reclose dead time starts when the line has gone dead. If Enabled, the line is required to go dead before a 3 phase auto-reclose dead time can start. If Disabled, dead time can start when other selected conditions are satisfied, irrespective of line volts.								
49	64	DTStart by CB Op	Disabled	0 = Disabled or 1 = Enabled	*	*	*	*
If Enabled, a dead time start is permitted only when the CB has tripped. If Disabled, a dead time start is permitted when other selected conditions are satisfied, irrespective of the CB position.								
49	66	Dead Line Time	5s	From 1s to 9999s step 1s		*		*
When 3PDTStart When LD is Enabled, and the line does not go dead within the set Dead Line Time period, then the logic will force the auto-reclose sequence to lockout after expiry of this time.								
49	66	Dead Line Time	5s	From 1s to 9999s step 1s	*		*	
When 3PDTStart When LD is Enabled, and the line does not go dead within the set Dead Line Time period, then the logic will force the auto-reclose sequence to lockout after expiry of this time.								
49	67	SP AR Dead Time	500ms	From 0s to 10s step 10ms		*		*
Dead time setting for single phase auto-reclose.								
49	67	SP AR Dead Time	500ms	From 0s to 10s step 10ms	*		*	
Dead time setting for single phase auto-reclose.								
49	68	3P AR DT Shot 1	300ms	From 10ms to 300s step 10ms		*		*
Dead time setting for three phase auto-reclose (first shot).								
49	68	3P AR DT Shot 1	300ms	From 10ms to 300s step 10ms	*		*	
Dead time setting for three phase auto-reclose (first shot).								
49	69	3P AR DT Shot 2	60s	From 1s to 9999s step 1s		*		*
Dead time setting for three phase auto-reclose (2nd shot).								
49	69	3P AR DT Shot 2	60s	From 1s to 9999s step 1s	*		*	
Dead time setting for three phase auto-reclose (2nd shot).								
49	6A	3P AR DT Shot 3	60s	From 1s to 9999s step 1s		*		*

Col	Row	MENU TEXT	Default Setting	Available Setting	P543/P545 No Distance	P544/P546 No Distance	P543/P545	P544/P546
Description								
Dead time setting for three phase auto-reclose (3rd shot).								
49	6A	3P AR DT Shot 3	60s	From 1s to 9999s step 1s	*		*	
Dead time setting for three phase auto-reclose (3rd shot).								
49	6B	3P AR DT Shot 4	60s	From 1s to 9999s step 1s		*		*
Dead time setting for three phase auto-reclose (4th shot).								
49	6B	3P AR DT Shot 4	60s	From 1s to 9999s step 1s	*		*	
Dead time setting for three phase auto-reclose (4th shot).								
49	6C	Follower Time	5s	From 0.1s to 300s step 10ms		*		*
Time delay setting for follower CB reclosing after leader CB has reclosed.								
49	6D	SPAR ReclaimTime	60s	From 1s to 600s step 1s		*		*
Reclaim time setting following single phase auto-reclosure.								
49	6D	SPAR ReclaimTime	60s	From 1s to 600s step 1s	*		*	
Reclaim time setting following single phase auto-reclosure.								
49	6E	3PAR ReclaimTime	180s	From 1s to 600s step 1s		*		*
Reclaim time setting following three phase auto-reclosure.								
49	6E	3PAR ReclaimTime	180s	From 1s to 600s step 1s	*		*	
Reclaim time setting following three phase auto-reclosure.								
49	6F	AR CBHealthyTime	5s	From 10ms to 9999s step 10ms	*		*	
Maximum waiting time to enable CB Closing by auto-reclose. Input DDB (436) CB Healthy CB Close by auto-reclose. If the set time runs out with the input DDB: CB Healthy low (= 0), alarm AR CB Unhealthy (DDB307) is set and the auto-reclose sequence is cancelled.								
49	6F	AR CBHealthyTime	5s	From 10ms to 9999s step 10ms		*		*
Maximum waiting time to enable CB Closing by auto-reclose. Input DDBs (436/437) are used for CB1 Healthy & CB2 Healthy respectively to enable CB1 and CB2 Close by auto-reclose. If the set time runs out with the input DDB: CBx Healthy low (= 0), alarm AR CBx Unhealthy (DDB307 or 329 for CB1 & CB2 respectively) is set and the CBx auto-reclose sequence is cancelled.								
49	70	AR CheckSyncTime	5s	From 10ms to 9999s step 10ms	*		*	
Maximum waiting time for relevant signal CB SCOK from system check logic, to enable CB Close by auto-reclose. If the set time runs out with the input signal CB SCOK low (= 0), System Check Synchronization fail alarm AR CB NO C/S (DDB 308) is set and the auto-reclose sequence is cancelled.								
49	70	AR CheckSyncTime	5s	From 10ms to 9999s step 10ms		*		*
Maximum waiting time for relevant signals CB1L SCOK or CB1F SCOK from system check logic, to enable CB1 Close by auto-reclose. Same waiting time setting applies to input signals CB2L SCOK or CB2F SCOK to enable CB2 Close by auto-reclose. If the set time runs out with the input signal CBx SCOK low (= 0), System Check Synchronization fail alarm AR CBx NO C/S (DDB 308 or 330 for CB1 & CB2 respectively) is set and the CBx auto-reclose sequence is cancelled.								

Col	Row	MENU TEXT	Default Setting	Available Setting	P543/P545 No Distance	P544/P546 No Distance	P543/P545	P544/P546
Description								
49	72	Z1 AR	Initiate AR	0 = Initiate AR or 1 = Block AR			*	*
Setting that determines impact of instantaneous zone 1 on AR operation. (Only in models with distance option)								
49	73	Diff AR	Initiate AR	0 = Initiate AR or 1 = Block AR	*	*	*	*
Setting that determines impact of the phase differential tripping on AR operation.								
49	74	Dist Aided AR	Initiate AR	0 = Initiate AR or 1 = Block AR			*	*
Setting that determines impact of the aided distance schemes tripping on AR operation. (Only in models with distance option)								
49	75	Z2T AR	Block AR	0 = No Action, 1 = Initiate AR or 2 = Block AR			*	*
Setting that determines impact of time delayed zone 2 on AR operation. Set Initiate AR if the trip should initiate a cycle, and Block AR if a time delayed trip should cause lockout. Set No action if Zone 2 tripping should exert no specific logic control on the recloser. (Only in models with distance option)								
49	76	Z3T AR	Block AR	0 = No Action, 1 = Initiate AR or 2 = Block AR			*	*
Similar application to Z3T AR. Selection for Zone 3 trips. (Only in models with distance option)								
49	77	ZPT AR	Block AR	0 = No Action, 1 = Initiate AR or 2 = Block AR			*	*
Similar application to ZPT AR. Selection for Zone 3 trips. (Only in models with distance option)								
49	78	Z4T AR	Block AR	0 = No Action, 1 = Initiate AR or 2 = Block AR			*	*
Similar application to Z4T AR. Selection for Zone 4 trips. (Only in models with distance option)								
49	79	DEF Aided AR	Block AR	0 = Initiate AR or 1 = Block AR			*	*
Setting that determines impact of aided Directional Earth Fault protection (DEF) on AR operation. (Only in models with distance option)								
49	7A	Dir. Comp AR	Block AR	0 = Initiate AR or 1 = Block AR			*	*
Setting that determines impact of aided Directional Comparison protection (DEF) on AR operation. (Only in models with distance option)								
49	7B	TOR AR	Block AR	0 = Initiate AR or 1 = Block AR			*	*
Setting that determines impact of Trip On Reclose (TOR) on AR operation. (Only in models with distance option)								
49	7C	I>1 AR	No Action	0 = No Action, 1 = Initiate AR or 2 = Block AR	*	*	*	*
Setting that determines impact of the first stage overcurrent protection on AR operation.								
49	7D	I>2 AR	No Action	0 = No Action, 1 = Initiate AR or 2 = Block AR	*	*	*	*

Col	Row	MENU TEXT	Default Setting	Available Setting	P543/P545 No Distance	P544/P546 No Distance	P543/P545	P544/P546
Description								
Setting that determines impact of the second stage overcurrent protection on AR operation.								
49	7E	I>3 AR	No Action	0 = No Action, 1 = Initiate AR or 2 = Block AR	*	*	*	*
Setting that determines impact of the third stage overcurrent protection on AR operation.								
49	7F	I>4 AR	No Action	0 = No Action, 1 = Initiate AR or 2 = Block AR	*	*	*	*
Setting that determines impact of the fourth stage overcurrent protection on AR operation.								
49	80	IN>1 AR	No Action	0 = No Action, 1 = Initiate AR or 2 = Block AR	*	*	*	*
Setting that determines impact of the first stage earth fault overcurrent protection on AR operation.								
49	81	IN>2 AR	No Action	0 = No Action, 1 = Initiate AR or 2 = Block AR	*	*	*	*
Setting that determines impact of the second stage earth fault overcurrent protection on AR operation.								
49	82	IN>3 AR	No Action	0 = No Action, 1 = Initiate AR or 2 = Block AR	*	*	*	*
Setting that determines impact of the third stage earth fault overcurrent protection on AR operation.								
49	83	IN>4 AR	No Action	0 = No Action, 1 = Initiate AR or 2 = Block AR	*	*	*	*
Setting that determines impact of the fourth stage earth fault overcurrent protection on AR operation.								
49	84	ISEF>1 AR	No Action	0 = No Action, 1 = Initiate AR or 2 = Block AR	*	*	*	*
Setting that determines impact of the first stage sensitive earth fault overcurrent protection on AR operation.								
49	85	ISEF>2 AR	No Action	0 = No Action, 1 = Initiate AR or 2 = Block AR	*	*	*	*
Setting that determines impact of the second stage sensitive earth fault overcurrent protection on AR operation.								
49	86	ISEF>3 AR	No Action	0 = No Action, 1 = Initiate AR or 2 = Block AR	*	*	*	*
Setting that determines impact of the third stage sensitive earth fault overcurrent protection on AR operation.								
49	87	ISEF>4 AR	No Action	0 = No Action, 1 = Initiate AR or 2 = Block AR	*	*	*	*
Setting that determines impact of the fourth stage sensitive earth fault overcurrent protection on AR operation.								
49	88	ZQT AR	Block AR	0 = No Action, 1 = Initiate AR or 2 = Block AR			*	*
Setting that determines impact of time delayed zone Q on AR operation. Set Initiate AR if the trip should initiate a cycle, and Block AR if a time delayed trip should cause lockout. Set No action if Zone Q tripping should exert no specific logic control on the re-closer. (Only in models with distance option)								
49	A5	AR SYS CHECKS			*	*	*	*

Col	Row	MENU TEXT	Default Setting	Available Setting	P543/P545 No Distance	P544/P546 No Distance	P543/P545	P544/P546
Description								
49	A6	CB SC all	Disabled	0 = Disabled or 1 = Enabled	*		*	
This setting determines whether a system check (e.g. live bus / dead line etc) is required for any auto-reclose of CB. If Enabled, system check is required for some or all reclosures. If Disabled, system check is not required for any reclosures.								
49	A6	CB1L SC all	Disabled	0 = Disabled or 1 = Enabled		*		*
This setting determines whether a system check (e.g. live bus / dead line etc) is required for any auto-reclose of CB1 as leader. If Enabled, system check is required for some or all reclosures. If Disabled, system check is not required for any reclosures.								
49	A7	CB SC Shot 1	Disabled	0 = Disabled or 1 = Enabled	*		*	
This setting determines whether a system check (e.g. live bus / dead line etc) is required for the first shot reclosure of CB. If Enabled, system check is required for the first shot reclosure. If Disabled, system check is not required for the first shot reclosure.								
49	A7	CB1L SC Shot 1	Disabled	0 = Disabled or 1 = Enabled		*		*
This setting determines whether a system check (e.g. live bus / dead line etc) is required for the first shot reclosure of CB1 as leader. If Enabled, system check is required for the first shot reclosure. If Disabled, system check is not required for the first shot reclosure.								
49	A8	CB SC ClsNoDly	Disabled	0 = Disabled or 1 = Enabled	*		*	
If CB SC ClsNoDly is Enabled, CB can reclose as leader as soon as the synchro check conditions are satisfied, without waiting for the dead time to elapse. This option is sometimes required for the second line end to reclose onto a line with delayed auto-reclosing (typical cycle: first line end recloses after the dead time with live bus & dead line, then the second line end recloses immediately with live bus & live line in synchronism).								
49	A8	CB1L SC ClsNoDly	Disabled	0 = Disabled or 1 = Enabled		*		*
If CB1L SC ClsNoDly is Enabled, CB1 can reclose as leader as soon as the synchro check conditions are satisfied, without waiting for the dead time to elapse. This option is sometimes required for the second line end to reclose onto a line with delayed auto-reclosing (typical cycle: first line end recloses after the dead time with live bus & dead line, then the second line end recloses immediately with live bus & live line in synchronism).								
49	A9	CB SC CS1	Disabled	0 = Disabled or 1 = Enabled	*		*	
This setting enables CB to auto-reclose as leader when the system satisfies all the System Check Synchronism Stage 1 criteria as defined under CB CS1 Status settings in the SYSTEM CHECKS column.								
49	A9	CB1L SC CS1	Disabled	0 = Disabled or 1 = Enabled		*		*
This setting enables CB1 to auto-reclose as leader when the system satisfies all the System Check Synchronism Stage 1 criteria as defined under CB1 CS1 Status settings in the SYSTEM CHECKS column.								
49	AA	CB SC CS2	Disabled	0 = Disabled or 1 = Enabled	*		*	
This setting enables CB to auto-reclose as leader when the system satisfies all the System Check Synchronism Stage 2 criteria as defined under the setting CB CS2 Status in the SYSTEM CHECKS column.								
49	AA	CB1L SC CS2	Disabled	0 = Disabled or 1 = Enabled		*		*
This setting enables CB1 to auto-reclose as leader when the system satisfies all the System Check Synchronism Stage 2 criteria as defined under the setting CB1 CS2 status in the SYSTEM CHECKS column.								
49	AB	CB SC DLLB	Disabled	0 = Disabled or 1 = Enabled	*		*	
This setting enables CB to auto-reclose as leader when the dead line & live bus1 conditions are satisfied as set in the SYSTEM CHECKS column.								

Col	Row	MENU TEXT	Default Setting	Available Setting	P543/P545 No Distance	P544/P546 No Distance	P543/P545	P544/P546
Description								
49	AB	CB1L SC DLLB	Disabled	0 = Disabled or 1 = Enabled		*		*
This setting enables CB1 to auto-reclose as leader when the dead line & live bus1 conditions are satisfied as set in the SYSTEM CHECKS column.								
49	AC	CB SC LLDB	Disabled	0 = Disabled or 1 = Enabled	*		*	
This setting enables CB to auto-reclose as leader when the live line & dead bus1 conditions are satisfied as set in the SYSTEM CHECKS column.								
49	AC	CB1L SC LLDB	Disabled	0 = Disabled or 1 = Enabled		*		*
This setting enables CB1 to auto-reclose as leader when the live line & dead bus1 conditions are satisfied as set in the SYSTEM CHECKS column.								
49	AD	CB SC DLDB	Disabled	0 = Disabled or 1 = Enabled	*		*	
This setting enables CB to auto-reclose as leader when the dead line & dead bus1 conditions are satisfied as set in the SYSTEM CHECKS column.								
49	AD	CB1L SC DLDB	Disabled	0 = Disabled or 1 = Enabled		*		*
This setting enables CB1 to auto-reclose as leader when the dead line & dead bus1 conditions are satisfied as set in the SYSTEM CHECKS column.								
49	AE	CB2L SC all	Disabled	0 = Disabled or 1 = Enabled		*		*
This setting enables CB1 to auto-reclose as leader when the dead line & dead bus1 conditions are satisfied as set in the SYSTEM CHECKS column.								
49	AF	CB2L SC Shot 1	Disabled	0 = Disabled or 1 = Enabled		*		*
This setting determines whether a system check (e.g. live bus / dead line etc) is required for the first shot reclosure of CB2 as leader. If Enabled, system check is required for the first shot reclosure. If Disabled, system check is not required for the first shot reclosure.								
49	B0	CB2L SC ClsNoDly	Disabled	0 = Disabled or 1 = Enabled		*		*
If CB2L SC ClsNoDly is Enabled, CB2 can reclose as leader as soon as the synchro check conditions are satisfied, without waiting for the dead time to elapse. This option is sometimes required for the second line end to reclose on a line with delayed auto-reclosing (typical cycle: the first line end recloses after the dead time with live bus & dead line, then the second line end recloses immediately with live bus & live line in synchronism).								
49	B1	CB2L SC CS1	Disabled	0 = Disabled or 1 = Enabled		*		*
This setting enables CB2 to auto-reclose as leader when the system satisfies all the System Check Synchronism Stage 1 criteria as defined under CB2 CS1 Status settings in the SYSTEM CHECKS column.								
49	B2	CB2L SC CS2	Disabled	0 = Disabled or 1 = Enabled		*		*
This setting enables CB2 to auto-reclose as leader when the system satisfies all the System Check Synchronism Stage 2 criteria as defined under CB2 CS2 Status settings in the SYSTEM CHECKS column.								
49	B3	CB2L SC DLLB	Disabled	0 = Disabled or 1 = Enabled		*		*
This setting enables CB2 to auto-reclose as leader when the dead line & live bus 2 conditions are satisfied as set in the SYSTEM CHECKS column.								
49	B4	CB2L SC LLDB	Disabled	0 = Disabled or 1 = Enabled		*		*

Col	Row	MENU TEXT	Default Setting	Available Setting	P543/P545 No Distance	P544/P546 No Distance	P543/P545	P544/P546
Description								
This setting enables CB2 to auto-reclose as leader when the live line & dead bus 2 conditions are satisfied as set in the SYSTEM CHECKS column.								
49	B5	CB2L SC DLDB	Disabled	0 = Disabled or 1 = Enabled		*		*
This setting enables CB2 to auto-reclose as leader when the dead line & dead bus 2 conditions are satisfied as set in the SYSTEM CHECKS column.								
49	B6	CB1F SC all	Disabled	0 = Disabled or 1 = Enabled		*		*
This setting determines whether a system check (e.g. live bus / dead line etc) is required for any auto-reclose of CB1 as follower. If Enabled, system check is required for some or all reclosures. If Disabled, system check is not required for any reclosures.								
49	B7	CB1F SC Shot 1	Disabled	0 = Disabled or 1 = Enabled		*		*
This setting determines whether a system check (e.g. live bus / dead line etc) is required for the first shot reclosure of CB1 as follower. If Enabled, system check is required for the first shot reclosure. If Disabled, system check is not required for the first shot reclosure.								
49	B8	CB1F SC CS1	Disabled	0 = Disabled or 1 = Enabled		*		*
This setting enables CB1 to auto-reclose as follower when the system satisfies all the System Check Synchronism Stage 1 conditions as listed under setting CB1 CS1 Status in the SYSTEM CHECKS column.								
49	B9	CB1F SC CS2	Disabled	0 = Disabled or 1 = Enabled		*		*
This setting enables CB1 to auto-reclose as follower when system satisfies all the System Check Synchronism Stage 2 conditions as listed under setting CB1 CS2 Status in the SYSTEM CHECKS settings.								
49	BA	CB1F SC DLLB	Disabled	0 = Disabled or 1 = Enabled		*		*
This setting enables CB1 to auto-reclose as follower when the dead line & live bus1 conditions are satisfied in the SYSTEM CHECKS column.								
49	BB	CB1F SC LLDB	Disabled	0 = Disabled or 1 = Enabled		*		*
This setting enables CB1 to auto-reclose as follower when the live line & dead bus1 conditions are satisfied in the SYSTEM CHECKS column.								
49	BC	CB1F SC DLDB	Disabled	0 = Disabled or 1 = Enabled		*		*
This setting enables CB1 to auto-reclose as follower when the "dead line" & "dead bus1" conditions are satisfied in the SYSTEM CHECKS settings.								
49	BD	CB2F SC all	Disabled	0 = Disabled or 1 = Enabled		*		*
This setting determines whether a system check (e.g. live bus / dead line etc) is required for any auto-reclose of CB2 as follower. If Enabled, system check is required for some or all reclosures. If Disabled, system check is not required for any reclosures.								
49	BE	CB2F SC Shot 1	Disabled	0 = Disabled or 1 = Enabled		*		*
This setting determines whether a system check (e.g. live bus / dead line etc) is required for the first shot reclosure of CB2 as follower. If Enabled, system check is required for the first shot reclosure. If Disabled, system check is not required for the first shot reclosure.								
49	BF	CB2F SC CS1	Disabled	0 = Disabled or 1 = Enabled		*		*
This setting enables CB2 to auto-reclose as follower when the system satisfies all the System Check Synchronism Stage 1 conditions as listed under setting CB2 CS1 Status in the SYSTEM CHECKS column.								

Col	Row	MENU TEXT	Default Setting	Available Setting	P543/P545 No Distance	P544/P546 No Distance	P543/P545	P544/P546
Description								
49	C0	CB2F SC CS2	Disabled	0 = Disabled or 1 = Enabled		*		*
This setting enables CB2 to auto-reclose as follower when system satisfies all the System Check Synchronism Stage 2 conditions as listed under setting CB2 CS2 Status in the SYSTEM CHECKS settings.								
49	C1	CB2F SC DLLB	Disabled	0 = Disabled or 1 = Enabled		*		*
This setting enables CB2 to auto-reclose as follower when the dead line & live bus 2 conditions are satisfied in the SYSTEM CHECKS column.								
49	C2	CB2F SC LLDB	Disabled	0 = Disabled or 1 = Enabled		*		*
This setting enables CB2 to auto-reclose as follower when the live line & dead bus 2 conditions are satisfied in the SYSTEM CHECKS column.								
49	C3	CB2F SC DLDB	Disabled	0 = Disabled or 1 = Enabled		*		*
This setting enables CB2 to auto-reclose as follower when the dead line & dead bus 2 conditions are satisfied in the SYSTEM CHECKS settings.								
49	C4	CB1IND SC all	Disabled	0 = Disabled or 1 = Enabled		*		*
This setting enables CB1 to auto-reclose as follower when the system satisfies all the System Check Synchronism Stage 1 conditions as listed under setting CB1 CS1 Status in the SYSTEM CHECKS column. Visible if Ind Follower AR is Enabled.								
49	C5	CB1IND SC Shot 1	Disabled	0 = Disabled or 1 = Enabled		*		*
This setting determines whether a system check (e.g. live bus / dead line etc) is required for the first shot reclosure of CB1 as follower. If Enabled, system check is required for the first shot reclosure. If Disabled, system check is not required for the first shot reclosure.								
49	C6	CB1IND SC CS1-1	Disabled	0 = Disabled or 1 = Enabled		*		*
This setting enables CB1 to auto-reclose as follower when the system satisfies all the System Check Synchronism Stage 1 conditions as listed under setting CB1 CS1 Status in the SYSTEM CHECKS column.								
49	C7	CB1IND SC CS1-2	Disabled	0 = Disabled or 1 = Enabled		*		*
This setting enables CB1 to auto-reclose as follower when system satisfies all the System Check Synchronism Stage 2 conditions as listed under setting CB1 CS2 Status in the SYSTEM CHECKS settings.								
49	C8	CB1IND SC DLLB	Disabled	0 = Disabled or 1 = Enabled		*		*
This setting enables CB1 to auto-reclose as follower when the dead line & live bus1 conditions are satisfied in the SYSTEM CHECKS column.								
49	C9	CB1IND SC LLDB	Disabled	0 = Disabled or 1 = Enabled		*		*
This setting enables CB1 to auto-reclose as follower when the live line & dead bus1 conditions are satisfied in the SYSTEM CHECKS column.								
49	CA	CB1IND SC DLDB	Disabled	0 = Disabled or 1 = Enabled		*		*
This setting enables CB1 to auto-reclose as follower when the "dead line" & "dead bus1" conditions are satisfied in the SYSTEM CHECKS settings.								
49	CB	CB2IND SC all	Disabled	0 = Disabled or 1 = Enabled		*		*
This setting enables CB2 to auto-reclose as follower when the system satisfies all the System Check Synchronism Stage 1 conditions as listed under setting CB2 CS1 Status in the SYSTEM CHECKS column. Visible if Ind Follower AR is Enabled.								
49	CC	CB2IND SC Shot 1	Disabled	0 = Disabled or 1 = Enabled		*		*

Col	Row	MENU TEXT	Default Setting	Available Setting	P543/P545 No Distance	P544/P546 No Distance	P543/P545	P544/P546
Description								
This setting determines whether a system check (e.g. live bus / dead line etc) is required for the first shot reclosure of CB2 as follower. If Enabled, system check is required for the first shot reclosure. If Disabled, system check is not required for the first shot reclosure.								
49	CD	CB2IND SC CS2-1	Disabled	0 = Disabled or 1 = Enabled		*		*
This setting enables CB2 to auto-reclose as follower when the system satisfies all the System Check Synchronism Stage 1 conditions as listed under setting CB2 CS1 Status in the SYSTEM CHECKS column.								
49	CE	CB2IND SC CS2-2	Disabled	0 = Disabled or 1 = Enabled		*		*
This setting enables CB2 to auto-reclose as follower when system satisfies all the System Check Synchronism Stage 2 conditions as listed under setting CB2 CS2 Status in the SYSTEM CHECKS settings.								
49	CF	CB2IND SC DLLB	Disabled	0 = Disabled or 1 = Enabled		*		*
This setting enables CB2 to auto-reclose as follower when the dead line & live bus1 conditions are satisfied in the SYSTEM CHECKS column.								
49	D0	CB2IND SC LLDB	Disabled	0 = Disabled or 1 = Enabled		*		*
This setting enables CB2 to auto-reclose as follower when the live line & dead bus1 conditions are satisfied in the SYSTEM CHECKS column.								
49	D1	CB2IND SC DLDB	Disabled	0 = Disabled or 1 = Enabled		*		*
This setting enables CB2 to auto-reclose as follower when the "dead line" & "dead bus1" conditions are satisfied in the SYSTEM CHECKS settings.								
49	E0	SPDT Ext Time	10ms	From 0s to 300s step 10ms	*	*	*	*
This setting sets the extended time for SPDT mode								
49	E1	3PDT Ext Time	10ms	From 0s to 300s step 10ms	*	*	*	*
This setting sets the extended time for 3PDT mode								
49	EA	CB1 Pole Dis. Tm	40ms	From 0s to 10s step 10ms	*	*	*	*
This setting sets pole discrepancy time for CB1								
49	EB	CB2 Pole Dis. Tm	40ms	From 0s to 10s step 10ms		*		*
This setting sets pole discrepancy time for CB2								

Table 22 - Auto-reclose function

3.22 Input Labels

The column **GROUP x INPUT LABELS** is used to individually label each opto input that is available in the relay. The text is restricted to 16 characters and is available if 'Input Labels' are set visible under CONFIGURATION column.

Col	Row	MENU TEXT	Default Setting	Available Setting	P543/P545 No Distance	P544/P546 No Distance	P543/P545	P544/P546
Description								
4A	00	GROUP 1 INPUT LABELS			*	*	*	*
This column contains settings for Input Labels								

Col	Row	MENU TEXT	Default Setting	Available Setting	P543/P545 No Distance	P544/P546 No Distance	P543/P545	P544/P546
Description								
4A	01	Opto Input 1	Input L1	From 32 to 234 step 1	*	*	*	*
Label for Opto Input 1								
4A	02	Opto Input 2	Input L2	From 32 to 234 step 1	*	*	*	*
Label for Opto Input 2								
4A	03	Opto Input 3	Input L3	From 32 to 234 step 1	*	*	*	*
Label for Opto Input 3								
4A	04	Opto Input 4	Input L4	From 32 to 234 step 1	*	*	*	*
Label for Opto Input 4								
4A	05	Opto Input 5	Input L5	From 32 to 234 step 1	*	*	*	*
Label for Opto Input 5								
4A	06	Opto Input 6	Input L6	From 32 to 234 step 1	*	*	*	*
Label for Opto Input 6								
4A	07	Opto Input 7	Input L7	From 32 to 234 step 1	*	*	*	*
Label for Opto Input 7								
4A	08	Opto Input 8	Input L8	From 32 to 234 step 1	*	*	*	*
Label for Opto Input 8								
4A	09	Opto Input 9	Input L9	From 32 to 234 step 1	*	*	*	*
Label for Opto Input 9								
4A	0A	Opto Input 10	Input L10	From 32 to 234 step 1	*	*	*	*
Label for Opto Input 10								
4A	0B	Opto Input 11	Input L11	From 32 to 234 step 1	*	*	*	*
Label for Opto Input 11								
4A	0C	Opto Input 12	Input L12	From 32 to 234 step 1	*	*	*	*
Label for Opto Input 12								
4A	0D	Opto Input 13	Input L13	From 32 to 234 step 1	*	*	*	*
Label for Opto Input 13								
4A	0E	Opto Input 14	Input L14	From 32 to 234 step 1	*	*	*	*
Label for Opto Input 14								
4A	0F	Opto Input 15	Input L15	From 32 to 234 step 1	*	*	*	*
Label for Opto Input 15								
4A	10	Opto Input 16	Input L16	From 32 to 234 step 1	*	*	*	*
Label for Opto Input 16								

Col	Row	MENU TEXT	Default Setting	Available Setting	P543/P545 No Distance	P544/P546 No Distance	P543/P545	P544/P546
Description								
4A	11	Opto Input 17	Input L17	From 32 to 234 step 1			*	*
Label for Opto Input 17								
4A	12	Opto Input 18	Input L18	From 32 to 234 step 1			*	*
Label for Opto Input 18								
4A	13	Opto Input 19	Input L19	From 32 to 234 step 1			*	*
Label for Opto Input 19								
4A	14	Opto Input 20	Input L20	From 32 to 234 step 1			*	*
Label for Opto Input 20								
4A	15	Opto Input 21	Input L21	From 32 to 234 step 1			*	*
Label for Opto Input 21								
4A	16	Opto Input 22	Input L22	From 32 to 234 step 1			*	*
Label for Opto Input 22								
4A	17	Opto Input 23	Input L23	From 32 to 234 step 1			*	*
Label for Opto Input 23								
4A	18	Opto Input 24	Input L24	From 32 to 234 step 1			*	*
Label for Opto Input 24								

Table 23 - Input labels

3.23 Virtual Input Labels

Col	Row	MENU TEXT	Default Setting	Available Setting
Description				
26	00	VIR I/P LABELS	0	0
This column contains settings for Virtual Input Labels				
26	01	Virtual Input 1	Virtual Input 1	From 32 to 234 step 1
Text label to describe each individual Virtual Input.				
26	02	Virtual Input 2	Virtual Input 2	From 32 to 234 step 1
Text label to describe each individual Virtual Input.				
26	03	Virtual Input 3	Virtual Input 3	From 32 to 234 step 1
Text label to describe each individual Virtual Input.				
26	04	Virtual Input 4	Virtual Input 4	From 32 to 234 step 1
Text label to describe each individual Virtual Input.				
26	05	Virtual Input 5	Virtual Input 5	From 32 to 234 step 1
Text label to describe each individual Virtual Input.				
26	06	Virtual Input 6	Virtual Input 6	From 32 to 234 step 1

Col	Row	MENU TEXT	Default Setting	Available Setting
Description				
Text label to describe each individual Virtual Input.				
26	07	Virtual Input 7	Virtual Input 7	From 32 to 234 step 1
Text label to describe each individual Virtual Input.				
26	08	Virtual Input 8	Virtual Input 8	From 32 to 234 step 1
Text label to describe each individual Virtual Input.				
26	09	Virtual Input 9	Virtual Input 9	From 32 to 234 step 1
Text label to describe each individual Virtual Input.				
26	0A	Virtual Input 10	Virtual Input 10	From 32 to 234 step 1
Text label to describe each individual Virtual Input.				
26	0B	Virtual Input 11	Virtual Input 11	From 32 to 234 step 1
Text label to describe each individual Virtual Input.				
26	0C	Virtual Input 12	Virtual Input 12	From 32 to 234 step 1
Text label to describe each individual Virtual Input.				
26	0D	Virtual Input 13	Virtual Input 13	From 32 to 234 step 1
Text label to describe each individual Virtual Input.				
26	0E	Virtual Input 14	Virtual Input 14	From 32 to 234 step 1
Text label to describe each individual Virtual Input.				
26	0F	Virtual Input 15	Virtual Input 15	From 32 to 234 step 1
Text label to describe each individual Virtual Input.				
26	10	Virtual Input 16	Virtual Input 16	From 32 to 234 step 1
Text label to describe each individual Virtual Input.				
26	11	Virtual Input 17	Virtual Input 17	From 32 to 234 step 1
Text label to describe each individual Virtual Input.				
26	12	Virtual Input 18	Virtual Input 18	From 32 to 234 step 1
Text label to describe each individual Virtual Input.				
26	13	Virtual Input 19	Virtual Input 19	From 32 to 234 step 1
Text label to describe each individual Virtual Input.				
26	14	Virtual Input 20	Virtual Input 20	From 32 to 234 step 1
Text label to describe each individual Virtual Input.				
26	15	Virtual Input 21	Virtual Input 21	From 32 to 234 step 1
Text label to describe each individual Virtual Input.				
26	16	Virtual Input 22	Virtual Input 22	From 32 to 234 step 1
Text label to describe each individual Virtual Input.				
26	17	Virtual Input 23	Virtual Input 23	From 32 to 234 step 1
Text label to describe each individual Virtual Input.				
26	18	Virtual Input 24	Virtual Input 24	From 32 to 234 step 1
Text label to describe each individual Virtual Input.				
26	19	Virtual Input 25	Virtual Input 25	From 32 to 234 step 1
Text label to describe each individual Virtual Input.				
26	1A	Virtual Input 26	Virtual Input 26	From 32 to 234 step 1
Text label to describe each individual Virtual Input.				
26	1B	Virtual Input 27	Virtual Input 27	From 32 to 234 step 1
Text label to describe each individual Virtual Input.				

Col	Row	MENU TEXT	Default Setting	Available Setting
Description				
26	1C	Virtual Input 28	Virtual Input 28	From 32 to 234 step 1
Text label to describe each individual Virtual Input.				
26	1D	Virtual Input 29	Virtual Input 29	From 32 to 234 step 1
Text label to describe each individual Virtual Input.				
26	1E	Virtual Input 30	Virtual Input 30	From 32 to 234 step 1
Text label to describe each individual Virtual Input.				
26	1F	Virtual Input 31	Virtual Input 31	From 32 to 234 step 1
Text label to describe each individual Virtual Input.				
26	20	Virtual Input 32	Virtual Input 32	From 32 to 234 step 1
Text label to describe each individual Virtual Input.				

Table 24 - Virtual Input labels

3.24 Output Labels

The column **GROUP x OUTPUT LABELS** is used to individually label each output relay that is available in the relay. The text is restricted to 16 characters and is available if 'Output Labels' are set visible under CONFIGURATION column.

Col	Row	MENU TEXT	Default Setting	Available Setting	P543/P545 No Distance	P544/P546 No Distance	P543/P545	P544/P546
Description								
4B	00	GROUP 1 OUTPUT LABELS			*	*	*	*
This column contains settings for Output Relay Labels								
4B	01	Relay 1	Output R1	From 32 to 234 step 1	*	*	*	*
Label for Output Relay 1								
4B	02	Relay 2	Output R2	From 32 to 234 step 1	*	*	*	*
Label for Output Relay 2								
4B	03	Relay 3	Output R3	From 32 to 234 step 1	*	*	*	*
Label for Output Relay 3								
4B	04	Relay 4	Output R4	From 32 to 234 step 1	*	*	*	*
Label for Output Relay 4								
4B	05	Relay 5	Output R5	From 32 to 234 step 1	*	*	*	*
Label for Output Relay 5								
4B	06	Relay 6	Output R6	From 32 to 234 step 1	*	*	*	*
Label for Output Relay 6								
4B	07	Relay 7	Output R7	From 32 to 234 step 1	*	*	*	*
Label for Output Relay 7								
4B	08	Relay 8	Output R8	From 32 to 234 step 1	*	*	*	*

Col	Row	MENU TEXT	Default Setting	Available Setting	P543/P545 No Distance	P544/P546 No Distance	P543/P545	P544/P546
Description								
Label for Output Relay 8								
4B	09	Relay 9	Output R9	From 32 to 234 step 1	*	*	*	*
Label for Output Relay 9								
4B	0A	Relay 10	Output R10	From 32 to 234 step 1	*	*	*	*
Label for Output Relay 10								
4B	0B	Relay 11	Output R11	From 32 to 234 step 1	*	*	*	*
Label for Output Relay 11								
4B	0C	Relay 12	Output R12	From 32 to 234 step 1	*	*	*	*
Label for Output Relay 12								
4B	0D	Relay 13	Output R13	From 32 to 234 step 1	*	*	*	*
Label for Output Relay 13								
4B	0E	Relay 14	Output R14	From 32 to 234 step 1	*	*	*	*
Label for Output Relay 14								
4B	0F	Relay 15	Output R15	From 32 to 234 step 1			*	*
Label for Output Relay 15								
4B	10	Relay 16	Output R16	From 32 to 234 step 1			*	*
Label for Output Relay 16								
4B	11	Relay 17	Output R17	From 32 to 234 step 1			*	*
Label for Output Relay 17								
4B	12	Relay 18	Output R18	From 32 to 234 step 1			*	*
Label for Output Relay 18								
4B	13	Relay 19	Output R19	From 32 to 234 step 1			*	*
Label for Output Relay 19								
4B	14	Relay 20	Output R20	From 32 to 234 step 1			*	*
Label for Output Relay 20								
4B	15	Relay 21	Output R21	From 32 to 234 step 1			*	*
Label for Output Relay 21								
4B	16	Relay 22	Output R22	From 32 to 234 step 1			*	*
Label for Output Relay 22								
4B	17	Relay 23	Output R23	From 32 to 234 step 1			*	*
Label for Output Relay 23								
4B	18	Relay 24	Output R24	From 32 to 234 step 1			*	*

Col	Row	MENU TEXT	Default Setting	Available Setting	P543/P545 No Distance	P544/P546 No Distance	P543/P545	P544/P546
Description								
Label for Output Relay 24								
4B	19	Relay 25	Output R25	From 32 to 234 step 1			*	*
Label for Output Relay 25								
4B	1A	Relay 26	Output R26	From 32 to 234 step 1			*	*
Label for Output Relay 26								
4B	1B	Relay 27	Output R27	From 32 to 234 step 1			*	*
Label for Output Relay 27								
4B	1C	Relay 28	Output R28	From 32 to 234 step 1			*	*
Label for Output Relay 28								
4B	1D	Relay 29	Output R29	From 32 to 234 step 1			*	*
Label for Output Relay 29								
4B	1E	Relay 30	Output R30	From 32 to 234 step 1			*	*
Label for Output Relay 30								
4B	1F	Relay 31	Output R31	From 32 to 234 step 1			*	*
Label for Output Relay 31								
4B	20	Relay 32	Output R32	From 32 to 234 step 1			*	*
Label for Output Relay 32								

Table 25 - Output labels

3.25 Virtual Output Labels

Col	Row	MENU TEXT	Default Setting	Available Setting
Description				
27	00	VIR O/P LABELS	0	0
This column contains settings for Virtual Output Labels				
27	01	Virtual Output 1	Virtual Output 1	From 32 to 234 step 1
Text label to describe each individual Virtual Output.				
27	02	Virtual Output 2	Virtual Output 2	From 32 to 234 step 1
Text label to describe each individual Virtual Output.				
27	03	Virtual Output 3	Virtual Output 3	From 32 to 234 step 1
Text label to describe each individual Virtual Output.				
27	04	Virtual Output 4	Virtual Output 4	From 32 to 234 step 1
Text label to describe each individual Virtual Output.				
27	05	Virtual Output 5	Virtual Output 5	From 32 to 234 step 1
Text label to describe each individual Virtual Output.				
27	06	Virtual Output 6	Virtual Output 6	From 32 to 234 step 1

Col	Row	MENU TEXT	Default Setting	Available Setting
Description				
Text label to describe each individual Virtual Output.				
27	07	Virtual Output 7	Virtual Output 7	From 32 to 234 step 1
Text label to describe each individual Virtual Output.				
27	08	Virtual Output 8	Virtual Output 8	From 32 to 234 step 1
Text label to describe each individual Virtual Output.				
27	09	Virtual Output 9	Virtual Output 9	From 32 to 234 step 1
Text label to describe each individual Virtual Output.				
27	0A	Virtual Output 10	Virtual Output10	From 32 to 234 step 1
Text label to describe each individual Virtual Output.				
27	0B	Virtual Output 11	Virtual Output11	From 32 to 234 step 1
Text label to describe each individual Virtual Output.				
27	0C	Virtual Output 12	Virtual Output12	From 32 to 234 step 1
Text label to describe each individual Virtual Output.				
27	0D	Virtual Output 13	Virtual Output13	From 32 to 234 step 1
Text label to describe each individual Virtual Output.				
27	0E	Virtual Output 14	Virtual Output14	From 32 to 234 step 1
Text label to describe each individual Virtual Output.				
27	0F	Virtual Output 15	Virtual Output15	From 32 to 234 step 1
Text label to describe each individual Virtual Output.				
27	10	Virtual Output 16	Virtual Output16	From 32 to 234 step 1
Text label to describe each individual Virtual Output.				
27	11	Virtual Output 17	Virtual Output17	From 32 to 234 step 1
Text label to describe each individual Virtual Output.				
27	12	Virtual Output 18	Virtual Output18	From 32 to 234 step 1
Text label to describe each individual Virtual Output.				
27	13	Virtual Output 19	Virtual Output19	From 32 to 234 step 1
Text label to describe each individual Virtual Output.				
27	14	Virtual Output 20	Virtual Output20	From 32 to 234 step 1
Text label to describe each individual Virtual Output.				
27	15	Virtual Output 21	Virtual Output21	From 32 to 234 step 1
Text label to describe each individual Virtual Output.				
27	16	Virtual Output 22	Virtual Output22	From 32 to 234 step 1
Text label to describe each individual Virtual Output.				
27	17	Virtual Output 23	Virtual Output23	From 32 to 234 step 1
Text label to describe each individual Virtual Output.				
27	18	Virtual Output 24	Virtual Output24	From 32 to 234 step 1
Text label to describe each individual Virtual Output.				
27	19	Virtual Output 25	Virtual Output25	From 32 to 234 step 1
Text label to describe each individual Virtual Output.				
27	1A	Virtual Output 26	Virtual Output26	From 32 to 234 step 1
Text label to describe each individual Virtual Output.				
27	1B	Virtual Output 27	Virtual Output27	From 32 to 234 step 1
Text label to describe each individual Virtual Output.				

Col	Row	MENU TEXT	Default Setting	Available Setting
Description				
27	1C	Virtual Output 28	Virtual Output28	From 32 to 234 step 1
Text label to describe each individual Virtual Output.				
27	1D	Virtual Output 29	Virtual Output29	From 32 to 234 step 1
Text label to describe each individual Virtual Output.				
27	1E	Virtual Output 30	Virtual Output30	From 32 to 234 step 1
Text label to describe each individual Virtual Output.				
27	1F	Virtual Output 31	Virtual Output31	From 32 to 234 step 1
Text label to describe each individual Virtual Output.				
27	20	Virtual Output 32	Virtual Output32	From 32 to 234 step 1
Text label to describe each individual Virtual Output.				

Table 26 - Virtual Output labels**3.26 DR Chan Labels**

Col	Row	MENU TEXT	Default Setting	Available Setting	P543/P545 No Distance	P544/P546 No Distance	P543/P545	P544/P546
Description								
2A	00	DR CHAN LABELS			*	*	*	*
This column contains settings for Disturbance Record Channel Labels								
2A	01	Digital Input 1	Digital I/P 1	From 32 to 234 step 1	*	*	*	*
Text label to describe each individual Disturbance Record channel								
2A	02	Digital Input 2	Digital I/P 2	From 32 to 234 step 1	*	*	*	*
Text label to describe each individual Disturbance Record channel								
2A	03	Digital Input 3	Digital I/P 3	From 32 to 234 step 1	*	*	*	*
Text label to describe each individual Disturbance Record channel								
2A	04	Digital Input 4	Digital I/P 4	From 32 to 234 step 1	*	*	*	*
Text label to describe each individual Disturbance Record channel								
2A	05	Digital Input 5	Digital I/P 5	From 32 to 234 step 1	*	*	*	*
Text label to describe each individual Disturbance Record channel								
2A	06	Digital Input 6	Digital I/P 6	From 32 to 234 step 1	*	*	*	*
Text label to describe each individual Disturbance Record channel								
2A	07	Digital Input 7	Digital I/P 7	From 32 to 234 step 1	*	*	*	*
Text label to describe each individual Disturbance Record channel								
2A	08	Digital Input 8	Digital I/P 8	From 32 to 234 step 1	*	*	*	*
Text label to describe each individual Disturbance Record channel								
2A	09	Digital Input 9	Digital I/P 9	From 32 to 234 step 1	*	*	*	*

Col	Row	MENU TEXT	Default Setting	Available Setting	P543/P545 No Distance	P544/P546 No Distance	P543/P545	P544/P546
Description								
Text label to describe each individual Disturbance Record channel								
2A	0A	Digital Input 10	Digital I/P 10	From 32 to 234 step 1	*	*	*	*
Text label to describe each individual Disturbance Record channel								
2A	0B	Digital Input 11	Digital I/P 11	From 32 to 234 step 1	*	*	*	*
Text label to describe each individual Disturbance Record channel								
2A	0C	Digital Input 12	Digital I/P 12	From 32 to 234 step 1	*	*	*	*
Text label to describe each individual Disturbance Record channel								
2A	0D	Digital Input 13	Digital I/P 13	From 32 to 234 step 1	*	*	*	*
Text label to describe each individual Disturbance Record channel								
2A	0E	Digital Input 14	Digital I/P 14	From 32 to 234 step 1	*	*	*	*
Text label to describe each individual Disturbance Record channel								
2A	0F	Digital Input 15	Digital I/P 15	From 32 to 234 step 1	*	*	*	*
Text label to describe each individual Disturbance Record channel								
2A	10	Digital Input 16	Digital I/P 16	From 32 to 234 step 1	*	*	*	*
Text label to describe each individual Disturbance Record channel								
2A	11	Digital Input 17	Digital I/P 17	From 32 to 234 step 1	*	*	*	*
Text label to describe each individual Disturbance Record channel								
2A	12	Digital Input 18	Digital I/P 18	From 32 to 234 step 1	*	*	*	*
Text label to describe each individual Disturbance Record channel								
2A	13	Digital Input 19	Digital I/P 19	From 32 to 234 step 1	*	*	*	*
Text label to describe each individual Disturbance Record channel								
2A	14	Digital Input 20	Digital I/P 20	From 32 to 234 step 1	*	*	*	*
Text label to describe each individual Disturbance Record channel								
2A	15	Digital Input 21	Digital I/P 21	From 32 to 234 step 1	*	*	*	*
Text label to describe each individual Disturbance Record channel								
2A	16	Digital Input 22	Digital I/P 22	From 32 to 234 step 1	*	*	*	*
Text label to describe each individual Disturbance Record channel								
2A	17	Digital Input 23	Digital I/P 23	From 32 to 234 step 1	*	*	*	*
Text label to describe each individual Disturbance Record channel								
2A	18	Digital Input 24	Digital I/P 24	From 32 to 234 step 1	*	*	*	*
Text label to describe each individual Disturbance Record channel								
2A	19	Digital Input 25	Digital I/P 25	From 32 to 234 step 1	*	*	*	*

Col	Row	MENU TEXT	Default Setting	Available Setting	P543/P545 No Distance	P544/P546 No Distance	P543/P545	P544/P546
Description								
Text label to describe each individual Disturbance Record channel								
2A	1A	Digital Input 26	Digital I/P 26	From 32 to 234 step 1	*	*	*	*
Text label to describe each individual Disturbance Record channel								
2A	1B	Digital Input 27	Digital I/P 27	From 32 to 234 step 1	*	*	*	*
Text label to describe each individual Disturbance Record channel								
2A	1C	Digital Input 28	Digital I/P 28	From 32 to 234 step 1	*	*	*	*
Text label to describe each individual Disturbance Record channel								
2A	1D	Digital Input 29	Digital I/P 29	From 32 to 234 step 1	*	*	*	*
Text label to describe each individual Disturbance Record channel								
2A	1E	Digital Input 30	Digital I/P 30	From 32 to 234 step 1	*	*	*	*
Text label to describe each individual Disturbance Record channel								
2A	1F	Digital Input 31	Digital I/P 31	From 32 to 234 step 1	*	*	*	*
Text label to describe each individual Disturbance Record channel								
2A	20	Digital Input 32	Digital I/P 32	From 32 to 234 step 1	*	*	*	*
Text label to describe each individual Disturbance Record channel								
2A	21	Digital Input 33	Digital I/P 33	From 32 to 234 step 1	*	*	*	*
Text label to describe each individual Disturbance Record channel								
2A	22	Digital Input 34	Digital I/P 34	From 32 to 234 step 1	*	*	*	*
Text label to describe each individual Disturbance Record channel								
2A	23	Digital Input 35	Digital I/P 35	From 32 to 234 step 1	*	*	*	*
Text label to describe each individual Disturbance Record channel								
2A	24	Digital Input 36	Digital I/P 36	From 32 to 234 step 1	*	*	*	*
Text label to describe each individual Disturbance Record channel								
2A	25	Digital Input 37	Digital I/P 37	From 32 to 234 step 1	*	*	*	*
Text label to describe each individual Disturbance Record channel								
2A	26	Digital Input 38	Digital I/P 38	From 32 to 234 step 1	*	*	*	*
Text label to describe each individual Disturbance Record channel								
2A	27	Digital Input 39	Digital I/P 39	From 32 to 234 step 1	*	*	*	*
Text label to describe each individual Disturbance Record channel								
2A	28	Digital Input 40	Digital I/P 40	From 32 to 234 step 1	*	*	*	*
Text label to describe each individual Disturbance Record channel								
2A	29	Digital Input 41	Digital I/P 41	From 32 to 234 step 1	*	*	*	*

Col	Row	MENU TEXT	Default Setting	Available Setting	P543/P545 No Distance	P544/P546 No Distance	P543/P545	P544/P546
Description								
Text label to describe each individual Disturbance Record channel								
2A	2A	Digital Input 42	Digital I/P 42	From 32 to 234 step 1	*	*	*	*
Text label to describe each individual Disturbance Record channel								
2A	2B	Digital Input 43	Digital I/P 43	From 32 to 234 step 1	*	*	*	*
Text label to describe each individual Disturbance Record channel								
2A	2C	Digital Input 44	Digital I/P 44	From 32 to 234 step 1	*	*	*	*
Text label to describe each individual Disturbance Record channel								
2A	2D	Digital Input 45	Digital I/P 45	From 32 to 234 step 1	*	*	*	*
Text label to describe each individual Disturbance Record channel								
2A	2E	Digital Input 46	Digital I/P 46	From 32 to 234 step 1	*	*	*	*
Text label to describe each individual Disturbance Record channel								
2A	2F	Digital Input 47	Digital I/P 47	From 32 to 234 step 1	*	*	*	*
Text label to describe each individual Disturbance Record channel								
2A	30	Digital Input 48	Digital I/P 48	From 32 to 234 step 1	*	*	*	*
Text label to describe each individual Disturbance Record channel								
2A	31	Digital Input 49	Digital I/P 49	From 32 to 234 step 1	*	*	*	*
Text label to describe each individual Disturbance Record channel								
2A	32	Digital Input 50	Digital I/P 50	From 32 to 234 step 1	*	*	*	*
Text label to describe each individual Disturbance Record channel								
2A	33	Digital Input 51	Digital I/P 51	From 32 to 234 step 1	*	*	*	*
Text label to describe each individual Disturbance Record channel								
2A	34	Digital Input 52	Digital I/P 52	From 32 to 234 step 1	*	*	*	*
Text label to describe each individual Disturbance Record channel								
2A	35	Digital Input 53	Digital I/P 53	From 32 to 234 step 1	*	*	*	*
Text label to describe each individual Disturbance Record channel								
2A	36	Digital Input 54	Digital I/P 54	From 32 to 234 step 1	*	*	*	*
Text label to describe each individual Disturbance Record channel								
2A	37	Digital Input 55	Digital I/P 55	From 32 to 234 step 1	*	*	*	*
Text label to describe each individual Disturbance Record channel								
2A	38	Digital Input 56	Digital I/P 56	From 32 to 234 step 1	*	*	*	*
Text label to describe each individual Disturbance Record channel								
2A	39	Digital Input 57	Digital I/P 57	From 32 to 234 step 1	*	*	*	*

Col	Row	MENU TEXT	Default Setting	Available Setting	P543/P545 No Distance	P544/P546 No Distance	P543/P545	P544/P546
Description								
Text label to describe each individual Disturbance Record channel								
2A	3A	Digital Input 58	Digital I/P 58	From 32 to 234 step 1	*	*	*	*
Text label to describe each individual Disturbance Record channel								
2A	3B	Digital Input 59	Digital I/P 59	From 32 to 234 step 1	*	*	*	*
Text label to describe each individual Disturbance Record channel								
2A	3C	Digital Input 60	Digital I/P 60	From 32 to 234 step 1	*	*	*	*
Text label to describe each individual Disturbance Record channel								
2A	3D	Digital Input 61	Digital I/P 61	From 32 to 234 step 1	*	*	*	*
Text label to describe each individual Disturbance Record channel								
2A	3E	Digital Input 62	Digital I/P 62	From 32 to 234 step 1	*	*	*	*
Text label to describe each individual Disturbance Record channel								
2A	3F	Digital Input 63	Digital I/P 63	From 32 to 234 step 1	*	*	*	*
Text label to describe each individual Disturbance Record channel								
2A	40	Digital Input 64	Digital I/P 64	From 32 to 234 step 1	*	*	*	*
Text label to describe each individual Disturbance Record channel								
2A	41	Digital Input 65	Digital I/P 65	From 32 to 234 step 1	*	*	*	*
Text label to describe each individual Disturbance Record channel								
2A	42	Digital Input 66	Digital I/P 66	From 32 to 234 step 1	*	*	*	*
Text label to describe each individual Disturbance Record channel								
2A	43	Digital Input 67	Digital I/P 67	From 32 to 234 step 1	*	*	*	*
Text label to describe each individual Disturbance Record channel								
2A	44	Digital Input 68	Digital I/P 68	From 32 to 234 step 1	*	*	*	*
Text label to describe each individual Disturbance Record channel								
2A	45	Digital Input 69	Digital I/P 69	From 32 to 234 step 1	*	*	*	*
Text label to describe each individual Disturbance Record channel								
2A	46	Digital Input 70	Digital I/P 70	From 32 to 234 step 1	*	*	*	*
Text label to describe each individual Disturbance Record channel								
2A	47	Digital Input 71	Digital I/P 71	From 32 to 234 step 1	*	*	*	*
Text label to describe each individual Disturbance Record channel								
2A	48	Digital Input 72	Digital I/P 72	From 32 to 234 step 1	*	*	*	*
Text label to describe each individual Disturbance Record channel								
2A	49	Digital Input 73	Digital I/P 73	From 32 to 234 step 1	*	*	*	*

Col	Row	MENU TEXT	Default Setting	Available Setting	P543/P545 No Distance	P544/P546 No Distance	P543/P545	P544/P546
Description								
Text label to describe each individual Disturbance Record channel								
2A	4A	Digital Input 74	Digital I/P 74	From 32 to 234 step 1	*	*	*	*
Text label to describe each individual Disturbance Record channel								
2A	4B	Digital Input 75	Digital I/P 75	From 32 to 234 step 1	*	*	*	*
Text label to describe each individual Disturbance Record channel								
2A	4C	Digital Input 76	Digital I/P 76	From 32 to 234 step 1	*	*	*	*
Text label to describe each individual Disturbance Record channel								
2A	4D	Digital Input 77	Digital I/P 77	From 32 to 234 step 1	*	*	*	*
Text label to describe each individual Disturbance Record channel								
2A	4E	Digital Input 78	Digital I/P 78	From 32 to 234 step 1	*	*	*	*
Text label to describe each individual Disturbance Record channel								
2A	4F	Digital Input 79	Digital I/P 79	From 32 to 234 step 1	*	*	*	*
Text label to describe each individual Disturbance Record channel								
2A	50	Digital Input 80	Digital I/P 80	From 32 to 234 step 1	*	*	*	*
Text label to describe each individual Disturbance Record channel								
2A	51	Digital Input 81	Digital I/P 81	From 32 to 234 step 1	*	*	*	*
Text label to describe each individual Disturbance Record channel								
2A	52	Digital Input 82	Digital I/P 82	From 32 to 234 step 1	*	*	*	*
Text label to describe each individual Disturbance Record channel								
2A	53	Digital Input 83	Digital I/P 83	From 32 to 234 step 1	*	*	*	*
Text label to describe each individual Disturbance Record channel								
2A	54	Digital Input 84	Digital I/P 84	From 32 to 234 step 1	*	*	*	*
Text label to describe each individual Disturbance Record channel								
2A	55	Digital Input 85	Digital I/P 85	From 32 to 234 step 1	*	*	*	*
Text label to describe each individual Disturbance Record channel								
2A	56	Digital Input 86	Digital I/P 86	From 32 to 234 step 1	*	*	*	*
Text label to describe each individual Disturbance Record channel								
2A	57	Digital Input 87	Digital I/P 87	From 32 to 234 step 1	*	*	*	*
Text label to describe each individual Disturbance Record channel								
2A	58	Digital Input 88	Digital I/P 88	From 32 to 234 step 1	*	*	*	*
Text label to describe each individual Disturbance Record channel								
2A	59	Digital Input 89	Digital I/P 89	From 32 to 234 step 1	*	*	*	*

Col	Row	MENU TEXT	Default Setting	Available Setting	P543/P545 No Distance	P544/P546 No Distance	P543/P545	P544/P546
Description								
Text label to describe each individual Disturbance Record channel								
2A	5A	Digital Input 90	Digital I/P 90	From 32 to 234 step 1	*	*	*	*
Text label to describe each individual Disturbance Record channel								
2A	5B	Digital Input 91	Digital I/P 91	From 32 to 234 step 1	*	*	*	*
Text label to describe each individual Disturbance Record channel								
2A	5C	Digital Input 92	Digital I/P 92	From 32 to 234 step 1	*	*	*	*
Text label to describe each individual Disturbance Record channel								
2A	5D	Digital Input 93	Digital I/P 93	From 32 to 234 step 1	*	*	*	*
Text label to describe each individual Disturbance Record channel								
2A	5E	Digital Input 94	Digital I/P 94	From 32 to 234 step 1	*	*	*	*
Text label to describe each individual Disturbance Record channel								
2A	5F	Digital Input 95	Digital I/P 95	From 32 to 234 step 1	*	*	*	*
Text label to describe each individual Disturbance Record channel								
2A	60	Digital Input 96	Digital I/P 96	From 32 to 234 step 1	*	*	*	*
Text label to describe each individual Disturbance Record channel								
2A	61	Digital Input 97	Digital I/P 97	From 32 to 234 step 1	*	*	*	*
Text label to describe each individual Disturbance Record channel								
2A	62	Digital Input 98	Digital I/P 98	From 32 to 234 step 1	*	*	*	*
Text label to describe each individual Disturbance Record channel								
2A	63	Digital Input 99	Digital I/P 99	From 32 to 234 step 1	*	*	*	*
Text label to describe each individual Disturbance Record channel								
2A	64	Digital Input 100	Digital I/P 100	From 32 to 234 step 1	*	*	*	*
Text label to describe each individual Disturbance Record channel								
2A	65	Digital Input 101	Digital I/P 101	From 32 to 234 step 1	*	*	*	*
Text label to describe each individual Disturbance Record channel								
2A	66	Digital Input 102	Digital I/P 102	From 32 to 234 step 1	*	*	*	*
Text label to describe each individual Disturbance Record channel								
2A	67	Digital Input 103	Digital I/P 103	From 32 to 234 step 1	*	*	*	*
Text label to describe each individual Disturbance Record channel								
2A	68	Digital Input 104	Digital I/P 104	From 32 to 234 step 1	*	*	*	*
Text label to describe each individual Disturbance Record channel								
2A	69	Digital Input 105	Digital I/P 105	From 32 to 234 step 1	*	*	*	*

Col	Row	MENU TEXT	Default Setting	Available Setting	P543/P545 No Distance	P544/P546 No Distance	P543/P545	P544/P546
Description								
Text label to describe each individual Disturbance Record channel								
2A	6A	Digital Input 106	Digital I/P 106	From 32 to 234 step 1	*	*	*	*
Text label to describe each individual Disturbance Record channel								
2A	6B	Digital Input 107	Digital I/P 107	From 32 to 234 step 1	*	*	*	*
Text label to describe each individual Disturbance Record channel								
2A	6C	Digital Input 108	Digital I/P 108	From 32 to 234 step 1	*	*	*	*
Text label to describe each individual Disturbance Record channel								
2A	6D	Digital Input 109	Digital I/P 109	From 32 to 234 step 1	*	*	*	*
Text label to describe each individual Disturbance Record channel								
2A	6E	Digital Input 110	Digital I/P 110	From 32 to 234 step 1	*	*	*	*
Text label to describe each individual Disturbance Record channel								
2A	6F	Digital Input 111	Digital I/P 111	From 32 to 234 step 1	*	*	*	*
Text label to describe each individual Disturbance Record channel								
2A	70	Digital Input 112	Digital I/P 112	From 32 to 234 step 1	*	*	*	*
Text label to describe each individual Disturbance Record channel								
2A	71	Digital Input 113	Digital I/P 113	From 32 to 234 step 1	*	*	*	*
Text label to describe each individual Disturbance Record channel								
2A	72	Digital Input 114	Digital I/P 114	From 32 to 234 step 1	*	*	*	*
Text label to describe each individual Disturbance Record channel								
2A	73	Digital Input 115	Digital I/P 115	From 32 to 234 step 1	*	*	*	*
Text label to describe each individual Disturbance Record channel								
2A	74	Digital Input 116	Digital I/P 116	From 32 to 234 step 1	*	*	*	*
Text label to describe each individual Disturbance Record channel								
2A	75	Digital Input 117	Digital I/P 117	From 32 to 234 step 1	*	*	*	*
Text label to describe each individual Disturbance Record channel								
2A	76	Digital Input 118	Digital I/P 118	From 32 to 234 step 1	*	*	*	*
Text label to describe each individual Disturbance Record channel								
2A	77	Digital Input 119	Digital I/P 119	From 32 to 234 step 1	*	*	*	*
Text label to describe each individual Disturbance Record channel								
2A	78	Digital Input 120	Digital I/P 120	From 32 to 234 step 1	*	*	*	*
Text label to describe each individual Disturbance Record channel								
2A	79	Digital Input 121	Digital I/P 121	From 32 to 234 step 1	*	*	*	*

Col	Row	MENU TEXT	Default Setting	Available Setting	P543/P545 No Distance	P544/P546 No Distance	P543/P545	P544/P546
Description								
Text label to describe each individual Disturbance Record channel								
2A	7A	Digital Input 122	Digital I/P 122	From 32 to 234 step 1	*	*	*	*
Text label to describe each individual Disturbance Record channel								
2A	7B	Digital Input 123	Digital I/P 123	From 32 to 234 step 1	*	*	*	*
Text label to describe each individual Disturbance Record channel								
2A	7C	Digital Input 124	Digital I/P 124	From 32 to 234 step 1	*	*	*	*
Text label to describe each individual Disturbance Record channel								
2A	7D	Digital Input 125	Digital I/P 125	From 32 to 234 step 1	*	*	*	*
Text label to describe each individual Disturbance Record channel								
2A	7E	Digital Input 126	Digital I/P 126	From 32 to 234 step 1	*	*	*	*
Text label to describe each individual Disturbance Record channel								
2A	7F	Digital Input 127	Digital I/P 127	From 32 to 234 step 1	*	*	*	*
Text label to describe each individual Disturbance Record channel								
2A	80	Digital Input 128	Digital I/P 128	From 32 to 234 step 1	*	*	*	*
Text label to describe each individual Disturbance Record channel								

Table 27 - DR Chan labels

3.27 SR/MR User Alarm Labels

Col	Row	MENU TEXT	Default Setting	Available Setting
Description				
28	00	USR ALARM LABELS	0	0
This column contains settings for Virtual Input Labels				
28	01	SR User Alarm 1	SR User Alarm 1	From 32 to 234 step 1
Text label to describe each individual User Alarm.				
28	02	SR User Alarm 2	SR User Alarm 2	From 32 to 234 step 1
Text label to describe each individual User Alarm.				
28	03	SR User Alarm 3	SR User Alarm 3	From 32 to 234 step 1
Text label to describe each individual User Alarm.				
28	04	SR User Alarm 4	SR User Alarm 4	From 32 to 234 step 1
Text label to describe each individual User Alarm.				
28	05	MR User Alarm 1	MR User Alarm 1	From 32 to 234 step 1
Text label to describe each individual User Alarm.				
28	06	MR User Alarm 2	MR User Alarm 2	From 32 to 234 step 1
Text label to describe each individual User Alarm.				
28	07	MR User Alarm 3	MR User Alarm 3	From 32 to 234 step 1

Col	Row	MENU TEXT	Default Setting	Available Setting
Description				
Text label to describe each individual User Alarm.				
28	08	MR User Alarm 4	MR User Alarm 4	From 32 to 234 step 1
Text label to describe each individual User Alarm.				

Table 28 - SR/MR User Alarm labels**3.28****EIA(RS)232 InterMiCOM Communications**

'InterMiCOM' operates via an EIA(RS)232 physical output on the back of the 2nd rear communication board. It provides 8 independently settable digital signals that can be conveyed between line ends. The InterMiCOM teleprotection is restricted to 2 ends. InterMiCOM input and output mapping has to be done in the Programmable Scheme Logic (PSL).

Col	Row	MENU TEXT	Default Setting	Available Setting
Description				
15	00	INTERMiCOM COMMS	0	
This column is only visible if the model number supports InterMiCOM and second rear comms board is fitted.				
15	01	IM Input Status	0	Not Settable
Displays the status of each InterMiCOM input signal, with IM1 signal starting from the right. When loop back mode is set, all bits will display zero.				
15	02	IM Ouput Status	0	Not Settable
Displays the status of each InterMiCOM output signal.				
15	10	Source Address	1	0 to 10 step 1
Setting for the unique relay address that is encoded in the InterMiCOM sent message.				
15	11	Receive Address	2	0 to 10 step 1
The aim of setting addresses is to establish pairs of relays which will only communicate with each other. Should an inadvertent channel misrouting or spurious loopback occur, an error will be logged, and the erroneous received data will be rejected. As an example, in a 2 ended scheme the following address setting would be correct: Local relay: Source Address = 1, Receive Address = 2 Remote relay: Source Address = 2, Receive Address = 1				
15	12	Baud Rate	9600	0 = 600, 1 = 1200, 2 = 2400, 3 = 4800, 4 = 9600 or 5 = 19200
Setting of the signalling speed in terms of number of bits per second. The speed will match the capability of the MODEM or other characteristics of the channel provided.				
15	20	Ch Statistics	Invisible	0 = Invisible, 1 = Visible
Settings that makes visible or invisible Channel Statistics on the LCD. The statistic is reset by either relay's powering down or using the 'Reset Statistics' cell.				
15	21	Rx Direct Count	0	Not Settable
Displays the number of valid Direct Tripping messages since last counter reset.				
15	22	Rx Perm Count	0	Not Settable
Displays the number of valid Permissive Tripping messages since last counter reset.				
15	23	Rx Block Count	0	Not Settable
Displays the number of valid Blocking messages since last counter reset.				
15	24	Rx NewData Count	0	Not Settable
Displays the number of different messages (change events) since last counter reset.				

Col	Row	MENU TEXT	Default Setting	Available Setting
Description				
15	25	Rx Errored Count	0	Not Settable
Displays the number of invalid received messages since last counter reset.				
15	26	Lost Messages	0	Not Settable
Displays the difference between the number of messages that were supposed to be received (based on set Baud Rate) and actual valid received messages since last reset.				
15	30	Elapsed Time	0	Not Settable
Displays the time in seconds since last counter reset.				
15	31	Reset Statistics	No	0 = No, 1 = Yes
Command that allows all Statistics and Channel Diagnostics to be reset.				
15	40	Ch Diagnostics	Invisible	0 = Invisible, 1 = Visible
Setting that makes visible or invisible Channel Diagnostics on the LCD. The diagnostic is reset by either relay's powering down or using the 'Reset Statistics' cell.				
15	41	Data CD Status	0	Not Settable
Indicates when the DCD line (pin 1 on EIA232 Connector) is energized. OK = DCD is energized FAIL = DCD is de-energized Absent = 2nd Rear port board is not fitted				
15	42	FrameSync Status	0	Not Settable
Indicates when the message structure and synchronization is valid. OK = Valid message structure and synchronization FAIL = Synchronization has been lost Absent = 2nd Rear port board is not fitted Unavailable = Hardware error present				
15	43	Message Status	0	Not Settable
Indicates when the percentage of received valid messages has fallen below the 'IM Msg Alarm Lvl' setting within the alarm time period. OK = Acceptable ratio of lost messages FAIL = Unacceptable ratio of lost messages Absent = 2nd Rear port board is not fitted Unavailable = Hardware error present				
15	44	Channel Status	0	Not Settable
Indicates the state of the InterMiCOM communication channel. OK = Channel healthy FAIL = Channel failure Absent = 2nd Rear port board is not fitted Unavailable = Hardware error present				
15	45	IM H/W Status	0	Not Settable
Indicates the state of InterMiCOM hardware OK = InterMiCOM hardware healthy Read or Write Error = InterMiCOM failure Absent = 2nd Rear port is not fitted or failed to initialize.				
15	50	Loopback Mode	Disabled	0 = Disabled, 1 = Internal or 2 = External
Setting to allow testing of the InterMiCOM channel. When 'Internal' is selected, only the local InterMiCOM software functionality is tested, whereby the relay will receive its own sent data. 'External' setting allows a hardware and software check, with an external link required to jumper the sent data onto the receive channel. During normal service condition Loopback mode must be disabled.				
15	51	Test Pattern	11111111(bin)	Bit 00=InterMiCOM 1 to Bit 07=InterMiCOM 8
Allows specific bit statuses to be inserted directly into the InterMiCOM message, to substitute real data. This is used for testing purposes.				
15	52	Loopback Status	0	Not Settable

Col	Row	MENU TEXT	Default Setting	Available Setting
Description				
Indicates the status of the InterMiCOM loopback mode OK = Loopback software (and hardware) is working correctly FAIL = Loopback mode failure Unavailable = Hardware error present.				

Table 29 - InterMiCOM comms

3.29 EIA(RS)232 InterMiCOM Conf 56/64 kbit/s Fiber Teleprotection – InterMiCOM 64

Col	Row	MENU TEXT	Default Setting	Available Setting
Description				
16	00	INTERMiCOM CONF	0	
This column is only visible if the model number supports InterMiCOM and second rear comms board is fitted.				
16	01	IM Msg Alarm Lvl	0.25	From 0% to 100% step 0.1%
Setting that is used to alarm for poor channel quality. If during the fixed 1.6s window the ratio of invalid messages to the total number of messages that should be received (based upon the 'Baud Rate' setting) exceeds the above threshold, a 'Message Fail' alarm will be issued.				
16	10	IM1 Cmd Type	Blocking	0 = Disabled, 1 = Direct, 2 = Permissive or 3 = Blocking
Setting that defines the operative mode of the InterMiCOM_1 signal. Selecting the channel response for this bit to Blocking allows fastest signalling, whereas setting to Direct offers higher security at the expense of speed. Selecting the channel response for this bit to Permissive offers higher dependability				
16	11	IM1 FallBackMode	Default	0 = Default or 1 = Latched
Setting that defines the status of IM1 signal in case of heavy noise and message synchronization being lost. If set to 'Latching' the last valid IM1 status will be maintained until the new valid message is received. If set to 'Default', the IM1 status, pre-defined by the user in 'IM1 DefaultValue' cell will be set. A new valid message will replace 'IM1 DefaultValue', once the channel recovers.				
16	12	IM1 DefaultValue	1	0 to 1 step 1
Setting that defines the IM1 fallback status.				
16	13	IM1 FrameSyncTim	1.5s	From 10ms to 1.5s step 10ms
Time delay after which 'IM1 DefaultValue' is applied, providing that no valid message is received in the meantime.				
16	18	IM2 Cmd Type	Blocking	0 = Disabled, 1 = Direct, 2 = Permissive or 3 = Blocking
Setting that defines the operative mode of the InterMiCOM_2 signal. Selecting the channel response for this bit to Blocking allows fastest signalling, whereas setting to Direct offers higher security at the expense of speed. Selecting the channel response for this bit to Permissive offers higher dependability				
16	19	IM2 FallBackMode	Default	0 = Default or 1 = Latched
Setting that defines the status of IM2 signal in case of heavy noise and message synchronization being lost. If set to 'Latching' the last valid IM2 status will be maintained until the new valid message is received. If set to 'Default', the IM2 status, pre-defined by the user in 'IM2 DefaultValue' cell will be set. A new valid message will replace 'IM2 DefaultValue', once the channel recovers.				
16	1A	IM2 DefaultValue	1	0 to 1 step 1
Setting that defines the IM2 fallback status.				
16	1B	IM2 FrameSyncTim	1.5s	From 10ms to 1.5s step 10ms
Time delay after which 'IM2 DefaultValue' is applied, providing that no valid message is received in the meantime.				
16	20	IM3 Cmd Type	Blocking	0 = Disabled, 1 = Direct, 2 = Permissive or 3 = Blocking

Col	Row	MENU TEXT	Default Setting	Available Setting
Description				
Setting that defines the operative mode of the InterMiCOM_3 signal. Selecting the channel response for this bit to Blocking allows fastest signalling, whereas setting to Direct offers higher security at the expense of speed. Selecting the channel response for this bit to Permissive offers higher dependability				
16	21	IM3 FallBackMode	Default	0 = Default or 1 = Latched
Setting that defines the status of IM3 signal in case of heavy noise and message synchronization being lost. If set to 'Latching' the last valid IM3 status will be maintained until the new valid message is received. If set to 'Default', the IM3 status, pre-defined by the user in 'IM3 DefaultValue' cell will be set. A new valid message will replace 'IM3 DefaultValue', once the channel recovers.				
16	22	IM3 DefaultValue	1	0 to 1 step 1
Setting that defines the IM3 fallback status.				
16	23	IM3 FrameSyncTim	1.5s	From 10ms to 1.5s step 10ms
Time delay after which 'IM3 DefaultValue' is applied, providing that no valid message is received in the meantime.				
16	28	IM4 Cmd Type	Blocking	0 = Disabled, 1 = Direct, 2 = Permissive or 3 = Blocking
Setting that defines the operative mode of the InterMiCOM_4 signal. Selecting the channel response for this bit to Blocking allows fastest signalling, whereas setting to Direct offers higher security at the expense of speed. Selecting the channel response for this bit to Permissive offers higher dependability				
16	29	IM4 FallBackMode	Default	0 = Default or 1 = Latched
Setting that defines the status of IM4 signal in case of heavy noise and message synchronization being lost. If set to 'Latching' the last valid IM4 status will be maintained until the new valid message is received. If set to 'Default', the IM4 status, pre-defined by the user in 'IM4 DefaultValue' cell will be set. A new valid message will replace 'IM4 DefaultValue', once the channel recovers.				
16	2A	IM4 DefaultValue	1	0 to 1 step 1
Setting that defines the IM4 fallback status.				
16	2B	IM4 FrameSyncTim	1.5s	From 10ms to 1.5s step 10ms
Time delay after which 'IM4 DefaultValue' is applied, providing that no valid message is received in the meantime.				
16	30	IM5 Cmd Type	Direct	0 = Disabled, 1 = Direct, 2 = Permissive or 3 = Blocking
Setting that defines the operative mode of the InterMiCOM_5 signal. Selecting the channel response for this bit to Blocking allows fastest signalling, whereas setting to Direct offers higher security at the expense of speed. Selecting the channel response for this bit to Permissive offers higher dependability				
16	31	IM5 FallBackMode	Default	0 = Default or 1 = Latched
Setting that defines the status of IM5 signal in case of heavy noise and message synchronization being lost. If set to 'Latching' the last valid IM5 status will be maintained until the new valid message is received. If set to 'Default', the IM5 status, pre-defined by the user in 'IM5 DefaultValue' cell will be set. A new valid message will replace 'IM5 DefaultValue', once the channel recovers.				
16	32	IM5 DefaultValue	0	0 to 1 step 1
Setting that defines the IM5 fallback status.				
16	33	IM5 FrameSyncTim	1.5s	From 10ms to 1.5s step 10ms
Time delay after which 'IM5 DefaultValue' is applied.				
16	38	IM6 Cmd Type	Direct	0 = Disabled, 1 = Direct, 2 = Permissive or 3 = Blocking
Setting that defines the operative mode of the InterMiCOM_6 signal. Selecting the channel response for this bit to Blocking allows fastest signalling, whereas setting to Direct offers higher security at the expense of speed. Selecting the channel response for this bit to Permissive offers higher dependability				
16	39	IM6 FallBackMode	Default	0 = Default or 1 = Latched

Col	Row	MENU TEXT	Default Setting	Available Setting
Description				
Setting that defines the status of IM6 signal in case of heavy noise and message synchronization being lost. If set to 'Latching' the last valid IM6 status will be maintained until the new valid message is received. If set to 'Default', the IM6 status, pre-defined by the user in 'IM6 DefaultValue' cell will be set. A new valid message will replace 'IM6 DefaultValue', once the channel recovers.				
16	3A	IM6 DefaultValue	0	0 to 1 step 1
Setting that defines the IM6 fallback status.				
16	3B	IM6 FrameSyncTim	1.5s	From 10ms to 1.5s step 10ms
Time delay after which 'IM6 DefaultValue' is applied.				
16	40	IM7 Cmd Type	Direct	0 = Disabled, 1 = Direct, 2 = Permissive or 3 = Blocking
Setting that defines the operative mode of the InterMiCOM_7 signal. Selecting the channel response for this bit to Blocking allows fastest signalling, whereas setting to Direct offers higher security at the expense of speed. Selecting the channel response for this bit to Permissive offers higher dependability				
16	41	IM7 FallBackMode	Default	0 = Default or 1 = Latched
Setting that defines the status of IM7 signal in case of heavy noise and message synchronization being lost. If set to 'Latching' the last valid IM7 status will be maintained until the new valid message is received. If set to 'Default', the IM7 status, pre-defined by the user in 'IM7 DefaultValue' cell will be set. A new valid message will replace 'IM7 DefaultValue', once the channel recovers.				
16	42	IM7 DefaultValue	0	0 to 1 step 1
Setting that defines the IM7 fallback status.				
16	43	IM7 FrameSyncTim	1.5s	From 10ms to 1.5s step 10ms
Time delay after which 'IM7 DefaultValue' is applied.				
16	48	IM8 Cmd Type	Direct	0 = Disabled, 1 = Direct, 2 = Permissive or 3 = Blocking
Setting that defines the operative mode of the InterMiCOM_8 signal. Selecting the channel response for this bit to Blocking allows fastest signalling, whereas setting to Direct offers higher security at the expense of speed. Selecting the channel response for this bit to Permissive offers higher dependability				
16	49	IM8 FallBackMode	Default	0 = Default or 1 = Latched
Setting that defines the status of IM8 signal in case of heavy noise and message synchronization being lost. If set to 'Latching' the last valid IM8 status will be maintained until the new valid message is received. If set to 'Default', the IM8 status, pre-defined by the user in 'IM8 DefaultValue' cell will be set. A new valid message will replace 'IM8 DefaultValue', once the channel recovers.				
16	4A	IM8 DefaultValue	0	0 to 1 step 1
Setting that defines the IM8 fallback status.				
16	4B	IM8 FrameSyncTim	1.5s	From 10ms to 1.5s step 10ms
Time delay after which 'IM8 DefaultValue' is applied.				

Table 30 - INTERMiCOM conf

4 CONTROL AND SUPPORT SETTINGS

These settings exist outside the Group settings, and are used to configure the control and support features that do not need to adapt according to changing system conditions. These settings are used to configure system data, date and time, CT/VT ratios, SCADA type communications interfaces, input conditioners, etc. They also used to control CB operation, measurements and recording functions.

The control and support settings are part of the main menu and are used to configure the global configuration for the relay. It includes submenu settings as shown here.

The control and support settings include:

- Relay configuration settings
- Open/close circuit breaker (may vary according to relay type or model)
- CT & VT ratio settings
- Reset LEDs
- Active protection setting group
- Password & language settings
- Communications settings
- Measurement settings
- Event & fault record settings
- User interface settings
- Commissioning settings
- Circuit breaker control & monitoring settings (may vary according to relay type or model)

4.1 System Data

This menu provides information for the device and general status of the relay.

Col	Row	Menu Text	Default Setting	Available Setting	P543 / P545 No Distance	P544 / P546 No Distance	P543 / P545	P544 / P546
Description								
00	00	SYSTEM DATA			*	*	*	*
This column contains general system settings								
00	01	Language	English	English / Français / Deutsche / Español /РУССКИЙ / 中文 (Chinese)	*	*	*	*
The default language used by the device. Selectable as English, French, German, Spanish, Russian or Chinese. Available languages depends upon selected model.								
00	03	Sys Fn Links	0(bin)	Bit 0 = Trip led self reset (1 = enable self reset), Bit 1 = Not Used, Bit 2 = Not Used, Bit 3 = Not Used, Bit 4 = Not Used, Bit 5 = Not Used, Bit 6 = Not Used or Bit 7 = Not Used	*	*	*	*
Setting to allow the fixed function trip LED to be self resetting (set to 1 to extinguish the LED after a period of healthy restoration of load current).								
00	04	Description	MiCOM P54x	From 32 to 234 step 1	*	*	*	*
16 character relay description. Can be edited.								
00	05	Plant Reference	MiCOM	From 32 to 234 step 1	*	*	*	*
Associated plant description and can be edited.								
00	06	Model Number	Model Number	<Model number>	*	*	*	*

Col	Row	Menu Text	Default Setting	Available Setting	P543 / P545 No Distance	P544 / P546 No Distance	P543 / P545	P544 / P546
Description								
Relay model number. This display cannot be altered.								
00	08	Serial Number	Serial Number	<Serial number>	*	*	*	*
Relay model number. This display cannot be altered.								
00	09	Frequency	50 Hz	50 Hz or 60 Hz	*	*	*	*
Relay set frequency. Settable either 50 or 60 Hz. Frequency shall be the same for all differential ends. This should only be changed with the Phase Differential disabled.								
00	0A	Comms Level	2	<conformance level displayed>	*	*	*	*
Displays the conformance of the relay to the Courier Level 2 comms.								
00	0B	Relay Address	255 1 1	0 to 255 step 1 (Courier) 0 to 254 step 1 (CS103) 0 to 65519 step 1 (DNP3)	*	*	*	*
Set the first rear port relay address. Build = Courier (Address available via LCD) Build = CS103 (Address available via LCD) Build = DNP3.0 (Address available via LCD)								
00	0C	Plant Status		Not Settable	*	*	*	*
Displays the circuit breaker plant status.								
00	0D	Control Status		Not Settable	*	*	*	*
Not used								
00	0E	Active Group		Not Settable	*	*	*	*
Displays the active settings group								
00	10	CB Trip/Close	No Operation	0 = No Operation, 1 = Trip, 2 = Close	*		*	
Supports trip and close commands if enabled in the Circuit Breaker Control menu.								
00	10	CB Trip/Close	No Operation	0 = No Operation, 1 = Trip, 2 = Close, 3 = No Operation, 4 = No Operation, 5 = No Operation, 6 = No Operation, 7 = No Operation, 8 = No Operation, 9 = Trip CB2, 10 = Close CB2		*		*
Supports trip and close commands if enabled in the Circuit Breaker Control menu.								
00	10	CB Trip/Close	No Operation	0 = No Operation, 1 = Trip, 2 = Close	*		*	
Supports trip and close commands if enabled in the Circuit Breaker Control menu.								
00	10	CB Trip/Close	No Operation	0 = No Operation, 1 = Trip, 2 = Close, 3 = No Operation, 4 = No Operation, 5 = No Operation, 6 = No Operation, 7 = No Operation, 8 = No Operation, 9 = Trip CB2, 10 = Close CB2		*		*
Supports trip and close commands if enabled in the Circuit Breaker Control menu.								
00	11	Software Ref. 1		<Software Ref. 1>	*	*	*	*
Displays the relay software version including protocol and relay model.								

Col	Row	Menu Text	Default Setting	Available Setting	P543 / P545 No Distance	P544 / P546 No Distance	P543 / P545	P544 / P546
Description								
00	12	Software Ref. 2		<Software Ref. 2>	*	*	*	*
Relay Ethernet card software reference. Visible when Ethernet card fitted.								
00	13	Software Ref. 3		<Software Ref. 3>	*	*	*	*
Relay Process Bus card software reference. Visible when Process Bus card fitted.								
00	14	NIC Platform Ref		<NIC platform reference>	*	*	*	*
Displays the relay NIC platform reference. Visible when Ethernet card fitted.								
00	15	IEC61850 Edition	2	Edition 1, Edition 2	*	*	*	*
This cell displays the supported IEC61850 Edition, only Ed2 is supported in Process Bus devices.								
00	16	ETH COMM Mode	Dual IP	Dual IP, PRP, HSR, RSTP	*	*	*	*
Sets the redundancy protocol. This setting can only be changed via the UI and the changes will cause the Ethernet board to reboot.								
00	17	PB COMM Mode	Dual IP	Dual IP, PRP	*	*	*	*
Sets the redundancy protocol of Process Bus board. This setting can only be changed via the UI and will cause the Process Bus board to reboot.								
00	20	Opto I/P Status		Not Settable	*	*	*	*
Display the status of the available opto inputs fitted.								
00	21	Relay O/P Status		Not Settable	*	*	*	*
Displays the status of all available output relays fitted. Not Valid if Contacts Blocked.								
00	22	Alarm Status 1		Not Settable	*	*	*	*
Displays the status of the first 32 alarms as a binary string.								
00	50	Alarm Status 1		Not Settable	*	*	*	*
Displays the status of the first 32 alarms as a binary string.								
00	51	Alarm Status 2		Not Settable	*	*	*	*
Displays the status of the next 32 alarms as a binary string. Includes fixed and user settable alarms.								
00	52	Alarm Status 3		Not Settable	*	*	*	*
Displays the status of the next 32 alarms as a binary string.								
00	D0	Access Level	ENGINEER	<Role>	*	*	*	*
Display the Role(s) of the current logged in user. Fixed as ENGINEER, OPERATOR or VIEWER for CSL0 models. SAT can configure up to 15 different Roles and will show NONE when no user has logged in.								
00	D3	New Eng.Level PW		ASCII 33 to 122	*	*	*	*
Allows user to change password for EngineerLevel on CSL0 models. Visible on UI only.								
00	D4	New Op.Level PW		ASCII 33 to 122	*	*	*	*
Allows user to change password for OperatorLevel on CSL0 models. Visible on UI only.								
00	DF	Security Feature	3	Not Settable	*	*	*	*
Displays the level of cyber security implemented								
00	E1	Password		<Password>	*	*	*	*
Used to send encrypted password. Not visible on UI.								
00	E5	Encryption Salt		<Encryption Salt>	*	*	*	*
Random data used with encrypted password. Not visible on UI.								
00	F1	Enter username		<User Name>	*	*	*	*
User selection for login. Not visible on UI.								

Col	Row	Menu Text	Default Setting	Available Setting	P543 / P545 No Distance	P544 / P546 No Distance	P543 / P545	P544 / P546
Description								
00	F2	Number of users	2	Special cell, not settable except for configuring via SAT for CSL1 models	*	*	*	*
Shows the number of users configured within the relays RBAC. Fixed at 2 (EngineerLevel and OperatorLevel) for CSL0 models. SAT can configure up to 15 for CSL1 models.								
00	F3	New UI pwd		<Second Simple Password>				
Hidden cell reserved for second password modification. Not in use currently.								
00	F4	New password		<Encrypted Password>	*	*	*	*
Allow password change if engineer or operator logged in and CSL0 model. Not visible on UI.								

Table 31 - System data

4.2 Circuit Breaker Control

The System Checks functionality differs between the P543/P545 and the P544/P546 since the P543/P545 can only control one circuit breaker, whereas the P544/P546 can control two. Accordingly, therefore, the settings are different for the two.

Circuit Breaker Control (P543/P545)

The IED/relay includes the following options for control of a single circuit breaker:

- Local tripping and closing, via the relay menu or hotkeys
- Local tripping and closing, via relay opto-isolated inputs
- Remote tripping and closing, using the relay communications

Circuit Breaker Control (P544/P546)

The IED/relay includes the following options for control of two circuit breakers:

- Local tripping and closing, via the relay menu or hotkeys
- Local tripping and closing, via relay opto-isolated inputs
- Remote tripping and closing, using the relay communications

Col	Row	MENU TEXT	Default Setting	Available Setting	P543/P545 No Distance	P544/P546 No Distance	P543/P545	P544/P546
Description								
07	00	CB CONTROL			*	*	*	*
This column controls the circuit Breaker Control configuration								
07	01	CB Control by	Disabled	0 = Disabled, 1 = Local, 2 = Remote, 3 = Local+Remote, 4 = Opto, 5 = Opto+local, 6 = Opto+Remote, 7 = Opto+Rem+local	*	*	*	*
Selects the type of circuit breaker control to be used								
07	02	Close Pulse Time	500ms	From 100ms to 10s step 10ms	*	*	*	*
Set period during which the CB should close when a CB close command is issued.								
07	03	Trip Pulse Time	500ms	From 100ms to 5s step 10ms	*	*	*	*
Set period during which the CB should trip when a CB trip command is issued.								

Col	Row	MENU TEXT	Default Setting	Available Setting	P543/P545 No Distance	P544/P546 No Distance	P543/P545	P544/P546
Description								
07	05	Man Close Delay	10s	From 10ms to 600s step 10ms	*	*	*	*
Set delay after operator controlled CB close sequence is initiated, before a CB close output can be issued. (Allows operator to retire to a place of safety before the CB close command is issued).								
07	06	CB Healthy Time	5s	From 10ms to 9999s step 10ms	*	*	*	*
Maximum waiting time for input DDB: CB1 Healthy (= gas pressure OK, spring charged etc) to enable CB1 Close by manual control. Same setting applies to DDB: CB2 Healthy to enable CB2 Close by manual control. If set time runs out with input DDB: CBx Healthy low (= 0), alarm Control CBx Unhealthy is set and CB close sequence is cancelled.								
07	07	Check Sync Time	5s	From 10ms to 9999s step 10ms	*	*	*	*
Maximum waiting time for input signal CB1MSCOK from system check logic, to enable CB1 Close by manual control. Same setting applies to input signal CB2MSCOK to enable CB2 Close by manual control. If set time runs out with input signal CBxMSCOK low (= 0), alarm Control CBx NoChSync is set and CB close sequence is cancelled.								
07	08	Lockout Reset	No	0 = No or 1 = Yes	*		*	
Command to reset the Lockout Alarm								
07	08	CB mon LO reset	No	0 = No or 1 = Yes		*		*
Command to reset the CB monitoring Lockout Alarm								
07	09	Reset Lockout by	CB Close	0 = User Interface or 1 = CB Close	*		*	
Setting that determines if a lockout condition will be reset by a manual circuit breaker close command or via the user interface.								
07	09	Rst CB mon LO by	CB Close	0 = User Interface or 1 = CB Close		*		*
Setting that determines if a lockout condition caused by CB monitoring conditions will be reset by a manual circuit breaker close command or via the user interface.								
07	0A	Man Close RstDly	5s	From 100ms to 600s step 10ms	*		*	
If Reset Lockout by is set to CB close then Man Close RstDly timer allows reset of Lockout state after set time delay								
07	0A	CB mon LO RstDly	5s	From 100ms to 600s step 10ms		*		*
If Rst CB mon LO by is set to CB close then CB mon LO RstDly timer allows reset of CB lockout state after set time delay								
07	0B	Autoreclose Mode	No Operation	0 = No Operation, 1 = In Service, 2 = Out of Service	*	*	*	*
Command to changes state of Auto-Reclose								
07	0C	Single Pole A/R	Disabled	0 = Disabled or 1 = Enabled	*		*	
Enable or disable AR for single phase fault types. Care: This setting also applies when auto-reclose is configured in 3 pole tripping applications. Even though the trip mode may be 3 pole only, the fact that the initiation was a single phase fault type is memorized.								
07	0D	Three Pole A/R	Enabled	0 = Disabled or 1 = Enabled	*		*	
Enable or disable AR for multi-phase faults.								
07	0E	AR Status		Not Settable	*	*	*	*
Displays the Auto Reclose Status: Out of Service or In Service								
07	0F	Total Reclosures		Not Settable	*		*	
Displays the number of successful re-closures.								
07	10	Reset Total A/R	No	0 = No or 1 = Yes	*		*	

Col	Row	MENU TEXT	Default Setting	Available Setting	P543/P545 No Distance	P544/P546 No Distance	P543/P545	P544/P546
Description								
Allows user to reset the auto-reclose counters.								
07	11	CB Status Input	52B 1 pole	0 = None 1 = 52A 3 pole 2 = 52B 3 pole 3 = 52A & 52B 3 pole * 4 = 52A 1 pole 5 = 52B 1 pole 6 = 52A & 52B 1 pole	*		*	
Setting to define the type of circuit breaker contacts that will be used for the circuit breaker control logic. Form A contacts match the status of the circuit breaker primary contacts, form B are opposite to the breaker status. When 1 pole is selected, individual contacts must be assigned in the Programmable Scheme Logic for phase A, phase B, and phase C. Setting 3 pole means that only a single contact is used, common to all 3 poles.								
07	11	CB1 Status Input	52B 1 pole	0 = None 1 = 52A 3 pole 2 = 52B 3 pole 3 = 52A & 52B 3 pole 4 = 52A 1 pole 5 = 52B 1 pole 6 = 52A & 52B 1 pole		*		*
Setting to define the type of circuit breaker contacts that will be used for the circuit breaker control logic. Form A contacts match the status of the circuit breaker primary contacts, form B are opposite to the breaker status. When 1 pole is selected, individual contacts must be assigned in the Programmable Scheme Logic for phase A, phase B, and phase C. Setting 3 pole means that only a single contact is used, common to all 3 poles.								
07	7F	CB Status Time	5s	From 0.1s to 5s step 10ms	*	*	*	*
Under healthy conditions the circuit breaker auxiliary contacts will be in opposite states. Should both sets of contacts be open or closed, it indicates that either the contacts, or the wiring, or the circuit breaker are defective and an alarm will be issued after CB Status Time delay. The time delay is set to avoid unwanted operation during normal switching duties.								
07	80	CB2 Status Input	52B 1 pole	0 = None 1 = 52A 3 pole 2 = 52B 3 pole 3 = 52A & 52B 3 pole 4 = 52A 1 pole 5 = 52B 1 pole 6 = 52A & 52B 1 pole		*		*
Setting to define the type of circuit breaker contacts that will be used for the circuit breaker control logic. Form A contacts match the status of the circuit breaker primary contacts, form B are opposite to the breaker status. When 1 pole is selected, individual contacts must be assigned in the Programmable Scheme Logic for phase A, phase B, and phase C. Setting 3 pole means that only a single contact is used, common to all 3 poles.								
07	81	CTRL CB2 Lead	No Operate	No Operate / Set CB2 Lead / Reset CB2 Lead		*		*
If Leader Select By is set to Control, this user control determines the preferred leader: Set / Reset (Reset = CB1 lead; Set = CB2 lead). This command is NON VOLATILE								
07	82	Reset AROK Ind	No	0 = No or 1 = Yes	*	*	*	*
If Res AROK by UI is set to Enabled, this command provides a pulse to reset the successful AR indication for both CB's								
07	83	Reset CB1 LO	No	0 = No or 1 = Yes		*		*
If Res LO by UI is set to Enabled, this command provides a pulse to reset the lockout for CB1. Note: This requires the condition that caused the lockout to have been cleared.								
07	83	Reset CB LO	No	0 = No or 1 = Yes	*		*	
If Res LO by UI is set to Enabled, this command provides a pulse to reset the lockout for CB. Note: This requires the condition that caused the lockout to have been cleared.								
07	84	Reset CB2 LO	No	0 = No or 1 = Yes		*		*

Col	Row	MENU TEXT	Default Setting	Available Setting	P543/P545 No Distance	P544/P546 No Distance	P543/P545	P544/P546
Description								
If Res LO by UI is set to Enabled, this command provides a pulse to reset the lockout for CB2. Note: This requires the condition that caused the lockout to have been cleared.								
07	85	CB1 Total Shots		Not Settable		*		*
Indicates the total number of CB1 reclosures								
07	85	CB Total Shots		Not Settable	*		*	
Indicates the total number of CB reclosures								
07	86	CB1 SUCC SPAR		Not Settable		*		*
Indicates the total number of CB1 successful 1 pole reclosures								
07	86	CB SUCC SPAR		Not Settable	*		*	
Indicates the total number of CB successful 1 pole reclosures								
07	87	CB1SUCC3PARShot1		Not Settable		*		*
Indicates the total number of CB1 successful 3 pole reclosures at 1st shot								
07	87	CB SUCC3PARShot1		Not Settable	*		*	
Indicates the total number of CB successful 3 pole reclosures at 1st shot								
07	88	CB1SUCC3PARShot2		Not Settable		*		*
Indicates the total number of CB1 successful 3 pole reclosures at 2nd shot								
07	88	CB SUCC3PARShot2		Not Settable	*		*	
Indicates the total number of CB successful 3 pole reclosures at 2nd shot								
07	89	CB1SUCC3PARShot3		Not Settable		*		*
Indicates the total number of CB1 successful 3 pole reclosures at 3rd shot								
07	89	CB SUCC3PARShot3		Not Settable	*		*	
Indicates the total number of CB successful 3 pole reclosures at 3rd shot								
07	8A	CB1SUCC3PARShot4		Not Settable		*		*
Indicates the total number of CB1 successful 3 pole reclosures at 4th shot								
07	8A	CB SUCC3PARShot4		Not Settable	*		*	
Indicates the total number of CB successful 3 pole reclosures at 4th shot								
07	8B	CB1 Failed Shots		Not Settable		*		*
Indicates the total number of CB1 failed reclose cycles								
07	8B	CB Failed Shots		Not Settable	*		*	
Indicates the total number of CB failed reclose cycles								
07	8C	Reset CB1 Shots	No	0 = No or 1 = Yes		*		*
This command resets all CB1 shots counters to zero								
07	8C	Reset CB Shots	No	0 = No or 1 = Yes	*		*	
This command resets all CB shots counters to zero								
07	8D	CB2 Total Shots		Not Settable		*		*
Indicates the total number of CB2 reclosures								
07	8E	CB2 SUCC SPAR		Not Settable		*		*
Indicates the total number of CB2 successful 1 pole reclosures								
07	8F	CB2SUCC3PARShot1		Not Settable		*		*
Indicates the total number of CB2 successful 3 pole reclosures at 1st shot								
07	90	CB2SUCC3PARShot2		Not Settable		*		*
Indicates the total number of CB2 successful 3 pole reclosures at 2nd shot								
07	91	CB2SUCC3PARShot3		Not Settable		*		*

Col	Row	MENU TEXT	Default Setting	Available Setting	P543/P545 No Distance	P544/P546 No Distance	P543/P545	P544/P546
Description								
Indicates the total number of CB2 successful 3 pole reclosures at 3rd shot								
07	92	CB2SUCC3PARShot4		Not Settable		*		*
Indicates the total number of CB2 successful 3 pole reclosures at 4th shot								
07	93	CB2 Failed Shots		Not Settable		*		*
Indicates the total number of CB2 failed reclose cycles								
07	94	Reset CB2 Shots	No	0 = No or 1 = Yes		*		*
This command resets all CB2 shots counters to zero								
07	96	Res AROK by UI	Enabled	0 = Disabled or 1 = Enabled	*	*	*	*
If Enabled, this allows the successful auto-reclose signal to be reset by user interface command Reset AROK Ind.								
07	97	Res AROK by NoAR	Disabled	0 = Disabled or 1 = Enabled	*	*	*	*
if Enabled, allows "successful autoreclose" signal reset by selecting CB autoreclosing disabled								
07	98	Res AROK by Ext	Disabled	0 = Disabled or 1 = Enabled	*	*	*	*
If Enabled, allows "successful autoreclose" signal reset by external DDB input								
07	99	Res AROK by TDly	Disabled	0 = Disabled or 1 = Enabled	*	*	*	*
if Enabled, allows "successful autoreclose" signal to reset after time AROK Reset Time								
07	9A	Res AROK by TDly	1s	From 1s to 9999s step 1s	*	*	*	*
Reset time for "successful autoreclose" signal if Res AROK by TDly is set to Enabled								
07	9B	Res LO by CB IS	Enabled	0 = Disabled or 1 = Enabled	*	*	*	*
if Enabled, allows reset of CB lockout state when CB is "In Service" (= closed for t > CBIS Time)								
07	9C	Res LO by UI	Enabled	0 = Disabled or 1 = Enabled	*	*	*	*
if Enabled, allows reset of CB lockout state by UI command								
07	9D	Res LO by NoAR	Disabled	0 = Disabled or 1 = Enabled	*	*	*	*
if Enabled, allows reset of CB lockout state by selecting CB autoreclosing disabled								
07	9E	Res LO by ExtDDB	Disabled	0 = Disabled or 1 = Enabled	*	*	*	*
if Enabled, allows reset of CB lockout state by external DDB input								
07	9F	Res LO by TDelay	Disabled	0 = Disabled or 1 = Enabled	*	*	*	*
if Enabled, allows reset of CB lockout state after time LO Reset Time								
07	A0	LO Reset Time	1s	From 1s to 9999s step 1s	*	*	*	*
CB lockout reset time if Res LO by TDelay is set to Enabled								

Table 32 - Circuit breaker control**4.3****Date and Time**

Displays the date and time as well as the battery condition.

Col	Row	Menu Text	Default Setting	Available Setting	P543 / P545 No Distance	P544 / P546 No Distance	P543 / P545	P544 / P546
Description								
08	00	DATE AND TIME			*	*	*	*
This column contains Date and Time settings								
08	01	Date/Time		<Date/Time>	*	*	*	*
Displays the relay's current date and time.								
08	02	Date		<Date>	*	*	*	*
Displays the date. Front Panel Menu only								
08	03	Time		<Time>	*	*	*	*
Displays the time. Front Panel Menu only								
08	04	IRIG-B Sync	Disabled	0 = Disabled or 1 = Enabled	*	*	*	*
Enable IRIG-B time synchronization.								
08	05	IRIG-B Status		Not Settable	*	*	*	*
Displays the status of IRIG-B: Card Not Fitted, Card Failed, Signal Healthy or No Signal								
08	06	Battery Status		Not Settable	*	*	*	*
Displays whether the battery is Healthy or Dead								
08	07	Battery Alarm	Enabled	0 = Disabled or 1 = Enabled	*	*	*	*
Setting that determines whether an unhealthy relay battery condition is alarmed or not								
08	13	SNTP Status		Not Settable	*	*	*	*
Ethernet versions only. Displays information about the SNTP time synchronization status: Disabled, Trying Server 1, Trying Server 2, Server 1 OK, Server 2 OK, No response or No valid clock.								
08	20	LocalTime Enable	Flexible	0 = Disabled, 1 = Fixed or 2 = Flexible	*	*	*	*
Setting to turn on/off local time adjustments. Disabled - No local time zone will be maintained. Time synchronization from any interface will be used to directly set the master clock and all displayed (or read) times on all interfaces will be based on the master clock with no adjustment. Fixed - A local time zone adjustment can be defined using the LocalTime offset setting and all interfaces will use local time except SNTP time synchronization and IEC 61850 timestamps. Flexible - A local time zone adjustment can be defined using the LocalTime offset setting and each interface can be assigned to the UTC zone or local time zone with the exception of the local interfaces which will always be in the local time zone and IEC 61850/SNTP which will always be in the UTC zone.								
08	21	LocalTime Offset	0min	From -720min to 720min step 15min	*	*	*	*
Setting to specify an offset of -12 to +12 hrs in 15 minute intervals for local time zone. This adjustment is applied to the time based on the master clock which is UTC/GMT								
08	22	DST Enable	Enabled	0 = Disabled or 1 = Enabled	*	*	*	*
Setting to turn on/off daylight saving time adjustment to local time.								
08	23	DST Offset	60min	From 30min to 60min step 30min	*	*	*	*
Setting to specify daylight saving offset which will be used for the time adjustment to local time.								
08	24	DST Start	Last	0 = First, 1 = Second, 2 = Third, 3 = Fourth or 4 = Last	*	*	*	*
Setting to specify the week of the month in which daylight saving time adjustment starts								

Col	Row	Menu Text	Default Setting	Available Setting	P543 / P545 No Distance	P544 / P546 No Distance	P543 / P545	P544 / P546
Description								
08	25	DST Start Day	Sunday	0 = Sunday, 1 = Monday, 2 = Tuesday, 3 = Wednesday, 4 = Thursday, 5 = Friday or 6 = Saturday	*	*	*	*
Setting to specify the day of the week in which daylight saving time adjustment starts								
08	26	DST Start Month	March	0 = January, 1 = February, 2 = March, 3 = April, 4 = May, 5 = June, 6 = July, 7 = August, 8 = September, 9 = October, 10 = November or 11 = December	*	*	*	*
Setting to specify the month in which daylight saving time adjustment starts								
08	27	DST Start Mins	60min	From 0min to 1425min step 15min	*	*	*	*
Setting to specify the time of day in which daylight saving time adjustment starts. This is set relative to 00:00 hrs on the selected day when time adjustment is to start								
08	28	DST End	Last	0 = First, 1 = Second, 2 = Third, 3 = Fourth or 4 = Last	*	*	*	*
Setting to specify the week of the month in which daylight saving time adjustment ends								
08	29	DST End Day	Sunday	0 = Sunday, 1 = Monday, 2 = Tuesday, 3 = Wednesday, 4 = Thursday, 5 = Friday or 6 = Saturday	*	*	*	*
Setting to specify the day of the week in which daylight saving time adjustment ends								
08	2A	DST End Month	October	0 = January, 1 = February, 2 = March, 3 = April, 4 = May, 5 = June, 6 = July, 7 = August, 8 = September, 9 = October, 10 = November or 11 = December	*	*	*	*
Setting to specify the month in which daylight saving time adjustment ends								
08	2B	DST End Mins	60min	From 0min to 1425min step 15min	*	*	*	*
Setting to specify the time of day in which daylight saving time adjustment ends. This is set relative to 00:00 hrs on the selected day when time adjustment is to end								
08	30	RP1 Time Zone	UTC	0 = UTC or 1 = Local	*	*	*	*
Setting for the rear port 1 interface to specify if time synchronization received will be local or universal time co-ordinated								
08	31	RP2 Time Zone	UTC	0 = UTC or 1 = Local	*	*	*	*
Setting for the rear port 2 interface to specify if time synchronization received will be local or universal time co-ordinated								
08	32	DNPOE Time Zone	UTC	0 = UTC or 1 = Local	*	*	*	*
DNP3.0 over Ethernet versions only. Setting to specify if time synchronisation received will be local or universal time co-ordinate.								
08	33	Tunnel Time Zone	UTC	0 = UTC or 1 = Local	*	*	*	*
Ethernet versions only for tunnelled courier. Setting to specify if time synchronization received will be local or universal time co-ordinate								

Col	Row	Menu Text	Default Setting	Available Setting	P543 / P545 No Distance	P544 / P546 No Distance	P543 / P545	P544 / P546
Description								
08	40	1588 Sync	DISABLE	0 = Disabled or 1 = Intfc 1 Enabled or 2 = Intfc 2 Enabled or 3 = Intfc 1 & 2 Enabled	*	*	*	*
The setting that indicate the 1588 enable or the Intfc 1,Intfc 2 OR Both.								
08	41	1588 DomainNum	0	0 to 255 step 1	*	*	*	*
The domain number of 1588 which define the scope of PTP message communication, state, operations, data sets, and timescale.								
08	42	1588 PdelInterv	0	From 0 to 5 step 1	*	*	*	*
The initialization value is implementation-specific consistent								
08	50	1588 Status		Not Settable	*	*	*	*
Indication the status of 1588								
08	51	InterfaceNum		Not Settable	*	*	*	*
The value of the port number								
08	52	OffsetFromMaster		Not Settable	*	*	*	*
An implementation-specific representation of the current value of the time difference between a master and a slave as computed by the slave								
08	53	PeerMeanPDelay		Not Settable	*	*	*	*
An estimate of the current one-way propagation delay on the link								
08	54	StepsRemoved		Not Settable	*	*	*	*
The number of communication paths traversed between the local clock and the grandmaster clock.								
08	55	ParentClockId		Not Settable	*	*	*	*
The clock clockIdentity of the parent clock.								
08	56	ParentPortNum		Not Settable	*	*	*	*
The value of parent port number								
08	57	ParentClockClass		Not Settable	*	*	*	*
The parent clock class which is the attribute defining a clock's TAI traceability								
08	58	ParentClockAcc		Not Settable	*	*	*	*
The parent clock accuracy which is the attribute defining the accuracy of a clock								
08	59	ParentClockVar		Not Settable	*	*	*	*
The parent clock variance which is the attribute defining the stability of a clock								
08	5A	ParentPriority1		Not Settable	*	*	*	*
A user configurable designation that a clock belongs to an ordered set of clocks from which a master is selected								
08	5B	ParentPriority2		Not Settable	*	*	*	*
A user configurable designation that provides finer grained ordering among otherwise equivalent clocks								

Table 33 - Date and time

4.4

CT/VT Ratios

The CT/VT ratio settings differ between the P543/P545 and the P544/P546 because of the different number of circuit breakers controlled.

Col	Row	MENU TEXT	Default Setting	Available Setting	P543/P545 No Distance	P544/P546 No Distance	P543/P545	P544/P546
Description								
0A	00	CT AND VT RATIOS			*	*	*	*
This column contains settings for Current and Voltage Transformer ratios								
0A	01	Main VT Primary	110V	From 100V to 1MV step 1V	*	*	*	*
Sets the main voltage transformer input primary voltage. V1=1 for Vn=100-120								
0A	02	Main VT Sec'y	110V	From 80V to 140V step 1V	*	*	*	*
Sets the main voltage transformer input secondary voltage.								
0A	03	CS VT Primary	110V	From 100V to 1MV step 1V	*		*	
Sets the check sync. voltage transformer input primary voltage. V2=1 for Vn=100-120								
0A	03	CB1 CS VT Prim'y	110V	From 100V to 1MV step 1V		*		*
Sets the CB1 check sync. voltage transformer input primary voltage. V2=1 for Vn=100-120								
0A	04	CS VT Secondary	110V	From 80V to 140V step 1V	*		*	
Sets the check sync. voltage transformer input secondary voltage.								
0A	04	CB1 CS VT Sec'y	110V	From 80V to 140V step 1V		*		*
Sets the CB1 check sync. voltage transformer input secondary voltage.								
0A	05	CB2 CS VT Prim'y	110V	From 100V to 1MV step 1V		*		*
Sets the CB2 check sync. voltage transformer input primary voltage. V3=1 for Vn=100-120								
0A	06	CB2 CS VT Sec'y	110V	From 80V to 140V step 1V		*		*
Sets the CB2 check sync. voltage transformer input secondary voltage.								
0A	07	Phase CT Primary	1A	From 1A to 30kA step 1A	*	*	*	*
Sets the phase current transformer input primary current rating. I1=Phase CT secondary rating								
0A	08	Phase CT Sec'y	1A	From 1A to 5A step 4A	*	*	*	*
Sets the phase current transformer input secondary current rating.								
0A	09	Phase CT2 Pri'y	1	From 1A to 30kA step 1A		*		*
Sets the CT2 current transformer input primary current rating. The ratio between CT2 primary and CT1 primary must be less than 10 otherwise a "Ct para mismatch" alarm is raised. The lower primary value CT would normally be applied to CT1 to align with the differential bias characteristic. I2=Phase CT secondary rating								
0A	0A	Phase CT2 Sec'y	1	From 1A to 5A step 4A		*		*
Sets the CT2 phase current transformer input secondary current rating.								
0A	0B	SEF CT Primary	1	From 1A to 30kA step 1A	*	*	*	*
Sets the sensitive earth fault current transformer input primary current rating. I3=SEF CT secondary rating								
0A	0C	SEF CT Secondary	1	From 1A to 5A step 4A	*	*	*	*
Sets the sensitive earth fault current transformer input secondary current rating.								

Col	Row	MENU TEXT	Default Setting	Available Setting	P543/P545 No Distance	P544/P546 No Distance	P543/P545	P544/P546
Description								
0A	0D	MComp CT Primary	1	From 1A to 30kA step 1A	*	*	*	*
Sets the mutual compensation current transformer input primary current rating. I4=Mutual Comp CT secondary rating								
0A	0E	MComp CT Sec'y	1	From 1A to 5A step 4A	*	*	*	*
Sets the mutual compensation current transformer input secondary current rating.								
0A	0F	CS Input	AN	0 = AN, 1 = BN, 2 = CN, 3 = AB, 4 = BC, 5 = CA		*		*
Selects the System Check Synchronism Input voltage measurement.								
0A	0F	CS Input	AN	0 = AN, 1 = BN, 2 = CN, 3 = AB, 4 = BC, 5 = CA, 6 = AN / 1.732, 7 = BN / 1.732, 8 = CN / 1.732	*		*	
Selects the System Check Synchronism Input voltage measurement.								
0A	10	Main VT Location	Line	0 = Line or 1 = Bus	*		*	
Selects the main voltage transformer location.								
0A	10	Main VT Location	Line	0 = Line or 1 = Bus1		*		*
Selects the main voltage transformer location.								
0A	11	CT Polarity or CT1 Polarity	Standard	0 = Standard or 1 = Inverted	*	*	*	*
To invert polarity (180 °) of the CT								
0A	12	CT2 Polarity	Standard	0 = Standard or 1 = Inverted		*		*
To invert polarity (180 °) of the CT2								
0A	13	SEF CT Polarity	Standard	0 = Standard or 1 = Inverted	*	*	*	*
To invert polarity (180 °) of the SEF CT								
0A	14	M CT Polarity	Standard	0 = Standard or 1 = Inverted	*	*	*	*
To invert polarity (180 °) of the Mutual CT								
0A	18	VT Connected	Yes	0 = No or 1 = Yes	*	*	*	*
To indicate if voltage transformers are connected to the relay. This MUST be set properly to ensure Pole Dead logic works correctly. If set to 'No', it will set VTS Slow Block and VTS Fast Block DDBs, but will not raise any alarms. It will also override the VTS enabled setting should the user set it. If set to 'Yes' this setting will have no effect.								
0A	21	CB1 CS VT PhShft	0	From -180° to 180° step 5°		*		*
Phase angle difference between selected phase ("C/S Input" 0A 0F) of Line VT input and applied "CB1 CS" VT input voltage under healthy system conditions								

Col	Row	MENU TEXT	Default Setting	Available Setting	P543/P545 No Distance	P544/P546 No Distance	P543/P545	P544/P546
Description								
0A	21	CS VT Ph Shift	0	From -180° to 180° step 5°	*		*	
Phase angle difference between selected phase ("C/S Input" 0A 0F) of Line VT input and applied "CB CS" VT input voltage under healthy system conditions								
0A	22	CB1 CS VT Mag	1	0.2 to 3 step 0.01		*		*
Ratio of voltage magnitudes of selected phase ("C/S Input" 0A 0F) of Line VT input and applied "CB CS" VT input voltage under healthy system conditions								
0A	22	CS VT Mag	1	0.2 to 3 step 0.01	*		*	
Ratio of voltage magnitudes of selected phase ("C/S Input" 0A 0F) of Line VT input and applied "CB CS" VT input voltage under healthy system conditions								
0A	23	CB2 CS VT PhShft	0	From -180° to 180° step 5°		*		*
Phase angle difference between selected phase ("C/S Input" 0A 0F) of Line VT input and applied "CB2 CS" VT input voltage under healthy system conditions								
0A	24	CB2 CS VT Mag	1	0.2 to 3 step 0.01		*		*
Ratio of voltage magnitudes of selected phase ("C/S Input" 0A 0F) of Line VT input and applied "CB2 CS" VT input voltage under healthy system conditions								

Table 34 - CT/VT ratios

4.5 Record Control

It is possible to disable the reporting of events from all interfaces that support setting changes. The settings that control the various types of events are in the Record Control column. The effect of setting each to disabled is as follows:

Col	Row	MENU TEXT	Default Setting	Available Setting	P543/P545 No Distance	P544/P546 No Distance	P543/P545	P544/P546
Description								
0B	00	RECORD CONTROL			*	*	*	*
This column contains settings for Record Controls								
0B	01	Clear Events	No	0 = No or 1 = Yes	*	*	*	*
Clear Event records								
0B	02	Clear Faults	No	0 = No or 1 = Yes	*	*	*	*
Clear Fault records								
0B	03	Clear Maint	No	0 = No or 1 = Yes	*	*	*	*
Clear Maintenance records								
0B	04	Alarm Event	Enabled	0 = Disabled or 1 = Enabled	*	*	*	*
Disabling this setting means that all the occurrences that produce an alarm will result in no event being generated.								

Col	Row	MENU TEXT	Default Setting	Available Setting	P543/P545 No Distance	P544/P546 No Distance	P543/P545	P544/P546
Description								
0B	05	Relay O/P Event	Enabled	0 = Disabled or 1 = Enabled	*	*	*	*
Disabling this setting means that no event will be generated for any change in logic state.								
0B	06	Opto Input Event	Enabled	0 = Disabled or 1 = Enabled	*	*	*	*
Disabling this setting means that no event will be generated for any change in logic input state.								
0B	07	General Event	Enabled	0 = Disabled or 1 = Enabled	*	*	*	*
Disabling this setting means that no General Events will be generated								
0B	08	Fault Rec Event	Enabled	0 = Disabled or 1 = Enabled	*	*	*	*
Disabling this setting means that no event will be generated for any fault that produces a fault record								
0B	09	Maint Rec Event	Enabled	0 = Disabled or 1 = Enabled	*	*	*	*
Disabling this setting means that no event will be generated for any occurrence that produces a maintenance record.								
0B	0A	Protection Event	Enabled	0 = Disabled or 1 = Enabled	*	*	*	*
Disabling this setting means that any operation of protection elements will not be logged as an event								
0B	2F	Flt Rec Extended	Disabled	0 = Disabled or 1 = Enabled	*	*	*	*
When this setting is disabled, the fault record contains a snap shot of the local, remote, differential and bias currents taken 1 cycle after the trip. With this setting enabled an additional snap shot of local, remote, differential and bias currents taken at the time the differential trips is included in the fault record.								
0B	30	Clear Dist Recs	No	0 = No or 1 = Yes	*	*	*	*
Clear Disturbance records								
0B	31	Security Event	Enabled	0 = Disabled or 1 = Enabled	*	*	*	*
Disabling this setting means that any operation of security elements will not be logged as an event								

Col	Row	MENU TEXT	Default Setting	Available Setting	P543/P545 No Distance	P544/P546 No Distance	P543/P545	P544/P546
Description								
0B	40	DDB 31 - 0	11111111111111111111111111111111(bin)	32-bit binary setting: 1 = event recording Enabled, 0 = event recording Disabled	*	*	*	*
Chooses whether any individual DDBs should be deselected as a stored event, by setting the relevant bit to 0 (zero). Typically used for repetitive recurrent changes such as an Opto input assigned for Minute Pulse clock synchronizing.								
0B	41	DDB 63 - 32	11111111111111111111111111111111(bin)	32-bit binary setting: 1 = event recording Enabled, 0 = event recording Disabled	*	*	*	*
Chooses whether any individual DDBs should be deselected as a stored event, by setting the relevant bit to 0 (zero). Typically used for repetitive recurrent changes such as an Opto input assigned for Minute Pulse clock synchronizing.								
0B	42	DDB 95 - 64	11111111111111111111111111111111(bin)	32-bit binary setting: 1 = event recording Enabled, 0 = event recording Disabled	*	*	*	*
Chooses whether any individual DDBs should be deselected as a stored event, by setting the relevant bit to 0 (zero). Typically used for repetitive recurrent changes such as an Opto input assigned for Minute Pulse clock synchronizing.								
0B	43	DDB 127 - 96	11111111111111111111111111111111(bin)	32-bit binary setting: 1 = event recording Enabled, 0 = event recording Disabled	*	*	*	*
Chooses whether any individual DDBs should be deselected as a stored event, by setting the relevant bit to 0 (zero). Typically used for repetitive recurrent changes such as an Opto input assigned for Minute Pulse clock synchronizing.								
0B	44	DDB 159 - 128	11111111111111111111111111111111(bin)	32-bit binary setting: 1 = event recording Enabled, 0 = event recording Disabled	*	*	*	*
Chooses whether any individual DDBs should be deselected as a stored event, by setting the relevant bit to 0 (zero). Typically used for repetitive recurrent changes such as an Opto input assigned for Minute Pulse clock synchronizing.								

Col	Row	MENU TEXT	Default Setting	Available Setting	P543/P545 No Distance	P544/P546 No Distance	P543/P545	P544/P546
Description								
0B	45	DDB 191 - 160	11111111111111111111111111111111(bin)	32-bit binary setting: 1 = event recording Enabled, 0 = event recording Disabled	*	*	*	*
Chooses whether any individual DDBs should be deselected as a stored event, by setting the relevant bit to 0 (zero). Typically used for repetitive recurrent changes such as an Opto input assigned for Minute Pulse clock synchronizing.								
0B	46	DDB 223 - 192	11111111111111111111111111111111(bin)	32-bit binary setting: 1 = event recording Enabled, 0 = event recording Disabled	*	*	*	*
Chooses whether any individual DDBs should be deselected as a stored event, by setting the relevant bit to 0 (zero). Typically used for repetitive recurrent changes such as an Opto input assigned for Minute Pulse clock synchronizing.								
0B	47	DDB 255 - 224	11111111111111111111111111111111(bin)	32-bit binary setting: 1 = event recording Enabled, 0 = event recording Disabled	*	*	*	*
Chooses whether any individual DDBs should be deselected as a stored event, by setting the relevant bit to 0 (zero). Typically used for repetitive recurrent changes such as an Opto input assigned for Minute Pulse clock synchronizing.								
0B	48	DDB 287 - 256	11111111111111111111111111111111(bin)	32-bit binary setting: 1 = event recording Enabled, 0 = event recording Disabled	*	*	*	*
Chooses whether any individual DDBs should be deselected as a stored event, by setting the relevant bit to 0 (zero). Typically used for repetitive recurrent changes such as an Opto input assigned for Minute Pulse clock synchronizing.								
0B	49	DDB 319 - 288	11111111111111111111111111111111(bin)	32-bit binary setting: 1 = event recording Enabled, 0 = event recording Disabled	*	*	*	*
Chooses whether any individual DDBs should be deselected as a stored event, by setting the relevant bit to 0 (zero). Typically used for repetitive recurrent changes such as an Opto input assigned for Minute Pulse clock synchronizing.								

Col	Row	MENU TEXT	Default Setting	Available Setting	P543/P545 No Distance	P544/P546 No Distance	P543/P545	P544/P546
Description								
0B	4A	DDB 351 - 320	11111111111111111111111111111111(bin)	32-bit binary setting: 1 = event recording Enabled, 0 = event recording Disabled	*	*	*	*
Chooses whether any individual DDBs should be deselected as a stored event, by setting the relevant bit to 0 (zero). Typically used for repetitive recurrent changes such as an Opto input assigned for Minute Pulse clock synchronizing.								
0B	4B	DDB 383 - 352	11111111111111111111111111111111(bin)	32-bit binary setting: 1 = event recording Enabled, 0 = event recording Disabled	*	*	*	*
Chooses whether any individual DDBs should be deselected as a stored event, by setting the relevant bit to 0 (zero). Typically used for repetitive recurrent changes such as an Opto input assigned for Minute Pulse clock synchronizing.								
0B	4C	DDB 415 - 384	11111111111111111111111111111111(bin)	32-bit binary setting: 1 = event recording Enabled, 0 = event recording Disabled	*	*	*	*
Chooses whether any individual DDBs should be deselected as a stored event, by setting the relevant bit to 0 (zero). Typically used for repetitive recurrent changes such as an Opto input assigned for Minute Pulse clock synchronizing.								
0B	4D	DDB 447 - 416	11111111111111111111111111111111(bin)	32-bit binary setting: 1 = event recording Enabled, 0 = event recording Disabled	*	*	*	*
Chooses whether any individual DDBs should be deselected as a stored event, by setting the relevant bit to 0 (zero). Typically used for repetitive recurrent changes such as an Opto input assigned for Minute Pulse clock synchronizing.								
0B	4E	DDB 479 - 448	11111111111111111111111111111111(bin)	32-bit binary setting: 1 = event recording Enabled, 0 = event recording Disabled	*	*	*	*
Chooses whether any individual DDBs should be deselected as a stored event, by setting the relevant bit to 0 (zero). Typically used for repetitive recurrent changes such as an Opto input assigned for Minute Pulse clock synchronizing.								

Col	Row	MENU TEXT	Default Setting	Available Setting	P543/P545 No Distance	P544/P546 No Distance	P543/P545	P544/P546
Description								
0B	4F	DDB 511 - 480	11111111111111111111111111111111(bin)	32-bit binary setting: 1 = event recording Enabled, 0 = event recording Disabled	*	*	*	*
Chooses whether any individual DDBs should be deselected as a stored event, by setting the relevant bit to 0 (zero). Typically used for repetitive recurrent changes such as an Opto input assigned for Minute Pulse clock synchronizing.								
0B	50	DDB 543 - 512	11111111111111111111111111111111(bin)	32-bit binary setting: 1 = event recording Enabled, 0 = event recording Disabled	*	*	*	*
Chooses whether any individual DDBs should be deselected as a stored event, by setting the relevant bit to 0 (zero). Typically used for repetitive recurrent changes such as an Opto input assigned for Minute Pulse clock synchronizing.								
0B	51	DDB 575 - 544	11111111111111111111111111111111(bin)	32-bit binary setting: 1 = event recording Enabled, 0 = event recording Disabled	*	*	*	*
Chooses whether any individual DDBs should be deselected as a stored event, by setting the relevant bit to 0 (zero). Typically used for repetitive recurrent changes such as an Opto input assigned for Minute Pulse clock synchronizing.								
0B	52	DDB 607 - 576	11111111111111111111111111111111(bin)	32-bit binary setting: 1 = event recording Enabled, 0 = event recording Disabled	*	*	*	*
Chooses whether any individual DDBs should be deselected as a stored event, by setting the relevant bit to 0 (zero). Typically used for repetitive recurrent changes such as an Opto input assigned for Minute Pulse clock synchronizing.								
0B	53	DDB 639 - 608	11111111111111111111111111111111(bin)	32-bit binary setting: 1 = event recording Enabled, 0 = event recording Disabled	*	*	*	*
Chooses whether any individual DDBs should be deselected as a stored event, by setting the relevant bit to 0 (zero). Typically used for repetitive recurrent changes such as an Opto input assigned for Minute Pulse clock synchronizing.								

Col	Row	MENU TEXT	Default Setting	Available Setting	P543/P545 No Distance	P544/P546 No Distance	P543/P545	P544/P546
Description								
0B	54	DDB 671 - 640	11111111111111111111111111111111(bin)	32-bit binary setting: 1 = event recording Enabled, 0 = event recording Disabled	*	*	*	*
Chooses whether any individual DDBs should be deselected as a stored event, by setting the relevant bit to 0 (zero). Typically used for repetitive recurrent changes such as an Opto input assigned for Minute Pulse clock synchronizing.								
0B	55	DDB 703 - 672	11111111111111111111111111111111(bin)	32-bit binary setting: 1 = event recording Enabled, 0 = event recording Disabled	*	*	*	*
Chooses whether any individual DDBs should be deselected as a stored event, by setting the relevant bit to 0 (zero). Typically used for repetitive recurrent changes such as an Opto input assigned for Minute Pulse clock synchronizing.								
0B	56	DDB 735 - 704	11111111111111111111111111111111(bin)	32-bit binary setting: 1 = event recording Enabled, 0 = event recording Disabled	*	*	*	*
Chooses whether any individual DDBs should be deselected as a stored event, by setting the relevant bit to 0 (zero). Typically used for repetitive recurrent changes such as an Opto input assigned for Minute Pulse clock synchronizing.								
0B	57	DDB 767 - 736	11111111111111111111111111111111(bin)	32-bit binary setting: 1 = event recording Enabled, 0 = event recording Disabled	*	*	*	*
Chooses whether any individual DDBs should be deselected as a stored event, by setting the relevant bit to 0 (zero). Typically used for repetitive recurrent changes such as an Opto input assigned for Minute Pulse clock synchronizing.								
0B	58	DDB 799 - 768	11111111111111111111111111111111(bin)	32-bit binary setting: 1 = event recording Enabled, 0 = event recording Disabled	*	*	*	*
Chooses whether any individual DDBs should be deselected as a stored event, by setting the relevant bit to 0 (zero). Typically used for repetitive recurrent changes such as an Opto input assigned for Minute Pulse clock synchronizing.								

Col	Row	MENU TEXT	Default Setting	Available Setting	P543/P545 No Distance	P544/P546 No Distance	P543/P545	P544/P546
Description								
0B	59	DDB 831 - 800	11111111111111111111111111111111(bin)	32-bit binary setting: 1 = event recording Enabled, 0 = event recording Disabled	*	*	*	*
Chooses whether any individual DDBs should be deselected as a stored event, by setting the relevant bit to 0 (zero). Typically used for repetitive recurrent changes such as an Opto input assigned for Minute Pulse clock synchronizing.								
0B	5A	DDB 863 - 832	11111111111111111111111111111111(bin)	32-bit binary setting: 1 = event recording Enabled, 0 = event recording Disabled	*	*	*	*
Chooses whether any individual DDBs should be deselected as a stored event, by setting the relevant bit to 0 (zero). Typically used for repetitive recurrent changes such as an Opto input assigned for Minute Pulse clock synchronizing.								
0B	5B	DDB 895 - 864	11111111111111111111111111111111(bin)	32-bit binary setting: 1 = event recording Enabled, 0 = event recording Disabled	*	*	*	*
Chooses whether any individual DDBs should be deselected as a stored event, by setting the relevant bit to 0 (zero). Typically used for repetitive recurrent changes such as an Opto input assigned for Minute Pulse clock synchronizing.								
0B	5C	DDB 927 - 896	11111111111111111111111111111111(bin)	32-bit binary setting: 1 = event recording Enabled, 0 = event recording Disabled	*	*	*	*
Chooses whether any individual DDBs should be deselected as a stored event, by setting the relevant bit to 0 (zero). Typically used for repetitive recurrent changes such as an Opto input assigned for Minute Pulse clock synchronizing.								
0B	5D	DDB 959 - 928	11111111111111111111111111111111(bin)	32-bit binary setting: 1 = event recording Enabled, 0 = event recording Disabled	*	*	*	*
Chooses whether any individual DDBs should be deselected as a stored event, by setting the relevant bit to 0 (zero). Typically used for repetitive recurrent changes such as an Opto input assigned for Minute Pulse clock synchronizing.								

Col	Row	MENU TEXT	Default Setting	Available Setting	P543/P545 No Distance	P544/P546 No Distance	P543/P545	P544/P546
Description								
0B	5E	DDB 991 - 960	11111111111111111111111111111111(bin)	32-bit binary setting: 1 = event recording Enabled, 0 = event recording Disabled	*	*	*	*
Chooses whether any individual DDBs should be deselected as a stored event, by setting the relevant bit to 0 (zero). Typically used for repetitive recurrent changes such as an Opto input assigned for Minute Pulse clock synchronizing.								
0B	5F	DDB 1023 - 992	11111111111111111111111111111111(bin)	32-bit binary setting: 1 = event recording Enabled, 0 = event recording Disabled	*	*	*	*
Chooses whether any individual DDBs should be deselected as a stored event, by setting the relevant bit to 0 (zero). Typically used for repetitive recurrent changes such as an Opto input assigned for Minute Pulse clock synchronizing.								
0B	60	DDB 1055 - 1024	11111111111111111111111111111111(bin)	32-bit binary setting: 1 = event recording Enabled, 0 = event recording Disabled	*	*	*	*
Chooses whether any individual DDBs should be deselected as a stored event, by setting the relevant bit to 0 (zero). Typically used for repetitive recurrent changes such as an Opto input assigned for Minute Pulse clock synchronizing.								
0B	61	DDB 1087 - 1056	11111111111111111111111111111111(bin)	32-bit binary setting: 1 = event recording Enabled, 0 = event recording Disabled	*	*	*	*
Chooses whether any individual DDBs should be deselected as a stored event, by setting the relevant bit to 0 (zero). Typically used for repetitive recurrent changes such as an Opto input assigned for Minute Pulse clock synchronizing.								
0B	62	DDB 1119 - 1088	11111111111111111111111111111111(bin)	32-bit binary setting: 1 = event recording Enabled, 0 = event recording Disabled	*	*	*	*
Chooses whether any individual DDBs should be deselected as a stored event, by setting the relevant bit to 0 (zero). Typically used for repetitive recurrent changes such as an Opto input assigned for Minute Pulse clock synchronizing.								

Col	Row	MENU TEXT	Default Setting	Available Setting	P543/P545 No Distance	P544/P546 No Distance	P543/P545	P544/P546
Description								
0B	63	DDB 1151 - 1120	11111111111111111111111111111111(bin)	32-bit binary setting: 1 = event recording Enabled, 0 = event recording Disabled	*	*	*	*
Chooses whether any individual DDBs should be deselected as a stored event, by setting the relevant bit to 0 (zero). Typically used for repetitive recurrent changes such as an Opto input assigned for Minute Pulse clock synchronizing.								
0B	64	DDB 1183 - 1152	11111111111111111111111111111111(bin)	32-bit binary setting: 1 = event recording Enabled, 0 = event recording Disabled	*	*	*	*
Chooses whether any individual DDBs should be deselected as a stored event, by setting the relevant bit to 0 (zero). Typically used for repetitive recurrent changes such as an Opto input assigned for Minute Pulse clock synchronizing.								
0B	65	DDB 1215 - 1184	11111111111111111111111111111111(bin)	32-bit binary setting: 1 = event recording Enabled, 0 = event recording Disabled	*	*	*	*
Chooses whether any individual DDBs should be deselected as a stored event, by setting the relevant bit to 0 (zero). Typically used for repetitive recurrent changes such as an Opto input assigned for Minute Pulse clock synchronizing.								
0B	66	DDB 1247 - 1216	11111111111111111111111111111111(bin)	32-bit binary setting: 1 = event recording Enabled, 0 = event recording Disabled	*	*	*	*
Chooses whether any individual DDBs should be deselected as a stored event, by setting the relevant bit to 0 (zero). Typically used for repetitive recurrent changes such as an Opto input assigned for Minute Pulse clock synchronizing.								
0B	67	DDB 1279 - 1248	11111111111111111111111111111111(bin)	32-bit binary setting: 1 = event recording Enabled, 0 = event recording Disabled	*	*	*	*
Chooses whether any individual DDBs should be deselected as a stored event, by setting the relevant bit to 0 (zero). Typically used for repetitive recurrent changes such as an Opto input assigned for Minute Pulse clock synchronizing.								

Col	Row	MENU TEXT	Default Setting	Available Setting	P543/P545 No Distance	P544/P546 No Distance	P543/P545	P544/P546
Description								
0B	68	DDB 1311 - 1280	11111111111111111111111111111111(bin)	32-bit binary setting: 1 = event recording Enabled, 0 = event recording Disabled	*	*	*	*
Chooses whether any individual DDBs should be deselected as a stored event, by setting the relevant bit to 0 (zero). Typically used for repetitive recurrent changes such as an Opto input assigned for Minute Pulse clock synchronizing.								
0B	69	DDB 1343 - 1312	11111111111111111111111111111111(bin)	32-bit binary setting: 1 = event recording Enabled, 0 = event recording Disabled	*	*	*	*
Chooses whether any individual DDBs should be deselected as a stored event, by setting the relevant bit to 0 (zero). Typically used for repetitive recurrent changes such as an Opto input assigned for Minute Pulse clock synchronizing.								
0B	6A	DDB 1375 - 1344	11111111111111111111111111111111(bin)	32-bit binary setting: 1 = event recording Enabled, 0 = event recording Disabled	*	*	*	*
Chooses whether any individual DDBs should be deselected as a stored event, by setting the relevant bit to 0 (zero). Typically used for repetitive recurrent changes such as an Opto input assigned for Minute Pulse clock synchronizing.								
0B	6B	DDB 1407 - 1376	11111111111111111111111111111111(bin)	32-bit binary setting: 1 = event recording Enabled, 0 = event recording Disabled	*	*	*	*
Chooses whether any individual DDBs should be deselected as a stored event, by setting the relevant bit to 0 (zero). Typically used for repetitive recurrent changes such as an Opto input assigned for Minute Pulse clock synchronizing.								
0B	6C	DDB 1439 - 1408	11111111111111111111111111111111(bin)	32-bit binary setting: 1 = event recording Enabled, 0 = event recording Disabled	*	*	*	*
Chooses whether any individual DDBs should be deselected as a stored event, by setting the relevant bit to 0 (zero). Typically used for repetitive recurrent changes such as an Opto input assigned for Minute Pulse clock synchronizing.								

Col	Row	MENU TEXT	Default Setting	Available Setting	P543/P545 No Distance	P544/P546 No Distance	P543/P545	P544/P546
Description								
0B	6D	DDB 1471 - 1440	11111111111111111111111111111111(bin)	32-bit binary setting: 1 = event recording Enabled, 0 = event recording Disabled	*	*	*	*
Chooses whether any individual DDBs should be deselected as a stored event, by setting the relevant bit to 0 (zero). Typically used for repetitive recurrent changes such as an Opto input assigned for Minute Pulse clock synchronizing.								
0B	6E	DDB 1503 - 1472	11111111111111111111111111111111(bin)	32-bit binary setting: 1 = event recording Enabled, 0 = event recording Disabled	*	*	*	*
Chooses whether any individual DDBs should be deselected as a stored event, by setting the relevant bit to 0 (zero). Typically used for repetitive recurrent changes such as an Opto input assigned for Minute Pulse clock synchronizing.								
0B	6F	DDB 1535 - 1504	11111111111111111111111111111111(bin)	32-bit binary setting: 1 = event recording Enabled, 0 = event recording Disabled	*	*	*	*
Chooses whether any individual DDBs should be deselected as a stored event, by setting the relevant bit to 0 (zero). Typically used for repetitive recurrent changes such as an Opto input assigned for Minute Pulse clock synchronizing.								
0B	70	DDB 1567 - 1536	11111111111111111111111111111111(bin)	32-bit binary setting: 1 = event recording Enabled, 0 = event recording Disabled	*	*	*	*
Chooses whether any individual DDBs should be deselected as a stored event, by setting the relevant bit to 0 (zero). Typically used for repetitive recurrent changes such as an Opto input assigned for Minute Pulse clock synchronizing.								
0B	71	DDB 1599 - 1568	11111111111111111111111111111111(bin)	32-bit binary setting: 1 = event recording Enabled, 0 = event recording Disabled	*	*	*	*
Chooses whether any individual DDBs should be deselected as a stored event, by setting the relevant bit to 0 (zero). Typically used for repetitive recurrent changes such as an Opto input assigned for Minute Pulse clock synchronizing.								

Col	Row	MENU TEXT	Default Setting	Available Setting	P543/P545 No Distance	P544/P546 No Distance	P543/P545	P544/P546
Description								
0B	72	DDB 1631 - 1600	11111111111111111111111111111111(bin)	32-bit binary setting: 1 = event recording Enabled, 0 = event recording Disabled	*	*	*	*
Chooses whether any individual DDBs should be deselected as a stored event, by setting the relevant bit to 0 (zero). Typically used for repetitive recurrent changes such as an Opto input assigned for Minute Pulse clock synchronizing.								
0B	73	DDB 1663 - 1632	11111111111111111111111111111111(bin)	32-bit binary setting: 1 = event recording Enabled, 0 = event recording Disabled	*	*	*	*
Chooses whether any individual DDBs should be deselected as a stored event, by setting the relevant bit to 0 (zero). Typically used for repetitive recurrent changes such as an Opto input assigned for Minute Pulse clock synchronizing.								
0B	74	DDB 1695 - 1664	11111111111111111111111111111111(bin)	32-bit binary setting: 1 = event recording Enabled, 0 = event recording Disabled	*	*	*	*
Chooses whether any individual DDBs should be deselected as a stored event, by setting the relevant bit to 0 (zero). Typically used for repetitive recurrent changes such as an Opto input assigned for Minute Pulse clock synchronizing.								
0B	75	DDB 1727 - 1696	11111111111111111111111111111111(bin)	32-bit binary setting: 1 = event recording Enabled, 0 = event recording Disabled	*	*	*	*
Chooses whether any individual DDBs should be deselected as a stored event, by setting the relevant bit to 0 (zero). Typically used for repetitive recurrent changes such as an Opto input assigned for Minute Pulse clock synchronizing.								
0B	76	DDB 1759 - 1728	11111111111111111111111111111111(bin)	32-bit binary setting: 1 = event recording Enabled, 0 = event recording Disabled	*	*	*	*
Chooses whether any individual DDBs should be deselected as a stored event, by setting the relevant bit to 0 (zero). Typically used for repetitive recurrent changes such as an Opto input assigned for Minute Pulse clock synchronizing.								

Col	Row	MENU TEXT	Default Setting	Available Setting	P543/P545 No Distance	P544/P546 No Distance	P543/P545	P544/P546
Description								
0B	77	DDB 1760 - 1791	11111111111111111111111111111111(bin)	32-bit binary setting: 1 = event recording Enabled, 0 = event recording Disabled	*	*	*	*
Chooses whether any individual DDBs should be deselected as a stored event, by setting the relevant bit to 0 (zero). Typically used for repetitive recurrent changes such as an Opto input assigned for Minute Pulse clock synchronizing.								
0B	78	DDB 1792 - 1823	11111111111111111111111111111111(bin)	32-bit binary setting: 1 = event recording Enabled, 0 = event recording Disabled	*	*	*	*
Chooses whether any individual DDBs should be deselected as a stored event, by setting the relevant bit to 0 (zero). Typically used for repetitive recurrent changes such as an Opto input assigned for Minute Pulse clock synchronizing.								
0B	79	DDB 1824 - 1855	11111111111111111111111111111111(bin)	32-bit binary setting: 1 = event recording Enabled, 0 = event recording Disabled	*	*	*	*
Chooses whether any individual DDBs should be deselected as a stored event, by setting the relevant bit to 0 (zero). Typically used for repetitive recurrent changes such as an Opto input assigned for Minute Pulse clock synchronizing.								
0B	7A	DDB 1856 - 1887	11111111111111111111111111111111(bin)	32-bit binary setting: 1 = event recording Enabled, 0 = event recording Disabled	*	*	*	*
Chooses whether any individual DDBs should be deselected as a stored event, by setting the relevant bit to 0 (zero). Typically used for repetitive recurrent changes such as an Opto input assigned for Minute Pulse clock synchronizing.								
0B	7B	DDB 1888 - 1919	11111111111111111111111111111111(bin)	32-bit binary setting: 1 = event recording Enabled, 0 = event recording Disabled	*	*	*	*
Chooses whether any individual DDBs should be deselected as a stored event, by setting the relevant bit to 0 (zero). Typically used for repetitive recurrent changes such as an Opto input assigned for Minute Pulse clock synchronizing.								

Col	Row	MENU TEXT	Default Setting	Available Setting	P543/P545 No Distance	P544/P546 No Distance	P543/P545	P544/P546
Description								
0B	7C	DDB 1920 - 1951	11111111111111111111111111111111(bin)	32-bit binary setting: 1 = event recording Enabled, 0 = event recording Disabled	*	*	*	*
Chooses whether any individual DDBs should be deselected as a stored event, by setting the relevant bit to 0 (zero). Typically used for repetitive recurrent changes such as an Opto input assigned for Minute Pulse clock synchronizing.								
0B	7D	DDB 1952 - 1983	11111111111111111111111111111111(bin)	32-bit binary setting: 1 = event recording Enabled, 0 = event recording Disabled	*	*	*	*
Chooses whether any individual DDBs should be deselected as a stored event, by setting the relevant bit to 0 (zero). Typically used for repetitive recurrent changes such as an Opto input assigned for Minute Pulse clock synchronizing.								
0B	7E	DDB 1984 - 2015	11111111111111111111111111111111(bin)	32-bit binary setting: 1 = event recording Enabled, 0 = event recording Disabled	*	*	*	*
Chooses whether any individual DDBs should be deselected as a stored event, by setting the relevant bit to 0 (zero). Typically used for repetitive recurrent changes such as an Opto input assigned for Minute Pulse clock synchronizing.								
0B	7F	DDB 2016 - 2047	11111111111111111111111111111111(bin)	32-bit binary setting: 1 = event recording Enabled, 0 = event recording Disabled	*	*	*	*
Chooses whether any individual DDBs should be deselected as a stored event, by setting the relevant bit to 0 (zero). Typically used for repetitive recurrent changes such as an Opto input assigned for Minute Pulse clock synchronizing.								

Table 35 - Record control

4.6 Disturbance Recorder Settings (Oscillography)

The disturbance recorder settings include the record duration and trigger position, selection of analog and digital signals to record, and the signal sources that trigger the recording.

The precise event recorder column (“Disturb. Recorder” menu) is visible when the “Disturb recorder” setting (“Configuration” column) = “visible”.

Important

In the following table there are rows which may appear to be duplicated. The convention here is that the:

- First line applies to single breaker variants (e.g. P443, P445, P543, P544 and P841A).
- Second line applies to dual circuit breaker versions (e.g. P446, P544, P546 and P841B).

Col	Row	MENU TEXT	Default Setting	Available Setting	P543/P545 No Distance	P544/P546 No Distance	P543/P545	P544/P546
Description								
0C	00	DISTURB RECORDER			*	*	*	*
This column contains settings for the Disturbance Recorder								
0C	01	Duration	1.5s	From 100ms to 10.5s step 10ms	*	*	*	*
This sets the overall recording time.								
0C	02	Trigger Position	33.30%	From 0% to 100% step 0.1%	*	*	*	*
This sets the trigger point as a percentage of the duration. For example, the default settings show that the overall recording time is set to 1.5 s with the trigger point being at 33.3% of this, giving 0.5 s pre-fault and 1s post fault recording times.								
0C	03	Trigger Mode	Single	0 = Single or 1 = Extended	*	*	*	*
If set to single mode, if a further trigger occurs whilst a recording is taking place, the recorder will ignore the trigger. However, if this has been set to Extended, the post trigger timer will be reset to zero, thereby extending the recording time.								
0C	04	Analog Channel 1	VA	0 = IA, 1 = IB, 2 = IC, 3 = IN, 4 = IN Sensitive, 5 = VA, 6 = VB, 7 = VC, 8 = IM, 9 = V Checksync, 10 = IA DIFF, 11 = IB DIFF, 12 = IC DIFF, 13 = I BIAS MAX, 14 = I H2 MAX or 15 = Unused	*		*	
Selects any available analogue input to be assigned to this channel (including derived IN residual current).								
0C	04	Analog Channel 1	VA	0 = IA, 1 = IB, 2 = IC, 3 = IN, 4 = IN Sensitive, 5 = VA, 6 = VB, 7 = VC, 8 = IM, 9 = V Checksync, 10 = IA2, 11 = IB2, 12 = IC2, 13 = IN2, 14 = V Checksync2, 15 = IA DIFF, 16 = IB DIFF, 17 = IC DIFF, 18 = I BIAS MAX, 19 = I H2 MAX or 20 = Unused		*		*
Selects any available analogue input to be assigned to this channel (including derived IN residual current).								
0C	05	Analog Channel 2	VB	0 = IA, 1 = IB, 2 = IC, 3 = IN, 4 = IN Sensitive, 5 = VA, 6 = VB, 7 = VC, 8 = IM, 9 = V Checksync, 10 = IA DIFF, 11 = IB DIFF, 12 = IC DIFF, 13 = I BIAS MAX, 14 = I H2 MAX or 15 = Unused	*		*	
Selects any available analogue input to be assigned to this channel (including derived IN residual current).								
0C	05	Analog Channel 2	VB	0 = IA, 1 = IB, 2 = IC, 3 = IN, 4 = IN Sensitive, 5 = VA, 6 = VB, 7 = VC, 8 = IM, 9 = V Checksync, 10 = IA2, 11 = IB2, 12 = IC2, 13 = IN2, 14 = V Checksync2, 15 = IA DIFF, 16 = IB DIFF, 17 = IC DIFF, 18 = I BIAS MAX, 19 = I H2 MAX or 20 = Unused		*		*
Selects any available analogue input to be assigned to this channel (including derived IN residual current).								

Col	Row	MENU TEXT	Default Setting	Available Setting	P543/P545 No Distance	P544/P546 No Distance	P543/P545	P544/P546
Description								
0C	06	Analog Channel 3	VC	0 = IA, 1 = IB, 2 = IC, 3 = IN, 4 = IN Sensitive, 5 = VA, 6 = VB, 7 = VC, 8 = IM, 9 = V Checksync, 10 = IA DIFF, 11 = IB DIFF, 12 = IC DIFF, 13 = I BIAS MAX, 14 = I H2 MAX or 15 = Unused	*		*	
Selects any available analogue input to be assigned to this channel (including derived IN residual current).								
0C	06	Analog Channel 3	VC	0 = IA, 1 = IB, 2 = IC, 3 = IN, 4 = IN Sensitive, 5 = VA, 6 = VB, 7 = VC, 8 = IM, 9 = V Checksync, 10 = IA2, 11 = IB2, 12 = IC2, 13 = IN2, 14 = V Checksync2, 15 = IA DIFF, 16 = IB DIFF, 17 = IC DIFF, 18 = I BIAS MAX, 19 = I H2 MAX or 20 = Unused		*		*
Selects any available analogue input to be assigned to this channel (including derived IN residual current).								
0C	07	Analog Channel 4	IA	0 = IA, 1 = IB, 2 = IC, 3 = IN, 4 = IN Sensitive, 5 = VA, 6 = VB, 7 = VC, 8 = IM, 9 = V Checksync, 10 = IA DIFF, 11 = IB DIFF, 12 = IC DIFF, 13 = I BIAS MAX, 14 = I H2 MAX or 15 = Unused	*		*	
Selects any available analogue input to be assigned to this channel (including derived IN residual current).								
0C	07	Analog Channel 4	IA	0 = IA, 1 = IB, 2 = IC, 3 = IN, 4 = IN Sensitive, 5 = VA, 6 = VB, 7 = VC, 8 = IM, 9 = V Checksync, 10 = IA2, 11 = IB2, 12 = IC2, 13 = IN2, 14 = V Checksync2, 15 = IA DIFF, 16 = IB DIFF, 17 = IC DIFF, 18 = I BIAS MAX, 19 = I H2 MAX or 20 = Unused		*		*
Selects any available analogue input to be assigned to this channel (including derived IN residual current).								
0C	08	Analog Channel 5	IB	0 = IA, 1 = IB, 2 = IC, 3 = IN, 4 = IN Sensitive, 5 = VA, 6 = VB, 7 = VC, 8 = IM, 9 = V Checksync, 10 = IA DIFF, 11 = IB DIFF, 12 = IC DIFF, 13 = I BIAS MAX, 14 = I H2 MAX or 15 = Unused	*		*	
Selects any available analogue input to be assigned to this channel (including derived IN residual current).								
0C	08	Analog Channel 5	IB	0 = IA, 1 = IB, 2 = IC, 3 = IN, 4 = IN Sensitive, 5 = VA, 6 = VB, 7 = VC, 8 = IM, 9 = V Checksync, 10 = IA2, 11 = IB2, 12 = IC2, 13 = IN2, 14 = V Checksync2, 15 = IA DIFF, 16 = IB DIFF, 17 = IC DIFF, 18 = I BIAS MAX, 19 = I H2 MAX or 20 = Unused		*		*
Selects any available analogue input to be assigned to this channel (including derived IN residual current).								
0C	09	Analog Channel 6	IC	0 = IA, 1 = IB, 2 = IC, 3 = IN, 4 = IN Sensitive, 5 = VA, 6 = VB, 7 = VC, 8 = IM, 9 = V Checksync, 10 = IA DIFF, 11 = IB DIFF, 12 = IC DIFF, 13 = I BIAS MAX, 14 = I H2 MAX or 15 = Unused	*		*	
Selects any available analogue input to be assigned to this channel (including derived IN residual current).								

Col	Row	MENU TEXT	Default Setting	Available Setting	P543/P545 No Distance	P544/P546 No Distance	P543/P545	P544/P546
Description								
0C	09	Analog Channel 6	IC	0 = IA, 1 = IB, 2 = IC, 3 = IN, 4 = IN Sensitive, 5 = VA, 6 = VB, 7 = VC, 8 = IM, 9 = V Checksync, 10 = IA2, 11 = IB2, 12 = IC2, 13 = IN2, 14 = V Checksync2, 15 = IA DIFF, 16 = IB DIFF, 17 = IC DIFF, 18 = I BIAS MAX, 19 = I H2 MAX or 20 = Unused		*		*
Selects any available analogue input to be assigned to this channel (including derived IN residual current).								
0C	0A	Analog Channel 7	IN	0 = IA, 1 = IB, 2 = IC, 3 = IN, 4 = IN Sensitive, 5 = VA, 6 = VB, 7 = VC, 8 = IM, 9 = V Checksync, 10 = IA DIFF, 11 = IB DIFF, 12 = IC DIFF, 13 = I BIAS MAX, 14 = I H2 MAX or 15 = Unused	*		*	
Selects any available analogue input to be assigned to this channel (including derived IN residual current).								
0C	0A	Analog Channel 7	IN	0 = IA, 1 = IB, 2 = IC, 3 = IN, 4 = IN Sensitive, 5 = VA, 6 = VB, 7 = VC, 8 = IM, 9 = V Checksync, 10 = IA2, 11 = IB2, 12 = IC2, 13 = IN2, 14 = V Checksync2, 15 = IA DIFF, 16 = IB DIFF, 17 = IC DIFF, 18 = I BIAS MAX, 19 = I H2 MAX or 20 = Unused		*		*
Selects any available analogue input to be assigned to this channel (including derived IN residual current).								
0C	0B	Analog Channel 8	IN Sensitive	0 = IA, 1 = IB, 2 = IC, 3 = IN, 4 = IN Sensitive, 5 = VA, 6 = VB, 7 = VC, 8 = IM, 9 = V Checksync, 10 = IA DIFF, 11 = IB DIFF, 12 = IC DIFF, 13 = I BIAS MAX, 14 = I H2 MAX or 15 = Unused	*		*	
Selects any available analogue input to be assigned to this channel (including derived IN residual current).								
0C	0B	Analog Channel 8	IN Sensitive	0 = IA, 1 = IB, 2 = IC, 3 = IN, 4 = IN Sensitive, 5 = VA, 6 = VB, 7 = VC, 8 = IM, 9 = V Checksync, 10 = IA2, 11 = IB2, 12 = IC2, 13 = IN2, 14 = V Checksync2, 15 = IA DIFF, 16 = IB DIFF, 17 = IC DIFF, 18 = I BIAS MAX, 19 = I H2 MAX or 20 = Unused		*		*
Selects any available analogue input to be assigned to this channel (including derived IN residual current).								
0C	0C	Digital Input 1	Output R1	See Data Types - G32	*	*	*	*
The digital channels may monitor any of the opto isolated inputs or output contacts, in addition to a number of internal relay digital signals, such as protection starts, LEDs etc.								
0C	0D	Input 1 Trigger	No Trigger	0 = No Trigger, 1 = Trigger L/H, 2 = Trigger H/L	*	*	*	*
Any of the digital channels may be selected to trigger the disturbance recorder on either a low to high or a high to low transition.								
0C	0E	Digital Input 2	Output R2	See Data Types - G32	*	*	*	*
The digital channels may monitor any of the opto isolated inputs or output contacts, in addition to a number of internal relay digital signals, such as protection starts, LEDs etc.								
0C	0F	Input 2 Trigger	No Trigger	0 = No Trigger, 1 = Trigger L/H, 2 = Trigger H/L	*	*	*	*
Any of the digital channels may be selected to trigger the disturbance recorder on either a low to high or a high to low transition.								

Col	Row	MENU TEXT	Default Setting	Available Setting	P543/P545 No Distance	P544/P546 No Distance	P543/P545	P544/P546
Description								
0C	10	Digital Input 3	Output R3	See Data Types - G32	*	*	*	*
The digital channels may monitor any of the opto isolated inputs or output contacts, in addition to a number of internal relay digital signals, such as protection starts, LEDs etc.								
0C	11	Input 3 Trigger	Trigger L/H	0 = No Trigger, 1 = Trigger L/H, 2 = Trigger H/L	*	*	*	*
Any of the digital channels may be selected to trigger the disturbance recorder on either a low to high or a high to low transition.								
0C	12	Digital Input 4	Output R4	See Data Types - G32	*	*	*	*
The digital channels may monitor any of the opto isolated inputs or output contacts, in addition to a number of internal relay digital signals, such as protection starts, LEDs etc.								
0C	13	Input 4 Trigger	No Trigger	0 = No Trigger, 1 = Trigger L/H, 2 = Trigger H/L	*	*	*	*
Any of the digital channels may be selected to trigger the disturbance recorder on either a low to high or a high to low transition.								
0C	14	Digital Input 5	Output R5	See Data Types - G32	*	*	*	*
The digital channels may monitor any of the opto isolated inputs or output contacts, in addition to a number of internal relay digital signals, such as protection starts, LEDs etc.								
0C	15	Input 5 Trigger	No Trigger	0 = No Trigger, 1 = Trigger L/H, 2 = Trigger H/L	*	*	*	*
Any of the digital channels may be selected to trigger the disturbance recorder on either a low to high or a high to low transition.								
0C	16	Digital Input 6	Output R6	See Data Types - G32	*	*	*	*
The digital channels may monitor any of the opto isolated inputs or output contacts, in addition to a number of internal relay digital signals, such as protection starts, LEDs etc.								
0C	17	Input 6 Trigger	No Trigger	0 = No Trigger, 1 = Trigger L/H, 2 = Trigger H/L	*	*	*	*
Any of the digital channels may be selected to trigger the disturbance recorder on either a low to high or a high to low transition.								
0C	18	Digital Input 7	Output R7	See Data Types - G32	*	*	*	*
The digital channels may monitor any of the opto isolated inputs or output contacts, in addition to a number of internal relay digital signals, such as protection starts, LEDs etc.								
0C	19	Input 7 Trigger	No Trigger	0 = No Trigger, 1 = Trigger L/H, 2 = Trigger H/L	*	*	*	*
Any of the digital channels may be selected to trigger the disturbance recorder on either a low to high or a high to low transition.								
0C	1A	Digital Input 8	Output R8	See Data Types - G32	*	*	*	*
The digital channels may monitor any of the opto isolated inputs or output contacts, in addition to a number of internal relay digital signals, such as protection starts, LEDs etc.								
0C	1B	Input 8 Trigger	No Trigger	0 = No Trigger, 1 = Trigger L/H, 2 = Trigger H/L	*	*	*	*
Any of the digital channels may be selected to trigger the disturbance recorder on either a low to high or a high to low transition.								
0C	1C	Digital Input 9	Output R9	See Data Types - G32	*	*	*	*
The digital channels may monitor any of the opto isolated inputs or output contacts, in addition to a number of internal relay digital signals, such as protection starts, LEDs etc.								
0C	1D	Input 9 Trigger	No Trigger	0 = No Trigger, 1 = Trigger L/H, 2 = Trigger H/L	*	*	*	*
Any of the digital channels may be selected to trigger the disturbance recorder on either a low to high or a high to low transition.								
0C	1E	Digital Input 10	Output R10	See Data Types - G32	*	*	*	*
The digital channels may monitor any of the opto isolated inputs or output contacts, in addition to a number of internal relay digital signals, such as protection starts, LEDs etc.								
0C	1F	Input 10 Trigger	No Trigger	0 = No Trigger, 1 = Trigger L/H, 2 = Trigger H/L	*	*	*	*

Col	Row	MENU TEXT	Default Setting	Available Setting	P543/P545 No Distance	P544/P546 No Distance	P543/P545	P544/P546
Description								
Any of the digital channels may be selected to trigger the disturbance recorder on either a low to high or a high to low transition.								
0C	20	Digital Input 11	Output R11	See Data Types - G32	*	*	*	*
The digital channels may monitor any of the opto isolated inputs or output contacts, in addition to a number of internal relay digital signals, such as protection starts, LEDs etc.								
0C	21	Input 11 Trigger	No Trigger	0 = No Trigger, 1 = Trigger L/H, 2 = Trigger H/L	*	*	*	*
Any of the digital channels may be selected to trigger the disturbance recorder on either a low to high or a high to low transition.								
0C	22	Digital Input 12	Output R12	See Data Types - G32	*	*	*	*
The digital channels may monitor any of the opto isolated inputs or output contacts, in addition to a number of internal relay digital signals, such as protection starts, LEDs etc.								
0C	23	Input 12 Trigger	No Trigger	0 = No Trigger, 1 = Trigger L/H, 2 = Trigger H/L	*	*	*	*
Any of the digital channels may be selected to trigger the disturbance recorder on either a low to high or a high to low transition.								
0C	24	Digital Input 13	Output R13	See Data Types - G32	*	*	*	*
The digital channels may monitor any of the opto isolated inputs or output contacts, in addition to a number of internal relay digital signals, such as protection starts, LEDs etc.								
0C	25	Input 13 Trigger	No Trigger	0 = No Trigger, 1 = Trigger L/H, 2 = Trigger H/L	*	*	*	*
Any of the digital channels may be selected to trigger the disturbance recorder on either a low to high or a high to low transition.								
0C	26	Digital Input 14	Output R14	See Data Types - G32	*	*	*	*
The digital channels may monitor any of the opto isolated inputs or output contacts, in addition to a number of internal relay digital signals, such as protection starts, LEDs etc.								
0C	27	Input 14 Trigger	No Trigger	0 = No Trigger, 1 = Trigger L/H, 2 = Trigger H/L	*	*	*	*
Any of the digital channels may be selected to trigger the disturbance recorder on either a low to high or a high to low transition.								
0C	28	Digital Input 15	Output R15	See Data Types - G32	*	*	*	*
The digital channels may monitor any of the opto isolated inputs or output contacts, in addition to a number of internal relay digital signals, such as protection starts, LEDs etc.								
0C	29	Input 15 Trigger	No Trigger	0 = No Trigger, 1 = Trigger L/H, 2 = Trigger H/L	*	*	*	*
Any of the digital channels may be selected to trigger the disturbance recorder on either a low to high or a high to low transition.								
0C	2A	Digital Input 16	Output R16	See Data Types - G32	*	*	*	*
The digital channels may monitor any of the opto isolated inputs or output contacts, in addition to a number of internal relay digital signals, such as protection starts, LEDs etc.								
0C	2B	Input 16 Trigger	No Trigger	0 = No Trigger, 1 = Trigger L/H, 2 = Trigger H/L	*	*	*	*
Any of the digital channels may be selected to trigger the disturbance recorder on either a low to high or a high to low transition.								
0C	2C	Digital Input 17	Input L1	See Data Types - G32	*	*	*	*
The digital channels may monitor any of the opto isolated inputs or output contacts, in addition to a number of internal relay digital signals, such as protection starts, LEDs etc.								
0C	2D	Input 17 Trigger	No Trigger	0 = No Trigger, 1 = Trigger L/H, 2 = Trigger H/L	*	*	*	*

Col	Row	MENU TEXT	Default Setting	Available Setting	P543/P545 No Distance	P544/P546 No Distance	P543/P545	P544/P546
Description								
Any of the digital channels may be selected to trigger the disturbance recorder on either a low to high or a high to low transition.								
0C	2E	Digital Input 18	Input L2	See Data Types - G32	*	*	*	*
The digital channels may monitor any of the opto isolated inputs or output contacts, in addition to a number of internal relay digital signals, such as protection starts, LEDs etc.								
0C	2F	Input 18 Trigger	No Trigger	0 = No Trigger, 1 = Trigger L/H, 2 = Trigger H/L	*	*	*	*
Any of the digital channels may be selected to trigger the disturbance recorder on either a low to high or a high to low transition.								
0C	30	Digital Input 19	Input L3	See Data Types - G32	*	*	*	*
The digital channels may monitor any of the opto isolated inputs or output contacts, in addition to a number of internal relay digital signals, such as protection starts, LEDs etc.								
0C	31	Input 19 Trigger	No Trigger	0 = No Trigger, 1 = Trigger L/H, 2 = Trigger H/L	*	*	*	*
Any of the digital channels may be selected to trigger the disturbance recorder on either a low to high or a high to low transition.								
0C	32	Digital Input 20	Input L4	See Data Types - G32	*	*	*	*
The digital channels may monitor any of the opto isolated inputs or output contacts, in addition to a number of internal relay digital signals, such as protection starts, LEDs etc.								
0C	33	Input 20 Trigger	No Trigger	0 = No Trigger, 1 = Trigger L/H, 2 = Trigger H/L	*	*	*	*
Any of the digital channels may be selected to trigger the disturbance recorder on either a low to high or a high to low transition.								
0C	34	Digital Input 21	Input L5	See Data Types - G32	*	*	*	*
The digital channels may monitor any of the opto isolated inputs or output contacts, in addition to a number of internal relay digital signals, such as protection starts, LEDs etc.								
0C	35	Input 21 Trigger	No Trigger	0 = No Trigger, 1 = Trigger L/H, 2 = Trigger H/L	*	*	*	*
Any of the digital channels may be selected to trigger the disturbance recorder on either a low to high or a high to low transition.								
0C	36	Digital Input 22	Input L6	See Data Types - G32	*	*	*	*
The digital channels may monitor any of the opto isolated inputs or output contacts, in addition to a number of internal relay digital signals, such as protection starts, LEDs etc.								
0C	37	Input 22 Trigger	No Trigger	0 = No Trigger, 1 = Trigger L/H, 2 = Trigger H/L	*	*	*	*
Any of the digital channels may be selected to trigger the disturbance recorder on either a low to high or a high to low transition.								
0C	38	Digital Input 23	Input L7	See Data Types - G32	*	*	*	*
The digital channels may monitor any of the opto isolated inputs or output contacts, in addition to a number of internal relay digital signals, such as protection starts, LEDs etc.								
0C	39	Input 23 Trigger	No Trigger	0 = No Trigger, 1 = Trigger L/H, 2 = Trigger H/L	*	*	*	*
Any of the digital channels may be selected to trigger the disturbance recorder on either a low to high or a high to low transition.								
0C	3A	Digital Input 24	Input L8	See Data Types - G32	*	*	*	*
The digital channels may monitor any of the opto isolated inputs or output contacts, in addition to a number of internal relay digital signals, such as protection starts, LEDs etc.								
0C	3B	Input 24 Trigger	No Trigger	0 = No Trigger, 1 = Trigger L/H, 2 = Trigger H/L	*	*	*	*

Col	Row	MENU TEXT	Default Setting	Available Setting	P543/P545 No Distance	P544/P546 No Distance	P543/P545	P544/P546
Description								
Any of the digital channels may be selected to trigger the disturbance recorder on either a low to high or a high to low transition.								
0C	3C	Digital Input 25	Input L9	See Data Types - G32	*	*	*	*
The digital channels may monitor any of the opto isolated inputs or output contacts, in addition to a number of internal relay digital signals, such as protection starts, LEDs etc.								
0C	3D	Input 25 Trigger	No Trigger	0 = No Trigger, 1 = Trigger L/H, 2 = Trigger H/L	*	*	*	*
Any of the digital channels may be selected to trigger the disturbance recorder on either a low to high or a high to low transition.								
0C	3E	Digital Input 26	Input L10	See Data Types - G32	*	*	*	*
The digital channels may monitor any of the opto isolated inputs or output contacts, in addition to a number of internal relay digital signals, such as protection starts, LEDs etc.								
0C	3F	Input 26 Trigger	No Trigger	0 = No Trigger, 1 = Trigger L/H, 2 = Trigger H/L	*	*	*	*
Any of the digital channels may be selected to trigger the disturbance recorder on either a low to high or a high to low transition.								
0C	40	Digital Input 27	Input L11	See Data Types - G32	*	*	*	*
The digital channels may monitor any of the opto isolated inputs or output contacts, in addition to a number of internal relay digital signals, such as protection starts, LEDs etc.								
0C	41	Input 27 Trigger	No Trigger	0 = No Trigger, 1 = Trigger L/H, 2 = Trigger H/L	*	*	*	*
Any of the digital channels may be selected to trigger the disturbance recorder on either a low to high or a high to low transition.								
0C	42	Digital Input 28	Input L12	See Data Types - G32	*	*	*	*
The digital channels may monitor any of the opto isolated inputs or output contacts, in addition to a number of internal relay digital signals, such as protection starts, LEDs etc.								
0C	43	Input 28 Trigger	No Trigger	0 = No Trigger, 1 = Trigger L/H, 2 = Trigger H/L	*	*	*	*
Any of the digital channels may be selected to trigger the disturbance recorder on either a low to high or a high to low transition.								
0C	44	Digital Input 29	Input L13	See Data Types - G32	*	*	*	*
The digital channels may monitor any of the opto isolated inputs or output contacts, in addition to a number of internal relay digital signals, such as protection starts, LEDs etc.								
0C	45	Input 29 Trigger	No Trigger	0 = No Trigger, 1 = Trigger L/H, 2 = Trigger H/L	*	*	*	*
Any of the digital channels may be selected to trigger the disturbance recorder on either a low to high or a high to low transition.								
0C	46	Digital Input 30	Input L14	See Data Types - G32	*	*	*	*
The digital channels may monitor any of the opto isolated inputs or output contacts, in addition to a number of internal relay digital signals, such as protection starts, LEDs etc.								
0C	47	Input 30 Trigger	No Trigger	0 = No Trigger, 1 = Trigger L/H, 2 = Trigger H/L	*	*	*	*
Any of the digital channels may be selected to trigger the disturbance recorder on either a low to high or a high to low transition.								
0C	48	Digital Input 31	Input L15	See Data Types - G32	*	*	*	*
The digital channels may monitor any of the opto isolated inputs or output contacts, in addition to a number of internal relay digital signals, such as protection starts, LEDs etc.								
0C	49	Input 31 Trigger	No Trigger	0 = No Trigger, 1 = Trigger L/H, 2 = Trigger H/L	*	*	*	*

Col	Row	MENU TEXT	Default Setting	Available Setting	P543/P545 No Distance	P544/P546 No Distance	P543/P545	P544/P546
Description								
Any of the digital channels may be selected to trigger the disturbance recorder on either a low to high or a high to low transition.								
0C	4A	Digital Input 32	Input L16	See Data Types - G32	*	*	*	*
The digital channels may monitor any of the opto isolated inputs or output contacts, in addition to a number of internal relay digital signals, such as protection starts, LEDs etc.								
0C	4B	Input 32 Trigger	No Trigger	0 = No Trigger, 1 = Trigger L/H, 2 = Trigger H/L	*	*	*	*
Any of the digital channels may be selected to trigger the disturbance recorder on either a low to high or a high to low transition.								
0C	50	Analog Channel 9	V Checksync	0 = IA, 1 = IB, 2 = IC, 3 = IN, 4 = IN Sensitive, 5 = VA, 6 = VB, 7 = VC, 8 = IM, 9 = V Checksync, 10 = IA DIFF, 11 = IB DIFF, 12 = IC DIFF, 13 = I BIAS MAX, 14 = I H2 MAX or 15 = Unused	*		*	
Selects any available analogue input to be assigned to this channel (including derived IN residual current).								
0C	50	Analog Channel 9	V Checksync	0 = IA, 1 = IB, 2 = IC, 3 = IN, 4 = IN Sensitive, 5 = VA, 6 = VB, 7 = VC, 8 = IM, 9 = V Checksync, 10 = IA2, 11 = IB2, 12 = IC2, 13 = IN2, 14 = V Checksync2, 15 = IA DIFF, 16 = IB DIFF, 17 = IC DIFF, 18 = I BIAS MAX, 19 = I H2 MAX or 20 = Unused		*		*
Selects any available analogue input to be assigned to this channel (including derived IN residual current).								
0C	51	Analog Channel 10	IM	0 = IA, 1 = IB, 2 = IC, 3 = IN, 4 = IN Sensitive, 5 = VA, 6 = VB, 7 = VC, 8 = IM, 9 = V Checksync, 10 = IA DIFF, 11 = IB DIFF, 12 = IC DIFF, 13 = I BIAS MAX, 14 = I H2 MAX or 15 = Unused	*		*	
Selects any available analogue input to be assigned to this channel (including derived IN residual current).								
0C	51	Analog Channel 10	IA2	0 = IA, 1 = IB, 2 = IC, 3 = IN, 4 = IN Sensitive, 5 = VA, 6 = VB, 7 = VC, 8 = IM, 9 = V Checksync, 10 = IA2, 11 = IB2, 12 = IC2, 13 = IN2, 14 = V Checksync2, 15 = IA DIFF, 16 = IB DIFF, 17 = IC DIFF, 18 = I BIAS MAX, 19 = I H2 MAX or 20 = Unused		*		*
Selects any available analogue input to be assigned to this channel (including derived IN residual current).								
0C	52	Analog Channel 11	IN	0 = IA, 1 = IB, 2 = IC, 3 = IN, 4 = IN Sensitive, 5 = VA, 6 = VB, 7 = VC, 8 = IM, 9 = V Checksync, 10 = IA DIFF, 11 = IB DIFF, 12 = IC DIFF, 13 = I BIAS MAX, 14 = I H2 MAX or 15 = Unused	*		*	
Selects any available analogue input to be assigned to this channel (including derived IN residual current).								

Col	Row	MENU TEXT	Default Setting	Available Setting	P543/P545 No Distance	P544/P546 No Distance	P543/P545	P544/P546
Description								
0C	52	Analog Channel 11	IB2	0 = IA, 1 = IB, 2 = IC, 3 = IN, 4 = IN Sensitive, 5 = VA, 6 = VB, 7 = VC, 8 = IM, 9 = V Checksync, 10 = IA2, 11 = IB2, 12 = IC2, 13 = IN2, 14 = V Checksync2, 15 = IA DIFF, 16 = IB DIFF, 17 = IC DIFF, 18 = I BIAS MAX, 19 = I H2 MAX or 20 = Unused		*		*
Selects any available analogue input to be assigned to this channel (including derived IN residual current).								
0C	53	Analog Channel 12	IN	0 = IA, 1 = IB, 2 = IC, 3 = IN, 4 = IN Sensitive, 5 = VA, 6 = VB, 7 = VC, 8 = IM, 9 = V Checksync, 10 = IA DIFF, 11 = IB DIFF, 12 = IC DIFF, 13 = I BIAS MAX, 14 = I H2 MAX or 15 = Unused	*		*	
Selects any available analogue input to be assigned to this channel (including derived IN residual current).								
0C	53	Analog Channel 12	IC2	0 = IA, 1 = IB, 2 = IC, 3 = IN, 4 = IN Sensitive, 5 = VA, 6 = VB, 7 = VC, 8 = IM, 9 = V Checksync, 10 = IA2, 11 = IB2, 12 = IC2, 13 = IN2, 14 = V Checksync2, 15 = IA DIFF, 16 = IB DIFF, 17 = IC DIFF, 18 = I BIAS MAX, 19 = I H2 MAX or 20 = Unused		*		*
Selects any available analogue input to be assigned to this channel (including derived IN residual current).								
0C	54	Analog Channel 13	Unused	0 = IA, 1 = IB, 2 = IC, 3 = IN, 4 = IN Sensitive, 5 = VA, 6 = VB, 7 = VC, 8 = IM, 9 = V Checksync, 10 = IA DIFF, 11 = IB DIFF, 12 = IC DIFF, 13 = I BIAS MAX, 14 = I H2 MAX or 15 = Unused	*		*	
Selects any available analogue input to be assigned to this channel (including derived IN residual current).								
0C	54	Analog Channel 13	Unused	0 = IA, 1 = IB, 2 = IC, 3 = IN, 4 = IN Sensitive, 5 = VA, 6 = VB, 7 = VC, 8 = IM, 9 = V Checksync, 10 = IA2, 11 = IB2, 12 = IC2, 13 = IN2, 14 = V Checksync2, 15 = IA DIFF, 16 = IB DIFF, 17 = IC DIFF, 18 = I BIAS MAX, 19 = I H2 MAX or 20 = Unused		*		*
Selects any available analogue input to be assigned to this channel (including derived IN residual current).								
0C	55	Analog Channel 14	Unused	0 = IA, 1 = IB, 2 = IC, 3 = IN, 4 = IN Sensitive, 5 = VA, 6 = VB, 7 = VC, 8 = IM, 9 = V Checksync, 10 = IA DIFF, 11 = IB DIFF, 12 = IC DIFF, 13 = I BIAS MAX, 14 = I H2 MAX or 15 = Unused	*		*	
Selects any available analogue input to be assigned to this channel (including derived IN residual current).								
0C	55	Analog Channel 14	Unused	0 = IA, 1 = IB, 2 = IC, 3 = IN, 4 = IN Sensitive, 5 = VA, 6 = VB, 7 = VC, 8 = IM, 9 = V Checksync, 10 = IA2, 11 = IB2, 12 = IC2, 13 = IN2, 14 = V Checksync2, 15 = IA DIFF, 16 = IB DIFF, 17 = IC DIFF, 18 = I BIAS MAX, 19 = I H2 MAX or 20 = Unused		*		*

Col	Row	MENU TEXT	Default Setting	Available Setting	P543/P545 No Distance	P544/P546 No Distance	P543/P545	P544/P546
Description								
Selects any available analogue input to be assigned to this channel (including derived IN residual current).								
0C	56	Analog Channel 15	Unused	0 = IA, 1 = IB, 2 = IC, 3 = IN, 4 = IN Sensitive, 5 = VA, 6 = VB, 7 = VC, 8 = IM, 9 = V Checksync, 10 = IA DIFF, 11 = IB DIFF, 12 = IC DIFF, 13 = I BIAS MAX, 14 = I H2 MAX or 15 = Unused	*		*	
Selects any available analogue input to be assigned to this channel (including derived IN residual current).								
0C	56	Analog Channel 15	Unused	0 = IA, 1 = IB, 2 = IC, 3 = IN, 4 = IN Sensitive, 5 = VA, 6 = VB, 7 = VC, 8 = IM, 9 = V Checksync, 10 = IA2, 11 = IB2, 12 = IC2, 13 = IN2 , 14 = V Checksync2, 15 = IA DIFF, 16 = IB DIFF, 17 = IC DIFF, 18 = I BIAS MAX, 19 = I H2 MAX or 20 = Unused		*		*
Selects any available analogue input to be assigned to this channel (including derived IN residual current).								
0C	57	Analog Channel 16	Unused	0 = IA, 1 = IB, 2 = IC, 3 = IN, 4 = IN Sensitive, 5 = VA, 6 = VB, 7 = VC, 8 = IM, 9 = V Checksync, 10 = IA DIFF, 11 = IB DIFF, 12 = IC DIFF, 13 = I BIAS MAX, 14 = I H2 MAX or 15 = Unused	*		*	
Selects any available analogue input to be assigned to this channel (including derived IN residual current).								
0C	57	Analog Channel 16	Unused	0 = IA, 1 = IB, 2 = IC, 3 = IN, 4 = IN Sensitive, 5 = VA, 6 = VB, 7 = VC, 8 = IM, 9 = V Checksync, 10 = IA2, 11 = IB2, 12 = IC2, 13 = IN2 , 14 = V Checksync2, 15 = IA DIFF, 16 = IB DIFF, 17 = IC DIFF, 18 = I BIAS MAX, 19 = I H2 MAX or 20 = Unused		*		*
Selects any available analogue input to be assigned to this channel (including derived IN residual current).								
0C	58	Analog Channel 17	Unused	0 = IA, 1 = IB, 2 = IC, 3 = IN, 4 = IN Sensitive, 5 = VA, 6 = VB, 7 = VC, 8 = IM, 9 = V Checksync, 10 = IA DIFF, 11 = IB DIFF, 12 = IC DIFF, 13 = I BIAS MAX, 14 = I H2 MAX or 15 = Unused	*		*	
Selects any available analogue input to be assigned to this channel (including derived IN residual current).								
0C	58	Analog Channel 17	Unused	0 = IA, 1 = IB, 2 = IC, 3 = IN, 4 = IN Sensitive, 5 = VA, 6 = VB, 7 = VC, 8 = IM, 9 = V Checksync, 10 = IA2, 11 = IB2, 12 = IC2, 13 = IN2 , 14 = V Checksync2, 15 = IA DIFF, 16 = IB DIFF, 17 = IC DIFF, 18 = I BIAS MAX, 19 = I H2 MAX or 20 = Unused		*		*
Selects any available analogue input to be assigned to this channel (including derived IN residual current).								
0C	59	Analog Channel 18	Unused	0 = IA, 1 = IB, 2 = IC, 3 = IN, 4 = IN Sensitive, 5 = VA, 6 = VB, 7 = VC, 8 = IM, 9 = V Checksync, 10 = IA DIFF, 11 = IB DIFF, 12 = IC DIFF, 13 = I BIAS MAX, 14 = I H2 MAX or 15 = Unused	*		*	

Col	Row	MENU TEXT	Default Setting	Available Setting	P543/P545 No Distance	P544/P546 No Distance	P543/P545	P544/P546
Description								
Selects any available analogue input to be assigned to this channel (including derived IN residual current).								
0C	59	Analog Channel 18	Unused	0 = IA, 1 = IB, 2 = IC, 3 = IN, 4 = IN Sensitive, 5 = VA, 6 = VB, 7 = VC, 8 = IM, 9 = V Checksync, 10 = IA2, 11 = IB2, 12 = IC2, 13 = IN2, 14 = V Checksync2, 15 = IA DIFF, 16 = IB DIFF, 17 = IC DIFF, 18 = I BIAS MAX, 19 = I H2 MAX or 20 = Unused		*		*
Selects any available analogue input to be assigned to this channel (including derived IN residual current).								
0C	5A	Analog Channel 19	Unused	0 = IA, 1 = IB, 2 = IC, 3 = IN, 4 = IN Sensitive, 5 = VA, 6 = VB, 7 = VC, 8 = IM, 9 = V Checksync, 10 = IA DIFF, 11 = IB DIFF, 12 = IC DIFF, 13 = I BIAS MAX, 14 = I H2 MAX or 15 = Unused	*		*	
Selects any available analogue input to be assigned to this channel (including derived IN residual current).								
0C	5A	Analog Channel 19	Unused	0 = IA, 1 = IB, 2 = IC, 3 = IN, 4 = IN Sensitive, 5 = VA, 6 = VB, 7 = VC, 8 = IM, 9 = V Checksync, 10 = IA2, 11 = IB2, 12 = IC2, 13 = IN2, 14 = V Checksync2, 15 = IA DIFF, 16 = IB DIFF, 17 = IC DIFF, 18 = I BIAS MAX, 19 = I H2 MAX or 20 = Unused		*		*
Selects any available analogue input to be assigned to this channel (including derived IN residual current).								
0C	5B	Analog Channel 20	Unused	0 = IA, 1 = IB, 2 = IC, 3 = IN, 4 = IN Sensitive, 5 = VA, 6 = VB, 7 = VC, 8 = IM, 9 = V Checksync, 10 = IA DIFF, 11 = IB DIFF, 12 = IC DIFF, 13 = I BIAS MAX, 14 = I H2 MAX or 15 = Unused	*		*	
Selects any available analogue input to be assigned to this channel (including derived IN residual current).								
0C	5B	Analog Channel 20	Unused	0 = IA, 1 = IB, 2 = IC, 3 = IN, 4 = IN Sensitive, 5 = VA, 6 = VB, 7 = VC, 8 = IM, 9 = V Checksync, 10 = IA2, 11 = IB2, 12 = IC2, 13 = IN2, 14 = V Checksync2, 15 = IA DIFF, 16 = IB DIFF, 17 = IC DIFF, 18 = I BIAS MAX, 19 = I H2 MAX or 20 = Unused		*		*
Selects any available analogue input to be assigned to this channel (including derived IN residual current).								
0C	70	Digital Input 33	Unused	See Data Types - G32	*	*	*	*
The digital channels may monitor any of the opto isolated inputs or output contacts, in addition to a number of internal relay digital signals, such as protection starts, LEDs etc.								
0C	71	Digital Input 34	Unused	See Data Types - G32	*	*	*	*
The digital channels may monitor any of the opto isolated inputs or output contacts, in addition to a number of internal relay digital signals, such as protection starts, LEDs etc.								
0C	72	Digital Input 35	Unused	See Data Types - G32	*	*	*	*
The digital channels may monitor any of the opto isolated inputs or output contacts, in addition to a number of internal relay digital signals, such as protection starts, LEDs etc.								

Col	Row	MENU TEXT	Default Setting	Available Setting	P543/P545 No Distance	P544/P546 No Distance	P543/P545	P544/P546
Description								
0C	73	Digital Input 36	Unused	See Data Types - G32	*	*	*	*
The digital channels may monitor any of the opto isolated inputs or output contacts, in addition to a number of internal relay digital signals, such as protection starts, LEDs etc.								
0C	74	Digital Input 37	Unused	See Data Types - G32	*	*	*	*
The digital channels may monitor any of the opto isolated inputs or output contacts, in addition to a number of internal relay digital signals, such as protection starts, LEDs etc.								
0C	75	Digital Input 38	Unused	See Data Types - G32	*	*	*	*
The digital channels may monitor any of the opto isolated inputs or output contacts, in addition to a number of internal relay digital signals, such as protection starts, LEDs etc.								
0C	76	Digital Input 39	Unused	See Data Types - G32	*	*	*	*
The digital channels may monitor any of the opto isolated inputs or output contacts, in addition to a number of internal relay digital signals, such as protection starts, LEDs etc.								
0C	77	Digital Input 40	Unused	See Data Types - G32	*	*	*	*
The digital channels may monitor any of the opto isolated inputs or output contacts, in addition to a number of internal relay digital signals, such as protection starts, LEDs etc.								
0C	78	Digital Input 41	Unused	See Data Types - G32	*	*	*	*
The digital channels may monitor any of the opto isolated inputs or output contacts, in addition to a number of internal relay digital signals, such as protection starts, LEDs etc.								
0C	79	Digital Input 42	Unused	See Data Types - G32	*	*	*	*
The digital channels may monitor any of the opto isolated inputs or output contacts, in addition to a number of internal relay digital signals, such as protection starts, LEDs etc.								
0C	7A	Digital Input 43	Unused	See Data Types - G32	*	*	*	*
The digital channels may monitor any of the opto isolated inputs or output contacts, in addition to a number of internal relay digital signals, such as protection starts, LEDs etc.								
0C	7B	Digital Input 44	Unused	See Data Types - G32	*	*	*	*
The digital channels may monitor any of the opto isolated inputs or output contacts, in addition to a number of internal relay digital signals, such as protection starts, LEDs etc.								
0C	7C	Digital Input 45	Unused	See Data Types - G32	*	*	*	*
The digital channels may monitor any of the opto isolated inputs or output contacts, in addition to a number of internal relay digital signals, such as protection starts, LEDs etc.								
0C	7D	Digital Input 46	Unused	See Data Types - G32	*	*	*	*
The digital channels may monitor any of the opto isolated inputs or output contacts, in addition to a number of internal relay digital signals, such as protection starts, LEDs etc.								
0C	7E	Digital Input 47	Unused	See Data Types - G32	*	*	*	*
The digital channels may monitor any of the opto isolated inputs or output contacts, in addition to a number of internal relay digital signals, such as protection starts, LEDs etc.								
0C	7F	Digital Input 48	Unused	See Data Types - G32	*	*	*	*

Col	Row	MENU TEXT	Default Setting	Available Setting	P543/P545 No Distance	P544/P546 No Distance	P543/P545	P544/P546
Description								
The digital channels may monitor any of the opto isolated inputs or output contacts, in addition to a number of internal relay digital signals, such as protection starts, LEDs etc.								
0C	80	Digital Input 49	Unused	See Data Types - G32	*	*	*	*
The digital channels may monitor any of the opto isolated inputs or output contacts, in addition to a number of internal relay digital signals, such as protection starts, LEDs etc.								
0C	81	Digital Input 50	Unused	See Data Types - G32	*	*	*	*
The digital channels may monitor any of the opto isolated inputs or output contacts, in addition to a number of internal relay digital signals, such as protection starts, LEDs etc.								
0C	82	Digital Input 51	Unused	See Data Types - G32	*	*	*	*
The digital channels may monitor any of the opto isolated inputs or output contacts, in addition to a number of internal relay digital signals, such as protection starts, LEDs etc.								
0C	83	Digital Input 52	Unused	See Data Types - G32	*	*	*	*
The digital channels may monitor any of the opto isolated inputs or output contacts, in addition to a number of internal relay digital signals, such as protection starts, LEDs etc.								
0C	84	Digital Input 53	Unused	See Data Types - G32	*	*	*	*
The digital channels may monitor any of the opto isolated inputs or output contacts, in addition to a number of internal relay digital signals, such as protection starts, LEDs etc.								
0C	85	Digital Input 54	Unused	See Data Types - G32	*	*	*	*
The digital channels may monitor any of the opto isolated inputs or output contacts, in addition to a number of internal relay digital signals, such as protection starts, LEDs etc.								
0C	86	Digital Input 55	Unused	See Data Types - G32	*	*	*	*
The digital channels may monitor any of the opto isolated inputs or output contacts, in addition to a number of internal relay digital signals, such as protection starts, LEDs etc.								
0C	87	Digital Input 56	Unused	See Data Types - G32	*	*	*	*
The digital channels may monitor any of the opto isolated inputs or output contacts, in addition to a number of internal relay digital signals, such as protection starts, LEDs etc.								
0C	88	Digital Input 57	Unused	See Data Types - G32	*	*	*	*
The digital channels may monitor any of the opto isolated inputs or output contacts, in addition to a number of internal relay digital signals, such as protection starts, LEDs etc.								
0C	89	Digital Input 58	Unused	See Data Types - G32	*	*	*	*
The digital channels may monitor any of the opto isolated inputs or output contacts, in addition to a number of internal relay digital signals, such as protection starts, LEDs etc.								
0C	8A	Digital Input 59	Unused	See Data Types - G32	*	*	*	*
The digital channels may monitor any of the opto isolated inputs or output contacts, in addition to a number of internal relay digital signals, such as protection starts, LEDs etc.								
0C	8B	Digital Input 60	Unused	See Data Types - G32	*	*	*	*
The digital channels may monitor any of the opto isolated inputs or output contacts, in addition to a number of internal relay digital signals, such as protection starts, LEDs etc.								

Col	Row	MENU TEXT	Default Setting	Available Setting	P543/P545 No Distance	P544/P546 No Distance	P543/P545	P544/P546
Description								
0C	8C	Digital Input 61	Unused	See Data Types - G32	*	*	*	*
The digital channels may monitor any of the opto isolated inputs or output contacts, in addition to a number of internal relay digital signals, such as protection starts, LEDs etc.								
0C	8D	Digital Input 62	Unused	See Data Types - G32	*	*	*	*
The digital channels may monitor any of the opto isolated inputs or output contacts, in addition to a number of internal relay digital signals, such as protection starts, LEDs etc.								
0C	8E	Digital Input 63	Unused	See Data Types - G32	*	*	*	*
The digital channels may monitor any of the opto isolated inputs or output contacts, in addition to a number of internal relay digital signals, such as protection starts, LEDs etc.								
0C	8F	Digital Input 64	Unused	See Data Types - G32	*	*	*	*
The digital channels may monitor any of the opto isolated inputs or output contacts, in addition to a number of internal relay digital signals, such as protection starts, LEDs etc.								
0C	90	Digital Input 65	Unused	See Data Types - G32	*	*	*	*
The digital channels may monitor any of the opto isolated inputs or output contacts, in addition to a number of internal relay digital signals, such as protection starts, LEDs etc.								
0C	91	Digital Input 66	Unused	See Data Types - G32	*	*	*	*
The digital channels may monitor any of the opto isolated inputs or output contacts, in addition to a number of internal relay digital signals, such as protection starts, LEDs etc.								
0C	92	Digital Input 67	Unused	See Data Types - G32	*	*	*	*
The digital channels may monitor any of the opto isolated inputs or output contacts, in addition to a number of internal relay digital signals, such as protection starts, LEDs etc.								
0C	93	Digital Input 68	Unused	See Data Types - G32	*	*	*	*
The digital channels may monitor any of the opto isolated inputs or output contacts, in addition to a number of internal relay digital signals, such as protection starts, LEDs etc.								
0C	94	Digital Input 69	Unused	See Data Types - G32	*	*	*	*
The digital channels may monitor any of the opto isolated inputs or output contacts, in addition to a number of internal relay digital signals, such as protection starts, LEDs etc.								
0C	95	Digital Input 70	Unused	See Data Types - G32	*	*	*	*
The digital channels may monitor any of the opto isolated inputs or output contacts, in addition to a number of internal relay digital signals, such as protection starts, LEDs etc.								
0C	96	Digital Input 71	Unused	See Data Types - G32	*	*	*	*
The digital channels may monitor any of the opto isolated inputs or output contacts, in addition to a number of internal relay digital signals, such as protection starts, LEDs etc.								
0C	97	Digital Input 72	Unused	See Data Types - G32	*	*	*	*
The digital channels may monitor any of the opto isolated inputs or output contacts, in addition to a number of internal relay digital signals, such as protection starts, LEDs etc.								
0C	98	Digital Input 73	Unused	See Data Types - G32	*	*	*	*

Col	Row	MENU TEXT	Default Setting	Available Setting	P543/P545 No Distance	P544/P546 No Distance	P543/P545	P544/P546
Description								
The digital channels may monitor any of the opto isolated inputs or output contacts, in addition to a number of internal relay digital signals, such as protection starts, LEDs etc.								
0C	99	Digital Input 74	Unused	See Data Types - G32	*	*	*	*
The digital channels may monitor any of the opto isolated inputs or output contacts, in addition to a number of internal relay digital signals, such as protection starts, LEDs etc.								
0C	9A	Digital Input 75	Unused	See Data Types - G32	*	*	*	*
The digital channels may monitor any of the opto isolated inputs or output contacts, in addition to a number of internal relay digital signals, such as protection starts, LEDs etc.								
0C	9B	Digital Input 76	Unused	See Data Types - G32	*	*	*	*
The digital channels may monitor any of the opto isolated inputs or output contacts, in addition to a number of internal relay digital signals, such as protection starts, LEDs etc.								
0C	9C	Digital Input 77	Unused	See Data Types - G32	*	*	*	*
The digital channels may monitor any of the opto isolated inputs or output contacts, in addition to a number of internal relay digital signals, such as protection starts, LEDs etc.								
0C	9D	Digital Input 78	Unused	See Data Types - G32	*	*	*	*
The digital channels may monitor any of the opto isolated inputs or output contacts, in addition to a number of internal relay digital signals, such as protection starts, LEDs etc.								
0C	9E	Digital Input 79	Unused	See Data Types - G32	*	*	*	*
The digital channels may monitor any of the opto isolated inputs or output contacts, in addition to a number of internal relay digital signals, such as protection starts, LEDs etc.								
0C	9F	Digital Input 80	Unused	See Data Types - G32	*	*	*	*
The digital channels may monitor any of the opto isolated inputs or output contacts, in addition to a number of internal relay digital signals, such as protection starts, LEDs etc.								
0C	A0	Digital Input 81	Unused	See Data Types - G32	*	*	*	*
The digital channels may monitor any of the opto isolated inputs or output contacts, in addition to a number of internal relay digital signals, such as protection starts, LEDs etc.								
0C	A1	Digital Input 82	Unused	See Data Types - G32	*	*	*	*
The digital channels may monitor any of the opto isolated inputs or output contacts, in addition to a number of internal relay digital signals, such as protection starts, LEDs etc.								
0C	A2	Digital Input 83	Unused	See Data Types - G32	*	*	*	*
The digital channels may monitor any of the opto isolated inputs or output contacts, in addition to a number of internal relay digital signals, such as protection starts, LEDs etc.								
0C	A3	Digital Input 84	Unused	See Data Types - G32	*	*	*	*
The digital channels may monitor any of the opto isolated inputs or output contacts, in addition to a number of internal relay digital signals, such as protection starts, LEDs etc.								
0C	A4	Digital Input 85	Unused	See Data Types - G32	*	*	*	*
The digital channels may monitor any of the opto isolated inputs or output contacts, in addition to a number of internal relay digital signals, such as protection starts, LEDs etc.								

Col	Row	MENU TEXT	Default Setting	Available Setting	P543/P545 No Distance	P544/P546 No Distance	P543/P545	P544/P546
Description								
0C	A5	Digital Input 86	Unused	See Data Types - G32	*	*	*	*
The digital channels may monitor any of the opto isolated inputs or output contacts, in addition to a number of internal relay digital signals, such as protection starts, LEDs etc.								
0C	A6	Digital Input 87	Unused	See Data Types - G32	*	*	*	*
The digital channels may monitor any of the opto isolated inputs or output contacts, in addition to a number of internal relay digital signals, such as protection starts, LEDs etc.								
0C	A7	Digital Input 88	Unused	See Data Types - G32	*	*	*	*
The digital channels may monitor any of the opto isolated inputs or output contacts, in addition to a number of internal relay digital signals, such as protection starts, LEDs etc.								
0C	A8	Digital Input 89	Unused	See Data Types - G32	*	*	*	*
The digital channels may monitor any of the opto isolated inputs or output contacts, in addition to a number of internal relay digital signals, such as protection starts, LEDs etc.								
0C	A9	Digital Input 90	Unused	See Data Types - G32	*	*	*	*
The digital channels may monitor any of the opto isolated inputs or output contacts, in addition to a number of internal relay digital signals, such as protection starts, LEDs etc.								
0C	AA	Digital Input 91	Unused	See Data Types - G32	*	*	*	*
The digital channels may monitor any of the opto isolated inputs or output contacts, in addition to a number of internal relay digital signals, such as protection starts, LEDs etc.								
0C	AB	Digital Input 92	Unused	See Data Types - G32	*	*	*	*
The digital channels may monitor any of the opto isolated inputs or output contacts, in addition to a number of internal relay digital signals, such as protection starts, LEDs etc.								
0C	AC	Digital Input 93	Unused	See Data Types - G32	*	*	*	*
The digital channels may monitor any of the opto isolated inputs or output contacts, in addition to a number of internal relay digital signals, such as protection starts, LEDs etc.								
0C	AD	Digital Input 94	Unused	See Data Types - G32	*	*	*	*
The digital channels may monitor any of the opto isolated inputs or output contacts, in addition to a number of internal relay digital signals, such as protection starts, LEDs etc.								
0C	AE	Digital Input 95	Unused	See Data Types - G32	*	*	*	*
The digital channels may monitor any of the opto isolated inputs or output contacts, in addition to a number of internal relay digital signals, such as protection starts, LEDs etc.								
0C	AF	Digital Input 96	Unused	See Data Types - G32	*	*	*	*
The digital channels may monitor any of the opto isolated inputs or output contacts, in addition to a number of internal relay digital signals, such as protection starts, LEDs etc.								
0C	B0	Digital Input 97	Unused	See Data Types - G32	*	*	*	*
The digital channels may monitor any of the opto isolated inputs or output contacts, in addition to a number of internal relay digital signals, such as protection starts, LEDs etc.								
0C	B1	Digital Input 98	Unused	See Data Types - G32	*	*	*	*

Col	Row	MENU TEXT	Default Setting	Available Setting	P543/P545 No Distance	P544/P546 No Distance	P543/P545	P544/P546
Description								
The digital channels may monitor any of the opto isolated inputs or output contacts, in addition to a number of internal relay digital signals, such as protection starts, LEDs etc.								
0C	B2	Digital Input 99	Unused	See Data Types - G32	*	*	*	*
The digital channels may monitor any of the opto isolated inputs or output contacts, in addition to a number of internal relay digital signals, such as protection starts, LEDs etc.								
0C	B3	Digital Input 100	Unused	See Data Types - G32	*	*	*	*
The digital channels may monitor any of the opto isolated inputs or output contacts, in addition to a number of internal relay digital signals, such as protection starts, LEDs etc.								
0C	B4	Digital Input 101	Unused	See Data Types - G32	*	*	*	*
The digital channels may monitor any of the opto isolated inputs or output contacts, in addition to a number of internal relay digital signals, such as protection starts, LEDs etc.								
0C	B5	Digital Input 102	Unused	See Data Types - G32	*	*	*	*
The digital channels may monitor any of the opto isolated inputs or output contacts, in addition to a number of internal relay digital signals, such as protection starts, LEDs etc.								
0C	B6	Digital Input 103	Unused	See Data Types - G32	*	*	*	*
The digital channels may monitor any of the opto isolated inputs or output contacts, in addition to a number of internal relay digital signals, such as protection starts, LEDs etc.								
0C	B7	Digital Input 104	Unused	See Data Types - G32	*	*	*	*
The digital channels may monitor any of the opto isolated inputs or output contacts, in addition to a number of internal relay digital signals, such as protection starts, LEDs etc.								
0C	B8	Digital Input 105	Unused	See Data Types - G32	*	*	*	*
The digital channels may monitor any of the opto isolated inputs or output contacts, in addition to a number of internal relay digital signals, such as protection starts, LEDs etc.								
0C	B9	Digital Input 106	Unused	See Data Types - G32	*	*	*	*
The digital channels may monitor any of the opto isolated inputs or output contacts, in addition to a number of internal relay digital signals, such as protection starts, LEDs etc.								
0C	BA	Digital Input 107	Unused	See Data Types - G32	*	*	*	*
The digital channels may monitor any of the opto isolated inputs or output contacts, in addition to a number of internal relay digital signals, such as protection starts, LEDs etc.								
0C	BB	Digital Input 108	Unused	See Data Types - G32	*	*	*	*
The digital channels may monitor any of the opto isolated inputs or output contacts, in addition to a number of internal relay digital signals, such as protection starts, LEDs etc.								
0C	BC	Digital Input 109	Unused	See Data Types - G32	*	*	*	*
The digital channels may monitor any of the opto isolated inputs or output contacts, in addition to a number of internal relay digital signals, such as protection starts, LEDs etc.								
0C	BD	Digital Input 110	Unused	See Data Types - G32	*	*	*	*
The digital channels may monitor any of the opto isolated inputs or output contacts, in addition to a number of internal relay digital signals, such as protection starts, LEDs etc.								

Col	Row	MENU TEXT	Default Setting	Available Setting	P543/P545 No Distance	P544/P546 No Distance	P543/P545	P544/P546
Description								
0C	BE	Digital Input 111	Unused	See Data Types - G32	*	*	*	*
The digital channels may monitor any of the opto isolated inputs or output contacts, in addition to a number of internal relay digital signals, such as protection starts, LEDs etc.								
0C	BF	Digital Input 112	Unused	See Data Types - G32	*	*	*	*
The digital channels may monitor any of the opto isolated inputs or output contacts, in addition to a number of internal relay digital signals, such as protection starts, LEDs etc.								
0C	C0	Digital Input 113	Unused	See Data Types - G32	*	*	*	*
The digital channels may monitor any of the opto isolated inputs or output contacts, in addition to a number of internal relay digital signals, such as protection starts, LEDs etc.								
0C	C1	Digital Input 114	Unused	See Data Types - G32	*	*	*	*
The digital channels may monitor any of the opto isolated inputs or output contacts, in addition to a number of internal relay digital signals, such as protection starts, LEDs etc.								
0C	C2	Digital Input 115	Unused	See Data Types - G32	*	*	*	*
The digital channels may monitor any of the opto isolated inputs or output contacts, in addition to a number of internal relay digital signals, such as protection starts, LEDs etc.								
0C	C3	Digital Input 116	Unused	See Data Types - G32	*	*	*	*
The digital channels may monitor any of the opto isolated inputs or output contacts, in addition to a number of internal relay digital signals, such as protection starts, LEDs etc.								
0C	C4	Digital Input 117	Unused	See Data Types - G32	*	*	*	*
The digital channels may monitor any of the opto isolated inputs or output contacts, in addition to a number of internal relay digital signals, such as protection starts, LEDs etc.								
0C	C5	Digital Input 118	Unused	See Data Types - G32	*	*	*	*
The digital channels may monitor any of the opto isolated inputs or output contacts, in addition to a number of internal relay digital signals, such as protection starts, LEDs etc.								
0C	C6	Digital Input 119	Unused	See Data Types - G32	*	*	*	*
The digital channels may monitor any of the opto isolated inputs or output contacts, in addition to a number of internal relay digital signals, such as protection starts, LEDs etc.								
0C	C7	Digital Input 120	Unused	See Data Types - G32	*	*	*	*
The digital channels may monitor any of the opto isolated inputs or output contacts, in addition to a number of internal relay digital signals, such as protection starts, LEDs etc.								
0C	C8	Digital Input 121	Unused	See Data Types - G32	*	*	*	*
The digital channels may monitor any of the opto isolated inputs or output contacts, in addition to a number of internal relay digital signals, such as protection starts, LEDs etc.								
0C	C9	Digital Input 122	Unused	See Data Types - G32	*	*	*	*
The digital channels may monitor any of the opto isolated inputs or output contacts, in addition to a number of internal relay digital signals, such as protection starts, LEDs etc.								
0C	CA	Digital Input 123	Unused	See Data Types - G32	*	*	*	*

Col	Row	MENU TEXT	Default Setting	Available Setting	P543/P545 No Distance	P544/P546 No Distance	P543/P545	P544/P546
Description								
The digital channels may monitor any of the opto isolated inputs or output contacts, in addition to a number of internal relay digital signals, such as protection starts, LEDs etc.								
0C	CB	Digital Input 124	Unused	See Data Types - G32	*	*	*	*
The digital channels may monitor any of the opto isolated inputs or output contacts, in addition to a number of internal relay digital signals, such as protection starts, LEDs etc.								
0C	CC	Digital Input 125	Unused	See Data Types - G32	*	*	*	*
The digital channels may monitor any of the opto isolated inputs or output contacts, in addition to a number of internal relay digital signals, such as protection starts, LEDs etc.								
0C	CD	Digital Input 126	Unused	See Data Types - G32	*	*	*	*
The digital channels may monitor any of the opto isolated inputs or output contacts, in addition to a number of internal relay digital signals, such as protection starts, LEDs etc.								
0C	CE	Digital Input 127	Unused	See Data Types - G32	*	*	*	*
The digital channels may monitor any of the opto isolated inputs or output contacts, in addition to a number of internal relay digital signals, such as protection starts, LEDs etc.								
0C	CF	Digital Input 128	Unused	See Data Types - G32	*	*	*	*
The digital channels may monitor any of the opto isolated inputs or output contacts, in addition to a number of internal relay digital signals, such as protection starts, LEDs etc.								

Table 36 - Disturbance recorder

4.7 Measurement Setup

Col	Row	MENU TEXT	Default Setting	Available Setting
Description				
0D	00	MEASURE'T SETUP	0	
This column contains settings for the measurement setup				
0D	01	Default Display	Banner	0 = Banner, 1 = 3Ph + N Current, 2 = 3Ph Voltage, 3 = Power, 4 = Date and Time, 5 = Description, 6 = Plant Reference, 7 = Frequency, 8 = Access Level
This indicates the default display which can only be changed whilst at the default display using the arrow keys for operator or higher level roles. Only visible on UI.				
0D	02	Local Values	Primary	0 = Primary or 1 = Secondary
This setting controls whether measured values via the front panel user interface and the front courier port are displayed as primary or secondary quantities.				
0D	03	Remote Values	Primary	0 = Primary or 1 = Secondary
This setting controls whether measured values via the rear communication port are displayed as primary or secondary quantities.				
0D	04	Measurement Ref	VA	0 = VA, 1 = VB, 2 = VC, 3 = IA, 4 = IB, 5 = IC
Using this setting the phase reference for all angular measurements by the relay can be selected. This reference is for Measurements 1. Measurements 3 uses always IA local as a reference				
0D	05	Measurement Mode	0	0 to 3 step 1

Col	Row	MENU TEXT	Default Setting	Available Setting
Description				
This setting is used to control the signing of the real and reactive power quantities; the signing convention used is defined in the Measurements and Recording chapter (P54x/EN MR).				
0D	06	Fix Dem Period	30min	From 1min to 99min step 1min
This setting defines the length of the fixed demand window				
0D	07	Roll Sub Period	30min	From 1min to 99min step 1min
These two settings are used to set the length of the window used for the calculation of rolling demand quantities				
0D	08	Num Sub Periods	1	1 to 15 step 1
This setting is used to set the resolution of the rolling sub window				
0D	09	Distance Unit	Miles	0 = Kilometres or 1 = Miles
This setting is used to select the unit of distance for fault location purposes, note that the length of the line is preserved when converting from km to miles and vice versa				
0D	0A	Fault Location	Distance	0 = Distance, 1 = Ohms, 2 = % of Line
The calculated fault location can be displayed using one of several options selected using this setting				
0D	0B	Remote2 Values	Primary	0 = Primary or 1 = Secondary
The setting defines whether the values measured via the 2nd Rear Communication port are displayed in primary or secondary terms.				

Table 37 - Measurement setup

4.8 Communications Settings

The communications settings apply to the rear communications ports only and will depend upon the particular protocol being used. Further details are given in the SCADA Communications chapter.

Depending on the values stored, the available settings may change too. The applicability of each setting is given in the description or available setting cell. These settings are available in the menu '**Communications**' column and are displayed.

These settings potentially cover a variety of different protocols and ports, including:

Col	Row	Menu Text	Default Setting	Available Setting	P543 / P545 No Distance	P544 / P546 No Distance	P543 / P545	P544 / P546
Description								
0E	00	COMMUNICATIONS			*	*	*	*
This column contains general communications settings								
0E	01	RP1 Protocol		Not Settable	*	*	*	*
Indicates the communications protocol that will be used on the rear communications port. Ordering option: Courier, IEC870-5-103 or DNP 3.0								
0E	02	RP1 Address	255 1 1	0 to 255 step 1 (Courier) 0 to 254 step 1 (CS103) 0 to 65519 step 1 (DNP3)	*	*	*	*
Rear Port 1 Protocol device address. This cell sets the unique address for the relay such that only one relay is accessed by master station software.								
0E	03	RP1 InactivTimer	15min	From 1min to 30min step 1min	*	*	*	*
Rear Port 1 Protocol inactivity timer. This cell controls how long the relay will wait without receiving any messages on the rear port before it reverts to its default state, including resetting any password access that was enabled.								

Col	Row	Menu Text	Default Setting	Available Setting	P543 / P545 No Distance	P544 / P546 No Distance	P543 / P545	P544 / P546
Description								
0E	04	RP1 Baud Rate	19200 bits/s	0=9600 bits/s 1=19200 bits/s (CS103) 0=1200 bits/s 1=2400 bits/s 2=4800 bits/s 3=9600 bits/s 4=19200 bits/s 5=38400 bits/s (DNP3)	*	*	*	*
Rear Port 1 Protocol serial bit/baud rate. This cell controls the communication speed between IED and master station. It is important that both IED and master station are set at the same speed setting.								
0E	05	RP1 Parity	None	0 = Odd, 1 = Even, 2 = None	*	*	*	*
Rear Port 1 Modbus/DNP3 Protocol parity. This cell controls the parity format used in the data frames. It is important that both IED and master station are set with the same parity setting.								
0E	06	RP1 Meas Period	10s	From 1s to 60s step 1s	*	*	*	*
Rear Port 1 IEC60870-5-103 Protocol measurement period. IEC60870-5-103 versions only. This cell controls the time interval that the IED will use between sending measurement data to the master station.								
0E	07	RP1 PhysicalLink	Copper	0 = Copper or 1 = Fibre Optic	*	*	*	*
Rear Port 1 Physical link selector. This cell defines whether an electrical EIA(RS) 485 or fiber optic connection is being used for communication between the master station and IED. This cell is only visible if a fibre optic board is fitted.								
0E	08	DNP Time Sync	Disabled	0 = Disabled or 1 = Enabled	*	*	*	*
Rear Port 1 DNP 3.0 Protocol time sync configuration. Enables or disables the relay requesting time sync. from the master via IIN bit 4 word 1.								
0E	09	Function Type	Differential 192	0 = Differential 192 or 1 = Distance 128			*	*
IEC60870-5-103 versions only. This cell defines the base Function type for IEC60870-5-103 protocol								
0E	09	Function Type	Phase Comp 192	0 = PhaseComp 192, 1 = Distance 128				
IEC60870-5-103 versions only. This cell defines the base Function type for IEC60870-5-103 protocol								
0E	0A	RP1 CS103Blicking	Disabled	0 = Disabled, 1 = Monitor blocking or 2 = Command blocking	*	*	*	*
IEC60870-5-103 versions only. There are three settings associated with this cell: Disabled - No blocking selected. Monitor Blocking - When the monitor blocking DDB Signal is active high, either by energizing an opto input or control input, reading of the status information and disturbance records is not permitted. When in this mode the relay returns a "termination of general interrogation" message to the master station. Command Blocking - When the command blocking DDB signal is active high, either by energizing an opto input or control input, all remote commands will be ignored (i.e. CB Trip/Close, change setting group etc.). When in this mode the relay returns a "negative acknowledgement of command" message to the master station.								
0E	0B	RP1 Card Status		Not Settable	*	*	*	*
Displays the status of the card in RP1								
0E	0C	RP1 Port Config	K Bus	0 = K Bus or 1 = EIA485 (RS485)	*	*	*	*
Courier versions only. This cell defines whether an electrical KBus or EIA(RS)485 is being used for communication between the master station and relay.								
0E	0D	RP1 Comms Mode	IEC60870 FT1.2	0 = IEC60870 FT1.2 or 1 = 10-bit No Parity	*	*	*	*
Courier versions only. The choice is either IEC 60870 FT1.2 for normal operation with 11-bit modems, or 10-bit no parity.								

Col	Row	Menu Text	Default Setting	Available Setting	P543 / P545 No Distance	P544 / P546 No Distance	P543 / P545	P544 / P546
Description								
0E	0E	RP1 Baud Rate	19200 bits/s	0 = 9600 bits/s, 1 = 19200 bits/s, 2 = 38400 bits/s	*	*	*	*
Courier versions only. This cell controls the communication speed between relay and master station. It is important that both relay and master station are set at the same speed setting.								
0E	0F	Meas Scaling	Primary	0 = Normalised, 1 = Primary, 2 = Secondary	*	*	*	*
DNP 3.0 and IEC61850+DNP3OE only. Setting to report analogue values in terms of primary, secondary or normalized (with respect to the CT/VT ratio setting) values.								
0E	10	Message Gap (ms)	0	0 to 50 step 1	*	*	*	*
DNP 3.0 and IEC61850+DNP3OE only. This setting allows the master station to have an interframe gap.								
0E	11	DNP Need Time	10min	From 1min to 30min step 1min	*	*	*	*
DNP 3.0 and IEC61850+DNP3OE only. The duration of time waited before requesting another time sync from the master. Change this setting needs to reboot relay to take effect.								
0E	12	DNP App Fragment	2048	100 to 2048 step 1	*	*	*	*
DNP 3.0 and IEC61850+DNP3OE only. The maximum message length (application fragment size) transmitted by the IED. Change this setting needs to reboot relay to take effect.								
0E	13	DNP App Timeout	2s	From 1s to 120s step 1s	*	*	*	*
DNP 3.0 and IEC61850+DNP3OE only. Duration of time waited, after sending a message fragment and awaiting a confirmation from the master. Change this setting needs to reboot relay to take effect.								
0E	14	DNP SBO Timeout	10s	From 1s to 10s step 1s	*	*	*	*
DNP 3.0 and IEC61850+DNP3OE only. Duration of time waited, after receiving a select command and awaiting an operate confirmation from the master. Change this setting needs to reboot relay to take effect.								
0E	15	DNP Link Timeout	0s	From 0s to 120s step 1s	*	*	*	*
DNP 3.0 and IEC61850+DNP3OE only. Duration of time that the IED will wait for a Data Link Confirmation from the master. A value of 0 means data link support disabled and 1 to 120 seconds is the timeout setting. Change this setting needs to reboot relay to take effect.								
0E	1F	ETH Protocol		Not Settable	*	*	*	*
Visible when Ethernet card fitted. Indicates the protocol used on the Network Interface Card: IEC61850 or IEC61850+DNP3								
0E	22	ETH MAC Addr1		Not Settable	*	*	*	*
Shows the MAC address of the 1st Ethernet port. Visible when Ethernet card fitted.								
0E	23	ETH MAC Addr2		Not Settable	*	*	*	*
Shows the MAC address of the 2nd Ethernet port. Visible when Ethernet card fitted.								
0E	24	PB MAC Addr1		Not Settable	*	*	*	*
Shows the MAC address of the 1st Process Bus Ethernet port. Visible when Process Bus card fitted.								
0E	25	PB MAC Addr2		Not Settable	*	*	*	*
Shows the MAC address of the 2nd Process Bus Ethernet port. Visible when Process Bus card fitted.								
0E	64	ETH Tunl Timeout	15min	From 1min to 30min step 1min	*	*	*	*
Duration of time to wait before an inactive tunnel to MiCOM S1 Studio is reset. Visible when Ethernet card fitted.								
0E	70	Redundancy Conf						

Col	Row	Menu Text	Default Setting	Available Setting	P543 / P545 No Distance	P544 / P546 No Distance	P543 / P545	P544 / P546
Description								
NIOS PARAMETERS. The redundant agency device configuration is used for SNMP server. This does not affect IEC61850 communications. Visible when redundant Ethernet card fitted and Comm Mode=PRP or HSR								
0E	71	MAC Address		Not Settable				
MAC address for the NIOS. The redundant agency device configuration is used for SNMP server. The MAC address is MAC2+1. This does not affect IEC61850 communications. Visible when redundant Ethernet card fitted and Comm Mode=PRP or HSR								
0E	72	IP Address	000.000.000.000	000.000.000.000 to 255.255.255.255				
The redundant agency device configuration is used for SNMP server. This does not affect IEC61850 communications. Visible when redundant Ethernet card fitted and Comm Mode=PRP or HSR.								
0E	73	Subnet Mask	000.000.000.000	000.000.000.000 to 255.255.255.255				
Subnet Mask for the NIOS. The redundant agency device configuration is used for SNMP server. This does not affect IEC61850 communications. Visible when redundant Ethernet card fitted and Comm Mode=PRP or HSR								
0E	74	Gateway	000.000.000.000	000.000.000.000 to 255.255.255.255				
Gateway for the NIOS. The redundant agency device configuration is used for SNMP server. This does not affect IEC61850 communications. Visible when redundant Ethernet card fitted and Comm Mode=PRP or HSR								
0E	75	RSTPPriority	32768	From 0 to 61440 step 4096	*	*	*	*
The manageable component of the Bridge Identifier, also known as the Bridge Priority								
0E	76	RSTPMaxAge	20	From 6 to 40 step 1	*	*	*	*
The maximum age of the information transmitted by the Bridge when it is the Root Bridge. In 802.1D-2004 standard (RSTP), chap 17.14, a Bridge shall enforce the following relationships: "2 × (RSTPForwardDelay – 1.0 seconds) >= RSTPMaxAge".								
0E	77	RSTPFwdDelay	15	From 4 to 30 step 1	*	*	*	*
The delay used by STP Bridges to transition Root and Designated Ports to Forwarding. In 802.1D-2004 standard (RSTP), chap 17.14, a Bridge shall enforce the following relationships: "2 × (RSTPForwardDelay – 1.0 seconds) >= RSTPMaxAge".								
0E	78	RSTPHelloTime	2	From 1 to 2 step 1	*	*	*	*
The interval between periodic transmissions of Configuration Messages by Designated Ports								
0E	7E	RSTPPortAStatus		Not Settable	*	*	*	*
Indication the status of port A.								
0E	7F	RSTPPortBStatus		Not Settable	*	*	*	*
Indication the status of port B.								
0E	80	REAR PORT2 (RP2)			*	*	*	*
RP2 versions only.								
0E	81	RP2 Protocol	Courier	Not Settable	*	*	*	*
RP2 versions only. Indicates the communications protocol that will be used on the rear communications port.								
0E	84	RP2 Card Status		Not Settable	*	*	*	*
RP2 versions only. Displays the status of the card in RP2: Unsupported, Card Not Fitted, EIA232 OK, EIA485 OK or K Bus OK								
0E	88	RP2 Port Config	EIA232 (RS232)	0 = EIA232 (RS232), 1 = EIA485 (RS485), 2 = K-Bus	*	*	*	*
RP2 versions only. This cell defines whether an electrical EIA(RS)232, EIA(RS)485 or KBus is being used for communication.								

Col	Row	Menu Text	Default Setting	Available Setting	P543 / P545 No Distance	P544 / P546 No Distance	P543 / P545	P544 / P546
Description								
0E	8A	RP2 Comms Mode	IEC60870 FT1.2	0 = IEC60870 FT1.2 Frame or 1 = 10-bit no parity	*	*	*	*
RP2 versions only. The choice is either IEC 60870 FT1.2 for normal operation with 11-bit modems, or 10-bit no parity.								
0E	90	RP2 Address	255	0 to 255 step 1	*	*	*	*
RP2 versions only. This cell sets the unique address for the relay such that only one relay is accessed by master station software.								
0E	92	RP2 InactivTimer	15min	From 1min to 30min step 1min	*	*	*	*
RP2 versions only. This cell controls how long the relay will wait without receiving any messages on the rear port before it reverts to its default state, including resetting any password access that was enabled.								
0E	94	RP2 Baud Rate	19200 bits/s	0 = 9600 bits/s, 1 = 19200 bits/s, 2 = 38400 bits/s	*	*	*	*
RP2 versions only. This cell controls the communication speed between relay and master station. It is important that both relay and master station are set at the same speed setting.								
0E	B1	DNP Need Time	10min	From 1min to 30min step 1min				
Standalone DNP3oE versions only (already obsolete). The duration of time waited before requesting another time sync from the master. Change this setting needs to reboot relay to take effect.								
0E	B2	DNP App Fragment	2048	100 to 2048 step 1				
Standalone DNP3oE versions only (already obsolete). The maximum message length (application fragment size) transmitted by the IED. Change this setting needs to reboot relay to take effect.								
0E	B3	DNP App Timeout	2s	From 1s to 120s step 1s				
Standalone DNP3oE versions only (already obsolete). Duration of time waited, after sending a message fragment and awaiting a confirmation from the master. Change this setting needs to reboot relay to take effect.								
0E	B4	DNP SBO Timeout	10s	From 1s to 10s step 1s				
Standalone DNP3oE versions only (already obsolete). Duration of time waited, after receiving a select command and awaiting an operate confirmation from the master. Change this setting needs to reboot relay to take effect.								

Table 38 - Communications settings

4.9

Commissioning Tests

To help minimising the time required to test MiCOM relays the relay provides several test facilities under the 'COMMISSION TESTS' menu heading.

There are menu cells which allow the status of the opto-isolated inputs, output relay contacts, internal Digital Data Bus (DDB) signals and user-programmable LEDs to be monitored. Additionally there are cells to test the operation of the output contacts, user-programmable LEDs.

This column is visible when the "Commission tests" setting ("Configuration" column) = "visible".

There are also cells to test the operation of, where available, the auto-reclose cycles.

Col	Row	MENU TEXT	Default Setting	Available Setting
Description				
0F	00	COMMISSION TESTS	0	
This column contains commissioning test settings				

Col	Row	MENU TEXT	Default Setting	Available Setting
Description				
When the 'Apply Test' command in this cell is issued the contacts set for operation (set to '1') in the 'Test Pattern' cell are energised. After the test has been applied the command text on the LCD will change to 'No Operation' and the contacts will remain in the Test State until reset issuing the 'Remove Test' command. The command text on the LCD will again revert to 'No Operation' after the 'Remove Test' command has been issued.				
Note: When the 'Test Mode' cell is set to 'Contacts Blocked' the 'Relay O/P Status' cell does not show the current status of the output relays and hence can not be used to confirm operation of the output relays. Therefore it will be necessary to physically monitor the state of each contact in turn.				
0F	10	Test LEDs	No Operation	0 = No Operation or 1 = Apply Test
When the 'Apply Test' command in this cell is issued the eighteen user-programmable LEDs will illuminate for approximately 2 seconds before they extinguish and the command text on the LCD reverts to 'No Operation'.				
0F	11	Test Autoreclose	No Operation	0 = No Operation, 1 = Trip 3 Pole, 2 = Trip Pole A, 3 = Trip Pole B, 4 = Trip Pole C
This is a command used to simulate a single pole or three phase tripping in order to test Auto-reclose cycle.				
0F	12	Static Test	Disabled	0 = Disabled or 1 = Enabled
When Static test is Enabled, delta phase selectors and the delta directional line are bypassed to allow the user to test the relay with older injection test sets that are incapable of simulating real dynamic step changes in current and voltage. Resulting trip times will be slower, as extra filtering of distance comparators is also switched-in.				
0F	13	Test Loopback	Disabled	0 = Disabled, 1 = External, 2 = Internal
Setting that allows communication loopback testing.				
0F	14	IM64 TestPattern	0000000000000000(bin)	Bit 00=IM64 Ch1 Output1 to Bit 07=IM64 Ch1 Output8, Bit 08=IM64 Ch2 Output1 to Bit 0F=IM64 Ch2 Output8
This cell is used to set the DDB signals included in the User Defined Inter-Relay Commands IM64 when the 'IM64 Test Mode' cell is set to 'Enable'.				
0F	15	IM64 Test Mode	Disabled	0 = Disabled or 1 = Enabled
When the Enable command in this cell is issued the DDB set for operation (set to '1') in the 'Test Pattern' cell change state.				
0F	1A	Red LED Status	0	Not Settable
This cell is an eighteen bit binary string that indicates which of the user-programmable LEDs on the relay are illuminated with the Red LED input active when accessing the relay from a remote location, a '1' indicating a particular LED is lit and a '0' not lit.				
0F	1B	Green LED Status	0	Not Settable
This cell is an eighteen bit binary string that indicates which of the user-programmable LEDs on the relay are illuminated with the Green LED input active when accessing the relay from a remote location, a '1' indicating a particular LED is lit and a '0' not lit.				

Table 39 - Commissioning tests

4.10

Circuit Breaker Condition Monitor Setup

The following table, detailing the options available for the Circuit Breaker condition monitoring, is taken from the relay menu. It includes the setup of the current broken facility and those features that can be set to raise an alarm or Circuit Breaker lockout.

The following table, detailing the options available for the Circuit Breaker condition monitoring for the P543/P545, is taken from the relay menu. It includes the setup of the ruptured current facility and those features that can be set to raise an alarm, or lockout the CB.

For the P544/P546 there is a similar set of settings duplicated for the second circuit breaker controlled. Although the menu text differs slightly to reflect the monitoring of two circuit breakers (CB1 and CB2), in all other respects the settings are the same.

Col	Row	MENU TEXT	Default Setting	Available Setting
Description				
10	00	CB MONITOR SETUP	0	
This column contains Circuit Breaker monitoring parameters				
10	01	Broken I [^]	2	1 to 2 step 0.1
This sets the factor to be used for the cumulative I [^] counter calculation that monitors the cumulative severity of the duty placed on the interrupter. This factor is set according to the type of Circuit Breaker used				
10	01	CB1 Broken I [^]	2	1 to 2 step 0.1
This sets the factor to be used for the cumulative I [^] counter calculation that monitors the cumulative severity of the duty placed on the interrupter. This factor is set according to the type of Circuit Breaker used				
10	02	I [^] Maintenance	Alarm Disabled	0 = Alarm Disabled or 1 = Alarm Enabled
Setting which determines if an alarm will be raised or not when the cumulative I [^] maintenance counter threshold is exceeded.				
10	02	CB1 I [^] Maint	Alarm Disabled	0 = Alarm Disabled or 1 = Alarm Enabled
Setting which determines if an alarm will be raised or not when the cumulative I [^] maintenance counter threshold is exceeded.				
10	03	I [^] Maintenance	1000	From 1A to 25kA step 1A
Setting that determines the threshold for the cumulative I [^] maintenance counter monitors.				
10	03	CB1 I [^] Maint	1000	From 1A to 25kA step 1A
Setting that determines the threshold for the cumulative I [^] maintenance counter monitors.				
10	04	I [^] Lockout	Alarm Disabled	0 = Alarm Disabled or 1 = Alarm Enabled
Setting which determines if an alarm will be raised or not when the cumulative I [^] lockout counter threshold is exceeded.				
10	04	CB1 I [^] Lockout	Alarm Disabled	0 = Alarm Disabled or 1 = Alarm Enabled
Setting which determines if an alarm will be raised or not when the cumulative I [^] lockout counter threshold is exceeded.				
10	05	I [^] Lockout	2000	From 1A to 25kA step 1A
Setting that determines the threshold for the cumulative I [^] lockout counter monitor. Set that should maintenance not be carried out, the relay can be set to lockout the auto-reclose function on reaching a second operations threshold.				
10	05	CB1 I [^] Lockout	2000	From 1A to 25kA step 1A
Setting that determines the threshold for the cumulative I [^] lockout counter monitor. Set that should maintenance not be carried out, the relay can be set to lockout the auto-reclose function on reaching a second operations threshold.				
10	06	No. CB Ops Maint	Alarm Disabled	0 = Alarm Disabled or 1 = Alarm Enabled
Setting to activate the number of circuit breaker operations maintenance alarm.				
10	06	No.CB1 Ops Maint	Alarm Disabled	0 = Alarm Disabled or 1 = Alarm Enabled
Setting to activate the number of circuit breaker operations maintenance alarm.				
10	07	No. CB Ops Maint	10	1 to 10000 step 1
Sets the threshold for number of circuit breaker operations maintenance alarm, indicating when preventative maintenance is due.				
10	07	No.CB1 Ops Maint	10	1 to 10000 step 1
Sets the threshold for number of circuit breaker operations maintenance alarm, indicating when preventative maintenance is due.				
10	08	No. CB Ops Lock	Alarm Disabled	0 = Alarm Disabled or 1 = Alarm Enabled
Setting to activate the number of circuit breaker operations lockout alarm.				
10	08	No.CB1 Ops Lock	Alarm Disabled	0 = Alarm Disabled or 1 = Alarm Enabled
Setting to activate the number of circuit breaker operations lockout alarm.				
10	09	No. CB Ops Lock	20	1 to 10000 step 1
Sets the threshold for number of circuit breaker operations lockout. The relay can be set to lockout the auto-reclose function on reaching a second operations threshold.				
10	09	No.CB1 Ops Lock	20	1 to 10000 step 1

Col	Row	MENU TEXT	Default Setting	Available Setting
Description				
Sets the threshold for number of circuit breaker operations lockout. The relay can be set to lockout the auto-reclose function on reaching a second operations threshold.				
10	0A	CB Time Maint	Alarm Disabled	0 = Alarm Disabled or 1 = Alarm Enabled
Setting to activate the circuit breaker operating time maintenance alarm.				
10	0A	CB1 Time Maint	Alarm Disabled	0 = Alarm Disabled or 1 = Alarm Enabled
Setting to activate the circuit breaker operating time maintenance alarm.				
10	0B	CB Time Maint	100ms	From 5ms to 500ms step 1ms
Setting for the circuit operating time threshold which is set in relation to the specified interrupting time of the circuit breaker.				
10	0B	CB1 Time Maint	100ms	From 5ms to 500ms step 1ms
Setting for the circuit operating time threshold which is set in relation to the specified interrupting time of the circuit breaker.				
10	0C	CB Time Lockout	Alarm Disabled	0 = Alarm Disabled or 1 = Alarm Enabled
Setting to activate the circuit breaker operating time lockout alarm.				
10	0C	CB1 Time Lockout	Alarm Disabled	0 = Alarm Disabled or 1 = Alarm Enabled
Setting to activate the circuit breaker operating time lockout alarm.				
10	0D	CB Time Lockout	200ms	From 5ms to 500ms step 1ms
Setting for the circuit breaker operating time threshold which is set in relation to the specified interrupting time of the circuit breaker. The relay can be set to lockout the auto-reclose function on reaching a second operations threshold.				
10	0D	CB1 Time Lockout	200ms	From 5ms to 500ms step 1ms
Setting for the circuit breaker operating time threshold which is set in relation to the specified interrupting time of the circuit breaker. The relay can be set to lockout the auto-reclose function on reaching a second operations threshold.				
10	0E	Fault Freq Lock	Alarm Disabled	0 = Alarm Disabled or 1 = Alarm Enabled
Enables the excessive fault frequency alarm.				
10	0E	CB1FitFreqLock	Alarm Disabled	0 = Alarm Disabled or 1 = Alarm Enabled
Enables the excessive fault frequency alarm.				
10	0F	Fault Freq Count	10	1 to 9999 step 1
Sets a circuit breaker frequent operations counter that monitors the number of operations over a set time period				
10	0F	CB1FitFreqCount	10	1 to 9999 step 1
Sets a circuit breaker frequent operations counter that monitors the number of operations over a set time period				
10	10	Fault Freq Time	3600s	From 0s to 9999s step 1s
Sets the time period over which the circuit breaker operations are to be monitored. Should the set number of trip operations be accumulated within this time period, an alarm can be raised. Excessive fault frequency/trips can be used to indicate that the circuit may need maintenance attention (e.g. Tree-felling or insulator cleaning).				
10	10	CB1FitFreqTime	3600s	From 0s to 9999s step 1s
Sets the time period over which the circuit breaker operations are to be monitored. Should the set number of trip operations be accumulated within this time period, an alarm can be raised. Excessive fault frequency/trips can be used to indicate that the circuit may need maintenance attention (e.g. Tree-felling or insulator cleaning).				
10	21	CB2 Broken I [∧] 2	2	1 to 2 step 0.1
This sets the factor to be used for the cumulative I [∧] counter calculation that monitors the cumulative severity of the duty placed on the interrupter. This factor is set according to the type of Circuit Breaker used				
10	22	CB2 I [∧] Maint	Alarm Disabled	0 = Alarm Disabled or 1 = Alarm Enabled
Setting which determines if an alarm will be raised or not when the cumulative I [∧] maintenance counter threshold is exceeded.				
10	23	CB2 I [∧] Maint	1000	From 1A to 25kA step 1A
Setting that determines the threshold for the cumulative I [∧] maintenance counter monitors.				
10	24	CB2 I [∧] Lockout	Alarm Disabled	0 = Alarm Disabled or 1 = Alarm Enabled
Setting which determines if an alarm will be raised or not when the cumulative I [∧] lockout counter threshold is exceeded.				
10	25	CB2 I [∧] Lockout	2000	From 1A to 25kA step 1A

Col	Row	MENU TEXT	Default Setting	Available Setting
Description				
Setting that determines the threshold for the cumulative I ^A lockout counter monitor. Set that should maintenance not be carried out, the relay can be set to lockout the auto-reclose function on reaching a second operations threshold.				
10	26	No.CB2 OPs Maint	Alarm Disabled	0 = Alarm Disabled or 1 = Alarm Enabled
Setting to activate the number of circuit breaker operations maintenance alarm.				
10	27	No.CB2 OPs Maint	10	1 to 10000 step 1
Sets the threshold for number of circuit breaker operations maintenance alarm, indicating when preventative maintenance is due.				
10	28	No.CB2 OPs Lock	Alarm Disabled	0 = Alarm Disabled or 1 = Alarm Enabled
Setting to activate the number of circuit breaker operations lockout alarm.				
10	29	No.CB2 OPs Lock	20	1 to 10000 step 1
Sets the threshold for number of circuit breaker operations lockout. The relay can be set to lockout the auto-reclose function on reaching a second operations threshold.				
10	2A	CB2 Time Maint	Alarm Disabled	0 = Alarm Disabled or 1 = Alarm Enabled
Setting to activate the circuit breaker operating time maintenance alarm.				
10	2B	CB2 Time Maint	100ms	From 5ms to 500ms step 1ms
Setting for the circuit operating time threshold which is set in relation to the specified interrupting time of the circuit breaker.				
10	2C	CB2 Time Lockout	Alarm Disabled	0 = Alarm Disabled or 1 = Alarm Enabled
Setting to activate the circuit breaker operating time lockout alarm.				
10	2D	CB2 Time Lockout	200ms	From 5ms to 500ms step 1ms
Setting for the circuit breaker operating time threshold which is set in relation to the specified interrupting time of the circuit breaker. The relay can be set to lockout the auto-reclose function on reaching a second operations threshold.				
10	2E	CB2FItFreqLock	Alarm Disabled	0 = Alarm Disabled or 1 = Alarm Enabled
Enables the excessive fault frequency alarm.				
10	2F	CB2FItFreqCount	10	1 to 9999 step 1
Sets a circuit breaker frequent operations counter that monitors the number of operations over a set time period				
10	30	CB2FItFreqTime	3600s	From 0s to 9999s step 1s
Sets the time period over which the circuit breaker operations are to be monitored. Should the set number of trip operations be accumulated within this time period, an alarm can be raised. Excessive fault frequency/trips can be used to indicate that the circuit may need maintenance attention (e.g. Tree-felling or insulator cleaning).				

Table 40 - Circuit breaker condition monitor setup

4.11 Opto Configuration

Col	Row	MENU TEXT	Default Setting	Available Setting
Description				
11	00	OPTO CONFIG	0	
This column contains opto-input configuration settings				
11	01	Global Nominal V	24/27V	0 = 24-27V, 1 = 30-34V, 2 = 48-54V, 3 = 110-125V, 4 = 220-250V or 5 = Custom
Sets the nominal battery voltage for all opto inputs by selecting one of the five standard ratings in the Global Nominal V settings. If Custom is selected then each opto input can individually be set to a nominal voltage value.				
11	02	Opto Input 1	24/27V	0 = 24/27V, 1 = 30/34V, 2 = 48/54V, 3 = 110/125V or 4 = 220/250V
Each opto input can individually be set to a nominal voltage value if custom is selected for the global setting.				

Col	Row	MENU TEXT	Default Setting	Available Setting
Description				
11	03	Opto Input 2	24/27V	0 = 24/27V, 1 = 30/34V, 2 = 48/54V, 3 = 110/125V or 4 = 220/250V
Each opto input can individually be set to a nominal voltage value if custom is selected for the global setting. The number of inputs may be up to 32, depending on MiCOM P54x model and I/O configuration.				
11	04	Opto Input 3	24/27V	0 = 24/27V, 1 = 30/34V, 2 = 48/54V, 3 = 110/125V or 4 = 220/250V
Each opto input can individually be set to a nominal voltage value if custom is selected for the global setting. The number of inputs may be up to 32, depending on MiCOM P54x model and I/O configuration.				
11	05	Opto Input 4	24/27V	0 = 24/27V, 1 = 30/34V, 2 = 48/54V, 3 = 110/125V or 4 = 220/250V
Each opto input can individually be set to a nominal voltage value if custom is selected for the global setting. The number of inputs may be up to 32, depending on MiCOM P54x model and I/O configuration.				
11	06	Opto Input 5	24/27V	0 = 24/27V, 1 = 30/34V, 2 = 48/54V, 3 = 110/125V or 4 = 220/250V
Each opto input can individually be set to a nominal voltage value if custom is selected for the global setting. The number of inputs may be up to 32, depending on MiCOM P54x model and I/O configuration.				
11	07	Opto Input 6	24/27V	0 = 24/27V, 1 = 30/34V, 2 = 48/54V, 3 = 110/125V or 4 = 220/250V
Each opto input can individually be set to a nominal voltage value if custom is selected for the global setting. The number of inputs may be up to 32, depending on MiCOM P54x model and I/O configuration.				
11	08	Opto Input 7	24/27V	0 = 24/27V, 1 = 30/34V, 2 = 48/54V, 3 = 110/125V or 4 = 220/250V
Each opto input can individually be set to a nominal voltage value if custom is selected for the global setting. The number of inputs may be up to 32, depending on MiCOM P54x model and I/O configuration.				
11	09	Opto Input 8	24/27V	0 = 24/27V, 1 = 30/34V, 2 = 48/54V, 3 = 110/125V or 4 = 220/250V
Each opto input can individually be set to a nominal voltage value if custom is selected for the global setting. The number of inputs may be up to 32, depending on MiCOM P54x model and I/O configuration.				
11	0A	Opto Input 9	24/27V	0 = 24/27V, 1 = 30/34V, 2 = 48/54V, 3 = 110/125V or 4 = 220/250V
Each opto input can individually be set to a nominal voltage value if custom is selected for the global setting. The number of inputs may be up to 32, depending on MiCOM P54x model and I/O configuration.				
11	0B	Opto Input 10	24/27V	0 = 24/27V, 1 = 30/34V, 2 = 48/54V, 3 = 110/125V or 4 = 220/250V
Each opto input can individually be set to a nominal voltage value if custom is selected for the global setting. The number of inputs may be up to 32, depending on MiCOM P54x model and I/O configuration.				
11	0C	Opto Input 11	24/27V	0 = 24/27V, 1 = 30/34V, 2 = 48/54V, 3 = 110/125V or 4 = 220/250V
Each opto input can individually be set to a nominal voltage value if custom is selected for the global setting. The number of inputs may be up to 32, depending on MiCOM P54x model and I/O configuration.				
11	0D	Opto Input 12	24/27V	0 = 24/27V, 1 = 30/34V, 2 = 48/54V, 3 = 110/125V or 4 = 220/250V
Each opto input can individually be set to a nominal voltage value if custom is selected for the global setting. The number of inputs may be up to 32, depending on MiCOM P54x model and I/O configuration.				
11	0E	Opto Input 13	24/27V	0 = 24/27V, 1 = 30/34V, 2 = 48/54V, 3 = 110/125V or 4 = 220/250V
Each opto input can individually be set to a nominal voltage value if custom is selected for the global setting. The number of inputs may be up to 32, depending on MiCOM P54x model and I/O configuration.				
11	0F	Opto Input 14	24/27V	0 = 24/27V, 1 = 30/34V, 2 = 48/54V, 3 = 110/125V or 4 = 220/250V

Col	Row	MENU TEXT	Default Setting	Available Setting
Description				
Each opto input can individually be set to a nominal voltage value if custom is selected for the global setting. The number of inputs may be up to 32, depending on MiCOM P54x model and I/O configuration.				
11	10	Opto Input 15	24/27V	0 = 24/27V, 1 = 30/34V, 2 = 48/54V, 3 = 110/125V or 4 = 220/250V
Each opto input can individually be set to a nominal voltage value if custom is selected for the global setting. The number of inputs may be up to 32, depending on MiCOM P54x model and I/O configuration.				
11	11	Opto Input 16	24/27V	0 = 24/27V, 1 = 30/34V, 2 = 48/54V, 3 = 110/125V or 4 = 220/250V
Each opto input can individually be set to a nominal voltage value if custom is selected for the global setting. The number of inputs may be up to 32, depending on MiCOM P54x model and I/O configuration.				
11	12	Opto Input 17	24/27V	0 = 24/27V, 1 = 30/34V, 2 = 48/54V, 3 = 110/125V or 4 = 220/250V
Each opto input can individually be set to a nominal voltage value if custom is selected for the global setting. The number of inputs may be up to 32, depending on MiCOM P54x model and I/O configuration.				
11	13	Opto Input 18	24/27V	0 = 24/27V, 1 = 30/34V, 2 = 48/54V, 3 = 110/125V or 4 = 220/250V
Each opto input can individually be set to a nominal voltage value if custom is selected for the global setting. The number of inputs may be up to 32, depending on MiCOM P54x model and I/O configuration.				
11	14	Opto Input 19	24/27V	0 = 24/27V, 1 = 30/34V, 2 = 48/54V, 3 = 110/125V or 4 = 220/250V
Each opto input can individually be set to a nominal voltage value if custom is selected for the global setting. The number of inputs may be up to 32, depending on MiCOM P54x model and I/O configuration.				
11	15	Opto Input 20	24/27V	0 = 24/27V, 1 = 30/34V, 2 = 48/54V, 3 = 110/125V or 4 = 220/250V
Each opto input can individually be set to a nominal voltage value if custom is selected for the global setting. The number of inputs may be up to 32, depending on MiCOM P54x model and I/O configuration.				
11	16	Opto Input 21	24/27V	0 = 24/27V, 1 = 30/34V, 2 = 48/54V, 3 = 110/125V or 4 = 220/250V
Each opto input can individually be set to a nominal voltage value if custom is selected for the global setting. The number of inputs may be up to 32, depending on MiCOM P54x model and I/O configuration.				
11	17	Opto Input 22	24/27V	0 = 24/27V, 1 = 30/34V, 2 = 48/54V, 3 = 110/125V or 4 = 220/250V
Each opto input can individually be set to a nominal voltage value if custom is selected for the global setting. The number of inputs may be up to 32, depending on MiCOM P54x model and I/O configuration.				
11	18	Opto Input 23	24/27V	0 = 24/27V, 1 = 30/34V, 2 = 48/54V, 3 = 110/125V or 4 = 220/250V
Each opto input can individually be set to a nominal voltage value if custom is selected for the global setting. The number of inputs may be up to 32, depending on MiCOM P54x model and I/O configuration.				
11	19	Opto Input 24	24/27V	0 = 24/27V, 1 = 30/34V, 2 = 48/54V, 3 = 110/125V or 4 = 220/250V
Each opto input can individually be set to a nominal voltage value if custom is selected for the global setting. The number of inputs may be up to 32, depending on MiCOM P54x model and I/O configuration.				
11	1A	Opto Input 25	24/27V	0 = 24/27V, 1 = 30/34V, 2 = 48/54V, 3 = 110/125V or 4 = 220/250V
Each opto input can individually be set to a nominal voltage value if custom is selected for the global setting. The number of inputs may be up to 32, depending on MiCOM P54x model and I/O configuration.				
11	1B	Opto Input 26	24/27V	0 = 24/27V, 1 = 30/34V, 2 = 48/54V, 3 = 110/125V or 4 = 220/250V
Each opto input can individually be set to a nominal voltage value if custom is selected for the global setting. The number of inputs may be up to 32, depending on MiCOM P54x model and I/O configuration.				

Col	Row	MENU TEXT	Default Setting	Available Setting
Description				
11	1C	Opto Input 27	24/27V	0 = 24/27V, 1 = 30/34V, 2 = 48/54V, 3 = 110/125V or 4 = 220/250V
Each opto input can individually be set to a nominal voltage value if custom is selected for the global setting. The number of inputs may be up to 32, depending on MiCOM P54x model and I/O configuration.				
11	1D	Opto Input 28	24/27V	0 = 24/27V, 1 = 30/34V, 2 = 48/54V, 3 = 110/125V or 4 = 220/250V
Each opto input can individually be set to a nominal voltage value if custom is selected for the global setting. The number of inputs may be up to 32, depending on MiCOM P54x model and I/O configuration.				
11	1E	Opto Input 29	24/27V	0 = 24/27V, 1 = 30/34V, 2 = 48/54V, 3 = 110/125V or 4 = 220/250V
Each opto input can individually be set to a nominal voltage value if custom is selected for the global setting. The number of inputs may be up to 32, depending on MiCOM P54x model and I/O configuration.				
11	1F	Opto Input 30	24/27V	0 = 24/27V, 1 = 30/34V, 2 = 48/54V, 3 = 110/125V or 4 = 220/250V
Each opto input can individually be set to a nominal voltage value if custom is selected for the global setting. The number of inputs may be up to 32, depending on MiCOM P54x model and I/O configuration.				
11	20	Opto Input 31	24/27V	0 = 24/27V, 1 = 30/34V, 2 = 48/54V, 3 = 110/125V or 4 = 220/250V
Each opto input can individually be set to a nominal voltage value if custom is selected for the global setting. The number of inputs may be up to 32, depending on MiCOM P54x model and I/O configuration.				
11	21	Opto Input 32	24/27V	0 = 24/27V, 1 = 30/34V, 2 = 48/54V, 3 = 110/125V or 4 = 220/250V
Each opto input can individually be set to a nominal voltage value if custom is selected for the global setting. The number of inputs may be up to 32, depending on MiCOM P54x model and I/O configuration.				
11	60	Opto Filter Cntl	11111110101101111111011 (bin)	32-bit binary setting: 0=disable filtering or 1=enable filtering
Selects each input with a pre-set filter of ½ cycle that renders the input immune to induced noise on the wiring. The number of available bits may be 16, 24 or 32, depending on the I/O configuration.				
11	80	Characteristic	Standard 60%-80%	0 = Standard 60% to 80% or 1 = 50% to 70%
Selects the pick-up and drop-off characteristics of the optos. Selecting the standard setting means they nominally provide a Logic 1 or On value for Voltages ³ 80% of the set lower nominal voltage and a Logic 0 or Off value for the voltages £60% of the set higher nominal voltage.				

Table 41 - Opto configuration

4.12

Control Inputs

The control inputs function as software switches that can be set or reset either locally or remotely. These inputs can be used to trigger any function that they are connected to as part of the PSL. They can also be set to perform a pre-defined control function. This is achieved by mapping in the Hotkey menu. The operating mode for each of the Control Inputs can be set individually.

This column is visible when the “Control I/P Config” setting (“Configuration” column) = “visible”.

Col	Row	MENU TEXT	Default Setting	Available Setting
Description				
12	00	CONTROL INPUTS	0	
This column contains settings for the type of control input (32 in all)				

Col	Row	MENU TEXT	Default Setting	Available Setting
Description				
12	01	Ctrl I/P Status	00000000000000000000000000000000(bin)	Binary Flag (32 bits) Indexed String (0 = Reset, 1 = Set)
Cell that is used to set (1) and reset (0) the selected Control Input by simply scrolling and changing the status of selected bits. This command will be then recognized and executed in the PSL. Alternatively, each of the 32 Control input can also be set and reset using the individual menu setting cells as follows:				
12	02	Control Input 1	No Operation	0 = No Operation, 1 = SET , 2 = RESET
Setting to allow Control Inputs 1 set/ reset.				
12	03	Control Input 2	No Operation	0 = No Operation, 1 = SET , 2 = RESET
Setting to allow Control Inputs 2 set/ reset.				
12	04	Control Input 3	No Operation	0 = No Operation, 1 = SET , 2 = RESET
Setting to allow Control Inputs 3 set/ reset.				
12	05	Control Input 4	No Operation	0 = No Operation, 1 = SET , 2 = RESET
Setting to allow Control Inputs 4 set/ reset.				
12	06	Control Input 5	No Operation	0 = No Operation, 1 = SET , 2 = RESET
Setting to allow Control Inputs 5 set/ reset.				
12	07	Control Input 6	No Operation	0 = No Operation, 1 = SET , 2 = RESET
Setting to allow Control Inputs 6 set/ reset.				
12	08	Control Input 7	No Operation	0 = No Operation, 1 = SET , 2 = RESET
Setting to allow Control Inputs 7 set/ reset.				
12	09	Control Input 8	No Operation	0 = No Operation, 1 = SET , 2 = RESET
Setting to allow Control Inputs 8 set/ reset.				
12	0A	Control Input 9	No Operation	0 = No Operation, 1 = SET , 2 = RESET
Setting to allow Control Inputs 9 set/ reset.				
12	0B	Control Input 10	No Operation	0 = No Operation, 1 = SET , 2 = RESET
Setting to allow Control Inputs 10 set/ reset.				
12	0C	Control Input 11	No Operation	0 = No Operation, 1 = SET , 2 = RESET
Setting to allow Control Inputs 11 set/ reset.				
12	0D	Control Input 12	No Operation	0 = No Operation, 1 = SET , 2 = RESET
Setting to allow Control Inputs 12 set/ reset.				
12	0E	Control Input 13	No Operation	0 = No Operation, 1 = SET , 2 = RESET
Setting to allow Control Inputs 13 set/ reset.				
12	0F	Control Input 14	No Operation	0 = No Operation, 1 = SET , 2 = RESET
Setting to allow Control Inputs 14 set/ reset.				
12	10	Control Input 15	No Operation	0 = No Operation, 1 = SET , 2 = RESET
Setting to allow Control Inputs 15 set/ reset.				
12	11	Control Input 16	No Operation	0 = No Operation, 1 = SET , 2 = RESET
Setting to allow Control Inputs 16 set/ reset.				
12	12	Control Input 17	No Operation	0 = No Operation, 1 = SET , 2 = RESET
Setting to allow Control Inputs 17 set/ reset.				
12	13	Control Input 18	No Operation	0 = No Operation, 1 = SET , 2 = RESET
Setting to allow Control Inputs 18 set/ reset.				
12	14	Control Input 19	No Operation	0 = No Operation, 1 = SET , 2 = RESET
Setting to allow Control Inputs 19 set/ reset.				

Col	Row	MENU TEXT	Default Setting	Available Setting
Description				
12	15	Control Input 20	No Operation	0 = No Operation, 1 = SET , 2 = RESET
Setting to allow Control Inputs 20 set/ reset.				
12	16	Control Input 21	No Operation	0 = No Operation, 1 = SET , 2 = RESET
Setting to allow Control Inputs 21 set/ reset.				
12	17	Control Input 22	No Operation	0 = No Operation, 1 = SET , 2 = RESET
Setting to allow Control Inputs 22 set/ reset.				
12	18	Control Input 23	No Operation	0 = No Operation, 1 = SET , 2 = RESET
Setting to allow Control Inputs 23 set/ reset.				
12	19	Control Input 24	No Operation	0 = No Operation, 1 = SET , 2 = RESET
Setting to allow Control Inputs 24 set/ reset.				
12	1A	Control Input 25	No Operation	0 = No Operation, 1 = SET , 2 = RESET
Setting to allow Control Inputs 25 set/ reset.				
12	1B	Control Input 26	No Operation	0 = No Operation, 1 = SET , 2 = RESET
Setting to allow Control Inputs 26 set/ reset.				
12	1C	Control Input 27	No Operation	0 = No Operation, 1 = SET , 2 = RESET
Setting to allow Control Inputs 27 set/ reset.				
12	1D	Control Input 28	No Operation	0 = No Operation, 1 = SET , 2 = RESET
Setting to allow Control Inputs 28 set/ reset.				
12	1E	Control Input 29	No Operation	0 = No Operation, 1 = SET , 2 = RESET
Setting to allow Control Inputs 29 set/ reset.				
12	1F	Control Input 30	No Operation	0 = No Operation, 1 = SET , 2 = RESET
Setting to allow Control Inputs 30 set/ reset.				
12	20	Control Input 31	No Operation	0 = No Operation, 1 = SET , 2 = RESET
Setting to allow Control Inputs 31 set/ reset.				
12	21	Control Input 32	No Operation	0 = No Operation, 1 = SET , 2 = RESET
Setting to allow Control Inputs 32 set/ reset.				
12	22	Ctl Stg I/P Stat	0000000000000000(bin)	Binary Flag (16 bits) Indexed String (0 = Disabled, 1 = Enabled)
Cell that is used to set (1) and reset (0) the selected Setting Input by simply scrolling and changing the status of selected bits. This command will be then recognized and executed in the PSL. Alternatively, each of the 32 Setting input can also be enabled and disabled using the individual menu setting cells as follows:				
12	23	Ctrl Setg I/P 33	Disabled	0 = Disabled, 1 = Enabled
Setting to allow Setting Input 33 enable/Disable.				
12	24	Ctrl Setg I/P 34	Disabled	0 = Disabled, 1 = Enabled
Setting to allow Setting Input 33 enable/Disable.				
12	25	Ctrl Setg I/P 35	Disabled	0 = Disabled, 1 = Enabled
Setting to allow Setting Input 33 enable/Disable.				
12	26	Ctrl Setg I/P 36	Disabled	0 = Disabled, 1 = Enabled
Setting to allow Setting Input 33 enable/Disable.				
12	27	Ctrl Setg I/P 37	Disabled	0 = Disabled, 1 = Enabled
Setting to allow Setting Input 33 enable/Disable.				
12	28	Ctrl Setg I/P 38	Disabled	0 = Disabled, 1 = Enabled
Setting to allow Setting Input 33 enable/Disable.				
12	29	Ctrl Setg I/P 39	Disabled	0 = Disabled, 1 = Enabled

Col	Row	MENU TEXT	Default Setting	Available Setting
Description				
Setting to allow Setting Input 33 enable/Disable.				
12	2A	Ctrl Setg I/P 40	Disabled	0 = Disabled, 1 = Enabled
Setting to allow Setting Input 33 enable/Disable.				
12	2B	Ctrl Setg I/P 41	Disabled	0 = Disabled, 1 = Enabled
Setting to allow Setting Input 33 enable/Disable.				
12	2C	Ctrl Setg I/P 42	Disabled	0 = Disabled, 1 = Enabled
Setting to allow Setting Input 33 enable/Disable.				
12	2D	Ctrl Setg I/P 43	Disabled	0 = Disabled, 1 = Enabled
Setting to allow Setting Input 33 enable/Disable.				
12	2E	Ctrl Setg I/P 44	Disabled	0 = Disabled, 1 = Enabled
Setting to allow Setting Input 33 enable/Disable.				
12	2F	Ctrl Setg I/P 45	Disabled	0 = Disabled, 1 = Enabled
Setting to allow Setting Input 33 enable/Disable.				
12	30	Ctrl Setg I/P 46	Disabled	0 = Disabled, 1 = Enabled
Setting to allow Setting Input 33 enable/Disable.				
12	31	Ctrl Setg I/P 47	Disabled	0 = Disabled, 1 = Enabled
Setting to allow Setting Input 33 enable/Disable.				
12	32	Ctrl Setg I/P 48	Disabled	0 = Disabled, 1 = Enabled
Setting to allow Setting Input 33 enable/Disable.				

Table 42 - Control inputs

4.13 Control Input Configuration

The control inputs function as software switches that can be set or reset either locally or remotely. These inputs can be used to trigger any function that they are connected to as part of the PSL.

This column is visible when the “Control I/P Config” setting (“Configuration” column) = “visible”.

Instead of operating the control inputs as described in the above section, they could also be set to perform a pre-defined control function. This is achieved by mapping in the Hotkey menu. The operating mode for each of the 32 Control Inputs can be set individually.

Col	Row	MENU TEXT	Default Setting	Available Setting
Description				
13	00	CTRL I/P CONFIG	0	
This column contains settings for the type of control input (32 in all)				
13	01	Hotkey Enabled	11111111111111111111111111111111(bin)	32-bit binary setting: 0=Not accessible via Hotkey Menu or 1=Accessible via Hotkey Menu
Setting to allow the control inputs to be individually assigned to the Hotkey menu by setting ‘1’ in the appropriate bit in the Hotkey Enabled cell. The hotkey menu allows the control inputs to be set, reset or pulsed without the need to enter the CONTROL INPUTS column. Not available on Chinese version relays (P54??????C???)				
13	10	Control Input 1	Latched	0 = Latched or 1 = Pulsed

Col	Row	MENU TEXT	Default Setting	Available Setting
Description				
Configures the control inputs as either 'latched' or 'pulsed'. A latched control input will remain in the set state until a reset command is given, either by the menu or the serial communications. A pulsed control input, however, will remain energized for 10 ms after the set command is given and will then reset automatically (i.e. no reset command required).				
13	11	Ctrl Command 1	SET/RESET	0 = ON/OFF, 1 = SET/RESET, 2 = IN/OUT, 3 = ENABLED/DISABLED
Allows the SET / RESET text, displayed in the hotkey menu, to be changed to something more suitable for the application of an individual control input, such as ON / OFF, IN / OUT etc.				
13	14	Control Input 2	Latched	0 = Latched or 1 = Pulsed
Configures the control inputs as either 'latched' or 'pulsed'.				
13	15	Ctrl Command 2	SET/RESET	0 = ON/OFF, 1 = SET/RESET, 2 = IN/OUT, 3 = ENABLED/DISABLED
Allows the SET / RESET text, displayed in the hotkey menu, to be changed to something more suitable for the application of an individual control input, such as ON / OFF, IN / OUT etc.				
13	18	Control Input 3	Latched	0 = Latched or 1 = Pulsed
Configures the control inputs as either 'latched' or 'pulsed'.				
13	19	Ctrl Command 3	SET/RESET	0 = ON/OFF, 1 = SET/RESET, 2 = IN/OUT, 3 = ENABLED/DISABLED
Allows the SET / RESET text, displayed in the hotkey menu, to be changed to something more suitable for the application of an individual control input, such as ON / OFF, IN / OUT etc.				
13	1C	Control Input 4	Latched	0 = Latched or 1 = Pulsed
Configures the control inputs as either 'latched' or 'pulsed'.				
13	1D	Ctrl Command 4	SET/RESET	0 = ON/OFF, 1 = SET/RESET, 2 = IN/OUT, 3 = ENABLED/DISABLED
Allows the SET / RESET text, displayed in the hotkey menu, to be changed to something more suitable for the application of an individual control input, such as ON / OFF, IN / OUT etc.				
13	20	Control Input 5	Latched	0 = Latched or 1 = Pulsed
Configures the control inputs as either 'latched' or 'pulsed'.				
13	21	Ctrl Command 5	SET/RESET	0 = ON/OFF, 1 = SET/RESET, 2 = IN/OUT, 3 = ENABLED/DISABLED
Allows the SET / RESET text, displayed in the hotkey menu, to be changed to something more suitable for the application of an individual control input, such as ON / OFF, IN / OUT etc.				
13	24	Control Input 6	Latched	0 = Latched or 1 = Pulsed
Configures the control inputs as either 'latched' or 'pulsed'.				
13	25	Ctrl Command 6	SET/RESET	0 = ON/OFF, 1 = SET/RESET, 2 = IN/OUT, 3 = ENABLED/DISABLED
Allows the SET / RESET text, displayed in the hotkey menu, to be changed to something more suitable for the application of an individual control input, such as ON / OFF, IN / OUT etc.				
13	28	Control Input 7	Latched	0 = Latched or 1 = Pulsed
Configures the control inputs as either 'latched' or 'pulsed'.				
13	29	Ctrl Command 7	SET/RESET	0 = ON/OFF, 1 = SET/RESET, 2 = IN/OUT, 3 = ENABLED/DISABLED
Allows the SET / RESET text, displayed in the hotkey menu, to be changed to something more suitable for the application of an individual control input, such as ON / OFF, IN / OUT etc.				
13	2C	Control Input 8	Latched	0 = Latched or 1 = Pulsed
Configures the control inputs as either 'latched' or 'pulsed'.				
13	2D	Ctrl Command 8	SET/RESET	0 = ON/OFF, 1 = SET/RESET, 2 = IN/OUT, 3 = ENABLED/DISABLED
Allows the SET / RESET text, displayed in the hotkey menu, to be changed to something more suitable for the application of an individual control input, such as ON / OFF, IN / OUT etc.				

Col	Row	MENU TEXT	Default Setting	Available Setting
Description				
13	30	Control Input 9	Latched	0 = Latched or 1 = Pulsed
Configures the control inputs as either 'latched' or 'pulsed'.				
13	31	Ctrl Command 9	SET/RESET	0 = ON/OFF, 1 = SET/RESET, 2 = IN/OUT, 3 = ENABLED/DISABLED
Allows the SET / RESET text, displayed in the hotkey menu, to be changed to something more suitable for the application of an individual control input, such as ON / OFF, IN / OUT etc.				
13	34	Control Input 10	Latched	0 = Latched or 1 = Pulsed
Configures the control inputs as either 'latched' or 'pulsed'.				
13	35	Ctrl Command 10	SET/RESET	0 = ON/OFF, 1 = SET/RESET, 2 = IN/OUT, 3 = ENABLED/DISABLED
Allows the SET / RESET text, displayed in the hotkey menu, to be changed to something more suitable for the application of an individual control input, such as ON / OFF, IN / OUT etc.				
13	38	Control Input 11	Latched	0 = Latched or 1 = Pulsed
Configures the control inputs as either 'latched' or 'pulsed'.				
13	39	Ctrl Command 11	SET/RESET	0 = ON/OFF, 1 = SET/RESET, 2 = IN/OUT, 3 = ENABLED/DISABLED
Allows the SET / RESET text, displayed in the hotkey menu, to be changed to something more suitable for the application of an individual control input, such as ON / OFF, IN / OUT etc.				
13	3C	Control Input 12	Latched	0 = Latched or 1 = Pulsed
Configures the control inputs as either 'latched' or 'pulsed'.				
13	3D	Ctrl Command 12	SET/RESET	0 = ON/OFF, 1 = SET/RESET, 2 = IN/OUT, 3 = ENABLED/DISABLED
Allows the SET / RESET text, displayed in the hotkey menu, to be changed to something more suitable for the application of an individual control input, such as ON / OFF, IN / OUT etc.				
13	40	Control Input 13	Latched	0 = Latched or 1 = Pulsed
Configures the control inputs as either 'latched' or 'pulsed'.				
13	41	Ctrl Command 13	SET/RESET	0 = ON/OFF, 1 = SET/RESET, 2 = IN/OUT, 3 = ENABLED/DISABLED
Allows the SET / RESET text, displayed in the hotkey menu, to be changed to something more suitable for the application of an individual control input, such as ON / OFF, IN / OUT etc.				
13	44	Control Input 14	Latched	0 = Latched or 1 = Pulsed
Configures the control inputs as either 'latched' or 'pulsed'.				
13	45	Ctrl Command 14	SET/RESET	0 = ON/OFF, 1 = SET/RESET, 2 = IN/OUT, 3 = ENABLED/DISABLED
Allows the SET / RESET text, displayed in the hotkey menu, to be changed to something more suitable for the application of an individual control input, such as ON / OFF, IN / OUT etc.				
13	48	Control Input 15	Latched	0 = Latched or 1 = Pulsed
Configures the control inputs as either 'latched' or 'pulsed'.				
13	49	Ctrl Command 15	SET/RESET	0 = ON/OFF, 1 = SET/RESET, 2 = IN/OUT, 3 = ENABLED/DISABLED
Allows the SET / RESET text, displayed in the hotkey menu, to be changed to something more suitable for the application of an individual control input, such as ON / OFF, IN / OUT etc.				
13	4C	Control Input 16	Latched	0 = Latched or 1 = Pulsed
Configures the control inputs as either 'latched' or 'pulsed'.				
13	4D	Ctrl Command 16	SET/RESET	0 = ON/OFF, 1 = SET/RESET, 2 = IN/OUT, 3 = ENABLED/DISABLED
Allows the SET / RESET text, displayed in the hotkey menu, to be changed to something more suitable for the application of an individual control input, such as ON / OFF, IN / OUT etc.				

Col	Row	MENU TEXT	Default Setting	Available Setting
Description				
13	50	Control Input 17	Latched	0 = Latched or 1 = Pulsed
Configures the control inputs as either 'latched' or 'pulsed'.				
13	51	Ctrl Command 17	SET/RESET	0 = ON/OFF, 1 = SET/RESET, 2 = IN/OUT, 3 = ENABLED/DISABLED
Allows the SET / RESET text, displayed in the hotkey menu, to be changed to something more suitable for the application of an individual control input, such as ON / OFF, IN / OUT etc.				
13	54	Control Input 18	Latched	0 = Latched or 1 = Pulsed
Configures the control inputs as either 'latched' or 'pulsed'.				
13	55	Ctrl Command 18	SET/RESET	0 = ON/OFF, 1 = SET/RESET, 2 = IN/OUT, 3 = ENABLED/DISABLED
Allows the SET / RESET text, displayed in the hotkey menu, to be changed to something more suitable for the application of an individual control input, such as ON / OFF, IN / OUT etc.				
13	58	Control Input 19	Latched	0 = Latched or 1 = Pulsed
Configures the control inputs as either 'latched' or 'pulsed'.				
13	59	Ctrl Command 19	SET/RESET	0 = ON/OFF, 1 = SET/RESET, 2 = IN/OUT, 3 = ENABLED/DISABLED
Allows the SET / RESET text, displayed in the hotkey menu, to be changed to something more suitable for the application of an individual control input, such as ON / OFF, IN / OUT etc.				
13	5C	Control Input 20	Latched	0 = Latched or 1 = Pulsed
Configures the control inputs as either 'latched' or 'pulsed'.				
13	5D	Ctrl Command 20	SET/RESET	0 = ON/OFF, 1 = SET/RESET, 2 = IN/OUT, 3 = ENABLED/DISABLED
Allows the SET / RESET text, displayed in the hotkey menu, to be changed to something more suitable for the application of an individual control input, such as ON / OFF, IN / OUT etc.				
13	60	Control Input 21	Latched	0 = Latched or 1 = Pulsed
Configures the control inputs as either 'latched' or 'pulsed'.				
13	61	Ctrl Command 21	SET/RESET	0 = ON/OFF, 1 = SET/RESET, 2 = IN/OUT, 3 = ENABLED/DISABLED
Allows the SET / RESET text, displayed in the hotkey menu, to be changed to something more suitable for the application of an individual control input, such as ON / OFF, IN / OUT etc.				
13	64	Control Input 22	Latched	0 = Latched or 1 = Pulsed
Configures the control inputs as either 'latched' or 'pulsed'.				
13	65	Ctrl Command 22	SET/RESET	0 = ON/OFF, 1 = SET/RESET, 2 = IN/OUT, 3 = ENABLED/DISABLED
Allows the SET / RESET text, displayed in the hotkey menu, to be changed to something more suitable for the application of an individual control input, such as ON / OFF, IN / OUT etc.				
13	68	Control Input 23	Latched	0 = Latched or 1 = Pulsed
Configures the control inputs as either 'latched' or 'pulsed'.				
13	69	Ctrl Command 23	SET/RESET	0 = ON/OFF, 1 = SET/RESET, 2 = IN/OUT, 3 = ENABLED/DISABLED
Allows the SET / RESET text, displayed in the hotkey menu, to be changed to something more suitable for the application of an individual control input, such as ON / OFF, IN / OUT etc.				
13	6C	Control Input 24	Latched	0 = Latched or 1 = Pulsed
Configures the control inputs as either 'latched' or 'pulsed'.				
13	6D	Ctrl Command 24	SET/RESET	0 = ON/OFF, 1 = SET/RESET, 2 = IN/OUT, 3 = ENABLED/DISABLED
Allows the SET / RESET text, displayed in the hotkey menu, to be changed to something more suitable for the application of an individual control input, such as ON / OFF, IN / OUT etc.				

Col	Row	MENU TEXT	Default Setting	Available Setting
Description				
13	70	Control Input 25	Latched	0 = Latched or 1 = Pulsed
Configures the control inputs as either 'latched' or 'pulsed'.				
13	71	Ctrl Command 25	SET/RESET	0 = ON/OFF, 1 = SET/RESET, 2 = IN/OUT, 3 = ENABLED/DISABLED
Allows the SET / RESET text, displayed in the hotkey menu, to be changed to something more suitable for the application of an individual control input, such as ON / OFF, IN / OUT etc.				
13	74	Control Input 26	Latched	0 = Latched or 1 = Pulsed
Configures the control inputs as either 'latched' or 'pulsed'.				
13	75	Ctrl Command 26	SET/RESET	0 = ON/OFF, 1 = SET/RESET, 2 = IN/OUT, 3 = ENABLED/DISABLED
Allows the SET / RESET text, displayed in the hotkey menu, to be changed to something more suitable for the application of an individual control input, such as ON / OFF, IN / OUT etc.				
13	78	Control Input 27	Latched	0 = Latched or 1 = Pulsed
Configures the control inputs as either 'latched' or 'pulsed'.				
13	79	Ctrl Command 27	SET/RESET	0 = ON/OFF, 1 = SET/RESET, 2 = IN/OUT, 3 = ENABLED/DISABLED
Allows the SET / RESET text, displayed in the hotkey menu, to be changed to something more suitable for the application of an individual control input, such as ON / OFF, IN / OUT etc.				
13	7C	Control Input 28	Latched	0 = Latched or 1 = Pulsed
Configures the control inputs as either 'latched' or 'pulsed'.				
13	7D	Ctrl Command 28	SET/RESET	0 = ON/OFF, 1 = SET/RESET, 2 = IN/OUT, 3 = ENABLED/DISABLED
Allows the SET / RESET text, displayed in the hotkey menu, to be changed to something more suitable for the application of an individual control input, such as ON / OFF, IN / OUT etc.				
13	80	Control Input 29	Latched	0 = Latched or 1 = Pulsed
Configures the control inputs as either 'latched' or 'pulsed'.				
13	81	Ctrl Command 29	SET/RESET	0 = ON/OFF, 1 = SET/RESET, 2 = IN/OUT, 3 = ENABLED/DISABLED
Allows the SET / RESET text, displayed in the hotkey menu, to be changed to something more suitable for the application of an individual control input, such as ON / OFF, IN / OUT etc.				
13	84	Control Input 30	Latched	0 = Latched or 1 = Pulsed
Configures the control inputs as either 'latched' or 'pulsed'.				
13	85	Ctrl Command 30	SET/RESET	0 = ON/OFF, 1 = SET/RESET, 2 = IN/OUT, 3 = ENABLED/DISABLED
Allows the SET / RESET text, displayed in the hotkey menu, to be changed to something more suitable for the application of an individual control input, such as ON / OFF, IN / OUT etc.				
13	88	Control Input 31	Latched	0 = Latched or 1 = Pulsed
Configures the control inputs as either 'latched' or 'pulsed'.				
13	89	Ctrl Command 31	SET/RESET	0 = ON/OFF, 1 = SET/RESET, 2 = IN/OUT, 3 = ENABLED/DISABLED
Allows the SET / RESET text, displayed in the hotkey menu, to be changed to something more suitable for the application of an individual control input, such as ON / OFF, IN / OUT etc.				
13	8C	Control Input 32	Latched	0 = Latched or 1 = Pulsed
Configures the control inputs as either 'latched' or 'pulsed'.				
13	8D	Ctrl Command 32	SET/RESET	0 = ON/OFF, 1 = SET/RESET, 2 = IN/OUT, 3 = ENABLED/DISABLED
Allows the SET / RESET text, displayed in the hotkey menu, to be changed to something more suitable for the application of an individual control input, such as ON / OFF, IN / OUT etc.				

Table 43 - Control input configuration

4.14 Function Keys				
Col	Row	MENU TEXT	Default Setting	Available Setting
17	00	FUNCTION KEYS	0	
This column contains the function key definitions				
17	01	Fn Key Status	0	Not Settable
Displays the status of each function key.				
17	02	Fn Key 1	Unlocked	0 = Disabled, 1 = Unlocked (Enabled), 2 = Locked
Setting to activate function key. The 'Lock' setting allows a function key output that is set to toggle mode to be locked in its current active state.				
17	03	Fn Key 1 Mode	Normal	0 = Normal or 1 = Toggled
Sets the function key in toggle or normal mode. In 'Toggle' mode, a single key press will set/latch the function key output as 'high' or 'low' in programmable scheme logic. This feature can be used to enable/disable relay functions. In the 'Normal' mode the function key output will remain 'high' as long as key is pressed.				
17	04	Fn Key 1 Label	Function Key 1	From 32 to 234 step 1
Allows the text of the function key to be changed to something more suitable for the application.				
17	05	Fn Key 2	Unlocked	0 = Disabled, 1 = Unlocked (Enabled), 2 = Locked
Setting to activate function key. The 'Lock' setting allows a function key output that is set to toggle mode to be locked in its current active position.				
17	06	Fn Key 2 Mode	Normal	0 = Normal or 1 = Toggled
Sets the function key in toggle or normal mode. In 'Toggle' mode, a single key press will set/latch the function key output as 'high' or 'low' in programmable scheme logic. This feature can be used to enable/disable relay functions. In the 'Normal' mode the function key output will remain 'high' as long as key is pressed.				
17	07	Fn Key 2 Label	Function Key 2	From 32 to 234 step 1
Allows the text of the function key to be changed to something more suitable for the application.				
17	08	Fn Key 3	Unlocked	0 = Disabled, 1 = Unlocked (Enabled), 2 = Locked
Setting to activate function key. The 'Lock' setting allows a function key output that is set to toggle mode to be locked in its current active position.				
17	09	Fn Key 3 Mode	Normal	0 = Normal or 1 = Toggled
Sets the function key in toggle or normal mode. In 'Toggle' mode, a single key press will set/latch the function key output as 'high' or 'low' in programmable scheme logic. This feature can be used to enable/disable relay functions. In the 'Normal' mode the function key output will remain 'high' as long as key is pressed.				
17	0A	Fn Key 3 Label	Function Key 3	From 32 to 234 step 1
Allows the text of the function key to be changed to something more suitable for the application.				
17	0B	Fn Key 4	Unlocked	0 = Disabled, 1 = Unlocked (Enabled), 2 = Locked
Setting to activate function key. The 'Lock' setting allows a function key output that is set to toggle mode to be locked in its current active position.				
17	0C	Fn Key 4 Mode	Normal	0 = Normal or 1 = Toggled
Sets the function key in toggle or normal mode. In 'Toggle' mode, a single key press will set/latch the function key output as 'high' or 'low' in programmable scheme logic. This feature can be used to enable/disable relay functions. In the 'Normal' mode the function key output will remain 'high' as long as key is pressed.				

Col	Row	MENU TEXT	Default Setting	Available Setting
Description				
17	0D	Fn Key 4 Label	Function Key 4	From 32 to 234 step 1
Allows the text of the function key to be changed to something more suitable for the application.				
17	0E	Fn Key 5	Unlocked	0 = Disabled, 1 = Unlocked (Enabled), 2 = Locked
Setting to activate function key. The 'Lock' setting allows a function key output that is set to toggle mode to be locked in its current active position.				
17	0F	Fn Key 5 Mode	Normal	0 = Normal or 1 = Toggled
Sets the function key in toggle or normal mode. In 'Toggle' mode, a single key press will set/latch the function key output as 'high' or 'low' in programmable scheme logic. This feature can be used to enable/disable relay functions. In the 'Normal' mode the function key output will remain 'high' as long as key is pressed.				
17	10	Fn Key 5 Label	Function Key 5	From 32 to 234 step 1
Allows the text of the function key to be changed to something more suitable for the application.				
17	11	Fn Key 6	Unlocked	0 = Disabled, 1 = Unlocked (Enabled), 2 = Locked
Setting to activate function key. The 'Lock' setting allows a function key output that is set to toggle mode to be locked in its current active position.				
17	12	Fn Key 6 Mode	Normal	0 = Normal or 1 = Toggled
Sets the function key in toggle or normal mode. In 'Toggle' mode, a single key press will set/latch the function key output as 'high' or 'low' in programmable scheme logic. This feature can be used to enable/disable relay functions. In the 'Normal' mode the function key output will remain 'high' as long as key is pressed.				
17	13	Fn Key 6 Label	Function Key 6	From 32 to 234 step 1
Allows the text of the function key to be changed to something more suitable for the application.				
17	14	Fn Key 7	Unlocked	0 = Disabled, 1 = Unlocked (Enabled), 2 = Locked
Setting to activate function key. The 'Lock' setting allows a function key output that is set to toggle mode to be locked in its current active position.				
17	15	Fn Key 7 Mode	Normal	0 = Normal or 1 = Toggled
Sets the function key in toggle or normal mode. In 'Toggle' mode, a single key press will set/latch the function key output as 'high' or 'low' in programmable scheme logic. This feature can be used to enable/disable relay functions. In the 'Normal' mode the function key output will remain 'high' as long as key is pressed.				
17	16	Fn Key 7 Label	Function Key 7	From 32 to 234 step 1
Allows the text of the function key to be changed to something more suitable for the application.				
17	17	Fn Key 8	Unlocked	0 = Disabled, 1 = Unlocked (Enabled), 2 = Locked
Setting to activate function key. The 'Lock' setting allows a function key output that is set to toggle mode to be locked in its current active position.				
17	18	Fn Key 8 Mode	Normal	0 = Normal or 1 = Toggled
Sets the function key in toggle or normal mode. In 'Toggle' mode, a single key press will set/latch the function key output as 'high' or 'low' in programmable scheme logic. This feature can be used to enable/disable relay functions. In the 'Normal' mode the function key output will remain 'high' as long as key is pressed.				
17	19	Fn Key 8 Label	Function Key 8	From 32 to 234 step 1
Allows the text of the function key to be changed to something more suitable for the application.				
17	1A	Fn Key 9	Unlocked	0 = Disabled, 1 = Unlocked (Enabled), 2 = Locked
Setting to activate function key. The 'Lock' setting allows a function key output that is set to toggle mode to be locked in its current active position.				
17	1B	Fn Key 9 Mode	Normal	0 = Normal or 1 = Toggled

Col	Row	MENU TEXT	Default Setting	Available Setting
Description				
Sets the function key in toggle or normal mode. In 'Toggle' mode, a single key press will set/latch the function key output as 'high' or 'low' in programmable scheme logic. This feature can be used to enable/disable relay functions. In the 'Normal' mode the function key output will remain 'high' as long as key is pressed.				
17	1C	Fn Key 9 Label	Function Key 9	From 32 to 234 step 1
Allows the text of the function key to be changed to something more suitable for the application.				
17	1D	Fn Key 10	Unlocked	0 = Disabled, 1 = Unlocked (Enabled), 2 = Locked
Setting to activate function key. The 'Lock' setting allows a function key output that is set to toggle mode to be locked in its current active position.				
17	1E	Fn Key 10 Mode	Normal	0 = Normal or 1 = Toggled
Sets the function key in toggle or normal mode. In 'Toggle' mode, a single key press will set/latch the function key output as 'high' or 'low' in programmable scheme logic. This feature can be used to enable/disable relay functions. In the 'Normal' mode the function key output will remain 'high' as long as key is pressed.				
17	1F	Fn Key 10 Label	Function Key 10	From 32 to 234 step 1
Allows the text of the function key to be changed to something more suitable for the application.				

Table 44 - Function keys

4.15 PB Config

The Process Bus board must be configured to the system and application by means of appropriate settings. The sequence in which the settings are listed and described in this section will be the **PB CONFIG** submenu in the IED submenu.

Col	Row	Menu Text	Default Setting	Available Setting	P543 / P545 No Distance	P544 / P546 No Distance	P543 / P545	P544 / P546
Description								
18	00	PB CONFIG			*	*	*	*
This column contains settings and status parameters relative to process bus								
18	01	MU OOS CONFIG	00000000(bin)	8 bits setting, 0 = MU OOS Disabled, 1 = MU OOS Enabled	*	*	*	*
Used to set one or more Merging Units to be run in Out of Service mode .								
18	02	AntiAlais Filter	Disabled	0 = Disabled, 1 = Enabled	*	*	*	*
This cell activates or deactivates the anti-aliasing filter, which conditions the Sampled Values from the Process Bus network.								
18	03	SMV Version	IEC61850=9-2LE	0=IEC61850=9-2LE, 1 = IEC61869	*	*	*	*
This cell selects which version of sampled values are used, if it is set to IEC61850-9-2LE, device will subscribe the sampled value compliant with IEC61850-9-2LE, otherwise, device will subscribe the sampled value compliant with IEC61869. If the MU device is configured to published IEC61850-9-2 compatible frames, the setting should be set to IEC61850-9-2LE.								
18	04	MUs Delay Offset	0s	From 0s to 3ms step 250us	*	*	*	*
This cell adjusts the maximum time-delay offset starting at the reception of the Ethernet message from the "first" Merging Unit (MU) to the reception of the Ethernet message from the "last" Merging Unit (MU). This time-delay should be adjusted to ensure all MU samples for the same time instant are received before sending to the relay processor.								
18	05	Mon Delay Offset	No	0 = No, 1 = Yes	*	*	*	*
When sampled values are received at the IED from different Merging Units, they do not arrive simultaneously due to differences in Merging Unit performance or different network path delays. After this setting is set to Yes, a command to monitor the maximum time-delay will be sent to Process Bus board. After Process Bus board has calculated a delay, it will send the delay time to main board for users to set a proper MUs Delay Offset.								

Col	Row	Menu Text	Default Setting	Available Setting	P543 / P545 No Distance	P544 / P546 No Distance	P543 / P545	P544 / P546
Description								
18	06	Max Delay Offset			*	*	*	*
This setting specifies the maximum time-delay supervised, supervision starting at the reception of the sampled value frame from the "first" Merging Unit to the reception of the sampled value frame from the last Merging Unit for each sample count. If >3ms, a -1 will be displayed.								
18	30	Synchro Mode	No SYNC CLK	0 = No SYNC CLK, 1 = Local Clock, 2 = Global Clock	*	*	*	*
This setting specifies the type of Sampled Value synchronization expected by the IED, depending on the application. Global Clock: The Sampled Values are synchronized with a global area clock (GPS like clock). Local Clock: The Sampled Values are synchronized with a local area clock signal at the substation. Sampled Value frames received with Global or Local synchronization are acceptable with this setting. No SYNC CLK: The Sampled Values do not need to be synchronized. With this setting the IED ignores the synchronization flag in the Sampled Value frames. "No SYNC CLK" is not allowed for P54x Phase Differential protection as it will cause Phase Differential protection mal-operation. For P54x Phase Differential protection, when Local Clock is selected, 1PPS of all Merging Units and P54x IEDs in the scheme must be connected to the same time source.								
18	31	SV Absence Alm			*	*	*	*
This is a data cell with 8 binary flags. It indicates the presence or absence of Sampled Values from each of the Merging Units the IED is communicating with. The cell data for each Merging Unit is continuously refreshed. Unused MUs will indicate a 0. 0: Sampled Values being received from the Merging Unit. 1: No Sampled Values being received from the Merging Unit.								
18	32	SV SmpSynch Alm			*	*	*	*
This is a data cell with 8 binary flags. It indicates whether the Sampled Values being received from each of the Merging Units has the Synchro as required by 1830 above. Unused MUs will indicate a 0 0: Sampled Values received are synchronized. 1: Sampled Values received are not synchronized.								
18	33	SV Test Alm				*		*
This is a data cell with a binary flag for each of the analogue groups within the relays. It indicates the status of the IEC 61850 Quality attribute 'Test' in the Sampled Value frame used for that channel. If a channel is marked Test then functions associated with that channel are blocked unless the relay is in 'Test Mode' or 'Contacts Blocked'								
18	33	SV Test Alm			*		*	
This is a data cell with a binary flag for each of the analogue groups within the relays. It indicates the status of the IEC 61850 Quality attribute 'Test' in the Sampled Value frame used for that channel. If a channel is marked Test then functions associated with that channel are blocked unless the relay is in 'Test Mode' or 'Contacts Blocked'								
18	33	SV Test Alm						
This is a data cell with a binary flag for each of the analogue groups within the relays. It indicates the status of the IEC 61850 Quality attribute 'Test' in the Sampled Value frame used for that channel. If a channel is marked Test then functions associated with that channel are blocked unless the relay is in 'Test Mode' or 'Contacts Blocked'								
18	34	SV Invalid Alm				*		*
This is a data cell with a binary flag for each of the analogue groups within the relay. It indicates the status of the IEC 61850 Quality attribute 'Invalid' in the Sampled Value frame used for that channel. If a channel is marked Invalid then functions associated with that channel are blocked.								
18	34	SV Invalid Alm			*		*	
This is a data cell with a binary flag for each of the analogue groups within the relay. It indicates the status of the IEC 61850 Quality attribute 'Invalid' in the Sampled Value frame used for that channel. If a channel is marked Invalid then functions associated with that channel are blocked.								
18	34	SV Invalid Alm						

Col	Row	Menu Text	Default Setting	Available Setting	P543 / P545 No Distance	P544 / P546 No Distance	P543 / P545	P544 / P546
Description								
This is a data cell with a binary flag for each of the analogue groups within the relay. It indicates the status of the IEC 61850 Quality attribute 'Invalid' in the Sampled Value frame used for that channel. If a channel is marked Invalid then functions associated with that channel are blocked.								
18	35	SV Quest Alm				*		*
This is a data cell with a binary flag for each of the analogue groups within the relay. It indicates the status of the IEC 61850 Quality attribute 'Questionable' in the Sampled Value frame used for that channel. If a channel is marked Questionable then functions associated with that channel are blocked.								
18	35	SV Quest Alm			*		*	
This is a data cell with a binary flag for each of the analogue groups within the relay. It indicates the status of the IEC 61850 Quality attribute 'Questionable' in the Sampled Value frame used for that channel. If a channel is marked Questionable then functions associated with that channel are blocked.								
18	35	SV Quest Alm						
This is a data cell with a binary flag for each of the analogue groups within the relay. It indicates the status of the IEC 61850 Quality attribute 'Questionable' in the Sampled Value frame used for that channel. If a channel is marked Questionable then functions associated with that channel are blocked.								

Table 45 - PB Config

4.16 IED Configurator (for IEC 61850 Configuration)

The contents of the IED CONFIGURATOR column (for IEC 61850 configuration) are mostly data cells, displayed for information but not editable. To edit the configuration, you need to use the IED (Intelligent Electronic Device) configurator tool within the Schneider Electric MiCOM S1 Studio software.

Col	Row	Menu Text	Default Setting	Available Setting	P543 / P545 No Distance	P544 / P546 No Distance	P543 / P545	P544 / P546
Description								
19	00	IED CONFIGURATOR			*	*	*	*
This column contains settings for IED Configurator settings (IEC61850 builds)								
19	05	Switch Conf.Bank	No action	0 = No action or 1 = Switch banks	*	*	*	*
Setting which allows the user to switch between the current configuration, held in the Active Memory Bank (and partly displayed below), to the configuration sent to and held in the Inactive Memory Bank.								
19	0A	Restore Conf.	No action	0 = No action or 1 = Restore Conf.	*	*	*	*
Used to restore data from MCL(MiCOM Configuration Language)/CID (Configured IED Descriptor) file. This file is specific, containing a single devices IEC61850 configuration information, and used for transferring data to/from the MiCOM IED.								
19	10	Active Conf.Name		Not Settable	*	*	*	*
IEC61850 versions only. The name of the configuration in the Active Memory Bank, usually taken from the SCL file.								
19	11	Active Conf.Rev		Not Settable	*	*	*	*
IEC61850 versions only. Configuration Revision number of the configuration in the Active Memory Bank, usually taken from the SCL file.								
19	20	Inact.Conf.Name		Not Settable	*	*	*	*
IEC61850 versions only. The name of the configuration in the Inactive Memory Bank, usually taken from the SCL file.								
19	21	Inact.Conf.Rev		Not Settable	*	*	*	*
IEC61850 versions only. Configuration Revision number of the configuration in the Inactive Memory Bank, usually taken from the SCL file.								

Col	Row	Menu Text	Default Setting	Available Setting	P543 / P545 No Distance	P544 / P546 No Distance	P543 / P545	P544 / P546
Description								
19	30	IP PARAMETERS			*	*	*	*
IP PARAMETERS								
19	31	IP Address 1		Not Settable	*	*	*	*
IEC61850 versions only. Displays the unique network IP address that identifies the relay on interface 1. A default IP address is encoded from MAC address 169.254.0.xxx, xxx = mod (The last byte of MAC1, 128) + 1.								
19	32	Subnet mask 1		Not Settable	*	*	*	*
IEC61850 versions only. Displays the sub-network mask for interface 1.								
19	33	Gateway 1		Not Settable	*	*	*	*
IEC61850 versions only. Displays the IP address of the gateway (proxy) that interface 1 is connected to.								
19	34	IP Address 2		Not Settable	*	*	*	*
Displays the unique network IP address that identifies the relay on interface 2. A default IP address is encoded from MAC address 169.254.0.xxx, xxx = mod (The last byte of MAC2, 128) + 1. Visible when redundant Ethernet card fitted.								
19	35	Subnet mask 2		Not Settable	*	*	*	*
Displays the sub-network mask for interface 2.								
19	36	Gateway 2		Not Settable	*	*	*	*
Displays the IP address of the gateway (proxy) that interface 2 is connected to.								
19	40	SNTP PARAMETERS			*	*	*	*
SNTP PARAMETERS								
19	41	SNTP Server 1		Not Settable	*	*	*	*
Displays the IP address of the primary SNTP server. Ethernet card fitted.								
19	42	SNTP Server 2		Not Settable	*	*	*	*
Displays the IP address of the secondary SNTP server. Ethernet card fitted.								
19	43	ROUTE RULE GTW 1			*	*	*	*
IEC61850 versions only.								
19	44	Dest. Network 1	0.0.0.0	<IP address of relay>	*	*	*	*
IEC61850 versions only. Displays the destination network address of the first route rule for gateway 1, if any.								
19	45	Subnet Mask 1	0.0.0.0	<Subnet mask of relay>	*	*	*	*
IEC61850 versions only. Displays the subnet mask of the first route rule for gateway 1, if any.								
19	46	Dest. Network 2	255.255.255.255	<IP address of relay>	*	*	*	*
IEC61850 versions only. Displays the destination network address of the second route rule for gateway 1, if any.								
19	47	Subnet Mask 2	255.255.255.255	<Subnet mask of relay>	*	*	*	*
IEC61850 versions only. Displays the subnet mask of the second route rule for gateway 1, if any.								
19	48	ROUTE RULE GTW 2			*	*	*	*
IEC61850 versions only.								
19	49	Dest. Network 1	0.0.0.0	<IP address of relay>	*	*	*	*
IEC61850 versions only. Displays the destination network address of the first route rule for gateway 2, if any.								
19	4A	Subnet Mask 1	0.0.0.0	<Subnet mask of relay>	*	*	*	*
IEC61850 versions only. Displays the subnet mask of the first route rule for gateway 2, if any.								
19	4B	Dest. Network 2	255.255.255.255	<IP address of relay>	*	*	*	*
IEC61850 versions only. Displays the destination network address of the second route rule for gateway 2, if any.								
19	4C	Subnet Mask 2	255.255.255.255	<Subnet mask of relay>	*	*	*	*

Col	Row	Menu Text	Default Setting	Available Setting	P543 / P545 No Distance	P544 / P546 No Distance	P543 / P545	P544 / P546
Description								
IEC61850 versions only. Displays the subnet mask of the second route rule for gateway 2, if any.								
19	4D	Act. Route Rule	No	0 = No or 1 = Yes	*	*	*	*
IEC61850 versions only. Active the route rules of gateways, if any.								
19	50	IEC 61850 SCL			*	*	*	*
IEC 61850 SCL								
19	51	IED Name		Not Settable	*	*	*	*
IED name, which is the unique name on the IEC 61850 network for the IED, usually taken from the SCL (Substation Configuration Language for XML) file.								
19	60	IEC 61850 GOOSE			*	*	*	*
IEC 61850 GOOSE								
19	70	GoEna	0000000000000000(bin)	Bit 00=gcb01 GoEna to Bit 0F=gcb16 GoEna	*	*	*	*
Setting to Disable (0) or Enable (1) the publishing of a GOOSE Control Block. Ethernet card fitted.								
19	71	Pub.simul.GOOSE	0000000000000000(bin)	Bit 00=gcb01 Sim Mode to Bit 0F=gcb16 Sim Mode	*	*	*	*
The Pub.Simul.GOOSE cell controls whether GOOSE are sent as Normal (0) or Simulated (1) GOOSE. When a GOOSE control block is set to Sim Mode its GOOSE is published as simulated. Simulated GOOSE are usually published by test equipment and this setting allows a test IED to be set up to simulate the IEDs in a substation.								
19	73	Sub.Siml.Signal	No	0 = No or 1 = Yes	*	*	*	*
In edition 2 mode when Sub.Sim.Signal is set to Yes the relay will look for simulated GOOSE or SV. If a simulated GOOSE or SV is found the relay will subscribe to it and will not respond to its normal GOOSE or SV until Sub.Siml.Signal is set to No. Other GOOSE or SV signals that are not being simulated will remain subscribing to normal GOOSE or SV. In edition 1 mode the relay will respond to both normal and test GOOSE.								

Table 46 - IED configurator (for IEC 61850 configuration)

4.17

56/64 kbit/s Fiber Teleprotection - InterMiCOM⁶⁴

The column **PROT COMMS/ IM64** is used to set up all the differential protection communications parameters required by differential protection and also the parameters required for teleprotection when Differential function is disabled and the relay is working as a Distance relay using InterMiCOM⁶⁴ for teleprotection purposes.

InterMiCOM⁶⁴ is a fiber-optic based teleprotection scheme, described in detail in the Operation and Application chapters of this manual. Only relays ordered with fiber ports support this feature. The communication uses 56 or 64 kbit/s channels.

In the settings listed here, Channel1 and Channel2 refer to the communications channels, and are associated with configuring the communications ports fitted to the co-processor board.

Each setting below that refers to Channel 2 is associated with the communications setting of the second communications channel (where fitted) and is visible only when 3 Terminal or Dual redundant teleprotection configuration is set.

Note InterMiCOM⁶⁴ provides 2 groups of 8 InterMiCOM⁶⁴ commands. These are referenced as Channel 1 / Channel 2. They have a subtly different meaning and should not be confused with communications channels 1 / 2.

InterMiCOM⁶⁴ input and output mapping has to be done in the Programmable Scheme Logic (PSL).

Col	Row	MENU TEXT	Default Setting	Available Setting	P543/P545 No Distance	P544/P546 No Distance	P543/P545	P544/P546
Description								
20	00	PROT COMMS/ IM64			*	*	*	*
This column contains settings for Current Differential/IM64 Configuration								
20	01	Scheme Setup	2 Terminal	0 = 3 Terminal, 1 = 2 Terminal, 2 = Dual Redundant	*	*	*	*
Settings to determine how many relay ends are connected in the differential zone or how many relays are connected to the teleprotection scheme for the protected line, with two or three ends possible. For a plain two terminal line, there is an additional option to use dual communication channels, to implement redundancy (i.e. employ a parallel "hot-standby" path).								
20	02	Address	0-0	0=0-0, 1=1-A, 2=2-A, 3=3-A, 4=4-A, 5=5-A, 6=6-A, 7=7-A, 8=8-A, 9=9-A, 10=10-A, 11=11-A, 12=12-A, 13=13-A, 14=14-A, 15=15-A, 16=16-A, 17=17-A, 18=18-A, 19=19-A, 20=20-A, 21=1-B, 22=2-B, 23=3-B, 24=4-B, 25=5-B, 26=6-B, 27=7-B, 28=8-B, 29=9-B, 30=10-B, 31=11-B, 32=12-B, 33=13-B, 34=14-B, 35=15-B, 36=16-B, 37=17-B, 38=18-B, 39=19-B, 40=20-B, 41=1-C, 42=2-C, 43=3-C, 44=4-C, 45=5-C, 46=6-C, 47=7-C, 48=8-C, 49=9-C, 50=10-C, 51=11-C, 52=12-C, 53=13-C, 54=14-C, 55=15-C, 56=16-C, 57=17-C, 58=18-C, 59=19-C, 60=20-C	*	*	*	*
In 3 terminal schemes, communicating groups of three relays may be configured. See below.								
20	03	Address	0-0	0=0-0, 1=1-A, 2=2-A, 3=3-A, 4=4-A, 5=5-A, 6=6-A, 7=7-A, 8=8-A, 9=9-A, 10=10-A, 11=11-A, 12=12-A, 13=13-A, 14=14-A, 15=15-A, 16=16-A, 17=17-A, 18=18-A, 19=19-A, 20=20-A, 21=1-B, 22=2-B, 23=3-B, 24=4-B, 25=5-B, 26=6-B, 27=7-B, 28=8-B, 29=9-B, 30=10-B, 31=11-B, 32=12-B, 33=13-B, 34=14-B, 35=15-B, 36=16-B, 37=17-B, 38=18-B, 39=19-B, 40=20-B	*	*	*	*
Setting for the unique relay address that is encoded in the Differential message and in the InterMiCOM64 sent message. The aim of setting the address is to establish pairs of relays which will only communicate with each other. Should an inadvertent fiber/MUX misrouting or spurious loopback occur, an error will be logged, and the erroneous received data will be rejected. As an example, in a 2 ended scheme the following address setting would be correct: Local relay: 1-A Remote relay: 1-B Address 0-0 is a universal address, whereby any relay will be free to communicate with any other (equivalent to disabling of the unique addressing). When PROT COMMS/IM64 is set to loop back mode, the address 0-0 will replace any existing address in the relay.								
20	10	Comms Mode	Standard	0 = Standard or 1 = IEEE C37.94	*	*	*	*

Col	Row	MENU TEXT	Default Setting	Available Setting	P543/P545 No Distance	P544/P546 No Distance	P543/P545	P544/P546
Description								
Setting that defines the data format that will be transmitted on the fiber outputs from the relay. If the Multiplexer accepts direct fiber inputs according to IEEE C37.94, the 'IEEE C37.94' setting is selected. For a direct fiber link between relays, and where the MUX connection is in electrical format (G.703), the 'Standard' message format needs to be set. For a setting change to take effect, rebooting of the relay will be required. The Comm Mode setting applies to both channels.								
20	11	Baud Rate Ch1	64kbits/s	0 = 64kbits/s or 1 = 56kbits/s	*	*	*	*
Channel 1 data rate setting for signalling between ends. The setting will depend on the MUX electrical interface, set 64kbit/s for G.703. For direct fiber connection between relays, 64kbit/s will offer slightly faster data transmission. The setting is invisible when IEEE C37.94 Comm Mode is selected.								
20	12	Baud Rate Ch2	64kbits/s	0 = 64kbits/s or 1 = 56kbits/s	*	*	*	*
Channel 2 data rate setting for signalling between ends. The setting will depend on the MUX electrical interface, set 64kbit/s for G.703. For direct fiber connection between relays, 64kbit/s will offer slightly faster data transmission. The setting is invisible when IEEE C37.94 Comm Mode is selected.								
20	13	Clock Source Ch1	Internal	0 = Internal or 1 = External	*	*	*	*
Setting that defines which clock source is used to synchronize data transmissions over channel 1. The setting will depend on communications configuration and external clock source availability. If relays are connected direct fiber over channel 1, 'Internal' setting should be selected. If channel 1 is routed via a multiplexer, either setting may be required (see Application Notes).								
20	14	Clock Source Ch2	Internal	0 = Internal or 1 = External	*	*	*	*
Setting that matches the clock source being used for data synchronization over channel 2.								
20	15	Ch1 N*64kbits/s	1	0 = Auto, 1 = 1, 2 = 2, 3 = 3, 4 = 4, 5 = 5, 6 = 6, 7 = 7, 8 = 8, 9 = 9, 10 = 10, 11 = 11 or 12 = 12	*	*	*	*
Setting for channel 1 when connected to MUX. When set to 'Auto' P54x will configure itself to match the multiplexer. The setting is visible only when IEEE C37.94 Comm Mode is selected.								
20	16	Ch2 N*64kbits/s	1	0 = Auto, 1 = 1, 2 = 2, 3 = 3, 4 = 4, 5 = 5, 6 = 6, 7 = 7, 8 = 8, 9 = 9, 10 = 10, 11 = 11 or 12 = 12	*	*	*	*
Setting for channel 2 when connected to Mux. The setting is visible only when IEEE C37.94 Comm Mode is selected.								
20	17	Comm Delay Tol	0.35ms	From 0.25ms to 1ms step 0.05ms	*	*	*	*
If successive calculated propagation times exceed this time delay setting, the relay will initiate a change in relay setting for a short time period ("Char Mod Time" setting) and will raise a Comm Delay Alarm.								
20	18	Comm Fail Timer	10s	From 100ms to 600s step 100ms	*	*	*	*
Time delay after which the 'Channel Fail Alarm' will be issued providing that no messages were received during the 'Channel Timeout' period or the 'Alarm Level' is exceeded.								
20	19	Comm Fail Mode	Ch 1 or 2 Fail	0 = Ch 1 Failure 1 = Ch 2 Failure 2 = Ch 1 or 2 Fail 3 = Ch 1 and 2 Fail	*	*	*	*
Fail mode setting that triggers the 'Channel Fail Alarm', providing that the Dual Redundancy or 3 ended scheme is set. Normally the alarm would be raised for any loss of an operational channel (logical OR combination). However, when relays in a 3 ended scheme are deliberately operated in Chain topology AND logic may be used, for indication when the scheme becomes finally inoperative, with no self-healing (signal rerouting) mode possible.								

Col	Row	MENU TEXT	Default Setting	Available Setting	P543/P545 No Distance	P544/P546 No Distance	P543/P545	P544/P546
Description								
20	1A	GPS Sync	GPS Disabled	0 = GPS Disabled, 1 = GPS Standard, 2 = GPS -> Inhibit, 3 = GPS -> Restrain	*	*	*	*
<p>Setting to define type of GPS Mode. Refer to Operating Guide for full explanation of settings. If set to GPS Disabled, Char Mod Time and Char Mod Ex are visible. Prop Delay Equal is invisible. If set to GPS Standard, Char Mod Time and Char Mod Ex are invisible. Prop Delay Equal is visible. If set to GPS -> Inhibit, Char Mod Time and Char Mod Ex are invisible. Prop Delay Equal is visible. If set to GPS -> Restrain, Char Mod Time, Char Mod Ex and Prop Delay Equal are visible.</p> <p>"GPS Disabled" is not allowed when P54x Process Bus IEDs are in the scheme as it will cause Phase Differential protection mal-operation.</p>								
20	1B	Char Mod Time	500ms	From 0s to 30s step 0.1ms	*	*	*	*
<p>Time delay during which the setting characteristic k1 is increased to 200% after successive calculated propagation delay time exceed the time delay setting Comm Delay Tol. This should be set to greater than the maximum switching delay expected.</p>								
20	1C	Prop Delay Equal	No Operation	0 = No operation or 1 = Restore Cdiff	*	*	*	*
<p>If a P54x relay working with GPS sample synchronization loses GPS and there is a further switch in the protection communications network, the relay becomes Inhibited. If GPS become active again, the relay will automatically reset. But if not, the user can remove the inhibited condition by using this setting. This should only be performed if it can be guaranteed that the communication receiver and transmitter path delays are equal. The setting is invisible when GPS Sync mode is disabled.</p>								
20	1D	Re-Configuration	Three Ended	0 = Three Ended, 1 = Two Ended, 2 = Two Ended, 3 = Two Ended	*	*	*	*
<p>This setting is to change the scheme from three ended scheme to two ended scheme or vice versa. An in deep explanation of relay performance for each case is given in chapter P54x/EN OP. The setting is invisible when 3 Terminal Scheme Setup is selected.</p>								
20	1E	Channel Timeout	100ms	From 100ms to 10s step 100ms	*	*	*	*
<p>A rolling time window beyond which any of the 8 IM signals that are set to 'Default' will be replaced by the corresponding 'IM_X Default Value' setting, providing that no valid message is received on that channel in the meantime. The 'Chnl Fail Alarm' timer will be also initiated. If only one channel is used, each out of 16 IM signals available that is set to 'Default' will convert to corresponding 'IM_X Default Value' If a Dual redundant or 3 ended scheme is selected, each out of 8 IM signals available that is set to 'Default' will convert to corresponding 'IM_X Default Value', but only for the affected channel.</p>								
20	1F	Alarm Level	0.25	From 0% to 100% step 0.1%	*	*	*	*
<p>Setting that is used to alarm for poor channel quality. If during a fixed 100 ms rolling window the number of invalid messages divided by the total number of messages that should be received (based upon the 'Baud Rate' setting) increase above the threshold, a 'Channel Fail Alarm' timer will be initiated.</p>								
20	20	Prop Delay Stats	Enabled	0 = Disabled or 1 = Enabled	*	*	*	*
<p>To enable (activate) or disable (turn off) the alarms of Maximum propagation delay time</p>								
20	21	MaxCh1 PropDelay	15ms	From 1ms to 50ms step 1ms	*	*	*	*
<p>When the protection communications are enabled, the overall propagation delay divided by 2 is calculated and the maximum value is determined and displayed in Measurements 4 column. This value is displayed and compared against this setting. If the setting is exceeded, an alarm MaxCh1 PropDelay (DDB 1386) is raised.</p>								
20	22	MaxCh2 PropDelay	15ms	From 1ms to 50ms step 1ms	*	*	*	*
<p>When the protection communications are enabled, the overall propagation delay divided by 2 is calculated and the maximum value is determined and displayed in Measurements 4 column. This value is displayed and compared against this setting. If the setting is exceeded, an alarm MaxCh2 PropDelay (DDB 1387) is raised.</p>								

Col	Row	MENU TEXT	Default Setting	Available Setting	P543/P545 No Distance	P544/P546 No Distance	P543/P545	P544/P546
Description								
20	23	TxRx Delay Stats	Enabled	0 = Disabled or 1 = Enabled	*	*	*	*
To enable (activate) or disable (turn off) the alarms of absolute difference between the Transmission and Reception propagation delay. This setting is visible only in case that GPS Sync is Enabled.								
20	24	MaxCh1 Tx-RxTime	15ms	From 1ms to 50ms step 1ms	*	*	*	*
When the protection communications and GPS Sync are enabled, the absolute difference between the Transmission and Reception propagation delay is calculated and the maximum value is determined and displayed in Measurements 4 column. This value is displayed and compared against this setting. If the setting is exceeded, an alarm MaxCh1 Tx-RxTime (DDB 1388) is raised.								
20	25	MaxCh2 Tx-RxTime	15ms	From 1ms to 50ms step 1ms	*	*	*	*
When the protection communications and GPS Sync are enabled, the absolute difference between the Transmission and Reception propagation delay is calculated and the maximum value is determined and displayed in Measurements 4 column. This value is displayed and compared against this setting. If the setting is exceeded, an alarm MaxCh2 Tx-RxTime (DDB 1389) is raised.								
20	26	GPS Fail Timer	0s	From 0s to 9999s step 100ms	*	*	*	*
Time delay setting after which the 'GPS Alarm' – DDB 310 is asserted following a loss of GPS signal or initiation by the GPS transient fail alarm function when active(see below).								
20	27	GPS Trans Fail	Disabled	0 = Disabled or 1 = Enabled	*	*	*	*
To enable (activate) or disable (turn off) the transient GPS Fail alarm function.								
20	28	GPS Trans Count	1	1 to 100 step 1	*	*	*	*
Sets the count for the number of failed GPS signals which must be exceeded in the set 'GPS Trans Timer' window after which the 'GPS Fail Timer' is initiated.								
20	29	GPS Trans Timer	1s	From 1s to 9999s step 100ms	*	*	*	*
Sets the rolling time window in which the 'GPS Trans Count' must be exceeded after which the 'GPS Fail Timer' is initiated.								
20	2B	GPS Sync los Dly	0s	From 0s to 9999s step 100ms	*	*	*	*
Time delay setting after which the 'GPS Alarm' – DDB 310 is asserted following a loss of GPS signal or initiation by the GPS transient fail alarm function when active(see below).								
20	30	IM1 Cmd Type	Permissive	0 = Direct or 1 = Permissive	*	*	*	*
Setting that defines the operative mode of the received InterMiCOM_1 signal. When 'Direct' tripping is chosen, for security reasons 2 consecutive valid messages have to be received before a change in the signal status will be acknowledged. That will impose an additional 1-2 ms delay comparing to 'Permissive' mode. Set 'Direct' in Direct Transfer Tripping (Intertripping) applications. Set 'Permissive' to accommodate any Permissive or Blocking scheme.								
20	31	IM1 FallBackMode	Default	0 = Default or 1 = Latched	*	*	*	*
Setting that defines the status of IM1 signal in case of heavy noise and message synchronization being lost. If set to Latching the last valid IM1 status will be maintained until the new valid message is received. If set to Default, the IM1 status, pre-defined by the user in IM1 Default Value cell will be set. A new valid message will replace IM1 Default Value, once the channel recovers.								
20	32	IM1 DefaultValue	0	0 to 1 step 1	*	*	*	*
Setting that defines the IM1 fallback status.								
20	34	IM2 Cmd Type	Permissive	0 = Direct or 1 = Permissive	*	*	*	*

Col	Row	MENU TEXT	Default Setting	Available Setting	P543/P545 No Distance	P544/P546 No Distance	P543/P545	P544/P546
Description								
Setting that defines the operative mode of the received InterMiCOM_2 signal. When 'Direct' tripping is chosen, for security reasons 2 consecutive valid messages have to be received before a change in the signal status will be acknowledged. That will impose an additional 1-2 ms delay comparing to 'Permissive' mode. Set 'Direct' in Direct Transfer Tripping (Intertripping) applications. Set 'Permissive' to accommodate any Permissive or Blocking scheme.								
20	35	IM2 FallBackMode	Default	0 = Default or 1 = Latched	*	*	*	*
Setting that defines the status of IM2 signal in case of heavy noise and message synchronization being lost. If set to Latching the last valid IM2 status will be maintained until the new valid message is received. If set to Default, the IM2 status, pre-defined by the user in IM2 Default Value cell will be set. A new valid message will replace IM2 Default Value, once the channel recovers.								
20	36	IM2 DefaultValue	0	0 to 1 step 1	*	*	*	*
Setting that defines the IM2 fallback status.								
20	38	IM3 Cmd Type	Permissive	0 = Direct or 1 = Permissive	*	*	*	*
Setting that defines the operative mode of the received InterMiCOM_3 signal. When 'Direct' tripping is chosen, for security reasons 2 consecutive valid messages have to be received before a change in the signal status will be acknowledged. That will impose an additional 1-2 ms delay comparing to 'Permissive' mode. Set 'Direct' in Direct Transfer Tripping (Intertripping) applications. Set 'Permissive' to accommodate any Permissive or Blocking scheme.								
20	39	IM3 FallBackMode	Default	0 = Default or 1 = Latched	*	*	*	*
Setting that defines the status of IM3 signal in case of heavy noise and message synchronization being lost. If set to Latching the last valid IM3 status will be maintained until the new valid message is received. If set to Default, the IM3 status, pre-defined by the user in IM3 Default Value cell will be set. A new valid message will replace IM3 Default Value, once the channel recovers.								
20	3A	IM3 DefaultValue	0	0 to 1 step 1	*	*	*	*
Setting that defines the IM3 fallback status.								
20	3C	IM4 Cmd Type	Permissive	0 = Direct or 1 = Permissive	*	*	*	*
Setting that defines the operative mode of the received InterMiCOM_4 signal. When 'Direct' tripping is chosen, for security reasons 2 consecutive valid messages have to be received before a change in the signal status will be acknowledged. That will impose an additional 1-2 ms delay comparing to 'Permissive' mode. Set 'Direct' in Direct Transfer Tripping (Intertripping) applications. Set 'Permissive' to accommodate any Permissive or Blocking scheme.								
20	3D	IM4 FallBackMode	Default	0 = Default or 1 = Latched	*	*	*	*
Setting that defines the status of IM4 signal in case of heavy noise and message synchronization being lost. If set to Latching the last valid IM4 status will be maintained until the new valid message is received. If set to Default, the IM4 status, pre-defined by the user in IM4 Default Value cell will be set. A new valid message will replace IM4 Default Value, once the channel recovers.								
20	3E	IM4 DefaultValue	0	0 to 1 step 1	*	*	*	*
Setting that defines the IM4 fallback status.								
20	40	IM5 Cmd Type	Permissive	0 = Direct or 1 = Permissive	*	*	*	*
Setting that defines the operative mode of the received InterMiCOM_5 signal. When 'Direct' tripping is chosen, for security reasons 2 consecutive valid messages have to be received before a change in the signal status will be acknowledged. That will impose an additional 1-2 ms delay comparing to 'Permissive' mode. Set 'Direct' in Direct Transfer Tripping (Intertripping) applications. Set 'Permissive' to accommodate any Permissive or Blocking scheme.								
20	41	IM5 FallBackMode	Default	0 = Default or 1 = Latched	*	*	*	*

Col	Row	MENU TEXT	Default Setting	Available Setting	P543/P545 No Distance	P544/P546 No Distance	P543/P545	P544/P546
Description								
Setting that defines the status of IM5 signal in case of heavy noise and message synchronization being lost. If set to Latching the last valid IM5 status will be maintained until the new valid message is received. If set to Default, the IM5 status, pre-defined by the user in IM5 Default Value cell will be set. A new valid message will replace IM5 Default Value, once the channel recovers.								
20	42	IM5 DefaultValue	0	0 to 1 step 1	*	*	*	*
Setting that defines the IM5 fallback status.								
20	44	IM6 Cmd Type	Permissive	0 = Direct or 1 = Permissive	*	*	*	*
Setting that defines the operative mode of the received InterMiCOM_6 signal. When 'Direct' tripping is chosen, for security reasons 2 consecutive valid messages have to be received before a change in the signal status will be acknowledged. That will impose an additional 1-2 ms delay comparing to 'Permissive' mode. Set 'Direct' in Direct Transfer Tripping (Intertripping) applications. Set 'Permissive' to accommodate any Permissive or Blocking scheme.								
20	45	IM6 FallBackMode	Default	0 = Default or 1 = Latched	*	*	*	*
Setting that defines the status of IM6 signal in case of heavy noise and message synchronization being lost. If set to Latching the last valid IM6 status will be maintained until the new valid message is received. If set to Default, the IM6 status, pre-defined by the user in IM6 Default Value cell will be set. A new valid message will replace IM6 Default Value, once the channel recovers.								
20	46	IM6 DefaultValue	0	0 to 1 step 1	*	*	*	*
Setting that defines the IM6 fallback status.								
20	48	IM7 Cmd Type	Permissive	0 = Direct or 1 = Permissive	*	*	*	*
Setting that defines the operative mode of the received InterMiCOM_7 signal. When 'Direct' tripping is chosen, for security reasons 2 consecutive valid messages have to be received before a change in the signal status will be acknowledged. That will impose an additional 1-2 ms delay comparing to 'Permissive' mode. Set 'Direct' in Direct Transfer Tripping (Intertripping) applications. Set 'Permissive' to accommodate any Permissive or Blocking scheme.								
20	49	IM7 FallBackMode	Default	0 = Default or 1 = Latched	*	*	*	*
Setting that defines the status of IM7 signal in case of heavy noise and message synchronization being lost. If set to Latching the last valid IM7 status will be maintained until the new valid message is received. If set to Default, the IM7 status, pre-defined by the user in IM7 Default Value cell will be set. A new valid message will replace IM7 Default Value, once the channel recovers.								
20	4A	IM7 DefaultValue	0	0 to 1 step 1	*	*	*	*
Setting that defines the IM7 fallback status.								
20	4C	IM8 Cmd Type	Permissive	0 = Direct or 1 = Permissive	*	*	*	*
Setting that defines the operative mode of the received InterMiCOM_8 signal. When 'Direct' tripping is chosen, for security reasons 2 consecutive valid messages have to be received before a change in the signal status will be acknowledged. That will impose an additional 1-2 ms delay comparing to 'Permissive' mode. Set 'Direct' in Direct Transfer Tripping (Intertripping) applications. Set 'Permissive' to accommodate any Permissive or Blocking scheme.								
20	4D	IM8 FallBackMode	Default	0 = Default or 1 = Latched	*	*	*	*
Setting that defines the status of IM8 signal in case of heavy noise and message synchronization being lost. If set to Latching the last valid IM8 status will be maintained until the new valid message is received. If set to Default, the IM8 status, pre-defined by the user in IM8 Default Value cell will be set. A new valid message will replace IM8 Default Value, once the channel recovers.								
20	4E	IM8 DefaultValue	0	0 to 1 step 1	*	*	*	*
Setting that defines the IM8 fallback status.								

Col	Row	MENU TEXT	Default Setting	Available Setting	P543/P545 No Distance	P544/P546 No Distance	P543/P545	P544/P546
Description								
20	60	Char Mod Reset	Disabled	0 = Disabled or 1 = Enabled	*	*	*	*
Setting to enable Char Mod Ex Time.								
20	61	Char Mod RstTime	500ms	From 0s to 30s step 0.1ms	*	*	*	*
If the Char Mod Time has started then the Char Mod Ex Timer runs. If at the end of this timer and until Char Mod Time has expired, the bias current is above 5% In, and differential current is below 10% of bias current on all phases, then the Char Mod Time will reset and the characteristic will return to normal. If these conditions are not met, then the characteristic remains increased for the duration of the Char Mod Time. Char Mod Ex Timer should be set greater than the minimum switching delay expected, and less than Char Mod Time.								

Table 47 - Prot comms/IM64

<i>Note</i>	<i>The IM1 – IM8 settings in the table above are applied the same to the 8 InterMiCOM⁶⁴ commands grouped as Channel 1 as to the 8 InterMiCOM⁶⁴ commands grouped as Channel 2. If IM1 Default Value is set to 0, then IM1 Channel 1, and IM1 Channel 2 will both default to 0.</i>
-------------	---

4.18 Control Input Labels

Col	Row	MENU TEXT	Default Setting	Available Setting
Description				
29	00	CTRL I/P LABELS	0	
This column contains settings for Control Input Labels				
29	01	Control Input 1	Control Input 1	From 32 to 234 step 1
Text label to describe each individual control input. This text is displayed when a control input is accessed by the hotkey menu. It is displayed in the programmable scheme logic description of the control input				
29	02	Control Input 2	Control Input 2	From 32 to 234 step 1
Text label to describe each individual control input. This text is displayed when a control input is accessed by the hotkey menu. It is displayed in the programmable scheme logic description of the control input				
29	03	Control Input 3	Control Input 3	From 32 to 234 step 1
Text label to describe each individual control input. This text is displayed when a control input is accessed by the hotkey menu. It is displayed in the programmable scheme logic description of the control input				
29	04	Control Input 4	Control Input 4	From 32 to 234 step 1
Text label to describe each individual control input. This text is displayed when a control input is accessed by the hotkey menu. It is displayed in the programmable scheme logic description of the control input				
29	05	Control Input 5	Control Input 5	From 32 to 234 step 1
Text label to describe each individual control input. This text is displayed when a control input is accessed by the hotkey menu. It is displayed in the programmable scheme logic description of the control input				
29	06	Control Input 6	Control Input 6	From 32 to 234 step 1
Text label to describe each individual control input. This text is displayed when a control input is accessed by the hotkey menu. It is displayed in the programmable scheme logic description of the control input				
29	07	Control Input 7	Control Input 7	From 32 to 234 step 1
Text label to describe each individual control input. This text is displayed when a control input is accessed by the hotkey menu. It is displayed in the programmable scheme logic description of the control input				
29	08	Control Input 8	Control Input 8	From 32 to 234 step 1
Text label to describe each individual control input. This text is displayed when a control input is accessed by the hotkey menu. It is displayed in the programmable scheme logic description of the control input				

Col	Row	MENU TEXT	Default Setting	Available Setting
Description				
29	19	Control Input 25	Control Input 25	From 32 to 234 step 1
Text label to describe each individual control input. This text is displayed when a control input is accessed by the hotkey menu. It is displayed in the programmable scheme logic description of the control input				
29	1A	Control Input 26	Control Input 26	From 32 to 234 step 1
Text label to describe each individual control input. This text is displayed when a control input is accessed by the hotkey menu. It is displayed in the programmable scheme logic description of the control input				
29	1B	Control Input 27	Control Input 27	From 32 to 234 step 1
Text label to describe each individual control input. This text is displayed when a control input is accessed by the hotkey menu. It is displayed in the programmable scheme logic description of the control input				
29	1C	Control Input 28	Control Input 28	From 32 to 234 step 1
Text label to describe each individual control input. This text is displayed when a control input is accessed by the hotkey menu. It is displayed in the programmable scheme logic description of the control input				
29	1D	Control Input 29	Control Input 29	From 32 to 234 step 1
Text label to describe each individual control input. This text is displayed when a control input is accessed by the hotkey menu. It is displayed in the programmable scheme logic description of the control input				
29	1E	Control Input 30	Control Input 30	From 32 to 234 step 1
Text label to describe each individual control input. This text is displayed when a control input is accessed by the hotkey menu. It is displayed in the programmable scheme logic description of the control input				
29	1F	Control Input 31	Control Input 31	From 32 to 234 step 1
Text label to describe each individual control input. This text is displayed when a control input is accessed by the hotkey menu. It is displayed in the programmable scheme logic description of the control input				
29	20	Control Input 32	Control Input 32	From 32 to 234 step 1
Text label to describe each individual control input. This text is displayed when a control input is accessed by the hotkey menu. It is displayed in the programmable scheme logic description of the control input				
29	21	Setting Input 33	Ctrl Setg I/P 33	From 32 to 234 step 1
Text label to describe each individual control input. This text is displayed when a control input is accessed by the hotkey menu. It is displayed in the programmable scheme logic description of the control input				
29	22	Setting Input 34	Ctrl Setg I/P 34	From 32 to 234 step 1
Text label to describe each individual control input. This text is displayed when a control input is accessed by the hotkey menu. It is displayed in the programmable scheme logic description of the control input				
29	23	Setting Input 35	Ctrl Setg I/P 35	From 32 to 234 step 1
Text label to describe each individual control input. This text is displayed when a control input is accessed by the hotkey menu. It is displayed in the programmable scheme logic description of the control input				
29	24	Setting Input 36	Ctrl Setg I/P 36	From 32 to 234 step 1
Text label to describe each individual control input. This text is displayed when a control input is accessed by the hotkey menu. It is displayed in the programmable scheme logic description of the control input				
29	25	Setting Input 37	Ctrl Setg I/P 37	From 32 to 234 step 1
Text label to describe each individual control input. This text is displayed when a control input is accessed by the hotkey menu. It is displayed in the programmable scheme logic description of the control input				
29	26	Setting Input 38	Ctrl Setg I/P 38	From 32 to 234 step 1
Text label to describe each individual control input. This text is displayed when a control input is accessed by the hotkey menu. It is displayed in the programmable scheme logic description of the control input				
29	27	Setting Input 39	Ctrl Setg I/P 39	From 32 to 234 step 1
Text label to describe each individual control input. This text is displayed when a control input is accessed by the hotkey menu. It is displayed in the programmable scheme logic description of the control input				
29	28	Setting Input 40	Ctrl Setg I/P 40	From 32 to 234 step 1
Text label to describe each individual control input. This text is displayed when a control input is accessed by the hotkey menu. It is displayed in the programmable scheme logic description of the control input				

Col	Row	MENU TEXT	Default Setting	Available Setting
Description				
29	29	Setting Input 41	Ctrl Setg I/P 41	From 32 to 234 step 1
Text label to describe each individual control input. This text is displayed when a control input is accessed by the hotkey menu. It is displayed in the programmable scheme logic description of the control input				
29	2A	Setting Input 42	Ctrl Setg I/P 42	From 32 to 234 step 1
Text label to describe each individual control input. This text is displayed when a control input is accessed by the hotkey menu. It is displayed in the programmable scheme logic description of the control input				
29	2B	Setting Input 43	Ctrl Setg I/P 43	From 32 to 234 step 1
Text label to describe each individual control input. This text is displayed when a control input is accessed by the hotkey menu. It is displayed in the programmable scheme logic description of the control input				
29	2C	Setting Input 44	Ctrl Setg I/P 44	From 32 to 234 step 1
Text label to describe each individual control input. This text is displayed when a control input is accessed by the hotkey menu. It is displayed in the programmable scheme logic description of the control input				
29	2D	Setting Input 45	Ctrl Setg I/P 45	From 32 to 234 step 1
Text label to describe each individual control input. This text is displayed when a control input is accessed by the hotkey menu. It is displayed in the programmable scheme logic description of the control input				
29	2E	Setting Input 46	Ctrl Setg I/P 46	From 32 to 234 step 1
Text label to describe each individual control input. This text is displayed when a control input is accessed by the hotkey menu. It is displayed in the programmable scheme logic description of the control input				
29	2F	Setting Input 47	Ctrl Setg I/P 47	From 32 to 234 step 1
Text label to describe each individual control input. This text is displayed when a control input is accessed by the hotkey menu. It is displayed in the programmable scheme logic description of the control input				
29	30	Setting Input 48	Ctrl Setg I/P 48	From 32 to 234 step 1
Text label to describe each individual control input. This text is displayed when a control input is accessed by the hotkey menu. It is displayed in the programmable scheme logic description of the control input				

Table 48 - Control input labels

4.19 Direct Access (Breaker Control and Hotkeys)

The Direct Access keys are the **0** and **1** keys situated directly below the LCD display. The user may assign the function of these two keys, to signal direct commands into the PSL logic. Two modes of use exist:

- Tripping and Closing commands to the circuit breaker
- **Hotkey** functions, whereby a mini menu of frequently required commands and operations is accessed. Operators can then easily access the required command, without needing to navigate the full relay menu.

Col	Row	MENU TEXT	Default Setting	Available Setting	P543/P545 No Distance	P544/P546 No Distance	P543/P545	P544/P546
Description								
09	00	CONFIGURATION			*	*	*	*
This column contains all the general configuration options								
09	01	Restore Defaults	No Operation	0 = No Operation, 1 = All Settings, 2 = Setting Group 1, 3 = Setting Group 2, 4 = Setting Group 3, 5 = Setting Group 4	*	*	*	*
Setting to restore a setting group to factory default settings. To restore the default values to the settings in any Group settings, set the 'restore defaults' cell to the relevant Group number. Alternatively it is possible to set the 'restore defaults' cell to 'all settings' to restore the default values to all of the IED's settings, not just the Group settings. The default settings will initially be placed in the scratchpad and will only be used by the relay after they have been confirmed by the user. Note: Restoring defaults to all settings includes the rear communication port settings, which may result in communication via the rear port being disrupted if the new (default) settings do not match those of the master station.								
09	02	Setting Group	Select via Menu	0 = Select via Menu or 1 = Select via PSL	*	*	*	*
Allows setting group changes to be initiated via Opto Input or via Menu								
09	03	Active Settings	Group 1	0 = Group 1, 1 = Group 2, 2 = Group 3, 3 = Group 4	*	*	*	*
Selects the active setting group.								
09	04	Save Changes	No Operation	0 = No Operation, 1 = Save, 2 = Abort	*	*	*	*
Saves all relay settings.								
09	05	Copy From	Group 1	0 = Group 1, 1 = Group 2, 2 = Group 3, 3 = Group 4	*	*	*	*
Allows displayed settings to be copied from a selected setting group								
09	06	Copy To	No Operation	0 = No Operation, 1 = Group 1, 2 = Group 2, 3 = Group 3	*	*	*	*
Allows displayed settings to be copied to a selected setting group (ready to paste).								
09	07	Setting Group 1	Enabled	0 = Disabled or 1 = Enabled	*	*	*	*

Col	Row	MENU TEXT	Default Setting	Available Setting	P543/P545 No Distance	P544/P546 No Distance	P543/P545	P544/P546
Description								
Settings Group 1. If the setting group is disabled from the configuration, then all associated settings and signals are hidden, with the exception of this setting (paste).								
09	08	Setting Group 2	Disabled	0 = Disabled or 1 = Enabled	*	*	*	*
Settings Group 2. If the setting group is disabled from the configuration, then all associated settings and signals are hidden, with the exception of this setting (paste).								
09	09	Setting Group 3	Disabled	0 = Disabled or 1 = Enabled	*	*	*	*
Settings Group 3. If the setting group is disabled from the configuration, then all associated settings and signals are hidden, with the exception of this setting (paste).								
09	0A	Setting Group 4	Disabled	0 = Disabled or 1 = Enabled	*	*	*	*
Settings Group 4. If the setting group is disabled from the configuration, then all associated settings and signals are hidden, with the exception of this setting (paste).								
09	0B	Distance	Enabled	0 = Disabled or 1 = Enabled			*	*
Only in models with Distance option. To enable (activate) or disable (turn off) the Distance Protection: ANSI 21P/21G.								
09	0C	Directional E/F	Enabled	0 = Disabled or 1 = Enabled			*	*
Only in models with Distance option. To enable (activate) or disable (turn off) the Directional Earth Fault (DEF) Protection used in a pilot aided scheme: ANSI 67N. This protection is independent from back up Earth fault protection described below.								
09	0F	Phase Diff	Enabled	0 = Disabled or 1 = Enabled	*	*	*	*
To enable (activate) or disable (turn off) the Differential Protection: ANSI 87. To get the differential protection fully active, it is necessary also to enable the differential protection in the group. Note that Phase Diff setting and InterMiCOM64 Fiber setting are mutually exclusive as with Phase Diff enabled, the digital message exchanged has the structure of the differential message (i.e. currents are sent to the remote end, etc) and with interMiCOM64 Fiber the digital message exchanged has the structure and properties of the InterMiCOM64 Fiber.								
09	10	Overcurrent	Disabled	0 = Disabled or 1 = Enabled	*	*	*	*
To enable (activate) or disable (turn off) the Phase Overcurrent Protection function. I> stages: ANSI 50/51/67P								
09	11	Neg Sequence O/C	Disabled	0 = Disabled or 1 = Enabled	*	*	*	*
To enable (activate) or disable (turn off) the Negative Sequence Overcurrent Protection function. I2> stages: ANSI 46/67								
09	12	Broken Conductor	Disabled	0 = Disabled or 1 = Enabled	*	*	*	*
To enable (activate) or disable (turn off) the Broken Conductor function. I2/I1> stage: ANSI 46BC								
09	13	Earth Fault	Disabled	0 = Disabled or 1 = Enabled	*	*	*	*
To enable (activate) or disable (turn off) the back up Earth Fault Protection function. IN >stages: ANSI 50/51/67N								
09	15	SEF/REF Prot'n	Disabled	0 = Disabled or 1 = Enabled	*	*	*	*
To enable (activate) or disable (turn off) the Sensitive Earth Fault/Restricted Earth fault Protection function. ISEF >stages: ANSI 50/51/67N. IREF>stage: ANSI 64.								
09	16	Residual O/V NVD	Disabled	0 = Disabled or 1 = Enabled	*	*	*	*
To enable (activate) or disable (turn off) the Residual Overvoltage Protection function. VN>stages: ANSI 59N								

Col	Row	MENU TEXT	Default Setting	Available Setting	P543/P545 No Distance	P544/P546 No Distance	P543/P545	P544/P546
Description								
09	17	Thermal Overload	Disabled	0 = Disabled or 1 = Enabled	*	*	*	*
To enable (activate) or disable (turn off) the Thermal Overload Protection function. ANSI 49.								
09	18	PowerSwing Block	Enabled	0 = Disabled or 1 = Enabled			*	*
Only in models with Distance option. To enable (activate) or disable (turn off) the power swing blocking/out of step: ANSI 68/78.								
09	1D	Volt Protection	Disabled	0 = Disabled or 1 = Enabled	*	*	*	*
To enable (activate) or disable (turn off) the Voltage Protection (under/overvoltage) function. V<, V> stages: ANSI 27/59.								
09	1E	Freq Protection	Disabled	0 = Disabled or 1 = Enabled	*	*	*	*
To enable (activate) or disable (turn off) the Frequency Protection (under/over frequency) function. F<, F> stages: ANSI 81O/U.								
09	1F	df/dt Protection	Disabled	0 = Disabled or 1 = Enabled	*	*	*	*
To enable (activate) or disable (turn off) the Rate of change of Frequency Protection function. df/dt> stages: ANSI 81R.								
09	20	CB Fail	Disabled	0 = Disabled or 1 = Enabled	*	*	*	*
To enable (activate) or disable (turn off) the Circuit Breaker Fail Protection function. ANSI 50BF.								
09	21	Supervision	Enabled	0 = Disabled or 1 = Enabled	*	*	*	*
To enable (activate) or disable (turn off) the Supervision (VTS & CTS) functions. ANSI VTS/CTS.								
09	23	System Checks	Disabled	0 = Disabled or 1 = Enabled	*	*	*	*
To enable (activate) or disable (turn off) the System Checks (Check Sync. and Voltage Monitor) function: ANSI 25.								
09	24	Auto-Reclose	Disabled	0 = Disabled or 1 = Enabled	*	*	*	*
To enable (activate) or disable (turn off) the Auto-reclose function. ANSI 79.								
09	25	Input Labels	Visible	0 = Invisible or 1 = Visible	*	*	*	*
Sets the Input Labels menu visible further on in the relay settings menu.								
09	26	Output Labels	Visible	0 = Invisible or 1 = Visible	*	*	*	*
Sets the Output Labels menu visible further on in the relay settings menu.								
09	28	CT & VT Ratios	Visible	0 = Invisible or 1 = Visible	*	*	*	*
Sets the Current & Voltage Transformer Ratios menu visible further on in the relay settings menu.								
09	29	Record Control	Visible	0 = Invisible or 1 = Visible	*	*	*	*
Sets the Record Control menu visible further on in the relay settings menu.								
09	2A	Disturb Recorder	Visible	0 = Invisible or 1 = Visible	*	*	*	*
Sets the Disturbance Recorder menu visible further on in the relay settings menu.								
09	2B	Measure't Setup	Visible	0 = Invisible or 1 = Visible	*	*	*	*
Sets the Measurement Setup menu visible further on in the relay settings menu.								
09	2C	Comms Settings	Visible	0 = Invisible or 1 = Visible	*	*	*	*

Col	Row	MENU TEXT	Default Setting	Available Setting	P543/P545 No Distance	P544/P546 No Distance	P543/P545	P544/P546
Description								
Sets the Communications Settings menu visible further on in the relay settings menu. These are the settings associated with the 2nd rear communications ports.								
09	2D	Commission Tests	Visible	0 = Invisible or 1 = Visible	*	*	*	*
Sets the Commissioning Tests menu visible further on in the relay settings menu.								
09	2E	Setting Values	Primary	0 = Primary or 1 = Secondary	*	*	*	*
This affects all protection settings that are dependent upon CT and VT ratios. All subsequent settings input must be based in terms of this reference.								
09	2F	Control Inputs	Visible	0 = Invisible or 1 = Visible	*	*	*	*
Activates the Control Input status and operation menu further on in the relay setting menu.								
09	35	Control I/P Config	Visible	0 = Invisible or 1 = Visible	*	*	*	*
Sets the Control Input Configuration menu visible further on in the relay setting menu.								
09	36	Ctrl I/P Labels	Visible	0 = Invisible or 1 = Visible	*	*	*	*
Sets the Control Input Labels menu visible further on in the relay setting menu.								
09	39	Direct Access	Enabled	0= Disabled, 1 = Enabled, 2 = Hotkey Only, or 3 = CB Ctrl Only	*	*	*	*
Defines what CB control direct access is allowed. The front direct access keys that are used as a short cut function of the menu may be: Disabled – No function visible on the LCD. Enabled – All control functions mapped to the Hotkeys and Control Trip/Close are available. Hotkey Only – Only control functions mapped to the Hotkeys are available on the LCD. CB Ctrl Only – Only Control Trip/Control Close command will appear on the relay's LCD. Not available on Chinese version relays (P54???????C???)								
09	41	InterMiCOM 64	Disabled	0 = Disabled or 1 = Enabled	*	*	*	*
To enable (activate) or disable (turn off) InterMiCOM64 (integrated 56/64kbit/s teleprotection). Note that Phase Diff setting and InterMiCOM64 Fiber setting are mutually exclusive as with Phase Diff enabled, the digital message exchanged has the structure of the differential message (i.e. currents are sent to the remote end, etc) and with InterMiCOM64 Fiber the digital message exchanged has the structure and properties of the InterMiCOM64 Fiber.								
09	50	Function Key	Visible	0 = Invisible or 1 = Visible	*	*	*	*
Sets the Function Key menu visible further on in the relay setting menu.								
09	70	VIR I/P Labels	Invisible	0 = Invisible or 1 = Visible	*	*	*	*
VIR I/P Labels Visible/Invisible								
09	80	VIR O/P Labels	Invisible	0 = Invisible or 1 = Visible	*	*	*	*
VIR O/P Labels Visible/Invisible								
09	90	Usr Alarm Labels	Invisible	0 = Invisible or 1 = Visible	*	*	*	*
USR Alarm Labels Visible/Invisible								
09	FB	RP1 Read Only	Disabled	0 = Disabled or 1 = Enabled	*	*	*	*

Col	Row	MENU TEXT	Default Setting	Available Setting	P543/P545 No Distance	P544/P546 No Distance	P543/P545	P544/P546
Description								
To enable (activate) or disable (turn off) Read Only Mode of Rear Port 1.								
09	FC	RP2 Read Only	Disabled	0 = Disabled or 1 = Enabled	*	*	*	*
To enable (activate) or disable (turn off) Read Only Mode of Rear Port 2.								
09	FD	NIC Read Only	Disabled	0 = Disabled or 1 = Enabled	*	*	*	*
Ethernet versions only. To enable (activate) or disable (turn off) Read Only Mode of Network Interface Card.								
09	FE	SettingValueBeh.	Independent	0 = Independent or 1 = Locked Mode	*	*	*	*
Independent: cell [092E] Setting Values will be independent in each interface. For example, the Front Port can have [092E] set to Secondary and a remote port can have [092E] set to Primary. Locked Mode: cell [092E] Setting Values are locked to the same value for all interfaces. All interfaces are have the same value for [092E]. Whichever interface selects Locked Mode will have its setting for [092E] applied to all interfaces. Any interface can then change [092E] and it will apply on all interfaces.								
09	FF	LCD Contrast	11	0 to 31 step 1	*	*	*	*
Sets the LCD contrast.								

Table 49 - Direct access (breaker control and “hotkeys”)

OPERATION

CHAPTER 5

Date (month/year):	01/2024
Products covered by this chapter:	This chapter covers the specific versions of the MiCOM products listed below. This includes only the following combinations of Software Version and Hardware Suffix.
Hardware suffix:	M
Software version:	K6
Connection diagrams:	10P54302 (SH 1 to 2) 10P54303 (SH 1 to 2) 10P54400 10P54404 (SH 1 to 2) 10P54405 (SH 1 to 2) 10P54502 (SH 1 to 2) 10P54503 (SH 1 to 2) 10P54504 (SH 1 to 2) 10P54600 10P54604 (SH 1 to 2) 10P54605 (SH 1 to 2) 10P54606 (SH 1 to 2)

CONTENTS

Page (OP) 5-

1	Operation of Individual Protection Functions	15
1.1	Phase Differential Characteristics	15
1.1.1	Time Alignment of Current Vectors	17
1.1.2	Capacitive Charging Current (all models)	21
1.1.3	CT Ratio Correction (all models)	22
1.1.4	Line Differential (87L) Conditioned to Overcurrent (OC)	22
1.2	Protection of Transformer Feeders	23
1.2.1	Transformer Magnetizing Inrush	23
1.2.2	3 to 2 Terminal Reconfiguration	30
1.2.3	Mesh Corner and 1½ Breaker Switched Substations	31
1.2.4	Stub Bus Protection	32
1.2.5	The Minimum Operating Current	32
1.3	Disabling/Enabling Differential Protection	33
1.4	Differential Relay Compatibility with Previous Versions	33
1.5	Differential Relay without Voltage Connections	33
1.6	Line Parameters Settings	34
1.6.1	Phase Rotation (Phase Sequence)	34
1.6.2	Tripping Mode - Selection of Single or 3-Phase Tripping	34
1.6.3	Selectable Zone Tripping Mode	35
1.6.4	Pole Dead Logic	36
1.6.5	Residual Compensation for Earth/Ground Faults	37
1.6.6	Mutual Compensation for Parallel Lines	38
1.7	Optional Distance Protection	38
1.8	Phase Fault Distance Protection (Distance option only) (for Software Versions BEFORE H3a)	39
1.9	Phase Fault Distance Protection (Distance option only) (for Software Version H3a and later)	39
1.10	Earth Fault Distance Protection (Distance option only) (for Software Versions BEFORE H3a)	40
1.11	Distance Protection Tripping Decision	41
1.12	Distance Protection Starting	42
1.13	Phase Selection (Distance option only)	43
1.13.1	Theory of Operation	43
1.14	Mho Element Polarization and Expansion (Distance option only)	45
1.14.1	Switch On To Fault Action for Zone 1 (Distance option only)	46
1.14.2	Offset Mho (Distance option only)	46
1.15	Quadrilateral Elements (Distance option only)	47
1.15.1	Directional Quadrilateral (Distance option only)	47

1.15.2	Offset Quadrilateral (Distance option only)	47
1.15.3	Reactance Line - Top Line of Quadrilateral (Distance option only)	48
1.15.4	Right Hand Resistive Reach Line (Distance option only)	50
1.15.5	Quadrilateral Phase Resistive Reaches (Distance option only)	50
1.16	Quadrilateral Ground Resistive Reaches (Distance option only)	50
1.17	Advanced Distance Elements Zone Settings (Distance option only)	51
1.17.1	Phase Fault Zone Settings (Distance option only)	51
1.17.2	Ground Fault Zone Settings (Distance option only)	51
1.17.3	Distance Zone Sensitivities (Distance option only)	52
1.18	Conventional and Capacitor VT Applications (Distance option only)	52
1.18.1	CVTs with Passive Suppression of Ferroresonance (Distance option only)	53
1.18.2	CVTs with Active Suppression of Ferroresonance (Distance option only)	53
1.19	Load Blinding (Load Avoidance) (Distance option only)	53
1.20	Distance Elements Basic Scheme Setting (Distance option only)	55
1.21	Power Swing Detection, Alarming and Blocking (Distance option only)	56
1.21.1	Detection of Power Swings (Distance option only)	56
1.21.2	Actions upon Power Swing Detection (Distance option only)	56
1.21.3	Detection of a Fault during a Power Swing (Distance option only)	57
1.21.4	Actions Upon Detection of a Fault during a Power Swing (Distance option only)	57
1.21.5	Power Swing Settings (Distance option only)	57
1.22	Out-of-Step Detection and Tripping (Distance option only)	59
1.22.1	Out of Step Detection (Distance option only)	59
1.23	Switch On To Fault (SOTF) and Trip On Reclose (TOR) (Distance Option only)	62
1.23.1	Switch On To Fault (SOTF) Mode	64
1.23.2	Trip On Reclose (TOR) Mode (Distance option only)	64
1.23.3	Polarization During Circuit Energization (Distance option only)	65
1.24	Directional Function - Setup DEF and Directional Comparison Elements (Distance Option only)	66
1.24.1	DEF Zero Sequence Polarization with "Virtual Current Polarizing" (Distance option only)	66
1.24.2	DEF Negative Sequence Polarization (Distance option only)	67
1.24.3	Delta Directional Comparison Principle and Setup (Distance option only)	67
1.24.4	Delta Directional Decision (Distance option only)	69
1.25	Channel Aided Schemes (Distance option only)	70
1.25.1	Distance Scheme PUR - Permissive Underreach Transfer Trip (Distance option only)	73
1.25.2	Distance Scheme POR - Permissive Overreach Transfer Trip (Distance option only)	75
1.25.3	Permissive Overreach Trip Reinforcement (Distance option only)	78
1.25.4	Permissive Overreach Scheme Weak Infeed Features (Distance option only)	78
1.25.5	Permissive Scheme Unblocking Logic - Loss of Guard (Distance option only)	79
1.25.6	Distance Scheme Blocking (Distance option only)	79
1.25.7	Distance Schemes Current Reversal Guard Logic (Distance option only)	81
1.25.8	Permissive Overreach Schemes Current Reversal Guard (Distance option only)	81
1.25.9	Blocking Scheme 1 and 2 Current Reversal Guard (Distance option only)	81

1.25.10	Aided DEF Ground Fault Scheme - Permissive Overreach (Distance option only)	82
1.25.11	Aided DEF Ground Fault Scheme – Blocking (Distance option only)	83
1.25.12	Delta Scheme POR - Permissive Overreach Transfer Trip (Distance option only)	83
1.25.13	Delta Blocking Scheme (Distance option only)	84
1.26	Zone 1 Extension and Loss of Load Schemes (Distance option only)	86
1.26.1	Zone 1 Extension Scheme (Distance option only)	86
1.26.2	Loss of Load (LoL) Accelerated Tripping (Distance option only)	87
1.27	Phase Fault Overcurrent Protection	90
1.27.1	Reset Characteristics for Overcurrent Elements	91
1.27.2	Directional Overcurrent Protection	91
1.27.3	Overcurrent (50)Backup to Line Differential (87L)	92
1.28	Voltage Memory / Synchronous Polarization	94
1.29	Thermal Overload Protection	95
1.29.1	Single Time Constant Characteristic	95
1.29.2	Dual Time Constant Characteristic (typically not applied for P54x)	96
1.30	Earth Fault (Ground Overcurrent), Sensitive Earth Fault (SEF) and Restricted Earth Fault (REF) Protection	96
1.30.1	IDG Curve	98
1.30.2	Restricted Earth Fault (REF) Protection	99
1.31	Directional Earth Fault (DEF) Protection	100
1.32	Residual Voltage Polarization	101
1.32.1	Negative Sequence Polarization (Not for SEF)	102
1.33	Negative Phase Sequence (NPS) Overcurrent Protection	103
1.33.1	Directionalizing the Negative Phase Sequence Overcurrent Element	104
1.34	Undervoltage Protection	105
1.35	Overvoltage Protection	107
1.35.1	Compensated Overvoltage	108
1.36	Residual Overvoltage (Neutral Displacement) Protection	109
1.37	Circuit Breaker Fail (CBF) Protection	110
1.37.1	Reset Mechanisms for Breaker Fail Timers	111
1.38	Broken Conductor Detection	115
1.39	Frequency Protection	115
1.40	Independent Rate of Change of Frequency Protection [81R]	117
1.40.1	Basic Functionality	117
1.41	Special Weak Infeed Logic for Stub End Transformer Terminals	119
<hr/>		
2	Communications between Relays	120
2.1	Communications Link Options	120
2.1.1	Direct Optical Fiber Link, 850 nm Multi-Mode Fiber	120
2.1.2	Direct Optical Fiber Link, 1300 nm Multi-Mode Fiber	120
2.1.3	Direct Optical Fiber Link, 1310 nm Single-Mode Fiber	121
2.1.4	Direct Optical Fiber Link, 1550 nm Single-Mode Fiber	121
2.1.5	IEEE C37.94 Interface to Multiplexer	121

2.1.6	Switched Communication Networks	122
2.1.7	Switched Communication Networks with Permanent or Semi-Permanent Split Routings	124
2.1.8	Optical Fiber to Electrical Interface Units	124
2.1.9	Multiplexer Link with G.703 Electrical Interface Using Auxiliary Optical Fibers and Type P-2M-L Interface	124
2.1.10	Multiplexer Link with G.703 Electrical Interface Using P-2M-L interface	125
2.1.11	Protection Communications Connection over Unconditioned Pilot Wires	125
2.1.12	Unconditioned 2 Wire Pilot Communications for Distances Greater than 1.2 km	125
2.1.13	Protection Communications Scheme Set-Up	125
2.1.14	Dual Redundant (“Hot Standby”)	125
2.1.15	Three Ended System	126
2.1.16	Protection Communications Address	126
2.1.17	Reconfiguration of Three-Ended System	127
2.1.18	User Reconfiguration	128
2.1.19	Energization Reconfiguration	129
2.2	InterMiCOM	130
2.2.1	Protection Signaling	130
2.2.2	InterMiCOM Variants	130
2.2.3	InterMiCOM Features	131
2.2.4	Definition of Teleprotection Commands	131
2.2.5	General Features & Implementation	132
2.2.6	Functional Assignment	132
2.3	MODEM InterMiCOM, EIA(RS)232 InterMiCOM or Copper InterMiCOM	134
2.3.1	Communications Media	134
2.3.2	General Features and Implementation	134
2.3.3	EIA(RS)232 Physical Connections	135
2.3.4	Direct Connection	135
2.3.5	EIA(RS)232 Modem Connection	136
2.3.6	RS422 Connection	136
2.3.7	Fiber Optic Connection	136
2.3.8	InterMiCOM Functional Assignment	137
2.4	InterMiCOM⁶⁴ Statistics & Diagnostics	138
2.4.1	InterMiCOM ⁶⁴ Scheme Setup - Application	138
2.4.2	Permissive Intertrip	139
2.4.3	Clock Source	139
2.4.4	Communication Alarm	140
2.4.5	Communication Error Statistics	140
2.4.6	Communications Delay Timer	140
2.4.7	Communications Fail Timer	140
2.4.8	Communications Fail Mode	141
2.4.9	Global Positioning System (GPS) Synchronizing Module	141
3	Operation of Non-Protection Functions	143
3.1	Voltage Transformer Supervision - Fuse Fail	143
3.1.1	Loss of One or Two-Phase Voltages	144

3.1.2	Loss of all Three Phase Voltages Under Load Conditions	144
3.1.3	Absence of Three Phase Voltages Upon Line Energization	144
3.1.4	VTS Logic	145
3.2	Current Transformer Supervision (CTS)	147
3.2.1	Differential CTS (no need of Local Voltage Measurements to Declare CTS)	147
3.2.2	Standard CTS (Voltage Dependant CTS no need of Communications to Declare CTS)	148
3.2.3	CTS Blocking	149
3.3	Transformer Magnetizing Inrush Detector	150
3.4	Function Keys	151
3.5	Setting Groups Selection	152
3.6	Control Inputs	153
3.7	Real Time Clock Synchronization via Opto-Inputs	155
3.8	Read Only Mode	156
3.8.1	Protocol/Port Implementation:	156
3.8.2	Courier Database Support	157
3.8.3	New DDB Signals	157
3.9	Fault Locator	158
3.9.1	Basic Theory for Ground Faults	158
3.9.2	Data Acquisition and Buffer Processing	158
3.9.3	Faulted Phase Selection	158
3.9.4	Fault Location Calculation	158
3.9.5	Obtaining the Vectors	159
3.9.6	Solving the Equation for the Fault Location	159
3.9.7	Mutual Compensation	160
4	Single CB Control: P543/P545 Operation	161
4.1	Single and Three Phase Auto-Reclosing	161
4.1.1	Time Delayed and High Speed Auto-Reclosing	161
4.1.2	Auto-Reclose Logic Inputs (P543/P545)	161
4.1.3	Internal Signals (P543/P545)	164
4.1.4	Auto-Reclose Logic Outputs (P543/P545)	164
4.1.5	Auto-Reclose Alarms (P543/P545)	165
4.1.6	Auto-Reclose Logic Operating Sequence (P543/P545)	166
4.1.7	Auto-Reclose: Main Operating Features (P543/P545)	169
4.1.8	Auto-Reclose Skip Shot 1 (P543/P545)	172
4.1.9	Auto-Reclose Logic Diagrams (P543/P545)	172
4.2	System Checks (including Check Synchronizer) (P543/P545)	179
4.2.1	Overview (P543/P545)	179
4.2.2	VT Selection (P543/P545)	179
4.2.3	Basic Functionality (P543/P545)	180
4.2.4	System Check Logic Outputs (P543/P545)	180
4.2.5	Check Sync 2 (P543/P545)	180
4.2.6	Synchronism Check (P543/P545)	181

4.3	Auto-Reclose/Check Synchronization Interface (P543/P545)	182
4.4	CB State Monitoring (P543/P545)	182
4.4.1	CB State Monitoring Features (P543/P545)	182
4.5	CB Condition Monitoring (P543/P545)	184
4.5.1	CB Condition Monitoring Features (P543/P545)	184
4.6	CB Control (P543/P545)	188
4.6.1	CB Control using Hotkeys (P543/P545)	191
4.6.2	CB Control using Function Keys (P543/P545)	191
5	Dual CB Control: P544/P546 Operation	193
5.1	Introduction	193
5.2	CB Scheme Designation (P544/P546)	193
5.3	Circuit Breaker Status (P544/P546)	194
5.4	Circuit Breaker Condition Monitoring (P544/P546)	195
5.4.1	Circuit Breaker Condition Monitoring Features (P544/P546)	195
5.5	Circuit Breaker Control (P544/P546)	202
5.5.1	CB Control using Hotkeys (P544/P546)	204
5.5.2	Circuit Breaker Control using Function Keys (P544/P546)	204
5.6	Single and Three Phase Auto-Reclosing (P544/P546)	206
5.6.1	Time Delayed and High Speed Auto-Reclosing (P544/P546)	206
5.6.2	Auto-Reclose Logic Inputs (P544/P546)	207
5.6.3	Internal Signals (P544/P546)	209
5.6.4	Auto-Reclose Logic Outputs (P544/P546)	209
5.6.5	Auto-Reclose Logic Operating Sequence (P544/P546)	210
5.6.6	Auto-Reclose: Main Operating Features (P544/P546)	213
5.7	Dual CB System Voltage Checks (P544/P546)	228
5.7.1	Dual CB System Checks Overview (P544/P546)	228
5.7.2	Dual CB System Voltage Checks Logic Diagrams (P544/P546)	228
5.7.3	Dual CB System Voltage Checks VT Selection (P544/P546)	228
5.7.4	Dual CB System Voltage Synchronism Checks (P544/P546)	229
5.7.5	Check Sync Enhancements for Dual CB Variants	230
5.8	Synchronism Check Functions (P544/P546)	231
5.8.1	Overview	231
5.8.2	Synchronous Systems and Asynchronous Systems/System Split	231
5.8.3	Synchronism Check Functions	231
6	P544/P546 CB Control and AR Figures	234
7	P544/P546 CB Control and AR Logic: Internal Signal Definitions	292

FIGURES

	Page (OP) 5-
Figure 1 - Relay bias characteristic	15
Figure 2 - Differential logic diagram	16
Figure 3 - Propagation delay measurement	17
Figure 4 - Example of switched synchronous digital hierarchy	19
Figure 5 - Data transmission	19
Figure 6 - Capacitive charging current	21
Figure 7 - Transformer magnetizing characteristic	24
Figure 8 - Magnetizing inrush waveforms	24
Figure 9 - Second harmonic restraint and blocking logic	27
Figure 10 - Fifth harmonic blocking logic	28
Figure 11 - Highset element logic	29
Figure 12 - Need for zero-sequence current filtering	30
Figure 13 - Breaker and a half application	31
Figure 14 - Stub bus protection	32
Figure 15 - Trip conversion scheme logic	34
Figure 16 - Pole dead logic for P543/P545	36
Figure 17 - Pole dead logic for P544/P546	37
Figure 18 - Phase fault Mho characteristics (Distance option only)	39
Figure 19 - Earth fault quadrilateral characteristics (Distance option only)	40
Figure 20 - General starting logic and end timers	42
Figure 21 - Phase to phase currents showing change for CN fault	43
Figure 22 - Expansion of zone 1 for the default polarizing setting $V_{pol}=1$ (Distance option only)	45
Figure 23 - Quadrilateral characteristics (directional line shown simplified) (Distance option only)	47
Figure 24 - Offset quadrilateral for zone 3 (Distance option only)	47
Figure 25 - Reactance line - top line of quadrilateral (Distance option only)	48
Figure 26 - Resistive reach line (load blinder) (Distance option only)	50
Figure 27 - Load blinder characteristics	54
Figure 28 - Basic scheme delayed trip (Distance option only)	55
Figure 29 - Power swing detected for 3 cycles continuous ΔI (Distance option only)	56
Figure 30 - Power swing blocking (Distance option only)	58
Figure 31 - Out-of-step detection characteristic (Distance option only)	59
Figure 32 - Out of step algorithm (Distance option only)	61
Figure 33 - Trip on close (Distance option only)	63
Figure 34 - Trip on close based on CNV level detectors (Distance option only)	64
Figure 35 - Sequence networks connection for an internal A-N fault (Distance option only)	68

Figure 36 - Aided scheme logic overview (Distance option only)	70
Figure 37 - Send logic (Distance option only)	71
Figure 38 - Receive logic (Distance option only)	72
Figure 39 - Aided tripping logic	72
Figure 40 - Permissive underreach transfer trip scheme (PUR) (Distance option only)	74
Figure 41 - PUR (Distance option only)	74
Figure 42 - Permissive overreach transfer trip scheme (POR) (Distance option only)	76
Figure 43 - POR Permissive OverReach	77
Figure 44 - Distance blocking scheme (BOP) (Distance option only)	80
Figure 45 - Example of fault current reverse of direction	81
Figure 46 - Blocking 1 (Distance option only)	81
Figure 47 - Blocking 2 (Distance option only)	82
Figure 48 - The DEF permissive scheme (Distance option only)	82
Figure 49 - Aided DEF (ground) permissive scheme logic (Distance option only)	82
Figure 50 - DEF blocking scheme (Distance option only)	83
Figure 51 - Aided DEF (ground) blocking scheme logic (Distance option only)	83
Figure 52 - Delta directional comparison POR scheme (Distance option only)	84
Figure 53 - Delta directional comparison BLOCKING scheme	85
Figure 54 - Zone 1 extension scheme	86
Figure 55 - Zone 1 extension	87
Figure 56 - Loss of load accelerated trip scheme (Distance option only)	88
Figure 57 - Loss of load (Distance option only)	89
Figure 58 - Directional overcurrent logic	92
Figure 59 - Thermal overload protection logic diagram	96
Figure 60 - IDG characteristic	98
Figure 61 - High impedance principle	99
Figure 62 - High impedance REF relay/CT connections	100
Figure 63 - Directional EF with neutral voltage polarization (single stage)	101
Figure 64 - Directional EF with negative sequence polarization (single stage)	102
Figure 65 - Negative sequence overcurrent non-directional operation	104
Figure 66 - Directionalizing the negative phase sequence overcurrent element	104
Figure 67 - Undervoltage - single and three-phase tripping mode (single stage)	105
Figure 68 - Overvoltage - single and three-phase tripping mode (single stage)	107
Figure 69 - Residual overvoltage logic (single stage)	109
Figure 70 - Decaying dc component	110
Figure 71 - Calculating a Zero Cross Detection Point using sample values	111
Figure 72 - CB Failure CB1 logic part 1	112
Figure 73 - CB Failure CB1 logic part 2	113
Figure 74 - Broken conductor logic	115
Figure 75 - Underfrequency logic (single stage)	116
Figure 76 - Overfrequency logic (single stage)	116

Figure 77 - Rate of change of frequency protection	117
Figure 78 - Weak infeed configuration on stub-fed radial circuit (parallel line is out of service)	119
Figure 82 - P540 850nm optical fibre connections	120
Figure 83 - P540 1300nm optical fibre connections	120
Figure 84 - P540 1310nm optical fibre connections	121
Figure 85 - P540 1550nm optical fibre connections	121
Figure 86 - Switched communication network	123
Figure 87 - Transient bias characteristic	123
Figure 88 - P54x connection to P-2M-L	124
Figure 89 - 3-terminal system connection	127
Figure 90 - Pictorial comparison of operating modes	132
Figure 91 - Example assignment of signals within the PSL	133
Figure 92 - Direct connection within the local substation	135
Figure 93 - InterMiCOM teleprotection via a MODEM link	136
Figure 94 - MODEM InterMiCOM teleprotection via a RS422 protocol	136
Figure 95 - MODEM InterMiCOM teleprotection via fiber optic	137
Figure 96 - Example assignment of signals within the PSL	137
Figure 97 - Triangulated InterMiCOM64 application	138
Figure 98 - Permissive intertrip	139
Figure 101 - VTS logic	146
Figure 102 - Differential CTS	148
Figure 103 - Voltage dependant CTS principle scheme	148
Figure 104 - Standard CTS	149
Figure 105 - Two-machine equivalent circuit	158
Figure 106 - Fault locator selection of fault current zero	159
Figure 107 - Auto-reclose timing diagram - single fault	167
Figure 108 - Auto-reclose timing diagram - repeated fault inception	167
Figure 109 - Auto-reclose timing diagram - fault with system synchronism	167
Figure 110 - Auto-reclose timing diagram - lockout for no checksynch	168
Figure 111 - Auto-reclose enable logic	172
Figure 112 - Auto-reclose single/three pole tripping	173
Figure 113 - Auto-reclose inhibit sequence count (P543/P545)	174
Figure 114 - Auto-reclose cycles (P543/P545)	175
Figure 115 - Auto-reclose close	176
Figure 116 - Auto-reclose lockout logic (P543/P545)	177
Figure 117 - Auto-reclose force 3-pole trip (P543/P545)	178
Figure 118 - Auto-reclose close notify (P543/P545)	178
Figure 119 - Ddb pole discrepancy trip (P543/P545)	178
Figure 120 - Auto-reclose/check sync interface (P543/P545)	182
Figure 121 - Circuit breaker condition monitoring - broken current (P543/P545)	185
Figure 122 - Circuit breaker condition monitoring - operation time (P543/P545)	186
Figure 123 - CB monitoring (P543/P545)	187

Figure 124 - Remote control of circuit breaker (P543/P545)	188
Figure 125 - Circuit breaker control (P543/P545)	190
Figure 126 - CB control hotkey menu	191
Figure 127 - CB control via function keys default PSL	192
Figure 128 - CB1 condition monitoring – broken current	197
Figure 129 - CB2 condition monitoring – broken current	197
Figure 130 - CB1 condition monitoring – operation time	198
Figure 131 - CB2 condition monitoring – operation time	199
Figure 132 - Circuit breaker 1 – monitoring	200
Figure 133 - Circuit breaker 2 – monitoring	201
Figure 134 - Remote control of circuit breaker	202
Figure 135 - Circuit breaker control via function keys default PSL	204
Figure 136 - Auto-reclose timing diagram – single breaker, single fault	212
Figure 137 - Auto-reclose timing diagram – repeated fault inception	212
Figure 138 - Auto-relse timing diagram leader/follower (1ph)	213
Figure 139 - Auto-relse timing diagram leader/follower (3ph)	213
Figure 140 - Synchro check functionality (P544/P546)	229
Figure AR-1 - Circuit breaker 1 - state monitor	235
Figure AR-2 - Circuit breaker 2 - state monitor	237
Figure AR-3 - CB1 & CB2 Open 1P, 2P, 2/3P, Any	237
Figure AR-4 - Circuit breaker in service	238
Figure AR-5 - Auto-reclose enable	238
Figure AR-6 - Lead & follower circuit breaker selection	239
Figure AR-7 - Leader/follower logic – 1 (for Software Versions BEFORE H1)	240
Figure AR-8 - Leader/follower logic – 1 (for Software Versions H1 and later)	241
Figure AR-9 - Leader/follower logic – 2	242
Figure AR-10 - Leader & follower AR modes enable	243
Figure AR-11 - Force three-phase trip	244
Figure AR-12 - Auto-reclose initiation	245
Figure AR-13 - Test trip & AR initiation	245
Figure AR-14 - CB1 1pole / 3-pole trip + AR initiation	246
Figure AR-15 - CB2 1 pole / 3-pole trip + AR initiation	247
Figure AR-16 - 1Ph, 2Ph & 3Ph fault memory	247
Figure AR-17 - CB1 Auto-reclose in progress	248
Figure AR-18 - CB2 Auto-reclose in progress	248
Figure AR-19 - Sequence counter	249
Figure AR-20 - Single phase AR cycle selection	250
Figure AR-21 - Protection re-operation + evolving fault + persistent fault	251
Figure AR-22 - Three phase AR cycle selection	252
Figure AR-23 - Dead time start enable	253
Figure AR-24 - Single phase AR lead CB dead time	254
Figure AR-25 - Three phase AR lead CB dead time enable	255
Figure AR-26 - Three phase AR lead CB dead time	255

Figure AR-27 - Follower AR enable (for Software Versions BEFORE H1)	256
Figure AR-28 - Follower AR enable (for Software Versions H1 and later)	257
Figure AR-29 - Single phase follower time	258
Figure AR-30 - Three phase follower time	259
Figure AR-31 - CB Auto close	260
Figure AR-32 - CB2 Auto close	261
Figure AR-33 - Prepare reclaim initiation	262
Figure AR-34 - Reclaim time	263
Figure AR-35 - Successful auto-reclose signals	264
Figure AR-36 - Reset CB1 successful AR indication	265
Figure AR-37 - Reset CB2 successful AR indication	266
Figure AR-38 - CB healthy & system check timers	267
Figure AR-39 - CB2 healthy & system check timers	267
Figure AR-40 - AR shots counters	268
Figure AR-41 - CB2 AR shots counters	269
Figure AR-42 - CB1 circuit breaker control	270
Figure AR-43 - CB2 circuit breaker control	271
Figure AR-44 - CB1 lead 3PAR system check	272
Figure AR-45 - CB2 lead 3PAR system check	273
Figure AR-46 - CB1 follow 3PAR system check	274
Figure AR-47 - CB2 follow 3PAR system check	275
Figure AR-48 - CB1 man. close system check	276
Figure AR-49 - CB2 man. close system check	277
Figure AR-50 - CB1 trip time monitor	278
Figure AR-51 - CB2 trip time monitor	279
Figure AR-52 - Auto-reclose lockout – CB1 (for Software Versions BEFORE H1)	280
Figure AR-53 - Auto-reclose lockout – CB1 (for Software Versions H1 and later)	281
Figure AR-54 - Auto-reclose lockout – CB1	282
Figure AR-55 - Auto-reclose lockout – CB2 (for Software Versions BEFORE H1)	283
Figure AR-56 - Auto-reclose lockout – CB2 (for Software Versions H1 and later)	284
Figure AR-57 - Auto-reclose lockout – CB2	285
Figure AR-58 - Reset CB1 lockout	285
Figure AR-59 - Reset CB2 lockout	286
Figure AR-60 - System checks – voltage monitor	287
Figure AR-61 - CB1 synch check signals	288
Figure AR-62 - CB2 synch check signals	289
Figure AR-63 - Pole discrepancy (for P54x except P546)	290
Figure AR-64 - Pole discrepancy (for P546 only)	290
Figure AR-65 - CB trip conversion	291

TABLES

	Page (OP) 5-
Table 1 - Basic scheme delayed trip (Distance option only)	55
Table 2 - Phase selector pickup and VNpol	67
Table 3 - Permissive scheme unblocking logic	79
Table 4 - Time delays associated with extended zone Z1X	86
Table 5 - IDMT curve descriptions, standards and constants	90
Table 6 - IDMT curve descriptions, standards and constants	91
Table 7 - Phases, operating currents and polarizing voltages	91
Table 8 - Functions, DDB numbers and descriptions	103
Table 9 - Functions, DDB numbers and descriptions	116
Table 10 - Functions, DDB numbers and descriptions	118
Table 11 - Address groups for two different relays	126
Table 12 - Address groups for three different relays	127
Table 13 - Pins, Acronyms and InterMiCOM Usage	135
Table 17 - Setting group active on relevant DDB signals	152
Table 18 - Control Inputs settings	153
Table 19 - Ctrl I/P Config settings	153
Table 20 - Ctrl I/P Labels settings	153
Table 21 - Time of Sync Pulse and Corrected times	155
Table 22 - Record Control settings	155
Table 23 - Contact positions, CB states and actions	183
Table 24 - CB Condition Min/Max values	184
Table 25 - Auxiliary contact position, CB state detected and Action	195
Table 26 - Circuit Breaker Condition Min/Max values	196
Table 27 - Leader CB, Leader AR mode, Follower CB and Follower AR Mode	206
Table 28 - System check options and settings	224
Table 29 - System check options and settings	225

1 OPERATION OF INDIVIDUAL PROTECTION FUNCTIONS

The MiCOM P54x is a line protection relay that includes phase differential protection on a per phase basis and optionally comprehensive full scheme distance protection. Each one of these protection functions can be configured to work separately or simultaneously. The distance protection can also be set to operate upon failure of the relay protection communications. With the inclusion of Aided Directional Earth Fault (DEF) the MiCOM P54x is a fully comprehensive and versatile line protection relay. The following sections detail the individual protection functions.

1.1 Phase Differential Characteristics

MiCOM P54x calculates the difference between the currents entering and leaving a protected zone. The protection operates when this difference exceeds a set threshold. Differential currents can also be generated during external fault conditions due to CT saturation. To provide stability for through fault conditions, the relay adopts a biasing technique. This method effectively raises the setting of the relay in proportion to the value of through fault current to prevent relay maloperation. The Relay bias characteristic diagram shows the operating characteristics of the P54x phase differential element. The differential current “I_diff” is calculated as the vector summation of the currents entering the protected zone. The bias current “I_bias” is the average of the measured current at each line end. It is found by the scalar sum of the currents at each terminal, divided by two. Each of these calculations is done on a phase-by-phase basis. The level of bias used for each element is the highest of the three calculated for optimum stability.

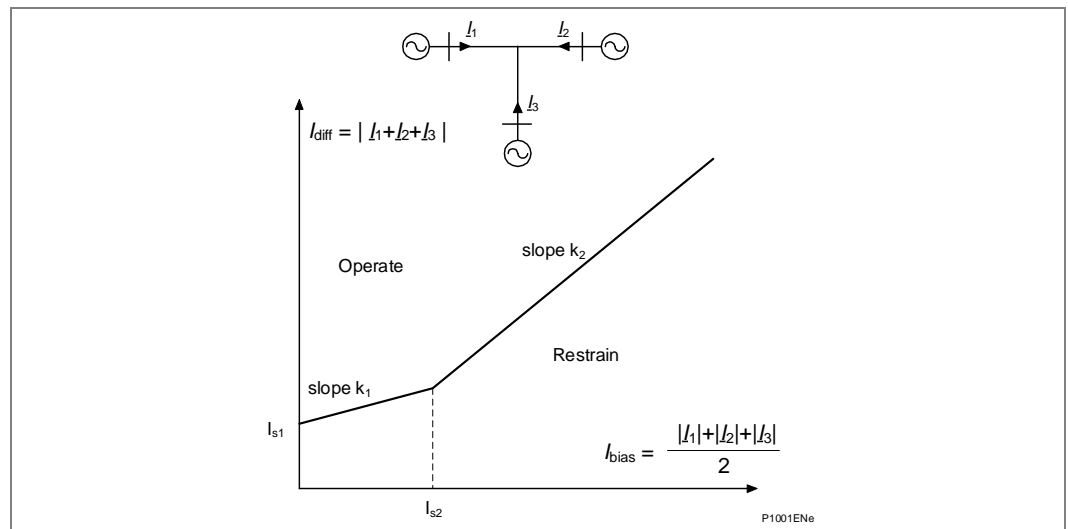

Figure 1 - Relay bias characteristic

The characteristic is determined by four protection settings:

- Is1 The basic differential current setting which determines the minimum pick-up level of the relay.
- k1 The lower percentage bias setting used when the bias current is below Is2. This provides stability for small CT mismatches, whilst ensuring good sensitivity to resistive faults under heavy load conditions.
- Is2 A bias current threshold setting, above which the higher percentage bias k2 is used.
- k2 The higher percentage bias setting used to improve relay stability under heavy through fault current conditions.

The tripping criteria can be formulated as:

1. For $|I_{bias}| < I_{s2}$,
 $|I_{diff}| > k1. |I_{bias}| + I_{s1}$
2. For $|I_{bias}| > I_{s2}$,
 $|I_{diff}| > k2. |I_{bias}| - (k2 - k1). I_{s2} + I_{s1}$

When a trip is issued by the differential element, in addition to tripping the local breaker, the relay will send a differential intertrip signal to the remote terminals. This will ensure tripping of all ends of the protected line, even for marginal fault conditions.

The differential protection can be time delayed using either a definite or inverse time characteristic.

The Id High Set element is an unrestrained element designed to provide high-speed operation in the event of CT saturation. Where transformer inrush restraint is used, the resultant second harmonic current produced from CT saturation may cause slow relay operation. The high set element will be automatically enabled when inrush restraint is enabled, otherwise it is not operational.

The logic diagram for Differential protection is shown in the following diagram:

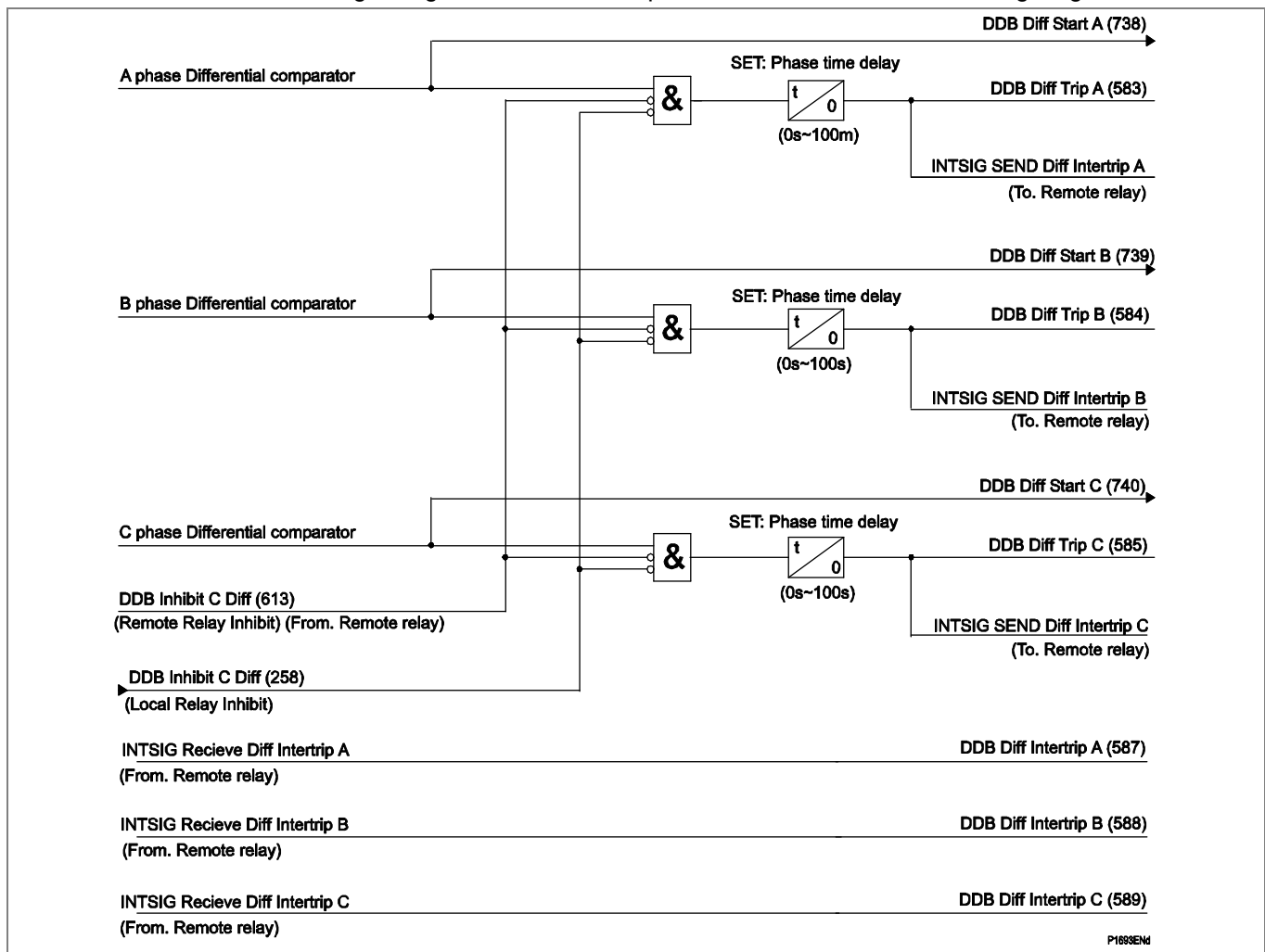

Figure 2 - Differential logic diagram

Note For 3 Terminal scheme, trip supervision is recommended.

1.1.1 Time Alignment of Current Vectors

1.1.1.1 Time Alignment of Current Vectors Without GPS (traditional technique)

This section relates to P54x relays when the GPS synchronization is not used.

To calculate differential current between line ends it is necessary that the current samples from each end are taken at the same moment in time. This can be achieved by time synchronizing the sampling, or alternatively, by the continuous calculation of the propagation delay between line ends. The P54x range of relays has adopted this second technique.

Consider a two-ended system shown in the Propagation delay measurement diagram.

Two identical relays, A and B are placed at the two ends of the line. Relay A samples its current signals at time tA1, tA2 etc., and relay B at time tB1, tB2 etc.

Note The sampling instants at the two ends will not, in general, be coincidental or of a fixed relationship, due to slight drifts in sampling frequencies.

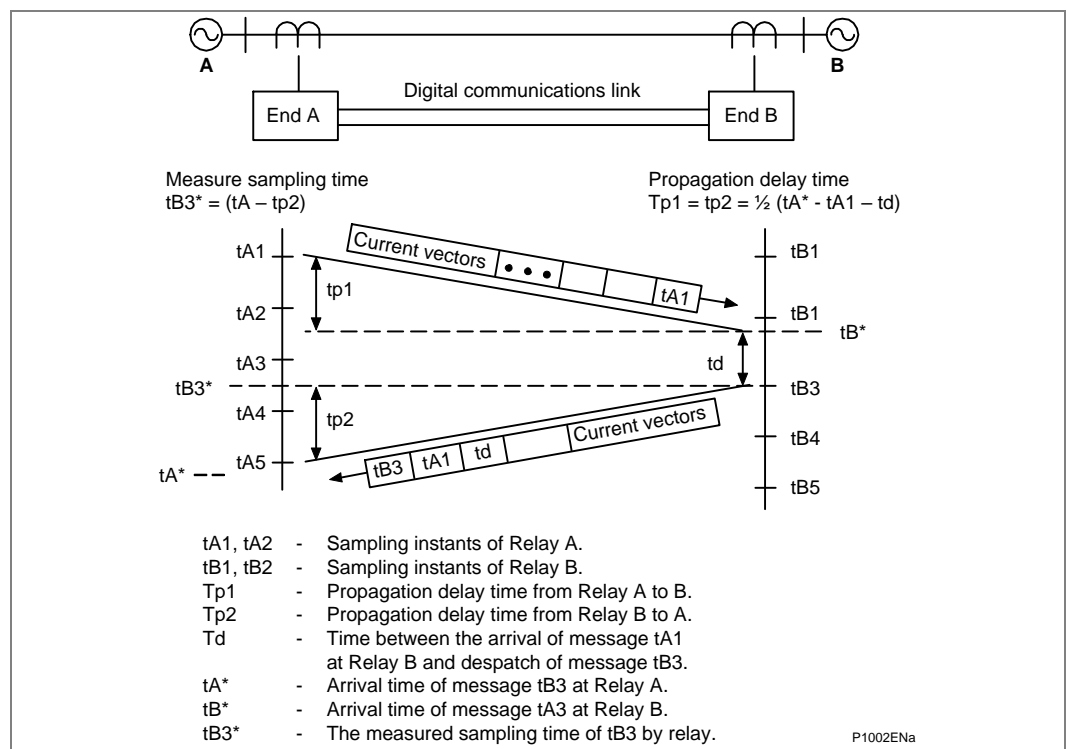

Figure 3 - Propagation delay measurement

Assume that at time tA1, relay A sends a data message to relay B. The message contains a time tag, tA1, together with other timing and status information and the current vector values calculated at tA1. The message arrives at end B after a channel propagation delay time, tp1. Relay B registers the arrival time of the message as tB*.

Since relays A and B are identical, relay B also sends out data messages to end A. Assume relay B sends out a data message at tB3. The message therefore contains the time tag tB3. It also returns the last received time tag from relay A (i.e. tA1) and the delay time, td, between the arrival time of the received message, tB*, and the sampling time, tB3, i.e. $t_d = (t_{B3} - t_{B^*})$.

The message arrives at end A after a channel propagation delay time, tp2. Its arrival time is registered by relay A as tA*. From the returned time tag, tA1, relay A can measure the total elapsed time as $(t_{A^*} - t_{A1})$. This equals the sum of the propagation delay times tp1, tp2 and the delay time td at end B.

Hence:

$$(t_{A^*} - t_{A1}) = (t_d + t_{p1} + t_{p2})$$

The relay assumes that the transmit and receive channels follow the same path and so have the same propagation delay time. This time can therefore be calculated as:

$$tp1 = tp2 = \frac{1}{2}(tA^* - tA1 - td)$$

Note *The propagation delay time is measured for each received sample and this can be used to monitor any change on the communication link.*

As the propagation delay time has now been deduced, the sampling instant of the received data from relay B (tB3*) can be calculated. As shown in the above Propagation delay measurement diagram, the sampling time tB3* is measured by relay A as:

$$tB3^* = (tA^* - tp2)$$

In the Propagation delay measurement diagram, tB3* is between tA3 and tA4. To calculate the differential and bias currents, the vector samples at each line end must correspond to the same point in time. It is necessary therefore to time align the received tB3* data to tA3 and tA4. This can be achieved by rotating the received current vector by an angle corresponding to the time difference between tB3* and tA3 (and tA4). For example a time difference of 1ms would require a vector rotation of $\frac{1}{20} * 360^\circ = 18^\circ$ for a 50 Hz system.

As two data samples can be compared with each data message, the process needs to be done only once every two samples, therefore reducing the communication bandwidth required.

Note *The current vectors of the three-phases need to be time aligned separately.*

1.1.1.2

Time Alignment of Current Vectors With GPS (all models)

The effect of the deployment of switched Synchronous Digital Hierarchy (SDH) networks on telecommunications circuits used in the application of numerical current differential protection to transmission lines.

Such telecommunications networks can be deployed in flexible, self-healing topologies. Typically, ring network topologies are employed and these are characterized by the ability to self-heal in the event of a failure of an interconnection channel.

Consider a simple ring topology with 6 nodes, A - F, and consider two equipment situated at nodes B and C. Under healthy conditions equipment at B communicates with equipment at C directly between nodes B and C and equipment at C communicates with equipment at B directly between nodes C and B. In this condition the communications propagation time between nodes B and C will be the same as that between nodes C and B and so the traditional technique described in could be used to apply numerical current differential protection (see the Example of switched synchronous digital hierarchy diagram).

If the link fails in one direction, say between the transmitter at node B and the receiver at node C, the self-healing ring can continue to transfer signals from node B to node C via the standby route through nodes B, A, F, E, D and then C (obviously a longer path). In this case the communication propagation delay times between nodes B and C differ in the two directions, and if the difference is greater than 1ms the traditional time alignment technique described in the Time Alignment of Current Vectors Without GPS (Traditional Technique) section is no longer adequate.

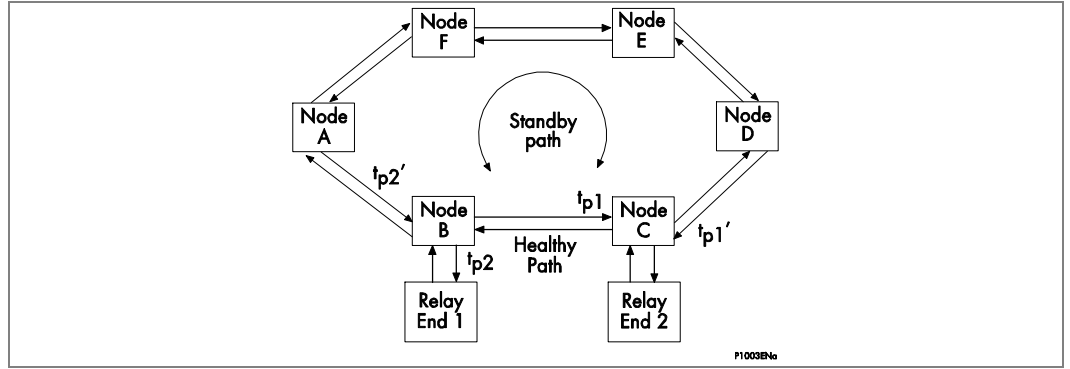

Figure 4 - Example of switched synchronous digital hierarchy

P54x make use of the timing information available from the GPS system to overcome the limitation of the traditional technique, and therefore allow application to communications that can provide a permanent or semi-permanent split path routing.

A 1 pulse per second output from a GPS receiver is used to ensure that the re-sampling of the currents at each relay occurs at the same instant in time. The technique is therefore not dependant on equal transmit and receive propagation delay times; changes in one or both of the propagation delay times also do not cause problems. These factors make it suitable for use with switched SDH networks.

The GPS technique is taken further, however, to overcome concerns about the reliability of the GPS system. Consider a similar two ended system to that shown in the Propagation delay measurement diagram where the re-sampling instants (t_{An} , t_{Bn}) are synchronized using the GPS timing information. Here the re-sampling instants at the two ends will be coincidental as shown in the Data transmission diagram.

Note The Data transmission diagram demonstrates a case where the communications path propagation delay times are not the same.

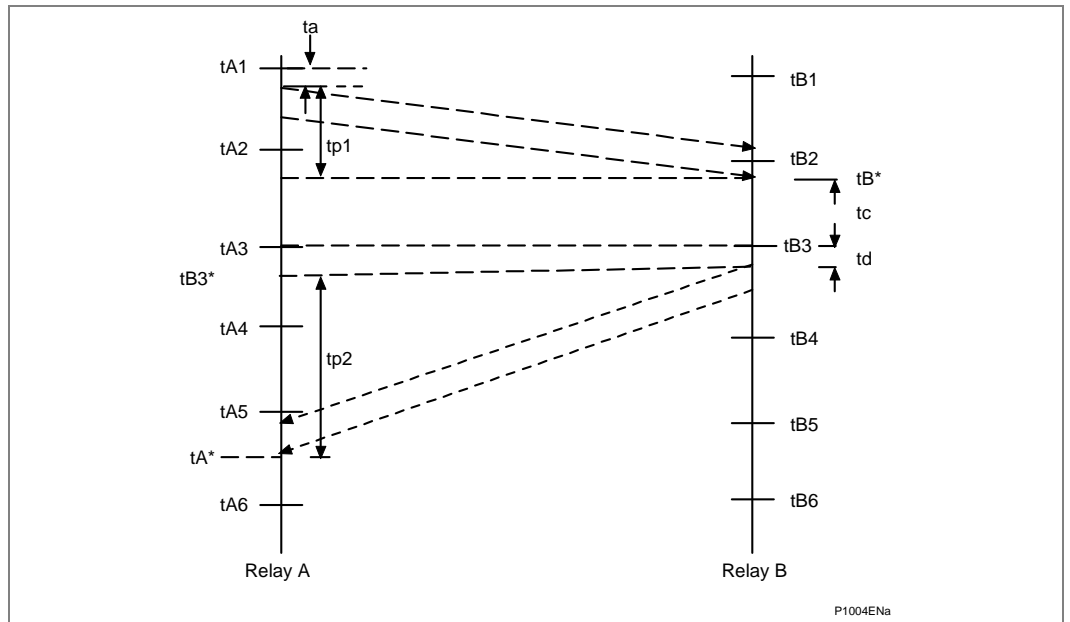

Figure 5 - Data transmission

Note Relay A can measure the total elapsed time = $(tA^* - tA1)$. This equals the sum of the propagation delay times $tp1$ and $tp2$, the delay in sending out the initial message ta , and the delay time $tc + td$ at end B. Hence

$$tp1 + tp2 = tA^* - tA1 - ta - tc - td$$

However, because of the GPS synchronization of the re-sampling instants, $tA3$ is at the same instant as $tB3$ (therefore $tB3^* = tA3$) we can use this knowledge to calculate the receive path delay

$$tp2 = tA^* - tA3 - td$$

And, by the same process the relay can also calculate $tp1$.

In the event of the GPS synchronizing signal becoming unavailable, the synchronization of the re-sampling instants at the different ends will be lost and the sampling will become asynchronous. However, the behavior depends on which mode is selected. If GPS -> Standard is selected, the time alignment of the current data will now be performed, by using the memorized value of propagation delay times prior to the GPS outage ($tp2$ in relay A and $tp1$ in relay B – (as shown in the Example of switched synchronous digital hierarchy diagram)). Each relay also keeps measuring the overall propagation delay, $tp1+tp2$. As long as the change in overall propagation delay does not exceed the setting value under PROT COMMS/IM64/Comm Delay Tol, it is considered that the communication path has not been switched, $tp2$ and $tp1$ at the two ends remains valid and the differential protection remains active. If the overall propagation delay exceeds the above mentioned setting, the differential protection will be inhibited. This patented “fallback” strategy ensures protection continuity even in the event of antenna vandalism, maintenance error, extremely adverse atmospheric conditions etc – all of which could result in GPS outage.

<i>Note</i>	<i>$tp1$ and $tp2$ do not need to be equal for the fallback strategy to become operational.</i>
-------------	---

If GPS -> Inhibit mode is selected and GPS synchronizing signal becomes unavailable and $tp1 = tp2$ then the time alignment is performed using the average loop delay. If at the time the GPS fails ($tp1$ not equal $tp2$, split path) then the time alignment can be performed using the memorized value of propagation delay prior to the GPS outage.

Each relay continues to measure the overall propagation delay, $tp1+tp2$. As long as the change in overall propagation delay does not exceed the Comm Delay Tol setting it is decided that the communication path has not been switched, $tp1$ and $tp2$ at the two ends remain valid and the protection remains active. If the change in overall propagation delay is greater than the Comm Delay Tol setting, the differential protection shall be inhibited.

If the GPS signal returns, continue in the GPS -> Standard mode of operation.

In GPS -> Restrain mode, behavior is similar to that of GPS -> Inhibit, except that when average loop delay is used, i.e. GPS Sync is lost, if the change in overall propagation delay is greater than the Comm Delay Tol setting, the differential protection shall be restrained by invoking the Char Mod Time functionality, and not inhibited.

<i>Note</i>	<i>For P54x Process Bus IEDs, in the event of the GPS synchronizing signal becoming unavailable and if the protection remains active, the communication path from Merging Units to P54x IED should not be switched.</i>
-------------	---

For P54x Process Bus IEDs, in the event of the GPS synchronizing signal becoming unavailable, the synchronization of the re-sampling instants at the different ends will be lost and the sampling will become asynchronous. However, the behavior depends on which mode is selected:

- 1) If GPS -> Standard is selected, the time alignment of the current data will now be performed, by using the memorized value of propagation delay times prior to the GPS outage (tp2 in relay A and tp1 in relay B – (as shown in the Example of switched synchronous digital hierarchy diagram)). Each relay also keeps measuring the overall propagation delay, tp1+tp2. As long as the change in overall propagation delay does not exceed the setting value under PROT COMMS/IM64/Comm Delay Tol, it is considered that the communication path has not been switched, tp2 and tp1 at the two ends remains valid and the differential protection remains active. If the overall propagation delay exceeds the above mentioned setting, the differential protection will be inhibited.
- 2) If GPS -> Inhibit mode is selected, the differential protection will be inhibited.
- 3) If GPS -> Restrain mode is selected, the differential protection will be inhibited.

Note It is not allowed that PROT COMMS/IM64 -> GPS Sync is set to "GPS Disable" for P54x Process Bus IEDs and P54x conventional IEDs communicating to with P54x Process Bus IEDs.

1.1.2

Capacitive Charging Current (all models)

The charging current of a line or cable will be seen as differential current. If this current is of a sufficiently high magnitude, as is the case for cables and long feeders, then relay maloperation could occur. Two issues are apparent with charging current; the first being inrush during line energization and the second being steady state charging current.

Inrush charging current is predominately high order harmonics (9th and 11th for example). The Fourier filtering used by the P54x relays will remove these frequency components and hence provide stability.

Steady state charging current is nominally at fundamental frequency and hence may cause relay maloperation.

To overcome this problem the P54x relays include a feature to extract the charging current from the measured current before the differential quantity is calculated.

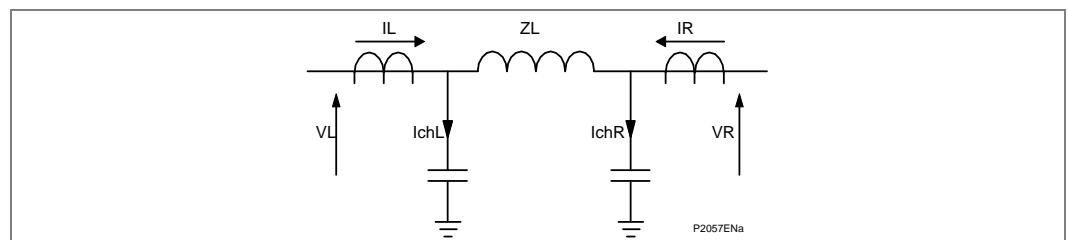

Figure 6 - Capacitive charging current

- IL = Local end line current
- Ir = Remote end line current
- VL = Local end voltage
- VR = Remote end voltage
- ZL = Line impedance
- IchL = Local end charging current
- IchR = Remote end charging current

By considering the Capacitive charging current diagram it is evident that the line charging current at a particular location is equal to the voltage at that location multiplied by the line positive sequence susceptance. It is therefore possible for the relays at each line end to calculate the respective line charging currents and compensate accordingly.

The differential current (I_d) can be calculated as follows:

$$I_d = I_L + I_R - (jV_L B_S/2) - (jV_R B_S/2)$$

$$I_d = \{I_L - (jV_L B_S/2)\} + \{I_R - (jV_R B_S/2)\}$$

$$I_d = \text{Local relay current} + \text{remote relay current}$$

Where BS is the line positive sequence susceptance.

This feature can be selectively enabled or disabled. If selected, the normal phase current data in the protection message is replaced by $\{I - (jVBS/2)\}$.

When applying a three end scheme with ends local (L), remote 1 (R1) and remote 2 (R2), the differential current is calculated as follows:

$$I_d = I_L + I_{R1} + I_{R2} - (jV_L B_s/3) - (jV_{R1} B_s/3) - (jV_{R2} B_s/3)$$

$$I_d = \{I_L - (jV_L B_s/3)\} + \{I_{R1} - (jV_{R1} B_s/3)\} + \{I_{R2} - (jV_{R2} B_s/3)\}$$

$$I_d = \text{Local relay current} + \text{remote 1 relay current} + \text{remote 2 relay current}$$

Where Bs is the total teed line positive sequence susceptance i.e.:

$$B_s = B_s \text{ from L-Tee} + B_s \text{ from R1 - Tee} + B_s \text{ from R2 - Tee}$$

The display of currents in the 'Measurements 3' column will be affected by this feature when selected.

1.1.3 CT Ratio Correction (all models)

To ensure correct operation of the differential element, it is important that under load and through fault conditions, the currents into the differential element of the relay balance. There are many cases where CT ratios at each end of the differential protection are different. Ratio correction factors are therefore provided. The CT ratio correction factors are applied to ensure that the signals to the differential algorithm are correct.

1.1.4 Line Differential (87L) Conditioned to Overcurrent (OC)

1.1.4.1 Selectable Overcurrent Conditioning (as from Software Version D1a)

In P54x devices, there sometimes needs to be a sufficient level of line current before allowing the differential protection to trip the circuit breakers. This can be implemented via the PSL using the existing overcurrent protection stages or via this additional dedicated overcurrent stage within the Line Differential protection menu.

Two menu cells with name OC Rel Status and I> Release are part of the phase differential menu. These additional settings are available via the relay menu ("GROUP x PHASE DIFF" menu Column).

Menu Text	Default setting	Setting Range
OC Rel Status	Disabled	Disabled or Enabled
I> Release	1.000A	0.08A to 4.0A, Step 0.01A

When "OC Rel Status" is set to Enabled, the differential protection will only issue a trip condition if the differential current is above the differential current tripping level and the line current is above the "I> Release" setting value.

When "OC Rel Status" is set to Disabled, the differential protection will issue a trip condition if the differential current is above the differential current tripping level.

The following DDBs have been added:

DDB No	Text	Description
DDB 1816	Diff Blk IA<	Overcurrent condition for phase differential trip blocking for phase A active (Current is less than setting threshold)
DDB 1817	Diff Blk IB<	Overcurrent condition for phase differential trip blocking for phase B active (Current is less than setting threshold)
DDB 1818	Diff Blk IC<	Overcurrent condition for phase differential trip blocking for phase C active (Current is less than setting threshold)

1.2 Protection of Transformer Feeders

Important	<p>These functions apply to the following products: P543. P544 using Software Version H1 or later. P545. P546 using Software Version H1 or later.</p>
------------------	--

MiCOM P543/P545 relays can be applied when power transformers are located in the differential zone. In order to obtain the correct performance of the relay for this application, MiCOM P543/P545 is provided with:

- Phase compensation to take into account any phase shift across the transformer, possible unbalance of signals from current transformers either side of windings, and the effects of the variety of earthing and winding arrangements. In P543 and P545, software Interposing CTs (ICTs) are provided to give the required compensation.
- Inrush blocking or restrain options to cater for high levels of magnetizing current during inrush conditions.
- For conditions where it is possible to temporarily load the transformer with a voltage in excess of the nominal voltage, the overfluxing blocking prevents unwanted tripping. The fifth harmonic blocking feature does not require a voltage signal. A fifth harmonic signal is derived from the differential current waveform on each phase and blocking is on a per phase basis. The overfluxing protection should be used in such applications to protect the transformer accordingly.
- CT ratio correction factor as mentioned in the *CT Ratio Correction (All Models)* section to match the transformer winding rated currents if needed.

On P543 or P545 relays where capacitive charging current compensation is available, there is a setting to select if capacitive charging current compensation is used or if interposing CTs are used.

1.2.1 Transformer Magnetizing Inrush

Important	<p>These functions apply to the following products: P543. P544 using Software Version H1 or later. P545. P546 using Software Version H1 or later.</p>
------------------	--

The magnetizing inrush current to a transformer appears as a large operating signal to the differential protection. Special measures are taken with the relay design to ensure that no maloperation occurs during inrush.

The *Transformer magnetizing characteristic* diagram shows a transformer magnetizing characteristic. To minimize material costs, weight and size, transformers are generally operated near to the 'knee point' of the magnetizing characteristic. Consequently, only a small increase in core flux above normal operating levels will result in a high magnetizing current.

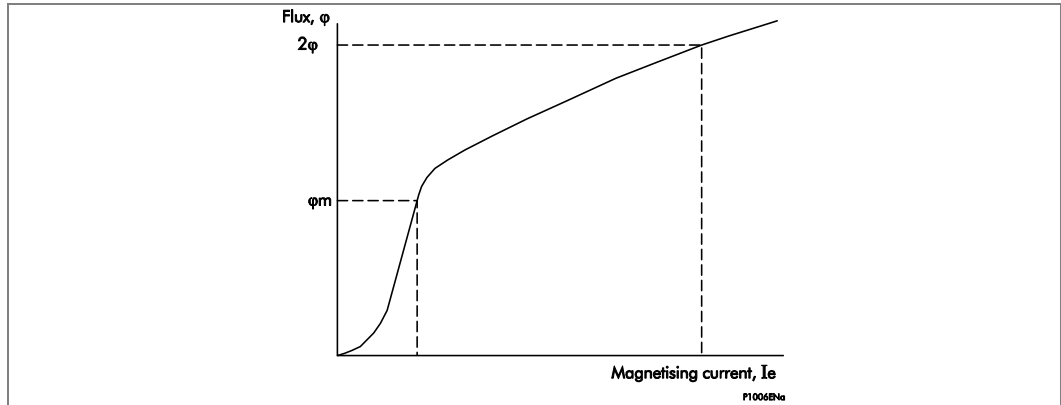

Figure 7 - Transformer magnetizing characteristic

Under normal steady state conditions, the magnetizing current associated with the operating flux level is relatively small (usually less than 1% of rated current). However, if a transformer winding is energized at a voltage zero, with no remnant flux, the flux level during the first voltage cycle (2 x normal max. flux) will result in core saturation and in a high, non-sinusoidal magnetizing current waveform. This current is commonly referred to as magnetizing inrush current and may persist for several cycles. The magnitude and duration of magnetizing inrush current waveforms are dependent upon a number of factors, such as transformer design, size, system fault level, point on wave of switching, number of banked transformers, etc. The *Magnetizing inrush waveforms* diagram shows typical transformer magnetizing currents for steady state and inrush conditions.

The magnetizing inrush current contains a high percentage of second harmonic. The P543 and P545 relays filter out this component of the waveform and use it as an additional bias quantity. The total bias used by the relay will therefore be a combination of the average load current on the line plus a multiple of the second harmonic component of the current. The multiplying factor is used to ensure stability and is a factory pre-set value.

Where P543 and P545 relays are used and inrush restrain function is enable, it must be ensure that this function is enabled at each end to avoid possible maloperation.

High set differential setting:

- When inrush restrain is enabled, a high set differential protection becomes active. This unrestrained instantaneous 'Id High Set' is provided to ensure rapid clearance for heavy internal faults with saturated CTs. The high set is not restrained by magnetizing inrush. A setting range $4 I_n - 32 I_n$ (RMS values) is provided on P543 and P545.

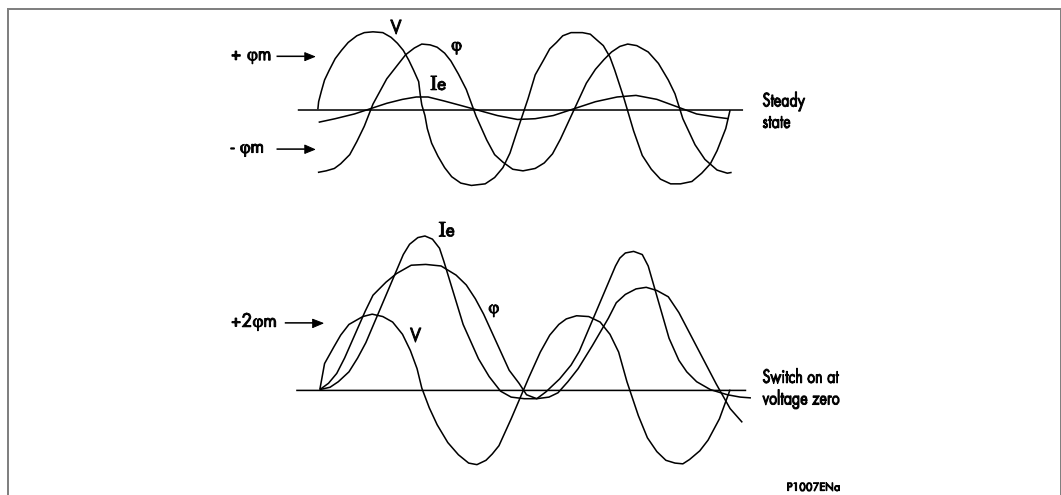

Figure 8 - Magnetizing inrush waveforms

The P543 and P545 relay provides a choice between harmonic restraint and blocking by setting option, both providing stability during transformer inrush conditions.

To select second harmonic Restraint or Blocking option, set the cell [3312: Inrush Restraint] under the **GROUP 1 PHASE DIFF** menu heading to Restraint or Blocking. Second harmonic restraints or blocking provide security during transformer energization.

1.2.1.1

Second Harmonic Restraint

Important	<p>These functions apply to the following products: P543. P544 using Software Version H1 or later. P545. P546 using Software Version H1 or later.</p>
------------------	--

The magnetizing inrush current contains a high percentage of second harmonic. The P543 and P545 relays filter out this component of the waveform and use it as an additional bias quantity. The total bias used by the relay will therefore be a combination of the average load current on the line plus a multiple of the second harmonic component of the current. The multiplying factor which is used to ensure stability is controlled by the setting cell [3314: Ih(2) Multiplier] under the **GROUP 1 PHASE DIFF** menu heading provided the setting cell [3312: Inrush Restraint] is set to Restraint .

This multiplier is used in additional bias calculation as per following formula:

IF Inrush Restraint setting is set to Restraint
 Additional bias = Ih(2) Multiplier * 1.414 * largest 2nd harmonic current
 ELSE
 Additional bias = 0

In the above equation 2nd harmonic current is derived from Fourier filtering techniques.

Where P543 and P545 relays are used and inrush restrain function is enabled, it must be ensured that this function is enabled at each end to avoid possible maloperation.

1.2.1.2

Second Harmonic Blocking

Important	<p>These functions apply to the following products: P543. P544 using Software Version H1 or later. P545. P546 using Software Version H1 or later.</p>
------------------	--

To select second harmonic blocking option, set the cell [3312: Inrush Restraint] under the **GROUP 1 PHASE DIFF** menu heading to Blocking.

Second harmonic blocking provides security during transformer energization.

For each phase, if the level of phase current is above 5% In, and if the ratio of second harmonic current, Ih(2) to fundamental in the line is above the settings at cell [3320: Ih(2) >%] then inrush conditions shall be detected which sets the appropriate phase block, to block local and remote ends.

Users have choice to apply Cross blocking or independent blocking by choosing the appropriate setting at cell [3321: Ih(2) CrossBlock] under the **GROUP 1 PHASE DIFF** menu heading. If **Ih(2) CrossBlock** is set to Disabled then independent blocking is used.

If independent blocking is enabled only the affected phase is blocked at all ends.If cross blocking is enabled all phases are blocked at all ends.

The following logic diagram shows the inhibiting of the differential algorithm by magnetizing inrush conditions:

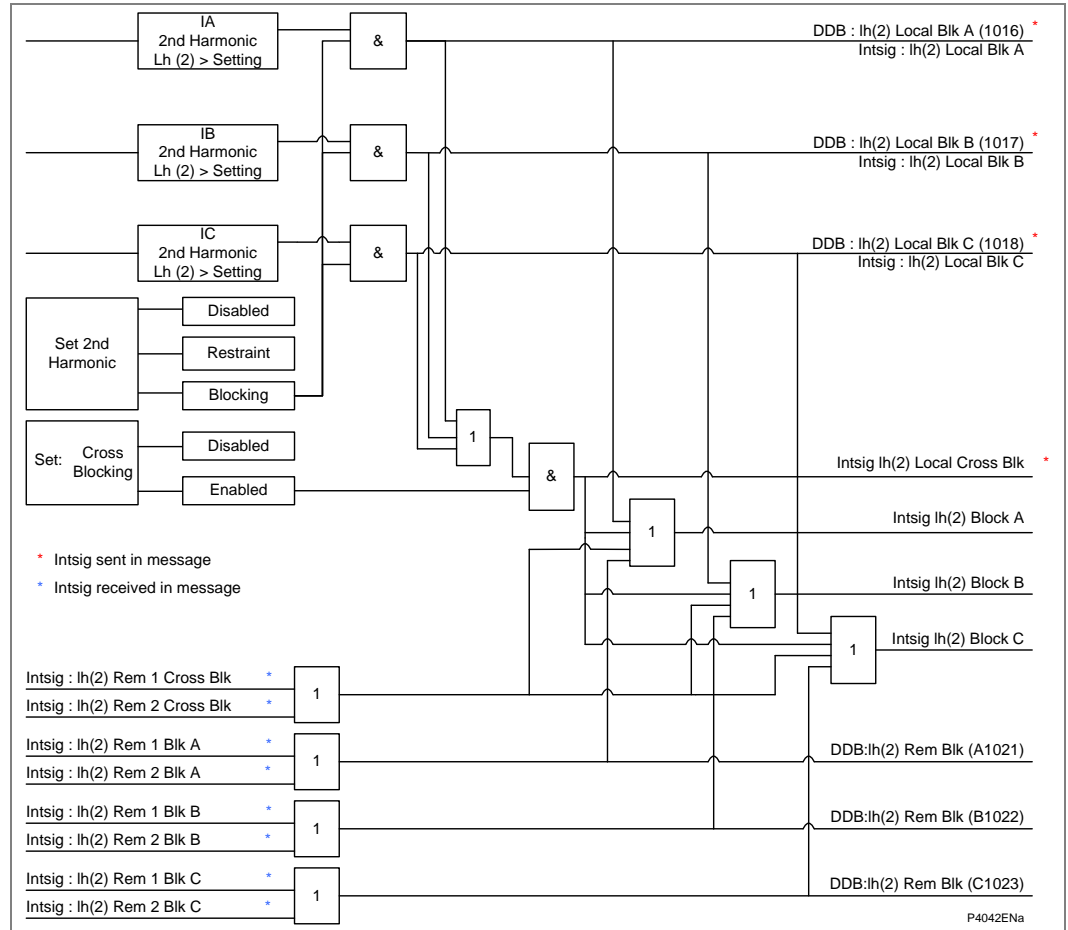

Figure 9 - Second harmonic restraint and blocking logic

1.2.1.3

Fifth Harmonic Blocking

Important **These functions apply to the following products:**
P543.
P544 using Software Version H1 or later.
P545.
P546 using Software Version H1 or later.

For each phase, if the level of phase current is above 5% I_n , and if the ratio of fifth harmonic current, $I_{h(5)}$ to fundamental in the line is above the settings at cell [3328: $I_{h(5)} > \%$] then the overfluxing conditions shall be detected which sets the appropriate phase block, to block local and remote ends.

Users have choice to apply Cross blocking or independent blocking by choosing the appropriate setting at cell [3329: $I_{h(5)}$ CrossBlock] under the **GROUP 1 PHASE DIFF** menu heading. If **$I_{h(5)}$ CrossBlock** is set to Disabled then independent blocking is used. If independent blocking is enabled only the affected phase is blocked at all ends. If cross blocking is enabled all phases are blocked at all ends.

The following logic diagram shows the inhibiting of the differential algorithm by overfluxing conditions:

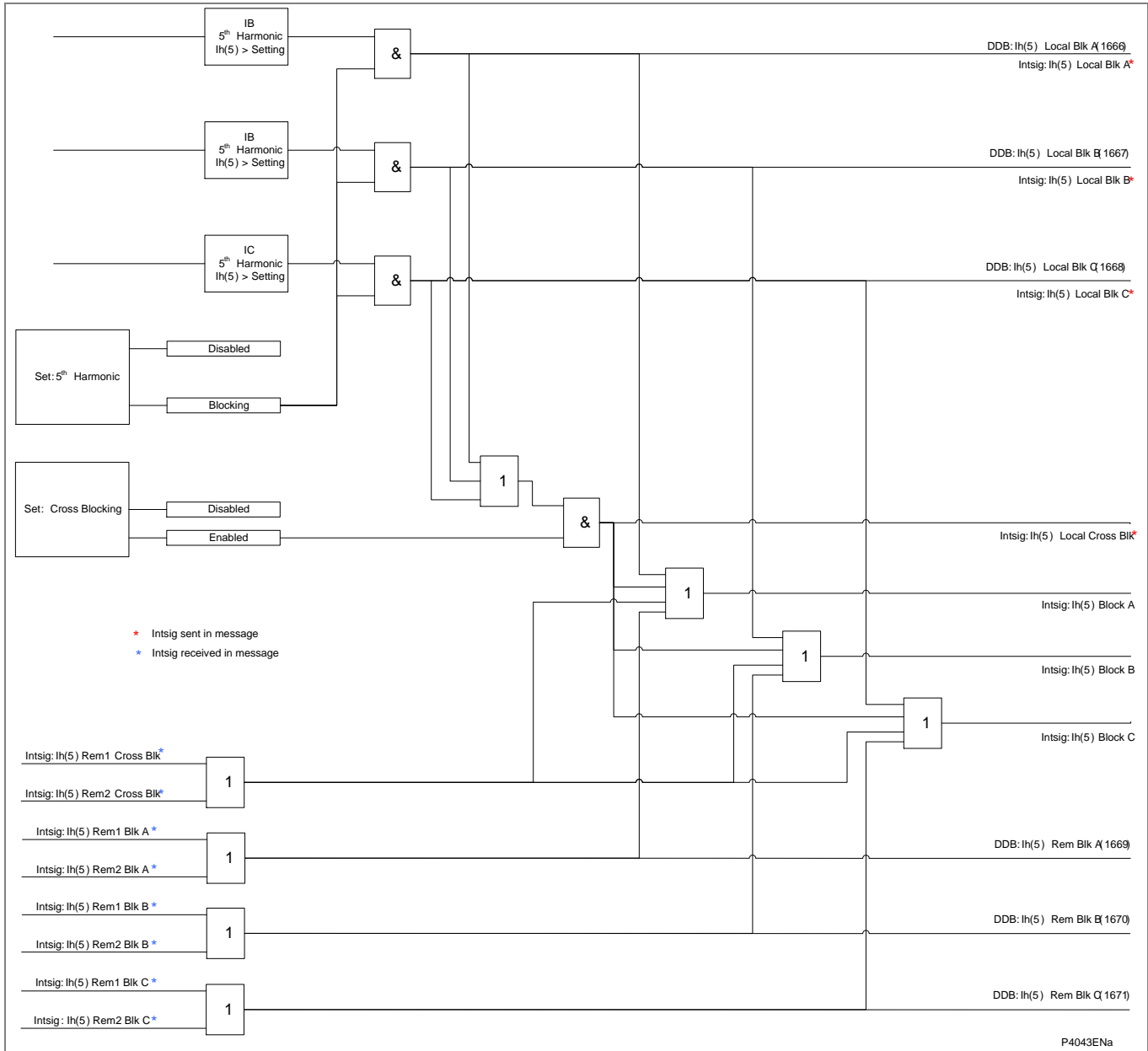

Figure 10 - Fifth harmonic blocking logic

1.2.1.4

High Set Differential

Important These functions apply to the following products:
P543.
P544 using Software Version H1 or later.
P545.
P546 using Software Version H1 or later.

When **Inrush Restraint** is set to Restraint or Blocking a high set differential protection becomes active. This unrestrained instantaneous **Id High Set** is provided to ensure rapid clearance for heavy internal faults with saturated CTs. The high set is not restrained by magnetizing inrush. A setting range $4 I_n$ - $32 I_n$ (RMS values) is provided on P543 and P545.

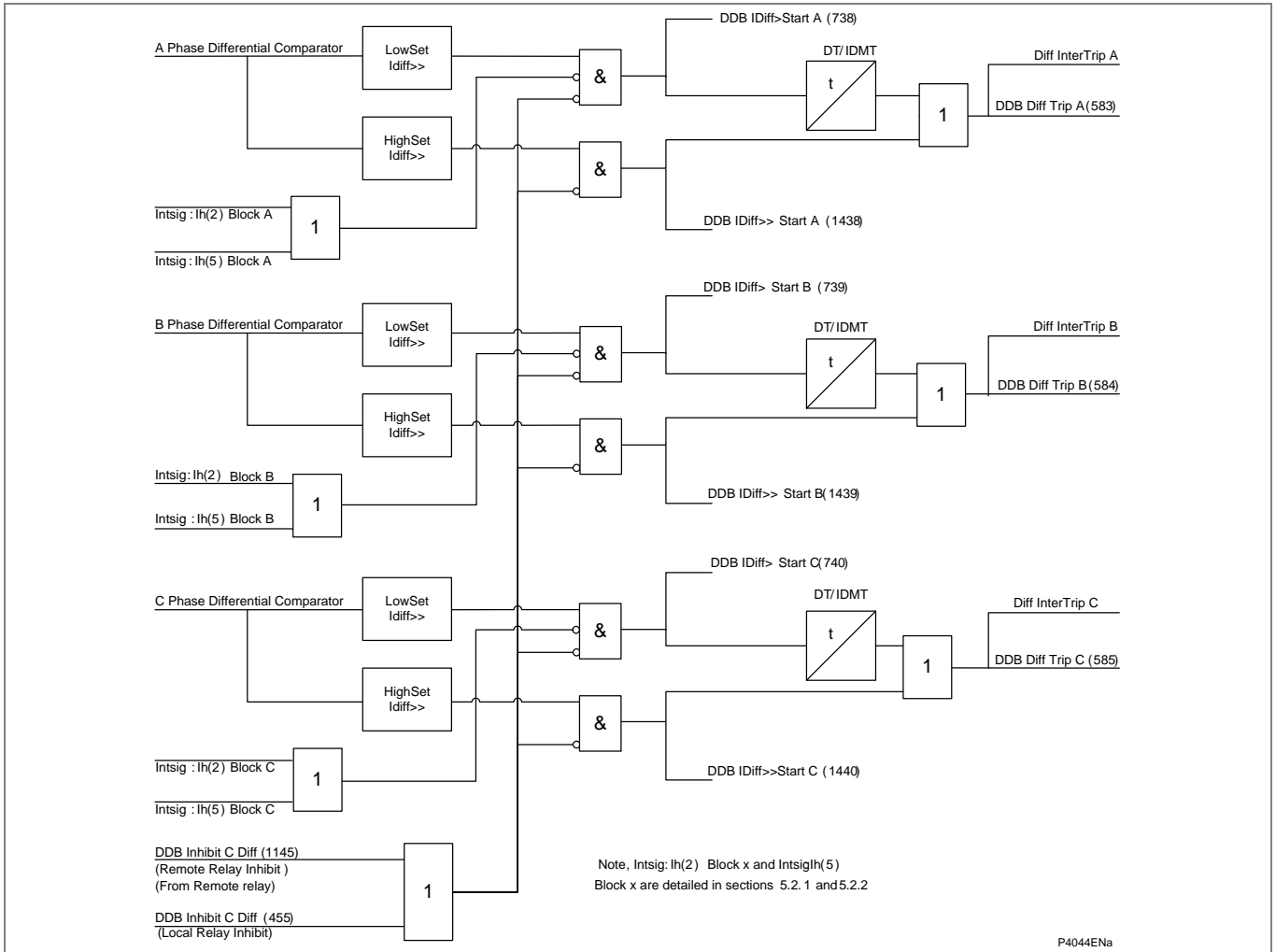

Figure 11 - Highset element logic

1.2.1.5

Phase Correction and Zero Sequence Current Filtering

To compensate for any phase shift between two windings of a transformer, it is necessary to provide phase correction. This was traditionally provided by the appropriate delta connection of main line CTs. Phase correction is provided in the P54x relays via software interposing CTs.

In addition to compensating for the phase shift of the protected transformer, it is also necessary to mimic the distribution of primary zero sequence current in the protection scheme.

The advantage of having replica interposing CTs is that it gives the P54x relays the flexibility to cater for line CTs connected in either star or delta, as well as being able to compensate for a variety of system earthing arrangements.

The *Need for zero-sequence current filtering* diagram shows the need for zero sequence current filtering for differential protection across a transformer. The power transformer delta winding acts as a 'trap' to zero sequence current. This current is therefore only seen on the star connection side of the transformer and hence as differential current.

The filtering of zero sequence current has traditionally been provided by appropriate delta connection of main line CT secondary windings. In the P54x relays, zero sequence current filtering is automatically implemented in software when a delta connection is set for a software interposing CT. Where a transformer winding can pass zero sequence current to an external earth fault, it is essential that some form of zero sequence current filtering is employed. This would also be applicable where in zone earthing transformers are used.

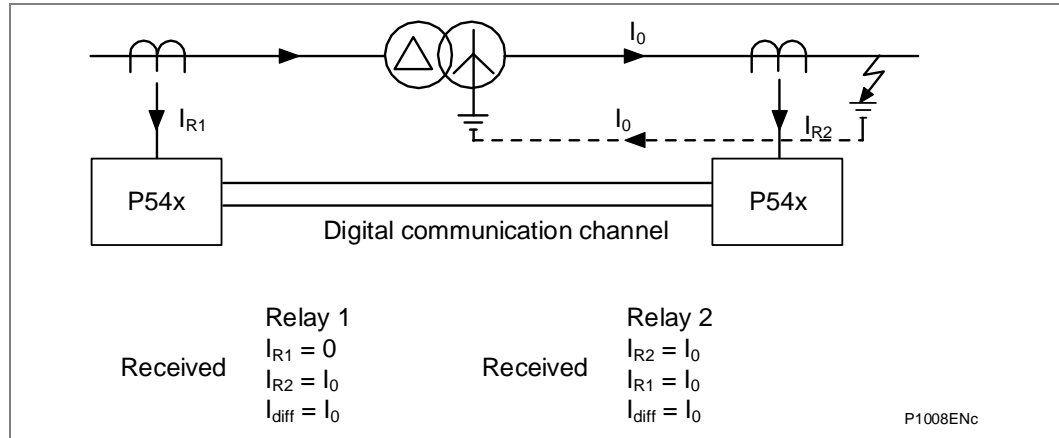

Figure 12 - Need for zero-sequence current filtering

1.2.2

3 to 2 Terminal Reconfiguration

The P54x relays can be configured for the protection of two or three terminal lines. This allows any of the relays to be applied to a two-ended line which may be converted to a three terminal line at a later date. Since only the 'configuration' setting needs to be changed to configure the relay for two or three terminal operation, no hardware changes are required when the third terminal is added, provided that 2 channels of fibre optics are already fitted.

For operational reasons, it may be necessary, under certain circumstances, to switch out one line end and its associated relay on a three terminal circuit. By altering the 'Reconfiguration' setting at any end of the line, an operator can command any pair of relays to work as a two terminal system. The 'configured out' relay can then be switched off, leaving the line to be protected by the other two relays. A restore command can be issued to reconfigure the system back to three terminal operation.

Four reconfiguration settings are available:

- Three ended
- Two ended local and remote 1 (L & R1)
- Two ended local and remote 2 (L & R2)
- Two ended remote 1 and remote 2 (R1 & R2)

Before a configuration command can be successfully initiated, it is necessary to energize the 'reconfiguration interlock' and 'Inhibit Current Differential' opto isolated inputs. The latter input will disable tripping via the current differential elements from all three relays to ensure that the scheme will remain stable during reconfiguration.

It must be ensured that the line end to be 'configured out' is open before issuing a reconfiguration command. If this is not done, any current flowing in or out of the 'configured out' end will be seen as fault current and may cause the other relays to operate.

If the new configuration setting issued to the local relay is L & R1 or L & R2, the trip outputs of the two '2-ended' relays will remain inhibited by the 'Inhibit Current Differential' input at the local relay. The 'inhibit trip/alarm outputs' opto should be de-energized to enable the trip outputs reconfigured scheme. If the new configuration setting is R1 & R2, the output contacts of the two remote relays will not be inhibited as they will ignore all commands from the local relay.

The scheme may be restored to a three terminal configuration by selecting 'three ended' at any terminal. This will occur irrespective of the status of the opto inputs but is subject to a healthy communications channel being detected.

1.2.3

Mesh Corner and 1½ Breaker Switched Substations

If differential protection is applied in a mesh corner or 1½ breaker switched substation, a P544 or P546 should be preferred to use it as they do have two independent CT inputs and therefore each one generates its own restrain. See also P54x/EN AP.

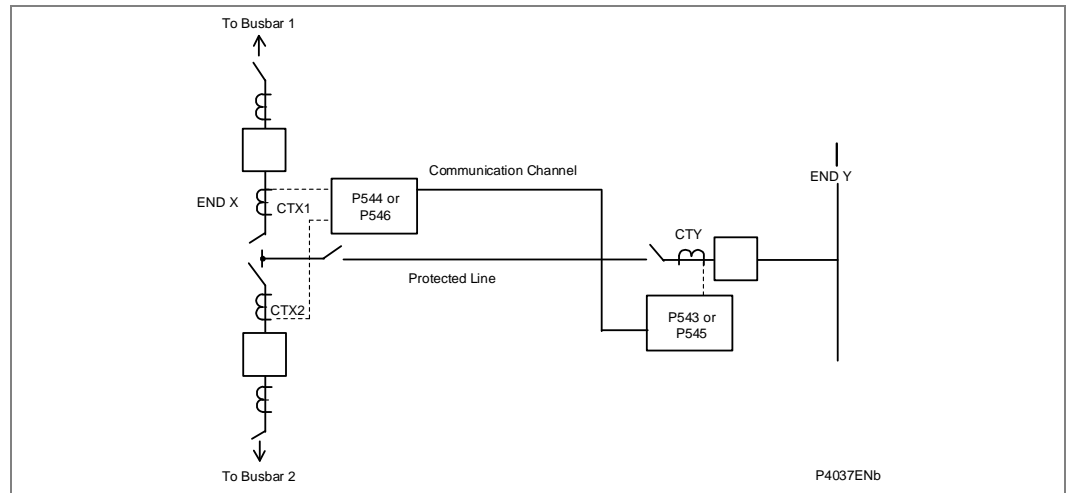

Figure 13 - Breaker and a half application

As shown in the *Breaker and a half application* diagram, a P544 or P546 relay should be used at the End X as the line is fed from a breaker and a half substation configuration. At End Y, a P543 or P545 should be installed.

Relay calculations for differential and bias currents are as follows for this case are as follows:

At End X

$$I_{diff} = \bar{I}_{CTX1} + \bar{I}_{CTX2} + \bar{I}_{CTY}$$

$$I_{bias} = (| I_{CTX1} | + | I_{CTX2} | + (\text{Additional bias if non zero}) \text{ or } | I_{REMOTE} |)/2$$

In this case Additional bias is zero as the P54x at the remote end has one single CT (P543 or P545).

Additional bias (to be sent to end Y) = is calculated on a per phase basis by scalar summing both local currents (ICTX1 and ICTX2) and selecting the largest of the three calculated. This current is included in the transmitted message.

At End Y

$$I_{diff} = \bar{I}_{CTY} + \bar{I}_{CTX1} + \bar{I}_{CTX2}$$

$$I_{bias} = (| I_{CTY} | + (\text{Additional bias if non zero}) \text{ or } | I_{REMOTE} |)/2$$

In this case Additional bias is the one sent by End X (relay with two CT inputs; P544 - P546).

1.2.4

Stub Bus Protection

The P54x relays include a facility to provide stub bus protection. When the line isolator is open, an auxiliary contact from the isolator can energize an input on the relay to enable this protection. When stub bus mode is enabled, all current values transmitted to the remote relays, and all those received from remote relays, are set to zero. The protection will now provide differential protection for the stub zone.

The local biased protection will operate as normal using the local currents with the exception that no differential, or permissive intertrips will be sent to the remote relay(s) and all such intertrips received will be ignored and also any trip will be 3-pole only. Direct Intertrips still operate as normal.

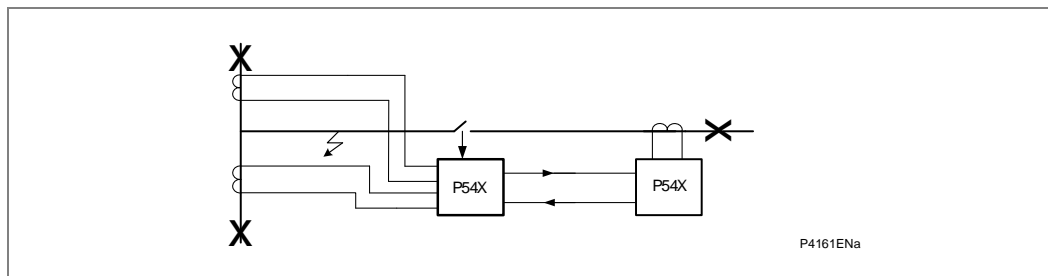

Figure 14 - Stub bus protection

For an internal fault the relay will operate, tripping the two local circuit breakers. When in stub bus mode, the relay will not send a differential intertrip signal.

In P544 and P546 with 2 sets in Stub bus mode the currents from the two sets of CTs are used for differential protection.

However, in P543 or P545 when in stub bus mode there is only 1 set of CT which effectively means if the current is above I_{s1} the relay will trip as there is no effective bias.

In stub bus mode, if the communication fails the differential protection is lost. A possible way to provide protection then would be to apply a high set overcurrent protection which can be enabled by settings when communication fails and in Stub bus mode.

1.2.5

The Minimum Operating Current

The minimum operating current is related, but not equal to, the I_{s1} setting.

Consider a single end fed fault with no load but fault current, I :

$$|I_{diff}| = I$$

$$|I_{bias}| = \frac{1}{2}I$$

Assuming $|I_{bias}| < I_{s2}$, then, using the equations from the *Phase Differential Characteristics* section, the relay will operate if:

$$|I_{diff}| > k1 \cdot |I_{bias}| + I_{s1} \quad \text{or}$$

$$I > k1 \cdot \frac{1}{2}I + I_{s1} \quad \text{or}$$

$$I > I_{s1} / (1 - 0.5 k1)$$

The minimum operating current is therefore a function of the I_{s1} and $k1$ settings. With $k1$ set to 30% and I_{s1} set to 0.2 pu, the minimum operating current will be:

$$I_{min} = 1.176 I_{s1}$$

$$I_{min} = 0.235 \text{ pu}$$

1.3 Disabling/Enabling Differential Protection

The differential function can be globally enabled or disabled using the CONFIGURATION /Phase Diff/Enabled-Disabled setting.

If the differential function is disabled globally (i.e. CONFIGURATION column), no current differential message is transmitted and no current differential measurements (Measurements 3) and channel communication statistics (Measurements 4) are displayed. Therefore a remote connected relay, will display a signaling fail and C Diff failure alarm.

If the differential function is enabled globally (i.e. CONFIGURATION column) and disabled within a group (i.e. group x column), current differential message is exchanged, current differential measurements (Measurements 3) and channel communication statistics (Measurements 4) are displayed, local current differential protection cannot trip but relay can receive a differential inter-trip from the remote end.

Enabling or Disabling Differential Protection for In-Zone Power Transformer

Differential protection with an in-zone transformer can be enabled from the local control panel. Enabling can be done separately for each setting group. To enable the differential protection, set the cell [3310: Compensation] to **Transformer** under the **GROUP 1 PHASE DIFF** menu heading.

1.4 Differential Relay Compatibility with Previous Versions

Current differential protection in P54x relays is as follows:

- P543-P546 models suffix M are compatible with each other
- In non-GPS mode P543-P546 models suffix M are compatible with relay models P543-P546 suffix B, G, J and K
- In GPS mode P543-P546 models suffix M are compatible with relay models P545-P546 suffix B, G, J and P543-P546 suffix K
- P543-P546 models suffix M are not compatible with suffix A models
- P543-P546 are not compatible with P541 and P542.

If a relay suffix K or M is communicating with a relay suffix B, G or J, a monitor bit labeled H/W B to J model in Measurement 4/Channel status will become 1. IM64 signals map to Intertrip signals on these versions. For example sending IM64 Ch1 Output1 from a relay suffix K or M will be received as Ch1 Intertrip 1 on a relay suffix B, G or J.

Differential Current Transformer Supervision (Differential CTS) in P543-P546 models suffix K or M are only compatible with P543-P546 models suffix K or M.

P543 and 546 with Process Bus interface are not compatible with version K3 and previous.

1.5 Differential Relay without Voltage Connections

Differential protection does not need phase or neutral voltage connections as this protection relies entirely on the currents measured at each end of the line.

If there are no voltage connections to the P54x relay, the VTs Connected Yes/No setting under CT AND VT RATIOS should be set to No. Once set to No, this will cause the relay VTS logic to set the VTS Slow Block and VTS Fast Block DDBs, but it will not raise any alarms. It will also override the VTS enabled setting should the user set it. The purpose of this is to stop the pole dead logic working incorrectly in the absence of voltage and current inputs.

1.6 Line Parameters Settings

1.6.1 Phase Rotation (Phase Sequence)

A setting is used to select whether the 3-phase voltage set is rotating in the standard ABC sequence, or whether the rotation is in reverse ACB order. The appropriate selection is required to ensure that all sequence components and faulted phase flagging/targeting is correct.

1.6.2 Tripping Mode - Selection of Single or 3-Phase Tripping

This selects whether instantaneous trips are permitted as Single pole, or will always be 3 pole. Protection elements considered as “instantaneous” are those normally set to trip with no intentional time delay, i.e.: Differential, directional earth/ground DEF aided scheme and if fitted, Zone 1 distance and distance channel aided scheme. The selection **1 and 3 pole** allows single pole tripping for single phase to ground faults. The selection **3 pole** converts all trip outputs to close Trip A, Trip B and Trip C contacts simultaneously, for three pole tripping applications.

In the case of the P544/P546, the tripping mode can be set independently for the two circuit breakers controlled.

Logic is provided to convert any double phase fault, or any evolving fault during a single pole auto-reclose cycle into a three phase trip. Two phase tripping is never permitted. This functionality is shown in the *Trip conversion scheme logic* diagram for P543/P545 and in AR Figure 63 (logic diagram supplement) for P544/P546 models.

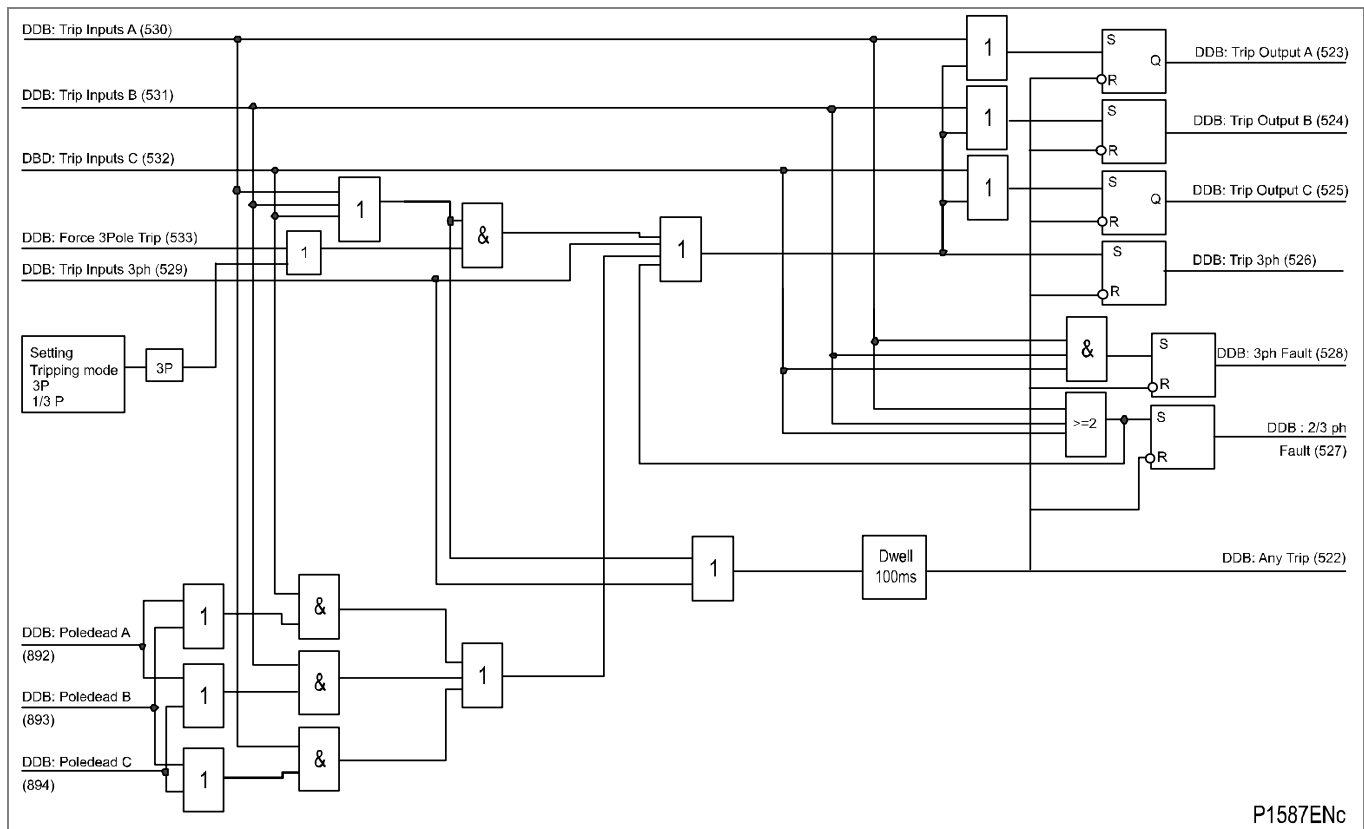

Figure 15 - Trip conversion scheme logic

1.6.3

Selectable Zone Tripping Mode

In the previous implementation, it is possible to configure all distance protection zones to trip single and/or 3-pole.

As from Software Version D1a, a new feature has been added to allow tripping mode selection on an individual zone-by-zone basis for each circuit breaker.

Five new menu cells for single circuit breaker and 10 new menu cells for dual circuit breaker added to in GROUP x LINE PARAMETERS menu list. These new additional menu cells are only applicable to variants with Distance protection.

These additional settings are available via the relay menu (“GROUP x LINE PARAMETERS” menu Column). The single circuit breaker variants (P543 and P545) menu cells are listed below and will only be visible if the “Tripping Mode” menu cell is set to “1 and 3 Pole”:

Menu Text	Default setting	Setting Options
Z1 Tripping Mode	3 Pole	3 Pole, 1 and 3 Pole
Z2 Tripping Mode	3 Pole	3 Pole, 1 and 3 Pole
ZP Tripping Mode	3 Pole	3 Pole, 1 and 3 Pole
ZQ Tripping Mode	3 Pole	3 Pole, 1 and 3 Pole
Z3 Tripping Mode	3 Pole	3 Pole, 1 and 3 Pole
Z4 Tripping Mode	3 Pole	3 Pole, 1 and 3 Pole

The dual circuit breaker variants (P544 and P546) menu cells are listed below, the CB1 cells will only be visible if the “CB1 Tripping Mode” menu cell is set to “1 and 3 Pole” and the CB2 cells will only be visible if the “CB2 Tripping Mode” menu cell is set to “1 and 3 Pole”.

Menu Text	Default setting	Setting Options
CB1Z1Trip Mode	3 Pole	3 Pole, 1 and 3 Pole
CB1Z2Trip Mode	3 Pole	3 Pole, 1 and 3 Pole
CB1ZPTrip Mode	3 Pole	3 Pole, 1 and 3 Pole
CB1Z3Trip Mode	3 Pole	3 Pole, 1 and 3 Pole
CB1Z4Trip Mode	3 Pole	3 Pole, 1 and 3 Pole
CB2Z1Trip Mode	3 Pole	3 Pole, 1 and 3 Pole
CB2Z2Trip Mode	3 Pole	3 Pole, 1 and 3 Pole
CB2ZPTrip Mode	3 Pole	3 Pole, 1 and 3 Pole
CB2Z3Trip Mode	3 Pole	3 Pole, 1 and 3 Pole
CB2Z4Trip Mode	3 Pole	3 Pole, 1 and 3 Pole

1.6.4 Pole Dead Logic

Pole dead logic is used by the relay to determine when the circuit breaker poles are open (“pole dead”). This indication may be forced, by means of status indication from CB auxiliary contacts (52a or 52b), or internally determined by the relay. When no auxiliary contacts are available, the relay uses an undercurrent level detector (ranged from 20mA to 3.2A, drop-off value=1.1*pick-up value), and an undervoltage level detector (ranged from 10V to 40V, drop-off value=1.15*pick-up value) to declare a “pole dead”.

Note If the VT is connected at the busbar side, auxiliary contacts (52a or 52b) must be connected to the relay for a correct pole dead indication. The logic diagrams, (Pole dead logic for P543/P545) and (Pole dead logic for P544/P546) below show the details:

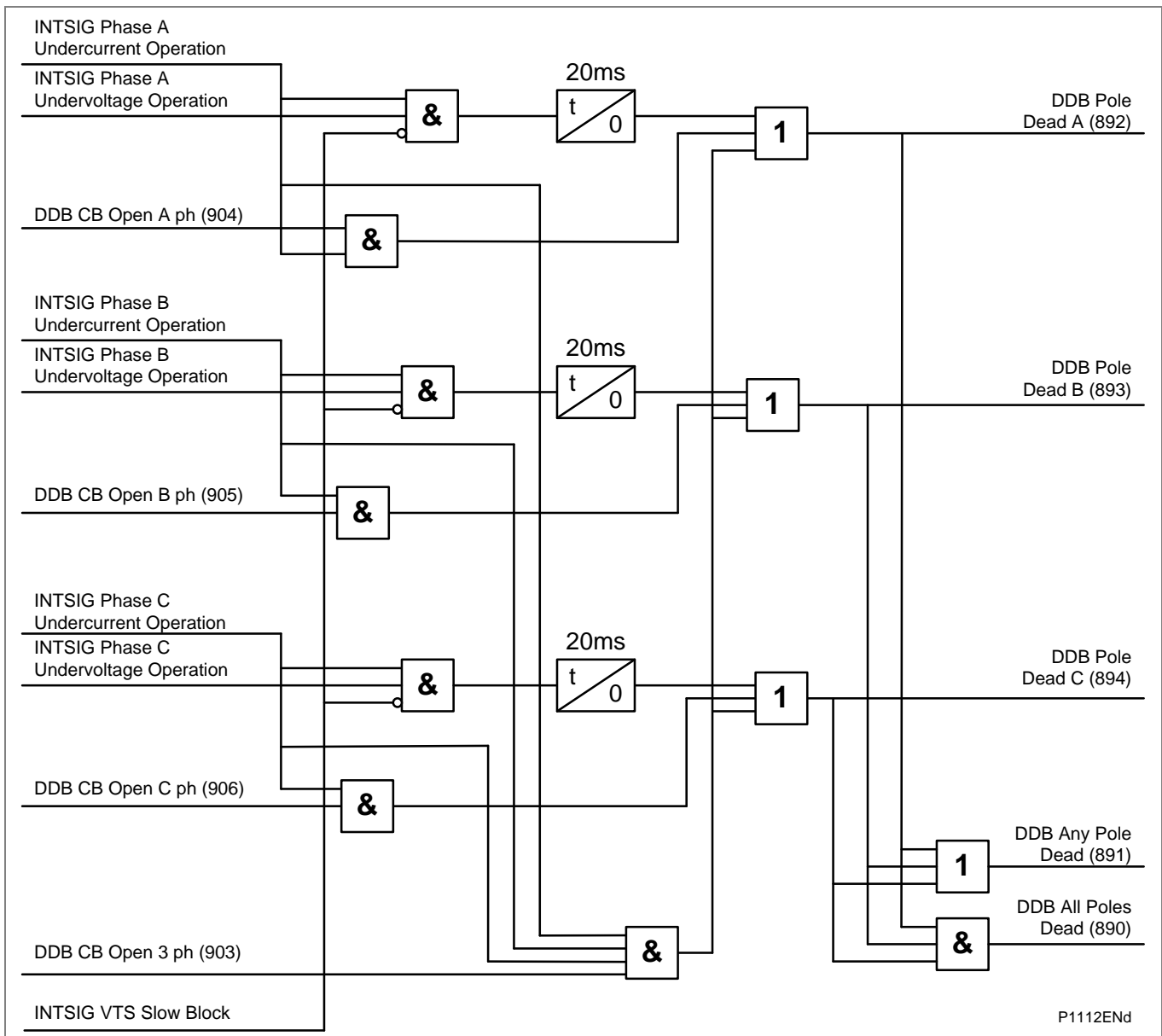

Figure 16 - Pole dead logic for P543/P545

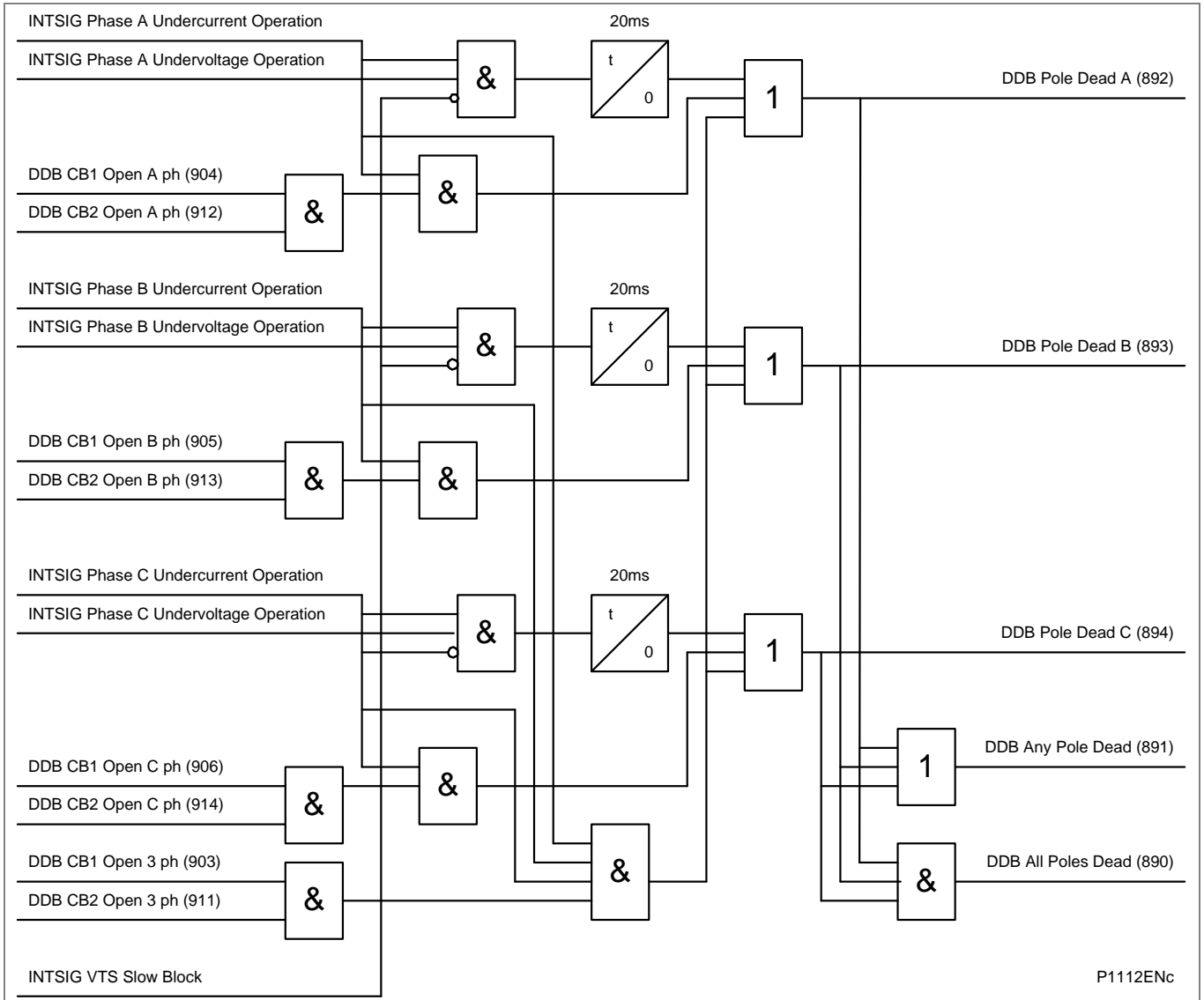

Figure 17 - Pole dead logic for P544/P546

1.6.5

Residual Compensation for Earth/Ground Faults

For earth faults, residual current (derived as the vector sum of phase current inputs ($I_a + I_b + I_c$)) is assumed to flow in the residual path of the earth loop circuit. Hence, the earth loop reach of any zone must be extended by a multiplication factor of $(1 + kZN)$ compared to the positive sequence reach for the corresponding phase fault element.

1.6.6

Mutual Compensation for Parallel Lines

Analysis of a ground fault on one circuit of a parallel over-head line shows that a fault locator positioned at one end of the faulty line will tend to over-reach while that at the other end will tend to under-reach. In cases of long lines with high mutual inductance, mutual zero sequence compensation can be used to improve the fault locator accuracy. The compensation is achieved by taking an input to the relay from the residual circuit of the current transformers in the parallel line.

The major disadvantage of standard mutual compensation is that faults on a parallel line can cause mal-operation of the healthy line protection. The MiCOM relay uses fast dynamic control of the mutual compensation, which prevents such mal-operations of the healthy line protection, while providing correct mutual compensation for faults inside the protected section. The dynamic control is achieved by effectively eliminating the mutual compensation above a set level of parallel line residual current (I_{MUTUAL}) compared to the protected line residual current (I_N).

- If the ratio: I_{MUTUAL}/I_N is less than the '**Mutual Cutoff**' setting, then full mutual compensation is applied to all distance zones, and the fault locator.
- If the ratio: I_{MUTUAL}/I_N is greater than the '**Mutual Cutoff**' setting, then no mutual compensation is applied.

1.7

Optional Distance Protection

The MiCOM IED has, by ordering option, a comprehensive integrated distance protection package. This consists of:

- Phase fault distance protection
- Earth/ground fault distance protection
- Power sing detection, alarm, and blocking
- Out-of-step detection and tripping
- Switch On To Fault (SOTF) and Trip On Reclose (TOR)
- Directional Schemes
- Aided schemes

These are described in the following sections and are marked as being applicable to the distance option only. If the distance option is not specified, these will not be applicable, and additional protection will be in the form of overcurrent etc.

1.8 Phase Fault Distance Protection (Distance option only) (for Software Versions BEFORE H3a)

The MiCOM relay has five zones of phase fault protection. It is possible to set all zones either with quadrilateral (polygon) characteristics, or with mho circles. Each zone can be set independently to be permanently disabled, permanently enabled or enabled in case of protection communication channel fail. The impedance plot (shown in the *Earth fault quadrilateral characteristics (Distance option only)* diagram) shows the characteristic when set for mho operation. The characteristic drawn for illustration is based on the default distance settings without dynamic expansion.

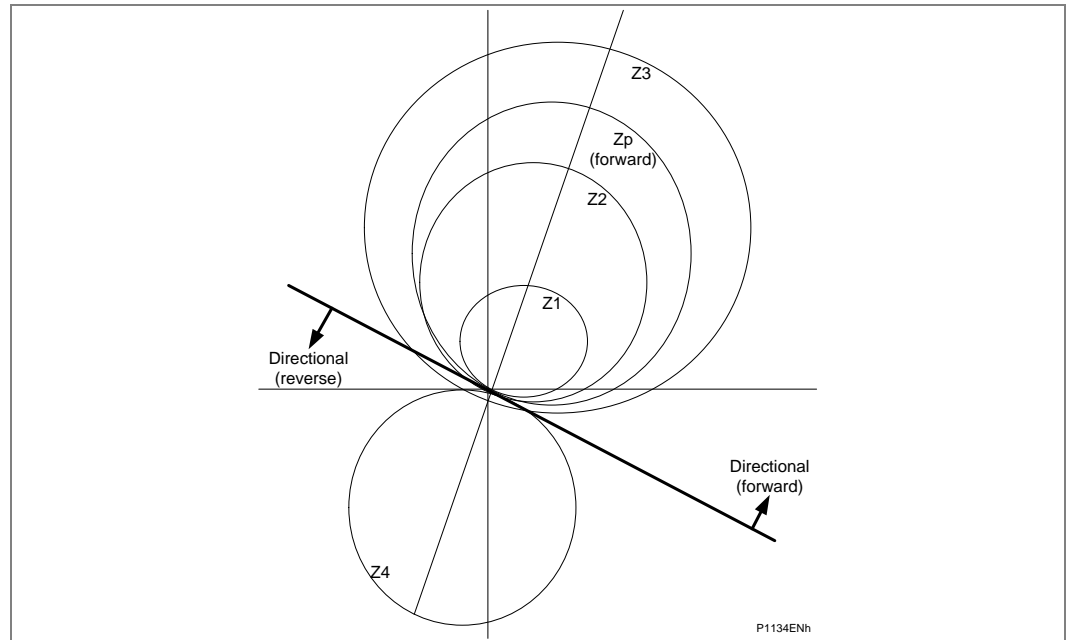

Figure 18 - Phase fault Mho characteristics (Distance option only)

The protection elements are directionalized as follows:

- Zones 1, 2 and 3 - Directional forward zones, as used in conventional three zone distance schemes. Note that Zone 1 can be extended to Zone 1X when required in zone 1 extension schemes.
- Zone P - Programmable directionality. Selectable as a directional forward or reverse zone.
- Zone 4 - Directional reverse zone.

1.9 Phase Fault Distance Protection (Distance option only) (for Software Version H3a and later)

The Distance Protection function has been modified in Software Version H3a. For more details, please refer to the *Distance Protection Zone and Timer Start Enhancements* section in the Application Notes chapter.

1.10 Earth Fault Distance Protection (Distance option only) (for Software Versions BEFORE H3a)

The MiCOM relay has 5 zones of earth (ground) fault protection. It is also possible to set all zones either with quadrilateral characteristics, or with mho circles. The choice of mho or quadrilateral is independent of the general characteristic selection for the phase fault elements. Each zone can be set independently to be permanently disabled, permanently enabled or enabled in case of protection communication channel fail.

All earth fault distance elements are directionalized as per the phase fault elements, and use residual compensation of the corresponding phase fault reach. The impedance plot shown in the *Earth fault quadrilateral characteristics* diagram adds the characteristics when set for quadrilateral operation.

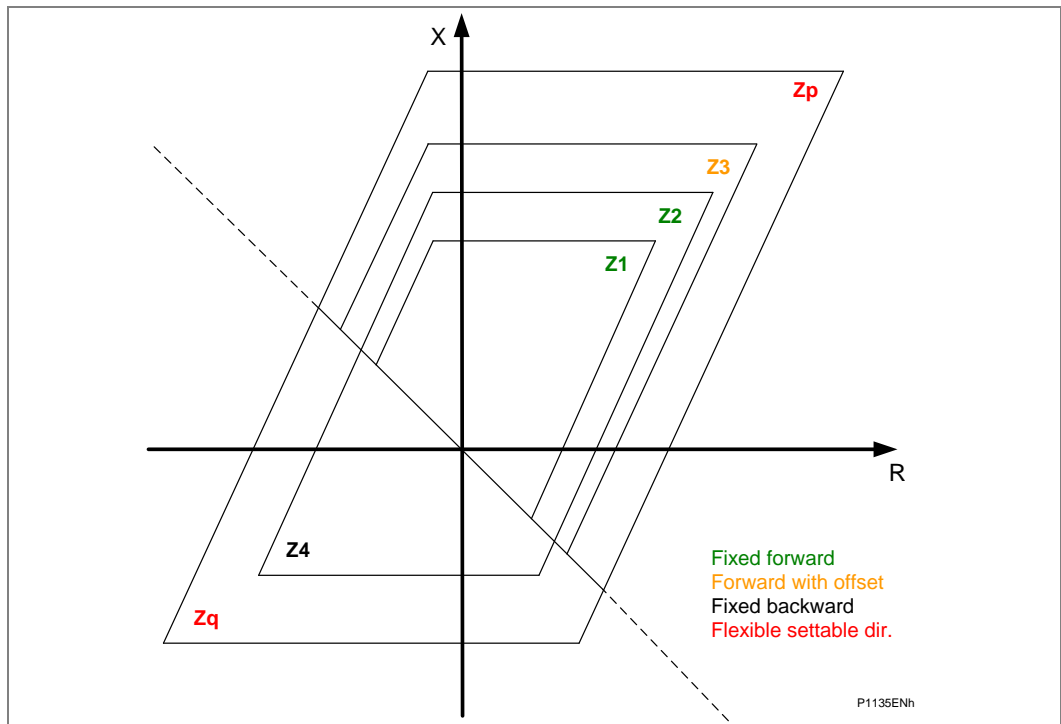

Figure 19 - Earth fault quadrilateral characteristics (Distance option only)

1.11

Distance Protection Tripping Decision

For the MiCOM relay, five conditions would generally need to be satisfied for a correct relay trip to result. These are:

- The phase selector needs to identify the faulted phases, and ensure that only the correct distance measuring zones may proceed to issue a trip. Possible phase selections are AN, BN, CN, AB, BC, CA, ABC. For double phase to ground faults, the selection is AB, BC or CA, with N (neutral) just for indication only.
- The loop current for the selected phase-ground or phase-phase loop must exceed the minimum sensitivity for the tripping zone. By default, this sensitivity is 5%In for ground faults, and both the faulted phases must exceed 5%In for phase-phase faults. The user may raise this minimum sensitivity if required, but this is not normally done.
- The faulted phase impedance must appear within a tripping (measuring) zone, corresponding to the phase selection. Five independent zones of protection are provided. The tripping zones are mho circles or quadrilateral, and selected independently for phase, and ground faults. The ground fault distance elements require compensation for the return impedance, this residual compensation modifies the replica impedance for each zone. Under conditions where a parallel line is present the relay can compensate for the mutual coupling between the lines; this adjusts the replica impedance in the same way as the residual compensated based on the current in the parallel line. The reach setting Z for ground fault mho and quadrilateral elements is determined as follows:

$$Z = Z1 + [(I_{res} / IP) \times Z_{res}] + [(I_{mut} / IP) \times Z_{mut}]$$

Where:

Z1	is the positive sequence reach setting
IP	is the current in the faulted phase
I _{res}	is the residual current (= I _a + I _b + I _c)
Z _{res}	is the residual impedance (= (Z ₀ -Z ₁)/3) = K _{res} x Z1
I _{mut}	is the residual current in the parallel line
Z _{mut}	is the mutual compensating impedance

- For directional zones within the relay (Zone 1, P, 2, 4 and Z3 if set directional), the delta directional line must agree with the tripping zone. For example, zone 1 is a forward directional zone, and must not trip for reverse faults behind the relay location. A zone 1 trip will only be permitted if the directional line issues a “forward” decision. The converse will be true for zone 4, which is reverse-looking and this needs a reverse decision by the directional line. If the delta directional cannot decide then conventional direction lines are used.
- The set time delay for the measuring zone must expire, with the fault impedance measured inside the zone characteristic for the duration. In general, Zone 1 has no time delay (“instantaneous”), all other zones have time delays. Where channel-aided distance schemes are used, the time delay tZ2 for overreaching Zone 2 may be bypassed under certain conditions.

To achieve fast, sub-cycle operation, the phase selection, measuring zones and directional line algorithms run in parallel, with their outputs gated in an AND configuration. This avoids sequential measurement which would slow the operation of the relay.

From version H4 the operating times for off-angle faults have been improved to an average of 30-35ms in all zone 1 (for f = 50Hz). Faults at the zone boundary will be cleared in higher times (10-20% of zone 1 area). Sub cycle operation is maintained for faults close to the relay characteristic up to 75% of zone reach setting.

1.12 Distance Protection Starting

With Software H3 and later the zone timer starting is selectable either 'Zone Start' (default) or 'General Start'. Before Software H3 only the 'Zone Start' behaviour is implemented. This section describes how both options will operate. The MiCOM P44y/P54x distance protection provides several starting elements (with dedicated DDBs):

- Zone 1 Ph starting ... Zone Q Ph starting
- Zone 1 Gnd starting ... Zone Q Gnd starting
- Delta Directional starting

Zone Start (Default)

In this operation mode the dedicated timers for each zone tZ1 ... tZQ are started individually with the measured impedance entering the zone and the correct phase selection (see also the Phase Selector section). This may result in different starting times for the zones and a longer tripping time in case the apparent impedance trajectory moves to smaller impedances. Each zone timer will stop individually if the measured impedance gets out of the zone reaches.

General Start

In this operation mode all zone timers tZ1 ... tZQ are started instantaneously with the first zone starting or delta starting as shown in the **General starting logic and end timers** diagram. The General Start signal will reset in case all zone and delta directional startings have reset.

In addition to the General Start signal two End Timers are available:

- Directional End Timer (**ZDir tEnd**) with directional setting **Dist tEnd Dir** (Forward, Reverse or Non-Directional)
- Non-Directional End Timer (**ZNonDir tEnd**)

The end timers can be used for Distance protection backup tripping e. g. in combination with a high reach setting for the used zones.

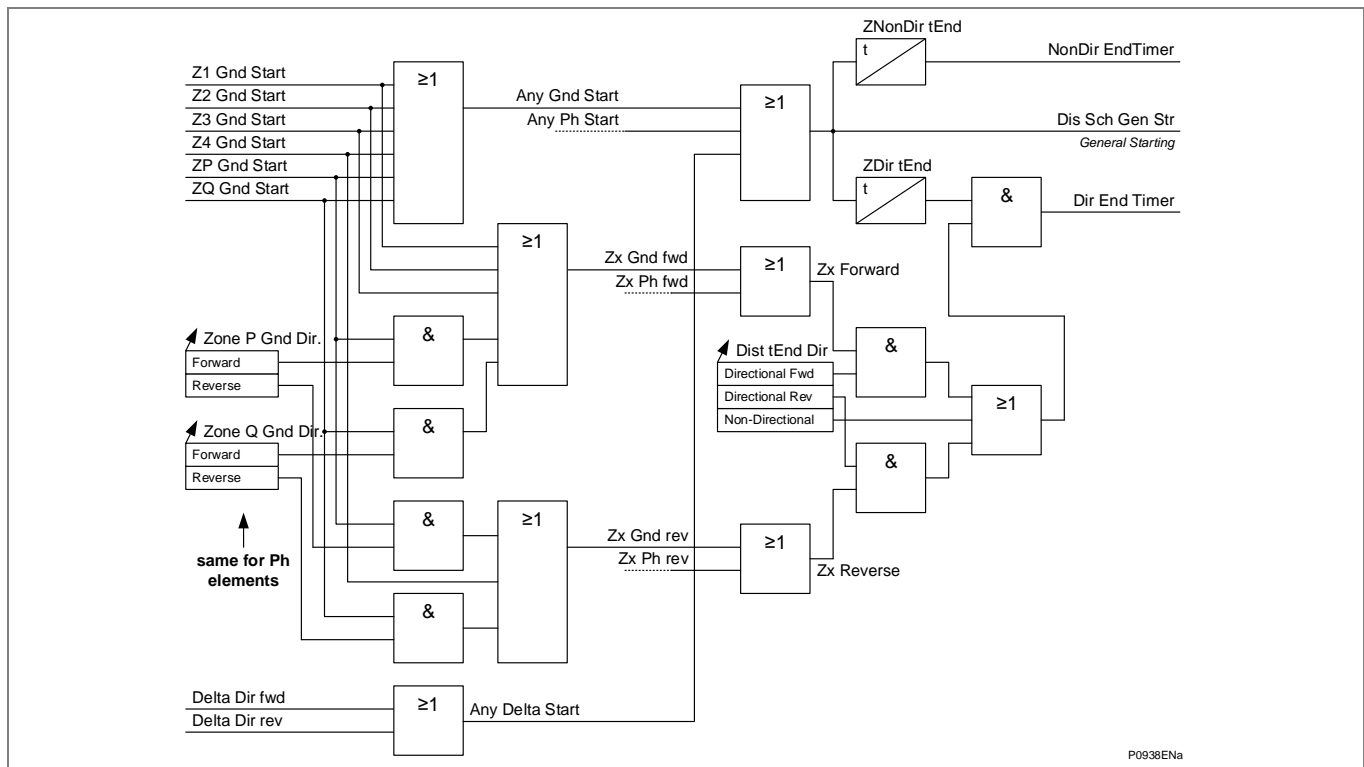

Figure 20 - General starting logic and end timers

1.13 Phase Selection (Distance option only)

Phase selection is the means by which the relay is able to identify exactly which phase are involved in the fault and allow the correct measuring zones to trip.

Operation of the distance elements, is controlled by the Superimposed Current Phase Selector. Only elements associated with the fault type selected by the phase selector are allowed to operate during a period of two cycles following the phase selection. If no such element operates, all elements are enabled for the following 5 cycles, before the phase selector returns to its quiescent state.

Operation of an enabled distance element, during the 2-cycle or 5-cycle period, causes the phase selector state to be maintained until the element resets. The one exception to this is when the phase selector decision changes while an element is operated. Here the selected elements are reset and the 2-cycle period re-starts with the new selection.

Note Any existing trip decision is not reset under this condition. After the first cycle following a selection, the phase selector is only permitted to change to a selection involving additional phases.

On double phase-to-ground faults, only the appropriate phase-phase elements are enabled. The indication of the involvement of ground is by operation of a biased neutral current level detector.

1.13.1 Theory of Operation

Selection of the faulted phase(s) is performed by comparing the magnitudes of the three-phase-to-phase superimposed currents. A single-phase-to-ground fault produces the same superimposed current on two of these signals and zero on the third. A phase-to-phase or double phase-to-ground fault produces one signal which is larger than the other two. A three-phase fault produces three superimposed currents which are the same size. Refer to the *Phase-to-phase currents showing change for CN fault* diagram to see how the change in current can be used to select the faulted phases for a CN fault.

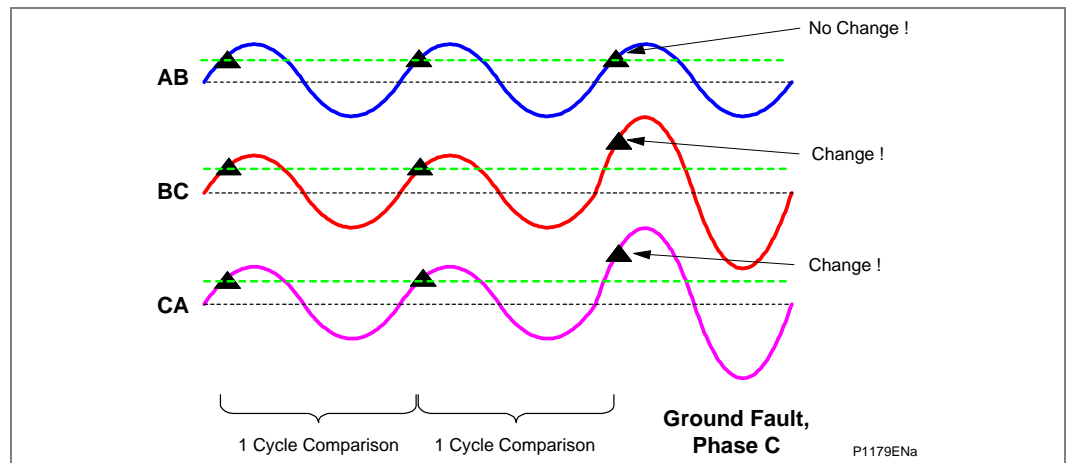

Figure 21 - Phase to phase currents showing change for CN fault

A superimposed current is deemed to be large enough to be included in the selection if it is greater than 80% of the largest superimposed current.

A controlled decay of the superimposed threshold ensures that the phase selector resets correctly on fault clearance.

Phase selection can only be made when any superimposed current exceeds 4% of nominal current (I_n) as a default value.

Under normal power system conditions, the superimposed currents are made by subtracting the phase-phase current sample taken 96 samples (2 cycles) earlier from the present sample.

When a fault is detected, resulting in a phase selection being made, the “previous” memorized sample used in the superimposed current calculation is taken from a re-cycled buffer of “previous” samples. This ensures that, if the fault develops to include other phases, the original selection is not lost. The re-cycling of the pre-fault buffers is continued until the phase selector resets, either because the fault is cleared or when the 5-cycle period has expired and no element has operated.

Under conditions on load with high levels of sub-synchronous frequencies, it is necessary to increase the ΔI phase selector threshold from its default (4% I_n) to prevent sporadic operation. This is automatically performed by the relay, which will self-adjust the threshold to prevent operation upon the noise signals, whilst still maintaining a high sensitivity to faults.

To facilitate testing of the Distance elements using test sets which do not provide a dynamic model to generate true fault delta conditions, a Static Test Mode setting is provided. This setting is found in the COMMISSIONING TESTS menu column. When set, this disables phase selector control and forces the relay to use a conventional (non-delta) directional line.

1.14

Mho Element Polarization and Expansion (Distance option only)

To ensure coverage for close-up faults, distance protection always includes a proportion of voltage memory. Therefore, when each zone characteristic is determined, the phase comparator used in the zone decision will use a mix of vectors “V” (the directly measured phase/line voltage), “I_Z” (a voltage constructed from the fault current and zone impedance reach setting) and “V_{pol}” (a polarizing voltage). The MiCOM relay allows the user to specify the composition of V_{pol}, deciding on how to mix the proportion of two voltage selections:

- The amount of directly measured (“self”) polarizing in the mix
- The amount of clean memory stored from before the fault inception

One of the additional benefits in adding memory into the polarizing mix is that mho characteristics will offer dynamic expansion in the event of a forward fault. This phenomenon is shown in the *Expansion of zone 1 for the default polarizing setting V_{pol}=1 (Distance option only)* diagram for the default setting V_{pol}=1, where a Zone 1 characteristic with reach Z will grow to cover 50% of Z_s to cover more fault arc resistance.

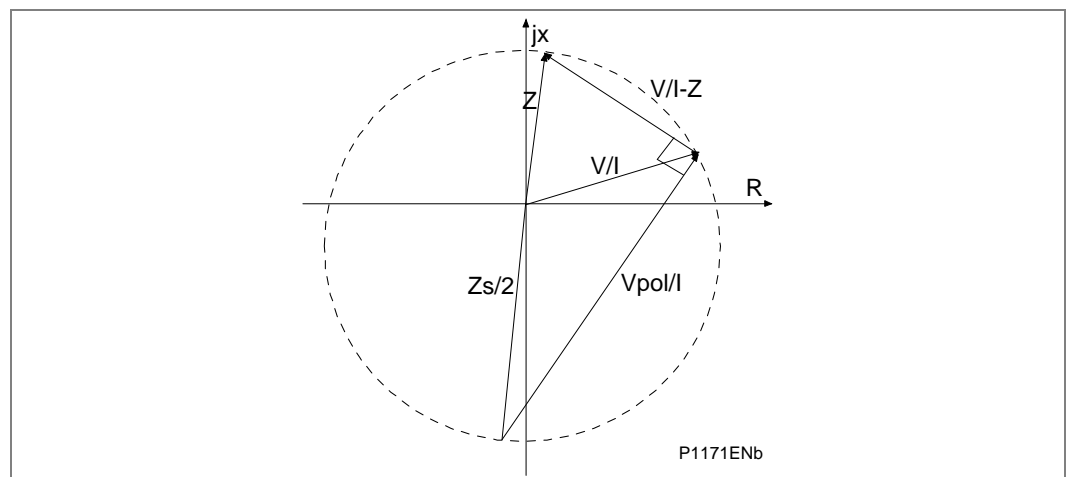

Figure 22 - Expansion of zone 1 for the default polarizing setting V_{pol}=1 (Distance option only)

Key: Z_s = Source impedance behind the relay location

The MiCOM relay does not allow the polarizing to be selected as entirely self polarized, or entirely memory polarized. V_{pol} always contains the directly measured self-polarized voltage, onto which a percentage of the pre-fault memory voltage can be added. The percentage memory addition is settable within the range 0.2 (20%) to 5 (500%).

Setting 20% means that most of the polarizing will be self-polarizing, with minimal mho circle expansion, and just enough memory to counteract any CVT transients. Setting 500% means that in the overall polarizing mix the ratio would be 1-part self polarizing to 5-parts memory. Such a high memory content would offer large dynamic expansion, covering 83% of the source impedance (Z_s) behind the relay.

$$\text{Mho expansion} = \frac{(\text{Polarizing Setting})}{(\text{Setting} + 1)} \cdot Z_s$$

This characteristic is used for Zones 1, P (optionally reversed), 2, 4 and Zone 3 if the offset is disabled.

The characteristic is generated by a phase comparison between V/ I-Z and the polarizing signal V_{pol}

Where:

- V is the fault voltage
- Vpol is a user selected mix of the fault voltage and pre-fault memory
- I is the fault current
- Z is the zone reach setting (including residual compensation for ground fault elements)
- Zs is the source impedance (included in the *Expansion of zone 1 for the default polarizing setting Vpol=1 (Distance option only)* diagram to show the position of the Vpol phasor)

The polarizing signal Vpol is a combination of the fault voltage and the stored vector taken from 2 cycles before the fault, which is a representation of the volts at the source.

$$V_{pol} = IZ_s + V \quad \text{or} \quad V_{pol}/I = Z_s + V/I$$

Operation occurs when the angle between the signals is greater than 90°, which is for faults inside the circle.

The validity of the voltage memory in the MiCOM relay extends to 16 cycles after loss of the VT input voltage. If no memory is available, the polarizing signal is substituted by cross polarizing from the unfaulted phase(s). For example if Vmem is unavailable, the voltages measured on phases B and C now are used, phase-shifted as necessary.

To produce the reversed zones (Zone 4 and, optionally, Zone P), the impedance Z is automatically set to a negative value.

1.14.1 Switch On To Fault Action for Zone 1 (Distance option only)

Operation of the distance elements is generally prevented if the polarizing signal magnitude is insufficient (less than 1V). The exception is for Zone 1, which following breaker closure is allowed to operate with a small (10%) reverse offset. This is to ensure operation when closing on to a close-up three-phase fault (Scenario: earthing/ground clamps inadvertently left in position).

In addition Z4 reverse operation is held if it operates in memory.

Other zones may have their zone time delays bypassed for SOTF/TOR, as detailed in the Application Notes chapter.

1.14.2 Offset Mho (Distance option only)

If the Zone 3 offset is enabled then it uses no memory polarizing and has a fixed reverse offset from the origin of a distance polar diagram. Characteristic angle and residual compensation are as per the forward settings.

1.15 Quadrilateral Elements (Distance option only)

The quadrilateral elements are made from combinations of reactance lines, directional lines and load blinders.

A counter, similar to that used for the mho element, is incremented when all the relevant phase comparisons indicate operation. A fast up-count of 6 is issued when the fault is within 80% of the reach of the zone, and well within the resistive reach boundary. Elsewhere, the increment is always 1 but a fast decrement (6) is used when the faulted phase current is less than half the minimum operating current setting. Therefore, an area of fast operation for faults near the characteristic angle is always available, whether mho or quadrilateral characteristics are applied.

1.15.1 Directional Quadrilateral (Distance option only)

This characteristic is used for Zones 1, P (optionally reversed), 2 and 4 (reversed). It is formed from two parallel reactance lines, two parallel resistive reach blinders and controlled by the delta or conventional directional line. The bottom reactance line (not shown on in the following diagram) and the left-hand reach blinder are automatically set to 25% of the reactance reach and the right-hand blinder, respectively. The reactance line is arranged to operate for faults below the line, the blinders for faults within the resistive reach limits, and the delta directional line for forward faults. The counter increments when all these conditions are satisfied.

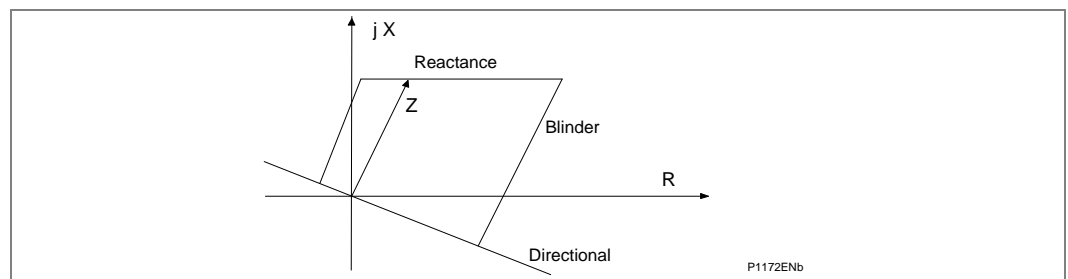

Figure 23 - Quadrilateral characteristics (directional line shown simplified) (Distance option only)

1.15.2 Offset Quadrilateral (Distance option only)

This characteristic is used for Zone 3 when the offset is enabled. It is formed from two reactance lines and two resistive reach blinders. The upper reactance line is arranged to operate for faults below it and the lower for fault above it. The right hand blinder is arranged to operate for faults to its left and the left hand blinder for faults to its right. The counter increments when all these conditions are satisfied.

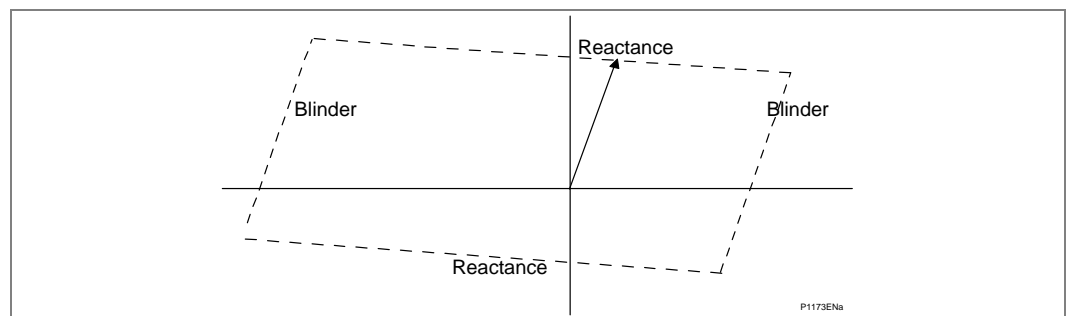

Figure 24 - Offset quadrilateral for zone 3 (Distance option only)

Note When Zone 3 is set offset in simple setting mode, the left-hand blinder and lower reactance line equal the offset percentage setting of the line impedance and fault resistance respectively. In the advanced setting mode, both lines can be set independently.

1.15.3

Reactance Line - Top Line of Quadrilateral (Distance option only)

The relay provides a flexible user settable top reactance line tilting mode:

1. Dynamic (self adaptive) tilt angle - applicable to ground distance only
2. Fixed tilt angle - applicable to phase distance and ground distance if Dynamic tilting is disabled

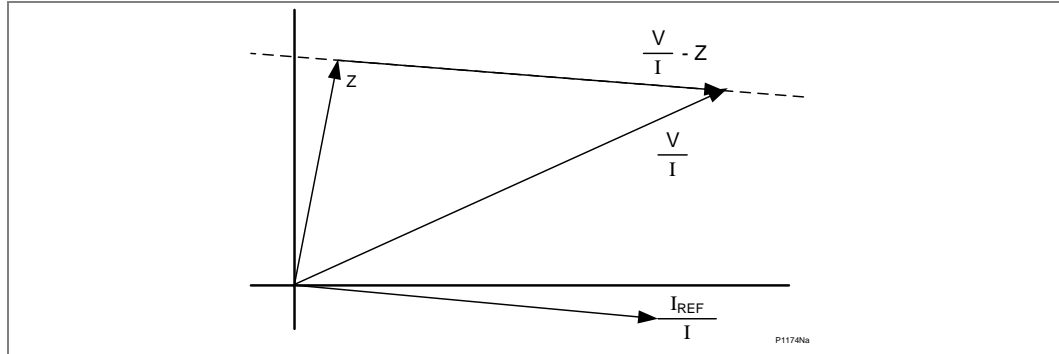

Figure 25 - Reactance line - top line of quadrilateral (Distance option only)

A reactance line is formed by the phase comparison between an operating signal $V/I - Z$, which is the same as that used for the equivalent mho element, and a polarizing signal I_{ref}/I .

Where:

V is the fault voltage

I is the fault current (always presented at zero degree)

Z is the zone reach setting, including residual compensation

I_{ref} is the negative sequence current for dynamic tilting or phase current for the fixed angle tilting that includes the initial tilt angle setting (set to -3° as default).

Dynamic Tilting:

When the Dynamic tilting is selected by a user, the top line of the ground distance quadrilateral characteristic will **start** tilting from the user settable angle (default angle is -3°) and tilt further for the angle difference between the fault current and the negative sequence current so that an overall tilt angle with the reference to fault (phase) current 'I' will be:

$$\text{Tilt angle} = \angle I_{ref}/I = \text{setting} + \angle(I_{ph}-I_2)$$

Operation occurs when the operating signal lags the polarizing signal.

The default starting (initial) tilt angle of -3° is introduced to reduce the possibility of overreach caused by any small differences between the negative sequence source impedances, and general CT/VT angle tolerances.

Negative sequence current is used for ground fault I_{ref} since it provides a better estimate of the current in the fault than either the faulted phase current or zero sequence current. As a result, the reactance line follows the fault resistance impedance and tilts up or down (depending on the load direction) starting from the set initial tilt angle to avoid underreach or overreach.

These additional constraints also exist to ensure that the top line does not tilt too far:

- The Zone 1 reactance (top) line can only stay at set initial tilt angle (-3° default) compared to the resistive axis, or can tilt down by $\angle(I_{ph}-I_2)$. The top line may never tilt up from set tilting angle, to ensure that Zone 1 does not overreach. This maintains grading/selectivity with downstream protection.
- The Zone 2 reactance (top) line can only ever stay at set tilt angle (-3° default) compared to the resistive axis, or can tilt up by $\angle(I_{ph}-I_2)$. The top line may never tilt down, to ensure that Zone 2 does not underreach. This is particularly important when Zone 2 is used to key channel-aided distance schemes.
- The maximum permissible tilt is $\pm 45^\circ$ either side of the set initial tilt angle (-3° default)

When one circuit breaker pole is open, during a single pole reclose sequence, the polarizing signal is replaced by the fault current with a -7° phase shift, allowing the protection of the remaining phases, even though the negative sequence current is not available. The additional phase shift is provided to reduce the possibility of overreach caused by the faulted phase as the reference.

Predetermined (Fixed Angle) Tilting:

For the phase quadrilateral characteristics and ground quad characteristics in case when Dynamic tilting is disabled, the fix angle setting settable by a user applies. Each zone has an independent tilt angle setting. The total tilting angle with the reference to fault current 'I' is equal to the set angle:

Tilt angle = $\angle I_{ref}/I$ = setting

Note *A minus angle is used to set a downwards tilt gradient, and a positive angle to tilt upwards.*

Operation occurs when the operating signal lags the polarizing signal. The setting range is $\pm 30^\circ$.

1.15.4

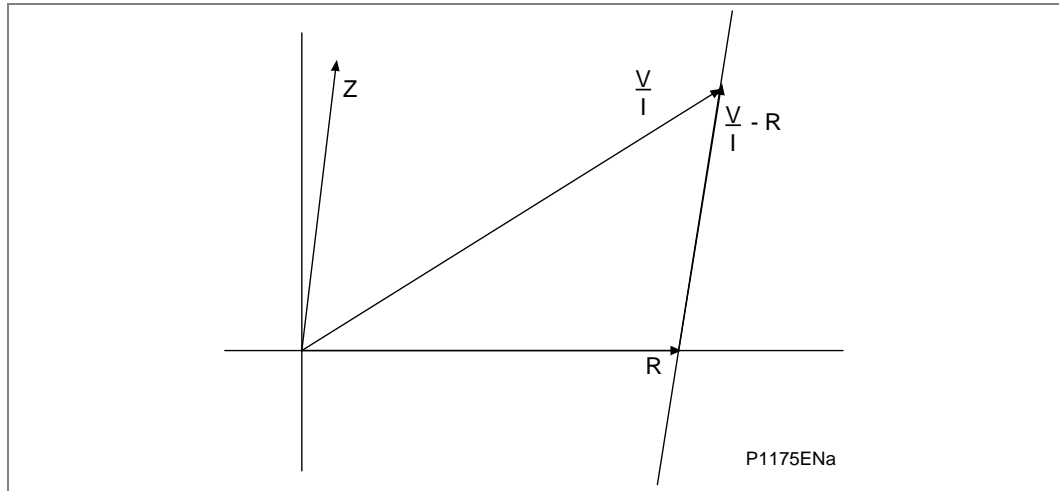
Right Hand Resistive Reach Line (Distance option only)**Figure 26 - Resistive reach line (load blinder) (Distance option only)**

A load blinder is formed by the phase comparison between an operating signal V/I and a polarizing signal Z

Where:

V is the fault voltage

I is the fault current

R is the resistive reach of the blinder

Z zone reach setting (including neutral compensation for ground distance)

Operation occurs when the operating signal leads the polarizing signal.

1.15.5 Quadrilateral Phase Resistive Reaches (Distance option only)

The resistive reach setting is used to select the resistive intercept of the quadrilaterals – the right-hand side of the zone.

<i>Note</i>	<i>The RPh setting applied defines the fault arc resistance that can be detected for a phase-phase fault. For such a fault, half of the fault resistance appears in the positive sequence network, and half in the negative sequence network. Therefore, as most injection test sets will plot impedance characteristics in positive sequence terms, the right-hand intercept will be found at half the setting applied (= Rph/2).</i>
-------------	--

1.16**Quadrilateral Ground Resistive Reaches (Distance option only)**

The resistive reach setting is used to select the resistive intercept of the quadrilaterals – the right-hand side of the zone. Note that the RG setting applied defines the fault arc resistance that can be detected for a single-phase-ground fault. For such a fault, the fault resistance appears in the out and return total fault loop, in which the line impedance is $Z_1 \times (1 + kZ_N)$. Therefore, as most injection test sets will plot impedance characteristics in positive sequence terms, the right-hand intercept will be found at less than setting applied ($= RG/[1+kZ_N]$).

1.17 Advanced Distance Elements Zone Settings (Distance option only)

For most applications the user will configure the relay in “Simple” setting mode, whereby all zone reaches are based on the protected line impedance, scaled by a reach percentage. In such a case there is then no need to set the individual zone ohmic reaches and compensation factors, because the automatic calculation will already have determined these settings. Therefore with Simple settings, the menu column GROUP x DISTANCE ELEMENTS will merely be a list of what settings have been automatically calculated and applied. This list is useful as a reference when commissioning and periodic injection testing.

Using the Advanced setting mode, the user has decided to set all the zones him/herself, and must complete all the reach and residual/mutual compensation settings on a per zone basis.

Note Distance zones are directionalized (where applicable) by a delta directional decision. The characteristic angle for this decision is set along with the Delta Directional configuration, in the GROUP x DISTANCE SETUP menu column. The default setting is 60°.

1.17.1 Phase Fault Zone Settings (Distance option only)

Each zone has two additional settings that are not accessible in the Simple set mode. These settings are:

- A tilt angle on the top line of any quadrilateral set for phase faults
- A minimum current sensitivity setting

By factory defaults, the Top Line of quadrilateral characteristics is not fixed as a horizontal reactance line. To account for phase angle tolerances in the line CT, VT and relay itself, the line is tilted downwards, at a “droop” of -3°. This tilt down helps to prevent zone 1 overreach.

In “Advanced” setting mode, the Top line tilt is settable.

The current *Sensitivity* setting for each zone is used to set the minimum current that must be flowing in each of the faulted phases before a trip can occur. If for example a phase A-B line fault is present, the relay must measure both currents I_a and I_b above the minimum set sensitivity. The default setting is 7.5% I_n for Zones 1 and 2, 5% I_n for other zones, ensuring that distance element operation is not constrained, right through to an SIR ratio of 60.

1.17.2 Ground Fault Zone Settings (Distance option only)

It should be noted that the Ground reach settings (Reach and Angle) are set according to the **positive sequence line impedance**, and so will generally be identical to the Phase reach settings.

The Top Line of ground quadrilateral characteristics is not fixed as a horizontal reactance line. To account for phase angle tolerances in the line CT, VT and relay itself, the line is tilted downwards, at a “droop” of -3°. This tilt down helps to prevent zone 1 overreach. However, to further improve performance this line incorporates an additional dynamic tilt, which will change according to the phase angle between the faulted phase current and the negative sequence current:

- Zone 1 can tilt down to avoid overreaching for pre-fault power export
- Zones 2 and 3 can tilt up to avoid underreaching for pre-fault power import

As the tilt is dynamic, this is why ground fault elements do not have a setting for the angle.

The current Sensitivity setting for each zone is used to set the minimum current that must be flowing in the faulted phase and the neutral before a trip can occur. If for example an A-ground fault is present, the relay must measure both currents I_a and $I_{residual}$ above the minimum set sensitivity.

The default setting is 7.5% In for Zones 1 and 2, 5% In for other zones, ensuring that distance element operation is not constrained, right through to an SIR ratio of 60.

1.17.3

Distance Zone Sensitivities (Distance option only)

When the Simple setting mode is selected, the minimum current sensitivity still applies, but the value is automatically calculated and applied based on the data entered into the simple settings fields. The criteria used to calculate the setting value is required to satisfy a minimum value of current flowing in the faulted loop and a requirement on the Zone reach point voltage. For Zones 3, P, and 4, the requirements are that the minimum current must be greater than 5% of rated current, and that the minimum voltage at the Zone reach point is 0.25 V. The current equating to the reach point criteria can be expressed as 0.25/Zone reach, and the sensitivity can be expressed as:

$$\text{Sensitivity (Z3, ZP, Z4)} = \max(5\%I_n, (0.25/\text{Zone reach}))$$

For Zones 1 and 2, the sensitivity is further qualified to ensure that they are set less sensitive than the reverse Zone 4. This is designed to ensure stability of the relay where applied with either an overreaching, or a blocking scheme. For Zones 1 and 2, the same criteria as for Zones 3, P, and 4 are applied, but in addition a minimum sensitivity criterion dependent upon the Zone 4 sensitivity is applied: the sensitivity must also exceed 1.5 x Zone 4 sensitivity. The sensitivity can be expressed as:

$$\begin{aligned} \text{Sensitivity (Z1, Z2)} &= \max(5\%I_n, (0.25/\text{Zone reach}), (1.5 \times \text{Zone 4 sensitivity})) \text{ OR} \\ \text{Sensitivity (Z1, Z2)} &= \max(5\%I_n, (0.25/\text{Zone reach}), (1.5 \times (0.25/\text{Zone 4 reach}))) \end{aligned}$$

Note 1 The dependency on the Zone 4 element always applies, even if Zone 4 is disabled.

Note 2 The default reach setting for Zones 1, 2, and 4 are 80%, 120%, and 150% respectively and for these settings, the "Zone dependent" terms can be reduced to:

$$\begin{aligned} 0.25/\text{Zone 1 reach} &= 0.25/(0.8 \times \text{line impedance}) \\ 0.25/\text{Zone 2 reach} &= 0.25/(1.2 \times \text{line impedance}) \\ 1.5 \times (0.25/\text{Zone 4 reach}) &= 0.25/\text{line impedance} \end{aligned}$$

In such cases, for Zone 1, the dominant Zone reach term will be that of Zone 1 and the equation can be reduced to:

$$\text{Sensitivity (Z1)} = \max(5\%I_n, (0.25/(0.8 \times \text{line impedance})))$$

And it can be shown that for lines with an impedance less than 6.25 Ω the Zone 1 reach term will dominate and the sensitivity will be greater than 5% In. Above this line impedance the sensitivity will be 5% In.

Similarly, for Zone 2, the dominant Zone reach term will be that of Zone 4 and the equation can be reduced to:

$$\text{Sensitivity (Z2)} = \max(5\%I_n, (0.25/\text{line impedance}))$$

For lines with an impedance less than 5 Ω, the Zone reach term will dominate and the sensitivity will be greater than 5% In. Above this line impedance the sensitivity will be 5% In.

In **Advanced** mode the same restrictions as minimum sensitivity should be applied to ensure distance element accuracy.

1.18

Conventional and Capacitor VT Applications (Distance option only)

The MiCOM relay achieves fast trip times due an optimized counting strategy. For faults on angle and up to 80% of the set reach of the zone, a counter increments quickly to reach the level at which a trip is issued. Near the characteristic boundary, the count increments slower to avoid transient overreach, and to ensure boundary accuracy. This strategy is entirely sufficient where conventional wound voltage transformers are used. Thus, where Capacitor-coupled Voltage Transformers (CVT) are not employed, the setting "**CVT Filters**" can be set to Disabled.

Where capacitor-coupled voltage transformers are employed, then for a close-up fault the transient component can be very large in relation to the fundamental component of fault voltage. The relay has setting options available to allow additional filtering to be switched-in when required, and the filter options to use depend on the likely severity of the CVT transient. The two filtering methods are explained below.

1.18.1 CVTs with Passive Suppression of Ferroresonance (Distance option only)

Passive suppression employs an anti-resonance design, and the resulting transient/distortion is fairly small. Sometimes such suppression is classed as a “**type 2**” CVT. In passive CVT applications, the affect on characteristic accuracy is generally negligible for source to line impedance ratios of less than 30 ($SIR < 30$). However, at high SIRs it is advisable to use the slower count strategy. This is achieved by setting “**CVT Filters**” to “**Passive**”.

It is important to note that by enabling this filter, the relay will not be slowed unless the SIR is above that set. If the line terminal has an SIR below the setting, the relay can still trip subcycle. It is only if the SIR is estimated higher than the setting that the instantaneous operating time will be increased by about a quarter of a power frequency cycle. The relay estimates the SIR as the ratio of nominal rated voltage V_n to the size of the comparator vector I_Z (in volts):

$$SIR = V_n / I_Z$$

Where:

V_n = Nominal phase to neutral voltage

I = Fault current

Z = Reach setting for the zone concerned

Thus for slower counting “**I**” would need to be low, as restricted by a relatively weak infeed, and “**Z**” would need to be small as per a short line.

1.18.2 CVTs with Active Suppression of Ferroresonance (Distance option only)

Active suppression employs a tuned L-C circuit within the CVT. The damping of transients is not as efficient as for the passive designs, and such suppression is often termed as being a **Type 1** CVT. In active CVT applications, to ensure reach point accuracy the setting **CVT Filters** is set to **Active**. The relay then varies the count strategy according to the calculated $SIR (= V_n / I_Z)$. Subcycle tripping is maintained for lower SIRs, up to a ratio of 2, with the instantaneous operating time increasing by about a quarter of a power frequency cycle at higher SIRs.

Transients caused by voltage dips, however severe, will not have an impact on the relay’s directional measurement as the MiCOM relay uses voltage memory.

1.19 Load Blinding (Load Avoidance) (Distance option only)

Load blinders are provided for both phase and ground fault distance elements, to prevent misoperation (mal-tripping) for heavy load flow. The purpose is to configure a blinder envelope which surrounds the expected worst case load limits, and to block tripping for any impedance measured within the blinded region. Only a fault impedance which is outside of the load area will be allowed to cause a trip. The blinder characteristics are shown in the *Load blinder characteristics* diagram.

In the diagram:

- Z denotes the Load/B Impedance setting. This sets the radius of the underimpedance circle.
- β denotes the Load/B Angle setting. This sets the angle of the two blinder boundary lines - the gradient of the rise or fall with respect to the resistive axis.

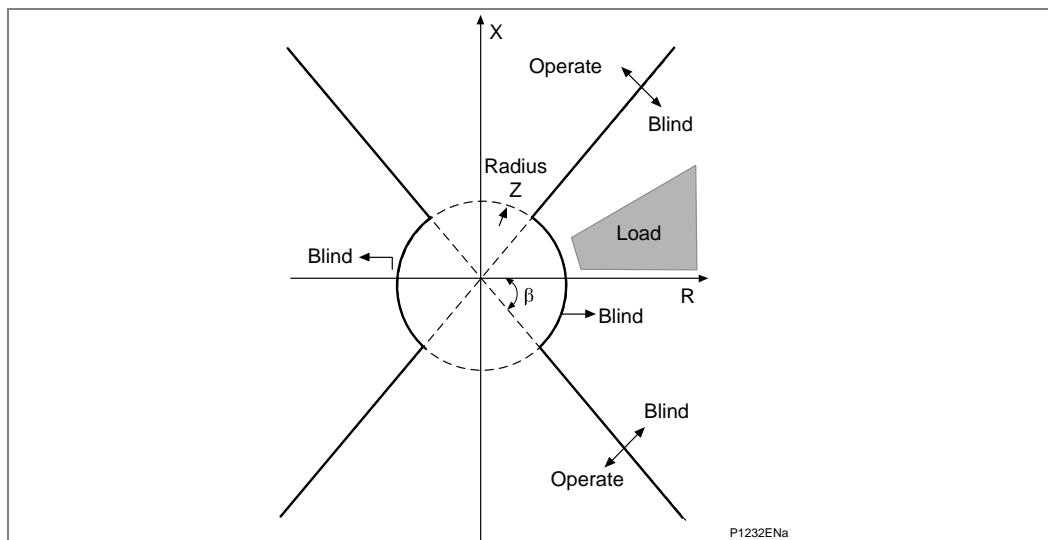

Figure 27 - Load blinder characteristics

The MiCOM relay has a facility to allow the load blinder to be bypassed any time the measured voltage for the phase in question falls below an undervoltage $V_{<}$ setting. Under such circumstances, the low voltage could not be explained by normal voltage excursion tolerances on-load. A fault is definitely present on the phase in question, and it is acceptable to override the blinder action and allow the distance zones to trip according to the entire zone shape. The benefit is that the resistive coverage for faults near to the relay location can be higher.

1.20

Distance Elements Basic Scheme Setting (Distance option only)

Configuration of which zones will trip, and the zone time delays is set in the menu column **GROUP x SCHEME LOGIC** (where x is the setting group). Phase and ground elements may have different time delays if required. Operation of distance zones according to their set time delays is termed the **Basic Scheme**, and is shown in the Basic scheme delayed trip diagram. The basic scheme always runs, regardless of any channel-aided acceleration schemes which may be enabled (see later).

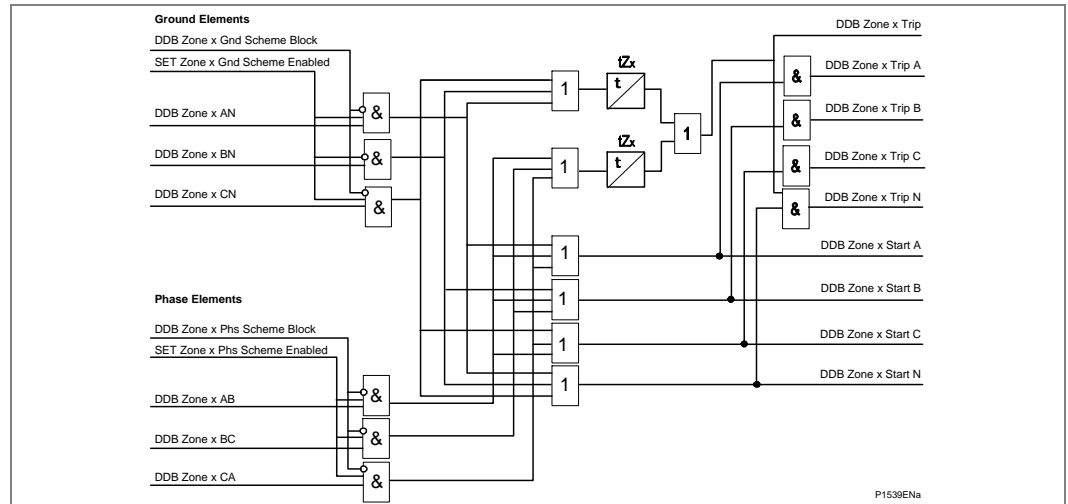

Figure 28 - Basic scheme delayed trip (Distance option only)

Signal	Zone 1	Zone 2	Zone 3	Zone P	Zone 4
Zone x Ground Block	384	386	388	390	392
Zone x Phase Block	385	387	389	391	393
Zone x AN	960	966	972	978	984
Zone x BN	961	967	973	979	985
Zone x CN	962	968	974	980	986
Zone x AB	963	969	975	981	987
Zone x BC	964	970	976	982	988
Zone x CA	965	971	977	983	989
Zone x Trip	608	613	618	623	628
Zone x Trip A	609	614	619	624	629
Zone x Trip B	610	615	620	625	630
Zone x Trip C	611	616	621	626	631
Zone x Trip N	612	617	622	627	632
Zone x Start A	741	745	749	753	757
Zone x Start B	742	746	750	754	758
Zone x Start C	743	747	751	755	759
Zone x Start N	744	748	752	756	760

Note The numbers in the table represent the DDB signals available in the PSL.

Table 1 - Basic scheme delayed trip (Distance option only)

1.21 Power Swing Detection, Alarming and Blocking (Distance option only)

1.21.1 Detection of Power Swings (Distance option only)

A power swing may cause the impedance presented to a distance relay to move away from the normal load area and into one or more of its tripping characteristics. In the case of a stable power swing it is important that the relay should not trip. The relay should also not trip during loss of stability since there may be a utility strategy for controlled system break up during such an event.

The power swing detection in the MiCOM relay is an advanced technique that uses superimposed current (ΔI) detector similar to the phase selection principle described above. However, for the power swing detector the current is always compared to that 2 cycles previous. For a fault condition this power swing detector (PSD) will reset after 2 cycles as no superimposed current is detected.

For a power swing, PSD will measure superimposed current for longer than 2 cycles, and it is the length of time for which the superimposed current persists that is used to distinguish between a fault and a power swing. A power swing is deemed to be in progress if a 3-phase selection, or a phase to phase selection when one pole is open, produced in this way is retained for more than 3 cycles, as shown in the following diagram. At this point the required distance zones can be blocked, to avoid tripping should the swing impedances cross into a tripping zone.

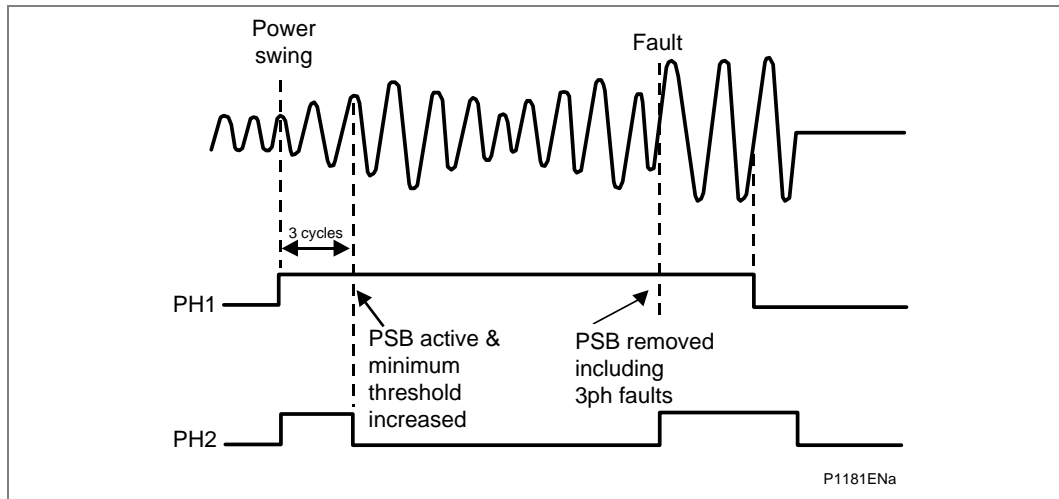

Figure 29 - Power swing detected for 3 cycles continuous ΔI (Distance option only)

To detect slow power swings, when the superimposed current remains below the minimum threshold ($5\%I_n$), a complementary method of detection could be used. This method requires zone 5 to be set. For the zone 5 setting, no system study is required, it is only needed to set the R5 and R5' reach below the minimum possible load impedance, (see the Application Notes chapter). If the fault impedance remains within a zone 5 for at least 1 cycle without phase selection operation, the slow swing is declared. This complementary method works in parallel to the automatic, setting free technique explained above.

Note *Zone 5 has a dual purpose: OST protection and slow swing detection. There is no conflict in zone 5 settings, i.e. zone 5 settings for OST protection (if applied) perfectly suit slow swing detection.*

1.21.2 Actions upon Power Swing Detection (Distance option only)

Once a power swing is detected, the following actions occur:

- Distance elements are blocked on selected zones providing blocking is enabled

- All zones are switched to self polarized mho characteristics for maximum stability during the swing
- A power swing block alarm is issued when the swing impedance enters a distance zone. The condition of entering an impedance zone avoids alarming for low current momentary swings that settle quickly
- When a power swing is in progress, the minimum threshold used by the phase selector is increased to twice the maximum superimposed current prevailing in the swing. Therefore, the phase selector resets once a power swing is detected. It can then be used to detect a fault during a power swing.

1.21.3 Detection of a Fault during a Power Swing (Distance option only)

A fault is detected during a swing when the phase selector operates, based on its increased threshold. Therefore, any operation of the phase selector will cause PSB unblocking, and allow a trip. Example scenarios are:

- A fault causes the delta current measured to increase above twice that stored during the swing (a step change in delta I rather than the expected gradual transition in a power swing).

1.21.4 Actions Upon Detection of a Fault during a Power Swing (Distance option only)

The block signal is only removed from zones that start within 2 cycles of a fault being detected. This improves stability for external faults during power swings. Any measuring zone that was detecting an impedance within its characteristic before the phase selector detected the fault will remain blocked. This minimizes the risk of tripping for a swing impedance that may naturally be passing through Zone 1, and could otherwise cause a spurious trip if all zones were unblocked on fault inception. Any measuring zone that picks up beyond the 2-cycle window will remain blocked. This minimizes the risk of tripping for a continued swing that may pass through Zone 1, and could otherwise cause a spurious trip if all zones were allowed to unblock together.

1.21.5 Power Swing Settings (Distance option only)

The power swing detection is setting free aided with slow swing detection that uses zone 5 and does not require any system study. The only setting available to a user, apart from zone 5, is to decide whether a zone should be blocked or allowed to trip after a power swing is detected. Zone by zone, it is possible to select one mode from the following:

Allow Trip	should a power swing locus remain within a trip zone characteristic for a duration equal to the zone time delay, the trip will be allowed to happen
Blocking	to keep stability for that zone, even if a power swing locus should enter it
Delayed Unblock	maintains the block for a set duration. If the swing is still present after the PSB Timeout Set window has expired, tripping is allowed as normal

Other setting possibilities are:

- Selection of PSB as "Indication" only will raise an alarm, without blocking any zones
- The *PSB Unblock Dly* function allows for any power swing block to be removed after a set period. For a persistent swing that does not stabilize, any blocked zones will be made free to trip once the timer has elapsed. In setting which relays will unblock, the user should consider which relay locations are natural split points for islanding the power system.

- The *PSB Reset Delay* is a time delay on drop-off timer, which maintains the PSB detection even after the swing has apparently stabilized. It is used to ensure that where the swing current passes through a natural minimum and delta I detection might reset, that the detection does not drop out/chatter. It can therefore be used to ensure a continual Power Swing indication when pole slipping (an unstable out of step condition) is in progress.

The following is a simplified logic diagram showing operation of the power swing blocking.

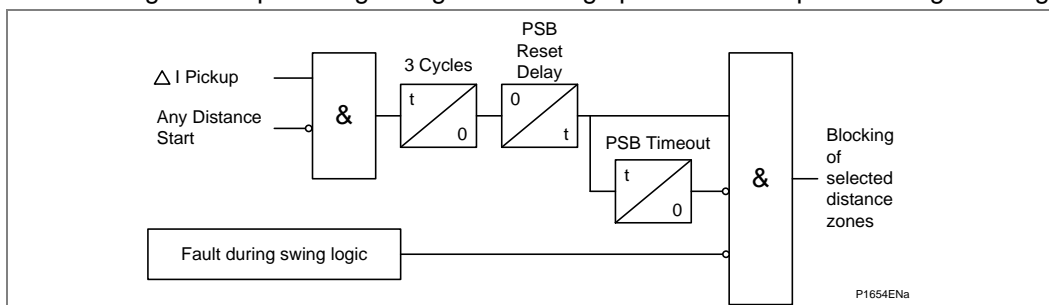

Figure 30 - Power swing blocking (Distance option only)

1.22 Out-of-Step Detection and Tripping (Distance option only)

Out-of-Step protection is used to split the power system into possibly stable areas of generation and load balance during unstable power oscillations. The points at which the system should be split are determined by detailed system stability studies.

The Out-of-Step function has four different setting options:

- Option 1 - Disabled
- Option 2 - Predictive OST
- Option 3 - OST
- Option 4 - Predictive OST or OST

When set **'Disabled'**, Out-of-Step function is not operational. The MiCOM relay also provides an option to split the system in advance by selecting the **'Predictive OST'** (sometimes called an early OST) to minimize the angle shift between two ends and aid stability in the split areas. The third setting option is to split the system on detection of the Out-of-Step condition i.e. when a pole slip occurs. The fourth option is a combination of the two.

1.22.1 Out of Step Detection (Distance option only)

The Out-of-Step detection is based on the well proven $\Delta Z/\Delta t$ principle associated with two concentric polygon characteristic, as in the *Out of step detection characteristic* diagram.

1.22.1.1 Characteristic (Distance option only)

Both polygon characteristics are independent and have independent settings for their respective reactance and resistive reaches.

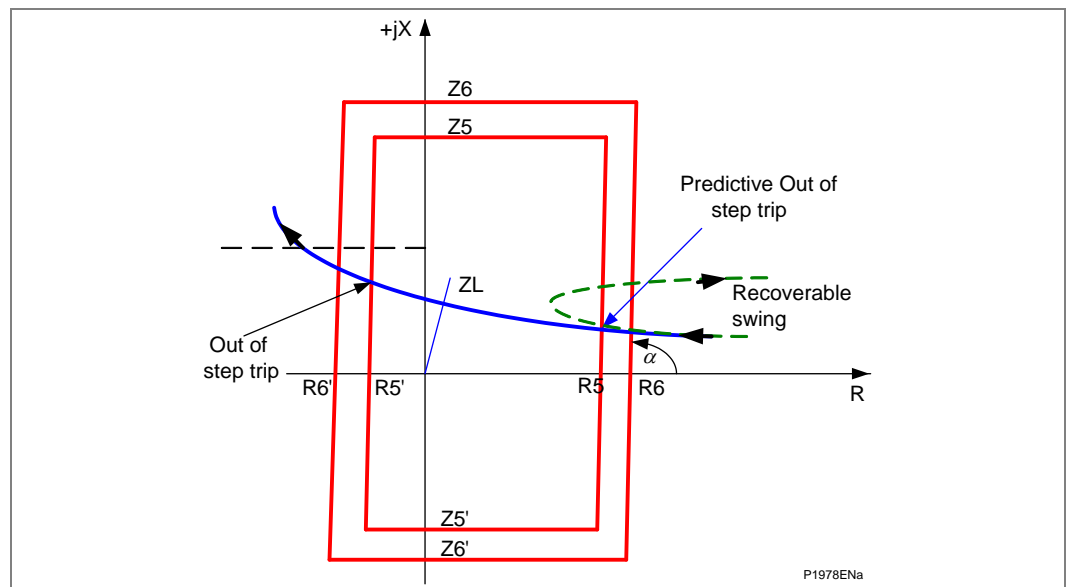

Figure 31 - Out-of-step detection characteristic (Distance option only)

Note Both the inner (Zone 5) and outer (Zone 6) characteristics, as shown above, are settable in positive sequence impedance terms to ensure correct Out-of-Step detection during open pole swing conditions. Hence, there is only one Z5 and Z6 positive sequence impedance polygon characteristic instead of six characteristics for each measured loop.

The measured positive sequence impedance is calculated as:

$$Z1 = V1/I1$$

Where V1 and I1 are positive sequence voltage and current derived from the measured phase quantities.

Note During symmetrical power oscillations, there is no difference between phase impedance loops and positive sequence impedance loop, whilst for the open pole oscillations the phase and positive sequence impedances are different. This fact must be considered during testing/commissioning.

All four resistive blinders are parallel, using the common angle setting ' α ' that corresponds to the angle of the total system impedance $Z_T (= Z_S + Z_L + Z_R)$, where Z_S and Z_R are equivalent positive sequence impedances at the sending and receiving ends and Z_L positive sequence line impedance. Tilting of the reactance line and residual compensation is not implemented.

In the *Out of step detection characteristic* diagram, the solid impedance trajectory represents the locus for the non-recoverable power oscillation, also known as pole slip or out of step condition. The dotted impedance trajectory on the other hand represents a recoverable power oscillation, usually called swings.

1.22.1.2

Operating Principle (Distance option only)

The Out-of-Step detection algorithm is based on measuring the speed of positive sequence impedance passing through the set ΔZ region. As soon as measured positive sequence impedance touches the outer polygon, a timer is started.

If the disturbance takes less than 25ms from entering zone 6 to entering zone 5, the relay will consider this to be a power system fault and not an out of step trip condition. The timer of 25ms is a fixed timer in the logic and not user accessible. During a power system fault, the speed of impedance change from a load to a fault is fast, but the relay may operate slower for marginal faults close to a zone boundary, particularly for high resistive faults inside the zone operating characteristic and close to the Z_5 boundary. Therefore, the fixed time of 25ms is implemented to provide sufficient time for a distance element to operate and therefore to distinguish between a fault and an extremely fast power system oscillation.

If the disturbance takes more than 25ms but less than ΔT set time from entering Zone 6 to entering Zone 5, this will be seen as a very fast oscillation. Therefore, the relay will trip if setting option 2 or 4 was selected. The minimum ΔT setting is 30ms, allowing 5ms margin to the fixed 25ms timer.

If the disturbance takes longer than the ΔT setting time to enter Zone 5 after entering Zone 6 then it is considered as a slow power oscillation. Upon entering Z_5 , the relay will record the polarity of the resistive part of the positive sequence impedance. Two scenarios are possible:

- If the resistive part of the positive sequence impedance leaves Z_5 with the same polarity as previously recorded on entering Zone 5, it is deemed a recoverable swing. No tripping will be issued.
- If the resistive part of the positive sequence impedance has the opposite polarity when exiting Zone 5 to that of the recorded polarity on Zone 5 entering, an Out of Step condition is recognized, followed by the tripping if setting option 3 or 4 was selected. It should be noted that in the case when the ΔT timer did not expire and setting option 3 is selected, the Out of Step condition will also be detected, followed by OST operation.

As the tripping mode for the detected Out of Step condition is always 3ph trip, the '**Predictive OST**' and OST DDB signals are mapped to the 3ph tripping in the default PSL. Also, Out of Step operation will block auto-reclose function. The Out of Step tripping time delay TOST is also available to delay the OST tripping command until the angle between internal voltages between two ends are at 240 deg closing towards 360 deg. This is to limit the voltage stress across the circuit breaker. In the case of a fault occurring during the swing condition, the out of step tripping function will be blocked.

The Out of Step algorithm is completely independent from the distance elements and setting free power swing detection function. The load blinder does not have any effect on the OST characteristics. For the Out of Step operation, the minimum positive sequence current of 5% I_n must be present.

The Out of Step algorithm is given in this diagram.

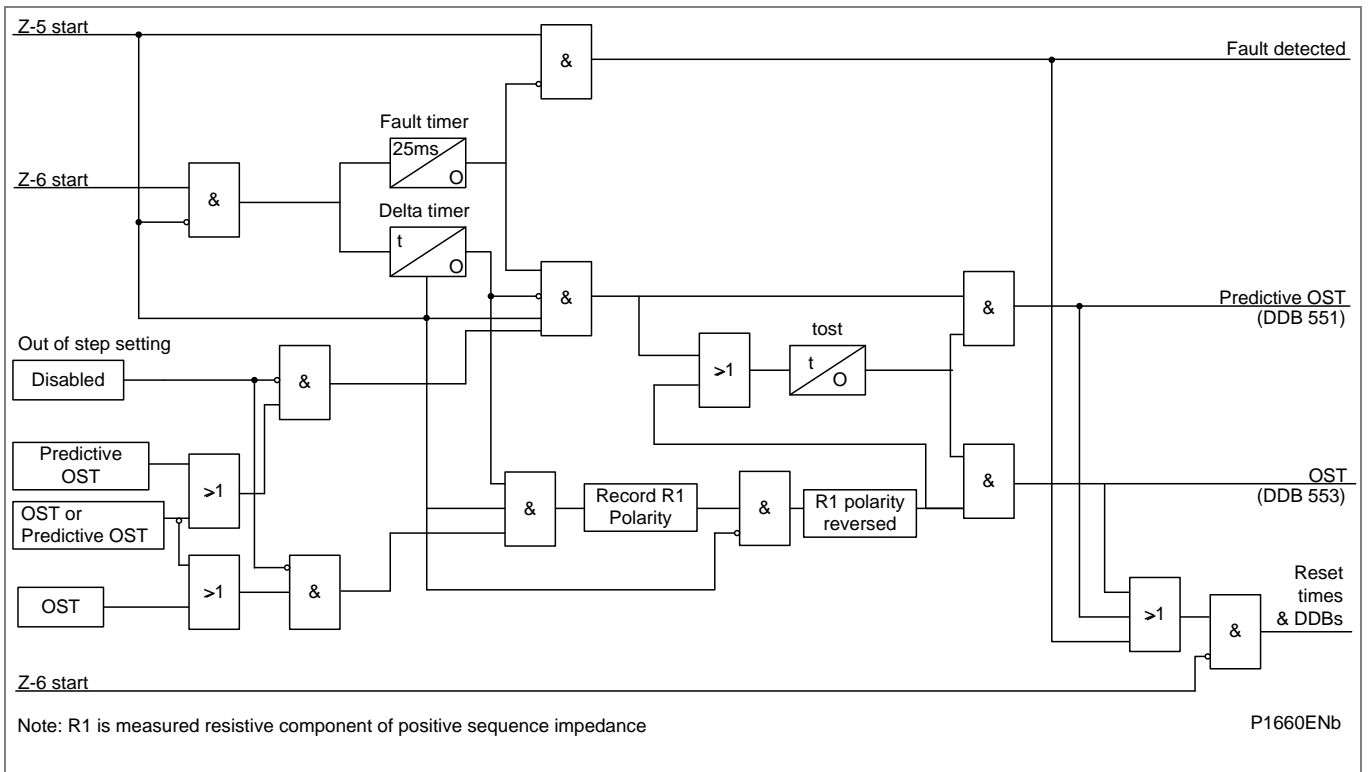

Figure 32 - Out of step algorithm (Distance option only)

1.23

Switch On To Fault (SOTF) and Trip On Reclose (TOR) (Distance Option only)

The settings for SOTF and TOR are included in the menu column “**TRIP ON CLOSE**” (TOC) within the MiCOM relay. The settings are designed to deal with two different scenarios.

- SOTF is designed to provide instantaneous operation of selected elements for a fault present on manual closure of the circuit breaker
- TOR is designed to provide instantaneous operation of selected elements for a persistent fault present on auto-reclosing of the circuit breaker

The SOTF and TOR functions are communally termed “**Trip on Close**” logic. The operation of these features is split into two Figures for clarity:

The *Trip on close* diagram shows Trip On Close function in relation with the Distance zones whilst the *Trip on close based on CNV level detectors* diagram presents Trip On Close driven by ‘**Current No Volt**’ level detectors. Both methods operate in parallel if mapped to the SOTF and TOR Tripping matrix in the setting file.

The ‘**Current No Volt**’ (CNV) level detectors are user settable in the ‘**GROUP X CB FAIL & P. Dead**’ column. The same setting is used for pole dead logic detection - see Settings Section for more details. The 20ms time delay in the *Trip on close based on CNV level detectors* diagram is to avoid a possible race between very fast overvoltage and undercurrent level detectors.

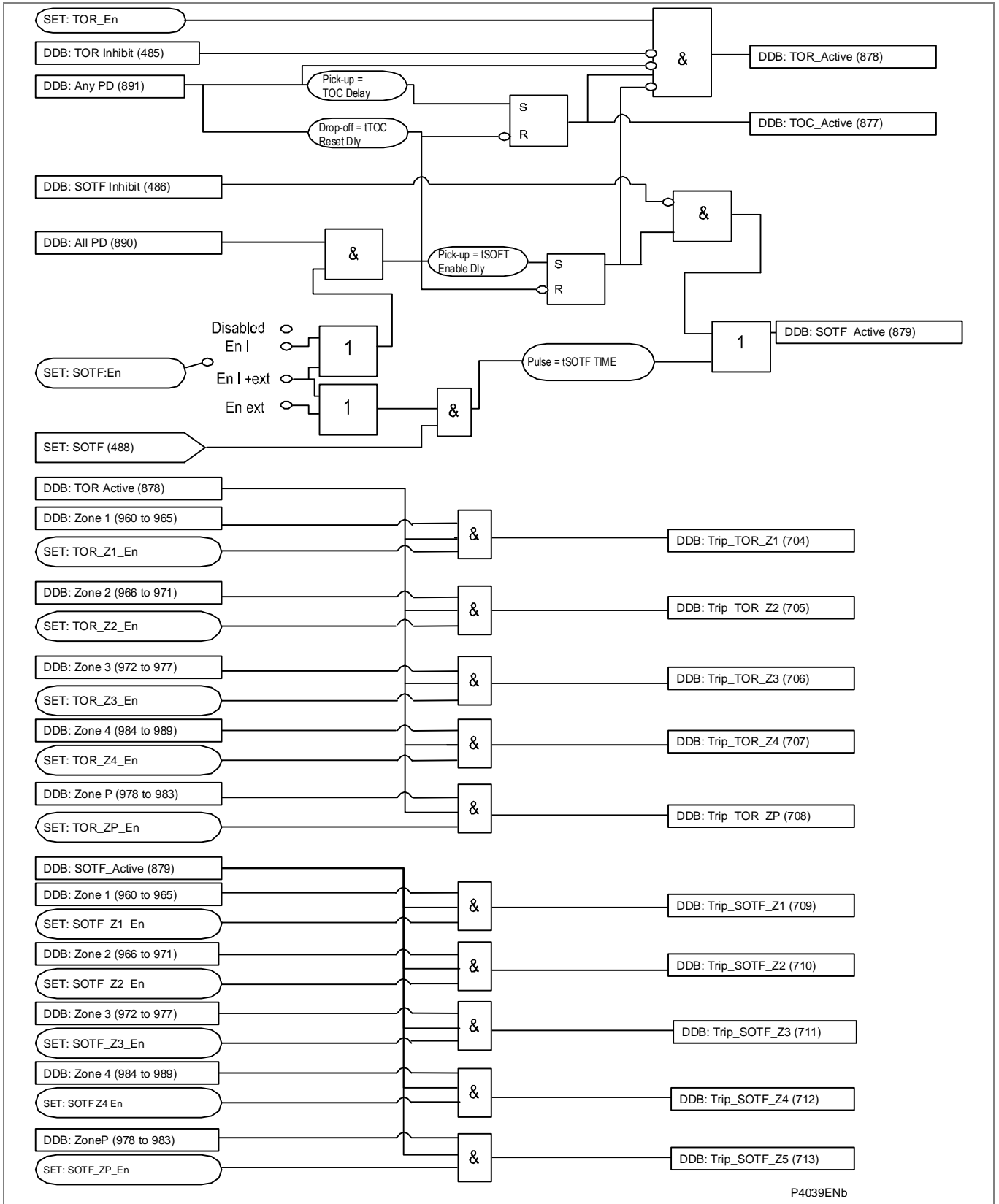

P4039ENb

Figure 33 - Trip on close (Distance option only)

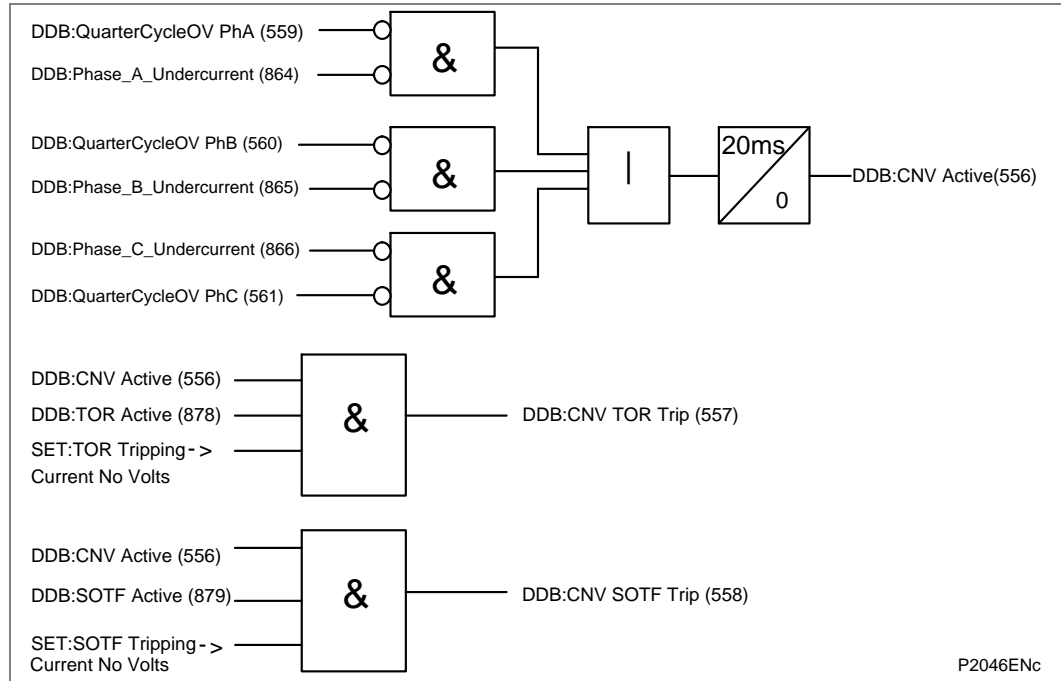

Figure 34 - Trip on close based on CNV level detectors (Distance option only)

1.23.1

Switch On To Fault (SOTF) Mode

The settings applied are as follows:

SOTF Status SOTF can be activated in three different ways:

1. Enabled by using pole dead logic detection logic. A *SOTF Delay* timer starts if “all pole dead” condition is detected. Once this timer expires, SOTF becomes enabled and remains active during the period set on “TOC Reset Delay” setting.
2. Enabled by an external pulse. SOTF becomes enabled after an external pulse (as a circuit breaker close command for example) linked to DDB “Set SOTF” (DDB 488) is ON. The function remains active for the duration of the “SOTF Pulse” setting.
3. Enabled by using the two previous methods.
With this feature *Enabled*, the relay operates in *Switch on to Fault* mode. Three pole instantaneous tripping (and auto-reclose blocking) occurs for any fault detected by the selected zones or/and **Current No Volt** level detectors when in Switch on to Fault mode. Whether this feature is enabled or disabled, the normal time delayed elements or aided channel scheme continues to function and can operate to trip the circuit.

TOC Reset Delay The SOTF (when enabled by pole dead detection logic) and TOR features remain in-service for the duration of the TOC reset delay once the circuit is energized.

SOTF Tripping Link While the Switch on to Fault Mode is active. The MiCOM relay will trip instantaneously for pick up of any zone selected in these links. To operate for faults on the entire circuit length it is recommended that at least Zone 1 and Zone 2 are selected. If no elements are selected then the normal time delayed elements and aided scheme provide the protection.

1.23.2

Trip On Reclose (TOR) Mode (Distance option only)

The settings applied are as follows:

- TOR Status With this feature Enabled, for a period following circuit breaker closure, the relay operates in Trip on Re-close mode. Three pole instantaneous tripping occurs for any fault detected by the selected zones or/and '**Current No Volt**' level detectors. Whether this feature is enabled or disabled, the normal time delayed elements or aided channel scheme continue to function and can operate to trip the circuit.
- TOC Reset Delay The SOTF and TOR features remain in-service for the duration of the TOC reset delay once the circuit is energized.
- TOC Delay Is a user settable time delay that starts upon opening the CB after which the '**TOR**' becomes active (enabled). The time delay must not exceed the minimum Dead Time setting as both times start simultaneously and TOR protection must be ready by the time of CB closing on potentially persistent faults.
- TOR Tripping Links While the Trip on Re-close Mode is active, the MiCOM relay will trip instantaneously for pick up of or/and '**Current No Volt**' level detectors any zone selected in these links. To operate for faults on the entire circuit length it is recommended that at least Zone 1 and Zone 2 are selected. If no elements are selected then the normal time delayed elements and aided scheme provide the protection.

1.23.3

Polarization During Circuit Energization (Distance option only)

While the Switch on to Fault and Trip on Re-close modes are active, the directionalized distance elements are partially cross polarized from other phases. The same proportion of healthy phase to faulted phase voltage as given by the Distance Polarizing setting in the DISTANCE SETUP menu is used.

Partial cross polarization is thus used in substitute for the normal memory polarizing, for the duration of the TOC window. If insufficient polarizing voltage is available, a slight reverse offset (10% of the forward reach) is included in the zone 1 characteristic to enable fast clearance of close-up 3-phase faults. Therefore, the mapping of CNV function to the SOTF tripping matrix is not essential.

1.24 Directional Function - Setup DEF and Directional Comparison Elements (Distance Option only)

The MiCOM P54x with distance option installed has one additional aided channel (“pilot”) scheme that can be used to supplement differential and distance protection.

- DEF Directional earth (ground) fault protection
- Delta ΔI and ΔV based directional comparison scheme

Both schemes are configured as unit protection, with a communication channel connected between the remote line ends.

To make use of these schemes, base setting data must be made in the GROUP x DISTANCE SETUP (for Delta comparison scheme) and GROUP x/ AIDED DEF (For Directional earth fault protection)

Any of the following conditions will block Aided DEF scheme:

- Phase selector picking up on either 2 or 3 phases.
- Assertion of “Any Trip” signal.

DEF FWD signal will be blocked in case of any or all pole dead conditions.

1.24.1 DEF Zero Sequence Polarization with “Virtual Current Polarizing” (Distance option only)

With earth fault protection, the polarizing (directional reference) signal requires to be representative of the earth fault condition. As residual voltage is generated during earth fault conditions, this quantity is commonly used to polarize the directional decision of DEF elements. The relay internally derives this voltage from the 3-phase voltage input which must be supplied from either a 5-limb or three single-phase VTs. These types of VT design allow the passage of residual flux and consequently permit the relay to derive the required residual voltage. In addition, the primary star point of the VT must be earthed. A three-limb VT has no path for residual flux and, is therefore unsuitable to supply the relay.

It is possible that small levels of residual voltage will be present under normal system conditions due to system imbalances, VT inaccuracies, relay tolerances etc. Hence, the relay includes a user settable threshold (DEF VNPol Set) which must be exceeded for the DEF function to be operational. Note that residual voltage is nominally 180° out of phase with residual current. Consequently, the DEF relays are polarized from the ‘-Vres’ quantity. This 180° phase shift is automatically introduced within the relay.

A distinct advantage is that the MiCOM relay can trip by this method of polarizing, even if VNpol is less than the set threshold. Provided that the superimposed current phase selector has identified the faulted phase (suppose phase A), it will remove that phase from the residual calculation $V_a + V_b + V_c$, leaving only $V_b + V_c$. The resultant polarizing voltage will have a large magnitude, and will be in the same direction as $-V_{res}$. This allows the relay to be applied even where very solid earthing behind the relay prevents residual voltage from being developed.

This technique of subtracting the faulted phase is given the description “virtual current polarizing” as it removes the need to use current polarizing from a CT in a transformer star (wye)-ground connection behind the relay. This would have been necessary with traditional relays.

The directional criteria with zero sequence (virtual current) polarization are given below:

Directional forward	$-90^\circ < (\text{angle}(IN) - \text{angle}(VN\text{pol}+180^\circ) - \text{RCA}) < 90^\circ$
Directional reverse	$-90^\circ > (\text{angle}(IN) - \text{angle}(VN\text{pol}+180^\circ) - \text{RCA}) > 90^\circ$

Where VNpol is as per the table below:

Phase selector pickup	VNpol
A Phase Fault	VB + VC
B Phase Fault	VA + VC
C Phase Fault	VA + VB
No Selection	VN = VA + VB + VC

Table 2 - Phase selector pickup and VNpol

1.24.2

DEF Negative Sequence Polarization (Distance option only)

In certain applications, the use of residual voltage polarization of DEF may either be not possible to achieve, or problematic. An example of the former case would be where a suitable type of VT was unavailable, for example if only a three-limb VT was fitted. An example of the latter case would be an HV/EHV parallel line application where problems with zero sequence mutual coupling may exist.

In either of these situations, the problem may be solved by the use of Negative Phase Sequence (NPS) quantities for polarization. This method determines the fault direction by comparison of NPS voltage with NPS current. The operate quantity, however, is still residual current (3I0). It requires a suitable voltage threshold to be set in cell **DEF 3V2pol Set**.

The directional criteria with negative sequence polarization are given below:

Directional forward $-90^\circ < (\text{angle}(3I2) - \text{angle}(3V2+180^\circ) - \text{RCA}) < 90^\circ$

Directional reverse $-90^\circ > (\text{angle}(3I2) - \text{angle}(3V2+180^\circ) - \text{RCA}) > 90^\circ$

Attention: In configuring V2 threshold (cell 39.06)

With firmware versions previous to version K5, the menu text shows: DEF V2pol Set

Starting with firmware version K5 and above, the menu text will show: DEF 3V2pol Set

3V2 is the polarizing quantity used in the firmware design since the product launch. So at all case The V2 polarization threshold to be set at 3 times the required V2 to achieve correct operation.

For example: If the required V2 threshold is 500V, cell 39.06 has to be set at 1500V, irrespective of menu text DEF V2pol Set in firmware's previous to K5.

1.24.3

Delta Directional Comparison Principle and Setup (Distance option only)



Note

The characteristic angle set in this section is also used by the DISTANCE PROTECTION. This is because distance zones are directionalized by the delta decision.

Delta directional comparison looks at the relative phase angle of the superimposed current ΔI compared to the superimposed voltage ΔV , at the instant of fault inception. The delta is only present when a fault occurs and a step change from the prefault steady-state load is generated by the fault itself. The element will issue a forward or reverse decision, which can be used to input into an aided channel unit protection scheme.

Under healthy network conditions, the system voltage will be close to Vn nominal, and load current will be flowing. Under such steady-state conditions, if the voltage measured on each phase now is compared with a stored memory from exactly two power system cycles previously (equal to 96 samples), the difference between them will be zero. Zero change equals zero "delta" ($\Delta V = 0$). The same will be generally true for the current ($\Delta I = 0$), except when there are changes in load current etc.

When a fault occurs on the system, the delta changes measured will be:

$\Delta V = \text{fault voltage (time "t")} - \text{prefault healthy voltage (t-96 samples)}$

$\Delta I = \text{fault current (time "t")} - \text{prefault load current (t-96 samples)}$

The delta measurements are a vector difference, resulting in a delta magnitude and angle. Under healthy system conditions, the pre-fault values will be those measured 2 cycles earlier, but when a fault is detected, the pre-fault values will be retained for the duration of the fault.

The changes in magnitude are used to detect the presence of the fault, and the angles are used to determine whether the fault is in the Forward or Reverse direction.

Consider a single-phase to ground fault as shown in the *Sequence networks connection for an internal A-N fault* diagram below.

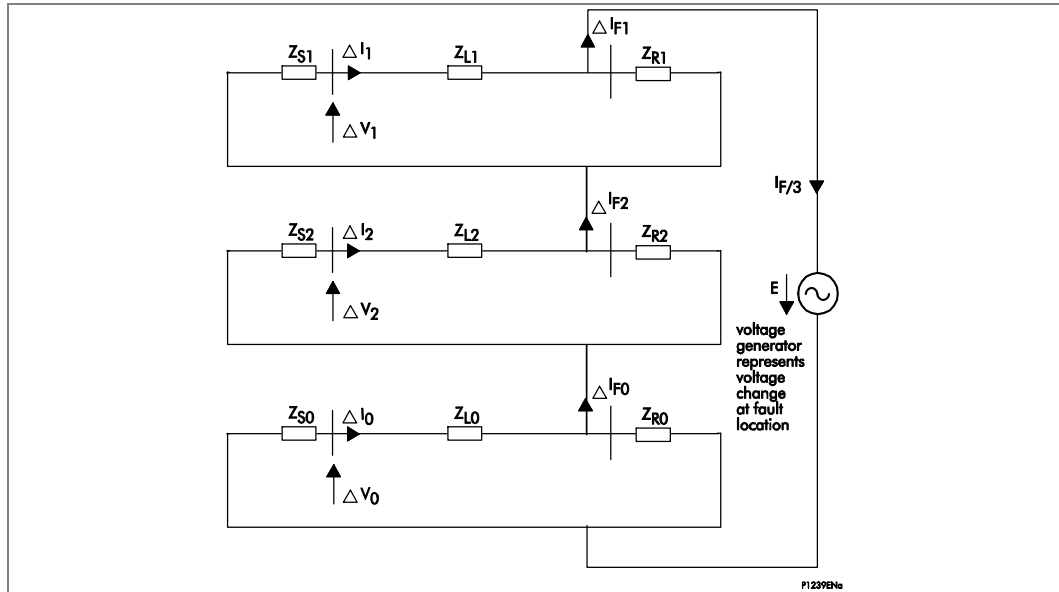

Figure 35 - Sequence networks connection for an internal A-N fault (Distance option only)

The fault is shown near to the busbar at end R of the line, and results in a connection of the positive, negative, and zero sequence networks in series. Drawing the delta diagram, it is seen that any fault is effectively a generator of Δ , connected at the location of fault inception. The characteristics are:

1. The ΔI generated by the fault is equal to the total fault arc current;
2. The ΔI will split into parallel paths, with part contribution from source "S", and part from remote end "R" of the line. Therefore, each relay will measure a lower proportion of delta I;
3. The ΔV generated by the fault is equal to the fault arc voltage minus the pre-fault voltage (and so will be in antiphase with the pre-fault voltage);
4. The ΔV will generally be smaller as measured at the relay location, due to the voltage collapse being smaller near to the source than at the fault itself. The delta V measured by a relay is effectively the voltage drop across the source impedance behind the relay location.

If a fault were to occur at any point on the protected line, the resulting ΔI and ΔV as measured at the relay location must be greater than the Delta I Fwd and Delta V Fwd settings, in order that the fault can be detected. (Scenarios (2) and (4) above must be verified for all fault types: Ph-G, Ph-Ph, Ph-Ph-G, and 3-phase).

1.24.4

Delta Directional Decision (Distance option only)

On fault inception, delta quantities are generated, and it is then simple for the relay to determine the direction of the fault:

Forward fault Delta V is a decrease in voltage, and so is in the negative sense; whereas delta I is a forward current flow and so is in the positive sense. Where delta I and delta V are approximately in antiphase, the fault is forward.

The exact angle relationship for the forward fault is:

$$\Delta V / \Delta I = - (\text{Source impedance, } Z_s)$$

Reverse fault Delta V is a decrease in voltage, and so is in the negative sense; delta I is an outfeed flowing in the reverse direction, so that too is in the negative sense. Where delta I and delta V are approximately in phase, the fault is reverse.

The exact angle relationship for the reverse fault is:

$$\Delta V / \Delta I = (\text{Remote Source impedance } Z_s' + Z_L)$$

Where ZL is protected line impedance and Zs' source impedance behind the relay.

An RCA angle setting in the relay allows the user to set the center of the directional characteristic, according to the amount the current will nominally lag the reference delta voltage. The characteristic boundary will then be ± 90 degrees either side of the set center.



Note Distance zone directionalizing shares the same characteristic angle setting used for Delta directional comparison protection, but uses fixed operating thresholds: ΔV=0.5V and ΔI=4%In. In distance applications, if the fault ΔV is below the setting of 0.5V, a conventional distance line ensures correct forward/reverse polarizing. This is not true for Delta directional aided schemes where sufficient ΔV must be present, for tripping to occur.

The directional criteria for delta directional decisions are given below:

Directional forward $-90^\circ < (\text{angle}(\Delta I) - \text{angle}(\Delta V + 180^\circ) - \text{RCA}) < 90^\circ$

Directional reverse $-90^\circ > (\text{angle}(\Delta I) - \text{angle}(\Delta V + 180^\circ) - \text{RCA}) > 90^\circ$

To facilitate testing of the Distance elements using test sets which do not provide a dynamic model to generate true fault delta conditions, a Static Test Mode setting is provided. This setting is found in the COMMISSIONING TESTS menu column. When set, this disables phase selector control and forces the relay to use a conventional (non-delta) directional line.

1.25 Channel Aided Schemes (Distance option only)

The MiCOM relay offers two sets of aided channel (“pilot”) schemes, which may be operated in parallel.

- Aided Scheme 1 May be keyed by distance and/or DEF and/or delta directional comparison
- Aided Scheme 2 May be keyed by distance and/or DEF and/or delta directional comparison

The provision of two discrete channel selections would allow the following to be implemented, as an example:

- Distance POR with DEF POR scheme operating over a common shared channel... Select both in AIDED SCHEME 1 only, with AIDED SCHEME 2 Disabled.
- Distance PUR with DEF BLOCKING operating over separate channels due to the dissimilar scheme types. Assign Distance to AIDED SCHEME 1, and DEF to AIDED SCHEME 2.
- Directional Comparison BLOCKING scheme with a second channel for a distance with DEF BLOCKING scheme operating in unison... Assign Delta to AIDED SCHEME 1, and both Distance/DEF to AIDED SCHEME 2.

Note Where schemes share a common channel, the signal send and signal receive logic operates in a logical “OR” mode.

Aided Scheme 1 and Aided Scheme 2 are two instances of the same logic. Each of these schemes provides the same options and can be independently applied. The scheme logic is split into three sections defined in the following diagram: send logic, receive logic, and aided tripping logic, as shown in the *Aided scheme logic overview* diagram. Detailed scheme descriptions follow later. As there are two instances of the aided scheme, any internal logic signals which are specific to the instance of the scheme are shown in the diagrams with two DDB numbers relating to the first and second instance, respectively.

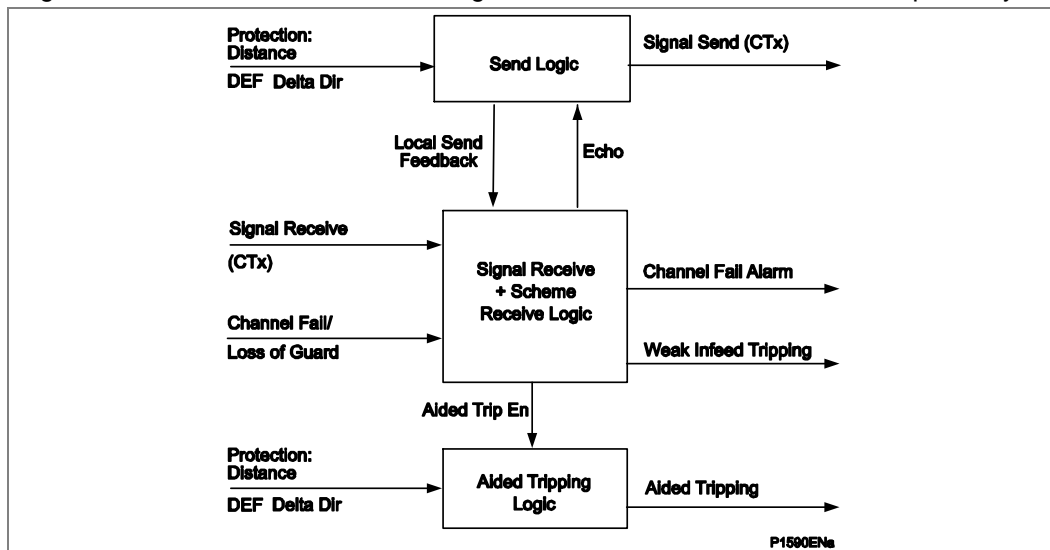

Figure 36 - Aided scheme logic overview (Distance option only)

The full Logic Diagrams of the Send, Receive and Aided Trip Logic are now attached here, for reference. It is not necessary to understand the entire logic in order to apply any scheme, as in later sections abbreviated scheme diagrams are available.

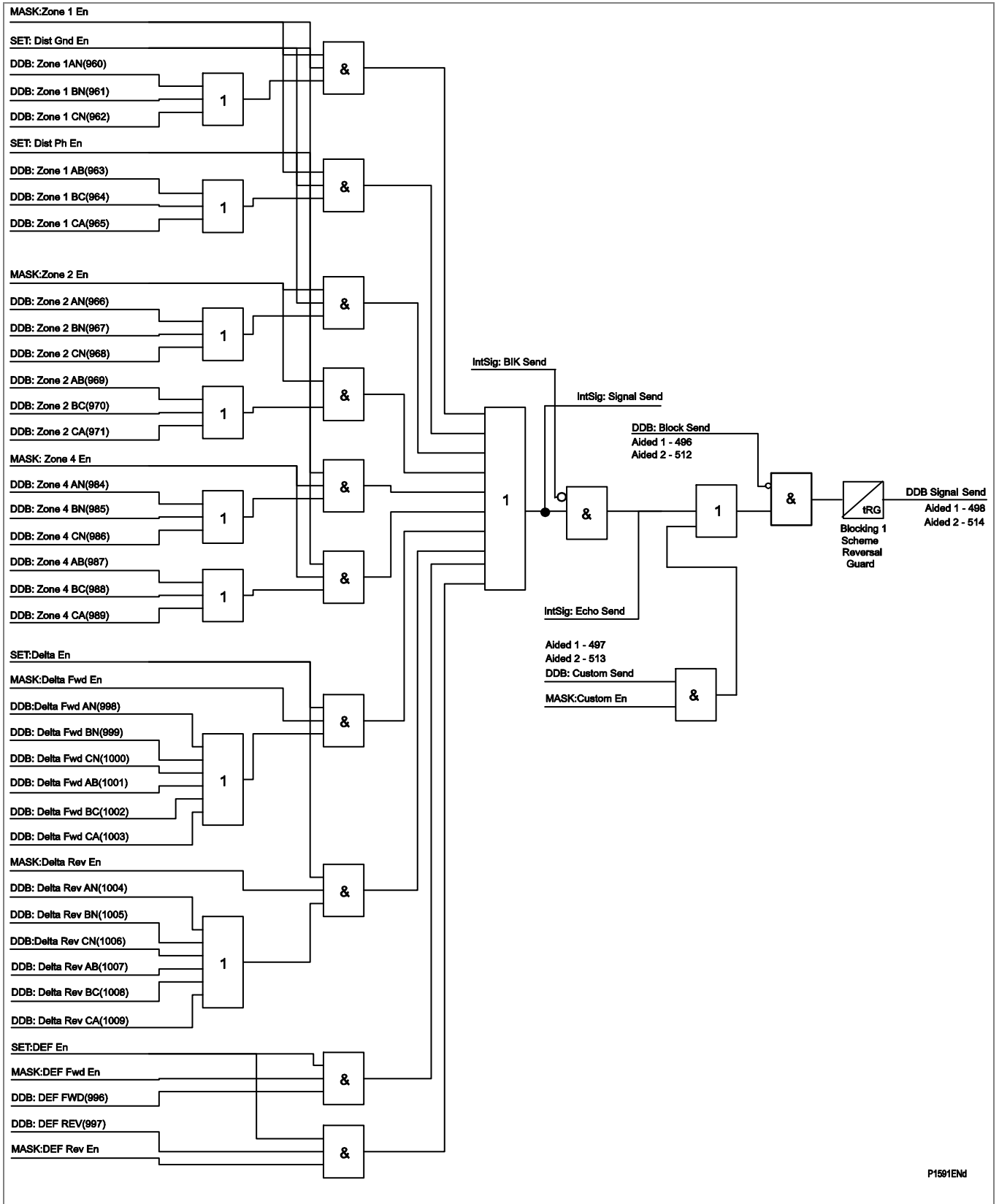

Figure 37 - Send logic (Distance option only)

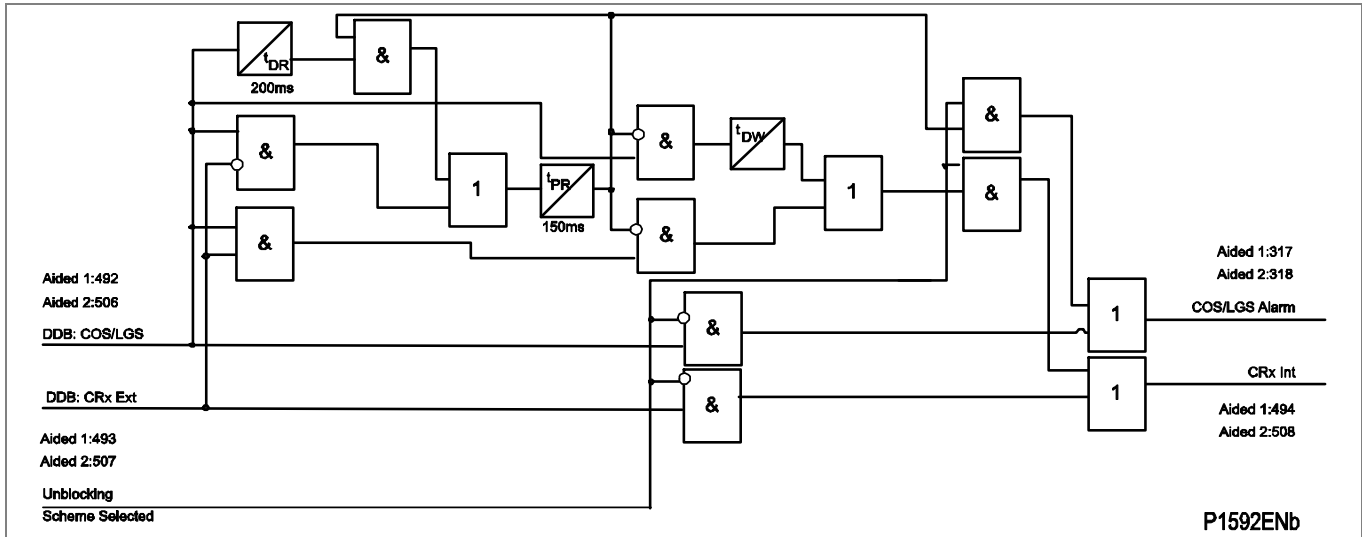

Figure 38 - Receive logic (Distance option only)

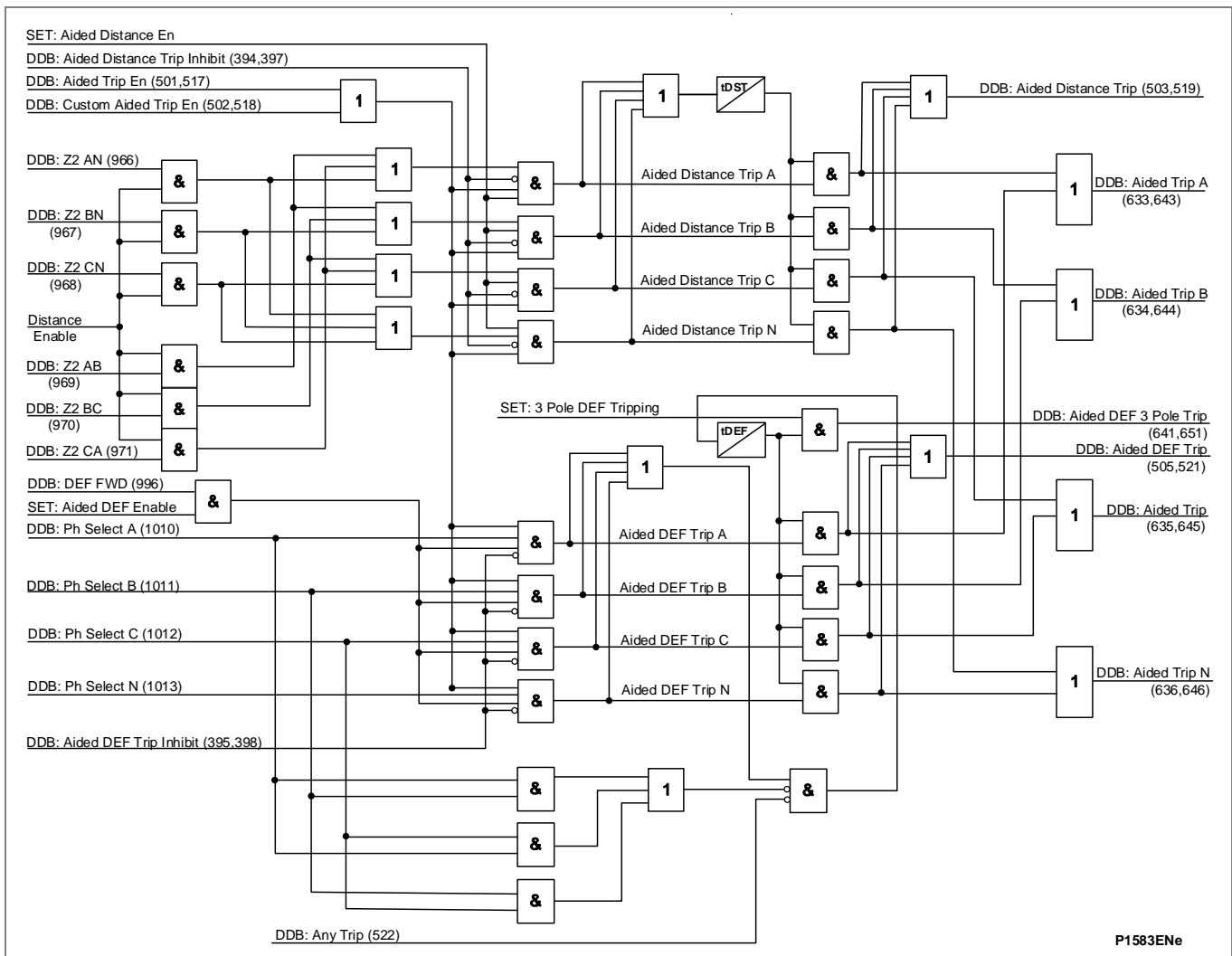

Figure 39 - Aided tripping logic

1.25.1

Distance Scheme PUR - Permissive Underreach Transfer Trip (Distance option only)

To provide fast fault clearance for all faults, both transient and permanent, along the length of the protected circuit, it is necessary to use a signal aided tripping scheme. The simplest of these is the Permissive UnderReach (PUR) protection scheme. The channel for a PUR scheme is keyed by operation of the underreaching zone 1 elements of the relay. If the remote relay has detected a forward fault upon receipt of this signal, the relay will operate with no additional delay. Faults in the last 20% (Note 1) of the protected line are therefore cleared with no intentional time delay.

<i>Note 1</i>	<i>Assuming a 20% typical "end-zone" when Zone 1 is set to 80% of the protected line.</i>
---------------	---

Some of the main features/requirements for a permissive underreaching scheme are:

- Only a simplex signaling channel is required
- The scheme has a high degree of security since the signaling channel is only keyed for faults within the protected line
- If the remote terminal of a line is open then faults in the remote 20% of the line will be cleared via the zone 2 time delay of the local relay
- If there is a weak or zero infeed from the remote line end, (i.e. current below the relay sensitivity), then faults in the remote 20% of the line will be cleared via the zone 2 time delay of the local relay
- If the signaling channel fails, Basic distance scheme tripping will be available

The *Permissive underreach transfer trip scheme (PUR)* diagram shows the simplified scheme logic.

Send logic: Zone 1

Permissive trip logic: Zone 2 plus Channel Received

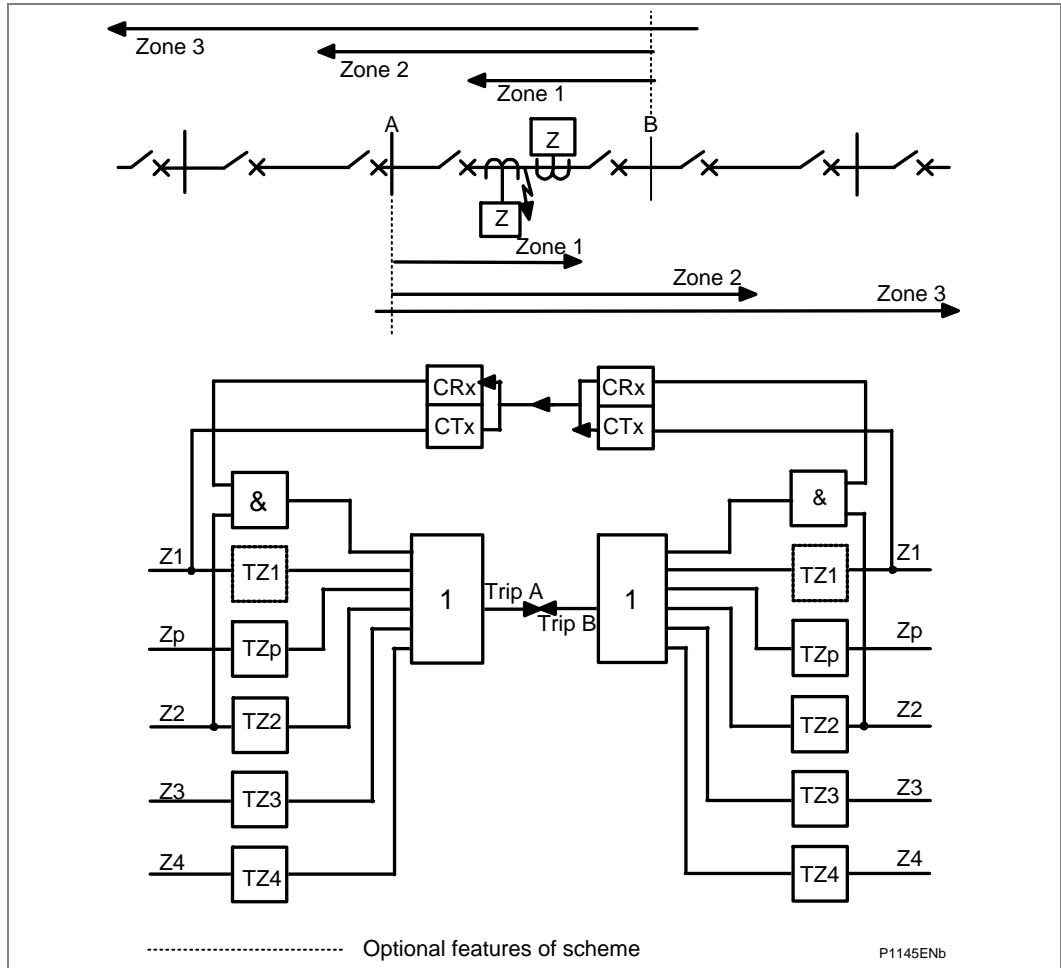

Figure 40 - Permissive underreach transfer trip scheme (PUR) (Distance option only)

Detailed logic is shown in in the following PUR (Distance option only) diagram:

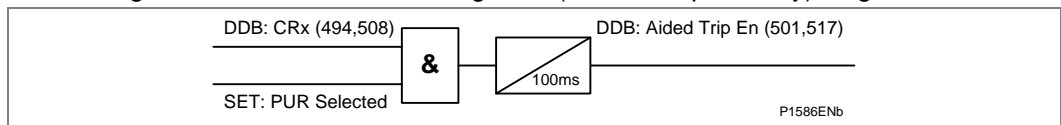

Figure 41 - PUR (Distance option only)

1.25.2

Distance Scheme POR - Permissive Overreach Transfer Trip (Distance option only)

The channel for a POR scheme is keyed by operation of the overreaching zone 2 elements of the relay. If the remote relay has detected a forward fault upon receipt of this signal, the relay will operate with no additional delay. Faults in the last 20% (Note 1) of the protected line are therefore cleared with no intentional time delay.

Note 1 Assuming a 20% typical “end-zone” when Zone 1 is set to 80% of the protected line.

Listed below are some of the main features/requirements for a permissive overreaching scheme:

- The scheme requires a duplex signaling channel to prevent possible relay maloperation due to spurious keying of the signaling equipment. This is needed because the signaling channel is keyed for faults external to the protected line.
- The POR scheme may be more advantageous than permissive underreach schemes for the protection of short transmission lines, since the resistive coverage of the Zone 2 elements may be greater than that of the Zone 1 elements.
- Current reversal guard logic is used to prevent healthy line protection maloperation for the high speed current reversals experienced in double circuit lines, caused by sequential opening of circuit breakers.
- If the signaling channel fails, Basic distance scheme tripping will be available.

Note The POR scheme also uses the reverse looking zone 4 of the relay as a reverse fault detector. This is used in the current reversal logic and in the optional weak infeed echo feature, shown dotted in the **Permissive overreach transfer trip scheme (POR)** diagram.

Send logic: Zone 2

Permissive trip logic: Zone 2 plus Channel Received

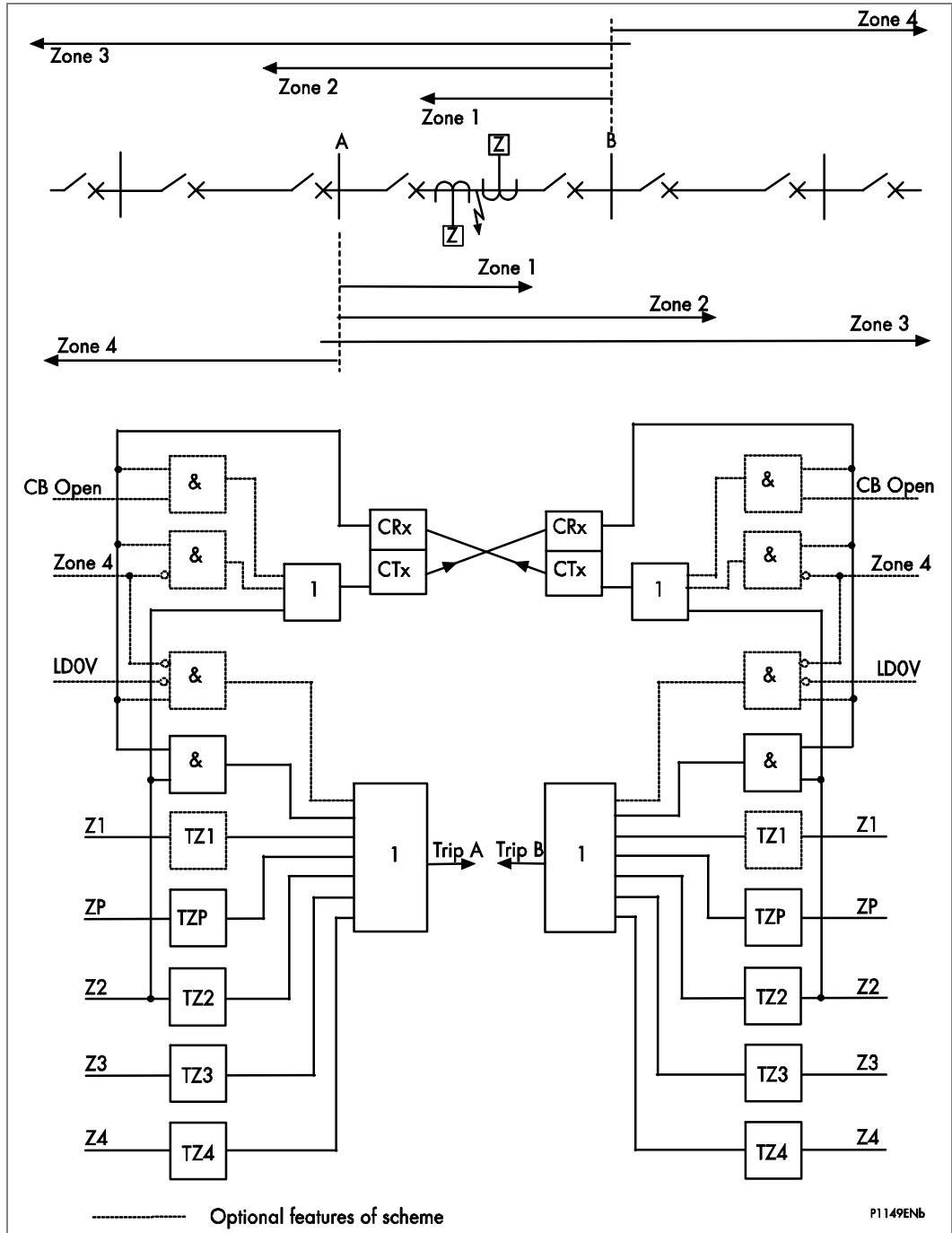

Figure 42 - Permissive overreach transfer trip scheme (POR) (Distance option only)

Detailed logic is shown in the following POR Permissive OverReach diagram:

Note The DDB Any Trip (522) feeds into a 100 ms delay on drop-off timer, which in turn leads to signal sending. This is a principle similar to the logic which results in a signal send for weak infeed and breaker open echoing.

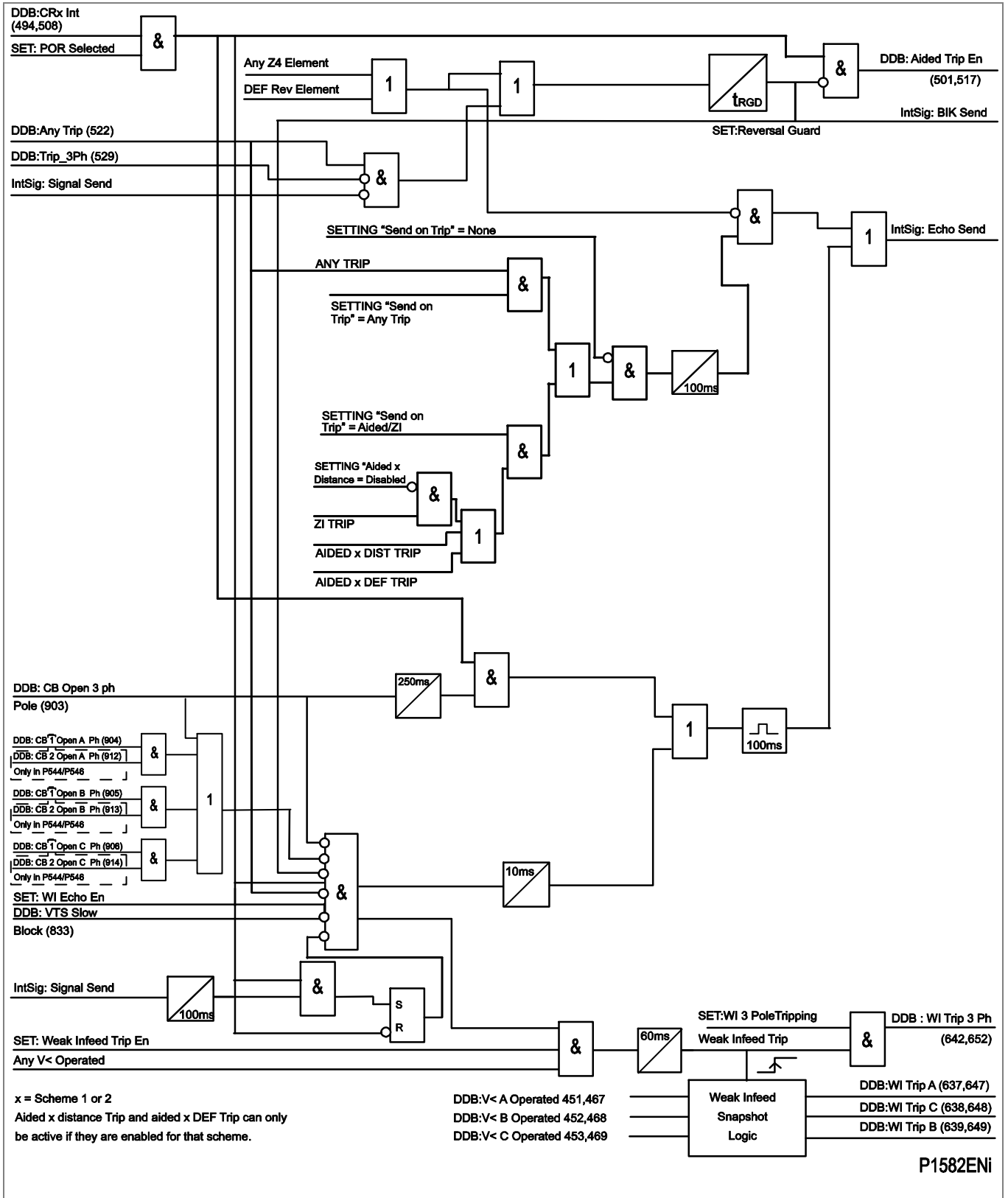

Figure 43 - POR Permissive OverReach

1.25.3 **Permissive Overreach Trip Reinforcement (Distance option only)**

The send logic in the POR scheme is done in such a way that for any trip command at the local end, the relay sends a channel signal to the remote end(s) in order to maximize the chances for the fault to be isolated at all ends. It should be noted that the send signal that is generated by the 'Any trip' command is sent on both channels, Ch1 and Ch2, if more than one channel is in use. This feature is termed permissive trip reinforcement, and is a deliberate attempt to ensure that synchronous tripping occurs at all line ends.

1.25.4 **Permissive Overreach Scheme Weak Infeed Features (Distance option only)**

Weak infeed logic can be enabled to run in parallel with the POR schemes. Two options are available: WI Echo, and WI Tripping.

Note Special stub-end transformer Weak Infeed is covered in the **Frequency Protection** section.

Weak Infeed Echo For permissive schemes, a signal would only be sent if the required signal send zone were to detect a fault. However, the fault current infeed at one line end may be so low as to be insufficient to operate any distance zones, and risks a failure to send the signal. Also, if one circuit breaker had already been left open, the current infeed would be zero. These are termed weak infeed conditions, and may result in slow fault clearance at the strong infeed line end (tripping after time tZ2). To avoid this slow tripping, the weak infeed relay can be set to "echo" back any channel received to the strong infeed relay (i.e. to immediately send a signal once a signal has been received). This allows the strong infeed relay to trip instantaneously in its permissive trip zone.

The additional signal send logic is:

Echo Send No Distance Zone Operation, plus Channel Received.

Weak Infeed Tripping Weak infeed echo logic ensures an aided trip at the strong infeed terminal but not at the weak infeed. The MiCOM P54x also has a setting option to allow tripping of the weak infeed circuit breaker of a faulted line. Three undervoltage elements, Va<, Vb< and Vc< are used to detect the line fault at the weak infeed terminal. This voltage check prevents tripping during spurious operations of the channel or during channel testing.

The additional weak infeed trip logic is:

Weak Infeed Trip No Distance Zone Operation, plus V<, plus Channel Received.

Weak infeed tripping is time delayed according to the WI Trip Delay value. Due to the use of phase segregated undervoltage elements, single pole tripping can be enabled for WI trips if required. If single pole tripping is disabled a three pole trip will result after the time delay.

1.25.5 Permissive Scheme Unblocking Logic - Loss of Guard (Distance option only)

This mode is designed for use with Frequency Shift Keyed (FSK) Power Line Carrier (PLC) communications. When the protected line is healthy a guard frequency is sent between line ends, to verify that the channel is in service. However, when a line fault occurs and a permissive trip signal must be sent over the line, the power line carrier frequency is shifted to a new (trip) frequency. Therefore, distance relays should receive either the guard, or trip frequency, but not both together. With any permissive scheme, the PLC communications are transmitted over the power line which may contain a fault. So, for certain fault types the line fault can attenuate the PLC signals, so that the permissive signal is lost and not received at the other line end. To overcome this problem, when the guard is lost and no “trip” frequency is received, the relay opens a window of time during which the permissive scheme logic acts as though a “trip” signal had been received. Two opto inputs to the relay need to be assigned, one is the Channel Receive opto, the second is designated Loss of Guard (the inverse function to guard received). The function logic is summarized in the table below.

System condition	Permissive channel received	Loss of guard	Permissive trip allowed	Alarm generated
Healthy Line	No	No	No	No
Internal Line Fault	Yes	Yes	Yes	No
Unblock	No	Yes	Yes, during a 150 ms window	Yes, delayed on pickup by 150 ms
Signaling Anomaly	Yes	No	No	Yes, delayed on pickup by 150 ms

Table 3 - Permissive scheme unblocking logic

The window of time during which the unblocking logic is enabled starts 10 ms after the guard signal is lost, and continues for 150 ms. The 10 ms delay gives time for the signaling equipment to change frequency as in normal operation. For the duration of any alarm condition, zone 1 extension logic will be invoked if the option Z1 Ext on Chan. Fail has been Enabled.

1.25.6 Distance Scheme Blocking (Distance option only)

The signaling channel is keyed from operation of the reverse zone 4 elements of the relay. If the remote relay has picked up in zone 2, then it will operate after the trip delay if no block is received. Listed below are some of the main features/requirements for a Blocking scheme:

- Blocking schemes require only a simplex signaling channel
- Reverse looking Zone 4 is used to send a blocking signal to the remote end to prevent unwanted tripping
- When a simplex channel is used, a Blocking scheme can easily be applied to a multi-terminal line provided that outfeed does not occur for any internal faults
- The blocking signal is transmitted over a healthy line, and so there are no problems associated with power line carrier signaling equipment
- Blocking schemes provides similar resistive coverage to the permissive overreach schemes
- Fast tripping will occur at a strong source line end, for faults along the protected line section, even if there is weak or zero infeed at the other end of the protected line
- If a line terminal is open, fast tripping will still occur for faults along the whole of the protected line length

- If the signaling channel fails to send a blocking signal during a fault, fast tripping will occur for faults along the whole of the protected line, but also for some faults within the next line section
- If the signaling channel is taken out of service, the relay will operate in the conventional basic mode
- A current reversal guard timer is included in the signal send logic to prevent unwanted trips of the relay on the healthy circuit, during current reversal situations on a parallel circuit

The *Distance blocking scheme (BOP)* diagram shows the simplified scheme logic.

Send logic: Reverse Zone 4

Trip logic: Zone 2, plus Channel NOT Received, delayed by T_p

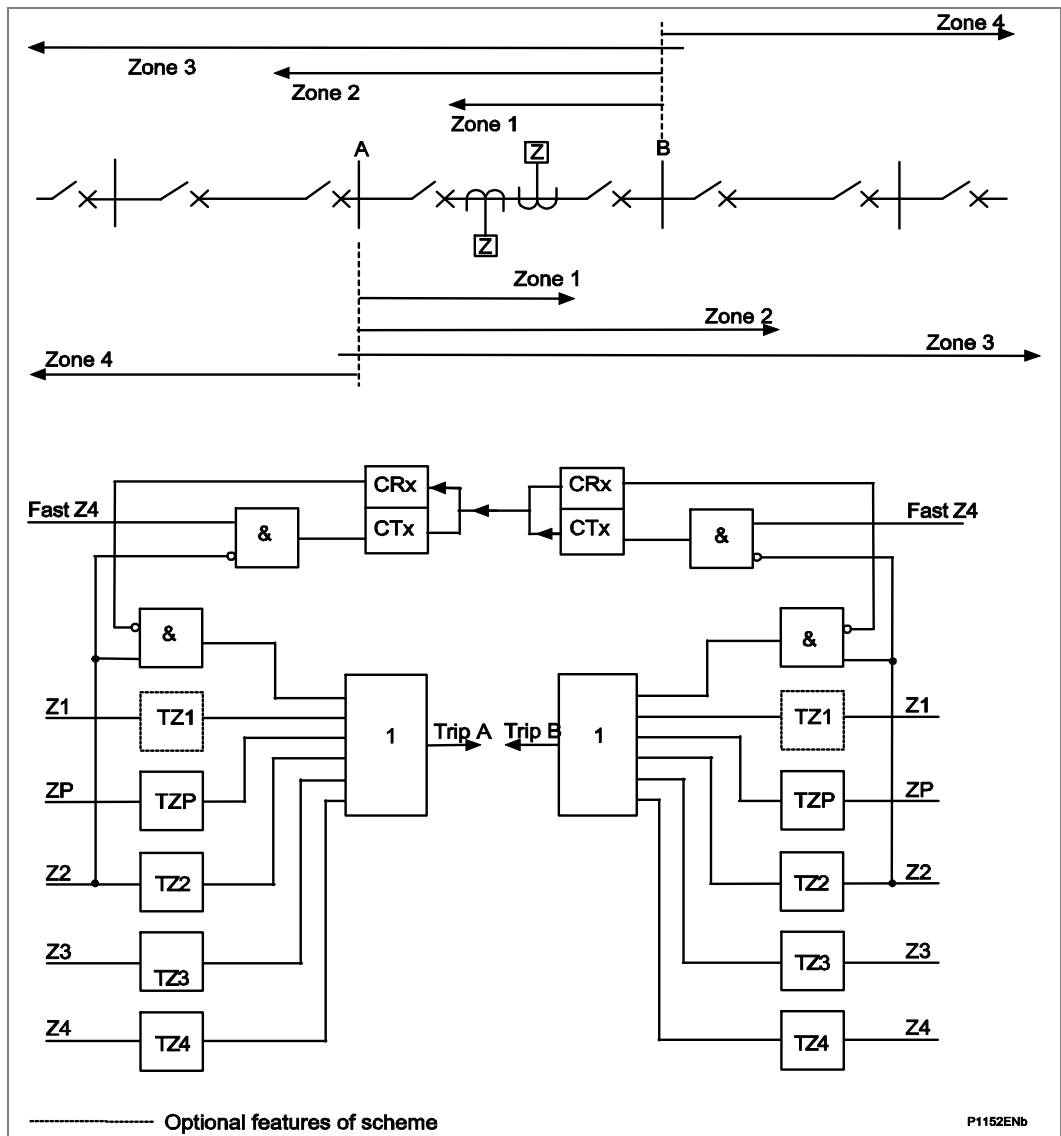

Figure 44 - Distance blocking scheme (BOP) (Distance option only)

1.25.7

Distance Schemes Current Reversal Guard Logic (Distance option only)

For double circuit lines, the fault current direction can change in one circuit when circuit breakers open sequentially to clear the fault on the parallel circuit. The change in current direction causes the overreaching distance elements to see the fault in the opposite direction to the direction in which the fault was initially detected (settings of these elements exceed 150% of the line impedance at each terminal). The race between operation and resetting of the overreaching distance elements at each line terminal can cause the Permissive Overreach, and Blocking schemes to trip the healthy line. A system configuration that could result in current reversals is shown in the *Example of fault current reverse of direction* diagram. For a fault on line L1 close to circuit breaker B, as circuit breaker B trips it causes the direction of current flow in line L2 to reverse.

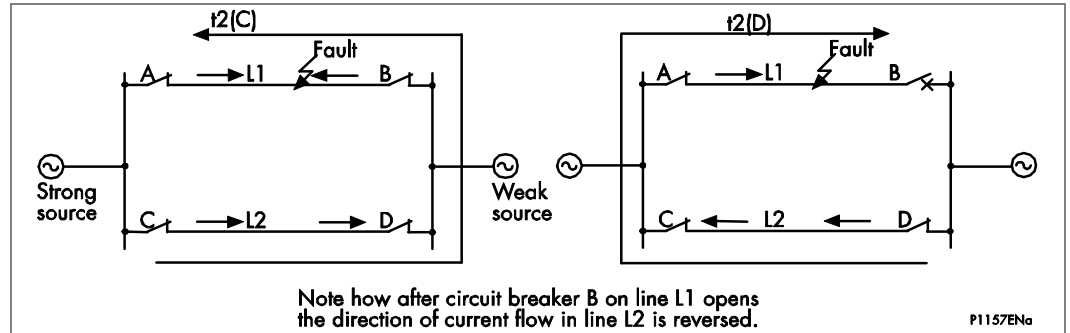

Figure 45 - Example of fault current reverse of direction

1.25.8

Permissive Overreach Schemes Current Reversal Guard (Distance option only)

The current reversal guard incorporated in the POR scheme logic is initiated when the reverse looking Zone 4 elements operate on a healthy line. Once the reverse looking Zone 4 elements have operated, the relay's permissive trip logic and signal send logic are inhibited at substation D. The reset of the current reversal guard timer is initiated when the reverse looking Zone 4 resets. A time delay $t_{REVERSAL\ GUARD}$ is required in case the overreaching trip element at end D operates before the signal send from the relay at end C has reset. Otherwise this would cause the relay at D to over trip. Permissive tripping for the relays at D and C substations is enabled again, once the faulted line is isolated and the current reversal guard time has expired.

1.25.9

Blocking Scheme 1 and 2 Current Reversal Guard (Distance option only)

The current reversal guard incorporated in the Blocking scheme logic is initiated when a blocking element picks-up to inhibit the channel-aided trip. When the current reverses and the reverse looking Zone 4 elements reset, the blocking signal is maintained by the timer $t_{REVERSAL\ GUARD}$. Therefore, the relays in the healthy line are prevented from over tripping due to the sequential opening of the circuit breakers in the faulted line. After the faulted line is isolated, the reverse-looking Zone 4 elements at substation C and the forward-looking elements at substation D will reset.

Two variants of Blocking scheme exist, Blocking 1, and Blocking 2. The only difference in functionality is:

- Blocking 1 - The Reversal Guard is applied to the Signal Send
- Blocking 2 - The Reversal Guard is applied to the Signal Receive

The difference in the receive logic is shown in the Logic Diagrams, *Blocking 1 (Distance option only)* and *Blocking 2 (Distance option only)* below:

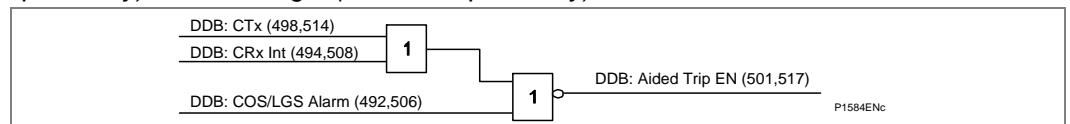

Figure 46 - Blocking 1 (Distance option only)

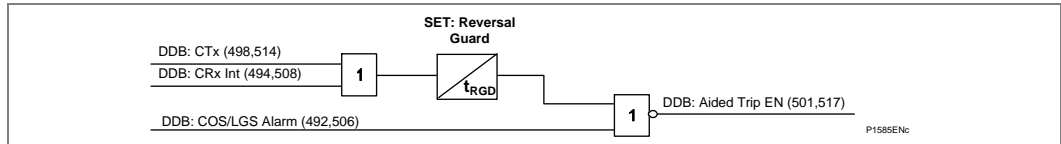

Figure 47 - Blocking 2 (Distance option only)

The relative merits of Blocking 1 and Blocking 2 are discussed in the Application Notes chapter.

1.25.10

Aided DEF Ground Fault Scheme - Permissive Overreach (Distance option only)

The DEF permissive scheme diagram shows the element reaches, and the Aided DEF (ground) permissive scheme logic diagram the simplified scheme logic. The signaling channel is keyed from operation of the forward IN> DEF element of the relay. If the remote relay has also detected a forward fault, then it will operate with no additional delay upon receipt of this signal.

Send logic: IN> Forward pickup

Permissive trip logic: IN> Forward plus Channel Received

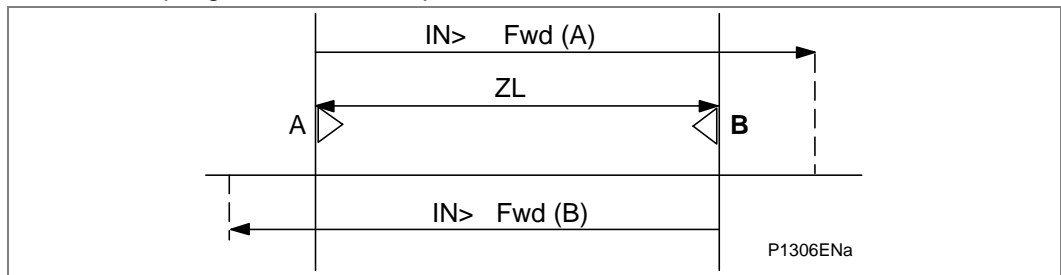

Figure 48 - The DEF permissive scheme (Distance option only)

The scheme has the same features/requirements as the corresponding distance scheme and provides sensitive protection for high resistance earth faults.

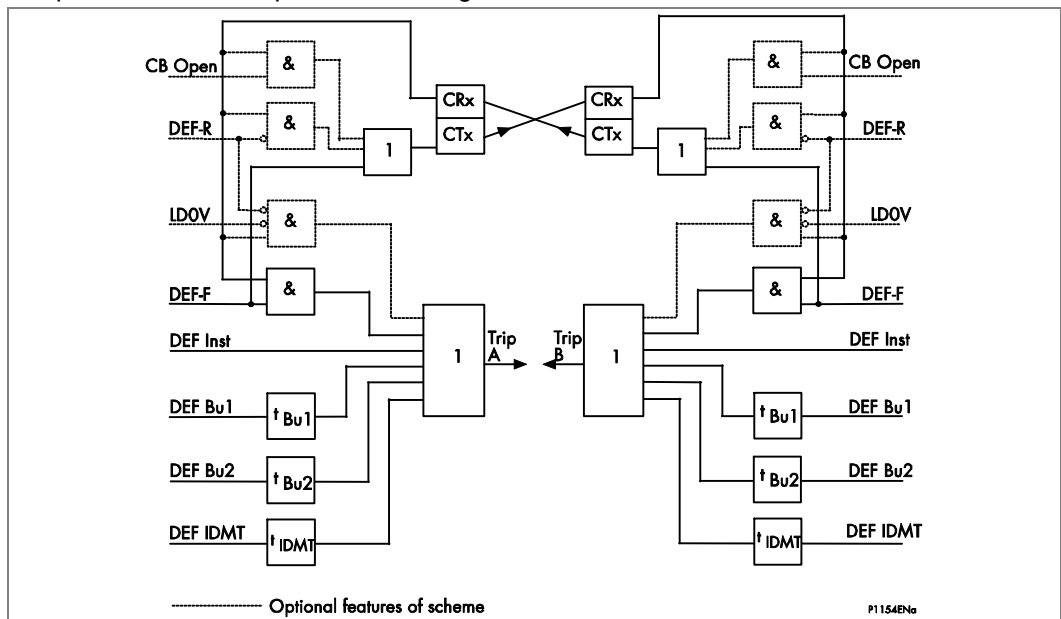

Figure 49 - Aided DEF (ground) permissive scheme logic (Distance option only)

1.25.11

Aided DEF Ground Fault Scheme – Blocking (Distance option only)

The DEF blocking scheme diagram shows the element reaches, and Aided DEF (ground) blocking scheme logic diagram the simplified scheme logic. The signaling channel is keyed from operation of the reverse DEF element of the relay. If the remote relay forward IN> element has picked up, then it will operate after the set Time Delay if no block is received.

Send logic: DEF Reverse

Trip logic: IN> Forward, plus Channel NOT Received, with small set delay

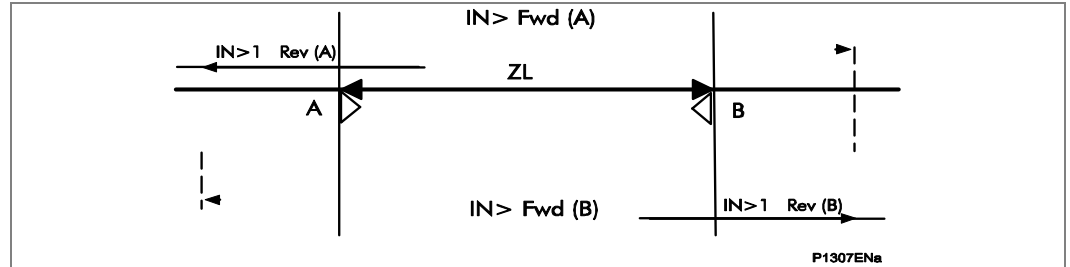

Figure 50 - DEF blocking scheme (Distance option only)

The scheme has the same features/requirements as the corresponding distance scheme and provides sensitive protection for high resistance earth faults. Where t is shown in the diagram this signifies the time delay associated with an element. To allow time for a blocking signal to arrive, a short time delay on aided tripping must be used.

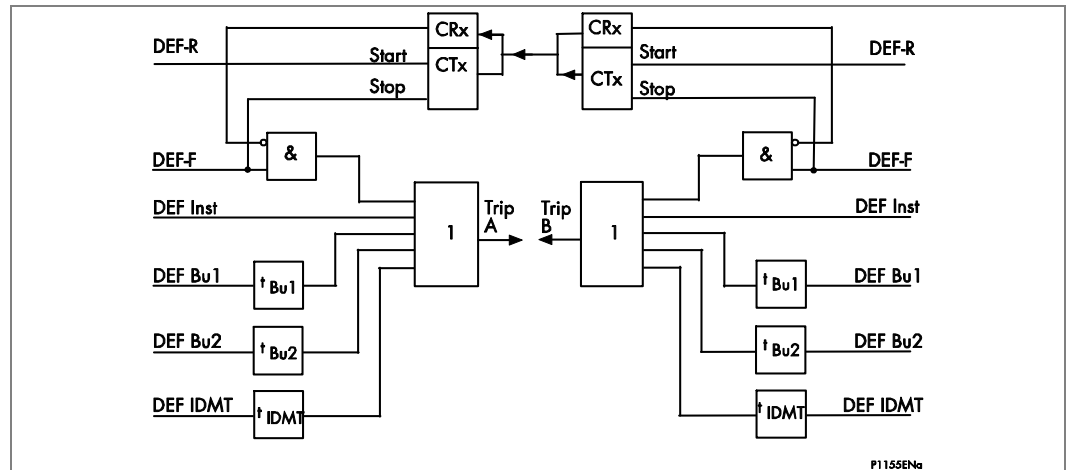

Figure 51 - Aided DEF (ground) blocking scheme logic (Distance option only)

1.25.12

Delta Scheme POR - Permissive Overreach Transfer Trip (Distance option only)

The channel for a directional comparison POR scheme is keyed by operation of the overreaching Delta Forward elements of the relay. If the remote relay has also detected a forward fault upon receipt of this signal, the relay will operate. Listed below are some of the main features/requirements for a permissive overreaching scheme:

- Permissive overreach schemes tend to be more secure than blocking schemes because forward directional decisions must be made at both ends of the line before tripping is allowed. Failure of the signaling channel will not result in unwanted tripping.
- If the infeed source at either end of the line is weak, the POR scheme must be supplemented with Weak Infeed logic.
- The scheme requires a duplex signaling channel to prevent possible relay maloperation due to spurious keying of the signaling equipment. This is necessary because the signaling channel is keyed for faults external to the protected line.

- Current reversal guard logic is used to prevent healthy line protection maloperation for the high speed current reversals experienced in double circuit lines, caused by sequential opening of circuit breakers.

- If the signaling channel fails, Basic distance scheme tripping will be available.

This scheme is similar to that used in the LFDC relay, and is shown in the *Delta directional comparison POR scheme* diagram:

Send logic: Δ Fault Forward

Permissive trip logic: Δ Fault Forward plus Channel Received.

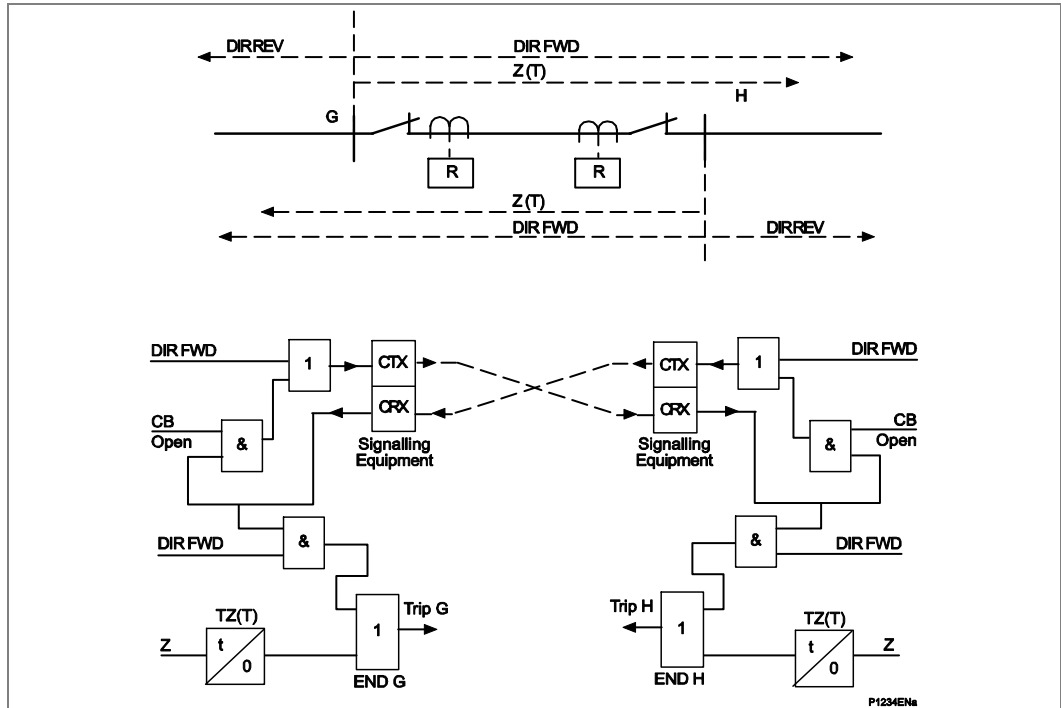

Figure 52 - Delta directional comparison POR scheme (Distance option only)

1.25.13

Delta Blocking Scheme (Distance option only)

The signaling channel is keyed from operation of the Delta Reverse elements of the relay. If the remote relay has detected Delta Forward, then it will operate after the trip delay if no block is received. Listed below are some of the main features/requirements for a permissive overreaching scheme:

- Blocking schemes require only a simplex signaling channel.
- The blocking signal is transmitted over a healthy line, and so there are no problems associated with power line carrier signaling equipment.
- Delta blocking schemes tend to be less secure than permissive schemes because failure of the signaling channel could result in an unwanted tripping later. Therefore blocking schemes are best supervised by use of a Channel out of Service indication.
- Fast tripping will occur at a strong source line end, for faults along the protected line section, even if there is weak or zero infeed at the other end of the protected line.
- If a line terminal is open, fast tripping will still occur for faults along the whole of the protected line length.

- A current reversal guard timer is included in the signal send logic to prevent unwanted trips of the relay on the healthy circuit, during current reversal situations on a parallel circuit.
- To allow time for a blocking signal to arrive, a short time delay on aided tripping, Delta dly, must be used.

This scheme is similar to that used in the relay, and is shown in the *Delta directional comparison BLOCKING scheme* diagram.

Send logic: Δ Fault Reverse

Trip logic: Δ Fault Forward, plus Channel NOT Received, delayed by T_p .

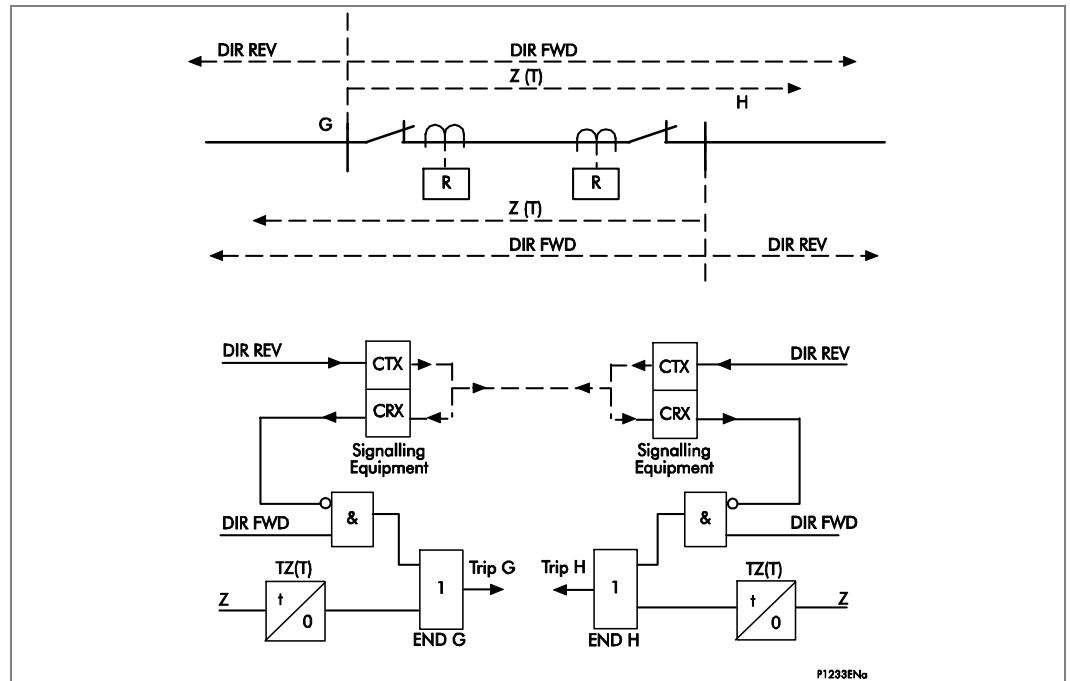

Figure 53 - Delta directional comparison BLOCKING scheme

1.26 Zone 1 Extension and Loss of Load Schemes (Distance option only)

The MiCOM relay offers additional non-channel distance schemes, notably Zone 1 extension, and loss of load.

1.26.1 Zone 1 Extension Scheme (Distance option only)

Auto-reclosure is widely used on radial overhead line circuits to re-establish supply following a transient fault. A Zone 1 extension scheme may therefore be applied to a radial overhead feeder to provide high speed protection for transient faults along the whole of the protected line. The Zone 1 extension scheme diagram shows the alternative reach selections for zone 1: Z1 or the extended reach Z1X.

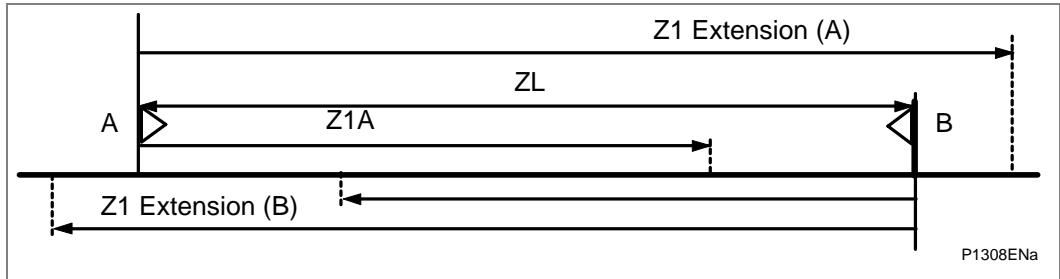

Figure 54 - Zone 1 extension scheme

In this scheme, Zone 1X is enabled and set to overreach the protected line. A fault on the line, including one in the end 20% not covered by zone 1, will now result in instantaneous tripping followed by auto-reclosure. Zone 1X has resistive reaches and residual compensation similar to Zone 1. The auto-recloser in the relay is used to inhibit tripping from zone 1X such that upon reclosure the relay will operate with Basic scheme logic only, to co-ordinate with downstream protection for permanent faults. Thus, transient faults on the line will be cleared instantaneously, which will reduce the probability of a transient fault becoming permanent. The scheme can, however, operate for some faults on an adjacent line, although this will be followed by auto-reclosure with correct protection discrimination. Increased circuit breaker operations would occur, together with transient loss of supply to a substation.

The time delays associated with extended zone Z1X are shown in the table below:

Scenario	Z1X Time Delay
First fault trip	= tZ1
Fault trip for persistent fault on auto-reclose	= tZ2

Table 4 - Time delays associated with extended zone Z1X

The Zone 1X reach is set as a percentage of the Zone 1 reach, i.e. as a reach multiplier.

Note	The Zone 1 extension scheme can be “Disabled”, permanently “Enabled” or just brought into service when the distance communication channel fails and the aided scheme would be inoperative. A selection of which out of the two channels available in The MiCOM relay is monitored, is provided, with selections from Channel 1 and Channel 2 in any combination. The Logic Diagram is attached as the Zone 1 extension diagram:
------	--

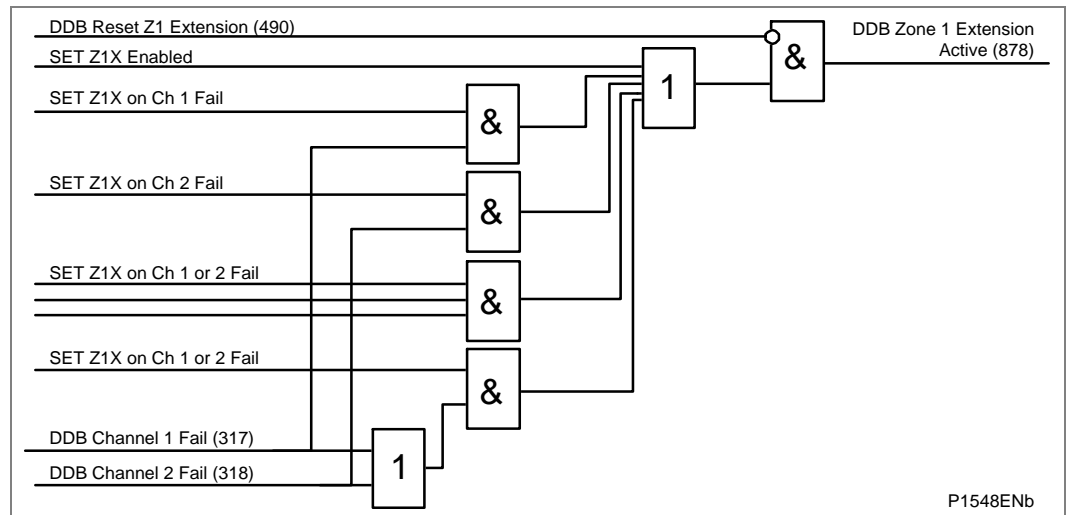

Figure 55 - Zone 1 extension

1.26.2

Loss of Load (LoL) Accelerated Tripping (Distance option only)

The loss of load accelerated trip logic is shown in abbreviated form in the *Loss of load accelerated trip scheme* diagram. The loss of load logic provides fast fault clearance for faults over the whole of a double end fed protected circuit for all types of fault, except three phase. The scheme has the advantage of not requiring a signaling channel. Alternatively, the logic can be chosen to be enabled when the channel associated with an aided scheme has failed. This failure is detected by permissive scheme unblocking logic, or a Channel Out of Service (COS) opto input. A selection of which out of the two channels available in the MiCOM relay is monitored, is provided, with selections from Channel 1 and Channel 2 in any combination.

Any fault located within the reach of Zone 1 will result in fast tripping of the local circuit breaker. For an end zone fault with remote infeed, the remote breaker will be tripped in Zone 1 by the remote relay and the local relay can recognize this by detecting the loss of load current in the healthy phases. This, coupled with operation of a Zone 2 comparator causes tripping of the local circuit breaker.

Before an accelerated trip can occur, load current must have been detected prior to the fault. The loss of load current opens a window during which time a trip will occur if a Zone 2 comparator operates. A typical setting for this window is 40 ms as shown in the *Loss of load* diagram, although this can be altered in the menu LoL Window cell. The accelerated trip is delayed by 18 ms to prevent initiation of a loss of load trip due to circuit breaker pole discrepancy occurring for clearance of an external fault. The local fault clearance time can be deduced as follows:

$$t = Z1d + 2CB + LDr + 18ms$$

Where:

Z1d = Maximum downstream zone 1 trip time

CB = Breaker operating time

LDr = Upstream level detector (LoL: I<) reset time

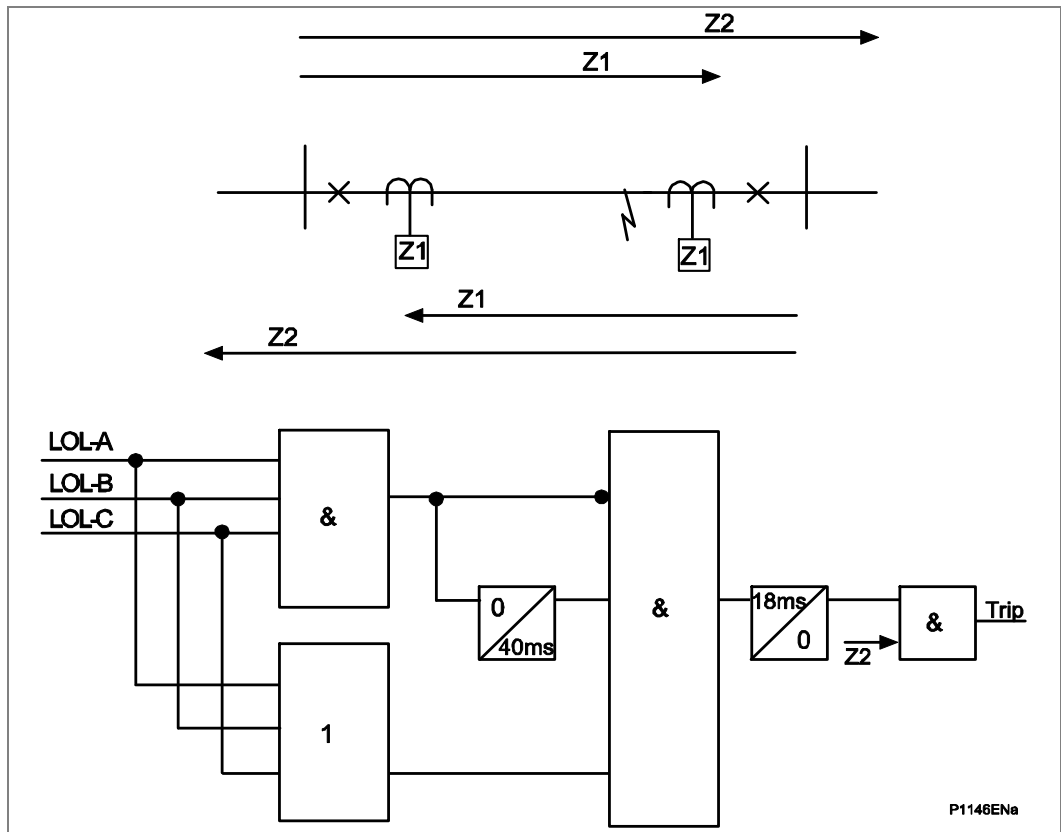

Figure 56 - Loss of load accelerated trip scheme (Distance option only)

For circuits with load tapped off the protected line, care must be taken in setting the loss of load feature to ensure that the $I <$ level detector setting is above the tapped load current. When selected, the loss of load feature operates in conjunction with the main distance scheme that is selected. In this way it provides high speed clearance for end zone faults when the Basic scheme is selected or, with permissive signal aided tripping schemes, it provides high speed back-up clearance for end zone faults if the channel fails.

Note *Loss of load tripping is only available where 3 pole tripping is used. The detailed logic follows in the **Loss of load** diagram.*

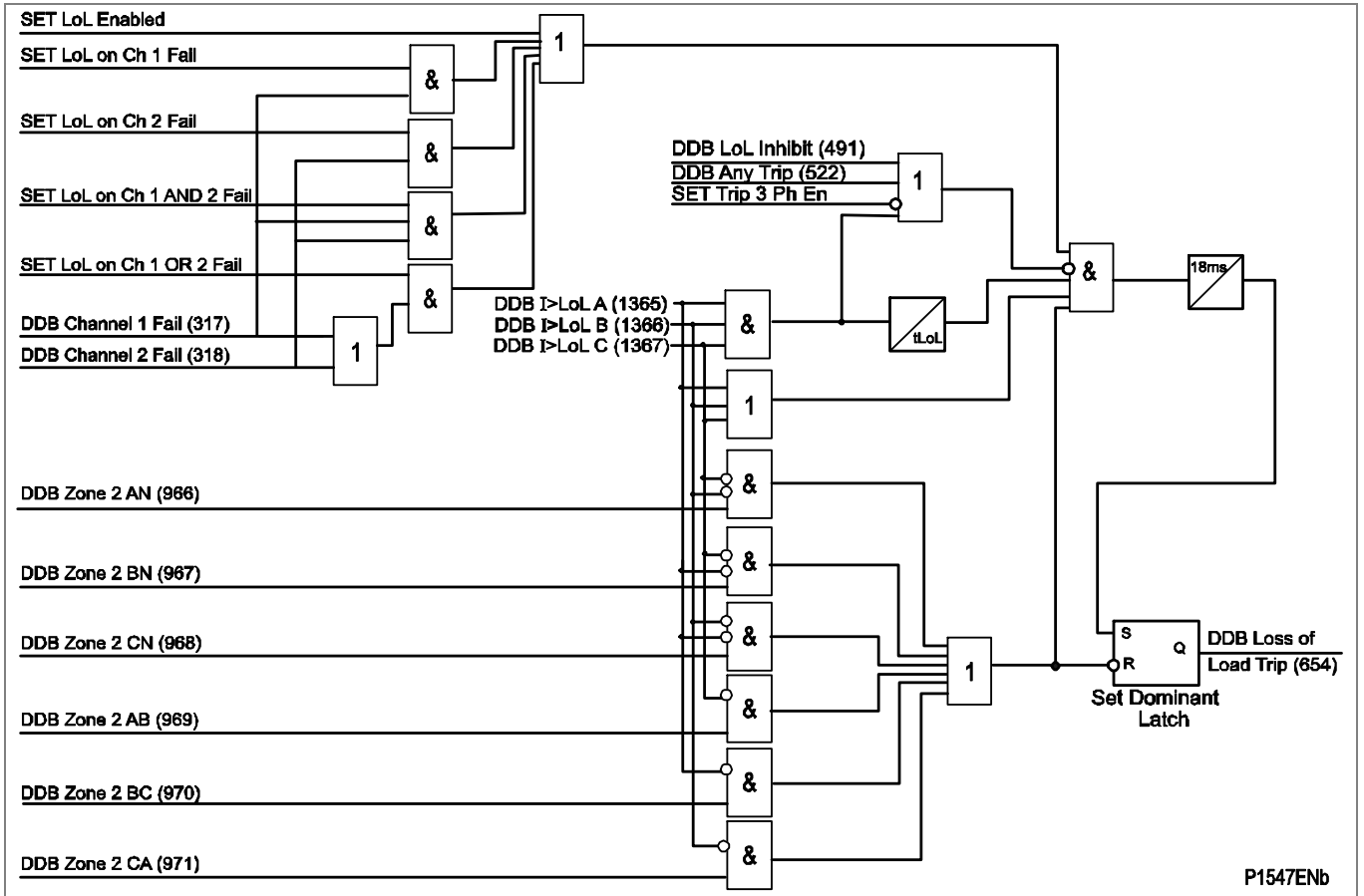

Figure 57 - Loss of load (Distance option only)

1.27 Phase Fault Overcurrent Protection

Phase fault overcurrent protection is a form of back-up protection that can be:

- Permanently disabled
- Permanently enabled
- Enabled only in case of VT fuse/MCB failure
- Enabled only in case of protection communication channel failure
- Enabled if VT fuse/MCB or protection communication channel fail
- Enabled if VT fuse/MCB and protection communication channel fail
- Enabled by CTS

In addition, each stage may be disabled by a DDB (463,464,465 or 466) Inhibit I > x (x = 1, 2, 3 or 4)

It should be noted that phase overcurrent protection is phase segregated, but the operation of any phase is mapped to 3-phase tripping in the default PSL.

The VTS element of the relay can be selected to either block the directional element or simply remove the directional control.

The first two stages can be set either inverse time or definite time only. The third and fourth stages have a DT characteristic only. Each stage can be configured to be directional forward, directional reverse or non-directional.

For the IDMT characteristics the following options are available.

The IEC/UK IDMT curves conform to this formula:

$$t = T \times \left(\frac{\beta}{(I/I_s)^\alpha - 1} + L \right)$$

The IEEE/US IDMT curves conform to this formula:

$$t = TD \times \left(\frac{\beta}{(I/I_s)^\alpha - 1} + L \right)$$

t	=	Operation time
β	=	Constant
I	=	Measured current
I _s	=	Current threshold setting
α	=	Constant
L	=	ANSI/IEEE constant (zero for IEC curves)
T	=	Time multiplier setting for IEC/UK curves
TD	=	Time multiplier setting for IEEE/US curves

IDMT Curve description	Standard	β Constant	α Constant	L Constant	I/I _s Limit
Standard Inverse	IEC	0.14	0.02	0	30
Very Inverse	IEC	13.5	1	0	30
Extremely Inverse	IEC	80	2	0	20
Long Time Inverse	UK	120	1	0	30
Moderately Inverse	IEEE	0.0515	0.02	0.114	80
Very Inverse	IEEE	19.61	2	0.491	60
Extremely Inverse	IEEE	28.2	2	0.1217	40
Inverse	US-C08	5.95	2	0.18	30
Short Time Inverse	US	0.16758	0.02	0.11858	80

Note For currents above I/I_s Limit the tripping time is fixed at the I/I_s Limit trip time.

Table 5 - IDMT curve descriptions, standards and constants

Note: The IEEE and US curves are set differently to the IEC/UK curves, with regard to the time setting. A time multiplier setting (TMS) is used to adjust the operating time of the IEC curves, whereas a time dial setting is employed for the IEEE/US curves. The menu is arranged such that if an IEC/UK curve is selected, the 'I> Time Dial' cell is not visible and vice versa for the TMS setting.

1.27.1

Reset Characteristics for Overcurrent Elements

The IEC/UK inverse characteristics can be used with a definite time reset characteristic, however, the IEEE/US curves may have an inverse or definite time reset characteristic. The following equation can be used to calculate the inverse reset time for IEEE/US curves:

$$t_{RESET} = \frac{TD \times S}{(1 - M^2)} \text{ in seconds}$$

Where:

- TD = Time dial setting for IEEE curves
- S = Constant
- M = I / Is

Curve description	Standard	S constant
Moderately Inverse	IEEE	4.85
Very Inverse	IEEE	21.6
Extremely Inverse	IEEE	29.1
Inverse	US	5.95
Short Time Inverse	US	2.261

Table 6 - IDMT curve descriptions, standards and constants

1.27.2

Directional Overcurrent Protection

The phase fault elements of the MiCOM P34x/P44y/P445/P54x/P841 relays are internally polarized by the quadrature phase-phase voltages, as shown in following *Phase, Operating Current and Polarizing Voltages* table.

Phase of Protection	Operate Current	Polarizing Voltage
A Phase	IA	VBC
B Phase	IB	VCA
C Phase	IC	VAB

Table 7 - Phases, operating currents and polarizing voltages

Under system fault conditions, the fault current vector will lag its nominal phase voltage by an angle dependent upon the system X/R ratio. It is therefore a requirement that the relay operates with maximum sensitivity for currents lying in this region. This is achieved by means of the relay characteristic angle (RCA) setting; this defines the angle by which the current applied to the relay must be displaced from the voltage applied to the relay to obtain maximum relay sensitivity. This is set in cell "**I>Char Angle**" in the overcurrent menu. On the relays, it is possible to set characteristic angles anywhere in the range -95° to +95°.

The functional logic block diagram for directional overcurrent is shown in the following *Directional overcurrent logic* diagram.

The overcurrent block is a level detector that detects that the current magnitude is above the threshold and together with the respective polarizing voltage, a directional check is performed based on the following criteria:

- Directional forward -90° < (angle(I) - angle(V) - RCA) < 90°
- Directional reverse -90° > (angle(I) - angle(V) - RCA) > 90°

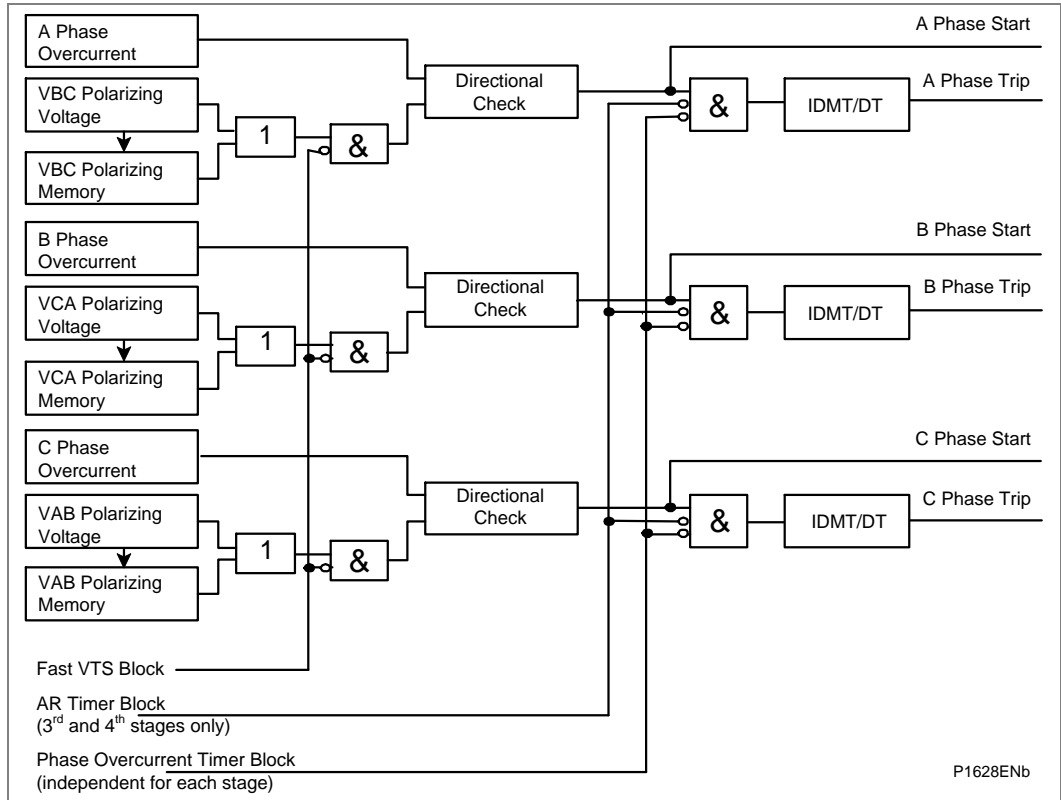

Figure 58 - Directional overcurrent logic

Any of the four overcurrent stages may be configured to be directional noting that IDMT characteristics are only selectable on the first two stages. When the element is selected as directional, a VTS Block option is available in the **I> Function Link** setting. When the relevant bit is set to 1, operation of the Voltage Transformer Supervision (VTS), will block the stage if directionalized. When set to 0, the stage will revert to non-directional upon operation of the VTS.

1.27.3

Overcurrent (50)Backup to Line Differential (87L)

As from Software Version D1, the Phase Overcurrent (Overcurrent) feature has now been modified

The CTS Block now has new setting options for enabling different combinations of the VTS, CTS and Channel Failure.

These new settings options are shown below.

In addition, modified DDBs (311, 313, 316, 319, 332, 455, 929, 1145 and 1146), affect how the different signals can alter the operation of the system.

An explanation of how the DDBs operate together is also shown below.

This feature includes the CTS Block DDB and now includes these setting option(s):

Existing Enable/Disable:

- Disabled
- Enabled
- Enabled VTS
- Enabled Ch Fail
- En VTSorCh Fail
- En VTSandCh Fail

Additions:

- Enabled CTS
- En VTSorCTS
- En Ch FailorCTS
- En VTSorCHForCTS
- En VTSandCTS
- En Ch FailandCTS
- En VTS CHF CTS

Explanation of how the DDBs operate together

The following DDBs are required: DDB 311, 313, 316 and 929.

Currently when Overcurrent is enabled as backup for Line Diff channel failure the following conditions are included.

- 1146 - DDB_BACKUP_IN (Backup Enabled) - is all of the following OR'd together
 - 313 - DDB_PROTECTION_FAILURE (C Diff Failure) - It indicates that differential protection communications are completely lost and therefore C diff does not work
OR
 - 319 - DDB_FREQ_ALARM (F out of Range)
OR
 - 332 - DDB_IN_COMPATABLE_RELAYS (Incompatible Rly)
OR
 - 455 - DDB_INHIBIT_CURRENT_DIFF_OPTO (Inhibit C Diff) - When linked to an opto input, inhibits differential relay at the local end and send an inhibit command to the remote end.
- 1145 - DDB_INHIBIT_CURRENT_DIFF (Inhibit C Diff)

The DDB_SIGNALLING_FAILURE (311) is effectively included in the DDB_PROTECTION_FAILURE (313) signal (as detailed below).

The DDB_SIGNALLING_FAILURE (316) is effectively included (it consists of DDB 455 OR 319 OR 1145) signal (as detailed below).

A summary of the DDB operation is given below:

Internally, the "Cdiff inhibited" signal is derived as follows:

DDB_INHIBIT_CD_PROTECTION (316 - C Diff Inhibited)

Consists of any of the following:

- DDB_INHIBIT_CURRENT_DIFF_OPTO (455 - Inhibit C Diff)
- DDB_INHIBIT_CURRENT_DIFF (1145 - Inhibit C Diff)
- DDB_FREQ_ALARM (319 - F out of Range)

Inhibit C Diff (1145) is Set when:

- The Loop propagation delay changes when NO GPS Pulse is present (or GPS is disabled).
- The relay (auxiliary supply) is power cycled in GPS mode with no GPS Input present.

An inhibit is received from the remote relay (via the protection comms). This may be due to the following:

- The remote relay Inhibit opto being active.
- The remote relay frequency alarm is present.
- The remote relay has inhibited for any other reason (Loop prop delay change or auxiliary power cycle etc.).

Inhibit C Diff (1145) is removed when:

- GPS Synch is re-established
- Prop Delay Equal Command is Executed (Local Relay Menu)
- Prop Delay Equal Command is Executed (Remote Relay Menu via Protection Comms)

Internally, the "Cdiff failure" signal derived as follows and why is current diff still able to trip when the "Cdiff failure".

This DDB (313 - Differential protection failure alarm) has a fixed 220ms drop-off timer, so the relay can operate while this is present. This DDB is based on DDB_SIGNALLING_FAILURE (311 - Signalling Fail), which is set if <75% (default) messages are received over a 100ms period. Also, the intertrip function is not inhibited (except by the local Opto Inhibit / Frequency Alarm). It is also possible that the protection can operate if the signalling fail alarm is present and messages are being received e.g. < 75% valid message (but operation will be slow).

1.28

Voltage Memory / Synchronous Polarization

For a close-up 3-phase fault, all three voltages will collapse to zero and no healthy phase voltages will be present. For this reason, the MiCOM relays include a synchronous polarization feature that stores the pre-fault voltage information and continues to apply it to the Directional Overcurrent (DOC) elements for a period of 3.2 seconds. This ensures that either instantaneous or time-delayed directional overcurrent elements will be allowed to operate, even with a 3-phase voltage collapse.

1.29 Thermal Overload Protection

The relay incorporates a current based thermal replica, using rms load current to model heating and cooling of the protected plant. The element can be set with both alarm and trip stages.

The heat generated within an item of plant, such as a cable or a transformer, is the resistive loss ($I^2R \times t$). Thus, heating is directly proportional to current squared. The thermal time characteristic used in the relay is therefore based on current squared, integrated over time. The relay automatically uses the largest phase current for input to the thermal model.

Equipment is designed to operate continuously at a temperature corresponding to its full load rating, where heat generated is balanced with heat dissipated by radiation etc. Over-temperature conditions therefore occur when currents in excess of rating are allowed to flow for a period of time. It can be shown that temperatures during heating follow exponential time constants and a similar exponential decrease of temperature occurs during cooling.

The relay provides two characteristics that may be selected according to the application.

Thermal overload protection may be disabled by DDB 478 Inhibit Thermal > .

1.29.1 Single Time Constant Characteristic

This characteristic is used to protect cables, dry type transformers (e.g. type AN), and capacitor banks.

The thermal time characteristic is given by:

$$t = -\tau \log_e \left(\frac{I^2 - (K \cdot I_{FLC})^2}{(I^2 - I_P^2)} \right)$$

Where:

t = Time to trip, following application of the overload current, I

τ = Heating and cooling time constant of the protected plant

I = Largest phase current

I_{FLC} = Full load current rating (relay setting 'Thermal Trip')

k = 1.05 constant, allows continuous operation up to <1.05 I_{FLC}

I_P = Steady state pre-loading before application of the overload

The time to trip varies depending on the load current carried before application of the overload, i.e. whether the overload was applied from 'hot' or 'cold'.

The thermal time constant characteristic may be rewritten as:

$$e^{(-t/\tau)} = \left(\frac{\theta - \theta_p}{\theta - 1} \right)$$

Where:

$$\theta = I^2/k^2 I_{FLC}^2$$

and

$$\theta_p = I_P^2/k^2 I_{FLC}^2$$

Where θ is the thermal state and is θ_p the pre-fault thermal state.

Note A current of 105%Is (kI_{FLC}) has to be applied for several time constants to cause a thermal state measurement of 100%

1.29.2

Dual Time Constant Characteristic (typically not applied for P54x)

This characteristic is used to protect oil-filled transformers with natural air cooling (e.g. type ONAN). The thermal model is similar to that with the single time constant, except that two timer constants must be set.

For marginal overloading, heat will flow from the windings into the bulk of the insulating oil. Thus, at low current, the replica curve is dominated by the long time constant for the oil. This provides protection against a general rise in oil temperature.

For severe overloading, heat accumulates in the transformer windings, with little opportunity for dissipation into the surrounding insulating oil. Thus, at high current, the replica curve is dominated by the short time constant for the windings. This provides protection against hot spots developing within the transformer windings.

Overall, the dual time constant characteristic provided within the relay serves to protect the winding insulation from ageing, and to minimize gas production by overheated oil. Note, however, that the thermal model does not compensate for the effects of ambient temperature change.

The thermal curve is defined as:

0.4e^{(-t/\tau_1)} + 0.6e^{(-t/\tau_2)} = \frac{I^2 - (k.IFLC)^2}{I^2 - I_p^2}

Where:

- \tau_1 = Heating and cooling time constant of the transformer windings
\tau_2 = Heating and cooling time constant for the insulating oil

In practice, it is difficult to solve this equation to give the operating time (t), therefore a graphical solution, using a spreadsheet package, is recommended. The spreadsheet can be arranged to calculate the current that will give a chosen operating time. The equation to calculate the current is defined as:

I = \sqrt{\frac{0.4I_p^2 \cdot e^{(-t/\tau_1)} + 0.6I_p^2 \cdot e^{(-t/\tau_2)} - k^2 \cdot I_{FLC}^2}{0.4 e^{(-t/\tau_1)} + 0.6 e^{(-t/\tau_2)} - 1}} Equation 1

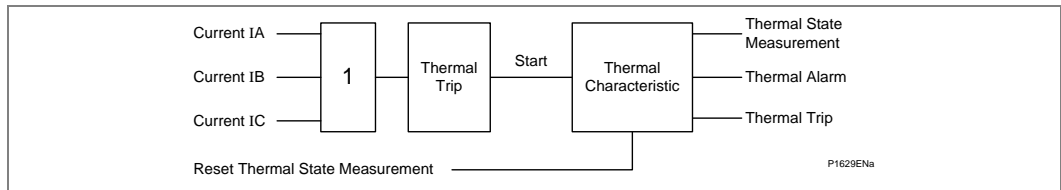

Figure 59 - Thermal overload protection logic diagram

The functional block diagram for the thermal overload protection is shown in the above diagram.

The magnitudes of the three phase input currents are compared and the largest magnitude taken as the input to the thermal overload function. If this current exceeds the thermal trip threshold setting a start condition is asserted.

1.30

Earth Fault (Ground Overcurrent), Sensitive Earth Fault (SEF) and Restricted Earth Fault (REF) Protection

The MiCOM P44y/P54x/P841 relays include backup earth fault protection. Two elements are available; a derived earth fault element (where the residual current to operate the element is derived from the addition of the three line CT currents) and a sensitive earth fault element where low current settings are required. The sensitive earth fault element has a separate CT input and would normally be connected to a core balance CT. The derived and sensitive earth fault elements both have four stages of protection. The first two stages can be set either inverse time or definite time only. The third and fourth stages have a DT characteristic only. Each stage can be configured to be directional forward, directional reverse or non-directional.

Note *The input CT which is designed specifically to operate at low current magnitudes is common to both the Sensitive Earth Fault (SEF) and high impedance Restricted Earth Fault (REF) protection, so these features are treated as mutually exclusive within the relay menu.*

A feature also exists whereby the protection can be enabled upon failure of the differential protection communication channel (not applicable to SEF and REF Functions). Earth fault Overcurrent IN> can be set to:

- Permanently disabled
- Permanently enabled
- Enabled only in case of VT fuse/MCB failure
- Enabled only in case of protection communication channel failure
- Enabled if VT fuse/MCB or protection communication channel fail
- Enabled if VT fuse/MCB and protection communication channel fail
- Enabled by CTS

In addition, each stage (not for SEF/REF) may be disabled by a DDB (467,468,469 and 470) **Inhibit IN > x** (x = 1, 2, 3 or 4).

The VTS element of the relay can be selected to either block the directional element or simply remove the directional control.

The IN> and ISEF> Function Links settings have the following effect:

- VTS Block - When the relevant is set to 1, operation of the Voltage Transformer Supervision (VTS) will block the stage if it directionalized. When set to 0 the stage will revert to non-directional upon operation of the VTS.

The inverse time characteristics available for the earth fault protection are the same as those for the phase overcurrent elements, but with the addition of an IDG curve characteristic.

Details of the IDG curve are provided below:

1.30.1

IDG Curve

The IDG curve is commonly used for time delayed earth fault protection in the Swedish market. This curve is available in stages 1 and 2 of Earth Fault 1, Earth Fault 2 and Sensitive Earth Fault protections.

The IDG curve is represented by the following equation:

$$t = 5.8 - 1.35 \log_e \left(\frac{I}{IN > Setting} \right) \text{ in seconds}$$

Where:

- I = Measured current
- IN>Setting = An adjustable setting which defines the start point of the characteristic

Although the start point of the characteristic is defined by the “IN>” setting, the actual relay current threshold is a different setting called “IDG Is”. The “IDG Is” setting is set as a multiple of “IN>”.

An additional setting “IDG Time” is also used to set the minimum operating time at high levels of fault current.

The following *IDG characteristic* diagram shows how the IDG characteristic is implemented.

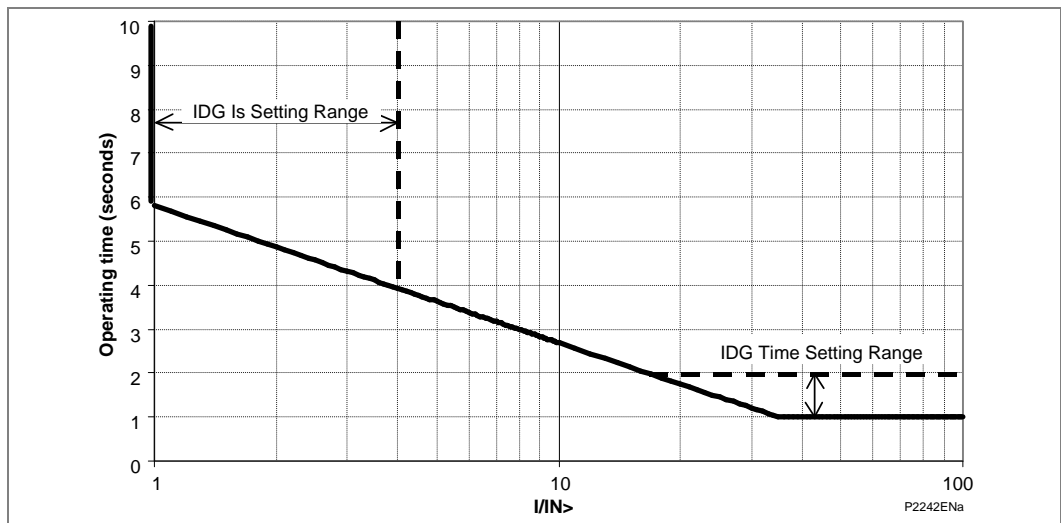

Figure 60 - IDG characteristic

1.30.2

Restricted Earth Fault (REF) Protection

The REF protection in the MiCOM P44y/P54x/P841 relays is a high impedance element which shares the same CT input as the SEF protection. Hence, only one of these elements may be selected.

The setting options are available under the **GROUP 1 SEF/REF PROT'N** menu.

The high impedance principle is best explained by considering a differential scheme where one CT is saturated for an external fault, as shown in the following *High impedance principle* diagram.

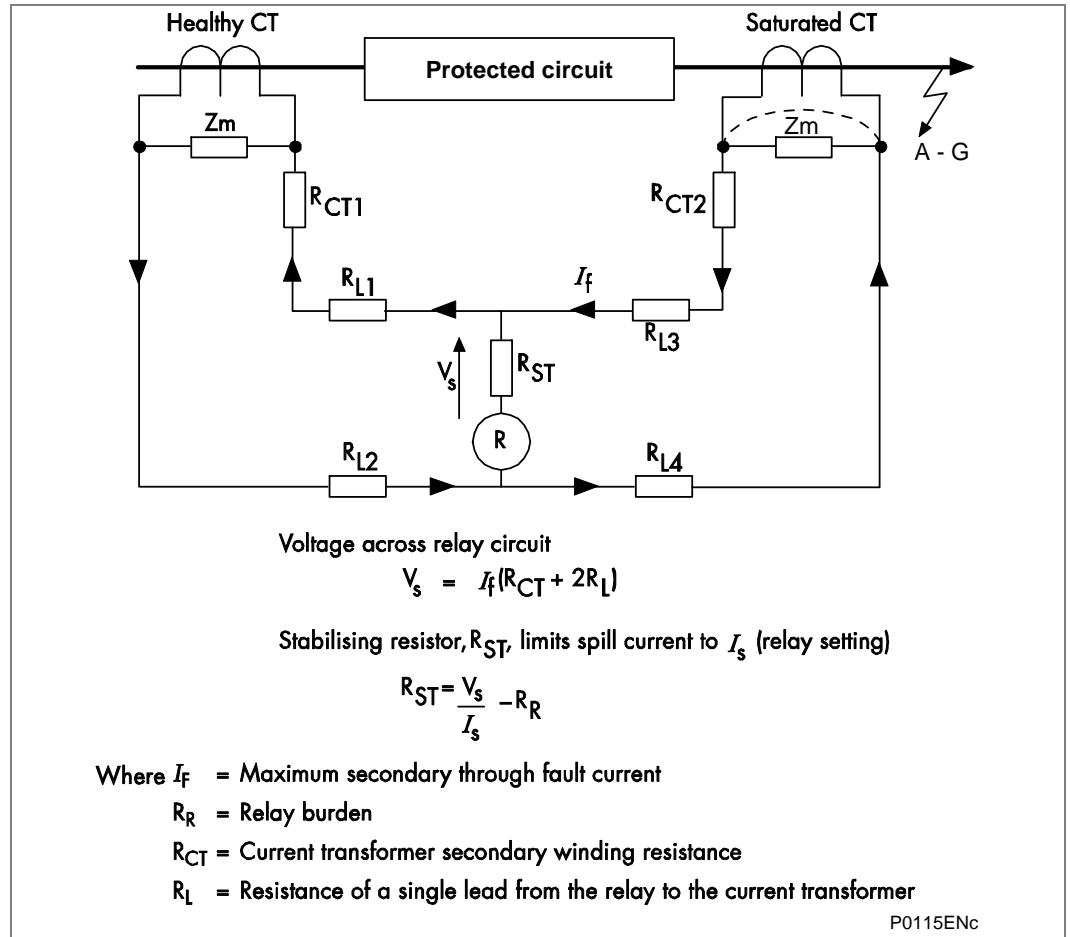

Figure 61 - High impedance principle

If the relay circuit is considered to be a very high impedance, the secondary current produced by the healthy CT will flow through the saturated CT. If CT magnetizing impedance of the saturated CT is considered to be negligible, the maximum voltage across the relay circuit will be equal to the secondary fault current multiplied by the connected impedance, $(R_{L3} + R_{L4} + R_{CT2})$.

The relay can be made stable for this maximum applied voltage by increasing the overall impedance of the relay circuit, such that the resulting current through the relay is less than its current setting. As the impedance of the relay input alone is relatively low, a series connected external resistor is required. The value of this resistor, R_{ST} , is calculated by the formula shown in the *High impedance principle* diagram. An additional non-linear, Metrosil, may be required to limit the peak secondary circuit voltage during internal fault conditions.

To ensure that the protection will operate quickly during an internal fault, the CT's used to operate the protection must have a knee point voltage of at least 4 V_s .

The necessary relay connections for high impedance REF are shown in the *High impedance REF relay/CT connections* diagram.

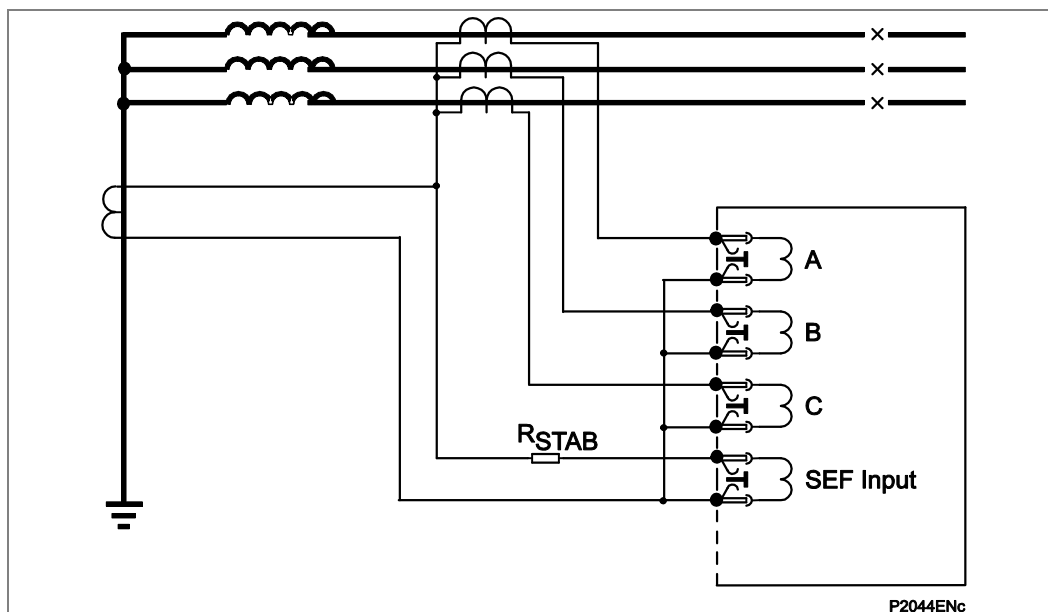

Figure 62 - High impedance REF relay/CT connections

1.31

Directional Earth Fault (DEF) Protection

As stated in the previous sections, each of the four stages of earth fault protection may be set to directional if required. Consequently, as with the application of directional overcurrent protection, a suitable voltage supply is required by the relay to provide the necessary polarization. Two options are available for polarization: Residual Voltage or Negative Sequence.

1.32 Residual Voltage Polarization

With earth fault protection, the polarizing signal requires to be representative of the earth fault condition. As residual voltage is generated during earth fault conditions, this quantity is commonly used to polarize DEF elements. The relay internally derives this voltage from the 3-phase voltage input which must be supplied from either a 5-limb or three single-phase VTs. These types of VT design allow the passage of residual flux and consequently permit the relay to derive the required residual voltage. In addition, the primary star point of the VT must be earthed. A three-limb VT has no path for residual flux and is therefore unsuitable to supply the relay.

Note Residual voltage is nominally 180° out of phase with residual current. Consequently, the DEF elements are polarized from the "-Vres" quantity. This 180° phase shift is automatically introduced within the relay.

The directional criteria with zero sequence (residual voltage) polarization are given below:

Directional forward $-90^\circ < (\text{angle}(\text{IN}) - \text{angle}(\text{VN}+180^\circ) - \text{RCA}) < 90^\circ$

Directional reverse $-90^\circ > (\text{angle}(\text{IN}) - \text{angle}(\text{VN}+180^\circ) - \text{RCA}) > 90^\circ$

The virtual current polarizing feature is not available for use with the backup earth fault elements - that is used exclusively in DEF aided schemes only.

The logic diagram for directional earth fault overcurrent with neutral voltage polarization is shown below.

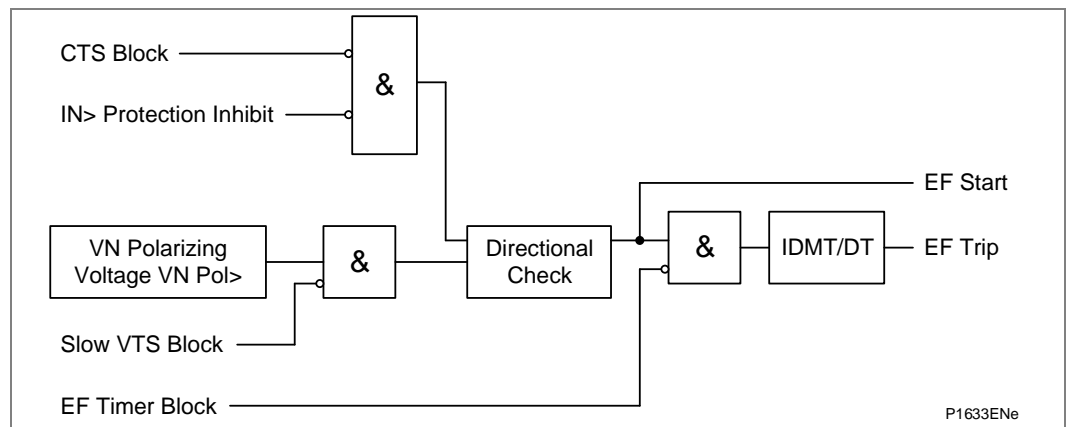

Figure 63 - Directional EF with neutral voltage polarization (single stage)

1.32.1

Negative Sequence Polarization (Not for SEF)

In certain applications, the use of residual voltage polarization of DEF may either be not possible to achieve, or problematic. An example of the former case would be where a suitable type of VT was unavailable, for example if only a three limb VT was fitted. An example of the latter case would be an HV/EHV parallel line application where problems with zero sequence mutual coupling may exist.

In either of these situations, the problem may be solved by using Negative Phase Sequence (NPS) quantities for polarization. This method determines the fault direction by comparison of NPS voltage with NPS current. The operate quantity, however, is still residual current.

This is available for selection on both the derived and measured standard earth fault elements (EF1 and EF2) but not on the SEF protection. It requires a suitable voltage and current threshold to be set in cells "IN>V2pol set" and "IN>I2pol set", respectively.

Negative sequence polarizing is not recommended for impedance earthed systems regardless of the type of VT feeding the relay. This is due to the reduced earth fault current limiting the voltage drop across the negative phase sequence source impedance (V2pol) to negligible levels. If this voltage is less than 0.5 volts the relay will cease to provide DEF.

The logic diagram for Directional Earth Fault (DEF) overcurrent with negative sequence polarization is shown in this diagram.

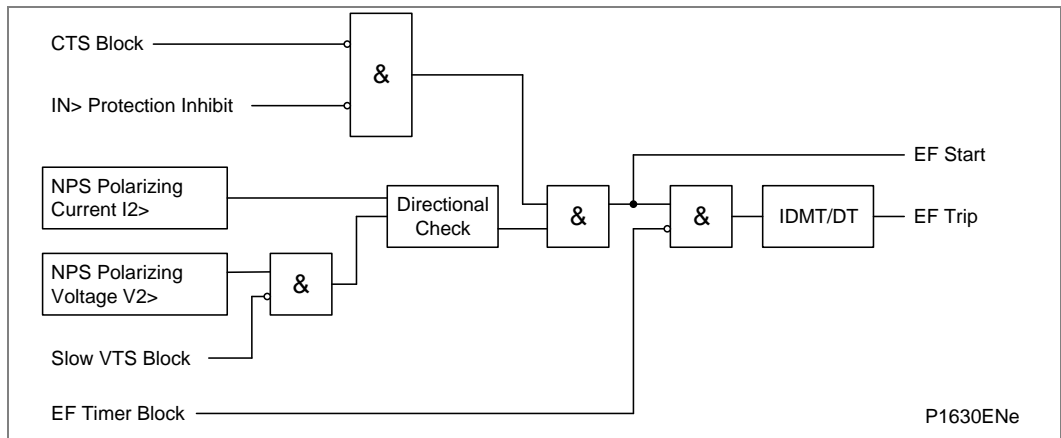

Figure 64 - Directional EF with negative sequence polarization (single stage)

The directional criteria with negative sequence polarization is given below:

- Directional forward $-90^\circ < (\text{angle}(I_2) - \text{angle}(V_2 + 180^\circ) - \text{RCA}) < 90^\circ$
- Directional reverse $-90^\circ > (\text{angle}(I_2) - \text{angle}(V_2 + 180^\circ) - \text{RCA}) > 90^\circ$

1.33 Negative Phase Sequence (NPS) Overcurrent Protection

The Negative Phase Sequence (NPS) overcurrent protection included in the P445/P54x/P841 relays provides four-stage non-directional/directional overcurrent protection with independent time delay characteristics. The first two stages of overcurrent protection have time-delayed characteristics which are selectable between Inverse Definite Minimum Time (IDMT), or Definite Time (DT). The third and fourth stages have definite time characteristics only. The inverse time delayed characteristics support both IEC and IEEE curves and please refer to the *Phase Fault Overcurrent Protection* section for a detailed description. The user may choose to directionalize operation of the elements, for either forward or reverse fault protection for which a suitable relay characteristic angle may be set. Alternatively, the elements may be set as non-directional.

For the NPS directional elements to operate, the relay must detect a polarizing voltage above a minimum threshold, "**I2> V2pol Set**".

When the element is selected as directional, a VTS Block option is available. When the relevant bit is set to 1, operation of the Voltage Transformer Supervision (VTS), will block the stage if directionalized. When set to 0, the stage will revert to non-directional upon operation of the VTS.

When enabled, the following signals are set by the negative sequence O/C logic according to the status of the monitored function.

Function	DDB	Description
I2> Inhibit	(DDB 562)	Inhibit all 4 stages when high
I2>1 Tmr. Block	(DDB 563)	Block timer on 1st stage when high
I2>2 Tmr. Block	(DDB 564)	Block timer on 1st stage when high
I2>3 Tmr. Block	(DDB 565)	Block timer on 1st stage when high
I2>4 Tmr. Block	(DDB 566)	Block timer on 1st stage when high
I2>1 Start	(DDB 567)	1st stage started when high
I2>2 Start	(DDB 568)	2nd stage started when high
I2>3 Start	(DDB 569)	3rd stage started when high
I2>4 Start	(DDB 570)	4th stage started when high
I2>1 Trip	(DDB 571)	1st stage tripped when high
I2>2 Trip	(DDB 572)	2nd stage tripped when high
I2>3 Trip	(DDB 573)	3rd stage tripped when high
I2>4 Trip	(DDB 574)	4th stage tripped when high

Table 8 - Functions, DDB numbers and descriptions

All the above signals are available as DDB signals for mapping in Programmable Scheme Logic (PSL). In addition the negative sequence overcurrent protection trips 1/2/3/4 are mapped internally to the block auto-reclose logic.

Negative sequence overcurrent protection starts 1/2/3/4 are mapped internally to the ANY START DDB signal – DDB 736.

The non-directional and directional operation is shown in these diagrams:

- Negative sequence overcurrent non-directional operation
- Directionalizing the negative phase sequence overcurrent element

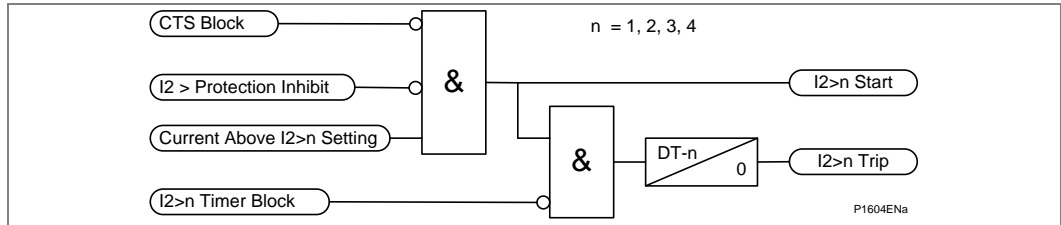

Figure 65 - Negative sequence overcurrent non-directional operation

1.33.1

Directionalizing the Negative Phase Sequence Overcurrent Element

Directionality is achieved by comparison of the angle between the negative phase sequence voltage and the negative phase sequence current. It may be selected to operate in either the forward or reverse direction.

A suitable relay characteristic angle setting (**I2> Char Angle**) is chosen to provide optimum performance. This setting should be set equal to the phase angle of the negative sequence current with respect to the inverted negative sequence voltage ($-V_2$), in order to be at the centre of the directional characteristic.

For the negative phase sequence directional elements to operate, the relay must detect a polarizing voltage above a minimum threshold, $I2> V2_{pol}$ Set. The logic diagram for negative sequence overcurrent protection (shown with directional operation) is attached as the *Directionalizing the negative phase sequence overcurrent element* diagram below.

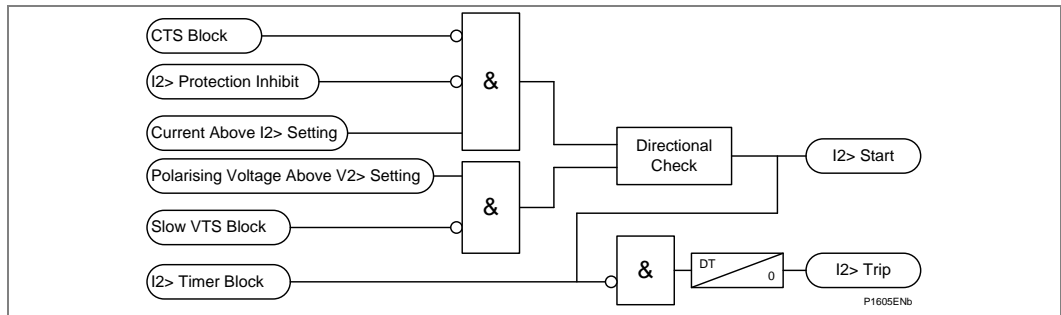

Figure 66 - Directionalizing the negative phase sequence overcurrent element

1.34 Undervoltage Protection

Both the under and overvoltage protection functions can be found in the relay menu **Volt Protection**. The measuring mode (ph-N or ph-ph) and operating mode (single phase or 3 phase) for both stages are independently settable.

Stage 1 may be selected as either IDMT, DT or Disabled, within the **V<1 function cell**. Stage 2 is DT only and is enabled/disabled in the **V<2 status cell**.

Two stages are included to provide both alarm and trip stages, where required. Alternatively, different time settings may be required depending upon the severity of the voltage dip.

Outputs are available for single or three phase conditions via the **V<Operate Mode cell**. When the protected feeder is de-energized, or the circuit breaker is opened, an undervoltage condition would be detected. Therefore, the **V<Polehead Inh** cell is included for each of the two stages to block the undervoltage protection from operating for this condition. If the cell is enabled, the relevant stage will become inhibited by the inbuilt pole dead logic within the relay. This logic produces an output when it detects either an open circuit breaker via auxiliary contacts feeding the relay opto inputs or it detects a combination of both undercurrent and undervoltage on any one phase.

The IDMT characteristic available on the first stage is defined by the formula:

$$t = K / (1 - M)$$

Where:

- K = Time multiplier setting
- t = Operating time in seconds
- M = Measured voltage/relay setting voltage (V< Voltage Set)

The logic diagram for the first stage undervoltage function is shown in the following *Undervoltage - single and three-phase tripping mode (single stage)* diagram.

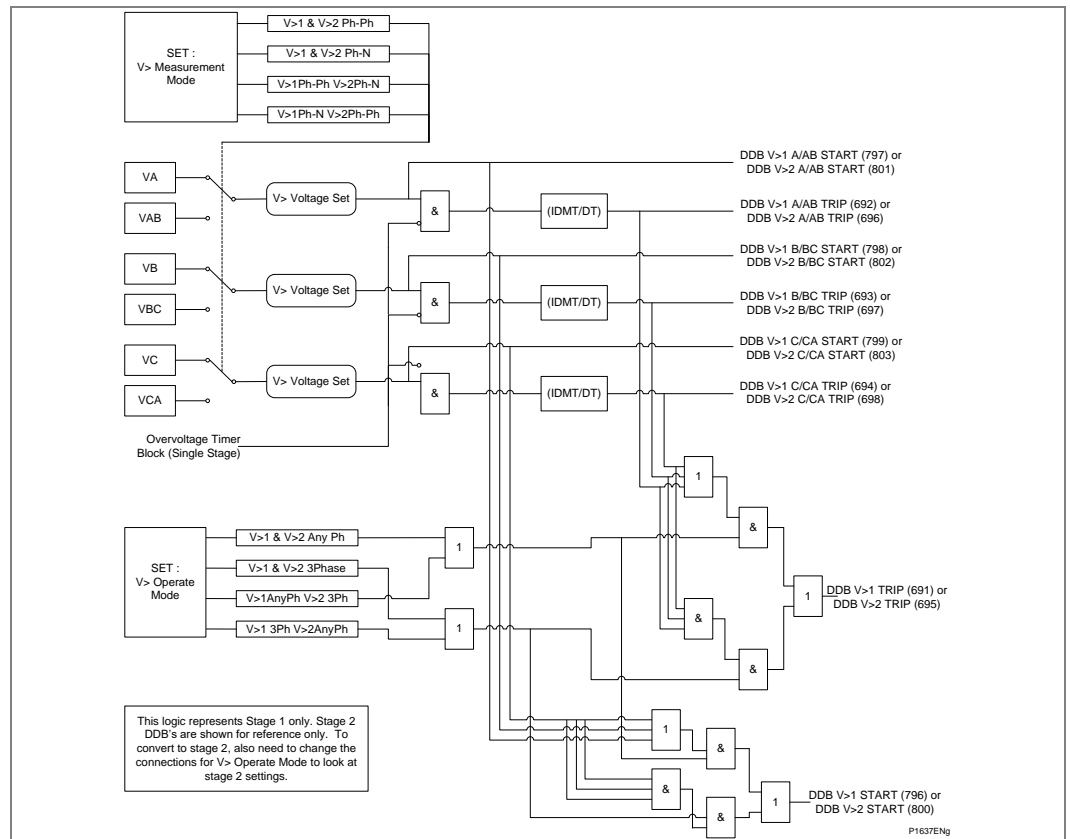

Figure 67 - Undervoltage - single and three-phase tripping mode (single stage)

<i>Note</i>	<i>Undervoltage protection is phase segregated, but the operation of any phase is mapped to 3-phase tripping in the default PSL.</i>
-------------	--

Each stage of Undervoltage protection may be disabled by a DDB (471 or 472) Inhibit $V_{x<}$.

1.35 Overvoltage Protection

Both the over and undervoltage protection functions can be found in the relay menu Volt Protection. The measuring mode (ph-N or ph-ph) and operating mode (single phase or 3 phase) for both stages are independently settable.

The IDMT characteristic available on the first stage is defined by the following formula:

$$t = K / (M - 1)$$

Where:

- K = Time Multiplier Setting (TMS)
- t = Operating Time in seconds
- M = Measured voltage / relay setting voltage (V> Voltage Set)

The logic diagram of the first stage overvoltage function is shown in this diagram.

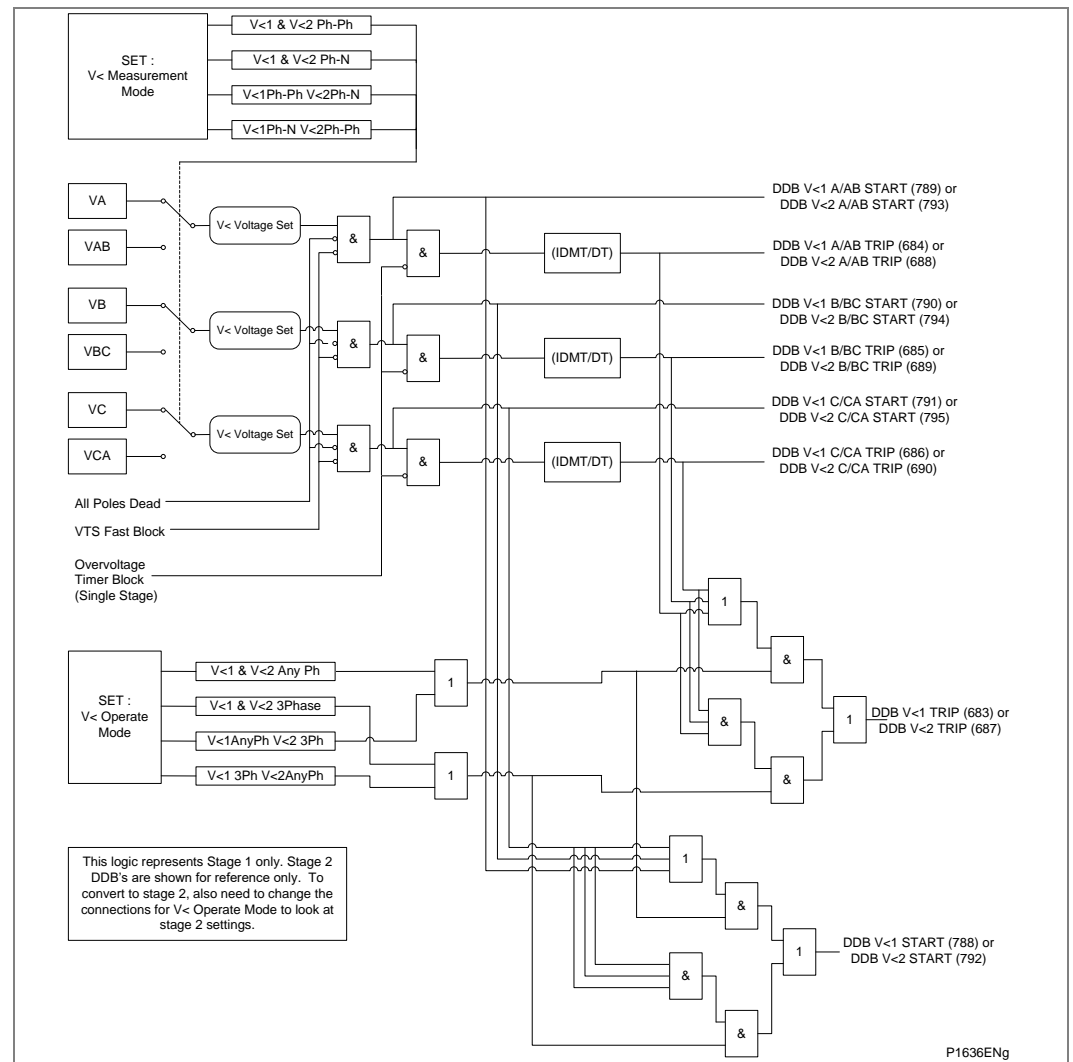

Figure 68 - Overvoltage - single and three-phase tripping mode (single stage)

Note Phase overvoltage protection is phase segregated, but the operation of any phase is mapped to 3-phase tripping in the default PSL.

Each stage of Overvoltage protection may be disabled by a DDB (473 or 474) Inhibit Vx> (x = 1, 2).

1.35.1

Compensated Overvoltage

The Compensated Overvoltage function calculates the positive sequence voltage at the remote terminal using the positive sequence local current and voltage and the line impedance and susceptance. This can be used on long transmission lines where Ferranti Overvoltages can develop under remote circuit breaker open conditions.

The Compensated overvoltage protection function can be found in the relay menu Volt Protection. The line impedance settings together with the line charging admittance in relay menu Line Parameters is used to calculate the remote voltage.

The relay uses the [A,B,C,D] transmission line equivalent model given these parameters:

Total Impedance:

$$Z = z \angle \theta \Omega$$

Total Susceptance:

$$Y = y \angle -90 \Omega$$

Line Length l

The remote voltage is calculated using the following equations:

$$\begin{bmatrix} \bar{V}_r \\ \bar{I}_r \end{bmatrix} = \begin{bmatrix} D & -C \\ -B & A \end{bmatrix} \times \begin{bmatrix} \bar{V}_s \\ \bar{I}_s \end{bmatrix}$$

Where:

V_r, I_r - Voltage and Current at the receiving end.

V_s, I_s - Measured (relay) Voltage and Current at the sending end.

$$A = D = \cosh(\gamma \times l)$$

$$B = Zc \times \sinh(\gamma \times l)$$

$$C = Yc \times \sinh(\gamma \times l)$$

$$\gamma \times l = \sqrt{ZY}$$

$$Zc = \frac{l}{Yc} = \sqrt{\frac{Z}{Y}}$$

Y = Total Line Capacitive Charging Susceptance

Zc = Characteristic Impedance of the line (Surge Impedance).

Two stages are included to provide both alarm and trip stages, where required.

Both stages are independently settable where Stage 1 may be selected as either IDMT, DT or Disabled, within the $V1 > 1$ Cmp Funct cell. Stage 2 is DT only and is enabled/disabled in the $V1 > Cmp$ Status cell.

The IDMT characteristic available on the first stage is defined by the formula:

$$t = K / (1 - M)$$

Where:

K = Time multiplier setting

t = Operating time in seconds

M = Remote Calculated voltage / relay setting voltage (PH-)

1.36 Residual Overvoltage (Neutral Displacement) Protection

The NVD element within the MiCOM P445/P44y/P54x/P841 is of two stage design, each stage having separate voltage and time delay settings. Stage 1 may be set to operate on either an IDMT or DT characteristic, whilst stage 2 may be set to DT only. Two stages are included for the NVD protection to account for applications which require both alarm and trip stages.

The relay internally derives the NVD voltage from the 3 input phases which must be supplied from either a 5-limb or three single-phase VTs. These types of VT design allow the passage of residual flux and consequently permit the relay to derive the required residual voltage. In addition, the primary star point of the VT must be earthed. A three limb VT has no path for residual flux and is therefore unsuitable to supply the relay.

The IDMT characteristic available on the first stage is defined by the formula:

$$t = K/(M - 1)$$

Where:

- K = Time multiplier setting
- t = Operating time in seconds
- M = Derived residual voltage/relay setting voltage (VN> Voltage Set)

The functional block diagram of the first stage residual overvoltage is shown below:

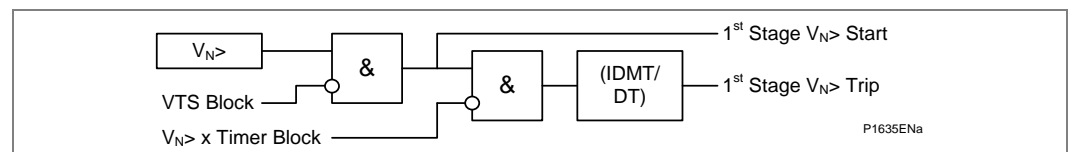

Figure 69 - Residual overvoltage logic (single stage)

Each stage of Residual Overvoltage protection may be disabled by a DDB (475 or 476) Inhibit VN>x (x = 1, 2).

1.37

Circuit Breaker Fail (CBF) Protection

The CBF protection incorporates two timers, 'CB Fail 1 Timer' and 'CB Fail 2 Timer', allowing configuration for the following scenarios:

- Simple CBF, where only CB Fail 1 Timer is enabled. For any protection trip, the CB Fail 1 Timer is started, and normally reset when the circuit breaker opens to isolate the fault. If breaker opening is not detected, CB Fail 1 Timer times out and closes an output contact assigned to breaker fail (using the programmable scheme logic). This contact is used to backtrip upstream switchgear, generally tripping all infeeds connected to the same busbar section.
- A re-tripping scheme, plus delayed backtripping. Here, CB Fail 1 Timer is used to route a trip to a second trip circuit of the same circuit breaker. This requires duplicated circuit breaker trip coils, and is known as re-tripping. Should re-tripping fail to open the circuit breaker, a backtrip may be issued following an additional time delay. The backtrip uses CB Fail 2 Timer, which is also started at the instant of the initial protection element trip.
- CBF elements CB Fail 1 Timer and CB Fail 2 Timer can be configured to operate for trips triggered by protection elements within the relay or via an external protection trip. The latter is achieved by allocating one of the relay opto-isolated inputs to CBF External Initiation using the programmable scheme logic.

In the existing designs, the fast undercurrent is used to determine if the circuit breaker has opened. This can take up to 160ms to reset under some fault conditions - for example, where the current resembles a slow decaying dc component after the circuit breaker has opened to clear the fault current. For example see the *Decaying dc component* diagram below.

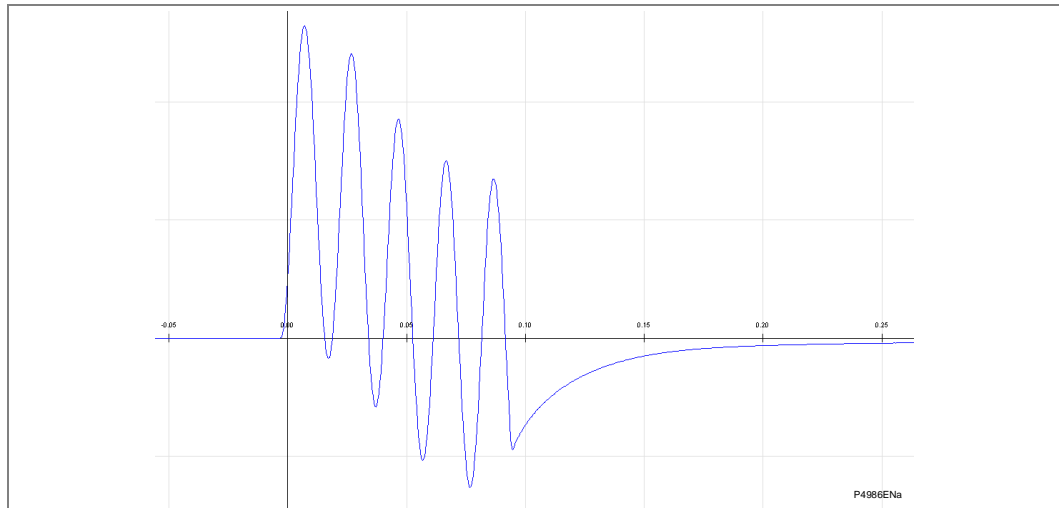

Figure 70 - Decaying dc component

The length of the operating time is primarily related to the usage of the combination of Fourier magnitudes and the 3-sample interpolation method used for the undercurrent reset algorithm. In some applications, a 160ms reset time is too slow.

We have introduced a Zero Cross Detector (ZCD) to shorten the reset time. In some cases, it is preferable to record measured sample values of a variable waveform. However, we have found it acceptable to record the magnitude of the waveform. For example, see the *Calculating a Zero Cross Detection Point using sample values* diagram below.

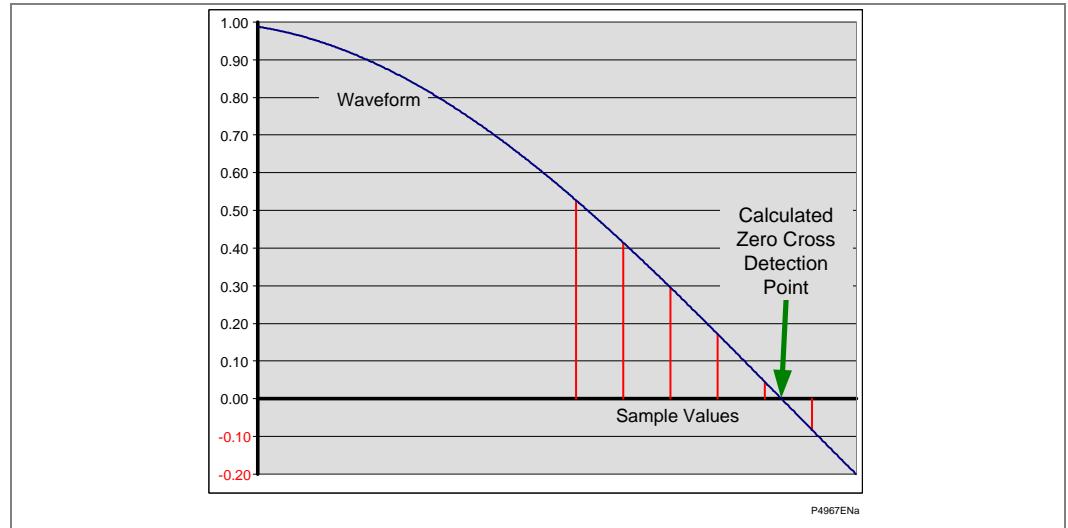

Figure 71 - Calculating a Zero Cross Detection Point using sample values

We have modified the CB Fail logic to incorporate the addition of ZCD signals with a time delayed drop off of 1/2 a cycle for each phase current and the SEF current. These are logically combined with the output of the breaker fail timers to determine breaker fail trip operation.

The objective of this software release is to improve the reset performance of the CB Fail. The target reset time is 3/4 cycle (i.e. 15ms for a 50Hz signal).

The CBF timer settings have the same setting range as the existing design but the step size has been reduced from 10ms to 1ms.

1.37.1

Reset Mechanisms for Breaker Fail Timers

The operation of this function depends on the Software Version which is used by the relay. This is for Software Version D1 and later.

Introduction

Circuit Breaker Failure (CBF) protection monitors whether the Circuit Breaker (CB) has opened in an acceptable time period after the protection devices have issued trip commands in response to a system fault condition. This is required to prevent further damage in the power system and isolate the fault in transmission or sub-transmission systems. The feature provides the facility to reset the CB failure condition via an external source (e.g. via an opto status input etc).

CB Fail External Reset

The CB Fail external reset functionality has been modified as follows:

New DDB signals have been added to reset the individual CB phase failure logic triggers, a separate DDB for all (i.e. three) phase triggers and a separate DDB for sensitive earth fault conditions. An additional four signals have been added for second circuit breaker for dual CB relay variants.

To achieve desired functionality, individual external reset signals are now connected via an OR gate together with the corresponding phase undercurrent signal at each stage of the logic in CB failure logic. After modification, the resultant CB failure logic looks like the ones shown in these figures:

- CB Failure CB1 logic part 1
- CB Failure CB1 logic part 2

The figures show failure logic for CB1 only, but the same logic also applies to CB2 functionality.

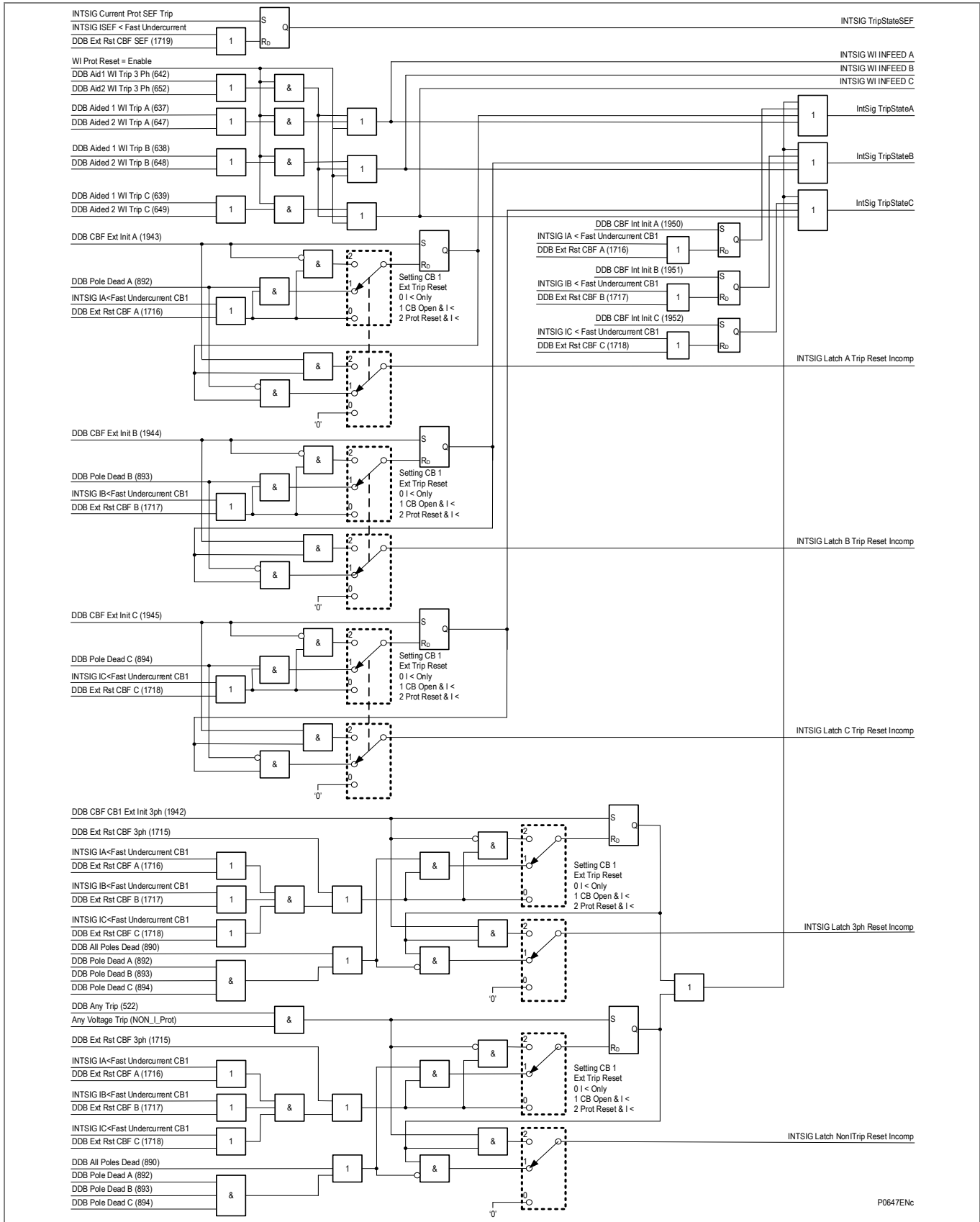

Figure 72 - CB Failure CB1 logic part 1

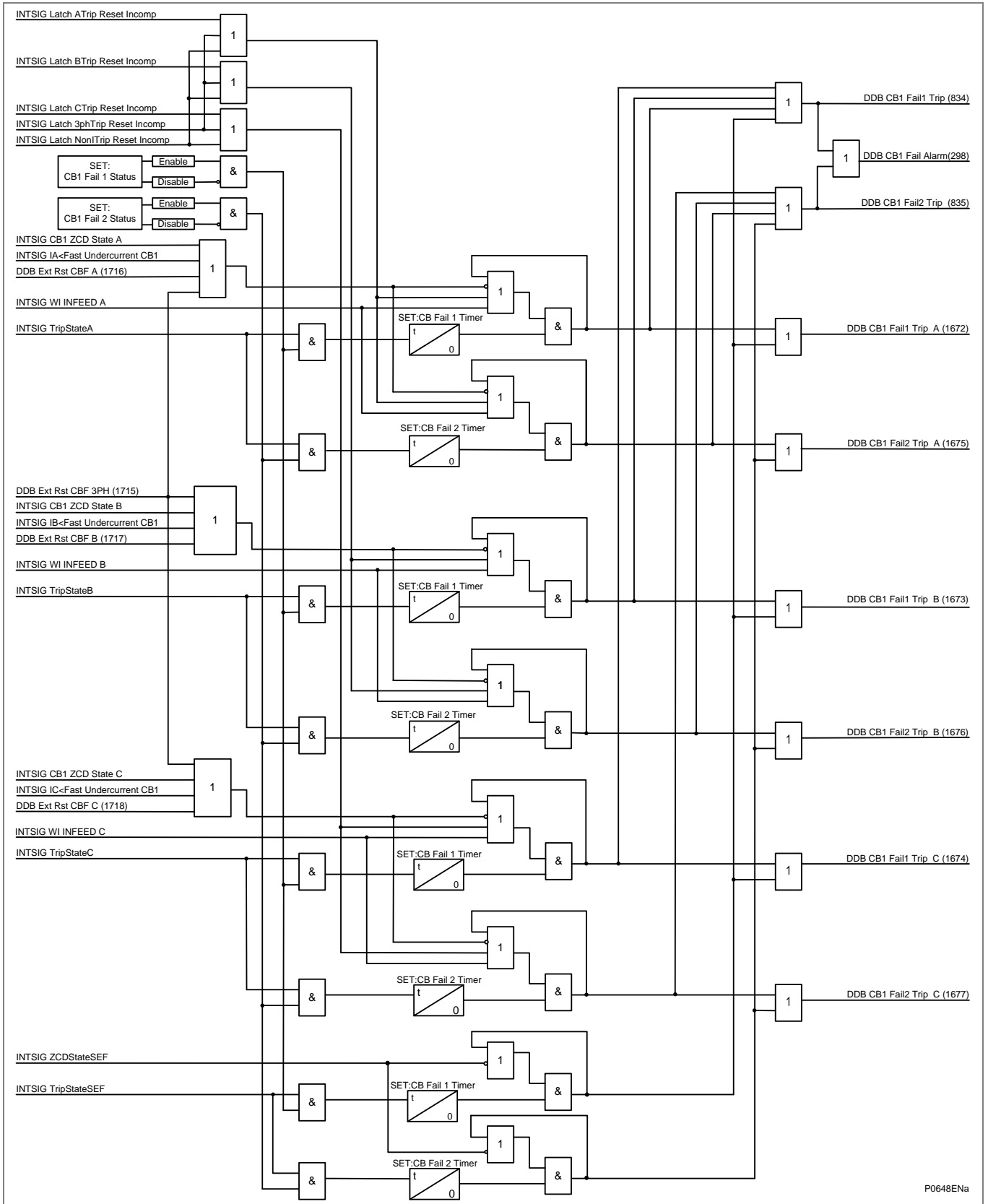

Figure 73 - CB Failure CB1 logic part 2

The Following DDB signals have been added (Single CB Variants).

DDB No.	English Text	Source	Description
1715	Ext Rst CBF	PSL	External Reset for CB 3 phase fail.
1716	Ext Rst CBF A	PSL	External Reset for CB A phase fail.
1717	Ext Rst CBF B	PSL	External Reset for CB B phase fail.
1718	Ext Rst CBF C	PSL	External Reset for CB C phase fail.
1719	Ext Rst SEF CBF	PSL	External Reset for SEF CB phase fail.

The Following DDB signals have been added (Dual CB Variants).

DDB No.	English Text	Source	Description
1715	Ext Rst CB1F	PSL	External Reset for CB1 3 phase fail.
1716	Ext Rst CB1F A	PSL	External Reset for CB1 A phase fail.
1717	Ext Rst CB1F B	PSL	External Reset for CB1 B phase fail.
1718	Ext Rst CB1F C	PSL	External Reset for CB1 C phase fail.
1719	Ext Rst SEF CBF	PSL	External Reset for SEF CB phase fail.
1720	Ext Rst CB2F	PSL	External Reset for CB2 3 phase fail.
1721	Ext Rst CB2F A	PSL	External Reset for CB2 A phase fail.
1722	Ext Rst CB2F B	PSL	External Reset for CB2 B phase fail.
1723	Ext Rst CB2F C	PSL	External Reset for CB2 C phase fail.

The above DDBs are available to the PSL and can be mapped to (e.g.) opto status inputs, function keys, control inputs etc. as required by the specific application.

The Following DDB signals are available to the PSL used to initialize the CB fail logic. (Single CB Variants).

DDB No.	English Text	Source	Description
1942	CBF Ext Init 3ph	PSL	CBF External Initialization trip 3 phase
1943	CBF Ext Init A	PSL	CBF External Initialization trip A phase
1944	CBF Ext Init B	PSL	CBF External Initialization trip B phase
1945	CBF Ext Init C	PSL	CBF External Initialization trip C phase
1950	CBF Int Init A	PSL	CBF Internal Initialization trip A phase
1951	CBF Int Init B	PSL	CBF Internal Initialization trip B phase
1952	CBF Int Init C	PSL	CBF Internal Initialization trip C phase

The following DDB signals are available to the PSL used to initialize the CB fail logic. Dual CB Variants.

DDB No.	English Text	Source	Description
1942	CBFCB1ExtlNit3ph	PSL	CBF CB1 External Initialization trip 3 phase
1943	CBF CB1ExtlNit A	PSL	CBF CB1 External Initialization trip A phase
1944	CBF CB1ExtlNit B	PSL	CBF CB1 External Initialization trip B phase
1945	CBF CB1ExtlNit C	PSL	CBF CB1 External Initialization trip C phase
1946	CBFCB2ExtlNit3ph	PSL	CBF CB2 External Initialization trip 3 phase
1947	CBF CB2Ext InitA	PSL	CBF CB2 External Initialization trip A phase
1948	CBF CB2Ext InitB	PSL	CBF CB2 External Initialization trip B phase
1949	CBF CB2Ext InitC	PSL	CBF CB2 External Initialization trip C phase
1950	CBF CB1Int InitA	PSL	CBF Internal Initialization trip A phase
1951	CBF CB1Int InitB	PSL	CBF Internal Initialization trip B phase
1952	CBF CB1Int InitC	PSL	CBF Internal Initialization trip C phase
1953	CBF CB2Int InitA	PSL	CBF CB2 Internal Initialization trip A phase
1954	CBF CB2Int InitB	PSL	CBF CB2 Internal Initialization trip B phase
1955	CBF CB2Int InitC	PSL	CBF CB2 Internal Initialization trip C phase

1.38 Broken Conductor Detection

The relay incorporates an element which measures the ratio of negative to positive phase sequence current (I_2/I_1). This will be affected to a lesser extent than the measurement of negative sequence current alone, since the ratio is approximately constant with variations in load current. Hence, a more sensitive setting may be achieved.

The *Broken conductor logic* diagram is as shown below. The ratio of I_2/I_1 is calculated and is compared with the threshold and if the threshold is exceeded then the delay timer is initiated. The CTS block signal is used to block the operation of the delay timer.

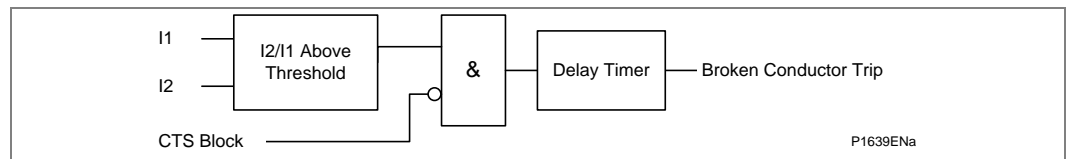

Figure 74 - Broken conductor logic

1.39 Frequency Protection

The P14x/P341/P34x/P391/P445/P44y/P54x/P64x/P841 feeder relay includes 4 stages of underfrequency and 2 stages of overfrequency protection to facilitate load shedding and subsequent restoration. The underfrequency stages may be optionally blocked by a pole dead (CB Open) condition. All the stages may be enabled/disabled in the "**F<n Status**" or "**F>n Status**" cell depending on which element is selected.

The logic diagram for the underfrequency logic is as shown in the following *Underfrequency logic (single stage)* diagram. Only a single stage is shown. The other three stages are identical in functionality.

If the frequency is below the setting and not blocked the DT timer is started. Blocking may come from the All_Poledead signal (selectively enabled for each stage) or the underfrequency timer block.

If the frequency cannot be determined, the function is also blocked.

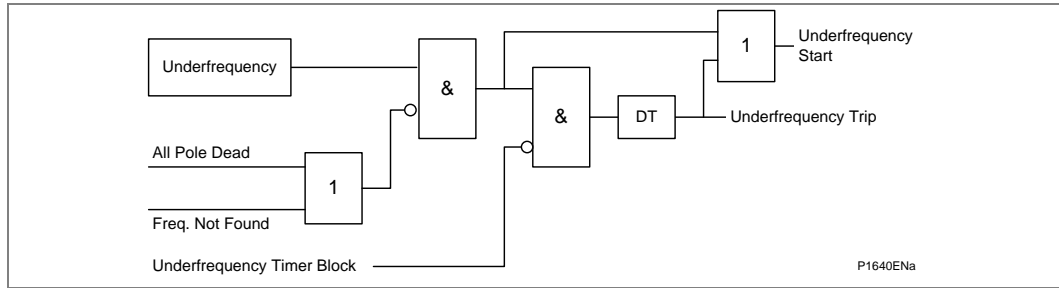

Figure 75 - Underfrequency logic (single stage)

The functional logic for the overfrequency function as shown in the *Overfrequency logic (single stage)* diagram. Only a single stage is shown as the other stages are functionally identical. If the frequency is above the setting and not blocked the DT timer is started and after this has timed out the trip is produced. Blocking may come from the All_Poledead signal (selectively enabled for each stage) or the overfrequency timer block.

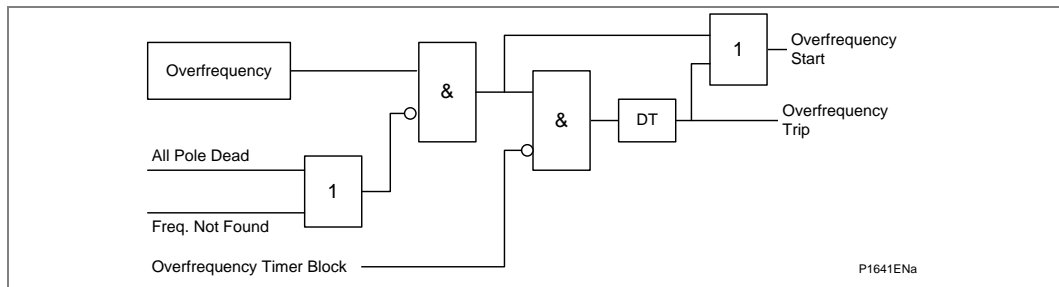

Figure 76 - Overfrequency logic (single stage)

When enabled, the following signals are set by the under/overfrequency logic according to the status of the monitored functions.

Function	DDB	Description
F<1 Timer Block	(DDB 1149)	Block Underfrequency Stage 1 Timer
F<2 Timer Block	(DDB 1150)	Block Underfrequency Stage 2 Timer
F<3 Timer Block	(DDB 1151)	Block Underfrequency Stage 3 Timer
F<4 Timer Block	(DDB 1152)	Block Underfrequency Stage 4 Timer
F>1 Timer Block	(DDB 1153)	Block Overfrequency Stage 1 Timer
F>2 Timer Block	(DDB 1154)	Block Overfrequency Stage 2 Timer
F<1 Start	(DDB 1155)	Underfrequency Stage 1 Start
F<2 Start	(DDB 1156)	Underfrequency Stage 2 Start
F<3 Start	(DDB 1157)	Underfrequency Stage 3 Start
F<4 Start	(DDB 1158)	Underfrequency Stage 4 Start
F>1 Start	(DDB 1159)	Overfrequency Stage 1 Start
F>2 Start	(DDB 1160)	Overfrequency Stage 2 Start

Function	DDB	Description
F<1 Trip	(DDB 1161)	Underfrequency Stage 1 Trip
F<2 Trip	(DDB 1162)	Underfrequency Stage 2 Trip
F<3 Trip	(DDB 1163)	Underfrequency Stage 3 Trip
F<4 Trip	(DDB 1164)	Underfrequency Stage 4 Trip
F>1 Trip	(DDB 1165)	Overfrequency Stage 1 Trip
F>2 Trip	(DDB 1166)	Overfrequency Stage 2 Trip
Inhibit F<1	(DDB 1167)	Inhibit stage 1 Under frequency protection
Inhibit F<2	(DDB 1168)	Inhibit stage 2 Under frequency protection
Inhibit F<3	(DDB 1169)	Inhibit stage 3 Under frequency protection
Inhibit F<4	(DDB 1170)	Inhibit stage 4 Under frequency protection
Inhibit F>1	(DDB 1171)	Inhibit stage 1 Over frequency protection
Inhibit F>2	(DDB 1172)	Inhibit stage 2 Over frequency protection

Table 9 - Functions, DDB numbers and descriptions

1.40 Independent Rate of Change of Frequency Protection [81R]

In the load shedding scheme below, it is assumed under falling frequency conditions that by shedding a stage of load, the system can be stabilized at frequency f_2 . For slow rates of decay, this can be achieved using the underfrequency protection element set at frequency f_1 with a suitable time delay. However, if the generation deficit is substantial, the frequency will rapidly decrease and it is possible that the time delay imposed by the underfrequency protection will not allow for frequency stabilization. In this case, the chance of system recovery will be enhanced by disconnecting the load stage based upon a measurement of rate of change of frequency and bypassing the time delay.

Considerable care should be taken when setting this element because it is not supervised by a frequency setting. Setting of the time delay or increasing the number of df/dt averaging cycles will lead to a more stable element but this should be considered against the loss of fast tripping capability as the tripping time is extended. However, a timer is included to provide a time delayed operation. The time delay will lead to a more stable element but this should be considered against the loss of fast tripping capability as the tripping time is extended. The use of time delay settings of 100ms or less with df/dt rates of less than 0.4Hz/s is not recommended as system frequency oscillations or voltage selection transients will likely cause instability. The element can be utilized to provide extra flexibility to a load shedding scheme in dealing with severe load to generation imbalances.

Since the rate of change monitoring is independent of frequency, the element can identify frequency variations occurring close to nominal frequency and therefore provide early warning to the operator on a developing frequency problem. Additionally, the element could also be used as an alarm to warn operators of unusually high system frequency variations.

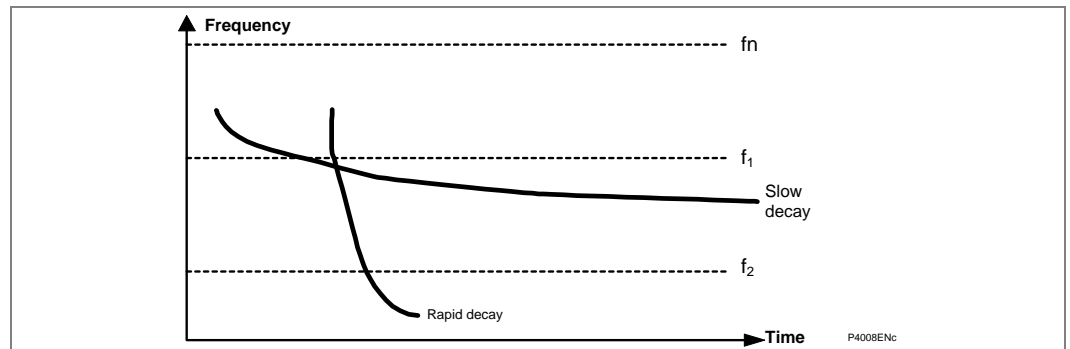

Figure 77 - Rate of change of frequency protection

1.40.1 Basic Functionality

The relay provides four independent stages of rate of change of frequency protection ($df/dt+t$). Depending upon whether the rate of change of frequency setting is set positive or negative, the element will react to rising or falling frequency conditions respectively, with an incorrect setting being indicated if the threshold is set to zero. The output of the element would normally be given a user-selectable time delay, although it is possible to set this to zero and create an instantaneous element.

An Independent setting is available for calculating the rate of change of frequency measurement, df/dt Avg. Cycles over a fixed period of either 6 or 12 cycles. This provides the ability to de-sensitize the frequency based protection element against oscillations in the power system frequency or voltage selection transients. The 12-cycle averaging window setting improves measurement accuracy, but slows down the protection start time following fault inception. The maximum fault detection start time following fault inception can be approximated as:

$$\text{Fault Detection Delay Time (cycles)} = 2 \times M + 1$$

Where M = No. of frequency averaging cycles df/dt .Av. Cycles

When enabled, the following signals are set by the df/dt logic according to the status of the monitored function.

Function	DDB	Description
df/dt> Inhibit	(DDB 592)	Inhibit all 4 stages when high
df/dt>1 Tmr. Block	(DDB 593)	Block timer on 1st stage when high
df/dt>2 Tmr. Block	(DDB 594)	Block timer on 2nd stage when high
df/dt>3 Tmr. Block	(DDB 595)	Block timer on 3rd stage when high
df/dt>4 Tmr. Block	(DDB 596)	Block timer on 4th stage when high
df/dt>1 Start	(DDB 597)	1st stage started when high
df/dt>2 Start	(DDB 598)	2nd stage started when high
df/dt>3 Start	(DDB 599)	3rd stage started when high
df/dt>4 Start	(DDB 600)	4th stage started when high
df/dt>1 Trip	(DDB 601)	1st stage tripped when high
df/dt>2 Trip	(DDB 602)	2nd stage tripped when high
df/dt>3 Trip	(DDB 603)	3rd stage tripped when high
df/dt>4 Trip	(DDB 604)	4th stage tripped when high

Table 10 - Functions, DDB numbers and descriptions

All the above signals are available as DDB signals for mapping in Programmable Scheme Logic (PSL).

1.41

Special Weak Infeed Logic for Stub End Transformer Terminals

The true weak infeed condition is when no current based protection element is sensitive enough to operate. This is the case when zero or minimal generation is connected at that terminal, and the prospective level of fault current flowing through the CT is insufficient for any forward/reverse protection operation. In such cases, the fault will be cleared using either POR or Blocking schemes and enabling WI Echo + Trip.

However, there could be a specific configuration as shown in the *Weak infeed configuration on stub-fed radial circuit (parallel line is out of service)* diagram that may not be detected by relay as a weak infeed condition, even if there is no generation at that end (left side - relay R2).

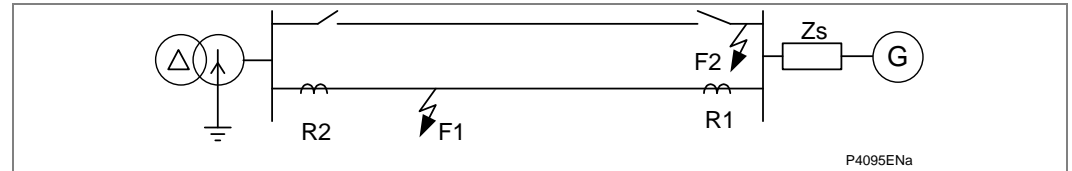

Figure 78 - Weak infeed configuration on stub-fed radial circuit (parallel line is out of service)

The reason is a star earthed transformer which, in case of phase to ground and double phase to ground faults, imposes a very low zero sequence impedance and almost infinite positive and negative sequence impedance, i.e. behaving as a source of zero sequence current only. In such a case, the zero sequence current I_0 will dominate over I_1 and I_2 at the weak end, where all three-phase currents will approximately equal I_0 (all in phase and equal in magnitude). This is true for F1 earth faults at R2, and for F2 earth faults at R1 and R2. The phase currents will be sufficient to pickup current level detectors in the MiCOM P44/P44y/P54x, and a true weak infeed condition will not be seen as such by the relay.

In such a stub-end feeding case, relay R2 may experience some overreach in the case of double-phase to ground faults. This is caused by the unusual current distribution making the MiCOM P445/P44y/P54x detect a single-phase fault condition (and potential single pole tripping only in single pole tripping applications).

For this unusual feeding arrangement, the MiCOM P445/P44y/P54x makes available a Zero sequence stabilizing feature, that measures the dominance of zero sequence current over negative sequence current (I_0/I_2). It promotes stability by forcing the relay to recognize the above configuration as a WI condition. It then blocks all distance elements, once the measured I_0/I_2 ratio exceeds the setting.

2 COMMUNICATIONS BETWEEN RELAYS

2.1 Communications Link Options

A number of communications options are available, for the communication channels between P54x system ends. The connection options are shown below. Choosing between each of them will depend on the type of communications equipment available. Where existing suitable multiplexer communication equipment is installed for other communication between substations, the 850nm option together with an appropriate ITU-T compatible electrical interface (P-2M-L) should be selected to match the existing multiplexer equipment. For more information, refer to the *Optical Fiber to Electrical Interface Units* section and the P-2M-L documentation.

Where an IEEE C37.94 compatible multiplexer is installed the 850 nm option should be configured to interface directly to the multiplexer, refer to the IEEE C37.94 Interface to Multiplexer section.

Where no multiplexer is installed, the direct optical fibre connection can be used, refer to these sections:

- Direct Optical Fiber Link, 850 nm Multi-Mode Fiber
- Direct Optical Fiber Link, 1300 nm Multi-Mode Fiber
- Direct Optical Fiber Link, 1310 nm Single-Mode Fiber
- Direct Optical Fiber Link, 1550 nm Single-Mode Fiber

The type of fibre used (multi-mode or single-mode and wavelength) will be determined by the distance between the ends of the P54x relay system, refer to optical budgets in the Application Notes chapter.

In any configuration, except the IEEE C37.94, the data rate may be selected as either 64kbit/sec or 56kbit/sec.

2.1.1 Direct Optical Fiber Link, 850 nm Multi-Mode Fiber

The relays are connected directly using two 850 nm multi-mode optical fibres for each signaling channel. Multi-mode fibre type 50/125 μm or 62.5/125 μm is suitable. BFOC/2.5 type fibre optic connectors are used. These are commonly known as “ST” connectors.

This is typically suitable for connection up to 1km.

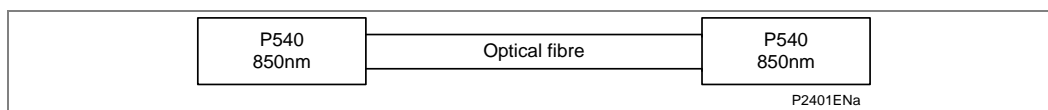

Figure 82 - P540 850nm optical fibre connections

2.1.2 Direct Optical Fiber Link, 1300 nm Multi-Mode Fiber

The relays are connected directly using two 1300 nm multi-mode fibres for each signaling channel. Multi-mode fibre type 50/125 μm or 62.5/125 μm is suitable. BFOC/2.5 type fibre optic connectors are used.

This is typically suitable for connection up to approximately 50 km (from April 2008). Pre-April 2008 relays were suitable for connection up to approximately 30 km.

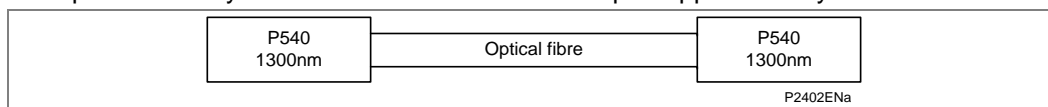

Figure 83 - P540 1300nm optical fibre connections

2.1.3

Direct Optical Fiber Link, 1310 nm Single-Mode Fiber

The relays are connected directly using two 1310 nm single-mode fibers, type 9/125 μm for each signaling channel. BFOC/2.5 type fibre optic connectors are used.

This is typically suitable for connection up to approximately 100 km (from April 2008). Pre-April 2008 relays were suitable for connection up to approximately 60 km.

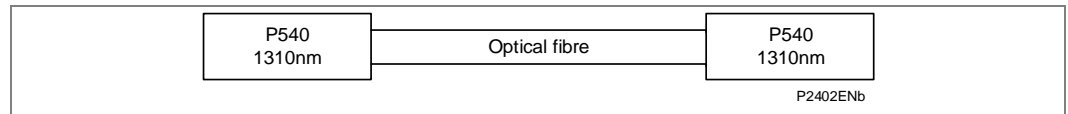

Figure 84 - P540 1310nm optical fibre connections

2.1.4

Direct Optical Fiber Link, 1550 nm Single-Mode Fiber

The relays are connected directly using two 1550 nm single-mode fibers, type 9/125 μm for each signaling channel. BFOC/2.5 type fibre optic connectors are used.

This is typically suitable for connection up to approximately 130 km (from April 2008). Pre-April 2008 relays were suitable for connection up to approximately 80 km.

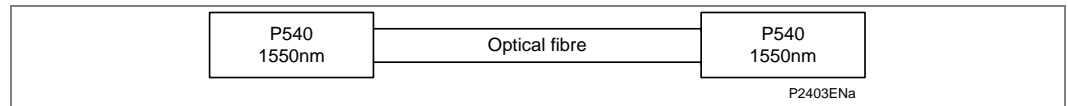

Figure 85 - P540 1550nm optical fibre connections

The list of all available fibre channel options is:

- 820 nm dual channel
- 1310 nm single-mode/single channel
- 1310 nm single-mode/dual channel
- 1300 nm multi-mode/single channel
- 1300 nm multi-mode/dual channel
- 1550 nm single-mode/single channel
- 1550 nm single-mode/dual channel
- Ch 1 850nm multi-mode + Ch 2 1310nm single-mode
- Ch 1 850nm multi-mode + Ch 2 1550nm single-mode
- Ch 1 1310nm single-mode + Ch 2 850nm multi-mode
- Ch 1 1300nm multi-mode + Ch 2 850nm multi-mode
- Ch 1 1550nm single-mode + Ch 2 850nm multi-mode

2.1.5

IEEE C37.94 Interface to Multiplexer

A P54x relay with 850 nm short haul optical interface is connected directly to the multiplexer by 850 nm multi-mode optical fiber. Multi-mode fibre type 50/125 μm or 62.5/125 μm is suitable. BFOC/2.5 type fibre optic connectors are used.

The setting Comms Mode should be set to IEEE C37.94.

Note *The relay must be powered off and on before this setting change becomes effective.*

The IEEE C37.94 standard defines an N*64kbts/s standard where N can be 1 – 12. N can be selected on the P54x or alternatively set to Auto in which case the relay will configure itself to match the multiplexer.

2.1.6

Switched Communication Networks

The P54x relays make use of digital communication signaling channels for the differential protection. For correct operation of this protection element, it is essential that the integrity of this link is continuously checked. For P54x relays, when GPS is not used it is also a requirement of this link that 'go' (tp1) and 'return' (tp2) times are similar (a difference of up to 1 ms can be tolerated). Times greater than this can result in relay instability.

Where switched communications networks are used, it is possible that during switching, a transient time period may exist with different 'go' and 'return' times. All P54x relays include a facility to ensure protection stability during this transient period.

One of the checks performed on the communications link is a check on the calculated propagation delay for each data message. During normal operation the difference in calculated time should be minimal (possible delays being introduced by multiplexers or other intermediary communication equipment). If successive calculated propagation delay times exceed a user settable value (250 – 1000 μ s), the relay will raise a comm delay alarm and initiate a change in relay setting for a short time period (Char Mod Time setting) to overcome any switching delay. This change in setting is shown in the *Transient bias characteristic* diagram whereby the relay bias setting, k1, is increased to 200%. This characteristic provides stability for all load conditions and will still allow tripping for most internal fault conditions.

The *Switched communication network* diagram shows a possible scenario for a switched network. Initially the P54x relays are communicating via path 1. The go and return times for this path are 2 ms and hence the calculated propagation delay is $(2 + 2)/2 = 2$ ms. When the channel is switched to path 2, a small time period exists where the P54x's could be sending messages via path 1 and returning via path 2.

The calculated propagation delay will now be $(2 + 5)/2 = 3.5$ ms. The resultant 1.5 ms error at each line end may cause the relay to maloperate due to incorrect time alignment of current vectors (see the *Time Alignment of Current Vectors Without GPS (traditional technique)* section). After a short delay, both 'go' and 'return' paths will follow route 2 and the calculated propagation delay will be $(5 + 5)/2 = 5$ ms. The relay will now be stable, as correct current vector time alignment exists at each line end.

The Char Mod timer is started when a change in propagation delay is detected. Any subsequent change during this period will cause the timer to restart. In the above example the timer will start for the first change (2 to 3.5 ms). The second change (3.5 ms to 5 ms) will cause the timer to restart, therefore allowing for multiple switching between communication paths.

A change in propagation delay may result in a temporary failure of the protection communications channel. If this occurs, the propagation delay change may not be detected by the relay. To overcome this problem, the Char Mod Timer is re-started when the channel recovers from a protection communications channel failure if the Char Mod Timer was running when the channel failure occurred.

When the **Char Mod Reset** setting is enabled, this timer operates in parallel with the **Char Mod Timer** (which is initiated by a propagation delay change) and allows the **Char Mod Timer** to be terminated early and the setting characteristic k1 to return to the normal setting value if there is no Differential Current present (i.e. the paths are assumed to be equal). This prevents the Characteristic being raised to 200% after the propagation delay change has stabilised to a new value.

If **Char Mod Reset** is Enabled and the **Char Mod Time** has started then the **Char Mod RstTime** runs. When the **Char Mod RstTime** expires and up to the point where the **Char Mod Timer** expires, the Bias and Differential currents are checked to determine if there is differential current present. If the bias current is above 5% I Nominal and differential current is below 10% of the bias current on all phases, then the **Char Mod Time** resets and the characteristic will return to normal. If these conditions are not met, then the characteristic remains increased for the duration of the **Char Mod Time**.

This will only be of benefit if the **Char Mod Reset Timer** setting is set to expire before the **Char Mod Time** expires, i.e. the **Char Mod RstTime** should be set greater than the minimum switching delay expected, and less than **Char Mod Time** setting.

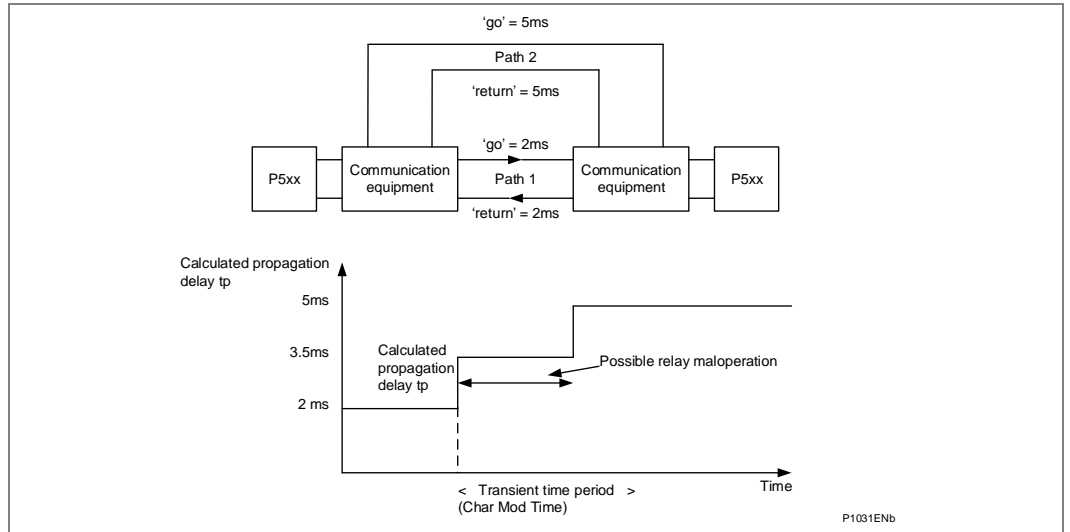

Figure 86 - Switched communication network

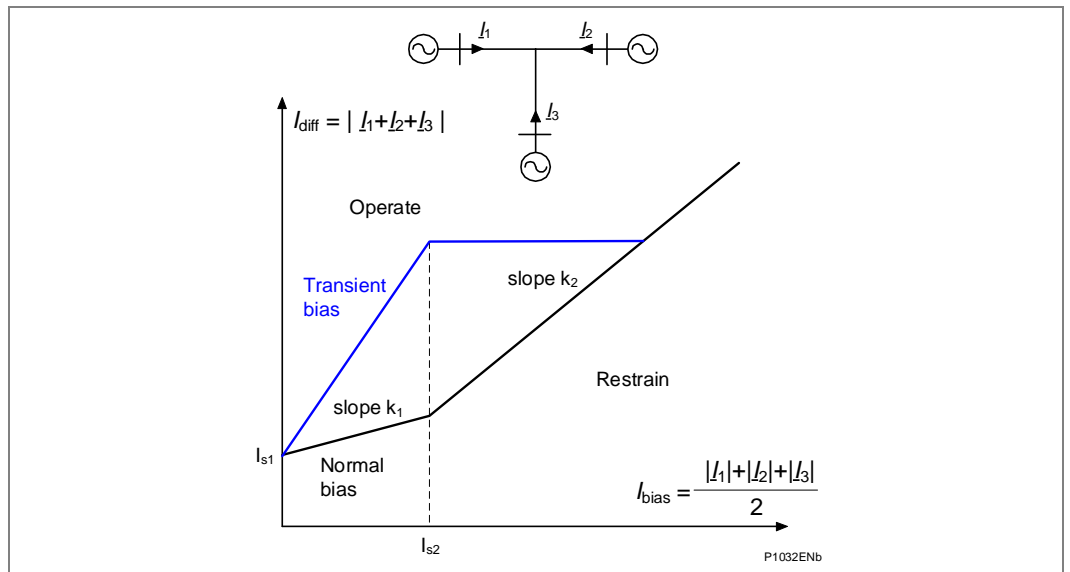

Figure 87 - Transient bias characteristic

2.1.7 Switched Communication Networks with Permanent or Semi-Permanent Split Routings

P54x relays, using timing information from the GPS system, are suitable for use on switched communication signaling channels for the differential protection. For correct operation of this protection element, it is essential that the integrity of this link is continuously checked. It is not, however, a requirement that 'go' (tp1) and 'return' (tp2) times are similar if the GPS synchronization feature is used.

2.1.8 Optical Fiber to Electrical Interface Units

To connect the P54x relays via a Pulse Code Modulation (PCM) multiplexer network or digital communication channel, Type P-2M-L type interface units are required. The following interface units are available:

- P-2M-L interface to multiplexing equipment supporting ITU-T (formerly CCITT) recommendation G.703 co-directional electrical interface

The data rate for each unit can be 56 kbit/sec or 64 kbit/sec as required for the data communications link.

P-2M-L is required per relay data channel (i.e. for each transmit and receive signal pair). It provides optical-to-electrical and electrical-to-optical signal conversion between the P54x relay and the multiplexer. The interface unit should be located as close to the PCM multiplexer as possible, to minimize any effects on the data of electromagnetic noise or interference.

The P-2M-L units are housed in a 1U, 19" case.

Fibre optic connections to the unit are made through BFOC/2.5 type connectors, more commonly known as 'ST' connectors.

The optical characteristics are similar to the P54x 850 nm multi-mode fibre optic interface (refer to optical budgets in the Application Notes chapter).

2.1.9 Multiplexer Link with G.703 Electrical Interface Using Auxiliary Optical Fibers and Type P-2M-L Interface

A P54x relay with 850 nm short haul optical interface is connected to a P-2M-L unit by 850 nm multi-mode optical fiber. Multi-mode fibre type 50/125 μm or 62.5/125 μm is suitable. BFOC/2.5 type fibre optic connectors are used. The P-2M-L unit converts the data between optical fibre and ITU-T compatible G.703 co-directional electrical interface. The G.703 output must be connected to an ITU-T compatible G.703 co-directional channel on the multiplexer.

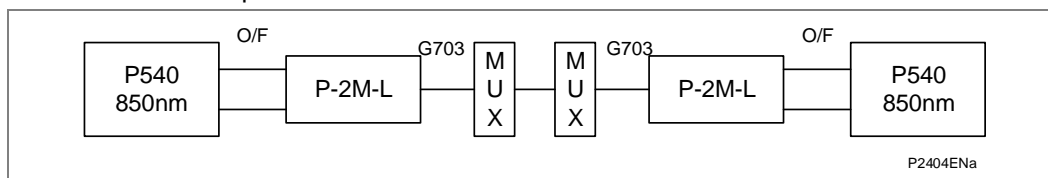

Figure 88 - P54x connection to P-2M-L

The P-2M-L unit supports the ITU-T Recommendation G.703 co-directional interface. The G.703 signals are isolated by pulse transformers to 1 kV.

Since the G.703 signals are only of ± 1 V magnitude, the cable connecting the P-2M-L unit and the multiplexer must be properly screened against electromagnetic noise and interference. The interface cable should consist of twisted pairs of 24 AWG, overall shielded, and have a characteristic impedance of about 120 Ω . It is generally recommended that the interface cable shield should be connected to the multiplexer frame ground only. The choice of grounding depends however on local codes and practices.

Electrical connections to the P-2M-L unit are made via a standard 28-way Midos connector. Please refer to Installation chapter for the external connection diagram.

The P54x must be set with Clock Source as 'External', refer to the *Clock Source* section.

2.1.10 Multiplexer Link with G.703 Electrical Interface Using P-2M-L interface

The P-2M-L Optical/Electrical Interface Unit is designed for teleprotection equipment (such as the P54x). It converts the optical signal from teleprotection equipment to an electrical signal (compliant with ITU-T G.703 2048Kbit/s). The converters can be connected to a telecommunications network to extend the communication distance of the teleprotection equipment.

Further info, please refer to P-2M-L user manual P2ML_EN_M_B11

2.1.11 Protection Communications Connection over Unconditioned Pilot Wires

It is possible to deploy P54x on certain circuits where unconditioned 2-wire or 4-wire pilots are available for communication. To achieve this requires a combination of P-2M-L series optical fibre to electrical interface units together with third-party baseband modems. The application will be restricted by the length and quality of the pilots, with maximum pilot lengths restricted to less than 20 km.

When considering applying a scheme based on P54x and P-2M-L in conjunction with baseband modems, the impact of the modem retrain time on the application needs to be understood before making the decision. Unconditioned 2-wire and 4-wire pilots are generally routed in proximity to the electrical power transmission and distribution feeders that they are helping to protect. As such, they are partial to electro-magnetic interference during switching or fault conditions on the power system. The induced interference on the pilots can cause disruption of the communications signals, and if this is sufficient to cause the synchronization of the communications to be lost, then the modems will have to re-synchronize, or retrain.

<i>Note</i>	<i>If communications breaks of up to 10 seconds during switching or fault conditions on the power system cannot be tolerated by the P54x application, a decision to implement a scheme using pilot wire circuits should be reviewed.</i>
-------------	--

2.1.12 Unconditioned 2 Wire Pilot Communications for Distances Greater than 1.2 km

When communicating via a pair of unconditioned pilots for distances greater than 1.2 km, a leased line or baseband modem can be used. For maximum security and performance it is strongly recommended that a screened twisted pair of 0.5 mm (or greater) conductors are used. When choosing between leased line or baseband modems the following aspects should be considered:

- Leased line modems have a maximum transmission speed of 19.2 kbit/sec., whereas baseband modems can transmit at 64 kbit/sec.
- Baseband modems have longer re-training times, typically between 10 to 60 s. If the connection between is temporarily lost, the protection communications will be interrupted until the re-training period has elapsed.
- Since baseband modems use synchronous communication protocols, there is typically a 20% performance gain over leased line modems that use asynchronous protocols.

2.1.13 Protection Communications Scheme Set-Up

The Scheme Set-up setting selects the connection between the system ends. A two ended system may have a single communication channel between the ends (2 Terminal option) or two independent communication channels to achieve dual redundancy (Dual Redundant option). A three ended system is selected by the option 3 Terminal.

2.1.14 Dual Redundant (“Hot Standby”)

If one of the channels has failed, the communication between the relays can still be maintained by the other healthy channel.

The dual redundant model provides redundancy for communication channels by transmitting and receiving messages over both channels. Each channel is monitored continuously by the relay. The messages from both channels are used to perform the relay functions. If only one channel is available, the messages from this healthy channel are used to perform the relay functions.

The messages are transmitted over the 2 channels alternately. Every message received is validated and processed, so that both channels are continuously monitored.

2.1.15

Three Ended System

In the event of a failure of a communication link between two line ends, the correct differential protection will be maintained as long as one relay (master relay) continues to communicate successfully with the other two relays (slave relays). In this degraded mode, the differential protection is performed by the master relay which can intertrip the slaves in the event of a fault being detected.

2.1.16

Protection Communications Address

The protection communication messages include an address field to ensure correct scheme connection.

There are twenty one options for groups of addresses. Each group is applied to one protection system, two ended or three ended, so there are two or three addresses within a group respectively.

All the address patterns are chosen to provide optimum noise immunity against bit corruption. There is no preference as to which address group is better than the other.

The groups of addresses available when 2 Terminal or Dual Redundant scheme is selected are as follows:

Address	Relay A	Relay B	Address	Relay A	Relay B
Universal Address	0-0	0-0			
Address Group 1	1-A	1-B	Address Group 11	11-A	11-B
Address Group 2	2-A	2-B	Address Group 12	12-A	12-B
Address Group 3	3-A	3-B	Address Group 13	13-A	13-B
Address Group 4	4-A	4-B	Address Group 14	14-A	14-B
Address Group 5	5-A	5-B	Address Group 15	15-A	15-B
Address Group 6	6-A	6-B	Address Group 16	16-A	16-B
Address Group 7	7-A	7-B	Address Group 17	17-A	17-B
Address Group 8	8-A	8-B	Address Group 18	18-A	18-B
Address Group 9	9-A	9-B	Address Group 19	19-A	19-B
Address Group 10	10-A	10-B	Address Group 20	20-A	20-B

Table 11 - Address groups for two different relays

For two relays to communicate with one another, their addresses have to be in the same address group. One relay should be assigned with address A and the other with address B. For example, if the group 1 address is used, the one relay should be given the address 1-A, and the other relay should be given the address 1-B.

The relay with address 1-A will only accept messages with the 1-A address and will send out messages carrying address 1-B. The relay assigned with address 1-B will only accept messages with address 1-B and will send out messages carrying address 1-A.

The groups of addresses available when 3 Terminal scheme is selected are as follows:

Address	Relay A	Relay B	Relay C	Address	Relay A	Relay B	Relay C
Address Group 1	1-A	1-B	1-C	Address Group 11	11-A	11-B	11-C
Address Group 2	2-A	2-B	2-C	Address Group 12	12-A	12-B	12-C
Address Group 3	3-A	3-B	3-C	Address Group 13	13-A	13-B	13-C
Address Group 4	4-A	4-B	4-C	Address Group 14	14-A	14-B	14-C
Address Group 5	5-A	5-B	5-C	Address Group 15	15-A	15-B	15-C
Address Group 6	6-A	6-B	6-C	Address Group 16	16-A	16-B	16-C
Address Group 7	7-A	7-B	7-C	Address Group 17	17-A	17-B	17-C
Address Group 8	8-A	8-B	8-C	Address Group 18	18-A	18-B	18-C
Address Group 9	9-A	9-B	9-C	Address Group 19	19-A	19-B	19-C
Address Group 10	10-A	10-B	10-C	Address Group 20	20-A	20-B	20-C

Table 12 - Address groups for three different relays

For three relays to work together as a protection system, their addresses must be in the same group and they should be assigned separately with addresses A, B and C. They must also have a fixed connection configuration, as shown in the *3-terminal system connection* diagram, in which channel 1 of one relay is connected to channel 2 of another relay.

For example, if the group 1 address is used, addresses 1-A, 1-B and 1-C should be assigned to relays A, B and C respectively. Relay A will only accept messages with address 1-A and will send messages carrying addresses 1-B and 1-C to channel 1 and channel 2 respectively. Relay B will only accept messages with address 1-B and will send messages carrying addresses 1-C and 1-A to channel 1 and to channel 2 respectively. Similarly relay C will only accept messages with address 1-C and will send messages carrying addresses 1-A and 1-B to channel 1 and to channel 2 respectively.

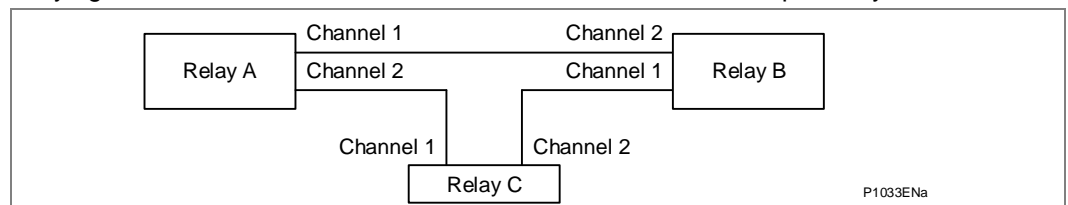

Figure 89 - 3-terminal system connection

2.1.17

Reconfiguration of Three-Ended System

This function only applies to relays which are set-up for 3 Terminal operation. The operation depends on the status of the communication channels, the relays in the scheme and various time periods. There are two general areas of operation, these being the change in configuration by a user and that generated by an energization of a relay. The various considerations applying to each of these cases are given below.

Four settings are provided as follows:

- Three Ended
- Two Ended Local and Remote 1 (L & R1)
- Two Ended Local and Remote 2 (L & R2)
- Two Ended Remote 1 and Remote 2 (R1 & R2)

Remote 1 and Remote 2 relate to protection signaling channel 1 and 2 respectively.

The operation of the reconfiguration is described in these sections:

- User Reconfiguration
- Energization Reconfiguration

2.1.18

User Reconfiguration

This covers the normal set-up of the relays into a 2-ended or 3-ended scheme depending on the state of the protected line and the relays. The facilities provided allow the user to initially use two relays to protect a two ended line and later to upgrade the scheme to three ended using a further relay. It also allows one end of a three ended scheme to be isolated and the other two ends to operate as a two ended scheme. This allows tests to be performed on the end that has been isolated and also allows for that relay to be removed altogether.

The change in configuration is enabled by two external interlocks and by the current state of the relay and its communications. If the scheme is changed from 3-ended to 2-ended, it is considered to be a reconfigure command. If the scheme is changed from 2-ended to 3-ended, it is considered to be a restore command. The checks performed for a reconfiguration are slightly different to those for a restore.

The operation of the change configuration logic is as follows:

1. The configuration setting is changed
2. The relay detects the change in setting and attempts to implement the new setting
3. If the relay configuration is 2-ended and the new setting is also 2-ended then the relay will block the change and issue a configuration error alarm

If the relay configuration is 2-ended and the new setting is 3-ended the relay will check that all the communications are healthy and send out the restore command to the other relays. It will then check that the scheme has stabilized at 3-ended after one second.

If any of the communications in the scheme were failed or if the scheme has not stabilized at 3-ended then the relay will return to its original 2-ended setting and issue a configuration error alarm.

If the scheme did stabilize at 3-ended then the Re-configuration setting will be updated.

If the relay configuration is 3-ended and the new setting is 2-ended L & R1 the relay will first check that the two interlock opto-inputs, Inhibit Diff and Interlock" are energized (note that the Inhibit Diff opto-input will inhibit the differential tripping, but the backup protection can still operate the trip outputs). These inputs are allocated to opto-inputs L3 and L4 in the default programmable scheme logic. The relay then checks that the communication with Remote 1 relay is healthy and sends out the command to the remote relays. It will then check that the scheme has stabilized at 2-ended L & R1 after one second.

If the interlocks are not energized or the communication with Remote 1 relay has failed or the scheme does not stabilize at 2-ended L & R1 then the relay will return to 3-ended and will issue a configuration error alarm.

If the scheme did stabilize at 2-ended L & R1 the Re-configuration setting will be updated.

If the relay configuration is 3-ended and the new setting is 2-ended L & R2 then the relay reacts similarly to a 2-ended L & R1 reconfiguration.

If the relay configuration is 3-ended and the new setting is 2-ended R1 & R2 then the relay reacts similarly to a 2-ended L & R1 reconfiguration.

2.1.19

Energization Reconfiguration

This type of configuration occurs when a relay is energized and the relay attempts to go into a configuration compatible with the other relays in the scheme. As far as possible the scheme will go to that which the user set up. There are, however, certain conditions which may prevent this from occurring.

The configuration that the relay takes up at power on is governed by these factors:

1. The scheme currently configured on the remote relays
2. The status of the communication links
3. The configuration stored in non-volatile memory before power down

Upon energization of a relay, the following events occur:

1. The relay checks whether any messages are arriving. If so then the configuration command in the first messages to arrive will be used as the relay configuration. This is subject to certain conditions. If the relay has a choice of 2-ended and 3-ended, it will assume the 2-ended scheme unless both incoming commands are 3-ended. If all three relays are 3-ended then they will remain so.
2. If no messages arrive from either end then after one second the relay will change to the configuration that was last selected, i.e. the configuration before power down. Once messages begin to arrive again, the relay will check them for validity against the current scheme. If one relay is 3-ended and the other is 2-ended then the configuration will change to 2-ended. If both are 3-ended or the same 2-ended scheme then that will become the configuration. If two relays have different 2-ended configurations then they are unable to determine which one to use and will each generate a configuration error alarm and each relay will remain in its current configuration. This condition can be cleared by restoring the relays or by removing the supply to the relay with the incorrect configuration.
3. If all the relays in a scheme are energized simultaneously then the configuration will revert to 3-ended if all the communication channels are healthy. This occurs because all the relays are waiting to be told their configuration and all default to 3-ended. This is a very unlikely event in normal use.
4. In cases where a communication channel has only half failed i.e. the receive channel has failed but not the transmit channel, then there may be configuration errors on power up due to the fact that the relays are not communicating correctly. If the status is available via the third relay and healthy communications via its two channels then the scheme will stabilize correctly.

2.2

InterMiCOM

Eight digital signals from local relay to the remote relay can be sent by using Programmable InterMiCOM⁶⁴ (IM⁶⁴) teleprotection available in MiCOM P54x/P841. This teleprotection uses the protection communication channel described in the *Communications Link Options* section.

In this scheme the signaling channel is used to convey simple ON/OFF data (from a local protection device) thereby providing some additional information to a remote device which can be used to accelerate in-zone fault clearance and/or prevent out-of-zone tripping.

2.2.1

Protection Signaling

To achieve fast fault clearance and correct discrimination for faults anywhere in a high voltage power network, it is necessary to signal between the points at which protection relays are connected. The following two distinct types of protection signaling can be identified.

Unit protection schemes:

In these schemes the signaling channel is used to convey analog data representative of the power system between relays. Typically current magnitude and/or phase information is communicated between line ends to enable a unit protection scheme to be implemented. These unit protection schemes are not covered by InterMiCOM or InterMiCOM⁶⁴. Instead, the MiCOM P44y, P52x, P54x and P841 range of current differential and phase comparison relays are available for unit applications.

Teleprotection - channel aided schemes

In channel-aided schemes the signaling channel is used to convey simple ON/OFF commands from a local protection device to a remote device to provide some additional information to be used in the protection scheme operation. The commands can be used to accelerate in-zone fault clearance or to prevent out-of-zone tripping, or both.

The InterMiCOM application is an effective replacement to the traditional hardwired logic and communication schemes used by protection relays for such teleprotection signaling. The MiCOM Px4x series products have a grouping of internal digital signals known as the digital data bus, DDB, that are used to implement the protection scheme logic. A number of these DDB signals are reserved as inputs and outputs for the InterMiCOM application. These are mapped using the Programmable Scheme Logic (PSL) support tool. The InterMiCOM application provides a means of transferring the status of these mapped DDB signals between the protection relays using dedicated full-duplex communications channels.

2.2.2

InterMiCOM Variants

There are two different types of integrated InterMiCOM teleprotection available in the MiCOM relays:

- An optical fiber implementation, InterMiCOM⁶⁴ - designed, primarily, to work over fiber optic and multiplexed digital communications channels with data rates of 56/64kbit/s. A total of 16 InterMiCOM⁶⁴ commands (16 inputs and 16 outputs) are available in the P443/P445/P446/P54x. These are arranged as two groups of 8 bits each, and are referred to as Channel 1 and Channel 2. Three InterMiCOM⁶⁴ scheme arrangements are possible:
 - Two-terminal with a single communications link
 - Two-terminal with a dual redundant communications link (sometimes referred to as 'hot standby')
 - Three terminal (or triangulated) scheme

- An electrical implementation of InterMiCOM, realised over an EIA(RS)232 medium typically for MODEM applications and referred to as MODEM InterMiCOM for ease of differentiation with InterMiCOM⁶⁴. MODEM InterMiCOM supports two-terminal applications with a single communications channel. Eight MODEM InterMiCOM commands can be transmitted between the line ends.

Provided the correct hardware options have been specified, it is possible to configure the P443/P445/P446/P54x to operate using either InterMiCOM⁶⁴ or MODEM InterMiCOM, or both. The selection is made under the CONFIGURATION column of the menu software.

2.2.3

InterMiCOM Features

The different requirements of applications that use teleprotection signaling for direct acting, permissive, or blocking schemes are all catered for by InterMiCOM. Communications are supervised and alarms and signal defaults can be defined to give controlled actions in the event of communications signals being distorted or unavailable. Communications statistics and loopback features are available to help with commissioning and testing purposes.

Both, InterMiCOM⁶⁴ and MODEM InterMiCOM teleprotection provide the ideal means to configure the schemes in the MiCOM relay. The selection between the two will generally depend on communications media availability, system configuration, distances, cost issues and utility practice.

2.2.4

Definition of Teleprotection Commands

Three generic types of teleprotection command can be defined. These are Intertripping, Permissive signaling, and Blocking. All teleprotection signals are initiated in a transmitting relay but, according to the application, the receiving relay may condition the signal according to the scheme requirements:

The decision to send a command is made by a local protective relay operation, and three generic types of InterMiCOM signal are available:

Intertripping In intertripping (direct or transfer tripping applications), the command is not supervised at the receiving end by any protection relay and simply causes CB operation. Since no checking of the received signal by another protection device is performed, it is absolutely essential that any noise on the signaling channel isn't seen as being a valid signal. In other words, an intertripping channel must be very secure.

Permissive In permissive applications, tripping is only permitted when the command coincides with a protection operation at the receiving end. Since this applies a second, independent check before tripping, the signaling channel for permissive schemes do not have to be as secure as for intertripping channels.

Blocking In blocking applications, tripping is only permitted when no signal is received but a protection operation has occurred. In other words, when a command is transmitted, the receiving end device is blocked from operating even if a protection operation occurs. Since the signal is used to prevent tripping, it is imperative that a signal is received whenever possible and as quickly as possible. In other words, a blocking channel must be fast and dependable.

The requirements for the three channel types are shown in the *Pictorial comparison of operating modes* diagram. This diagram shows that a blocking signal should be fast and dependable; a direct intertrip signal should be very secure and a permissive signal is an intermediate compromise of speed, security and dependability. In MODEM applications, all three modes can be applied to selected signaling bits within each message.

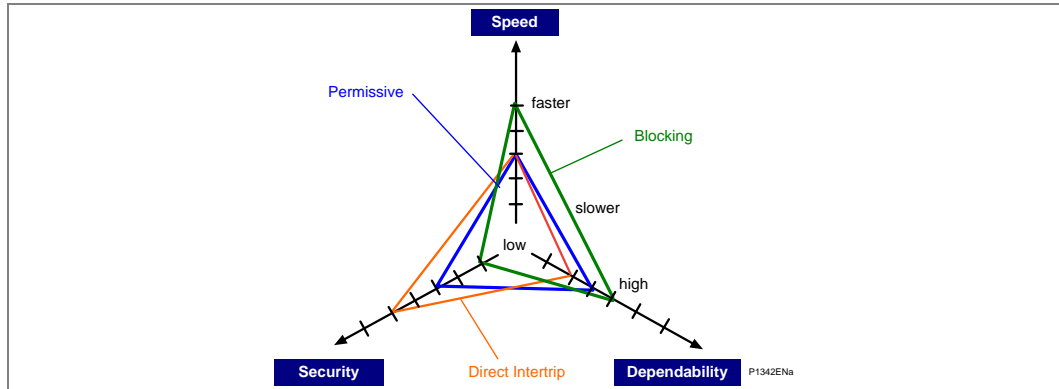

Figure 90 - Pictorial comparison of operating modes

In MODEM InterMiCOM applications, selected signaling bits within each message can be conditioned to provide optimal characteristics for each of the three teleprotection command types.

In InterMiCOM⁶⁴ applications, the framing and error checking of a single command message is sufficient to meet the security of a permissive application, while the speed is sufficiently fast to meet the needs of a blocking scheme. Accordingly in InterMiCOM⁶⁴ applications, there is no differentiation between blocking commands or permissive commands, so that only signals being used for direct intertripping with higher security requirements need to be differentiated from those in permissive (or blocking) schemes.

2.2.5

General Features & Implementation

InterMiCOM⁶⁴ provides a direct fibre output from the relay's co-processor board that can be connected either directly to the protection at the opposite end(s) or through a MUX device as describe in the *Communications Link Options* section.

InterMiCOM⁶⁴ can work:

- With Differential protection (in this case differential protection is enabled) or
- Standalone (in this case differential protection is disabled and InterMiCOM⁶⁴ is enabled)

The number of available teleprotection commands is 8. In Dual redundant schemes 8 commands per channel are transmitted to and received from the remote end. In 3 ended configurations, 8 commands are transmitted bidirectional between each and every pair of relays. Unique relay addressing is available to prevent any spurious operation should a multiplexer inadvertently fall out of step and misroute messages.

2.2.6

Functional Assignment

The settings to control the mode of the intertrip signals are made using the relay's menu software. In addition to this, it is necessary to assign InterMiCOM input and output signals in the relay Programmable Scheme Logic (PSL) editor. Two icons are provided on the PSL editor of MiCOM S1 (S1 Studio) for Integral tripping In and Integral tripping out which can be used to assign the eight intertripping commands. The example shown below in the *Example assignment of signals within the PSL* diagram shows a Control Input_1 connected to the Intertrip O/P1 signal which would then be transmitted to the remote end. At the remote end, the Intertrip I/P1 signal would then be assigned within the PSL. In this example, we can see that when intertrip signal 1 is received from the remote relay, the local end relay would operate an output contact, R1.

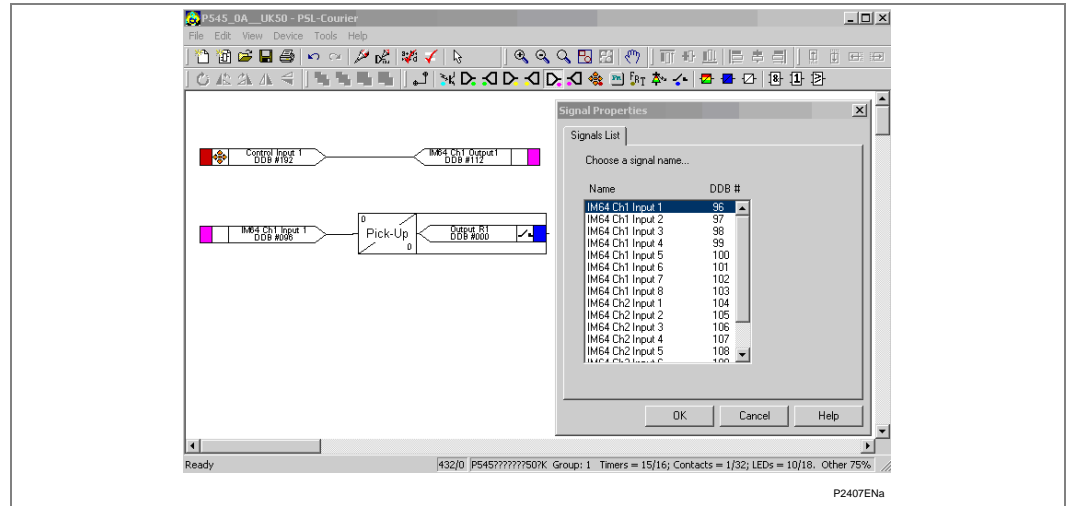

Figure 91 - Example assignment of signals within the PSL

Note When an InterMiCOM signal is sent from the local relay, only the remote end relay will react to this command. The local end relay will only react to InterMiCOM commands initiated at the remote end and received locally, and vice-versa. InterMiCOM can, therefore, be described as a duplex teleprotection system.

2.3 MODEM InterMiCOM, EIA(RS)232 InterMiCOM or Copper InterMiCOM

2.3.1 Communications Media

InterMiCOM can transfer up to eight commands over one communication channel. Due to recent expansions in communication networks, most signaling channels are now digital schemes using multiplexed fiber optics. For this reason, InterMiCOM provides a standard EIA(RS)232 output using digital signaling techniques. This digital signal can be converted using suitable devices to any communications media as required. The EIA(RS)232 output may alternatively be connected to a MODEM link.

Regardless of whether analogue or digital systems are being used, all the requirements of teleprotection commands are governed by an international standard IEC60834-1:1999 and InterMiCOM is compliant with the essential requirements of this standard. This standard governs the speed requirements of the commands as well as the probability of unwanted commands being received (security) and the probability of missing commands (dependability).

2.3.2 General Features and Implementation

InterMiCOM provides eight commands over a single communications link, with the mode of operation of each command being individually selectable within the **IM# Cmd Type** cell. **Blocking** mode provides the fastest signaling speed (available on commands 1 - 4), **Direct Intertrip** mode provides the most secure signaling (available on commands 1 - 8) and **Permissive** mode provides the most dependable signaling (available on commands 5 - 8). Each command can also be disabled so that it has no effect in the logic of the relay.

Since many applications will involve the commands being sent over a multiplexed communications channel, it is necessary to ensure that only data from the correct relay is used. Both relays in the scheme must be programmed with a unique pair of addresses that correspond with each other in the **Source Address** and **Receive Address** cells. For example, at the local end relay if we set the **Source Address** to 1, the **Receive Address** at the remote end relay must also be set to 1. Similarly, if the remote end relay has a **Source Address** set to 2, the **Receive Address** at the local end must also be set to 2. All four addresses must not be set identical in any given relay scheme if the possibility of incorrect signaling is to be avoided.

In particular, the two pairs of addresses should be set to be different in any scheme to avoid the possibility of incorrect operation during inadvertent loopback connections, and any schemes sharing the same communications services should be set to have different address pairs in order to avoid any problems caused by inadvertent cross-channel connections.

Noise in the communications channel should not be interpreted as valid messages by the relay. For this reason, InterMiCOM uses a combination of unique pair addressing described above, basic signal format checking and for **Direct Intertrip** commands an 8-bit Cyclic Redundancy Check (CRC) is also performed. This CRC calculation is performed at both the sending and receiving end relay for each message and then compared to maximize the security of the **Direct Intertrip** commands.

An alarm is provided if noise on the communications channel becomes excessive.

During periods of excessive noise, it is possible that the synchronization of the message structure will be lost and accurate decoding of the messages may not be possible.

Predictable operation of InterMiCOM is assured during such noisy periods by means of the **IM# FallBackMode** cell. The status of the last received valid command can be maintained until a new valid message is received by setting the **IM# FallBackMode** cell to **Latched**. Alternatively, a known fallback state can be assigned to the command by setting the **IM# FallBackMode** cell to **Default**. In this latter case, the time period between communication disruption and the default state being restored will need to be set in the **IM# FrameSynTim** cell and the default value will need to be set in **IM# DefaultValue** cell. Upon subsequent receipt of a valid message, all the timer periods will be reset and the new valid command states will be used.

If there is a total communications failure, the relay will use the fallback (failsafe) strategy as described above. Total failure of the channel is considered when no message data is received for four power system cycles or if there is a loss of the DCD line.

2.3.3

EIA(RS)232 Physical Connections

InterMiCOM on the Px40 relays is implemented using a 9-pin 'D' type female connector (labeled SK5) located at the bottom of the 2nd Rear communication board. This connector on the Px40 relay is wired in DTE (Data Terminating Equipment) mode, as shown in the *EIA(RS)232 Physical Connections* table:

Pin	Acronym	InterMiCOM Usage
1	DCD	"Data Carrier Detect" is only used when connecting to modems otherwise this should be tied high by connecting to terminal 4.
2	RxD	"Receive Data"
3	TxD	"Transmit Data"
4	DTR	"Data Terminal Ready" is permanently tied high by the hardware since InterMiCOM requires a permanently open communication channel.
5	GND	"Signal Ground"
6	Not used	-
7	RTS	"Ready To Send" is permanently tied high by the hardware since InterMiCOM requires a permanently open communication channel.
8	Not used	-
9	Not used	-

Table 13 - Pins, Acronyms and InterMiCOM Usage

Depending upon whether a direct or modem connection between the two relays in the scheme is being used, the required pin connections are described below.

2.3.4

Direct Connection

The EIA(RS)232 protocol only allows for short transmission distances due to the signalling levels used and therefore the connection shown below is limited to less than 15m. However, this may be extended by introducing suitable EIA(RS)232 to fiber optic convertors, such as the CILI 204. Depending upon the type of convertor and fiber used, direct communication over a few kilometres can easily be achieved.

This type of connection should also be used when connecting to multiplexers that have no ability to control the DCD line.

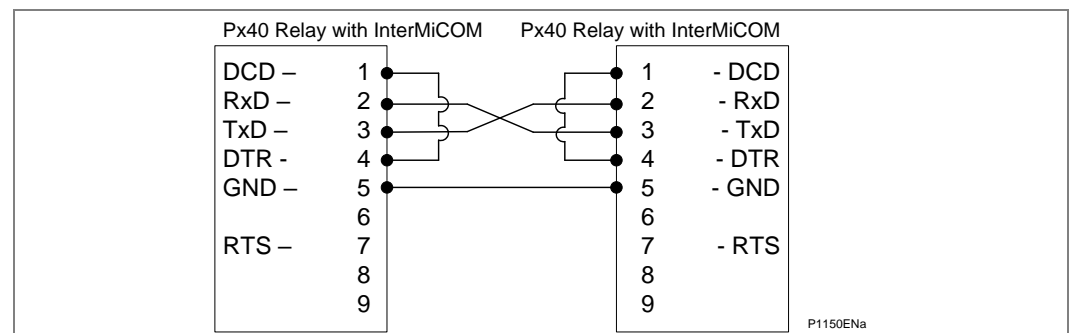

Figure 92 - Direct connection within the local substation

2.3.5 EIA(RS)232 Modem Connection

For long distance communication, modems may be used in which the case the following connections should be made.

This type of connection should also be used when connecting to multiplexers that have the ability to control the DCD line. With this type of connection it should be noted that the maximum distance between the Px40 relay and the modem should be 15m, and that a baud rate suitable for the communications path used should be selected.

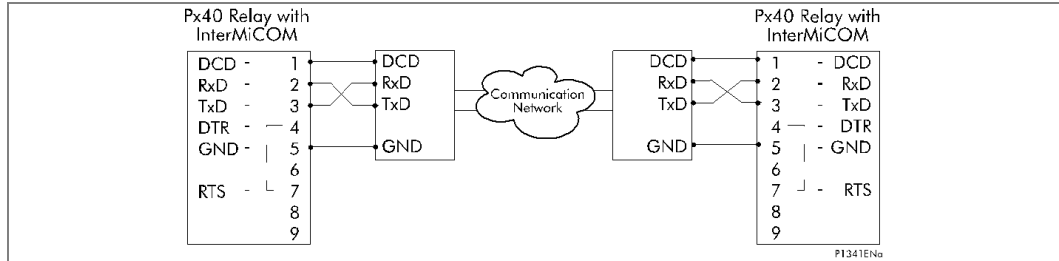

Figure 93 - InterMiCOM teleprotection via a MODEM link

2.3.6 RS422 Connection

RS232 to RS422 converter such as Schneider Electric CK212 may also be used for a longer distance application; it can be formed as shown in the InterMiCOM teleprotection via a RS422 protocol diagram:

With this type of connection, the maximum distance between the Px40 relay and the converter should be 15m.

Up to 1.2km length can be achieved with this type of protocol, depending on the converter performance.

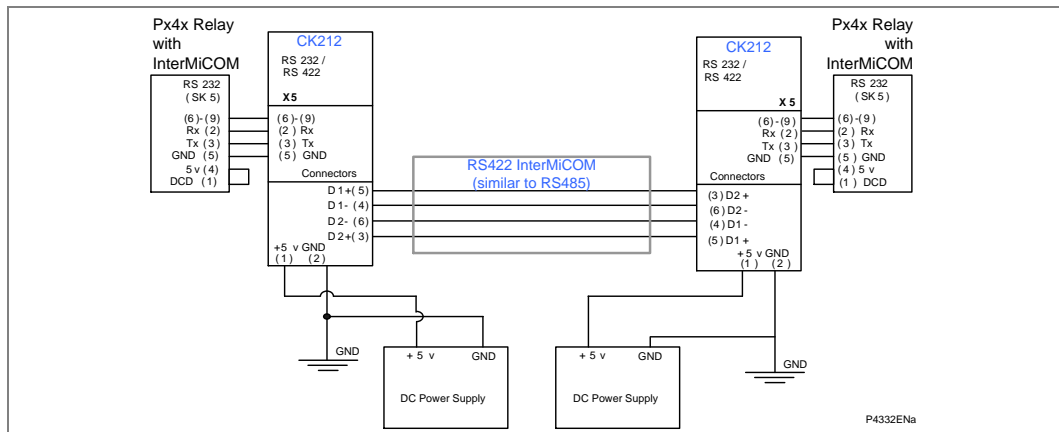

Figure 94 - MODEM InterMiCOM teleprotection via a RS422 protocol

2.3.7 Fiber Optic Connection

For long distance communication, a fiber optic converter may be used connected as shown in the InterMiCOM teleprotection via fiber optic diagram.

With this type of connection, the maximum distance between the Px40 relay and the converter should be 15m.

The length that can be achieved is depending on the converter performance.

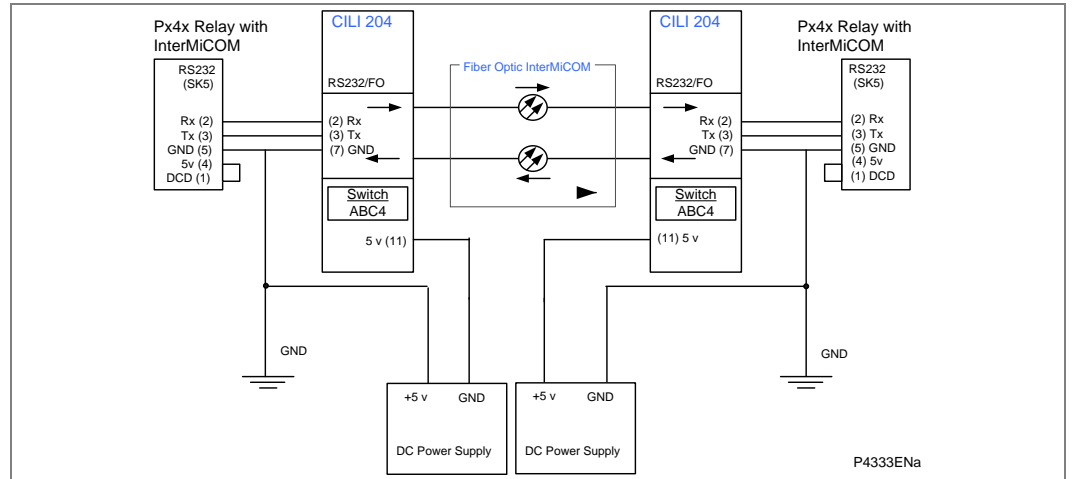

Figure 95 - MODEM InterMiCOM teleprotection via fiber optic

2.3.8

InterMiCOM Functional Assignment

Even though settings are made on the relay to control the mode of the intertrip signals, it is necessary to assign InterMiCOM input and output signals in the relay Programmable Scheme Logic (PSL) if InterMiCOM is to be successfully implemented. Two icons are provided on the PSL editor of MiCOM S1 for “Integral tripping In” and “Integral tripping out” which can be used to assign the eight intertripping commands. The example shown in the *Example assignment of signals within the PSL* diagram shows a “Control Input_1” connected to the “Intertrip O/P1” signal which would then be transmitted to the remote end. At the remote end, the “Intertrip I/P1” signal could then be assigned within the PSL. In this example, we can see that when intertrip signal 1 is received from the remote relay, the local end relay would operate an output contact, R1.

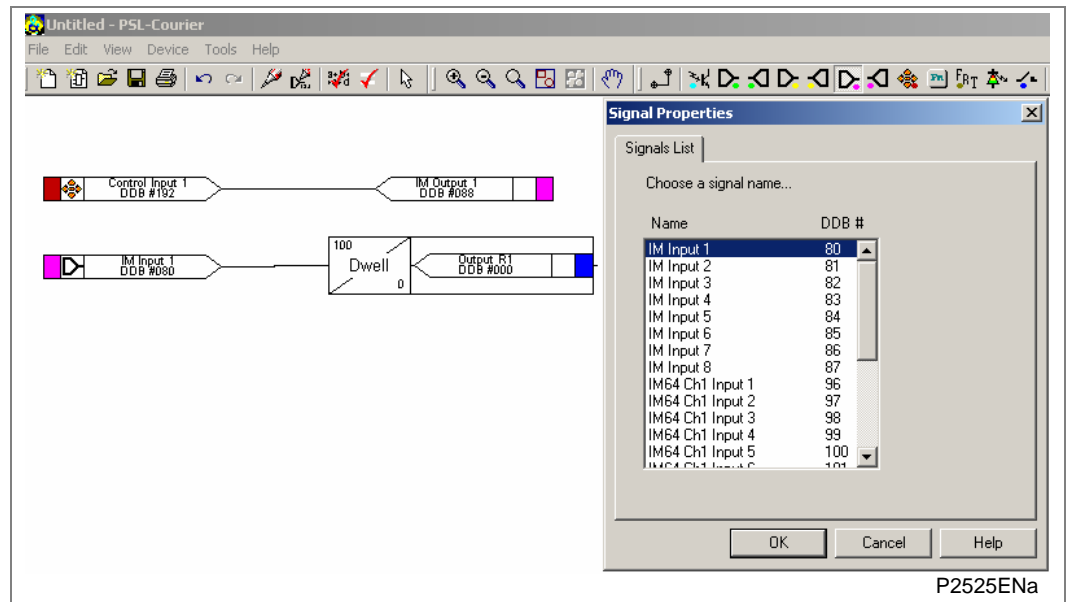

Figure 96 - Example assignment of signals within the PSL

It should be noted that when an InterMiCOM signal is sent from the local relay, only the remote end relay will react to this command. The local end relay will only react to InterMiCOM commands initiated at the remote end. InterMiCOM is thus suitable for teleprotection schemes requiring Duplex signaling.

2.4 InterMiCOM64 Statistics & Diagnostics

It is possible to hide the channel diagnostics and statistics from view by setting the “**Ch Statistics**” and/or “**Ch Diagnostics**” cells to “**Invisible**”. All channel statistics are reset when the relay is powered up, or by user selection using the “**Reset Statistics**” cell.

2.4.1 InterMiCOM64 Scheme Setup - Application

InterMiCOM64 can be applied to either 2 or 3 ended configurations. By simply mapping the Tx and Rx signals using the Programmable Scheme Logic (PSL). For mapping of the InterMiCOM64 commands in the PSL please refer to the *Functional Assignment* section. For security reasons, two MiCOM P54x relays may be connected in a Dual Redundant scheme, in which case both channels will be in use. This scheme is also known as a ‘Hot Standby’ scheme but it should be noted that Channel 1 has no priority over Channel 2 - the data that arrives first will be stored in the buffer and used in the PSL, whilst the same data received via the slower channel will simply be discarded.

The InterMiCOM64 connection for a 3-ended application is shown below.

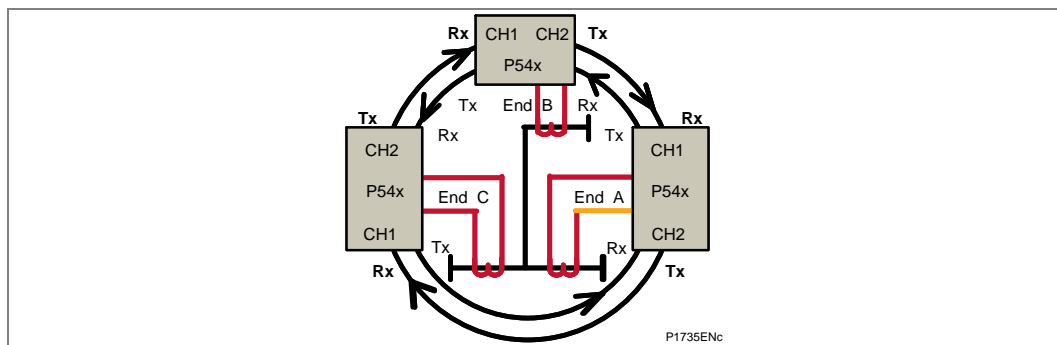

Figure 97 - Triangulated InterMiCOM64 application

If InterMiCOM64 is working as standalone feature (i.e. Differential protection is disabled and InterMiCOM64 is enabled), a pass-through feature allows the scheme to remain in service in case of one channel outage. It should be noted that in the case when one leg of the communication triangle fails, i.e. channel A-C becomes unavailable, the InterMiCOM64 will continue to provide the full teleprotection scheme between all 3 ends. In this new ‘Chain’ topology, relays A and C will receive and transmit teleprotection commands via relay B, which means that the original ‘Triangle’ topology is not necessary. The retransmitting done by relay B (A-B-C and C-B-A) provides the self-healing for the lost links A-C and C-A).

Some users may apply Chain topology also as a means to save cost (two legs may be cheaper to install than full triangulation).

2.4.1.1 Teleprotection Communications Address

The protection communication messages include an address field to ensure correct scheme connection. There are twenty one options for groups of addresses. The description of them is exactly the same as per differential protection addresses described in the *Protection Communications Address* section.

2.4.1.2 IMx Fallback Mode

In case the received message is corrupted due to ether channel failure or lost synchronization, the user can pre-define the status of each command individually as Latched or Default. The new status will take effect after the ‘Channel Timeout’ user settable time has elapsed. The “Default” mode allows a failsafe logic status to be applied.

2.4.1.3 InterMiCOM64 and Differential Communications

The Differential function can be globally enabled or disabled using the CONFIGURATION /Phase Diff/ Enabled-Disabled setting.

If the Differential function is enabled, communication messages between the relays will have the complete differential format including currents and additional bias. In addition, the GROUP X/PHASE DIFF/Enabled-Disabled setting will be displayed allowing the differential functionality to be enabled or disabled on a per group basis.

If the Differential function is disabled in Configuration column, a CONFIGURATION/InterMiCOM⁶⁴/Enabled-Disabled setting will be displayed. The InterMiCOM⁶⁴ function could be enabled and the communication messages between the relays will have a different format compared with those of the differential function. The message format will include digital signals only and will be shorter and faster.

If differential protection in group is disabled, the InterMiCOM⁶⁴ function can work with the differential message format or with an inherent stand-alone format where only digital signals are transmitted. The stand-alone message format has a pass through feature and is slightly faster than using the InterMiCOM⁶⁴ function with the differential message format.

2.4.2

Permissive Intertrip

The P54x relays include a facility to send a permissive intertrip command over the protection communication channel, as shown below.

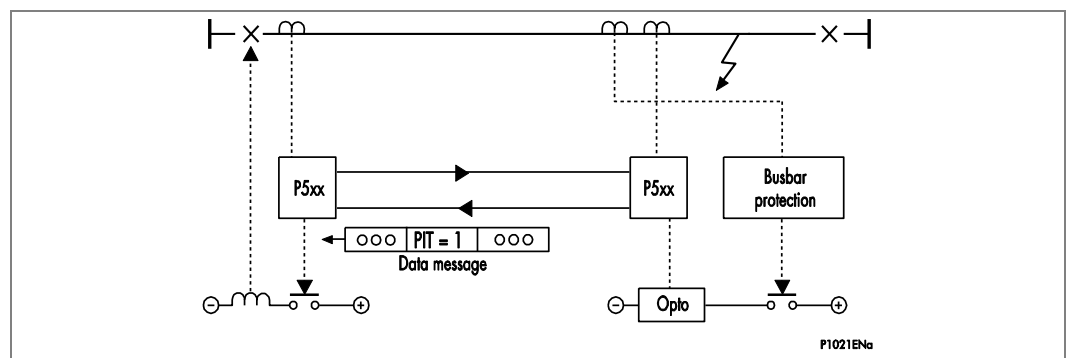

Figure 98 - Permissive intertrip

An opto input can be assigned for this purpose. When the associated opto input is energized at END B, the PIT flag is set in the communication message. Upon receipt of this message, the relay at END A initiates the PIT timer which times out and trips the circuit breaker, providing that the Remote or Local current (according to setting PIT I selection/ Remote or Local) remains above its basic current threshold setting (Is1), times out, the relay closes it's three-phase differential trip contacts. The remote relay provides indication of the permissive intertrip.

The permissive intertrip timer is settable between 0 and 200 ms. This time should be set to provide discrimination with other protection. For example, in the *Permissive intertrip* diagram, the time delay should be set to allow the busbar protection to clear the fault in the event of a genuine busbar fault. A typical setting may be 100 - 150 ms.

2.4.3

Clock Source

A clock source is required to synchronize data transmissions between the system ends. This may be provided either by the P54x relays (internal) or may be a function of the telecommunications equipment (external). The P54x relays have a setting for each of Channel 1 and Channel 2 to set the Clock Source to either "Internal" or "External" according to the communications system configuration.

This setting is not applicable if IEEE C37.94 mode selected.

2.4.4 Communication Alarm

A communication alarm is raised by the relay if the message error rate exceeds the setting value under PROT COMMS/IM64/ Alarm Level (default = 25%) and persists over a defined period of time (refer to the *Switched Communication Networks* section). This is equivalent to a Bit Error Rate (BER) of 1.5×10^{-3} .

A communication alarm is also raised if the received message indicates failure of the signaling channel at the remote end.

2.4.5 Communication Error Statistics

To aid the bit error evaluation of the communication link, communication error statistics are kept by the relay. These give the number of Errored messages detected, the number of Lost Messages, and the number of Valid Messages received for each of the two channels. The number of errored messages detected complies with ITU-T G8.21 and is as follows:

Number of errored seconds	Number of seconds containing 1 or more errored or lost messages
Number of severely errored seconds	Number of seconds containing 31 or more errored or lost messages
Number of degraded minutes	Number of minutes containing 2 or more errored or lost messages

<p><i>Note</i> <i>Any severely errored seconds are ignored when working out the minute intervals</i></p>

The number of lost messages recorded is intended as an indicator for noises under normal communication conditions and not for recording long communication breaks. The lost message count is accumulated by incrementing a counter when a message is rejected by the Error code check, message length check and the sequential time tag check.

The error statistics are automatically cleared on power-up. They can also be cleared using the Clear Statistics setting in Measurements column of the menu.

2.4.6 Communications Delay Timer

The communications delay timer is the maximum difference in the measured channel propagation delay time between consecutive messages that the relay will tolerate before switching the settings, as described in the *Switched Communication Networks* section.

This setting is factory set to 350 μ s. It should be increased to a suitable value if the propagation delay time is expected to vary considerably such as in the case of a microwave link with multiple repeaters.

2.4.7 Communications Fail Timer

The communication fail timer is the time during which communication errors must be continuously detected before the channel is declared failed. This governs the implementation of the communication alarm and the 'Protection Scheme Inoperative' alarm. The setting is normally set to the maximum of 10 seconds so that the two alarms will not be affected by short bursts of noises or interruptions. The communication fail time setting however may be set to a lower value of say 200 or 300 ms if the alarm contacts are to be used for enabling standby protection, or to signal a change-over to reserve communication facilities should the communication link become noisy or fail completely.

2.4.8 Communications Fail Mode

The Communications Fail Mode is used to select the channel(s) responsible for raising the communication alarm when configured for dual redundant communications. Three options are available: 'Ch 1 Failure', 'Ch 2 Failure', 'Ch1 or Ch 2 Fail' and 'Ch1 and Ch 2 Fail'. If 'Ch 1 Failure' is selected, the communication alarm will only be raised if channel 1 has failed. If 'Ch 2 Failure' is selected, the communication alarm will only be raised if channel 2 has failed. If 'Ch 1 or Ch 2 Fail' is selected, the communication alarm will be raised if either channel has failed.

2.4.9 Global Positioning System (GPS) Synchronizing Module

MiCOM P54x Current Differential relays can use a satellite-derived one pulse per second synchronizing signal via a GPS Module.

The minimum requirements for the GPS synchronization device is:

GPS receiver:

- Relative to actual GPS time when in over-determined clock mode and synchronized to GPS: ± 50 ns

1 PPS Fiber Optic Output:

- Wavelength: 850 nm
- Fiber: multi-mode glass fiber 50/125 μ m or 62.5/125 μ m
- Maximum absolute error (between the actual GPS time and the rising edge of the 1 PPS signal): ± 50 ns
- The pulse width: 200 ms ± 1 ms
- The rise and fall time of the 1 PPS signal: less than 20 ns between 10 % and 90 % amplitude points
- The maximum jitter of the 1 PPS signal: ± 100 ns
- Maximum error between two units both synchronized to GPS: $< \pm 200$ ns with cable delay compensation applied

Relay output:

- minimum 1
- recommended 4
- to transmit the following alarms:
 - 'Device NOT Healthy'
 - 'GPS NOT Healthy'
 - 'Not Synchronized'
 - 'Test Mode On'
 - 'Antenna Fail'

LEDs:

- minimum 4
- recommended 8
- to show the following indications:
 - 'Device HEALTHY' (recommended green LED)
 - 'GPS HEALTHY' (recommended green LED)
 - This LED is to be illuminated if the GPS Receiver Module is functioning correctly (even if the GPS antenna is not connected).
 - 'SYNC' (recommended green LED)
 - This LED is to be illuminated when the device is being synchronized from the incoming GPS signal.
 - '1 PPS' LED (recommended green LED)
 - This LED flashes once per second.

- 'TEST' LED (recommended red or orange LED)
 - This alarm LED flashes once per second when one or more fiber outputs is in commissioning mode.
- 'ANTENNA FAIL' (recommended red LED)
 - This alarm LED is to be illuminated to indicate that there is a problem with the antenna.
- 'WRONG POSITION' (recommended red LED)
 - This alarm LED is to be illuminated when the stored position of the antenna does not match with the GPS receiver derived position.
 - This alarm LED is also to be illuminated when the GPS receiver hardware sets its alarm bit to indicate an incorrect position is detected.
- 'DEFAULT' (recommended red LED)
 - This alarm LED is to be illuminated when the P594 is using default settings.

Depending on the GPS synchronization device chosen according to the above requirements, a separate GPS device manual is required. Please consult operation engineer for more details of GPS synchronization device.

3 OPERATION OF NON-PROTECTION FUNCTIONS

The protection functionality of the P543, P544, P545, and P546 are very similar, and a common operational description can be applied. For the non-protection functions, some of the functionality is the same and, similarly, a common operational description can be applied. The principal difference between different models is that:

- The P543 and P545 can control only a **single** circuit breaker
- The P544 and P546 can control **two** circuit breakers

For this reason, the circuit breaker monitoring and control software differs between the P543/P545 and the P544/P546, and a common operational description cannot be applied.

This section describes the operation of the non-protection functions common to all models and that are not associated with circuit breaker monitoring and control.

Separate sections are assigned to describe the P543/P545 operational control of a single circuit breaker, and the P544/P546 operational control of dual circuit breakers.

3.1 Voltage Transformer Supervision - Fuse Fail

The Voltage Transformer Supervision (VTS) feature is used to detect failure of the ac voltage inputs to the relay. This may be caused by internal voltage transformer faults, overloading, or faults on the interconnecting wiring to relays. This usually results in one or more VT fuses blowing. Following a failure of the ac voltage input there would be a misrepresentation of the phase voltages on the power system, as measured by the relay, which may result in maloperation.

The VTS logic in the relay is designed to detect the voltage failure, and automatically adjust the configuration of protection elements whose stability would otherwise be compromised. A time-delayed alarm output is also available.

A setting VTs Connected Yes/No (Voltage transformers connected to the relay) under CT AND VT RATIOS will:

- When set to yes this setting will have no effect.
- When set to No it causes the VTS logic to set the VTS Slow Block and VTS Fast Block DDBs, but not raise any alarms. It will also override the VTS enabled setting should the user set it. The effect of this is to stop the pole dead logic working incorrectly with the presence of no voltage and no current but not the CB open part of the logic and also block the distance, under voltage and other voltage dependant functions.

VTS can be declared by a Miniature Circuit Breaker (MCB) status input, by an internal logic using relay measurement or both. A setting VTS Mode (Measured + MCB /Measured Only/MCB Only) is available to select the method to declare VT failure.

For the measured method, there are three main aspects to consider regarding the failure of the VT supply. These are defined below:

- Loss of one or two-phase voltages
- Loss of all three-phase voltages under load conditions
- Absence of three-phase voltages upon line energization

3.1.1 Loss of One or Two-Phase Voltages

If one or two phase voltages drop below the fixed 10V level detectors a VTS will be initiated. In addition, the VTS feature within the relay operates on detection of Negative Phase Sequence (NPS) voltage without the presence of NPS current. This gives operation for the loss of one or two phase voltages. Stability of the VTS function is assured during system fault conditions, by the presence of NPS current. The use of negative sequence quantities ensures correct operation even where three-limb or 'V' connected (open delta) VTs are used.

Negative Sequence VTS Element:

The negative sequence thresholds used by the element are $V2 = 10 \text{ V}$ and $I2 = 0.05$ to 0.5 In settable (defaulted to 0.05 In).

3.1.2 Loss of all Three Phase Voltages Under Load Conditions

Under the loss of all three phase voltages to the relay, there will be no negative phase sequence quantities present to operate the VTS function. However, under such circumstances, a collapse of the three phase voltages will occur. If this is detected without a corresponding change in any of the phase current signals (which would be indicative of a fault), a VTS condition will be raised. In practice, the relay detects the presence of superimposed current signals, which are changes in the current applied to the relay. These signals are generated by comparison of the present value of the current with that exactly one cycle previously. Under normal load conditions, the value of superimposed current should therefore be zero. Under a fault condition a superimposed current signal will be generated which will prevent operation of the VTS.

The phase voltage level detectors are fixed and will drop off at 10 V and pickup at 30 V.

The sensitivity of the superimposed current elements is fixed at 0.1 In.

3.1.3 Absence of Three Phase Voltages Upon Line Energization

If a VT were inadvertently left isolated prior to line energization, incorrect operation of voltage dependent elements could result. The previous VTS element detected 3-phase VT failure by absence of all 3-phase voltages with no corresponding change in current. On line energization there will, however, be a change in current (as a result of load or line charging current for example). An alternative method of detecting 3-phase VT failure is therefore required on-line energization.

The absence of voltage measurements on all three phases with line energized can result of two conditions:

- A 3-phase VT failure
- A close up 3-phase fault

The first condition would require blocking of the voltage dependent function and the second would require tripping.

To differentiate between these two conditions, an overcurrent level detector ("VTS $I_{max} > I_{nh}$ ") will prevent a VTS block from being issued if it operates. This element should be set in excess of any non-fault based currents on line energization (load, line charging current, transformer inrush current if applicable), but below the level of current produced by a close up three phase fault. If the line is now closed where a 3-phase VT failure is present, the overcurrent detector will not operate and a VTS block will be applied. Closing onto a 3-phase fault will result in operation of the overcurrent detector and prevent a VTS block being applied.

This logic will only be enabled during a live line condition (as indicated by the relays pole dead logic) to prevent operation under dead system conditions, where no voltage will be present and the **VTS I> Inhibit** overcurrent element will not be picked up.

<i>Note</i>	<i>VTS I> Inhibit logic is equally applicable for the situation where loss of all three-phase voltages occurs under load conditions (refer the Loss of all Three Phase Voltages Under Load Conditions section). If the setting of VTS I> Inhibit is less than the load current and if three-phase VT fails during normal load, VTS block will not be applied. Hence it is important that the VTS I> Inhibit is always set above the expected load current.</i>
-------------	--

3.1.4

VTS Logic

The relay may respond as follows, on operation of any VTS element:

- VTS set to provide alarm indication only;
- Optional blocking of voltage dependent protection elements;
- Optional conversion of directional overcurrent elements to non-directional protection (available when set to Blocking mode only). These settings are found in the Function Links cell of the relevant protection element columns in the menu.

The VTS I> Inhibit or VTS I2> Inhibit elements are used to override a VTS block in event of a fault occurring on the system which could trigger the VTS logic. Once the VTS block has been established, however, then it would be undesirable for subsequent system faults to override the block. The VTS block will therefore be latched after a user settable time delay 'VTS Time Delay'. Once the signal has latched then two methods of resetting are available. The first is manually via the front panel interface (or remote communications) provided the VTS condition has been removed and secondly, when in 'Auto' mode, by the restoration of the 3-phase voltages above the phase level detector settings mentioned previously.

A VTS indication will be given after the VTS Time Delay has expired. In the case where the VTS is set to indicate only the relay may potentially maloperate, depending on which protection elements are enabled. In this case the VTS indication will be given prior to the VTS time delay expiring if a trip signal is given.

The VTS can be inhibited by connecting a signal to the "Inhibit VTS" input in the PSL. When using single pole tripping this should be active during pole open conditions when a line VT is used to prevent VTS operation on reclose preventing distance operation.

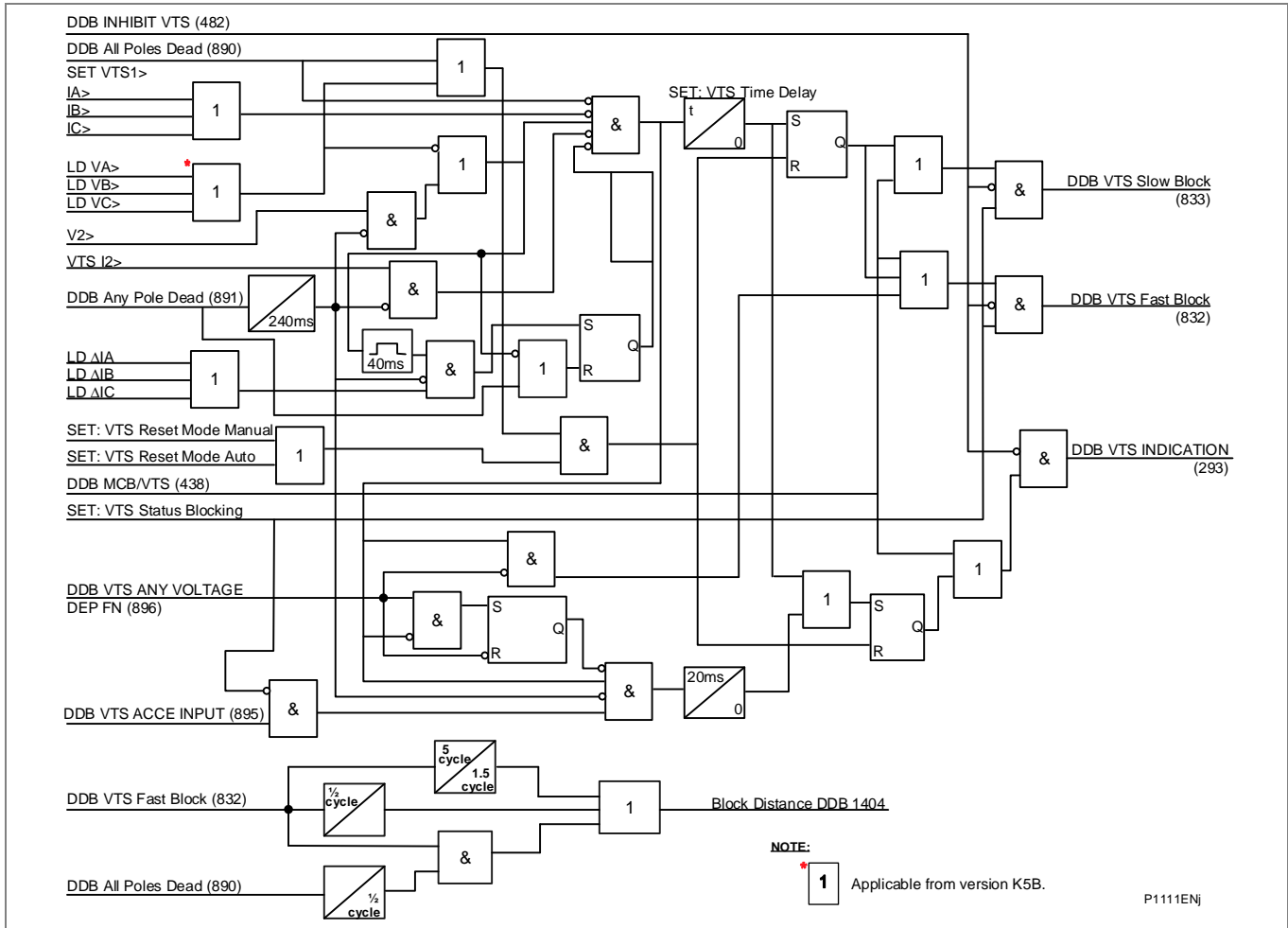

Figure 101 - VTS logic

This scheme is also able to correctly operate under very low load or even no load conditions, by the combination of time delayed signals derived from the DDB signals **VTS Fast block** and **All Poles Dead**, to generate the **Block Distance DDB**.

Note All non-distance elements are blocked by the "VTS Fast Block" DDB.

Where a Miniature Circuit Breaker (MCB) is used to protect the voltage transformer ac output circuits, it is common to use MCB auxiliary contacts to indicate a three-phase output disconnection. As previously described, it is possible for the VTS logic to operate correctly without this input. However, this facility has been provided for compatibility with various utilities current practices. Energizing an opto-isolated input assigned to **DDB: MCB/VTS** on the relay will therefore provide the necessary block.

3.2 Current Transformer Supervision (CTS)

The Current Transformer Supervision (CTS) feature is used to detect failure of one or more of the ac phase current inputs to the relay. Failure of a phase CT or an open circuit of the interconnecting wiring can result in incorrect operation of any current operated element. Additionally, interruption in the ac current circuits risks dangerous CT secondary voltages being generated.

MiCOM P54x has two methods to achieve CTS feature:

- The first method called differential (I diff) method uses the ratio between positive and negative sequence currents to determine CT failure. Is non voltage dependant and relies on channel communications to declare a CTS condition.
- The second method called standard method relies on local measurements of zero sequence currents and voltages to declare CTS. The user should select what method to use according to the application.

Both methods could be applied in parallel. The setting options per each setting group are: CTS Disabled/ Idiff CTS/ Standard CTS/ (Idiff+Standard). It should be noted that the 'CTS Status' (Restrained/Indication), 'CTS Reset Mode' (Manual/Auto) and 'CTS Time Delay' are common for both algorithms.

3.2.1 Differential CTS (no need of Local Voltage Measurements to Declare CTS)

Differential CT supervision scheme is based upon measurement of the ratio of I2 to I1 at all line ends. When this ratio is small (theoretically zero), one of four conditions is present:

- The system is unloaded - both I2 and I1 are zero
- The system is loaded but balanced - I2 is zero
- The system has a three-phase fault present - I2 is zero
- There is a genuine 3-phase CT problem - unlikely, would probably develop from a single or two phase condition

If the ratio is non-zero, we can assume one of two conditions are present:

- The system has an asymmetric fault - both I2 and I1 are non-zero
- There is a 1 or 2 phase CT problem - both I2 and I1 are non-zero

Any measurement at a single end doesn't provide any more information than this, but if the ratio is calculated at all ends and compared, the MiCOM P54x assumes:

- If the ratio is non-zero at more than two ends, it is almost certainly a genuine fault condition and so the CT supervision is prevented from operating.
- If the ratio is non-zero at one end, there is a chance of either a CT problem or a single-end fed fault condition.

A second criteria looks to see whether the differential system is loaded or not. For this purpose MiCOM P54x looks at the positive sequence current I1. If load current is detected at one-end only, MiCOM P54x assumes that this is an internal fault condition and prevents CTS operation, but if load current is detected at two or more ends, CTS operation is permitted.

There are two modes of operation, Indication and Restrained. In Indication mode, a CTS alarm is raised but no effect on tripping. In Restrained mode, the differential protection is blocked during 20 ms after CT failure detection and then the setting for the Current Differential is raised to above load current. The CTS covers 2 sets of CTs in P544 and P546 as well as one set of CTs on P543 and P545.

In order to achieve correct operation of the scheme, it is necessary that differential CTS is enabled at each end of the protected zone.

Differential current transformer supervision (Differential CTS) in P543 - P546 models suffix K are only compatible with P543 - P546 models suffix K.

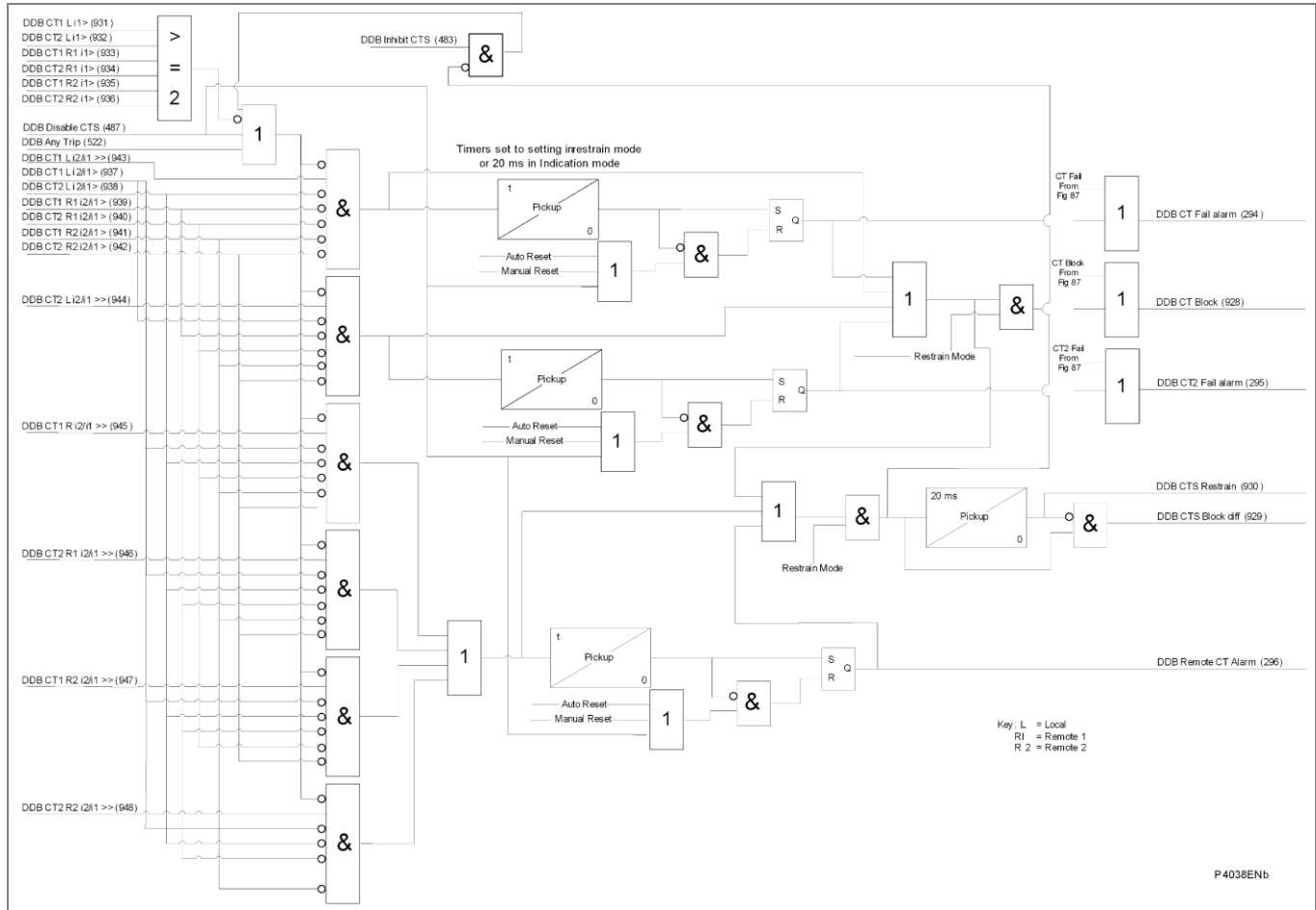

Figure 102 - Differential CTS

3.2.2

Standard CTS (Voltage Dependant CTS no need of Communications to Declare CTS)

The standard CT Supervision (CTS) feature operates on detection of derived zero sequence current, in the absence of a corresponding derived zero sequence voltage that would normally accompany it. The voltage transformer connection used must be able to refer zero sequence voltages from the primary to the secondary side. Therefore, this element should only be enabled where the VT is of five limb construction, or comprises three single-phase units, and has the primary star point earthed.

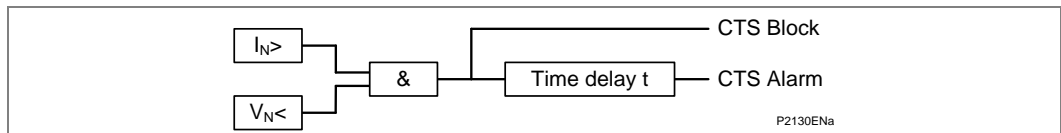

Figure 103 - Voltage dependant CTS principle scheme

Operation of the element will produce a time-delayed alarm visible on the LCD, an event record and a DDB 294: CT Fail Alarm, with an instantaneous block (DDB 928: CTS Block) for inhibition of protection elements see the above *Voltage dependant CTS principle scheme* diagram.

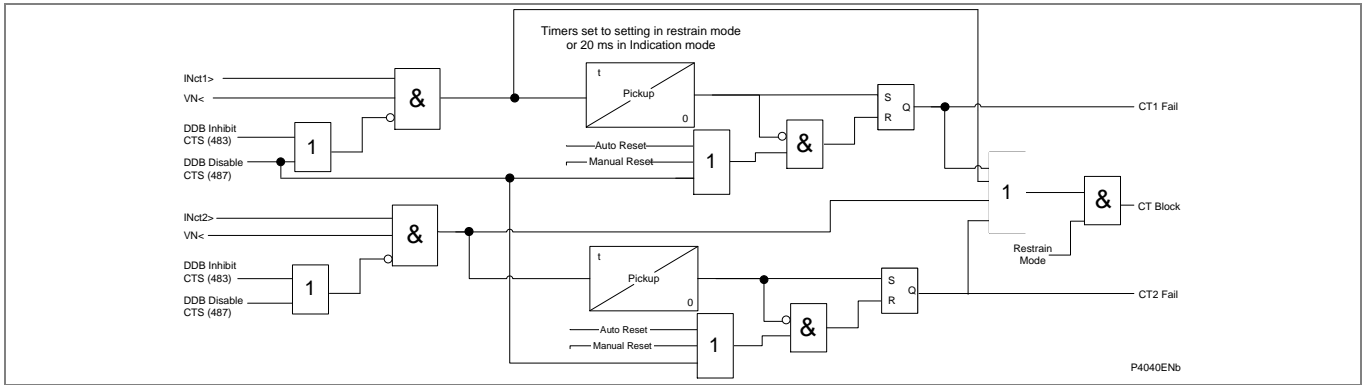

Figure 104 - Standard CTS

3.2.3

CTS Blocking

The standard and differential methods will always block protection elements operating from derived quantities: Broken Conductor, Earth Fault and Neg Seq O/C. The differential method will also restrain the differential protection. Other protection functions such as DEF can be selectively blocked by customizing the PSL, gating DDB 928: CTS Block (originated by either method) or DDB 929 CTS Block Diff with the protection function logic.

3.3**Transformer Magnetizing Inrush Detector**

In the *Transformer Magnetizing Inrush (P443/P543/P545)* and the *High set differential setting* section it is described how inrush is taken into account by the differential protection. As this inrush restrain technique is only valid for differential protection, there is a need of a separate inrush detector in order to prevent operation of other functions if needed.

The MiCOM P443/P445/P54x distance protection has been designed as a fast protection relay. It is therefore not desirable that distance zones should be slowed by forcing them to wait for a detection/no detection of transformer inrush current (in general applications). For this reason, the relay has no second harmonic blocking of the distance elements in the standard protection algorithms.

However, should a user wish to employ, for example, a long Zone 1 reach through a transformer, it is possible to implement harmonic blocking for magnetizing inrush current. Provided that the Inrush Detection is **Enabled**, the user can then pick up the output of the I(2)/I(1) detectors in the Programmable Scheme Logic (PSL). The user can then assign blocking functions in the PSL as necessary, because as stated above this detector does not directly route into the relay's fixed logic.

3.4 Function Keys

The relay offers users 10 function keys for programming any operator control functionality via PSL. Each function key has an associated programmable tri-colour LED that can be programmed to give the desired indication on function key activation.

These function keys can be used to trigger any function that they are connected to as part of the PSL. The function key commands can be found in the 'Function Keys' menu (see the Settings chapter). In the 'Fn. Key Status' menu cell there is a 10-bit word which represent the 10 function key commands and their status can be read from this 10-bit word.

In the programmable scheme logic editor 10 function key signals, which can be set to a logic 1 or On state, as described above, are available to perform control functions defined by the user.

<i>Note</i> <i>The 10 function key signals use DDB 1096 - 1105.</i>

The "Function Keys" column has 'Fn. Key n Mode' cell which allows the user to configure the function key as either 'Toggled' or 'Normal'. In the 'Toggle' mode the function key DDB signal output will remain in the set state until a reset command is given, by activating the function key on the next key press. In the 'Normal' mode, the function key DDB signal will remain energized for as long as the function key is pressed and will then reset automatically.

A minimum pulse duration can be programmed for a function key by adding a minimum pulse timer to the function key DDB output signal.

The "Fn. Key n Status" cell is used to enable/unlock or disable the function key signals in PSL. The 'Lock' setting has been specifically provided to allow the locking of a function key thus preventing further activation of the key on consequent key presses. This allows function keys that are set to 'Toggled' mode and their DDB signal active 'high', to be locked in their active state thus preventing any further key presses from deactivating the associated function. Locking a function key that is set to the "Normal" mode causes the associated DDB signals to be permanently off. This safety feature prevents any inadvertent function key presses from activating or deactivating critical relay functions.

The "Fn. Key Labels" cell makes it possible to change the text associated with each individual function key. This text will be displayed when a function key is accessed in the function key menu, or it can be displayed in the PSL.

The status of the function keys is stored in battery backed memory. In the event that the auxiliary supply is interrupted the status of all the function keys will be recorded.

Following the restoration of the auxiliary supply the status of the function keys, prior to supply failure, will be reinstated. If the battery is missing or flat the function key DDB signals will set to logic 0 once the auxiliary supply is restored.

<i>Note</i> <i>The relay will only recognize a single function key press at a time and that a minimum key press duration of approximately 200msec. is required before the key press is recognized in PSL. This deglitching feature avoids accidental double presses.</i>
--

3.5

Setting Groups Selection

The setting groups can be changed either via opto inputs, via a menu selection, via the hotkey menu or via function keys. In the Configuration column if 'Setting Group - select via optos' is selected then any opto input or function key can be programmed in PSL to select the setting group as shown in the table below. If 'Setting Group - select via menu' is selected then in the Configuration column the 'Active Settings - Group1/2/3/4' can be used to select the setting group.

The setting group can be changed via the hotkey menu providing 'Setting Group select via menu' is chosen.

Two DDB signals are available in PSL for selecting a setting group via an opto input or function key selection. The following table illustrates the setting group that is active on activation of the relevant DDB signals.

DDB 542 SG select x1	DDB 543 SG select 1x	Selected setting group
0	0	1
1	0	2
0	1	3
1	1	4

Note *Each setting group has its own PSL. Once a PSL has been designed it can be sent to any one of 4 setting groups within the relay. When downloading a PSL to the relay the user will be prompted to enter the desired setting group to which it will be sent. This is also the case when extracting a PSL from the relay.*

Table 17 - Setting group active on relevant DDB signals

3.6 Control Inputs

As from Software Versions C1/D1/F1/G4/H4/J4, there are now 32 Standard Control Inputs and 16 additional Settable Control Inputs available. These are settable via the “CONTROL INPUTS” folder and are located after the standard “Control Input” labels in the relevant settings file.

The control inputs function as software switches that can be set or reset either locally or remotely. These inputs can be used to trigger any function that they are connected to as part of the PSL. There are three setting columns associated with the control inputs that are: “CONTROL INPUTS”, “CTRL. I/P CONFIG.” and “CTRL. I/P LABELS”. The function of these columns is described below:

Menu Text	Default Setting	Setting Range	Step Size
CONTROL INPUTS			
Ctrl I/P Status	00000000000000000000000000000000		
Control Input 1	No Operation	No Operation, Set, Reset	
Control Input 2 to 32	No Operation	No Operation, Set, Reset	

Table 18 - Control Inputs settings

The Control Input commands can be found in the **Control Input** menu. In the **Ctrl. I/P status** menu cell there is a 32-bit word which represent the 32 control input commands. The status of the 32 control inputs can be read from this 32-bit word. The 32 control inputs can also be set and reset from this cell by setting a 1 to set or 0 to reset a particular control input. Alternatively, each of the 32 Control Inputs can be set and reset using the individual menu setting cells **Control Input 1, 2, 3** etc. The Control Inputs are available through the relay menu as described above and also via the rear communications.

In the programmable scheme logic editor 32 Control Input signals which can be set to a logic 1 or On state, as described above, are available to perform control functions defined by the user.

In the PSL editor 32 Control Input signals, use DDB 191 – 223.

Menu Text	Default Setting	Setting Range	Step Size
CTRL. I/P CONFIG.			
Hotkey Enabled	11111111111111111111111111111111		
Control Input 1	Latched	Latched, Pulsed	
Ctrl Command 1	Set/Reset	Set/Reset, In/Out, Enabled/Disabled, On/Off	
Control Input 2 to 32	Latched	Latched, Pulsed	
Ctrl Command 2 to 32	Set/Reset	Set/Reset, In/Out, Enabled/Disabled, On/Off	

Table 19 - Ctrl I/P Config settings

Menu Text	Default Setting	Setting Range	Step Size
CTRL. I/P LABELS			
Control Input 1	Control Input 1	16 character text	
Control Input 2 to 32	Control Input 2 to 32	16 character text	

Table 20 - Ctrl I/P Labels settings

The **CTRL. I/P CONFIG.** column has several functions one of which allows the user to configure the control inputs as either **latched** or **pulsed**. A latched control input will remain in the set state until a reset command is given, either by the menu or the serial communications. A pulsed control input, however, will remain energized for 10ms after the set command is given and will then reset automatically (i.e. no reset command required).

In addition to the latched/pulsed option this column also allows the control inputs to be individually assigned to the **Hotkey** menu by setting **1** in the appropriate bit in the **Hotkey Enabled** cell. The hotkey menu allows the control inputs to be set, reset or pulsed without the need to enter the **CONTROL INPUTS** column. The **Ctrl. Command** cell also allows the SET/RESET text, displayed in the hotkey menu, to be changed to something more suitable for the application of an individual control input, such as **ON/OFF, IN/OUT** etc.

The **CTRL. I/P LABELS** column makes it possible to change the text associated with each individual control input. This text will be displayed when a control input is accessed by the hotkey menu, or it can be displayed in the PSL.

<i>Note</i>	<i>Apart from pulsed operation, the status of the control inputs is stored in battery backed memory. If the auxiliary supply is interrupted the status of all the inputs will be recorded. Following the restoration of the auxiliary supply the status of the control inputs, prior to supply failure, will be reinstated. If the battery is missing or flat the control inputs will set to logic 0 once the auxiliary supply is restored.</i>
-------------	---

3.7

Real Time Clock Synchronization via Opto-Inputs

In modern protective schemes it is often desirable to synchronize the relays real time clock so that events from different relays can be placed in chronological order. This can be done using the IRIG-B input, if fitted, or via the communication interface connected to the substation control system. In addition to these methods, the relay offers the facility to synchronize via an opto-input by routing it in PSL to DDB 400 (Time Sync.). Pulsing this input will result in the real time clock snapping to the nearest minute if the pulse input is ± 3 s of the relay clock time. If the real time clock is within 3 s of the pulse the relay clock will crawl (the clock will slow down or get faster over a short period) to the correct time. The recommended pulse duration is 20 ms to be repeated no more than once per minute. An example of the time sync function is shown below:

Time of "Sync. Pulse"	Corrected time
19:47:00 to 19:47:29	19:47:00 This assumes a time format of hh:mm:ss
19:47:30 to 19:47:59	19:48:00

Table 21 - Time of Sync Pulse and Corrected times

To avoid the event buffer from being filled with unnecessary time sync. events, it is possible to ignore any event that generated by the time sync. opto input. This can be done by applying the following settings:

Menu text	Value
RECORD CONTROL	
Opto Input Event	Enabled
Protection Event	Enabled
DDB 062 - 032 (Opto Inputs)	Set "Time Sync." associated opto to 0

Table 22 - Record Control settings

To improve the recognition time of the time sync. opto input by approximately 10 ms, the opto input filtering could be disabled. This is achieved by setting the appropriate bit to 0 in the **Opto Filter Cntl** cell in the **OPTO CONFIG** column.

Disabling the filtering may make the opto input more susceptible to induced noise. Fortunately the effects of induced noise can be minimized by using the methods described in the *Product Design* chapter.

3.8 Read Only Mode

With IEC 61850 and Ethernet / Internet communication capabilities, security has become a pressing issue. The Px40 relay provides a facility to allow the user to enable or disable the change in configuration remotely. This feature is available only in relays with Courier, Courier with IEC 60870-5-103, Courier with IEC 61850 and Courier with IEC 60870-5-103 and IEC 61850 protocol options. It has to be noted that in IEC 60870-5-103 protocol, Read Only Mode function is different from the existing Command block feature.

3.8.1 Protocol/Port Implementation:**3.8.1.1 IEC 60870-5-103 Protocol on Rear Port 1:**

The protocol does not support settings but the indications, measurands and disturbance records commands are available at the interface.

Allowed:

- Poll Class 1 (read spontaneous events)
- Poll Class 2 (read measurands)
- GI sequence (ASDU7 'Start GI', Poll Class 1)
- Transmission of Disturbance Records sequence (ASDU24, ASDU25, Poll Class 1)
- Time Synchronization (ASDU6)
- General Commands (ASDU20), namely:
 - INF23 activate characteristic 1
 - INF24 activate characteristic 2
 - INF25 activate characteristic 3
 - INF26 activate characteristic 4

Blocked:

- Write parameter (=change setting) (private ASDUs)
- General Commands (ASDU20), namely:
 - INF16 auto-recloser on/off
 - INF19 LED reset
 - Private INFs (e.g CB open/close, Control Inputs)

3.8.1.2 Courier Protocol on Rear Port 1/2 and Ethernet**Allowed:**

- Read settings, statuses, measurands
- Read records (event, fault, disturbance)
- Time Synchronization command
- Change active setting group command

(2) Courier Protocol**Blocked:**

- All setting changes
- Reset Indication (Trip LED) command
- Operate Control Input commands
- CB operation commands
- Auto-reclose operation commands
- Reset demands / thermal etc... command
- Clear event / fault / maintenance / disturbance record commands
- Test LEDs & contacts commands

3.8.1.3**IEC 61850****Allowed:**

- Read statuses, measurands
- Generate Reports
- Extract Disturbance Records
- Time Synchronization
- Change active setting group

Blocked:

All controls, including:

- Enable / Disable protection
- Operate Control Inputs
- CB operations (Close / Trip, Lock)
- Reset LEDs

3.8.2**Courier Database Support**

Three new settings, one for each remote communications port at the back of the relay are created to support the enabling and disabling of the read only mode at each port.

The **NIC Read Only** setting will apply to all the communications protocols (including the Tunnelled Courier) that are transmitted via the Ethernet Port. Their default values are 'Disabled'.

Depending on the product options, the Modbus and DNP3 communications interfaces that do not support the feature will ignore these settings.

3.8.3**New DDB Signals**

The remote read only mode is also available in the PSL via three dedicated DDB signals:

- RP1 Read Only
- RP2 Read Only
- NIC Read Only

Through careful scheme logic design, the activations of these read only signals can be facilitated via Opto Inputs, Control Inputs and Function Keys.

These DDBs are available in every build, however they are effective only in Courier, IEC 60870-5-103 build and in latest IEC 61850 (firmware version 42/57 onwards). Depending on the product options, the setting cells may not be available in Modbus and DNP3.0.

3.9 Fault Locator

The relay has an integral fault locator that uses information from the current and voltage inputs to provide a distance to fault location. The sampled data from the analog input circuits is written to a cyclic buffer until a fault condition is detected. The data in the input buffer is then held to allow the fault calculation to be made. When the fault calculation is complete the fault location information is available in the relay fault record.

When applied to parallel circuits mutual flux coupling can alter the impedance seen by the fault locator. The coupling will contain positive, negative and zero sequence components. In practice the positive and negative sequence coupling is insignificant. The effect on the fault locator of the zero sequence mutual coupling can be eliminated by using the mutual compensation feature provided.

3.9.1 Basic Theory for Ground Faults

A two-machine equivalent circuit of a faulted power system is shown below.

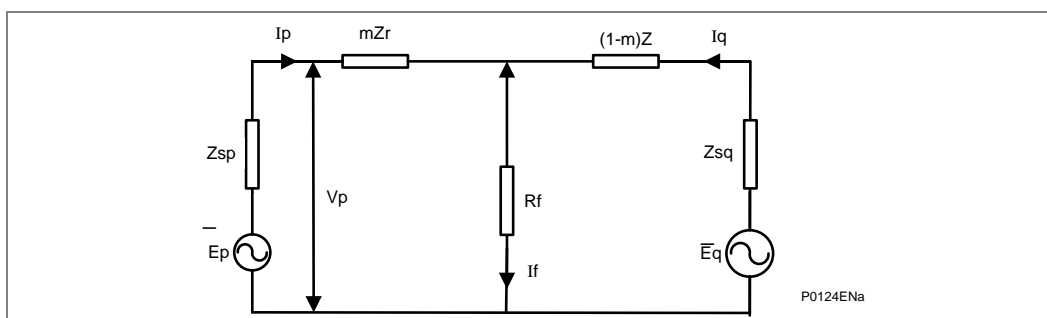

Figure 105 - Two-machine equivalent circuit

From this diagram, the fault location (m) can be found by estimating I_f and solving the following *Fault Location* equation.

Equation 2: Fault Location

$$V_p = mI_p Z_r + I_f R_f$$

3.9.2 Data Acquisition and Buffer Processing

The fault locator stores the sampled data within a 12 cycle cyclic buffer at a resolution of 48 samples per cycle. When the fault recorder is triggered the data in the buffer is frozen such that the buffer contains 6 cycles of pre-trigger data and 6 cycles of post-trigger data. Fault calculation commences shortly after this trigger point.

The trigger for the fault recorder is user selectable via the PSL.

The fault locator can store data for up to four faults. This ensures that fault location can be calculated for all shots on a typical multiple reclose sequence.

3.9.3 Faulted Phase Selection

Phase selection is derived from the current differential protection or the superimposed current phase selector.

Phase selection and fault location calculations can only be made if the current change exceeds 5% I_n .

3.9.4 Fault Location Calculation

This works by:

1. First obtaining the vectors
2. Selecting the faulted phase(s)
3. Estimating the phase of the fault current, I_f , for the faulted phase(s)
4. Solving the *Fault Location* equation for the fault location m at the instant of time where $I_f = 0$

3.9.5

Obtaining the Vectors

Different sets of vectors are chosen depending on the type of fault identified by the phase selection algorithm. The calculation using the *Fault Location* equation is applied for either a phase-to-ground fault or a phase-to-phase fault.

Thus for an A-phase to ground fault:

Equation 3: A-phase to ground fault

$$\begin{aligned} I_{pZr} &= I_a * Z_{Line} + I_n * Z_{Line} * k_{ZN} \\ \text{And} \\ V_p &= V_A \end{aligned}$$

For an A-phase to B-phase fault:

Equation 4: A-phase to B-phase fault

$$\begin{aligned} I_{pZr} &= I_a * Z_{Line} - I_b * Z_{Line} \\ \text{And} \\ V_p &= V_A - V_B \end{aligned}$$

For a Ground fault:

The calculation for a ground fault is modified when mutual compensation is used:

Equation 5: ground fault

$$I_{pZr} = I_a * Z_{Line} + I_n * Z_{Line} * k_{ZN} + I_m * Z_{Line} * k_{Zm}$$

3.9.6

Solving the Equation for the Fault Location

As the sine wave of I_f passes through zero, the instantaneous values of the sine waves V_p and I_{pZr} can be used to solve the *Fault Location* equation for the fault location m . (The term $I_f R_f$ being zero.)

This is determined by shifting the calculated vectors of V_p and I_{pZr} by the angle $(90^\circ - \text{angle of fault current } I_f)$ and then dividing the real component of V_p by the real component of I_{pZr} . See the *Fault locator selection of fault current zero* diagram below.

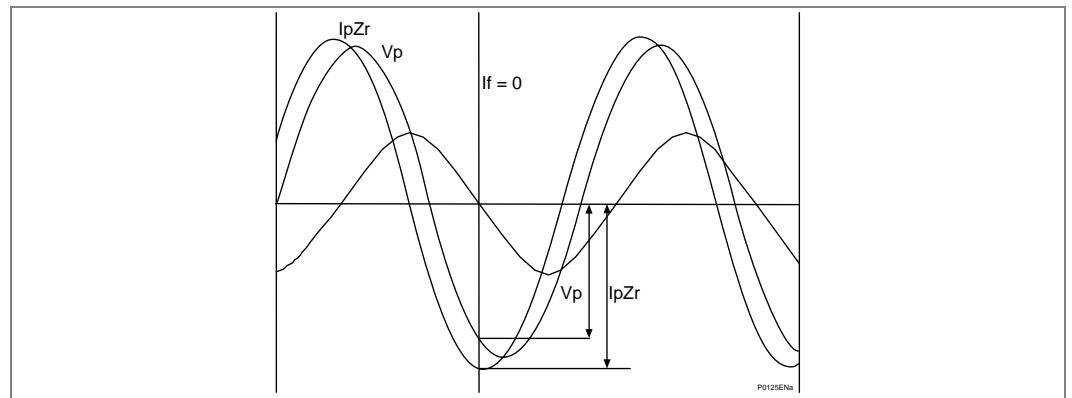

Figure 106 - Fault locator selection of fault current zero

i.e.:

Phase advanced vector V_p

$$\begin{aligned} V_p &= |V_p| (\cos(s) + j\sin(s)) * (\sin(d) + j\cos(d)) \\ V_p &= |V_p| [-\sin(s-d) + j\cos(s-d)] \end{aligned}$$

Phase advanced vector I_{pZr}

$$\begin{aligned} I_{pZr} &= |I_{pZr}| (\cos(e) + j\sin(e)) * (\sin(d) + j\cos(d)) \\ I_{pZr} &= |I_{pZr}| [-\sin(e-d) + j\cos(e-d)] \end{aligned}$$

Therefore from the *Fault Location* equation:

$$\begin{aligned} m &= V_p \div (I_p * Z_r) \text{ at } I_f = 0 \\ m &= V_p \sin(s-d) / (I_{pZr} * \sin(e-d)) \end{aligned}$$

Where:

- d = angle of fault current I_f
- s = angle of V_p
- e = angle of I_{pZr}

Hence, the relay evaluates m which is the fault location as a percentage of the fault locator line impedance setting and then calculates the output fault location by multiplying this by the line length setting. When calculated, the fault location can be found in the fault record under the "**VIEW RECORDS**" column in the Fault Location cells. Distance to fault is available in kilometers, miles, impedance or percentage of line length.

3.9.7

Mutual Compensation

Analysis of a ground fault on one circuit of a parallel over-head line shows that a fault locator positioned at one end of the faulty line will tend to over-reach while that at the other end will tend to under-reach. In cases of long lines with high mutual inductance, mutual zero sequence compensation can be used to improve the fault locator accuracy. The compensation is achieved by taking an input to the relay from the residual circuit of the current transformers in the parallel line.

The MiCOM P443/P54x/P841 provides mutual compensation for both the fault locator function, AND the distance protection zones.

4 SINGLE CB CONTROL: P543/P545 OPERATION

This section describes the P443/P543/P545 operational control of a single circuit breaker. The circuit breaker control and monitoring in the P443/P543/P545 provides single-phase or three-phase switching of a feeder controlled by a single circuit breaker.

4.1 Single and Three Phase Auto-Reclosing

4.1.1 Time Delayed and High Speed Auto-Reclosing

The MiCOM P443/P543/P545 will initiate auto-reclosure following any current differential, Zone 1, or distance-aided scheme trips which occur. In addition, the user can selectively decide to auto-reclose for trips from time-delayed distance zones, overcurrent and earth (ground) elements, and DEF aided schemes.

The auto-reclose function offers multi-shot auto-reclose control, selectable to perform up to a four shot cycle. Dead times (Note 1) for all shots (Note 2) are independently adjustable. Should the CB close successfully at the end of the dead time, a Reclaim Time starts. If the circuit breaker does not trip again, the auto-reclose function resets at the end of the reclaim time. If the protection trips again during the reclaim time the relay advances to the next shot in the programmed cycle, or, if all programmed reclose attempts have been made, goes to lockout.

<i>Note</i>	Dead Time denotes the open (dead) interval delay of the CB.
-------------	--

<i>Note 2</i>	A Shot is a reclosure attempt.
---------------	---------------------------------------

Logic diagrams to explain the operation of the auto-reclose feature are grouped together at the end of this section.

4.1.2 Auto-Reclose Logic Inputs (P543/P545)

The auto-reclose function uses inputs in the logic, which can be assigned and activated from any of the opto-isolated inputs on the relay via the Programmable Scheme Logic (PSL). Contacts from external equipment may be used to influence the auto-recloser via the optos, noting that the CB Status (open/closed) must also be available via auxiliary contact inputs to the relay.

These logic inputs can also be assigned and activated from other sources. The function of these inputs is described below, identified by their DDB signal text. The inputs can be selected to accept either a normally open or a normally closed contact, programmable via the PSL editor.

4.1.2.1 CB Healthy (P543/P545)

The majority of Circuit Breakers (CBs) are only capable of providing one trip-close-trip cycle. Following this, it is necessary to re-establish sufficient energy in the CB before the CB can be reclosed. The CB Healthy input is used to ensure that there is sufficient energy available to close and trip the CB before initiating a CB close command. If on completion of the dead time, sufficient energy is not detected by the relay from the CB Healthy input for a period given by the CB Healthy time timer, lockout will result and the CB will remain open.

4.1.2.2 BAR (P543/P545)

External inputs can be used to block auto-reclose. The signal “Block CB AR” DDB (448) is available for mapping via the PSL from an opto input or a communications input. The “Block CB AR” input, if asserted, will block the operation of the auto-reclose cycle and, if auto-reclose is in progress, it will force the circuit breaker to lockout.

Typically, it is used where, dependent upon the type of protection operation, auto-reclose may, or may not, be required. An example is on a transformer feeder, where auto-reclosing may be initiated from the feeder protection but blocked from the transformer protection. “Block CB AR” can also be used in cases where the auto-reclose cycle is likely to fail for conditions associated with the protected circuit. The input can be used for example if, anywhere during the dead time, a circuit breaker indicates that it is not capable of switching (low gas pressure or loss of vacuum alarm occurs).

4.1.2.3 Reset Lockout (P543/P545)

The following DDB signal is available for mapping in PSL from opto inputs or communications inputs: DDB (446) “Reset Lockout.”

4.1.2.4 Pole Discrepancy (P543/P545)

Circuit breakers with independent mechanisms for each pole normally incorporate a ‘phases not together’ or ‘pole discrepancy’ protection device which automatically trips all three-phases if they are not all in the same position i.e. all open or all closed.

During single pole auto-reclosing a pole discrepancy condition is deliberately introduced and the pole discrepancy device must not operate for this condition. This may be achieved by using a delayed action pole discrepancy device with a delay longer than the single pole auto-reclose dead time, “SP AR Dead Time”. Alternatively, a signal can be given from the relay during the single pole auto-reclose dead time, “AR 1 Pole In Prog”, DDB (845), to inhibit the external pole discrepancy device.

In the relay, the “Pole Discrepancy” input is activated by a signal from an external device indicating that all three poles of the CB are not in the same position. The “Pole Discrepancy” inputs DDB (451) forces a 3 pole trip on the circuit breaker through PSL mapping.

The Pole Discrepancy input is activated by a signal from an external device indicating that all three poles of the CB are not in the same position. The Pole Discrepancy input forces a 3-pole trip which will cancel any single pole auto-reclose in progress and start three pole auto-reclose in progress.

4.1.2.5 Auto-Reclose Enable (P543/P545) Software D1a and Later

This is an Output signal available in the PSL, which can be mapped to an opto status input to enable the autoreclose as long as the below conditions are satisfied.

Autoreclose can be Enabled or Disabled. This is done using a combination of Setting changes, starting with DDB 1384 (AR Enable) operation. Here is what is needed to Enable or Disable the Autoreclose:

AR Enabled = Autoreclose Enabled (0924 = 1) AND
(AR Telecontrol In Service (070B = 1) OR AR Enable DDB active (DDB 1384 = 1))
AND

(AR Enable CB1 DDB Active (DDB 1609 = 1) OR AR Enable CB2 DDB Active
(DDB 1605 = 1))

AR Disabled = Autoreclose Enabled (0924 = 0) OR
(AR Telecontrol Out of Service (070B = 2) AND AR Enable DDB active (DDB 1384 = 0)) OR
(AR Enable CB1 DDB Active (DDB 1609 = 1) AND AR Enable CB2 DDB Active
(DDB 1605 = 1))

<i>Note</i>	<i>More details are provided in the Auto-Reclose Skip Shot 1 (P543/P545) and the Auto-Reclose (P544/P546) sections.</i>
-------------	---

Here is the new description of DDB 1384:

DDB No	Text	Description
DDB 1384	AR Enable	External input via DDB mapped in PSL to enable AR, but ONLY if "Enable AR CB1" DDB or "Enable AR CB2" DDB is set and "Auto-Reclose" Configuration setting is enabled.

4.1.2.6 Enable 1 Pole AR (P543/P545)

The En 1 Pole Reclose input is used to select the single-phase auto-reclose operating mode.

4.1.2.7 Enable 3-pole AR(P543/P545)

The En 3-pole Reclose input is used to select the three-phase auto-reclose operating mode.

4.1.2.8 External Trip (P543/P545)

The External Trip 3Ph input and the External Trip A, External Trip B and External Trip C inputs can be used to initiate three or single-phase auto-reclose.

<i>Note</i>	<i>These signals are not used to trip the CB but do initiate auto-reclose. To trip the CB directly they could be assigned to the trip contacts of the relay in the PSL.</i>
-------------	---

4.1.3 Internal Signals (P543/P545)

4.1.3.1 Trip Initiate Signals (P543/P545)

The Trip Inputs A, Trip Inputs B and Trip Inputs C signals are used to initiate signals or three-phase auto-reclose.

<i>Note</i>	<i>For single-phase auto-reclose these signals must be mapped in the PSL as shown in the default.</i>
-------------	---

4.1.3.2 CB Status (P543/P545)

The CB Open 3 ph, CB Open A ph, CB Open B ph and CB Open C ph, signals are used to indicate if a CB is open three or single-phase. These are driven from the internal pole dead logic and the CB auxiliary inputs.

The CB Closed 3 ph, CB Closed A ph, CB Closed B ph and CB Closed C ph, signals are used to indicate if a CB is closed three or single-phase. These are driven from the internal pole dead logic and the CB auxiliary inputs.

4.1.3.3 Check Synch OK and System Check OK (P543/P545)

DDB (883) "Check Sync1 OK" & DDB (884) "Check Sync2 OK" are output from the circuit breaker Check Sync logic and indicate conditions for the circuit breaker sync check stage1 & 2 are satisfied.

4.1.4 Auto-Reclose Logic Outputs (P543/P545)

Any auto-reclose lockout condition will reset all auto-reclose in progress signals associated with the circuit breaker (e.g. "ARIP").

4.1.4.1 AR 1 Pole in Progress (P543/P545)

The "AR 1Pole in Prog" (DDB 845) output signal indicates that single-phase auto-reclose is in progress. The output remains high from protection initiation until lockout, or successful reclosure of the circuit breaker which is indicated by the circuit breaker successful auto-reclose signal, "CB Succ 1P AR" (DDB 1571).

4.1.4.2 AR 3-pole in Progress (P543/P545)

The "AR 3Pole in Prog" (DDB 844) output signal indicates that three-phase auto-reclose is in progress. The output remains high from protection initiation until lockout, or successful reclosure of the circuit breaker which is indicated by the circuit breaker successful auto-reclose signal, "CB Succ 3P AR".

4.1.4.3 Successful Close (P543/P545)

The AR Successful Reclose output indicates that an auto-reclose cycle has been successfully completed. A successful auto-reclose signal is given after the CB has tripped from the protection and reclosed whereupon the fault has been cleared and the reclaim time has expired resetting the auto-reclose cycle. The successful auto-reclose output is reset at the next CB trip or from one of the reset lockout methods; see the 'Reset from lockout' section.

4.1.4.4 AR Status (P543/P545)

The A/R In Status 1P output indicates that the relay is in the single-phase auto-reclose mode. The A/R In Status 3P output indicates that the relay is in the three-phase auto-reclose mode.

4.1.4.5 Auto Close (P543/P545)

The Auto Close output indicates that the auto-reclose logic has issued a close signal to the CB. This output feeds a signal to the control close pulse timer and remains on until the CB has closed. This signal may be useful during relay commissioning to check the operation of the auto-reclose cycle. This signal is combined with the manual close signal to produce the signal Control Close which should be mapped to an output contact.

4.1.5 Auto-Reclose Alarms (P543/P545)

The following DDB signals will produce a relay alarm. These are described below, identified by their DDB signal text.

4.1.5.1 AR No Checksync (Latched) (P543/P545)

The AR No Checksync alarm indicates that the system voltages were not in synchronism at the end of the Check Sync Time, leading to a lockout condition. This alarm can be reset using one of the reset lockout methods; see the 'Reset from lockout' section.

4.1.5.2 AR CB Unhealthy (Latched) (P543/P545)

The AR CB Unhealthy alarm indicates that the CB Healthy input was not energized at the end of the CB Healthy Time, leading to a lockout condition. The CB Healthy input is used to indicate that there is sufficient energy in the CB operating mechanism to close and trip the CB at the end of the dead time. This alarm can be reset using one of the reset lockout methods; see the *Reset from Lockout* section.

4.1.5.3 AR Lockout (Self Reset) (P543/P545)

The AR Lockout alarm indicates that the relay is in a lockout state and that further reclose attempts will not be made; see the *Reset from Lockout* section for more details. This alarm can be reset using one of the reset lockout methods; see the *Reset from Lockout* section.

4.1.6

Auto-Reclose Logic Operating Sequence (P543/P545)

An auto-reclose cycle can be internally initiated by operation of a protection element, provided the circuit breaker is closed until the instant of protection operation. The user can, via a setting, determine if the auto-reclose shall be initiated on the rising edge of the protection trip (Protection Op) or on the falling edge (Protection Reset).

If single pole auto-reclose [A/R Status 1P] only is enabled then if the first fault is a single-phase fault the single pole dead time (1 Pole Dead Time) and single pole auto-reclose in progress [AR 1pole in prog] starts on the rising or falling edge (according to the setting) of the single-phase trip. If the relay has been set to allow more than one single pole reclose [Single Pole Shot >1] then any subsequent single-phase faults will be converted to 3-pole trips. The three pole dead times ("Dead Time 2, Dead Time 3, Dead Time 4") [Dead Time 2, 3, 4] and three pole auto-reclose in progress [AR 3pole in prog] will start on the rising or falling edge (according to the setting) of the three pole trip for the 2nd, 3rd and 4th trips [shots]. For a multi-phase fault the relay will lockout on the rising or falling edge (according to the setting) of the three-phase trip.

If three pole auto-reclose [A/R Status 3P] only is enabled then for any fault the three pole dead time ("Dead Time 1, Dead Time 2, Dead Time 3, Dead Time 4") [Dead Time 1, 2, 3, 4] and three pole auto-reclose in progress [AR 3pole in prog] starts on the rising or falling edge (according to the setting) of the three-phase trip. The logic forces a 3-pole trip [Force 3-pole AR] for any single-phase fault if three pole auto-reclose [A/R Status 3P] only is enabled.

If single [A/R Status 1P] and three-phase auto-reclose [A/R Status 3P] are enabled then if the first fault is a single-phase fault the single pole dead time ("1 Pole Dead Time") [1 Pole Dead Time] and single pole auto-reclose in progress [AR 1pole in prog] starts on the rising or falling edge (according to the setting) of the single-phase trip. If the first fault is a multi-phase fault the three pole dead time ("Dead Time 1") and three pole auto-reclose in progress [AR 3pole in prog] starts on the rising or falling edge (according to the setting) of the three-phase trip. If the relay has been set to allow more than one reclose [Three Pole Shot >1] then any subsequent faults will be converted to 3-pole trips [Force 3-pole AR]. The three pole dead times ("Dead Time 2, Dead Time 3, Dead Time 4") [Dead Time 2, 3, 4] and three pole auto-reclose in progress [AR 3pole in prog] will start on the rising or falling edge (according to the setting) of the three pole trip for the 2nd, 3rd and 4th trips [shots]. If a single-phase fault evolves to a multi-phase fault during the single pole dead time [1 Pole Dead Time] then single pole auto-reclose in progress [AR 1pole in prog] is stopped and the three pole dead time [Dead Time 1] and three pole auto-reclose in progress [AR 3pole in prog] is started.

At the end of the relevant dead time, the auto-reclose single-phase or three-phase in progress signal is reset and a CB close signal is given, provided system conditions are suitable. The system conditions to be met for closing are that the system voltages are in synchronism or dead line/live bus or live line/dead bus conditions exist, indicated by the internal check synchronizing element and that the circuit breaker closing spring, or other energy source, is fully charged indicated from the CB Healthy input. The CB close signal is cut-off when the circuit breaker closes. For single pole auto-reclose no voltage or synchronism check is required as synchronizing power is flowing in the two healthy phases. Check synchronizing for the first three-phase cycle is controlled by a setting.

When the CB has closed the reclaim time ("Reclaim Time") starts. If the circuit breaker does not trip again, the auto-reclose function resets at the end of the reclaim time. If the protection operates during the reclaim time the relay either advances to the next shot in the programmed auto-reclose cycle, or, if all programmed reclose attempts have been made, goes to lockout.

Every time the relay trips the sequence counter is incremented by 1. The relay compares the Single Pole Shots and Three Pole Shots counter values to the sequence count. If the fault is single-phase and the sequence count is greater than the Single Pole Shots setting then the relay will lockout. If the fault is multi-phase phase and the sequence count is greater than the Three Pole Shots setting then the relay will also lockout.

For example, if Single Pole Shots = 2 and Three Pole Shots = 1, after two phase-phase faults the relay will lockout because the sequence count = 2 which is greater than the Three Pole Shots target of 1 and the second fault was a multi-phase fault. If there was a permanent earth fault the relay would trip and reclose twice and on the third application of earth fault current it would lockout. This is because on the third application of fault current the sequence count would be greater than the Single Pole Shots target of 2 and the third fault was an earth fault. There is no lockout at the second trip because the second trip was single-phase and the sequence count is not greater than the Single Pole Shots target of 2. If there was a single-phase fault which evolved to a phase-phase-ground fault then the relay would trip and reclose and on the second multi-phase fault would lockout. This is because on the second application of fault current the sequence count is greater than the Three Pole Shots target of 1 and the second fault was a multi-phase fault.

The total number of auto-reclosures is shown in the CB Control menu under Total Reclosures. This value can be reset to zero with the Reset Total A/R command.

The selection of which protection is used to initiate auto-reclose can be made using the settings Initiate AR, No Action or Block AR for the protection functions listed in the auto-reclose menu. See the *Auto-reclose Initiation* section for more details.

For multi-phase faults the auto-reclose logic can be set to allow auto-reclose block for 2 and 3-phase faults or to block auto-reclose for 3-phase faults only using the setting Multi Phase AR - Allow AR/BAR 2 & 3 Phase/BAR 3 Phase in the Auto-reclose settings.

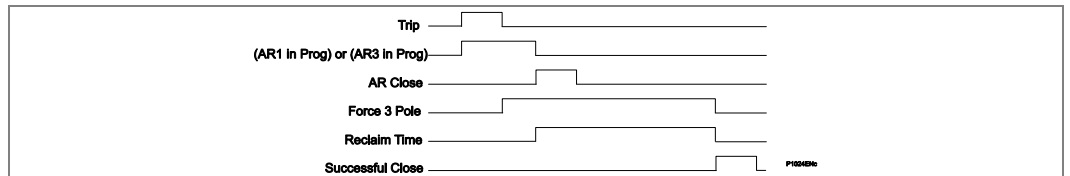

Figure 107 - Auto-reclose timing diagram - single fault

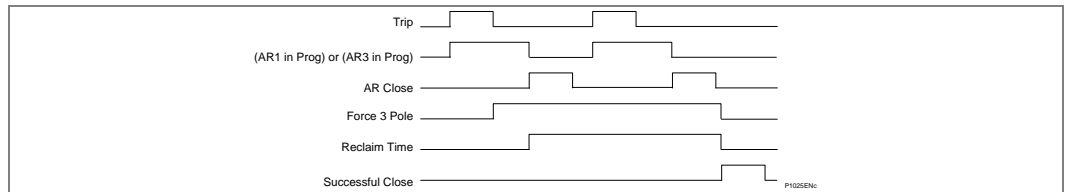

Figure 108 - Auto-reclose timing diagram - repeated fault inception

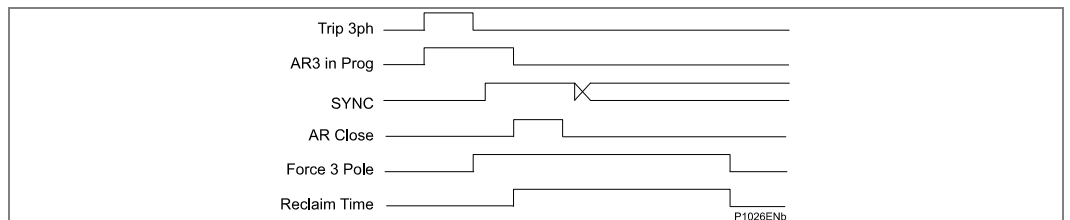

Figure 109 - Auto-reclose timing diagram - fault with system synchronism

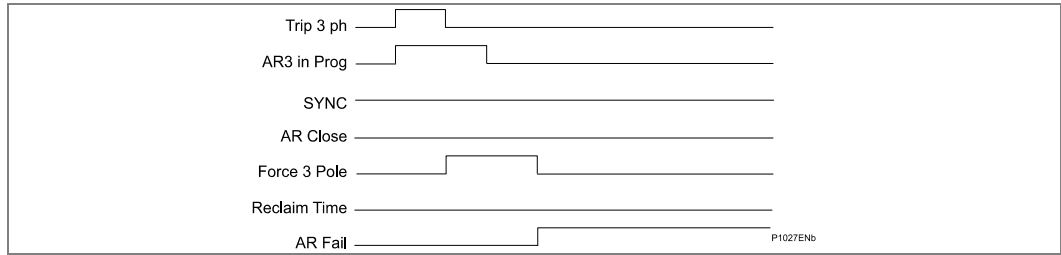

Figure 110 - Auto-reclose timing diagram - lockout for no checksynch

4.1.7

Auto-Reclose: Main Operating Features (P543/P545)

As from Software Version H4, the possible statuses of the Auto-Reclose function have changed. The new method means that the function now works in the same way across the whole P54x range. It does this because of the following DDB Numbers.

DDB Numbers 856, 857, 1532 and 1533

DDB Nos 856 and 857 have never been included in the MiCOM P544/P546 products.

In the MiCOM P543/P545 (running on Software Version 57), DDB Nos 856 and 857 were available to show the mode (3P, 1P) for the Auto-Reclose (AR) function.

In the MiCOM P543/P545 (running on Software Version D1), DDB Nos 856 and 857 were removed.

As from Software Version H4a, the following situation applies:

DDB No	Source	Element Name	Description
856	Autoreclose	DDB_AR_IN_SERVICE_3P	3 Pole auto-recloser in service – the auto-reclose function has been enabled either in the relay menu, or by an auto input.
857	Autoreclose	DDB_AR_IN_SERVICE_1P	Single pole auto-recloser in service – the auto-reclose function has been enabled either in the relay menu, or by an auto input.
1532	Autoreclose	DDB_AR_IN_SERVICE_3P_FOLLOWER	Follower 3 Pole auto-recloser in service – the auto-reclose function has been enabled either in the relay menu, or by an auto input.
1533	Autoreclose	DDB_AR_IN_SERVICE_1P_FOLLOWER	Follower Single pole auto-recloser in service – the auto-reclose function has been enabled either in the relay menu, or by an auto input.

- For MiCOM P44y/P54x products with a single CB application (P543/P545), DDB Nos 856 and 857 again show the mode (3P, 1P).
- For MiCOM P44y/P54x products with a dual CB application (P544/P546), DDB Nos 856 and 857 again show the mode (3P, 1P) for the leader CB.
- For MiCOM P44y/P54x products with a dual CB application (P544/P546), DDB Nos 1532 and 1533 show the mode (3P, 1P) for the follower CB.

4.1.7.1

Auto-Reclose Modes (P543/P545)

The auto-reclose function has three operating modes:

- Single-Pole Auto-reclose
- Three-Pole Auto-reclose
- Single/Three-Pole Auto-reclose

Single-pole and three-pole auto-reclose modes can be selected from opto inputs assigned for **En 1 Pole Reclose** and **En 3-pole Reclose** respectively. Energizing both opto inputs would select the single/three pole operating mode. Alternatively, the settings **Single Pole A/R - Enabled/Disabled** and **Three Pole A/R - Enabled/Disabled** in the CB Control menu can also be used to select the operating modes. How these operating modes affect the operating sequence is described above.

4.1.7.2

Auto-Reclose Initiation (P543/P545)

Auto-reclose is initiated from the internal protection of the relay:

- By default, all “instantaneous” schemes will initiate auto-reclose, therefore current differential, Zone 1 distance, Aided Scheme 1, and Aided Scheme 2 will all initiate AR.

- For these instantaneous tripping elements, it is possible to override initiation for user set combinations of multi-phase faults if required, by use of the 'Multi Phase AR' Block setting. This will prevent auto-reclose initiation, and drive the sequence to lockout.
- The directional aided schemes, the DEF schemes and TOR (distance option only) can be selected to Initiate AR or Block AR in the auto reclose settings. The overcurrent, earthfault, and other distance zones (where optionally specified) can be selected to Initiate AR, Block AR or cause No Action in the auto reclose settings.

4.1.7.3 Auto-Reclose Inhibit Following Manual Close (P543/P545)

The AR Inhibit Time setting can be used to prevent auto-reclose being initiated when the CB is manually closed onto a fault. Auto-reclose is disabled for the AR Inhibit Time following manual CB closure.

4.1.7.4 Auto-Reclose Lockout (P543/P545)

If protection operates during the reclaim time, following the final reclose attempt, the relay will be driven to lockout and the auto-reclose function will be disabled until the lockout condition is reset. This will produce an alarm, AR Lockout.

The block auto-reclose logic in the relay will also cause an auto-reclose lockout if auto-reclose is in progress. The **BAR** input assigned to an opto input will block auto-reclose and cause a lockout if auto-reclose is in progress. The auto-reclose logic can also be set to block auto-reclose for 2 and 3-phase faults or to block auto-reclose for 3-phase faults only using the setting **Multi Phase AR - Allow AR/BAR 2&3 Phase/BAR 3 Phase** in the Auto-reclose menu. Also, the protection functions can be individually selected to block auto-reclose using the settings, **Initiate AR**, **No Action** or **Block AR** in the Auto-reclose menu.

Auto-reclose lockout can also be caused by the CB failing to close because the CB springs are not charged/low gas pressure or there is no synchronism between the system voltages indicated by the **AR CB Unhealthy** and **AR No Checksync** alarms.

An auto-reclose lockout is also given if the CB is open at the end of the reclaim time.

*Note CB Lockout, can also be caused by the CB condition monitoring functions maintenance lockout, excessive fault frequency lockout, broken current lockout, CB failed to trip and CB failed to close and manual close - no check synchronism and CB unhealthy. These lockout alarms are mapped to a composite signal **CB Lockout Alarm**.*

4.1.7.5 Reset from Lockout (P543/P545)

The **Reset Lockout** input assigned to an opto input can be used to reset the auto-reclose function following lockout and reset any auto-reclose alarms, provided that the signals which initiated the lockout have been removed. Lockout can also be reset from the clear key or the CB CONTROL command **Lockout Reset**.

The **Reset Lockout** by setting, **CB Close/User interface** in CB CONTROL is used to enable/ disable reset of lockout automatically from a manual close after the manual close time **AR Inhibit Time**.

4.1.7.6 System Check on Shot 1 (P543/P545)

The SysChk on Shot 1 setting is used to Enable/Disable system checks for the first reclose after a 3-pole trip in an auto-reclose cycle. When the SysChk on Shot 1 is set to Disabled no system checks are required for the first reclose which may be preferred when high speed auto-reclose is applied to avoid the extra time for a system check. Subsequent reclose attempts in a multi-shot cycle will still require a system check.

4.1.7.7 Immediate Auto-Reclose with Check Synchronism (P543/P545)

The CS AR Immediate setting allows immediate auto-reclosure without waiting for the expiry of the settable dead time, provided the check synchronism conditions are met and a fault is not detected. The intention is to allow the local end to reclose immediately if the remote end has already reclosed successfully and the synchronizing conditions are met.

This feature applies when the setting is enabled. It applies to all dead times, just for three pole auto-reclose and just for Live Line-Live Bus condition (plus other check synchronizing conditions of phase angle, frequency etc).

When set to disabled the relay will wait for the relevant dead time.

4.1.7.8

Discrimination Timer Setting (P543/P545)

A single-phase fault can result in a single-phase trip and a single-pole auto-reclose cycle will be started, however the fault may evolve during the dead time to affect another phase. For an evolving fault, the protection issues a three-phase trip.

The discrimination timer starts simultaneously with the dead time timer, and is used to discriminate from which point in time an evolving fault is identified as no longer one continued evolution of the first fault, but is now a discrete second fault condition. If the evolving fault occurs before the expiry of the discrimination time, the protection will start a three-pole auto-reclose cycle if permitted. If however, the second phase fault occurs after the discrimination time, the automatic reclose function is blocked, and driven to AR Lockout.

4.1.8 Auto-Reclose Skip Shot 1 (P543/P545)

As from Software Version D1a, the Auto-Reclose can now be configured so that it skips the first shot. This means that the first AR cycle is skipped (missed), and so starts Dead Time 2 at the first reclose attempt.

This is done by changing DDB No 1384 (Skip Shot 1 = Enabled/Disabled) as required.

This means that this signal can now be mapped from an opto to a comms input.

This is an Output signal available in the PSL, which can be mapped to an opto status input to force the autoreclose to skip shot 1.

DDB No	Text	Description
DDB 1384	AR Skip Shot1	DDB mapped in PSL from opto or comms input: if setting "AR Skip Shot 1" = Enable and this input is high when a protection operation initiates an autoreclose cycle, then the sequence counter advances directly to SC:COUNT = 2 so the autoreclose cycle skips (omits) Shot 1 and instead starts at Dead Time 2 for the first reclose attempt.

4.1.9 Auto-Reclose Logic Diagrams (P543/P545)

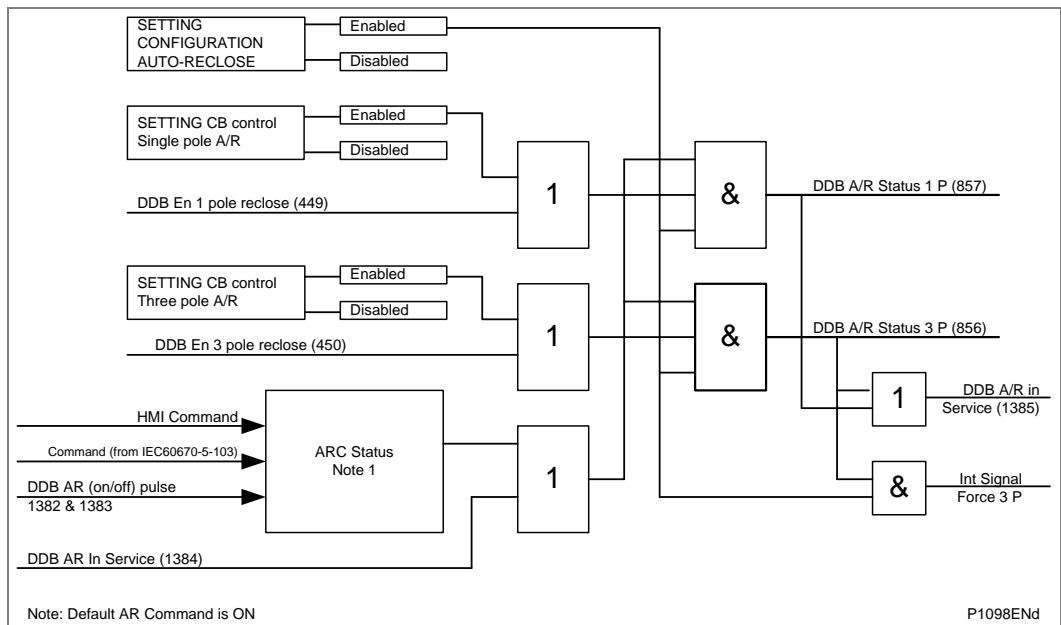
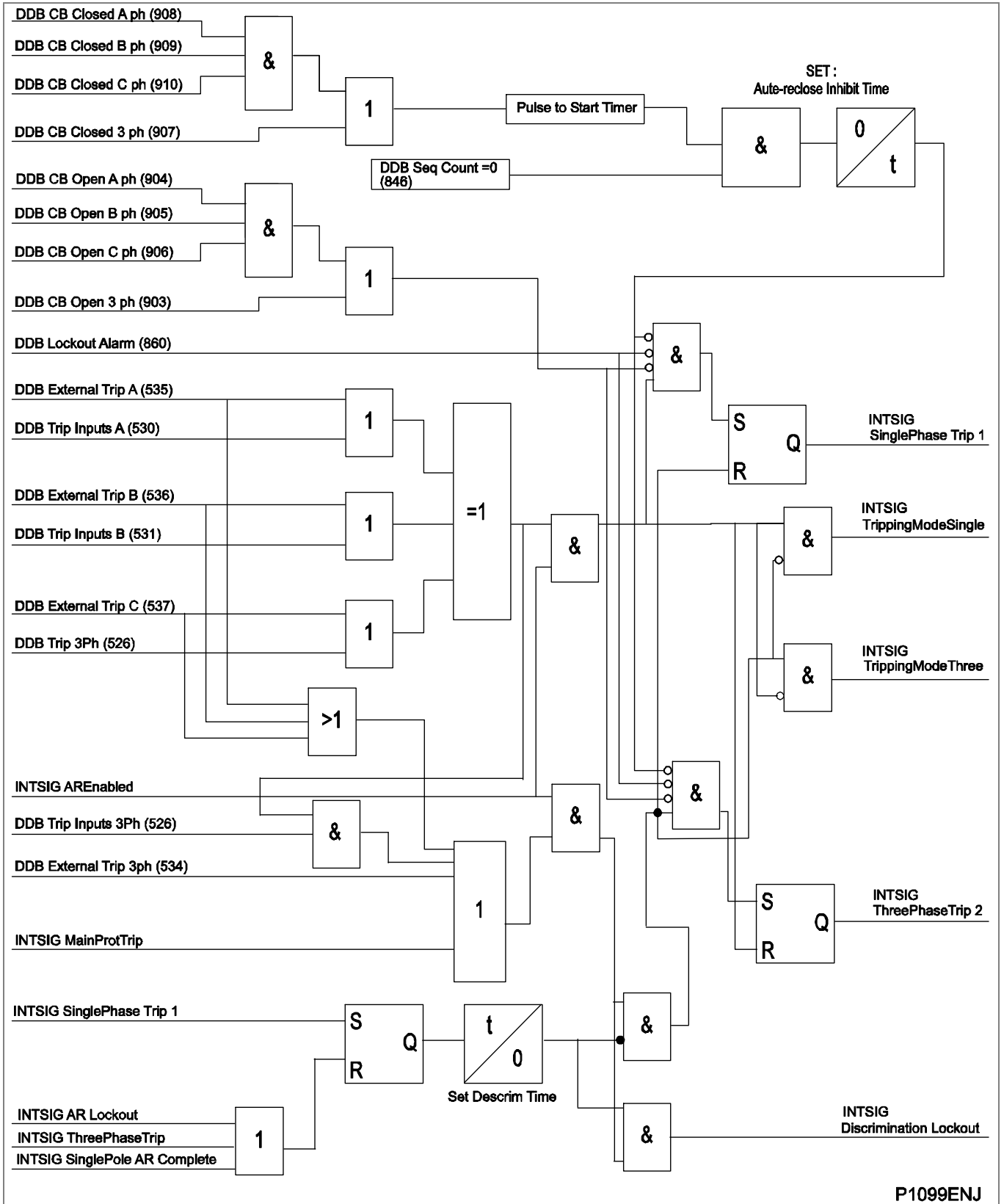

Figure 111 - Auto-reclose enable logic



P1099ENJ

Figure 112 - Auto-reclose single/three pole tripping

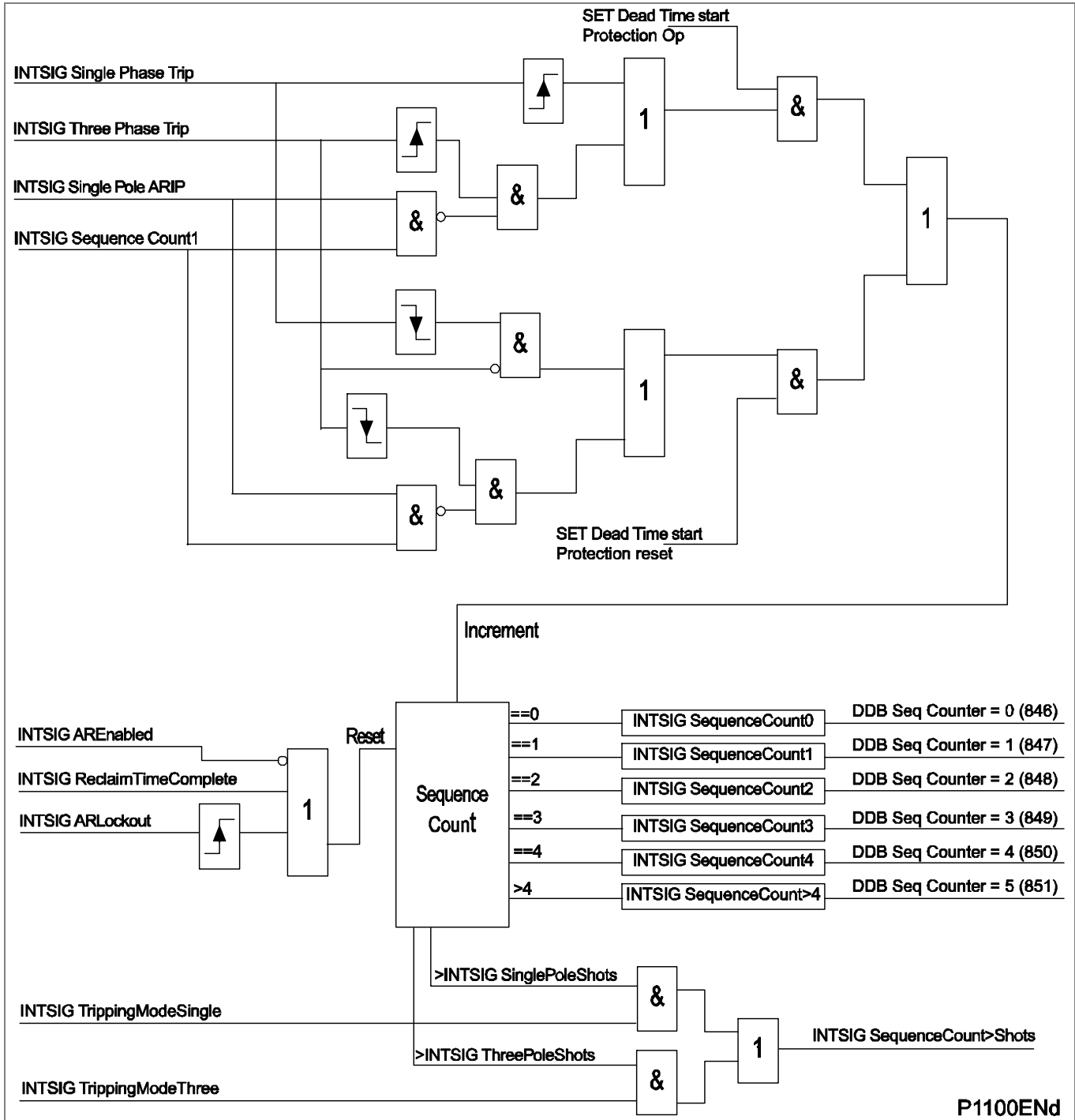

Figure 113 - Auto-reclose inhibit sequence count (P543/P545)

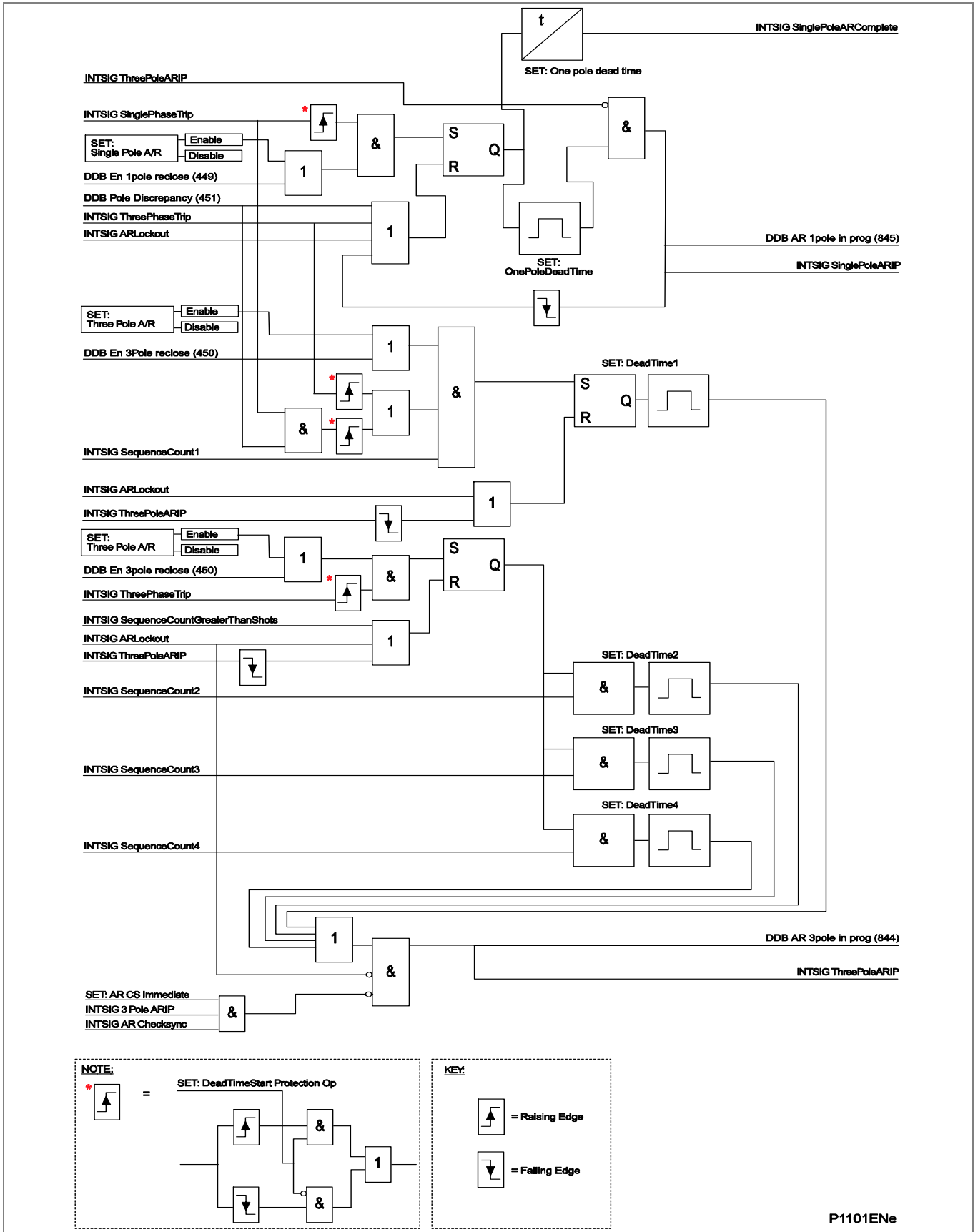

Figure 114 - Auto-reclose cycles (P543/P545)

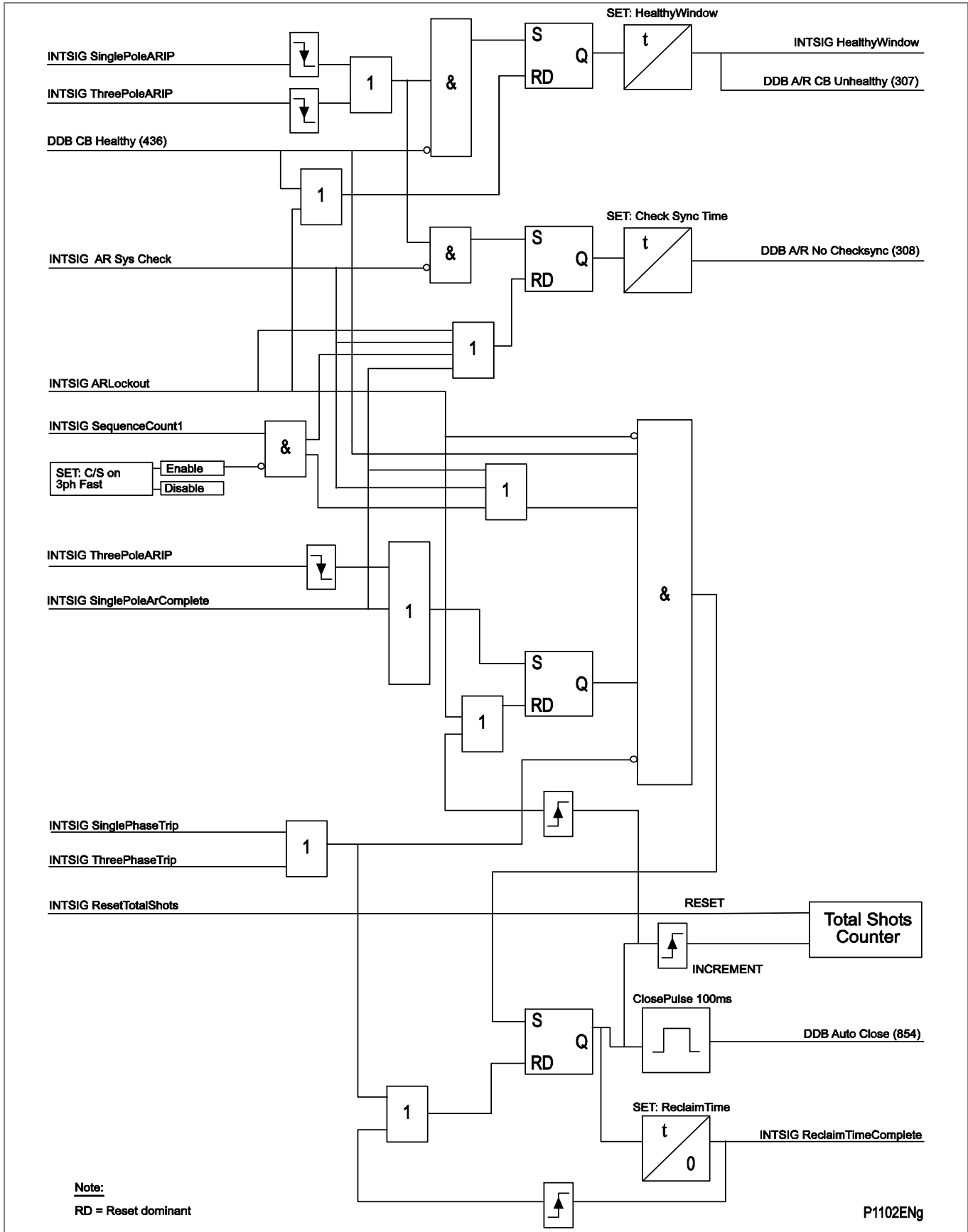

Figure 115 - Auto-reclose close

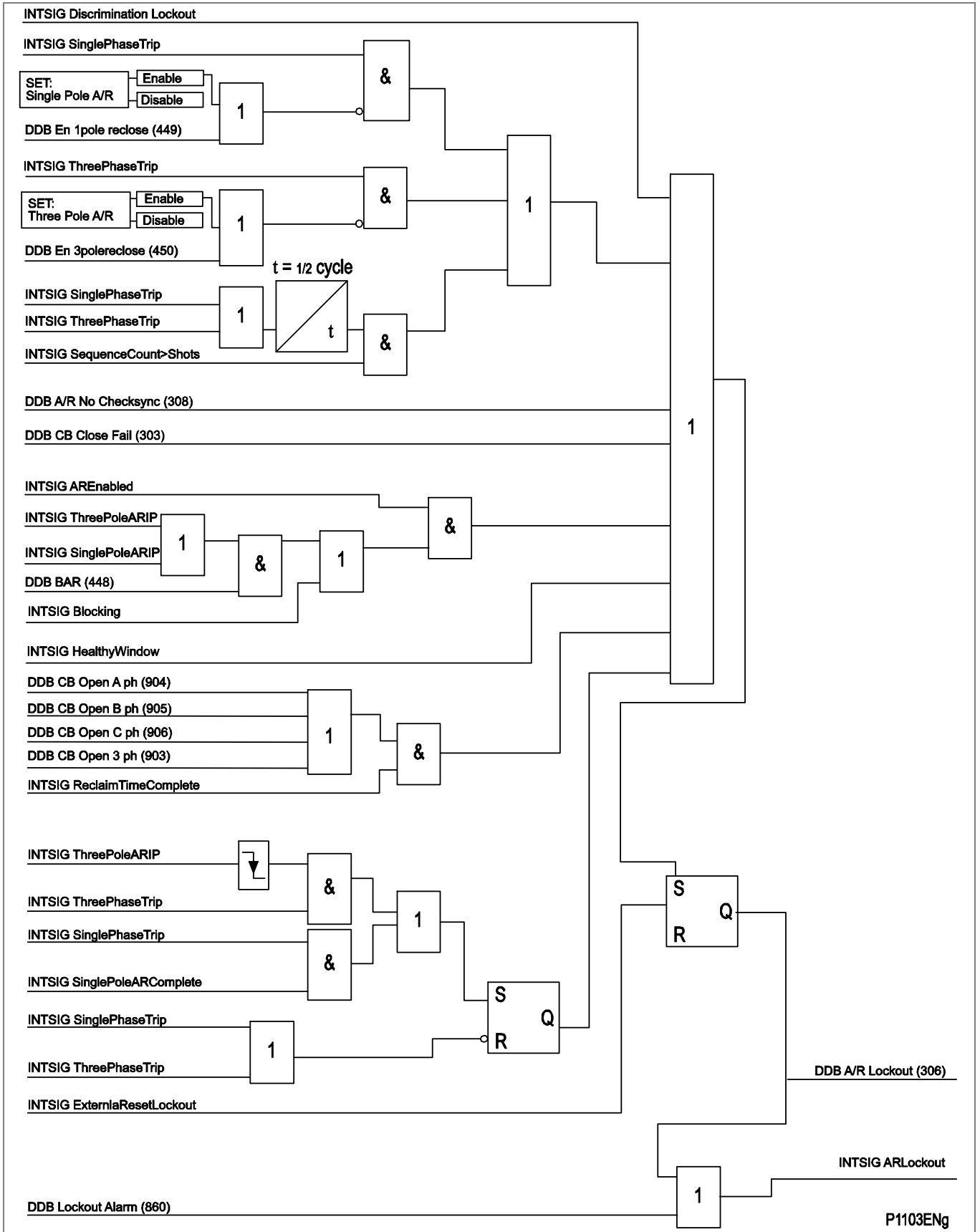

Figure 116 - Auto-reclose lockout logic (P543/P545)

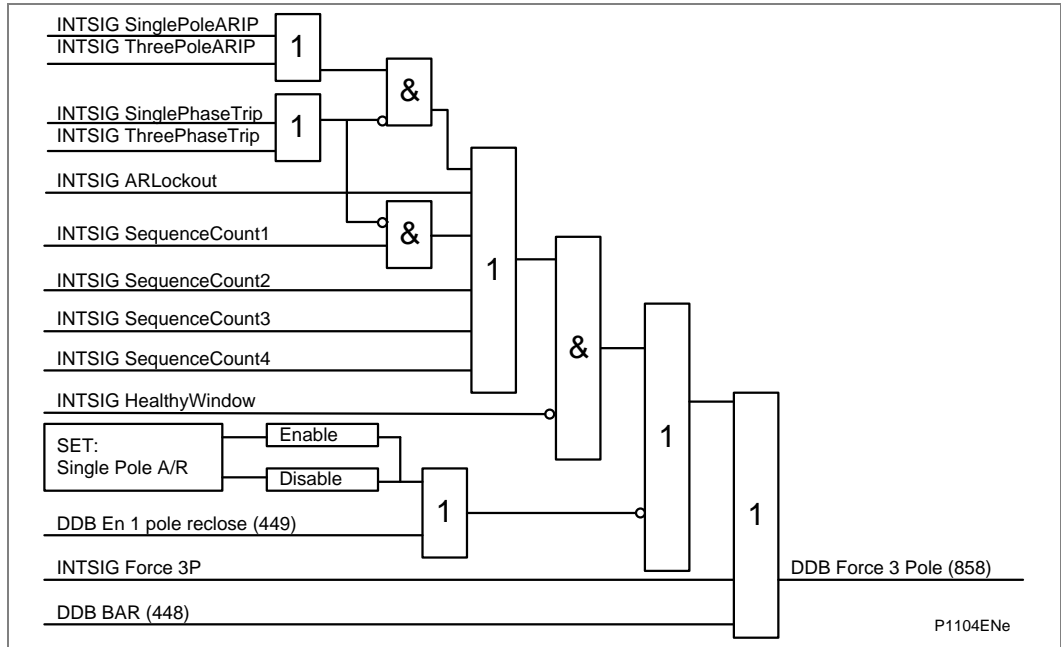

Figure 117 - Auto-reclose force 3-pole trip (P543/P545)

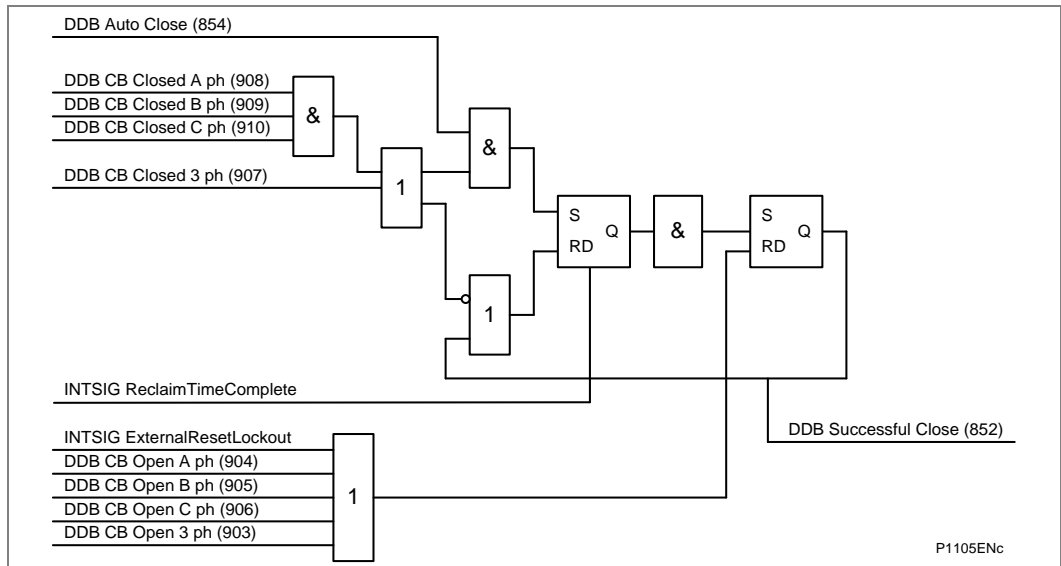

Figure 118 - Auto-reclose close notify (P543/P545)

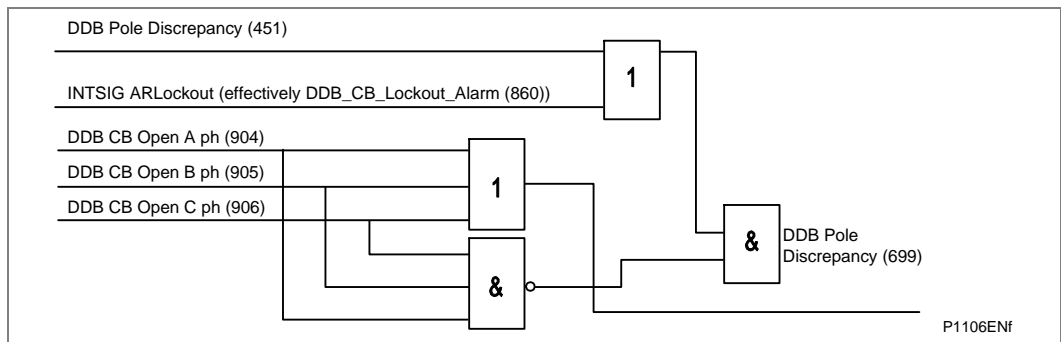

Figure 119 - Ddb pole discrepancy trip (P543/P545)

4.2 System Checks (including Check Synchronizer) (P543/P545)

4.2.1 Overview (P543/P545)

In some situations it is possible for both “bus” and “line” sides of a Circuit Breaker (CB) to be live when the CB is open, for example at the ends of a feeder which has a power source at each end. Therefore, when closing the CB, it is normally necessary to check that the network conditions on both sides are suitable, before giving a CB Close command. This applies to both manual CB closing and auto-reclosure. If a CB is closed when the line and bus voltages are both live, with a large phase angle, frequency or magnitude difference between them, the system could be subjected to an unacceptable shock, resulting in loss of stability, and possible damage to connected machines.

System checks involve monitoring the voltages on both sides of a circuit breaker, and, if both sides are live, performing a synchronism check to determine whether the phase angle, frequency and voltage magnitude differences between the voltage vectors, are within permitted limits.

The pre-closing system conditions for a given Circuit Breaker (CB) depend on the system configuration and, for auto-reclosing, on the selected auto-reclose program. For example, on a feeder with delayed auto-reclosing, the CBs at the two line ends are normally arranged to close at different times. The first line end to close usually has a live bus and a dead line immediately before reclosing, and charges the line (dead line charge) when the CB closes. The second line end CB sees live bus and live line after the first CB has reclosed. If there is a parallel connection between the ends of the tripped feeder, they are unlikely to go out of synchronism, i.e. the frequencies will be the same, but the increased impedance could cause the phase angle between the two voltages to increase. Therefore the second CB to close might need a synchronism check, to ensure that the phase angle has not increased to a level which would cause unacceptable shock to the system when the CB closes.

If there are no parallel interconnections between the ends of the tripped feeder, the two systems could lose synchronism, and the frequency at one end could “slip” relative to the other end. In this situation, the second line end would require a synchronism check comprising both phase angle and slip frequency checks.

If the second line end busbar has no power source other than the feeder which has tripped, the circuit breaker will see a live line and dead bus assuming the first circuit breaker has reclosed. When the second line end circuit breaker closes the bus will charge from the live line (dead bus charge).

4.2.2 VT Selection (P543/P545)

The MiCOM P443/P445/P543/P545 has a three-phase **Main VT** input and a single-phase **Check Sync VT** input. Depending on the primary system arrangement, the main three-phase VT for the relay may be located on either the busbar side or the line side of the circuit breaker, with the check sync VT being located on the other side. Hence, the relay has to be programmed with the location of the Main VT. This is done using the **Main VT Location** setting in the CT & VT RATIOS menu.

The Check Sync VT may be connected to either a phase to phase or phase to neutral voltage, and for correct synchronism check operation, the relay has to be programmed with the required connection. The C/S Input setting in the CT & VT RATIOS menu should be set to A-N, B-N, C-N, A-B, B-C or C-A A-N/1.732, B-N/1.732 or C-N/1.732 as appropriate.

4.2.3 Basic Functionality (P543/P545)

System check logic is collectively enabled or disabled as required, by setting **System Checks** in the CONFIGURATION menu. The associated settings are available in SYSTEM CHECKS, sub-menus VOLTAGE MONITORS, CHECK SYNC and SYSTEM SPLIT. If **System Checks** is selected to Disabled, the associated SYSTEM CHECKS menu becomes invisible, and a Sys checks Inactive DDB signal is set.

In most situations where synchronism check is required, the Check Sync 1 function alone will provide the necessary functionality, and the Check Sync 2 and System Split signals can be ignored.

4.2.4 System Check Logic Outputs (P543/P545)

When enabled, the MiCOM P443/P445/P543/P545 system check logic sets signals as listed below, according to the status of the monitored voltages.

Line Live	If the Line voltage magnitude is not less than VOLTAGE MONITORS - Live Voltage setting
Line Dead	If the Line voltage magnitude is less than VOLTAGE MONITORS - Dead Voltage setting
Bus Live	If the Bus voltage magnitude is not less than VOLTAGE MONITORS - Live Voltage setting
Bus Dead	If the Bus voltage magnitude is less than VOLTAGE MONITORS - Dead Voltage setting
Check Sync 1 OK	If Check Sync 1 Status is Enabled, the Line and Bus voltages are both live, and the parameters meet the CHECK SYNC - Check Sync 1 ---- settings
Check Sync 2 OK	If Check Sync 2 Status is Enabled, the Line and Bus voltages are both live, and the parameters meet the CHECK SYNC - Check Sync 2 ---- settings
System Split	If SS Status is Enabled, the Line and Bus voltages are both live, and the measured phase angle between the voltage vectors is greater than SYSTEM SPLIT - SS Phase Angle setting

All the above signals are available as DDB signals for mapping in Programmable Scheme Logic (PSL). In addition, the Checksync 1 & 2 signals are "hard coded" into the auto-reclose logic.

4.2.5 Check Sync 2 (P543/P545)

Check Sync 2 and System Split functions are included for situations where the maximum permitted slip frequency and phase angle for synchronism check can change according to actual system conditions. A typical application is on a closely interconnected system, where synchronism is normally retained when a given feeder is tripped, but under some circumstances, with parallel interconnections out of service, the feeder ends can drift out of synchronism when the feeder is tripped. Depending on the system and machine characteristics, the conditions for safe circuit breaker closing could be, for example:

Condition 1: for synchronized systems, with zero or very small slip:

slip * 50 mHz; phase angle <30°

Condition 2: for unsynchronized systems, with significant slip:

slip * 250 mHz; phase angle <10° and decreasing

By enabling both Check Sync 1, set for condition 1, and Check Sync 2, set for condition 2, the relay can be configured to allow CB closure if either of the two conditions is detected.

For manual circuit breaker closing with synchro check, some utilities might prefer to arrange the logic to check initially for condition 1 only. However, if a System Split is detected before the condition 1 parameters are satisfied, the relay will switch to checking for condition 2 parameters instead, based upon the assumption that a significant degree of slip must be present when system split conditions are detected. This can be arranged by suitable PSL logic, using the system check DDB signals.

4.2.6 Synchronism Check (P543/P545)

Check Sync 1 and Check Sync 2 are two synchro check logic modules with similar functionality, but independent settings.

For either module to function:

The System Checks setting must be Enabled AND
 The individual Check Sync 1(2) Status setting must be Enabled AND
 The module must be individually "enabled", by activation of DDB signal Check Sync 1(2) Enabled, mapped in PSL

When enabled, each logic module sets its output signal when:

Line volts and bus volts are both live (Line Live and Bus Live signals both set)
 AND

Measured phase angle is < Check Sync 1(2) Phase Angle setting AND
 (For Check Sync 2 only), the phase angle magnitude is decreasing (Check Sync 1 can operate with increasing or decreasing phase angle provided other conditions are satisfied)
 AND

If Check Sync 1(2) Slip Control is set to Frequency or Frequency + Timer, the measured slip frequency is < Check Sync 1(2) Slip Freq setting
 AND

If Check Sync Voltage Blocking is set to OV, UV + OV, OV + DiffV or UV + OV + DiffV, both line volts and bus volts magnitudes are < Check Sync Overvoltage setting
 AND

If Check Sync Voltage Blocking is set to UV, UV + OV, UV + DiffV or UV + OV + DiffV, both line volts and bus volts magnitudes are > Check Sync Undervoltage setting
 AND

If Check Sync Voltage Blocking is set to DiffV, UV + DiffV, OV + DiffV or UV + OV + DiffV, the voltage magnitude difference between line volts and bus volts is < Check Sync Diff Voltage setting
 AND

If Check Sync 1(2) Slip Control is set to Timer or Frequency + Timer, the above conditions have been true for a time > or = Check Sync 1(2) Slip Timer setting

<i>Note</i>	<i>Live Line/Dead Bus and Dead Bus/Line functionality is provided as part of the default PSL.</i>
-------------	---

4.3 Auto-Reclose/Check Synchronization Interface (P543/P545)

Output signals from the internal system check function and signals from an external system check device are combined and made available as two internal inputs to the auto-reclose function. One internal input permits auto-reclose based on system check conditions being met. The other internal input permits immediate auto-reclose based on check synchronism conditions being met, if this feature is enabled (CS AR Immediate).

The logic diagram for the interaction between the auto-reclose and system checks is shown below.

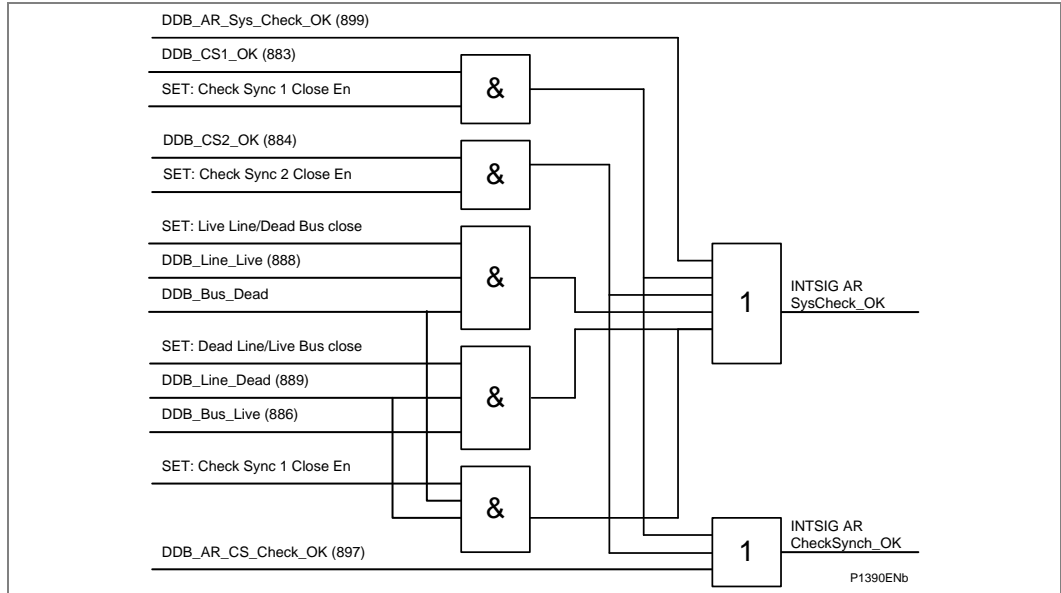

Figure 120 - Auto-reclose/check sync interface (P543/P545)

If an external system check device is to be used with the internal auto-reclose function then logic inputs are available for the purpose and can be assigned to opto-isolated inputs using the PSL. These logic inputs are.

- AR Check Synch OK
- AR System Check OK/SYNC

4.4 CB State Monitoring (P543/P545)

The relay incorporates circuit breaker state monitoring, giving an indication of the position of the circuit breaker, or, if the state is unknown, an alarm is raised.

4.4.1 CB State Monitoring Features (P543/P545)

To monitor the CBs and isolators, the following recommended functions shall be set in the PSL.

MiCOM relays can be set to monitor normally open (52a) and normally closed (52b) auxiliary contacts of the circuit breaker. Under healthy conditions, these contacts will be in opposite states. Should both sets of contacts be open, this would indicate one of the following conditions:

- Auxiliary contacts / wiring defective
- Circuit Breaker (CB) is defective
- CB is in isolated position

Should both sets of contacts be closed, only one of these conditions would apply:

- Auxiliary contacts / wiring defective
- Circuit Breaker (CB) is defective

If any of the above conditions exist, an alarm will be issued after the time delay set in the PSL. A normally open / normally closed output contact can be assigned to this function via the Programmable Scheme Logic (PSL). The time delay is set to avoid unwanted operation during normal switching duties.

Note *If the Circuit Breaker is under "not ready" status, the relay will not send any trip order to the Circuit Breaker.*

In the CB CONTROL column of the relay menu there is a setting called 'CB Status Input'. This cell can be set at one of these options:

None	
52A	3 pole
52B	3 pole
52A & 52B	3 pole
52A	1 pole
52B	1 pole
52A & 52B	1 pole

Where 'None' is selected no CB status will be available. This will directly affect any function within the relay that requires this signal, for example CB control, auto-reclose, etc. Where only 52a is used on its own then the relay will assume a 52b signal from the absence of the 52a signal. Circuit breaker status information will be available in this case but no discrepancy alarm will be available. The above is also true where only a 52b is used. If both 52a and 52b are used then status information will be available and in addition a discrepancy alarm will be possible, according to the following table. 52a and 52b inputs are assigned to relay opto-isolated inputs via the PSL.

Auxiliary Contact Position		CB State Detected	Action
52A	52B		
Open	Closed	Breaker Open	Circuit breaker healthy
Closed	Open	Breaker Closed	Circuit breaker healthy
Closed	Closed	State Unknown	Alarm raised if the condition persists for longer than "CB supervision timer" delay time setting
Open	Open	State Unknown	Alarm raised if the condition persists for longer than "CB supervision timer" delay time setting

Table 23 - Contact positions, CB states and actions

Where single pole tripping is used then an open breaker condition will only be given if all three-phases indicate an open condition. Similarly for a closed breaker condition indication that all three-phases are closed must be given. For single pole tripping applications 52A-a, 52A-b and 52A-c and/or 52B-a, 52B-b and 52B-c inputs should be used.

The CB state monitoring logic is shown in Figure AR-.

4.5 CB Condition Monitoring (P543/P545)

Periodic maintenance of circuit breakers is needed to ensure that the trip circuit and mechanism operate correctly and also that the interrupting capability has not been compromised due to previous fault interruptions. Generally, such maintenance is based on a fixed time interval or a fixed number of fault current interruptions. These methods of monitoring circuit breaker condition give a rough guide only and can lead to excessive maintenance. The circuit breaker monitoring features of the MiCOM relay can help with more efficient maintenance regimes.

If inputs relevant to the circuit breakers are available to the relay via the opto isolated inputs, the logic will be able to determine the state of each circuit breaker.

4.5.1 CB Condition Monitoring Features (P543/P545)

For each circuit breaker trip operation the relay records statistics as shown in the following table taken from the relay menu. The menu cells shown are counter values only. The Min./Max. values in this case show the range of the counter values. These cells can not be set:

Menu text	Default	Setting		Step size
		Min.	Max.	
CB Operations {3 pole tripping}	0	0	10000	1
Displays the total number of 3-pole trips issued by the relay.				
Total IA Broken	0	0	25000 In [^]	1
Displays the total fault current interrupted by the relay for the A phase.				
Total IB Broken	0	0	25000 In [^]	1
Displays the total fault current interrupted by the relay for the B phase.				
Total IC Broken	0	0	25000 In [^]	1 In [^]
Displays the total fault current interrupted by the relay for the C phase.				
CB Operate Time	0	0	0.5 s	0.001
Displays the calculated CB operating time.				
Reset CB Data	No		Yes, No	
Reset the CB condition counters.				

Table 24 - CB Condition Min/Max values

The above counters may be reset to zero, for example, following a maintenance inspection and overhaul.

The circuit breaker condition monitoring counters will be updated every time the relay issues a trip command. In cases where the breaker is tripped by an external protection device it is also possible to update the CB condition monitoring. This is achieved by allocating one of the relays opto-isolated inputs (using the programmable scheme logic) to accept a trigger from an external device. The signal that is mapped to the opto is called **External Trip**, DDB 115.

<p><i>Note</i> <i>When in Commissioning Test Mode the CB condition monitoring counters will not be updated.</i></p>

The measurement of circuit breaker operating time, broken current and the overall CB Monitoring logic are shown in the following diagrams.

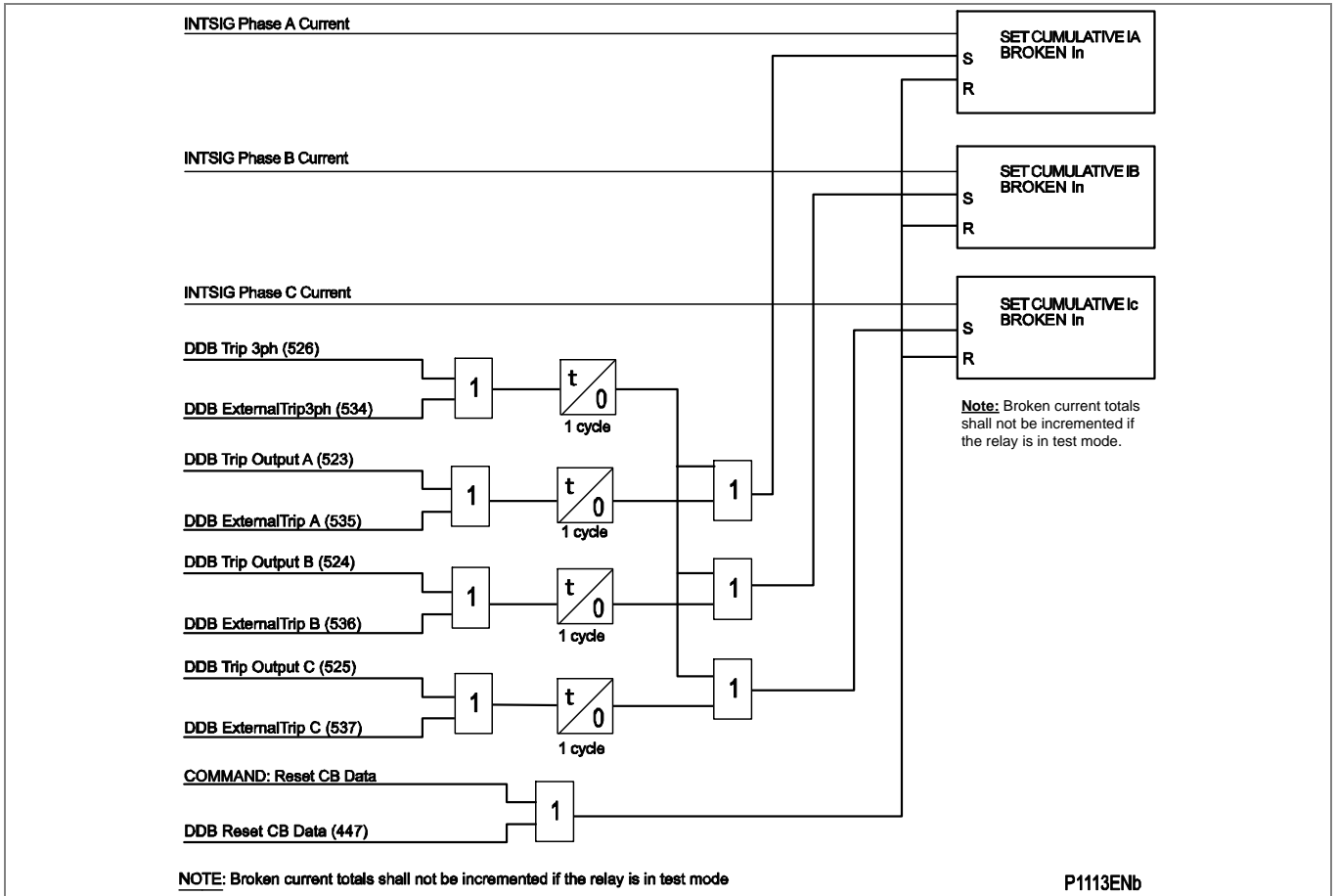

Figure 121 - Circuit breaker condition monitoring - broken current (P543/P545)

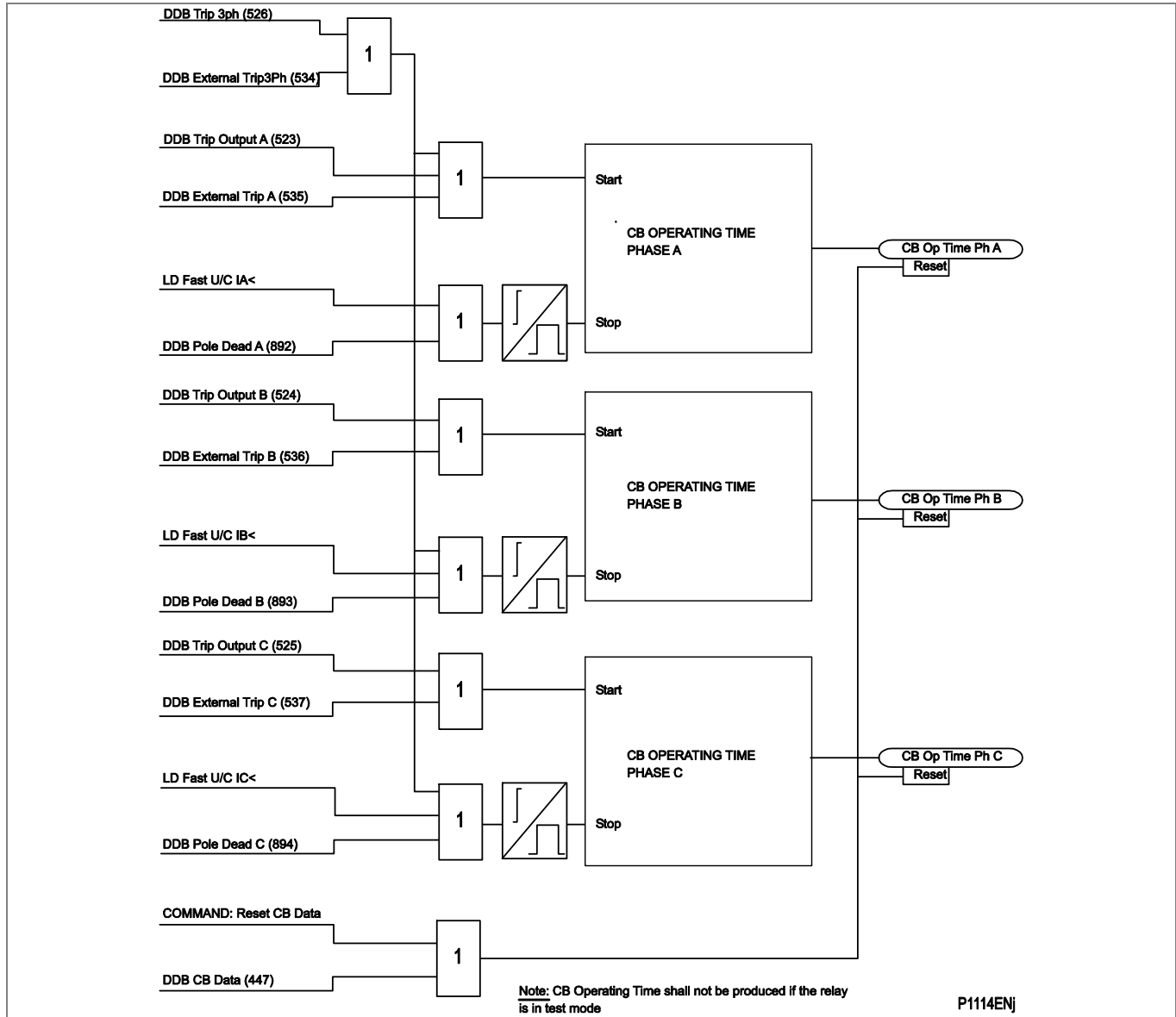

Figure 122 - Circuit breaker condition monitoring - operation time (P543/P545)

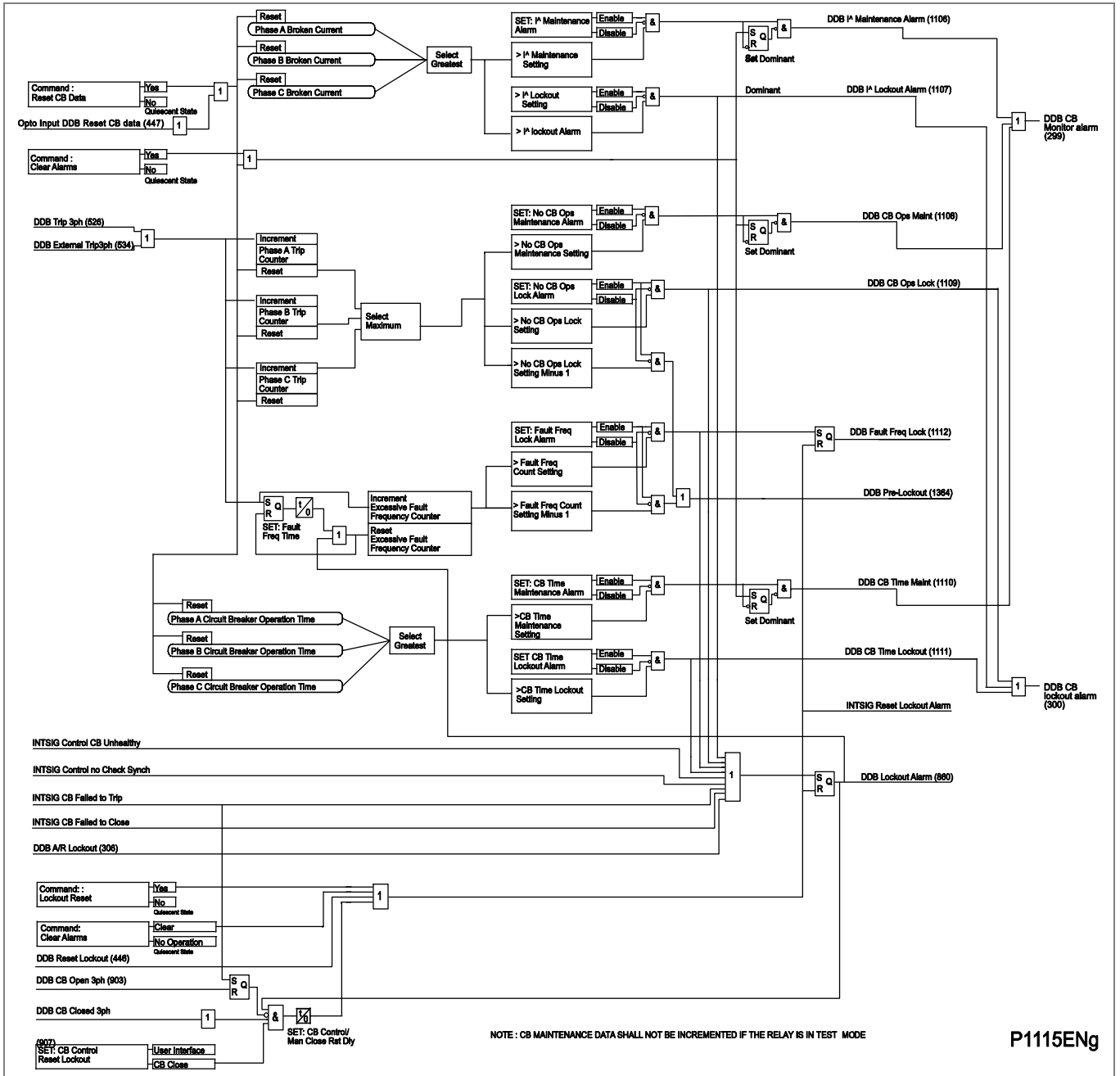

Figure 123 - CB monitoring (P543/P545)

4.6

CB Control (P543/P545)

The relay includes the following options for control of a single circuit breaker:

- Local tripping and closing, via the relay menu
- Local tripping and closing, via relay opto-isolated inputs
- Remote tripping and closing, using the relay communications

It is recommended that separate relay output contacts are allocated for remote circuit breaker control and protection tripping. This enables the control outputs to be selected via a local/remote selector switch. Where this feature is not required the same output contact(s) can be used for both protection and remote tripping.

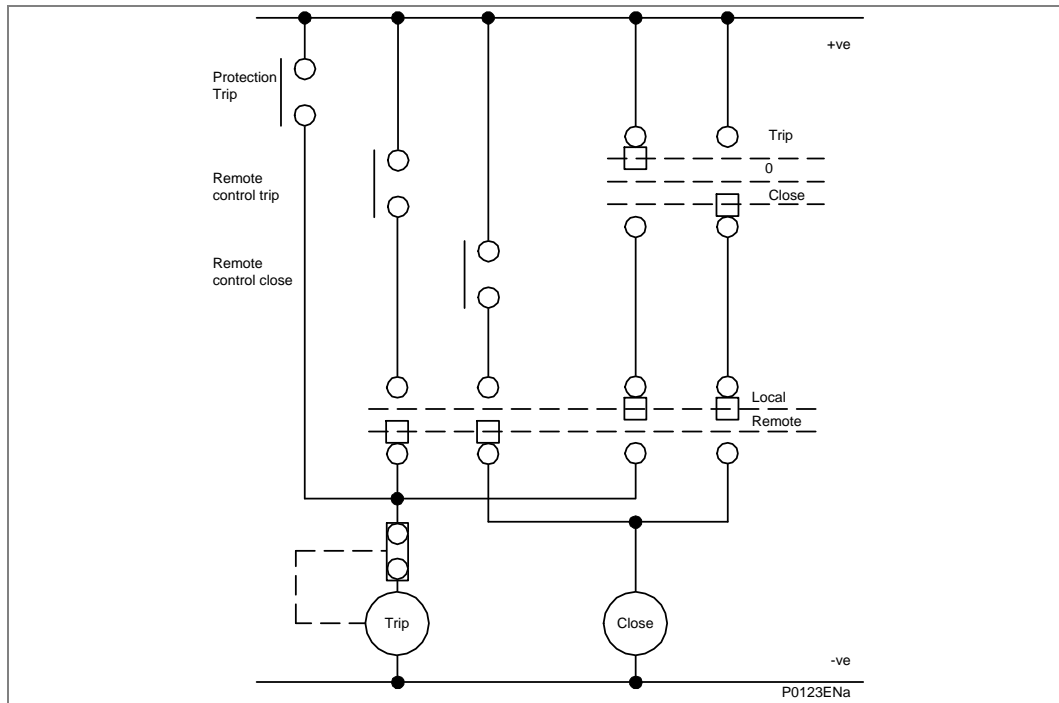

Figure 124 - Remote control of circuit breaker (P543/P545)

A manual trip will be possible if the circuit breaker is closed. Likewise, a close command can only be issued if the CB is initially open.

Therefore, it will be necessary to use the breaker 52A and/or 52B contacts (the different selection options are given from the 'CB Status Input' cell above). If no CB auxiliary contacts are available then this cell should be set to None. Under these circumstances no CB control (manual or auto) will be possible.

A circuit breaker close command **CB Close** will initiate closing of the circuit breaker. The output contact, however, can be set to operate following a user defined time delay (**Man Close Delay**). This is designed to give personnel time to retreat from the circuit breaker following the close command. This time delay applies to all manual circuit breaker close commands.

The control close cycle can be cancelled at any time before the output contact operates by any appropriate trip signal, or by activating DDB443: **Reset Close Delay**.

An **Auto Close CB** signal from the **Auto close** logic bypasses the **Man Close Delay** time, and the **CB Close** output operate immediately to close the circuit breaker.

The length of the trip or close control pulse is set via the **Trip Pulse Time** and **Close Pulse Time** settings respectively. These should be set long enough to ensure the breaker has completed its open or close cycle before the pulse has elapsed.

<i>Note</i>	<i>The manual trip and close commands are found in the SYSTEM DATA column and the hotkey menu.</i>
-------------	--

If an attempt to close the breaker is being made, and a protection trip signal is generated, the protection trip command overrides the close command.

When the check synchronisation function ('**System check**' menu) is enabled, it can be used to control manual circuit breaker close commands. When the check synchronism criteria are satisfied, '**CBC Close**' pulse is emitted. The '**C/S Window**' time delay is used to set manual closure according to system check logic. If the system check criteria are not satisfied before that time-delay elapses, the relay will lockout and issue alarm.

In addition, a CB Healthy information (from the CB), connected to one of the relay's opto-isolators, will indicate the circuit breaker condition for closing availability. When "CB Healthy input" (DDB: '**CB Healthy**') is used, the '**Healthy Window**' time-delay can be set to adjust the manual close of the CB. If the CB does not indicate a healthy condition during this time-delay period, the relay will lockout and issue an alarm.

Where auto-reclose is used it may be desirable to block its operation when performing a manual close. In general, the majority of faults following a manual closure will be permanent faults and it will be undesirable to auto-reclose.

The 'AR Inhibit Time' setting can be used to prevent auto-reclose being initiated when the CB is manually closed onto a fault. Auto-reclose is disabled for the AR Inhibit Time following manual CB closure.

If the CB fails to respond to the control command (indicated by no change in the state of CB Status inputs) a 'CB Failed to Trip' or 'CB Failed to Close' alarm will be generated after the relevant trip or close pulses have expired. These alarms can be viewed on the relay LCD display, remotely via the relay communications, or can be assigned to operate output contacts for annunciation using the relays Programmable Scheme Logic (PSL).

Important

The "CB Healthy Time" timer and "Check Sync Time" timer described in this menu section are applicable to manual circuit breaker operations only. These settings are duplicated in the auto-reclose menu for auto-reclose applications.

The 'Lockout Reset' and 'Reset Lockout by' setting cells in the menu are applicable to CB Lockouts associated with manual circuit breaker closure, CB Condition monitoring (Number of circuit breaker operations, for example) and auto-reclose lockouts.

The CB Control Logic is shown in Figure 125.

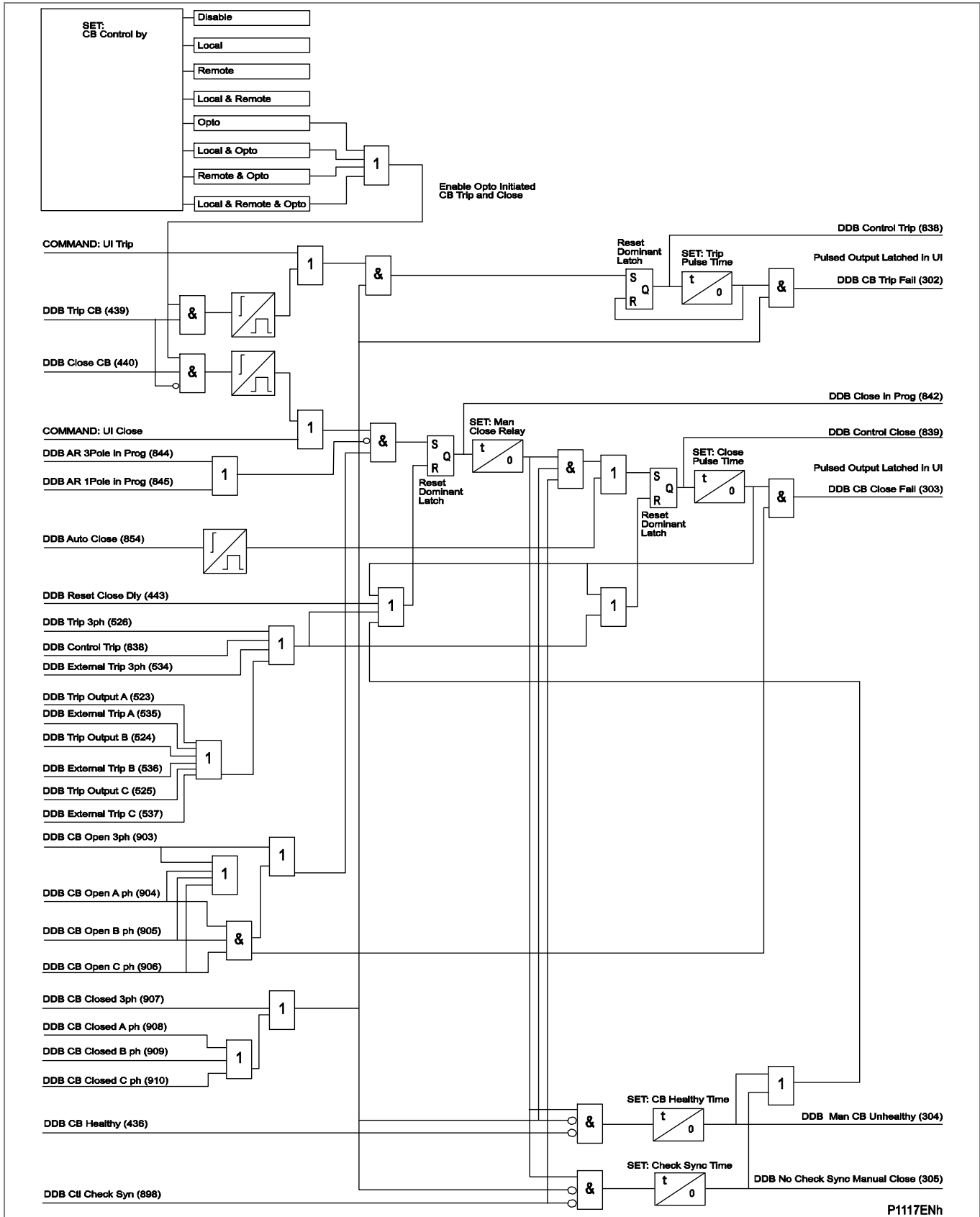

Figure 125 - Circuit breaker control (P543/P545)

4.6.1

CB Control using Hotkeys (P543/P545)

The hotkeys allow direct access to the manual trip and close commands without the need to use the SYSTEM DATA menu column. Red or green color coding can be applied when used in circuit breaker control applications.

IF <<TRIP>> or <<CLOSE>> is selected the user is prompted to confirm the execution of the relevant command. If a trip is executed, a screen displaying the circuit breaker status will be displayed once the command has been completed. If a close is executed a screen with a timing bar will appear while the command is being executed. This screen has the option to cancel or restart the close procedure. The timer used is taken from the manual close delay timer setting in the CB CONTROL menu. If the command has been executed, a screen confirming the present status of the circuit breaker will be displayed. The user is then prompted to select the next appropriate command or to exit - this will return to the default relay screen.

If no keys are pressed for a period of 25 seconds whilst the P445/P44y/P54x/P74x/P841 is waiting for the command confirmation, the P445/P44y/P54x/P74x/P841 will revert to showing the circuit breaker status. If no key presses are made for a period of 25 seconds whilst the P445/P44y/P54x/P74x/P841 is displaying the circuit breaker status screen, the P445/P44y/P54x/P74x/P841 will revert to the default relay screen. The *Circuit breaker control hotkey menu* diagram shows the hotkey menu associated with circuit breaker control functionality.

To avoid accidental operation of the trip and close functionality, the hotkey circuit breaker control commands are disabled for 10 seconds after exiting the hotkey menu.

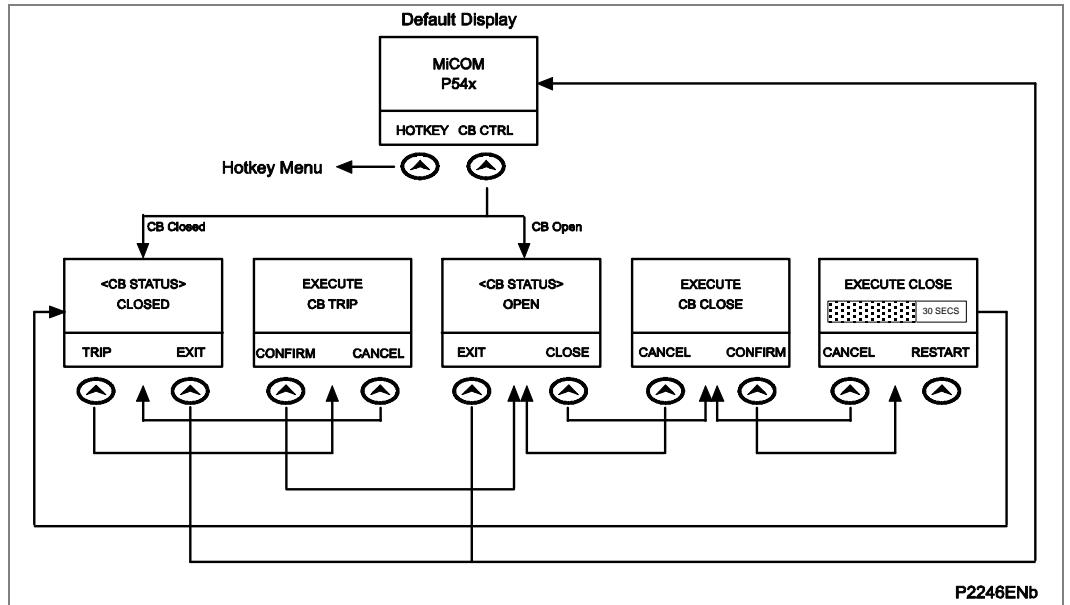

Figure 126 - CB control hotkey menu

4.6.2

CB Control using Function Keys (P543/P545)

The function keys allow direct control of the circuit breaker if programmed to do this in the PSL. Local tripping and closing must be set in the CB CONTROL menu "CB control by" cell to one of the via "opto" settings to enable this functionality. All circuit breaker manual control settings and conditions will apply for manual tripping and closing via function keys.

The following default logic can be programmed to activate this feature:

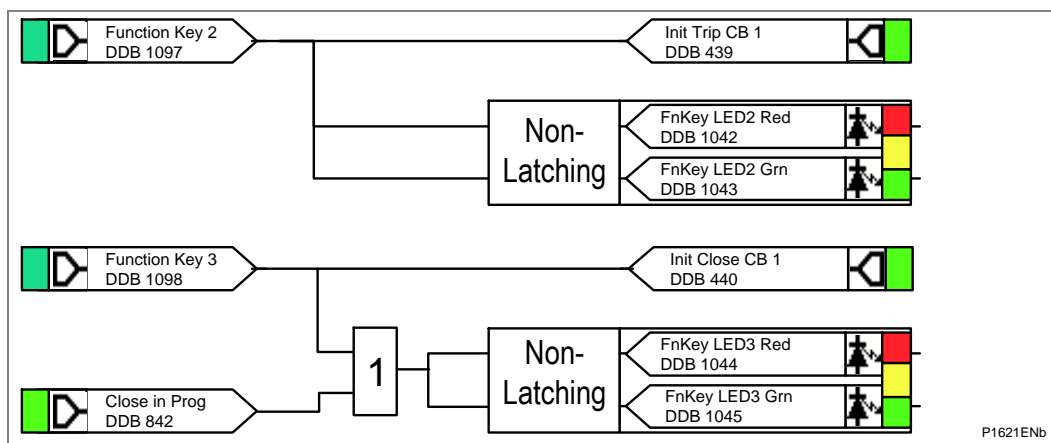

Figure 127 - CB control via function keys default PSL

Function key 2 and function key 3 are both enabled and set to 'Normal' Mode and the associated DDB signals (1097) and (1098) will be active high '1' on a key press.

The following DDB signals must be mapped to the relevant function key:

- Init Trip CB (DDB 439) - Initiate manual circuit breaker trip (CB or CB1)
- Init Close CB (DDB 440) - Initiate manual circuit breaker close (CB or CB1)

The programmable function key LEDs have been mapped such that the LEDs will indicate yellow whilst the keys are activated.

5 DUAL CB CONTROL: P544/P546 OPERATION

This section describes the P544/P546 operational control of dual circuit breakers.

5.1 Introduction

The circuit breaker control and monitoring in the dual-breaker P446/P544/P546/P841B provides single-phase or three-phase switching of a feeder controlled by two circuit breakers at a line end, for example in a one and a half switch configuration or at a mesh type (ring bus) installation. It can also be set to manage switching of a feeder controlled by a single circuit breaker.

This section introduces the operation of the circuit breaker scheme, describes the circuit breaker state monitoring, condition monitoring, and circuit breaker control, and then the circuit breaker auto-reclose operation.

The control of circuit breaker switching sequences represents a complex logic arrangement. The operation is best understood by reference to the design logic diagrams that have been used to implement the functionality. For ease of reference, all these logic diagrams have been put together in a supplementary **CB Control and AR Figures** section in this chapter. Any diagrams that are not explicitly shown in this chapter will be found in the AR figures section and will be clearly indicated.

The inputs and outputs of the logic described are, in many cases, DDB signals that are available to the Programmable Scheme Logic (PSL). A description of these signals can be found in the Programmable Logic chapter of this manual. Other signals are also used to define the operation but are internal to the logic of the circuit breaker control. Unlike the DDB signals, these internal signals cannot be accessed using the PSL. They are hard-coded into the application software. A second supplementary section lists these signals and provides a brief description to aid understanding.

5.2 CB Scheme Designation (P544/P546)

In the dual-breaker P446/P544/P546/P841B, the two controlled circuit breakers are designated CB1 and CB2. CB1 connects the P446/P544/P546/P841B to Bus1 and CB2 connects the P446/P544/P546/P841B to Bus 2.

It is possible to configure the P446/P544/P546/P841B for use in a single circuit breaker application using either CB1 control or CB2 control. If operating like this, all text, etc., associated with the unused circuit breaker is hidden.

<i>Note</i>	<i>In some of the menu text, the reference to which circuit breaker is being described, is not explicitly stated (for example, "CB Operations" in the circuit breaker monitoring features. In all such cases, an unqualified "CB" reference should be assumed to be associated with CB1. "CB2" is always used to explicitly indicate CB2. An unqualified "CB" or an explicit "CB1" refers to CB1. CBx indicates either CB1 or CB2.</i>
-------------	---

5.3

Circuit Breaker Status (P544/P546)

For each circuit breaker, the P446/P544/P546/P841B incorporates circuit breaker state monitoring, giving an indication of the position of each circuit breaker or, if the state is unknown, an alarm is raised.

The P446/P544/P546/P841 can be set to monitor normally open (52A) and normally closed (52B) auxiliary contacts of the circuit breaker. Under healthy conditions, the 52A and 52B contacts should be in opposite states. Should both sets of contacts be open, this would indicate one of the following conditions:

- Auxiliary contacts/wiring defective
- Circuit breaker is defective
- Circuit breaker is in an isolated position

Should both sets of contacts be closed, only one of these conditions would apply:

- Auxiliary contacts/wiring defective
- Circuit Breaker is defective

If any of the above conditions exist, an alarm will be issued after time delay as set in “CB Status time” in the CB CONTROL settings column of the menu. A normally open / normally closed output contact can be assigned to this function via the PSL. The time delay is set to avoid unwanted operation during normal switching duties where fleeting abnormal circuit breaker status conditions may exist as the contacts change state.

Note *The “CB Status time” setting is one setting applied equally to both controlled circuit breakers.*

In the CB CONTROL column of the relay menu there are two settings: “CB1 Status Input” and “CB2 Status Input”. Each cell can be set at one of the following seven options to control CB1 and/or CB2:

None	
52A	3 pole
52B	3 pole
52A & 52B	3 pole
52A	1 pole
52B	1 pole
52A & 52B	1 pole

If **None** is selected, no circuit breaker status will be available. This will directly affect any function within the relay that requires this signal, for example circuit breaker control, auto-reclose, etc.

Where only **52A** (open when the circuit breaker is open, closed when the circuit breaker is closed) is used then the relay will assume a **52B** signal from the absence of the **52A** signal. Circuit breaker status information will be available in this case but no discrepancy alarm will be available. The above is also true where only a **52B** (closed when the circuit breaker is open, open when the circuit breaker is closed) is used.

If both **52A** and **52B** are used then status information will be available and in addition a discrepancy alarm “CBx Status Alarm” (x = 1 or 2) will be possible, according to the following table. **52A** and **52B** inputs are assigned to relay opto-isolated inputs via the PSL.

Auxiliary contact position		CB State Detected	Action
52A	52B		
Open	Closed	Breaker Open	Circuit breaker healthy
Closed	Open	Breaker Closed	Circuit breaker healthy
Closed	Closed	CB Failure	Alarm raised if the condition persists for greater than "CB Status time"
Open	Open	State Unknown	Alarm raised if the condition persists for greater than "CB Status time"

Table 25 - Auxiliary contact position, CB state detected and Action

In the internal logic of the P446/P544/P546/P841, the breaker position used in the algorithm is considered to be open when the **CB State Detected** is **Breaker Open**. In all other cases, the breaker position is considered to be closed. Therefore, during operation of the circuit breaker, if the condition '52A=52B=0' or '52A=52B=1' is encountered, the circuit breaker is considered to be closed.

Where single pole tripping is used, then an open breaker condition will only be given if all three-phases indicate an open condition. Similarly for a closed breaker condition, indication that all three-phases are closed must be given. For single pole tripping applications 52A-a, 52A-b and 52A-c and/or 52B-a, 52B-b and 52B-c inputs should be used. The circuit breaker state monitoring logic diagram is shown in the *Circuit breaker - state monitor* or *Circuit breaker 1/2 - state monitor* diagram(s).

If inputs relevant to each of the circuit breakers (CB1 and CB2) are available to the relay via the opto isolated inputs, the logic will be able to determine the state of each circuit breaker.

5.4

Circuit Breaker Condition Monitoring (P544/P546)

Periodic maintenance of circuit breakers is needed to ensure that the trip circuit and mechanism operate correctly and also that the interrupting capability has not been compromised due to previous fault interruptions. Generally, such maintenance is based on a fixed time interval or a fixed number of fault current interruptions. These methods of monitoring circuit breaker condition give a rough guide only and can lead to excessive maintenance. The circuit breaker monitoring features of the MiCOM relay can help with more efficient maintenance regimes.

5.4.1

Circuit Breaker Condition Monitoring Features (P544/P546)

For each circuit breaker trip operation the relay records statistics as shown in the following table taken from the relay menu. The menu cells shown are counter values only. The Min./Max. values in this case show the range of the counter values. These cells can not be set:

Menu text	Default	Setting		Step size
		Min.	Max.	
CB1 A Operations	0	0	10000	1
Displays the total number of A phase trips issued by the relay for CB1.				
CB1 B Operations	0	0	10000	1
Displays the total number of B phase trips issued by the relay for CB1.				
CB1 C Operations	0	0	10000	1
Displays the total number of C phase trips issued by the relay for CB1.				
CB1 IA Broken	0	0	25000 In [^]	1
Displays the total fault current interrupted by the relay for the A phase for CB1.				
CB1 IB Broken	0	0	25000 In [^]	1
Displays the total fault current interrupted by the relay for the A phase for CB1.				
CB1 IC Broken	0	0	25000 In [^]	1 In [^]
Displays the total fault current interrupted by the relay for the A phase for CB1.				
CB1 Operate Time	0	0	0.5s	0.001
Displays the calculated CB1 operating time.				
Reset CB1 Data	No		Yes, No	
Reset the CB1 condition counters.				
CB2 A Operations	0	0	10000	1
Displays the total number of A phase trips issued by the relay for CB2.				
CB2 B Operations	0	0	10000	1
Displays the total number of B phase trips issued by the relay for CB2.				
CB2 C Operations	0	0	10000	1
Displays the total number of C phase trips issued by the relay for CB2.				
CB2 IA Broken	0	0	25000 In [^]	1
Displays the total fault current interrupted by the relay for the A phase for CB2.				
CB2 IB Broken	0	0	25000 In [^]	1
Displays the total fault current interrupted by the relay for the A phase for CB2.				
CB2 IC Broken	0	0	25000 In [^]	1In [^]
Displays the total fault current interrupted by the relay for the A phase for CB2.				
CB2 Operate Time	0	0	0.5 s	0.001
Displays the calculated CB2 operating time.				
Reset CB2 Data	No		Yes, No	
Reset the CB2 condition counters.				

Table 26 - Circuit Breaker Condition Min/Max values

The above counters may be reset to zero, for example, following a maintenance inspection and overhaul.

The circuit breaker condition monitoring counters will be updated every time the relay issues a trip command. In cases where the breaker is tripped by an external protection device it is also possible to update the CB condition monitoring. This is achieved by allocating one of the relays opto-isolated inputs (using the programmable scheme logic) to accept a trigger from an external device. The signal that is mapped to the opto is called **External Trip**, DDB 115.

<i>Note</i>	<i>When in Commissioning Test Mode the CB condition monitoring counters will not be updated.</i>
-------------	---

The measurement of circuit breaker broken current, operating time and the overall circuit breaker monitoring logic diagram, are shown in:

- Figure 128 - CB1 condition monitoring – broken current
- Figure 129 - CB2 condition monitoring – broken current
- Figure 130 - CB1 condition monitoring – operation time
- Figure 131 - CB2 condition condition monitoring – operation time
- Figure 132 - Circuit breaker 1 – monitoring
- Figure 133 - Circuit breaker 2 – monitoring

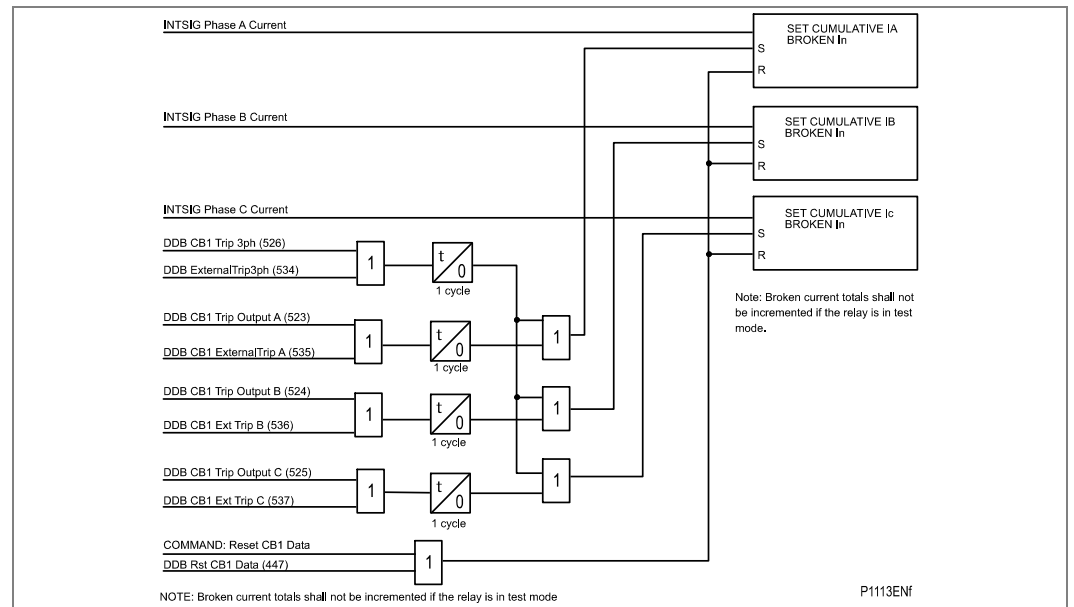

Figure 128 - CB1 condition monitoring – broken current

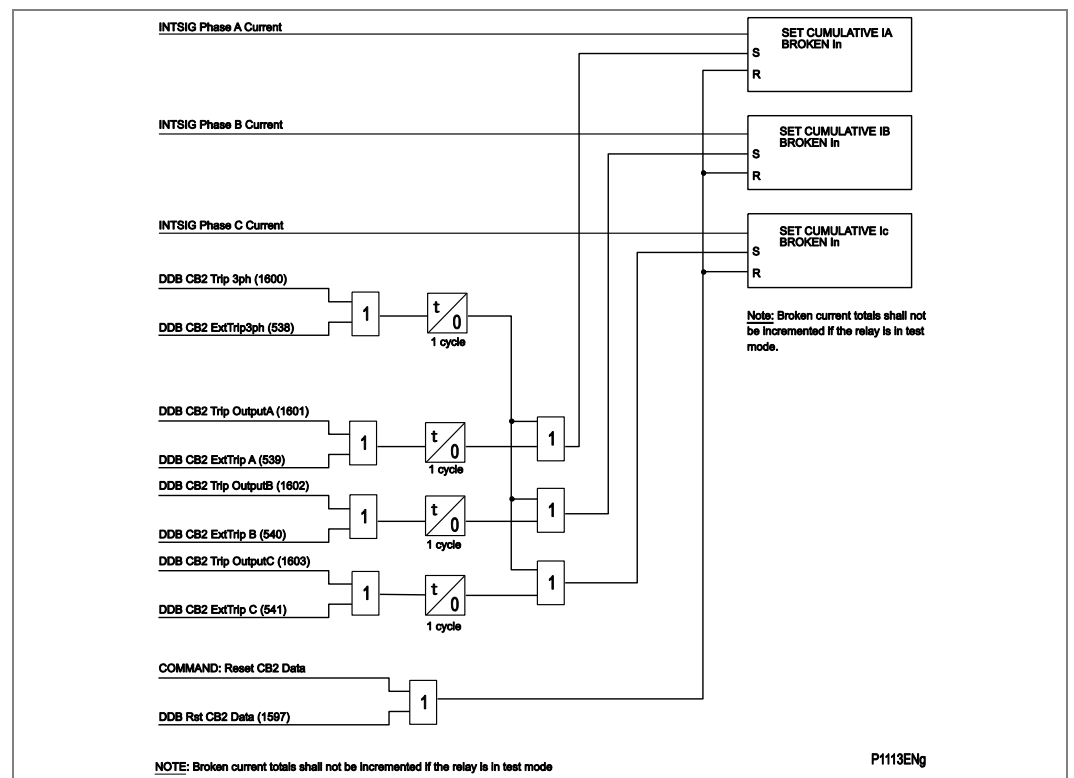

Figure 129 - CB2 condition monitoring – broken current

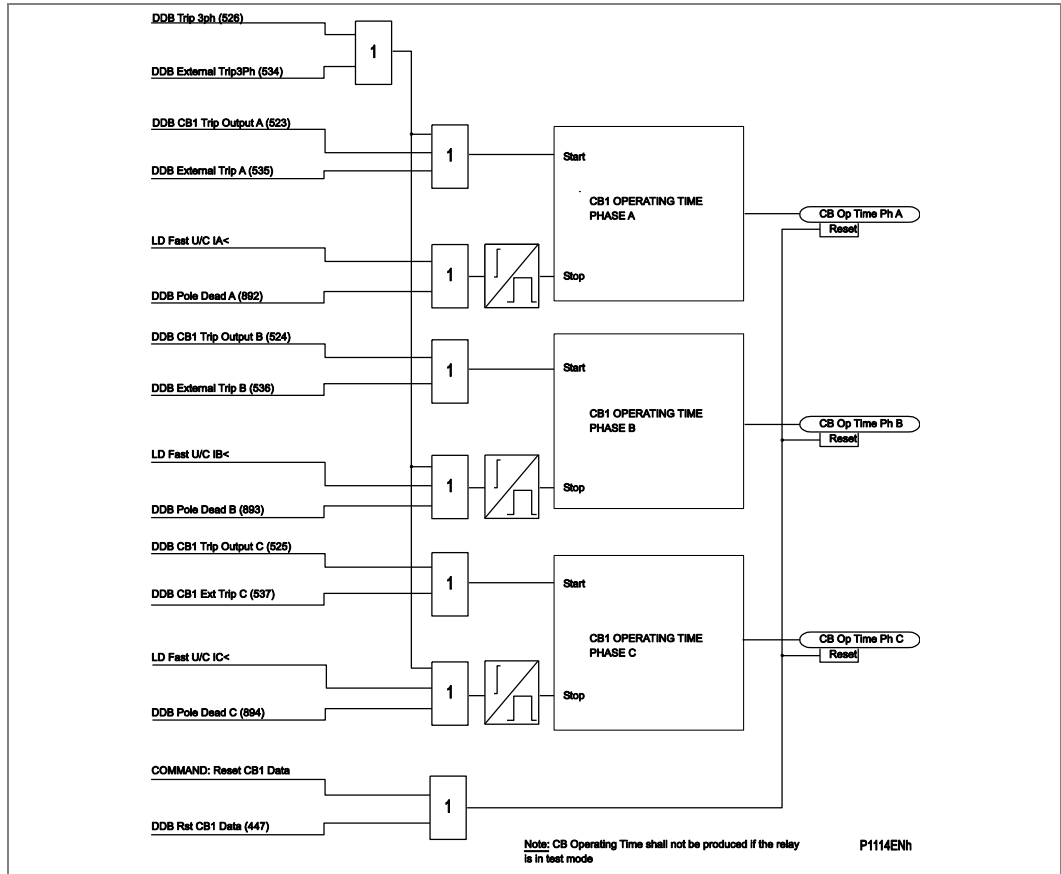

Figure 130 - CB1 condition monitoring – operation time

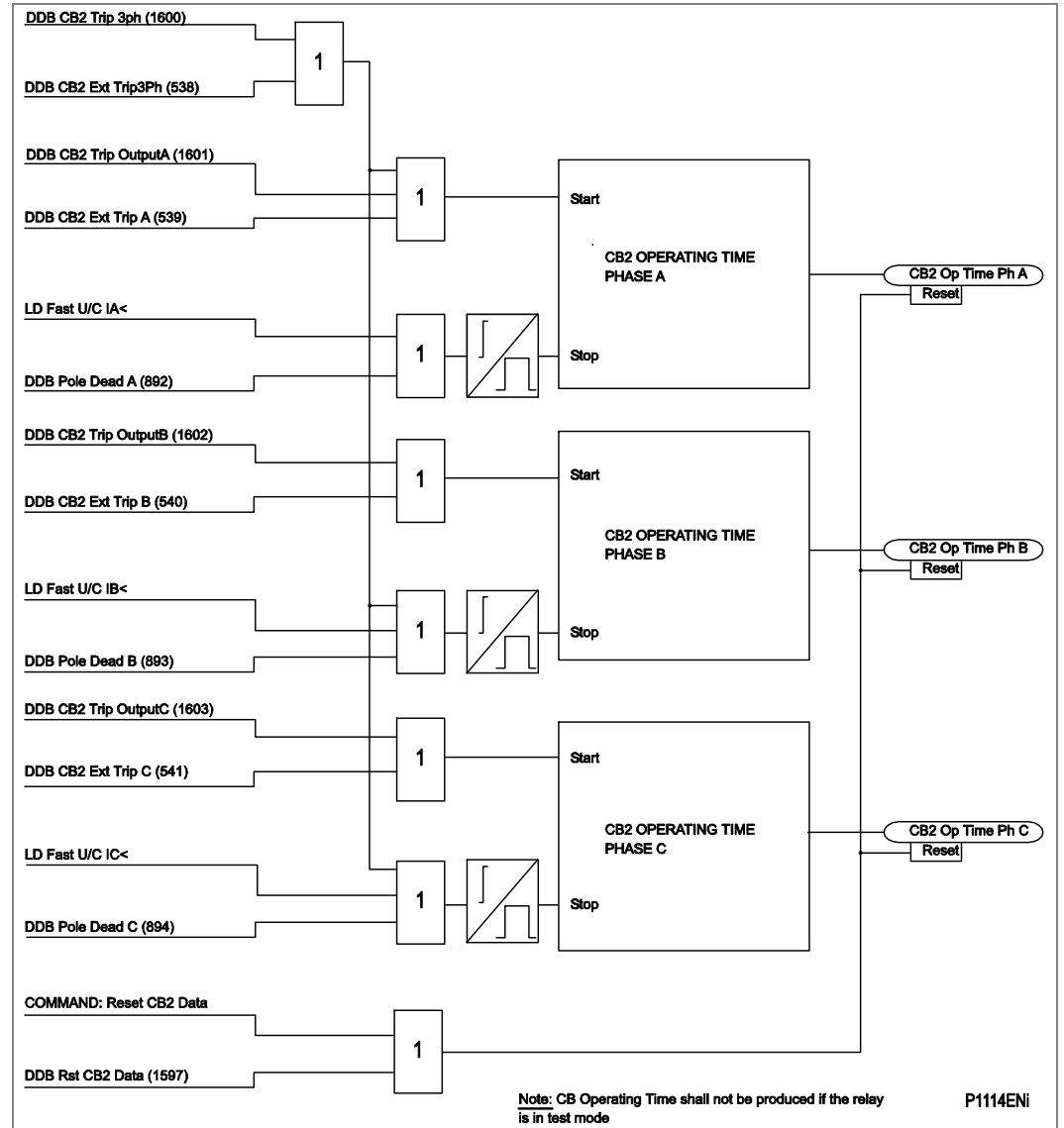
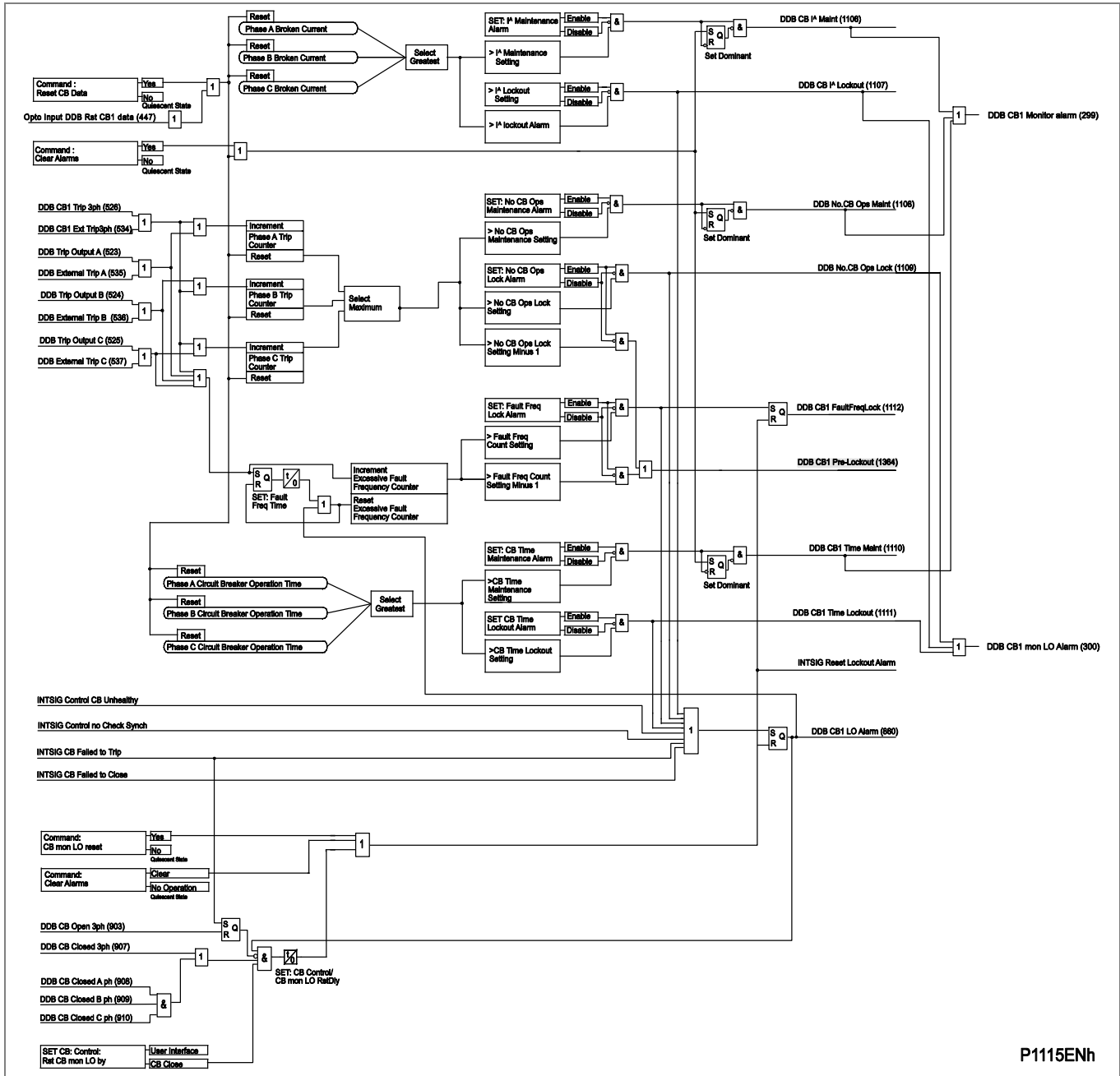

Figure 131 - CB2 condition monitoring – operation time



P1115ENh

Figure 132 - Circuit breaker 1 – monitoring

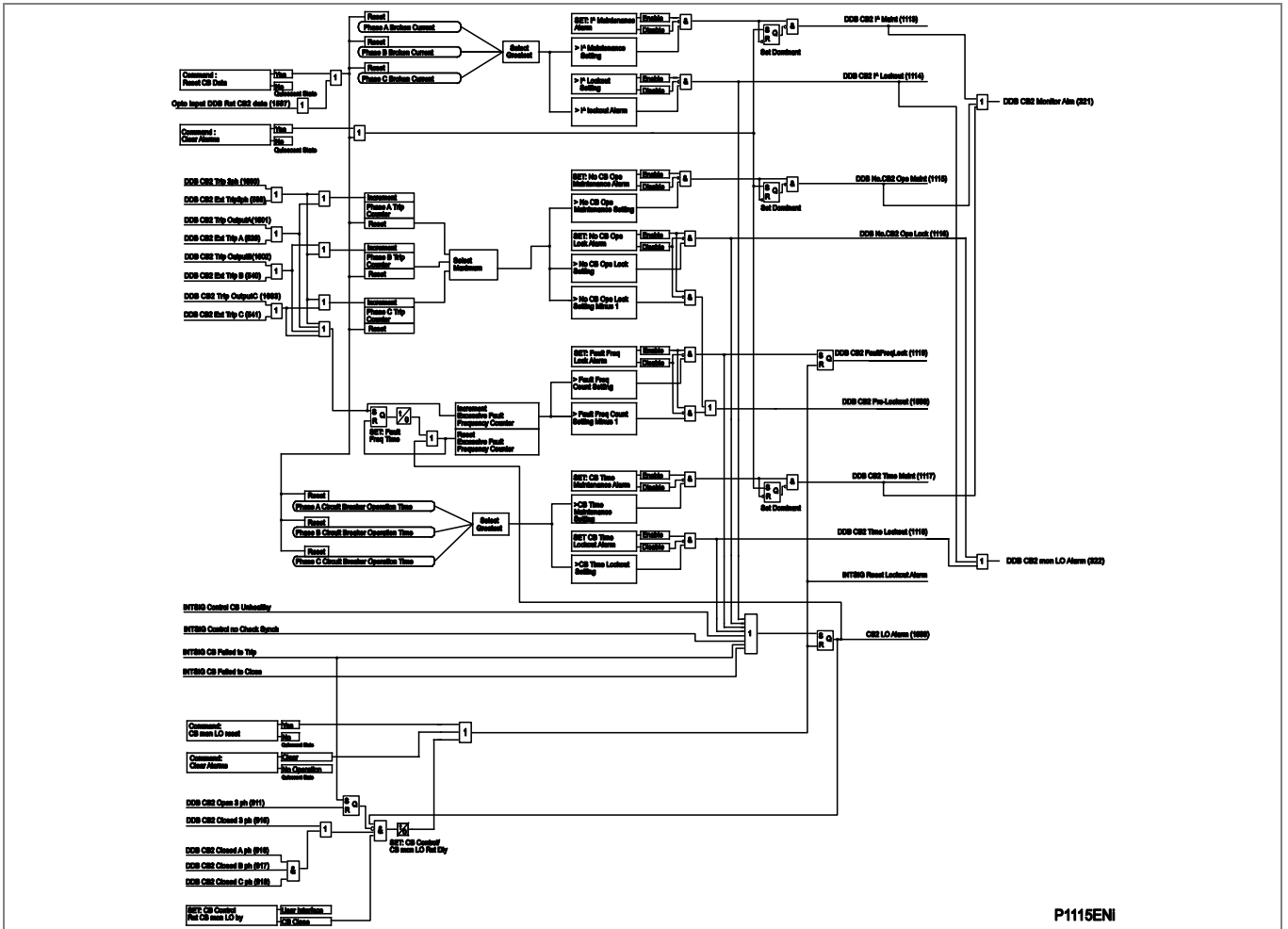

Figure 133 - Circuit breaker 2 – monitoring

5.5 Circuit Breaker Control (P544/P546)

This functionality shows how a circuit breaker close signal from the auto-reclose logic “AutoClose CBx” (x = 1 or 2) is applied alongside operator controlled circuit breaker close and trip control.

See AR Figure AR-45 and Figure AR-46 (logic diagram supplement) for CB1 & CB2 circuit breaker control respectively.

The P446/P544/P546/P841 includes the following options for the control of each of the two circuit breakers:

- Local tripping and closing, via the relay menu or *Hotkeys*
- Local tripping and closing, via relay opto-isolated inputs
- Remote tripping and closing, using the relay communications
- Auto-reclosing via “Auto Close CB1” or “Auto Close CB2” signal from CB1 & CB2 Auto Close logic.

It is recommended that separate relay output contacts are allocated for remote circuit breaker control and protection tripping. This enables the control outputs to be selected via a local/remote selector switch as shown in the *Remote control of circuit breaker* diagram. Where this feature is not required the same output contact(s) can be used for both protection and remote tripping.

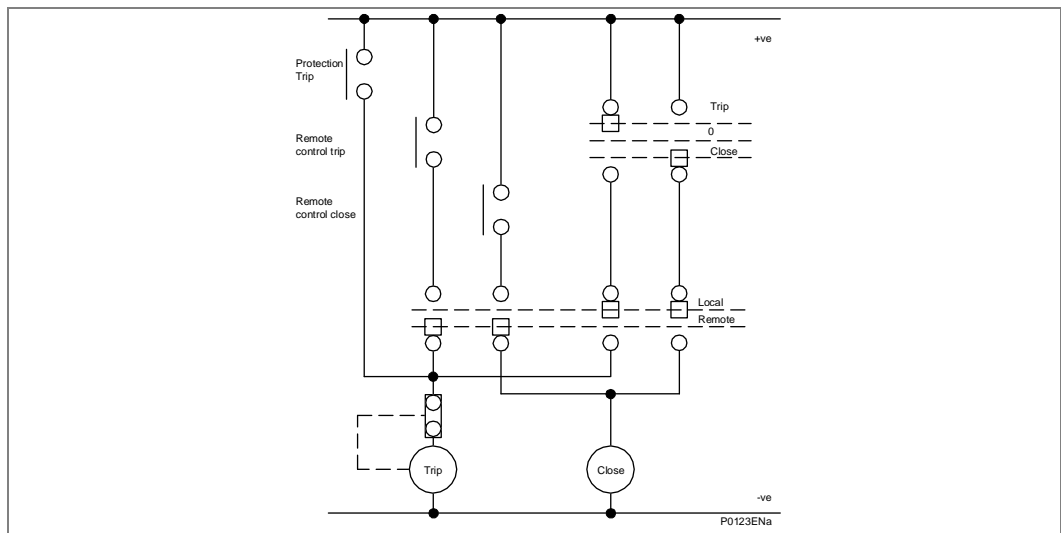

Figure 134 - Remote control of circuit breaker

In the case of the P446/P544/P546/P841B, the two circuit breakers may be selectively controlled both locally and remotely if relay contacts are assigned to allow a separate control trip contact and a separate control close for each circuit breaker i.e. four output relay contacts.

A manual trip will be possible if the circuit breaker is closed. Likewise, a close command can only be issued if the CB is open.

Therefore, it will be necessary to use the breaker positions 52A and/or 52B contacts via the PSL (the different selection options are given from the **CBx Status Input** cell above). If no CB auxiliary contacts are available, this cell should be set to **None**. Under these circumstances no circuit breaker control (manual or auto) will be possible.

A circuit breaker close command (“Close CB1” for CB1 or “Close CB2” for CB2) will initiate closing of the circuit breaker. The output contact, however, can be set to operate following a user defined time delay (‘Man Close Delay’). This is designed to give personnel time to retreat from the circuit breaker following the close command. This time delay applies to all manual circuit breaker close commands.

The control close cycle can be cancelled at any time before the output contact operates by any appropriate trip signal, or by activating DDB (443): “Rst CB1 CloseDly” for CB1 or by DDB (1419): “Rst CB2 CloseDly” for CB2.

An “Auto Close CB1” or “Auto Close CB2” signal from the “Auto close” logic bypasses the “Man Close Delay” time, and the “CB1 Close” or “CB2 Close” outputs operate immediately to close the circuit breaker.

The length of the trip or close control pulse is set via the “Trip Pulse Time” and “Close Pulse Time” settings respectively. These should be set long enough to ensure the breaker has completed its open or close cycle before the pulse has elapsed.

<i>Note</i>	<i>The manual trip and close commands are found in the SYSTEM DATA column and the hotkey menu.</i>
-------------	--

If an attempt to close the breaker is being made, and a protection trip signal is generated, the protection trip command overrides the close command.

If the system check synchronism function is set, this can be enabled to supervise manual circuit breaker close commands. A circuit breaker close output will only be issued if the check synchronism criteria are satisfied. Different system check criteria can be selected for control closing CB1 and CB2. A user settable time delay (“Check Sync Time”) is included to supervise manual closure with check synchronizing criteria. If the check synchronism criteria are not satisfied in this time period following a close command the relay will lockout and alarm.

Before manual reclosure, in addition to a synchronism check there is also a circuit breaker healthy check, “CB Healthy”, which requires the circuit breaker to be capable of closing safely (for example, having its closing spring fully charged and/or gas pressure sufficient for a close and immediate fault trip), as indicated by DDB input “CBx Healthy” (x = 1 or 2). A user settable time delay “CB Healthy Time” is included for manual closure with this check. If the circuit breaker does not indicate a healthy condition in this time period following a close command (DDB input is still low when the set time has elapsed) then the relay will lockout the relevant circuit breaker and set an alarm.

If auto-reclose is used it may be desirable to block its operation when performing a manual close. In general, the majority of faults following a manual closure will be permanent faults and it will be undesirable to allow auto-reclose.

To ensure that auto-reclosing is not initiated for a manual Circuit Breaker (CB) closure on to a pre-existing fault (switch on to fault), the AUTO-RECLOSE menu setting “CB IS Time” (CB In Service Time) should be set for the desired time window. This setting ensures that auto-reclose initiation is inhibited for a period equal to setting “CB IS Time” following a manual CB closure. If a protection operation occurs during the inhibit period, auto-reclosing is not initiated.

Following manual CB closure, if either a single-phase or a three-phase fault occurs during the inhibit period, the CB is tripped three-phase, but auto-reclose is not locked out for this condition.

If the CB fails to respond to the control command (indicated by no change in the state of CBx Status inputs) a ‘CBx Trip Fail’ or ‘CBx Close Fail’ alarm (x = 1 or 2) will be generated after the relevant ‘Trip pulse Time’ or ‘Close Pulse Time’ has expired. These alarms can be viewed on the relay LCD display, remotely via the relay communications, or can be assigned to operate output contacts for annunciation using the relays Programmable Scheme Logic (PSL).

Important The “CB Healthy Time” timer and “Check Sync Time” timer described in this menu section are applicable to manual circuit breaker operations only. These settings are duplicated in the auto-reclose menu for auto-reclose applications.

For the description of settings and commands related to the various methods for resetting circuit breaker lockouts, refer to section 5.6.6.19 - Reset CB Lockout.

5.5.1 CB Control using Hotkeys (P544/P546)

The hotkeys allow direct access to the manual trip and close commands without the need to use the SYSTEM DATA menu column. Red or green color coding can be applied when used in circuit breaker control applications.

IF <<TRIP>> or <<CLOSE>> is selected the user is prompted to confirm the execution of the relevant command. If a trip is executed, a screen displaying the circuit breaker status will be displayed once the command has been completed. If a close is executed a screen with a timing bar will appear while the command is being executed. This screen has the option to cancel or restart the close procedure. The timer used is taken from the manual close delay timer setting in the CB CONTROL menu. If the command has been executed, a screen confirming the present status of the circuit breaker will be displayed. The user is then prompted to select the next appropriate command or to exit - this will return to the default relay screen.

If no keys are pressed for a period of 25 seconds whilst the P445/P44y/P54x/P74x/P841 is waiting for the command confirmation, the P445/P44y/P54x/P74x/P841 will revert to showing the circuit breaker status. If no key presses are made for a period of 25 seconds whilst the P445/P44y/P54x/P74x/P841 is displaying the circuit breaker status screen, the P445/P44y/P54x/P74x/P841 will revert to the default relay screen. The *Circuit breaker control hotkey menu* diagram shows the hotkey menu associated with circuit breaker control functionality.

To avoid accidental operation of the trip and close functionality, the hotkey circuit breaker control commands are disabled for 10 seconds after exiting the hotkey menu.

5.5.2 Circuit Breaker Control using Function Keys (P544/P546)

The function keys allow direct control of the circuit breaker if programmed to do this in the PSL. Local tripping and closing must be set in the CB CONTROL menu “CB control by” cell to one of the via “opto” settings to enable this functionality. All circuit breaker manual control settings and conditions will apply for manual tripping and closing via function keys.

The following default logic can be programmed to activate this feature:

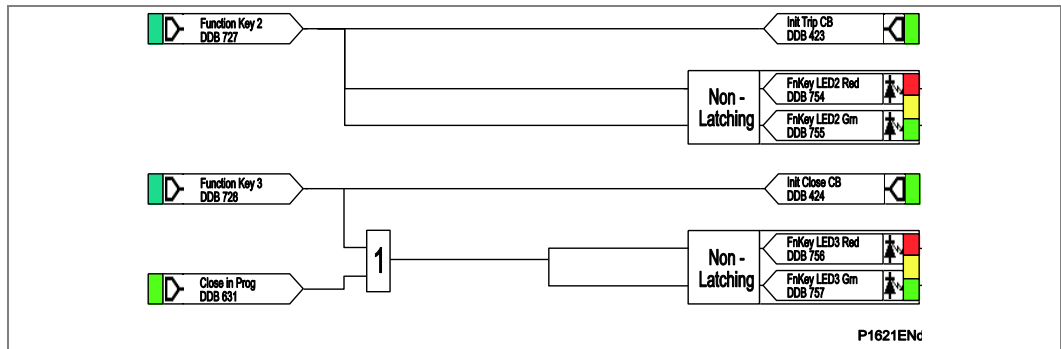

Figure 135 - Circuit breaker control via function keys default PSL

Function key 2 and function key 3 are both enabled and set to ‘Normal’ Mode and the associated DDB signals (1097) and (1098) will be active high ‘1’ on a key press.

The following DDB signals must be mapped to the relevant function key:

- Init Trip CB (DDB 439) - Initiate manual circuit breaker trip (CB or CB1)
- Init Close CB (DDB 440) - Initiate manual circuit breaker close (CB or CB1)

The programmable function key LEDs have been mapped such that the LEDs will indicate yellow whilst the keys are activated.

The diagram shows the control of CB1 only for simplicity. CB2 can be controlled in a similar way and the relevant DDB signals are (441) Init Trip CB2, and (442) Init Close CB2.

5.6

Single and Three Phase Auto-Reclosing (P544/P546)

The auto-reclose scheme in the P544/P546 provides single-phase or three-phase auto-reclosing of a feeder terminal switched by one or two circuit breakers.

With the P544/P546, the user can select to initiate auto-reclosure following any Zone 1, or distance-aided scheme trips which occur. In addition, the user can selectively decide to auto-reclose for trips from time-delayed distance zones, overcurrent and earth (ground) elements, and DEF aided schemes.

In a two-circuit breaker scheme, the circuit breakers are normally arranged to reclose sequentially with one designated leader circuit breaker reclosing after a set **dead time** followed, if the leader circuit breaker remains closed, by the second circuit breaker after a further delay, the **follower time**. In the operational description, the two circuit breakers are designated as CB1 and CB2.

The scheme can be configured by menu settings, by control commands, or by opto inputs to operate in any of the following modes for the first shot (first auto-reclose attempt):

Leader CB	Leader AR mode	Follower CB	Follower AR Mode
CB1	1Ph	CB2	1Ph or 3Ph
CB1	3Ph	CB2	3Ph
CB1	1/3Ph	CB2	1/3Ph or 3Ph
CB1	1Ph, 3P or 1/3Ph	No follower AR	No follower AR
CB2	1Ph	CB1	1Ph or 3Ph
CB2	3Ph	CB1	3Ph
CB2	1/3Ph	CB1	1/3Ph or 3Ph
CB2	1Ph, 3P or 1/3Ph	No follower AR	No follower AR

If "1Ph" or "1/3Ph" follower auto-reclose mode is selected, the follower can perform single-phase auto-reclose only if the leader circuit breaker has performed single-phase auto-reclose. If the leader has tripped and reclosed three-phase, the follower is also forced to trip three-phase, and will then reclose three-phase provided three-phase auto-reclose is permitted for the follower circuit breaker. If the follower circuit breaker trips three-phase, and three-phase auto-reclose is not permitted for the follower, then the follower circuit breaker will lock out without reclosing.

Single phase reclosing is permitted only for the first shot of an auto-reclose cycle. If two or more shots are enabled, then in a multi-shot auto-reclose cycle the second and subsequent trips and reclosures will be three-phase.

Table 27 - Leader CB, Leader AR mode, Follower CB and Follower AR Mode

The scheme can be configured to control a single CB installation. If the menu setting "Num CBs" is set to "CB1 Only", all menu settings and indications relating to CB2 are redundant and hidden, and the scheme controls only CB1. If the menu setting "Num CBs" is set to "CB2 Only", all menu settings and indications relating to CB1 are redundant and hidden, and the scheme controls only CB2. In these single CB configurations, the selected CB auto-reclose can be selected to "1Ph", "3Ph" or "1/3Ph AR mode" indicating single-phase, three-phase, or single/three-phase operation.

5.6.1

Time Delayed and High Speed Auto-Reclosing (P544/P546)

The auto-reclose function offers multi-shot auto-reclose control, selectable to perform up to a four shot cycle. Dead times (Note 1) for all shots (Note 2) are independently adjustable. Should the CB close successfully at the end of the dead time, a Reclaim Time starts. If the circuit breaker does not trip again, the auto-reclose function resets at the end of the reclaim time. If the protection trips again during the reclaim time the relay advances to the next shot in the programmed cycle, or, if all programmed reclose attempts have been made, goes to lockout.

Note **Dead Time** denotes the open (dead) interval delay of the CB.

Note 2 A **Shot** is a reclosure attempt.

5.6.2 Auto-Reclose Logic Inputs (P544/P546)

The auto-reclose function uses inputs in the logic, which can be assigned and activated from any of the opto-isolated inputs on the relay via the Programmable Scheme Logic (PSL). Contacts from external equipment may be used to influence the auto-recloser via the optos, noting that the CB Status (open/closed) must also be available via auxiliary contact inputs to the relay.

These logic inputs can also be assigned and activated from other sources. The function of these inputs is described below, identified by their DDB signal text. The inputs can be selected to accept either a normally open or a normally closed contact, programmable via the PSL editor.

5.6.2.1 CB Healthy (P544/P546)

The majority of circuit breakers are only capable of providing one trip-close-trip cycle. Following this, it is necessary to re-establish sufficient energy in the CB (spring charged, gas pressure healthy, etc.) before the CB can be reclosed.

The CB Healthy input is used to ensure that there is sufficient energy available to close and trip the circuit breaker before initiating a CB Close command. If on completion of the dead time, the DDB "CB Healthy" input is low, and remains low for a period given by the "CB Healthy Time" timer, lockout will result and the circuit breaker will remain open. DDBs (436 & 437) are used for "CB1 Healthy" & "CB2 Healthy" respectively to enable "CB1 Close" and "CB2 Close" by auto-reclose. The "CB Healthy Time" setting is common to both CB1 and CB2.

This check can be disabled by not allocating an opto input for DDB "CB Healthy". The signal defaults to high if no logic is mapped to DDB within the PSL in the relay.

5.6.2.2 Inhibit Auto-Reclose (P544/P546)

An external input can be used to inhibit auto-reclose. The signal is available for mapping via the PSL from an opto input or a communications input.

The signal is "Inhibit AR", DDB (1420). Where there are two circuit breakers, this single signal applies to both CB1 and CB2.

Energising the input will cause any auto-switching to be inhibited. Any auto-reclose in progress will be reset and inhibited, but not locked out. It is provided to ensure that auto-switching does not interfere with any manual switching. A typical application would be on a mesh-corner scheme where manual switching is being performed on the mesh, for which any auto-reclose would cause interference.

If a single-phase auto-reclose cycle is in progress and a single pole of the circuit breaker is tripped when this signal is raised, a 'force three-phase trip output', ("AR Force 3 pole", DDB (858)) will be set. This is to force the circuit breaker to trip the other phases thereby ensuring that all poles will be in the same state (and avoiding a pole stuck condition) when subsequent closing of the circuit breaker is attempted.

5.6.2.3 Block Auto-Reclose (P544/P546)

External inputs can be used to block auto-reclose. Two signals (one for each circuit breaker controlled) are available for mapping via the PSL from opto inputs or communications inputs. The two signals are:

- “Block CB1 AR” DDB (448)
- “Block CB2 AR” DDB (1421)

The “Block CB AR” input, if asserted, will block the operation of the auto-reclose cycle and, if auto-reclose is in progress, it will force the circuit breaker to lockout.

Typically, it is used where, dependent upon the type of protection operation, auto-reclose may, or may not, be required. An example is on a transformer feeder, where auto-reclosing may be initiated from the feeder protection but blocked from the transformer protection.

“Block CB AR” can also be used in cases where the auto-reclose cycle is likely to fail for conditions associated with the protected circuit. The input can be used for example if, anywhere during the dead time, a circuit breaker indicates that it is not capable of switching (low gas pressure or loss of vacuum alarm occurs).

5.6.2.4 Reset Lockout (P544/P546)

The Reset Lockout input can be used to reset the auto-reclose function following lockout and reset any auto-reclose alarms, provided that the signals which initiated the lockout have been removed.

These DDB signals are available for mapping in PSL from opto inputs or communications inputs:

- DDB (446) “Rst CB1 Lockout”: Reset Lockout Opto Input to reset CB1 Lockout state
- DDB (1422) “Rst CB2 Lockout”: Reset Lockout Opto Input to reset CB2 Lockout state

5.6.2.5 Pole Discrepancy (P544/P546)

Circuit breakers with independent mechanisms for each pole normally incorporate a ‘phases not together’ or ‘pole discrepancy’ protection device which automatically trips all three-phases if they are not all in the same position i.e. all open or all closed.

During single-pole auto-reclosing a pole discrepancy condition is deliberately introduced and the pole discrepancy device must not operate for this condition. This may be achieved by using a delayed action pole discrepancy device with a delay longer than the single-pole auto-reclose dead time, “SP AR Dead Time”.

Alternatively, a signal can be given from the relay during the single-pole auto-reclose dead time, “AR 1 Pole In Progress”, to inhibit the external pole discrepancy device.

In the relay, the “Pole Discrepancy” input is activated by a signal from an external device indicating that all three poles of the CB are not in the same position. The “Pole Discrepancy” inputs, DDB (451) & DDB (1606) forces a 3 pole trip on CB1 & CB2 respectively through PSL mapping.

The logic diagram for the pole discrepancy is shown in Figure AR-63 - Pole discrepancy.

5.6.2.6 External Trip (P544/P546)

The “External Trip 3Ph” input and the “External Trip A”, “External Trip B” and “External Trip C” inputs can be used to initiate three or single-phase auto-reclose. Note, these signals are not used to trip the circuit breaker but do initiate auto-reclose. To trip the circuit breaker directly they could be assigned to the trip contacts of the relay in the PSL.

The following DDB signals are available for mapping in PSL from opto inputs to initiate auto-reclosing.

- DDB (535): “CB1 Ext Trip A”
- DDB (536): “CB1 Ext Trip B”
- DDB (537): “CB1 Ext Trip C”
- DDB (534): “CB1 Ext Trip 3Ph”
- DDB (539): “CB2 Ext Trip A”
- DDB (540): “CB2 Ext Trip B”
- DDB (541): “CB2 Ext Trip C”
- DDB (538): “CB2 Ext Trip 3Ph”

5.6.3 Internal Signals (P544/P546)

5.6.3.1 Trip Initiate Signals (P544/P546)

The Trip Inputs A, Trip Inputs B and Trip Inputs C signals are used to initiate signals or three-phase auto-reclose.

Note For single-phase auto-reclose these signals must be mapped in the PSL as shown in the default.

5.6.3.2 Circuit Breaker Status (P544/P546)

The CB Open 3 ph, CB Open A ph, CB Open B ph and CB Open C ph, signals are used to indicate if a CB is open three or single-phase. These are driven from the internal pole dead logic and the CB auxiliary inputs.

The CB Closed 3 ph, CB Closed A ph, CB Closed B ph and CB Closed C ph, signals are used to indicate if a CB is closed three or single-phase. These are driven from the internal pole dead logic and the CB auxiliary inputs.

5.6.3.3 Check Synch OK and System Check OK (P544/P546)

Internal signals generated from the internal system check function and external system check equipment are used by the internal auto-reclose logic to permit auto-reclosure.

DDB (883) “CB1 CS1 OK” & DDB (884) “CB1 CS2 OK” are output from CB1 Check Sync logic and indicate conditions for CB1 sync check stage1 & 2 are satisfied.

DDB (1577) “CB2 CS1 OK” & DDB (1463) “CB2 CS2 OK” are output from CB2 Check Sync logic and indicate conditions for CB2 sync check stage 1 & 2 are satisfied.

5.6.4 Auto-Reclose Logic Outputs (P544/P546)

The following DDB signals can be masked to a relay contact in the PSL or assigned to a Monitor Bit in Commissioning Tests, to provide information about the status of the auto-reclose cycle. These are described below, identified by their DDB signal text.

Any auto-reclose lockout condition will reset all auto-reclose in progress signals associated with the circuit breaker (e.g. “ARIP”).

5.6.4.1 AR 1Pole in Prog

The “CB1 AR 1p InProg” (DDB 845) and the “CB2 AR 1p InProg” (DDB 855) output signals indicate that single-phase auto-reclose is in progress. The outputs remain high from protection initiation until lockout, or successful reclosure of the circuit breaker which is indicated by the circuit breaker successful auto-reclose signals, “CB1 Succ 1P AR” (DDB 1571) and “CB2 Succ 1P AR” (DDB 1451) generated by the logic for CB1 and CB2 respectively.

5.6.4.2

AR 3Pole in Prog

The “CB1 AR 3p InProg” (DDB 844) and “CB2 AR 3p InProg” (DDB 1411) output signals indicate that three-phase auto-reclose is in progress. The outputs remain high from protection initiation until lockout, or successful reclosure of the circuit breaker which is indicated by the circuit breaker successful auto-reclose signals, “CB1 Succ 3P AR” (DDB 852) and “CB2 Succ 3P AR” (DDB 1452) for generated by the logic for CB1 and CB2 respectively.

5.6.5

Auto-Reclose Logic Operating Sequence (P544/P546)

For simplicity, the auto-reclose operating sequence is described for the case of a single circuit breaker, CB1 only.

The same operating sequence would apply if CB2 only was enabled.

In a dual breaker application, the same operating sequence would apply to the leader circuit breaker and, provided the leader circuit breaker remained closed after the set dead time, the follower circuit breaker would reclose after a further delay (the follower time).

<i>Note</i>	<i>In a dual circuit breaker application, the settings describing single and three-phase auto-reclose “AR 1P” “AR 3P” and “AR 1/3P” below would change in the dual breaker case to reflect the mode of the leader circuit breaker “L1P”, “L3P”, “L1/3P”.</i>
-------------	--

Following this introduction to the logic sequence, is a comprehensive description of the auto-reclose and circuit breaker operation.

An auto-reclose cycle can be internally initiated by operation of a protection element, provided the circuit breaker is closed until the instant of protection operation.

The operation of the auto-reclose sequence is controlled by the “Dead Timers”. The user can, via settings, determine what conditions will be used to initiate the dead timers as described in the *Dead Time Control* section. In general, however, and for the purposes of this description, the dead timers can be considered to start upon initiation of the auto-reclose cycle by the protection.

If only single-phase auto-reclose “AR 1P” is enabled then the logic allows only a single shot auto-reclose. For a single-phase fault, the single-phase dead timer “SP AR Dead Time” starts, and the single-phase auto-reclose in progress signal “CB AR 1pole in prog” (DDB 845) is asserted. For a multi-phase fault the logic triggers a three-phase trip and goes to lockout.

If only three-phase auto-reclose “AR 3P” is enabled then, for any fault, the three-phase dead timers: “3P AR DT Shot 1”, “3P AR DT Shot 2”, “3P AR DT Shot 3”, “3P AR DT Shot 4”, (Dead Time 1, 2, 3, 4) are started and the three-phase auto-reclose in progress signal “CB AR 3pole in prog” (DDB 844) is asserted. The logic forces a three-phase trip by setting “AR Force 3 pole” (DDB 858) for any single-phase fault if only three-phase auto-reclose “AR 3P” is enabled.

If single and three-phase auto-reclose "AR1/3P" are enabled then, if the first fault is a single-phase fault the single-phase dead time "SP AR Dead Time" is started and the single-phase auto-reclose in progress signal "AR 1pole in prog" (DDB 845) is asserted. If the first fault is a multi-phase fault the three-phase dead timer "3P AR DT Shot 1" is started and the three-phase auto-reclose in progress signal "AR 3pole in prog" (DDB 844) is asserted. If the relay has been set to allow more than one reclose ("AR Shots >1") then any subsequent faults will be converted to three-phase trips by setting the signal "AR Force 3 pole" (DDB 858). The three-phase dead times "3P AR DT Shot 2", "3P AR DT Shot 3" and "3P AR DT Shot 4" (Dead Times 2, 3, 4) will be started for the 2nd, 3rd and 4th trips (shots) respectively. The three-phase auto-reclose in progress signal "AR 3pole in prog" (DDB 844) will be asserted. If a single-phase fault evolves to a multi-phase fault during the single-phase dead time ("SP AR Dead Time") then single-phase auto-reclose is stopped. The single-phase auto-reclose in progress signal "AR 1pole in prog" (DDB 845) is reset, the three-phase auto-reclose in progress signal "AR 3pole in prog" (DDB 844) is set, and the three-phase dead timer "3P AR DT Shot 1" is started.

At the end of the relevant dead time, provided system conditions are suitable, a circuit breaker close signal is given. The system conditions to be met for closing are that the system voltages are in synchronism or that the dead line/live bus or live line/dead bus conditions exist, indicated by the internal system check synchronizing element, and that the circuit breaker closing spring, or other energy source, is fully charged as indicated by the "CB Healthy" input. The circuit breaker close signal is cut-off when the circuit breaker closes. For single-phase auto-reclose no voltage or synchronism check is required as synchronizing power is flowing in the two healthy phases. For three-phase auto-reclosing, for the first shot only, auto-reclose can be performed without checking that the voltages are in synchronism by means of a setting. This setting, "CBxL SC Shot 1", can be set to "Enabled" to perform synch-checks on shot 1 for CB1 or CB2, or "Disabled" to not perform the checks.

When the circuit breaker has closed, the "Set CB1 Close" (DDB 1565) signal from the "CB autoclose logic" goes high and the reclaim time ("Reclaim Time") starts. If the circuit breaker has remained closed and not tripped again when the reclaim timer expires, the auto-reclose cycle is complete, and signal "CB1 Succ 1P AR" (DDB1571) or "CB1 Succ 3P AR" (DDB 852) is generated to indicate the successful reclosure. These signals also increment the relevant circuit breaker successful auto-reclose shot counters "CB1 SUCC SPAR", "CB1 SUCC 3PAR Shot1", "CB1 SUCC 3PAR Shot2", "CB1 SUCC 3PAR Shot3" and "CB1 SUCC 3PAR Shot4", as well as resetting the circuit breaker auto-reclose in progress "CB1 ARIP" signal.

If the protection operates and circuit breaker trips during the reclaim time the relay either advances to the next shot in the programmed auto-reclose cycle, or, if all programmed reclose attempts have been made, the circuit breaker goes to lockout. Every time the relay trips the sequence counter is incremented by 1 and the reclaim time starts again after each shot, following the "Set CB1 Close" signal going high again.

For multi-phase faults the auto-reclose logic can be set to allow auto-reclose block for 2 and 3-phase faults or to allow auto-reclose block for 3-phase faults only using the setting "Multi Phase AR" in the AUTORECLOSE settings, where the options are "Allow Autoclose", "BAR 2 & 3 ph" and "BAR 3 Phase".

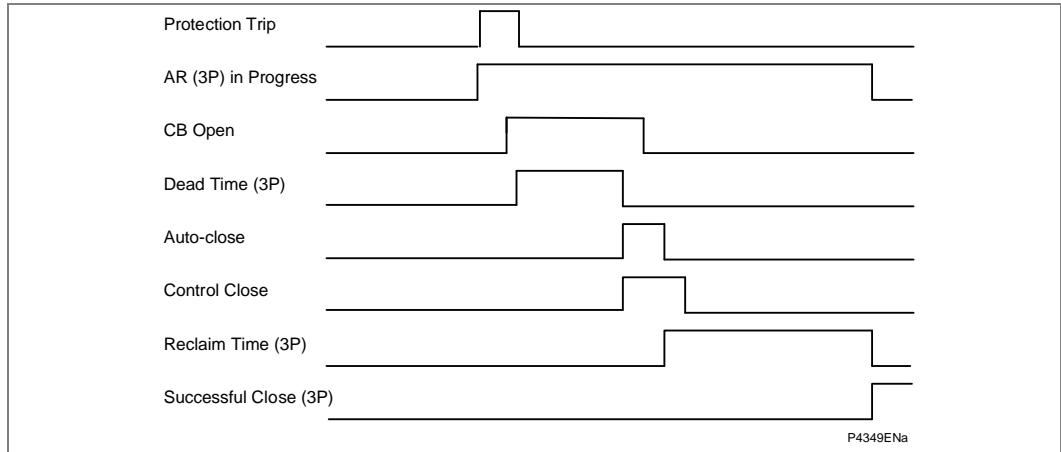

Figure 136 - Auto-reclose timing diagram – single breaker, single fault

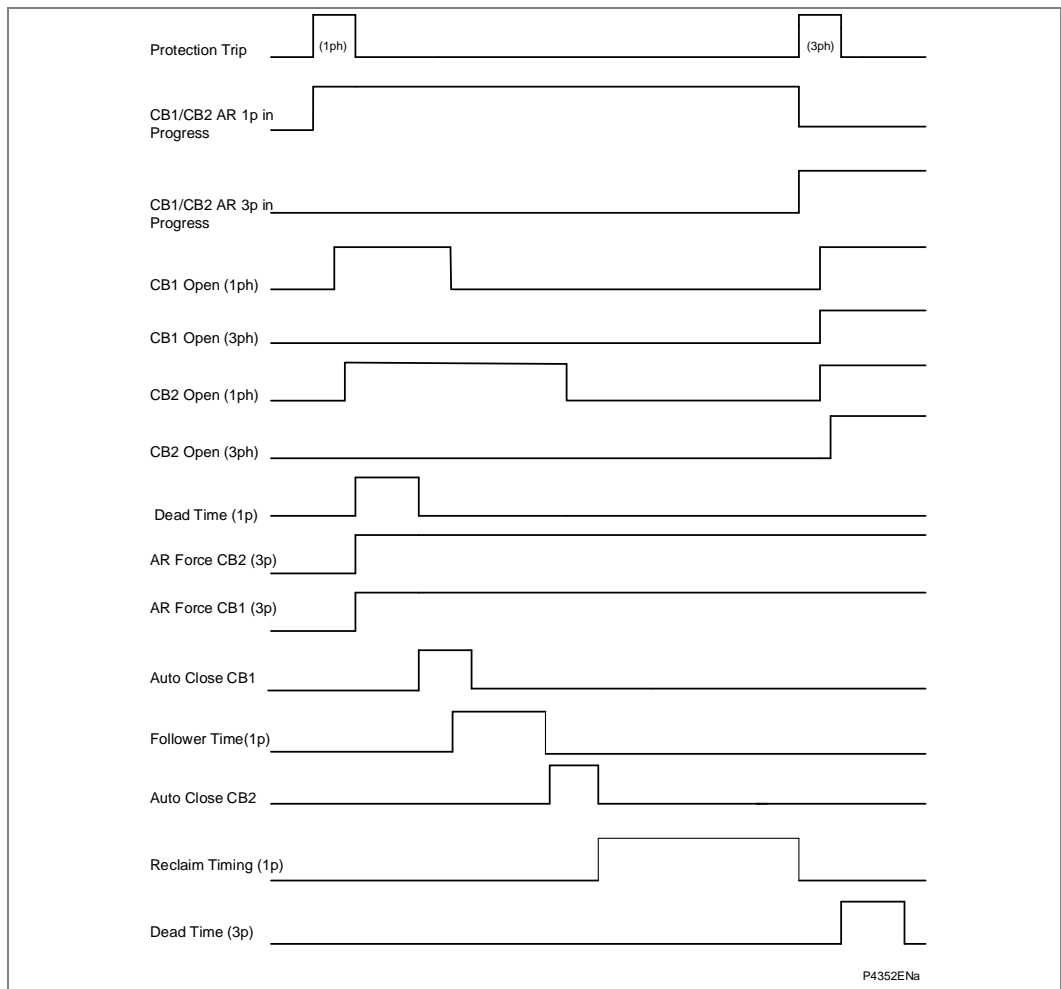

Figure 137 - Auto-reclose timing diagram – repeated fault inception

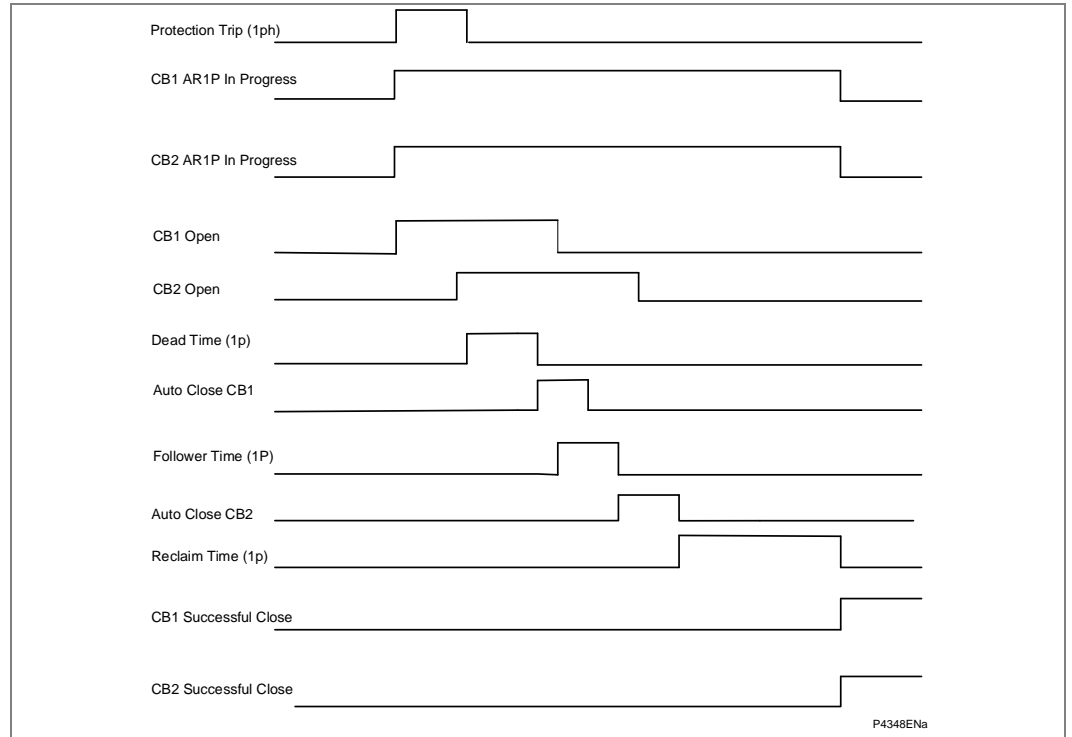

Figure 138 - Auto-reclose timing diagram leader/follower (1ph)

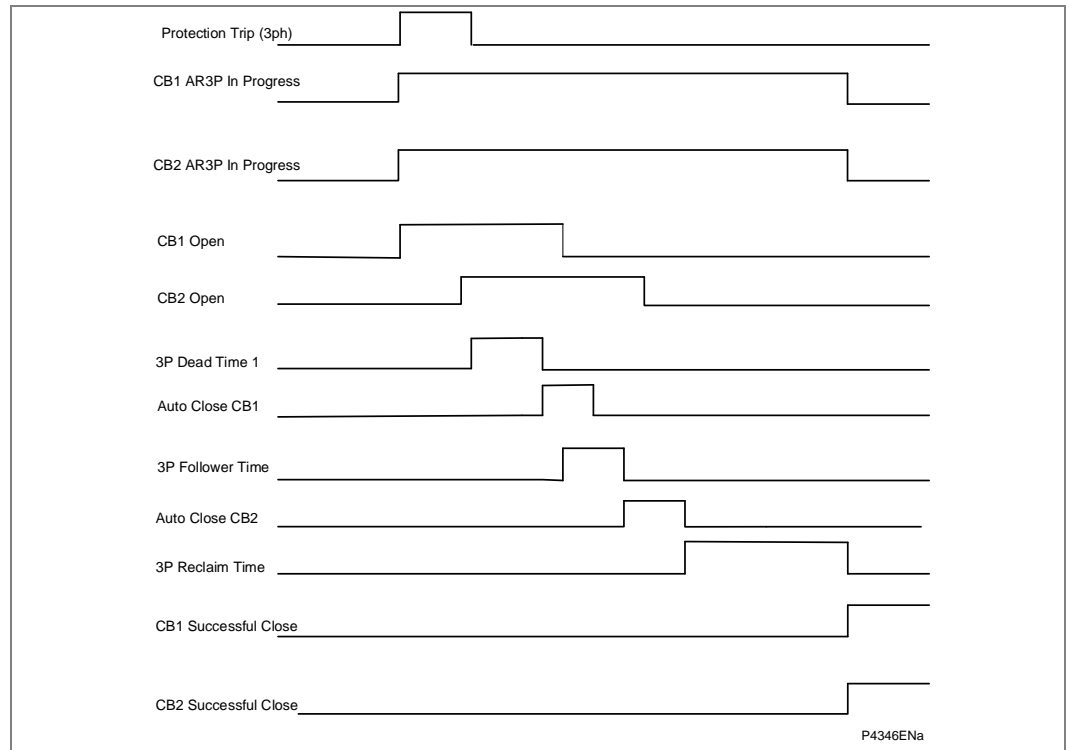

Figure 139 - Auto-reclose timing diagram leader/follower (3ph)

5.6.6

Auto-Reclose: Main Operating Features (P544/P546)

As from Software Version H4, the possible statuses of the Auto-Reclose function have changed. The new method means that the function now works in the same way across the whole P54x range. It does this because of the following DDB Numbers.

DDB Numbers 856, 857, 1532 and 1533

DDB Nos 856 and 857 have never been included in the MiCOM P544/P546 products.

In the MiCOM P543/P545 (running on Software Version 57), DDB Nos 856 and 857 were available to show the mode (3P, 1P) for the Auto-Reclose (AR) function.

In the MiCOM P543/P545 (running on Software Version D1), DDB Nos 856 and 857 were removed.

As from Software Version H4a, the following situation applies:

DDB No	Source	Element Name	Description
856	Autoreclose	DDB_AR_IN_SERVICE_3P	3 Pole auto-recloser in service – the auto-reclose function has been enabled either in the relay menu, or by an auto input.
857	Autoreclose	DDB_AR_IN_SERVICE_1P	Single pole auto-recloser in service – the auto-reclose function has been enabled either in the relay menu, or by an auto input.
1532	Autoreclose	DDB_AR_IN_SERVICE_3P_FOLLOWER	Follower 3 Pole auto-recloser in service – the auto-reclose function has been enabled either in the relay menu, or by an auto input.
1533	Autoreclose	DDB_AR_IN_SERVICE_1P_FOLLOWER	Follower Single pole auto-recloser in service – the auto-reclose function has been enabled either in the relay menu, or by an auto input.

- For MiCOM P44y/P54x products with a single CB application (P543/P545), DDB Nos 856 and 857 again show the mode (3P, 1P).
- For MiCOM P44y/P54x products with a dual CB application (P544/P546), DDB Nos 856 and 857 again show the mode (3P, 1P) for the leader CB.
- For MiCOM P44y/P54x products with a dual CB application (P544/P546), DDB Nos 1532 and 1533 show the mode (3P, 1P) for the follower CB.

5.6.6.1**Circuit Breaker In Service (P544/P546)**

The circuit breaker in service logic is shown in Figure AR-4.

To be available for auto-reclosing, the circuit breaker has to be “in service” when the auto-reclose is initiated by a protection operation. The circuit breaker is considered to be “in service” if it has been in a closed state for a period equal to or greater than the setting “CB IS Time”.

A short adjustable time delay, “CB IS Memory Time”, allows for situations where, due to very fast acting circuit breaker auxiliary switches, when a circuit breaker trips following a fault, the circuit breaker change of state from closed to open is detected in the auto-reclose initiation logic before the “AR Initiate” signal from the protection is recognized.

Once an auto-reclose cycle has been started, the “in service” signal for the circuit breaker stays set until the end of the auto-reclose cycle.

The “CBx In Service” (x = 1 or 2) signal resets if the CB opens, or if the corresponding CB Auto-Reclose In Progress (ARIP) signal resets.

5.6.6.2**Auto-Reclose Enable (P544/P546)**

The auto-reclose enable logic is shown in Figure AR-5.

A master enable/disable signal provides overall control of the auto-reclose function for the circuit breakers. If the “Auto-reclose” setting cell in the CONFIGURATION column of the menu is set to “enabled” the auto-recloser can be brought into service with other commands (described below) providing further control.

In the figure, the auto-recloser is enabled when the “AR In Service” DDB (1385) is driven high. To achieve this, as well as enabling the “Auto-reclose” setting cell in the CONFIGURATION column of the menu, the following conditions below must be met:

1. Auto-reclose must be enabled for at least one of the circuit breakers (CB1/CB2). This is achieved by enabling DDB input “AR Enable CB1” (1609) for CB1 and/or “AR Enable CB2” (1605) for CB2. Both these DDBs signals default to “high” if not mapped in the PSL so, if they are not mapped, this part of the logic will always be satisfied.
2. Auto-reclosing needs to be enabled from an opto input mapped to the “AR Enable” DDB (1384), or one of the following conditions must be met:
A menu command from the HMI “Auto-reclose Mode” cell in the CB CONTROL column of the menu is used to bring the auto-recloser into service, or,
For a P446/P544/P546/P841 having IEC 60870-5-103 communications, a standardised enable auto-reclose command is received via the communications link, or,
The auto-recloser is brought into service by the pulsing of the “AR Pulse On” DDB (1382).

The result of the logic above is the auto-reclose status. This can be seen in the data cell “AR Status” in the CB CONTROL column of the menu, and will be either “In Service” or “Out of Service”.

5.6.6.3

Software Version D1a and Later

This is an Output signal available in the PSL, which can be mapped to an opto status input to enable the autoreclose as long as the below conditions are satisfied.

Autoreclose can be Enabled or Disabled. This is done using a combination of Setting changes, starting with DDB 1384 (AR Enable) operation. Here is what is needed to Enable or Disable the Autoreclose:

AR Enabled = Autoreclose Enabled (0924 = 1) AND

(AR Telecontrol In Service (070B = 1) OR AR Enable DDB active (DDB 1384 = 1))
AND

(AR Enable CB1 DDB Active (DDB 1609 = 1) OR AR Enable CB2 DDB Active (DDB 1605 = 1))

AR Disabled = Autoreclose Enabled (0924 = 0) OR

(AR Telecontrol Out of Service (070B = 2) AND AR Enable DDB active (DDB 1384 = 0)) OR

(AR Enable CB1 DDB Active (DDB 1609 = 1) AND AR Enable CB2 DDB Active (DDB 1605 = 1))

<i>Note</i>	<i>More details are provided in the Auto-Reclose Skip Shot 1 (P543/P545) and the Auto-Reclose (P544/P546) sections.</i>
-------------	---

Here is the new description of DDB 1384:

DDB No	Text	Description
DDB 1384	AR Enable	External input via DDB mapped in PSL to enable AR, but ONLY if “Enable AR CB1” DDB or “Enable AR CB2” DDB is set and “Auto-Reclose” Configuration setting is enabled.

5.6.6.4

Leader & Follower CB Selection (P544/P546)

The leader and follower circuit breaker selection logic is shown in Figure AR-6.

The method of selecting the preferred leader and follower circuit breakers is determined by the menu setting “Leader Select By:”, which can be set to “Leader by Menu”, “Leader by Opto” or “Leader by Ctrl”.

If "Leader Select By:" is set to "Leader by Menu", a further setting, "Select Leader:", becomes visible and is used to select the preferred leader circuit breaker by setting "Select Leader:" either to "Sel Leader CB1" or "Sel Leader CB2".

If "Leader Select By:" is set to "Leader by Opto", the preferred leader circuit breaker is determined by the status of the input DDB (1408): "CB2 Lead". If the input DDB (1408) "CB2 Lead" is low, then preferred leader circuit breaker is CB1. If DDB "CB2 Lead" is high then it selects CB2 as the preferred leader.

If "Leader Select By:" is set to "Leader by Control", then the preferred leader circuit breaker is determined by the user control command "CTRL CB2 Lead" cell found under the CB CONTROL column in the relay menu. If the command applied is "Reset CB2 Lead", CB1 is selected as the preferred leader. Applying "Set CB2 Lead" command selects CB2 as the preferred leader.

If "Num CBs" is set to "Both CB1 &CB2", either CB1 or CB2 can be selected as leader. If the setting "Num CBs" is set to "CB1 Only", CB1 is selected as leader. Similarly, CB2 is selected as leader if the setting "Num CBs" is set to "CB2 Only".

Provided that the circuit breaker is available for auto-reclose (i.e. the circuit breaker is: "in service", not locked out, and enabled for auto-reclosing - refer the *Auto-Reclose Enable* and *Auto-Reclose Mode and Leader and Follower Circuit Breaker* sections), the "preferred" leader circuit breaker will be the "active" leading circuit breaker in the auto-reclose cycle.

If the "preferred" leader circuit breaker is not available for auto-reclosing then, provided it is available for auto-reclose, the "non-preferred" circuit breaker becomes the "active" leader. If this is the case there will be no follower circuit breaker.

If both circuit breakers are available for auto-reclosing and follower reclosing is enabled, then the "preferred leader" will be the "active" leader and the "non-preferred" circuit breaker will be the follower.

5.6.6.5

Auto-Reclose Mode for Leader & Follower Circuit Breaker (P544/P546)

The auto-reclose mode for the leader and follower circuit breaker logic is shown in Figure AR-10.

Once auto-reclosing is enabled, the specific reclosing modes which can be applied to each circuit breaker are selected.

The auto-reclose function has three operating modes:

- Single Phase Auto-reclose (1P)
- Three Phase Auto-reclose (3P)
- Single/Three Phase Auto-reclose(1/3P)

Single phase reclosing is permitted only for the first shot of an auto-reclose cycle. If two or more shots are enabled, then, in a multi-shot auto-reclose cycle, the second and subsequent trips and reclosures will always be three-phase.

The settings for the reclosing modes are affected by the number of circuit breakers, "Num CBs", setting in the AUTO-RECLOSE column of the menu.

5.6.6.5.1

Auto-Reclose Mode with One Circuit Breaker (P544/P546)

If "Num CBs" is set to "CB1 Only" or "CB2 Only", only one circuit breaker will be controlled, and a setting "AR Mode" is visible which controls the specific auto-reclosing mode for the active circuit breaker.

The following setting options are available: "AR 1P", "AR 1/3P", "AR 3P" & "Opto".

Single phase auto-reclosing of the circuit breaker is permitted if “AR Mode” is set to “AR 1P” or “AR 1/3P”. Three phase auto-reclosing of the circuit breaker is permitted if “AR Mode” is set to “AR 3P” or “AR 1/3P”.

If the “AR Mode” selection is by “Opto” then the reclose mode for the active circuit breaker is determined by the status of two DDB inputs: “Lead AR 1P” (1497) to enable single-phase auto-reclose, and “Lead AR 3P” (1498) to enable three-phase auto-reclose.

5.6.6.5.2

Auto-Reclose Mode with Two Circuit Breakers (P544/P546)

If “Num CBs” is set to “Both CB1&CB2” then a setting “Lead/Foll ARMode” becomes visible and is used to control the specific reclosing modes that are applied to each circuit breaker. The options available are:

- “L1P F1P”
- “L1P F3P”
- “L3P F3P”
- “L1/3P F1/3P”
- “L1/3P F3P”
- “Opto”

Where L refers to the leader circuit breaker, F refers to the follower circuit breaker, 1P implies single-phase, 3P implies three-phase, and 1/3P implies single or three-phase, so a setting of “L1/3P F3P” would mean that the leader circuit breaker could perform single or three-phase auto-reclose, whilst the follower would perform three-phase auto-reclose only.

If the auto-reclose mode selection is by “Opto” then the reclose mode for the active leader is determined by the status of two DDB inputs: “Lead AR 1P” (1497) to enable single-phase auto-reclose, and “Lead AR 3P” (1498) to enable three-phase auto-reclose. The reclose mode for the active follower is determined by the status of two DDB inputs: “Follower AR 1P” (1409) to enable single-phase auto-reclose, and “Follower AR 3P” (1410) to enable three-phase auto-reclose.

Where the selected follower auto-reclose mode supports single-phase tripping, the follower can perform single-phase auto-reclose only if the leader circuit breaker has performed single-phase auto-reclose. If the leader has tripped and reclosed three-phase, the follower is also forced to trip three-phase. The follower will reclose three-phase provided three-phase auto-reclose is permitted for the follower circuit breaker. If the follower circuit breaker trips three-phase and three-phase auto-reclose is not permitted for the follower, then the follower circuit breaker locks out without reclosing.

5.6.6.6

Force Three Phase Trip (P544/P546)

The force three-phase trip logic is shown in Figure AR-11.

Following single-phase tripping, whilst the auto-reclose cycle is in progress, and upon resetting of the protection elements, an output signal DDB associated with the tripped circuit breaker is asserted high.

In the case of CB1, this is “DDB: AR Force CB1 3P” (858).

In the case of CB2, this is “DDB: AR Force CB2 3P” (1485).

These signals are applied to any associated protection trip conversion logic to force all protection trips to be converted to three-phase trips for the associated circuit breaker, for any subsequent faults that occur whilst the auto-reclose cycle remains in progress.

5.6.6.7

Auto-Reclose Initiation (P544/P546)

The auto-reclose initiation logic is shown in Figure AR-12, Figure AR-13, Figure AR-14 and Figure AR-15.

Auto-reclose is initiated from the internal protection of the relay:

- Protection functions hosted by the P446/P544/P546/P841
- External protection equipment
- Trip test

Auto-reclose initiation will start an auto-reclose for any circuit breaker that is in service and enabled for auto-reclose: CB1 auto-reclose will start if CB1 is in service and enabled for auto-reclose; CB2 auto-reclose will start if CB2 is in service and enabled for auto-reclose.

When an auto-reclose cycle is started, the relevant circuit breaker auto-reclose in progress “CB1 ARIP” and/or “CB2 ARIP” signal is set, and remains set until the end of the cycle for the associated circuit breaker. The end of the cycle is signified by successful reclosure, or by lockout.

An auto-reclose cycle can be initiated by operation of any of the following:

- Auto-Reclose Initiation by Host Relay Protection Function (P544/P546)
- Auto-Reclose Initiation by External Protection Equipment (P544/P546)

The following DDB signals are available for mapping in the PSL from opto inputs or communication inputs to initiate auto-reclosing.

- DDB (535): CB1 Ext Trip A
- DDB (536): CB1 Ext Trip B
- DDB (537): CB1 Ext Trip C
- DDB (534): CB1 Ext Trip 3Ph
- DDB (539): CB2 Ext Trip A
- DDB (540): CB2 Ext Trip B
- DDB (541): CB2 Ext Trip C
- DDB (538): CB2 Ext Trip 3Ph

If mapped, activation of the input to the DDB will initiate auto-reclose.

- Auto-Reclose Initiation and Cycle by Trip Test (P544/P546)

5.6.6.7.1

Auto-Reclose Initiation by Host Relay Protection Function (P544/P546)

Many protection functions in the P544/P546 (for example differential trips, Zone 1 trips, distance-aided scheme trips, time-delayed distance zones, overcurrent and earth (ground) elements, DEF and directional aided schemes.) can be programmed to initiate or block auto-reclose by selecting the Initiate AR, or Block AR options in the settings which are available under the AUTORECLOSE settings column of the menu. Operation of a protection function selected for auto-reclose will initiate auto-reclose. Operation of a protection function selected to block auto-reclose will block and force a lockout.

5.6.6.7.2

Auto-Reclose Initiation by External Protection Equipment (P544/P546)

The following DDB signals are available for mapping in the PSL from opto inputs or communication inputs to initiate auto-reclosing.

- DDB (535): CB1 Ext Trip A
- DDB (536): CB1 Ext Trip B
- DDB (537): CB1 Ext Trip C
- DDB (534): CB1 Ext Trip 3Ph
- DDB (539): CB2 Ext Trip A
- DDB (540): CB2 Ext Trip B
- DDB (541): CB2 Ext Trip C
- DDB (538): CB2 Ext Trip 3Ph

If mapped, activation of the input to the DDB will initiate auto-reclose.

5.6.6.7.3

Auto-Reclose Initiation and Cycle by Trip Test (P544/P546)

A user command (“Test Autoreclose” under COMMISSION TESTS) in the P446/P544/P546/P841 menu can be used to initiate an auto-reclose cycle. Four separate commands can be executed, each command comprising a 100 ms pulse output when the relevant “execute” option is selected. Available commands are: “Trip Pole A” / “Trip Pole B” / “Trip Pole C” / “Trip 3 Pole”. There is also a “No Operation” option to exit the command field without initiating a test.

5.6.6.8

Sequence Counter (P544/P546)

The sequence counter logic is shown in Figure AR-19.

The auto-reclose logic includes a counter known as the sequence counter. Unless auto-reclose is in progress, the sequence counter will have a value of 0. Following a trip, and subsequent auto-reclose initiation, the sequence counter is incremented. The counter provides output signals indicating how many initiation events have occurred in any auto-reclose cycle. These signals are available as user indications and are used in the logic to select the appropriate dead timers, or, for a persistent fault, force a lockout.

The logic generates the following sequence counter outputs which are used in the auto-reclose shots counter logic (refer to the *Circuit Breaker Auto-Reclose Shots Counters* section).

- DDB 847: “Seq. Counter = 1” is set when the counter is at 1;
- DDB 848: “Seq. Counter = 2” is set when the counter is at 2;
- DDB 849: “Seq. Counter = 3” is set when the counter is at 3; and
- DDB 850: “Seq. Counter = 4” is set when the counter is at 4.

Every time the relay trips the sequence counter is incremented by 1. The auto-reclose logic compares the sequence counter values to the number of auto-reclose shots setting, “AR Shots”. If the counter value exceeds the setting then the auto-reclose is locked out.

In the case of a successful auto-reclose cycle the sequence counter resets to zero.

5.6.6.9

Auto-Reclose Cycle Selection (P544/P546)

The auto-reclose cycle selection determines, for a dual breaker configuration, the logic to determine which of the circuit breakers will act as leader/follower and whether the reclosing will be single-phase or three-phase.

The logic is shown in Figure AR-20 and Figure AR-22.

In a dual circuit breaker arrangement, when an auto-reclose cycle is started, single-phase or three-phase reclosing is asserted for each circuit breaker, according to whether the circuit breaker has tripped single-phase or three-phase, and according to whether single-phase and/or three-phase reclosing is permitted for that circuit breaker. Dependent upon the settings and trip performed, each circuit breaker can perform:

- Single-phase reclose as Leader (with or without follower)
- Single-phase reclose as Follower (provided the leader is also selected to single-phase auto-reclose)
- Three-phase reclose as Leader (with or without follower)
- Three-phase reclose as Follower

5.6.6.10

Dead Time Control (P544/P546)

The dead time control logic is shown in Figure AR-23, Figure AR-25, Figure AR-26 and Figure AR-27.

Once an auto-reclose cycle has started, the conditions to enable the dead time to run are determined by menu settings, circuit breaker status, protection status, the nature of the auto-reclose cycle (single-phase or three-phase) and opto inputs from external sources.

Three settings are involved in controlling the dead time start:

- “DT Start by Prot”
- “3PDTStart WhenLD”
- “DTStart by CB Op”.

The “DT Start by Prot” setting is always visible and has three options “Protection Reset”, “Protection Op”, and “Disable”. These options set the basic conditions for starting the dead time.

The ‘dead time started by protection operation’ condition can, optionally, be qualified by a check that the line is dead.

The ‘dead time started by protection reset’ condition can, optionally, be qualified by a check, that the circuit breaker is open, as well as by an optional check that the line is dead (note*).

If the DT Start by Prot” is set to “Disable”, the circuit breaker must be open for the dead time to start. This condition can, optionally be qualified by a check that the line is dead (note*).

The qualification to check that the ‘line is dead’ is provided by setting “3PDTStart WhenLD” to “Enabled”.

The qualification to check that the ‘circuit breaker is open’ is provided by setting “DTStart by CB Op” to “Enabled”.

In a dual circuit breaker scheme (“Num CBs” set to “Both CB1 & CB2”) if the “DTStart by CB Op” is set to enabled, both circuit breakers must be tripped to enable the dead time to start. For a single-phase auto-reclose cycle, the leader circuit breaker has to be tripped single-phase. For a three-phase auto-reclose cycle, both circuit breakers have to be tripped three-phase.

<i>Note*</i> <i>This is only applicable when tripping/auto-reclose is three-phase.</i>
--

5.6.6.11

Follower CB Enable and Time Control (P544/P546)

The follower circuit breaker control logic is shown in Figure AR-29, Figure AR-30 and Figure AR-31.

When a leader/follower auto-reclose cycle is initiated, the conditions for the follower delay period (“Follower Time”) to start are determined by the leader circuit breaker operation, the follower circuit breaker status, the menu setting “BF if LFail CIs” (Block Follower reclose if Leader CB Fails to close), and opto inputs from external sources. The basic condition to start the follower delay is that the leader circuit breaker must have reclosed.

If the menu setting “BF if LFail CIs” is set to “Disabled”, the follower circuit breaker will reclose even if the leader circuit breaker fails to reclose (for example, due to the absence of a “CB Healthy” signal). When “BF if LFail CIs” is set to “Disabled” an additional menu setting “Dynamic F/L” becomes visible to further control the operation of the follower circuit breaker. If the setting “Dynamic F/L” is set to “Enabled”, the follower circuit breaker will reclose with no deliberate additional delay, i.e. at approximately the same instant that the leader circuit breaker would have closed if it had been healthy. If the menu setting “Dynamic F/L” is set to “Disabled”, the follower circuit breaker will reclose after an additional delay equal to the set “Follower Time”.

If the menu setting “BF if LFail CIs” is set to “Enabled” then, if the leader circuit breaker fails to reclose, the follower circuit breaker cycle is cancelled and auto-reclosing of both circuit breakers is locked out.

The follower circuit breaker must be open for the follower delay time to start. For a single-phase follower auto-reclose cycle, the follower circuit breaker has to be open single-phase. For a three-phase follower auto-reclose cycle, the follower circuit breaker has to be open three-phase.

When the follower delay time has timed out, the relevant internal signal “CBxSPFTCOMP” or “CBx3PFTCOMP” (x = 1 or 2) is applied to the “CB AutoClose” logic, described in the *CB1 and CB2 Auto Close* section to indicate that the follower time is complete.

5.6.6.12

CB1 and CB2 Auto Close (P544/P546)

The CB1 and CB2 auto close logic is shown in Figure AR-36 and Figure AR-37.

When the end of a dead time or the end of a follower time is indicated by one of the following internal signals, the auto close logic is executed:

- CB1 SPDTCOMP
- CB1 3PDTCOMP
- CB2 SPDTCOMP
- CB2 3PDTCOMP
- CB1 SPFTCOMP
- CB1 3PFTCOMP
- CB2 SPFTCOMP
- CB2 3PFTCOMP

The auto close logic checks that all necessary conditions are satisfied before issuing a “AutoClose CB1” or “AutoClose CB2” signal to the CB1 and CB2 overall control scheme as described in the *Circuit Breaker Control* section.

For any reclosure, the circuit breaker must be healthy (mechanism OK to close, and retrip if necessary) and it should not be in a lockout state.

For any single-phase reclosure, the circuit breaker must be open on one phase. For any three-phase reclosure, the circuit breaker must be open on all three-phases and the appropriate system check conditions (live bus/dead line, synch check etc) must be satisfied.

The system check conditions for CB1 leader reclose, CB2 leader reclose, CB1 follower reclose and CB2 follower reclose are independently selectable by menu settings and are described in the *System Checks for Circuit Breaker Closing* section.

The auto close signals (“AutoClose CB1”, “AutoClose CB2”) sent to the circuit breaker control scheme are pulses lasting 100 milliseconds. Another pair of signals “Set CB1 Close” & “Set CB2 Close”, DDBs (1565/1449) are set in conjunction with the auto close signals, but these remain set until either the end of the auto-reclose cycle, or the next protection operation. These signals are used to initiate the “Reclaim timing logic” and the “CB AR Shots Counters” logic, described in these sections:

- Reclaim Time & Successful Auto-Reclose (P544/P546)
- If “Res AROK by UI” is set to enabled, all the “successful auto-reclose” signals can be reset by user interface command “Reset AROK Ind” from the CB CONTROL settings column.
- If “Res AROK by NoAR” is set to enabled, the “successful auto-reclose” signals for each circuit breaker can be reset by temporarily generating an “AR disabled” signal for each circuit breaker according to the logic described in the *Autoreclose Enable Logics* section.

- If “Res AROK by Ext” is set to enabled, the “successful autoreclose” signals for can be reset by activation of the relevant input “Ext Rst CB1 AROK” or “Ext Rst CB2 AROK” (DDB1517 or 1417) mapped in the PSL.
- If “Res AROK by TDly” is set to enabled, the “successful autoreclose” signals for are automatically reset after a user defined time delay as set in "Res AROK by TDly" setting.
- Circuit Breaker Healthy and System Check Timers (P544/P546)
- CB1 & CB2 Auto-Reclose Shots Counters (P544/P546)

5.6.6.13

Reclaim Time & Successful Auto-Reclose (P544/P546)

The reclaim time logic is shown in Figure AR-36 and Figure AR-37.

The successful auto-reclose logic is shown in Figure AR-38, Figure AR-39 and Figure AR-40.

The “Set CB1 Close” & “Set CB1 Close”, DDBs (1565/1449) signals from the auto close logic are used to enable the reclaim timers. Depending on whether the circuit breaker has tripped single-phase or three-phase, and whether single-phase and/or three-phase reclosing is permitted for the circuit breaker, either the single-phase reclaim timer “SPAR Reclaim Time” or the three-phase reclaim timer “3PAR Reclaim Time” is enabled.

If any protection re-operates before the reclaim time has timed out, the sequence counter is incremented. The counter signal advances from ‘Seq Counter = n’ to ‘Seq Counter = (n+1)’, resets any “...DTCOMP” signal and prepares the logic for the next dead time to start when conditions are suitable. The operation also resets the “Set CB Close” signal, and hence the reclaim timer is also stopped and reset. The “Reclaim time” starts again if the “Set CB Close” signal goes high following completion of a dead time in a subsequent auto-reclose cycle.

If CB1 is closed and has not tripped again when the reclaim time is complete, signals “CB1 Succ 1P AR”, (DDB1571) or “CB1 Succ 3P AR”, (DDB 852) are generated to indicate the successful reclosure.

Similarly, If CB2 is reclosed during the auto-reclose cycle and remains closed when the reclaim time is complete, signals “CB2 Succ 1P AR”, (DDB 1451) or “CB2 Succ 3P AR”, (DDB 1452) are generated to indicate successful reclosure.

These signals also increment the relevant circuit breaker successful auto-reclose shot counters and reset the relevant “ARIP” signal.

The “successful auto-reclose” signals generated from the logic can be reset by various commands and settings options available under CB CONTROL menu settings column.

These settings are described below:

- If “Res AROK by UI” is set to enabled, all the “successful auto-reclose” signals can be reset by user interface command “Reset AROK Ind” from the CB CONTROL settings column.
- If “Res AROK by NoAR” is set to enabled, the “successful auto-reclose” signals for each circuit breaker can be reset by temporarily generating an “AR disabled” signal for each circuit breaker according to the logic described in the *Autoreclose Enable Logics* section.
- If “Res AROK by Ext” is set to enabled, the “successful autoreclose” signals for can be reset by activation of the relevant input “Ext Rst CB1 AROK” or “Ext Rst CB2 AROK” (DDB1517 or 1417) mapped in the PSL.
- If “Res AROK by TDly” is set to enabled, the “successful autoreclose” signals for are automatically reset after a user defined time delay as set in "Res AROK by TDly" setting.

5.6.6.14**Circuit Breaker Healthy and System Check Timers (P544/P546)**

The circuit breaker healthy and system check timers logic is shown in Figure AR-42 and Figure AR-43.

This logic provides signals to cancel auto-reclosing for either circuit breaker if the circuit breaker is not healthy (e.g. low gas pressure or, for three-phase auto-reclosing, the required line & bus voltage conditions are not satisfied) when the scheme is ready to close the circuit breaker.

In this logic, both CB1 and CB2 share the settings “AR CBHealthy Time” and “AR CheckSync Time”.

For either circuit breaker, at the completion of any dead time or follower time, the logic starts an “AR CBHealthy timer”. If the “CB Healthy” signal (DDB 436 or 437) becomes high before the set time is complete, the timer stops and, if all other relevant circuit breaker closing conditions are satisfied the scheme issues the “CB AutoClose” signal. If the “CB Healthy” signal, (DDB 436 or 437) signal stays low, then at the end of the set “AR CBHealthy time” an “AR CB Unhealthy” alarm signal (DDB 307 or 329) is set. This forces the circuit breaker auto-reclose sequence to be cancelled.

Additionally, for either circuit breaker, at the completion of any three-phase dead time or three-phase follower time, the logic starts an “AR CheckSync Time”. If the circuit breaker synchro-check OK signal {“CB L SCOK “ (DDB 1573 or 1455) or “CB F SCOK” (DDB 1491 or 1456)} goes high before the set time is complete, the timer stops and, if all other relevant circuit breaker closing conditions are satisfied, the scheme issues the “CB AutoClose” signal. If the “System check OK” signal stays low, then at the end of the “AR CheckSync Time” an alarm “AR CB No C/S” (DDB 308 or 330) is set which informs that the check synchronism is not satisfied for that circuit breaker and forces the auto-reclose sequence to be cancelled.

5.6.6.15**CB1 & CB2 Auto-Reclose Shots Counters (P544/P546)**

The CB1 & CB2 auto-reclose shots counter logic is shown in Figure AR-40 and Figure AR-41.

A number of counters are provided to enable analysis circuit breaker auto-reclosing history. Each circuit breaker has a set of counters that are stored in non-volatile memory, so that the data is maintained even in the event of a failure of the auxiliary supply.

Logic signals from the “Sequence counters” is combined with “successful auto-reclose” signals and “auto-reclose lockout” signals to provide the following summary for each circuit breaker:

- Overall total shots (No. of reclose attempts)
“CBx Total Shots”
- Number of successful single-phase reclosures
“CBx SUCC SPAR”
- Number of successful 1st shot three-phase reclosures
“CBx SUCC3PARShot1”
- Number of successful 2nd shot three-phase reclosures
“CBx SUCC3PARShot2”
- Number of successful 3rd shot three-phase reclosures
“CBx SUCC3PARShot3”
- Number of successful 4th shot three-phase reclosures
“CBx SUCC3PARShot4”
- Number of failed auto-reclose cycles which forced CB to lockout
“CBx Failed Shots”

All the counter contents are accessible through the CB CONTROL column of the menu.

For each individual circuit breaker, these counters can be reset either by user commands “Reset CB1 Shots” or “Reset CB2 Shots” from the CB CONTROL settings column, or by activation of the relevant input “Ext Rst CB1 Shots” or “Ext Rst CB2 Shots” (DDB 1518 or 1418) mapped in the PSL.

5.6.6.16

System Checks for Circuit Breaker Closing (P544/P546)

The system checks for circuit breaker closing logic is shown in Figure AR-44 to Figure AR-49.

For three-phase auto-reclosing and control closing of the circuit breakers, system voltage checks are separately selectable for:

- CB1 reclosing as leader
- CB1 reclosing as follower
- CB1 control close
- CB2 reclosing as leader
- CB2 reclosing as follower
- CB2 control close

In the AUTORECLOSE settings, if the “Num CBs” is set to “CB1 Only” or “CB2 Only”, then the operation of the circuit breaker will be the same as described for the corresponding leader circuit breaker (for example CB1 operation will be the same as described by CB1L in the diagrams and descriptions).

The system check options for each circuit breaker are enabled or disabled in the “CBx SC all” setting (x = 1L, 2L, 1F, 2F) in the AUTORECLOSE column of the menu. If set to “Disabled”, then no system checks are required on any shot, and the relevant settings are invisible. Otherwise, the system check options that can be enabled for each breaker (as leader or follower) are:

System check option	Setting
System checks not required for first shot of auto-reclose	“CBx SC Shot1”
Fast synchronism check (note 2)	“CBx SC ClsNoDly”
Check synchronism stage 1 (note 1)	“CBx SC CS1”
Check synchronism stage 2 (note 1)	“CBx SC CS2”
Dead line / Live Bus	“CBx SC DLLB”
Live Line / Dead bus	“CBx SC LLDB”
Dead line / Dead bus	“CBx SC DLDB”
<p><i>Note 1</i> Two separate (independent) system synchronism check stages are available for each circuit breaker. Each stage has different slip frequency and phase angle settings as described in the System Voltage Checks section.</p>	
<p><i>Note 2</i> A “fast synchronism check auto-reclose” option is available for the three-phase auto-reclose as leader circuit breaker, by menu setting “CBx SC ClsNoDly”. When the setting is enabled, then if the line and bus come into synchronism (i.e. line energised from remote end) at any time after the three-phase dead time has started, a “AutoClose CB” signal is issued immediately without waiting for the dead time to elapse. This option is sometimes required for the second line end to reclose on a line with delayed auto-reclosing (typical cycle: first line end reclose after dead time with live bus & dead line, then second line end reclose immediately with live bus & live line in synchronism).</p>	

Table 28 - System check options and settings

Manual reclosing for each circuit breaker is controlled according to the settings in the SYSTEM CHECKS column of the menu. The system check options for each circuit breaker are enabled or disabled in the “CBxM SC all” setting (x = 1 or 2) in the SYSTEM CHECKS column of the menu. If set to “Disabled”, then no system checks are required for manual closure, and the relevant settings are invisible. Otherwise, the system check options that can be enabled for each breaker (as leader or follower) are:

System check option	Setting
Check synchronism stage 1 (refer note 1 above)	“CBM SC CS1”
Check synchronism stage 2 (refer note 1 above)	“CBM SC CS2”
Dead line / Live Bus	“CBM SC DLLB”
Live Line / Dead bus	“CBM SC LLDB”
Dead line / Dead bus	“CBM SC DLDB”

Table 29 - System check options and settings

5.6.6.17

CB1 & CB2 Trip Time Monitor (P544/P546)

The circuit breaker trip time monitor logic is shown in Figure AR-50 and Figure AR-51. This logic checks that the circuit breaker trips correctly following the issuing of a protection trip signal.

When any protection trip signal is issued a timer, “Trip Pulse Time” is started.

The “Trip Pulse Time” setting is common to both CB1 and CB2 and is used in the trip time monitor logic and in the circuit breaker control logic.

If the circuit breaker trips correctly (single-phase or three-phase according to the trip signal and settings) the timer resets and the auto-reclose cycle, if enabled, proceeds normally. If either circuit breaker fails to trip correctly within the set time, the signal “CB1 Fail Pr Trip” (1575) and/or “CB2 Fail Pr Trip” (1459) is issued and the affected circuit breaker auto-reclose cycle is forced to lock out.

5.6.6.18

Autoreclose Lockout (P544/P546)

The auto-reclose lockout logic is shown in Figure AR-52 to Figure AR-57.

Auto-reclose lockout of a circuit breaker will be triggered by a number of events. These are outlined below:

- Protection operation during reclaim time. If, following the final reclose attempt, the protection operates during the reclaim time, the relay will be driven to lockout and the auto-reclose function will be disabled until the lockout condition is reset.
- Persistent fault. A fault is considered persistent if the protection re-operates after the last permitted shot.

- Block auto-reclose. The block auto-reclose logic can cause a lockout if auto-reclose is in progress. If asserted, the “Block CBx AR” input (DDB 448 /1421) mapped in the PSL will, if auto-reclose is in progress, block auto-reclose and cause a lockout.
- Multi phase faults. The logic can be set to block auto-reclose either for two-phase or three-phase faults, or to block auto-reclose for three-phase faults only. For this, the setting “Multi Phase AR” applies, where the options are “Allow AR”, “BAR 2&3 Phase” & “BAR 3 Phase” in the AUTORECLOSE column of the menu.
- Protection function selection. The protection functions can be individually selected to block auto-reclose and force lockout. If enabled, the protection functions in the AUTORECLOSE column of the menu can be set to “Block AR”. Selecting “Block AR” will cause a lockout if the particular protection function operates.
- Circuit breaker failure to close. If the circuit breaker fails to close because, for example, the circuit breaker springs are not charged, the gas pressure is low, or there is no synchronism between the system voltages indicated by the “AR CBx Unhealthy” and “AR CBx No Checksync” alarms, auto-reclose will be blocked and forced to lockout.
- Circuit breaker open at the end of the reclaim time. An auto-reclose lockout is forced if the circuit breaker is open at the end of the reclaim time.
- Circuit breaker fails to close when the close command is issued.
- Block follower if leader fails to close is set. If the setting “BF if Lfail CIs” in the AUTORECLOSE column of the menu is set to “Enable”, the active follower circuit breaker will lockout if the leader circuit breaker fails to reclose.
- Circuit breaker fails to trip correctly.
- Three phase dead time started by line dead violation. If the line does not go dead within the “Dead Line Time” time setting when the dead time start is determined by the menu setting “3PDTStart WhenLD”, the logic will force the auto-reclose sequence to lockout after expiry of the setting time.
- Single phase evolving to multi phase fault. If, after expiry of the discriminating time from the “Protection Re-operation + Evolving” fault logic (refer the Auto-Reclose Cycle Selection section), a single-phase fault evolves into a two, or three-phase fault, the internal signal “Evolve Lock” will be asserted that will force the auto-reclose to lockout.
- Leader/Follower invalid selection via opto. If the “Leader/Follower AR” mode in the AUTORECLOSE menu is set to be selected via the opto-inputs, “Opto”, then if the logic detects an invalid auto-reclose mode combination selection, it will force both CB1 & CB2 to lockout if a trip occurs.

If CB1 or CB2 is locked out, the logic generates the alarms “CBx AR Lockout” (DDB 306 /328) for the corresponding circuit breaker. In this condition, auto-reclose of the circuit breaker cannot be initiated until the corresponding lockout has been reset. The methods of resetting from the lockout state are discussed in the next section.

<i>Note</i>	<i>CB Lockout, can also be caused by the CB condition monitoring functions maintenance lockout, excessive fault frequency lockout, broken current lockout, CB failed to trip and CB failed to close and manual close - no check synchronism and CB unhealthy. These lockout alarms are mapped to a composite signal CB Lockout Alarm.</i>
-------------	--

These lockout alarms are mapped to a signals “CBx mon LO Alarm” (DDBs 300 & 322 for CB1 and CB2 respectively) and “CBx LO Alarm”. (DDBs 860 & 1599 for CB1 and CB2 respectively).

5.6.6.19

Reset Circuit Breaker Lockout (P544/P546)

The lockout conditions caused by the circuit breaker condition monitoring functions (including manual close failure) described in the *Auto-Reclose Lockout* section can be reset according to the condition of the “Rst CB mon LO by” setting found in the CB CONTROL column of the menu.

The “Rst CB mon LO by” setting has two options “CB Close”, and “User interface”. If “Rst CB mon LO By” is set to “CB Close” then closure of the circuit breaker will be a trigger for lockout reset. If set to “CB Close”, a further setting, “CB mon LO RstDly”, becomes visible. This is a timer setting that is applied between the circuit breaker closing, and the lockout being reset.

If “Rst CB mon LO By” is set to “User Interface” then a further command appears in the the CB CONTROL column of the menu, “CB mon LO reset”. This command can be used to reset the lockout.

This logic is included in the Figure 132 and Figure 133.

An auto-reclose lockout state of a circuit breaker will generate an auto-reclose circuit breaker lockout alarm (“AR CBx lockout”) and DDB 306 or 328 is set, corresponding to CB1 or CB2 being locked out.

This is shown in the logic diagrams Figure AR-58 and Figure AR-59.

The auto-reclose lockout conditions can be reset by various commands and settings options found under the CB CONTROL column of the menu.

These settings and commands are described below:

- If “Res LO by CB IS” is set to “Enabled”, the CB lockout is reset if the CB is manually closed successfully. For this the CB must remain closed long enough so that it enters the “In Service” state. (See the *Circuit Breaker In Service* section and the *Remote Control of Circuit Breaker* diagram(s)).
- If “Res LO by UI” is set to “Enabled”, the CB lockout can be reset by the user interface commands “Reset CB1 LO” or “Reset CB2 LO” found in the CB CONTROL column of the menu.
- If “Res LO by NoAR” is set to “Enabled”, the CB lockout can be reset by temporarily generating an “AR disabled” signal according to the logic described in the *Auto-Reclose Enable* section, “Auto-reclose Enable” logic.

This is shown in the logic diagram in AR 0.

- If “Res LO by ExtDDB” is set to “Enabled”, the CB lockout can be reset by activation of the relevant input DDB “Reset Lockout” (DDB 446) in the PSL.
- If “Res LO by ExtDDB” is set to “Enabled”, the CB lockout can be reset by activation of the relevant input DDB “Rst CB1 Lockout” or “Rst CB2 Lockout” (DDB 446 / 1422) in the PSL.

The reset circuit breaker auto-reclose lockout logic is shown in Figure AR-58 and Figure AR-59.

5.7 Dual CB System Voltage Checks (P544/P546)

5.7.1 Dual CB System Checks Overview (P544/P546)

In some situations it is possible for both “bus” and “line” sides of a Circuit Breaker (CB) to be live when the CB is open, for example at the ends of a feeder which has a power source at each end. Therefore, when closing the CB, it is normally necessary to check that the network conditions on both sides are suitable, before giving a “CB Close” command. This applies to both manual CB closing and auto-reclosure. If a CB is closed when the line and bus voltages are both live, with a large phase angle, frequency or magnitude difference between them, the system could be subjected to an unacceptable shock, resulting in loss of stability, and possible damage to connected machines.

System checks involve monitoring the voltages on both sides of a CB, and, if both sides are live, performing a synchronism check to determine whether the phase angle, frequency and voltage magnitude differences between the voltage vectors, are within permitted limits.

The pre-closing system conditions for a given CB depend on the system configuration and, for auto-reclosing, on the selected auto-reclose program. For example, on a feeder with delayed auto-reclosing, the CBs at the two line ends are normally arranged to close at different times. The first line end to close usually has a live bus and a dead line immediately before reclosing, and charges the line (dead line charge) when the CB closes. The second line end circuit breaker sees live bus and live line after the first CB has re-closed. If there is a parallel connection between the ends of the tripped feeder, they are unlikely to go out of synchronism, i.e. the frequencies will be the same, but the increased impedance could cause the phase angle between the two voltages to increase. Therefore the second CB to close might need a synchronism check, to ensure that the phase angle has not increased to a level that would cause unacceptable shock to the system when the CB closes.

If there are no parallel interconnections between the ends of the tripped feeder, the two systems could lose synchronism, and the frequency at one end could “slip” relative to the other end. In this situation, the second line end would require a synchronism check comprising both phase angle and slip frequency checks.

If the second line end busbar has no power source other than the feeder that has tripped; the circuit breaker will see a live line and dead bus assuming the first circuit breaker has re-closed. When the second line end circuit breaker closes the bus will charge from the live line (dead bus charge).

5.7.2 Dual CB System Voltage Checks Logic Diagrams (P544/P546)

The system voltage checks logic is shown in:

- Figure AR-60
- Figure AR-61
- Figure AR-62.

5.7.3 Dual CB System Voltage Checks VT Selection (P544/P546)

The system voltage checks function performs a comparison of the line voltage and the bus voltage.

For a single circuit breaker application, there will be two voltage inputs to compare – one from the Voltage Transformer (VT) input from the line side of the circuit breaker, and one from the VT on the bus side of the circuit breaker.

For a dual circuit breaker installation (breaker-and-a-half switch or mesh/ring bus), three VT inputs are required, one from the common point of the two circuit breakers, identified as the line, one from the bus side of CB1, and the third from the bus side of CB2.

In most cases the line VT input will be three-phase, whereas the bus VTs will be single-phase.

Since the bus VT inputs are normally single-phase, the system voltage checks are made on single-phases, and since the VT may be connected to either a phase-to-phase or phase-to-neutral voltage, then for correct synchronism check operation, the P446/P544/P546/P841 has to be programmed with the appropriate connection. The “CS Input” setting in the “CT AND VT RATIOS” can be set to “A-N”, “B-N”, “C-N”, “A-B”, “B-C” or “C-A” according to the application.

The single-phase Bus1 VT and Bus 2 VT inputs each have associated phase shift and voltage magnitude compensation settings “CB1 CS VT PhShft”, “CB1 CS VT Mag”, “CB2 CS VT PhShft” and “CB2 CS VT Mag”, to compensate for healthy voltage angle and magnitude differences between the Bus VT input and the selected line VT reference phase. This allows the bus VT inputs to be taken from VT windings with different rated voltages or phase connections to the reference voltage (for example, they could be taken from VTs on opposite sides of a transformer). Any voltage measurements or comparisons using bus VT inputs are made using the compensated values.

The system checks logic comprises two modules, one to monitor the voltages, and one to check for synchronism.

The voltage monitor determines the voltage magnitudes, frequencies and relative phase angles of the VT inputs using the same VT inputs as the check sync reference phase voltage setting “CS Input”. The “Live Line”, “Dead Line”, etc., outputs from the voltage monitor are qualified by blocking inputs from the P544/P546/P841, external VT supervision, VT secondary MCB auxiliary switch contacts, and by external inputs mapped in the PSL to DDBs (1522, etc.) to individually inhibit the output DDBs (888, etc.) for each function.

5.7.4

Dual CB System Voltage Synchronism Checks (P544/P546)

Two synchronism check stages are provided to compare the line and bus voltages when closing a circuit breaker.

Synchronism check logic is enabled or disabled per circuit breaker, by settings “Sys Checks CB1” to “Enable” or “Disable”, and “Sys Checks CB2” to “Enable”, or “Disable”.

If “System Checks CB1” is set to “Disable”, all other menu settings associated with system checks and synchronism checks for CB1 become invisible, and a DDB (880) signal “SChksInactiveCB1” is set.

Similarly if “System Checks CB2” is set to “Disable”, all other menu settings associated with system checks and synchronism checks for CB2 become invisible, and a DDB (1484) signal “SChksInactiveCB2” is set.

The overall check synchronism functionality is illustrated below:

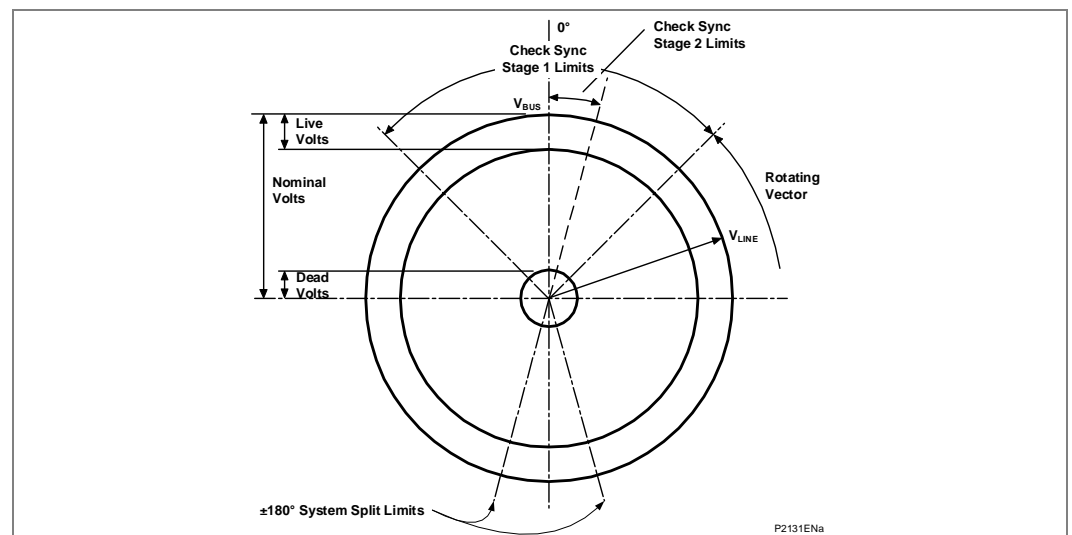

Figure 140 - Synchro check functionality (P544/P546)

5.7.5

Check Sync Enhancements for Dual CB Variants

The selection of voltages to be compared for the Check Sync function is now very flexible. A number of DDBs have been created for this purpose (DDB 1692-1695, DDB 1898-1909).

For each CB the Checksync Sel 1 signal controls the input used as the line voltage for the check sync function.

1. If the Checksync Sel 1 signal is low, the selected (single phase or phase to phase voltage) from the line voltage will be used.
2. If the Checksync Sel 1 signal is high, the remote bus voltage (For CB1 this is V C/S 2) is used as the line voltage by the check sync function. This voltage is used after the gain and phase compensation have been applied to be normalised to the phase voltage.
3. For each CB, the Checksync Sel 2 DDB signal controls the input used as the bus voltage for the checksync function
4. If the Checksync Sel 2 signal is low, the bus voltage follows the existing behaviour (CB1 using Vc/s1 and CB2 using Vc/s2). The appropriate compensation factors are applied to each input as shown in Figure 1.
5. If the Checksync Sel 2 signal is high, the remote bus voltage (For CB1 this is V C/S 2) is used as the bus voltage by the check sync function. This voltage is used after the gain and phase compensation have been applied to be normalised to the phase voltage.
6. The status of the two input select signals does not affect the Voltage Monitoring function. It continues to provide the live/dead status of the Line and the two busbars based on the fixed mapping.
7. To provide the voltage status for the bus and line side of each CB, the checksync function produces specific Bus and Line, Live/Dead signals from the perspective of the CB (DDB 1898-1909).
8. The CB Line/Bus Live/Dead status is determined using the plant status signals from the voltage Monitoring, combined with the Checksync input Selection DDBs, according to the logic defined in Figure 2 and 3.
9. The Line under/overvoltage function is based on the switched line input signal according the status of Checksync Sel 1.

5.8 Synchronism Check Functions (P544/P546)

5.8.1 Overview

Two stages of system synchronism check supervision are provided for each circuit breaker. When required, they control the manual closing and/or auto-reclosing of the associated circuit breaker. "CB1 CS1" and "CB1 CS2" supervise CB1, whilst "CB2 CS1" and "CB2 CS2" supervise CB2.

The functionality of the first two stages (CB1 CS1 and CB2 CS1) is the same for each, but each circuit breaker has individual settings.

The functionality of the second two stages (CB1 CS2 and CB2 CS2) is the same for each, with each circuit breaker having individual settings. The functionality is similar to the first stages, but the second stages have an additional "adaptive" setting.

The synchronism check function in P446/P544/P546/P841 relays can be set to provide appropriate synchronism check supervision of circuit breaker closing for either synchronous or asynchronous systems.

5.8.2 Synchronous Systems and Asynchronous Systems/System Split

Systems in which the frequency difference ("slip frequency") between the voltages on either side of an open CB is practically zero are described as "synchronous". Such systems are typically interconnected by other circuits in parallel with the open CB, which help to maintain synchronism even while the CB is open.

Systems which are electrically separated when a specific CB is open do not have parallel connections of sufficiently low impedance to maintain synchronism, and in the absence of any power flow between them the frequencies can drift apart, giving a significant slip frequency. Such systems are described as "asynchronous" or "split", and are recognised by a measured slip frequency greater than the limiting slip frequency setting for synchronous systems.

5.8.3 Synchronism Check Functions

Two independently settable synchronism check functions are provided for each circuit breaker controlled by the relay.

CB1 CS1 and/or CB1 CS2 can be applied to supervise closing of circuit breaker CB1.

CB2 CS1 and/or CB2 CS2 can be applied to supervise closing of circuit breaker CB2.

CB1 CS1 and CB2 CS1 are designed to be applied for synchronism check on synchronous systems, while CB1 CS2 and CB2 CS2 provide additional features which may be required for synchronism check on asynchronous systems. In situations where it is possible for the voltages on either side of a circuit breaker to be either synchronous or asynchronous depending on plant connections elsewhere on the system, both CBx CS1 and CBx CS2 can be enabled, to provide a permissive close signal if either set of permitted closing conditions is satisfied.

Each synchronism check function, as well as having the basic maximum phase angle difference and slip frequency settings, can also be set to inhibit circuit breaker closing if selected "blocking" conditions such as overvoltage, undervoltage or excessive voltage magnitude difference are detected. In addition, CB1 CS2 and CB2 CS2 each require the phase angle difference to be decreasing in magnitude to permit circuit breaker closing, and each has an additional "Freq+CB Comp" choice to issue the permissive close signal when the predicted phase angle difference immediately prior to the instant of circuit breaker main contacts closing (i.e. after CB Close time) is as close as practicable to zero.

Slip frequency can be defined as the difference between the voltage signals on either side of the circuit breaker, and represents a measure of the rate of change of phase between the two signals.

Having two system synchronism check stages available for each circuit breaker allows the circuit breaker closing to be enabled under different system conditions (for example, low slip / moderate phase angle, or moderate slip / small phase angle).

When the check synchronism criteria is satisfied, a DDB signal "CBx CSy OK" is set (x = 1 or 2, y = 1 or 2).

For "CB1 CS1 OK" DDB (883) to be set, the following conditions are necessary:

- Settings "Sys Checks CB1" and "CB1 CS1 Status" must **both** be Enabled; AND
- "Live Line" and "Live Bus 1" signals are both set; AND
- None of the selected "CB1 CS1 Volt. Blk" conditions (V<, V>, VDiff) are true; AND
- The measured phase angle magnitude is less than the "CB1 CS1 Angle" setting; AND

- If "CB1 CS1 SlipCtrl" is set to Frequency or Timer+Freq, the measured slip frequency between the line VT and Bus1 VT is less than the "CB1 CS1 SlipFreq" setting, OR If "CB1 CS1 SlipCtrl" is set to Timer or Timer+Freq, the above conditions have been true for a time more than or equal to the "CB1 CS1 SlipTimer" setting.

For signal "CB1 CS2 OK" DDB (884) to be set, the following conditions are necessary:

- Settings "Sys Checks CB1" and "CB1 CS2 Status" must **both** be Enabled; AND
- "Live Line" and "Live Bus 1" signals are both set; AND
- None of the selected "CB1 CS2 Volt. Blk" conditions (V<, V>, VDiff) are true; AND
- If "CB1 CS2 SlipCtrl" is set to Frequency or Timer+Freq, the measured slip frequency between the line VT and Bus1 VT is less than the "CB1 CS2 SlipFreq" setting, OR If "CB1 CS2 SlipCtrl" is set to Timer or Timer+Freq, the above conditions have been true for a time more than or equal to the "CB1 CS2 SlipTimer" setting; AND
- The measured phase angle magnitude is decreasing; AND
- If "CB1 CS2 SlipCtrl" is NOT set to Freq+CB Comp, OR "ADAPTIVE_CHECKSYNC" is NOT defined, the measured phase angle magnitude is less than the "CB1 CS2 Angle" setting; OR If "CB1 CS2 SlipCtrl" is set to Freq+CB Comp, AND "ADAPTIVE_CHECKSYNC" is defined, AND if the predicted phase angle is less than the "CB1 CS2 Angle" setting AND as close as possible to zero AND still decreasing in magnitude.

For "CB2 CS1 OK" DDB (1577) to be set, the following conditions are necessary:

- Settings "Sys Checks CB2" and "CB2 CS1 Status" must **both** be Enabled; AND
- "Live Line" and "Live Bus 2" signals are both set; AND
- None of the selected "CB2 CS1 Volt. Blk" conditions (V<, V>, VDiff) are true; AND
- The measured phase angle magnitude is less than the "CB2 CS1 Angle" setting; AND

- If "CB2 CS1 SlipCtrl" is set to Frequency or Timer+Freq, the measured slip frequency between the line VT and Bus 2 VT is less than the "CB2 CS1 SlipFreq" setting, OR If "CB2 CS1 SlipCtrl" is set to Timer or Timer+Freq, the above conditions have been true for a time more than or equal to the "CB2 CS1 SlipTimer" setting.

For signal "CB2 CS2 OK" DDB (1463) to be set, these conditions are necessary:

- Settings "Sys Checks CB2" and "CB2 CS2 Status" must **both** be Enabled; AND
- "Live Line" and "Live Bus 2" signals are both set; AND
- None of the selected "CB2 CS2 Volt. Blk" conditions (V<, V>, VDiff) are true; AND
- If "CB2 CS2 SlipCtrl" is set to Frequency or Timer+Freq, the measured slip frequency between the line VT and Bus2 VT is less than the "CB2 CS2 SlipFreq" setting, OR If "CB2 CS2 SlipCtrl" is set to Timer or Timer+Freq, the above conditions have been true for a time more than or equal to the "CB2 CS2 SlipTimer" setting; AND
- The measured phase angle magnitude is decreasing; AND
- If "CB2 CS2 SlipCtrl" is NOT set to Freq+CB Comp, OR "ADAPTIVE_CHECKSYNC" is NOT defined, the measured phase angle magnitude is less than the "CB2 CS2 Angle" setting; OR If "CB2 CS2 SlipCtrl" is set to Freq+CB Comp, AND "ADAPTIVE_CHECKSYNC" is defined, AND if the predicted phase angle when CB2 closes (after "CB2 CI Time" setting) is less than the "CB2 CS2 Angle" setting AND as close as possible to zero AND still decreasing in magnitude.

6 P544/P546 CB CONTROL AND AR FIGURES

In Figure AR-1 to Figure AR-65, reference is made to Fig numbers. These refer to figures in the AR sequence. For example, references to Fig 1 refers to Figure AR-1, Fig 2 to Figure AR-2, Fig 3 to Figure AR-4, Fig 4 to Figure AR-4 up to Fig 65 to Figure AR-65.

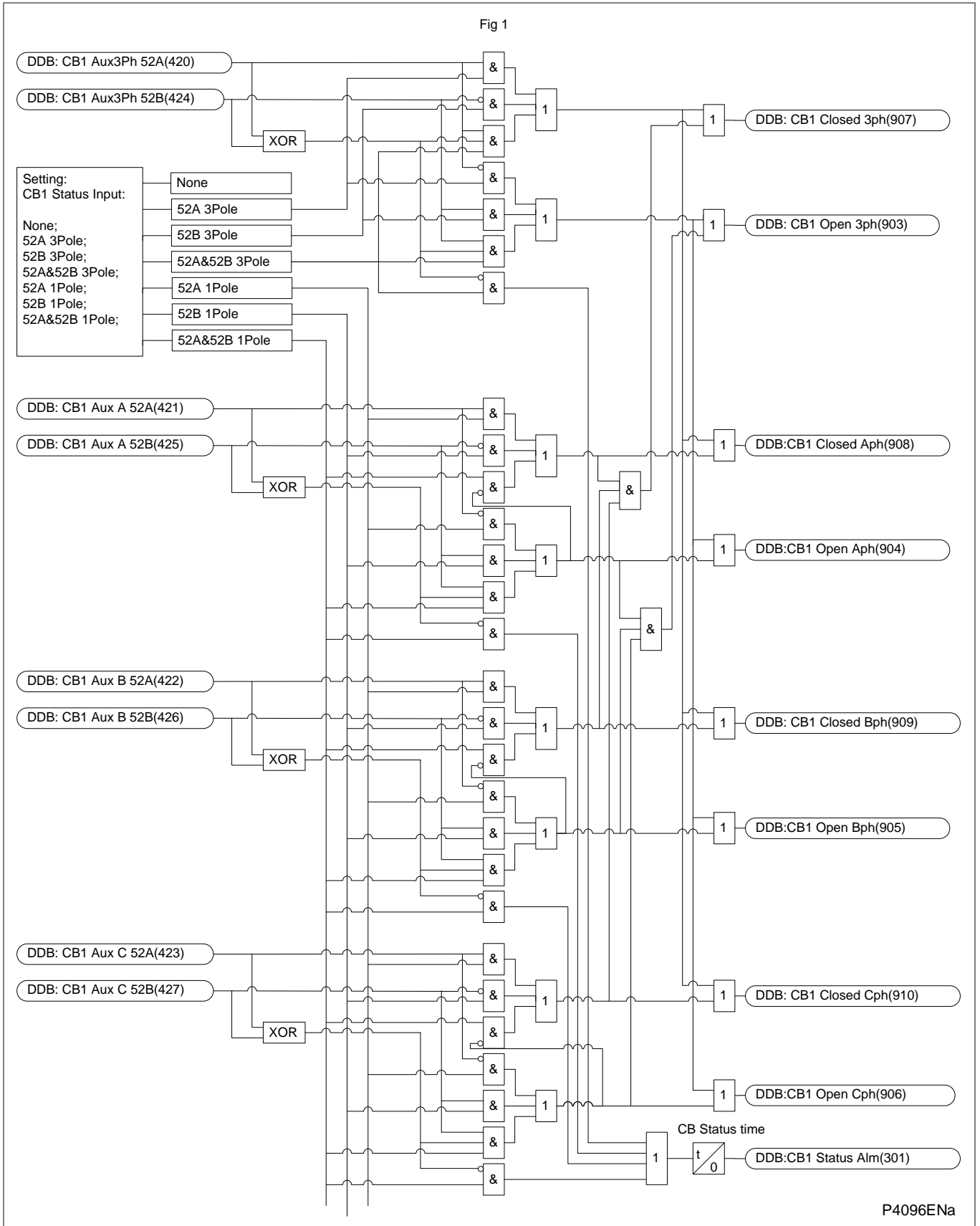
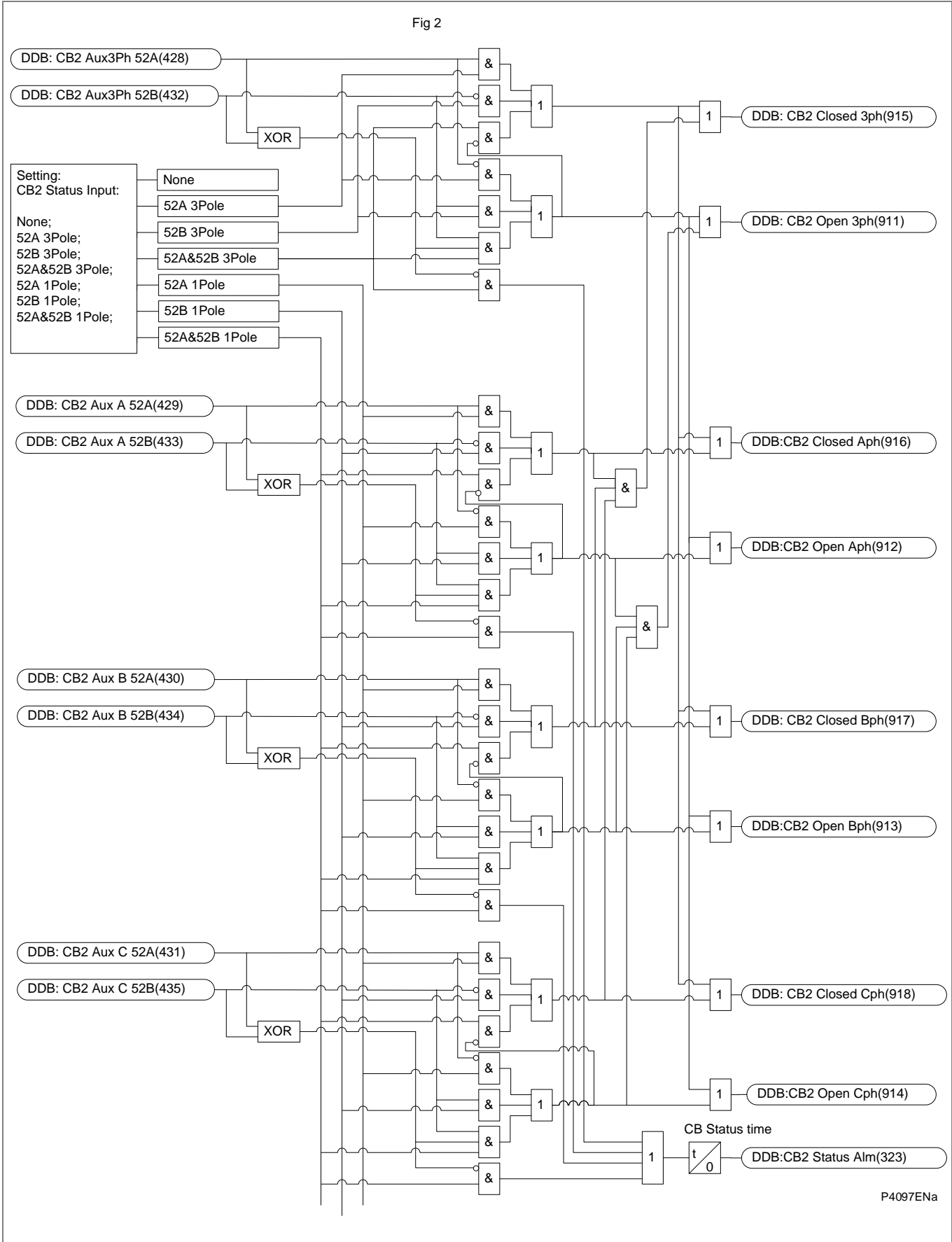

Figure AR-1 - Circuit breaker 1 - state monitor

Fig 2



P4097ENa

Figure AR-2 - Circuit breaker 2 - state monitor

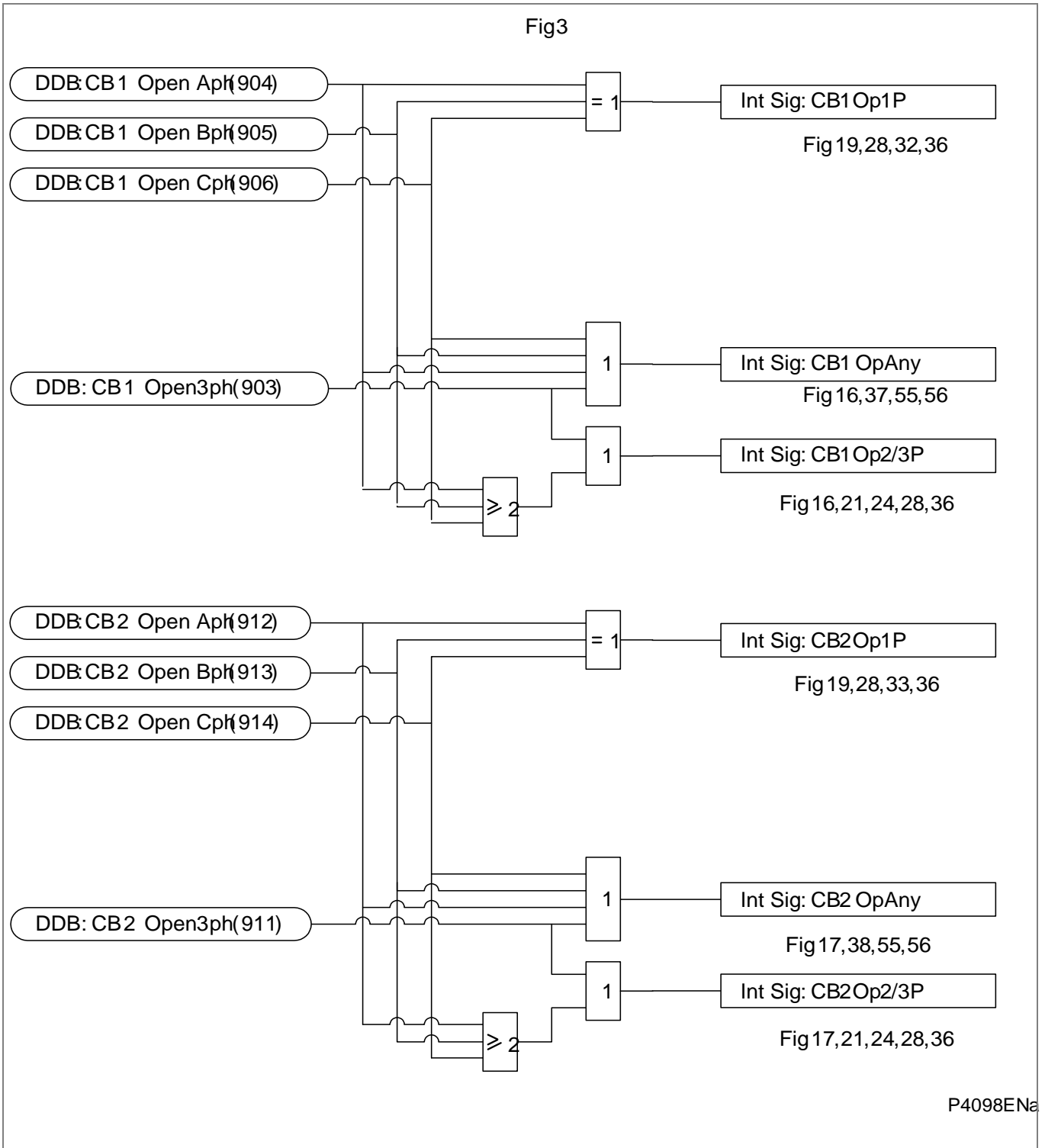

Figure AR-3 - CB1 & CB2 Open 1P, 2P, 2/3P, Any

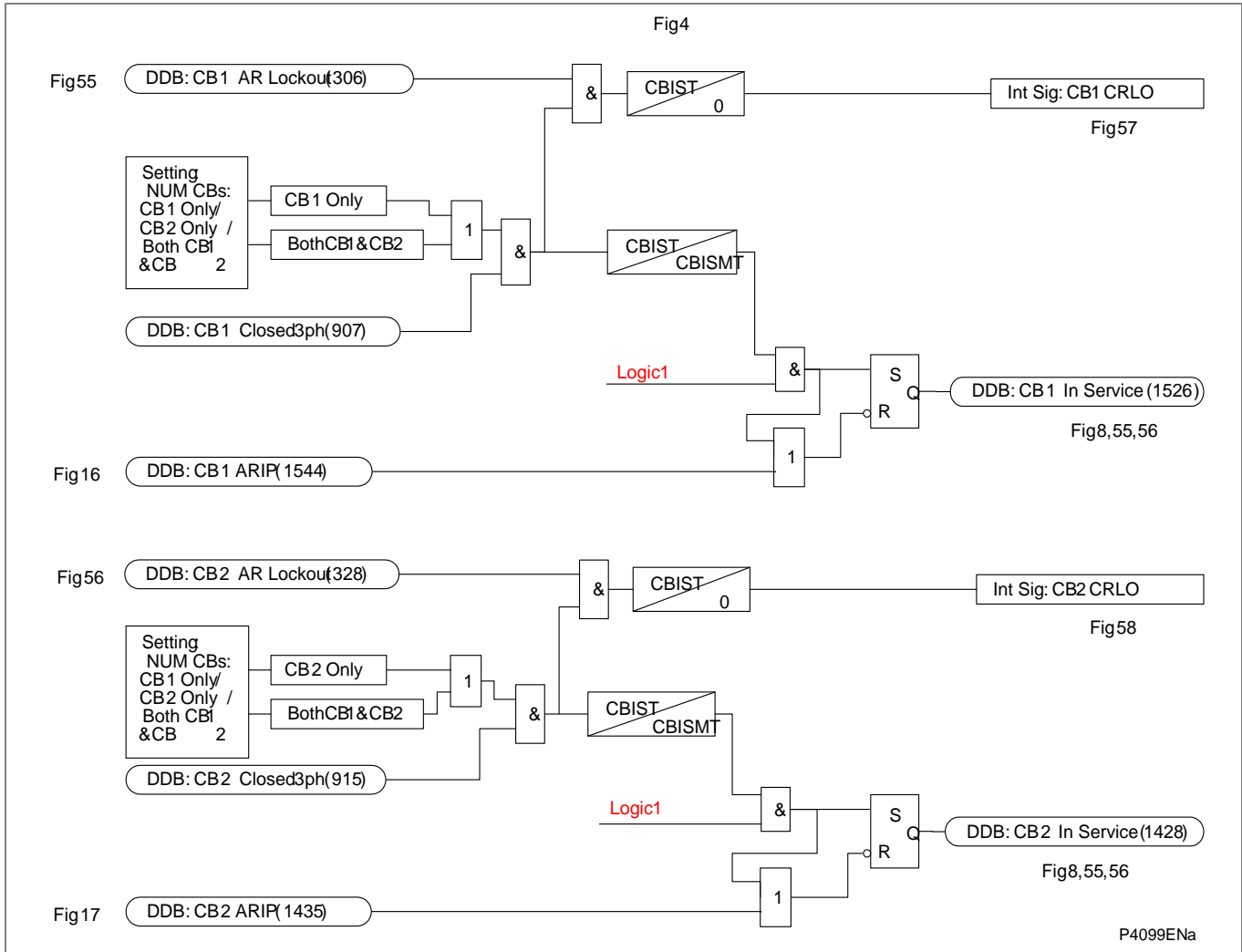

Figure AR-4 - Circuit breaker in service

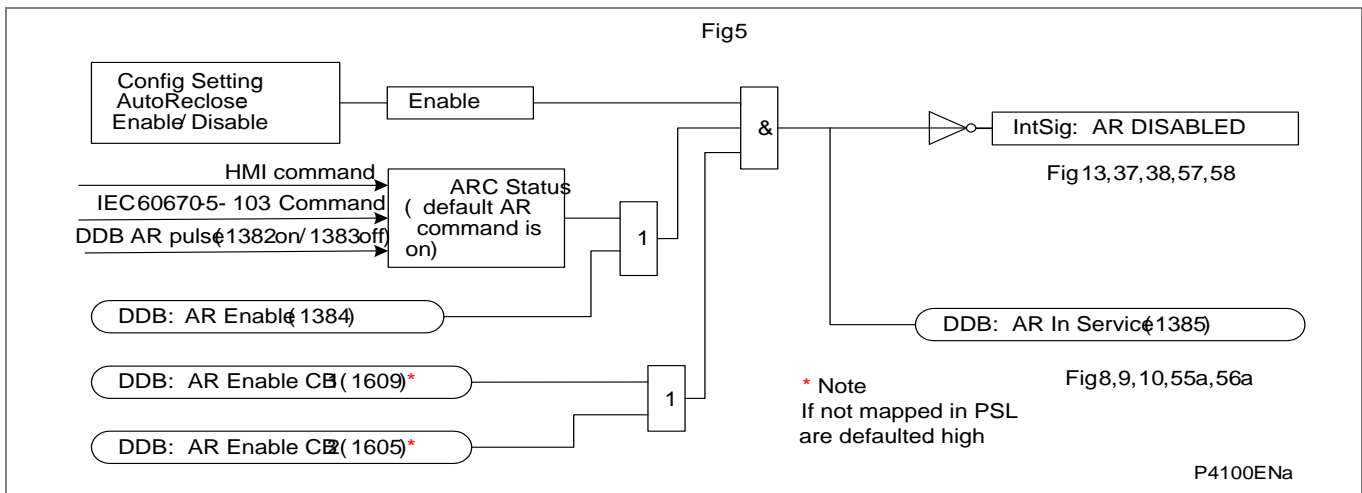

Figure AR-5 - Auto-reclose enable

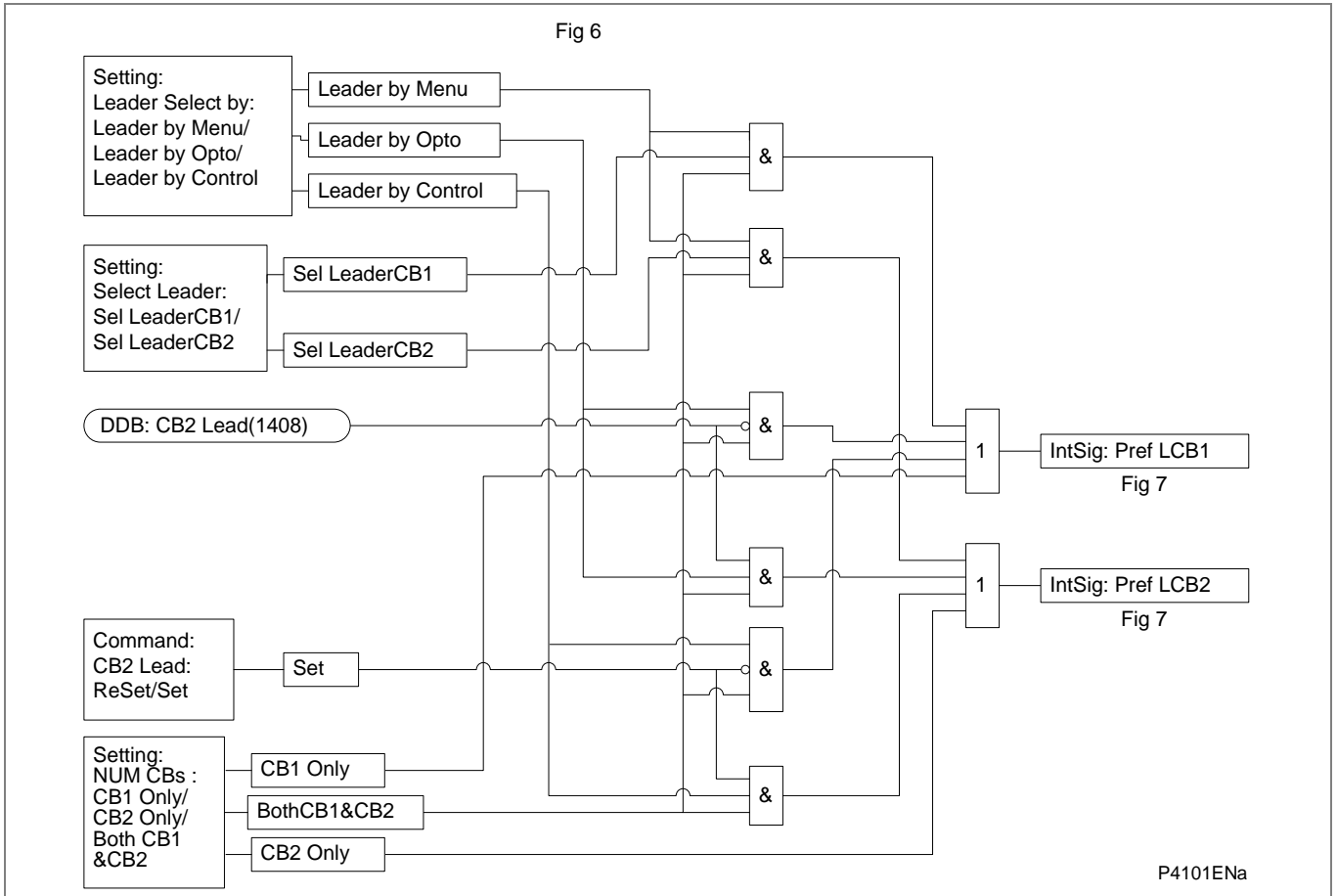

Figure AR-6 - Lead & follower circuit breaker selection

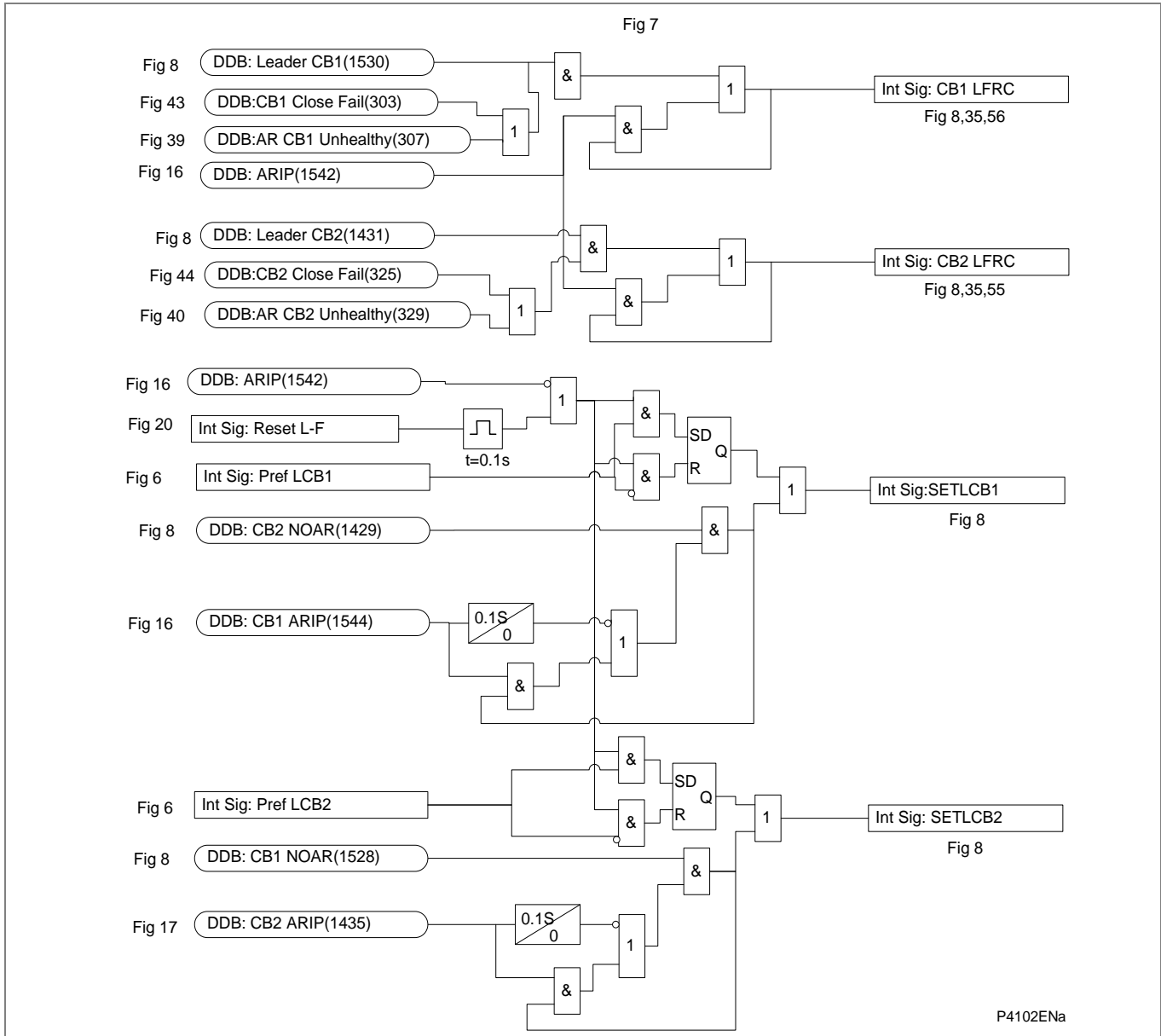

Figure AR-7 - Leader/follower logic – 1 (for Software Versions BEFORE H1)

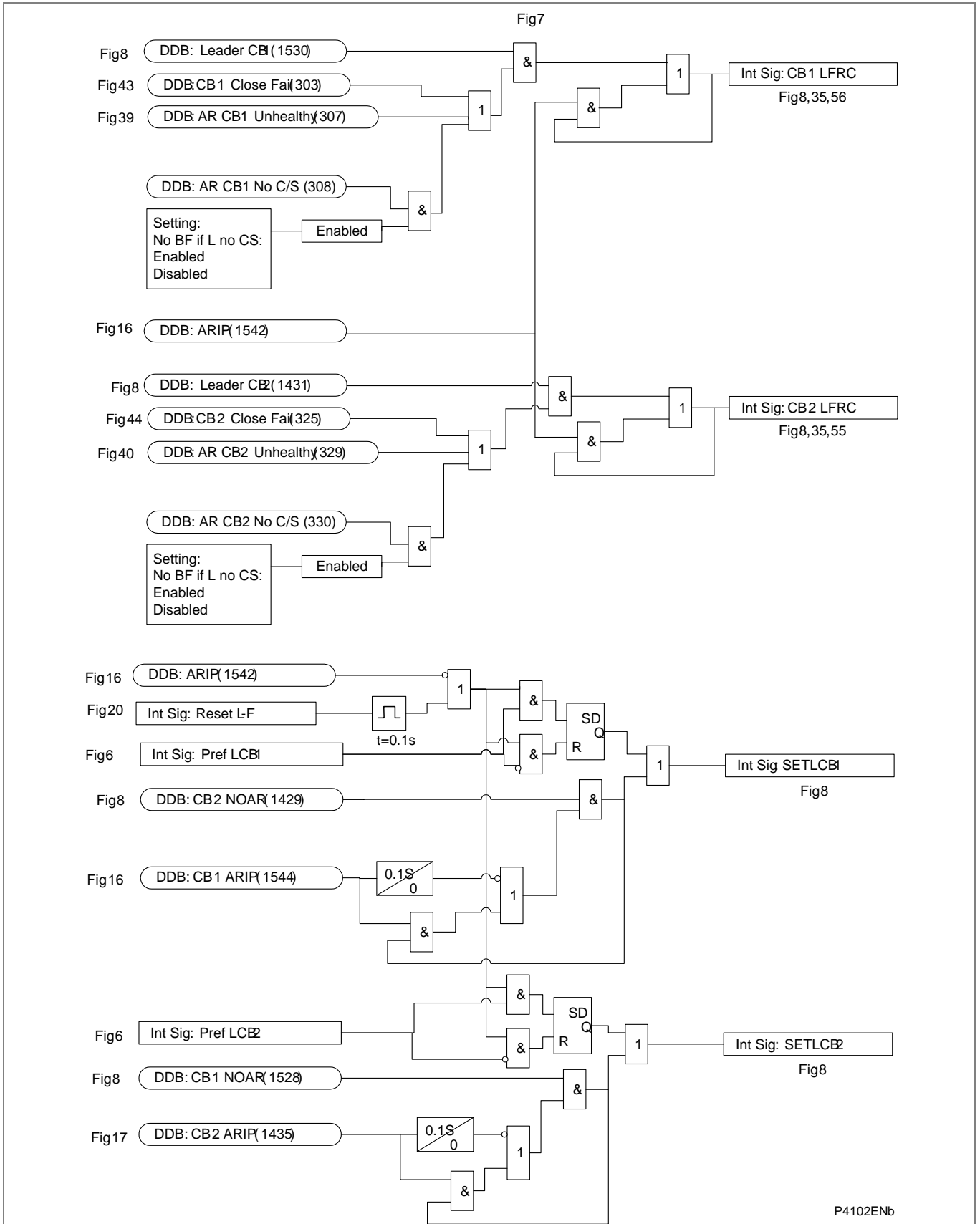

Figure AR-8 - Leader/follower logic – 1 (for Software Versions H1 and later)

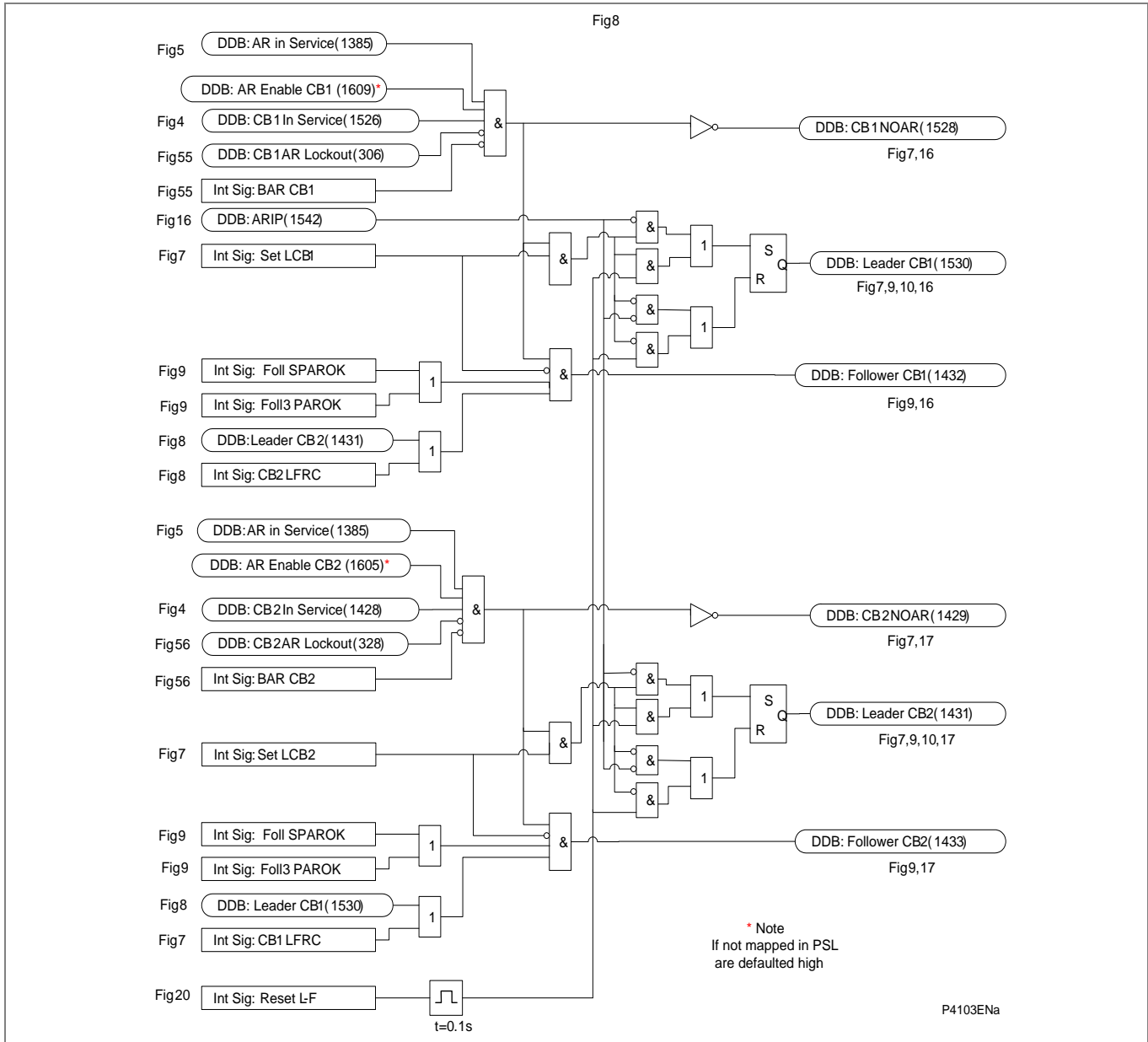

Figure AR-9 - Leader/follower logic – 2

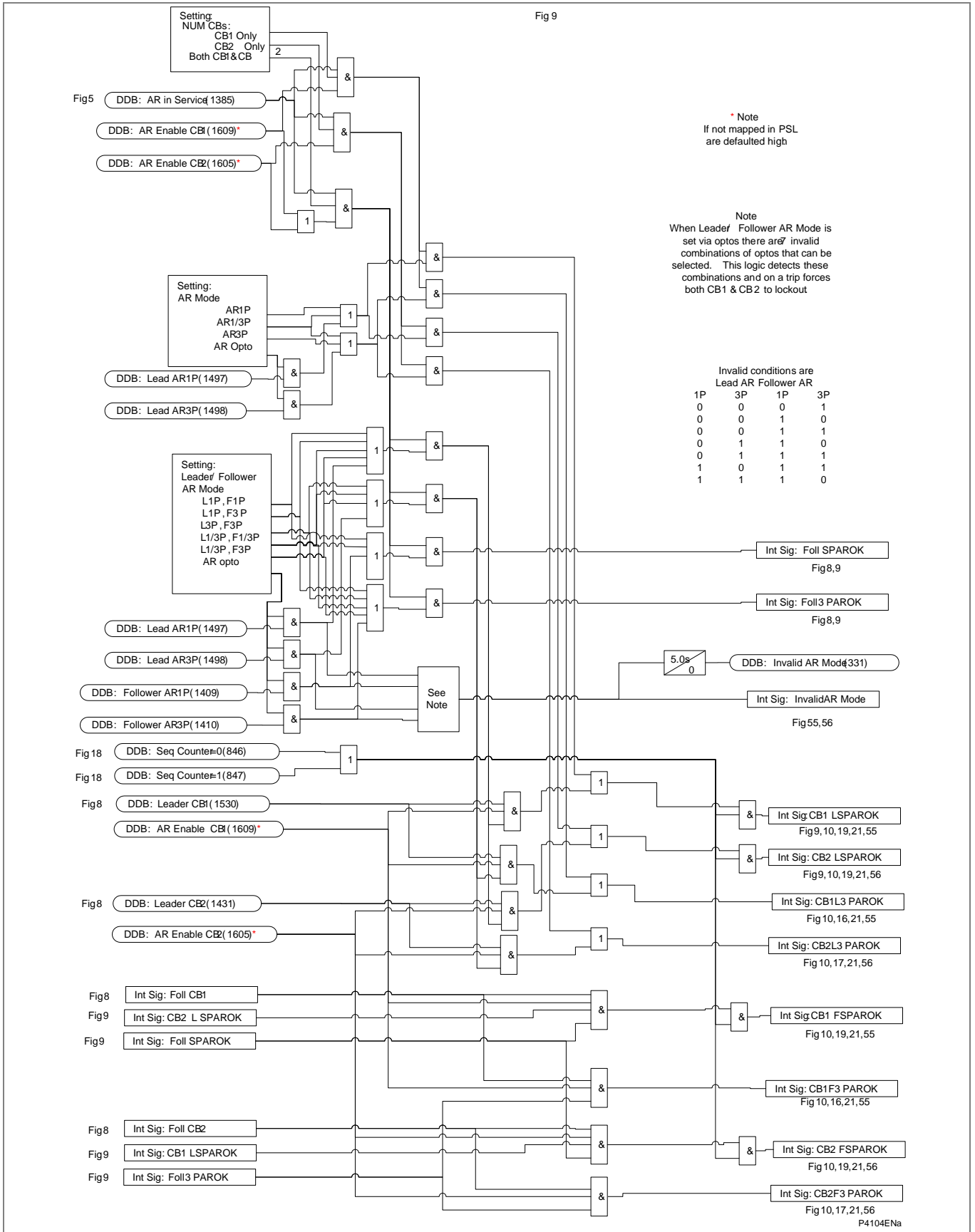

Figure AR-10 - Leader & follower AR modes enable

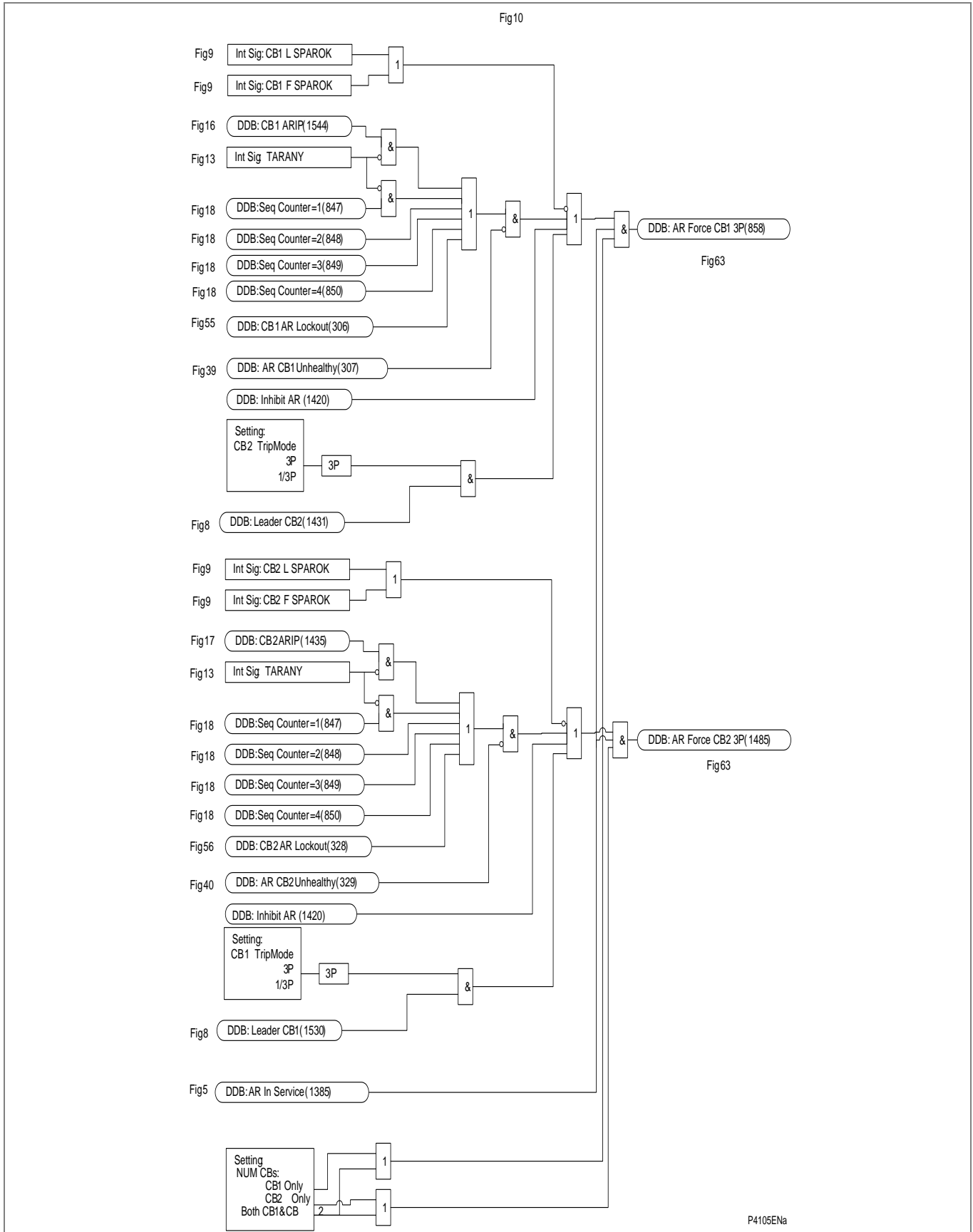

Figure AR-11 - Force three-phase trip

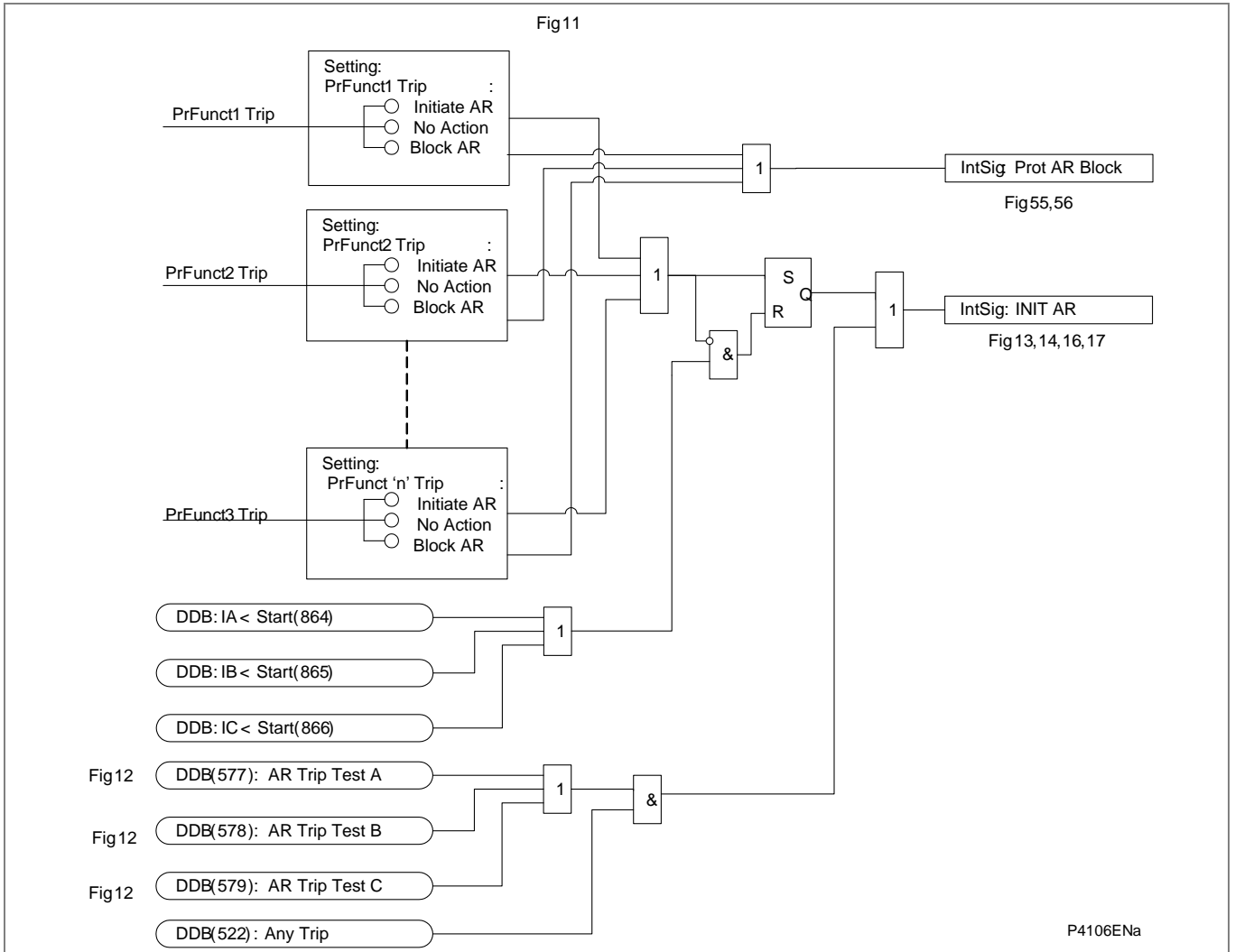

Figure AR-12 - Auto-reclose initiation

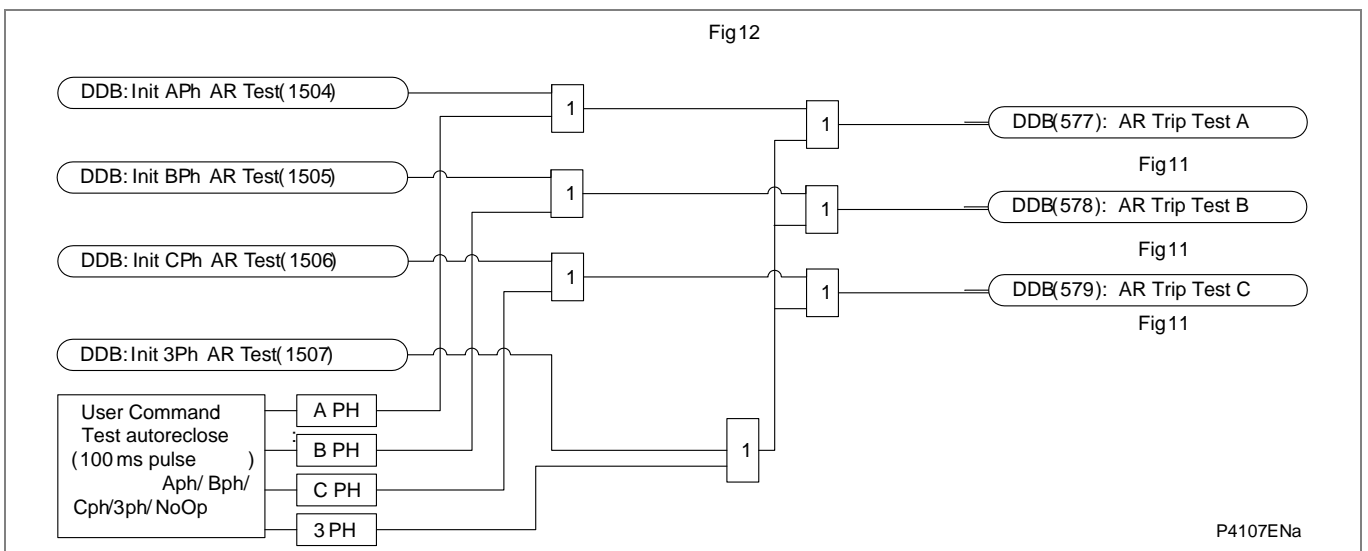

Figure AR-13 - Test trip & AR initiation

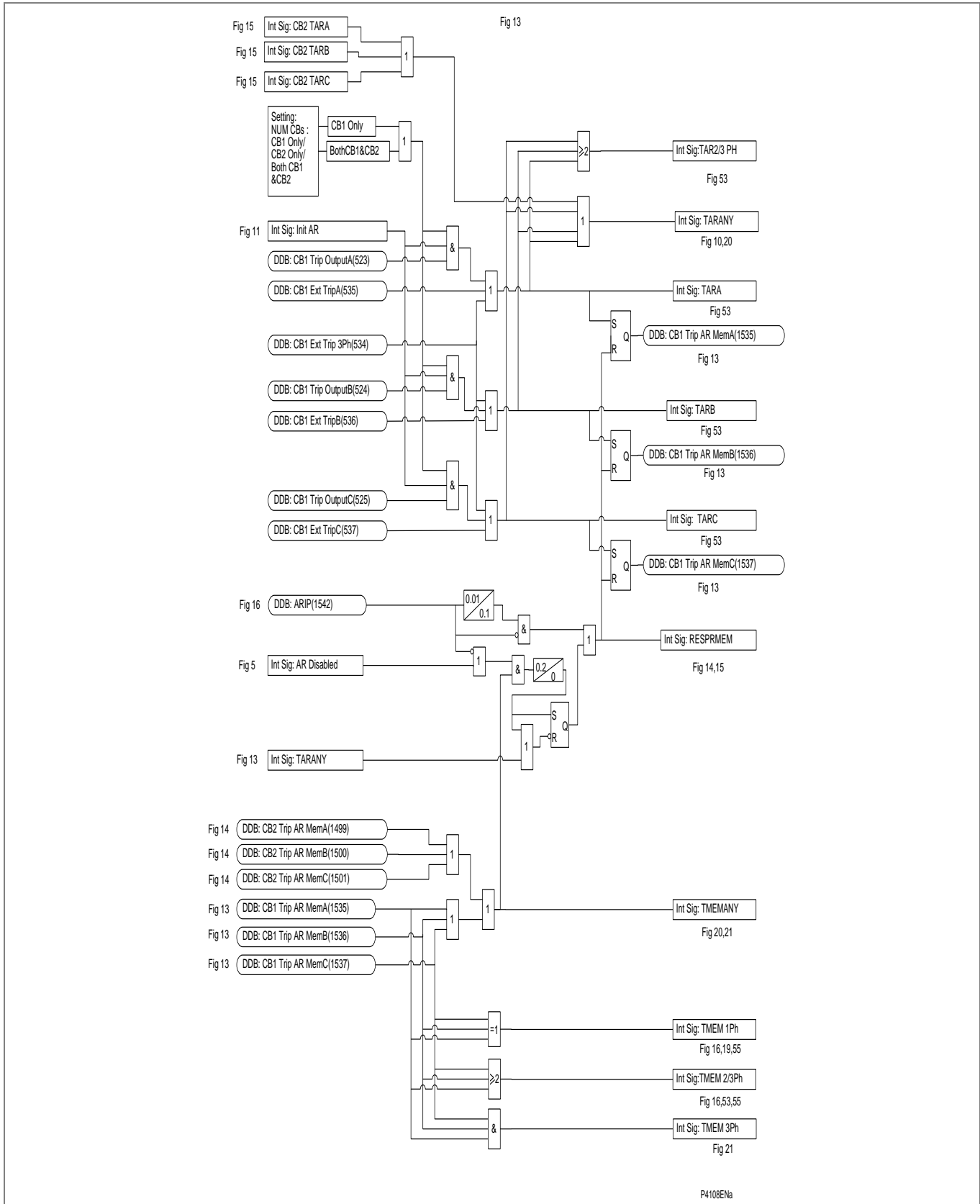

Figure AR-14 - CB1 1pole / 3-pole trip + AR initiation

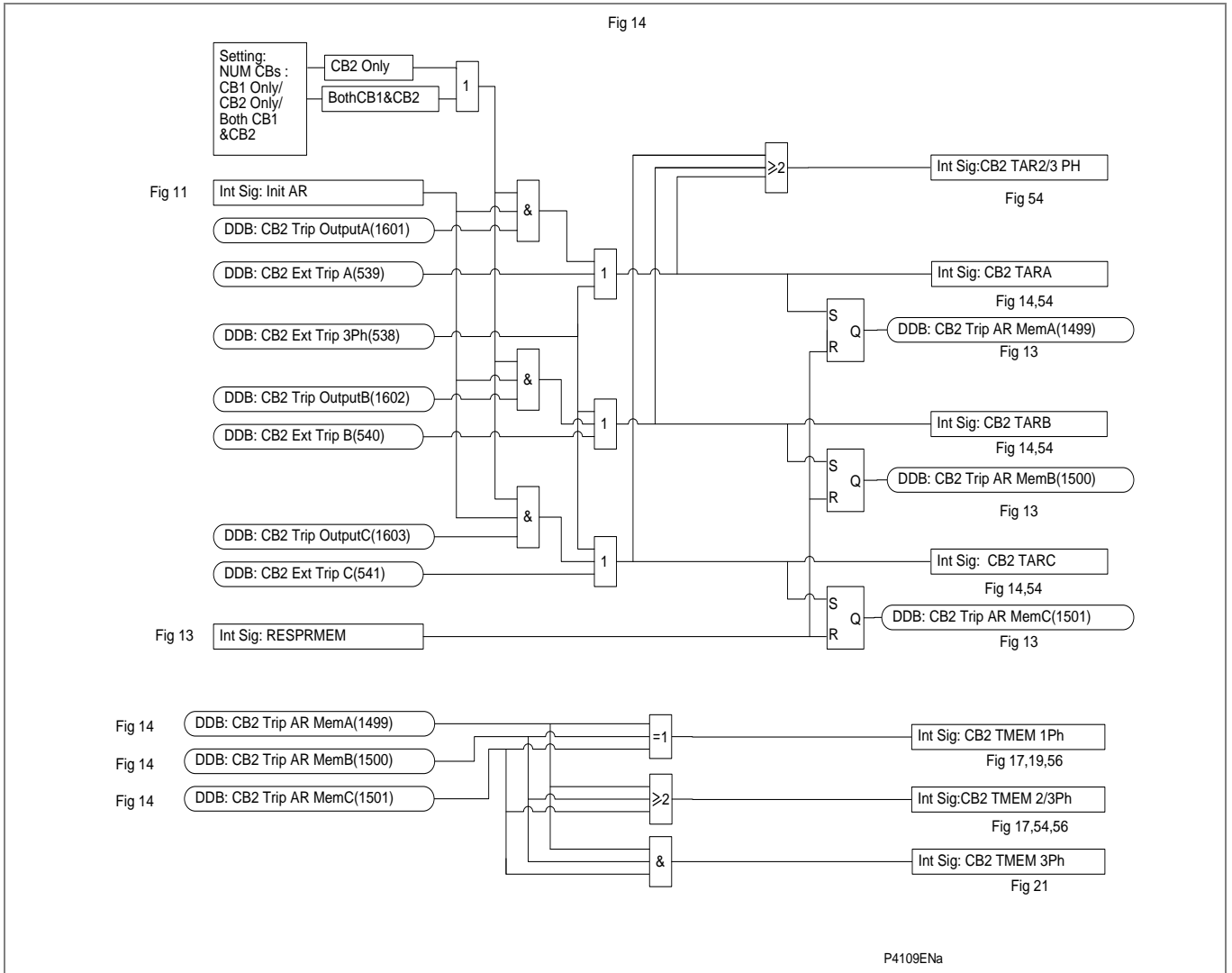

Figure AR-15 - CB2 1 pole / 3-pole trip + AR initiation

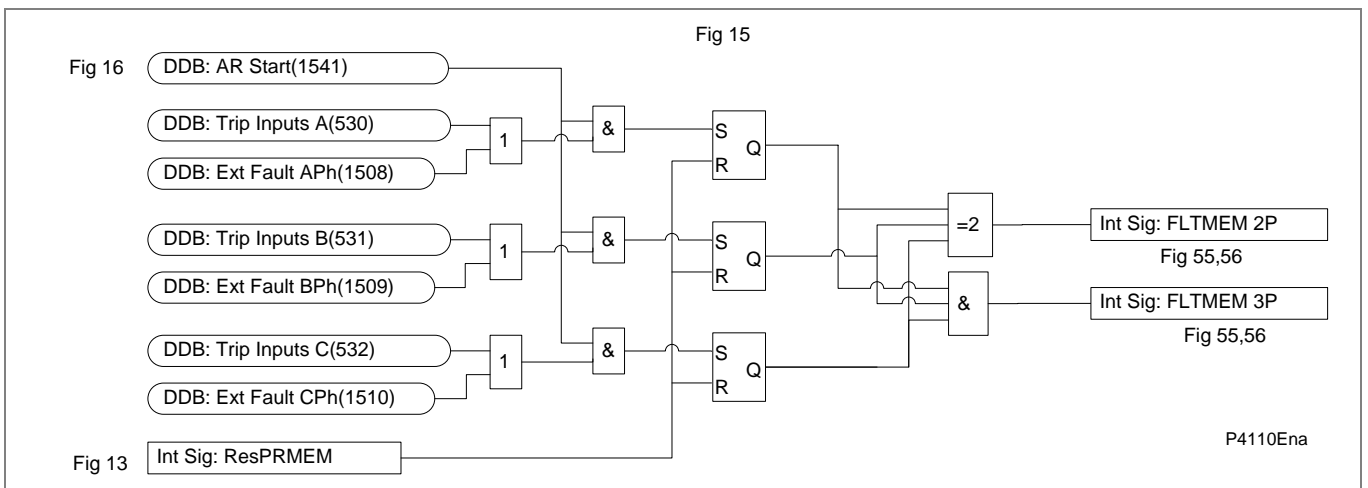

Figure AR-16 - 1Ph, 2Ph & 3Ph fault memory

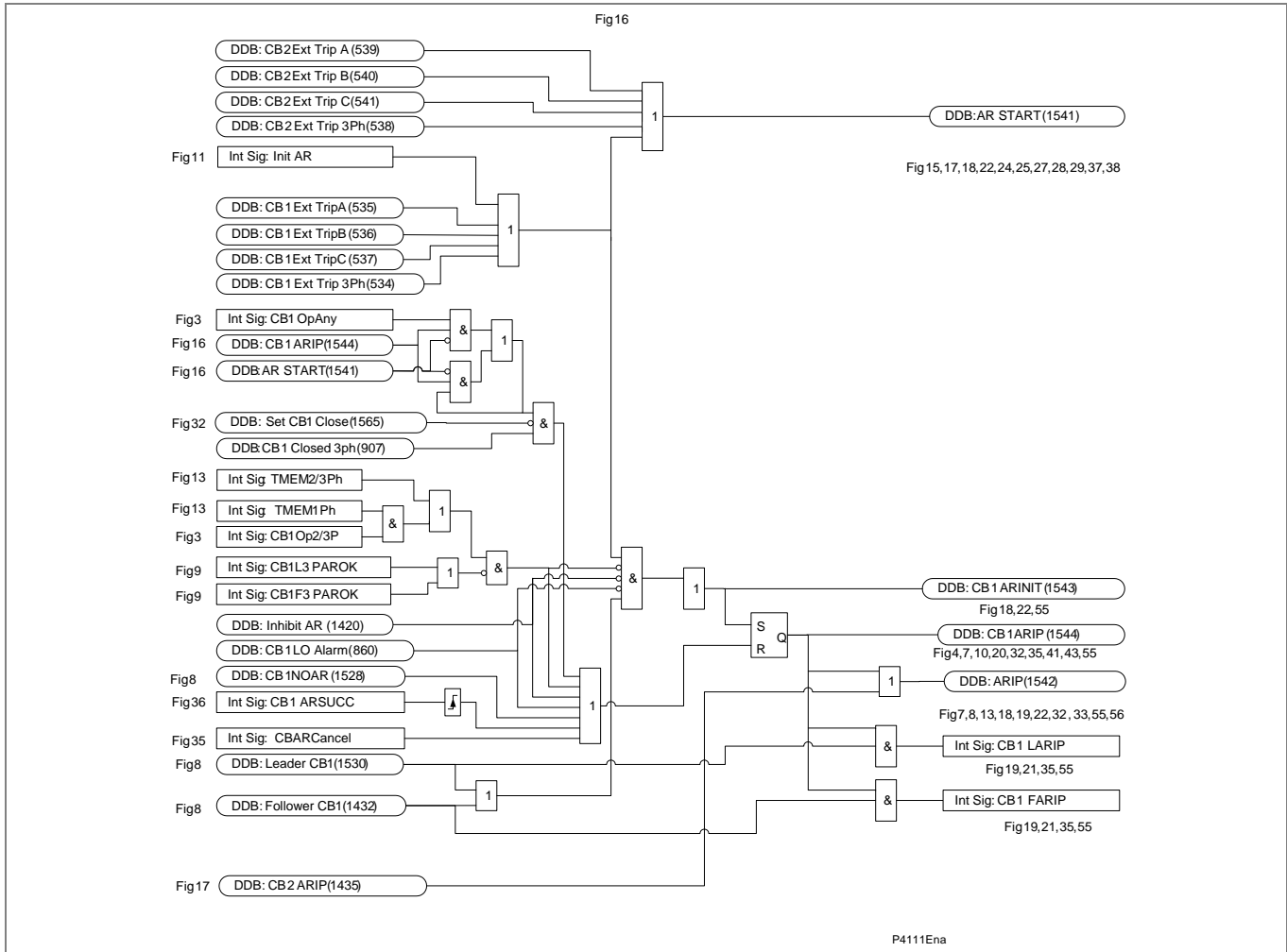

Figure AR-17 - CB1 Auto-reclose in progress

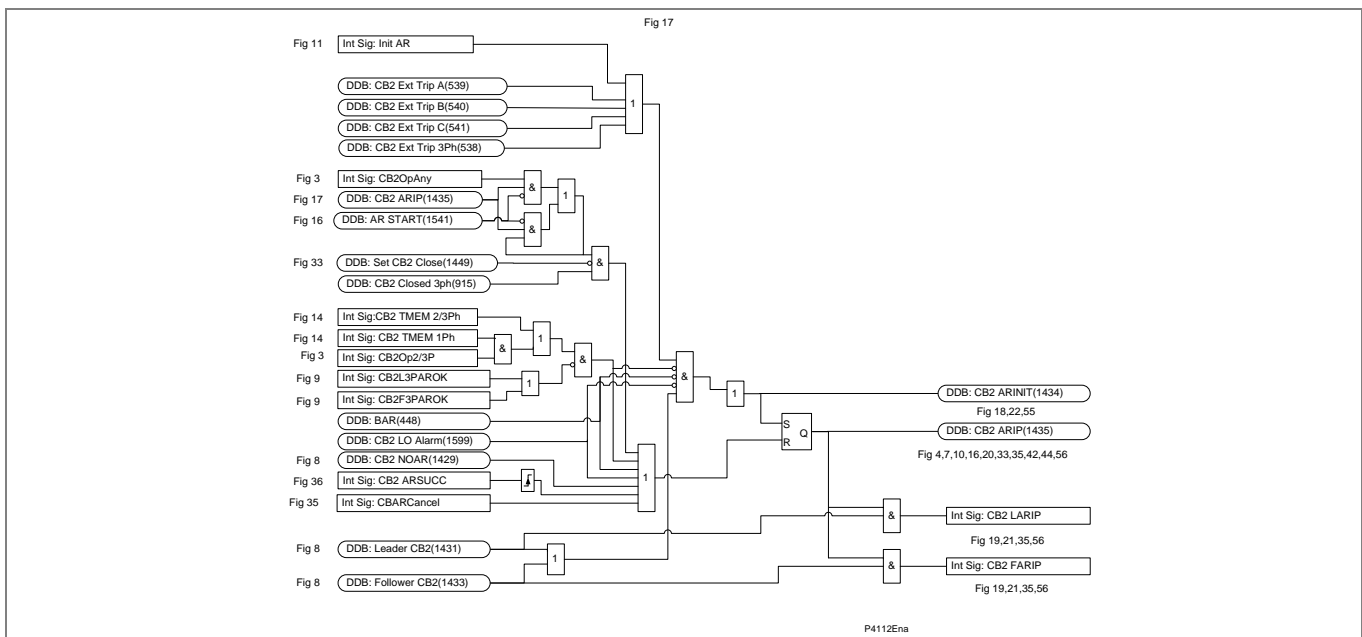

Figure AR-18 - CB2 Auto-reclose in progress

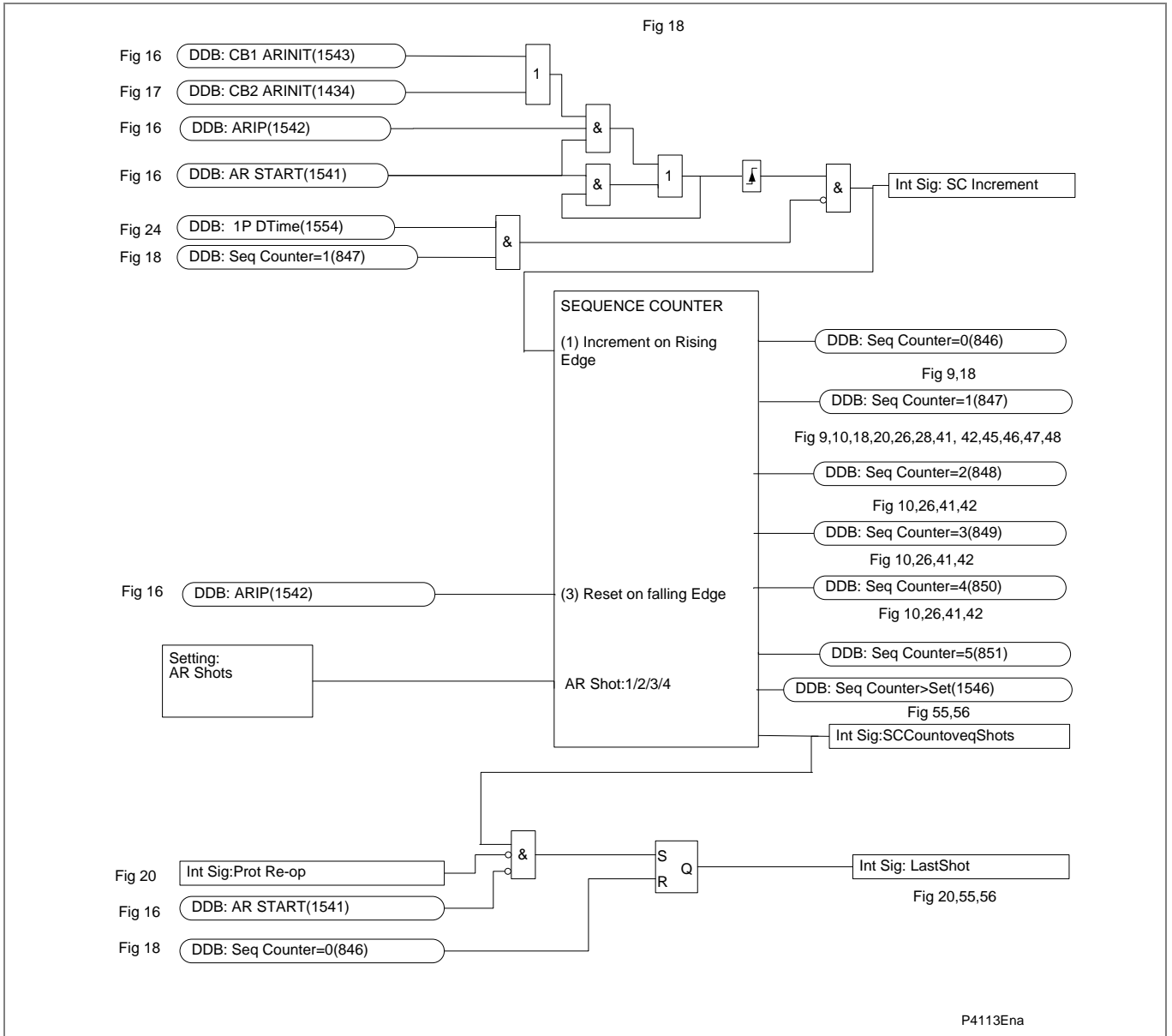

Figure AR-19 - Sequence counter

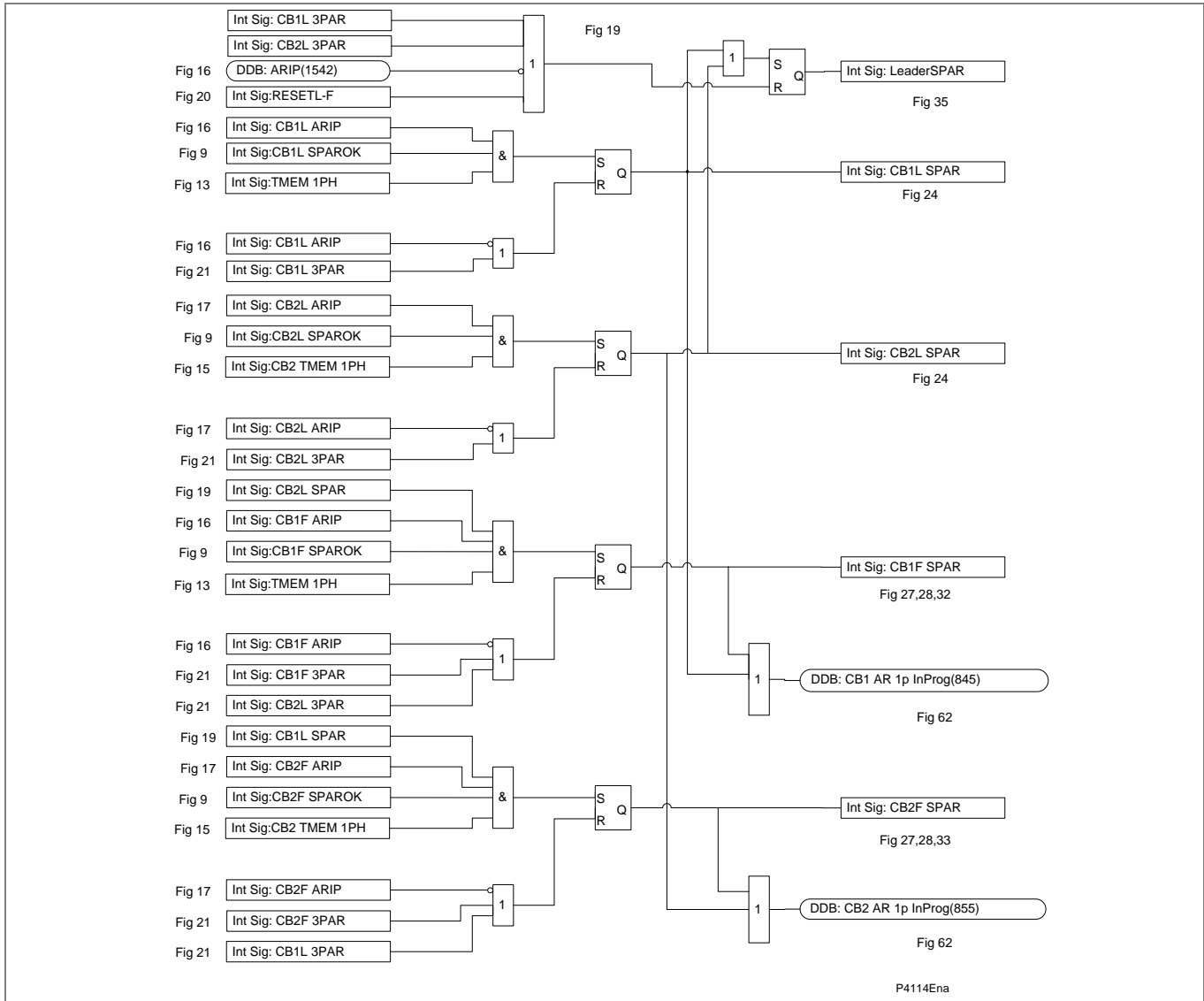

Figure AR-20 - Single phase AR cycle selection

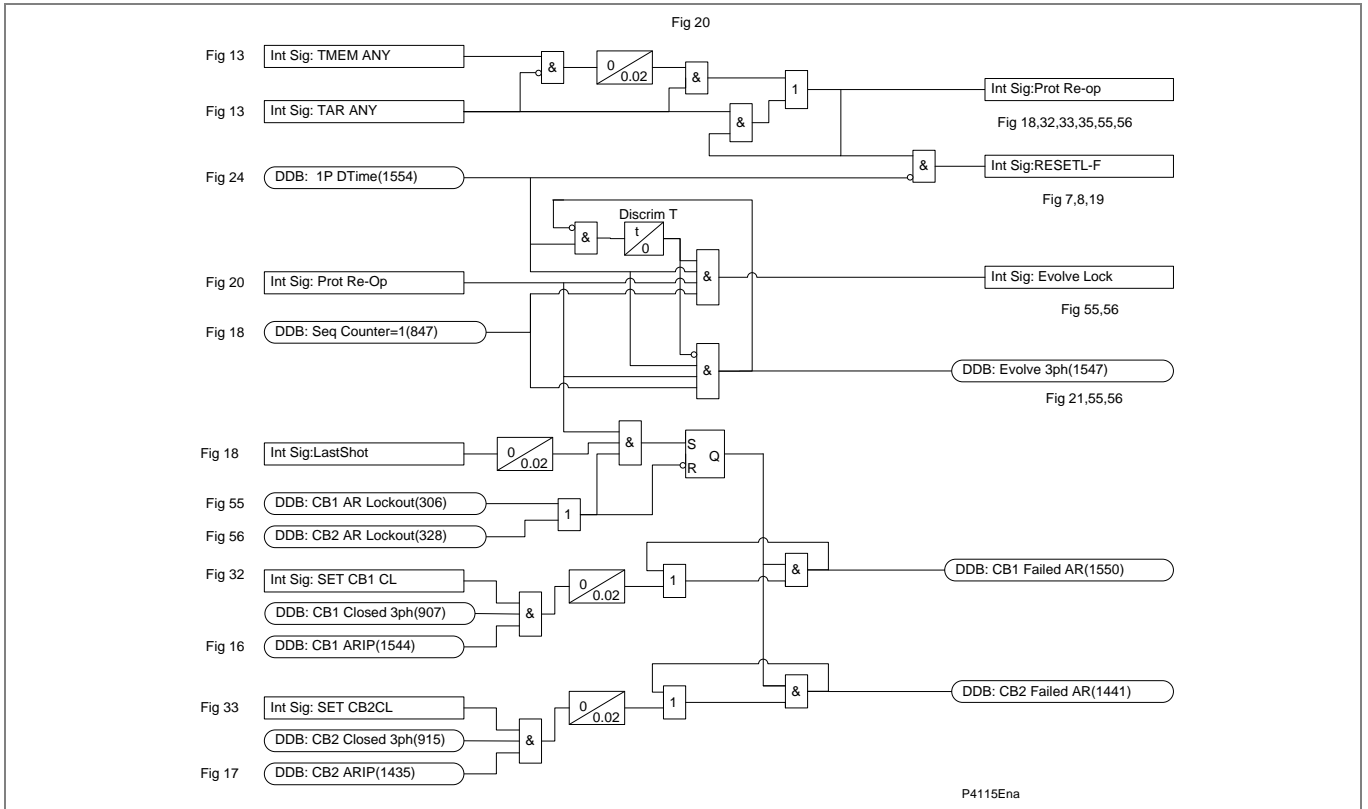

Figure AR-21 - Protection re-operation + evolving fault + persistent fault

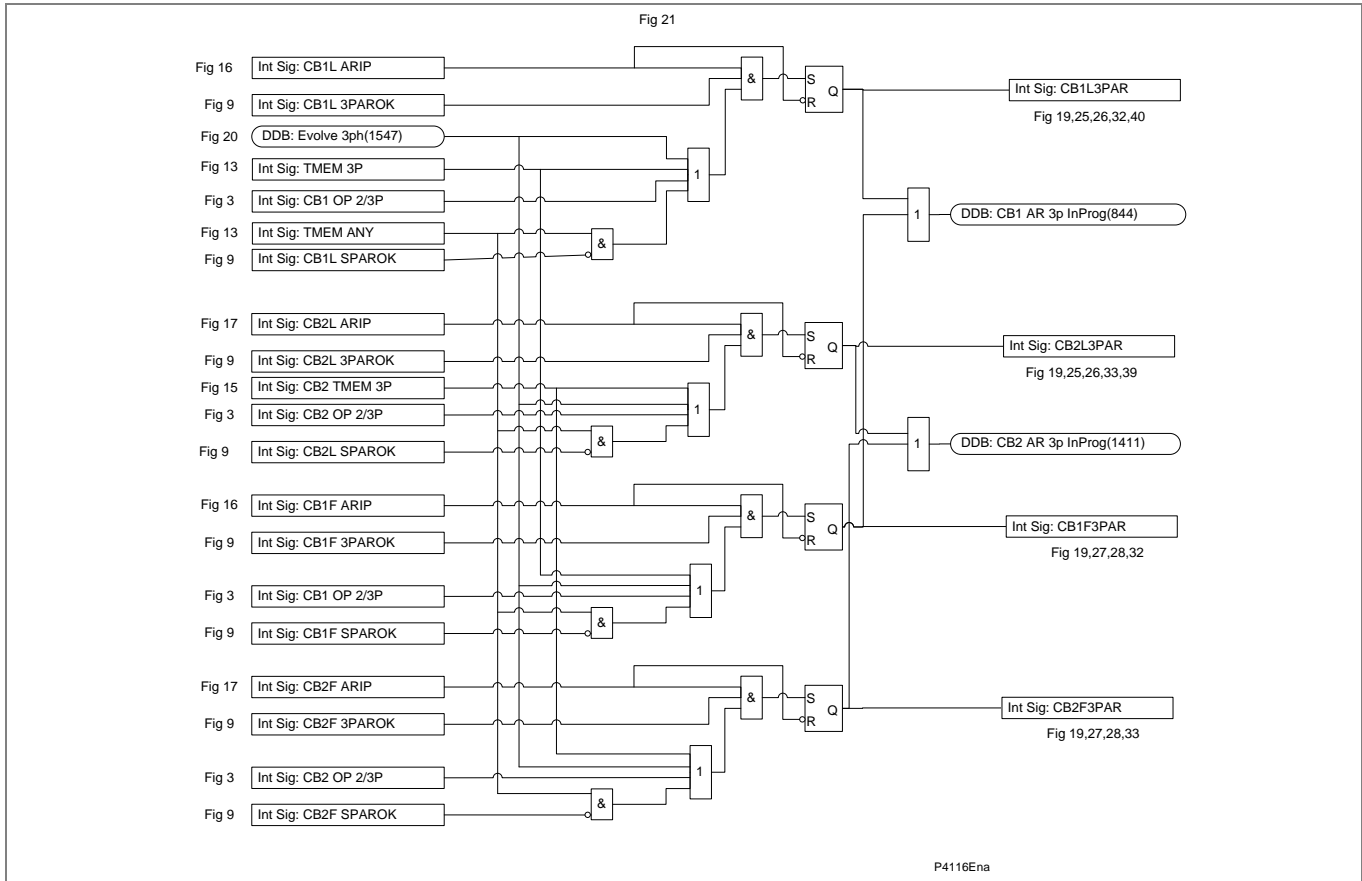

Figure AR-22 - Three phase AR cycle selection

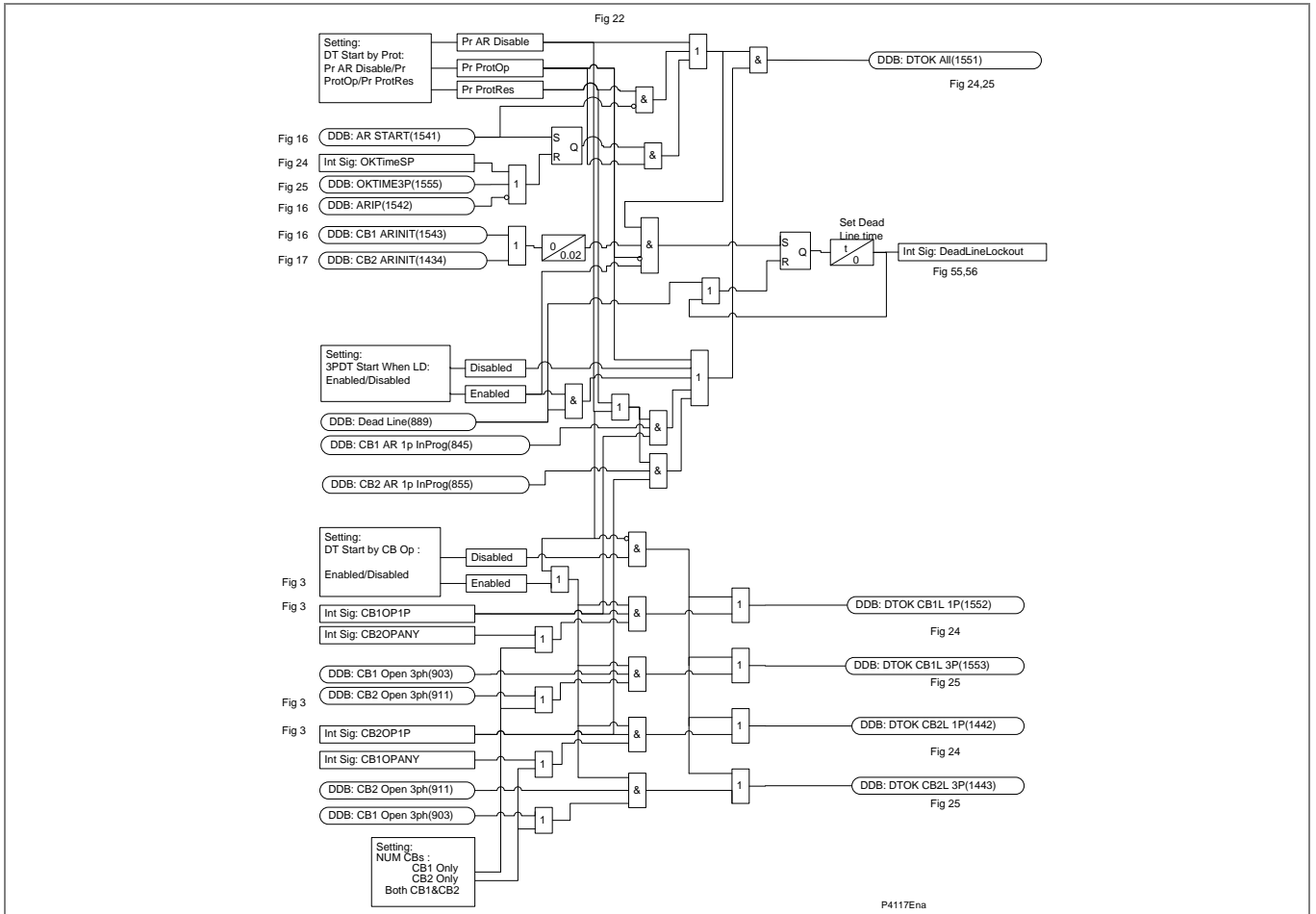

Figure AR-23 - Dead time start enable

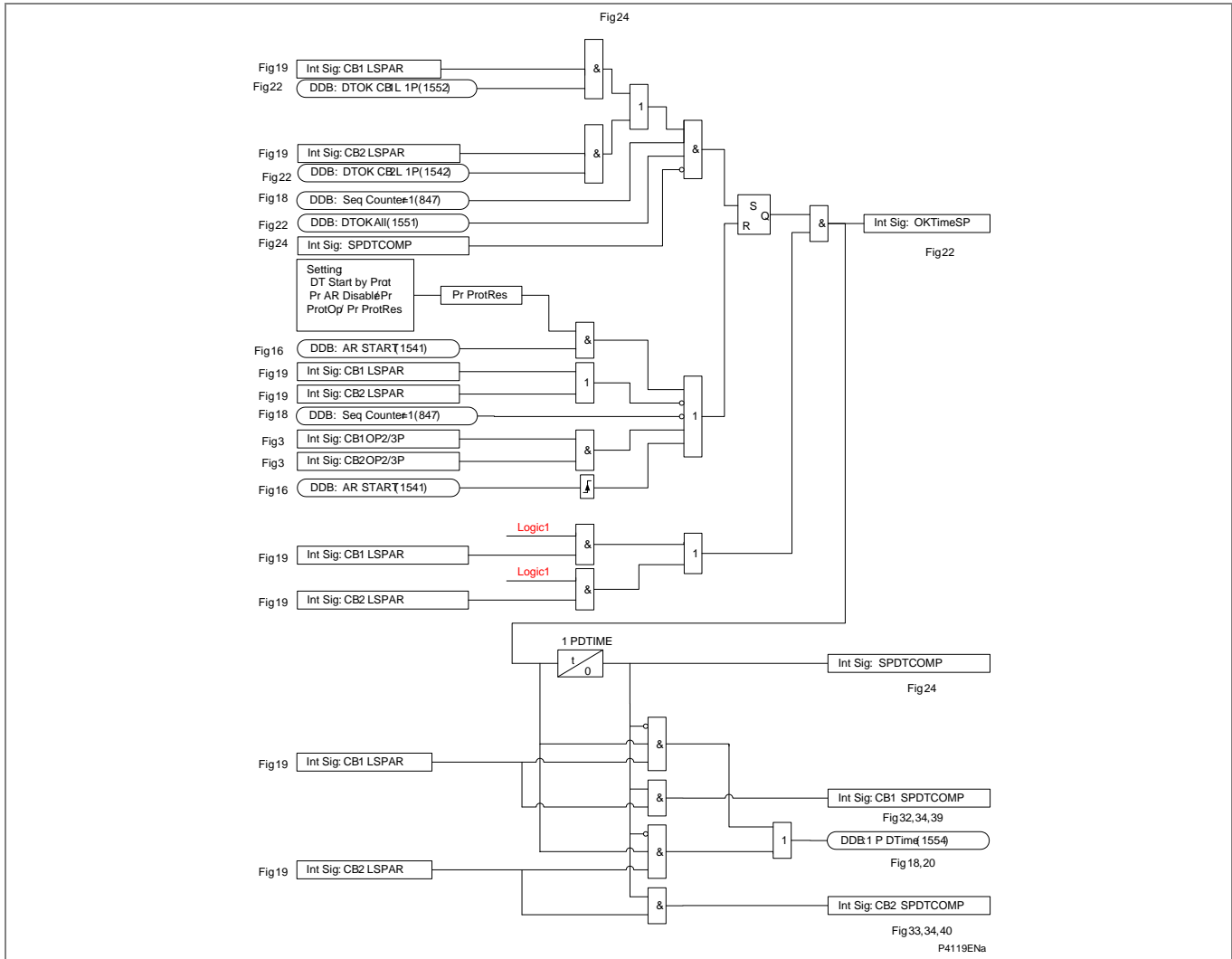

Figure AR-24 - Single phase AR lead CB dead time

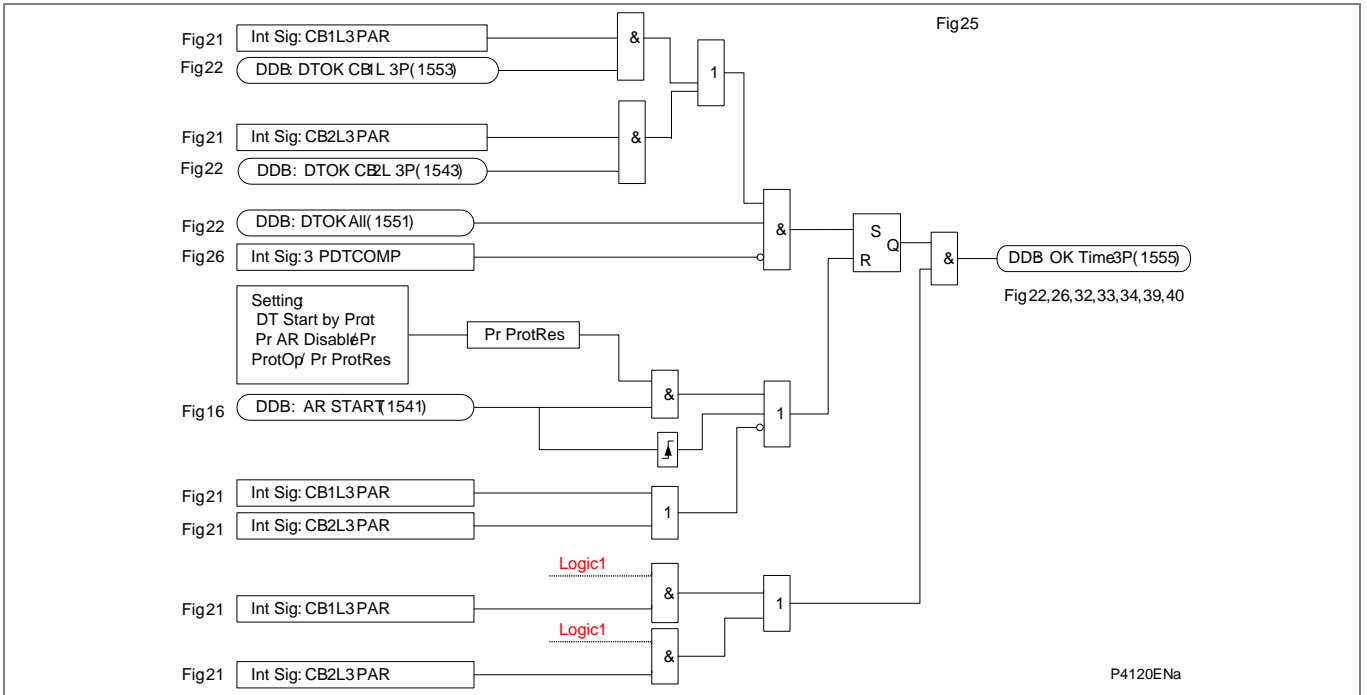

Figure AR-25 - Three phase AR lead CB dead time enable

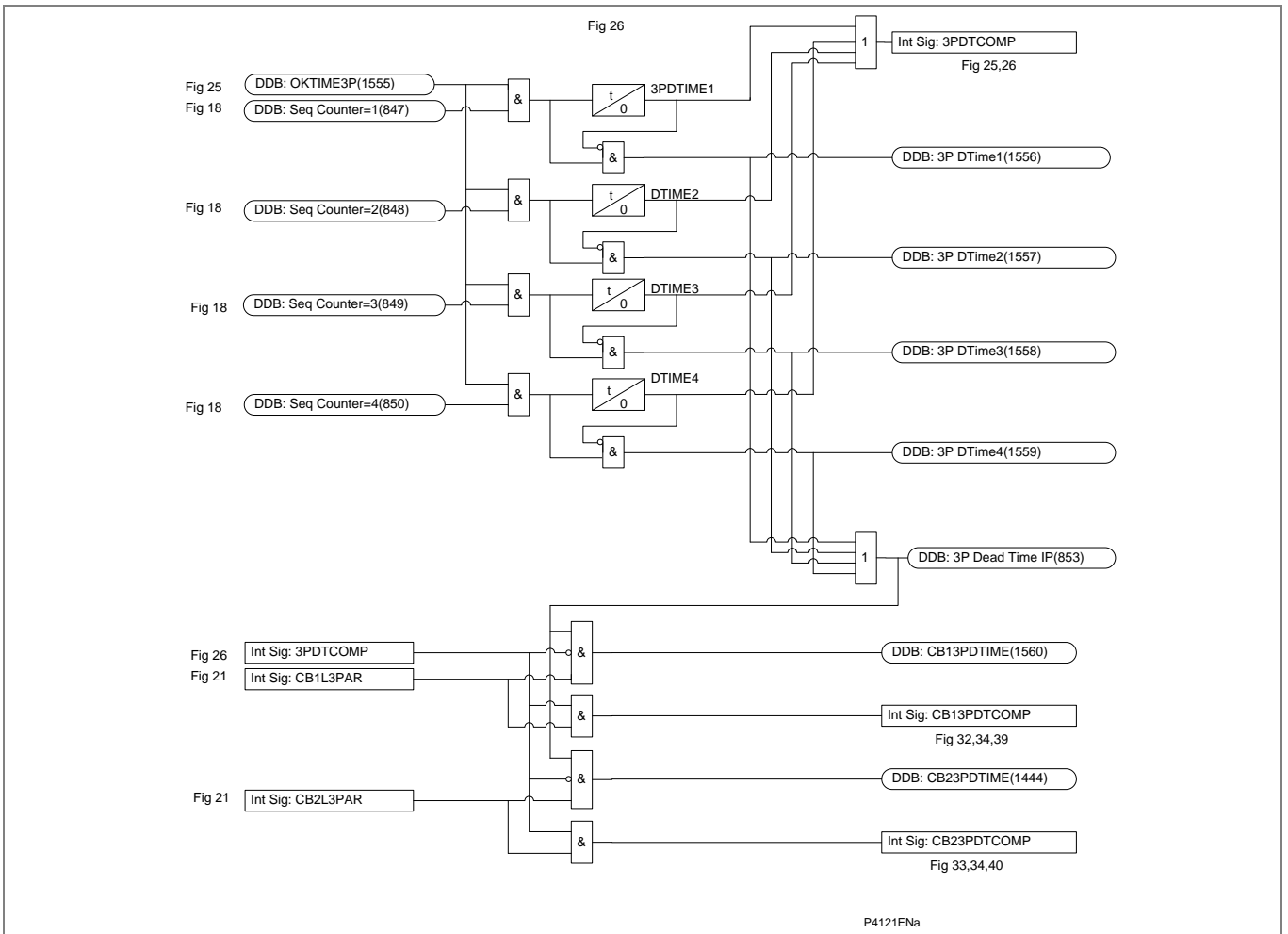

Figure AR-26 - Three phase AR lead CB dead time

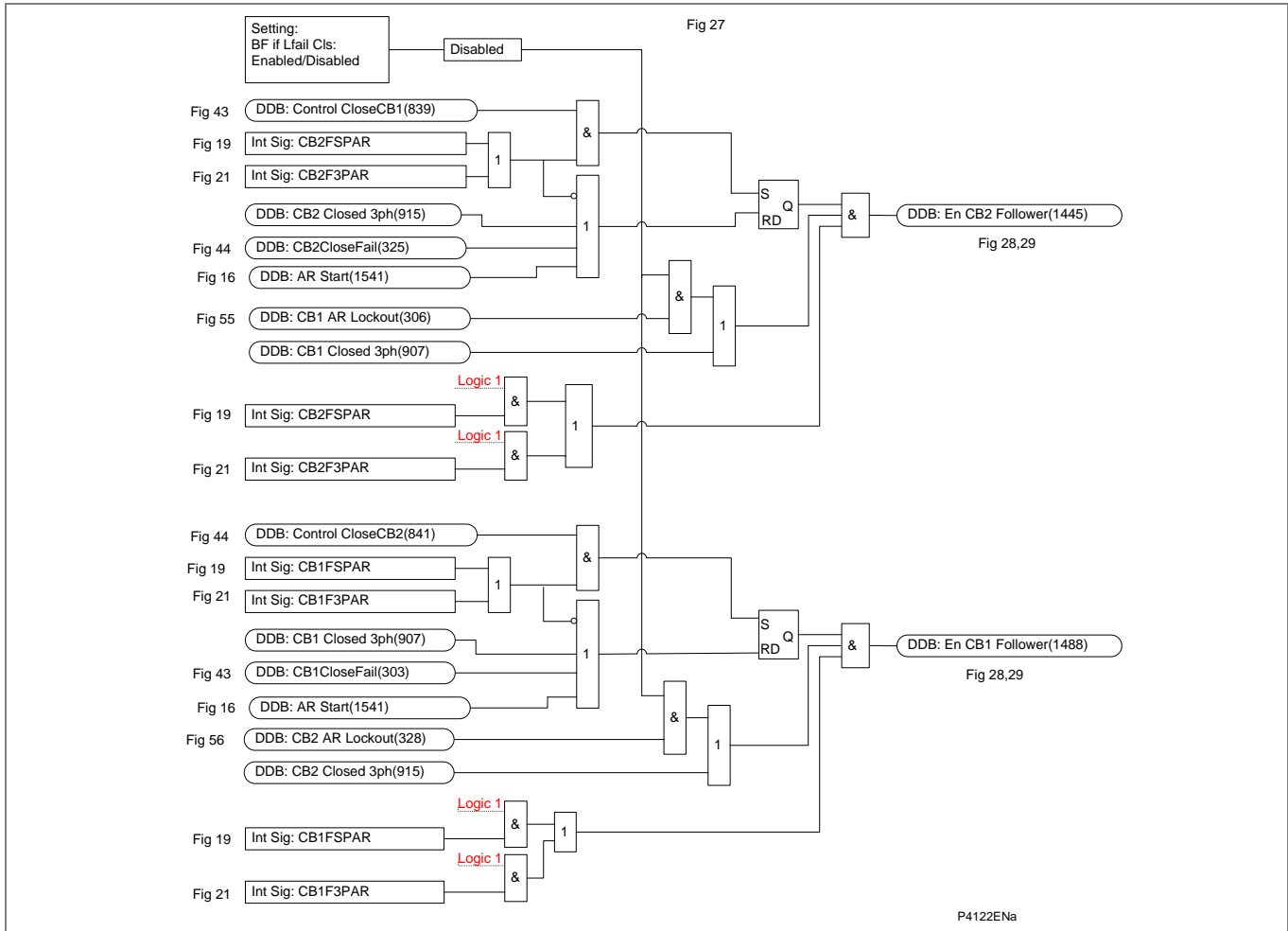

Figure AR-27 - Follower AR enable (for Software Versions BEFORE H1)

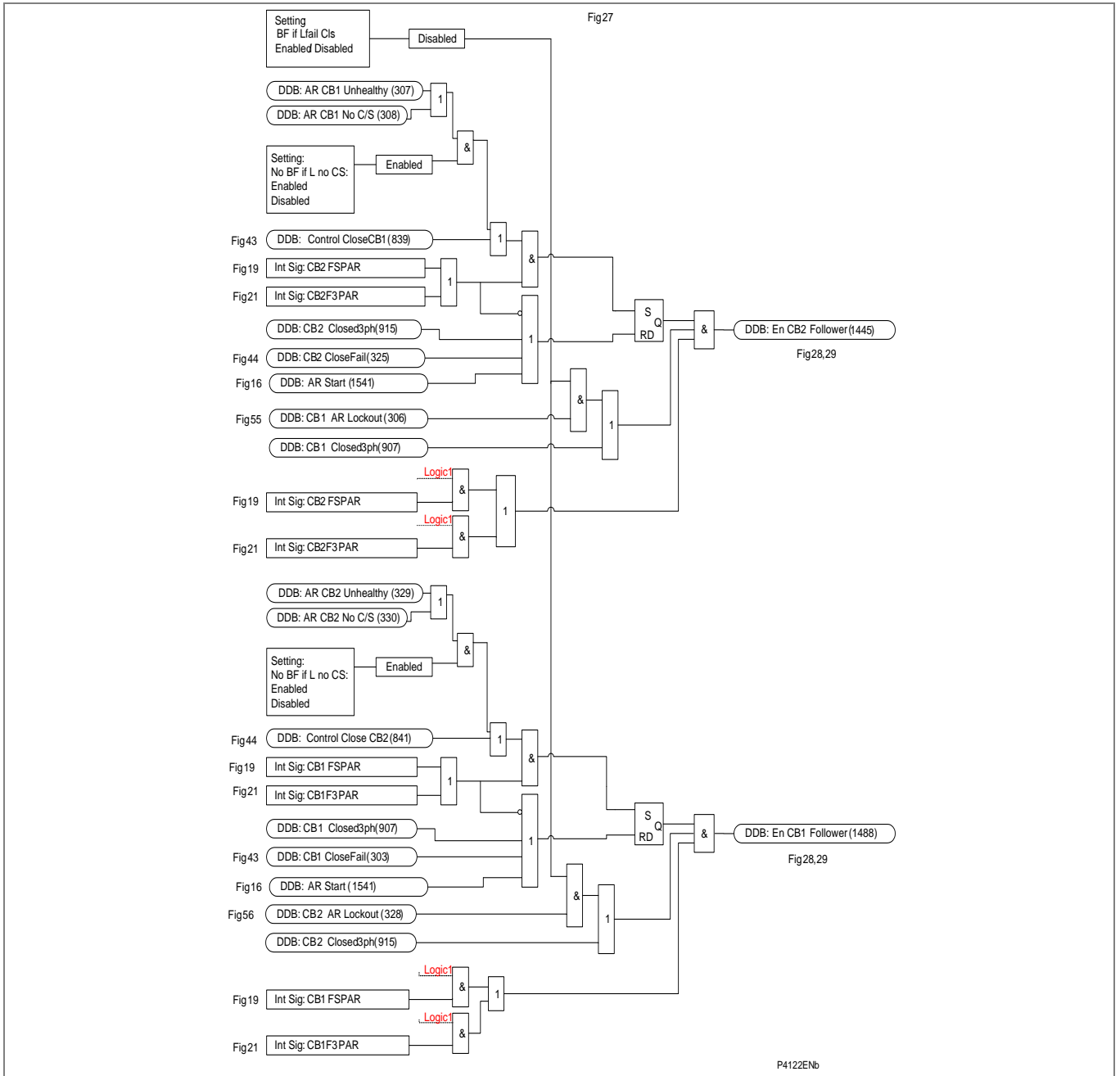

Figure AR-28 - Follower AR enable (for Software Versions H1 and later)

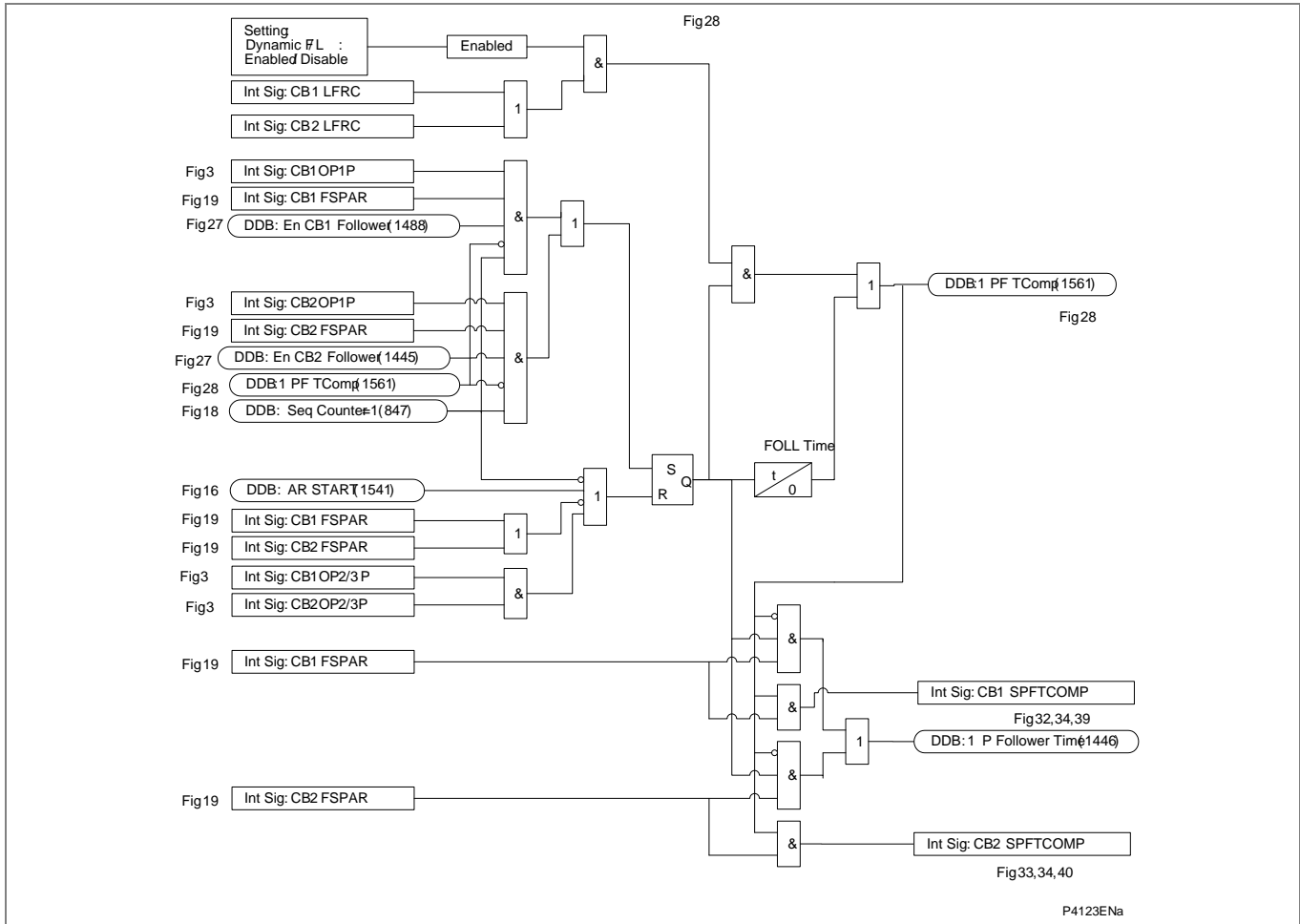

Figure AR-29 - Single phase follower time

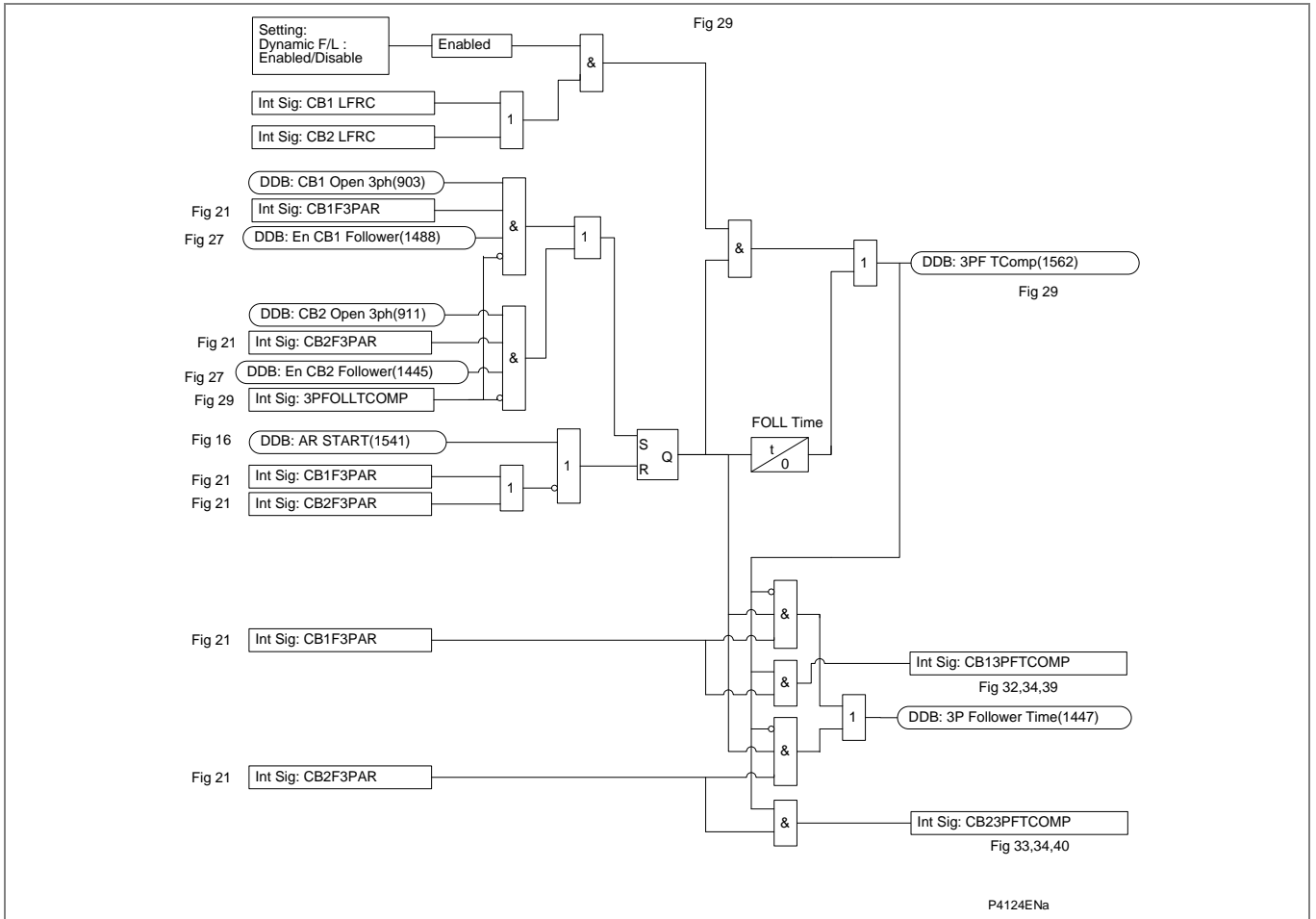

Figure AR-30 - Three phase follower time

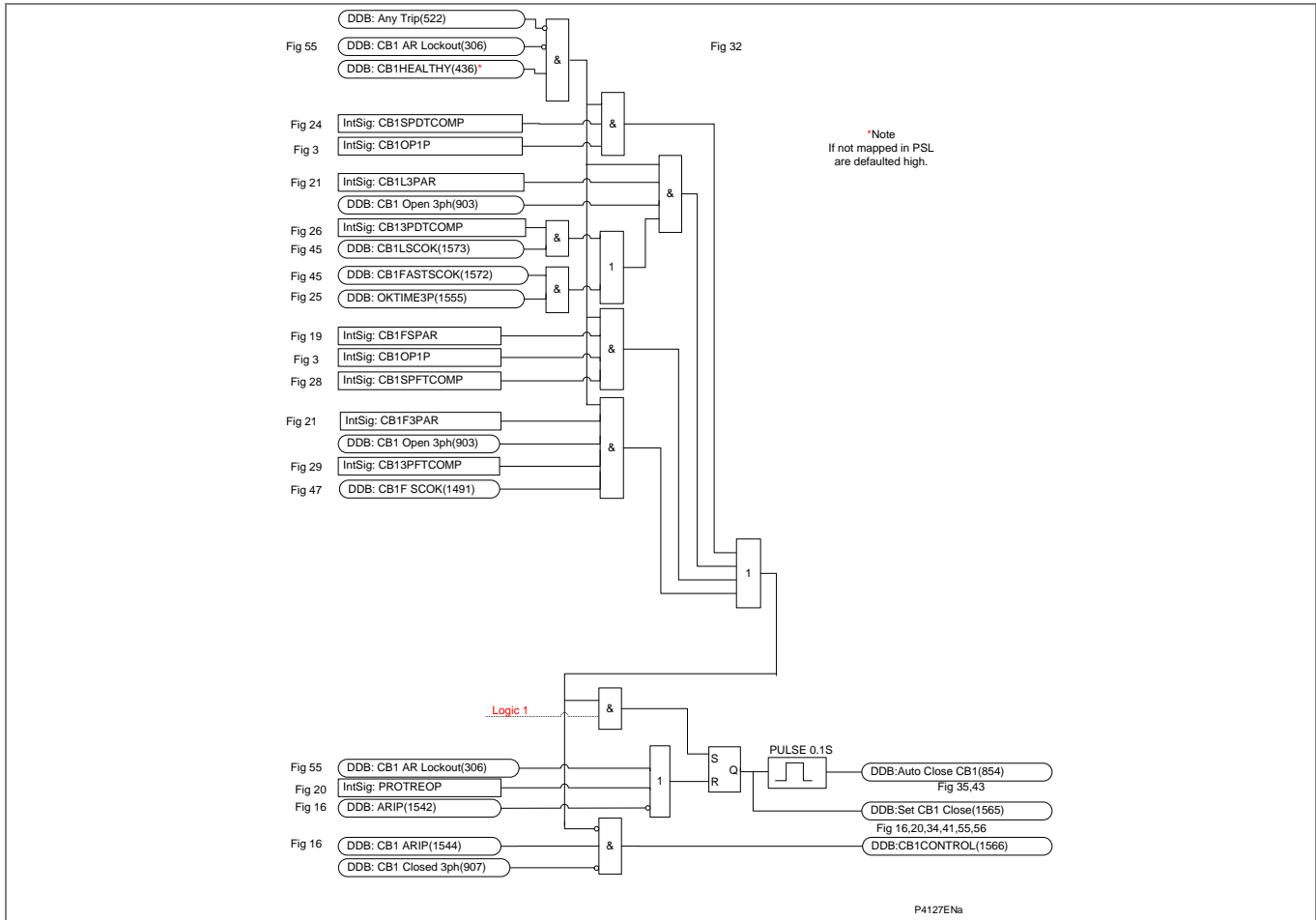

Figure AR-31 - CB Auto close

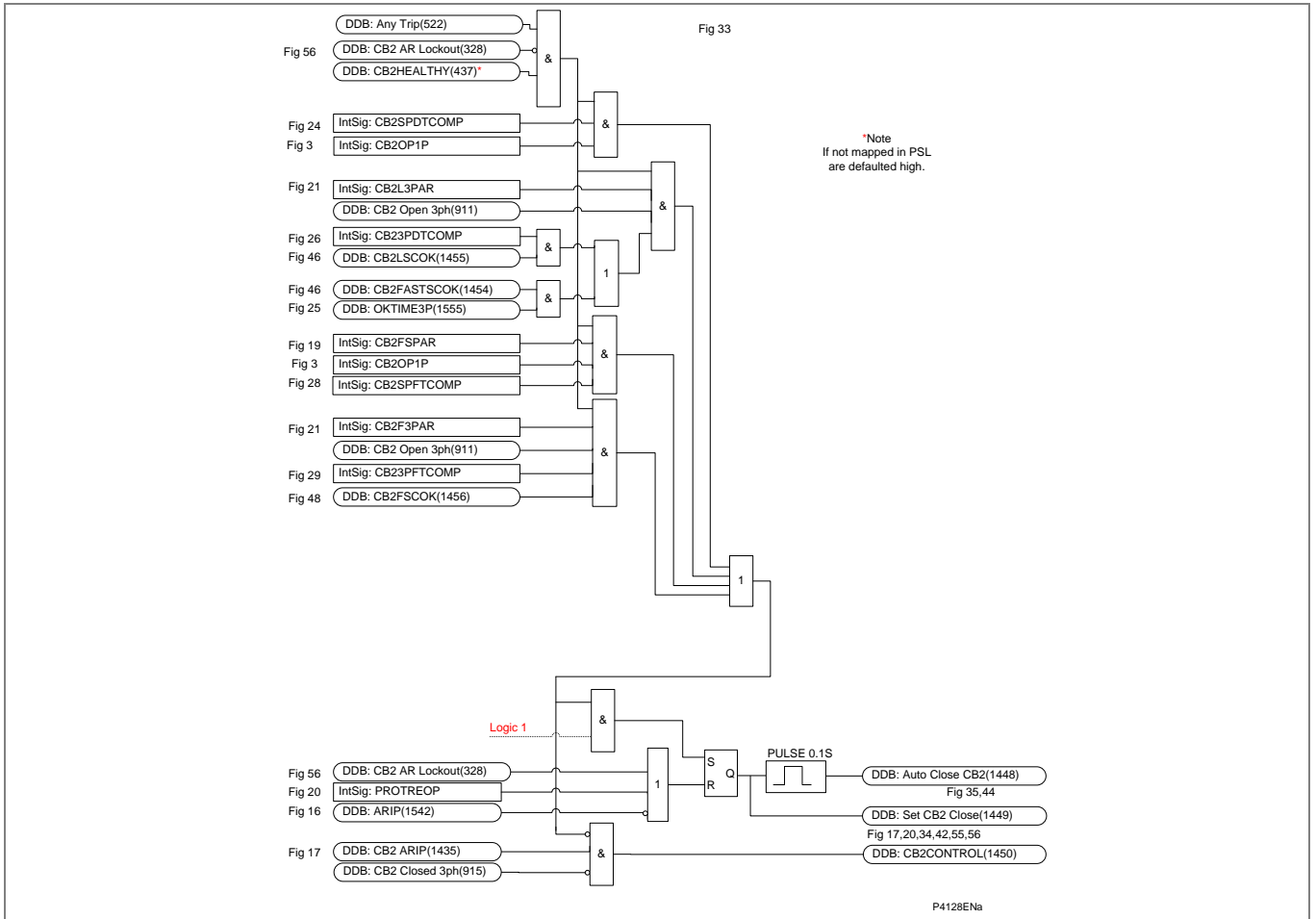

Figure AR-32 - CB2 Auto close

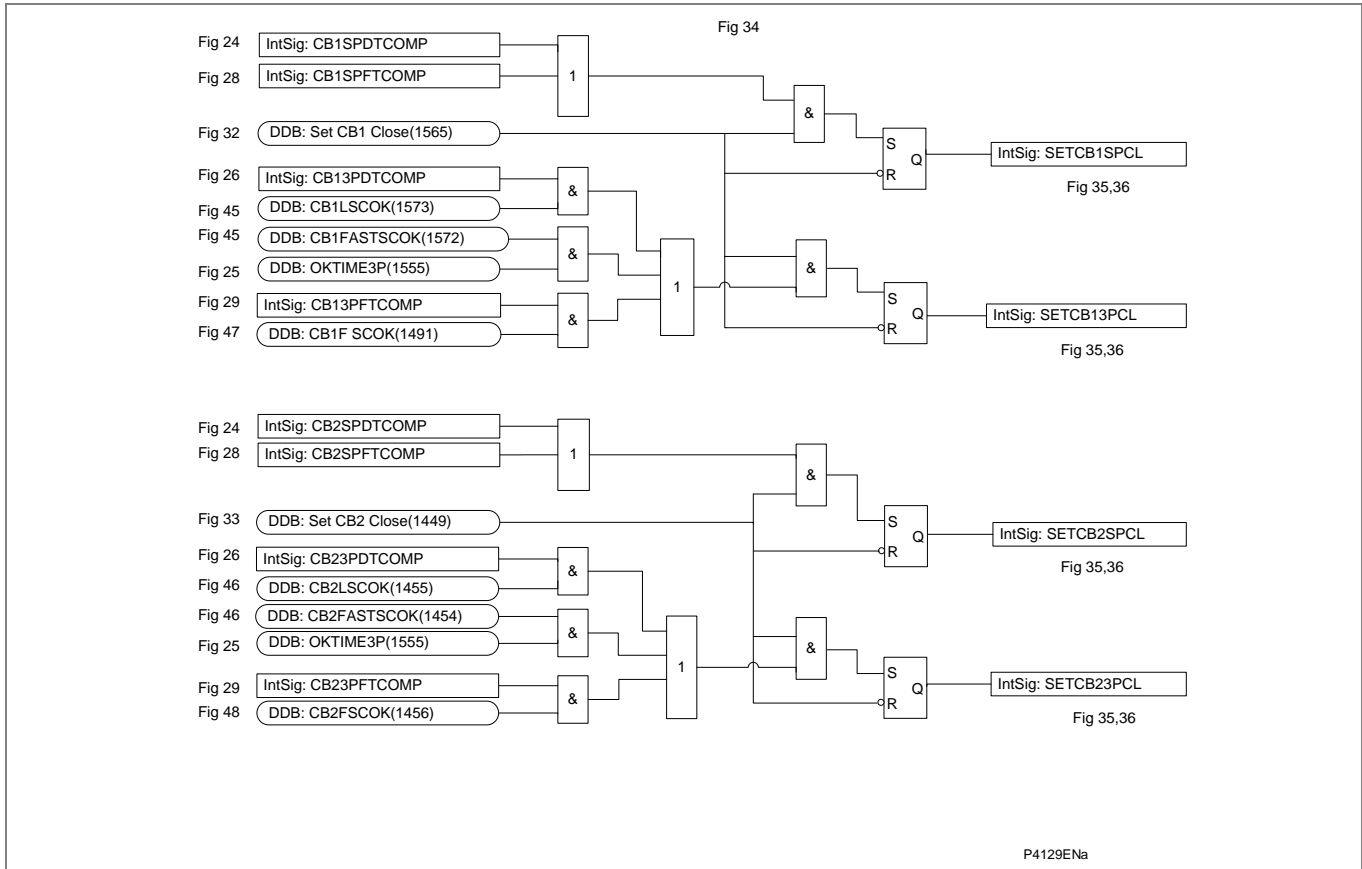

Figure AR-33 - Prepare reclaim initiation

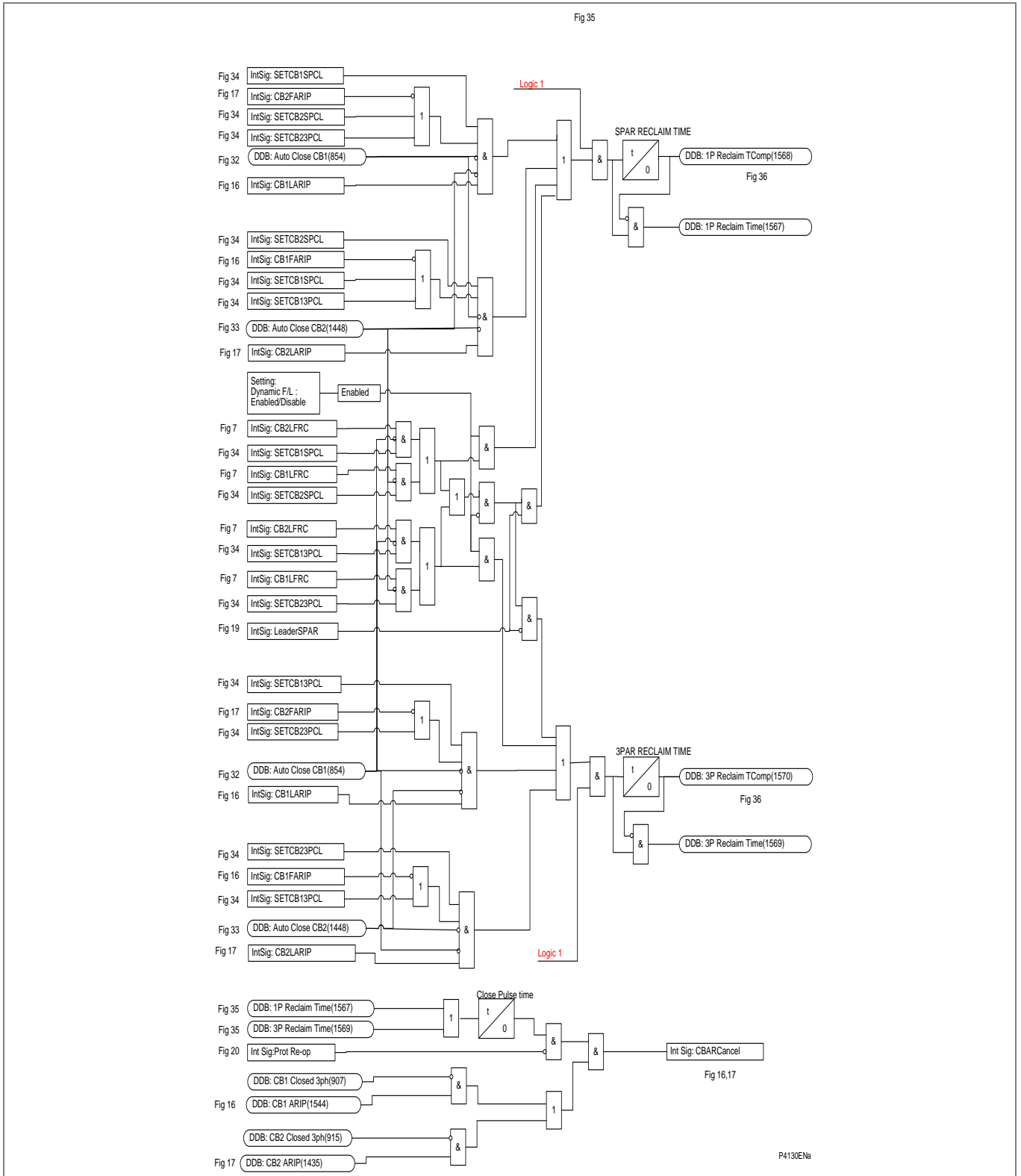

Figure AR-34 - Reclaim time

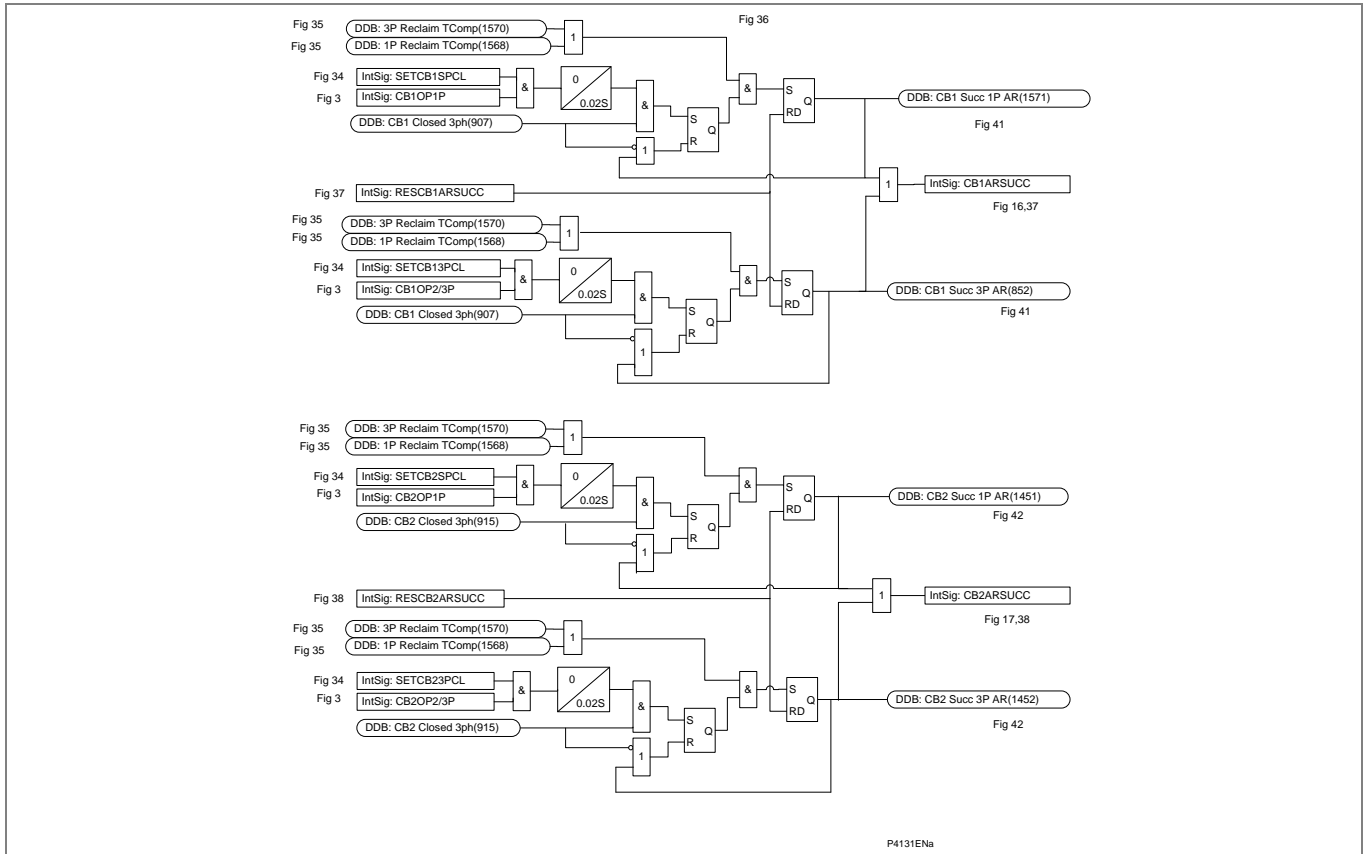

Figure AR-35 - Successful auto-reclose signals

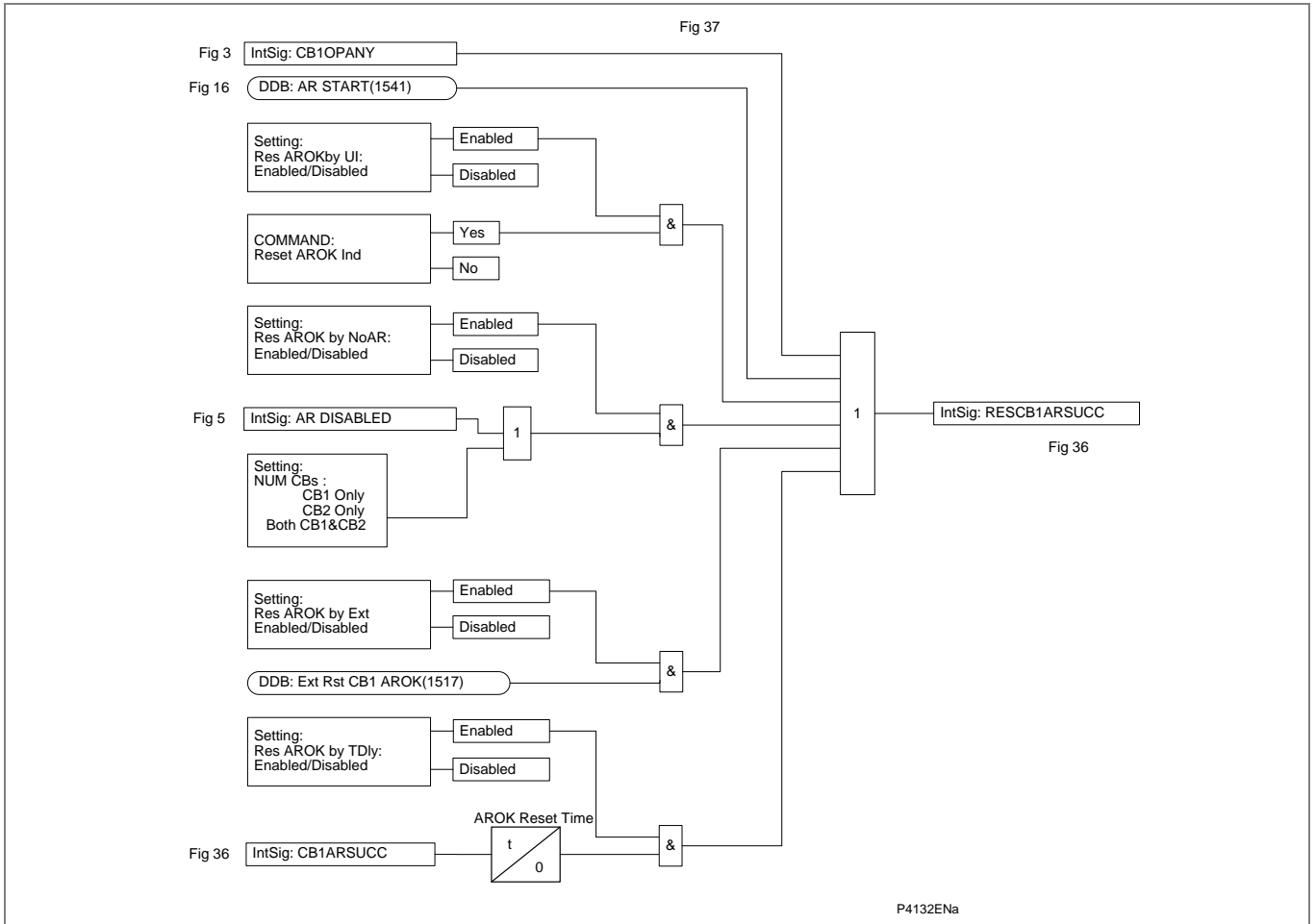

Figure AR-36 - Reset CB1 successful AR indication

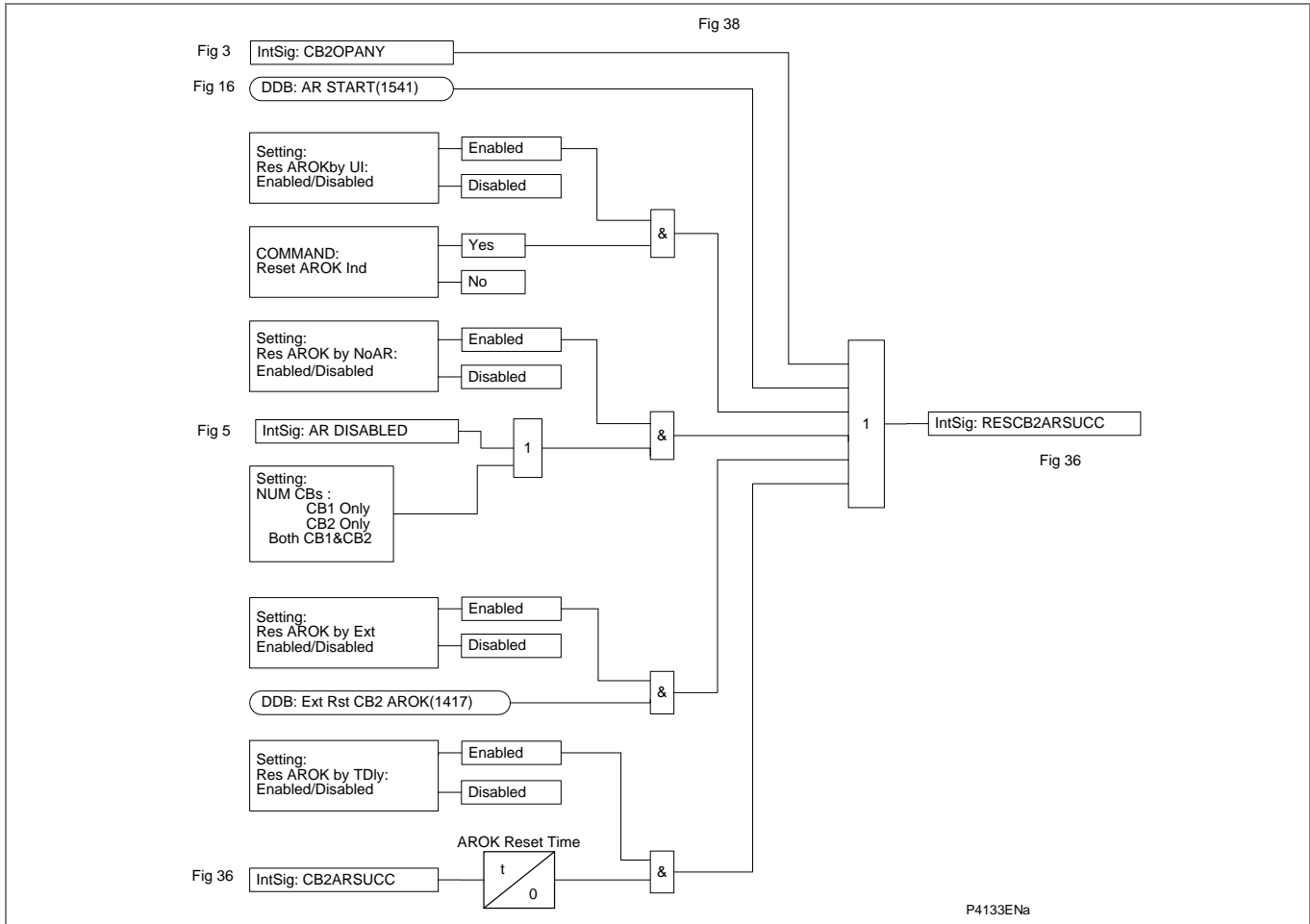

Figure AR-37 - Reset CB2 successful AR indication

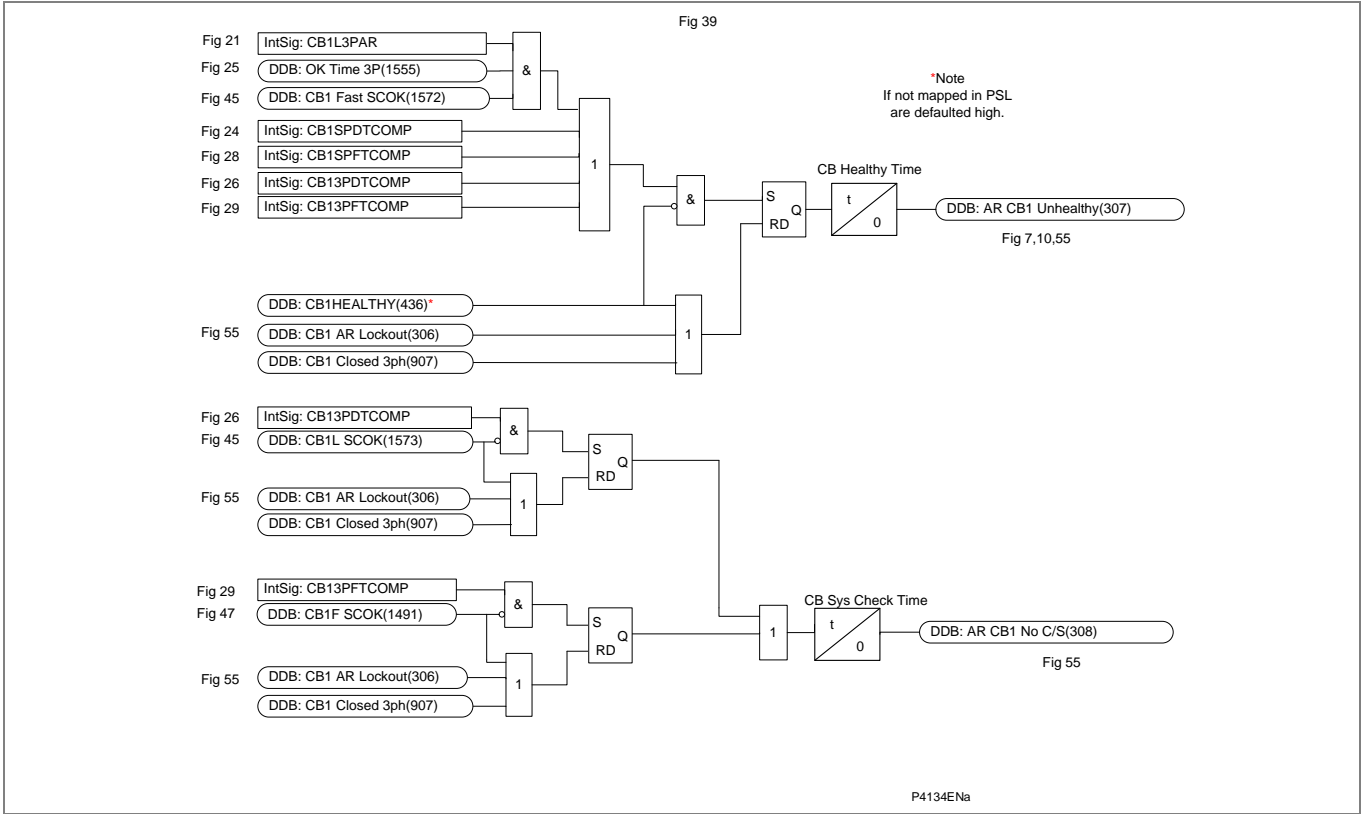

Figure AR-38 - CB healthy & system check timers

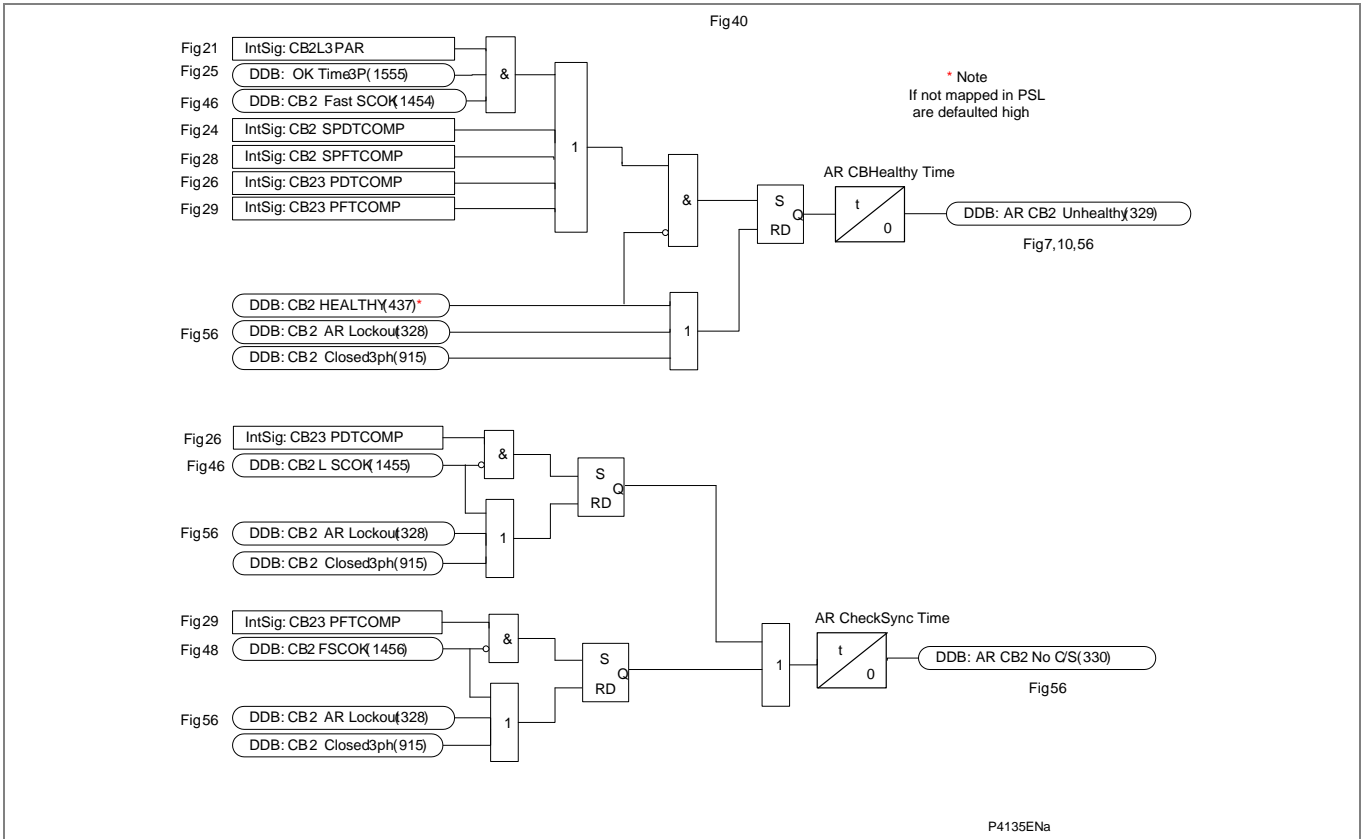

Figure AR-39 - CB2 healthy & system check timers

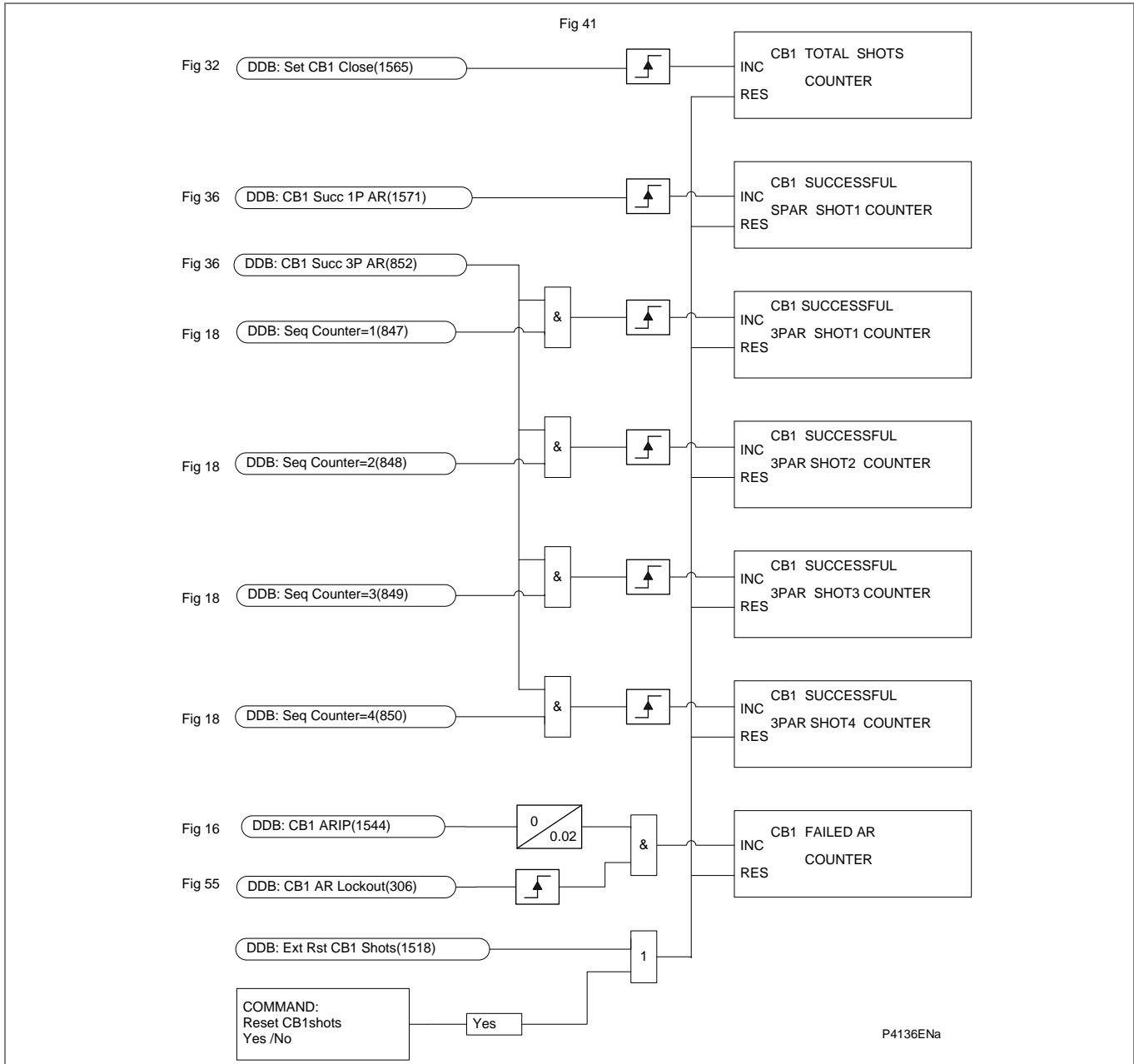

Figure AR-40 - AR shots counters

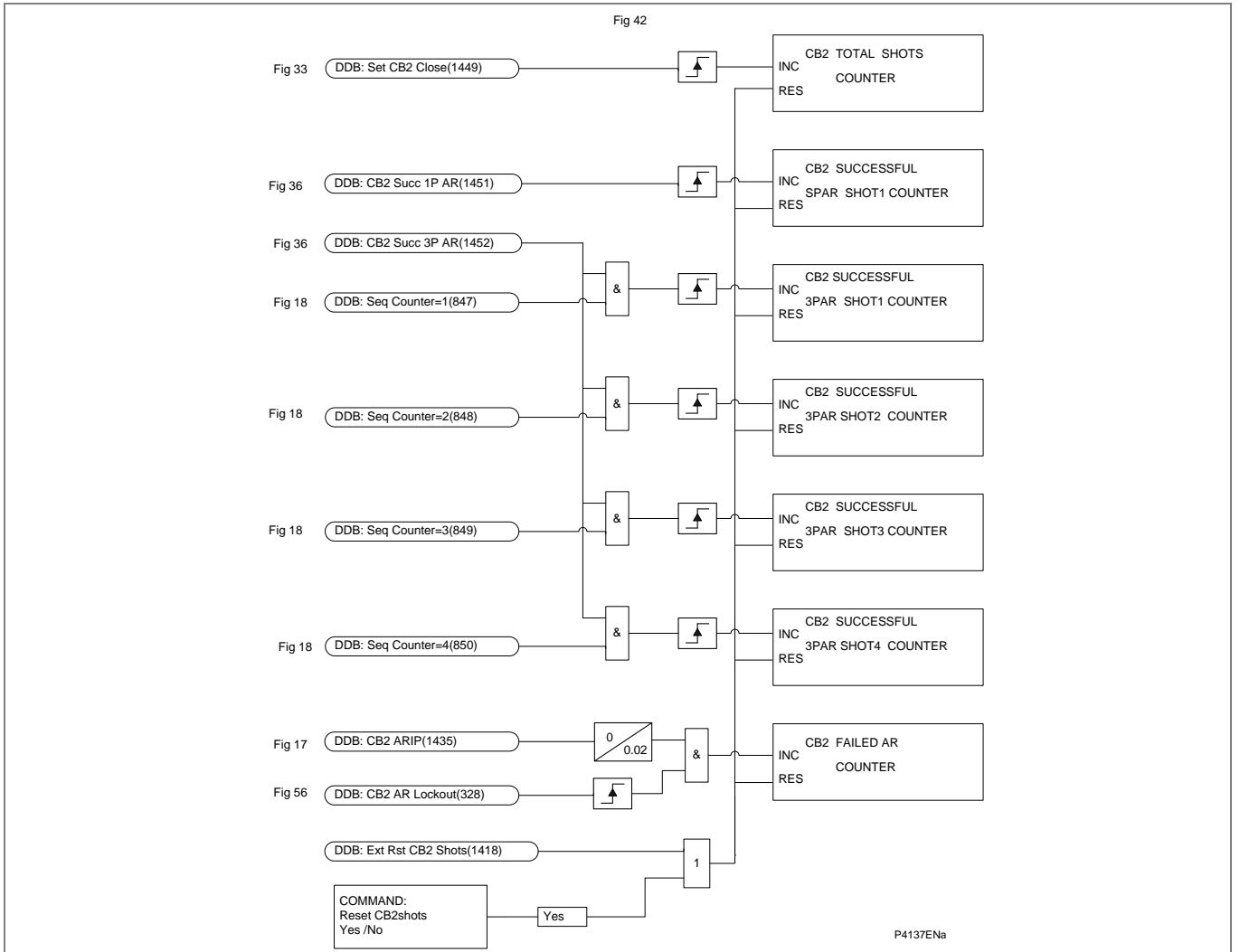

Figure AR-41 - CB2 AR shots counters

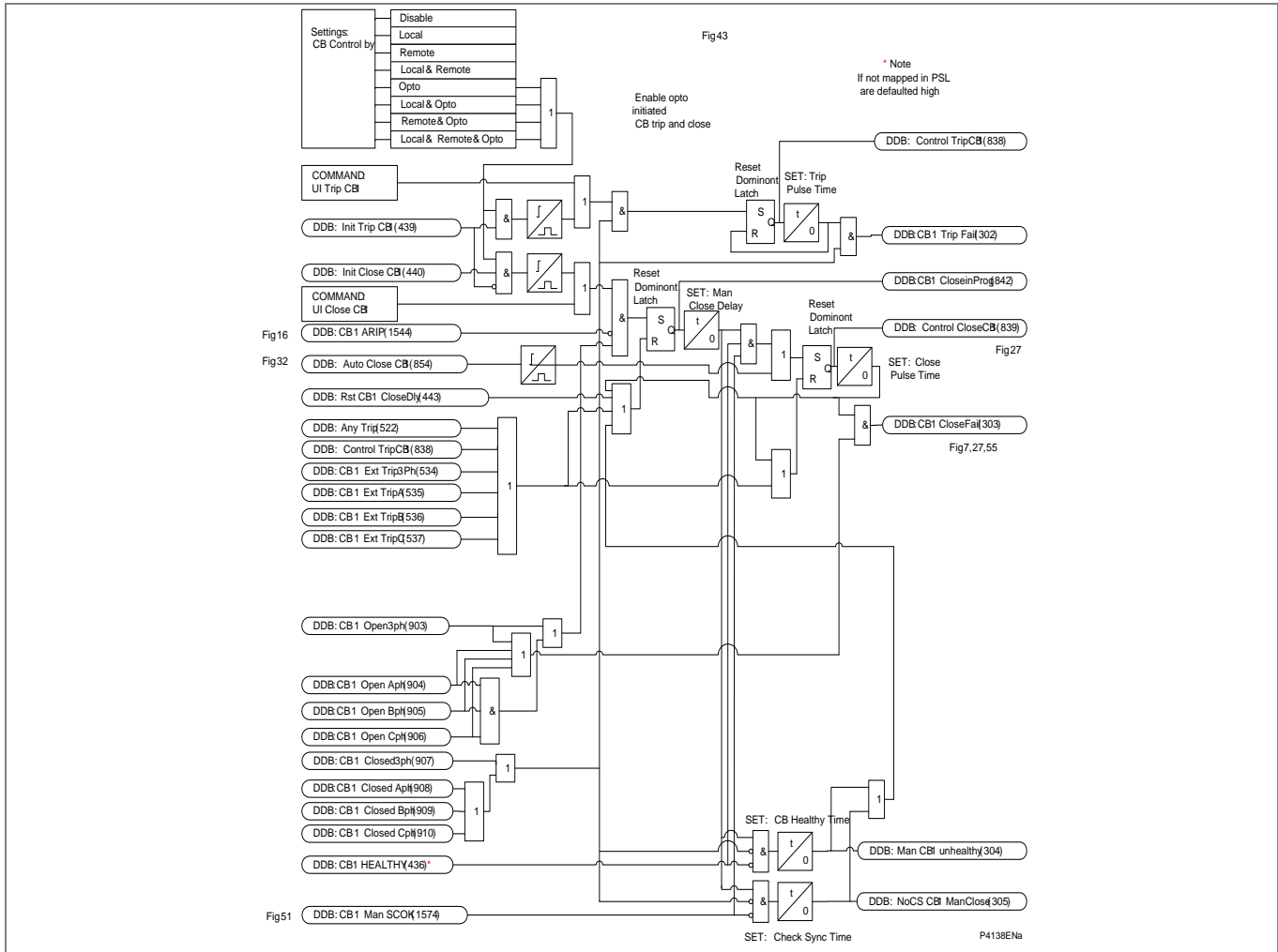

Figure AR-42 - CB1 circuit breaker control

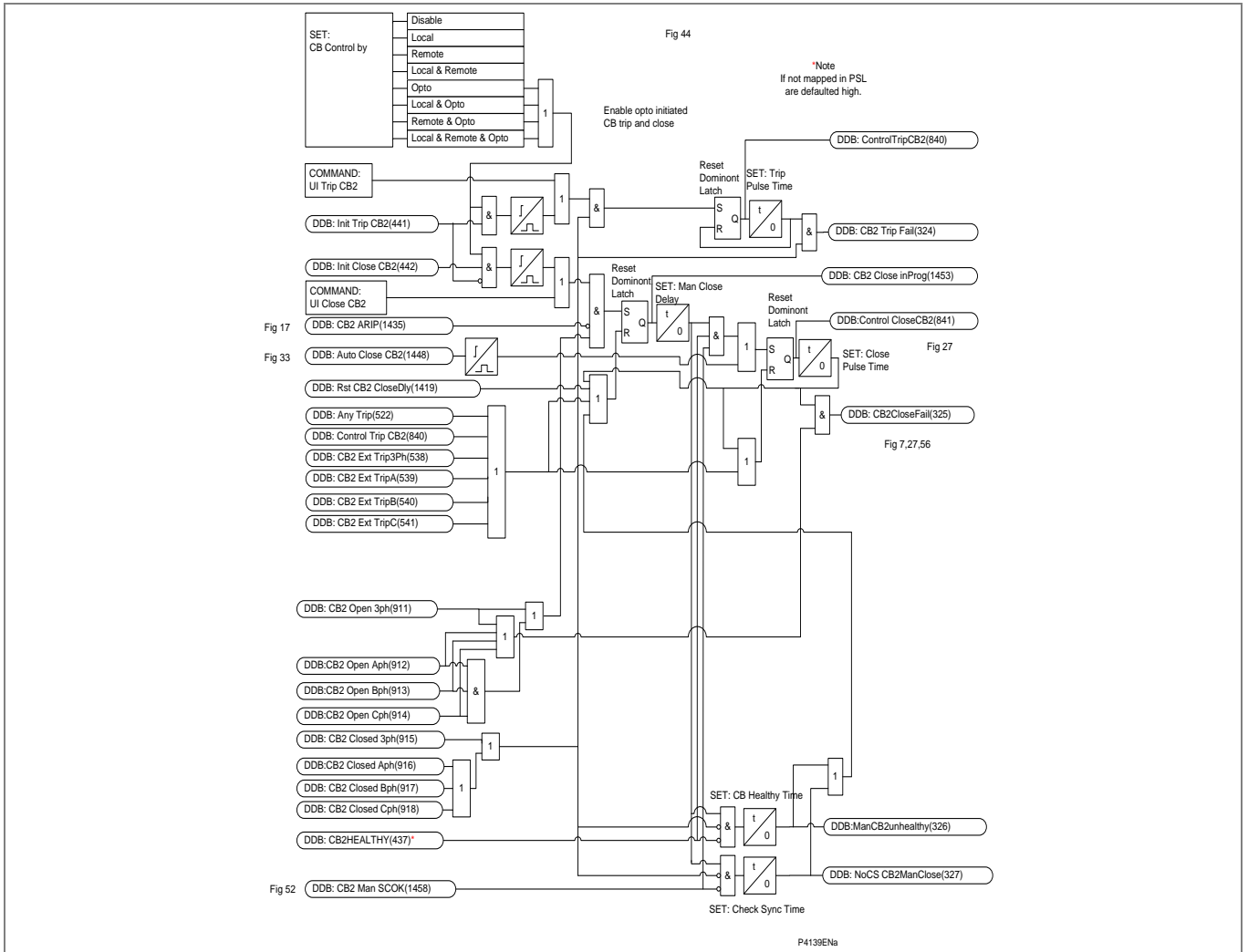

Figure AR-43 - CB2 circuit breaker control

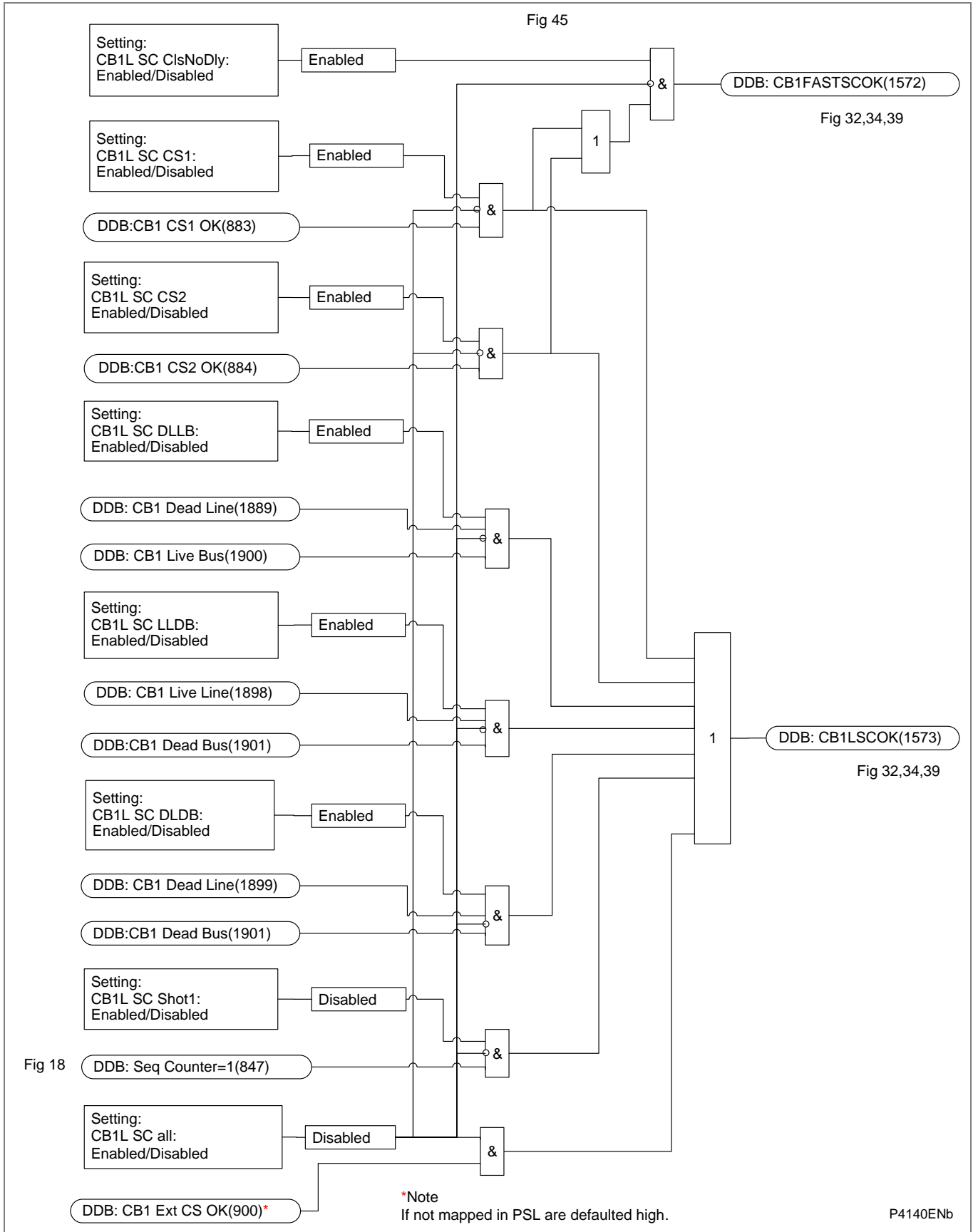

Figure AR-44 - CB1 lead 3PAR system check

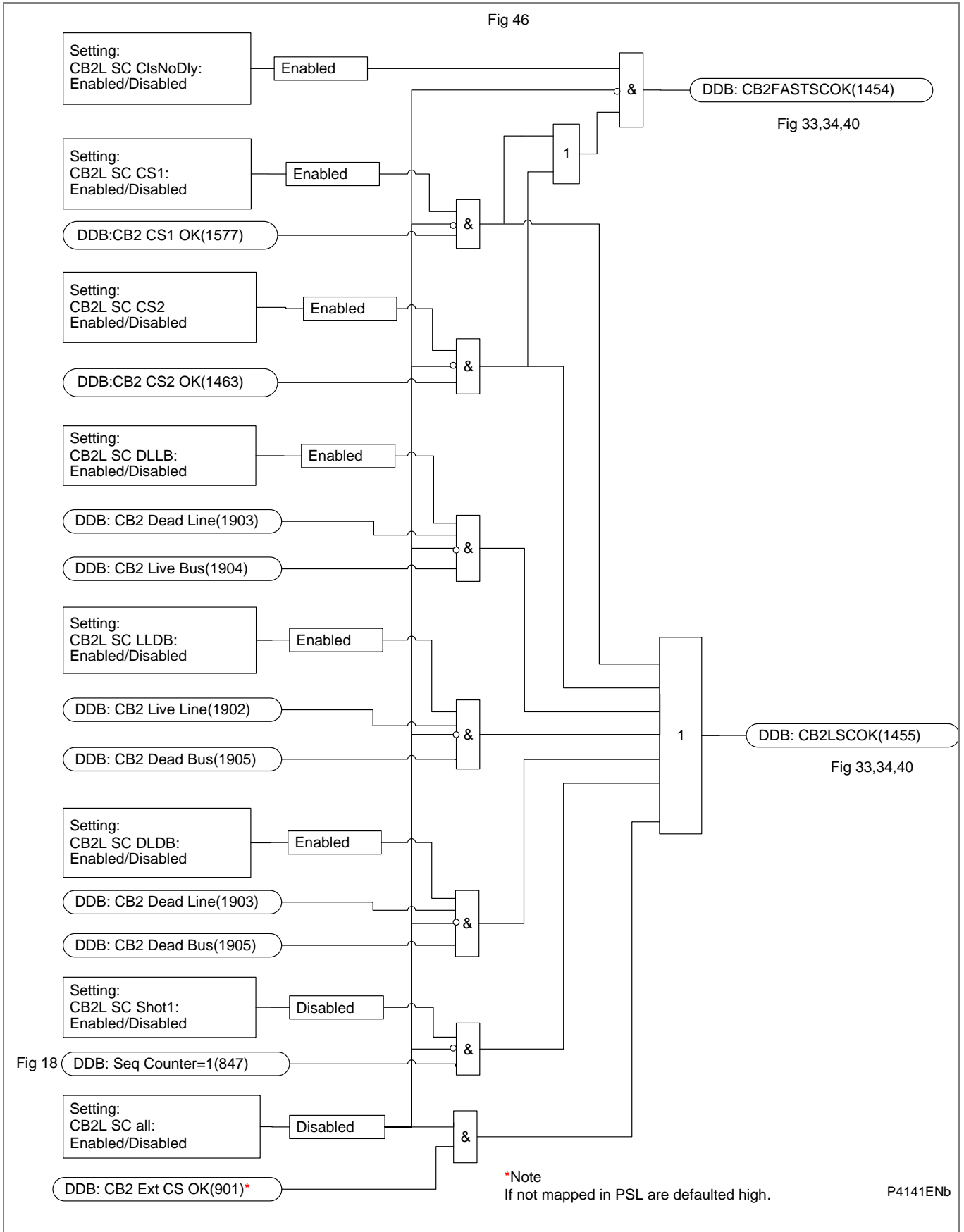

Figure AR-45 - CB2 lead 3PAR system check

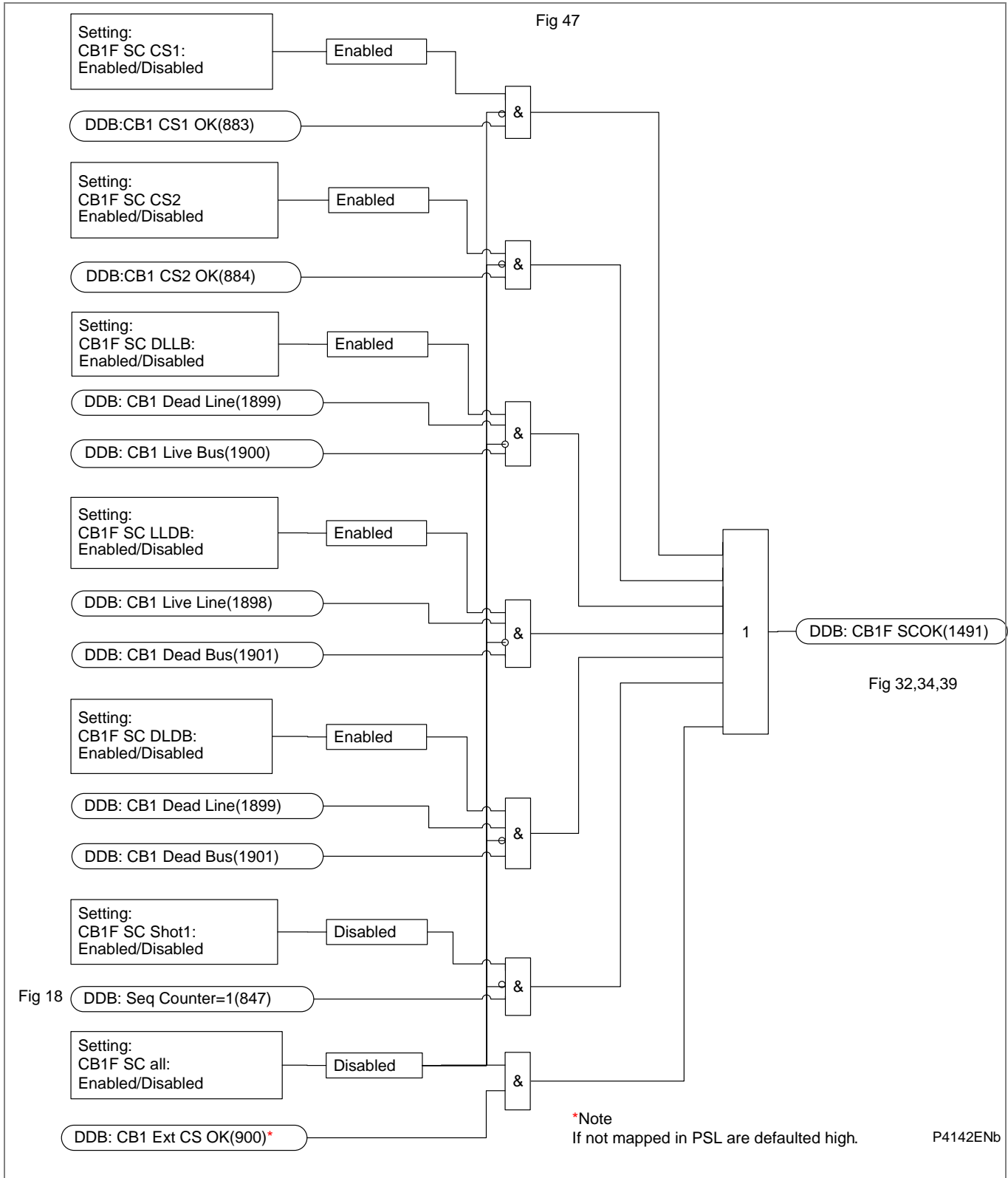

Figure AR-46 - CB1 follow 3PAR system check

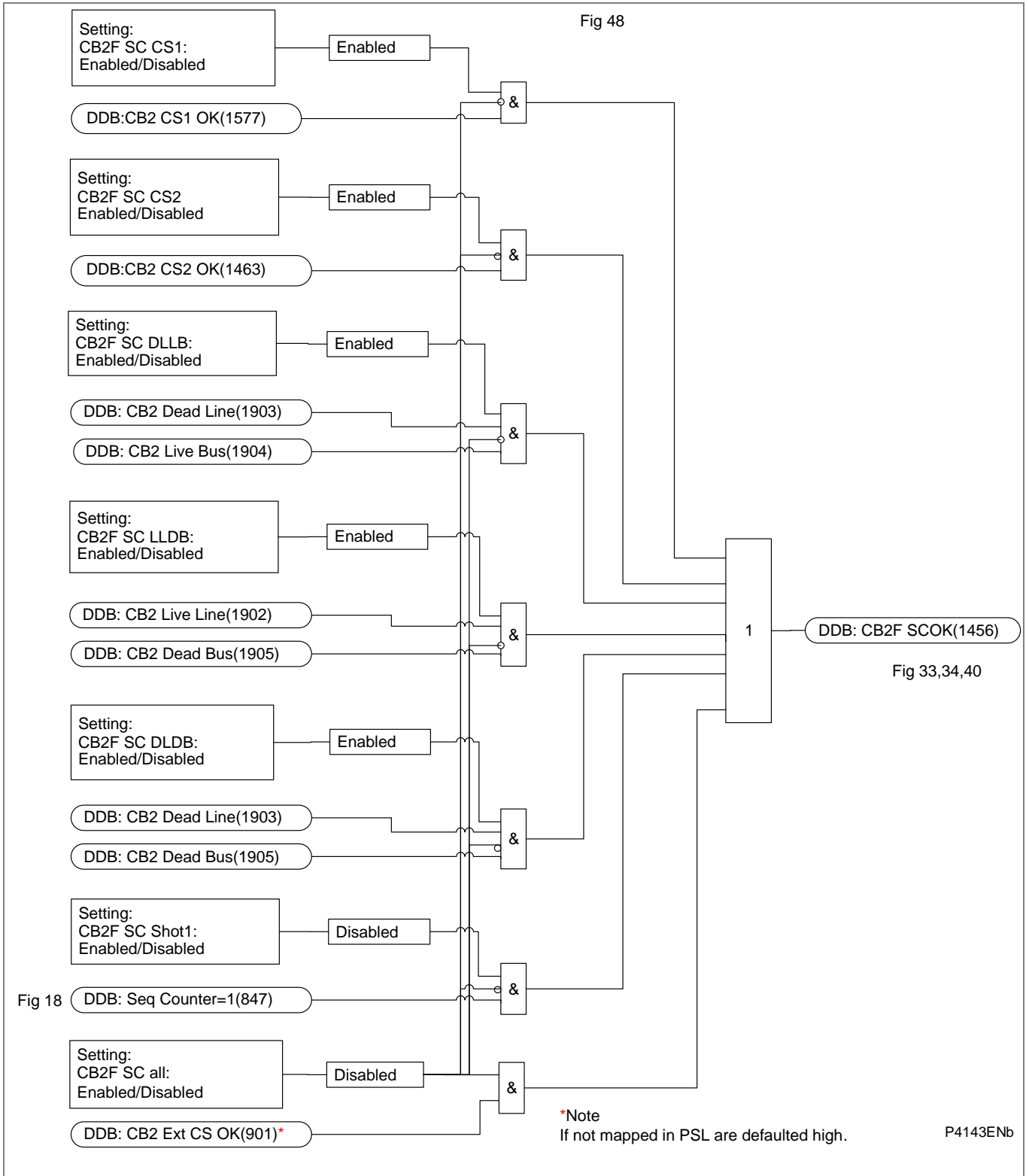

Figure AR-47 - CB2 follow 3PAR system check

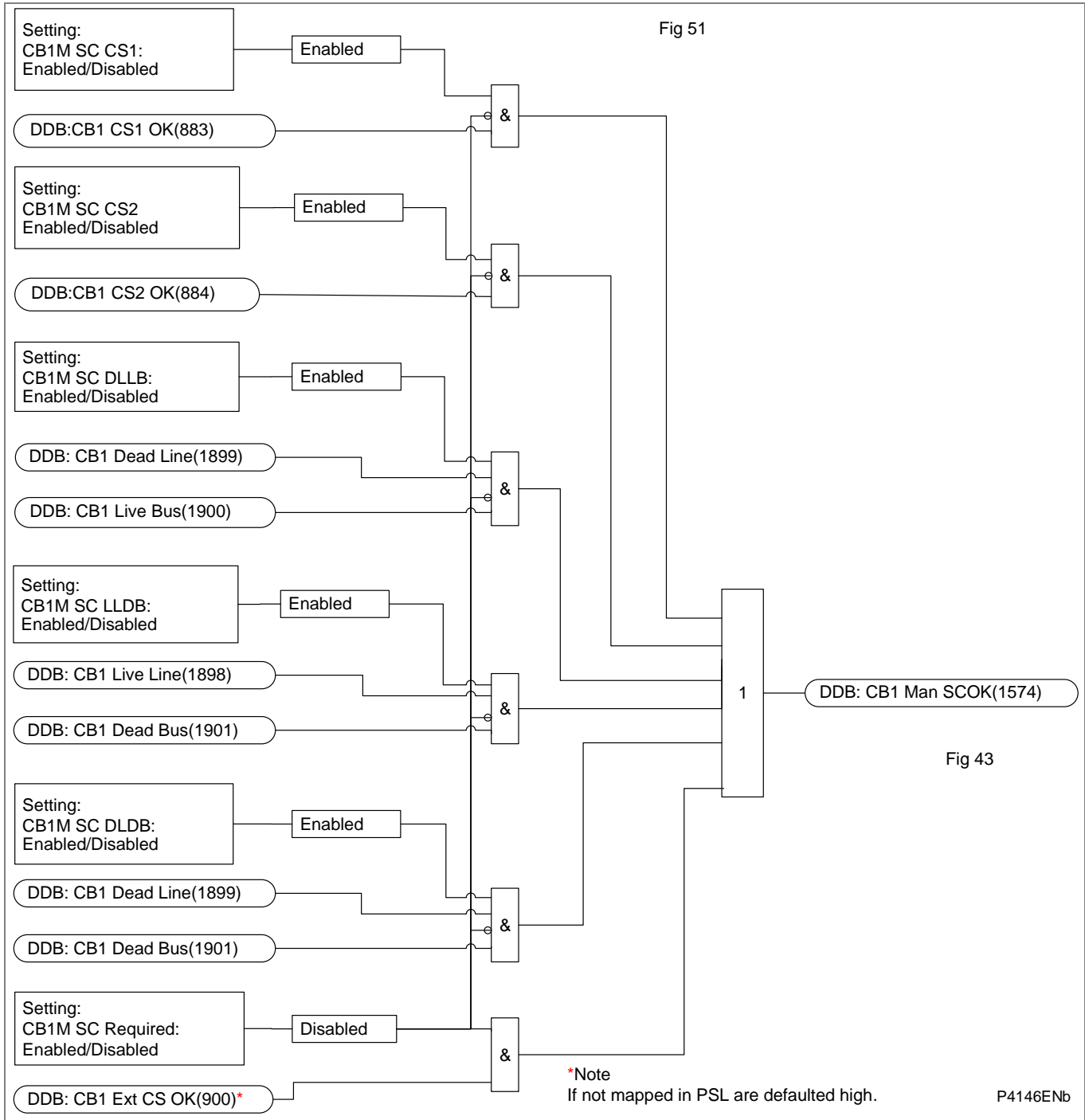

Figure AR-48 - CB1 man. close system check

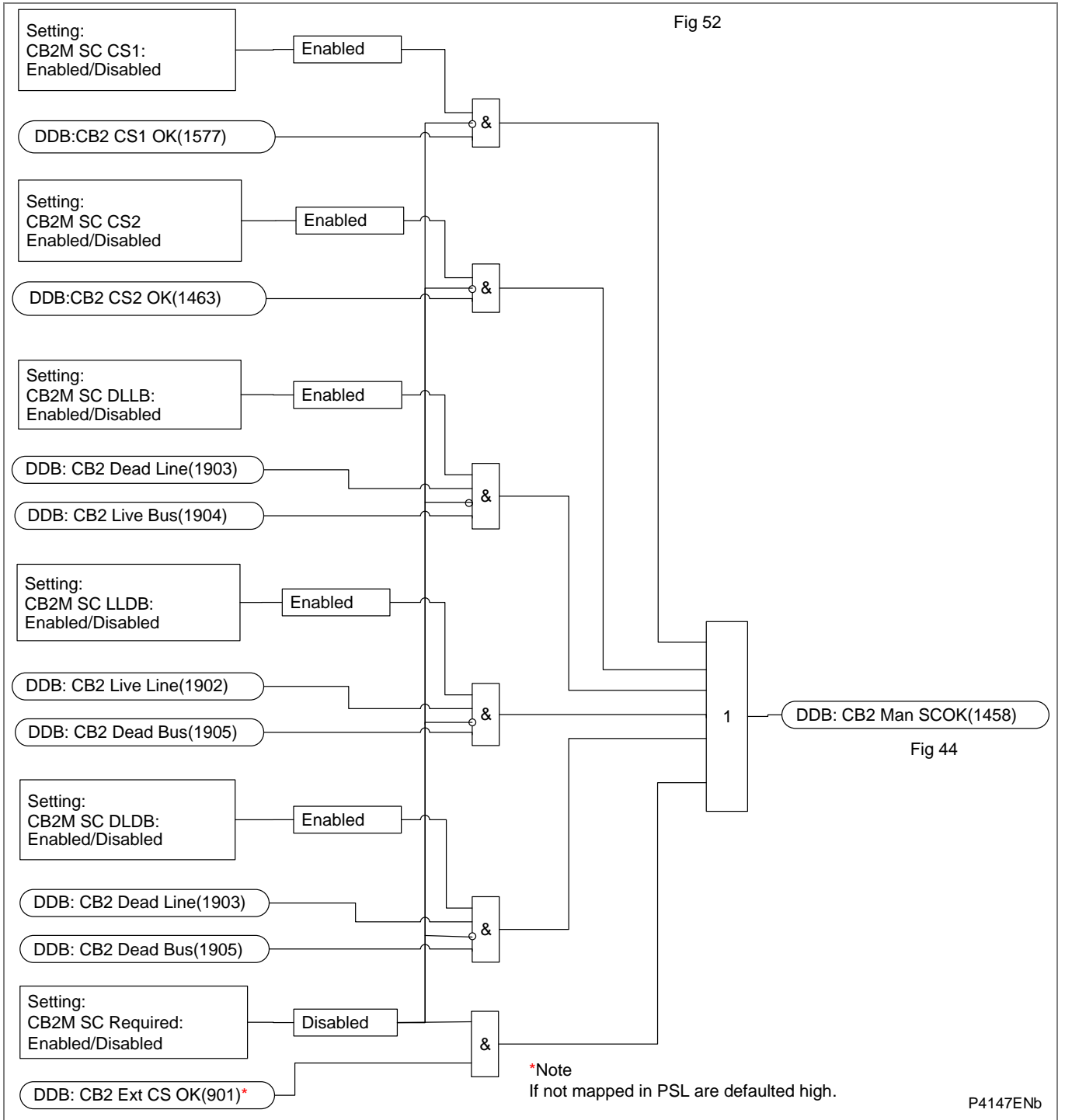

Figure AR-49 - CB2 man. close system check

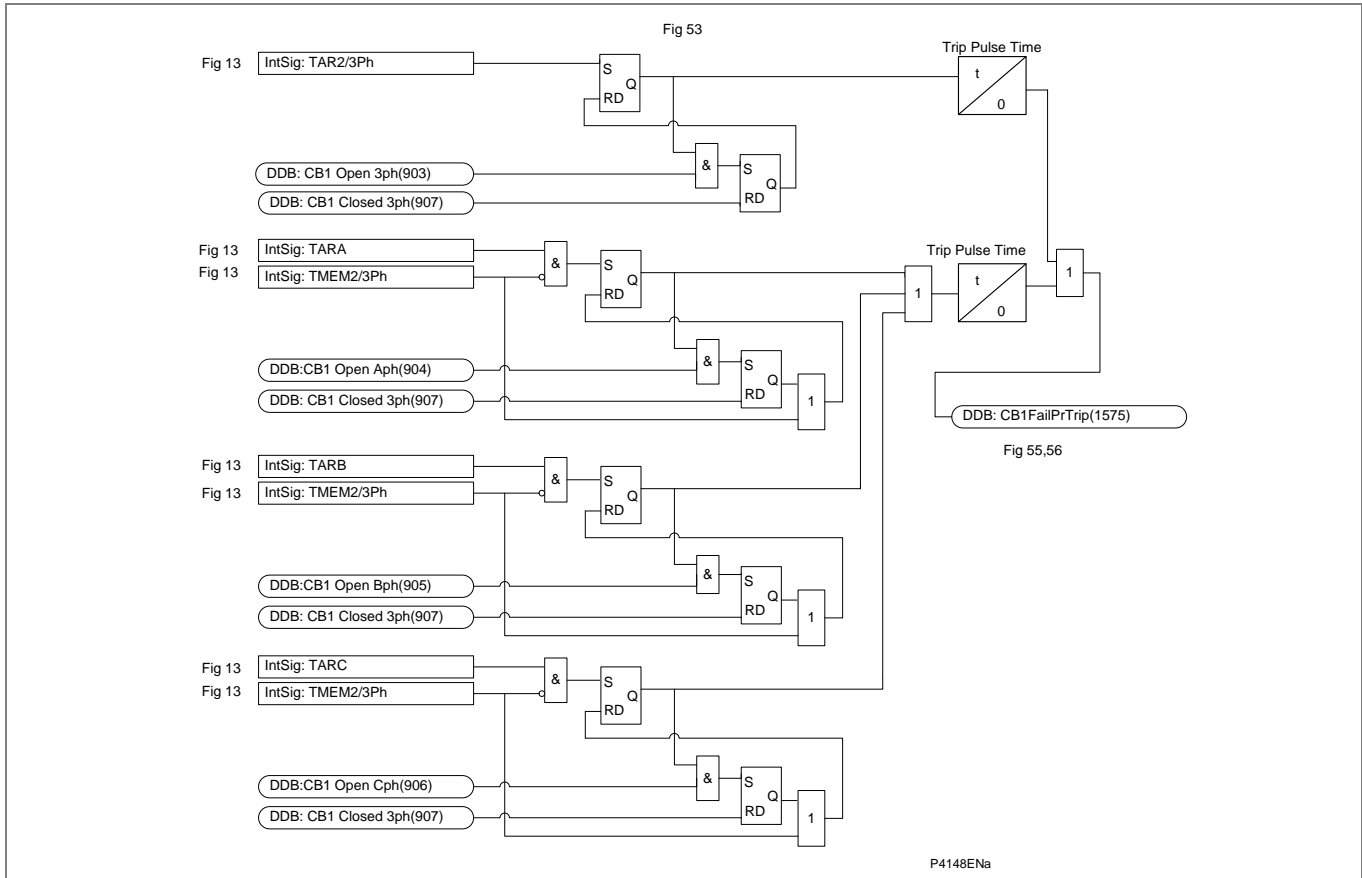

Figure AR-50 - CB1 trip time monitor

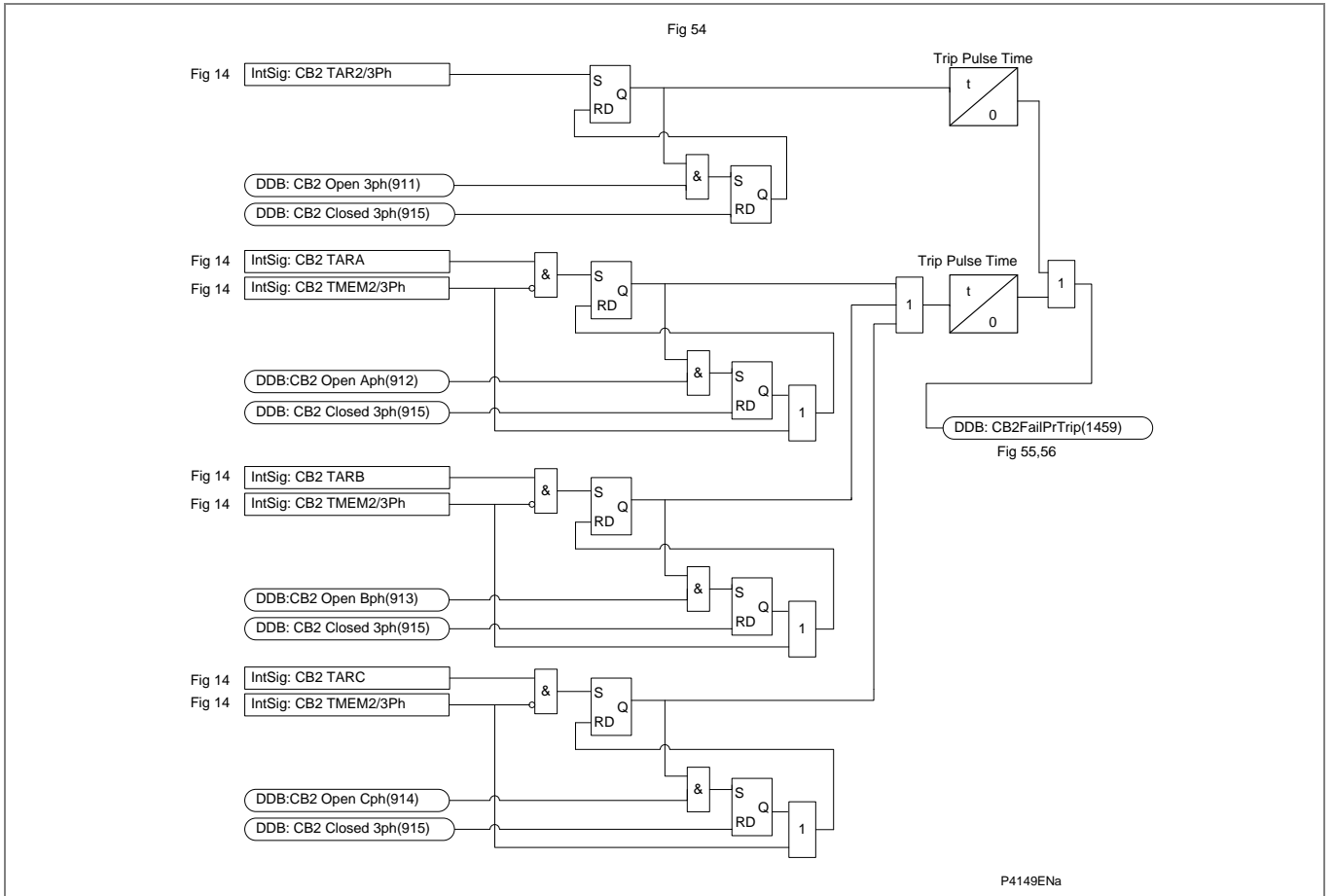

Figure AR-51 - CB2 trip time monitor

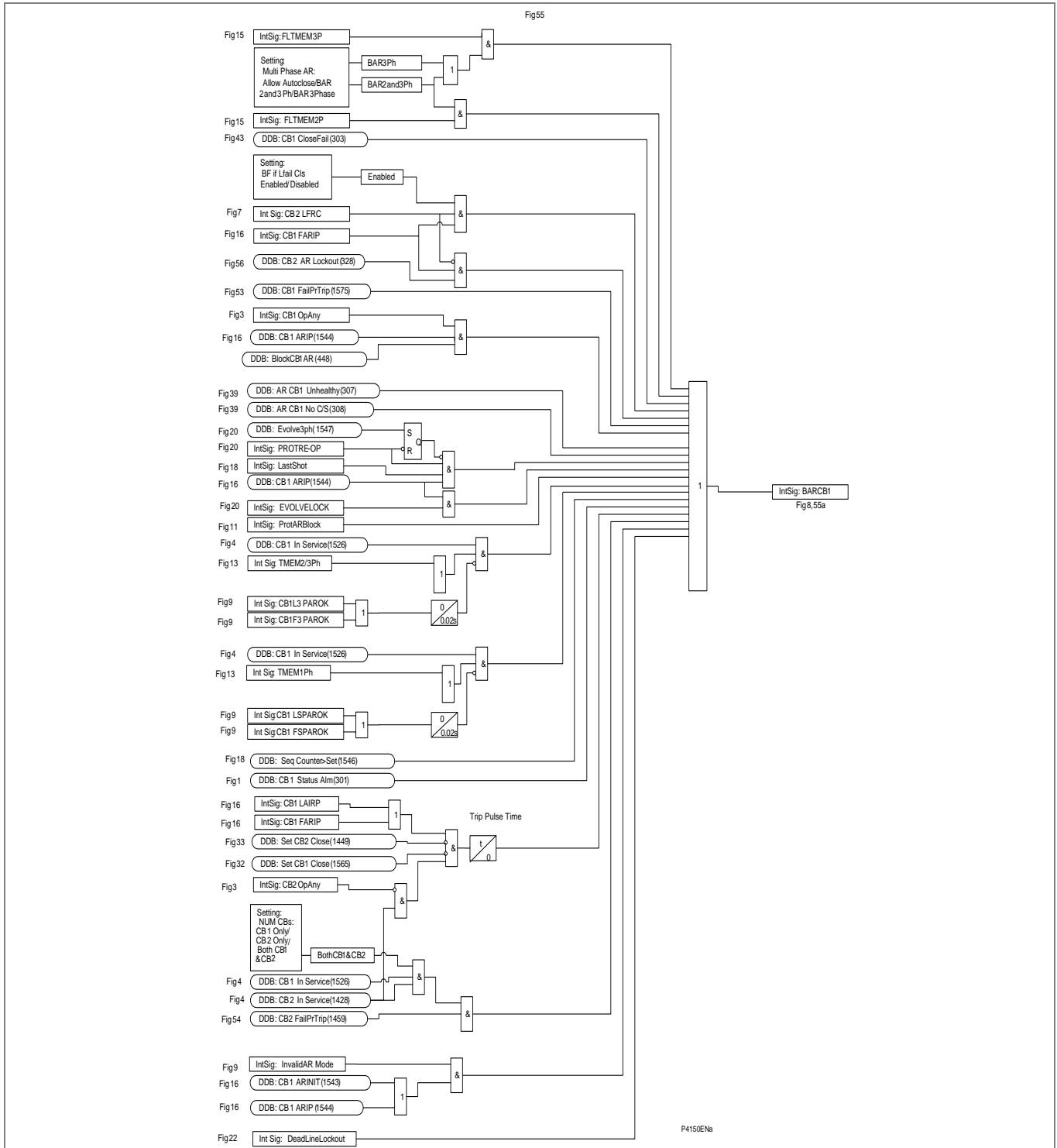

Figure AR-52 - Auto-reclose lockout – CB1 (for Software Versions BEFORE H1)

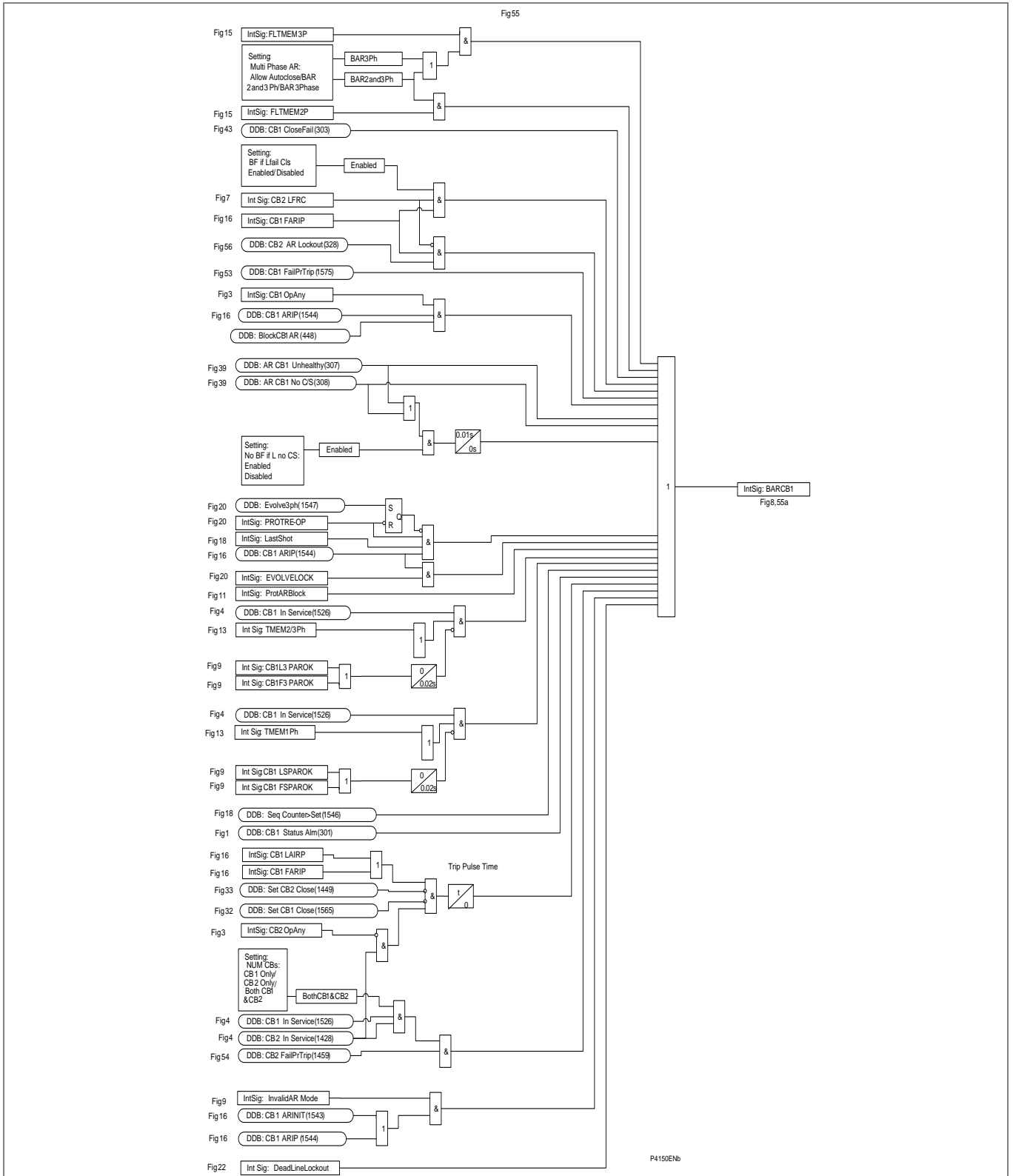

Figure AR-53 - Auto-reclose lockout – CB1 (for Software Versions H1 and later)

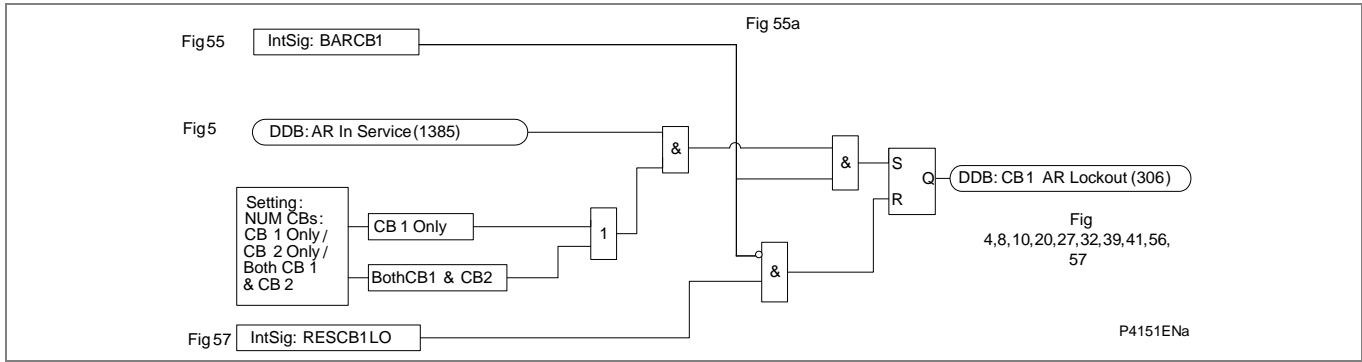

Figure AR-54 - Auto-reclose lockout – CB1

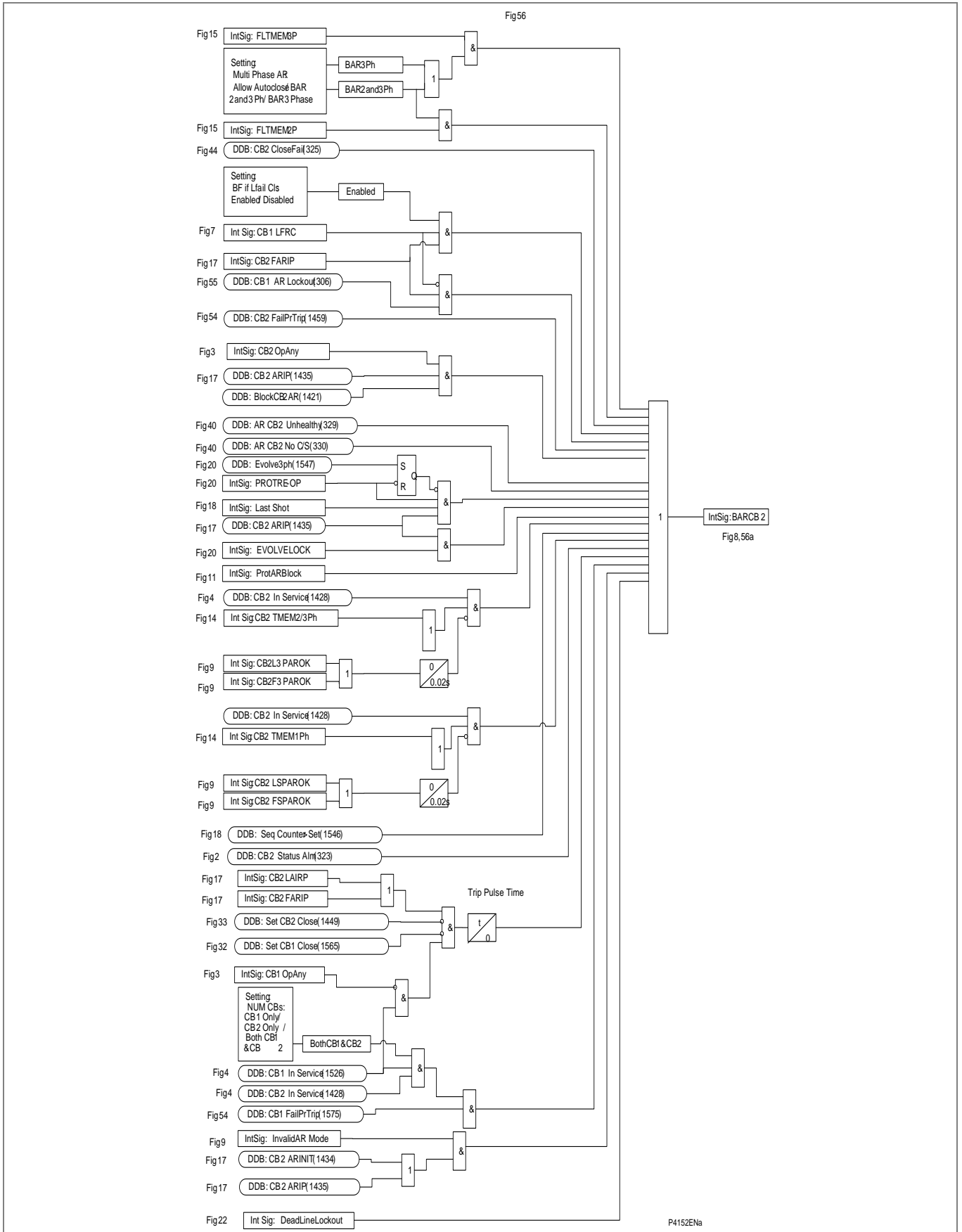

Figure AR-55 - Auto-reclose lockout – CB2 (for Software Versions BEFORE H1)

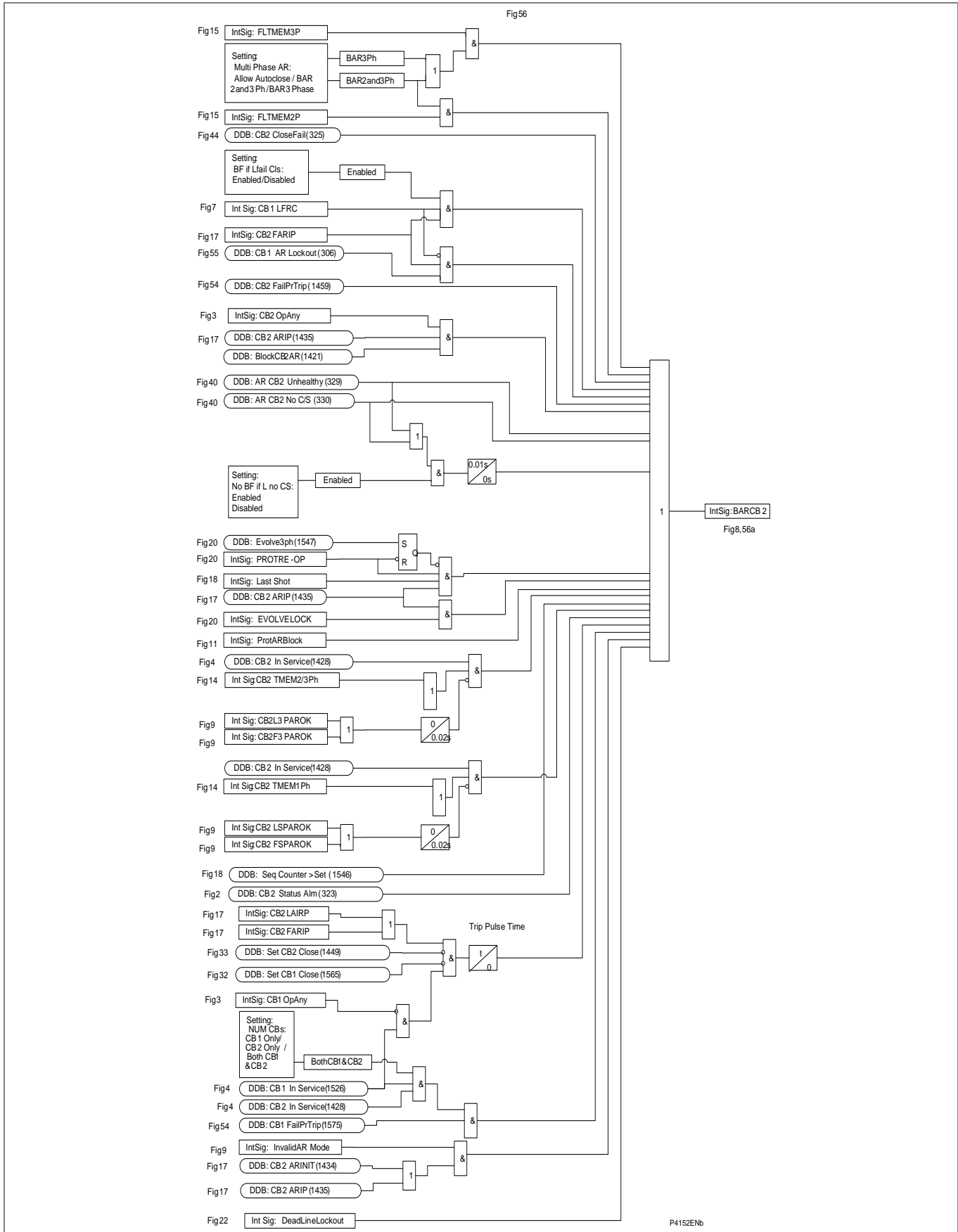

Figure AR-56 - Auto-reclose lockout – CB2 (for Software Versions H1 and later)

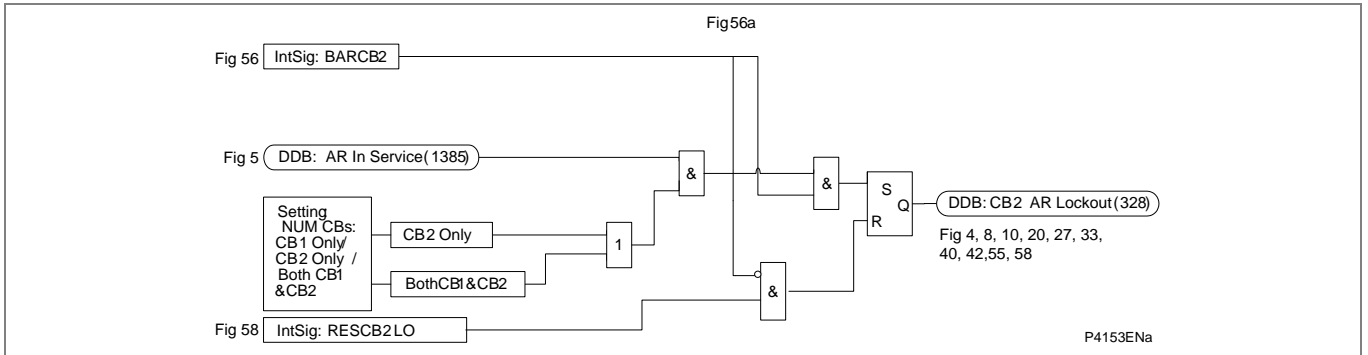

Figure AR-57 - Auto-reclose lockout – CB2

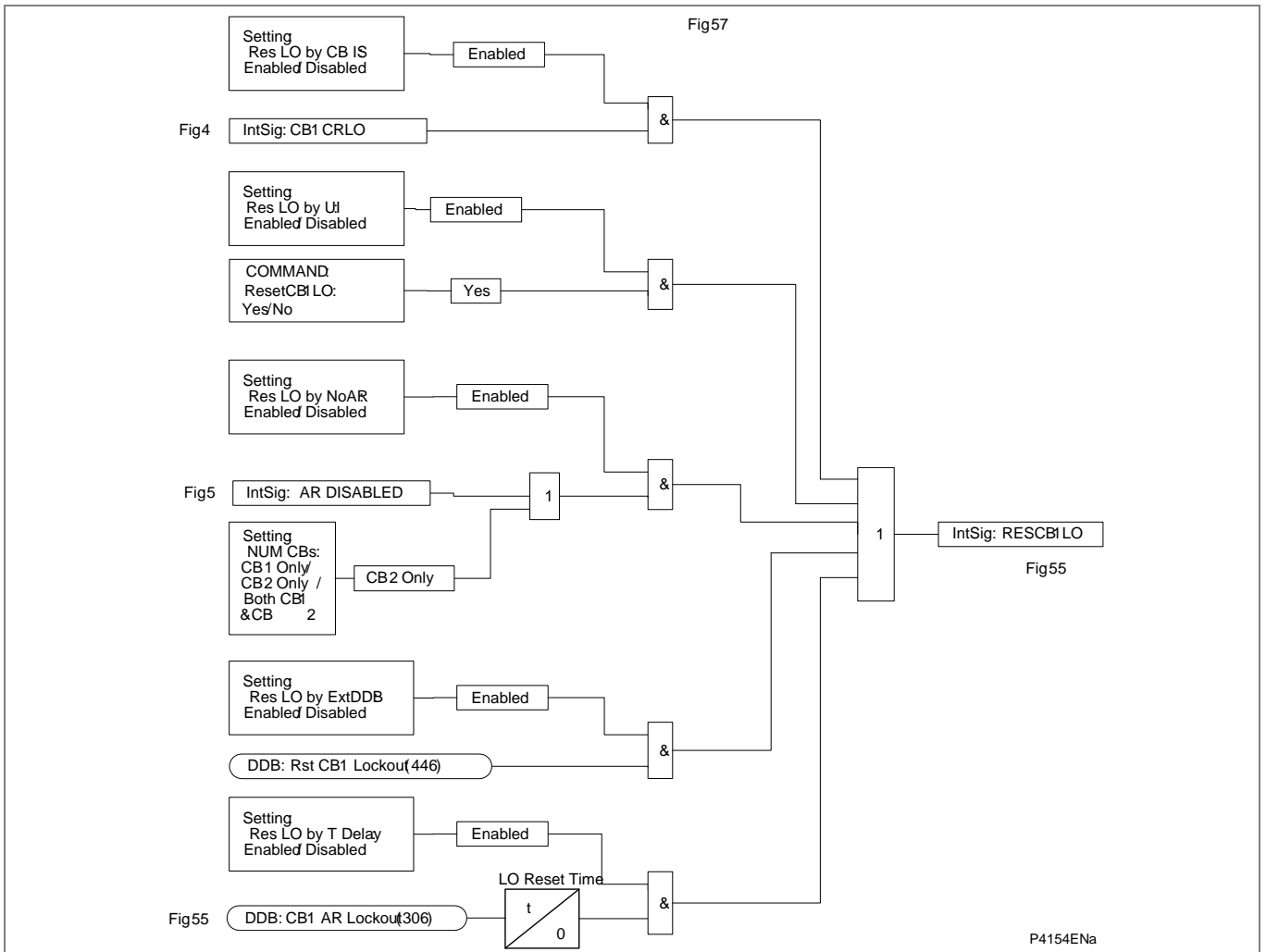

Figure AR-58 - Reset CB1 lockout

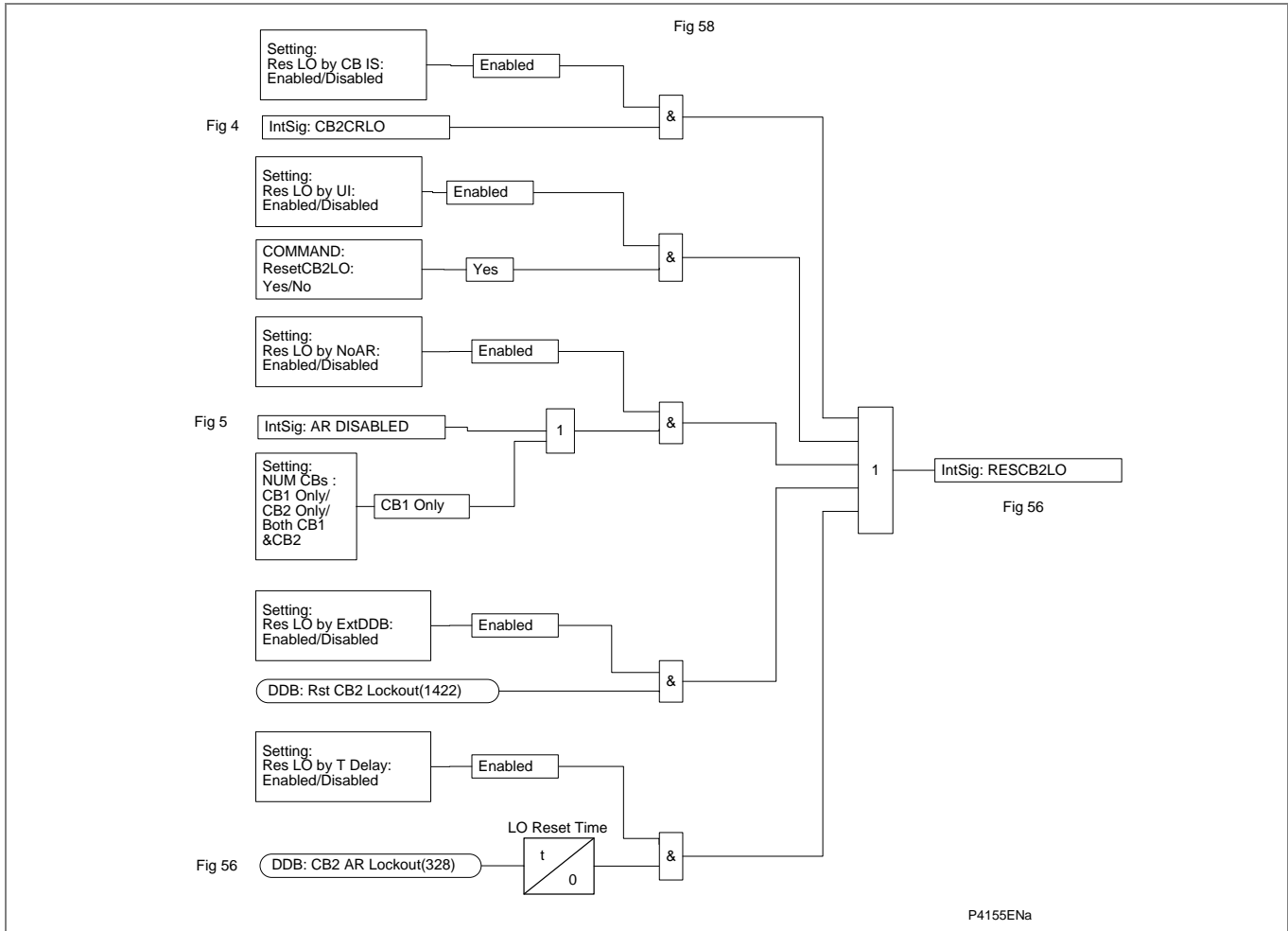

Figure AR-59 - Reset CB2 lockout

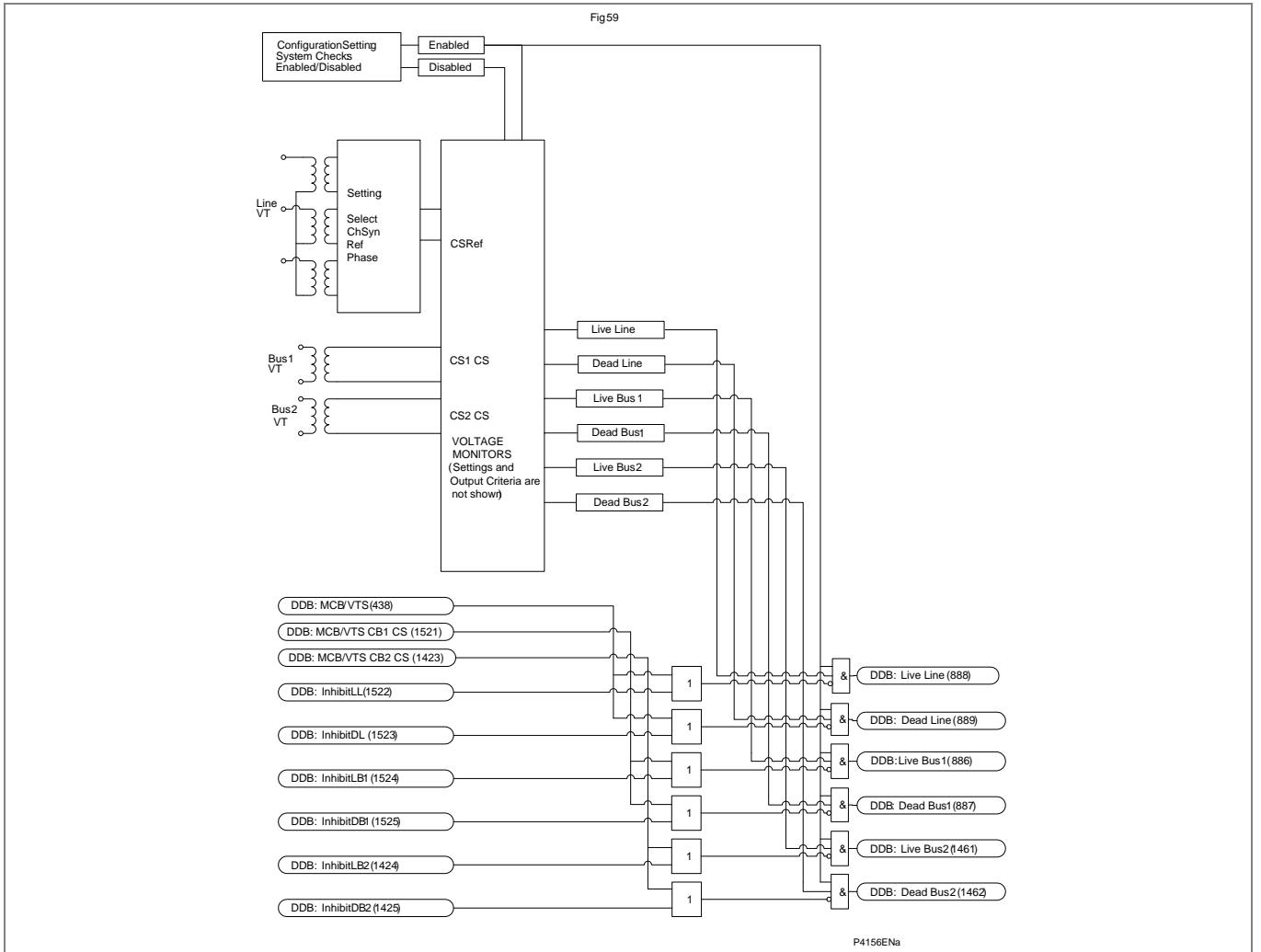

Figure AR-60 - System checks – voltage monitor

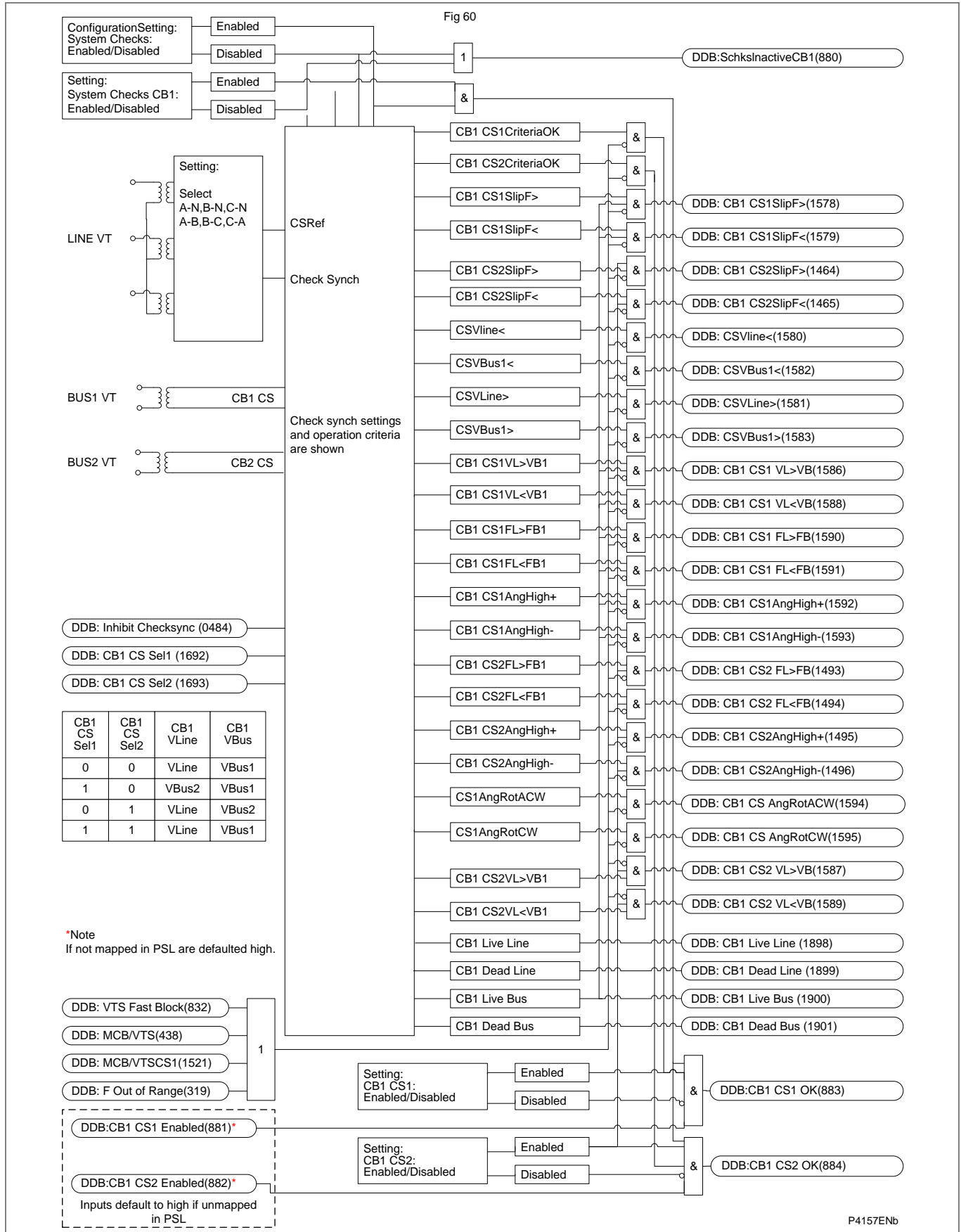

Figure AR-61 - CB1 synch check signals

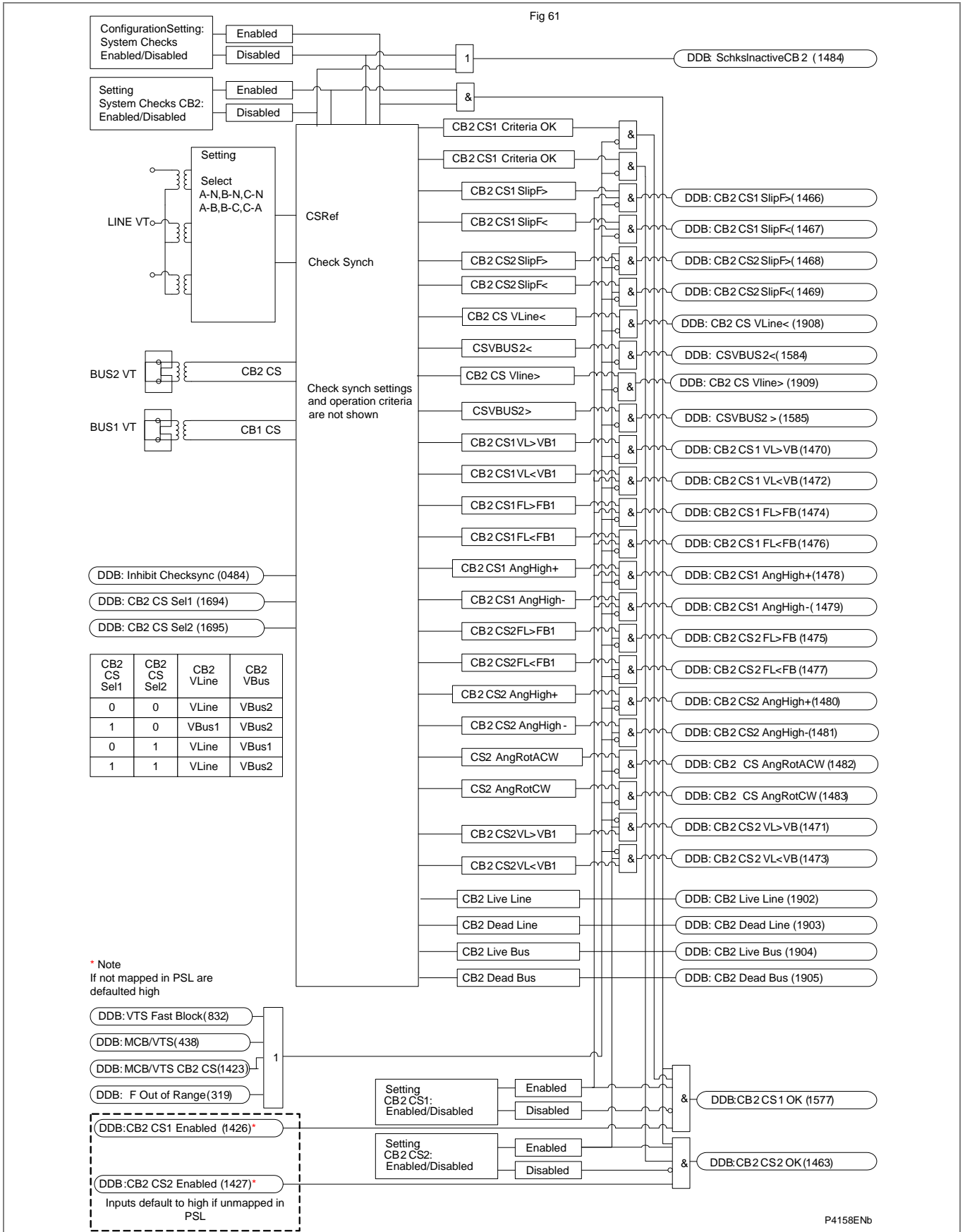

Figure AR-62 - CB2 synch check signals

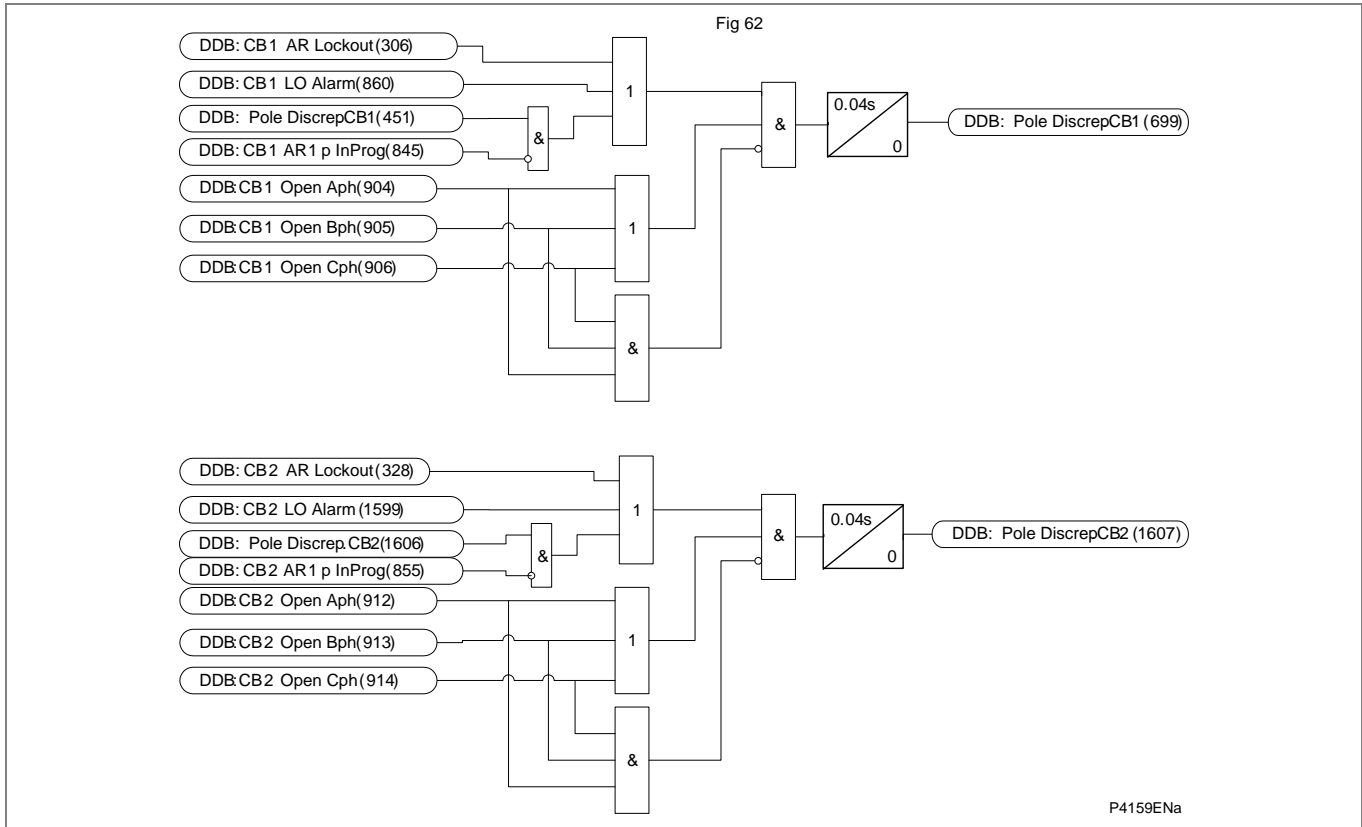

Figure AR-63 - Pole discrepancy (for P54x except P546)

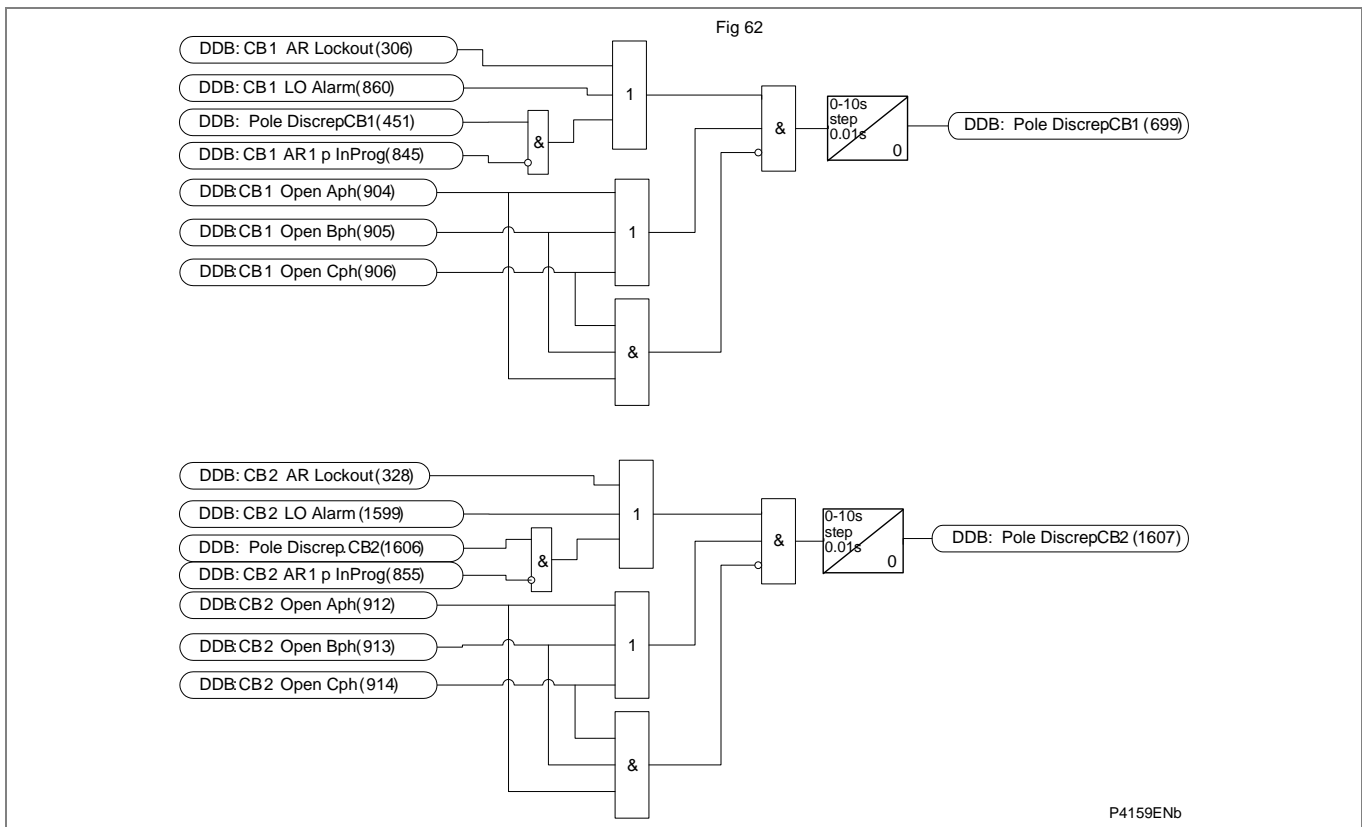

Figure AR-64 - Pole discrepancy (for P546 only)

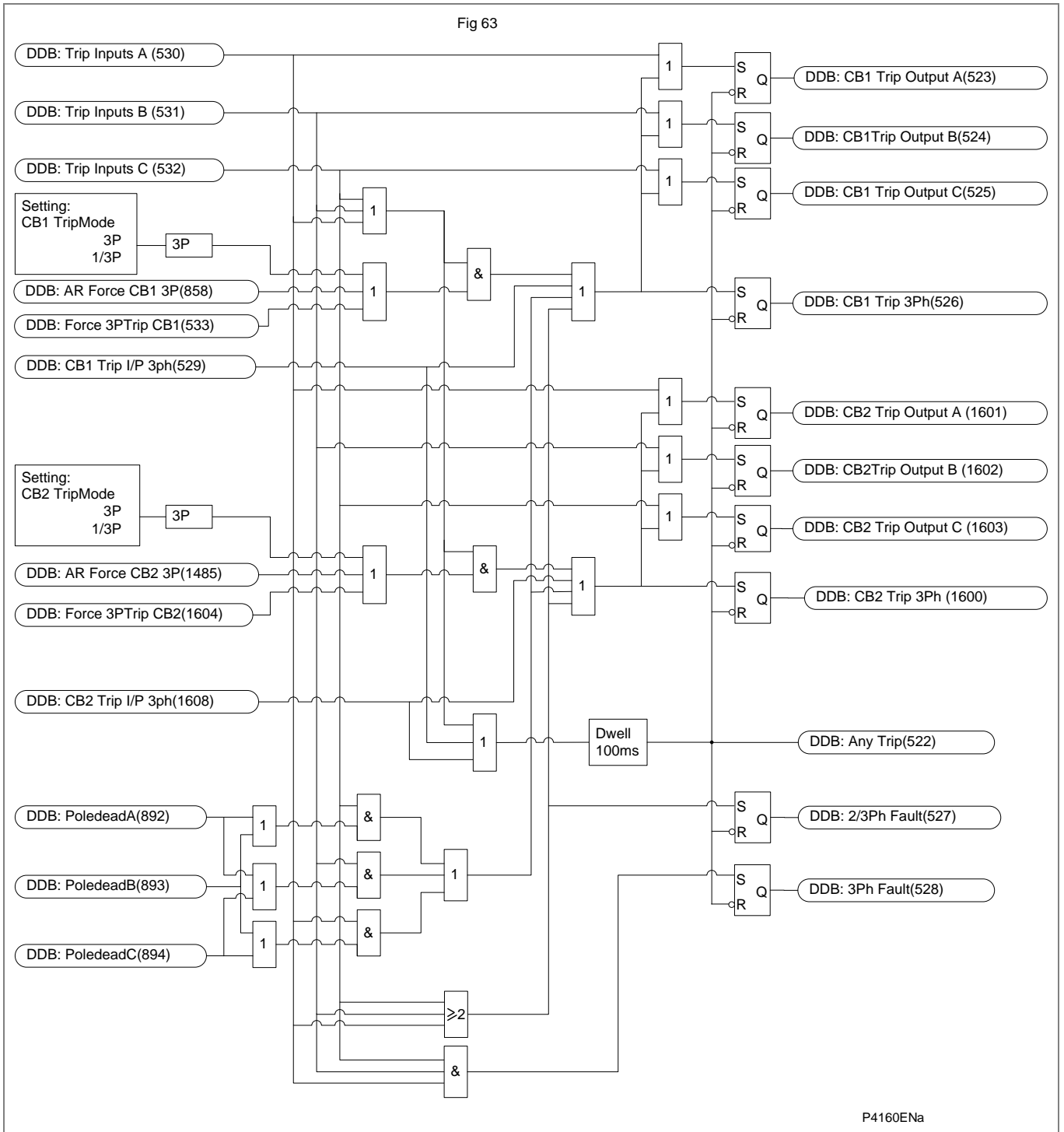

Figure AR-65 - CB trip conversion

7 P544/P546 CB CONTROL AND AR LOGIC: INTERNAL SIGNAL DEFINITIONS

The CB control functionality of the P544/P546 is described in Figure AR-1 to Figure AR-65 in the previous section. Within that description a number of signals that are internal to the logic of the CB control are featured. Unlike the DDB signals, these internal signals cannot be accessed using the PSL, as they are hard-coded into the application software. This section lists those signals and provides a brief description. This section lists **only** the hard-coded internal signals used in the CB control. The DDB signals featuring in the logic are described in the Programmable Logic chapter (P54x/EN PL) of this manual.

Name	Description
3PDTCOMP	Int Sig: Three phase dead time complete
AR DISABLED	Int Sig: Overall autoreclosing disabled
BAR CB1	Int Sig from "Autoreclose Lockout – CB1"
BAR CB2	Int Sig from "Autoreclose Lockout – CB2"
CB1 3PDTCOMP	Int Sig: CB1 3PAR dead time complete
CB1 3PFTCOMP	Int Sig: CB1 3PAR follower time complete
CB1 3POK	Int Sig: CB1 OK for 3P AR (leader or follower)
CB1 ARSUCC	Int Sig: CB1 auto-reclose successful
CB1 CS1 AngHigh-	Int Sig + DDB: Line/Bus1 phase angle in range: -CB1 CS1 Angle to -180deg
CB1 CS1 AngHigh+	Int Sig + DDB: Line/Bus1 phase angle in range: +CB1 CS1 Angle to +180deg
CB1 CS1 FL<FB	Int Sig + DDB: Bus1 F > (Line F + "CB1 CS1 SlipFreq")
CB1 CS1 FL>FB	Int Sig + DDB: Line F > (Bus1 F + "CB1 CS1 SlipFreq")
CB1 CS1 OK	Int Sig + DDB: CB1 CS1 is enabled and Line and Bus 1 voltages meet CB1 CS1 settings
CB1 CS1 SlipF<	Int Sig + DDB: Line-Bus 1 slip freq < CB1 CS1 SlipFreq setting
CB1 CS1 SlipF>	Int Sig + DDB: Line-Bus 1 slip freq > CB1 CS1 SlipFreq setting
CB1 CS1 VL<VB	Int Sig + DDB: Bus1 V > (Line V + "CB1 CS1 VDiff")
CB1 CS1 VL>VB	Int Sig + DDB: Line V > (Bus1 V + "CB1 CS1 VDiff")
CB1 CS2AngHigh-	Int Sig + DDB: Line/Bus1 phase angle in range: -CB1 CS2 Angle to -180deg
CB1 CS2AngHigh+	Int Sig + DDB: Line/Bus1 phase angle in range: +CB1 CS2 Angle to +180deg
CB1 CS2FL<FB	Int Sig + DDB: Bus1 F > (Line F + "CB1 CS2 SlipFreq")
CB1 CS2FL>FB	Int Sig + DDB: Line F > (Bus1 F + "CB1 CS2 SlipFreq")
CB1 CS2OK	Int Sig + DDB: CB1 CS2 is enabled and Line and Bus 1 voltages meet CB1 CS2 settings
CB1 CS2SlipF<	Int Sig + DDB: Line-Bus 1 slip freq < CB1 CS2 SlipFreq setting
CB1 CS2SlipF>	Int Sig + DDB: Line-Bus 1 slip freq > CB1 CS2 SlipFreq setting
CB1 CS2VL<VB	Int Sig + DDB: Bus1 V > (Line V + "CB1 CS2 VDiff")
CB1 CS2VL>VB	Int Sig + DDB: Line V > (Bus1 V + "CB1 CS2 VDiff")
CB1 FARIP	Int Sig: CB1 ARIP as follower
CB1 LARIP	Int Sig: CB1 ARIP as leader
CB1 Op1P	Int Sig: CB1 open single-phase
CB1 Op2/3P	Int Sig: CB1 open on 2 or 3-phases
CB1 OpAny	Int Sig: CB1 open on 1, 2 or 3-phases
CB1 SPOK	Int Sig: CB1 OK for SP AR (leader or follower)
CB1 SysCh Off	Int Sig + DDB: CB1 CS1 & CB1 CS2 checks disabled
CB1CRLO	Int Sig: CB1 in service – reset CB1 lockout
CB1F3PAR	Int Sig from "Three Phase AR Cycle Selection"
CB1F3PAROK	Int Sig: CB1 OK to 3Ph AR as follower

Name	Description
CB1FSPAR	Int Sig: CB1 SPAR in progress as follower
CB1FSPAROK	Int Sig: CB1 OK to SP AR as follower
CB1L3PAR	Int Sig from "Three Phase AR Cycle Selection"
CB1L3PAR	Int Sig from "Single Phase AR Cycle Selection"
CB1L3PAROK	Int Sig: CB1 OK to 3Ph AR as leader
CB1LFRC	Int Sig: CB1 failed to reclose as leader
CB1LFRC	Int Sig from "Leader/Follower Logic – 1"
CB1LSPAR	Int Sig from "Single Phase AR Cycle Selection"
CB1LSPAROK	Int Sig: CB1 OK to SP AR as leader
CB1SPDTCOMP	Int Sig: CB1 SP dead time complete
CB1SPFTCOMP	Int Sig: CB1 SP follower time complete
CB2 3PDTCOMP	Int Sig: CB2 3PAR dead time complete
CB2 3PFTCOMP	Int Sig: CB2 3PAR follower time complete
CB2 3POK	Int Sig: CB2 OK for 3P AR (leader or follower)
CB2 ARSUCC	Int Sig: CB2 auto-reclose successful
CB2 CS1 AngHigh-	Int Sig + DDB: Line/Bus2 phase angle in range: -CB2 CS1 Angle to -180deg
CB2 CS1 AngHigh+	Int Sig + DDB: Line/Bus2 phase angle in range: +CB2 CS1 Angle to +180deg
CB2 CS1 FL<FB	Int Sig + DDB: Bus2 F > (Line F + "CB2 CS1 SlipFreq")
CB2 CS1 FL>FB	Int Sig + DDB: Line F > (Bus2 F + "CB2 CS1 SlipFreq")
CB2 CS1 OK	Int Sig + DDB: CB2 CS1 is enabled and Line and Bus 2 voltages meet CB2 CS1 settings
CB2 CS1 SlipF<	Int Sig + DDB: Line-Bus 2 slip freq < CB2 CS1 SlipFreq setting
CB2 CS1 SlipF>	Int Sig + DDB: Line-Bus 2 slip freq > CB2 CS1 SlipFreq setting
CB2 CS1 VL<VB	Int Sig + DDB: Bus2 V > (Line V + "CB2 CS1 VDiff")
CB2 CS1 VL>VB	Int Sig + DDB: Line V > (Bus2 V + "CB2 CS1 VDiff")
CB2 CS2AngHigh-	Int Sig + DDB: Line/Bus2 phase angle in range: -CB2 CS2 Angle to -180deg
CB2 CS2AngHigh+	Int Sig + DDB: Line/Bus2 phase angle in range: +CB2 CS2 Angle to +180deg
CB2 CS2FL<FB	Int Sig + DDB: Bus2 F > (Line F + "CB2 CS2 SlipFreq")
CB2 CS2FL>FB	Int Sig + DDB: Line F > (Bus2 F + "CB2 CS2 SlipFreq")
CB2 CS2OK	Int Sig + DDB: CB2 CS2 is enabled and Line and Bus 2 voltages meet CB2 CS2 settings
CB2 CS2SlipF<	Int Sig + DDB: Line-Bus 2 slip freq < CB2 CS2 SlipFreq setting
CB2 CS2SlipF>	Int Sig + DDB: Line-Bus 2 slip freq > CB2 CS2 SlipFreq setting
CB2 CS2VL<VB	Int Sig + DDB: Bus2 V > (Line V + "CB2 CS2 VDiff")
CB2 CS2VL>VB	Int Sig + DDB: Line V > (Bus2 V + "CB2 CS2 VDiff")
CB2 FARIP	Int Sig: CB2 ARIP as follower
CB2 LARIP	Int Sig: CB2 ARIP as leader
CB2 Op1P	Int Sig: CB2 open single-phase
CB2 Op2/3P	Int Sig: CB2 open on 2 or 3-phases
CB2 OpAny	Int Sig: CB2 open on 1, 2 or 3-phases
CB2 SPOK	Int Sig: CB2 OK for SP AR (leader or follower)
CB2 SysCh Off	Int Sig + DDB: CB2 CS1 & CB2 CS2 checks disabled
CB2 TAR 2/3Ph	Int Sig: 2Ph or 3Ph trip & AR initiation CB2
CB2 TARA	Int Sig: A Ph trip & AR initiation CB2
CB2 TARB	Int Sig: B Ph trip & AR initiation CB2
CB2 TARC	Int Sig: C Ph trip & AR initiation CB2

Name	Description
CB2 TMEM 1Ph	Int Sig: CB1 1Ph trip +AR AR initiation memory CB2
CB2 TMEM 2/3Ph	Int Sig: CB1 2Ph trip +AR AR initiation memory CB2
CB2 TMEM 3Ph	Int Sig: CB1 3Ph trip +AR AR initiation memory CB2
CB2CRLO	Int Sig: CB2 in service – reset CB2 lockout
CB2F3PAR	Int Sig from “Three Phase AR Cycle Selection”
CB2F3PAROK	Int Sig: CB2 OK to 3Ph AR as follower
CB2FSPAR	Int Sig: CB2 SPAR in progress as follower
CB2FSPAROK	Int Sig: CB2 OK to SP AR as follower
CB2L3PAR	Int Sig from “Three Phase AR Cycle Selection”
CB2L3PAROK	Int Sig: CB2 OK to 3Ph AR as leader
CB2LFRC	Int Sig: CB2 failed to reclose as leader
CB2LFRC	Int Sig from “Leader/Follower Logic – 1”
CB2LSPAR	Int Sig from “Single Phase AR Cycle Selection”
CB2LSPAROK	Int Sig: CB2 OK to SP AR as leader
CB2SPDTCOMP	Int Sig: CB2 SP dead time complete
CB2SPFTCOMP	Int Sig: CB2 SP follower time complete
CBARCancel	Int Sig: Stop and reset CB1 and CB2 AR In progress
CS VBus1<	Int Sig + DDB: Bus1 Volts < CS UV setting
CS VBus1>	Int Sig + DDB: Bus1 Volts > CS OV setting
CS VBus2<	Int Sig + DDB: Bus2 Volts < CS UV setting
CS VBus2>	Int Sig + DDB: Bus2 Volts > CS OV setting
CS VLine<	Int Sig + DDB: Line Volts < CS UV setting
CS VLine>	Int Sig + DDB: Line Volts > CS OV setting
CS1 Ang Rot ACW	Int Sig + DDB: Line freq > (Bus1 freq + 0.001Hz) (CS1 Angle Rotating Anticlockwise)
CS1 Ang Rot CW	Int Sig + DDB: Bus1 freq > (Line freq + 0.001Hz) (CS1 Angle Rotating Clockwise)
CS2 Ang Rot ACW	Int Sig + DDB: Line freq > (Bus2 freq + 0.001Hz) (CS2 Angle Rotating Anticlockwise)
CS2 Ang Rot CW	Int Sig + DDB: Bus2 freq > (Line freq + 0.001Hz) (CS2 Angle Rotating Clockwise)
Dead Bus 1	Int Sig + DDB: CS1 V magnitude < Dead Bus 1 setting
Dead Bus 2	Int Sig + DDB: CS2 V magnitude < Dead Bus 2 setting
Dead Line	Int Sig + DDB: Line V magnitude < Dead Line setting
DeadLineLockout	Int Sig: When setting “3PDT Start When LD” is set to Enabled and the line does not go dead for a time set by “Dead Line Time” then this signal will force the auto-reclose sequence to lockout.
ENABLE CB13PDT	Int Sig: Enable dead time for CB1 3PAR
ENABLE CB1SPDT	Int Sig: Enable dead time for CB1 SPAR
ENABLE CB23PDT	Int Sig: Enable dead time for CB2 3PAR
ENABLE CB2SPDT	Int Sig: Enable dead time for CB2 SPAR
EVOLVE LOCK	Int Sig: Lockout for 2nd trip after Discrim Tim
F Out of Range	Int Sig from frequency tracking logic
FLTMEM 2P	Int Sig: 2 Ph fault memory
FLTMEM 3P	Int Sig: 3 Ph fault memory
Foll CB1	Int Sig from “Leader & Follower Logic – 2”
Foll CB2	Int Sig from “Leader & Follower Logic – 2”
Foll3PAROK	Int Sig from “Leader & Follower AR Modes Enable”
FollSPAROK	Int Sig from “Leader & Follower AR Modes Enable”

Name	Description
INIT AR	Int Sig: Host protection required to initiate AR
Invalid AR Mode	Int Sig: An invalid state is being indicated by the logic that determines AR mode by opto.
Last Shot	Int Sig: the last shot
Live Bus 1	Int Sig + DDB: CS1 V magnitude >= Live Bus 1 setting
Live Bus 2	Int Sig + DDB: CS2 V magnitude >= Live Bus 2 setting
Live Line	Int Sig + DDB: Line V magnitude >= Live Line setting
OK Time SP	Int Sig from "Single Phase AR Lead CB Dead Time"
PrefLCB1	Int Sig: CB1 is the preferred leader
PrefLCB2	Int Sig: CB2 is the preferred leader
Prot AR Block*	Int Sig: Host protection required to block AR
Prot Re-op	Int Sig from "Protection Re-operation + Evolving Fault"
RESCB1ARSUCC	Int Sig from "Reset CB1 Successful AR Indication"
RESCB1LO	Int Sig from "Reset CB1 Lockout"
RESCB2ARSUCC	Int Sig from "Reset CB2 Successful AR Indication"
RESCB2LO	Int Sig from "Reset CB2 Lockout"
Reset L-F	Int Sig: From "Protection Re-operation + Evolving fault"
RESRMEM	Int Sig: Reset "trip & AR" memory
SC Increment	Int Sig: Increment the sequence counter
SCCountoveqShots	Int Sig: Sequence counter has exceeded setting
SET CB1CL	Int Sig from "CB1 Auto Close"
SET CB2CL	Int Sig from "CB2 Auto Close"
SET LCB1	Int Sig: CB1 selected leader
SET LCB1	Int Sig from "Leader/Follower Logic – 1"
SET LCB2	Int Sig: CB2 selected leader
SET LCB2	Int Sig from "Leader/Follower Logic – 1"
SETCB13PCL	Int Sig: CB1 three-phase close given
SETCB1SPCL	Int Sig: CB1 single-phase close given
SETCB23PCL	Int Sig: CB2 three-phase close given
SETCB2SPCL	Int Sig: CB2 single-phase close given
SPDTCOMP	Int Sig: Single phase dead time complete
TAR 2/3Ph	Int Sig: 2Ph or 3Ph trip & AR initiation
TARA	Int Sig: A Ph trip & AR initiation
TARANY	Int Sig from "CB1 1 Pole / 3-pole Trip + AR Initiation"
TARANY	Int Sig: Any trip & AR initiation
TARB	Int Sig: B Ph trip & AR initiation
TARC	Int Sig: C Ph trip & AR initiation
TMEM 1Ph	Int Sig: CB1 1Ph trip +AR AR initiation memory
TMEM 2/3Ph	Int Sig: CB1 2Ph trip +AR AR initiation memory
TMEM 3Ph	Int Sig: CB1 3Ph trip +AR AR initiation memory
TMEM ANY	Int Sig: Any Ph trip & AR initiation memory

Notes:

APPLICATION NOTES

CHAPTER 6

Date:	10/2022
Products covered by this chapter:	This chapter covers the specific versions of the MiCOM products listed below. This includes only the following combinations of Software Version and Hardware Suffix.
Hardware suffix:	M
Software version:	K6
Connection diagrams:	10P54302 (SH 1 to 2) 10P54303 (SH 1 to 2) 10P54304 (SH 1 to 2) 10P54400 10P54404 (SH 1 to 2) 10P54405 (SH 1 to 2) 10P54502 (SH 1 to 2) 10P54503 (SH 1 to 2) 10P54504 (SH 1 to 2) 10P54600 10P54604 (SH 1 to 2) 10P54605 (SH 1 to 2) 10P54606 (SH 1 to 2)

CONTENTS

Page (AP) 6-

1	Introduction	11
1.1	Protection of Overhead Line, Cable, and Hybrid Circuits	11
2	Application of Individual Protection Functions	13
2.1	Differential Protection	13
2.1.1	Setting of the Phase Differential Characteristic	13
2.1.2	Relay Sensitivity under Heavy Load Conditions	16
2.1.3	CT Ratio Correction	17
2.1.4	Transformers in Zone Applications	17
2.1.4.1	Magnetizing Inrush Stabilization	18
2.1.4.2	Second Harmonic Restraint	20
2.1.4.3	Second Harmonic Blocking	20
2.1.4.4	Fifth Harmonic Blocking	21
2.1.4.5	CT Ratio Correction	22
2.1.4.6	Phase Correction and Zero Sequence Current Filtering	22
2.1.4.7	High Set Differential Setting	22
2.1.5	Mesh Corner and 1½ Breaker Switched Substations	23
2.1.6	Small Tapped Loads (Tee Feeds)	23
2.2	Distance Protection and Aided DEF (Distance option only)	24
2.2.1	Simple and Advanced Setting Mode (Distance option only)	24
2.2.2	Line Parameters Settings (Distance option only)	24
2.2.3	Residual Compensation for Earth/Ground Faults (Distance option only)	24
2.2.4	Mutual Compensation for Parallel Lines	24
2.2.5	Selection of Starting Behaviour	25
2.2.6	Selection of Distance Operating Characteristic	26
2.2.6.1	Phase Characteristic	26
2.2.6.2	Ground Characteristic	27
2.2.7	Zone Reaches - Recommended Settings	28
2.2.8	Quadrilateral Phase Resistive Reaches	29
2.2.9	Quadrilateral Ground Resistive Reaches and Tilting	29
2.2.9.1	Dynamic Tilting:	29
2.2.10	Phase Fault Zone Settings	31
2.2.11	Distance Directional Principle and Setup	32
2.2.12	Delta Directional - Selection of RCA	32
2.2.13	Distance Setup - Filtering, Load Blinding and Polarizing	32
2.2.13.1	Digital Filtering	32
2.2.13.2	CVTs with Passive Suppression of Ferroresonance	32
2.2.13.3	CVTs with Active Suppression of Ferroresonance	32
2.2.14	Load Blinding (Load Avoidance)	33
2.2.14.1	Recommended Polarizing Settings	33
2.2.15	Distance Elements Basic Scheme Setting	34
2.2.16	Power Swing Alarming and Blocking	35

2.2.17	Out-of-Step Protection	36
2.2.18	Critical Stability Angle	36
2.2.18.1	Setting Option Recommendation	37
2.2.18.2	Blinder Limits Determination	38
2.2.18.3	Delta t, R5 and R6 Setting Determination	40
2.2.18.4	Tost (Trip Delay) Setting	41
2.2.18.5	Blinder Angle Setting	41
2.2.18.6	Out-of-Step Operation on Series Compensated Lines	41
2.2.19	Switch On To Fault (SOTF) Mode	42
2.2.20	Trip On Reclose Mode	42
2.2.21	Setup of DEF	42
2.2.22	DEF Zero Sequence Polarization	42
2.2.23	DEF Negative Sequence Polarization	42
2.2.24	General Setting Guidelines for DEF (Directional Ground Overcurrent)	43
2.2.25	Delta Directional Comparison Principle and Setup	43
2.2.26	Delta Directional Comparison - Selection of ΔI and ΔV Threshold	43
2.3	Distance Protection Application for Series Compensated Lines	45
2.3.1	Series Capacitor Protection	45
2.3.2	Transient Effects in Case of Line Faults	45
2.3.2.1	Reduced Apparent Fault Impedance	45
2.3.2.2	Sub-Synchronous Resonances	46
2.3.2.3	Voltage Reversal	47
2.3.2.4	Current Reversal	47
2.3.3	Distance Protection Settings Guidelines	47
2.4	Channel Aided Schemes	49
2.4.1	Distance Scheme PUR - Permissive Underreach Transfer Trip	49
2.4.2	Distance Scheme POR - Permissive Overreach Transfer Trip	49
2.4.3	Permissive Overreach Trip Reinforcement	49
2.4.4	Permissive Overreach Scheme Weak Infeed Features	49
2.4.5	Distance Scheme Blocking	50
2.4.6	Permissive Overreach Schemes Current Reversal Guard	50
2.4.7	Blocking Scheme Current Reversal Guard	50
2.4.8	Aided DEF Ground Fault Scheme - Permissive Overreach	50
2.4.9	Aided DEF Ground Fault Scheme - Blocking	50
2.4.10	Delta Scheme POR - Permissive Overreach Transfer Trip	50
2.4.11	Delta Blocking Scheme	51
2.4.12	Delta Schemes Current Reversal Guard Timer	51
2.5	Loss of Load Accelerated Tripping (LoL) (Distance option only)	51
2.6	Phase Fault Overcurrent Protection	52
2.6.1	Directional Overcurrent Characteristic Angle Settings	52
2.7	Thermal Overload Protection	53
2.7.1	Single Time Constant Characteristic	53
2.7.2	Dual Time Constant Characteristic	53
2.8	Earth Fault (Ground Overcurrent) and Sensitive Earth Fault (SEF) protection	53
2.8.1	Directional Earth Fault Protection	54

2.8.1.1	Residual Voltage Polarization	54
2.8.2	General Setting Guidelines for Directional Earth Fault (Ground Overcurrent) Protection	54
2.8.3	Sensitive Earth Fault (SEF) Protection Element	54
2.8.4	Restricted Earth Fault (REF) Protection	55
2.8.4.1	Setting Guidelines for High Impedance Restricted Earth Fault (REF)	56
2.8.4.2	Use of METROSIL Non-Linear Resistors	56
2.9	Negative Phase Sequence (NPS) Overcurrent Protection	59
2.9.1	NPS Current Threshold, 'I2> Current Set'	59
2.9.2	Time Delay for the NPS Overcurrent Element, 'I2> Time Delay'	59
2.9.3	Directionalizing the Negative Phase Sequence Overcurrent Element	60
2.10	Undervoltage Protection	60
2.11	Overvoltage Protection	60
2.12	Compensated Overvoltage Protection	61
2.13	Residual Overvoltage (Neutral Displacement) Protection	62
2.13.1	Setting Guidelines	63
2.14	Circuit Breaker Fail (CBF) Protection	64
2.14.1	Breaker Fail Timer Settings	64
2.14.2	Breaker Fail Undercurrent Settings	64
2.15	Broken Conductor Detection	65
2.15.1	Setting Guidelines	65
2.16	Communication between Relays	66
2.16.1	Optical Budgets	66
2.16.2	Clock Source Setting	67
2.16.3	Data Rate	67
2.17	Integral Intertripping	68
2.17.1	EIA(RS)232 InterMiCOM ("Modem InterMiCOM")	69
2.18	InterMiCOM⁶⁴ ("Fiber InterMiCOM")	71
2.18.1	IMx Command Type	71
2.18.2	IMx Fallback Mode	71
3	Worked Protection Example and other Protection Tips	72
3.1	Differential Protection Setting Examples	72
3.1.1	Differential Element	72
3.1.2	Transformer Feeder Examples	73
3.1.3	Teed Feeder Example	74
3.1.4	Three Winding Transformer in Zone with Different Rated CTs Example	75
3.2	Distance Protection Setting Example	78
3.2.1	Objective	78
3.2.2	System Data	78
3.2.3	Relay Settings	78
3.2.4	Line Impedance	79
3.2.5	Residual Compensation For Ground Fault Elements	79
3.2.6	Zone 1 Phase and Ground Reach Settings	79
3.2.7	Zone 2 Phase and Ground Reach Settings	80

3.2.8	Zone 3 Phase and Ground Reach Settings	80
3.2.9	Zone 3 Reverse Reach	80
3.2.10	Zone 4 Reverse Settings with POR and BLOCKING Schemes	80
3.2.11	Load Avoidance	81
3.2.12	Additional Settings for Quadrilateral Applications	81
3.2.12.1	Phase Fault Resistive Reaches (Rph)	81
3.2.12.2	Ground Fault Resistive Reaches (RGnd)	82
3.3	Teed Feeder Protection	83
3.3.1	Apparent Impedance seen by the Distance Elements	83
3.3.2	Permissive Overreach (POR) Schemes	83
3.3.3	Permissive Underreach Schemes	83
3.3.4	Blocking Schemes	84
3.4	VT Connections	85
3.4.1	Open Delta (Vee Connected) VTs	85
3.4.2	VT Single Point Earthing	85
3.5	Trip Circuit Supervision (TCS)	86
3.5.1	TCS Scheme 1	86
3.5.1.1	Scheme Description	86
3.5.1.2	Scheme 1 PSL	87
3.5.2	TCS Scheme 2a	88
3.5.2.1	Scheme Description	88
3.5.2.2	Scheme 2a PSL	88
3.5.3	TCS Scheme 2b	89
3.5.3.1	Scheme Description	89
3.5.3.2	Scheme 2b PSL	89
3.5.4	TCS Scheme 3	90
3.5.4.1	Scheme Description	90
3.5.4.2	Scheme 3 PSL	90
3.6	Fault Detector / Trip Supervision (Software Version H4 and later)	91
3.7	InterMiCOM⁶⁴ Application Example	93
3.7.1	InterMiCOM ⁶⁴ Mapping for Three Ended Application – Blocking or PUR example	93
3.7.2	InterMiCOM ⁶⁴ Application Example General Advice	94
3.7.3	Three-Ended Applications	95
3.7.4	Intermicom64 Application Example Scheme Description	95
3.7.5	Intermicom64 Application Example Channel Supervision	96
3.7.6	Intermicom64 Application Example Transfer Trip	96
3.7.7	InterMiCOM64 Application Example - Mapping for Two Ended Application	96
3.7.8	Intermicom64 Application Example - Dual Redundant Communications Channels	97
3.7.9	Intermicom64 Application Example - Scheme Co-Ordination Timers	97
3.7.9.1	InterMiCOM64 Application Example - Distance PUR Permissive Underreach	97
3.7.9.2	InterMiCOM64 Application Example - Distance POR Permissive Overreach	97
3.7.9.3	InterMiCOM64 Application Example - Distance Blocking	97
3.7.9.4	InterMiCOM64 Application Example - Directional earth Fault (DEF) POR Permissive Overreach	97
3.7.9.5	InterMiCOM64 Application Example - Directional Earth Fault (DEF) Blocking	97
3.7.9.6	InterMiCOM64 Application Example - Delta Directional POR Permissive Overreach	97
3.7.9.7	InterMiCOM64 Application Example - Delta Directional Blocking	98

3.7.10	Fallback Mode for InterMiCOM64 bits	98
4	Application of Non-Protection Functions	99
4.1	Single and Three Phase Auto-Reclosing	99
4.1.1	Time Delayed and High Speed Auto-Reclosing	99
4.1.2	Auto-Reclose Logic Operating Sequence	99
4.1.2.1	Pole Discrepancy Timer for P54x (except P546)	99
4.1.2.2	Pole Discrepancy Timer for P546 Only	99
4.1.3	Setting Guidelines	100
4.1.3.1	Circuit Breaker Healthy	100
4.1.3.2	Number of Shots	100
4.1.3.3	Dead Timer Setting	100
4.1.3.4	Follower Time Setting (P544 and P546 only)	100
4.1.3.5	De-Ionizing Time	101
4.1.3.6	Example Minimum Dead Time Calculation	102
4.1.3.7	Reclaim Timer Setting	102
4.2	Current Transformer Supervision (CTS)	103
4.2.1	Standard CTS	103
4.2.2	Differential CTS	103
4.3	Circuit Breaker Condition Monitoring	104
4.3.1	Setting the ΣI^{\wedge} Thresholds	104
4.3.2	Setting the Number of Operations Thresholds	104
4.3.3	Setting the Operating Time Thresholds	104
4.3.4	Setting the Excessive Fault Frequency Thresholds	104
4.4	Read Only Mode	105
5	Two Circuit Breaker Control (P446) Worked Example	106
5.1	Introduction	106
5.2	Circuit Breaker Status	107
5.3	Voltage Inputs	107
5.4	Application Settings	108
5.4.1	CB CONTROL Menu:	108
5.4.2	CONFIGURATION Menu:	108
5.4.3	CT & VT RATIOS Menu:	108
5.4.4	GROUP 1 LINE PARAMETERS Menu:	108
5.4.5	GROUP 1 DISTANCE Menu:	109
5.4.6	GROUP 1 PHASE DIFF Menu:	109
5.4.7	GROUP 1 SYSTEM CHECKS Menu:	109
5.4.8	GROUP 1 AUTORECLOSE Menu:	110
5.5	PSL (Programmable Scheme Logic) Mapping	111
6	Two Circuit Breaker Control (P546)	112
7	Current Transformer (CT) Requirements	113
7.1	Recommended CT Classes (British and IEC)	113
7.2	Current Differential Requirements	113

7.3	Zone 1 Reach Point Accuracy (RPA)	114
7.4	Zone 1 Close-Up Fault Operation	114
7.5	Time Delayed Distance Zones	115
7.6	Determining V_k for an IEEE "C" Class CT	115
7.7	Worked Example for CT Requirements	115
7.7.1	System Data	115
7.7.2	Calculation of Primary X/R	115
7.7.3	Calculation of Source Impedance Z_s	116
7.7.4	Calculation of Full Line Impedance (full 100 kms)	116
7.7.5	Calculation of Total Impedance Till Remote Bus Bar	116
7.7.6	Calculation of Through Fault X/R	116
7.7.7	Calculation of Through Fault I_f	116
7.7.8	Calculation of Line Impedance Till Zone1 Reach Point (80kms)	116
7.7.9	Calculation of Total Impedance till Zone1 Reach Point	116
7.7.10	Calculation of X/R till Zone1 Reach Point	116
7.7.11	Calculation of Fault Current Till Zone1 Reach Point	116
7.7.12	CT V_k for Current Differential Protection	117
7.7.13	CT V_k for Distance Zone1 Reach Point	117
7.7.14	CT V_k for Distance Zone1 Close-Up Fault	117
7.7.15	CT V_k for Distance Time Delayed Zones	117
7.7.16	V_k to be Considered	117
8	High Break Output Contacts	118
9	Auxiliary Supply Fuse Rating	119

FIGURES

	Page (AP) 6-
Figure 1 - Differential 3-terminal scheme - internal fault	15
Figure 2 - Differential 3-terminal scheme - external fault	15
Figure 3 - Steady state magnetizing inrush current	18
Figure 4 - Magnetizing inrush current during energization	18
Figure 5 - Variation of amplitude reduction factor	19
Figure 6 - Typical overflux current waveform	21
Figure 7 - Breaker and a half switched substation	23
Figure 8 - Zone reach setting with load blinders and underimpedance starting for application example	26
Figure 9 - Settings required to apply a Mho zone (Distance option only)	27
Figure 10 - Settings required to apply a quadrilateral zone (Distance option only)	27
Figure 11 - Example of a high resistive zone 1 fault that falls outside zone 1 characteristic when the starting tilt angle of -3° is set (over-tilting effect)	30
Figure 12 - Basic time stepped distance scheme	34
Figure 13 - Power transfer in relation to angle difference θ between 2 ends	36
Figure 14 - Setting determination for the positive sequence resistive component R538	39
Figure 15 - R6 _{MAX} determination	39
Figure 16 - Example of timer reset due to MOVs operation	41
Figure 17 - Overvoltage protection for series compensation (simplified)	45
Figure 18 - Effect of series capacitor location to apparent impedance for faults along the line A-B	46
Figure 19 - Apparent impedance with sub-synchronous oscillations effecting zone 1 operation (simulated data)	47
Figure 20 - Positioning of core balance current transformers	55
Figure 21 - Calculated Ferranti voltage rise on 345 kV and 765 kV lines	61
Figure 22 - Residual voltage, solidly earthed system	62
Figure 23 - Residual voltage, resistance earthed system	63
Figure 24 - Typical plain feeder circuit	72
Figure 25 - Typical transformer feeder circuit	73
Figure 26 - Typical teed feeder application	74
Figure 27 - Three winding transformer in zone application	76
Figure 28 - System assumed for worked example	78
Figure 29 - Teed feeder application - apparent impedances seen by relay	83
Figure 30 - Teed feeder applications	84
Figure 31 - TCS scheme 1	86
Figure 32 - PSL for TCS schemes 1 and 3	87
Figure 33 - TCS scheme 2a	88
Figure 34 - PSL for TCS schemes 2a	88
Figure 35 - TCS scheme 2b	89

Figure 36 - PSL for TCS schemes 2b	89
Figure 37 - TCS scheme 3	90
Figure 38 - InterMiCOM⁶⁴ mapping in a three ended application	94
Figure 39 - Two circuit breaker auto-reclose application	106
Figure 40 - PSL mapping of some of the opto inputs and relay outputs	111

TABLES

	Page (AP) 6-
Table 1 - Typical cable/line charging currents (UK, 50 Hz)	14
Table 2 - Selection of phase compensation factors	22
Table 3 - Lowest SIR ratio and Recommended ΔV Fwd (as a % of V_n)	43
Table 4 – Degree of compensation and resonant frequency	46
Table 5 - Typical time constant values	53
Table 6 - Typical time constant values	53
Table 7 - Optical optical budgets and maximum transmission distances for relays from April 2008 and onwards	66
Table 8 - Original optical budgets and maximum transmission distances for Pre-April 2008 relays	66
Table 9 - Typical operating times (PSL at send relay, to PSL state change at receive)	71
Table 10 - Resistor values for TCS scheme 1	87
Table 11 - Resistor values for TCS scheme 3	90
Table 12 - Phase Association Logic	91
Table 13 - IEC Monitor Changes	92
Table 14 - DNP3 Mapping	92
Table 15 - Minimum Fault Arc De-Ionizing Time (Three Pole Tripping)	101

1 INTRODUCTION

1.1 Protection of Overhead Line, Cable, and Hybrid Circuits

Overhead lines, typically ranging from 10 kV distribution lines to 800 kV transmission lines, are probably the most fault susceptible items of plant in a modern power system. It is therefore essential that the protection associated with them provides secure and reliable operation.

For distribution systems, continuity of supply is of paramount importance. The majority of faults on overhead lines are transient or semi-permanent in nature. Multi-shot auto-reclose cycles are therefore commonly used in conjunction with instantaneous tripping elements to increase system availability. For permanent faults it is essential that only the faulted section of plant is isolated. As such, high speed, discriminative fault clearance is often a fundamental requirement of any protection scheme on a distribution network.

The requirements for a transmission network must also take into account system stability. Where systems are not highly interconnected the use of single phase tripping and high speed auto-reclosure is often required. This in turn dictates the need for very high speed protection to reduce overall fault clearance times.

Many line configurations exist which need to be addressed. Transmission applications may typically consist of 2 or 3 terminal applications, possibly fed from breaker and a half or mesh arrangements. Lower voltage applications may again be 2 or 3 terminal configurations with the added complications of in zone transformers or small teed load transformers.

Charging current may also adversely affect protection. This is a problem particularly with cables and long transmission lines. Both the initial inrush and steady state charging current must not cause relay maloperation and preferably should not compromise protection performance.

Physical distance must be taken into account. Some EHV transmission lines can be up to several hundred kilometers in length. If high speed, discriminative protection is to be applied, it will be necessary to transfer information between line ends. This not only puts the onus on the security of signaling equipment but also on the protection in the event of loss of this signal.

Back-up protection is also an important feature of any protection scheme. In the event of equipment failure, such as signaling equipment or switchgear, for example, it is necessary to provide alternative forms of fault clearance. It is desirable to provide back-up protection which can operate with minimum time delay and yet discriminate with both the main protection and protection elsewhere on the system.

Transmission and distribution systems are essential to route power from the point of generation to the region(s) of demand. The means of transport is generally via overhead lines, which must have maximum in-service availability. The exposed nature of overhead lines make them fault-prone, and protection devices must trip to initiate isolation of any faulted circuit.

Most of the faults that occur on overhead lines, however, are transient or semi-permanent in nature and are cleared simply by the act of isolating the circuit. Once the fault is cleared, system stability and availability can be addressed by auto-reclosing the circuit to bring it back into service. For distribution systems, continuity of supply is of paramount importance.

In addition to fast fault clearance to prevent plant damage, the requirements for a transmission network must also take into account system stability. Where systems are not highly interconnected the use of single phase tripping and high-speed multi-shot auto-reclosure is often required. This in turn dictates the need for very high-speed protection to reduce overall fault clearance times.

The MiCOM IED provides fast, highly selective protection, to trip for genuine line faults. The current differential principle easily detects intercircuit, evolving and cross country faults amongst others as the relay works on a per phase basis. It is also immune to voltage measurement problems such as CVT transients and power swings on the system and the most important benefit of all; differential principle offers the most selective line protection.

A combination with a full scheme distance protection and aided Directional Earth Fault (DEF) makes the relay a complete and versatile solution for line protection. Differential and distance protection can be set to operate to work separately or simultaneously. Distance can also be set to work upon failure of the relay protection communications. These options allow the user to set different protection schemes such as Differential as main 1 and Distance as main 2 or vice versa, Differential as main 1 and Distance as backup, etc.

Distance protection on the MiCOM IED offers advanced load blinding and disturbance detection techniques such as power swing blocking to ensure stability when no tripping is required. Selectable mho and quadrilateral (polygon) characteristics allow versatile deployment as main protection for all effectively-earthed transmission and distribution circuits, whether lines, cables or hybrid (a mix of part cable, part overhead line).

2 APPLICATION OF INDIVIDUAL PROTECTION FUNCTIONS

These sections detail the individual protection functions in addition to where and how they may be applied. Worked examples show how the settings are applied to the relay.

2.1 Differential Protection

Compensation Feature

(Applies to current differential variants only), e.g. P543, P544, P545 and P546 firmware versions.

When using the COMPENSATION feature, all relays in the protection scheme should be set to same configuration, i.e. ALL relays in the scheme set to "None", ALL relays in the scheme set to "Cap Charging", or ALL relays in the scheme set to "Transformer". Failure to adhere to this may result in unexpected relay operation e.g. mal-tripping or failure to operate.

2.1.1 Setting of the Phase Differential Characteristic

The characteristic is determined by four protection settings. All of them are user adjustable. This flexibility in settings allows the relay characteristic to be tailored to suit particular sensitivity and CT requirements. To simplify the protection engineer's task, we strongly recommend three of the settings be fixed to:

$I_{s2} = 2.0 \text{ pu}$

$k1 = 30\%$

Provides stability for small CT mismatches, whilst ensuring good sensitivity to resistive faults under heavy load conditions

$k2 = 150\%$

(2 terminal applications) or 100% (3 terminal applications).

Provides stability under heavy through fault current conditions

These settings will give a relay characteristic suitable for most applications leaving only I_{s1} setting to be decided by the user.

I_{s1}

This is the basic differential current setting which determines the minimum pick-up level of the relay. The value of this setting should be in excess of any mismatch between line ends, if any, and should also account for line charging current, where necessary.

If voltage inputs are connected to the relay, there is a feature to extract the charging current from the measured current before the differential quantity is calculated. In this case, it is necessary to enter the line positive sequence susceptance value. If capacitive charging current is enable, I_{s1} may be set below the value of line charging current if required, however it is suggested that I_{s1} is chosen only sufficiently below the charging current to offer the required fault resistance coverage as described here after.

The following table shows some typical steady state charging currents for various lines and cables.

Voltage (kV)	Core formation and spacing	Conductor size in mm ²	Charging current A/km
11 kV Cable	Three-core	120	1.2
33 kV Cable	Three-core	120	1.8
33 kV Cable	Close-trefoil	300	2.5
66 kV Cable	Flat, 127 mm	630	10
132 kV Overhead Line		175	0.22
132 kV Overhead Line		400	0.44
132 kV Cable	Three-core	500	10
132 kV Cable	Flat, 520 mm	600	20
275 kV Overhead Line		2 x 175	0.58
275 kV Overhead Line		2 x 400	0.58
275 kV Cable	Flat, 205 mm	1150	19
275 kV Cable	Flat, 260 mm	2000	24
400 kV Overhead Line		2 x 400	0.85
400 kV Overhead Line		4 x 400	0.98
400 kV Cable	Flat, 145 mm	2000	28
400 kV Cable	Tref., 585 mm	3000	33

Table 1 - Typical cable/line charging currents (UK, 50 Hz)

If capacitive charging current is disable, the setting of Is1 must be set above 2.5 times the steady state charging current. Where charging current is low or negligible, the recommended factory default setting of 0.2 In should be applied.

The tripping criteria can be formulated as:

- for $|I_{bias}| < I_{s2}$,
 $|I_{diff}| > k1 \cdot |I_{bias}| + I_{s1}$
- for $|I_{bias}| > I_{s2}$,
 $|I_{diff}| > k2 \cdot |I_{bias}| - (k2 - k1) \cdot I_{s2} + I_{s1}$

From Software Version D1a

The Phase Comparison Algorithm was changed in Software Version D1a. The new method operates as follows.

The CT saturation detection uses a Phase Comparison algorithm (similar to P746 phase comparison solution) to supervise the Current Differential operation.

The Phase comparison algorithm provides immunity to CT saturation.

Phase Comparison confirms that a fault is either internal or external to the protected line section.

Advantages of phase comparison:

- It is an additional tripping criterion. It only allows the line differential algorithm to operate if the fault is detected as internal.
- On an external fault (with a saturating CT) which then evolves to an internal fault, phase comparison allows the trip even if the CT remains saturated.

A trip will occur when the fault condition is detected as internal.

This algorithm operates using the measured Fourier values on a phase by phase basis.

- Phase comparison current criteria: Phase Comparison algorithm only uses currents above "Phase Comparison" current threshold = "Max I load/Inom" Setting value.
- This phase comparison current criteria is a on a "per line end" algorithm, i.e. the algorithm runs independently in each relay within the line differential protection scheme.

Example to illustrate the algorithm for a given line end:

Consider one end (“end m”) with one CT (“CT m”)

CT m has the following ratio characteristics:

“primary current CTm”/ “secondary current CTm”

I_m is the current flowing in CT m

To be considered as internal, angles of all local and remote currents shall be within 90° of each other (on an individual phase by phase basis).

If there is only one current above the *Max I load/Inom* current, the fault is considered internal

- The phase of a saturated current may vary from -90° to +90° (CT requirements have to be fulfilled)

Using cases to illustrate the behavior of the application:

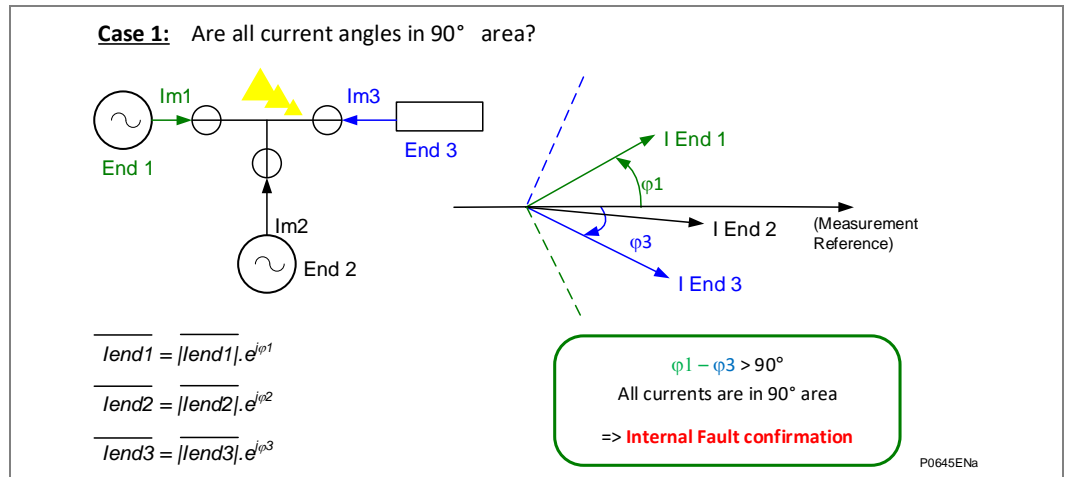

Figure 1 - Differential 3-terminal scheme - internal fault

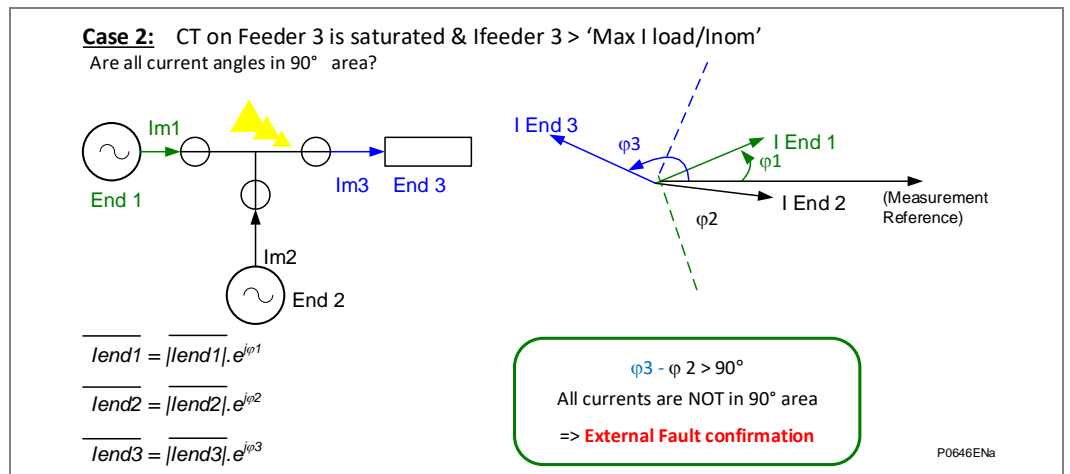

Figure 2 - Differential 3-terminal scheme - external fault

Settings

Two new menu cells have been added to the “PHASE DIFF” menu for this feature.

Menu Text	Default Setting	Available Settings
Diff CT Sat Stab	Disabled	Enabled or Disabled
Enable (activate) or Disable (turn-off) the Current Transformer CT Saturation detection algorithm. Default is “Disabled”, i.e. operation is as per previous releases.		

Menu Text	Default Setting	Settings Range		Step Size
		Min.	Max.	
Max I load/Inom	1.3	0.5	4.00	0.05
This specifies the minimum current level required before the phase comparison restraint condition is deemed as valid, it is used to block the CT saturation detection for load current. This is normally set above the load current expected during internal high resistance fault conditions.				

The Following DDB signals have been added.

DDB No.	English Text	Source	Description
1792	Idiff Sat Block	C Diff	Current differential Saturation detected (on any phase).
1793	Idiff Sat Bk PhA	C Diff	Current differential Saturation detected on Phase A
1794	Idiff Sat Bk PhB	C Diff	Current differential Saturation detected on Phase B
1795	Idiff Sat Bk PhC	C Diff	Current differential Saturation detected on Phase C

These DDBs are available to the PSL and can be mapped to (e.g.) LED etc if needed.

2.1.2

Relay Sensitivity under Heavy Load Conditions

The sensitivity of the relay is governed by its settings and the magnitude of load current in the system. For a three-ended system, with relays X, Y and Z, the following applies:

$$\begin{aligned} |\text{Idiff}| &= |(IX + IY + IZ)| \\ |\text{Ibias}| &= 0.5 (|IX| + |IY| + |IZ|) \end{aligned}$$

Assume a load current of I_L flowing from end X to Y and Z. Assume also a high resistance fault of current I_F being singly fed from end X. For worst case analysis, we can also assume I_F to be in phase with I_L :

$$\begin{aligned} IX &= IL + IF \\ IY &= -yIL \text{ where } 0 < y < 1 \\ IZ &= -(1-y) IL \\ |\text{Idiff}| &= |IF| \\ |\text{Ibias}| &= |IL| + 0.5 |IF| \end{aligned}$$

Relay sensitivity when $|\text{Ibias}| < I_{s2}$:

For $|\text{Ibias}| < I_{s2}$, the relay would operate if:

$$\begin{aligned} |\text{Idiff}| &> k_1 |\text{Ibias}| + I_{s1} && \text{or} \\ |IF| &> k_1 (|IL| + 0.5 |IF|) + I_{s1} && \text{or} \\ (1 - 0.5 k_1) |IF| &> (k_1 |IL| + I_{s1}) && \text{or} \\ |IF| &> (k_1 |IL| + I_{s1}) / (1 - 0.5 k_1) \end{aligned}$$

For $I_{s1} = 0.2$ pu, $k_1 = 30\%$ and $I_{s2} = 2.0$ pu, then

$$\begin{aligned} \text{for } |IL| = 1.0 \text{ pu, the relay would operate if } |IF| &> 0.59 \text{ pu} \\ \text{for } |IL| = 1.59 \text{ pu, the relay would operate if } |IF| &> 0.80 \text{ pu} \end{aligned}$$

If $|IF| = 0.80$ pu and $|IL| = 1.59$ pu, then $|\text{Ibias}| = 1.99$ pu which reaches the limit of the low percentage bias curve.

Relay sensitivity when $|\text{Ibias}| > I_{s2}$:

For $|\text{Ibias}| > I_{s2}$, the relay would operate if

$$\begin{aligned} |\text{Idiff}| &> k_2 |\text{Ibias}| - (k_2 - k_1) I_{s2} + I_{s1} && \text{or} \\ |IF| &> k_2 (|IL| + 0.5 |IF|) - (k_2 - k_1) I_{s2} + I_{s1} && \text{or} \\ (1 - 0.5 k_2) |IF| &> (k_2 |IL| - (k_2 - k_1) I_{s2} + I_{s1}) && \text{or} \\ |IF| &> (k_2 |IL| - (k_2 - k_1) I_{s2} + I_{s1}) / (1 - 0.5 k_2) \end{aligned}$$

For $I_{s1} = 0.2$ pu, $k_1 = 30\%$, $I_{s2} = 2.0$ pu and $k_2 = 100\%$, then,

$$\begin{aligned} \text{for } |IL| = 2.0 \text{ pu, the relay would operate if } |IF| &> 1.6 \text{ pu} \\ \text{for } |IL| = 2.5 \text{ pu, the relay would operate if } |IF| &> 2.6 \text{ pu} \end{aligned}$$

Fault resistance coverage:

Assuming the fault resistance, R_F , is much higher than the line impedance and source impedance, then for a 33kV system and 400/1 CT:

$$\begin{aligned} |I_F| &= (V_{ph-n} / R_F) * (1/CT \text{ ratio}) \text{ pu} \\ &= (33000 / \sqrt{3}) / R_F / 400 \text{ pu} \\ &= 47.63 / R_F \text{ pu} \end{aligned}$$

Based on the above analysis, the relay will detect a fault current in excess of 0.59 pu with a load current of 1 pu flowing. The fault resistance would have to be less than $47.63/0.59 = 81 \Omega$ in this case.

With a short-time overload current of 2.0 pu, the relay will be able to detect a fault resistance of $47.63/1.6 = 30 \Omega$ or lower.

The fault resistance coverage is also affected by the phase comparator "Max I load/Inom" setting if Differential CT Saturation Stability is Enabled. With this feature enabled load current must drop below the "Max I load/Inom" setting to allow the differential element to operate.

2.1.3**CT Ratio Correction**

Ideally, the compensated current values should be arranged to be as close as possible to relay rated current to provide optimum relay sensitivity.

If there is no mismatch between the CTs, the CT correction factor should be set to 1. Otherwise it is generally set to CT primary/Min scheme CT primary. For example, on a scheme with 400/5 CTs at one end and 800/1 CTs at the other, the correction factor would be $400/400=1$ at the 400/5 end and $800/400=2$ at the 800/1 end.

2.1.4**Transformers in Zone Applications**

In applying the well established principles of differential protection to transformers, a variety of considerations have to be taken into account. These include compensation for any phase shift across the transformer, possible unbalance of signals from current transformers either side of windings, and the effects of the variety of earthing and winding arrangements. In addition to these factors, which can be compensated for by correct application of the relay, the effects of normal system conditions on relay operation must also be considered. The differential element must restrain for system conditions which could result in maloperation of the relay, such as high levels of magnetizing current during inrush conditions.

In traditional transformer feeder differential schemes, the requirements for phase and ratio correction were met by correct selection of line current transformers.

The following feature applies to: P543, P544 (Software H1 and later), P545 and P546 (Software H1 and later).

In these relays, software Interposing CTs (ICTs) are provided which can give the required compensation. The advantage of having replica interposing CTs is that it gives the P54x relays the flexibility to cater for line CTs connected in either star or delta, as well as being able to compensate for a variety of system earthing arrangements. These relays also include a magnetizing inrush restraint and blocking facility.

INRUSH Restraint/Blocking

(Applies to current differential variants only), e.g. P543, P544, P545 and P546 firmware versions.

When using the INRUSH Restraint/Blocking feature, all relays in the protection scheme should be set to same configuration, i.e. ALL relays in the scheme set to "Disabled", ALL relays in the scheme set to "Restraint", or ALL relays in the scheme set to "Blocking". Failure to adhere to this may result in relay operation e.g. mal-tripping or failure to operate.

2.1.4.1

Magnetizing Inrush Stabilization

The following feature(s) applies to:
P543, P544 (Software H1 and later), P545 and P546 (Software H1 and later).

When a transformer is first energized, a transient magnetizing current flows, which may reach instantaneous peaks of 8 to 30 times the full load current. The factors controlling the duration and magnitude of the magnetizing inrush are:

- Size of the transformer bank
- Size of the power system
- Resistance in the power system from the source to the transformer bank
- Residual flux level
- Type of iron used for the core and its saturation level.

There are three conditions which can produce a magnetizing inrush effect:

- First energization
- Voltage recovery following external fault clearance
- Sympathetic inrush due to a parallel transformer being energized.

The following diagram shows under normal steady state conditions the flux in the core changes from maximum negative value to maximum positive value during one half of the voltage cycle, which is a change of 2.0 maximum.

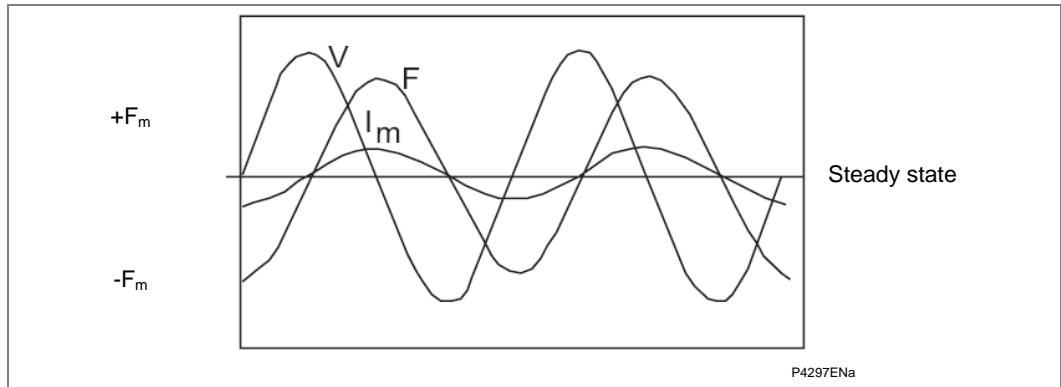

Figure 3 - Steady state magnetizing inrush current

If the transformer is energized at a voltage zero when the flux would normally be at its maximum negative value, the flux will rise to twice its normal value over the first half cycle of voltage. To establish this flux, a high magnetizing inrush current is required. The first peak of this current can be as high as 30 times the transformer rated current. This initial rise could be further increased if there was any residual flux in the core at the moment the transformer was energized.

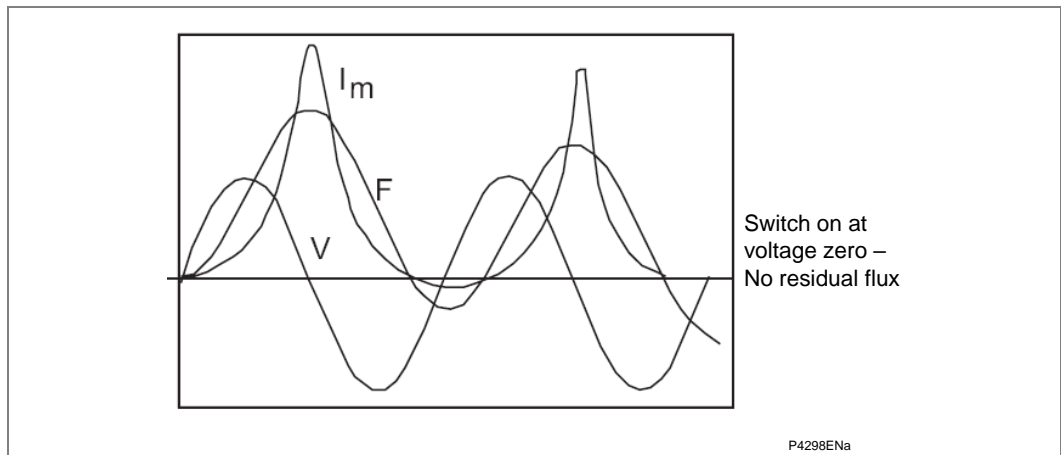

Figure 4 - Magnetizing inrush current during energization

As the flux enters the highly saturated portion of the magnetizing characteristic, the inductance falls and the current rises rapidly. Magnetizing impedance is of the order of 2000% but under heavily saturated conditions this can reduce to around 40%, which is an increase in magnetizing current of 50 times normal. This figure can represent 5 or 6 times normal full load current.

Analysis of a typical magnitude inrush current wave shows (fundamental = 100%):

Component	-DC	2nd H	3rd H	4th H	5th H	6th H	7th H
	55%	63%	26.8%	5.1%	4.1%	3.7%	2.4%

The offset in the wave is only restored to normal by the circuit losses. The time constant of the transient can be quite long, typically 0.1 second for a 100 KVA transformer and up to 1 second for larger units. The initial rate of decay is high due to the low value of air core reactance. When below saturation level, the rate of decay is much slower. The following graph shows the rate of decay of the DC offset in a 50 Hz or 60 Hz system in terms of amplitude reduction factor between successive peaks.

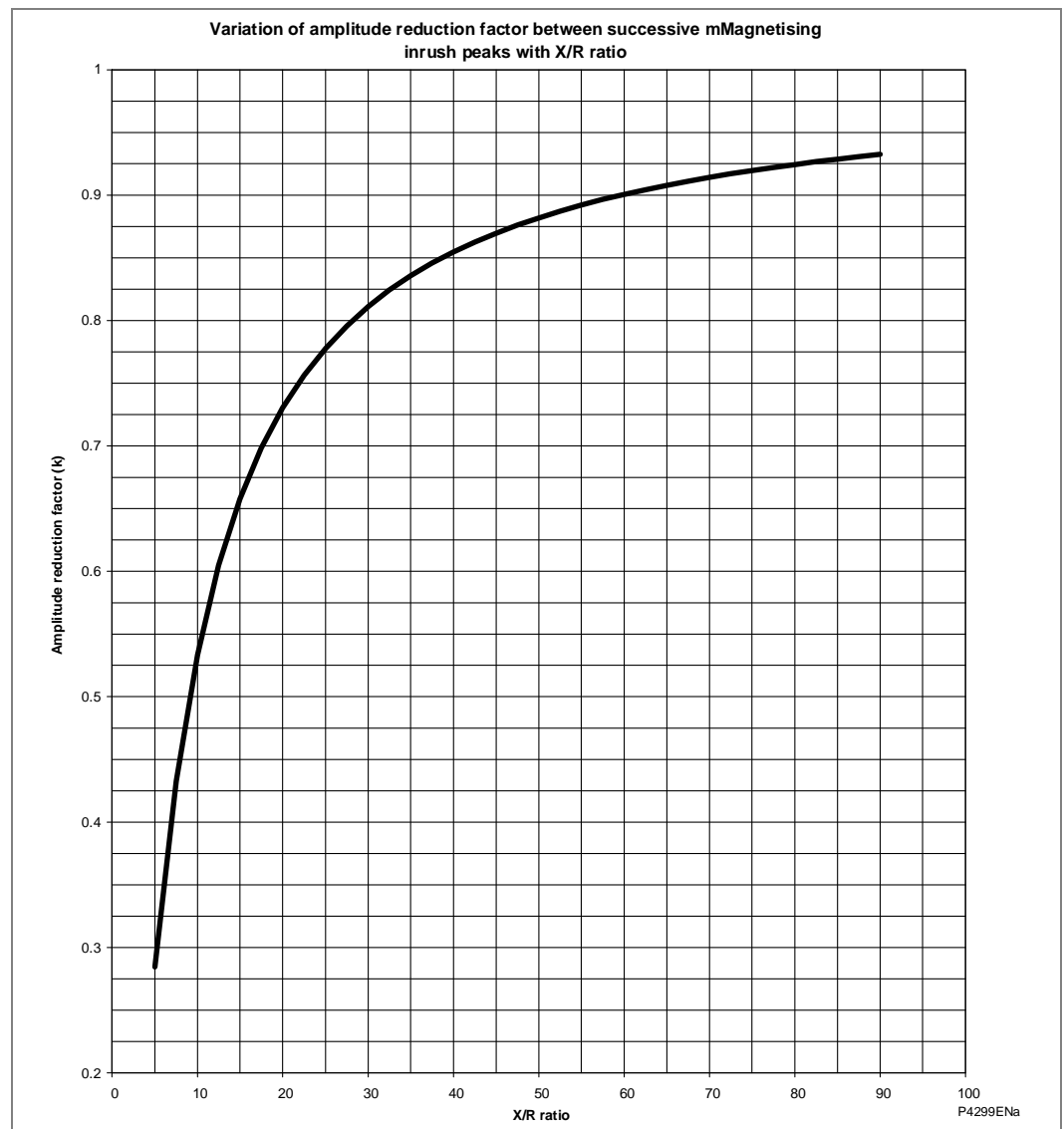

Figure 5 - Variation of amplitude reduction factor

The magnitude of the inrush current is limited by the air core inductance of the windings under extreme saturation conditions. A transformer with concentric windings will draw a higher magnetizing current when energized from the LV side, since this winding is usually on the inside and has a lower air core inductance. Sandwich windings have approximately equal magnitude currents for both LV and HV. Resistance in the source will reduce the magnitude current and increase the rate of decay.

The magnetizing inrush phenomenon is associated with a transformer winding which is being energized where no balancing current is present in the other winding(s). This current appears as a large operating signal for the differential protection. Therefore, special measures are taken with the relay design to ensure that no maloperation occurs during inrush. The fact that the inrush current has a high proportion of harmonics having twice the system frequency offers a possibility of stabilization against tripping by the inrush current.

The following feature(s) applies to:

P543, P544 (Software H1 and later), P545 and P546 (Software H1 and later).

These relays provide a choice between harmonic restraint and blocking by setting option, both providing stability during transformer inrush conditions.

To select second harmonic Restraint or Blocking option, set the cell [3312: Inrush Restraint] under the **GROUP 1 PHASE DIFF** menu heading to Restraint or Blocking.

Second harmonic restraints or blocking provide security during transformer energization.

2.1.4.2

Second Harmonic Restraint

The following feature(s) applies to:

P543, P544 (Software H1 and later), P545 and P546 (Software H1 and later).

The magnetizing inrush current contains a high percentage of second harmonic. These relays filter out this component of the waveform and use it as an additional bias quantity.

The total bias used by the relay will therefore be a combination of the average load current on the line plus a multiple of the second harmonic component of the current. The multiplying factor which is used to ensure stability is controlled by the setting cell [3314: Ih(2) Multiplier] under the **GROUP 1 PHASE DIFF** menu heading provided the setting cell [3312: Inrush Restraint] is set to Restraint .

This multiplier is used in additional bias calculation as per following formula:

IF Inrush Restraint setting is set to Restraint

$$\text{Additional bias} = \text{Ih}(2) \text{ Multiplier} * 1.414 * \text{largest 2nd harmonic current}$$

ELSE

$$\text{Additional bias} = 0$$

In the above equation second harmonic current is derived from Fourier filtering techniques.

Where these relays are used and inrush restrain function is enabled, it must be ensured that this function is enabled at each end to avoid possible maloperation.

2.1.4.3

Second Harmonic Blocking

The following feature(s) applies to:

P543, P544 (Software H1 and later), P545 and P546 (Software H1 and later).

To select second harmonic blocking option, set the cell [3312: Inrush Restraint] under the **GROUP 1 PHASE DIFF** menu heading to **Blocking**.

Second harmonic blocking provides security during transformer energization.

For each phase, if the level of phase current is above 5% In, and if the ratio of second harmonic current ,Ih(2) to fundamental in the line is above the settings at cell [3320: Ih(2) >%] then inrush conditions shall be detected which sets the appropriate phase block, to block local and remote ends.

Users can choose to apply Cross blocking or independent blocking by choosing the appropriate setting at cell [3321: Ih(2) CrossBlock] under the **GROUP 1 PHASE DIFF** menu heading. If **Ih(2) CrossBlock** is set to **Disabled** then independent blocking is used. If independent blocking is enabled only the affected phase is blocked at all ends. If cross blocking is enabled all phases are blocked at all ends.

2.1.4.4

Fifth Harmonic Blocking

The following feature(s) applies to:

P543, P544 (Software H1 and later), P545 and P546 (Software H1 and later).

The fifth Harmonic blocking feature is available for possible use to prevent unwanted operation of the low set differential element under transient overfluxing conditions.

When overfluxing occurs, the transformer core becomes partially saturated and the resultant magnetizing current waveforms increase in magnitude and become harmonically distorted. Such waveforms have a significant fifth harmonic content, which can be extracted and used as a means of identifying the abnormal operating condition.

The fifth harmonic blocking threshold is adjustable between 5 - 100%. The threshold should be adjusted so that blocking will be effective when the magnetizing current rises above the chosen threshold setting of the low-set differential protection.

For example, when a load is suddenly disconnected from a power transformer the voltage at the input terminals of the transformer may rise by 10-20% of the rated value. Since the voltage increases, the flux, which is the integral of the excitation voltage, also increases. As a result, the transformer steady state excitation current becomes higher. The resulting excitation current flows in one winding only and therefore appears as differential current which may rise to a value high enough to operate the differential protection. A typical differential current waveform during such a condition is shown in the Typical overflux current waveform diagram shown below. A typical setting for **Ih(5)%** is 35%

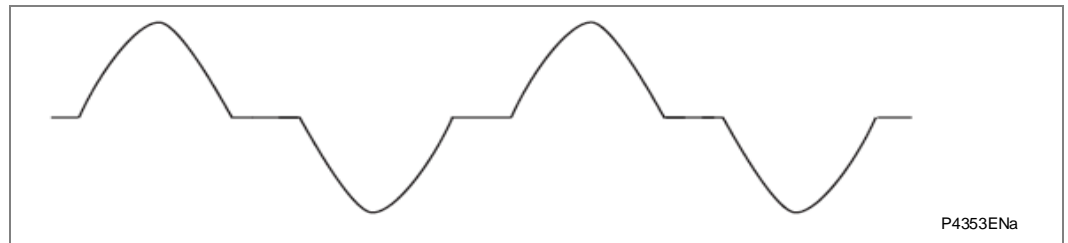

Figure 6 - Typical overflux current waveform

To offer some protection against damage due to persistent overfluxing that might be caused by a geomagnetic disturbance, the fifth harmonic blocking element can be routed to an output contact using an associated timer. Operation of this element could be used to give an alarm to the network control centre. If such alarms are received from a number of transformers, they could serve as a warning of geomagnetic disturbance so that operators could take some action to safeguard the power system. Alternatively, this element can be used to initiate tripping in the event of prolonged pick up of a fifth harmonic measuring element. It is not expected that this type of overfluxing condition would be detected by the AC overfluxing protection. This form of time delayed tripping should only be applied in regions where geomagnetic disturbances are a known problem and only after proper evaluation through simulation testing.

<i>Note</i>	<i>These relays determine the fundamental components and the fifth harmonic components from the line currents and provide fifth harmonic blocking option when the setting cell [3312: Inrush Restraint] under the GROUP 1 PHASE DIFF menu is set to Blocking.</i>
-------------	---

For each phase, if the level of phase current is above 5% I_n , and if the ratio of fifth harmonic current, $I_h(5)$ to fundamental in the line is above the settings at cell [3328: $I_h(5) > \%$] then the overfluxing conditions shall be detected which sets the appropriate phase block, to block local and remote ends.

Users can choose to apply Cross blocking or independent blocking by choosing the appropriate setting at cell [3329: $I_h(5)$ CrossBlock] under the **GROUP 1 PHASE DIFF** menu heading. If **Ih(5) CrossBlock** is set to **Disabled** then independent blocking is used. If independent blocking is enabled only the affected phase is blocked at all ends. If cross blocking is enabled all phases are blocked at all ends.

2.1.4.5 CT Ratio Correction

In many cases the HV and LV current transformer primary ratings will not exactly match the transformer winding rated currents. The CT correction factor must be set to ensure that the signals to the differential algorithm are correct to guarantee current balance of the differential element under load and through fault conditions. To minimize unbalance due to tap changer operation, current inputs to the differential element should be matched for the mid-tap position. If there is no mismatch between the CTs, the CT correction factor should be set to 1.

The compensated current values should be arranged to be as close as possible to relay rated current to provide optimum relay sensitivity

When a Star/Delta software interposing CT is chosen, no additional account has to be taken for the $\sqrt{3}$ factor which would be introduced by the delta winding. This is accounted for by the relay.

2.1.4.6 Phase Correction and Zero Sequence Current Filtering

Selection of the phase correction settings will be dependant on the phase shift required across the transformer and on zero sequence filtering elements with CT correction factors, the phase correction is applied to each relay. Providing replica ICTs in software has the advantage of being able to cater for line CTs connected in either star as well as being able to cater for zero sequence current filtering

To aid selection of the correct setting on the relay menu, some examples of selection of phase compensation factors are shown in the following table.

Transformer connection	Transformer phase shift	Vectorial compensation (relay setting)	
		HV	LV
Dy1	- 30°	Yy0 (0 deg)	Yd11 (+30 deg)
Yd1	- 30°	Yd1 (-30 deg)	Yy0 (0 deg)
Dy5	- 150°	Yy0 (0 deg)	Yd7 (+150 deg)
Yd5	- 150°	Yd5 (-150 deg)	Yy0 (0 deg)
Dy7	+ 150°	Yy0 (0 deg)	Yd5 (-150 deg)
Yd7	+ 150°	Yd7 (+150 deg)	Yy0 (0 deg)
Dy11	+ 30°	Yy0 (0 deg)	Yd1 (-30 deg)
Yd11	+ 30°	Yd11 (+30 deg)	Yy0 (0 deg)
YNyn	0°	Ydy0 (0 deg)	Ydy0 (0 deg)

Table 2 - Selection of phase compensation factors

As shown in the table, a delta winding is introduced with the Y side software ICT. This provides the required zero sequence trap, as would have been the case if the vector correction factor had been provided using an external ICT.

Whenever an in zone earthing connection is provided, a zero sequence trap should always be provided. For instance if a YNyn power transformer is in the protected zone, there will be some difference between HV and LV zero sequence magnetizing current of the transformer. This is normally small, but to avoid any problems with any application the above rule for zero sequence traps should be applied with earthed windings.

2.1.4.7 High Set Differential Setting

The following feature(s) applies to:

P543, P544 (Software H1 and later), P545 and P546 (Software H1 and later).

When **Inrush Restraint** is set to Restraint or Blocking, a high set differential protection becomes active. This is provided to ensure rapid clearance for heavy internal faults with saturated CTs. Because high set is not restrained by magnetizing inrush, hence the setting must be set such that it will not operate for the largest inrush currents expected. It is difficult to accurately predict the maximum anticipated level of inrush current. Typical waveforms peak values are of the order of 8-10x rated current. A worst case estimation of inrush could be made by dividing the transformer full load current by the per unit leakage reactance quoted by the transformer manufacturer.

2.1.5

Mesh Corner and 1½ Breaker Switched Substations

Where a line is fed from a mesh corner or 1½ breaker switched substation, as shown in the following diagram, then two options are available for CT connections to the relay. The first is by paralleling the two sets of line CTs into a common input, 'A'. The second is by using two separate inputs for each set of line CTs, 'B'. The P544 and P546 relays are designed with an additional set of input CTs specifically for this purpose.

In the case of a through fault as shown, the relay connected to circuit 'A' should see no current and as such, will remain stable. Under this condition, it should be noted that no bias is produced in the relay. To ensure relay stability, the two sets of line CTs should be as near as identical in all characteristics, and equally loaded, such that the relaying connection is at the equipotential point of the secondary leads.

In the case of circuit 'B' no differential current should result. A large bias current will however exist, providing a high degree of stability in the event of a through fault. This bias will also ensure stability where CTs are not closely matched. Therefore, circuit 'B' is the preferred connection for such applications and so the P544 and P546 relay models would normally be specified.

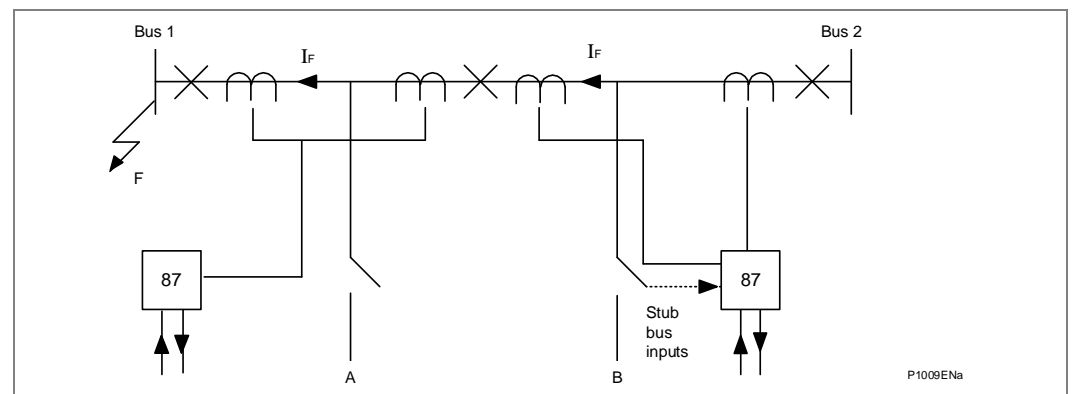

Figure 7 - Breaker and a half switched substation

2.1.6

Small Tapped Loads (Tee Feeds)

Where transformer loads are tapped off the protected line it is not always necessary to install CTs at this location. Provided that the tee-off load is light, differential protection can be configured for the main line alone. The settings 'Phase Char', 'Phase Time Delay' and 'TMS' or 'Time Dial' in the "Selection of phase compensation factors" table allow the differential element to time grade with IDMT overcurrent relays or fuses protecting the tap. This keeps stability of the differential protection for external faults on the tee circuit

2.2 Distance Protection and Aided DEF (Distance option only)

The MiCOM IED has, by ordering option, a comprehensive integrated distance protection package. This consists of:

- Phase fault distance protection
- Earth/ground fault distance protection
- Power sing detection, alarm, and blocking
- Out-of-step detection and tripping
- Switch On To Fault (SOTF) and Trip On Reclose (TOR)
- Directional Schemes
- Aided schemes

These are described in the following sections and are marked as being applicable to the distance option only. If the distance option is not specified, the following features will not be applicable.

Note *The Zone Q and General Starting features were introduced in Software H3.*

2.2.1 Simple and Advanced Setting Mode (Distance option only)

The relay has two setting modes for distance protection: “**Simple**” and “**Advanced**”.

In the majority of cases, “**Simple**” setting is recommended, and allows the user merely to enter the line parameters such as length, impedances and residual compensation. Then, instead of entering distance zone impedance reaches in ohms, zone settings are entered in terms of **percentage of the protected line**. This makes the relay particularly suited to use along with any installed LFZP Optimho relays, as the reduced number of settings mimics the Autocalc facility within Opticom software.

The “**Advanced**” setting mode is recommended for the networks where the protected and adjacent lines are of dissimilar construction, requiring independent zone characteristic angles and residual compensation. In this setting mode all individual distance ohmic reach and residual compensation settings and operating current thresholds per each zone are accessible. This makes the relay adaptable to any specific application.

2.2.2 Line Parameters Settings (Distance option only)

It is essential (especially when using the “simple” setting mode) that the data relating to 100% of the protected line is entered here. Take care to input the Line Impedance that correctly corresponds to either Primary or Secondary, whichever has been chosen as the basis for Settings Values in the Configuration column.

2.2.3 Residual Compensation for Earth/Ground Faults (Distance option only)

For earth faults, residual current (derived as the vector sum of phase current inputs ($I_a + I_b + I_c$) is assumed to flow in the residual path of the earth loop circuit. Therefore, the earth loop reach of any zone must generally be extended by a multiplication factor of $(1 + k_{ZN})$ compared to the positive sequence reach for the corresponding phase fault element.



Caution **The k_{ZN} Angle is different than previous LFZP, SHNB, and LFZR relays: When importing settings from these older products, subtract. angle $\angle Z1$.**

2.2.4 Mutual Compensation for Parallel Lines

Typically a mutual cut off factor of 1.5 is chosen to give a good margin of safety between the requirements of correct mutual compensation for faults inside the protected line and eliminating misoperations for faults on the adjacent line.

2.2.5**Selection of Starting Behaviour**

With Software H3 and later the zone timer starting is selectable either 'Zone Start' (default) and 'General Start'. Before Software H3 only the 'Zone Start' behaviour is implemented.

The choice of the starting behaviour will be defined by the transmission or distribution system operator's philosophy. Zone starting is commonly used in English distance philosophy regions (for example, the UK, Spain and South America) while general starting is mainly used in German speaking countries and Poland.

The advantage of using 'General Starting' is a shorter fault clearance time in the case of evolving faults. If all timer stages run in parallel and the detected fault moves from an "outer zone" (e.g. zone 3) into an "inner zone" (e.g. Zone 2), the timer for the inner zone must not be started or re-started. A potential disadvantage of this selection is that fault clearance times may end up being too short to fit into the installed base.

End Timers

End timers by origin principle in mechanical relays were independent from distance zone measuring elements, to operate independently from these complex mechanics which might fail to operate. They were solely depending on general starting and directional relays. In numerical design, we have no "mechanical" (or electronic) independence, but the back-up protection philosophy of these end-timers is maintained (e.g. to avoid non-operation due to too narrow zone settings).

Application Example for an Underimpedance Starting Scheme (Software H3 and later)

For a distance protection application 3 zones in forward direction and 2 zones in reverse direction are requested. In addition a non-directional and a directional backup protection using End timers are needed. A polygonal characteristic shall be used.

The application can be solved in P44y/P54x using all six zones (see figure below):

- Polygonal tripping zones
 - Zone 1, 2 and P in forward direction
 - Zone 4 and Q in reverse direction
- Underimpedance starting (non-directional)
 - Zone 3 with offset enabled covering all other zones (highest zone reach)
 - Zone 3 tripping disabled
 - Load blinder settings effecting Zones 3
- Starting behaviour is 'General Start' using both End Timers (Non-directional and directional)

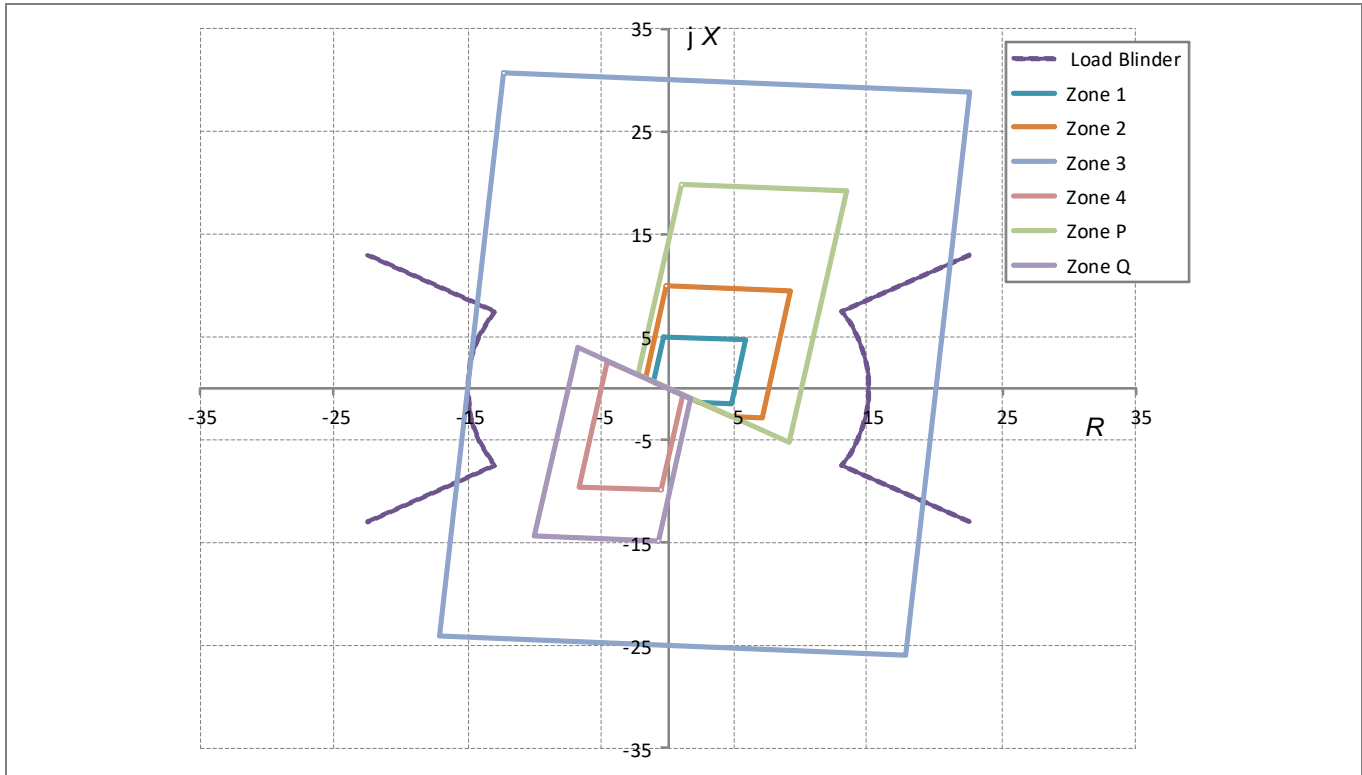

Figure 8 - Zone reach setting with load blinders and underimpedance starting for application example

2.2.6 Selection of Distance Operating Characteristic

In general, these characteristics are recommended:

- Short line applications: Mho phase fault and quadrilateral earth fault zones.
- Open delta (vee-connected) VT applications: Mho phase fault, with earth fault distance disabled, and directional earth fault only used for earth fault protection.
- Series compensated lines: Recommend always to use mho characteristics for both phase and earth faults.

2.2.6.1 Phase Characteristic

This phase characteristic selection is common to all zones, allowing mho or quadrilateral selection. Generally, the characteristic chosen will match the utility practice. If applied for line protection similarly to LFZP Optimho, LFZR, SHNB Micromho or SHPM Quadramho models in the Schneider Electric range, a mho selection is recommended. For cable applications, or to set similarly to the MiCOM P441/P442/P444 models, a quadrilateral selection is recommended.

The following figure shows the basic settings needed to configure a forward-looking mho zone, assuming that the load blinder is enabled.

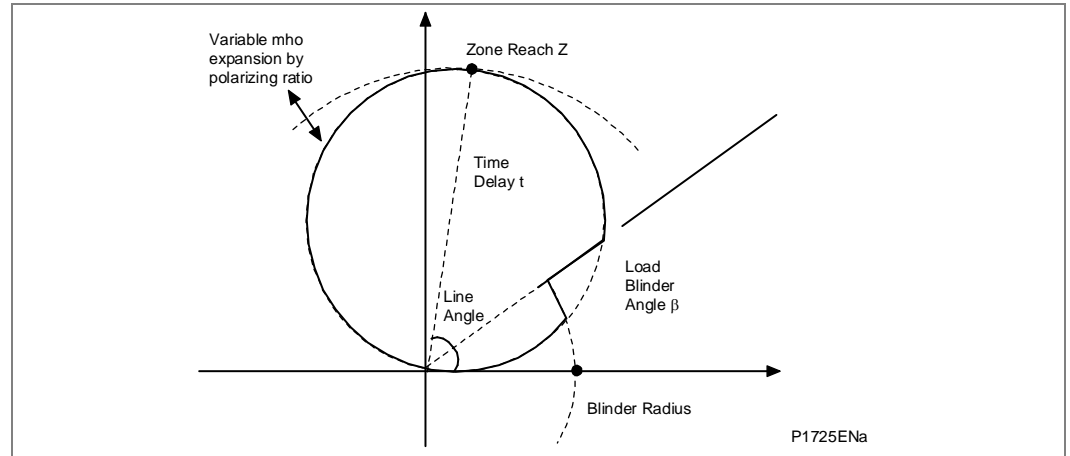

Figure 9 - Settings required to apply a Mho zone (Distance option only)

The following figure shows the basic settings needed to configure a forward-looking quadrilateral zone (blinder not shown).

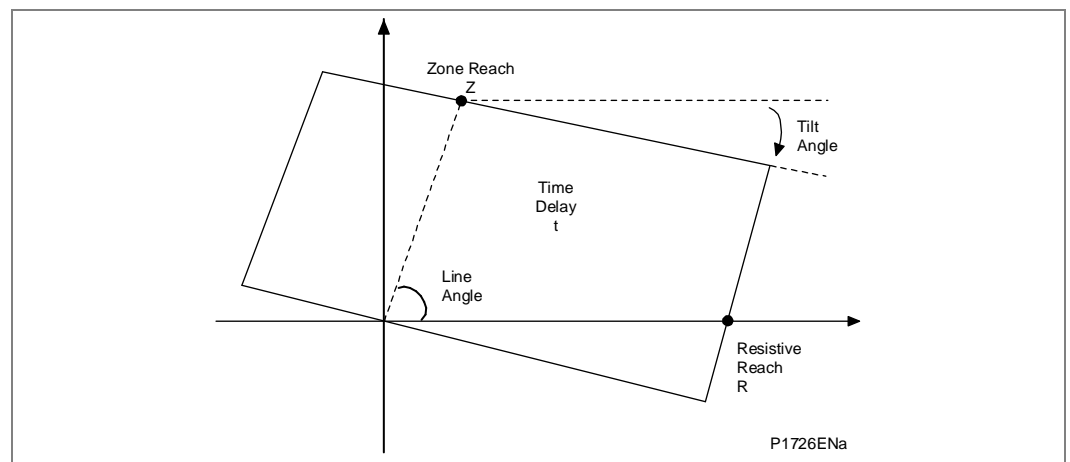

Figure 10 - Settings required to apply a quadrilateral zone (Distance option only)

2.2.6.2

Ground Characteristic

In general, the same setting philosophy would be followed for ground distance protection as is used for the phase elements. This selection is common to all zones, allowing mho or quadrilateral selection and generally, the characteristic chosen will match the utility practice. If applied for long and medium length line protection similarly to LFZP Optimho, LFZR, SHNB Micromho or SHPM Quadramho models in the Schneider Electric range, a mho selection is recommended. For cable applications, or to set similarly to the MiCOM P441/P442/P444 models, a quadrilateral selection is recommended.

Quadrilateral ground characteristics are also recommended for all lines shorter than 10 miles (16 km). This is to ensure that the resistive fault arc coverage is not dependent on mho circle dynamic expansion, but will be a known set value.

2.2.7 Zone Reaches - Recommended Settings

The Zone 1 elements of a distance relay should be set to cover as much of the protected line as possible, allowing instantaneous tripping for as many faults as possible. In most applications the zone 1 reach (Z1) should not be able to respond to faults beyond the protected line. For an underreaching application the zone 1 reach must therefore be set to account for any possible overreaching errors. These errors come from the relay, the VTs and CTs and inaccurate line impedance data. It is therefore recommended that the reach of the zone 1 distance elements is restricted to 80% of the protected line impedance (positive phase sequence line impedance), with zone 2 elements set to cover the final 20% of the line.

The Zone 2 elements should be set to cover the 20% of the line not covered by zone 1. Allowing for underreaching errors, the zone 2 reach (Z2) should be set in excess of 120% of the protected line impedance for all fault conditions. Where aided tripping schemes are used; fast operation of the zone 2 elements is required. It is therefore beneficial to set zone 2 to reach as far as possible, such that faults on the protected line are well within reach. A constraining requirement is that, where possible, zone 2 does not reach beyond the zone 1 reach of adjacent line protection. For this reason the zone 2 reach should be set to cover ≤50% of the shortest adjacent line impedance, if possible.

The Zone 3 elements would usually be used to provide overall back-up protection for adjacent circuits. The zone 3 reach (Z3) is therefore set to approximately 120% of the combined impedance of the protected line plus the longest adjacent line. A higher apparent impedance of the adjacent line may need to be allowed where fault current can be fed from multiple sources or flow via parallel paths.

Zone 3 may also be programmed with a slight reverse (“rev”) offset, in which case its reach in the reverse direction is set as a percentage of the protected line impedance too. This would typically provide back-up protection for the local busbar, where the offset reach is set to 20% for short lines (<30 km) or 10% for longer lines.

Zone P is a reversible directional zone. The setting chosen for Zone P, if used at all, will depend upon its application. Typical applications include its use as an additional time delayed zone or as a reverse back-up protection zone for busbars and transformers. Use of zone P as an additional forward zone of protection may be required by some users to line up with any existing practice of using more than three forward zones of distance protection.

The Zone 4 elements may also provide back-up protection for the local busbar. Where zone 4 is used to provide reverse directional decisions for Blocking or Permissive Overreach schemes, zone 4 must reach further behind the relay than zone 2 for the remote end relay. In such cases the reverse reach should be as below (depends on characteristic used):

Mho: $Z4 \geq ((\text{Remote zone 2 reach}) \times 120\%)$

Quadrilateral: $Z4 \geq ((\text{Remote zone 2 reach}) \times 120\%) \text{ minus the protected line impedance}$

Note In the case of the mho, the line impedance is not subtracted. This ensures that whatever the amount of dynamic expansion of the circle, the reverse looking zone will always detect all solid and resistive faults capable of detection by zone 2 at the remote line end.

2.2.8

Quadrilateral Phase Resistive Reaches

Two setting modes are possible for resistive reach coverage:

- Common** In this mode, all zones share one common fault resistive reach setting
- Proportional** With this mode, the aspect ratio of (zone reach): (resistive reach) is the same for all zones. The “Fault Resistance” defines a reference fault at the remote end of the line, and depending on the zone reach percentage setting, the resistive reach will be at that same percentage of the Fault Resistance set. For example, if the zone 1 reach is 80% of the protected line, its resistive reach will be 80% of the reference “Fault Resistance”.

Proportional setting is used to mimic Germanic protection practice, and to avoid zones being excessively broad (large resistive reach width compared to zone reach length). In general, for easiest injection testing, the aspect ratio of any zone is best within the 1:15 range:

$$1/15^{\text{th}} \leq Z \text{ reach} / R \text{ reach setting} \leq 15$$

The resistive reach settings (RPh and RG) should be selected according to the utility practice. If no such guidance exists, a starting point for Zone 1 is:

- Cables** Choose Resistive Reach = 3 x Zone 1 reach
- Overhead lines** Choose Resistive Reach according to the following formula:
Resistive reach = [2.3 - 0.0045 x Line length (km)] x Zone 1 reach
- Lines longer than 400 km** Choose: 0.5 x Zone 1 reach

2.2.9

Quadrilateral Ground Resistive Reaches and Tilting

Note Because the fault current for a ground fault may be limited by tower footing resistance, high soil resistivity, and weak infeeding; any arcing resistance is often higher than for a corresponding phase fault at the same location. It may be necessary to set the RG ground resistive settings to be higher than the RPh phase setting (i.e. boosted higher than the rule of thumb described previously). A setting of RG three times that of RPh is not uncommon.

The P443/P446/P54x/P547 allows two different methods of tilting the top reactance line:

- Automatic adjustment of the top reactance line angle
- Fix setting of the top line that will over-ride dynamic tilting

Both methods are detailed in the Operation chapter.

2.2.9.1

Dynamic Tilting:

Medium/ Long Lines:

In the case of medium and long line applications where Quad distance ground characteristic is used, the recommended setting is 'Dynamic tilt' enabled at starting tilt angle of -3° (as per default settings). The -3° is set to compensate for possible CT/VT and line data errors.

For high resistive faults during power exporting, the under-reaching zone 1 is only allowed to tilt down by the angle difference between the faulted phase and negative sequence current $\angle(I_{ph}-I_2)$ starting from the -3° set angle. This ensures stability of zone 1 for high resistance faults beyond the zone 1 reach even during heavy load conditions (high load angle between two voltage sources) and sufficient sensitivity for high resistance internal faults. The tilt angle for all other zones (that are by nature over-reaching zones) will remain at -3 deg.

In the case of power importing, zone 1 will remain at -3° whilst all other zones will be allowed to tilt up by the $\angle(I_{ph}-I_2)$ angle difference, starting from -3°. This will increase the zone 2 and zone 4 resistive reaches and secure correct operation in POR and blocking type schemes.

Short Lines:

For very short lines, typically below 10 Miles (16 km), the ratio of resistive to reactance reach setting (R/X) could easily exceed 10. For such applications the geometrical shape of the Quad characteristic could be such that the top reactance line is close or even crosses the resistive axis as shown below:

The below illustration shows an example of high resistive zone 1 fault that falls outside zone 1 characteristic when the starting tilt angle of -3° is set (over-tilting effect). (Distance option only)

In the case of high resistance external faults on a short line, particularly under heavy power exporting conditions, zone 1 will remain stable due to dynamic downwards tilting of the top line as explained earlier but the detection of high resistance internal faults especially towards the end of the line needs consideration. In such applications a user has a choice to either detect high resistance faults using highly sensitive Aided DEF or Delta Directional schemes or to clear the fault with distance ground protection. If distance is to operate, it is necessary to eliminate over-tilting for internal faults by reducing the initial -3° tilting angle to zero so that the overall top line tilt will equal to $\angle (I_{ph}-I_2)$ angle only.

As shown in the above illustration, the internal resistive fault will then fall in the zone 1 operating characteristic. However, it should be noted that for short lines the load angle is relatively low when compared to long transmission lines for the same transfer capacity and therefore the top line dynamic tilting may be moderate. Therefore it may be necessary to reduce the zone one reach to guarantee zone 1 stability. This is particularly recommended if distance is operating in an aided scheme. To summarize, for very short lines with large R/X setting ratios, it is recommended to set the initial tilt angle to zero and zone 1 reach to 70-75% of the line impedance.

Note The above discussion assumes homogenous networks where the angle of the negative sequence current derived at relaying point is very close to the total fault current angle. If the network is non-homogenous, there will be a difference in angle that will cause inaccurate dynamic tilting, hence in such networks either quad with fixed tilt angle or even Mho characteristic should be considered in order to avoid zone 1 over-reach.

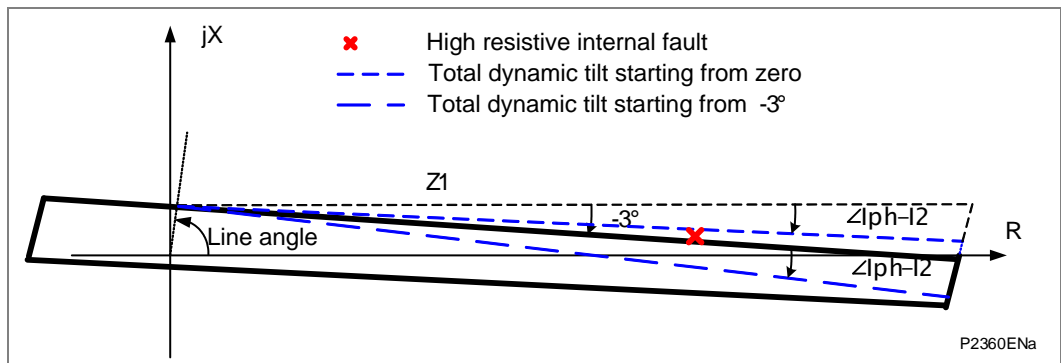

Figure 11 - Example of a high resistive zone 1 fault that falls outside zone 1 characteristic when the starting tilt angle of -3° is set (over-tilting effect)

Fixed Tilt Angle:

As an alternative to Dynamic tilting, a user can set a fixed tilt angle. This is applicable to applications where the power flow direction is unidirectional.

Exporting End:

To secure stability, the tilt angle of zone 1 at exporting end has to be set negative and above the maximum angle difference between sources feeding the resistive faults. This data should be known from load flow study, but if unavailable, the minimum recommended setting would be the angle difference between voltage and current measured at local end during the heaviest load condition coupled with reduced zone 1 reach of 70-75% of the line impedance.

<i>Note</i>	<i>The previous illustration of a high resistive zone 1 fault shows that at sharp fixed tilt angle, the effective resistive coverage would be significantly reduced, and therefore for the short lines the dynamic tilting (with variable tilt angle depending on fault resistance and location) is preferred. For all other over-reaching zones set tilting angle to zero.</i>
-------------	---

Importing End:

Set zone 1 tilt angle to zero and for all other zones the typical setting should be positive and between +(5-10)°.

<i>Note</i>	<i>The setting accuracy for over-reaching zones is not crucial because it will not pose a risk for relay's maloperation, the purpose is only to boost zone 2 and zone 4 reach and improve distance aided schemes.</i>
-------------	---

2.2.10**Phase Fault Zone Settings**

Each zone has two additional settings that are not accessible in the Simple set mode. These settings are:

- A tilt angle on the top line of any quadrilateral set for phase faults;
- A minimum current sensitivity setting.

By factory defaults, the Top Line of quadrilateral characteristics is not fixed as a horizontal reactance line. To account for phase angle tolerances in the line CT, VT and relay itself, the line is tilted downwards, at a “**droop**” of -3° . This tilt down helps to prevent zone 1 overreach.

The fixed Tilt setting on the phase elements may also be used to compensate for overreach effects when prefault heavy load export was flowing. In such cases, fault arc resistance will be phase shifted on the impedance polar plot, tilting down towards the resistive axis (i.e. not appearing to be fully resistive in nature). For long lines with heavy power flow, the Zone 1 top line might be tilted downwards within the range -5 to -15° , mimicking the phase shift of the resistance.

<i>Note</i>	<i>A minus angle is used to set a downwards tilt gradient, and a positive angle to tilt upwards.</i>
-------------	--

<i>Note</i>	<i>mho characteristics have an inherent tendency to avoid unwanted overreaching, making them very desirable for long line protection, and one of the reasons for their inclusion within the MICOM P443/P446/P54x/P547 relay.</i>
-------------	--

The current Sensitivity setting for each zone is used to set the minimum current that must be flowing in each of the faulted phases before a trip can occur. It is recommended to leave these settings at their default. The exception is where the relay is made more insensitive to match the lesser sensitivity of older relays existing on the power system, or to grade with the pickup setting of any ground overcurrent protection for tee-off circuits.

2.2.11 Distance Directional Principle and Setup

2.2.12 Delta Directional - Selection of RCA

Distance zones are directionalized by the delta decision. For delta directional decisions, the RCA settings must be based on the average source + line impedance angle for a fault anywhere internal or external to the line. Typically, the **Delta Char Angle** is set to 60°, as it is not essential for this setting to be precise. When a fault occurs, the delta current will never be close to the characteristic boundary, so an approximate setting is good enough.

The 60° angle is associated with mainly inductive sources and will work perfectly well for most applications. However, in series compensated line applications where the capacitor is physically located behind the line VT the Delta directional characteristic angle needs adjusting. In such applications the capacitor is included in the equivalent source impedance and the overall source impedance as seen by the relay will become predominantly capacitive if the inductance of the source (normally strong source) is less than the capacitor value. In this case, the calculated operating angle during an internal fault may not fall within the default 60° delta directional line operating boundary and that could potentially lead to an incorrect (reverse) directional decision. A zero degree shift will be most suitable for such a fault, but the constraining factor is the case of external faults for which the source is always inductive regardless of the degree of compensation and for which the 60° shift is most appropriate. To ensure correct, reliable and fast operation for both fault locations in case of predominantly capacitive source, a **Delta Char Angle setting of 30° is strongly recommended.**

2.2.13 Distance Setup - Filtering, Load Blinding and Polarizing

2.2.13.1 Digital Filtering

In most applications, it is recommended that **Standard** filtering is used. This will ensure that the relay offers fast, sub-cycle tripping. In certain rare cases, such as where lines are immediately adjacent to High Voltage DC (HVDC) transmission, the current and voltage inputs may be severely distorted under fault conditions. The resulting non-fundamental harmonics could affect the reach point accuracy of the relay. To prevent the relay being affected, a '**Special**' set of filters are available.

<i>Note</i>	<i>When using the long line filter the instantaneous operating time is increased by about a quarter of a power frequency cycle.</i>
-------------	---

2.2.13.2 CVTs with Passive Suppression of Ferroresonance

Set a **Passive** CVT filter for any type 2 CVT (those with an anti-resonance design). An SIR cutoff setting needs to be applied, above which the relay operation is deliberately slowed by a quarter of a cycle. A typical setting is **SIR = 30**, below which the relay will trip sub-cycle, and if the infeed is weak the CVT filter adapts to slow the relay and prevent transient overreach.

2.2.13.3 CVTs with Active Suppression of Ferroresonance

Set an **Active** CVT filter for any type 1 CVT.

2.2.14 Load Blinding (Load Avoidance)

For security, it is highly recommended that the blinder is Enabled, especially for lines above 150 km (90 miles), to prevent non-harmonic low-frequency transients causing load encroachment problems, and for any networks where power swings might be experienced.

The impedance radius must be set lower than the worst-case loading, and this is often taken as 120% overloading in one line, multiplied by two to account for increased loading during outages or fault clearance in an adjacent parallel circuit. Then an additional allowance for measuring tolerances results in a recommended setting typically 1/3rd (or even 1/4th in some countries such as UK) of the rated full load current:

$$Z \leq (\text{Rated phase voltage } V_n) / (I_{FLC} \times 3)$$

When the load is at the worst-case power factor, it should remain below the beta setting. So, if we assume a typical worst-case 0.85 power factor, then:

$$\beta \geq \text{Cos}^{-1}(0.85) \text{ plus } 15^\circ \text{ margin} \geq 47^\circ$$

And, to ensure that line faults are detected, $\beta \leq (\text{Line Angle} - 15^\circ)$.

In practice, an angle half way between the worst-case leading load angle, and the protected line impedance angle, is often used.

The MiCOM P443/P445/P446/P54x/P547 has a facility to allow the load blinder to be bypassed any time the measured voltage for the phase in question falls below an undervoltage V< setting. Under such circumstances, the low voltage could not be explained by normal voltage excursion tolerances on-load. A fault is definitely present on the phase in question, and it is acceptable to override the blinder action and allow the distance zones to trip according to the entire zone shape. The benefit is that the resistive coverage for faults near to the relay location can be higher.

The undervoltage setting must be lower than the lowest phase-neutral voltage under heavy load flow and depressed system voltage conditions. The typical maximum V< setting is **70% V_n**.

2.2.14.1 Recommended Polarizing Settings

Cable applications	In line with LFZP123 or LFZR applications for cable feeders, use only minimum 20% (0.2) memory, which results in minimum mho expansion. This keeps the protected line section well within the expanded mho, thereby ensuring better accuracies and faster operating times for close-up faults.
Series compensated lines	Use a mho with maximum memory polarizing (setting = 5). The large memory content will ensure correct operation even with the negative reactance effects of the compensation capacitors seen either within Zs, or within the line impedance.
Short lines	For lines shorter than 10 miles (16 km), or with an SIR higher than 15, use maximum memory polarizing (setting = 5). This ensures sufficient characteristic expansion to cover fault arc resistance.
General line applications	Use any setting between 0.2 and 1.

2.2.15

Distance Elements Basic Scheme Setting

The **Zone 1** time delay (tZ1) is generally set to zero, giving instantaneous operation.

The **Zone 2** time delay (tZ2) is set to co-ordinate with zone 1 fault clearance time for adjacent lines. The total fault clearance time will consist of the downstream zone 1 operating time plus the associated breaker operating time. Allowance must also be made for the zone 2 elements to reset following clearance of an adjacent line fault and also for a safety margin. A typical minimum zone 2 time delay is of the order of 200 ms.

The **Zone 3** time delay (tZ3) is typically set with the same considerations made for the zone 2 time delay, except that the delay needs to co-ordinate with the downstream zone 2 fault clearance. A typical minimum zone 3 operating time would be in the region of 400 ms.

The **Zone 4** time delay (tZ4) needs to co-ordinate with any protection for adjacent lines in the relay's reverse direction.

Note (1) The MiCOM P443/P445/P446/P54x/P547 allows separate time delays to be applied to both phase and ground fault zones, for example where ground fault delays are set longer to time grade with external ground/earth overcurrent protection.

Note (2) Any zone (“#”) which may reach through a power transformer reactance, and measure secondary side faults within that impedance zone should have a small time delay applied. This is to avoid tripping on the inrush current when energizing the transformer. As a general rule, if: Z# Reach setting > 50% XT transformer reactance, set: tZ# ≥ 100 ms. Alternatively, the 2nd harmonic detector that is available in the Programmable Scheme Logic may be used to block zones that may be at risk of tripping on inrush current. Settings for the inrush detector are found in the SUPERVISION menu column.

Figure 12 shows the typical application of the Basic scheme.

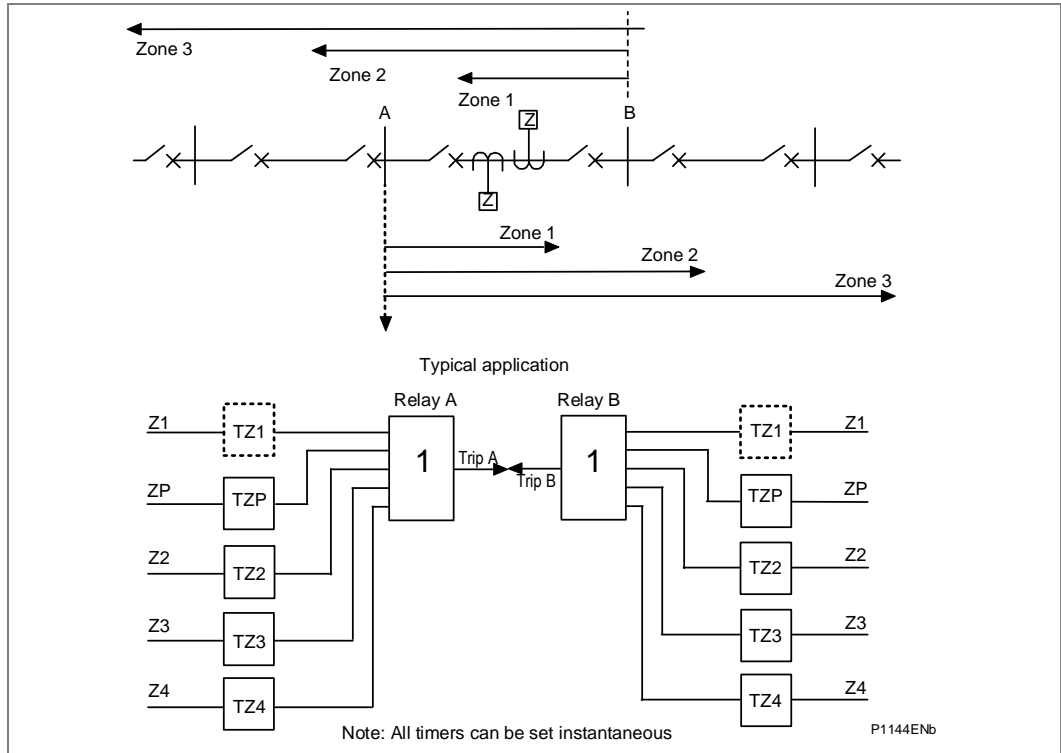

Figure 12 - Basic time stepped distance scheme

2.2.16

Power Swing Alarming and Blocking

Power Swing Blocking (PSB) is used to set either blocking or indication for out-of-step conditions. If blocking mode is selected, a user can individually select for each zone to be either blocked or allow tripping. The power swing detection is based on superimposed current, and is largely settings free.

The *PSB Unblock Dly* function allows any power swing block to be removed after a set period of time. For a persistent swing that does not stabilize, any blocked zones will be made free to trip once the timer has elapsed. In setting which relays will unblock, the user should consider which relay locations are natural split points for islanding the power system.

The PSB technique employed in the MiCOM P443/P445/P446/P54x/P547 has the significant advantage that it is adaptive and requires no user-set thresholds in order to detect swings faster than 0.5 Hz. The PSB relies on the delta techniques internal to the relay, which automatically detect swings. During the power oscillations slower than 0.5 Hz the continuous ΔI phase current integral to the detection technique for swing conditions may fall below the sensitive threshold of $\Delta I=0.05$ In therefore may not operate. These slow swings will usually occur following sudden load changes or single pole tripping on the weaker systems where the displacement of initial power transfer is not severe. The slow swings of up to 1 Hz are by its nature recoverable swings but the swing impedance may stay longer inside the distance characteristics until the oscillations are damped by the power system. Therefore, to guarantee system stability during very slow swings it is recommended to set a blinder to complement the automatic, setting free detection algorithm. Zone 5 is used as a blinder for slow swing detection as well as for the Out-of-Step (OST) protection described in the next section. Zone 5 settings are therefore visible even if OST protection is disabled. The slow swing condition will be declared if positive sequence impedance is detected inside zone 5 for more than a cycle without phase selection operation. The slow swing detection operates in parallel to automatic swing detection mechanism.

No system calculation is needed for zone 5 setting, it is only important to set zone 5 smaller than the minimum possible load impedance with a security margin:

In case the OST is enabled the R5, R5', Z5 and Z5' settings will be adequate for very slow swing detection. If, however, the OST protection is disabled, set:

$$R5=R5'=0.85 \times Z<$$

$$Z5=Z5'=2 \times Z_{line}$$

where Z< is load blinder radius determined in the Load Blinding (Load Avoidance) section.

The user decides which zones are required to be blocked.

Two timers are available:

- The **PSB Reset Delay** is used to maintain the PSB status when ΔI naturally is low during the swing cycle (near the current maxima and minima in the swing envelope). A typical setting of 0.2s is used to seal-in the detection until ΔI has chance to appear again.
- The **PSB Unblock Dly** is used to time the duration for which the swing is present. The intention is to allow the distinction between a stable and an unstable swing. If after the timeout period the swing has still not stabilized, the block for selected zones can be released ("unblocking"), giving the opportunity to split the system. If no unblocking is required at the location of this relay, set to maximum.

The maximum value of the PSB Unblock Dly setting has been increased from 10 seconds to 20 seconds.

PSB can be disabled on distribution systems, where power swings would not normally be experienced.

2.2.17

Out-of-Step Protection

The MiCOM P443/P446/P54x/P547 provides an integrated Out-of-Step (OST) protection, therefore avoiding a need for a separate stand alone Out-of-Step relays. Unlike the power swing detection, the OST protection requires settings and is completely independent from the setting free Power swing detection.

This section provides a discussion and a guidance of how to set the OST protection.

Settings based on system studies must be applied when '**Predictive OST**' operation mode is selected as the high setting accuracy is needed to avoid premature system splitting in the case of severe power oscillations that do not lead to pole slip conditions. For the **OST** setting the same method may be used but an exhaustive stability study may not be required as it will be shown later that the **total system impedance ZT and system split points** are adequate to set the relay for this scenario.

The MiCOM P443/P446/P54x/P547 OST protection can operate as a stand alone protection, i.e. Distance protection may be completely disabled under Configuration column.

2.2.18

Critical Stability Angle

What is the angle between two ends when a power system oscillation could be declared as a pole slip? Consider the power angle curves as in shown in the figure below.

The figure represents power angle curves, with no AR being performed, as follows:

- Curve 1 - Pre-fault system operation via parallel lines where transmitted power is P_0
- Curve 2 - Transmitted power significantly reduced during two-phase to ground fault
- Curve 3 - New power curve when the parallel line is tripped (fault cleared)

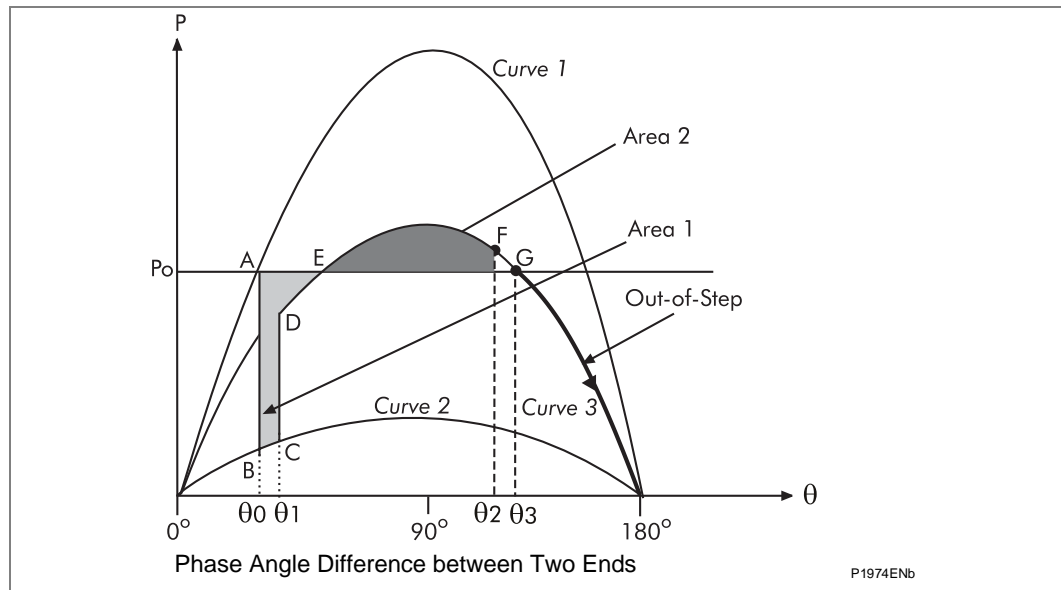

Figure 13 - Power transfer in relation to angle difference θ between 2 ends

It can be seen that at a fault instance, the operating point A moves to B, with a lower transfer level. There is therefore a surplus of power $\Delta P=AB$ at the sending end and the corresponding deficit at the receiving end. The sending end machines start to speed up, and the receiving end machines to slow down, so phase angle θ increases, and the operating point moves along curve 2 until the fault is cleared, when the phase angle is θ_1 . The operating point now moves to point D on curve 3 which represents one line in service. There is still a power surplus at the sending end, and deficit at the receiving end, so the machines continue to drift apart and the operating point moves along curve 3. If, at some point between E and G (point F) the machines are rotating at the same speed, the phase angle will stop increasing. According to the Equal Area Criterion, this occurs when area 2 is equal to area 1. The sending end will now start to slow down and receiving end to speed up. Therefore, the phase angle starts to decrease and the operating point moves back towards E. As the operating point passes E, the net sending end deficit again becomes a surplus and the receiving end surplus becomes a deficit, so the sending end machines begin to speed up and the receiving end machines begin to slow down. With no losses, the system operating point would continue to oscillate around point E on curve 3, but in practice the oscillation is damped, and the system eventually settles at operating point E.

To resume, if $\text{area 1} < \text{area 2}$, the system will stay in synchronism. This swing is usually called a **recoverable power swing**. If, on contrary, the system passes point G with a further increase in angle difference between sending and receiving ends, the system drifts out of synchronism and becomes unstable. This will happen if the initial power transfer P_o was set too high in the Power transfer diagram shown above, so that the area 1 is greater than area 2. This power swing is not recoverable and is usually called **out of step** or **out of synchronism** or **pole slip** condition. After this, only system separation and re-synchronizing of the machines can restore normal system operation.

In the Power transfer diagram shown above, the point G is shown at approximately 120° deg, but it is not true in all cases. If, for example the pre-fault transmitted power (P_o) was too high and if the fault clearance was slow, the area 1 will be greater so for the system to recover the angle θ would be close to 90 deg. On contrarily, if the pre-fault transmitted power P_o was low and fault clearance fast, the area 1 will be small, so that based on area comparison, the angle θ could go closer to 180 deg and the system will still remain stable.

The actual angle difference at which system will become unstable could only be determined by a particular system studies, but for the purpose of settings recommendation where 'OST' setting is selected, the typical angle beyond which system will not recover is assumed to be 120 deg.

2.2.18.1

Setting Option Recommendation

The relay provides these different setting options:

- Disabled
- Predictive OST
- OST
- Predictive OST or OST

Set **Option 1** on all lines except the line where tripping due to unrecoverable power oscillations is required or for the system where power oscillations are not severe - mainly in well interconnected systems operating with 3-phase tripping.

Setting **Option 2** (and 4) is the best setting option from the system point of view, perhaps not being widely used in the past. Some utilities prefer an early system split to minimize the angle shift between ends and maximize the chances for the remaining two halves to stabilize as quickly as possible. Special care must be taken when this method is applied to ensure that the actual circuit breaker opening does not occur when the internal voltages at two ends are in anti phase. This is due to the fact that most breakers are not designed to interrupt at double nominal voltage and any attempt to break at that point would lead to flash over and possible circuit breaker damage. The fact is that setting Option 2 (and 4) will be mainly applied to detect and trip fast power oscillations. When this is coupled with a typical 2 cycle circuit breaker operating time, the two voltages angles may rapidly move in opposite directions at the time of opening the circuit breaker. Therefore, if this setting option is chosen, the above facts must be taken into account so that the actual CB opening must occur well before the angle difference between two ends approaches 180 degrees. On that basis, accurate settings have to be determined based on exhaustive system studies.

Setting **Option 3** is the most commonly used approach. Once the Out-of-Step conditions are detected, the OST command will split the system at pre-determined points. The slight disadvantages of this method in comparison to Option 2 (and 4) is that the power oscillation will escalate further, thus causing more difficulties for the split parts to remain stable but the advantage is that the timing of the circuit breaker operation ('tripping angle') is easily controlled and the decision to split the system will be correct even if errors were made in the system data and setting parameters. This extra security is achieved by measuring and confirming the change of polarity of the resistive part of positive sequence impedance on zone 5 exit (reset).

Setting **Option 4** provides 2 stages of Out-of-Step detection and tripping. If the power system oscillation is very fast, the combination of ΔR and Delta t setting (as discussed below) must be set in such a way that 'Predictive OST' operates. If however the oscillation is slower, the condition for the 'Predictive OST' will not be met and the 'OST' will operate later upon Z5 reset, providing that the change in polarity of the resistive component was detected. This is to distinguish between a slower non-recoverable oscillation and recoverable swings.

2.2.18.2

Blinder Limits Determination

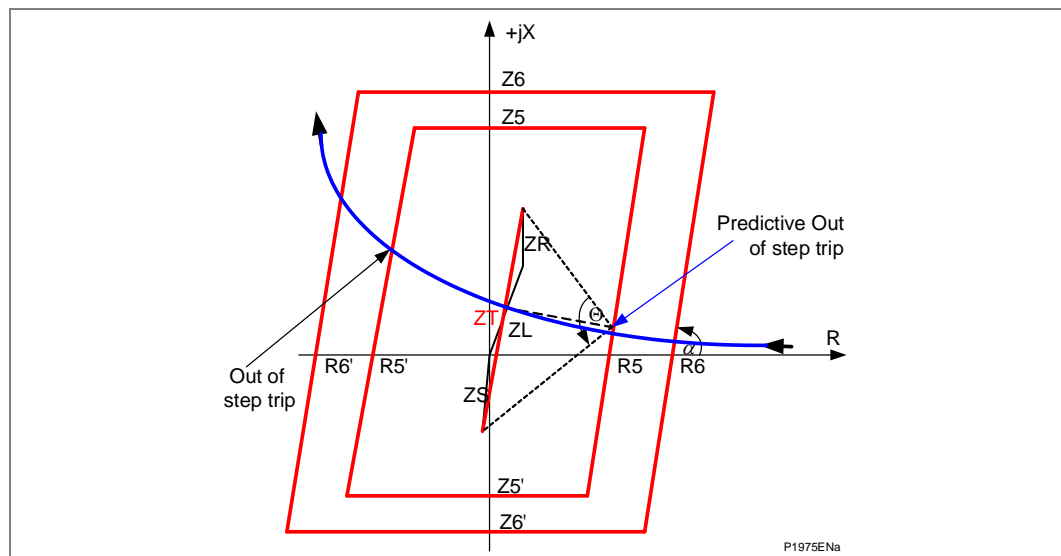

Figure 14 - Setting determination for the positive sequence resistive component R5

Consider the Out of Step characteristic versus angle θ between two ends. The following figure shows the setting determination for the positive sequence resistive component R5 (P443/P446/P547 or P54x (for Distance option only)).

Firstly, determine the minimum inner resistive reach R5.

$$R_{5\min} = \frac{\frac{Z_T}{2}}{\tan \frac{\theta}{2}}$$

Where Z_T is a total system positive sequence impedance that equals to $Z_S + Z_L + Z_S$, where Z_S and Z_R are equivalent positive sequence impedances at the sending and receiving ends and Z_L positive sequence line impedance. ' θ ' is an angle difference between the internal voltages at sending and receiving ends beyond which no system recovery is possible.

The next step is to determine the maximum (limit value) for the outer resistive reach R_6 . It must be insured that Point A in the $R_{6\max}$ determination diagram below does not overlap with the load area for the worst assumed power factor of 0.85 and the lowest possible Z_T angle α .

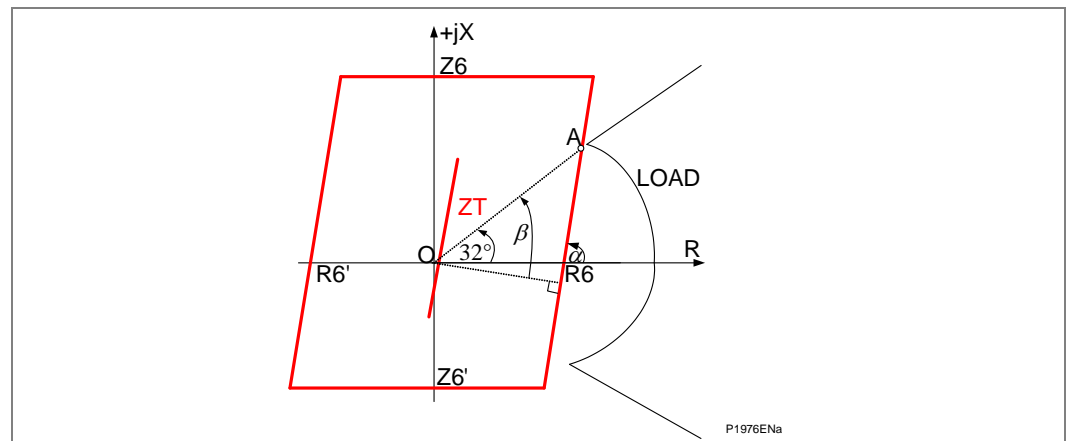

Figure 15 - $R_{6\max}$ determination

$$\beta = 32 + 90 - \alpha$$

$$Z_{\text{load min}} = OA$$

$$R_{6\max} < Z_{\text{load min}} \times \cos \beta$$

Where:

- $Z_{\text{load min}}$ is the minimum load impedance radius calculated above which already has built in sufficient margin
- 32 deg is the load angle that corresponds to the lower power factor of 0.85
- ' α ' is the load blinder angle that matches Z_T angle

The setting of negative resistance R_5' should equal the R_5 to accommodate the 'load import' condition. Starting from the limit values $R_{5\min}$ and $R_{6\max}$ the actual R_5 and R_6 (including the corresponding R_5' and R_6') reaches will be set in conjunction with the 'Delta t' setting below.

Note

$R_{6\max}$ reach must be greater than the maximum resistive reach of any distance zone to ensure correct initiation of the 25 ms and 'Delta t' timers. However, the $R_{5\min}$ reach could be set below the distance maximum resistive reach (inside the distance characteristic) if an extensive resistive coverage is required, meaning that Out of Step protection does not pose a restriction to the quad applications.

Setting of reactance lines Z5 and Z6 will depend on how far from the relay location the power oscillations are to be detected. Normally, there is only one point where the system is to be initially split and that point will be determined by system studies. For that reason, the Out of Step protection must be enabled at that location and disabled on all others. To detect the Out of step conditions, the Z5'-Z5 and Z6'-Z6 setting must be set to comfortably encompass the total system impedance ZT, as shown in the Setting determination for the positive sequence resistive component R5 diagram. Typical setting could be:

$$Z5 = Z5' = 1/2 \times 2 ZT = ZT$$

The Z6 and Z6' setting is not of great importance and could be set to $Z6 = Z6' = 1.1 \times Z5$

2.2.18.3

Delta t, R5 and R6 Setting Determination

The R5MIN and R6MAX settings determined above are only limit values, the actual R5 and R6 need to be determine in relation to the '**Delta t**' timer.

Predictive OST setting:

For the 'Predictive OST' setting it is important to:

- Set R6 (and R6') equal to R6MAX
- Set R5 as close as practical to R6MAX

The aim of pushing the R5 setting to the right is to detect the fast oscillation as soon as possible to gain sufficient time to operate the breaker before the two source voltages are in opposite direction. The only restriction would be the limitation of the '**Delta t**' minimum time delay of 30 ms and the speed of oscillation. Set '**Delta t**' so that the following condition is satisfied:

'Delta t' does not expire after positive sequence impedance has passed the R6-R5 region

For this setting, knowledge of the accurate rate of change of swing impedance when crossing the R6-R5 region is essential and therefore must be based on system studies. Assumption that the rate of change of the positive sequence impedance during crossing the R6-R5 region is average rate of change for the whole swing cycle is wrong and could easily lead to incorrect '**Predictive OST**' operation.

Note For the fault, the R6-R5 region will be passed faster than 25 ms, therefore even very fast oscillations of 7 Hz will not be mistaken with the fault condition and '**Predictive OST**' will not operate.

OST Setting:

For the 'OST' setting option the precise setting of blinders and '**Delta t**' is not necessary. This is based on the fact that:

The wider the ΔR region and the shorter the Δt setting, any oscillation will be successfully detected. The only condition is that the fault impedance must pass through the ΔR region faster than Δt setting.

Therefore, for the '**OST**' setting assume that $\theta = 120^\circ$ and set:

- $R5 = R5' = R5_{MIN} = ZT/3.46$
- $R6 = R6' = R6_{MAX}$
- $\Delta t = 30 \text{ ms}$

The point is that '**Delta t**' always expires, therefore the above setting will secure the detection of a wide range of oscillations, starting from very slow oscillations caused by recoverable swings up to the fastest oscillation of 7 Hz. It should be noted that any fault impedance will pass the R6-R5 region faster than the minimum settable '**Delta t**' time of 30 ms.

Predictive OST or OST setting:

As per 'Predictive OST' above.

2.2.18.4 Tost (Trip Delay) Setting

Tost must be set zero for setting Option 2 and 4 above.

For setting Option 3, Tost should normally be set to zero. It is only the case if a user wants to operate breaker at the angle closer to 360 degrees (when voltages are in phase) when time delay could be applied.

2.2.18.5 Blinder Angle Setting

Set blinders angle 'α' same as total system impedance ZT angle.

2.2.18.6 Out-of-Step Operation on Series Compensated Lines

The maximum phase currents during out of step condition rarely exceed $2xI_n$ RMS, which corresponds to the minimum swing impedance passing through zone 1. Since the Metal-Oxide Varistors (MOV) bypass level is normally set between $2-3I_n$, they will not operate during the power oscillations and therefore in majority of applications will not make any impact on Out of Step operation.

Consider a worst case scenario when the power oscillations are triggered upon fault clearance on the parallel line. In that case approximately twice the load current will start flowing through the remaining circuit, increase further and eventually exceed the MOV threshold. Since the R6-R5 region is usually set far from zone 1 the chances that the positive sequence impedance's trajectory may traverse in and out of the set ΔR region due to MOV's operation, are remote. If MOV's do operate within the ΔR region (see the Example of a timer reset due to MOV diagram below), a timer, that has been initiated, may reset and be re-initiated or the impedance may remain within ΔR region for a slightly longer duration. This is due to the fact that resistive and capacitive components will be added to the measured impedance during MOV operation as per the figure below. This effect may have an impact on the 'Delta t' measurement if 'Predictive OST' setting is used. If the recommendation to set R5MIN as close as practically possible to the R6MAX is followed, the chances that the swing currents will exceed MOV threshold within the ΔR region is very remote. If a study shows that the MOV's could operate within the ΔR region, it is recommended to set 'Predictive OST and OST' operating mode to cover all eventualities.

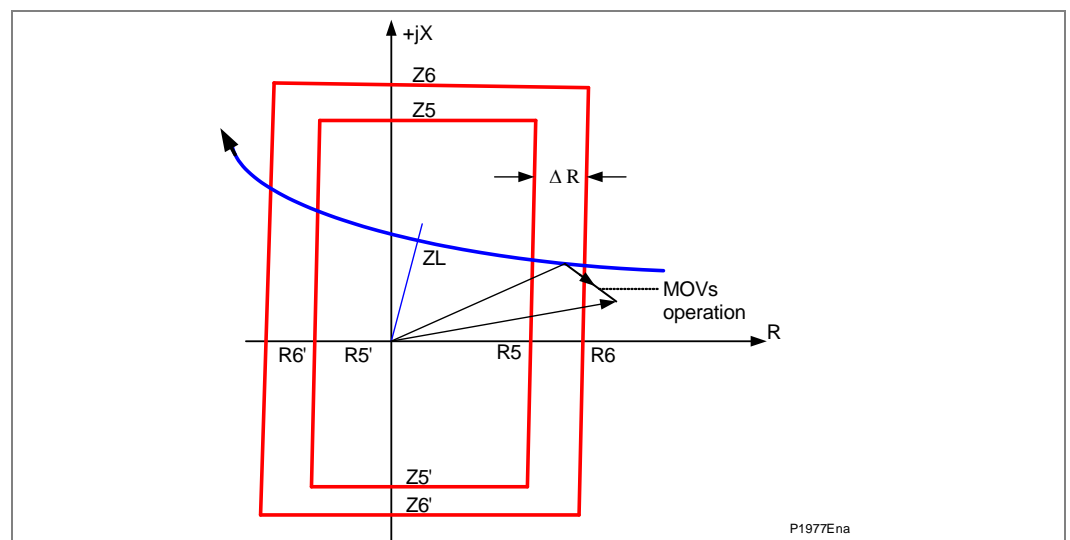

Figure 16 - Example of timer reset due to MOVs operation

Note If 'OST' setting is chosen, the timer when triggered, will eventually expire as the power oscillations progress, therefore MOV operation will not have any impact on Out of Step operation.

2.2.19 Switch On To Fault (SOTF) Mode

To ensure fast isolation of faults (for example a closed three phase earth/grounding switch) upon energization, it is recommended this feature is enabled with appropriate zones and/or 'Current No Volt' (CNV) level detectors, depend on utility practices.

When busbar VTs are used, 'Pole Dead' signal will not be produced and a user has to connect circuit breaker auxiliary contacts for correct operation. This is not necessary if the SOTF is activated by an external pulse.

SOTF delay	The time chosen should be longer than the slowest delayed-auto-reclose dead time, but shorter than the time in which the system operator might re-energize a circuit once it had opened/tripped. 110 seconds is recommended as a typical setting.
SOTF pulse	Typically this could be set to at 500 ms. This time is enough to establish completely the voltage memory of distance protection.
TOC reset delay	500 ms is recommended as a typical setting (chosen to be in excess of the 16 cycles length of memory polarizing, allowing full memory charging before normal protection resumes).

2.2.20 Trip On Reclose Mode

To ensure fast isolation of all persistent faults following the circuit breaker reclosure. It is recommended this feature is enabled with appropriate zones selected and/or 'Current No Volt' (CNV) level detectors.

TOC Delay	The TOR is activated after 'TOC Delay' has expired. The setting <u>must not exceed the minimum AR Dead Time setting</u> to make sure that the TOR is active immediately upon reclose command.
TOC reset delay	500 ms is recommended as a typical setting (as per SOTF).

2.2.21 Setup of DEF

2.2.22 DEF Zero Sequence Polarization

In practice, the typical zero sequence voltage on a healthy system can be as high as 1% (i.e.: 3% residual), and the VT error could be 1% per phase. A VNpol Set setting between 1% and 4%.Vn is typical, to avoid spurious detection on standing signals. The residual voltage measurement provided in the **Measurements** column of the menu may assist in determining the required threshold setting during commissioning, as this will indicate the level of standing residual voltage present. The Virtual Current Polarizing feature will create a VNpol which is always large, regardless of whether actual VN is present.

With DEF, the residual current under fault conditions lies at an angle lagging the polarizing voltage. Hence, negative characteristic angle settings are required for DEF applications. This is set in cell 'DEF Char Angle' in the relevant earth fault menu.

The following angle settings are recommended for a residual voltage polarized relay:

- Distribution systems (solidly earthed) ⇒ -45°
- Transmissions systems (solidly earthed) ⇒ -60°

2.2.23 DEF Negative Sequence Polarization

For negative sequence polarization, the RCA settings must be based on the angle of the upstream negative phase sequence source impedance. A typical setting is -60°.

2.2.24 General Setting Guidelines for DEF (Directional Ground Overcurrent)

DEF forward threshold	This setting determines the current sensitivity (trip sensitivity) of the DEF aided scheme. This setting must be set higher than any standing residual current unbalance. A typical setting will be between 10 and 20% I_n .
DEF reverse threshold	This setting determines the current sensitivity for the reverse ground fault. The setting must always be below the DEF forward threshold for correct operation of Blocking scheme and to provide stability for current reversal in parallel line applications. The recommended setting is 2/3 of DEF forward setting. This setting has to be above the maximum steady state residual current unbalance.

2.2.25 Delta Directional Comparison Principle and Setup

For delta directional decisions, the RCA settings must be based on the average source + line impedance angle for a fault anywhere internal or external to the line. Typically, the **Delta Char Angle** is set to 60°, as it is not essential for this setting to be precise. When a fault occurs, the delta current will never be close to the characteristic boundary, so an approximate setting is good enough.

2.2.26 Delta Directional Comparison - Selection of ΔI and ΔV Threshold

For best performance, it is suggested that the delta I Fwd current threshold is set at 10 to 20% I_n . This will ensure detection of all fault types, provided that the fault current contribution to an earth fault at the remote end of the line will generate at least this amount of delta. Selection of the correct Delta V Forward setting is achieved with reference to the table below (SIR = Source to Line impedance ratio):

Lowest SIR ratio of the system	Recommended ΔV Fwd (as a % of V_n)
≥ 0.3	4%
≥ 0.5	6%
≥ 1	9%
≥ 2	13%
≥ 3	15%
≥ 5	17%
≥ 10	19%
25 – 60	21%

Table 3 - Lowest SIR ratio and Recommended ΔV Fwd (as a % of V_n)

For the reverse fault detectors, these must be set more sensitively, as they are used to invoke the blocking and current reversal guard elements. It is suggested that all reverse detectors are set at 66 to 80% of the setting of the forward detector, typically:

- Delta V Rev = Delta V Fwd x 0.66
- Delta I Rev = Delta I Fwd x 0.66

This setting philosophy is in-accordance with the well-proven Schneider Electric LFDC relay.

Deltas by their nature are present only for 2 cycles on fault inception. If any distance elements are enabled, these will automatically allow the delta forward or reverse decisions to “**seal-in**”, until such time as the fault is cleared from the system. Therefore, as a minimum, some distance zone(s) must be enabled as fault detectors. It does not matter what time delay is applied for the zone(s) – this can either be the typical distance delay for that Zone, or set to maximum (10 s) if no distance tripping is required. As a minimum, Zone 3 must be enabled, with a reverse reach such as to allow seal-in of Delta Rev, and a forward reach to allow seal-in of Delta Fwd. The reaches applicable would be:

- Zone 3 Forward Set at least as long as a conventional Zone 2 (120-150% of the protected line)
- Zone 3 Reverse Set at least as long as a conventional Zone 4, or supplement by assigning Zone 4 itself if a large reverse reach is not preferred for Zone 3.

A mho characteristic is generally advised in such starter applications, although quadrilaterals are acceptable. As the mho starter is likely to have a large radius, applying the Load Blinder is strongly advised.

2.3 Distance Protection Application for Series Compensated Lines

Series compensation is applied to long transmission lines to increase the loadability (i.e. maximum electrical power transfer) of the line. The compensation is done by a series connected capacitor $X_C = -1 / (\omega C)$ which reduces the effective reactance of the line $X = X_L + X_C = \omega L - 1 / (\omega C)$. The degree of compensation is specified as $k_C = X_C / X_L$ and can typically reach values up to 70 % (some lines are being trialled with >100% compensation which are not discussed here). The location of the series capacitor is a matter of network planning, installation logistics, available space and costs. Typically, this is at the end of one line but can be at both ends or somewhere in the middle.

2.3.1 Series Capacitor Protection

To protect the capacitor from transient overvoltages a parallel connected Metal-Oxide Varistor (MOV) and/or spark gap are used. The spark gap is designed to bypass the capacitor in case of overvoltages caused by fault currents higher than $2 \dots 3 I_{Load}$. Depending on the overvoltage the spark gap will operate in a few milliseconds. The MOV will reduce the voltage in cases of smaller (external) fault currents. A sensitive overcurrent element detects the operated spark gap and will bypass the capacitor for the duration of the fault current using a bypass circuit breaker.

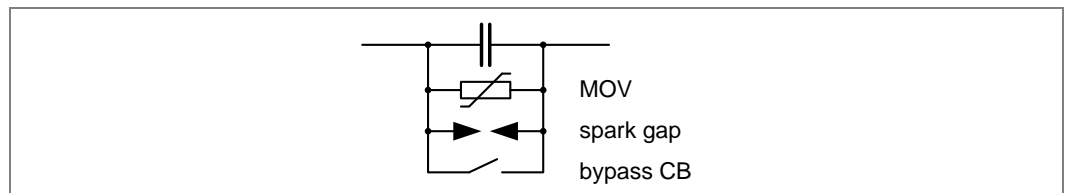

Figure 17 - Overvoltage protection for series compensation (simplified)

In case of high fault currents the spark gap will operate and the capacitor is shorted. In this case the impedance measurements and directional decision are the same as a normal line. In case of small fault currents the spark gap might not operate and the series capacitor will influence the distance protection measurements at the line ends. This effect will depend upon the capacitors location.

2.3.2 Transient Effects in Case of Line Faults

These fault situations compare the impedance depending upon the spark gap operation.

2.3.2.1 Reduced Apparent Fault Impedance

The series compensation reduces the electrical length of the line. This diagram shows the impedance seen by a distance relay for the same line length and degree of compensation.

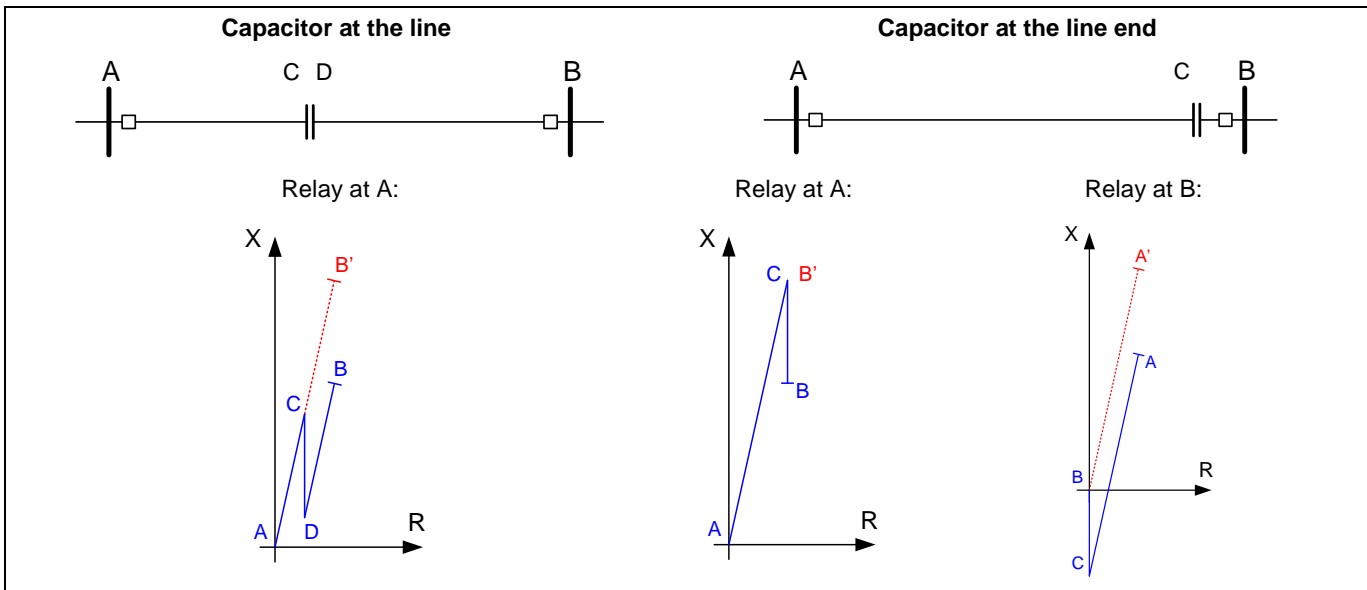

Figure 18 - Effect of series capacitor location to apparent impedance for faults along the line A-B

Depending upon the spark gap operation (solid line = capacitor active; dashed line = capacitor bypassed) a fault at the remote line end will be seen with different reaches. In case the capacitor is at the line end and in front of the relay, the apparent impedance becomes negative for close faults.

2.3.2.2

Sub-Synchronous Resonances

The line impedance and the series capacitor form an oscillating circuit R-L-C. The resonant frequency f_0 depends on the degree of compensation k_c and network frequency f_N :

degree of compensation k_c	resonant frequency f_0 for $f_N = 50$ Hz
10 %	16 Hz
30 %	27 Hz
50 %	35 Hz
70 %	42 Hz

Table 4 – Degree of compensation and resonant frequency

These oscillations overlay the fault current and voltages measured by the relay and therefore impact the apparent impedance. The damping of this sub-synchronous oscillation will depend on the network topology.

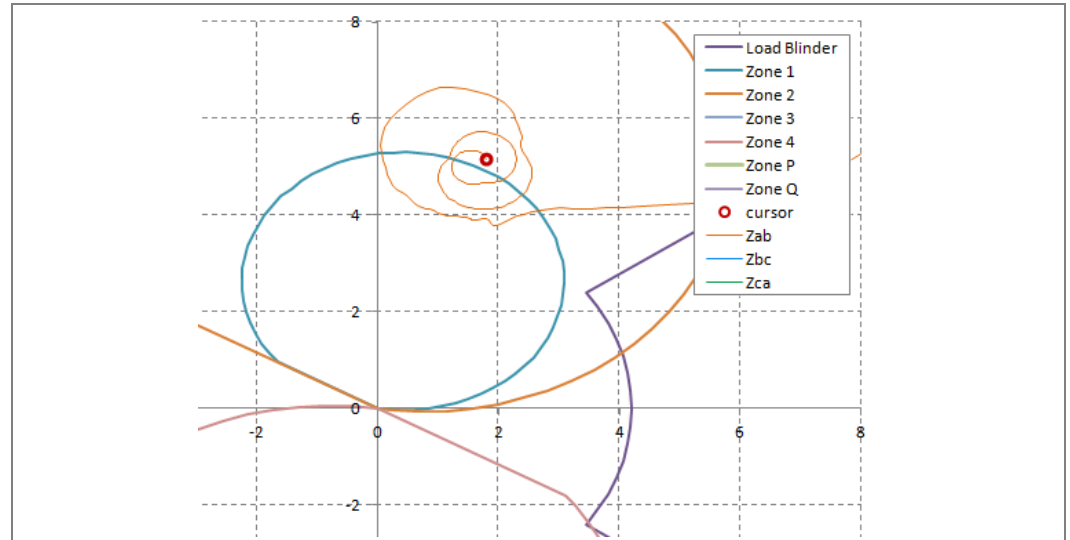

Figure 19 - Apparent impedance with sub-synchronous oscillations effecting zone 1 operation (simulated data)

In the previous diagram the apparent impedance seen by a relay using Fourier filters is plotted for sub-synchronous oscillations effecting the voltages and currents for an external fault. The trajectory crosses several times the zone 1 MHO characteristic. An overreach is likely to occur.

2.3.2.3

Voltage Reversal

If the apparent fault reactance is negative ($X = f \cdot X_L + X_C < 0$) and the total fault loop impedance (including the source reactance X_{STC}) is still positive, the measured voltage will lag behind the current. The directional decision will be faulty in cases where the polarizing voltage is made up on the phase voltages only. Incorporating memorized voltages will ensure correct directional decisions. A MHO relay with a high proportion of memory polarization will dynamically expand and detect the fault correctly. Therefore, a MHO characteristic with a high amount of memorized voltage is required.

2.3.2.4

Current Reversal

In extreme cases the effective fault current loop reactance becomes negative ($X = X_{STC} f \cdot X_L + X_C < 0$) – this might be the case for a high degree of compensation and faults in close-up range – a capacitive fault current will flow. In such situations the directional decision (based on a voltage memory) will not be correct. Delta-Directional principles (i.e. directional evaluation based on ΔU and ΔI quantities) will perform better under such conditions and should be preferred. Also, line differential protection will not operate for internal faults due to the current reversal. Typically faults close to the relay will result in high fault currents which will trigger the spark gap and current reversal will not occur.

2.3.3

Distance Protection Settings Guidelines

Due to the transient effects it is recommended to perform a network study if distance protection is applied for series compensated lines. Also, the impact of series compensation on adjacent lines needs to be considered.

The traditional approach of setting zone 1 reach at about 80% of the line impedance does not work for series compensated lines due to the reduced apparent impedance and sub-synchronous oscillations explained above. The zone 1 will overreach the series compensated line in case the spark gap does not bypass the capacitor and will trip the line for external faults, which is commonly not accepted.

A common approach for zone 1 reach setting is:

$$X_1 = k_{trans} \cdot k_{st}(X_L + X_C)$$

with:

$$X_L = \omega L \quad \text{line reactance,}$$

$$X_C = -1/\omega C \quad \text{series capacitor reactance,}$$

$$k_{st} \quad \text{reach grading factor (around 0.8),}$$

$$k_{trans} \quad \text{transient factor considering the sub-synchronous oscillations (based on system studies)}$$

Zone 2 reach setting is chosen as for non-compensated lines (considering the capacitor is bypassed). This approach will lead to a potential overreach in case the capacitor is not bypassed. It can be accepted as the zone 2 operation is typically just a backup to the unit protection with line differential and signaling scheme. Cross polarized MHO characteristic with a high amount of memorized voltage is recommended.

Example

Series compensated line with grading factor $k_{st} = 0.85$, transient factor $k_{trans} = 0.7$, degree of compensation $k_c = 50\%$:

$$X_1 = 0.7 \cdot 0.85(X_L - 0.5 X_L) = 0.3X_L$$

That means only 30 % of the series compensated line is protected in zone 1 (instantaneous tripping). Distance aided schemes (e.g. POR) are therefore highly recommended for full line protection with fast tripping.

2.4 Channel Aided Schemes

The MiCOM P443/P445/P446/P54x/P547 offers two sets of aided channel (“pilot”) schemes, which may be operated in parallel.

Aided Scheme 1 May be keyed by distance and/or DEF and/ or delta directional comparison

Aided Scheme 2 May be keyed by distance and/or DEF and/ or delta directional comparison

When schemes share the same channel, the same generic scheme type will be applied - i.e. ALL Permissive Overreach, or ALL Blocking.

2.4.1 Distance Scheme PUR - Permissive Underreach Transfer Trip

This scheme is similar to that used in the MiCOM P44x (see note) distance relays. It allows an instantaneous Z2 trip on receipt of the signal from the remote end protection.

Note Matches PUP Z2 mode in P44x (P442/P444).

Send logic: Zone 1

Permissive trip logic: Zone 2 plus Channel Received

The “**Dist dly**” trip time setting should be set to Zero, for fast fault clearance.

2.4.2 Distance Scheme POR - Permissive Overreach Transfer Trip

This scheme is similar to that used in the MiCOM P44x (see note) distance relays. The POR scheme also uses the reverse looking zone 4 of the relay as a reverse fault detector. This is used in the current reversal logic and in the optional weak infeed echo feature.

Note Matches POP Z2 mode in P44x (P442/P444).

Send logic: Zone 2

Permissive trip logic: Zone 2 plus Channel Received

The “**Dist dly**” trip time setting should be set to Zero, for fast fault clearance.

2.4.3 Permissive Overreach Trip Reinforcement

The send logic in the POR scheme is done in such a way that for any trip command at the local end, the relay sends a channel signal to the remote end(s) in order to maximize the chances for the fault to be isolated at all ends.

Note The send signal is generated by the ‘**Any trip**’ command and is sent on both channels, Ch1 and Ch2, if more than one channel is in use. This feature is termed **permissive trip reinforcement**, and is a deliberate attempt to ensure that synchronous tripping occurs at all line ends.

2.4.4 Permissive Overreach Scheme Weak Infeed Features

Where weak infeed tripping is employed, a typical voltage setting is 70% of rated phase-neutral voltage. Weak infeed tripping is time delayed according to the **WI Trip Delay** value, usually set at 60 ms.

2.4.5 Distance Scheme Blocking

To allow time for a blocking signal to arrive, a short time delay on aided tripping, “Dist dly”, must be used, as follows:

Recommended Dly setting = Max. Signaling channel operating time + 1 power frequency cycle.

This scheme is similar to that used in the LFZP Optimho, SHNB Micromho, LFZR, and MiCOM P44x (see note) distance relays.

Note Matches BOP Z2 mode in P441/P442/P444.

Send logic: Reverse Zone 4

Trip logic: Zone 2, plus Channel NOT Received, delayed by Tp

Note Two variants of a Blocking scheme are provided, Blocking 1 and Blocking 2. Both schemes operate identically, except that the reversal guard timer location in the logic changes. Blocking 2 may sometimes allow faster unblocking when a fault evolves from external to internal, and hence a faster trip.

2.4.6 Permissive Overreach Schemes Current Reversal Guard

The recommended setting is:

tREVERSAL GUARD = Maximum signaling channel reset time + 35 ms.

2.4.7 Blocking Scheme Current Reversal Guard

The recommended setting is:

- Where Duplex signaling channels are used:
tREVERSAL GUARD = Maximum signaling channel operating time + 20 ms.
- Where Simplex signaling channels are used:
tREVERSAL GUARD = Maximum signaling channel operating time - minimum signaling channel reset time + 20 ms.

2.4.8 Aided DEF Ground Fault Scheme - Permissive Overreach

This POR scheme is similar to that used in all other Schneider Electric relays.

Send logic: IN> Forward pickup

Permissive trip logic: IN> Forward plus Channel Received

Note The Time Delay for a permissive scheme aided trip would normally be set to zero.

2.4.9 Aided DEF Ground Fault Scheme - Blocking

This scheme is similar to that used in all other Schneider Electric relays.

Send logic: DEF Reverse

Trip logic: IN> Forward, plus Channel NOT Received, with a small set delay

To allow time for a blocking signal to arrive, a short time delay on aided tripping must be used.

The recommended

Time Delay setting = max. Signaling channel operating time + 20 ms.

2.4.10 Delta Scheme POR - Permissive Overreach Transfer Trip

This scheme is similar to that used in the LFDC relay.

Send logic: Δ Fault Forward

Permissive trip logic: Δ Fault Forward plus Channel Received.

The Delta Delay trip time setting should be set to zero, for fast fault clearance.

2.4.11 Delta Blocking Scheme

This scheme is similar to that used in the LFDC relay.

Send logic: Δ Fault Reverse

Trip logic: Δ Fault Forward, plus Channel NOT Received, delayed by T_p .

Recommended Dly setting = Max. signaling channel operating time + 6 ms.

2.4.12 Delta Schemes Current Reversal Guard Timer

Similar to the distance protection schemes, current reversals during fault clearance on an adjacent parallel line need to be treated with care. To prevent misoperation (mal-tripping) of the protection on the unfaulted line, a current reversal guard timer must be set. The recommended setting for both POR and BLOCKING schemes is:

tREVERSAL GUARD = Maximum signaling channel reset time + 35 ms

2.5 Loss of Load Accelerated Tripping (LoL) (Distance option only)

For circuits with load tapped off the protected line, care must be taken in setting the Loss of Load (LoL) feature to ensure that the I_c level detector setting is above the tapped load current. When selected, the LoL feature operates in conjunction with the main distance scheme that is selected. In this way it provides high speed clearance for end zone faults when the Basic scheme is selected or, with permissive signal aided tripping schemes, it provides high speed back-up clearance for end zone faults if the channel fails.

2.6

Phase Fault Overcurrent Protection

Settings for the time delayed overcurrent element should be selected to ensure discrimination with surrounding protection. Setting examples for phase fault overcurrent protection can be found in the Network Protection and Automation Guide (NPAG), a comprehensive reference textbook available from Schneider Electric.

**Caution**

The IEEE C.37.112 standard for IDMT curves permits some freedom to manufacturers at which Time Dial (TD) value the reference curve applies. Rather than pick a mid-range value, for the MiCOM device the reference curve norm applies at a time dial of 1. The TD is a multiplier on the reference curve, used to achieve the desired tripping time. Take care when working with other suppliers' relays which may take TD = 5, or TD = 7 as a mid-range value to define the IDMT curve. The equivalent MiCOM device setting to match those relays is achieved by dividing the imported setting by 5 or 7.

This caution applies to the MiCOM P443 / P445 / P446 / P54x / P841.

Phase Overcurrent Function

(Applies to Dual CB variants only), e.g. P544, P546, P446 and P841B firmware versions. Please note that when using Overcurrent stages 3 and/or 4 (I>3 and/or I>4 respectively) for Circuit Breaker failure detection, where the protection stage is set to monitor an individual CT input (e.g. CT1 OR CT2). The user should not use the same overcurrent stages for backup protection because of the different Current sensitivity (setting) levels required for CB Failure and Backup Overcurrent.

2.6.1

Directional Overcurrent Characteristic Angle Settings

The relay uses a 90° connection angle for the directional overcurrent elements. The relay characteristic angles in this case are nominally set to:

- +30° Plain feeders, zero sequence source behind relay
- +45° Transformer feeder, zero sequence source in front of relay

It is possible to set the RCA to match the system fault angle exactly, but we recommend that these figures are followed, as these provide satisfactory performance and stability under a wide range of system conditions.

2.7 Thermal Overload Protection

Thermal overload protection can be used to prevent electrical plant from operating at temperatures higher than the designed maximum withstand. Prolonged overloading causes excessive heating, which may result in premature ageing of the insulation, or in extreme cases, insulation failure.

2.7.1 Single Time Constant Characteristic

The current setting is calculated as:

Thermal Trip = Permissible continuous loading of the plant item/CT ratio.

Typical time constant values are given in the following table. The relay setting, 'Time Constant 1', is in minutes.

An alarm can be raised on reaching a thermal state corresponding to a percentage of the trip threshold. A typical setting might be 'Thermal Alarm' = 70% of thermal capacity.

	Time constant τ (minutes)	Limits
Air-core reactors	40	
Capacitor banks	10	
Overhead lines	10	Cross section $\geq 100 \text{ mm}^2$ Cu or 150 mm^2 Al
Cables	60 - 90	Typical, at 66 kV and above
Busbars	60	

Table 5 - Typical time constant values

2.7.2 Dual Time Constant Characteristic

The current setting is calculated as:

Thermal Trip = Permissible continuous loading of the transformer / CT ratio.

Typical time constant values are shown in the following table:

An alarm can be raised on reaching a thermal state corresponding to a percentage of the trip threshold. A typical setting might be 'Thermal Alarm' = 70% of thermal capacity.

<i>Note</i>	<i>The thermal time constants given in the above tables are typical only. Reference should always be made to the plant manufacturer for accurate information.</i>
-------------	---

	$\tau 1$ (minutes)	$\tau 2$ (minutes)	Limits
Oil-filled transformer	5	120	Rating 400 - 1600 kVA

Table 6 - Typical time constant values

<i>Note</i>	<i>The thermal time constants given in Figure 11 and Figure 12 are typical only. Always refer to the plant manufacturer for accurate information.</i>
-------------	---

2.8 Earth Fault (Ground Overcurrent) and Sensitive Earth Fault (SEF) protection

Earth Fault

(Applies to Dual CB variants only), e.g. P544, P546, P446 and P841B firmware versions. Please note that when using Earth Fault stages 3 and/or 4 (IN>3 and/or IN>4 respectively) for Circuit Breaker failure detection, where the protection stage is set to monitor an individual CT input (e.g. CT1 OR CT2). The user should not use the same Earth Fault stages for backup protection because of the different Current sensitivity (setting) levels required for CB Failure and Backup Earth Fault.

**Caution**

The IEEE C.37.112 standard for IDMT curves permits some freedom to manufacturers at which Time Dial (TD) value the reference curve applies. Rather than pick a mid-range value, for the MiCOM device the reference curve norm applies at a time dial of 1. The TD is a multiplier on the reference curve, used to achieve the desired tripping time. Take care when working with other suppliers' relays which may take TD = 5, or TD = 7 as a mid-range value to define the IDMT curve. The equivalent MiCOM device setting to match those relays is achieved by dividing the imported setting by 5 or 7.

This caution applies to the MiCOM P443 / P445 / P446 / P54x / P841.

2.8.1 Directional Earth Fault Protection

2.8.1.1 Residual Voltage Polarization

It is possible that small levels of residual voltage will be present under normal system conditions due to system imbalances, VT inaccuracies, relay tolerances etc. Hence, the relay includes a user settable threshold (**IN>VNPoI Set**) which must be exceeded in order for the DEF function to be operational. In practice, the typical zero sequence voltage on a healthy system can be as high as 1% (i.e.: 3% residual), and the VT error could be 1% per phase. A setting between 1% and 4% is typical. The residual voltage measurement provided in the **Measurements** column of the menu may assist in determining the required threshold setting during commissioning, as this will indicate the level of standing residual voltage present.

2.8.2 General Setting Guidelines for Directional Earth Fault (Ground Overcurrent) Protection

When setting the Relay Characteristic Angle (RCA) for the Directional Earth Fault (DEF) element, a positive angle setting was specified. This was due to the fact that the quadrature polarizing voltage lagged the nominal phase current by 90°; i.e. the position of the current under fault conditions was leading the polarizing voltage and hence a positive RCA was required. With DEF, the residual current under fault conditions lies at an angle lagging the polarizing voltage. Hence, negative RCA settings are required for DEF applications. This is set in cell '**I>N**' in the relevant earth fault menu.

The following angle settings are recommended for a residual voltage polarized relay:

- Distribution systems (solidly earthed) -45°
- Transmissions systems (solidly earthed) -60°

For negative sequence polarization, the RCA settings must be based on the angle of the upstream negative phase sequence source impedance.

2.8.3 Sensitive Earth Fault (SEF) Protection Element

Sensitive Earth Fault (SEF) would normally be fed from a Core Balance Current Transformer (CBCT) mounted around the three phases of the feeder cable. However, care must be taken in the positioning of the CT with respect to the earthing of the cable sheath. See below.

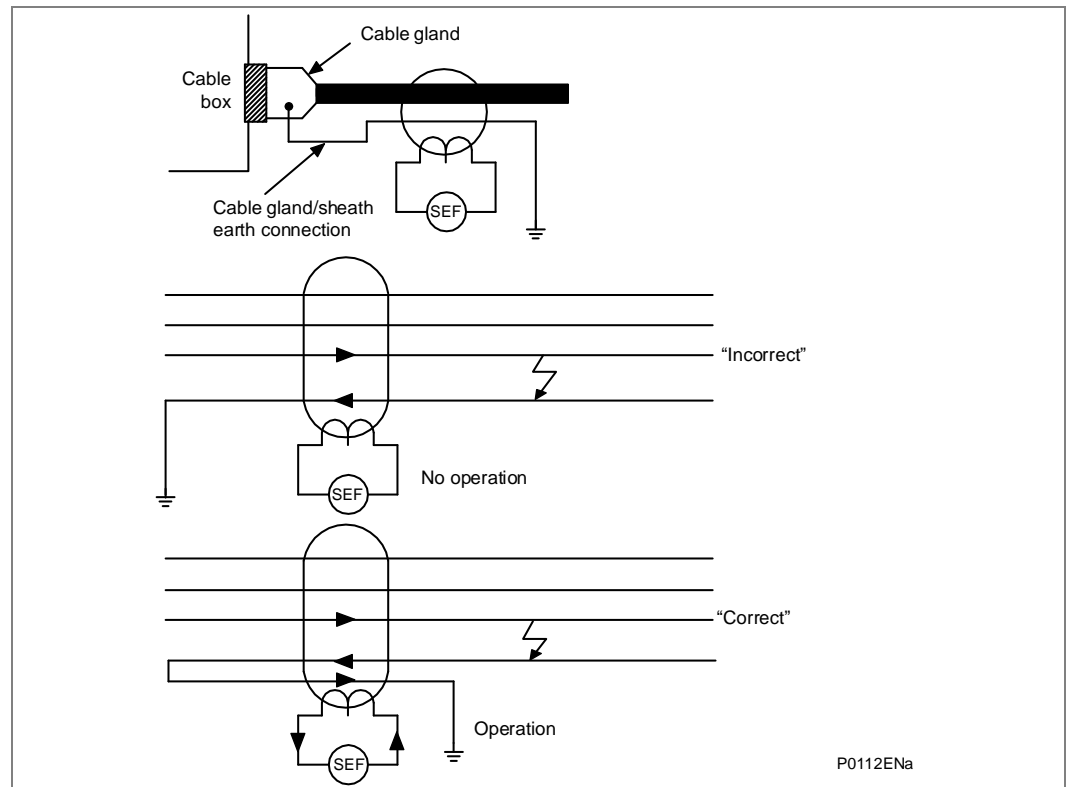

Figure 20 - Positioning of core balance current transformers

As can be seen from the above illustration, if the cable sheath is terminated at the cable gland and earthed directly at that point, a cable fault (from phase to sheath) will not result in any unbalance current in the core balance CT. Hence, prior to earthing, the connection must be brought back through the CBCT and earthed on the feeder side. This then ensures correct relay operation during earth fault conditions.

2.8.4

Restricted Earth Fault (REF) Protection

Earth faults occurring on a transformer winding or terminal may be of limited magnitude, either due to the impedance present in the earth path or by the percentage of transformer winding that is involved in the fault. It is common to apply standby earth fault protection fed from a single CT in the transformer earth connection - this provides time-delayed protection for a transformer winding or terminal fault. In general, particularly as the size of the transformer increases, it becomes unacceptable to rely on time delayed protection to clear winding or terminal faults as this would lead to an increased amount of damage to the transformer. A common requirement is therefore to provide instantaneous phase and earth fault protection. Applying differential protection across the transformer may fulfill these requirements. However, an earth fault occurring on the LV winding, particularly if it is of a limited level, may not be detected by the differential relay, as it is only measuring the corresponding HV current. Therefore, instantaneous protection that is restricted to operating for transformer earth faults only is applied. This is referred to as Restricted Earth Fault (REF) Protection.

When applying differential protection such as REF, some suitable means must be employed to give the protection stability under external fault conditions, therefore ensuring that relay operation only occurs for faults on the transformer winding / connections.

Two methods are commonly used; bias or high impedance. The biasing technique operates by measuring the level of through current flowing and altering the relay sensitivity accordingly. The high impedance technique ensures that the relay circuit is of sufficiently high impedance such that the differential voltage that may occur under external fault conditions is less than that required to drive setting current through the relay.

The REF protection in the relays can be configured to operate as high impedance element. Following sections describe the application of the relay for high impedance element.

Note The high impedance REF element of the relay shares the same CT input as the SEF protection. Hence, only one of these elements may be selected.

2.8.4.1

Setting Guidelines for High Impedance Restricted Earth Fault (REF)

From the **SEF/REF options** cell, **Hi Z REF** must be selected to enable this protection.

The only setting cell then visible is **IREF>Is**, which may be programmed with the required differential current setting. This would typically be set to give a primary operating current of either 30% of the minimum earth fault level for a resistance earthed system or between 10 and 60% of rated current for a solidly earthed system.

The primary operating current (Iop) will be a function of the current transformer ratio, the relay operating current (IREF>Is1), the number of current transformers in parallel with a relay element (n) and the magnetizing current of each current transformer (Ie) at the stability voltage (Vs). This relationship can be expressed in three ways:

- To determine the maximum current transformer magnetizing current to achieve a specific primary operating current with a particular relay operating current:

$$I_e < \frac{1}{n} \times \left(\frac{I_{op}}{CT \text{ ratio}} - I_{REF > I_s} \right)$$

- To determine the minimum relay current setting to achieve a specific primary operating current with a given current transformer magnetizing current.

$$I_{REF > I_s} < \left(\frac{I_{op}}{CT \text{ ratio}} - n I_e \right)$$

2.8.4.2

Use of METROSIL Non-Linear Resistors

Metrosils are used to limit the peak voltage developed by the current transformers under internal fault conditions, to a value below the insulation level of the current transformers, relay and interconnecting leads, which are normally able to withstand 3000 V peak.

The following formulae should be used to estimate the peak transient voltage that can be produced for an internal fault. The peak voltage produced during an internal fault will be a function of the current transformer kneepoint voltage and the prospective voltage that would be produced for an internal fault if current transformer saturation did not occur.

$$V_p = 2 \sqrt{2V_k (V_f - V_k)}$$

$$V_f = I_f (R_{ct} + 2R_L + R_{ST})$$

Where:

Vp = Peak voltage developed by the CT under internal fault conditions

Vk = Current transformer kneepoint voltage

Vf = Maximum voltage that would be produced if CT saturation did not occur

If = Maximum internal secondary fault current

Rct = Current transformer secondary winding resistance

RL = Maximum lead burden from current transformer to relay

RST = Relay stabilizing resistor

When the value given by the formulae is greater than 3000 V peak, Metrosils should be applied. They are connected across the relay circuit and serve the purpose of shunting the secondary current output of the current transformer from the relay to prevent very high secondary voltages.

Metrosils are externally mounted and take the form of annular discs. Their operating characteristics follow the expression:

$$V = C I^{0.25}$$

Where:

V = Instantaneous voltage applied to the non-linear resistor (Metrosil)

C = Constant of the non-linear resistor (Metrosil)

I = Instantaneous current through the non-linear resistor (Metrosil)

With a sinusoidal voltage applied across the Metrosil, the RMS current would be approximately 0.52 x the peak current. This current value can be calculated as follows:

$$I(\text{rms}) = 0.52 \left(\frac{V_s(\text{rms}) \times \sqrt{2}}{C} \right)^4$$

Where:

V_s(rms) = rms value of the sinusoidal voltage applied across the metrosil.

This is because the current waveform through the Metrosil is not sinusoidal but appreciably distorted.

For satisfactory application of a non-linear resistor (Metrosil), its characteristic should be such that it complies with these requirements:

- At the relay voltage setting, the non-linear resistor (Metrosil) current should be as low as possible, but no greater than approximately 30 mA rms for 1 A current transformers and approximately 100 mA rms for 5 A current transformers.
- At the maximum secondary current, the non-linear resistor (Metrosil) should limit the voltage to 1500V rms or 2120V peak for 0.25 second. At higher relay voltage settings, it is not always possible to limit the fault voltage to 1500V rms, so higher fault voltages may have to be tolerated.

The following tables show the typical Metrosil types that will be required, depending on relay current rating, REF voltage setting etc.

Metrosil Units for Relays with a 1 Amp CT

The Metrosil units with 1 Amp CTs have been designed to comply with the following restrictions:

1. At the relay voltage setting, the Metrosil current should be less than 30 mA rms.
2. At the maximum secondary internal fault current the Metrosil unit should limit the voltage to 1500 V rms if possible.

The Metrosil units normally recommended for use with 1Amp CT's are as shown below:

Relay voltage setting	Nominal characteristic		Recommended Metrosil type	
	C	β	Single pole relay	Triple pole relay
Up to 125 V rms	450	0.25	600 A/S1/S256	600 A/S3/1/S802
125 to 300 V rms	900	0.25	600 A/S1/S1088	600 A/S3/1/S1195

Note Single pole Metrosil units are normally supplied without mounting brackets unless otherwise specified by the customer.

Metrosil units for relays with a 5 amp CT

These Metrosil units have been designed to comply with these requirements:

- At the relay voltage setting, the Metrosil current should be less than 100 mA rms (the actual maximum currents passed by the units shown below their type description).
- At the maximum secondary internal fault current the Metrosil unit should limit the voltage to 1500 V rms for 0.25 secs. At the higher relay settings, it is not possible to limit the fault voltage to 1500 V rms hence higher fault voltages have to be tolerated (indicated by *, **, ***).

The Metrosil units normally recommended for use with 5 Amp CTs and single pole relays are as shown in the following table:

Secondary internal fault current	Recommended Metrosil type			
	Relay voltage setting			
	Amps rms	Up to 200 V rms	250 V rms	275 V rms
50 A	600 A/S1/S1213 C = 540/640 35 mA rms	600 A/S1/S1214 C = 670/800 40 mA rms	600 A/S1/S1214 C = 670/800 50 mA rms	600 A/S1/S1223 C = 740/870* 50 mA rms
100 A	600 A/S2/P/S1217 C = 470/540 70 mA rms	600 A/S2/P/S1215 C = 570/670 75 mA rms	600 A/S2/P/S1215 C = 570/670 100 mA rms	600 A/S2/P/S1196 C = 620/740* 100 mA rms
150 A	600 A/S3/P/S1219 C = 430/500 100 mA rms	600 A/S3/P/S1220 C = 520/620 100 mA rms	600 A/S3/P/S1221 C = 570/670** 100 mA rms	600 A/S3/P/S1222 C = 620/740*** 100 mA rms
Note:			**2200 V peak	*2400 V peak ***2600 V peak

In some situations single disc assemblies may be acceptable, contact Schneider Electric for detailed applications.

1. The Metrosil units recommended for use with 5 Amp CTs can also be applied for use with triple pole relays and consist of three single pole units mounted on the same central stud but electrically insulated from each other. To order these units please specify **Triple pole Metrosil type**, followed by the single pole type reference.
2. Metrosil units for higher relay voltage settings and fault currents can be supplied if required.
3. To express the protection primary operating current for a particular relay operating current and with a particular level of magnetizing current.

$$I_{op} = (\text{CT ratio}) \times (I_{REF} > I_s + nI_c)$$

To achieve the required primary operating current with the current transformers that are used, a current setting ($I_{REF} > I_s$) must be selected for the high impedance element, as detailed in expression (ii) above. The setting of the stabilizing resistor (RST) must be calculated in the following manner, where the setting is a function of the required stability voltage setting (V_s) and the relay current setting ($I_{REF} > I_s$).

Note The following formula assumes negligible relay burden.

Note The stabilizing resistor that can be supplied is continuously adjustable up to its maximum declared resistance.

$$R_{st} = \frac{V_s}{I_{REF} > I_s} = \frac{I_F (R_{CT} + 2R_L)}{I_{REF} > I_s}$$

2.9 Negative Phase Sequence (NPS) Overcurrent Protection

The following section describes how Negative Phase Sequence (NPS) overcurrent protection may be applied in conjunction with standard overcurrent and earth fault protection to alleviate some less common application difficulties:

- NPS overcurrent elements give greater sensitivity to resistive phase-to-phase faults, where phase overcurrent elements may not operate.
- In certain applications, residual current may not be detected by an earth fault relay due to the system configuration. For example, an earth fault relay applied on the delta side of a Dy (delta-wye) transformer is unable to detect earth faults on the star (wye) side. However, negative sequence current will be present on both sides of the transformer for any fault condition, irrespective of the transformer configuration. Therefore, a NPS overcurrent element may be employed to provide time-delayed back-up protection for any uncleared asymmetrical faults downstream.
- It may be required to simply alarm for the presence of negative phase sequence currents on the system. Operators may then investigate the cause of the unbalance.

2.9.1 NPS Current Threshold, 'I₂> Current Set'

The current pick-up threshold must be set higher than the NPS current due to the maximum normal load unbalance on the system. This can be set practically at the commissioning stage, making use of the relay measurement function to display the standing NPS current, and setting at least 20% above this figure.

Where the NPS element is required to operate for specific uncleared asymmetric faults, a precise threshold setting would have to be based upon an individual fault analysis for that particular system due to the complexities involved. However, to ensure operation of the protection, the current pick-up setting must be set approximately 20% below the lowest calculated NPS fault current contribution to a specific remote fault condition.

2.9.2 Time Delay for the NPS Overcurrent Element, 'I₂> Time Delay'

As stated above, correct setting of the time delay for this function is vital. It should also be noted that this element is applied primarily to provide back-up protection to other protective devices or to provide an alarm. Hence, in practice, it would be associated with a long time delay.

It must be ensured that the time delay is set greater than the operating time of any other protective device (at minimum fault level) on the system which may respond to unbalanced faults.

2.9.3 Directionalizing the Negative Phase Sequence Overcurrent Element

Where NPS current may flow in either direction through a relay location, such as parallel lines, directional control of the element should be employed. Directionality is achieved by comparison of the angle between the NPS voltage and the NPS current and the element may be selected to operate in either the forward or reverse direction. A suitable relay characteristic angle setting ($I_2 > \text{Char Angle}$) is chosen to provide optimum performance. This setting should be set equal to the phase angle of the negative sequence current with respect to the inverted negative sequence voltage ($-V_2$), in order to be at the center of the directional characteristic.

The angle that occurs between V_2 and I_2 under fault conditions is directly dependent upon the negative sequence source impedance of the system. However, typical settings for the element are as follows;

- For a transmission system the RCA should be set equal to -60°
- For a distribution system the RCA should be set equal to -45°

For the NPS directional elements to operate, the relay must detect a polarizing voltage above a minimum threshold, $I_2 > V_2 \text{pol Set}$. This must be set in excess of any steady state NPS voltage. This may be determined during the commissioning stage by viewing the NPS measurements in the relay.

2.10 Undervoltage Protection

In most applications, undervoltage protection is not required to operate during system earth (ground) fault conditions. If this is the case, the element should be selected in the menu to operate from a phase to phase voltage measurement, as this quantity is less affected by single phase voltage depressions due to earth faults. The measuring mode (ph-N or ph-ph) and operating mode (single phase or 3 phase) for both stages are independently settable.

The voltage threshold setting for the undervoltage protection should be set at some value below the voltage excursions which may be expected under normal system operating conditions. This threshold is dependent upon the system in question but typical healthy system voltage excursions may be in the order of -10% of nominal value.

Similar comments apply with regard to a time setting for this element, i.e. the required time delay is dependent upon the time for which the system is able to withstand a depressed voltage.

2.11 Overvoltage Protection

The inclusion of the two stages and their respective operating characteristics allows for a number of possible applications;

- Use of the IDMT characteristic gives the option of a longer time delay if the overvoltage condition is only slight but results in a fast trip for a severe overvoltage. As the voltage settings for both of the stages are independent, the second stage could then be set lower than the first to provide a time delayed alarm stage if required.
- Alternatively, if preferred, both stages could be set to definite time and configured to provide the required alarm and trip stages.
- If only one stage of overvoltage protection is required, or if the element is required to provide an alarm only, the remaining stage may be disabled within the relay menu.

This type of protection must be co-ordinated with any other overvoltage relays at other locations on the system. This should be carried out in a similar manner to that used for grading current operated devices. The measuring mode (ph-N or ph-ph) and operating mode (single phase or 3 phase) for both stages are independently settable.

2.12 Compensated Overvoltage Protection

Temporary overvoltages in the order of seconds (even minutes) which may originate from switching or load rejection may damage primary plant equipment. In particular, this type of overvoltage protection is applied to protect long transmission lines against Ferranti effect overvoltages where the transmission line is energized from one end only. The following figure shows the Ferranti overvoltages calculated for a 345 kV and 765 kV transmission line for different line lengths based on the formulas as in the Operation chapter.

The two stage compensated overvoltage element can be applied as alarming or trip elements. Both stages' time delays should be set not to pick-up for transient overvoltages in the system with a typical time delays of 1-2 seconds upwards being adequate for most applications. In the example above for a 345 kV transmission line of 400 km line length, the alarm threshold (stage 1) can be set to 105% and the trip threshold set to 110% for example.

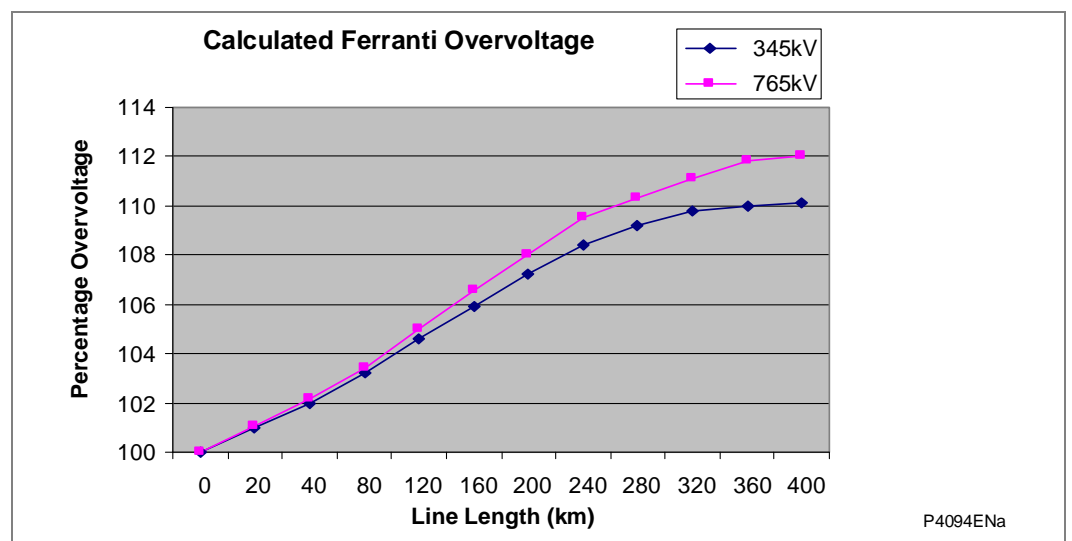

Figure 21 - Calculated Ferranti voltage rise on 345 kV and 765 kV lines

2.13 Residual Overvoltage (Neutral Displacement) Protection

On a healthy three phase power system, the addition of each of the three phase to earth voltages is nominally zero, as it is the vector addition of three balanced vectors at 120° to one another. However, when an earth (ground) fault occurs on the primary system this balance is upset and a 'residual' voltage is produced.

Note This condition causes a rise in the neutral voltage with respect to earth which is commonly referred to as **neutral voltage displacement** or NVD.

The following figure shows the residual voltages that are produced during earth fault conditions occurring on a solid earthed power system.

As shown in below the residual voltage measured by a relay for an earth fault on a solidly earthed system is solely dependent upon the ratio of source impedance behind the relay to line impedance in front of the relay, up to the point of fault. For a remote fault, the Z_s/Z_l ratio will be small, resulting in a correspondingly small residual voltage. As such, depending upon the relay setting, such a relay would only operate for faults up to a certain distance along the system. The value of residual voltage generated for an earth fault condition is given by the general formula shown.

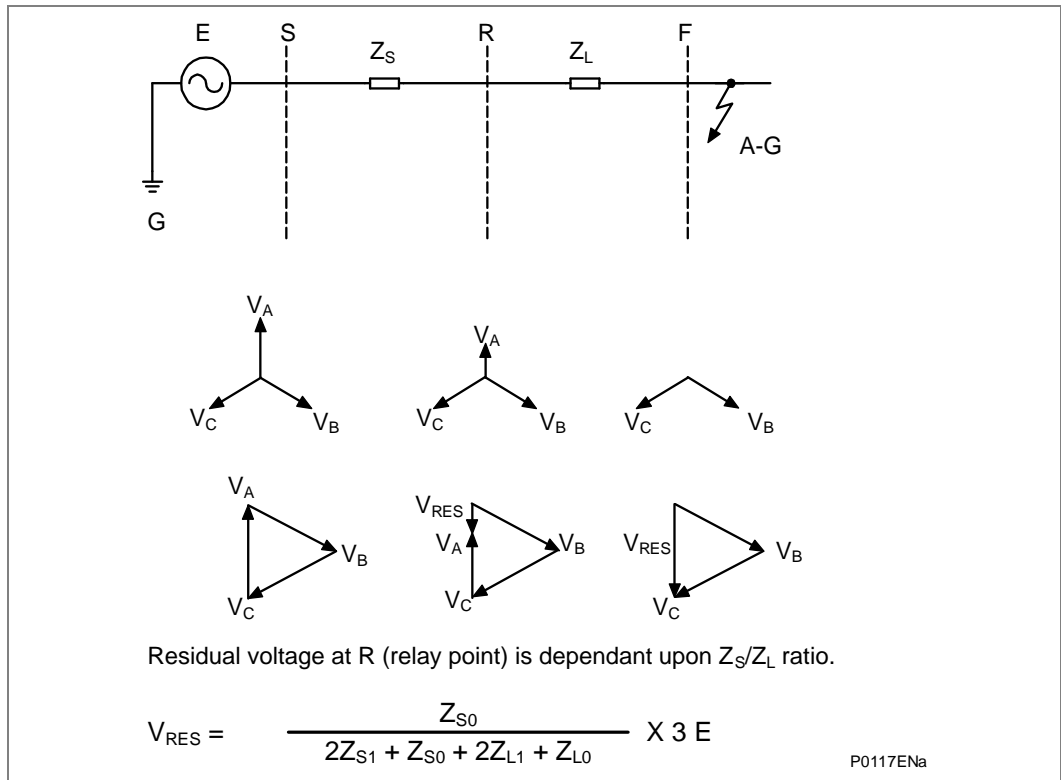

Figure 22 - Residual voltage, solidly earthed system

The following figure shows the residual voltages that are produced during earth fault conditions occurring on an impedance earthed power system.

This shows that a resistance earthed system will always generate a relatively large degree of residual voltage, as the zero sequence source impedance now includes the earthing impedance. It follows then, that the residual voltage generated by an earth fault on an insulated system will be the highest possible value (3 x phase-neutral voltage), as the zero sequence source impedance is infinite.

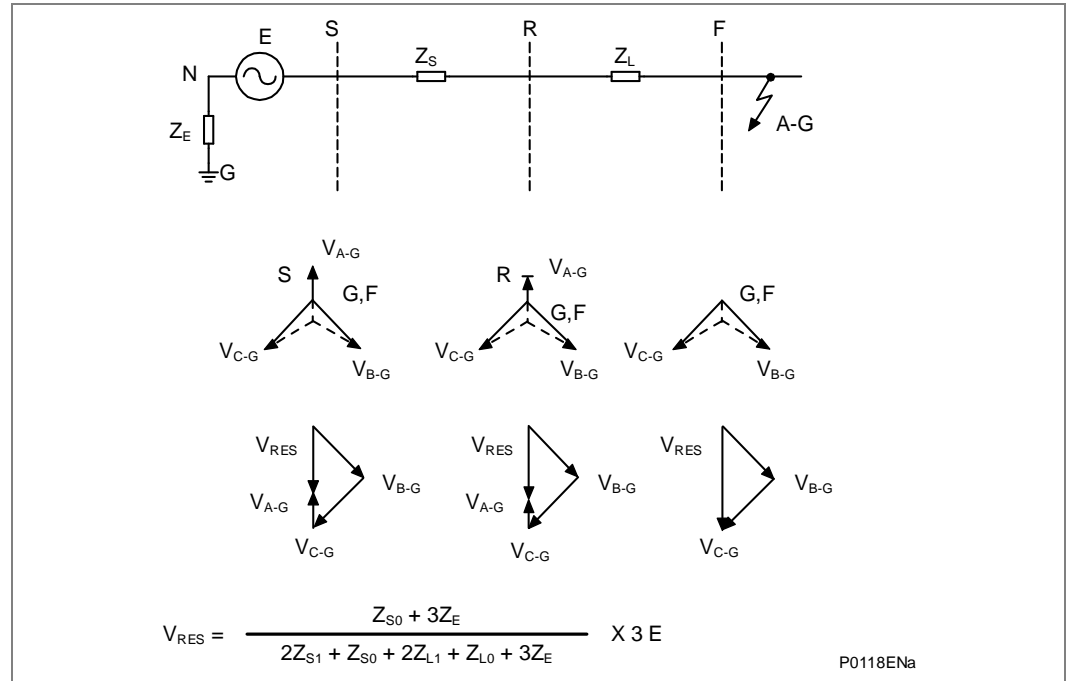

Figure 23 - Residual voltage, resistance earthed system

The detection of a residual overvoltage condition is an alternative means of earth fault detection, which does not require any measurement of zero sequence current. This may be particularly advantageous at a tee terminal where the infeed is from a delta winding of a transformer (and the delta acts as a zero-sequence current trap).

Note Where residual overvoltage protection is applied, such a voltage will be generated for a fault occurring anywhere on that section of the system and hence the NVD protection must co-ordinate with other earth/ground fault protection.

2.13.1

Setting Guidelines

The formula referred to here are shown in Figure 22 and Figure 23.

The voltage setting applied to the elements depends on the magnitude of residual voltage that is expected to occur during the earth fault condition. This in turn is dependent on the method of system earthing employed and may be calculated by using the formulae previously given in the previous diagrams. It must also be ensured that the relay is set above any standing level of residual voltage that is present on the system.

Note IDMT characteristics are selectable on the first stage of NVD so that elements located at various points on the system may be time graded with one another.

2.14 Circuit Breaker Fail (CBF) Protection

2.14.1 Breaker Fail Timer Settings

Typical timer settings to use are as follows:

CB fail reset mechanism	tBF time delay	Typical delay for 2 ½ cycle circuit breaker
Initiating element reset	CB interrupting time + element reset time (max.) + error in tBF timer + safety margin	$50 + 45 + 10 + 50 = 155$ ms
CB open	CB auxiliary contacts opening/closing time (max.) + error in tBF timer + safety margin	$50 + 10 + 50 = 110$ ms
Undercurrent elements	CB interrupting time + undercurrent element (max.) + safety margin	$50 + 25 + 50 = 125$ ms
<p><i>Note</i> All CB Fail resetting involves the operation of the undercurrent elements. Where element reset or CB open resetting is used the undercurrent time setting should still be used if this proves to be the worst case.</p>		
<p>The examples above consider direct tripping of a 2½ cycle circuit breaker.</p>		
<p><i>Note</i> Where auxiliary tripping relays are used, an additional 10-15 ms must be added to allow for trip relay operation.</p>		

2.14.2 Breaker Fail Undercurrent Settings

The phase undercurrent settings ($I_{<}$) must be set less than load current, to ensure that $I_{<}$ operation indicates that the circuit breaker pole is open. A typical setting for overhead line or cable circuits is 20% I_n , reduced to 10% or 5% where the infeed has a high SIR ratio (e.g. at a spur terminal with embedded generation infeed).

The sensitive earth fault protection (SEF) undercurrent element must be set less than the respective trip setting, typically as follows:

$$I_{SEF<} = (I_{SEF>} \text{ trip}) / 2$$

2.15 Broken Conductor Detection

The majority of faults on a power system occur between one phase and ground or two phases and ground. These are known as shunt faults and arise from lightning discharges and other overvoltages which initiate flashovers. Alternatively, they may arise from other causes such as birds on overhead lines or mechanical damage to cables etc. Such faults result in an appreciable increase in current and hence in the majority of applications are easily detectable.

Another type of unbalanced fault that can occur on the system is the series or open circuit fault. These can arise from broken conductors, maloperation of single phase switchgear, or single-phasing of fuses. Series faults will not cause an increase in phase current on the system and hence are not readily detectable by standard protection. However, they will produce an unbalance and a resultant level of negative phase sequence current, which can be detected.

It is possible to apply a negative phase sequence overcurrent relay to detect the above condition. However, on a lightly loaded line, the negative sequence current resulting from a series fault condition may be very close to, or less than, the full load steady state unbalance arising from CT errors, load unbalance etc. A negative sequence element therefore would not operate at low load levels.

2.15.1 Setting Guidelines

For a broken conductor affecting a single point earthed power system, there will be little zero sequence current flow and the ratio of I_2/I_1 that flows in the protected circuit will approach 100%. In the case of a multiple earthed power system (assuming equal impedance's in each sequence network), the ratio I_2/I_1 will be 50%.

In practice, the levels of standing negative phase sequence current present on the system govern this minimum setting. This can be determined from a system study, or by making use of the relay measurement facilities at the commissioning stage. If the latter method is adopted, it is important to take the measurements during maximum system load conditions, to ensure that all single-phase loads are accounted for.

Note *A minimum value of 8% negative phase sequence current is required for successful relay operation.*

As sensitive settings have been employed, it can be expected that the element will operate for any unbalance condition occurring on the system (for example, during a single pole auto-reclose cycle). Hence, a long time delay is needed to ensure co-ordination with other protective devices. A 60 second time delay setting may be typical. For example, this information was recorded by the relay during commissioning;

$I_{full\ load}$	=	500 A
I_2	=	50 A

Therefore, the quiescent I_2/I_1 ratio is given by:

I_2/I_1	=	$50/500 = 0.1$
-----------	---	----------------

To allow for tolerances and load variations a setting of 20% of this value may be typical: Therefore, set $I_2/I_1 = 0.2$

In a double circuit (parallel line) application, using a 40% setting will ensure that the broken conductor protection will operate only for the circuit that is affected. Setting 0.4 results in no pick-up for the parallel healthy circuit.

Set I_2/I_1 Time Delay = 60 s to allow adequate time for short circuit fault clearance by time delayed protections.

2.16 Communication between Relays

2.16.1 Optical Budgets

When applying any of the P54x range of current differential relays it is important to select the appropriate protection communications interface. This will depend on the fiber used and distance between devices. The following table shows the optical budgets of the available communications interfaces.

From April 2008	850 nm Multi mode	1300 nm Multi mode	1310 nm Single mode	1550 nm Single mode
Min. transmit output level (average power)	-19.8 dBm	-6 dBm	-6 dBm	-6 dBm
Receiver sensitivity (average power)	-25.4 dBm	-49 dBm	-49 dBm	-49 dBm
Optical budget	5.6 dB	43.0 dB	43.0 dB	43.0 dB
Less safety margin (3 dB)	2.6 dB	40.0 dB	40.0 dB	40.0 dB
Typical cable loss	2.6 dB/km	0.8 dB/km	0.4 dB/km	0.3 dB/km
Max. transmission distance	1 km	50.0 km	100.0 km	130 km

Note From April 2008, the optical budgets and hence also the maximum transmission distances of the 1300 nm multi-mode, 1310 nm single-mode and 1550 nm single-mode fiber interfaces have been increased, to the values shown in the table above.

Table 7 - Optical optical budgets and maximum transmission distances for relays from April 2008 and onwards

The new interface cards are identified by “**43dB**” marked in the centre of the back-plate, visible from the rear of the relay. These new fiber interfaces are fully backward-compatible with the original equivalent interface. However, to achieve the increased distance, both/all ends of the P443/P445 scheme would need to use the new interface. Pre-April 2008 relays will have the original optical budgets and maximum transmission distances, as shown below.

Pre-April 2008	850 nm Multi mode	1300 nm Multi mode	1310 nm Single mode	1550 nm Single mode
Min. transmit output level (average power)	-19.8 dBm	-10 dBm	-10 dBm	-10 dBm
Receiver sensitivity (average power)	-25.4 dBm	-37 dBm	-37 dBm	-37 dBm
Optical budget	5.6 dB	27.0 dB	27.0 dB	27.0 dB
Less safety margin (3dB)	2.6 dB	24.0 dB	24.0 dB	24.0 dB
Typical cable loss	2.6 dB/km	0.8 dB/km	0.4 dB/km	0.3 dB/km
Max. transmission distance	1 km	30.0 km	60.0 km	80 km

Table 8 - Original optical budgets and maximum transmission distances for Pre-April 2008 relays

The total optical budget is given by transmitter output level minus the receiver sensitivity and will indicate the total allowable losses that can be tolerated between devices. A safety margin of 3 dB is also included in the above table. This allows for degradation of the fiber due to ageing and any losses in cable joints. The remainder of the losses will come from the fiber itself. The figures given are typical only and should only be used as a guide.

In general, the 1300 nm, 1310 nm, and 1550 nm interfaces will be used for direct connections between relays. The 850 nm would be used where multiplexing equipment is employed.

2.16.2

Clock Source Setting

The Clock Source should be set to "Internal" at all system ends, where they are connected by direct optical fiber, as the P54x at each end has to supply the clock. The Clock Source should be set to External at all system ends, where the ends are connected by multiplexer equipment which is receiving a master clock signal from the multiplexer network.

Note *The Clock Source must be set to "Internal" when P54x is connected to multiplexer equipment via P-2M-L.*

It is important that there is a single master clock source on the multiplexer network and that the multiplexer equipment at each end is synchronized to this clock.

Note *This setting is not applicable if IEEE C37.94 mode selected.*

2.16.3

Data Rate

The data rate for signaling between the two or three ends may be set to either 64kbit/sec or 56kbit/sec as appropriate.

If there is a direct fiber connection between the ends, the data rate would usually be set to 64kbit/sec, as this gives a slightly faster trip time.

If there is a multiplexer network between the ends, then this will determine the data rate to be used by the MiCOM P443/P445/P446/P54x system. The electrical interface to the multiplexer (G.703 co-directional) will be provided on either a 64kbit/sec or 56kbit/sec channel, and the MiCOM P443/P445/P446/P54x at each end must be set to match this data rate.

Generally, North American multiplexer networks are based on 56kbit/sec (and multiples thereof) channels, whereas multiplexer networks in the rest of the world are based on 64kbit/sec (and multiples thereof) channels.

This setting is not applicable if IEEE C37.94 mode selected.

2.17 Integral Intertripping

For software versions D1 and earlier:

MiCOM P443/P445/P446/P54x devices support integral intertripping in the form of InterMiCOM.

InterMiCOM can use an auxiliary EIA(RS)232 connection (MODEM InterMiCOM), or it can be realised by means of an integral optical fiber communication connection (fiber InterMiCOM, or InterMiCOM⁶⁴). An EIA(RS)232 (MODEM) InterMiCOM provides a single, full duplex communication channel, suitable for connection between two MiCOM P443/P445/P446/P54x relays. The fiber InterMiCOM (InterMiCOM⁶⁴) can provide up to two full-duplex communications channels. It can be used to connect two MiCOM P443/P445/P446/P54x relays using a single channel, or redundancy can be added by using dual communications. Alternatively, InterMiCOM⁶⁴ can be used to connect three MiCOM P443/P445/P446/P54x devices in a triangulated scheme for the protection of Teed feeders. MODEM InterMiCOM and InterMiCOM⁶⁴ are completely independent. They have separate settings, are described by separate DDB signals.

As a general rule, where possible, InterMiCOM⁶⁴ would be preferable from an application point of view since it is faster, and based on optical fibers it has high immunity to electro-magnetic interference. If the high speed communication channel requirement of InterMiCOM⁶⁴ cannot be provided, EIA(RS)232 provides a cost effective alternative.

Because of the differences between the implementation of EIA(RS)232 InterMiCOM and InterMiCOM⁶⁴, the settings associated with each implementation are different. Refer to P54x/EN ST for details of all settings. There are settings to prevent inadvertent cross-connection or loopback of communications channels (address settings), settings to accommodate different channel requirements (baud rate, clock source, channel selection) as well as the different settings used for channel quality monitoring and signal management actions in the event of channel failures.

The received InterMiCOM signals are continually monitored for quality and availability. In the event of quality or availability of the received signals falling below set levels, then an alarm can be raised.

Note An alarm indicating the signaling has failed, refers only to the incoming signals. The remote relay will monitor the other direction of the communications link for quality of transmission. If indication of the quality of the signal transmitted from the local relay for reception at the remote relay is required, then one of the InterMiCOM command channels can be used to reflect this back.

For software versions D1a and later:

Introduction

When a trip is issued by the differential element, in addition to tripping the local breaker, the relay will send a differential intertrip signal to the remote terminals. This will ensure tripping of all ends of the protected line, even for marginal fault conditions.

Selectable Inter-Tripping

The Line Differential communication channel Inter-tripping signals can be Enabled / Disabled independently via the relay menu ("GROUP x PHASE DIFF" menu Column).

Menu Text	Default setting	Setting Range
Intertrip CH1	Enabled	Disabled or Enabled
Intertrip CH2	Enabled	Disabled or Enabled

When set to Disabled, Differential Intertrips will NOT be sent to the remote end via the selected protection communications channel.

When set to Enabled, Differential Intertrips will be sent to the remote end via the selected protection communications channel, i.e. operation is as per the existing products without these settings.

The settings should be applied at all relays in the current differential protection scheme.

2.17.1

EIA(RS)232 InterMiCOM (“Modem InterMiCOM”)

The settings needed for the implementation of MODEM InterMiCOM are stored in two columns of the menu structure. The first column entitled **INTERMICOM COMMS** contains all the information to configure the communication channel and also contains the channel statistics and diagnostic facilities. The second column entitled **INTERMICOM CONF** selects the format of each signal and its fallback operation mode.

The settings needed for the InterMiCOM signaling are largely dependant on whether a direct or indirect (modem/multiplexed) connection between the scheme ends is used.

Direct connections will either be short metallic or dedicated fiber optic based (by means of suitable EIA(RS)232 to optical fiber converters) and hence can be set to have the highest signaling speed of 19200b/s. Due to this high signaling rate, the difference in operating speed between the direct, permissive and blocking type signals is so small that the most secure signaling (direct intertrip) can be selected without any significant loss of speed. In turn, since the direct intertrip signaling requires the full checking of the message frame structure and CRC checks, it would seem prudent that the **IM# Fallback Mode** be set to Default with a minimal intentional delay by setting **IM# FrameSyncTim** to 10 msec. In other words, whenever two consecutive messages have an invalid structure, the relay will immediately revert to the default value until a new valid message is received.

For indirect connections, the settings that can be applied will become more application and communication media dependent. As for the direct connections, consider only the fastest baud rate but this will usually increase the cost of the necessary modem/multiplexer. In addition, devices operating at these high baud rates may suffer from **data jams** during periods of interference and in the event of communication interruptions, may require longer re-synchronization periods. Both of these factors will reduce the effective communication speed thereby leading to a recommended baud rate setting of 9.6 kbit/s. As the baud rate decreases, the communications will become more robust with fewer interruptions, but the overall signaling times will increase.

Since it is likely that slower baud rates will be selected, the choice of signaling mode becomes significant. However, once the signaling mode has been chosen it is necessary to consider what should happen during periods of noise when message structure and content can be lost. If **Blocking** mode is selected, only a small amount of the total message is actually used to provide the signal, which means that in a noisy environment there is still a good likelihood of receiving a valid message. In this case, it is recommended that the **IM# Fallback Mode** is set to **Default** with a reasonably long **IM# FrameSyncTim**. A typical default selection of Default = 1 (blocking received substitute) would generally apply as the failsafe assignment for blocking schemes.

If **Direct Intertrip** mode is selected, the whole message structure must be valid and checked to provide the signal, which means that in a very noisy environment the chances of receiving a valid message are quite small. In this case, it is recommended that the **IM# Fallback Mode** is set to **Default** with a minimum **IM# FrameSyncTim** setting i.e. whenever a non-valid message is received, InterMiCOM will use the set default value. A typical default selection of Default = 0 (intertrip NOT received substitute) would generally apply as the failsafe assignment for intertripping schemes.

If **Permissive** mode is selected, the chances of receiving a valid message is between that of the **Blocking** and **Direct Intertrip** modes. In this case, it is possible that the **IM# Fallback Mode** is set to **Latched**. The table below highlights the recommended **IM# FrameSyncTim** settings for the different signaling modes and baud rates:

Baud rate	Minimum recommended "IM# FrameSyncTim" Setting		Minimum setting (ms)	Maximum setting (ms)
	Direct intertrip mode	Blocking mode		
600	100	250	100	1500
1200	50	130	50	1500
2400	30	70	30	1500
4800	20	40	20	1500
9600	10	20	10	1500
19200	10	10	10	1500

Note No recommended setting is given for the Permissive mode since it is anticipated that **Latched** operation will be selected. If **Default mode** is selected, the **IM# FrameSyncTim** setting should be set greater than the minimum settings listed above. If the **IM# FrameSyncTim** setting is set lower than the minimum setting listed above, there is a danger that the relay will monitor a correct change in message as a corrupted message.

A setting of 25% is recommended for the communications failure alarm.

2.18 InterMiCOM⁶⁴ (“Fiber InterMiCOM”)

The protection signaling channels of the P54x primarily intended to provide the capability for implementing current differential protection are also capable of supporting InterMiCOM⁶⁴ teleprotection. If the P54x is configured to provide differential protection, then the InterMiCOM⁶⁴ commands (IMx command) are transmitted together with the current differential signals. If the differential protection of the P54x is not being employed, then the communications messages are restructured to provide InterMiCOM⁶⁴ signaling of the type supported by the MiCOM P446, P443 and P445 relays. In either case, the fundamental operation of the InterMiCOM⁶⁴ commands is the same.

2.18.1 IMx Command Type

Due to the fast data rate, there is not so much difference in real performance between the three generic modes of teleprotection (Direct Intertrip, Permissive and Blocking), so only two are implemented for InterMiCOM⁶⁴. Direct Intertripping is available, with the second mode a combined mode for Permissive/Blocking (the latter is named as ‘Permissive’ in the menu). To increase the security for Intertripping (Direct transfer tripping), the InterMiCOM⁶⁴ Direct command is issued only when 2 valid consecutive messages are received. The recommended setting is:

- For Blocking schemes set ‘Permissive’
- For Permissive scheme set ‘Permissive’
- For Transfer (inter)tripping set ‘Direct’

The setting files provide independent setting for each of the first 8 commands. Due to the fast data rate, there will be minimal speed difference between the two mode options. Both will give a typical operating time (PSL trigger at the send relay, to PSL state change at the receive relay) as shown in this table:

Channel Mode Setting	Application	Typical Delay (ms)	Maximum (ms)	Comments
Permissive	Direct Fiber	3 to 7	9	Assuming no repeaters (no source of digital noise).
	Multiplexed Link	5 to 8 + MUX	12 + MUX	For channel bit error rate up to 1×10^{-3} .
Direct Intertrip	Direct Fiber	4 to 8	10	Assuming no repeaters (no source of digital noise).
	Multiplexed Link	6 to 8 + MUX	13 + MUX	For channel bit error rate up to 1×10^{-3} .

Table 9 - Typical operating times (PSL at send relay, to PSL state change at receive)

These figures are for InterMiCOM⁶⁴ used as a standalone feature. For use with differential message, add 2 ms for permissive mode and 4 ms for direct intertrip at 64 Kb/sec.

When using InterMiCOM⁶⁴ to implement Aided Scheme 1 or 2, we suggest assuming a conservative worst-case channel delay of 15 ms (pickup and reset delay), for the purposes of blocking and reversal guard calculations. The multiplexer delay should be added if applicable, taking into account longer standby path re-routings which might be experienced in the event of self-healing in a SONET/SDH telecomms network.

When using InterMiCOM⁶⁴ as a standalone feature in 3-terminal applications, where fallback to “chain” topology is possible in the event of failure of one communications leg in the triangle, longer times may be experienced. In fallback mode, retransmission of the messages occurs so the path length is doubled. Overall command times to the final end can be doubled.

2.18.2 IMx Fallback Mode

When the ‘Default’ setting is selected, the following ‘IMx Default Value’ settings are recommended: For Intertripping schemes set **0**, for Blocking schemes set **1**. In Permissive applications, the user may prefer to latch the last healthy received state.

3 WORKED PROTECTION EXAMPLE AND OTHER PROTECTION TIPS

3.1 Differential Protection Setting Examples

3.1.1 Differential Element

All four settings are user adjustable. This flexibility in settings allows the relay characteristic to be tailored to suit particular sensitivity and CT requirements. To simplify the protection engineer's task, we strongly recommend three of the settings be fixed to:

$$\begin{aligned} I_{s2} &= 2.0 \text{ pu} \\ k1 &= 30\% \\ k2 &= 150\% \text{ (2 terminal applications) or } 100\% \text{ (3 terminal applications)} \end{aligned}$$

These settings will give a relay characteristic suitable for most applications. It leaves only the I_{s1} setting to be decided by the user. The value of this setting should be greater than any mismatch between line ends, if any, and should also account for line charging current, where necessary.

By considering the circuit shown in the *Typical Plain Feeder Circuit* diagram below, the settings for the phase current differential element can be established.

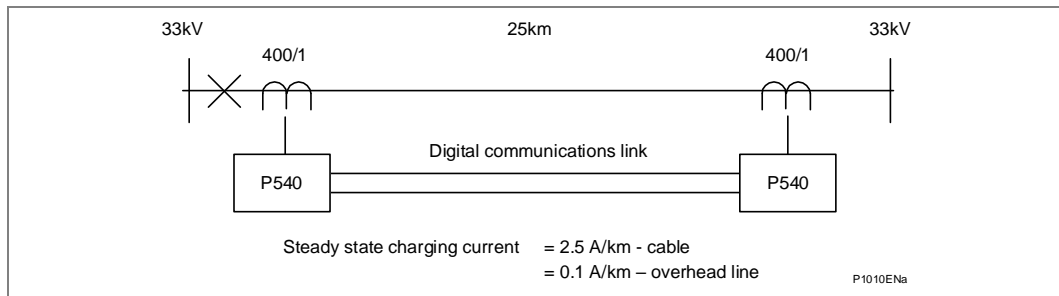

Figure 24 - Typical plain feeder circuit

The following settings should be set as follows:

$$\begin{aligned} I_{s2} &= 2.0 \text{ pu} \\ k1 &= 30\% \\ k2 &= 150\% \text{ (for a two terminal application)} \end{aligned}$$

This leaves the setting of I_{s1} to be established.

In the case that voltage inputs are not in place, no facility to account for line charging current is available. The setting of I_{s1} must therefore be set above 2.5 times the steady state charging current value. In this example, assume a cable is used and there are no VT inputs connected to the relay:

$$\begin{aligned} I_{s1} &> 2.5 \times I_{ch} \\ I_{s1} &> 2.5 \times (25\text{km} \times 2.5 \text{ A/km}) \\ I_{s1} &> 156.25 \text{ A} \end{aligned}$$

The line CTs are rated at 400 amps primary. The setting of I_{s1} must therefore exceed $156.25/400 = 0.391 \text{ pu}$. Therefore select:

$$I_{s1} = 0.4 \text{ pu}$$

If VT is connected, a facility exists to overcome the effects of the line charging current. It will be necessary in this case to enter the line positive sequence susceptance value. This can be calculated from the line charging current as follows (assuming a VT ratio of 33 kV / 110 V):

$$I_{ch} = 25 \times 2.5 \text{ A} = 62.5 \text{ A}$$

Susceptance

$$B = \omega C = I_{ch}/V$$

$$B = 62.5 \text{ A}/(33/\sqrt{3}) \text{ kV primary}$$

$$B = 3.28 \times 10^{-3} \text{ S primary}$$

Therefore set:

$$B = 3.28 \text{ mS primary} (= 2.46 \text{ mS secondary})$$

Is1 may now be set below the value of line charging current if required, however it is suggested that Is1 is chosen only sufficiently below the charging current to offer the required fault resistance coverage as described in the *Relay Sensitivity under Heavy Load Conditions* section. Where charging current is low or negligible, the recommended factory default setting of 0.2 In should be applied.

3.1.2

Transformer Feeder Examples

Ratio Correction Example:

P543 / P545 relays are suitable for the protection of transformer feeders. For example:

20MVA Transformer, Dyn1, 33/11 kV

HV CT ratio - 400/1

LV CT ratio - 1500/1

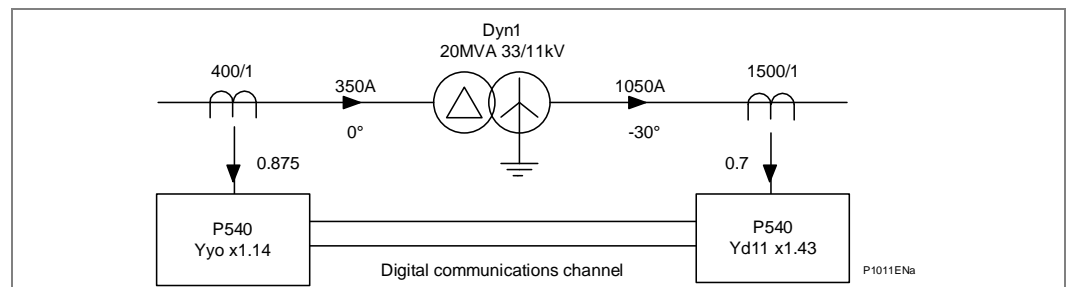

Figure 25 - Typical transformer feeder circuit

It is necessary to calculate the required ratio correction factor to apply to the relays at each line end.

$$33 \text{ kV full load current} = 20 \text{ MVA}/(33 \text{ kV} \cdot \sqrt{3}) = 350 \text{ A}$$

$$\text{Secondary current} = 350 \times 1/400 = 0.875 \text{ A}$$

$$11 \text{ kV full load current} = 20 \text{ MVA}/(11 \text{ kV} \cdot \sqrt{3}) = 1050 \text{ A}$$

$$\text{Secondary current} = 1050 \times 1/1500 = 0.7 \text{ A}$$

Each of these secondary currents should be corrected to relay rated current; in this case 1A.

HV ratio correction factor $1/0.875 = 1.14$ [Setting applied to relay]

LV ratio correction factor $1/0.7 = 1.43$ [Setting applied to relay]

When a Star/Delta software interposing CT is chosen, no additional account has to be taken for the $\sqrt{3}$ factor which would be introduced by the delta winding. This is accounted for by the relay.

Phase Correction Example:

Using the same transformer as shown in the Typical Transformer Feeder Circuit diagram shown above it is now necessary to correct for the phase shift between the HV and LV windings.

The transformer connection shows that the delta connected high voltage line current leads the low voltage line current by 30°. To ensure that this phase shift does not create a differential current, the phase shift must be corrected in the LV secondary circuit. The LV relay software interposing CT is effectively a winding replica of the main power transformer. It not only provides a +30° phase shift, but also performs the necessary function of filtering out any LV zero sequence current component.

Hence, the HV relay setting requires no phase shift or zero sequence current filtering (as HV winding is delta connected). The LV relay setting requires phase shifting by +30° and also requires zero sequence current filtering (as LV winding is star connected).

Set: HV = Yy0
LV = Yd11 (+30°)

It is important when considering the software ICT connection, to account for both the phase shift and zero sequence current filtering. For example, with the transformer in the Typical Transformer Feeder Circuit diagram shown above, it would have been possible to provide phase compensation by applying Yd1 and Yy0 settings to the HV and LV relays respectively. Although this provides correct phase shift compensation, no zero sequence current filtering exists on the LV side and hence relay maloperation could occur for an external earth fault.

3.1.3

Teed Feeder Example

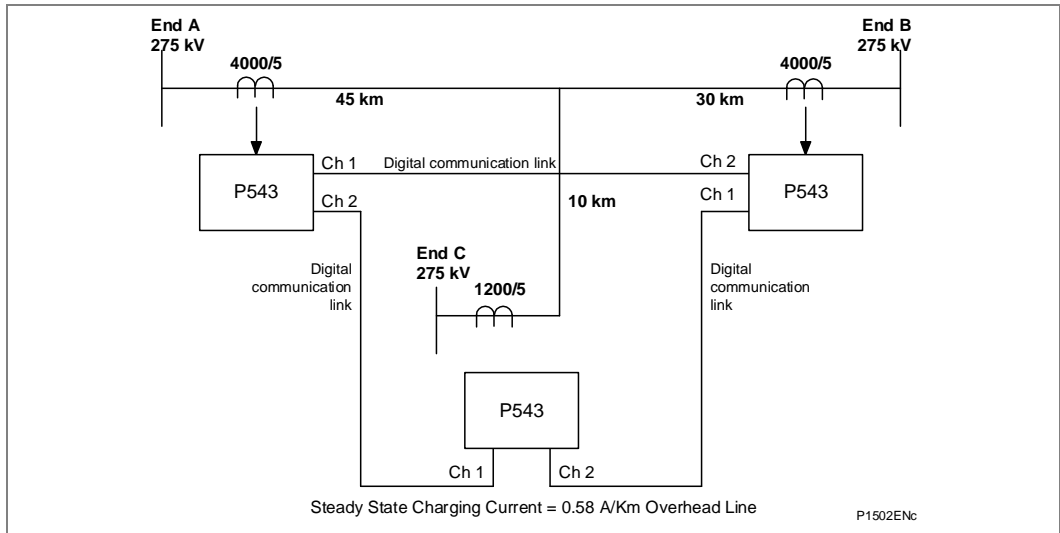

Figure 26 - Typical teed feeder application

If there are no VT inputs connected, P54x relays do not have facilities to account for charging line current, therefore the setting Is1 must be 2.5 times the steady state charging current.

If VT inputs are connected, there is a facility to overcome the effect of charging current. As mentioned before, it is necessary to enter the positive sequence susceptance value.

Considering the charging current on the circuit shown in the previous Typical Feed Feeder Application diagram, the following calculation is done:

- $I_{ch} = 0.58 \text{ A} (45 + 30 + 10) = 49.3 \text{ A}$
- $\text{Susceptance} = \omega C = I_{ch}/V$
- $B = 49.3 \text{ A} / (275 / \sqrt{3}) \text{ kV primary}$
- $B = 0.31 \times 10^{-3} \text{ S primary.}$

As the CT ratio on the three ends are different, it is necessary to apply a correction factor in order to ensure secondary currents balance for all conditions:

To calculate the Correction Factor (CF), the same primary current must be used even this current is not the expected load transfer for every branch. This will ensure secondary current balance for all conditions.

A good approximation to calculate the CF, would be to use the primary rated current of the smallest CT ratio as a base current. In this case we will use the primary rated CT current at End C, to correct the secondary currents to the relay rated current:

For End A 1200 A

- Secondary current = $1200 \times 5/4000 = 1.5 \text{ A}$
- $CF = 5/1.5 = 3.33$

For End B 1200 A

- Secondary current = $1200 \times 5/4000 = 1.5 \text{ A}$
- $CF = 5/1.5 = 3.33$

For End C 1200 A prim = 5 A sec

- Secondary current = $1200 \times 5/1200 = 5 \text{ A}$
- $CF = 5/5 = 1$

As mentioned in the Differential Element Example, these settings are recommended:

$$Is1 = 0.2 I_n$$

$$Is2 = 2 I_n$$

$$K1 = 30\%$$

$$K2 = 100\%$$

Therefore, settings in secondary values for each end are:

$$Is1 = 0.2 I_n = 1 \text{ A}$$

$$Is2 = 2 I_n = 10 \text{ A}$$

Note Settings shown in primary values at ends A and B appear different compared with end C. This is not a problem as the currents at ends A and B will be multiplied by the CF, when the differential calculation is done. There would not be a requirement to alter settings by CF as the relay works in secondary values.

Susceptance Settings:

For Ends A and B

With a VT ratio 275 kV/110 V and CT ratio 4000/5

$$RCT = 800$$

$$RVT = 2500$$

$$B = 310 \mu\text{S}$$

$$\text{Secondary susceptance} = 310 \mu\text{S} \times RVT / RCT = 968 \mu\text{S}$$

For End C

With a VT ratio 275 kV/110 V and CT ratio 1200/5

$$B = 310 \mu\text{S}$$

$$\text{Secondary susceptance} = 310 \mu\text{S} \times RVT / RCT = 3.22 \text{ mS sec.}$$

3.1.4

Three Winding Transformer in Zone with Different Rated CTs Example

P543 / P545 relays are suitable for the protection of three winding transformers in zone.

An example is shown in the *Three winding transformer in zone application* diagram.

100 MVA/100MVA/30MVA Transformer, Yyn0d1, 400 kV/110 kV/30 kV

HV, 400 kV CT ratio - 600/1

MV, 110 kV CT ratio - 1200/1

LV, 30 kV CT ratio - 2000/5

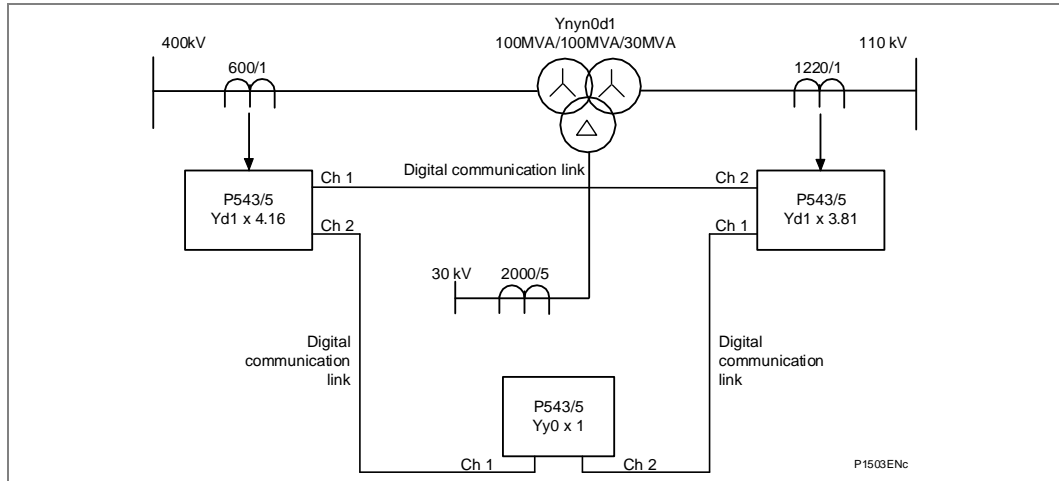

Figure 27 - Three winding transformer in zone application

These three relays must be rated differently, i.e. 1A for HV and MV side and 5 A for 30 kV side. This does not present a problem for P54x relays as the digital signals representing the currents are in pu.

It is necessary to calculate the required ratio Correction Factor (CF) as well as the phase correction factor for each end. To choose the appropriate vector compensation, it is necessary to account for phase current and zero sequence current filtering as explained in example the above Transformer Feeder Example section.

To calculate the CF range, it is necessary to use the same MVA base for the three sides of the transformer although the third winding actually has a lower rated MVA. This is to ensure secondary current balance for all conditions.

For HV side:	$100 \text{ MVA} / (400 \text{ kV} \cdot \sqrt{3})$	=	144.34 A.
	Secondary current	=	$144.34 \times 1/600 = 0.24 \text{ A}$
For MV side:	$100 \text{ MVA} / (110 \text{ kV} \cdot \sqrt{3})$	=	524.86 A.
	Secondary current	=	$524.86 \times 1/1200 = 0.44 \text{ A}$
For LV side:	$100 \text{ MVA} / (30 \text{ kV} \cdot \sqrt{3})$	=	1924.5 A.
	Secondary current	=	$1924.5 \times 5/2000 = 4.81 \text{ A}$

Each secondary current should be corrected to relay rated current, in this case 1A for HV and MV side and 5 A for 30 kV side

$$\text{HV ratio CF} = 1/0.24 = 4.16$$

$$\text{MV ratio CF} = 1/0.44 = 2.29$$

$$\text{LV ratio CF} = 5/4.81 = 1.04$$

To choose the vector compensation connection, it should be noted that the Wye connected HV line is in phase with the MV line current and leads the LV line current by 30° . Therefore for LV side, the phase shift must be compensated.

To account for the zero sequence current filtering in the case of an external earth fault, it is necessary to connect the Wye connected power transformer windings to an interposing current transformer (internal relay ICT) to trap the zero sequence current (the secondary side being connected delta).

To account for both vector compensation and zero sequence current filtering, the following vectorial compensation setting is recommended:

- For HV side = Yd1 (-30 deg)
- For MV side = Yd1 (-30 deg)
- For LV side = Yy0 (0 deg)

<i>Note</i>	<i>It is not necessary to include the $\sqrt{3}$ factor in the calculation as this is incorporated in the relay algorithm.</i>
-------------	---

P543 and P545 relays are suitable for transformer applications, as such an inrush restrain is provided on these relay models. By enabling inrush restrain, an additional current differential high setting (Id High set) becomes enable.

When the inrush restrain feature is enabled, it is necessary that this function is enabled in the relay at each line end (3 ends).

For the differential calculation the same recommended settings for the previous examples are recommended:

- $I_{s1} = 0.2 I_n$
- $I_{s2} = 2 I_n$
- $K1 = 30\%$
- $K2 = 100\%$

Therefore, settings in secondary values are:

For relays rated to 1 A (HV and MV sides) $I_{s1} = 200 \text{ mA}$ and $I_{s2} = 2 \text{ A}$

For relay rated to 5 A (LV side) $I_{s1} = 1 \text{ A}$ and $I_{s2} = 10 \text{ A}$

For the current differential high setting (Id High set) the setting must be in excess of the anticipated inrush current after ratio correction. Assuming that maximum inrush is 12 times the nominal transformer current, it would be safe to set the relays at 15 times the nominal current, therefore the setting would be:

Id high set : for HV side = $15 I_n = 15 \text{ A}$
 for MV side = $15 I_n = 15 \text{ A}$
 for LV side = $15 I_n = 75 \text{ A}$

3.2 Distance Protection Setting Example

3.2.1 Objective

To protect the 100 km double circuit line between Green Valley and Blue River substations using a MiCOM P445/P54x in distance POR Permissive Overreach mode and to set the relay at Green Valley substation, shown in the following diagram. It is assumed that mho characteristics will be used.

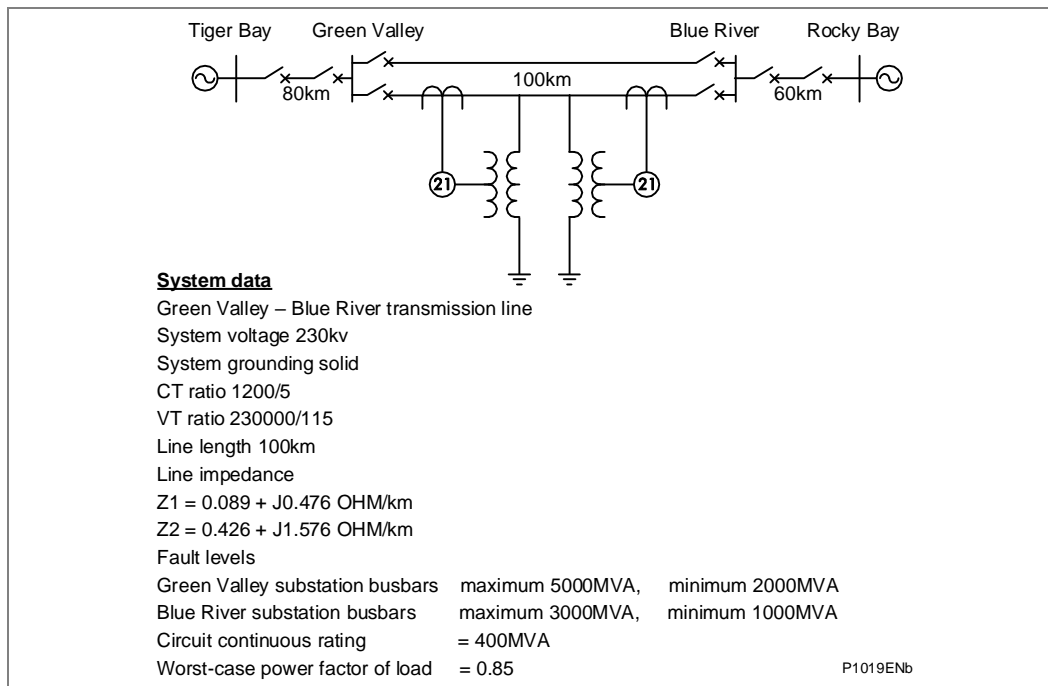

Figure 28 - System assumed for worked example

3.2.2 System Data

Line length:	100 km
Line impedances:	$Z1 = 0.089 + j0.476 = 0.484 \angle 79.4^\circ \Omega/\text{km}$ $Z0 = 0.426 + j1.576 = 1.632 \angle 74.8^\circ \Omega/\text{km}$ $Z0/Z1 = 3.372 \angle -4.6^\circ$
CT ratio:	1 200/5
VT ratio:	230 000/115

3.2.3 Relay Settings

It is assumed that Zone 1 Extension is not used and that only three forward zones are required. Settings on the relay can be performed in primary or secondary quantities and impedances can be expressed as either polar or rectangular quantities (menu selectable). For the purposes of this example, secondary quantities are used.

3.2.4 Line Impedance

$$\text{Ratio of secondary to primary impedance} = \frac{1200 / 5}{230000 / 115} = 0.12$$

$$\text{Line impedance secondary} = \text{ratio CT/VT} \times \text{line impedance primary.}$$

$$\begin{aligned} \text{Line Impedance} &= 100 \times 0.484 \angle 79.4^\circ \text{ (primary)} \times 0.124 \\ &= 5.81 \angle 79.4^\circ \Omega \text{ secondary.} \end{aligned}$$

$$\text{Select Line Angle} = 80^\circ \text{ for convenience.}$$

Therefore set Line Impedance and Line Angle: = 5.81 $\angle 80^\circ$ Ω secondary.

3.2.5 Residual Compensation For Ground Fault Elements

The residual compensation factor can be applied independently to certain zones if required. This feature is useful where line impedance characteristics change between sections or where hybrid circuits are used. In this example, the line impedance characteristics do not change and as such a common KZN factor can be applied to each zone. This is set as a ratio **kZN Res. Comp**, and an angle **kZN Angle**:

$$\begin{aligned} \text{kZN Res. Comp, } |kZN| &= (Z_0 - Z_1) / 3Z_1 \text{ i.e.: As a ratio} \\ \text{kZN Angle, } \angle kZN &= \angle (Z_0 - Z_1) / 3Z_1 \text{ Set in degrees} \\ ZL_0 - ZL_1 &= (0.426 + j1.576) - (0.089 + j0.476) \\ &= 0.337 + j1.1 \\ &= 1.15 \angle 72.9^\circ \end{aligned}$$

$$kZN = \frac{1.15 \angle 72.9^\circ}{3 \times 0.484 \angle 79.4^\circ} = 0.79 \angle -6.5^\circ$$

Therefore, select:

$$\text{kZN Res. Comp} = 0.7$$

$$\text{kZN Angle} = -6.5^\circ$$

3.2.6 Zone 1 Phase and Ground Reach Settings

Required Zone 1 reach is to be 80% of the line impedance between Green Valley and Blue River substations.

Setting the Relay in the SIMPLE setting mode (recommended):

- Set Zone 1 Ph and Zone 1 Gnd reach = 80%

From this the relay will automatically calculate the required ohmic reaches, or they can be entered manually in the ADVANCED mode, as follows:

$$\text{Required Zone 1 reach} = 0.8 \times 100 \times 0.484 \angle 79.4^\circ \times 0.12$$

$$Z1 = 4.64 \angle 79.4^\circ \Omega \text{ secondary}$$

$$\text{The Line Angle} = 80^\circ$$

$$\text{Therefore actual Zone 1 reach, } Z1 = 4.64 \angle 80^\circ \Omega \text{ secondary.}$$

3.2.7 Zone 2 Phase and Ground Reach Settings

Required Zone 2 impedance = (Green Valley-Blue River) line impedance + 50% (Blue River-Rocky Bay) line impedance

$$Z2 = (100+30) \times 0.484 \angle 79.4^\circ \times 0.12 = 7.56 \angle 79.4^\circ \Omega \text{ secondary.}$$

$$\text{The Line Angle} = 80^\circ$$

$$\text{Actual Zone 2 reach setting} = 7.56 \angle 80^\circ \Omega \text{ secondary}$$

Alternatively, in SIMPLE setting mode, this reach can be set as a percentage of the protected line. Typically a figure of at least 120% is used.

3.2.8 Zone 3 Phase and Ground Reach Settings

Required Zone 3 forward reach = (Green Valley-Blue River + Blue River-Rocky Bay) x 1.2

$$= (100+60) \times 1.2 \times 0.484 \angle 79.4^\circ \times 0.12$$

$$Z3 = 11.15 \angle 79.4^\circ \text{ ohms secondary}$$

$$\text{Actual Zone 3 forward reach setting} = 11.16 \angle 80^\circ \text{ ohms secondary}$$

Alternatively, in SIMPLE setting mode, this reach can be set as a percentage of the protected line.

3.2.9 Zone 3 Reverse Reach

In the absence of other special requirements, Zone 3 can be given a small reverse reach setting, of $Z3' = 10\%$. This is acceptable because the protected line length is > 30km.

3.2.10 Zone 4 Reverse Settings with POR and BLOCKING Schemes

Where zone 4 is used to provide reverse directional decisions for Blocking or Permissive Overreach schemes, zone 4 must reach further behind the relay than zone 2 for the remote relay. This can be achieved by setting: $Z4 \geq ((\text{Remote zone 2 reach}) \times 120\%)$, where mho characteristics are used.

Remote Zone 2 reach = (Blue River-Green Valley) line impedance + 50% (Green Valley-Tiger Bay) line impedance

$$= (100+40) \times 0.484 \angle 79.4^\circ \times 0.12$$

$$= 8.13 \angle 79.4^\circ \Omega \text{ secondary}$$

$$Z4 \geq ((8.13 \angle 79.4^\circ) \times 120\%) - (5.81 \angle 79.4^\circ)$$

$$= 3.95 \angle 79.4^\circ$$

$$\text{Minimum zone 4 reverse reach setting} = 3.96 \angle 80^\circ \text{ ohms secondary}$$

3.2.11

Load Avoidance

The maximum full load current of the line can be determined from the calculation:

$$I_{FLC} = \frac{[(\text{Rated MVA}_{FLC}) / (\sqrt{3} \times \text{Line kV})]}{1}$$

In practice, relay settings must allow for a level of overloading, typically a maximum current of 120% I_{FLC} prevailing on the system transmission lines. Also, for a double circuit line, during the auto-reclose dead time of fault clearance on the adjacent circuit, twice this level of current may flow on the healthy line for a short period of time. Therefore the circuit current loading could be $2.4 \times I_{FLC}$.

With such a heavy load flow, the system voltage may be depressed, typically with phase voltages down to 90% of V_n nominal.

Allowing for a tolerance in the measuring circuit inputs (line CT error, VT error, relay tolerance, and safety margin), this results in a load impedance which might be 3 times the expected "rating".

To avoid the load, the blinder impedance needs to be set:

$$\begin{aligned} Z &\leq \frac{(\text{Rated phase-ground voltage } V_n)}{(I_{FLC} \times 3)} \\ &= \frac{(115/\sqrt{3})}{(I_{FLC} \times 3)} \end{aligned}$$

Set the $V <$ Blinder voltage threshold at the recommended 70% of $V_n = 66.4 \times 0.7 = 45 \text{ V}$.

3.2.12

Additional Settings for Quadrilateral Applications

3.2.12.1

Phase Fault Resistive Reaches (Rph)

In primary impedance terms, RPh reaches must be set to cover the maximum expected phase-to-phase fault resistance. Ideally, RPh must be set greater than the maximum fault arc resistance for a phase-phase fault, calculated as follows:

$$R_a = \frac{(28710 \times L)}{I_f^{1.4}}$$

Where:

I_f = Minimum expected phase-phase fault current (A);

L = Maximum phase conductor separation (m);

R_a = Arc resistance, calculated from the van Warrington formula (Ω).

Typical figures for R_a (primary Ω) are given in the following table, for different values of minimum expected phase fault current.

Conductor spacing (m)	Typical system voltage (kV)	$I_f = 1 \text{ kA}$	$I_f = 2 \text{ kA}$	$I_f = 3 \text{ kA}$
4	110 - 132	7.2 Ω	2.8 Ω	1.6 Ω
8	220 - 275	14.5 Ω	5.5 Ω	3.1 Ω
11	380 - 400	19.9 Ω	7.6 Ω	4.3 Ω

Note Dual-end infeed effects will make a fault resistance appear higher, because each relay cannot measure the current contribution from the remote line end. The apparent fault resistance increase factor could be 2 to 8 times the calculated resistance. Therefore it is recommended that the Zone resistive reaches are set to say, 4 times the primary arc resistance calculation.

Typical figures for R_a (primary Ω) for different values of minimum expected phase fault current

In the example, the minimum phase fault level is 1000 MVA. This is equivalent to an effective short-circuit fault feeding impedance of:

$$Z = \text{kV}^2/\text{MVA} = 2302/1000 = 53 \Omega \text{ (primary)}$$

The lowest phase fault current level is equivalent to:

$$\begin{aligned} I_{\text{fault}} &= (\text{MVA} \times 1000)/(\sqrt{3} \times \text{kV}) \\ &= (1000 \times 1000)/(\sqrt{3} \times 230) \\ &= 2.5 \text{ kA} \end{aligned}$$

And this fault current in the van Warrington formula would give an arc resistance of:

$$R_a = 4 \Omega$$

As this impedance is relatively small compared to the value “Z” calculated above, there is no need to perform an iterative equation to work out the actual expected I_{fault} (which would in reality be lower due to the added R_a arc resistance in the fault loop). It will suffice to increase the calculated R_a by the recommended factor of four, and a little extra to account for the fault current being lower than that calculated. So, in this case use a minimum setting of $5 \times R_a$, which is 20Ω primary.

It is obvious that the setting could easily be set above 20Ω on the primary system (perhaps following the rule of thumb formula in the Quadrilateral Phase Resistive Reaches section earlier in this chapter). Typically, all zone resistive reaches would be set greater than this 20Ω primary figure, and ideally less than the load impedance (see the Load Avoidance section).

3.2.12.2

Ground Fault Resistive Reaches (RGnd)

Fault resistance would comprise arc-resistance and tower footing resistance. A typical resistive reach coverage setting would be 40Ω on the primary system.

For high resistance earth faults, the situation may arise where no distance elements could operate. In this case it will be necessary to provide supplementary earth fault protection, for example using the relay Channel Aided DEF protection. In such cases it is not essential to set large resistive reaches for ground distance, and then R_{Gnd} can be set according to the rule of thumb formula in the Quadrilateral Ground Resistive Reaches and Tilting section earlier in this chapter.

3.3 Teed Feeder Protection

The application of distance relays to three terminal lines is fairly common. However, several problems arise when applying distance protection to three terminal lines.

3.3.1 Apparent Impedance seen by the Distance Elements

The following illustration shows a typical three terminal line arrangement. For a fault at the busbars of terminal B the impedance seen by a relay at terminal A will be equal to:

$$Z_a = Z_{at} + Z_{bt} + [Z_{bt} \cdot (I_c/I_a)]$$

Relay A will underreach for faults beyond the tee-point with infeed from terminal C. When terminal C is a relatively strong source, the underreaching effect can be substantial. For a zone 2 element set to 120% of the protected line, this effect may result in non-operation of the element for internal faults. This not only effects time delayed zone 2 tripping but also channel-aided schemes. Where infeed is present, it will be necessary for Zone 2 elements at all line terminals to overreach both remote terminals with allowance for the effect of tee-point infeed. Zone 1 elements must be set to underreach the true impedance to the nearest terminal without infeed. Both these requirements can be met through use of the alternative setting groups.

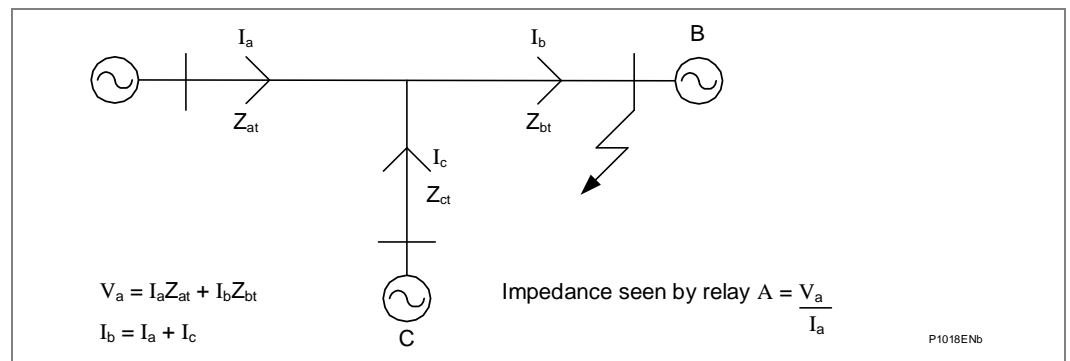

Figure 29 - Teed feeder application - apparent impedances seen by relay

3.3.2 Permissive Overreach (POR) Schemes

To ensure operation for internal faults in a POR scheme, the relays at the three terminals should be able to see a fault at any point within the protected feeder. This may demand very large zone 2 reach settings to deal with the apparent impedances seen by the relays.

A POR scheme requires the use of two signaling channels. A permissive trip can only be issued upon operation of zone 2 and receipt of a signal from both remote line ends. The requirement for an 'AND' function of received signals must be realized through use of contact logic external to the relay, or the internal Programmable Scheme Logic (PSL). Although a POR scheme can be applied to a three terminal line, the signaling requirements make its use unattractive.

3.3.3 Permissive Underreach Schemes

For a PUR scheme, the signaling channel is only keyed for internal faults. Permissive tripping is allowed for operation of zone 2 plus receipt of a signal from either remote line end. This makes the signaling channel requirements for a PUR less demanding than for a POR. A common Power Line Carrier (PLC) signaling channel or a triangulated signaling arrangement can be used. This makes a PUR for a teed feeder attractive than a POR. The channel is keyed from operation of zone 1 tripping elements. Provided at least one zone 1 element can see an internal fault then aided tripping will occur at the other terminals if the overreaching zone 2 setting requirement has been met. There are however two cases where this is not possible:

The following figure is divided into three parts: (i), (ii) and (iii).

- (i) shows where a short tee is connected close to another terminal. Here zone 1 elements set to 80% of the shortest relative feeder length do not overlap. This leaves a section not covered by any zone 1 element. Any fault in this section would result in zone 2 time-delayed tripping.
- (ii) shows where terminal 'C' has no infeed. Faults close to this terminal will not operate the relay at 'C' and hence the fault will be cleared by the zone 2 time-delayed elements of the relays at 'A' and 'B'.
- (iii) shows a further difficulty for a PUR scheme. Here current is outfed from terminal 'C' for an internal fault. The relay at 'C' will see the fault as reverse and not operate until the breaker at 'B' has opened; i.e. sequential tripping will occur.

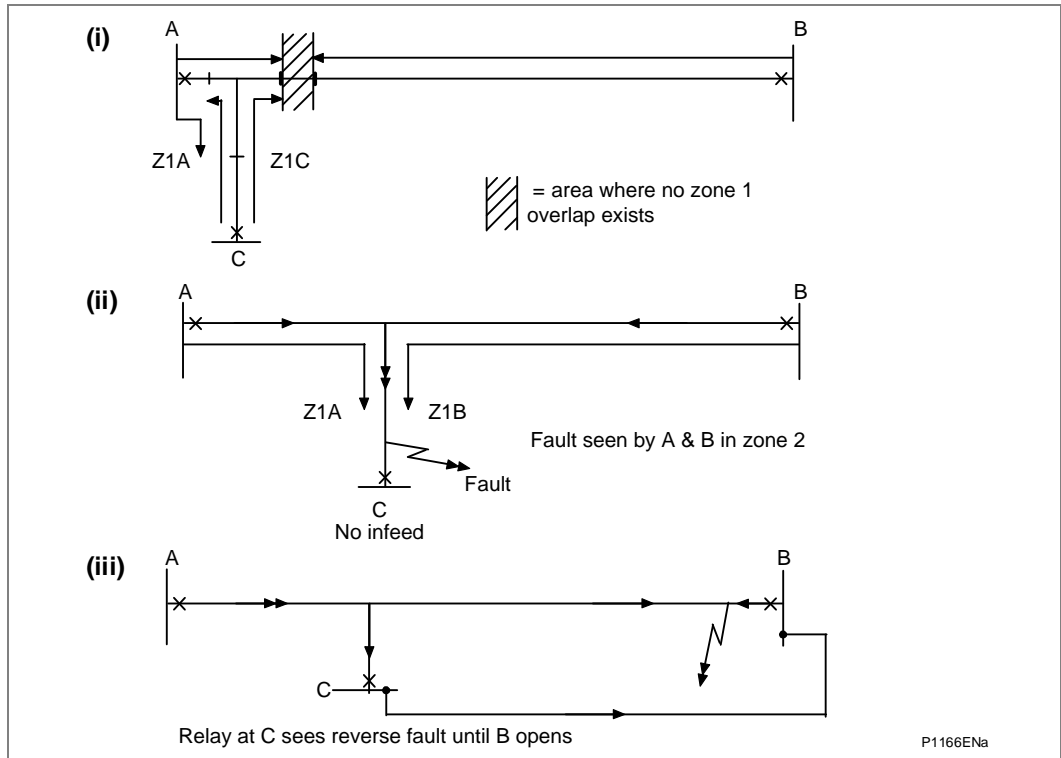

Figure 30 - Teed feeder applications

3.3.4

Blocking Schemes

Blocking schemes are particularly suited to the protection of teed feeders, since high speed operation can be achieved where there is no current infeed from one or more terminals. The scheme also has the advantage that only a common simplex channel or a triangulated simplex channel is required.

The major disadvantage of blocking schemes is highlighted in section (iii) of the previous figure where fault current is outfed from a terminal for an internal fault condition. Relay 'C' sees a reverse fault condition. This results in a blocking signal being sent to the two remote line ends, preventing tripping until the normal zone 2 time delay has expired.

3.4 VT Connections

3.4.1 Open Delta (Vee Connected) VTs

MiCOM relays can be used with V-connected VTs by connecting the VT secondaries to:

- C19, C20 and C21 input terminals, with the C22 input left unconnected for P14x, P341, P342, P343, P344, P345, P443, P445, P543, P544 and P841A
- D19, D20 and D21 input terminals, with the D22 input left unconnected for P446, P545, P546, P547 and P841B
- C2, C4 and E2 input terminals, with the Vn input left unconnected for P64x (P642, P643 & P645)

For more details, see the see the *Connection Diagrams* chapter.

This type of VT arrangement cannot pass zero-sequence (residual) voltage to the relay, or provide any phase to neutral voltage quantities. Therefore any protection that is dependent upon phase to neutral voltage measurements should be disabled.

The ground directional comparison elements, ground distance elements, neutral voltage displacement (residual overvoltage) and CT supervision all use phase-to-neutral voltage signals for their operation and should be disabled. The DEF elements should be selected for negative sequence polarization to avoid the use of phase-to-neutral voltages. Under and over voltage protection can be set as phase-to-phase measuring elements, whereas all other protection elements should remain operational.

The accuracy of the single phase voltage measurements can be impaired when using vee connected VT's. The relay attempts to derive the phase to neutral voltages from the phase to phase voltage vectors. If the impedance of the voltage inputs were perfectly matched the phase to neutral voltage measurements would be correct, provided the phase to phase voltage vectors were balanced. However, in practice there are small differences in the impedance of the voltage inputs, which can cause small errors in the phase to neutral voltage measurements. This may give rise to an apparent residual voltage. This problem also extends to single phase power measurements that are also dependent upon their respective single phase voltages.

The phase to neutral voltage measurement accuracy can be improved by connecting three, well-matched, load resistors between the relevant phase voltage inputs and neutral thus creating a 'virtual' neutral point. The load resistor values must be chosen so that their power consumption is within the limits of the VT. It is recommended that 10 k Ω \pm 1% (6 W) resistors are used for the 110 V (Vn) rated relay, assuming the VT can supply this burden.

The connections are as follows for different MiCOM relays:

Phase Voltage Inputs	Neutral	MiCOM IEDs
C19, C20, C21	C22	P14x, P341, P342, P343, P344, P345, P443, P445, P446, P543, P544, P841A
D19, D20, D21	D22	P545, P546, P841B

3.4.2 VT Single Point Earthing

The MiCOM P14x/P341/P34x/P391/P443/P445/P446/P54x/P547/P64x/P841 will function correctly with conventional 3-phase VTs earthed at any one point on the VT secondary circuit. Typical earthing examples being neutral earthing, or B-phase (UK: "yellow phase" earthing).

3.5 Trip Circuit Supervision (TCS)

The trip circuit, in most protective schemes, extends beyond the IED enclosure and passes through components such as fuses, links, relay contacts, auxiliary switches and other terminal boards. This complex arrangement, coupled with the importance of the trip circuit, has led to dedicated schemes for its supervision.

Several Trip Circuit Supervision (TCS) scheme variants are offered. Although there are no dedicated settings for TCS, the following schemes can be produced using the Programmable Scheme Logic (PSL).

A user alarm is used in the PSL to issue an alarm message on the relay front display. If necessary, the user alarm can be re-named using the menu text editor to indicate that there is a fault with the trip circuit.

3.5.1 TCS Scheme 1

3.5.1.1 Scheme Description

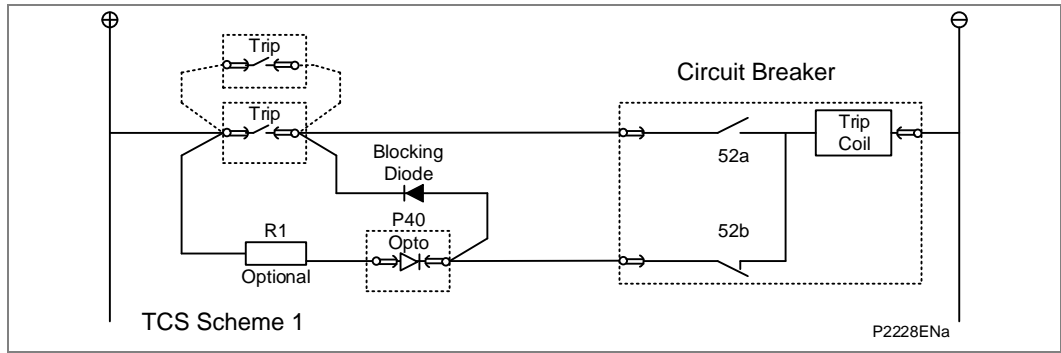

Figure 31 - TCS scheme 1

This scheme provides supervision of the trip coil with the breaker open or closed, however, pre-closing supervision is not provided. This scheme is also incompatible with latched trip contacts, as a latched contact will short out the opto for greater than the recommended DDO timer setting of 400ms. If breaker status monitoring is required a further 1 or 2 opto inputs must be used.

Note A 52a CB auxiliary contact follows the CB position and a 52b contact is the opposite.

When the breaker is closed, supervision current passes through the opto input, blocking diode and trip coil. When the breaker is open current still flows through the opto input and into the trip coil via the 52b auxiliary contact. Hence, no supervision of the trip path is provided whilst the breaker is open. Any fault in the trip path will only be detected on CB closing, after a 400ms delay.

Resistor R1 is an optional resistor that can be fitted to prevent maloperation of the circuit breaker if the opto input is inadvertently shorted, by limiting the current to <60mA. The resistor should not be fitted for auxiliary voltage ranges of 30/34 volts or less, as satisfactory operation can no longer be guaranteed. The table below shows the appropriate resistor value and voltage setting (**Opto Config.** menu) for this scheme. This TCS scheme will function correctly even without resistor R1, since the opto input automatically limits the supervision current to less than 10mA. However, if the opto is accidentally shorted the circuit breaker may trip.

Auxiliary Voltage (Vx)	Resistor R1 (ohms)	Opto Voltage Setting with R1 Fitted
24/27	-	-
30/34	-	-
48/54	1.2k	24/27
110/125	2.5k	48/54
220/250	5.0k	110/125

Note When R1 is not fitted the opto voltage setting must be set equal to supply voltage of the supervision circuit.

Table 10 - Resistor values for TCS scheme 1

3.5.1.2

Scheme 1 PSL

The next figure shows the scheme logic diagram for the TCS scheme 1. Any of the available opto inputs can be used to show whether or not the trip circuit is healthy. The delay on drop off timer operates as soon as the opto is energized, but will take 400ms to drop off/reset in the event of a trip circuit failure. The 400ms delay prevents a false alarm due to voltage dips caused by faults in other circuits or during normal tripping operation when the opto input is shorted by a self-reset trip contact. When the timer is operated the NC (normally closed) output relay opens and the LED and user alarms are reset.

The 50ms delay on pick-up timer prevents false LED and user alarm indications during the relay power up time, following an auxiliary supply interruption.

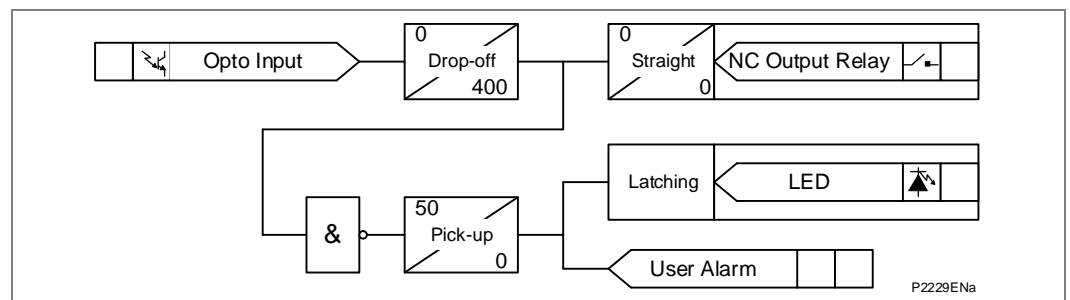

Figure 32 - PSL for TCS schemes 1 and 3

3.5.2 TCS Scheme 2a

3.5.2.1 Scheme Description

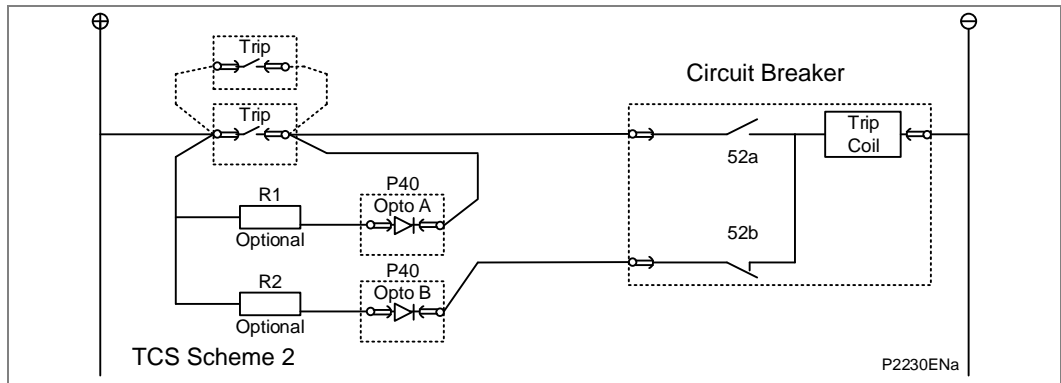

Figure 33 - TCS scheme 2a

Much like scheme 1, this scheme provides supervision of the trip coil with the breaker open or closed and also does not provide pre-closing supervision. However, using two opto inputs allows the relay to correctly monitor the circuit breaker status since they are connected in series with the CB auxiliary contacts. This is achieved by assigning Opto A to the 52a contact and Opto B to the 52b contact. Provided the **Circuit Breaker Status** is set to **52a and 52b** (CB CONTROL column) the relay will correctly monitor the status of the breaker. This scheme is also fully compatible with latched contacts as the supervision current will be maintained through the 52b contact when the trip contact is closed.

When the breaker is closed, supervision current passes through opto input A and the trip coil. When the breaker is open current flows through opto input B and the trip coil. As with scheme 1, no supervision of the trip path is provided whilst the breaker is open. Any fault in the trip path will only be detected on CB closing, after a 400 ms delay.

As with scheme 1, optional resistors R1 and R2 can be added to prevent tripping of the CB if either opto is shorted. The resistor values of R1 and R2 are equal and can be set the same as R1 in scheme 1.

3.5.2.2 Scheme 2a PSL

The PSL for this scheme is practically the same as that of scheme 1. The main difference being that both opto inputs must be off before a trip circuit fail alarm is given.

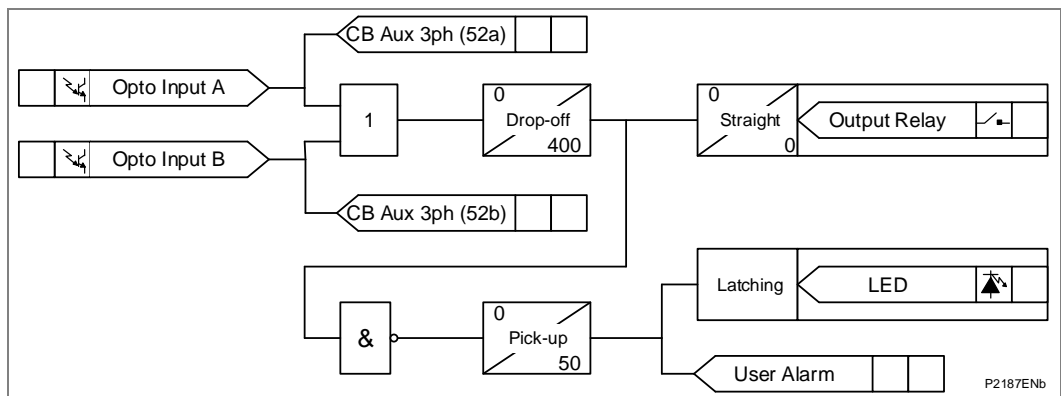

Figure 34 - PSL for TCS schemes 2a

3.5.3

TCS Scheme 2b

3.5.3.1

Scheme Description

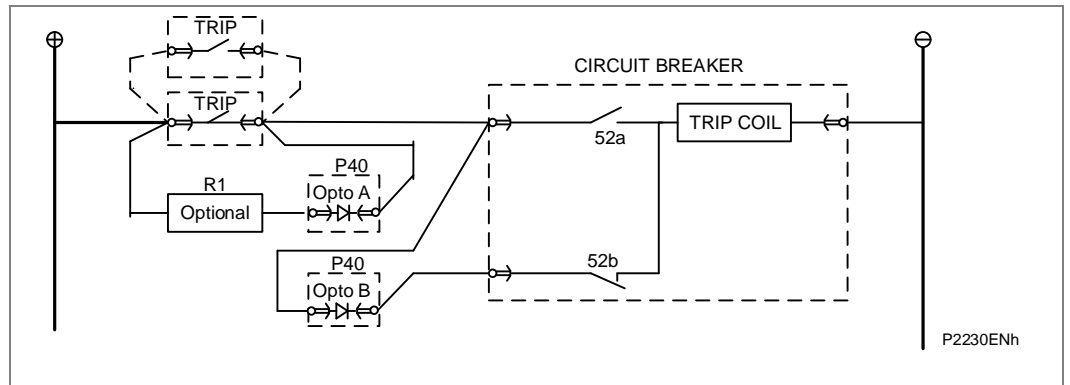

Figure 35 - TCS scheme 2b

This is a similar scheme to 2a but allows more of the wiring to be supervised whilst the breaker is open (but not the full trip path). This scheme is also fully compatible with latched contacts as the supervision current will be maintained through the 52b contact when the trip contact is closed. When the breaker is closed, supervision current passes through opto input A and the trip coil. When the breaker is open current flows through opto input A and opto input B and the trip coil. As with scheme 1, no supervision of the full trip path is provided whilst the breaker is open. Any fault in the trip path will only be detected on CB closing, after a 400 ms delay.

Note For this circuit to work it cannot be used for 24/27V or 30/34V applications as the voltage threshold of the inputs will not operate in series.
 For 48/54V applications it can be used with the optos set to 30/34V with no resistor or 24/27 with a 1.2k resistor.
 For 48/110V applications it can be used with 48/54V setting with no resistor or a 2.5k resistor.
 For 220/250V the optos can be set to 220/250V with no resistor or 110/125 with a 5k resistor.

3.5.3.2

Scheme 2b PSL

The PSL for Scheme 2b is similar to Scheme 2a but without CB Aux inputs.

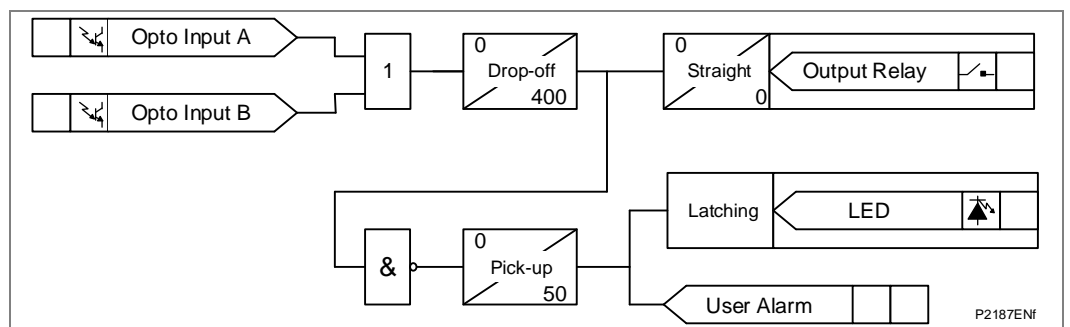

Figure 36 - PSL for TCS schemes 2b

3.5.4 TCS Scheme 3

3.5.4.1 Scheme Description

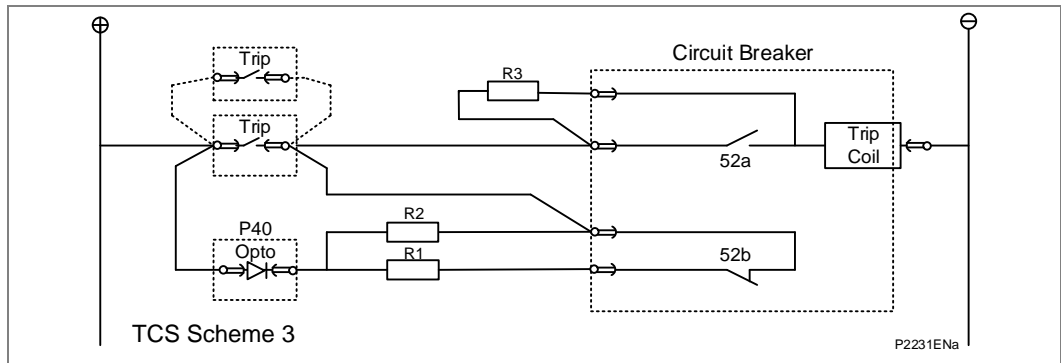

Figure 37 - TCS scheme 3

Scheme 3 is designed to provide supervision of the trip coil with the breaker open or closed, but unlike schemes 1 and 2, it also provides pre-closing supervision. Since only one opto input is used, this scheme is not compatible with latched trip contacts. If circuit breaker status monitoring is required a further 1 or 2 opto inputs must be used.

When the breaker is closed, supervision current passes through the opto input, resistor R2 and the trip coil. When the breaker is open current flows through the opto input, resistors R1 and R2 (in parallel), resistor R3 and the trip coil. Unlike schemes 1 and 2, supervision current is maintained through the trip path with the breaker in either state, thus giving pre-closing supervision.

As with schemes 1 and 2, resistors R1 and R2 are used to prevent false tripping, if the opto-input is accidentally shorted. However, unlike the other two schemes, this scheme is dependent upon the position and value of these resistors. Removing them would result in incomplete trip circuit monitoring. The table below shows the resistor values and voltage settings required for satisfactory operation.

Auxiliary Voltage (Vx)	Resistor R1 & R2 (ohms)	Resistor R3 (ohms)	Opto Voltage Setting
24/27	-	-	-
30/34	-	-	-
48/54	1.2k	0.6k	24/27
110/125	2.5k	1.2k	48/54
220/250	5.0k	2.5k	110/125

Note Scheme 3 is not compatible with auxiliary supply voltages of 30/34 volts and below.

Table 11 - Resistor values for TCS scheme 3

3.5.4.2 Scheme 3 PSL

The PSL for scheme 3 is identical to that of scheme 1.

3.6

Fault Detector / Trip Supervision (Software Version H4 and later)

The overall trip supervision element can be enabled/disabled. When enabled, it can also be enabled/disabled for each of these protection functions.

This feature relates to using fault detectors to supervise the trip signals coming from the line differential and distance protection functions. This supervision element includes these features:

- fast trip time (i.e. the trip signal of the protection function is not delayed due to the supervision element)
- independent of the differential communications channel
- where needed, it can be based only on current criteria (as some schemes may not be using voltage detection)

Condition	Code	Selected Trip Conditions
Overcurrent	I>	the (selected) trip condition(s) will be released if the phase current is above the overcurrent current threshold setting
Over Neutral Current	IN>	the (selected) trip condition(s) will be released if the derived neutral current is above the neutral current threshold setting
Over Delta Current	OCD>	the (selected) trip condition(s) will be released if the calculated delta currents are above the over delta current threshold setting
Under Phase-to-Phase Voltage	Vpp<	the (selected) trip condition(s) will be released if the calculated phase to phase voltages are below the phase to phase under voltage threshold setting
Under Phase-to-Ground Voltage	Vpn<	the (selected) trip condition(s) will be released if the calculated phases to ground voltages are below the phase to ground under voltage threshold setting
Under Delta Voltage	UVD>	the (selected) trip condition(s) will be released if the calculated delta voltages are above the under delta voltage threshold setting

Phase Associated Logic

This table lists the phase relationships between the protection and supervision elements:

Supervision Elements	I>			IN>	OCD>			Vpp<			Vpn<			UVD>		
Protection element phases	A	B	C	N	A	B	C	AB	BC	CA	A	B	C	A	B	C
A	X			X	X			X		X	X			X		
B		X		X		X		X	X			X			X	
C			X	X			X		X	X		X				X

Table 12 - Phase Association Logic

DDB Changes

Several DDB numbers have been modified, including:

P543, P544, P545 & P546 = 1889 to 1892

DDB No (Ordinal)	English Definition	Description
1889	TS IDiff. Blk	Provides an indication that Line Differential is blocked by the trip supervision elements. Set to one when any of the supervising elements is enabled for the Line Differential function but none of the elements has met the criteria and the trip signal is high.
1890	CdiffTripA Blk	Current Diff Trip A Block by Trip Supervision
1891	CdiffTripB Blk	Current Diff Trip B Block by Trip Supervision
1892	CdiffTripC Blk	Current Diff Trip C Block by Trip Supervision

Note The Programming Scheme Logic chapter contains details of these DDB Nos.

Monitor points with INF numbers 86 to 93 are available in P443, P445, P446, P543, P544, P545 & P546.

Monitor points with INF numbers 86 to 93 are available in P543, P544, P545 & P546 only.

See IEC870 Monitor sheet of the Menu Database for further details.

COT	Diff Primary		Distance Primary		AR Primary		Description
	FUN	INF	FUN	INF	FUN	INF	
	202	86	138	86	170	86	Supervision block on Z1 Trip
	202	87	138	87	170	87	Supervision block on Z2 Trip
	202	88	138	88	170	88	Supervision block on Z3 Trip
	202	89	138	89	170	89	Supervision block on Z4 Trip
	202	90	138	90	170	90	Supervision block on ZP Trip
	202	91	138	91	170	91	Supervision block on ZQ Trip
	202	92	138	92	170	92	Supervision block on aided1 Z Trip
	202	93	138	93	170	93	Supervision block on aided2 Z Trip
	202	94	138	94	170	94	Supervision block on IDiff Trip

Table 13 - IEC Monitor Changes

All the below Binary Input points except "TS IDiff.Blk" are available in P443, P445, P446, P543, P544, P545 and P546. Binary Input point "TS IDiff.Blk" is available in P543, P544, P545 and P546 only.

See DNPEV Binary Inputs sheet of the Manu Database for further details.

P443	P445	P446	P543 / P545 No Distance	P544 / P546 No Distance	P543 / P545	P544 / P546	P547	P841 A	P841 B	Name / Description	DDB No.
611	573	712			662	764				TS Dist. Z1 Blk	1881
612	574	713			663	765				TS Dist. Z2 Blk	1882
613	575	714			664	766				TS Dist. Z3 Blk	1883
614	576	715			665	767				TS Dist. Z4 Blk	1884
615	577	716			666	768				TS Dist. ZP Blk	1885
616	578	717			667	769				TS Dist. ZQ Blk	1886
618	579	718			668	770				TS Aided1 Z Blk	1887
619	580	719			669	771				TS Aided2 Z Blk	1888
					670	772				TS IDiff. Blk	1889

Table 14 - DNP3 Mapping

These points are not mapped in IEC61850.

3.7 InterMiCOM⁶⁴ Application Example

The protection signaling channels of the P54x primarily intended to provide the capability for implementing current differential protection are also capable of supporting InterMiCOM⁶⁴ teleprotection. If the P54x is configured to provide differential protection, then the InterMiCOM⁶⁴ commands (IMx command) are transmitted together with the current differential signals. If the differential protection of the P54x is not being employed, then the communications messages are restructured to provide InterMiCOM⁶⁴ signaling of the type supported by the MiCOM P446, P443 and P445 relays. In either case, the fundamental operation of the InterMiCOM⁶⁴ commands is the same, but the way in which communications failures are handled differs. In a differential scheme, failure or disturbance of communications could cause failure of the protection scheme and the alarming requirements are high. In a scheme where differential protection is not being employed, and InterMiCOM⁶⁴ is being employed to transfer command status between the line ends, communications disturbances may be less critical and this is reflected in the InterMiCOM⁶⁴ implementation of P446, P443 and P445.

An example of how to apply an InterMiCOM⁶⁴ scheme is given below. This assumes that the P54x has been configured as a P443/P445 (i.e. no differential protection) and takes account of different level of communication disturbance alarming provided in this configuration. It is also assumed that the optional distance protection is included. This example should be read in conjunction with the InterMiCOM⁶⁴ section of the Operation chapter of the MiCOM P446, P443 or P445 Technical Manual.

3.7.1 InterMiCOM⁶⁴ Mapping for Three Ended Application – Blocking or PUR example

Figure 38 shows a suggested InterMiCOM⁶⁴ mapping:

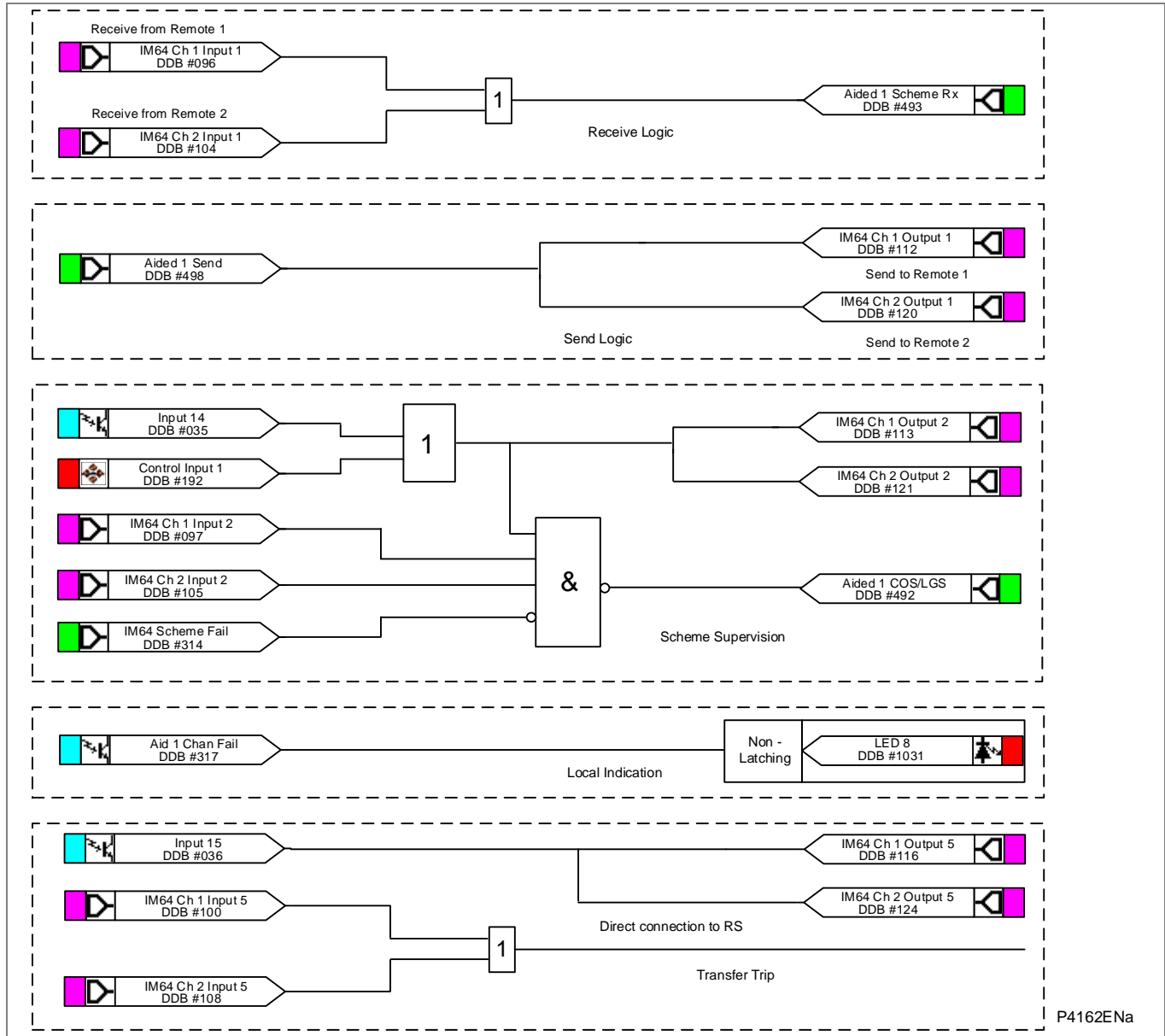

Figure 38 - InterMiCOM⁶⁴ mapping in a three ended application

3.7.2 InterMiCOM⁶⁴ Application Example General Advice

MiCOM relays have standard, pre-configured aided scheme logic internal to each relay. Thus, it is not necessary to draw the zone logic for Permissive Underreach, Permissive Overreach or Blocking schemes within the PSL. To gain the benefit of selecting a proven and tested scheme, the standard “Aided” scheme logic should be used.

When InterMiCOM⁶⁴ is being used as the transmission medium for the aided channel signal(s), all that is required is to create one-to-one mapping between the Aided scheme logic, and the InterMiCOM⁶⁴ (IM64) signals to be used. The PSL editor is used to perform the simple mapping required.

To configure the signal SEND logic:

- Route the required Aided send DDB signal to the IM64 Output to be used

To configure the signal RECEIVE logic:

- Route the required IM64 Input signal to the Aided scheme Rx DDB input

3.7.3

Three-Ended Applications

The example in the “InterMiCOM⁶⁴ Application Example General Advice” section shows a three terminal application, in this case in a BLOCKING or PUR scheme mode.

Note: This breaks with the rule of the one-to-one mapping as described in the InterMiCOM⁶⁴ Application Example General Advice section. In three terminal schemes, the input to the Aided scheme is some kind of logic combination of the signals received from the two remote ends:

- BLOCKING schemes are recommended to take a logical OR of the incoming IM64 signals, before being mapped to Aided scheme Rx. This is to ensure that if the fault is declared as external at any line end, Zone 2 accelerated tripping at the local end is blocked.
- PERMISSIVE UNDERREACH schemes are recommended to take a logical OR of the incoming IM64 signals, before being mapped to Aided scheme Rx. Thus, if the fault is declared as internal at any remote line end, Zone 2 accelerated tripping at the local end is allowed. As Zone 1 is an underreaching element, it can only key the channel for an internal fault, so there is no need for AND logic.
- PERMISSIVE OVERREACH schemes are recommended to take a logical AND of the incoming IM64 signals, before being mapped to Aided scheme Rx. This is to ensure that the fault must be seen as forward from both remote ends before Zone 2 accelerated tripping at the local end is allowed. As Zone 2 keys the channel, confirmation of a forward decision at all three line ends must be confirmed before aided scheme tripping is permitted.

In all three terminal schemes, the send logic is a one-to-many mapping. The Aided send is mapped to the IM64 signals which transmit to both remote ends. The connection to Ch1 (channel 1), and Ch2 (channel 2) ensures communication to the two remote ends. In case of channel failure between any two relays, the ‘**Aided 1 COS/LGS**’ signal will become high in the relay that is not receiving and activate the FallBackMode. Therefore, to preserve the stability in 3-ended blocking scheme, the corresponding ‘**IM_X DefaultValue**’ in the setting file must be set high. It should be noted that in the PUR and POR schemes such a precaution is not necessary since the aided signal can not be sent via broken communications.

3.7.4

Intermicom64 Application Example Scheme Description

The scheme in the InterMiCOM⁶⁴ mapping in a three ended application diagram is assumed as a case study. The top half of the page shows the mapping of the send and receive logic as already described. It can be seen that the first InterMiCOM bit (Input 1) is being used for the purposes of Aided scheme 1.

Notes Two Aided schemes are available, Aided 1 and Aided 2. This allows for example an independent Distance aided scheme, and a DEF aided scheme to be configured. Whether Aided 1 is used alone, or Aided 2 is used too will depend on the utility preference. Further detail is available in the MiCOM Technical Manual.

The InterMiCOM⁶⁴ bits are duplex in nature, in other words InterMiCOM⁶⁴ bit 1 between the relay at line end A and B is completely independent from the same bit traveling from end B to A.

For simplicity, it is recommended that Aided scheme 1 is mapped to IM64 bit 1.

Likewise, where Aided scheme 2 is applied, it is more logical to assign IM64 bit 2, providing that it is not already used in the PSL for some other function.

3.7.5 Intermicom64 Application Example Channel Supervision

For teleprotection schemes, it is commonplace to configure alarming in the event of channel failure. The third dotted box on the case study provides full monitoring of the scheme in three ended applications. Here, IM64 bit 2 is permanently energized when the channel is healthy. The OR gate shows how an opto input (L4) and a Control Input might be used as prerequisites for healthy signaling:

- The use of an opto input allows a check that correct DC battery voltages are present for local teleprotection purposes, or perhaps that a selector switch has not taken the scheme out of service.
- The use of a Control Input allows switching in or out of the teleprotection via menu commands on the relay concerned. This provides convenient in-out switching of the entire teleprotection scheme by visiting/addressing just one line end relay.

The exact logic condition to declare the local “signaling healthy” condition will be chosen such as to reflect the utility’s practices. In the example shown, this logical condition is then mapped to IM64 Output 2 (bit 2), for transmitting to the two remote line ends.

In order to declare that the signaling scheme is healthy, bit 2 (the assigned health-check bit) must be received from both remote ends. This can be combined with a general check on InterMiCOM⁶⁴ messaging, DDB#314. The AND gate shows that signaling is only healthy if:

- The local DC battery voltage/control state is set to allow teleprotection operation,
- The remote end health-check bits are both received successfully,
- The scheme alarms have not detected messaging failures (IM64 Scheme Fail).

A logical “AND” combination is used, with the gate output inverted to feed into the aided scheme logic. This scheme failure output then feeds the standard “Channel out of Service” (COS) logic.

The fourth dotted box illustrates how the same scheme failure alarm (COS) can then be simply mapped to any LED indication, or output contact for alarming.

Note *If a simpler scheme is preferred, it is not necessary to assign a health-check bit. In such instances, the IM64 Scheme Fail alarm alone can be used to drive COS. However, if a test mode selection were to disable the aided scheme at one end, the other line ends would have no indication of the depleted operation. For this reason, the use of the health-check bit is recommended.*

3.7.6 Intermicom64 Application Example Transfer Trip

The case study scheme shows a suggested Transfer Trip (“Intertrip”) in the lower dotted box area. This is an optional addition (or alternative) with any aided scheme. The example shows an opto input (L5) which is being used to initiate the intertrip, mapped to send IM64 bit 5 to both remote ends. On receipt of the intertrip bit from any remote line end, the OR gate is used to map the received intertrip to whichever output relay trips the local breaker. In the diagram, relay 3 is shown as an example.

Again it can be seen that the PSL is the means by which the InterMiCOM⁶⁴ signals are driven, and to where any received bits are routed too.

3.7.7 InterMiCOM64 Application Example - Mapping for Two Ended Application

The same scheme principle as shown in the InterMiCOM⁶⁴ mapping in a three-ended application diagram applies in a two-ended application. The scheme will be simplified, whereby Aided Send signals are mapped directly to IM64 bits, on a one-to-one mapping. The IM64 bit received from the remote end is also mapped directly to the Aided Scheme Rx signal, requiring no AND or OR logic combination.

3.7.8 Intermicom64 Application Example - Dual Redundant Communications Channels

In dual redundant operation, the user has the option to send end-end signals via two paths. The two paths (channels) are defined as Ch1 and Ch2. Several factors can be taken into account when using this mode:

- The assignment of IM64 bits is completely independent, per channel. For example if all 8 possible bits per channel are assigned to discrete functions, this allows a total of 16 end-end signals.
- The receive logic should employ AND (“both”) or OR (“any”) logic gate functions to combine the dual redundant signals, as appropriate to the desired operation.

3.7.9 Intermicom64 Application Example - Scheme Co-Ordination Timers

Distance and DEF and delta directional aided schemes use scheme co-ordination timers to ensure correct operation. The function of these is documented in the Operation chapter of the Technical Manual. However, when using InterMiCOM⁶⁴ as the teleprotection channel, the time delays applied can be different to those used for traditional channels. This is due, mainly, to the fact that the response time of opto inputs and output contacts is bypassed. An output contact will take typically 3 to 5ms to close, and an opto input will take 1 to 2ms to recognize a change of state. Thus, using InterMiCOM⁶⁴ will save around 5-6ms for I/O response time.

The new time delays appropriate for Dist Dly and Current Reversal Guard timers are as listed in the following sections. Where direct fiber connections are used for InterMiCOM⁶⁴, ignore the + MUX addition. Where a multiplexed link is used, the + MUX figure should account for the multiplexer response time. If this is unknown, it can be obtained for the specific installation using the appropriate measurement in the MEASUREMENTS 4 menu column.

3.7.9.1 InterMiCOM64 Application Example - Distance PUR Permissive Underreach

- Dist dly = zero

3.7.9.2 InterMiCOM64 Application Example - Distance POR Permissive Overreach

- Dist dly = zero
- tREV. Guard = 40ms + MUX

3.7.9.3 InterMiCOM64 Application Example - Distance Blocking

- Dist dly (50Hz) = 25ms + MUX
- Dist dly (60Hz) = 22ms + MUX
- tREV. Guard = 25ms + MUX

3.7.9.4 InterMiCOM64 Application Example - Directional earth Fault (DEF) POR Permissive Overreach

- DEF dly = zero
- tREV. Guard = 50ms + MUX

3.7.9.5 InterMiCOM64 Application Example - Directional Earth Fault (DEF) Blocking

- DEF dly = 25ms + MUX
- tREV. Guard = 35ms + MUX

3.7.9.6 InterMiCOM64 Application Example - Delta Directional POR Permissive Overreach

- Delta dly = zero
- tREVERSAL GUARD = 40ms + MUX

3.7.9.7**InterMiCOM64 Application Example - Delta Directional Blocking**

- Delta dly = 14ms + MUX
- tREVERSAL GUARD = 25ms + MUX

<i>Note</i>	<i>When adding any multiplexer delays, the maximum response time of the multiplexed link should be assumed. This should include any addition for rerouting in self-healing networks.</i>
-------------	--

3.7.10**Fallback Mode for InterMiCOM64 bits**

On temporary loss of the InterMiCOM⁶⁴ channel, the user may select to latch the last healthy signal for a period of time, or to fallback to a chosen default value.

- For Intertripping schemes, reverting to a default state of 0 is recommended;
- For Blocking schemes set, reverting to a default state of 1 is recommended;
- For Permissive applications, latching the last healthy received state is recommended.

4 APPLICATION OF NON-PROTECTION FUNCTIONS

4.1 Single and Three Phase Auto-Reclosing

4.1.1 Time Delayed and High Speed Auto-Reclosing

An analysis of faults on any overhead line network has shown that 80-90% are transient in nature.

In the majority of fault incidents, if the faulty line is immediately tripped out, and time is allowed for the fault arc to de-ionize, reclosure of the circuit breakers will result in the line being successfully re-energized. Auto-reclose schemes are employed to automatically reclose a switching device a set time after it has been opened due to operation of protection, where transient and semi-permanent faults are prevalent.

The principal benefit gained by the application of auto-reclosing to overhead line feeders is improved supply continuity and possibly reduced costs since fewer personnel may be required. On some systems the application of high speed auto-reclose may permit a higher level of power transfer while retaining transient stability for most faults which are likely to occur. High speed single phase auto-reclosure can offer increased benefits over high speed three phase auto-reclosure in terms of a higher power transfer limit and reduced stress on reclosing.

4.1.2 Auto-Reclose Logic Operating Sequence

The MiCOM P543 and P545 have a standard auto-reclose scheme configured to permit control of one circuit breaker only.

The MiCOM P544 and P546 can be used in applications such as breaker-and-a-half, or ring bus topologies, where two circuit breakers feed each line and both need to be controlled by the auto-reclose logic.

For high speed auto-reclose only the instantaneous protection would normally be set to initiate auto-reclose. This is because for best results when applying high speed auto-reclose to improve a system stability limit, it is important that the fault should be cleared as quickly as possible from both line ends.

The auto-reclose scheme in the P446/P544/P546/P547/P841B provides auto-reclosing of a feeder terminal switched by two circuit breakers. The two circuit breakers are normally arranged to reclose sequentially with one designated leader circuit breaker reclosing after a set dead time followed, if the leader circuit breaker remains closed, by the second circuit breaker after a further delay, the follower time.

4.1.2.1 Pole Discrepancy Timer for P54x (except P546)

The pole discrepancy timer is fixed at 0.04s.

4.1.2.2 Pole Discrepancy Timer for P546 Only

In some schemes, there is a need to use pole discrepancy logic in P546 relay. Once a pole discrepancy situation has been detected, a timer starts to run. Once this timer has elapsed, an output relay contact or a virtual output signal indicates that there is a pole discrepancy.

It is possible to develop a PSL logic scheme (with digital inputs with the position of the CB pole A, B and C, gates and timer). However, these schemes can become complex; with them sometimes starting to approach the limit for the maximum capacity (in terms of gates, timers or even logic equations).

Hence, the pole discrepancy timer has now been enhanced so that it allows a range of different times to be set. Previously, the configurable pole discrepancy timer was shown to be fixed at 0.04s. whereas it is now in the range 0 to 10s with a step of 0.01s.

4.1.3 Setting Guidelines

4.1.3.1 Circuit Breaker Healthy

The P443/P446/P54x/P547/P841 monitors the state of the auxiliary contacts (52A, 52B) of the controlled circuit breaker(s) to determine healthy circuit breaker status before allowing auto-reclose. Monitoring of the auxiliary contacts is recommended, but this check can be disabled by not allocating opto inputs to this function, and deliberately applying logic 1 onto the corresponding DDB signals within the PSL.

4.1.3.2 Number of Shots

An important consideration is the ability of the circuit breaker to perform several trip close operations in quick succession and the effect of these operations on the maintenance period.

The fact that 80 - 90% of faults are transient highlights the advantage of single shot schemes. If statistical information for the power system shows that a moderate percentage of faults are semi-permanent, further Delayed Auto-Reclose (DAR) shots may be used provided that system stability is not threatened.

<i>Note</i>	<i>DAR shots will always be three pole.</i>
-------------	---

4.1.3.3 Dead Timer Setting

High speed auto-reclose may be required to maintain stability on a network with two or more power sources. For high speed auto-reclose the system disturbance time should be minimized by using fast protection, <30 ms, such as distance or feeder differential protection (for P54x/P841) or distance or phase comparison (for P547) and fast circuit breakers <60 ms. For stability between two sources a system dead time of ≤300 ms may typically be required. The minimum system dead time considering just the CB is the trip mechanism reset time plus the CB closing time.

Minimum **relay** dead time settings are governed primarily by two factors:

- Time taken for de-ionization of the fault path
- Circuit breaker characteristics

Also it is essential that the protection fully resets during the dead time, so that correct time discrimination will be maintained after reclosure onto a fault. For high speed auto-reclose instantaneous reset of protection is required.

For **highly interconnected** systems synchronism is unlikely to be lost by the tripping out of a single line. Here the best policy may be to adopt longer dead times, to allow time for power swings on the system resulting from the fault to settle.

4.1.3.4 Follower Time Setting (P544 and P546 only)

In the application of auto-reclosing to a feeder terminal switched by two circuit breakers, the P446/P544/P546/P841B provides the necessary control for both circuit breakers. The two circuit breakers are normally arranged to re-close sequentially with one designated leader circuit breaker reclosing after a set dead time followed, if the leader circuit breaker remains closed, by the second, follower, circuit breaker after a further delay, the follower time.

The follower time is provided to prevent un-necessary operation of the follower circuit breaker. The follower time should be set sufficiently long as to avoid an un-necessary closure of the follower circuit breaker where conditions are such that it would be required to trip again.

After expiry of the dead time, the leader circuit breaker will attempt a reclosure. The minimum value of the follower time should allow sufficient time for the auto-reclosure of the lead circuit breaker to be considered successful. Consider a worst case where the phase differential elements are unavailable and back-up protection is being provided by the distance elements. Take the case of reclosure onto a dead line with a persistent fault at the remote end of the line. Local end protection (Time delayed Back up protection, like distance Z2 element) may detect this fault after set time delay (typically > 200 ms), time must be allowed for the leader circuit breaker to re-trip (50 - 100 ms), and a safety margin needs to be added so that typically, the minimum follower time could be around 500 ms. If the reclosure of the lead circuit breaker is successful, the follower circuit breaker can be allowed to reclose. Delaying the reclosure of the follower circuit breaker will allow any transients to decay before the switching and if the transient decay figure is known, can be used to determine a minimum follower time value. The larger of the two values can then be used as the minimum follower time.

<i>Note</i>	<i>Since the follower circuit breaker should only be re-closed if the system is healthy, and, since in a dual circuit breaker scheme where the system is healthy the follower circuit breaker acts more like a bus coupler, there is no real requirement for fast switching and a time delay in excess of 1s might be appropriate. Indeed, in the P446/P544/P546/P841B default follower time is chosen as 5s and this can comfortably be applied to most applications.</i>
-------------	--

4.1.3.5

De-ionizing Time

The de-ionization time of a fault arc depends on circuit voltage, conductor spacing, fault current and duration, wind speed and capacitive coupling from adjacent conductors. As circuit voltage is generally the most significant, minimum de-ionizing times can be specified as in the table below.

<i>Note</i>	<i>For single pole high-speed auto-reclose, the capacitive current induced from the healthy phases can increase the time taken to de-ionize fault arcs.</i>
-------------	---

Line voltage (kV)	Minimum de-energization time (s)
66	0.1
110	0.15
132	0.17
220	0.28
275	0.3
400	0.5

Table 15 - Minimum Fault Arc De-ionizing Time (Three Pole Tripping)

4.1.3.6

Example Minimum Dead Time Calculation

The following circuit breaker and system characteristics are to be used:

- CB Operating time (Trip coil energized → Arc interruption): 50 ms (a);
- CB Opening + Reset time (Trip coil energized → Trip mechanism reset): 200 ms (b);
- Protection reset time: < 80 ms (c);
- CB Closing time (Close command → Contacts make): 85 ms (d).

De-ionizing time for 220 kV line:

280 ms (e) for a three-phase trip. (560 ms for a single pole trip).

The minimum relay dead time setting is the greater of:

- (a) + (c) = 50 + 80 = 130 ms, to allow protection reset;
- (a) + (e) - (d) = 50 + 280 - 85 = 245 ms, to allow de-ionizing (three pole);
- = 50 + 560 - 85 = 525 ms, to allow de-ionizing (single pole).

In practice a few additional cycles would be added to allow for tolerances, so **3P - Dead Time 1** could be chosen as ≥ 300 ms, and **1P - Dead Time** could be chosen as ≥ 600 ms. The overall system dead time is found by adding (d) to the chosen settings, and then subtracting (a). (This gives 335 ms and 635 ms respectively here).

4.1.3.7

Reclaim Timer Setting

A number of factors influence the choice of the reclaim timer, such as;

- Fault incidence/Past experience - Small reclaim times may be required where there is a high incidence of recurrent lightning strikes to prevent unnecessary lockout for transient faults
- Spring charging time - For high speed auto-reclose the reclaim time may be set longer than the spring charging time. A minimum reclaim time of >5 s may be needed to allow the CB time to recover after a trip and close before it can perform another trip-close-trip cycle. This time will depend on the duty (rating) of the CB. For delayed auto-reclose there is no need as the dead time can be extended by an extra CB healthy check AR Inhibit Time window time if there is insufficient energy in the CB
- Switchgear Maintenance - Excessive operation resulting from short reclaim times can mean shorter maintenance intervals
- The Reclaim Time setting is generally set greater than the tZ2 distance zone delay

4.2 Current Transformer Supervision (CTS)

MiCOM P54x has two methods of detecting CT problems: Differential CTS and Standard CTS as detailed in the Operation Section. Both methods could be applied simultaneously and that is a significant advantage because all protection elements that would tend to operate upon CT failure will be successfully prevented from operating. The Differential CTS method should be used whenever differential protection is used, whilst the Standard CTS stabilizes all local ground protections. Therefore, to be on a safe side and cover all eventualities the recommended setting is '1 diff + Standard CTS' mode. Note that the 'CTS Reset mode' and 'CTS Time delay' are common for both techniques.

4.2.1 Standard CTS

The residual voltage setting, **CTS Vn< Inhibit** and the residual current setting, **CTS In> set**, should be set to avoid unwanted operation during healthy system conditions. For example **CTS Vn< Inhibit** should be set to at least 120% of the maximum steady state residual voltage. The **CTS In> set** will typically be set below minimum load current. The time-delayed alarm, **CTS Time Delay**, is generally set to 5 seconds.

Where the magnitude of residual voltage during a ground/earth fault is unpredictable, the element can be disabled to prevent protection elements being blocked during fault conditions.

Standard CTS must not be used to inhibit the operation of Current differential protection as this is a local supervision and therefore it will not be fast enough to inhibit the operation of the differential protection at the remote end.

4.2.2 Differential CTS

Phase Is1 CTS setting must be set above the phase current of the maximum load transfer expected, normally at 1.2 In. This setting defines the minimum pick-up level of the current differential protection once the current transformer supervision CTS is detected.

CTS i1> setting, once exceeded, indicates that the circuit is loaded. A default setting of 0.1 In is considered suitable for most applications, but could be lowered in case of oversized CTs.

CTS i2/i1> This setting should be in excess of the worst unbalanced load expected in the circuit under normal operation. It is recommended to read out the values of i2 and i1 in the MEASUREMENT 1 column and set the ratio above 5% of the actual ratio.

CTS i2/i1>> We strongly recommend to keep the default setting (40% In). If the ratio i2/i1 exceeds the value of this setting at only one end, the CT failure is declared.

<i>Note</i>	<i>The minimum generated i2/i1 ratio will be 50% (case of one CT secondary phase lead being lost), and therefore setting of 40% is considered appropriate to guarantee sufficient operating speed.</i>
-------------	--

Any of the previous methods will always block protection elements operating from derived quantities: Broken Conductor, Earth Fault and Neg Seq O/C. Other protections can be selectively blocked by customizing the PSL, gating DDB 928: CTS Block (originated by either method) or DDB 929 CTS Block Diff with the protection function logic.

4.3 Circuit Breaker Condition Monitoring

4.3.1 Setting the $\Sigma I^2 t$ Thresholds

Where overhead lines are prone to frequent faults and are protected by Oil Circuit Breakers (OCBs), oil changes account for a large proportion of the life cycle cost of the switchgear. Generally, oil changes are performed at a fixed interval of circuit breaker fault operations. However, this may result in premature maintenance where fault currents tend to be low, and hence oil degradation is slower than expected. The $\Sigma I^2 t$ counter monitors the cumulative severity of the duty placed on the interrupter allowing a more accurate assessment of the circuit breaker condition to be made.

For OCBs, the dielectric withstand of the oil generally decreases as a function of $\Sigma I^2 t$. This is where 'I' is the fault current broken, and 't' is the arcing time within the interrupter tank (not the interrupting time). As the arcing time cannot be determined accurately, the relay would normally be set to monitor the sum of the broken current squared, by setting 'Broken I^2 ' = 2.

For other types of circuit breaker, especially those operating on higher voltage systems, practical evidence suggests that the value of 'Broken I^2 ' = 2 may be inappropriate. In such applications 'Broken I^2 ' may be set lower, typically 1.4 or 1.5. An alarm in this instance may be indicative of the need for gas/vacuum interrupter HV pressure testing, for example. The setting range for 'Broken I^2 ' is variable between 1.0 and 2.0 in 0.1 steps. It is imperative that any maintenance program must be fully compliant with the switchgear manufacturer's instructions.

4.3.2 Setting the Number of Operations Thresholds

Every operation of a circuit breaker results in some degree of wear for its components. Therefore, routine maintenance, such as oiling of mechanisms, may be based upon the number of operations. Suitable setting of the maintenance threshold will allow an alarm to be raised, indicating when preventative maintenance is due. Should maintenance not be carried out, the relay can be set to lockout the auto-reclose function on reaching a second operations threshold. This prevents further reclosure when the circuit breaker has not been maintained to the standard demanded by the switchgear manufacturer's maintenance instructions.

Certain circuit breakers, such as Oil Circuit Breakers (OCBs) can only perform a certain number of fault interruptions before requiring maintenance attention. This is because each fault interruption causes carbonizing of the oil, degrading its dielectric properties. The maintenance alarm threshold **No CB Ops. Maint.** may be set to indicate the requirement for oil sampling for dielectric testing, or for more comprehensive maintenance. Again, the lockout threshold **No CB Ops. Lock** may be set to disable auto-reclosure when repeated further fault interruptions could not be guaranteed. This minimizes the risk of oil fires or explosion.

4.3.3 Setting the Operating Time Thresholds

Slow CB operation is also indicative of the need for mechanism maintenance. Therefore, alarm and lockout thresholds (CB Time Maint./CB Time Lockout) are provided and are settable in the range of 5 to 500 ms. This time is set in relation to the specified interrupting time of the circuit breaker.

4.3.4 Setting the Excessive Fault Frequency Thresholds

Persistent faults will generally cause auto-reclose lockout, with subsequent maintenance attention. Intermittent faults such as clashing vegetation may repeat outside of any reclaim time, and the common cause might never be investigated. For this reason it is possible to set a frequent operations counter on the relay which allows the number of operations **Fault Freq. Count** over a set time period **Fault Freq. Time** to be monitored. A separate alarm and lockout threshold can be set.

4.4**Read Only Mode**

With IEC 61850 and Ethernet/Internet communication capabilities, security has become a pressing issue. The Px40 IED provides a facility to allow the user to enable or disable the change in configuration remotely.

Read Only mode can be enabled/disabled for the following rear ports:

- Rear Port 1 - IEC 60870-5-103 and Courier protocols
- Rear Port 2 (if fitted) - Courier protocol
- Ethernet Port (if fitted) - Courier protocol (**tunnelled**)

5 TWO CIRCUIT BREAKER CONTROL (P446) WORKED EXAMPLE

A worked example of the control of a feeder switched by a dual circuit breaker is presented below. Detailed explanation of the control of such a scheme is presented in the Operation chapter of this manual.

5.1

Introduction

This application example is for two shot, single and three phase, auto-reclosing at one end of a 500kV overhead transmission line switched by two circuit breakers in a **“one and a half switch”** configuration.

The single line diagram for the circuit is shown below. This example outlines the settings required for auto-reclosing using a MiCOM P446/P544/P546/P841 relay at sub-station A. The single line diagram for the circuit is shown in Figure 39.

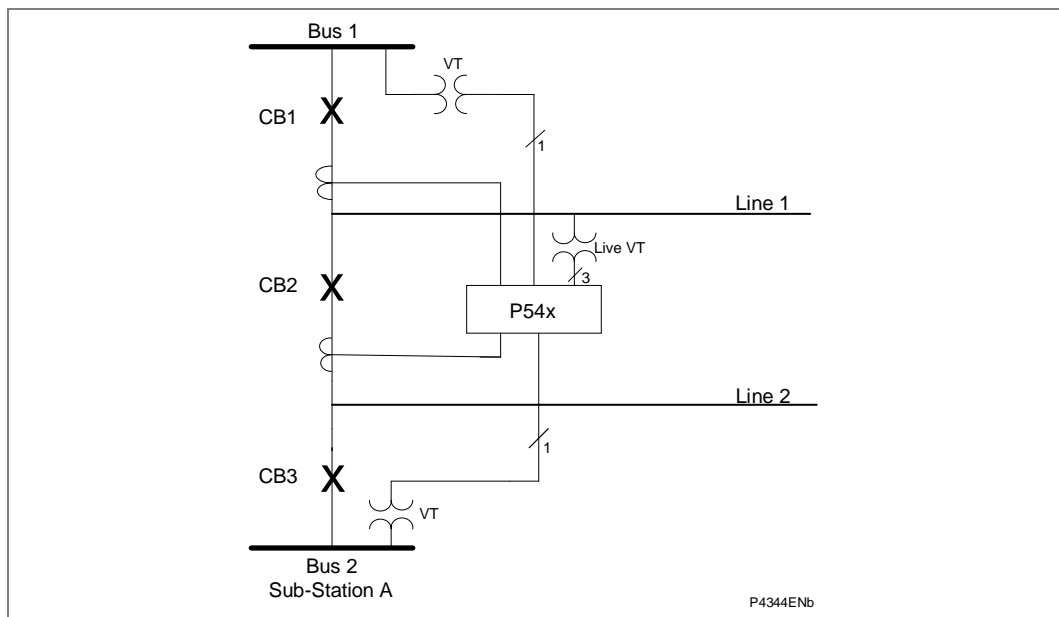

Figure 39 - Two circuit breaker auto-reclose application

Auto-reclosing is considered to be initiated by differential protection, by distance protection tripping for a fault in Zone 1 or by aided high speed tripping. It is also possible to initiate auto-reclose by an external protection device, in which case the auto-reclose initiation would be provided by an opto input.

The circuit breakers are capable of either single phase or three phase tripping. Circuit Breaker 1 (CB1) is designated as Leader and will reclose before Circuit Breaker 2 (CB2). CB2 becomes the designated Follower, and will reclose after a Follower Time delay after CB1 has successfully reclosed.

The “**Leader**”, CB1 is arranged for single/three phase tripping and re-closing. The “**Follower**”, CB2 is arranged to trip three phase for all faults.

For a single phase fault, CB1 will trip single phase and CB2 will trip three phase. When the fault has been cleared, CB1 will re-close single phase without any system voltage checks after the selected “**Single Phase AR dead time**”, then, after the follower time delay, CB2 will re-close three phase, subject to a synchronism check between the line and Bus 2.

For a two phase or three phase fault, both circuit breakers will trip three phase. When the fault has been cleared, CB1 will re-close three phase after the selected “**Three Phase AR dead time**”, with either live bus/dead line or live bus/live line check synchronism between the line and Bus 1. When CB1 has successfully re-closed, after the follower time delay, CB2 will re-close three phase, subject to a synchronism check between the line and Bus 2.

For live line/live bus three phase re-closing of either circuit breaker, acceptable conditions are typically:

- The phase angle difference is not greater than 20 degrees;
- The slip frequency is not greater than 0.05Hz/s; and
- The magnitudes of both the applied line voltage and “**compensated**” Bus voltage are between 85% and 120% of nominal; and
- The magnitude of the difference between the applied line voltage and the “**compensated**” Bus voltage on either side of the circuit breaker is not greater than 10% of nominal.

It is assumed that re-closing at the remote line end will be either single phase with no system voltage checks, or three phase with live bus/live line synchronism check.

5.2

Circuit Breaker Status

The circuit breaker open/closed status is signaled to the auto-reclose scheme by separate type 52B auxiliary switch contacts on each circuit breaker pole (contact open when circuit breaker phase is closed, contact closed when the circuit breaker pole is open).

5.3

Voltage Inputs

The voltage inputs to the auto-reclose equipment are:

- 3 phase input (3P + N, magnitude 110V Ph-Ph, 63.5V Ph-N) from a line VT or Bus1 VT, connected to the line VT or Bus1 VT input;
- 1 phase input (A-B, magnitude 110V) from a Bus1 VT or line VT connected to the Bus1 VT or line VT (CB1 CS VT), input;
- 1 phase input (A-B, magnitude 110V) from a Bus2 VT connected to the Bus2 VT (CB2 CS VT), input.

Under healthy system conditions each bus VT input leads to Neutral Line VT input by 30 degrees and has voltage magnitude of 110 V (assumes settings in secondary values).

5.4 Application Settings

Typical values for the principal settings and user commands related to the auto-reclosing and system voltage check functions are given below. They are presented in the order in which they appear in the menu. The hexadecimal numbers in brackets/parentheses represent the Courier cell location in the menu.

5.4.1 CB CONTROL Menu:

In the CB CONTROL column, the “**Autoreclose Mode**” command (07 0B) should be activated by setting to “**In Service**”;

The data cell “**AR Status**” (07 0E) should display “**In Service**”.

The “**CB1 Status Input**” (07 11): should be set to “**52B 1Pole**”;

The “**CB2 Status Input**” (07 80): should be set to “**52B 1Pole**”.

5.4.2 CONFIGURATION Menu:

In the CONFIGURATION column, the following should all be set to “**Enabled**”:

- “**Distance**” (09 0B)
- “**System Checks**” (09 23)
- “**Auto-Reclose**” (09 24)

5.4.3 CT & VT RATIOS Menu:

In the CT & VT RATIOS column, the following should be set:

- “**Main VT Primary**” (0A 01): set nominal system primary ph-ph voltage (500kV);
- “**Main VT Sec’y**” (0A 02): set “**110 V**”;
- “**CB1 CS VT Prim’y**” (0A 03): set nominal system primary ph-ph voltage (500kV);
- “**CB1 CS VT Sec’y**” (0A 04): set “**110 V**”;
- “**CB2 CS VT Prim’y**” (0A 05): set nominal system primary ph-ph voltage (500kV);
- “**CB2 CS VT Sec’y**” (0A 06): set “**110 V**”;
- “**CS Input**” (0A 0F): set “**A-N**”;
- “**CB1 CS VT PhShft**” (0A 21): set “**-30 degrees**” (this creates a “**compensated**” Bus1 phase angle normally in phase with the selected “**CS Input**”);
- “**CB1 CS VT Mag**” (0A 22): set “**0.58**” (this creates a “**compensated**” Bus1 voltage magnitude normally equal to that of the selected “**CS Input**”);
- “**CB2 CS VT PhShft**” (0A 23): set “**-30 degrees**” (this creates a “**compensated**” Bus2 phase angle normally in phase with the selected “**CS Input**”);
- “**CB2 CS VT Mag**” (0A 24): set “**0.58**” (creates a “**compensated**” Bus2 voltage magnitude normally equal to that of the selected “**CS Input**”);

Note *VT secondary voltage settings in this section of the menu are always set in terms of phase to phase values, even when the actual inputs are taken from phase to neutral VT terminals.*

5.4.4 GROUP 1 LINE PARAMETERS Menu:

In the GROUP 1 LINE PARAMETERS column, the following should be set:

- “**CB1 Tripping Mode**” (30 0C): set “**1 and 3 Pole**”;
- “**CB2 Tripping Mode**” (30 0E): set “**3 Pole**”.

5.4.5**GROUP 1 DISTANCE Menu:**

- In the GROUP 1 DISTANCE column, appropriate settings should be applied and the elements enabled as per the operational requirements. Operation of the zone 1 tripping and/or the operation of the aided schemes will initiate auto-reclose.

5.4.6**GROUP 1 PHASE DIFF Menu:**

- In the GROUP 1 PHASE DIFF column, appropriate settings should be applied and the elements enabled as per the operational requirements. Operation of phase differential tripping will initiate auto-reclose.

5.4.7**GROUP 1 SYSTEM CHECKS Menu:**

In the GROUP 1 SYSTEM CHECKS column, the following should be set:

- “**Live Line**” (48 85): set “**32 V**” (typical setting 50% of nominal applied voltage of selected “**CS Input**” (set to A-N in this example));
- “**Dead Line**” (48 86): set “**13 V**” (typical setting 20% of nominal applied voltage of selected “**CS Input**” (set to A-N in this example));
- “**Live Bus 1**” (48 87): set “**32 V**” (typical setting 50% of “**compensated**” nominal applied voltage);
- “**Dead Bus 1**” (48 88): set “**13 V**” (typical setting 20% of “**compensated**” nominal applied voltage).
- “**Live Bus 2**” (48 89): set “**32 V**” (typical setting 50% of “**compensated**” nominal applied voltage);
- “**Dead Bus 2**” (48 8A): set “**13 V**” (typical setting 20% of “**compensated**” nominal applied voltage);
- “**CS UV**” (48 8B): set “**54 V**” (typical setting 85% of nominal applied voltage of selected “**CS Input**” (set to A-N in this example));
- “**CS OV**” (48 8C): set “**76 V**” (typical setting 120% of nominal applied voltage of selected “**CS Input**” (set to A-N in this example));
- “Sys Checks CB1” (48 8D): set “Enabled”;
- “CB1 CS Volt. Blk” (48 8E): set “V< V> and Vdiff”;
- “CB1 CS1 Status” (48 8F): set “Enabled”;
- “CB1 CS1 Angle” (48 90): set “20 degrees”;
- “**CB1 CS1 Vdiff**” (48 91): set “**6.5 V**” (typical setting 10% of nominal applied voltage of selected “**CS Input**” (set to A-N in this example));
- “CB1 CS1 SlipCtrl” (48 92): set “Frequency”;
- “CB1 CS1 SlipFreq” (48 93): set “50 mHz”;
- “CB1 CS2 Status” (48 94): set “Disabled”;
- “Sys Checks CB2” (48 9C): set “Disabled”;
- “CB2 CS Volt. Blk” (48 9D): set “V<”;
- “CB2 CS1 Status” (48 9E): set “Enabled”;
- “CB2 CS1 Angle” (48 9F): set “20 degrees”;
- “**CB2 CS1 Vdiff**” (48 A0): set “**6.5 V**”;
- “CB2 CS1 SlipCtrl” (48 A1): set “Frequency”;
- “CB2 CS1 SlipFreq” (48 A2): set “50 mHz”;
- “CB2 CS2 Status” (48 A4): set “Disabled”;

5.4.8

GROUP 1 AUTORECLOSE Menu:

In the GROUP 1 AUTORECLOSE column, the following should be set:

- “Num CBs” (49 50): set “**Both CB1&CB2**”;
- “Lead/Foll ARMode” (49 53): set “**L 1/3P, F 3P**”;
- “Leader Select By” (49 55): set “**Menu**”;
- “Select Leader” (49 56): set “**Sel Leader CB1**”;
- “BF if LFail CIs” (49 57): set “**Enabled**”;
- “AR Shots” (49 59): set “**2**”;
- “Multi Phase AR” (49 5C): set “**Allow Autoclose**”;
- “Discrim Time” (49 5D): set “**0.5 sec**” (set as per application requirements);
- “CB IS Time” (49 60): set “**5 sec**” (this requires the circuit breaker to have been in the closed position for at least 5 seconds before fault occurrence will enable auto-reclose initiation. It is designed to prevent auto-reclosure for a fault immediately after manual circuit breaker closure (switch on to fault));
- “CB IS Memory Time” (49 61): set “**0.5 sec**”;
- “DT Start by Prot” (49 62): set “**Protection Reset**” (measured dead time starts when protection resets);
- “3PDTStart WhenLD” (49 63): set “**Disabled**”;
- “DTStart by CB Op” (49 64): set “**Disabled**”;
- “SP AR Dead Time” (49 67): set “**0.5 sec**” (typical);
- “3P AR DT Shot 1” (49 68): set “**0.3 sec**” (or as per application requirements and considerations at circuit breaker location);
- “3P AR DT Shot 2” (49 68): set “**60 sec**” (or as per application requirements and considerations at the circuit breaker location);
- “Follower Time” (49 6C): set “**5 sec**” (typical);
- “SPAR ReclaimTime” (49 6D): set “**180 sec**” (or as required to suit circuit breaker duty cycle);
- “3P AR ReclaimTime” (49 6E): set “**180 sec**” (or as required to suit circuit breaker duty cycle);
- “AR CBHealthyTime” (49 6F): set “**0.3 sec**”;
- “AR CheckSyncTime” (49 70): set “**0.3 sec**”;
- “Z1 AR” (49 72): set “**Initiate AR**”;
- “Dist Aided AR” (49 74): set “**Initiate AR**”;
- All other protection inputs (“Z2T AR” (49 72) onwards): set “**Block AR**”;
- “CB1L SC all” (49 A6): set “**Enabled**”;
- “CB1L SC Shot 1” (49 A7): set “**Enabled**”;
- “CB1L SC CIsNoDly” (49 A8): set “**Disabled**”;
- “CB1L SC CS1” (49 A9): set “**Enabled**”;
- “CB1L SC CS2” (49 AA): set “**Disabled**”;
- “CB1L SC DLLB” (49 AB): set “**Enabled**”;
- “CB1L SC LLDB” (49 AC): set “**Disabled**”;
- “CB1L SC DLDB” (49 AD): set “**Disabled**”;
- “CB2F SC all” (49 BD): set “**Enabled**”;
- “CB2F SC Shot 1” (49 BE): set “**Enabled**”;
- “CB2F SC CS1” (49 BF): set “**Enabled**”;
- “CB2F SC CS2” (49 C0): set “**Disabled**”;
- “CB2F SC DLLB” (49 C1): set “**Disabled**”;
- “CB2F SC LLDB” (49 C2): set “**Disabled**”;
- “CB2F SC DLDB” (49 C3): set “**Disabled**”.

5.5

PSL (Programmable Scheme Logic) Mapping

The PSL mapping of some of the opto inputs and relay outputs for this application example are shown below for guidance.

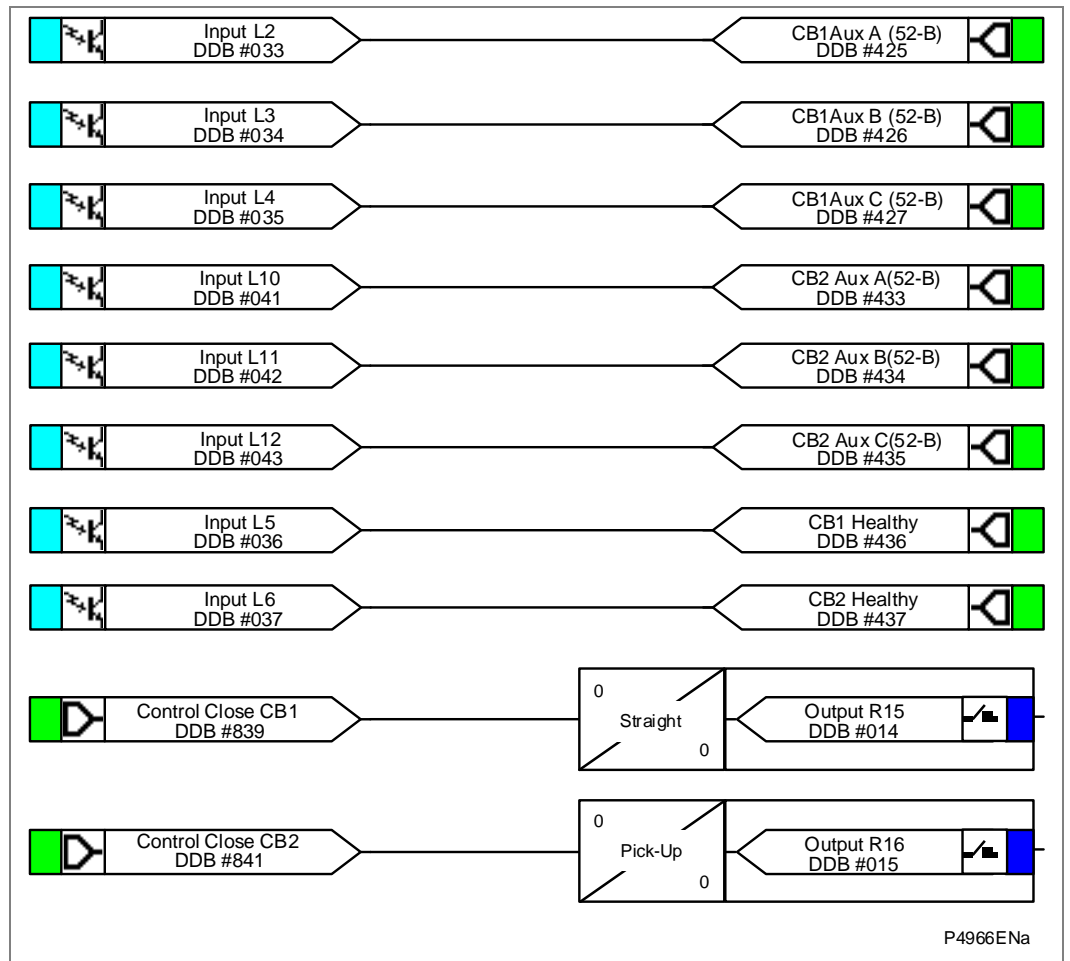

Figure 40 - PSL mapping of some of the opto inputs and relay outputs

In order to test the application example, as well as applying appropriate current and voltage connections, the settings, and the PSL, it will be necessary to employ some secondary test equipment capable of mimicking the circuit breaker status.

For any specific application, the Application Engineer must analyze the particular power systems to determine the appropriate settings and PSL mappings.

6 TWO CIRCUIT BREAKER CONTROL (P546)

Protection schemes sometimes need to use the Circuit Breaker (CB) Failure function when using two MiCOM P546 relays. The scheme may require the CB Fail function to start via internal trip or external trip (through activation of digital input). When there is an external trip, the scheme may need to condition the External CB Fail Start to an overcurrent value. This means that for an External CB Fail Start, the activation of the DI and the overcurrent value must both be present.

This means that the PSL needs to be used, and this needs to gate an AND gate with the DI and the overcurrent starting signal to the "CBF External initiation" to initiate the CB failure logic.

In previous versions of the MiCOM P546 relay, the overcurrent stages did not take into account each of the CT inputs but the summation of both. Hence, because the summation of both CTs is zero, the external CB function will not work as requested (i.e. because there won't be the required overcurrent condition so the external CB failure function won't operate). This has been seen as a problem in certain installations.

This function has now been modified so that there is one phase overcurrent and one neutral overcurrent stage associated to CT1 set and one phase overcurrent and one neutral overcurrent stage associated to CT2. This solves the problem, allowing two P546 relays to be used in this way. This is achieved by adding new options into the relevant settings. The options added include "I>3, IN>3, I>4 and IN>4" and the analogue input as "CT1+CT2", "CT1 or CT2".

7 CURRENT TRANSFORMER (CT) REQUIREMENTS

7.1 Recommended CT Classes (British and IEC)

Class PX current transformers with a knee point voltage greater or equal than that calculated can be used.

Class 5P protection CTs can be used, noting that the knee point voltage equivalent these offer can be approximated from:

$$V_k = (VA \times ALF) / I_n + (R_{CT} \times ALF \times I_n)$$

Where:

VA = Voltampere burden rating

ALF = Accuracy limit factor

I_n = CT nominal secondary current

7.2 Current Differential Requirements

The CTs shall have equivalent measurement behaviors at all ends of the protected line.

For accuracy, Class PX or Class 5P Current Transformers (CTs) are strongly recommended but P, TPX, PX and TPY CTs can be mixed at the line ends but not with TPZ CTs. The knee point voltage of the CTs should comply with the minimum requirements of the formulae shown below.

$$V_k \geq K \cdot I_n (R_{ct} + 2 R_L)$$

Where:

V_k = Required IEC knee point voltage

K = Dimensioning factor

I_n = CT nominal secondary current

R_{ct} = CT resistance

R_L = One-way lead impedance from CT to relay

K is a constant depending on:

If = Maximum value of through fault current for stability (multiple of I_n)

X/R = Primary system X/R ratio

For relays with Differential CT Saturation Stabilization (Diff CT Sat Stab) Disabled:

K is determined as follows:

For relays set at I_{s1} = 20%, I_{s2} = 2 I_n, k₁ = 30%, k₂ = 150%:

K must be the highest of:

$$K \geq 40 + (0.07 \times (I_f \times X/R))$$

Or

$$K \geq 65$$

This is valid for (I_f × X/R) ≤ 1000

For higher (I_f × X/R) up to 1600:

$$K = 107$$

For relays set at I_{s1} = 20%, I_{s2} = 2 I_n, k₁ = 30%, k₂ = 100%:

K must be the highest of:

$$K \geq 40 + (0.35 \times (I_f \times X/R))$$

Or

$$K \geq 65$$

This is valid for (I_f × X/R) ≤ 600

For higher (I_f × X/R) up to 1600:

$$K = 256$$

For relays with Differential CT Saturation Stabilization Enabled:

From Software Version D1, the K factors are as follows:

K = 50 where X/R < 80

K = 65 where X/R ≥ 80

For relays with Differential CT Saturation Stabilization Enabled:

From Software Version H7, the K factors are as follows:

X/R	K limit for If ≤ 20 In	K limit for If > 20 In
X/R ≤ 10	K = 1.7 If + 13	K = 0.7 If + 36
10 < X/R < 40	K = 1.3 If + 21	K = 0.7 If + 36
X/R ≥ 40	K = 0.7 If + 36	

With these CT requirements, P54x will operate correctly for both internal and external faults:

- Operating time ≤ 35ms for internal faults
- Stability for external faults

7.3 Zone 1 Reach Point Accuracy (RPA)

$V_k \geq K_{RPA} \times I_{F Z1} \times (1 + X/R) \cdot (R_{CT} + R_L)$

Where:

Vk = Required CT knee point voltage (volts)

IF Z1 = Max. secondary phase fault current at Zone 1 reach point (A)

X/R = Primary system reactance/resistance ratio

RCT = CT secondary winding resistance (Ω)

RL = Single lead resistance from CT to relay (Ω)

KRPA = Fixed dimensioning factor

= 0.6 for all overhead line applications, or where sub-cycle tripping times are required for Zone1 element (see Note 3 below)

= 0.35 for power cable applications, where sub-cycle tripping times are not required for Zone1 elements (see Note 3 below)

When KRPA of 0.35 is used, we recommend that the following need to be strictly followed.

Note 1	For SOTF and TOR elements, select the level detectors to trip. To ensure this, in the setting file, under GROUP settings, under SCHEME LOGIC, under SOTF tripping and TOR tripping, please also select "Current No Volts" option.
Note 2	Zone1 impedance reach should not be set more than 70% of the line length.
Note 3	For transmission applications with system voltage of 220kV or above, when used as MAIN protection, Schneider Electric recommend that you apply sub-cycle distance protection.

7.4 Zone 1 Close-Up Fault Operation

An additional calculation must be performed for all cables, and any lines where the source impedance ratio might be less than SIR = 2.

$V_k \geq K_{max} \times I_{F max} \times (R_{CT} + R_L)$

Where:

Kmax = Fixed dimensioning factor = **always 1.4**

IF max = Max. secondary phase fault current (A).

Then, the highest of the two calculated knee points must be used.

Note	It is not necessary to repeat the calculation for earth faults, as the phase reach calculation (3φ) is the worst-case for CT dimensioning.
------	--

7.5 Time Delayed Distance Zones

When a time delayed distance zone is being used, there is no need to calculate the required V_k separately. This is due to the employed time delay (usually more than 3 times the primary time constant for a fault at the remote bus of the protected feeder), which overrides the transient conditions. When it is insisted to do some calculations for the time delayed distance zone, then we should use the following equation

$$V_k > I_f (R_{CT} + R_L)$$

Where I_f is the current for a fault at the remote bus of the protected feeder (in other words, the through fault current for the current differential function)

7.6 Determining V_k for an IEEE "C" Class CT

Where American/IEEE standards are used to specify CTs, the C class voltage rating can be checked to determine the equivalent V_k (knee point voltage according to IEC). The equivalence formula is:

$$V_k = [(C \text{ rating in volts}) \times 1.05] + [100 \times R_{CT}]$$

7.7 Worked Example for CT Requirements

The Power system and the line parameters (Line length: 100 km) as given in the Distance Protection Setting Example section is used here to calculate CT requirements.

Important Notes to be Considered

- Current differential – Both I_f and X/R are to be calculated for a through fault
- Distance Zone1 reach point case – Both I_f and X/R are to be calculated for a fault at Zone1 reach point
- For calculating the CT requirements, the bus bar short time symmetrical fault rating shall be considered as the bus fault level.
- When there are only indicative X/R s available, then the circuit breaker's dc breaking capacity shall be used to arrive at the primary time constant (and hence the primary system X/R). The derivation shall be obtained from the circuit breaker manufacturer; practical primary time constants arrived in such a way vary between 50 ms (applicable for 66 kV and 132 kV breakers) and 120 ms (applicable for 220 kV and 400 kV breakers). 150 ms is a practical figure for generator circuit breakers.

7.7.1 System Data

In the following example, the following parameters have been considered for the CT calculations:

System voltage - 230 kV
 System frequency - 50 Hz
 System grounding - solid

Single circuit operation between Green Valley and Blue River

CT ratio - 1200/1
 Line length - 100 kms
 Line positive sequence impedance $Z_1 = 0.089 + j 0.476 \text{ ohm / km}$
 Bus fault level - 40 kA
 Primary time constant = 120 ms

7.7.2 Calculation of Primary X/R

Primary X/R till the Green Valley bus = $2 * \pi * f * \text{primary time constant in s}$
 = $2 * \pi * 50 * 0.12$
 Primary X/R till the bus = 37.7

7.7.3 Calculation of Source Impedance Zs

$$\begin{aligned}\text{Source Impedance } Z_s &= 230 \text{ kV} / (1.732 * 40 \text{ kA}) \\ &= 3.32 \text{ ohms} \\ \text{Source angle} &= \tan^{-1} (X/R) \\ &= \tan^{-1} (37.7) \\ &= 88.48 \text{ deg} \\ \text{Hence, } Z_s &= 0.088 + j 3.317 \text{ ohms}\end{aligned}$$

7.7.4 Calculation of Full Line Impedance (full 100 kms)

$$\begin{aligned}Z_1 &= 0.089 + j 0.476 \text{ ohm / km} \\ Z_L &= 8.9 + j 47.6 \text{ ohms} \\ Z_L &= 48.42 \text{ ohms with an angle } 79.4 \text{ deg}\end{aligned}$$

7.7.5 Calculation of Total Impedance Till Remote Bus Bar

$$\begin{aligned}Z_T = Z_s + Z_L &= 8.988 + j 50.917 \text{ ohms} \\ &= 51.7 \text{ ohms with an angle of } 80 \text{ deg}\end{aligned}$$

7.7.6 Calculation of Through Fault X/R

$$\begin{aligned}X/R \text{ thro} &= 50.917 / 8.988 \\ &= 5.66\end{aligned}$$

7.7.7 Calculation of Through Fault If

$$\begin{aligned}\text{If thro} &= 230\text{kV} / (1.732 * 51.7) \\ &= 2568.5 \text{ A primary} \\ &= 2.14 \text{ A (secondary)}\end{aligned}$$

7.7.8 Calculation of Line Impedance Till Zone1 Reach Point (80kms)

$$\begin{aligned}Z_{\text{zone1}} &= 0.8 * Z_L = 7.12 + j 38.08 \text{ ohms} \\ &= 38.73 \text{ ohms with an angle of } 79.4 \text{ deg}\end{aligned}$$

7.7.9 Calculation of Total Impedance till Zone1 Reach Point

$$\begin{aligned}Z_{T\text{zone1}} &= Z_s + Z_{\text{zone1}} \\ &= 7.208 + j 41.397 \text{ ohms} \\ &= 42.019 \text{ ohms with an angle of } 80 \text{ deg}\end{aligned}$$

7.7.10 Calculation of X/R till Zone1 Reach Point

$$\begin{aligned}X/R \text{ zone1} &= 41.397 / 7.208 \\ &= 5.74\end{aligned}$$

7.7.11 Calculation of Fault Current Till Zone1 Reach Point

$$\begin{aligned}\text{If zone1} &= 230 \text{ kV} / (1.732 * 42.019) \\ &= 3160.34 \text{ A (primary)} \\ &= 2.63 \text{ A (secondary)}\end{aligned}$$

7.7.12 CT Vk for Current Differential Protection

$$\begin{aligned} \text{If thro} * X/R \text{ thro} &= 2.14 * 5.66 \\ &= 12.11 \end{aligned}$$

The appropriate equation for K and Vk to be is used from the Current Differential Requirements section.

$$K > 40 + (0.07 * 12.11) \text{ OR } K > 65$$

$$K > 40.8 \text{ OR } K > 65$$

Hence K = 65

$$V_k \geq K \cdot I_n (R_{ct} + 2 RL)$$

$$V_k > 65 (R_{CT} + 2 RL)$$

7.7.13 CT Vk for Distance Zone1 Reach Point

$$V_k \geq KRPA \times I_F z_1 \times (1 + X/R). (R_{CT} + RL) \text{ (From the Zone 1 Reach Point Accuracy (RPA) section).}$$

$$V_k > 0.6 * 2.63 * (1+5.74) * (R_{CT}+RL)$$

$$V_k > 10.65 (R_{CT} + RL)$$

7.7.14 CT Vk for Distance Zone1 Close-Up Fault

$SIR = Z_s / Z_{zone1} = 3.32 / 38.73$ is less than 2; so we need to do this Vk calculation
Close-up fault current = 40kA (primary) = 33.33 A (secondary)

$$V_k \geq K_{max} \times I_{F \text{ max}} \times (R_{CT} + RL) \text{ (from the Zone 1 Close-Up Fault Operation section)}$$

$$V_k > 1.4 * 33.33 * (R_{CT} + RL)$$

$$V_k > 46.67 (R_{CT} + RL)$$

7.7.15 CT Vk for Distance Time Delayed Zones

$$V_k > I_f (R_{CT} + RL) \text{ (from the Time Delayed Distance Zones section).}$$

$$V_k > I_f \text{ thro} * (R_{CT} + RL)$$

$$V_k > 2.14 (R_{CT} + RL)$$

7.7.16 Vk to be Considered

Using the above sections, the different Vk requirements are to be calculated for all the functions that will be enabled, or that will be brought into operation. Then the highest Vk shall be considered for the CT design.

8 HIGH BREAK OUTPUT CONTACTS

The high break contacts allow the elimination of auxiliary relays. This in turn helps in the provision of cost effective solutions, minimizing space, wiring, commissioning time, etc. According to the model selected, in addition to standard output relay boards, one or two '**high break**' output relay boards can be fitted. Each houses four normally open output contacts suitable for breaking loads higher than can be broken with the standard contacts. The performance and possible application scenarios of these contacts are described in the Technical Data (TD) and Product Design (PD) chapters of this manual.

9 AUXILIARY SUPPLY FUSE RATING

In the Safety Information part of this manual, the maximum allowable fuse rating of 16A is quoted. To allow time grading with fuses upstream, a lower fuselink current rating is often preferable. Use of standard ratings of between 6A and 16A is recommended. Low voltage fuselinks, rated at 250V minimum and compliant with IEC60269-2 general application type gG are acceptable, with high rupturing capacity. This gives equivalent characteristics to HRC "red spot" fuses type NIT/TIA often specified historically.

The table below recommends advisory limits on relays connected per fused spur. This applies to MiCOM Px40 series devices with hardware suffix C and higher, as these have inrush current limitation on switch-on, to conserve the fuse-link.

Maximum Number of MiCOM Px40 Relays Recommended Per Fuse				
Battery Nominal Voltage	6A	10A Fuse	15 or 16A Fuse	Fuse Rating > 16A
24 to 54V	2	4	6	Not permitted
60 to 125V	4	8	12	Not permitted
138 to 250V	6	10	16	Not permitted
Alternatively, Miniature Circuit Breakers (MCBs) may be used to protect the auxiliary supply circuits.				

USING THE PSL EDITOR

CHAPTER 7

Chapter Applicability	
Date:	08/2017
Products covered by this chapter:	This chapter covers the specific versions of the MiCOM products listed below. This includes only the following combinations of Software Version and Hardware Suffix.
Hardware Suffix:	All MiCOM Px4x products
Software Version:	All MiCOM Px4x products
Connection Diagrams:	This chapter may use any of these connection diagrams:
P14x (P141, P142, P143 & P145):	10P141xx (xx = 01 to 02) 10P142xx (xx = 01 to 05) 10P143xx (xx = 01 to 11) 10P145xx (xx = 01 to 11)
P24x (P241, P242 & P243):	10P241xx (xx = 01 to 02) 10P242xx (xx = 01) 10P243xx (xx = 01)
P34x (P342, P343, P344, P345 & P391):	10P342xx (xx = 01 to 17) 10P343xx (xx = 01 to 19) 10P344xx (xx = 01 to 12) 10P345xx (xx = 01 to 07) 10P391xx (xx = 01 to 02)
P341:	10P341xx (xx = 01 to 12)
P445:	10P445xx (xx = 01 to 04)
P44x (P442 & P444):	10P44101 (SH 1 & 2) 10P44201 (SH 1 & 2) 10P44202 (SH 1) 10P44203 (SH 1 & 2) 10P44401 (SH 1) 10P44402 (SH 1) 10P44403 (SH 1 & 2) 10P44404 (SH 1) 10P44405 (SH 1) 10P44407 (SH 1 & 2)
P44y (P443 & P446):	10P44303 (SH 01 and 03) 10P44304 (SH 01 and 03) 10P44305 (SH 01 and 03) 10P44306 (SH 01 and 03) 10P44600 10P44601 (SH 1 to 2) 10P44602 (SH 1 to 2) 10P44603 (SH 1 to 2)
P54x (P543, P544, P545 & P546):	10P54302 (SH 1 to 2) 10P54303 (SH 1 to 2) 10P54400 10P54404 (SH 1 to 2) 10P54405 (SH 1 to 2) 10P54502 (SH 1 to 2) 10P54503 (SH 1 to 2) 10P54600 10P54604 (SH 1 to 2)

	10P54605 (SH 1 to 2) 10P54606 (SH 1 to 2)
P547:	10P54702xx (xx = 01 to 02) 10P54703xx (xx = 01 to 02) 10P54704xx (xx = 01 to 02) 10P54705xx (xx = 01 to 02)
P64x (P642, P643 & P645):	10P642xx (xx = 1 to 10) 10P643xx (xx = 1 to 6) 10P645xx (xx = 1 to 9)
P74x (P741, P742 & P743):	10P740xx (xx = 01 to 07)
P746:	10P746xx (xx = 00 to 21)
P841:	10P84100 10P84101 (SH 1 to 2) 10P84102 (SH 1 to 2) 10P84103 (SH 1 to 2) 10P84104 (SH 1 to 2) 10P84105 (SH 1 to 2)
P849:	10P849xx (xx = 01 to 06)

Notes:

CONTENTS

1. Overview	9
2. Easergy Studio PSL Editor	10
2.1 How to Obtain Easergy Studio.....	10
2.2 To Start Easergy Studio.....	10
2.3 To Open a Pre-Existing System.....	10
2.4 To Start the PSL Editor.....	10
2.5 How to use MiCOM PSL Editor.....	11
2.6 Warnings.....	11
3. Toolbar and Commands	13
3.1 Standard Tools.....	13
3.2 Alignment Tools.....	13
3.3 Drawing Tools.....	14
3.4 Nudge Tools.....	14
3.5 Rotation Tools.....	15
3.6 Structure Tools.....	15
3.7 Zoom and Pan Tools.....	15
3.8 Logic Symbols.....	16
4. PSL Logic Signals Properties	18
4.1 Signal Properties Menu.....	18
4.2 Link Properties.....	18
4.2.1 Rules for Linking Symbols.....	18
4.3 Opto Signal Properties.....	19
4.4 Input Signal Properties.....	19
4.5 Output Signal Properties.....	19
4.6 GOOSE Input Signal Properties.....	19
4.7 GOOSE Output Signal Properties.....	20
4.8 Control In Signal Properties.....	20
4.9 InterMiCOM Output Commands Properties.....	20
4.10 InterMiCOM Input Commands Properties.....	20
4.11 Function Key Properties.....	21
4.12 Fault Recorder Trigger Properties.....	21
4.13 LED Signal Properties.....	21
4.14 Contact Signal Properties.....	21
4.15 LED Conditioner Properties.....	21
4.16 Contact Conditioner Properties.....	22
4.17 Timer Properties.....	22

4.18 Gate Properties.....	23
4.19 SR Programmable Gate Properties.....	23
4.20 PSL Signal Grouping Modes.....	24
<hr/>	
5. Specific Tasks.....	26
5.1 Digital Input Label Operation (P44y, P54x, P445 & P841 only).....	26
5.2 Virtual Input Label Operation.....	26
5.3 Virtual Output Label Operation.....	27
5.4 SR/MR User Alarm Label Operation.....	27
5.5 Settable Control Input Operation (P14x, P44y, P54x, P445 & P841 only).....	28
5.6 Settable Control Setg I/P Label Operation (P14x, P44y, P54x, P445 & P841 only).....	29
<hr/>	
6. Making a Record of MiCOM Px40 Device Settings.....	31
6.1 Using Easergy Studio to Manage Device Settings.....	31
6.2 Extract Settings from a MiCOM Px40 Device.....	31
6.3 Send Settings to a MiCOM Px40 Device.....	31

FIGURES

Figure 1 - Example of a PSL Editor Module.....	11
Figure 2 - Link Properties.....	18
Figure 3 - Red, green and yellow LED outputs.....	22
Figure 4 - Contact conditioner settings.....	22
Figure 5 - Timer Settings.....	23
Figure 6 - Gate properties.....	23
Figure 7 - SR latch component properties.....	24
Figure 8 - PSL diagram.....	25
Figure 9 - Easergy Studio Disturb Recorder table diagram.....	25
Figure 10 - DR Chan Labels tree.....	26
Figure 11 - Digital Input 1 dialog box.....	26
Figure 12 - DR Chan Labels tree.....	26
Figure 13 - Easergy StudioVIR I/P Labels Tree.....	26
Figure 14 - Virtual Input 1 dialog box.....	27
Figure 15 - Easergy Studio VIR I/P Labels Tree.....	27
Figure 16 - Easergy Studio VIR O/P Labels Tree.....	27
Figure 17 - Easergy Studio USR Labels Tree.....	28
Figure 18 - User Alarm dialog box.....	28
Figure 19 - Virtual Input 1 settings.....	28
Figure 20 - Easergy Studio Control Inputs tree.....	28
Figure 21 - Ctrl Setg I/P 33 dialog box.....	29
Figure 22 - Easergy Studio Control Inputs (Ctl Setg I/P 33) tree.....	29
Figure 23 - Ctrl Stg I/P Stat dialog box.....	29
Figure 24 - Easergy Studio Control I/P Labels (Ctl Setg I/P 33) tree.....	29

Figure 25 - Ctrl Setg I/P 33 dialog box.....	30
Figure 26 - Easergy Studio Control I/P Labels (Ctl Setg I/P 33) tree.....	30

TABLES

Table 1 - SR programmable gate properties.....	24
--	----

Notes:

1. OVERVIEW

The purpose of the Programmable Scheme Logic (PSL) is to allow the relay user to configure an individual protection scheme to suit their own particular application. This is achieved through the use of programmable logic gates and delay timers.

The input to the PSL is any combination of the status of opto inputs. It is also used to assign the mapping of functions to the opto inputs and output contacts, the outputs of the protection elements, e.g. protection starts and trips, and the outputs of the fixed protection scheme logic. The fixed scheme logic provides the relay's standard protection schemes.

The PSL itself consists of software logic gates and timers. The logic gates can be programmed to perform a range of different logic functions and can accept any number of inputs. The timers are used either to create a programmable delay, and/or to condition the logic outputs, e.g. to create a pulse of fixed duration on the output regardless of the length of the pulse on the input. The outputs of the PSL are the LEDs on the front panel of the relay and the output contacts at the rear.

The execution of the PSL logic is event driven; the logic is processed whenever any of its inputs change, for example as a result of a change in one of the digital input signals or a trip output from a protection element. Also, only the part of the PSL logic that is affected by the particular input change that has occurred is processed. This reduces the amount of processing time that is used by the PSL; even with large, complex PSL schemes the relay trip time will not lengthen.

This system provides flexibility for the user to create their own scheme logic design. However, it also means that the PSL can be configured into a very complex system; hence setting of the PSL is implemented through the PC support package Easergy Studio.

Note

MiCOM S1 Studio has been renamed as Easergy Studio.

2. EASERGY STUDIO PSL EDITOR

Note

MiCOM S1 Studio has been renamed as Easergy Studio.

The PSL Editor can be used inside Easergy Studio or directly.

This chapter assumes that you are using the PSL Editor from within Easergy Studio.

If you use it from Easergy Studio, the Studio software will be locked whilst you are using the PSL editor software. The Studio software will be unlocked when you close the PSL Editor software.

The Easergy Studio product is updated periodically. These updates provide support for new features (such as allowing you to manage new MiCOM products, as well as using new software releases and hardware suffixes). The updates may also include fixes.

Accordingly, we strongly advise customers to use the latest Schneider Electric version of Easergy Studio.

2.1 How to Obtain Easergy Studio

Easergy Studio is available from the Schneider Electric website:

- www.schneider-electric.com

2.2 To Start Easergy Studio

To Start the Easergy Studio software, click the **Start > Programs > Schneider Electric > Easergy Studio > Easergy Studio** menu option.

2.3 To Open a Pre-Existing System

Within Easergy Studio, click the **File + Open System** menu option.

Navigate to where the scheme is stored, then double-click to open the scheme.

2.4 To Start the PSL Editor

The PSL editor lets you connect to any MiCOM device front port, retrieve and edit its PSL files and send the modified file back to a suitable MiCOM device.

Px30 and Px40 products are edited different versions of the PSL Editor. There is one link to the Px30 editor and one link to the Px40 editor.

To start the PSL editor for Px40 products:

Highlight the PSL file you wish to edit, and then either:

Double-click the highlighted PSL file,

Click the open icon or

In the Easergy Studio main menu, select **Tools > PSL PSL editor (Px40)** menu.

The PSL Editor will then start, and show you the relevant PSL Diagram(s) for the file you have opened. An example of such a PSL diagram is shown in the [Example of a PSL editor module](#) diagram.

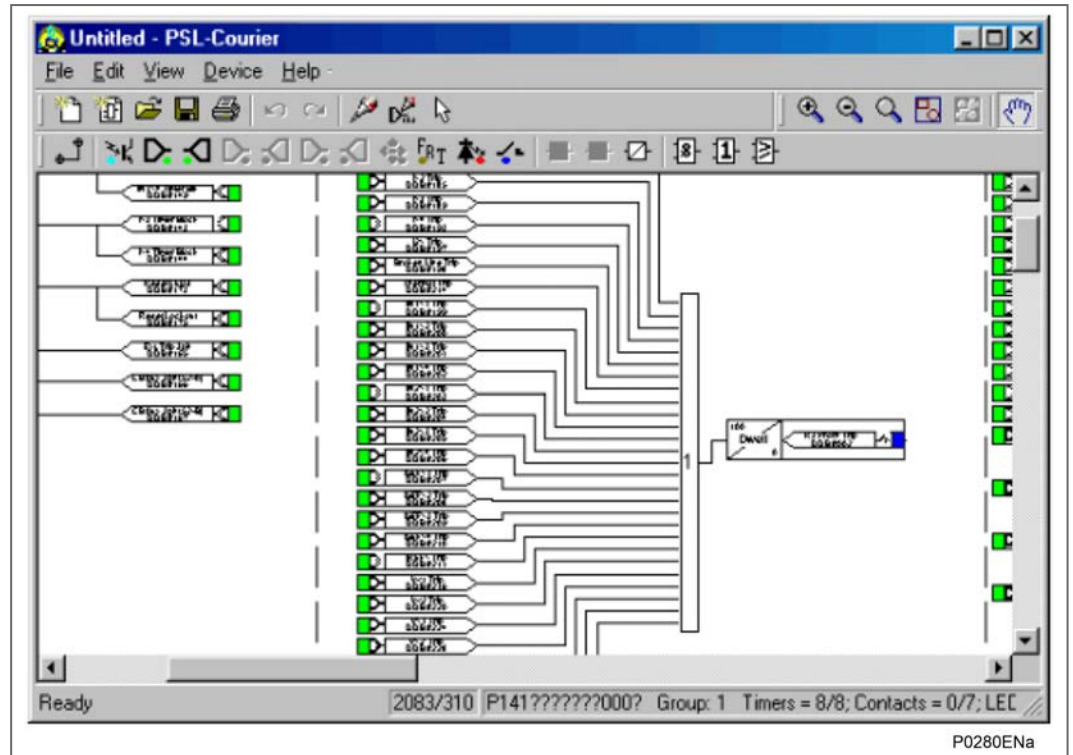

Figure 1 - Example of a PSL Editor Module

2.5 How to use MiCOM PSL Editor

The MiCOM PSL editor lets you:

- Start a new PSL diagram
- Extract a PSL file from a MiCOM Px40 IED
- Open a diagram from a PSL file
- Add logic components to a PSL file
- Move components in a PSL file
- Edit link of a PSL file
- Add link to a PSL file
- Highlight path in a PSL file
- Use a conditioner output to control logic
- Download PSL file to a MiCOM Px40 IED
- Print PSL files

For a detailed discussion on how to use these functions, please refer to the Easergy Studio help file.

2.6 Warnings

Before the scheme is sent to the relay checks are done. Various warning messages may be displayed as a result of these checks.

The Editor first reads in the model number of the connected relay, then compares it with the stored model number. A "wildcard" comparison is used. If a model mismatch occurs, a warning is generated before sending starts. Both the stored model number and the number read from the relay are displayed with the warning. However, the user must decide if the settings to be sent are compatible with the relay that is connected. Ignoring the warning could lead to undesired behavior of the relay.

If there are any potential problems of an obvious nature then a list will be generated. The types of potential problems that the program attempts to detect are:

- One or more gates, LED signals, contact signals, and/or timers have their outputs linked directly back to their inputs. An erroneous link of this sort could lock up the relay, or cause other more subtle problems to arise.
- Inputs to Trigger (ITT) exceeds the number of inputs. If a programmable gate has its ITT value set to greater than the number of actual inputs; the gate can never activate. There is no lower ITT value check. A 0-value does not generate a warning.
- Too many gates. There is a theoretical upper limit of 256 gates in a scheme, but the practical limit is determined by the complexity of the logic. In practice the scheme would have to be very complex, and this error is unlikely to occur.
- Too many links. There is no fixed upper limit to the number of links in a scheme. However, as with the maximum number of gates, the practical limit is determined by the complexity of the logic. In practice the scheme would have to be very complex, and this error is unlikely to occur.













3. TOOLBAR AND COMMANDS

There are a number of toolbars available for easy navigation and editing of PSL.

3.1 Standard Tools



For file management and printing.







	Blank Scheme	Create a blank scheme based on a relay model.
	Default Configuration	Create a default scheme based on a relay model.
	Open	Open an existing diagram.
	Save	Save the active diagram.
	Print	Display the Windows Print dialog, enabling you to print the current diagram.
	Undo	Undo the last action.
	Redo	Redo the previously undone action.
	Re-Draw	Redraw the diagram.
	No of DDBs	Display the DDB numbers of the links.
	Calculate CRC	Calculate unique number based on both the function and layout of the logic.
	Compare Files	Compare current file with another stored on disk.
	Select	Enable the select function. While this button is active, the mouse pointer is displayed as an arrow. This is the default mouse pointer. It is sometimes referred to as the selection pointer.

Point to a component and click the left mouse button to select it. Several components may be selected by clicking the left mouse button on the diagram and dragging the pointer to create a rectangular selection area.

3.2 Alignment Tools

To align logic elements horizontally or vertically into groups.



	Align Top	Align all selected components so the top of each is level with the others.
	Align Middle	Align all selected components so the middle of each is level with the others.
	Align Bottom	Align all selected components so the bottom of each is level with the others.
	Align Left	Align all selected components so the leftmost point of each is level with the others.
	Align Centre	Align all selected components so the centre of each is level with the others.
	Align Right	Align all selected components so the rightmost point of each is level with the others.

3.3 Drawing Tools

To add text comments and other annotations, for easier reading of PSL schemes.



	Rectangle	When selected, move the mouse pointer to where you want one of the corners to be hold down the left mouse button and move it to where you want the diagonally opposite corner to be. Release the button. To draw a square hold down the SHIFT key to ensure height and width remain the same.
	Ellipse	When selected, move the mouse pointer to where you want one of the corners to be hold down the left mouse button and move until the ellipse is the size you want it to be. Release the button. To draw a circle hold down the SHIFT key to ensure height and width remain the same.
	Line	When selected, move the mouse pointer to where you want the line to start, hold down left mouse, move to the position of the end of the line and release button. To draw horizontal or vertical lines only hold down the SHIFT key.
	Polyline	When selected, move the mouse pointer to where you want the polyline to start and click the left mouse button. Now move to the next point on the line and click the left button. Double click to indicate the final point in the polyline.
	Curve	When selected, move the mouse pointer to where you want the polycurve to start and click the left mouse button. Each time you click the button after this a line will be drawn, each line bisects its associated curve. Double click to end. The straight lines will disappear leaving the polycurve. Note: whilst drawing the lines associated with the polycurve, a curve will not be displayed until either three lines in succession have been drawn or the polycurve line is complete.
	Text	When selected, move the mouse pointer to where you want the text to begin and click the left mouse button. To change the font, size or colour, or text attributes select Properties from the right mouse button menu.
	Image	When selected, the Open dialog is displayed, enabling you to select a bitmap or icon file. Click Open, position the mouse pointer where you want the image to be and click the left mouse button.

3.4 Nudge Tools



To move logic elements.



The nudge tool buttons enable you to shift a selected component a single unit in the selected direction, or five pixels if the SHIFT key is held down.

As well as using the tool buttons, single unit nudge actions on the selected components can be achieved using the arrow keys on the keyboard.





	Nudge Up	Shift the selected component(s) upwards by one unit. Holding down the SHIFT key while clicking on this button will shift the component five units upwards.
---	----------	--

	Nudge Down	Shift the selected component(s) downwards by one unit. Holding down the SHIFT key while clicking on this button will shift the component five units downwards.
	Nudge Left	Shift the selected component(s) to the left by one unit. Holding down the SHIFT key while clicking on this button will shift the component five units to the left.
	Nudge Right	Shift the selected component(s) to the right by one unit. Holding down the SHIFT key while clicking on this button will shift the component five units to the right.

3.5 Rotation Tools

To spin, mirror and flip.







	Free Rotate	Enable the rotation function. While rotation is active components may be rotated as required. Press the ESC key or click on the diagram to disable the function.
	Rotate Left	Rotate the selected component 90 degrees to the left.
	Rotate Right	Rotate the selected component 90 degrees to the right.
	Flip Horizontal	Flip the component horizontally.
	Flip Vertical	Flip the component vertically.

3.6 Structure Tools

To change the stacking order of logic components.









	Bring to Front	Bring the selected components in front of all other components.
	Send to Back	Bring the selected components behind all other components.
	Bring Forward	Bring the selected component forward one layer.
	Send Backward	Send the selected component backwards one layer.

3.7 Zoom and Pan Tools

For scaling the displayed screen size, viewing the entire PSL, or zooming to a selection.

















	Zoom In	Increases the Zoom magnification by 25%.
	Zoom Out	Decreases the Zoom magnification by 25%.
	Zoom	Enable the zoom function. While this button is active, the mouse pointer is displayed as a magnifying glass. Right-clicking will zoom out and left-clicking will zoom in. Press the ESC key to return to the selection pointer. Click and drag to zoom in to an area.







	Zoom to Fit	Display at the highest magnification that will show all the diagram's components.
	Zoom to Selection	Display at the highest magnification that will show the selected component(s).
	Pan	Enable the pan function. While this button is active, the mouse pointer is displayed as a hand. Hold down the left mouse button and drag the pointer across the diagram to pan. Press the ESC key to return to the selection pointer.

3.8 Logic Symbols

This toolbar provides icons to place each type of logic element into the scheme diagram. Not all elements are available in all devices. Icons will only be displayed for those elements available in the selected device. Depending on the device, the toolbar may not include Function key or coloured LED conditioner/signal or Contact conditioner or SR Gate icons.



Link Create a link between two logic symbols.	
Opto Signal Create an opto signal.	
Input Signal Create an input signal.	
Output Signal Create an output signal.	
GOOSE In Create an input signal to logic to receive a UCA2.0 or IEC 61850 GOOSE message transmitted from another IED.	
GOOSE Out Create an output signal from logic to transmit a UCA2.0 or IEC 61850 GOOSE message to another IED.	
Control In Create an input signal to logic that can be operated from an external command.	
Integral Intertripping In/InterMiCOM In Create an input signal to logic to receive a MiCOM command transmitted from another IED. InterMiCOM is not available for all products.	
Integral Intertripping Out/InterMiCOM Out Create an output signal from logic to transmit a MiCOM command to another IED. InterMiCOM is not available for all products.	
Function Key Create a function key input signal.	
Trigger Signal Create a fault record trigger.	
LED Signal Create an LED input signal that repeats the status of the LED. The icon colour shows whether the product uses mono-colour or tri-color LEDs.	
Contact Signal Create a contact signal.	
LED Conditioner Create a LED conditioner. The icon colour shows whether the product uses mono-colour or tri-color LEDs.	

Contact Conditioner Create a contact conditioner. Contact conditioning is not available for all products.	
Timer Create a timer.	
AND Gate Create an AND Gate.	
OR Gate Create an OR Gate.	
Programmable Gate Create a programmable gate.	
SR gate Create an SR gate.	

4. PSL LOGIC SIGNALS PROPERTIES

The logic signal toolbar is used for the selection of logic signals.

This allows you to link signals together to program the PSL. A number of different properties are associated with each signal. In the following sections, these are characterized by the use of an icon from the toolbar; together with a signal name and a DDB number. The name and DDB number are shown in a pointed rectangular block, which includes a colour code, the icon, the name, DDB No and a directional pointer. One example of such a block (for P54x for Opto Signal 1 DDB No #032) is shown below:

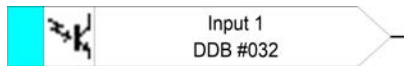

More examples of these are shown in the following properties sections.

Important

The DDB Numbers vary according to the particular product and the particular name, so that Opto Signal 1 may not be DDB No #032 for all products. The various names and DDB numbers illustrated below are provided as an example. You need to look up the DDB numbers for the signal and the specific MiCOM product you are working on in the relevant DDB table for your chosen product. Available functions will depend on model/firmware version.

4.1 Signal Properties Menu

The logic signal toolbar is used for the selection of logic signals. To use this:

- Use the logic toolbar to select logic signals.
This is enabled by default but to hide or show it, select **View > Logic Toolbar**.
- Zoom in or out of a logic diagram using the toolbar icon or select **View > Zoom Percent**.
- Right-click any logic signal and a context-sensitive menu appears.
- Certain logic elements show the **Properties...** option. Select this and a **Component Properties** window appears. The Component Properties window and the signals listed vary depending on the logic symbol selected.

The following subsections describe each of the available logic symbols.

4.2 Link Properties

Links form the logical link between the output of a signal, gate or condition and the input to any element.

Any link that is connected to the input of a gate can be inverted. Right-click the input and select **Properties...** The **Link Properties** window appears.



Figure 2 - Link Properties

4.2.1 Rules for Linking Symbols

An inverted link is shown with a small circle on the input to a gate. A link must be connected to the input of a gate to be inverted.

Links can only be started from the output of a signal, gate, or conditioner, and can only be ended at an input to any element.

Signals can only be an input or an output. To follow the convention for gates and conditioners, input signals are connected from the left and output signals to the right. The Editor automatically enforces this convention.

A link is refused for the following reasons:

- An attempt to connect to a signal that is already driven. The reason for the refusal may not be obvious because the signal symbol may appear elsewhere in the diagram. Right-click the link and select Highlight to find the other signal. Click anywhere on the diagram to disable the highlight.
- An attempt is made to repeat a link between two symbols. The reason for the refusal may not be obvious because the existing link may be represented elsewhere in the diagram.

4.3 Opto Signal Properties

Each opto input can be selected and used for programming in PSL. Activation of the opto input drives an associated DDB signal.

For example, activating opto Input L1 asserts DDB 032 in the PSL for the P14x, P34x, P44y, P445, P54x, P547, P74x, P746, P841, P849 products.



DDB Nos

“Input 1 DDB #064” applies to: P24x, P64x.

“Opto Label DDB #064” applies to: P44x.

4.4 Input Signal Properties

Relay logic functions provide logic output signals that can be used for programming in PSL. Depending on the relay functionality, operation of an active relay function drives an associated DDB signal in PSL.

For example, DDB 671 is asserted in the PSL for the P44y, P547 & P841 product if the active earth fault 1, stage 1 protection operate/trip.



4.5 Output Signal Properties

Relay logic functions provide logic input signals that can be used for programming in PSL. Depending on the relay functionality, activation of the output signal will drive an associated DDB signal in PSL and cause an associated response to the relay function.

For example, if DDB 409 is asserted in the PSL for the P44y, P54x, P547 and P841 product, it will block the sensitive earth function stage 1 timer.



4.6 GOOSE Input Signal Properties

The PSL interfaces with the GOOSE Scheme Logic using virtual inputs. The Virtual Inputs can be used in much the same way as the Opto Input signals.

The logic that drives each of the Virtual Inputs is contained within the relay's GOOSE Scheme Logic file. It is possible to map any number of bit-pairs, from any enrolled device, using logic gates onto a Virtual Input (see MiCOM S1 StudioEasergy Studio help file for more details). The number of available GOOSE virtual inputs is shown in the Programmable Logic chapter.

For example DDB 224 will be asserted in PSL for the P44y, P54x, P547 & P841 product should virtual input 1 operate.

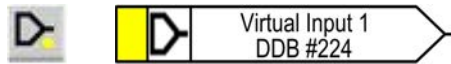

4.7 GOOSE Output Signal Properties

The PSL interfaces with the GOOSE Scheme Logic using 32 virtual outputs. Virtual outputs can be mapped to bit-pairs for transmitting to any enrolled devices.

For example if DDB 256 is asserted in PSL for the P44y, P54x, P547 and P841 product, Virtual Output 32 and its associated mappings will operate.

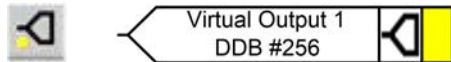

4.8 Control In Signal Properties

There are 32 control inputs which can be activated via the relay menu, 'hotkeys' or via rear communications. Depending on the programmed setting i.e. latched or pulsed, an associated DDB signal will be activated in PSL when a control input is operated.

For example, when operated control input 1 will assert DDB 192 in the PSL for the P44y, P54x, P547 and P841 products.



4.9 InterMiCOM Output Commands Properties

There are 16 InterMiCOM outputs that could be selected and use for teleprotection, remote commands, etc. "InterMiCOM Out" is a send command to a remote end that could be mapped to any logic output or opto input. This will be transmitted to the remote end as corresponding "InterMiCOM In" command for the P14x, P44y, P445 & P54x products.

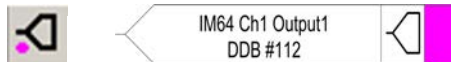

4.10 InterMiCOM Input Commands Properties

There are 16 InterMiCOM inputs that could be selected and use for teleprotection, remote commands, etc. "InterMiCOM In" is a received signal from remote end that could be mapped to a selected output relay or logic input.



Example:

Relay End A

At end A, InterMiCOM Output 1 is mapped to the command indication "Clear Statistics" (issued at end A).

Relay End B

At end B, InterMiCOM Input 1 is mapped to the command "Clear Statistics".

Upon receive of IM64 1 from relay at end A, the relay at end B will reset its statistics.



4.11 Function Key Properties

Each function key can be selected and used for programming in PSL. Activation of the function key will drive an associated DDB signal and the DDB signal will remain active depending on the programmed setting i.e. toggled or normal. Toggled mode means the DDB signal will remain latched or unlatched on key press and normal means the DDB will only be active for the duration of the key press.



For example, operate function key 1 to assert DDB 1096 in the PSL for the P44y, P54x, P547 or P841 products.

4.12 Fault Recorder Trigger Properties

The fault recording facility can be activated by driving the fault recorder trigger DDB signal. For example assert DDB 702 to activate the fault recording in the PSL for the P44y, P54x, P547 or P841 product.



4.13 LED Signal Properties

All programmable LEDs will drive associated DDB signal when the LED is activated. For example DDB 1036 will be asserted when LED 7 is activated for the P44y, P54x, P547 or P841 product.

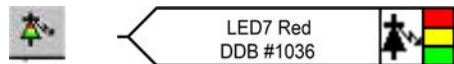

4.14 Contact Signal Properties

All relay output contacts will drive associated DDB signal when the output contact is activated.

For example, DDB 009 will be asserted when output R10 is activated for all products.

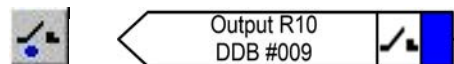

4.15 LED Conditioner Properties

1. Select the LED name from the list (only shown when inserting a new symbol).
2. Configure the LED output to be Red, Yellow or Green.

Configure a Green LED by driving the Green DDB input.

Configure a RED LED by driving the RED DDB input.

Configure a Yellow LED by driving the RED and GREEN DDB inputs simultaneously.

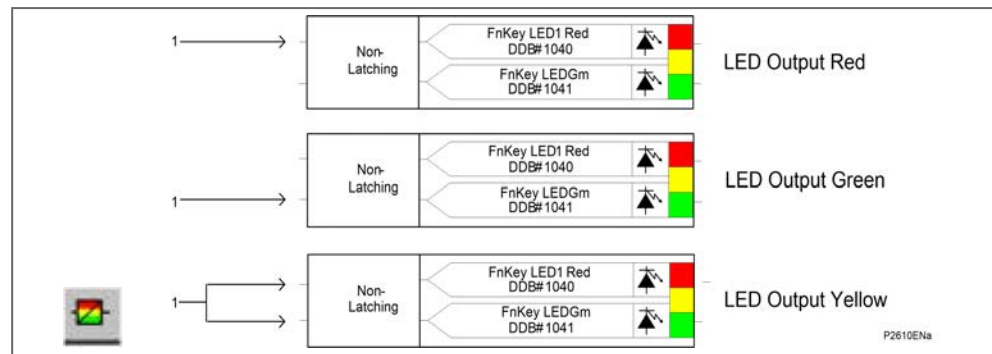

Figure 3 - Red, green and yellow LED outputs

3. Configure the LED output to be latching or non-latching.

DDB #642 and DDB #643 applies to these products: P14x, P44x, P74x, P746 and P849.

DDB #1040 and DDB #1041 applies to these products: P24x, P34x, P44y, P54x, P547, P64x and P841.

4.16 Contact Conditioner Properties

Each contact can be conditioned with an associated timer that can be selected for pick up, drop off, dwell, pulse, pick-up/drop-off, straight-through, or latching operation.

Straight-through means it is not conditioned in any way whereas **Latching** is used to create a sealed-in or lockout type function.

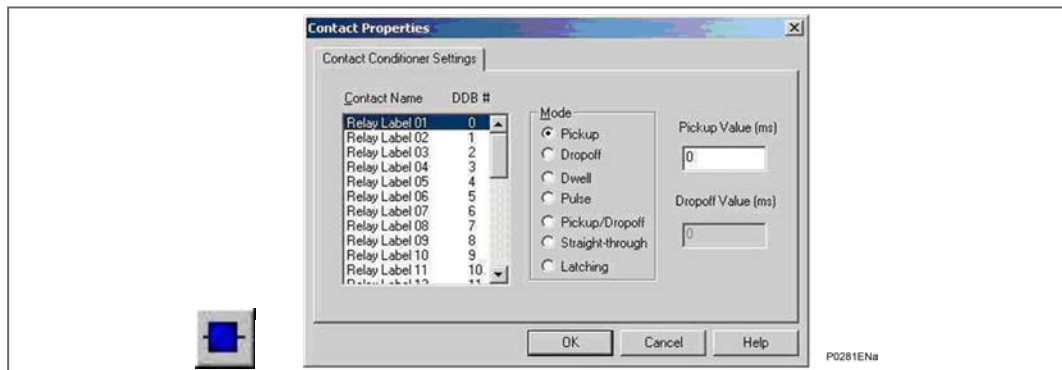

Figure 4 - Contact conditioner settings

1. Select the contact name from the **Contact Name** list (only shown when inserting a new symbol).
2. Choose the conditioner type required in the **Mode** tick list.
3. Set the **Pick-up** Time (in milliseconds), if required.
4. Set the **Drop-off** Time (in milliseconds), if required.

4.17 Timer Properties

Each timer can be selected for pick up, drop off, dwell, pulse or pick-up/drop-off operation.

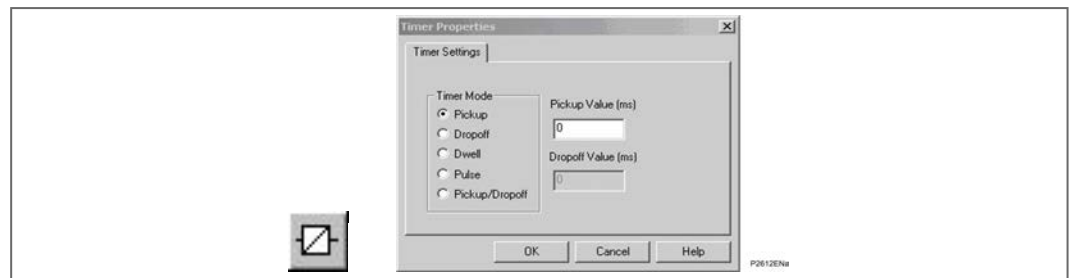

Figure 5 - Timer Settings

1. Choose the operation mode from the **Timer Mode** tick list.
2. Set the Pick-up Time (in milliseconds), if required.
3. Set the Drop-off Time (in milliseconds), if required.

4.18 Gate Properties

A Gate may be an AND, OR, or programmable gate.



An AND gate requires that all inputs are TRUE for the output to be TRUE.



An OR gate requires that one or more input is TRUE for the output to be TRUE.



A Programmable gate requires that the number of inputs that are TRUE is equal to or greater than its 'Inputs to Trigger' setting for the output to be TRUE.

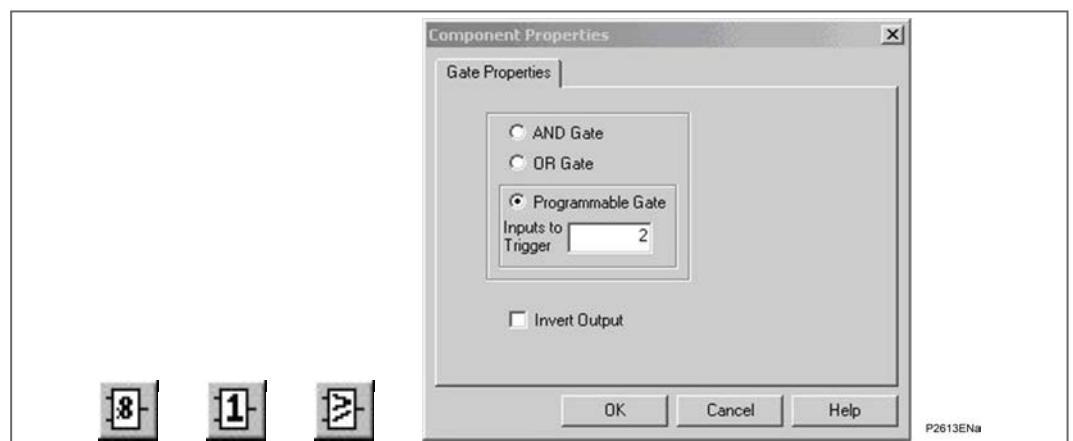

Figure 6 - Gate properties

1. Select the Gate type AND, OR, or Programmable.
2. Set the number of inputs to trigger when Programmable is selected.
3. Select if the output of the gate should be inverted using the Invert Output check box. An inverted output is indicated with a "bubble" on the gate output.

4.19 SR Programmable Gate Properties

For many products a number of programmable SR Latches are added. They are configured by an appropriate version of PSL Editor (S1v2.14 version 5.0.0 or greater) where an SRQ icon features on the toolbar.

Each SR latch has a Q output. The Q output may be inverted in the PSL Editor under the SR Latch component properties window. The SR Latches may be configured as Standard (no input dominant), Set Dominant or Reset Dominant in the PSL Editor under the SR Latch component properties window. The truth table for the SR Latches is given below.

A Programmable SR gate can be selected to operate with these latch properties:

S input	R input	O - Standard	O – Set input dominant	O – Reset input dominant
0	0	0	0	0
0	1	0	0	0
1	0	1	1	1
1	1	0	1	0

Table 1 - SR programmable gate properties

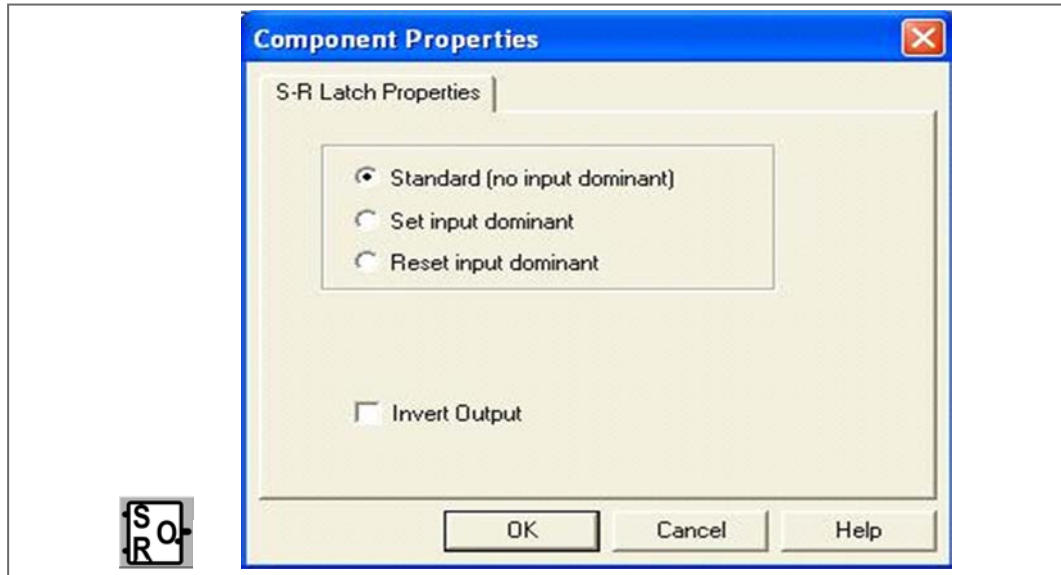

Figure 7 - SR latch component properties

Select if the output of the gate should be inverted using the Invert Output check box. An inverted output is indicated with a "bubble" on the gate output.

4.20 PSL Signal Grouping Modes

PSL Signal Grouping Nodes

For Software Version D1a and later, these DDB "Group" Nodes can be mapped to individual or multiple DDBs in the PSL:

- PSL Group Sig 1
- PSL Group Sig 2
- PSL Group Sig 3
- PSL Group Sig 4

There are now four additional DDB Group Sig x Nodes that can be mapped to individual or multiple DDBs in the PSL. These can then be set to trigger the DR via the DISTURBANCE RECORD menu.

These "Nodes" are general and can also be used to group signals together in the PSL for any other reason. These four nodes are available in each of the four PSL setting groups.

Number	PSL Group Sig
992	PSL Group Sig 1
993	PSL Group Sig 2
994	PSL Group Sig 3
995	PSL Group Sig 4

1. For a control input, the DR can be triggered directly by triggering directly from the Individual Control Input (e.g. Low to High (L to H) change)
2. For an input that cannot be triggered directly, or where any one of a number of DDBs are required to trigger a DR, map the DDBs to the new PSL Group signal and then trigger the DR on this.

e.g. in the PSL:

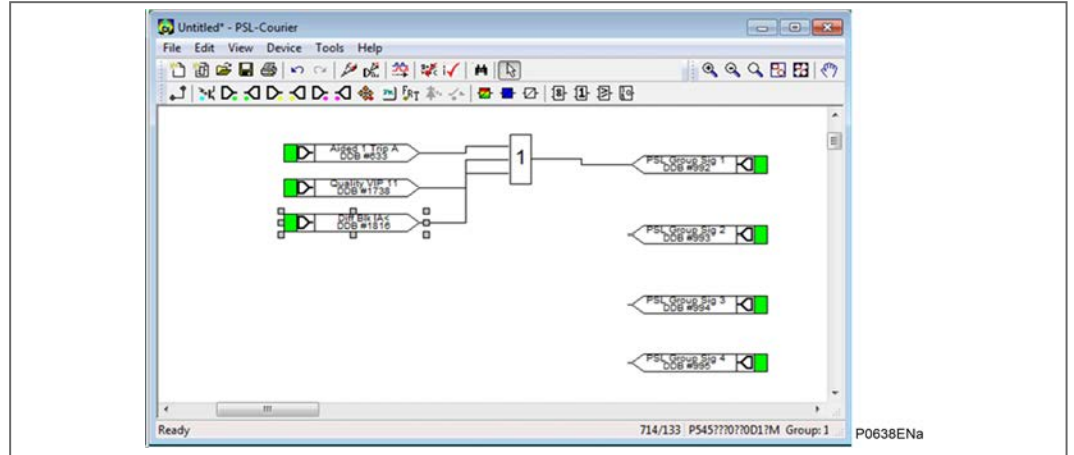

Figure 8 - PSL diagram

In the DR Settings:

- Digital Input 1 is triggered by the PSL Group Sig 1 (L to H)
- Digital Input 2 is triggered by Control Input 1 (L to H)

Name	Value	Address (C.R)
CT AND VT RATIOS		
RECORD CONTROL		
DISTURB RECORDER		
Duration	1.500 s	0C.01
Trigger Position	33.30 %	0C.02
Trigger Mode	Single	0C.03
Analog Channel 1	VA	0C.04
Analog Channel 2	VB	0C.05
Analog Channel 3	VC	0C.06
Analog Channel 4	IA	0C.07
Analog Channel 5	IB	0C.08
Analog Channel 6	IC	0C.09
Analog Channel 7	IN	0C.0A
Analog Channel 8	IN Sensitive	0C.0B
Digital Input 1	PSL Group Sig 1	0C.0C
Input 1 Trigger	Trigger L/H	0C.0D
Digital Input 2	Control Input 1	0C.0E
Input 2 Trigger	Trigger L/H	0C.0F
Digital Input 3	Relay 3	0C.10
Input 3 Trigger	Trigger L/H	0C.11
Digital Input 4	PSL Group Sig 1	0C.12
Input 4 Trigger	Trigger H/L	0C.13
Digital Input 5	Control Input 1	0C.14
Input 5 Trigger	Trigger H/L	0C.15
Digital Input 6	Relay 6	0C.16
Input 6 Trigger	No Trigger	0C.17
Digital Input 7	Relay 7	0C.18
Input 7 Trigger	No Trigger	0C.19
Digital Input 8	Relay 8	0C.1A

Figure 9 - Easergy Studio Disturb Recorder table diagram

If triggering on both edges is required map another DR channel to the H/L as well:

- Digital Input 4 is triggered by the PSL Group Sig 1 (H to L)
- Digital Input 5 is triggered by Control Input 1 (H to L)

5. SPECIFIC TASKS

Note

MiCOM S1 Studio has been renamed as Easergy Studio.

5.1 Digital Input Label Operation (P44y, P54x, P445 & P841 only)

The digital input labels can be modified via the MiCOM Px40 user interface or Easergy Studio. The following example is using Version 5.0.0.

The digital input labels are available in the “DR CHAN LABELS” folder in the settings file as shown below:

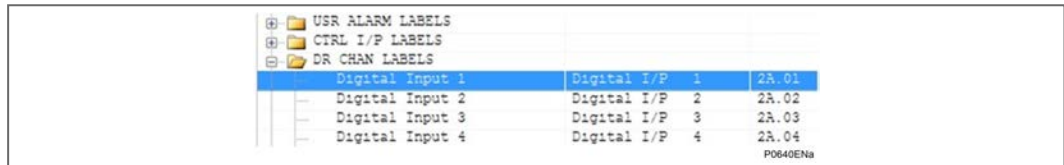

Figure 10 - DR Chan Labels tree

Easergy Studio removes leading spaces from the value field so making the ‘D’ look as if it’s the 1st character in the label. The default values above in fact have a leading space which is used to switch off the use of the label as show below in the change settings view.

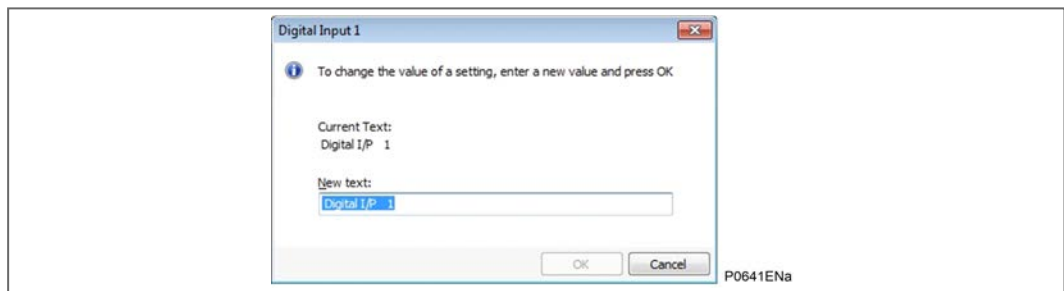

Figure 11 - Digital Input 1 dialog box

Pressing OK will save the setting and return to the settings page as follows:

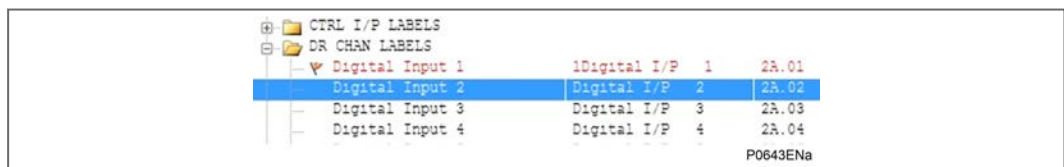

Figure 12 - DR Chan Labels tree

Digital Input 1 label will now be used in the Disturbance Record when the settings file is downloaded to the relay.

5.2 Virtual Input Label Operation

The Virtual Input labels can be modified via the MiCOM Px40 user interface or Easergy Studio. The following example is using Version 5.0.0.

The default labels are available in the “VIR I/P LABELS” (or “VIRT I/P LABELS”) folder in the settings file as shown below:

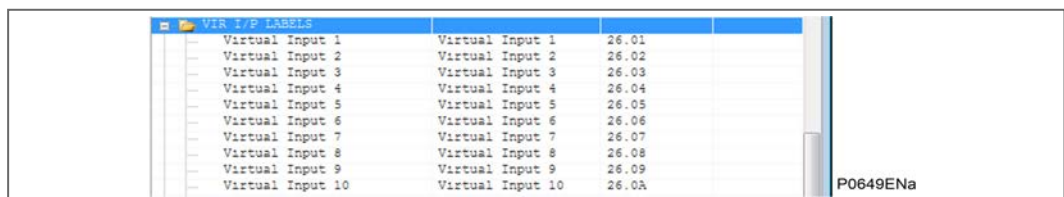

Figure 13 - Easergy StudioVIR I/P Labels Tree

The default “Virtual Input” labels can be changed to suit the customer requirements. For example, to change default text from “Virtual Input 1” to “Customer Func 1” open the Virtual Input 1 dialog box, and change “Virtual Input 1” in the New Text: text box to be “Customer Func 1”, as follows:

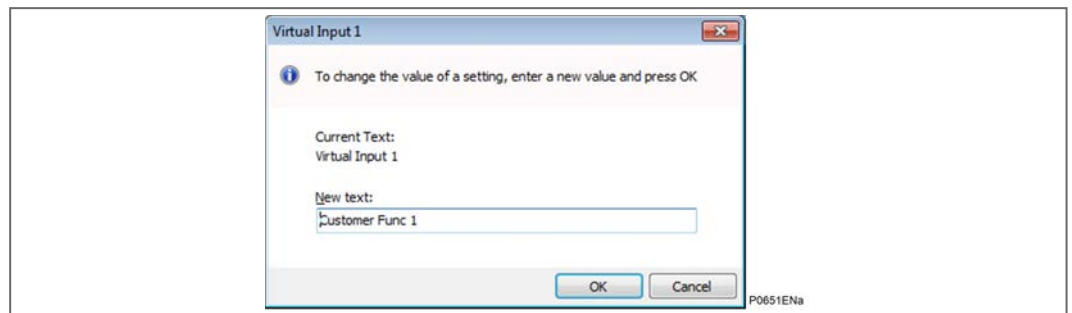

Figure 14 - Virtual Input 1 dialog box

Pressing OK will save the setting and return to the settings page as follows: The above “Customer Func 1” label text will now be used in place of “Virtual Input 1” in the Disturbance / Event Records after the settings file is downloaded to the relay.

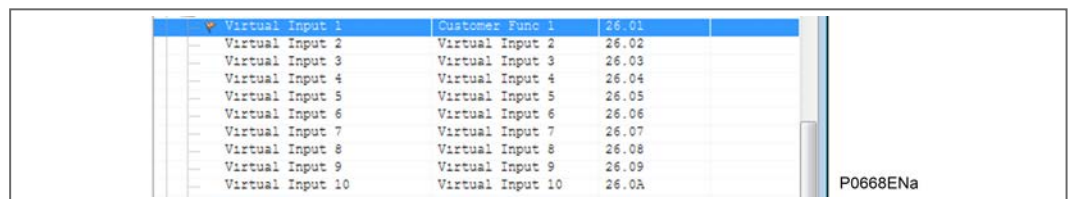

Figure 15 - Easergy Studio VIR I/P Labels Tree

The above “Customer Func 1” label text will now be used in place of “Virtual Input 1” in the Disturbance / Event Records after the settings file is downloaded to the relay.

5.3 Virtual Output Label Operation

The Virtual Output labels can be modified via the MiCOM Px40 user interface or Easergy Studio. The following example is using Version 5.0.0.

The virtual Output labels are available in the “VIR O/P LABELS” ” (or “VIRT O/P LABELS”) folder in the settings file as shown below:

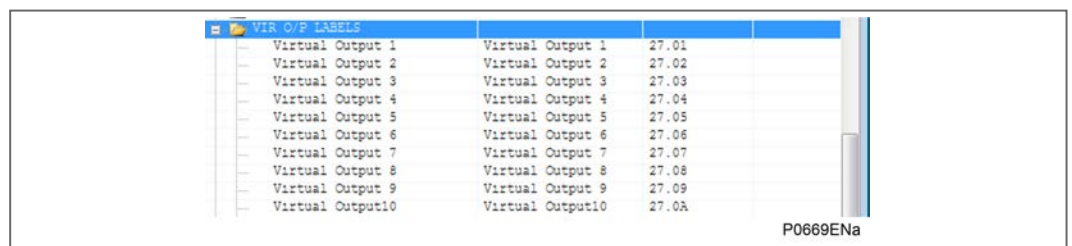

Figure 16 - Easergy Studio VIR O/P Labels Tree

The default “Virtual Output Labels” can be changed to suit the customer requirements. The process is identical to the previously described procedure for the Virtual Input Labels.

5.4 SR/MR User Alarm Label Operation

The SR/MR User Alarm input labels can be modified via the MiCOM Px40 user interface or Easergy Studio. This example is using Version 5.0.0.

The default “SR User Alarm” and “MR User Alarm” labels can be changed to suit the customer requirements. For example, to change default text from “SR User Alarm 1” to “Customer Alarm 1” open the SR User Alarm 1 dialog box and change “SR User Alarm 1” in the New Text: Text box to be “Customer Alarm 1”.

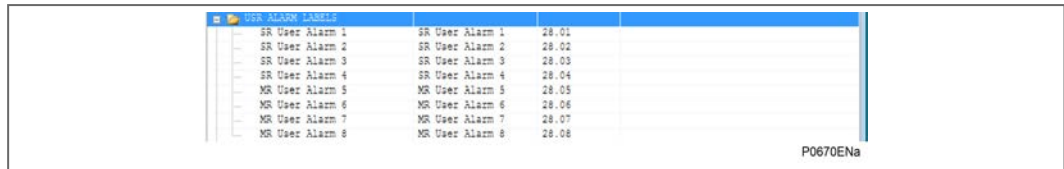

Figure 17 - Easergy Studio USR Labels Tree

The default “SR User Alarm” and “MR User Alarm” labels can be changed to suit the customer requirements. For example, to change default text from “SR User Alarm 1” to “Customer Alarm 1” open the SR User Alarm 1 dialog box and change “SR User Alarm 1” in the New Text: Text box to be “Customer Alarm 1”.

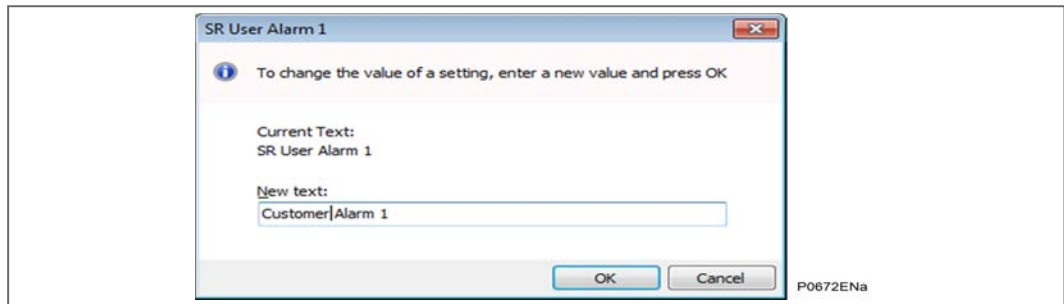

Figure 18 - User Alarm dialog box

Pressing OK will save the setting and return to the settings page as follows:

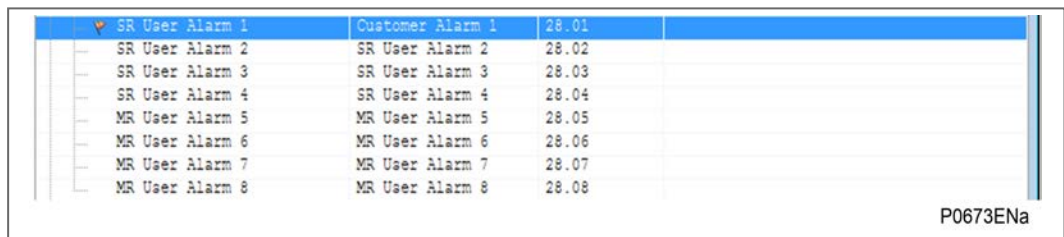

Figure 19 - Virtual Input 1 settings

The above “Customer Alarm 1” label text will now be used in place of “SR User Alarm 1” in the Disturbance / Event Records after the settings file is downloaded to the relay.

5.5 Settable Control Input Operation (P14x, P44y, P54x, P445 & P841 only)

The settings should be applied to all relays in the current differential protection scheme. As from Software Versions C1/D1/F1/G4/H4/J4, there are now 32 Standard Control Inputs and 16 additional Settable Control Inputs available. These are settable via the “CONTROL INPUTS” folder and are located after the standard “Control Input” labels in the relevant settings file.

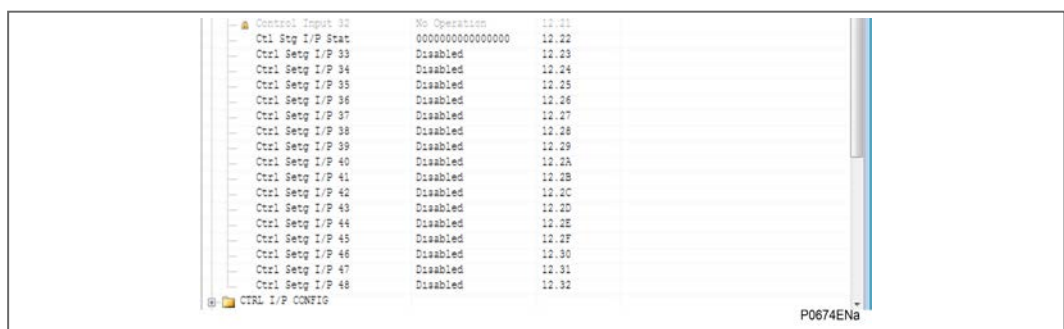

Figure 20 - Easergy Studio Control Inputs tree

Each Settable control Input “Ctrl Setg I/P xx” can be controlled using Enable / Disable settings. To change from (the default) Disabled to Enabled, open the Ctrl Setg I/P xx dialog box, then change Disabled to Enabled in the New Setting drop-down list box:

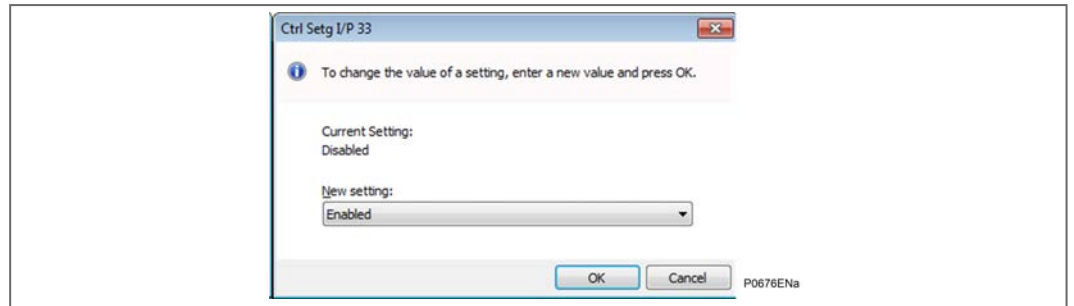

Figure 21 - Ctrl Stg I/P 33 dialog box

Pressing OK will save the setting and return to the settings page as follows:

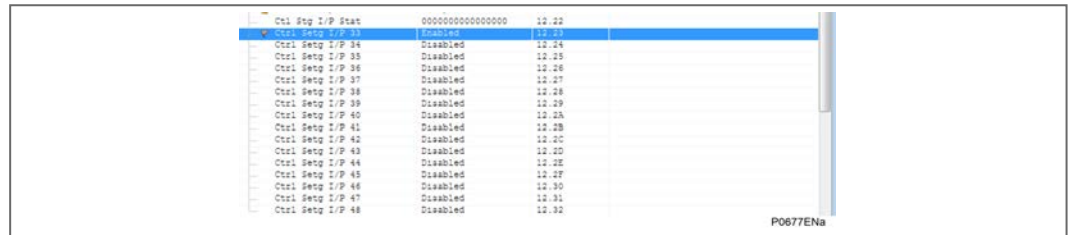

Figure 22 - Easergy Studio Control Inputs (Ctl Stg I/P 33) tree

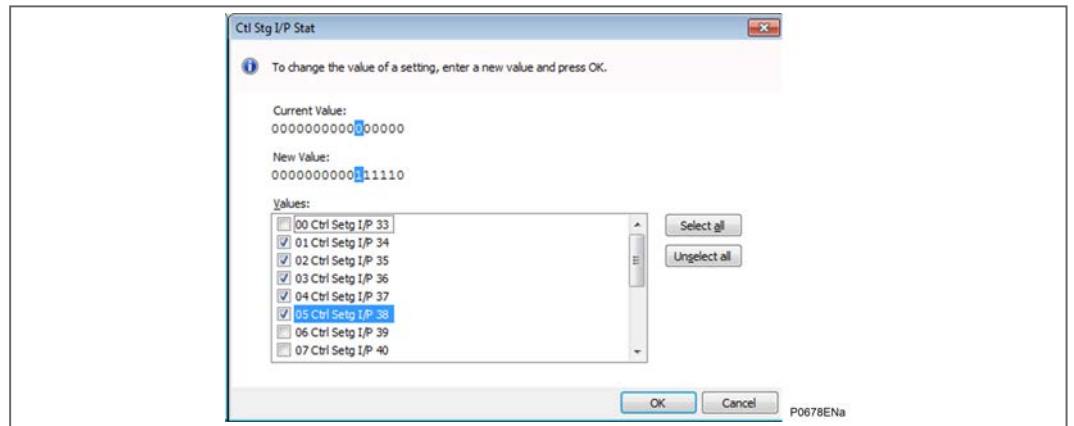

Figure 23 - Ctrl Stg I/P Stat dialog box

The setting “Ctl Stg I/P Stat” can be used to control multiple “Ctrl Stg I/P” at the same time, e.g. clear Ctrl Stg I/P 33 and set Ctrl Stg I/P 34 to 38, but please note that the status will not be reflected in the individual inputs settings or vice versa.

This cell may be hidden in the Easergy Studio files.

5.6 Settable Control Stg I/P Label Operation (P14x, P44y, P54x, P445 & P841 only)

The default labels are available in the “CTRL I/P LABELS” folder and are located after the standard “Control Input” labels in the settings file as shown below:

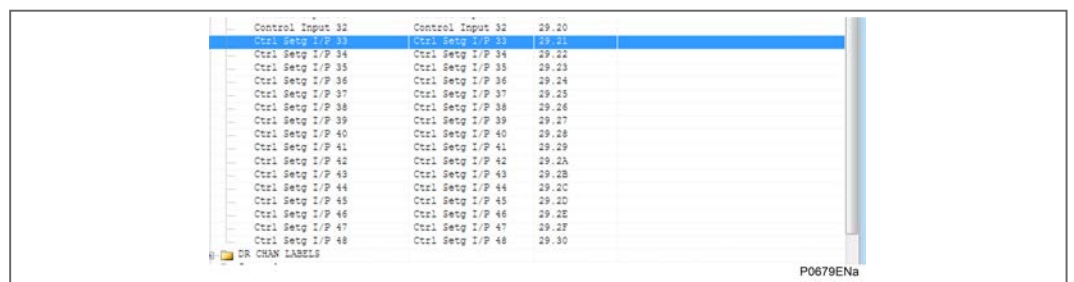

Figure 24 - Easergy Studio Control I/P Labels (Ctl Stg I/P 33) tree

The default “Ctrl Stg I/P” labels can be changed to suit the customer requirements using the same procedure as for the standard “Control Inputs”. For example to change the default text

from “Ctrl Setg I/P 33” to “Custom Ctrl Sg 1” open the Ctrl Setg I/P 33 dialog box, then change “Ctrl Setg I/P 33” in the New Text: box to be “Custom Ctrl Sg 1”.

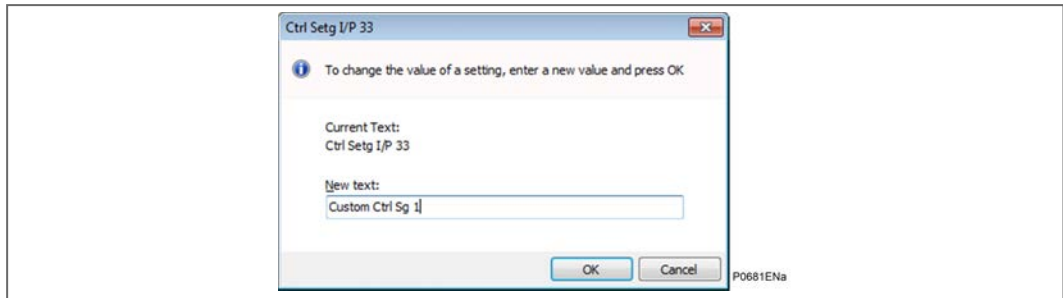

Figure 25 - Ctrl Setg I/P 33 dialog box

Pressing OK will save the setting and return to the settings page as follows:

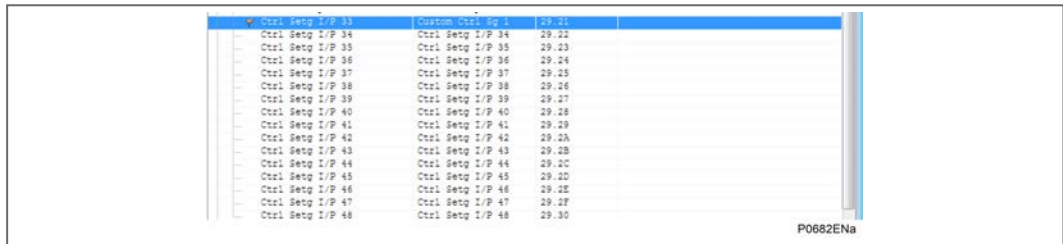

Figure 26 - Easergy Studio Control I/P Labels (Ctrl Setg I/P 33) tree

The above “Custom Ctrl Sg 1” label text will now be used in place of “Ctrl Setg I/P 33” in the Disturbance / Event Records after the settings file is downloaded to the relay.

6. MAKING A RECORD OF MICOM PX40 DEVICE SETTINGS

6.1 Using Easergy Studio to Manage Device Settings

An engineer often needs to create a record of what settings have been applied to a device. In the past, they could have used paper printouts of all the available settings, and mark up the ones they had used. Keeping such a paper-based Settings Records could be time-consuming and prone to error (e.g. due to being settings written down incorrectly).

The MiCOM S1 StudioEasergy Studio software lets you read from or write to MiCOM devices.

- **Extract** lets you download all the settings from a MiCOM Px40 device. A summary is given in the [Extract Settings from a MiCOM Px40 Device](#) section.
- **Send** lets you send the settings you currently have open in Easergy Studio. A summary is given in the [Send Settings to a MiCOM Px40 Device](#) section.

In most cases, it will be quicker and less error prone to extract settings electronically and store them in a settings file on a memory stick. In this way, there will be a digital record which is certain to be accurate. It is also possible to archive these settings files in a repository; so they can be used again or adapted for another use.

Full details of how to do this is provided in the Easergy Studio help.

A quick summary of the main steps is given here. In each case, you need to make sure that:

- Your computer includes the Easergy Studio software.
- Your computer and the MiCOM device are powered on.
- You have used a suitable cable to connect your computer to the MiCOM device (Front Port, Rear Port, Ethernet port or Modem as available).

6.2 Extract Settings from a MiCOM Px40 Device

Full details of how to do this is provided in the Easergy Studio help.

As a quick guide, you need to do the following:

1. In Easergy Studio, click the **Quick Connect...** button.
2. Select the relevant **Device Type** in the **Quick Connect** dialog box.
3. Click the relevant port in the **Port Selection** dialog box.
4. Enter the relevant connection parameters in the **Connection Parameters** dialog box and click the **Finish** button
5. Studio will try to communicate with the Px40 device. It will display a **connected** message if the connection attempt is successful.
6. The device will appear in the **Studio Explorer** pane on the top-left hand side of the interface.
7. Click the **+** button to expand the options for the device, then click on the **Settings** folder.
8. Right-click on **Settings** and select the **Extract Settings** link to read the settings on the device and store them on your computer or a memory stick attached to your computer.
9. After retrieving the settings file, close the dialog box by clicking the **Close** button.

6.3 Send Settings to a MiCOM Px40 Device

Full details of how to do this is provided in the Easergy Studio help.

As a quick guide, you need to do the following:

1. In Easergy Studio, click the **Quick Connect...** button.
2. Select the relevant **Device Type** in the **Quick Connect** dialog box.

3. Click the relevant **port** in the **Port Selection** dialog box.
4. Enter the relevant **connection parameters** in the **Connection Parameters** dialog box and click the **Finish** button
5. Studio will try to communicate with the Px40 device. It will display a **connected** message if the connection attempt is successful.
6. The device will appear in the **Studio Explorer** pane on the top-left hand side of the interface.
7. Click the **+** button to expand the options for the device, then click on the **Settings link**.
8. Right-click on the **device name** and select the **Send link**.

Note

When you send settings to a MiCOM Px40 device, the data is stored in a temporary location at first. This temporary data is tested to make sure it is complete. If the temporary data is complete, it will be programmed into the MiCOM Px40 device. This avoids the risk of a device being programmed with incomplete or corrupt settings.

9. In the **Send To** dialog box, select the settings file(s) you wish to send, then click the **Send** button.
10. Close the the **Send To** dialog box by clicking the **Close** button.

PROGRAMMABLE LOGIC

CHAPTER 8

Date:	10/2022
Products covered by this chapter:	This chapter covers the specific versions of the MiCOM products listed below. This includes only the following combinations of Software Version and Hardware Suffix.
Hardware suffix:	M
Software version:	K6
Connection diagrams:	10P54302 (SH 1 to 2) 10P54303 (SH 1 to 2) 10P54304 (SH 1 to 2) 10P54400 10P54404 (SH 1 to 2) 10P54405 (SH 1 to 2) 10P54502 (SH 1 to 2) 10P54503 (SH 1 to 2) 10P54504 (SH 1 to 2) 10P54600 10P54604 (SH 1 to 2) 10P54605 (SH 1 to 2) 10P54606 (SH 1 to 2)

CONTENTS

Page (PL) 8-

1	Overview	7
2	Description of the Digital Database (DDB)	8
3	Factory Default Programmable Scheme Logic (PSL) Settings	113
4	Logic Input and Output Mappings	114
4.1	Logic Input Mappings	114
4.2	Standard Relay Output Contact Mappings	115
4.3	Optional High Break Relay Output Contact Mappings	117
4.4	Programmable LED Output Mappings	120
4.5	Fault Recorder Start Mappings	123
4.6	PSL Data Column	123
4.7	PSL Signal Grouping Modes	123
5	Viewing and Printing Default PSL Diagrams	125
5.1	Typical Mappings	125
5.2	Download and Print PSL Diagrams	125
6	MICOM P543 with Distance PSL	126
6.1	Output Input Mappings	126
6.2	Output Contacts	127
6.3	Output Contacts	128
6.4	LEDs	129
7	MiCOM P543 Without Distance PSL	139
7.1	Output Input Mappings	139
7.2	Output Contacts	140
7.3	Output Contacts	141
7.4	LEDs	142
8	MiCOM P544 With Distance PSL	151
8.1	Output Input Mappings	151
8.2	Output Contacts	152
8.3	Output Contacts	153
8.4	Output Contacts	154
9	MiCOM P544 Without Distance PSL	164
9.1	Output Input Mappings	164
9.2	Output Contacts	165

9.3	Output Contacts	166
9.4	Output Contacts	167
9.5	LEDs	168
<hr/>		
10	MiCOM P545 With Distance PSL	177
10.1	Output Input Mappings	177
10.2	Output Contacts	178
10.3	Output Contacts	179
10.4	Output Contacts	180
10.5	LEDs	181
<hr/>		
11	MiCOM P545 Without Distance PSL	191
11.1	Output Input Mappings	191
11.2	Output Contacts	192
11.3	Output Contacts	193
11.4	Output Contacts	194
11.5	LEDs	195
<hr/>		
12	MiCOM P546 With Distance PSL	204
12.1	Output Input Mappings	204
12.2	Output Contacts	205
12.3	Output Contacts	206
12.4	Output Contacts	207
12.5	Output Contacts	208
12.6	LEDs	217
<hr/>		
13	MiCOM P546 Without Distance PSL	218
13.1	Output Input Mappings	218
13.2	Output Contacts	219
13.3	Output Contacts	220
13.4	Output Contacts	221
13.5	Output Contacts	222
13.6	LEDs	231
<hr/>		
14	MiCOM P543 Process Bus With Distance PSL	232
14.1	Output Input Mappings	232
14.2	Opto Inputs and Output Contacts	247
14.3	LEDs	250
<hr/>		
15	MiCOM P546 Process Bus with Distance PSL	251
15.1	Output Input Mappings	251
15.2	Opto Inputs and Output Contacts	264

15.3 LEDs

267

TABLES

	Page (PL) 8-
Table 1 - Digital database point list sorted by DDB number	112
Table 2 - Factory default PSL settings for P54x models	113
Table 3 - Default opto-isolated input mappings	114
Table 4 - Default relay output contact mappings for P543 and P544	115
Table 5 - Default relay output contact mappings for P545 and P546	116
Table 6 - Default standard and high break output contact mappings for P543 and P544	117
Table 7 - Default standard and high break output contact mappings for P545	118
Table 8 - Default standard and high break output contact mappings for P546 (16 standard and 8 high break)	118
Table 9 - Default standard and high break output contact mappings for P546 (8 standard and 12 high break)	119
Table 10 - Default mappings for programmable LEDs for P543	120
Table 11 - Default mappings for programmable LEDs for P544	121
Table 12 - Default mappings for programmable LEDs for P545	122
Table 13 - Fault Recorder Start Mappings	123

Notes:

1 OVERVIEW

The purpose of the Programmable Scheme Logic (PSL) is to allow the user to configure an individual protection scheme to suit their own particular application. This is achieved through the use of programmable logic gates and delay timers.

The input to the PSL is any combination of the status of opto inputs. It is also used to assign the mapping of functions to the opto inputs and output contacts, the outputs of the protection elements, e.g. protection starts and trips, and the outputs of the fixed protection scheme logic. The fixed scheme logic provides the relay's standard protection schemes.

The PSL itself consists of software logic gates and timers. The logic gates can be programmed to perform a range of different logic functions and can accept any number of inputs. The timers are used either to create a programmable delay, and/or to condition the logic outputs, e.g. to create a pulse of fixed duration on the output regardless of the length of the pulse on the input. The outputs of the PSL are the LEDs on the front panel of the relay and the output contacts at the rear.

The execution of the PSL logic is event driven; the logic is processed whenever any of its inputs change, for example as a result of a change in one of the digital input signals. Also, only the part of the PSL logic that is affected by the particular input change that has occurred is processed. This reduces the amount of processing time that is used by the PSL. This means that even with large, complex PSL schemes the device trip time will not lengthen.

This system provides flexibility for the user to create their own scheme logic design. It also means that the PSL can be configured into a very complex system, hence setting of the PSL is implemented through the PC support package MiCOM S1 Studio.

How to edit the PSL schemes is described in the "Using the PSL Editor" chapter.

This chapter contains details of the logic nodes which are specific to this product, together with any PSL diagrams which we have published for this product.

2 DESCRIPTION OF THE DIGITAL DATABASE (DDB)

The following table shows the available DDB Numbers, a Description of what they are and which products they apply to. Where a range of DDB Numbers apply to a consecutively-numbered range of related items, the DDB Number range is shown. For example, DDB No 0 to 11 to cover Output Relay 1 to Output Relay 11; or 2nd Harmonic A to C to cover 2nd Harmonic A, 2nd Harmonic B and 2nd Harmonic C. If a DDB Number is not shown, it is not used in this range of products.

Note Where applicable. Not all nodes appear in every product variant.

DDB No	Source	Element Name	Description	English Text	P543/P545 No Distance	P544/P546 No Distance	P543/ P545	P544/ P546
0	Output conditioner	DDB_OUTPUT_RELAY_1	Programmable Output Relay 1 is energized. Not valid if Contacts Blocked	Relay 1	*	*	*	*
1	Output conditioner	DDB_OUTPUT_RELAY_2	Programmable Output Relay 2 is energized. Not valid if Contacts Blocked	Relay 2	*	*	*	*
2	Output conditioner	DDB_OUTPUT_RELAY_3	Programmable Output Relay 3 is energized. Not valid if Contacts Blocked	Relay 3	*	*	*	*
3	Output conditioner	DDB_OUTPUT_RELAY_4	Programmable Output Relay 4 is energized. Not valid if Contacts Blocked	Relay 4	*	*	*	*
4	Output conditioner	DDB_OUTPUT_RELAY_5	Programmable Output Relay 5 is energized. Not valid if Contacts Blocked	Relay 5	*	*	*	*
5	Output conditioner	DDB_OUTPUT_RELAY_6	Programmable Output Relay 6 is energized. Not valid if Contacts Blocked	Relay 6	*	*	*	*
6	Output conditioner	DDB_OUTPUT_RELAY_7	Programmable Output Relay 7 is energized. Not valid if Contacts Blocked	Relay 7	*	*	*	*
7	Output conditioner	DDB_OUTPUT_RELAY_8	Programmable Output Relay 8 is energized. Not valid if Contacts Blocked	Relay 8	*	*	*	*
8	Output conditioner	DDB_OUTPUT_RELAY_9	Programmable Output Relay 9 is energized. Not valid if Contacts Blocked	Relay 9	*	*	*	*
9	Output conditioner	DDB_OUTPUT_RELAY_10	Programmable Output Relay 10 is energized. Not valid if Contacts Blocked	Relay 10	*	*	*	*
10	Output conditioner	DDB_OUTPUT_RELAY_11	Programmable Output Relay 11 is energized. Not valid if Contacts Blocked	Relay 11	*	*	*	*
11	Output conditioner	DDB_OUTPUT_RELAY_12	Programmable Output Relay 12 is energized. Not valid if Contacts Blocked	Relay 12	*	*	*	*
12	Output conditioner	DDB_OUTPUT_RELAY_13	Programmable Output Relay 13 is energized. Not valid if Contacts Blocked	Relay 13	*	*	*	*
13	Output conditioner	DDB_OUTPUT_RELAY_14	Programmable Output Relay 14 is energized. Not valid if Contacts Blocked	Relay 14	*	*	*	*
14	Output conditioner	DDB_OUTPUT_RELAY_15	Programmable Output Relay 15 is energized. Not valid if Contacts Blocked	Relay 15	*	*	*	*
15	Output conditioner	DDB_OUTPUT_RELAY_16	Programmable Output Relay 16 is energized. Not valid if Contacts Blocked	Relay 16	*	*	*	*
16	Output conditioner	DDB_OUTPUT_RELAY_17	Programmable Output Relay 17 is energized. Not valid if Contacts Blocked	Relay 17	*	*	*	*
17	Output conditioner	DDB_OUTPUT_RELAY_18	Programmable Output Relay 18 is energized. Not valid if Contacts Blocked	Relay 18	*	*	*	*
18	Output conditioner	DDB_OUTPUT_RELAY_19	Programmable Output Relay 19 is energized. Not valid if Contacts Blocked	Relay 19	*	*	*	*
19	Output conditioner	DDB_OUTPUT_RELAY_20	Programmable Output Relay 20 is energized. Not valid if Contacts Blocked	Relay 20	*	*	*	*
20	Output conditioner	DDB_OUTPUT_RELAY_21	Programmable Output Relay 21 is energized. Not valid if Contacts Blocked	Relay 21	*	*	*	*

DDB No	Source	Element Name	Description	English Text	P543P54 Yn5 Distance	P544P54 Yn5 Distance	P543/ P544/ P545	P544/ P545/ P546
21	Output conditioner	DDB_OUTPUT_RELAY_22	Programmable Output Relay 22 is energized. Not valid if Contacts Blocked	Relay 22	*	*	*	*
22	Output conditioner	DDB_OUTPUT_RELAY_23	Programmable Output Relay 23 is energized. Not valid if Contacts Blocked	Relay 23	*	*	*	*
23	Output conditioner	DDB_OUTPUT_RELAY_24	Programmable Output Relay 24 is energized. Not valid if Contacts Blocked	Relay 24	*	*	*	*
24	Output conditioner	DDB_OUTPUT_RELAY_25	Programmable Output Relay 25 is energized. Not valid if Contacts Blocked	Relay 25	*	*	*	*
25	Output conditioner	DDB_OUTPUT_RELAY_26	Programmable Output Relay 26 is energized. Not valid if Contacts Blocked	Relay 26	*	*	*	*
26	Output conditioner	DDB_OUTPUT_RELAY_27	Programmable Output Relay 27 is energized. Not valid if Contacts Blocked	Relay 27	*	*	*	*
27	Output conditioner	DDB_OUTPUT_RELAY_28	Programmable Output Relay 28 is energized. Not valid if Contacts Blocked	Relay 28	*	*	*	*
28	Output conditioner	DDB_OUTPUT_RELAY_29	Programmable Output Relay 29 is energized. Not valid if Contacts Blocked	Relay 29	*	*	*	*
29	Output conditioner	DDB_OUTPUT_RELAY_30	Programmable Output Relay 30 is energized. Not valid if Contacts Blocked	Relay 30	*	*	*	*
30	Output conditioner	DDB_OUTPUT_RELAY_31	Programmable Output Relay 31 is energized. Not valid if Contacts Blocked	Relay 31	*	*	*	*
31	Output conditioner	DDB_OUTPUT_RELAY_32	Programmable Output Relay 32 is energized. Not valid if Contacts Blocked	Relay 32	*	*	*	*
32	Opto Input	DDB_OPTO_ISOLATOR_1	From opto input 1 - when opto energized	Opto 1	*	*	*	*
33	Opto Input	DDB_OPTO_ISOLATOR_2	From opto input 2 - when opto energized	Opto 2	*	*	*	*
34	Opto Input	DDB_OPTO_ISOLATOR_3	From opto input 3 - when opto energized	Opto 3	*	*	*	*
35	Opto Input	DDB_OPTO_ISOLATOR_4	From opto input 4 - when opto energized	Opto 4	*	*	*	*
36	Opto Input	DDB_OPTO_ISOLATOR_5	From opto input 5 - when opto energized	Opto 5	*	*	*	*
37	Opto Input	DDB_OPTO_ISOLATOR_6	From opto input 6 - when opto energized	Opto 6	*	*	*	*
38	Opto Input	DDB_OPTO_ISOLATOR_7	From opto input 7 - when opto energized	Opto 7	*	*	*	*
39	Opto Input	DDB_OPTO_ISOLATOR_8	From opto input 8 - when opto energized	Opto 8	*	*	*	*
40	Opto Input	DDB_OPTO_ISOLATOR_9	From opto input 9 - when opto energized	Opto 9	*	*	*	*
41	Opto Input	DDB_OPTO_ISOLATOR_10	From opto input 10 - when opto energized	Opto 10	*	*	*	*
42	Opto Input	DDB_OPTO_ISOLATOR_11	From opto input 11 - when opto energized	Opto 11	*	*	*	*
43	Opto Input	DDB_OPTO_ISOLATOR_12	From opto input 12 - when opto energized	Opto 12	*	*	*	*
44	Opto Input	DDB_OPTO_ISOLATOR_13	From opto input 13 - when opto energized	Opto 13	*	*	*	*
45	Opto Input	DDB_OPTO_ISOLATOR_14	From opto input 14 - when opto energized	Opto 14	*	*	*	*
46	Opto Input	DDB_OPTO_ISOLATOR_15	From opto input 15 - when opto energized	Opto 15	*	*	*	*
47	Opto Input	DDB_OPTO_ISOLATOR_16	From opto input 16 - when opto energized	Opto 16	*	*	*	*
48	Opto Input	DDB_OPTO_ISOLATOR_17	From opto input 17 - when opto energized	Opto 17	*	*	*	*
49	Opto Input	DDB_OPTO_ISOLATOR_18	From opto input 18 - when opto energized	Opto 18	*	*	*	*
50	Opto Input	DDB_OPTO_ISOLATOR_19	From opto input 19 - when opto energized	Opto 19	*	*	*	*
51	Opto Input	DDB_OPTO_ISOLATOR_20	From opto input 20 - when opto energized	Opto 20	*	*	*	*
52	Opto Input	DDB_OPTO_ISOLATOR_21	From opto input 21 - when opto energized	Opto 21	*	*	*	*
53	Opto Input	DDB_OPTO_ISOLATOR_22	From opto input 22 - when opto energized	Opto 22	*	*	*	*
54	Opto Input	DDB_OPTO_ISOLATOR_23	From opto input 23 - when opto energized	Opto 23	*	*	*	*
55	Opto Input	DDB_OPTO_ISOLATOR_24	From opto input 24 - when opto energized	Opto 24	*	*	*	*
56	Opto Input	DDB_OPTO_ISOLATOR_25	From opto input 25 - when opto energized	Opto 25	*	*	*	*

DDB No	Source	Element Name	Description	English Text	P543/P545 No Distance	P544/P546 No Distance	P543/P545	P544/P546
57	Opto Input	DDB_OPTO_ISOLATOR_26	From opto input 26 - when opto energized	Opto 26	*		*	
58	Opto Input	DDB_OPTO_ISOLATOR_27	From opto input 27 - when opto energized	Opto 27	*		*	
59	Opto Input	DDB_OPTO_ISOLATOR_28	From opto input 28 - when opto energized	Opto 28	*		*	
60	Opto Input	DDB_OPTO_ISOLATOR_29	From opto input 29 - when opto energized	Opto 29	*		*	
61	Opto Input	DDB_OPTO_ISOLATOR_30	From opto input 30 - when opto energized	Opto 30	*		*	
62	Opto Input	DDB_OPTO_ISOLATOR_31	From opto input 31 - when opto energized	Opto 31	*		*	
63	Opto Input	DDB_OPTO_ISOLATOR_32	From opto input 32 - when opto energized	Opto 32	*		*	
56	Opto Input	DDB_OPTO_ISOLATOR_25	Unused	Unused		*		*
57	Opto Input	DDB_OPTO_ISOLATOR_26	Unused	Unused		*		*
58	Opto Input	DDB_OPTO_ISOLATOR_27	Unused	Unused		*		*
59	Opto Input	DDB_OPTO_ISOLATOR_28	Unused	Unused		*		*
60	Opto Input	DDB_OPTO_ISOLATOR_29	Unused	Unused		*		*
61	Opto Input	DDB_OPTO_ISOLATOR_30	Unused	Unused		*		*
62	Opto Input	DDB_OPTO_ISOLATOR_31	Unused	Unused		*		*
63	Opto Input	DDB_OPTO_ISOLATOR_32	Unused	Unused		*		*
64		DDB_UNUSED_64	Unused	Unused	*	*	*	*
65		DDB_UNUSED_65	Unused	Unused	*	*	*	*
66		DDB_UNUSED_66	Unused	Unused	*	*	*	*
67		DDB_UNUSED_67	Unused	Unused	*	*	*	*
68		DDB_UNUSED_68	Unused	Unused	*	*	*	*
69		DDB_UNUSED_69	Unused	Unused	*	*	*	*
70		DDB_UNUSED_70	Unused	Unused	*	*	*	*
71		DDB_UNUSED_71	Unused	Unused	*	*	*	*
72		DDB_UNUSED_72	Unused	Unused	*	*	*	*
73		DDB_UNUSED_73	Unused	Unused	*	*	*	*
74		DDB_UNUSED_74	Unused	Unused	*	*	*	*
75		DDB_UNUSED_75	Unused	Unused	*	*	*	*
76		DDB_UNUSED_76	Unused	Unused	*	*	*	*
77		DDB_UNUSED_77	Unused	Unused	*	*	*	*
78		DDB_UNUSED_78	Unused	Unused	*	*	*	*
79		DDB_UNUSED_79	Unused	Unused	*	*	*	*
80	InterMiCOM	DDB_INTERIN_1	InterMiCOM Input 1 - is driven by a message from the remote line end	IM Input 1	*	*	*	*
81	InterMiCOM	DDB_INTERIN_2	InterMiCOM Input 2 - is driven by a message from the remote line end	IM Input 2	*	*	*	*
82	InterMiCOM	DDB_INTERIN_3	InterMiCOM Input 3 - is driven by a message from the remote line end	IM Input 3	*	*	*	*
83	InterMiCOM	DDB_INTERIN_4	InterMiCOM Input 4 - is driven by a message from the remote line end	IM Input 4	*	*	*	*
84	InterMiCOM	DDB_INTERIN_5	InterMiCOM Input 5 - is driven by a message from the remote line end	IM Input 5	*	*	*	*
85	InterMiCOM	DDB_INTERIN_6	InterMiCOM Input 6 - is driven by a message from the remote line end	IM Input 6	*	*	*	*
86	InterMiCOM	DDB_INTERIN_7	InterMiCOM Input 7 - is driven by a message from the remote line end	IM Input 7	*	*	*	*

DDB No	Source	Element Name	Description	English Text	P543/P545 Distance	P544/P546 Distance	P543/ P545	P544/ P546
87	InterMiCOM	DDB_INTERIN_8	InterMiCOM Input 8 - is driven by a message from the remote line end	IM Input 8	*	*	*	*
88	PSL	DDB_INTEROUT_1	InterMiCOM Output 1 - is an output to the remote line end	IM Output 1	*	*	*	*
89	PSL	DDB_INTEROUT_2	InterMiCOM Output 2 - is an output to the remote line end	IM Output 2	*	*	*	*
90	PSL	DDB_INTEROUT_3	InterMiCOM Output 3 - is an output to the remote line end	IM Output 3	*	*	*	*
91	PSL	DDB_INTEROUT_4	InterMiCOM Output 4 - is an output to the remote line end	IM Output 4	*	*	*	*
92	PSL	DDB_INTEROUT_5	InterMiCOM Output 5 - is an output to the remote line end	IM Output 5	*	*	*	*
93	PSL	DDB_INTEROUT_6	InterMiCOM Output 6 - is an output to the remote line end	IM Output 6	*	*	*	*
94	PSL	DDB_INTEROUT_7	InterMiCOM Output 7 - is an output to the remote line end	IM Output 7	*	*	*	*
95	PSL	DDB_INTEROUT_8	InterMiCOM Output 8 - is an output to the remote line end	IM Output 8	*	*	*	*
96	IM64	DDB_IM64_CH1_1_IN	IM64 Ch1 input 1 - is driven by a message from the remote line end	IM64 Ch1 Input 1	*	*	*	*
97	IM64	DDB_IM64_CH1_2_IN	IM64 Ch1 input 2 - is driven by a message from the remote line end	IM64 Ch1 Input 2	*	*	*	*
98	IM64	DDB_IM64_CH1_3_IN	IM64 Ch1 input 3 - is driven by a message from the remote line end	IM64 Ch1 Input 3	*	*	*	*
99	IM64	DDB_IM64_CH1_4_IN	IM64 Ch1 input 4 - is driven by a message from the remote line end	IM64 Ch1 Input 4	*	*	*	*
100	IM64	DDB_IM64_CH1_5_IN	IM64 Ch1 input 5 - is driven by a message from the remote line end	IM64 Ch1 Input 5	*	*	*	*
101	IM64	DDB_IM64_CH1_6_IN	IM64 Ch1 input 6 - is driven by a message from the remote line end	IM64 Ch1 Input 6	*	*	*	*
102	IM64	DDB_IM64_CH1_7_IN	IM64 Ch1 input 7 - is driven by a message from the remote line end	IM64 Ch1 Input 7	*	*	*	*
103	IM64	DDB_IM64_CH1_8_IN	IM64 Ch1 input 8 - is driven by a message from the remote line end	IM64 Ch1 Input 8	*	*	*	*
104	IM64	DDB_IM64_CH2_1_IN	IM64 Ch2 input 1 - is driven by a message from the remote line end	IM64 Ch2 Input 1	*	*	*	*
105	IM64	DDB_IM64_CH2_2_IN	IM64 Ch2 input 2 - is driven by a message from the remote line end	IM64 Ch2 Input 2	*	*	*	*
106	IM64	DDB_IM64_CH2_3_IN	IM64 Ch2 input 3 - is driven by a message from the remote line end	IM64 Ch2 Input 3	*	*	*	*
107	IM64	DDB_IM64_CH2_4_IN	IM64 Ch2 input 4 - is driven by a message from the remote line end	IM64 Ch2 Input 4	*	*	*	*
108	IM64	DDB_IM64_CH2_5_IN	IM64 Ch2 input 5 - is driven by a message from the remote line end	IM64 Ch2 Input 5	*	*	*	*
109	IM64	DDB_IM64_CH2_6_IN	IM64 Ch2 input 6 - is driven by a message from the remote line end	IM64 Ch2 Input 6	*	*	*	*
110	IM64	DDB_IM64_CH2_7_IN	IM64 Ch2 input 7 - is driven by a message from the remote line end	IM64 Ch2 Input 7	*	*	*	*
111	IM64	DDB_IM64_CH2_8_IN	IM64 Ch2 input 8 - is driven by a message from the remote line end	IM64 Ch2 Input 8	*	*	*	*
112	PSL	DDB_IM64_CH1_1_OUT	IM64 Ch1 output 1 - mapping what will be sent to the remote line end	IM64 Ch1 Output1	*	*	*	*

DDB No	Source	Element Name	Description	English Text	P543/P545 No Distance	P544/P546 No Distance	P543/ P545	P544/ P546
113	PSL	DDB_IM64_CH1_2_OUT	IM64 Ch1 output 2 - mapping what will be sent to the remote line end	IM64 Ch1 Output2	*	*	*	*
114	PSL	DDB_IM64_CH1_3_OUT	IM64 Ch1 output 3 - mapping what will be sent to the remote line end	IM64 Ch1 Output3	*	*	*	*
115	PSL	DDB_IM64_CH1_4_OUT	IM64 Ch1 output 4 - mapping what will be sent to the remote line end	IM64 Ch1 Output4	*	*	*	*
116	PSL	DDB_IM64_CH1_5_OUT	IM64 Ch1 output 5 - mapping what will be sent to the remote line end	IM64 Ch1 Output5	*	*	*	*
117	PSL	DDB_IM64_CH1_6_OUT	IM64 Ch1 output 6 - mapping what will be sent to the remote line end	IM64 Ch1 Output6	*	*	*	*
118	PSL	DDB_IM64_CH1_7_OUT	IM64 Ch1 output 7 - mapping what will be sent to the remote line end	IM64 Ch1 Output7	*	*	*	*
119	PSL	DDB_IM64_CH1_8_OUT	IM64 Ch1 output 8 - mapping what will be sent to the remote line end	IM64 Ch1 Output8	*	*	*	*
120	PSL	DDB_IM64_CH2_1_OUT	IM64 Ch2 output 1 - mapping what will be sent to the remote line end	IM64 Ch2 Output1	*	*	*	*
121	PSL	DDB_IM64_CH2_2_OUT	IM64 Ch2 output 2 - mapping what will be sent to the remote line end	IM64 Ch2 Output2	*	*	*	*
122	PSL	DDB_IM64_CH2_3_OUT	IM64 Ch2 output 3 - mapping what will be sent to the remote line end	IM64 Ch2 Output3	*	*	*	*
123	PSL	DDB_IM64_CH2_4_OUT	IM64 Ch2 output 4 - mapping what will be sent to the remote line end	IM64 Ch2 Output4	*	*	*	*
124	PSL	DDB_IM64_CH2_5_OUT	IM64 Ch2 output 5 - mapping what will be sent to the remote line end	IM64 Ch2 Output5	*	*	*	*
125	PSL	DDB_IM64_CH2_6_OUT	IM64 Ch2 output 6 - mapping what will be sent to the remote line end	IM64 Ch2 Output6	*	*	*	*
126	PSL	DDB_IM64_CH2_7_OUT	IM64 Ch2 output 7 - mapping what will be sent to the remote line end	IM64 Ch2 Output7	*	*	*	*
127	PSL	DDB_IM64_CH2_8_OUT	IM64 Ch2 output 8 - mapping what will be sent to the remote line end	IM64 Ch2 Output8	*	*	*	*
96	IM64	DDB_IM64_CH1_1_IN	Unused	Unused				
97	IM64	DDB_IM64_CH1_2_IN	Unused	Unused				
98	IM64	DDB_IM64_CH1_3_IN	Unused	Unused				
99	IM64	DDB_IM64_CH1_4_IN	Unused	Unused				
100	IM64	DDB_IM64_CH1_5_IN	Unused	Unused				
101	IM64	DDB_IM64_CH1_6_IN	Unused	Unused				
102	IM64	DDB_IM64_CH1_7_IN	Unused	Unused				
103	IM64	DDB_IM64_CH1_8_IN	Unused	Unused				
104	IM64	DDB_IM64_CH2_1_IN	Unused	Unused				
105	IM64	DDB_IM64_CH2_2_IN	Unused	Unused				
106	IM64	DDB_IM64_CH2_3_IN	Unused	Unused				
107	IM64	DDB_IM64_CH2_4_IN	Unused	Unused				
108	IM64	DDB_IM64_CH2_5_IN	Unused	Unused				
109	IM64	DDB_IM64_CH2_6_IN	Unused	Unused				
110	IM64	DDB_IM64_CH2_7_IN	Unused	Unused				
111	IM64	DDB_IM64_CH2_8_IN	Unused	Unused				
112	PSL	DDB_IM64_CH1_1_OUT	Unused	Unused				
113	PSL	DDB_IM64_CH1_2_OUT	Unused	Unused				

DDB No	Source	Element Name	Description	English Text	P543/P545 Distance	P544/P546 Distance	P543/ P545	P544/ P546
114	PSL	DDB_IM64_CH1_3_OUT	Unused	Unused				
115	PSL	DDB_IM64_CH1_4_OUT	Unused	Unused				
116	PSL	DDB_IM64_CH1_5_OUT	Unused	Unused				
117	PSL	DDB_IM64_CH1_6_OUT	Unused	Unused				
118	PSL	DDB_IM64_CH1_7_OUT	Unused	Unused				
119	PSL	DDB_IM64_CH1_8_OUT	Unused	Unused				
120	PSL	DDB_IM64_CH2_1_OUT	Unused	Unused				
121	PSL	DDB_IM64_CH2_2_OUT	Unused	Unused				
122	PSL	DDB_IM64_CH2_3_OUT	Unused	Unused				
123	PSL	DDB_IM64_CH2_4_OUT	Unused	Unused				
124	PSL	DDB_IM64_CH2_5_OUT	Unused	Unused				
125	PSL	DDB_IM64_CH2_6_OUT	Unused	Unused				
126	PSL	DDB_IM64_CH2_7_OUT	Unused	Unused				
127	PSL	DDB_IM64_CH2_8_OUT	Unused	Unused				
128	PSL	DDB_OUTPUT_CON_1	Input to relay 1 output conditioner	Relay Cond 1	*	*	*	*
129	PSL	DDB_OUTPUT_CON_2	Input to relay 2 output conditioner	Relay Cond 2	*	*	*	*
130	PSL	DDB_OUTPUT_CON_3	Input to relay 3 output conditioner	Relay Cond 3	*	*	*	*
131	PSL	DDB_OUTPUT_CON_4	Input to relay 4 output conditioner	Relay Cond 4	*	*	*	*
132	PSL	DDB_OUTPUT_CON_5	Input to relay 5 output conditioner	Relay Cond 5	*	*	*	*
133	PSL	DDB_OUTPUT_CON_6	Input to relay 6 output conditioner	Relay Cond 6	*	*	*	*
134	PSL	DDB_OUTPUT_CON_7	Input to relay 7 output conditioner	Relay Cond 7	*	*	*	*
135	PSL	DDB_OUTPUT_CON_8	Input to relay 8 output conditioner	Relay Cond 8	*	*	*	*
136	PSL	DDB_OUTPUT_CON_9	Input to relay 9 output conditioner	Relay Cond 9	*	*	*	*
137	PSL	DDB_OUTPUT_CON_10	Input to relay 10 output conditioner	Relay Cond 10	*	*	*	*
138	PSL	DDB_OUTPUT_CON_11	Input to relay 11 output conditioner	Relay Cond 11	*	*	*	*
139	PSL	DDB_OUTPUT_CON_12	Input to relay 12 output conditioner	Relay Cond 12	*	*	*	*
140	PSL	DDB_OUTPUT_CON_13	Input to relay 13 output conditioner	Relay Cond 13	*	*	*	*
141	PSL	DDB_OUTPUT_CON_14	Input to relay 14 output conditioner	Relay Cond 14	*	*	*	*
142	PSL	DDB_OUTPUT_CON_15	Input to relay 15 output conditioner	Relay Cond 15	*	*	*	*
143	PSL	DDB_OUTPUT_CON_16	Input to relay 16 output conditioner	Relay Cond 16	*	*	*	*
144	PSL	DDB_OUTPUT_CON_17	Input to relay 17 output conditioner	Relay Cond 17	*	*	*	*
145	PSL	DDB_OUTPUT_CON_18	Input to relay 18 output conditioner	Relay Cond 18	*	*	*	*
146	PSL	DDB_OUTPUT_CON_19	Input to relay 19 output conditioner	Relay Cond 19	*	*	*	*
147	PSL	DDB_OUTPUT_CON_20	Input to relay 20 output conditioner	Relay Cond 20	*	*	*	*
148	PSL	DDB_OUTPUT_CON_21	Input to relay 21 output conditioner	Relay Cond 21	*	*	*	*
149	PSL	DDB_OUTPUT_CON_22	Input to relay 22 output conditioner	Relay Cond 22	*	*	*	*
150	PSL	DDB_OUTPUT_CON_23	Input to relay 23 output conditioner	Relay Cond 23	*	*	*	*
151	PSL	DDB_OUTPUT_CON_24	Input to relay 24 output conditioner	Relay Cond 24	*	*	*	*
152	PSL	DDB_OUTPUT_CON_25	Input to relay 25 output conditioner	Relay Cond 25	*	*	*	*
153	PSL	DDB_OUTPUT_CON_26	Input to relay 26 output conditioner	Relay Cond 26	*	*	*	*
154	PSL	DDB_OUTPUT_CON_27	Input to relay 27 output conditioner	Relay Cond 27	*	*	*	*
155	PSL	DDB_OUTPUT_CON_28	Input to relay 28 output conditioner	Relay Cond 28	*	*	*	*
156	PSL	DDB_OUTPUT_CON_29	Input to relay 29 output conditioner	Relay Cond 29	*	*	*	*
157	PSL	DDB_OUTPUT_CON_30	Input to relay 30 output conditioner	Relay Cond 30	*	*	*	*

DDB No	Source	Element Name	Description	English Text	P543/P545 5 No Distance	P544/P546 6 No Distance	P543/ P545	P544/ P546
158	PSL	DDB_OUTPUT_CON_31	Input to relay 31 output conditioner	Relay Cond 31	*	*	*	*
159	PSL	DDB_OUTPUT_CON_32	Input to relay 32 output conditioner	Relay Cond 32	*	*	*	*
160		DDB_UNUSED_160	Unused	Unused	*	*	*	*
161		DDB_UNUSED_161	Unused	Unused	*	*	*	*
162		DDB_UNUSED_162	Unused	Unused	*	*	*	*
163		DDB_UNUSED_163	Unused	Unused	*	*	*	*
164		DDB_UNUSED_164	Unused	Unused	*	*	*	*
165		DDB_UNUSED_165	Unused	Unused	*	*	*	*
166		DDB_UNUSED_166	Unused	Unused	*	*	*	*
167		DDB_UNUSED_167	Unused	Unused	*	*	*	*
168		DDB_UNUSED_168	Unused	Unused	*	*	*	*
169		DDB_UNUSED_169	Unused	Unused	*	*	*	*
170		DDB_UNUSED_170	Unused	Unused	*	*	*	*
171		DDB_UNUSED_171	Unused	Unused	*	*	*	*
172		DDB_UNUSED_172	Unused	Unused	*	*	*	*
173		DDB_UNUSED_173	Unused	Unused	*	*	*	*
174		DDB_UNUSED_174	Unused	Unused	*	*	*	*
175		DDB_UNUSED_175	Unused	Unused	*	*	*	*
176		DDB_UNUSED_176	Unused	Unused	*	*	*	*
177		DDB_UNUSED_177	Unused	Unused	*	*	*	*
178		DDB_UNUSED_178	Unused	Unused	*	*	*	*
179		DDB_UNUSED_179	Unused	Unused	*	*	*	*
180		DDB_UNUSED_180	Unused	Unused	*	*	*	*
181		DDB_UNUSED_181	Unused	Unused	*	*	*	*
182		DDB_UNUSED_182	Unused	Unused	*	*	*	*
183		DDB_UNUSED_183	Unused	Unused	*	*	*	*
184		DDB_UNUSED_184	Unused	Unused	*	*	*	*
185		DDB_UNUSED_185	Unused	Unused	*	*	*	*
186		DDB_UNUSED_186	Unused	Unused	*	*	*	*
187		DDB_UNUSED_187	Unused	Unused	*	*	*	*
188		DDB_UNUSED_188	Unused	Unused	*	*	*	*
189		DDB_UNUSED_189	Unused	Unused	*	*	*	*
190		DDB_UNUSED_190	Unused	Unused	*	*	*	*
191		DDB_UNUSED_191	Unused	Unused	*	*	*	*
192	Virtual Input Command	DDB_CONTROL_1	Control input 1 - for SCADA and menu commands into PSL	Control Input 1	*	*	*	*
193	Virtual Input Command	DDB_CONTROL_2	Control input 2 - for SCADA and menu commands into PSL	Control Input 2	*	*	*	*
194	Virtual Input Command	DDB_CONTROL_3	Control input 3 - for SCADA and menu commands into PSL	Control Input 3	*	*	*	*
195	Virtual Input Command	DDB_CONTROL_4	Control input 4 - for SCADA and menu commands into PSL	Control Input 4	*	*	*	*
196	Virtual Input Command	DDB_CONTROL_5	Control input 5 - for SCADA and menu commands into PSL	Control Input 5	*	*	*	*

DDB No	Source	Element Name	Description	English Text	P543/P545 Distance	P544/P546 Distance	P543/ P545	P544/ P546
197	Virtual Input Command	DDB_CONTROL_6	Control input 6 - for SCADA and menu commands into PSL	Control Input 6	*	*	*	*
198	Virtual Input Command	DDB_CONTROL_7	Control input 7 - for SCADA and menu commands into PSL	Control Input 7	*	*	*	*
199	Virtual Input Command	DDB_CONTROL_8	Control input 8 - for SCADA and menu commands into PSL	Control Input 8	*	*	*	*
200	Virtual Input Command	DDB_CONTROL_9	Control input 9 - for SCADA and menu commands into PSL	Control Input 9	*	*	*	*
201	Virtual Input Command	DDB_CONTROL_10	Control input 10 - for SCADA and menu commands into PSL	Control Input 10	*	*	*	*
202	Virtual Input Command	DDB_CONTROL_11	Control input 11 - for SCADA and menu commands into PSL	Control Input 11	*	*	*	*
203	Virtual Input Command	DDB_CONTROL_12	Control input 12 - for SCADA and menu commands into PSL	Control Input 12	*	*	*	*
204	Virtual Input Command	DDB_CONTROL_13	Control input 13 - for SCADA and menu commands into PSL	Control Input 13	*	*	*	*
205	Virtual Input Command	DDB_CONTROL_14	Control input 14 - for SCADA and menu commands into PSL	Control Input 14	*	*	*	*
206	Virtual Input Command	DDB_CONTROL_15	Control input 15 - for SCADA and menu commands into PSL	Control Input 15	*	*	*	*
207	Virtual Input Command	DDB_CONTROL_16	Control input 16 - for SCADA and menu commands into PSL	Control Input 16	*	*	*	*
208	Virtual Input Command	DDB_CONTROL_17	Control input 17 - for SCADA and menu commands into PSL	Control Input 17	*	*	*	*
209	Virtual Input Command	DDB_CONTROL_18	Control input 18 - for SCADA and menu commands into PSL	Control Input 18	*	*	*	*
210	Virtual Input Command	DDB_CONTROL_19	Control input 19 - for SCADA and menu commands into PSL	Control Input 19	*	*	*	*
211	Virtual Input Command	DDB_CONTROL_20	Control input 20 - for SCADA and menu commands into PSL	Control Input 20	*	*	*	*
212	Virtual Input Command	DDB_CONTROL_21	Control input 21 - for SCADA and menu commands into PSL	Control Input 21	*	*	*	*
213	Virtual Input Command	DDB_CONTROL_22	Control input 22 - for SCADA and menu commands into PSL	Control Input 22	*	*	*	*
214	Virtual Input Command	DDB_CONTROL_23	Control input 23 - for SCADA and menu commands into PSL	Control Input 23	*	*	*	*
215	Virtual Input Command	DDB_CONTROL_24	Control input 24 - for SCADA and menu commands into PSL	Control Input 24	*	*	*	*
216	Virtual Input Command	DDB_CONTROL_25	Control input 25 - for SCADA and menu commands into PSL	Control Input 25	*	*	*	*
217	Virtual Input Command	DDB_CONTROL_26	Control input 26 - for SCADA and menu commands into PSL	Control Input 26	*	*	*	*
218	Virtual Input Command	DDB_CONTROL_27	Control input 27 - for SCADA and menu commands into PSL	Control Input 27	*	*	*	*
219	Virtual Input Command	DDB_CONTROL_28	Control input 28 - for SCADA and menu commands into PSL	Control Input 28	*	*	*	*
220	Virtual Input Command	DDB_CONTROL_29	Control input 29- for SCADA and menu commands into PSL	Control Input 29	*	*	*	*
221	Virtual Input Command	DDB_CONTROL_30	Control input 30 - for SCADA and menu commands into PSL	Control Input 30	*	*	*	*
222	Virtual Input Command	DDB_CONTROL_31	Control input 31 - for SCADA and menu commands into PSL	Control Input 31	*	*	*	*

DDB No	Source	Element Name	Description	English Text	P543/P545 No Distance	P544/P546 No Distance	P543/ P545	P544/ P546
223	Virtual Input Command	DDB_CONTROL_32	Control input 32 - for SCADA and menu commands into PSL	Control Input 32	*	*	*	*
224	GOOSE Input Command	DDB_GOOSEIN_1	Virtual Input 1 - received from GOOSE message	Virtual Input 1	*	*	*	*
225	GOOSE Input Command	DDB_GOOSEIN_2	Virtual Input 2 - received from GOOSE message	Virtual Input 2	*	*	*	*
226	GOOSE Input Command	DDB_GOOSEIN_3	Virtual Input 3 - received from GOOSE message	Virtual Input 3	*	*	*	*
227	GOOSE Input Command	DDB_GOOSEIN_4	Virtual Input 4 - received from GOOSE message	Virtual Input 4	*	*	*	*
228	GOOSE Input Command	DDB_GOOSEIN_5	Virtual Input 5 - received from GOOSE message	Virtual Input 5	*	*	*	*
229	GOOSE Input Command	DDB_GOOSEIN_6	Virtual Input 6 - received from GOOSE message	Virtual Input 6	*	*	*	*
230	GOOSE Input Command	DDB_GOOSEIN_7	Virtual Input 7 - received from GOOSE message	Virtual Input 7	*	*	*	*
231	GOOSE Input Command	DDB_GOOSEIN_8	Virtual Input 8 - received from GOOSE message	Virtual Input 8	*	*	*	*
232	GOOSE Input Command	DDB_GOOSEIN_9	Virtual Input 9 - received from GOOSE message	Virtual Input 9	*	*	*	*
233	GOOSE Input Command	DDB_GOOSEIN_10	Virtual Input 10 - received from GOOSE message	Virtual Input 10	*	*	*	*
234	GOOSE Input Command	DDB_GOOSEIN_11	Virtual Input 11 - received from GOOSE message	Virtual Input 11	*	*	*	*
235	GOOSE Input Command	DDB_GOOSEIN_12	Virtual Input 12 - received from GOOSE message	Virtual Input 12	*	*	*	*
236	GOOSE Input Command	DDB_GOOSEIN_13	Virtual Input 13 - received from GOOSE message	Virtual Input 13	*	*	*	*
237	GOOSE Input Command	DDB_GOOSEIN_14	Virtual Input 14 - received from GOOSE message	Virtual Input 14	*	*	*	*
238	GOOSE Input Command	DDB_GOOSEIN_15	Virtual Input 15 - received from GOOSE message	Virtual Input 15	*	*	*	*
239	GOOSE Input Command	DDB_GOOSEIN_16	Virtual Input 16 - received from GOOSE message	Virtual Input 16	*	*	*	*
240	GOOSE Input Command	DDB_GOOSEIN_17	Virtual Input 17 - received from GOOSE message	Virtual Input 17	*	*	*	*
241	GOOSE Input Command	DDB_GOOSEIN_18	Virtual Input 18 - received from GOOSE message	Virtual Input 18	*	*	*	*
242	GOOSE Input Command	DDB_GOOSEIN_19	Virtual Input 19 - received from GOOSE message	Virtual Input 19	*	*	*	*
243	GOOSE Input Command	DDB_GOOSEIN_20	Virtual Input 20 - received from GOOSE message	Virtual Input 20	*	*	*	*
244	GOOSE Input Command	DDB_GOOSEIN_21	Virtual Input 21 - received from GOOSE message	Virtual Input 21	*	*	*	*
245	GOOSE Input Command	DDB_GOOSEIN_22	Virtual Input 22 - received from GOOSE message	Virtual Input 22	*	*	*	*
246	GOOSE Input Command	DDB_GOOSEIN_23	Virtual Input 23 - received from GOOSE message	Virtual Input 23	*	*	*	*
247	GOOSE Input Command	DDB_GOOSEIN_24	Virtual Input 24 - received from GOOSE message	Virtual Input 24	*	*	*	*
248	GOOSE Input Command	DDB_GOOSEIN_25	Virtual Input 25 - received from GOOSE message	Virtual Input 25	*	*	*	*

DDB No	Source	Element Name	Description	English Text	P543/P54 5 No. Distance	P544/P54 4 No. Distance	P543/ P545	P544/ P546
249	GOOSE Input Command	DDB_GOOSEIN_26	Virtual Input 26 - received from GOOSE message	Virtual Input 26	*	*	*	*
250	GOOSE Input Command	DDB_GOOSEIN_27	Virtual Input 27 - received from GOOSE message	Virtual Input 27	*	*	*	*
251	GOOSE Input Command	DDB_GOOSEIN_28	Virtual Input 28 - received from GOOSE message	Virtual Input 28	*	*	*	*
252	GOOSE Input Command	DDB_GOOSEIN_29	Virtual Input 29 - received from GOOSE message	Virtual Input 29	*	*	*	*
253	GOOSE Input Command	DDB_GOOSEIN_30	Virtual Input 30 - received from GOOSE message	Virtual Input 30	*	*	*	*
254	GOOSE Input Command	DDB_GOOSEIN_31	Virtual Input 31 - received from GOOSE message	Virtual Input 31	*	*	*	*
255	GOOSE Input Command	DDB_GOOSEIN_32	Virtual Input 32 - received from GOOSE message	Virtual Input 32	*	*	*	*
256	PSL	DDB_GOOSEOUT_1	Virtual output 1 - allows user to control a binary signal which can be mapped via SCADA protocol output to other devices	Virtual Output 1	*	*	*	*
257	PSL	DDB_GOOSEOUT_2	Virtual output 2 - allows user to control a binary signal which can be mapped via SCADA protocol output to other devices	Virtual Output 2	*	*	*	*
258	PSL	DDB_GOOSEOUT_3	Virtual output 3 - allows user to control a binary signal which can be mapped via SCADA protocol output to other devices	Virtual Output 3	*	*	*	*
259	PSL	DDB_GOOSEOUT_4	Virtual output 4 - allows user to control a binary signal which can be mapped via SCADA protocol output to other devices	Virtual Output 4	*	*	*	*
260	PSL	DDB_GOOSEOUT_5	Virtual output 5 - allows user to control a binary signal which can be mapped via SCADA protocol output to other devices	Virtual Output 5	*	*	*	*
261	PSL	DDB_GOOSEOUT_6	Virtual output 6 - allows user to control a binary signal which can be mapped via SCADA protocol output to other devices	Virtual Output 6	*	*	*	*
262	PSL	DDB_GOOSEOUT_7	Virtual output 7 - allows user to control a binary signal which can be mapped via SCADA protocol output to other devices	Virtual Output 7	*	*	*	*
263	PSL	DDB_GOOSEOUT_8	Virtual output 8 - allows user to control a binary signal which can be mapped via SCADA protocol output to other devices	Virtual Output 8	*	*	*	*
264	PSL	DDB_GOOSEOUT_9	Virtual output 9 - allows user to control a binary signal which can be mapped via SCADA protocol output to other devices	Virtual Output 9	*	*	*	*
265	PSL	DDB_GOOSEOUT_10	Virtual output 10 - allows user to control a binary signal which can be mapped via SCADA protocol output to other devices	Virtual Output10	*	*	*	*
266	PSL	DDB_GOOSEOUT_11	Virtual output 11 - allows user to control a binary signal which can be mapped via SCADA protocol output to other devices	Virtual Output11	*	*	*	*
267	PSL	DDB_GOOSEOUT_12	Virtual output 12 - allows user to control a binary signal which can be mapped via SCADA protocol output to other devices	Virtual Output12	*	*	*	*
268	PSL	DDB_GOOSEOUT_13	Virtual output 13 - allows user to control a binary signal which can be mapped via SCADA protocol output to other devices	Virtual Output13	*	*	*	*

DDB No	Source	Element Name	Description	English Text	P543/P545 No	P544/P546 Distance	P543/P545 No	P544/P546 Distance	P543/P545	P544/P546
269	PSL	DDB_GOOSEOUT_14	Virtual output 14 - allows user to control a binary signal which can be mapped via SCADA protocol output to other devices	Virtual Output14	*	*	*	*	*	*
270	PSL	DDB_GOOSEOUT_15	Virtual output 15 - allows user to control a binary signal which can be mapped via SCADA protocol output to other devices	Virtual Output15	*	*	*	*	*	*
271	PSL	DDB_GOOSEOUT_16	Virtual output 16 - allows user to control a binary signal which can be mapped via SCADA protocol output to other devices	Virtual Output16	*	*	*	*	*	*
272	PSL	DDB_GOOSEOUT_17	Virtual output 17 - allows user to control a binary signal which can be mapped via SCADA protocol output to other devices	Virtual Output17	*	*	*	*	*	*
273	PSL	DDB_GOOSEOUT_18	Virtual output 18 - allows user to control a binary signal which can be mapped via SCADA protocol output to other devices	Virtual Output18	*	*	*	*	*	*
274	PSL	DDB_GOOSEOUT_19	Virtual output 19 - allows user to control a binary signal which can be mapped via SCADA protocol output to other devices	Virtual Output19	*	*	*	*	*	*
275	PSL	DDB_GOOSEOUT_20	Virtual output 20 - allows user to control a binary signal which can be mapped via SCADA protocol output to other devices	Virtual Output20	*	*	*	*	*	*
276	PSL	DDB_GOOSEOUT_21	Virtual output 21 - allows user to control a binary signal which can be mapped via SCADA protocol output to other devices	Virtual Output21	*	*	*	*	*	*
277	PSL	DDB_GOOSEOUT_22	Virtual output 22 - allows user to control a binary signal which can be mapped via SCADA protocol output to other devices	Virtual Output22	*	*	*	*	*	*
278	PSL	DDB_GOOSEOUT_23	Virtual output 23 - allows user to control a binary signal which can be mapped via SCADA protocol output to other devices	Virtual Output23	*	*	*	*	*	*
279	PSL	DDB_GOOSEOUT_24	Virtual output 24 - allows user to control a binary signal which can be mapped via SCADA protocol output to other devices	Virtual Output24	*	*	*	*	*	*
280	PSL	DDB_GOOSEOUT_25	Virtual output 25 - allows user to control a binary signal which can be mapped via SCADA protocol output to other devices	Virtual Output25	*	*	*	*	*	*
281	PSL	DDB_GOOSEOUT_26	Virtual output 26 - allows user to control a binary signal which can be mapped via SCADA protocol output to other devices	Virtual Output26	*	*	*	*	*	*
282	PSL	DDB_GOOSEOUT_27	Virtual output 27 - allows user to control a binary signal which can be mapped via SCADA protocol output to other devices	Virtual Output27	*	*	*	*	*	*
283	PSL	DDB_GOOSEOUT_28	Virtual output 28 - allows user to control a binary signal which can be mapped via SCADA protocol output to other devices	Virtual Output28	*	*	*	*	*	*
284	PSL	DDB_GOOSEOUT_29	Virtual output 29 - allows user to control a binary signal which can be mapped via SCADA protocol output to other devices	Virtual Output29	*	*	*	*	*	*
285	PSL	DDB_GOOSEOUT_30	Virtual output 30 - allows user to control a binary signal which can be mapped via SCADA protocol output to other devices	Virtual Output30	*	*	*	*	*	*
286	PSL	DDB_GOOSEOUT_31	Virtual output 31 - allows user to control a binary signal which can be mapped via SCADA protocol output to other devices	Virtual Output31	*	*	*	*	*	*

DDB No	Source	Element Name	Description	English Text	P543/P54 5 Inp Distance	P544/P54 5 Inp Distance	P543/ P544/ P545	P544/ P546
287	PSL	DDB_GOOSEOUT_32	Virtual output 32 - allows user to control a binary signal which can be mapped via SCADA protocol output to other devices	Virtual Output32	*	*	*	*
288	Group Selection	DDB_ILLEGAL_OPTO_SETTINGS_GROUP	Setting group selection opto inputs have detected an invalid (disabled) settings group	SG-opto Invalid	*	*	*	*
289	Commissioning Test	DDB_OOS_ALARM	Protection disabled - typically out of service due to test mode	Prot'n Disabled	*	*	*	*
290	Commissioning Test	DDB_STATIC_TEST_MODE	Static test mode option bypasses the delta phase selectors, power swing detection and reverts to conventional directional line and cross polarization to allow testing with test sets that can not simulate a real fault	Static Test Mode			*	*
290	Commissioning Test	DDB_STATIC_TEST_MODE	Unused	Reserved	*	*		
291	C Diff	DDB_LOOPBACK_TEST	Loopback test in service (external or internal)	Test Loopback	*	*	*	*
291	Phase Comparison	DDB_PLC_CHANNEL_FAIL	PLC Channel Fail	PLC Channel Fail				
291	C Diff	DDB_LOOPBACK_TEST	Unused	Reserved				
292	C Diff	DDB_IM64_TEST_MODE	Indication that relay is in test mode	Test IM64	*	*	*	*
292	Phase comparison	DDB_EX_TRANS_ALARM	Extended Transmission Alarm Indication	Ex Trans Alarm				
292	C Diff	DDB_IM64_TEST_MODE	Unused	Reserved				
293	VT Supervision	DDB_VTS_INDICATION	VTS indication alarm- failed VT (fuse blow) detected by VT supervision	VT Fail Alarm	*	*	*	*
294	CT Supervision	DDB_CTS_INDICATION	CTS indication alarm (CT supervision alarm)	CT Fail Alarm	*		*	
294	CT Supervision	DDB_CTS_INDICATION	CT1S indication alarm (CT supervision alarm) In the cases of two CTs: - If standard CTS is used, this indication is ON in case of failure on any of the CTs - If Diff CTS is used this indication is ON in case of failure on CT1	CT1 Fail Alarm		*		*
295	CT Supervision	DDB_CT2S_INDICATION	CT2S indication alarm (CT supervision alarm). This indication is ON If Diff CTS is used and there is a failure on CT2	CT2 Fail Alarm		*		*
295	CT Supervision	DDB_CT2S_INDICATION	Unused	Reserved	*		*	
296	CT Supervision	DDB_REMOTE_CTS_INDICATION	CTS remote indication alarm (CT supervision alarm)	Remote CT Alarm	*	*	*	*
296	CT Supervision	DDB_REMOTE_CTS_INDICATION	Unused	Reserved				
297	Powerswing Blocking	DDB_PSB_ALARM	Powerswing blocking will block any distance zone selected in the setting file	Power Swing			*	*
297	Powerswing Blocking	DDB_PSB_ALARM	Unused	Reserved	*	*		
298	CB Fail	DDB_BREAKER_FAIL_ALARM	Circuit breaker fail alarm	CB Fail Alarm	*		*	
299	CB Monitoring	DDB_CB_MONITOR_ALARM	This alarm indicates that DDB I ^ Maint. Alarm (1106) or DDB CB OPs Maint. (1108) or DDB CB Time Maint. (1110)	CB Monitor Alarm	*		*	
300	CB Monitoring	DDB_CB_MONITOR_LOCKOUT	This alarm indicates that DDB I ^ Lockout Alarm (1107) or DDB CB Ops Lock (1109) or DDB CB Time lockout (1111)	CB Lockout Alarm	*		*	
300	CB Monitoring	DDB_CB_MONITOR_LOCKOUT	This alarm indicates that DDB I ^ Lockout Alarm (1107) or DDB CB Ops Lock (1109) or DDB CB Time lockout (1111)	CB Mon LO Alarm				

DDB No	Source	Element Name	Description	English Text	P543/P545 No Distance	P544/P546 No Distance	P543/ P545	P544/ P546
301	CB Status	DDB_CB_STATUS_ALARM	Indication of problems by circuit breaker state monitoring - example defective auxiliary contacts	CB Status Alarm	*		*	
302	CB Control	DDB_CB_FAILED_TO_TRIP	Circuit breaker failed to trip (after a manual/operator) trip command	CB Trip Fail	*		*	
303	CB Control	DDB_CB_FAILED_TO_CLOSE	Circuit breaker failed to close (after a manual/operator or auto-reclose close command)	CB Close Fail	*		*	
304	CB Control	DDB_CONTROL_CB_UNHEALTHY	Manual circuit breaker unhealthy output signal indicating that the circuit breaker has not closed successfully after a manual close command. (A successful close also requires The circuit breaker healthy signal to reappear within the "healthy window" timeout)	Man CB Unhealthy	*		*	
305	CB Control	DDB_CONTROL_NO_CHECK_SYNC	Indicates that the check synchronism signal has failed to appear for a manual close	No C/S Man Close	*		*	
306	Autoreclose	DDB_AR_LOCKOUT	Indicates an auto-reclose lockout condition - no further auto-reclosures possible until resetting	A/R Lockout	*		*	
307	Autoreclose	DDB_AR_CB_UNHEALTHY	Auto-reclose circuit breaker unhealthy signal, output from auto-reclose logic. Indicates during auto-reclose in progress, if the circuit breaker has to become healthy within the circuit breaker healthy time window	A/R CB Unhealthy	*		*	
308	Autoreclose	DDB_AR_NO_CHECK_SYNC	Indicates during auto-reclose in progress, if system checks have not been satisfied within the check synchronizing time window	A/R No Checksync	*		*	
298	CB Fail	DDB_BREAKER_FAIL_ALARM	Circuit breaker (CB1) fail alarm	CB1 Fail Alarm		*		*
299	CB Monitoring	DDB_CB_MONITOR_ALARM	CB1 Monitor Alarm	CB1 Monitor Alm		*		*
300	CB Monitoring	DDB_CB_MONITOR_LOCKOUT	CB1 Monitor Lockout Alarm	CB1 Mon LO Alarm		*		*
301	CB Status	DDB_CB_STATUS_ALARM	CB1 Status Alarm - set when CB1 status is determined by inputs from BOTH 52A and 52B type auxiliary contacts (setting "CB1 Status Input = 52A&52B-xPole), and both inputs are in the same state (both = 0 or both = 1) for time period => 5sec, indicating a problem with the auxiliary switch mechanism).	CB1 Status Alm		*		*
302	CB Control	DDB_CB_FAILED_TO_TRIP	CB1 Failed to Trip - alarm set if CB1 does not trip within set Trip Pulse Time when CB1 trip command is issued.	CB1 Trip Fail		*		*
303	CB Control	DDB_CB_FAILED_TO_CLOSE	CB1 Failed to Close - alarm set if CB1 fails to close within set Close Pulse Time when CB1 close command is issued	CB1 Close Fail		*		*
304	CB Control	DDB_CONTROL_CB_UNHEALTHY	Control CB1 Unhealthy - alarm set if CB1 remains "unhealthy" for CB Control set time "CB Healthy Time" when operator controlled CB1 close sequence is initiated. (Please see description for CB Control setting "CB Healthy Time").	ManCB1 Unhealthy		*		*

DDB No	Source	Element Name	Description	English Text	P543P54 N No. Distance	P544P54 N No. Distance	P543/ P545	P544/ P546
305	CB Control	DDB_CONTROL_NO_CHECK_SYNC	Control No Checksync - alarm set if selected system check conditions for manual closing CB1 remain unsatisfied for CB Control set time "Check Sync Time" when operator controlled CB1 close sequence is initiated. (Please see description for CB Control setting "Check Sync Time").	NoCS CB1ManClose	*			*
306	Autoreclose	DDB_AR_LOCKOUT	Autoclose Lockout/RLY BAR - alarm set when CB1 autoreclose is locked out.	CB1 AR Lockout	*			*
307	Autoreclose	DDB_AR_CB_UNHEALTHY	No Healthy (AR) - alarm set if CB1 remains "unhealthy" for Autoreclose set time "CB Healthy Time" when CB1 close sequence is initiated by autoreclose function. (Please see description for Autoreclose setting "CB Healthy Time").	AR CB1 Unhealthy	*			*
308	Autoreclose	DDB_AR_NO_CHECK_SYNC	No Check Sync / AR Fail - alarm set if selected system check conditions for autoreclosing CB1 remain unsatisfied for Autoreclose set time "Check Sync Time" when CB1 close sequence is initiated by autoreclose function. (Please see description for Autoreclose setting "Check Sync Time").	AR CB1 No C/S	*			*
309	Check sync	DDB_SYSTEM_SPLIT_ALARM	Unused	Reserved	*	*	*	*
310	C Diff	DDB_LOCAL_GPS_FAIL	Indicates that GPS is lost	GPS Alarm	*	*	*	*
310	C Diff	DDB_LOCAL_GPS_FAIL	Unused	Reserved				
311	C Diff	DDB_SIGNALLING_FAILURE	If a differential protection communication path has remained failed for a period which is longer than the "Comms Fail Timer", this alarm is ON	Signalling Fail	*	*	*	*
311	C Diff	DDB_SIGNALLING_FAILURE	Unused	Reserved				
312	C Diff	DDB_PROPAGATION_DELAY_FAILURE	If successive calculated propagation delay times exceed time delay setting "Comm Delay Tol", this alarms is ON	Comm Delay Alarm	*	*	*	*
312	C Diff	DDB_PROPAGATION_DELAY_FAILURE	Unused	Reserved				
312	Phase comparison	DDB_PLC_EX_TRANS_ALARM	PLC Extended Transmission Alarm	PLC Ex Trans Alm				
313	C Diff	DDB_PROTECTION_FAILURE	It indicates that differential protection communications are completely lost and therefore C diff does not work	C Diff Failure	*	*	*	*
313	C Diff	DDB_PROTECTION_FAILURE	Unused	Reserved				
313	Phase comparison	DDB_PROTECTION_FAILURE	Phase Comparison protection failure alarm	Ph Comp Failure				
314		DDB_FIB_IM_SCHEME_FAIL	It indicates that communications between relays are completely lost and therefore IM64 does not work	IM64 SchemeFail	*	*	*	*
314	Stability test	DDB_STAB_AB_FAIL	Stability AB fail	Stab AB Fail				
314		DDB_FIB_IM_SCHEME_FAIL	Unused	Reserved				
315	C Diff	DDB_IEEE_37_94	t will appear in case of at least one of the following: CH1 (or CH2) loss of signal, CH1 (or CH2) PATH_YELLOW or CH1 (or CH2) BAD_RX_N	IEEE C37.94 Fail	*	*	*	*
315	Stability test	DDB_STAB_AC_FAIL	Stability AC fail	Stab AC Fail				
315	C Diff	DDB_IEEE_37_94	Unused	Reserved				

DDB No	Source	Element Name	Description	English Text	P543/P545 No Distance	P544/P545 No Distance	P543/ P545	P544/ P546
316	C Diff	DDB_INHIBIT_CD_PROTECTION	Indicate that a differential protection has been inhibited	C Diff Inhibited	*	*	*	*
316	C Diff	DDB_INHIBIT_CD_PROTECTION	Unused	Reserved				
316	Stability test	DDB_STAB_A_FAIL	Stability A fail	Stab A Fail				
317	PSL	DDB_AIDED1_LGS_ALARM	Aided channel scheme 1 - channel out of service indication, indicating channel failure	Aid 1 Chan Fail			*	*
318	PSL	DDB_AIDED2_LGS_ALARM	Aided channel scheme 2 - channel out of service indication, indicating channel failure	Aid 2 Chan Fail			*	*
317	PSL	DDB_AIDED1_LGS_ALARM	Unused	Reserved	*	*		
318	PSL	DDB_AIDED2_LGS_ALARM	Unused	Reserved	*	*		
319	Frequency Tracking	DDB_FREQ_ALARM	Frequency out of range alarm	F out of Range	*	*	*	*
320	CB2 Fail	DDB_BREAKER_FAIL_ALARM_2	Circuit breaker 2 fail alarm	CB2 Fail Alarm		*		*
321	CB Monitoring	DDB_CB2_MONITOR_ALARM	This alarm indicates that DDB CB2 I ^ Maint. Alarm (1113) or DDB CB2 OPs Maint. (1115) or DDB CB2 Time Maint. (1117)	CB2 Monitor Alm		*		*
322	CB Monitoring	DDB_CB2_MONITOR_LOCKOUT	This alarm indicates that DDB CB2 I ^ Lockout Alarm (1114) or DDB CB Ops Lock (1116) or DDB CB Time lockout (1118)	CB2 Mon LO Alarm		*		*
323	CB2 Status	DDB_CB2_STATUS_ALARM	Indication of problems by circuit breaker 2 state monitoring - example defective auxiliary contacts	CB2 Status Alm		*		*
324	CB2 Control	DDB_CB2_FAILED_TO_TRIP	Circuit breaker 2 failed to trip (after a manual/operator) trip command	CB2 Trip Fail		*		*
325	CB2 Control	DDB_CB2_FAILED_TO_CLOSE	Circuit breaker 2 failed to close (after a manual/operator or auto-reclose close command)	CB2 Close Fail		*		*
326	CB2 Control	DDB_CONTROL_CB2_UNHEALTHY	Manual circuit breaker unhealthy output signal indicating that the circuit breaker 2 has not closed successfully after a manual close command. (A successful close also requires The circuit breaker healthy signal to reappear within the "healthy window" timeout)	ManCB2 Unhealthy		*		*
320	CB2 Fail	DDB_BREAKER_FAIL_ALARM_2	Unused	Reserved	*		*	
321	CB Monitoring	DDB_CB2_MONITOR_ALARM	Unused	Reserved	*		*	
322	CB Monitoring	DDB_CB2_MONITOR_LOCKOUT	Unused	Reserved	*		*	
323	CB2 Status	DDB_CB2_STATUS_ALARM	Unused	Reserved	*		*	
324	CB2 Control	DDB_CB2_FAILED_TO_TRIP	Unused	Reserved	*		*	
325	CB2 Control	DDB_CB2_FAILED_TO_CLOSE	Unused	Reserved	*		*	
326	CB2 Control	DDB_CONTROL_CB2_UNHEALTHY	Unused	Reserved	*		*	
327	CB2 Control	DDB_CONTROL_NO_CHECK_SYNC_2	Indicates that the check synchronism signal has failed to appear for a manual close	NoCS CB2ManClose		*		*
328	Autoreclose	DDB_AR_LOCKOUT_2	Indicates an auto-reclose lockout condition - no further auto-reclosures possible until resetting	CB2 AR Lockout		*		*
329	Autoreclose	DDB_AR_CB2_UNHEALTHY	Auto-reclose circuit breaker unhealthy signal, output from auto-reclose logic. Indicates during auto-reclose in progress, if the circuit breaker has to become healthy within the circuit breaker healthy time window	AR CB2 Unhealthy		*		*

DDB No	Source	Element Name	Description	English Text	P543/P545 No. Distance	P544/P546 No. Distance	P543/P545	P544/P546
330	Autoreclose	DDB_AR_NO_CHECK_SYNC_2	Indicates during auto-reclose in progress, if system checks have not been satisfied within the check synchronizing time window	AR CB2 No C/S	*		*	*
327	CB2 Control	DDB_CONTROL_NO_CHECK_SYNC_2	Unused	Reserved	*		*	
328	Autoreclose	DDB_AR_LOCKOUT_2	Unused	Reserved	*		*	
329	Autoreclose	DDB_AR_CB2_UNHEALTHY	Unused	Reserved	*		*	
330	Autoreclose	DDB_AR_NO_CHECK_SYNC_2	Unused	Reserved	*		*	
331	Autoreclose	DDB_INVALID_AR_MODE	AR Mode selected via optos is not supported	Invalid AR Mode		*		*
331	Autoreclose	DDB_INVALID_AR_MODE	Unused	Reserved	*		*	
332	C Diff	DDB_IN_COMPATABLE_RELAYS	Incompatible relays	Incompatible Rly	*	*	*	*
332	C Diff	DDB_IN_COMPATABLE_RELAYS	Unused	Reserved				
332	Stability test	DDB_STAB_B_FAIL	Stability B fail	Stab B Fail				
333	C Diff	DDB_MESSAGE_FORMAT_FAIL	Invalid Message Format	InValid Mesg Fmt	*	*	*	*
333	Stability test	DDB_STAB_C_FAIL	Stability C fail	Stab C Fail				
333	C Diff	DDB_MESSAGE_FORMAT_FAIL	Unused	Reserved				
334	Co-processor interface	DDB_MAIN_PROTECTION_FAIL	Indicates a failure in differential or distance or DEF	Main Prot. Fail	*	*	*	*
334	Co-processor interface	DDB_MAIN_PROTECTION_FAIL	Unused	Reserved				
335	C Diff	DDB_CONFIGURATION_ERROR	In three ended schemes on power up, the relays check to see if one of them should be configured out. Under some circumstances it is possible for them to fail to resolve this in which case they produce the DDB_CONFIGURATION_ERROR alarm	Config Error	*	*	*	*
336	C Diff	DDB_RE_CONFIGURATION_ERROR	Indicates that RESTORE or RECONFIGURE or CONFIGURE operations have failed	Re-Config Error	*	*	*	*
335	C Diff	DDB_CONFIGURATION_ERROR	Unused	Reserved				
335	Stability test	DDB_STAB_TEST_FAIL	Stability test fail	Stab Test Fail				
336	C Diff	DDB_RE_CONFIGURATION_ERROR	Unused	Reserved				
337	C Diff	DDB_PROT_COMMS_MODE	This is an alarm which indicates that C3794 comms have been changed to standard or vice versa and relay must be rebooted	Comms Changed	*	*	*	*
337	C Diff	DDB_PROT_COMMS_MODE	Unused	Reserved				
338	C Diff	DDB_MAX_PROP_DELAY_ALARM	Maximum Propagation Delay Alarm	Max Prop. Alarm	*	*	*	*
338	C Diff	DDB_MAX_PROP_DELAY_ALARM	Unused	Reserved				
339	CT Setting	DDB_CT_MISMATCH_ALARM	CT2 ratio/CT1 ratio out of range	Ct para mismatch		*		*
339	CT Setting	DDB_CT_MISMATCH_ALARM	Unused	Reserved	*		*	
340		DDB_ALARM_52	Unused	Reserved	*	*	*	*
341		DDB_ALARM_53	Unused	Reserved	*	*	*	*
342		DDB_ALARM_54	Unused	Reserved	*	*	*	*
343		DDB_ALARM_55	Unused	Reserved	*	*	*	*
344	PSL	DDB_ALARM_56	Triggers user alarm 1 message to be alarmed on LCD display (self-resetting)	SR User Alarm 1	*	*	*	*
345	PSL	DDB_ALARM_57	Triggers user alarm 2 message to be alarmed on LCD display (self-resetting)	SR User Alarm 2	*	*	*	*
346	PSL	DDB_ALARM_58	Triggers user alarm 3 message to be alarmed on LCD display (self-resetting)	SR User Alarm 3	*	*	*	*

DDB No	Source	Element Name	Description	English Text	P543/P545 No Distance	P544/P545 No Distance	P543/P545 No Distance	P544/P545 No Distance
347	PSL	DDB_ALARM_59	Triggers user alarm 4 message to be alarmed on LCD display (self-resetting)	SR User Alarm 4	*	*	*	*
348	PSL	DDB_ALARM_60	Triggers user alarm 5 message to be alarmed on LCD display (manual-resetting)	MR User Alarm 5	*	*	*	*
349	PSL	DDB_ALARM_61	Triggers user alarm 6 message to be alarmed on LCD display (manual-resetting)	MR User Alarm 6	*	*	*	*
350	PSL	DDB_ALARM_62	Triggers user alarm 7 message to be alarmed on LCD display (manual-resetting)	MR User Alarm 7	*	*	*	*
351	PSL	DDB_ALARM_63	Triggers user alarm 8 message to be alarmed on LCD display (manual-resetting)	MR User Alarm 8	*	*	*	*
352	Self monitoring	DDB_BATTERY_FAIL	Front panel miniature battery failure - either battery removed from slot, or low voltage	Battery Fail	*	*	*	*
353	Self monitoring	DDB_FIELD_VOLTS_FAIL	48V field voltage failure	Field Volts Fail	*	*	*	*
354	Self monitoring	DDB_REAR_COMMS_FAIL	Comm2 hardware failure - second rear communications board	Rear Comm 2 Fail	*	*	*	*
355	Ethernet Interface	DDB_GOOSE_MISSING_IED	The IED is not subscribed to a publishing IED in the current scheme	GOOSE IED Absent	*	*	*	*
356	Ethernet Interface	DDB_ECARD_NOT_FITTED	Ethernet board not fitted	NIC Not Fitted	*	*	*	*
357	Ethernet Interface	DDB_NIC_NOT_RESPONDING	Ethernet board not responding	NIC No Response	*	*	*	*
358	Ethernet Interface	DDB_NIC_FATAL_ERROR	Ethernet board unrecoverable error	NIC Fatal Error	*	*	*	*
359	Ethernet Interface	DDB_NIC_SOFTWARE_RELOAD	Ethernet problem	NIC Soft. Reload	*	*	*	*
360	SW	DDB_MU_OOS_ALARM	MU OOS Alarm	MU OOS Alarm	*	*	*	*
361	SW	DDB_INVALID_SV_CONFIG_ALARM	Invalid IEC 61850 Configuration Alarm for PB	Invalid SV conf.	*	*	*	*
362	SW	DDB_SV_ABSENCE_ALARM	SV Absence Alarm	SV Absence Alm	*	*	*	*
363	Ethernet Interface	DDB_SW_MISMATCH_ALARM	Ethernet board software not compatible with main CPU	NIC SW Mis-Match	*	*	*	*
364	Ethernet Interface	DDB_NIC_IP_ADDRESS_CONFLICT	The IP address of the IED is already used by another IED	IP Addr Conflict	*	*	*	*
365	InterMiCOM	DDB_INTERMICOM_LOOPBACK	EIA(RS)232 InterMiCOM indication that Loopback testing is in progress	IM Loopback	*	*	*	*
366	InterMiCOM	DDB_INTERMICOM_MESSAGE	EIA(RS)232 InterMiCOM Message Failure alarm. Setting that is used to alarm for poor channel quality. If during the fixed 1.6 s rolling window the ratio of invalid messages to the total number of messages that should be received (based upon the 'Baud Rate' setting) exceeds the above threshold, a 'Message Fail' alarm will be issued	IM Message Fail	*	*	*	*
367	InterMiCOM	DDB_INTERMICOM_DCD	EIA(RS)232 InterMiCOM Data Channel Detect Fail i.e. modem failure	IM Data CD Fail	*	*	*	*
368	InterMiCOM	DDB_INTERMICOM_CHANNEL	EIA(RS)232 InterMiCOM Channel Failure alarm. No messages were received during the alarm time setting	IM Channel Fail	*	*	*	*
369	Self monitoring	DDB_BACKUP_DATA_IN_USE	This is an alarm that is ON if any setting fail during the setting changing process. If this happens, the relay will use the last known good setting	Backup Setting	*	*	*	*
370		DDB_PLATFORM_ALARM_19	Platform Alarm 19	Reserved	*	*	*	*

DDB No	Source	Element Name	Description	English Text	P543/P545 Distance	P544/P546 Distance	P543/ P544/ P545/ P546
371		DDB_PLATFORM_ALARM_20	Platform Alarm 20	Reserved	*	*	*
372	SW	DDB_BBRAM_TEST_FAIL_ALARM	BBRAM Failure Alarm	BBRAM Failure	*	*	*
373	SW	DDB_INVALID_DNPOE_IP_ALARM	Invalid DNPoE IP Configuration Alarm	Invalid DNPoE IP	*	*	*
374	SW	DDB_INVALID_CONFIG_ALARM	Invalid IEC 61850 Configuration Alarm	Invalid Config.	*	*	*
375	SW	DDB_TEST_MODE_ALARM	Test Mode Activated Alarm	Test Mode Alm	*	*	*
376	SW	DDB_CONT_BLK_ALARM	Contacts Blocked Alarm	Contacts Blk Alm	*	*	*
377	SW	DDB_HW_MISMATCH_ALARM	Main card/Ethernet card hw option mismatch Alarm	NIC HW Mismatch	*	*	*
378	SW	DDB_IEC61850_VER_MISMATCH_ALARM	Main card/Ethernet card IEC61850 ver mismatch Alarm	NIC APP Mismatch	*	*	*
379	SW	DDB_ACCEPT_SIMULATED_ALM	IEC 61850 accept simulated GOOSE and SV alarm	Sim.Signal Alm	*	*	*
380	SW	DDB_SV_SMPSYNCH_ALARM	SV SmpSynch alarm	SV SmpSynch Alm	*	*	*
381	SW	DDB_SV_TEST_ALARM	SV Test alarm	SV Test Alm	*	*	*
382	SW	DDB_SV_INVALID_ALARM	SV Invalid alarm	SV Invalid Alm	*	*	*
383	SW	DDB_SV_QUESTIONABLE_ALARM	SV Questionable alarm	SV Quest Alm	*	*	*
384	PSL	DDB_ZONE_1_GND_BLOCK	Zone 1 ground basic scheme blocking	Block Zone 1 Gnd			*
385	PSL	DDB_ZONE_1_PHS_BLOCK	Zone 1 phase basic scheme blocking	Block Zone 1 Phs			*
386	PSL	DDB_ZONE_2_GND_BLOCK	Zone 2 ground basic scheme blocking	Block Zone 2 Gnd			*
387	PSL	DDB_ZONE_2_PHS_BLOCK	Zone 2 phase basic scheme blocking	Block Zone 2 Phs			*
388	PSL	DDB_ZONE_3_GND_BLOCK	Zone 3 ground basic scheme blocking	Block Zone 3 Gnd			*
389	PSL	DDB_ZONE_3_PHS_BLOCK	Zone 3 phase basic scheme blocking	Block Zone 3 Phs			*
390	PSL	DDB_ZONE_P_GND_BLOCK	Zone P ground basic scheme blocking	Block Zone P Gnd			*
391	PSL	DDB_ZONE_P_PHS_BLOCK	Zone P phase basic scheme blocking	Block Zone P Phs			*
392	PSL	DDB_ZONE_4_GND_BLOCK	Zone 4 ground basic scheme blocking	Block Zone 4 Gnd			*
393	PSL	DDB_ZONE_4_PHS_BLOCK	Zone 4 phase basic scheme blocking	Block Zone 4 Phs			*
394	PSL	DDB_AIDED1_DIST_TRIP_INHIBIT	Block distance aided scheme 1 tripping	Aid1 InhibitDist			*
395	PSL	DDB_AIDED1_DEF_TRIP_INHIBIT	Block DEF aided scheme 1 tripping	Aid1 Inhibit DEF			*
384	PSL	DDB_ZONE_1_GND_BLOCK	Unused	Unused	*	*	
385	PSL	DDB_ZONE_1_PHS_BLOCK	Unused	Unused	*	*	
386	PSL	DDB_ZONE_2_GND_BLOCK	Unused	Unused	*	*	
387	PSL	DDB_ZONE_2_PHS_BLOCK	Unused	Unused	*	*	
388	PSL	DDB_ZONE_3_GND_BLOCK	Unused	Unused	*	*	
389	PSL	DDB_ZONE_3_PHS_BLOCK	Unused	Unused	*	*	
390	PSL	DDB_ZONE_P_GND_BLOCK	Unused	Unused	*	*	
391	PSL	DDB_ZONE_P_PHS_BLOCK	Unused	Unused	*	*	
392	PSL	DDB_ZONE_4_GND_BLOCK	Unused	Unused	*	*	
393	PSL	DDB_ZONE_4_PHS_BLOCK	Unused	Unused	*	*	
394	PSL	DDB_AIDED1_DIST_TRIP_INHIBIT	Unused	Unused	*	*	
395	PSL	DDB_AIDED1_DEF_TRIP_INHIBIT	Unused	Unused	*	*	
396	PSL	DDB_AIDED1_DIR_TRIP_INHIBIT	Block Delta directional aided scheme 1 tripping	Aid1 Inhib Delta			*
396	PSL	DDB_AIDED1_DIR_TRIP_INHIBIT	Unused	Unused	*	*	
397	PSL	DDB_AIDED2_DIST_TRIP_INHIBIT	Block distance aided scheme 2 tripping	Aid2 InhibitDist			*

DDB No	Source	Element Name	Description	English Text	P543/P545 No Distance	P544/P546 No Distance	P543/ P545	P544/ P546
398	PSL	DDB_AIDED2_DEF_TRIP_INHIBIT	Block DEF aided scheme 2 tripping	Aid2 Inhibit DEF			*	*
397	PSL	DDB_AIDED2_DIST_TRIP_INHIBIT	Unused	Unused	*	*		
398	PSL	DDB_AIDED2_DEF_TRIP_INHIBIT	Unused	Unused	*	*		
399	PSL	DDB_AIDED2_DIR_TRIP_INHIBIT	Block Delta directional aided scheme 2 tripping	Aid2 Inhibit DIR			*	*
399	PSL	DDB_AIDED2_DIR_TRIP_INHIBIT	Unused	Unused	*	*		
400	PSL	DDB_TIMESYNC	Time synchronism by opto pulse	Time Synch	*	*	*	*
401	PSL	DDB_POC_1_TIMER_BLOCK	Block phase overcurrent stage 1 time delayed tripped trip	I>1 Timer Block	*	*	*	*
402	PSL	DDB_POC_2_TIMER_BLOCK	Block phase overcurrent stage 2 time delayed tripped trip	I>2 Timer Block	*	*	*	*
403	PSL	DDB_POC_3_TIMER_BLOCK	Block phase overcurrent stage 3 time delayed trip	I>3 Timer Block	*	*	*	*
404	PSL	DDB_POC_4_TIMER_BLOCK	Block phase overcurrent stage 4 time delayed trip	I>4 Timer Block	*	*	*	*
405	PSL	DDB_EF1_1_TIMER_BLOCK	Block standby earth fault stage 1 time delayed trip	IN>1 Timer Block	*	*	*	*
406	PSL	DDB_EF1_2_TIMER_BLOCK	Block standby earth fault stage 2 time delayed trip	IN>2 Timer Block	*	*	*	*
407	PSL	DDB_EF1_3_TIMER_BLOCK	Block standby earth fault stage 3 time delayed trip	IN>3 Timer Block	*	*	*	*
408	PSL	DDB_EF1_4_TIMER_BLOCK	Block standby earth fault stage 4 time delayed trip	IN>4 Timer Block	*	*	*	*
409	PSL	DDB_SEF_1_TIMER_BLOCK	Block sensitive earth fault stage 1 time delayed trip	ISEF>1 Timer Blk	*	*	*	*
410	PSL	DDB_SEF_2_TIMER_BLOCK	Block sensitive earth fault stage 2 time delayed trip	ISEF>2 Timer Blk	*	*	*	*
411	PSL	DDB_SEF_3_TIMER_BLOCK	Block sensitive earth fault stage 3 time delayed trip	ISEF>3 Timer Blk	*	*	*	*
412	PSL	DDB_SEF_4_TIMER_BLOCK	Block sensitive earth fault stage 4 time delayed trip	ISEF>4 Timer Blk	*	*	*	*
413	PSL	DDB_NEGSEQOC_TIMER_BLOCK	Unused	Unused	*	*	*	*
414	PSL	DDB_PUV_1_TIMER_BLOCK	Block phase undervoltage stage 1 time delayed trip	V<1 Timer Block	*	*	*	*
415	PSL	DDB_PUV_2_TIMER_BLOCK	Block phase undervoltage stage 2 time delayed trip	V<2 Timer Block	*	*	*	*
416	PSL	DDB_POV_1_TIMER_BLOCK	Block phase overvoltage stage 1 time delayed trip	V>1 Timer Block	*	*	*	*
417	PSL	DDB_POV_2_TIMER_BLOCK	Block phase overvoltage stage 2 time delayed trip	V>2 Timer Block	*	*	*	*
418	PSL	DDB_RESOV_1_TIMER_BLOCK	Block residual overvoltage stage 1 time delayed trip	VN>1 Timer Blk	*	*	*	*
419	PSL	DDB_RESOV_2_TIMER_BLOCK	Block residual overvoltage stage 2 time delayed trip	VN>2 Timer Blk	*	*	*	*
420	PSL	DDB_CB_THREE_PHASE_52A	52-A (CB closed) CB auxiliary input (3 phase)	CB Aux 3ph(52-A)	*		*	
421	PSL	DDB_CB_PHASE_A_52A	52-A (CB A phase closed) CB auxiliary	CB Aux A(52-A)	*		*	
422	PSL	DDB_CB_PHASE_B_52A	52-A (CB B phase closed) CB auxiliary	CB Aux B(52-A)	*		*	
423	PSL	DDB_CB_PHASE_C_52A	52-A (CB C phase closed) CB auxiliary	CB Aux C(52-A)	*		*	
421	PSL	DDB_CB_PHASE_A_52A	Unused	Unused				

DDB No	Source	Element Name	Description	English Text	P543/P54 5 No. Distance	P544/P54 4 No. Distance	P545/ P544/ P546	P544/ P546
422	PSL	DDB_CB_PHASE_B_52A	Unused	Unused				
423	PSL	DDB_CB_PHASE_C_52A	Unused	Unused				
424	PSL	DDB_CB_THREE_PHASE_52B	52-B (CB open) CB auxiliary input (3 phase)	CB Aux 3ph(52-B)	*		*	
425	PSL	DDB_CB_PHASE_A_52B	52-B (CB A phase open) CB auxiliary input	CB Aux A(52-B)	*		*	
426	PSL	DDB_CB_PHASE_B_52B	52-B (CB B phase open) CB auxiliary input	CB Aux B(52-B)	*		*	
427	PSL	DDB_CB_PHASE_C_52B	52-B (CB C phase open) CB auxiliary input	CB Aux C(52-B)	*		*	
425	PSL	DDB_CB_PHASE_A_52B	Unused	Unused				
426	PSL	DDB_CB_PHASE_B_52B	Unused	Unused				
427	PSL	DDB_CB_PHASE_C_52B	Unused	Unused				
420	PSL	DDB_CB_THREE_PHASE_52A	52-A (CB1 closed) CB auxiliary input (3 phase)	CB1Aux 3ph(52-A)		*		*
421	PSL	DDB_CB_PHASE_A_52A	52-A (CB1 A phase closed) CB auxiliary	CB1Aux A (52-A)		*		*
422	PSL	DDB_CB_PHASE_B_52A	52-A (CB1 B phase closed) CB auxiliary	CB1Aux B (52-A)		*		*
423	PSL	DDB_CB_PHASE_C_52A	52-A (CB1 C phase closed) CB auxiliary	CB1Aux C (52-A)		*		*
424	PSL	DDB_CB_THREE_PHASE_52B	52-B CB Contact Input	CB1Aux 3ph(52-B)		*		*
425	PSL	DDB_CB_PHASE_A_52B	52-B CB Contact Input A Phase	CB1Aux A (52-B)		*		*
426	PSL	DDB_CB_PHASE_B_52B	52-B CB Contact Input B Phase	CB1Aux B (52-B)		*		*
427	PSL	DDB_CB_PHASE_C_52B	52-B CB Contact Input C Phase	CB1Aux C (52-B)		*		*
428	PSL	DDB_CB2_THREE_PHASE_52A	52-A (CB2 closed) CB2 auxiliary input (3 phase)	CB2 Aux3ph(52-A)		*		*
429	PSL	DDB_CB2_PHASE_A_52A	52-A (CB2 A phase closed) CB auxiliary	CB2 Aux A(52-A)		*		*
430	PSL	DDB_CB2_PHASE_B_52A	52-A (CB2 B phase closed) CB2 auxiliary	CB2 Aux B(52-A)		*		*
431	PSL	DDB_CB2_PHASE_C_52A	52-A (CB2 C phase closed)CB2 auxiliary	CB2 Aux C(52-A)		*		*
432	PSL	DDB_CB2_THREE_PHASE_52B	52-B (CB2 open) CB2 auxiliary input (3 phase)	CB2 Aux3ph(52-B)		*		*
433	PSL	DDB_CB2_PHASE_A_52B	52-B (CB2 A phase open) CB2 auxiliary input	CB2 Aux A(52-B)		*		*
434	PSL	DDB_CB2_PHASE_B_52B	52-B (CB2 B phase open) CB2 auxiliary input	CB2 Aux B(52-B)		*		*
435	PSL	DDB_CB2_PHASE_C_52B	52-B (CB2 C phase open) CB2 auxiliary input	CB2 Aux C(52-B)		*		*
428	PSL	DDB_CB2_THREE_PHASE_52A	Unused	Unused	*		*	
429	PSL	DDB_CB2_PHASE_A_52A	Unused	Unused	*		*	
430	PSL	DDB_CB2_PHASE_B_52A	Unused	Unused	*		*	
431	PSL	DDB_CB2_PHASE_C_52A	Unused	Unused	*		*	
432	PSL	DDB_CB2_THREE_PHASE_52B	Unused	Unused	*		*	
433	PSL	DDB_CB2_PHASE_A_52B	Unused	Unused	*		*	
434	PSL	DDB_CB2_PHASE_B_52B	Unused	Unused	*		*	
435	PSL	DDB_CB2_PHASE_C_52B	Unused	Unused	*		*	
436	PSL	DDB_CB_HEALTHY	Circuit breaker healthy (input to auto-recloser - that the CB has enough energy to allow re-closing)	CB Healthy	*		*	
436	PSL	DDB_CB_HEALTHY	Circuit breaker healthy (input to auto-recloser - that the CB1 has enough energy to allow re-closing)	CB1 Healthy		*		*
437	PSL	DDB_CB2_HEALTHY	Circuit breaker healthy (input to auto-recloser - that the CB2 has enough energy to allow re-closing)	CB2 Healthy		*		*
437	PSL	DDB_CB2_HEALTHY	Unused	Unused	*		*	

DDB No	Source	Element Name	Description	English Text	P543P54 5 No Distance	P544P54 6 No Distance	P545/ P545	P544/ P546
438	PSL	DDB_VTS_MCB_OPTO	VT supervision input - signal from external miniature circuit breaker showing MCB tripped	MCB/VTS	*	*	*	*
439	PSL	DDB_LOGIC_INPUT_TRIP	Initiate tripping of circuit breaker from a manual command	Init Trip CB	*		*	
440	PSL	DDB_LOGIC_INPUT_CLOSE	Initiate closing of circuit breaker from a manual command	Init Close CB	*		*	
439	PSL	DDB_LOGIC_INPUT_TRIP	Initiate tripping of circuit breaker 1 from a manual command	Init Trip CB1		*		*
440	PSL	DDB_LOGIC_INPUT_CLOSE	Initiate closing of circuit breaker 1 from a manual command	Init Close CB1		*		*
441	PSL	DDB_LOGIC_INPUT_TRIP_2	Initiate tripping of circuit breaker 2 from a manual command	Init Trip CB2		*		*
442	PSL	DDB_LOGIC_INPUT_CLOSE_2	Initiate closing of circuit breaker 2 from a manual command	Init Close CB2		*		*
441	PSL	DDB_LOGIC_INPUT_TRIP_2	Unused	Unused	*		*	
442	PSL	DDB_LOGIC_INPUT_CLOSE_2	Unused	Unused	*		*	
443	PSL	DDB_RESET_CB_CLOSE_DELAY	Reset Manual CB Close Timer Delay (stop & reset Manual Close Delay time for closing CB).	Reset Close Dly	*		*	
443	PSL	DDB_RESET_CB_CLOSE_DELAY	Reset Manual CB Close Timer Delay (stop & reset Manual Close Delay time for closing CB1).	Rst CB1 CloseDly		*		*
444	PSL	DDB_RESET_RELAYS_LEDS	Reset latched relays & LEDs (manual reset of any lockout trip contacts, auto-reclose lockout, and LEDs)	Reset Relays/LED	*	*	*	*
445	PSL	DDB_RESET_THERMAL	Reset thermal state to 0%	Reset Thermal	*	*	*	*
446	PSL	DDB_RESET_LOCKOUT	Manual control to reset auto-recloser from lockout	Reset Lockout	*		*	
446	PSL	DDB_RESET_LOCKOUT	Reset Lockout Opto Input to reset CB1 Lockout state	Rst CB1 Lockout		*		*
447	PSL	DDB_RESET_ALL_VALUES	Reset circuit breaker maintenance values	Reset CB Data	*		*	
447	PSL	DDB_RESET_ALL_VALUES	Reset CB1 Maintenance values	Rst CB1 Data		*		*
448	PSL	DDB_BLOCK_AR	DDB mapped in PSL from opto or comms input. External signal to force CB1 autoreclose to lockout.	Block CB1 AR		*		*
448	PSL	DDB_BLOCK_AR	DDB mapped in PSL from opto or comms input. External signal to force CB autoreclose to lockout.	Block CB AR	*		*	
449	PSL	DDB_INP_SPAR	Unused	Unused				
450	PSL	DDB_INP_TPAR	Enable 3 pole reclose from an external input	En 3pole reclose				
449	PSL	DDB_INP_SPAR	Unused	Unused	*	*	*	*
450	PSL	DDB_INP_TPAR	Unused	Unused	*	*	*	*
451	PSL	DDB_INP_TR2P	Pole discrepancy (from external detector) - input used to force a 2nd single pole trip to move to a 3 pole auto-reclose cycle	Pole Discrepancy	*		*	
451	PSL	DDB_INP_TR2P	Pole discrepancy (from external detector) - input used to force a 2nd single pole trip to move to a 3 pole auto-reclose cycle	Pole Discrep.CB1		*		*
452	PSL	DDB_INTERNAL_LOOPBACK	To enable loopback mode via opto input	Loopback Mode	*	*	*	*
453		DDB_PERMISSIVE_INTERTRIP_OPTO	Permissive intertrip mapping what will be sent to the remote line end	Perm Intertrip	*	*	*	*

DDB No	Source	Element Name	Description	English Text	P543/P54 5 No. Distance	P544/P54 4 No. Distance	P545/ P545	P544/ P546
454		DDB_STUB_BUS_ENABLED	To enable stub bus protection in relays with two CT inputs. When enabled, all current values transmitted to the remote relays, and all those received from remote relays, are set to zero. Differential intertrip signals are not sent The protection provides differential protection for the stub zone	Stub Bus Enabled	*	*	*	*
455		DDB_INHIBIT_CURRENT_DIFF_OPTO	When linked to an opto input, inhibits differential relay at the local end and send an inhibit command to the remote end	Inhibit C Diff	*	*	*	*
456		DDB_RECONFIGURATION_INTERLOCK	This must be energized (along with DDB 455 - inhibit C Diff) at the time that a relay configuration is changed from 3 ended to 2 ended scheme. This usually should be driven from a 52-B contact of the CB connected to the line end that is taken out of service	Recon Interlock	*	*	*	*
457	PSL	DDB_OVERRIDE_INHIBIT	If a P54x relay working with GPS sample synchronization loses GPS and there is a further switch in the protection communications network, the relay becomes Inhibit. If GPS become active again, the relay will automatically reset. But if not, the user can remove the inhibited condition by energizing this DDB signal as long as it is ensured that propagation delay times are equal	Prop Delay Equal	*	*	*	*
452	PSL	DDB_INTERNAL_LOOPBACK	Unused	Unused				
453		DDB_PERMISSIVE_INTERTRIP_OPTO	Unused	Unused				
454		DDB_STUB_BUS_ENABLED	Unused	Unused				
455		DDB_INHIBIT_CURRENT_DIFF_OPTO	Unused	Unused				
456		DDB_RECONFIGURATION_INTERLOCK	Unused	Unused				
457	PSL	DDB_OVERRIDE_INHIBIT	Unused	Unused				
458	PSL	DDB_INHIBIT_WI	Inhibit weak infeed aided scheme logic	Inhibit WI			*	*
458	PSL	DDB_INHIBIT_WI	Unused	Unused	*	*		
459	PSL	DDB_TEST_MODE	Commissioning tests - automatically places relay in test mode	Test Mode	*	*	*	*
460	PSL	DDB_COMMAND_BLOCKING	For IEC-870-5-103 protocol only, used for "Command Blocking" (relay ignores SCADA commands)	103 CommandBlock	*	*	*	*
461	PSL	DDB_MONITOR_BLOCKING	For IEC-870-5-103 protocol only, used for "Monitor Blocking" (relay is quiet - issues no messages via SCADA port)	103 MonitorBlock	*	*	*	*
462		DDB_UNUSED_462	Unused	Unused	*	*	*	*
463	PSL	DDB_INHIBIT_POC1	Inhibit stage 1 overcurrent protection	Inhibit I>1	*	*	*	*
464	PSL	DDB_INHIBIT_POC2	Inhibit stage 2 overcurrent protection	Inhibit I>2	*	*	*	*
465	PSL	DDB_INHIBIT_POC3	Inhibit stage 3 overcurrent protection	Inhibit I>3	*	*	*	*
466	PSL	DDB_INHIBIT_POC4	Inhibit stage 4 overcurrent protection	Inhibit I>4	*	*	*	*
467	PSL	DDB_INHIBIT_EF1	Inhibit stage 1 earth fault protection	Inhibit IN>1	*	*	*	*
468	PSL	DDB_INHIBIT_EF2	Inhibit stage 2 earth fault protection	Inhibit IN>2	*	*	*	*
469	PSL	DDB_INHIBIT_EF3	Inhibit stage 3 earth fault protection	Inhibit IN>3	*	*	*	*
470	PSL	DDB_INHIBIT_EF4	Inhibit stage 4 earth fault protection	Inhibit IN>4	*	*	*	*
471	PSL	DDB_INHIBIT_UV1	Inhibit stage 1 undervoltage protection	Inhibit V<1	*	*	*	*

DDB No	Source	Element Name	Description	English Text	P543/P545 5 No Distance	P544/P546 6 No Distance	P543/ P545	P544/ P546
472	PSL	DDB_INHIBIT_UV2	Inhibit stage 2 undervoltage protection	Inhibit V<2	*	*	*	*
473	PSL	DDB_INHIBIT_OV1	Inhibit stage 1 overvoltage protection	Inhibit V>1	*	*	*	*
474	PSL	DDB_INHIBIT_OV2	Inhibit stage 2 overvoltage protection	Inhibit V>2	*	*	*	*
475	PSL	DDB_INHIBIT_RESOV1	Inhibit stage 2 overvoltage protection	Inhibit VN>1	*	*	*	*
476	PSL	DDB_INHIBIT_RESOV2	Inhibit stage 2 residual overvoltage protection	Inhibit VN>2	*	*	*	*
477	PSL	DDB_INHIBIT_NPS	Unused	Unused	*	*	*	*
478	PSL	DDB_INHIBIT_THERMAL	Inhibit thermal overload protection	Inhibit Thermal	*	*	*	*
479	PSL	DDB_INHIBIT_CBS	Inhibit circuit breaker state monitoring (no alarm for defective/stuck auxiliary contact)	InhibitCB Status	*	*	*	*
480	PSL	DDB_INHIBIT_CBF	Inhibit circuit breaker fail protection	Inhibit CB Fail	*	*	*	*
481	PSL	DDB_INHIBIT_BCL	Broken conductor protection	Inhibit OpenLine	*	*	*	*
482	PSL	DDB_INHIBIT_VTS	Inhibit VT supervision (including turn OFF MCB's) via PSL	Inhibit VTS	*	*	*	*
483	PSL	DDB_INHIBIT_CTS	Inhibit CT supervision (both differential and standard CTS) via PSL	Inhibit CTS	*	*	*	*
484	PSL	DDB_INHIBIT_CHKSYN	Inhibit checksync. (Both stages and for each CB)	InhibitChecksync	*	*	*	*
485	PSL	DDB_INHIBIT_TOR	Inhibit trip on reclose (TOR)	Inhibit TOR			*	*
486	PSL	DDB_INHIBIT_SOTF	Inhibit switch onto fault (SOTF)	Inhibit SOTF			*	*
485	PSL	DDB_INHIBIT_TOR	Unused	Unused	*	*		
486	PSL	DDB_INHIBIT_SOTF	Unused	Unused	*	*		
487	PSL	DDB_DISABLE_CTS	To disable differential CTS via PSL	Disable CTS	*	*	*	*
487	PSL	DDB_DISABLE_CTS	Unused	Unused				
488	PSL	DDB_SET_SOTF	To enable SOTF logic by an external pulse. When this input is energized by an external pulse, SOTF becomes enabled during "SOTF Pulse" time setting	Set SOTF			*	*
489	Zone 1 Extension Scheme	DDB_RESET_Z1_EXT	AR reset Z1X reach back to Z1 reach in Z1 extension scheme	AR Reset Z1 EXT			*	*
490	PSL	DDB_RESET_ZONE1_EXT	Reset zone Z1X back to Z1 reach using logic input (i.e. case when external AR and Z1 extension scheme are used)	Reset Zone 1 Ext			*	*
491	PSL	DDB_INHIBIT_LOL	Inhibit Loss of Load scheme function	Inhibit LoL			*	*
492	PSL	DDB_AIDED1_COS_LGS	Aided 1 channel out of service signal (COS) or loss of guard signal (LGS) in distance unblocking schemes. This signal is normally driven from an opto input on conventional channels or from InterMiCOM	Aided 1 COS/LGS			*	*
493	PSL	DDB_AIDED1_CRX_EXT	Aided channel 1 - external signal received, for input to distance fixed scheme logic	Aided1 Scheme Rx			*	*
494	Aided Scheme Logic	DDB_AIDED1_CRX_INT	Aided channel 1 - internal signal received generated in the signal receive logic	Aided 1 Receive			*	*
488	PSL	DDB_SET_SOTF	Unused	Unused	*	*		
489	Zone 1 Extension Scheme	DDB_RESET_Z1_EXT	Unused	Unused	*	*		
490	PSL	DDB_RESET_ZONE1_EXT	Unused	Unused	*	*		
491	PSL	DDB_INHIBIT_LOL	Unused	Unused	*	*		

DDB No	Source	Element Name	Description	English Text	P543P54 N/A Distance	P544P54 N/A Distance	P543/ P544/ P545/ P546	P543/ P544/ P545/ P546
492	PSL	DDB_AIDED1_COS_LGS	Unused	Unused	*	*		
493	PSL	DDB_AIDED1_CRX_EXT	Unused	Unused	*	*		
494	Aided Scheme Logic	DDB_AIDED1_CRX_INT	Unused	Unused	*	*		
495		DDB_UNUSED_495	Unused	Unused	*	*	*	*
496	PSL	DDB_AIDED1_BLOCK_SEND	Prevent sending by customized logic - aided scheme 1	Aid1 Block Send			*	*
497	PSL	DDB_AIDED1_PROGRAM_SEND	Programmable send logic for special customized scheme (aided channel 1)	Aid1 Custom Send			*	*
498	Aided Scheme Logic	DDB_AIDED1_SEND	Aided channel 1 send - internal send signal generated in signal send logic	Aided 1 Send			*	*
499	PSL	DDB_AIDED1_CUSTOM_TIMER_IN	When using a custom programmable aided scheme 1, the user is able to include a current reversal guard timer. Energizing this DDB will additionally start this timer, from PSL	Aid1 Custom T In			*	*
500	Aided Scheme Logic	DDB_AIDED1_CUSTOM_TIMER_OUT	When using customized aided scheme 1, this signal is used to indicate any additional condition that should be treated as permission for an aided trip (for example a permissive signal received could be connected, or a blocking signal could be inverted and then connected)	Aid1 CustomT Out			*	*
501	Aided Scheme Logic	DDB_AIDED1_TRIP_ENABLE	Aided scheme 1 trip enable - this is a permissive signal used to accelerate zone 2, or a blocking signal which has been inverted. It is a signal output, part-way through the internal fixed logic of aided schemes	Aid1 Trip Enable			*	*
502	PSL	DDB_AIDED1_CUSTOM_TRIP_ENABLE	Aid1 custom trip enable	Aid1 Custom Trip			*	*
503	Aided Scheme Logic	DDB_AIDED1_DIST_TRIP	Aided scheme 1 distance trip command (output from aided tripping logic)	Aid 1 Dist Trip			*	*
496	PSL	DDB_AIDED1_BLOCK_SEND	Unused	Unused	*	*		
497	PSL	DDB_AIDED1_PROGRAM_SEND	Unused	Unused	*	*		
498	Aided Scheme Logic	DDB_AIDED1_SEND	Unused	Unused	*	*		
499	PSL	DDB_AIDED1_CUSTOM_TIMER_IN	Unused	Unused	*	*		
500	Aided Scheme Logic	DDB_AIDED1_CUSTOM_TIMER_OUT	Unused	Unused	*	*		
501	Aided Scheme Logic	DDB_AIDED1_TRIP_ENABLE	Unused	Unused	*	*		
502	PSL	DDB_AIDED1_CUSTOM_TRIP_ENABLE	Unused	Unused	*	*		
503	Aided Scheme Logic	DDB_AIDED1_DIST_TRIP	Unused	Unused	*	*		
504	Aided Scheme Logic	DDB_AIDED1_DIR_TRIP	Aided Scheme 1 Delta Directional Trip command (output from Aided tripping logic)	Aid 1 Delta Trip			*	*
504	Aided Scheme Logic	DDB_AIDED1_DIR_TRIP	Unused	Unused	*	*		
505	Aided Scheme Logic	DDB_AIDED1_DEF_TRIP	Aided scheme 1 DEF trip command (output from aided tripping logic)	Aid 1 DEF Trip			*	*

DDB No	Source	Element Name	Description	English Text	P543/P545 No	P544/P546 Distance	P543/P545 No	P544/P546 Distance	P543/P545	P544/P546
506	PSL	DDB_AIDED2_COS_LGS	Aided 2 channel out of service signal (COS) or loss of guard signal (LGS) in distance unblocking schemes. This signal is normally driven from an opto input on conventional channels or from InterMiCOM	Aided 2 COS/LGS					*	*
507	PSL	DDB_AIDED2_CRX_EXT	Aided channel 2 - external signal received, for input to distance fixed scheme logic	Aided2 Scheme Rx					*	*
508	Aided Scheme Logic	DDB_AIDED2_CRX_INT	Aided channel 2 - internal signal received generated in the signal receive logic	Aided 2 Receive					*	*
505	Aided Scheme Logic	DDB_AIDED1_DEF_TRIP	Unused	Unused	*	*				
506	PSL	DDB_AIDED2_COS_LGS	Unused	Unused	*	*				
507	PSL	DDB_AIDED2_CRX_EXT	Unused	Unused	*	*				
508	Aided Scheme Logic	DDB_AIDED2_CRX_INT	Unused	Unused	*	*				
509	RP1 Read Only	DDB_REMOTEREADONLY_RP1	RP1 Read Only DDB	RP1 Read Only	*	*	*	*		
510	RP2 Read Only	DDB_REMOTEREADONLY_RP2	RP2 Read Only DDB	RP2 Read Only	*	*	*	*		
511	NIC Read Only	DDB_REMOTEREADONLY_NIC	NIC Read Only DDB	NIC Read Only	*	*	*	*		
512	PSL	DDB_AIDED2_BLOCK_SEND	Prevent sending by customized logic - aided scheme 2	Aid2 Block Send					*	*
513	PSL	DDB_AIDED2_PROGRAM_SEND	Programmable send logic for special customized scheme (aided channel 2)	Aid2 Custom Send					*	*
514	Aided Scheme Logic	DDB_AIDED2_SEND	Aided channel 2 send - internal send signal generated in signal send logic	Aided 2 Send					*	*
515	PSL	DDB_AIDED2_CUSTOM_TIMER_IN	When using a custom programmable aided scheme 2, the user is able to include a current reversal guard timer. Energizing this DDB will additionally start this timer, from PSL	Aid2 Custom T In					*	*
516	Aided Scheme Logic	DDB_AIDED2_CUSTOM_TIMER_OUT	When using customized aided scheme 2, this signal is used to indicate any additional condition that should be treated as permission for an aided trip (for example a permissive signal received could be connected, or a blocking signal could be inverted and then connected)	Aid2 CustomT Out					*	*
517	Aided Scheme Logic	DDB_AIDED2_TRIP_ENABLE	Aided scheme 2 trip enable - this is a permissive signal used to accelerate zone 2, or a blocking signal which has been inverted. It is a signal output, part-way through the internal fixed logic of aided schemes	Aid2 Trip Enable					*	*
518	PSL	DDB_AIDED2_CUSTOM_TRIP_ENABLE	Aid2 custom trip enable	Aid2 Custom Trip					*	*
519	Aided Scheme Logic	DDB_AIDED2_DIST_TRIP	Aided scheme 2 distance trip command (output from aided tripping logic)	Aid 2 Dist Trip					*	*
512	PSL	DDB_AIDED2_BLOCK_SEND	Unused	Unused	*	*				
513	PSL	DDB_AIDED2_PROGRAM_SEND	Unused	Unused	*	*				
514	Aided Scheme Logic	DDB_AIDED2_SEND	Unused	Unused	*	*				
515	PSL	DDB_AIDED2_CUSTOM_TIMER_IN	Unused	Unused	*	*				
516	Aided Scheme Logic	DDB_AIDED2_CUSTOM_TIMER_OUT	Unused	Unused	*	*				
517	Aided Scheme Logic	DDB_AIDED2_TRIP_ENABLE	Unused	Unused	*	*				

DDB No	Source	Element Name	Description	English Text	P543P54 5 No. Distance	P544P54 4 No. Distance	P545/ P544/ P546	P544/ P546
518	PSL	DDB_AIDED2_CUSTOM_TRIP_ENABLE	Unused	Unused	*	*		
519	Aided Scheme Logic	DDB_AIDED2_DIST_TRIP	Unused	Unused	*	*		
520	Aided Scheme Logic	DDB_AIDED2_DIR_TRIP	Aided Scheme 2 Delta Directional Trip command (output from Aided tripping logic)	Aid 2 Delta Trip			*	*
520	Aided Scheme Logic	DDB_AIDED2_DIR_TRIP	Unused	Unused	*	*		
521	Aided Scheme Logic	DDB_AIDED2_DEF_TRIP	Aided scheme 2 DEF trip command (output from aided tripping logic)	Aid 2 DEF Trip			*	*
521	Aided Scheme Logic	DDB_AIDED2_DEF_TRIP	Unused	Unused	*	*		
522	Trip Conversion Logic	DDB_ANY_TRIP	Any trip signal - can be used as the trip command in three-pole tripping applications	Any Trip	*	*	*	*
523	Trip Conversion Logic	DDB_TRIP_A_PHASE	Trip signal for phase A - used as a command to drive trip A output contact(s). Takes the output from the internal trip conversion logic	Trip Output A	*		*	
524	Trip Conversion Logic	DDB_TRIP_B_PHASE	Trip signal for phase B - used as a command to drive trip B output contact(s). Takes the output from the internal trip conversion logic	Trip Output B	*		*	
525	Trip Conversion Logic	DDB_TRIP_C_PHASE	Trip signal for phase C - used as a command to drive trip C output contact(s). Takes the output from the internal trip conversion logic	Trip Output C	*		*	
523	Trip Conversion Logic	DDB_TRIP_A_PHASE	Trip signal for CB1 phase A - used as a command to drive CB1 trip A output contact(s). Takes the output from the internal trip conversion logic	CB1 Trip OutputA		*		*
524	Trip Conversion Logic	DDB_TRIP_B_PHASE	Trip signal for CB1 phase B - used as a command to drive CB1 trip B output contact(s). Takes the output from the internal trip conversion logic	CB1 Trip OutputB		*		*
525	Trip Conversion Logic	DDB_TRIP_C_PHASE	Trip signal for CB1 phase C - used as a command to drive CB1 trip C output contact(s). Takes the output from the internal trip conversion logic	CB1 Trip OutputC		*		*
523	Trip Conversion Logic	DDB_TRIP_A_PHASE	Unused	Unused				
524	Trip Conversion Logic	DDB_TRIP_B_PHASE	Unused	Unused				
525	Trip Conversion Logic	DDB_TRIP_C_PHASE	Unused	Unused				
526	Trip Conversion Logic	DDB_TRIP_3PH	Trip signal for 3ph - used as a command to drive trip 3ph output contact(s). Takes the output from the internal trip conversion logic	Trip 3ph	*		*	
526	Trip Conversion Logic	DDB_TRIP_3PH	Trip signal for CB1 3ph - used as a command to drive CB1 trip 3ph output contact(s). Takes the output from the internal trip conversion logic	CB1 Trip 3ph		*		*
527	Trip Conversion Logic	DDB_TR_23_PHASE_FAULT	2 or 3 phase fault indication - used to flag whether the fault is polyphase. Typically used to control auto-reclose logic, where auto-reclosing is allowed only for single phase faults	2/3 Ph Fault	*	*	*	*

DDB No	Source	Element Name	Description	English Text	P543/P545 No	P544/P546 Distance	P543/P545 No	P544/P546 Distance	P543/P545	P544/P546
528	Trip Conversion Logic	DDB_TR_3_PHASE_FAULT	3 phase fault indication. Typically used to control auto-reclose logic, where auto-reclosing is blocked for faults affecting all three phases together	3 Ph Fault	*	*	*	*	*	*
529	PSL	DDB_TR_3_PHASE	Trip 3 phase - input to trip latching logic	Trip Inputs 3Ph	*		*			
529	PSL	DDB_TR_3_PHASE	CB1 Trip 3 Phase - Input to Trip Latching Logic	CB1 Trip I/P 3Ph			*			*
530	PSL	DDB_TR_A_PHASE	A phase trip - input to trip conversion logic. Essential to ensure correct single or three pole trip command results (e.g. converts a 2 pole trip to 3 phase)	Trip Inputs A	*	*	*	*	*	*
531	PSL	DDB_TR_B_PHASE	B phase trip - input to trip conversion logic. Essential to ensure correct single or three pole trip command results (e.g. converts a 2 pole trip to 3 phase)	Trip Inputs B	*	*	*	*	*	*
532	PSL	DDB_TR_C_PHASE	C phase trip - input to trip conversion logic. Essential to ensure correct single or three pole trip command results (e.g. converts a 2 pole trip to 3 phase)	Trip Inputs C	*	*	*	*	*	*
533	PSL	DDB_FORCE_3_POLE_TRIP	Force any trip which is issued to always be 3 pole (trip conversion - used in single pole trip applications, to signal when single pole tripping and re-closing is either unwanted, or impossible)	Force 3Pole Trip	*		*			
533	PSL	DDB_FORCE_3_POLE_TRIP	External DDB input to host protection trip conversion logic to force 3 Pole tripping of CB1 for all faults	Force 3PTrip CB1			*			*
534	PSL	DDB_EXTERNAL_TRIP_3PH	External trip 3 phase - signal from external protection to initiate auto-reclose (if enabled)	External Trip3ph	*		*			
535	PSL	DDB_EXTERNAL_TRIP_A	External trip A phase - signal from external protection to initiate auto-reclose (if enabled)	External Trip A	*		*			
536	PSL	DDB_EXTERNAL_TRIP_B	External trip B phase - signal from external protection to initiate auto-reclose (if enabled)	External Trip B	*		*			
537	PSL	DDB_EXTERNAL_TRIP_C	External trip C phase - signal from external protection to initiate auto-reclose (if enabled)	External Trip C	*		*			
535	PSL	DDB_EXTERNAL_TRIP_A	Unused	Unused						
536	PSL	DDB_EXTERNAL_TRIP_B	Unused	Unused						
537	PSL	DDB_EXTERNAL_TRIP_C	Unused	Unused						
534	PSL	DDB_EXTERNAL_TRIP_3PH	CB1 Ext Trip3ph - signal from external protection to initiate three phase autoreclosing of CB1	CB1 Ext Trip3ph			*			*
535	PSL	DDB_EXTERNAL_TRIP_A	CB1 Ext Trip A - signal from external protection to initiate single phase autoreclosing (A Ph) of CB1	CB1 Ext Trip A			*			*
536	PSL	DDB_EXTERNAL_TRIP_B	CB1 Ext Trip B - signal from external protection to initiate single phase autoreclosing (B Ph) of CB1	CB1 Ext Trip B			*			*
537	PSL	DDB_EXTERNAL_TRIP_C	CB1 Ext Trip C - signal from external protection to initiate single phase autoreclosing (C Ph) of CB1	CB1 Ext Trip C			*			*
538	PSL	DDB_CB2_EXTERNAL_TRIP_3PH	CB2 Ext Trip3ph - signal from external protection to initiate three phase autoreclosing of CB2	CB2 Ext Trip3ph			*			*

DDB No	Source	Element Name	Description	English Text	P543/P545 N No. Distance	P543/P545 N No. Distance	P543/ P545	P544/ P546
539		DDB_CB2_EXTERNAL_TRIP_A	CB2 Ext Trip A - signal from external protection to initiate single phase autoreclosing (A Ph) of CB2	CB2 Ext Trip A		*		*
540		DDB_CB2_EXTERNAL_TRIP_B	CB2 Ext Trip B - signal from external protection to initiate single phase autoreclosing (B Ph) of CB2	CB2 Ext Trip B		*		*
541		DDB_CB2_EXTERNAL_TRIP_C	CB2 Ext Trip C - signal from external protection to initiate single phase autoreclosing (C Ph) of CB2	CB2 Ext Trip C		*		*
538		DDB_CB2_EXTERNAL_TRIP_3PH	Unused	Unused	*		*	
539		DDB_CB2_EXTERNAL_TRIP_A	Unused	Unused	*		*	
540		DDB_CB2_EXTERNAL_TRIP_B	Unused	Unused	*		*	
541		DDB_CB2_EXTERNAL_TRIP_C	Unused	Unused	*		*	
542		DDB_SG_SELECTOR_X1	Setting group selector X1 (low bit)-selects SG2 if only DDB 542 signal is active. SG1 is active if both DDB 542 & DDB 543=0 SG4 is active if both DDB 542 & DDB 543=1	SG Select x1	*	*	*	*
543		DDB_SG_SELECTOR_1X	Setting group selector 1X (high bit)-selects SG3 if only DDB 543 is active. SG1 is active if both DDB 542 & DDB 543=0 SG4 is active if both DDB 542 & DDB 543=1	SG Select 1x	*	*	*	*
544	PSL	DDB_CLEAR_STATISTICS	To reset all statistics values cumulated on the relay. If mapped, the input for this signal could come from a command of the remote end (DDB 1020 - clear stats cmd -) via IM64	Clear Statistics	*	*	*	*
544	PSL	DDB_CLEAR_STATISTICS	Unused	Unused				
545	Stability test	DDB_STAB_TEST_PASS	Stability test pass	Stab Test Pass				
546	Phase Comparison	DDB_BLOCK_DELTA	Delta starter block	Block Delta				
547	Phase Comparison	DDB_BLOCK_PHASE_COMP	Phase Comp block	Block Phase Comp				
548	Phase Comparison	DDB_BLOCK_START_I2	I2 starter block	Block Start I2				
549	Phase Comparison	DDB_SET_TRANS_START	Set Transient starter	Set Trans Start				
545	Stability test	DDB_STAB_TEST_PASS	Unused	Unused	*	*	*	*
546	Phase Comparison	DDB_BLOCK_DELTA	Unused	Unused	*	*	*	*
547	Phase Comparison	DDB_BLOCK_PHASE_COMP	Unused	Unused	*	*	*	*
548	Phase Comparison	DDB_BLOCK_START_I2	Unused	Unused	*	*	*	*
549	Phase Comparison	DDB_SET_TRANS_START	Unused	Unused	*	*	*	*
550	PSL	DDB_INHIBIT_PREDICTIVE_OST_TRIP	Block predictive out of step tripping command	Inh Pred. OST			*	*
551	Out Of Step Tripping	DDB_PREDICTIVE_OST_TRIP	Predictive out of step trip	Pred. OST			*	*
552	PSL	DDB_INHIBIT_OST_TRIP	Block out of step tripping command	Inhibit OST			*	*
553	Out Of Step Tripping	DDB_OST_TRIP	Out of step trip	OST			*	*
550	Out Of Step Tripping	DDB_INHIBIT_PREDICTIVE_OST_TRIP	Unused	Unused	*	*		

DDB No	Source	Element Name	Description	English Text	P543/P545 No	P544/P546 Distance	P543/P545 No	P544/P546 Distance	P543/P545	P544/P546
551	Out Of Step Tripping	DDB_PREDICTIVE_OST_TRIP	Unused	Unused	*	*				
552	Out Of Step Tripping	DDB_INHIBIT_OST_TRIP	Unused	Unused	*	*				
553	Out Of Step Tripping	DDB_OST_TRIP	Unused	Unused	*	*				
554	Out Of Step Tripping	DDB_START_Z5	Positive sequence impedance is detected in Z5	Start Z5				*	*	
555	Out Of Step Tripping	DDB_START_Z6	Positive sequence impedance is detected in Z6	Start Z6				*	*	
554	Out Of Step Tripping	DDB_START_Z5	Unused	Unused	*	*				
555	Out Of Step Tripping	DDB_START_Z6	Unused	Unused	*	*				
556	Distance Basic Scheme	DDB_CNV_ACTIVE	Level detector Current No Volts (CNV) exceeded	CNV ACTIVE				*	*	
557	Distance Basic Scheme	DDB_CNV_TOR_TRIP	Trip on Reclose trip due to Current No Volts (CNV) level detectors	TOR Trip CNV				*	*	
558	Distance Basic Scheme	DDB_CNV_SOTF_TRIP	Switch on to Fault trip due to Current No Volts (CNV) level detectors	SOTF Trip CNV				*	*	
559	Distance Basic Scheme	DDB_QUARTER_CYCLE_OV_PHA	Phase A Fast Overvoltage level detector used by Current No Volts (CNV)	Fast OV PHA				*	*	
560	Distance Basic Scheme	DDB_QUARTER_CYCLE_OV_PHB	Phase B Fast Overvoltage level detector used by Current No Volts (CNV)	Fast OV PHB				*	*	
561	Distance Basic Scheme	DDB_QUARTER_CYCLE_OV_PHC	Phase C Fast Overvoltage level detector used by Current No Volts (CNV)	Fast OV PHC				*	*	
556	Distance Basic Scheme	DDB_CNV_ACTIVE	Unused	Unused	*	*				
557	Distance Basic Scheme	DDB_CNV_TOR_TRIP	Unused	Unused	*	*				
558	Distance Basic Scheme	DDB_CNV_SOTF_TRIP	Unused	Unused	*	*				
559	Distance Basic Scheme	DDB_QUARTER_CYCLE_OV_PHA	Unused	Unused	*	*				
560	Distance Basic Scheme	DDB_QUARTER_CYCLE_OV_PHB	Unused	Unused	*	*				
561	Distance Basic Scheme	DDB_QUARTER_CYCLE_OV_PHC	Unused	Unused	*	*				
562	PSL	DDB_NPSOC_INHIBIT	Inhibit Neg Sequence overcurrent protection	I2> Inhibit	*	*	*	*	*	*
563	PSL	DDB_NPSOC_1_TIMER_BLOCK	Block Neg Sequence overcurrent stage 1 time delayed trip	I2>1 Tmr Blk	*	*	*	*	*	*
564	PSL	DDB_NPSOC_2_TIMER_BLOCK	Block Neg Sequence overcurrent stage 2 time delayed trip	I2>2 Tmr Blk	*	*	*	*	*	*
565	PSL	DDB_NPSOC_3_TIMER_BLOCK	Block Neg Sequence overcurrent stage 3 time delayed trip	I2>3 Tmr Blk	*	*	*	*	*	*
566	PSL	DDB_NPSOC_4_TIMER_BLOCK	Block Neg Sequence overcurrent stage 4 time delayed trip	I2>4 Tmr Blk	*	*	*	*	*	*
567	Neg Sequence overcurrent	DDB_NPSOC_1_START	1st stage Neg Sequence overcurrent start	I2>1 Start	*	*	*	*	*	*
568	Neg Sequence overcurrent	DDB_NPSOC_2_START	2nd stage Neg Sequence overcurrent start	I2>2 Start	*	*	*	*	*	*

DDB No	Source	Element Name	Description	English Text	P543/P544 5 Inp. Distance	P544/P545 Distance	P543/ P544/ P545	P544/ P546
569	Neg Sequence overcurrent	DDB_NPSOC_3_START	3rd stage Neg Sequence overcurrent start	I2>3 Start	*	*	*	*
570	Neg Sequence overcurrent	DDB_NPSOC_4_START	4th stage Neg Sequence overcurrent start	I2>4 Start	*	*	*	*
571	Neg Sequence overcurrent	DDB_NPSOC_1_TRIP	1st stage Neg Sequence overcurrent trip	I2>1 Trip	*	*	*	*
572	Neg Sequence overcurrent	DDB_NPSOC_2_TRIP	2nd stage Neg Sequence overcurrent trip	I2>2 Trip	*	*	*	*
573	Neg Sequence overcurrent	DDB_NPSOC_3_TRIP	3rd stage Neg Sequence overcurrent trip	I2>3 Trip	*	*	*	*
574	Neg Sequence overcurrent	DDB_NPSOC_4_TRIP	4th stage Neg Sequence overcurrent trip	I2>4 Trip	*	*	*	*
575	Phase comparison	DDB_ICAP_MODE_SECURE	Secure Icap mode setting	Icap mode 1				
575	Phase comparison	DDB_ICAP_MODE_SECURE	Unused	Unused	*	*	*	*
576	Commissioning Test	DDB_AR_TRIP_TEST	Auto-reclose trip test cycle in progress. Indication that a manually-initiated test cycle is in progress	AR Trip Test	*		*	
576	Commissioning Test	DDB_AR_TRIP_TEST	Autoreclose trip test	AR Trip Test		*		*
577	Commissioning Test	DDB_AR_TRIP_TEST_A	Auto-reclose trip test A phase. Indication that a manually-initiated test cycle is in progress	AR Trip Test A	*	*	*	*
578	Commissioning Test	DDB_AR_TRIP_TEST_B	Auto-reclose trip test B phase. Indication that a manually-initiated test cycle is in progress	AR Trip Test B	*	*	*	*
579	Commissioning Test	DDB_AR_TRIP_TEST_C	Auto-reclose trip test C phase. Indication that a manually-initiated test cycle is in progress	AR Trip Test C	*	*	*	*
577	Commissioning Test	DDB_AR_TRIP_TEST_A	Unused	Unused				
578	Commissioning Test	DDB_AR_TRIP_TEST_B	Unused	Unused				
579	Commissioning Test	DDB_AR_TRIP_TEST_C	Unused	Unused				
580	Autoreclose	DDB_AR_INIT_3PH	Initiate 3 phase auto-reclose (signal to an external re-closer)	AR Init 3Ph	*		*	
580	Autoreclose	DDB_AR_INIT_3PH	Unused	Unused		*		*
581	Autoreclose	DDB_AR_BLOCK_AR	Block Autoreclose	Block AR	*		*	
581	Autoreclose	DDB_AR_BLOCK_AR	Unused	Unused		*		*
582	C Diff	DDB_DIFFERENTIAL_TRIP	Current differential trip	Diff Trip	*	*	*	*
583	C Diff	DDB_DIFFERENTIAL_TRIP_A	Current differential A phase trip	Diff Trip A	*	*	*	*
584	C Diff	DDB_DIFFERENTIAL_TRIP_B	Current differential B phase trip	Diff Trip B	*	*	*	*
585	C Diff	DDB_DIFFERENTIAL_TRIP_C	Current differential C phase trip	Diff Trip C	*	*	*	*
586	C Diff	DDB_DIFFERENTIAL_INTERTRIP	Current differential intertrip	Diff InterTrip	*	*	*	*
587	C Diff	DDB_DIFFERENTIAL_INTERTRIP_A	Current differential A phase intertrip	Diff InterTrip A	*	*	*	*
588	C Diff	DDB_DIFFERENTIAL_INTERTRIP_B	Current differential B phase intertrip	Diff InterTrip B	*	*	*	*
589	C Diff	DDB_DIFFERENTIAL_INTERTRIP_C	Current differential C phase intertrip	Diff InterTrip C	*	*	*	*
590	C Diff	DDB_PERMISSIVE_INTERTRIP	Permissive intertrip	Perm InterTrip	*	*	*	*
591	C Diff	DDB_STUB_BUS_TRIP	Stub bus trip	Stub Bus Trip	*	*	*	*
582	SW	DDB_DIFFERENTIAL_TRIP	Unused	Unused				

DDB No	Source	Element Name	Description	English Text	P543/P545 No Distance	P544/P546 No Distance	P543/P545 No Distance	P544/P546 No Distance
583	SW	DDB_DIFFERENTIAL_TRIP_A	Unused	Unused				
584	SW	DDB_DIFFERENTIAL_TRIP_B	Unused	Unused				
585	SW	DDB_DIFFERENTIAL_TRIP_C	Unused	Unused				
586	SW	DDB_DIFFERENTIAL_INTERTRIP	Unused	Unused				
587	SW	DDB_DIFFERENTIAL_INTERTRIP_A	Unused	Unused				
588	SW	DDB_DIFFERENTIAL_INTERTRIP_B	Unused	Unused				
589	SW	DDB_DIFFERENTIAL_INTERTRIP_C	Unused	Unused				
590	SW	DDB_PERMISSIVE_INTERTRIP	Unused	Unused				
591	SW	DDB_STUB_BUS_TRIP	Unused	Unused				
592	PSL	DDB_DFDT_INHIBIT	Inhibit df/dt protection	df/dt> Inhibit	*	*	*	*
593	PSL	DDB_DFDT_1_TIMER_BLOCK	Block df/dt Stage 1 Timer	df/dt>1 Tmr Blk	*	*	*	*
594	PSL	DDB_DFDT_2_TIMER_BLOCK	Block df/dt Stage 2 Timer	df/dt>2 Tmr Blk	*	*	*	*
595	PSL	DDB_DFDT_3_TIMER_BLOCK	Block df/dt Stage 3 Timer	df/dt>3 Tmr Blk	*	*	*	*
596	PSL	DDB_DFDT_4_TIMER_BLOCK	Block df/dt Stage 4 Timer	df/dt>4 Tmr Blk	*	*	*	*
597	df/dt protection	DDB_DFDT_1_START	df/dt Stage 1 Start	df/dt>1 Start	*	*	*	*
598	df/dt protection	DDB_DFDT_2_START	df/dt Stage 2 Start	df/dt>2 Start	*	*	*	*
599	df/dt protection	DDB_DFDT_3_START	df/dt Stage 3 Start	df/dt>3 Start	*	*	*	*
600	df/dt protection	DDB_DFDT_4_START	df/dt Stage 4 Start	df/dt>4 Start	*	*	*	*
601	df/dt protection	DDB_DFDT_1_TRIP	df/dt Stage 1 Trip	df/dt>1 Trip	*	*	*	*
602	df/dt protection	DDB_DFDT_2_TRIP	df/dt Stage 2 Trip	df/dt>2 Trip	*	*	*	*
603	df/dt protection	DDB_DFDT_3_TRIP	df/dt Stage 3 Trip	df/dt>3 Trip	*	*	*	*
604	df/dt protection	DDB_DFDT_4_TRIP	df/dt Stage 4 Trip	df/dt>4 Trip	*	*	*	*
605		DDB_UNUSED_605	Unused	Unused	*	*	*	*
606		DDB_UNUSED_606	Unused	Unused	*	*	*	*
607		DDB_UNUSED_607	Unused	Unused	*	*	*	*
608	Distance Basic Scheme	DDB_ZONE_1_TRIP	Zone 1 Trip	Zone 1 Trip			*	*
609	Distance Basic Scheme	DDB_ZONE_1_TRIP_A	Zone 1 A Phase Trip	Zone 1 A Trip			*	*
610	Distance Basic Scheme	DDB_ZONE_1_TRIP_B	Zone 1 B Phase Trip	Zone 1 B Trip			*	*
611	Distance Basic Scheme	DDB_ZONE_1_TRIP_C	Zone 1 C Phase Trip	Zone 1 C Trip			*	*
612	Distance Basic Scheme	DDB_ZONE_1_TRIP_N	Zone 1 N Trip	Zone 1 N Trip			*	*
613	Distance Basic Scheme	DDB_ZONE_2_TRIP	Zone 2 Trip	Zone 2 Trip			*	*
614	Distance Basic Scheme	DDB_ZONE_2_TRIP_A	Zone 2 A Phase Trip	Zone 2 A Trip			*	*
615	Distance Basic Scheme	DDB_ZONE_2_TRIP_B	Zone 2 B Phase Trip	Zone 2 B Trip			*	*
616	Distance Basic Scheme	DDB_ZONE_2_TRIP_C	Zone 2 C Phase Trip	Zone 2 C Trip			*	*
617	Distance Basic Scheme	DDB_ZONE_2_TRIP_N	Zone 2 N Trip	Zone 2 N Trip			*	*
618	Distance Basic Scheme	DDB_ZONE_3_TRIP	Zone 3 Trip	Zone 3 Trip			*	*

DDB No	Source	Element Name	Description	English Text	P543P54 P544 Distance	P543/ P544/ P546	P545/ P546
619	Distance Basic Scheme	DDB_ZONE_3_TRIP_A	Zone 3 A Phase Trip	Zone 3 A Trip		*	*
620	Distance Basic Scheme	DDB_ZONE_3_TRIP_B	Zone 3 B Phase Trip	Zone 3 B Trip		*	*
621	Distance Basic Scheme	DDB_ZONE_3_TRIP_C	Zone 3 C Phase Trip	Zone 3 C Trip		*	*
622	Distance Basic Scheme	DDB_ZONE_3_TRIP_N	Zone 3 N Trip	Zone 3 N Trip		*	*
623	Distance Basic Scheme	DDB_ZONE_P_TRIP	Zone P Trip	Zone P Trip		*	*
624	Distance Basic Scheme	DDB_ZONE_P_TRIP_A	Zone P A Phase Trip	Zone P A Trip		*	*
625	Distance Basic Scheme	DDB_ZONE_P_TRIP_B	Zone P B Phase Trip	Zone P B Trip		*	*
626	Distance Basic Scheme	DDB_ZONE_P_TRIP_C	Zone P C Phase Trip	Zone P C Trip		*	*
627	Distance Basic Scheme	DDB_ZONE_P_TRIP_N	Zone P N Trip	Zone P N Trip		*	*
628	Distance Basic Scheme	DDB_ZONE_4_TRIP	Zone 4 Trip	Zone 4 Trip		*	*
629	Distance Basic Scheme	DDB_ZONE_4_TRIP_A	Zone 4 A Phase Trip	Zone 4 A Trip		*	*
630	Distance Basic Scheme	DDB_ZONE_4_TRIP_B	Zone 4 B Phase Trip	Zone 4 B Trip		*	*
631	Distance Basic Scheme	DDB_ZONE_4_TRIP_C	Zone 4 C Phase Trip	Zone 4 C Trip		*	*
632	Distance Basic Scheme	DDB_ZONE_4_TRIP_N	Zone 4 N Phase Trip	Zone 4 N Trip		*	*
633	Aided Scheme Logic	DDB_AIDED1_TRIP_A	Aided channel scheme 1 trip A phase	Aided 1 Trip A		*	*
634	Aided Scheme Logic	DDB_AIDED1_TRIP_B	Aided channel scheme 1 trip B phase	Aided 1 Trip B		*	*
635	Aided Scheme Logic	DDB_AIDED1_TRIP_C	Aided channel scheme 1 trip C phase	Aided 1 Trip C		*	*
636	Aided Scheme Logic	DDB_AIDED1_TRIP_N	Aided channel scheme 1 trip involving ground (N)	Aided 1 Trip N		*	*
637	Aided Scheme Logic	DDB_AIDED1_WI_TRIP_A	Aided scheme 1 weak infeed trip phase A	Aid 1 WI Trip A		*	*
638	Aided Scheme Logic	DDB_AIDED1_WI_TRIP_B	Aided scheme 1 weak infeed trip phase B	Aid 1 WI Trip B		*	*
639	Aided Scheme Logic	DDB_AIDED1_WI_TRIP_C	Aided scheme 1 weak infeed trip phase C	Aid 1 WI Trip C		*	*
608	Distance Basic Scheme	DDB_ZONE_1_TRIP	Unused	Unused	*	*	
609	Distance Basic Scheme	DDB_ZONE_1_TRIP_A	Unused	Unused	*	*	
610	Distance Basic Scheme	DDB_ZONE_1_TRIP_B	Unused	Unused	*	*	
611	Distance Basic Scheme	DDB_ZONE_1_TRIP_C	Unused	Unused	*	*	
612	Distance Basic Scheme	DDB_ZONE_1_TRIP_N	Unused	Unused	*	*	

DDB No	Source	Element Name	Description	English Text	P543/P545 No Distance	P544/P546 No Distance	P543/P545	P544/P546
613	Distance Basic Scheme	DDB_ZONE_2_TRIP	Unused	Unused	*	*		
614	Distance Basic Scheme	DDB_ZONE_2_TRIP_A	Unused	Unused	*	*		
615	Distance Basic Scheme	DDB_ZONE_2_TRIP_B	Unused	Unused	*	*		
616	Distance Basic Scheme	DDB_ZONE_2_TRIP_C	Unused	Unused	*	*		
617	Distance Basic Scheme	DDB_ZONE_2_TRIP_N	Unused	Unused	*	*		
618	Distance Basic Scheme	DDB_ZONE_3_TRIP	Unused	Unused	*	*		
619	Distance Basic Scheme	DDB_ZONE_3_TRIP_A	Unused	Unused	*	*		
620	Distance Basic Scheme	DDB_ZONE_3_TRIP_B	Unused	Unused	*	*		
621	Distance Basic Scheme	DDB_ZONE_3_TRIP_C	Unused	Unused	*	*		
622	Distance Basic Scheme	DDB_ZONE_3_TRIP_N	Unused	Unused	*	*		
623	Distance Basic Scheme	DDB_ZONE_P_TRIP	Unused	Unused	*	*		
624	Distance Basic Scheme	DDB_ZONE_P_TRIP_A	Unused	Unused	*	*		
625	Distance Basic Scheme	DDB_ZONE_P_TRIP_B	Unused	Unused	*	*		
626	Distance Basic Scheme	DDB_ZONE_P_TRIP_C	Unused	Unused	*	*		
627	Distance Basic Scheme	DDB_ZONE_P_TRIP_N	Unused	Unused	*	*		
628	Distance Basic Scheme	DDB_ZONE_4_TRIP	Unused	Unused	*	*		
629	Distance Basic Scheme	DDB_ZONE_4_TRIP_A	Unused	Unused	*	*		
630	Distance Basic Scheme	DDB_ZONE_4_TRIP_B	Unused	Unused	*	*		
631	Distance Basic Scheme	DDB_ZONE_4_TRIP_C	Unused	Unused	*	*		
632	Distance Basic Scheme	DDB_ZONE_4_TRIP_N	Unused	Unused	*	*		
633	Aided Scheme Logic	DDB_AIDED1_TRIP_A	Unused	Unused	*	*		
634	Aided Scheme Logic	DDB_AIDED1_TRIP_B	Unused	Unused	*	*		
635	Aided Scheme Logic	DDB_AIDED1_TRIP_C	Unused	Unused	*	*		
636	Aided Scheme Logic	DDB_AIDED1_TRIP_N	Unused	Unused	*	*		
637	Aided Scheme Logic	DDB_AIDED1_WI_TRIP_A	Unused	Unused	*	*		
638	Aided Scheme Logic	DDB_AIDED1_WI_TRIP_B	Unused	Unused	*	*		

DDB No	Source	Element Name	Description	English Text	P543P54 5 Inverse Distance	P544P54 5 Inverse Distance	P543/ P544/ P545/ P546	P543/ P544/ P545/ P546
639	Aided Scheme Logic	DDB_AIDED1_WI_TRIP_C	Unused	Unused	*	*		
640	Aided Scheme Logic	DDB_AIDED1_DIR_3P_TRIP	Aided scheme 1 Delta directional Trip 3 Phase	Aid1 Delta Tr3Ph			*	*
640	Aided Scheme Logic	DDB_AIDED1_DIR_3P_TRIP	Unused	Unused	*	*		
641	Aided Scheme Logic	DDB_AIDED1_DEF_3P_TRIP	Aided 1 directional earth fault scheme trip 3 phase	Aid1 DEF Trip3Ph			*	*
642	Aided Scheme Logic	DDB_AIDED1_WI_3P_TRIP	Aided channel scheme 1 - weak infeed logic trip 3 phase	Aid1 WI Trip 3Ph			*	*
643	Aided Scheme Logic	DDB_AIDED2_TRIP_A	Aided channel scheme 2 trip A phase	Aided 2 Trip A			*	*
644	Aided Scheme Logic	DDB_AIDED2_TRIP_B	Aided channel scheme 2 trip B phase	Aided 2 Trip B			*	*
645	Aided Scheme Logic	DDB_AIDED2_TRIP_C	Aided channel scheme 2 trip C phase	Aided 2 Trip C			*	*
646	Aided Scheme Logic	DDB_AIDED2_TRIP_N	Aided channel scheme 2 trip involving ground (N)	Aided 2 Trip N			*	*
647	Aided Scheme Logic	DDB_AIDED2_WI_TRIP_A	Aided scheme 2 weak infeed trip phase A	Aid 2 WI Trip A			*	*
648	Aided Scheme Logic	DDB_AIDED2_WI_TRIP_B	Aided scheme 2 weak infeed trip phase B	Aid 2 WI Trip B			*	*
649	Aided Scheme Logic	DDB_AIDED2_WI_TRIP_C	Aided scheme 2 weak infeed trip phase C	Aid 2 WI Trip C			*	*
641	Aided Scheme Logic	DDB_AIDED1_DEF_3P_TRIP	Unused	Unused	*	*		
642	Aided Scheme Logic	DDB_AIDED1_WI_3P_TRIP	Unused	Unused	*	*		
643	Aided Scheme Logic	DDB_AIDED2_TRIP_A	Unused	Unused	*	*		
644	Aided Scheme Logic	DDB_AIDED2_TRIP_B	Unused	Unused	*	*		
645	Aided Scheme Logic	DDB_AIDED2_TRIP_C	Unused	Unused	*	*		
646	Aided Scheme Logic	DDB_AIDED2_TRIP_N	Unused	Unused	*	*		
647	Aided Scheme Logic	DDB_AIDED2_WI_TRIP_A	Unused	Unused	*	*		
648	Aided Scheme Logic	DDB_AIDED2_WI_TRIP_B	Unused	Unused	*	*		
649	Aided Scheme Logic	DDB_AIDED2_WI_TRIP_C	Unused	Unused	*	*		
650	Aided Scheme Logic	DDB_AIDED2_DIR_3P_TRIP	Aided scheme 2 Delta directional Trip 3 Phase	Aid2 Delta Tr3Ph			*	*
650	Aided Scheme Logic	DDB_AIDED2_DIR_3P_TRIP	Unused	Unused	*	*		
651	Aided Scheme Logic	DDB_AIDED2_DEF_3P_TRIP	Aided 2 directional earth fault scheme trip 3 phase	Aid2 DEF Trip3Ph			*	*
652	Aided Scheme Logic	DDB_AIDED2_WI_3P_TRIP	Aided channel scheme 2 - weak infeed logic trip 3 phase	Aid2 WI Trip 3Ph			*	*
651	Aided Scheme Logic	DDB_AIDED2_DEF_3P_TRIP	Unused	Unused	*	*		

DDB No	Source	Element Name	Description	English Text	P543/P545 No Distance	P544/P546 No Distance	P543/ P545	P544/ P546
652	Aided Scheme Logic	DDB_AIDED2_WI_3P_TRIP	Unused	Unused	*	*		
653	PTP	DDB_1588_STATUS	IEEE1588 Status Signal Valid	1588 Status	*	*	*	*
654	Loss of Load Logic	DDB_LOL_TRIP	Loss of Load Trip	Loss ofLoad Trip			*	*
654	Loss of Load Logic	DDB_LOL_TRIP	Unused	Unused	*	*		
655	Overcurrent	DDB_POC_1_3PH_TRIP	1st stage phase overcurrent trip 3 phase	I>1 Trip	*	*	*	*
656	Overcurrent	DDB_POC_1_PH_A_TRIP	1st stage phase overcurrent trip phase A	I>1 Trip A	*	*	*	*
657	Overcurrent	DDB_POC_1_PH_B_TRIP	1st stage phase overcurrent trip phase B	I>1 Trip B	*	*	*	*
658	Overcurrent	DDB_POC_1_PH_C_TRIP	1st stage phase overcurrent trip phase C	I>1 Trip C	*	*	*	*
659	Overcurrent	DDB_POC_2_3PH_TRIP	2nd stage phase overcurrent trip 3 phase	I>2 Trip	*	*	*	*
660	Overcurrent	DDB_POC_2_PH_A_TRIP	2nd stage phase overcurrent trip phase A	I>2 Trip A	*	*	*	*
661	Overcurrent	DDB_POC_2_PH_B_TRIP	2nd stage phase overcurrent trip phase B	I>2 Trip B	*	*	*	*
662	Overcurrent	DDB_POC_2_PH_C_TRIP	2nd stage phase overcurrent trip phase C	I>2 Trip C	*	*	*	*
663	Overcurrent	DDB_POC_3_3PH_TRIP	3rd stage phase overcurrent trip 3 phase	I>3 Trip	*	*	*	*
664	Overcurrent	DDB_POC_3_PH_A_TRIP	3rd stage phase overcurrent trip phase A	I>3 Trip A	*	*	*	*
665	Overcurrent	DDB_POC_3_PH_B_TRIP	3rd stage phase overcurrent trip phase B	I>3 Trip B	*	*	*	*
666	Overcurrent	DDB_POC_3_PH_C_TRIP	3rd stage phase overcurrent trip phase C	I>3 Trip C	*	*	*	*
667	Overcurrent	DDB_POC_4_3PH_TRIP	4th stage phase overcurrent trip 3 phase	I>4 Trip	*	*	*	*
668	Overcurrent	DDB_POC_4_PH_A_TRIP	4th stage phase overcurrent trip phase A	I>4 Trip A	*	*	*	*
669	Overcurrent	DDB_POC_4_PH_B_TRIP	4th stage phase overcurrent trip phase B	I>4 Trip B	*	*	*	*
670	Overcurrent	DDB_POC_4_PH_C_TRIP	4th stage phase overcurrent trip phase C	I>4 Trip C	*	*	*	*
671	Earth Fault	DDB_EF1_1_TRIP	1st stage stand by earth fault (SBEF) protection trip	IN>1 Trip	*	*	*	*
672	Earth Fault	DDB_EF1_2_TRIP	2nd stage stand by earth fault (SBEF) protection trip	IN>2 Trip	*	*	*	*
673	Earth Fault	DDB_EF1_3_TRIP	3rd stage stand by earth fault (SBEF) protection trip	IN>3 Trip	*	*	*	*
674	Earth Fault	DDB_EF1_4_TRIP	4th stage stand by earth fault (SBEF) protection trip	IN>4 Trip	*	*	*	*
675	SEF	DDB_SEF_1_TRIP	1st stage sensitive earth fault (SEF) protection trip	ISEF>1 Trip	*	*	*	*
676	SEF	DDB_SEF_2_TRIP	2nd stage sensitive earth fault (SEF) protection trip	ISEF>2 Trip	*	*	*	*
677	SEF	DDB_SEF_3_TRIP	3rd stage sensitive earth fault (SEF) protection trip	ISEF>3 Trip	*	*	*	*
678	SEF	DDB_SEF_4_TRIP	4th stage sensitive earth fault (SEF) protection trip	ISEF>4 Trip	*	*	*	*
679	Broken Conductor	DDB_BROKEN_CONDUCTOR_TRIP	Broken Conductor Trip	Broken Wire Trip	*	*	*	*
680	Thermal overload	DDB_THERMAL_TRIP	Thermal Overload Trip	Thermal Trip	*	*	*	*
681	PSL	DDB_BLOCK_GND_ZP_START	Block Start Zp (Ph-Gnd)	Blk Start Gnd Zp				
681		DDB_BLOCK_GND_ZP_START	Unused	Unused	*	*	*	*
682	SEF	DDB_REF_TRIP	Restricted earth fault (REF) protection trip	IREF> Trip	*	*	*	*
683	Undervoltage	DDB_PUV_1_3PH_TRIP	Undervoltage stage 1, three phase trip	V<1 Trip	*	*	*	*
684	Undervoltage	DDB_PUV_1_PH_A_TRIP	Undervoltage stage 1 A/AB phase trip	V<1 Trip A/AB	*	*	*	*

DDB No	Source	Element Name	Description	English Text	P543/54 5 Inp. Distance	P544/54 4 Inp. Distance	P545/ P544/ P546	P546/ P544/ P546
685	Undervoltage	DDB_PUV_1_PH_B_TRIP	Undervoltage stage 1 B/BC phase trip	V<1 Trip B/BC	*	*	*	*
686	Undervoltage	DDB_PUV_1_PH_C_TRIP	Undervoltage stage 1 C/CA phase trip	V<1 Trip C/CA	*	*	*	*
687	Undervoltage	DDB_PUV_2_3PH_TRIP	Undervoltage stage 2, three phase trip	V<2 Trip	*	*	*	*
688	Undervoltage	DDB_PUV_2_PH_A_TRIP	Undervoltage stage 2 A/AB phase trip	V<2 Trip A/AB	*	*	*	*
689	Undervoltage	DDB_PUV_2_PH_B_TRIP	Undervoltage stage 2 B/BC phase trip	V<2 Trip B/BC	*	*	*	*
690	Undervoltage	DDB_PUV_2_PH_C_TRIP	Undervoltage stage 2 C/CA phase trip	V<2 Trip C/CA	*	*	*	*
691	Overvoltage	DDB_POV_1_3PH_TRIP	Overvoltage stage 1, three phase trip	V>1 Trip	*	*	*	*
692	Overvoltage	DDB_POV_1_PH_A_TRIP	Overvoltage stage 1 A/AB phase trip	V>1 Trip A/AB	*	*	*	*
693	Overvoltage	DDB_POV_1_PH_B_TRIP	Overvoltage stage 1 B/BC phase trip	V>1 Trip B/BC	*	*	*	*
694	Overvoltage	DDB_POV_1_PH_C_TRIP	Overvoltage stage 1 C/CA phase trip	V>1 Trip C/CA	*	*	*	*
695	Overvoltage	DDB_POV_2_3PH_TRIP	Overvoltage stage 2, three phase trip	V>2 Trip	*	*	*	*
696	Overvoltage	DDB_POV_2_PH_A_TRIP	Overvoltage stage 2 A/AB phase trip	V>2 Trip A/AB	*	*	*	*
697	Overvoltage	DDB_POV_2_PH_B_TRIP	Overvoltage stage 2 B/BC phase trip	V>2 Trip B/BC	*	*	*	*
698	Overvoltage	DDB_POV_2_PH_C_TRIP	Overvoltage stage 2 C/CA phase trip	V>2 Trip C/CA	*	*	*	*
699	Pole discrepancy	DDB_POLE_DISCREPENCE_TRIP	Pole discrepancy signal to force a three pole trip conversion, if the relay detects one pole dead, and no auto-reclose in progress	Pole Discrepancy	*		*	
699	Pole discrepancy	DDB_POLE_DISCREPENCE_TRIP	Pole Discrepancy (signal raised when a pole discrepancy state is detected on CB1)	Pole Discrep.CB1		*		*
700	Residual overvoltage	DDB_RESOV_1_TRIP	Residual overvoltage stage 1 trip	VN>1 Trip	*	*	*	*
701	Residual overvoltage	DDB_RESOV_2_TRIP	Residual overvoltage stage 2 trip	VN>2 Trip	*	*	*	*
702	PSL	DDB_FAULT_RECORDER_START	Trigger for Fault Recorder	Fault REC TRIG	*	*	*	*
703	Neg Sequence overcurrent	DDB_NEGSEQOC_TRIP	Unused	Unused	*	*	*	*
704	Trip on Close	DDB_ZONE_1_TOR_TRIP	TOR trip zone 1 (trip on reclose)	TOR Trip Zone 1			*	*
705	Trip on Close	DDB_ZONE_2_TOR_TRIP	TOR Trip Zone 2	TOR Trip Zone 2			*	*
706	Trip on Close	DDB_ZONE_3_TOR_TRIP	TOR Trip Zone 3	TOR Trip Zone 3			*	*
707	Trip on Close	DDB_ZONE_4_TOR_TRIP	TOR Trip Zone 4	TOR Trip Zone 4			*	*
708	Trip on Close	DDB_ZONE_P_TOR_TRIP	TOR Trip Zone P	TOR Trip Zone P			*	*
709	Trip on Close	DDB_ZONE_1_SOTF_TRIP	SOTF trip zone 1 (switch on to fault)	SOTF Trip Zone 1			*	*
710	Trip on Close	DDB_ZONE_2_SOTF_TRIP	SOTF Trip Zone 2	SOTF Trip Zone 2			*	*
711	Trip on Close	DDB_ZONE_3_SOTF_TRIP	SOTF Trip Zone 3	SOTF Trip Zone 3			*	*
712	Trip on Close	DDB_ZONE_4_SOTF_TRIP	SOTF Trip Zone 4	SOTF Trip Zone 4			*	*
713	Trip on Close	DDB_ZONE_P_SOTF_TRIP	SOTF Trip Zone P	SOTF Trip Zone P			*	*
704	Trip on Close	DDB_ZONE_1_TOR_TRIP	Unused	Unused	*	*		
705	Trip on Close	DDB_ZONE_2_TOR_TRIP	Unused	Unused	*	*		
706	Trip on Close	DDB_ZONE_3_TOR_TRIP	Unused	Unused	*	*		
707	Trip on Close	DDB_ZONE_4_TOR_TRIP	Unused	Unused	*	*		
708	Trip on Close	DDB_ZONE_P_TOR_TRIP	Unused	Unused	*	*		
709	Trip on Close	DDB_ZONE_1_SOTF_TRIP	Unused	Unused	*	*		
710	Trip on Close	DDB_ZONE_2_SOTF_TRIP	Unused	Unused	*	*		
711	Trip on Close	DDB_ZONE_3_SOTF_TRIP	Unused	Unused	*	*		
712	Trip on Close	DDB_ZONE_4_SOTF_TRIP	Unused	Unused	*	*		

DDB No	Source	Element Name	Description	English Text	P543/P545 No Distance	P544/P546 No Distance	P543/ P545	P544/ P546
713	Trip on Close	DDB_ZONE_P_SOTF_TRIP	Unused	Unused	*	*		
714	SW	DDB_CH_TEST_COMPLETED	Channel test completed	Ch. Test Done				
715	SW	DDB_CH_TEST_START	Channel test started	Ch. Manual Test				
716	Phase comparison	DDB_UNSTABILISING	Phase comp unstabalising	Unstblise PhComp				
717	SW	DDB_BLOCK_CHANNEL_TEST	Block Channel test	Block Chan Test				
718	SW	DDB_CLP_INITIATE	CLP initiate	CLP Initiate				
719	SW	DDB_CLP_OPERATION	CLP operation	CLP Operation				
714	SW	DDB_CH_TEST_COMPLETED	Unused	Unused	*	*	*	*
715	SW	DDB_CH_TEST_START	Unused	Unused	*	*	*	*
716	Phase comparison	DDB_UNSTABILISING	Unused	Unused	*	*	*	*
717	SW	DDB_BLOCK_CHANNEL_TEST	Unused	Unused	*	*	*	*
718	SW	DDB_CLP_INITIATE	Unused	Unused	*	*	*	*
719	SW	DDB_CLP_OPERATION	Unused	Unused	*	*	*	*
720		DDB_UNUSED_720	Unused	Unused	*	*	*	*
721	PSL	DDB_CONT_MAN_TEST	Continuous manual test	Cont Man Test				
722	PSL	DDB_BLOCK_PLC	Block PLC Keying	Block Keying PLC				
721	PSL	DDB_CONT_MAN_TEST	Unused	Unused	*	*	*	*
722	PSL	DDB_BLOCK_PLC	Unused	Unused	*	*	*	*
723	Phase Comparison	DDB_PHASE_COMP_TRIP	Phase comparison trip	Phase Comp Trip				
724	Phase comparison	DDB_PHASE_COMP_TRIP_A	Phase comparison trip A	Phase Comp Trp A				
725	Phase comparison	DDB_PHASE_COMP_TRIP_B	Phase comparison trip B	Phase Comp Trp B				
726	Phase comparison	DDB_PHASE_COMP_TRIP_C	Phase comparison trip C	Phase Comp Trp C				
727	phase comparison	DDB_PHASE_COMP_TRIP_3PH	Phase comparison trip 3ph	PhComp Trp 3Ph				
723	Phase Comparison	DDB_PHASE_COMP_TRIP	Unused	Unused	*	*	*	*
724	Phase comparison	DDB_PHASE_COMP_TRIP_A	Unused	Unused	*	*	*	*
725	Phase comparison	DDB_PHASE_COMP_TRIP_B	Unused	Unused	*	*	*	*
726	Phase comparison	DDB_PHASE_COMP_TRIP_C	Unused	Unused	*	*	*	*
727	Phase comparison	DDB_PHASE_COMP_TRIP_3PH	Unused	Unused	*	*	*	*
728	PSL	DDB_TRANS_START_ENABLED	Trans Start Enabled	Trans Start En				
729	PSL	DDB_BLOCK_PH_Z2_START	Block Start Z2 (Ph-Ph)	Blk Start Ph Z2				
730	PSL	DDB_BLOCK_PH_Z3_START	Block Start Z3 (Ph-Ph)	Blk Start Ph Z3				
731	PSL	DDB_BLOCK_PH_Z4_START	Block Start Z4 (Ph-Ph)	Blk Start Ph Z4				
732	PSL	DDB_BLOCK_PH_ZP_START	Block Start Zp (Ph-Ph)	Blk Start Ph Zp				
733	PSL	DDB_BLOCK_GND_Z2_START	Block Start Z2 (Ph-Gnd)	Blk Start Gnd Z2				
734	PSL	DDB_BLOCK_GND_Z3_START	Block Start Z3 (Ph-Gnd)	Blk Start Gnd Z3				

DDB No	Source	Element Name	Description	English Text	P543/P545 No. Distance	P544/P546 No. Distance	P543/P545	P544/P546
735	PSL	DDB_BLOCK_GND_Z4_START	Block Start Z4 (Ph-Gnd)	Blk Start Gnd Z4				
728	SW	DDB_TRANS_START_ENABLED	Unused	Unused	*	*	*	*
729	SW	DDB_BLOCK_PH_Z2_START	Unused	Unused	*	*	*	*
730	SW	DDB_BLOCK_PH_Z3_START	Unused	Unused	*	*	*	*
731	SW	DDB_BLOCK_PH_Z4_START	Unused	Unused	*	*	*	*
732	SW	DDB_BLOCK_PH_ZP_START	Unused	Unused	*	*	*	*
733	SW	DDB_BLOCK_GND_Z2_START	Unused	Unused	*	*	*	*
734	SW	DDB_BLOCK_GND_Z3_START	Unused	Unused	*	*	*	*
735	SW	DDB_BLOCK_GND_Z4_START	Unused	Unused	*	*	*	*
736	PSL	DDB_ANY_START	Any Start	Any Start	*	*	*	*
737	C Diff	DDB_DIFFERENTIAL_START	Current differential start	IDiff>Start	*	*	*	*
738	C Diff	DDB_DIFFERENTIAL_START_A	Current differential A phase start	IDiff>Start A	*	*	*	*
739	C Diff	DDB_DIFFERENTIAL_START_B	Current differential B phase start	IDiff>Start B	*	*	*	*
740	C Diff	DDB_DIFFERENTIAL_START_C	Current differential C phase start	IDiff>Start C	*	*	*	*
737	SW	DDB_DIFFERENTIAL_START	Unused	Unused				
738	SW	DDB_DIFFERENTIAL_START_A	Unused	Unused				
739	SW	DDB_DIFFERENTIAL_START_B	Unused	Unused				
740	SW	DDB_DIFFERENTIAL_START_C	Unused	Unused				
741	Distance Basic Scheme	DDB_ZONE_1_START_A	Zone 1 A Phase Start	Zone 1 A Start			*	*
742	Distance Basic Scheme	DDB_ZONE_1_START_B	Zone 1 B Phase Start	Zone 1 B Start			*	*
743	Distance Basic Scheme	DDB_ZONE_1_START_C	Zone 1 C Phase Start	Zone 1 C Start			*	*
744	Distance Basic Scheme	DDB_ZONE_1_START_N	Zone 1 ground element start	Zone 1 N Start			*	*
745	Distance Basic Scheme	DDB_ZONE_2_START_A	Zone 2 A Phase Start	Zone 2 A Start			*	*
746	Distance Basic Scheme	DDB_ZONE_2_START_B	Zone 2 B Phase Start	Zone 2 B Start			*	*
747	Distance Basic Scheme	DDB_ZONE_2_START_C	Zone 2 C Phase Start	Zone 2 C Start			*	*
748	Distance Basic Scheme	DDB_ZONE_2_START_N	Zone 2 ground element start	Zone 2 N Start			*	*
749	Distance Basic Scheme	DDB_ZONE_3_START_A	Zone 3 A Phase Start	Zone 3 A Start			*	*
750	Distance Basic Scheme	DDB_ZONE_3_START_B	Zone 3 B Phase Start	Zone 3 B Start			*	*
751	Distance Basic Scheme	DDB_ZONE_3_START_C	Zone 3 C Phase Start	Zone 3 C Start			*	*
752	Distance Basic Scheme	DDB_ZONE_3_START_N	Zone 3 N Start	Zone 3 N Start			*	*
753	Distance Basic Scheme	DDB_ZONE_P_START_A	Zone P A Phase Start	Zone P A Start			*	*
754	Distance Basic Scheme	DDB_ZONE_P_START_B	Zone P B Phase Start	Zone P B Start			*	*
755	Distance Basic Scheme	DDB_ZONE_P_START_C	Zone P C Phase Start	Zone P C Start			*	*

DDB No	Source	Element Name	Description	English Text	P543/P545 No Distance	P544/P546 No Distance	P543/P545	P544/P546
756	Distance Basic Scheme	DDB_ZONE_P_START_N	Zone P N Start	Zone P N Start			*	*
757	Distance Basic Scheme	DDB_ZONE_4_START_A	Zone 4 A Phase Start	Zone 4 A Start			*	*
758	Distance Basic Scheme	DDB_ZONE_4_START_B	Zone 4 B Phase Start	Zone 4 B Start			*	*
759	Distance Basic Scheme	DDB_ZONE_4_START_C	Zone 4 C Phase Start	Zone 4 C Start			*	*
760	Distance Basic Scheme	DDB_ZONE_4_START_N	Zone 4 N Start	Zone 4 N Start			*	*
741	Distance Basic Scheme	DDB_ZONE_1_START_A	Unused	Unused	*	*		
742	Distance Basic Scheme	DDB_ZONE_1_START_B	Unused	Unused	*	*		
743	Distance Basic Scheme	DDB_ZONE_1_START_C	Unused	Unused	*	*		
744	Distance Basic Scheme	DDB_ZONE_1_START_N	Unused	Unused	*	*		
745	Distance Basic Scheme	DDB_ZONE_2_START_A	Unused	Unused	*	*		
746	Distance Basic Scheme	DDB_ZONE_2_START_B	Unused	Unused	*	*		
747	Distance Basic Scheme	DDB_ZONE_2_START_C	Unused	Unused	*	*		
748	Distance Basic Scheme	DDB_ZONE_2_START_N	Unused	Unused	*	*		
749	Distance Basic Scheme	DDB_ZONE_3_START_A	Unused	Unused	*	*		
750	Distance Basic Scheme	DDB_ZONE_3_START_B	Unused	Unused	*	*		
751	Distance Basic Scheme	DDB_ZONE_3_START_C	Unused	Unused	*	*		
752	Distance Basic Scheme	DDB_ZONE_3_START_N	Unused	Unused	*	*		
753	Distance Basic Scheme	DDB_ZONE_P_START_A	Unused	Unused	*	*		
754	Distance Basic Scheme	DDB_ZONE_P_START_B	Unused	Unused	*	*		
755	Distance Basic Scheme	DDB_ZONE_P_START_C	Unused	Unused	*	*		
756	Distance Basic Scheme	DDB_ZONE_P_START_N	Unused	Unused	*	*		
757	Distance Basic Scheme	DDB_ZONE_4_START_A	Unused	Unused	*	*		
758	Distance Basic Scheme	DDB_ZONE_4_START_B	Unused	Unused	*	*		
759	Distance Basic Scheme	DDB_ZONE_4_START_C	Unused	Unused	*	*		
760	Distance Basic Scheme	DDB_ZONE_4_START_N	Unused	Unused	*	*		
761	Overcurrent	DDB_POC_1_3PH_START	1st stage overcurrent start 3 phase	I>1 Start	*	*	*	*

DDB No	Source	Element Name	Description	English Text	P543/P544 5 Inp. Distance	P544/P545 4 Inp. Distance	P543/ P545	P544/ P546
762	Overcurrent	DDB_POC_1_PH_A_START	1st stage overcurrent start phase A	I>1 Start A	*	*	*	*
763	Overcurrent	DDB_POC_1_PH_B_START	1st stage overcurrent start phase B	I>1 Start B	*	*	*	*
764	Overcurrent	DDB_POC_1_PH_C_START	1st stage overcurrent start phase C	I>1 Start C	*	*	*	*
765	Overcurrent	DDB_POC_2_3PH_START	2nd stage overcurrent start 3 phase	I>2 Start	*	*	*	*
766	Overcurrent	DDB_POC_2_PH_A_START	2nd stage overcurrent start phase A	I>2 Start A	*	*	*	*
767	Overcurrent	DDB_POC_2_PH_B_START	2nd stage overcurrent start phase B	I>2 Start B	*	*	*	*
768	Overcurrent	DDB_POC_2_PH_C_START	2nd stage overcurrent start phase C	I>2 Start C	*	*	*	*
769	Overcurrent	DDB_POC_3_3PH_START	3rd stage overcurrent start 3 phase	I>3 Start	*	*	*	*
770	Overcurrent	DDB_POC_3_PH_A_START	3rd stage overcurrent start phase A	I>3 Start A	*	*	*	*
771	Overcurrent	DDB_POC_3_PH_B_START	3rd stage overcurrent start phase B	I>3 Start B	*	*	*	*
772	Overcurrent	DDB_POC_3_PH_C_START	3rd stage overcurrent start phase C	I>3 Start C	*	*	*	*
773	Overcurrent	DDB_POC_4_3PH_START	4th stage overcurrent start 3 phase	I>4 Start	*	*	*	*
774	Overcurrent	DDB_POC_4_PH_A_START	4th stage overcurrent start phase A	I>4 Start A	*	*	*	*
775	Overcurrent	DDB_POC_4_PH_B_START	4th stage overcurrent start phase B	I>4 Start B	*	*	*	*
776	Overcurrent	DDB_POC_4_PH_C_START	4th Stage overcurrent start phase C	I>4 Start C	*	*	*	*
777	Earth Fault	DDB_EF1_1_START	1st stage stand by earth fault (SBEF) overcurrent start	IN>1 Start	*	*	*	*
778	Earth Fault	DDB_EF1_2_START	2nd stage stand by earth fault (SBEF) overcurrent start	IN>2 Start	*	*	*	*
779	Earth Fault	DDB_EF1_3_START	3rd stage stand by earth fault (SBEF) overcurrent start	IN>3 Start	*	*	*	*
780	Earth Fault	DDB_EF1_4_START	4th stage stand by earth fault (SBEF) overcurrent start	IN>4 Start	*	*	*	*
781	SW	DDB_SEF_1_START	1st stage sensitive earth fault (SEF) overcurrent start	ISEF>1 Start	*	*	*	*
782	SW	DDB_SEF_2_START	2nd stage sensitive earth fault (SEF) overcurrent start	ISEF>2 Start	*	*	*	*
783	SW	DDB_SEF_3_START	3rd stage sensitive earth fault (SEF) overcurrent start	ISEF>3 Start	*	*	*	*
784	SW	DDB_SEF_4_START	4th stage sensitive earth fault (SEF) overcurrent start	ISEF>4 Start	*	*	*	*
785	Thermal overload	DDB_THERMAL_ALARM	Thermal Overload Alarm	Thermal Alarm	*	*	*	*
786		DDB_PH_BLOCKED_OC_START	Unused	Unused	*	*	*	*
787		DDB_N_BLOCKED_OC_START	Unused	Unused	*	*	*	*
788	Undervoltage	DDB_PUV_1_3PH_START	Undervoltage stage 1, three phase start	V<1 Start	*	*	*	*
789	Undervoltage	DDB_PUV_1_PH_A_START	Undervoltage stage 1, A phase start	V<1 Start A/AB	*	*	*	*
790	Undervoltage	DDB_PUV_1_PH_B_START	Undervoltage stage 1, B phase start	V<1 Start B/BC	*	*	*	*
791	Undervoltage	DDB_PUV_1_PH_C_START	Undervoltage stage 1, C phase start	V<1 Start C/CA	*	*	*	*
792	Undervoltage	DDB_PUV_2_3PH_START	Undervoltage stage 2, three phase start	V<2 Start	*	*	*	*
793	Undervoltage	DDB_PUV_2_PH_A_START	Undervoltage stage 2, A phase start	V<2 Start A/AB	*	*	*	*
794	Undervoltage	DDB_PUV_2_PH_B_START	Undervoltage stage 2, B phase start	V<2 Start B/BC	*	*	*	*
795	Undervoltage	DDB_PUV_2_PH_C_START	Undervoltage stage 2, C phase start	V<2 Start C/CA	*	*	*	*
796	Overvoltage	DDB_POV_1_3PH_START	Overvoltage stage 1, three phase start	V>1 Start	*	*	*	*
797	Overvoltage	DDB_POV_1_PH_A_START	Overvoltage stage 1, A phase start	V>1 Start A/AB	*	*	*	*
798	Overvoltage	DDB_POV_1_PH_B_START	Overvoltage stage 1, B phase start	V>1 Start B/BC	*	*	*	*

DDB No	Source	Element Name	Description	English Text	P543/P545 No Distance	P544/P546 No Distance	P543/P545 No Distance	P544/P546 No Distance
799	Overvoltage	DDB_POV_1_PH_C_START	Overvoltage stage 1, C phase start	V>1 Start C/CA	*	*	*	*
800	Overvoltage	DDB_POV_2_3PH_START	Overvoltage stage 1, C phase start	V>2 Start	*	*	*	*
801	Overvoltage	DDB_POV_2_PH_A_START	Overvoltage stage 2, A phase start	V>2 Start A/AB	*	*	*	*
802	Overvoltage	DDB_POV_2_PH_B_START	Overvoltage stage 2, B phase start	V>2 Start B/BC	*	*	*	*
803	Overvoltage	DDB_POV_2_PH_C_START	Overvoltage stage 2, C phase start	V>2 Start C/CA	*	*	*	*
804	Residual overvoltage	DDB_RESOV_1_START	Residual overvoltage stage 1 start	VN>1 Start	*	*	*	*
805	Residual overvoltage	DDB_RESOV_2_START	Residual overvoltage stage 2 start	VN>2 Start	*	*	*	*
806	Neg Sequence overcurrent	DDB_NEGSEQOC_START	Unused	Unused	*	*	*	*
807	Phase Comparison	DDB_DELTA_I2_LOW	Delta I2 Low Start	Del I2 Lo Start				
808	Phase Comparison	DDB_DELTA_I2_HIGH	Delta I2 High Start	Del I2 Hi Start				
809	Phase Comparison	DDB_DELTA_I1_LOW	Delta I1 Low Start	Del I1 Lo Start				
810	Phase Comparison	DDB_DELTA_I1_HIGH	Delta I1 High Start	Del I1 Hi Start				
811	Phase Comparison	DDB_START_I2_LOW	Threshold I2 Low Start	I2 Lo Start				
812	Phase Comparison	DDB_START_I2_HIGH	Threshold I2 High Start	I2 Hi Start				
813	Phase Comparison	DDB_START_I1_LOW	Threshold I1 Low Start	I1 Lo Start				
814	Phase Comparison	DDB_START_I1_HIGH	Threshold I1 High Start	I1 Hi Start				
815	Phase Comparison	DDB_START_V2_LOW	V2 Low Start	V2 Lo Start				
816	Phase Comparison	DDB_START_V2_HIGH	V2 High Start	V2 Hi Start				
817	Phase Comparison	DDB_PH_Z2_LOW	Z2 Low Start (Ph-Ph)	Ph Z2 Lo Start				
818	Phase Comparison	DDB_PH_Z2_HIGH	Z2 High Start (Ph-Ph)	Ph Z2 Hi Start				
819	Phase Comparison	DDB_PH_Z3_LOW	Z3 Low Start (Ph-Ph)	Ph Z3 Lo Start				
820	Phase Comparison	DDB_PH_Z3_HIGH	Z3 High Start (Ph-Ph)	Ph Z3 Hi Start				
821	Phase Comparison	DDB_PH_Z4_LOW	Z4 Low Start (Ph-Ph)	Ph Z4 Lo Start				
822	Phase Comparison	DDB_PH_Z4_HIGH	Z4 High Start (Ph-Ph)	Ph Z4 Hi Start				
823	Phase Comparison	DDB_PH_ZP_LOW	ZP Low Start (Ph-Ph)	Ph ZP Lo Start				
824	Phase Comparison	DDB_PH_ZP_HIGH	ZP High Start (Ph-Ph)	Ph ZP Hi Start				
825	Phase Comparison	DDB_ANY_DELTA_START	Any delta current start	Any Delta Start				
826	Phase Comparison	DDB_ANY_THRESH_START	Any thesh current start	Any Thresh Start				

DDB No	Source	Element Name	Description	English Text	P543/P54 P544 Distance	P543/P54 P544 Distance	P543/ P544/ P545	P544/ P546
827	Phase Comparison	DDB_ANY_LOW_SET	Any low starter start	Any Low Set				
828	Phase Comparison	DDB_ANY_HI_SET	Any high starter start	Any High Set				
807	Phase Comparison	DDB_DELTA_I2_LOW	Unused	Unused	*	*	*	*
808	Phase Comparison	DDB_DELTA_I2_HIGH	Unused	Unused	*	*	*	*
809	Phase Comparison	DDB_DELTA_I1_LOW	Unused	Unused	*	*	*	*
810	Phase Comparison	DDB_DELTA_I1_HIGH	Unused	Unused	*	*	*	*
811	Phase Comparison	DDB_START_I2_LOW	Unused	Unused	*	*	*	*
812	Phase Comparison	DDB_START_I2_HIGH	Unused	Unused	*	*	*	*
813	Phase Comparison	DDB_START_I1_LOW	Unused	Unused	*	*	*	*
814	Phase Comparison	DDB_START_I1_HIGH	Unused	Unused	*	*	*	*
815	Phase Comparison	DDB_START_V2_LOW	Unused	Unused	*	*	*	*
816	Phase Comparison	DDB_START_V2_HIGH	Unused	Unused	*	*	*	*
817	Phase Comparison	DDB_PH_Z2_LOW	Unused	Unused	*	*	*	*
818	Phase Comparison	DDB_PH_Z2_HIGH	Unused	Unused	*	*	*	*
819	Phase Comparison	DDB_PH_Z3_LOW	Unused	Unused	*	*	*	*
820	Phase Comparison	DDB_PH_Z3_HIGH	Unused	Unused	*	*	*	*
821	Phase Comparison	DDB_PH_Z4_LOW	Unused	Unused	*	*	*	*
822	Phase Comparison	DDB_PH_Z4_HIGH	Unused	Unused	*	*	*	*
823	Phase Comparison	DDB_PH_ZP_LOW	Unused	Unused	*	*	*	*
824	Phase Comparison	DDB_PH_ZP_HIGH	Unused	Unused	*	*	*	*
825	Phase Comparison	DDB_ANY_DELTA_START	Unused	Unused	*	*	*	*
826	Phase Comparison	DDB_ANY_THRESH_START	Unused	Unused	*	*	*	*
827	Phase Comparison	DDB_ANY_LOW_SET	Unused	Unused	*	*	*	*
828	Phase Comparison	DDB_ANY_HI_SET	Unused	Unused	*	*	*	*
829	Poledead	DDB_PHASE_A_UNDERVOLTAGE	Phase A undervoltage level detector used in the pole dead logic.	VA< start	*	*	*	*
830	Poledead	DDB_PHASE_B_UNDERVOLTAGE	Phase B undervoltage level detector used in the pole dead logic.	VB< start	*	*	*	*

DDB No	Source	Element Name	Description	English Text	P543/P545 No	P544/P546 Distance	P543/P545 No	P544/P546 Distance	P543/P545	P544/P546
831	Poledead	DDB_PHASE_C_UNDERVOLTAGE	Phase C undervoltage level detector used in the pole dead logic.	VC< start	*	*	*	*	*	*
832	VT Supervision	DDB_VTS_FAST_BLOCK	VT supervision fast block - blocks elements which would otherwise maloperate immediately a fuse failure event occurs	VTS Fast Block	*	*	*	*	*	*
833	VT Supervision	DDB_VTS_SLOW_BLOCK	VT supervision slow block - blocks elements which would otherwise maloperate some time after a fuse failure event occurs	VTS Slow Block	*	*	*	*	*	*
834	CB Fail	DDB_CBF1_TRIP_3PH	tBF1 trip 3Ph - three phase output from circuit breaker failure logic, stage 1	CBfail1 Trip 3ph	*		*			
835	CB Fail	DDB_CBF2_TRIP_3PH	tBF2 trip 3Ph - three phase output from circuit breaker failure logic, stage 2	CBfail2 Trip 3ph	*		*			
834	CB Fail	DDB_CBF1_TRIP_3PH	CBfail1 Trip 3ph	CB1 Fail1 Trip		*			*	
835	CB Fail	DDB_CBF2_TRIP_3PH	CBfail2 Trip 3ph	CB1 Fail2 Trip		*			*	
836	CB Fail	DDB_CB2F1_TRIP_3PH	tBF1 trip 3Ph - three phase output from circuit breaker failure 2 logic, stage 1	CB2 Fail1 Trip		*			*	
837	CB Fail	DDB_CB2F2_TRIP_3PH	tBF2 trip 3Ph - three phase output from circuit breaker failure 2 logic, stage 2	CB2 Fail2 Trip		*			*	
836	CB Fail	DDB_CB2F1_TRIP_3PH	Unused	Unused	*		*			
837	CB Fail	DDB_CB2F2_TRIP_3PH	Unused	Unused	*		*			
838	CB Control	DDB_CONTROL_TRIP	Control trip - operator trip instruction to the circuit breaker, via menu, or SCADA. (Does not operate for protection element trips)	Control Trip	*		*			
839	CB Control	DDB_CONTROL_CLOSE	Control close command to the circuit breaker. Operates for a manual close command (menu, SCADA), and additionally is driven by the auto-reclose close command	Control Close	*		*			
838	CB Control	DDB_CONTROL_TRIP	Control trip - operator trip instruction to circuit breaker 1, via menu, or SCADA. (Does not operate for protection element trips)	Control TripCB1		*			*	
839	CB Control	DDB_CONTROL_CLOSE	Control close command to circuit breaker 1. Operates for a manual close command (menu, SCADA), and additionally is driven by the auto-reclose close command	Control CloseCB1		*			*	
840	CB Control	DDB_CONTROL_TRIP_2	Control trip - operator trip instruction to circuit breaker 2, via menu, or SCADA. (Does not operate for protection element trips)	Control TripCB2		*			*	
841	CB Control	DDB_CONTROL_CLOSE_2	Control close command to circuit breaker 2. Operates for a manual close command (menu, SCADA), and additionally is driven by the auto-reclose close command	Control CloseCB2		*			*	
840	CB Control	DDB_CONTROL_TRIP_2	Unused	Unused	*		*			
841	CB Control	DDB_CONTROL_CLOSE_2	Unused	Unused	*		*			
842	CB Control	DDB_CONTROL_CLOSE_IN_PROGRESS	Control close in progress - the relay has been given an instruction to close the circuit breaker, but the manual close timer delay has not yet finished timing out	Close in Prog	*		*			
842	CB Control	DDB_CONTROL_CLOSE_IN_PROGRESS	Control Close in Progress	CB1 Close inProg		*			*	

DDB No	Source	Element Name	Description	English Text	P543P54 5 No. Distance	P544P54 4 No. Distance	P543/ P545	P544/ P546
843	Autoreclose	DDB_AR_BLOCK_MAIN_PROTECTION	AR Block Main Protection. In P841 etc, there is no specific output DDB to block selected protection functions. If such a feature is required for a particular application, appropriate mapping should be created in PSL, using output DDBs from sequence counter, single phase dead time and three phase dead time logic as required.	Block Main Prot	*	*	*	*
844	Autoreclose	DDB_AR_3_POLE_IN_PROGRESS	Auto-reclose 3 pole in progress (dead time is running)	AR 3pole in prog	*		*	
844	Autoreclose	DDB_AR_3_POLE_IN_PROGRESS	CB1 Auto Reclose/(AR 3 pole) in Progress	CB1 AR 3p InProg		*		*
845	Autoreclose	DDB_AR_1_POLE_IN_PROGRESS	Single pole auto-reclose in progress (dead time is running)	AR 1pole in prog	*		*	
845	Autoreclose	DDB_AR_1_POLE_IN_PROGRESS	CB1 AR 1pole in progress	CB1 AR 1p InProg		*		*
845	Autoreclose	DDB_AR_1_POLE_IN_PROGRESS	Unused	Unused				
846	Autoreclose	DDB_SEQ_COUNT_0	Auto-reclose sequence counter is at zero - no previous faults have been cleared within recent history. The sequence count is at zero because no reclaim times are timing out, and the auto-recloser is not locked out. The recloser is awaiting the first protection trip, and all programmed cycles are free to follow	Seq Counter = 0	*	*	*	*
847	Autoreclose	DDB_SEQ_COUNT_1	The first fault trip has happened in a new auto-reclose sequence. Dead time 1, or reclaim time 1 are in the process of timing out	Seq Counter = 1	*	*	*	*
848	Autoreclose	DDB_SEQ_COUNT_2	Auto-reclose sequence counter is at 2. This means that the initial fault trip happened, and then another trip followed, moving the counter on to 2	Seq Counter = 2	*	*	*	*
849	Autoreclose	DDB_SEQ_COUNT_3	Auto-reclose sequence counter is at 3. This means that the initial fault trip happened, and then 2 trips followed, moving the counter on to 3	Seq Counter = 3	*	*	*	*
850	Autoreclose	DDB_SEQ_COUNT_4	Auto-reclose sequence counter is at 4. This means that the initial fault trip happened, and then 3 trips followed, moving the counter on to 4	Seq Counter = 4	*	*	*	*
851	Autoreclose	DDB_SEQ_COUNT_5	Seq Counter = 5 (In 2CB AR, there is no output specifically for seq counter = 5. However there is a DDB output for Seq Counter > 4. may need a different allocation for DDB#851 in 2CB AR scheme.	Seq Counter = 5	*	*	*	*
852	Autoreclose	DDB_AR_SUCCESSFUL_RECLOSE	This signal is set when CB has successfully completed a three phase autoreclose cycle.	CB Succ 3P AR	*		*	
852	Autoreclose	DDB_AR_SUCCESSFUL_RECLOSE	This signal is set when CB1 has successfully completed a three phase autoreclose cycle.	CB1 Succ 3P AR		*		*
853	Autoreclose	DDB_DEAD_TIME_IN_PROGRESS	2CB logic provides separate output DDBs indicating (i) single phase dead time in progress, (ii) three phase dead time in progress (all shots), (iii) 3 ph 1st shot dead time in progress, (iv) 3 ph 2nd shot dead time in progress, (v) 3 ph 3rd shot dead time in progress, (vi) 3 ph 4th shot dead time in progress.	3P Dead Time IP		*		*
853	Autoreclose	DDB_DEAD_TIME_IN_PROGRESS	Unused	Unused	*		*	

DDB No	Source	Element Name	Description	English Text	P543/P545 No Distance	P544/P546 No Distance	P543/ P545	P544/ P546
854	Autoreclose	DDB_AUTO_CLOSE	Auto-reclose command to the circuit breaker	Auto Close	*		*	
854	Autoreclose	DDB_AUTO_CLOSE	This is a signal issued by the autoreclose logic to the general CB1 Control logic when the conditions to autoreclose CB1 are satisfied (dead time complete, CB healthy etc).	Auto Close CB1		*		*
855	Autoreclose	DDB_AR_1_POLE_IN_PROGRESS_2	Single pole auto-reclose in progress (dead time is running) CB2	CB2 AR 1p InProg		*		*
855	Autoreclose	DDB_UNUSED_855	Unused	Unused	*		*	
856	Autoreclose	DDB_AR_IN_SERVICE_3P	3 Pole auto-recloser in service - the auto-reclose function has been enabled either in the relay menu, or by an opto input	A/R Status 3P	*	*	*	*
857	Autoreclose	DDB_AR_IN_SERVICE_1P	Single pole auto-recloser in service - the auto-reclose function has been enabled either in the relay menu, or by an opto input	A/R Status 1P	*	*	*	*
858	Autoreclose	DDB_AR_FORCE_3_POLE_TRIPS	Due to the sequence count reached, lockout, or any outage of the internal auto-recloser - this signal instructs any other trips to be forced to three pole trips	AR Force 3 pole	*		*	
858	Autoreclose	DDB_AR_FORCE_3_POLE_TRIPS	This DDB is set when the autoreclose logic has determined that single pole tripping/autoreclosing is not permitted for CB1. It can be applied in PSL when required to force trip conversion logic for internal and/or external protection to three phase trip mode for CB1.	AR Force CB1 3P		*		*
857	Autoreclose	DDB_AR_IN_SERVICE_1P	Unused	Unused				
858	Autoreclose	DDB_AR_FORCE_3_POLE_TRIPS	Unused	Unused				
859	Autoreclose	DDB_AR_BLOCKED	It indicates that AR has been blocked (ex. from external input BAR)	AR Blocked	*	*	*	*
860	CB Control	DDB_CB_LOCKOUT_ALARM	Composite lockout alarm - circuit breaker locked out due to auto-recloser, or condition monitoring reasons	Lockout Alarm	*		*	
860	CB Control	DDB_CB_LOCKOUT_ALARM	Composite Lockout Alarm - circuit breaker locked out due to auto-recloser, or condition monitoring	CB1 LO Alarm		*		*
861	C Diff	DDB_LOCAL_GPS_FAIL_INST	Instantaneous GPS Alarm initiated immediately on loss of the GPS 1 pulse per second input signal	GPSAlarm Instant	*	*	*	*
861	C Diff	DDB_LOCAL_GPS_FAIL_INST	Unused	Unused				
862	IRIG-B Inmon	DDB_IRIGB_SIGNAL_VALID	IRIG-B Status Signal Valid	IRIG-B Valid	*	*	*	*
863	SW	DDB_LOGIC_0	Logic 0 for use in PSL. This can be used to force a DDB, contact, LED, InterMiCOM or Virtual Output low (or high by using an inversion gate)	Logic 0 Ref.	*	*	*	*
864	Undercurrent	DDB_PHASE_A_UNDERCURRENT	A phase undercurrent level detector pickup (detects low current). It is used for breaker failure in models with one CT input and also it is used for fault record reset (as the sum CTs in models with two CTs)	IA< Start	*	*	*	*
865	Undercurrent	DDB_PHASE_B_UNDERCURRENT	B phase undercurrent level detector pickup (detects low current). It is used for breaker failure in models with one CT input and also it is used for fault record reset (as the sum CTs in models with two CTs)	IB< Start	*	*	*	*

DDB No	Source	Element Name	Description	English Text	P543/P54 N No. Distance	P544/P54 N No. Distance	P543/ P544/ P545	P544/ P546
866	Undercurrent	DDB_PHASE_C_UNDERCURRENT	C phase undercurrent level detector pickup (detects low current). It is used for breaker failure in models with one CT input and also it is used for fault record reset (as the sum CTs in models with two CTs)	IC< Start	*	*	*	*
867	Undercurrent	DDB_PHASE_A_UNDERCURRENT_CB1	A phase undercurrent level detector pickup (detects low current in CT1). It is used for breaker failure in models with two CT inputs	CB1 IA< Start		*		*
868	Undercurrent	DDB_PHASE_B_UNDERCURRENT_CB1	B phase undercurrent level detector pickup (detects low current in CT1). It is used for breaker failure in models with two CT inputs	CB1 IB< Start		*		*
869	Undercurrent	DDB_PHASE_C_UNDERCURRENT_CB1	C phase undercurrent level detector pickup (detects low current in CT1). It is used for breaker failure in models with two CT inputs	CB1 IC< Start		*		*
870	Undercurrent	DDB_PHASE_A_UNDERCURRENT_CB2	A phase undercurrent level detector pickup (detects low current in CT2). It is used for breaker failure in models with two CT inputs	CB2 IA< Start		*		*
871	Undercurrent	DDB_PHASE_B_UNDERCURRENT_CB2	B phase undercurrent level detector pickup (detects low current in CT2). It is used for breaker failure in models with two CT inputs	CB2 IB< Start		*		*
872	Undercurrent	DDB_PHASE_C_UNDERCURRENT_CB2	C phase undercurrent level detector pickup (detects low current in CT2). It is used for breaker failure in models with two CT inputs	CB2 IC< Start		*		*
867	Undercurrent	DDB_PHASE_A_UNDERCURRENT_CB1	Unused	Unused	*		*	
868	Undercurrent	DDB_PHASE_B_UNDERCURRENT_CB1	Unused	Unused	*		*	
869	Undercurrent	DDB_PHASE_C_UNDERCURRENT_CB1	Unused	Unused	*		*	
870	Undercurrent	DDB_PHASE_A_UNDERCURRENT_CB2	Unused	Unused	*		*	
871	Undercurrent	DDB_PHASE_B_UNDERCURRENT_CB2	Unused	Unused	*		*	
872	Undercurrent	DDB_PHASE_C_UNDERCURRENT_CB2	Unused	Unused	*		*	
873	Undercurrent	DDB_SEF_UNDERCURRENT	SEF undercurrent level detector pickup (detects low current in CT SEF)	ISEF< Start	*	*	*	*
874	Undercurrent	DDB_UNUSED_874	Unused	Unused	*	*	*	*
875	Undercurrent	DDB_UNUSED_875	Unused	Unused	*	*	*	*
876	Zone 1 Extension Scheme	DDB_ZONE1_EXT_ACTIVE	Zone 1 extension active - zone 1 is operating in its reach extended mode	Z1X Active			*	*
877	Trip on Close	DDB_TOC_ACTIVE	Trip on close functions (either SOTF or TOR) active. These elements are in-service for a period of time following circuit breaker closure	TOC Active			*	*
878	Trip on Close	DDB_TOR_ACTIVE	Trip on re-close protection is active - indicated TOC delay timer has elapsed after circuit breaker opening, and remains in-service on auto-reclosure for the duration of the trip on close window	TOR Active			*	*
879	Trip on Close	DDB_SOTF_ACTIVE	Switch on to fault protection is active - in service on manual breaker closure, and then remains in-service for the duration of the trip on close window	SOTF Active			*	*
876	Zone 1 Extension Scheme	DDB_ZONE1_EXT_ACTIVE	Unused	Unused	*	*		
877	Trip on Close	DDB_TOC_ACTIVE	Unused	Unused	*	*		
878	Trip on Close	DDB_TOR_ACTIVE	Unused	Unused	*	*		

DDB No	Source	Element Name	Description	English Text	P543/P545 No	P544/P546 Distance	P543/P545 No	P544/P546 Distance	P543/P545	P544/P546
879	Trip on Close	DDB_SOTF_ACTIVE	Unused	Unused	*	*				
880	Check sync	DDB_SYSCHECKS_INACTIVE	System checks inactive (output from the check synchronism, and other voltage checks)	SysChks Inactive	*			*		
881	PSL	DDB_CHECKSYNC_1_ENABLED	Check sync. stage 1 enabled	CS1 Enabled	*			*		
882	PSL	DDB_CHECKSYNC_2_ENABLED	Check sync. stage 2 enabled	CS2 Enabled	*			*		
883	Check sync	DDB_CHECKSYNC_1_OK	Check sync. stage 1 OK	Check Sync 1 OK	*			*		
884	Check sync	DDB_CHECKSYNC_2_OK	Check sync. stage 2 OK	Check Sync 2 OK	*			*		
880	Check sync	DDB_SYSCHECKS_INACTIVE	Output from CB1 system check logic: indicates system checks for CB1 are disabled (setting "System Checks CB1" = Disabled or global setting "System Checks" = Disabled)+D2269	SChksInactiveCB1			*		*	
881	PSL	DDB_CHECKSYNC_1_ENABLED	DDB input must be high to enable CB1 check sync 1 logic to operate. Defaults to high if not mapped in PSL; if mapped in PSL must be driven high.	CB1 CS1 Enabled			*		*	
882	PSL	DDB_CHECKSYNC_2_ENABLED	DDB input must be high to enable CB1 check sync 2 logic to operate. Defaults to high if not mapped in PSL; if mapped in PSL must be driven high.	CB1 CS2 Enabled			*		*	
883	Check sync	DDB_CHECKSYNC_1_OK	Output from CB1 Check Sync logic, when enabled: indicates set conditions for CB1 sync check type 1 are satisfied.	CB1 CS1 OK			*		*	
884	Check sync	DDB_CHECKSYNC_2_OK	Output from CB1 Check Sync logic, when enabled: indicates set conditions for CB1 sync check type 2 are satisfied.	CB1 CS2 OK			*		*	
885	PSL	DDB_SYSTEM_SPLIT_ENABLED	Unused	Unused	*	*	*	*	*	*
886	Voltage Monitoring	DDB_SYSCHECKS_BUS_LIVE	Indicates live bus condition is detected	Live Bus	*			*		
887	Voltage Monitoring	DDB_SYSCHECKS_BUS_DEAD	Indicates dead bus condition is detected	Dead Bus	*			*		
886	Voltage Monitoring	DDB_SYSCHECKS_BUS_LIVE	Indicates Bus 1 input is live, i.e. voltage >= setting "Live Bus 1"	Live Bus 1			*		*	
887	Voltage Monitoring	DDB_SYSCHECKS_BUS_DEAD	Indicates Bus 1 input is dead, i.e. voltage < setting "Dead Bus 1"	Dead Bus 1			*		*	
888	Voltage Monitoring	DDB_SYSCHECKS_LINE_LIVE	Indicates live line condition is detected	Live Line	*	*	*	*	*	*
889	Voltage Monitoring	DDB_SYSCHECKS_LINE_DEAD	Indicates dead line condition is detected	Dead Line	*	*	*	*	*	*
890	Poledead logic	DDB_ALL_POLEDEAD	Pole dead logic detects 3 phase breaker open	All Poles Dead	*	*	*	*	*	*
891	Poledead logic	DDB_ANY_POLEDEAD	Pole dead logic detects at least one breaker pole open	Any Pole Dead	*	*	*	*	*	*
892	Poledead logic	DDB_PHASE_A_POLEDEAD	Phase A Pole Dead	Pole Dead A	*	*	*	*	*	*
893	Poledead logic	DDB_PHASE_B_POLEDEAD	Phase B Pole Dead	Pole Dead B	*	*	*	*	*	*
894	Poledead logic	DDB_PHASE_C_POLEDEAD	Phase C Pole Dead	Pole Dead C	*	*	*	*	*	*
895	Fixed Logic	DDB_VTS_ACCELERATE_INPUT	Accelerate Ind	VTS Acc Ind	*	*	*	*	*	*
896	Fixed Logic	DDB_VTS_ANY_VOLTAGE_DEP_FN	Any Voltage Dependent	VTS Volt Dep	*	*	*	*	*	*
897	PSL	DDB_SYNC_AR_CS_CHECK_OK	Input to the auto-reclose logic to indicate system in synchronism	AR Check Sync OK	*	*	*	*	*	*

DDB No	Source	Element Name	Description	English Text	P543/P54 N No. Distance	P544/P54 N No. Distance	P543/ P544/ P545	P544/ P546
898	PSL	DDB_SYNC_CTRL_SYS_CHECK_OK	Input to the circuit breaker control logic to indicate manual check synchronization conditions are satisfied	Ctrl Check Sync	*	*	*	*
899	PSL	DDB_SYNC_AR_SYS_CHECK_OK	Input to the auto-reclose logic to indicate system checks conditions are satisfied	AR Sys Checks OK	*	*	*	*
900	PSL	DDB_CB1_EXT_CS_OK	External check-sync is OK for CB1	CB1 Ext CS OK	*	*	*	*
901	PSL	DDB_CB2_EXT_CS_OK	External check-sync is OK for CB2	CB2 Ext CS OK		*		*
901	PSL	DDB_CB2_EXT_CS_OK	Unused	Unused	*		*	
902	PSL	DDB_UNUSED_902	Unused	Unused	*	*	*	*
903	CB Status	DDB_CB_OPEN	Circuit breaker is open, all three phases	CB Open 3 ph	*		*	
904	CB Status	DDB_CB_PHASE_A_OPEN	Circuit breaker A phase is open	CB Open A ph	*		*	
905	CB Status	DDB_CB_PHASE_B_OPEN	Circuit breaker B phase is open	CB Open B ph	*		*	
906	CB Status	DDB_CB_PHASE_C_OPEN	Circuit breaker C phase is open	CB Open C ph	*		*	
904	CB Status	DDB_CB_PHASE_A_OPEN	Unused	Unused				
905	CB Status	DDB_CB_PHASE_B_OPEN	Unused	Unused				
906	CB Status	DDB_CB_PHASE_C_OPEN	Unused	Unused				
907	CB Status	DDB_CB_CLOSED	Circuit breaker is closed, all three phases	CB Closed 3 ph	*		*	
908	CB Status	DDB_CB_PHASE_A_CLOSED	Circuit breaker A phase is closed	CB Closed A ph	*		*	
909	CB Status	DDB_CB_PHASE_B_CLOSED	Circuit breaker B phase is closed	CB Closed B ph	*		*	
910	CB Status	DDB_CB_PHASE_C_CLOSED	Circuit breaker C phase is closed	CB Closed C ph	*		*	
908	CB Status	DDB_CB_PHASE_A_CLOSED	Unused	Unused				
909	CB Status	DDB_CB_PHASE_B_CLOSED	Unused	Unused				
910	CB Status	DDB_CB_PHASE_C_CLOSED	Unused	Unused				
903	CB Status	DDB_CB_OPEN	CB1 Open 3 ph	CB1 Open 3 ph		*		*
904	CB Status	DDB_CB_PHASE_A_OPEN	CB1 Open A ph	CB1 Open A ph		*		*
905	CB Status	DDB_CB_PHASE_B_OPEN	CB1 Open B ph	CB1 Open B ph		*		*
906	CB Status	DDB_CB_PHASE_C_OPEN	CB1 Open C ph	CB1 Open C ph		*		*
907	CB Status	DDB_CB_CLOSED	CB1 Closed 3 ph	CB1 Closed 3 ph		*		*
908	CB Status	DDB_CB_PHASE_A_CLOSED	CB1 Closed A ph	CB1 Closed A ph		*		*
909	CB Status	DDB_CB_PHASE_B_CLOSED	CB1 Closed B ph	CB1 Closed B ph		*		*
910	CB Status	DDB_CB_PHASE_C_CLOSED	CB1 Closed C ph	CB1 Closed C ph		*		*
911	CB Status	DDB_CB2_OPEN	Circuit breaker 2 is open, all three phases	CB2 Open 3 ph		*		*
912	CB Status	DDB_CB2_PHASE_A_OPEN	Circuit breaker 2 A phase is open	CB2 Open A ph		*		*
913	CB Status	DDB_CB2_PHASE_B_OPEN	Circuit breaker 2 A phase is open	CB2 Open B ph		*		*
914	CB Status	DDB_CB2_PHASE_C_OPEN	Circuit breaker 2 A phase is open	CB2 Open C ph		*		*
915	CB Status	DDB_CB2_CLOSED	Circuit breaker 2 is closed, all three phases	CB2 Closed 3 ph		*		*
916	CB Status	DDB_CB2_PHASE_A_CLOSED	Circuit breaker 2 A phase is closed	CB2 Closed A ph		*		*
917	CB Status	DDB_CB2_PHASE_B_CLOSED	Circuit breaker 2 B phase is closed	CB2 Closed B ph		*		*
918	CB Status	DDB_CB2_PHASE_C_CLOSED	Circuit breaker 2 C phase is closed	CB2 Closed C ph		*		*
911		DDB_CB2_OPEN	Unused	Unused	*		*	
912		DDB_CB2_PHASE_A_OPEN	Unused	Unused	*		*	
913		DDB_CB2_PHASE_B_OPEN	Unused	Unused	*		*	
914		DDB_CB2_PHASE_C_OPEN	Unused	Unused	*		*	
915		DDB_CB2_CLOSED	Unused	Unused	*		*	
916		DDB_CB2_PHASE_A_CLOSED	Unused	Unused	*		*	

DDB No	Source	Element Name	Description	English Text	P543/P545 No Distance	P544/P546 No Distance	P543/P545 No Distance	P544/P546 No Distance
917		DDB_CB2_PHASE_B_CLOSED	Unused	Unused	*		*	
918		DDB_CB2_PHASE_C_CLOSED	Unused	Unused	*		*	
919	PSL	DDB_INHIBIT_COMP_OV1	Inhibit the first stage compensated overvoltage element	Inhibit Cmp V1>1	*	*	*	*
920	PSL	DDB_INHIBIT_COMP_OV2	Inhibit the second stage compensated overvoltage element	Inhibit Cmp V1>2	*	*	*	*
921	PSL	DDB_PCOV_1_TIMER_BLOCK	Block the first stage compensated overvoltage element	Cmp V1>1 Tim Blk	*	*	*	*
922	PSL	DDB_PCOV_2_TIMER_BLOCK	Block the second stage compensated overvoltage element	Cmp V1>2 Tim Blk	*	*	*	*
923	Overvoltage	DDB_PCOV_1_3PH_START	1st stage compensated overvoltage start signal	V1>1 Cmp Start	*	*	*	*
924	Overvoltage	DDB_PCOV_2_3PH_START	2nd stage compensated overvoltage start signal	V1>2 Cmp Start	*	*	*	*
925	Overvoltage	DDB_PCOV_1_3PH_TRIP	1st stage compensated overvoltage trip signal	V1>1 Cmp Trip	*	*	*	*
926	Overvoltage	DDB_PCOV_2_3PH_TRIP	2nd stage compensated overvoltage trip signal	V1>2 Cmp Trip	*	*	*	*
927		DDB_UNUSED_927	Unused	Unused	*	*	*	*
928		DDB_CTS_BLOCK	Standard or differential CT supervision block (current transformer supervision)	CTS Block	*	*	*	*
929	CT Supervision	DDB_CTS_BLOCK_DIFF	Differential CT supervision block (current transformer supervision)	CTS Block Diff	*	*	*	*
930	CT Supervision	DDB_CTS_RESTRAIN	Differential CT supervision restrain (current transformer supervision)	CTS Restrain	*	*	*	*
931	CT Supervision	DDB_CTS_L1_I1	Positive sequence current in local end CT1 exceed CTS i1> setting	CT1 L i1>	*	*	*	*
932	CT Supervision	DDB_CTS_L2_I1	Positive sequence current in local end CT2 exceed CTS i1> setting	CT2 L i1>		*		*
932	CT Supervision	DDB_CTS_L2_I1	Unused	Unused	*		*	
933	CT Supervision	DDB_CTS_R1_1_I1	Positive sequence current in remote 1 end CT1 exceed CTS i1> setting	CT1 R1 i1>	*	*	*	*
934	CT Supervision	DDB_CTS_R1_2_I1	Positive sequence current in remote 1 end CT2 exceed CTS i1> setting	CT2 R1 i1>	*	*	*	*
935	CT Supervision	DDB_CTS_R2_1_I1	Positive sequence current in remote 2 end CT1 exceed CTS i1> setting	CT1 R2 i1>	*	*	*	*
936	CT Supervision	DDB_CTS_R2_2_I1	Positive sequence current in remote 2 end CT2 exceed CTS i1> setting	CT2 R2 i1>	*	*	*	*
937	CT Supervision	DDB_CTS_L1_I2/I1_L	i2/i1 ratio in local end CT1 exceed CTS i2/i1> setting	CT1 L i2/i1>	*	*	*	*
938	CT Supervision	DDB_CTS_L2_I2/I1_L	i2/i1 ratio in local end CT2 exceed CTS i2/i1> setting	CT2 L i2/i1>		*		*
938	CT Supervision	DDB_CTS_L2_I2/I1_L	Unused	Unused	*		*	
939	CT Supervision	DDB_CTS_R1_1_I2/I1_L	i2/i1 ratio in remote 1 end CT1 exceed CTS i2/i1> setting	CT1 R1 i2/i1>	*	*	*	*
940	CT Supervision	DDB_CTS_R1_2_I2/I1_L	i2/i1 ratio in remote 1 end CT2 exceed CTS i2/i1> setting	CT2 R1 i2/i1>	*	*	*	*
941	CT Supervision	DDB_CTS_R2_1_I2/I1_L	i2/i1 ratio in remote 2 end CT1 exceed CTS i2/i1> setting	CT1 R2 i2/i1>	*	*	*	*
942	CT Supervision	DDB_CTS_R2_2_I2/I1_L	i2/i1 ratio in remote 2 end CT2 exceed CTS i2/i1> setting	CT2 R2 i2/i1>	*	*	*	*

DDB No	Source	Element Name	Description	English Text	P543/P544 Distance	P544/P545 Distance	P543/ P545	P544/ P546
943	CT Supervision	DDB_CTS_L1_I2I1_H	i2/i1 ratio in local end CT1 exceed CTS i2/i1>> setting	CT1 L i2/i1>>	*	*	*	*
944	CT Supervision	DDB_CTS_L2_I2I1_H	i2/i1 ratio in local end CT2 exceed CTS i2/i1>> setting	CT2 L i2/i1>>		*		*
944	CT Supervision	DDB_CTS_L2_I2I1_H	Unused	Unused	*		*	
945	CT Supervision	DDB_CTS_R1_1_I2I1_H	i2/i1 ratio in remote 1 end CT1 exceed CTS i2/i1>> setting	CT1 R1 i2/i1>>	*	*	*	*
946	CT Supervision	DDB_CTS_R1_2_I2I1_H	i2/i1 ratio in remote 1 end CT2 exceed CTS i2/i1>> setting	CT2 R1 i2/i1>>	*	*	*	*
947	CT Supervision	DDB_CTS_R2_1_I2I1_H	i2/i1 ratio in remote 2 end CT1 exceed CTS i2/i1>> setting	CT1 R2 i2/i1>>	*	*	*	*
948	CT Supervision	DDB_CTS_R2_2_I2I1_H	i2/i1 ratio in remote 2 end CT2 exceed CTS i2/i1>> setting	CT2 R2 i2/i1>>	*	*	*	*
929	CT Supervision	DDB_CTS_BLOCK_DIFF	Unused	Unused				
930	CT Supervision	DDB_CTS_RESTRAIN	Unused	Unused				
931	CT Supervision	DDB_CTS_L1_I1	Unused	Unused				
932	CT Supervision	DDB_CTS_L2_I1	Unused	Unused				
933	CT Supervision	DDB_CTS_R1_1_I1	Unused	Unused				
934	CT Supervision	DDB_CTS_R1_2_I1	Unused	Unused				
935	CT Supervision	DDB_CTS_R2_1_I1	Unused	Unused				
936	CT Supervision	DDB_CTS_R2_2_I1	Unused	Unused				
937	CT Supervision	DDB_CTS_L1_I2I1_L	Unused	Unused				
938	CT Supervision	DDB_CTS_L2_I2I1_L	Unused	Unused				
939	CT Supervision	DDB_CTS_R1_1_I2I1_L	Unused	Unused				
940	CT Supervision	DDB_CTS_R1_2_I2I1_L	Unused	Unused				
941	CT Supervision	DDB_CTS_R2_1_I2I1_L	Unused	Unused				
942	CT Supervision	DDB_CTS_R2_2_I2I1_L	Unused	Unused				
943	CT Supervision	DDB_CTS_L1_I2I1_H	Unused	Unused				
944	CT Supervision	DDB_CTS_L2_I2I1_H	Unused	Unused				
945	CT Supervision	DDB_CTS_R1_1_I2I1_H	Unused	Unused				
946	CT Supervision	DDB_CTS_R1_2_I2I1_H	Unused	Unused				
947	CT Supervision	DDB_CTS_R2_1_I2I1_H	Unused	Unused				
948	CT Supervision	DDB_CTS_R2_2_I2I1_H	Unused	Unused				
949		DDB_UNUSED_949	Unused	Unused	*	*	*	*
950		DDB_UNUSED_950	Unused	Unused	*	*	*	*
951		DDB_UNUSED_951	Unused	Unused	*	*	*	*
952	PSL	DDB_FLTREC_FLT_A	Faulted phase A - must be assigned, as this sets the start flag used in records, and on the LCD display	Faulted Phase A	*	*	*	*
953	PSL	DDB_FLTREC_FLT_B	Faulted phase B - must be assigned, as this sets the start flag used in records, and on the LCD display	Faulted Phase B	*	*	*	*
954	PSL	DDB_FLTREC_FLT_C	Faulted phase C - must be assigned, as this sets the start flag used in records, and on the LCD display	Faulted Phase C	*	*	*	*
955	PSL	DDB_FLTREC_FLT_N	Faulted phase N (fault involves ground) - must be assigned, as this sets the start flag used in records, and on the LCD display	Faulted Phase N	*	*	*	*

DDB No	Source	Element Name	Description	English Text	P543/P545 No Distance	P544/P546 No Distance	P543/P545 No Distance	P544/P546 No Distance
956	PSL	DDB_FLTREC_STRT_A	Started phase A - must be assigned, as this sets the start flag used in records, and on the LCD display	Started Phase A	*	*	*	*
957	PSL	DDB_FLTREC_STRT_B	Started phase B - must be assigned, as this sets the start flag used in records, and on the LCD display	Started Phase B	*	*	*	*
958	PSL	DDB_FLTREC_STRT_C	Started phase C - must be assigned, as this sets the start flag used in records, and on the LCD display	Started Phase C	*	*	*	*
959	PSL	DDB_FLTREC_STRT_N	Started phase N (fault involves ground) - must be assigned, as this sets the start flag used in records, and on the LCD display	Started Phase N	*	*	*	*
960	Distance Elements	DDB_ZONE_1_AN	Zone 1 AN ground fault element	Zone1 AN Element			*	*
961	Distance Elements	DDB_ZONE_1_BN	Zone 1 BN ground fault element	Zone1 BN Element			*	*
962	Distance Elements	DDB_ZONE_1_CN	Zone 1 CN ground fault element	Zone1 CN Element			*	*
963	Distance Elements	DDB_ZONE_1_AB	Zone 1 AB phase fault element	Zone1 AB Element			*	*
964	Distance Elements	DDB_ZONE_1_BC	Zone 1 BC phase fault element	Zone1 BC Element			*	*
965	Distance Elements	DDB_ZONE_1_CA	Zone 1 CA phase fault element	Zone1 CA Element			*	*
966	Distance Elements	DDB_ZONE_2_AN	Zone 2 AN ground fault element	Zone2 AN Element			*	*
967	Distance Elements	DDB_ZONE_2_BN	Zone 2 BN ground fault element	Zone2 BN Element			*	*
968	Distance Elements	DDB_ZONE_2_CN	Zone 2 CN ground fault element	Zone2 CN Element			*	*
969	Distance Elements	DDB_ZONE_2_AB	Zone 2 AB phase fault element	Zone2 AB Element			*	*
970	Distance Elements	DDB_ZONE_2_BC	Zone 2 BC phase fault element	Zone2 BC Element			*	*
971	Distance Elements	DDB_ZONE_2_CA	Zone 2 CA phase fault element	Zone2 CA Element			*	*
972	Distance Elements	DDB_ZONE_3_AN	Zone 3 AN ground fault element	Zone3 AN Element			*	*
973	Distance Elements	DDB_ZONE_3_BN	Zone 3 BN ground fault element	Zone3 BN Element			*	*
974	Distance Elements	DDB_ZONE_3_CN	Zone 3 CN ground fault element	Zone3 CN Element			*	*
975	Distance Elements	DDB_ZONE_3_AB	Zone 3 AB phase fault element	Zone3 AB Element			*	*
976	Distance Elements	DDB_ZONE_3_BC	Zone 3 BC phase fault element	Zone3 BC Element			*	*
977	Distance Elements	DDB_ZONE_3_CA	Zone 3 CA phase fault element	Zone3 CA Element			*	*
978	Distance Elements	DDB_ZONE_P_AN	Zone P AN ground fault element	ZoneP AN Element			*	*
979	Distance Elements	DDB_ZONE_P_BN	Zone P BN ground fault element	ZoneP BN Element			*	*

DDB No	Source	Element Name	Description	English Text	P543P54 Yn5 Distance	P544P54 Yn5 Distance	P545/ P545	P544/ P546
980	Distance Elements	DDB_ZONE_P_CN	Zone P CN ground fault element	ZoneP CN Element			*	*
981	Distance Elements	DDB_ZONE_P_AB	Zone P AB phase fault element	ZoneP AB Element			*	*
982	Distance Elements	DDB_ZONE_P_BC	Zone P BC phase fault element	ZoneP BC Element			*	*
983	Distance Elements	DDB_ZONE_P_CA	Zone P CA phase fault element	ZoneP CA Element			*	*
984	Distance Elements	DDB_ZONE_4_AN	Zone 4 AN ground fault element	Zone4 AN Element			*	*
985	Distance Elements	DDB_ZONE_4_BN	Zone 4 BN ground fault element	Zone4 BN Element			*	*
986	Distance Elements	DDB_ZONE_4_CN	Zone 4 CN ground fault element	Zone4 CN Element			*	*
987	Distance Elements	DDB_ZONE_4_AB	Zone 4 AB phase fault element	Zone4 AB Element			*	*
988	Distance Elements	DDB_ZONE_4_BC	Zone 4 BC phase fault element	Zone4 BC Element			*	*
989	Distance Elements	DDB_ZONE_4_CA	Zone 4 CA phase fault element	Zone4 CA Element			*	*
960	Distance Elements	DDB_ZONE_1_AN	Unused	Unused	*	*		
961	Distance Elements	DDB_ZONE_1_BN	Unused	Unused	*	*		
962	Distance Elements	DDB_ZONE_1_CN	Unused	Unused	*	*		
963	Distance Elements	DDB_ZONE_1_AB	Unused	Unused	*	*		
964	Distance Elements	DDB_ZONE_1_BC	Unused	Unused	*	*		
965	Distance Elements	DDB_ZONE_1_CA	Unused	Unused	*	*		
966	Distance Elements	DDB_ZONE_2_AN	Unused	Unused	*	*		
967	Distance Elements	DDB_ZONE_2_BN	Unused	Unused	*	*		
968	Distance Elements	DDB_ZONE_2_CN	Unused	Unused	*	*		
969	Distance Elements	DDB_ZONE_2_AB	Unused	Unused	*	*		
970	Distance Elements	DDB_ZONE_2_BC	Unused	Unused	*	*		
971	Distance Elements	DDB_ZONE_2_CA	Unused	Unused	*	*		
972	Distance Elements	DDB_ZONE_3_AN	Unused	Unused	*	*		
973	Distance Elements	DDB_ZONE_3_BN	Unused	Unused	*	*		
974	Distance Elements	DDB_ZONE_3_CN	Unused	Unused	*	*		
975	Distance Elements	DDB_ZONE_3_AB	Unused	Unused	*	*		

DDB No	Source	Element Name	Description	English Text	P543/P545 No Distance	P544/P546 No Distance	P543/ P545	P544/ P546
976	Distance Elements	DDB_ZONE_3_BC	Unused	Unused	*	*		
977	Distance Elements	DDB_ZONE_3_CA	Unused	Unused	*	*		
978	Distance Elements	DDB_ZONE_P_AN	Unused	Unused	*	*		
979	Distance Elements	DDB_ZONE_P_BN	Unused	Unused	*	*		
980	Distance Elements	DDB_ZONE_P_CN	Unused	Unused	*	*		
981	Distance Elements	DDB_ZONE_P_AB	Unused	Unused	*	*		
982	Distance Elements	DDB_ZONE_P_BC	Unused	Unused	*	*		
983	Distance Elements	DDB_ZONE_P_CA	Unused	Unused	*	*		
984	Distance Elements	DDB_ZONE_4_AN	Unused	Unused	*	*		
985	Distance Elements	DDB_ZONE_4_BN	Unused	Unused	*	*		
986	Distance Elements	DDB_ZONE_4_CN	Unused	Unused	*	*		
987	Distance Elements	DDB_ZONE_4_AB	Unused	Unused	*	*		
988	Distance Elements	DDB_ZONE_4_BC	Unused	Unused	*	*		
989	Distance Elements	DDB_ZONE_4_CA	Unused	Unused	*	*		
990		DDB_UNUSED_990	Unused	Unused	*	*	*	*
991		DDB_UNUSED_991	Unused	Unused	*	*	*	*
992	PSL	DDB_TRIGGER_NODE_1	PSL Group Sig. 1	PSL Group Sig 1	*	*	*	*
993	PSL	DDB_TRIGGER_NODE_2	PSL Group Sig. 2	PSL Group Sig 2	*	*	*	*
994	PSL	DDB_TRIGGER_NODE_3	PSL Group Sig. 3	PSL Group Sig 3	*	*	*	*
995	PSL	DDB_TRIGGER_NODE_4	PSL Group Sig. 4	PSL Group Sig 4	*	*	*	*
996	Directional Earth Fault	DDB_DEF_FWD	DEF forward (directional earth fault aided scheme detector)	DEF Forward			*	*
997	Directional Earth Fault	DDB_DEF_REV	DEF reverse (directional earth fault aided scheme detector)	DEF Reverse			*	*
996	Directional Earth Fault	DDB_DEF_FWD	Unused	Unused	*	*		
997	Directional Earth Fault	DDB_DEF_REV	Unused	Unused	*	*		
998	Delta directional Element	DDB_DELTA_DIR_FWD_AN	Delta directional scheme forward AN detection	Delta Dir FWD AN			*	*
999	Delta directional Element	DDB_DELTA_DIR_FWD_BN	Delta directional scheme forward BN detection	Delta Dir FWD BN			*	*
1000	Delta directional Element	DDB_DELTA_DIR_FWD_CN	Delta directional scheme forward CN detection	Delta Dir FWD CN			*	*
1001	Delta directional Element	DDB_DELTA_DIR_FWD_AB	Delta directional scheme forward AB detection	Delta Dir FWD AB			*	*

DDB No	Source	Element Name	Description	English Text	P543/P544 P5 No. Distance	P544/P545 P5 No. Distance	P543/ P544/ P545	P544/ P546
1002	Delta directional Element	DDB_DELTA_DIR_FWD_BC	Delta directional scheme forward BC detection	Delta Dir FWD BC			*	*
1003	Delta directional Element	DDB_DELTA_DIR_FWD_CA	Delta directional scheme forward CA detection	Delta Dir FWD CA			*	*
1004	Delta directional Element	DDB_DELTA_DIR_REV_AN	Delta directional scheme reverse AN detection	Delta Dir Rev AN			*	*
1005	Delta directional Element	DDB_DELTA_DIR_REV_BN	Delta directional scheme reverse BN detection	Delta Dir Rev BN			*	*
1006	Delta directional Element	DDB_DELTA_DIR_REV_CN	Delta directional scheme reverse CN detection	Delta Dir Rev CN			*	*
1007	Delta directional Element	DDB_DELTA_DIR_REV_AB	Delta directional scheme reverse AB detection	Delta Dir Rev AB			*	*
1008	Delta directional Element	DDB_DELTA_DIR_REV_BC	Delta directional scheme reverse BC detection	Delta Dir Rev BC			*	*
1009	Delta directional Element	DDB_DELTA_DIR_REV_CA	Delta directional scheme reverse CA detection	Delta Dir Rev CA			*	*
998	Delta directional Element	DDB_DELTA_DIR_FWD_AN	Unused	Unused	*	*		
999	Delta directional Element	DDB_DELTA_DIR_FWD_BN	Unused	Unused	*	*		
1000	Delta directional Element	DDB_DELTA_DIR_FWD_CN	Unused	Unused	*	*		
1001	Delta directional Element	DDB_DELTA_DIR_FWD_AB	Unused	Unused	*	*		
1002	Delta directional Element	DDB_DELTA_DIR_FWD_BC	Unused	Unused	*	*		
1003	Delta directional Element	DDB_DELTA_DIR_FWD_CA	Unused	Unused	*	*		
1004	Delta directional Element	DDB_DELTA_DIR_REV_AN	Unused	Unused	*	*		
1005	Delta directional Element	DDB_DELTA_DIR_REV_BN	Unused	Unused	*	*		
1006	Delta directional Element	DDB_DELTA_DIR_REV_CN	Unused	Unused	*	*		
1007	Delta directional Element	DDB_DELTA_DIR_REV_AB	Unused	Unused	*	*		
1008	Delta directional Element	DDB_DELTA_DIR_REV_BC	Unused	Unused	*	*		
1009	Delta directional Element	DDB_DELTA_DIR_REV_CA	Unused	Unused	*	*		
1010	Phase Selector	DDB_PHS_SEL_A	Phase selector - phase A pickup	Phase Select A			*	*
1011	Phase Selector	DDB_PHS_SEL_B	Phase selector - phase B pickup	Phase Select B			*	*
1012	Phase Selector	DDB_PHS_SEL_C	Phase selector - phase C pickup	Phase Select C			*	*
1013	Phase Selector	DDB_PHS_SEL_N	Phase selector - neutral indication	Phase Select N			*	*
1014	Powerswing Blocking	DDB_PSB_DETECTED	Power swing detected	P Swing Detector			*	*
1015	Powerswing Blocking	DDB_PSB_FAULT	Power swing block fault	PSB Fault			*	*
1010	Phase Selector	DDB_PHS_SEL_A	Unused	Unused	*	*		
1011	Phase Selector	DDB_PHS_SEL_B	Unused	Unused	*	*		

DDB No	Source	Element Name	Description	English Text	P543/P545 No	P544/P546 Distance	P543/P545 No	P544/P546 Distance	P543/P545	P544/P546
1012	Phase Selector	DDB_PHS_SEL_C	Unused	Unused	*	*				
1013	Phase Selector	DDB_PHS_SEL_N	Unused	Unused	*	*				
1014	Powerswing Blocking	DDB_PSB_DETECTED	Unused	Unused	*	*				
1015	Powerswing Blocking	DDB_PSB_FAULT	Unused	Unused	*	*				
1016	Inrush Detector	DDB_HARMONIC_2_A	2nd harmonic current ratio exceeds threshold on phase A (may be used to block any instantaneous distance elements that reach through the reactance of a power transformer)	lh(2) Loc Blk A	*	*	*	*	*	*
1017	Inrush Detector	DDB_HARMONIC_2_B	2nd harmonic current ratio exceeds threshold on phase B (may be used to block any instantaneous distance elements that reach through the reactance of a power transformer)	lh(2) Loc Blk B	*	*	*	*	*	*
1018	Inrush Detector	DDB_HARMONIC_2_C	2nd harmonic current ratio exceeds threshold on phase C (may be used to block any instantaneous distance elements that reach through the reactance of a power transformer)	lh(2) Loc Blk C	*	*	*	*	*	*
1019	Inrush Detector	DDB_HARMONIC_2_N	2nd harmonic current ratio exceeds threshold on neutral current measurement (may be used to block any instantaneous distance elements that reach through the reactance of a power transformer)	lh(2) Loc Blk N	*	*	*	*	*	*
1016	Inrush Detector	DDB_HARMONIC_2_A	Unused	Unused						
1017	Inrush Detector	DDB_HARMONIC_2_B	Unused	Unused						
1018	Inrush Detector	DDB_HARMONIC_2_C	Unused	Unused						
1019	Inrush Detector	DDB_HARMONIC_2_N	Unused	Unused						
1020	SW	DDB_UNUSED_1020	Unused	Unused	*	*	*	*	*	*
1020	SW	DDB_CLEAR_STATISTICS_CMD	This is an indication of the command "Clear Statistics" available in the PSL. This DDB could be used to reset statistics at the remote end (via IM64) by linking it to DDB 544 - clear statistics - at the remote end	Clear Stats Cmd						
1021	SW	DDB_HARMONIC_2_REM_BLOCK_A	Indication that remote end phase A is blocked by 2nd harmonic	lh(2) Rem Blk A	*	*	*	*	*	*
1022	SW	DDB_HARMONIC_2_REM_BLOCK_B	Indication that remote end phase B is blocked by 2nd harmonic	lh(2) Rem Blk B	*	*	*	*	*	*
1023	SW	DDB_HARMONIC_2_REM_BLOCK_C	Indication that remote end phase C is blocked by 2nd harmonic	lh(2) Rem Blk C	*	*	*	*	*	*
1021	SW	DDB_HARMONIC_2_REM_BLOCK_A	Unused	Unused						
1022	SW	DDB_HARMONIC_2_REM_BLOCK_B	Unused	Unused						
1023	SW	DDB_HARMONIC_2_REM_BLOCK_C	Unused	Unused						
1024	Tri LED Red 1	DDB_OUTPUT_TRI_LED_1_RED	Programmable LED 1 red is energized	LED1 Red	*	*	*	*	*	*
1025	Tri LED Green 1	DDB_OUTPUT_TRI_LED_1_GRN	Programmable LED 1 green is energized	LED1 Grn	*	*	*	*	*	*
1026	Tri LED Red 2	DDB_OUTPUT_TRI_LED_2_RED	Programmable LED 2 red is energized	LED2 Red	*	*	*	*	*	*
1027	Tri LED Green 2	DDB_OUTPUT_TRI_LED_2_GRN	Programmable LED 2 green is energized	LED2 Grn	*	*	*	*	*	*
1028	Tri LED Red 3	DDB_OUTPUT_TRI_LED_3_RED	Programmable LED 3 red is energized	LED3 Red	*	*	*	*	*	*
1029	Tri LED Green 3	DDB_OUTPUT_TRI_LED_3_GRN	Programmable LED 3 green is energized	LED3 Grn	*	*	*	*	*	*

DDB No	Source	Element Name	Description	English Text	P543/P54 Yn5 Distance	P544/P54 Yn5 Distance	P545/ P544/ P546	P544/ P546
1030	Tri LED Red 4	DDB_OUTPUT_TRI_LED_4_RED	Programmable LED 4 red is energized	LED4 Red	*	*	*	*
1031	Tri LED Green 4	DDB_OUTPUT_TRI_LED_4_GRN	Programmable LED 4 green is energized	LED4 Grn	*	*	*	*
1032	Tri LED Red 5	DDB_OUTPUT_TRI_LED_5_RED	Programmable LED 5 red is energized	LED5 Red	*	*	*	*
1033	Tri LED Green 5	DDB_OUTPUT_TRI_LED_5_GRN	Programmable LED 5 green is energized	LED5 Grn	*	*	*	*
1034	Tri LED Red 6	DDB_OUTPUT_TRI_LED_6_RED	Programmable LED 6 red is energized	LED6 Red	*	*	*	*
1035	Tri LED Green 6	DDB_OUTPUT_TRI_LED_6_GRN	Programmable LED 6 green is energized	LED6 Grn	*	*	*	*
1036	Tri LED Red 7	DDB_OUTPUT_TRI_LED_7_RED	Programmable LED 7 red is energized	LED7 Red	*	*	*	*
1037	Tri LED Green 7	DDB_OUTPUT_TRI_LED_7_GRN	Programmable LED 7 green is energized	LED7 Grn	*	*	*	*
1038	Tri LED Red 8	DDB_OUTPUT_TRI_LED_8_RED	Programmable LED 8 red is energized	LED8 Red	*	*	*	*
1039	Tri LED Green 8	DDB_OUTPUT_TRI_LED_8_GRN	Programmable LED 8 green is energized	LED8 Grn	*	*	*	*
1040	Tri LED Red 9	DDB_OUTPUT_TRI_LED_9_RED	Programmable function key LED 1 red is energized	FnKey LED1 Red	*	*	*	*
1041	Tri LED Green 9	DDB_OUTPUT_TRI_LED_9_GRN	Programmable function key LED 1 green is energized	FnKey LED1 Grn	*	*	*	*
1042	Tri LED Red 10	DDB_OUTPUT_TRI_LED_10_RED	Programmable function key LED 2 red is energized	FnKey LED2 Red	*	*	*	*
1043	Tri LED Green 10	DDB_OUTPUT_TRI_LED_10_GRN	Programmable function key LED 2 green is energized	FnKey LED2 Grn	*	*	*	*
1044	Tri LED Red 11	DDB_OUTPUT_TRI_LED_11_RED	Programmable function key LED 3 red is energized	FnKey LED3 Red	*	*	*	*
1045	Tri LED Green 11	DDB_OUTPUT_TRI_LED_11_GRN	Programmable function key LED 3 green is energized	FnKey LED3 Grn	*	*	*	*
1046	Tri LED Red 12	DDB_OUTPUT_TRI_LED_12_RED	Programmable function key LED 4 red is energized	FnKey LED4 Red	*	*	*	*
1047	Tri LED Green 12	DDB_OUTPUT_TRI_LED_12_GRN	Programmable function key LED 4 green is energized	FnKey LED4 Grn	*	*	*	*
1048	Tri LED Red 13	DDB_OUTPUT_TRI_LED_13_RED	Programmable function key LED 5 red is energized	FnKey LED5 Red	*	*	*	*
1049	Tri LED Green 13	DDB_OUTPUT_TRI_LED_13_GRN	Programmable function key LED 5 green is energized	FnKey LED5 Grn	*	*	*	*
1050	Tri LED Red 14	DDB_OUTPUT_TRI_LED_14_RED	Programmable function key LED 6 red is energized	FnKey LED6 Red	*	*	*	*
1051	Tri LED Green 14	DDB_OUTPUT_TRI_LED_14_GRN	Programmable function key LED 6 green is energized	FnKey LED6 Grn	*	*	*	*
1052	Tri LED Red 15	DDB_OUTPUT_TRI_LED_15_RED	Programmable function key LED 7 red is energized	FnKey LED7 Red	*	*	*	*
1053	Tri LED Green 15	DDB_OUTPUT_TRI_LED_15_GRN	Programmable function key LED 7 green is energized	FnKey LED7 Grn	*	*	*	*
1054	Tri LED Red 16	DDB_OUTPUT_TRI_LED_16_RED	Programmable function key LED 8 red is energized	FnKey LED8 Red	*	*	*	*
1055	Tri LED Green 16	DDB_OUTPUT_TRI_LED_16_GRN	Programmable function key LED 8 green is energized	FnKey LED8 Grn	*	*	*	*
1056	Tri LED Red 17	DDB_OUTPUT_TRI_LED_17_RED	Programmable function key LED 9 red is energized	FnKey LED9 Red	*	*	*	*
1057	Tri LED Green 17	DDB_OUTPUT_TRI_LED_17_GRN	Programmable function key LED 9 green is energized	FnKey LED9 Grn	*	*	*	*

DDB No	Source	Element Name	Description	English Text	P543/P545 No	Distance	P544/P546 No	Distance	P543/P545	P544/P546
1058	Tri LED Red 18	DDB_OUTPUT_TRI_LED_18_RED	Programmable function key LED 10 red is energized	FnKey LED10 Red	*	*	*	*	*	*
1059	Tri LED Green 18	DDB_OUTPUT_TRI_LED_18_GRN	Programmable function key LED 10 green is energized	FnKey LED10 Grn	*	*	*	*	*	*
1060	LED_CON_R1	DDB_TRI_LED_RED_CON_1	Assignment of input signal to drive output LED 1 red	LED1 Con R	*	*	*	*	*	*
1061	LED_CON_G1	DDB_TRI_LED_GRN_CON_1	Assignment of signal to drive output LED 1 green. To drive LED 1 yellow DDB 676 and DDB 677 must be driven at the same time	LED1 Con G	*	*	*	*	*	*
1062	LED_CON_R2	DDB_TRI_LED_RED_CON_2	Assignment of input signal to drive output LED 2 red	LED2 Con R	*	*	*	*	*	*
1063	LED_CON_G2	DDB_TRI_LED_GRN_CON_2	Assignment of signal to drive output LED 2 green. To drive LED 2 yellow DDB 678 and DDB 679 must be driven at the same time	LED2 Con G	*	*	*	*	*	*
1064	LED_CON_R3	DDB_TRI_LED_RED_CON_3	Assignment of input signal to drive output LED 3 red	LED3 Con R	*	*	*	*	*	*
1065	LED_CON_G3	DDB_TRI_LED_GRN_CON_3	Assignment of signal to drive output LED 3 green. To drive LED 3 yellow DDB 680 and DDB 681 must be driven at the same time	LED3 Con G	*	*	*	*	*	*
1066	LED_CON_R4	DDB_TRI_LED_RED_CON_4	Assignment of input signal to drive output LED 4 red	LED4 Con R	*	*	*	*	*	*
1067	LED_CON_G4	DDB_TRI_LED_GRN_CON_4	Assignment of signal to drive output LED 4 green. To drive LED 4 yellow DDB 682 and DDB 683 must be driven at the same time	LED4 Con G	*	*	*	*	*	*
1068	LED_CON_R5	DDB_TRI_LED_RED_CON_5	Assignment of input signal to drive output LED 5 red	LED5 Con R	*	*	*	*	*	*
1069	LED_CON_G5	DDB_TRI_LED_GRN_CON_5	Assignment of signal to drive output LED 5 green. To drive LED 5 yellow DDB 684 and DDB 685 must be driven at the same time	LED5 Con G	*	*	*	*	*	*
1070	LED_CON_R6	DDB_TRI_LED_RED_CON_6	Assignment of input signal to drive output LED 6 red	LED6 Con R	*	*	*	*	*	*
1071	LED_CON_G6	DDB_TRI_LED_GRN_CON_6	Assignment of signal to drive output LED 6 green. To drive LED 6 yellow DDB 686 and DDB 687 must be driven at the same time	LED6 Con G	*	*	*	*	*	*
1072	LED_CON_R7	DDB_TRI_LED_RED_CON_7	Assignment of input signal to drive output LED 7 red	LED7 Con R	*	*	*	*	*	*
1073	LED_CON_G7	DDB_TRI_LED_GRN_CON_7	Assignment of signal to drive output LED 7 green. To drive LED 7 yellow DDB 688 and DDB 689 must be driven at the same time	LED7 Con G	*	*	*	*	*	*
1074	LED_CON_R8	DDB_TRI_LED_RED_CON_8	Assignment of input signal to drive output LED 8 red	LED8 Con R	*	*	*	*	*	*
1075	LED_CON_G8	DDB_TRI_LED_GRN_CON_8	Assignment of signal to drive output LED 8 green. To drive LED 8 yellow DDB 690 and DDB 691 must be driven at the same time	LED8 Con G	*	*	*	*	*	*
1076	LED_CON_R9	DDB_TRI_LED_RED_CON_9	Assignment of signal to drive output function key LED 1 red. This LED is associated with function key 1	FnKey LED1 ConR	*	*	*	*	*	*
1077	LED_CON_G9	DDB_TRI_LED_GRN_CON_9	Assignment of signal to drive output function key LED 1 green. This LED is associated with function key 1. To drive function key LED, yellow DDB 692 and DDB 693 must be active at the same time	FnKey LED1 ConG	*	*	*	*	*	*

DDB No	Source	Element Name	Description	English Text	P543P54 5 Nbr Distance	P544P54 4 Nbr Distance	P543/ P545	P544/ P546
1078	LED_CON_R10	DDB_TRI_LED_RED_CON_10	Assignment of signal to drive output function key LED 2 red. This LED is associated with function key 2	FnKey LED2 ConR	*	*	*	*
1079	LED_CON_G10	DDB_TRI_LED_GRN_CON_10	Assignment of signal to drive output function key LED 2 green. This LED is associated with function key 2. To drive function key LED, yellow DDB 694 and DDB 695 must be active at the same time	FnKey LED2 ConG	*	*	*	*
1080	LED_CON_R11	DDB_TRI_LED_RED_CON_11	Assignment of signal to drive output function key LED 3 red. This LED is associated with function key 3	FnKey LED3 ConR	*	*	*	*
1081	LED_CON_G11	DDB_TRI_LED_GRN_CON_11	Assignment of signal to drive output function key LED 3 green. This LED is associated with function key 3. To drive function key LED, yellow DDB 696 and DDB 697 must be active at the same time	FnKey LED3 ConG	*	*	*	*
1082	LED_CON_R12	DDB_TRI_LED_RED_CON_12	Assignment of signal to drive output function key LED 4 red. This LED is associated with function key 4	FnKey LED4 ConR	*	*	*	*
1083	LED_CON_G12	DDB_TRI_LED_GRN_CON_12	Assignment of signal to drive output function key LED 4 green. This LED is associated with function key 4. To drive function key LED, yellow DDB 698 and DDB 699 must be active at the same time	FnKey LED4 ConG	*	*	*	*
1084	LED_CON_R13	DDB_TRI_LED_RED_CON_13	Assignment of signal to drive output function key LED 5 red. This LED is associated with function key 5	FnKey LED5 ConR	*	*	*	*
1085	LED_CON_G13	DDB_TRI_LED_GRN_CON_13	Assignment of signal to drive output function key LED 5 green. This LED is associated with function key 5. To drive function key LED, yellow DDB 700 and DDB 701 must be active at the same time	FnKey LED5 ConG	*	*	*	*
1086	LED_CON_R14	DDB_TRI_LED_RED_CON_14	Assignment of signal to drive output function key LED 6 red. This LED is associated with function key 6	FnKey LED6 ConR	*	*	*	*
1087	LED_CON_G14	DDB_TRI_LED_GRN_CON_14	Assignment of signal to drive output function key LED 6 green. This LED is associated with function key 6. To drive function key LED, yellow DDB 702 and DDB 703 must be active at the same time	FnKey LED6 ConG	*	*	*	*
1088	LED_CON_R15	DDB_TRI_LED_RED_CON_15	Assignment of signal to drive output function key LED 7 red. This LED is associated with function key 7	FnKey LED7 ConR	*	*	*	*
1089	LED_CON_G15	DDB_TRI_LED_GRN_CON_15	Assignment of signal to drive output function key LED 7 green. This LED is associated with function key 7. To drive function key LED, yellow DDB 704 and DDB 705 must be active at the same time	FnKey LED7 ConG	*	*	*	*
1090	LED_CON_R16	DDB_TRI_LED_RED_CON_16	Assignment of signal to drive output function key LED 8 red. This LED is associated with function key 8	FnKey LED8 ConR	*	*	*	*
1091	LED_CON_G16	DDB_TRI_LED_GRN_CON_16	Assignment of signal to drive output function key LED 8 green. This LED is associated with function key 8. To drive function key LED, yellow DDB 706 and DDB 707 must be active at the same time	FnKey LED8 ConG	*	*	*	*

DDB No	Source	Element Name	Description	English Text	P543/P545 No	P544/P546 Distance	P543/P545 No	P544/P546 Distance	P543/P545	P544/P546
1092	LED_CON_R17	DDB_TRI_LED_RED_CON_17	Assignment of signal to drive output function key LED 9 red. This LED is associated with function key 9	FnKey LED9 ConR	*	*	*	*	*	*
1093	LED_CON_G17	DDB_TRI_LED_GRN_CON_17	Assignment of signal to drive output function key LED 9 green. This LED is associated with function key 9. To drive function key LED, yellow DDB 708 and DDB 709 must be active at the same time	FnKey LED9 ConG	*	*	*	*	*	*
1094	LED_CON_R18	DDB_TRI_LED_RED_CON_18	Assignment of signal to drive output function key LED 10 red. This LED is associated with function key 10	FnKey LED10 ConR	*	*	*	*	*	*
1095	LED_CON_G18	DDB_TRI_LED_GRN_CON_18	Assignment of signal to drive output function key LED 10 green. This LED is associated with function key 10. To drive function key LED, yellow DDB 710 and DDB 711 must be active at the same time	FnKey LED10 ConG	*	*	*	*	*	*
1096	Function Key 1	DDB_FN_KEY_1	Function key 1 is activated. In 'Normal' mode it is high on keypress and in 'Toggle' mode remains high/low on single keypress	Function Key 1	*	*	*	*	*	*
1097	Function Key 2	DDB_FN_KEY_2	Function key 2 is activated. In 'Normal' mode it is high on keypress and in 'Toggle' mode remains high/low on single keypress	Function Key 2	*	*	*	*	*	*
1098	Function Key 3	DDB_FN_KEY_3	Function key 3 is activated. In 'Normal' mode it is high on keypress and in 'Toggle' mode remains high/low on single keypress	Function Key 3	*	*	*	*	*	*
1099	Function Key 4	DDB_FN_KEY_4	Function key 4 is activated. In 'Normal' mode it is high on keypress and in 'Toggle' mode remains high/low on single keypress	Function Key 4	*	*	*	*	*	*
1100	Function Key 5	DDB_FN_KEY_5	Function key 5 is activated. In 'Normal' mode it is high on keypress and in 'Toggle' mode remains high/low on single keypress	Function Key 5	*	*	*	*	*	*
1101	Function Key 6	DDB_FN_KEY_6	Function key 6 is activated. In 'Normal' mode it is high on keypress and in 'Toggle' mode remains high/low on single keypress	Function Key 6	*	*	*	*	*	*
1102	Function Key 7	DDB_FN_KEY_7	Function key 7 is activated. In 'Normal' mode it is high on keypress and in 'Toggle' mode remains high/low on single keypress	Function Key 7	*	*	*	*	*	*
1103	Function Key 8	DDB_FN_KEY_8	Function key 8 is activated. In 'Normal' mode it is high on keypress and in 'Toggle' mode remains high/low on single keypress	Function Key 8	*	*	*	*	*	*
1104	Function Key 9	DDB_FN_KEY_9	Function key 9 is activated. In 'Normal' mode it is high on keypress and in 'Toggle' mode remains high/low on single keypress	Function Key 9	*	*	*	*	*	*
1105	Function Key 10	DDB_FN_KEY_10	Function key 10 is activated. In 'Normal' mode it is high on keypress and in 'Toggle' mode remains high/low on single keypress	Function Key 10	*	*	*	*	*	*
1024	LED Conditioner	DDB_OUTPUT_LED_1	Programmable LED 1	LED 1						
1025	LED Conditioner	DDB_OUTPUT_LED_2	Programmable LED 2	LED 2						
1026	LED Conditioner	DDB_OUTPUT_LED_3	Programmable LED 3	LED 3						
1027	LED Conditioner	DDB_OUTPUT_LED_4	Programmable LED 4	LED 4						

DDB No	Source	Element Name	Description	English Text	P543/P54 N/A Distance	P544/P54 N/A Distance	P543/ P544/ P545	P544/ P546
1028	LED Conditioner	DDB_OUTPUT_LED_5	Programmable LED 5	LED 5				
1029	LED Conditioner	DDB_OUTPUT_LED_6	Programmable LED 6	LED 6				
1030	LED Conditioner	DDB_OUTPUT_LED_7	Programmable LED 7	LED 7				
1031	LED Conditioner	DDB_OUTPUT_LED_8	Programmable LED 8	LED 8				
1032		DDB_UNUSED_1032	Unused	Unused				
1033		DDB_UNUSED_1033	Unused	Unused				
1034		DDB_UNUSED_1034	Unused	Unused				
1035		DDB_UNUSED_1035	Unused	Unused				
1036		DDB_UNUSED_1036	Unused	Unused				
1037		DDB_UNUSED_1037	Unused	Unused				
1038		DDB_UNUSED_1038	Unused	Unused				
1039		DDB_UNUSED_1039	Unused	Unused				
1040		DDB_UNUSED_1040	Unused	Unused				
1041		DDB_UNUSED_1041	Unused	Unused				
1042		DDB_UNUSED_1042	Unused	Unused				
1043		DDB_UNUSED_1043	Unused	Unused				
1044		DDB_UNUSED_1044	Unused	Unused				
1045		DDB_UNUSED_1045	Unused	Unused				
1046		DDB_UNUSED_1046	Unused	Unused				
1047		DDB_UNUSED_1047	Unused	Unused				
1048		DDB_UNUSED_1048	Unused	Unused				
1049		DDB_UNUSED_1049	Unused	Unused				
1050		DDB_UNUSED_1050	Unused	Unused				
1051		DDB_UNUSED_1051	Unused	Unused				
1052		DDB_UNUSED_1052	Unused	Unused				
1053		DDB_UNUSED_1053	Unused	Unused				
1054		DDB_UNUSED_1054	Unused	Unused				
1055		DDB_UNUSED_1055	Unused	Unused				
1056		DDB_UNUSED_1056	Unused	Unused				
1057		DDB_UNUSED_1057	Unused	Unused				
1058		DDB_UNUSED_1058	Unused	Unused				
1059		DDB_UNUSED_1059	Unused	Unused				
1060		DDB_UNUSED_1060	Unused	Unused				
1061		DDB_UNUSED_1061	Unused	Unused				
1062		DDB_UNUSED_1062	Unused	Unused				
1063		DDB_UNUSED_1063	Unused	Unused				
1064		DDB_UNUSED_1064	Unused	Unused				
1065		DDB_UNUSED_1065	Unused	Unused				
1066		DDB_UNUSED_1066	Unused	Unused				
1067		DDB_UNUSED_1067	Unused	Unused				
1068		DDB_UNUSED_1068	Unused	Unused				

DDB No	Source	Element Name	Description	English Text	P543/P545 No Distance	P544/P546 No Distance	P543/ P545	P544/ P546
1069		DDB_UNUSED_1069	Unused	Unused				
1070	PSL	DDB_LED_CON_1	Input to LED Output Condition	LED Cond IN 1				
1071	PSL	DDB_LED_CON_2	Input to LED Output Condition	LED Cond IN 2				
1072	PSL	DDB_LED_CON_3	Input to LED Output Condition	LED Cond IN 3				
1073	PSL	DDB_LED_CON_4	Input to LED Output Condition	LED Cond IN 4				
1074	PSL	DDB_LED_CON_5	Input to LED Output Condition	LED Cond IN 5				
1075	PSL	DDB_LED_CON_6	Input to LED Output Condition	LED Cond IN 6				
1076	PSL	DDB_LED_CON_7	Input to LED Output Condition	LED Cond IN 7				
1077	PSL	DDB_LED_CON_8	Input to LED Output Condition	LED Cond IN 8				
1078		DDB_UNUSED_1078	Unused	Unused				
1079		DDB_UNUSED_1079	Unused	Unused				
1080		DDB_UNUSED_1080	Unused	Unused				
1081		DDB_UNUSED_1081	Unused	Unused				
1082		DDB_UNUSED_1082	Unused	Unused				
1083		DDB_UNUSED_1083	Unused	Unused				
1084		DDB_UNUSED_1084	Unused	Unused				
1085		DDB_UNUSED_1085	Unused	Unused				
1086		DDB_UNUSED_1086	Unused	Unused				
1087		DDB_UNUSED_1087	Unused	Unused				
1088		DDB_UNUSED_1088	Unused	Unused				
1089		DDB_UNUSED_1089	Unused	Unused				
1090		DDB_UNUSED_1090	Unused	Unused				
1091		DDB_UNUSED_1091	Unused	Unused				
1092		DDB_UNUSED_1092	Unused	Unused				
1093		DDB_UNUSED_1093	Unused	Unused				
1094		DDB_UNUSED_1094	Unused	Unused				
1095		DDB_UNUSED_1095	Unused	Unused				
1096		DDB_UNUSED_1096	Unused	Unused				
1097		DDB_UNUSED_1097	Unused	Unused				
1098		DDB_UNUSED_1098	Unused	Unused				
1099		DDB_UNUSED_1099	Unused	Unused				
1100		DDB_UNUSED_1100	Unused	Unused				
1101		DDB_UNUSED_1101	Unused	Unused				
1102		DDB_UNUSED_1102	Unused	Unused				
1103		DDB_UNUSED_1103	Unused	Unused				
1104		DDB_UNUSED_1104	Unused	Unused				
1105		DDB_UNUSED_1105	Unused	Unused				
1106	CB Monitoring	DDB_BROKEN_CURRENT_ALARM	Broken current maintenance alarm - circuit breaker cumulative duty alarm set-point	CB I ^A Maint	*		*	
1107	CB Monitoring	DDB_BROKEN_CURRENT_LOCKOUT	Broken current lockout alarm - circuit breaker cumulative duty has been exceeded	CB I ^A Lockout	*		*	
1108	CB Monitoring	DDB_MAINTENANCE_ALARM	No of circuit breaker operations maintenance alarm - indicated due to circuit breaker trip operations threshold	No.CB OPs Maint	*		*	

DDB No	Source	Element Name	Description	English Text	P543/P54 N/A Distance	P544/P54 N/A Distance	P543/ P545	P544/ P546
1109	CB Monitoring	DDB_MAINTENANCE_LOCKOUT	No of circuit breaker operations maintenance lockout - excessive number of circuit breaker trip operations, safety lockout	No.CB OPs Lock	*		*	
1110	CB Monitoring	DDB_EXCESSIVE_OP_TIME_ALARM	Excessive circuit breaker operating time maintenance alarm - excessive operation time alarm for the circuit breaker (slow interruption time)	CB Time Maint	*		*	
1111	CB Monitoring	DDB_EXCESSIVE_OP_TIME_LOCKOUT	Excessive circuit breaker operating time lockout alarm - excessive operation time alarm for the circuit breaker (too slow interruption)	CB Time Lockout	*		*	
1112	CB Monitoring	DDB_EFF_LOCKOUT	Excessive fault frequency lockout alarm	CB FaultFreqLock	*		*	
1106	CB Monitoring	DDB_BROKEN_CURRENT_ALARM	Broken current maintenance alarm - circuit breaker cumulative duty alarm set-point CB1	CB1 I [^] Maint		*		*
1107	CB Monitoring	DDB_BROKEN_CURRENT_LOCKOUT	Broken current lockout alarm - circuit breaker cumulative duty has been exceeded CB1	CB1 I [^] Lockout		*		*
1108	CB Monitoring	DDB_MAINTENANCE_ALARM	No of circuit breaker operations maintenance alarm - indicated due to circuit breaker trip operations threshold CB1	No.CB1 OPs Maint		*		*
1109	CB Monitoring	DDB_MAINTENANCE_LOCKOUT	No of circuit breaker operations maintenance lockout - excessive number of circuit breaker trip operations, safety lockout CB1	No.CB1 OPs Lock		*		*
1110	CB Monitoring	DDB_EXCESSIVE_OP_TIME_ALARM	Excessive circuit breaker operating time maintenance alarm - excessive operation time alarm for the circuit breaker (slow interruption time) CB1	CB1 Time Maint		*		*
1111	CB Monitoring	DDB_EXCESSIVE_OP_TIME_LOCKOUT	Excessive circuit breaker operating time lockout alarm - excessive operation time alarm for the circuit breaker (too slow interruption) CB1	CB1 Time Lockout		*		*
1112	CB Monitoring	DDB_EFF_LOCKOUT	Excessive fault frequency lockout alarm CB1	CB1FaultFreqLock		*		*
1113	CB2 Monitoring	DDB_BROKEN_CURRENT_ALARM_2	Broken current maintenance alarm - circuit breaker cumulative duty alarm set-point CB2	CB2 I [^] Maint		*		*
1114	CB2 Monitoring	DDB_BROKEN_CURRENT_LOCKOUT_2	Broken current lockout alarm - circuit breaker cumulative duty has been exceeded CB2	CB2 I [^] Lockout		*		*
1115	CB2 Monitoring	DDB_MAINTENANCE_ALARM_2	No of circuit breaker operations maintenance alarm - indicated due to circuit breaker trip operations threshold CB2	No.CB2 OPs Maint		*		*
1116	CB2 Monitoring	DDB_MAINTENANCE_LOCKOUT_2	No of circuit breaker operations maintenance lockout - excessive number of circuit breaker trip operations, safety lockout CB2	No.CB2 OPs Lock		*		*
1117	CB2 Monitoring	DDB_EXCESSIVE_OP_TIME_ALARM_2	Excessive circuit breaker operating time maintenance alarm - excessive operation time alarm for the circuit breaker (slow interruption time) CB2	CB2 Time Maint		*		*
1118	CB2 Monitoring	DDB_EXCESSIVE_OP_TIME_LOCKOUT_2	Excessive circuit breaker operating time lockout alarm - excessive operation time alarm for the circuit breaker (too slow interruption) CB2	CB2 Time Lockout		*		*
1119	CB2 Monitoring	DDB_EFF_LOCKOUT_2	Excessive fault frequency lockout alarm CB2	CB2FaultFreqLock		*		*
1113	CB2 Monitoring	DDB_BROKEN_CURRENT_ALARM_2	Unused	Unused	*		*	
1114	CB2 Monitoring	DDB_BROKEN_CURRENT_LOCKOUT_2	Unused	Unused	*		*	
1115	CB2 Monitoring	DDB_MAINTENANCE_ALARM_2	Unused	Unused	*		*	

DDB No	Source	Element Name	Description	English Text	P543/P545 No Distance	P544/P546 No Distance	P543/ P545	P544/ P546
1116	CB2 Monitoring	DDB_MAINTENANCE_LOCKOUT_2	Unused	Unused	*		*	
1117	CB2 Monitoring	DDB_EXCESSIVE_OP_TIME_ALARM_2	Unused	Unused	*		*	
1118	CB2 Monitoring	DDB_EXCESSIVE_OP_TIME_LOCKOUT_2	Unused	Unused	*		*	
1119	CB2 Monitoring	DDB_EFF_LOCKOUT_2	Unused	Unused	*		*	
1120	C Diff	DDB_SIGNALLING_FAIL_CH1_RX	Reception of messages on channel 1 has stopped	SignalFail Ch1Rx	*	*	*	*
1121	C Diff	DDB_SIGNALLING_FAIL_CH1_TX	Transmission of messages on channel 1 has stopped	SignalFail Ch1Tx	*	*	*	*
1122	C Diff	DDB_REMOTE_1_GPS_FAIL	It indicates that GPS sampling synchronization (for protection purposes) running on channel 1 is lost	Ch 1 GPS Fail	*	*	*	*
1120	C Diff	DDB_SIGNALLING_FAIL_CH1_RX	Unused	Unused				
1121	C Diff	DDB_SIGNALLING_FAIL_CH1_TX	Unused	Unused				
1122	C Diff	DDB_REMOTE_1_GPS_FAIL	Unused	Unused				
1123	Fibre Monitor Bits	DDB_MUX_CLK_ERROR_CH1	This is an alarm that appears if the channel 1 baud rate is outside the limits 52 kbits/s or 70 Kbits/s	Ch1 Mux Clk	*	*	*	*
1124	Fibre Monitor Bits	DDB_IEEE37_94_CH1_LOSS_OF_SIG	Mux indicates signal lost over channel 1	Ch1 Signal Lost	*	*	*	*
1125	Fibre Monitor Bits	DDB_IEEE37_94_CH1_PATH_YELLOW	One way communication. Local relay that is sending over Ch1 indicates that remote end is not receiving	Ch1 Path Yellow	*	*	*	*
1126	Fibre Monitor Bits	DDB_IEEE37_94_CH1_BAD_RX_N	Indication of mismatch between Ch1 N*64kbits/s setting and Mux	Ch1 Mismatch RxN	*	*	*	*
1127	Fibre Monitor Bits	DDB_CH1_TIMEOUT	Indication that no valid message is received over channel 1 during 'Channel Timeout' window	Ch1 Timeout	*	*	*	*
1128	Fibre Monitor Bits	DDB_CH1_MESS_LEVEL	Indicates poor channel 1 quality	Ch1 Degraded	*	*	*	*
1129	Fibre Monitor Bits	DDB_CH1_PASSTHROUGH	Ch1 data received via Ch 2 in 3 ended configuration - self healing indication -	Ch1 Passthrough	*	*	*	*
1123	Fibre Monitor Bits	DDB_MUX_CLK_ERROR_CH1	Unused	Unused				
1124	Fibre Monitor Bits	DDB_IEEE37_94_CH1_LOSS_OF_SIG	Unused	Unused				
1125	Fibre Monitor Bits	DDB_IEEE37_94_CH1_PATH_YELLOW	Unused	Unused				
1126	Fibre Monitor Bits	DDB_IEEE37_94_CH1_BAD_RX_N	Unused	Unused				
1127	Fibre Monitor Bits	DDB_CH1_TIMEOUT	Unused	Unused				
1128	Fibre Monitor Bits	DDB_CH1_MESS_LEVEL	Unused	Unused				
1129	Fibre Monitor Bits	DDB_CH1_PASSTHROUGH	Unused	Unused				
1130	C Diff	DDB_SIGNALLING_FAIL_CH2_RX	Reception of messages on channel 2 has stopped	SignalFail Ch2Rx	*	*	*	*
1131	C Diff	DDB_SIGNALLING_FAIL_CH2_TX	Transmission of messages on channel 1 has stopped	SignalFail Ch2Tx	*	*	*	*

DDB No	Source	Element Name	Description	English Text	P543/P54 5 Nbrs Distance	P544/P54 5 Nbrs Distance	P543/ P544/ P545	P544/ P546
1132	C Diff	DDB_REMOTE_2_GPS_FAIL	It indicates that GPS sampling synchronization (for protection purposes) running on channel 2 is lost	Ch 2 GPS Fail	*	*	*	*
1130	C Diff	DDB_SIGNALLING_FAIL_CH2_RX	Unused	Unused				
1131	C Diff	DDB_SIGNALLING_FAIL_CH2_TX	Unused	Unused				
1132	C Diff	DDB_REMOTE_2_GPS_FAIL	Unused	Unused				
1133	Fibre Monitor Bits	DDB_MUX_CLK_ERROR_CH2	This is an alarm that appears if the channel 2 baud rate is outside the limits 52kbits/s or 70 kbits/s	Ch2 Mux Clk	*	*	*	*
1134	Fibre Monitor Bits	DDB_IEEE37_94_CH2_LOSS_OF_SIG	Mux indicates signal lost over channel 2	Ch2 Signal Lost	*	*	*	*
1135	Fibre Monitor Bits	DDB_IEEE37_94_CH2_PATH_YELLOW	One way communication. Local relay that is sending over Ch2 indicates that remote end is not receiving	Ch2 Path Yellow	*	*	*	*
1136	Fibre Monitor Bits	DDB_IEEE37_94_CH2_BAD_RX_N	Indication of mismatch between InterMiCOM64 Ch 2 setting and Mux	Ch2 Mismatch RxN	*	*	*	*
1137	Fibre Monitor Bits	DDB_CH2_TIMEOUT	Indication that no valid message is received over channel 2 during 'Channel Timeout' window	Ch2 Timeout	*	*	*	*
1138	Fibre Monitor Bits	DDB_CH2_MESS_LEVEL	Indicates poor channel 2 quality	Ch2 Degraded	*	*	*	*
1139	Fibre Monitor Bits	DDB_CH2_PASSTHROUGH	Ch2 data received via Ch 1 in 3 ended configuration - self healing indication -	Ch2 Passthrough	*	*	*	*
1133	Fibre Monitor Bits	DDB_MUX_CLK_ERROR_CH2	Unused	Unused				
1134	Fibre Monitor Bits	DDB_IEEE37_94_CH2_LOSS_OF_SIG	Unused	Unused				
1135	Fibre Monitor Bits	DDB_IEEE37_94_CH2_PATH_YELLOW	Unused	Unused				
1136	Fibre Monitor Bits	DDB_IEEE37_94_CH2_BAD_RX_N	Unused	Unused				
1137	Fibre Monitor Bits	DDB_CH2_TIMEOUT	Unused	Unused				
1138	Fibre Monitor Bits	DDB_CH2_MESS_LEVEL	Unused	Unused				
1139	Fibre Monitor Bits	DDB_CH2_PASSTHROUGH	Unused	Unused				
1140	C Diff	DDB_CONFIGURED	relay is already configured	Config Same	*	*	*	*
1141	C Diff	DDB_RECONFIGURE_OK	reconfigure was successful	Reconfig Pass	*	*	*	*
1142	C Diff	DDB_RECONFIGURE_FAIL	reconfigure was unsuccessful	Reconfig Fail	*	*	*	*
1143	C Diff	DDB_RESTORE_OK	restore was successful	Restore Pass	*	*	*	*
1144	C Diff	DDB_RESTORE_FAIL	restore was unsuccessful	Restore Fail	*	*	*	*
1145	C Diff	DDB_INHIBIT_CURRENT_DIFF	Inhibit Current Differential	Inhibit C Diff	*	*	*	*
1140		DDB_CONFIGURED	Unused	Unused				
1141		DDB_RECONFIGURE_OK	Unused	Unused				
1142		DDB_RECONFIGURE_FAIL	Unused	Unused				
1143		DDB_RESTORE_OK	Unused	Unused				
1144		DDB_RESTORE_FAIL	Unused	Unused				
1145		DDB_INHIBIT_CURRENT_DIFF	Unused	Unused				

DDB No	Source	Element Name	Description	English Text	P543/P545 No Distance	P544/P546 No Distance	P543/P545	P544/P546
1146		DDB_BACKUP_IN	Backup Enabled	Backup Enabled	*	*	*	*
1146		DDB_BACKUP_IN	Unused	Unused				
1147		DDB_FL_CURRENT_PROT_SEF_TRIP	SEF Trip	SEF Trip	*	*	*	*
1148		DDB_CURRENT_PROT_SEF_TRIP	Current Prot SEF Trip	B Fail SEF Trip	*	*	*	*
1149	PSL	DDB_UFREQ_1_TIMER_BLOCK	Block Underfrequency Stage 1 Timer	F<1 Timer Block	*	*	*	*
1150	PSL	DDB_UFREQ_2_TIMER_BLOCK	Block Underfrequency Stage 2 Timer	F<2 Timer Block	*	*	*	*
1151	PSL	DDB_UFREQ_3_TIMER_BLOCK	Block Underfrequency Stage 3 Timer	F<3 Timer Block	*	*	*	*
1152	PSL	DDB_UFREQ_4_TIMER_BLOCK	Block Underfrequency Stage 4 Timer	F<4 Timer Block	*	*	*	*
1153	PSL	DDB_OFREQ_1_TIMER_BLOCK	Block Overfrequency Stage 1 Timer	F>1 Timer Block	*	*	*	*
1154	PSL	DDB_OFREQ_2_TIMER_BLOCK	Block Overfrequency Stage 2 Timer	F>2 Timer Block	*	*	*	*
1155	Frequency Protection	DDB_UFREQ_1_START	Under frequency Stage 1 start	F<1 Start	*	*	*	*
1156	Frequency Protection	DDB_UFREQ_2_START	Under frequency Stage 2 start	F<2 Start	*	*	*	*
1157	Frequency Protection	DDB_UFREQ_3_START	Under frequency Stage 3 start	F<3 Start	*	*	*	*
1158	Frequency Protection	DDB_UFREQ_4_START	Under frequency Stage 4 start	F<4 Start	*	*	*	*
1159	Frequency Protection	DDB_OFREQ_1_START	Over frequency Stage 1 start	F>1 Start	*	*	*	*
1160	Frequency Protection	DDB_OFREQ_2_START	Over frequency Stage 2 start	F>2 Start	*	*	*	*
1161	Frequency Protection	DDB_UFREQ_1_TRIP	Under frequency Stage 1 trip	F<1 Trip	*	*	*	*
1162	Frequency Protection	DDB_UFREQ_2_TRIP	Under frequency Stage 2 trip	F<2 Trip	*	*	*	*
1163	Frequency Protection	DDB_UFREQ_3_TRIP	Under frequency Stage 3 trip	F<3 Trip	*	*	*	*
1164	Frequency Protection	DDB_UFREQ_4_TRIP	Under frequency Stage 4 trip	F<4 Trip	*	*	*	*
1165	Frequency Protection	DDB_OFREQ_1_TRIP	Over frequency Stage 1 Trip	F>1 Trip	*	*	*	*
1166	Frequency Protection	DDB_OFREQ_2_TRIP	Over frequency Stage 2 Trip	F>2 Trip	*	*	*	*
1167	PSL	DDB_INHIBIT_UF1	Inhibit Stage 1 Underfrequency protection	Inhibit F<1	*	*	*	*
1168	PSL	DDB_INHIBIT_UF2	Inhibit Stage 2 Underfrequency protection	Inhibit F<2	*	*	*	*
1169	PSL	DDB_INHIBIT_UF3	Inhibit Stage 3 Underfrequency protection	Inhibit F<3	*	*	*	*
1170	PSL	DDB_INHIBIT_UF4	Inhibit Stage 4 Underfrequency protection	Inhibit F<4	*	*	*	*
1171	PSL	DDB_INHIBIT_OF1	Inhibit Stage 1 Overfrequency protection	Inhibit F>1	*	*	*	*
1172	PSL	DDB_INHIBIT_OF2	Inhibit Stage 2 Overfrequency protection	Inhibit F>2	*	*	*	*
1173	SW	DDB_NIC_LINK_1_FAIL	Network Interface Card link 1 fail indication	ETH Link 1 Fail	*	*	*	*
1174	SW	DDB_NIC_LINK_2_FAIL	Network Interface Card link 2 fail indication	ETH Link 2 Fail	*	*	*	*
1175	SW	DDB_NIC_LINK_3_FAIL	Network Interface Card link 3 fail indication	ETH Link 3 Fail	*	*	*	*
1176	SW	DDB_UI_LOGGEDIN	User logged into UI	Logged into UI	*	*	*	*
1177	SW	DDB_FCUR_LOGGEDIN	User logged into front port courier	Logged into FP	*	*	*	*
1178	SW	DDB_RP1_LOGGEDIN	User logged into Rear Port1 courier	Logged into RP1	*	*	*	*
1179	SW	DDB_RP2_LOGGEDIN	User logged into Rear Port2 courier	Logged into RP2	*	*	*	*

DDB No	Source	Element Name	Description	English Text	P543/P54 5 No. Distance	P544/P54 Distance	P543/ P545	P544/ P546
1180	SW	DDB_TNL_LOGGEDIN	User logged into turnneled courier	Logged into TNL	*	*	*	*
1181	SW	DDB_CPR_LOGGEDIN	User logged into co-processor courier	Logged into CPR	*	*	*	*
1182	SW	DDB_DST_STATUS	If this location DST is in effect now	DST status	*	*	*	*
1183		DDB_UNUSED_1183	Unused	Unused	*	*	*	*
1184	Commissioning Test	DDB_MONITOR_PORT_1	Monitor port signal 1 - allows mapped monitor signals to be mapped to disturbance recorder or contacts	Monitor Bit 1	*	*	*	*
1185	Commissioning Test	DDB_MONITOR_PORT_2	Monitor port signal 2 - allows mapped monitor signals to be mapped to disturbance recorder or contacts	Monitor Bit 2	*	*	*	*
1186	Commissioning Test	DDB_MONITOR_PORT_3	Monitor port signal 3 - allows mapped monitor signals to be mapped to disturbance recorder or contacts	Monitor Bit 3	*	*	*	*
1187	Commissioning Test	DDB_MONITOR_PORT_4	Monitor port signal 4 - allows mapped monitor signals to be mapped to disturbance recorder or contacts	Monitor Bit 4	*	*	*	*
1188	Commissioning Test	DDB_MONITOR_PORT_5	Monitor port signal 5 - allows mapped monitor signals to be mapped to disturbance recorder or contacts	Monitor Bit 5	*	*	*	*
1189	Commissioning Test	DDB_MONITOR_PORT_6	Monitor port signal 6 - allows mapped monitor signals to be mapped to disturbance recorder or contacts	Monitor Bit 6	*	*	*	*
1190	Commissioning Test	DDB_MONITOR_PORT_7	Monitor port signal 7 - allows mapped monitor signals to be mapped to disturbance recorder or contacts	Monitor Bit 7	*	*	*	*
1191	Commissioning Test	DDB_MONITOR_PORT_8	Monitor port signal 8 - allows mapped monitor signals to be mapped to disturbance recorder or contacts	Monitor Bit 8	*	*	*	*
1192	Fault recorder	DDB_NEW_FAULT_REC	New Fault Record	New Fault Record	*	*	*	*
1193	PSL	DDB_UNUSED_DR	Unused	Unused	*	*	*	*
1194	PSL	DDB_PSLINT_1	PSL Internal Node	PSL Int 1	*	*	*	*
1195	PSL	DDB_PSLINT_2	PSL Internal Node	PSL Int 2	*	*	*	*
1196	PSL	DDB_PSLINT_3	PSL Internal Node	PSL Int 3	*	*	*	*
1197	PSL	DDB_PSLINT_4	PSL Internal Node	PSL Int 4	*	*	*	*
1198	PSL	DDB_PSLINT_5	PSL Internal Node	PSL Int 5	*	*	*	*
1199	PSL	DDB_PSLINT_6	PSL Internal Node	PSL Int 6	*	*	*	*
1200	PSL	DDB_PSLINT_7	PSL Internal Node	PSL Int 7	*	*	*	*
1201	PSL	DDB_PSLINT_8	PSL Internal Node	PSL Int 8	*	*	*	*
1202	PSL	DDB_PSLINT_9	PSL Internal Node	PSL Int 9	*	*	*	*
1203	PSL	DDB_PSLINT_10	PSL Internal Node	PSL Int 10	*	*	*	*
1204	PSL	DDB_PSLINT_11	PSL Internal Node	PSL Int 11	*	*	*	*
1205	PSL	DDB_PSLINT_12	PSL Internal Node	PSL Int 12	*	*	*	*
1206	PSL	DDB_PSLINT_13	PSL Internal Node	PSL Int 13	*	*	*	*
1207	PSL	DDB_PSLINT_14	PSL Internal Node	PSL Int 14	*	*	*	*
1208	PSL	DDB_PSLINT_15	PSL Internal Node	PSL Int 15	*	*	*	*
1209	PSL	DDB_PSLINT_16	PSL Internal Node	PSL Int 16	*	*	*	*
1210	PSL	DDB_PSLINT_17	PSL Internal Node	PSL Int 17	*	*	*	*
1211	PSL	DDB_PSLINT_18	PSL Internal Node	PSL Int 18	*	*	*	*

DDB No	Source	Element Name	Description	English Text	P543/P545 No Distance	P544/P546 No Distance	P543/ P545	P544/ P546
1212	PSL	DDB_PSLINT_19	PSL Internal Node	PSL Int 19	*	*	*	*
1213	PSL	DDB_PSLINT_20	PSL Internal Node	PSL Int 20	*	*	*	*
1214	PSL	DDB_PSLINT_21	PSL Internal Node	PSL Int 21	*	*	*	*
1215	PSL	DDB_PSLINT_22	PSL Internal Node	PSL Int 22	*	*	*	*
1216	PSL	DDB_PSLINT_23	PSL Internal Node	PSL Int 23	*	*	*	*
1217	PSL	DDB_PSLINT_24	PSL Internal Node	PSL Int 24	*	*	*	*
1218	PSL	DDB_PSLINT_25	PSL Internal Node	PSL Int 25	*	*	*	*
1219	PSL	DDB_PSLINT_26	PSL Internal Node	PSL Int 26	*	*	*	*
1220	PSL	DDB_PSLINT_27	PSL Internal Node	PSL Int 27	*	*	*	*
1221	PSL	DDB_PSLINT_28	PSL Internal Node	PSL Int 28	*	*	*	*
1222	PSL	DDB_PSLINT_29	PSL Internal Node	PSL Int 29	*	*	*	*
1223	PSL	DDB_PSLINT_30	PSL Internal Node	PSL Int 30	*	*	*	*
1224	PSL	DDB_PSLINT_31	PSL Internal Node	PSL Int 31	*	*	*	*
1225	PSL	DDB_PSLINT_32	PSL Internal Node	PSL Int 32	*	*	*	*
1226	PSL	DDB_PSLINT_33	PSL Internal Node	PSL Int 33	*	*	*	*
1227	PSL	DDB_PSLINT_34	PSL Internal Node	PSL Int 34	*	*	*	*
1228	PSL	DDB_PSLINT_35	PSL Internal Node	PSL Int 35	*	*	*	*
1229	PSL	DDB_PSLINT_36	PSL Internal Node	PSL Int 36	*	*	*	*
1230	PSL	DDB_PSLINT_37	PSL Internal Node	PSL Int 37	*	*	*	*
1231	PSL	DDB_PSLINT_38	PSL Internal Node	PSL Int 38	*	*	*	*
1232	PSL	DDB_PSLINT_39	PSL Internal Node	PSL Int 39	*	*	*	*
1233	PSL	DDB_PSLINT_40	PSL Internal Node	PSL Int 40	*	*	*	*
1234	PSL	DDB_PSLINT_41	PSL Internal Node	PSL Int 41	*	*	*	*
1235	PSL	DDB_PSLINT_42	PSL Internal Node	PSL Int 42	*	*	*	*
1236	PSL	DDB_PSLINT_43	PSL Internal Node	PSL Int 43	*	*	*	*
1237	PSL	DDB_PSLINT_44	PSL Internal Node	PSL Int 44	*	*	*	*
1238	PSL	DDB_PSLINT_45	PSL Internal Node	PSL Int 45	*	*	*	*
1239	PSL	DDB_PSLINT_46	PSL Internal Node	PSL Int 46	*	*	*	*
1240	PSL	DDB_PSLINT_47	PSL Internal Node	PSL Int 47	*	*	*	*
1241	PSL	DDB_PSLINT_48	PSL Internal Node	PSL Int 48	*	*	*	*
1242	PSL	DDB_PSLINT_49	PSL Internal Node	PSL Int 49	*	*	*	*
1243	PSL	DDB_PSLINT_50	PSL Internal Node	PSL Int 50	*	*	*	*
1244	PSL	DDB_PSLINT_51	PSL Internal Node	PSL Int 51	*	*	*	*
1245	PSL	DDB_PSLINT_52	PSL Internal Node	PSL Int 52	*	*	*	*
1246	PSL	DDB_PSLINT_53	PSL Internal Node	PSL Int 53	*	*	*	*
1247	PSL	DDB_PSLINT_54	PSL Internal Node	PSL Int 54	*	*	*	*
1248	PSL	DDB_PSLINT_55	PSL Internal Node	PSL Int 55	*	*	*	*
1249	PSL	DDB_PSLINT_56	PSL Internal Node	PSL Int 56	*	*	*	*
1250	PSL	DDB_PSLINT_57	PSL Internal Node	PSL Int 57	*	*	*	*
1251	PSL	DDB_PSLINT_58	PSL Internal Node	PSL Int 58	*	*	*	*
1252	PSL	DDB_PSLINT_59	PSL Internal Node	PSL Int 59	*	*	*	*
1253	PSL	DDB_PSLINT_60	PSL Internal Node	PSL Int 60	*	*	*	*
1254	PSL	DDB_PSLINT_61	PSL Internal Node	PSL Int 61	*	*	*	*
1255	PSL	DDB_PSLINT_62	PSL Internal Node	PSL Int 62	*	*	*	*

DDB No	Source	Element Name	Description	English Text	P543/P545 Yn5 Distance	P544/P546 Yn5 Distance	P543/ P545	P544/ P546
1256	PSL	DDB_PSLINT_63	PSL Internal Node	PSL Int 63	*	*	*	*
1257	PSL	DDB_PSLINT_64	PSL Internal Node	PSL Int 64	*	*	*	*
1258	PSL	DDB_PSLINT_65	PSL Internal Node	PSL Int 65	*	*	*	*
1259	PSL	DDB_PSLINT_66	PSL Internal Node	PSL Int 66	*	*	*	*
1260	PSL	DDB_PSLINT_67	PSL Internal Node	PSL Int 67	*	*	*	*
1261	PSL	DDB_PSLINT_68	PSL Internal Node	PSL Int 68	*	*	*	*
1262	PSL	DDB_PSLINT_69	PSL Internal Node	PSL Int 69	*	*	*	*
1263	PSL	DDB_PSLINT_70	PSL Internal Node	PSL Int 70	*	*	*	*
1264	PSL	DDB_PSLINT_71	PSL Internal Node	PSL Int 71	*	*	*	*
1265	PSL	DDB_PSLINT_72	PSL Internal Node	PSL Int 72	*	*	*	*
1266	PSL	DDB_PSLINT_73	PSL Internal Node	PSL Int 73	*	*	*	*
1267	PSL	DDB_PSLINT_74	PSL Internal Node	PSL Int 74	*	*	*	*
1268	PSL	DDB_PSLINT_75	PSL Internal Node	PSL Int 75	*	*	*	*
1269	PSL	DDB_PSLINT_76	PSL Internal Node	PSL Int 76	*	*	*	*
1270	PSL	DDB_PSLINT_77	PSL Internal Node	PSL Int 77	*	*	*	*
1271	PSL	DDB_PSLINT_78	PSL Internal Node	PSL Int 78	*	*	*	*
1272	PSL	DDB_PSLINT_79	PSL Internal Node	PSL Int 79	*	*	*	*
1273	PSL	DDB_PSLINT_80	PSL Internal Node	PSL Int 80	*	*	*	*
1274	PSL	DDB_PSLINT_81	PSL Internal Node	PSL Int 81	*	*	*	*
1275	PSL	DDB_PSLINT_82	PSL Internal Node	PSL Int 82	*	*	*	*
1276	PSL	DDB_PSLINT_83	PSL Internal Node	PSL Int 83	*	*	*	*
1277	PSL	DDB_PSLINT_84	PSL Internal Node	PSL Int 84	*	*	*	*
1278	PSL	DDB_PSLINT_85	PSL Internal Node	PSL Int 85	*	*	*	*
1279	PSL	DDB_PSLINT_86	PSL Internal Node	PSL Int 86	*	*	*	*
1280	PSL	DDB_PSLINT_87	PSL Internal Node	PSL Int 87	*	*	*	*
1281	PSL	DDB_PSLINT_88	PSL Internal Node	PSL Int 88	*	*	*	*
1282	PSL	DDB_PSLINT_89	PSL Internal Node	PSL Int 89	*	*	*	*
1283	PSL	DDB_PSLINT_90	PSL Internal Node	PSL Int 90	*	*	*	*
1284	PSL	DDB_PSLINT_91	PSL Internal Node	PSL Int 91	*	*	*	*
1285	PSL	DDB_PSLINT_92	PSL Internal Node	PSL Int 92	*	*	*	*
1286	PSL	DDB_PSLINT_93	PSL Internal Node	PSL Int 93	*	*	*	*
1287	PSL	DDB_PSLINT_94	PSL Internal Node	PSL Int 94	*	*	*	*
1288	PSL	DDB_PSLINT_95	PSL Internal Node	PSL Int 95	*	*	*	*
1289	PSL	DDB_PSLINT_96	PSL Internal Node	PSL Int 96	*	*	*	*
1290	PSL	DDB_PSLINT_97	PSL Internal Node	PSL Int 97	*	*	*	*
1291	PSL	DDB_PSLINT_98	PSL Internal Node	PSL Int 98	*	*	*	*
1292	PSL	DDB_PSLINT_99	PSL Internal Node	PSL Int 99	*	*	*	*
1293	PSL	DDB_PSLINT_100	PSL Internal Node	PSL Int 100	*	*	*	*
1294	VT Supervision	DDB_VTS_IA_OPERATED	"VTS I> Inhibit " setting has been exceeded in phase a	VTS Ia>	*	*	*	*
1295	VT Supervision	DDB_VTS_IB_OPERATED	"VTS I> Inhibit " setting has been exceeded in phase b	VTS Ib>	*	*	*	*
1296	VT Supervision	DDB_VTS_IC_OPERATED	"VTS I> Inhibit " setting has been exceeded in phase c	VTS Ic>	*	*	*	*
1297	VT Supervision	DDB_VTS_VA_OPERATED	Va has exceed 30 volts (drop off at 10 volts)	VTS Va>	*	*	*	*

DDB No	Source	Element Name	Description	English Text	P543/P545 No Distance	P544/P546 No Distance	P543/ P545	P544/ P546
1298	VT Supervision	DDB_VTS_VB_OPERATED	Vb has exceed 30 volts (drop off at 10 volts)	VTS Vb>	*	*	*	*
1299	VT Supervision	DDB_VTS_VC_OPERATED	Vc has exceed 30 volts (drop off at 10 volts)	VTS Vc>	*	*	*	*
1300	VT Supervision	DDB_VTS_I2_OPERATED	"VTS I2> Inhibit " setting has been exceeded	VTS I2>	*	*	*	*
1301	VT Supervision	DDB_VTS_V2_OPERATED	V2 has exceed 10 volts	VTS V2>	*	*	*	*
1302	VT Supervision	DDB_VTS_DELTA_IA_OPERATED	Superimposed phase a current has exceed 0.1In	VTS Ia delta>	*	*	*	*
1303	VT Supervision	DDB_VTS_DELTA_IB_OPERATED	Superimposed phase b current has exceed 0.1In	VTS Ib delta>	*	*	*	*
1304	VT Supervision	DDB_VTS_DELTA_IC_OPERATED	Superimposed phase c current has exceed 0.1In	VTS Ic delta>	*	*	*	*
1305	Distance diagnostic	DDB_ZONE_1_AN_RAW	Z1 AN Comparator	Z1 AN Comparator			*	*
1306	Distance diagnostic	DDB_ZONE_1_BN_RAW	Z1 BN Comparator	Z1 BN Comparator			*	*
1307	Distance diagnostic	DDB_ZONE_1_CN_RAW	Z1 CN Comparator	Z1 CN Comparator			*	*
1308	Distance diagnostic	DDB_ZONE_1_AB_RAW	Z1 AB Comparator	Z1 AB Comparator			*	*
1309	Distance diagnostic	DDB_ZONE_1_BC_RAW	Z1 BC Comparator	Z1 BC Comparator			*	*
1310	Distance diagnostic	DDB_ZONE_1_CA_RAW	Z1 CA Comparator	Z1 CA Comparator			*	*
1311	Distance diagnostic	DDB_ZONE_2_AN_RAW	Z2 AN Comparator	Z2 AN Comparator			*	*
1312	Distance diagnostic	DDB_ZONE_2_BN_RAW	Z2 BN Comparator	Z2 BN Comparator			*	*
1313	Distance diagnostic	DDB_ZONE_2_CN_RAW	Z2 CN Comparator	Z2 CN Comparator			*	*
1314	Distance diagnostic	DDB_ZONE_2_AB_RAW	Z2 AB Comparator	Z2 AB Comparator			*	*
1315	Distance diagnostic	DDB_ZONE_2_BC_RAW	Z2 BC Comparator	Z2 BC Comparator			*	*
1316	Distance diagnostic	DDB_ZONE_2_CA_RAW	Z2 CA Comparator	Z2 CA Comparator			*	*
1317	Distance diagnostic	DDB_ZONE_3_AN_RAW	Z3 AN Comparator	Z3 AN Comparator			*	*
1318	Distance diagnostic	DDB_ZONE_3_BN_RAW	Z3 BN Comparator	Z3 BN Comparator			*	*
1319	Distance diagnostic	DDB_ZONE_3_CN_RAW	Z3 CN Comparator	Z3 CN Comparator			*	*
1320	Distance diagnostic	DDB_ZONE_3_AB_RAW	Z3 AB Comparator	Z3 AB Comparator			*	*
1321	Distance diagnostic	DDB_ZONE_3_BC_RAW	Z3 BC Comparator	Z3 BC Comparator			*	*
1322	Distance diagnostic	DDB_ZONE_3_CA_RAW	Z3 CA Comparator	Z3 CA Comparator			*	*
1323	Distance diagnostic	DDB_ZONE_P_AN_RAW	ZP AN Comparator	ZP AN Comparator			*	*
1324	Distance diagnostic	DDB_ZONE_P_BN_RAW	ZP BN Comparator	ZP BN Comparator			*	*

DDB No	Source	Element Name	Description	English Text	P543/P544 Distance	P544/P545 Distance	P543/ P544/ P545	P544/ P546
1325	Distance diagnostic	DDB_ZONE_P_CN_RAW	ZP CN Comparator	ZP CN Comparator			*	*
1326	Distance diagnostic	DDB_ZONE_P_AB_RAW	ZP AB Comparator	ZP AB Comparator			*	*
1327	Distance diagnostic	DDB_ZONE_P_BC_RAW	ZP BC Comparator	ZP BC Comparator			*	*
1328	Distance diagnostic	DDB_ZONE_P_CA_RAW	ZP CA Comparator	ZP CA Comparator			*	*
1329	Distance diagnostic	DDB_ZONE_4_AN_RAW	Z4 AN Comparator	Z4 AN Comparator			*	*
1330	Distance diagnostic	DDB_ZONE_4_BN_RAW	Z4 BN Comparator	Z4 BN Comparator			*	*
1331	Distance diagnostic	DDB_ZONE_4_CN_RAW	Z4 CN Comparator	Z4 CN Comparator			*	*
1332	Distance diagnostic	DDB_ZONE_4_AB_RAW	Z4 AB Comparator	Z4 AB Comparator			*	*
1333	Distance diagnostic	DDB_ZONE_4_BC_RAW	Z4 BC Comparator	Z4 BC Comparator			*	*
1334	Distance diagnostic	DDB_ZONE_4_CA_RAW	Z4 CA Comparator	Z4 CA Comparator			*	*
1335	Distance diagnostic	DDB_LDBN	IN> Bias	IN> Bias			*	*
1336		DDB_WI_I0_I2	WI Detect I0/I2	WI Detect I0/I2			*	*
1305	Distance diagnostic	DDB_ZONE_1_AN_RAW	Unused	Unused	*	*		
1306	Distance diagnostic	DDB_ZONE_1_BN_RAW	Unused	Unused	*	*		
1307	Distance diagnostic	DDB_ZONE_1_CN_RAW	Unused	Unused	*	*		
1308	Distance diagnostic	DDB_ZONE_1_AB_RAW	Unused	Unused	*	*		
1309	Distance diagnostic	DDB_ZONE_1_BC_RAW	Unused	Unused	*	*		
1310	Distance diagnostic	DDB_ZONE_1_CA_RAW	Unused	Unused	*	*		
1311	Distance diagnostic	DDB_ZONE_2_AN_RAW	Unused	Unused	*	*		
1312	Distance diagnostic	DDB_ZONE_2_BN_RAW	Unused	Unused	*	*		
1313	Distance diagnostic	DDB_ZONE_2_CN_RAW	Unused	Unused	*	*		
1314	Distance diagnostic	DDB_ZONE_2_AB_RAW	Unused	Unused	*	*		
1315	Distance diagnostic	DDB_ZONE_2_BC_RAW	Unused	Unused	*	*		
1316	Distance diagnostic	DDB_ZONE_2_CA_RAW	Unused	Unused	*	*		
1317	Distance diagnostic	DDB_ZONE_3_AN_RAW	Unused	Unused	*	*		
1318	Distance diagnostic	DDB_ZONE_3_BN_RAW	Unused	Unused	*	*		

DDB No	Source	Element Name	Description	English Text	P543/P545 No Distance	P544/P546 No Distance	P543/P545	P544/P546
1319	Distance diagnostic	DDB_ZONE_3_CN_RAW	Unused	Unused	*	*		
1320	Distance diagnostic	DDB_ZONE_3_AB_RAW	Unused	Unused	*	*		
1321	Distance diagnostic	DDB_ZONE_3_BC_RAW	Unused	Unused	*	*		
1322	Distance diagnostic	DDB_ZONE_3_CA_RAW	Unused	Unused	*	*		
1323	Distance diagnostic	DDB_ZONE_P_AN_RAW	Unused	Unused	*	*		
1324	Distance diagnostic	DDB_ZONE_P_BN_RAW	Unused	Unused	*	*		
1325	Distance diagnostic	DDB_ZONE_P_CN_RAW	Unused	Unused	*	*		
1326	Distance diagnostic	DDB_ZONE_P_AB_RAW	Unused	Unused	*	*		
1327	Distance diagnostic	DDB_ZONE_P_BC_RAW	Unused	Unused	*	*		
1328	Distance diagnostic	DDB_ZONE_P_CA_RAW	Unused	Unused	*	*		
1329	Distance diagnostic	DDB_ZONE_4_AN_RAW	Unused	Unused	*	*		
1330	Distance diagnostic	DDB_ZONE_4_BN_RAW	Unused	Unused	*	*		
1331	Distance diagnostic	DDB_ZONE_4_CN_RAW	Unused	Unused	*	*		
1332	Distance diagnostic	DDB_ZONE_4_AB_RAW	Unused	Unused	*	*		
1333	Distance diagnostic	DDB_ZONE_4_BC_RAW	Unused	Unused	*	*		
1334	Distance diagnostic	DDB_ZONE_4_CA_RAW	Unused	Unused	*	*		
1335	Distance diagnostic	DDB_LDBN	Unused	Unused	*	*		
1336		DDB_WI_I0_I2	Unused	Unused	*	*		
1337	Delta directional Diagnostic	DDB_DELTA_DIR_FWD_AN_RAW	Delta Directional Forward AN	Delta Dir FWD AN			*	*
1338	Delta directional Diagnostic	DDB_DELTA_DIR_FWD_BN_RAW	Delta Directional Forward BN	Delta Dir FWD BN			*	*
1339	Delta directional Diagnostic	DDB_DELTA_DIR_FWD_CN_RAW	Delta Directional Forward CN	Delta Dir FWD CN			*	*
1340	Delta directional Diagnostic	DDB_DELTA_DIR_FWD_AB_RAW	Delta Directional Forward AB	Delta Dir FWD AB			*	*
1341	Delta directional Diagnostic	DDB_DELTA_DIR_FWD_BC_RAW	Delta Directional Forward BC	Delta Dir FWD BC			*	*
1342	Delta directional Diagnostic	DDB_DELTA_DIR_FWD_CA_RAW	Delta Directional Forward CA	Delta Dir FWD CA			*	*
1343	Delta directional Diagnostic	DDB_DELTA_DIR_REV_AN_RAW	Delta Directional Reverse AN	Delta Dir Rev AN			*	*
1344	Delta directional Diagnostic	DDB_DELTA_DIR_REV_BN_RAW	Delta Directional Reverse BN	Delta Dir Rev BN			*	*

DDB No	Source	Element Name	Description	English Text	P543/P54 5 No. Distance	P544/P54 4 No. Distance	P543/ P544/ P545	P544/ P546
1345	Delta directional Diagnostic	DDB_DELTA_DIR_REV_CN_RAW	Delta Directional Reverse CN	Delta Dir Rev CN			*	*
1346	Delta directional Diagnostic	DDB_DELTA_DIR_REV_AB_RAW	Delta Directional Reverse AB	Delta Dir Rev AB			*	*
1347	Delta directional Diagnostic	DDB_DELTA_DIR_REV_BC_RAW	Delta Directional Reverse BC	Delta Dir Rev BC			*	*
1348	Delta directional Diagnostic	DDB_DELTA_DIR_REV_CA_RAW	Delta Directional Reverse CA	Delta Dir Rev CA			*	*
1337	Delta directional Diagnostic	DDB_DELTA_DIR_FWD_AN_RAW	Unused	Unused	*	*		
1338	Delta directional Diagnostic	DDB_DELTA_DIR_FWD_BN_RAW	Unused	Unused	*	*		
1339	Delta directional Diagnostic	DDB_DELTA_DIR_FWD_CN_RAW	Unused	Unused	*	*		
1340	Delta directional Diagnostic	DDB_DELTA_DIR_FWD_AB_RAW	Unused	Unused	*	*		
1341	Delta directional Diagnostic	DDB_DELTA_DIR_FWD_BC_RAW	Unused	Unused	*	*		
1342	Delta directional Diagnostic	DDB_DELTA_DIR_FWD_CA_RAW	Unused	Unused	*	*		
1343	Delta directional Diagnostic	DDB_DELTA_DIR_REV_AN_RAW	Unused	Unused	*	*		
1344	Delta directional Diagnostic	DDB_DELTA_DIR_REV_BN_RAW	Unused	Unused	*	*		
1345	Delta directional Diagnostic	DDB_DELTA_DIR_REV_CN_RAW	Unused	Unused	*	*		
1346	Delta directional Diagnostic	DDB_DELTA_DIR_REV_AB_RAW	Unused	Unused	*	*		
1347	Delta directional Diagnostic	DDB_DELTA_DIR_REV_BC_RAW	Unused	Unused	*	*		
1348	Delta directional Diagnostic	DDB_DELTA_DIR_REV_CA_RAW	Unused	Unused	*	*		
1349	Distance diagnostic	DDB_ZONE_1_BLOCKED	Zone 1 Blocked by PSB	Zone 1 Blocked			*	*
1350	Distance diagnostic	DDB_ZONE_2_BLOCKED	Zone 2 Blocked by PSB	Zone 2 Blocked			*	*
1351	Distance diagnostic	DDB_ZONE_3_BLOCKED	Zone 3 Blocked by PSB	Zone 3 Blocked			*	*
1352	Distance diagnostic	DDB_ZONE_P_BLOCKED	Zone P Blocked by PSB	Zone P Blocked			*	*
1353	Distance diagnostic	DDB_ZONE_4_BLOCKED	Zone 4 Blocked by PSB	Zone 4 Blocked			*	*
1354	Distance diagnostic	DDB_MEM_VALID	Memory Valid	Mem. Valid			*	*
1355	Phase Selector	DDB_PH_TWO_CYCLE	Phase Sel Two Cycle	Ph Two Cycle			*	*
1356	Phase Selector	DDB_PH_FIVE_CYCLE	Phase Sel Five Cycle	Ph Five Cycle			*	*
1357	Phase Selector	DDB_FROZEN	Buffer Frozen	Ph Frozen			*	*
1358	Aided Scheme Logic	DDB_AIDED1_WI_LEVEL_DETECT_A	Aided 1 WI V< A	Aided 1 WI V< A			*	*
1359	Aided Scheme Logic	DDB_AIDED1_WI_LEVEL_DETECT_B	Aided 1 WI V< B	Aided 1 WI V< B			*	*

DDB No	Source	Element Name	Description	English Text	P53/P54 5 No Distance	P54/P54 6 No Distance	P543/ P545	P544/ P546
1360	Aided Scheme Logic	DDB_AIDED1_WI_LEVEL_DETECT_C	Aided 1 WI V< C	Aided 1 WI V< C			*	*
1361	Aided Scheme Logic	DDB_AIDED2_WI_LEVEL_DETECT_A	Aided 2 WI V< A	Aided 2 WI V< A			*	*
1362	Aided Scheme Logic	DDB_AIDED2_WI_LEVEL_DETECT_B	Aided 2 WI V< B	Aided 2 WI V< B			*	*
1363	Aided Scheme Logic	DDB_AIDED2_WI_LEVEL_DETECT_C	Aided 2 WI V< C	Aided 2 WI V< C			*	*
1349	Distance diagnostic	DDB_ZONE_1_BLOCKED	Unused	Unused	*	*		
1350	Distance diagnostic	DDB_ZONE_2_BLOCKED	Unused	Unused	*	*		
1351	Distance diagnostic	DDB_ZONE_3_BLOCKED	Unused	Unused	*	*		
1352	Distance diagnostic	DDB_ZONE_P_BLOCKED	Unused	Unused	*	*		
1353	Distance diagnostic	DDB_ZONE_4_BLOCKED	Unused	Unused	*	*		
1354	Distance diagnostic	DDB_MEM_VALID	Unused	Unused	*	*		
1355	Phase Selector	DDB_PH_TWO_CYCLE	Unused	Unused	*	*		
1356	Phase Selector	DDB_PH_FIVE_CYCLE	Unused	Unused	*	*		
1357	Phase Selector	DDB_FROZEN	Unused	Unused	*	*		
1358	Aided Scheme Logic	DDB_AIDED1_WI_LEVEL_DETECT_A	Unused	Unused	*	*		
1359	Aided Scheme Logic	DDB_AIDED1_WI_LEVEL_DETECT_B	Unused	Unused	*	*		
1360	Aided Scheme Logic	DDB_AIDED1_WI_LEVEL_DETECT_C	Unused	Unused	*	*		
1361	Aided Scheme Logic	DDB_AIDED2_WI_LEVEL_DETECT_A	Unused	Unused	*	*		
1362	Aided Scheme Logic	DDB_AIDED2_WI_LEVEL_DETECT_B	Unused	Unused	*	*		
1363	Aided Scheme Logic	DDB_AIDED2_WI_LEVEL_DETECT_C	Unused	Unused	*	*		
1364	CB Control	DDB_CB_PRE_LOCKOUT	Pre-Lockout	Pre-Lockout	*		*	
1364	CB Control	DDB_CB_PRE_LOCKOUT	Output from CB1 monitoring logic	CB1 Pre-Lockout		*		*
1365	Loss of Load logic	DDB_LOL_LEVEL_DETECT_A	Loss of Load level detector A	I> LoL A			*	*
1366	Loss of Load logic	DDB_LOL_LEVEL_DETECT_B	Loss of Load level detector B	I> LoL B			*	*
1367	Loss of Load logic	DDB_LOL_LEVEL_DETECT_C	Loss of Load level detector C	I> LoL C			*	*
1365	Loss of Load logic	DDB_LOL_LEVEL_DETECT_A	Unused	Unused	*	*		
1366	Loss of Load logic	DDB_LOL_LEVEL_DETECT_B	Unused	Unused	*	*		
1367	Loss of Load logic	DDB_LOL_LEVEL_DETECT_C	Unused	Unused	*	*		
1368	Frequency Tracking	DDB_FREQ_ABOVE_RANGE_LIMIT	Freq High	Freq High	*	*	*	*

DDB No	Source	Element Name	Description	English Text	P543/P545 Distance	P544/P546 Distance	P543/ P545	P544/ P546
1369	Frequency Tracking	DDB_FREQ_BELOW_RANGE_LIMIT	Freq Low	Freq Low	*	*	*	*
1370	Frequency Tracking	DDB_FREQ_NOT_FOUND	Freq Not found	Freq Not found	*	*	*	*
1371	Frequency Tracking	DDB_FREQ_STOP_TRACK	Stop Freq Track	Stop Freq Track	*	*	*	*
1372	3d/4th Harmonic Restraint A Phase	DDB_FOURTH_HARM_A	3rd/4th Harmonic Restraint A Phase	3d/4th HarmonicA	*	*	*	*
1373	3d/4th Harmonic Restraint B Phase	DDB_FOURTH_HARM_B	3rd/4th Harmonic Restraint B Phase	3d/4th HarmonicB	*	*	*	*
1374	3d/4th Harmonic Restraint C Phase	DDB_FOURTH_HARM_C	3rd/4th Harmonic Restraint C Phase	3d/4th HarmonicC	*	*	*	*
1372	3d/4th Harmonic Restraint A Phase	DDB_FOURTH_HARM_A	Unused	Unused				
1373	3d/4th Harmonic Restraint B Phase	DDB_FOURTH_HARM_B	Unused	Unused				
1374	3d/4th Harmonic Restraint C Phase	DDB_FOURTH_HARM_C	Unused	Unused				
1375		DDB_TELEPROTECTION_DISTURBED	This is an output signal available in the PSL, that could be mapped to "C Diff Failure" for IEC870-5-103	Teleprot Disturb	*	*	*	*
1376		DDB_BACK_UP_SUPERVISION	This applies only if distance primary FUN is selected (in IEC870-5-103) This signal is ON if an overcurrent stage is selected to be enabled on VTS and distance is blocked by VTS	>> Backup Super			*	*
1376		DDB_BACK_UP_SUPERVISION	Unused	Unused	*	*		
1377		DDB_POC_TRIP_BY_VTS	This applies only if distance primary FUN is selected (in IEC870-5-103) This signal is ON if DDB 1376 is ON and one of the overcurrent stages set to be enabled on VTS condition trips	> Trip by VTS	*	*	*	*
1378		DDB_TELEPROTECTION_SENT	This applies only if distance primary FUN is selected (in IEC870-5-103) This is an output signal available in the PSL, which could be mapped to a signal send of one of the two teleprotection channels	Teleprot Tx			*	*
1379		DDB_TELEPROTECTION_RECEIVED	This applies only if distance primary FUN is selected (in IEC870-5-103) This is an output signal available in the PSL, which could be mapped to a signal receive of one of the two teleprotection channels	Teleprot Rx			*	*
1378		DDB_TELEPROTECTION_SENT	Unused	Unused	*	*		

DDB No	Source	Element Name	Description	English Text	P543/P545 No	P544/P546 Distance	P543/P545 No	P544/P546 Distance	P543/P545	P544/P546
1379		DDB_TELEPROTECTION_RECEIVED	Unused	Unused	*	*				
1380		DDB_GROUP_WARNING	This is an output signal available in the PSL, which can be mapped in IEC870-5-103 to a minor defect which does not shut down the main protection	Group Warning	*	*	*	*	*	*
1381		DDB_GROUP_ALARM	This is an output signal available in the PSL, which can be mapped in IEC870-5-103 to a major problem normally linked to the watchdog	Group Alarm	*	*	*	*	*	*
1382		DDB_AR_ON_PULSE	This is an output signal available in the PSL, which can be mapped to enable AR via pulse	AR On Pulse	*	*	*	*	*	*
1383		DDB_AR_OFF_PULSE	This is an output signal available in the PSL, which can be mapped to disable AR via pulse	AR Off Pulse	*	*	*	*	*	*
1384		DDB_AR_ENABLE	External input via DDB mapped in PSL to enable AR if Enable AR CB1 or Enable AR CB2 is set and AR Configuration setting is enabled	AR Enable	*	*	*	*	*	*
1385		DDB_AR_IN_SERVICE	Auto-reclose in service	AR In Service	*	*	*	*	*	*
1386		DDB_MAX_CH1_PROP_DELAY	Setting MaxCh 1 PropDelay has been exceeded	MaxCh1 PropDelay	*	*	*	*	*	*
1387		DDB_MAX_CH2_PROP_DELAY	Setting MaxCh 2 PropDelay has been exceeded	MaxCh2 PropDelay	*	*	*	*	*	*
1386		DDB_MAX_CH1_PROP_DELAY	Unused	Unused						
1387		DDB_MAX_CH2_PROP_DELAY	Unused	Unused						
1388		DDB_MAX_CH1_TXRX_TIME	Setting MaxCh1 Tx-RxTime has been exceeded	MaxCh1 Tx-RxTime	*	*	*	*	*	*
1389		DDB_MAX_CH2_TXRX_TIME	Setting MaxCh2 Tx-RxTime has been exceeded	MaxCh2 Tx-RxTime	*	*	*	*	*	*
1388		DDB_MAX_CH1_TXRX_TIME	Unused	Unused						
1389		DDB_MAX_CH2_TXRX_TIME	Unused	Unused						
1390	Distance diagnostic	DDB_ZONE_V_AN_RAW	ZV AN Comparator	ZV AN Comparator				*	*	
1391	Distance diagnostic	DDB_ZONE_V_BN_RAW	ZV BN Comparator	ZV BN Comparator				*	*	
1392	Distance diagnostic	DDB_ZONE_V_CN_RAW	ZV CN Comparator	ZV CN Comparator				*	*	
1393	Distance diagnostic	DDB_ZONE_V_AB_RAW	ZV AB Comparator	ZV AB Comparator				*	*	
1394	Distance diagnostic	DDB_ZONE_V_BC_RAW	ZV BC Comparator	ZV BC Comparator				*	*	
1395	Distance diagnostic	DDB_ZONE_V_CA_RAW	ZV CA Comparator	ZV CA Comparator				*	*	
1390		DDB_ZONE_V_AN_RAW	Unused	Unused	*	*				
1391		DDB_ZONE_V_BN_RAW	Unused	Unused	*	*				
1392		DDB_ZONE_V_CN_RAW	Unused	Unused	*	*				
1393		DDB_ZONE_V_AB_RAW	Unused	Unused	*	*				
1394		DDB_ZONE_V_BC_RAW	Unused	Unused	*	*				
1395		DDB_ZONE_V_CA_RAW	Unused	Unused	*	*				
1396	Phase Comparison	DDB_GND_Z2_LOW	Z2 Low Start (Ph-Gnd)	Gnd Z2 Lo Start						

DDB No	Source	Element Name	Description	English Text	P543/P545 Distance	P544/P546 Distance	P543/ P545	P544/ P546
1397	Phase Comparison	DDB_GND_Z2_HIGH	Z2 High Start (Ph-Gnd)	Gnd Z2 Hi Start				
1398	Phase Comparison	DDB_GND_Z3_LOW	Z3 Low Start (Ph-Gnd)	Gnd Z3 Lo Start				
1399	Phase Comparison	DDB_GND_Z3_HIGH	Z3 High Start (Ph-Gnd)	Gnd Z3 Hi Start				
1400	Phase Comparison	DDB_GND_Z4_LOW	Z4 Low Start (Ph-Gnd)	Gnd Z4 Lo Start				
1401	Phase Comparison	DDB_GND_Z4_HIGH	Z4 High Start (Ph-Gnd)	Gnd Z4 Hi Start				
1402	Phase Comparison	DDB_GND_ZP_LOW	ZP Low Start (Ph-Gnd)	Gnd ZP Lo Start				
1403	Phase Comparison	DDB_GND_ZP_HIGH	ZP High Start (Ph-Gnd)	Gnd ZP Hi Start				
1396		DDB_GND_Z2_LOW	Unused	Unused	*	*	*	*
1397		DDB_GND_Z2_HIGH	Unused	Unused	*	*	*	*
1398		DDB_GND_Z3_LOW	Unused	Unused	*	*	*	*
1399		DDB_GND_Z3_HIGH	Unused	Unused	*	*	*	*
1400		DDB_GND_Z4_LOW	Unused	Unused	*	*	*	*
1401		DDB_GND_Z4_HIGH	Unused	Unused	*	*	*	*
1402		DDB_GND_ZP_LOW	Unused	Unused	*	*	*	*
1403		DDB_GND_ZP_HIGH	Unused	Unused	*	*	*	*
1404	Transfer	DDB_VTS_BLOCK_DIST	Signal from the VTS logic that can be used to block operation of the distance elements	VTS Blk Distance			*	*
1404	Transfer	DDB_VTS_BLOCK_DIST	Unused	Unused	*	*		
1405		DDB_UNUSED_1405	Unused	Unused	*	*	*	*
1406		DDB_UNUSED_1406	Unused	Unused	*	*	*	*
1407		DDB_UNUSED_1407	Unused	Unused	*	*	*	*
1408	PSL	DDB_CB2_LEAD	If setting "Leader Select By:" = Opto, then preferred leader CB is CB1 if input DDB "CB2 LEAD" is low, or CB2 if DDB "CB2 LEAD" is high.	CB2 Lead		*		*
1409	PSL	DDB_FOLLOW_AR_SP	If setting "Foll AR Mode" = Opto, then if input DDB "FARSP" is high, the follower CB is enabled for single phase autoreclose, if "FARSP" is low, the follower CB is NOT enabled for single phase autoreclose.D2215	Foll AR Mode 1P		*		*
1410	PSL	DDB_FOLLOW_AR_3P	If setting "Foll AR Mode" = Opto, then if input DDB "FAR3P" is high, the follower CB is enabled for three phase autoreclose, if "FAR3P" is low, the follower CB is NOT enabled for three phase autoreclose.	Foll AR Mode 3P		*		*
1408		DDB_CB2_LEAD	Unused	Unused	*		*	
1409		DDB_FOLLOW_AR_SP	Unused	Unused	*		*	
1410		DDB_FOLLOW_AR_3P	Unused	Unused	*		*	
1411	Autoreclose	DDB_AR_3_POLE_IN_PROGRESS_2	Autoreclose in progress CB2	CB2 AR 3p InProg		*		*
1411		DDB_UNUSED_1411	Unused	Unused	*		*	
1412	PSL	DDB_EN_CB2_INDEPENDENT	Unused	Unused		*		*
1413	PSL	DDB_CB2_SPDT_EXTERNAL	Unused	Unused		*		*

DDB No	Source	Element Name	Description	English Text	P543/P545 No	P544/P546 Distance	P543/P545 No	P544/P546 Distance	P543/P545	P544/P546
1414	PSL	DDB_CB2_3PDT_EXTERNAL	Unused	Unused			*		*	*
1415	PSL	DDB_CB2_ARPERMIT	Unused	Unused			*		*	*
1416	PSL	DDB_CB2_AR_STOP	Unused	Unused			*		*	*
1417	PSL	DDB_EXTERNAL_RES_CB2_AROK	DDB mapped in PSL from opto or comms input. This input DDB is used when required to reset any CB2 Successful Autoreclose" signal.	Ext Rst CB2 AROK			*		*	*
1418	PSL	DDB_EXTERNAL_RES_CB2_SHOTS	DDB mapped in PSL from opto or comms input. This input DDB is used when required to reset the CB2 cumulative "Shots" counters.	Ext Rst CB2Shots			*		*	*
1419	PSL	DDB_RESET_CB2_CLOSE_DELAY	DDB mapped in PSL. Reset Manual CB2 Close Timer Delay (stop & reset Manual Close Delay time for closing CB2).	Rst CB2 CloseDly			*		*	*
1412		DDB_EN_CB2_INDEPENDENT	Unused	Unused	*				*	
1413		DDB_CB2_SPDT_EXTERNAL	Unused	Unused	*				*	
1414		DDB_CB2_3PDT_EXTERNAL	Unused	Unused	*				*	
1415		DDB_CB2_ARPERMIT	Unused	Unused	*				*	
1416		DDB_CB2_AR_STOP	Unused	Unused	*				*	
1417		DDB_EXTERNAL_RES_CB2_AROK	Unused	Unused	*				*	
1418		DDB_EXTERNAL_RES_CB2_SHOTS	Unused	Unused	*				*	
1419		DDB_RESET_CB2_CLOSE_DELAY	Unused	Unused	*				*	
1420	PSL	DDB_INHIBIT_AR	DDB mapped in PSL from opto or comms input. External signal to inhibit autoreclose.	Inhibit AR	*	*	*	*	*	*
1421	PSL	DDB_BLOCK_CB2_AR	DDB mapped in PSL from opto or comms input. External signal to force CB2 autoreclose to lockout.	Block CB2 AR			*		*	*
1422	PSL	DDB_RESET_CB2_LOCKOUT	DDB mapped in PSL from opto or comms input. Reset Lockout Opto Input to reset CB2 Lockout state	Rst CB2 Lockout			*		*	*
1423	PSL	DDB_MCB_VTS_CS2	DDB mapped in PSL from opto input (Bus2 VT secondary MCB tripped or VT fail detected by external VTS scheme), or signal from host relay VTS scheme	MCB/VTS CB2 CS			*		*	*
1424	PSL	DDB_INHIBIT_LIVE_BUS2	DDB mapped in PSL from opto input (external signal to inhibit Live Bus 2 function)	Inhibit LB2			*		*	*
1425	PSL	DDB_INHIBIT_DEAD_BUS2	DDB mapped in PSL from opto input (external signal to inhibit Dead Bus 2 function)	Inhibit DB2			*		*	*
1421		DDB_BLOCK_CB2_AR	Unused	Unused	*				*	
1422		DDB_RESET_CB2_LOCKOUT	Unused	Unused	*				*	
1423		DDB_MCB_VTS_CS2	Unused	Unused	*				*	
1424		DDB_INHIBIT_LIVE_BUS2	Unused	Unused	*				*	
1425		DDB_INHIBIT_DEAD_BUS2	Unused	Unused	*				*	
1426	PSL	DDB_CHECKSYNC2_1_ENABLED	DDB mapped in PSL from opto input or logic DDBs (enable CB2 CS1 check synchronism function)	CB2 CS1 Enabled			*		*	*
1427	PSL	DDB_CHECKSYNC2_2_ENABLED	DDB mapped in PSL from opto input or logic DDBs (enable CB2 CS2 check synchronism function)	CB2 CS2 Enabled			*		*	*
1426		DDB_CHECKSYNC2_1_ENABLED	Unused	Unused	*				*	
1427		DDB_CHECKSYNC2_2_ENABLED	Unused	Unused	*				*	

DDB No	Source	Element Name	Description	English Text	P543/P545 N/A Distance	P544/P546 N/A Distance	P543/ P545	P544/ P546
1428		DDB_CB2_IN_SERVICE	Signal from CB In Service logic, indicating that CB2 is "In Service", i.e. can be initiated to autoreclose,	CB2 In Service	*		*	
1429	Autoreclose	DDB_CB2_NO_AR	CB2 not available for autoreclose	CB2 NoAR	*		*	
1428		DDB_CB2_IN_SERVICE	Unused	Unused	*		*	
1429		DDB_CB2_NO_AR	Unused	Unused	*		*	
1430		DDB_UNUSED_1430	Unused	Unused	*	*	*	*
1431	Autoreclose	DDB_LEAD_CB2	CB2 set as leader	Leader CB2		*		*
1432	Autoreclose	DDB_FOLLOW_CB	CB1 set as follower	Follower CB1		*		*
1433	Autoreclose	DDB_FOLLOW_CB2	CB2 set as follower	Follower CB2		*		*
1434	Autoreclose	DDB_CB2_AR_INIT	Indicates initiation of a CB2 autoreclose cycle	CB2 AR Init		*		*
1435	Autoreclose	DDB_CB2_AR_INPROGRESS	CB2 autoreclose cycle in progress	CB2 ARIP		*		*
1436	Autoreclose	DDB_CB2_IND_AR_INPROGRESS	Unused	Unused		*		*
1431		DDB_LEAD_CB2	Unused	Unused	*		*	
1432		DDB_FOLLOW_CB	Unused	Unused	*		*	
1433		DDB_FOLLOW_CB2	Unused	Unused	*		*	
1434		DDB_CB2_AR_INIT	Unused	Unused	*		*	
1435		DDB_CB2_AR_INPROGRESS	Unused	Unused	*		*	
1436		DDB_CB2_IND_AR_INPROGRESS	Unused	Unused	*		*	
1437	SW	DDB_DIFFERENTIAL_HIGHSTART	Current differential High Set start	IDiff>>Start	*	*	*	*
1438	SW	DDB_DIFFERENTIAL_HIGHSTART_A	Current differential High Set A phase start	IDiff>>Start A	*	*	*	*
1439	SW	DDB_DIFFERENTIAL_HIGHSTART_B	Current differential High Set B phase start	IDiff>>Start B	*	*	*	*
1440	SW	DDB_DIFFERENTIAL_HIGHSTART_C	Current differential High Set C phase start	IDiff>>Start C	*	*	*	*
1437	SW	DDB_DIFFERENTIAL_HIGHSTART	Unused	Unused				
1438	SW	DDB_DIFFERENTIAL_HIGHSTART_A	Unused	Unused				
1439	SW	DDB_DIFFERENTIAL_HIGHSTART_B	Unused	Unused				
1440	SW	DDB_DIFFERENTIAL_HIGHSTART_C	Unused	Unused				
1441		DDB_CB2_FAIL_AR	CB2 autoreclose failed due to persistent fault	CB2 Failed AR		*		*
1442		DDB_DEAD_TIME_OK_CB2LSP	Output DDB indicates conditions to enable CB2 lead single phase autoreclose dead time to run are satisfied	DTOK CB2L 1P		*		*
1443		DDB_DEAD_TIME_OK_CB2L3P	Output DDB indicates conditions to enable CB2 lead three phase autoreclose dead time to run are satisfied	DTOK CB2L 3P		*		*
1444		DDB_CB2_3POLE_DEAD_TIME	Indicates CB2 three phase autoreclose dead time running	CB2 3P DTime		*		*
1445		DDB_ENABLE_CB2_FOLLOWER	Indicates conditions are satisfied to enable CB2 follower sequence	En CB2 Follower		*		*
1446		DDB_SPOLE_FOLLOWER_TIME	Indicates a single pole autoreclose follower time is running (either CB)	1P Follower Time		*		*
1447		DDB_3POLE_FOLLOWER_TIME	Indicates a three pole autoreclose follower time is running (either CB)	3P Follower Time		*		*
1448		DDB_CB2_AUTO_CLOSE	Signal from autoreclose logic to initiate CB2 close via "CB2 CB Control"	Auto Close CB2		*		*
1449		DDB_SET_CB2_CLOSE	Indicates a CB2 Auto Close signal has been issued	Set CB2 Close		*		*

DDB No	Source	Element Name	Description	English Text	P543/P545 No Distance	P544/P546 No Distance	P543/ P545	P544/ P546
1450		DDB_CB2_CONTROL	Output DDB can be applied to inhibit CB2 reclose by adjacent scheme until local autoreclose scheme confirms it is OK to close CB2	CB2 Control		*		*
1451		DDB_CB2_SUCCESSFUL_SPAR	CB2 successful single phase AR	CB2 Succ 1P AR		*		*
1452		DDB_CB2_SUCCESSFUL_3PAR	CB2 successful three phase AR	CB2 Succ 3P AR		*		*
1453		DDB_CB2_CTRL_CLOSE_IN_PROGRESS	CB2 Manual Close initiated – awaiting Man Close Delay time	CB2 Close inProg		*		*
1454		DDB_CB2_FAST_SYSTEM_CHECK_OK	OK to reclose CB2 with sync check without waiting for dead time to complete	CB2 Fast SCOK		*		*
1455		DDB_CB2_LEADER_SYSTEM_CHECK_OK	System conditions OK to reclose CB2 as leader when dead time complete	CB2L SCOK		*		*
1456		DDB_CB2_FOLLOWER_SYSTEM_CHECK_OK	System conditions OK to reclose CB2 when follower time complete	CB2F SCOK		*		*
1457		DDB_CB2_IND_SYSTEM_CHECK_OK	Unused	Unused		*		*
1458		DDB_CB2_MANUAL_SYSTEM_CHECK_OK	System conditions OK to manually close CB2	CB2 Man SCOK		*		*
1459		DDB_CB2_FAIL_PROTECTION_TRIP	signal to force CB2 AR lockout if CB2 fails to trip when protection operates	CB2 Fail Pr Trip		*		*
1460		DDB_CB2_LOCKOUT	Unused	Unused		*		*
1441		DDB_CB2_FAIL_AR	Unused	Unused	*		*	
1442		DDB_DEAD_TIME_OK_CB2LSP	Unused	Unused	*		*	
1443		DDB_DEAD_TIME_OK_CB2L3P	Unused	Unused	*		*	
1444		DDB_CB2_3POLE_DEAD_TIME	Unused	Unused	*		*	
1445		DDB_ENABLE_CB2_FOLLOWER	Unused	Unused	*		*	
1446		DDB_SPOLE_FOLLOWER_TIME	Unused	Unused	*		*	
1447		DDB_3POLE_FOLLOWER_TIME	Unused	Unused	*		*	
1448		DDB_CB2_AUTO_CLOSE	Unused	Unused	*		*	
1449		DDB_SET_CB2_CLOSE	Unused	Unused	*		*	
1450		DDB_CB2_CONTROL	Unused	Unused	*		*	
1451		DDB_CB2_SUCCESSFUL_SPAR	Unused	Unused	*		*	
1452		DDB_CB2_SUCCESSFUL_3PAR	Unused	Unused	*		*	
1453		DDB_CB2_CTRL_CLOSE_IN_PROGRESS	Unused	Unused	*		*	
1454		DDB_CB2_FAST_SYSTEM_CHECK_OK	Unused	Unused	*		*	
1455		DDB_CB2_LEADER_SYSTEM_CHECK_OK	Unused	Unused	*		*	
1456		DDB_CB2_FOLLOWER_SYSTEM_CHECK_OK	Unused	Unused	*		*	
1457		DDB_CB2_IND_SYSTEM_CHECK_OK	Unused	Unused	*		*	
1458		DDB_CB2_MANUAL_SYSTEM_CHECK_OK	Unused	Unused	*		*	
1459		DDB_CB2_FAIL_PROTECTION_TRIP	Unused	Unused	*		*	
1460		DDB_CB2_LOCKOUT	Unused	Unused	*		*	
1461		DDB_SYSCHECKS_BUS2_LIVE	Indicates Bus 2 input is live, i.e. voltage >= setting [48 89]	Live Bus 2		*		*
1462		DDB_SYSCHECKS_BUS2_DEAD	Indicates Bus 2 input is dead i.e. voltage < setting [48 8A]	Dead Bus 2		*		*
1463		DDB_CHECKSYNC2_2_OK	CB2 close with synchronism check type 2 is permitted (setting [48 A2]= Enabled), and Line and Bus 2 voltages satisfy relay settings for CB2 synchronism check type 2	CB2 CS2 OK		*		*
1461		DDB_SYSCHECKS_BUS2_LIVE	Unused	Unused	*		*	

DDB No	Source	Element Name	Description	English Text	P543/P54 5 No. Distance	P544/P54 4 No. Distance	P543/ P544/ P545	P544/ P546
1462		DDB_SYSCHECKS_BUS2_DEAD	Unused	Unused	*		*	
1463		DDB_CHECKSYNC2_2_OK	Unused	Unused	*		*	
1464		DDB_CS2_SLIP_O	Line-Bus 1 slip freq > setting [48 98] (frequency difference (slip) between line voltage and bus 1 voltage is greater than maximum slip permitted for CB1 synchronism check type 2)	CB1 CS2 SlipF>		*		*
1464		DDB_CS2_SLIP_O	Line-Bus 1 slip freq > setting [48 98] (frequency difference (slip) between line voltage and bus 1 voltage is greater than maximum slip permitted for CB synchronism check type 2)	CS2 SlipF>	*		*	
1465		DDB_CS2_SLIP_U	Line-Bus 1 slip freq < setting [48 98] (frequency difference (slip) between line voltage and bus 1 voltage is within the permitted range for CB1 synchronism check type 2)	CB1 CS2 SlipF<		*		*
1465		DDB_CS2_SLIP_U	Line-Bus 1 slip freq < setting [48 98] (frequency difference (slip) between line voltage and bus voltage is within the permitted range for CB synchronism check type 2)	CS2 SlipF<	*		*	
1466		DDB_CS2_1_SLIP_O	Line-Bus 2 slip freq > setting [48 A1] (frequency difference (slip) between line voltage and bus 2 voltage is greater than maximum slip permitted for CB2 synchronism check type 1)	CB2 CS1 SlipF>		*		*
1467		DDB_CS2_1_SLIP_U	Line-Bus 2 slip freq < setting [48 A1] (frequency difference (slip) between line voltage and bus 2 voltage is within the permitted range for CB2 synchronism check type 1)	CB2 CS1 SlipF<		*		*
1468		DDB_CS2_2_SLIP_O	Line-Bus 2 slip freq > setting [48 A6] (frequency difference (slip) between line voltage and bus 2 voltage is greater than maximum slip permitted for CB2 synchronism check type 2)	CB2 CS2 SlipF>		*		*
1469		DDB_CS2_2_SLIP_U	Line-Bus 2 slip freq < setting [48 A6] (frequency difference (slip) between line voltage and bus 2 voltage is within the permitted range for CB2 synchronism check type 2)	CB2 CS2 SlipF<		*		*
1466		DDB_CS2_1_SLIP_O	Unused	Unused	*		*	
1467		DDB_CS2_1_SLIP_U	Unused	Unused	*		*	
1468		DDB_CS2_2_SLIP_O	Unused	Unused	*		*	
1469		DDB_CS2_2_SLIP_U	Unused	Unused	*		*	
1470		DDB_SYSCHECKS2_1_VLINE_DIFF_HIGH	Unused	Unused	*		*	
1471		DDB_SYSCHECKS2_2_VLINE_DIFF_HIGH	Unused	Unused	*		*	
1472		DDB_SYSCHECKS2_1_VBUS_DIFF_HIGH	Unused	Unused	*		*	
1473		DDB_SYSCHECKS2_2_VBUS_DIFF_HIGH	Unused	Unused	*		*	
1474		DDB_CS2_1_LINE_FREQ_GT_BUS_FREQ	Unused	Unused	*		*	
1475		DDB_CS2_2_LINE_FREQ_GT_BUS_FREQ	Unused	Unused	*		*	
1476		DDB_CS2_1_LINE_FREQ_LT_BUS_FREQ	Unused	Unused	*		*	
1477		DDB_CS2_2_LINE_FREQ_LT_BUS_FREQ	Unused	Unused	*		*	

DDB No	Source	Element Name	Description	English Text	P543/P545 No Distance	P544/P546 No Distance	P543/ P545	P544/ P546
1478		DDB_CS2_1_ANGLE_NOT_OK_POS	Unused	Unused	*		*	
1479		DDB_CS2_1_ANGLE_NOT_OK_NEG	Unused	Unused	*		*	
1480		DDB_CS2_2_ANGLE_NOT_OK_POS	Unused	Unused	*		*	
1481		DDB_CS2_2_ANGLE_NOT_OK_NEG	Unused	Unused	*		*	
1482		DDB_SYSCHECKS2_ANGLE_ACW	Unused	Unused	*		*	
1483		DDB_SYSCHECKS2_ANGLE_CW	Unused	Unused	*		*	
1484		DDB_SYSCHECKS_INACTIVE2	Unused	Unused	*		*	
1485		DDB_AR_FORCE_3_POLE_TRIPS_CB2	Unused	Unused	*		*	
1470		DDB_SYSCHECKS2_1_VLINE_DIFF_HIGH	Voltage magnitude difference between Line V and Bus2 V is greater than setting [48 9F] (line V > Bus V)	CB2 CS1 VL>VB		*		*
1471		DDB_SYSCHECKS2_2_VLINE_DIFF_HIGH	Voltage magnitude difference between Line V and Bus2 V is greater than setting [48 A4] (line V > Bus V)	CB2 CS2 VL>VB		*		*
1472		DDB_SYSCHECKS2_1_VBUS_DIFF_HIGH	Voltage magnitude difference between Line V and Bus2 V is greater than setting [48 9F] (line V < Bus V)	CB2 CS1 VL<VB		*		*
1473		DDB_SYSCHECKS2_2_VBUS_DIFF_HIGH	Voltage magnitude difference between Line V and Bus2 V is greater than setting [48 A4] (line V < Bus V)	CB2 CS2 VL<VB		*		*
1474		DDB_CS2_1_LINE_FREQ_GT_BUS_FREQ	Frequency difference between Line V and Bus2 V is greater than setting [48 A1] (line freq > Bus freq)	CB2 CS1 FL>FB		*		*
1475		DDB_CS2_2_LINE_FREQ_GT_BUS_FREQ	Frequency difference between Line V and Bus2 V is greater than setting [48 A6] (line freq > Bus freq)	CB2 CS2 FL>FB		*		*
1476		DDB_CS2_1_LINE_FREQ_LT_BUS_FREQ	Frequency difference between Line V and Bus2 V is greater than setting [48 A1] (line freq < Bus freq)	CB2 CS1 FL<FB		*		*
1477		DDB_CS2_2_LINE_FREQ_LT_BUS_FREQ	Frequency difference between Line V and Bus2 V is greater than setting [48 A6] (line freq < Bus freq)	CB2 CS2 FL<FB		*		*
1478		DDB_CS2_1_ANGLE_NOT_OK_POS	Line/Bus2 phase angle in range: setting [48 9E] to +180deg (anticlockwise from Vbus)	CB2 CS1 AngHigh+		*		*
1479		DDB_CS2_1_ANGLE_NOT_OK_NEG	Line/Bus2 phase angle in range: setting [48 9E] to -180deg (clockwise from Vbus)	CB2 CS1 AngHigh-		*		*
1480		DDB_CS2_2_ANGLE_NOT_OK_POS	Line/Bus2 phase angle in range: setting [48 A3] to +180deg (anticlockwise from Vbus)	CB2 CS2 AngHigh+		*		*
1481		DDB_CS2_2_ANGLE_NOT_OK_NEG	Line/Bus2 phase angle in range: setting [48 A3] to -180deg (clockwise from Vbus)	CB2 CS2 AngHigh-		*		*
1482		DDB_SYSCHECKS2_ANGLE_ACW	Line freq > (Bus2 freq + 0.001Hz) (Line voltage vector rotating anticlockwise relative to VBus2)	CB2 CS AngRotACW		*		*
1483		DDB_SYSCHECKS2_ANGLE_CW	Bus2 freq > (Line freq + 0.001Hz) (Line voltage vector rotating clockwise relative to VBus2)	CB2 CS AngRotCW		*		*
1484		DDB_SYSCHECKS_INACTIVE2	Output from CB2 system check logic: indicates system checks for CB2 are disabled (setting "System Checks CB2" = Disabled or global setting "System Checks" = Disabled)	SChksInactiveCB2		*		*

DDB No	Source	Element Name	Description	English Text	P543P54 Yn5 Distance	P544P54 Yn5 Distance	P543/ P544/ P545	P544/ P546
1485	Autoreclose	DDB_AR_FORCE_3_POLE_TRIPS_CB2	This DDB is set when the autoreclose logic has determined that single pole tripping/autoreclosing is not permitted for CB2. It can be applied in PSL when required to force trip conversion logic for internal and/or external protection to three phase trip mode for CB2.	AR Force CB2 3P	*		*	
1486		DDB_UNUSED_1486	Unused	Unused	*	*	*	*
1487		DDB_CB_IND_AR_INPROGRESS	Unused	Unused	*		*	
1488		DDB_ENABLE_CB_FOLLOWER	Unused	Unused	*		*	
1489		DDB_SPOLE_INDEPENDENT_TIME	Unused	Unused	*		*	
1490		DDB_3POLE_INDEPENDENT_TIME	Unused	Unused	*		*	
1491		DDB_CB_FOLLOWR_SYSTEM_CHECK_OK	Unused	Unused	*		*	
1492		DDB_CB_IND_SYSTEM_CHECK_OK	Unused	Unused	*		*	
1487	Autoreclose	DDB_CB_IND_AR_INPROGRESS	Unused	Unused		*		*
1488		DDB_ENABLE_CB_FOLLOWER	Indicates conditions are satisfied to enable CB1 follower sequence	En CB1 Follower		*		*
1489		DDB_SPOLE_INDEPENDENT_TIME	Unused	Unused		*		*
1490		DDB_3POLE_INDEPENDENT_TIME	Unused	Unused		*		*
1491		DDB_CB_FOLLOWR_SYSTEM_CHECK_OK	System conditions OK to reclose CB1 when follower time complete	CB1F SCOK		*		*
1492		DDB_CB_IND_SYSTEM_CHECK_OK	Unused	Unused		*		*
1493		DDB_CS2_LINE_FREQ_GT_BUS_FREQ	Frequency difference between Line V and Bus1 V is greater than setting [48 98] (line freq > Bus freq)	CB1 CS2 FL>FB		*		*
1494		DDB_CS2_LINE_FREQ_LT_BUS_FREQ	Frequency difference between Line V and Bus1 V is greater than setting [48 98] (line freq < Bus freq)	CB1 CS2 FL<FB		*		*
1495		DDB_CS2_ANGLE_NOT_OK_POS	Line/Bus1 phase angle in range: setting [48 95] to +180deg (anticlockwise from Vbus)	CB1 CS2 AngHigh+		*		*
1496		DDB_CS2_ANGLE_NOT_OK_NEG	Line/Bus1 phase angle in range: setting [48 95] to -180deg (clockwise from Vbus)	CB1 CS2 AngHigh-		*		*
1493		DDB_CS2_LINE_FREQ_GT_BUS_FREQ	Frequency difference between Line V and Bus1 V is greater than setting [48 98] (line freq > Bus freq)	CS2 FL>FB	*		*	
1494		DDB_CS2_LINE_FREQ_LT_BUS_FREQ	Frequency difference between Line V and Bus1 V is greater than setting [48 98] (line freq < Bus freq)	CS2 FL<FB	*		*	
1495		DDB_CS2_ANGLE_NOT_OK_POS	Line/Bus1 phase angle in range: setting [48 95] to +180deg (anticlockwise from Vbus)	CS2 AngHigh+	*		*	
1496		DDB_CS2_ANGLE_NOT_OK_NEG	Line/Bus1 phase angle in range: setting [48 95] to -180deg (clockwise from Vbus)	CS2 AngHigh-	*		*	
1497	PSL	DDB_LEAD_AR_SP	If setting "Lead AR Mode" = Opto, then if input DDB "AR Mode 1P" is high, the leader CB is enabled for single phase autoreclose, if "AR Mode 1P" is low, the leader CB is NOT enabled for single phase autoreclose.	AR Mode 1P	*	*	*	*
1498	PSL	DDB_LEAD_AR_3P	If setting "Lead AR Mode" = Opto, then if input DDB "AR Mode 3P" is high, the leader CB is enabled for three phase autoreclose, if "AR Mode 3P" is low, the leader CB is NOT enabled for three phase autoreclose.	AR Mode 3P	*	*	*	*

DDB No	Source	Element Name	Description	English Text	P543/P545 No Distance	P544/P546 No Distance	P543/P545	P544/P546
1499		DDB_CB2_TRIP_AR_MEMORY_A	CB2 A Ph trip & AR initiation memory	CB2 Trip AR MemA		*		*
1500		DDB_CB2_TRIP_AR_MEMORY_B	CB2 B Ph trip & AR initiation memory	CB2 Trip AR MemB		*		*
1501		DDB_CB2_TRIP_AR_MEMORY_C	CB2 C Ph trip & AR initiation memory	CB2 Trip AR MemC		*		*
1499		DDB_CB2_TRIP_AR_MEMORY_A	Unused	Unused	*		*	
1500		DDB_CB2_TRIP_AR_MEMORY_B	Unused	Unused	*		*	
1501		DDB_CB2_TRIP_AR_MEMORY_C	Unused	Unused	*		*	
1502		DDB_UNUSED_1502	Unused	Unused	*	*	*	*
1503	PSL	DDB_EN_CB_INDEPENDENT	Unused	Unused		*		*
1503		DDB_EN_CB_INDEPENDENT	Unused	Unused	*		*	
1504	PSL	DDB_INIT_APH_AR_TEST	DDB mapped in PSL from opto or comms input. Input high-low operation will initiate APH test trip & autoreclose cycle	Init APH AR Test	*	*	*	*
1505	PSL	DDB_INIT_BPH_AR_TEST	DDB mapped in PSL from opto or comms input. Input high-low operation will initiate BPh test trip & autoreclose cycle	Init BPh AR Test	*	*	*	*
1506	PSL	DDB_INIT_CPH_AR_TEST	DDB mapped in PSL from opto or comms input. Input high-low operation will initiate CPh test trip & autoreclose cycle	Init CPh AR Test	*	*	*	*
1507	PSL	DDB_INIT_3PH_AR_TEST	DDB mapped in PSL from opto or comms input. Input high-low operation will initiate 3Ph test trip & autoreclose cycle	Init 3P AR Test	*	*	*	*
1508	PSL	DDB_EXTERNAL_FAULT_A	DDB mapped in PSL from opto or comms input: indicates external protection operated for fault involving A phase	Ext Fault APH	*	*	*	*
1509	PSL	DDB_EXTERNAL_FAULT_B	DDB mapped in PSL from opto or comms input: indicates external protection operated for fault involving C phase	Ext Fault BPh	*	*	*	*
1510	PSL	DDB_EXTERNAL_FAULT_C	DDB mapped in PSL from opto or comms input: indicates external protection operated for fault involving C phase	Ext Fault CPh	*	*	*	*
1511	PSL	DDB_AR_SKIP_SHOT1	DDB mapped in PSL from opto or comms input: if setting "AR Skip Shot 1" = Enable and this input is high when a protection operation initiates an autoreclose cycle, then the sequence counter advances directly to SC:COUNT = 2 so the autoreclose cycle skips (omits) Shot 1 and instead starts at Dead Time 2 for the first reclose attempt.	AR Skip Shot1	*	*	*	*
1512	PSL	DDB_CB_SPDT_EXTERNAL	Unused	Unused		*		*
1513	PSL	DDB_CB_3PDT_EXTERNAL	Unused	Unused		*		*
1514	PSL	DDB_CB_ARPERMIT	Unused	Unused		*		*
1515	PSL	DDB_CB_AR_STOP	Unused	Unused		*		*
1511	PSL	DDB_AR_SKIP_SHOT1	Unused	Unused				
1512	PSL	DDB_CB_SPDT_EXTERNAL	Unused	Unused	*		*	
1513	PSL	DDB_CB_3PDT_EXTERNAL	Unused	Unused	*		*	
1514	PSL	DDB_CB_ARPERMIT	Unused	Unused	*		*	
1515	PSL	DDB_CB_AR_STOP	Unused	Unused	*		*	
1516	PSL	DDB_EXTERNAL_RECLAIM_TIME	Unused	Unused	*	*	*	*

DDB No	Source	Element Name	Description	English Text	P543/P544 In No. Distance	P544/P545 In No. Distance	P543/ P544/ P545	P544/ P546
1517	PSL	DDB_EXTERNAL_RES_CB_AROK	DDB mapped in PSL from opto or comms input. This input DDB is used when required to reset any CB1 "Successful Autoreclose" signal.	Ext Rst CB1 AROK	*		*	
1518	PSL	DDB_EXTERNAL_RES_CB_SHOTS	DDB mapped in PSL from opto or comms input. This input DDB is used when required to reset the CB1 cumulative "Shots" counters.	Ext Rst CB1Shots		*		*
1517	PSL	DDB_EXTERNAL_RES_CB_AROK	DDB mapped in PSL from opto or comms input. This input DDB is used when required to reset any CB "Successful Autoreclose" signal.	Ext Rst AROK	*		*	
1518	PSL	DDB_EXTERNAL_RES_CB_SHOTS	DDB mapped in PSL from opto or comms input. This input DDB is used when required to reset the CB cumulative "Shots" counters.	Ext Rst CB Shots	*		*	
1519	PSL	DDB_UNUSED_1519	Unused	Unused	*	*	*	*
1520	PSL	DDB_UNUSED_1520	Unused	Unused	*	*	*	*
1521	PSL	DDB_MCB_VTS_CS1	DDB mapped in PSL from opto input (Bus1 VT secondary MCB tripped or VT fail detected by external VTS scheme), or signal from host relay VTS scheme	MCB/VTS CB1 CS	*	*	*	*
1522	PSL	DDB_INHIBIT_LIVE_LINE	DDB mapped in PSL from opto input (external signal to inhibit Live Line function)	Inhibit LL	*	*	*	*
1523	PSL	DDB_INHIBIT_DEAD_LINE	DDB mapped in PSL from opto input (external signal to inhibit Dead Line function)	Inhibit DL	*	*	*	*
1524	PSL	DDB_INHIBIT_LIVE_BUS1	DDB mapped in PSL from opto input (external signal to inhibit Live Bus 1 function)	Inhibit LB1		*		*
1525	PSL	DDB_INHIBIT_DEAD_BUS1	DDB mapped in PSL from opto input (external signal to inhibit Dead Bus 1 function)	Inhibit DB1		*		*
1524	PSL	DDB_INHIBIT_LIVE_BUS1	DDB mapped in PSL from opto input (external signal to inhibit Live Bus function)	Inhibit LB	*		*	
1525	PSL	DDB_INHIBIT_DEAD_BUS1	DDB mapped in PSL from opto input (external signal to inhibit Dead Bus function)	Inhibit DB	*		*	
1526		DDB_CB1_IN_SERVICE	CB1 In Service (can be initiated for autoreclose)	CB1 In Service		*		*
1526		DDB_CB1_IN_SERVICE	CB In Service (can be initiated for autoreclose)	CB In Service	*		*	
1527		DDB_UNUSED_1527	Unused	Unused	*	*	*	*
1528	Autoreclose	DDB_CB_NO_AR	CB1 not available for autoreclose	CB1 NoAR		*		*
1528	Autoreclose	DDB_CB_NO_AR	CB not available for autoreclose	CB NoAR				
1528		DDB_CB_NO_AR	Unused	Unused	*		*	
1529		DDB_UNUSED_1529	Unused	Unused	*	*	*	*
1530	Autoreclose	DDB_LEAD_CB	CB1 set as leader	Leader CB1		*		*
1530		DDB_LEAD_CB	Unused	Unused	*		*	
1531		DDB_UNUSED_1531	Unused	Unused	*	*	*	*
1532	Autoreclose	DDB_AR_IN_SERVICE_3P_FOLLOWER	Follower 3 Pole auto-recloser in service - the auto-reclose function has been enabled either in the relay menu, or by an opto input	Follow A/R 3P		*		*
1533	Autoreclose	DDB_AR_IN_SERVICE_1P_FOLLOWER	Follower Single pole auto-recloser in service - the auto-reclose function has been enabled either in the relay menu, or by an opto input	Follow A/R 1P		*		*
1534		DDB_UNUSED_1534	Unused	Unused		*		*

DDB No	Source	Element Name	Description	English Text	P543/P545 No	P544/P546 Distance	P543/P545 No	P544/P546 Distance
1535		DDB_TRIP_AR_MEMORY_A	A Ph trip & AR initiation memory	CB1 Trip AR MemA		*		*
1536		DDB_TRIP_AR_MEMORY_B	B Ph trip & AR initiation memory	CB1 Trip AR MemB		*		*
1537		DDB_TRIP_AR_MEMORY_C	C Ph trip & AR initiation memory	CB1 Trip AR MemC		*		*
1532		DDB_UNUSED_1532	Unused	Unused	*		*	
1533		DDB_UNUSED_1533	Unused	Unused	*		*	
1534		DDB_UNUSED_1534	Unused	Unused	*		*	
1535		DDB_TRIP_AR_MEMORY_A	A Ph trip & AR initiation memory	Trip AR MemA	*		*	
1536		DDB_TRIP_AR_MEMORY_B	B Ph trip & AR initiation memory	Trip AR MemB	*		*	
1537		DDB_TRIP_AR_MEMORY_C	C Ph trip & AR initiation memory	Trip AR MemC	*		*	
1538	SW	DDB_TS_OC_A_S1	Trip supervision: l> phaseA stage1	TS l> pHa s1	*	*	*	*
1539	SW	DDB_TS_OC_A_S2	Trip supervision: l> phaseA stage2	TS l> pHa s2	*	*	*	*
1540	SW	DDB_TS_OC_A_S3	Trip supervision: l> phaseA stage3	TS l> pHa s3	*	*	*	*
1541	Autoreclose	DDB_AR_START	Any AR initiation signal present	AR Start	*	*	*	*
1542	Autoreclose	DDB_AR_IN_PROGRESS	Any AR cycle in progress	ARIP	*	*	*	*
1543	Autoreclose	DDB_CB_AR_INIT	CB1 AR cycle initiation	CB1 AR Init		*		*
1544	Autoreclose	DDB_CB_AR_INPROGRESS	CB1 AR cycle in progress	CB1 ARIP		*		*
1543	Autoreclose	DDB_CB_AR_INIT	CB AR cycle initiation	AR Initiation	*		*	
1544	Autoreclose	DDB_CB_AR_INPROGRESS	CB AR cycle in progress	CB ARIP	*		*	
1545	SW	DDB_TS_OC_B_S1	Trip supervision: l> phaseB stage1	TS l> pHb s1	*	*	*	*
1546		DDB_SEQ_COUNT_GREATER_THAN_SHOTS	Sequence counts greater than shots	Seq Counter>Set	*	*	*	*
1547		DDB_EVOLVE_3PHASE	Convert SPAR to 3PAR. DDB mapped to give 100ms pulse to CB1 Trip 3Ph and CB2 Trip 3Ph outputs	Evolve 3Ph	*	*	*	*
1548	SW	DDB_TS_OC_B_S2	Trip supervision: l> phaseB stage2	TS l> pHb s2	*	*	*	*
1549	SW	DDB_TS_OC_B_S3	Trip supervision: l> phaseB stage3	TS l> pHb s3	*	*	*	*
1550		DDB_CB_FAIL_AR	CB1 AR failed due to persistent fault	CB1 Failed AR		*		*
1550		DDB_CB_FAIL_AR	CB AR failed due to persistent fault	CB Failed AR	*		*	
1551		DDB_DEADTIME_OK_ALL	Enabling condition for any dead time	DTOK All	*	*	*	*
1552		DDB_DEAD_TIME_OK_CB1LSP	required for CB1 lead SPAR D Time	DTOK CB1L 1P		*		*
1553		DDB_DEAD_TIME_OK_CB1L3P	required for CB1 lead 3PAR D Time	DTOK CB1L 3P		*		*
1552		DDB_DEAD_TIME_OK_CB1LSP	required for CB SPAR D Time	DTOK CB 1P	*		*	
1553		DDB_DEAD_TIME_OK_CB1L3P	required for CB 3PAR D Time	DTOK CB 3P	*		*	
1554		DDB_SPDT_IN_PROGRESS	Single pole dead time in progress	1P DTime	*	*	*	*
1555		DDB_OK_TIME_3POLE	OK to start 3PAR dead time	OK Time 3P	*	*	*	*
1556		DDB_3POLE_DEAD_TIME1	3Phase dead time 1 running	3P DTime1	*	*	*	*
1557		DDB_3POLE_DEAD_TIME2	3Phase dead time 2 running	3P DTime2	*	*	*	*
1558		DDB_3POLE_DEAD_TIME3	3Phase dead time 3 running	3P DTime3	*	*	*	*
1559		DDB_3POLE_DEAD_TIME4	3Phase dead time 4 running	3P DTime4	*	*	*	*
1560		DDB_CB_3POLE_DEAD_TIME	CB1 3PAR dead time running	CB1 3P DTime		*		*
1560		DDB_CB_3POLE_DEAD_TIME	CB 3PAR dead time running	3P Dtime	*		*	
1561		DDB_SPOLE_FT_COMPLETE	Either CB SP follower time complete	1PF TComp		*		*
1562		DDB_3POLE_FT_COMPLETE	Either CB 3P follower time complete	3PF TComp		*		*

DDB No	Source	Element Name	Description	English Text	P543/P54 5 Inverse Distance	P544/P54 5 Inverse Distance	P543/ P544/ P546	P544/ P546
1563		DDB_IND_SPOLE_FT_COMPLETE	Unused	Unused	*		*	
1564		DDB_IND_3POLE_FT_COMPLETE	Unused	Unused	*		*	
1561		DDB_SPOLE_FT_COMPLETE	Unused	Unused	*		*	
1562		DDB_3POLE_FT_COMPLETE	Unused	Unused	*		*	
1563		DDB_IND_SPOLE_FT_COMPLETE	Unused	Unused	*		*	
1564		DDB_IND_3POLE_FT_COMPLETE	Unused	Unused	*		*	
1565		DDB_SET_CB_CLOSE	DDB (Optional PSL mapping to indication)	Set CB1 Close		*		*
1566		DDB_CB_CONTROL	Inhibits CB1 reclose by adjacent scheme	CB1 Control		*		*
1565		DDB_SET_CB_CLOSE	DDB (Optional PSL mapping to indication)	Set CB Close	*		*	
1566		DDB_CB_CONTROL	Inhibits CB reclose by adjacent scheme	CB Control	*		*	
1567		DDB_SP_RECLAIM_TIME	Single Ph AR reclaim time running	1P Reclaim Time	*	*	*	*
1568		DDB_SP_RECLAIM_TIME_COMPLETE	Single Ph AR reclaim time complete	1P Reclaim TComp	*	*	*	*
1569		DDB_TP_RECLAIM_TIME	Three Ph AR reclaim time running	3P Reclaim Time	*	*	*	*
1570		DDB_TP_RECLAIM_TIME_COMPLETE	Three Ph AR reclaim time complete	3P Reclaim TComp	*	*	*	*
1571		DDB_CB_SUCCESSFUL_SPAR	CB1 successful single phase AR	CB1 Succ 1P AR		*		*
1572		DDB_CB_FAST_SYSTEM_CHECK_OK	OK to reclose CB1 with sync check without waiting for dead time to complete	CB1 Fast SCOK		*		*
1573		DDB_CB_LEADER_SYSTEM_CHECK_OK	System conditions OK to reclose CB1 when dead time complete	CB1L SCOK		*		*
1574		DDB_CB_MANUAL_SYSTEM_CHECK_OK	System conditions OK to manually close CB1	CB1 Man SCOK		*		*
1575		DDB_CB_FAIL_PROTECTION_TRIP	signal to force CB1 AR lockout	CB1 Fail Pr Trip		*		*
1571		DDB_CB_SUCCESSFUL_SPAR	CB successful single phase AR	CB Succ 1P AR	*		*	
1572		DDB_CB_FAST_SYSTEM_CHECK_OK	OK to reclose CB with sync check without waiting for dead time to complete	CB Fast SCOK	*		*	
1573		DDB_CB_LEADER_SYSTEM_CHECK_OK	System conditions OK to reclose CB when dead time complete	CB SCOK	*		*	
1574		DDB_CB_MANUAL_SYSTEM_CHECK_OK	System conditions OK to manually close CB	CB Man SCOK	*		*	
1575		DDB_CB_FAIL_PROTECTION_TRIP	signal to force CB AR lockout	CB Fail Pr Trip	*		*	
1576		DDB_CB_LOCKOUT	Unused	Unused	*	*	*	*
1577		DDB_CHECKSYNC2_1_OK	CB2 CS1 is enabled and Line and Bus 2 voltages meet CB2 CS1 settings	CB2 CS1 OK		*		*
1577		DDB_CHECKSYNC2_1_OK	Unused	Unused	*		*	
1578		DDB_CS1_SLIP_O	Line-Bus 1 slip freq > setting [48 93] (frequency difference (slip) between line voltage and bus 1 voltage is greater than maximum slip permitted for CB1 synchronism check type 1)	CB1 CS1 SlipF>		*		*
1579		DDB_CS1_SLIP_U	Line-Bus 1 slip freq < setting [48 93] (frequency difference (slip) between line voltage and bus 1 voltage is greater than maximum slip permitted for CB1 synchronism check type 1)	CB1 CS1 SlipF<		*		*
1578		DDB_CS1_SLIP_O	Line-Bus slip freq > setting [48 93] (frequency difference (slip) between line voltage and bus voltage is greater than maximum slip permitted for CB synchronism check type 1)	CS1 SlipF>	*		*	

DDB No	Source	Element Name	Description	English Text	P543/P545 No	P544/P546 Distance	P543/P545 No	P544/P546 Distance	P543/P545	P544/P546
1579		DDB_CS1_SLIP_U	Line-Bus slip freq < setting [48 93] (frequency difference (slip) between line voltage and bus voltage is greater than maximum slip permitted for CB synchronism check type 1)	CS1 SlipF<	*				*	
1580		DDB_SYSCHECKS_VLINE_U	Line Volts < setting [48 8B]	CS VLine<	*	*	*	*	*	*
1581		DDB_SYSCHECKS_VLINE_O	Line Volts > setting [48 8C]	CS VLine>	*	*	*	*	*	*
1582		DDB_SYSCHECKS_VBUS_U	Bus1 Volts < setting [48 8B]	CS VBus1<		*			*	
1583		DDB_SYSCHECKS_VBUS_O	Bus1 Volts > setting [48 8C]	CS VBus1>		*			*	
1582		DDB_SYSCHECKS_VBUS_U	Bus Volts < setting [48 8B]	CS VBus<	*				*	
1583		DDB_SYSCHECKS_VBUS_O	Bus Volts > setting [48 8C]	CS VBus>	*				*	
1584		DDB_SYSCHECKS_VBUS2_U	Bus2 Volts < setting [48 8B]	CS VBus2<		*			*	
1585		DDB_SYSCHECKS_VBUS2_O	Bus2 Volts > setting [48 8C]	CS VBus2>		*			*	
1584		DDB_SYSCHECKS_VBUS2_U	Unused	Unused	*				*	
1585		DDB_SYSCHECKS_VBUS2_O	Unused	Unused	*				*	
1586		DDB_SYSCHECKS_VLINE_DIFF_HIGH	Voltage magnitude difference between Line V and Bus1 V is greater than setting [48 91] (line V > Bus V)	CB1 CS1 VL>VB		*			*	
1587		DDB_SYSCHECKS1_2_VLINE_DIFF_HIGH	Voltage magnitude difference between Line V and Bus1 V is greater than setting [48 96] (line V > Bus V)	CB1 CS2 VL>VB		*			*	
1588		DDB_SYSCHECKS_VBUS_DIFF_HIGH	Voltage magnitude difference between Line V and Bus1 V is greater than setting [48 91] (line V < Bus V)	CB1 CS1 VL<VB		*			*	
1589		DDB_SYSCHECKS1_2_VBUS_DIFF_HIGH	Voltage magnitude difference between Line V and Bus1 V is greater than setting [48 96] (line V < Bus V)	CB1 CS2 VL<VB		*			*	
1590		DDB_CS1_LINE_FREQ_GT_BUS_FREQ	Frequency difference between Line V and Bus1 V is greater than setting [48 93] (line freq > Bus freq)	CB1 CS1 FL>FB		*			*	
1591		DDB_CS1_LINE_FREQ_LT_BUS_FREQ	Frequency difference between Line V and Bus1 V is greater than setting [48 93] (line freq < Bus freq)	CB1 CS1 FL<FB		*			*	
1592		DDB_CS1_ANGLE_NOT_OK_POS	Line/Bus1 phase angle in range: setting [48 90] to +180deg (anticlockwise from Vbus)	CB1 CS1 AngHigh+		*			*	
1593		DDB_CS1_ANGLE_NOT_OK_NEG	Line/Bus1 phase angle in range: setting [48 90] to -180deg (anticlockwise from Vbus)	CB1 CS1 AngHigh-		*			*	
1594		DDB_SYSCHECKS_ANGLE_ACW	Line freq > (Bus1 freq + 0.001Hz) (Line voltage vector rotating anticlockwise relative to VBus1)	CB1 CS AngRotACW		*			*	
1595		DDB_SYSCHECKS_ANGLE_CW	Bus1 freq > (Line freq + 0.001Hz) (Line voltage vector rotating clockwise relative to VBus1)	CB1 CS AngRotCW		*			*	
1586		DDB_SYSCHECKS_VLINE_DIFF_HIGH	Voltage magnitude difference between Line V and Bus V is greater than setting [48 91] (line V > Bus V)	CS1 VL>VB	*				*	
1587		DDB_SYSCHECKS1_2_VLINE_DIFF_HIGH	Voltage magnitude difference between Line V and Bus V is greater than setting [48 96] (line V > Bus V)	CS2 VL>VB	*				*	
1588		DDB_SYSCHECKS_VBUS_DIFF_HIGH	Voltage magnitude difference between Line V and Bus V is greater than setting [48 91] (line V < Bus V)	CS1 VL<VB	*				*	

DDB No	Source	Element Name	Description	English Text	P543/P544 P5 No. Distance	P544/P545 P5 No. Distance	P543/ P544/ P545	P544/ P546
1589		DDB_SYSCHECKS1_2_VBUS_DIFF_HIGH	Voltage magnitude difference between Line V and Bus V is greater than setting [48 96] (line V < Bus V)	CS2 VL<VB	*		*	
1590		DDB_CS1_LINE_FREQ_GT_BUS_FREQ	Frequency difference between Line V and Bus V is greater than setting [48 93] (line freq > Bus freq)	CS1 FL>FB	*		*	
1591		DDB_CS1_LINE_FREQ_LT_BUS_FREQ	Frequency difference between Line V and Bus V is greater than setting [48 93] (line freq < Bus freq)	CS1 FL<FB	*		*	
1592		DDB_CS1_ANGLE_NOT_OK_POS	Line/Bus phase angle in range: setting [48 90] to +180deg (anticlockwise from Vbus)	CS1 AngHigh+	*		*	
1593		DDB_CS1_ANGLE_NOT_OK_NEG	Line/Bus phase angle in range: setting [48 90] to -180deg (anticlockwise from Vbus)	CS1 AngHigh-	*		*	
1594		DDB_SYSCHECKS_ANGLE_ACW	Line freq > (Bus freq + 0.001Hz) (Line voltage vector rotating anticlockwise relative to VBus1)	CS AngRotACW	*		*	
1595		DDB_SYSCHECKS_ANGLE_CW	Bus freq > (Line freq + 0.001Hz) (Line voltage vector rotating clockwise relative to VBus1)	CS AngRotCW	*		*	
1596		DDB_UNUSED_1596	Unused	Unused	*	*	*	*
1597		DDB_RESET_ALL_VALUES_2	Rst CB2 All Val	Rst CB2 Data		*		*
1598		DDB_CB2_PRE_LOCKOUT	Output from CB2 monitoring logic	CB2 Pre-Lockout		*		*
1599		DDB_CB2_LOCKOUT_ALARM	CB2 LO Alarm	CB2 LO Alarm		*		*
1597		DDB_RESET_ALL_VALUES_2	Unused	Unused	*		*	
1598		DDB_CB2_PRE_LOCKOUT	Unused	Unused	*		*	
1599		DDB_CB2_LOCKOUT_ALARM	Unused	Unused	*		*	
1600	Trip Conversion Logic	DDB_TRIP_3PH_2	3 Phase Trip 2	CB2 Trip 3ph		*		*
1601	Trip Conversion Logic	DDB_TRIP_A_PHASE_2	A Phase Trip 2	CB2 Trip OutputA		*		*
1602	Trip Conversion Logic	DDB_TRIP_B_PHASE_2	B Phase Trip 2	CB2 Trip OutputB		*		*
1603	Trip Conversion Logic	DDB_TRIP_C_PHASE_2	C Phase Trip 2	CB2 Trip OutputC		*		*
1604	PSL	DDB_FORCE_3_POLE_TRIP_2	External input via DDB to force host relay trip conversion logic to issue a three phase trip signal to CB2 for all faults	Force 3PTrip CB2		*		*
1605		DDB_AR_ENABLE_CB2	External input via DDB to enable CB2, if "in service", to be initiated for autoreclosing by an AR initiation signal from protection. DDB input defaults to high if not mapped in PSL, so CB2 AR initiation is permitted.	AR Enable CB2		*		*
1606	PSL	DDB_INP_TR2P_2	Pole Discrepancy	Pole Discrep.CB2		*		*
1607	Pole discrepancy	DDB_POLE_DISCREPENCE_TRIP_2	Pole Discrepancy	Pole Discrep.CB2		*		*
1608	PSL	DDB_TR_3_PHASE_CB2	Trip 3 Phase - Input to Trip Latching Logic	CB2 Trip I/P 3Ph		*		*
1600	Trip Conversion Logic	DDB_TRIP_3PH_2	Unused	Unused	*		*	
1601	Trip Conversion Logic	DDB_TRIP_A_PHASE_2	Unused	Unused	*		*	
1602	Trip Conversion Logic	DDB_TRIP_B_PHASE_2	Unused	Unused	*		*	

DDB No	Source	Element Name	Description	English Text	P543/P545 No Distance	P544/P546 No Distance	P543/P545	P544/P546
1603	Trip Conversion Logic	DDB_TRIP_C_PHASE_2	Unused	Unused	*		*	
1604	PSL	DDB_FORCE_3_POLE_TRIP_2	Unused	Unused	*		*	
1605		DDB_AR_ENABLE_CB2	Unused	Unused	*		*	
1606		DDB_INP_TR2P_2	Unused	Unused	*		*	
1607	Pole discrepancy	DDB_POLE_DISCREPENCE_TRIP_2	Unused	Unused	*		*	
1608	PSL	DDB_TR_3_PHASE_CB2	Unused	Unused	*		*	
1609		DDB_AR_ENABLE_CB1	External input via DDB mapped in PSL to enable CB1, if "in service", to be initiated for autoreclosing by an AR initiation signal from protection. DDB input defaults to high if not mapped in PSL, so CB1 AR initiation is permitted.	AR Enable CB1		*		*
1609		DDB_AR_ENABLE_CB1	External input via DDB mapped in PSL to enable CB, if "in service", to be initiated for autoreclosing by an AR initiation signal from protection. DDB input defaults to high if not mapped in PSL, so CB AR initiation is permitted.	AR Enable CB	*		*	
1610		DDB_CB1_INDEPENDENT_INIT_A_PHASE	Unused	Unused		*		*
1611		DDB_CB1_INDEPENDENT_INIT_B_PHASE	Unused	Unused		*		*
1612		DDB_CB1_INDEPENDENT_INIT_C_PHASE	Unused	Unused		*		*
1613		DDB_CB2_INDEPENDENT_INIT_A_PHASE	Unused	Unused		*		*
1614		DDB_CB2_INDEPENDENT_INIT_B_PHASE	Unused	Unused		*		*
1615		DDB_CB2_INDEPENDENT_INIT_C_PHASE	Unused	Unused		*		*
1610		DDB_CB1_INDEPENDENT_INIT_A_PHASE	Unused	Unused	*		*	
1611		DDB_CB1_INDEPENDENT_INIT_B_PHASE	Unused	Unused	*		*	
1612		DDB_CB1_INDEPENDENT_INIT_C_PHASE	Unused	Unused	*		*	
1613		DDB_CB2_INDEPENDENT_INIT_A_PHASE	Unused	Unused	*		*	
1614		DDB_CB2_INDEPENDENT_INIT_B_PHASE	Unused	Unused	*		*	
1615		DDB_CB2_INDEPENDENT_INIT_C_PHASE	Unused	Unused	*		*	
1616	PSL	DDB_PSLINT_101	PSL Internal Node	PSL Int 101	*	*	*	*
1617	PSL	DDB_PSLINT_102	PSL Internal Node	PSL Int 102	*	*	*	*
1618	PSL	DDB_PSLINT_103	PSL Internal Node	PSL Int 103	*	*	*	*
1619	PSL	DDB_PSLINT_104	PSL Internal Node	PSL Int 104	*	*	*	*
1620	PSL	DDB_PSLINT_105	PSL Internal Node	PSL Int 105	*	*	*	*
1621	PSL	DDB_PSLINT_106	PSL Internal Node	PSL Int 106	*	*	*	*
1622	PSL	DDB_PSLINT_107	PSL Internal Node	PSL Int 107	*	*	*	*
1623	PSL	DDB_PSLINT_108	PSL Internal Node	PSL Int 108	*	*	*	*
1624	PSL	DDB_PSLINT_109	PSL Internal Node	PSL Int 109	*	*	*	*
1625	PSL	DDB_PSLINT_110	PSL Internal Node	PSL Int 110	*	*	*	*
1626	PSL	DDB_PSLINT_111	PSL Internal Node	PSL Int 111	*	*	*	*
1627	PSL	DDB_PSLINT_112	PSL Internal Node	PSL Int 112	*	*	*	*
1628	PSL	DDB_PSLINT_113	PSL Internal Node	PSL Int 113	*	*	*	*
1629	PSL	DDB_PSLINT_114	PSL Internal Node	PSL Int 114	*	*	*	*
1630	PSL	DDB_PSLINT_115	PSL Internal Node	PSL Int 115	*	*	*	*

DDB No	Source	Element Name	Description	English Text	P543P54 5 Inp. Distance	P544P54 5 Inp. Distance	P545 P544/ P546	P546 P544/ P546
1631	PSL	DDB_PSLINT_116	PSL Internal Node	PSL Int 116	*	*	*	*
1632	PSL	DDB_PSLINT_117	PSL Internal Node	PSL Int 117	*	*	*	*
1633	PSL	DDB_PSLINT_118	PSL Internal Node	PSL Int 118	*	*	*	*
1634	PSL	DDB_PSLINT_119	PSL Internal Node	PSL Int 119	*	*	*	*
1635	PSL	DDB_PSLINT_120	PSL Internal Node	PSL Int 120	*	*	*	*
1636	PSL	DDB_PSLINT_121	PSL Internal Node	PSL Int 121	*	*	*	*
1637	PSL	DDB_PSLINT_122	PSL Internal Node	PSL Int 122	*	*	*	*
1638	PSL	DDB_PSLINT_123	PSL Internal Node	PSL Int 123	*	*	*	*
1639	PSL	DDB_PSLINT_124	PSL Internal Node	PSL Int 124	*	*	*	*
1640	PSL	DDB_PSLINT_125	PSL Internal Node	PSL Int 125	*	*	*	*
1641	PSL	DDB_PSLINT_126	PSL Internal Node	PSL Int 126	*	*	*	*
1642	PSL	DDB_PSLINT_127	PSL Internal Node	PSL Int 127	*	*	*	*
1643	PSL	DDB_PSLINT_128	PSL Internal Node	PSL Int 128	*	*	*	*
1644	PSL	DDB_PSLINT_129	PSL Internal Node	PSL Int 129	*	*	*	*
1645	PSL	DDB_PSLINT_130	PSL Internal Node	PSL Int 130	*	*	*	*
1646	PSL	DDB_PSLINT_131	PSL Internal Node	PSL Int 131	*	*	*	*
1647	PSL	DDB_PSLINT_132	PSL Internal Node	PSL Int 132	*	*	*	*
1648	PSL	DDB_PSLINT_133	PSL Internal Node	PSL Int 133	*	*	*	*
1649	PSL	DDB_PSLINT_134	PSL Internal Node	PSL Int 134	*	*	*	*
1650	PSL	DDB_PSLINT_135	PSL Internal Node	PSL Int 135	*	*	*	*
1651	PSL	DDB_PSLINT_136	PSL Internal Node	PSL Int 136	*	*	*	*
1652	PSL	DDB_PSLINT_137	PSL Internal Node	PSL Int 137	*	*	*	*
1653	PSL	DDB_PSLINT_138	PSL Internal Node	PSL Int 138	*	*	*	*
1654	PSL	DDB_PSLINT_139	PSL Internal Node	PSL Int 139	*	*	*	*
1655	PSL	DDB_PSLINT_140	PSL Internal Node	PSL Int 140	*	*	*	*
1656	PSL	DDB_PSLINT_141	PSL Internal Node	PSL Int 141	*	*	*	*
1657	PSL	DDB_PSLINT_142	PSL Internal Node	PSL Int 142	*	*	*	*
1658	PSL	DDB_PSLINT_143	PSL Internal Node	PSL Int 143	*	*	*	*
1659	PSL	DDB_PSLINT_144	PSL Internal Node	PSL Int 144	*	*	*	*
1660	PSL	DDB_PSLINT_145	PSL Internal Node	PSL Int 145	*	*	*	*
1661	PSL	DDB_PSLINT_146	PSL Internal Node	PSL Int 146	*	*	*	*
1662	PSL	DDB_PSLINT_147	PSL Internal Node	PSL Int 147	*	*	*	*
1663	PSL	DDB_PSLINT_148	PSL Internal Node	PSL Int 148	*	*	*	*
1664	PSL	DDB_PSLINT_149	PSL Internal Node	PSL Int 149	*	*	*	*
1665	PSL	DDB_PSLINT_150	PSL Internal Node	PSL Int 150	*	*	*	*
1666	SW	DDB_HARMONIC_5_A	5th harmonic current ratio exceeds threshold on phase A	lh(5) Loc Blk A	*	*	*	*
1667	SW	DDB_HARMONIC_5_B	5th harmonic current ratio exceeds threshold on phase B	lh(5) Loc Blk B	*	*	*	*
1668	SW	DDB_HARMONIC_5_C	5th harmonic current ratio exceeds threshold on phase C	lh(5) Loc Blk C	*	*	*	*
1669	SW	DDB_HARMONIC_5_REM_BLOCK_A	Indication that remote end phase A is blocked by 5th harmonic	lh(5) Rem Blk A	*	*	*	*
1670	SW	DDB_HARMONIC_5_REM_BLOCK_B	Indication that remote end phase B is blocked by 5th harmonic	lh(5) Rem Blk B	*	*	*	*

DDB No	Source	Element Name	Description	English Text	P543/P54 5 No Distance	P544/P54 6 No Distance	P545/ P545	P544/ P546
1671	SW	DDB_HARMONIC_5_REM_BLOCK_C	Indication that remote end phase C is blocked by 5th harmonic	lh(5) Rem Blk C	*	*	*	*
1666		DDB_HARMONIC_5_A	Unused	Unused				
1667		DDB_HARMONIC_5_B	Unused	Unused				
1668		DDB_HARMONIC_5_C	Unused	Unused				
1669		DDB_HARMONIC_5_REM_BLOCK_A	Unused	Unused				
1670		DDB_HARMONIC_5_REM_BLOCK_B	Unused	Unused				
1671		DDB_HARMONIC_5_REM_BLOCK_C	Unused	Unused				
1672	SW	DDB_CB_PHASE_A_RETRIP	tBF1 trip phase A for CB1	CB1 Fail1 Trip A		*		*
1672	SW	DDB_CB_PHASE_A_RETRIP	tBF1 trip phase A for CB	CB Fail1 Trip A	*		*	
1673	SW	DDB_CB_PHASE_A_BKTRIP	tBF2 trip phase A for CB1	CB1 Fail2 Trip A		*		*
1673	SW	DDB_CB_PHASE_A_BKTRIP	tBF2 trip phase A for CB	CB Fail2 Trip A	*		*	
1674	SW	DDB_CB_PHASE_B_RETRIP	tBF1 trip phase B for CB1	CB1 Fail1 Trip B		*		*
1674	SW	DDB_CB_PHASE_B_RETRIP	tBF1 trip phase B for CB	CB Fail1 Trip B	*		*	
1675	SW	DDB_CB_PHASE_B_BKTRIP	tBF2 trip phase B for CB1	CB1 Fail2 Trip B		*		*
1675	SW	DDB_CB_PHASE_B_BKTRIP	tBF2 trip phase B for CB	CB Fail2 Trip B	*		*	
1676	SW	DDB_CB_PHASE_C_RETRIP	tBF1 trip phase C for CB1	CB1 Fail1 Trip C		*		*
1676	SW	DDB_CB_PHASE_C_RETRIP	tBF1 trip phase C for CB	CB Fail1 Trip C	*		*	
1677	SW	DDB_CB_PHASE_C_BKTRIP	tBF2 trip phase C for CB1	CB1 Fail2 Trip C		*		*
1677	SW	DDB_CB_PHASE_C_BKTRIP	tBF2 trip phase C for CB	CB Fail2 Trip C	*		*	
1678	SW	DDB_CB2_PHASE_A_RETRIP	tBF1 trip phase A for CB2	CB2 Fail1 Trip A		*		*
1678	SW	DDB_CB2_PHASE_A_RETRIP	Unused	Unused	*		*	
1679	SW	DDB_CB2_PHASE_A_BKTRIP	tBF2 trip phase A for CB2	CB2 Fail2 Trip A		*		*
1679	SW	DDB_CB2_PHASE_A_BKTRIP	Unused	Unused	*		*	
1680	SW	DDB_CB2_PHASE_B_RETRIP	tBF1 trip phase B for CB2	CB2 Fail1 Trip B		*		*
1680	SW	DDB_CB2_PHASE_B_RETRIP	Unused	Unused	*		*	
1681	SW	DDB_CB2_PHASE_B_BKTRIP	tBF2 trip phase B for CB2	CB2 Fail2 Trip B		*		*
1681	SW	DDB_CB2_PHASE_B_BKTRIP	Unused	Unused	*		*	
1682	SW	DDB_CB2_PHASE_C_RETRIP	tBF1 trip phase C for CB2	CB2 Fail1 Trip C		*		*
1682	SW	DDB_CB2_PHASE_C_RETRIP	Unused	Unused	*		*	
1683	SW	DDB_CB2_PHASE_C_BKTRIP	tBF2 trip phase C for CB2	CB2 Fail2 Trip C		*		*
1683	SW	DDB_CB2_PHASE_C_BKTRIP	Unused	Unused	*		*	
1684	SW	DDB_CT_PHASE_A_ZCD	CT1 phase A Zero Cross Detector	CT1A ZCD		*		*
1684	SW	DDB_CT_PHASE_A_ZCD	CT phase A Zero Cross Detector	CT A ZCD	*		*	
1685	SW	DDB_CT_PHASE_B_ZCD	CT1 phase B Zero Cross Detector	CT1B ZCD		*		*
1685	SW	DDB_CT_PHASE_B_ZCD	CT phase B Zero Cross Detector	CT B ZCD	*		*	
1686	SW	DDB_CT_PHASE_C_ZCD	CT1 phase C Zero Cross Detector	CT1C ZCD		*		*
1686	SW	DDB_CT_PHASE_C_ZCD	CT phase C Zero Cross Detector	CT C ZCD	*		*	
1687	SW	DDB_CT2_PHASE_A_ZCD	CT2 phase A Zero Cross Detector	CT2A ZCD		*		*
1687	SW	DDB_CT2_PHASE_A_ZCD	Unused	Unused	*		*	
1688	SW	DDB_CT2_PHASE_B_ZCD	CT2 phase B Zero Cross Detector	CT2B ZCD		*		*
1688	SW	DDB_CT2_PHASE_B_ZCD	Unused	Unused	*		*	
1689	SW	DDB_CT2_PHASE_C_ZCD	CT2 phase C Zero Cross Detector	CT2C ZCD		*		*
1689	SW	DDB_CT2_PHASE_C_ZCD	Unused	Unused	*		*	

DDB No	Source	Element Name	Description	English Text	P543/P54 Yn5 Distance	P544/P54 Yn5 Distance	P543/ P545	P544/ P546
1690	SW	DDB_CT_IN_ZCD	CT1 and CT2 Zero Cross Detector	CT IN ZCD	*	*	*	*
1691		DDB_UNUSED_1691	Unused	Unused	*	*	*	*
1692	PSL	DDB_CB1_CS_V1_SEL	DDB to select the input for the "Line" voltage for CB1	CB1 C/S Select 1		*		*
1693	PSL	DDB_CB1_CS_V2_SEL	DDB to select the input for the "Bus" voltage for CB1	CB1 C/S Select 2		*		*
1694	PSL	DDB_CB2_CS_V1_SEL	DDB to select the input for the "Line" voltage for CB2	CB2 C/S Select 1		*		*
1695	PSL	DDB_CB2_CS_V2_SEL	DDB to select the input for the "Bus" voltage for CB2	CB2 C/S Select 2		*		*
1692		DDB_UNUSED_1692	Unused	Unused	*		*	
1693		DDB_UNUSED_1693	Unused	Unused	*		*	
1694		DDB_UNUSED_1694	Unused	Unused	*		*	
1695		DDB_UNUSED_1695	Unused	Unused	*		*	
1696	PSL	DDB_IEC_USR_OPN_1	IEC61850 User Dual Point Status 1 Open	IEC Usr 01 Open	*	*	*	*
1697	PSL	DDB_IEC_USR_CLS_1	IEC61850 User Dual Point Status 1 Closed	IEC Usr 01 Close	*	*	*	*
1698	PSL	DDB_IEC_USR_OPN_2	IEC61850 User Dual Point Status 2 Open	IEC Usr 02 Open	*	*	*	*
1699	PSL	DDB_IEC_USR_CLS_2	IEC61850 User Dual Point Status 2 Closed	IEC Usr 02 Close	*	*	*	*
1700	PSL	DDB_IEC_USR_OPN_3	IEC61850 User Dual Point Status 3 Open	IEC Usr 03 Open	*	*	*	*
1701	PSL	DDB_IEC_USR_CLS_3	IEC61850 User Dual Point Status 3 Closed	IEC Usr 03 Close	*	*	*	*
1702	PSL	DDB_IEC_USR_OPN_4	IEC61850 User Dual Point Status 4 Open	IEC Usr 04 Open	*	*	*	*
1703	PSL	DDB_IEC_USR_CLS_4	IEC61850 User Dual Point Status 4 Closed	IEC Usr 04 Close	*	*	*	*
1704	PSL	DDB_IEC_USR_OPN_5	IEC61850 User Dual Point Status 5 Opened	IEC Usr 05 Open	*	*	*	*
1705	PSL	DDB_IEC_USR_CLS_5	IEC61850 User Dual Point Status 5 Closed	IEC Usr 05 Close	*	*	*	*
1706	PSL	DDB_IEC_USR_OPN_6	IEC61850 User Dual Point Status 6 Open	IEC Usr 06 Open	*	*	*	*
1707	PSL	DDB_IEC_USR_CLS_6	IEC61850 User Dual Point Status 6 Closed	IEC Usr 06 Close	*	*	*	*
1708	PSL	DDB_IEC_USR_OPN_7	IEC61850 User Dual Point Status 7 Open	IEC Usr 07 Open	*	*	*	*
1709	PSL	DDB_IEC_USR_CLS_7	IEC61850 User Dual Point Status 7 Closed	IEC Usr 07 Close	*	*	*	*
1710	PSL	DDB_IEC_USR_OPN_8	IEC61850 User Dual Point Status 8 Open	IEC Usr 08 Open	*	*	*	*
1711	PSL	DDB_IEC_USR_CLS_8	IEC61850 User Dual Point Status 8 Closed	IEC Usr 08 Close	*	*	*	*
1712	SW	DDB_TS_OC_C_S1	Trip supervision: I> phaseC stage1	TS I> pHc s1	*	*	*	*
1713	SW	DDB_TS_OC_C_S2	Trip supervision: I> phaseC stage2	TS I> pHc s2	*	*	*	*
1714	SW	DDB_TS_OC_C_S3	Trip supervision: I> phaseC stage3	TS I> pHc s3	*	*	*	*
1715	PSL	DDB_EXT_RESET_CB_FAIL_3PH	External Reset for CB 3 phase fail	Ext Rst CBF	*		*	
1716	PSL	DDB_EXT_RESET_CB_FAIL_A	External Reset for CB A phase fail	Ext Rst CBF A	*		*	
1717	PSL	DDB_EXT_RESET_CB_FAIL_B	External Reset for CB B phase fail	Ext Rst CBF B	*		*	
1718	PSL	DDB_EXT_RESET_CB_FAIL_C	External Reset for CB C phase fail	Ext Rst CBF C	*		*	
1719	PSL	DDB_EXT_RESET_CB_FAIL_SEF	External Reset for SEF CB fail	Ext Rst SEF CBF	*		*	
1715	PSL	DDB_EXT_RESET_CB1_FAIL_3PH	External Reset for CB1 3 phase fail	Ext Rst CB1F		*		*
1716	PSL	DDB_EXT_RESET_CB1_FAIL_A	External Reset for CB1 A phase fail	Ext Rst CB1F A		*		*
1717	PSL	DDB_EXT_RESET_CB1_FAIL_B	External Reset for CB1 B phase fail	Ext Rst CB1F B		*		*
1718	PSL	DDB_EXT_RESET_CB1_FAIL_C	External Reset for CB1 C phase fail	Ext Rst CB1F C		*		*
1719	PSL	DDB_EXT_RESET_CB_FAIL_SEF	External Reset for SEF CB fail	Ext Rst SEF CBF		*		*
1720	PSL	DDB_EXT_RESET_CB2_FAIL_3PH	External Reset for CB2 3 phase fail	Ext Rst CB2F		*		*
1721	PSL	DDB_EXT_RESET_CB2_FAIL_A	External Reset for CB2 A phase fail	Ext Rst CB2F A		*		*

DDB No	Source	Element Name	Description	English Text	P543/P545 No	P544/P546 Distance	P543/P545 No	P544/P546 Distance
1722	PSL	DDB_EXT_RESET_CB2_FAIL_B	External Reset for CB2 B phase fail	Ext Rst CB2F B		*		*
1723	PSL	DDB_EXT_RESET_CB2_FAIL_C	External Reset for CB2 C phase fail	Ext Rst CB2F C		*		*
1720		DDB_UNUSED_1720	Unused	Unused	*		*	
1721		DDB_UNUSED_1721	Unused	Unused	*		*	
1722		DDB_UNUSED_1722	Unused	Unused	*		*	
1723		DDB_UNUSED_1723	Unused	Unused	*		*	
1724		DDB_UNUSED_1724	Unused	Unused	*	*	*	*
1725	SW	DDB_TS_OCN_A_S1	Trip supervision: IN> phaseA stage1	TS IN> pH A s1	*	*	*	*
1726	SW	DDB_TS_OCN_A_S2	Trip supervision: IN> phaseA stage2	TS IN> pH A s2	*	*	*	*
1727	SW	DDB_TS_OCN_A_S3	Trip supervision: IN> phaseA stage3	TS IN> pH A s3	*	*	*	*
1728	GOOSE Input Command	DDB_VIP_QUALITY_1	GOOSE virtual input 1 - provides the Quality attributes of any data object in an incoming GOOSE message	Quality VIP 1	*	*	*	*
1729	GOOSE Input Command	DDB_VIP_QUALITY_2	GOOSE virtual input 2 - provides the Quality attributes of any data object in an incoming GOOSE message	Quality VIP 2	*	*	*	*
1730	GOOSE Input Command	DDB_VIP_QUALITY_3	GOOSE virtual input 3 - provides the Quality attributes of any data object in an incoming GOOSE message	Quality VIP 3	*	*	*	*
1731	GOOSE Input Command	DDB_VIP_QUALITY_4	GOOSE virtual input 4 - provides the Quality attributes of any data object in an incoming GOOSE message	Quality VIP 4	*	*	*	*
1732	GOOSE Input Command	DDB_VIP_QUALITY_5	GOOSE virtual input 5 - provides the Quality attributes of any data object in an incoming GOOSE message	Quality VIP 5	*	*	*	*
1733	GOOSE Input Command	DDB_VIP_QUALITY_6	GOOSE virtual input 6 - provides the Quality attributes of any data object in an incoming GOOSE message	Quality VIP 6	*	*	*	*
1734	GOOSE Input Command	DDB_VIP_QUALITY_7	GOOSE virtual input 7 - provides the Quality attributes of any data object in an incoming GOOSE message	Quality VIP 7	*	*	*	*
1735	GOOSE Input Command	DDB_VIP_QUALITY_8	GOOSE virtual input 8 - provides the Quality attributes of any data object in an incoming GOOSE message	Quality VIP 8	*	*	*	*
1736	GOOSE Input Command	DDB_VIP_QUALITY_9	GOOSE virtual input 9 - provides the Quality attributes of any data object in an incoming GOOSE message	Quality VIP 9	*	*	*	*
1737	GOOSE Input Command	DDB_VIP_QUALITY_10	GOOSE virtual input 10 - provides the Quality attributes of any data object in an incoming GOOSE message	Quality VIP 10	*	*	*	*
1738	GOOSE Input Command	DDB_VIP_QUALITY_11	GOOSE virtual input 11 - provides the Quality attributes of any data object in an incoming GOOSE message	Quality VIP 11	*	*	*	*
1739	GOOSE Input Command	DDB_VIP_QUALITY_12	GOOSE virtual input 12 - provides the Quality attributes of any data object in an incoming GOOSE message	Quality VIP 12	*	*	*	*
1740	GOOSE Input Command	DDB_VIP_QUALITY_13	GOOSE virtual input 13 - provides the Quality attributes of any data object in an incoming GOOSE message	Quality VIP 13	*	*	*	*
1741	GOOSE Input Command	DDB_VIP_QUALITY_14	GOOSE virtual input 14 - provides the Quality attributes of any data object in an incoming GOOSE message	Quality VIP 14	*	*	*	*

DDB No	Source	Element Name	Description	English Text	P543/P54 5 No. Distance	P544/P54 4 No. Distance	P543/ P544/ P545	P544/ P546
1742	GOOSE Input Command	DDB_VIP_QUALITY_15	GOOSE virtual input 15 - provides the Quality attributes of any data object in an incoming GOOSE message	Quality VIP 15	*	*	*	*
1743	GOOSE Input Command	DDB_VIP_QUALITY_16	GOOSE virtual input 16 - provides the Quality attributes of any data object in an incoming GOOSE message	Quality VIP 16	*	*	*	*
1744	GOOSE Input Command	DDB_VIP_QUALITY_17	GOOSE virtual input 17 - provides the Quality attributes of any data object in an incoming GOOSE message	Quality VIP 17	*	*	*	*
1745	GOOSE Input Command	DDB_VIP_QUALITY_18	GOOSE virtual input 18 - provides the Quality attributes of any data object in an incoming GOOSE message	Quality VIP 18	*	*	*	*
1746	GOOSE Input Command	DDB_VIP_QUALITY_19	GOOSE virtual input 19 - provides the Quality attributes of any data object in an incoming GOOSE message	Quality VIP 19	*	*	*	*
1747	GOOSE Input Command	DDB_VIP_QUALITY_20	GOOSE virtual input 20 - provides the Quality attributes of any data object in an incoming GOOSE message	Quality VIP 20	*	*	*	*
1748	GOOSE Input Command	DDB_VIP_QUALITY_21	GOOSE virtual input 21 - provides the Quality attributes of any data object in an incoming GOOSE message	Quality VIP 21	*	*	*	*
1749	GOOSE Input Command	DDB_VIP_QUALITY_22	GOOSE virtual input 22 - provides the Quality attributes of any data object in an incoming GOOSE message	Quality VIP 22	*	*	*	*
1750	GOOSE Input Command	DDB_VIP_QUALITY_23	GOOSE virtual input 23 - provides the Quality attributes of any data object in an incoming GOOSE message	Quality VIP 23	*	*	*	*
1751	GOOSE Input Command	DDB_VIP_QUALITY_24	GOOSE virtual input 24 - provides the Quality attributes of any data object in an incoming GOOSE message	Quality VIP 24	*	*	*	*
1752	GOOSE Input Command	DDB_VIP_QUALITY_25	GOOSE virtual input 25 - provides the Quality attributes of any data object in an incoming GOOSE message	Quality VIP 25	*	*	*	*
1753	GOOSE Input Command	DDB_VIP_QUALITY_26	GOOSE virtual input 26 - provides the Quality attributes of any data object in an incoming GOOSE message	Quality VIP 26	*	*	*	*
1754	GOOSE Input Command	DDB_VIP_QUALITY_27	GOOSE virtual input 27 - provides the Quality attributes of any data object in an incoming GOOSE message	Quality VIP 27	*	*	*	*
1755	GOOSE Input Command	DDB_VIP_QUALITY_28	GOOSE virtual input 28 - provides the Quality attributes of any data object in an incoming GOOSE message	Quality VIP 28	*	*	*	*
1756	GOOSE Input Command	DDB_VIP_QUALITY_29	GOOSE virtual input 29 - provides the Quality attributes of any data object in an incoming GOOSE message	Quality VIP 29	*	*	*	*
1757	GOOSE Input Command	DDB_VIP_QUALITY_30	GOOSE virtual input 30 - provides the Quality attributes of any data object in an incoming GOOSE message	Quality VIP 30	*	*	*	*
1758	GOOSE Input Command	DDB_VIP_QUALITY_31	GOOSE virtual input 31 - provides the Quality attributes of any data object in an incoming GOOSE message	Quality VIP 31	*	*	*	*
1759	GOOSE Input Command	DDB_VIP_QUALITY_32	GOOSE virtual input 32 - provides the Quality attributes of any data object in an incoming GOOSE message	Quality VIP 32	*	*	*	*

DDB No	Source	Element Name	Description	English Text	P543/P545 No Distance	P544/P545 No Distance	P543/ P545	P544/ P546
1760	GOOSE Input Command	DDB_VIP_PUB_PRES_1	GOOSE virtual input 1- indicates if the GOOSE publisher responsible for publishing the data that derives a virtual input is present.	PubPres VIP 1	*	*	*	*
1761	GOOSE Input Command	DDB_VIP_PUB_PRES_2	GOOSE virtual input 2- indicates if the GOOSE publisher responsible for publishing the data that derives a virtual input is present.	PubPres VIP 2	*	*	*	*
1762	GOOSE Input Command	DDB_VIP_PUB_PRES_3	GOOSE virtual input 3- indicates if the GOOSE publisher responsible for publishing the data that derives a virtual input is present.	PubPres VIP 3	*	*	*	*
1763	GOOSE Input Command	DDB_VIP_PUB_PRES_4	GOOSE virtual input 4- indicates if the GOOSE publisher responsible for publishing the data that derives a virtual input is present.	PubPres VIP 4	*	*	*	*
1764	GOOSE Input Command	DDB_VIP_PUB_PRES_5	GOOSE virtual input 5- indicates if the GOOSE publisher responsible for publishing the data that derives a virtual input is present.	PubPres VIP 5	*	*	*	*
1765	GOOSE Input Command	DDB_VIP_PUB_PRES_6	GOOSE virtual input 6- indicates if the GOOSE publisher responsible for publishing the data that derives a virtual input is present.	PubPres VIP 6	*	*	*	*
1766	GOOSE Input Command	DDB_VIP_PUB_PRES_7	GOOSE virtual input 7- indicates if the GOOSE publisher responsible for publishing the data that derives a virtual input is present.	PubPres VIP 7	*	*	*	*
1767	GOOSE Input Command	DDB_VIP_PUB_PRES_8	GOOSE virtual input 8- indicates if the GOOSE publisher responsible for publishing the data that derives a virtual input is present.	PubPres VIP 8	*	*	*	*
1768	GOOSE Input Command	DDB_VIP_PUB_PRES_9	GOOSE virtual input 9- indicates if the GOOSE publisher responsible for publishing the data that derives a virtual input is present.	PubPres VIP 9	*	*	*	*
1769	GOOSE Input Command	DDB_VIP_PUB_PRES_10	GOOSE virtual input 10- indicates if the GOOSE publisher responsible for publishing the data that derives a virtual input is present.	PubPres VIP 10	*	*	*	*
1770	GOOSE Input Command	DDB_VIP_PUB_PRES_11	GOOSE virtual input 11- indicates if the GOOSE publisher responsible for publishing the data that derives a virtual input is present.	PubPres VIP 11	*	*	*	*
1771	GOOSE Input Command	DDB_VIP_PUB_PRES_12	GOOSE virtual input 12- indicates if the GOOSE publisher responsible for publishing the data that derives a virtual input is present.	PubPres VIP 12	*	*	*	*
1772	GOOSE Input Command	DDB_VIP_PUB_PRES_13	GOOSE virtual input 13- indicates if the GOOSE publisher responsible for publishing the data that derives a virtual input is present.	PubPres VIP 13	*	*	*	*
1773	GOOSE Input Command	DDB_VIP_PUB_PRES_14	GOOSE virtual input 14- indicates if the GOOSE publisher responsible for publishing the data that derives a virtual input is present.	PubPres VIP 14	*	*	*	*
1774	GOOSE Input Command	DDB_VIP_PUB_PRES_15	GOOSE virtual input 15- indicates if the GOOSE publisher responsible for publishing the data that derives a virtual input is present.	PubPres VIP 15	*	*	*	*
1775	GOOSE Input Command	DDB_VIP_PUB_PRES_16	GOOSE virtual input 16- indicates if the GOOSE publisher responsible for publishing the data that derives a virtual input is present.	PubPres VIP 16	*	*	*	*
1776	GOOSE Input Command	DDB_VIP_PUB_PRES_17	GOOSE virtual input 17- indicates if the GOOSE publisher responsible for publishing the data that derives a virtual input is present.	PubPres VIP 17	*	*	*	*
1777	GOOSE Input Command	DDB_VIP_PUB_PRES_18	GOOSE virtual input 18- indicates if the GOOSE publisher responsible for publishing the data that derives a virtual input is present.	PubPres VIP 18	*	*	*	*

DDB No	Source	Element Name	Description	English Text	P543/P545 No. Distance	P544/P546 No. Distance	P543/P545	P544/P546
1778	GOOSE Input Command	DDB_VIP_PUB_PRES_19	GOOSE virtual input 19- indicates if the GOOSE publisher responsible for publishing the data that derives a virtual input is present.	PubPres VIP 19	*	*	*	*
1779	GOOSE Input Command	DDB_VIP_PUB_PRES_20	GOOSE virtual input 20- indicates if the GOOSE publisher responsible for publishing the data that derives a virtual input is present.	PubPres VIP 20	*	*	*	*
1780	GOOSE Input Command	DDB_VIP_PUB_PRES_21	GOOSE virtual input 21- indicates if the GOOSE publisher responsible for publishing the data that derives a virtual input is present.	PubPres VIP 21	*	*	*	*
1781	GOOSE Input Command	DDB_VIP_PUB_PRES_22	GOOSE virtual input 22- indicates if the GOOSE publisher responsible for publishing the data that derives a virtual input is present.	PubPres VIP 22	*	*	*	*
1782	GOOSE Input Command	DDB_VIP_PUB_PRES_23	GOOSE virtual input 23- indicates if the GOOSE publisher responsible for publishing the data that derives a virtual input is present.	PubPres VIP 23	*	*	*	*
1783	GOOSE Input Command	DDB_VIP_PUB_PRES_24	GOOSE virtual input 24- indicates if the GOOSE publisher responsible for publishing the data that derives a virtual input is present.	PubPres VIP 24	*	*	*	*
1784	GOOSE Input Command	DDB_VIP_PUB_PRES_25	GOOSE virtual input 25- indicates if the GOOSE publisher responsible for publishing the data that derives a virtual input is present.	PubPres VIP 25	*	*	*	*
1785	GOOSE Input Command	DDB_VIP_PUB_PRES_26	GOOSE virtual input 26- indicates if the GOOSE publisher responsible for publishing the data that derives a virtual input is present.	PubPres VIP 26	*	*	*	*
1786	GOOSE Input Command	DDB_VIP_PUB_PRES_27	GOOSE virtual input 27- indicates if the GOOSE publisher responsible for publishing the data that derives a virtual input is present.	PubPres VIP 27	*	*	*	*
1787	GOOSE Input Command	DDB_VIP_PUB_PRES_28	GOOSE virtual input 28- indicates if the GOOSE publisher responsible for publishing the data that derives a virtual input is present.	PubPres VIP 28	*	*	*	*
1788	GOOSE Input Command	DDB_VIP_PUB_PRES_29	GOOSE virtual input 29- indicates if the GOOSE publisher responsible for publishing the data that derives a virtual input is present.	PubPres VIP 29	*	*	*	*
1789	GOOSE Input Command	DDB_VIP_PUB_PRES_30	GOOSE virtual input 30- indicates if the GOOSE publisher responsible for publishing the data that derives a virtual input is present.	PubPres VIP 30	*	*	*	*
1790	GOOSE Input Command	DDB_VIP_PUB_PRES_31	GOOSE virtual input 31- indicates if the GOOSE publisher responsible for publishing the data that derives a virtual input is present.	PubPres VIP 31	*	*	*	*
1791	GOOSE Input Command	DDB_VIP_PUB_PRES_32	GOOSE virtual input 32- indicates if the GOOSE publisher responsible for publishing the data that derives a virtual input is present.	PubPres VIP 32	*	*	*	*
1792	SW	DDB_DIFFERENTIAL_PHASECOMP	Current differential Saturation Block	Idiff Sat Block	*	*	*	*
1793	SW	DDB_DIFFERENTIAL_PHASECOMP_A	Current differential Saturation Block Phase A	Idiff Sat Bk PhA	*	*	*	*
1794	SW	DDB_DIFFERENTIAL_PHASECOMP_B	Current differential Saturation Block Phase B	Idiff Sat Bk PhB	*	*	*	*
1795	SW	DDB_DIFFERENTIAL_PHASECOMP_C	Current differential Saturation Block Phase C	Idiff Sat Bk PhC	*	*	*	*
1792		DDB_UNUSED_1792	Unused	Unused				
1793		DDB_UNUSED_1793	Unused	Unused				
1794		DDB_UNUSED_1794	Unused	Unused				
1795		DDB_UNUSED_1795	Unused	Unused				
1796	IEC 103	DDB_DIST_PROT_ENABLED	Distance protection function enabled in configuration settings	Distance Enabled			*	*

DDB No	Source	Element Name	Description	English Text	P543/P545 No Distance	P544/P546 No Distance	P543/ P545	P544/ P546
1797	IEC 103	DDB_DEF_PROT_ENABLED	Directional Earth Fault protection function enabled in configuration settings	DEF Enabled			*	*
1796		DDB_UNUSED_1796	Unused	Unused	*	*		
1797		DDB_UNUSED_1797	Unused	Unused	*	*		
1798	IEC 103	DDB_PHASE_DIFF_PROT_ENABLED	Phase difference protection function enabled in configuration settings	Ph Diff Enabled	*	*	*	*
1798		DDB_UNUSED_1798	Unused	Unused				
1799	IEC 103	DDB_PHASE_COMP_PROT_ENABLED	Phase comparison protection function enabled in configuration settings	Ph Comp Enabled				
1799		DDB_UNUSED_1799	Unused	Unused	*	*	*	*
1800	IEC 103	DDB_OVERCURRENT_PROT_ENABLED	Overcurrent function enabled in configuration settings	OC Enabled	*	*	*	*
1801	IEC 103	DDB_NEG_SEQ_OC_PROT_ENABLED	Negative Sequence Overcurrent function enabled in configuration settings	Neg OC Enabled	*	*	*	*
1802	IEC 103	DDB_BROKEN_COND_PROT_ENABLED	Broken conductor protection function enabled in configuration settings	Broke cond Enab	*	*	*	*
1803	IEC 103	DDB_EARTH_FAULT_PROT_ENABLED	Earth Fault protection function enabled in configuration settings	EF Enabled	*	*	*	*
1804	IEC 103	DDB_SEF_REF_PROT_ENABLED	SEF/REF protection function enabled in configuration settings	SEF/REF Enabled	*	*	*	*
1805	IEC 103	DDB_RESIDUAL_OV_NVD_PROT_ENABLED	Residual OV NVD protection function enabled in configuration settings	Res OV NVD Enab	*	*	*	*
1806	IEC 103	DDB_THERMAL_OL_PROT_ENABLED	Thermal overload protection function enabled in configuration settings	Therm OL Enabled	*	*	*	*
1807	IEC 103	DDB_PSB_PROT_ENABLED	Power swing block protection function enabled in configuration settings	PSB Enabled			*	*
1807		DDB_UNUSED_1807	Unused	Unused	*	*		
1808	IEC 103	DDB_CLP_PROT_ENABLED	Cold load pickup protection function enabled in configuration settings	CLP Enabled				
1808		DDB_UNUSED_1808	Unused	Unused	*	*	*	*
1809	IEC 103	DDB_VOLTAGE_PROT_ENABLED	Voltage protection function enabled in configuration settings	Volt Prt Enabled	*	*	*	*
1810	IEC 103	DDB_FREQ_PROT_ENABLED	Frequency protection function enabled in configuration settings	Freq Prt Enabled	*	*	*	*
1811	IEC 103	DDB_DFDT_PROT_ENABLED	df/dt function enabled in configuration settings	dfdt Enabled	*	*	*	*
1812	IEC 103	DDB_CBFail_PROT_ENABLED	CBFail protection function enabled in configuration settings	CBFail Enabled	*	*	*	*
1813	IEC 103	DDB_SUPERVISION_PROT_ENABLED	Supervision protection function enabled in configuration setting	SuperVis Enabled	*	*	*	*
1814	IEC 103	DDB_SYS_CHECKS_PROT_ENABLED	System checks function enabled in configuration settings	SysChk Enabled	*	*	*	*
1815	IEC 103	DDB_AUTO_RECLOSE_PROT_ENABLED	Auto reclose protection function enabled in configuration settings	AutoRec Enabled	*	*	*	*
1816	SW	DDB_OC_COND_BLK_DIFF_TRIP_PH_A	Overcurrent condition for phase differential trip blocking for phase A	Diff Blk IA<	*	*	*	*
1817	SW	DDB_OC_COND_BLK_DIFF_TRIP_PH_B	Overcurrent condition for phase differential trip blocking for phase B	Diff Blk IB<	*	*	*	*
1818	SW	DDB_OC_COND_BLK_DIFF_TRIP_PH_C	Overcurrent condition for phase differential trip blocking for phase C	Diff Blk IC<	*	*	*	*

DDB No	Source	Element Name	Description	English Text	P543/P545 Yn5 Distance	P544/P546 Yn5 Distance	P543/ P544/ P545/ P546	P543/ P544/ P545/ P546
1816		DDB_UNUSED_1816	Unused	Unused				
1817		DDB_UNUSED_1817	Unused	Unused				
1818		DDB_UNUSED_1818	Unused	Unused				
1819	SW	DDB_SETTING_INPUT_33	setting input 33 menu settings into PSL	Ctrl Setg I/P 33	*	*	*	*
1820	SW	DDB_SETTING_INPUT_34	setting input 34 menu settings into PSL	Ctrl Setg I/P 34	*	*	*	*
1821	SW	DDB_SETTING_INPUT_35	setting input 35 menu settings into PSL	Ctrl Setg I/P 35	*	*	*	*
1822	SW	DDB_SETTING_INPUT_36	setting input 36 menu settings into PSL	Ctrl Setg I/P 36	*	*	*	*
1823	SW	DDB_SETTING_INPUT_37	setting input 37 menu settings into PSL	Ctrl Setg I/P 37	*	*	*	*
1824	SW	DDB_SETTING_INPUT_38	setting input 38 menu settings into PSL	Ctrl Setg I/P 38	*	*	*	*
1825	SW	DDB_SETTING_INPUT_39	setting input 39 menu settings into PSL	Ctrl Setg I/P 39	*	*	*	*
1826	SW	DDB_SETTING_INPUT_40	setting input 40 menu settings into PSL	Ctrl Setg I/P 40	*	*	*	*
1827	SW	DDB_SETTING_INPUT_41	setting input 41 menu settings into PSL	Ctrl Setg I/P 41	*	*	*	*
1828	SW	DDB_SETTING_INPUT_42	setting input 42 menu settings into PSL	Ctrl Setg I/P 42	*	*	*	*
1829	SW	DDB_SETTING_INPUT_43	setting input 43 menu settings into PSL	Ctrl Setg I/P 43	*	*	*	*
1830	SW	DDB_SETTING_INPUT_44	setting input 44 menu settings into PSL	Ctrl Setg I/P 44	*	*	*	*
1831	SW	DDB_SETTING_INPUT_45	setting input 45 menu settings into PSL	Ctrl Setg I/P 45	*	*	*	*
1832	SW	DDB_SETTING_INPUT_46	setting input 46 menu settings into PSL	Ctrl Setg I/P 46	*	*	*	*
1833	SW	DDB_SETTING_INPUT_47	setting input 47 menu settings into PSL	Ctrl Setg I/P 47	*	*	*	*
1834	SW	DDB_SETTING_INPUT_48	setting input 48 menu settings into PSL	Ctrl Setg I/P 48	*	*	*	*
1835	PSL	DDB_ZONE_Q_GND_BLOCK	Zone Q ground basic scheme blocking	Block Zone Q Gnd			*	*
1836	PSL	DDB_ZONE_Q_PHS_BLOCK	Zone Q phase basic scheme blocking	Block Zone Q Phs			*	*
1837	Distance Basic Scheme	DDB_ZONE_Q_TRIP	Zone Q Trip	Zone Q Trip			*	*
1838	Distance Basic Scheme	DDB_ZONE_Q_TRIP_A	Zone Q A Phase Trip	Zone Q A Trip			*	*
1839	Distance Basic Scheme	DDB_ZONE_Q_TRIP_B	Zone Q B Phase Trip	Zone Q B Trip			*	*
1840	Distance Basic Scheme	DDB_ZONE_Q_TRIP_C	Zone Q C Phase Trip	Zone Q C Trip			*	*
1841	Distance Basic Scheme	DDB_ZONE_Q_TRIP_N	Zone Q N Phase Trip	Zone Q N Trip			*	*
1842	Trip on Close	DDB_ZONE_Q_TOR_TRIP	TOR Trip Zone Q	TOR Trip Zone Q			*	*
1843	Trip on Close	DDB_ZONE_Q_SOTF_TRIP	SOTF Trip Zone Q	SOTF Trip Zone Q			*	*
1835		DDB_ZONE_Q_GND_BLOCK	Unused	Unused	*	*		
1836		DDB_ZONE_Q_PHS_BLOCK	Unused	Unused	*	*		
1837		DDB_ZONE_Q_TRIP	Unused	Unused	*	*		
1838		DDB_ZONE_Q_TRIP_A	Unused	Unused	*	*		
1839		DDB_ZONE_Q_TRIP_B	Unused	Unused	*	*		
1840		DDB_ZONE_Q_TRIP_C	Unused	Unused	*	*		
1841		DDB_ZONE_Q_TRIP_N	Unused	Unused	*	*		
1842		DDB_ZONE_Q_TOR_TRIP	Unused	Unused	*	*		
1843		DDB_ZONE_Q_SOTF_TRIP	Unused	Unused	*	*		
1844	PSL	DDB_BLOCK_PH_ZQ_START	Block Start ZQ (Ph-Ph)	Blk Start Ph ZQ				
1845	PSL	DDB_BLOCK_GND_ZQ_START	Block Start ZQ (Ph-Gnd)	Blk Start Gnd ZQ				
1844		DDB_BLOCK_PH_ZQ_START	Unused	Unused	*	*	*	*

DDB No	Source	Element Name	Description	English Text	P543/P545 No Distance	P544/P546 No Distance	P543/P545	P544/P546
1845		DDB_BLOCK_GND_ZQ_START	Unused	Unused	*	*	*	*
1846	Distance Basic Scheme	DDB_ZONE_Q_START_A	Zone Q A Phase Start	Zone Q A Start			*	*
1847	Distance Basic Scheme	DDB_ZONE_Q_START_B	Zone Q B Phase Start	Zone Q B Start			*	*
1848	Distance Basic Scheme	DDB_ZONE_Q_START_C	Zone Q C Phase Start	Zone Q C Start			*	*
1849	Distance Basic Scheme	DDB_ZONE_Q_START_N	Zone Q N Start	Zone Q N Start			*	*
1850	Distance Elements	DDB_ZONE_Q_AN	Zone Q AN ground fault element	ZoneQ AN Element			*	*
1851	Distance Elements	DDB_ZONE_Q_BN	Zone Q BN ground fault element	ZoneQ BN Element			*	*
1852	Distance Elements	DDB_ZONE_Q_CN	Zone Q CN ground fault element	ZoneQ CN Element			*	*
1853	Distance Elements	DDB_ZONE_Q_AB	Zone Q AB phase fault element	ZoneQ AB Element			*	*
1854	Distance Elements	DDB_ZONE_Q_BC	Zone Q BC phase fault element	ZoneQ BC Element			*	*
1855	Distance Elements	DDB_ZONE_Q_CA	Zone Q CA phase fault element	ZoneQ CA Element			*	*
1856	Distance diagnostic	DDB_ZONE_Q_AN_RAW	ZQ AN Comparator	ZQ AN Comparator			*	*
1857	Distance diagnostic	DDB_ZONE_Q_BN_RAW	ZQ BN Comparator	ZQ BN Comparator			*	*
1858	Distance diagnostic	DDB_ZONE_Q_CN_RAW	ZQ CN Comparator	ZQ CN Comparator			*	*
1859	Distance diagnostic	DDB_ZONE_Q_AB_RAW	ZQ AB Comparator	ZQ AB Comparator			*	*
1860	Distance diagnostic	DDB_ZONE_Q_BC_RAW	ZQ BC Comparator	ZQ BC Comparator			*	*
1861	Distance diagnostic	DDB_ZONE_Q_CA_RAW	ZQ CA Comparator	ZQ CA Comparator			*	*
1862	Distance diagnostic	DDB_ZONE_Q_BLOCKED	Zone Q Blocked by PSB	Zone Q Blocked			*	*
1863	Phase Comparison	DDB_PH_ZQ_LOW	ZQ Low Start (Ph-Ph)	Ph ZQ Lo Start				
1864	Phase Comparison	DDB_PH_ZQ_HIGH	ZQ High Start (Ph-Ph)	Ph ZQ Hi Start				
1865	Phase Comparison	DDB_GND_ZQ_LOW	ZQ Low Start (Ph-Gnd)	Gnd ZQ Lo Start				
1866	Phase Comparison	DDB_GND_ZQ_HIGH	ZQ High Start (Ph-Gnd)	Gnd ZQ Hi Start				
1846		DDB_ZONE_Q_START_A	Unused	Unused	*	*		
1847		DDB_ZONE_Q_START_B	Unused	Unused	*	*		
1848		DDB_ZONE_Q_START_C	Unused	Unused	*	*		
1849		DDB_ZONE_Q_START_N	Unused	Unused	*	*		
1850		DDB_ZONE_Q_AN	Unused	Unused	*	*		
1851		DDB_ZONE_Q_BN	Unused	Unused	*	*		
1852		DDB_ZONE_Q_CN	Unused	Unused	*	*		

DDB No	Source	Element Name	Description	English Text	P543/P545 Distance	P544/P546 Distance	P543/ P545	P544/ P546
1853		DDB_ZONE_Q_AB	Unused	Unused	*	*		
1854		DDB_ZONE_Q_BC	Unused	Unused	*	*		
1855		DDB_ZONE_Q_CA	Unused	Unused	*	*		
1856		DDB_ZONE_Q_AN_RAW	Unused	Unused	*	*		
1857		DDB_ZONE_Q_BN_RAW	Unused	Unused	*	*		
1858		DDB_ZONE_Q_CN_RAW	Unused	Unused	*	*		
1859		DDB_ZONE_Q_AB_RAW	Unused	Unused	*	*		
1860		DDB_ZONE_Q_BC_RAW	Unused	Unused	*	*		
1861		DDB_ZONE_Q_CA_RAW	Unused	Unused	*	*		
1862		DDB_ZONE_Q_BLOCKED	Unused	Unused	*	*		
1863		DDB_PH_ZQ_LOW	Unused	Unused	*	*	*	*
1864		DDB_PH_ZQ_HIGH	Unused	Unused	*	*	*	*
1865		DDB_GND_ZQ_LOW	Unused	Unused	*	*	*	*
1866		DDB_GND_ZQ_HIGH	Unused	Unused	*	*	*	*
1867	SW	DDB_TS_OCN_B_S1	Trip supervision: IN> phaseB stage1	TS IN> pHB s1	*	*	*	*
1868	SW	DDB_TS_OCN_B_S2	Trip supervision: IN> phaseB stage2	TS IN> pHB s2	*	*	*	*
1869	SW	DDB_TS_OCN_B_S3	Trip supervision: IN> phaseB stage3	TS IN> pHB s3	*	*	*	*
1870		DDB_UNUSED_1870	Unused	Unused	*	*	*	*
1871	SW	DDB_DIST_SCHEME_GENERAL_START	Distance Scheme General Start	Dis Sch Gen Str			*	*
1872	SW	DDB_DIST_DIR_TEND_ELAPSE	Directional end timer elapse	Dir End Timer			*	*
1873	SW	DDB_DIST_NON_DIR_TEND_ELAPSE	Non Directional end timer elapse	NonDir EndTimer			*	*
1871		DDB_DIST_SCHEME_GENERAL_START	Unused	Unused	*	*		
1872		DDB_DIST_DIR_TEND_ELAPSE	Unused	Unused	*	*		
1873		DDB_DIST_NON_DIR_TEND_ELAPSE	Unused	Unused	*	*		
1874	SW	DDB_TS_OCN_C_S1	Trip supervision: IN> phaseC stage1	TS IN> pHc s1	*	*	*	*
1875	SW	DDB_TS_OCN_C_S2	Trip supervision: IN> phaseC stage2	TS IN> pHc s2	*	*	*	*
1876	SW	DDB_TS_OCN_C_S3	Trip supervision: IN> phaseC stage3	TS IN> pHc s3	*	*	*	*
1877	SW	DDB_TS_UVPP_A_S1	Trip supervision: Vpp< phaseA stage1	TS Vpp< pHa s1	*	*	*	*
1878	SW	DDB_TS_UVPP_A_S2	Trip supervision: Vpp< phaseA stage2	TS Vpp< pHa s2	*	*	*	*
1879	SW	DDB_TS_UVPP_A_S3	Trip supervision: Vpp< phaseA stage3	TS Vpp< pHa s3	*	*	*	*
1880		DDB_UNUSED_1880	Unused	Unused	*	*	*	*
1881	SW	DDB_Z1_TRIP_SUPERVISION_BLOCK	Supervision block on Z1 Trip	TS Dist. Z1 Blk			*	*
1882	SW	DDB_Z2_TRIP_SUPERVISION_BLOCK	Supervision block on Z2 Trip	TS Dist. Z2 Blk			*	*
1883	SW	DDB_Z3_TRIP_SUPERVISION_BLOCK	Supervision block on Z3 Trip	TS Dist. Z3 Blk			*	*
1884	SW	DDB_Z4_TRIP_SUPERVISION_BLOCK	Supervision block on Z4 Trip	TS Dist. Z4 Blk			*	*
1885	SW	DDB_ZP_TRIP_SUPERVISION_BLOCK	Supervision block on ZP Trip	TS Dist. ZP Blk			*	*
1886	SW	DDB_ZQ_TRIP_SUPERVISION_BLOCK	Supervision block on ZQ Trip	TS Dist. ZQ Blk			*	*
1887	SW	DDB_AIDED1_DIST_TRIP_SUPER_BLOCK	Supervision block on aided1 Z Trip	TS Aided1 Z Blk			*	*
1888	SW	DDB_AIDED2_DIST_TRIP_SUPER_BLOCK	Supervision block on aided2 Z Trip	TS Aided2 Z Blk			*	*
1889	SW	DDB_IDIFF_TRIP_SUPERVISION_BLOCK	Supervision block on IDiff Trip	TS IDiff. Blk			*	*
1881		DDB_Z1_TRIP_SUPERVISION_BLOCK	Unused	Unused	*	*		
1882		DDB_Z2_TRIP_SUPERVISION_BLOCK	Unused	Unused	*	*		
1883		DDB_Z3_TRIP_SUPERVISION_BLOCK	Unused	Unused	*	*		
1884		DDB_Z4_TRIP_SUPERVISION_BLOCK	Unused	Unused	*	*		

DDB No	Source	Element Name	Description	English Text	P543/P545 No Distance	P544/P546 No Distance	P543/P545 No Distance	P544/P546 No Distance
1885		DDB_ZP_TRIP_SUPERVISION_BLOCK	Unused	Unused	*	*		
1886		DDB_ZQ_TRIP_SUPERVISION_BLOCK	Unused	Unused	*	*		
1887		DDB_AIDED1_DIST_TRIP_SUPER_BLOCK	Unused	Unused	*	*		
1888		DDB_AIDED2_DIST_TRIP_SUPER_BLOCK	Unused	Unused	*	*		
1889		DDB_IDIFF_TRIP_SUPERVISION_BLOCK	Unused	Unused	*	*		
1890	SW	DDB_TS_CDIFF_ALLOW_TRIP_A	Current Diff Trip A Block by Trip Supervision	CdiffTripA Blk			*	*
1891	SW	DDB_TS_CDIFF_ALLOW_TRIP_B	Current Diff Trip B Block by Trip Supervision	CdiffTripB Blk			*	*
1892	SW	DDB_TS_CDIFF_ALLOW_TRIP_C	Current Diff Trip C Block by Trip Supervision	CdiffTripC Blk			*	*
1890		DDB_TS_CDIFF_ALLOW_TRIP_A	Unused	Unused	*	*		
1891		DDB_TS_CDIFF_ALLOW_TRIP_B	Unused	Unused	*	*		
1892		DDB_TS_CDIFF_ALLOW_TRIP_C	Unused	Unused	*	*		
1893	PSL	DDB_CBF_NONITRIP	CB Fail Non current trip	CBFNonITrip	*	*	*	*
1894	SW	DDB_TS_UVPP_B_S1	Trip supervision: Vpp< phaseB stage1	TS Vpp< pHB s1	*	*	*	*
1895	SW	DDB_TS_UVPP_B_S2	Trip supervision: Vpp< phaseB stage2	TS Vpp< pHB s2	*	*	*	*
1896	SW	DDB_TS_UVPP_B_S3	Trip supervision: Vpp< phaseB stage3	TS Vpp< pHB s3	*	*	*	*
1897		DDB_UNUSED_1897	Unused	Unused	*	*	*	*
1898	Check sync	DDB_CB1_CS_LINE_LIVE	Indicates Selected CB1 live line condition is detected	CB1 Live Line		*		*
1899	Check sync	DDB_CB1_CS_LINE_DEAD	Indicates Selected CB1 dead line condition is detected	CB1 Dead Line		*		*
1900	Check sync	DDB_CB1_CS_BUS_LIVE	Indicates Selected CB1 Bus input is live	CB1 Live Bus		*		*
1901	Check sync	DDB_CB1_CS_BUS_DEAD	Indicates Selected CB1 Bus input is dead	CB1 Dead Bus		*		*
1902	Check sync	DDB_CB2_CS_LINE_LIVE	Indicates Selected CB2 live line condition is detected	CB2 Live Line		*		*
1903	Check sync	DDB_CB2_CS_LINE_DEAD	Indicates Selected CB2 dead line condition is detected	CB2 Dead Line		*		*
1904	Check sync	DDB_CB2_CS_BUS_LIVE	Indicates Selected CB2 Bus input is live	CB2 Live Bus		*		*
1905	Check sync	DDB_CB2_CS_BUS_DEAD	Indicates Selected CB2 Bus input is dead	CB2 Dead Bus		*		*
1898		DDB_UNUSED_1898	Unused	Unused	*		*	
1899		DDB_UNUSED_1899	Unused	Unused	*		*	
1900		DDB_UNUSED_1900	Unused	Unused	*		*	
1901		DDB_UNUSED_1901	Unused	Unused	*		*	
1902		DDB_UNUSED_1902	Unused	Unused	*		*	
1903		DDB_UNUSED_1903	Unused	Unused	*		*	
1904		DDB_UNUSED_1904	Unused	Unused	*		*	
1905		DDB_UNUSED_1905	Unused	Unused	*		*	
1906		DDB_UNUSED_1906	Unused	Unused	*	*	*	*
1907		DDB_UNUSED_1907	Unused	Unused	*	*	*	*
1908		DDB_CB2_CS_VLINE_U	CB2 Check Synchronisation Line Volts < setting threshold	CB2 CS VLine<		*		*
1909		DDB_CB2_CS_VLINE_O	CB2 Check Synchronisation Line Volts > setting threshold	CB2 CS VLine>		*		*
1908		DDB_UNUSED_1908	Unused	Unused	*		*	
1909		DDB_UNUSED_1909	Unused	Unused	*		*	
1910		DDB_UNUSED_1910	Unused	Unused	*	*	*	*

DDB No	Source	Element Name	Description	English Text	P543/P54 S No. Distance	P544/P54 S No. Distance	P543/ P544/ P545	P544/ P546
1911	SW	DDB_TS_UVPP_C_S1	Trip supervision: Vpp< phaseC stage1	TS Vpp< pHc s1	*	*	*	*
1912	SW	DDB_TS_UVPP_C_S2	Trip supervision: Vpp< phaseC stage2	TS Vpp< pHc s2	*	*	*	*
1913	SW	DDB_TS_UVPP_C_S3	Trip supervision: Vpp< phaseC stage3	TS Vpp< pHc s3	*	*	*	*
1914	PSL	DDB_CHAN_ALT	Alternate other analogue channels	Channel Alt	*	*	*	*
1915	PSL	DDB_VCS1_ALT	Alternate VCS 1	Check Sync Alt1	*	*	*	*
1916	PSL	DDB_VCS2_ALT	Alternate VCS 2	Check Sync Alt2		*		*
1916		DDB_UNUSED_1916	Unused	Unused	*		*	
1917	SW	DDB_PB_LINK_1_FAIL	Process Bus Network Interface link 1 fail indication	PB Link 1 Fail	*	*	*	*
1918	SW	DDB_PB_LINK_2_FAIL	Process Bus Network Interface link 2 fail indication	PB Link 2 Fail	*	*	*	*
1919	SW	DDB_PB_LINK_3_FAIL	Process Bus Network Interface link 3 fail indication	PB Link 3 Fail	*	*	*	*
1920	SW	DDB_MU1_ABSENCE	MU1 Absence	MU1 Absence	*	*	*	*
1921	SW	DDB_MU2_ABSENCE	MU2 Absence	MU2 Absence	*	*	*	*
1922	SW	DDB_MU3_ABSENCE	MU3 Absence	MU3 Absence	*	*	*	*
1923	SW	DDB_MU4_ABSENCE	MU4 Absence	MU4 Absence	*	*	*	*
1924	SW	DDB_MU5_ABSENCE	MU5 Absence	MU5 Absence	*	*	*	*
1925	SW	DDB_MU6_ABSENCE	MU6 Absence	MU6 Absence	*	*	*	*
1926	SW	DDB_MU7_ABSENCE	MU7 Absence	MU7 Absence	*	*	*	*
1927	SW	DDB_MU8_ABSENCE	MU8 Absence	MU8 Absence	*	*	*	*
1928	SW	DDB_MAIN_VT_INHIBIT	Main VT Inhibit	Main VT Inhibit	*	*	*	*
1929	SW	DDB_CS_VT1_INHIBIT	CS VT1 Inhibit	CS VT1 Inhibit	*	*	*	*
1930	SW	DDB_PHASE_CT1_INHIBIT	Phs CT1 Inhibit	Phs CT1 Inhibit	*	*	*	*
1931	SW	DDB_MCOMP_CT_INHIBIT	Mcomp CT Inhibit	Mcomp CT Inhibit	*	*	*	*
1931		DDB_UNUSED_1931	Unused	Unused				
1932	SW	DDB_SEF_CT_INHIBIT	SEF CT Inhibit	SEF CT Inhibit	*	*	*	*
1933	SW	DDB_PHASE_CT2_INHIBIT	Phs CT2 Inhibit	Phs CT2 Inhibit		*		*
1934	SW	DDB_CS_VT2_INHIBIT	CS VT2 Inhibit	CS VT2 Inhibit		*		*
1933		DDB_UNUSED_1933	Unused	Unused	*		*	
1934		DDB_UNUSED_1934	Unused	Unused	*		*	
1935	SW	DDB_MAIN_VT_SYNC_ALM	Main VT Synch alarm	Main VT Sync Alm	*	*	*	*
1936	SW	DDB_CS_VT1_SYNC_ALM	CS VT1 Synch alarm	CS VT1 Sync Alm	*	*	*	*
1937	SW	DDB_PHASE_CT1_SYNC_ALM	Phs CT1 Synch alarm	Phs CT1 Sync Alm	*	*	*	*
1938	SW	DDB_MCOMP_CT_SYNC_ALM	Mcomp CT Synch alarm	McompCT Sync Alm	*	*	*	*
1938		DDB_UNUSED_1938	Unused	Unused				
1939	SW	DDB_SEF_CT_SYNC_ALM	SEF CT Synch alarm	SEF CT Sync Alm	*	*	*	*
1940	SW	DDB_PHASE_CT2_SYNC_ALM	Phs CT2 Synch alarm	Phs CT2 Sync Alm		*		*
1941	SW	DDB_CS_VT2_SYNC_ALM	CS VT2 Synch alarm	CS VT2 Sync Alm		*		*
1940		DDB_UNUSED_1940	Unused	Unused	*		*	
1941		DDB_UNUSED_1941	Unused	Unused	*		*	
1942	PSL	DDB_EXT_CBF_INIT_3PH	CBF External Initialization trip 3 phase	CBF Ext Init 3ph	*		*	
1942	PSL	DDB_EXT_CBF_INIT_3PH	CBF CB1 External Initialization trip 3 phase	CBFCB1ExtInit3ph		*		*
1943	PSL	DDB_EXT_CBF_INIT_A	CBF External Initialization trip A phase	CBF Ext Init A	*		*	

DDB No	Source	Element Name	Description	English Text	P543/P545 No Distance	P544/P546 No Distance	P543/ P545	P544/ P546
1944	PSL	DDB_EXT_CBF_INIT_B	CBF External Initialization trip B phase	CBF Ext Init B	*		*	
1945	PSL	DDB_EXT_CBF_INIT_C	CBF External Initialization trip C phase	CBF Ext Init C	*		*	
1943	PSL	DDB_EXT_CBF_INIT_A	Unused	Unused				
1944	PSL	DDB_EXT_CBF_INIT_B	Unused	Unused				
1945	PSL	DDB_EXT_CBF_INIT_C	Unused	Unused				
1943	PSL	DDB_EXT_CBF_INIT_A	CBF CB1 External Initialization trip A phase	CBF CB1ExtInit A		*	*	
1944	PSL	DDB_EXT_CBF_INIT_B	CBF CB1 External Initialization trip B phase	CBF CB1ExtInit B		*	*	
1945	PSL	DDB_EXT_CBF_INIT_C	CBF CB1 External Initialization trip C phase	CBF CB1ExtInit C		*	*	
1946	PSL	DDB_EXT_CBF_INIT_3PH_CB2	CBF CB2 External Initialization trip 3 phase	CBFCB2ExtInit3ph		*	*	
1946	PSL	DDB_EXT_CBF_INIT_3PH_CB2	Unused	Unused	*		*	
1947	PSL	DDB_EXT_CBF_INIT_A_CB2	CBF CB2 External Initialization trip A phase	CBF CB2Ext InitA		*	*	
1948	PSL	DDB_EXT_CBF_INIT_B_CB2	CBF CB2 External Initialization trip B phase	CBF CB2Ext InitB		*	*	
1949	PSL	DDB_EXT_CBF_INIT_C_CB2	CBF CB2 External Initialization trip C phase	CBF CB2Ext InitC		*	*	
1947	PSL	DDB_EXT_CBF_INIT_A_CB2	Unused	Unused	*		*	
1948	PSL	DDB_EXT_CBF_INIT_B_CB2	Unused	Unused	*		*	
1949	PSL	DDB_EXT_CBF_INIT_C_CB2	Unused	Unused	*		*	
1950	PSL	DDB_INT_CBF_INIT_A	CBF Internal Initialization trip A phase	CBF Int Init A	*		*	
1951	PSL	DDB_INT_CBF_INIT_B	CBF Internal Initialization trip B phase	CBF Int Init B	*		*	
1952	PSL	DDB_INT_CBF_INIT_C	CBF Internal Initialization trip C phase	CBF Int Init C	*		*	
1950	PSL	DDB_INT_CBF_INIT_A	CBF Internal Initialization trip A phase	CBF CB1Int InitA		*	*	
1951	PSL	DDB_INT_CBF_INIT_B	CBF Internal Initialization trip B phase	CBF CB1Int InitB		*	*	
1952	PSL	DDB_INT_CBF_INIT_C	CBF Internal Initialization trip C phase	CBF CB1Int InitC		*	*	
1950	PSL	DDB_INT_CBF_INIT_A	Unused	Unused				
1951	PSL	DDB_INT_CBF_INIT_B	Unused	Unused				
1952	PSL	DDB_INT_CBF_INIT_C	Unused	Unused				
1953	PSL	DDB_INT_CBF_INIT_A_CB2	CBF CB2 Internal Initialization trip A phase	CBF CB2Int InitA		*	*	
1954	PSL	DDB_INT_CBF_INIT_B_CB2	CBF CB2 Internal Initialization trip B phase	CBF CB2Int InitB		*	*	
1955	PSL	DDB_INT_CBF_INIT_C_CB2	CBF CB2 Internal Initialization trip C phase	CBF CB2Int InitC		*	*	
1953	PSL	DDB_INT_CBF_INIT_A_CB2	Unused	Unused	*		*	
1954	PSL	DDB_INT_CBF_INIT_B_CB2	Unused	Unused	*		*	
1955	PSL	DDB_INT_CBF_INIT_C_CB2	Unused	Unused	*		*	
1956	SW	DDB_TS_UVPN_A_S1	Trip supervision: Vpn< phaseA stage1	TS Vpn< pH A s1	*	*	*	*
1957	SW	DDB_TS_UVPN_A_S2	Trip supervision: Vpn< phaseA stage2	TS Vpn< pH A s2	*	*	*	*
1958	SW	DDB_TS_UVPN_A_S3	Trip supervision: Vpn< phaseA stage3	TS Vpn< pH A s3	*	*	*	*
1959	SW	DDB_TS_UVPN_B_S1	Trip supervision: Vpn< phaseB stage1	TS Vpn< pH B s1	*	*	*	*
1960	SW	DDB_TS_UVPN_B_S2	Trip supervision: Vpn< phaseB stage2	TS Vpn< pH B s2	*	*	*	*
1961	SW	DDB_TS_UVPN_B_S3	Trip supervision: Vpn< phaseB stage3	TS Vpn< pH B s3	*	*	*	*
1962	SW	DDB_TS_UVPN_C_S1	Trip supervision: Vpn< phaseC stage1	TS Vpn< pH C s1	*	*	*	*
1963	SW	DDB_TS_UVPN_C_S2	Trip supervision: Vpn< phaseC stage2	TS Vpn< pH C s2	*	*	*	*
1964	SW	DDB_TS_UVPN_C_S3	Trip supervision: Vpn< phaseC stage3	TS Vpn< pH C s3	*	*	*	*
1965	SW	DDB_TS_OCD_A_S1	Trip supervision: OCD> phaseA stage1	TS OCD> pH A s1	*	*	*	*
1966	SW	DDB_TS_OCD_A_S2	Trip supervision: OCD> phaseA stage2	TS OCD> pH A s2	*	*	*	*
1967	SW	DDB_TS_OCD_A_S3	Trip supervision: OCD> phaseA stage3	TS OCD> pH A s3	*	*	*	*
1968	SW	DDB_TS_OCD_B_S1	Trip supervision: OCD> phaseB stage1	TS OCD> pH B s1	*	*	*	*

DDB No	Source	Element Name	Description	English Text	P543/P545 Distance	P544/P546 Distance	P543/ P545	P544/ P546
1969	SW	DDB_TS_OCD_B_S2	Trip supervision: OCD> phaseB stage2	TS OCD> phB s2	*	*	*	*
1970	SW	DDB_TS_OCD_B_S3	Trip supervision: OCD> phaseB stage3	TS OCD> phB s3	*	*	*	*
1971	SW	DDB_TS_OCD_C_S1	Trip supervision: OCD> phaseC stage1	TS OCD> phC s1	*	*	*	*
1972	SW	DDB_TS_OCD_C_S2	Trip supervision: OCD> phaseC stage2	TS OCD> phC s2	*	*	*	*
1973	SW	DDB_TS_OCD_C_S3	Trip supervision: OCD> phaseC stage3	TS OCD> phC s3	*	*	*	*
1974	SW	DDB_TS_UVD_A_S1	Trip supervision: UVD> phaseA stage1	TS UVD> phA s1	*	*	*	*
1975	SW	DDB_TS_UVD_A_S2	Trip supervision: UVD> phaseA stage2	TS UVD> phA s2	*	*	*	*
1976	SW	DDB_TS_UVD_A_S3	Trip supervision: UVD> phaseA stage3	TS UVD> phA s3	*	*	*	*
1977	SW	DDB_TS_UVD_B_S1	Trip supervision: UVD> phaseB stage1	TS UVD> phB s1	*	*	*	*
1978	SW	DDB_TS_UVD_B_S2	Trip supervision: UVD> phaseB stage2	TS UVD> phB s2	*	*	*	*
1979	SW	DDB_TS_UVD_B_S3	Trip supervision: UVD> phaseB stage3	TS UVD> phB s3	*	*	*	*
1980	SW	DDB_TS_UVD_C_S1	Trip supervision: UVD> phaseC stage1	TS UVD> phC s1	*	*	*	*
1981	SW	DDB_TS_UVD_C_S2	Trip supervision: UVD> phaseC stage2	TS UVD> phC s2	*	*	*	*
1982	SW	DDB_TS_UVD_C_S3	Trip supervision: UVD> phaseC stage3	TS UVD> phC s3	*	*	*	*
1983		DDB_UNUSED_1983	Unused	Unused	*	*	*	*
1984	PSL	DDB_TIMERIN_1	Input to auxiliary timer 1	Timer in 1	*	*	*	*
1985	PSL	DDB_TIMERIN_2	Input to auxiliary timer 2	Timer in 2	*	*	*	*
1986	PSL	DDB_TIMERIN_3	Input to auxiliary timer 3	Timer in 3	*	*	*	*
1987	PSL	DDB_TIMERIN_4	Input to auxiliary timer 4	Timer in 4	*	*	*	*
1988	PSL	DDB_TIMERIN_5	Input to auxiliary timer 5	Timer in 5	*	*	*	*
1989	PSL	DDB_TIMERIN_6	Input to auxiliary timer 6	Timer in 6	*	*	*	*
1990	PSL	DDB_TIMERIN_7	Input to auxiliary timer 7	Timer in 7	*	*	*	*
1991	PSL	DDB_TIMERIN_8	Input to auxiliary timer 8	Timer in 8	*	*	*	*
1992	PSL	DDB_TIMERIN_9	Input to auxiliary timer 9	Timer in 9	*	*	*	*
1993	PSL	DDB_TIMERIN_10	Input to auxiliary timer 10	Timer in 10	*	*	*	*
1994	PSL	DDB_TIMERIN_11	Input to auxiliary timer 11	Timer in 11	*	*	*	*
1995	PSL	DDB_TIMERIN_12	Input to auxiliary timer 12	Timer in 12	*	*	*	*
1996	PSL	DDB_TIMERIN_13	Input to auxiliary timer 13	Timer in 13	*	*	*	*
1997	PSL	DDB_TIMERIN_14	Input to auxiliary timer 14	Timer in 14	*	*	*	*
1998	PSL	DDB_TIMERIN_15	Input to auxiliary timer 15	Timer in 15	*	*	*	*
1999	PSL	DDB_TIMERIN_16	Input to auxiliary timer 16	Timer in 16	*	*	*	*
2000	PSL	DDB_TIMERIN_17	Input to auxiliary timer 17	Timer in 17	*	*	*	*
2001	PSL	DDB_TIMERIN_18	Input to auxiliary timer 18	Timer in 18	*	*	*	*
2002	PSL	DDB_TIMERIN_19	Input to auxiliary timer 19	Timer in 19	*	*	*	*
2003	PSL	DDB_TIMERIN_20	Input to auxiliary timer 20	Timer in 20	*	*	*	*
2004	PSL	DDB_TIMERIN_21	Input to auxiliary timer 21	Timer in 21	*	*	*	*
2005	PSL	DDB_TIMERIN_22	Input to auxiliary timer 22	Timer in 22	*	*	*	*
2006	PSL	DDB_TIMERIN_23	Input to auxiliary timer 23	Timer in 23	*	*	*	*
2007	PSL	DDB_TIMERIN_24	Input to auxiliary timer 24	Timer in 24	*	*	*	*
2008	PSL	DDB_TIMERIN_25	Input to auxiliary timer 25	Timer in 25	*	*	*	*
2009	PSL	DDB_TIMERIN_26	Input to auxiliary timer 26	Timer in 26	*	*	*	*
2010	PSL	DDB_TIMERIN_27	Input to auxiliary timer 27	Timer in 27	*	*	*	*
2011	PSL	DDB_TIMERIN_28	Input to auxiliary timer 28	Timer in 28	*	*	*	*
2012	PSL	DDB_TIMERIN_29	Input to auxiliary timer 29	Timer in 29	*	*	*	*

DDB No	Source	Element Name	Description	English Text	P543/P545 No Distance	P544/P546 No Distance	P543/ P545	P544/ P546
2013	PSL	DDB_TIMERIN_30	Input to auxiliary timer 30	Timer in 30	*	*	*	*
2014	PSL	DDB_TIMERIN_31	Input to auxiliary timer 31	Timer in 31	*	*	*	*
2015	PSL	DDB_TIMERIN_32	Input to auxiliary timer 32	Timer in 32	*	*	*	*
2016	Auxiliary Timer	DDB_TIMEROUT_1	Output from auxiliary timer 1	Timer out 1	*	*	*	*
2017	Auxiliary Timer	DDB_TIMEROUT_2	Output from auxiliary timer 2	Timer out 2	*	*	*	*
2018	Auxiliary Timer	DDB_TIMEROUT_3	Output from auxiliary timer 3	Timer out 3	*	*	*	*
2019	Auxiliary Timer	DDB_TIMEROUT_4	Output from auxiliary timer 4	Timer out 4	*	*	*	*
2020	Auxiliary Timer	DDB_TIMEROUT_5	Output from auxiliary timer 5	Timer out 5	*	*	*	*
2021	Auxiliary Timer	DDB_TIMEROUT_6	Output from auxiliary timer 6	Timer out 6	*	*	*	*
2022	Auxiliary Timer	DDB_TIMEROUT_7	Output from auxiliary timer 7	Timer out 7	*	*	*	*
2023	Auxiliary Timer	DDB_TIMEROUT_8	Output from auxiliary timer 8	Timer out 8	*	*	*	*
2024	Auxiliary Timer	DDB_TIMEROUT_9	Output from auxiliary timer 9	Timer out 9	*	*	*	*
2025	Auxiliary Timer	DDB_TIMEROUT_10	Output from auxiliary timer 10	Timer out 10	*	*	*	*
2026	Auxiliary Timer	DDB_TIMEROUT_11	Output from auxiliary timer 11	Timer out 11	*	*	*	*
2027	Auxiliary Timer	DDB_TIMEROUT_12	Output from auxiliary timer 12	Timer out 12	*	*	*	*
2028	Auxiliary Timer	DDB_TIMEROUT_13	Output from auxiliary timer 13	Timer out 13	*	*	*	*
2029	Auxiliary Timer	DDB_TIMEROUT_14	Output from auxiliary timer 14	Timer out 14	*	*	*	*
2030	Auxiliary Timer	DDB_TIMEROUT_15	Output from auxiliary timer 15	Timer out 15	*	*	*	*
2031	Auxiliary Timer	DDB_TIMEROUT_16	Output from auxiliary timer 16	Timer out 16	*	*	*	*
2032	Auxiliary Timer	DDB_TIMEROUT_17	Output from auxiliary timer 17	Timer out 17	*	*	*	*
2033	Auxiliary Timer	DDB_TIMEROUT_18	Output from auxiliary timer 18	Timer out 18	*	*	*	*
2034	Auxiliary Timer	DDB_TIMEROUT_19	Output from auxiliary timer 19	Timer out 19	*	*	*	*
2035	Auxiliary Timer	DDB_TIMEROUT_20	Output from auxiliary timer 20	Timer out 20	*	*	*	*
2036	Auxiliary Timer	DDB_TIMEROUT_21	Output from auxiliary timer 21	Timer out 21	*	*	*	*
2037	Auxiliary Timer	DDB_TIMEROUT_22	Output from auxiliary timer 22	Timer out 22	*	*	*	*
2038	Auxiliary Timer	DDB_TIMEROUT_23	Output from auxiliary timer 23	Timer out 23	*	*	*	*
2039	Auxiliary Timer	DDB_TIMEROUT_24	Output from auxiliary timer 24	Timer out 24	*	*	*	*
2040	Auxiliary Timer	DDB_TIMEROUT_25	Output from auxiliary timer 25	Timer out 25	*	*	*	*
2041	Auxiliary Timer	DDB_TIMEROUT_26	Output from auxiliary timer 26	Timer out 26	*	*	*	*
2042	Auxiliary Timer	DDB_TIMEROUT_27	Output from auxiliary timer 27	Timer out 27	*	*	*	*
2043	Auxiliary Timer	DDB_TIMEROUT_28	Output from auxiliary timer 28	Timer out 28	*	*	*	*
2044	Auxiliary Timer	DDB_TIMEROUT_29	Output from auxiliary timer 29	Timer out 29	*	*	*	*
2045	Auxiliary Timer	DDB_TIMEROUT_30	Output from auxiliary timer 30	Timer out 30	*	*	*	*
2046	Auxiliary Timer	DDB_TIMEROUT_31	Output from auxiliary timer 31	Timer out 31	*	*	*	*
2047	Auxiliary Timer	DDB_TIMEROUT_32	Output from auxiliary timer 32	Timer out 32	*	*	*	*

Table 1 - Digital database point list sorted by DDB number

3 FACTORY DEFAULT PROGRAMMABLE SCHEME LOGIC (PSL) SETTINGS

The following section details the default settings of the PSL.
The P54x model options are as follows:

Model	Opto inputs	Relay outputs
P543xxx?xxxxxxM	16	14
P543xxx#xxxxxxM	16	7 standard and 4 high break
P544xxx?xxxxxxM	16	14
P544xxx#xxxxxxM	16	7 standard and 4 high break
P545xxx?xxxxxxM	24	32
P545xxx#xxxxxxM	24	16 standard and 8 high break
P545xxx\$xxxxxxM	32	32
P546xxx?xxxxxxM	24	32
P546xxx#xxxxxxM	24	16 standard and 8 high break
P546xxx£xxxxxxM	24	8 standard and 12 high break
<p><i>Note</i> ? is for models with only standard output contacts = A, B, C, D, E, F, G, H, J, K, L, M or R.</p>		
<p><i>Note</i> # is for models with standard and high break contacts = S, T, U, V, W, X, Z, 0, 1, 2, 3, 4 or 5.</p>		
<p><i>Note</i> \$ is for models with 32 opto inputs with standard and high break contacts = 8 or 9</p>		
<p><i>Note</i> £ is for models with standard and high break contacts = I, N, O, P, Q, 8, 9.</p>		

Table 2 - Factory default PSL settings for P54x models

4 LOGIC INPUT AND OUTPUT MAPPINGS

4.1 Logic Input Mappings

The default mappings for each of the opto-isolated inputs are in Table 3.

Opto-input No	Relay text	P543	P544	P545	P546
		Function	Function	Function	Function
1	Input L1	L1 Inhibit Diff	L1 Inhibit Diff	L1 Inhibit Diff	L1 Inhibit Diff
2	Input L2	L2 Interlock	L2 Interlock	L2 Interlock	L2 BAR
3	Input L3	L3 Aid 1 Receive	L3 Aid 1 Receive	L3 Aid 1 Receive	L3 Aid 1 Receive
4	Input L4	L4 Aid 1 COS/LGS	L4 Aid 1 COS/LGS	L4 Aid 1 COS/LGS	L4 Aid 1 COS/LGS
5	Input L5	L5 Reset LEDs	L5 Reset LEDs	L5 Reset LEDs	L5 Reset LEDs
6	Input L6	L6 Ext Trip A	L6 CB2 AuxA 52-B	L6 Ext Trip A	L6 CB2 AuxA 52-B
7	Input L7	L7 Ext Trip B	L7 CB2 AuxB 52-B	L7 Ext Trip B	L7 CB2 AuxB 52-B
8	Input L8	L8 Ext Trip C	L8 CB2 AuxC 52-B	L8 Ext Trip C	L8 CB2 AuxC 52-B
9	Input L9	L9 CB AuxA 52-B	L9 CB AuxA 52-B	L9 CB AuxA 52-B	L9 CB AuxA 52-B
10	Input L10	L10 CB AuxB 52-B	L10 CB AuxB 52-B	L10 CB AuxB 52-B	L10 CB AuxB 52-B
11	Input L11	L11 CB AuxC 52-B	L11 CB AuxC 52-B	L11 CB AuxC 52-B	L11 CB AuxC 52-B
12	Input L12	L12 MCB/VTs	L12 MCB/VTs	L12 MCB/VTs	L12 MCB/VTs
13	Input L13	L13 CB Close Man	L13 CB1 CloseMan	L13 CB Close Man	L13 CB1 CloseMan
14	Input L14	L14 Reset Lckout	L14 CB2 CloseMan	L14 Reset Lckout	L14 CB2 CloseMan
15	Input L15	L15 CB Healthy	L15 Not Used	L15 CB Healthy	L15 CB1 Healthy
16	Input L16	L16 BAR	L16 Stub Bus En	L16 BAR	L16 Stub Bus En
17	Input L17	n/a	n/a	L17 PIT	L17 CB2 Healthy
18	Input L18	n/a	n/a	L18 Prop Dly Eq	L18 IM64
19	Input L19	n/a	n/a	L19 IM64 1	L19 CB1 Ext Trip A
20	Input L20	n/a	n/a	L20 IM64 2	L20 CB1 Ext Trip B
21	Input L21	n/a	n/a	L21 IM64 3	L21 CB1 Ext Trip C
22	Input L22	n/a	n/a	L22 IM64 4	L22 CB2 Ext Trip A
23	Input L23	n/a	n/a	L23 Not Used	L23 CB2 Ext Trip B
24	Input L24	n/a	n/a	L24 Not Used	L24 CB2 Ext Trip C
25	Input L25	n/a	n/a	L25 Not Used	n/a
26	Input L26	n/a	n/a	L26 Not Used	n/a
27	Input L27	n/a	n/a	L27 Not Used	n/a
28	Input L28	n/a	n/a	L28 Not Used	n/a
29	Input L29	n/a	n/a	L29 Not Used	n/a
30	Input L30	n/a	n/a	L30 Not Used	n/a
31	Input L31	n/a	n/a	L31 Not Used	n/a
32	Input L32	n/a	n/a	L32 Not Used	n/a

Table 3 - Default opto-isolated input mappings

4.2 Standard Relay Output Contact Mappings

The default mappings for each of the relay output contacts appear in Table 4 and Table 5

Relay Contact No	Relay text	P543		P544	
		Relay conditioner	Function	Relay conditioner	Function
1	Output R1	Straight-through	R1 Trip Z1	Straight-through	R1 Trip Diff/Z1
2	Output R2	Straight-through	R2 SignalingFail	Straight-through	R2 SignalingFail
3	Output R3	Dwell 100 ms	R3 Any Trip	Dwell 100 ms	R3 Any Trip
4	Output R4	Dwell 500 ms	R4 General Alarm	Dwell 500 ms	R4 General Alarm
5	Output R5	Straight-through	R5 IM64 1	Straight-through	R5 IM64 1
6	Output R6	Dwell 100 ms	R6 CB Fail Time1	Dwell 100 ms	R6 CB1 Fail1Trip
7	Output R7	Straight-through	R7 Cntl CB Close	Straight-through	R7 Cntl CB1 Close
8	Output R8	Straight-through	R8 Cntl CB Trip	Straight-through	R8 Cntl CB1 Trip
9	Output R9	Dwell 100 ms	R9 Trip A	Dwell 100 ms	R9 Trip A
10	Output R10	Dwell 100 ms	R10 Trip B	Dwell 100 ms	R10 Trip B
11	Output R11	Dwell 100 ms	R11 Trip C	Dwell 100 ms	R11 Trip C
12	Output R12	Straight-through	R12 AR in Prog	Dwell 100 ms	R12 CB2 Fail1Trip
13	Output R13	Straight-through	R13 SuccessClose	Straight-through	R13 CntlCB2Close
14	Output R14	Straight-through	R14 AR Lockout	Straight-through	R14 Cntl CB2Trip

Note A fault record can be generated by connecting one or a number of contacts to the Fault Record Trigger in PSL. It is recommended that the triggering contact be 'self reset' and not a latching. If a latching contact were chosen the fault record would not be generated until the contact had fully reset.

Table 4 - Default relay output contact mappings for P543 and P544

Relay Contact No	Relay Text	P545		P546	
		Relay Conditioner	Function	Relay Conditioner	Function
1	Output R1	Straight-through	R1 Trip Z1	Straight-through	R1 Trip Z1
2	Output R2	Straight-through	R2 SignalingFail	Straight-through	R2 SignalingFail
3	Output R3	Dwell 100 ms	R3 Any Trip	Dwell 100 ms	R3 Any Trip
4	Output R4	Dwell 500 ms	R4 General Alarm	Dwell 500 ms	R4 General Alarm
5	Output R5	Straight-through	R5 IM64 1	Straight-through	R5 IM64 1
6	Output R6	Dwell 100 ms	R6 CB Fail Time1	Dwell 100 ms	R6 CB1 Fail1Trip
7	Output R7	Straight-through	R7 Cntl CB Close	Straight-through	R7 Cntl CB1 Close
8	Output R8	Straight-through	R8 Cntl CB Trip	Straight-through	R8 Cntl CB1 Trip
9	Output R9	Dwell 100 ms	R9 Trip A	Dwell 100 ms	R9 CB1 Trip A
10	Output R10	Dwell 100 ms	R10 Trip B	Dwell 100 ms	R10 CB1 Trip B
11	Output R11	Dwell 100 ms	R11 Trip C	Dwell 100 ms	R11 CB1 Trip C
12	Output R12	Straight-through	R12 AR in Prog	Dwell 100 ms	R12 CB2 Fail1Trip
13	Output R13	Straight-through	R13 SuccessClose	Straight-through	R13 CntlCB2Close
14	Output R14	Straight-through	R14 AR Lockout	Straight-through	R14 Cntl CB2Trip
15	Output R15	Straight-through	R15 AR InService	Dwell 100 ms	R15 CB1 Fail2Trip
16	Output R16	Straight-through	R16 BAR	Dwell 100 ms	R16 CB2 Fail2Trip
17	Output R17	Dwell 100 ms	R17 Trip A	Dwell 100 ms	R17 CB2 Trip A
18	Output R18	Dwell 100 ms	R18 Trip B	Dwell 100 ms	R18 CB2 Trip B

Relay Contact No	Relay Text	P545		P546	
		Relay Conditioner	Function	Relay Conditioner	Function
19	Output R19	Dwell 100 ms	R19 Trip C	Dwell 100 ms	R19 CB2 Trip C
20	Output R20	Straight-through	R20 DistInst Trp	Straight-through	R20 DistInst Trp
21	Output R21	Straight-through	R21 Dist Dly Trp	Straight-through	R21 Dist Dly Trp
22	Output R22	Straight-through	R22 Aid DEF Trip	Straight-through	R22 Aid DEF Trip
23	Output R23	Straight-through	R23 Any Start	Straight-through	R23 Any Start
24	Output R24	Straight-through	R24 Aid 1 Send	Straight-through	R24 Aid 1 Send
25	Output R25	Straight-through	R25 GPS Fail	Straight-through	R25 GPS Fail
26	Output R26	Straight-through	R26 Diff Trip	Straight-through	R26 Diff Trip
27	Output R27	Straight-through	R27 VTS	Straight-through	R27 VTS
28	Output R28	Straight-through	R28 PSB	Straight-through	R28 PSB
29	Output R29	Straight-through	R29 IM64 2	Straight-through	R29 AR CB1 Lockout
30	Output R30	Straight-through	R30 IM64 3	Straight-through	R30 AR CB2 Lockout
31	Output R31	Straight-through	R31 IM64 4	Straight-through	R31 ARIP
32	Output R32	Straight-through	R32 Not Used	Straight-through	R32 SuccessClose

Note *A fault record can be generated by connecting one or a number of contacts to the Fault Record Trigger in PSL. It is recommended that the triggering contact be 'self reset' and not a latching. If a latching contact were chosen the fault record would not be generated until the contact had fully reset.*

Table 5 - Default relay output contact mappings for P545 and P546

4.3 Optional High Break Relay Output Contact Mappings

The default mappings for each of the standard and high break relay output contacts appear in Table 6 to Table 9:

Relay Contact No	Relay Text		P543		P544	
			P543 Relay Conditioner	Function	P543 Relay Conditioner	Function
1	Output R1		Straight-through	R1 Trip Diff/Z1	Straight-through	R1 Trip Diff/Z1
2	Output R2		Straight-through	R2 SignalingFail	Straight-through	R2 SignalingFail
3	Output R3		Dwell 100 ms	R3 Any Trip	Dwell 100 ms	R3 Any Trip
4	Output R4		Dwell 500 ms	R4 General Alarm	Dwell 500 ms	R4 General Alarm
5	Output R5		Straight-through	R5 IM64 1	Straight-through	R5 IM64 1
6	Output R6		Dwell 100 ms	R6 CB Fail Time1	Dwell 100 ms	R6 CB1 Fail1Trip
7	Output R7		Straight-through	R7 Cntl CB Close	Straight-through	R7 CB2 Fail1Trip
8	Output R8	HBC	Dwell 100 ms	R8 Trip A	Dwell 100 ms	R8 Trip A
9	Output R9	HBC	Dwell 100 ms	R9 Trip B	Dwell 100 ms	R9 Trip B
10	Output R10	HBC	Dwell 100 ms	R10 Trip C	Dwell 100 ms	R10 Trip C
11	Output R11	HBC	Dwell 100 ms	R11 Any Trip	Dwell 100 ms	R11 Any Trip

HBC = High-Break Contact

Table 6 - Default standard and high break output contact mappings for P543 and P544

Relay Contact No	P545 relay text	P545 relay conditioner	Function	
1	Output R1	Straight-through	R1 Trip Z1	
2	Output R2	Straight-through	R2 SignalingFail	
3	Output R3	Dwell 100 ms	R3 Any Trip	
4	Output R4	Dwell 500 ms	R4 General Alarm	
5	Output R5	Straight-through	R5 IM64 1	
6	Output R6	Dwell 100 ms	R6 CB Fail Time1	
7	Output R7	Straight-through	R7 Cntl CB Close	
8	Output R8	Straight-through	R8 Cntl CB Trip	
9	Output R9	Dwell 100 ms	R9 Trip A	
10	Output R10	Dwell 100 ms	R10 Trip B	
11	Output R11	Dwell 100 ms	R11 Trip C	
12	Output R12	Straight-through	R12 AR in Prog	
13	Output R13	Straight-through	R13 SuccessClose	
14	Output R14	Straight-through	R14 AR Lockout	
15	Output R15	Straight-through	R15 AR InService	
16	Output R16	Straight-through	R16 Aid 1 Send	
17	Output R17	Dwell 100 ms	R17 Trip A	High break contact
18	Output R18	Dwell 100 ms	R18 Trip B	High break contact
19	Output R19	Dwell 100 ms	R19 Trip C	High break contact
20	Output R20	Dwell 100 ms	R20 Any Trip	High break contact
21	Output R21	Dwell 100 ms	R21 Trip A	High break contact
22	Output R22	Dwell 100 ms	R22 Trip B	High break contact
23	Output R23	Dwell 100 ms	R23 Trip C	High break contact

Relay Contact No	P545 relay text	P545 relay conditioner	Function	
24	Output R24	Dwell 100 ms	R24 Any Trip	High break contact
HBC = High-Break Contact				

Table 7 - Default standard and high break output contact mappings for P545

Relay Contact No	P546 relay text	P546 relay conditioner	Function	
Note	This table shows the P546 model with 16 standard outputs and 8 high break outputs (Option S).			
1	Output R1	Straight-through	R1 Trip Z1	
2	Output R2	Straight-through	R2 SignalingFail	
3	Output R3	Dwell 100 ms	R3 Any Trip	
4	Output R4	Dwell 500 ms	R4 General Alarm	
5	Output R5	Straight-through	R5 IM64 1	
6	Output R6	Dwell 100 ms	R6 CB1 Fail1Trip	
7	Output R7	Straight-through	R7 Cntl CB1 Close	
8	Output R8	Straight-through	R8 Cntl CB1 Trip	
9	Output R9	Dwell 100 ms	R9 CB1 Trip A	
10	Output R10	Dwell 100 ms	R10 CB1 Trip B	
11	Output R11	Dwell 100 ms	R11 CB1 Trip C	
12	Output R12	Dwell 100 ms	R12 Any Start	
13	Output R13	Straight-through	R13 CntlCB2Close	
14	Output R14	Straight-through	R14 Cntl CB2Trip	
15	Output R15	Dwell 100 ms	R15 CB2 Fail1Trip	
16	Output R16	Dwell 100 ms	R16 Aid 1 Send	
17	Output R17	Dwell 100 ms	R17 CB1 Trip A	High break contact
18	Output R18	Dwell 100 ms	R18 CB1 Trip B	High break contact
19	Output R19	Dwell 100 ms	R19 CB1 Trip C	High break contact
20	Output R20	Dwell 100 ms	R20 CB1 Trip 3ph	High break contact
21	Output R21	Dwell 100 ms	R21 CB2 Trip A	High break contact
22	Output R22	Dwell 100 ms	R22 CB2 Trip B	High break contact
23	Output R23	Dwell 100 ms	R23 CB2 Trip C	High break contact
24	Output R24	Dwell 100 ms	R24 CB2 Trip 3ph	High break contact

Table 8 - Default standard and high break output contact mappings for P546 (16 standard and 8 high break)

Relay Contact No	P546 relay text	P546 relay conditioner	Function	
Note	This table shows the P546 model with 8 standard outputs and 12 high break outputs.			
1	Output R1	Straight-through	R1 Trip Z1	
2	Output R2	Straight-through	R2 SignalingFail	
3	Output R3	Dwell 100 ms	R3 Any Trip	
4	Output R4	Dwell 500 ms	R4 General Alarm	
5	Output R5	Straight-through	R5 IM64 1	
6	Output R6	Dwell 100 ms	R6 CB1 Fail1Trip	

Relay Contact No	P546 relay text	P546 relay conditioner	Function	
7	Output R7	Straight-through	R7 Cntl CB1 Close	
8	Output R8	Straight-through	R8 Cntl CB1 Trip	
9	Output R9	Dwell 100 ms	R9 CB1 Trip A	High break contact
10	Output R10	Dwell 100 ms	R10 CB1 Trip B	High break contact
11	Output R11	Dwell 100 ms	R11 CB1 Trip C	High break contact
12	Output R12	Dwell 100 ms	R12 CB2 Fail1Trip	High break contact
13	Output R13	Dwell 100 ms	R13 CntlCB2Close	High break contact
14	Output R14	Dwell 100 ms	R14 Cntl CB2Trip	High break contact
15	Output R15	Dwell 100 ms	R15 CB1 Fail2Trip	High break contact
16	Output R16	Dwell 100 ms	R16 CB2 Fail2Trip	High break contact
17	Output R17	Dwell 100 ms	R17 CB2 Trip A	High break contact
18	Output R18	Dwell 100 ms	R18 CB2 Trip B	High break contact
19	Output R19	Dwell 100 ms	R19 CB2 Trip C	High break contact
20	Output R20	Dwell 100 ms	R20 DistInst Trp	High break contact

Table 9 - Default standard and high break output contact mappings for P546 (8 standard and 12 high break)

4.4 Programmable LED Output Mappings

The default mappings for each of the programmable LEDs appear in Table 10 to Table 12.

LED No	LED Input connection/text	Latched	P543 LED function indication
1	LED 1 Red	Yes	Diff Trip
2	LED 2 Red	Yes	Dist Inst Trip
3	LED 3 Red	Yes	Dist Delay Trip
4	LED 4 Red	No	Signaling Fail
5	LED 5 Red	No	Any Start
6	LED 6 Red	No	AR in Progress
7	LED 7 Red	No	AR Lockout
8	LED 8 Red	No	Test Loopback
9	FnKey LED1 Red	No	Not Mapped
10	FnKey LED2 Red	No	Not Mapped
11	FnKey LED3 Red	No	Not Mapped
12	FnKey LED4 Red	No	Not Mapped
13	FnKey LED5 Red	No	Not Mapped
14	FnKey LED6 Red	No	Not Mapped
15	FnKey LED7 Red	No	Not Mapped
16	FnKey LED8 Red	No	Not Mapped
17	FnKey LED9 Red	No	Not Mapped
18	FnKey LED10 Red	No	Not Mapped

Table 10 - Default mappings for programmable LEDs for P543

LED No	LED input connection/text	Latched	P544 LED function indication
1	LED 1 Red	Yes	Diff Trip
2	LED 2 Red	Yes	Dist Inst Trip
3	LED 3 Red	Yes	Dist Delay Trip
4	LED 4 Red	No	Signaling Fail
5	LED 5 Red	No	Any Start
6	LED 6 Red	No	Not Used
7	LED 7 Red	No	Test Loopback
8	LED 8 Red	No	AR In Service
9	FnKey LED1 Red	No	CB1 A Open
	FnKey LED1 Green	No	CB1 A Closed
	FnKey LED1 Amber	No	Not Mapped
10	FnKey LED2 Red	No	CB1 B Open
	FnKey LED2 Green	No	CB1 B Closed
	FnKey LED2 Amber	No	Not Mapped
11	FnKey LED3 Red	No	CB1 C Open
	FnKey LED3 Green	No	CB1 C Closed
	FnKey LED3 Amber	No	Not Mapped
12	FnKey LED4 Red	No	CB1 AR Lockout
	FnKey LED4 Green	No	Not Mapped
	FnKey LED4 Amber	No	Not Mapped

LED No	LED input connection/text	Latched	P544 LED function indication
13	FnKey LED5 Red	No	Not Mapped
	FnKey LED5 Green	No	CB1 AR Successful
	FnKey LED5 Amber	No	CB1 ARIP
14	Funky LED6 Red	No	CB2 A Open
	FnKey LED6 Green	No	CB2 A Closed
	FnKey LED6 Amber	No	Not Mapped
15	Funky LED7 Red	No	CB2 B Open
	FnKey LED7 Green	No	CB2 B Closed
	FnKey LED7 Amber	No	Not Mapped
16	Funky LED8 Red	No	CB2 C Open
	FnKey LED8 Green	No	CB2 C Closed
	FnKey LED8 Amber	No	Not Mapped
17	Funky LED9 Red	No	CB2 AR Lockout
	FnKey LED9 Green	No	Not Mapped
	FnKey LED9 Amber	No	Not Mapped
18	Funky LED10 Red	No	Not Mapped
	FnKey LED10 Green	No	CB2 AR Successful
	FnKey LED10 Amber	No	CB2 ARIP

Table 11 - Default mappings for programmable LEDs for P544

LED No	LED input connection/text	Latched	P545 LED function indication
1	LED 1 Red	Yes	Diff Trip
2	LED 2 Red	Yes	Dist Inst Trip
3	LED 3 Red	Yes	Dist Delay Trip
4	LED 4 Red	No	Signaling Fail
5	LED 5 Red	No	Any Start
6	LED 6 Red	No	AR in Progress
7	LED 7 Red	No	AR Lockout
8	LED 8 Red	No	Test Loopback
9	Funky LED1 Red	No	Not Mapped
10	Funky LED2 Red	No	Not Mapped
11	Funky LED3 Red	No	Not Mapped
12	Funky LED4 Red	No	Not Mapped
13	Funky LED5 Red	No	Not Mapped
14	Funky LED6 Red	No	Not Mapped
15	Funky LED7 Red	No	Not Mapped
16	Funky LED8 Red	No	Not Mapped
17	Funky LED9 Red	No	Not Mapped
18	Funky LED10 Red	No	Not Mapped
1	LED 1 Red	Yes	Diff Trip
2	LED 2 Red	Yes	Dist Inst Trip
3	LED 3 Red	Yes	Dist Delay Trip
4	LED 4 Red	No	Signaling Fail
5	LED 5 Red	No	Any Start

LED No	LED input connection/text	Latched	P545 LED function indication
6	LED 6 Red	No	Not Used
7	LED 7 Red	No	Test Loopback
8	LED 8 Red	No	AR In Service
9	Funky LED1 Red	No	CB1 A Open
	Funky LED1 Green	No	CB1 A Closed
	Funky LED1 Amber	No	Not Mapped
10	Funky LED2 Red	No	CB1 B Open
	Funky LED2 Green	No	CB1 B Closed
	Funky LED2 Amber	No	Not Mapped
11	Funky LED3 Red	No	CB1 C Open
	Funky LED3 Green	No	CB1 C Closed
	Funky LED3 Amber	No	Not Mapped
12	Funky LED4 Red	No	CB1 AR Lockout
	Funky LED4 Green	No	Not Mapped
	Funky LED4 Amber	No	Not Mapped
13	Funky LED5 Red	No	Not Mapped
	Funky LED5 Green	No	CB1 AR Successful
	Funky LED5 Amber	No	CB1 ARIP
14	Funky LED6 Red	No	CB2 A Open
	Funky LED6 Green	No	CB2 A Closed
	Funky LED6 Amber	No	Not Mapped
15	Funky LED7 Red	No	CB2 B Open
	Funky LED7 Green	No	CB2 B Closed
	Funky LED7 Amber	No	Not Mapped
16	Funky LED8 Red	No	CB2 C Open
	Funky LED8 Green	No	CB2 C Closed
	Funky LED8 Amber	No	Not Mapped
17	Funky LED9 Red	No	CB2 AR Lockout
	Funky LED9 Green	No	Not Mapped
	Funky LED9 Amber	No	Not Mapped
18	Funky LED10 Red	No	Not Mapped
	Funky LED10 Green	No	CB2 AR Successful
	Funky LED10 Amber	No	CB2 ARIP

Table 12 - Default mappings for programmable LEDs for P545

4.5 Fault Recorder Start Mappings

The default mappings for the signal which initiates a fault record is as shown below:

Initiating Signal	Fault Trigger
DDB Any Trip (522)	Initiate fault recording from main protection trip

Table 13 - Fault Recorder Start Mappings

4.6 PSL Data Column

The relay contains a PSL DATA column that can be used to track PSL modifications. A total of 12 cells are contained in the PSL DATA column, 3 for each setting group. The function for each cell is shown below:

Grp PSL Ref	When downloading a PSL to the relay, the user will be prompted to enter which groups the PSL is for and a reference ID. The first 32 characters of the reference ID will be displayed in this cell. The 4 and 6 keys can be used to scroll through 32 characters as only 16 can be displayed at any one time.
18 Nov 2002 08:59:32.047	This cell displays the date and time when the PSL was down loaded to the relay.
Grp 1 PSL ID - 2062813232	This is a unique number for the PSL that has been entered. Any change in the PSL will result in a different number being displayed.

Note The above cells are repeated for each setting group.

4.7 PSL Signal Grouping Modes

There are now four additional **DDB Group Sig x** Nodes that can be mapped to individual or multiple DDBs in the PSL. These can then be set to trigger the DR via the DISTURBANCE RECORD menu.

These "Nodes" are general and can also be used to group signals together in the PSL for any other reason. These four nodes are available in each of the four PSL setting groups.

Number	PSL Group Sig
992	PSL Group Sig 1
993	PSL Group Sig 2
994	PSL Group Sig 3
995	PSL Group Sig 4

1. For a control input, the DR can be triggered directly by triggering directly from the Individual Control Input (e.g. Low to High (L to H) change)
2. For an input that cannot be triggered directly, or where any one of a number of DDBs are required to trigger a DR, map the DDBs to the new PSL Group sig n and then trigger the DR on this.

e.g. in the PSL:

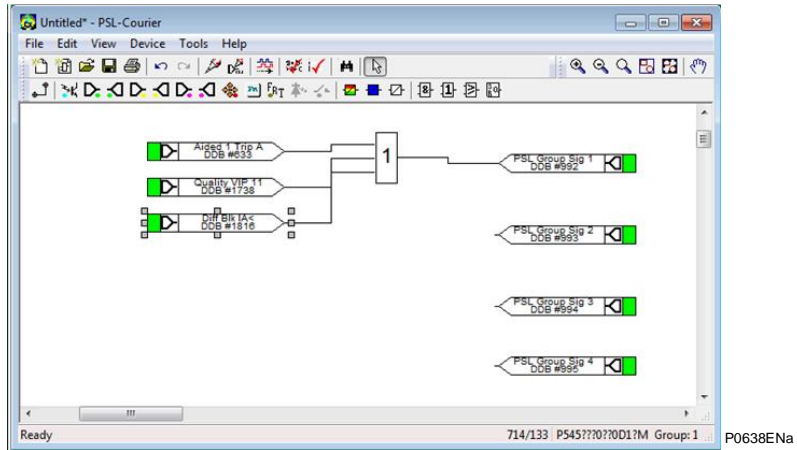

In the DR Settings:

- Digital Input 1 is triggered by the PSL Group Sig 1 (L to H)
- Digital Input 2 is triggered by Control Input 1 (L to H)

The screenshot shows the MiCOM S1 Studio V5.0.0 interface. The 'Studio Explorer' on the left shows a project tree with 'System [Newdd]' and 'Device [P545]'. The main window displays a table of settings for 'Newdd.P545.000'. The table has columns for Name, Value, and Address (C.R.).

Name	Value	Address (C.R.)
CT AND VT RATIOS		
RECORD CONTROL		
DISTURB RECORDER		
Duration	1.500 s	0C.01
Trigger Position	33.30 %	0C.02
Trigger Mode	Single	0C.03
Analog Channel 1	VA	0C.04
Analog Channel 2	VB	0C.05
Analog Channel 3	VC	0C.06
Analog Channel 4	IA	0C.07
Analog Channel 5	IB	0C.08
Analog Channel 6	IC	0C.09
Analog Channel 7	IN	0C.0A
Analog Channel 8	IN Sensitive	0C.0B
Digital Input 1	PSL Group Sig 1	0C.0C
Input 1 Trigger	Trigger L/H	0C.0D
Digital Input 2	Control Input 1	0C.0E
Input 2 Trigger	Trigger L/H	0C.0F
Digital Input 3	Relay 3	0C.10
Input 3 Trigger	Trigger L/H	0C.11
Digital Input 4	PSL Group Sig 1	0C.12
Input 4 Trigger	Trigger H/L	0C.13
Digital Input 5	Control Input 1	0C.14
Input 5 Trigger	Trigger H/L	0C.15
Digital Input 6	Relay 6	0C.16
Input 6 Trigger	No Trigger	0C.17
Digital Input 7	Relay 7	0C.18
Input 7 Trigger	No Trigger	0C.19
Digital Input 8	Relay 8	0C.1A

If triggering on both edges is required map another DR channel to the H/L as well
Digital Input 4 is triggered by the PSL Group Sig 1 (H to L)
Digital Input 5 is triggered by Control Input 1 (H to L)

5 VIEWING AND PRINTING DEFAULT PSL DIAGRAMS

5.1 Typical Mappings

It is possible to view and print the default PSL diagrams for the device. Typically, these diagrams allow you to see these mappings:

- Opto Input Mappings
- Output Relay Mappings
- LED Mappings
- Start Indications
- Phase Trip Mappings
- System Check Mapping

Important

The following PSL diagrams show the DDB numbers for a specific MiCOM product, with a specific software version to run on a specific hardware platform. Descriptions, DDB Numbers, Inputs and Outputs may vary for different products, software or hardware.

5.2 Download and Print PSL Diagrams

To download and print the default PSL diagrams for the device:

1. Close Easergy Studio.
2. Select **Programs** > then navigate through to > **Easergy Studio** > **Data Model Manager**.
3. Click **Add** then **Next**.
4. Click **Internet** then **Next**.
5. Select your language then click **Next**.
6. From the tree view, select the model and software version.
7. Click **Install**. When complete click **OK**.
8. Close the Data Model Manager and start Easergy Studio.
9. Select Tools > PSL Editor (Px40).
10. In the PSL Editor select **File** > **Open**. The downloaded PSL files are in C:\Program Files\ directory located in the \Easergy Studio\Courier\PSL\Defaults sub-directory.
11. Highlight the required PSL diagram and select **File** > **Print**.

6 MICOM P543 WITH DISTANCE PSL

6.1 Output Input Mappings

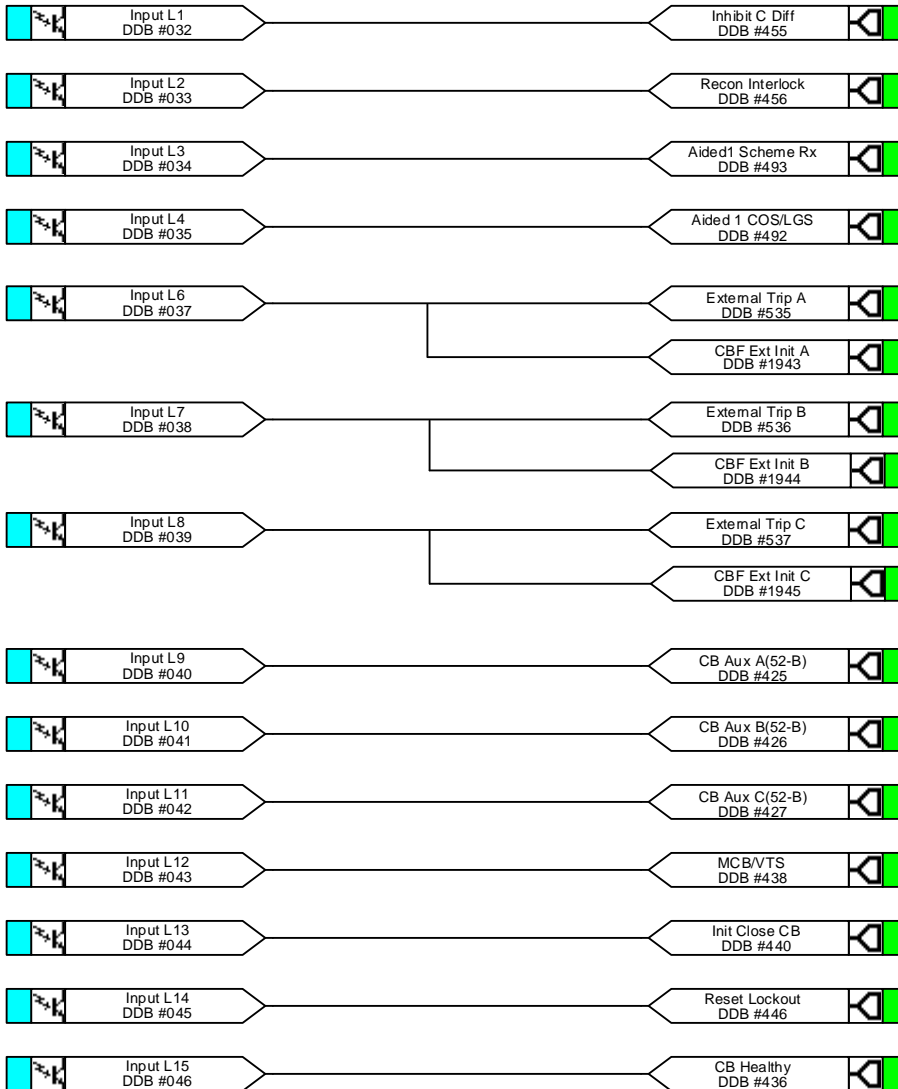

External Trips:
Initiate Auto-reclose
(if enabled). CBF
initiation is
segregated

Opto L5 & L16 can be found on other pages

P0701ENc

6.2 Output Contacts

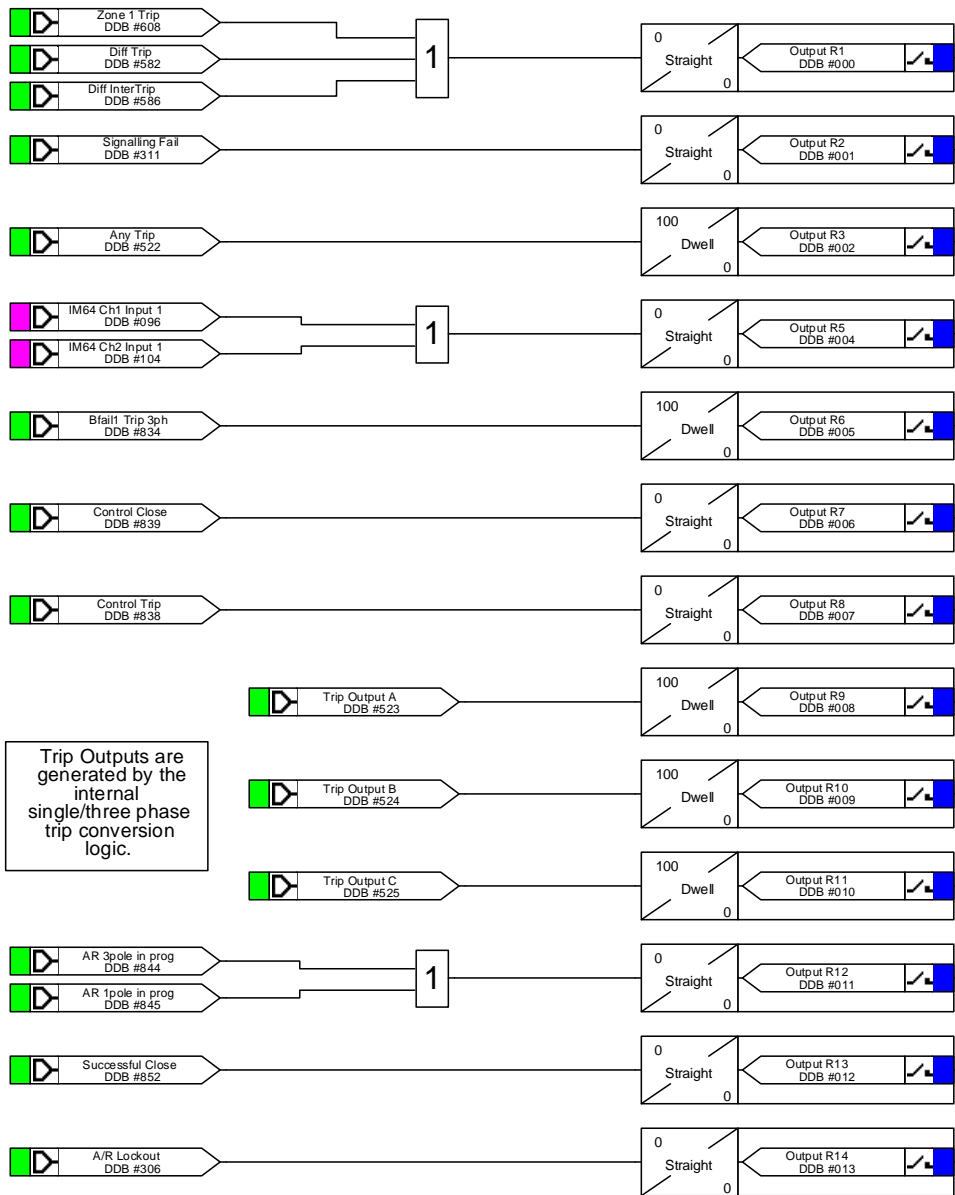

P0702ENa

6.3 Output Contacts

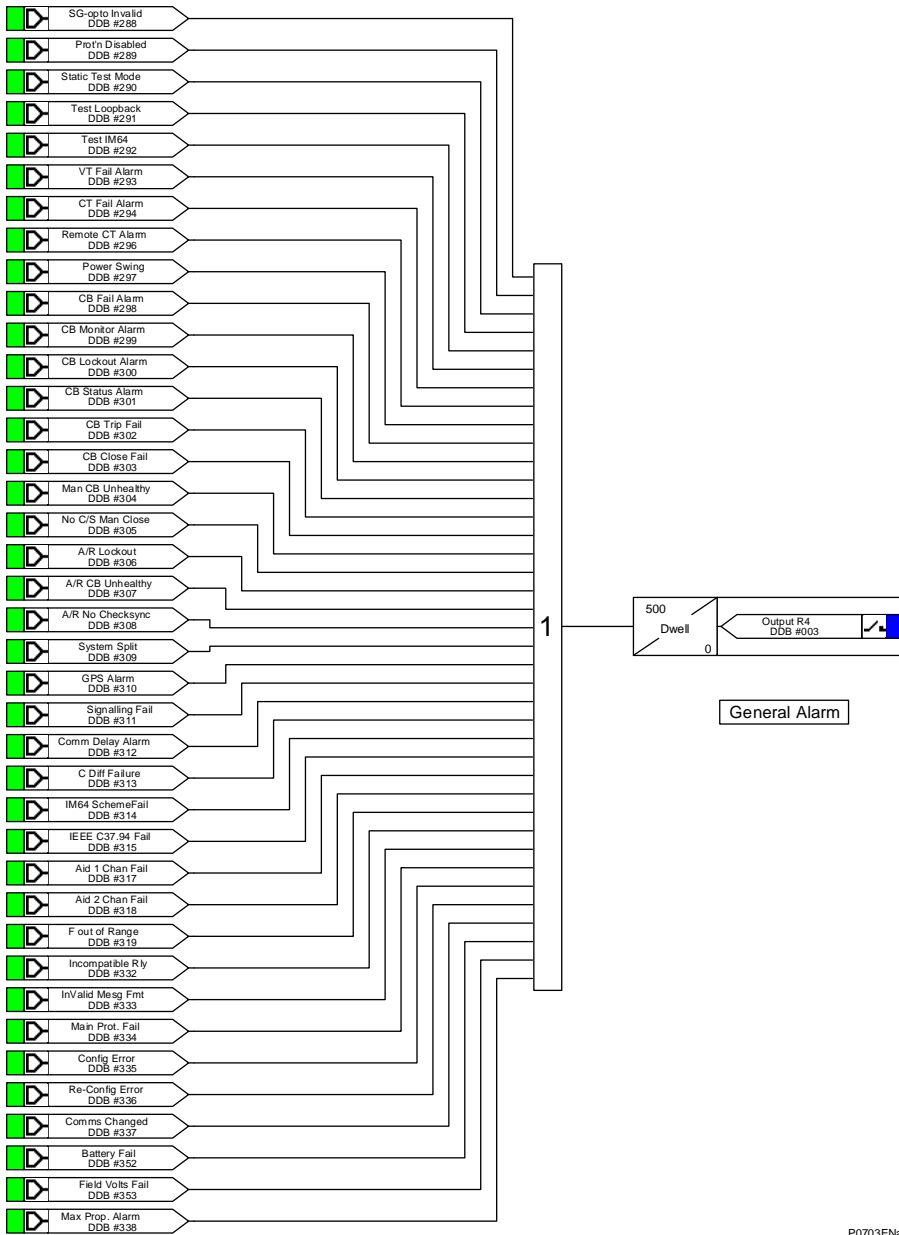

P0703ENa

6.4 LEDs

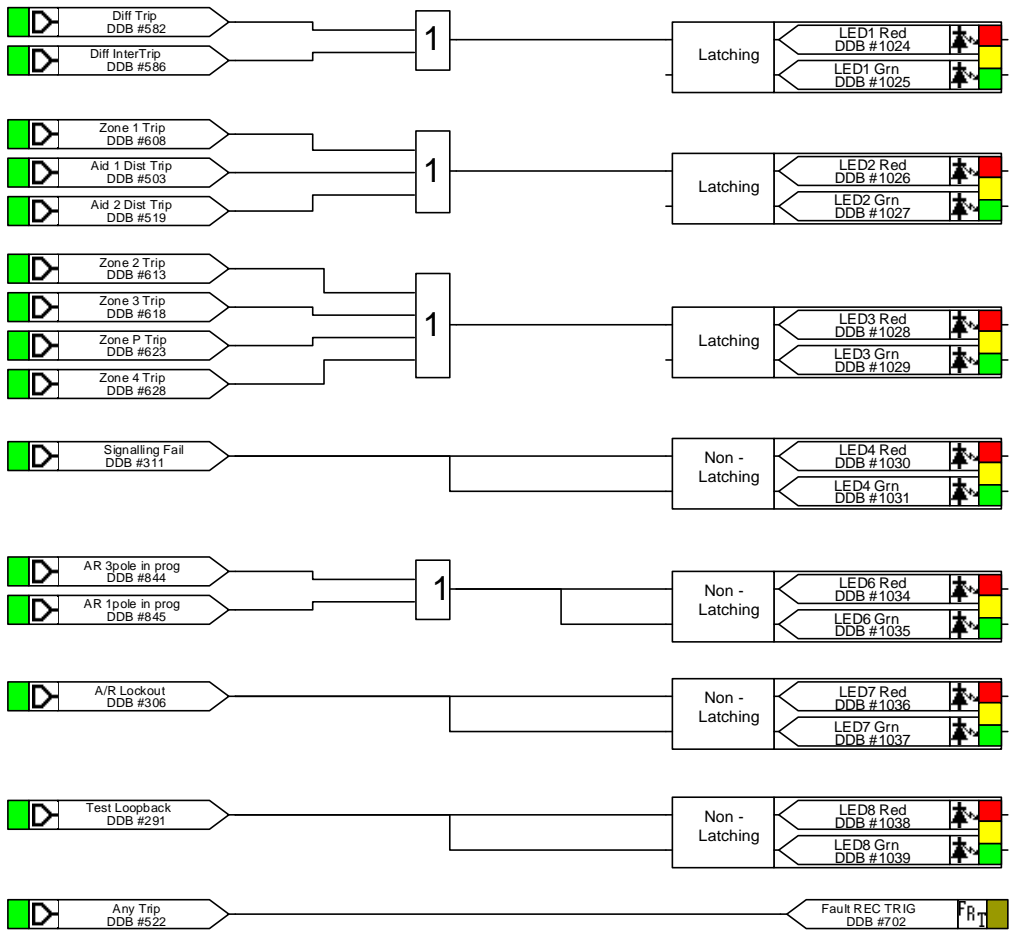

P0704ENa

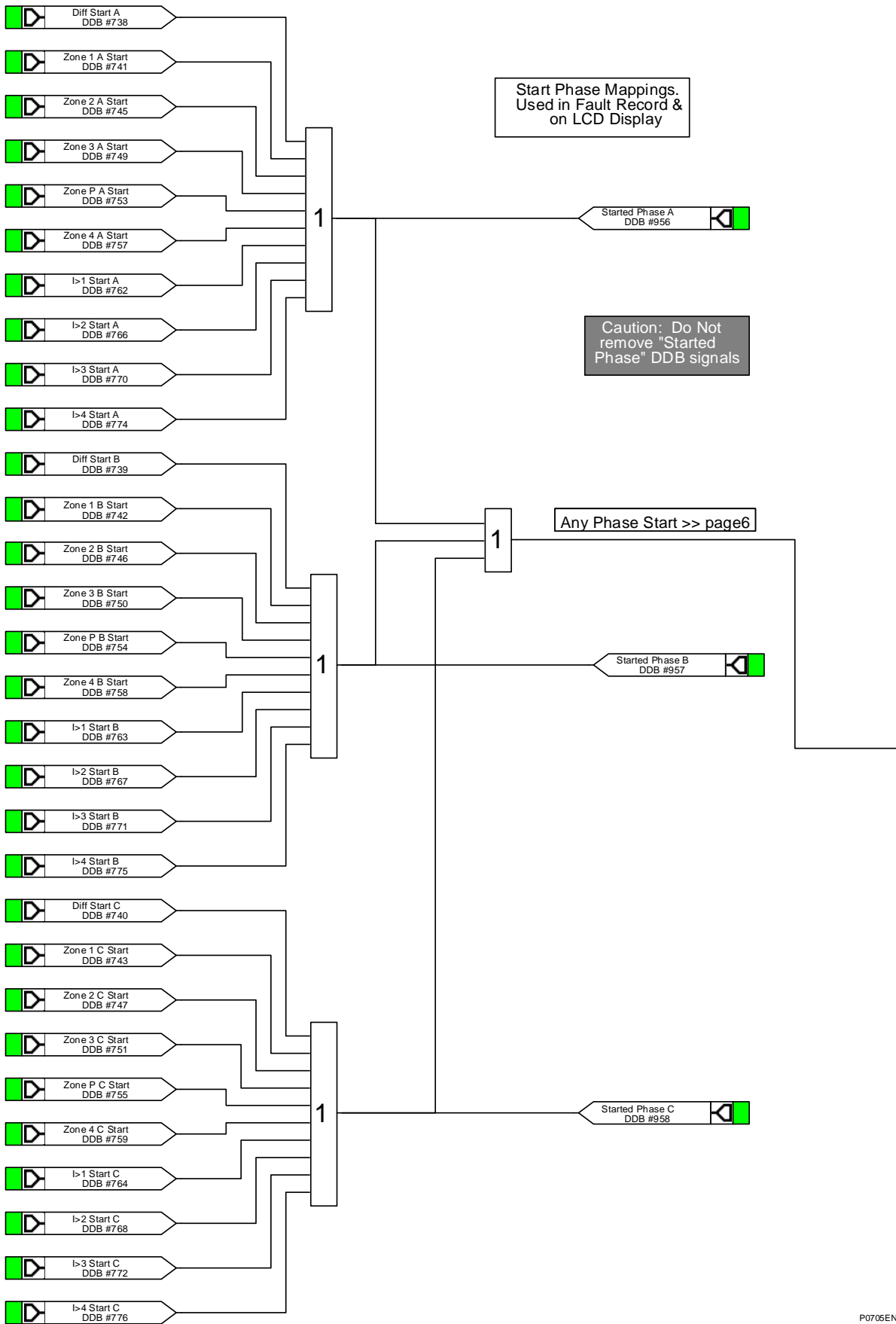

P0705ENa

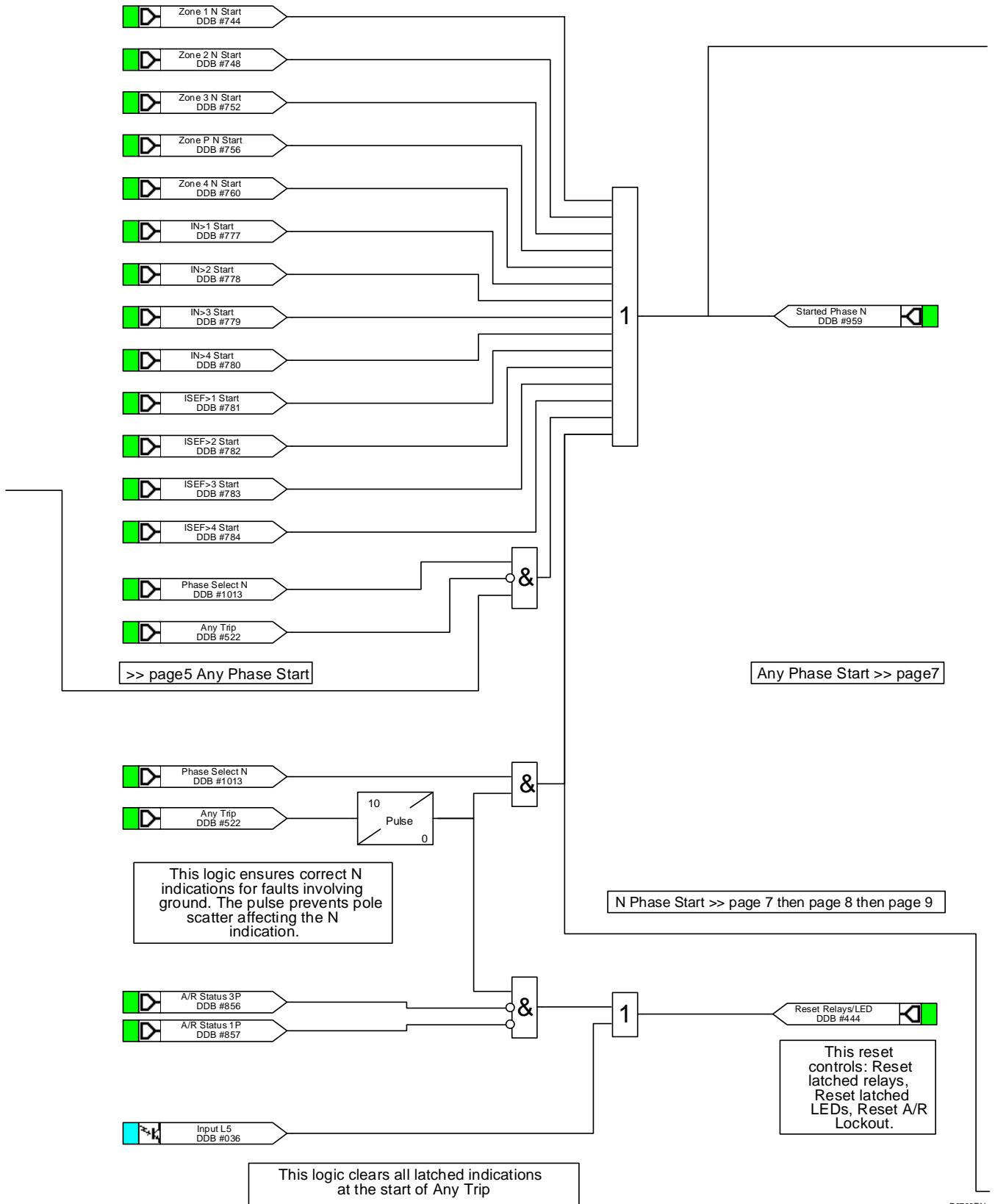

P0706ENa

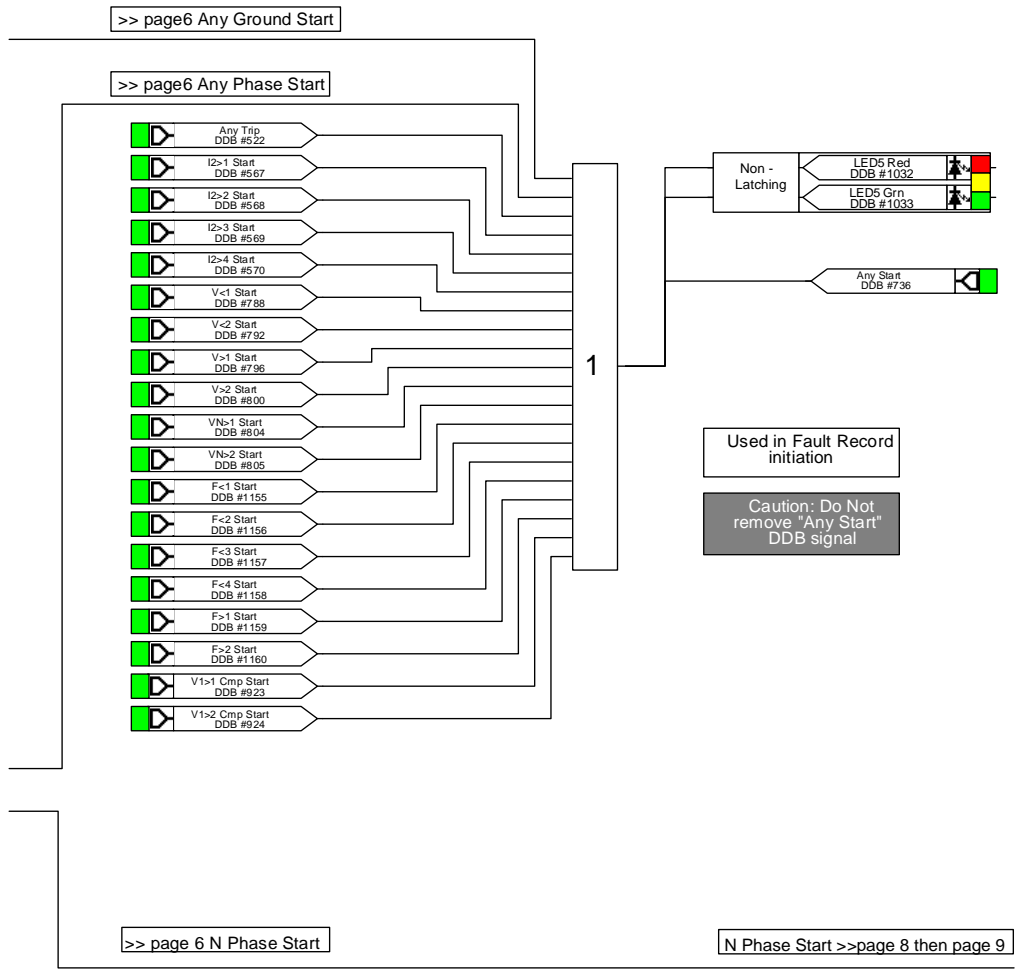

P0707ENa

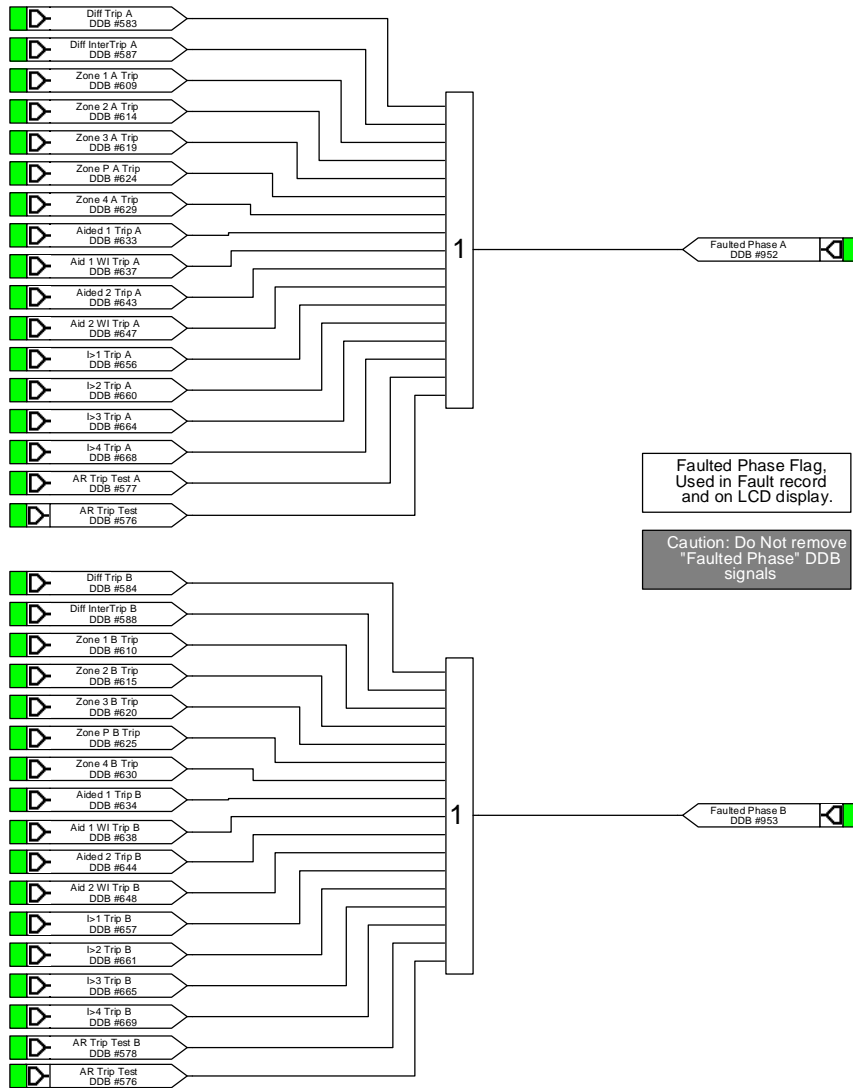

>> page 6 then page 7 N Phase Start

N Phase Start >> page 9

P0708ENa

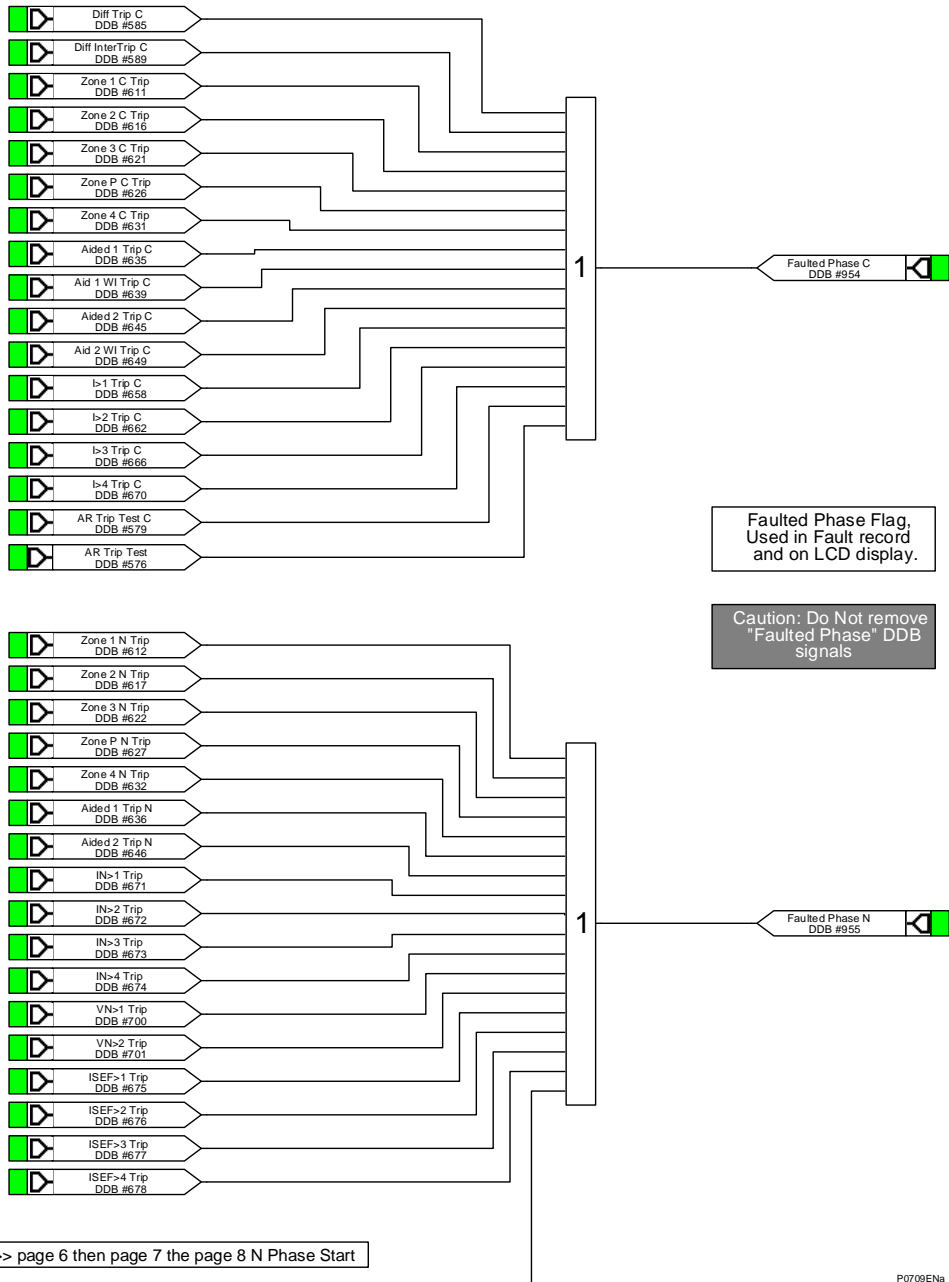

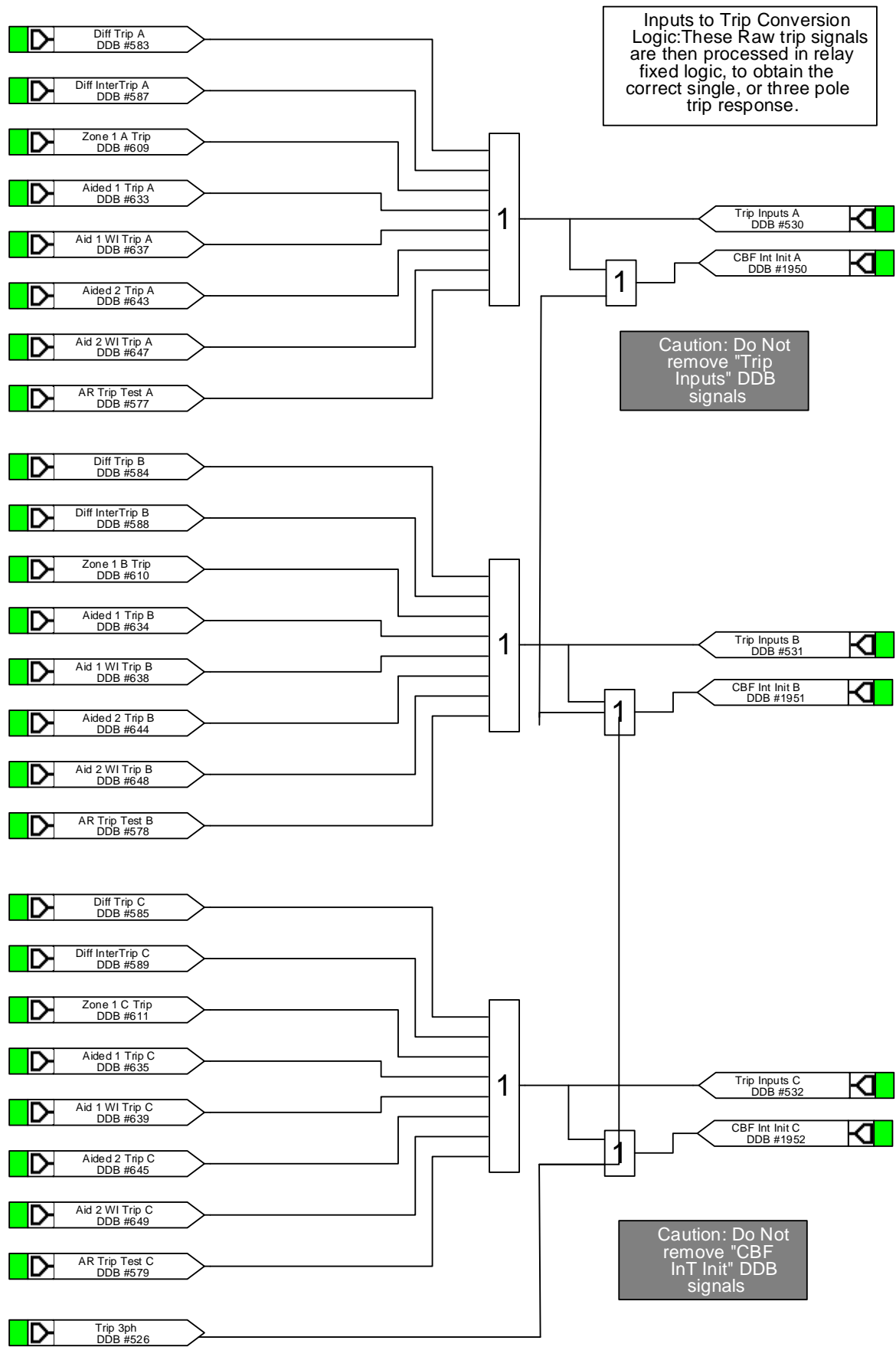

P0710ENb

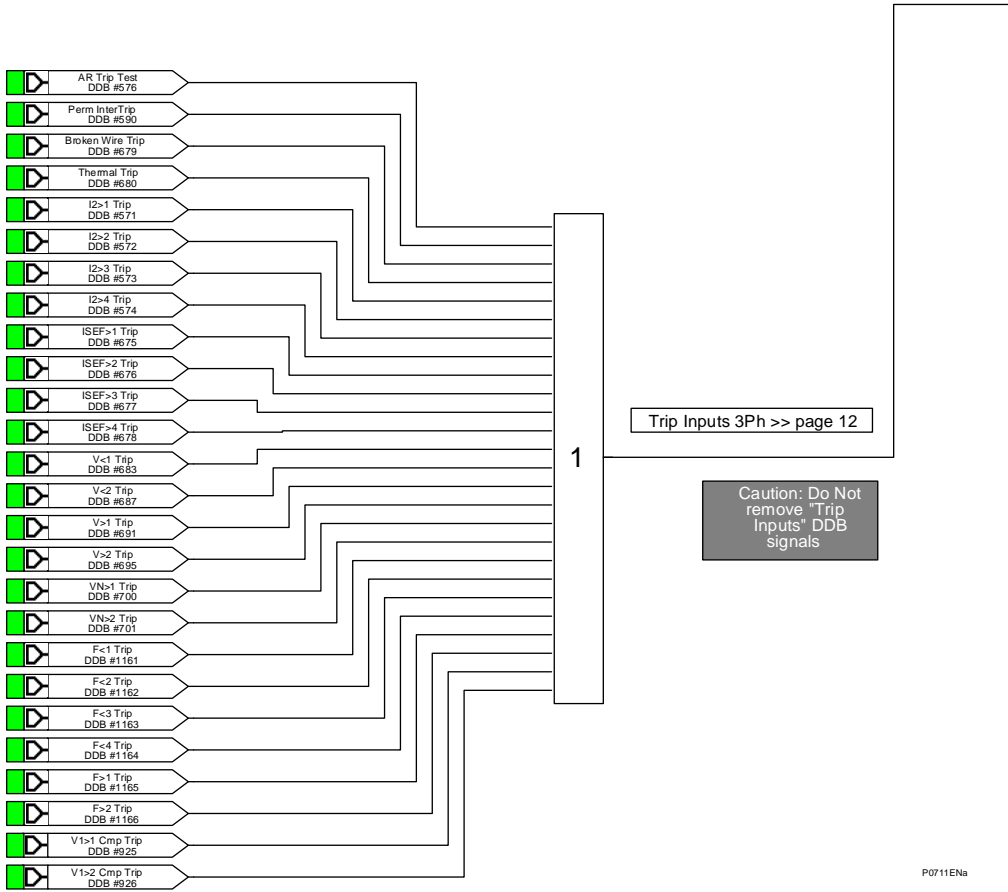

page 11 >> Trip Inputs 3Ph

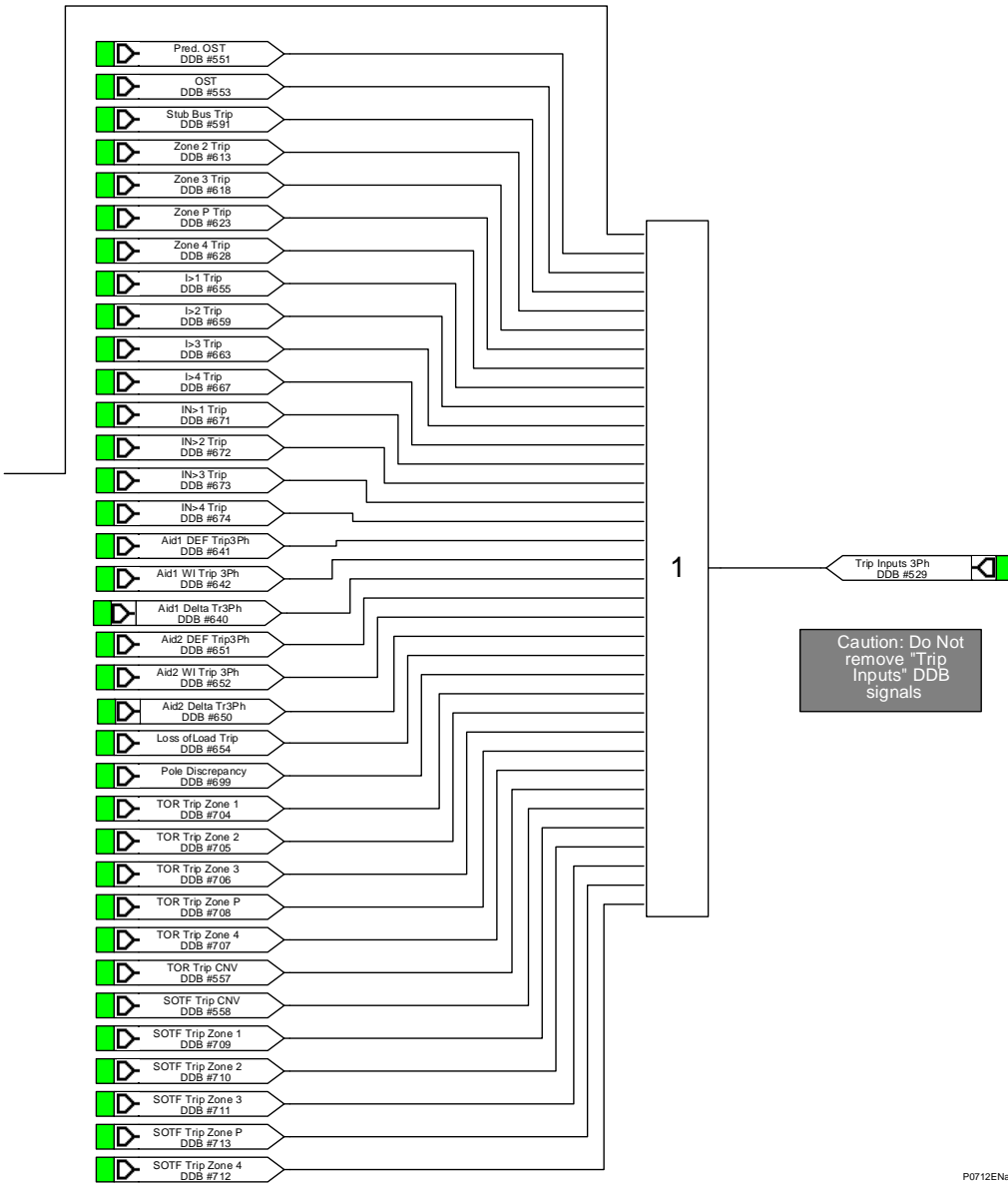

P0712ENa

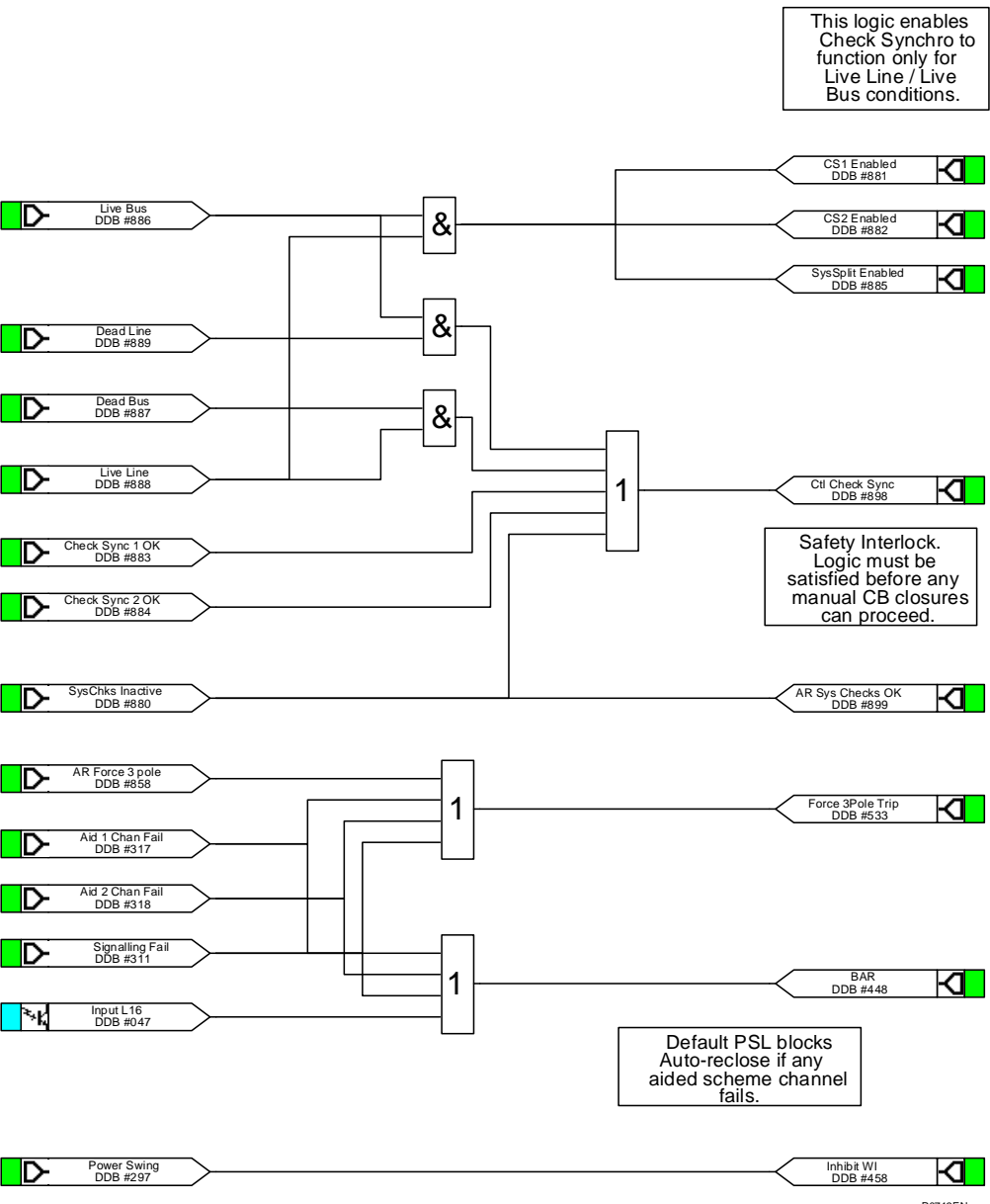

7 MICOM P543 WITHOUT DISTANCE PSL

7.1 Output Input Mappings

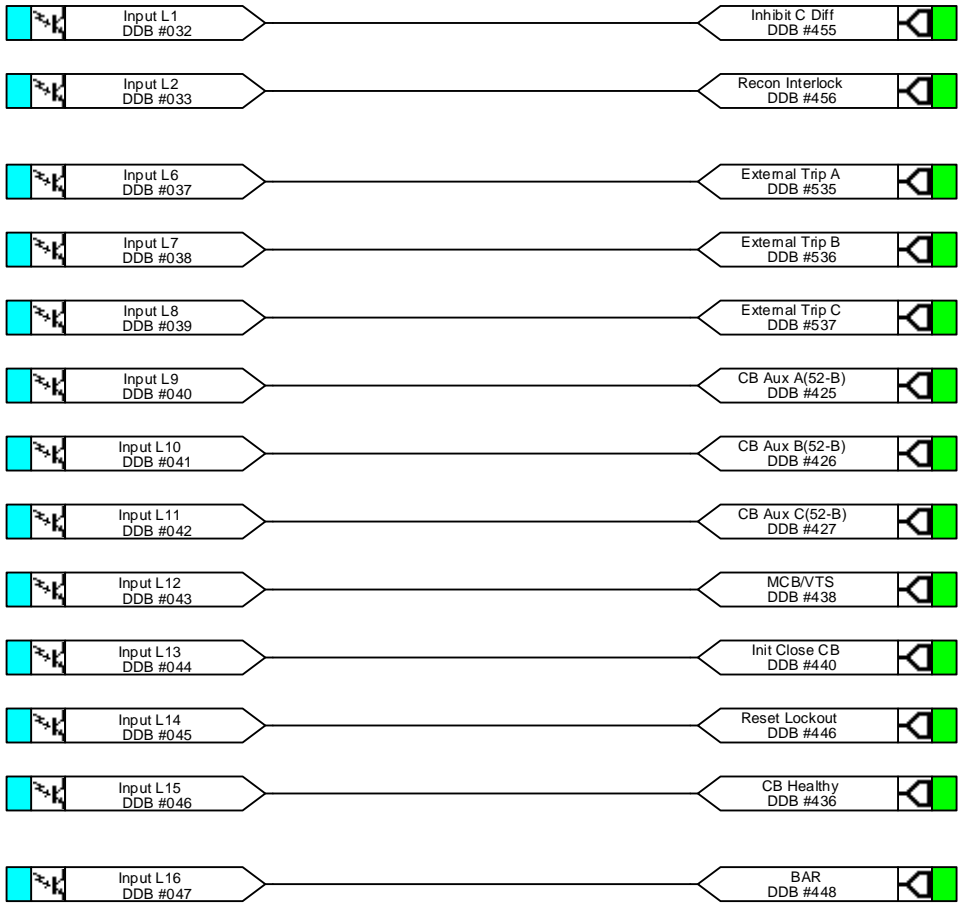

External Trips:
Initiate
Auto-reclose
(if enabled).

Opto L5 can be found on other pages

P0714ENb

7.2 Output Contacts

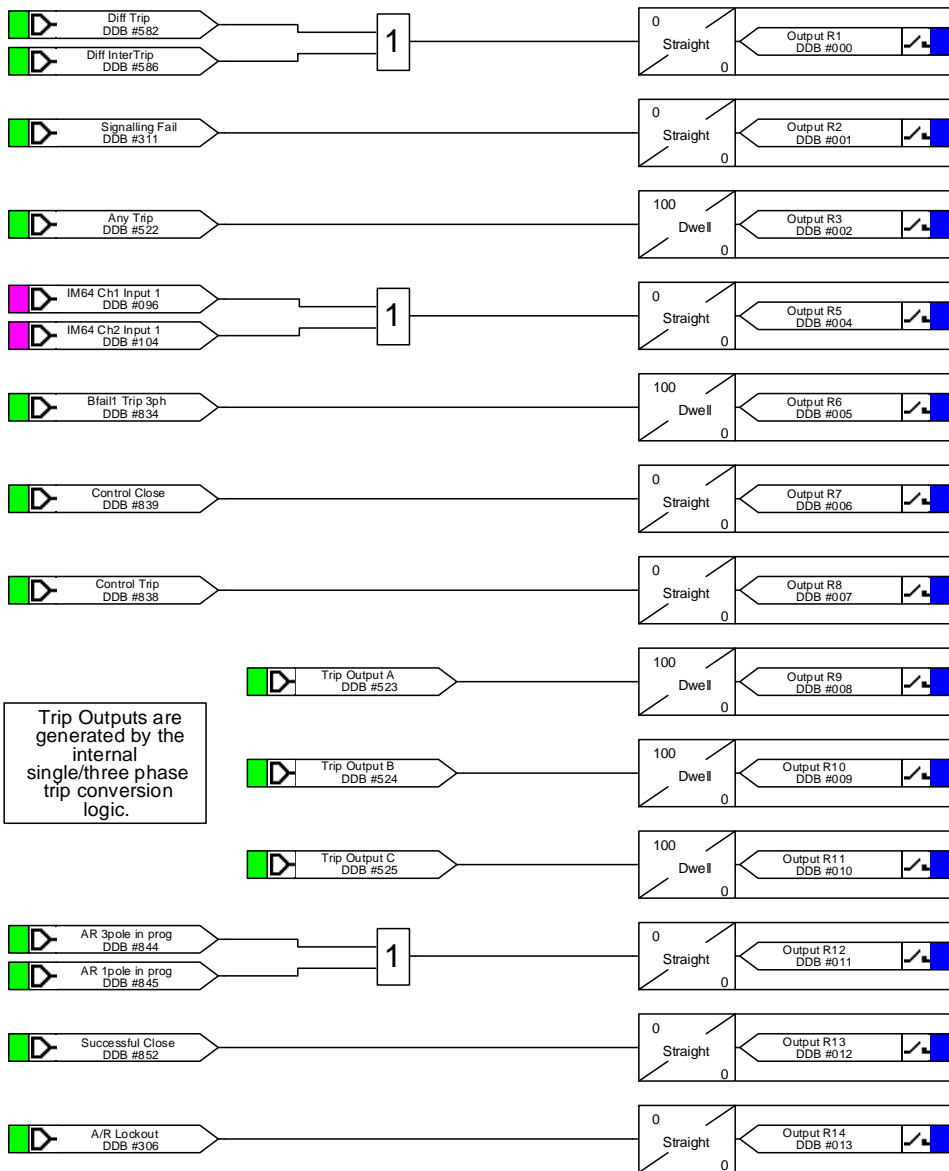

Trip Outputs are generated by the internal single/three phase trip conversion logic.

P0715ENa

7.3 Output Contacts

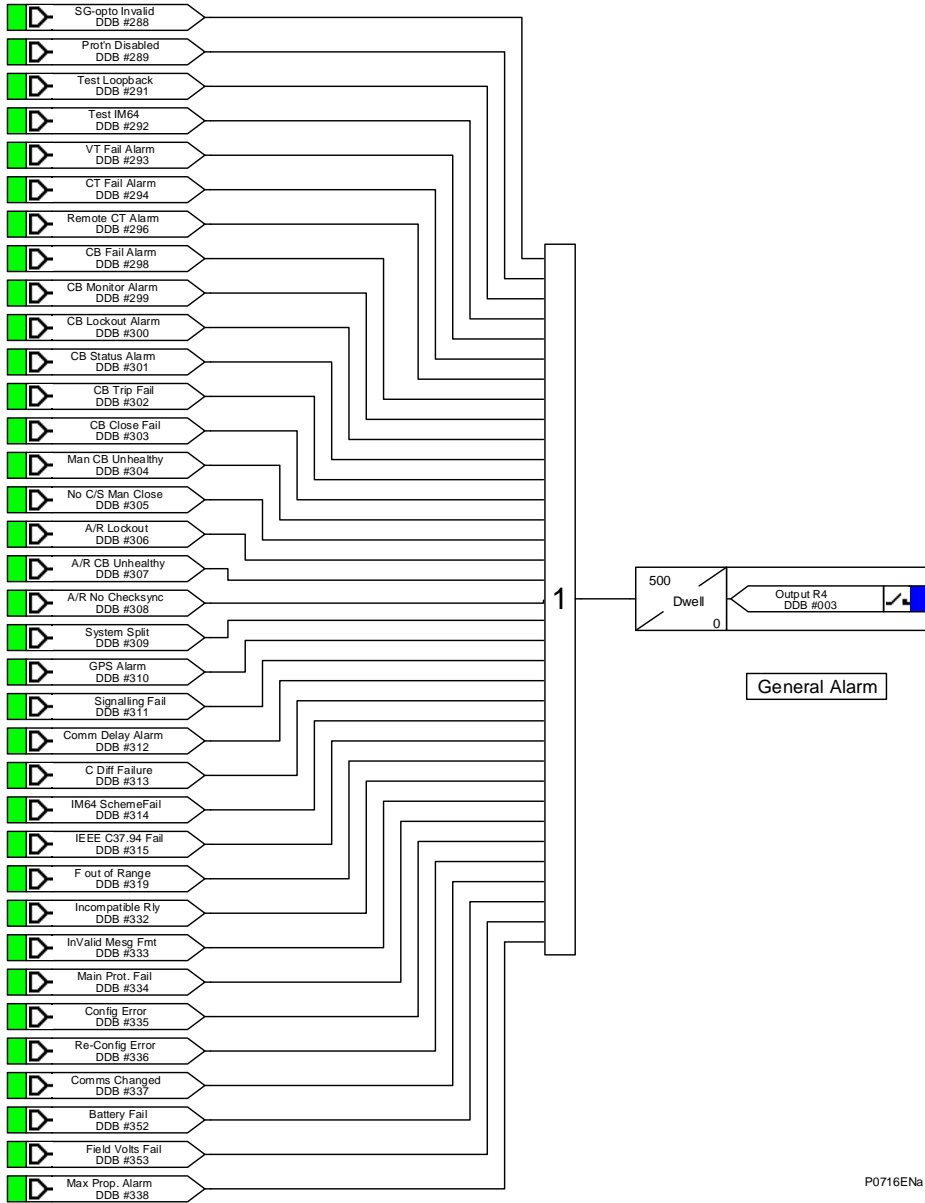

7.4 LEDs

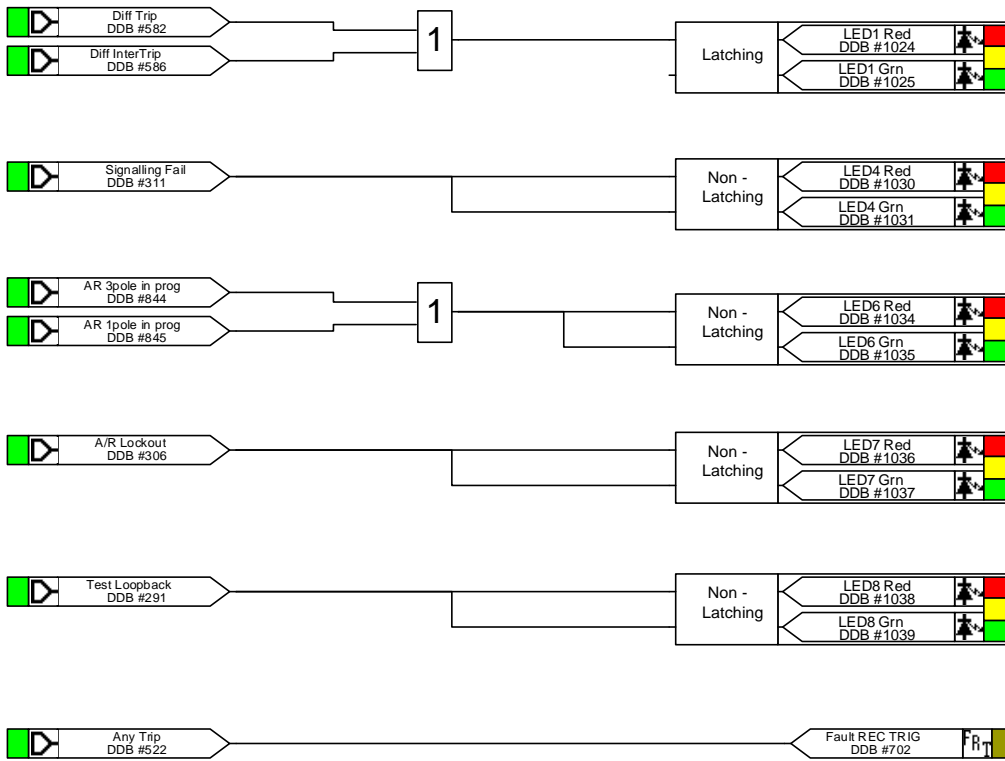

P0717ENa

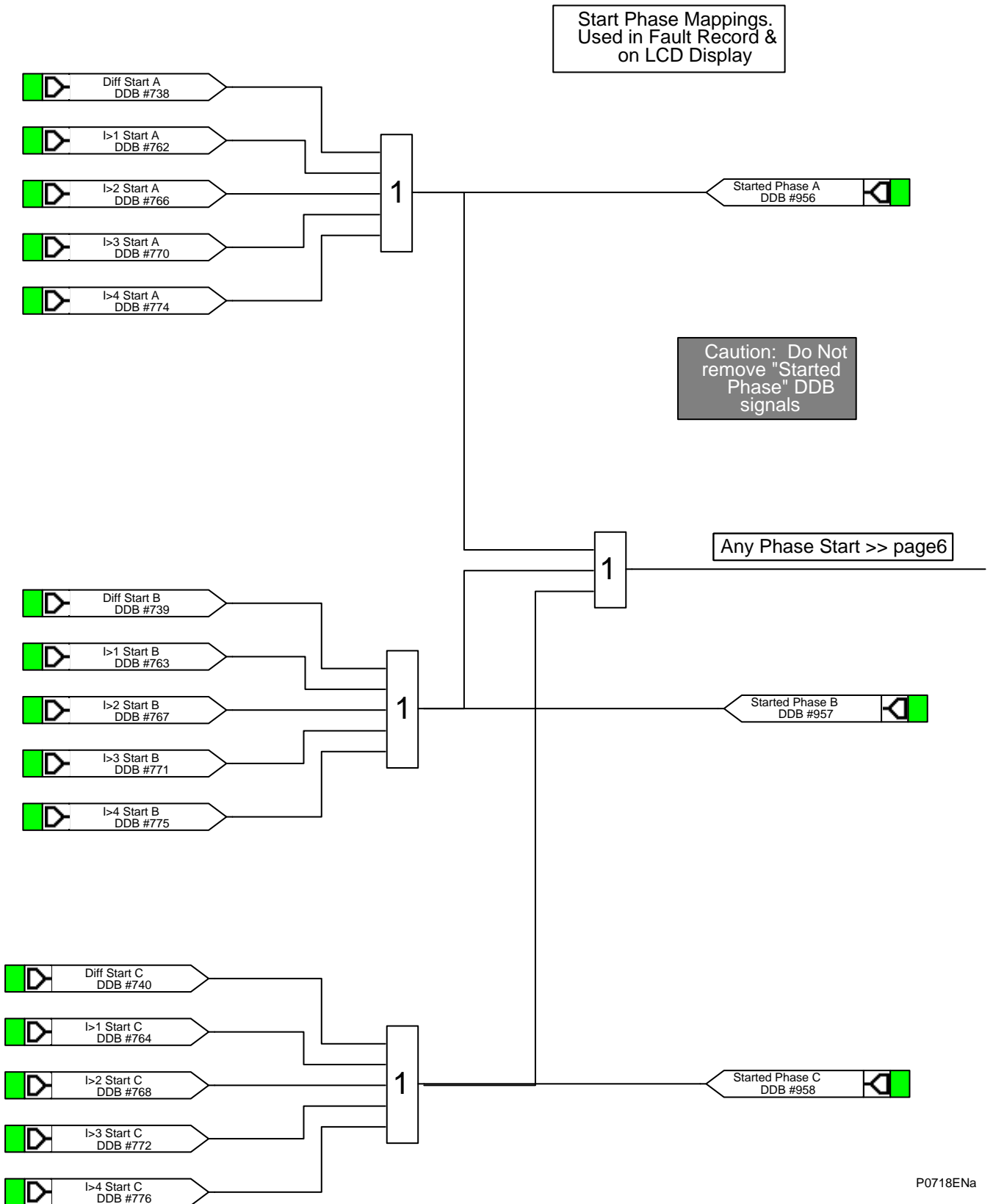

P0718ENa

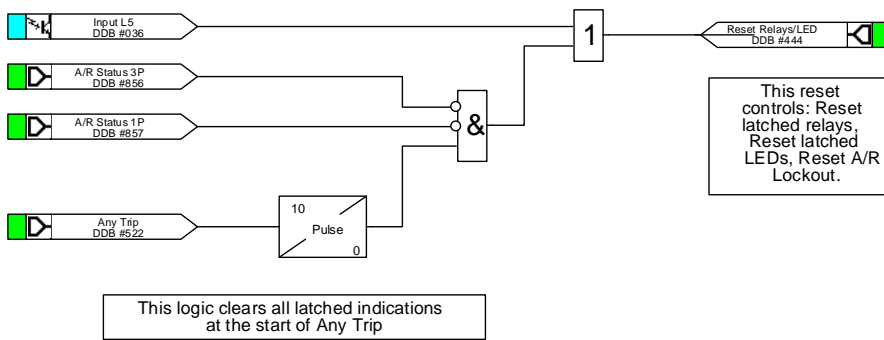
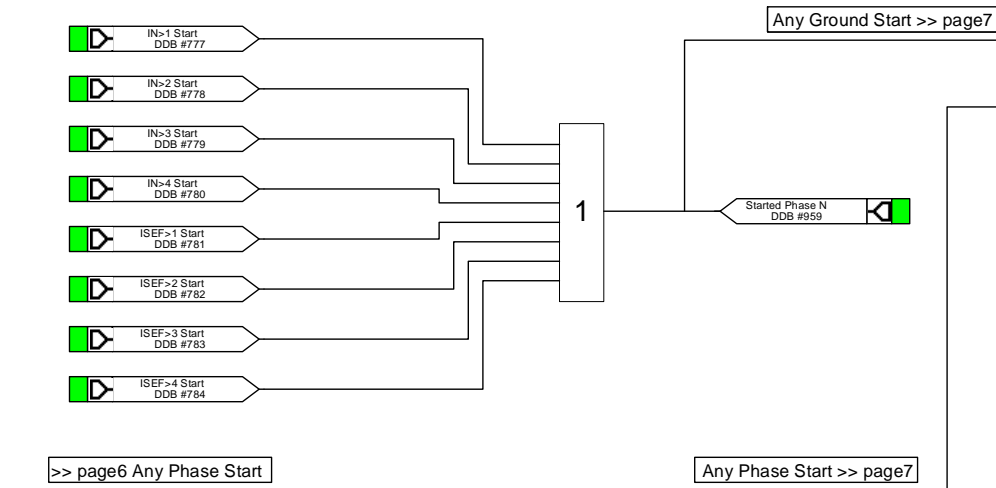

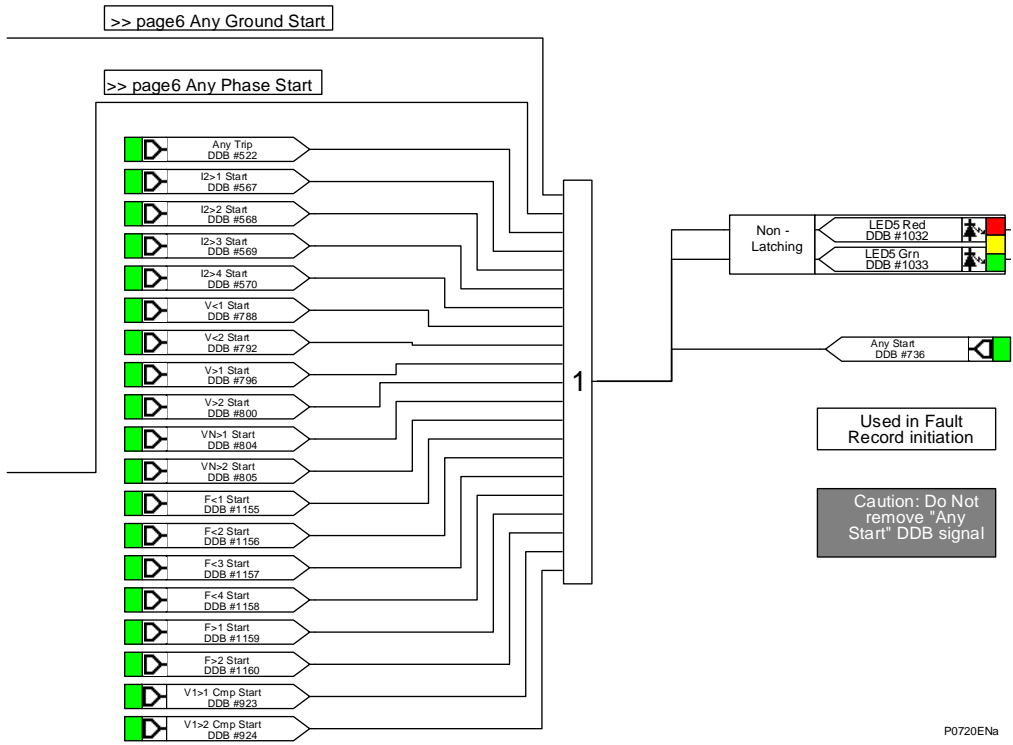

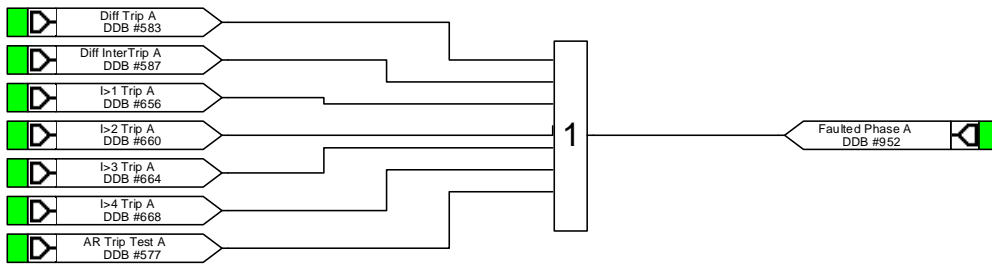

Faulted Phase Flag,
Used in Fault record
and on LCD display.

Caution: Do Not remove
"Faulted Phase" DDB
signals

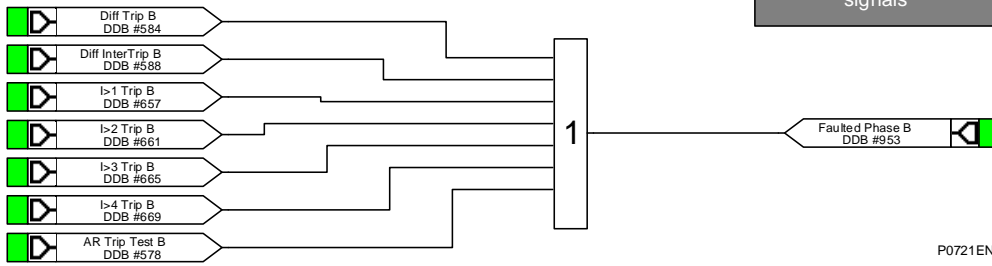

P0721ENa

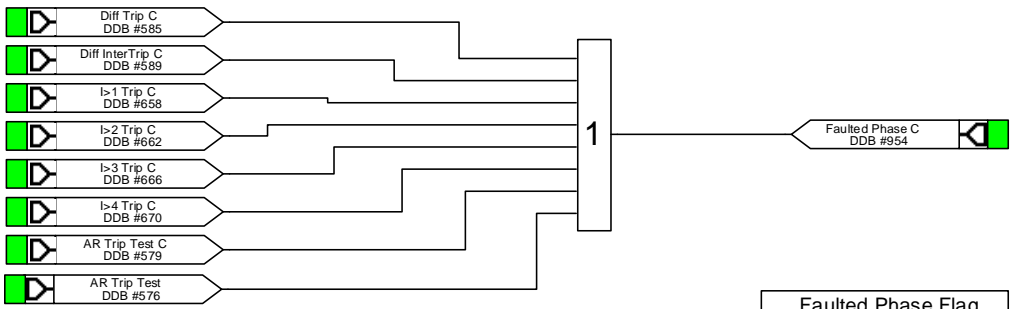

Faulted Phase Flag,
Used in Fault record
and on LCD display.

Caution: Do Not remove
"Faulted Phase" DDB
signals

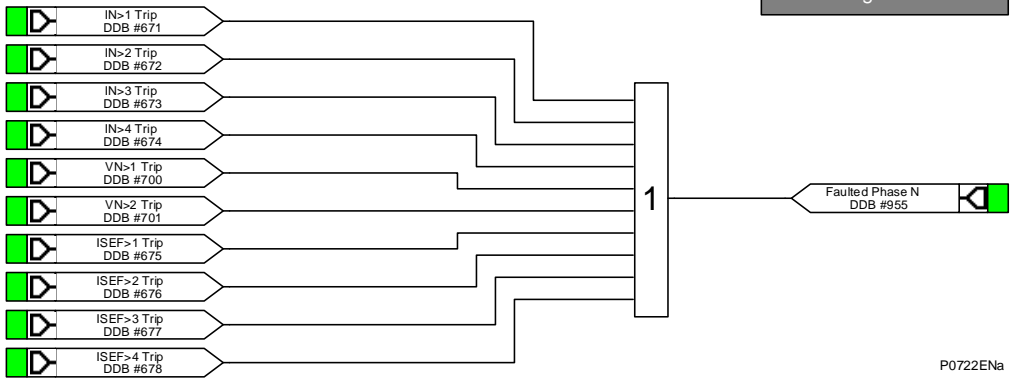

P0722ENa

Inputs to Trip Conversion Logic: These Raw trip signals are then processed in relay fixed logic, to obtain the correct single, or three pole trip response.

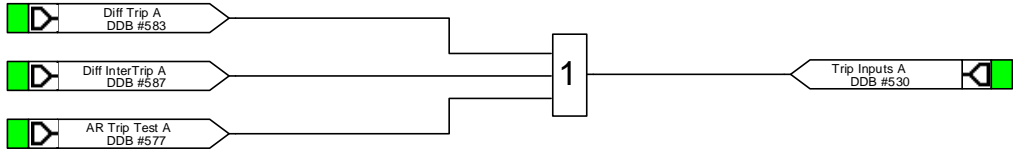

Caution: Do Not remove "Trip Inputs" DDB signals

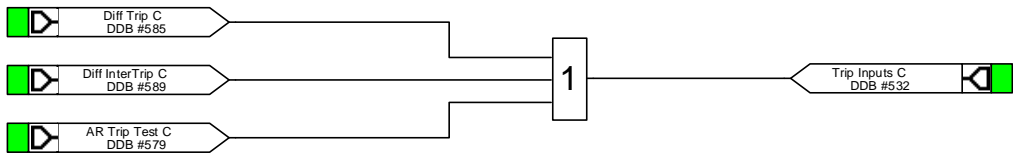
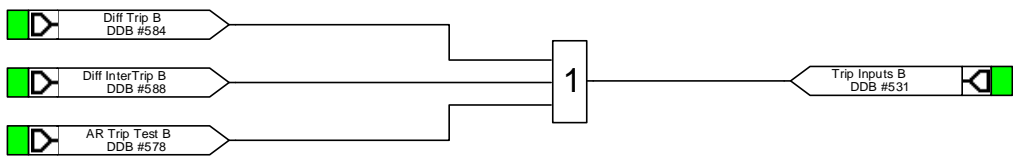

P0723ENa

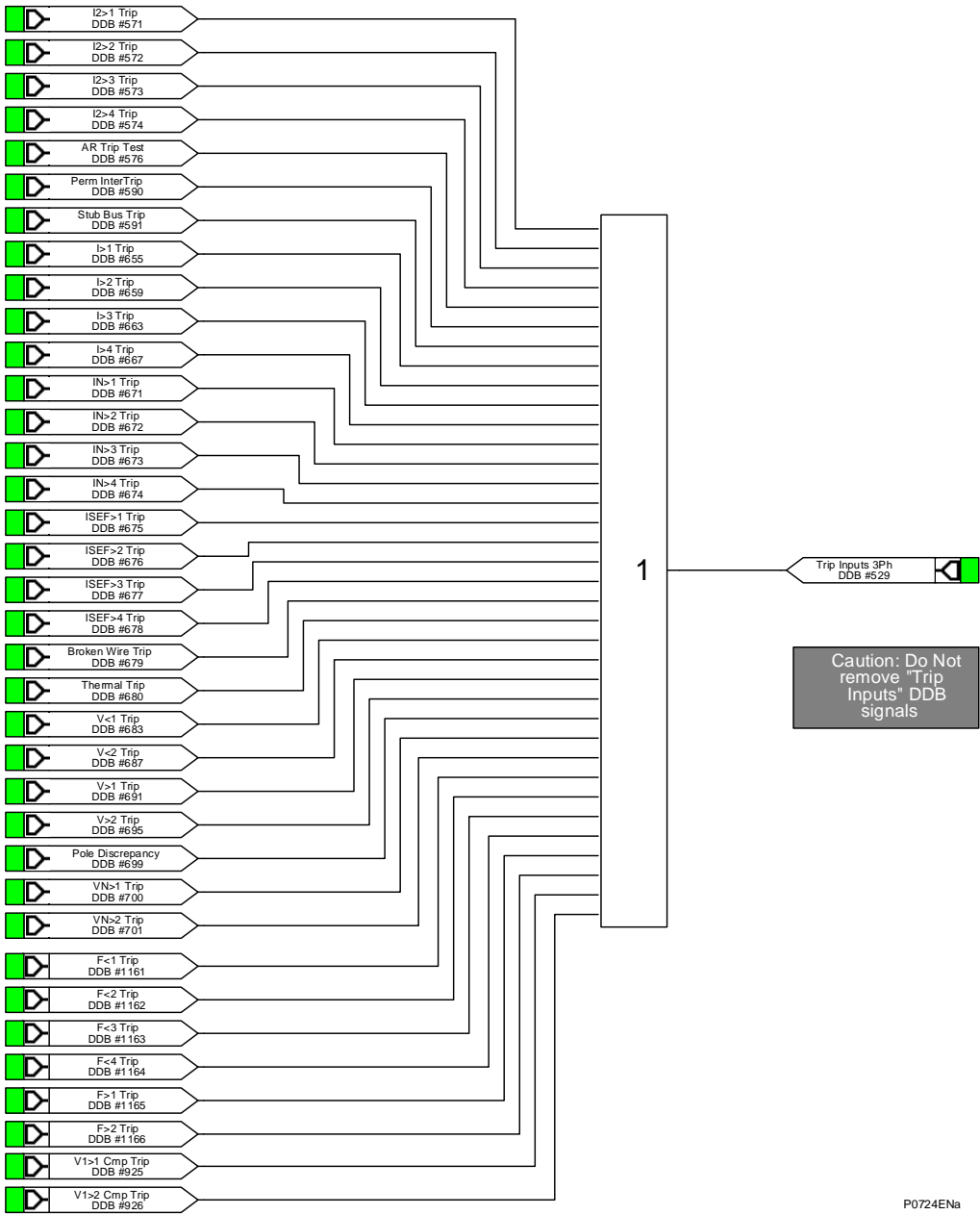

This logic enables Check Synchro to function only for Live Line / Live Bus conditions.

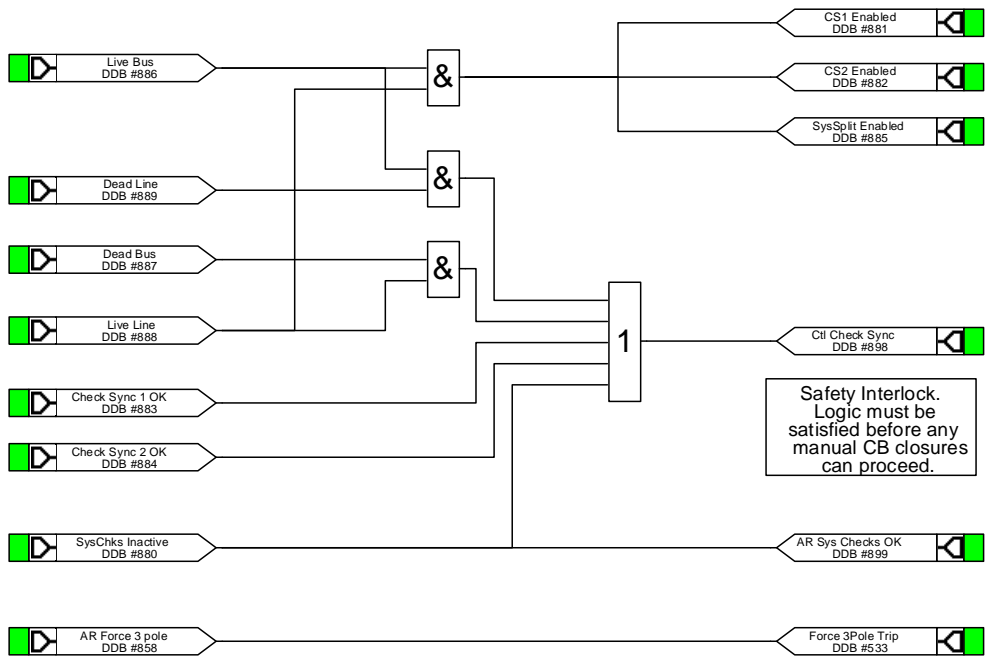

Safety Interlock. Logic must be satisfied before any manual CB closures can proceed.

P0725ENa

8 MICOM P544 WITH DISTANCE PSL

8.1 Output Input Mappings

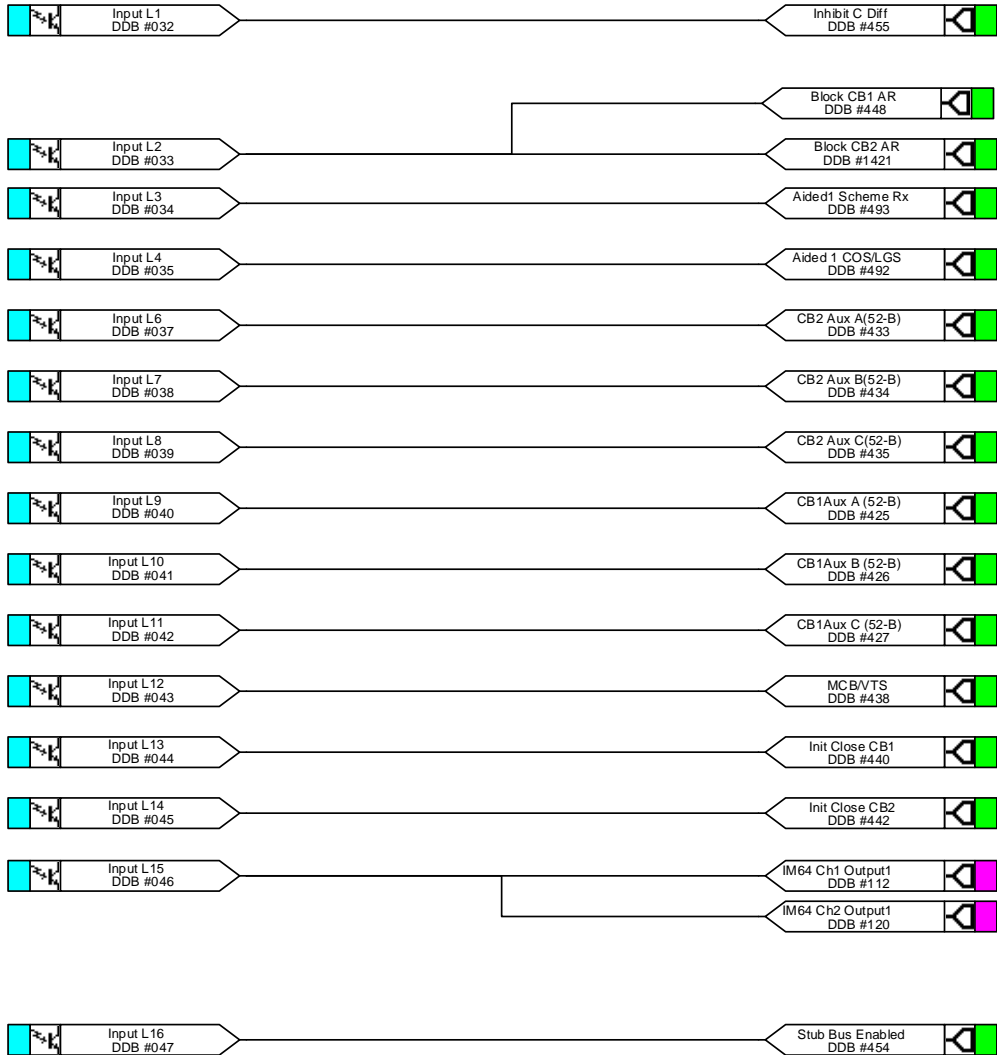

Opto L5 can be found on other pages

P0726ENa

8.2 Output Contacts

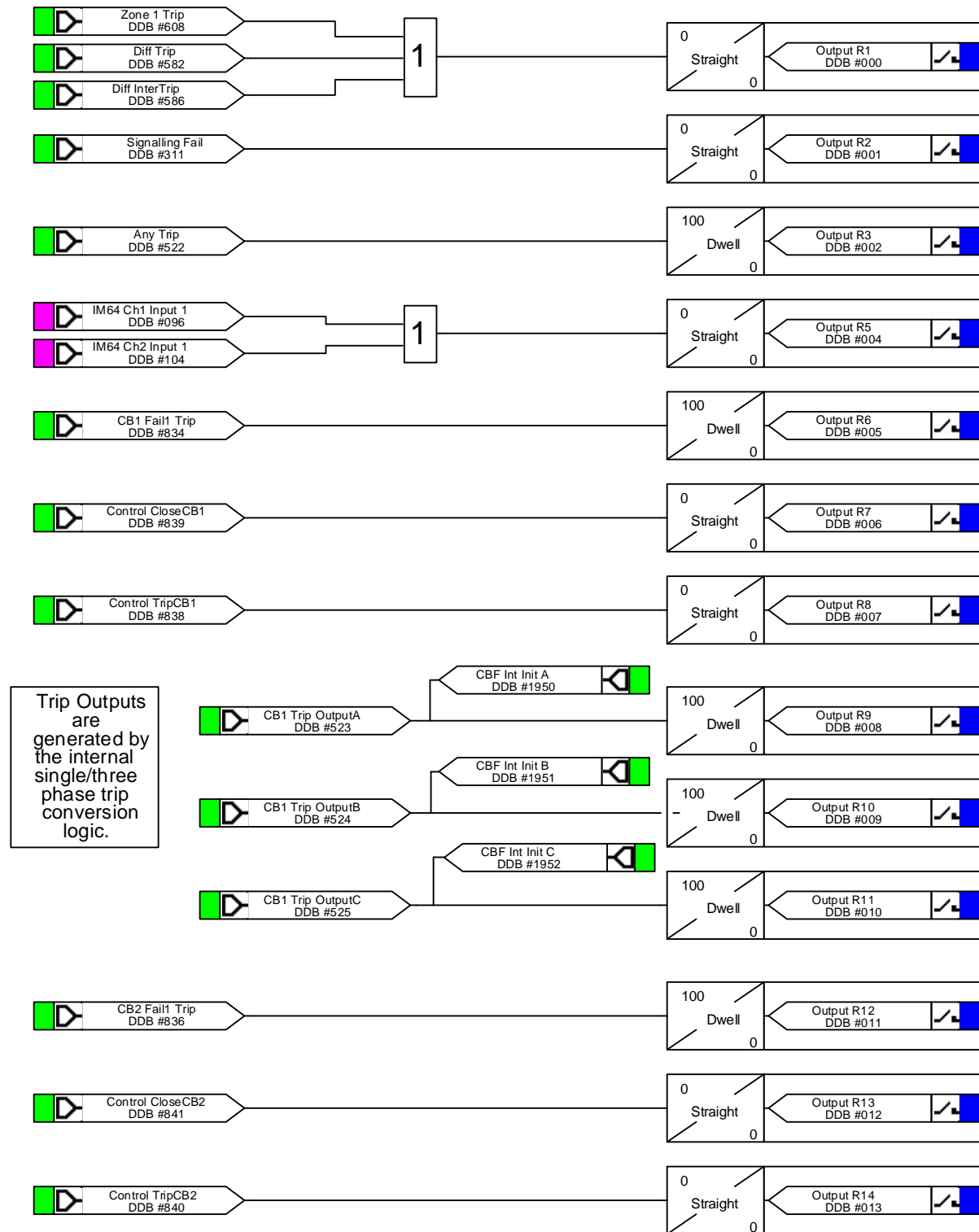

P0727ENb

8.3 Output Contacts

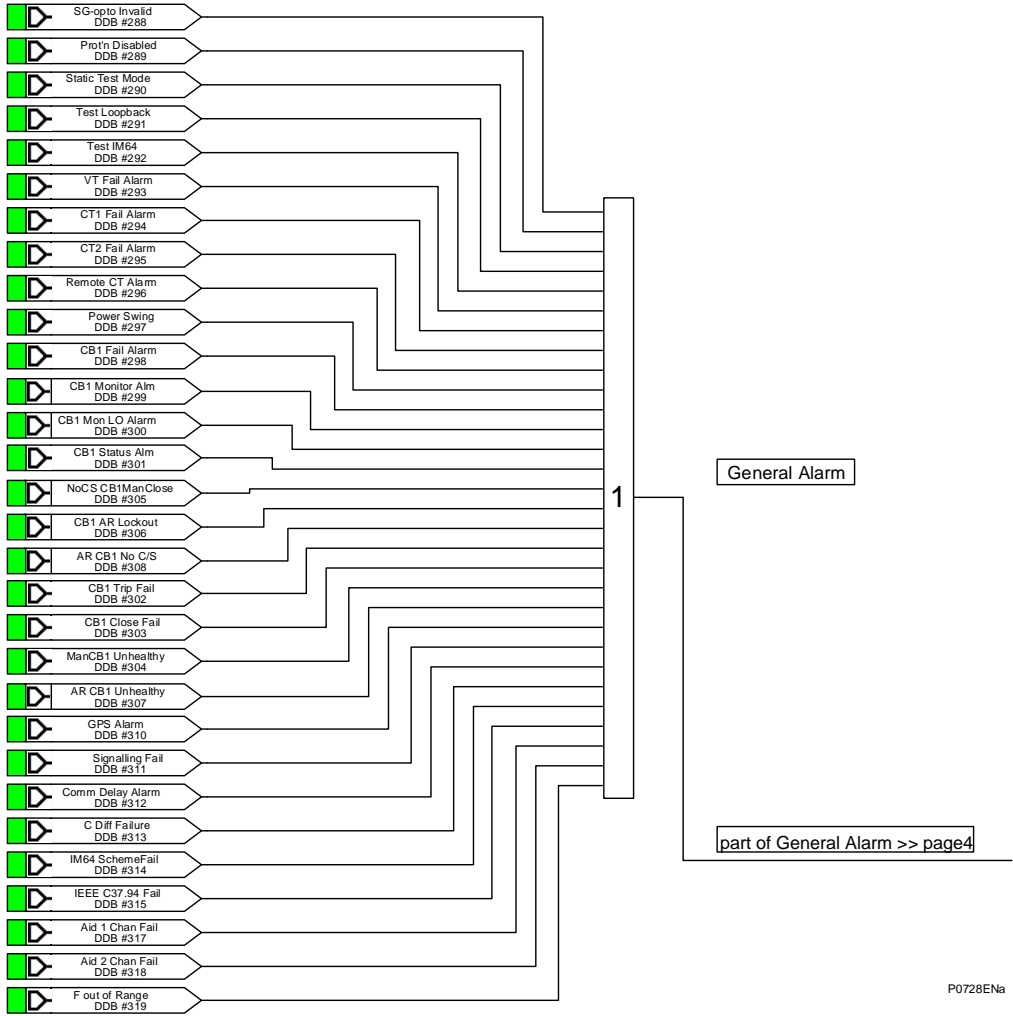

P0728ENa

8.4 Output Contacts

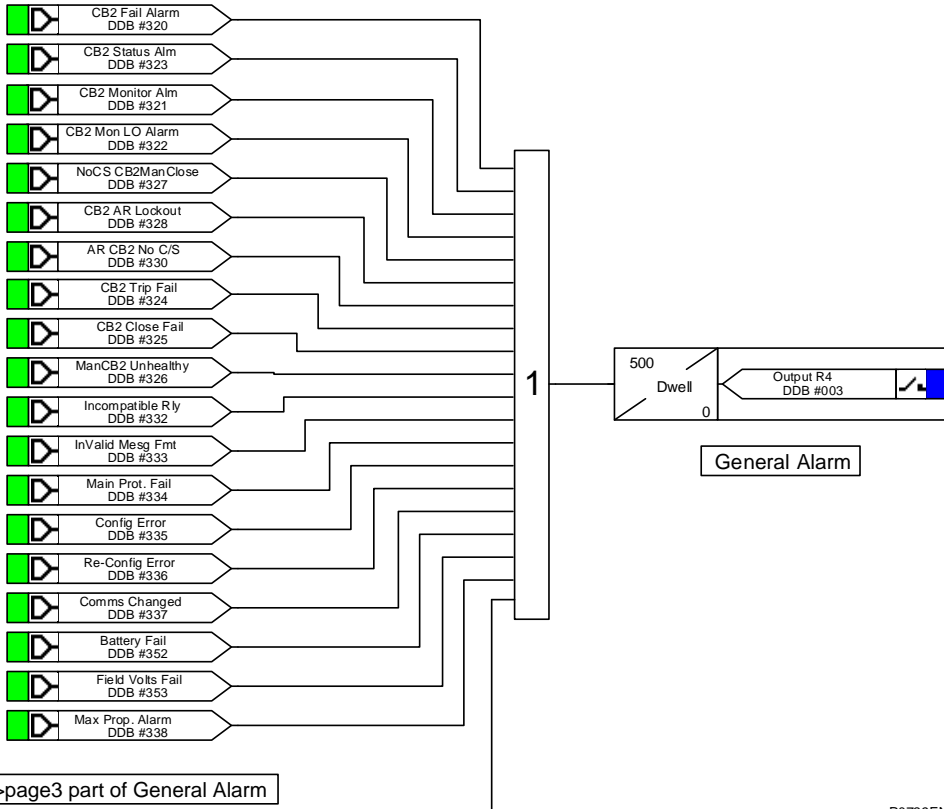

P0729ENa

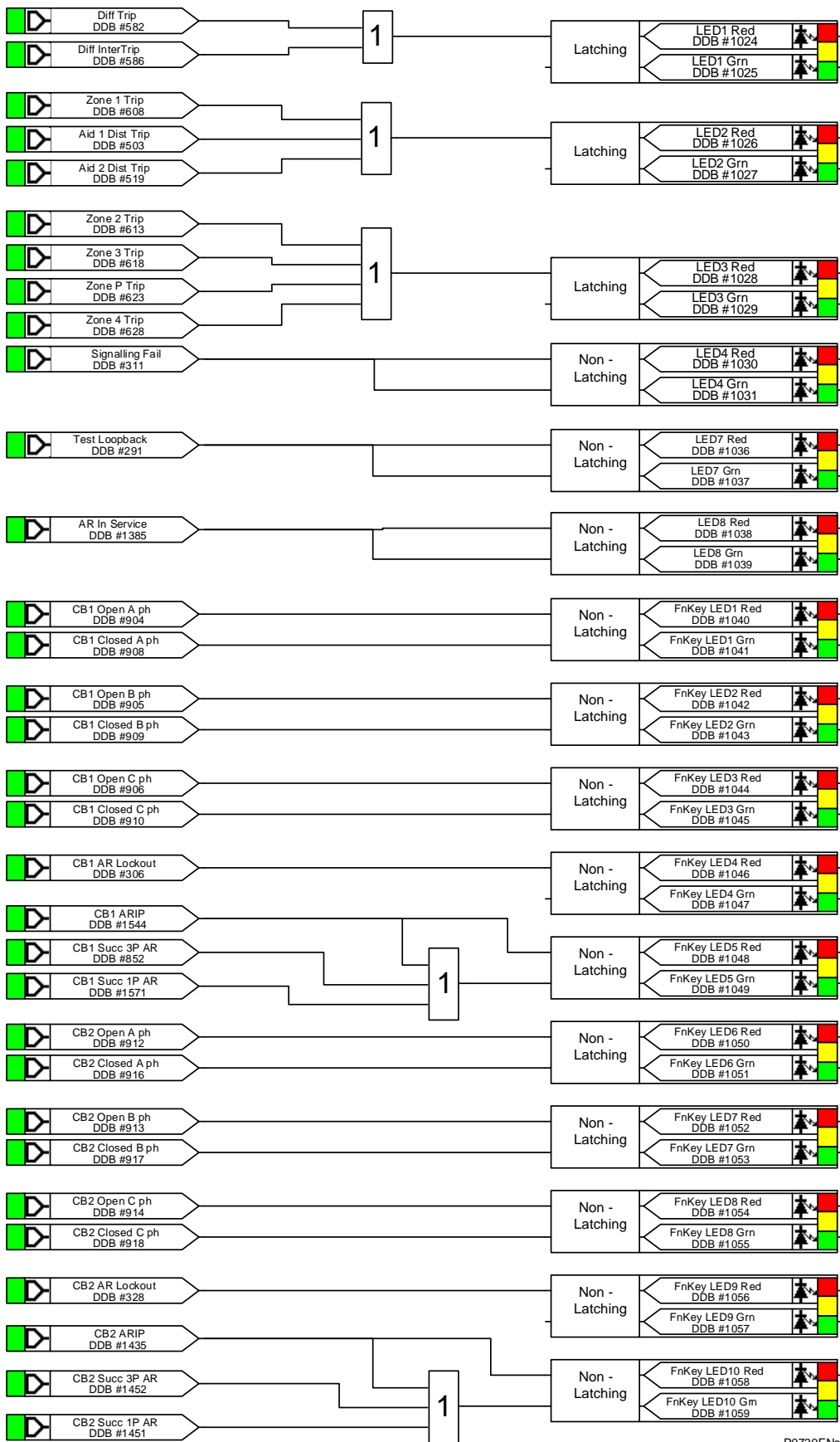

P0730ENa

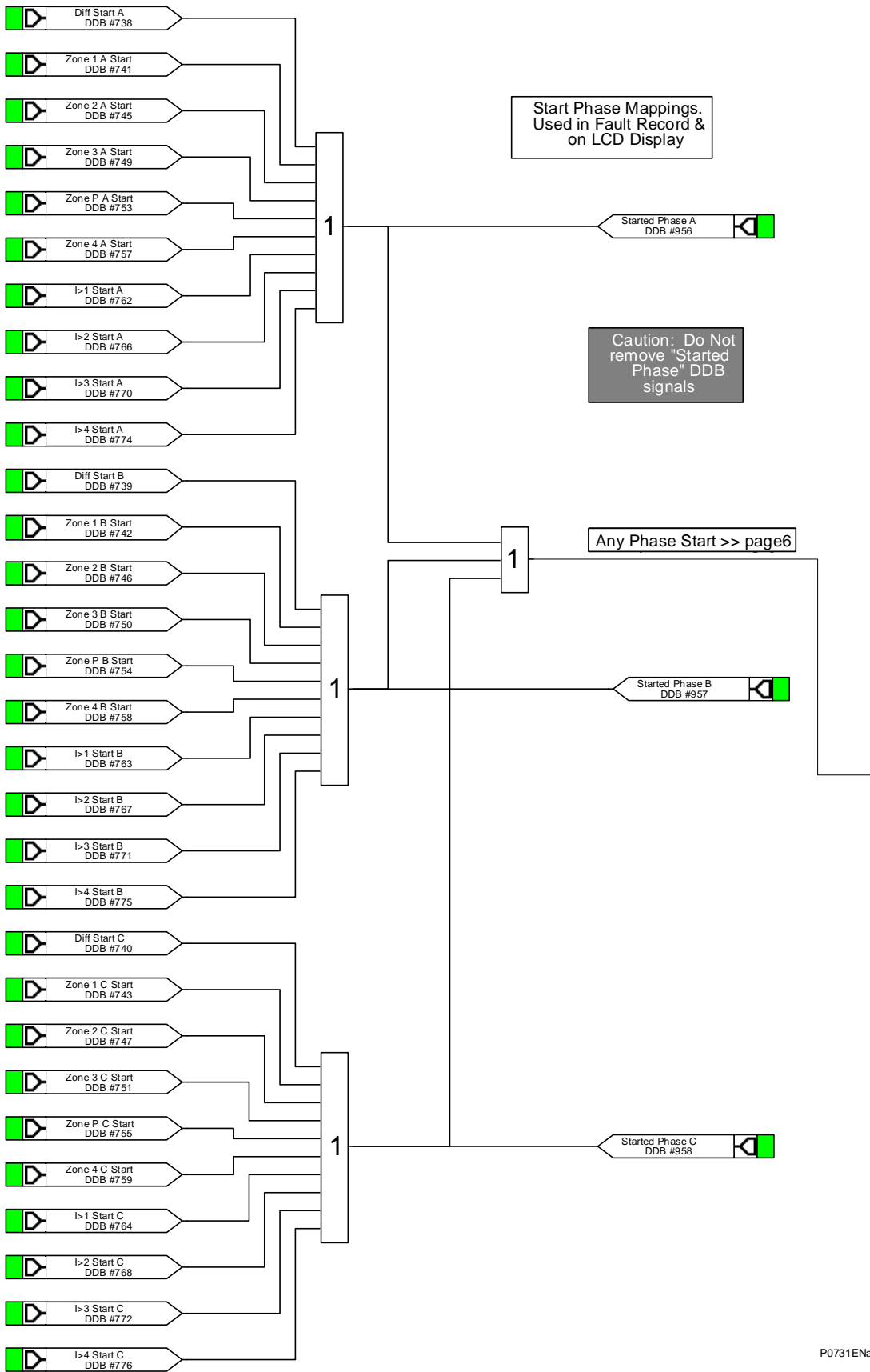

P0731ENa

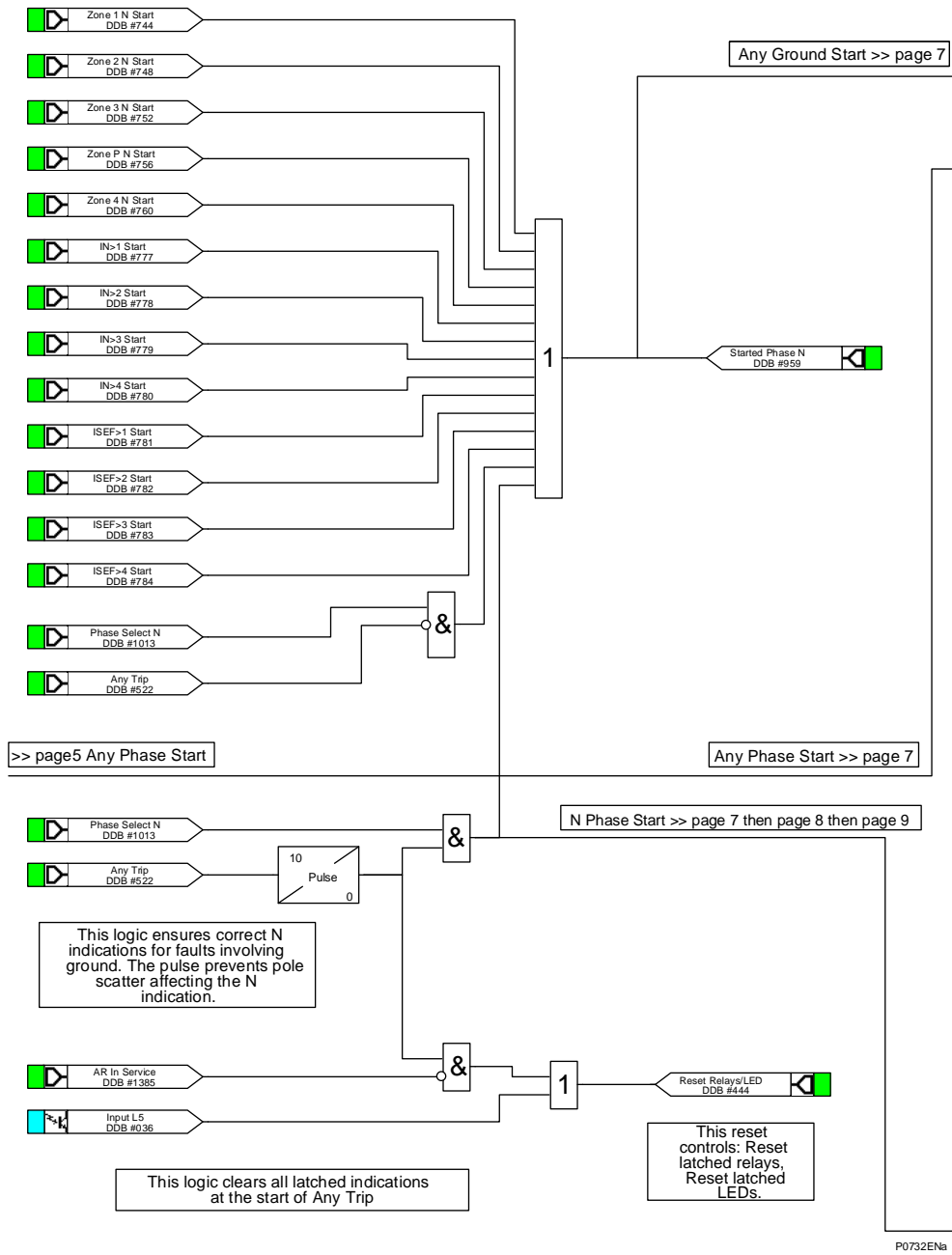

>> page 6 Any Ground Start

>> page 6 Any Phase Start

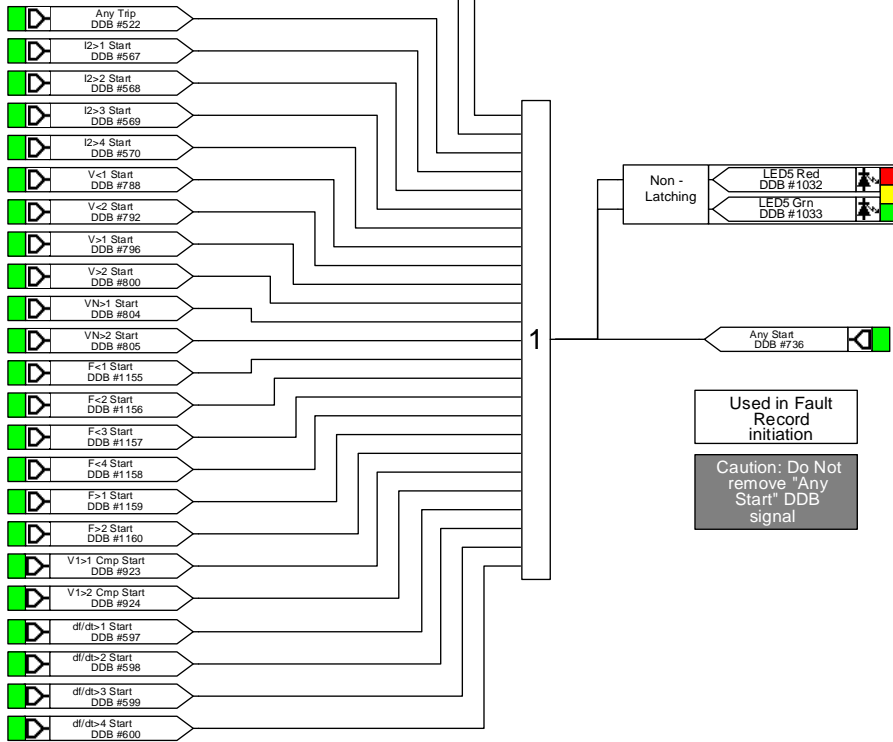

>> page 6 N Phase Start

N Phase Start >>page 8 then page 9

P0733ENa

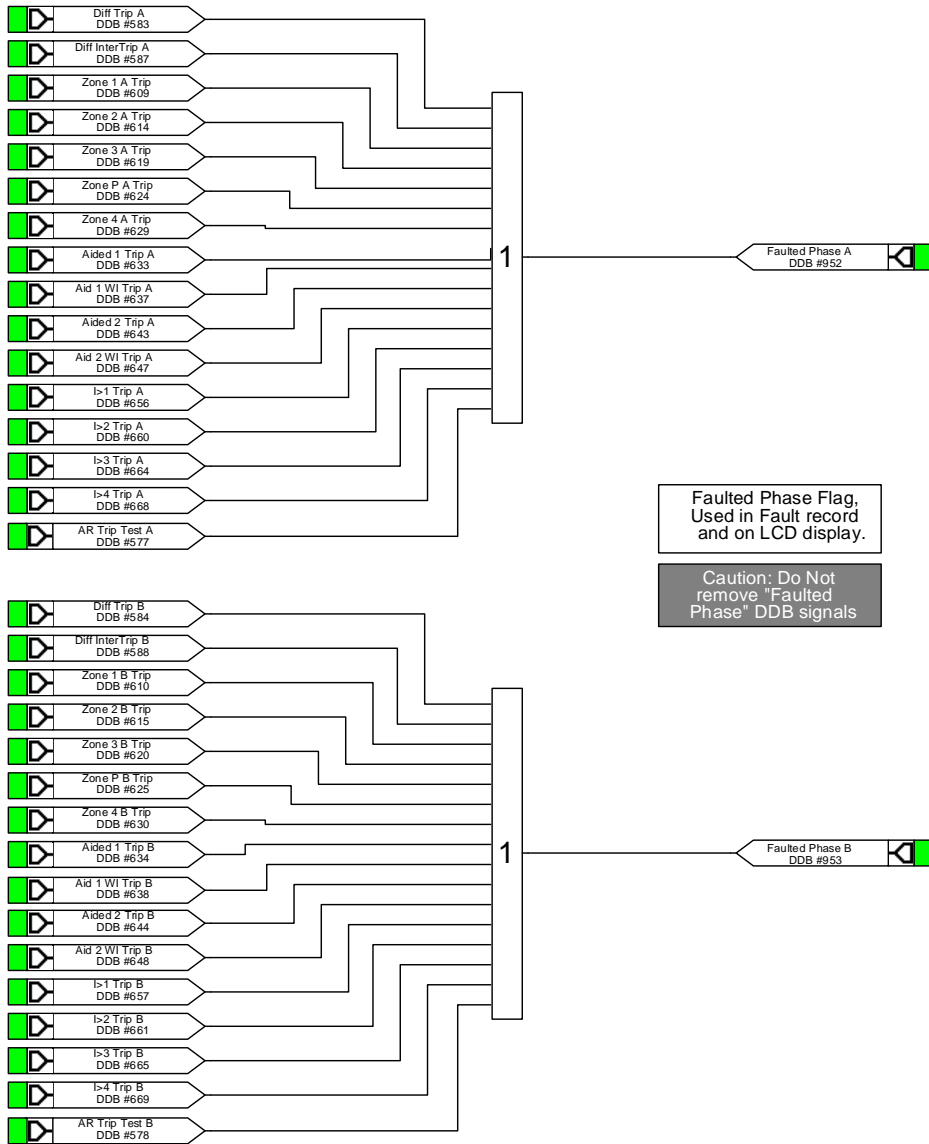

>> page 6 then page 7 N Phase Start

N Phase Start >> page 9

P0734ENa

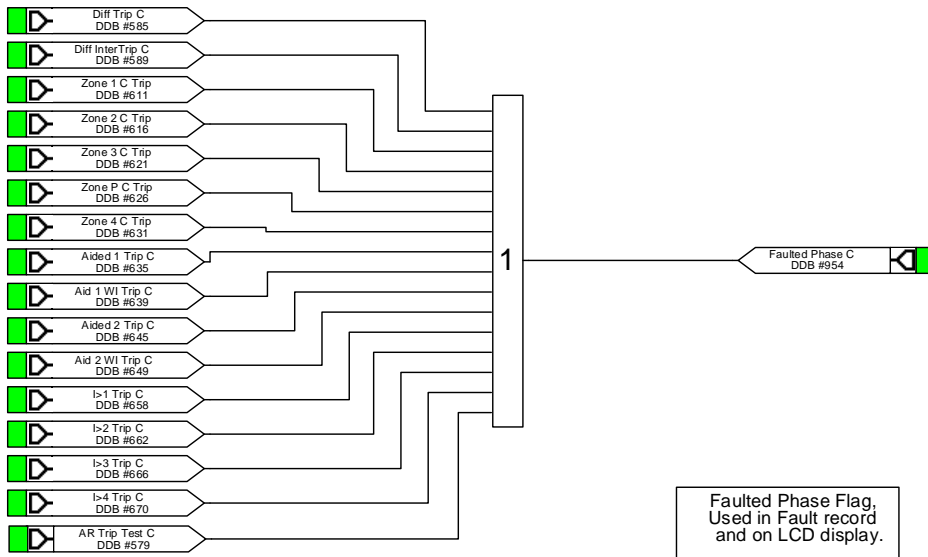

Faulted Phase Flag, Used in Fault record and on LCD display.

Caution: Do Not remove "Faulted Phase" DDB signals

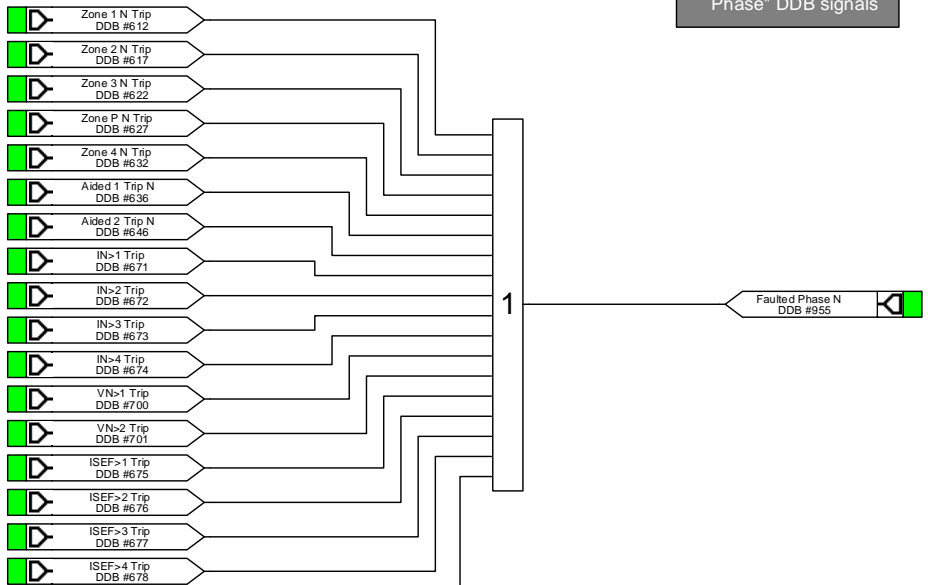

>> page 6 then page 7 then page 8 N Phase Start

P0735ENa

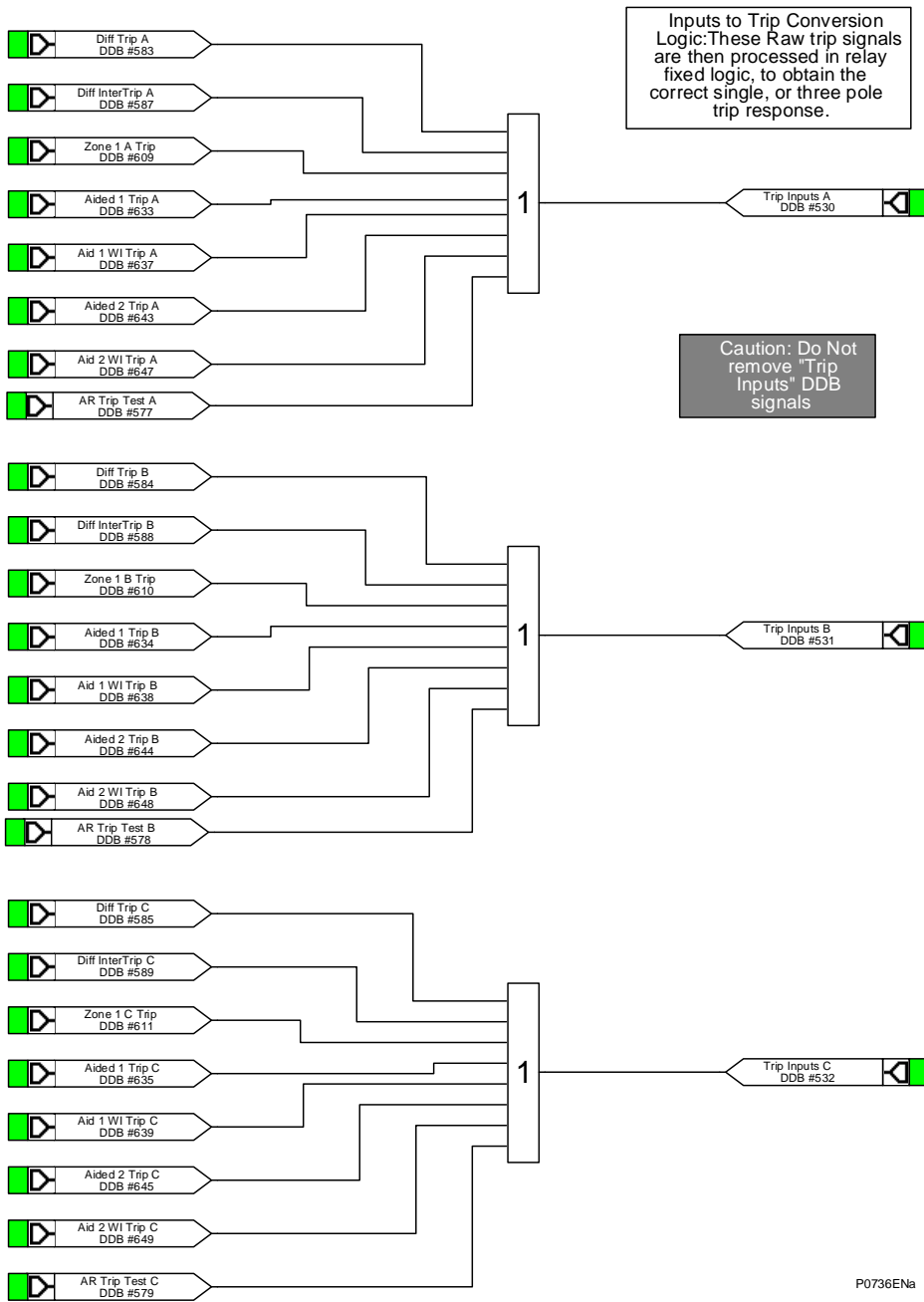

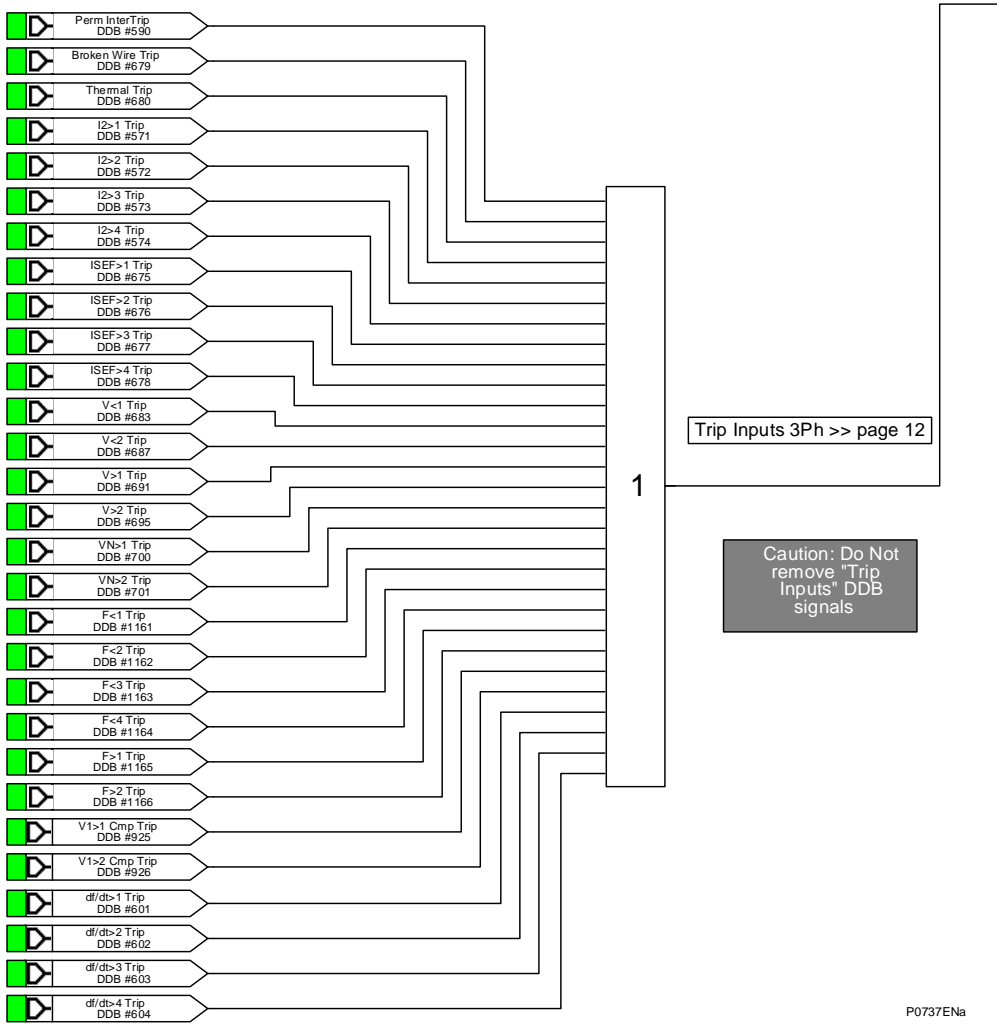

page 12 >> Trip Inputs 3Ph

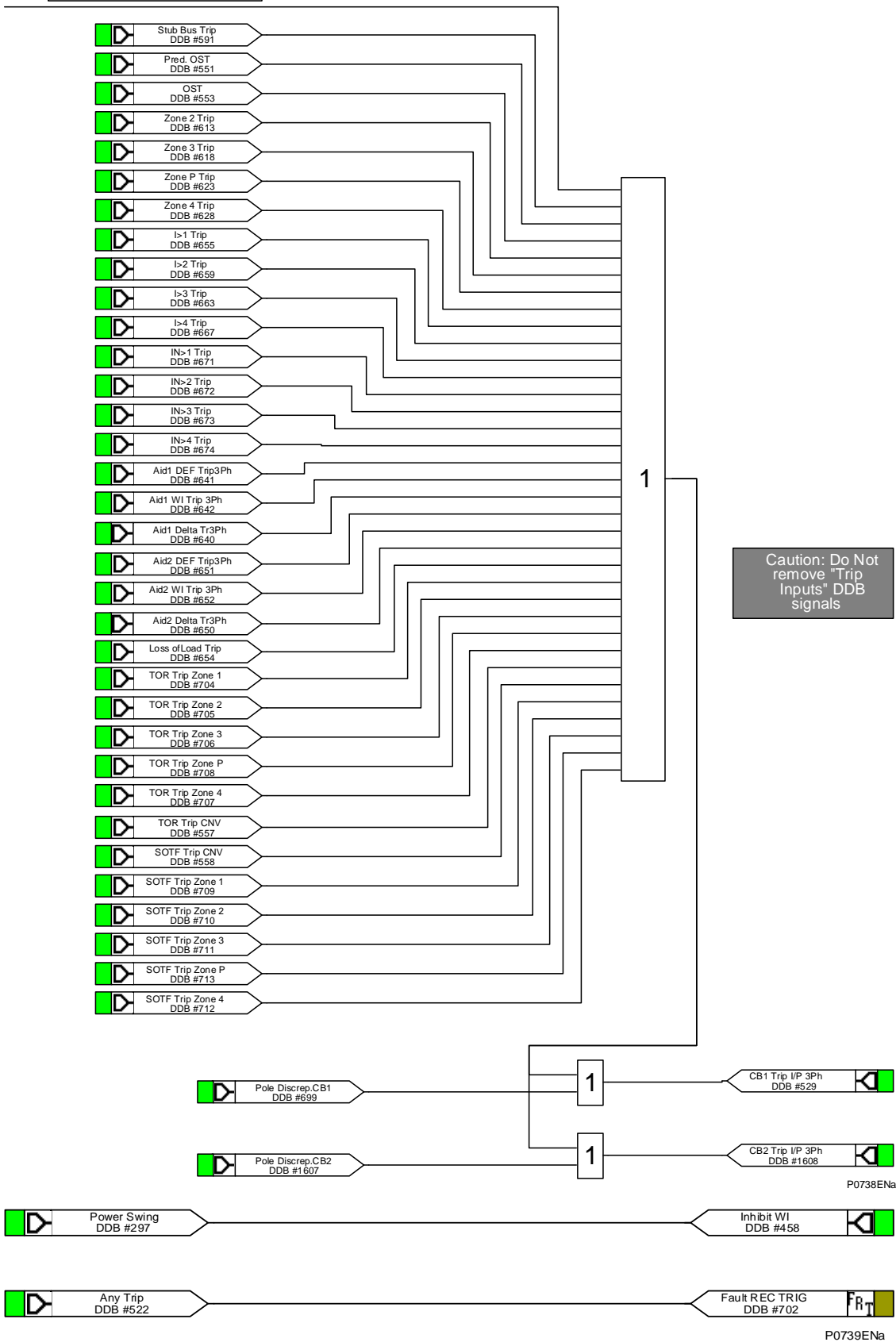

9 MICOM P544 WITHOUT DISTANCE PSL

9.1 Output Input Mappings

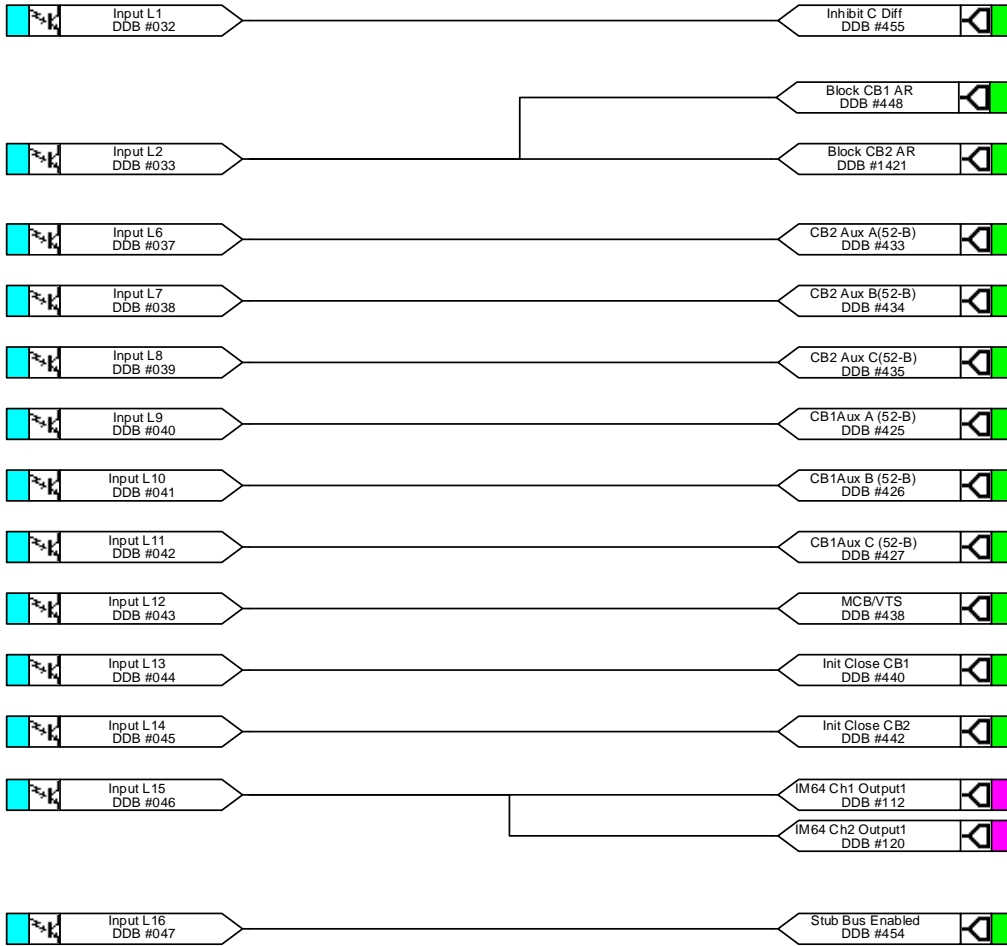

Opto L5 can be found on other pages

P0740ENa

9.2 Output Contacts

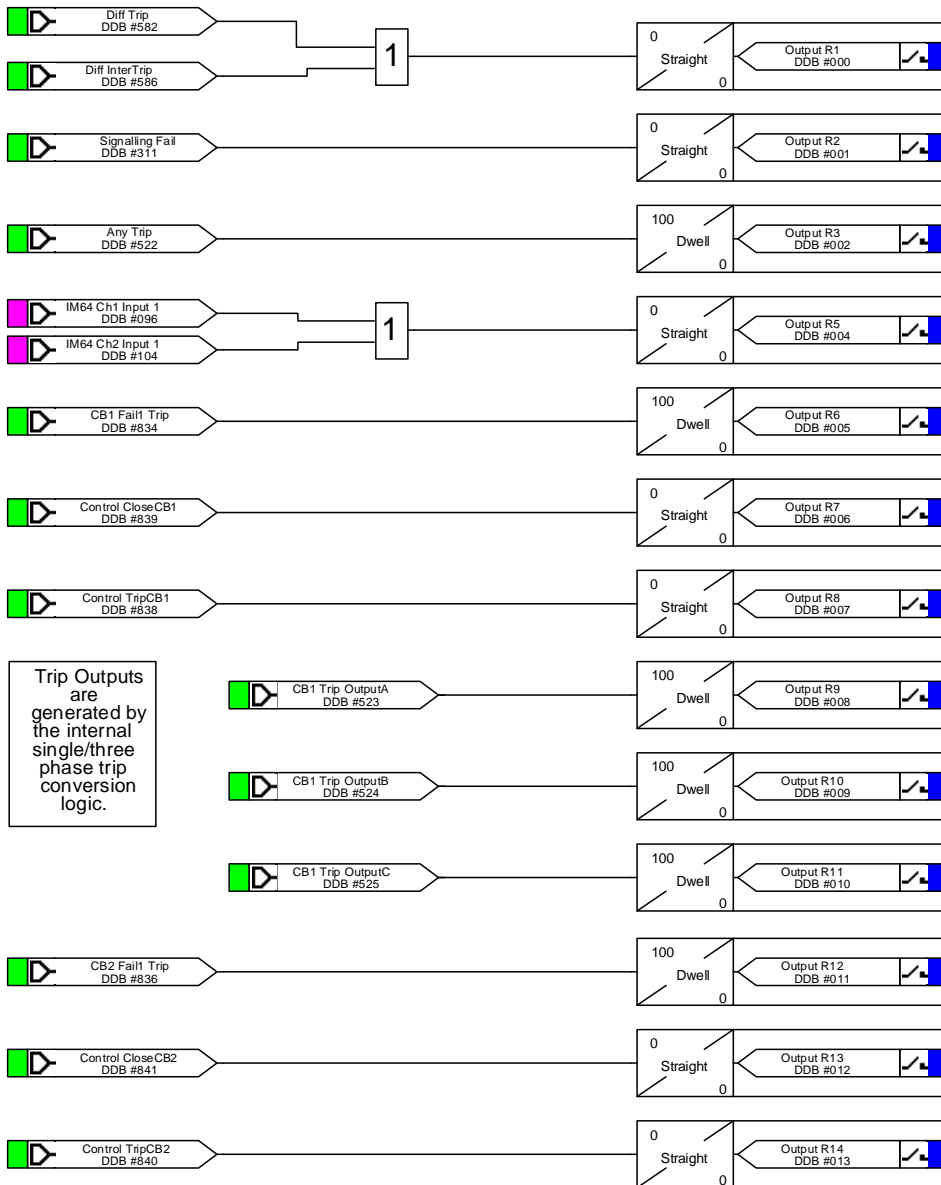

P0741ENa

9.3 Output Contacts

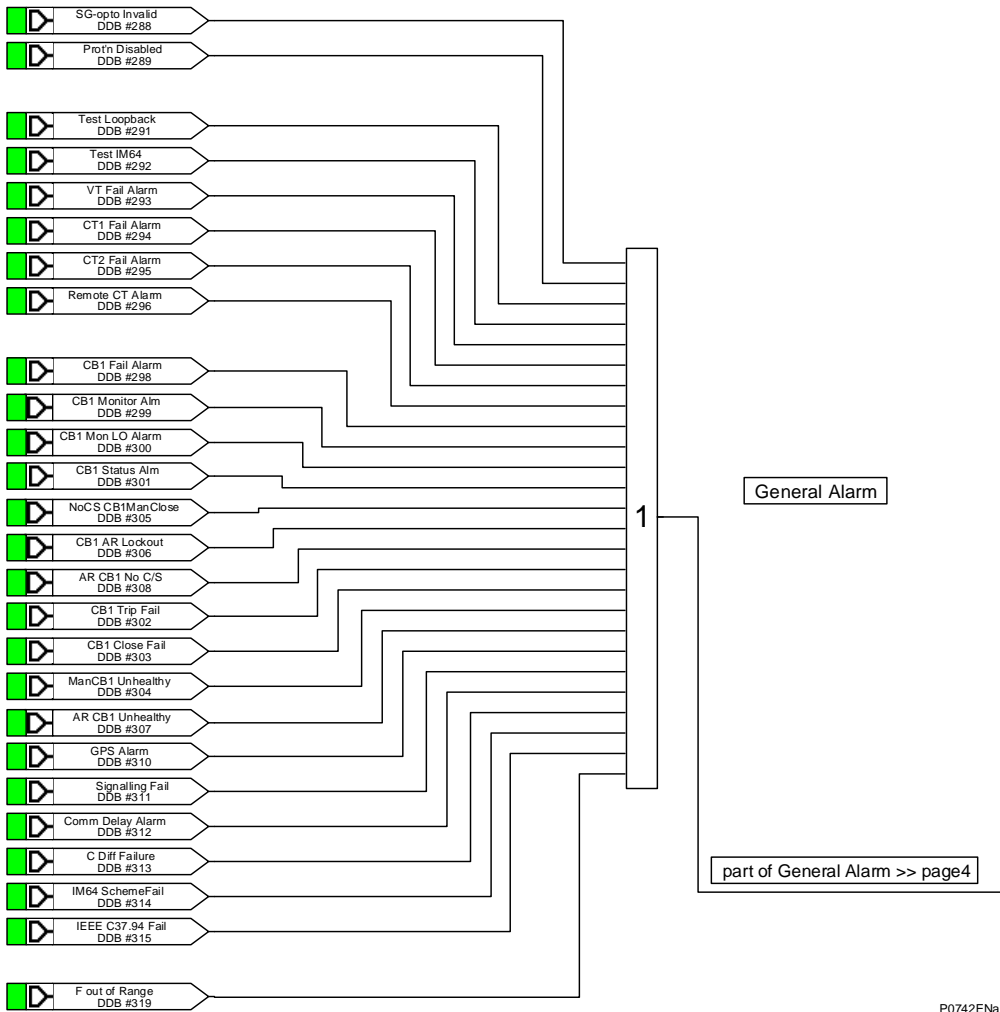

P0742ENa

9.4 Output Contacts

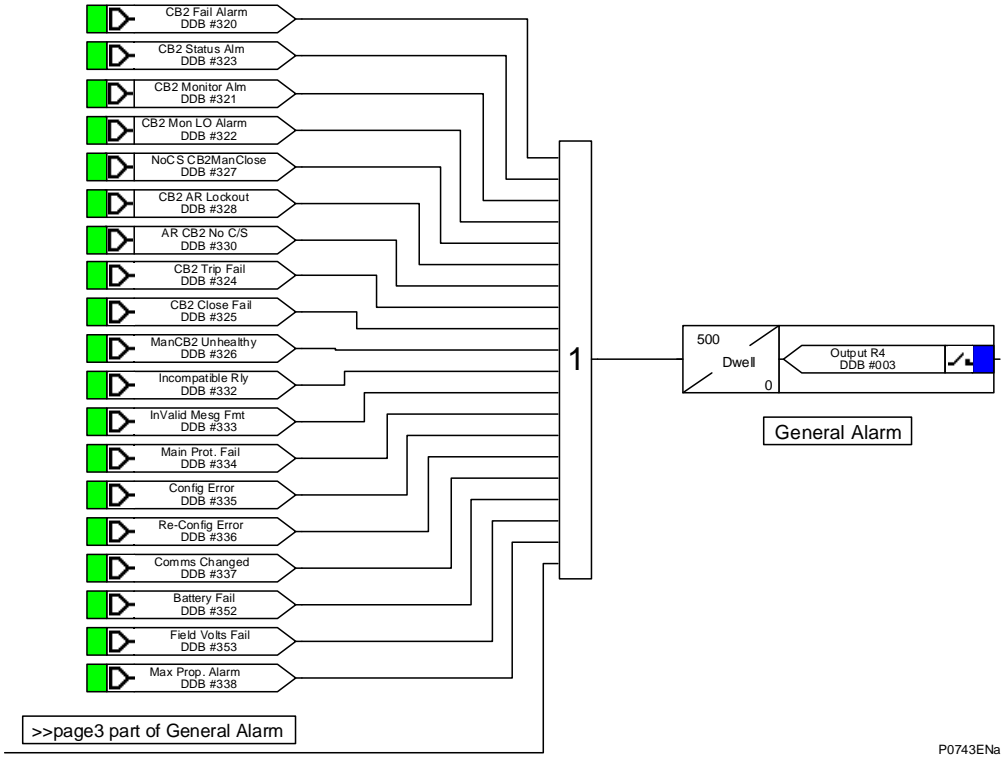

P0743ENa

9.5 LEDs

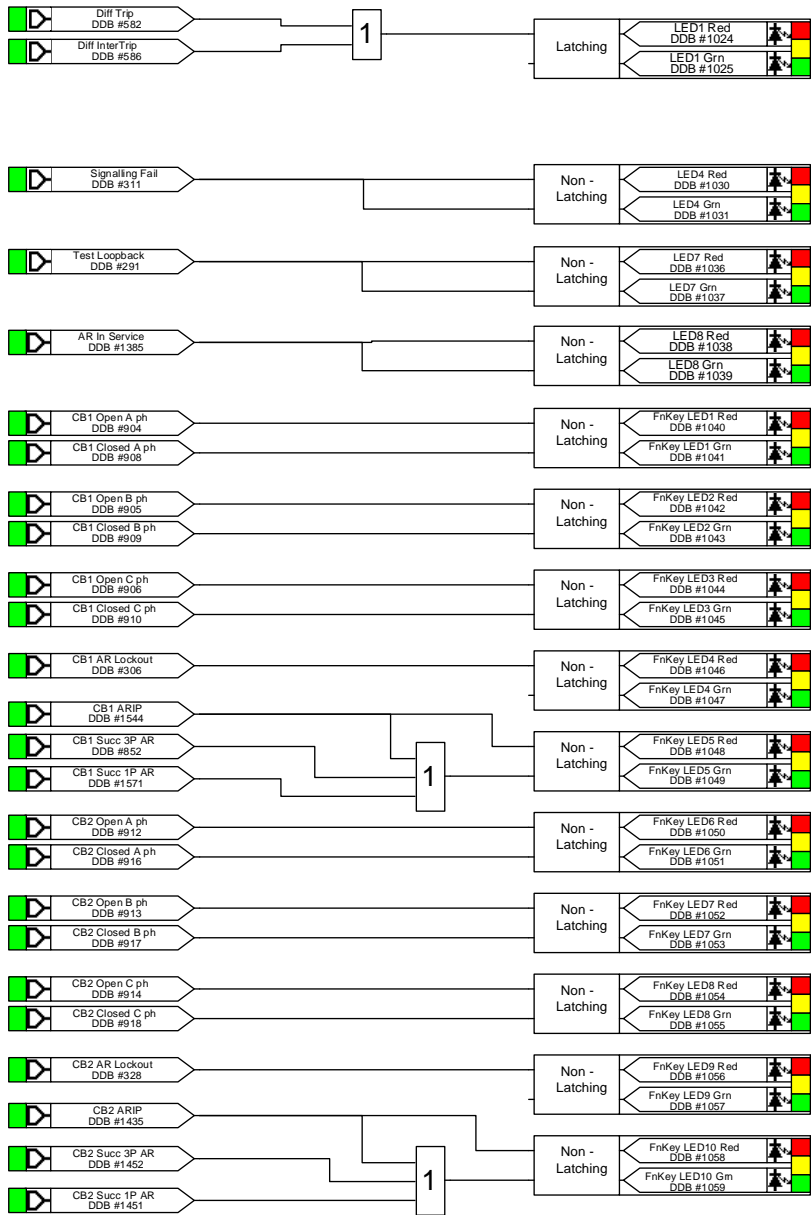

P0744ENa

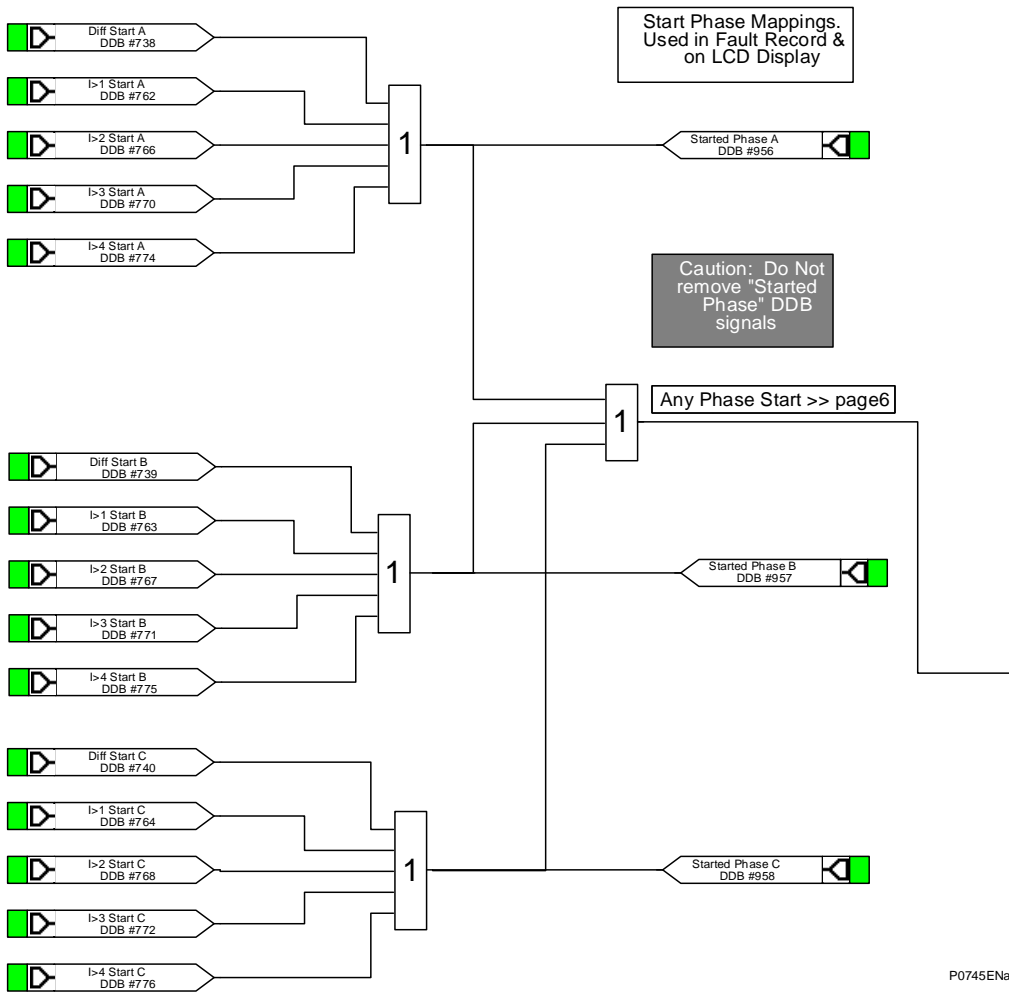

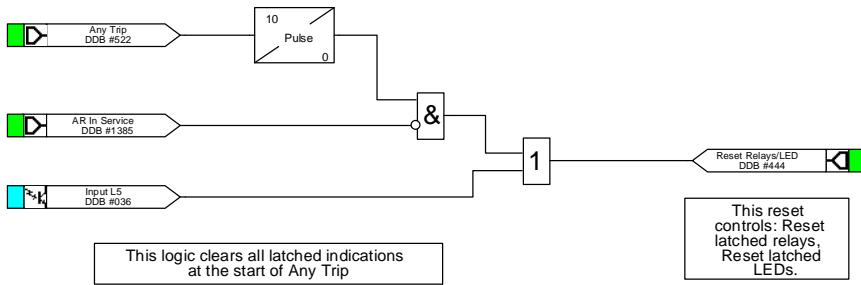
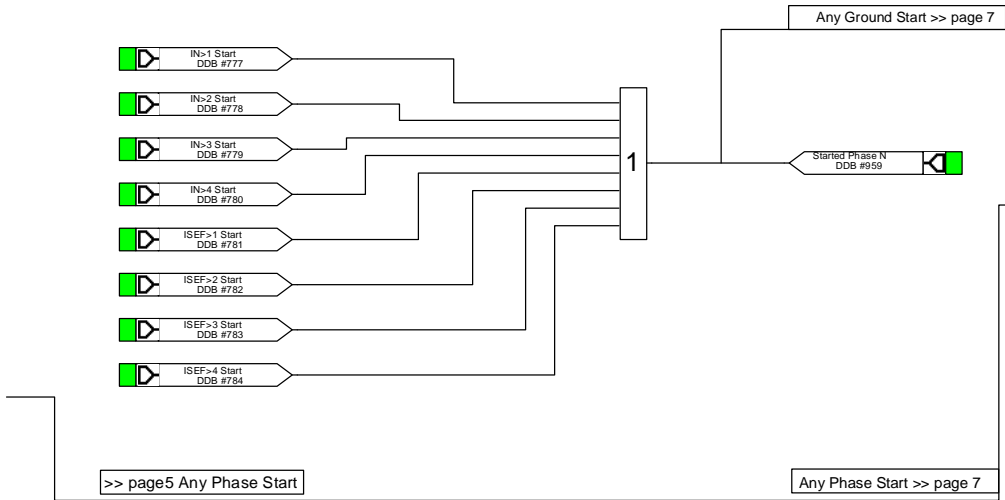

P0746ENa

>> page 6 Any Ground Start

>> page 6 Any Phase Start

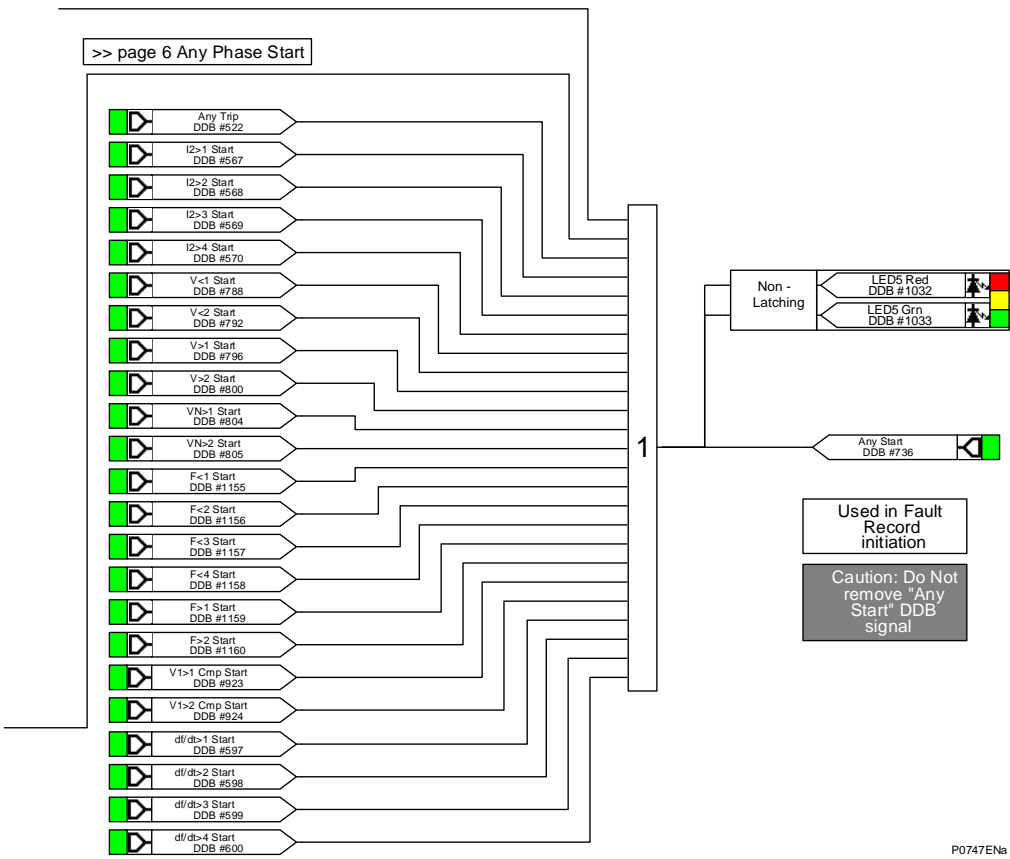

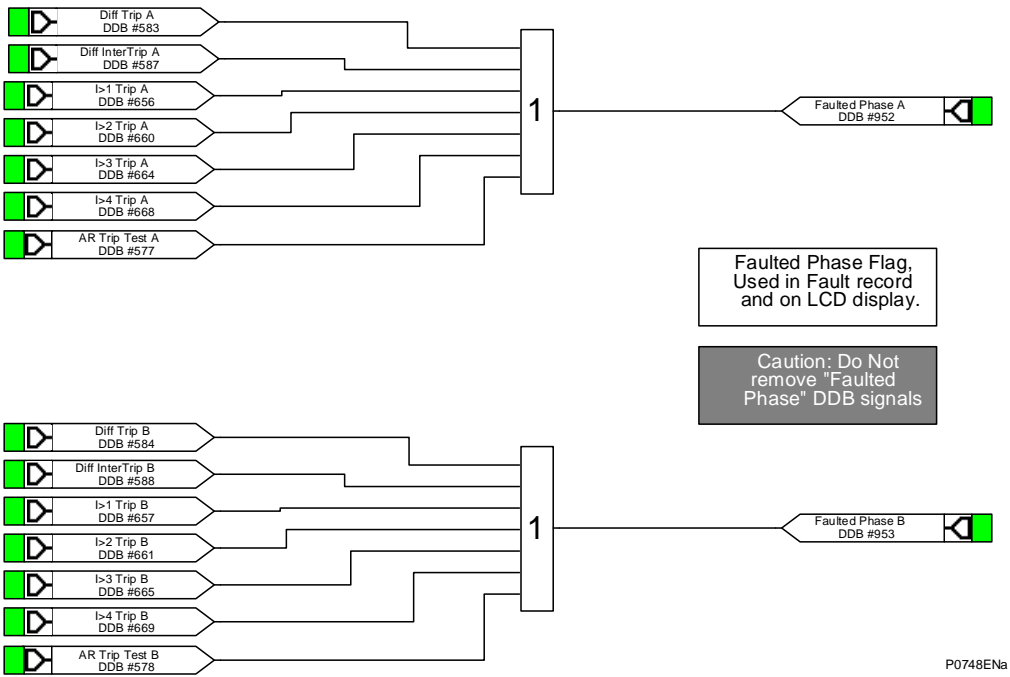

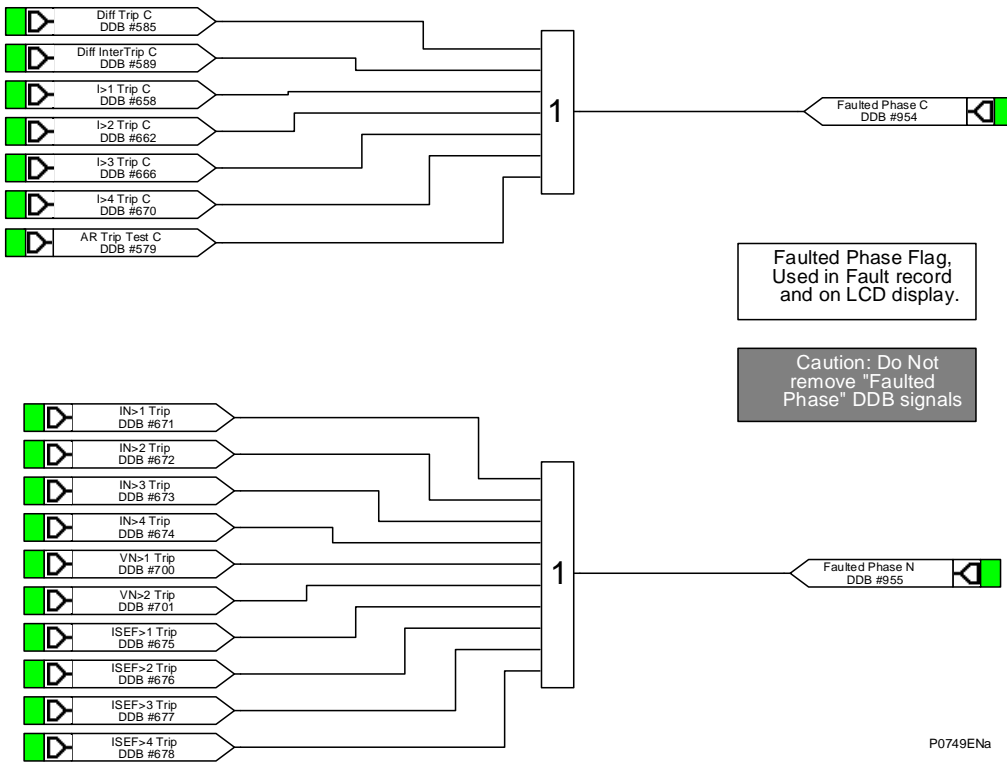

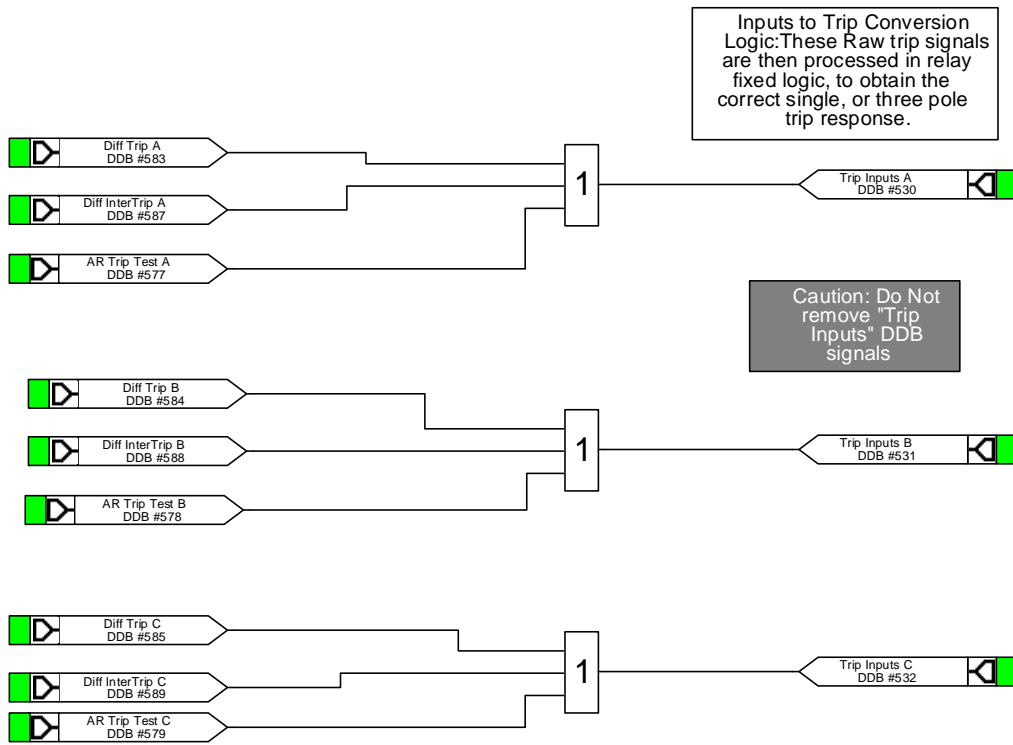

P0750ENa

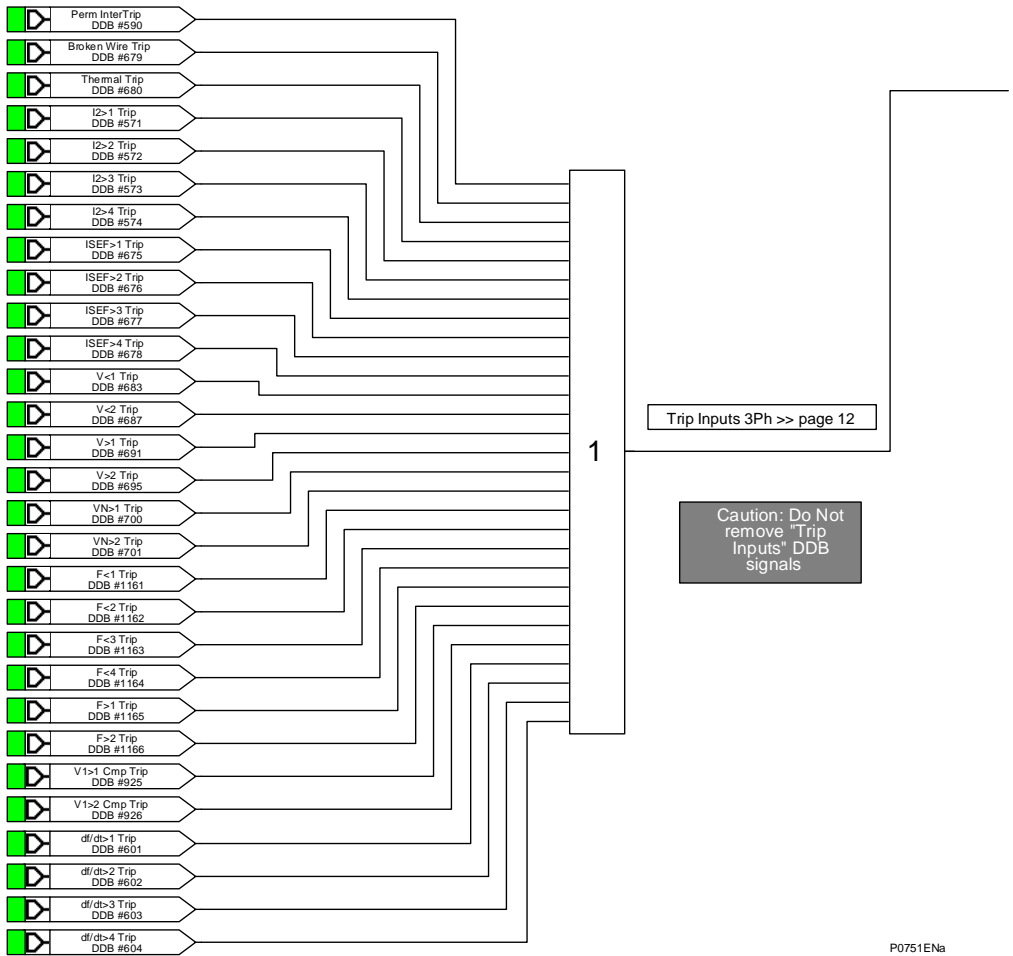

page 12 >> Trip Inputs 3Ph

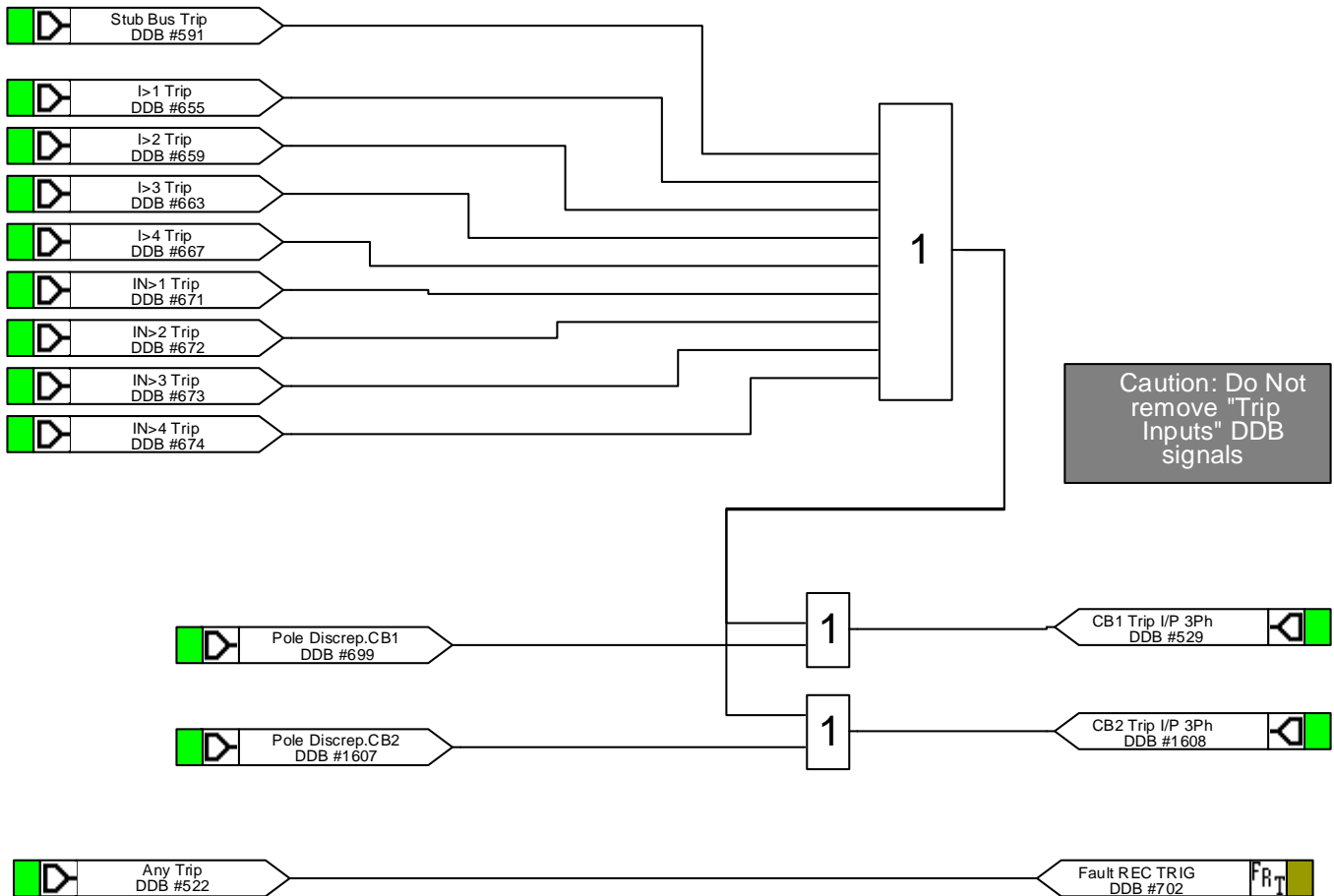

P0752ENa

10 MICOM P545 WITH DISTANCE PSL

10.1 Output Input Mappings

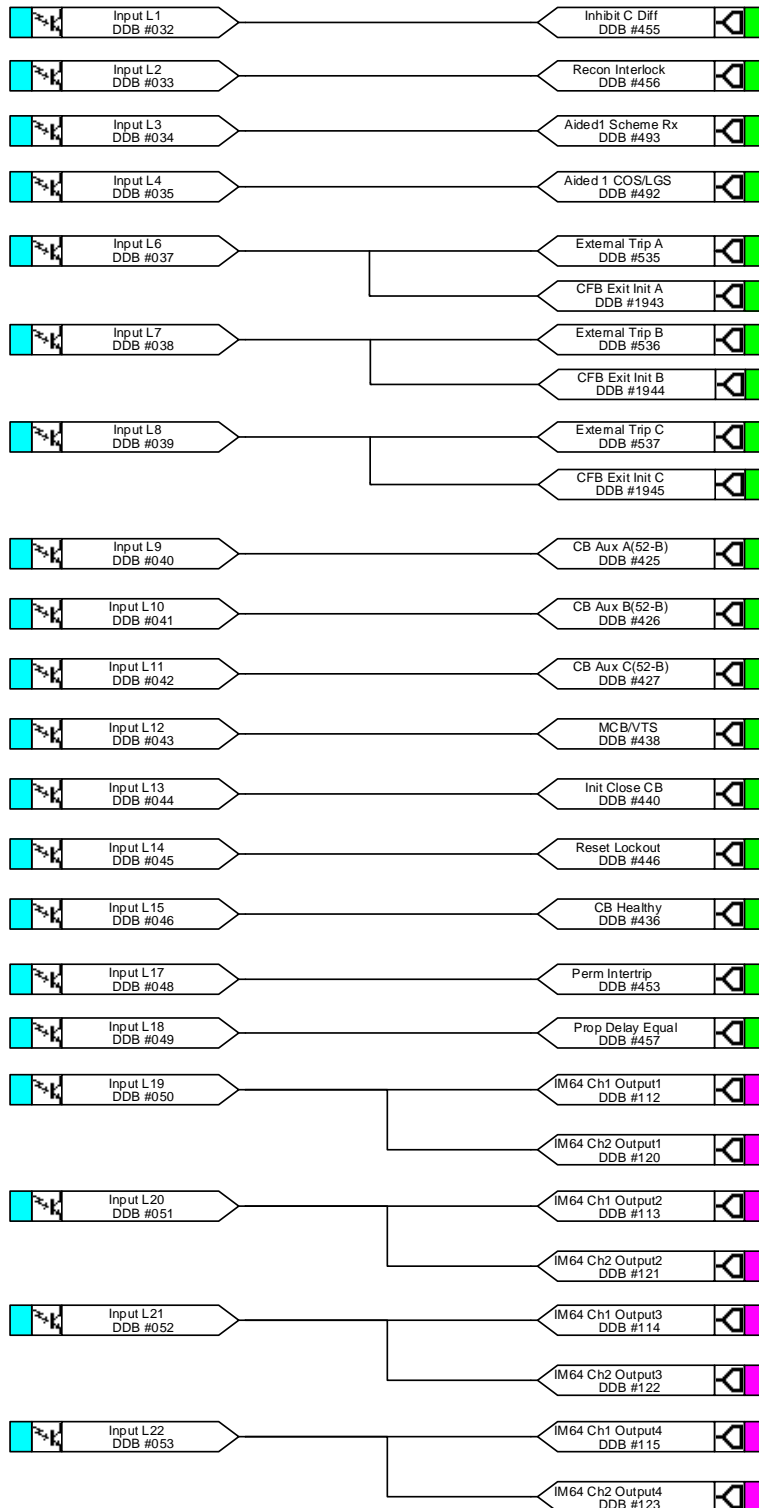

External Trips:
Initiate Auto-
Reclose (if
enabled). CBF
initiation is
segregated.

Opto L5 & L16 can be found on other pages

P0753ENc

10.2 Output Contacts

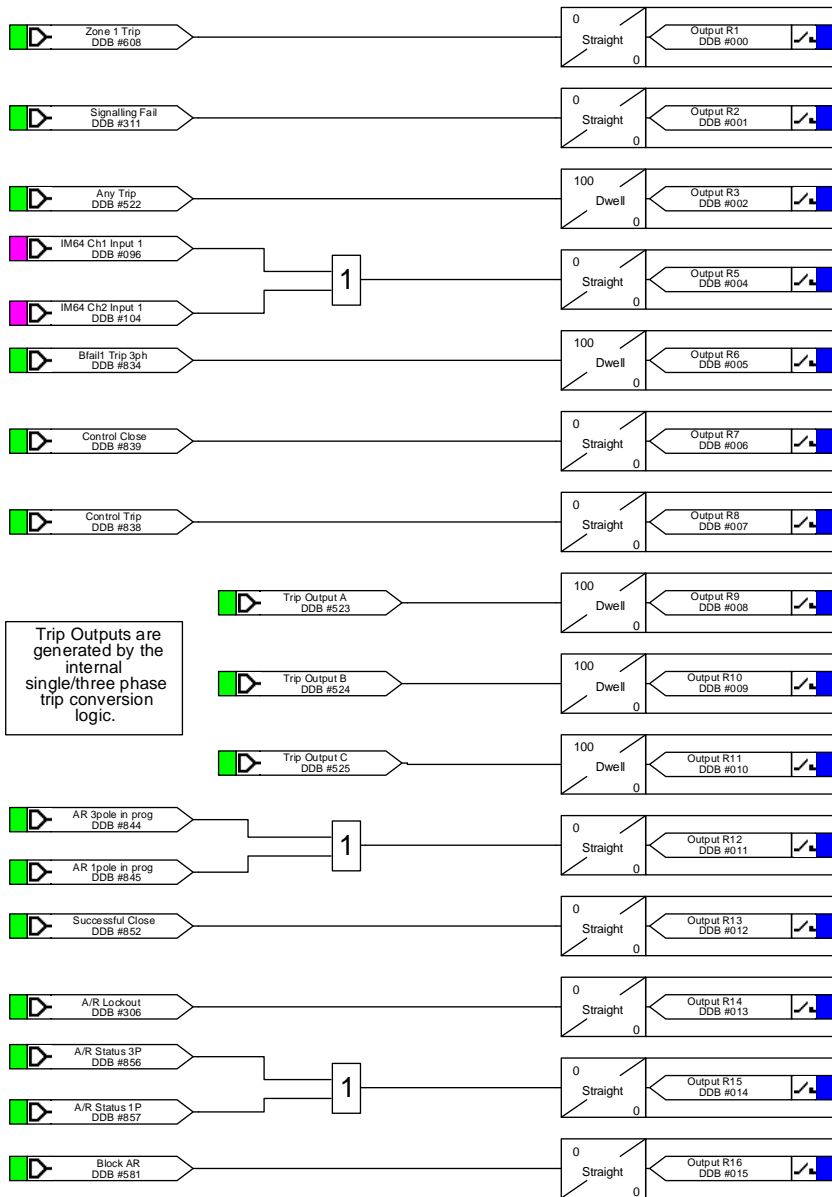

Trip Outputs are generated by the internal single/three phase trip conversion logic.

P0754ENa

10.3 Output Contacts

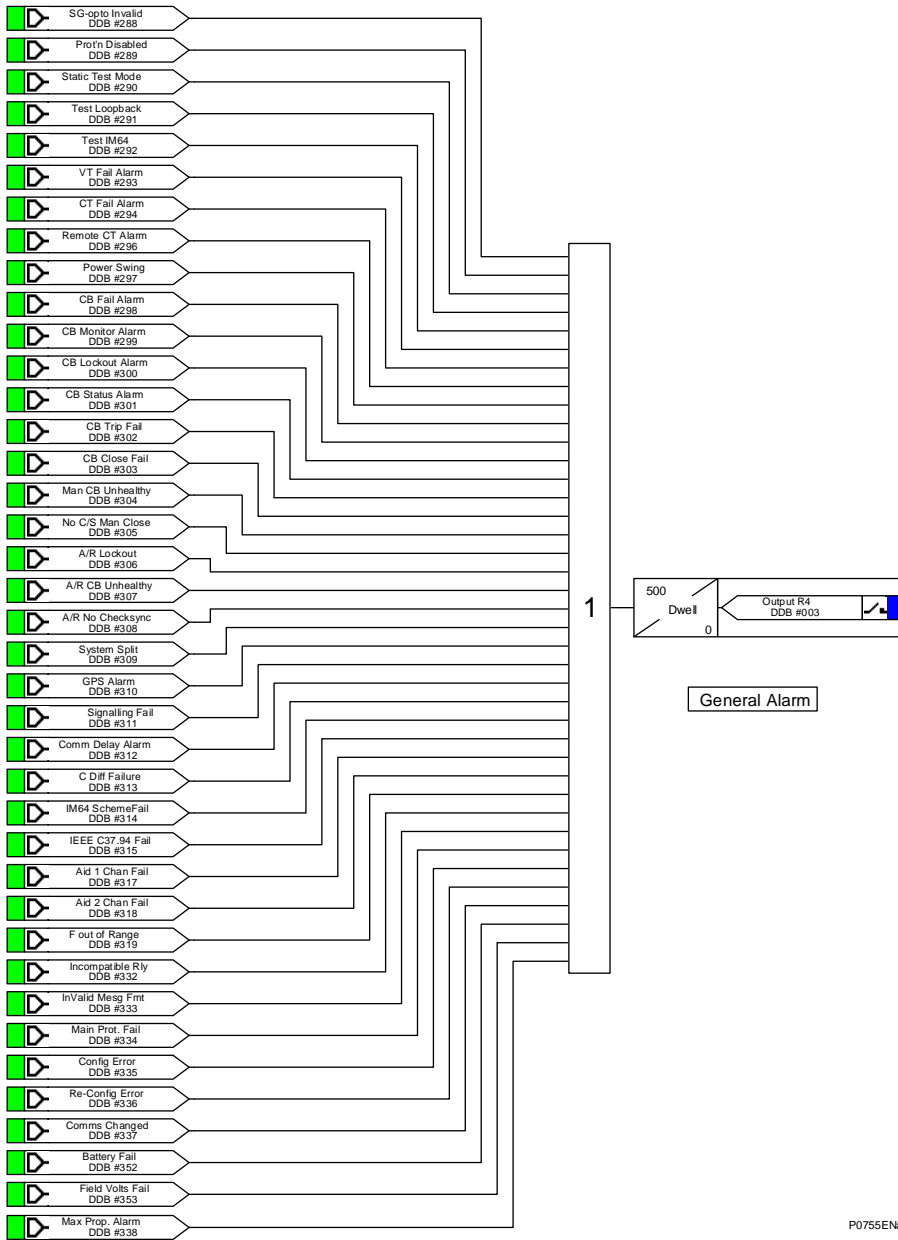

10.4 Output Contacts

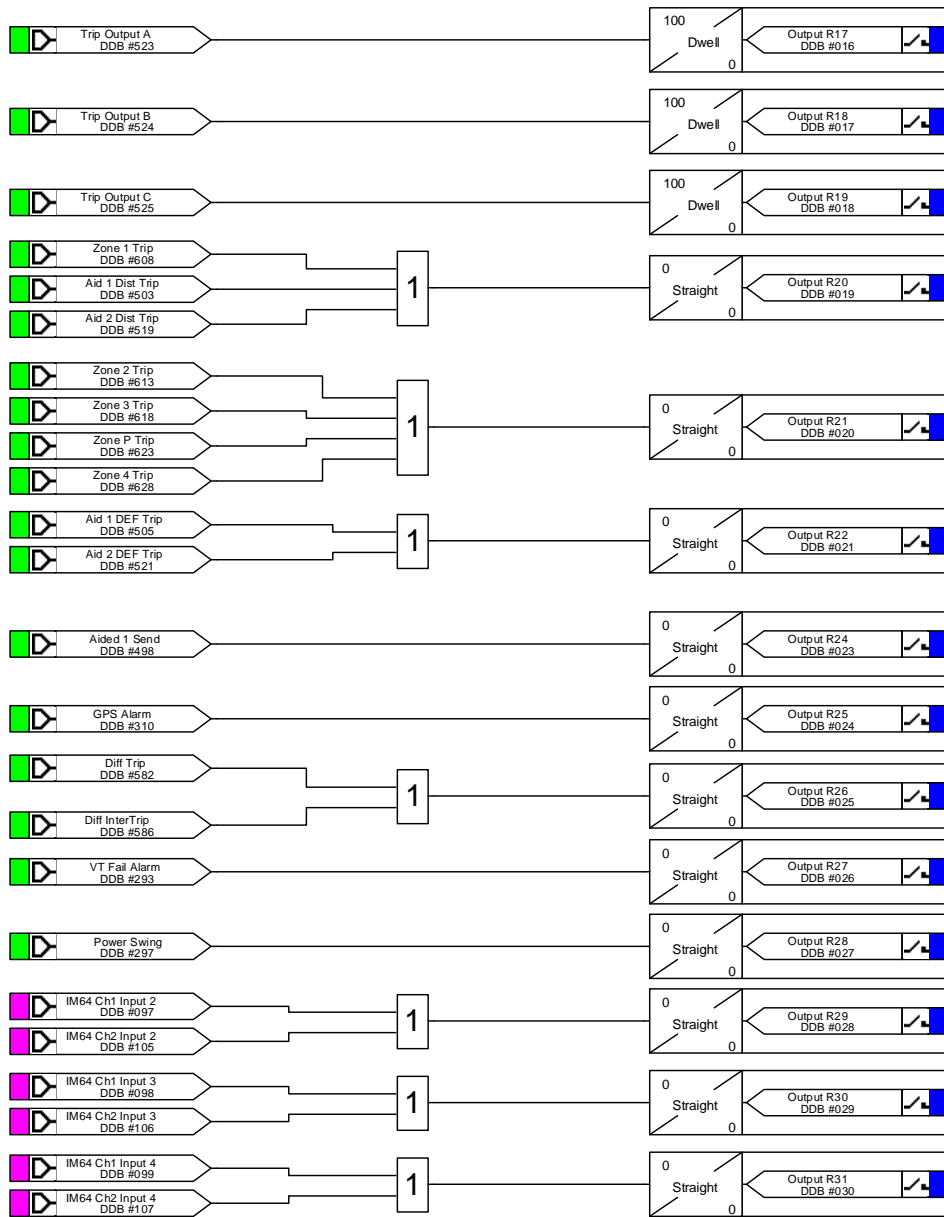

P0756ENa

10.5 LEDs

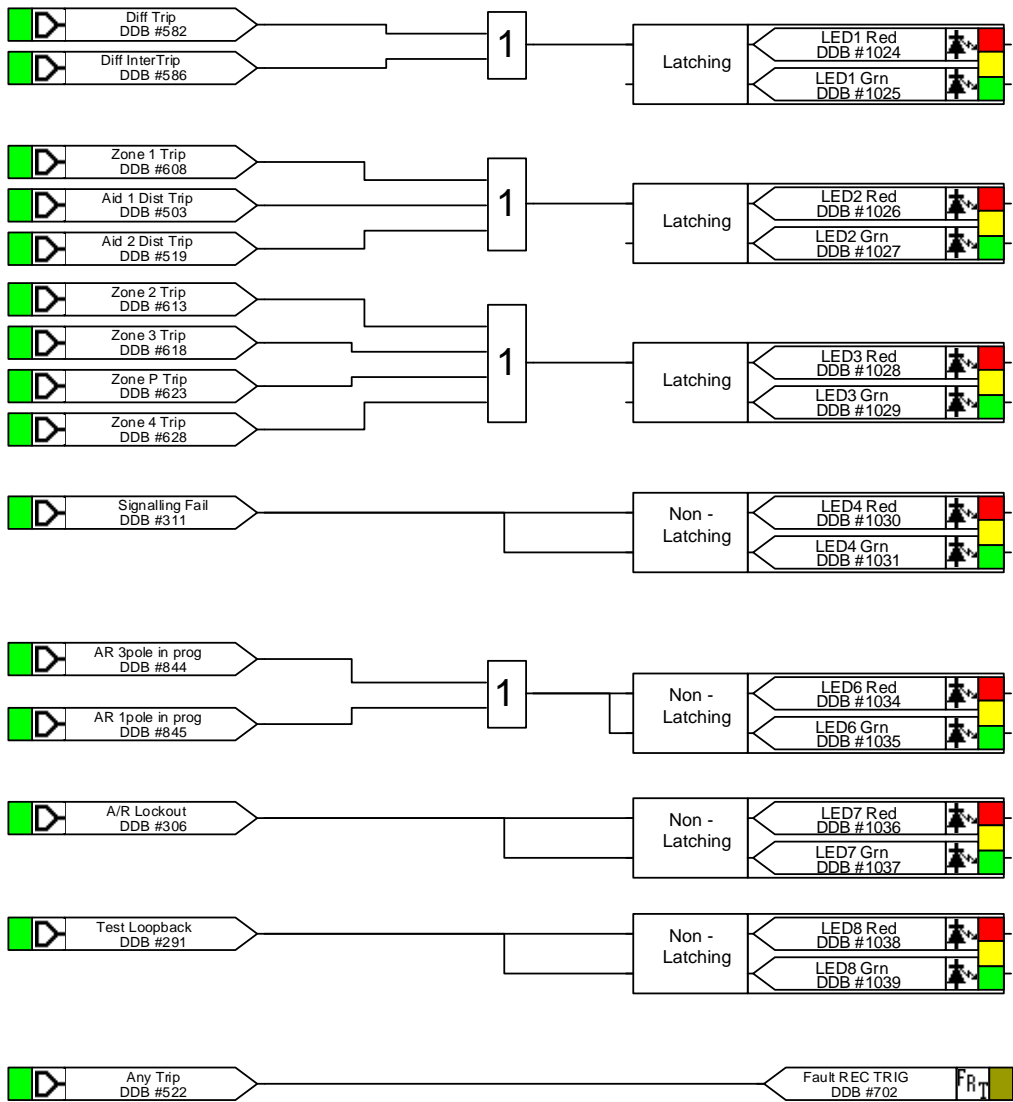

P0757ENa

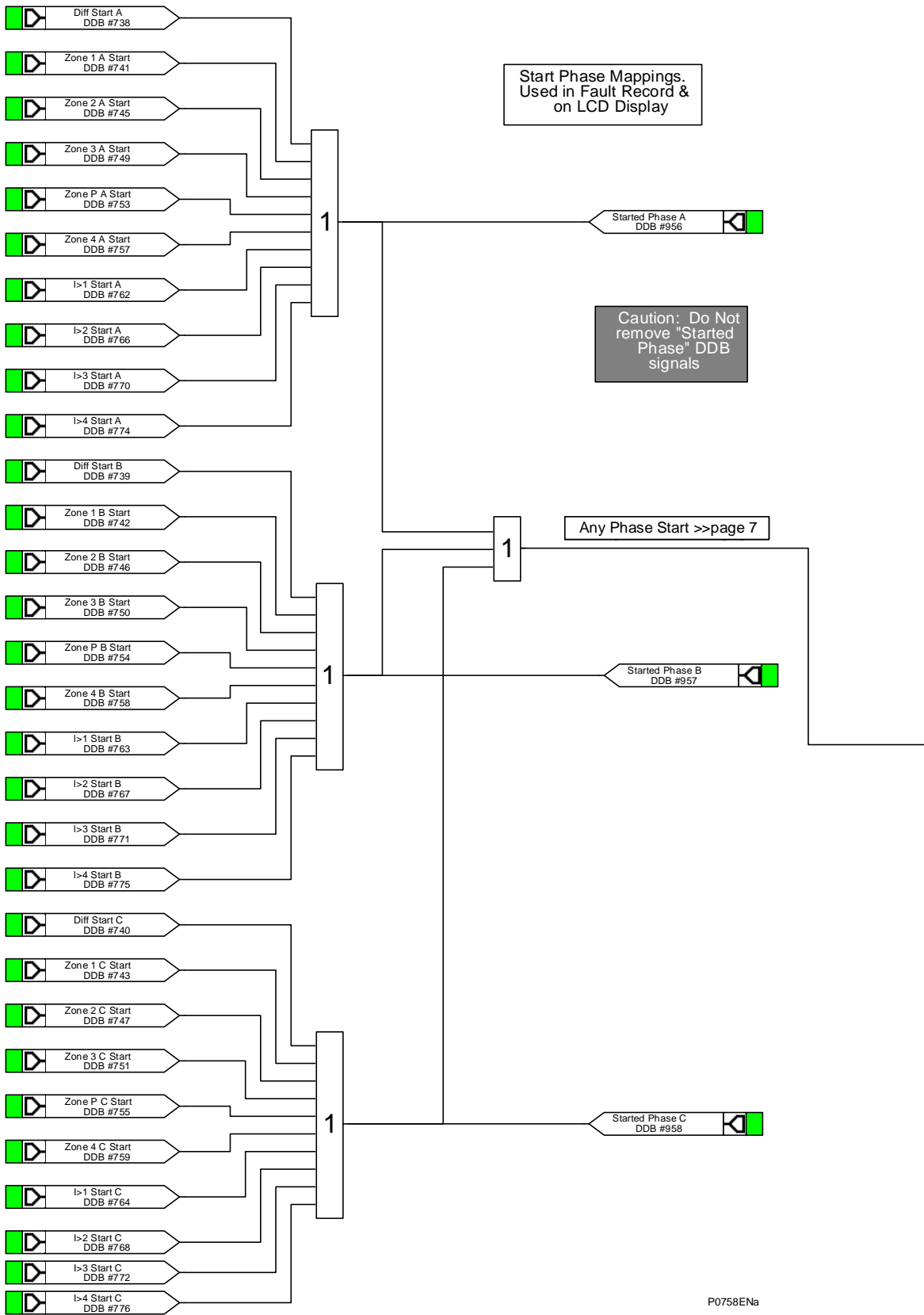

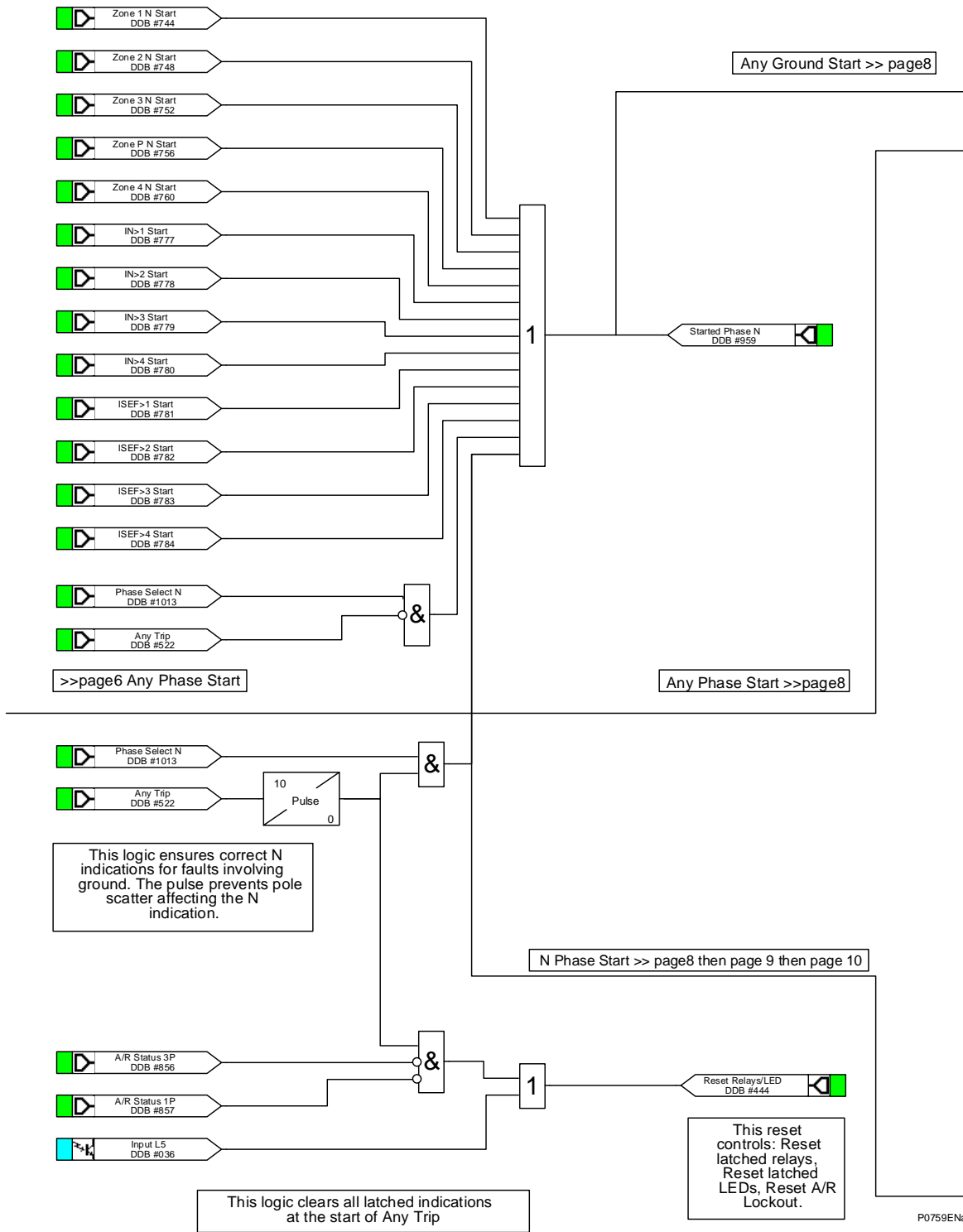

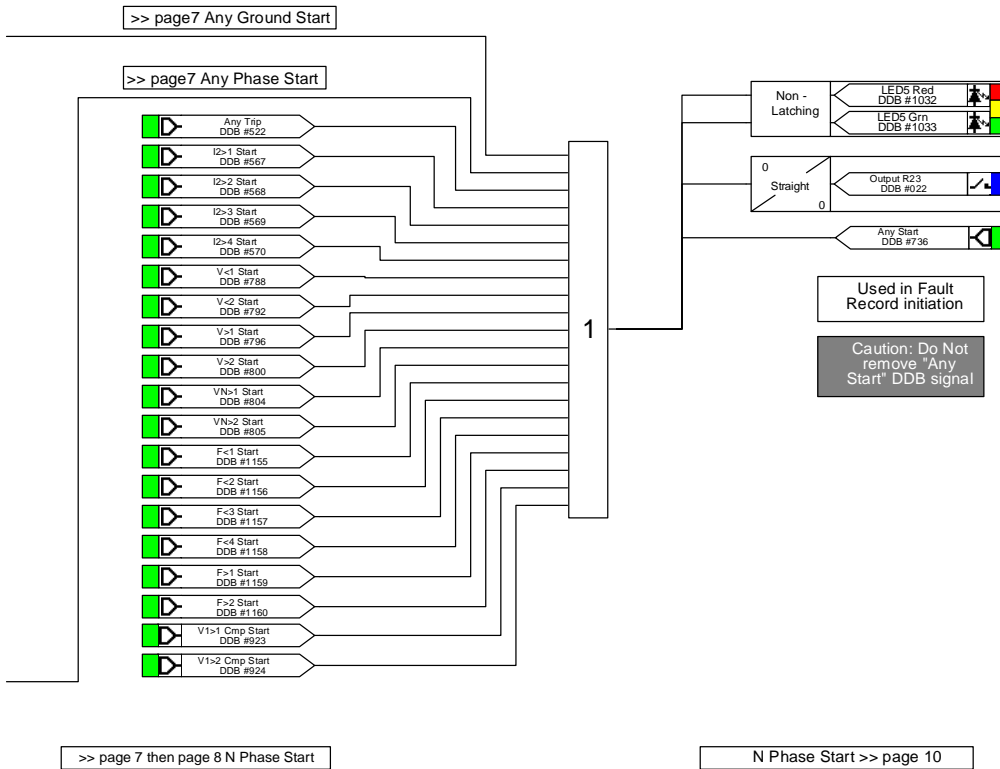

P0760ENa

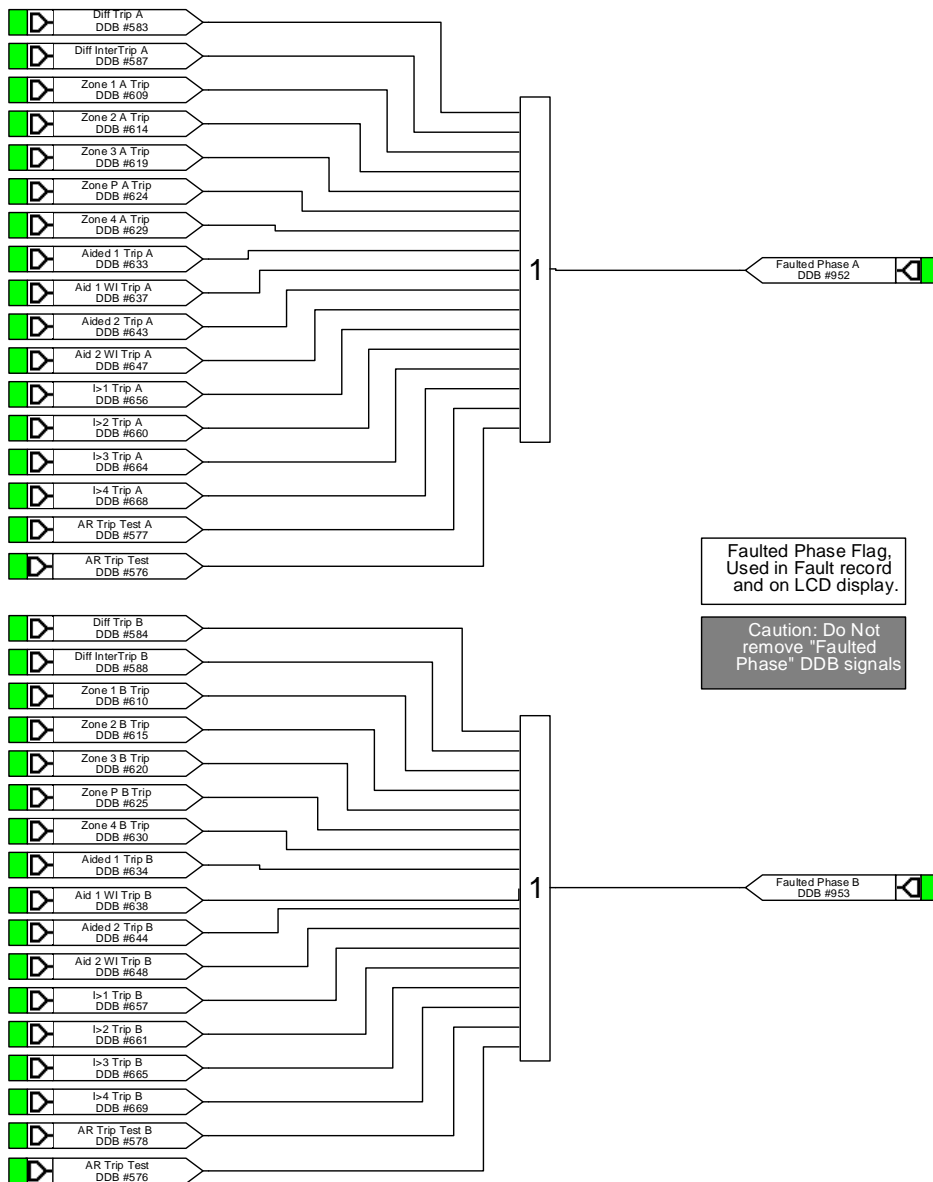

>> page 7 then page 8 N Phase Start

N Phase Start >> page 10

P0761ENa

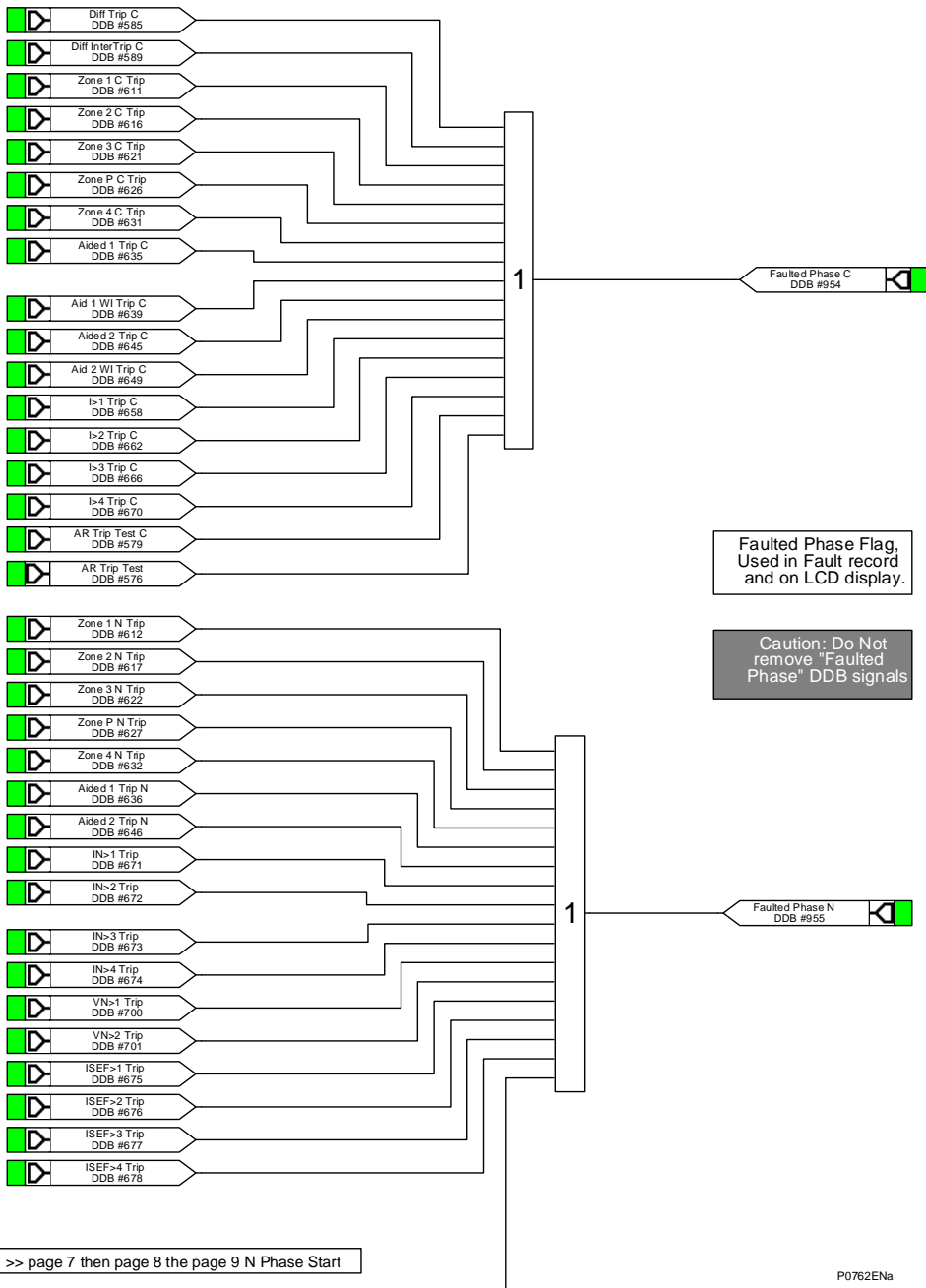

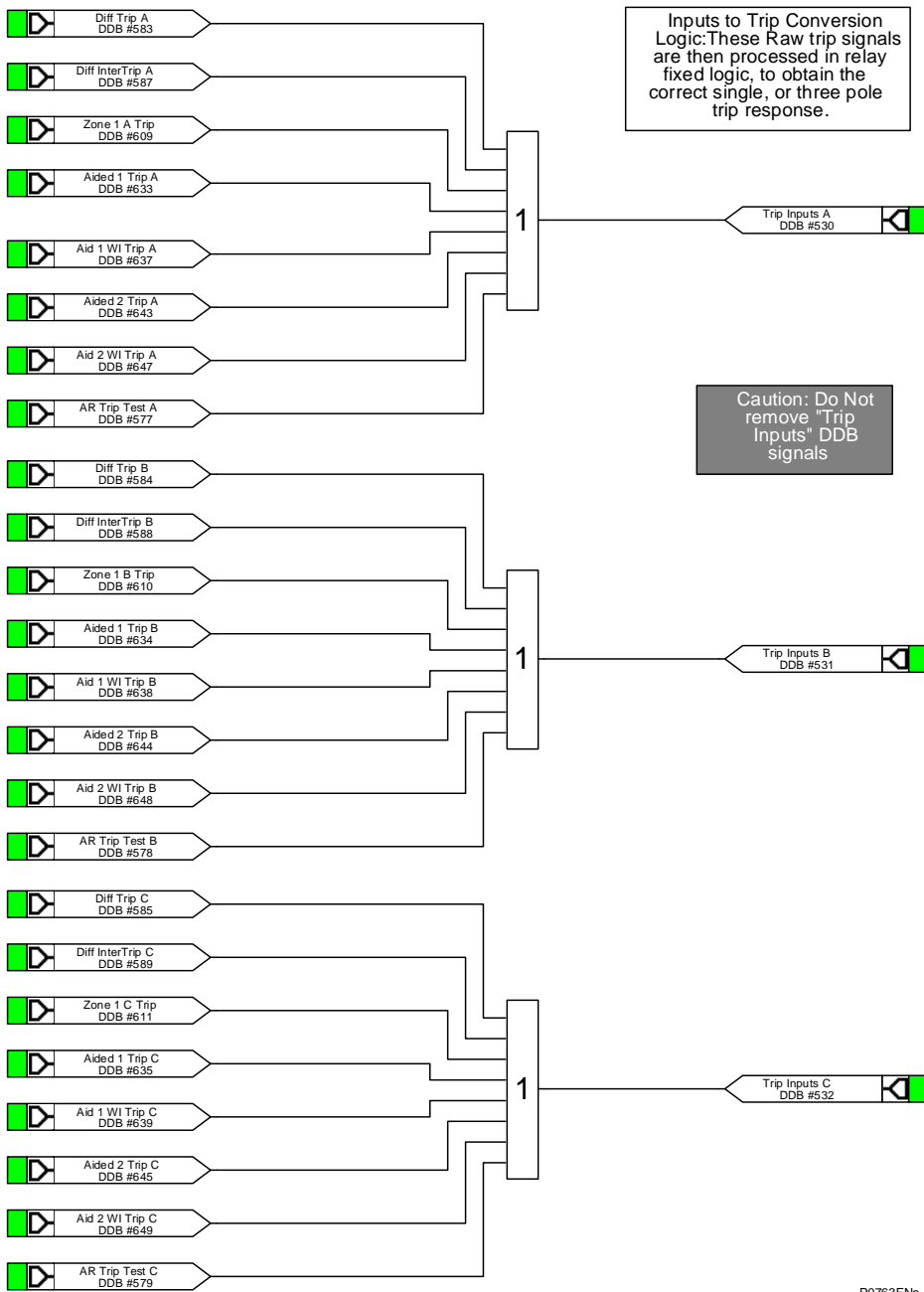

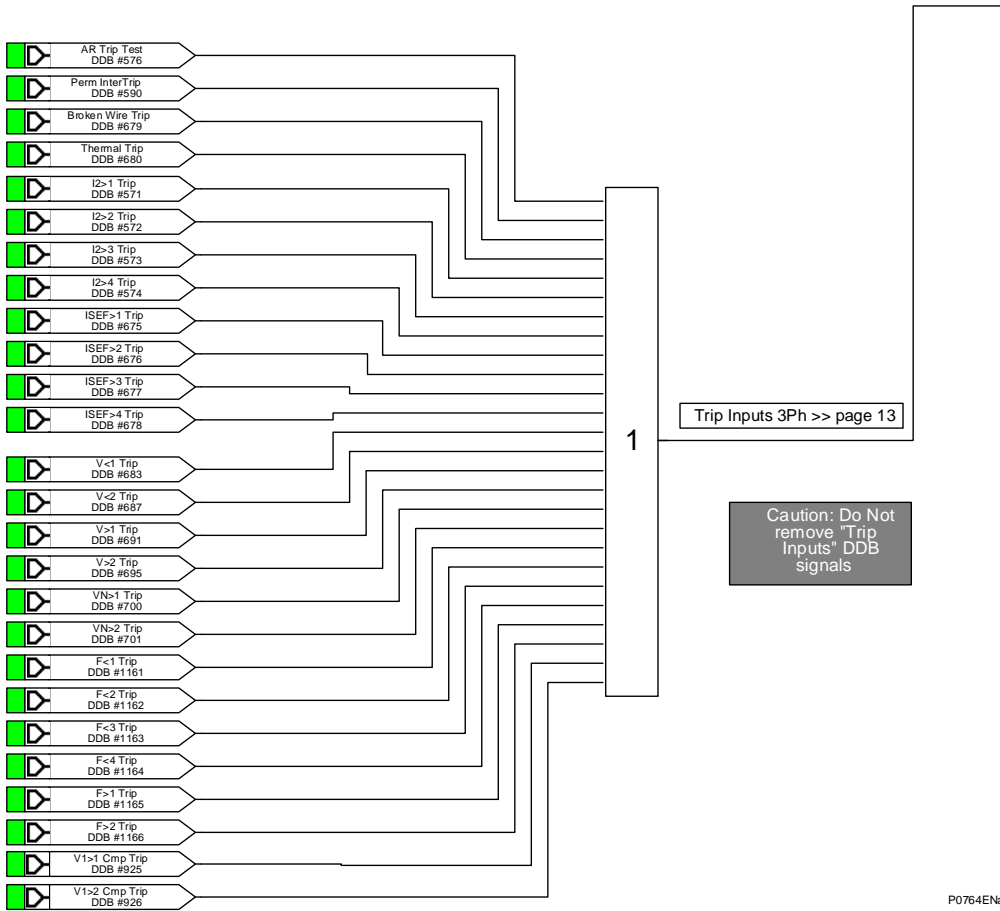

P0764ENa

page 12 >> Trip Inputs 3Ph

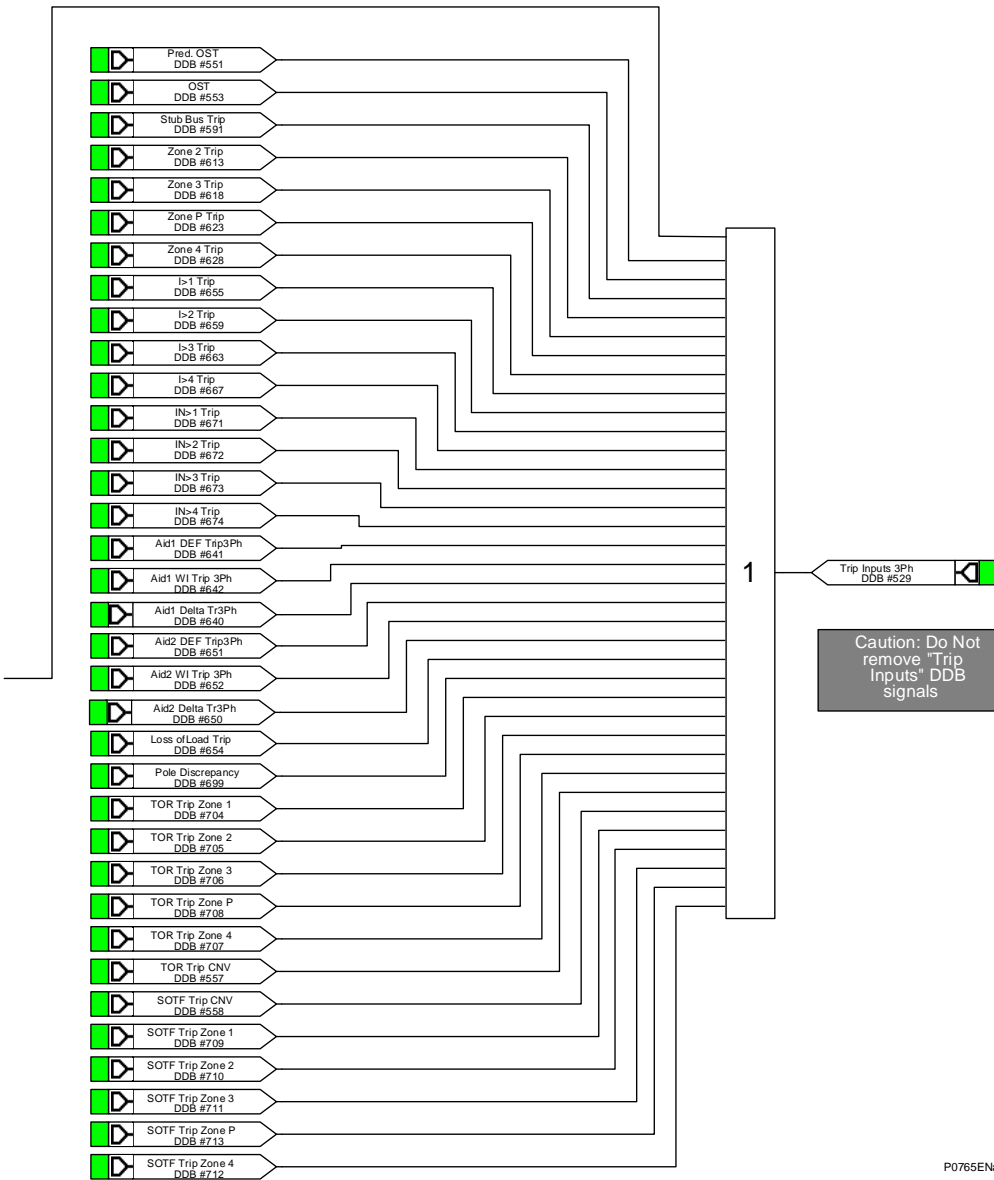

P0765ENa

This logic enables Check Synchro to function only for Live Line / Live Bus conditions.

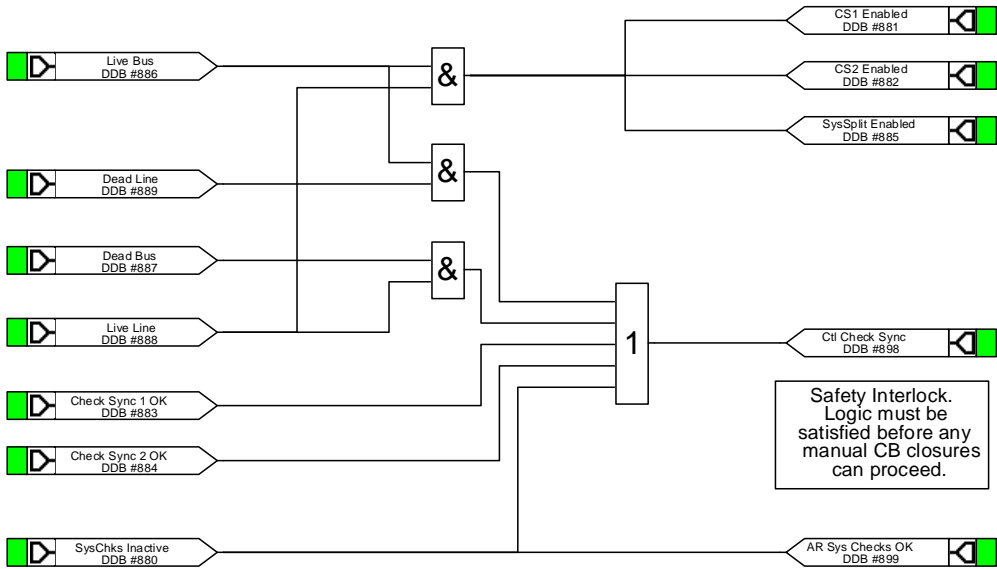

Safety Interlock. Logic must be satisfied before any manual CB closures can proceed.

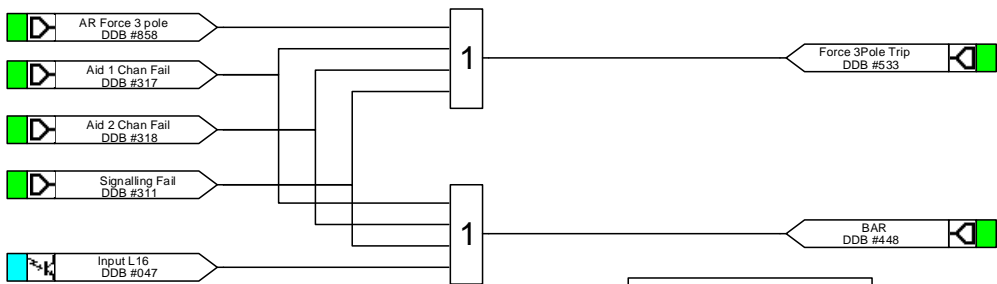

Default PSL blocks Auto-reclose if any aided scheme channel fails.

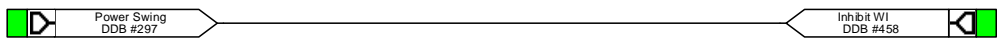

P0766ENa

11 MICOM P545 WITHOUT DISTANCE PSL

11.1 Output Input Mappings

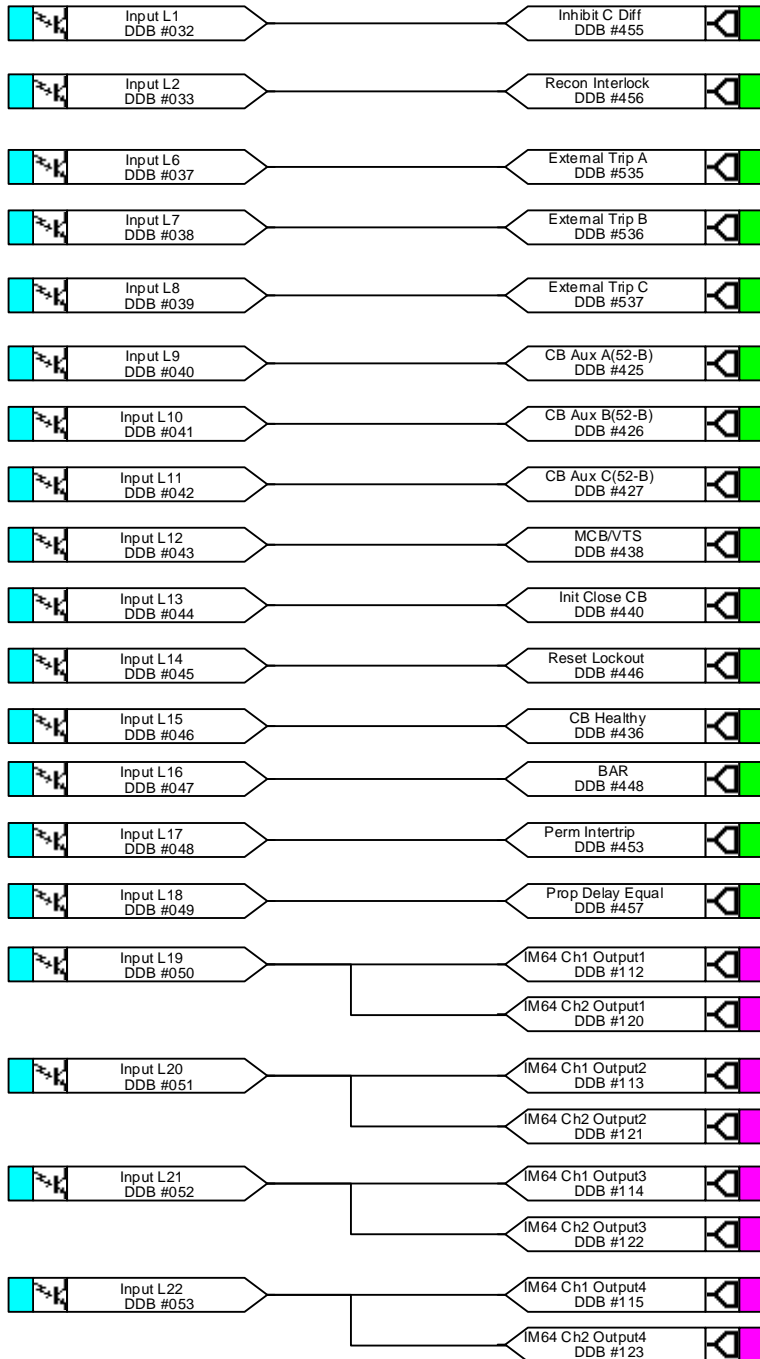

External Trips:
Initiate
Auto-reclose
(if enabled).

Opto L5 can be found on other pages

P0767ENb

11.2 Output Contacts

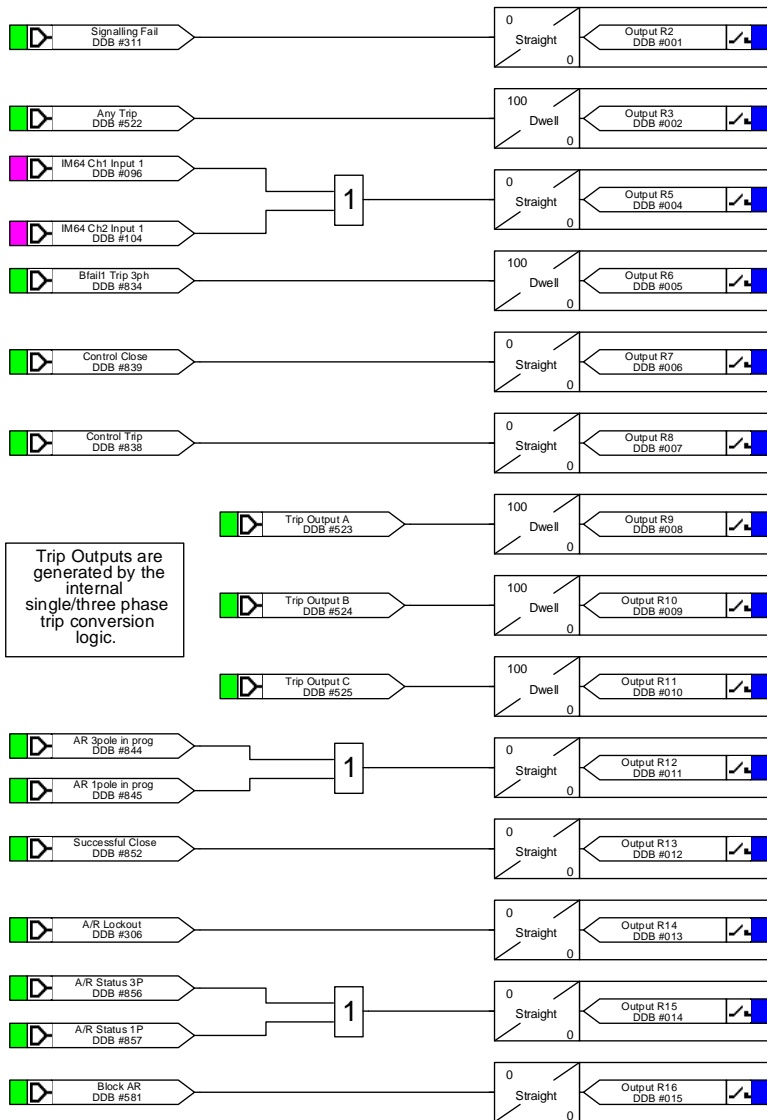

Trip Outputs are generated by the internal single/three phase trip conversion logic.

P0768ENa

11.3 Output Contacts

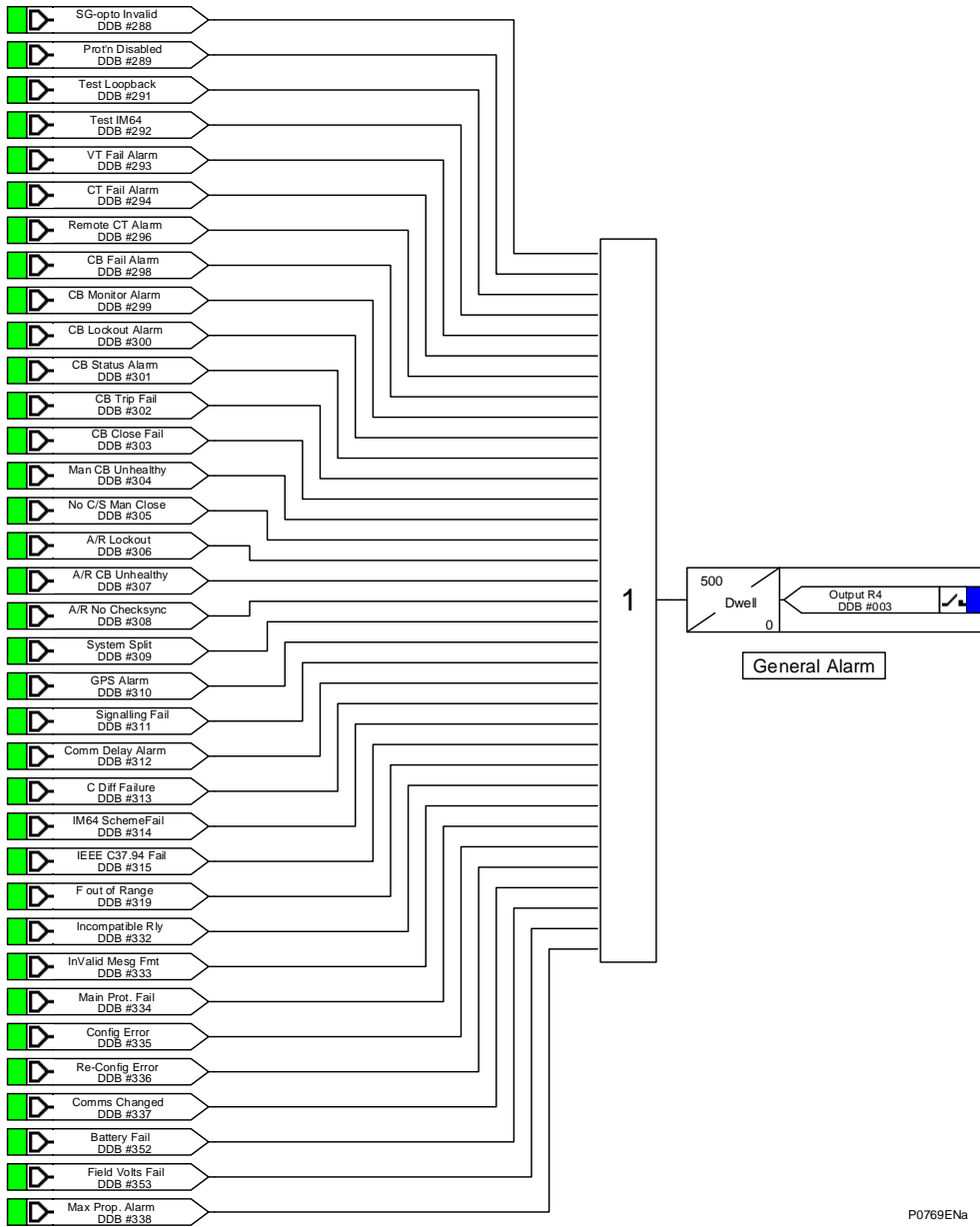

P0769ENa

11.4 Output Contacts

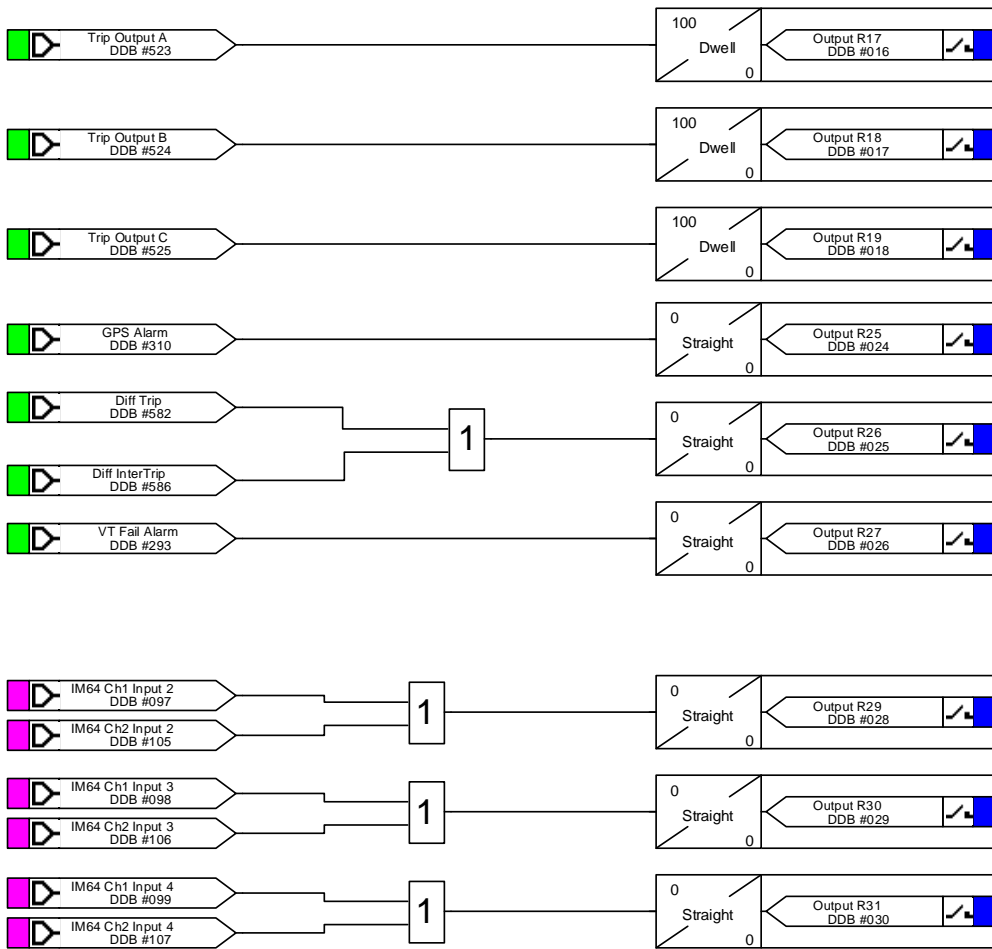

P0770ENa

11.5 LEDs

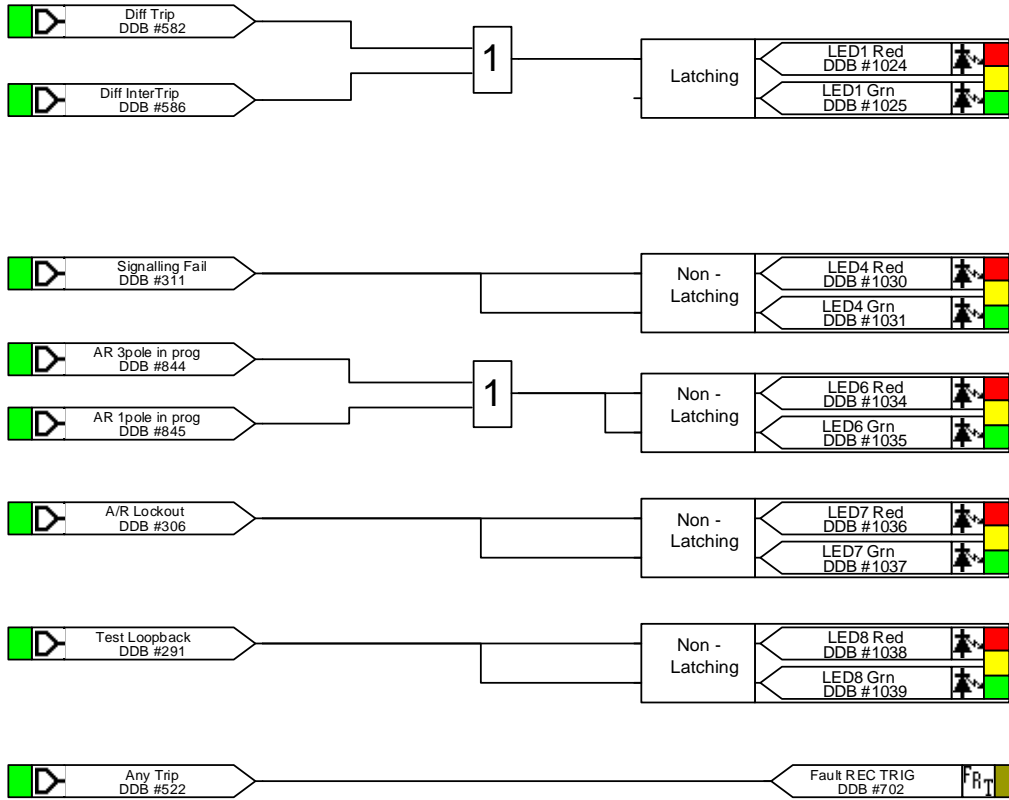

P0771ENa

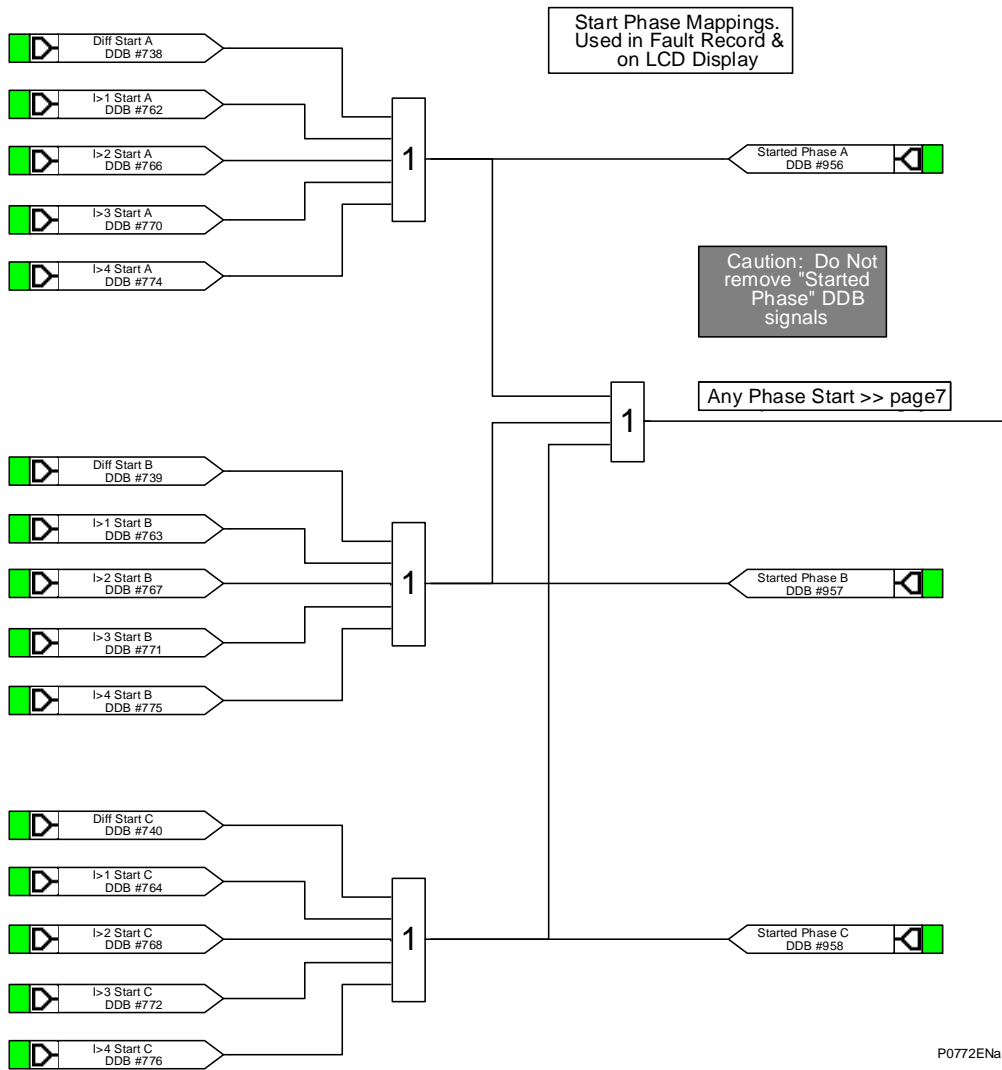

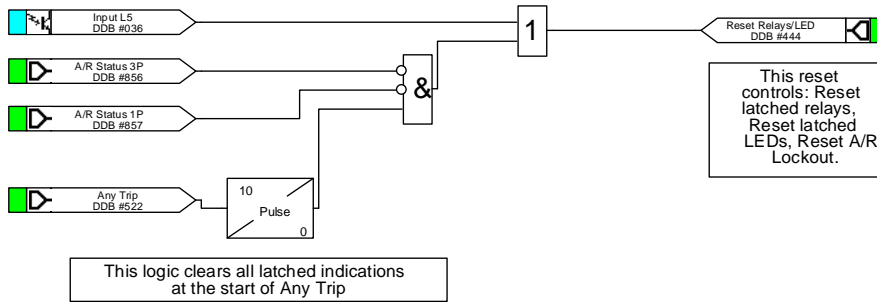
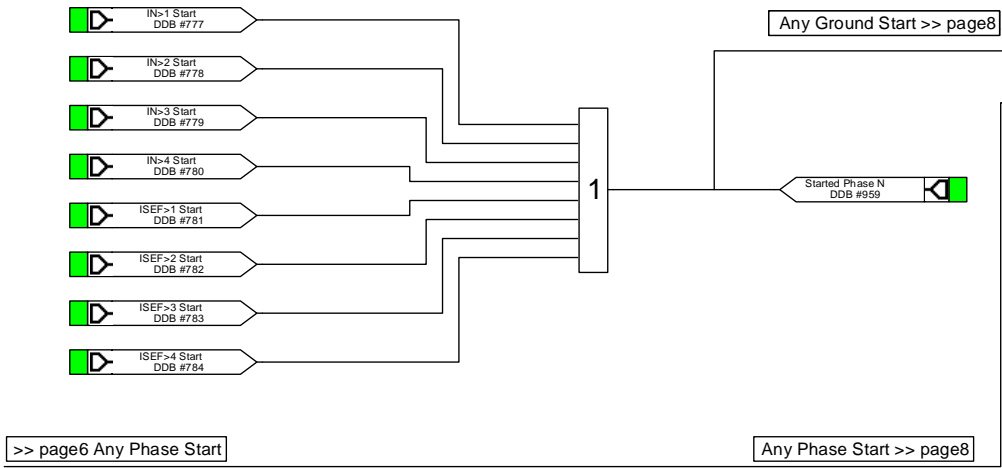

P0773ENa

>> page7 Any Ground Start

>> page7 Any Phase Start

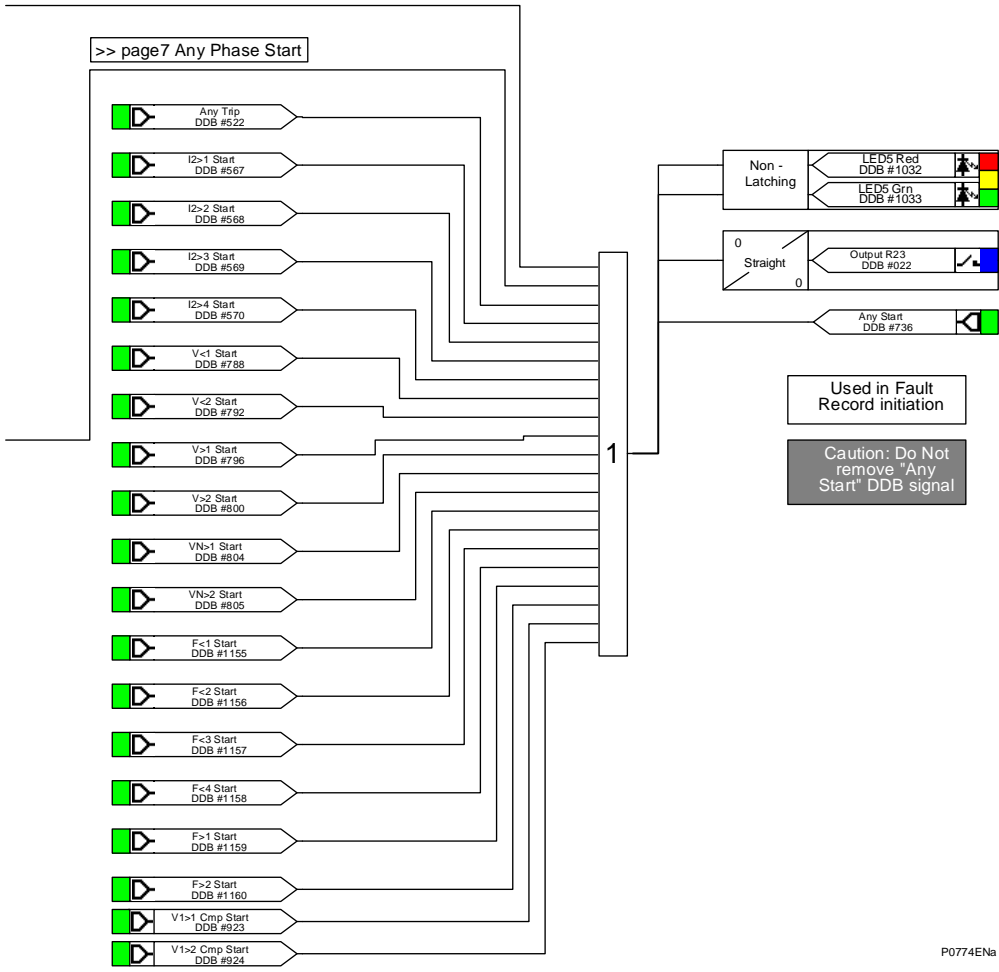

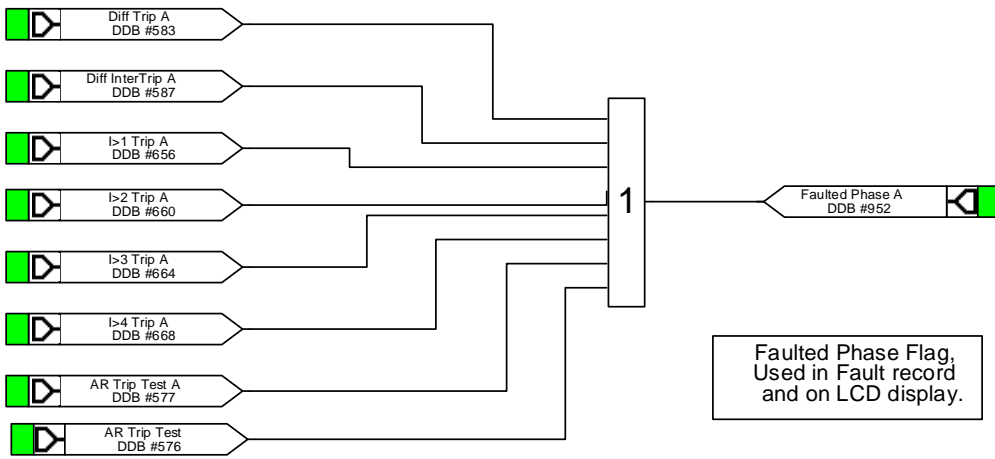

Faulted Phase Flag,
Used in Fault record
and on LCD display.

Caution: Do Not remove
"Faulted Phase" DDB
signals

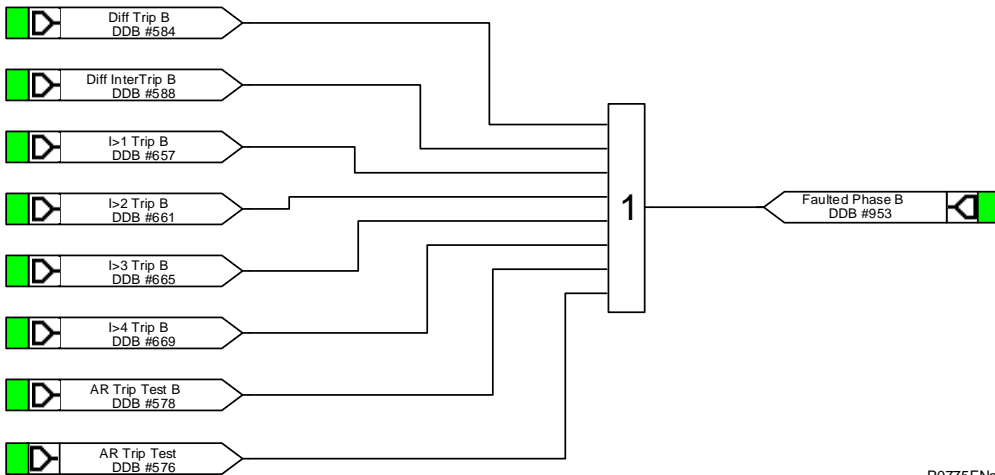

P0775ENa

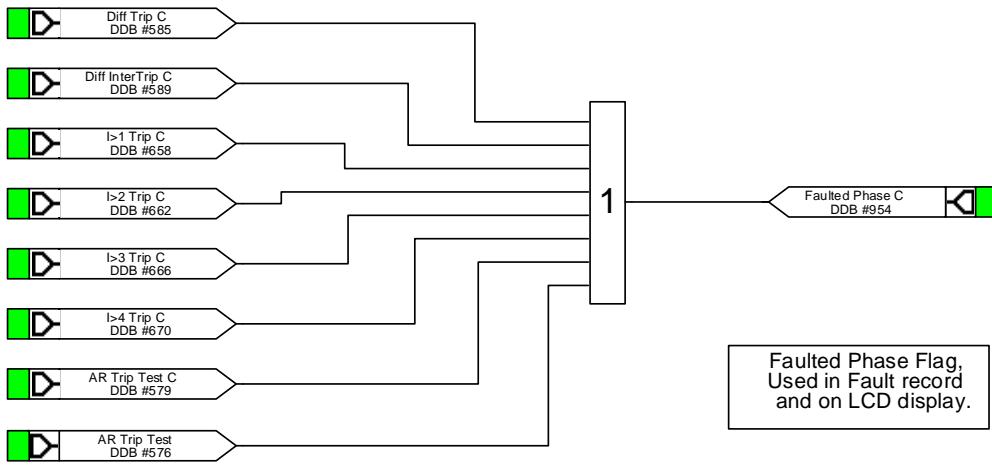

Faulted Phase Flag,
Used in Fault record
and on LCD display.

Caution: Do Not remove
"Faulted Phase" DDB
signals

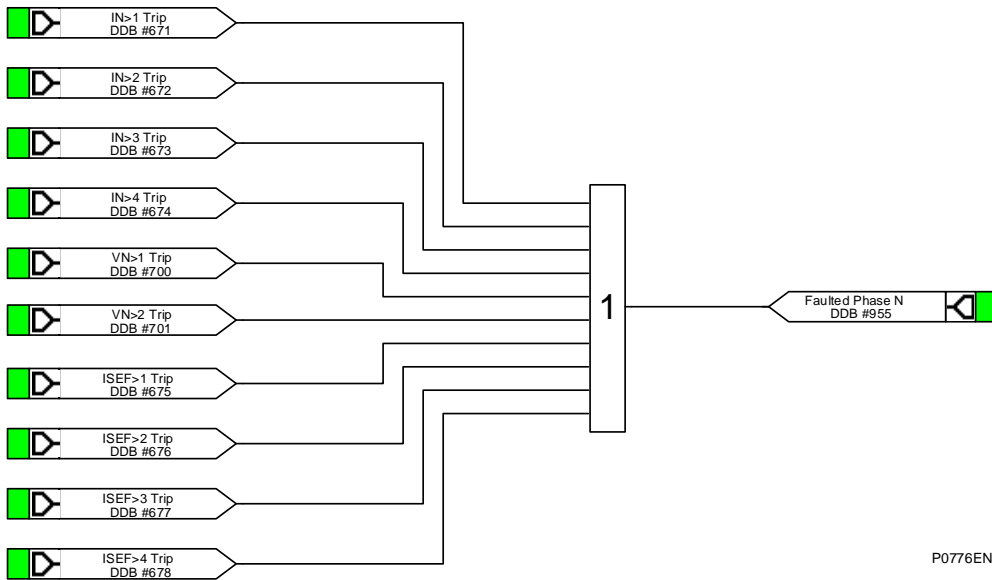

P0776ENa

Inputs to Trip Conversion Logic: These Raw trip signals are then processed in relay fixed logic, to obtain the correct single, or three pole trip response.

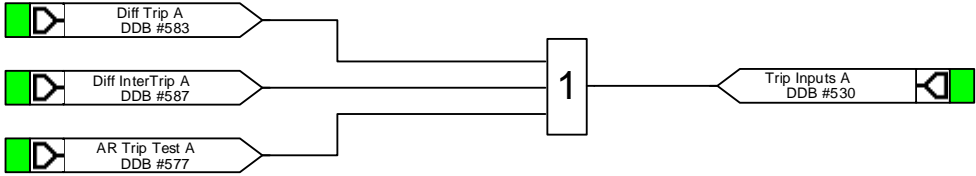

Caution: Do Not remove "Trip Inputs" DDB signals

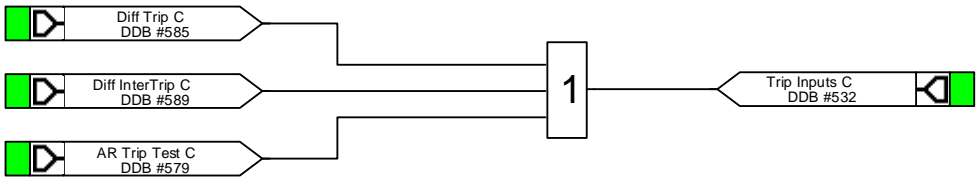
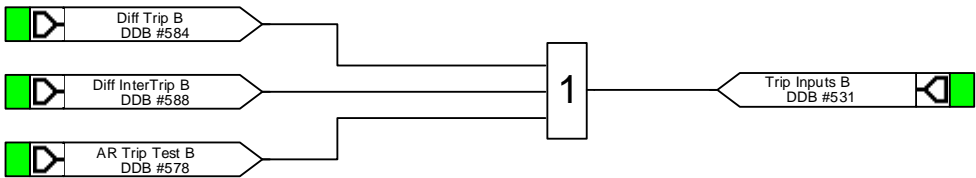

P0777ENa

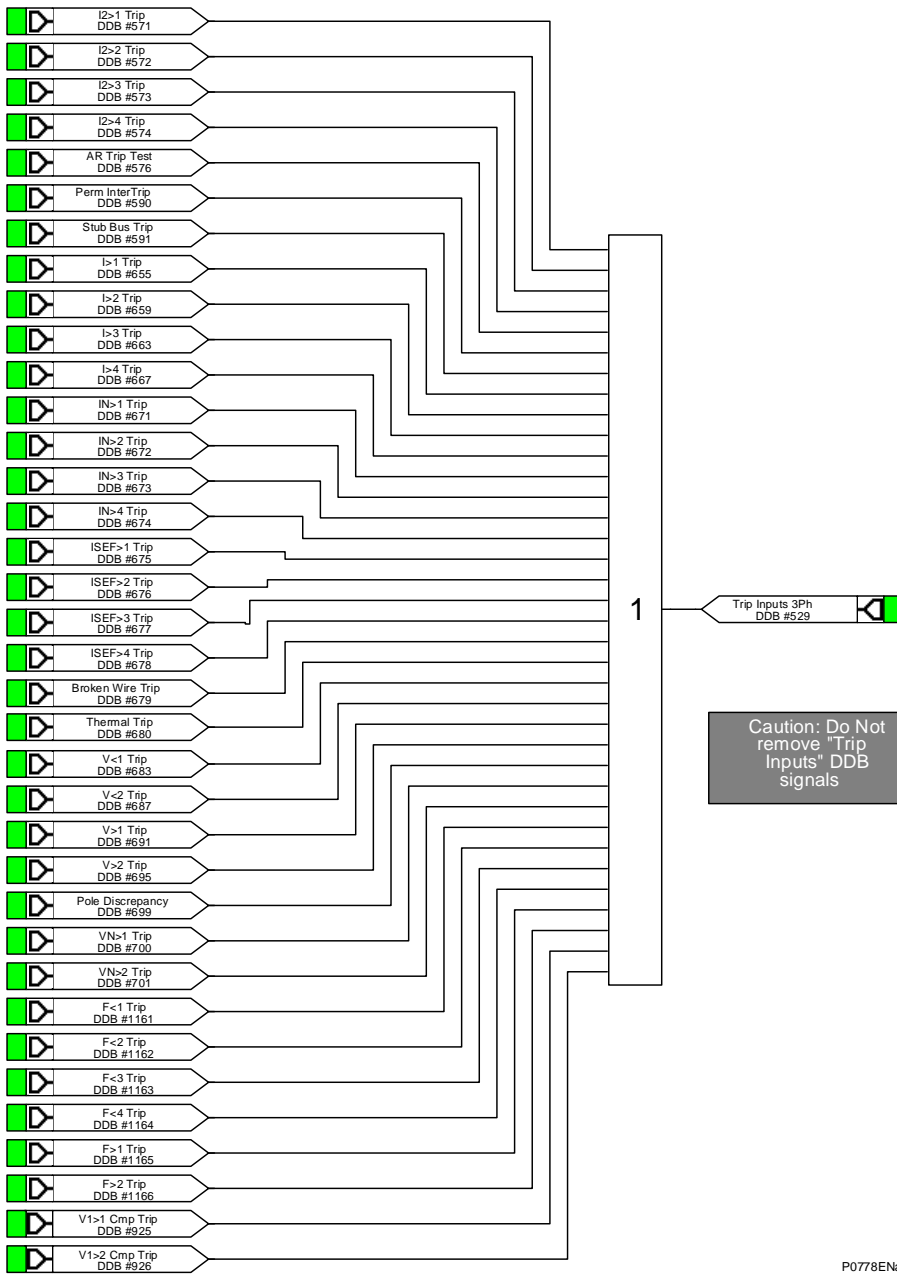

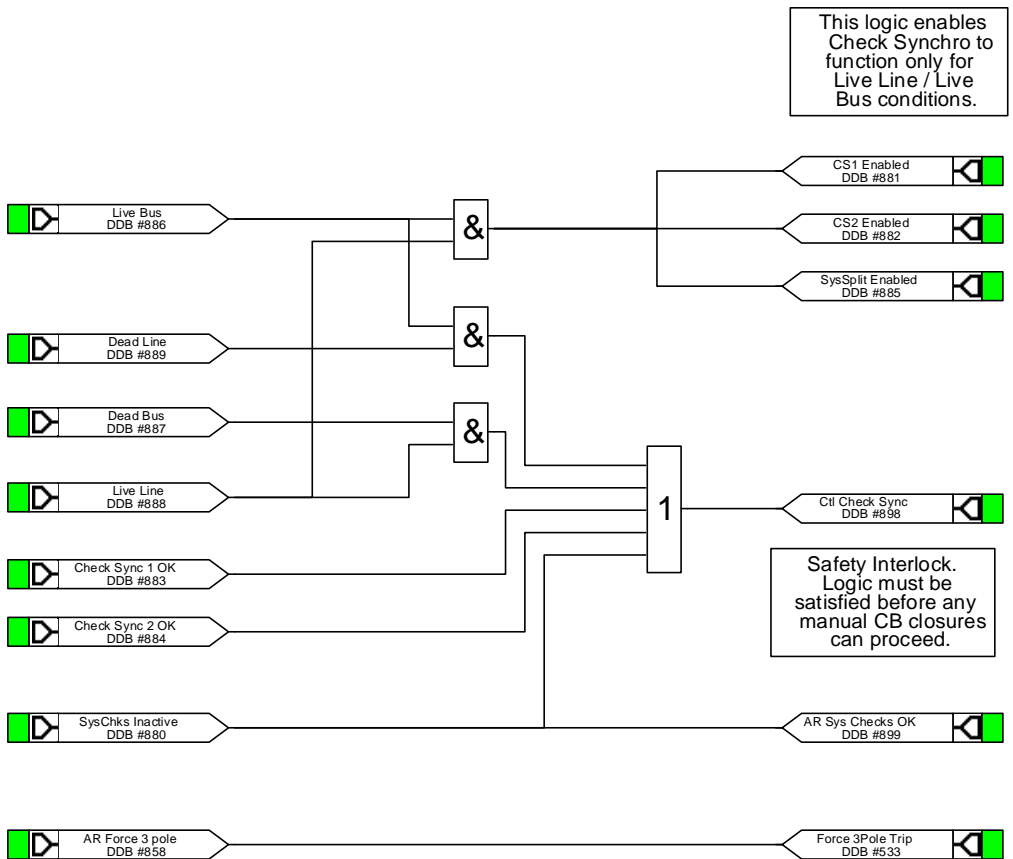

P0779ENa

12 MICOM P546 WITH DISTANCE PSL

12.1 Output Input Mappings

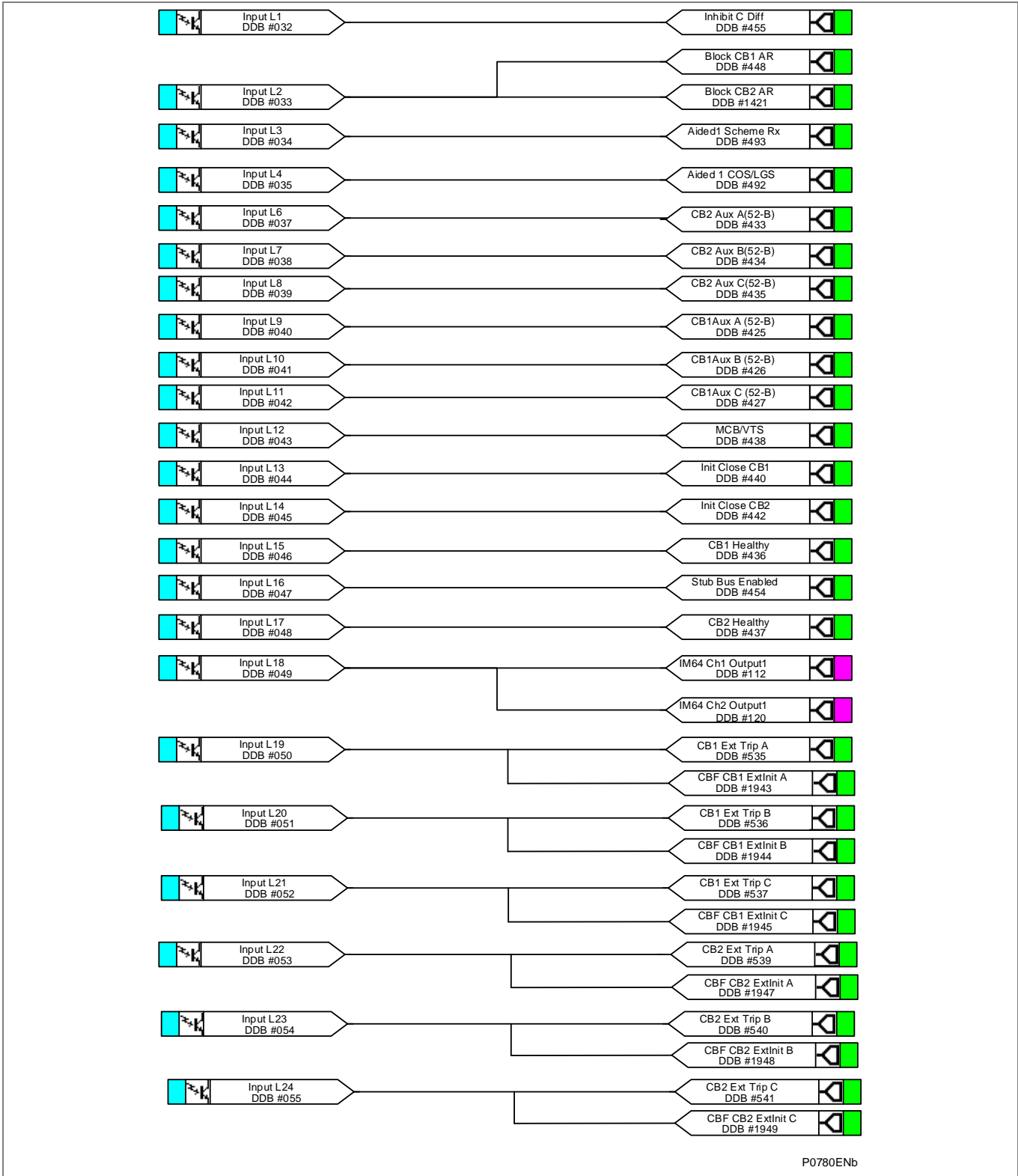

12.2 Output Contacts

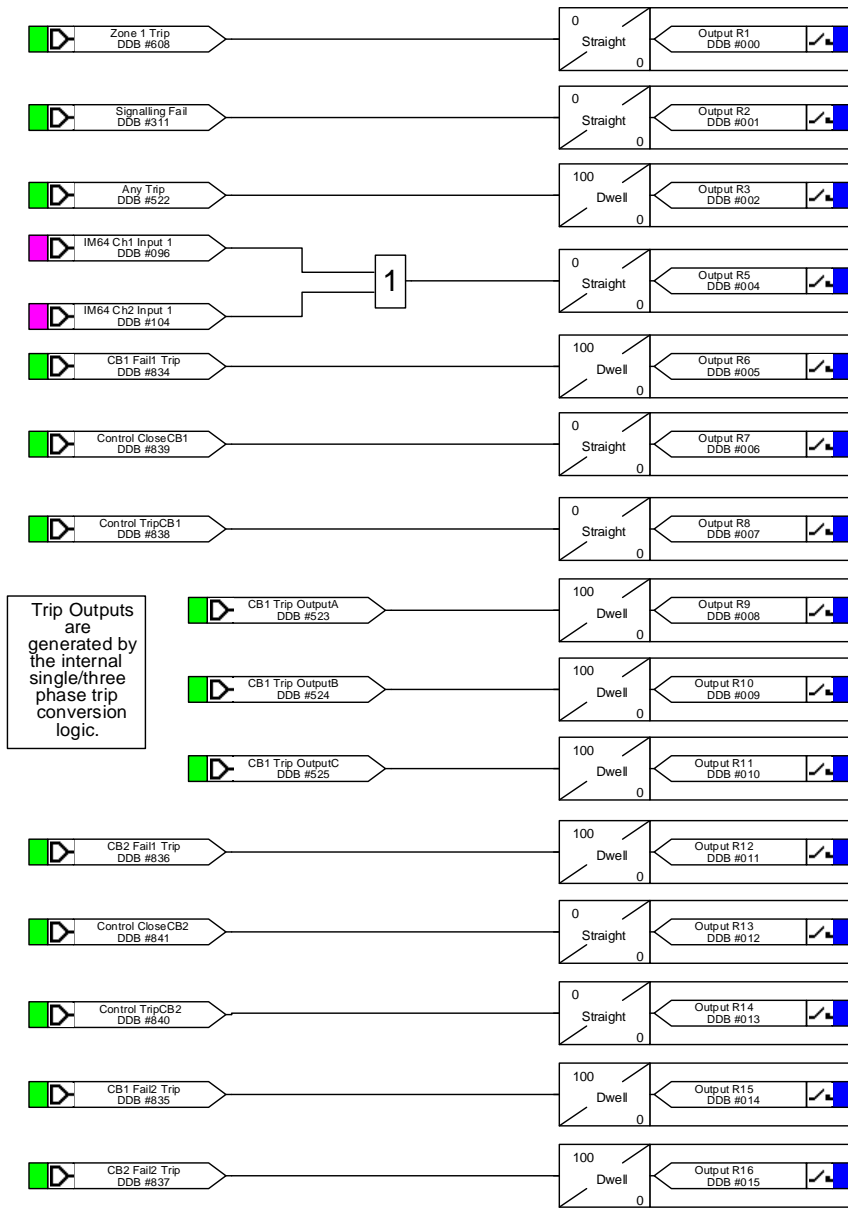

Trip Outputs are generated by the internal single/three phase trip conversion logic.

P0781ENa

12.3 Output Contacts

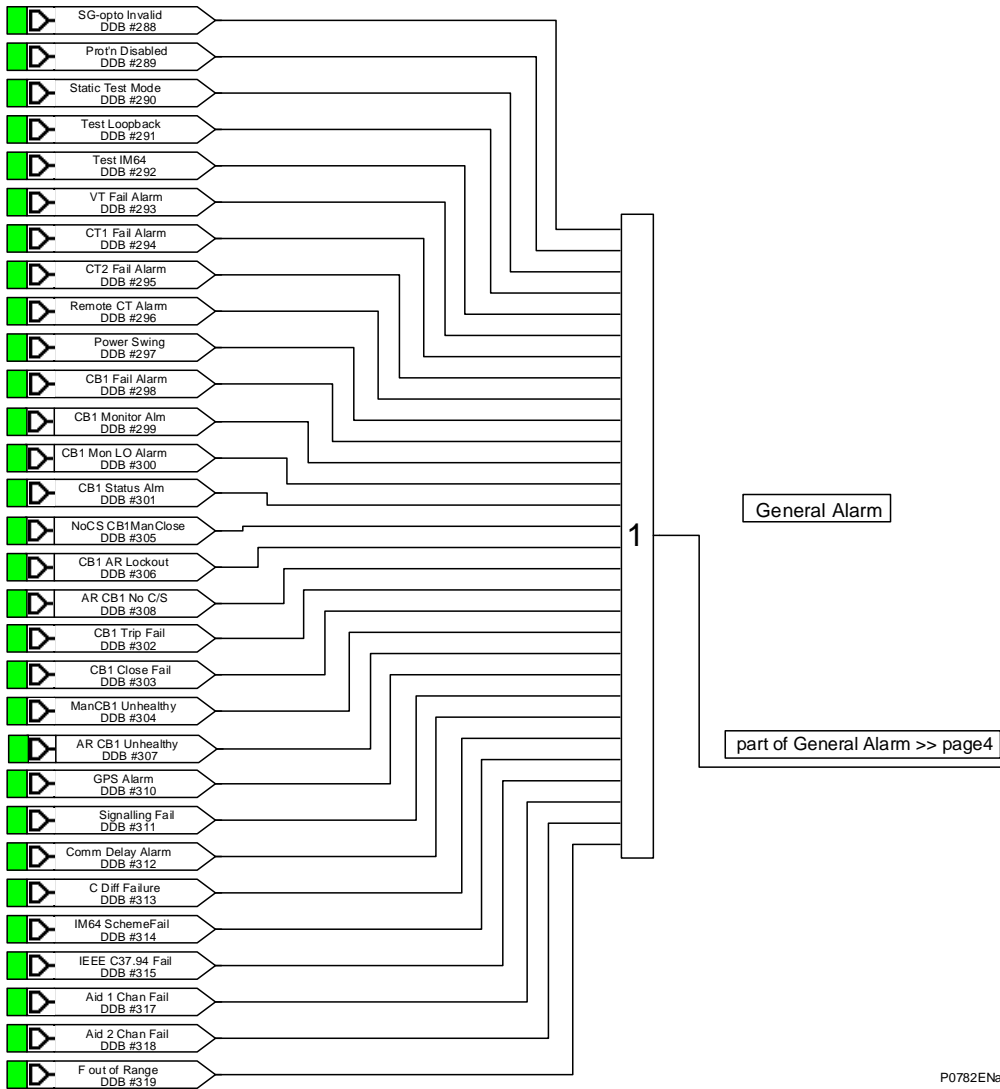

12.4 Output Contacts

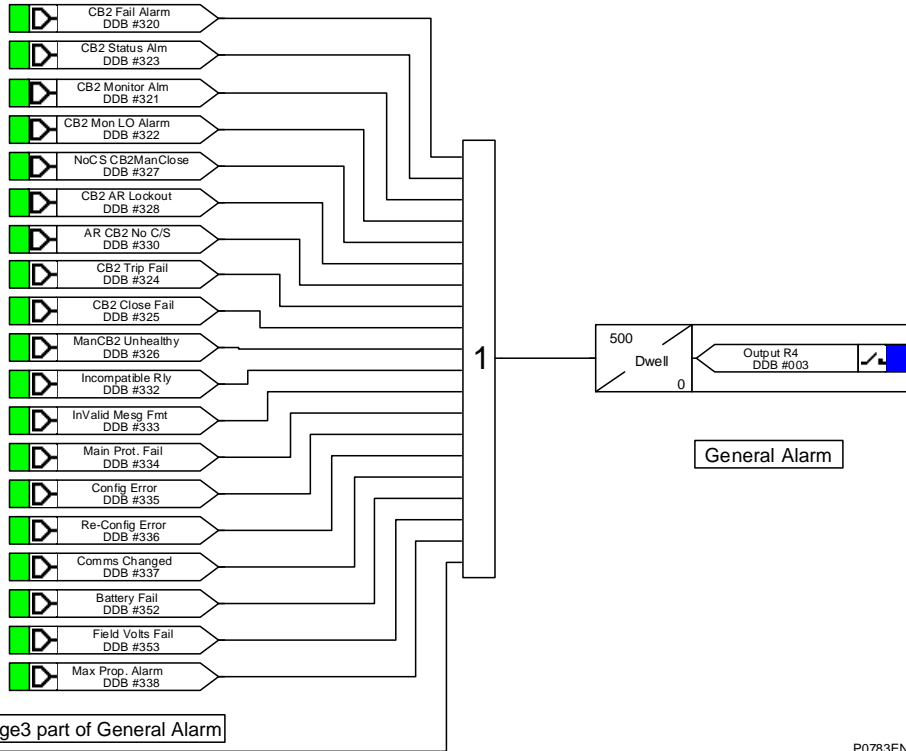

P0783ENa

12.5 Output Contacts

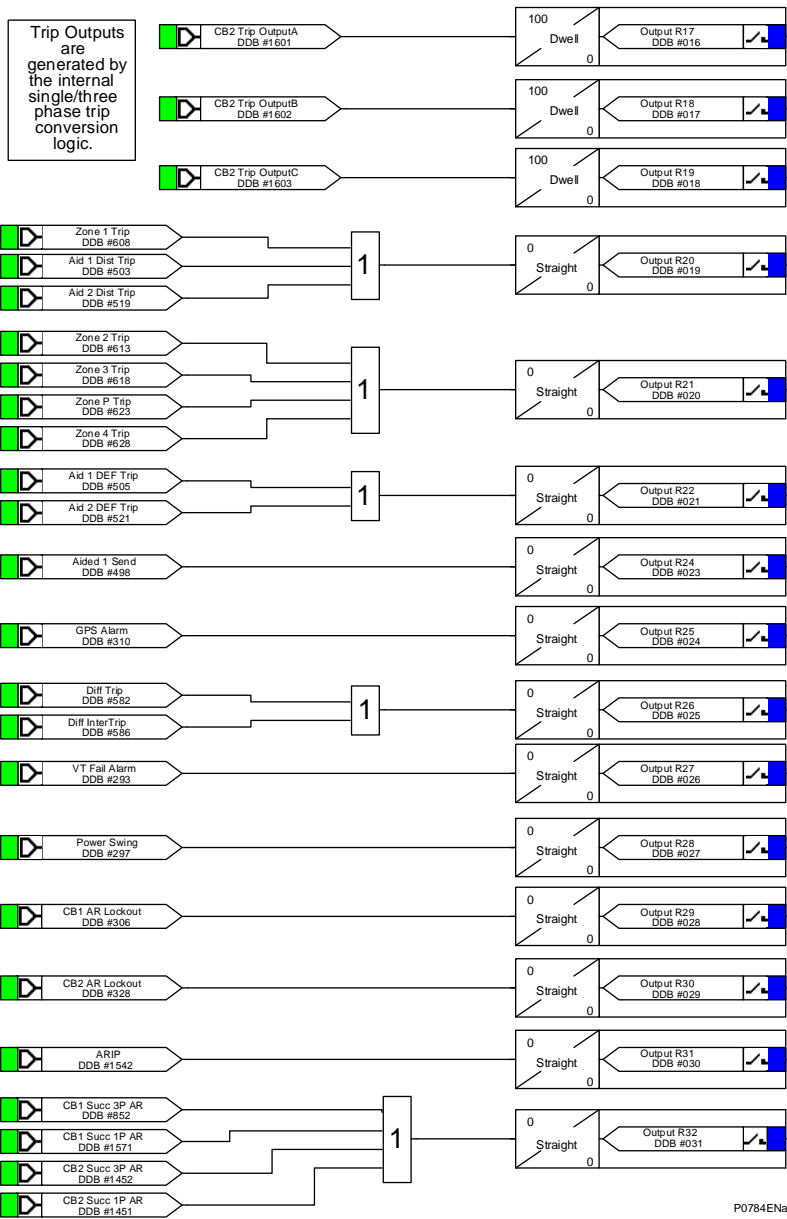

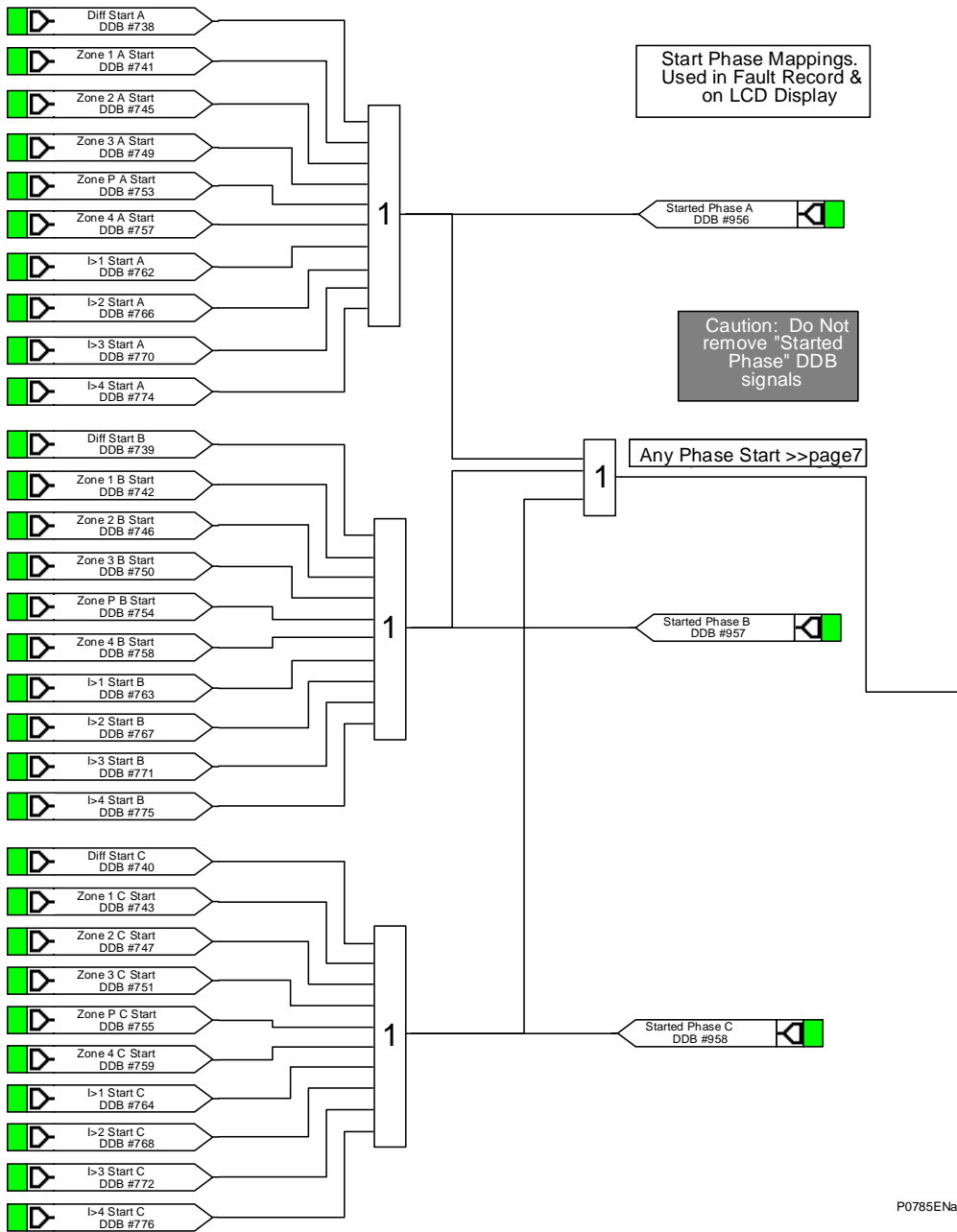

P0785ENa

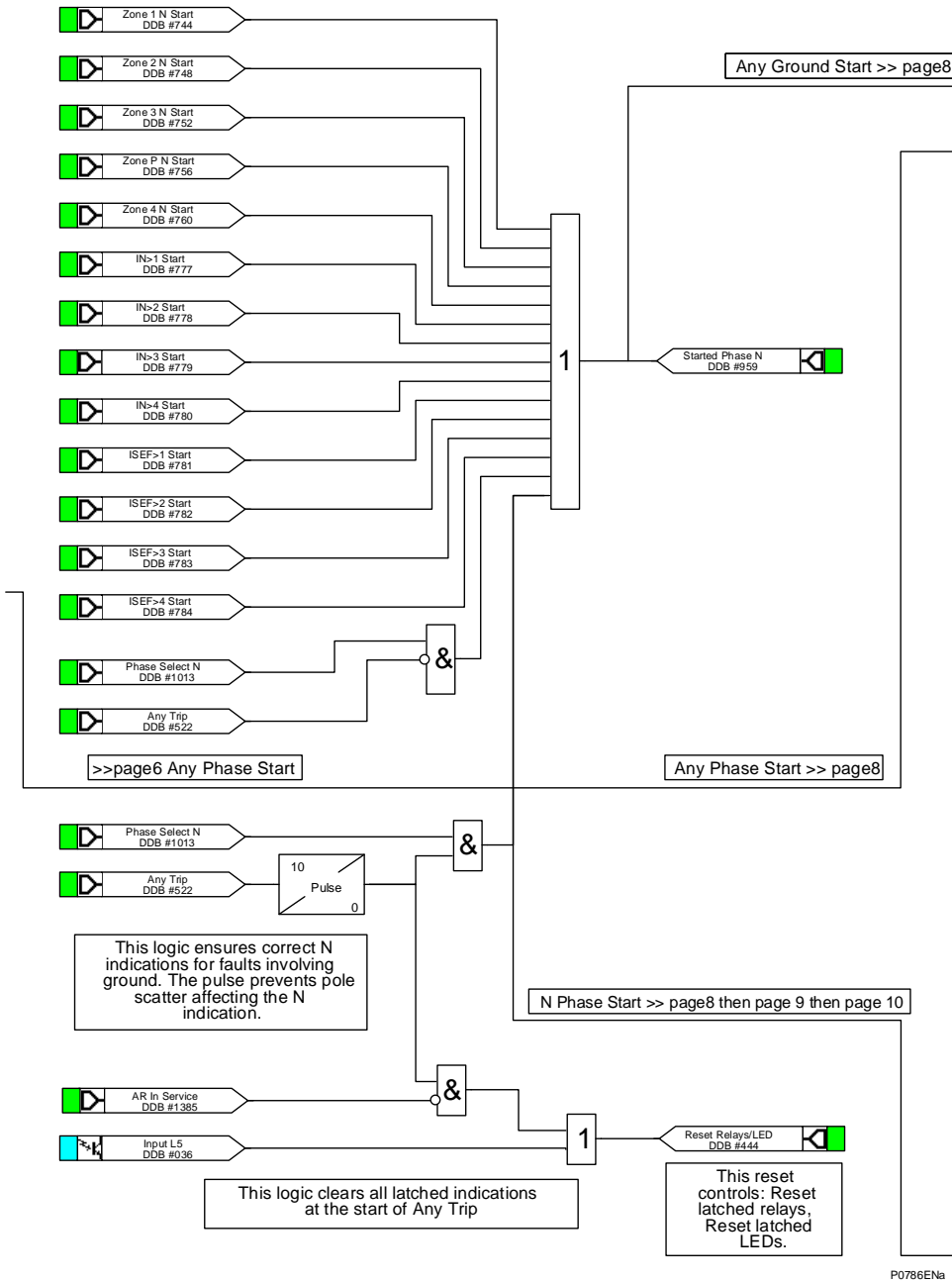

P0786ENa

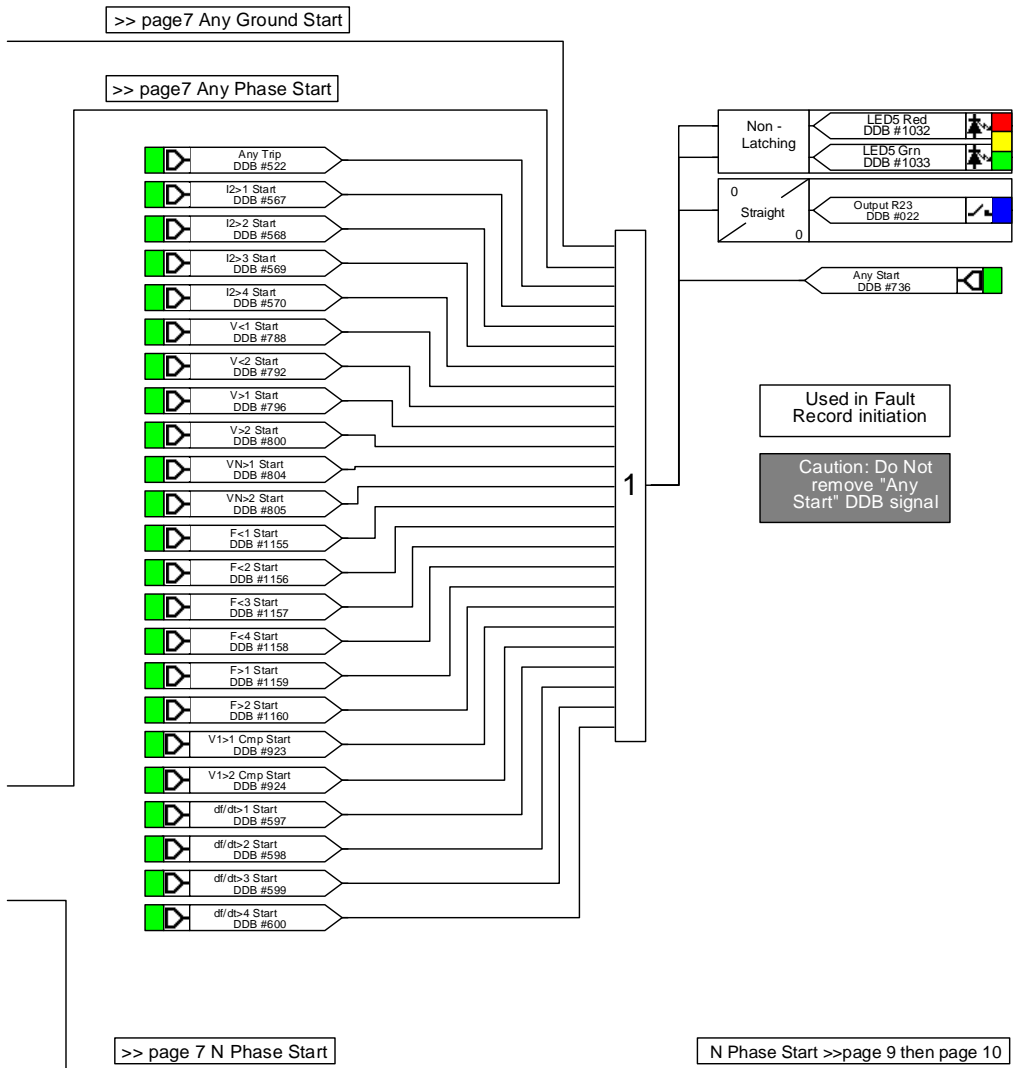

P0787ENa

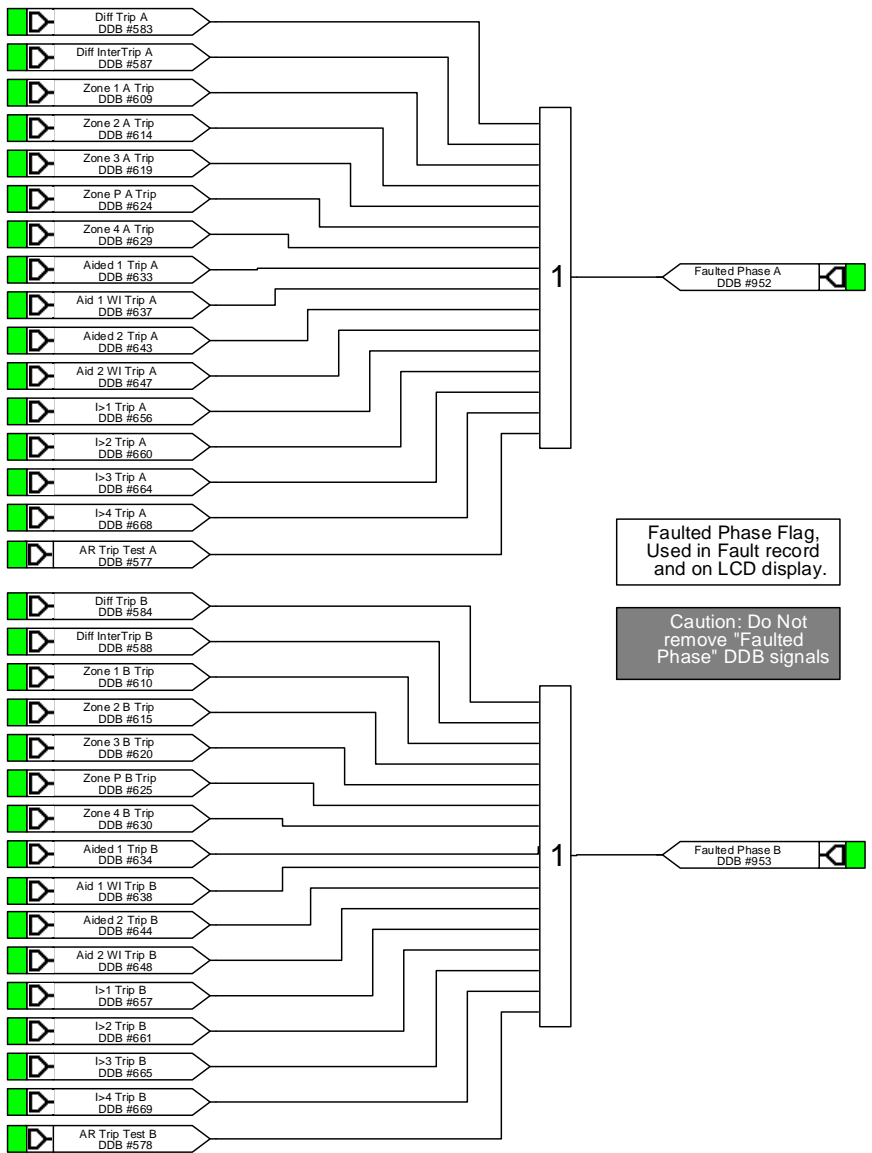

>> page 7 then page 8 N Phase Start

N Phase Start >> page 10

P0788ENa

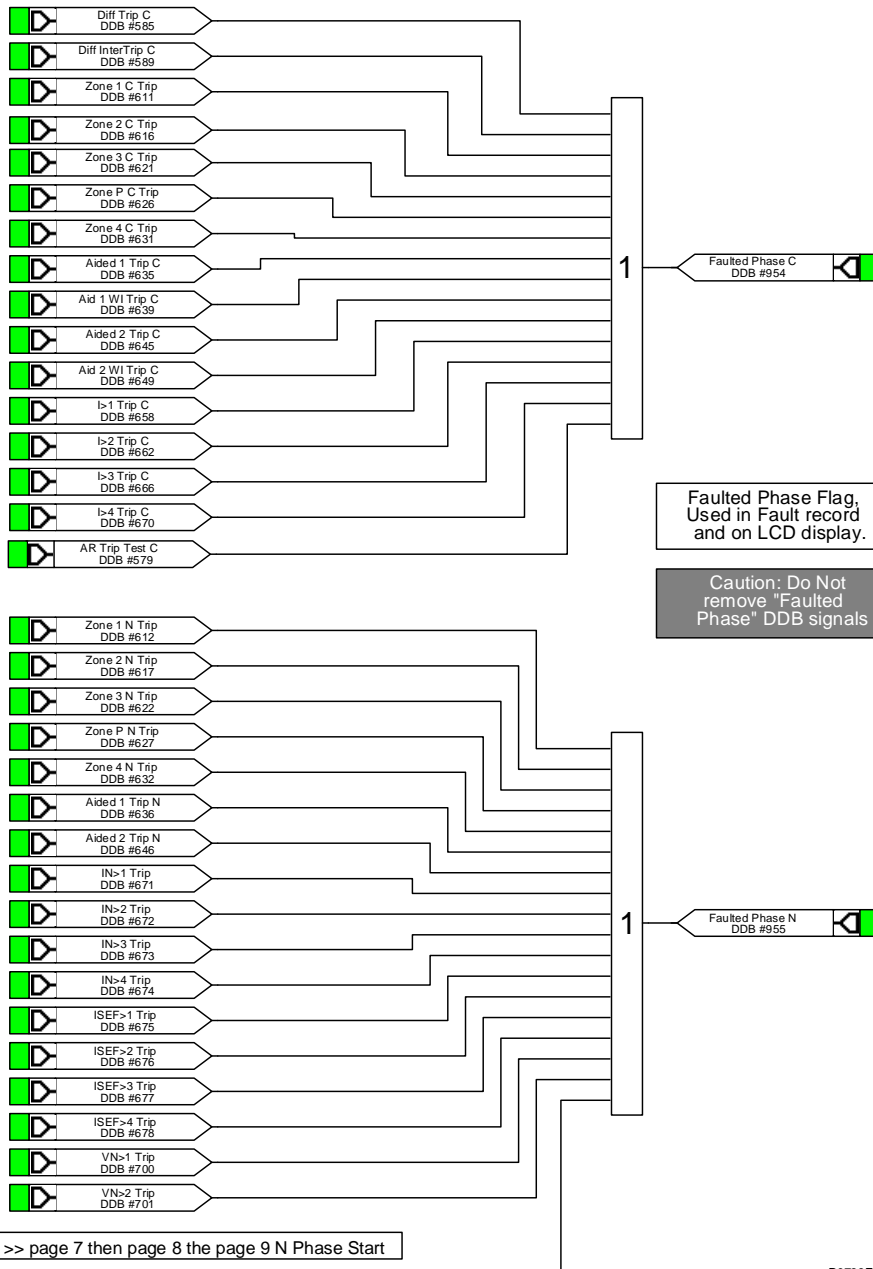

P0789ENa

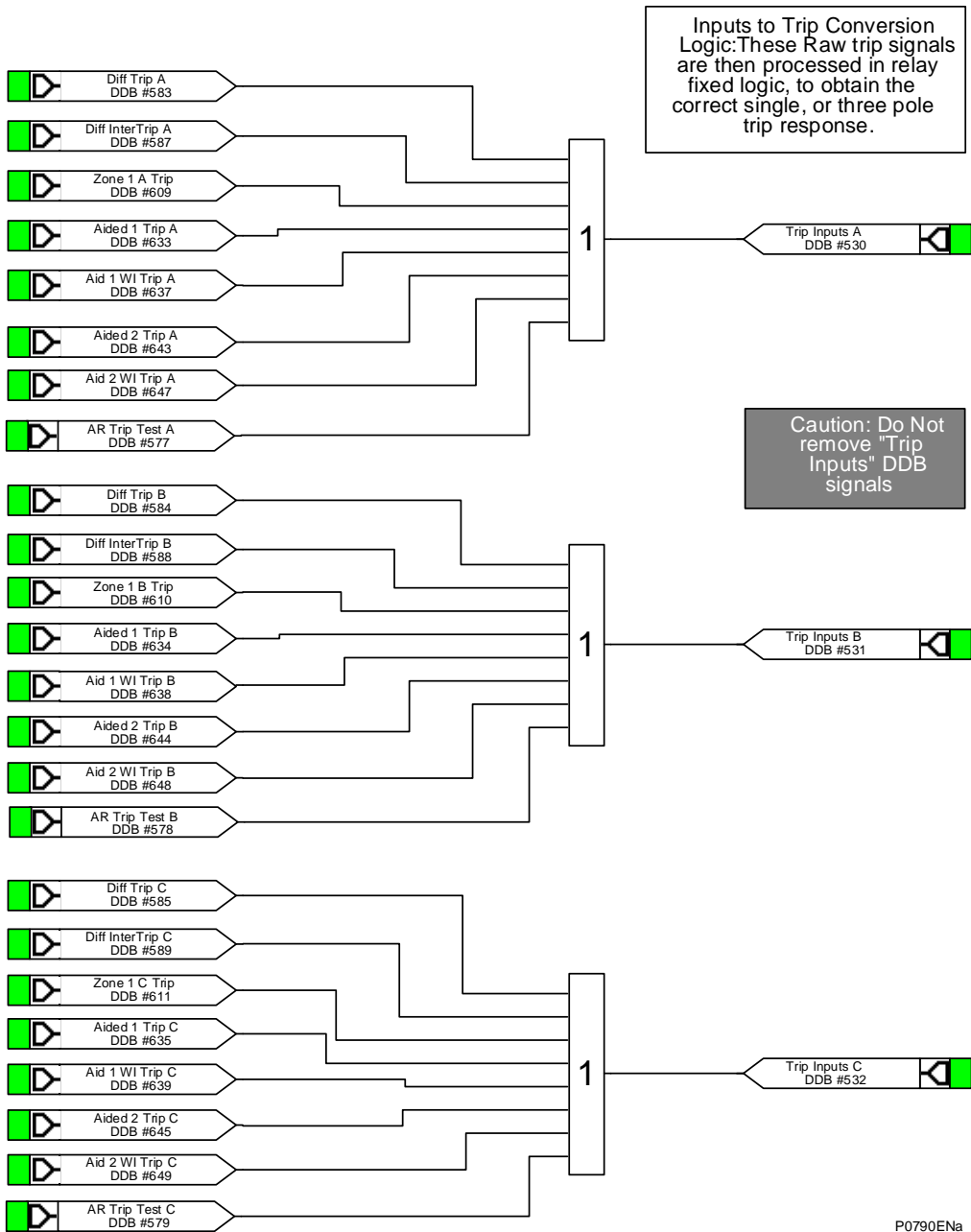

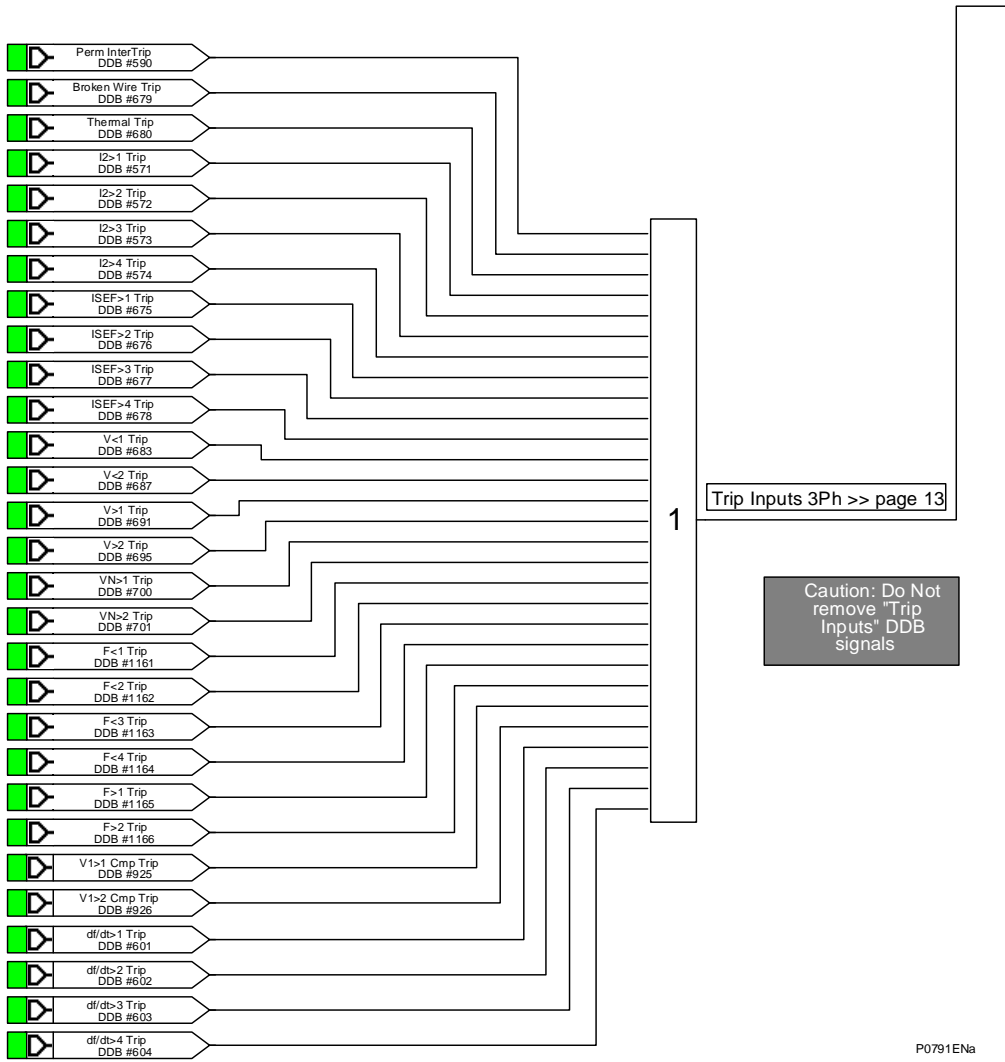

P0791ENa

page 12 >> Trip Inputs 3Ph

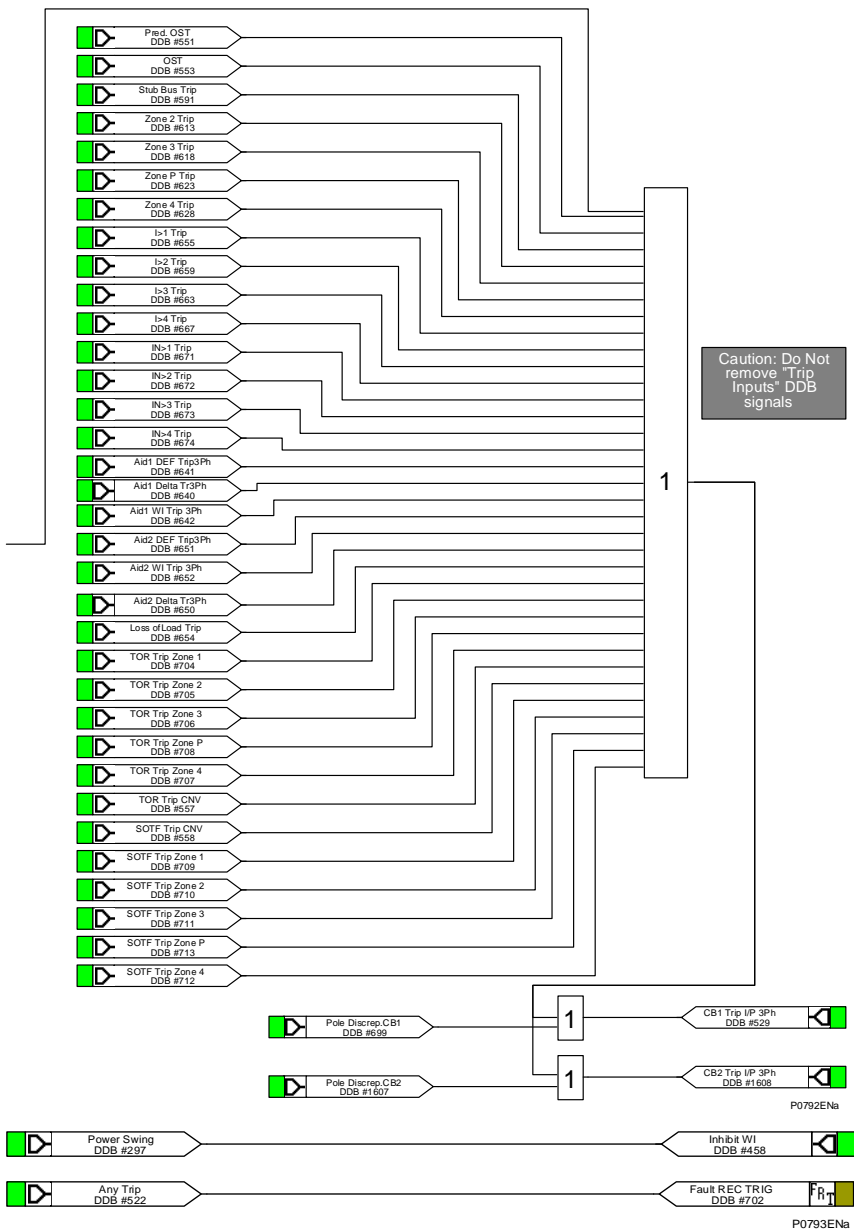

12.6 LEDs

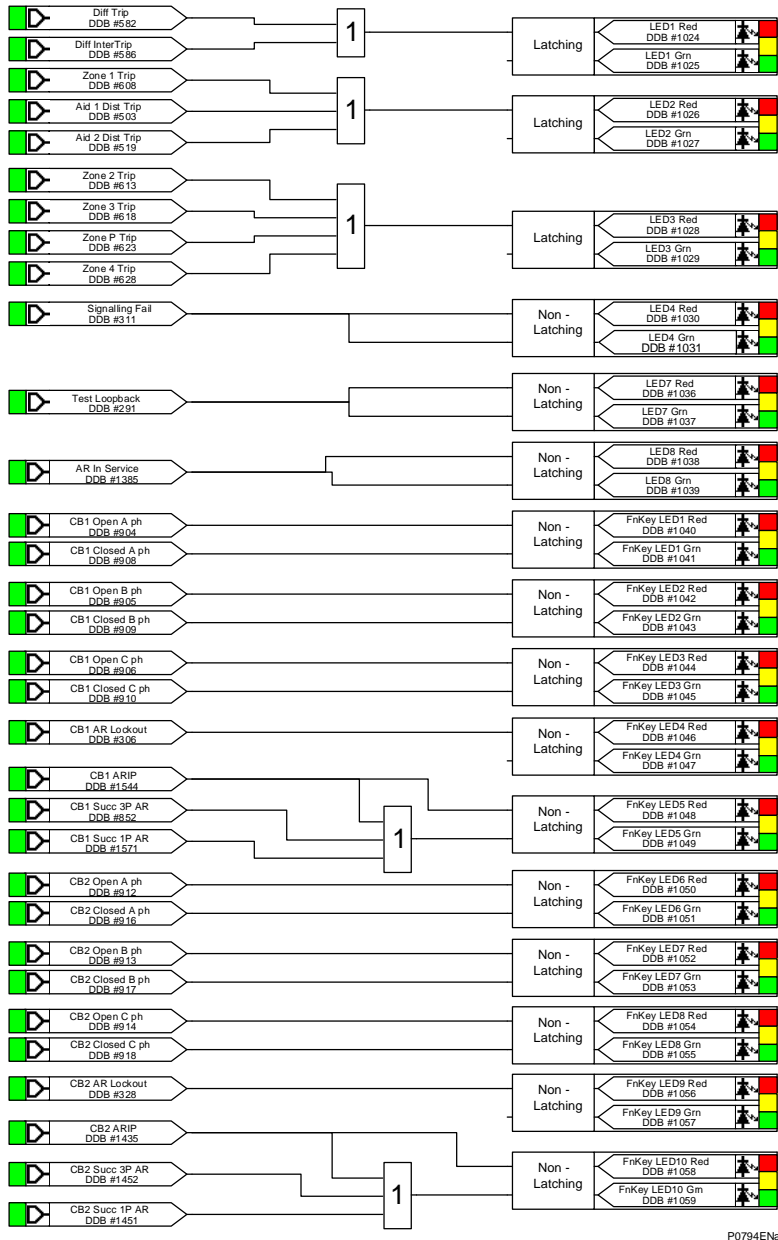

P0794ENa

13 MICOM P546 WITHOUT DISTANCE PSL

13.1 Output Input Mappings

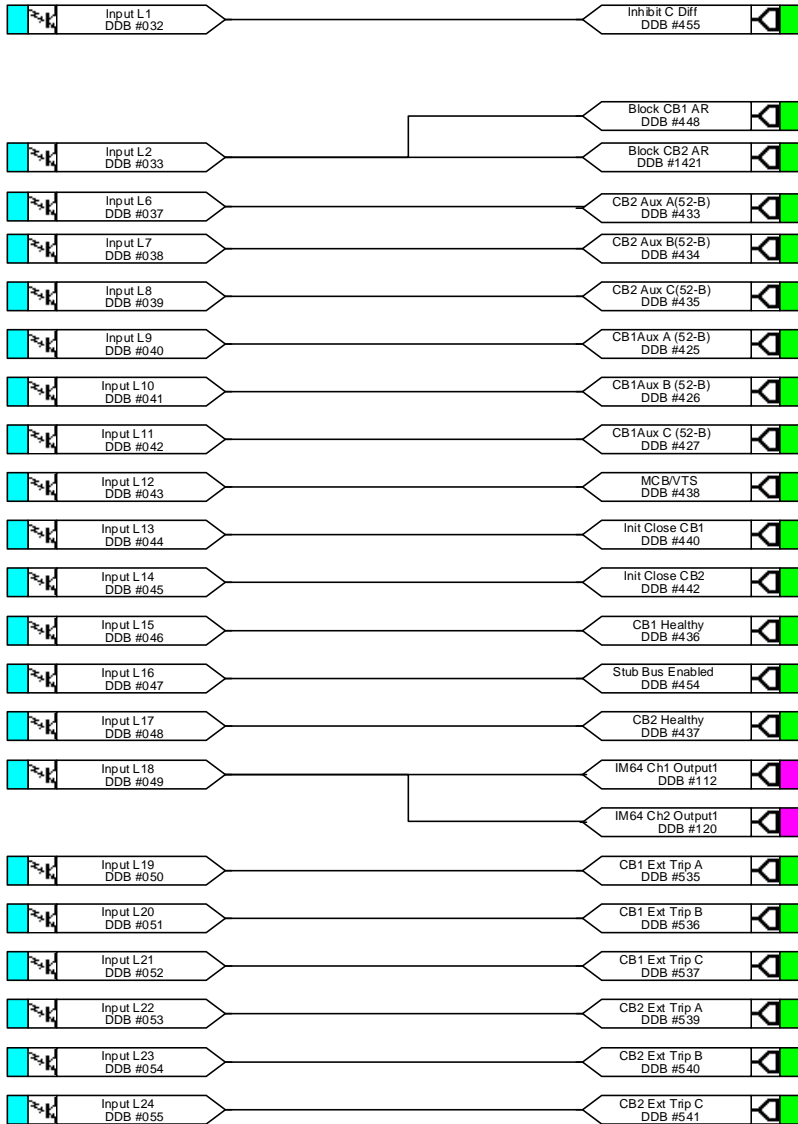

Opto L5 can be found on other pages

P0795ENa

13.2 Output Contacts

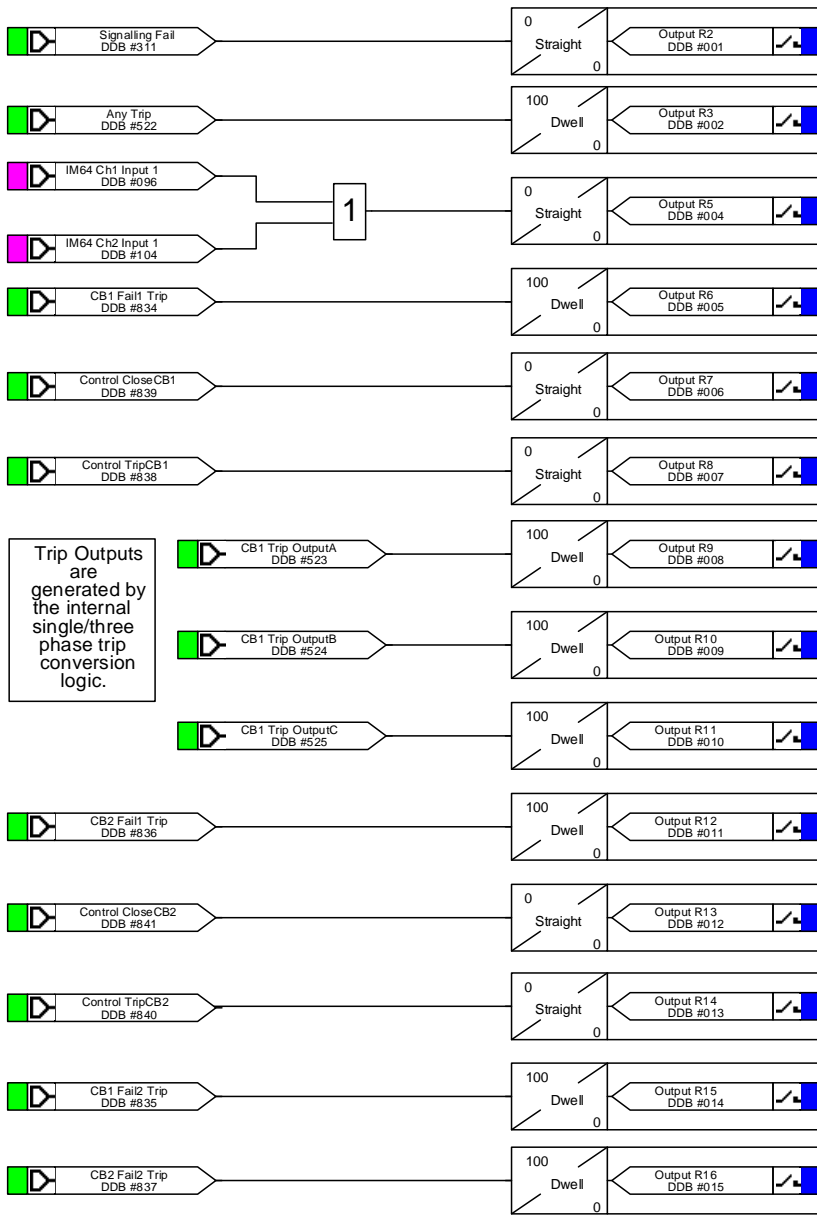

Trip Outputs are generated by the internal single/three phase trip conversion logic.

P0796ENa

13.3 Output Contacts

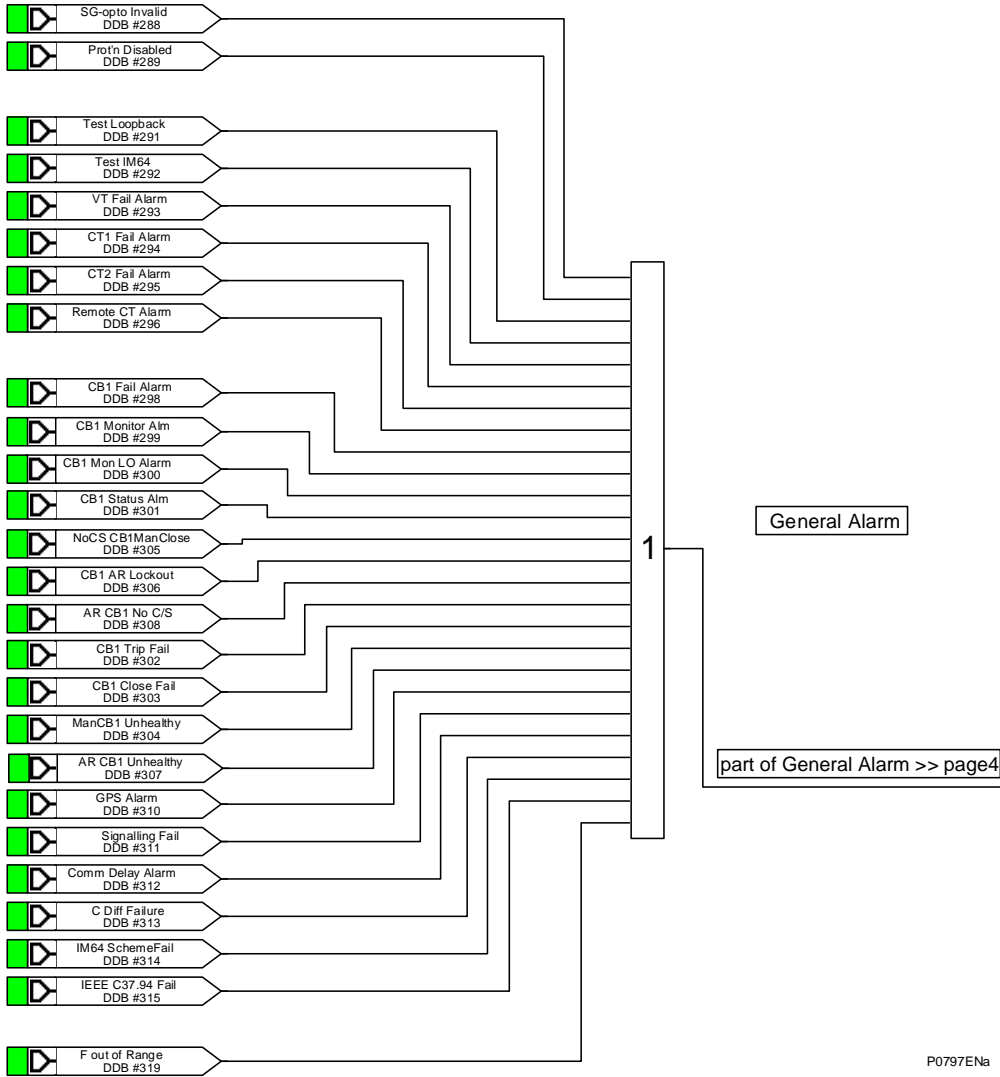

13.4 Output Contacts

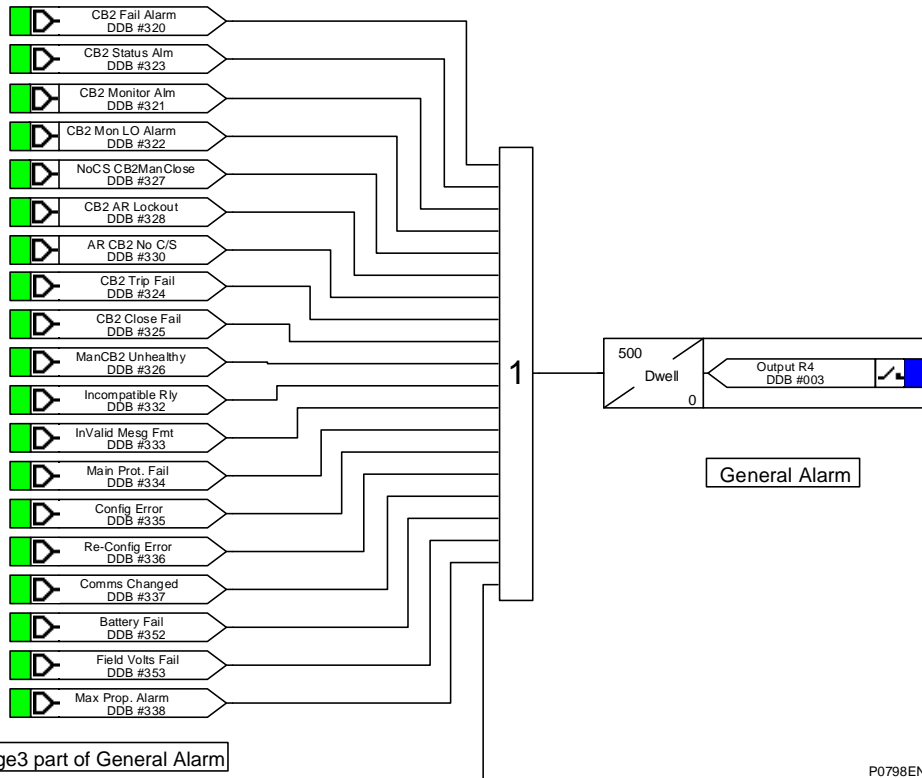

P0798ENa

13.5 Output Contacts

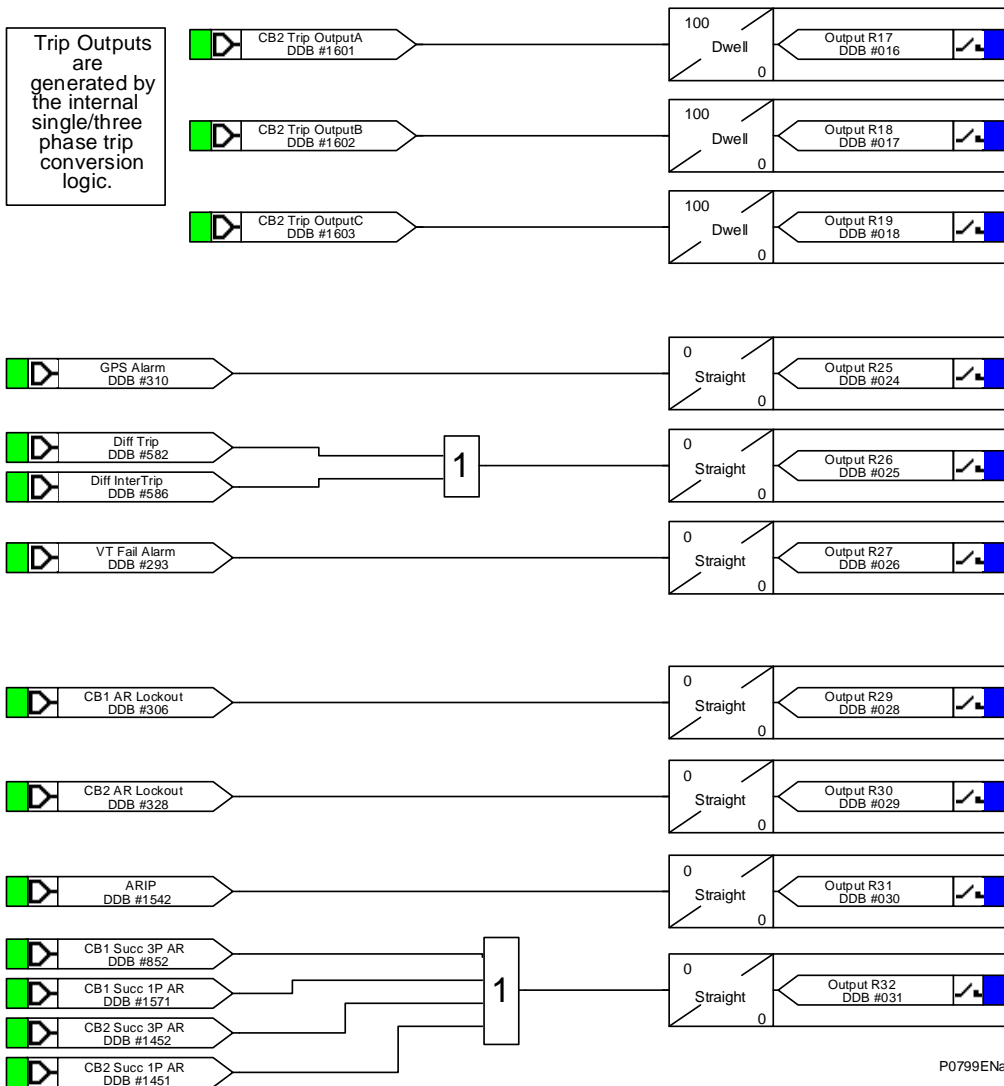

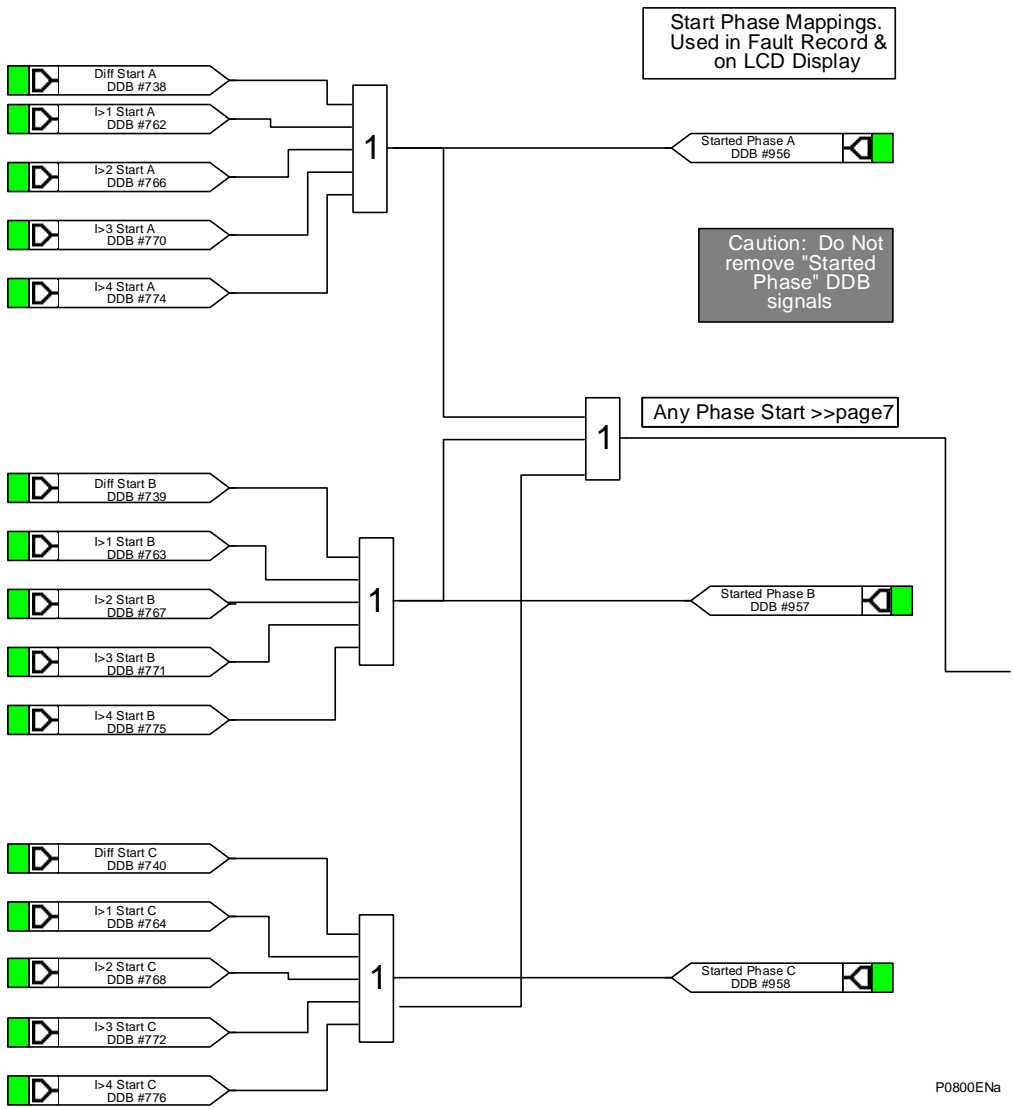

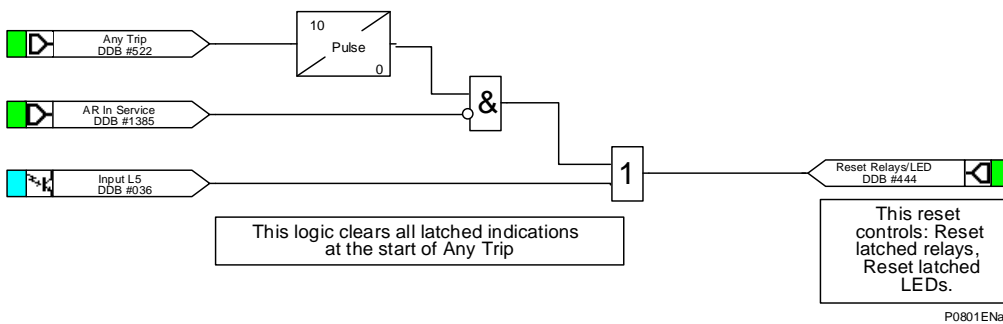
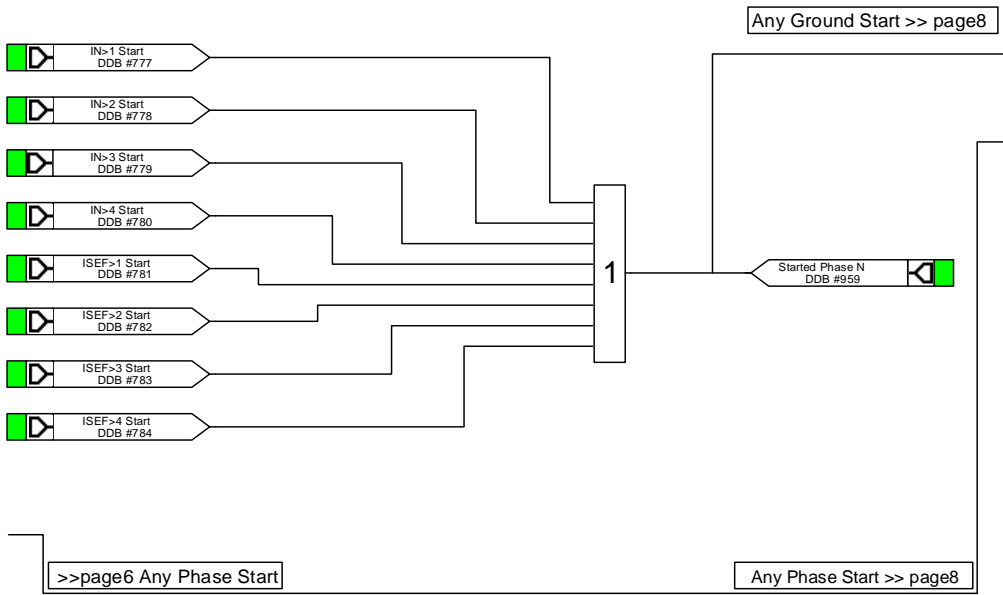

>> page7 Any Ground Start

>> page7 Any Phase Start

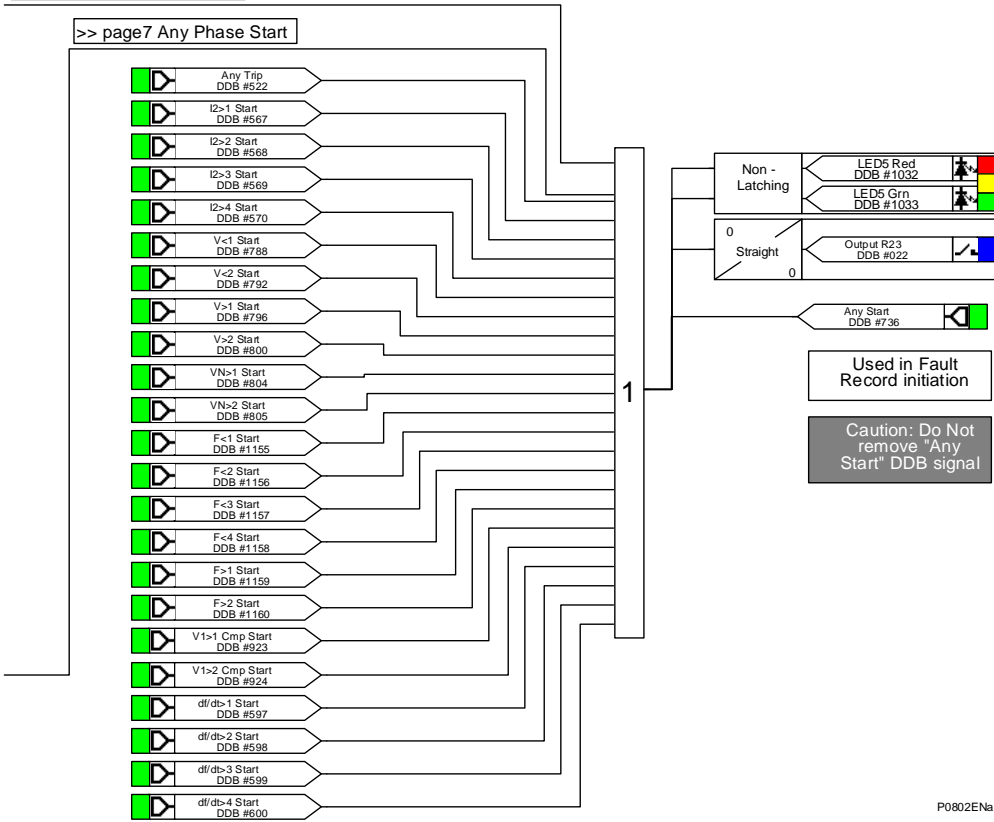

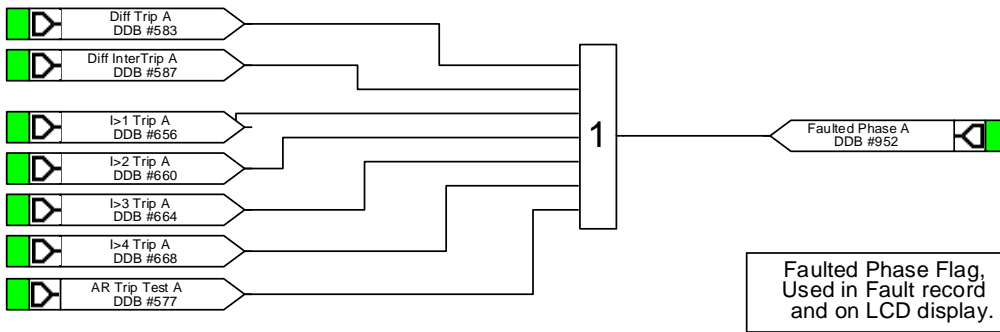

Faulted Phase Flag,
Used in Fault record
and on LCD display.

Caution: Do Not
remove "Faulted
Phase" DDB signals

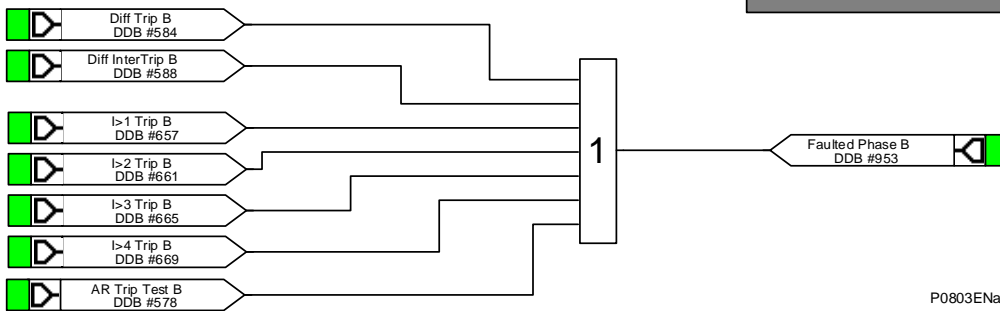

P0803ENa

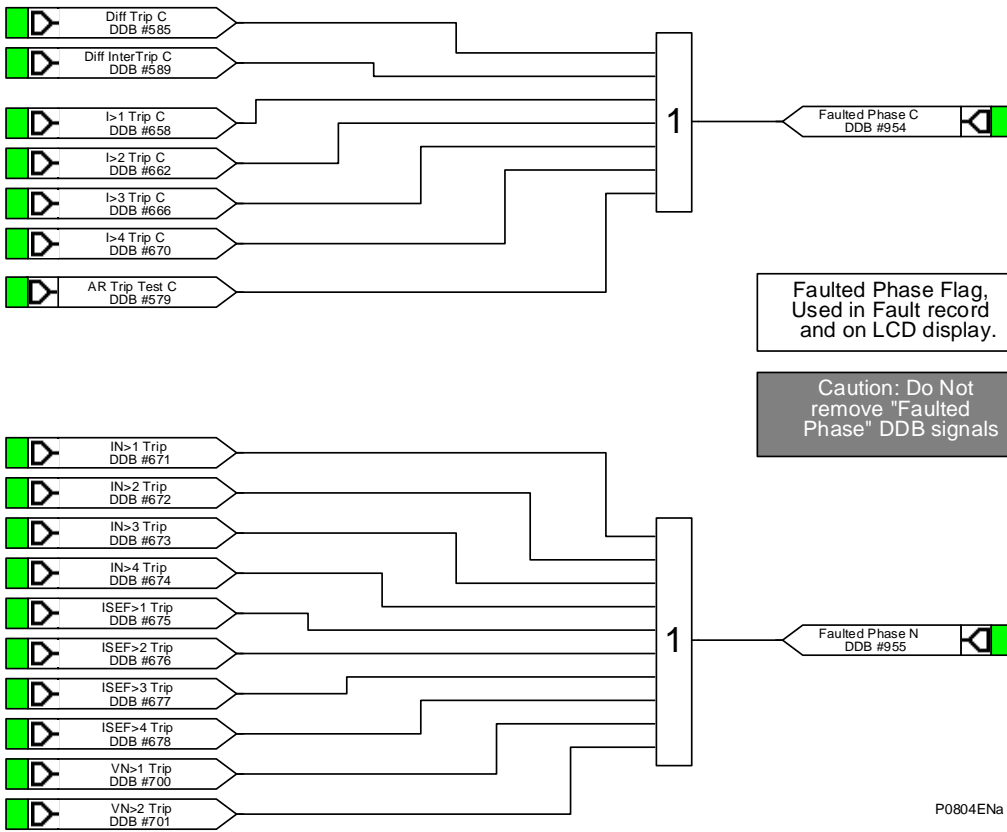

Inputs to Trip Conversion Logic: These Raw trip signals are then processed in relay fixed logic, to obtain the correct single, or three pole trip response.

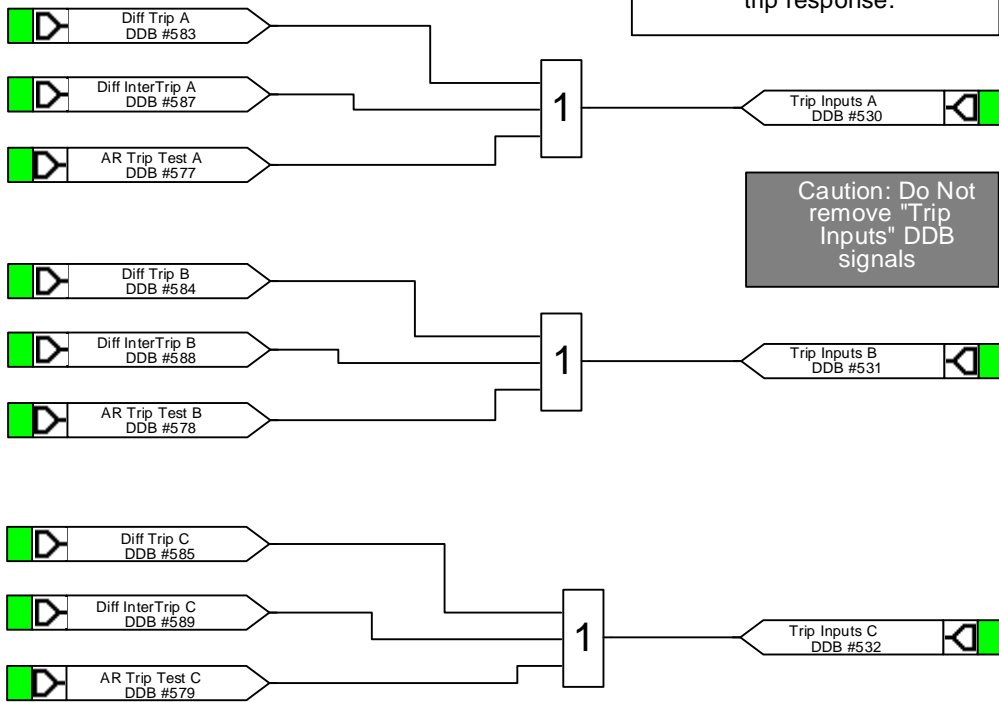

Caution: Do Not remove "Trip Inputs" DDB signals

P0805ENa

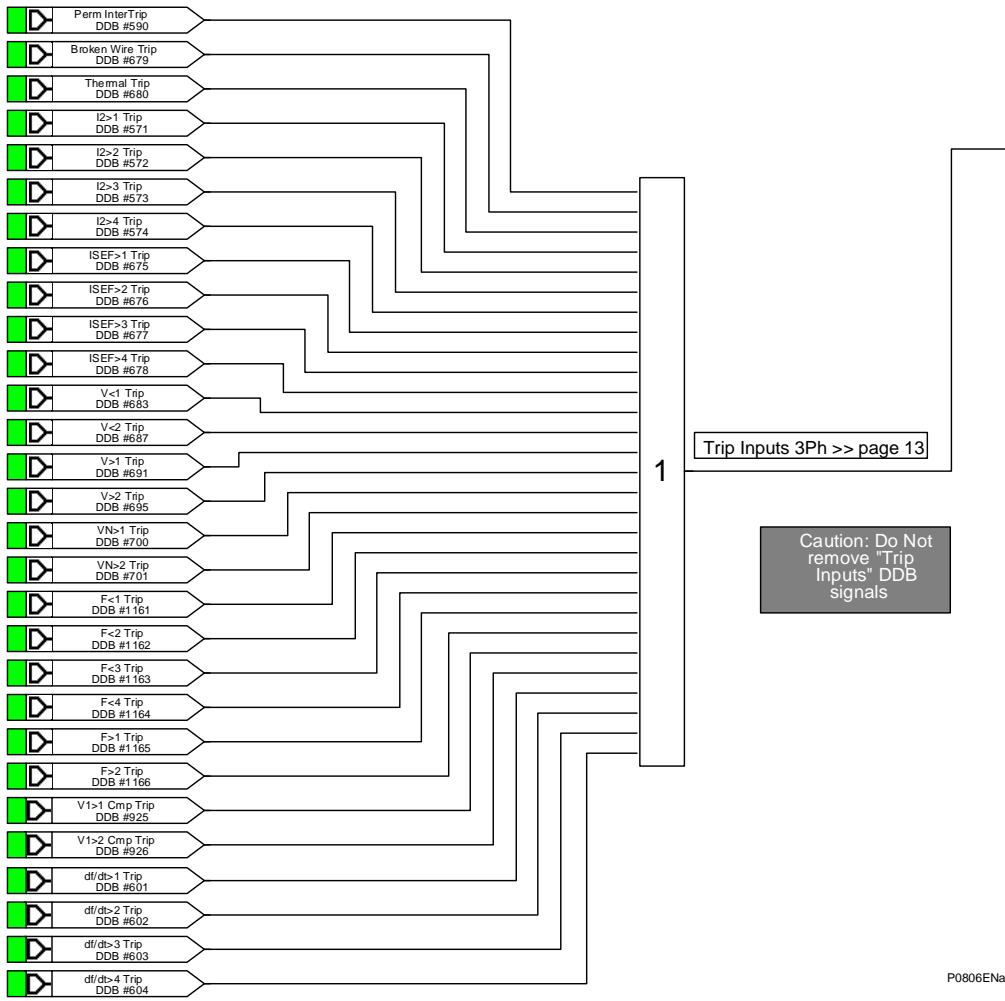

page 12 >> Trip Inputs 3Ph

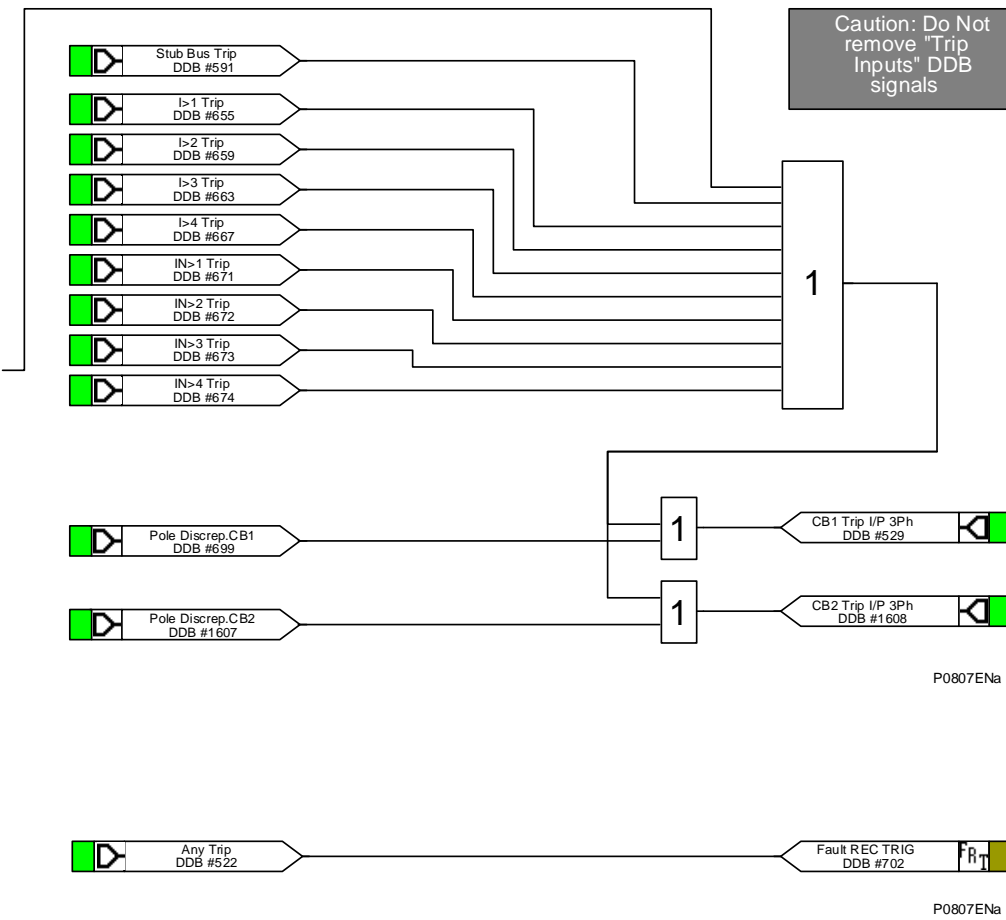

13.6 LEDs

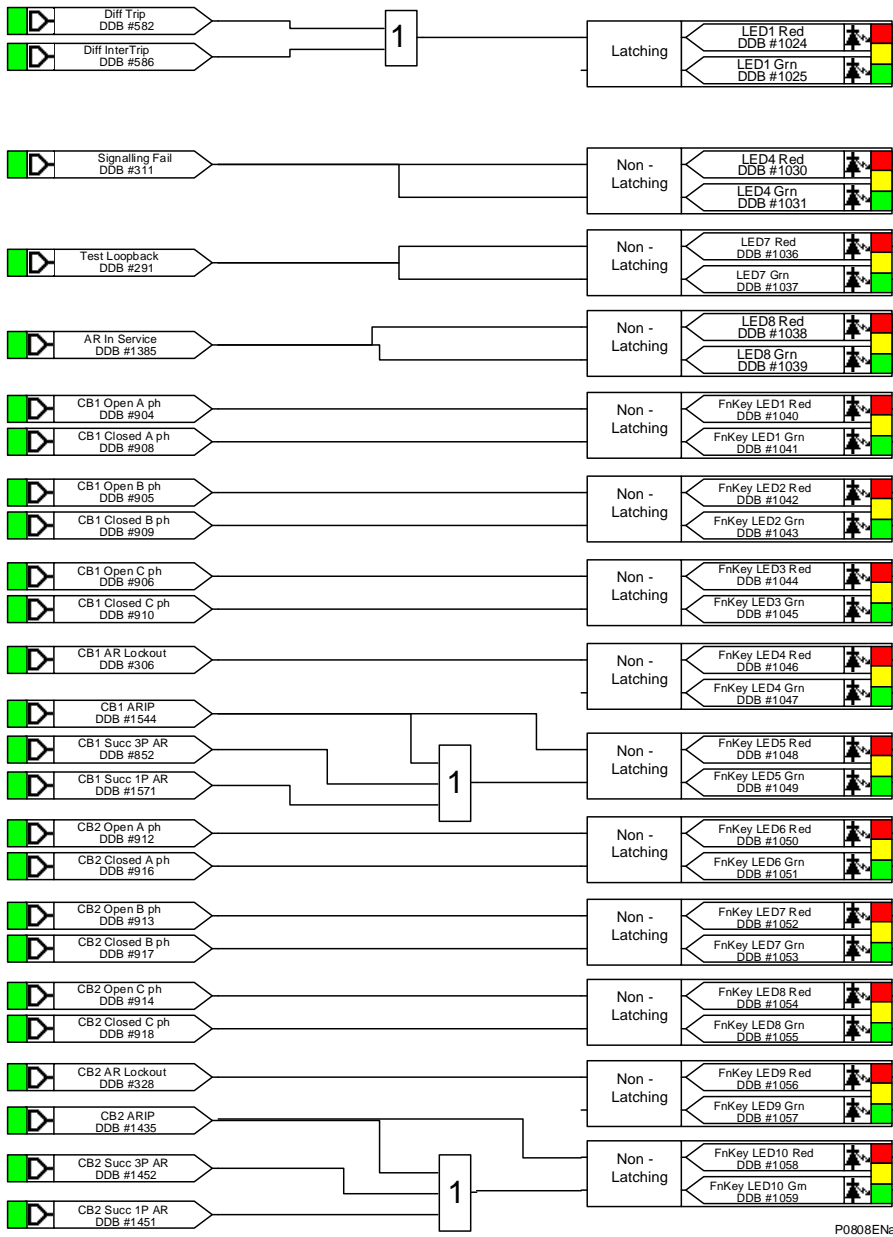

P0808ENa

14 MICOM P543 PROCESS BUS WITH DISTANCE PSL

14.1 Output Input Mappings

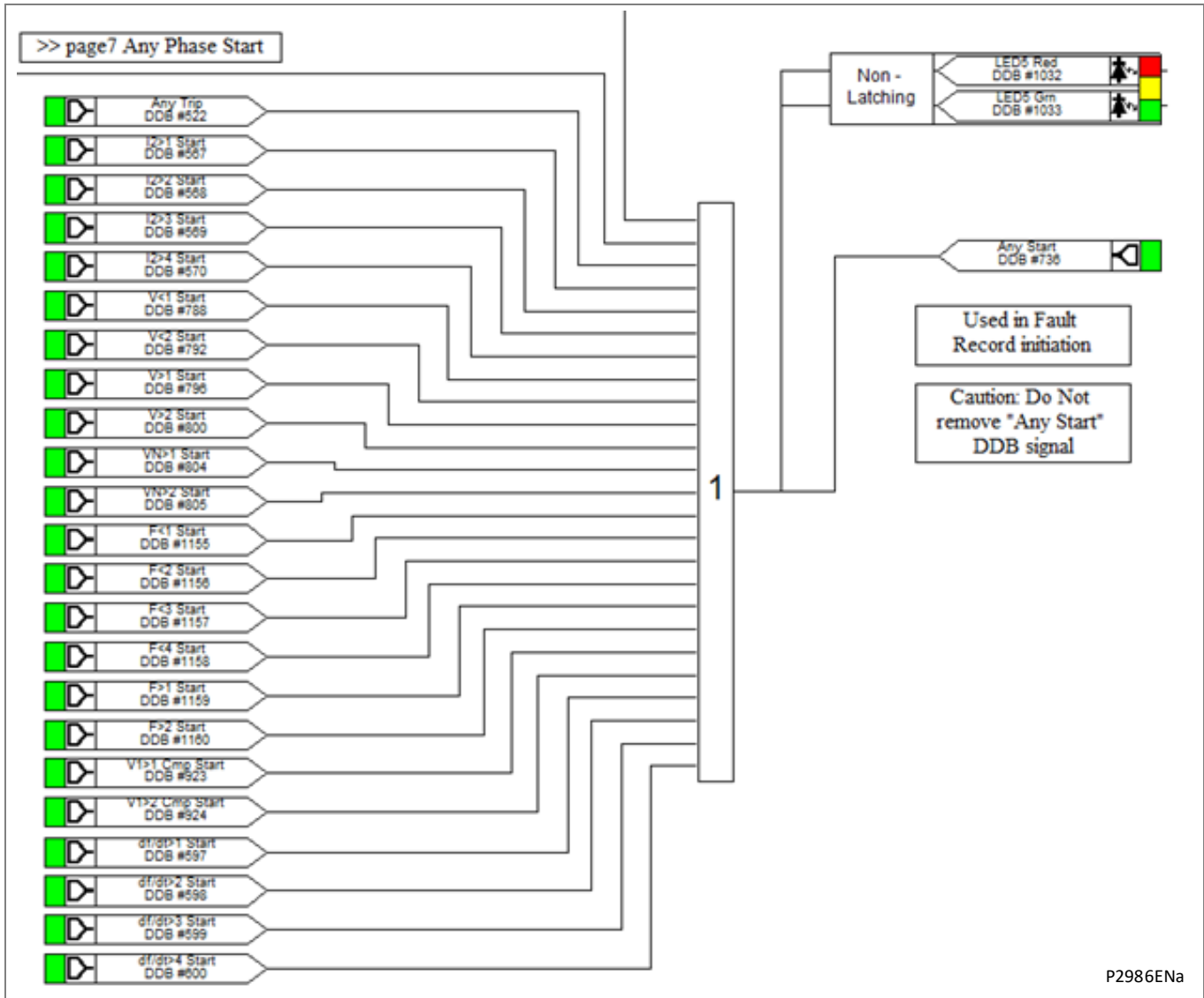

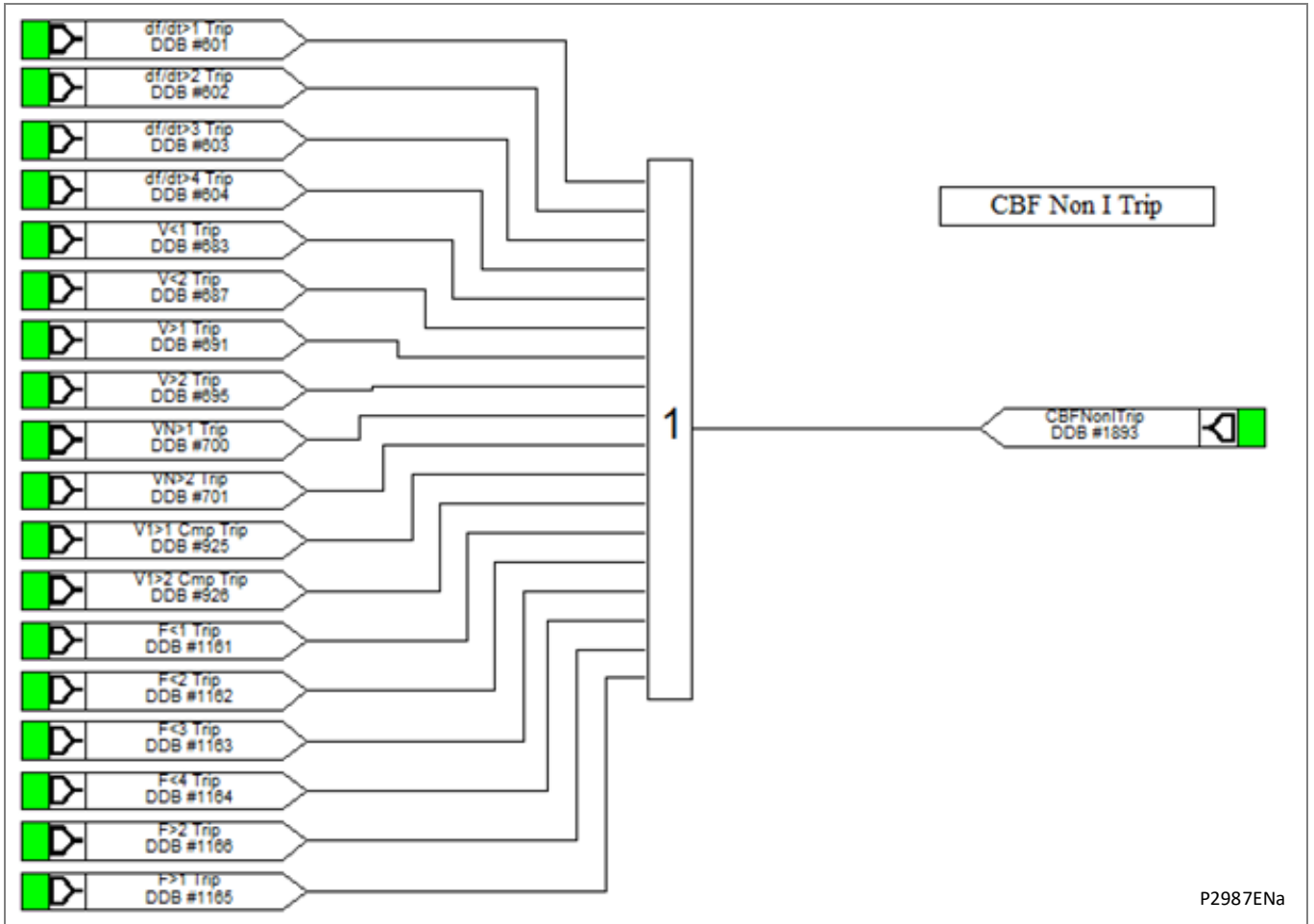

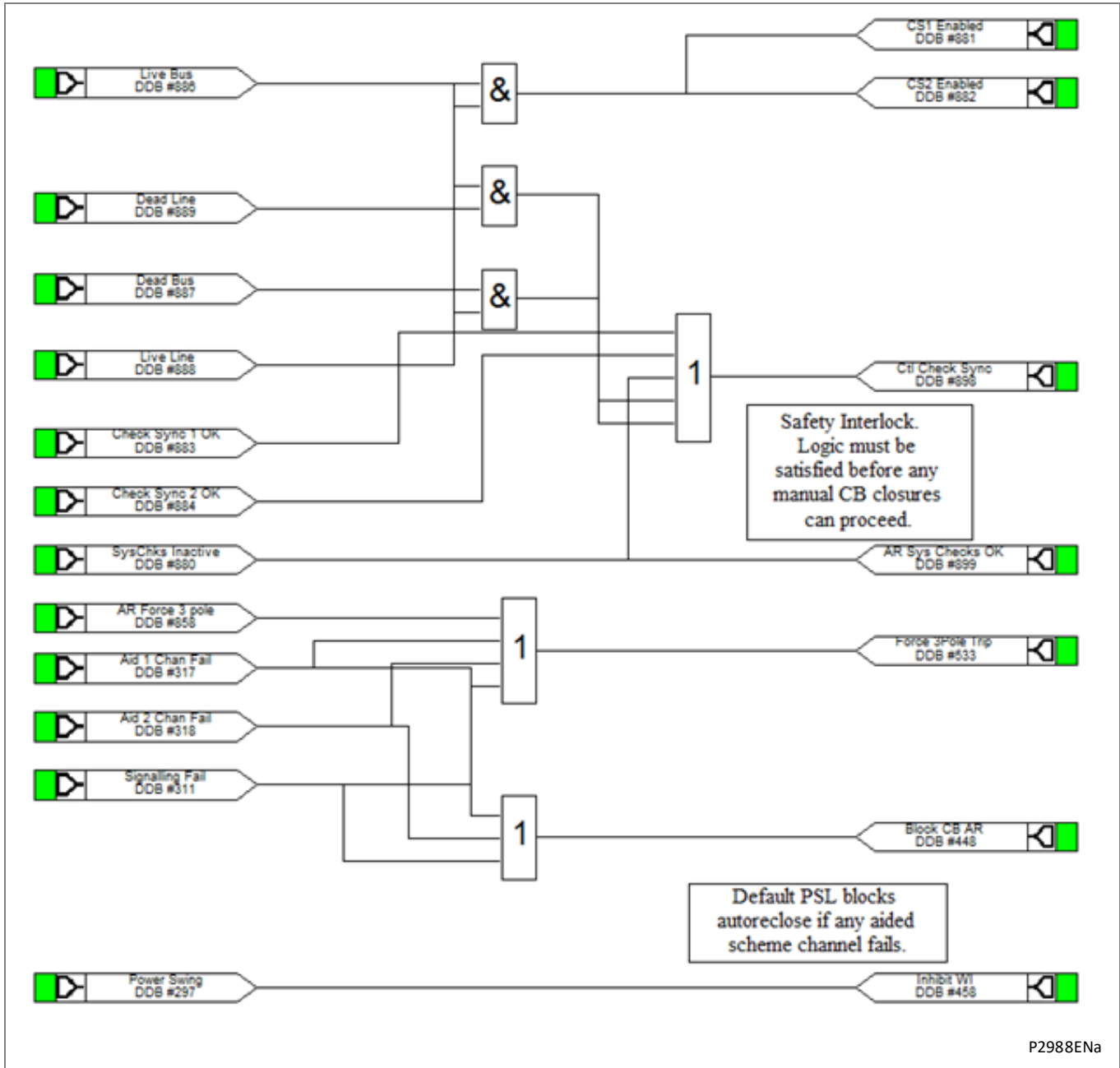

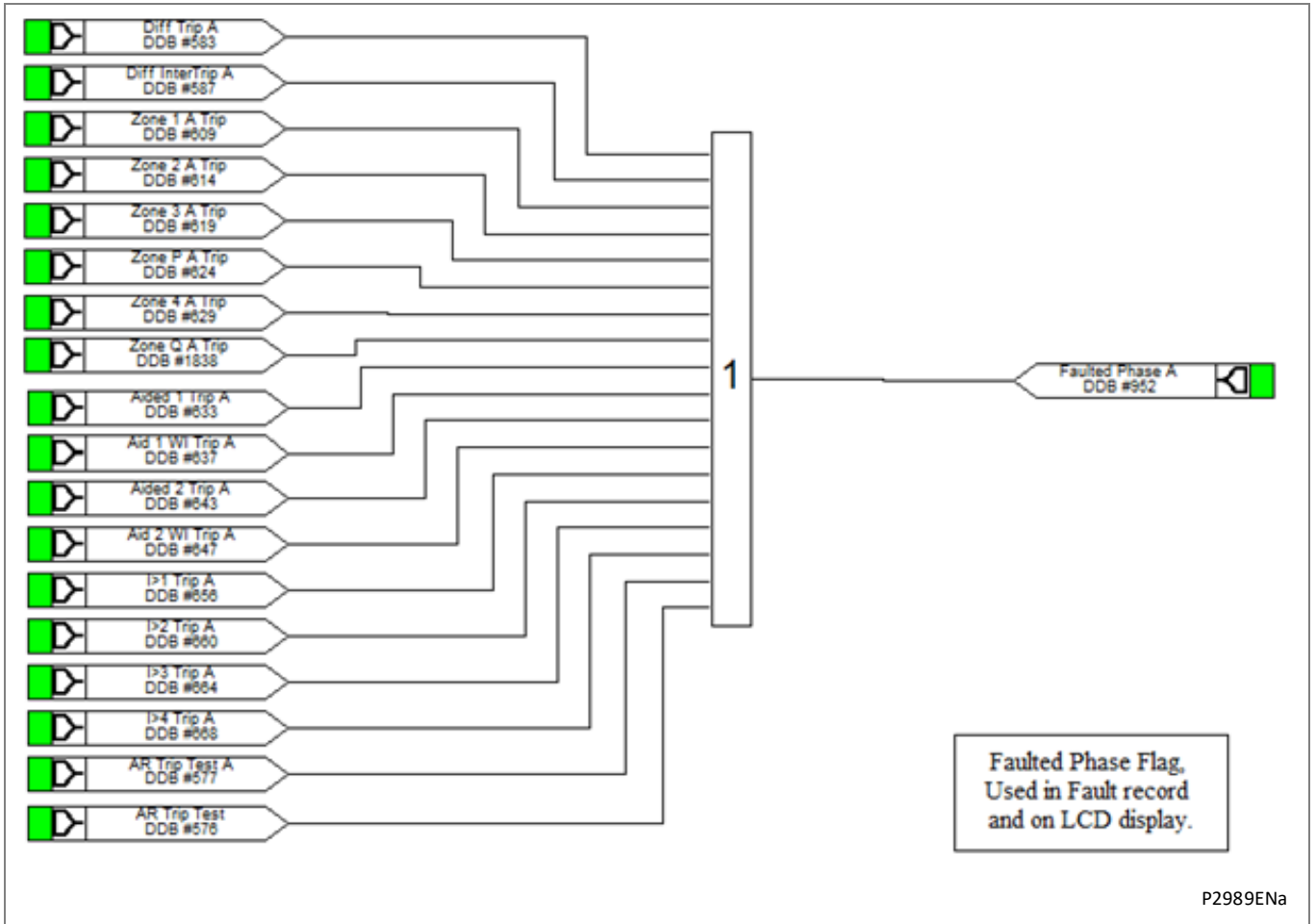

P2989ENa

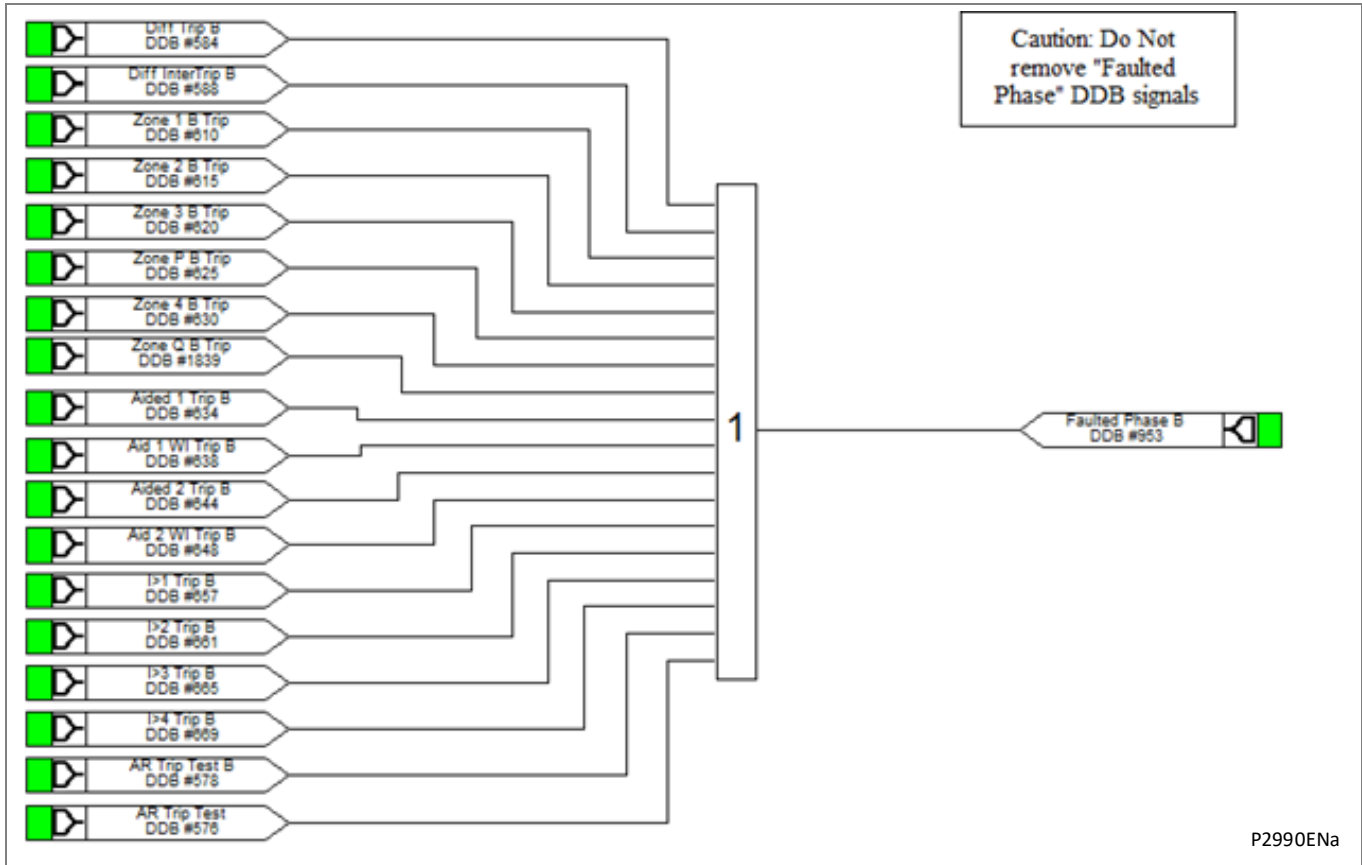

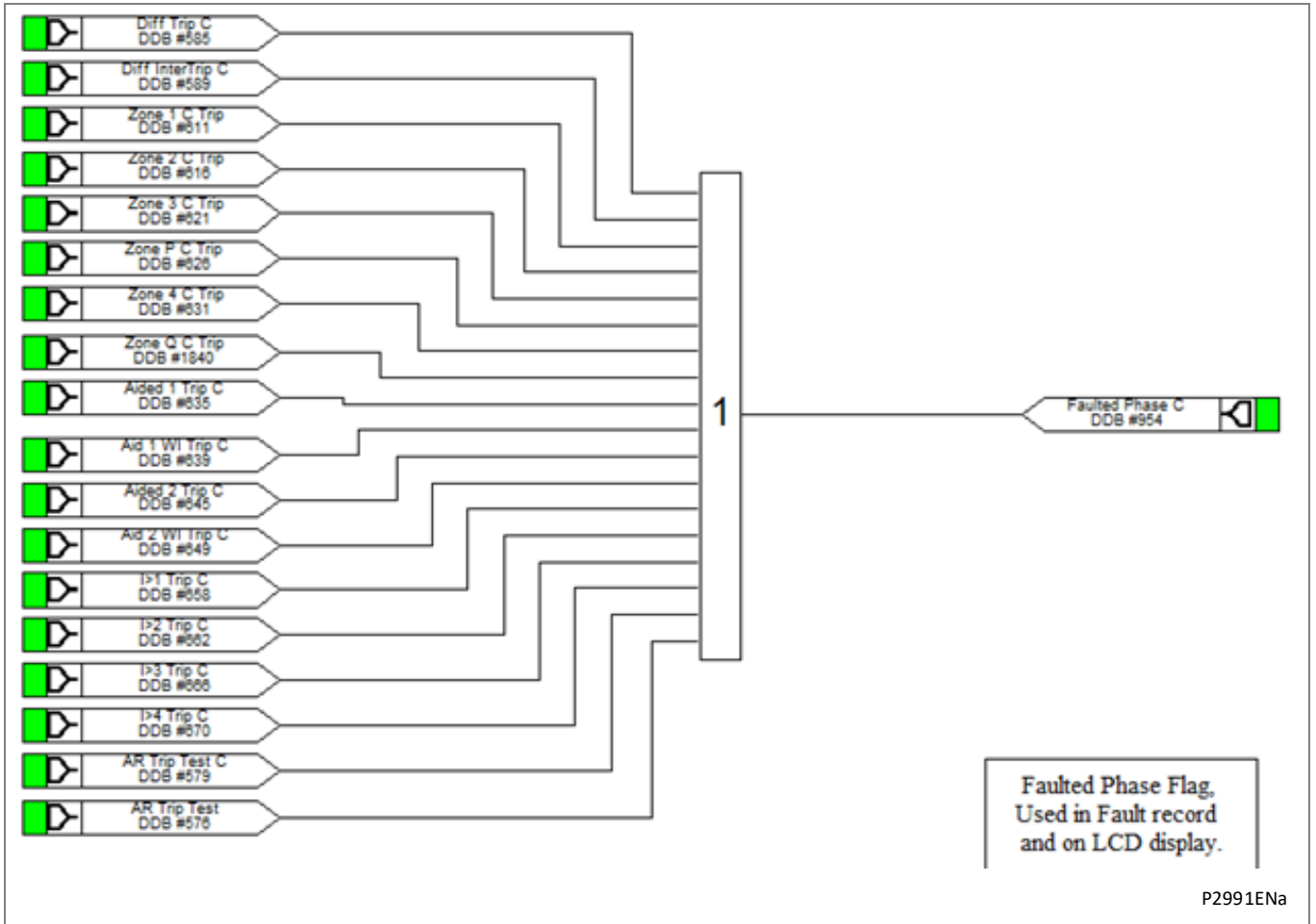

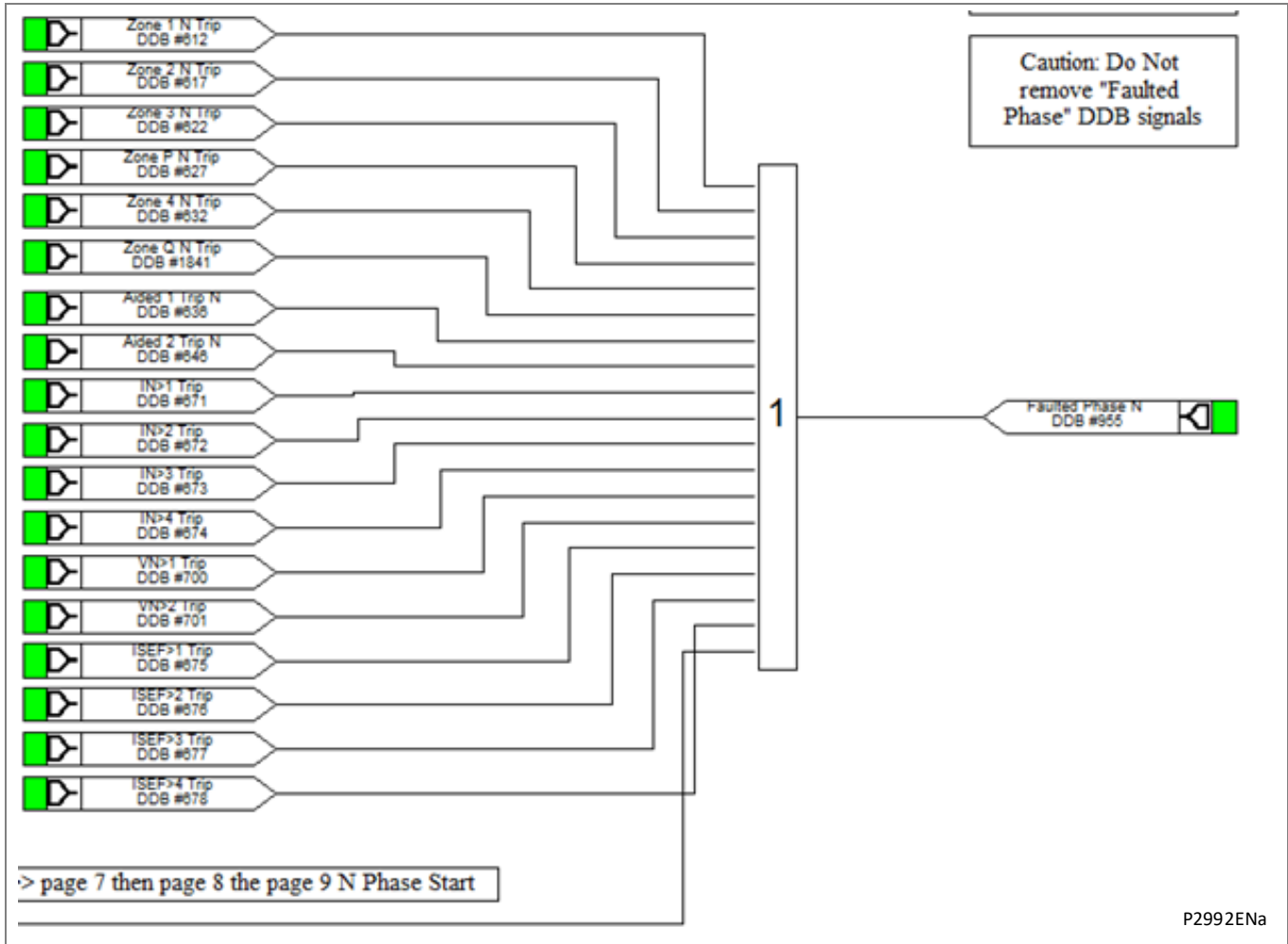

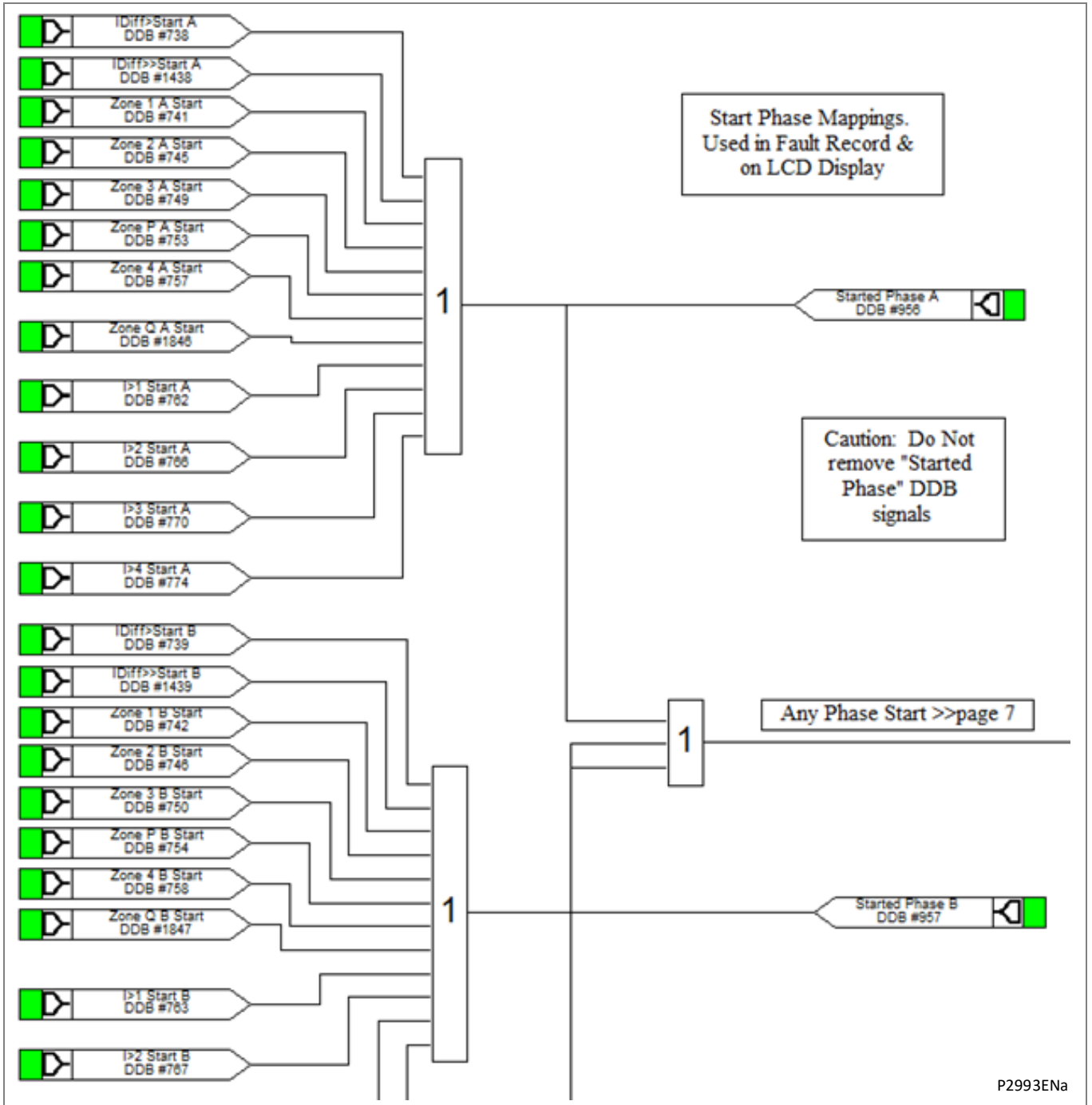

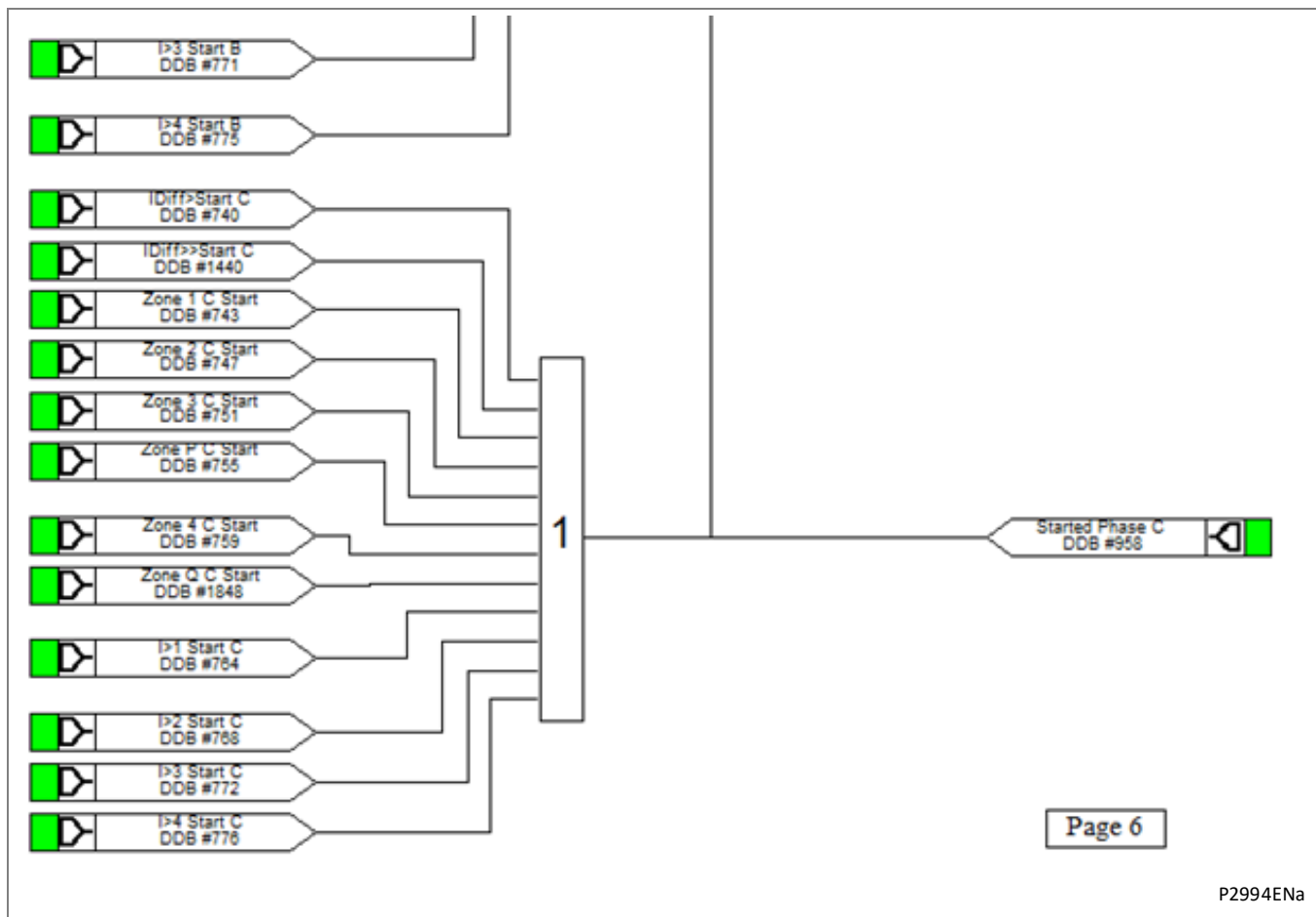

P2994ENa

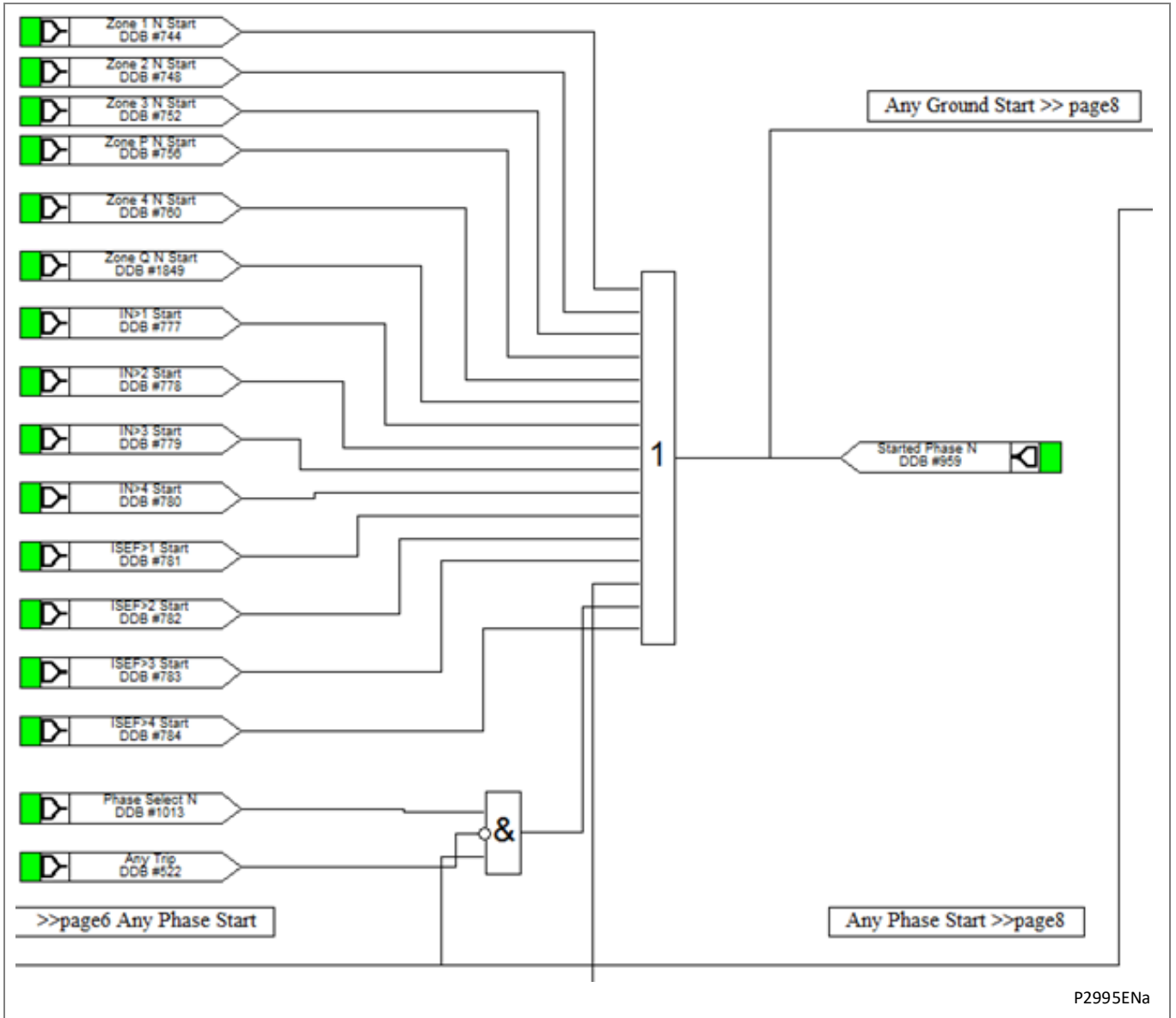

P2995ENa

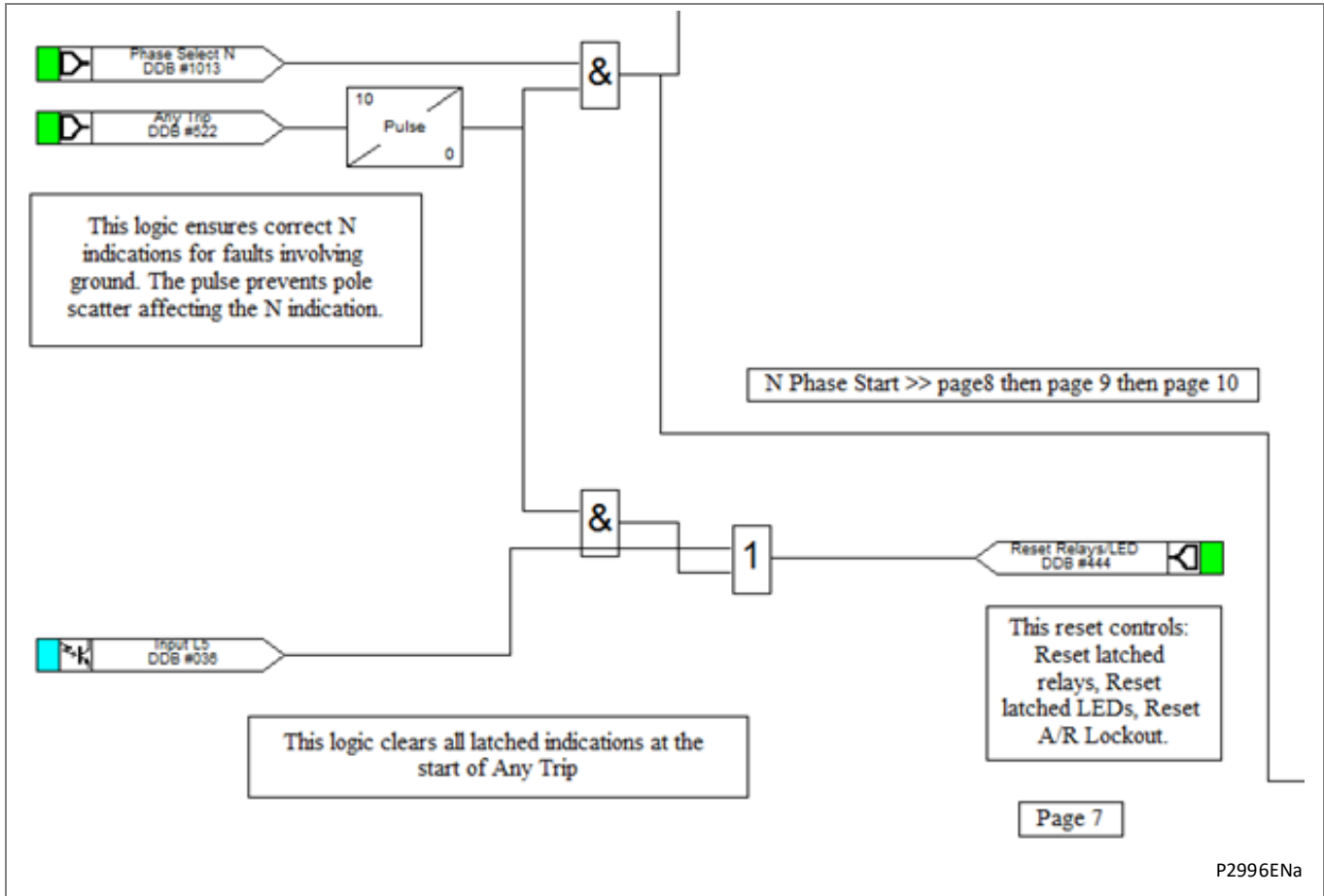

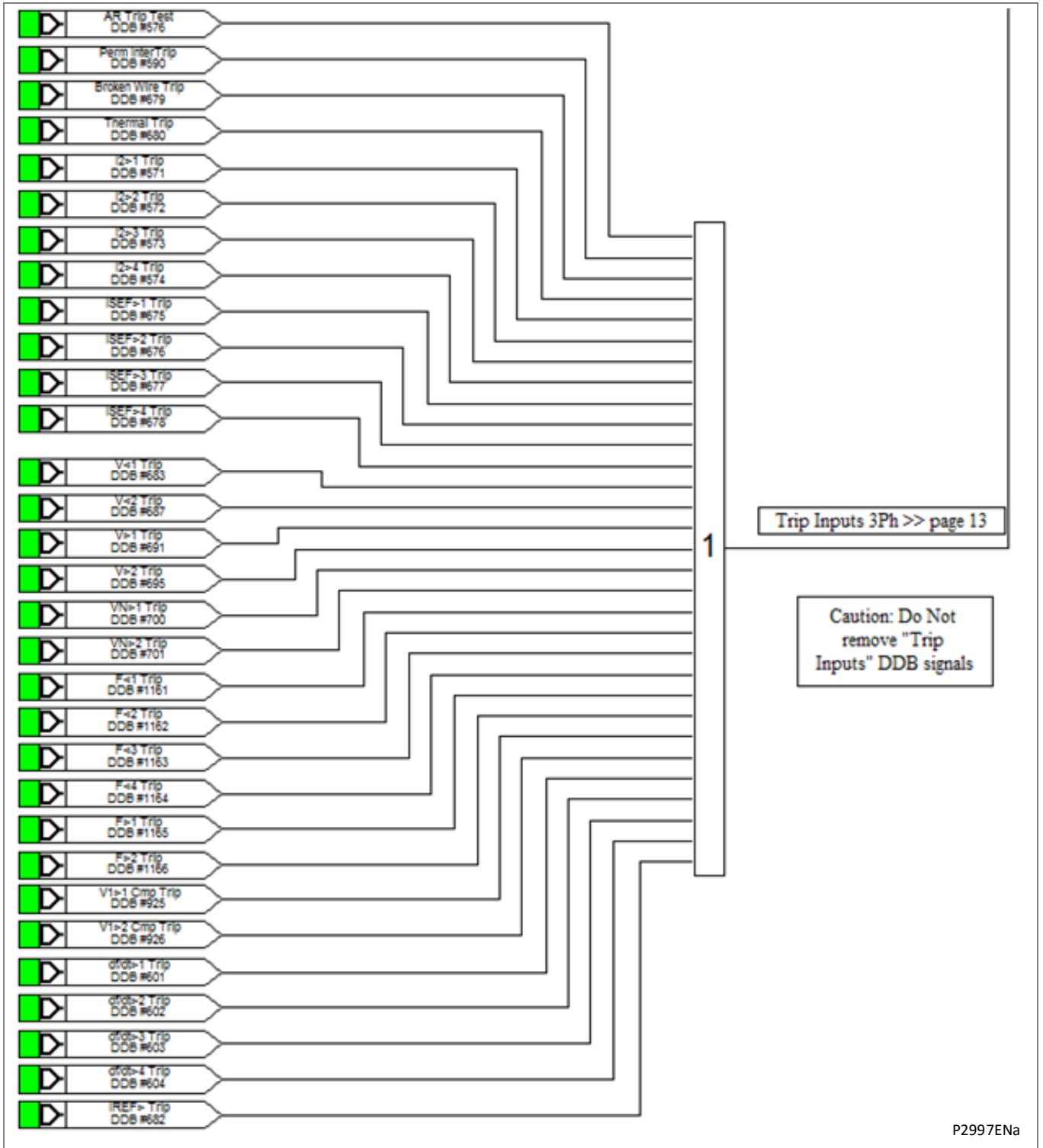

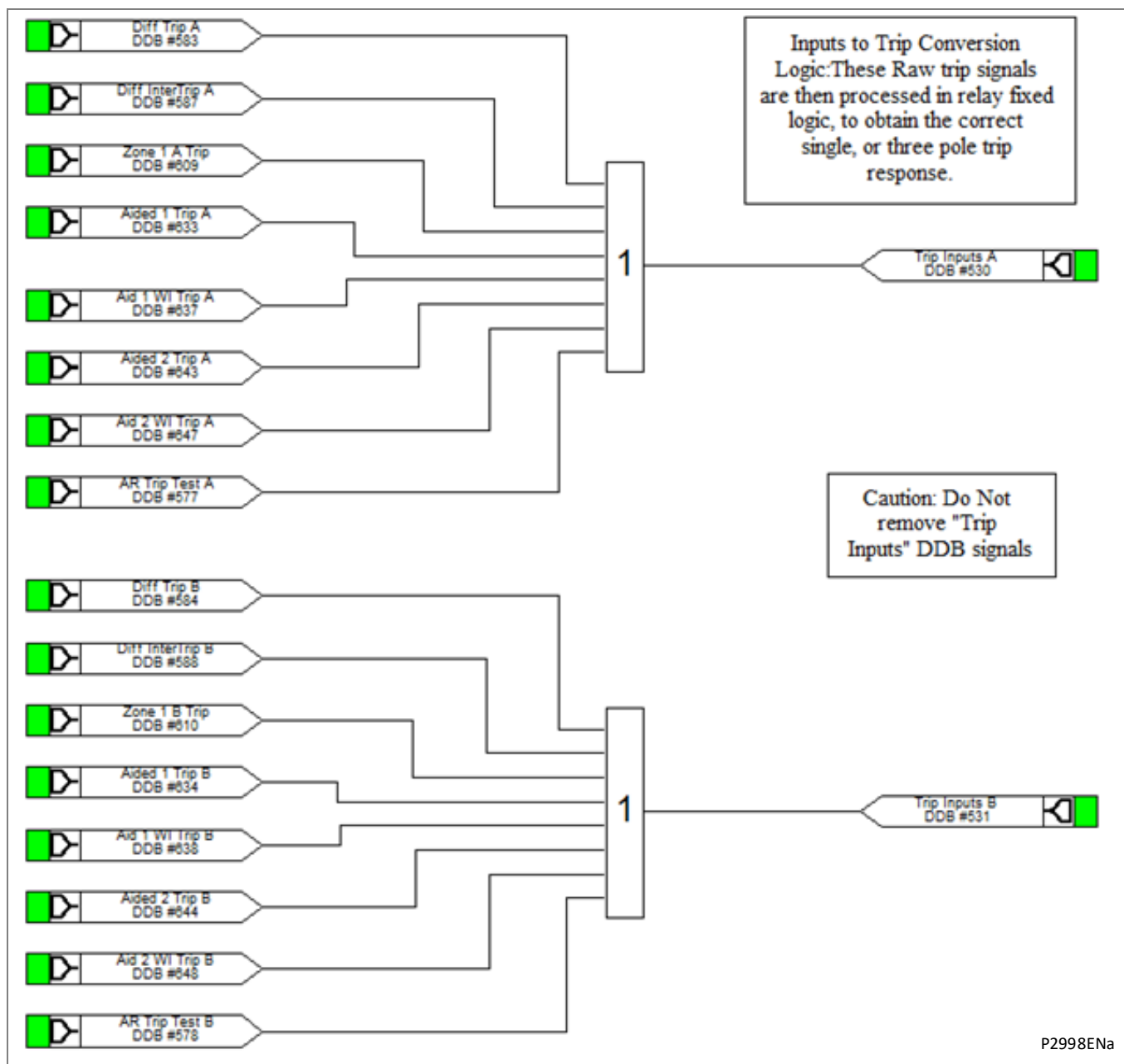

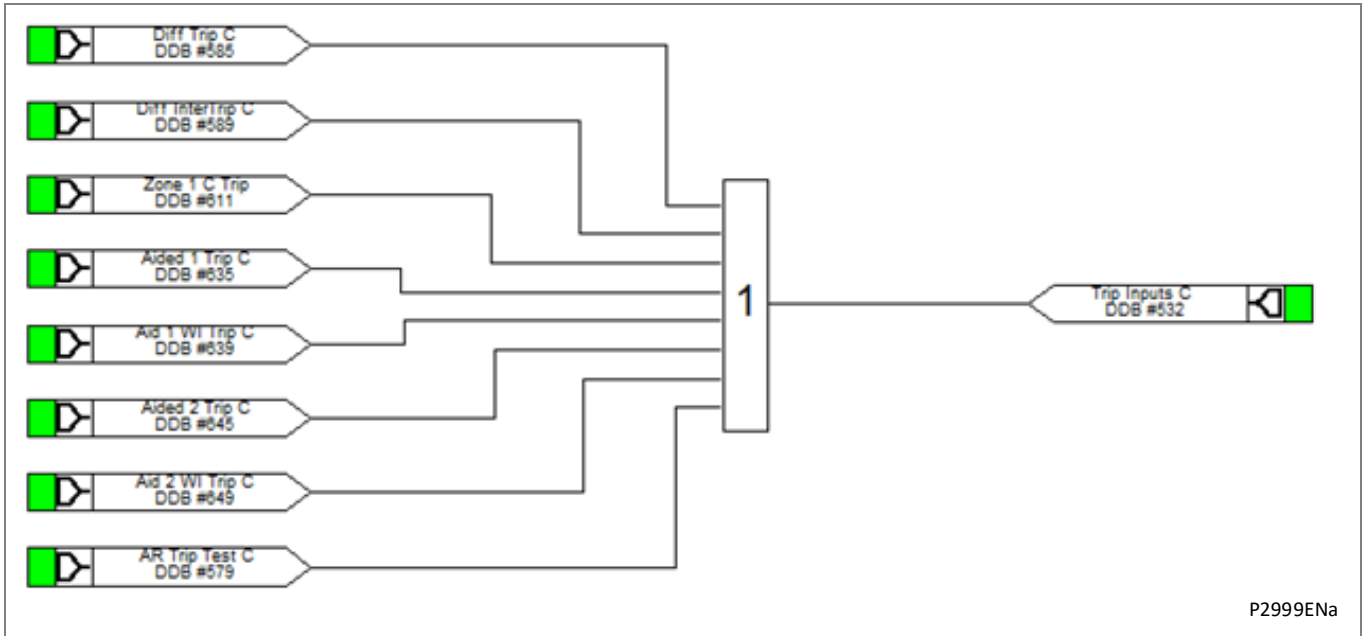

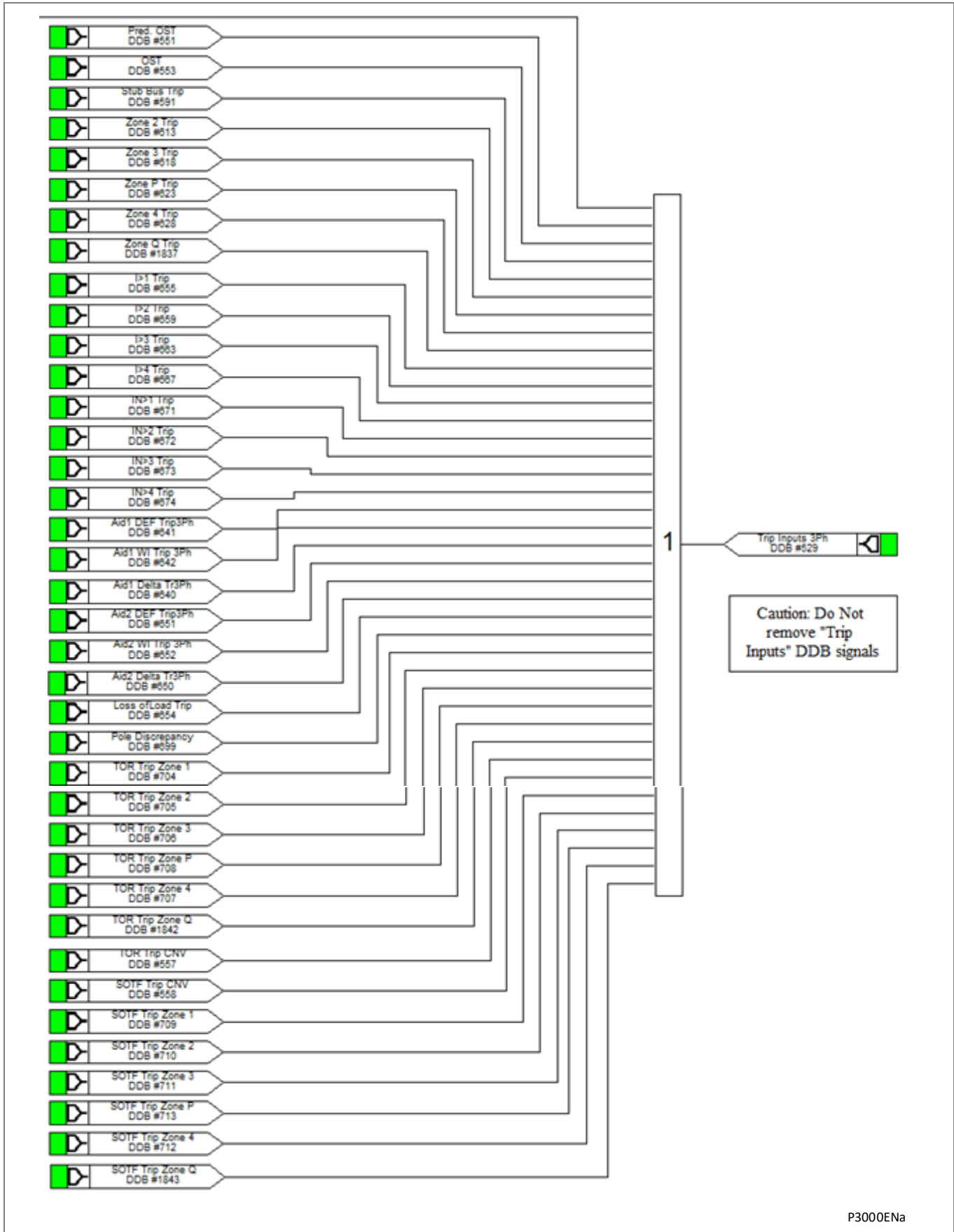

14.2 Opto Inputs and Output Contacts

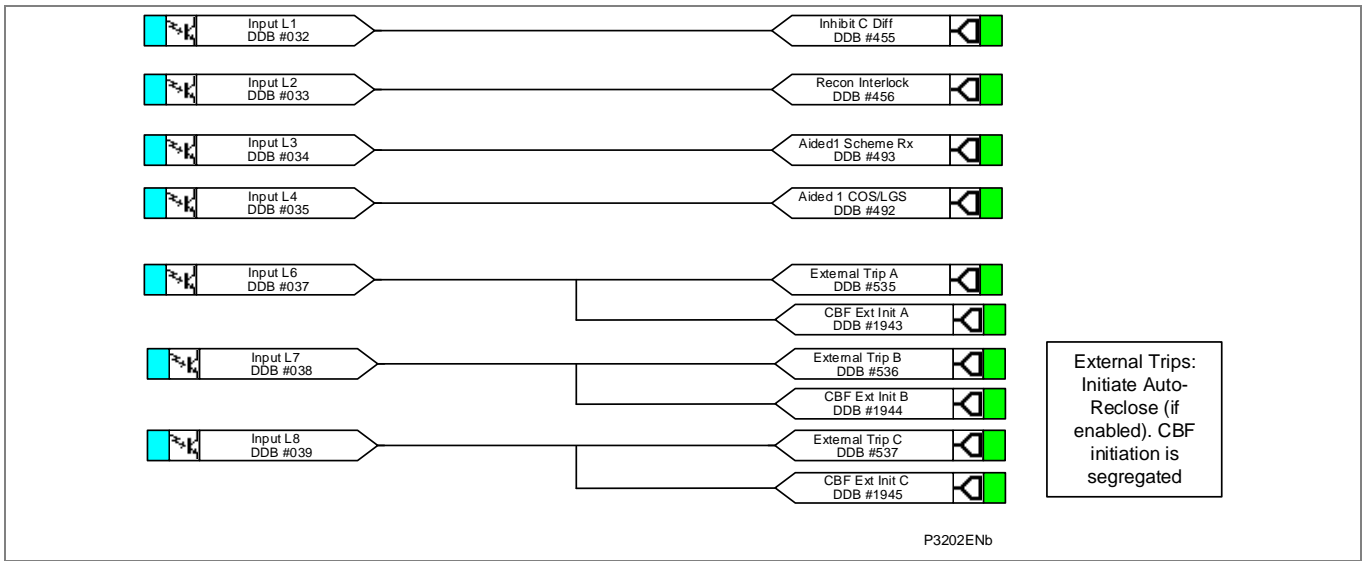

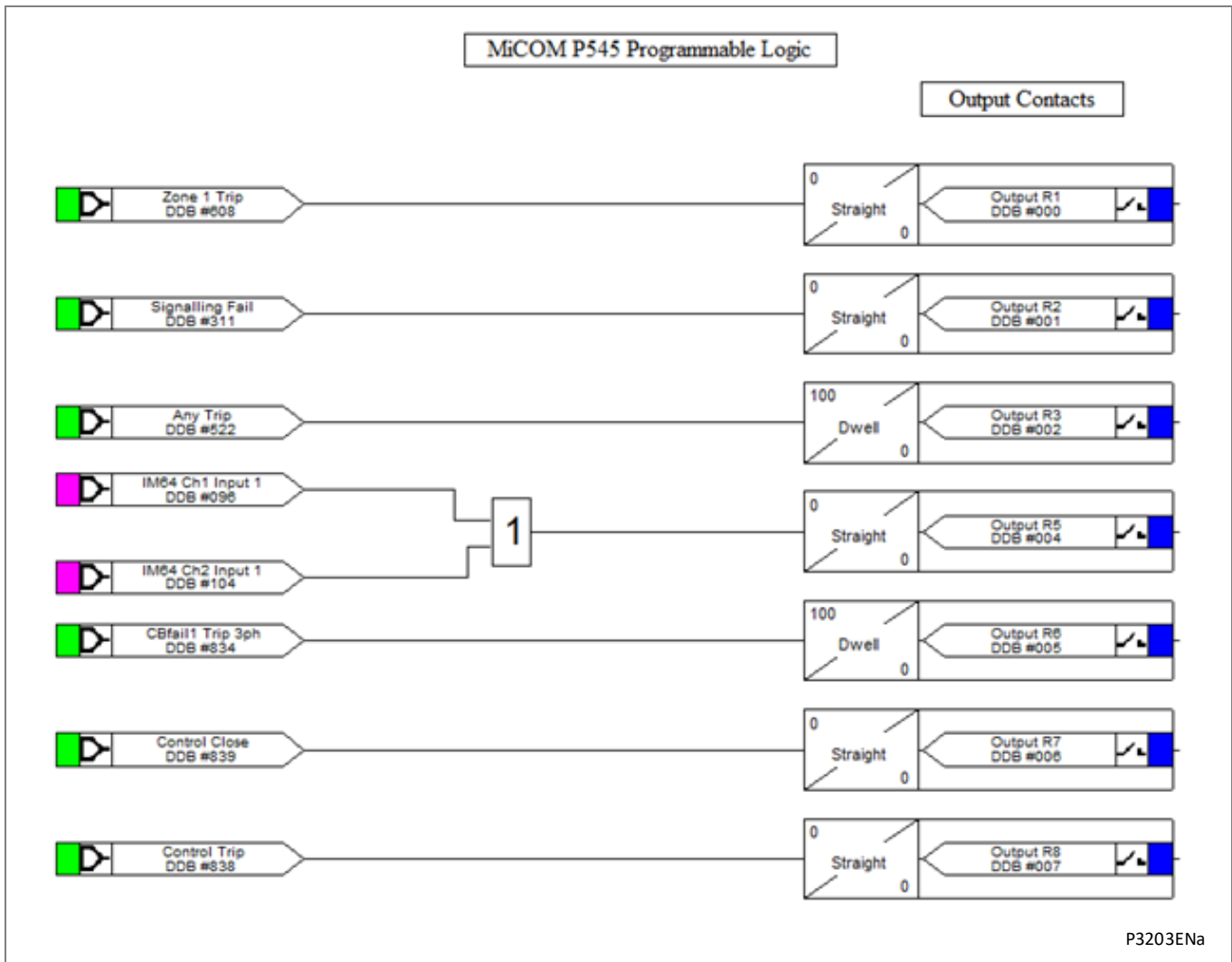

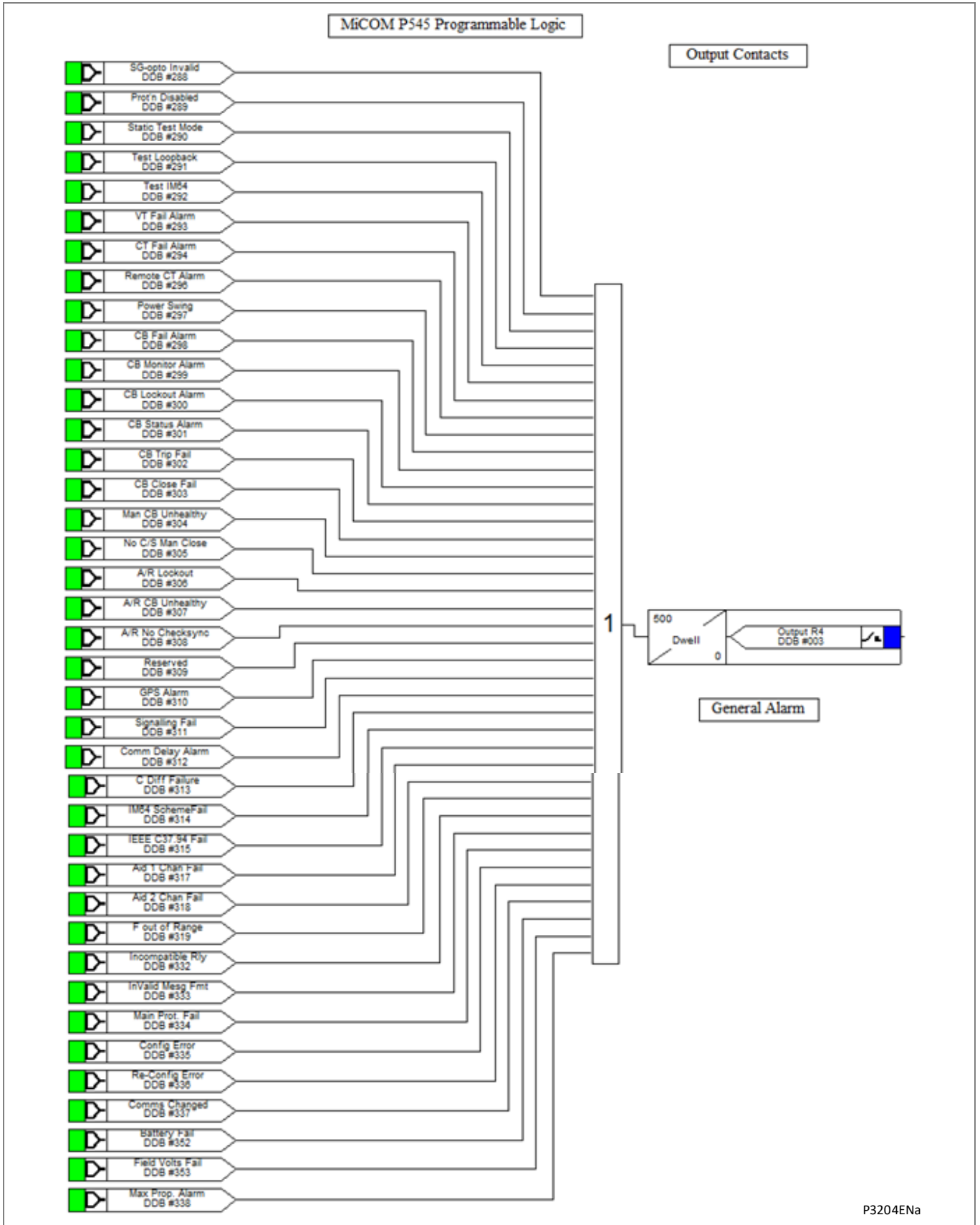

14.3 LEDs

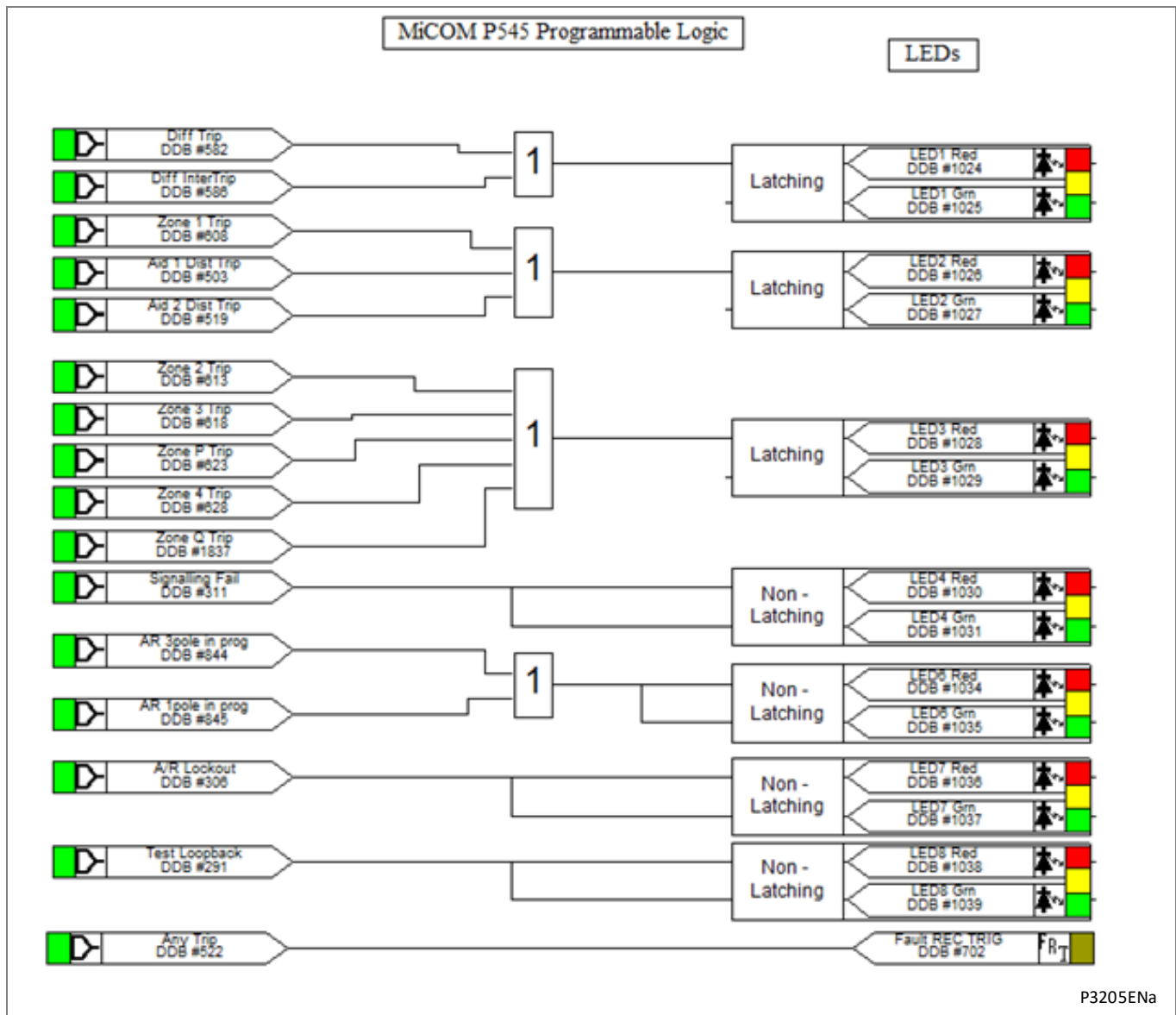

15 MICOM P546 PROCESS BUS WITH DISTANCE PSL

15.1 Output Input Mappings

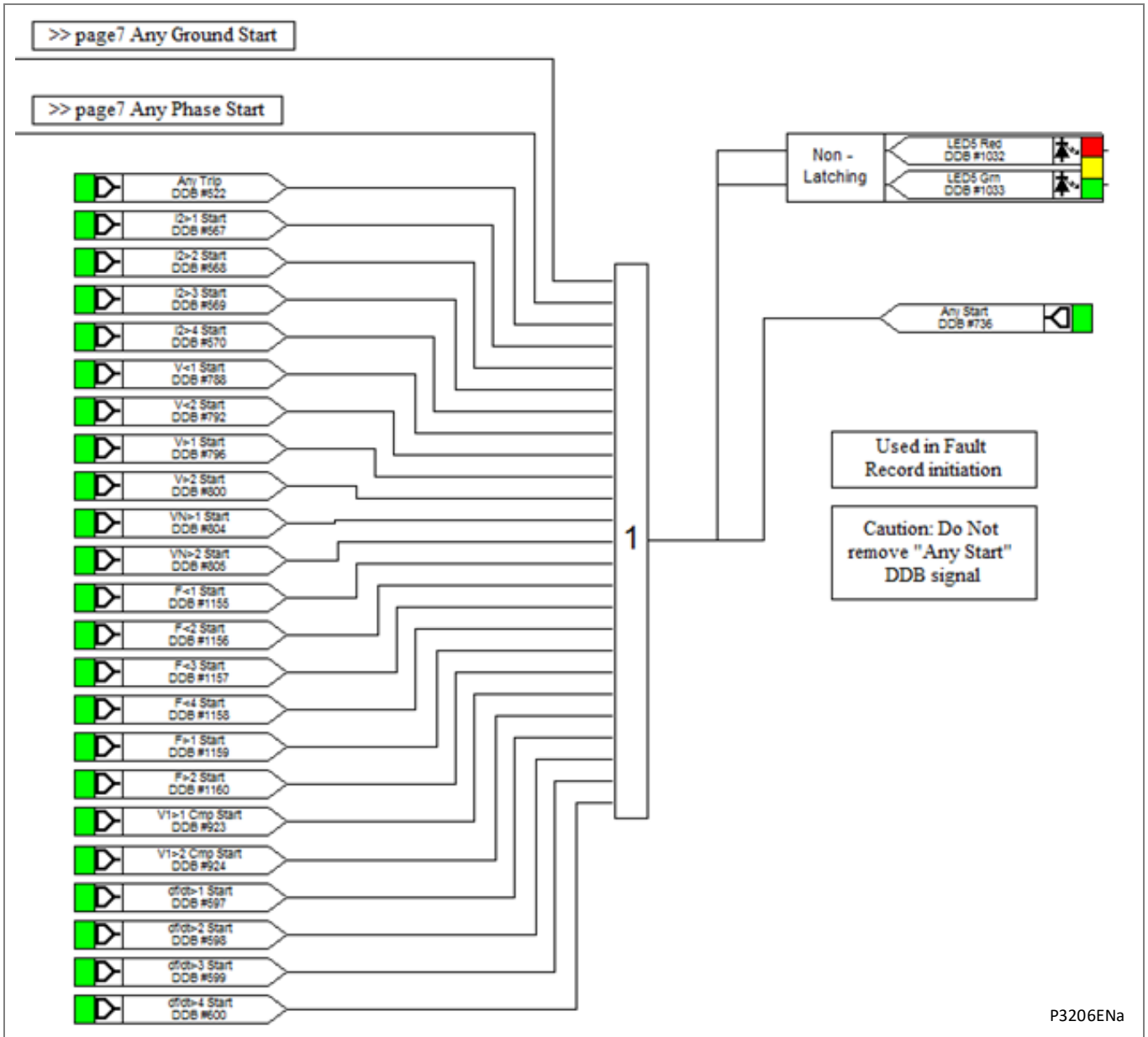

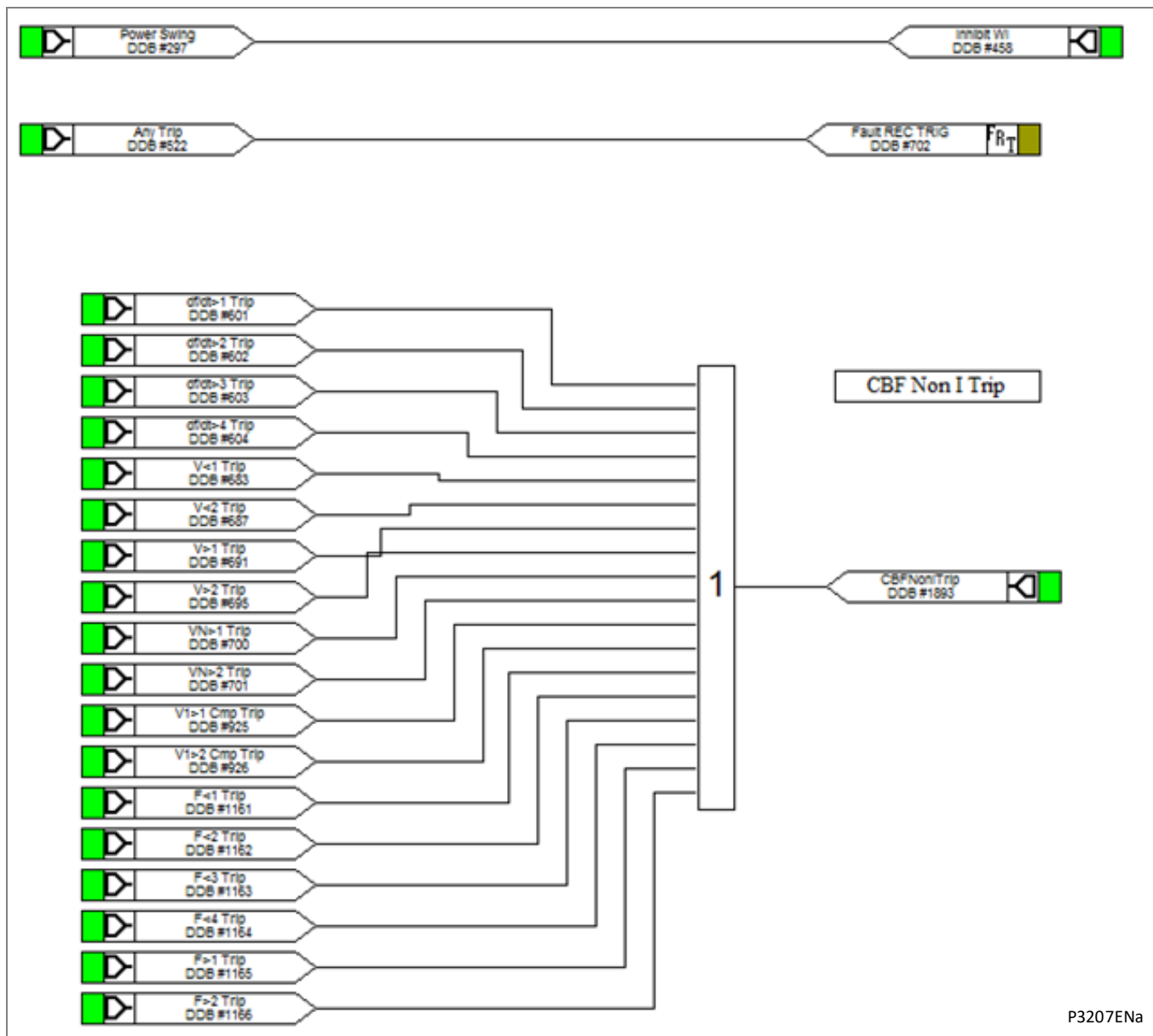

P3207ENa

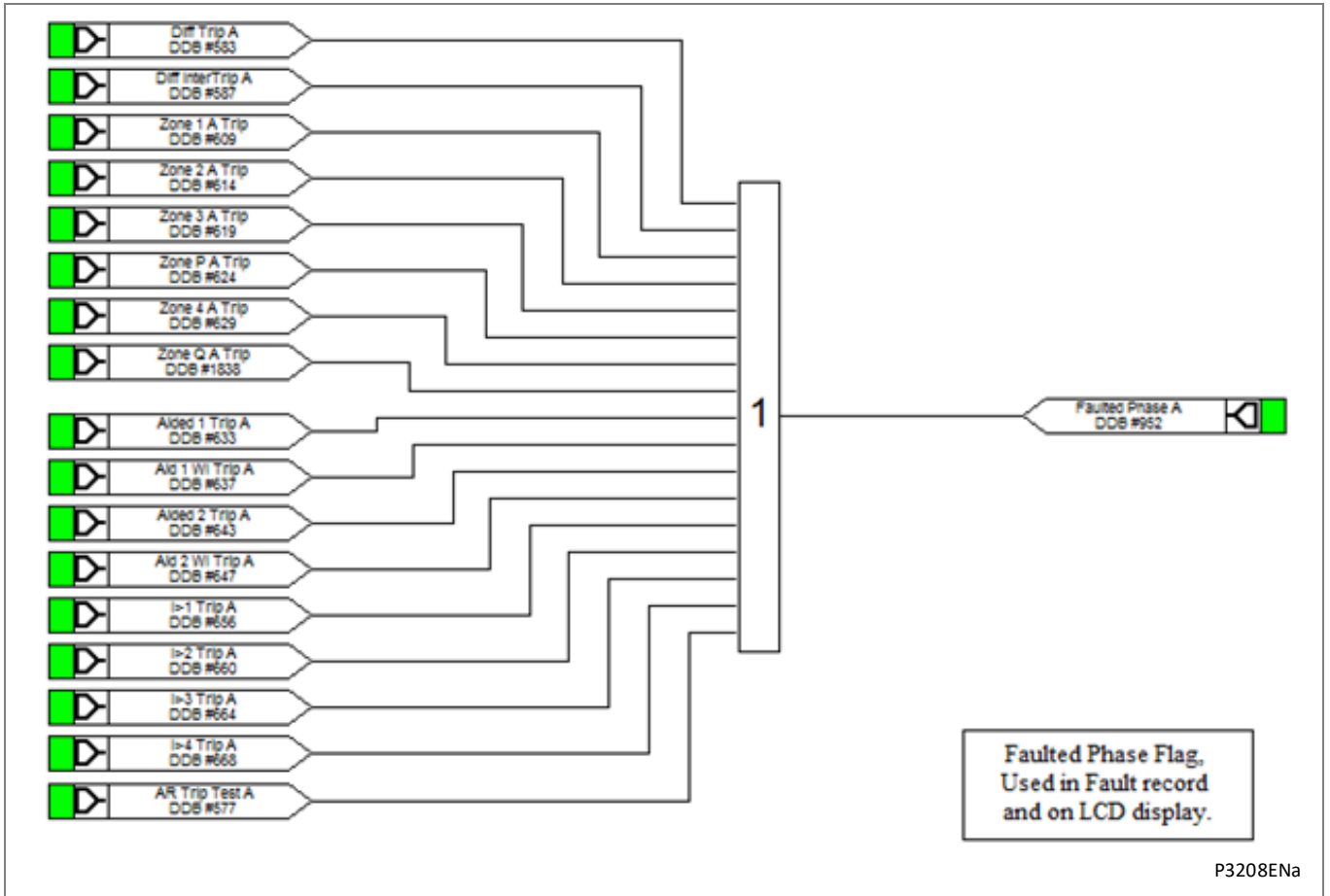

P3208ENa

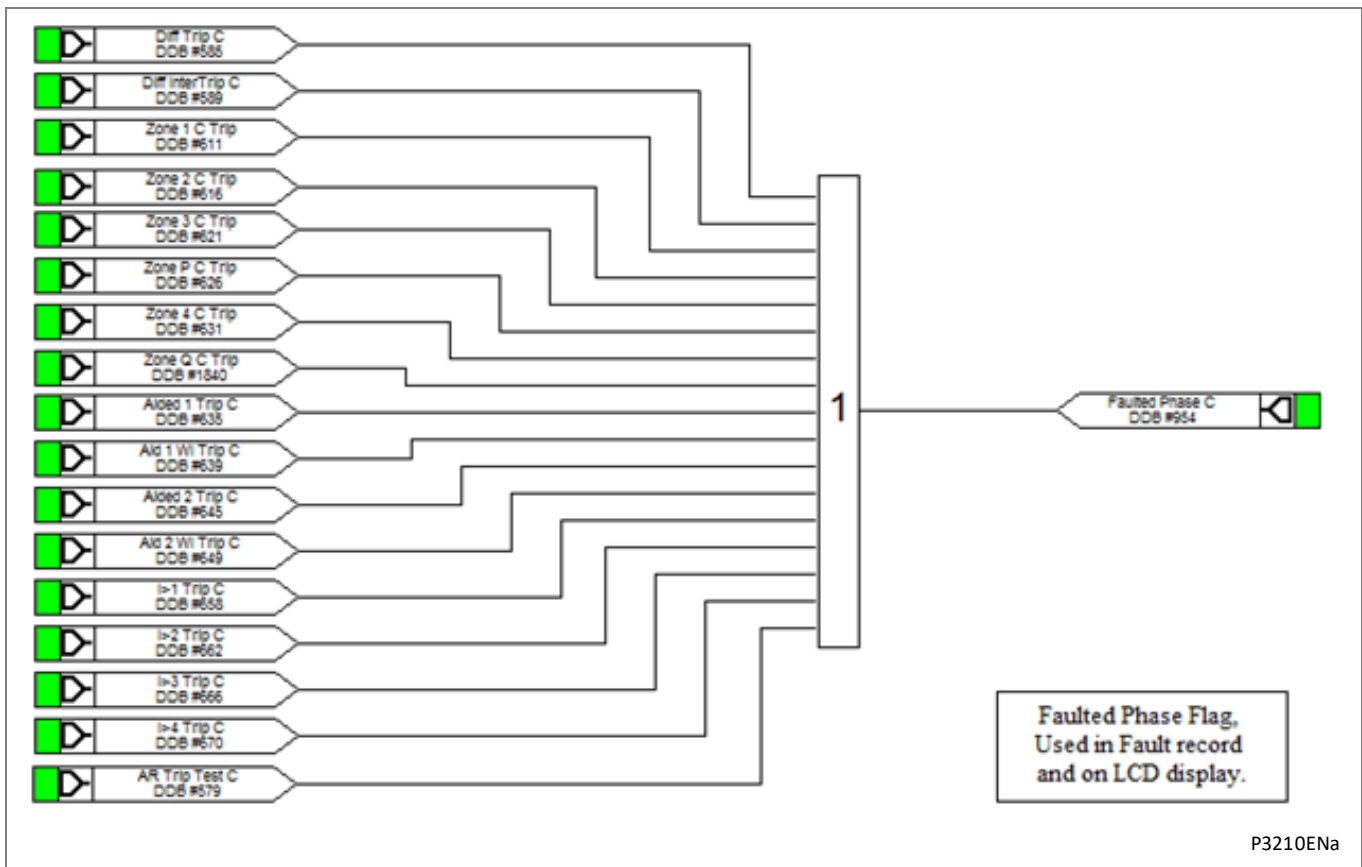
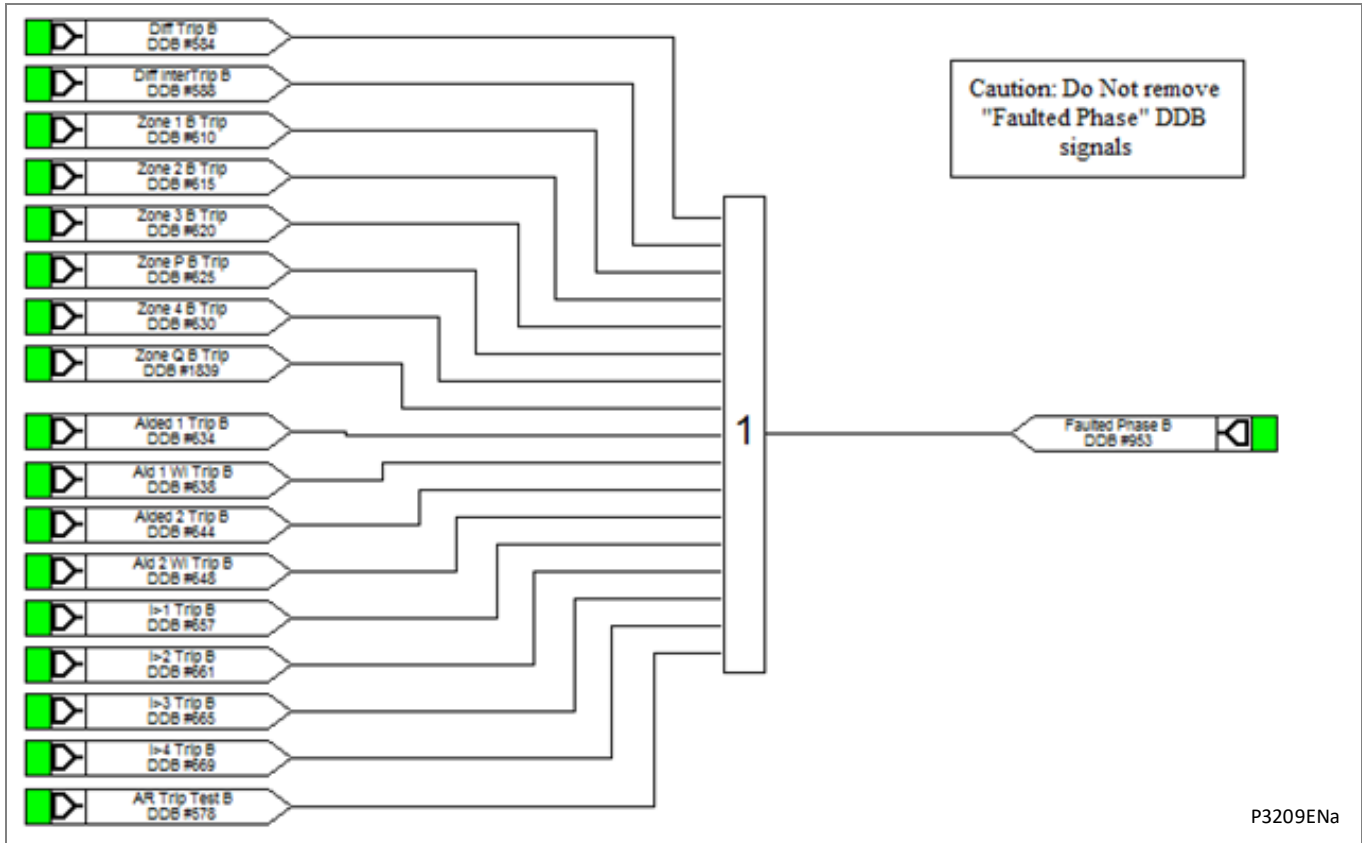

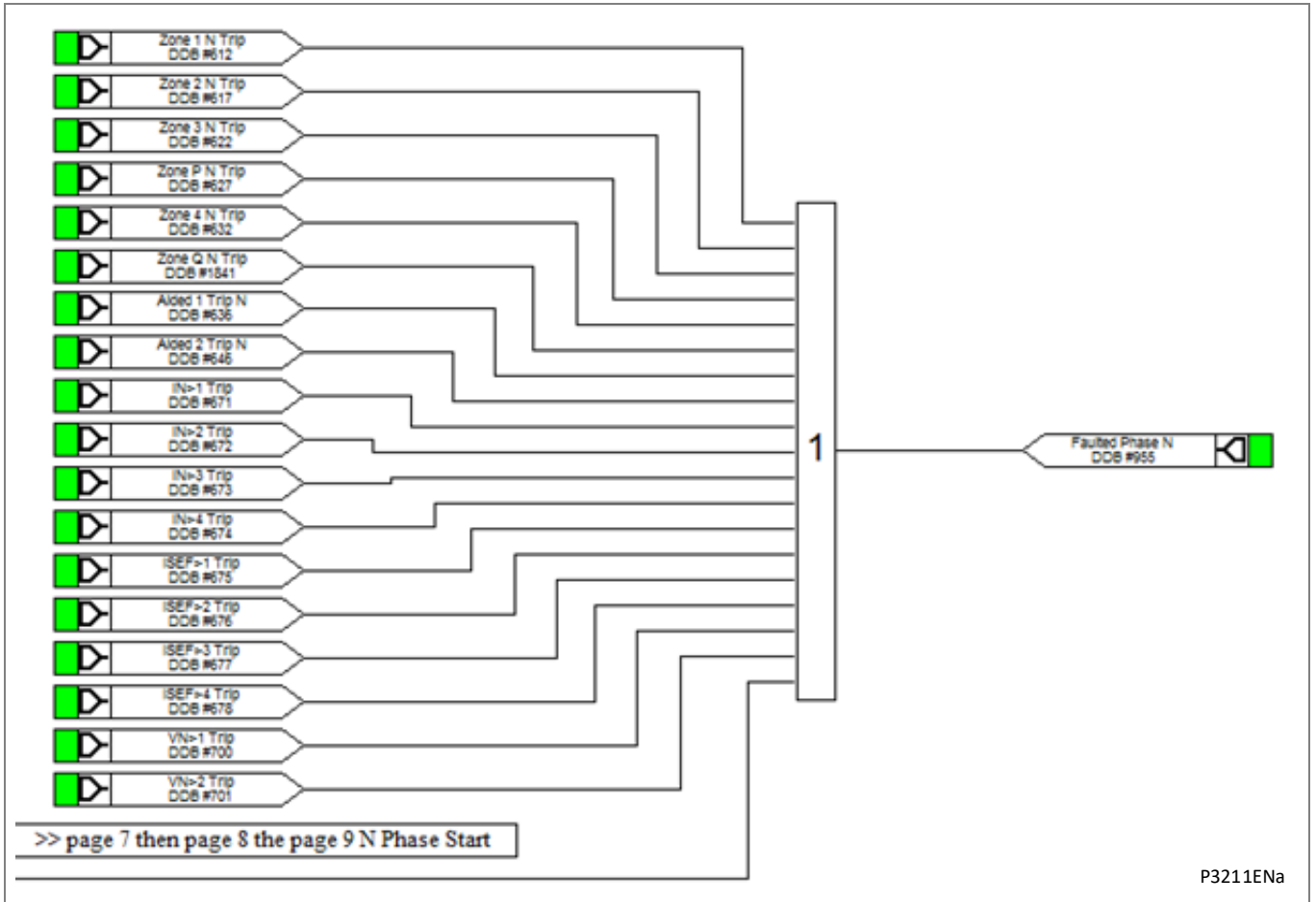

P3211ENa

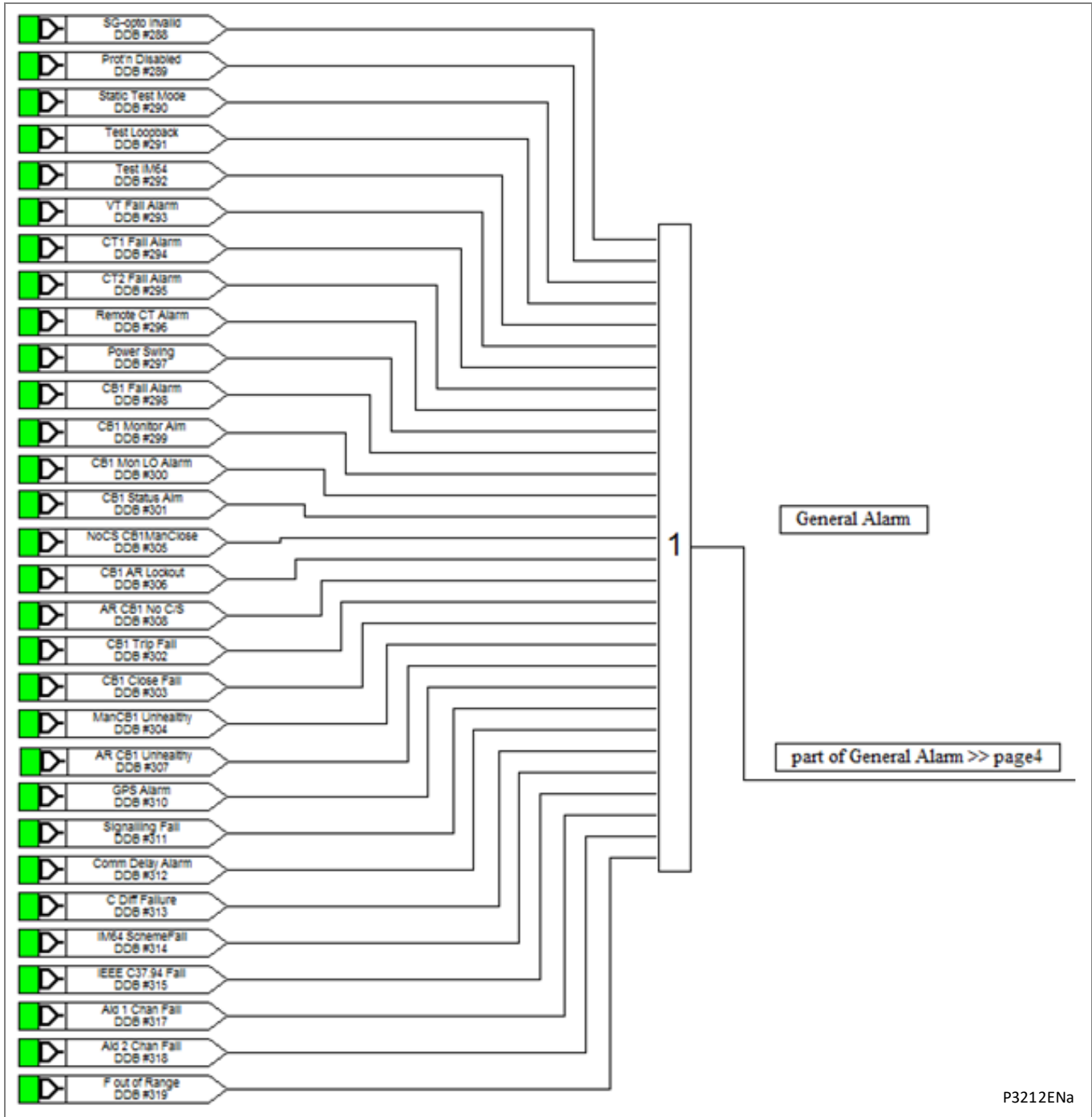

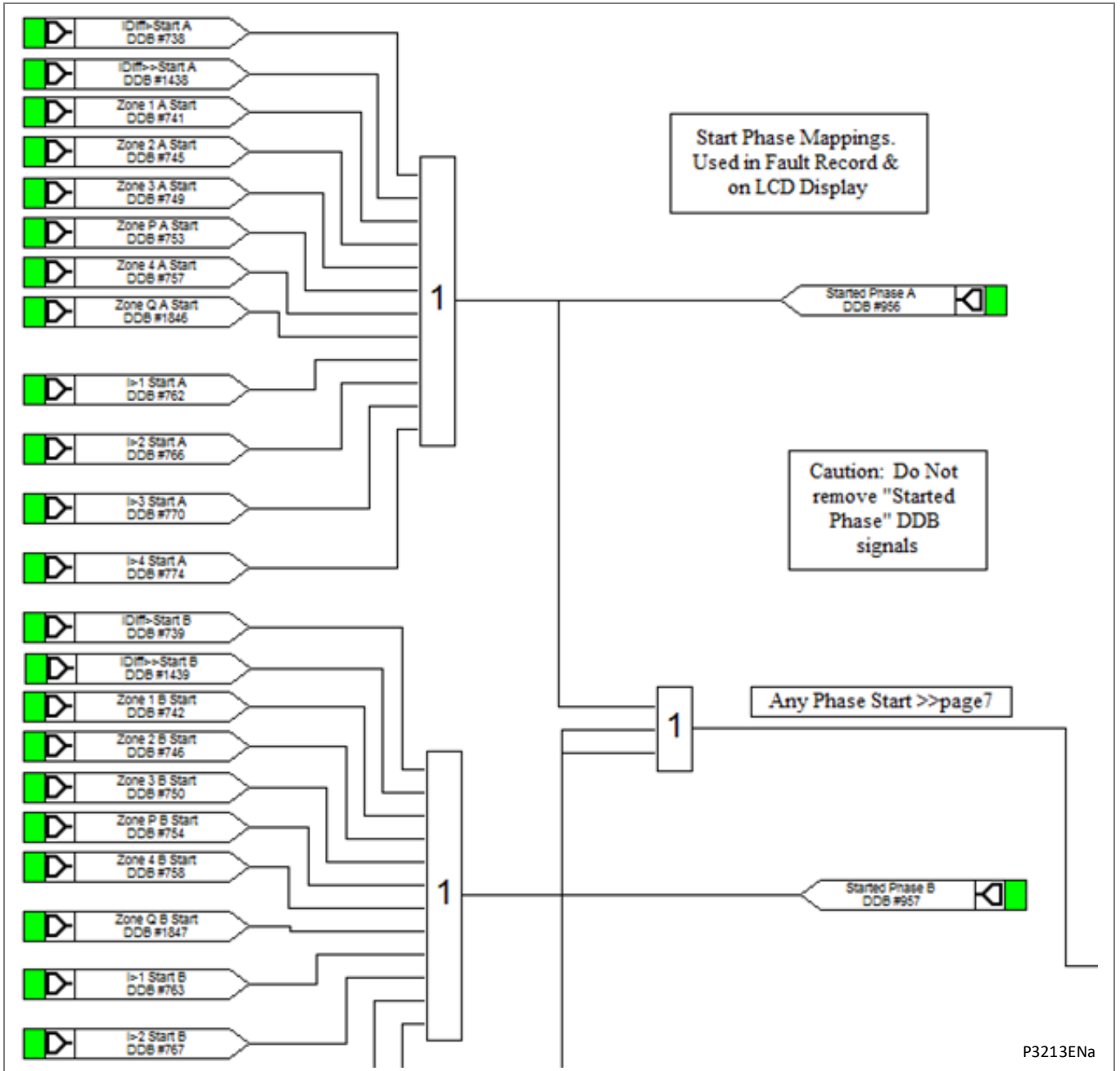

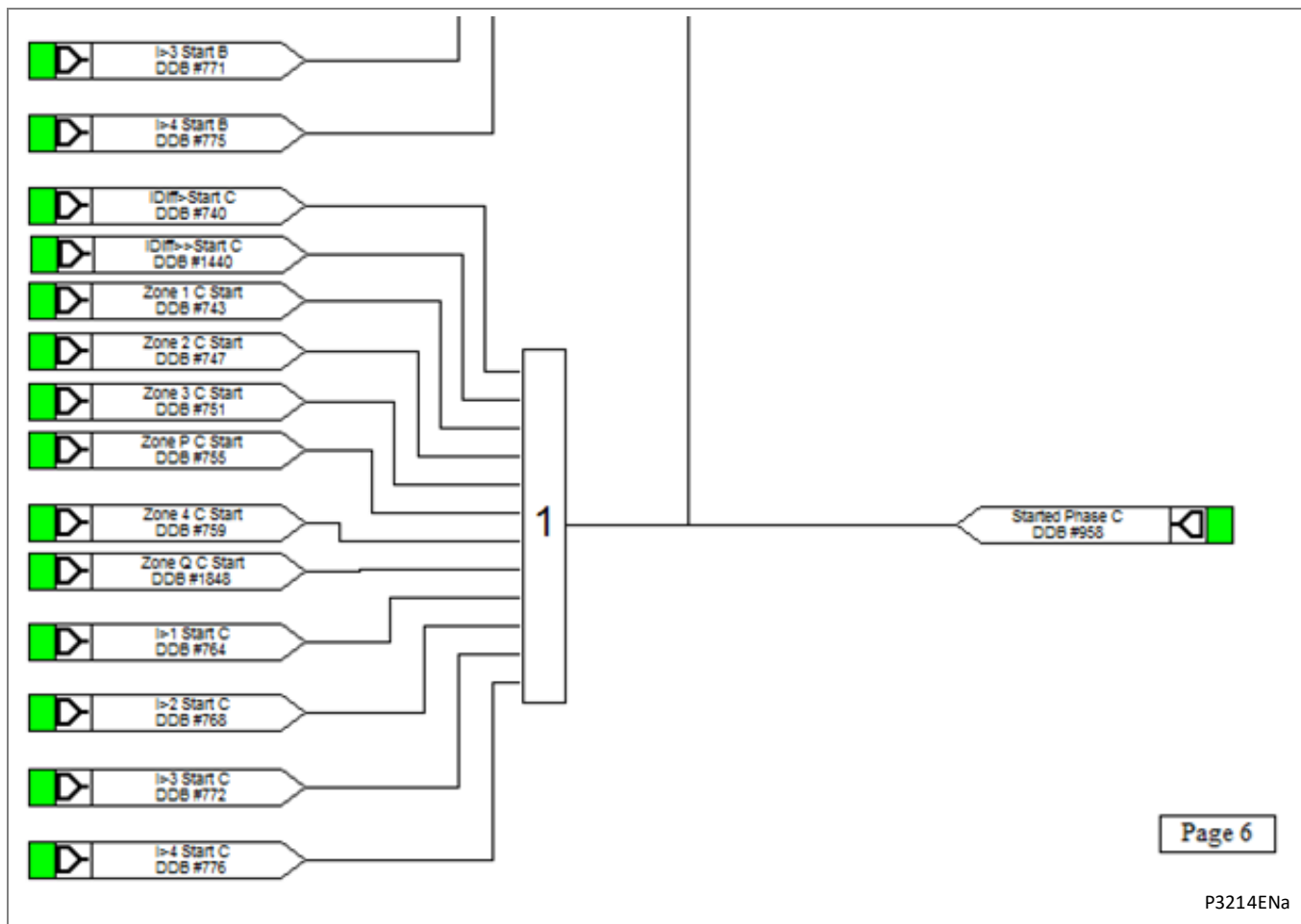

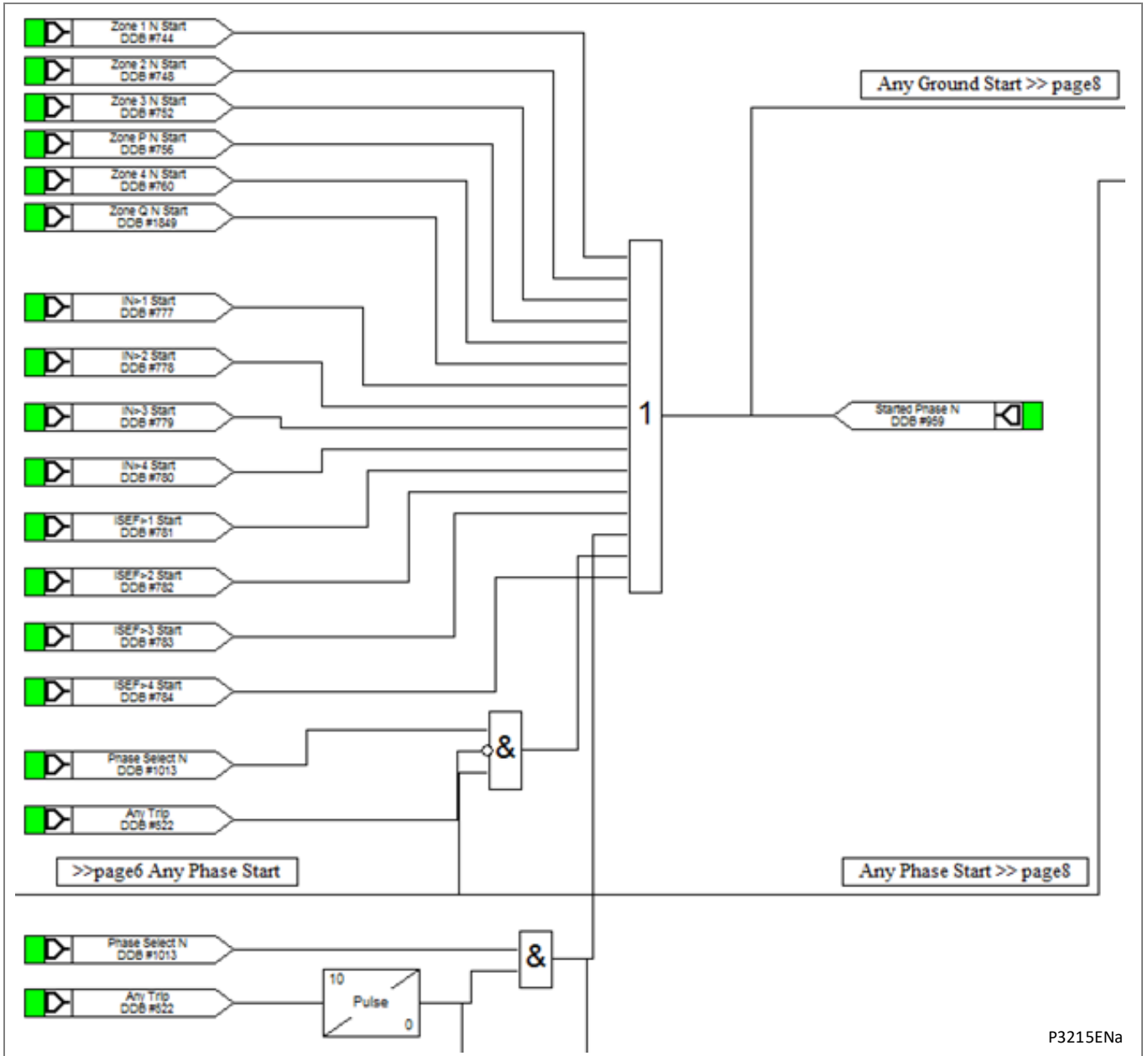

P3215ENa

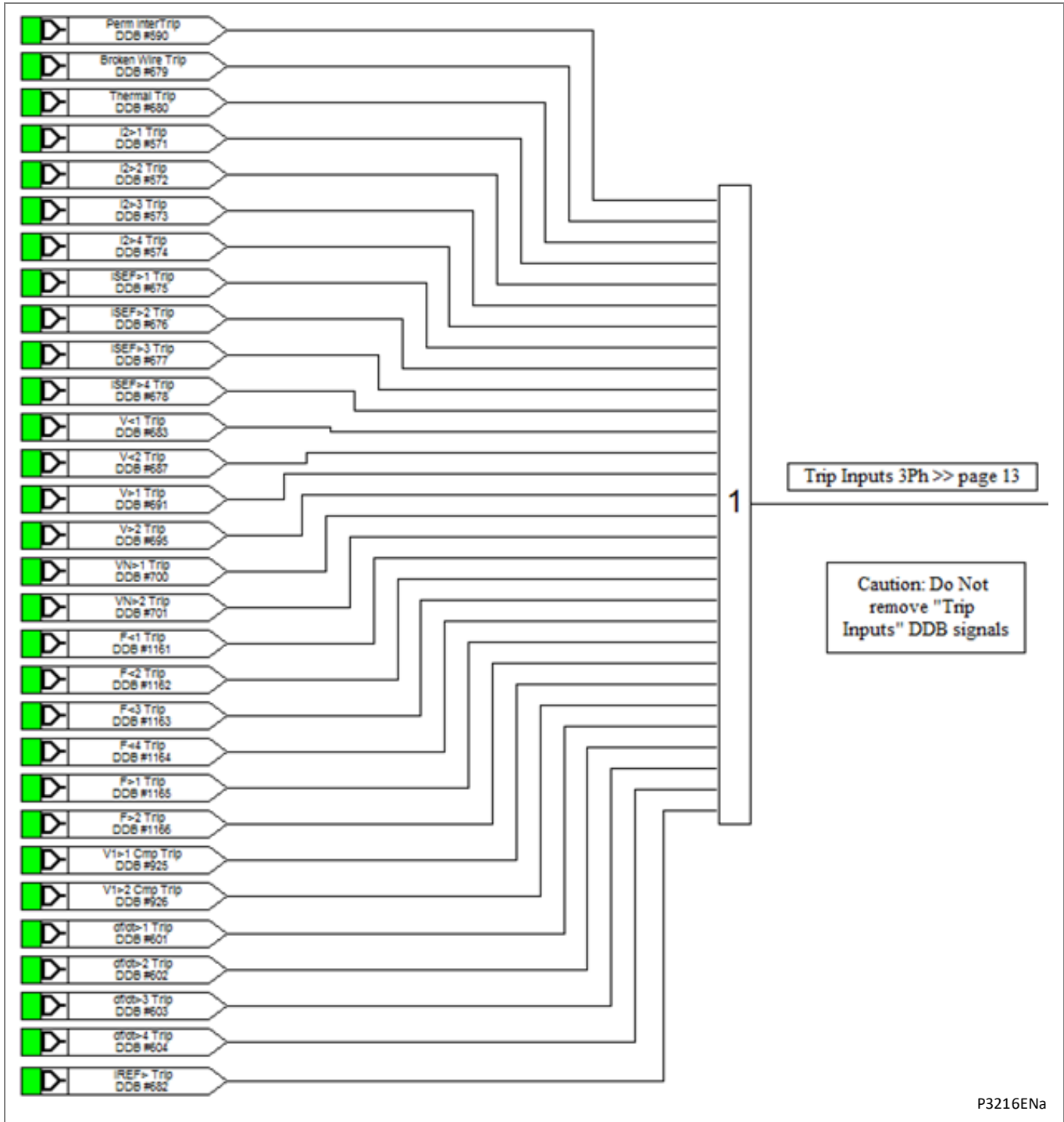

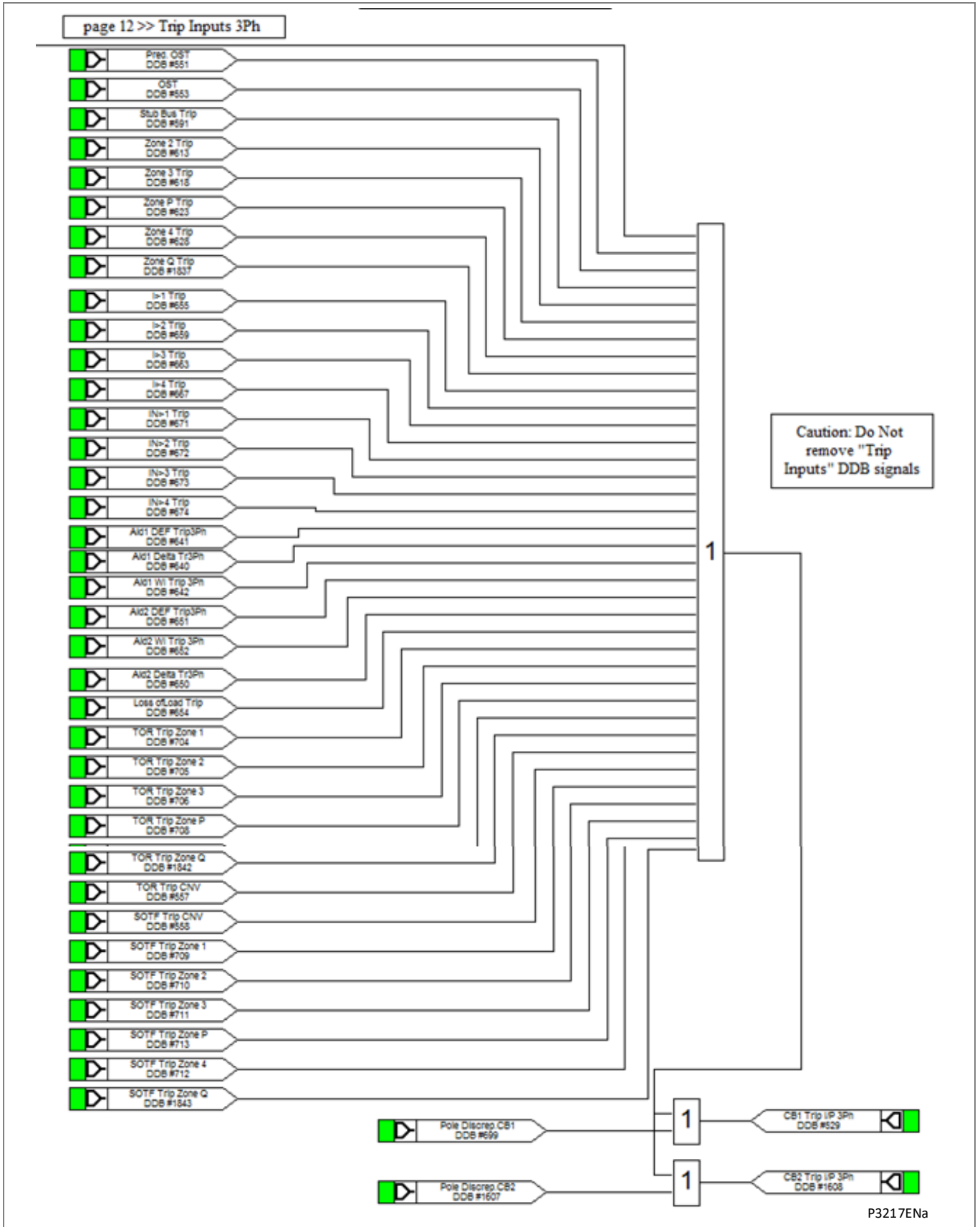

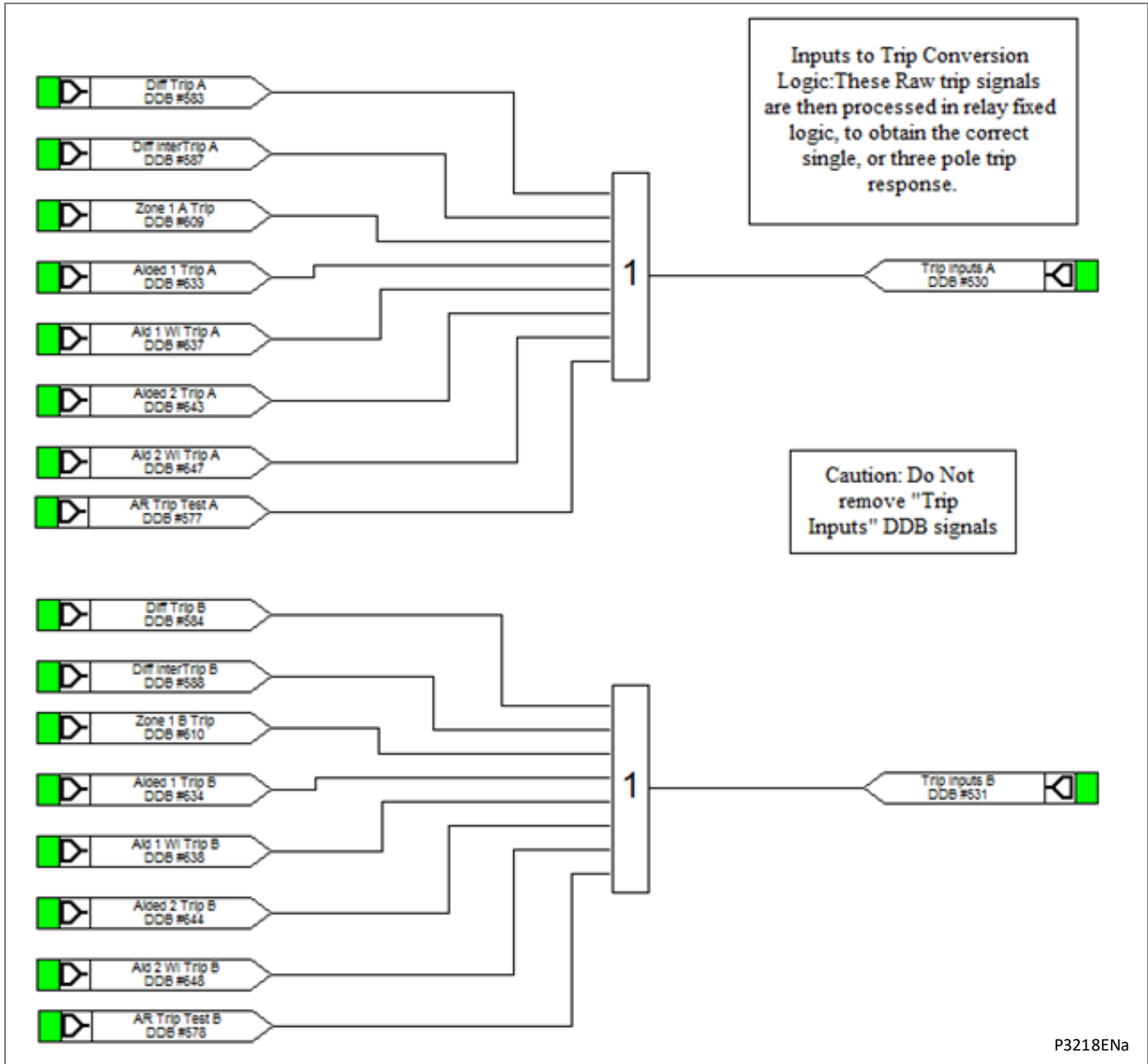

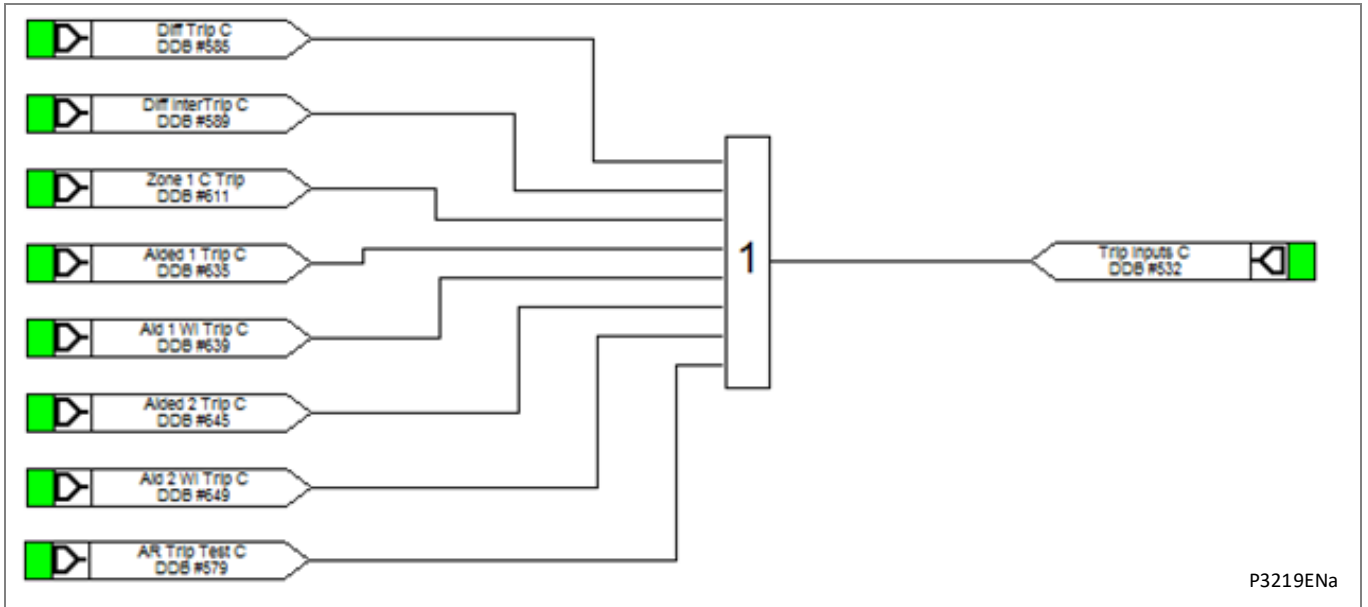

15.2 Opto Inputs and Output Contacts

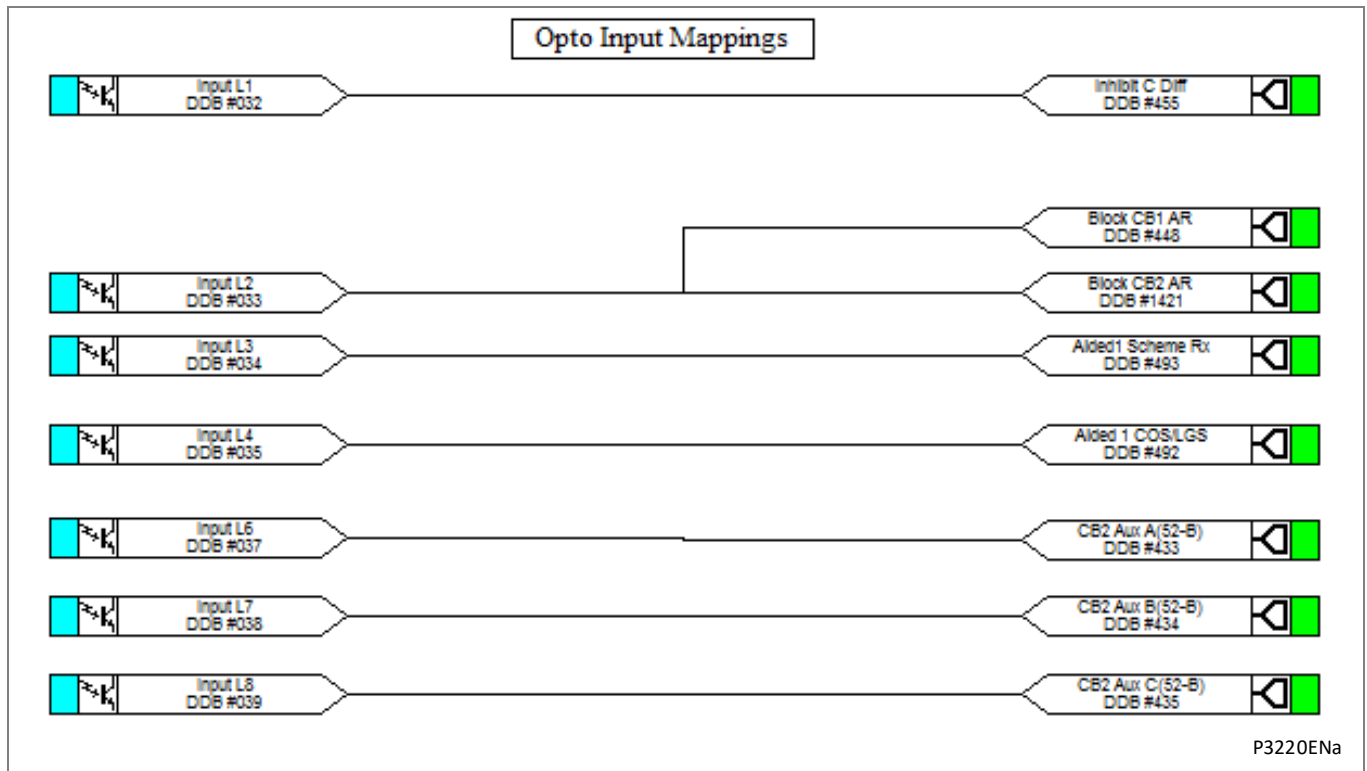

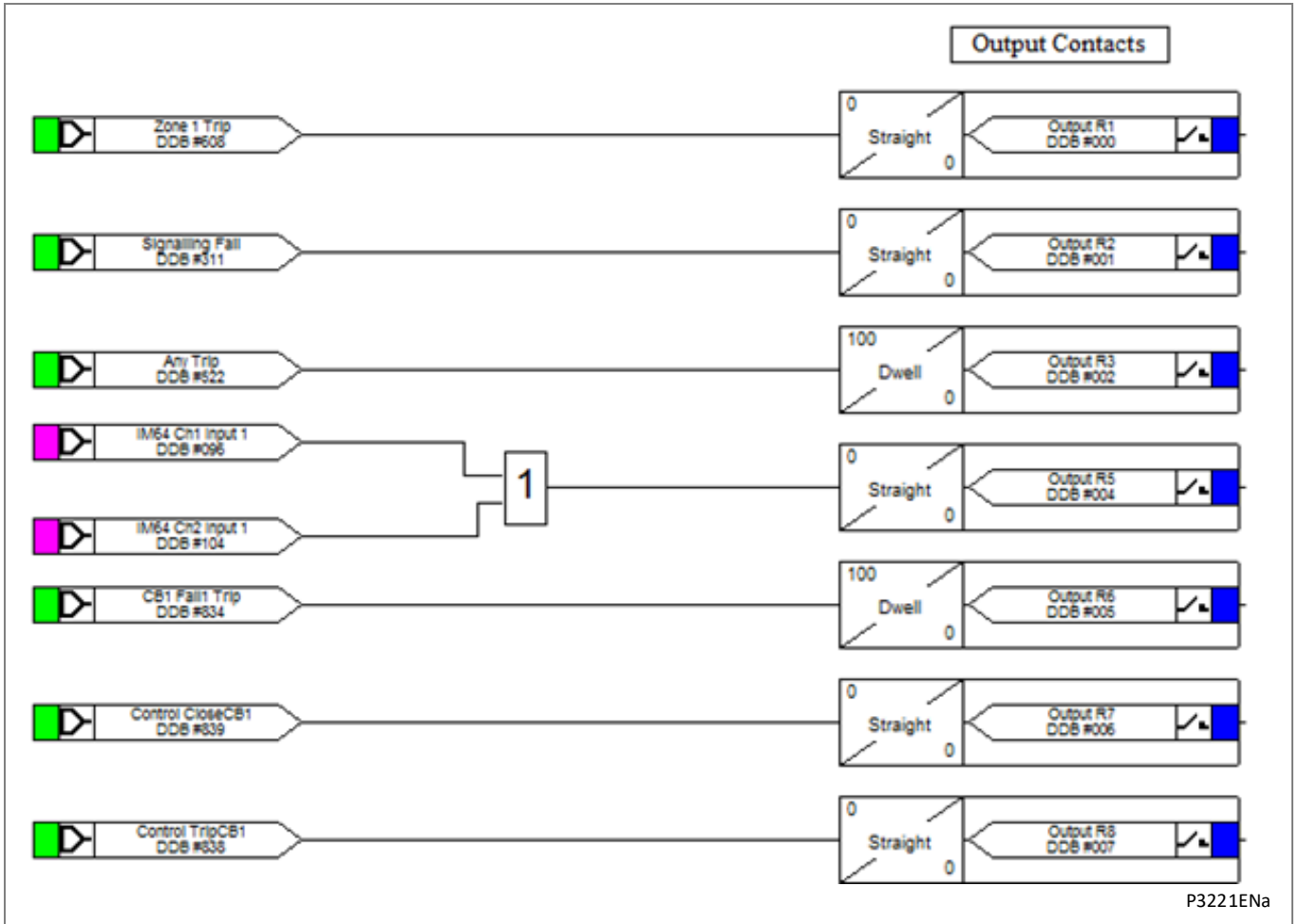

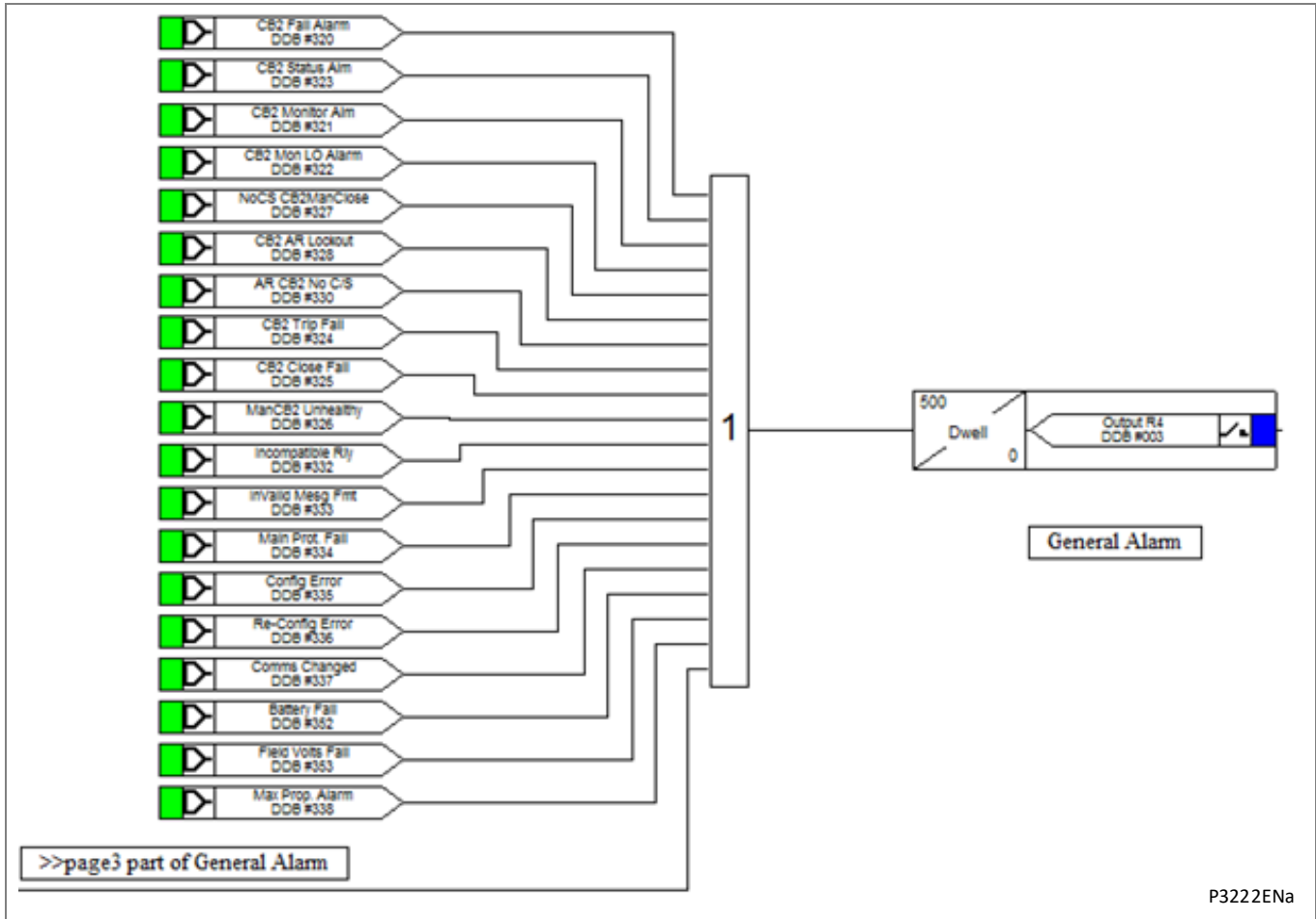

15.3 LEDs

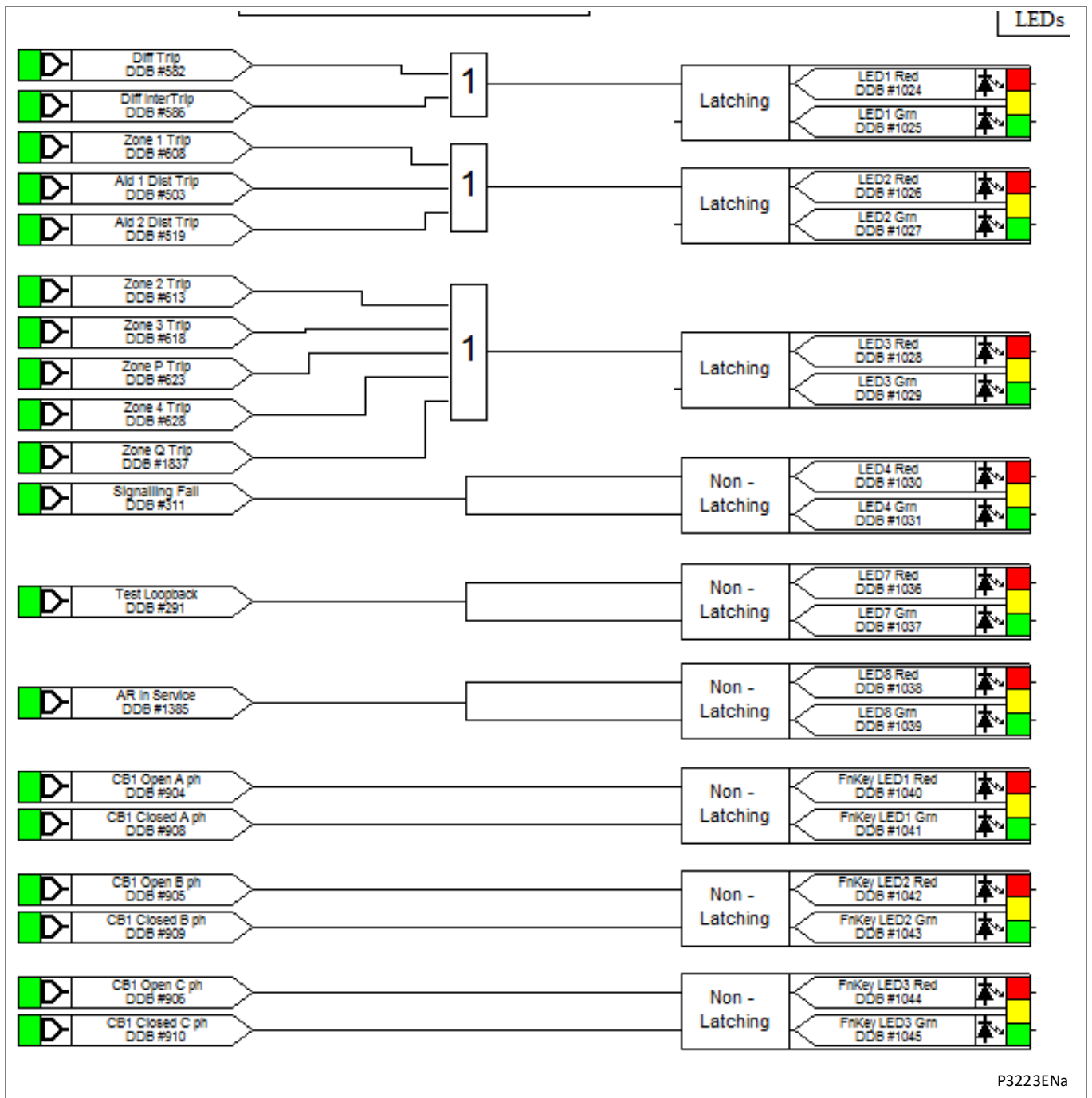

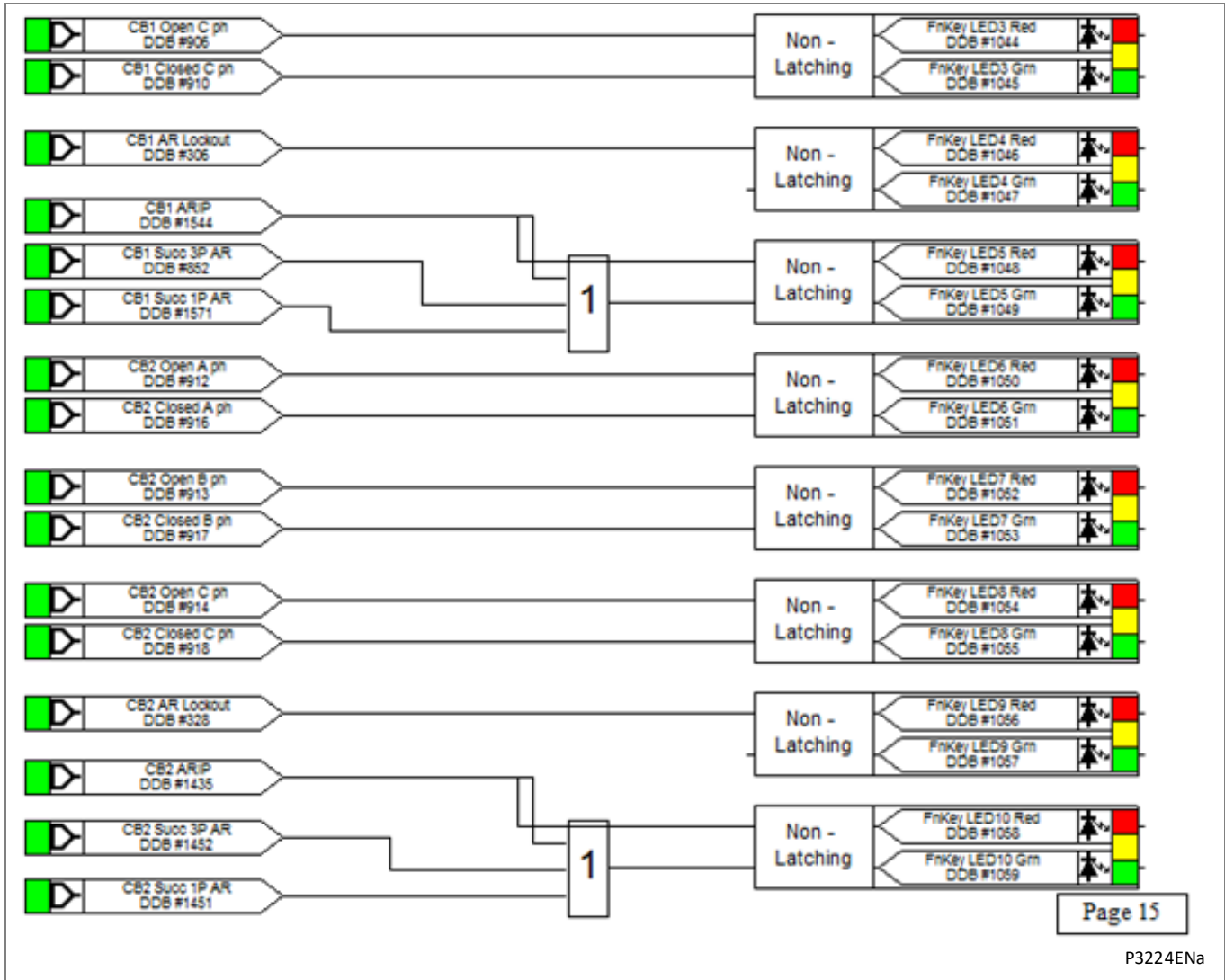

MEASUREMENTS AND RECORDING

CHAPTER 9

Date:	10/2022
Products covered by this chapter:	This chapter covers the specific versions of the MiCOM products listed below. This includes only the following combinations of Software Version and Hardware Suffix.
Hardware suffix:	M
Software version:	K6
Connection diagrams:	10P54302 (SH 1 to 2) 10P54303 (SH 1 to 2) 10P54304 (SH 1 to 2) 10P54400 10P54404 (SH 1 to 2) 10P54405 (SH 1 to 2) 10P54502 (SH 1 to 2) 10P54503 (SH 1 to 2) 10P54504 (SH 1 to 2) 10P54600 10P54604 (SH 1 to 2) 10P54605 (SH 1 to 2) 10P54606 (SH 1 to 2)

CONTENTS

Page (MR) 9-

1	Introduction	5
2	Event and Fault Records	6
2.1	View Records Column	6
2.2	Types of Event	6
2.3	Change of State of Opto-Isolated Inputs	7
2.4	Change of State of one or more Output Relay Contacts	7
2.5	Relay Alarm Conditions	7
2.6	Protection Element Starts and Trips	8
2.7	General Events	9
2.8	Fault Records	9
2.9	Maintenance Reports	9
2.10	Setting Changes	10
2.11	Resetting of Event/Fault Records	10
2.12	Viewing Event Records via Easergy Studio Support Software	10
2.13	Event Filtering	11
3	Disturbance Recorder	18
4	Measurements	31
4.1	Measured Voltages and Currents	31
4.2	Sequence Voltages and Currents	31
4.3	Slip Frequency	31
4.4	Power and Energy Quantities	31
4.5	RMS. Voltages and Currents	32
4.6	Demand Values	32
4.6.1	Fixed Demand Values	32
4.6.2	Rolling Demand Values	32
4.6.3	Peak Demand Values	32
4.7	Settings	32
4.8	Measurement Display Quantities	33
4.9	Measurements 4 Column	35

TABLES

	Page (MR) 9-
Table 1 - View records	6
Table 2 - Alarm conditions and event text/values	8
Table 3 - Event filtering	17
Table 4 - Disturbance recorder for digital channel	29
Table 5 - Measurement setup	33
Table 6 - Measurement 1, 2, 3 and 4	35

1 INTRODUCTION

The relay is equipped with integral measurements, event, fault and disturbance recording facilities suitable for analysis of complex system disturbances.

The relay is flexible enough to allow for the programming of these facilities to specific user application requirements. These requirements are discussed in the sections which follow.

2 EVENT AND FAULT RECORDS

The relay records and time tags up to 250 or 512 events (only up to 250 events in the P24x and P44x) and stores them in non-volatile (battery-backed up) memory. This lets the system operator establish the sequence of events that occurred in the relay following a particular power system condition or switching sequence. When the available space is used up, the oldest event is automatically overwritten by the new one (i.e. first in, first out).

The relay's real-time clock provides the time tag to each event, to a resolution of 1 ms. The event records can be viewed either from the front plate LCD or remotely using the communications ports (using any available protocols, such as Courier or MODBUS).

For local viewing on the LCD of event, fault and maintenance records, select the **VIEW RECORDS** menu column.

For extraction from a remote source using communications, see the *SCADA Communications* chapter or the MiCOM S1 Studio instructions.

For a full list of all the event types and the meaning of their values, see the Menu Database document.

2.1 View Records Column

VIEW RECORDS	
LCD reference	Description
Select Event	Setting range from 0 to 1023. This selects the required event record from the possible 1024 that may be stored. A value of 0 corresponds to the latest event and so on.
Time & Date	Time & Date Stamp for the event given by the internal Real Time Clock.
Event Text	Up to 32 Character description of the Event (refer to following sections).
Event Value	Up to 32 Bit Binary Flag or integer representative of the Event (refer to following sections).
Select Fault	Setting range from 0 to 14. This selects the required fault record from the possible 15 that may be stored. A value of 0 corresponds to the latest fault and so on.
	The following cells show all the fault flags, protection starts, protection trips, fault location, measurements etc. associated with the fault, i.e. the complete fault record.
Select Maint.	Setting range from 0 to 9. This selects the required maintenance report from the possible 10 that may be stored. A value of 0 corresponds to the latest report and so on.
Maint. Text	Up to 16 Character description of the occurrence (refer to following sections).
Maint. Type/Main Data	These cells are numbers representative of the occurrence. They form a specific error code which should be quoted in any related correspondence to Report Data.
Reset Indication	Either Yes or No. This serves to reset the trip LED indications provided that the relevant protection element has reset.

Table 1 - View records

2.2 Types of Event

An event may be a change of state of a control input or output relay, an alarm condition, or a setting change. The following sections show the various items that constitute an event:

2.3 Change of State of Opto-Isolated Inputs

If one or more of the opto (logic) inputs has changed state since the last time the protection algorithm ran, the new status is logged as an event. When this event is selected to be viewed on the LCD, three cells appear, as in shown here:

Time & date of event "LOGIC INPUTS1" "Event Value 0101010101010101"

The Event Value is a multi-bit word (see note) showing the status of the opto inputs, where the least significant bit (extreme right) corresponds to opto input 1. The same information is present if the event is extracted and viewed using a PC.

<i>Note</i>	<i>For P24x or P44x the Event Value is an 8 or 16 bit word. For P34x or P64x it is an 8, 12, 16, 24 or 32-bit word. For P445 it is an 8, 12 or 16-bit word. For P44y, P54x, P547 or P841, it is an 8, 12, 16 or 24-bit word. For P74x it is a 12, 16, 24 or 32-bit word. For P746 or P849 it is a 32-bit word.</i>
-------------	---

2.4 Change of State of one or more Output Relay Contacts

If one or more of the output relay contacts have changed state since the last time the protection algorithm ran, the new status is logged as an event. When this event is selected to be viewed on the LCD, three cells appear, as shown here:

Time and Date of Event Output Contacts Event Value 0101010101010101010
--

The Event Value is a multi-bit word (see Note) showing the status of the output contacts, where the least significant bit (extreme right) corresponds to output contact 1, etc. The same information is present if the event is extracted and viewed using a PC.

<i>Note</i>	<i>For P24x the Event Value is is a 7 or 16-bit word. For P34x or P64x it is an 7, 11, 14, 15, 16, 22, 24 or 32-bit word. For P445 it is an 8, 12 or 16-bit word. For P44x it is a 7, 14 or 21 bit word. For P44y, P54x, P547 or P841, it is an 8, 12, 16, 24 or 32 bit word. For P74x it is a 12, 16, 24 or 32 bit word. For P746 or P849 it is a 24-bit word.</i>
-------------	---

2.5 Relay Alarm Conditions

Any alarm conditions generated by the relays are logged as individual events. This table shows examples of some of the alarm conditions and how they appear in the event list:

Alarm Status 1		Alarm Status 2		Alarm Status 3	
Bit	Text	Bit	Text	Bit	Text
0	SG-opto Invalid	0	CB2 Fail Alarm	0	Battery Fail
1	Prot'n Disabled	1	CB2 Monitor Alm	1	Field Volt Fail
2	Static Test Mode	2	CB2 Mon LO Alarm	2	Comm2 H/W FAIL
3	Test Loopback	3	CB2 Status Alm	3	GOOSE IED Absent
4	Test IM64	4	CB2 Trip Fail	4	NIC Not Fitted
5	VT Fail Alarm	5	CB2 Close Fail	5	NIC No Response
6	CT Fail Alarm	6	ManCB2 Unhealthy	6	NIC Fatal Error
7	CT2 Fail Alarm	7	NoCS CB2ManClose	7	Unused
8	Remote CT Alarm	8	CB2 AR Lockout	8	Unused
9	Power Swing	9	AR CB2 Unhealthy	9	Unused
10	CB Fail Alarm	10	AR CB2 No C/S	10	Unused
11	CB Monitor Alarm	11	Invalid AR Mode	11	NIC SW Mis-Match
12	CB Lockout Alarm	12	Incompatible Rly	12	IP Addr Conflict
13	CB Status Alarm	13	InValid Mesg Fmt	13	IM Loopback
14	CB Trip Fail	14	Main Prot. Fail	14	IM Message Fail
15	CB Close Fail	15	Config Error	15	IM Data CD Fail
16	Man CB Unhealthy	16	Re-Config Error	16	IM Channel Fail
17	No CS ManClose	17	Comms Changed	17	Backup Setting
18	A/R Lockout	18	Max Prop. Alarm	18	Bad DNP Settings
19	A/R CB Unhealthy	19	Ct para mismatch	19	Unused
20	A/R No Checksync	20	Reserved	20	Unused
21	Reserved	21	Reserved	21	Invalid DNPoE IP
22	GPS Alarm	22	Reserved	22	Invalid Config.
23	Signalling Fail	23	Reserved	23	Test Mode Alm
24	Comm Delay Alarm	24	SR User Alarm 1	24	Contacts Blk Alm
25	C Diff Failure	25	SR User Alarm 2	25	NIC H/W Mismatch
26	IM64 SchemeFail	26	SR User Alarm 3	26	NIC APP Mismatch
27	IEEE C37.94 Fail	27	SR User Alarm 4	27	Simul. GOOSE Alm
28	C Diff Inhibited	28	MR User Alarm 5	28	Unused
29	Aid 1 Chan Fail	29	MR User Alarm 6	29	Unused
30	Aid 2 Chan Fail	30	MR User Alarm 7	30	Unused
31	F out of Range	31	MR User Alarm 8	31	Unused

Table 2 - Alarm conditions and event text/values

The previous table shows the abbreviated description given to the various alarm conditions and a corresponding value between 0 and 31. This value is appended to each alarm event in a similar way to the input and output events described previously. It is used by the event extraction software, such as MiCOM S1 Studio, to identify the alarm and is therefore invisible if the event is viewed on the LCD. ON or OFF is shown after the description to signify whether the particular condition has become operated or has reset.

2.6

Protection Element Starts and Trips

Any operation of protection elements, (either a start or a trip condition) is logged as an event record, consisting of a text string indicating the operated element and an event value. This value is intended for use by the event extraction software, such as MiCOM S1 Studio, rather than for the user, and is invisible when the event is viewed on the LCD.

2.7 General Events

Several events come under the heading of **General Events**. An example appears here.

Nature of event	Displayed text in event record	Displayed value
Password modified, either from the front or the rear port.	PW modified F, R or R2	0 F=11, R=16, R2=38.

A complete list of the General Events is in the Relay Menu Database document. This is a separate document, for each MiCOM Px4x product or product range. They are normally available for download from www.schneider-electric.com

2.8 Fault Records

Each time a fault record is generated, an event is also created. The event states that a fault record was generated, with a corresponding time stamp.

Further down the **VIEW RECORDS** column, select the Select Fault cell to view the actual fault record, which is selectable from up to 15 records. These records consist of fault flags, fault location, fault measurements, etc. The time stamp given in the fault record is more accurate than the corresponding stamp given in the event record as the event is logged some time after the actual fault record is generated.

The latest fault record can also be retrieved over DNP3.0 and IEC61850, please refer to the Object 30 Analog Input section in the SCADA Communications chapter as well as the IEC 61850 in MiCOM Relays section for detailed information.

The fault record is triggered from the **Fault REC. TRIG.** signal assigned in the default programmable scheme logic. Normally this is assigned to relay 3, protection trip, but in the P746 it is assigned to Any Start or Any Trip. The fault measurements in the fault record are given at the time of the protection start.

The fault recorder does not stop recording until any start or relay 3 (protection trip) resets in order to record all the protection flags during the fault.

It is recommended that the triggering contact (relay 3 for example) be 'self reset' and not latching. If a latching contact were chosen the fault record would not be generated until the contact had fully reset.

2.9 Maintenance Reports

Internal failures detected by the self-monitoring circuitry, such as watchdog failure, field voltage failure etc. are logged into a maintenance report. The maintenance report holds up to 10 such **Events** and is accessed from the **Select Maint** cell at the bottom of the **VIEW RECORDS** column.

Each entry consists of a self explanatory text string and a **Type** and **Data** cell, which are explained in the menu extract at the beginning of this section.

Each time a Maintenance Report is generated, an event is also created. The event simply states that a report was generated, with a corresponding time stamp.

2.10 Setting Changes

Changes to any setting in the relay are logged as an event. For example:

Type of setting change	Displayed text in event record	Displayed value
Control/Support Setting	C & S Changed	22
Group # Change	Group # Changed	#
Where # = 1 to 4		
<p><i>Note</i> <i>Control/Support settings are communications, measurement, CT/VT ratio settings etc, which are not duplicated in the setting groups. When any of these settings are changed, the event record is created simultaneously. Changes to protection or disturbance recorder settings only generate an event once the settings have been confirmed at the 'setting trap'.</i></p>		

2.11 Resetting of Event/Fault Records

To delete the event, fault or maintenance reports, use the **RECORD CONTROL** column.

2.12 Viewing Event Records via Easergy Studio Support Software

When the event records are extracted and viewed on a PC they look slightly different than when viewed on the LCD. The following shows an example of how various events appear when displayed using Easergy Studio:

```
Monday 24 October 2008 15:32:49 GMT I>1 Start ON
MiCOM : MiCOM P54x
Model Number: P543218A1M054/50K
Address: 001 Column: 00 Row: 23
Event Type: Protection operation
Monday 24 October 2008 15:32:52 GMT Fault Recorded
MiCOM : MiCOM P54x
Model Number: P543218A1M054/50K
Address: 001 Column: 01 Row: 00
Event Type: Fault record
Monday 24 October 2008 15:33:11 GMT Logic Inputs
MiCOM : MiCOM P54x
Model Number: P543218A1M054/50K
Address: 001 Column: 00 Row: 20
Event Type: Logic input changed state
Monday 24 October 2008 15:34:54 GMT Output Contacts
MiCOM : MiCOM P54x
Model Number: P543218A1M054/50K
Address: 001 Column: 00 Row: 21
Event Type: Relay output changed state
Monday 24 October 2008 15:35:55 GMT A/R Lockout ON
MiCOM : MiCOM P54x
Model Number: P543218A1M054/50K
Address: 001 Column: 00 Row: 22
Event Type: Alarm event
Tuesday 25 October 2016 20:18:22.988 GMT Zone 1 Trip ON
MiCOM : MiCOM P54x
Model Number: P543218A1M054/50K
Address: 001 Column: 0F Row: 30
Event Type: Setting event
```

The first line gives the description and time stamp for the event, while the additional information displayed below may be collapsed using the +/- symbol.

For further information regarding events and their specific meaning, refer to the *Menu Database* document. This standalone document not included in this manual.

2.13 Event Filtering

Event reporting can be disabled from all interfaces that support setting changes. The settings that control the various types of events are in the RECORD CONTROL column. The effect of setting each to disabled is shown in the following table:

Note Some occurrences can result in more than one type of event, e.g. a battery failure will produce an alarm event and a maintenance record event.

If the Protection Event setting is Enabled, a further set of settings is revealed which allow the event generation by individual DDB signals to be enabled or disabled.

For further information on events and their specific meaning, see the *Relay Menu Database* document.

MENU TEXT	Col	Row	Default Setting	Available Setting
Description				
RECORD CONTROL	0B	0	0	
This column contains settings for Record Controls				
Clear Events	0B	1	No	0 = No or 1 = Yes
Clear Event records				
Clear Faults	0B	2	No	0 = No or 1 = Yes
Clear Fault records				
Clear Maint	0B	3	No	0 = No or 1 = Yes
Clear Maintenance records				
Alarm Event	0B	4	Enabled	0 = Disabled or 1 = Enabled
Disabling this setting means that all the occurrences that produce an alarm will result in no event being generated.				
Relay O/P Event	0B	5	Enabled	0 = Disabled or 1 = Enabled
Disabling this setting means that no event will be generated for any change in logic state.				
Opto Input Event	0B	6	Enabled	0 = Disabled or 1 = Enabled
Disabling this setting means that no event will be generated for any change in logic input state.				
General Event	0B	7	Enabled	0 = Disabled or 1 = Enabled
Disabling this setting means that no General Events will be generated				
Fault Rec Event	0B	8	Enabled	0 = Disabled or 1 = Enabled
Disabling this setting means that no event will be generated for any fault that produces a fault record				
Maint Rec Event	0B	9	Enabled	0 = Disabled or 1 = Enabled
Disabling this setting means that no event will be generated for any occurrence that produces a maintenance record.				
Protection Event	0B	0A	Enabled	0 = Disabled or 1 = Enabled
Disabling this setting means that any operation of protection elements will not be logged as an event				
Flt Rec Extended	0B	2F	Disabled	0 = Disabled or 1 = Enabled
When this setting is disabled, the fault record contains a snap shot of the local, remote, differential and bias currents taken 1 cycle after the trip. With this setting enabled an additional snap shot of local, remote, differential and bias currents taken at the time the differential trips is included in the fault record.				
Clear Dist Recs	0B	30	No	0 = No or 1 = Yes
Clear Disturbance records				
Security Event	0B	31	Enabled	0 = Disabled or 1 = Enabled
Disabling this setting means that any operation of security elements will not be logged as an event				
DDB 31 - 0	0B	40	0xFFFFFFFF	32-bit binary setting: 1 = event recording Enabled, 0 = event recording Disabled

MENU TEXT	Col	Row	Default Setting	Available Setting
Description				
Chooses whether any individual DDBs should be deselected as a stored event, by setting the relevant bit to 0 (zero). Typically used for repetitive recurrent changes such as an Opto input assigned for Minute Pulse clock synchronizing.				
DDB 63 - 32	0B	41	0xFFFFFFFF	32-bit binary setting: 1 = event recording Enabled, 0 = event recording Disabled
Chooses whether any individual DDBs should be deselected as a stored event, by setting the relevant bit to 0 (zero). Typically used for repetitive recurrent changes such as an Opto input assigned for Minute Pulse clock synchronizing.				
DDB 95 - 64	0B	42	0xFFFFFFFF	32-bit binary setting: 1 = event recording Enabled, 0 = event recording Disabled
Chooses whether any individual DDBs should be deselected as a stored event, by setting the relevant bit to 0 (zero). Typically used for repetitive recurrent changes such as an Opto input assigned for Minute Pulse clock synchronizing.				
DDB 127 - 96	0B	43	0xFFFFFFFF	32-bit binary setting: 1 = event recording Enabled, 0 = event recording Disabled
Chooses whether any individual DDBs should be deselected as a stored event, by setting the relevant bit to 0 (zero). Typically used for repetitive recurrent changes such as an Opto input assigned for Minute Pulse clock synchronizing.				
DDB 159 - 128	0B	44	0xFFFFFFFF	32-bit binary setting: 1 = event recording Enabled, 0 = event recording Disabled
Chooses whether any individual DDBs should be deselected as a stored event, by setting the relevant bit to 0 (zero). Typically used for repetitive recurrent changes such as an Opto input assigned for Minute Pulse clock synchronizing.				
DDB 191 - 160	0B	45	0xFFFFFFFF	32-bit binary setting: 1 = event recording Enabled, 0 = event recording Disabled
Chooses whether any individual DDBs should be deselected as a stored event, by setting the relevant bit to 0 (zero). Typically used for repetitive recurrent changes such as an Opto input assigned for Minute Pulse clock synchronizing.				
DDB 223 - 192	0B	46	0xFFFFFFFF	32-bit binary setting: 1 = event recording Enabled, 0 = event recording Disabled
Chooses whether any individual DDBs should be deselected as a stored event, by setting the relevant bit to 0 (zero). Typically used for repetitive recurrent changes such as an Opto input assigned for Minute Pulse clock synchronizing.				
DDB 255 - 224	0B	47	0xFFFFFFFF	32-bit binary setting: 1 = event recording Enabled, 0 = event recording Disabled
Chooses whether any individual DDBs should be deselected as a stored event, by setting the relevant bit to 0 (zero). Typically used for repetitive recurrent changes such as an Opto input assigned for Minute Pulse clock synchronizing.				
DDB 287 - 256	0B	48	0xFFFFFFFF	32-bit binary setting: 1 = event recording Enabled, 0 = event recording Disabled
Chooses whether any individual DDBs should be deselected as a stored event, by setting the relevant bit to 0 (zero). Typically used for repetitive recurrent changes such as an Opto input assigned for Minute Pulse clock synchronizing.				
DDB 319 - 288	0B	49	0xFFFFFFFF	32-bit binary setting: 1 = event recording Enabled, 0 = event recording Disabled
Chooses whether any individual DDBs should be deselected as a stored event, by setting the relevant bit to 0 (zero). Typically used for repetitive recurrent changes such as an Opto input assigned for Minute Pulse clock synchronizing.				
DDB 351 - 320	0B	4A	0xFFFFFFFF	32-bit binary setting: 1 = event recording Enabled, 0 = event recording Disabled
Chooses whether any individual DDBs should be deselected as a stored event, by setting the relevant bit to 0 (zero). Typically used for repetitive recurrent changes such as an Opto input assigned for Minute Pulse clock synchronizing.				
DDB 383 - 352	0B	4B	0xFFFFFFFF	32-bit binary setting: 1 = event recording Enabled, 0 = event recording Disabled
Chooses whether any individual DDBs should be deselected as a stored event, by setting the relevant bit to 0 (zero). Typically used for repetitive recurrent changes such as an Opto input assigned for Minute Pulse clock synchronizing.				
DDB 415 - 384	0B	4C	0xFFFFFFFF	32-bit binary setting: 1 = event recording Enabled, 0 = event recording Disabled
Chooses whether any individual DDBs should be deselected as a stored event, by setting the relevant bit to 0 (zero). Typically used for repetitive recurrent changes such as an Opto input assigned for Minute Pulse clock synchronizing.				

MENU TEXT	Col	Row	Default Setting	Available Setting
Description				
DDB 447 - 416	0B	4D	0xFFFFFFFF	32-bit binary setting: 1 = event recording Enabled, 0 = event recording Disabled
Chooses whether any individual DDBs should be deselected as a stored event, by setting the relevant bit to 0 (zero). Typically used for repetitive recurrent changes such as an Opto input assigned for Minute Pulse clock synchronizing.				
DDB 479 - 448	0B	4E	0xFFFFFFFF	32-bit binary setting: 1 = event recording Enabled, 0 = event recording Disabled
Chooses whether any individual DDBs should be deselected as a stored event, by setting the relevant bit to 0 (zero). Typically used for repetitive recurrent changes such as an Opto input assigned for Minute Pulse clock synchronizing.				
DDB 511 - 480	0B	4F	0xFFFFFFFF	32-bit binary setting: 1 = event recording Enabled, 0 = event recording Disabled
Chooses whether any individual DDBs should be deselected as a stored event, by setting the relevant bit to 0 (zero). Typically used for repetitive recurrent changes such as an Opto input assigned for Minute Pulse clock synchronizing.				
DDB 543 - 512	0B	50	0xFFFFFFFF	32-bit binary setting: 1 = event recording Enabled, 0 = event recording Disabled
Chooses whether any individual DDBs should be deselected as a stored event, by setting the relevant bit to 0 (zero). Typically used for repetitive recurrent changes such as an Opto input assigned for Minute Pulse clock synchronizing.				
DDB 575 - 544	0B	51	0xFFFFFFFF	32-bit binary setting: 1 = event recording Enabled, 0 = event recording Disabled
Chooses whether any individual DDBs should be deselected as a stored event, by setting the relevant bit to 0 (zero). Typically used for repetitive recurrent changes such as an Opto input assigned for Minute Pulse clock synchronizing.				
DDB 607 - 576	0B	52	0xFFFFFFFF	32-bit binary setting: 1 = event recording Enabled, 0 = event recording Disabled
Chooses whether any individual DDBs should be deselected as a stored event, by setting the relevant bit to 0 (zero). Typically used for repetitive recurrent changes such as an Opto input assigned for Minute Pulse clock synchronizing.				
DDB 639 - 608	0B	53	0xFFFFFFFF	32-bit binary setting: 1 = event recording Enabled, 0 = event recording Disabled
Chooses whether any individual DDBs should be deselected as a stored event, by setting the relevant bit to 0 (zero). Typically used for repetitive recurrent changes such as an Opto input assigned for Minute Pulse clock synchronizing.				
DDB 671 - 640	0B	54	0xFFFFFFFF	32-bit binary setting: 1 = event recording Enabled, 0 = event recording Disabled
Chooses whether any individual DDBs should be deselected as a stored event, by setting the relevant bit to 0 (zero). Typically used for repetitive recurrent changes such as an Opto input assigned for Minute Pulse clock synchronizing.				
DDB 703 - 672	0B	55	0xFFFFFFFF	32-bit binary setting: 1 = event recording Enabled, 0 = event recording Disabled
Chooses whether any individual DDBs should be deselected as a stored event, by setting the relevant bit to 0 (zero). Typically used for repetitive recurrent changes such as an Opto input assigned for Minute Pulse clock synchronizing.				
DDB 735 - 704	0B	56	0xFFFFFFFF	32-bit binary setting: 1 = event recording Enabled, 0 = event recording Disabled
Chooses whether any individual DDBs should be deselected as a stored event, by setting the relevant bit to 0 (zero). Typically used for repetitive recurrent changes such as an Opto input assigned for Minute Pulse clock synchronizing.				
DDB 767 - 736	0B	57	0xFFFFFFFF	32-bit binary setting: 1 = event recording Enabled, 0 = event recording Disabled
Chooses whether any individual DDBs should be deselected as a stored event, by setting the relevant bit to 0 (zero). Typically used for repetitive recurrent changes such as an Opto input assigned for Minute Pulse clock synchronizing.				
DDB 799 - 768	0B	58	0xFFFFFFFF	32-bit binary setting: 1 = event recording Enabled, 0 = event recording Disabled
Chooses whether any individual DDBs should be deselected as a stored event, by setting the relevant bit to 0 (zero). Typically used for repetitive recurrent changes such as an Opto input assigned for Minute Pulse clock synchronizing.				
DDB 831 - 800	0B	59	0xFFFFFFFF	32-bit binary setting: 1 = event recording Enabled, 0 = event recording Disabled

MENU TEXT	Col	Row	Default Setting	Available Setting
Description				
Chooses whether any individual DDBs should be deselected as a stored event, by setting the relevant bit to 0 (zero). Typically used for repetitive recurrent changes such as an Opto input assigned for Minute Pulse clock synchronizing.				
DDB 863 - 832	0B	5A	0xFFFFFFFF	32-bit binary setting: 1 = event recording Enabled, 0 = event recording Disabled
Chooses whether any individual DDBs should be deselected as a stored event, by setting the relevant bit to 0 (zero). Typically used for repetitive recurrent changes such as an Opto input assigned for Minute Pulse clock synchronizing.				
DDB 895 - 864	0B	5B	0xFFFFFFFF	32-bit binary setting: 1 = event recording Enabled, 0 = event recording Disabled
Chooses whether any individual DDBs should be deselected as a stored event, by setting the relevant bit to 0 (zero). Typically used for repetitive recurrent changes such as an Opto input assigned for Minute Pulse clock synchronizing.				
DDB 927 - 896	0B	5C	0xFFFFFFFF	32-bit binary setting: 1 = event recording Enabled, 0 = event recording Disabled
Chooses whether any individual DDBs should be deselected as a stored event, by setting the relevant bit to 0 (zero). Typically used for repetitive recurrent changes such as an Opto input assigned for Minute Pulse clock synchronizing.				
DDB 959 - 928	0B	5D	0xFFFFFFFF	32-bit binary setting: 1 = event recording Enabled, 0 = event recording Disabled
Chooses whether any individual DDBs should be deselected as a stored event, by setting the relevant bit to 0 (zero). Typically used for repetitive recurrent changes such as an Opto input assigned for Minute Pulse clock synchronizing.				
DDB 991 - 960	0B	5E	0xFFFFFFFF	32-bit binary setting: 1 = event recording Enabled, 0 = event recording Disabled
Chooses whether any individual DDBs should be deselected as a stored event, by setting the relevant bit to 0 (zero). Typically used for repetitive recurrent changes such as an Opto input assigned for Minute Pulse clock synchronizing.				
DDB 1023 - 992	0B	5F	0xFFFFFFFF	32-bit binary setting: 1 = event recording Enabled, 0 = event recording Disabled
Chooses whether any individual DDBs should be deselected as a stored event, by setting the relevant bit to 0 (zero). Typically used for repetitive recurrent changes such as an Opto input assigned for Minute Pulse clock synchronizing.				
DDB 1055 - 1024	0B	60	0xFFFFFFFF	32-bit binary setting: 1 = event recording Enabled, 0 = event recording Disabled
Chooses whether any individual DDBs should be deselected as a stored event, by setting the relevant bit to 0 (zero). Typically used for repetitive recurrent changes such as an Opto input assigned for Minute Pulse clock synchronizing.				
DDB 1087 - 1056	0B	61	0xFFFFFFFF	32-bit binary setting: 1 = event recording Enabled, 0 = event recording Disabled
Chooses whether any individual DDBs should be deselected as a stored event, by setting the relevant bit to 0 (zero). Typically used for repetitive recurrent changes such as an Opto input assigned for Minute Pulse clock synchronizing.				
DDB 1119 - 1088	0B	62	0xFFFFFFFF	32-bit binary setting: 1 = event recording Enabled, 0 = event recording Disabled
Chooses whether any individual DDBs should be deselected as a stored event, by setting the relevant bit to 0 (zero). Typically used for repetitive recurrent changes such as an Opto input assigned for Minute Pulse clock synchronizing.				
DDB 1151 - 1120	0B	63	0xFFFFFFFF	32-bit binary setting: 1 = event recording Enabled, 0 = event recording Disabled
Chooses whether any individual DDBs should be deselected as a stored event, by setting the relevant bit to 0 (zero). Typically used for repetitive recurrent changes such as an Opto input assigned for Minute Pulse clock synchronizing.				
DDB 1183 - 1152	0B	64	0xFFFFFFFF	32-bit binary setting: 1 = event recording Enabled, 0 = event recording Disabled
Chooses whether any individual DDBs should be deselected as a stored event, by setting the relevant bit to 0 (zero). Typically used for repetitive recurrent changes such as an Opto input assigned for Minute Pulse clock synchronizing.				
DDB 1215 - 1184	0B	65	0xFFFFFFFF	32-bit binary setting: 1 = event recording Enabled, 0 = event recording Disabled
Chooses whether any individual DDBs should be deselected as a stored event, by setting the relevant bit to 0 (zero). Typically used for repetitive recurrent changes such as an Opto input assigned for Minute Pulse clock synchronizing.				

MENU TEXT	Col	Row	Default Setting	Available Setting
Description				
DDB 1247 - 1216	0B	66	0xFFFFFFFF	32-bit binary setting: 1 = event recording Enabled, 0 = event recording Disabled
Chooses whether any individual DDBs should be deselected as a stored event, by setting the relevant bit to 0 (zero). Typically used for repetitive recurrent changes such as an Opto input assigned for Minute Pulse clock synchronizing.				
DDB 1279 - 1248	0B	67	0xFFFFFFFF	32-bit binary setting: 1 = event recording Enabled, 0 = event recording Disabled
Chooses whether any individual DDBs should be deselected as a stored event, by setting the relevant bit to 0 (zero). Typically used for repetitive recurrent changes such as an Opto input assigned for Minute Pulse clock synchronizing.				
DDB 1311 - 1280	0B	68	0xFFFFFFFF	32-bit binary setting: 1 = event recording Enabled, 0 = event recording Disabled
Chooses whether any individual DDBs should be deselected as a stored event, by setting the relevant bit to 0 (zero). Typically used for repetitive recurrent changes such as an Opto input assigned for Minute Pulse clock synchronizing.				
DDB 1343 - 1312	0B	69	0xFFFFFFFF	32-bit binary setting: 1 = event recording Enabled, 0 = event recording Disabled
Chooses whether any individual DDBs should be deselected as a stored event, by setting the relevant bit to 0 (zero). Typically used for repetitive recurrent changes such as an Opto input assigned for Minute Pulse clock synchronizing.				
DDB 1375 - 1344	0B	6A	0xFFFFFFFF	32-bit binary setting: 1 = event recording Enabled, 0 = event recording Disabled
Chooses whether any individual DDBs should be deselected as a stored event, by setting the relevant bit to 0 (zero). Typically used for repetitive recurrent changes such as an Opto input assigned for Minute Pulse clock synchronizing.				
DDB 1407 - 1376	0B	6B	0xFFFFFFFF	32-bit binary setting: 1 = event recording Enabled, 0 = event recording Disabled
Chooses whether any individual DDBs should be deselected as a stored event, by setting the relevant bit to 0 (zero). Typically used for repetitive recurrent changes such as an Opto input assigned for Minute Pulse clock synchronizing.				
DDB 1439 - 1408	0B	6C	0xFFFFFFFF	32-bit binary setting: 1 = event recording Enabled, 0 = event recording Disabled
Chooses whether any individual DDBs should be deselected as a stored event, by setting the relevant bit to 0 (zero). Typically used for repetitive recurrent changes such as an Opto input assigned for Minute Pulse clock synchronizing.				
DDB 1471 - 1440	0B	6D	0xFFFFFFFF	32-bit binary setting: 1 = event recording Enabled, 0 = event recording Disabled
Chooses whether any individual DDBs should be deselected as a stored event, by setting the relevant bit to 0 (zero). Typically used for repetitive recurrent changes such as an Opto input assigned for Minute Pulse clock synchronizing.				
DDB 1503 - 1472	0B	6E	0xFFFFFFFF	32-bit binary setting: 1 = event recording Enabled, 0 = event recording Disabled
Chooses whether any individual DDBs should be deselected as a stored event, by setting the relevant bit to 0 (zero). Typically used for repetitive recurrent changes such as an Opto input assigned for Minute Pulse clock synchronizing.				
DDB 1535 - 1504	0B	6F	0xFFFFFFFF	32-bit binary setting: 1 = event recording Enabled, 0 = event recording Disabled
Chooses whether any individual DDBs should be deselected as a stored event, by setting the relevant bit to 0 (zero). Typically used for repetitive recurrent changes such as an Opto input assigned for Minute Pulse clock synchronizing.				
DDB 1567 - 1536	0B	70	0xFFFFFFFF	32-bit binary setting: 1 = event recording Enabled, 0 = event recording Disabled
Chooses whether any individual DDBs should be deselected as a stored event, by setting the relevant bit to 0 (zero). Typically used for repetitive recurrent changes such as an Opto input assigned for Minute Pulse clock synchronizing.				
DDB 1599 - 1568	0B	71	0xFFFFFFFF	32-bit binary setting: 1 = event recording Enabled, 0 = event recording Disabled
Chooses whether any individual DDBs should be deselected as a stored event, by setting the relevant bit to 0 (zero). Typically used for repetitive recurrent changes such as an Opto input assigned for Minute Pulse clock synchronizing.				
DDB 1631 - 1600	0B	72	0xFFFFFFFF	32-bit binary setting: 1 = event recording Enabled, 0 = event recording Disabled

MENU TEXT	Col	Row	Default Setting	Available Setting
Description				
Chooses whether any individual DDBs should be deselected as a stored event, by setting the relevant bit to 0 (zero). Typically used for repetitive recurrent changes such as an Opto input assigned for Minute Pulse clock synchronizing.				
DDB 1663 - 1632	0B	73	0xFFFFFFFF	32-bit binary setting: 1 = event recording Enabled, 0 = event recording Disabled
Chooses whether any individual DDBs should be deselected as a stored event, by setting the relevant bit to 0 (zero). Typically used for repetitive recurrent changes such as an Opto input assigned for Minute Pulse clock synchronizing.				
DDB 1695 - 1664	0B	74	0xFFFFFFFF	32-bit binary setting: 1 = event recording Enabled, 0 = event recording Disabled
Chooses whether any individual DDBs should be deselected as a stored event, by setting the relevant bit to 0 (zero). Typically used for repetitive recurrent changes such as an Opto input assigned for Minute Pulse clock synchronizing.				
DDB 1727 - 1696	0B	75	0xFFFFFFFF	32-bit binary setting: 1 = event recording Enabled, 0 = event recording Disabled
Chooses whether any individual DDBs should be deselected as a stored event, by setting the relevant bit to 0 (zero). Typically used for repetitive recurrent changes such as an Opto input assigned for Minute Pulse clock synchronizing.				
DDB 1759 - 1728	0B	76	0xFFFFFFFF	32-bit binary setting: 1 = event recording Enabled, 0 = event recording Disabled
Chooses whether any individual DDBs should be deselected as a stored event, by setting the relevant bit to 0 (zero). Typically used for repetitive recurrent changes such as an Opto input assigned for Minute Pulse clock synchronizing.				
DDB 1760 - 1791	0B	77	0xFFFFFFFF	32-bit binary setting: 1 = event recording Enabled, 0 = event recording Disabled
Chooses whether any individual DDBs should be deselected as a stored event, by setting the relevant bit to 0 (zero). Typically used for repetitive recurrent changes such as an Opto input assigned for Minute Pulse clock synchronizing.				
DDB 1792 - 1823	0B	78	0xFFFFFFFF	32-bit binary setting: 1 = event recording Enabled, 0 = event recording Disabled
Chooses whether any individual DDBs should be deselected as a stored event, by setting the relevant bit to 0 (zero). Typically used for repetitive recurrent changes such as an Opto input assigned for Minute Pulse clock synchronizing.				
DDB 1824 - 1855	0B	79	0xFFFFFFFF	32-bit binary setting: 1 = event recording Enabled, 0 = event recording Disabled
Chooses whether any individual DDBs should be deselected as a stored event, by setting the relevant bit to 0 (zero). Typically used for repetitive recurrent changes such as an Opto input assigned for Minute Pulse clock synchronizing.				
DDB 1856 - 1887	0B	7A	0xFFFFFFFF	32-bit binary setting: 1 = event recording Enabled, 0 = event recording Disabled
Chooses whether any individual DDBs should be deselected as a stored event, by setting the relevant bit to 0 (zero). Typically used for repetitive recurrent changes such as an Opto input assigned for Minute Pulse clock synchronizing.				
DDB 1888 - 1919	0B	7B	0xFFFFFFFF	32-bit binary setting: 1 = event recording Enabled, 0 = event recording Disabled
Chooses whether any individual DDBs should be deselected as a stored event, by setting the relevant bit to 0 (zero). Typically used for repetitive recurrent changes such as an Opto input assigned for Minute Pulse clock synchronizing.				
DDB 1920 - 1951	0B	7C	0xFFFFFFFF	32-bit binary setting: 1 = event recording Enabled, 0 = event recording Disabled
Chooses whether any individual DDBs should be deselected as a stored event, by setting the relevant bit to 0 (zero). Typically used for repetitive recurrent changes such as an Opto input assigned for Minute Pulse clock synchronizing.				
DDB 1952 - 1983	0B	7D	0xFFFFFFFF	32-bit binary setting: 1 = event recording Enabled, 0 = event recording Disabled
Chooses whether any individual DDBs should be deselected as a stored event, by setting the relevant bit to 0 (zero). Typically used for repetitive recurrent changes such as an Opto input assigned for Minute Pulse clock synchronizing.				
DDB 1984 - 2015	0B	7E	0xFFFFFFFF	32-bit binary setting: 1 = event recording Enabled, 0 = event recording Disabled
Chooses whether any individual DDBs should be deselected as a stored event, by setting the relevant bit to 0 (zero). Typically used for repetitive recurrent changes such as an Opto input assigned for Minute Pulse clock synchronizing.				

MENU TEXT	Col	Row	Default Setting	Available Setting
Description				
DDB 2016 - 2047	0B	7F	0xFFFFFFFF	32-bit binary setting: 1 = event recording Enabled, 0 = event recording Disabled
Chooses whether any individual DDBs should be deselected as a stored event, by setting the relevant bit to 0 (zero). Typically used for repetitive recurrent changes such as an Opto input assigned for Minute Pulse clock synchronizing.				

Table 3 - Event filtering

3 DISTURBANCE RECORDER

The integral enhanced disturbance recorder has an area of memory specifically set aside for record storage. The number of records that may be stored by the relay is dependent on the selected recording duration and the installed software release.

The relay can typically store a pre-set minimum number of records, each of a pre-set duration. These may vary between different MiCOM products.

Disturbance records continue to be recorded until the available memory is exhausted, at which time the oldest record(s) are overwritten to make space for the newest one.

The recorder stores actual samples that are taken at a rate of pre-defined number of samples per cycle. Again, this may vary between different MiCOM products.

Each disturbance record consists of a number of analog data channels and digital data channels.

The relevant CT and VT ratios for the analog channels are also extracted to enable scaling to primary quantities. If a CT ratio is set less than unity, the relay will choose a scaling factor of zero for the appropriate channel.

The minimum number of records and duration is as follows:

- For Software Release 47/57 V/W/X and earlier:
 - minimum of 20 records, each of 1.5 seconds duration
- For Software Release A0/B0:
 - minimum of 15 records, each of 3.0 seconds duration

The recorder stores actual samples that are taken at a rate of 48 samples per cycle.

The number of analog data channels and 32 digital data channels for each disturbance record is as follows:

- For Software Release 47/57 V/W/X and earlier:
 - 12 analog data channels and 32 digital data channels
- For Software Release A0/B0:
 - 20 analog data channels and 128 digital data channels

There are now four additional **DDB Group Sig x** Nodes that can be mapped to individual or multiple DDBs in the PSL. These can then be set to trigger the DR via the DISTURBANCE RECORD menu.

These "Nodes" are general and can also be used to group signals together in the PSL for any other reason. These four nodes are available in each of the four PSL setting groups.

1. For a control input, the DR can be triggered directly by triggering directly from the Individual Control Input (e.g. Low to High (L to H) change)
2. For an input that cannot be triggered directly, or where any one of a number of DDBs are required to trigger a DR, map the DDBs to the new PSL Group sig n and then trigger the DR on this.

e.g. in the PSL:

In the DR Settings:

- Digital Input 1 is triggered by the PSL Group Sig 1 (L to H)
- Digital Input 2 is triggered by Control Input 1 (L to H)

If triggering on both edges is required map another DR channel to the H/L as well

Digital Input 4 is triggered by the PSL Group Sig 1 (H to L)

Digital Input 5 is triggered by Control Input 1 (H to L)

MENU TEXT	Col	Row	Default Setting	Available Setting
Description				
DISTURB RECORDER	0C	0	0	
This column contains settings for the Disturbance Recorder				

MENU TEXT	Col	Row	Default Setting	Available Setting
Description				
Duration	0C	1	1.5	0.1s to 10.5s step 0.01s
This sets the overall recording time.				
Trigger Position	0C	2	33.3	0 to 100 step 0.1
This sets the trigger point as a percentage of the duration. For example, the default settings show that the overall recording time is set to 1.5 s with the trigger point being at 33.3% of this, giving 0.5 s pre-fault and 1s post fault recording times.				
Trigger Mode	0C	3	Single	0 = Single or 1 = Extended
If set to single mode, if a further trigger occurs whilst a recording is taking place, the recorder will ignore the trigger. However, if this has been set to Extended, the post trigger timer will be reset to zero, thereby extending the recording time.				
Analog Channel 1	0C	4	VA	0 = IA, 1 = IB, 2 = IC, 3 = IN, 4 = IN Sensitive, 5 = VA, 6 = VB, 7 = VC, 8 = IM or 9 = V Checksync
Selects any available analogue input to be assigned to this channel (including derived IN residual current).				
Analog Channel 1	0C	4	VA	0 = IA, 1 = IB, 2 = IC, 3 = IN, 4 = IN Sensitive, 5 = VA, 6 = VB, 7 = VC, 8 = IM, 9 = V Checksync, 10 = IA2, 11 = IB2, 12 = IC2, 13 = IN2 or 14 = V Checksync2
Selects any available analogue input to be assigned to this channel (including derived IN residual current).				
Analog Channel 2	0C	5	VB	0 = IA, 1 = IB, 2 = IC, 3 = IN, 4 = IN Sensitive, 5 = VA, 6 = VB, 7 = VC, 8 = IM or 9 = V Checksync
Selects any available analogue input to be assigned to this channel (including derived IN residual current).				
Analog Channel 2	0C	5	VB	0 = IA, 1 = IB, 2 = IC, 3 = IN, 4 = IN Sensitive, 5 = VA, 6 = VB, 7 = VC, 8 = IM, 9 = V Checksync, 10 = IA2, 11 = IB2, 12 = IC2, 13 = IN2 or 14 = V Checksync2
Selects any available analogue input to be assigned to this channel (including derived IN residual current).				
Analog Channel 3	0C	6	VC	0 = IA, 1 = IB, 2 = IC, 3 = IN, 4 = IN Sensitive, 5 = VA, 6 = VB, 7 = VC, 8 = IM or 9 = V Checksync
Selects any available analogue input to be assigned to this channel (including derived IN residual current).				
Analog Channel 3	0C	6	VC	0 = IA, 1 = IB, 2 = IC, 3 = IN, 4 = IN Sensitive, 5 = VA, 6 = VB, 7 = VC, 8 = IM, 9 = V Checksync, 10 = IA2, 11 = IB2, 12 = IC2, 13 = IN2 or 14 = V Checksync2
Selects any available analogue input to be assigned to this channel (including derived IN residual current).				
Analog Channel 4	0C	7	IA	0 = IA, 1 = IB, 2 = IC, 3 = IN, 4 = IN Sensitive, 5 = VA, 6 = VB, 7 = VC, 8 = IM or 9 = V Checksync
Selects any available analogue input to be assigned to this channel (including derived IN residual current).				
Analog Channel 4	0C	7	IA	0 = IA, 1 = IB, 2 = IC, 3 = IN, 4 = IN Sensitive, 5 = VA, 6 = VB, 7 = VC, 8 = IM, 9 = V Checksync, 10 = IA2, 11 = IB2, 12 = IC2, 13 = IN2 or 14 = V Checksync2
Selects any available analogue input to be assigned to this channel (including derived IN residual current).				
Analog Channel 5	0C	8	IB	0 = IA, 1 = IB, 2 = IC, 3 = IN, 4 = IN Sensitive, 5 = VA, 6 = VB, 7 = VC, 8 = IM or 9 = V Checksync
Selects any available analogue input to be assigned to this channel (including derived IN residual current).				
Analog Channel 5	0C	8	IB	0 = IA, 1 = IB, 2 = IC, 3 = IN, 4 = IN Sensitive, 5 = VA, 6 = VB, 7 = VC, 8 = IM, 9 = V Checksync, 10 = IA2, 11 = IB2, 12 = IC2, 13 = IN2 or 14 = V Checksync2
Selects any available analogue input to be assigned to this channel (including derived IN residual current).				
Analog Channel 6	0C	9	IC	0 = IA, 1 = IB, 2 = IC, 3 = IN, 4 = IN Sensitive, 5 = VA, 6 = VB, 7 = VC, 8 = IM or 9 = V Checksync
Selects any available analogue input to be assigned to this channel (including derived IN residual current).				
Analog Channel 6	0C	9	IC	0 = IA, 1 = IB, 2 = IC, 3 = IN, 4 = IN Sensitive, 5 = VA, 6 = VB, 7 = VC, 8 = IM, 9 = V Checksync, 10 = IA2, 11 = IB2, 12 = IC2, 13 = IN2 or 14 = V Checksync2

MENU TEXT	Col	Row	Default Setting	Available Setting
Description				
Selects any available analogue input to be assigned to this channel (including derived IN residual current).				
Analog Channel 7	0C	0A	IN	0 = IA, 1 = IB, 2 = IC, 3 = IN, 4 = IN Sensitive, 5 = VA, 6 = VB, 7 = VC, 8 = IM or 9 = V Checksync
Selects any available analogue input to be assigned to this channel (including derived IN residual current).				
Analog Channel 7	0C	0A	IN	0 = IA, 1 = IB, 2 = IC, 3 = IN, 4 = IN Sensitive, 5 = VA, 6 = VB, 7 = VC, 8 = IM, 9 = V Checksync, 10 = IA2, 11 = IB2, 12 = IC2, 13 = IN2 or 14 = V Checksync2
Selects any available analogue input to be assigned to this channel (including derived IN residual current).				
Analog Channel 8	0C	0B	IN Sensitive	0 = IA, 1 = IB, 2 = IC, 3 = IN, 4 = IN Sensitive, 5 = VA, 6 = VB, 7 = VC, 8 = IM or 9 = V Checksync
Selects any available analogue input to be assigned to this channel (including derived IN residual current).				
Analog Channel 8	0C	0B	IN Sensitive	0 = IA, 1 = IB, 2 = IC, 3 = IN, 4 = IN Sensitive, 5 = VA, 6 = VB, 7 = VC, 8 = IM, 9 = V Checksync, 10 = IA2, 11 = IB2, 12 = IC2, 13 = IN2 or 14 = V Checksync2
Selects any available analogue input to be assigned to this channel (including derived IN residual current).				
Digital Input 1	0C	0C	Relay 1	See Data Types - G32
The digital channels may monitor any of the opto isolated inputs or output contacts, in addition to a number of internal relay digital signals, such as protection starts, LEDs etc.				
Input 1 Trigger	0C	0D	No Trigger	0 = No Trigger, 1 = Trigger L/H, 2 = Trigger H/L
Any of the digital channels may be selected to trigger the disturbance recorder on either a low to high or a high to low transition.				
Digital Input 2	0C	0E	Relay 2	See Data Types - G32
The digital channels may monitor any of the opto isolated inputs or output contacts, in addition to a number of internal relay digital signals, such as protection starts, LEDs etc.				
Input 2 Trigger	0C	0F	No Trigger	0 = No Trigger, 1 = Trigger L/H, 2 = Trigger H/L
Any of the digital channels may be selected to trigger the disturbance recorder on either a low to high or a high to low transition.				
Digital Input 3	0C	10	Relay 3	See Data Types - G32
The digital channels may monitor any of the opto isolated inputs or output contacts, in addition to a number of internal relay digital signals, such as protection starts, LEDs etc.				
Input 3 Trigger	0C	11	Trigger L/H	0 = No Trigger, 1 = Trigger L/H, 2 = Trigger H/L
Any of the digital channels may be selected to trigger the disturbance recorder on either a low to high or a high to low transition.				
Digital Input 4	0C	12	Relay 4	See Data Types - G32
The digital channels may monitor any of the opto isolated inputs or output contacts, in addition to a number of internal relay digital signals, such as protection starts, LEDs etc.				
Input 4 Trigger	0C	13	No Trigger	0 = No Trigger, 1 = Trigger L/H, 2 = Trigger H/L
Any of the digital channels may be selected to trigger the disturbance recorder on either a low to high or a high to low transition.				
Digital Input 5	0C	14	Relay 5	See Data Types - G32
The digital channels may monitor any of the opto isolated inputs or output contacts, in addition to a number of internal relay digital signals, such as protection starts, LEDs etc.				
Input 5 Trigger	0C	15	No Trigger	0 = No Trigger, 1 = Trigger L/H, 2 = Trigger H/L
Any of the digital channels may be selected to trigger the disturbance recorder on either a low to high or a high to low transition.				
Digital Input 6	0C	16	Relay 6	See Data Types - G32
The digital channels may monitor any of the opto isolated inputs or output contacts, in addition to a number of internal relay digital signals, such as protection starts, LEDs etc.				
Input 6 Trigger	0C	17	No Trigger	0 = No Trigger, 1 = Trigger L/H, 2 = Trigger H/L
Any of the digital channels may be selected to trigger the disturbance recorder on either a low to high or a high to low transition.				
Digital Input 7	0C	18	Relay 7	See Data Types - G32

MENU TEXT	Col	Row	Default Setting	Available Setting
Description				
The digital channels may monitor any of the opto isolated inputs or output contacts, in addition to a number of internal relay digital signals, such as protection starts, LEDs etc.				
Input 7 Trigger	0C	19	No Trigger	0 = No Trigger, 1 = Trigger L/H, 2 = Trigger H/L
Any of the digital channels may be selected to trigger the disturbance recorder on either a low to high or a high to low transition.				
Digital Input 8	0C	1A	Relay 8	See Data Types - G32
The digital channels may monitor any of the opto isolated inputs or output contacts, in addition to a number of internal relay digital signals, such as protection starts, LEDs etc.				
Input 8 Trigger	0C	1B	No Trigger	0 = No Trigger, 1 = Trigger L/H, 2 = Trigger H/L
Any of the digital channels may be selected to trigger the disturbance recorder on either a low to high or a high to low transition.				
Digital Input 9	0C	1C	Relay 9	See Data Types - G32
The digital channels may monitor any of the opto isolated inputs or output contacts, in addition to a number of internal relay digital signals, such as protection starts, LEDs etc.				
Input 9 Trigger	0C	1D	No Trigger	0 = No Trigger, 1 = Trigger L/H, 2 = Trigger H/L
Any of the digital channels may be selected to trigger the disturbance recorder on either a low to high or a high to low transition.				
Digital Input 10	0C	1E	Relay 10	See Data Types - G32
The digital channels may monitor any of the opto isolated inputs or output contacts, in addition to a number of internal relay digital signals, such as protection starts, LEDs etc.				
Input 10 Trigger	0C	1F	No Trigger	0 = No Trigger, 1 = Trigger L/H, 2 = Trigger H/L
Any of the digital channels may be selected to trigger the disturbance recorder on either a low to high or a high to low transition.				
Digital Input 11	0C	20	Relay 11	See Data Types - G32
The digital channels may monitor any of the opto isolated inputs or output contacts, in addition to a number of internal relay digital signals, such as protection starts, LEDs etc.				
Input 11 Trigger	0C	21	No Trigger	0 = No Trigger, 1 = Trigger L/H, 2 = Trigger H/L
Any of the digital channels may be selected to trigger the disturbance recorder on either a low to high or a high to low transition.				
Digital Input 12	0C	22	Relay 12	See Data Types - G32
The digital channels may monitor any of the opto isolated inputs or output contacts, in addition to a number of internal relay digital signals, such as protection starts, LEDs etc.				
Input 12 Trigger	0C	23	No Trigger	0 = No Trigger, 1 = Trigger L/H, 2 = Trigger H/L
Any of the digital channels may be selected to trigger the disturbance recorder on either a low to high or a high to low transition.				
Digital Input 13	0C	24	Relay 13	See Data Types - G32
The digital channels may monitor any of the opto isolated inputs or output contacts, in addition to a number of internal relay digital signals, such as protection starts, LEDs etc.				
Input 13 Trigger	0C	25	No Trigger	0 = No Trigger, 1 = Trigger L/H, 2 = Trigger H/L
Any of the digital channels may be selected to trigger the disturbance recorder on either a low to high or a high to low transition.				
Digital Input 14	0C	26	Relay 14	See Data Types - G32
The digital channels may monitor any of the opto isolated inputs or output contacts, in addition to a number of internal relay digital signals, such as protection starts, LEDs etc.				
Input 14 Trigger	0C	27	No Trigger	0 = No Trigger, 1 = Trigger L/H, 2 = Trigger H/L
Any of the digital channels may be selected to trigger the disturbance recorder on either a low to high or a high to low transition.				
Digital Input 15	0C	28	Opto Input 1	See Data Types - G32
The digital channels may monitor any of the opto isolated inputs or output contacts, in addition to a number of internal relay digital signals, such as protection starts, LEDs etc.				
Input 15 Trigger	0C	29	No Trigger	0 = No Trigger, 1 = Trigger L/H, 2 = Trigger H/L
Any of the digital channels may be selected to trigger the disturbance recorder on either a low to high or a high to low transition.				
Digital Input 16	0C	2A	Opto Input 2	See Data Types - G32

MENU TEXT	Col	Row	Default Setting	Available Setting
Description				
The digital channels may monitor any of the opto isolated inputs or output contacts, in addition to a number of internal relay digital signals, such as protection starts, LEDs etc.				
Input 16 Trigger	0C	2B	No Trigger	0 = No Trigger, 1 = Trigger L/H, 2 = Trigger H/L
Any of the digital channels may be selected to trigger the disturbance recorder on either a low to high or a high to low transition.				
Digital Input 17	0C	2C	Opto Input 3	See Data Types - G32
The digital channels may monitor any of the opto isolated inputs or output contacts, in addition to a number of internal relay digital signals, such as protection starts, LEDs etc.				
Input 17 Trigger	0C	2D	No Trigger	0 = No Trigger, 1 = Trigger L/H, 2 = Trigger H/L
Any of the digital channels may be selected to trigger the disturbance recorder on either a low to high or a high to low transition.				
Digital Input 18	0C	2E	Opto Input 4	See Data Types - G32
The digital channels may monitor any of the opto isolated inputs or output contacts, in addition to a number of internal relay digital signals, such as protection starts, LEDs etc.				
Input 18 Trigger	0C	2F	No Trigger	0 = No Trigger, 1 = Trigger L/H, 2 = Trigger H/L
Any of the digital channels may be selected to trigger the disturbance recorder on either a low to high or a high to low transition.				
Digital Input 19	0C	30	Opto Input 5	See Data Types - G32
The digital channels may monitor any of the opto isolated inputs or output contacts, in addition to a number of internal relay digital signals, such as protection starts, LEDs etc.				
Input 19 Trigger	0C	31	No Trigger	0 = No Trigger, 1 = Trigger L/H, 2 = Trigger H/L
Any of the digital channels may be selected to trigger the disturbance recorder on either a low to high or a high to low transition.				
Digital Input 20	0C	32	Opto Input 6	See Data Types - G32
The digital channels may monitor any of the opto isolated inputs or output contacts, in addition to a number of internal relay digital signals, such as protection starts, LEDs etc.				
Input 20 Trigger	0C	33	No Trigger	0 = No Trigger, 1 = Trigger L/H, 2 = Trigger H/L
Any of the digital channels may be selected to trigger the disturbance recorder on either a low to high or a high to low transition.				
Digital Input 21	0C	34	Opto Input 7	See Data Types - G32
The digital channels may monitor any of the opto isolated inputs or output contacts, in addition to a number of internal relay digital signals, such as protection starts, LEDs etc.				
Input 21 Trigger	0C	35	No Trigger	0 = No Trigger, 1 = Trigger L/H, 2 = Trigger H/L
Any of the digital channels may be selected to trigger the disturbance recorder on either a low to high or a high to low transition.				
Digital Input 22	0C	36	Opto Input 8	See Data Types - G32
The digital channels may monitor any of the opto isolated inputs or output contacts, in addition to a number of internal relay digital signals, such as protection starts, LEDs etc.				
Input 22 Trigger	0C	37	No Trigger	0 = No Trigger, 1 = Trigger L/H, 2 = Trigger H/L
Any of the digital channels may be selected to trigger the disturbance recorder on either a low to high or a high to low transition.				
Digital Input 23	0C	38	Opto Input 9	See Data Types - G32
The digital channels may monitor any of the opto isolated inputs or output contacts, in addition to a number of internal relay digital signals, such as protection starts, LEDs etc.				
Input 23 Trigger	0C	39	No Trigger	0 = No Trigger, 1 = Trigger L/H, 2 = Trigger H/L
Any of the digital channels may be selected to trigger the disturbance recorder on either a low to high or a high to low transition.				
Digital Input 24	0C	3A	Opto Input 10	See Data Types - G32
The digital channels may monitor any of the opto isolated inputs or output contacts, in addition to a number of internal relay digital signals, such as protection starts, LEDs etc.				
Input 24 Trigger	0C	3B	No Trigger	0 = No Trigger, 1 = Trigger L/H, 2 = Trigger H/L
Any of the digital channels may be selected to trigger the disturbance recorder on either a low to high or a high to low transition.				
Digital Input 25	0C	3C	Opto Input 11	See Data Types - G32

MENU TEXT	Col	Row	Default Setting	Available Setting
Description				
The digital channels may monitor any of the opto isolated inputs or output contacts, in addition to a number of internal relay digital signals, such as protection starts, LEDs etc.				
Input 25 Trigger	0C	3D	No Trigger	0 = No Trigger, 1 = Trigger L/H, 2 = Trigger H/L
Any of the digital channels may be selected to trigger the disturbance recorder on either a low to high or a high to low transition.				
Digital Input 26	0C	3E	Opto Input 12	See Data Types - G32
The digital channels may monitor any of the opto isolated inputs or output contacts, in addition to a number of internal relay digital signals, such as protection starts, LEDs etc.				
Input 26 Trigger	0C	3F	No Trigger	0 = No Trigger, 1 = Trigger L/H, 2 = Trigger H/L
Any of the digital channels may be selected to trigger the disturbance recorder on either a low to high or a high to low transition.				
Digital Input 27	0C	40	Opto Input 13	See Data Types - G32
The digital channels may monitor any of the opto isolated inputs or output contacts, in addition to a number of internal relay digital signals, such as protection starts, LEDs etc.				
Input 27 Trigger	0C	41	No Trigger	0 = No Trigger, 1 = Trigger L/H, 2 = Trigger H/L
Any of the digital channels may be selected to trigger the disturbance recorder on either a low to high or a high to low transition.				
Digital Input 28	0C	42	Opto Input 14	See Data Types - G32
The digital channels may monitor any of the opto isolated inputs or output contacts, in addition to a number of internal relay digital signals, such as protection starts, LEDs etc.				
Input 28 Trigger	0C	43	No Trigger	0 = No Trigger, 1 = Trigger L/H, 2 = Trigger H/L
Any of the digital channels may be selected to trigger the disturbance recorder on either a low to high or a high to low transition.				
Digital Input 29	0C	44	Opto Input 15	See Data Types - G32
The digital channels may monitor any of the opto isolated inputs or output contacts, in addition to a number of internal relay digital signals, such as protection starts, LEDs etc.				
Input 29 Trigger	0C	45	No Trigger	0 = No Trigger, 1 = Trigger L/H, 2 = Trigger H/L
Any of the digital channels may be selected to trigger the disturbance recorder on either a low to high or a high to low transition.				
Digital Input 30	0C	46	Opto Input 16	See Data Types - G32
The digital channels may monitor any of the opto isolated inputs or output contacts, in addition to a number of internal relay digital signals, such as protection starts, LEDs etc.				
Input 30 Trigger	0C	47	No Trigger	0 = No Trigger, 1 = Trigger L/H, 2 = Trigger H/L
Any of the digital channels may be selected to trigger the disturbance recorder on either a low to high or a high to low transition.				
Digital Input 31	0C	48	Not Used	See Data Types - G32
The digital channels may monitor any of the opto isolated inputs or output contacts, in addition to a number of internal relay digital signals, such as protection starts, LEDs etc.				
Input 31 Trigger	0C	49	No Trigger	0 = No Trigger, 1 = Trigger L/H, 2 = Trigger H/L
Any of the digital channels may be selected to trigger the disturbance recorder on either a low to high or a high to low transition.				
Digital Input 32	0C	4A	Not Used	See Data Types - G32
The digital channels may monitor any of the opto isolated inputs or output contacts, in addition to a number of internal relay digital signals, such as protection starts, LEDs etc.				
Input 32 Trigger	0C	4B	No Trigger	0 = No Trigger, 1 = Trigger L/H, 2 = Trigger H/L
Any of the digital channels may be selected to trigger the disturbance recorder on either a low to high or a high to low transition.				
Analog Channel 9	0C	50	V Checksync	0 = IA, 1 = IB, 2 = IC, 3 = IN, 4 = IN Sensitive, 5 = VA, 6 = VB, 7 = VC, 8 = IM or 9 = V Checksync
Selects any available analogue input to be assigned to this channel (including derived IN residual current).				
Analog Channel 9	0C	50	V Checksync	0 = IA, 1 = IB, 2 = IC, 3 = IN, 4 = IN Sensitive, 5 = VA, 6 = VB, 7 = VC, 8 = IM, 9 = V Checksync, 10 = IA2, 11 = IB2, 12 = IC2, 13 = IN2 or 14 = V Checksync2
Selects any available analogue input to be assigned to this channel (including derived IN residual current).				

MENU TEXT	Col	Row	Default Setting	Available Setting
Description				
Analog Channel 10	0C	51	IN	0 = IA, 1 = IB, 2 = IC, 3 = IN, 4 = IN Sensitive, 5 = VA, 6 = VB, 7 = VC, 8 = IM or 9 = V Checksync
Selects any available analogue input to be assigned to this channel (including derived IN residual current).				
Analog Channel 10	0C	51	IA2	0 = IA, 1 = IB, 2 = IC, 3 = IN, 4 = IN Sensitive, 5 = VA, 6 = VB, 7 = VC, 8 = IM, 9 = V Checksync, 10 = IA2, 11 = IB2, 12 = IC2, 13 = IN2 or 14 = V Checksync2
Selects any available analogue input to be assigned to this channel (including derived IN residual current).				
Analog Channel 11	0C	52	IN	0 = IA, 1 = IB, 2 = IC, 3 = IN, 4 = IN Sensitive, 5 = VA, 6 = VB, 7 = VC, 8 = IM or 9 = V Checksync
Selects any available analogue input to be assigned to this channel (including derived IN residual current).				
Analog Channel 11	0C	52	IB2	0 = IA, 1 = IB, 2 = IC, 3 = IN, 4 = IN Sensitive, 5 = VA, 6 = VB, 7 = VC, 8 = IM, 9 = V Checksync, 10 = IA2, 11 = IB2, 12 = IC2, 13 = IN2 or 14 = V Checksync2
Selects any available analogue input to be assigned to this channel (including derived IN residual current).				
Analog Channel 12	0C	53	IN	0 = IA, 1 = IB, 2 = IC, 3 = IN, 4 = IN Sensitive, 5 = VA, 6 = VB, 7 = VC, 8 = IM or 9 = V Checksync
Selects any available analogue input to be assigned to this channel (including derived IN residual current).				
Analog Channel 12	0C	53	IC2	0 = IA, 1 = IB, 2 = IC, 3 = IN, 4 = IN Sensitive, 5 = VA, 6 = VB, 7 = VC, 8 = IM, 9 = V Checksync, 10 = IA2, 11 = IB2, 12 = IC2, 13 = IN2 or 14 = V Checksync2
Selects any available analogue input to be assigned to this channel (including derived IN residual current).				
Analog Channel 13	0C	54	Unused	0
0				
Analog Channel 13	0C	54	Unused	0
0				
Analog Channel 14	0C	55	Unused	0
0				
Analog Channel 14	0C	55	Unused	0
0				
Analog Channel 15	0C	56	Unused	0
0				
Analog Channel 15	0C	56	Unused	0
0				
Analog Channel 16	0C	57	Unused	0
0				
Analog Channel 16	0C	57	Unused	0
0				
Analog Channel 17	0C	58	Unused	0
0				
Analog Channel 17	0C	58	Unused	0
0				
Analog Channel 18	0C	59	Unused	0
0				
Analog Channel 18	0C	59	Unused	0
0				

MENU TEXT	Col	Row	Default Setting	Available Setting
Description				
Analog Channel 19	0C	5A	Unused	0
0				
Analog Channel 19	0C	5A	Unused	0
0				
Analog Channel 20	0C	5B	Unused	0
0				
Analog Channel 20	0C	5B	Unused	0
0				
Digital Input 33	0C	70	Unused	0
0				
Digital Input 34	0C	71	Unused	0
0				
Digital Input 35	0C	72	Unused	0
0				
Digital Input 36	0C	73	Unused	0
0				
Digital Input 37	0C	74	Unused	0
0				
Digital Input 38	0C	75	Unused	0
0				
Digital Input 39	0C	76	Unused	0
0				
Digital Input 40	0C	77	Unused	0
0				
Digital Input 41	0C	78	Unused	0
0				
Digital Input 42	0C	79	Unused	0
0				
Digital Input 43	0C	7A	Unused	0
0				
Digital Input 44	0C	7B	Unused	0
0				
Digital Input 45	0C	7C	Unused	0
0				
Digital Input 46	0C	7D	Unused	0
0				
Digital Input 47	0C	7E	Unused	0
0				
Digital Input 48	0C	7F	Unused	0
0				
Digital Input 49	0C	80	Unused	0
0				
Digital Input 50	0C	81	Unused	0

MENU TEXT	Col	Row	Default Setting	Available Setting
Description				
0				
Digital Input 51	0C	82	Unused	0
0				
Digital Input 52	0C	83	Unused	0
0				
Digital Input 53	0C	84	Unused	0
0				
Digital Input 54	0C	85	Unused	0
0				
Digital Input 55	0C	86	Unused	0
0				
Digital Input 56	0C	87	Unused	0
0				
Digital Input 57	0C	88	Unused	0
0				
Digital Input 58	0C	89	Unused	0
0				
Digital Input 59	0C	8A	Unused	0
0				
Digital Input 60	0C	8B	Unused	0
0				
Digital Input 61	0C	8C	Unused	0
0				
Digital Input 62	0C	8D	Unused	0
0				
Digital Input 63	0C	8E	Unused	0
0				
Digital Input 64	0C	8F	Unused	0
0				
Digital Input 65	0C	90	Unused	0
0				
Digital Input 66	0C	91	Unused	0
0				
Digital Input 67	0C	92	Unused	0
0				
Digital Input 68	0C	93	Unused	0
0				
Digital Input 69	0C	94	Unused	0
0				
Digital Input 70	0C	95	Unused	0
0				
Digital Input 71	0C	96	Unused	0
0				

MENU TEXT	Col	Row	Default Setting	Available Setting
Description				
Digital Input 72	0C	97	Unused	0
0				
Digital Input 73	0C	98	Unused	0
0				
Digital Input 74	0C	99	Unused	0
0				
Digital Input 75	0C	9A	Unused	0
0				
Digital Input 76	0C	9B	Unused	0
0				
Digital Input 77	0C	9C	Unused	0
0				
Digital Input 78	0C	9D	Unused	0
0				
Digital Input 79	0C	9E	Unused	0
0				
Digital Input 80	0C	9F	Unused	0
0				
Digital Input 81	0C	A0	Unused	0
0				
Digital Input 82	0C	A1	Unused	0
0				
Digital Input 83	0C	A2	Unused	0
0				
Digital Input 84	0C	A3	Unused	0
0				
Digital Input 85	0C	A4	Unused	0
0				
Digital Input 86	0C	A5	Unused	0
0				
Digital Input 87	0C	A6	Unused	0
0				
Digital Input 88	0C	A7	Unused	0
0				
Digital Input 89	0C	A8	Unused	0
0				
Digital Input 90	0C	A9	Unused	0
0				
Digital Input 91	0C	AA	Unused	0
0				
Digital Input 92	0C	AB	Unused	0
0				
Digital Input 93	0C	AC	Unused	0

MENU TEXT	Col	Row	Default Setting	Available Setting
Description				
0				
Digital Input 94	0C	AD	Unused	0
0				
Digital Input 95	0C	AE	Unused	0
0				
Digital Input 96	0C	AF	Unused	0
0				
Digital Input 97	0C	B0	Unused	0
0				
Digital Input 98	0C	B1	Unused	0
0				
Digital Input 99	0C	B2	Unused	0
0				
Digital Input 100	0C	B3	Unused	0
0				
Digital Input 101	0C	B4	Unused	0
0				
Digital Input 102	0C	B5	Unused	0
0				
Digital Input 103	0C	B6	Unused	0
0				
Digital Input 104	0C	B7	Unused	0
0				
Digital Input 105	0C	B8	Unused	0
0				
Digital Input 106	0C	B9	Unused	0
0				
Digital Input 107	0C	BA	Unused	0
0				
Digital Input 108	0C	BB	Unused	0
0				
Digital Input 109	0C	BC	Unused	0
0				
Digital Input 110	0C	BD	Unused	0
0				
Digital Input 111	0C	BE	Unused	0
0				
Digital Input 112	0C	BF	Unused	0
0				
Digital Input 113	0C	C0	Unused	0
0				
Digital Input 114	0C	C1	Unused	0
0				

MENU TEXT	Col	Row	Default Setting	Available Setting
Description				
Digital Input 115	0C	C2	Unused	0
0				
Digital Input 116	0C	C3	Unused	0
0				
Digital Input 117	0C	C4	Unused	0
0				
Digital Input 118	0C	C5	Unused	0
0				
Digital Input 119	0C	C6	Unused	0
0				
Digital Input 120	0C	C7	Unused	0
0				
Digital Input 121	0C	C8	Unused	0
0				
Digital Input 122	0C	C9	Unused	0
0				
Digital Input 123	0C	CA	Unused	0
0				
Digital Input 124	0C	CB	Unused	0
0				
Digital Input 125	0C	CC	Unused	0
0				
Digital Input 126	0C	CD	Unused	0
0				
Digital Input 127	0C	CE	Unused	0
0				
Digital Input 128	0C	CF	Unused	0
0				

Table 4 - Disturbance recorder for digital channel

The pre and post fault recording times are set by a combination of the **Duration** and **Trigger Position** cells. **Duration** sets the overall recording time and the **Trigger Position** sets the trigger point as a percentage of the duration.

- For Software Release 47/57 V/W/X and earlier:
 - The default settings show that the overall recording time is set to 1.5 s with the trigger point being at 33.3% of this, giving 0.5 s pre-fault and 1s post fault recording times.
- For Software Release A0/B0:
 - The default settings show that the overall recording time is set to 3.0 s with the trigger point being at 33.3% of this, giving 1.0 s pre-fault and 1.0 s post-fault recording times.

If a further trigger occurs while a recording is taking place, the recorder ignores the trigger if the **Trigger Mode** is set to **Single**. However, if this is set to **Extended**, the post-trigger timer is reset to zero, extending the recording time.

As can be seen from the menu, each of the analog channels is selectable from the available analog inputs to the relay. The digital channels may be mapped to any of the opto isolated inputs or output contacts, in addition to several internal relay digital signals, such as protection starts and LEDs. The complete list of these signals may be found by viewing the available settings in the relay menu or using a setting file in MiCOM S1 Studio. Any of the digital channels may be selected to trigger the disturbance recorder on either a low-to-high or a high-to-low transition, using the **Input Trigger** cell. The default trigger settings are that any dedicated trip output contacts, such as relay 3, trigger the recorder.

It is not possible to view the disturbance records locally using the LCD; they must be extracted using suitable software such as MiCOM S1 Studio. This process is fully explained in the *SCADA Communications* chapter.

4 MEASUREMENTS

The relay produces a variety of both directly measured and calculated power system quantities. These measurement values are updated every second and can be viewed in the **Measurements** columns (up to three) of the relay or using the MiCOM S1 Studio Measurement viewer.

The relay can measure and display these quantities:

- Phase Voltages
- Local and Remote Currents
- Differential and Bias Currents on a Per Phase Basis
- Sequence Voltages and Currents
- Slip Frequency
- Power and Energy Quantities
- Rms. Voltages and Currents
- Peak, Fixed and Rolling Demand Values

There are also measured values from the protection functions, which are also displayed under the measurement columns of the menu; these are described in the section on the relevant protection function.

4.1 Measured Voltages and Currents

The relay produces both phase-to-ground and phase-to-phase voltage and current values. They are produced directly from the Discrete Fourier Transform (DFT) used by the relay protection functions and present both magnitude and phase angle measurement.

Currents mentioned above can be seen on the Measurement 1 column. The relay also shows local and remote currents in Measurement 3 column. These currents have the same treatment as the currents used for differential protection purposes.

4.2 Sequence Voltages and Currents

Sequence quantities are produced by the relay from the measured Fourier values; these are displayed as magnitude and phase angle values.

4.3 Slip Frequency

The relay produces a slip frequency measurement by measuring the rate of change of phase angle, between the bus and line voltages, over a one-cycle period. The slip frequency measurement assumes the bus voltage to be the reference phasor.

4.4 Power and Energy Quantities

Using the measured voltages and currents the relay calculates the apparent, real and reactive power quantities. These are produced phase-by-phase. Three-phase values are based on the sum of the three individual phase values. The signing of the real and reactive power measurements can be controlled using the measurement mode setting. The options are as follows.

Measurement mode	Parameter	Signing
0 (Default)	Export Power Import Power Lagging Vars Leading VArS	+ - + -
1	Export Power Import Power Lagging Vars Leading VArS	- + + -
2	Export Power Import Power Lagging Vars Leading VArS	+ - - +
3	Export Power Import Power Lagging Vars Leading VArS	- + - +

In addition to the measured power quantities, the relay calculates the power factor phase-by-phase, in addition to a three-phase power factor.

These power values are also used to increment the total real and reactive energy measurements. Separate energy measurements are maintained for the total exported and imported energy. The energy measurements are incremented up to maximum values of 1000 GWhr or 1000 GVARhr, at which point they reset to zero. It is also possible to reset these values using the menu or remote interfaces using the **Reset Demand** cell.

4.5 RMS. Voltages and Currents

RMS phase voltage and current values are calculated by the relay using the sum of the samples squared over a cycle of sampled data.

4.6 Demand Values

The relay produces fixed, rolling and peak demand values. Using the reset demand menu cell it is possible to reset these quantities from the user interface or the remote communications.

4.6.1 Fixed Demand Values

The fixed demand value is the average value of a quantity over the specified interval; values are produced for each phase current and for three-phase real and reactive power. The fixed demand values displayed by the relay are those for the previous interval. The values are updated at the end of the fixed demand period.

4.6.2 Rolling Demand Values

The rolling demand values are similar to the fixed demand values, the difference being that a sliding window is used. The rolling demand window consists of several smaller sub-periods. The resolution of the sliding window is the sub-period length, with the displayed values updated at the end of each of the sub-periods.

4.6.3 Peak Demand Values

Peak demand values are produced for each phase current and the real and reactive power quantities. These display the maximum value of the measured quantity since the last reset of the demand values.

4.7 Settings

The settings shown under the heading **MEASURE'T SETUP** can be used to configure the relay measurement function. See the following Measurements table for more details:

MENU TEXT	Col	Row	Default Setting	Available Setting
Description				
MEASURE'T SETUP	0D	0	0	
This column contains settings for the measurement setup				
Default Display	0D	1	Description	0 = User Banner, 1 = 3Ph + N Current, 2 = 3Ph Voltage, 3 = Power, 4 = Date and Time, 5 = Description, 6 = Plant Reference, 7 = Frequency, 8 = Access Level
This setting can be used to select the default display from a range of options, note that it is also possible to view the other default displays whilst at the default level using the 4 and 6 keys. However once the 15 minute timeout elapses the default display will revert to that selected by this setting.				
Local Values	0D	2	Primary	0 = Primary or 1 = Secondary
This setting controls whether measured values via the front panel user interface and the front courier port are displayed as primary or secondary quantities.				
Remote Values	0D	3	Primary	0 = Primary or 1 = Secondary
This setting controls whether measured values via the rear communication port are displayed as primary or secondary quantities.				
Measurement Ref	0D	4	VA	0 = VA, 1 = VB, 2 = VC, 3 = IA, 4 = IB, 5 = IC
Using this setting the phase reference for all angular measurements by the relay can be selected. This reference is for Measurements 1. Measurements 3 uses always IA local as a reference				
Measurement Mode	0D	5	0	0 to 3 step 1
This setting is used to control the signing of the real and reactive power quantities; the signing convention used is defined in the Measurements and Recording chapter (P54x/EN MR).				
Fix Dem Period	0D	6	30	1 to 99 step 1
This setting defines the length of the fixed demand window				
Roll Sub Period	0D	7	30	1 to 99 step 1
These two settings are used to set the length of the window used for the calculation of rolling demand quantities				
Num Sub Periods	0D	8	1	1 to 15 step 1
This setting is used to set the resolution of the rolling sub window				
Distance Unit	0D	9	Miles	0 = Kilometres or 1 = Miles
This setting is used to select the unit of distance for fault location purposes, note that the length of the line is preserved when converting from km to miles and vice versa				
Fault Location	0D	0A	Distance	0 = Distance, 1 = Ohms, 2 = % of Line
The calculated fault location can be displayed using one of several options selected using this setting				
Remote 2 Values	0D	0B	Primary	0 = Primary or 1 = Secondary
The setting defines whether the values measured via the 2nd Rear Communication port are displayed in primary or secondary terms.				

Table 5 - Measurement setup

4.8 Measurement Display Quantities

The relay has Measurement columns for viewing measurement quantities. These can also be viewed with MiCOM S1 Studio and are shown below.

MEASUREMENTS 1	MEASUREMENTS 2		MEASUREMENTS 3		MEASUREMENTS 4	
IA Magnitude	0 A	A Phase Watts	0 W	IA Local	0 A	Ch 1 Prop Delay
IA Phase Angle	0 deg	B Phase Watts	0 W	IA Angle Local	0 deg	Ch 2 Prop Delay
IB Magnitude	0 A	C Phase Watts	0 W	IB Local	0 A	Ch1 Rx Prop Delay
IB Phase Angle	0 deg	A Phase VArS	0 Var	IB Angle Local	0 deg	Ch1 Tx Prop Delay

MEASUREMENTS 1		MEASUREMENTS 2		MEASUREMENTS 3		MEASUREMENTS 4	
IC Magnitude	0 A	B Phase VArS	0 Var	IC Local	0 A	Ch2 Rx Prop Delay	
IC Phase Angle	0 deg	C Phase VArS	0 Var	IC Angle Local	0 deg	Ch2 Tx Prop Delay	
IN Derived Mag.	0 A	A Phase VA	0 VA	IA remote 1	0 A	Channel 1 Status	
IN Derived Angle	0 deg	B Phase VA	0 VA	IA Ang remote 1	0 deg	Channel 2 Status	
ISEF Magnitude	0 A	C Phase VA	0 VA	IB remote 1	0 A	IM64 Rx Status	
ISEF Angle	0 deg	3 Phase Watts	0 W	IB Ang remote 1	0 deg	STATISTICS	
I1 Magnitude	0 A	3 Phase VArS	0 VAr	IC remote 1	0 A	Last Reset on	
I2 Magnitude	0 A	3 Phase VA	0 VA	IC Ang remote 1	0 deg	Date/Time	
I0 Magnitude	0 A	3Ph Power Factor	0	IA remote 2	0 A	Ch1 No.Vald Mess	
IA RMS	0 A	APh Power Factor	0	IA Ang remote 2	0 deg	Ch1 No.Err Mess	
IB RMS	0 A	BPh Power Factor	0	IB remote 2	0 A	Ch1 No.Errorred s	
IC RMS	0 A	CPh Power Factor	0	IB Ang remote 2	0 deg	Ch1 No.Sev Err s	
IN RMS	0 A	3Ph WHours Fwd	0 Wh	IC remote 2	0 A	Ch1 No. Dgraded m	
VAB Magnitude	0 V	3Ph WHours Rev	0 Wh	IC Ang remote 2	0 deg	Ch2 No.Vald Mess	
VAB Phase Angle	0 deg	3Ph VArHours Fwd	0 VArh	IA Differential	0 A	Ch2 No.Err Mess	
VBC Magnitude	0 V	3Ph VArHours Rev	0 VArh	IB Differential	0 A	Ch2 No.Errorred s	
VBC Phase Angle	0 deg	3Ph W Fix Demand	0 W	IC Differential	0 A	Ch2 No.Sev Err s	
VCA Magnitude	0 V	3Ph VArS Fix Dem.	0 VAr	IA Bias	0 A	Ch2 No. Dgraded m	
VCA Phase Angle	0 deg	IA Fixed Demand	0 A	IB Bias	0 A	Max Ch 1 Prop Delay	
VAN Magnitude	0 V	IB Fixed Demand	0 A	IC Bias	0 A	Max Ch 2 Prop Delay	
VAN Phase Angle	0 deg	IC Fixed Demand	0 A			Max Ch1 TxRx Time	
VBN Magnitude	0 V	3 Ph W Roll Dem.	0 W			Max Ch2 TxRx Time	
VBN Phase Angle	0 deg	3Ph VArS Roll Dem.	0 VAr			Clear Statistics	
VCN Magnitude	0 V	IA Roll Demand	0 A				
VCN Phase Angle	0 deg	IB Roll Demand	0 A				
V1 Magnitude	0 V	IC Roll Demand	0 A				
V2 Magnitude	0 V	3Ph W Peak Dem.	0 W				
V0 Magnitude	0 V	3Ph VAr Peak Dem.	0 VAr				
VAN RMS	0 V	IA Peak Demand	0 A				
VBN RMS	0 V	IB Peak Demand	0 A				
VCN RMS	0 V	IC Peak Demand	0 A				
VAB RMS	0 V	Reset Demand	No				
VBC RMS	0 V						
VCA RMS	0 V						
Frequency							
CB1 CS Volt Mag	0 V						
CB1 CS Volt Ang	0 deg						
CB1 Bus-Line Ang	0 deg						
CB1 CS Slip Freq							
IM Magnitude	0 A						
IM Phase Angle	0 deg						
I1 Magnitude	0 A						
I1 Phase Angle	0 deg						

MEASUREMENTS 1		MEASUREMENTS 2		MEASUREMENTS 3		MEASUREMENTS 4	
I2 Magnitude	0 A						
I2 Phase Angle	0 deg						
I0 Magnitude	0 A						
I0 Phase Angle	0 deg						
V1 Magnitude	0 V						
V1 Phase Angle	0 deg						
V2 Magnitude	0 V						
V2 Phase Angle	0 deg						
V0 Magnitude	0 V						
V0 Phase Angle	0 deg						
CB2 CS Volt Mag	0 V						
CB2 CS Volt Ang	0 deg						
CB2 Bus-Line Ang	0 deg						
CB2 CS Slip Freq							
VRem Magnitude	0 V						
VRem Phase Ang	0 deg						
IA CT1 Magnitude	0 A						
IA CT1 Phase Ang	0 deg						
IB CT1 Magnitude	0 A						
IB CT1 Phase Ang	0 deg						
IC CT1 Magnitude	0 A						
IC CT1 Phase Ang	0 deg						
IA CT2 Magnitude	0 A						
IA CT2 Phase Ang	0 deg						
IB CT2 Magnitude	0 A						
IB CT2 Phase Ang	0 deg						
IC CT2 Magnitude	0 A						
IC CT2 Phase Ang	0 deg						

Table 6 - Measurement 1, 2, 3 and 4

4.9

Measurements 4 Column

Channel 1 and Channel 2 propagation times are displayed in seconds. These times are the ones calculated with asynchronous sampling (sometimes called “ping pong” method). Ch1/Ch2 Rx Prop Delay Ch1 and Ch1/Ch2 Tx Prop Delay are displayed in seconds. These times are the ones calculated with synchronous sampling (by using GPS), therefore they are displayed only when GPS method is active (setting PROT COMMS - IM64/GPS Sync/Enabled)

‘Channel Status 1’ is a diagnostics flag associated with Channel 1 condition (Channel 2 is the same).

- Bit “Max Tx-Rx Time” If the **GPS Synch** is enabled and the **TxRx Time Stats** is enabled, this bit indicates that the delay time between message transmission and reception is above the setting.
- Bit “Max Prop Delay” If the **Prop Delay Stats** is enabled, this bit indicates that the propagation delay time is above the setting.
- Bit “H/W B to J mode” If a relay suffix K (or higher) is communicating with a relay suffix B, G or J, this bit is 1.
- Bit “Passthrough” This indicates that, in a three-terminal configuration, Ch1 data has been received on Ch2 via the self healing ring mechanism.
- Bit “Message Level” Is indicative of the quality of the signal on Channel 1.
- Bit “Timeout” Indication that no valid messages are received over Channel 1 during the ‘Channel Timeout’ window.
- Bit “Mismatch Rxn” Indication of mismatch between the InterMiCOM64 Ch1 setting and that of the associated multiplexer.
- Bit “Path Yellow” An indication of one way communication. The local relay is being informed by the remote connected relay that the remote connected relay is not receiving messages from the local one.
- Bit “Signal Lost” An indication from the associated multiplexer that Channel1 signals are being lost.
- Bit “Mux Clk F Error” This is an alarm that appears if the Channel 1 baud rate is outside the limits 52 Kbis/s or 70 Kbits/s
- Bit “Remote GPS” Indicates the status of the remote GPS on Channel 1.
- Bit “Local GPS” Indicates the status of the local GPS on Channel 1.
- Bit “Tx” Indication of transmission on Channel 1.
- Bit “Rx” Indication of reception on Channel 1.

‘IM64 Rx Status’ is a 16 bit word that displays the status of received commands as “1” or “0”.

‘Last Reset on’ displays the time and date of last statistics reset.

‘Ch1/Ch2 No. of valid messages’ displays the number of received valid messages over channel 1/2 since last statistics reset.

‘Ch1/Ch2 No. of Errored messages’ displays the number of invalid messages over channel 1/Ch 2 since last statistics reset.

The number of errored messages complies with ITU- G8.21 and is as follows:

‘Ch1/Ch2 No. Errored seconds’ displays the number of seconds containing 1 or more errored or lost messages

‘Ch1/Ch2 No. Severely Errored seconds’ displays the number of seconds containing 31 or more errored or lost messages (see Note 1).

<p><i>Note 1</i> <i>Any severely errored seconds are ignored when working out the minutes intervals</i></p>
--

‘Ch1/Ch2 No. Degraded minutes’ displays the number of minutes containing 2 or more errored or lost messages.

The number of lost messages recorded is intended as an indicator for noises under normal communication conditions and not for recording long communication breaks. The lost message count is accumulated by incrementing a counter when a message is rejected by the Error code check, message length check and the sequential time tag check.

‘Max Ch 1/2 Prop Delay’ displays the maximum value of the overall propagation delay divided by 2 when the protection communications are enabled.

The error statistics are automatically cleared on power-up. They can also be cleared using the Clear Statistics setting in Measurements column of the menu.

PRODUCT DESIGN

CHAPTER 10

Applicability**Date:** 01/2024**Products covered by this chapter:**

This chapter covers the specific versions of the MiCOM products listed below. This includes **only** the following combinations of Software Version and Hardware Suffix.

Hardware Suffix:

Product	Hardware Suffix
P141 / P142 / P143	L or later
P145	M or later
P241	L or later
P242 / P243	M or later
P341	L or later
P342	L or later
P343 / P344 / P345	M or later
P391	A or later
P44x (P442 / P444)	M or later
P44y (P443 / P446)	M or later
P445	L or later
P54x (P543 / P544 / P545 / P546)	M or later
P642	L or later
P643 / P645	M or later
P741 / P743	M or later
P742	L or later
P746	M or later
P841 (P841A / P841B)	M or later
P849	M or later

Software Version:

Product	Software Version
P14x (P141 / P142 / P143 / P145)	B5 or later
P24x (P241 / P242 / P243)	D1 or later
P341	B3 / E3 or later
P342 / P343 / P344 / P345 / P391	B3 or later
P445	K1 or later
P44x (P442 / P444)	E3 or later
P44y (P443 / P446)	K1 or later
P54x (P543 / P544 / P545 / P546)	K1 or later
P64x (P642 / P643 / P645)	B4 or later
P74x (P741 / P742 / P743)	B1 or later
P746_1 / P746_2	B5 / C5 or later
P841A / P841B	L1 / K1 or later
P849	B2 or later

Connection Diagrams:	This chapter list the connection diagram for the product:
P14x (P141, P142, P143 & P145):	10P141xx (xx = 01 to 02) 10P142xx (xx = 01 to 05) 10P143xx (xx = 01 to 11) 10P145xx (xx = 01 to 11)
P24x (P241, P242 & P243):	10P241xx (xx = 01 to 02) 10P242xx (xx = 01) 10P243xx (xx = 01)
P34x (P342, P343, P344, P345 & P391)	10P342xx (xx = 01 to 17) 10P343xx (xx = 01 to 19) 10P344xx (xx = 01 to 12) 10P345xx (xx = 01 to 07) 10P391xx (xx = 01 to 02)
P445:	10P445xx (xx = 01 to 04)
P44x (P442 & P444):	10P44101 (SH 1 & 2) 10P44201 (SH 1 & 2) 10P44202 (SH 1) 10P44203 (SH 1 & 2) 10P44401 (SH 1) 10P44402 (SH 1) 10P44403 (SH 1 & 2) 10P44404 (SH 1) 10P44405 (SH 1) 10P44407 (SH 1 & 2)
P44y:	10P44303 (SH 01 and 03) 10P44304 (SH 01 and 03) 10P44305 (SH 01 and 03) 10P44306 (SH 01 and 03) 10P44600 10P44601 (SH 1 to 2) 10P44602 (SH 1 to 2) 10P44603 (SH 1 to 2)
P54x (P543, P544, P545 & P546):	10P54302 (SH 1 to 2) 10P54303 (SH 1 to 2) 10P54304 (SH 1 to 2) 10P54400 10P54404 (SH 1 to 2) 10P54405 (SH 1 to 2) 10P54502 (SH 1 to 2) 10P54503 (SH 1 to 2) 10P54504 (SH 1 to 2) 10P54600 10P54604 (SH 1 to 2) 10P54605 (SH 1 to 2) 10P54606 (SH 1 to 2)
P547:	10P54702xx (xx = 01 to 02) 10P54703xx (xx = 01 to 02) 10P54704xx (xx = 01 to 02) 10P54705xx (xx = 01 to 02)
P64x (P642, P643 & P645):	10P642xx (xx = 1 to 10)

	10P643xx (xx = 1 to 6) 10P645xx (xx = 1 to 9)
P74x:	10P740xx (xx = 01 to 07)
P746:	10P746xx (xx = 00 to 21)
P841:	10P84100 10P84101 (SH 1 to 2) 10P84102 (SH 1 to 2) 10P84103 (SH 1 to 2) 10P84104 (SH 1 to 2) 10P84105 (SH 1 to 2)
P849:	10P849xx (xx = 01 to 06)

CONTENTS

1. Relay System Overview	9
1.1 Hardware Overview	9
1.2 Mechanical Layout	10
1.3 Processor Board	10
1.4 Internal Communication Buses	10
1.4.1 Co-Processor Board (optionally with InterMiCOM64 Fiber Teleprotection).....	11
1.5 Input Module	11
1.5.1 Transformer Board.....	12
1.5.2 Input Board.....	12
1.5.3 Universal Opto Isolated Logic Inputs.....	14
1.6 Power Supply Module (including Output relays)	16
1.6.1 Power Supply Board (including EIA(RS)485 Communication Interface).....	16
1.6.2 Output Relay Board.....	17
1.6.3 High Break Relay Board.....	18
1.6.3.1 High Break Contact Applications.....	19
1.6.4 Input/Output (4+4) Relay Board.....	20
1.7 Product Specific Options	20
1.8 Current Loop Input Output (CLIO) Board	20
1.9 IRIG-B Modulated and/or Un-modulated Board (Optional)	22
1.10 Resistance Temperature Detector (RTD) Board (Optional)	22
1.11 Second Rear Communications Board (Optional)	22
1.11.1 Rear Communications and InterMiCOM (P445 Model D, P741 & P743 only).....	23
1.12 Ethernet Board (Optional)	23
2. Relay Software	26
2.1 Real-Time Operating System	26
2.2 System Services Software	27
2.3 Platform Software	27
2.3.1 Record Logging.....	27
2.3.2 Settings Database.....	28
2.3.3 Database Interface.....	28
2.4 Protection and Control Software	28
2.4.1 Sample Acquisition without a Co-Processor (P14x, P64x, P841).....	29
2.4.2 Sample Acquisition with a Co-Processor (P54x, P44y & P445 Model D).....	29
2.4.3 Signal Processing.....	29
2.4.4 Main Protection Digital Filtering - Co-Processor Board.....	29
2.4.4.1 Differential Protection (P54x only).....	29
2.4.4.2 Distance Protection Filters (P44y and P54x).....	30
2.4.6 Frequency Response.....	30
2.4.6.1 Fourier Filtering.....	32
2.4.7 Programmable Scheme Logic (PSL).....	32

2.4.7.1 PSL Data	32
2.4.8 Function Key Interface	33
2.4.9 Event, Fault and Maintenance Recording	33
2.5 Disturbance Recorder	34
2.6 Communication Software for P74x	34
<hr/>	
3. Fault Locator	36
3.1 Basic Theory for Ground Faults (for P14x)	36
3.2 Data Acquisition and Buffer Processing (for P14x)	36
3.3 Faulted Phase Selection (for P14x)	36
3.4 Fault Location Calculation (for P14x)	37
3.4.1 Obtaining the Vectors (for P14x)	37
3.4.2 Solving the Equation for the Fault Location (for P14x)	37
<hr/>	
4. Self Testing and Diagnostics	39
4.1 Startup Self-Testing	39
4.1.1 System Boot	39
4.1.2 Initialization Software	39
4.1.3 Platform Software Initialization and Monitoring	40
4.2 Continuous Self-Testing	40

TABLES

Table 1 - PCBs and voltage/current inputs for different relay types	12
Table 2 - Threshold levels	15
Table 3 - Numbers of opto inputs for different models	16
Table 4 - Power supply options	16
Table 5 - Numbers of relay contacts for different models	18
Table 6 - Numbers of boards and relay outputs for different models	19
Table 7 - Numbers of alarms, event records, fault records and maintenance records for different software versions	28
Table 8 - Disturbance recorder channels, signals, times and records for different models	34

FIGURES

Figure 1 - Relay modules and information flow diagram	9
Figure 2 - Main input board diagram	13
Figure 3 - Main input module diagram	14
Figure 4 - High break contact operation diagram	19
Figure 5 - Current loop input output board diagram	22
Figure 6 - Rear communications port diagram	23
Figure 7 - Ethernet board connectors (3 RJ45 or 2 LC + RJ45 or 1 RJ45)	25

Figure 8 - Relay software structure diagram.....	26
Figure 9 - Frequency response (for P14x, P24x, P341, P34x and P64x) diagram.....	31
Figure 10 - Frequency response (for P44y, P54x and P445) diagram.....	31
Figure 11 - Frequency response (for P841) diagram.....	31
Figure 12 - System overview diagram.....	35
Figure 13 - Two machine equivalent circuit diagram.....	36
Figure 14 - Fault locator selection of fault current zero diagram.....	38
Figure 15 - Start-up self-testing logic diagram.....	42
Figure 16 - Continuous self-testing logic diagram.....	43

Notes:

1. RELAY SYSTEM OVERVIEW

1.1 Hardware Overview

The relay is based on a modular hardware design where each module performs a separate function. This section describes the functional operation of the various hardware modules. Some modules are essential while others are optional depending on the user's requirements (see 1.7 - Product Specific Options and 1.12 - Ethernet Board (Optional)).

All modules are connected by a parallel data and address bus which allows the processor board to send and receive information to and from the other modules as required.

There is also a separate serial data bus for transferring sample data from the input module to the processor. See the Figure 1 - Relay modules and information flow diagram.

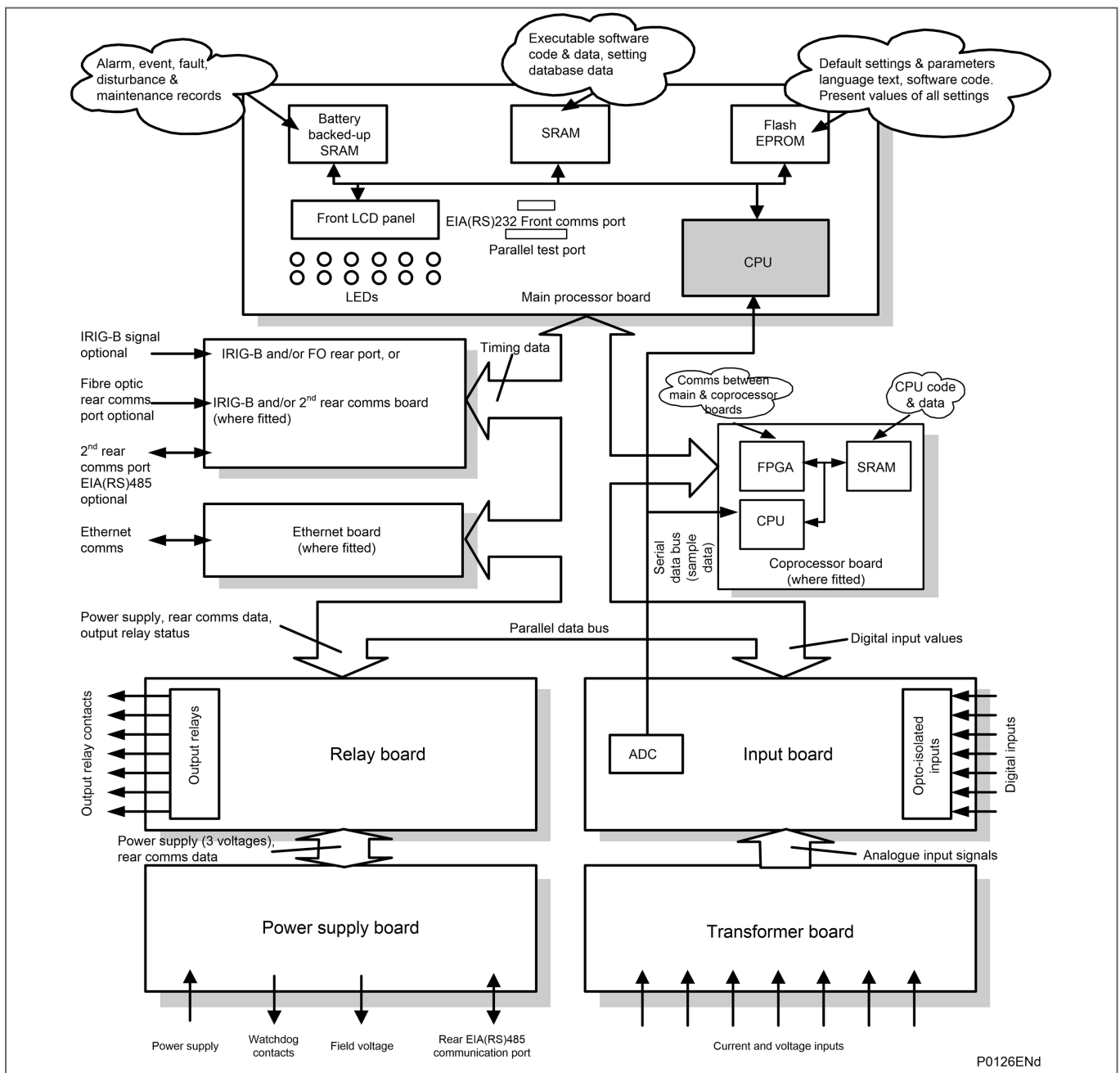

Figure 1 - Relay modules and information flow diagram

1.2 Mechanical Layout

The relay case is pre-finished steel with a conductive covering of aluminum and zinc. This provides good earthing at all joints with a low impedance path to earth that is essential for shielding from external noise. The boards and modules use multi-point grounding (earthing) to improve immunity to external noise and minimize the effect of circuit noise. Ground planes are used on boards to reduce impedance paths and spring clips are used to ground the module metalwork.

Heavy duty terminal blocks are used at the rear of the relay for the current and voltage signal connections. Medium duty terminal blocks are used for the digital logic input signals, output relay contacts, power supply and rear communication port. A BNC connector is used for the optional IRIG-B signal. 9-pin and 25-pin female D-connectors are used at the front of the relay for data communication.

Inside the relay the boards plug into the connector blocks at the rear, and can be removed from the front of the relay only. The connector blocks to the relay's CT inputs have internal shorting links inside the relay. These automatically short the current transformer circuits before they are broken when the board is removed.

The front panel consists of a membrane keypad with tactile dome keys, an LCD and 12 or 22 LEDs (depending on the model) mounted on an aluminum backing plate.

1.3 Processor Board

The processor board performs all calculations for the relay and controls the operation of all other modules in the relay. The processor board also contains and controls the user interfaces (LCD, LEDs, keypad and communication interfaces).

The relay is based around a TMS320VC33-150MHz (peak speed), floating-point, 32-bit Digital Signal Processor (DSP) operating at a clock frequency of half this speed. This processor performs all the calculations for the relay, including the protection functions, control of the data communication and user interfaces including the operation of the LCD, keypad and LEDs.

The processor board is directly behind the relay's front panel. This allows the LCD and LEDs and front panel communication ports to be mounted on the processor board. These ports are:

- The 9-pin D-connector for EIA(RS)232 serial communications used for Easergy Studio and Courier communications.
- The 25-pin D-connector relay test port for parallel communication.

All serial communication is handled using a Field Programmable Gate Array (FPGA). The main processor board has:

- 8 MB SRAM for the working area. This is fast access (zero wait state) volatile memory used to temporarily store and execute the processor software.
- 8 MB flash ROM to store the software code, text, configuration data, default settings, and present settings.
- 4 MB battery-backed SRAM to store disturbance, event, fault and maintenance records.

1.4 Internal Communication Buses

The relay has two internal buses for the communication of data between different modules. The main bus is a parallel link that is part of a 64-way ribbon cable. The ribbon cable carries the data and address bus signals in addition to control signals and all power supply lines. Operation of the bus is driven by the main processor board that operates as a master while all other modules in the relay are slaves.

The second bus is a serial link that is used exclusively for communicating the digital sample values from the input module to the main processor board. The DSP has a built-in serial port that is used to read the sample data from the serial bus. The serial bus is also carried on the 64-way ribbon cable.

1.4.1 Co-Processor Board (optionally with InterMiCOM⁶⁴ Fiber Teleprotection)

Important

The Co-processor board is not present in the P14x, P341, P34x, P44x, P64x, P746, P841 or P849 relays.

A co-processor board is used to process the distance protection and delta directional algorithms. It contains the optical fiber transmit and receive hardware and serial data communication controller for the InterMiCOM⁶⁴ teleprotection. InterMiCOM⁶⁴ is an extra cost ordering option.

A second processor board is used in the relay for the processing of the distance and delta protection algorithms. The processor used on the second board is the same as that used on the main processor board. The second processor board has provision for fast access (zero wait state) SRAM for use with both program and data memory storage. This memory can be accessed by the main processor board via the parallel bus, and this route is used at power-on to download the software for the second processor from the flash memory on the main processor board. Further communication between the two processor boards is achieved via interrupts and the shared SRAM. The serial bus carrying the sample data is also connected to the co-processor board, using the processor's built-in serial port, as on the main processor board.

The co-processor board also handles any communication with the remote differential relay(s). This is achieved via BFOC 2.5 - ST optical fiber connections at the rear and hence the co-processor board holds the optical modules to transmit and receive data over the fiber links. One or two channels will be provided, each comprising a Rx (receive) and a Tx (transmit) fiber as a pair. The channels, when fitted according to an ordering option, are labeled Ch1 and Ch2.

1.5 Input Module

The input module provides the interface between the relay processor board(s) and the analog and digital signals coming into the relay. The input module consists of the main 1.5.2 - Input Board and the 1.5.1 - Transformer Board.

Model	Input Boards	Transformer Boards	Voltage Inputs	Current Inputs	Notes
P14x	1	1	4	5	
P241	1	1	3	4	
P242	1	1	3	4	
P243	1	2	3	7	
P342	1	1	3	5	
P343	1	2	4/5/6	8/9	
P344	1	2	4/5/6	8/9	P344 input module is the same as P343 but with an additional voltage input, providing 5 voltage inputs and 8 current inputs
P345	1	2	4/5/6	8/9	P345 input module is the same as P344 but with an additional 20 Hz current and 20 Hz voltage input for 100% stator earth fault protection
P442	1	1	4	5	

Model	Input Boards	Transformer Boards	Voltage Inputs	Current Inputs	Notes
P443	1	1	4	5	
P444	1	1	4	5	
P445	1	1	4	4	
P446	1	2	5	8	
P543	1	1	4	5	
P544	1	2	5	8	
P545	1	1	4	5	
P546	1	2	5	8	
P642	1	1	1 or 2	8	
P643	1	1	2	3 or 9	
P645	1	1	2	9	
P741	0	0	0	0	
P742	1	1	0	4	
P743	1	1	3	4	
P746_1	1	1	3	18	
P746_2	1	1	-	21	
P841A	1	1	4	5	
P841B	1	2	5	8	
P849	1	1	-	-	

Table 1 - PCBs and voltage/current inputs for different relay types

1.5.1 Transformer Board

The transformer board holds a number of Voltage Transformers (VTs) and Current Transformers (CTs). Some model/options may also have an auxiliary transformer board which can provide more VTs and CTs.

The current inputs will accept either 1A or 5A nominal current (observe menu and wiring options) and the voltage inputs can be specified for either 110V or 440V nominal voltage (order option). The transformers are used both to step-down the currents and voltages to levels appropriate to the relay's electronic circuitry and to provide effective isolation between the relay and the power system. The connection arrangements of both the current and voltage transformer secondary's provide differential input signals to the main input board to reduce noise.

1.5.2 Input Board

The main input board is shown as a block diagram in the Figure 2 - Main input board diagram. It provides the circuitry for the digital input signals and the Analog-to-Digital (A-D) conversion for the analog signals. It takes the differential analog signals from the CTs and VTs on the transformer board(s), converts these to digital samples and transmits the samples to the main processor board through the serial data bus. On the input board, the analog signals are converted using a dedicated sigma-delta A-D convertor for each channel. This allows all of the channels to be sampled concurrently with no sampling skew between channels. The digital input signals are opto isolated on this board to prevent excessive voltages on these inputs causing damage to the relay's internal circuitry. The sampled signals are then digitally filtered prior to the data being sent to the main processor via the serial link.

In models using the second transformer board, a second input board is also fitted to provide the A-D conversion for the additional channels

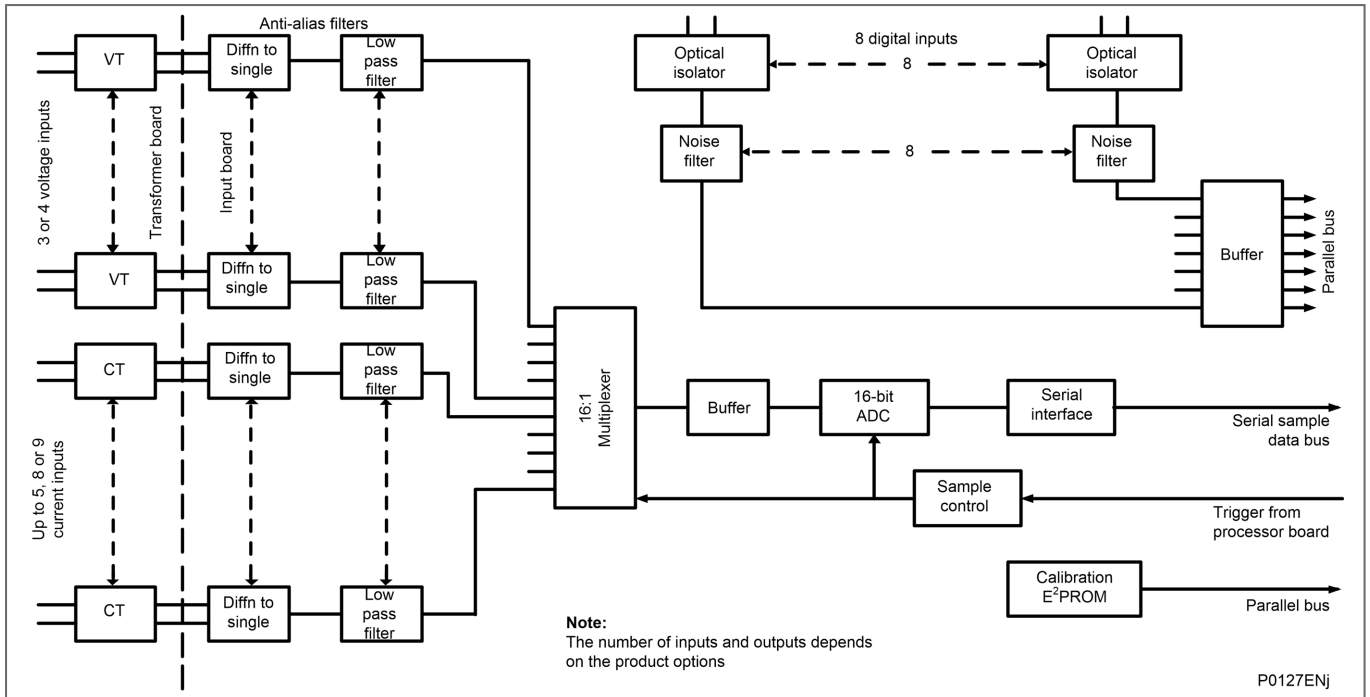

Figure 2 - Main input board diagram

Three spare channels are used to sample three different reference voltages for continually checking the operation of the multiplexer and the accuracy of the A-D converter. Generally, with a 2.4kHz sample frequency, the sample rate is maintained at 48 samples per cycle at 50Hz (or 40 samples per cycle @ 60Hz) of the power waveform by a logic control circuit which is driven by the frequency tracking function on the main processor board.

Note

For the P14x, P24x & P64x, the sample rate is 24 samples per cycle.

The calibration non-volatile memory holds the calibration coefficients which are used by the processor board to correct for any amplitude or phase errors introduced by the transformers and analog circuitry.

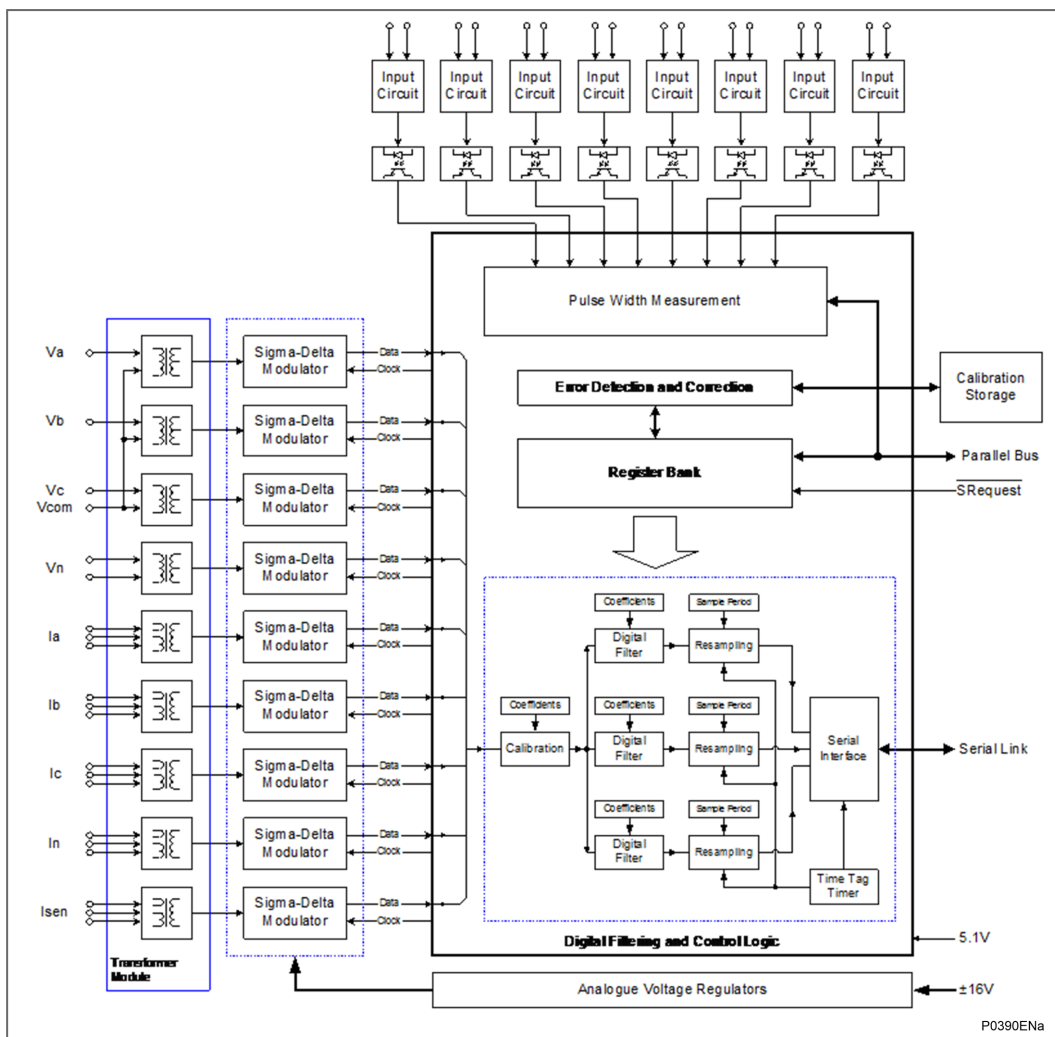

Figure 3 - Main input module diagram

The other function of the input board is to read the signals on the digital inputs and send them through the parallel data bus to the processor board. The input board holds eight optical isolators for connecting up to eight digital input signals. Opto-isolators are used with digital signals for the same reason as transformers are used with analog signals: to isolate the relay’s electronics from the power system environment. The input board has hardware filters to remove noise from the digital signals. The digital signals are then buffered so they can be read on the parallel data bus. Depending on the relay model, more than eight digital input signals can be accepted by the relay. This is done using an additional opto-board that contains the same provision for eight isolated digital inputs as the main input board, but does not contain any of the circuits for analog signals which are provided on the main input board.

1.5.3 Universal Opto Isolated Logic Inputs

This series of relays have universal opto-isolated logic inputs that can be programmed for the nominal battery voltage of the circuit of which they are a part. This allows different voltages for different circuits such as signaling and tripping. They can also be programmed as Standard 60% - 80% or 50% - 70% to satisfy different operating constraints.

Threshold levels are shown in this table:

Nominal battery voltage (Vdc)	Standard 60% - 80%		50% - 70%	
	No operation (Logic 0) Vdc	Operation (Logic 1) Vdc	No operation (Logic 0) Vdc	Operation (Logic 1) Vdc
24/27	<16.2	>19.2	<12.0	>16.8

Nominal battery voltage (Vdc)	Standard 60% - 80%		50% - 70%	
	No operation (Logic 0) Vdc	Operation (Logic 1) Vdc	No operation (Logic 0) Vdc	Operation (Logic 1) Vdc
30/34	<20.4	>24.0	<15.0	>21.0
48/54	<32.4	>38.4	<24.0	>33.6
110/125	<75.0	>88.0	<55.0	>77.0
220/250	<150.0	>176.0	<110.0	>154.0

Table 2 - Threshold levels

This lower value eliminates fleeting pick-ups that may occur during a battery earth fault, when stray capacitance may present up to 50% of battery voltage across an input.

Each input also has selectable filtering. This allows a pre-set ½ cycle filter to be used to prevent induced noise on the wiring. However, although the ½ cycle filter is secure it can be slow, particularly for intertripping. If the ½ cycle filter is switched off to improve speed, double pole switching or screened twisted cable may be needed on the input to reduce ac noise.

The first method is to use double pole switching on the input, the second is to use screened twisted cable on the input circuit.

Model	Opto Inputs	Notes
P14x	32	achieved by the inclusion of three opto-input cards that will increase the total number of opto-inputs to 32
P241	8	
P242 / P243	16	
P442	16	
P443 A / C	16	
P443 B / D	24	
P443 Y	32	
P444	24	
P445 A	8	
P445 B	12	achieved by the inclusion of a special combined input output board which has 4 inputs and 4 outputs
P445 C / D	16	
P446	24	
P543 / P544	16	
P545	24	Or 32 by certain ordering options
P546	24	
P642	12	
P643 / P645	24	
P741	8	
P742xxxA	16	
P742xxxB	8	
P743xxxA	24	
P743xxxB	16	
P743xxxC	24	
P743xxxD	16	

Model	Opto Inputs	Notes
P841 A	16	
P841 B	24	

Table 3 - Numbers of opto inputs for different models

1.6 Power Supply Module (including Output relays)

The power supply module contains two boards, one for the power supply unit and the other for the output relays. It provides power to all of the other modules in the relay, as well as the EIA (RS)485 electrical connection for the rear communication port. The second board of the power supply module contains the relays that provide the output contacts.

1.6.1 Power Supply Board (including EIA(RS)485 Communication Interface)

The power supply module also provides a 48V external field supply output to drive the opto isolated digital inputs (or the substation battery may be used to drive the optos).

One of three different configurations of the power supply board can be fitted to the relay. This is specified at the time of order and depends on the nature of the supply voltage that will be connected to the relay. The options are shown in this table:

Nominal dc range	Nominal ac range
24 - 32 V dc	dc only
48 - 110 V dc	dc only
110 - 250 V dc	100 - 240 V ac rms

Table 4 - Power supply options

The output from all versions of the power supply module are used to provide isolated power supply rails to all of the other modules in the relay. Three voltage levels are used in the relay: 5.1 V for all of the digital circuits, ± 16 V for the analog electronics such as on the input board, and 22 V for driving the output relay coils and the RTD board if fitted. All power supply voltages including the 0 V earth line are distributed around the relay through the 64-way ribbon cable. The power supply board also provides the 48 V field voltage*. This is brought out to terminals on the back of the relay so that it can be used to drive the optically-isolated digital inputs.

*** Note**

It is compulsory to add an EMC Filter to use the field voltage outputs to prevent any noise or high frequency disturbance.

The EMC Filter must be connected to the protection relay with a three-wires cable of appr. 1m length.

The earth port of the EMC filter must only be connected to the earth terminal of Px4x; the metal housing of the filter should not be connected to the ground plane.

Proposal:

Schaffner EMC Filter (FN2010-1-06, 1A max - 250V), or equivalent



Important

MiCOM P44y (P443 & P446), P445, P54x (P543, P544, P545 & P546), P74x (P741, P742 & P743) and P841 relays do not support MODBUS.

The two other functions provided by the power supply board are the EIA(RS)485 communications interface and the watchdog contacts for the relay. The EIA(RS)485 interface is used with the relay's rear communication port to provide communication using one of either Courier, MODBUS, IEC60870-5-103, or DNP3.0 protocols. The EIA(RS)485 hardware supports half-duplex communication and provides optical isolation of the serial data that is transmitted and received. All internal communication of data from the power supply board is through the output relay board connected to the parallel bus.

The watchdog facility has two output relay contacts, one Normally Open (N/O) and one Normally Closed (N/C). These are driven by the main processor board and indicate that the relay is in a healthy state.

The power supply board incorporates inrush current limiting. This limits the peak inrush current, during energization, to approximately 10 A.

1.6.2 Output Relay Board

The standard output relay boards hold different numbers of relays with Normally Open (N/O) contacts and with ChangeOver (C/O) contacts. The relevant numbers are as follows:

There are two versions of the output relay board:

- one with seven relays, three Normally Open (N/O) contacts and four Changeover (C/O) contacts and
- one with eight relays, six N/O contacts and two C/O contacts.

For relay models with Hardware Suffix A, only the seven-output relay boards were available. For equivalent relay models in Hardware Suffix B or greater the base numbers of output contacts, using the seven-output relay boards, is being maintained for compatibility. The eight-output relay board is only used for new relay models or existing relay models available in new case sizes or to provide additional output contacts to existing models for Hardware Suffix B or greater.

Model	Relay Contacts	Normally Open Contacts	Changeover Contacts	Notes
P14x	8	6	2	For the P145, up to 32 output contacts using up to four standard output relay boards
P24x	7 / 8	3 / 6	4 / 2	
P442	7 / 8	3 / 6	4 /	Up to three boards depending on model
P443	8	6	2	Up to four boards depending on model
P444	7 / 8	3 / 6	2	Up to three boards depending on model
P445	8	6	4 / 2	In a 40TE case only 1 output board can be fitted In the 60TE case 2 boards are an option
P446	8	6	2	Up to four boards depending on model
P543 / P544	7	3	2	Up to 32 outputs using one or two standard output relay boards
P545 / P546	8	6	4	Up to 32 outputs using up to four standard output relay boards
P642	8	6	2	Up to 12 outputs using up to one standard output relay boards
P643 / P645	8	6	2	Up to 24 outputs using up to two standard output relay boards
P741	8	6	2	
P742xxxA	16	6	2	

Model	Relay Contacts	Normally Open Contacts	Changeover Contacts	Notes
P742xxxB	8	6	2	
P743xxxA	24	14	2	
P743xxxB	16	12	4	
P743xxxC	24	6	2	
P743xxxD	16	6	2	
P841 A	7	3	4	In a standard configuration, this uses two output relay boards
P841 B	8	6	2	In a standard configuration, this uses four output relay boards

Table 5 - Numbers of relay contacts for different models

The relays are driven from the 22 V power supply line. The relays' state is written to or read from using the parallel data bus. Depending on the relay model, more than seven output contacts may be provided, through the use of up to three extra relay boards. Each additional relay board provides a further seven or eight output relays.

1.6.3 High Break Relay Board

All the relays are driven from the 22 V power supply line. The state of the relay is written to or read from using the parallel data bus.

A 'high break' output relay board is fitted in addition to a standard output relay board. This houses four normally-open (N/O) output contacts suitable for breaking loads higher than can be broken with the standard contacts. These boards are arranged as follows:

Relay Model	No of high break output relay boards	Total standard relay outputs	Total high break relay outputs
P142	1	15	4
P143 / P145	1 or 2	32	8
P24x	3		
P442	3		
P443 C	1	16	4
P443 D	2	16	8
P444	3		
P445 D	1	8	4
P446 B	3	8	12
P446 C	2	16	8
P543 / P544	1 (to replace a standard board)	7	4
P545	2 (to replace standard boards)	16	8
P546 A	2 (to replace standard boards)	16	8
P546 B	3 (to replace standard boards)	8	12
P642		12	4
P643 / P645		24	8
P74x		4	
P746		32	16
P841 A		7	4

Relay Model	No of high break output relay boards	Total standard relay outputs	Total high break relay outputs
P841 B		16	8
P841 C		8	12
P841 D		16	8
P841 E		8	12

Table 6 - Numbers of boards and relay outputs for different models

Important
These relay contacts are polarity-sensitive. External wiring must comply with the polarity requirements described in the external connection diagram to ensure correct operation.

This board uses a hybrid of MOSFET Solid State Devices (SSD) in parallel with high capacity relay output contacts. The MOSFET has a varistor across it to provide protection which is required when switching off inductive loads because the stored energy in the inductor causes a reverse high voltage which could damage the MOSFET.

When there is a control input command to operate an output contact, the miniature relay is operated at the same time as the SSD. The miniature relay contact closes in nominally 3.5 ms and is used to carry the continuous load current; the SSD operates in <0.2 ms and is switched off after 7.5 ms. When the control input resets to open the contacts, the SSD is again turned on for 7.5 ms. The miniature relay resets in nominally 3.5 ms before the SSD so the SSD is used to break the load. The SSD absorbs the energy when breaking inductive loads and so limits the resulting voltage surge. This contact arrangement is for switching dc circuits only. As the SSD comes on very fast (<0.2 ms) these high break output contacts have the added advantage of being very fast operating. See the Figure 4 - High break contact operation diagram.

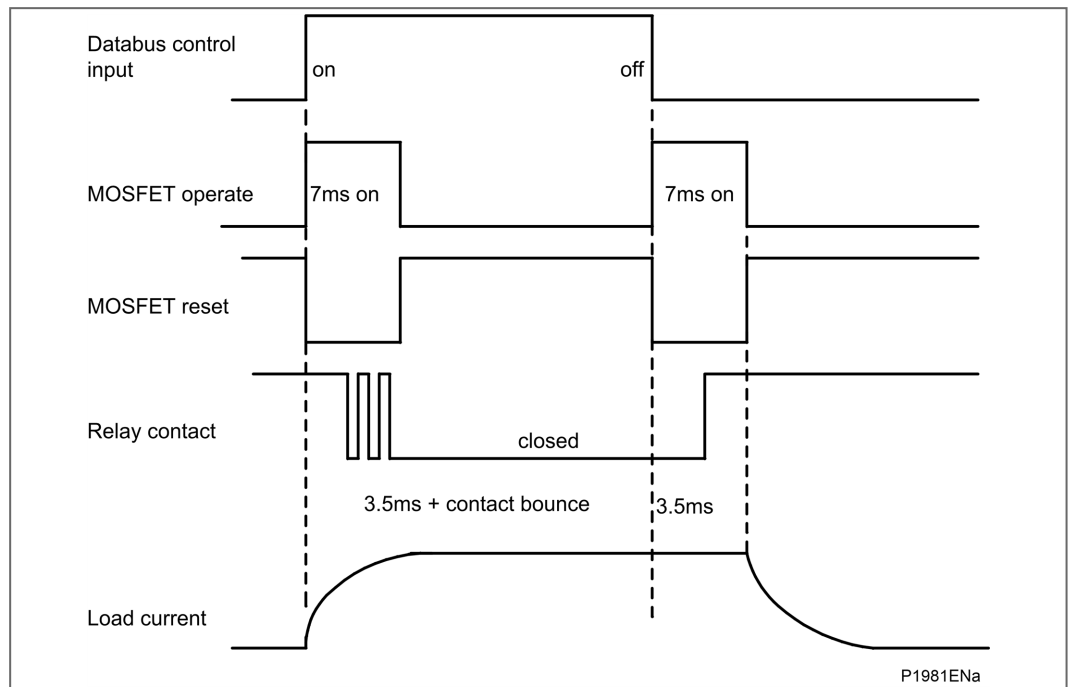

Figure 4 - High break contact operation diagram

1.6.3.1 High Break Contact Applications

1. Efficient Scheme Engineering

In traditional hardwired scheme designs, high break capability could only be achieved using external electromechanical trip relays. External tripping relays

can be used or the high break contacts inside MiCOM relays can be used, reducing panel space.

2. Accessibility of CB Auxiliary Contacts

Common practice is to use circuit breaker 52a (CB Closed) auxiliary contacts to break the trip coil current on breaker opening, easing the duty on the protection contacts. In cases such as operation of disconnectors, or retrofitting, 52a contacts may be unavailable or unreliable. High break contacts can be used to break the trip coil current in these applications.

3. Breaker Fail

The technique to use 52a contacts in trip circuits was described above. However, in the event of failure of the local circuit breaker (stuck breaker), or defective auxiliary contacts (stuck contacts), the 52a contact action is incorrect. The interrupting duty at the local breaker then falls on the relay output contacts which may not be rated to perform this duty. MiCOM high break contacts will avoid the risk of burnt relay contacts.

4. Initiation of Teleprotection

The MiCOM high break contacts also offer fast making, which can provide faster tripping. Also fast keying of teleprotection is a benefit. Fast keying bypasses the usual contact operation time so that permissive, blocking and intertrip commands can be routed faster.

1.6.4 Input/Output (4+4) Relay Board

The input/output relay board has four isolated digital inputs and four output relays. Two of the relays have normally open contacts and two have changeover contacts. The output relays are driven from the 22 V power supply line. The relays' state is written to or read from using the parallel data bus.

This is used with variants of:

- P142 relay that has 12 opto inputs and 11 output contacts.
- P145 (B model) that has 12 opto inputs and 12 output contacts.
- P642 relay option that has 12 opto inputs and 12 output relay contacts.

1.7 Product Specific Options

Product Specific Options may mean that an additional board may be present if it was specified when the relay was ordered. The product specific options commonly allow a choice of RTD, CLIO, different numbers of Optos, Relays (including High Break relays). These options are shown in the *Ordering Options* section in *Chapter 1 – Introduction*.

- 1.8 - Current Loop Input Output (CLIO) Board
- 1.9 - IRIG-B Modulated and/or Un-modulated Board (Optional)
- 1.10 - Resistance Temperature Detector (RTD) Board (Optional)
- 1.11 - Second Rear Communications Board (Optional)
- 1.12 - Ethernet Board (Optional)

1.8 Current Loop Input Output (CLIO) Board

The Current Loop Input Output (CLIO) board is an order option. The CLIO board is powered from the 22 V power rail that is used to drive the output relays.

Four analog (or current loop) inputs are provided for transducers with ranges of 0 to 1 mA, 0 to 10 mA, 0 to 20 mA or 4 to 20 mA. The input current data is read by the processor through the parallel data bus, and is used to provide measurements from various transducers such as vibration monitors, tachometers and pressure transducers.

For each of the four current loop inputs there are two separate input circuits, 0 to 1 mA and 0 to 20 mA. The latter is also used for 0 to 10 mA and 4 to 20 mA transducer inputs. The anti-alias filters have a nominal cut-off frequency (3 dB point) of 23 Hz to reduce power system interference from the incoming signals. Four analog current outputs are provided with ranges of 0 to 1 mA, 0 to 10 mA, 0 to 20 mA or 4 to 20 mA which can alleviate the need for separate transducers. These may be used to feed standard moving coil ammeters for analog indication of certain measured quantities or into a SCADA using an existing analog RTU.

Each of the four current loop outputs provides one 0 to 1 mA output, one 0 to 20 mA output and one common return. Suitable software scaling of the value written to the board allows the 0 to 20 mA output to also provide 0 to 10 mA and 4 to 20 mA. Screened leads are recommended for use on the current loop output circuits.

The refresh interval for the outputs is nominally 50 ms. Any measurements that do not fit this timing are updated once every second.

All external connections to the current loop I/O board are made using the same 15-way light duty I/O connector SL3.5/15/90F used on the RTD board. Two such connectors are used, one for the current loop outputs and one for the current loop inputs.

The I/O connectors accommodate wire sizes in the range 1/0.85 mm (0.57 mm²) to 1/1.38 mm (1.5 mm²) and their multiple conductor equivalents. The use of screened cable is recommended. The screen terminations should be connected to the case earth of the relay.

Basic Insulation (300 V) is provided between analog inputs or outputs and earth, and between analog inputs and outputs. However, there is no insulation between one input and another or one output and another.

Connection	IO Blocks	Connection
Outputs		
Screen channel 1		0 - 10/0 - 20/4 - 20 mA channel 1 0 - 1 mA channel 1 Common return channel 1
Screen channel 2		0 - 10/0 - 20/4 - 20 mA channel 2 0 - 1 mA channel 2 Common return channel 2
Screen channel 3		0 - 10/0 - 20/4 - 20 mA channel 3 0 - 1 mA channel 3 Common return channel 3
Screen channel 4		0 - 10/0 - 20/4 - 20 mA channel 4 0 - 1 mA channel 4 Common return channel 4
Inputs		

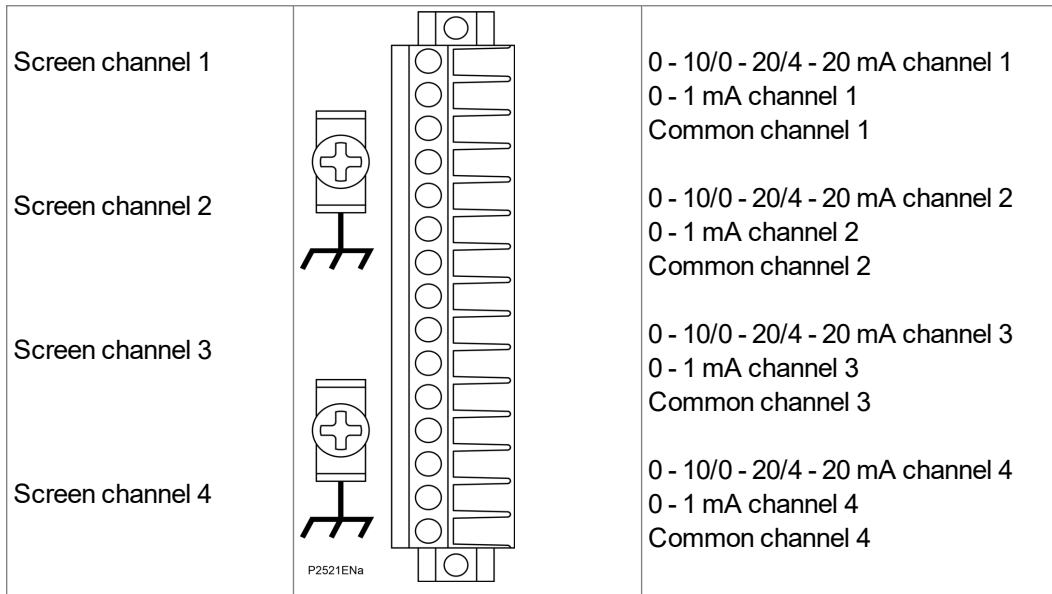

Figure 5 - Current loop input output board diagram

1.9 IRIG-B Modulated and/or Un-modulated Board (Optional)

The optional IRIG-B board is an order option that can be fitted to provide an accurate timing reference for the relay. This can be used wherever an IRIG-B signal is available. The IRIG-B signal is connected to the board with a BNC connector on the back of the relay. The timing information is used to synchronize the relay's internal real-time clock to an accuracy of 1 ms. The internal clock is then used for the time tagging of the event, fault maintenance and disturbance records.

Modulated IRIG-B is available on its own or with any of the other communications options. Un-modulated is only available on the optional Ethernet boards

1.10 Resistance Temperature Detector (RTD) Board (Optional)

The optional Resistance Temperature Detectors (RTD) board is used to monitor the winding and ambient temperature readings from up to ten PT100 RTD that are each connected using a 3-wire connection. The board is powered from the 22 V power rail that is used to drive the output relays. The RTD board includes two redundant channels that are connected to high stability resistors to provide reference readings. These are used to check the operation of the RTD board. The temperature data is read by the processor through the parallel data bus, and is used to provide thermal protection of the windings.

1.11 Second Rear Communications Board (Optional)

Important

MiCOM P44y (P443 & P446), P445, P54x (P543, P544, P545 & P546), P74x (P741, P742 & P743) and P841 relays do not support MODBUS.

For relays with Courier, MODBUS, IEC60870-5-103 or DNP3.0 protocol on the first rear communications port there is the hardware option of a second rear communications port, which runs the Courier language. This can be used over one of three physical links: twisted pair K-BUS (non-polarity sensitive), twisted pair EIA(RS)485 (connection polarity sensitive) or EIA(RS)232.

This optional second rear port is designed typically for dial-up modem access by protection engineers and operators, when the main port is reserved for SCADA traffic.

The port supports full local or remote protection and control access by Easergy Studio software. The second rear port is also available with an on board IRIG-B input.

The second rear communications board, Ethernet and IRIG-B boards are mutually exclusive since they use the same hardware slot. Two versions of second rear communications board are available; with and without modulated IRIG-B. The second rear communications board is shown in the Figure 6 - Rear communications port diagram.

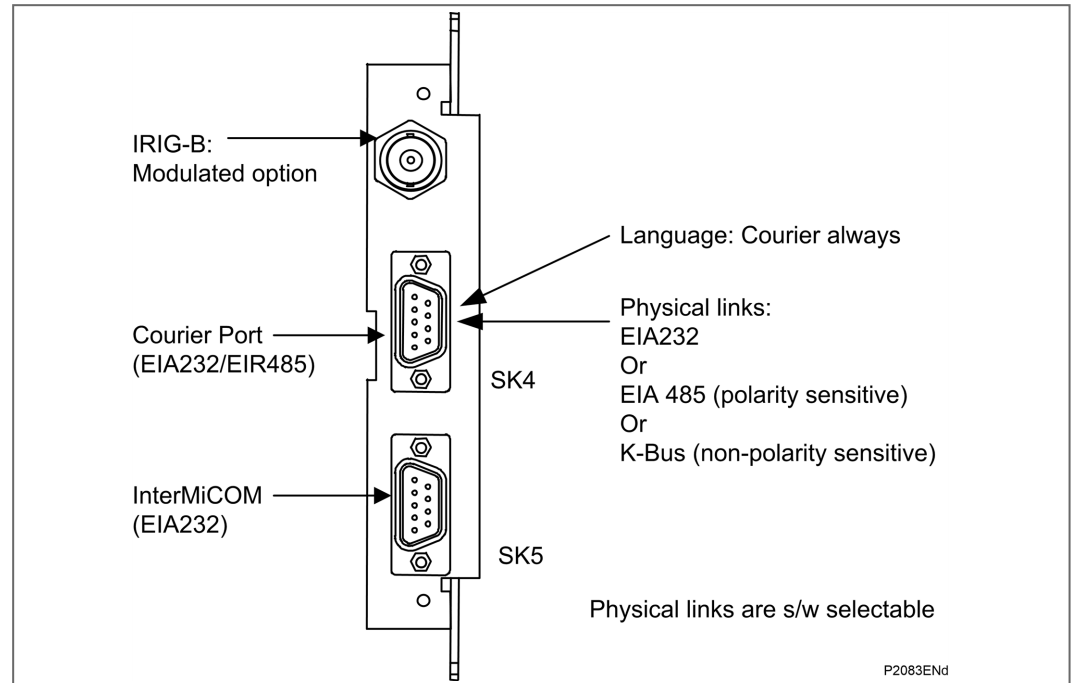

Figure 6 - Rear communications port diagram

1.11.1 Rear Communications and InterMiCOM (P445 Model D, P741 & P743 only)

On ordering this board within a relay, both 2nd rear communications and InterMiCOM will become connection and setting options. The user may then enable either one, or both, as demanded by the installation.

SK4: The second rear communications port runs the Courier language. This can be used over one of three physical links: twisted pair K-Bus (non polarity sensitive), twisted pair EIA (RS)485 (connection polarity sensitive) or EIA(RS)232.

SK5: The InterMiCOM board is used to connect to an EIA(RS)232 link, allowing up to eight programmable signaling bits to be transferred from/to the remote line end relay. A suitable EIA(RS)232 link must exist between the two line ends, for example a MODEM, or via a compatible multiplexer (check compatibility before ordering the relay).

1.12 Ethernet Board (Optional)

This is a mandatory board for IEC 61850 enabled relays. It provides network connectivity through either copper or fiber media at rates of 10Mb/s (copper only) or 100Mb/s. There is also an option on this board to specify IRIG-B board port (modulated and/or un-modulated). This board, the IRIG-B board mentioned in the Hardware Communications Options section and second rear comms. board mentioned in the IRIG-B Board section are mutually exclusive as they all use slot A within the relay case.

All modules are connected by a parallel data and address bus that allows the processor board to send and receive information to and from the other modules as required. There is also a separate serial data bus for conveying sample data from the input module to the processor. The relay modules and information flow diagram shows the modules of the relay and the flow of information between them.

This optional board is required for providing network connectivity using IEC 61850 and/or DNP3oE. There are a variety of different boards which provide Ethernet connectivity.

Important

The choice of communication board options varies according to the Hardware Suffix and the Software Version of the MiCOM product. These are shown in the Ordering Options section in Chapter 1 – Introduction.

By way of example, the board options may include:

- single-port Ethernet boards (which use 100 Mbits/s Copper and modulated/unmodulated IRIG-B connectivity)
- Redundant Ethernet with PRP/HSR/RSTP/Dual IP and a mixture of LC/RJ45 ports and modulated/unmodulated IRIG-B connectivity

These options are mutually exclusive as they all use slot A in the relay case.

Note

Each Ethernet board has a unique MAC address used for each Ethernet communication interface. The MAC address is printed on the rear of the board, next to the Ethernet sockets.

Note

The 100 Mbits/s Fiber Optic ports use LC type connectors and are suitable for 1300 nm multi-mode fiber type.

Copper ports use RJ45 type connectors. When using copper Ethernet, it is important to use Shielded Twisted Pair (STP) or Foil Twisted Pair (FTP) cables, to shield the IEC 61850 communications against electromagnetic interference. The RJ45 connector at each end of the cable must be shielded, and the cable shield must be connected to this RJ45 connector shield, so that the shield is grounded to the relay case. Both the cable and the RJ45 connector at each end of the cable must be Category 5 minimum, as specified by the IEC 61850 standard.

It is recommended that each copper Ethernet cable is limited to a maximum length of 3 m and confined to one bay or cubicle.

When using IEC61850 communications through the Ethernet board, the rear EIA(RS)485 and front EIA(RS)232 ports are available for simultaneous use. The front port always uses the Courier protocol. The rear port protocol depends upon the protocol option selected.

One example of an Ethernet board is shown in this Figure 7 - Ethernet board connectors (3 RJ45 or 2 LC + RJ45 or 1 RJ45):

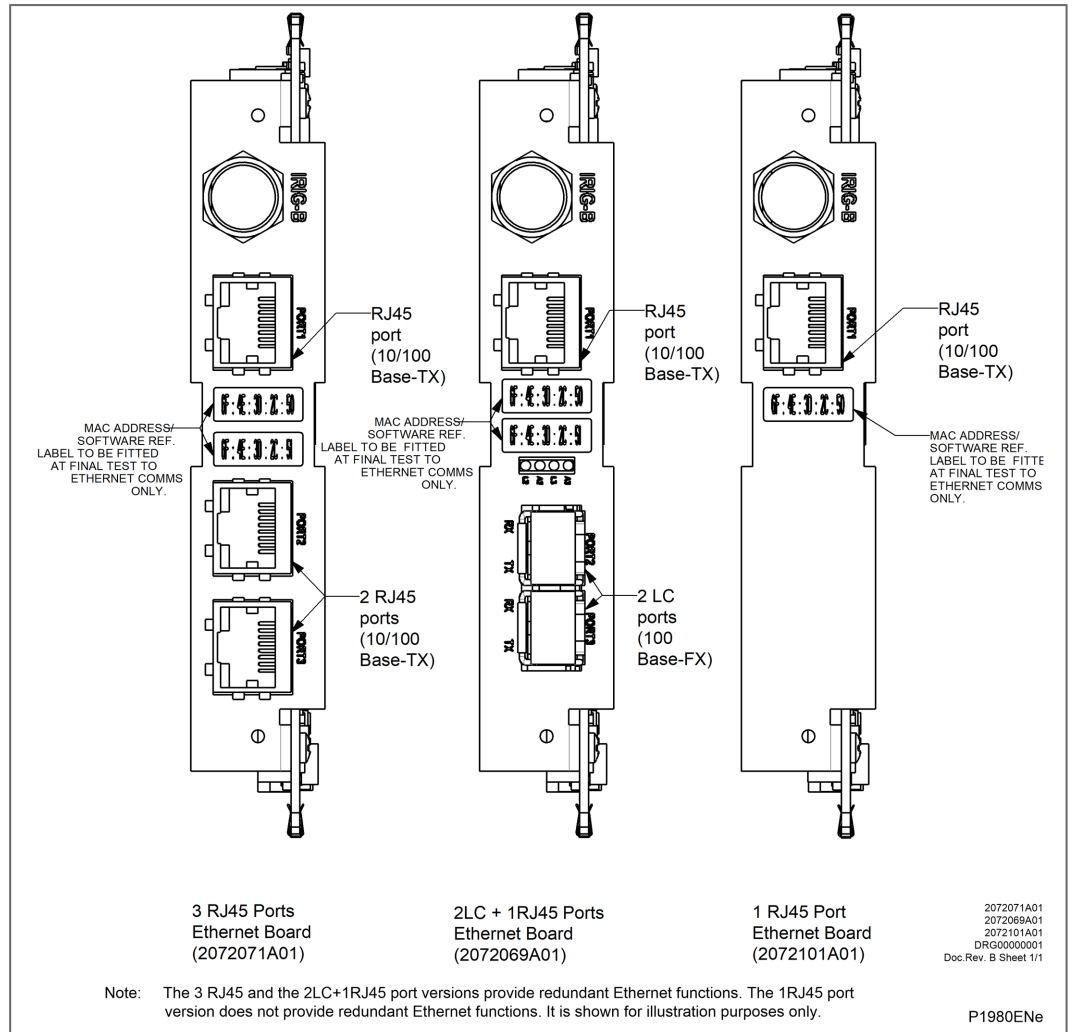

Figure 7 - Ethernet board connectors (3 RJ45 or 2 LC + RJ45 or 1 RJ45)

2. RELAY SOFTWARE

The relay software was introduced in the overview of the relay at the start of this chapter. The software can be considered to be made up of these sections:

- 2.1 - Real-Time Operating System
- 2.2 - System Services Software
- 2.3 - Platform Software
- 2.4 - Protection and Control Software

These four elements are all processed by the same processor board. This section describes in detail the platform software and the protection and control software, which between them control the functional behavior of the relay. The following Figure 8 - Relay software structure diagram shows the structure of the relay software.

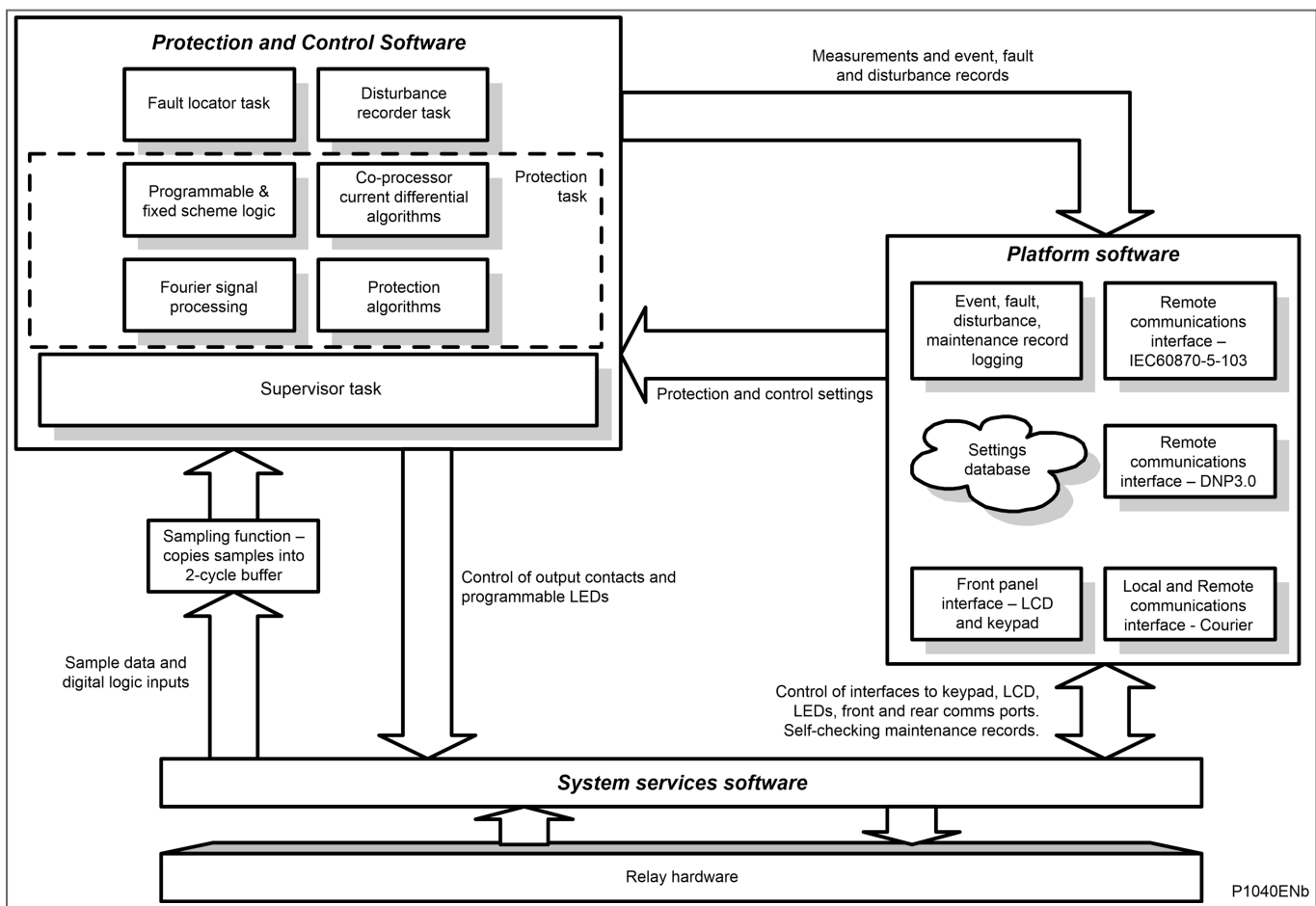

Figure 8 - Relay software structure diagram

2.1 Real-Time Operating System

As explained in the hardware overview, each relay contains one main board and one coprocessor board. These two boards use two different operating systems:

- For main board software: a real time operating system provides a framework for the different parts of the relay's software to operate within. To this end, the software is split into tasks. The real-time operating system is responsible for scheduling the processing of these tasks such that they are carried out in the time available and in the desired order of priority.

- For coprocessor board software: a sequencer manages all the functions implemented on the coprocessor board. Each function is executed at a fixed frequency. Consequently the CPU load of the coprocessor is fixed and independent of the network's frequency.

The real-time operating system is responsible for scheduling the processing of these tasks such that they are carried out in the time available and in the desired order of priority. The operating system is also responsible for the exchange of information between tasks, in the form of messages.

2.2 System Services Software

As shown in the Figure 8 - Relay software structure diagram, the system services software provides the low-level control of the relay hardware. It also provides the interface between the relay's hardware and the higher-level functionality of the platform software and the protection and control software.

For example, the system services software provides drivers for items such as the LCD display, the keypad and the remote communication ports. It also controls the boot of the processor and downloading of the processor code into SRAM from non-volatile flash EPROM at power up.

2.3 Platform Software

Important

MiCOM P44y (P443 & P446), P445, P54x (P543, P544, P545 & P546), P74x (P741, P742 & P743) and P841 relays do not support MODBUS.

The platform software has these main functions:

- To deal with the management of the relay settings.
- To control the logging of all records that are generated by the protection software, including alarms and event, fault, disturbance and maintenance records.
- To store and maintain a database of all of the relay's settings in non-volatile memory.
- To provide the internal interface between the settings database and each of the relay's user interfaces. These interfaces are the front panel interface and the front and rear communication ports, using whichever communication protocol has been specified (Courier, MODBUS, IEC60870-5-103 and DNP3.0). The platform software converts the information from the database into the format required.

The platform software notifies the protection and control software of all settings changes and logs data as specified by the protection and control software.

2.3.1 Record Logging

The logging function is provided to store all alarms, events, faults and maintenance records. The records for all these incidents are logged in battery backed-up SRAM to provide a non-volatile log of what has happened. The relay maintains four logs: one each for alarms, event records, fault records and maintenance records. The logs are maintained such that the oldest record is overwritten with the newest record.

The maximum number of alarms, event records, fault records and maintenance records varies depending on the product, the software and the model options, as shown below:

Software	Versions prior to 41/51	Versions 41/51 to A0/B0	Versions H1 and later
Alarms (maximum)	96	96	96
Events Records	512 (0 - 511)	1024 (0 - 1023)	1024 (0 - 1023)
Fault Records	5 (0 - 4)	10 (0 - 9)	15 (0 - 14)
Maintenance Records	5 (0 - 4)	10 (0 - 9)	10 (0 - 9)

Table 7 - Numbers of alarms, event records, fault records and maintenance records for different software versions

The logging function can be initiated from the protection software or the platform software, and is responsible for logging of a maintenance record in the event of a relay failure. This includes errors that have been detected by the platform software itself or error that are detected by either the system services or the protection software functions. See also 4 - Self Testing and Diagnostics.

2.3.2 Settings Database

The settings database contains all of the settings and data for the relay, including the protection, disturbance recorder and control and support settings. The settings are maintained in non-volatile memory. The platform software's management of the settings database make sure that only one user interface modifies the database settings at any one time. This feature is used to avoid confusion between different parts of the software during a setting change. For changes to protection settings and disturbance recorder settings, the platform software operates a 'scratchpad' in SRAM memory. This allows a number of setting changes to be made in any order but applied to the protection elements, disturbance recorder and saved in the database in non-volatile memory, at the same time. If a setting change affects the protection and control task, the database advises it of the new values.

The database is directly compatible with Courier communications.

2.3.3 Database Interface

The other function of the platform software is to implement the relay's internal interface between the database and each of the relay's user interfaces. The database of settings and measurements must be accessible from all the relay's user interfaces to allow read and modify operations. The platform software presents the data in the appropriate format for each user interface.

2.4 Protection and Control Software

The protection and control software interfaces with the platform software for settings changes and logging of records, and with the system services software for acquisition of sample data and access to output relays and digital opto-isolated inputs. It also performs the calculations for all of the protection algorithms of the relay. This includes digital signal processing such as Fourier filtering and ancillary tasks such as the disturbance recorder.

The protection and control software task processes all of the protection elements and measurement functions of the relay. It has to communicate with both the system services software and the platform software, and organize its own operations. The protection software has the highest priority of any of the software tasks in the relay, to provide the fastest possible protection response. It also has a supervisor task that controls the start-up of the task and deals with the exchange of messages between the task and the platform software.

After initialization at start-up, the protection & control task waits until there are enough samples to process. The sampling function is called by the system services software and takes each set of new samples from the input module and stores them in a two-cycle buffer. The protection & control software resumes execution when the number of unprocessed samples in the buffer reaches a certain number. However, the protection elements are split into groups so that different elements are processed each time, with every element being processed at least once per cycle. The protection and control software is suspended again when all of its processing on a set of samples is complete. This allows operations by other software tasks to take place.

2.4.1 Sample Acquisition without a Co-Processor (P14x, P64x, P841)

The acquisition of samples on the main processor board is controlled by a 'sampling function' which is called by the system services software and takes each set of new samples from the input module and stores them in a two-cycle buffer. The scheduling of the sampling function dictates the scheduling of the protection and control tasks.

2.4.2 Sample Acquisition with a Co-Processor (P54x, P44y & P445 Model D)

After initialization at start-up, the protection and control task on the main processor board is suspended until the co-processor board re-starts via an interrupt. Where the co-processor board has failed, the protection task will automatically start after six analog samples have been received. In normal operation the task will be re-started by the co-processor 16 times per cycle. The acquisition of samples on the main processor board is controlled by a 'sampling function' which is called by the system services software and takes each set of new samples from the input module and stores them in a two-cycle buffer, these samples are also stored concurrently by the co-processor.

2.4.3 Signal Processing

The sampling function filters the digital input signals from the opto-isolators and tracks the frequency of the analog signals. The digital inputs are checked against their previous value over a period of half a cycle. Therefore a change in the state of one of the inputs must be maintained over at least half a cycle before it is registered with the protection and control software.

The frequency tracking of the analog input signals is achieved by a recursive Fourier algorithm which is applied to one of the input signals, and works by detecting a change in the measured signal's phase angle. The calculated value of the frequency is used to modify the sample rate being used by the input module to achieve a constant sample rate of 24 or 48 samples per cycle of the power waveform. The value of the frequency is also stored for use by the protection and control task.

When the protection and control task is re-started by the sampling function, it calculates the Fourier components for the analog signals. The Fourier components are calculated using a one-cycle, 24 or 48-sample Discrete Fourier Transform (DFT). The DFT is always calculated using the last cycle of samples from the 2-cycle buffer, which is the most recent data. Used in this way, the DFT extracts the power frequency fundamental component from the signal and produces the magnitude and phase angle of the fundamental in rectangular component format. The DFT provides an accurate measurement of the fundamental frequency component, and effective filtering of harmonic frequencies and noise. This performance is achieved with the relay input module which provides hardware anti-alias filtering to attenuate frequencies above the half sample rate, and frequency tracking to maintain a sample rate of 24 samples per cycle. The Fourier components of the input current and voltage signals are stored in memory so they can be accessed by all of the protection elements' algorithms. The samples from the input module are also used in an unprocessed form by the disturbance recorder for waveform recording and to calculate true RMS values of current, voltage and power for metering purposes.

2.4.4 Main Protection Digital Filtering - Co-Processor Board

2.4.4.1 Differential Protection (P54x only)

The differential protection is based on the relays at the line ends exchanging data messages four times per cycle. To achieve this the co-processor takes the frequency-tracked samples at 48 samples per cycle from the input board and converts these to 8 samples per cycle based on the nominal frequency (i.e. not frequency tracked). The co-processor calculates the Fourier transform of the fixed rate samples after every sample, using a one-cycle window.

This generates current measurements eight times per cycle which are used for the differential

protection algorithm and transmitted to the remote relay(s) using the HDLC (High-level Data Link Control) communication protocol.

The co-processor is also responsible for managing intertripping commands via the communication link, and re-configuration instigated from the remote relay(s). Data exchange between the co-processor board and the main processor board is achieved through the use of shared memory on the co-processor board. When the main processor accesses this memory, the co-processor is temporarily halted. After the co-processor code has been copied onto the board at initialization, the main traffic between the two boards consists of setting change information, commands from the main processor, differential protection measurements and output data.

2.4.5 Distance Protection Filters (P44y and P54x)

Important

This applies to the MiCOM P44y/P54x products which include distance protection options. More recent Software (such as D1 and H4) includes distance protection options, but exclude non-distance variants. Depending on the specific model and the options, older software (such as 41, 42, 44, 45, 47, A0 and C0) may not include distance protection.

The current and voltage inputs are filtered, using Finite Impulse Response (FIR) digital filters to reduce the effects of non-power frequency components in the input signals, such as DC offsets in current waveforms, and Capacitor Voltage Transformer (CVT) transients in the voltages.

- The P44y/P54x uses a combination of a ¼-cycle filter using 12 coefficients, a ½-cycle filter using 24 coefficients, and a one-cycle filter using 48 coefficients.

The relay automatically performs intelligent switching in the application of the filters, to select the best balance of removal of transients with fast response.

Note

The protection elements themselves then perform additional filtering, for example implemented by the trip count strategy.

2.4.6 Frequency Response

Important

This applies to the MiCOM P44y/P54x products which include distance protection options. More recent Software (such as D1 and H4) includes distance protection options, but exclude non-distance variants. Depending on the specific model and the options, older software (such as 41, 42, 44, 45, 47, A0 and C0) may not include distance protection.

With the exception of the RMS measurements, all other measurements and protection functions are based on the Fourier-derived fundamental component. The fundamental component is extracted by using a 24-sample DFT. This gives good harmonic rejection for frequencies up to the 23rd harmonic. The 23rd is the first predominant harmonic that is not attenuated by the Fourier filter and this is known as an 'Alias'. However, the Alias is attenuated by approximately 85% by an additional, analog, 'anti-aliasing' filter (low pass filter). The combined effect of the anti-aliasing and Fourier filters is shown in the Figure 9 - Frequency response (for P14x, P24x, P341, P34x and P64x) diagram:

The combined effect of the anti-aliasing and Fourier filters is shown in the following Figure 10 - Frequency response (for P44y, P54x and P445) diagram. This shows the frequency response of the 12, 24 and 48 coefficient filters, noting that all have a gain of unity at the fundamental.

For the P841, the combined effect of the anti-aliasing and Fourier filters is shown in the following Figure 11 - Frequency response (for P841) diagram. This shows the frequency

response of the coefficient filter, noting the gain of unity at the fundamental. Unlike some other products, only the full cycle filter response applies to the P841.

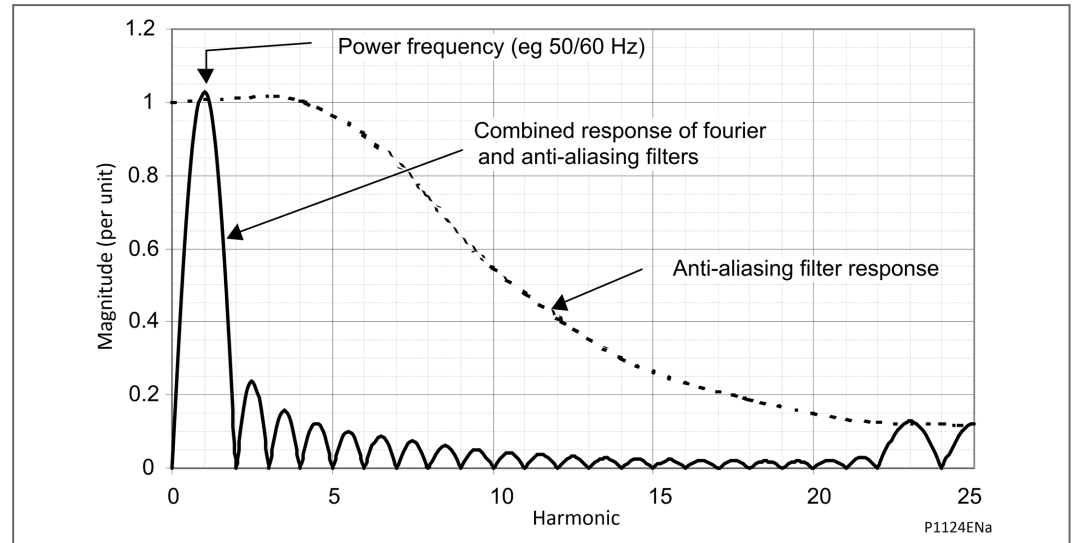

Figure 9 - Frequency response (for P14x, P24x, P341, P34x and P64x) diagram

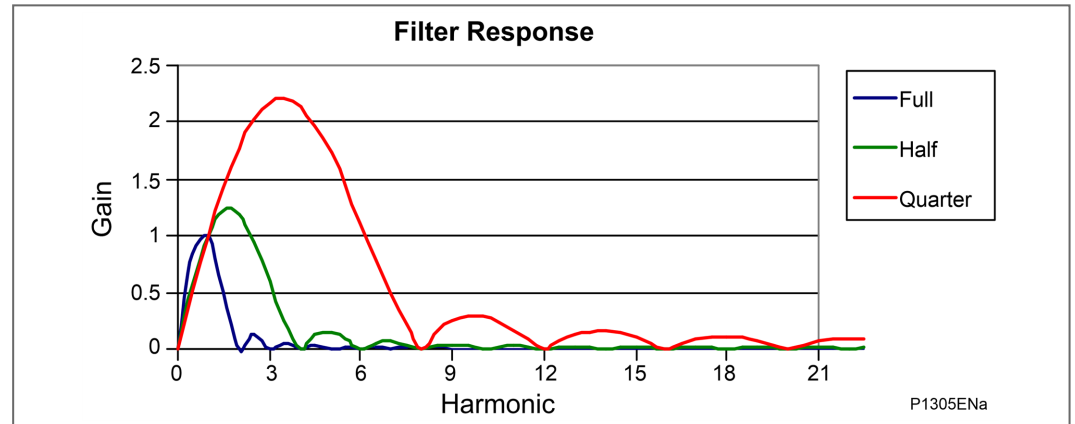

Figure 10 - Frequency response (for P44y, P54x and P445) diagram

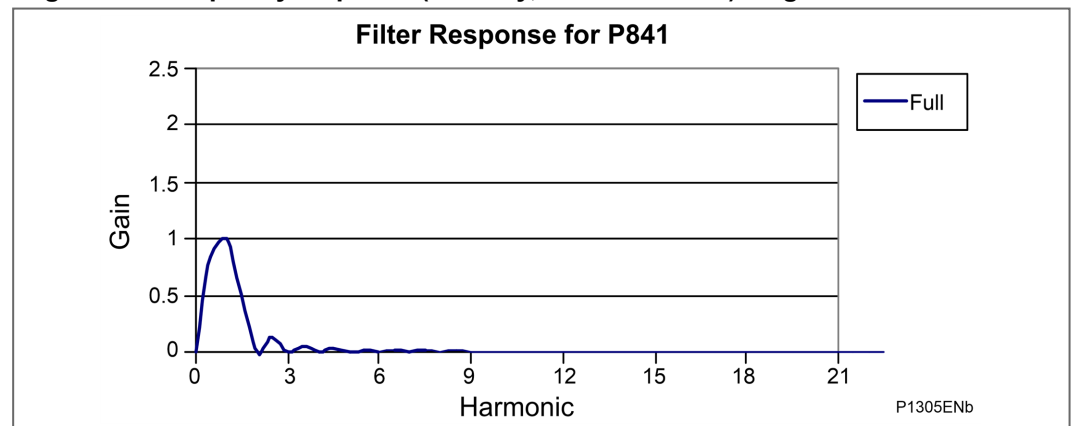

Figure 11 - Frequency response (for P841) diagram

For power frequencies that are not equal to the selected rated frequency, the harmonics are attenuated to zero amplitude. For small deviations of ± 1 Hz, this is not a problem but to allow for larger deviations, frequency tracking is used.

Frequency tracking automatically adjusts the sampling rate of the analog to digital conversion to match the applied signal. In the absence of a suitable signal to amplitude track, the sample rate defaults to the selected rated frequency (F_n). If the a signal is in the tracking range of 45 to 66 Hz (40 to 70 Hz for P341 and P34x), the relay locks onto the signal and the measured

frequency coincides with the power frequency as shown in the above *Frequency response* diagrams. The outputs for harmonics up to the 23rd are zero. The relay frequency tracks off any voltage or current in the order VA/VB/VC/IA/IB/IC down to 10% Vn for voltage and 5%In for current.

2.4.6.1 Fourier Filtering

All backup protection and measurement functions use one-cycle Fourier digital filtering to extract the power frequency component. This filtering is performed on the main processor board.

2.4.7 Programmable Scheme Logic (PSL)

The Programmable Scheme Logic (PSL) allows the relay user to configure an individual protection scheme to suit their own particular application. This is done with programmable logic gates and delay timers.

The input to the PSL is any combination of the status of the digital input signals from the opto-isolators on the input board, the outputs of the protection elements such as protection starts and trips, and the outputs of the fixed PSL. The fixed PSL provides the relay's standard protection schemes. The PSL consists of software logic gates and timers. The logic gates can be programmed to perform a range of different logic functions and can accept any number of inputs. The timers are used either to create a programmable delay or to condition the logic outputs, such as to create a pulse of fixed duration on the output, regardless of the length of the pulse on the input. The outputs of the PSL are the LEDs on the front panel of the relay and the output contacts at the rear.

The execution of the PSL logic is event driven: the logic is processed whenever any of its inputs change, for example as a result of a change in one of the digital input signals or a trip output from a protection element. Also, only the part of the PSL logic that is affected by the particular input change that has occurred is processed. This reduces the amount of processing time that is used by the PSL. The protection and control software updates the logic delay timers and checks for a change in the PSL input signals every time it runs.

This system provides flexibility for the user to create their own scheme logic design. However, it also means that the PSL can be configured into a very complex system, and because of this setting of the PSL is implemented through the PC support package Easergy Studio Studio.

2.4.7.1 PSL Data

In the PSL editor in Easergy Studio, when a PSL file is downloaded to the relay the user can specify the group to download the file and a 32 character PSL reference description. This PSL reference is shown in the **Grp. 1/2/3/4 PSL Ref.** cell in the **PSL DATA** menu in the relay. The download date and time and file checksum for each group's PSL file is also shown in the **PSL DATA** menu in cells **Date/Time** and **Grp. 1/2/3/4 PSL ID**. The PSL data can be used to show if a PSL has been changed and can be useful in providing information for version control of PSL files.

The default PSL Reference description is **Default PSL** followed by the model number, for example, **Default PSL Pxxx?????0yy0?** where Pxxx refers to the model such as P54x, P44y, P445, P746 or P841 and yy refers to the software version such as 05. This is the same for all protection setting groups (since the default PSL is the same for all groups). Since the LCD display (bottom line) only has space for 16 characters, the display must be scrolled to see all 32 characters of the PSL Reference description.

The default date and time is the date and time when the defaults were loaded.

Note

The PSL DATA column information is only supported by Courier and MODBUS, but not DNP3.0 or IEC60870-5-103.

Note

The PSL DATA column information is visible via the relay front panel interface or over the Courier communications protocol.

2.4.8 Function Key Interface

The ten function keys interface directly into the PSL as digital input signals and are processed based on the PSLs event-driven execution. However, a change of state is only recognized when a key press is executed, on average for longer than 200 ms. The time to register a change of state depends on whether the function key press is executed at the start or the end of a protection task cycle, with the additional hardware and software scan time included. A function key press can provide a latched (toggled mode) or output on key press only (normal mode) depending on how it is programmed and can be configured to individual protection scheme requirements. The latched state signal for each function key is written to non-volatile memory and read from non-volatile memory during relay power up, allowing the function key state to be reinstated after power-up if the relay power is lost.

2.4.9 Event, Fault and Maintenance Recording

A change in any digital input signal or protection element output signal is used to indicate that an event has taken place. When this happens, the protection and control task sends a message to the supervisor task to show that an event is available to be processed. The protection and control task writes the event data to a fast buffer in SRAM that is controlled by the supervisor task. When the supervisor task receives either an event or fault record message, it instructs the platform software to create the appropriate log in battery backed-up SRAM. The supervisor's buffer is faster than battery backed-up SRAM, therefore the protection software is not delayed waiting for the records to be logged by the platform software. However, if a large number of records to be logged are created in a short time, some may be lost if the supervisor's buffer is full before the platform software is able to create a new log in battery backed-up SRAM. If this occurs, an event is logged to indicate this loss of information.

Maintenance records are created in a similar manner with the supervisor task instructing the platform software to log a record when it receives a maintenance record message. However, it is possible that a maintenance record may be triggered by a fatal error in the relay, in which case it may not be possible to successfully store a maintenance record, depending on the nature of the problem. See 4 - Self Testing and Diagnostics.

Fault records are stored in the sequence of events. They can be viewed locally or remotely and include:

- Faulty phase(s)
- Protection Tripped
- Protection Started
- Fault Alarms
- Fault Date and Time
- Active Group
- Frequency
- Fault duration
- CB operating time
- Relay operating time
- Fault Location
- Primary or Secondary magnitude and phase of prefault phase, neutral and mutual currents
- Primary or Secondary magnitude and phase of fault phase, neutral and mutual currents
- Primary or Secondary magnitude of local and remote currents

- Primary or Secondary magnitude of differential and bias currents
- Communication measurements

2.5 Disturbance Recorder

The analog values and logic signals are routed from the protection and control software to the disturbance recorder software. The platform software interfaces with the disturbance recorder to allow the stored records to be extracted.

The enhanced disturbance recording is started from any relay start or trip, or any specific opto-isolator input or internal information. The recording time is user selectable up to a *Maximum Recording Time*.

The disturbance recorder operates as a separate task to the protection and control task. It can record the waveforms for *Maximum Calibrated Analog Channels* and the values for *Maximum Digital Signals*. Additional calculated analogue channels are also available and can be added up to a maximum of 20 channels in total. The *Minimum No of Records* and *Maximum No of Records* varies from one product to another as shown here:

Product	Maximum calibrated analog channels	Maximum digital signals	Maximum Recording Time	Minimum No of Records	Maximum No of Records
P14x	9	128	10.5		
P24x	8	32	10		
P341	9	128	10.5		
P342, P343, P344, P345 & P391	9	128	10.5		
P44x	8	32	10		
P44y	13	128	50	5 records of 10 secs each	50 records of 10 secs each
P445	8	128	10.5		
P54x	13	128	50	5 records of 10 secs each	50 records of 10 secs each
P64x	21	32	10		
P74x	8	32	10		
P746	21; 27 (B6/C6)	32; 80 (B6/C6)	10		
P841	8	128	10		
P849	8	32	10		

Table 8 - Disturbance recorder channels, signals, times and records for different models

The enhanced disturbance recorder is supplied with data once per cycle by the protection and control task. The enhanced disturbance recorder collates the data that it receives into the required length disturbance record. The enhanced disturbance records that can also store the data in COMTRADE format can be extracted using Easergy Studio, allowing the use of other packages to view the recorded data.

2.6 Communication Software for P74x

The communication software manages optical fibre communication between the central unit and the peripheral units. This includes the control of data exchanged transmitted and the

synchronisation of peripheral units. With this object, the communication software interfaces with the sequencer used in co-processors boards.

In accordance with sequencer used in coprocessor board, the communication software sends frames at fixed frequency equal to 2400Hz. Likewise the contents of the frames is independent of the frequency and of the status of the protections. The frames are split in fixed parts according to the priority of each application. For example trip order and current sample are respectively transmitted at 2400Hz and 1200Hz whereas the internal courier communication or date & time are exchange at low frequency.

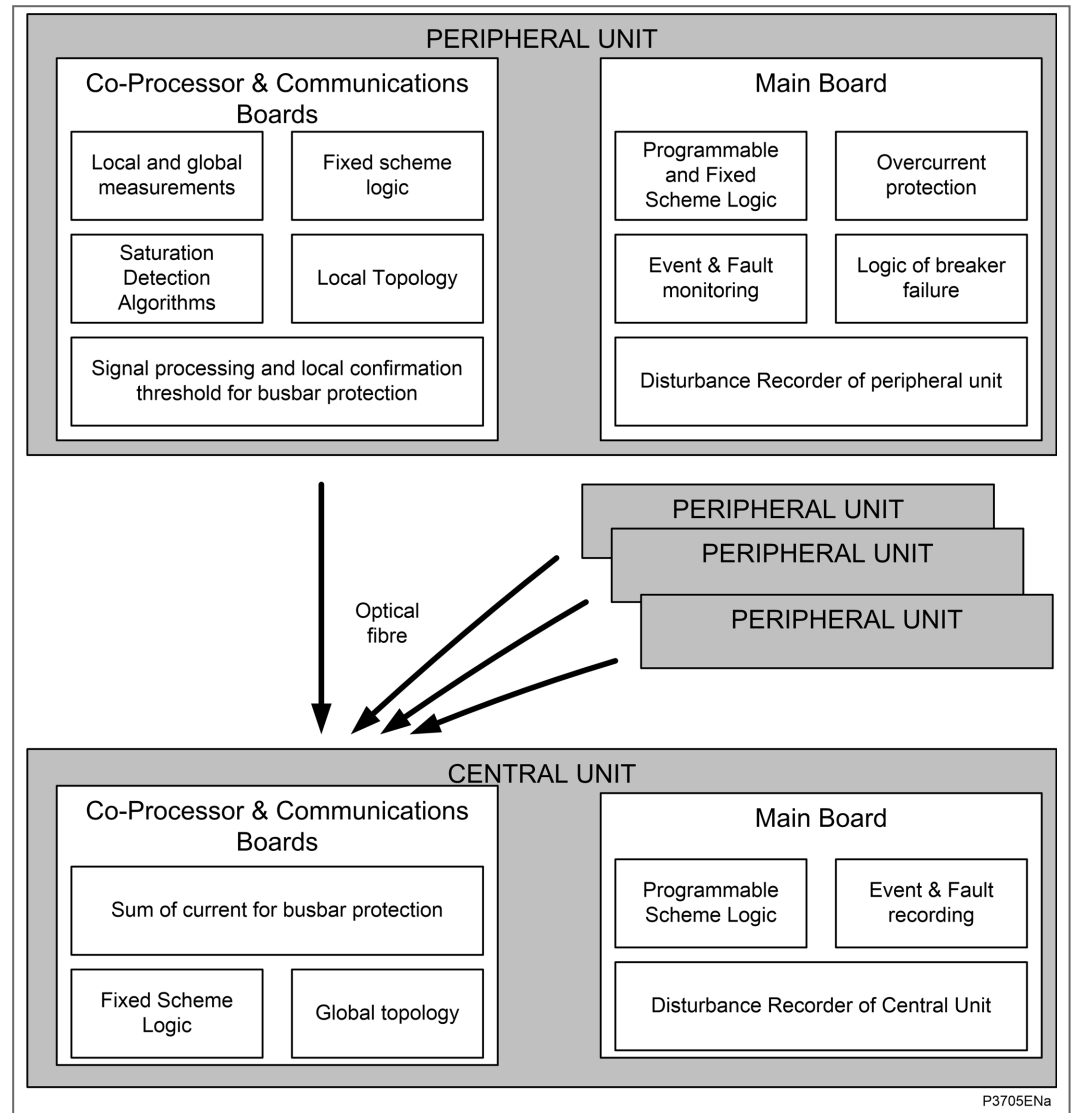

Figure 12 - System overview diagram

3. FAULT LOCATOR

The relay has an integral fault locator (which is separate from the protection and control task). The fault locator samples data from analog current and voltage inputs and writes it to a cyclic 12-cycle buffer until a fault condition is detected. It then uses this data to provide a distance to fault location feature.

The data in the input buffer is then held to allow the fault calculation to be made and to calculate a distance to fault location. The calculated location of the fault is sent to the protection and control task which includes it in the fault record for the fault. When the fault record is complete (i.e. includes the fault location), the protection and control task can send a message to the supervisor task to log the fault record.

3.1 Basic Theory for Ground Faults (for P14x)

A two-machine equivalent circuit of a faulted power system is shown below.

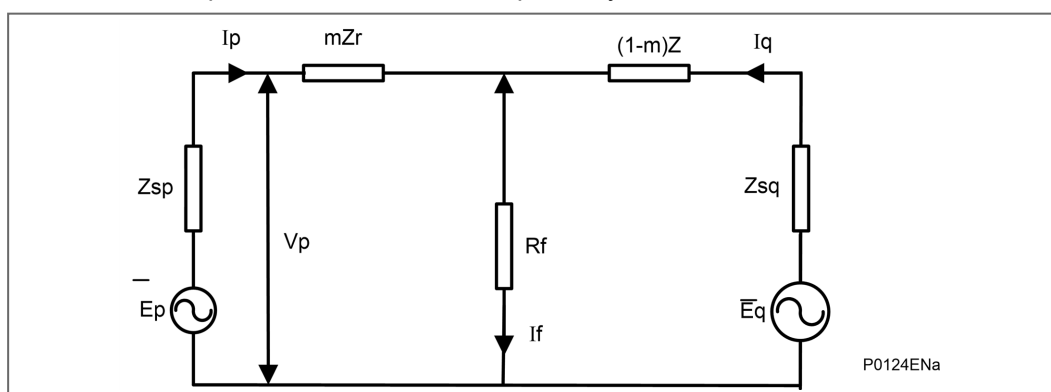

Figure 13 - Two machine equivalent circuit diagram

From this diagram, the fault location (m) can be found by estimating I_f and solving the following **Fault Location** equation.

Equation 1 - Fault Location

$$V_p = mI_p Z_r + I_f R_f$$

3.2 Data Acquisition and Buffer Processing (for P14x)

The fault locator stores the sampled data within a 12 cycle cyclic buffer at a resolution of 24 samples per cycle. When the fault recorder is triggered the data in the buffer is frozen such that the buffer contains 6 cycles of pre-trigger data and 6 cycles of post trigger data. Fault calculation commences shortly after this trigger point.

The trigger for the fault locator is user selectable via the PSL.

The fault locator can store data for up to four faults. This ensures that fault location can be calculated for all shots on a typical multiple re-close sequence.

3.3 Faulted Phase Selection (for P14x)

Selection of the faulted phase(s) is performed by comparing the magnitude of the pre fault and post fault values of the three phase-to-phase currents. A single phase-to-ground fault produces the same change on two of these signals and zero on the third. A phase-to-phase or double phase-to-ground fault produces one signal that is larger than the other two. A three-phase fault produces the same change on all 3 currents.

Current changes are considered to be the same if they are within 20% of each other. Phase selection and fault location calculation can only be made if the current change exceeds 5% I_n .

3.4 Fault Location Calculation (for P14x)

This works by:

1. First obtaining the vectors
2. Selecting the faulted phase(s)
3. Estimating the phase of the fault current, I_f , for the faulted phase(s)
4. Solving the Fault Location equation for the fault location m at the instant of time where $I_f = 0$

3.4.1 Obtaining the Vectors (for P14x)

Different sets of vectors are chosen depending on the type of fault identified by the phase selection algorithm. The calculation using the **Fault Location** equation is applied for either a phase-to-ground fault or a phase-to-phase fault. Thus:

For an A-phase to ground fault:

Equation 2 - A-phase to ground fault

$$I_p Z_r = I_a (Z_{line} / \theta_{line}) + I_n (Z_{residual} / \theta_{residual})$$

And

$$V_p = V_A$$

For an A-phase to B-phase fault:

Equation 3 - A-phase to B-phase fault

$$I_p Z_r = I_a (Z_{line} / \theta_{line}) - I_b (Z_{residual} / \theta_{residual})$$

And

$$V_p = V_A - V_B$$

3.4.2 Solving the Equation for the Fault Location (for P14x)

As the sine wave of I_f passes through zero, the instantaneous values of the sine waves V_p and I_p can be used to solve the *Fault Location* equation for the fault location m . (The term $I_f R_f$ being zero.)

This is determined by shifting the calculated vectors of V_p and $I_p Z_r$ by the angle (90° - angle of fault current) and then dividing the real component of V_p by the real component of $I_p Z_r$. See the Figure 14 - Fault locator selection of fault current zero diagram.

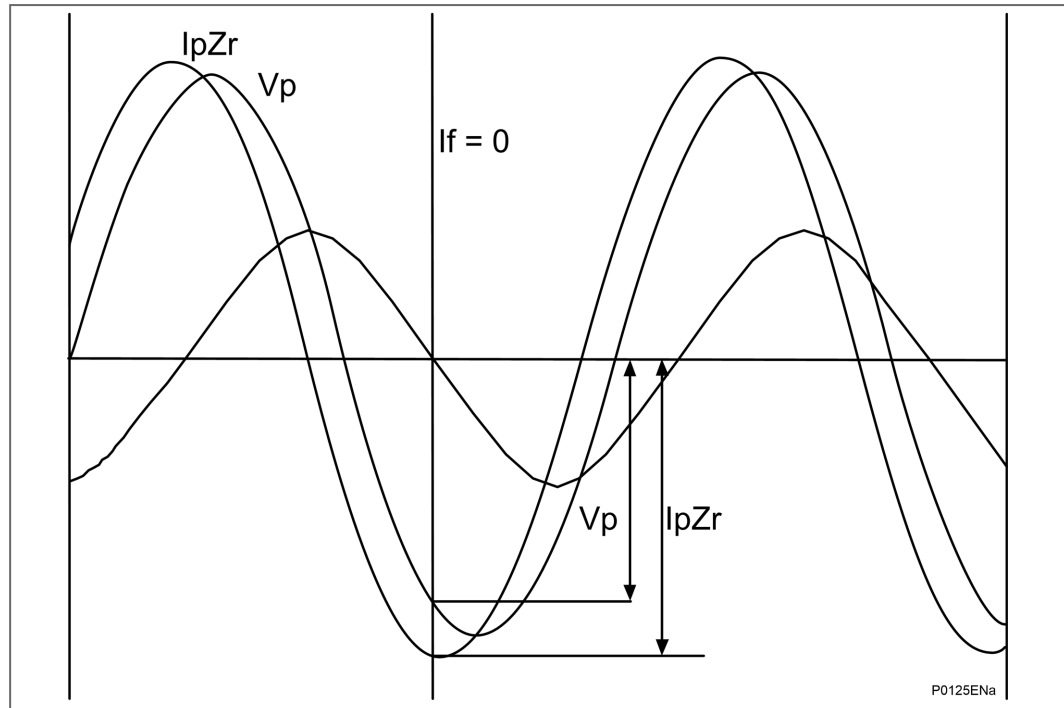

Figure 14 - Fault locator selection of fault current zero diagram
i.e.:

Phase advanced vector V_p

$$V_p = |V_p| (\cos(s) + j\sin(s)) * (\sin(d) + j\cos(d))$$

$$V_p = |V_p| [-\sin(s-d) + j\cos(s-d)]$$

Phase advanced vector $I_p Z_r$

$$I_p Z_r = |I_p Z_r| (\cos(e) + j\sin(e)) * (\sin(d) + j\cos(d))$$

$$I_p Z_r = |I_p Z_r| [-\sin(e-d) + j\cos(e-d)]$$

Therefore from the Fault Location equation:

$$m = V_p \div (I_p * Z_r) \text{ at } I_f = 0$$

$$m = V_p \sin(s-d) / (I_p Z_r * \sin(e-d))$$

Where:

d = angle of fault current I_f

s = angle of V_p

e = angle of $I_p Z_r$

Hence, the relay evaluates m which is the fault location as a percentage of the fault locator line impedance setting and then calculates the output fault location by multiplying this by the line length setting. When calculated, the fault location can be found in the fault record under the **VIEW RECORDS** column in the Fault Location cells. Distance to fault is available in kilometers, miles, impedance or percentage of line length.

4. SELF TESTING AND DIAGNOSTICS

The relay includes several self-monitoring functions to check the operation of its hardware and software when it is in service. These are included so that if an error or fault occurs in the relay's hardware or software, the relay is able to detect and report the problem and attempt to resolve it by performing a reboot. The relay must therefore be out of service for a short time, during which the **Healthy** LED on the front of the relay is OFF and, the watchdog contact at the rear is ON. If the reboot fails to resolve the problem, the relay takes itself permanently out of service; the **Healthy** LED stays OFF and watchdog contact stays ON.

If a problem is detected by the self-monitoring functions, the relay stores a maintenance record in battery backed-up SRAM.

The self-monitoring is implemented in two stages:

- firstly a thorough diagnostic check that is performed when the relay is booted-up
- secondly a continuous self-checking operation that checks the operation of the relay's critical functions while it is in service.

4.1 Startup Self-Testing

The self-testing that is carried out when the relay is started takes a few seconds to complete, during which time the relay's protection is unavailable. This is shown by the **Healthy** LED on the front of the relay which is ON when the relay has passed all tests and entered operation. If the tests detect a problem, the relay remains out of service until it is manually restored to working order.

The operations that are performed at start-up are:

- 4.1.1 - System Boot
- 4.1.2 - Initialization Software
- 4.1.3 - Platform Software Initialization and Monitoring

4.1.1 System Boot

The integrity of the flash memory is verified using a checksum before the program code and data are copied into SRAM and executed by the processor. When the copy is complete the data then held in SRAM is checked against that in flash memory to ensure they are the same and that no errors have occurred in the transfer of data from flash memory to SRAM. The entry point of the software code in SRAM is then called which is the relay initialization code.

4.1.2 Initialization Software

The initialization process includes the operations of initializing the processor registers and interrupts, starting the watchdog timers (used by the hardware to determine whether the software is still running), starting the real-time operating system and creating and starting the supervisor task.

In the initialization process the relay checks the following.

- The status of the battery
- The integrity of the battery backed-up SRAM that stores event, fault and disturbance records
- The voltage level of the field voltage supply that drives the opto-isolated inputs
- The operation of the LCD controller
- The watchdog operation

When the initialization software routine is complete, the supervisor task starts the platform software.

If the startup follows a watchdog reboot due to BBRAM memory corruption, the relay will raise the BBRAM failure indication DDB which is available for mapping in the PSL.

At the conclusion of the initialization software the supervisor task begins the process of starting the platform software. The checking that is made in the process of starting the co-processor board is as follows:

- A check is made for the presence of, and a valid response from, the co-processor board
- The SRAM on the co-processor board is checked with a test bit pattern before the co-processor code is transferred from the flash EPROM

Any of these checks which produces an error results in the co-processor board being left out of service and the relay relying on the other protection functions which are provided by the main processor board.

If the startup follows a watchdog reboot due to memory corruption, the relay will raise the BBRAM failure indication DDB which is available for mapping in the PSL.

4.1.3 Platform Software Initialization and Monitoring

In starting the platform software, the relay checks the integrity of the data held in non-volatile memory with a checksum, the operation of the real-time clock, and the IRIG-B board if fitted. The final test that is made concerns the input and output of data; the presence and healthy condition of the input board is checked and the analog data acquisition system is checked through sampling the reference voltage.

At the successful conclusion of all of these tests the relay is entered into service and the protection started-up.

4.2 Continuous Self-Testing

When the relay is in service, it continually checks the operation of the critical parts of its hardware and software. The checking is carried out by the 2.2 - System Services Software and the results reported to the 2.3 - Platform Software.

The functions that are checked are as follows:

- The flash EPROM containing all program code and language text is verified by a checksum
- The SRAM containing all data other than the code and constant data is verified with a checksum
- The non-volatile memory containing setting values is verified by a checksum, whenever its data is accessed
- The battery status
- The level of the field voltage
- The integrity of the digital signal I/O data from the opto-isolated inputs and the relay contacts, is checked by the data acquisition function every time it is executed. The operation of the analog data acquisition system is checked by the acquisition function every time it is executed. This is done by sampling the reference voltage on a spare multiplexed channel
- The operation of the IRIG-B board is checked, where it is fitted, by the software that reads the time and date from the board

If the Ethernet board is fitted, it is checked by the software on the main processor board. If the Ethernet board fails to respond, an alarm is raised and the board is reset in an attempt to resolve the problem.

In addition, the following checks may be made too:

- The correct operation of the CLIO board is checked (where fitted)
- The operation of the Ethernet board is checked (where fitted), by the software on the main processor card. If the Ethernet board fails to respond an alarm is raised and the card is reset to try to resolve the problem

In the unlikely event that one of the checks detects an error in the relay's subsystems, the platform software is notified and it will attempt to log a maintenance record in battery backed-up SRAM. If the problem is with the battery status or the IRIG B board, the relay continues in operation. However, for problems detected in any other area the relay shuts down and reboots. This results in a period of up to 5 seconds when protection is unavailable, but the complete restart of the relay including all initializations should clear most problems that could occur. An integral part of the start-up procedure is a thorough diagnostic self-check. If this detects the same problem that caused the relay to restart, the restart has not cleared the problem and the relay takes itself permanently out of service. This is indicated by the **Healthy** LED on the front of the relay which goes OFF, and the watchdog contact that goes ON.

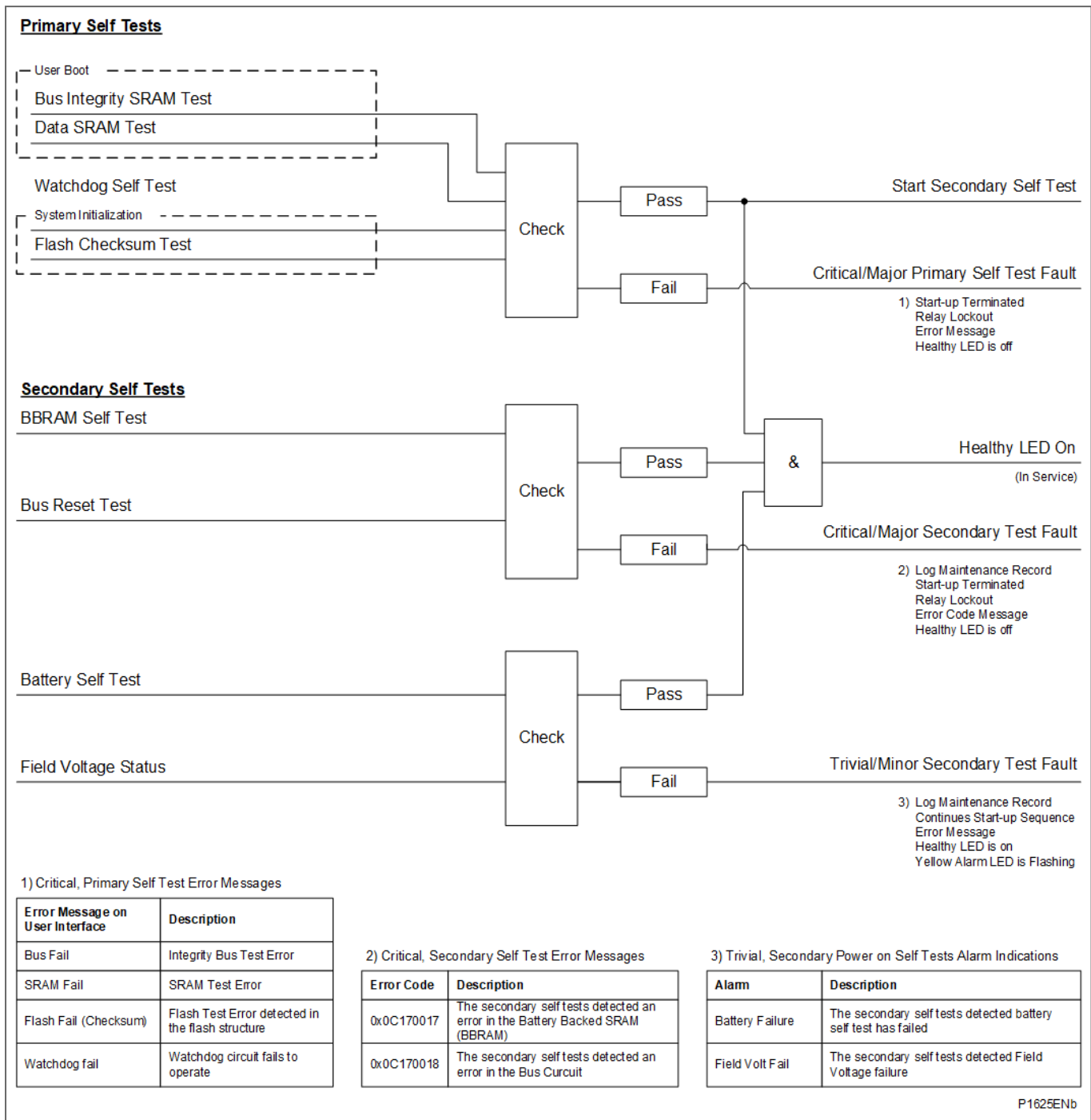

Figure 15 - Start-up self-testing logic diagram

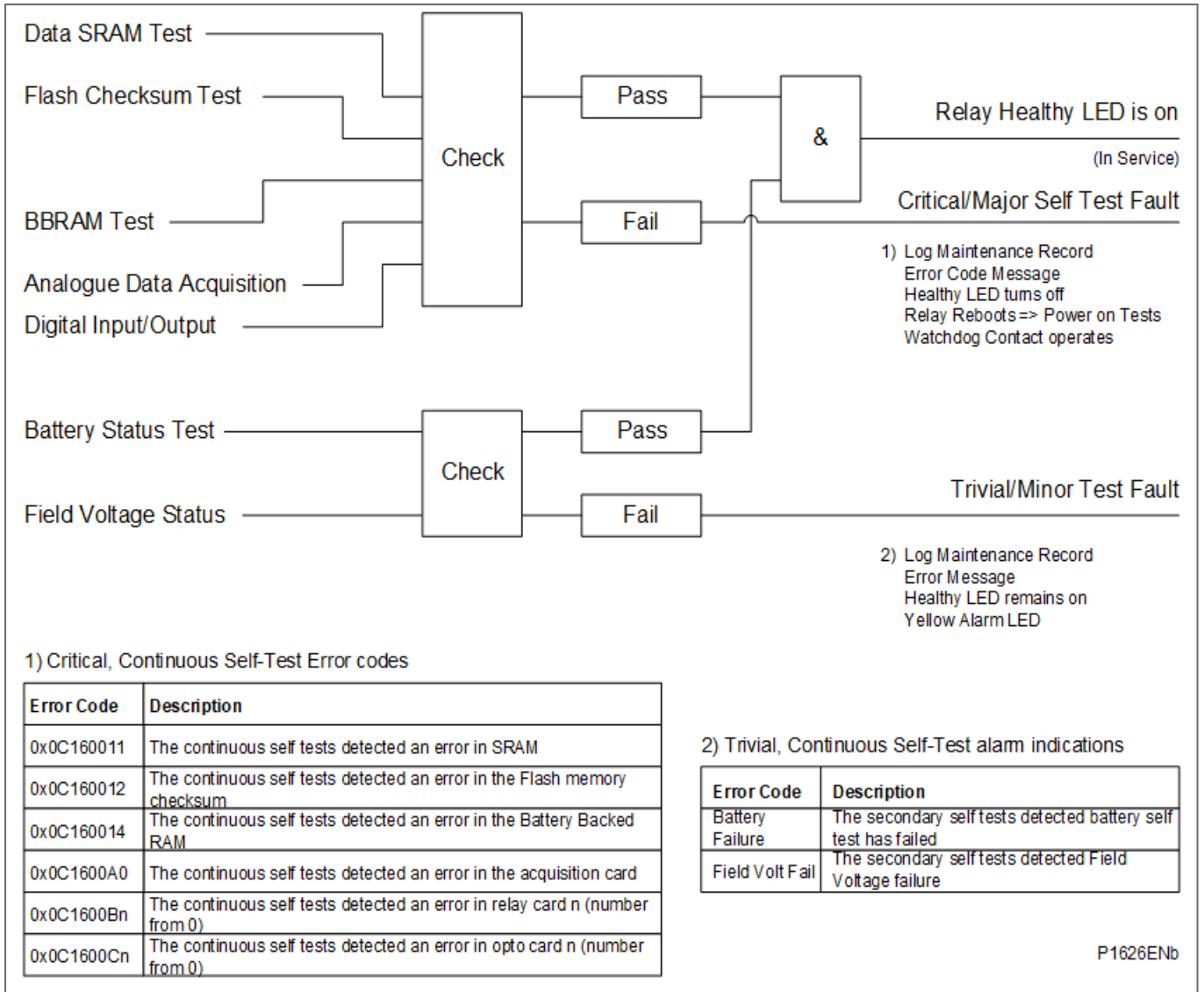

Figure 16 - Continuous self-testing logic diagram

COMMISSIONING

CHAPTER 11

Date:	02/2024
Products covered by this chapter:	This chapter covers the specific versions of the MiCOM products listed below. This includes only the following combinations of Software Version and Hardware Suffix.
Hardware suffix:	M
Software version:	K6
Connection diagrams:	10P54302 (SH 1 to 2) 10P54303 (SH 1 to 2) 10P54304 (SH 1 to 2) 10P54400 10P54404 (SH 1 to 2) 10P54405 (SH 1 to 2) 10P54502 (SH 1 to 2) 10P54503 (SH 1 to 2) 10P54504 (SH 1 to 2) 10P54600 10P54604 (SH 1 to 2) 10P54605 (SH 1 to 2) 10P54606 (SH 1 to 2)

CONTENTS

Page (CM) 11-

p		
1	Introduction	9
2	Commissioning Test Menu	10
2.1	Opto I/P Status	11
2.2	Relay O/P Status	11
2.3	Test Port Status	11
2.4	Red and Green LED Status	11
2.5	Monitor Bits 1 to 8	11
2.6	Test Mode	12
2.7	Test Pattern	12
2.8	Contact Test	12
2.9	Test LEDs	12
2.10	Test Auto-Reclose	13
2.11	Static Test Mode	14
2.12	Loopback Mode	14
2.13	IM64 Test Pattern	15
2.14	IM64 Test Mode	15
2.15	Using a Monitor/Download Port Test Box	15
3	Setting Familiarization	16
4	Equipment Required for Commissioning	17
4.1	Minimum Equipment Required	17
4.2	Optional Equipment	17
5	Product Checks	18
5.1	With the Relay De-Energized	18
5.1.1	Visual Inspection	19
5.1.2	Current Transformer Shorting Contacts (Optional Check)	19
5.1.3	Insulation	21
5.1.4	External Wiring	21
5.1.5	Watchdog Contacts	21
5.1.6	Auxiliary Supply	22
5.2	With the Relay Energized	23
5.2.1	Watchdog Contacts	23
5.2.2	Liquid Crystal Display (LCD) Front Panel Display	23
5.2.3	Date and Time	23
5.2.3.1	With an IRIG-B Signal	24

5.2.3.2	Without an IRIG-B Signal	24
5.2.4	Light Emitting Diodes (LEDs)	24
5.2.4.1	Testing the Alarm and Out of Service LEDs	24
5.2.4.2	Testing the Trip LED	25
5.2.4.3	Testing the User-Programmable LEDs	25
5.2.5	Field Voltage Supply	25
5.2.6	Input Opto-Isolators	26
5.2.7	Output Relays	27
5.2.8	Rear Communications Port	28
5.2.8.1	Courier Communications	28
5.2.8.2	IEC 60870-5-103 (VDEW) Communications	28
5.2.8.3	DNP3.0 Communications Interface	29
5.2.9	Second Rear Communications Port	30
5.2.9.1	K-Bus Configuration	30
5.2.9.2	EIA(RS)485 Configuration	30
5.2.9.3	EIA(RS)232 Configuration	30
5.2.10	Current Inputs	31
5.2.11	Voltage Inputs	32
5.3	IEDs which use the Process Bus Interface	34
5.3.1	IED Configured with One Merging Unit (MU)	34
5.3.2	IED Configured with Two or More Merging Units (MUs)	35
6	Protection Communications Loopback	36
6.1	Protection Communications	36
6.1.1	Communications Loopback Setting	37
6.1.1.1	Channel 1 Transmit Power Level	37
6.1.1.2	Channel 2 Transmit Power Level	37
6.1.2	Loopback Communications Configuration	37
6.1.3	Fiber Connection	37
6.1.4	Communications using P-2M-L Interface Units (G.703)	38
6.1.4.1	P-2M-L Visual Inspection	38
6.1.4.2	P-2M-L Insulation	38
6.1.4.3	P-2M-L External Wiring	38
6.1.4.4	P-2M-L Auxiliary Supply	38
6.1.4.5	P-2M-L Light Emitting Diode (LED)	38
6.1.4.6	P-2M-L Optical Received Signal Level	38
6.1.4.7	P-2M-L Loopback	39
6.1.4.8	P-2M-L Optical Transmitter Signal Level	39
6.1.4.9	P54x Optical Received Signal Level from P-2M-L	39
6.1.5	Loopback Test	39
7	GPS Synchronization	40
7.1	Commissioning Mode for P54x Relay without Process Bus	40
7.1.1	GPS Synchronization Device Optical Signal Strength at P54x Relay without Process Bus	40
7.1.2	Check Synchronization Signal at P54x Relay without Process Bus	40
7.1.3	Check GPS Failure Condition	40
7.1.4	Restore GPS	40

7.2	Commissioning Mode for P54x Relay with Process Bus	41
7.3	Commissioning Mode	41
<hr/>		
8	Setting Checks	42
8.1	Apply Application-Specific Settings	42
8.1.1	Protection Communications Loopback	42
8.1.2	Reset Statistics	43
8.2	Demonstrate Correct Relay Operation	43
8.3	Demonstrate Correct Relay Operation - Current Differential Elements	43
8.3.1	Current Differential Bias Characteristic	43
8.3.1.1	Connect the Test Circuit	43
8.3.1.2	Lower Slope	44
8.3.1.3	Upper Slope	44
8.3.2	Current Differential Operation and Contact Assignment	45
8.3.2.1	Phase A	45
8.3.2.2	Phase B	45
8.3.2.3	Phase C	45
8.4	Demonstrate Correct Relay Operation - Non-Current Differential Elements	46
8.4.1	Protection Dependencies	46
8.4.2	Distance Protection Single-End Testing	46
8.4.2.1	Connection and Preliminaries	46
8.4.2.2	Zone 1 Reach Check	47
8.4.2.3	Zone 2 Reach Check	47
8.4.2.4	Zone 3 Reach Check	48
8.4.2.5	Zone 4 Reach Check (if Enabled)	48
8.4.2.6	Zone P Reach Check (if Enabled)	48
8.4.2.7	Resistive Reach (Quadrilateral Characteristics only)	48
8.4.2.8	Load Blinder	48
8.4.3	Distance Protection Operation and Contact Assignment	48
8.4.3.1	Phase A	48
8.4.3.2	Phase B	49
8.4.3.3	Phase C	49
8.4.3.4	Time Delay Settings t_{Z1} Ph, and $t_{Z2} - t_{Z4}$	49
8.4.4	Distance Protection Scheme Testing	49
8.4.4.1	Scheme Trip Test for Zone 1 Extension Only	50
8.4.4.2	Scheme Trip Tests for Permissive Schemes (PUR/POR only)	50
8.4.4.3	Scheme Trip Tests for Blocking Scheme Only	51
8.4.4.4	Signal Send Test for Permissive Schemes (PUR/POR Only)	51
8.4.4.5	Signal Send Test for Blocking Scheme Only	51
8.4.5	Scheme Timer Settings	52
8.4.6	Delta Directional Comparison	52
8.4.6.1	Connection and Preliminaries	52
8.4.6.2	Single-Ended Injection Test	52
8.4.6.3	Forward Fault Preparation	53
8.4.7	Delta Directional Comparison Operation and Contact Assignment	53
8.4.7.1	Phase A	53
8.4.7.2	Phase B	53
8.4.7.3	Phase C	54

8.4.8	Delta Directional Comparison Scheme Testing	54
8.4.8.1	Signal Send Test for Permissive Schemes (POR/POTT Only)	54
8.4.8.2	Signal Send Test FOR Blocking Schemes Only	54
8.4.9	Out-of-Step Protection (OST) Protection (if Enabled)	54
8.4.9.1	Predictive OST Setting	55
8.4.9.2	OST Setting	55
8.4.9.3	Predictive and OST Setting	56
8.4.9.4	'Tost' Timer Test	56
8.4.10	Directional Earth Fault Aided Scheme (Ground Current Pilot Scheme)	56
8.4.10.1	Connect the Test Circuit	56
8.4.10.2	DEF Aided Scheme - Forward Fault Trip Test	57
8.4.11	DEF Aided Scheme - Scheme Testing	57
8.4.11.1	Signal Send Test for Permissive Schemes (POR/POTT Only)	57
8.4.11.2	Signal Send Test for Blocking Schemes Only	58
8.4.12	Backup Phase Overcurrent Protection	58
8.4.12.1	Connect the Test Circuit	58
8.4.12.2	Perform the Test	59
8.4.12.3	Check the Operating Time	59
8.4.13	Restoration of Communications and Clearing VTS	59
8.5	Check Trip and Auto-Reclose Cycle	60
9	End-to-End Protection Communication Tests	61
9.1	Remove Local Loopbacks	61
9.1.1	Direct Fiber and C37.94 Connections	61
9.1.1.1	Direct Fiber Connections	61
9.1.1.2	Fiber Connections to C37.94	62
9.1.2	Communications using P-2M-L Interface Units	62
9.2	Remote Loopback Removal	62
9.2.1	Remove Loopbacks at Remote Terminal Connected to Channel 1	62
9.2.2	Remove Loopbacks at Remote Terminal Connected to Channel 2	63
9.3	Verify Communications between Relays	63
9.3.1	Communications Statistics and Status - Non-GPS Synchronised	63
9.3.2	Communications Statistics and Status - GPS Synchronised with GPS synchronization device	63
10	End-to-End Scheme Tests	64
10.1	Signaling Channel Check	64
10.1.1	Aided Scheme 1	64
10.1.1.1	Remote End Preparation to Observe Channel Arrival	64
10.1.1.2	Application of the Test	64
10.1.1.3	Channel Check in the Opposite Direction	65
10.1.2	Aided Scheme 2	65
11	On-Load Checks	66
11.1	Confirm Current and Voltage Transformer Wiring	66
11.1.1	Voltage Connections	66
11.1.2	Current Connections	67

11.2	Measure Capacitive Charging Current	67
11.3	Check Differential Current	67
11.4	Check Consistency of Current Transformer Polarity	67
11.5	On Load Directional Test	68
11.6	Signaling Channel Check (if Not Already Completed)	68
12	Final Checks	69

TABLES

	Page (CM) 11-
Table 1 - Commission tests	10
Table 2 - Current transformer shorting contact locations	20
Table 3 - Watchdog contact status	21
Table 4 - Operational range of auxiliary supply Vx	22
Table 5 - Field voltage terminals	25
Table 6 - EIA(RS)485 terminals	28
Table 7 - 2 nd rear communications port K-Bus terminals	30
Table 8 - Second rear communications port EIA(RS)232 terminals	31
Table 9 - CT ratio settings	32
Table 10 - Voltage input terminals	32
Table 11 - Voltage ratio settings	33
Table 12 - Record the transmit power level	37
Table 13 - Bias and differential currents (lower slope)	44
Table 14 - Bias and differential currents (upper slope)	45
Table 15 - Tripping and single/double circuit breakers	45
Table 16 - Tripping and single/double circuit breakers	48
Table 17 - Fault types and responses	50
Table 18 - Relay responses	53
Table 19 - Tripping and single/double circuit breakers	53
Table 20 - Predictive OST state sequence	55
Table 21 - OST state sequence	56
Table 22 - Relay responses	57
Table 23 - Characteristic operating times for I>1	59
Table 24 - Measurement values	62
Table 25 - Maximum/Minimum transmitter power	62
Table 26 - Test port status responses	65
Table 27 - Measured voltages and VT ratio settings	66

FIGURES

	Page (CM) 11-
Figure 1 - Auto-reclose default PSL - P543 & P545 SW ver 44 and 54	13
Figure 2 - Auto-reclose default PSL - P544 & P546 SW ver 45 and 55	13
Figure 3 - Rear terminal blocks on size 80TE case	19
Figure 4 - Location of securing screws for heavy duty terminal blocks	20
Figure 5 - Connection for bias characteristic testing	43
Figure 6 - Four state impedances	55

1

INTRODUCTION

MiCOM P40 relays are fully numerical in their design, implementing all protection and non-protection functions in software. The relays use a high degree of self-checking and give an alarm in the unlikely event of a failure. Therefore, the commissioning tests do not need to be as extensive as with non-numeric electronic or electro-mechanical relays.

To commission numeric relays, you only need to verify that the hardware is functioning correctly and the application-specific software settings have been applied to the relay. You don't need to test every function of the relay if the settings have been verified by one of these methods:

- Extracting the settings applied to the relay using appropriate setting software (preferred method)
- Using the operator interface

To confirm that the product is operating correctly once the application-specific settings have been applied, perform a test on a single protection element.

Unless previously agreed to the contrary, the customer is responsible for determining the application-specific settings to be applied to the relay and for testing any scheme logic applied by external wiring or configuration of the relay's internal Programmable Scheme Logic (PSL).

Blank commissioning test and setting records are available for completion as needed.

As the relay's menu language is user-selectable, the Commissioning Engineer can change it to allow accurate testing as long as the menu is restored to the customer's preferred language on completion.

To simplify the specifying of menu cell locations in these Commissioning Instructions, they are given in the form [courier reference: COLUMN HEADING, Cell Text]. For example, the cell for selecting the menu language (first cell under the column heading) is in the System Data column (column 00) so it is given as [0001: SYSTEM DATA, Language].

**Warning**

Before carrying out any work on the equipment, you should be familiar with the contents of the latest issue of the Safety Guide, Safety Information and Technical Data chapters and the equipment rating label(s).

**Caution**

The relay must not be disassembled in any way during commissioning.

2 COMMISSIONING TEST MENU

To help minimize the time needed to test MiCOM relays the relay provides several test facilities under the '**COMMISSION TESTS**' menu heading. There are menu cells which allow the status of the opto-isolated inputs, output relay contacts, internal Digital Data Bus (DDB) signals and user-programmable LEDs to be monitored. Additionally there are cells to test the operation of the output contacts, user-programmable LEDs and, where available, the auto-reclose cycles.

The following table shows the relay menu of commissioning tests, including the available setting ranges and factory defaults. Each of the main menu tests are described in more detail in the following sections.

COMMISSION TESTS for P54x		
Menu Text	Default Setting	Settings
Opto I/P Status	-	-
Relay O/P Status	-	-
Test Port Status	-	-
LED Status	-	-
Monitor Bit 1	1060: LED_CON_R1	0 to 1791
Monitor Bit 2	1062: LED_CON_R2	0 to 1791
Monitor Bit 3	1064: LED_CON_R3	0 to 1791
Monitor Bit 4	1066: LED_CON_R4	0 to 1791
Monitor Bit 5	1068: LED_CON_R5	-
Monitor Bit 6	1070 :LED_CON_R6	-
Monitor Bit 7	1072: LED_CON_R7	-
Monitor Bit 8	1074: LED_CON_R8	-
Test Mode	Disabled	Disabled, Test Mode, Contacts Blocked
Test Pattern	All bits set to 0	0 = Not Operated, 1 = Operated
Contact Test	No Operation	No Operation, Apply Test, Remove Test
Test LEDs	No Operation	No Operation, Apply Test
Test Auto-reclose	No Operation	No Operation, 3 Pole Test
Red LED Status	-	-
Green LED Status	-	-
Static Test	Disabled	Enabled, Disabled
Loopback Mode	Disabled	Disabled, Internal, External
IM64 TestPattern	All bits set to 0	0 = Not Operated, 1 = Operated
IM64 Test Mode	Disabled	Disabled or Enabled
<i>Note P54x = P543, P544, P545 and P546. P54x does not include P547</i>		
<i>Note See Relay Menu Database for details of DDB signals</i>		

Table 1 - Commission tests

2.1 Opto I/P Status

This menu cell displays the status of the relay's opto-isolated inputs as a binary string, a '1' indicating an energized opto-isolated input and a '0' a de-energized one. If the cursor is moved along the binary numbers the corresponding label text will be displayed for each logic input.

It can be used during commissioning or routine testing to monitor the status of the opto-isolated inputs whilst they are sequentially energized with a suitable dc voltage.

2.2 Relay O/P Status

This menu cell displays the status of the Digital Data Bus (DDB) signals that result in energization of the output relays as a binary string, a '1' indicating an operated state and '0' a non-operated state. If the cursor is moved along the binary numbers the corresponding label text will be displayed for each relay output.

The information displayed can be used during commissioning or routine testing to indicate the status of the output relays when the relay is 'in service'. Additionally fault finding for output relay damage can be performed by comparing the status of the output contact under investigation with it's associated bit.

Note When the 'Test Mode' cell is set to 'Enabled' this cell will continue to indicate which contacts would operate if the relay was in-service, it does not show the actual status of the output relays.

2.3 Test Port Status

This menu cell displays the status of the eight Digital Data Bus (DDB) signals that have been allocated in the 'Monitor Bit' cells. If the cursor is moved along the binary numbers the corresponding DDB signal text string will be displayed for each monitor bit.

By using this cell with suitable monitor bit settings, the state of the DDB signals can be displayed as various operating conditions or sequences are applied to the relay. Thus the Programmable Scheme Logic (PSL) can be tested.

2.4 Red and Green LED Status

The 'Red LED Status' and 'Green LED Status' cells are 18-bit binary strings that indicate which of the user-programmable LEDs on the relay are illuminated when accessing the relay from a remote location, a '1' indicating a particular LED is lit and a '0' not lit. When the status of a particular LED in both cells is '1', this indicates the LEDs illumination is yellow.

2.5 Monitor Bits 1 to 8

The eight 'Monitor Bit' cells allow the user to select the status of which digital data bus signals can be observed in the 'Test Port Status' cell or via the monitor/download port. Each 'Monitor Bit' is set by entering the required Digital Data Bus (DDB) signal number from the list of available DDB signals in the Programmable Logic chapter. The pins of the monitor/download port used for monitor bits are given in the following table. The signal ground is available on pins 18, 19, 22 and 25.

Monitor bit	1	2	3	4	5	6	7	8
Monitor/download port pin	11	12	15	13	20	21	23	24

The required DDB signal numbers are 0 – 1791.



Warning The monitor/download port is not electrically isolated against induced voltages on the communications channel. It should therefore only be used for local communications.

2.6 Test Mode

The Test Mode menu cell (in the COMMISSION TESTS column) is used to allow secondary injection testing to be performed on the relay.

To select test mode set the Test Mode menu cell to 'Test Mode'. It causes an alarm condition to be recorded, the yellow ALARM LED to light and an alarm message 'Test Mode Alm' to be generated.

Test Mode freezes any information stored in the CB CONDITION column and (in IEC60870-5-103 builds) changes the Cause Of Transmission (COT) to Test Mode. For relays supporting IEC 61850 Edition 2, the test bit for data quality attribute shall set to TRUE, and the Logical Device Mode will set to test.

Test mode can also be enabled by energizing an opto mapped to the Test Mode signal.

To enable testing of output contacts set the Test Mode cell to Contacts Blocked. It causes an alarm condition to be recorded, the yellow ALARM LED to light and an alarm message 'Contacts Blk Alm' to be generated.

In Contact Blocked mode, the protection function still works but the contacts will not operate. Also the test pattern and contact test functions are visible, which can be used to manually operate the output contacts. For relays supporting IEC 61850 Edition 2, the test bit for data quality attribute shall set to TRUE, and the Logical Device Mode will set to test/blocked.

Contacts Blocked can also be enabled by energizing an opto mapped to the Contacts Blocked signal.

Once testing is complete the cell must be set back to 'Disabled' to restore the relay back to service.



WARNING If you use or enable Test Mode, you must disable Test Mode before putting the relay back into active service. IT IS POTENTIALLY EXTREMELY UNSAFE TO ATTEMPT TO USE ANY RELAY WHICH IS STILL IN TEST MODE IN ACTIVE SERVICE.

2.7 Test Pattern

The 'Test Pattern' cell is used to select the output relay contacts that will be tested when the 'Contact Test' cell is set to 'Apply Test'. The cell has a binary string with one bit for each user-configurable output contact which can be set to '1' to operate the output under test conditions and '0' to not operate it.

2.8 Contact Test

When the 'Apply Test' command in this cell is issued the contacts set for operation (set to '1') in the 'Test Pattern' cell change state. After the test has been applied the command text on the LCD will change to 'No Operation' and the contacts will remain in the Test State until reset issuing the 'Remove Test' command. The command text on the LCD will again revert to 'No Operation' after the 'Remove Test' command has been issued.

Note When the 'Test Mode' cell is set to 'Enabled' the 'Relay O/P Status' cell does not show the current status of the output relays and hence can not be used to confirm operation of the output relays. Therefore it will be necessary to monitor the state of each contact in turn.

2.9 Test LEDs

When the 'Apply Test' command in this cell is issued the eight/eighteen user-programmable LEDs will illuminate for approximately 2 seconds before they extinguish and the command text on the LCD reverts to 'No Operation'.

2.10

Test Auto-Reclose

Where the relay provides an auto-reclose function, this cell will be available for testing the sequence of circuit breaker trip and auto-reclose cycles with the settings applied.

Issuing the command '3 Pole Trip' will cause the relay to perform the first three phase trip/reclose cycle so that associated output contacts can be checked for operation at the correct times during the cycle. Once the trip output has operated the command text will revert to 'No Operation' whilst the rest of the auto-reclose cycle is performed. To test subsequent three phase auto-reclose cycles repeat the '3 Pole Trip' command.

Similarly, where single pole auto-reclosing is available, the cycles for each single pole can be checked by sequentially issuing the 'Pole A Test', 'Pole B Test' or 'Pole C Test', as appropriate.

Note The default settings for the relay's programmable scheme logic has the 'AR Trip Test' signals mapped to the 'Trip Input' signals as shown in the "Auto-reclose default PSL - P543 & P545 SW ver 44 and 54" diagram (P543 & P545 software version 54) and in the "Auto-reclose default PSL - P544 & P546 SW ver 45 and 55" diagram (P544 & P546 software version 55). If the programmable scheme logic has been changed, it is essential that these signals retain this mapping for the 'Test Auto-reclose' facility to work.

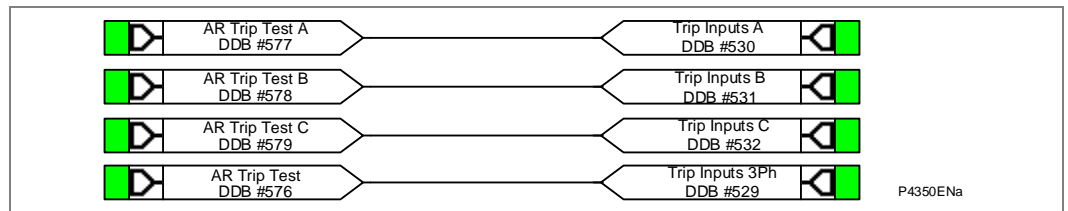

Figure 1 - Auto-reclose default PSL - P543 & P545 SW ver 44 and 54

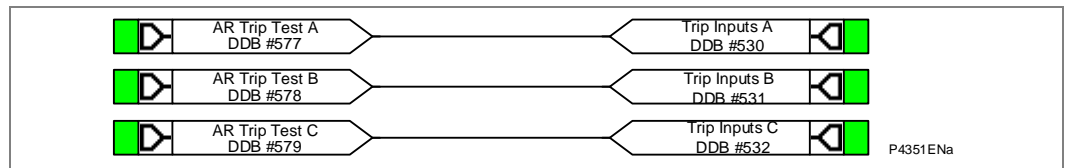

Figure 2 - Auto-reclose default PSL - P544 & P546 SW ver 45 and 55

2.11

Static Test Mode

Modern dynamic secondary injection test sets are able to accurately mimic real power system faults. The test sets mimic an instantaneous fault “shot”, with the real rate of rise of current, and any decaying DC exponential component, according to the point on (voltage) wave of fault inception. Injections for all three phases provide a six signal set of analog inputs: Va, Vb, Vc, Ia, Ib, Ic. Such injection test sets can be used with the P44y (P443/P446), P445, P54x, with no special testing limitations.

Conversely, older test sets may not properly simulate:

- A healthy prefault voltage memory
- A real fault shot (instead a gradually varying current or voltage may be used)
- The rate of rise of current and DC components
- A six signal set of analog inputs (instead, these may offer for example: Va, Vb, Ia, Ib only, to test for an A-B injection)

Such injection sets may be referred to as “Static” simulators.

As the P44y (P443/P446), P445 and P54x relies on voltage memories and delta step changes as would happen on a real power system, certain functions within the relay must be disabled or bypassed to allow injection testing. Selecting the **Static Mode** test option serves to bypass the delta phase selectors, and power swing detection.

For the tests, the delta directional line is also replaced by a conventional distance directional line, and the digital filtering slows to use a fixed one cycle window. Memory polarizing is replaced by cross-polarizing from unfaulted phases.

The Static Test mode allows older injection test sets to be retained, and used to commission and test the P44y, P445 & P54x.

<i>Note</i>	<i>Trip times may be up to ½ cycle longer when tested in the static mode, due to the nature of the test voltage and current, and the slower filtering. This is normal, and perfectly acceptable.</i>
-------------	--

2.12

Loopback Mode

If the P54x relay is used as a current differential relay, i.e. [090F Phase Diff] within [09 CONFIGURATION] is enabled, the loopback test facilities provide to the user with the ability to check the current differential protection. On the other hand, if the P54x relay is not used as a current differential relay, i.e. [090F Phase Diff] is disabled and [0941 InterMiCOM⁶⁴ Fiber] is enabled within [09 CONFIGURATION], the loopback test facilities, provide to the user with the ability to check the InterMiCOM⁶⁴ signaling.

<i>Note</i>	<i>Selecting the [0F13 Loopback Mode] to Internal, only the internal software of the relay is checked whereas External will check both the software and hardware.</i>
-------------	---

When the relay is switched into either ‘Loopback Mode’, the relay will automatically use generic addresses (address 0-0) and will respond as if it is connected to a remote relay with the current at the remote end equal to and in phase with the current injected at the local end. The signals sent and received (IM64) continue to be routed to and from the signals defined in the programmable logic.

2.13 IM64 Test Pattern

The [0F14 IM64Test Pattern] cell is used in conjunction with the [IM64 Test Mode] cell to set a 16-bit pattern (8 bits per channel) that is transmitted by the InterMiCOM⁶⁴ message whilst ever the 'IM64 Test Mode' cell is set to 'Enable'. The 'IM64 Test Pattern' cell has a binary string with one bit for each User Defined Inter-Relay Commands which can be set to '1' to operate the IM64 output under test conditions and '0' to not operate it.

2.14 IM64 Test Mode

When the **Enable** command in this cell [0F15] is issued, the InterMiCOM⁶⁴ commands change to reflect the state to the values set in the 'IM64 Test Pattern' cell. If set to 'Disable', the InterMiCOM⁶⁴ commands reflect the state of the signals generated by the protection and control functionality of the relay.

2.15 Using a Monitor/Download Port Test Box

A monitor/download port test box containing 8 LEDs and a switchable audible indicator is available from Schneider Electric, or one of their regional sales offices. It is housed in a small plastic box with a 25-pin male D-connector that plugs directly into the relay's monitor/download port. There is also a 25-pin female D-connector which allows other connections to be made to the monitor/download port whilst the monitor/download port test box is in place.

Each LED corresponds to one of the monitor bit pins on the monitor/download port with '**Monitor Bit 1**' being on the left hand side when viewing from the front of the relay. The audible indicator can either be selected to sound if a voltage appears on any of the eight monitor pins or remain silent so that indication of state is by LED alone.

3 SETTING FAMILIARIZATION

When first commissioning a relay, allow sufficient time to become familiar with how to apply the settings.

The *Menu Database document* and the *Introduction or Settings* chapters contain a detailed description of the menu structure of Schneider Electric relays. The menu database is a separate document which can be downloaded from our website:

www.schneider-electric.com

With the secondary front cover in place, all keys except the 5 key are accessible. All menu cells can be read. LEDs and alarms can be reset. However, no protection or configuration settings can be changed, or fault and event records cleared.

Removing the secondary front cover allows access to all keys so that settings can be changed, LEDs and alarms reset, and fault and event records cleared. However, to make changes to menu cells, the appropriate user role and password is needed.

Alternatively, if a portable PC with suitable setting software is available (such as Easergy Studio), the menu can be viewed one page at a time, to display a full column of data and text. This PC software also allows settings to be entered more easily, saved to a file for future reference, or printed to produce a settings record. Refer to the PC software user manual for details. If the software is being used for the first time, allow sufficient time to become familiar with its operation.

4 EQUIPMENT REQUIRED FOR COMMISSIONING

4.1 Minimum Equipment Required

The minimum equipment needed varies slightly, depending on the features provided by each type of MiCOM product. The list of minimum equipment is given below:

- Multifunctional dynamic current and voltage injection test set.
- Multimeter with suitable ac current range, and ac and dc voltage ranges of 0 - 440V and 0 - 250V respectively.
- Continuity tester (if not included in multimeter).
- Phase angle meter.
- Phase rotation meter.

<i>Note</i>	<i>Modern test equipment may contain many of the above features in one unit.</i>
-------------	--

- Fiber optic power meter.
- Fiber optic test leads (type and number according to application).
- Please refer to GPS synchronization device manual.
- Overcurrent test set with interval timer
- 110 V ac voltage supply (if stage 1 of the overcurrent function is set directional)
- 100 Ω precision wire wound or metal film resistor, 0.1% tolerance ($0^{\circ}\text{C} \pm 2^{\circ}\text{C}$)

Additional equipment is needed for relays which use the Process Bus interface. This is a typical list of equipment required for testing the Process Bus interface in the IED.

- IED test kit (such as Omicron) capable of generating IEC61850-9-2LE or IEC61869 Sampled Values. Multiple streams may be required depending upon the application.
- Ethernet switch(es)
- Fibre optic cables or RJ45 ethernet wires

Specific requirement for P54x devices are listed below:

- GPS synchronization on the IED test kit which can generate Sampled Value frames with Global 1 PPS

4.2 Optional Equipment

- Multi-finger test plug type Easergy test plug (if Easergy test block type is installed)
- An electronic or brushless insulation tester with a dc output not exceeding 500 V (for insulation resistance testing when required)
- A portable PC, with an RS232 port as well as appropriate software. This allows the rear communications port to be tested. If this is used, and it can save considerable time during commissioning.
- K-Bus to EIA(RS)232 protocol converter (if the first rear EIA(RS)485 K-Bus port or second rear port configured for K-Bus is being tested and one is not already installed)
- EIA(RS)485 to EIA(RS)232 converter (if first rear EIA(RS)485 port or second rear port configured for EIA(RS)485 is being tested)
- A printer, for printing a setting record from the portable PC

5 PRODUCT CHECKS

These product checks cover all aspects of the relay that need to be checked to ensure:

- that it has not been physically damaged before commissioning
- that it is functioning correctly and
- that all input quantity measurements are within the stated tolerances

If the application-specific settings have been applied to the relay before commissioning, it is advisable to make a copy of the settings to allow their restoration later.

If Programmable Scheme Logic (PSL) (other than the default settings with which the relay was supplied) has been applied, the default settings should be restored before commissioning. This can be done by:

- Obtaining a setting file from the customer. This requires a portable PC with appropriate setting software for transferring the settings from the PC to the relay.
- Extracting the settings from the relay itself. This requires a portable PC with appropriate setting software.
- Manually creating a setting record. This could be done by stepping through the front panel menu using the front panel user interface.



Warning Before carrying out any work on the equipment, you should be familiar with the contents of the latest issue of the Safety Guide, Safety Information and Technical Data chapters and the equipment rating label(s).

Connect the device to the network. Check the Link and Activity LEDs are functioning. This section shows typical network connections.

If the default RBAC has been changed then a username/password combination must be provided to allow access to change relay settings.

Note If the password has been lost, a recovery password can be obtained from Schneider Electric.

5.1 With the Relay De-Energized

The following group of tests should be carried out without the auxiliary supply applied to the relay and with the trip circuit isolated.

Before inserting the test plug, refer to the scheme diagram to ensure this will not cause damage or a safety hazard. For example, the test block may be associated with protection current transformer circuits. Before the test plug is inserted into the test block, make sure the sockets in the test plug which correspond to the current transformer secondary windings are linked.



Warning The current and voltage transformer connections must be isolated from the relay for these checks. If a MiCOM P991 or an Easergy test block is provided, insert the Easergy or MiCOM P992 test plug, which open-circuits all wiring routed through the test block.



Danger Never open-circuit the secondary circuit of a current transformer because the high voltage produced may be lethal. It could also damage insulation.

If a test block is not provided, isolate the voltage transformer supply to the relay using the panel links or connecting blocks. Short-circuit and disconnect the line current transformers from the relay terminals. Where means of isolating the auxiliary supply and trip circuit (such as isolation links, fuses and MCB) are provided, these should be used. If this is impossible, the wiring to these circuits must be disconnected and the exposed ends suitably terminated to prevent them from being a safety hazard.

5.1.1 Visual Inspection



Caution Check the rating information under the top access cover on the front of the relay. Check that the relay being tested is correct for the protected line or circuit. Ensure that the circuit reference and system details are entered onto the setting record sheet. Double-check the CT secondary current rating, and be sure to record the actual CT tap which is in use.

1. De-energize the IED.
2. Visually inspect the connectors and check the external wiring is correct. Carefully examine the relay to see that no physical damage has occurred since installation.

Ensure that the case earthing connections, at the bottom left-hand corner at the rear of the relay case, are used to connect the relay to a local earth bar using an adequate conductor.

5.1.2 Current Transformer Shorting Contacts (Optional Check)

If needed, the current transformer shorting contacts can be checked to ensure they close when the heavy-duty terminal block shown in the following figure is disconnected from the current input PCB. The heavy-duty terminal block location depends on the relay model.

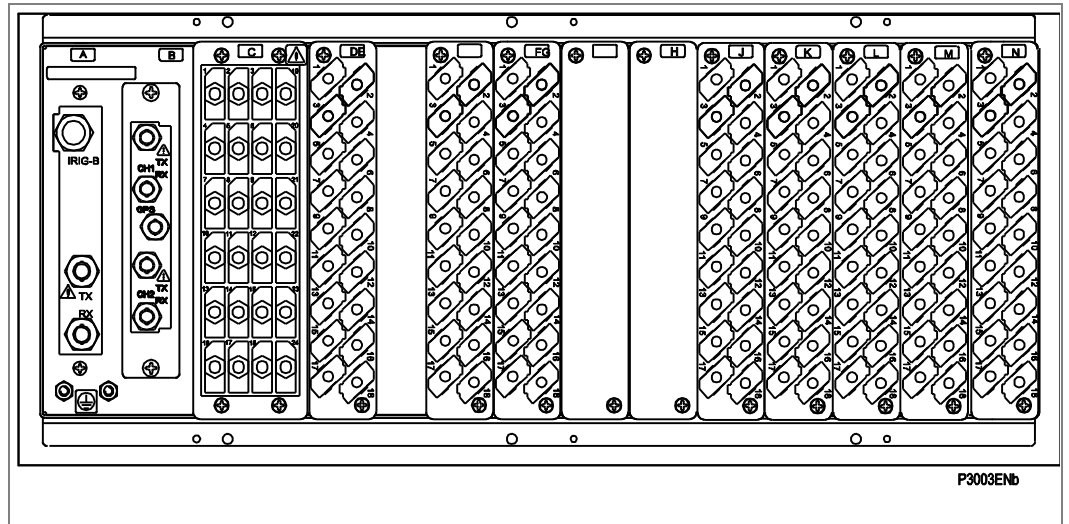

Figure 3 - Rear terminal blocks on size 80TE case

Heavy duty terminal blocks are fastened to the rear panel using four Pozidriv or PZ1 screws. These are at the top and bottom between the first and second, and third and fourth, columns of terminals (see the *Location of Securing Screws for Terminal Blocks* diagram below).

Note Use a magnetic-bladed screwdriver to avoid losing screws or leaving them in the terminal block.

Pull the terminal block away from the rear of the case and check with a continuity tester that all the shorting switches being used are closed. The following table(s) shows the terminals between which shorting contacts are fitted.

Current input	Shorting contact between terminals			
	P543	P544	P545 & P547	P546
	1 A - common - 5 A			
I _A	C3 - C2 - C1	C3 - C2 - C1	D3 - D2 - D1	D3 - D2 - D1
I _B	C6 - C5 - C4	C6 - C5 - C4	D6 - D5 - D4	D6 - D5 - D4
I _C	C9 - C8 - C7	C9 - C8 - C7	D9 - D8 - D7	D9 - D8 - D7
I _A (CT2)	Not applicable	E3 - E2 - E1	Not applicable	F3 - F2 - F1
I _B (CT2)	Not applicable	E6 - E5 - E4	Not applicable	F6 - F5 - F4
I _C (CT2)	Not applicable	E9 - E8 - E7	Not applicable	F9 - F8 - F7
I _{SEF}	C15 - C14 - C13	C15 - C14 - C13	D15 - D14 - D13	D15 - D14 - D13
I _M	C12 - C11 - C10	C12 - C11 - C10	D12 - D11 - D10	D12 - D11 - D10

Table 2 - Current transformer shorting contact locations

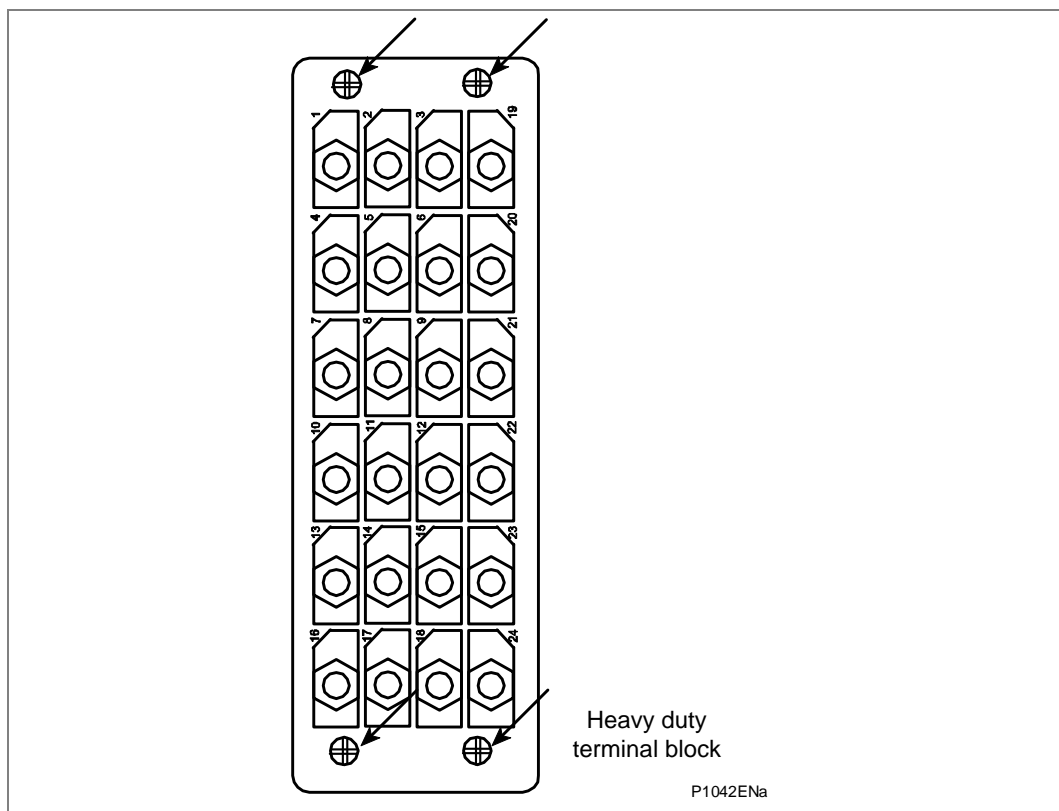

Figure 4 - Location of securing screws for heavy duty terminal blocks

5.1.3

Insulation

Insulation resistance tests are only necessary during commissioning if it is required for them to be done and they haven't been performed during installation.

Isolate all wiring from the earth and test the insulation with an electronic or brushless insulation tester at a dc voltage not exceeding 500 V. Terminals of the same circuits should be temporarily connected together.

The main groups of relay terminals are:

- a) Voltage transformer circuits
- b) Current transformer circuits
- c) Auxiliary voltage supply
- d) Field voltage output and opto-isolated control inputs
- e) Relay contacts
- f) EIA(RS)485 communication port
- g) Case earth

The insulation resistance should be greater than 100 MΩ at 500 V.

On completion of the insulation resistance tests, ensure all external wiring is correctly reconnected to the unit.

5.1.4

External Wiring



Caution Check that the external wiring is correct to the relevant relay diagram and scheme diagram. Ensure as far as practical that phasing/phase rotation appears to be as expected. The relay diagram number appears on the rating label under the top access cover on the front of the relay. Schneider Electric supply the corresponding connection diagram with the order acknowledgement for the relay.

If a MiCOM P991 or an Easergy test block is provided, check the connections against the wiring diagram. It is recommended that the supply connections are to the live side of the test block (colored orange with the odd numbered terminals 1, 3, 5, 7, and so on). The auxiliary supply is normally routed through terminals 13 (supply positive) and 15 (supply negative), with terminals 14 and 16 connected to the relay's positive and negative auxiliary supply terminals respectively. However, check the wiring against the schematic diagram for the installation to ensure compliance with the customer's normal practice.

5.1.5

Watchdog Contacts

Using a continuity tester, check that the watchdog contacts are in the states shown in the *Watchdog contact status* table for a de-energized relay.

Terminals		Contact state	
		Relay de-energized	Relay energized
J11 - J12	(P543 & P544)	Closed	Open
J13 - J14	(P543 & P544)	Open	Closed
M11 - M12	(P545 & P546 & P547)	Closed	Open
M13 - M14	(P545 & P546 & P547)	Open	Closed

Table 3 - Watchdog contact status

5.1.6

Auxiliary Supply



Caution *The relay can be operated from either a dc only or an ac/dc auxiliary supply depending on the relay’s nominal supply rating. The incoming voltage must be within the operating range specified in the following table.*

Without energizing the relay, measure the auxiliary supply to ensure it is within the operating range.

Note *The relay can withstand an ac ripple of up to 12% of the upper rated voltage on the dc auxiliary supply.*

Nominal Supply Rating		Operating Ranges	
dc	ac	dc	ac
24 - 32 V	[-]	19 to 38 V	-
48 - 110 V	[-]	37 to 150 V	-
110 - 250 V	[100 - 240 V]	87 to 300 V	80 to 265 V

Table 4 - Operational range of auxiliary supply Vx



Caution *Do not energize the relay using the battery charger with the battery disconnected as this can irreparably damage the relay’s power supply circuitry.*



Caution **Energize the relay only if the auxiliary supply is within the operating range. If a test block is provided, it may be necessary to link across the front of the test plug to connect the auxiliary supply to the relay.**

5.2 With the Relay Energized

The following group of tests verify that the relay hardware and software is functioning correctly and should be carried out with the auxiliary supply applied to the relay.



Caution

The current and voltage transformer connections must remain isolated from the relay for these checks. The trip circuit should also remain isolated to prevent accidental operation of the associated circuit breaker.



Caution

The InterMiCOM64 communication channel (when fitted) should be disconnected to prevent the remote end relay being affected during the tests.

5.2.1 Watchdog Contacts

Using a continuity tester, check that the watchdog contacts are in the states shown in the *Watchdog contact status* table for an energized relay.

5.2.2 Liquid Crystal Display (LCD) Front Panel Display

The Liquid Crystal Display (LCD) is designed to operate in a wide range of substation ambient temperatures. For this purpose, the Px40 relays have an **LCD Contrast** setting. This allows the user to adjust the lightness or darkness of the displayed characters. The contrast is factory preset to account for a standard room temperature, however it may be necessary to adjust the contrast to give the best in-service display. To change the contrast, at the bottom of the **CONFIGURATION** column, use cell [09FF: LCD Contrast] to increment (darker) or decrement (lighter), as required.



Important

Before applying a contrast setting, ensure that it does not make the display too light or dark so the menu text becomes unreadable. If this happens, it is possible to restore the display by downloading an Easergy Studio setting file, with the LCD Contrast set in the typical range of 7 to 11.

5.2.3 Date and Time

Before setting the date and time, ensure that the factory-fitted battery isolation strip that prevents battery drain during transportation and storage has been removed. With the lower access cover open, the presence of the battery isolation strip can be checked by a red tab protruding from the positive side of the battery compartment. Lightly pressing the battery to prevent it falling out of the battery compartment, pull the red tab to remove the isolation strip.

The data and time should now be set to the correct values. The method of setting depends on whether accuracy is being maintained through the optional Inter-Range Instrumentation Group standard B (IRIG-B) port on the rear of the relay or by using IEEE1588 and SNTP via Ethernet.

5.2.3.1

With an IRIG-B Signal

If a satellite time clock signal conforming to IRIG-B is provided and the relay has the optional IRIG-B port fitted, the satellite clock equipment should be energized.

To allow the relay's time and date to be maintained from an external IRIG-B source cell [DATE and TIME, IRIG-B Sync.] must be set to **Enabled**.

Ensure the relay is receiving the IRIG-B signal by checking that cell [DATE and TIME, IRIG-B Status] reads **Active**.

Once the IRIG-B signal is active, adjust the time offset of the universal coordinated time (satellite clock time) on the satellite clock equipment so that local time is displayed.

Check the time, date and month are correct in cell [0801: DATE and TIME, Date/Time]. The IRIG-B signal does not contain the current year so needs to be set manually in this cell.

If the auxiliary supply fails, with a battery fitted in the compartment behind the bottom access cover, the time and date is maintained. Therefore, when the auxiliary supply is restored, the time and date are correct and need not be set again.

To test this, remove the IRIG-B signal, then remove the auxiliary supply from the relay. Leave the relay de-energized for approximately 30 seconds. On re-energization, the time in cell [DATE and TIME, Date/Time] should be correct. Then reconnect the IRIG-B signal.

5.2.3.2

Without an IRIG-B Signal

<i>Note</i>	<i>For P741 the IRIG-B signal may not apply to the Central Unit only. For the P742/P743 it may apply to the Peripheral Unit only.</i>
-------------	---

If the time and date is not being maintained by an IRIG-B signal, ensure that cell [0804: DATE and TIME, IRIG-B Sync.] is set to **Disabled**.

Set the date and time to the correct local time and date using cell [0801: DATE and TIME, Date/Time].

If the auxiliary supply fails, with a battery fitted in the compartment behind the bottom access cover, the time and date are maintained. Therefore when the auxiliary supply is restored, the time and date are correct and need not be set again.

To test this, remove the auxiliary supply from the relay for approximately 30 seconds. On re-energization, the time in cell [0801: DATE and TIME, Date/Time] should be correct.

5.2.4

Light Emitting Diodes (LEDs)

On power-up, the green LED should switch on and stay on, indicating that the relay is healthy. The relay has non-volatile memory which stores the state (on or off) of the alarm, trip and, if configured to latch, user-programmable LED indicators when the relay was last energized from an auxiliary supply. Therefore, these indicators may also switch on when the auxiliary supply is applied.

If any of these LEDs are on, reset them before proceeding with further testing. If the LED successfully resets (the LED switches off), there is no testing required for that LED because it is known to be operational.

<i>Note</i>	<i>It is likely that alarms related to the communications channels will not reset at this stage.</i>
-------------	--

5.2.4.1

Testing the Alarm and Out of Service LEDs

The alarm and out of service LEDs can be tested using the **COMMISSIONING TESTS** menu column. Set cell [0F0D: COMMISSIONING TESTS, Test Mode] to **Contacts Blocked**. Check that the out of service LED is on continuously and the alarm LED flashes.

It is not necessary to return cell [0F0D: COMMISSIONING TESTS, Test Mode] to **Disabled** at this stage because the test mode will be required for later tests.

5.2.4.2 Testing the Trip LED

The trip LED can be tested by initiating a manual circuit breaker trip from the relay. However, the trip LED will operate during the setting checks performed later. Therefore, no further testing of the trip LED is required at this stage.

5.2.4.3 Testing the User-Programmable LEDs

To test the user-programmable LEDs set cell [0F10: COMMISSIONING TESTS, Test LEDs] to **Apply Test**. Check that all the programmable LEDs on the relay switch on.

5.2.5 Field Voltage* Supply

The relay generates a field voltage of nominally 48 V that can be used to energize the opto-isolated inputs (alternatively the substation battery may be used).

Measure the field voltage across terminals 7 and 9 on the terminal block shown in the following table. Check that the field voltage is in the range 40 V to 60 V when no load is connected and that the polarity is correct.

Repeat for terminals 8 and 10

Supply rail	Terminal	Product
+ve	J7 & J8	P543 & P544
-ve	J9 & J10	P543 & P544
+ve	M7 & M8	P545 & P546
-ve	M9 & M10	P545 & P546

Table 5 - Field voltage terminals

* Note

It is compulsory to add an EMC Filter to use the field voltage outputs to prevent any noise or high frequency disturbance.

*The EMC Filter must be connected to the protection relay with a **three-wires cable** of appr. 1m length.*

*The earth port of the EMC filter must **only** be connected to the earth terminal of Px4x; the metal housing of the filter **should** not be connected to the ground plane.*

Proposal:

Schaffner EMC Filter (FN2010-1-06, 1A max - 250V), or equivalent



5.2.6

Input Opto-Isolators

This test checks that all the opto-isolated inputs on the relay are functioning correctly.

- P543 and P544 have 16 opto inputs
- P545 and P546 have 24 opto inputs

Energize the opto-isolated inputs one at a time; see the external connection diagrams in the *Connection Diagrams* chapter for terminal numbers. Ensure that the correct opto input nominal voltage is set in the **Opto Config**. Menu. Ensure correct polarity and connect the field supply voltage to the appropriate terminals for the input being tested. Each opto input also has selectable filtering. This allows use of a pre-set filter of ½ cycle that renders the input immune to induced noise on the wiring.

<i>Note</i>	<i>The opto-isolated inputs may be energized from an external dc auxiliary supply (such as the station battery) in some installations. Check that this is not the case before connecting the field voltage, otherwise damage to the relay may result. If an external 24/27 V, 30/34 V, 48/54 V, 110/125 V, 220/250 V supply is being used it will be connected to the relay's optically isolated inputs directly. If an external supply is used it must be energized for this test, but only after confirming that it is suitably rated, with less than 12% ac ripple.</i>
-------------	--

The status of each opto-isolated input can be viewed using either cell [0020: SYSTEM DATA, Opto I/P Status] or [0F01: COMMISSIONING TESTS, Opto I/P Status], a **1** indicating an energized input and a **0** indicating a de-energized input. When each opto-isolated input is energized, one of the characters on the bottom line of the display changes, to indicate the new state of the inputs.

5.2.7

Output Relays

This test checks that all the output relays are functioning correctly.

Model	Outputs
P543 and P544	14 standard or Combination of 7 + 4 High-Break
P545	32 standard or Combination of 16 + 8 High-Break
P546	32 standard OR Combination of 16 + 8 High-Break OR Combination of 8 + 12 High-Break

<i>Note</i>	<i>The High-Break contacts are polarity sensitive. External wiring should, wherever possible, be verified against polarity requirements described in the external connection diagram to ensure correct high-break operation when in service.</i>
-------------	--

Ensure that the cell [0F0D: COMMISSIONING TESTS, Test Mode] is set to **Contacts Blocked**.

The output relays should be energized one at a time. To select output relay 1 for testing, set cell [0F0E: COMMISSIONING TESTS, Test Pattern] to 00000000000000000000000000000001.

Connect a continuity tester across the terminals corresponding to output relay 1 as shown in the relevant external connection diagram in the *Connection Diagrams* chapter.

To operate the output relay, set cell [0F0F: COMMISSIONING TESTS, Contact Test] to **Apply Test**. Operation is confirmed by the continuity tester operating for a normally open contact and ceasing to operate for a normally closed contact. Measure the resistance of the contacts in the closed state.

Reset the output relay by setting cell [0F0F: COMMISSIONING TESTS, Contact Test] to **Remove Test**.

<i>Note</i>	<i>Ensure that the thermal ratings of anything connected to the output relays during the contact test procedure are not exceeded by the associated output relay being operated for too long. Keep the time between application and removal of contact test to a minimum.</i>
-------------	--

Repeat the test for the rest of the relays (the numbers depend on the model).

Return the relay to service by setting cell [0F0D: COMMISSIONING TESTS, Test Mode] to **Disabled**.

5.2.8 Rear Communications Port

This test should only be performed where the relay is to be accessed from a remote location and varies depending on the communications standard adopted.

It is not the intention of the test to verify the operation of the complete system from the relay to the remote location, just the relay's rear communications port and any protocol converter necessary.

A variety of communications protocols may be available. For further details, please see whichever of these sections are relevant for the device you are commissioning:

5.2.8.1 Courier Communications

It is possible to connect the PC to the relay installed. The terminal numbers for the relay's first rear K-Bus, RS485 port are shown in the following table. However, as the installed protocol converter is not being used in the test, only the correct operation of the relay's K-Bus port will be confirmed.

Connection		Terminal	
RS485	IEC 60870-5-103 or DNP3.0	P54x	Product
Screen	Screen	M16	P545, P546
1	+ve	M17	P545, P546
2	-ve	M18	P545, P546
Screen	Screen	J16	P543, P544
1	+ve	J17	P543, P544
2	-ve	J18	P543, P544

Table 6 - EIA(RS)485 terminals

Ensure that the communications baud rate and parity settings in the application software are set the same as those on the protocol. The relay's Courier address in cell [0E02: COMMUNICATIONS, Remote Address] must be set to a value between 1 and 254.

Check that communications can be established with this relay using the portable PC.

5.2.8.2 IEC 60870-5-103 (VDEW) Communications

If the relay has the optional fiber optic communications port fitted, the port to be used should be selected by setting cell [0E07: COMMUNICATIONS, Physical Link] to **Fiber Optic** or **EIA(RS)485**.

IEC60870-5-103/VDEW communication systems are designed to have a local Master Station and this should be used to verify that the relay's rear fiber optic or EIA(RS)485 port, as appropriate, is working.

Ensure that the relay address and baud rate settings in the application software are set the same as those in cells [0E02: COMMUNICATIONS, Remote Address] and [0E04: COMMUNICATIONS, Baud Rate] of the relay.

Check, using the Master Station, that communications with the relay can be established.

5.2.8.3**DNP3.0 Communications Interface**

Connect a portable PC running the appropriate DNP3.0 Master Station Software to the relay's first rear EIA(RS)485 port using an EIA(RS)485 to EIA(RS)232 interface converter. The terminal numbers for the relay's EIA(RS)485 port are shown in the *EIA(RS)485 terminals* table.

Ensure that the relay address, baud rate and parity settings in the application software are set the same as those in cells [0E02: COMMUNICATIONS, Remote address], [0E04: COMMUNICATIONS, Baud Rate] and [0E05: COMMUNICATIONS, Parity] of the relay. Check that communications with this relay can be established.

If the relay has the optional fiber optic communications port fitted, the port to be used should be selected by setting cell [0E07: COMMUNICATIONS, Physical Link] to **Fiber Optic**. Ensure that the relay address and baud rate settings in the application software are set the same as those in cell [0E04: COMMUNICATIONS, Baud Rate] of the relay. Check that, using the Master Station, communications with the relay can be established.

5.2.9 Second Rear Communications Port

This test should only be performed where the relay is to be accessed from a remote location and varies depending on the communications standard being adopted.

It is not the intention of the test to verify the operation of the complete system from the relay to the remote location, just the relay's rear communications port and any protocol converter necessary.

The second rear communications port uses Courier communications allowing remote engineering access with Easergy MiCOM Studio.

5.2.9.1 K-Bus Configuration

It is possible to connect the PC to the relay installed. The terminal numbers for the relay's K-Bus port are shown in the following table. However, as the installed protocol converter is not being used in the test, only the correct operation of the relay's K-Bus port is confirmed.

Pin*	Connection
4	EIA(RS)485 - 1 (+ ve)
7	EIA(RS)485 - 2 (- ve)
* All other pins unconnected.	

Table 7 - 2nd rear communications port K-Bus terminals

Ensure that the communications baud rate and parity settings in the application software are set the same as those on the protocol converter. The relay's Courier address in cell [0E90: COMMUNICATIONS, RP2 Address] must be set to a value between 1 and 254. The second rear communication's port configuration [0E88: COMMUNICATIONS RP2 Port Config.] must be set to K-Bus.

Check that communications can be established with this relay using the portable PC.

5.2.9.2 EIA(RS)485 Configuration

If an EIA(RS)485 to EIA(RS)232 converter (Schneider Electric CK222) is installed, connect a portable PC running the appropriate software (Easergy Studio) to the EIA(RS)232 side of the converter and the second rear communications port of the relay to the EIA(RS)485 side of the converter.

The terminal numbers for the relay's EIA(RS)485 port are shown in the *Second rear communications port K-Bus terminals* table.

Ensure that the communications baud rate and parity settings in the application software are the same as those in the relay. The relay's Courier address in cell [0E90: COMMUNICATIONS, RP2 Address] must be set to a value between 1 and 254. The second rear communications port's configuration [0E88: COMMUNICATIONS RP2 Port Config.] must be set to EIA(RS)485.

Check that communications can be established with this relay using the portable PC.

5.2.9.3 EIA(RS)232 Configuration

Connect a portable PC running the appropriate software (Easergy Studio) to the rear EIA(RS)232 port of the relay. This port is compliant with EIA(RS)574; the 9-pin version of EIA(RS)232, see www.tiaonline.org.

The second rear communications port connects using the 9-way female D-type connector (SK4). The connection is compliant with EIA(RS)574.

Pin	Connection
1	No Connection
2	RxD
3	TxD
4	DTR#
5	Ground
6	No Connection
7	RTS#
8	CTS#
9	No Connection

These pins are control lines for use with a modem.

Table 8 - Second rear communications port EIA(RS)232 terminals

Connections to the second rear port configured for EIA(RS)232 operation can be made using a screened multi-core communication cable up to 15 m long, or a total capacitance of 2500 pF. Terminate the cable at the relay end with a 9-way, metal-shelled, D-type male plug. The terminal numbers for the relay's EIA(RS)232 port are shown in the previous table.

Ensure that the communications baud rate and parity settings in the application software are set the same as those in the relay. The relay's Courier address in cell [0E90: COMMUNICATIONS, RP2 Address] must be set to a value between 1 and 254. The second rear communication's port configuration [0E88: COMMUNICATIONS RP2 Port Config] must be set to EIA(RS)232.

Check that communications can be established with this relay using the portable PC.

5.2.10

Current Inputs

This test verifies that the accuracy of current measurement is within acceptable tolerances.

All relays leave the factory set for operation at a system frequency of 50 Hz. If operation at 60 Hz is required, this must be set in cell [0009: SYSTEM DATA, Frequency].

Caution	<i>To avoid spurious operation of protection elements during injection testing, ensure that current operated elements are disabled.</i>
----------------	--

Apply current equal to the line current transformer secondary winding rating to each current transformer input of the corresponding rating in turn, checking its magnitude using a multimeter. Refer to the *Current input terminals* table for the corresponding reading in the relay's **MEASUREMENTS 1** columns, as appropriate, and record the value displayed. The measured current values displayed on the relay LCD, or on a portable PC connected to the front communication port, are either in primary or secondary Amperes. If cell [0D02: MEASURE'T SETUP, Local Values] is set to **Primary**, the values displayed should be equal to the applied current multiplied by the corresponding current transformer ratio set in the **CT and VT RATIOS** menu column (see the *CT ratio settings* table). If cell [0D02: MEASURE'T SETUP, Local Values] is set to **Secondary**, the value displayed should be equal to the applied current.

Note	<i>If a PC connected to the relay's rear communications port is used to display the measured current, the process is similar. However, the setting of cell [0D03: MEASURE'T SETUP, Remote Values] determines whether the displayed values are in primary or secondary Amperes.</i>
-------------	--

The measurement accuracy of the relay is $\pm 1\%$ (5% for P741/P742/P743/P746). However, an additional allowance must be made for the accuracy of the test equipment being used.

Current Input	P543	P544	P545	P546	P547
	Shorting Contact Between Terminals 1A - Common - 5A				
I _A	C3 - C2 - C1	C3 - C2 - C1	D3 - D2 - D1	D3 - D2 - D1	D3 - D2 - D1
I _B	C6 - C5 - C4	C6 - C5 - C4	D6 - D5 - D4	D6 - D5 - D4	D6 - D5 - D4
I _C	C9 - C8 - C7	C9 - C8 - C7	D9 - D8 - D7	D9 - D8 - D7	D9 - D8 - D7
I _M					
I _{SEF}	C15 - C14 - C13	C15 - C14 - C13	D15 - D14 - D13	D15 - D14 - D13	D15 - D14 - D13
I _{A2}					
I _{B2}					
I _{C2}					
I _A (CT2)		E3 - E2 - E1		F3 - F2 - F1	
I _B (CT2)		E6 - E5 - E4		F6 - F5 - F4	
I _C (CT2)		E9 - E8 - E7		F9 - F8 - F7	
I _M	C12 - C11 - C10	C12 - C11 - C10	D12 - D11 - D10	D12 - D11 - D10	D12 - D11 - D10

	P54x
Menu cell	Corresponding CT ratio (in VT and CT RATIO column (0A) of menu)
[0201: IA Magnitude] [0203: IB Magnitude] [0205: IC Magnitude]	$\frac{[0A07 : \text{Phase CT Primary}]}{[0A08 : \text{Phase CT Secondary}]}$
[020B: ISEF Magnitude]	$\frac{[0A0B : \text{SEF amp CT Primary}]}{[0A0C : \text{SEF amp CT Secondary}]}$
[0232: IM Magnitude]	$\frac{[0A0D : \text{Mcomp CT Primary}]}{[0A0E : \text{Mcomp CT Secondary}]}$

Table 9 - CT ratio settings**5.2.11****Voltage Inputs**

This test verifies the accuracy of voltage measurement is within the acceptable tolerances.

Apply rated voltage to each voltage transformer input in turn, checking its magnitude using a multimeter. Refer to the *Voltage Input Terminals* table for the corresponding reading in the relay's **MEASUREMENTS 1** column and record the value displayed.

Cell in Measurements 1 Column (02)	Voltage applied to	
	P543 & P544	P545 & P546
[021A: VAN Magnitude]	C19-C22	D19 - D22
[021C: VBN Magnitude]	C20-C22	D20 - D22
[021E: VCN Magnitude]	C21-C22	D21 - D22
[022E: (CB1) Voltage Mag]	C23 - C24	D23 - D24
[024C: CB2 CS Volt Mag]	N/A	F23 - F24
* Voltage reference for synchrocheck		

Table 10 - Voltage input terminals

The measured voltage values displayed on the relay LCD or a portable PC connected to the front communication port are either in primary or secondary volts. If cell [0D02: MEASURE'T SETUP, Local Values] is set to **Primary**, the values displayed should be equal to the applied voltage multiplied by the corresponding voltage transformer ratio set in the **VT and CT RATIOS** menu column (see the following *VT ratio settings* table). If cell [0D02: MEASURE'T SETUP, Local Values] is set to **Secondary**, the value displayed should be equal to the applied voltage.

Note If a PC connected to the relay's rear communications port is used to display the measured voltage, the process is similar. However, the setting of cell [0D03: MEASURE'T SETUP, Remote Values] determines whether the displayed values are in primary or secondary volts.

The measurement accuracy of the relay is $\pm 1\%$. However, an additional allowance must be made for the accuracy of the test equipment being used.

Cell in MEASUREMENTS 1 column (02)	Corresponding CT ratio (in 'CT and VT RATIOS' column (0A) of menu)
	P54x
[021A: VAN Magnitude] [021C: VBN Magnitude] [021E: VCN Magnitude]	[0A01 : Main CT Primary] ----- [0A02 : Main CT Secondary]
[022E: Voltage Mag]	[0A03 : C/S VT Primary] ----- [0A04 : C/S VT Secondary]
[024C: CB2 CS Volt Mag] (P544 & P546 only)	[0A05 : CB2 CS VT Prim'y] ----- [0A06 : CB2 CS VT Sec'y]

Table 11 - Voltage ratio settings

5.3 IEDs which use the Process Bus Interface

5.3.1 IED Configured with One Merging Unit (MU)

The settings for the Process Bus interface are in the IED menu **IED Config**. See the Settings chapter.

1. If necessary, isolate or block any outgoing trips from the IED. If physical contacts from the IED are wired in the scheme, in **COMMISSION TESTS** menu, set **Test Mode** to **Contacts Blocked** if operation of the contacts is not desired. If GOOSE outputs are used, from the main IED menu COMMISSIONING TEST column select **Test Mode**.
2. Connect the IEDs Ethernet port on the Process Bus board to the Sampled Value source. If necessary this can be routed through an Ethernet switch.
3. Make a valid SV configuration (a CID file via **IED Configurator**) and download it to relay and activate the configuration bank.
4. Check that the MU configuration in the CID file matches the actual Sampled Value source (test kit or Merging Unit). Make any changes in the source Sampled Value configuration. This prevents mismatches in Sampled Value when the IED is put into service when testing existing schemes.
5. Set the IED **Synchro Mode** to **No SYNC CLK** so the IED accepts Sampled Value frames with or without synchronization.
6. Generate Sampled Value frames with the rated current and voltage as required in the IED's Sampled Value configuration.
7. In the **MEASUREMENTS** menu, check the magnitudes and phase angles are displayed correctly. The display may be in primary or secondary values. Also, the IED's CT ratio or VT ratio settings affect the display. A typical accuracy of 1% can be expected for magnitudes.
8. Change the SV configuration configured in the test kit or Merging Unit to mismatch the Sampled Value configuration of the relay. Check the data cell **SV Absence Alm** displays '*****1' (where * is a don't care state for this test, normally its value is 0) for the Merging Unit configured in the CID. Check that all **MEASUREMENTS** displays for voltage or current are zero.
9. Depending on the scheme, if Merging Unit is configured to publish SV in IEC61869 format, set **SMV Version** to **IEC61869**, if Merging Unit is configured to publish SV in IEC61850-9-2LE compatible format, set **SMV Version** to **IEC61850-9-2LE**.

5.3.2

IED Configured with Two or More Merging Units (MUs)

The settings for the IEC61850-9-2LE or IEC61869 interface are in the IED menu **PB CONFIG**.

1. If necessary, isolate or block any outgoing trips from the IED. If physical contacts from the IED are wired in the scheme, in **COMMISSION TESTS** menu, set **Test Mode** to **Contacts Blocked** if operation of the contacts is not desired. If GOOSE outputs are used, from the main IED menu COMMISSIONING TEST column select **Test Mode**.
2. Connect the IEDs Ethernet port on Process Bus board to an Ethernet switch, which is connected to the Sampled Value sources. If necessary this can be routed through an Ethernet switch.
3. Make a valid SV configuration (a CID file via **IED Configurator**) and download it to relay and activate the configuration bank.
4. Check that the MU configuration in the CID file matches the actual Sampled Value source (test kit or Merging Unit). Make any changes in the source Sampled Value configuration. This prevents mismatches in Sampled Value when the IED is put into service when testing existing schemes.
5. Set the IED Synchro Alarm to 'Local Clock' so the IED accepts Sampled Value frames with local or global synchronization.
6. Check that the Sampled Value source (test kit or Merging Unit) is GPS synchronized.
7. Check the receipt of Sampled Value frames one by one for each Logical Node configured in the IED.

Repeat the following steps for each Merging Unit, configuring them one by one in the Sampled Value source(s).

1. Generate Sampled Value frames with the rated current and voltage as required in the IED's Logical Node configuration. You can check the receipt of Sampled Value frames for the configured Logical Node.
2. In the **MEASUREMENTS** menu, check the magnitudes and phase angles are displayed correctly. The display may be in primary or secondary values. Also, the IED's CT ratio or VT ratio settings affect the display. A typical accuracy of 1% can be expected for magnitudes.
3. Change the SV configuration configured in the test kit or Merging Unit to mismatch the Sampled Value configuration of the relay. Check the data cell **SV Absence Alm** displays '00000001' (where * is a don't care state for this test, normally its value is 0) for the first Merging Unit configured in the CID, or '*****1*' (where * is a don't care state for this test, normally its value is 0) for the second Merging Unit configured in the CID. Check that all **MEASUREMENTS** displays for voltage or current are zero.

6 PROTECTION COMMUNICATIONS LOOPBACK

If the MiCOM relay is being used in a scheme with phase differential or InterMiCOM⁶⁴ communications it will be necessary to configure a loopback on the communications. If this is not the case, skip to the *Setting Checks* section.

Unless direct fiber optic communications are being used, the loopback should be made as close as possible to where the communication link leaves the substation such that as much of the wiring as possible and all associated communication signal converters are included in the test.

6.1 Protection Communications

This test verifies that the relay's fiber optic protection signaling ports together with any associated P-2M-L interface units are operating correctly.

A number of different fiber-optic interfaces are available. These are described in detail in the Operations (OP) and Application Notes (AP) sections of this manual. In general, 1300nm multi-mode fiber optics, 1310nm single-mode fiber optics and 1550nm single-mode fiber optics are used for direct fiber optic connections. 850nm multi-mode fiber optic connections are employed in conjunction with multiplexing telecommunications equipment. It is important that any optical fibers used for testing are correct for the interface(s) specified. Optical fibers should be terminated with BFOC2.5 (ST2.5) connectors. For multi-mode applications the use of 50/125 μ m cored fiber is recommended. Any fiber-optic test leads used for measurements should be sufficiently long to assure mode stripping, and a minimum length of 10m (30ft) is recommended to achieve this.

A P-2M-L unit will be situated near the multiplexer in applications where communications between P54x relays is via multiplexed electrical communication channels and the PCM multiplexer is installed remote from the relay room. This unit provides bi-directional optical to electrical signal conversion between the cross-site optical fiber from the relay and the electrical interface of the multiplexer.

Using the relay menu structure, ensure either:

- The current differential protection is enabled by setting the [090F Phase Diff] cell in the configuration column, or if the current differential protection is not being used,
- The InterMiCOM⁶⁴ communications is enabled by setting the [0941 InterMiCOM64] cell in the configuration column,

The method of testing is similar whether communications between relays is via dedicated optical fibers, using a P-2M-L unit to interface the relay's fiber optic communications channel to a multiplexer, or direct fiber connection to a multiplexer supporting the IEEE C37.94 standard. However, where P-2M-L interface units are being used, there are a number of extra tests on the P-2M-L units that need to be performed refer to the following section:

- 6.1.4 - Communications using P-2M-L Interface Units (G.703)

If the relay is to be connected to a multiplexer supporting the IEEE C37.94 standard, the loopback testing is performed exactly the same as for a direct fiber connection described in the *Loopback Communications Configuration* section.

<i>Note</i>	<i>It is possible that two channels may have different implementations and the sections describing the commissioning of the interfaces and the loopback tests should be used as relevant to each channel.</i>
-------------	---

Caution	When connecting or disconnecting optical fibers care should be taken not to look directly into the transmit port or end of the optical fiber.
----------------	--

6.1.1 Communications Loopback Setting

The loopback test can be used to establish correct operation of the local communication interface.



Caution In loopback mode the signals sent & received via the communications interface continue to be routed to & from the signals defined in the programmable logic. If InterMiCOM⁶⁴ is enabled, the same applies, but in this case, if the IM64 Test Mode is set to 'Enabled', a test pattern, IM64 Test Pattern is transmitted instead. This can be useful for testing.

Set cell [0F13 Test Loopback] to 'External'.

6.1.1.1 Channel 1 Transmit Power Level

Using an appropriate fiber optic cable, connect the Channel 1 transmitter (TX1) to an optical power meter. Check the average power transmitted is in the range in the following table.

Relays manufactured pre April 2008	850 nm multi-mode	1300 nm multi-mode	1310 nm single-mode
Maximum transmitter power (average value)	-19.8 dBm	-7 dBm	-7 dBm
Minimum transmitter power (average value)	-22.8 dBm	-13 dBm	-13 dBm
Relays manufactured post April 2008	850 nm multi-mode	1300 nm multi-mode	1310 nm single-mode
Maximum transmitter power (average value)	-19.8 dBm	-3 dBm	-3 dBm
Minimum transmitter power (average value)	-22.8 dBm	-9 dBm	-9 dBm

Table 12 - Record the transmit power level

6.1.1.2 Channel 2 Transmit Power Level

Repeat section 6.1.1.1 for channel 2 (if fitted).

6.1.2 Loopback Communications Configuration

A communications loopback will need to be made on the protection signaling communications. Either one or two channels will be fitted according to specification. A combination of direct fiber connection or multiplexed (using P-2M-L units) connection can be used on each of the channels. The following sections describe how the various loopbacks are made:

- 6.1.3 - Fiber Connection
- 6.1.4 - Communications using P-2M-L Interface Units (G.703)
- 6.1.5 - Loopback Test

They should be followed as appropriate to configure the loopback on channel 1 and the loopback on channel 2 (if fitted), before proceeding to the loopback test described in the *Loopback Test* section.

If the communications is being realized using P-2M-L interface units, then start by connecting the appropriate optical fiber(s) between the channel transmitter(s) on the P54x that will be used to make connection to the P-2M-L optical receiver(s) and then proceed to the relevant sections below that describe the commissioning of the P-2M-L interface units.

6.1.3 Fiber Connection

Where direct fiber connections are being used (or where multiplexer channels conforming to the IEEE C37.94 standard are being used), using an appropriate optical fiber cable, connect the channel transmitter to the channel receiver port on the rear of the relay.

6.1.4 Communications using P-2M-L Interface Units (G.703)

6.1.4.1 P-2M-L Visual Inspection

Carefully examine the unit to see that no physical damage has occurred since installation. The rating information given under the top access cover on the front of the unit should be checked to ensure it is correct for the particular installation.

Ensure that the case earthing connection, top left-hand corner at the rear of the case, is used to connect the unit to a local earth bar using an adequate conductor.

6.1.4.2 P-2M-L Insulation

Insulation resistance tests are only necessary during commissioning if it is required for them to be done and they haven't been performed during installation.

Isolate all wiring from the earth and test the insulation with an electronic or brushless insulation tester at a dc voltage not exceeding 500 V. The auxiliary dc supply terminals should be temporarily connected together.

The insulation resistance should be greater than 100 M Ω at 500 V.

On completion of the insulation resistance tests, ensure all external wiring is correctly reconnected to the P-2M-L.

6.1.4.3 P-2M-L External Wiring

Check that the external wiring is correct to the relevant connection diagram or scheme diagram. The connection diagram number appears on the rating label under the top access cover on the front of the P-2M-L. The corresponding connection diagram will have been supplied with the Schneider Electric order acknowledgement for the P-2M-L.



Caution It is especially important that the dc supplies are wired with the correct polarity.

6.1.4.4 P-2M-L Auxiliary Supply

P-2M-L units operate from a dc only auxiliary supply within the operative range of 19 V to 65 V for a 24 - 48 V version and 87.5 V to 300 V for a 110 - 250 V version.

Without energizing the P-2M-L units measure the auxiliary supply to ensure it is within the operating range.

It should be noted that the P-2M-L interface unit is designed to withstand an ac ripple component of up to 12% of the normal dc auxiliary supply. However, in all cases the peak value of the dc supply must not exceed the maximum specified operating limit.



Caution Do not energize the P-2M-L using the battery charger with the battery disconnected as this can irreparably damage the unit's power supply circuitry.

6.1.4.5 P-2M-L Light Emitting Diode (LED)

On power up the green 'SUPPLY HEALTHY' LED should have illuminated and stayed on, therefore indicating that the P-2M-L is healthy.

6.1.4.6 P-2M-L Optical Received Signal Level

With an optical cable connected to the P54x optical transmitter as instructed in the *Loopback Communications Configuration* section, disconnect the other end of the cable from the P-2M-L receiver (RX) and use an optical power meter to measure the received signal strength. The value should be in the range -16.8 dBm to -25.4 dBm. Record the measured value and replace the connector to the P-2M-L receiver.

6.1.4.7**P-2M-L Loopback**

It is necessary to loop the transmitted electrical G.703 signal presented on terminals 3 and 4 of the P-2M-L to the received signal presented on terminals 7 and 8. If test links have been designed into the scheme to facilitate this they should be used. Alternatively, remove any external wiring from terminals 3, 4, 7 and 8 at the rear of each P-2M-L unit. Loopback the G.703 signals on each unit by connecting a wire link between terminals 3 and 7, and a second wire between terminals 4 and 8.

6.1.4.8**P-2M-L Optical Transmitter Signal Level**

Using an appropriate fiber optic cable, connect the optical transmitter (TX) to an optical power meter. Check that the average power transmitted is within the range -16.8 dBm to -22.8 dBm.

Record the transmit power level.

Connect the appropriate optical fiber to connect the P-2M-L transmitter to the P54x optical receiver and return to the P54x relay.

6.1.4.9**P54x Optical Received Signal Level from P-2M-L**

Return to the P54x relay. Disconnect the fiber from the P54x optical receiver that connects to the optical transmitter of the P-2M-L and measure the received signal level. The value should be in the range -16.8 dBm to -25.4 dBm. Record the measurement and then reconnect the fiber to the optical receiver.

6.1.5**Loopback Test**

Set cell [0F14 IM64 Test Mode] to 'Enabled', and use cell [0F15 IM64 Test Pattern] to set a bit pattern to be sent via the InterMiCOM⁶⁴ loopback. To verify the correct operation of loopback test, check in the [MEASUREMENTS 4] column that the contents of cell 'IM64 Rx Status' matches with the test pattern set. The communication statistics will indicate the number of valid and any errored messages received, note that the propagation delay measurement will not be valid in this mode of operation. The relay will now respond as if it is connected to a remote relay. The relay will indicate a loopback alarm which can only be cleared by setting the 'Test Loopback' to disabled.



Note

For P44y and P445, the propagation delay measurement will not be valid in this mode of operation. The relay will now respond as if it is connected to a remote relay. The relay will indicate a loopback alarm which can only be cleared by setting the 'Test Loopback' to disabled.



Note

In loopback mode the signals sent and received via the protection communications / InterMiCOM⁶⁴ interface continue to be routed to and from the signals defined in the programmable logic.



Note

A test pattern can be also sent to the remote end in order to test the whole InterMiCOM communication path by enabling (0F14 IM64 Test Mode) and connecting two ends. If such a test is performed, special care has to be taken as the test pattern will be executed via PSL at the remote end.

7 GPS SYNCHRONIZATION

The P54x has a feature whereby the timing information used to align the local and remote current vectors used in the phase differential algorithm can be very accurately synchronized via the Global Positioning Satellite (GPS) system. If specified, a GPS synchronizing unit is employed to decipher GPS signals and provide the P54x relay with a suitable synchronizing signal.

If the P54x is using GPS synchronization to enhance the phase current differential protection, then the associated GPS synchronization device unit will need to be commissioned in accordance with the relevant commissioning instructions. Please refer to GPS synchronization device manual.

7.1 Commissioning Mode for P54x Relay without Process Bus

7.1.1 GPS Synchronization Device Optical Signal Strength at P54x Relay without Process Bus

With the interconnecting optical fiber connected to the optical transmitter of the GPS synchronization device prescribed by the scheme, and with the GPS synchronization device in 'Test Cycle Mode', at the P54x end, measure the received signal strength. The value should be in the range -16.8 dBm to -25.4 dBm. Record the value.

7.1.2 Check Synchronization Signal at P54x Relay without Process Bus

Disable the 'Test Cycle Mode' at the GPS synchronization device. Connect the fiber from the GPS synchronization device to the GPS synchronizing input of the P54x relay. Enable GPS synchronization in [201A: PROT COMMS/IM64, GPS Sync Enabled] menu cell of the relay. Check that the relay is recognizing the GPS synchronization in [0507 MEASUREMENTS 4, Channel 1 Status] of the relay.

If the GPS synchronization signal is being received, with the communications configured for loopback, the 'Local GPS' and Remote GPS' bits should both be set in the channel status such that the display reads *****11** (* is not relevant for this test).

7.1.3 Check GPS Failure Condition

Disconnect the fiber from the GPS synchronization device and check that the display reverts to *****00**.

7.1.4 Restore GPS

Reconnect the fiber and check again that the display reads *****11**.

7.2 Commissioning Mode for P54x Relay with Process Bus

The P54x needs a 1PPS GPS input to function correctly. See the IED manual for GPS synchronization tests.

7.3 Commissioning Mode

Global synchronization is needed for a current differential scheme to function correctly. The protection function is inhibited if global synchronization is not present. As IED test kits may not be able to generate Sampled Value frames with global synchronization, the IED has a commissioning mode which allows the differential function to be tested with local synchronization alone.

1. In the **PB CONFIG** menu, set **Synchro Mode** to *Local Clock*. The current differential protection function then executed for Sampled Value frames received with either Local Clock or Global Clock synchronization. But if Merging Unit is not synchronized with global 1 PPS signal, the differential current will be compared to actual differential current, the value only can be used as a reference due to the phase rotation basis is not established.
2. Test the current differential protection function using a test kit synchronized to GPS, publishing Sampled Value frames with Local Clock synchronization.
3. When the commissioning tests are complete, set the **Synchro Mode** to *Global Clock* before the IED is returned to service. The current differential protection operates only with Global 1 PPS synchronization.
4. Check the Merging Unit's maximum delay and if necessary adjust the **MUs Delay Offset** setting. If the monitored maximum delay offset is -1, it means the time difference of different SV arrived at device is longer than 3ms, which cannot meet the protection running condition, the whole network needs to be reconfigured to find why there is such a huge transmission delay for some Merging Units.

8 SETTING CHECKS

The setting checks ensure that all of the application-specific relay settings (both the relay's function and Programmable Scheme Logic (PSL) settings) for the particular installation have been correctly applied to the relay.

If the application-specific settings are not available, ignore sections 8.1 and 8.2.



Caution **The trip circuit should remain isolated during these checks to prevent accidental operation of the associated circuit breaker.**

8.1 Apply Application-Specific Settings

There are different methods of applying the settings:

- Transferring settings from a pre-prepared setting file to the relay using a laptop PC running the appropriate software (such as Easergy Studio). Use the front EIA(RS)232 port (under the bottom access cover), or the first rear communications port (Courier protocol with a protocol converter connected), or the second rear communications port. This is the preferred method for transferring function settings as it is much faster and there is less margin for error. If PSL other than the default settings with which the relay is supplied is used, this is the only way of changing the settings.
If a setting file has been created for the particular application and provided on a memory device, the commissioning time is further reduced, especially if application-specific PSL is applied to the relay.
- Enter the settings manually using the relay's operator interface. This method is not suitable for changing the PSL.



Caution **When the installation needs application-specific Programmable Scheme Logic (PSL), it is essential that the appropriate .psl file is downloaded (sent) to the relay, for each setting group that will be used. If the user fails to download the required .psl file to any setting group that may be brought into service, the factory default PSL will still be resident. This may have severe operational and safety consequences.**

Note *If, as a result of applying the application settings, the communication mode [2010 Comms Mode] has been changed, then a 'comms changed' alarm will be raised on the user interface. This alarm can only be cleared by power cycling the relay. If the alarm appears, remove and then re-apply the auxiliary supply to the relay.*

8.1.1 Protection Communications Loopback

If the phase differential protection is enabled, and/or InterMiCOM⁶⁴ is being used for the signalling channel, the communication loopbacks that were tested earlier need to be maintained whilst scheme testing is being performed. Cell [0F13 Test Loopback] of the COMMISSIONING TEST column should be set to 'External', the contents of cell [0F15 IM64 TestPattern] should have all bits set to 0 initially, and cell [0F15 IM64 Test Mode] should be set to 'Enabled'.

8.1.2 Reset Statistics

The protection communications / InterMiCOM communications statistics should be reset at this point. For MODEM InterMiCOM the [1531 Reset Statistics] in the InterMiCOM COMMS column of the menu is used. For InterMiCOM⁶⁴ the [0530 Clear Statistics] cell in the MEASUREMENTS 4 column should be used.

8.2 Demonstrate Correct Relay Operation

The *Current Inputs* and *Voltage Inputs* tests have already demonstrated that the relay is within calibration, thus the purpose of these tests is as follows:

- To determine that the primary protection function of the relay, current differential or distance can trip according to the correct application settings
- To verify correct setting of any aided scheme DEF (ground overcurrent) protection
- To verify correct assignment of the trip contacts, by monitoring the response to a selection of fault injections.

8.3 Demonstrate Correct Relay Operation - Current Differential Elements

8.3.1 Current Differential Bias Characteristic

If the phase differential elements are enabled, they should be tested.

If the phase differential elements are not being used, proceed to the *Demonstrate Correct Relay Operation - Non-Current Differential Elements* section.

To avoid spurious operation of any distance, overcurrent, earth fault or breaker fail elements, these should be disabled for the duration of the differential element tests. This is done in the relay's CONFIGURATION column. Ensure that cells [090B: Distance], [090C: Directional E/F], [0910: Overcurrent], [0913: Earth Fault] and [0920: CB Fail] are all set to "Disabled". Make a note of which elements need to be re-enabled after testing. The relay should also be set to loopback mode isolating it from the remote end. Refer to the *Communications Loopback Setting* section.

Note The following tests assume a CT correction value of 1. For other values of CT correction the injection and result values should be adjusted by dividing the expected values by the correction factor. For example, with a correction factor of 2, 1pu injection is $1/2 * I_n$.

8.3.1.1 Connect the Test Circuit

The following tests require a variable transformer and two resistors connected as shown in the *Connection for bias characteristic testing* diagram. Alternatively an injection test set can be used to supply I_a and I_b .

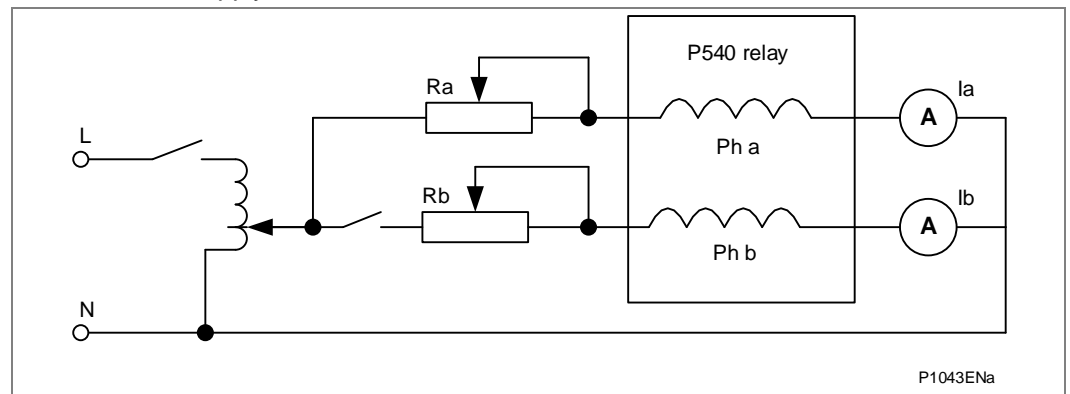

Figure 5 - Connection for bias characteristic testing

A current is injected into the A phase which is used as the bias current and another current is injected into the B phase which is used as differential current. I_a is always greater than I_b .

8.3.1.2

Lower Slope

If three LEDs have been assigned to give phase segregated trip information, Trip A, Trip B and Trip C, these may be used to indicate correct per-phase operation. If not, monitor options will need to be used - see the next paragraph.

Go to the COMMISSION TESTS column in the menu, scroll down and change cells [0F05: Monitor Bit 1] to 523, [0F06: Monitor Bit 2] to 524 and [0F07: Monitor Bit 3] to 525. Doing so, cell [0F04: Test Port Status] will appropriately set or reset the bits that now represent Trip Output A (DDB #523), Trip Output B (DDB #524) and Trip Output C (DDB #525) with the rightmost bit representing Phase A Trip. From now on you should monitor the indication of [0F03: Test Port Status]. Also make sure that the relay is in loopback mode by setting cell [0F13 Test Loopback] to 'External' and applying either a loop-back fiber on the relay or loopback is selected on the P-2M-L as described in the *Communications Loopback Setting* section. Alternatively setting cell [0F13 Test Loopback] to 'Internal'.

Adjust the variac and the resistor to give a bias current of 1pu in the A-phase. (NOTE: 1pu = 1A into terminals C3-C2 for 1 A applications; or 1 pu = 5 A into terminals C1-C2 for 5 A applications). The relay will trip and any contacts associated with the A-phase will operate, and bit 1 (rightmost) of [0F03: Test Port Status] will be set to 1. Some LEDs, including the yellow alarm LED, will go off, but ignore them for the moment.

When the current in A Phase is established, close the switch and slowly increase the current in the B phase from zero until Phase B trips (bit 2 of [0F03: Test Port Status] is set to 1). Record the phase B current magnitude and check that it corresponds to the information overleaf.

Switch OFF the ac supply, read and clear all alarms.

Bias current		Differential current	Magnitude of differential current	
Phase	Magnitude	Phase		
A	1pu	B	2 Terminal & Dual Redundant	0.25 pu +/-10%
			3 Terminal	0.216 pu +/-10%
Assumption: $I_{s1} = 0.2$ pu, $k_1 = 30\%$, $I_{s2} = 2.0$ pu				

Table 13 - Bias and differential currents (lower slope)

For other differential settings or current injected into A phase (I_a), the formula below can be used (enter slope in pu form, i.e. percentage/100):

2 Terminal & Dual Redundant:

B phase operate current is $0.5 \times [I_{s1} + [I_a \times k_1]]$ pu +/- 10% -

3 Terminal:

B phase operate current is $0.333 \times [I_{s1} + (1.5 \times I_a \times k_1)]$ pu +/- 10% -

Ensure that $I_a < I_{s2}$

8.3.1.3

Upper Slope

Repeat the test in the previous **Lower Slope** section with the bias current set in the A-phase to be 3pu.

When the current in A Phase is established, close the switch and slowly increase the current in the B phase from zero until phase B trips (bit 2 of [0F03: Test Port Status] is set to 1). Record the phase B current magnitude and check that it corresponds to the information below.

Switch OFF the ac supply and reset the alarms.

Bias current		Differential current	Magnitude of differential current		
Phase	Magnitude	Phase		k ₂	
A	3pu	B	2 Terminal & Dual Redundant	150%	1.15pu +/-10%
				100%	0.9pu +/-10%
			3 Terminal	150%	1.51pu +/-10%
				100%	1.1pu +/-10%

Assumption: I_{s1} = 0.2pu, k₁ = 30%, I_{s2} = 2.0pu, k₂ as above

Table 14 - Bias and differential currents (upper slope)

For other differential settings or current injected into A phase (I_a), the formula below can be used (enter slopes in pu form, i.e. percentage/100):

2 Terminal & Dual Redundant:

$$\text{Operate current is } 0.5 \times [(I_a \times k_2) - \{(k_2 - k_1) \times I_{s2}\} + I_{s1}] \text{ pu } +/- 20\%$$

3 Terminal:

$$\text{Operate current is } 0.333 \times [(1.5 \times I_a \times k_2) - \{(k_2 - k_1) \times I_{s2}\} + I_{s1}] \text{ pu } +/- 20\%$$

Ensure that I_a > I_{s2}

Note For 5 A applications the duration of current injections should be short to avoid overheating of the variac or injection test set.

8.3.2

Current Differential Operation and Contact Assignment

8.3.2.1

Phase A

Retaining the same test circuit as before, prepare for an instantaneous injection of 3 pu current in the A phase, with no current in the B phase (B phase switch open). Connect a timer to start when the fault injection is applied, and to stop when the trip occurs. To verify correct output contact mapping use the trip contacts that would be expected to trip the circuit breaker(s), as shown in the table. For two breaker applications, stop the timer once both CB1 and CB2 trip contacts have closed. This can be achieved by connecting the contacts in series to stop the timer.

	Single breaker	Two circuit breakers
Three Pole Tripping	Any Trip	Any Trip (CB1) and Any Trip (CB2)
Single Pole Tripping	Trip A	Trip A (CB1) and Trip A (CB2)

Table 15 - Tripping and single/double circuit breakers

8.3.2.2

Phase B

Reconfigure the test equipment to inject fault current into the B phase. Repeat the test in the above *Phase A* section, this time ensuring that the breaker trip contacts relative to B phase operation close correctly. Record the phase B trip time. Switch OFF the ac supply and reset the alarms.

8.3.2.3

Phase C

Repeat the steps described in *Phase B* for the C phase.

The average of the recorded operating times for the three phases should be less than 40 ms for 50 Hz, and less than 35 ms for 60 Hz when set for instantaneous operation. Switch OFF the ac supply and reset the alarms.

Note For applications using magnetizing inrush current restraint, use a test current higher than the [3313: Inrush High] setting to obtain fast operating times. At least twice setting is recommended.

Where an IDMT or definite time delay is set in the GROUP 1 PHASE DIFF menu column, the expected operating time is typically within +/- 5% of that for the curve equation plus the “instantaneous” delay quoted above.

On completion of the tests any distance, overcurrent, earth fault or breaker fail elements which were disabled for testing purposes must have their original settings restored in the CONFIGURATION column.

8.4 Demonstrate Correct Relay Operation - Non-Current Differential Elements

8.4.1 Protection Dependencies

The principle non-differential protection elements (distance, overcurrent, and earth fault) can be set to have dependencies the availability of the phase differential and the status of the Voltage Transformer Supervision (VTS) Function.

The distance protection can be permanently enabled, or it can be set so that it is only enabled in the event of a failure of the protection communications channel(s).

The overcurrent and earth faults elements can be permanently enabled, or can be set so that they are only enabled in the event of a failure of the protection communications channel(s), or can be set that they are only enabled in the event of a VTS alarm, or can be set so that they are enabled according to a logical combination of both conditions.

If these elements are enabled with a dependency upon the above conditions, then it will be necessary to simulate the condition in order to test the correct operation of the protection function.

Communications failure can be achieved by setting cell [0F13: Test Loopback] to **Disabled** and observing that the relay raises a Comms Fail alarm.

<i>Note</i>	<i>If forcing a communication failure is necessary, it will be necessary to clear communications alarms and reset the statistics at the end of the tests.</i>
-------------	---

VTS alarm can be raised by applying a 3-phase voltage to the VT inputs and then removing one phase voltage for a duration exceeding the VTS Time Delay setting. At the end of the tests, it will be necessary to ensure that the VTS alarm is cleared.

8.4.2 Distance Protection Single-End Testing

Refer to the previous *Protection Dependencies* section, check for any possible dependency conditions and simulate as appropriate.

If the distance protection function is being used, the reaches and time delays should be tested. If not, skip to the *Scheme Timer Settings* section.

To avoid spurious operation of overcurrent, DEF/earth fault or breaker fail elements, these should be disabled for the duration of the distance element tests. This is done in the relay's CONFIGURATION column. Ensure that cells [090C: Directional E/F DEF], [0910: Overcurrent], [0913: Earth Fault] and [0920: CB Fail] are all set to **Disabled**. If the distance element is enabled without qualification of communication channel failure, then the current differential element [090F: Phase Diff], should be disabled. If the distance protection is enabled on communication channel failure, then the differential element should remain enabled and the communication should be disrupted to cause a suitable failure of the phase differential protection.

8.4.2.1 Connection and Preliminaries

The relay should now be connected to equipment able to supply phase-phase and phase-neutral volts with current in the correct phase relation for a particular type of fault on the selected relay characteristic angle. The facility for altering the loop impedance (phase-to-ground fault or phase-phase) presented to the relay is essential.

It is recommended that a 3-phase digital/electronic injection test set is used for ease of commissioning. If this is not available, two setting changes may need to be made on the relay, for the duration of testing:



Caution 1 To facilitate testing of the Distance elements using test sets which do not provide a dynamic model to generate true fault delta conditions, a Static Test Mode setting is provided. This setting is found in the *Commissioning Tests* menu column. When set, this disables phase selector control and forces the relay to use a conventional (non-delta) directional line.



Caution 2 For lower specification test equipment that cannot apply a full three-phase set of healthy simulated pre-fault voltages, the VT supervision may need to be disabled to avoid spurious pickup. This is achieved in the CONFIGURATION column, by setting cell [0921: Supervision] to Disabled.

Connect the test equipment to the relay via the test block(s) taking care not to open-circuit any CT secondary. If Easergy test blocks are used, the live side of the test plug **must** be provided with shorting links before it is inserted into the test block.

8.4.2.2

Zone 1 Reach Check

The zone 1 element is set to be directional forward.

Apply a dynamic A phase to neutral fault, slightly in excess of the expected reach. The duration of the injection should be in excess of the tZ1 timer setting, but less than tZ2 (settings found in the DISTANCE menu column). Observe that no trip should occur, and the red Trip LED remains extinguished.

Reduce the impedance and reapply this to the relay. This procedure should be repeated until a trip occurs. The display will show Alarms/Faults present and the Alarm and Trip LEDs will illuminate. To view the alarm message press the read key 1, repeat presses of this key should be used to verify that phase A was the "Start Element". Keep pressing the 1 key until the yellow alarm LED changes from flashing to being steadily on. To reset the alarms press the **C** key. This will clear the fault record from the display.

Record the impedance at which the relay tripped. The measured impedance should be within +/- 10% of the expected reach.

Modern injection test sets usually calculate the expected fault loop impedance from the relay settings, for those that do not:

- Connections for an A-N fault. The appropriate loop impedance is given by the vector sum:
- $Z1 + Z1 \text{ residual} = Z1 + (Z1 \times kZN \text{ Res Comp} \angle kZN \text{ Angle}) \Omega$.

8.4.2.3

Zone 2 Reach Check

The zone 2 element is set to be directional forward.

Apply a dynamic B-C fault, slightly in excess of the expected reach. The duration of the injection should be in excess of the tZ2 timer setting, but less than tZ3. Repeat as in the *Zone 1 Reach Check* section to find the zone reach.

Record the impedance at which the relay tripped. The measured impedance should be within +/- 10% of the expected reach. Read and reset the alarms.

Modern injection test sets usually calculate the expected fault loop impedance from the relay settings, for those that do not:

Connections for a B-C fault. The reach for phase-phase should be checked and the operation of the appropriate contacts confirmed. The appropriate loop impedance is now given by:

$$2 \times Z2 \Omega$$

8.4.2.4

Zone 3 Reach Check

The zone 3 element is set to be directional forward.

Apply a dynamic C-A fault, slightly in excess of the expected reach. The duration of the injection should be in excess of the tZ3 timer setting (typically tZ3 + 100ms). Repeat as in the *Zone 1 Reach Check* section to find the zone reach.

Record the impedance at which the relay tripped. The measured impedance should be within +/- 10% of the expected reach. Read and reset the alarms.

Only a visual check that the correct reverse offset (Z3') has been applied is needed. The setting is found in cell [3143: Z3' Ph Rev Reach] and [31A3: Z3' Gnd Rev Reach].

8.4.2.5

Zone 4 Reach Check (if Enabled)

The zone 4 element is set to be directional reverse.

Apply a dynamic B-N fault, slightly in excess of the expected reach. The duration of the injection should be in excess of the tZ4 timer setting (typically tZ4 + 100 ms). Repeat as in the *Zone 1 Reach Check* section to find the zone reach.

Record the impedance at which the relay tripped. The measured impedance should be within +/- 10% of the expected reach. Read and reset the alarms.

8.4.2.6

Zone P Reach Check (if Enabled)

The zone P element can be set to be forward or reverse directional. The current injected must be in the appropriate direction to match the setting in the "DISTANCE SETUP" menu column (cells [3151] and [31B1]).

Apply a dynamic C-N fault, slightly in excess of the expected reach. The duration of the injection should be in excess of the tZP timer setting (typically tZP + 100ms). Repeat as in the *Zone 1 Reach Check* section to find the zone reach.

Record the impedance at which the relay tripped. The measured impedance should be within +/- 10% of the expected reach. Read and reset the alarms.

8.4.2.7

Resistive Reach (Quadrilateral Characteristics only)

Only a visual check that the correct settings for phase and ground element resistive reaches have been applied is needed. The relevant settings are R1Ph, R2Ph, R3Ph, R3Ph reverse, R4Ph and RP Ph for phase fault zones. The settings are R1Gnd, R2Gnd, R3Gnd, R3Gnd reverse, R4Gnd and RP Gnd for ground fault zones.

Note *Zone 3 has an independent setting for the forward resistance reach (right-hand resistive reach line), and the reverse resistance reach (left-hand resistive reach line).*

8.4.2.8

Load Blinder

Only a visual check that the correct settings for the load blinder have been applied is needed. The settings are found at the end of the DISTANCE SETUP menu column, cells [31D4] to [31D6]. It must be verified that [31D5: Load B/Angle] is set at least 10 degrees less than the [3004: Line Angle] setting in the LINE PARAMETERS menu column.

8.4.3

Distance Protection Operation and Contact Assignment

8.4.3.1

Phase A

Prepare a dynamic A phase to neutral fault, at half the Zone 1 reach. Connect a timer to start when the fault injection is applied, and to stop when the trip occurs. To verify correct output contact mapping use the trip contacts that would be expected to trip the circuit breaker(s), as shown in the table. For two breaker applications, stop the timer once CB1 and CB2 trip contacts have both closed, monitored by connecting the contacts in series to stop the timer if necessary.

	Single Breaker	Two Circuit Breakers
Three Pole Tripping	Any Trip	Any Trip (CB1) and Any Trip (CB2)
Single Pole Tripping	Trip A	Trip A (CB1) and Trip A (CB2)

Table 16 - Tripping and single/double circuit breakers

Apply the fault and record the phase A trip time. Switch OFF the ac supply and reset the alarms.

8.4.3.2

Phase B

Reconfigure to test a B phase fault. Repeat the test in the Phase A section, this time ensuring that the breaker trip contacts relative to B phase operation close correctly. Record the phase B trip time. Switch OFF the ac supply and reset the alarms.

8.4.3.3

Phase C

Repeat Phase B for the C phase.

The average of the recorded operating times for the three phases should typically be less than 20ms for 50Hz, and less than 16.7ms for 60Hz when set for instantaneous operation. Switch OFF the ac supply and reset the alarms.

- Where a non-zero tZ1 Gnd time delay is set in the DISTANCE menu column, the expected operating time is typically within +/- 5% of the tZ1 setting plus the “instantaneous” delay quoted above.

8.4.3.4

Time Delay Settings tZ1 Ph, and tZ2 - tZ4

Only a visual check that the correct time delay settings have been applied is needed. The relevant settings in the SCHEME LOGIC column are:

[3409: tZ1 Ph Time Delay]

[3411: tZ2 Ph Time Delay] and [3412: tZ2 Gnd Time Delay]

[3419: tZ3 Ph Time Delay] and [341A: tZ3 Gnd Time Delay]

[3421: tZP Ph Time Delay] and [3422: tZP Gnd Time Delay]

[3429: tZ4 Ph Time Delay] and [342A: tZ4 Gnd Time Delay]

Note *The P54x/P547 allows separate time delay settings for phase (“Ph”) and ground (“Gnd”) fault elements. BOTH must be checked to ensure that they have been set correctly.*

8.4.4

Distance Protection Scheme Testing

The relay will be tested for its response to internal and external fault simulations, but the engineer must note that the response will depend upon the aided channel (pilot) scheme that is selected. For a conventional signaling scheme, the table overleaf indicates the expected response for various test scenarios, according to the scheme selection, and status of the opto-input that is assigned to the “**Aided Receive Ext**” channel receive for the distance scheme. The response to the “**Reset Z1 Extension**” opto is shown in the case of a Zone 1 Extension scheme.

Testing of the P54x distance scheme is detailed in the case of conventional signaling scheme implementation as it is expected that the signaling will be independent to that of the communication for the phase differential protection. In the case where an InterMiCOM⁶⁴ scheme is being employed to provide the signaling, it may be that the scheme logic does not use opto-inputs for the aided scheme implementation and that internal logic signals (DDBs) will need to be set/reset in order to test the operation of the protection scheme. The IM64 Test Mode in conjunction with the IM64 Test Pattern should be used to assert/monitor the relevant signals.

Ensure that the injection test set timer is still connected to measure the time taken for the relay to trip. A series of fault injections will be applied, with a Zone 1, end-of-line, or Zone 4 fault simulated. At this stage, merely note the method in which each fault will be applied, but do not inject yet:

- Zone 1 fault A dynamic forward A-B fault at half the Zone 1 reach will be simulated.
- End of line fault A dynamic forward A-B fault at the remote end of the line will be simulated. The fault impedance simulated should match the [3003: Line Impedance] setting in the LINE PARAMETERS menu column.
- Zone 4 fault A dynamic reverse A-B fault at half the Zone 4 reach will be simulated.

Fault Type Simulated	RELAY RESPONSE					
	Forward Fault in Zone 1		Forward Fault at End of Line (Within Z1X/Z2)		Reverse Fault in Zone 4	
Signal Receive Opto	ON	OFF	ON	OFF	ON	OFF
Zone 1 Extension	Trip	Trip	No trip	Trip	No trip	No trip
Blocking Scheme	Trip, No signal send	Trip, No signal send	No trip, No signal send	Trip, No signal send	No trip, Signal send	No trip, Signal send
Permissive Scheme (PUR/PUTT)	Trip, Signal send	Trip, Signal send	Trip, No signal send	Trip, No signal send	No trip, No signal send	No trip, No signal send
Permissive Scheme (POR/POTT)	Trip, Signal send	Trip, Signal send	Trip, Signal send	No trip, Signal send	No trip, No signal send	No trip, No signal send

Table 17 - Fault types and responses

8.4.4.1

Scheme Trip Test for Zone 1 Extension Only

The Reset Zone 1 Extension opto input should first be ON (energized). This should be performed by applying a continuous DC voltage onto the required opto input, either from the test set, station battery, or relay field voltage (commissioning engineer to ascertain the best method).

With the opto energized, inject an end of line fault. The duration of injection should be set to 100 ms. No Trip should occur.

De-energize the Reset Z1X opto (remove the temporary energization link, to turn it OFF). Repeat the test injection, and record the operating time. This should typically be less than 20ms for 50Hz, and less than 16.7ms for 60Hz when set for instantaneous operation. Switch OFF the ac supply and reset the alarms.

- Where a non-zero tZ1 Ph time delay is set in the DISTANCE menu column, the expected operating time is typically within +/- 5% of the tZ1 setting plus the “instantaneous” delay quoted above.

8.4.4.2

Scheme Trip Tests for Permissive Schemes (PUR/POR only)

This test applies to both Permissive Underreach, and Permissive Overreach aided scheme applications.

As in the table, for a Permissive scheme the Signal Receive opto input will need to be ON (energized). This should be performed by applying a continuous DC voltage onto the required opto input, either from the test set, station battery, or relay field voltage (commissioning engineer to ascertain the best method).

With the opto energized, inject an end of line fault, and record the operating time. The measured operating time should typically be less than 20ms for 50Hz, and less than 16.7ms for 60Hz when set for instantaneous operation. Switch OFF the ac supply and reset the alarms.

- Where a non-zero Distance Dly time delay is set in the DISTANCE menu column, the expected operating time is typically within +/- 5% of the tZ1 setting plus the “instantaneous” delay quoted above.

De-energize the channel received opto (remove the temporary energization link, to turn it OFF).

8.4.4.3**Scheme Trip Tests for Blocking Scheme Only**

The Signal Receive opto input should first be ON (energized). This should be performed by applying a continuous DC voltage onto the required opto input, either from the test set, station battery, or relay field voltage (commissioning engineer to ascertain the best method).

With the opto energized, inject an end of line fault. The duration of injection should be set to 100ms. No trip should occur.

De-energize the channel received opto (remove the temporary energization link, to turn it OFF).

Repeat the test injection, and record the operating time. Switch OFF the ac supply and reset the alarms.

- For blocking schemes, a non-zero Distance Dly time delay is set, so the expected operating time is typically within +/- 5% of the delay setting plus the P54x “instantaneous” operating delay. The trip time should thus be less than 20 ms for 50 Hz, and less than 16.7 ms for 60 Hz, plus 1.05 x Delay setting.

8.4.4.4**Signal Send Test for Permissive Schemes (PUR/POR Only)**

This test applies to both Permissive Underreach, and Permissive Overreach scheme applications.

Firstly, reconnect the test set so that the timer is no longer stopped by the Trip contact, but is now stopped by the **Signal Send contact** (the contact that would normally be connected to the pilot/signaling channel).

Inject a Zone 1 fault, and record the signal send contact operating time. The measured operating time should typically be less than 20ms for 50Hz, and less than 16.7ms for 60Hz applications. Switch OFF the ac supply and reset the alarms.

8.4.4.5**Signal Send Test for Blocking Scheme Only**

Firstly, reconnect the test set so that the timer is no longer stopped by the Trip contact, but is now stopped by the **Signal Send contact** (the contact that would normally be connected to the pilot/signaling channel).

Inject a Zone 4 fault, and record the signal send contact operating time. The measured operating time should typically be less than 20ms for 50Hz, and less than 16.7ms for 60Hz applications. Switch OFF the ac supply and reset the alarms.

8.4.5 Scheme Timer Settings

Only a visual check that the correct time delay settings have been applied is needed. The relevant settings in the AIDED SCHEMES column are:

- [344A: tRev. Guard] if applicable/visible
- [344B: Unblocking Delay] if applicable/visible
- [3453: WI Trip Delay] if applicable/visible



Caution On completion of the tests any delta directional, DEF, overcurrent, earth fault, breaker fail or supervision elements which were disabled for testing purposes must have their original settings restored in the CONFIGURATION column. Ensure that the Static Test Mode has been left *Disabled*. Ensure that any wires/leads temporarily fitted to energize the channel receive opto input have been removed.

8.4.6 Delta Directional Comparison

If the delta directional comparison aided scheme is being used, the operation should be tested. If not, skip to the *Directional Earth Fault Aided Scheme (Ground Current Pilot Scheme)* section.

To avoid spurious operation of any distance, overcurrent, DEF/earth fault or breaker fail elements, these should be disabled for the duration of the delta element tests. This is done in the relay's CONFIGURATION column. Ensure that cells [090B: Distance], [090F] differential, [090C: DEF], [0910: Overcurrent], [0913: Earth Fault] and [0920: CB Fail] are all set to **Disabled**. Make a note of which elements need to be re-enabled after testing.

8.4.6.1 Connection and Preliminaries

It is recommended that a 3-phase digital/electronic injection test set is used for ease of commissioning.

Connect the test equipment to the relay via the test block(s) taking care not to open-circuit any CT secondary. If Easergy test blocks are used, the live side of the test plug must be provided with shorting links before it is inserted into the test block.

8.4.6.2 Single-Ended Injection Test

This set of injection tests aims to determine that a single MiCOM relay, at one end of the scheme is performing correctly. The relay is tested in isolation, with the communications channel to the remote line terminal disconnected. Verify that the MiCOM relay cannot send or receive channel scheme signals to/from the remote line end.

The relay will be tested for its response to forward and reverse fault injections, but the engineer must note that the response will depend upon the aided channel (pilot) scheme that is selected. For a conventional signaling scheme, the *Relay responses* table shows the expected response for various test scenarios, according to the scheme selection, and status of the opto-input that is assigned to the **Aided Receive Ext** channel receive for the delta scheme.

Testing the P54x/P547 directional comparison scheme is described for a conventional signaling scheme as it is expected that the signaling will be independent of the communication for the phase differential protection. Where an InterMiCOM⁶⁴ scheme is being used to provide the signaling, it may be that the scheme logic does not use opto-inputs for the aided scheme implementation and that internal logic signals (DDBs) will need to be set/reset to test the operation of the protection scheme. Use the IM64 Test Mode in conjunction with the IM64 Test Pattern to assert/monitor the relevant signals.

Direction of fault test injection	RELAY RESPONSE			
	Forward fault		Reverse fault	
Signal receive opto	ON	OFF	ON	OFF
Blocking scheme	No Trip, No Signal Send	Trip, No Signal Send	No Trip, Signal Send	No Trip, Signal Send
Permissive scheme (POR/POTT)	Trip, Signal Send	No Trip, Signal Send	No Trip, No Signal Send	No Trip, No Signal Send

Table 18 - Relay responses

8.4.6.3

Forward Fault Preparation

Configure the test set to inject a dynamic sequence of injection, as follows:

Step 1: Simulate a healthy 3-phase set of balanced voltages, each of magnitude V_n . No load current should be simulated. The duration of injection should be set to 1 second. Step 1 thus mimics a healthy unloaded line, prior to the application of a fault

Step 2: Simulate a forward fault on the A-phase. The A-phase voltage must be simulated to drop by 3 times the [3313: ΔV Fwd] setting, i.e:

$$V_a = V_n - 3 \times \Delta V \text{ Fwd}$$

The fault current on the A-phase should be set to 3 times the [3315: ΔI Fwd] setting, lagging V_a by a phase angle equal to the line angle, i.e:

$$I_a = 3 \times \Delta I \text{ Fwd} \angle -\theta \text{ Line}$$

Phases B and C should retain their healthy prefault voltage, and no current. The duration of injection should be set to 100 ms longer than the *Delta Dly* time setting.

8.4.7

Delta Directional Comparison Operation and Contact Assignment

A forward fault will be injected as described above, with the intention to cause a scheme trip. As in the table, for a Permissive scheme the Signal Receive opto input will need to be ON (energized). This should be performed by applying a continuous DC voltage onto the required opto input, either from the test set, station battery, or relay field voltage (commissioning engineer to ascertain the best method).

For a Blocking scheme, the opto should remain de-energized ("OFF").

8.4.7.1

Phase A

Prepare a dynamic A phase to neutral fault, as detailed above. Ensure that the test set is simulating Steps 1 and 2 as one continuous transition. Connect a timer to start when the **fault** injection (Step 2) is applied, and to stop when the trip occurs. To verify correct output contact mapping use the trip contacts that would be expected to trip the circuit breaker(s), as shown in the following table. For two-breaker applications, stop the timer once CB1 and CB2 trip contacts have both closed, monitored by connecting the contacts in series to stop the timer if necessary.

	Single breaker	Two circuit breakers
Three Pole Tripping	Any Trip	Any Trip (CB1) and Any Trip (CB2)
Single Pole Tripping	Trip A	Trip A (CB1) and Trip A (CB2)

Table 19 - Tripping and single/double circuit breakers

Apply the fault and record the phase A trip time. Switch OFF the ac supply and reset the alarms.

8.4.7.2

Phase B

Reconfigure to test a B phase fault. Repeat the test in Phase A above, this time ensuring that the breaker trip contacts relative to B phase operation close correctly. Record the phase B trip time. Switch OFF the ac supply and reset the alarms.

8.4.7.3

Phase C

Repeat Phase B for the C phase.

The average of the recorded operating times for the three phases should typically be less than 20 ms for 50 Hz, and less than 16.7 ms for 60 Hz when set for instantaneous operation, as in Permissive schemes. Switch OFF the ac supply and reset the alarms.

For Blocking schemes, where a non-zero Delta Dly time delay is set, the expected operating time is typically within +/- 5% of the delay setting plus the "instantaneous" delay quoted above.

8.4.8

Delta Directional Comparison Scheme Testing

8.4.8.1

Signal Send Test for Permissive Schemes (POR/POTT Only)

Firstly, reconnect the test set so that the timer is no longer stopped by the Trip contact, but is now stopped by the **Signal Send contact** (the contact that would normally be connected to the pilot/signaling channel).

Repeat the forward fault injection, and record the signal send contact operating time. The measured operating time should typically be less than 20 ms for 50 Hz, and less than 16.7 ms for 60 Hz applications. Switch OFF the ac supply and reset the alarms.

8.4.8.2

Signal Send Test FOR Blocking Schemes Only

Configure the test set to inject a dynamic sequence of injection, as follows:

Step 1: Simulate a healthy 3-phase set of balanced voltages, each of magnitude V_n . No load current should be simulated. The duration of injection should be set to 1 second. Step 1 therefore mimics a healthy unloaded line, prior to the application of a fault

Step 2: Simulate a reverse fault on the A-phase. The A-phase voltage must be simulated to drop by 3 times the [3314: ΔV Rev] setting, i.e.:

$$V_a = V_n - 3 \times \Delta V \text{ Rev}$$

The fault current on the A-phase should be set to 3 times the [3316: ΔI Rev] setting, and in antiphase to the forward injections, i.e.:

$$I_a = 3 \times \Delta I \text{ Rev} \angle 180^\circ - \theta \text{ Line}$$

Phases B and C should retain their healthy prefault voltage, and no current. The duration of injection should be set to 100 ms.

Prepare the dynamic A phase reverse fault, as detailed above. Ensure that the test set is simulating Steps 1 and 2 as one continuous transition. Connect a timer to start when the **fault** injection (Step 2) is applied, and to stop when the Delta scheme **Signal Send** contact closes. Apply the test, and record the signal send contact response time. Switch OFF the ac supply and reset the alarms.

The recorded operating time should typically be less than 20ms for 50 Hz, and less than 16.7ms for 60 Hz applications.

**Caution**

On completion of the tests any current differential, distance, DEF, overcurrent, earth fault, breaker fail or supervision elements which were disabled for testing purposes must have their original settings restored in the CONFIGURATION column. Ensure that any wires/leads temporarily fitted to energize the channel receive opto input have been removed.

8.4.9

Out-of-Step Protection (OST) Protection (if Enabled)

If the Out-of-Step Tripping (OST) protection function is being used, it should be tested. If not, skip to the *Directional Earth Fault Aided Scheme (Ground Current Pilot Scheme)* section.

Out-of-Step Tripping (OST) protection applies only to MiCOM relays with hardware version J or later, and with software version 33 or later.

This test is suitable for injection sets with a state sequencer function as dynamic impedance conditions are going to be tested. Up to four states impedances that will be applied during the Out of Step commissioning are shown in this diagram.

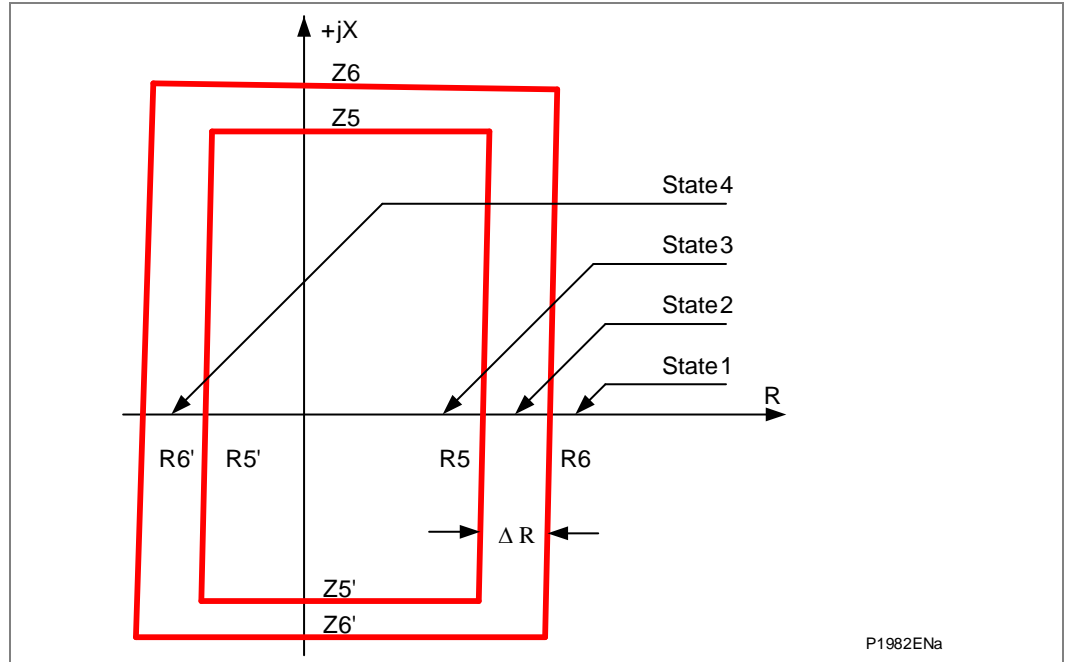

Figure 6 - Four state impedances

Depending on the Out of Step settings, follow one of these options.

- Predictive OST Setting
- OST Setting
- Predictive and OST Setting
- 'Tost' Timer Test

8.4.9.1

Predictive OST Setting

Clear all alarms. Set Tost to zero. Based on healthy voltages ($V_A = V_B = V_C = 57.8V$) calculate the currents to generate the impedances as shown in the following *Predictive OST state sequence* table:

	State 1	State 2	State 3
Apply $I_A = I_B = I_C =$	$\frac{57.8}{1.1 * R6}$	$\frac{57.8}{R5 + \frac{1}{2} (R6-R5)}$	$\frac{57.8}{0.9 * R5}$
Angle	0°	0°	0°
Duration	500 ms	Longer than 25 ms but shorter than 'Delta t' set time	500 ms
<i>Note</i> Angle is the angle between voltages and their respective currents.			

Table 20 - Predictive OST state sequence

Now apply the 3 state sequence to the relay under test and observe that the relay has tripped 3 phase and that an associated 'Predictive OST' alarm is displayed on the local LCD.

Clear all alarms.

8.4.9.2

OST Setting

Clear all alarms. Set Tost to zero. Based on healthy voltages ($V_A = V_B = V_C = 57.8 V$) calculate the currents to generate the impedances as shown in the following *OST state sequence* table:

	State 1	State 2	State 3	State 4
Apply $I_A = I_B = I_C =$	$\frac{57.8}{1.1 * R6}$	$\frac{57.8}{R5 + \frac{1}{2} (R6-R5)}$	$\frac{57.8}{0.9 * R5}$	$\frac{57.8}{1.1 * R5}$
Angle	0°	0°	0°	180°
Duration	500 ms	Longer than 'Delta t' set time	100 ms	500 ms
<p><i>Note</i> <i>The Angle is the angle between voltages and their respective currents. Also note that in state 4 the currents are displaced 180° from their respective voltages.</i></p>				

Table 21 - OST state sequence

Now apply the 4 state sequence to the relay under test and observe that the relay has tripped 3 phase and that an associated 'OST' alarm is displayed on the local LCD.

8.4.9.3**Predictive and OST Setting**

As per 'Predictive OST' above.

8.4.9.4**'Tost' Timer Test**

Repeat the test as for 'Predictive OST' and observe that the 3-phase tripping will come up after 'Tost' set time delay. Record the operating time in the commissioning record sheet.

8.4.10**Directional Earth Fault Aided Scheme (Ground Current Pilot Scheme)**

If the Aided DEF protection function is being used, it should be tested.

If not, skip to the *Backup Phase Overcurrent Protection* section.

Refer to the *Protection Dependencies* section, and check for any possible dependency conditions and simulate as appropriate.

To avoid spurious operation of any phase diff, distance, overcurrent, earth fault or breaker fail elements, these should be disabled for the duration of the DEF tests. This is done in the relay's CONFIGURATION column. If the earth fault element is enabled without qualification of communication channel failure, then the current differential element [090F: Phase Diff], should be disabled. If the earth fault protection is enabled on communication channel failure, then the differential element should remain enabled and the communication should be disrupted to cause a suitable failure of the phase differential protection. Make a note of which elements need to be re-enabled after testing. Testing of the P54x DEF scheme is detailed in the case of conventional signaling scheme implementation as it is expected that the signaling will be independent to that of the communication for the phase differential protection. In the case where an InterMiCOM⁶⁴ scheme is being employed to provide the signaling, it may be that the scheme logic does not use opto-inputs for the aided scheme implementation and that internal logic signals (DDBs) will need to be set/reset in order to test the operation of the protection scheme. The InterMiCOM⁶⁴ Test Mode in conjunction with the IM64 Test Pattern should be used to assert/monitor the relevant signals.

This set of injection tests aims to determine that a single relay, at one end of the scheme is performing correctly. The relay is tested in isolation, with the communications channel to the remote line terminal disconnected. Verify that the relay cannot send or receive channel scheme signals to/from the remote line end.

8.4.10.1**Connect the Test Circuit**

Determine which output relay(s) has/have been selected to operate when a DEF trip occurs by viewing the relay's Programmable Scheme Logic (PSL).

If the trip outputs are phase-segregated (i.e. a different output relay allocated for each phase), the relay assigned for tripping on 'A' phase faults should be used.

Connect the output relay so that its operation will Trip the test set and stop the timer.



Connect the current output of the test set to the 'A' phase current transformer input of the relay. Connect, all three phase voltages to the relay Va, Vb, and Vc. Ensure that the timer will start when the current is applied to the relay.

Ensure that the timer is reset, and prepare the test shot below:

- Simulate a forward fault on the A-phase. The A-phase voltage must be simulated to drop by 4 times the [3905] or [3906] : "DEF Vpol" setting, i.e.:

$$V_a = V_n - (4 \times \text{DEF Vpol})$$

The fault current on the A-phase should be set to 2 times the [3907: DEF Threshold] setting, and in the forward direction. For a forward fault, the current Ia should lag the voltage Va by the **DEF Char Angle** setting, i.e.:

$$I_a = 2 \times I_N \text{ DEF Threshold} \angle \theta_{\text{DEF}}$$

Phases B and C should retain their healthy prefault voltage, and no current. The duration of the injection should be in excess of the **DEF Delay** setting (typically tDEF Delay + 100 ms).

Direction of fault test injection	RELAY RESPONSE			
	Forward fault		Reverse fault	
Signal Receive Opto	ON	OFF	ON	OFF
Blocking Scheme	No Trip, No Signal Send	Trip, No Signal Send	No Trip, Signal Send	No Trip, Signal Send
Permissive Scheme (POR/POTT)	Trip, Signal Send	No Trip, Signal Send	No Trip, No Signal Send	No Trip, No Signal Send

Table 22 - Relay responses

A **forward** fault will be injected as described, with the intention to cause a scheme trip. As shown in the above *Relay responses* table, for a Permissive scheme the Signal Receive opto input will need to be ON (energized). This should be performed by applying a continuous DC voltage onto the required opto input, either from the test set, station battery, or relay field voltage (commissioning engineer to ascertain the best method). For a blocking scheme, the opto should remain de-energized ("OFF").

8.4.10.2

DEF Aided Scheme - Forward Fault Trip Test

Apply the fault and record the (phase A) Trip time. Switch OFF the ac supply and reset the alarms.

- The aided ground fault (DEF) scheme Trip time for POR schemes should be less than 40 ms
- For blocking schemes, where a non-zero DEF Dly time delay is set, the expected operating time is typically within +/- 5% of the delay setting plus the "instantaneous" (40 ms) delay quoted above.
- There is no need to repeat the test for phases B and C, as these Trip assignments have already been proven by the distance/delta Trip tests.

8.4.11

DEF Aided Scheme - Scheme Testing

8.4.11.1

Signal Send Test for Permissive Schemes (POR/POTT Only)

Firstly, reconnect the test set so that the timer is no longer stopped by the Trip contact, but is now stopped by the **Signal Send contact** (the contact that would normally be connected to the pilot/signaling channel).

Repeat the forward fault injection, and record the signal send contact operating time. The measured operating time should typically be less than 40ms. Switch OFF the ac supply and reset the alarms.

8.4.11.2

Signal Send Test for Blocking Schemes Only

Firstly, reconnect the test set so that the timer is no longer stopped by the Trip contact, but is now stopped by the **Signal Send contact** (the contact that would normally be connected to the pilot/signaling channel).
Secondly, reverse the current flow direction on the “A” phase, to simulate a **reverse** fault. Perform the reverse fault injection, and record the signal send contact operating time. The measured operating time should typically be less than 40 ms. Switch OFF the ac supply and reset the alarms.



Caution *On completion of the tests any phase diff, distance, overcurrent, earth fault, breaker fail or supervision elements which were disabled for testing purposes must have their original settings restored in the CONFIGURATION column. Ensure that any wires/leads temporarily fitted to energize the channel receive opto input have been removed.*

8.4.12

Backup Phase Overcurrent Protection

If the overcurrent protection function is being used, the I>1 element should be tested. If not, skip to the *Restoration of Communications and Clearing VTS* section.
Refer to the *Protection Dependencies* section, check for any possible dependency conditions and simulate as appropriate.
To avoid spurious operation of any distance, DEF, earth fault or breaker fail elements, these should be disabled for the duration of the overcurrent tests. This is done in the relay’s CONFIGURATION column. If the overcurrent element is enabled without qualification of communication channel failure, then the current differential element [090F: Phase Diff], should be disabled. If the overcurrent protection is enabled on communication channel failure, then the differential element should remain enabled and the communication should be disrupted to cause a suitable failure of the phase differential protection. Make a note of which elements need to be re-enabled after testing.

8.4.12.1

Connect the Test Circuit

Determine which output relay has been selected to operate when an I>1 trip occurs by viewing the relay’s PSL.
The relay assigned for Trip Output A (DDB 523) faults should be used.
Stage 1 should be mapped directly to an output relay in the PSL. If default PSL is used, Relay 3 can be used as I1> is mapped to Trip inputs 3 Ph (DDB 529) that in turn is internally mapped to Any Trip (DDB 522) mapped to relay 3 (see the *Trip Conversion Logic* in the *Operation* chapter).
Connect the output relay so that its operation will trip the test set and stop the timer.
Connect the current output of the test set to the ‘A’ phase current transformer input of the relay (terminals C3 and C2 where 1A current transformers are being used and terminals C1 and C2 for 5A current transformers).



If [3503: GROUP 1 OVERCURRENT, I>1 Directional] is set to ‘Directional Fwd’, the current should flow out of terminal C2 but into C2 if set to ‘Directional Rev’.
If cell [3503: GROUP 1 OVERCURRENT, I>1 Directional] has been set to ‘Directional Fwd’ or ‘Directional Rev’ then rated voltage should be applied to terminals C20 and C21. Ensure that the timer will start when the current is applied to the relay.

Note *If the timer does not stop when the current is applied and stage 1 has been set for directional operation, the connections may be incorrect for the direction of operation set. Try again with the current connections reversed.*

8.4.12.2

Perform the Test

Ensure that the timer is reset.

Apply a current of twice the setting in cell [3504: GROUP 1 OVERCURRENT, I>1 Current Set] to the relay and note the time displayed when the timer stops.

Check that the red trip LED has illuminated.

8.4.12.3

Check the Operating Time

Check that the operating time recorded by the timer is in the range shown in the *Characteristic operating times for I>1* table below.

Note Except for the definite time characteristic, the operating times given in the table are for a time multiplier or time dial setting of 1. Therefore, to obtain the operating time at other time multiplier or time dial settings, the time given in Table 14 must be multiplied by the setting of cell [3506: GROUP 1 OVERCURRENT, I>1 TMS] for IEC and UK characteristics or cell [3507: GROUP 1 OVERCURRENT, Time Dial] for IEEE and US characteristics.

In addition, for definite time and inverse characteristics there is an additional delay of up to 0.02 second and 0.08 second respectively that may need to be added to the relay's acceptable range of operating times.

For all characteristics, allowance must be made for the accuracy of the test equipment being used.

Characteristic	Operating time at twice current setting and time multiplier/ time dial setting of 1.0	
	Nominal (seconds)	Range (seconds)
DT	[3505: I>1 Time Delay] setting	Setting ±2%
IEC S Inverse	10.03	9.53 - 10.53
IEC V Inverse	13.50	12.83 - 14.18
IEC E Inverse	26.67	24.67 – 28.67
UK LT Inverse	120.00	114.00 - 126.00
IEEE M Inverse	3.8	3.61 – 4.0
IEEE V Inverse	7.03	6.68 - 7.38
IEEE E Inverse	9.50	9.02 – 9.97
US Inverse	2.16	2.05 - 2.27
US ST Inverse	12.12	11.51 - 12.73

Table 23 - Characteristic operating times for I>1



Caution

On completion of the tests any current differential, distance, overcurrent, earth fault, breaker fail or supervision elements which were disabled for testing purposes must have their original settings restored in the CONFIGURATION column.

8.4.13

Restoration of Communications and Clearing VTS

If, during the testing described in the *Demonstrate Correct Relay Operation - Non-Current Differential Element* section, it was necessary to create communication failure conditions and/or VTS alarm conditions, these should be cleared now. If communications failure was achieved by setting cell [0F13: Test Loopback] to **Disabled**, then this should be reset to **Enabled**.

Reset the protection communications statistics.

8.5 Check Trip and Auto-Reclose Cycle

If the auto-reclose function is being used, the circuit breaker trip and auto-reclose cycle can be tested automatically at the application-specific settings.

In order to test the trip and close operation without operating the breaker, the following criterion must be satisfied:

- The “CB Healthy” DDB should not be mapped, or if it is mapped, it must be asserted high.
- The CB status inputs (52 A, etc.) should not be mapped, or if they are mapped, they should be activated so as to mimic the circuit breaker operation.
- If configured for single pole tripping, either the **VT Connected** setting should be set to **No**, or appropriate voltage signals need to be applied to prevent the pole dead logic from converting to 3-pole tripping.

To test the first three-phase auto-reclose cycle, set cell [0F11: COMMISSION TESTS, Test Auto-reclose] to ‘3 Pole Test’. The relay will perform a trip/reclose cycle. Repeat this operation to test the subsequent three-phase auto-reclose cycles.

Check all output relays used for circuit breaker tripping and closing, blocking other devices, etc. operate at the correct times during the trip/close cycle.

The auto-reclose cycles for single phase trip conditions can be checked one at a time by sequentially setting cell [0F11: COMMISSION TESTS, Test Auto-reclose] to ‘Pole A Test’, ‘Pole B Test’ and ‘Pole C Test’.

9 END-TO-END PROTECTION COMMUNICATION TESTS

If, as is likely to be the case, the P54x relay is being used in a scheme with phase differential or InterMiCOM⁶⁴ communications it will be necessary to perform end-to-end tests of the protection communications channels. If this is not the case, skip to the On-Load Checks section.

In the *Communications Loopback* section, InterMiCOM communications loopbacks were applied to enable completion of the local end tests. In this section any loopbacks are removed and, if possible, satisfactory communications between line ends of the MiCOM relays in the scheme will be confirmed.

Note End-to-end communication requires the provision of a working telecommunication channel between line ends (which may be a multiplexed link or may be a direct connection). If the telecommunication channel is not available, it will not be possible to establish end-to-end communication. Nonetheless unless otherwise directed by local operational practice, the instructions in the **End-To-End Protection Communications Tests** section should be followed such that the scheme is ready for full operation when the telecommunications channels becomes available.

Note The trip circuit should remain isolated during these checks to prevent accidental operation of the associated circuit breaker.

9.1 Remove Local Loopbacks

As well as removing the loopback test, this section checks that all wiring and optical fibers are reconnected. If interface units are installed the application-specific settings will also be applied.

Check the alarm records to ensure that no communications failure alarms have occurred whilst the loopback test has been in progress.

Note If it was necessary to 'fail' the communications whilst testing the non-current differential elements, it may be prudent to observe the communications behavior for a few minutes before proceeding to remove the loopbacks.

Set cell [0F15 Test Mode] to **Disabled**.

Set cell [0F13 Loopback Mode] to **Disabled**.

Restore the communications channels as per the appropriate sub-section below.

9.1.1 Direct Fiber and C37.94 Connections

In the *InterMiCOM64 Fiber Communications* section, most of the required optical signal power levels were measurements were taken. If all signaling uses P-2M-L interface units, then no further measurements are required. If direct fiber or C37.94 communications are used then it will be necessary to make further measurements.

9.1.1.1 Direct Fiber Connections

It is necessary to check the optical power level received from the remote relay(s).

Remove the loopback test fiber(s) and at both ends of each channel used, reconnect the fiber optic cables for communications between relays, ensuring correct placement.



Caution When connecting or disconnecting optical fibres care should be taken not to look directly into the transmit port or end of the optical fibre.

For each channel fitted, in turn, remove the fiber connecting to the optical receiver (RX) and, using an optical power meter measure the strength of the signal received from the remote relay. The measurements should be within the values shown in the tables below:

Relays Manufactured Pre April 2008	850nm multi-mode	1300nm multi-mode	1310nm single-mode
Maximum Transmitter Power (Average Value)	-16.8dBm	-6dBm	-6dBm
Minimum Transmitter Power (Average Value)	-25.4dBm	-49dBm	-49dBm

Relays Manufactured Post April 2008	850nm multi-mode	1300nm multi-mode	1310nm single-mode
Maximum Transmitter Power (Average Value)	-16.8dBm	-7dBm	-7dBm
Minimum Transmitter Power (Average Value)	-25.4dBm	-37dBm	-37dBm

Table 24 - Measurement values

Record the received power level(s).

Reconnect the fiber(s) to the MiCOM receiver(s).

9.1.1.2**Fiber Connections to C37.94**

It is necessary to check the optical power level received from the MiCOM at the C37.94 multiplexer, as well as that received by the MiCOM from the C37.94 multiplexer.

Remove the loopback test fibers and at both ends of each channel used, reconnect the fiber optic cables for communications between relays and the C37.94 compatible multiplexer, ensuring correct placement.

**Caution**

When connecting or disconnecting optical fibres care should be taken not to look directly into the transmit port or end of the optical fibre.

In a similar manner to that described in the *Direct Fiber Connections* section, check that the value received from the MiCOM at the C37.94 multiplexer, as well as that received by the MiCOM from the C37.94 multiplexer are in the range presented in the table below:

Maximum Transmitter Power (Average Value)	-16.8dBm
Minimum Transmitter Power (Average Value)	-25.4dBm

Table 25 - Maximum/Minimum transmitter power

Record the received power level(s).

Reconnect the fiber(s).

9.1.2**Communications using P-2M-L Interface Units**

Return to the P-2M-L units.

**Warning**

Ensure that all external wiring that has been removed to facilitate testing is replaced in accordance with the relevant connection diagram or scheme diagram.

If applicable, replace the secondary front cover on the P-2M-L units.

9.2**Remote Loopback Removal****9.2.1****Remove Loopbacks at Remote Terminal Connected to Channel 1**

Repeat the following sections as needed at the remote end relay connected to channel 1.

- Direct Fiber and C37.94 Connections
- Communications using P-2M-L Interface Units

9.2.2 Remove Loopbacks at Remote Terminal Connected to Channel 2

Repeat the following sections as needed at the remote end relay connected to channel 2.

- Direct Fiber and C37.94 Connections
- Communications using P-2M-L Interface Units

9.3 Verify Communications between Relays

9.3.1 Communications Statistics and Status - Non-GPS Synchronised

- Reset any alarm indications and check that no further communications failure alarms are raised.
- Check channel status and propagation delays in [MEASUREMENTS 4] column for channel1 (and channel 2 where fitted).
- Specifically check that the first two bits in 'Channel Status' (Rx and Tx) are displaying '1' i.e. 11***** (where * indicates a 'don't care' state).
- Clear the statistics and record the number of valid messages and the number of errored messages after a minimum period of 1 hour.
- Check that the ratio of errored/good messages is better than 10^{-4} .
- Record the measured message propagation delays for channel 1, and channel 2 (if fitted).

9.3.2 Communications Statistics and Status - GPS Synchronised with GPS synchronization device

- Reset any alarm indications and check that no further communications failure alarms are raised.
- Check channel status and propagation delays in [MEASUREMENTS 4] column for channel1 (and channel 2 where fitted).
- Specifically check that the first four bits in 'Channel Status' (Rx, Tx, Local GPS, and remote GPS) are displaying '1' i.e. 1111***** (where * indicates a 'don't care' state).
- Clear the statistics and record the number of valid messages and the number of errored messages after a minimum period of 1 hour.
- Check that the ratio of errored/good messages is better than 10^{-4} .
- Record the measured message propagation delays for channel 1, and channel 2 (if fitted).

10 END-TO-END SCHEME TESTS

If an external signalling channel is being employed to provide aided scheme signaling (i.e. an aided protection scheme is being realised without InterMiCOM protection signaling, it should be tested. If only basic schemes are being used, or if InterMiCOM is being used to realise the schemes, skip to the *Modem InterMiCOM Scheme Testing* section.

10.1 Signaling Channel Check

This section aims to check that the signaling channel is able to transmit the ON/OFF signals used in aided schemes between the remote line ends. Before testing, check that the channel is healthy (for example, if a power line carrier link is being used, it may not be possible to perform the tests until the protected circuit is live and has in-service). If the channel tests must be postponed, make a note to perform them as described in the *On-Load Checks* section.

10.1.1 Aided Scheme 1

If Aided Scheme 1 is enabled, it must be tested. This is achieved by operating output contacts as in the *Output Relays* section to mimic the relay sending an aided channel signal.

Put the relay in test mode by setting cell [0F0D: COMMISSION TESTS, Test Mode] to **Blocked**.

Record which contact is assigned as the *Signal Send 1* output. Select this output contact as the one to test. And advise the remote end engineer that the contact is about to be tested.

10.1.1.1 Remote End Preparation to Observe Channel Arrival

At the remote end, the engineer must confirm the assignment of the Monitor Bits in the COMMISSION TESTS column in the menu, in order to be able to see the aided channel on arrival. Scroll down and ensure cells are set: [0F05: Monitor Bit 1] to 493, and [0F09: Monitor Bit 5] to 507. In doing so, cell [0F03: Test Port Status] will appropriately set or reset the bits that now represent Aided 1 Scheme Receive (DDB #493), and Aided 2 Scheme Receive (DDB #507), with the rightmost bit representing Aided Channel 1. From now on the remote end engineer should monitor the indication of [0F03: Test Port Status].

10.1.1.2 Application of the Test

At the local end, to operate the output relay set cell [0F0F: COMMISSION TESTS, Contact Test] to **Apply Test**.

Reset the output relay by setting cell [0F0F: COMMISSION TESTS, Contact Test] to **Remove Test**.

<i>Note</i>	<i>It should be ensured that thermal ratings of anything connected to the output relays during the contact test procedure are not exceeded by the associated output relay being operated for too long. It is therefore advised that the time between application and removal of the contact test is kept to the minimum.</i>
-------------	--

Check with the engineer at the remote end that the Aided Channel 1 signal did change state as expected. The Test Port Status should have responded as in the table below:

DDB No.				507				493
Monitor Bit	8	7	6	5	4	3	2	1
Contact Test OFF	X	X	X	X	X	X	X	0
Contact Test Applied (ON)	X	X	X	X	X	X	X	1
Test OFF	X	X	X	X	X	X	X	0

<i>Note</i>	<i>"X" = Wildcard/denotes don't care</i>
-------------	--

Table 26 - Test port status responses

Return the relay to service by setting cell [0F0D: COMMISSION TESTS, Test Mode] to 'Disabled'.

10.1.1.3**Channel Check in the Opposite Direction**

Repeat the aided scheme 1 test procedure, but this time to check that the channel responds correctly when keyed from the remote end. The remote end commissioning engineer should perform the contact test, with the Monitor Option observed at the local end.

10.1.2**Aided Scheme 2**

If applicable, now repeat the test for Aided Channel 2. Repeat as per the *Channel Check in the Opposite Direction* section above, checking that Monitor Bit 5 responds correctly for channel transmission in both directions (from the local end to the remote end, and vice versa).

Return the relay to service by setting cell [0F0D: COMMISSION TESTS, Test Mode] to **Disabled**.

11 ON-LOAD CHECKS

The objectives of the on-load checks are to:

- Confirm the external wiring to the current and voltage inputs is correct.
- Measure the magnitude of capacitive current
- Ensure the on-load differential current is well below the relay setting
- Check the polarity of the line current transformers at each end is consistent.
- Directionality check for directional elements.

However, these checks can only be carried out if there are no restrictions preventing the energization of the plant being protected and the other P54x/P547 relays in the group have been commissioned.



Caution Remove all test leads and temporary shorting leads, and replace any external wiring that was removed to allow testing.



Caution If any of the external wiring was disconnected from the relay to run any tests, make sure that all connections are restored according to the external connection or scheme diagram.

11.1 Confirm Current and Voltage Transformer Wiring

11.1.1 Voltage Connections



Caution Using a multimeter, measure the voltage transformer secondary voltages to ensure they are correctly rated. Check that the system phase rotation is correct using a phase rotation meter.

Compare the values of the secondary phase voltages with the relay's measured values, which can be found in the **MEASUREMENTS 1** menu column.

If cell [0D02: MEASURE'T SETUP, Local Values] is set to **Secondary**, the values displayed on the relay LCD or a portable PC connected to the front EIA(RS)232 communication port should be equal to the applied secondary voltage. The values should be within 1% of the applied secondary voltages/currents (5% for P74x). However, an additional allowance must be made for the accuracy of the test equipment being used.

If cell [0D02: MEASURE'T SETUP, Local Values] is set to **Primary**, the values displayed should be equal to the applied secondary voltage multiplied the corresponding voltage transformer ratio set in the **CT and VT RATIOS** menu column (see the following table). Again, the values should be within 1% of the expected value (5% for P74x), plus an additional allowance for the accuracy of the test equipment being used.

Voltage	Cell in MEASUREMENTS 1 Column (02)	Corresponding VT Ratio in 'VT and CT RATIO' Column (0A) of Menu
V _{AB} V _{BC} V _{CA} V _{AN} V _{BN} V _{CN}	[0214: V _{AB} Magnitude] [0216: V _{BC} Magnitude] [0218: V _{CA} Magnitude] [021A: V _{AN} Magnitude] [021C: V _{BN} Magnitude] [021E: V _{CN} Magnitude]	[0A01 : Main VT Primary] [0A02 : Main VT Secondary]
V _{CHECKSYNC.}	[022E: CB1 CS Volt Mag.]	[0A03 : (CB1) CS VTPrim'y] [0A04 : (CB1) CS VT Sec'y]
V _{CHECKSYNC2} (NOT P445/P841 A)	[024C: CB2 CS2 Volt Mag] (NOT P443/P445)	[0A05 : CB2 CS VTPrim'y] [0A06 : CB2 CS VT Sec'y]

Table 27 - Measured voltages and VT ratio settings

11.1.2

Current Connections

**Caution**

Measure the current transformer secondary values for each input using a multimeter connected in series with corresponding relay current input.

Check that the current transformer polarities are correct by measuring the phase angle between the current and voltage, either against a phase meter already installed on site and known to be correct or by determining the direction of power flow by contacting the system control center.

Caution

Ensure the current flowing in the neutral circuit of the current transformers is negligible.

Compare the values of the secondary phase currents (and any phase angle) with the relay's measured values, which can be found in the **MEASUREMENTS 1** menu column. If cell [0D02: MEASURE'T SETUP, Local Values] is set to **Secondary**, the current displayed on the relay LCD or a portable PC connected to the front EIA(RS)232 communication port should be equal to the applied secondary current. The values should be within 1% of the applied secondary currents. However, an additional allowance must be made for the accuracy of the test equipment being used.

If cell [0D02: MEASURE'T SETUP, Local Values] is set to **Primary**, the current displayed should be equal to the applied secondary current multiplied by the corresponding current transformer ratio set in the **CT & VT RATIOS** menu column (see the *Measured Voltages and VT Ratio Settings* table). Again the values should be within 1% of the expected value, plus an additional allowance for the accuracy of the test equipment being used.

11.2

Measure Capacitive Charging Current

With the feeder energized from one end only, compare the local and remote measured currents in the MEASUREMENTS 3 menu column to confirm that the feeder capacitive charging current is similar to that expected on all three phases.

Check that the setting of cell [3302: GROUP 1 PHASE DIFF, Phase Is1] is higher than 2.5 times the capacitive charging current. If this is not the case, notify the Engineer who determined the original settings of the setting required to ensure stability under normal operating conditions.

11.3

Check Differential Current

With the feeder supplying load current check that the relay measurements in the MEASUREMENTS 3 menu column are as expected and that the differential current is similar to the value of capacitive charging current previously measured for all.

11.4

Check Consistency of Current Transformer Polarity

The load current should be high enough to be certain beyond doubt that the main current transformers are connected with the same polarity to each relay in the group.

There is a possibility on cable circuits with high line capacitance that the load current could be masked by the capacitive charging current. If necessary reverse the connections to the main current transformers and check that the 'A' phase differential current in cell [0419: MEASUREMENTS 3, IA Differential] is significantly higher than for the normal connection. If the differential current falls with the connection reversed, the main current transformers may not be correct and should be thoroughly checked. Repeat the test for phases 'B' and 'C' using cells [0420: MEASUREMENTS 3, IB Differential] and [0419: MEASUREMENTS 3, IC Differential] respectively.

11.5 On Load Directional Test

This test is important to ensure that directionalized overcurrent and fault locator functions have the correct forward/reverse response to fault and load conditions.

Firstly the actual direction of power flow on the system must be ascertained, using adjacent instrumentation or protection already in-service, or a knowledge of the prevailing network operation conditions.

- For load current flowing in the Forward direction - i.e. power export to the remote line end, cell [0301: MEASUREMENTS 2, A Phase Watts] should show **positive** power signing
- For load current flowing in the Reverse direction - i.e. power import from the remote line end, cell [0301: MEASUREMENTS 2, A Phase Watts] should show **negative** power signing

<i>Note</i>	<i>The check above applies only for Measurement Modes 0 (default), and 2. This should be checked in [0D05: MEASURE'T. SETUP, Measurement Mode = 0 or 2]. If measurement modes 1 or 3 are used, the expected power flow signing would be opposite to that shown in the bullets above.</i>
-------------	--

In the event of any uncertainty, check the phase angle of the phase currents with respect to their phase voltage.

11.6 Signaling Channel Check (if Not Already Completed)

If the aided scheme signaling channel(s) was/were not tested already in the *Signalling Channel Check* section they should be tested now. This test may be avoided only with the agreement of the customer, or if only the basic scheme is used.

12 FINAL CHECKS

The tests are now complete.

**Caution**

Remove all test or temporary shorting leads. If it has been necessary to disconnect any of the external wiring from the relay to perform the wiring verification tests, make sure all connections are replaced according to the relevant external connection or scheme diagram.

Ensure that the relay is restored to service by checking that cell [0F0D: COMMISSIONING TESTS, Test Mode] and [0F12: COMMISSION TESTS, Static Test] are set to 'Disabled'.

The settings applied should be carefully checked against the required application-specific settings to ensure that they are correct, and have not been mistakenly altered during testing.

There are two methods of checking the settings:

- Extract the settings from the relay using a portable PC running the appropriate software via the front EIA(RS)232 port, located under the bottom access cover, or rear communications port. Compare the settings transferred from the relay with the original written application-specific setting record. (For cases where the customer has only provided a printed copy of the required settings but a portable PC is available).
- Step through the settings using the relay's operator interface and compare them with the original application-specific setting record. Ensure that all protection elements required have been ENABLED in the CONFIGURATION column.

If the relay is in a new installation or the circuit breaker has just been maintained, the circuit breaker maintenance and current counters should be zero. These counters can be reset using cell [0609/0619: CB CONDITION, Reset All Values]. If the required access level is not active, the relay will prompt for a password to be entered so that the setting change can be made.

If the menu language was changed to allow accurate testing, it must now be restored to the customer's preferred language.

If a MiCOM P991 or Easergy test block is installed, remove the MiCOM P992 or Easergy test plug and replace the test block cover so that the protection is put into service.

Ensure that all event records, fault records, disturbance records, alarms and LEDs have been reset before leaving the relay.

If applicable, replace the secondary front cover on the relay.

Notes:

TEST AND SETTING RECORDS

CHAPTER 12

Applicability

Date: 11/2022

Products covered by this chapter:

This chapter covers the specific versions of the MiCOM products listed below. This includes **only** the following combinations of Software Version and Hardware Suffix.

Hardware Suffix:

MiCOM P54x (P543, P544, P545 & P546)	M
--------------------------------------	---

Software Version:

MiCOM P54x (P543, P544, P545 & P546)	K6
--------------------------------------	----

Connection Diagrams: This chapter list the connection diagram for the product:

P54x (P543, P544, P545 & P546):	10P54302 (SH 1 to 2) 10P54303 (SH 1 to 2) 10P54304 (SH 1 to 2) 10P54400 10P54404 (SH 1 to 2) 10P54405 (SH 1 to 2) 10P54502 (SH 1 to 2) 10P54503 (SH 1 to 2) 10P54504 (SH 1 to 2) 10P54600 10P54604 (SH 1 to 2) 10P54605 (SH 1 to 2) 10P54606 (SH 1 to 2)
---------------------------------	--

CONTENTS

1. Test Record.....	5
1.1 About this Chapter.....	5
1.2 Date.....	5
1.3 Front Plate Information.....	5
1.4 Test Equipment Used.....	5
1.5 Checklist.....	6
1.6 Engineer Details.....	23
2. Creating a Setting Record.....	24
2.1 Extract Settings from a MiCOM Px40 Device.....	24
2.2 Send Settings to a MiCOM Px40 Device.....	25

Notes:

1. TEST RECORD

1.1 About this Chapter

The Commissioning chapter provides instructions on how to commission the relay – including how to calibrate it and how to establish that it is functioning as intended.

This chapter provides you with a series of templates. You can use this to record the tests which have been made and the settings which have been used. You should use this chapter in conjunction with the Commissioning chapter and any work instructions you have as to what functionality and settings the relay should use.

1.2 Date

Date:

Station:
VT Ratio: / V

Engineer:
Circuit:
System Frequency: Hz
CT Ratio (tap in use): /A

1.3 Front Plate Information

Relay type	MiCOM P543, P544, P545 & P546
Model number	
Serial number	
Rated current I_n	
Rated voltage V_n	
Auxiliary voltage V_x	

1.4 Test Equipment Used

This section should be completed to allow future identification of protective devices that have been commissioned using equipment that is later found to be defective or incompatible but may not be detected during the commissioning procedure.

Overcurrent test set	Model: Serial No:	
Injection test set	Model: Serial No:	
Phase angle meter	Model: Serial No:	
Phase rotation meter	Model: Serial No:	
Optical power meter	Model: Serial No:	
Insulation tester	Model: Serial No:	
Setting software:	Type: Version:	

1.5 Checklist



Have all relevant safety instructions been followed?

Yes	<input type="checkbox"/>	No	<input type="checkbox"/>
-----	--------------------------	----	--------------------------

Explanatory Notes

In the following pages you need to complete or delete the entries as appropriate.
 na or N/A means Not Applicable.
 nm or N/M means Not Measured.
 N/O means Normally Open and N/C means Normally Closed; and is shown in the relevant diagram in the Connection Diagrams chapter.
 The numbers in **bold** on the left-hand side represent the relevant Section number in the Commissioning chapter.

5.	PRODUCT CHECKS					
5.1	With the relay de-energized					
5.1.1	Visual inspection					
	Relay damaged?	Yes	<input type="checkbox"/>	No	<input type="checkbox"/>	
	Rating information correct for installation?	Yes	<input type="checkbox"/>	No	<input type="checkbox"/>	
	Case earth installed?	Yes	<input type="checkbox"/>	No	<input type="checkbox"/>	
5.1.2	Current transformer shorting contacts close?	Yes	<input type="checkbox"/>	No	<input type="checkbox"/>	N/M <input type="checkbox"/>
5.1.3	Insulation resistance >100 MΩ at 500 V dc	Yes	<input type="checkbox"/>	No	<input type="checkbox"/>	N/M <input type="checkbox"/>
5.1.4	External wiring					
	Wiring checked against diagram?	Yes	<input type="checkbox"/>	No	<input type="checkbox"/>	
	Test block connections checked?	Yes	<input type="checkbox"/>	No	<input type="checkbox"/>	N/A <input type="checkbox"/>
5.1.5	Watchdog Contacts (Auxiliary Supply Off)					
	Terminals 11 and 12	Contact closed?	Yes	<input type="checkbox"/>	No	<input type="checkbox"/>
		Contact resistance		Ω	N/M	<input type="checkbox"/>
	Terminals 13 and 14	Contact open?	Yes	<input type="checkbox"/>	No	<input type="checkbox"/>
5.1.6	Measured auxiliary supply				V ac/dc	
5.2	With the relay energized					
5.2.1	Watchdog contacts (auxiliary supply on)					
	Terminals 11 and 12	Contact open?	Yes	<input type="checkbox"/>	No	<input type="checkbox"/>
	Terminals 13 and 14	Contact closed?	Yes	<input type="checkbox"/>	No	<input type="checkbox"/>
		Contact resistance		Ω	N/M	<input type="checkbox"/>
5.2.2	LCD front panel display					
	LCD contrast setting used					
5.2.3	Date and Time					
	Clock set to local Time?	Yes	<input type="checkbox"/>	No	<input type="checkbox"/>	
	Time maintained when auxiliary supply removed?	Yes	<input type="checkbox"/>	No	<input type="checkbox"/>	
5.2.4	Light Emitting Diodes (LEDs)					
	Relay healthy (green) LED working?	Yes	<input type="checkbox"/>	No	<input type="checkbox"/>	
	Alarm (yellow) LED working?	Yes	<input type="checkbox"/>	No	<input type="checkbox"/>	

	Out of service (yellow) LED working?	Yes	<input type="checkbox"/>	No	<input type="checkbox"/>
	Trip (red) LED working?	Yes	<input type="checkbox"/>	No	<input type="checkbox"/>
	All programmable LEDs working? (may be 8 or 18 depending on the model)	Yes	<input type="checkbox"/>	No	<input type="checkbox"/>

5.2.5 Field Supply Voltage

5.2.6 Input opto-isolators (numbers vary depending on the product)

Opto input 1	Working?	Yes	<input type="checkbox"/>	No	<input type="checkbox"/>	
Opto input 2	Working?	Yes	<input type="checkbox"/>	No	<input type="checkbox"/>	
Opto input 3	Working?	Yes	<input type="checkbox"/>	No	<input type="checkbox"/>	
Opto input 4	Working?	Yes	<input type="checkbox"/>	No	<input type="checkbox"/>	
Opto input 5	Working?	Yes	<input type="checkbox"/>	No	<input type="checkbox"/>	
Opto input 6	Working?	Yes	<input type="checkbox"/>	No	<input type="checkbox"/>	
Opto input 7	Working?	Yes	<input type="checkbox"/>	No	<input type="checkbox"/>	
Opto input 8	Working?	Yes	<input type="checkbox"/>	No	<input type="checkbox"/>	
Opto input 9	Working?	Yes	<input type="checkbox"/>	No	<input type="checkbox"/>	
Opto input 10	Working?	Yes	<input type="checkbox"/>	No	<input type="checkbox"/>	
Opto input 11	Working?	Yes	<input type="checkbox"/>	No	<input type="checkbox"/>	
Opto input 12	Working?	Yes	<input type="checkbox"/>	No	<input type="checkbox"/>	
Opto input 13	Working?	Yes	<input type="checkbox"/>	No	<input type="checkbox"/>	
Opto input 14	Working?	Yes	<input type="checkbox"/>	No	<input type="checkbox"/>	
Opto input 15	Working?	Yes	<input type="checkbox"/>	No	<input type="checkbox"/>	
Opto input 16	Working?	Yes	<input type="checkbox"/>	No	<input type="checkbox"/>	
Opto input 17	Working?	Yes	<input type="checkbox"/>	No	<input type="checkbox"/>	N/A <input type="checkbox"/>
Opto input 18	Working?	Yes	<input type="checkbox"/>	No	<input type="checkbox"/>	N/A <input type="checkbox"/>
Opto input 19	Working?	Yes	<input type="checkbox"/>	No	<input type="checkbox"/>	N/A <input type="checkbox"/>
Opto input 20	Working?	Yes	<input type="checkbox"/>	No	<input type="checkbox"/>	N/A <input type="checkbox"/>
Opto input 21	Working?	Yes	<input type="checkbox"/>	No	<input type="checkbox"/>	N/A <input type="checkbox"/>
Opto input 22	Working?	Yes	<input type="checkbox"/>	No	<input type="checkbox"/>	N/A <input type="checkbox"/>
Opto input 23	Working?	Yes	<input type="checkbox"/>	No	<input type="checkbox"/>	N/A <input type="checkbox"/>
Opto input 24	Working?	Yes	<input type="checkbox"/>	No	<input type="checkbox"/>	N/A <input type="checkbox"/>
Opto input 25	Working?	Yes	<input type="checkbox"/>	No	<input type="checkbox"/>	N/A <input type="checkbox"/>
Opto input 26	Working?	Yes	<input type="checkbox"/>	No	<input type="checkbox"/>	N/A <input type="checkbox"/>
Opto input 27	Working?	Yes	<input type="checkbox"/>	No	<input type="checkbox"/>	N/A <input type="checkbox"/>
Opto input 28	Working?	Yes	<input type="checkbox"/>	No	<input type="checkbox"/>	N/A <input type="checkbox"/>
Opto input 29	Working?	Yes	<input type="checkbox"/>	No	<input type="checkbox"/>	N/A <input type="checkbox"/>
Opto input 30	Working?	Yes	<input type="checkbox"/>	No	<input type="checkbox"/>	N/A <input type="checkbox"/>
Opto input 31	Working?	Yes	<input type="checkbox"/>	No	<input type="checkbox"/>	N/A <input type="checkbox"/>
Opto input 32	Working?	Yes	<input type="checkbox"/>	No	<input type="checkbox"/>	N/A <input type="checkbox"/>

5.2.6 Input opto-isolators (numbers vary depending on the product)

Opto input 1	Working?	Yes	<input type="checkbox"/>	No	<input type="checkbox"/>	
Opto input 2	Working?	Yes	<input type="checkbox"/>	No	<input type="checkbox"/>	

	Opto input 3	Working?	Yes	<input type="checkbox"/>	No	<input type="checkbox"/>		
	Opto input 4	Working?	Yes	<input type="checkbox"/>	No	<input type="checkbox"/>		
	Opto input 5	Working?	Yes	<input type="checkbox"/>	No	<input type="checkbox"/>		
	Opto input 6	Working?	Yes	<input type="checkbox"/>	No	<input type="checkbox"/>		
	Opto input 7	Working?	Yes	<input type="checkbox"/>	No	<input type="checkbox"/>		
	Opto input 8	Working?	Yes	<input type="checkbox"/>	No	<input type="checkbox"/>		
	Opto input 9	Working?	Yes	<input type="checkbox"/>	No	<input type="checkbox"/>		
	Opto input 10	Working?	Yes	<input type="checkbox"/>	No	<input type="checkbox"/>		
	Opto input 11	Working?	Yes	<input type="checkbox"/>	No	<input type="checkbox"/>		
	Opto input 12	Working?	Yes	<input type="checkbox"/>	No	<input type="checkbox"/>		
	Opto input 13	Working?	Yes	<input type="checkbox"/>	No	<input type="checkbox"/>		
	Opto input 14	Working?	Yes	<input type="checkbox"/>	No	<input type="checkbox"/>		
	Opto input 15	Working?	Yes	<input type="checkbox"/>	No	<input type="checkbox"/>		
	Opto input 16	Working?	Yes	<input type="checkbox"/>	No	<input type="checkbox"/>		
	Opto input 17	Working?	Yes	<input type="checkbox"/>	No	<input type="checkbox"/>	N/A	<input type="checkbox"/>
	Opto input 18	Working?	Yes	<input type="checkbox"/>	No	<input type="checkbox"/>	N/A	<input type="checkbox"/>
	Opto input 19	Working?	Yes	<input type="checkbox"/>	No	<input type="checkbox"/>	N/A	<input type="checkbox"/>
	Opto input 20	Working?	Yes	<input type="checkbox"/>	No	<input type="checkbox"/>	N/A	<input type="checkbox"/>
	Opto input 21	Working?	Yes	<input type="checkbox"/>	No	<input type="checkbox"/>	N/A	<input type="checkbox"/>
	Opto input 22	Working?	Yes	<input type="checkbox"/>	No	<input type="checkbox"/>	N/A	<input type="checkbox"/>
	Opto input 23	Working?	Yes	<input type="checkbox"/>	No	<input type="checkbox"/>	N/A	<input type="checkbox"/>
	Opto input 24	Working?	Yes	<input type="checkbox"/>	No	<input type="checkbox"/>	N/A	<input type="checkbox"/>
	Opto input 25	Working?	Yes	<input type="checkbox"/>	No	<input type="checkbox"/>	N/A	<input type="checkbox"/>
	Opto input 26	Working?	Yes	<input type="checkbox"/>	No	<input type="checkbox"/>	N/A	<input type="checkbox"/>
	Opto input 27	Working?	Yes	<input type="checkbox"/>	No	<input type="checkbox"/>	N/A	<input type="checkbox"/>
	Opto input 28	Working?	Yes	<input type="checkbox"/>	No	<input type="checkbox"/>	N/A	<input type="checkbox"/>
	Opto input 29	Working?	Yes	<input type="checkbox"/>	No	<input type="checkbox"/>	N/A	<input type="checkbox"/>
	Opto input 30	Working?	Yes	<input type="checkbox"/>	No	<input type="checkbox"/>	N/A	<input type="checkbox"/>
	Opto input 31	Working?	Yes	<input type="checkbox"/>	No	<input type="checkbox"/>	N/A	<input type="checkbox"/>
	Opto input 32	Working?	Yes	<input type="checkbox"/>	No	<input type="checkbox"/>	N/A	<input type="checkbox"/>

5.2.7	Output Relays							
	Relay 1	working?	Yes	<input type="checkbox"/>	No	<input type="checkbox"/>	N/A	<input type="checkbox"/>
		Contact resistance		Ω	N/M	<input type="checkbox"/>		
	Relay 2	working?	Yes	<input type="checkbox"/>	No	<input type="checkbox"/>	N/A	<input type="checkbox"/>
		Contact resistance		Ω	N/M	<input type="checkbox"/>		
	Relay 3	working?	Yes	<input type="checkbox"/>	No	<input type="checkbox"/>	N/A	<input type="checkbox"/>
		Contact resistance		Ω	N/M	<input type="checkbox"/>		
	Relay 4	working?	Yes	<input type="checkbox"/>	No	<input type="checkbox"/>	N/A	<input type="checkbox"/>
		Contact resistance (N/C)		Ω	N/M	<input type="checkbox"/>		
		Contact resistance (N/O)		Ω	N/M	<input type="checkbox"/>		
	Relay 5	working?	Yes	<input type="checkbox"/>	No	<input type="checkbox"/>	N/A	<input type="checkbox"/>

		Contact resistance (N/C)		Ω	N/M	<input type="checkbox"/>	
		Contact resistance (N/O)		Ω	N/M	<input type="checkbox"/>	
	Relay 6	working?	Yes	<input type="checkbox"/>	No	<input type="checkbox"/>	N/A <input type="checkbox"/>
		Contact resistance (N/C)		Ω	N/M	<input type="checkbox"/>	
		Contact resistance (N/O)		Ω	N/M	<input type="checkbox"/>	
	Relay 7	working?	Yes	<input type="checkbox"/>	No	<input type="checkbox"/>	N/A <input type="checkbox"/>
		Contact resistance (N/C)		Ω	N/M	<input type="checkbox"/>	
		Contact resistance (N/O)		Ω	N/M	<input type="checkbox"/>	
	Relay 8	working?	Yes	<input type="checkbox"/>	No	<input type="checkbox"/>	N/A <input type="checkbox"/>
		Contact resistance (N/C)		Ω	N/M	<input type="checkbox"/>	
		Contact resistance (N/O)		Ω	N/M	<input type="checkbox"/>	
	Relay 9	working?	Yes	<input type="checkbox"/>	No	<input type="checkbox"/>	N/A <input type="checkbox"/>
		Contact resistance		W	N/M	<input type="checkbox"/>	
	Relay 10	working?	Yes	<input type="checkbox"/>	No	<input type="checkbox"/>	N/A <input type="checkbox"/>
		Contact resistance		W	N/M	<input type="checkbox"/>	
	Relay 11	working?	Yes	<input type="checkbox"/>	No	<input type="checkbox"/>	N/A <input type="checkbox"/>
		Contact resistance (N/C)		W	N/M	<input type="checkbox"/>	
		Contact resistance (N/O)		W	N/M	<input type="checkbox"/>	
	Relay 12	working?	Yes	<input type="checkbox"/>	No	<input type="checkbox"/>	N/A <input type="checkbox"/>
		Contact resistance (N/C)		W	N/M	<input type="checkbox"/>	
		Contact resistance (N/O)		W	N/M	<input type="checkbox"/>	
	Relay 13	working?	Yes	<input type="checkbox"/>	No	<input type="checkbox"/>	N/A <input type="checkbox"/>
		Contact resistance (N/C)		W	N/M	<input type="checkbox"/>	
		Contact resistance (N/O)		W	N/M	<input type="checkbox"/>	
	Relay 14	working?	Yes	<input type="checkbox"/>	No	<input type="checkbox"/>	N/A <input type="checkbox"/>
		Contact resistance (N/C)		W	N/M	<input type="checkbox"/>	
		Contact resistance (N/O)		W	N/M	<input type="checkbox"/>	
	Relay 15	working?	Yes	<input type="checkbox"/>	No	<input type="checkbox"/>	N/A <input type="checkbox"/>
		Contact resistance (N/C)		W	N/M	<input type="checkbox"/>	
		Contact resistance (N/O)		W	N/M	<input type="checkbox"/>	
	Relay 16	working?	Yes	<input type="checkbox"/>	No	<input type="checkbox"/>	N/A <input type="checkbox"/>
		Contact resistance (N/C)		W	N/M	<input type="checkbox"/>	
		Contact resistance (N/O)		W	N/M	<input type="checkbox"/>	
	Relay 17	working?	Yes	<input type="checkbox"/>	No	<input type="checkbox"/>	N/A <input type="checkbox"/>
		Contact resistance		W	N/M	<input type="checkbox"/>	
	Relay 18	working?	Yes	<input type="checkbox"/>	No	<input type="checkbox"/>	N/A <input type="checkbox"/>
		Contact resistance		W	N/M	<input type="checkbox"/>	
	Relay 19	working?	Yes	<input type="checkbox"/>	No	<input type="checkbox"/>	N/A <input type="checkbox"/>
		Contact resistance		W	N/M	<input type="checkbox"/>	
	Relay 20	working?	Yes	<input type="checkbox"/>	No	<input type="checkbox"/>	N/A <input type="checkbox"/>
		Contact resistance		W	N/M	<input type="checkbox"/>	

	Relay 21	working?	Yes	<input type="checkbox"/>	No	<input type="checkbox"/>	N/A	<input type="checkbox"/>
		Contact resistance		W	N/M	<input type="checkbox"/>		
	Relay 22	working?	Yes	<input type="checkbox"/>	No	<input type="checkbox"/>	N/A	<input type="checkbox"/>
		Contact resistance		W	N/M	<input type="checkbox"/>		
	Relay 23	working?	Yes	<input type="checkbox"/>	No	<input type="checkbox"/>	N/A	<input type="checkbox"/>
		Contact resistance (N/C)		W	N/M	<input type="checkbox"/>		
		Contact resistance (N/O)		W	N/M	<input type="checkbox"/>		
	Relay 24	working?	Yes	<input type="checkbox"/>	No	<input type="checkbox"/>	N/A	<input type="checkbox"/>
		Contact resistance (N/C)		W	N/M	<input type="checkbox"/>		
		Contact resistance (N/O)		W	N/M	<input type="checkbox"/>		
	Relay 25	working?	Yes	<input type="checkbox"/>	No	<input type="checkbox"/>	N/A	<input type="checkbox"/>
		Contact resistance		W	N/M	<input type="checkbox"/>		
	Relay 26	working?	Yes	<input type="checkbox"/>	No	<input type="checkbox"/>	N/A	<input type="checkbox"/>
		Contact resistance		W	N/M	<input type="checkbox"/>		
	Relay 27	working?	Yes	<input type="checkbox"/>	No	<input type="checkbox"/>	N/A	<input type="checkbox"/>
		Contact resistance		W	N/M	<input type="checkbox"/>		
	Relay 28	working?	Yes	<input type="checkbox"/>	No	<input type="checkbox"/>	N/A	<input type="checkbox"/>
		Contact resistance		W	N/M	<input type="checkbox"/>		
	Relay 29	working?	Yes	<input type="checkbox"/>	No	<input type="checkbox"/>	N/A	<input type="checkbox"/>
		Contact resistance		W	N/M	<input type="checkbox"/>		
	Relay 30	working?	Yes	<input type="checkbox"/>	No	<input type="checkbox"/>	N/A	<input type="checkbox"/>
		Contact resistance		W	N/M	<input type="checkbox"/>		
	Relay 31	working?	Yes	<input type="checkbox"/>	No	<input type="checkbox"/>	N/A	<input type="checkbox"/>
		Contact resistance (N/C)		W	N/M	<input type="checkbox"/>		
		Contact resistance (N/O)		W	N/M	<input type="checkbox"/>		
	Relay 32	working?	Yes	<input type="checkbox"/>	No	<input type="checkbox"/>	N/A	<input type="checkbox"/>
		Contact resistance (N/C)		W	N/M	<input type="checkbox"/>		
		Contact resistance (N/O)		W	N/M	<input type="checkbox"/>		
	High break Relay 8	External wiring polarity check?	Yes	<input type="checkbox"/>	No	<input type="checkbox"/>	N/A	<input type="checkbox"/>
	High break Relay 9	External wiring polarity check?	Yes	<input type="checkbox"/>	No	<input type="checkbox"/>	N/A	<input type="checkbox"/>
	High break Relay 10	External wiring polarity check?	Yes	<input type="checkbox"/>	No	<input type="checkbox"/>	N/A	<input type="checkbox"/>
	High break Relay 11	External wiring polarity check?	Yes	<input type="checkbox"/>	No	<input type="checkbox"/>	N/A	<input type="checkbox"/>
	High break Relay 17	External wiring polarity check?	Yes	<input type="checkbox"/>	No	<input type="checkbox"/>	N/A	<input type="checkbox"/>
	High break Relay 18	External wiring polarity check?	Yes	<input type="checkbox"/>	No	<input type="checkbox"/>	N/A	<input type="checkbox"/>
	High break Relay 19	External wiring polarity check?	Yes	<input type="checkbox"/>	No	<input type="checkbox"/>	N/A	<input type="checkbox"/>
	High break Relay 20	External wiring polarity check?	Yes	<input type="checkbox"/>	No	<input type="checkbox"/>	N/A	<input type="checkbox"/>
	High break Relay 21	External wiring polarity check?	Yes	<input type="checkbox"/>	No	<input type="checkbox"/>	N/A	<input type="checkbox"/>
	High break Relay 22	External wiring polarity check?	Yes	<input type="checkbox"/>	No	<input type="checkbox"/>	N/A	<input type="checkbox"/>
	High break Relay 23	External wiring polarity check?	Yes	<input type="checkbox"/>	No	<input type="checkbox"/>	N/A	<input type="checkbox"/>
	High break Relay 24	External wiring polarity check?	Yes	<input type="checkbox"/>	No	<input type="checkbox"/>	N/A	<input type="checkbox"/>
	High break Relay 9	External wiring polarity check?	Yes	<input type="checkbox"/>	No	<input type="checkbox"/>	N/A	<input type="checkbox"/>

	High break Relay 10	External wiring polarity check?	Yes	<input type="checkbox"/>	No	<input type="checkbox"/>	N/A	<input type="checkbox"/>
	High break Relay 11	External wiring polarity check?	Yes	<input type="checkbox"/>	No	<input type="checkbox"/>	N/A	<input type="checkbox"/>
	High break Relay 12	External wiring polarity check?	Yes	<input type="checkbox"/>	No	<input type="checkbox"/>	N/A	<input type="checkbox"/>
	High break Relay 13	External wiring polarity check?	Yes	<input type="checkbox"/>	No	<input type="checkbox"/>	N/A	<input type="checkbox"/>
	High break Relay 14	External wiring polarity check?	Yes	<input type="checkbox"/>	No	<input type="checkbox"/>	N/A	<input type="checkbox"/>
	High break Relay 15	External wiring polarity check?	Yes	<input type="checkbox"/>	No	<input type="checkbox"/>	N/A	<input type="checkbox"/>
	High break Relay 16	External wiring polarity check?	Yes	<input type="checkbox"/>	No	<input type="checkbox"/>	N/A	<input type="checkbox"/>
	High break Relay 17	External wiring polarity check?	Yes	<input type="checkbox"/>	No	<input type="checkbox"/>	N/A	<input type="checkbox"/>
	High break Relay 18	External wiring polarity check?	Yes	<input type="checkbox"/>	No	<input type="checkbox"/>	N/A	<input type="checkbox"/>
	High break Relay 19	External wiring polarity check?	Yes	<input type="checkbox"/>	No	<input type="checkbox"/>	N/A	<input type="checkbox"/>
	High break Relay 20	External wiring polarity check?	Yes	<input type="checkbox"/>	No	<input type="checkbox"/>	N/A	<input type="checkbox"/>

Current Inputs							
	Displayed Current		Primary	<input type="checkbox"/>	Secondary	<input type="checkbox"/>	
	Earth Fault CT Ratio	$\frac{[E/F CT Primary]}{[E/F CT Sec'y]}$		A	N/A	<input type="checkbox"/>	

	Input CT	Applied Value	Displayed Value
--	----------	---------------	-----------------

5.2.14	Voltage Inputs						
	Displayed Voltage		Primary	<input type="checkbox"/>	Secondary	<input type="checkbox"/>	
	Main VT Ratio	$\frac{[Main VT Primary]}{[Main VT Sec'y]}$		V	N/A	<input type="checkbox"/>	
	VN VT Ratio	$\frac{[VN VT Primary]}{[VN VT Secondary]}$		V	N/A	<input type="checkbox"/>	
	VN2 VTRatio	$\frac{[VN2 VT Primary]}{[VN2 VT Secondary]}$		V	N/A	<input type="checkbox"/>	
	C/S VT Ratio	$\frac{[C/S VT Prim'y]}{[C/S VT Sec'y]}$		V	N/A	<input type="checkbox"/>	

	Input VT	Applied Value	Displayed Value
	VN2 (P344/P345 only)	V N/A <input type="checkbox"/>	V
	C/S Voltage (P345 only)	V N/A <input type="checkbox"/>	V

6.	Protection Communications Loopback							
6.1	Protection Communications							
6.1.1	Loopback Mode set to External?	Yes	<input type="checkbox"/>	No	<input type="checkbox"/>			
6.1.1.1	Channel 1 transmit power level	.		dBm	N/A	<input type="checkbox"/>		
6.1.1.2	Channel 1 transmit power level	.		dBm	N/A	<input type="checkbox"/>		
6.1.2	Loopback Communications Configuration							
	Type of fiber optic connection for channel 1	Direct	<input type="checkbox"/>	C37.94	<input type="checkbox"/>	N/A	<input type="checkbox"/>	
		P-2M-L	<input type="checkbox"/>		<input type="checkbox"/>		<input type="checkbox"/>	
	Fiber connections made with P-2M-L unit on Ch 1?	Yes	<input type="checkbox"/>	N/A	<input type="checkbox"/>			
	Type of fiber optic connection for channel 2	Direct	<input type="checkbox"/>	C37.94	<input type="checkbox"/>	N/A	<input type="checkbox"/>	
		P-2M-L	<input type="checkbox"/>		<input type="checkbox"/>		<input type="checkbox"/>	
	Fiber connections made with P-2M-L unit on Ch 2?	Yes	<input type="checkbox"/>	N/A	<input type="checkbox"/>			
6.2.3	Fiber loopback connection made for 'Direct' or 'C37.94' on Ch 1?	Yes	<input type="checkbox"/>	N/A	<input type="checkbox"/>			
	Fiber loopback connection made for 'Direct' or 'C37.94' on Ch 2?	Yes	<input type="checkbox"/>	N/A	<input type="checkbox"/>			
6.2.n	Communications using P-2M-L units: n=4 for P-2M-L Apply to MiCOM Ch1 and/or Ch2 as appropriate							
6.2.n.1	Visual inspection (P-2M-L units only) Ch1							
	Ch 1 unit damaged?	Yes	<input type="checkbox"/>	No	<input type="checkbox"/>	N/A	<input type="checkbox"/>	
	Ch 1 rating information correct?	Yes	<input type="checkbox"/>	No	<input type="checkbox"/>	N/A	<input type="checkbox"/>	
	Ch 1 earthed?	Yes	<input type="checkbox"/>	No	<input type="checkbox"/>	N/A	<input type="checkbox"/>	
6.2.n.2	Insulation resistance (P-2M-L units only)							
	Ch 1 unit	Yes	<input type="checkbox"/>	No	<input type="checkbox"/>	N/T	<input type="checkbox"/>	N/A <input type="checkbox"/>
6.2.n.3	External wiring (P-2M-L units only)							
	Ch 1 unit checked against diagram?	Yes	<input type="checkbox"/>	No	<input type="checkbox"/>	N/A	<input type="checkbox"/>	
6.2.n.4	Measured auxiliary supply (P-2M-L units only)							
	Ch 1 unit				V dc/ac	N/A	<input type="checkbox"/>	
6.2.n.5	Light emitting diodes (P-2M-L units only)							
	Ch 1 unit LEDs working?	Yes	<input type="checkbox"/>	No	<input type="checkbox"/>	N/A	<input type="checkbox"/>	
6.2.n.6	P-2M-L optical received signal level							
	Signal strength received by P-2M-L connected to Ch 1				dBm	N/A	<input type="checkbox"/>	
6.2.n.7	P-2M-L loopback configured?							
	Signal strength received by P-2M-L connected to Ch 1				dBm	N/A	<input type="checkbox"/>	
6.2.n.8	Signal strength transmitted by P-2M-L on Ch 1							
					dBm	N/A	<input type="checkbox"/>	
6.2.n.9	MiCOM optical received signal level Ch 1 from P-2M-L							
					dBm	N/A	<input type="checkbox"/>	
6.2.n.1	Visual inspection (P-2M-L units only) Ch2							
	Ch 2 unit damaged?	Yes	<input type="checkbox"/>	No	<input type="checkbox"/>	N/A	<input type="checkbox"/>	
	Ch 2 rating information correct?	Yes	<input type="checkbox"/>	No	<input type="checkbox"/>	N/A	<input type="checkbox"/>	
	Ch 2 earthed?	Yes	<input type="checkbox"/>	No	<input type="checkbox"/>	N/A	<input type="checkbox"/>	
6.2.n.2	Insulation resistance (P-2M-L units only)							

	Ch 2 unit	Yes	<input type="checkbox"/>	No	<input type="checkbox"/>	N/T	<input type="checkbox"/>	N/A	<input type="checkbox"/>
6.2.n.3	External wiring (P-2M-L units only)								
	Ch 2 unit checked against diagram?	Yes	<input type="checkbox"/>	No	<input type="checkbox"/>	N/A	<input type="checkbox"/>		<input type="checkbox"/>
6.2.n.4	Measured auxiliary supply P-2M-L units only)								
	Ch 2 unit					V dc/ac	N/A		<input type="checkbox"/>
6.2.n.5	Light emitting diodes (P-2M-L units only)								
	Ch 2 unit LEDs working?	Yes	<input type="checkbox"/>	No	<input type="checkbox"/>	N/A	<input type="checkbox"/>		<input type="checkbox"/>
6.2.n.6	P-2M-L optical received signal level								
	Signal strength received by P-2M-L connected to Ch 2					dBm	N/A		<input type="checkbox"/>
6.2.n.7	P-2M-L loopback configured?	Yes	<input type="checkbox"/>			dBm	N/A		<input type="checkbox"/>
	Signal strength received by P-2M-L connected to Ch 2					dBm	N/A		<input type="checkbox"/>
6.2.n.8	Signal strength transmitted by P-2M-L on Ch 2					dBm	N/A		<input type="checkbox"/>
6.2.n.9	MiCOM optical received signal level Ch 2 from P-2M-L					dBm	N/A		<input type="checkbox"/>
6.2.7	IM64 loopback test								
	IM64 test pattern set								
	IM64 Rx status observed								

7.		GPS Synchronization				
7.1.1	GPS synchronization device commissioned?	Yes	<input type="checkbox"/>	N/A	<input type="checkbox"/>	
7.1.2	GPS synchronization device optical signal strength at P54x relay		dBm	N/A	<input type="checkbox"/>	
7.1.3	Check synchronization signal at P54x relay	Yes	<input type="checkbox"/>	N/A	<input type="checkbox"/>	
	Bit pattern **11***** ?					
7.1.4	Check GPS Failure Condition	Bit pattern **00***** ?	Yes	<input type="checkbox"/>	N/A	<input type="checkbox"/>
7.1.5	Restore GPS	Bit pattern **11***** ?	Yes	<input type="checkbox"/>	N/A	<input type="checkbox"/>

8.	SETTING CHECKS						
8.1	Application-specific function settings applied?	Yes	<input type="checkbox"/>	No	<input type="checkbox"/>		
	Application-specific Programmable Scheme Logic (PSL) settings applied?	Yes	<input type="checkbox"/>	No	<input type="checkbox"/>	N/A	<input type="checkbox"/>
	Relay power-off and on if IM64 Comms Mode changed?	Yes	<input type="checkbox"/>	N/A	<input type="checkbox"/>		
8.1.1	Loopback Mode and Test Pattern configured?	Yes	<input type="checkbox"/>	N/A	<input type="checkbox"/>		
8.1.2	Communications statistics reset?	Yes	<input type="checkbox"/>	N/A	<input type="checkbox"/>		
8.3	Testing the current differential protection						
8.3.1.1	Elements to be re-enabled after testing (mark any that have been temporarily disabled)	Distance	<input type="checkbox"/>				
		Earth Fault	<input type="checkbox"/>				
		Overcurrent	<input type="checkbox"/>				
		DEF	<input type="checkbox"/>				
		CB Fail	<input type="checkbox"/>				
		N/A	<input type="checkbox"/>				
8.3.1.2	Current Differential lower slope pickup						A
8.3.1.3	Current Differential upper slope pickup						A
8.3.2.1	Current Differential Phase A Contact Routing OK?	Yes	<input type="checkbox"/>	No	<input type="checkbox"/>		
	Current Differential Phase A Trip Time						s
8.3.2.2	Current Differential Phase B Contact Routing OK?	Yes	<input type="checkbox"/>	No	<input type="checkbox"/>		
	Current Differential Phase B Trip Time						s
8.3.2.3	Current Differential Phase C Contact Routing OK?	Yes	<input type="checkbox"/>	No	<input type="checkbox"/>		
	Current Differential Phase C Trip Time						s
	Average Trip Time, Phases A, B and C						s
8.4.1	Protection dependencies noted and preparations made?	Yes	<input type="checkbox"/>	N/A	<input type="checkbox"/>		
8.4.2	Injection testing - distance zones						
8.4.2.1	Elements to be re-enabled after testing (mark any that have been temporarily disabled)	Earth Fault	<input type="checkbox"/>				
		Overcurrent	<input type="checkbox"/>				
		DEF	<input type="checkbox"/>				
		CB Fail	<input type="checkbox"/>				
		N/A	<input type="checkbox"/>				
8.4.2.2	Zone 1 reach check - impedance at trip			Ω	N/M	<input type="checkbox"/>	
8.4.2.3	Zone 2 reach check - impedance at trip			Ω	N/M	<input type="checkbox"/>	
8.4.2.4	Zone 3 reach check - impedance at trip			Ω	N/M	<input type="checkbox"/>	
8.4.2.5	Zone 4 reach check - impedance at trip			Ω	N/M	<input type="checkbox"/>	
8.4.2.6	Zone P reach check - impedance at trip			Ω	N/M	<input type="checkbox"/>	
8.4.2.7	Resistive reach						
	Visual inspection						
	Phase & ground element resistive reach settings are correct?	Yes	<input type="checkbox"/>	No	<input type="checkbox"/>		
8.4.2.8	Load Blinder						
	Visual inspection						
	Load blinder settings are correct?	Yes	<input type="checkbox"/>	No	<input type="checkbox"/>	N/A	<input type="checkbox"/>
	Load blinder angle applied	Yes	<input type="checkbox"/>	No	<input type="checkbox"/>	N/A	<input type="checkbox"/>

8.4.3.1	Distance Phase A Contact Routing OK?	Yes	<input type="checkbox"/>	No	<input type="checkbox"/>
	Distance Phase A trip time		ms		
8.4.3.2	Distance Phase B Contact Routing OK?	Yes	<input type="checkbox"/>	No	<input type="checkbox"/>
	Distance Phase B trip time		ms		
8.4.3.3	Distance Phase C Contact Routing OK?	Yes	<input type="checkbox"/>	No	<input type="checkbox"/>
	Distance Phase C trip time		ms		
	Average trip time, phases A, B and C		ms		
8.4.3.4	Time delay settings tZ1 Ph, and tZ2 - tZ4				
	Visual inspection				
	Time delay settings are correct?	Yes	<input type="checkbox"/>	No	<input type="checkbox"/>
8.4.4	Distance protection scheme testing				
8.4.4.1	Scheme trip zone 1 extension scheme				
	No trip for fault with reset Z1X energized	Yes	<input type="checkbox"/>	No	<input type="checkbox"/>
8.4.4.2	Trip time with reset Z1X de-energized		ms		
	Scheme trip permissive schemes (PUR/POR)				
8.4.4.3	Trip time with signal receive energized	Yes	<input type="checkbox"/>	No	<input type="checkbox"/>
	Scheme trip blocking scheme				
	No trip for fault with signal receive energized	Yes	<input type="checkbox"/>	No	<input type="checkbox"/>
	Trip time with signal receive de-energized		ms		
8.4.4.4	Signal send test for permissive schemes				
	Signal send operate time		ms		
8.4.4.5	Signal send blocking schemes				
	Signal send operate time		ms		
8.4.5	Scheme timer settings				
	Visual inspection				
	Time delays settings are correct?	Yes	<input type="checkbox"/>	No	<input type="checkbox"/>
	All disabled elements which were noted/circled previously are restored?	Yes	<input type="checkbox"/>	No	<input type="checkbox"/>
8.4.6	Delta directional comparison				
	Elements to be re-enabled after testing (mark any that have been temporarily disabled)	Current Diff	<input type="checkbox"/>		
		Distance	<input type="checkbox"/>		
		Earth Fault	<input type="checkbox"/>		
		Overcurrent	<input type="checkbox"/>		
		CB Fail	<input type="checkbox"/>		
		N/A	<input type="checkbox"/>		
8.4.7.1	Directional comparison protection Phase A contact routing OK?	Yes	<input type="checkbox"/>	No	<input type="checkbox"/>
	Directional comparison protection Phase A trip time		ms		
8.4.7.2	Directional comparison protection Phase B contact routing OK?	Yes	<input type="checkbox"/>	No	<input type="checkbox"/>
	Directional comparison protection Phase B trip time		ms		
8.4.7.3	Directional comparison protection Phase C contact routing OK?	Yes	<input type="checkbox"/>	No	<input type="checkbox"/>
	Directional comparison protection phase C trip time		ms		
	Average trip time, phases A, B and C		ms		

8.4.8.1	Signal send test for permissive schemes					
	Signal send operate time					ms
8.4.8.2	Signal send blocking schemes					
	Signal send operate time					ms
	All disabled elements which were noted/circled previously are restored?		Yes	<input type="checkbox"/>	No	<input type="checkbox"/>
8.4.9	Out-Of-Step(OST) Protection?					
8.4.9.1	Predictive OST	Enabled	<input type="checkbox"/>	N/A	<input type="checkbox"/>	
	Operated correctly?	Yes	<input type="checkbox"/>	No	<input type="checkbox"/>	
	Operating time					ms
8.4.9.2	OST	Enabled	<input type="checkbox"/>	N/A	<input type="checkbox"/>	
	Operated correctly?	Yes	<input type="checkbox"/>	No	<input type="checkbox"/>	
	Operating time					ms
8.4.9.3	Predictive and OST	Enabled	<input type="checkbox"/>	N/A	<input type="checkbox"/>	
	Operated correctly?	Yes	<input type="checkbox"/>	No	<input type="checkbox"/>	
	Operating time					ms
8.4.9.4	TOST Timer text					
	Trip time					ms
8.4.10	Injection testing - DEF Aided Scheme					
	Elements to be re-enabled after testing (mark any that have been temporarily disabled)		Current Diff	<input type="checkbox"/>		
			Distance	<input type="checkbox"/>		
			Earth Fault	<input type="checkbox"/>		
			Overcurrent	<input type="checkbox"/>		
			CB Fail	<input type="checkbox"/>		
			N/A	<input type="checkbox"/>		
8.4.10.2	DEF aided scheme trip time					ms
8.4.11.1	DEF signal send time permissive scheme					ms
8.4.11.2	DEF signal send time blocking scheme					ms
	All disabled elements which were noted/circled previously are restored?		Yes	<input type="checkbox"/>	No	<input type="checkbox"/>
8.4.12	Back-up phase overcurrent protection					
	Elements to be re-enabled after testing (mark any that have been temporarily disabled)		Current Diff	<input type="checkbox"/>		
			Distance	<input type="checkbox"/>		
			Earth Fault	<input type="checkbox"/>		
			DEF	<input type="checkbox"/>		
			CB Fail	<input type="checkbox"/>		
			N/A	<input type="checkbox"/>		
	Overcurrent type (set in call [$I > 1$ Direction])	Directional	<input type="checkbox"/>	Non-Directional	<input type="checkbox"/>	
	Applied Voltage					V/N/A
	Applied Current					A
	Expected Operating Time					s

8.4.12.3	Measured Operating Time							s
	All disabled elements which were noted/circled previously are restored?	Yes	<input type="checkbox"/>	No	<input type="checkbox"/>			<input type="checkbox"/>
8.4.12.4	Restore Communications and clear VTS?	Yes	<input type="checkbox"/>	N/A				<input type="checkbox"/>
8.5	Trip and auto-reclose cycle checked?							
	3 pole cycle tested?	Yes	<input type="checkbox"/>	No	<input type="checkbox"/>	N/A	<input type="checkbox"/>	<input type="checkbox"/>
	Pole A cycle tested?	Yes	<input type="checkbox"/>	No	<input type="checkbox"/>	N/A	<input type="checkbox"/>	<input type="checkbox"/>
	Pole B cycle tested?	Yes	<input type="checkbox"/>	No	<input type="checkbox"/>	N/A	<input type="checkbox"/>	<input type="checkbox"/>
	Pole C cycle tested?	Yes	<input type="checkbox"/>	No	<input type="checkbox"/>	N/A	<input type="checkbox"/>	<input type="checkbox"/>

9.1	Communication Alarm Check						
	Any Ch1 communication alarm?	Yes	<input type="checkbox"/>	No	<input type="checkbox"/>		
	Any Ch2 communication alarm?	Yes	<input type="checkbox"/>	No	<input type="checkbox"/>	N/A	<input type="checkbox"/>
9.1.1	Restore Communication Channels						
9.1.1.1	Direct fiber connection						
	Optical received signal level Ch 1			dBm	N/A		<input type="checkbox"/>
	Optical received signal level Ch 2			dBm	N/A		<input type="checkbox"/>
9.1.1.2	Fiber connections to C37.94						
	Optical received signal level from C37.94 Ch 1			dBm	N/A		<input type="checkbox"/>
	Optical received signal level at C37.94 Ch 1			dBm	N/A		<input type="checkbox"/>
	Optical received signal level from C37.94 Ch 1			dBm	N/A		<input type="checkbox"/>
	Optical received signal level at C37.94 Ch			dBm	N/A		<input type="checkbox"/>
9.1.1 - 9.1.4	All local connections restored?						
	Local Ch 1	Yes	<input type="checkbox"/>	No	<input type="checkbox"/>		
	Local Ch 2	Yes	<input type="checkbox"/>	No	<input type="checkbox"/>	N/A	<input type="checkbox"/>
	Cover replaced? (GPS synchronization device only)						
	Local Ch 1	Yes	<input type="checkbox"/>	No	<input type="checkbox"/>	N/A	<input type="checkbox"/>
	Local Ch 2	Yes	<input type="checkbox"/>	No	<input type="checkbox"/>	N/A	<input type="checkbox"/>
9.2.1	All connections restored at relay connected to Ch1?	Yes	<input type="checkbox"/>	No	<input type="checkbox"/>	N/A	<input type="checkbox"/>
9.2.2	All connections restored at relay connected to Ch2?	Yes	<input type="checkbox"/>	No	<input type="checkbox"/>	N/A	<input type="checkbox"/>
9.3	Verify communications between relays						
	Alarms reset?	Yes	<input type="checkbox"/>	No	<input type="checkbox"/>		<input type="checkbox"/>
	Ch 1 propagation time delay						ms
	Ch 2 propagation time delay				ms	N/A	<input type="checkbox"/>
	Channel 1 valid message incrementing and errored messages zero?						
	Channel 2 valid message incrementing and errored messages zero?						
	Statistics reset at (time)	HH:MM:SS					
	Statistics measured at (reset time + 1 hr minimum)	HH:MM:SS					
	Statistics measurements						
	Ch 1 No. valid messages	No	<input type="checkbox"/>	N/A			<input type="checkbox"/>
	Ch 1 No. err messages	No	<input type="checkbox"/>	N/A			<input type="checkbox"/>
	Ch 1 errored/valid	No	<input type="checkbox"/>	N/A			<input type="checkbox"/>
	Ch 1 errored/valid < 10 ⁻⁴	No	<input type="checkbox"/>	N/A			<input type="checkbox"/>
	Ch 2 No. valid messages	No	<input type="checkbox"/>	N/A			<input type="checkbox"/>
	Ch 2 No. err messages	No	<input type="checkbox"/>	N/A			<input type="checkbox"/>
	Ch 2 errored/valid>	No	<input type="checkbox"/>	N/A			<input type="checkbox"/>
	Ch 2 errored/valid < 10 ⁻⁴	No	<input type="checkbox"/>	N/A			<input type="checkbox"/>

END-TO-END SCHEME TESTS						
Signaling channel check						
Aided scheme 1 signaling channel test						
Local - remote end signal received	Yes	<input type="checkbox"/>	No	<input type="checkbox"/>	N/A	<input type="checkbox"/>
Remote - local end signal received	Yes	<input type="checkbox"/>	No	<input type="checkbox"/>	N/A	<input type="checkbox"/>
Aided scheme 2 signaling channel test						
Local - remote end signal received	Yes	<input type="checkbox"/>	No	<input type="checkbox"/>	N/A	<input type="checkbox"/>
Remote - local end signal received	Yes	<input type="checkbox"/>	No	<input type="checkbox"/>	N/A	<input type="checkbox"/>

10.	MODEM InterMiCOM Scheme Testing
	If applicable, provide details of scheme tests undertaken and results obtained.

ON-LOAD CHECKS						
Test wiring removed?	Yes	<input type="checkbox"/>	No	<input type="checkbox"/>		
Voltage inputs and phase rotation OK?	Yes	<input type="checkbox"/>	No	<input type="checkbox"/>		
Current inputs and polarities OK?	Yes	<input type="checkbox"/>	No	<input type="checkbox"/>		
Capacitive Charging Current Checked??	Yes	<input type="checkbox"/>	No	<input type="checkbox"/>	N/A	<input type="checkbox"/>
CT Polarity Consistency Checked??	Yes	<input type="checkbox"/>	No	<input type="checkbox"/>	N/A	<input type="checkbox"/>
On-load test performed? (If "No", give reason why) ...	Yes	<input type="checkbox"/>	No	<input type="checkbox"/>		
Relay is correctly directionalized?	Yes	<input type="checkbox"/>	No	<input type="checkbox"/>	N/A	<input type="checkbox"/>
Signaling channel check	Yes	<input type="checkbox"/>	Tested in	<input type="checkbox"/>	N/A	<input type="checkbox"/>

1.6 Engineer Details

COMMENTS #
(# Optional, for site observations or utility-specific notes).

Commissioning Engineer:
Date:

Customer Witness:
Date:

2. CREATING A SETTING RECORD

You often need to create a record of what settings have been applied to a device. In the past, you could have used paper printouts of all the available settings, and mark up the ones you had used. Keeping such a paper-based Settings Records can be time consuming and prone to error (e.g. due to being settings written down incorrectly).

The Easergy Studio software lets you read/write MiCOM devices.

- **Extract** lets you download all the settings from a MiCOM Px40 device. A summary is given in Extract Settings from a MiCOM Px40 Device below.
- **Send** lets you send the settings you currently have open in the Easergy Studio software. A summary is given in Send Settings to a MiCOM Px40 Device below.

The Easergy Studio product is updated periodically. These updates provide support for new features (such as allowing you to manage new MiCOM products, as well as using new software releases and hardware suffixes). The updates may also include fixes.

Accordingly, we strongly advise customers to use the latest Schneider Electric version of Easergy Studio.

In most cases, it will be quicker and less error prone to extract settings electronically and store them in a settings file on a memory stick. In this way, there will be a digital record which is certain to be accurate. It is also possible to archive these settings files in a repository; so they can be used again or adapted for another use.

Full details of how to do these tasks is provided in the Easergy Studio help.

A quick summary of the main steps is given below. In each case you need to make sure that:

- Your computer includes the Easergy Studio software.
- Your computer and the MiCOM device are powered on.
- You have used a suitable cable to connect your computer to the MiCOM device (Front Port, Rear Port, Ethernet port or Modem as available).

2.1 Extract Settings from a MiCOM Px40 Device

Full details of how to do this is provided in the Easergy Studio help.

As a quick guide, you need to do the following:

1. In **Easergy Studio**, click the **Quick Connect...** button.
2. Select the relevant **Device Type** in the **Quick Connect** dialog box.
3. Click the relevant **port** in the **Port Selection** dialog box.
4. Enter the relevant **connection parameters** in the **Connection Parameters** dialog box and click the **Finish** button
5. Easergy Studio will try to communicate with the Px40 device. It will display a **Connected** message if the connection attempt is successful.
6. The **device** will appear in the Studio Explorer pane on the top-left of the interface.
7. Click the **+** button to expand the **options** for the device, then click on the **Settings** folder.
8. Right-click on **Settings** and select the **Extract Settings** link to read the settings on the device and store them on your computer or a memory stick.
9. After retrieving the settings file, close the dialog box by clicking the **Close** button.

2.2 Send Settings to a MiCOM Px40 Device

Full details of how to do this is provided in the Easergy Studio help.

As a quick guide, you need to do the following:

1. In **Easergy Studio**, click the **Quick Connect...** button.
2. Select the relevant **Device Type** in the **Quick Connect** dialog box.
3. Click the relevant **port** in the **Port Selection** dialog box.
4. Enter the relevant **connection parameters** in the **Connection Parameters** dialog box and click the **Finish** button
5. Easergy Studio will try to communicate with the Px40 device. It will display a **connected** message if the connection attempt is successful.
6. The device will appear in the Studio Explorer pane on the top-left hand side of the interface.
7. Click the **+** button to **expand** the options for the device and then right-click on the **Settings** link.
8. To **add** an existing file, right-click the **settings** folder and choose **Add Existing File**.
9. To **create** a new file, right-click the **settings** folder and select **Add**. A file with the next sequential number will be created. **Double-click the file to edit**.
10. Right-click on the **device name** and select the **Send** link.

Note

When you send settings to a MiCOM Px40 device, the data is stored in a temporary location at first. This temporary data is tested to make sure it is complete. If the temporary data is complete, it will be programmed into the MiCOM Px40 device. This avoids the risk of a device being programmed with incomplete or corrupt settings.

11. In the **Send To** dialog box, select the **settings file(s)** you wish to send, then click the **Send** button.
12. Close the **Send To dialog box** by clicking the **Close** button.

Notes:

MAINTENANCE

CHAPTER 13

Chapter Applicability	
Date:	09/2016
Products covered by this chapter:	
This chapter covers the specific versions of the MiCOM products listed below. This includes only the following combinations of Software Version and Hardware Suffix.	
Hardware Suffix:	All MiCOM Px4x products
Software Version:	All MiCOM Px4x products
Connection Diagrams:	This chapter may use any of these connection diagrams:
P14x (P141, P142, P143 & P145):	10P141xx (xx = 01 to 02) 10P142xx (xx = 01 to 05) 10P143xx (xx = 01 to 11) 10P145xx (xx = 01 to 11)
P24x (P241, P242 & P243):	10P241xx (xx = 01 to 02) 10P242xx (xx = 01) 10P243xx (xx = 01)
P34x (P342, P343, P344, P345 & P391):	10P342xx (xx = 01 to 17) 10P343xx (xx = 01 to 19) 10P344xx (xx = 01 to 12) 10P345xx (xx = 01 to 07) 10P391xx (xx = 01 to 02)
P445:	10P445xx (xx = 01 to 04)
P44x (P442 & P444):	10P44101 (SH 1 & 2) 10P44201 (SH 1 & 2) 10P44202 (SH 1) 10P44203 (SH 1 & 2) 10P44401 (SH 1) 10P44402 (SH 1) 10P44403 (SH 1 & 2) 10P44404 (SH 1) 10P44405 (SH 1) 10P44407 (SH 1 & 2)
P44y (P443 & P446):	10P44303 (SH 01 and 03) 10P44304 (SH 01 and 03) 10P44305 (SH 01 and 03) 10P44306 (SH 01 and 03) 10P44600 10P44601 (SH 1 to 2) 10P44602 (SH 1 to 2) 10P44603 (SH 1 to 2)
P54x (P543, P544, P545 & P546):	10P54302 (SH 1 to 2) 10P54303 (SH 1 to 2) 10P54400 10P54404 (SH 1 to 2) 10P54405 (SH 1 to 2) 10P54502 (SH 1 to 2) 10P54503 (SH 1 to 2) 10P54600 10P54604 (SH 1 to 2)

	10P54605 (SH 1 to 2) 10P54606 (SH 1 to 2)
P547:	10P54702xx (xx = 01 to 02) 10P54703xx (xx = 01 to 02) 10P54704xx (xx = 01 to 02) 10P54705xx (xx = 01 to 02)
P64x (P642, P643 & P645):	10P642xx (xx = 1 to 10) 10P643xx (xx = 1 to 6) 10P645xx (xx = 1 to 9)
P74x (P741, P742 & P743):	10P740xx (xx = 01 to 07)
P746:	10P746xx (xx = 00 to 21)
P841:	10P84100 10P84101 (SH 1 to 2) 10P84102 (SH 1 to 2) 10P84103 (SH 1 to 2) 10P84104 (SH 1 to 2) 10P84105 (SH 1 to 2)
P849:	10P849xx (xx = 01 to 06)

Notes:

CONTENTS

1. Maintenance Period	7
2. Maintenance Checks	8
2.1 Alarms.....	8
2.2 Opto-Isolators.....	8
2.3 Output Relays.....	8
2.4 Measurement Accuracy.....	8
3. Method of Repair	9
3.1 Replacing the Complete Equipment IED/Relay.....	9
3.2 Replacing a PCB.....	10
4. Re-Calibration	11
5. Changing the Battery	12
5.1 Instructions for Replacing the Battery.....	12
5.2 Post Modification Tests.....	12
5.3 Battery Disposal.....	12
6. Cleaning	13

Notes:

1. MAINTENANCE PERIOD



Warning

Before inspecting any wiring, performing any tests or carrying out any work on the equipment, you should be familiar with the contents of the Safety Information and Technical Data sections and the information on the equipment's rating label.

It is recommended that products supplied by Schneider Electric receive periodic monitoring after installation. In view of the critical nature of protective and control equipment, and their infrequent operation, it is desirable to confirm that they are operating correctly at regular intervals.

Schneider Electric protection and control equipment is designed for a life in excess of 20 years.

MiCOM relays are self-supervising and so require less maintenance than earlier designs. Most problems will result in an alarm so that remedial action can be taken. However, some periodic tests should be done to ensure that the equipment is functioning correctly and the external wiring is intact.

If the customer's organization has a preventative maintenance policy, the recommended product checks should be included in the regular program. Maintenance periods depend on many factors, such as:

- The operating environment
- The accessibility of the site
- The amount of available manpower
- The importance of the installation in the power system
- The consequences of failure

2. MAINTENANCE CHECKS

Although some functionality checks can be performed from a remote location by using the communications ability of the equipment, these are predominantly restricted to checking that the equipment, is measuring the applied currents and voltages accurately, and checking the circuit breaker maintenance counters. Therefore, it is recommended that maintenance checks are performed locally (i.e. at the equipment itself).

**Warning**

Before carrying out any work on the equipment, you should be familiar with the contents of the Safety Information chapter/Safety Guide SFTY/5L M/L11 or later issue, the Technical Data chapter and the ratings on the equipment rating label.

**Warning**

If a P391 is used, you should also be familiar with the ratings and warning statements in the P391 technical manual.

2.1 Alarms

The alarm status LED should first be checked to identify if any alarm conditions exist. If so, press the read key (Ⓜ) repeatedly to step through the alarms.

Clear the alarms to extinguish the LED.

2.2 Opto-Isolators

The opto-isolated inputs can be checked to ensure that the equipment responds to energization by repeating the commissioning test detailed in the Commissioning chapter.

2.3 Output Relays

The output relays can be checked to ensure that they operate by repeating the commissioning test detailed in the Commissioning chapter.

2.4 Measurement Accuracy

If the power system is energized, the values measured by the equipment can be compared with known system values to check that they are in the approximate range that is expected. If they are, the analog/digital conversion and calculations are being performed correctly by the relay. Suitable test methods can be found in the Commissioning chapter.

Alternatively, the values measured by the equipment can be checked against known values injected via the test block, if fitted, or injected directly into the equipment terminals. Suitable test methods can be found in the Commissioning chapter. These tests will prove the calibration accuracy is being maintained.

3. METHOD OF REPAIR

If the equipment should develop a fault whilst in service, depending on the nature of the fault, the watchdog contacts will change state and an alarm condition will be flagged. Due to the extensive use of surface-mount components, faulty Printed Circuit Boards (PCBs) should be replaced, as it is not possible to perform repairs on damaged PCBs. Therefore, either the complete equipment module or just the faulty PCB (as identified by the in-built diagnostic software), can be replaced. Advice about identifying the faulty PCB can be found in the Troubleshooting chapter.

The preferred method is to replace the complete equipment module as it ensures that the internal circuitry is protected against electrostatic discharge and physical damage at all times and overcomes the possibility of incompatibility between replacement PCBs. However, it may be difficult to remove installed equipment due to limited access in the back of the cubicle and the rigidity of the scheme wiring.

Replacing PCBs can reduce transport costs but requires clean, dry conditions on site and higher skills from the person performing the repair. If the repair is not performed by an approved service center, the warranty will be invalidated.



Warning

Before carrying out any work on the equipment, you should be familiar with the contents of the Safety Information chapter/Safety Guide SFTY/5L M/L11 or later issue, the Technical Data chapter and the ratings on the equipment rating label.

This should ensure that no damage is caused by incorrect handling of the electronic components.

3.1 Replacing the Complete Equipment IED/Relay

The case and rear terminal blocks have been designed to facilitate removal of the IED/relay should replacement or repair become necessary without having to disconnect the scheme wiring.



Warning

Before working at the rear of the equipment, isolate all voltage and current supplies to the equipment.

Note

The MiCOM range has integral current transformer shorting switches which will close when the heavy duty terminal block is removed.

1. Disconnect the equipment's earth, IRIG-B and fiber optic connections, as appropriate, from the rear of the device.

There are two types of terminal block used on the equipment, medium and heavy duty, which are fastened to the rear panel using Pozidriv or PZ1 screws. The P24x/P34x/P64x ranges also includes an RTD/CLIO terminal block option. These block types are shown in the Commissioning chapter.

Important

The use of a magnetic bladed screwdriver is recommended to minimize the risk of the screws being left in the terminal block or lost.

2. Without exerting excessive force or damaging the scheme wiring, pull the terminal blocks away from their internal connectors.
3. Remove the screws used to fasten the equipment to the panel, rack, etc. These are the screws with the larger diameter heads that are accessible when the access covers are fitted and open.

**Warning**

If the top and bottom access covers have been removed, do not remove the screws with the smaller diameter heads which are accessible. These screws secure the front panel to the equipment.

4. Withdraw the equipment carefully from the panel, rack, etc. because it will be heavy due to the internal transformers.

To reinstall the repaired or replacement equipment, follow the above instructions in reverse, ensuring that each terminal block is relocated in the correct position and the case earth, IRIG-B and fiber optic connections are replaced. To facilitate easy identification of each terminal block, they are labeled alphabetically with 'A' on the left-hand side when viewed from the rear.

Once reinstallation is complete, the equipment should be re-commissioned using the instructions in the Commissioning chapter.

3.2 Replacing a PCB

Replacing PCBs and other internal components must be undertaken only by Service Centers approved by Schneider Electric. Failure to obtain the authorization of Schneider Electric after sales engineers prior to commencing work may invalidate the product warranty.

**Warning**

Before removing the front panel to replace a PCB, remove the auxiliary supply and wait at least 30 seconds for the capacitors to discharge. We strongly recommend that the voltage and current transformer connections and trip circuit are isolated.

Schneider Electric support teams are available world-wide. We strongly recommend that any repairs be entrusted to those trained personnel. For this reason, details on product disassembly and re-assembly are not included here.

4. RE-CALIBRATION

Re-calibration is not required when a PCB is replaced unless it happens to be one of the boards in the input module; the replacement of either directly affects the calibration.

**Warning**

Although it is possible to carry out re-calibration on site, this requires test equipment with suitable accuracy and a special calibration program to run on a PC. It is therefore recommended that the work be carried out by the manufacturer, or entrusted to an approved service center.

5. CHANGING THE BATTERY

Each relay/IED has a battery to maintain status data and the correct time when the auxiliary supply voltage fails. The data maintained includes event, fault and disturbance records and the thermal state at the time of failure.

This battery will periodically need changing, although an alarm will be given as part of the relay's/IEDs continuous self-monitoring in the event of a low battery condition.

If the battery-backed facilities are not required to be maintained during an interruption of the auxiliary supply, the steps below can be followed to remove the battery, but do not replace with a new battery.



Warning

Before carrying out any work on the equipment, you should be familiar with the contents of the Safety Information chapter/Safety Guide SFTY/5L M/L11 or later issue, the Technical Data chapter and the ratings on the equipment rating label.

5.1 Instructions for Replacing the Battery

1. Open the bottom access cover on the front of the equipment.
2. Gently extract the battery from its socket. If necessary, use a small, insulated screwdriver to prize the battery free.
3. Ensure that the metal terminals in the battery socket are free from corrosion, grease and dust.
4. The replacement battery should be removed from its packaging and placed into the battery holder, taking care to ensure that the polarity markings on the battery agree with those adjacent to the socket.



Note

Only use a type ½AA Lithium battery with a nominal voltage of 3.6 V and safety approvals such as UL (Underwriters Laboratory), CSA (Canadian Standards Association) or VDE (Vereinigung Deutscher Elektrizitätswerke).

5. Ensure that the battery is securely held in its socket and that the battery terminals are making good contact with the metal terminals of the socket.
6. Close the bottom access cover.

5.2 Post Modification Tests

To ensure that the replacement battery will maintain the time and status data if the auxiliary supply fails, check cell [0806: DATE and TIME, Battery Status] reads 'Healthy'.

If further confirmation that the replacement battery is installed correctly is required, the commissioning test is described in the Commissioning chapter, 'Date and Time', can be performed.

5.3 Battery Disposal

The battery that has been removed should be disposed of in accordance with the disposal procedure for Lithium batteries in the country in which the equipment is installed.

6. CLEANING

**Warning**

Before cleaning the equipment ensure that all ac and dc supplies, current transformer and voltage transformer connections are isolated to prevent any chance of an electric shock whilst cleaning.

The equipment may be cleaned using a lint-free cloth moistened with clean water. The use of detergents, solvents or abrasive cleaners is not recommended as they may damage the relay's surface and leave a conductive residue.

Notes:

TROUBLESHOOTING

CHAPTER 14

Applicability	
Date:	12/2021
Products covered by this chapter:	
This chapter covers the specific versions of the MiCOM products listed below. This includes only the following combinations of Software Version and Hardware Suffix.	
Hardware Suffix:	
MiCOM Px4x	All
Software Version:	
MiCOM Px4x	All
Connection Diagrams:	
This chapter list the connection diagram for the product:	
P14x (P141, P142, P143 & P145):	10P141xx (xx = 01 to 02) 10P142xx (xx = 01 to 05) 10P143xx (xx = 01 to 11) 10P145xx (xx = 01 to 11)
P24x (P241, P242 & P243):	10P241xx (xx = 01 to 02) 10P242xx (xx = 01) 10P243xx (xx = 01)
P34x (P342, P343, P344, P345 & P391)	10P342xx (xx = 01 to 17) 10P343xx (xx = 01 to 19) 10P344xx (xx = 01 to 12) 10P345xx (xx = 01 to 07) 10P391xx (xx = 01 to 02)
P445:	10P445xx (xx = 01 to 04)
P44x (P442 & P444):	10P44101 (SH 1 & 2) 10P44201 (SH 1 & 2) 10P44202 (SH 1) 10P44203 (SH 1 & 2) 10P44401 (SH 1) 10P44402 (SH 1) 10P44403 (SH 1 & 2) 10P44404 (SH 1) 10P44405 (SH 1) 10P44407 (SH 1 & 2)
P44y:	10P44303 (SH 01 and 03) 10P44304 (SH 01 and 03) 10P44305 (SH 01 and 03) 10P44306 (SH 01 and 03) 10P44600 10P44601 (SH 1 to 2) 10P44602 (SH 1 to 2) 10P44603 (SH 1 to 2)
P54x (P543, P544, P545 & P546):	10P54302 (SH 1 to 2) 10P54303 (SH 1 to 2) 10P54304 (SH 1 to 2) 10P54400 10P54404 (SH 1 to 2)

	10P54405 (SH 1 to 2) 10P54502 (SH 1 to 2) 10P54503 (SH 1 to 2) 10P54504 (SH 1 to 2) 10P54600 10P54604 (SH 1 to 2) 10P54605 (SH 1 to 2) 10P54606 (SH 1 to 2)
P547:	10P54702xx (xx = 01 to 02) 10P54703xx (xx = 01 to 02) 10P54704xx (xx = 01 to 02) 10P54705xx (xx = 01 to 02)
P64x (P642, P643 & P645):	10P642xx (xx = 1 to 10) 10P643xx (xx = 1 to 6) 10P645xx (xx = 1 to 9)
P74x:	10P740xx (xx = 01 to 07)
P746:	10P746xx (xx = 00 to 21)
P841:	10P84100 10P84101 (SH 1 to 2) 10P84102 (SH 1 to 2) 10P84103 (SH 1 to 2) 10P84104 (SH 1 to 2) 10P84105 (SH 1 to 2)
P849:	10P849xx (xx = 01 to 06)

Notes:

CONTENTS

1. Introduction	7
2. Initial Problem Identification	8
3. Power Up Errors	9
4. Error Message/Code on Power-up	10
5. Out of Service LED Illuminated on Power Up	11
6. Error Code during Operation	12
7. Mal-Operation of the Relay during Testing	13
7.1 Failure of Output Contacts	13
7.2 Failure of Opto-Isolated Inputs	13
7.3 Incorrect Analog Signals	14
7.4 PSL Editor Troubleshooting	14
7.4.1 Diagram Reconstruction after Recover from Relay.....	14
7.4.2 PSL Version Check.....	14
8. Repair and Modification Procedure	15
9. Repair / Modification Return Authorization Form	16

TABLES

Table 1 - Problem identification.....	8
Table 2 - Failure of relay to power up.....	9
Table 3 - Power-up self-test error.....	10
Table 4 - Out-of-Service LED illuminated.....	11
Table 5 - Failure of output contacts.....	13

Notes:

1. INTRODUCTION

**Warning**

Before carrying out any work on the equipment, you should be familiar with the contents of the Safety Information chapter/Safety Guide SFTY/5L M/L11 or later issue, the Technical Data chapter and the ratings on the equipment rating label.

The purpose of this chapter of the service manual is to allow an error condition on the relay to be identified so that appropriate corrective action can be taken.

If the relay has developed a fault, it should be possible in most cases to identify which relay module requires attention. The Maintenance chapter advises on the recommended method of repair where faulty modules need replacing. It is not possible to perform an on-site repair to a faulted module.

In cases where a faulty relay/module is being returned to the manufacturer or one of their approved service centers, a completed copy of the [Repair/Modification Return Authorization Form](#) located at the end of this chapter should be included.

2. INITIAL PROBLEM IDENTIFICATION

Consult the following table to find the description that best matches the problem experienced, then consult the section referenced to perform a more detailed analysis of the problem.

Symptom	Refer To
Relay fails to power up	Power-Up Errors section
Relay powers up - but indicates error and halts during power-up sequence	Error Message/Code On Power-Up section
Relay Powers up but Out of Service LED is illuminated	Out of Service LED illuminated on Power Up section
Error during normal operation	Error Code During Operation section
Mal-operation of the relay during testing	Mal-Operation of the Relay during Testing section

Table 1 - Problem identification

3. POWER UP ERRORS

If the relay does not appear to power up then the following procedure can be used to determine whether the fault is in the external wiring, auxiliary fuse, power supply module of the relay or the relay front panel.

Test	Check	Action
1	1 Measure auxiliary voltage on terminals 1 and 2; verify voltage level and polarity against rating the label on front. Terminal 1 is -dc, 2 is +dc	If auxiliary voltage is present and correct, then proceed to test 2. Otherwise the wiring/fuses in auxiliary supply should be checked.
2	Do LEDs/and LCD backlight illuminate on power-up, also check the N/O watchdog contact for closing.	If they illuminate or the contact closes and no error code is displayed then error is probably in the main processor board (front panel). If they do not illuminate and the contact does not close then proceed to test 3.
3	Check Field voltage output (nominally 48V DC)	If field voltage is not present then the fault is probably in the relay power supply module.

Table 2 - Failure of relay to power up

4. ERROR MESSAGE/CODE ON POWER-UP

During the power-up sequence of the relay self-testing is performed as indicated by the messages displayed on the LCD. If an error is detected by the relay during these self-tests, an error message will be displayed and the power-up sequence will be halted. If the error occurs when the relay application software is executing, a maintenance record will be created and the relay will reboot.

Test	Check	Action										
1	Is an error message or code permanently displayed during power up?	If relay locks up and displays an error code permanently then proceed to Test 2. If the relay prompts for input by the user proceed to Test 4. If the relay re-boots automatically then proceed to Test 5.										
2	Record displayed error, then remove and re-apply relay auxiliary supply.	Record whether the same error code is displayed when the relay is rebooted. If no error code is displayed then contact the local service center stating the error code and relay information. If the same code is displayed proceed to Test 3.										
3	<p>Error code Identification</p> <p>Following text messages (in English) will be displayed if a fundamental problem is detected preventing the system from booting:</p> <table border="0"> <tr> <td>Bus Fail</td> <td>address lines</td> </tr> <tr> <td>SRAM Fail</td> <td>data lines</td> </tr> <tr> <td>FLASH Fail</td> <td>format error</td> </tr> <tr> <td>FLASH Fail</td> <td>checksum</td> </tr> <tr> <td>Code Verify</td> <td>Fail</td> </tr> </table> <p>These hex error codes relate to errors detected in specific relay modules:</p>	Bus Fail	address lines	SRAM Fail	data lines	FLASH Fail	format error	FLASH Fail	checksum	Code Verify	Fail	<p>These messages indicate that a problem has been detected on the main processor board of the relay (located in the front panel).</p>
Bus Fail	address lines											
SRAM Fail	data lines											
FLASH Fail	format error											
FLASH Fail	checksum											
Code Verify	Fail											
	0c140005/0c0d0000	Input Module (inc. Opto-isolated inputs)										
	0c140006/0c0e0000	Output Relay Cards										
	Last 4 digits provide details on the actual error	Other error codes relate to problems within the main processor board hardware or software. It will be necessary to contact Schneider Electric with details of the problem for a full analysis.										
4	Relay displays message for corrupt settings and prompts for restoration of defaults to the affected settings.	The power up tests have detected corrupted relay settings, it is possible to restore defaults to allow the power-up to be completed. It will then be necessary to re-apply the application-specific settings.										

Table 3 - Power-up self-test error

5. OUT OF SERVICE LED ILLUMINATED ON POWER UP

Test	Check	Action	
1	Using the relay menu confirm whether the Commission Test/Test Mode setting is Contact Blocked. Otherwise proceed to test 2.	If the setting is Contact Blocked then disable the test mode and, verify that the Out of Service LED is extinguished.	
2	Select and view the last maintenance record from the menu (in the View Records).	Check for H/W Verify Fail this indicates a discrepancy between the relay model number and the hardware; examine the "Maint. Data", this indicates the causes of the failure using bit fields:	
		Bit	Meaning
		0	The application type field in the model number does not match the software ID
		1	The application field in the model number does not match the software ID
		2	The variant 1 field in the model number does not match the software ID
		3	The variant 2 field in the model number does not match the software ID
		4	The protocol field in the model number does not match the software ID
		5	The language field in the model number does not match the software ID
		6	The VT type field in the model number is incorrect (110V VTs fitted)
		7	The VT type field in the model number is incorrect (440V VTs fitted)
		8	The VT type field in the model number is incorrect (no VTs fitted)

Table 4 - Out-of-Service LED illuminated

6. ERROR CODE DURING OPERATION

The relay performs continuous self-checking, if an error is detected then an error message will be displayed, a maintenance record will be logged and the relay will reset (after a 1.6 second delay). A permanent problem (for example due to a hardware fault) will generally be detected on the power up sequence, following which the relay will display an error code and halt. If the problem was transient in nature then the relay should reboot correctly and continue in operation. The nature of the detected fault can be determined by examination of the maintenance record logged.

There are also two cases where a maintenance record will be logged due to a detected error where the relay will not reset. These are detection of a failure of either the field voltage or the lithium battery, in these cases the failure is indicated by an alarm message, however the relay will continue to operate.

If the field voltage is detected to have failed (the voltage level has dropped below threshold), then a scheme logic signal is also set. This allows the scheme logic to be adapted in the case of this failure (for example if a blocking scheme is being used).

In the case of a battery failure it is possible to prevent the relay from issuing an alarm using the setting under the Date and Time section of the menu. This setting 'Battery Alarm' can be set to 'Disabled' to allow the relay to be used without a battery, without an alarm message being displayed.

In the case of an RTD board failure, an alarm "RTD board fail" message is displayed, the RTD protection is disabled, but the operation of the rest of the relay functionality is unaffected.

7. MAL-OPERATION OF THE RELAY DURING TESTING

7.1 Failure of Output Contacts

An apparent failure of the relay output contacts may be caused by the relay configuration; the following tests should be performed to identify the real cause of the failure.

Note

The relay self-tests verify that the coil of the contact has been energized, an error will be displayed if there is a fault in the output relay board.

Test	Check	Action
1	Is the Out of Service LED illuminated?	Illumination of this LED may indicate that the relay is Contact Blocked or that the protection has been disabled due to a hardware verify error (see the Out of service LED illuminated table.
2	Examine the Contact status in the Commissioning section of the menu.	If the relevant bits of the contact status are operated, proceed to test 4, if not proceed to test 3.
3	Verify by examination of the fault record or by using the test port whether the protection element is operating correctly. If the protection element does not operate verify whether the test is being correctly applied.	If the protection element does operate, it will be necessary to check the PSL to ensure that the mapping of the protection element to the contacts is correct.
4	Using the Commissioning/Test mode function apply a test pattern to the relevant relay output contacts and verify whether they operate (note the correct external connection diagram should be consulted). A continuity tester can be used at the rear of the relay for this purpose.	If the output relay does operate, the problem must be in the external wiring to the relay. If the output relay does not operate this could indicate a failure of the output relay contacts (note that the self-tests verify that the relay coil is being energized). Ensure that the closed resistance is not too high for the continuity tester to detect.

Table 5 - Failure of output contacts

7.2 Failure of Opto-Isolated Inputs

The opto-isolated inputs are mapped onto the relay internal signals using the PSL. If an input does not appear to be recognized by the relay scheme logic the Commission Tests/Opto Status menu option can be used to verify whether the problem is in the opto-isolated input itself or the mapping of its signal to the scheme logic functions. If the opto-isolated input does appear to be read correctly then it will be necessary to examine its mapping within the PSL.

Ensure the voltage rating for the opto inputs has been configured correctly with applied voltage. If the opto-isolated input state is not being correctly read by the relay the applied signal should be tested. Verify the connections to the opto-isolated input using the correct wiring diagram and the correct nominal voltage settings in any standard or custom menu settings. Next, using a voltmeter verify that 80% opto setting voltage is present on the terminals of the opto-isolated input in the energized state. If the signal is being correctly applied to the relay then the failure may be on the input card itself. Depending on which opto-isolated input has failed this may require replacement of either the complete analog input module (the board within this module cannot be individually replaced without re-calibration of the relay) or a separate opto board.

7.3 Incorrect Analog Signals

The measurements may be configured in primary or secondary to assist. If it is suspected that the analog quantities being measured by the relay are not correct then the measurement function of the relay can be used to verify the nature of the problem. The measured values displayed by the relay should be compared with the actual magnitudes at the relay terminals. Verify that the correct terminals are being used (in particular the dual rated CT inputs) and that the CT and VT ratios set on the relay are correct. The correct 120 degree displacement of the phase measurements should be used to confirm that the inputs have been correctly connected.

7.4 PSL Editor Troubleshooting

A failure to open a connection could be because of one or more of the following:

- The relay address is not valid (note: this address is always 1 for the front port).
- Password is not valid
- Communication Set-up - COM port, Baud rate, or Framing - is not correct
- Transaction values are not suitable for the relay and/or the type of connection
- Modem configuration is not valid. Changes may be necessary when using a modem
- The connection cable is not wired correctly or broken. See MiCOM S1 connection configurations

7.4.1 Diagram Reconstruction after Recover from Relay

Although the extraction of a scheme from a relay is supported, the facility is provided as a way of recovering a scheme in the event that the original file is unobtainable.

The recovered scheme will be logically correct, but much of the original graphical information is lost. Many signals will be drawn in a vertical line down the left side of the canvas. Links are drawn orthogonally using the shortest path from A to B.

Any annotation added to the original diagram (titles, notes, etc.) are lost.

Sometimes a gate type may not be what was expected, e.g. a 1-input AND gate in the original scheme will appear as an OR gate when uploaded. Programmable gates with an inputs-to-trigger value of 1 will also appear as OR gates.

7.4.2 PSL Version Check

The PSL is saved with a version reference, time stamp and CRC check. This gives a visual check whether the default PSL is in place or whether a new application has been downloaded.

8. REPAIR AND MODIFICATION PROCEDURE

Please follow these steps to return an Automation product to us:

1. Get the Repair and Modification Authorization Form (RMA).
A copy of the RMA form is shown at the end of this section.
2. Fill in the RMA form.
Fill in only the white part of the form.
Please ensure that all fields marked **(M)** are completed such as:
 - Equipment model
 - Model No. and Serial No.
 - Description of failure or modification required (please be specific)
 - Value for customs (in case the product requires export)
 - Delivery and invoice addresses
 - Contact details
3. Receive from local service contact, the information required to ship the product.
Your local service contact will provide you with all the information:
 - Pricing details
 - RMA No
 - Repair center address
If required, an acceptance of the quote must be delivered before going to next stage.
4. Send the product to the repair center.
Address the shipment to the repair center specified by your local contact.
Ensure all items are protected by appropriate packaging: anti-static bag and foam protection.
Ensure a copy of the import invoice is attached with the unit being returned.
Ensure a copy of the RMA form is attached with the unit being returned.
E-mail or fax a copy of the import invoice and airway bill document to your local contact.

9. REPAIR / MODIFICATION RETURN AUTHORIZATION FORM

FIELDS IN GREY TO BE FILLED IN BY SCHNEIDER ELECTRIC PERSONNEL ONLY

Reference RMA:		Date:	
Repair Center Address: (for shipping)	Service Type:		LSC PO No.:
	<input type="checkbox"/>	Retrofit	
	<input type="checkbox"/>	Warranty	
	<input type="checkbox"/>	Paid service	
	<input type="checkbox"/>	Under repair contract	
<input type="checkbox"/>	Wrong supply		
Schneider Electric - Local Contact Details:			
Name:		Telephone No.:	
E-mail:		Fax No.:	

IDENTIFICATION OF UNIT

Fields marked **(M)** are mandatory, delays in return will occur if not completed.

Model No./Part No.: (M)	Site Name/Project:		
Manufacturer Reference: (M)	Commissioning Date:		
Serial No.: (M)	Under Warranty:	<input type="checkbox"/>	Yes <input type="checkbox"/> No
Software Version:	Additional Information:		
Quantity:	Customer P.O (if paid):		

FAULT INFORMATION

Type of Failure		Found Defective	
Hardware fail	<input type="checkbox"/>	During FAT/inspection	<input type="checkbox"/>
Mechanical fail/visible defect	<input type="checkbox"/>	On receipt	<input type="checkbox"/>
Software fail	<input type="checkbox"/>	During installation/commissioning	<input type="checkbox"/>
Other:	<input type="checkbox"/>	During operation	<input type="checkbox"/>
		Other:	<input type="checkbox"/>
Fault Reproducibility			
Fault persists after removing, checking on test bench	<input type="checkbox"/>		
Fault persists after re-energization	<input type="checkbox"/>		
Intermittent fault	<input type="checkbox"/>		

Description of Failure Observed or Modification Required
Please be specific(M)

FOR REPAIRS ONLY

Would you like us to install an updated firmware version after repair?	<input type="checkbox"/>	Yes	<input type="checkbox"/>	No
--	--------------------------	-----	--------------------------	----

CUSTOMS & INVOICING INFORMATION (required to allow return of repaired items)

Value for Customs (M)				
Customer Invoice Address ((M) if paid)	Customer Return Delivery Address (full street address) (M)			
	Part shipment accepted	<input type="checkbox"/>	Yes	<input type="checkbox"/> No
	OR Full shipment required	<input type="checkbox"/>	Yes	<input type="checkbox"/> No
Contact Name:	Contact Name:			
Telephone No.:	Telephone No.:			
Fax No.:	Fax No.:			
E-mail:	E-mail:			

REPAIR TERMS

1	Please ensure that a copy of the import invoice is attached with the returned unit, together with the airway bill document. Please fax/e-mail a copy of the appropriate documentation (M).
2	Please ensure the Purchase Order is released, for paid service, to allow the unit to be shipped.
3	Submission of equipment to Schneider Electric is deemed as authorization to repair and acceptance of quote.
4	Please ensure all items returned are marked as Returned for 'Repair/Modification' and protected by appropriate packaging (anti-static bag for each board and foam protection).

Notes:

SCADA COMMUNICATIONS

CHAPTER 15

Applicability

Date: 11/2022

Products covered by this chapter:

This chapter covers the specific versions of the MiCOM products listed below. This includes **only** the following combinations of Software Version and Hardware Suffix.

Hardware Suffix:

P54x (P543/P544/P545/P546)	M or later
----------------------------	------------

Software Suffix:

P54x (P543/P544/P545/P546)	K1 or later
----------------------------	-------------

Connection Diagrams: This chapter list the connection diagram for the product:

P54x (P543, P544, P545 & P546):	10P54302 (SH 1 to 2) 10P54303 (SH 1 to 2) 10P54304 (SH 1 to 2) 10P54400 10P54404 (SH 1 to 2) 10P54405 (SH 1 to 2) 10P54502 (SH 1 to 2) 10P54503 (SH 1 to 2) 10P54504 (SH 1 to 2) 10P54600 10P54604 (SH 1 to 2) 10P54605 (SH 1 to 2) 10P54606 (SH 1 to 2)
---------------------------------	--

CONTENTS

1. Introduction	6
1.1 Read Only Mode (Command Blocking)	6
2. Connections to the Communications Ports	8
2.1 Front Port	8
2.2 Rear Communication Port - EIA(RS)-485	8
2.3 Second Rear Communications Port (RP2) (Courier)	8
2.3.1 Courier Protocol.....	9
2.3.1.1 Event Extraction.....	9
2.3.1.2 Disturbance Record Extraction.....	9
2.3.2 Connection to the Second Rear Port.....	9
2.4 EIA(RS)-485 Bus	10
2.4.1 EIA(RS)-485 Bus Termination.....	10
2.4.2 EIA(RS)-485 Bus Connections & Topologies.....	10
2.4.3 EIA(RS)-485 Biasing.....	10
2.4.4 K-Bus Connections.....	11
2.4.5 Courier Communications.....	11
2.4.6 IEC 60870-5 CS 103 Communications.....	11
2.4.7 DNP3.0 Communication.....	12
3. Configuring the Communications Ports	13
3.1 Introduction	13
3.2 Configuring the Front Courier Port	13
3.3 Configuring the First Rear Courier Port (RP1)	13
3.4 Configuring the IEC 60870-5 CS 103 Rear Port, RP1	15
3.5 Configuring DNP3.0 Communications Rear Port RP1	16
3.6 Configuring the (Optional) DNP3.0 over Ethernet Port	18
3.7 Configuring the Second Rear Courier Port, RP2	19
3.8 Configuring the Ethernet Communication (Option)	20
3.9 Fiber Optic Converter (option)	20
3.10 Second Rear Port EIA(RS)-485 Example	21
3.11 Second Rear Port EIA(RS)-232 Example	21
3.12 SK5 Port Connection	21
4. Courier Interface	22
4.1 Courier Protocol	22
4.2 Front Courier Port	22
4.3 Supported Command Set	23
4.4 Courier Database	23
4.5 Setting Changes	24

4.5.1 Method 1.....	24
4.5.2 Method 2.....	24
4.5.3 Relay Settings.....	24
4.5.4 Setting Transfer Mode.....	25
4.6 Event Extraction.....	25
4.6.1 Automatic Event Extraction.....	25
4.6.2 Event Types.....	25
4.6.3 Event Format.....	25
4.6.4 Manual Event Record Extraction.....	26
4.7 Disturbance Record Extraction.....	27
4.8 Programmable Scheme Logic (PSL) Settings.....	27
<hr/>	
5. IEC60870-5-103 Interface.....	29
5.1 Physical Connection and Link Layer.....	29
5.2 Initialization.....	29
5.3 Time Synchronization.....	29
5.4 Spontaneous Events.....	30
5.5 General Interrogation (GI).....	30
5.6 Cyclic Measurements.....	30
5.7 Commands.....	30
5.8 Test Mode.....	30
5.9 Disturbance Records.....	31
5.10 Blocking of Monitor Direction.....	31
5.11 Setting Changes through IEC103 Protocol.....	31
<hr/>	
6. DNP3.0 Interface.....	33
6.1 DNP3.0 Protocol.....	33
6.2 DNP3.0 Menu Setting.....	33
6.3 Object 1 Binary Inputs.....	34
6.4 Object 10 Binary Outputs.....	34
6.5 Object 20 Binary Counters.....	35
6.6 Object 30 Analog Input.....	35
6.7 Object 40 Analog Output.....	36
6.8 DNP3.0 Configuration using Easergy Studio.....	36
6.8.1 DNP3.0 over Ethernet runs concurrently with IEC61850.....	37
<hr/>	
7. IEC 61850 Ethernet Interface.....	39
7.1 Introduction.....	39
7.2 What is IEC 61850?.....	39
7.2.1 Interoperability.....	39
7.2.2 Data Model.....	39
7.3 IEC 61850 in MiCOM Relays.....	40
7.3.1 Capability.....	41

7.3.2 IEC 61850 Configuration	43
7.3.2.1 Configuration Banks	43
7.3.2.2 Network Connectivity	44
7.4 Data Model of MiCOM Relays	44
7.5 Communication Services of MiCOM Relays	44
7.6 Peer-to-Peer (GSE) Communications	44
7.6.1 Scope	45
7.6.2 Simulation GOOSE Configuration	45
7.6.3 High Performance GOOSE	46
7.7 Ethernet Functionality	46
7.7.1 Ethernet Disconnection	46
7.7.2 Redundant Ethernet Communication Ports (optional)	46
7.7.3 Loss of Power	46
7.7.4 Courier Tunneling via Secure Ethernet Communications	46
7.7.4.1 Introduction	46
7.7.4.2 Setting up a Connection	47

TABLES

Table 1 - Port configurations and communication protocols	9
Table 2 - Pin connections over EIA(RS)-232 and EIS(RS)-485	10
Table 3 - DNP3.0 menu in the Communications column	33
Table 4 - Unsolicited Responses configuration of DNP over Ethernet	37
Table 5 - Protocol running options for different board types	38
Table 6 - Abbreviations of Different IP	38

FIGURES

Figure 1 - EIA(RS)-485 bus connection arrangements	11
Figure 2 - Second rear port EIA(RS)-485 example	21
Figure 3 - Second rear port EIA(RS)-232 example	21
Figure 4 - Behaviour when control input is set to be pulsed or latched	34
Figure 5 - Data model layers in IEC 61850	40

1. INTRODUCTION

This chapter describes the remote interfaces of the MiCOM relay in enough detail to allow integration in a substation communication network.

The supported protocols include:

- Courier
- MODBUS
- IEC-60870-5-103
- DNP3.0
- IEC 61850 Ethernet Interface

Note

MODBUS is not included in MiCOM P44y (P443 / P446), P445, P54x (P543 / P544 / P545 / P546), P841 and P74x (P741 / P742 / P743) products. DNP3.0 is not supported in MiCOM P24x (P241 / P242 / P243) and P74x (P741 / P742 / P743). IEC 60870-5-103 is not available for P74x.

1.1 Read Only Mode (Command Blocking)

A Read Only mode is available for the rear communication ports of the Px40 relays. When Read Only mode is enabled for a port, all setting changes and most commands/control actions are blocked (not accepted by the relay). The full functionality is described below. It is similar to the 'Command Blocking' setting of Px30 relays.

Read Only mode can be enabled/disabled for the following rear ports:

- Rear Port 1 – IEC 60870-5-103 and Courier protocols
- Rear Port 2 (if fitted) – Courier protocol
- Ethernet Port (if fitted) – Courier protocol (“tunnelled”)

Read Only mode is not currently required for IEC 61850, as there are no settings or controls implemented.

Read Only mode does not apply to the Front Port, that is intended for local connection only.

The following settings enable and disable the Read Only Mode:

- [09FB: CONFIGURATION, RP1 Read Only]
- [09FC: CONFIGURATION, RP2 Read Only]
- [09FD: CONFIGURATION, NIC Read Only]

Read Only mode can only be disabled from either the front panel User Interface or via the Front Port.

Read Only mode can be enabled/disabled in the PSL by using the DDB signals 'RP1 Read Only', 'RP2 Read Only', 'NIC Read Only'.

When Read Only mode is enabled, the commands that are blocked (not accepted by the relay) and the commands that are allowed (accepted by the relay) are as follows.

(1) IEC 60870-5-103 Protocol

Blocked:

- INF16 auto-recloser on/off (ASDU20)
- INF17 teleprotection on/off (ASDU20)
- INF18 protection on/off (ASDU20)
- INF19 LED reset (ASDU20)
- private INFs e.g CB open/close, Control Inputs (ASDU20)

Allowed:

- Poll Class 1 (read spontaneous events)
- Poll Class 2 (read measurands)

General Interrogation (GI) sequence
Transmission of Disturbance Records sequence
Time Synchronisation (ASDU6)
INF23 activate characteristic 1 (ASDU20)
INF24 activate characteristic 2 (ASDU20)
INF25 activate characteristic 3 (ASDU20)
INF26 activate characteristic 4 (ASDU20)

(2) Courier Protocol

Blocked:

All setting changes
Reset Indication (Trip LED) command
Operate Control Input commands
CB operation commands
Auto-reclose operation commands
Reset demands / thermal etc... command
Clear event / fault / maintenance / disturbance record commands
Test LEDs & contacts commands

Allowed:

Read settings, statuses, measurands
Read records (event, fault, disturbance)
Time Synchronization command
Change active setting group command

2. CONNECTIONS TO THE COMMUNICATIONS PORTS

2.1 Front Port

The front communications port is not intended for permanent connection. The front communications port supports the Courier protocol and is implemented on an EIA(RS)232 connection. A 9-pin connector type, as described in the 'Getting Started' (GS) chapter of this manual, is used, and the cabling requirements are detailed in the 'Connection Diagrams' (CD) chapter of this manual.

2.2 Rear Communication Port - EIA(RS)-485

The rear EIA(RS)-485 communication port is provided by a 3-terminal screw connector on the back of the relay. See the Connection Diagrams chapter for details of the connection terminals. The rear port provides K-Bus/EIA(RS)-485 serial data communication and is intended for use with a permanently-wired connection to a remote control center. Of the three connections, two are for the signal connection, and the other is for the earth shield of the cable.

If the IEC60870-5-103, or the DNP3.0 protocols are specified as the interface for the rear port, then connections conform entirely to the EIA(RS)485 standards outline below. If, however, the Courier protocol is specified as the rear port protocol, the interface can be set either to EIA(RS)485 or K-Bus. The configuration of the port as either EIA(RS)485 or K-Bus is described later together with K-Bus details, but as connection to the port is affected by this choice, you should note these points:

- Connection to an EIA(RS)485 device is polarity sensitive, whereas K-Bus connection is not. In all other respects (bus wiring, topology, connection, biasing, and termination) K-Bus can be considered the same as EIA(RS)485.
- Whilst connection to or between an EIA(RS)485 port and an EIA(RS)232 port on a PC can be implemented using a general purpose EIA(RS)485 to EIA(RS)232 converter.

All rear port communication interfaces are fully isolated and suitable for permanent connection. EIA(RS)485 (and K-Bus) connections allow up to 32 devices to be 'daisy-chained' together using a simple twisted pair electrical connection.

The protocol provided by the relay is indicated in the relay menu in the **Communications** column. Using the keypad and LCD, first check that the **Comms. settings** cell in the **Configuration** column is set to **Visible**, then move to the **Communications** column. The first cell down the column shows the communication protocol that is being used by the rear port.

Note

Unless the K-Bus option is chosen for the rear port, correct polarity must be observed for the signal connections. In all other respects (bus wiring, topology, connection, biasing and termination) K-Bus can be considered the same as EIA(RS)485.

2.3 Second Rear Communications Port (RP2) (Courier)

Relays with Courier, MODBUS, IEC60870-5-103 or DNP3.0 protocol on the first rear communications port have the option of a second rear port, running the Courier language. The second port is typically for dial-up modem access by protection engineers or operators, when the main port is reserved for SCADA traffic. Communication is through one of three physical links: K-Bus, EIA(RS)-485 or EIA(RS)-232. The port supports full local or remote protection and control access using Easergy Studio.

When changing the port configuration between K-Bus, EIA(RS)-485 and EIA(RS)-232, reboot the relay to update the hardware configuration of the second rear port.

The EIA(RS)-485 and EIA(RS)-232 protocols can be configured to operate with a modem, using an IEC60870 10-bit frame.

If both rear communications ports are connected to the same bus, make sure their address settings are not the same to avoid message conflicts.

Port Configuration	Valid Communication Protocol
K-Bus	K-Bus
EIA(RS)-232	IEC60870 FT1.2, 11-bit frame IEC60870, 10-bit frame
EIA(RS)-485	IEC60870 FT1.2, 11-bit frame IEC60870, 10-bit frame

Table 1 - Port configurations and communication protocols

2.3.1 Courier Protocol

The second rear communications port is functionally the same as described in the previous section for a Courier rear communications port, with the following exceptions:

2.3.1.1 Event Extraction

Automatic event extraction is not supported when the first rear port protocol is Courier, MODBUS or CS103. It is supported when the first rear port protocol is DNP3.0.

2.3.1.2 Disturbance Record Extraction

Automatic disturbance record extraction is not supported when the first rear port protocol is Courier, MODBUS or CS103. It is supported when the first rear port protocol is DNP3.0.

2.3.2 Connection to the Second Rear Port

The second rear Courier port connects using the 9-way female D-type connector (SK4) in the middle of the card end plate (between the IRIG-B connector and lower D-type). The connection complies with EIA(RS)-574.

For IEC60870-5-2 over EIA(RS)-232	
Pin	Connection
1	No Connection
2	RxD
3	TxD
4	DTR#
5	Ground
6	No Connection
7	RTS#
8	CTS#
9	No Connection
# - These pins are control lines for use with a modem.	

For K-bus or IEC60870-5-2 over EIA(RS)-485	
Pin*	Connection
4	EIA(RS)-485 - 1 (+ ve)
7	EIA(RS)-485 - 2 (- ve)
* - All other pins unconnected.	

Notes

Connector pins 4 and 7 are used by both the EIA(RS)-232 and EIA(RS)-485 physical layers, but for different purposes. Therefore, the cables should be removed during configuration switches.

When using the EIA(RS)-485 protocol, an EIA(RS)-485 to EIA(RS)-232 converter is needed to connect the relay to a modem or PC running Easergy Studio. A Schneider Electric CK222 is recommended.

EIA(RS)-485 is polarity sensitive, with pin 4 positive (+) and pin 7 negative (-).

Table 2 - Pin connections over EIA(RS)-232 and EIS(RS)-485

2.4 EIA(RS)-485 Bus

The EIA(RS)-485 two-wire connection provides a half-duplex fully isolated serial connection to the product. The connection is polarized and while the product's connection diagrams show the polarization of the connection terminals, there is no agreed definition of which terminal is which. If the master is unable to communicate with the product and the communication parameters match, make sure the two-wire connection is not reversed.

EIA(RS)-485 provides the capability to connect multiple devices to the same two-wire bus. MODBUS is a master-slave protocol, so one device is the master, and the remaining devices are slaves. It is not possible to connect two masters to the same bus, unless they negotiate bus access.

2.4.1 EIA(RS)-485 Bus Termination

The EIA(RS)-485 bus must have 120 Ω (Ohm) $\frac{1}{2}$ Watt terminating resistors fitted at either end across the signal wires, see the EIA(RS)-485 bus connection arrangements diagram below. Some devices may be able to provide the bus terminating resistors by different connection or configuration arrangements, in which case separate external components are not needed. However, this product does not provide such a facility, so if it is located at the bus terminus, an external termination resistor is needed.

2.4.2 EIA(RS)-485 Bus Connections & Topologies

The EIA(RS)-485 standard requires each device to be directly connected to the physical cable that is the communications bus. Stubs and tees are expressly forbidden, as are star topologies. Loop bus topologies are not part of the EIA(RS)-485 standard and are forbidden by it.

Two-core screened cable is recommended. The specification of the cable depends on the application, although a multi-strand 0.5 mm² per core is normally adequate. Total cable length must not exceed 1000 m. The screen must be continuous and connected at one end, normally at the master connection point. It is important to avoid circulating currents, especially when the cable runs between buildings, for both safety and noise reasons.

This product does not provide a signal ground connection. If the bus cable has a signal ground connection, it must be ignored. However, the signal ground must have continuity for the benefit of other devices connected to the bus. For both safety and noise reasons, the signal ground must never be connected to the cable's screen or to the product's chassis.

2.4.3 EIA(RS)-485 Biasing

It may also be necessary to bias the signal wires to prevent jabber. Jabber occurs when the signal level has an indeterminate state because the bus is not being actively driven. This can occur when all the slaves are in receive mode and the master is slow to switch from receive mode to transmit mode. This may be because the master purposefully waits in receive mode, or even in a high impedance state, until it has something to transmit. Jabber causes the receiving device(s) to miss the first bits of the first character in the packet, which results in the slave rejecting the message and consequentially not responding. Symptoms of this are poor response times (due to retries), increasing message error counters, erratic communications, and even a complete failure to communicate.

Biasing requires that the signal lines are weakly pulled to a defined voltage level of about 1 V. There should only be one bias point on the bus, which is best situated at the master connection point. The DC source used for the bias must be clean, otherwise noise is injected. Some devices may (optionally) be able to provide the bus bias, in which case external components are not required.

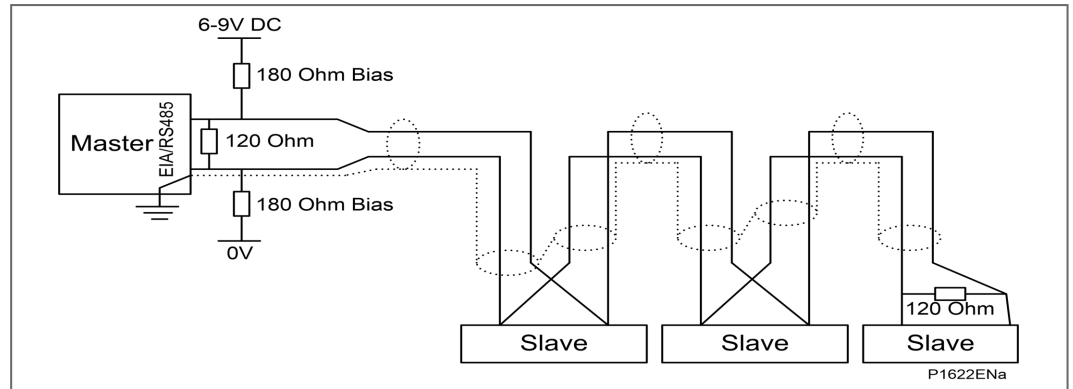

Figure 1 - EIA(RS)-485 bus connection arrangements

It is possible to use the product's field voltage output (48 V DC) to bias the bus using values of 2.2 k Ω ($\frac{1}{2}W$) as bias resistors instead of the 180 Ω resistors shown in the *EIA(RS)-485 bus connection arrangements* diagram. Note these warnings apply:

Warnings

It is extremely important that the 120 Ω termination resistors are fitted. Otherwise the bias voltage may be excessive and may damage the devices connected to the bus.

As the field voltage is much higher than that required, Schneider Electric cannot assume responsibility for any damage that may occur to a device connected to the network as a result of incorrect application of this voltage.

Ensure the field voltage is not used for other purposes, such as powering logic inputs, because noise may be passed to the communication network.

2.4.4 K-Bus Connections

K-Bus is a robust signaling method based on EIA(RS)485 voltage levels. K-Bus incorporates message framing and uses a 64 kbits/s synchronous HDLC protocol with FM0 modulation to increase speed and security. For this reason is not possible to use a standard EIA(RS)232 to EIA(RS)485 converter to connect with K-Bus devices. Nor is it possible to connect K-Bus to an EIA(RS)485 computer port.

As K-Bus is implemented on an EIA(RS)485 layer, the connection details are very similar to those described in the previous sections.

2.4.5 Courier Communications

Courier is the communication language developed to allow remote interrogation of its range of protection relays. Courier uses a master and slave. EIA(RS)-232 on the front panel allows only one slave but EIA(RS)-485 on the back panel allows up to 32 daisy-chained slaves. Each slave unit has a database of information and responds with information from its database when requested by the master unit.

The relay is a slave unit that is designed to be used with a Courier master unit such as Easergy Studio, MiCOM S10, PAS&T or a SCADA system. Easergy Studio is specifically designed for setting changes with the relay.

2.4.6 IEC 60870-5 CS 103 Communications

The IEC specification IEC 60870-5-103: Telecontrol Equipment and Systems, Part 5: Transmission Protocols Section 103 defines the use of standards IEC 60870-5-1 to IEC 60870-5-5 to perform communication with protection equipment. The standard configuration for the IEC 60870-5-103 protocol is to use a twisted pair connection over distances up to 1000 m. As an option for IEC 60870-5-103, the rear port can be specified to use a fiber optic

connection for direct connection to a master station. The relay operates as a slave in the system, responding to commands from a master station. The method of communication uses standardized messages which are based on the VDEW communication protocol.

To use the rear port with IEC 60870-5-103 communication, configure the relay's communication settings using the keypad and LCD user interface.

There are three settings associated with this cell; these are:

- **Disabled**
No blocking selected.
- **Monitor Blocking**
When the monitor blocking DDB Signal is active high, either by energizing an opto input or control input, reading of the status information and disturbance records is not permitted. When in this mode the relay returns a "Termination of general interrogation" message to the master station.
- **Command Blocking**
When the command blocking DDB signal is active high, either by energizing an opto input or control input, all remote commands are ignored, such as CB Trip/Close or change setting group. When in this mode the relay returns a **negative acknowledgement of command** message to the master station.

2.4.7 DNP3.0 Communication

The DNP3.0 protocol is defined and administered by the DNP User Group. Information about the user group, DNP3.0 in general and protocol specifications can be found on their website: www.dnp.org

The relay operates as a DNP3.0 slave and supports subset level 2 of the protocol plus some of the features from level 3. DNP3.0 communication is achieved using a twisted pair connection to the rear port and can be used over a distance of 1000 m with up to 32 slave devices.

3. CONFIGURING THE COMMUNICATIONS PORTS

3.1 Introduction

Courier works on a master/slave basis where the slave units contain information in the form of a database, and respond with information from the database when it is requested by a master unit.

The relay is a slave unit that is designed to be used with a Courier master unit such as Easergy Studio, PAS&T or a SCADA system.

3.2 Configuring the Front Courier Port

The front EIA(RS)232 9-pin port supports the Courier protocol for one-to-one communication. It is designed for use during installation, commissioning and maintenance and is not suitable for permanent connection. Since this interface is not intended to link the relay to a substation communication system, not all of the features of the Courier interface are supported; the port is not configurable and the following parameters apply:

Physical presentation	EIA(RS)232 via 9-pin connector
Frame format	IEC60870-5 FT1.2 = 11-bit (8 Even 1)
Address	1
Baud rate	19200 bps

Note

As part of the limited implementation of Courier on the front port, neither automatic extraction of event and disturbance records, nor busy response are supported.)

3.3 Configuring the First Rear Courier Port (RP1)

Once the physical connection is made to the relay, configure the relay's communication settings using the keypad and LCD user interface.

1. In the relay menu, select the **Configuration** column, then check that the **Comms. settings** cell is set to **Visible**.
2. Select the Communications column. Only two settings apply to the rear port using Courier, the relay's address and the inactivity timer. Synchronous communication uses a fixed baud rate of 64 kbits/s.
3. Move down the **Communications** column from the column heading to the first cell down. This shows the communication protocol.

RP1 Protocol
Courier

4. The next cell down the column controls the address of the relay. As up to 32 relays can be connected to one K-Bus spur, each relay must have a unique address so messages from the master control station are accepted by one relay only. Courier uses an integer (from 0 to 254) for the relay address that is set with this cell.

Important:

No two relays should have the same Courier address. The master station uses the Courier address to communicate with the relay.

RP1 Address
1

5. The next cell down controls the inactivity timer.

RP1 Inactiv timer
10.00 mins.

The inactivity timer controls how long the relay waits without receiving any messages on the rear port before it reverts to its default state, including revoking any password access that was enabled. For the rear port this can be set between 1 and 30 minutes.

Note

Protection and disturbance recorder settings that are modified using an online editor such as PAS&T must be confirmed with a write to the 'Save changes' cell of the 'Configuration' column. Off-line editors such as Easergy Studio do not require this action for the setting changes to take effect.

The next cell down controls the physical media used for the communication.

RP1 Physical link
Copper

The default setting is to select the electrical (copper) connection. If the optional fiber optic interface is fitted to the relay, then this setting can be changed to '**Fiber optic**'. This cell is invisible if a second rear communications port or an Ethernet card is fitted, as they are mutually exclusive and occupy the same physical location.

6. If the Physical link selection is copper, the next cell down becomes visible to further define the configuration:

RP1 Port Config
KBus

The setting choice is between K-Bus and EIA(RS)485. Selecting K-Bus allows connection with K-series devices, but means that a converter must be used to make a connection. If the EIA(RS)485 selection is made, direct connections can be made to proprietary equipment such as MODEMs. If the EIA(RS)485 selection is made, then two further cells become visible to control the frame format and the communication speed:

7. The frame format is selected in the RP1 Comms mode setting:

RP1 Comms Mode
IEC60870 FT1.2

The standard default is the IEC 60870-FT1.2. This is an 11-bit framing.

Alternatively, a 10-bit framing may be selected for use with MODEMs that do not support 11-bit framing.

8. The final RP1 cell controls the communication speed or baud rate:

RP1 Baud Rate
19200 bits/s

Courier communications is asynchronous and three baud rate selections are available to allow the relay communication rate to be matched to that of the connected equipment. Three baud rates are supported by the relay, '9600 bits/s', '19200 bits/s' and '38400 bits/s'.

Important

If you modify protection and disturbance recorder settings using an on-line editor such as PAS&T, you must confirm them. To do this, from the Configuration column select the Save changes cell. Off-line editors such as Easergy Studio do not need this action for the setting changes to take effect.

3.4 Configuring the IEC 60870-5 CS 103 Rear Port, RP1

The IEC specification IEC 60870-5-103: Telecontrol Equipment and Systems, Part 5: Transmission Protocols Section 103 defines the use of standards IEC 60870-5-1 to IEC 60870-5-5 to perform communication with protection equipment. The standard configuration for the IEC 60870-5-103 protocol is to use a twisted pair connection over distances up to 1000 m. As an option for IEC 60870-5-103, the rear port can be specified to use a fiber optic connection for direct connection to a master station. The relay operates as a slave in the system, responding to commands from a master station. The method of communication uses standardized messages which are based on the VDEW communication protocol.

To use the rear port with IEC 60870-5-103 communication, configure the relay's communication settings using the keypad and LCD user interface.

1. In the relay menu, select the **Configuration** column, then check that the **Comms. settings** cell is set to **Visible**.
2. Select the **Communications** column. Four settings apply to the rear port using IEC 60870-5-103 that are described below.
Move down the 'COMMUNICATIONS' column from the column heading to the first cell to confirm the communication protocol:

Protocol IEC60870-5-10r

3. The next cell sets the address of the relay on the IEC 60870-5-103 network:

Remote Address 162

Up to 32 relays can be connected to one IEC 60870-5-103 spur, and therefore it is necessary for each relay to have a unique address so that messages from the master control station are accepted by one relay only. IEC 60870-5-103 uses an integer number between 0 and 254 for the relay address. It is important that no two relays have the same address. The address is then used by the master station to communicate with the relay.

4. The next cell down the column controls the baud rate to be used:

Baud rate 9600 bits/s

IEC 60870-5-103 communication is asynchronous. Two baud rates are supported by the relay, '9600 bits/s' and '19200 bits/s'. It is important that whatever baud rate is selected on the relay is the same as that set on the IEC 60870-5-103 master station.

5. The next cell down controls the period between IEC 60870-5-103 measurements:

Measure't period 30.00 s

The IEC 60870-5-103 protocol allows the relay to supply measurements at regular intervals. The interval between measurements is controlled by this cell, and can be set between 1 and 60 seconds.

6. An optional fiber optic card is available in the relay to allow optical connection to the IEC 60870-5-103 communication to be made over an optical connection. When fitted, it converts between EIA(RS)485 signals and fiber optic signals and the following cell is visible in the menu column:

Physical link Copper

The default setting is to select the electrical (copper) connection. If the optional fiber optic interface is fitted to the relay, then this setting can be changed to 'Fiber optic'. This cell is invisible if a second rear communications port or an Ethernet card is fitted, as they are mutually exclusive and occupy the same physical location.

7. The following cell which may be displayed, is not currently used but is available for future expansion.

InactivTimer

8. The next cell down can be used for monitor or command blocking:

CS103 Blocking

There are three settings associated with this cell; these are:

- **Disabled**
No blocking selected.
- **Monitor Blocking**
When the monitor blocking DDB Signal is active high, either by energizing an opto input or control input, reading of the status information and disturbance records is not permitted. When in this mode the relay returns a "Termination of general interrogation" message to the master station.
- **Command Blocking**
When the command blocking DDB signal is active high, either by energizing an opto input or control input, all remote commands are ignored, such as CB Trip/Close or change setting group. When in this mode the relay returns a **negative acknowledgement of command** message to the master station.

3.5 Configuring DNP3.0 Communications Rear Port RP1

The DNP3.0 protocol is defined and administered by the DNP User Group. Information about the user group, DNP3.0 in general and protocol specifications can be found on their website: www.dnp.org

The relay operates as a DNP3.0 slave and supports subset level 2 of the protocol plus some of the features from level 3. DNP3.0 communication is achieved using a twisted pair connection to the rear port and can be used over a distance of 1000 m with up to 32 slave devices.

1. To use the rear port with DNP3.0 communication, configure the relay's communication settings using the keypad and LCD user interface.
2. In the relay menu, select the **Configuration** column, then check that the **Comms. settings** cell is set to **Visible**.
3. Four settings apply to the rear port using IEC 60870-5-103 that are described below.
4. Move down the 'COMMUNICATIONS' column from the column heading to the first cell that indicates the communications protocol:

RP1 Protocol
DNP3.0

5. The next cell sets the device address on the DNP3.0 network:

RP1 Address
232

Up to 32 devices can be connected to one DNP3.0 spur, and therefore it is necessary for each device to have a unique address so that messages from the

master control station are accepted by only one device. DNP3.0 uses a decimal number between 1 and 65519 for the device address. It is important that no two devices have the same address. The address is then used by the DNP3.0 master station to communicate with the relay.

6. The next cell sets the baud rate to be used:

RP1 Baud Rate 9600 bits/s

DNP3.0 communication is asynchronous. Six baud rates are supported by the relay '1200bits/s', '2400bits/s', '4800bits/s', '9600bits/s', '19200bits/s' and '38400bits/s'. It is important that whatever baud rate is selected on the relay is the same as that set on the DNP3.0 master station.

7. The next cell controls the parity format used in the data frames:

RP1 Parity None

The parity can be set to be one of None, Odd or Even. It is important that whatever parity format is selected on the relay is the same as that set on the DNP3.0 master station. An optional fiber optic card is available in the relay to allow optical connection to the IEC 60870-5-103 communication to be made over an optical connection. When fitted, it converts between EIA(RS)485 signals and fiber optic signals and the following cell is visible in the menu column.

8. The next cell down the column controls the physical media used for the communication.

RP1 Physical link Copper

The default setting is to select the electrical (copper) connection. If the optional fiber optic interface is fitted to the relay, then this setting can be changed to Fiber optic. This cell is invisible if a second rear communications port or an Ethernet card is fitted, as they are mutually exclusive and occupy the same physical location.

9. The next cell down the column sets the time synchronization request from the master by the relay:

RP1 Time Sync. Enabled

The time synchronization can be set to either enabled or disabled. If enabled it allows the DNP3.0 master to synchronize the time.

10. Analogue values can be set to be reported in terms of primary, secondary or normalized (with respect to the CT/VT ratio setting) values:

Meas Scaling Primary

11. A message gap setting is provided:

Message Gap ϕ

This allows a gap between message frames to be set to enable compatibility with different master stations. The setting for enabling/disabling DNP3.0 time synchronization is described above. When DNP3.0 time sync is enabled, the required rate of synchronization, known as the "need time", needs to be set.

- 12. A setting allows different "need time" to be set with setting range from 1 - 30 minutes, step of 1 minute and default at 10 minutes:

DNP Need Time
10mins

The transmitted application fragment size can be set to ensure that a Master Station cannot be held too long before a complete reply is received and allow it to move on to next IED in a token ring polling setup.

- 13. The maximum overall response message length can be configured:

DNP App Fragment
2048

A single fragment size is 249. Depending on circumstances, a user may set the fragment size as a multiple of 249 in order to optimize segment packing efficiency in fragments. However it can also be useful to allow "odd" sizes for users to choose under specific circumstances, such as if sending data inside SMS frames, through packet radios, etc. In such cases it can be useful to select the fragment size such that each packet occupies a single "transmission media frame".

In some cases, communication to the outstation is made over slow, packet switched networks which can add seconds to the communication latency.

- 14. A setting is provided to allow the application layer timeout to be set:

DNP App Timeout
2s

- 15. Select Before Operate (SBO) timeouts can be set.

If the DNP3.0 "Select a trip command" causes the relay's internal logic to block automatic tripping, then a corruption of the DNP3.0 "Operate" message could delay the trip. The delay of tripping can be set:

DNP SBO Timeout
10s

- 16. The DNP link timeout can be set:

DNP Link Timeout
10s

3.6 Configuring the (Optional) DNP3.0 over Ethernet Port

When DNP3.0 is provided over Ethernet, settings similar to those described above for the EIA(RS)485 connection are provided for the following :-

- Time Sync.
- Meas. Scaling
- DNP Need Time
- DNP App Fragment
- DNP App Timeout
- DNP SBO Timeout

For these settings, please refer to the descriptions provided in the previous section.

As well as these, other settings as described below are provided to complete the configuration of the DNP3.0 over Ethernet configuration.

A timeout setting is added that defines how long the device will wait before an inactive tunnel connection to the master station is reset:

NIC Tunl Timeout
5 mins

The NIC Link Report configures how a failed/disconnected network link (copper or fiber) is reported. Options are to report an alarm, an event, or nothing:

NIC Link Report
Alarm

The duration of time elapsed, after a failed network link is detected and before communication by the alternative media interface is attempted, can be set:

NIC Link Timeout
60s

The rate at which the SNTP server is polled can be set:

SNTP Poll Rate
64s

3.7 Configuring the Second Rear Courier Port, RP2

For relays having the second rear (Courier) communications port fitted, the settings are located immediately below the ones for the first port described above. The second rear communications port only supports the Courier protocol and the settings are similar to those for Courier RP1. The first cell displays:

1. Move down the settings until the following sub heading is displayed.

Rear Port 2

2. The next cell defines the protocol, which is fixed at Courier for RP2.

RP2 protocol
Courier

3. The following cell indicates the status of the hardware.

RP2 card status
EIA(RS)232 OK

4. The following cell allows for selection of the port configuration.

RP2 port config.
EIA(RS)232

5. The port can be configured for EIA(RS)232, EIA(RS)485 or K-Bus.

As in the case of the first rear Courier port, if K-Bus is not selected certain other cells to control the communication mode and speed become visible. If either EIA(RS)232 or EIA(RS)485 is selected for the port configuration, the next cell is visible and selects the communication mode.

RP2 comms. Mode
IEC60870 FT1.2

6. The standard default is the IEC 60870 FT1.2 for normal operation with 11-bit modems. Alternatively, a 10-bit framing with no parity bit can be selected for special cases.
7. The next cell down sets the communications port address.

RP2 address
255

Since up to 32 devices can be connected to one K-bus spur, it is necessary for each device to have a unique address so that messages from the master control station are accepted by one device only. Courier uses an integer number between 0 and 254 for the device address that is set with this cell. It is important that no two devices have the same Courier address. The Courier address is then used by the master station to communicate with the device. The default value is 255 and must be changed to a value in the range 0 to 254 before use.

- 8. The following cell controls the inactivity timer.

RP2 InactivTimer 15 mins.

- 9. The inactivity timer controls how long the relay will wait without receiving any messages on the rear port before it reverts to its default state. This includes revoking any password access that was enabled. The inactivity timer can be set between 1 and 30 minutes.
- 10. If either EIA(RS)232 or EIA(RS)485 is selected for the port configuration, the following cell is visible and selects the communication speed (baud rate):

RP2 baud rate 19200

Courier communications is asynchronous and three selections are available to allow the relay communication rate to be matched to that of the connected equipment. The three baud rates supported by the relay are: '9600 bits/s', '19200 bits/s' and '38400 bits/s'.

3.8 Configuring the Ethernet Communication (Option)

It is possible to communicate through an Ethernet network using a Schneider Electric I4XS4UE (refer to the Redundant Ethernet Board (REB) chapter for the connections).

Connection for Ethernet communication can be made either by standard RJ45 electrical connections or by multi-mode optical fibers suitable for 1300 nm transmission and terminated with LC connectors.

3.9 Fiber Optic Converter (option)

An optional fiber optic card is available in this product. This converts the EIA(RS)485 protocols into a fiber optic output. This communication card is available for use on Courier, MODBUS (for products listed in the Supported Protocols table), IEC60870-5-103 and DNP3.0 it adds the following setting to the communication column. This controls the physical media used for the communication:

Physical link Copper

The default setting is to select the electrical EIA(RS)485 connection. If the optional fiber optic connectors are fitted to the relay, then this setting can be changed to 'Fiber optic'. This cell is also invisible if a second rear comms. port, or Ethernet card is fitted, as it is mutually exclusive with the fiber optic connectors, and occupies the same physical location.

Where this is used, connection should be made using either 50/125µm or 62.5/125µm multi-mode optical fibers terminated with BFOC/2.5 (ST) connectors.

3.10 Second Rear Port EIA(RS)-485 Example

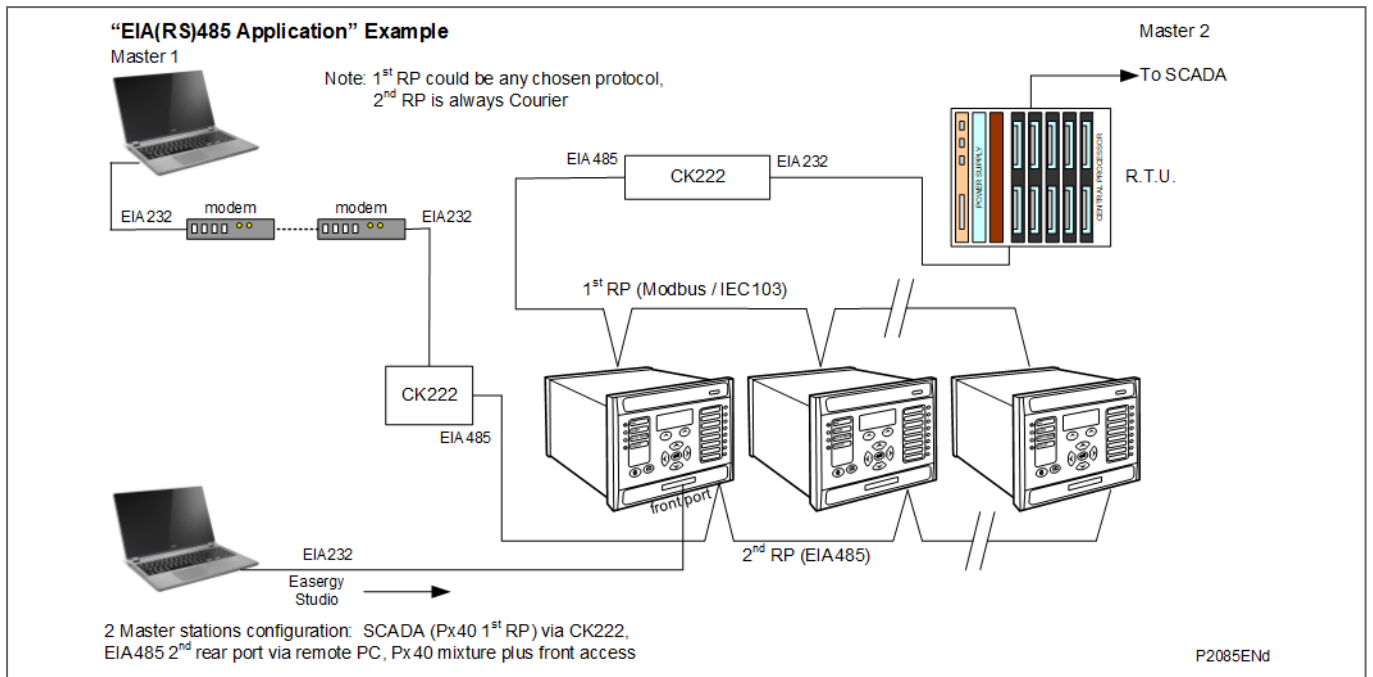

Figure 2 - Second rear port EIA(RS)-485 example

3.11 Second Rear Port EIA(RS)-232 Example

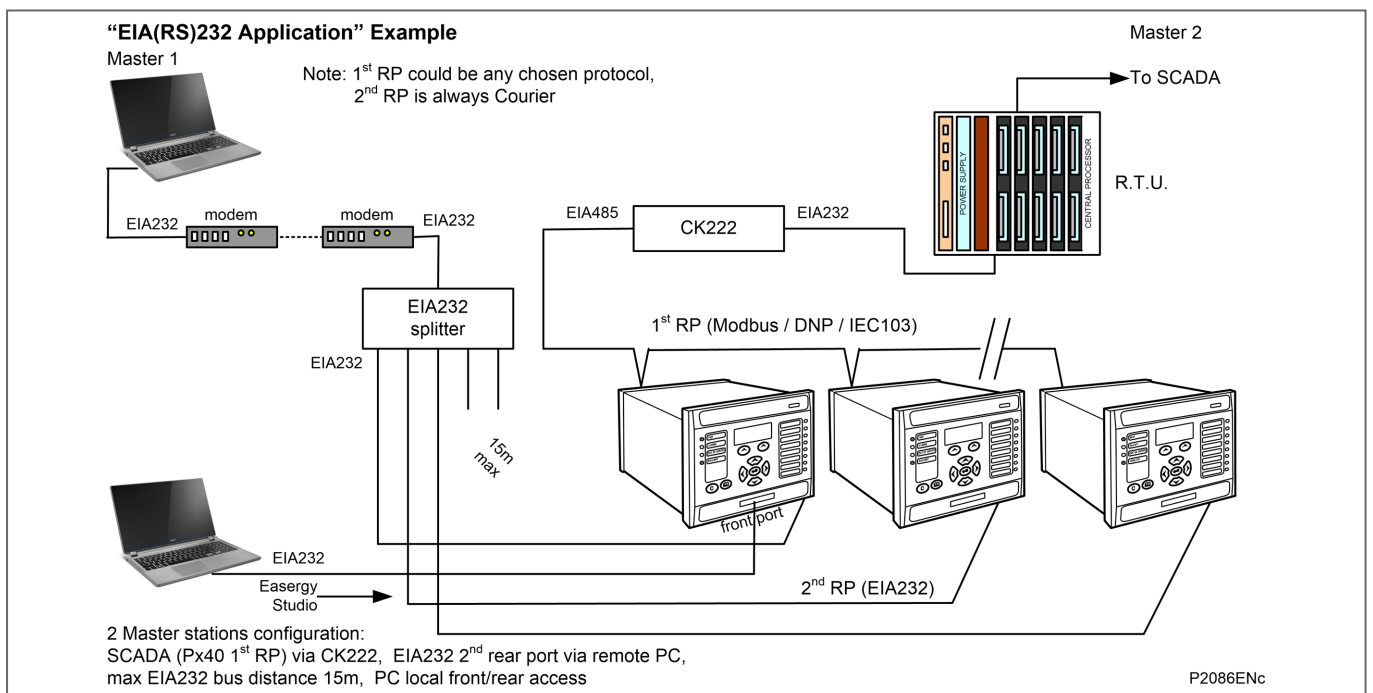

Figure 3 - Second rear port EIA(RS)-232 example

3.12 SK5 Port Connection

The lower 9-way D-type connector (SK5) is currently unsupported. Do not connect to this port.

4. COURIER INTERFACE

4.1 Courier Protocol

Courier is a Schneider Electric communication protocol. The concept of the protocol is that a standard set of commands is used to access a database of settings and data in the relay. This allows a generic master to be able to communicate with different slave devices. The application-specific aspects are contained in the database rather than the commands used to interrogate it, so the master station does not need to be preconfigured.

The same protocol can be used through two physical links K-Bus or EIA(RS)-232.

K-Bus is based on EIA(RS)-485 voltage levels with HDLC FM0 encoded synchronous signaling and its own frame format. The K-Bus twisted pair connection is unpolarized, whereas the EIA(RS)-485 and EIA(RS)-232 interfaces are polarized. The EIA(RS)-232 interface uses the IEC60870-5 FT1.2 frame format.

The relay supports an IEC60870-5 FT1.2 connection on the front-port. This is intended for temporary local connection and is not suitable for permanent connection. This interface uses a fixed baud rate, 11-bit frame, and a fixed device address.

The rear interface is used to provide a permanent connection for K-Bus and allows multidrop connection. Although K-Bus is based on EIA(RS)-485 voltage levels, it is a synchronous HDLC protocol using FM0 encoding. It is not possible to use a standard EIA(RS)-232 to EIA(RS)-485 converter to convert IEC60870-5 FT1.2 frames to K-Bus. Also it is not possible to connect K-Bus to an EIA(RS)-485 computer port.

For a detailed description of the Courier protocol, command-set and link description, see the following documentation:

R6509	K-Bus Interface Guide
R6510	IEC60870 Interface Guide
R6511	Courier Protocol
R6512	Courier User Guide

Alternatively for direct connections, the fiber optic converter card may be used to convert the rear EIA(RS)485 port into a fiber optic (ST) port. See the Fiber Optic Converter (option) section for more information.

4.2 Front Courier Port

The front EIA(RS)-232 9 pin port supports the Courier protocol for one-to-one communication. This port complies with EIA(RS)-574; the 9-pin version of EIA(RS)-232, see www.tiaonline.org. It is designed for use during installation and commissioning/maintenance and is not suitable for permanent connection. Since this interface is not used to link the relay to a substation communication system, some of the features of Courier are not implemented. These are as follows:

- Automatic extraction of Event Records:
 - Courier Status byte does not support the Event flag.
 - Send Event/Accept Event commands are not implemented.
- Automatic extraction of Disturbance records:
 - Courier Status byte does not support the Disturbance flag.
- Busy Response Layer:
 - Courier Status byte does not support the Busy flag, the only response to a request is the final data.
- Fixed Address:

- The address of the front Courier port is always 1; the Change Device address command is not supported.
- Fixed Baud Rate:
 - 19200 bps.
 - Although automatic extraction of event and disturbance records is not supported, it is possible to manually access this data through the front port.

4.3 Supported Command Set

The following Courier commands are supported by the relay:

- Protocol Layer:
 - Reset Remote Link
 - Poll Status
 - Poll Buffer*
- Setting Changes:
 - Enter Setting Mode
 - Preload Setting
 - Abort Setting
 - Execute Setting
 - Reset Menu Cell
 - Set Value
- Low Level Commands:
 - Send Event*
 - Accept Event*
 - Send Block
 - Store Block Identifier
 - Store Block Footer
- Control Commands:
 - Select Setting Group
 - Change Device Address*
 - Set Real Time
- Menu Browsing:
 - Get Column Headings
 - Get Column Text
 - Get Column Values
 - Get Strings
 - Get Text
 - Get Value
 - Get Column Setting Limits

Note

Commands marked with an asterisk (*) are not supported through the front Courier port.

4.4 Courier Database

The Courier database is two-dimensional. Each cell in the database is referenced by a row and column address. Both the column and the row can take a range from 0 to 255. Addresses in the database are specified as hexadecimal values, for example, 0A02 is column 0A (10 decimal) row 02. Associated settings or data are part of the same column. Row zero of the

column has a text string to identify the contents of the column and to act as a column heading.

The *Relay Menu Database* document contains the complete database definition for the relay. For each cell location the following information is stated:

- Cell Text
- Cell Data type
- Cell value
- Whether the cell is settable, if so
 - Minimum value
 - Maximum value
 - Step size
- Password Level required to allow setting changes
- String information (for Indexed String or Binary flag cells)

4.5 Setting Changes

(See R6512, Courier User Guide - Chapter 9)

Courier provides two mechanisms for making setting changes, both of these are supported by the relay. Either method can be used for editing any of the settings in the relay database.

4.5.1 Method 1

This uses a combination of three commands to perform a settings change:

- Enter Setting Mode
 - Checks that the cell is settable and returns the limits.
- Preload Setting
 - Places a new value to the cell. This value is echoed to ensure that setting corruption has not taken place. The validity of the setting is not checked by this action. Execute Setting Confirms the setting change. If the change is valid, a positive response is returned. If the setting change fails, an error response is returned.
- Abort Setting
 - This command can be used to abandon the setting change.

This is the most secure method. It is ideally suited to on-line editors because the setting limits are taken from the relay before the setting change is made. However, this method can be slow if many settings are being changed because three commands are required for each change.

4.5.2 Method 2

The **Set Value** command can be used to directly change a setting, the response to this command is either a positive confirm or an error code to indicate the nature of a failure. This command can be used to implement a setting more rapidly than the previous method, however the limits are not extracted from the relay. This method is most suitable for off-line setting editors such as Easergy Studio, or for issuing preconfigured (SCADA) control commands.

4.5.3 Relay Settings

There are three categories of settings in the relay database:

- Control and support
- Disturbance recorder
- Protection settings group

Setting changes made to the control and support settings are implemented immediately and stored in non-volatile memory. Changes made to either the Disturbance recorder settings or the Protection Settings Groups are stored in a 'scratchpad' memory and are not immediately implemented by the relay.

To action setting changes stored in the scratchpad the **Save Changes** cell in the **Configuration** column must be written to. This allows the changes to either be confirmed and stored in non-volatile memory, or the setting changes to be aborted.

4.5.4 Setting Transfer Mode

If it is necessary to transfer all of the relay settings to or from the relay, a cell in the **Communication System Data** column can be used. This cell (location BF03) when set to 1 makes all of the relay settings visible. Any setting changes made with the relay set in this mode are stored in scratchpad memory, including control and support settings. When the value of BF03 is set back to 0, any setting changes are verified and stored in non-volatile memory.

4.6 Event Extraction

Events can be extracted either automatically (rear port only) or manually (either Courier port). For automatic extraction all events are extracted in sequential order using the standard Courier event mechanism, this includes fault/maintenance data if appropriate. The manual approach allows the user to select events, faults, or maintenance data at random from the stored records.

4.6.1 Automatic Event Extraction

(See Chapter 7 Courier User Guide, publication R6512).

This method is intended for continuous extraction of event and fault information as it is produced. It is only supported through the rear Courier port.

When new event information is created, the Event bit is set in the Status byte. This indicates to the Master device that event information is available. The oldest, unextracted event can be extracted from the relay using the Send Event command. The relay responds with the event data, which is either a Courier Type 0 or Type 3 event. The Type 3 event is used for fault records and maintenance records.

Once an event has been extracted from the relay, the Accept Event can be used to confirm that the event has been successfully extracted. If all events have been extracted, the event bit is reset. If there are more events still to be extracted, the next event can be accessed using the Send Event command as before.

4.6.2 Event Types

Events are created by the relay under these circumstances:

- Change of state of output contact
- Change of state of opto input
- Protection element operation
- Alarm condition
- Setting change
- Password entered/timed-out
- Fault record (Type 3 Courier Event)
- Maintenance record (Type 3 Courier Event)

4.6.3 Event Format

The Send Event command results in these fields being returned by the relay:

- Cell reference
- Time stamp
- Cell text
- Cell value

The Relay Menu Database document for the relevant product, contains a table of the events created by the relay and indicates how the contents of the above fields are interpreted. Fault records and Maintenance records return a Courier Type 3 event, which contains the above fields with two additional fields:

- Event extraction column
- Event number

These events contain additional information that is extracted from the relay using the referenced extraction column. Row 01 of the extraction column contains a setting that allows the fault/maintenance record to be selected. This setting should be set to the event number value returned in the record. The extended data can be extracted from the relay by uploading the text and data from the column.

4.6.4 Manual Event Record Extraction

Column 01 of the database can be used for manual viewing of event, fault, and maintenance records. The contents of this column depend on the nature of the record selected. It is possible to select events by event number and to directly select a fault record or maintenance record by number.

Event Record selection (Row 01)

This cell can be set to a value between 0 to 249 to select from 250 stored events. 0 selects the most recent record and 249 the oldest stored record. For simple event records, (Type 0) cells 0102 to 0105 contain the event details. A single cell is used to represent each of the event fields. If the event selected is a fault or maintenance record (Type 3), the remainder of the column contains the additional information.

Fault Record Selection (Row 05)

This cell can be used to select a fault record directly, using a value between 0 and 4 to select one of up to five stored fault records. (0 is the most recent fault and 4 is the oldest). The column then contains the details of the fault record selected.

Maintenance Record Selection (Row F0)

This cell can be used to select a maintenance record using a value between 0 and 4. This cell operates in a similar way to the fault record selection.

If this column is used to extract event information from the relay, the number associated with a particular record changes when a new event or fault occurs.

Event Record selection (Row 01)

This cell can be set to a value between 0 to 249/511 (see Note) to select from 250/512 (see Note) stored events. 0 selects the most recent record and 249/511 (see Note) the oldest stored record. For simple event records, (Type 0) cells 0102 to 0105 contain the event details. A single cell is used to represent each of the event fields. If the event selected is a fault or maintenance record (Type 3), the remainder of the column contains the additional information.

Note

0 to 249 and 250 stored events for P14x, P341, P34x, P391, P445, P44y, P54x, P64x and P841.

0 to 511 and 512 stored events for P24x, P44x, P74x, P746 and P849.

Fault Record Selection (Row 05) (not applicable to MiCOM P849)

This cell can be used to select a fault record directly, using a value between 0 and 4 to select one of up to five stored fault records. (0 is the most recent fault and 4 is the oldest). The column then contains the details of the fault record selected.

Maintenance Record Selection (Row F0)

This cell can be used to select a maintenance record using a value between 0 and 4. This cell operates in a similar way to the fault record selection.

If this column is used to extract event information from the relay, the number associated with a particular record changes when a new event or fault occurs.

4.7 Disturbance Record Extraction

The stored disturbance records in the relay are accessible in a compressed format through the Courier interface. The records are extracted using column B4. Cells required for extraction of uncompressed disturbance records are not supported.

Select Record Number (Row 01)

This cell can be used to select the record to be extracted. Record 0 is the oldest unextracted record, already extracted older records are assigned positive values, and negative values are used for more recent records. To help automatic extraction through the rear port, the Disturbance bit of the Status byte is set by the relay whenever there are unextracted disturbance records.

Once a record has been selected, using the above cell, the time and date of the record can be read from cell 02. The disturbance record can be extracted using the block transfer mechanism from cell B00B. The file extracted from the relay is in a compressed format. Use Easergy Studio to decompress this file and save the disturbance record in the COMTRADE format.

As has been stated, the rear Courier port can be used to extract disturbance records automatically as they occur. This operates using the standard Courier mechanism, see Chapter 8 of the *Courier User Guide*. The front Courier port does not support automatic extraction although disturbance record data can be extracted manually from this port.

4.8 Programmable Scheme Logic (PSL) Settings

The Programmable Scheme Logic (PSL) settings can be uploaded from and downloaded to the relay using the block transfer mechanism defined in the Courier User Guide.

These cells are used to perform the extraction:

- B204 Domain
Used to select either PSL settings (upload or download) or PSL configuration data (upload only)
- B208 Sub-Domain
Used to select the Protection Setting Group to be uploaded or downloaded.
- B20C Version
Used on a download to check the compatibility of the file to be downloaded with the relay.
- B21C Transfer Mode
Used to set up the transfer process.
- B120 Data Transfer Cell
Used to perform upload or download.

The PSL settings can be uploaded and downloaded to and from the relay using this mechanism. If it is necessary to edit the settings, Easergy Studio must be used because the

data is compressed. Easergy Studio also performs checks on the validity of the settings before they are downloaded to the relay.

5. IEC60870-5-103 INTERFACE

The IEC60870-5-103 interface is a master/slave interface with the relay as the slave device. The relay conforms to compatibility level 2; compatibility level 3 is not supported. These IEC60870-5-103 facilities are supported by this interface:

- Initialization (Reset)
- Time Synchronization
- Event Record Extraction
- General Interrogation
- Cyclic Measurements
- General Commands
- Disturbance Record Extraction
- Private Codes

5.1 Physical Connection and Link Layer

Two connection options are available for IEC60870-5-103, either the rear EIA(RS)-485 port or an optional rear fiber optic port. If the fiber optic port is fitted, the active port can be selected using the front panel menu or the front Courier port. However the selection is only effective following the next relay power up.

For either of the two connection modes, both the relay address and baud rate can be selected using the front panel menu or the front Courier port. Following a change to either of these two settings a reset command is required to re-establish communications, see the description of the reset command in the Initialization section.

5.2 Initialization

Whenever the relay has been powered up, or if the communication parameters have been changed, a reset command is required to initialize the communications. The relay responds to either of the two reset commands (Reset CU or Reset FCB). However, the Reset CU clears any unsent messages in the relay's transmit buffer.

The relay responds to the reset command with an identification message ASDU 5. The Cause Of Transmission (COT) of this response is either Reset CU or Reset FCB depending on the nature of the reset command. For information on the content of ASDU 5 see section *IEC60870-5-103* in the *Relay Menu Database* document.

In addition to the ASDU 5 identification message, if the relay has been powered up it also produces a power-up event.

5.3 Time Synchronization

The relay time and date can be set using the time synchronization feature of the IEC60870-5-103 protocol. The relay corrects for the transmission delay as specified in IEC60870-5-103. If the time synchronization message is sent as a send / confirm message, the relay responds with a confirm. Whether the time-synchronization message is sent as a send / confirm or a broadcast (send / no reply) message, a time synchronization Class 1 event is generated.

If the relay clock is synchronised using the IRIG-B input, it is not possible to set the relay time using the IEC60870-5-103 interface. If the time is set using the interface, the relay creates an event using the current date and time from the internal clock, which is synchronised to IRIG-B.

5.4 Spontaneous Events

Events are categorized using the following information:

- Function Type
- Information Number

The *IEC60870-5-103* profile in the *Relay Menu Database* document, contains a complete listing of all events produced by the relay.

5.5 General Interrogation (GI)

The General Interrogation (GI) request can be used to read the status of the relay, the function numbers, and information numbers that are returned during the GI cycle. See *the IEC60870-5-103* profile in the *Relay Menu Database* document.

5.6 Cyclic Measurements

The relay produces measured values using ASDU 9 cyclically. This can be read from the relay using a Class 2 poll (note ADSU 3 is not used). The rate at which the relay produces new measured values can be controlled using the Measurement Period setting. This setting can be edited from the front panel menu or the front Courier port and is active immediately following a change.

The measurands transmitted by the relay are sent as a proportion of 2.4 times the rated value of the analog value.

5.7 Commands

A list of the supported commands is contained in the *Relay Menu Database* document. The relay responds to other commands with an ASDU 1, with a Cause of Transmission (COT) indicating 'negative acknowledgement'.

5.8 Test Mode

Using either the front panel menu or the front Courier port, it is possible to disable the relay output contacts to allow secondary injection testing to be performed. This is interpreted as 'test mode' by the IEC60870-5-103 standard. An event is produced to indicate both entry to and exit from test mode. Spontaneous events and cyclic measured data transmitted while the relay is in test mode has a COT of 'test mode'.

The **Test Mode** menu cell (in the **COMMISSION TESTS** column) is used to allow secondary injection testing to be performed on the relay.

To select test mode set the Test Mode menu cell to **Test Mode**. It causes an alarm condition to be recorded, the yellow ALARM LED to light and an alarm message **Test Mode Alm** to be generated.

Test Mode freezes any information stored in the **CB CONDITION** column and (in IEC60870-5-103 builds) changes the Cause Of Transmission (COT) to Test Mode. For relays supporting IEC 61850 Edition 2, the test bit for data quality attribute shall set to TRUE, and the Logical Device Mode will set to test.

Test Mode can also be enabled by energizing an opto mapped to the **Test Mode** signal.

To enable testing of output contacts set the **Test Mode** cell to **Contacts Blocked**. It causes an alarm condition to be recorded, the yellow ALARM LED to light and an alarm message 'Contacts Blk Alm' to be generated.

In **Contact Blocked** mode, the protection function still works but the contacts will not operate. Also, the **Test Pattern** and contact test functions are visible, which can be used to manually operate the output contacts. For relays supporting IEC 61850 Edition 2, the test bit for data quality attribute shall set to TRUE, and the Logical Device Mode will set to test/blocked.

Contacts Blocked can also be enabled by energizing an opto mapped to the **Contacts Blocked** signal.

Once testing is complete the cell must be set back to **Disabled** to restore the relay back to service.

WARNING

If you use or enable Test Mode, you must disable Test Mode before putting the relay back into active service.

IT IS POTENTIALLY EXTREMELY UNSAFE TO ATTEMPT TO USE ANY RELAY WHICH IS STILL IN TEST MODE IN ACTIVE SERVICE.

5.9 Disturbance Records

For Software Releases prior to B0 (i.e. 57 and earlier):

The disturbance records are stored in uncompressed format and can be extracted using the standard mechanisms described in IEC60870-5-103.

Note

IEC60870-5-103 only supports up to 8 records.

For Software Release B0 - A & B:

The disturbance records are stored in uncompressed format and can be extracted using the standard mechanisms described in IEC60870-5-103. The Enhanced Disturbance Recorder software releases mean the relay can store a minimum of 15 records, each of 1.5 seconds duration.

Using relays with IEC 60870-5 CS 103 communication means they can store the same total record length. However, the IEC 60870-5 CS 103 communication protocol dictates that only 8 records (of 3 seconds duration) can be extracted via the rear port.

For Other Software Releases:

The disturbance records are stored in uncompressed format and can be extracted using the standard mechanisms described in IEC60870-5-103.

Where available, the Enhanced Disturbance Recorder software releases mean the relay can store a minimum of 15 records, each of 3.0 seconds duration.

Using relays with IEC 60870-5 CS 103 communication means they can store the same total record length. However, the IEC 60870-5 CS 103 communication protocol dictates that only 8 records (of 3 seconds duration) can be extracted via the rear port.

5.10 Blocking of Monitor Direction

The relay supports a facility to block messages in the Monitor direction and in the Command direction. Messages can be blocked in the Monitor and Command directions using the menu commands, Communications - CS103 Blocking - Disabled / Monitor Blocking / Command Blocking or DDB signals Monitor Blocked and Command Blocked.

5.11 Setting Changes through IEC103 Protocol

The IEC 870-5-103 Standard suggests using the generic services for read/write operations on the proprietary data of different manufacture protection equipments, the directory structure specified by the standard for accessing the generic data is the same as the Px40 setting

structure. With the generic services selected in the Platform Software full access to the relay's database is possible over the first rear communications port using the IEC60870-5-103 protocol with Level 3 compatibility.

Each cell in the database has an attribute that defines whether it is included in the list of cells that are subject to a General Interrogation of Generic data.

The following Group 1,2,3 and 4 settings will be included in the GGI:

- Overcurrent, Neg Seq O/C, Broken Conductor, Earth Fault 1 and 2,
- SEF/REF Prot'n, Residual O/V NVD, Thermal Overload, NEG Sequence O/V,
- Cold Load Pickup, Selective Logic, Admit Protection, Power Protection,
- Volt Protection, Freq Protection, CB FAIL & I<, Supervision,
- Fault Locator, System Checks, Autoreclose, ADV.Frequency.

6. DNP3.0 INTERFACE

6.1 DNP3.0 Protocol

The DNP3.0 protocol is defined and administered by the DNP Users Group. For information on the user group, DNP3.0 in general and the protocol specifications, see

www.dnp.org

The descriptions given there are intended to accompany the device profile document that is included in the Relay Menu Database document. The DNP3.0 protocol is not described here, please refer to the documentation available from the user group. The device profile document specifies the full details of the DNP3.0 implementation for the relay. This is the standard format DNP3.0 document that specifies which objects; variations and qualifiers are supported. The device profile document also specifies what data is available from the relay using DNP3.0. The relay operates as a DNP3.0 slave and supports subset level 2 of the protocol, plus some of the features from level 3.

DNP3.0 communication uses the EIA(RS)-485 communication port at the rear of the relay. The data format is 1 start bit, 8 data bits, an optional parity bit and 1 stop bit. Parity is configurable (see menu settings below)

6.2 DNP3.0 Menu Setting

The following settings are in the DNP3.0 menu in the **Communications** column.

Settings	Range	Description
Remote Address	0 - 65519	DNP3.0 address of relay (decimal)
Baud Rate	1200, 2400, 4800, 9600, 19200, 38400	Selectable baud rate for DNP3.0 serial communication
Parity	None, Odd, Even	Parity setting
DNP Time Sync	Disabled, Enabled	Enables or disables the relay requesting time sync. from the master via IIN bit 4 word 1.
Meas Scaling	Primary, Secondary or Normalised	Setting to report analog values in terms of primary, secondary or normalized (with respect to the CT/VT ratio setting) values.
Message Gap (ms)	0-50	DNP3.0 versions only. This setting allows the master station to have an interframe gap.
DNP Need Time	1 - 30 mins	The length of time waited before requesting another time sync from the master.
DNP App Fragment	100 - 2048 bytes	The maximum message length (application fragment size) transmitted by the relay.
DNP App Timeout	1 - 120 s	The length of time waited after sending a message fragment and waiting for a confirmation from the master.
DNP SBO Timeout	1 - 10 s	The length of time waited after receiving a select command and waiting for an operate confirmation from the master.
DNP Link Timeout	0 - 120 s	The length of time the relay waits for a Data Link Confirm from the master. A value of 0 means data link support disabled and 1 to 120 seconds is the timeout setting.

Table 3 - DNP3.0 menu in the Communications column

6.3 Object 1 Binary Inputs

Object 1, binary inputs, contains information describing the state of signals in the relay, which mostly form part of the Digital Data Bus (DDB). In general these include the state of the output contacts and input optos, alarm signals and protection start and trip signals. The 'DDB number' column in the device profile document provides the DDB numbers for the DNP3.0 point data. These can be used to cross-reference to the DDB definition list. See the *Relay Menu Database* document. The binary input points can also be read as change events using object 2 and object 60 for class 1-3 event data.

6.4 Object 10 Binary Outputs

Object 10, binary outputs, contains commands that can be operated using DNP3.0. Therefore the points accept commands of type pulse on [null, trip, close] and latch on/off as detailed in the device profile in the Relay Menu Database document and execute the command once for either command. The other fields are ignored (queue, clear, trip/close, in time and off time).

There is an additional image of the control inputs. Described as alias control inputs, they reflect the state of the control input, but with a dynamic nature.

- If the Control Input DDB signal is already SET and a new DNP SET command is sent to the Control Input, the Control Input DDB signal goes momentarily to RESET and then back to SET.
- If the Control Input DDB signal is already RESET and a new DNP RESET command is sent to the Control Input, the Control Input DDB signal goes momentarily to SET and then back to RESET.

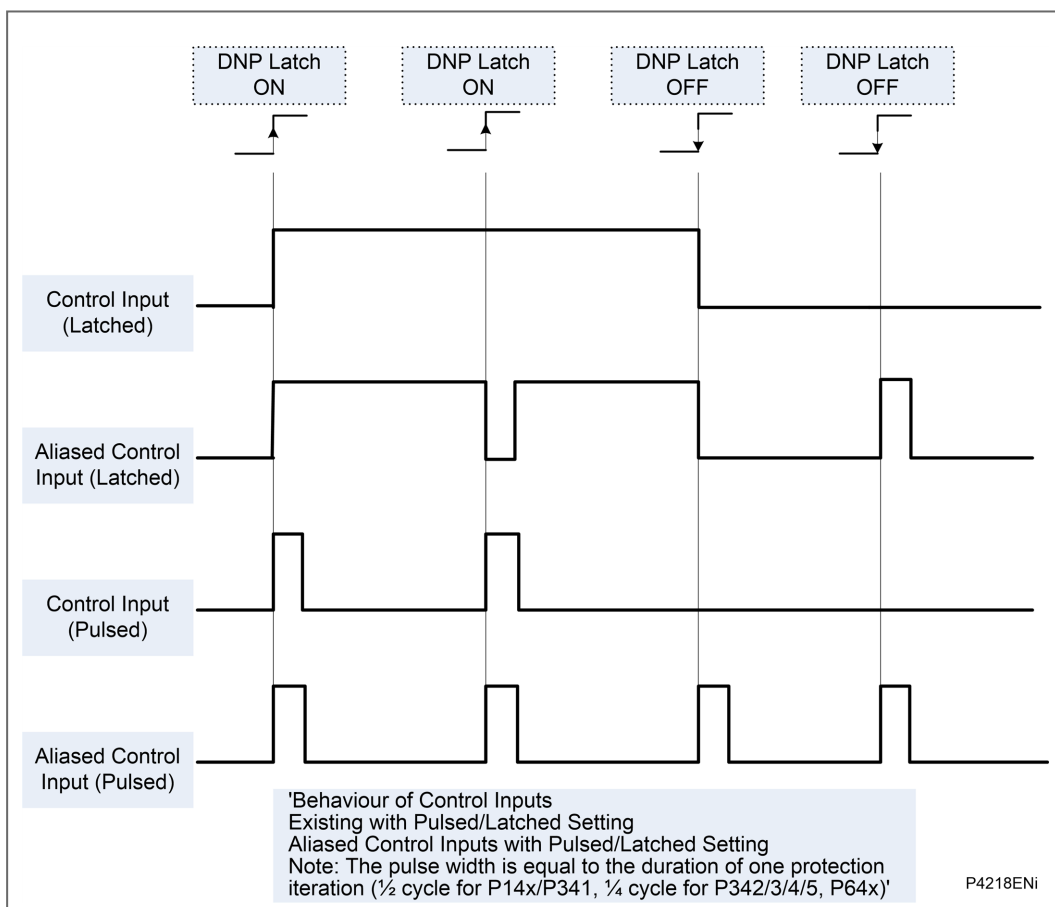

Figure 4 - Behaviour when control input is set to be pulsed or latched

Many of the relay's functions are configurable so some of the object 10 commands described in the following sections may not be available. A read from object 10 reports the point as off-line and an operate command to object 12 generates an error response.

Examples of object 10 points that maybe reported as off-line are:

- Activate setting groups:
Ensure setting groups are enabled
- CB trip/close:
Ensure remote CB control is enabled
- Reset NPS thermal:
Ensure NPS thermal protection is enabled
- Reset thermal O/L:
Ensure thermal overload protection is enabled
- Reset RTD flags
Ensure RTD Inputs is enabled
- Control inputs:
Ensure control inputs are enabled

6.5 Object 20 Binary Counters

Object 20, binary counters, contains cumulative counters and measurements. The binary counters can be read as their present 'running' value from object 20, or as a 'frozen' value from object 21. The running counters of object 20 accept the read, freeze and clear functions. The freeze function takes the current value of the object 20 running counter and stores it in the corresponding object 21 frozen counter. The freeze and clear function resets the object 20 running counter to zero after freezing its value.

Binary counter and frozen counter change event values are available for reporting from object 22 and object 23 respectively. Counter change events (object 22) only report the most recent change, so the maximum number of events supported is the same as the total number of counters. Frozen counter change events (object 23) are generated when ever a freeze operation is performed and a change has occurred since the previous freeze command. The frozen counter event queues will store the points for up to two freeze operations.

6.6 Object 30 Analog Input

Object 30, analog inputs, contains information from the relay's measurements columns in the menu. All Object 30 points can be reported as 16 or 32-bit integer values with flag, 16 or 32-bit integer values without flag, as well as short floating point values.

Analogue values can be reported to the master station as primary, secondary or normalized values (which takes into account the relay's CT and VT ratios) and this is settable in the DNP3.0 Communications Column in the relay. Corresponding deadband settings can be displayed in terms of a primary, secondary or normalized value. Deadband point values can be reported and written using Object 34 variations.

The deadband is the setting used to determine whether a change event should be generated for each point. The change events can be read using Object 32 or Object 60. These events are generated for any point which has a value changed by more than the deadband setting since the last time the data value was reported.

Any analog measurement that is unavailable when it is read is reported as offline. For example, the frequency when the current and voltage frequency is outside the tracking range of the relay or the thermal state when the thermal protection is disabled in the configuration column. All Object 30 points are reported as secondary values in DNP3.0 (with respect to CT and VT ratios).

The following fault data can be mapped in DNP3.0 protocol in serial and Ethernet connections:

- Fault voltages
- Fault currents
- Fault location
- Operating time of relay
- Operating time of breaker
- Fault time
- Fault date

The latest fault records only will be retrieved over DNP3.0.

6.7 Object 40 Analog Output

The conversion to fixed-point format requires the use of a scaling factor, which is configurable for the various types of data within the relay such as current, voltage, and phase angle. All Object 40 points report the integer scaling values and Object 41 is available to configure integer scaling quantities.

6.8 DNP3.0 Configuration using Easergy Studio

A PC support package for DNP3.0 is available as part of Easergy Studio to allow configuration of the relay's DNP3.0 response. The PC is connected to the relay using a serial cable to the 9-pin connector on the front of the relay, see the *Introduction* chapter.

The configuration data is uploaded from the relay to the PC in a block of compressed format data and downloaded to the relay in a similar manner after modification. The new DNP3.0 configuration takes effect in the relay after the download is complete. To restore the default configuration at any time, from the **Configuration** column, select the **Restore Defaults** cell then select **All Settings**.

In Easergy Studio, the DNP3.0 data is shown in four main folders, one folder each for the point configuration, integer scaling, default variation (data format) and DNP over Ethernet. The point configuration also includes screens for binary inputs, binary outputs, counters and analogue input configuration. Note that if the DNP3.0 over Ethernet plus IEC61850 option is chosen, DNP over Ethernet configuration will be used to configure DNP3.0 over Ethernet, and this part of configuration will be ignored by DNP3.0 serial.

For the IP configuration of DNP over Ethernet, please refer to the *DNP3.0 over Ethernet runs concurrently with IEC61850* section.

DNP3.0 over Ethernet includes support for unsolicited responses.

For the Unsolicited Responses configuration of DNP over Ethernet, please refer to this table:

Setting Name	Explanation
unsolAllowed	Determines whether unsolicited responses are allowed. If unsolAllowed is set to disabled, no unsolicited responses will be generated. Requests to enable or disable unsolicited responses will fail and the master station will reply indicating bad function information. If it is configured to allow unsolicited mode (enabled), the relay will be able to send event data in an unsolicited response after it receives a request from the master station containing function code ENABLE_UN SOLICITED(0x14) that enables some or all points to initiate unsolicited responses.
unsolMaxRetries	Specify the maximum number of unsolicited retries before changing to the 'offline' retry period (30 seconds).

Setting Name	Explanation
	unsolRetryDelay Specifies the time, in seconds, to delay after an unsolicited confirm timeout before retrying the unsolicited response.
unsolClass1MaxDelay	If unsolicited responses are enabled, unsolClassXMaxDelay specifies the maximum amount of time in seconds after an event in the corresponding class is received before an unsolicited response will be generated. A configured value of 0 indicates that responses are not delayed.
unsolClass2MaxDelay	
unsolClass3MaxDelay	
unsolClass1MaxEvents	If unsolicited responses are enabled, unsolClassXMaxEvents specifies the maximum number of events in the corresponding class to be allowed before an unsolicited response will be generated.
unsolClass2MaxEvents	
unsolClass3MaxEvents	

Table 4 - Unsolicited Responses configuration of DNP over Ethernet**Important**

At most 6 clients are supported to connect to device at the same time in DNP3.0 over Ethernet protocol.

6.8.1 DNP3.0 over Ethernet runs concurrently with IEC61850

DNP3.0 over Ethernet can run concurrently with IEC61850 if DNP3.0 over Ethernet plus IEC61850 option is chosen. Below table describes the different cases of the usage of DNP3.0 over Ethernet service and IEC61850 service. IEC61850 service will always run under this situation, but DNPoE service only runs when certain requirements are met.

Board Type	Dual or PRP / HSR / RSTP	Configuration file	Interface 1		Interface 2		Invalid DNPoE IP Alarm
			IP address	DNP3oE	IP address	DNP3oE	
Q or R	Doesn't matter	Default IEC61850 configuration No DNP setting or IP_DNP is 0.0.0.0	DEF_IP_1	Disabled	DEF_IP_2	Disabled	No
	Dual	Default IEC61850 configuration Customized DNP setting with valid IP_DNP	IP_DNP	Run	DEF_IP_2	N/A	No
	PRP/HSR/RSTP		DEF_IP_1	N/A	IP_DNP	Run	No
	Doesn't matter	Customized IEC61850 configuration No DNPoE setting or IP_DNP is 0.0.0.0	IP_1	Disabled	IP_2	Disabled	No
	Doesn't matter	Customized IEC61850 configuration Customized DNPoE setting where IP_DNP = IP_1	IP_1	Run	IP_2	N/A	No
	Doesn't matter	Customized IEC61850 configuration Customized DNPoE setting where IP_DNP = IP_2	IP_1	N/A	IP_2	Run	No
	Doesn't matter	Customized IEC61850 configuration Customized DNPoE setting where IP_DNP ≠ IP_1 and IP_DNP ≠ IP_2	IP_1	Disabled	IP_2	Disabled	Yes
S	N/A	Default IEC61850 configuration No DNPoE setting or IP_DNP is 0.0.0.0	DEF_IP_1	Disabled	N/A	N/A	No
	N/A	Default IEC61850 configuration Customized DNPoE setting with valid IP_DNP	IP_DNP	Run	N/A	N/A	No

Board Type	Dual or PRP / HSR / RSTP	Configuration file	Interface 1		Interface 2		Invalid DNPoE IP Alarm
			IP address	DNP3oE	IP address	DNP3oE	
	N/A	Customized IEC61850 configuration No DNPoE setting or IP_DNP is 0.0.0.0	IP_1	Disabled	N/A	N/A	No
	N/A	Customized IEC61850 configuration Customized DNPoE setting where IP_DNP = IP_1	IP_1	Run	N/A	N/A	No
	N/A	Customized IEC61850 configuration Customized DNPoE setting where IP_DNP ≠ IP_1	IP_1	Disabled	N/A	N/A	Yes
<p>Note For detailed information about different interfaces please refer to the Dual IP in MiCOM section in the Dual Redundant Ethernet Board (DREB) chapter.</p>							

Table 5 - Protocol running options for different board types

For these IP abbreviations please refer to this table:

Abbreviation	Description
DEF_IP_1	Default IP of interface 1 with default IEC61850 configuration
DEF_IP_2	Default IP of interface 2 with default IEC61850 configuration
IP_1	IP of interface 1 configured in a IEC61850 configuration file
IP_2	IP of interface 2 configured in a IEC61850 configuration file
IP_DNP	IP configured in DNP over Ethernet setting

Table 6 - Abbreviations of Different IP

Note
Running DNP3.0 serial and DNP3.0 over Ethernet concurrently is not recommended.

7. IEC 61850 ETHERNET INTERFACE

7.1 Introduction

IEC 61850 is the international standard for Ethernet-based communication in substations. It enables integration of all protection, control, measurement and monitoring functions in a substation, and provides the means for interlocking and inter-tripping. It combines the convenience of Ethernet with the security which is essential in substations today.

The MiCOM protection relays can integrate with the PACiS substation control systems, to complete Schneider Electric's offer of a full IEC 61850 solution for the substation. The majority of MiCOM Px3x and Px4x relay types can be supplied with Ethernet, in addition to traditional serial protocols. Relays which have already been delivered with UCA2.0 on Ethernet can be easily upgraded to IEC 61850.

7.2 What is IEC 61850?

IEC 61850 is a 14-part international standard, which defines a communication architecture for substations. It is more than just a protocol and provides:

- Standardized models for IEDs and other equipment in the substation
- Standardized communication services (the methods used to access and exchange data)
- Standardized formats for configuration files
- Peer-to-peer (for example, relay to relay) communication

The standard includes mapping of data onto Ethernet. Using Ethernet in the substation offers many advantages, most significantly including:

- High-speed data rates (currently 100 Mbits/s, rather than tens of kbits/s or less used by most serial protocols)
- Multiple masters (called "clients")
- Ethernet is an open standard in every-day use

Schneider Electric has been involved in the Working Groups which formed the standard, building on experience gained with UCA2.0, the predecessor of IEC 61850.

7.2.1 Interoperability

A major benefit of IEC 61850 is interoperability. IEC 61850 standardizes the data model of substation IEDs which simplifies integration of different vendors' products. Data is accessed in the same way in all IEDs, regardless of the vendor, even though the protection algorithms of different vendors' relays may be different.

IEC 61850-compliant devices are not interchangeable, you cannot replace one device with another (although they are interoperable). However, the terminology is predefined and anyone with knowledge of IEC 61850 can quickly integrate a new device without mapping all of the new data. IEC 61850 improves substation communications and interoperability at a lower cost to the end user.

7.2.2 Data Model

To ease understanding, the data model of any IEC 61850 IED can be viewed as a hierarchy of information. The categories and naming of this information is standardized in the IEC 61850 specification.

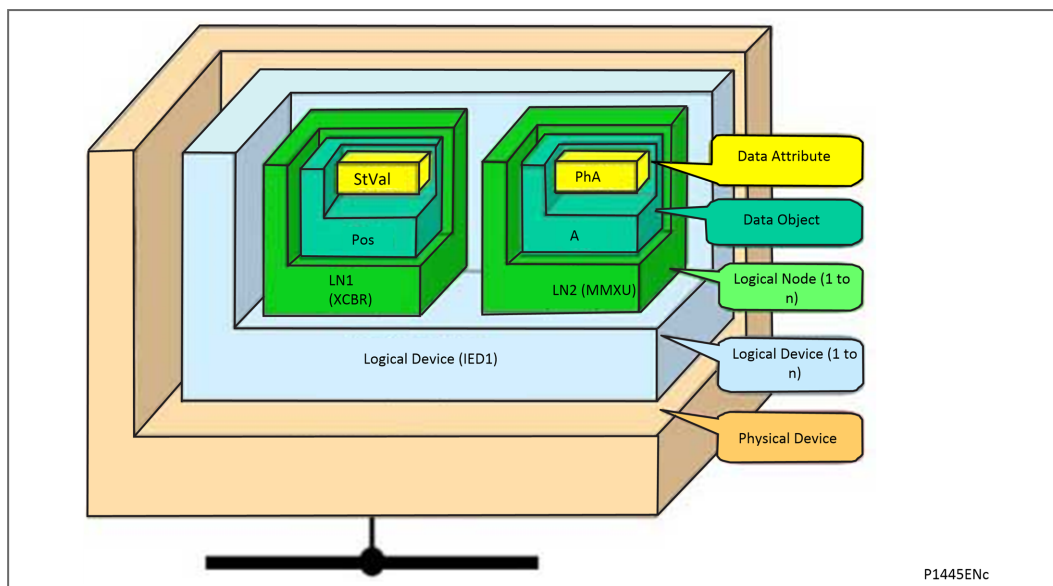

Figure 5 - Data model layers in IEC 61850

The levels of this hierarchy can be described as follows:

- **Physical Device**
 - Identifies the actual IED in a system. Typically the device's name or IP address can be used (for example **Feeder_1** or **10.0.0.2**).
- **Logical Device**
 - Identifies groups of related Logical Nodes in the Physical Device. For the MiCOM relays, five Logical Devices exist: **Control, Measurements, Protection, Records, System**.
- **Wrapper/Logical Node Instance**
 - Identifies the major functional areas in the IEC 61850 data model. Either 3 or 6 characters are used as a prefix to define the functional group (wrapper) while the actual functionality is identified by a 4 character Logical Node name, suffixed by an instance number. For example, XCBR1 (circuit breaker), MMXU1 (measurements), FrqPTOF2 (overfrequency protection, stage 2).
- **Data Object**
 - This next layer is used to identify the type of data presented. For example, **Pos** (position) of Logical Node type **XCBR**.
- **Data Attribute**
 - This is the actual data (such as measurement value, status, and description). For example, stVal (status value) indicates the actual position of the circuit breaker for Data Object type **Pos** of Logical Node type **XCBR**.

7.3 IEC 61850 in MiCOM Relays

IEC 61850 is implemented in MiCOM relays by use of a separate Ethernet card. This card manages the majority of the IEC 61850 implementation and data transfer to avoid any impact on the performance of the protection.

To communicate with an IEC 61850 IED on Ethernet, it is necessary only to know its IP address. This can then be configured into either:

- An IEC 61850 client (or master), for example a PACiS computer (MiCOM C264) or HMI, or
- An MMS browser, with which the full data model can be retrieved from the IED, without any prior knowledge

7.3.1 Capability

The IEC 61850 interface provides these capabilities:

- Read access to measurements

All measurands are presented using the measurement Logical Nodes (LNs), in the Measurements Logical Device (LD). Reported measurement values are refreshed by the relay once per second, in line with the relay user interface.

The following fault data have been mapped in LN RFLO1 of LD Records of IEC61850 data model:

- Fault voltages, Fault currents and Fault location
- Operating time of relay and Operating time of breaker
- Fault time, Fault date, etc...

Only the latest fault record can be retrieved over IEC61850.

- Generation of unbuffered reports on change of status/measurement

Unbuffered reports, when enabled, report any change of state in statuses and measurements (according to deadband settings).

- Support for time synchronization over an Ethernet link

Time synchronization is supported using Simple Network Time Protocol (SNTP). This protocol is used to synchronize the internal real time clock of the relays.

- GOOSE peer-to-peer communication

GOOSE communications of statuses are included as part of the IEC 61850 implementation. See Peer-to-Peer (GSE) Communications for more details.

- Disturbance record extraction

Disturbance records can be extracted from MiCOM relays by file transfer, as ASCII format COMTRADE files.

- Controls

The following control services are available:

- Direct Control
- Direct Control with enhanced security
- Select Before Operate (SBO) with enhanced security
- Controls are applied to open and close circuit breakers using XCBR.Pos and DDB signals 'Control Trip' and 'Control Close'.
- System/LLN0.LLN0.LEDRs are used to reset any trip LED indications.

Setting changes (e.g. of protection settings) are not supported in the current IEC 61850 implementation. In order to keep this process as simple as possible, such setting changes are done using Easergy Studio Settings & Records program. This can be done as previously using the front port serial connection of the relay, or now optionally over the Ethernet link if preferred (this is known as "tunneling").

- Reports

Reports only include data objects that have changed and not the complete dataset. The exceptions to this are a General Interrogation request and integrity reports.

- Buffered Reports

Eight Buffered Report Control Blocks, (BRCB), are provided in SYSTEM/LLN0 in Logical Device 'System'.

Buffered reports are configurable to use any configurable dataset located in the same Logical device as the BRCB (SYSTEM/LLN0).

- **Unbuffered Reports**

Sixteen Unbuffered Report Control Blocks (URCB) are provided in SYSTEM/LLN0 in Logical Device 'System'.

Unbuffered reports are configurable to use any configurable dataset located in the same Logical device as the URCB (SYSTEM/LLN0).
- **Configurable Data Sets**

It is possible to create and configure datasets in any Logical Node using the IED Configurator. The maximum number of datasets will be specified in an IED's ICD file. An IED is capable of handling 100 datasets.
- **Published GOOSE message**

Eight GOCBs are provided in SYSTEM/LLN0.
- **Uniqueness of control**

The Uniqueness of control mechanism is implemented to be consistent with the PACiS mechanism. This requires the relay to subscribe to the OrdRun signal from all devices in the system and be able to publish such a signal in a GOOSE message.
- **Select Active Setting Group**

Functional protection groups can be enabled or disabled using private mod/beh attributes in the Protection/LLN0.OcpMod object. Setting groups are selectable using the Setting Group Control Block class, (SGCB). The Active Setting Group can be selected using the System/LLN0.SP.SGCB.ActSG data attribute in Logical Device 'System'.
- **Quality for GOOSE**

It is possible to process the quality attributes of any Data Object in an incoming GOOSE message. Devices that do not support IEC61850 quality flags send quality attributes as all zeros. The supported quality attributes for outgoing GOOSE messages are described in the Protocol Implementation eXtra Information for Testing (PIXIT) document.
- **Address List**

An Address List document (to be titled ADL) is produced for each IED which shows the mapping between the IEC61850 data model and the internal data model of the IED. It includes a mapping in the reverse direction, which may be more useful. This document is separate from the PICS/MICS document.
- **Originator of Control**

Originator of control mechanism is implemented for operate response message and in the data model on the ST of the related control object, consistent with the PACiS mechanism.
- **Metering**

MMTR (metering) logical node is implemented in P14x products. All metered values in the MMTR logical node are of type BCR. The actVal attribute of the BCR class is of type INT128, but this type is not supported by the SISCO MMSLite library. Instead, an INT64 value will be encoded for transmission. A SPC data object named MTTRs has been included in the MMTR logical node. This control will reset the demand measurements. A SPC data object named MTTRs is also included in the PTTR logical node. This control will reset the thermal measurements.
- **Scaled Measurements**

The Unit definition, as per IEC specifies an SI unit and an optional multiplier for each measurement. This allows a magnitude of measurement to be specified e.g. mA, A, kA, MA.

- General Service Tracking

This allows a service to be reported, as soon as the tracking data object is a DataSet member of the DataSet associated to a buffered or unbuffered report control block (BRCB / URCB).

The service track only supports Buffered report tracking service and unbuffered report tracking service.

The multiplier will always be included in the Unit definition and will be configurable in SCL, but not settable at runtime. It will apply to the magnitude, rangeC.min & rangeC.max attributes. rangeC.min & rangeC.max will not be settable at runtime to be more consistent with Px30 and to reduce configuration problems regarding deadbands.

Setting changes, such as changes to protection settings, are done using Easergy Studio. These changes can also be done using the relay's front port serial connection or the relay's Ethernet link, and is known as "tunneling".

7.3.2 IEC 61850 Configuration

One of the main objectives of IEC 61850 is to allow IEDs to be directly configured from a configuration file generated at system configuration time. At the system configuration level, the capabilities of the IED are determined from an IED capability description file (ICD), which is provided with the product. Using a collection of these ICD files from different products, the entire protection of a substation can be designed, configured and tested (using simulation tools) before the product is even installed into the substation.

To help this process, the Easergy Studio Support Software provides an IEC61850 IED Configurator tool. Select **Tools > IEC61850 IED Configurator**. This tool allows the preconfigured IEC 61850 configuration file (SCD or CID) to be imported and transferred to the IED. The configuration files for MiCOM relays can also be created manually, based on their original IED Capability Description (ICD) file.

Other features include the extraction of configuration data for viewing and editing, and a sophisticated error-checking sequence. The error checking ensures the configuration data is valid for sending to the IED and ensures the IED functions correctly in the substation.

To help the user, some configuration data is available in the **IED CONFIGURATOR** column of the relay user interface, allowing read-only access to basic configuration data.

7.3.2.1 Configuration Banks

To promote version management and minimize down-time during system upgrades and maintenance, the MiCOM relays have incorporated a mechanism consisting of multiple configuration banks. These configuration banks are categorized as:

- Active Configuration Bank
- Inactive Configuration Bank

Any new configuration sent to the relay is automatically stored in the inactive configuration bank, therefore not immediately affecting the current configuration. Both active and inactive configuration banks can be extracted at any time.

When the upgrade or maintenance stage is complete, the IED Configurator tool can be used to transmit a command to a single IED. This command authorizes the activation of the new configuration contained in the inactive configuration bank, by switching the active and inactive configuration banks. This technique ensures that the system down-time is minimized to the start-up time of the new configuration. The capability to switch the configuration banks is also available using the **IED CONFIGURATOR** column.

For version management, data is available in the **IED CONFIGURATOR** column in the relay user interface, displaying the SCL Name and Revision attributes of both configuration banks.

7.3.2.2 Network Connectivity

Note

This section presumes a prior knowledge of IP addressing and related topics. Further details on this topic may be found on the Internet (search for IP Configuration) and in numerous relevant books.

Configuration of the relay IP parameters (IP Address, Subnet Mask, Gateway) and SNTP time synchronization parameters (SNTP Server 1, SNTP Server 2) is performed by the IED Configurator tool. If these parameters are not available using an SCL file, they must be configured manually.

If the assigned IP address is duplicated elsewhere on the same network, the remote communications do not operate in a fixed way. However, the relay checks for a conflict at power up and every time the IP configuration is changed. An alarm is raised if an IP conflict is detected.

Use the **Gateway** setting to configure the relay to accept data from networks other than the local network.

7.4 Data Model of MiCOM Relays

The data model naming adopted in the Px30 and Px40 relays has been standardized for consistency. The Logical Nodes are allocated to one of the five Logical Devices, as appropriate, and the wrapper names used to instantiate Logical Nodes are consistent between Px30 and Px40 relays.

The data model is described in the Model Implementation Conformance Statement (MICS) document, which is available separately. The MICS document provides lists of Logical Device definitions, Logical Node definitions, Common Data Class and Attribute definitions, Enumeration definitions, and MMS data type conversions. It generally follows the format used in Parts 7-3 and 7-4 of the IEC 61850 standard.

7.5 Communication Services of MiCOM Relays

The IEC 61850 communication services which are implemented in the Px30 and Px40 relays are described in the Protocol Implementation Conformance Statement (PICS) document, which is available separately. The PICS document provides the Abstract Communication Service Interface (ACSI) conformance statements as defined in Annex A of Part 7-2 of the IEC 61850 standard.

7.6 Peer-to-Peer (GSE) Communications

The implementation of IEC 61850 Generic Object Oriented Substation Event (GOOSE) sets the way for cheaper and faster inter-relay communications. The generic substation event model provides fast and reliable system-wide distribution of input and output data values. The generic substation event model is based on autonomous decentralization. This provides an efficient method of allowing simultaneous delivery of the same generic substation event information to more than one physical device, by using multicast services.

The use of multicast messaging means that IEC 61850 GOOSE uses a publisher-subscriber system to transfer information around the network*. When a device detects a change in one of its monitored status points, it publishes (sends) a new message. Any device that is interested in the information subscribes (listens) to the data message.

Note*

Multicast messages cannot be routed across networks without specialized equipment.

Each new message is retransmitted at user-configurable intervals until the maximum interval is reached, to overcome possible corruption due to interference and collisions. In practice,

the parameters which control the message transmission cannot be calculated. Time must be allocated to the testing of GOOSE schemes before or during commissioning; in just the same way a hardwired scheme must be tested.

7.6.1 Scope

A maximum of 32 virtual outputs and 32 virtual inputs are available within the PSL which can be mapped directly to a published dataset in a GOOSE message (only 1 fixed dataset is supported). All published GOOSE signals are BOOLEAN values.

Note

Previous releases of this product could use up to 32 virtual outputs. The B0 release allows you to use up to 32 virtual inputs.

Note

Analogue Goose subscribing: A new GGIO3 is provided for analogue value subscribing, the received analogue values will not be sent to the main card. The values will be stored only on the IEC 61850 data mode.

Each GOOSE signal contained in a subscribed GOOSE message can be mapped to any of the 32 virtual outputs and 32 virtual inputs within the PSL. The virtual inputs allow the mapping to internal logic functions for protection control, directly to output contacts or LEDs for monitoring.

The MiCOM relay can subscribe to all GOOSE messages but only these data types can be decoded and mapped to a virtual input:

- BOOLEAN
- BSTR2
- INT16
- INT32
- INT8
- UINT16
- UINT32
- UINT8

7.6.2 Simulation GOOSE Configuration

From Easergy Studio select Tools > IEC 61850 IED Configurator (Ed.2). Make sure the configuration is correct as this ensures efficient GOOSE scheme operation.

The relay can be set to publish/subscribe simulation/test GOOSE; it is important that this setting is returned to publish/receive normal GOOSE messages after testing to permit normal operation of the application and GOOSE messaging.

The relay provides a single setting to receive Simulated GOOSE, however it manages each subscribed GOOSE signal independently when the setting is set to simulated GOOSE. Each subscription (virtual input) will continue to respond to GOOSE messages without the simulation flag set; however once the relay receives a GOOSE for a subscription with the simulation flag set, it will respond to this and ignore messages without the simulation flag set. Other subscriptions (virtual inputs) which have not received a GOOSE message with the simulation flag will continue to operate as before. When the setting is reset back to normal GOOSE messaging the relay will ignore all GOOSE messages with the simulation flag set and act on GOOSE messages without the simulation flag.



WARNING

If you set the GOOSE in Simulation Mode, you MUST set it back to normal GOOSE after testing.

IT IS POTENTIALLY EXTREMELY UNSAFE TO ATTEMPT TO USE ANY RELAY WHICH IS STILL IN GOOSE SIMULATION MODE.

7.6.3 High Performance GOOSE

In addition, the Px40 device is designed to provide maximum performance through an optimized publishing mechanism. This optimized mechanism is enabled so that the published GOOSE message is mapped using only the data attributes rather than mapping a complete data object. If data objects are mapped, the GOOSE messaging will operate correctly; but without the benefit of the optimized mechanism.

A pre-configured dataset named as "HighPerformGOOSE" is available in Ed.2 ICD template, which include all data attributes of all virtual outputs. We recommend using this dataset to get the benefit of better GOOSE performance. The optimized mechanism also applies to Ed.1 but without such a pre-configured dataset.

7.7 Ethernet Functionality

Settings relating to a failed Ethernet link are available in the 'COMMUNICATIONS' column of the relay user interface.

Note

Setting relating to the failed link is removed for the new Ethernet and the behaviour is fixed as Event.

7.7.1 Ethernet Disconnection

IEC 61850 'Associations' are unique and made to the relay between the client (master) and server (IEC 61850 device). If the Ethernet is disconnected, such associations are lost and must be re-established by the client. The TCP_KEEPALIVE function is implemented in the relay to monitor each association and terminate any which are no longer active.

7.7.2 Redundant Ethernet Communication Ports (optional)

For information regarding the Redundant Ethernet communication ports, refer to the stand alone document Px4x/EN REB/B11.

7.7.3 Loss of Power

If the relay's power is removed, the relay allows the client to re-establish associations without a negative impact on the relay's operation. As the relay acts as a server in this process, the client must request the association. Uncommitted settings are cancelled when power is lost. Reports requested by connected clients are reset and must be re-enabled by the client when the client next creates the new association to the relay.

7.7.4 Courier Tunneling via Secure Ethernet Communications

7.7.4.1 Introduction

When the IED and Easergy Studio are connected via the Ethernet port they will communicate securely using TLS.

The benefits of secure communication are:

- Help in the prevention of unwanted eavesdropping between Easergy Studio (MiCOM S1 Studio) and the IED
- Help in the prevention of modification of data between Easergy Studio (MiCOM S1 Studio) and the IED
- Ensure integrity of data
- Prevent replay of data at a later data

Note

The communication will be done using port 4422, ensure this port is left unblocked on your network.

7.7.4.2 Setting up a Connection

As a quick guide you need to do the following:

1. In Easergy Studio, click the Quick Connect... button
2. Select the relevant Device Type in the Quick Connect dialog box.
3. Select Ethernet port
4. Enter the relevant data i.e. IP address of IED
5. Click Finish
6. Easergy Studio will attempt to communicate with the device

Note

When attempting to connect to the IED via Ethernet Easergy Studio will first attempt to communicate with the IED via secure communication if this is not possible it will use open communication with no encryption.

For secure communication please ensure port 4422 is left unblocked on the firewalls on which Easergy Studio is running.

Notes:

INSTALLATION

CHAPTER 16

Applicability

Date:	11/2023
--------------	---------

Products covered by this chapter:

This chapter covers the specific versions of the MiCOM products listed below. This includes **only** the following combinations of Software Version and Hardware Suffix.

Hardware Suffix:

Product	Hardware Suffix
P141 / P142 / P143	J / L or later
P145	J / M or later
P241	J or later
P242 / P243	K or later
P342	J or later
P343 / P344 / P345	K or later
P341	J / L or later
P445	J / L or later
P44x (P442 / P444)	L / M or later
P44y (P443 / P446)	K / M or later
P54x (P543 / P544 / P545 / P546)	K / M or later
P642	J / L or later
P643 / P645	K / M or later
P74x (P741 / P742 / P743)	J / K or later
P746	K / M or later
P841	K / M or later
P849	K / M or later

Software Version:

Product	Software Version
P14x (P141 / P142 / P143 / P145)	43 / 44 / 46 / B0 / B1 / B2 or later
P24x (P241 / P242 / P243)	57 or later
P341	B0 / E0 or later
P342 / P343 / P344 / P345	36 or later
P445	35 / 36 / J4 or later
P44x (P442 / P444)	E0 / E1 or later
P44y (P443 / P446)	55 / H4 or later
P54x (P543 / P544 / P545 / P546)	45 / 55 / H4 or later
P64x (P642 / P643 / P645)	04 / A0 / B1 / B2 or later
P74x (P741 / P742 / P743)	51 / A0 / B1 or later
P746	A0 / B1 / B2 / C1 / C2 or later
P841	45 / 55 / G4 / H4 or later
P849	A0 / B1 or later

Connection Diagrams:	This chapter list the connection diagram for the product:
-----------------------------	---

P14x (P141, P142, P143 & P145):	10P141xx (xx = 01 to 02) 10P142xx (xx = 01 to 05) 10P143xx (xx = 01 to 11) 10P145xx (xx = 01 to 11)
P24x (P241, P242 & P243):	10P241xx (xx = 01 to 02) 10P242xx (xx = 01) 10P243xx (xx = 01)
P34x (P342, P343, P344, P345 & P391)	10P342xx (xx = 01 to 17) 10P343xx (xx = 01 to 19) 10P344xx (xx = 01 to 12) 10P345xx (xx = 01 to 07) 10P391xx (xx = 01 to 02)
P445:	10P445xx (xx = 01 to 04)
P44x (P442 & P444):	10P44101 (SH 1 & 2) 10P44201 (SH 1 & 2) 10P44202 (SH 1) 10P44203 (SH 1 & 2) 10P44401 (SH 1) 10P44402 (SH 1) 10P44403 (SH 1 & 2) 10P44404 (SH 1) 10P44405 (SH 1) 10P44407 (SH 1 & 2)
P44y:	10P44303 (SH 01 and 03) 10P44304 (SH 01 and 03) 10P44305 (SH 01 and 03) 10P44306 (SH 01 and 03) 10P44600 10P44601 (SH 1 to 2) 10P44602 (SH 1 to 2) 10P44603 (SH 1 to 2)
P54x (P543, P544, P545 & P546):	10P54302 (SH 1 to 2) 10P54303 (SH 1 to 2) 10P54304 (SH 1 to 2) 10P54400 10P54404 (SH 1 to 2) 10P54405 (SH 1 to 2) 10P54502 (SH 1 to 2) 10P54503 (SH 1 to 2) 10P54504 (SH 1 to 2) 10P54600 10P54604 (SH 1 to 2) 10P54605 (SH 1 to 2) 10P54606 (SH 1 to 2)
P547:	10P54702xx (xx = 01 to 02) 10P54703xx (xx = 01 to 02) 10P54704xx (xx = 01 to 02) 10P54705xx (xx = 01 to 02)
P64x (P642, P643 & P645):	10P642xx (xx = 1 to 10) 10P643xx (xx = 1 to 6) 10P645xx (xx = 1 to 9)

P74x:	10P740xx (xx = 01 to 07)
P746:	10P746xx (xx = 00 to 21)
P841:	10P84100 10P84101 (SH 1 to 2) 10P84102 (SH 1 to 2) 10P84103 (SH 1 to 2) 10P84104 (SH 1 to 2) 10P84105 (SH 1 to 2)
P849:	10P849xx (xx = 01 to 06)

CONTENTS

1. Introduction to MiCOM Range	7
2. Receipt, Handling, Storage and Unpacking Relays	8
2.1 Receipt of Relays.....	8
2.2 Handling of Electronic Equipment.....	8
2.3 Storage.....	9
2.4 Unpacking.....	9
3. Relay Mounting	10
3.1 Rack Mounting.....	11
3.2 Panel Mounting.....	12
4. Relay Wiring	14
4.1 Medium and Heavy Duty Terminal Block Connections.....	14
4.2 EIA(RS)485 Port.....	15
4.3 Current Loop Input Output (CLIO) Connections (if applicable).....	15
4.4 IRIG-B Connections (if applicable).....	15
4.5 EIA(RS)232 Port.....	15
4.6 Optical Fiber Connectors (when applicable).....	15
4.7 Ethernet Port for IEC 61850 and/or DNP30 (where applicable).....	16
4.7.1 Fiber Optic (FO) Port.....	16
4.7.2 RJ-45 Metallic Port.....	16
4.8 RTD Connections (if applicable).....	16
4.9 Download/Monitor Port.....	17
4.10 Second EIA(RS)232/485 Port.....	17
4.10.1 Connection to the Second Rear Port.....	18
4.10.1.1 For IEC 60870-5-2 over EIA(RS)232/574.....	18
4.10.1.2 For K-bus or IEC 60870-5-2 over EIA(RS)485.....	18
4.11 Earth Connection (Protective Conductor).....	19
5. Case Dimensions	20
5.1 40TE Case Dimensions.....	21
5.2 60TE Case Dimensions.....	22
5.3 80TE Case Dimensions.....	23

TABLES

Table 1 - Products, sizes and part numbers.....	11
Table 2 - Blanking plates.....	12

Table 3 - IP52 sealing rings.....	13
Table 4 - Signals on the Ethernet connector.....	16
Table 5 - Pin connections for IEC 60870-5-2 over EIA(RS)232/574.....	18
Table 6 - Pin connections for K-bus or IEC 60870-5-2 over EIA(RS)485.....	19
Table 7 - Products and case sizes.....	20

FIGURES

Figure 1 - Location of battery isolation strip.....	11
Figure 2 - Rack mounting of relays.....	12
Figure 3 - 40TE Case Dimensions.....	21
Figure 4 - 60TE Case Dimensions.....	22
Figure 5 - 80TE Case Dimensions.....	23

1. INTRODUCTION TO MICOM RANGE

About MiCOM Range

MiCOM is a comprehensive solution capable of meeting all electricity supply requirements. It comprises a range of components, systems and services from Schneider Electric.

Central to the MiCOM concept is flexibility. MiCOM provides the ability to define an application solution and, through extensive communication capabilities, integrate it with your power supply control system.

The components within MiCOM are:

- P range protection relays
- C range control products
- M range measurement products for accurate metering and monitoring
- S range versatile PC support and substation control packages

MiCOM products include extensive facilities for recording information on the state and behaviour of the power system using disturbance and fault records. They can also provide measurements of the system at regular intervals to a control centre enabling remote monitoring and control to take place. For up-to-date information, please see:

www.schneider-electric.com

MiCOM Px4x Products

The MiCOM Px4x series of protection devices provide a wide range of protection and control functions and meet the requirements of a wide market segment.

Different parts of the Px4x range provide different functions. These include:

Relay	Main Functions
P14x	Feeder Management relay suitable for MV and HV systems
P24x	Motors and rotating machine management relay for use on a wide range of synchronous and induction machines
P34x	Generator Protection for small to sophisticated generator systems and interconnection protection
P445	Full scheme Distance Protection relays for MV, HV and EHV systems
P44x	Full scheme Distance Protection relays for MV, HV and EHV systems
P44y	Full scheme Distance Protection relays for MV, HV and EHV systems
P54x	Line Differential protection relays for HV/EHV systems with multiple communication options and phase comparison protection for use with PLC
P547	Line Differential protection relays for HV/EHV systems with multiple communication options and phase comparison protection for use with PLC
P64x	Transformer Protection Relays
P74x	Numerical Busbar Protection for use on MV, HV and EHV busbars
P746	Numerical Busbar Protection for use on MV, HV and EHV busbars
P84x	Breaker Failure protection relays

Note

During 2011, the International Electrotechnical Commission classified the voltages into different levels (IEC 60038). The IEC defined LV, MV, HV and EHV as follows: LV is up to 1000V. MV is from 1000V up to 35 kV. HV is from 110 kV or 230 kV. EHV is above 230 KV. There is still ambiguity about where each band starts and ends. A voltage level defined as LV in one country or sector, may be described as MV in a different country or sector. Accordingly, LV, MV, HV and EHV suggests a possible range, rather than a fixed band. Please refer to your local Schneider Electric office for more guidance.

2. RECEIPT, HANDLING, STORAGE AND UNPACKING RELAYS

2.1 Receipt of Relays

Protective relays, although generally of robust construction, require careful treatment prior to installation on site.

Upon receipt, relays should be examined immediately to ensure no external damage has been sustained in transit. If damage has been sustained, a claim should be made to the transport contractor and Schneider Electric should be promptly notified.

Relays that are supplied unmounted and not intended for immediate installation should be returned to their protective polythene bags and delivery carton. See the Storage section for more information about the storage of relays.

2.2 Handling of Electronic Equipment



Warning

Before carrying out any work on the equipment, you should be familiar with the contents of the Safety Information chapter/Safety Guide SFTY/5L M/L11 or later issue, the Technical Data chapter and the ratings on the equipment rating label.

A person's normal movements can easily generate electrostatic potentials of several thousand volts. Discharge of these voltages into semiconductor devices when handling electronic circuits can cause serious damage which, although not always immediately apparent, will reduce the reliability of the circuit. This is particularly important to consider where the circuits use Complementary Metal Oxide Semiconductors (CMOS), as is the case with these relays.

The electronic circuits inside the relay are protected from electrostatic discharge when housed in the case. Do not expose them to risk by removing the front panel or Printed Circuit Boards (PCBs) unnecessarily.

Each PCB incorporates the highest practicable protection for its semiconductor devices. However, if it becomes necessary to remove a PCB, the following precautions should be taken to preserve the high reliability and long life for which the relay has been designed and manufactured.

- Before removing a PCB, ensure that you are at the same electrostatic potential as the equipment by touching the case.
- Handle analogue input modules by the front panel, frame or edges of the circuit boards. PCBs should only be handled by their edges. Avoid touching the electronic components, printed circuit tracks or connectors.
- Do not pass the module to another person without first ensuring you are both at the same electrostatic potential. Shaking hands achieves equipotential.
- Place the module on an anti-static surface, or on a conducting surface which is at the same potential as yourself.
- If it is necessary to store or transport printed circuit boards removed from the case, place them individually in electrically conducting anti-static bags.

In the unlikely event that you are making measurements on the internal electronic circuitry of a relay in service, it is preferable that you are earthed to the case with a conductive wrist strap. Wrist straps should have a resistance to ground between 500k Ω to 10M Ω . If a wrist strap is not available, you should maintain regular contact with the case to prevent a build-up of electrostatic potential. Instrumentation which may be used for making measurements should also be earthed to the case whenever possible.

More information on safe working procedures for all electronic equipment can be found in IEC 61340-5-1. It is strongly recommended that detailed investigations on electronic circuitry or modification work should be carried out in a special handling area such as described in the aforementioned Standard document.

2.3 Storage

If relays are not to be installed immediately upon receipt, they should be stored in a place free from dust and moisture in their original cartons. Where de-humidifier bags have been included in the packing they should be retained. The action of the de-humidifier crystals will be impaired if the bag is exposed to ambient conditions and may be restored by gently heating the bag for about an hour prior to replacing it in the carton.

To prevent battery drain during transportation and storage a battery isolation strip is fitted during manufacture. With the lower access cover open, presence of the battery isolation strip can be checked by a red tab protruding from the positive side.

Care should be taken on subsequent unpacking that any dust which has collected on the carton does not fall inside. In locations of high humidity the carton and packing may become impregnated with moisture and the de-humidifier crystals will lose their efficiency.

Prior to installation, relays should be stored at a temperature of between -40°C to $+70^{\circ}\text{C}$ (-13°F to $+158^{\circ}\text{F}$).

2.4 Unpacking

Our products leave our factory in closed, sealed original packaging. If at receipt of the delivery the transport packaging is open or the seal is broken, the confidentiality and authenticity of the information contained in the products cannot be ensured.

Care must be taken when unpacking and installing the relays so that none of the parts are damaged and additional components are not accidentally left in the packing or lost. Make sure that any user's CDROM or technical documentation is NOT discarded, and accompanies the relay to its destination substation.

Note

With the lower access cover open, the red tab of the battery isolation strip will be seen protruding from the positive side of the battery compartment. Do not remove this strip because it prevents battery drain during transportation and storage and will be removed as part of the commissioning tests.

Relays must only be handled by skilled persons.

The site should be well lit to facilitate inspection, clean, dry and reasonably free from dust and excessive vibration. This particularly applies to installations which are being carried out at the same time as construction work.

3. RELAY MOUNTING

MiCOM relays are dispatched either individually or as part of a panel/rack assembly.

Individual relays are normally supplied with an outline diagram showing the dimensions for panel cut-outs and hole centres. This information can also be found in the product publication.

Secondary front covers can also be supplied as an option item to prevent unauthorised changing of settings and alarm status. They are available in sizes 40TE and 60TE. The 60TE cover also fits the 80TE case size of the relay.

The old GN0037/GN0038 part numbers are now obsolete.

They have been replaced by parts see **Note 1**.

Product	Size	Part No (Obsolete)	Replacement Part No
P40	40TE 60TE / 80TE	GN0037 001 GN0038 001	see Note 1 see Note 1
P14x	40TE 60TE / 80TE	GN0037 001 GN0038 001	see Note 1 see Note 1
P24xxxxxxxxxxxA P24xxxxxxxxxxxC	40TE 60TE / 80TE	GN0037 001 GN0038 001	see Note 1 see Note 1
P24xxxxxxxxxxxJ P24xxxxxxxxxxxK	40TE 60TE / 80TE		see Note 1 see Note 1
P34xxxxxxxxxxxA P34xxxxxxxxxxxC	40TE 60TE / 80TE	GN0037 001 GN0038 001	see Note 1 see Note 1
P34xxxxxxxxxxxJ P34xxxxxxxxxxxK	40TE 60TE / 80TE		see Note 1 see Note 1
P44x	40TE 60TE / 80TE	GN0037 001 GN0038 001	see Note 1 see Note 1
P44y	60TE / 80TE	GN0038 001	see Note 1
P445	40TE 60TE / 80TE	GN0037 001 GN0038 001	see Note 1 see Note 1
P54x	60TE / 80TE	GN0038 001	see Note 1
P547	60TE / 80TE	GN0038 001	see Note 1
P64xxxxxxxxxxxA/B/C	40TE 60TE / 80TE	GN0037 001 GN0038 001	see Note 1 see Note 1
P64xxxxxxxxxxxJ/K	40TE 60TE / 80TE		see Note 1 see Note 1
P74x P74x	40TE 60TE	GN0037 001 GN0038 001	see Note 1 see Note 1
P746	80TE	GN0038 001	see Note 1
P841	60TE / 80TE	GN0038 001	see Note 1
P849	80TE	GN0038 001	see Note 1

Product	Size	Part No (Obsolete)	Replacement Part No
Note			
Part Numbers suitable for rack-mounting have an "N" as the 10th digit.			
Part Numbers suitable for panel-mounting have an "M" as the 10th digit.			
Size 40TE may be GN0242 001 and 60TE/80TE as GN0243 001.			
Note 1			
All parts for panel mounted are centralized in a SAREL catalogue.			
This SAREL SE catalogue parts is available by asking at this email address:			
fr-iff-ue@schneider-electric.com			

Table 1 - Products, sizes and part numbers

The design of the relay is such that the fixing holes in the mounting flanges are only accessible when the access covers are open and hidden from sight when the covers are closed.

If a MiCOM P991 or Easergy test block is to be included with the relays, we recommend you position the test block on the right-hand side of the associated relays (when viewed from the front). This minimises the wiring between the relay and test block, and allows the correct test block to be easily identified during commissioning and maintenance tests.

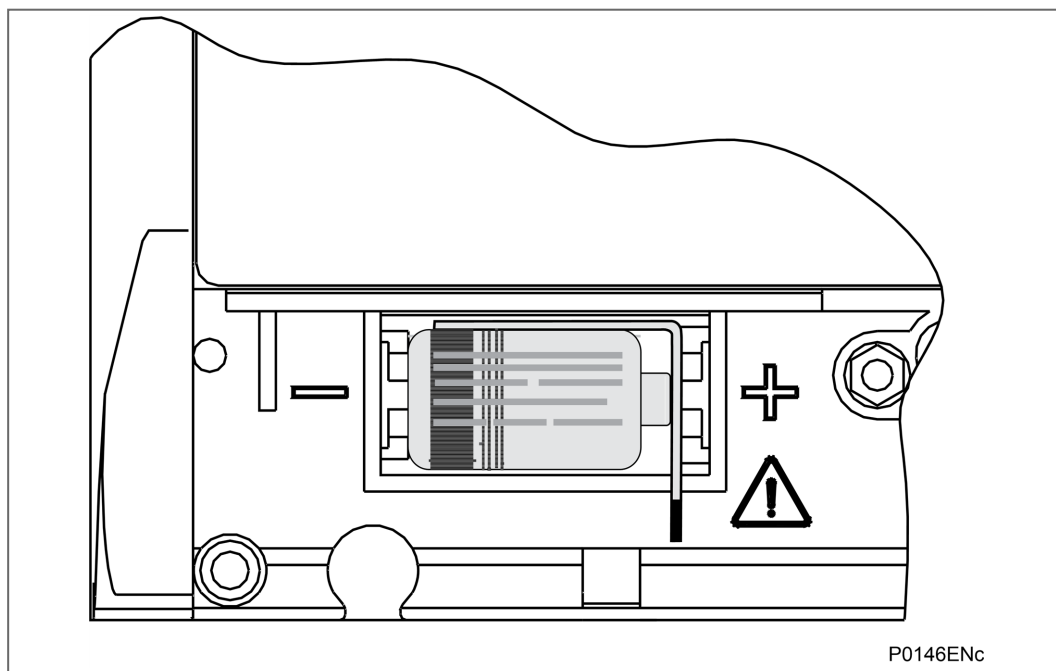

Figure 1 - Location of battery isolation strip

If you need to test correct relay operation during the installation, the battery isolation strip can be removed but should be replaced if commissioning of the scheme is not imminent. This will prevent unnecessary battery drain during transportation to site and installation. The red tab of the isolation strip can be seen protruding from the positive side of the battery compartment when the lower access cover is open. To remove the isolation strip, pull the red tab whilst lightly pressing the battery to prevent it falling out of the compartment. When replacing the battery isolation strip, ensure that the strip is refitted as shown in the Location of battery isolation strip diagram, i.e. with the strip behind the battery with the red tab protruding.

3.1 Rack Mounting

Virtually all MiCOM relays can be rack mounted using single tier rack frames (part number see **Note 1**), see the **Rack mounting of relays** diagram below. These frames have dimensions in accordance with IEC 60297 and are supplied pre-assembled ready to use. On

a standard 483 mm rack this enables combinations of case widths up to a total equivalent of size 80TE to be mounted side-by-side.

The two horizontal rails of the rack frame have holes drilled at approximately 26 mm intervals and the relays are attached via their mounting flanges using M4 Taptite self-tapping screws with captive 3 mm thick washers (also known as a SEMS unit). (see **Note 1**)



Warning
Risk of damage to the front cover moulding. Do not use conventional self-tapping screws, including those supplied for mounting other relays because they have slightly larger heads.

Once the tier is complete, the frames are fastened into the racks using mounting angles at each end of the tier.

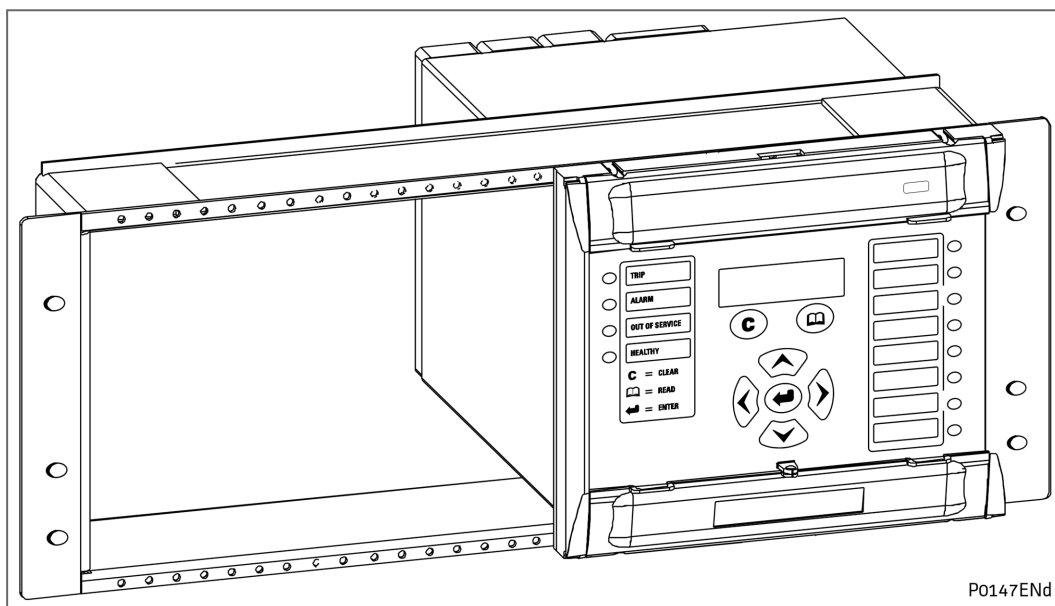

Figure 2 - Rack mounting of relays

Relays can be mechanically grouped into single tier (4U) or multi-tier arrangements by the rack frame. This enables schemes using MiCOM products to be pre-wired together prior to mounting.

Use blanking plates if there are empty spaces. The spaces may be for future installation of relays or because the total size is less than 80TE on any tier. Blanking plates can also be used to mount ancillary components. The following Blanking plates table shows the sizes that can be ordered.

Note
Blanking plates are only available in grey.

Case size summation	Blanking plate part number
10TE	see Note 1
20TE	see Note 1
30TE	see Note 1
40TE	see Note 1

Table 2 - Blanking plates

3.2 Panel Mounting

The relays can be flush mounted into panels using M4 SEMS Taptite self-tapping screws with captive 3 mm thick washers (also known as a SEMS unit). (see **Note 1**)

**Warning**

Risk of damage to the front cover moulding. Do not use conventional self-tapping screws, including those supplied for mounting other relays because they have slightly larger heads.

Alternatively tapped holes can be used if the panel has a minimum thickness of 2.5 mm.

If several relays are mounted in a single cut-out in the panel, mechanically group them together horizontally or vertically to form rigid assemblies prior to mounting in the panel.

Note

Fastening MiCOM relays with pop rivets is not advised because this does not allow easy removal if repair is necessary.

Rack-mounting panel-mounted versions: it is possible to rack-mount some relay versions which have been designed to be panel-mounted. The relay is mounted on a single-tier rack frame, which occupies the full width of the rack. To make sure a panel-mounted relay assembly complies with BS EN60529 IP52, fit a metallic sealing strip between adjoining relays (see **Note 1**) and a sealing ring from the following **IP52 sealing rings** table around the complete assembly.

Width	Single tier	Double tier
40TE	see Note 1	see Note 1
45TE	see Note 1	see Note 1
50TE	see Note 1	see Note 1
55TE	see Note 1	see Note 1
60TE	see Note 1	see Note 1
65TE	see Note 1	see Note 1
70TE	see Note 1	see Note 1
75TE	see Note 1	see Note 1
80TE	see Note 1	see Note 1

Table 3 - IP52 sealing rings

4. RELAY WIRING

This section serves as a guide to selecting the appropriate cable and connector type for each terminal on the MiCOM relay.



Warning

Before carrying out any work on the equipment, you should be familiar with the contents of the Safety Information chapter/Safety Guide SFTY/5L M/L11 or later issue, the Technical Data chapter and the ratings on the equipment rating label.

4.1 Medium and Heavy Duty Terminal Block Connections

Key:

Heavy duty terminal block:	CT and VT circuits, terminals with "C", "D", "E" or "F" prefix (depending on the relay)
Medium duty:	All other terminal blocks (grey color)

Loose relays are supplied with sufficient M4 screws for making connections to the rear mounted terminal blocks using ring terminals, with a recommended maximum of two ring terminals per relay terminal.

The following minimum wire sizes are recommended:

Current Transformers	2.5mm ²
Auxiliary Supply Vx	1.5mm ²
RS485 Port	See separate section
Rotor winding to P391	1.0mm ²
Other circuits	1.0mm ²

Due to the limitations of the ring terminal, the maximum wire size that can be used for any of the medium or heavy duty terminals is 6.0mm² using ring terminals that are not pre-insulated. Where it required to only use pre-insulated ring terminals, the maximum wire size that can be used is reduced to 2.63mm² per ring terminal. If a larger wire size is required, two wires should be used in parallel, each terminated in a separate ring terminal at the relay.

The wire used for all connections to the medium and heavy duty terminal blocks, except the RS485 port, should have a minimum voltage rating of 300Vrms.

It is recommended that the auxiliary supply wiring should be protected by a 16A maximum High Rupture Capacity (HRC) fuse of type NIT or TIA. For safety reasons, current transformer circuits must never be fused. Other circuits should be appropriately fused to protect the wire used.

Note

The high-break contacts optional fitted to P44y (P443/P446) and P54x relays are polarity sensitive. External wiring must respect the polarity requirements which are shown on the external connection diagram to ensure correct operation.

Each opto input has selectable filtering. This allows use of a pre-set filter of ½ cycle which renders the input immune to induced noise on the wiring: although this method is secure it can be slow, particularly for intertripping. This can be improved by switching off the ½ cycle filter in which case one of the following methods to reduce ac noise should be considered. The first method is to use double pole switching on the input, the second is to use screened twisted cable on the input circuit. The recognition time of the opto inputs without the filtering is <2 ms and with the filtering is <12 ms.

4.2 EIA(RS)485 Port

Connections to the first rear EIA(RS)485 port use ring terminals. 2-core screened cable is recommended with a maximum total length of 1000m or 200nF total cable capacitance.

A typical cable specification would be:

Each core:	16/0.2mm copper conductors. PVC insulated
Nominal conductor area:	0.5mm ² per core
Screen:	Overall braid, PVC sheathed

See the SCADA Communications chapter for details of setting up an EIA(RS)485 bus.

4.3 Current Loop Input Output (CLIO) Connections (if applicable)

Where current loop inputs and outputs are available on a MiCOM relay, the connections are made using screw clamp connectors, as per the RTD inputs, on the rear of the relay which can accept wire sizes between 0.1 mm² and 1.5 mm². It is recommended that connections between the relay and the current loop inputs and outputs are made using a screened cable. The wire should have a minimum voltage rating of 300 Vrms.

4.4 IRIG-B Connections (if applicable)

The IRIG-B input and BNC connector have a characteristic impedance of 50Ω. It is recommended that connections between the IRIG-B equipment and the relay are made using coaxial cable of type RG59LSF with a halogen free, fire retardant sheath.

4.5 EIA(RS)232 Port

Short term connections to the RS232 port, located behind the bottom access cover, can be made using a screened multi-core communication cable up to 15m long, or a total capacitance of 2500pF. The cable should be terminated at the relay end with a 9-way, metal shelled, D-type male plug. The Getting Started chapter of this manual details the pin allocations.

4.6 Optical Fiber Connectors (when applicable)



Warning

LASER LIGHT RAYS: Where fibre optic communication devices are fitted, never look into the end of a fiber optic due to the risk of causing serious damage to the eye. Optical power meters should be used to determine the operation or signal level of the device. Non-observance of this rule could possibly result in personal injury.

If electrical to optical converters are used, they must have management of character idle state capability (for when the fibre optic cable interface is "Light off").

Specific care should be taken with the bend radius of the fibres, and the use of optical shunts is not recommended as these can degrade the transmission path over time.

The relay uses 1300nm multi mode 100BaseFx and BFOC 2.5 - (ST/LC according to the MiCOM model) connectors (one Tx – optical emitter, one Rx – optical receiver).

4.7 Ethernet Port for IEC 61850 and/or DNP30 (where applicable)

4.7.1 Fiber Optic (FO) Port

The relays can have 100 Mbps Ethernet port. Fibre Optic (FO) connection is recommended for use in permanent connections in a substation environment. The 100 Mbit port uses a type LC connector (according to the MiCOM model), compatible with fiber multimode 50/125 μm or 62.5/125 μm to 1300 nm.

Note

The new LC fiber optical connector can be used with the Px40 Enhanced Ethernet Board.

4.7.2 RJ-45 Metallic Port

Due to possibility of noise and interference on this part, it is recommended that this connection type be used for short-term connections and over short distance. Ideally, where the relays and switches are located in the same cubicle.

The connector for the Ethernet port is a shielded RJ-45. The following Signals on the Ethernet connector table shows the signals and pins on the connector.

Pin	Signal Name	Signal Definition
1	TXP	Transmit (positive)
2	TXN	Transmit (negative)
3	RXP	Receive (positive)
4	-	Not used
5	-	Not used
6	RXN	Receive (negative)
7	-	Not used
8	-	Not used

Table 4 - Signals on the Ethernet connector

4.8 RTD Connections (if applicable)

Where RTD inputs are available on a MiCOM relay, the connections are made using screw clamp connectors on the rear of the relay that can accept wire sizes between 0.1 mm² and 1.5 mm². The connections between the relay and the RTDs must be made using a screened 3-core cable with a total resistance less than 10 Ω . The cable should have a minimum voltage rating of 300 Vrms.

A 3-core cable should be used even for 2-wire RTD applications, as it allows for the cable's resistance to be removed from the overall resistance measurement. In such cases the third wire is connected to the second wire at the point the cable is joined to the RTD.

The screen of each cable must only be earthed at one end, preferably at the relay end and must be continuous. Multiple earthing of the screen can cause circulating current to flow along the screen, which induces noise and is unsafe.

It is recommended to minimize noise pick-up in the RTD cables by keeping them close to earthed metal casings and avoiding areas of high electromagnetic and radio interference. The RTD cables should not be run adjacent to or in the same conduit as other high voltage or current cables.

A typical cable specification would be:

Each core:	7/0.2 mm copper conductors heat resistant PVC insulated
Nominal conductor area:	0.22 mm ² per core

Screen:	Nickel-plated copper wire braid heat resistant PVC sheathed
---------	---

The extract below may be useful in defining cable recommendations for the RTDs.

Noise pick-up by cables can be categorized in to three types:

- Resistive
- Capacitive
- Inductive

Resistive coupling requires there to be an electrical connection to the noise source. So assuming that the wire and cable insulation is sound and that the junctions are clean then this can be dismissed.

Capacitive coupling requires there to be sufficient capacitance for the impedance path to the noise source to be small enough to allow for significant coupling. This is a function of the dielectric strength between the signal cable on the noise source and the potential (i.e. power) of the noise source.

Inductive coupling occurs when the signal cable is adjacent to a cable/wire carrying the noise or it is exposed to a radiated EMF.

Standard screened cable is normally used to protect against capacitively coupled noise, but in order for it to be effective the screen must only be bonded to the system ground at one point, otherwise a current could flow and the noise would be coupled in to the signal wires of the cable. There are different types of screening available, but basically there are two types: aluminum foil wrap and tin-copper braid.

Foil screens are good for low to medium frequencies and braid is good for high frequencies. High-fidelity screen cables provide both types.

Protection against magnetic inductive coupling requires very careful cable routing and magnetic shielding. The latter can be achieved with steel-armored cable and the use of steel cable trays. It is important that the armor of the cable is grounded at both ends so that the EMF of the induced current cancels the field of the noise source and hence shields the cables conductors from it. (However, the design of the system ground must be considered and care taken to not bridge two isolated ground systems since this could be hazardous and defeat the objectives of the original ground design). The cable should be laid in the cable trays as close as possible to the metal of the tray and under no circumstance should any power cable be in or near to the tray. (Power cables should only cross the signal cables at 90 degrees and never be adjacent to them).

Both the capacitive and inductive screens must be contiguous from the RTD probes to the relay terminals.

The best types of cable are those provided by the RTD manufactures. These tend to be three conductors (a so-called "triad") which are screened with foil. Such triad cables are available in armored forms as well as multi-triad armored forms.

4.9 Download/Monitor Port

Short term connections to the download/monitor port, located behind the bottom access cover, can be made using a screened 25-core communication cable up to 4m long. The cable should be terminated at the relay end with a 25-way, metal shelled, D-type male plug.

The Getting Started and Commissioning chapters this manual details the pin allocations.

4.10 Second EIA(RS)232/485 Port

Relays with Courier, MODBUS, IEC 60870-5-103 or DNP3 protocol on the first rear communications port have the option of a second rear port, running Courier protocol.

Note: IEC-60870-5-103, DNP3.0 and MODBUS are not supported in P74x.

The second rear communications port can be used over one of three physical links:

- twisted pair K-Bus (non-polarity sensitive),
- twisted pair EIA(RS)485 (connection polarity sensitive) or
- EIA(RS)232. This EIA(RS)232 port is actually compliant to EIA(RS)574; the 9-pin version of EIA(RS)232, see www.tiaonline.org.

4.10.1 Connection to the Second Rear Port

The second rear Courier port connects via a 9-way female D-type connector (SK4) in the middle of the card end plate (in between IRIG-B connector and lower D-type). The connection is compliant to EIA(RS)574.

4.10.1.1 For IEC 60870-5-2 over EIA(RS)232/574

Pin	Connection
1	No Connection
2	RxD
3	TxD
4	DTR#
5	Ground
6	No Connection
7	RTS #
8	CTS #
9	No Connection
# - These pins are control lines for use with a modem.	

Table 5 - Pin connections for IEC 60870-5-2 over EIA(RS)232/574

Connections to the second rear port configured for EIA(RS)232 operation can be made using a screened multi-core communication cable up to 15 m long, or a total capacitance of 2500 pF. The cable should be terminated at the relay end with a 9-way, metal shelled, D-type male plug. The table above details the pin allocations.

4.10.1.2 For K-bus or IEC 60870-5-2 over EIA(RS)485

Pin*	Connection
4	EIA(RS)485 - 1 (+ ve)
7	EIA(RS)485 - 2 (- ve)
* - All other pins connected	
<p>Note</p> <p>Connector pins 4 and 7 are used by both the EIA(RS)232/574 and EIA(RS)485 physical layers, but for different purposes. Therefore, the cables should be removed during configuration switches.</p> <p>For the EIA(RS)485 protocol an EIA(RS)485 to EIA(RS)232/574 converter will be required to connect a modem or PC running MiCOM S1 Studio, to the relay. A Schneider Electric CK222 is recommended.</p> <p>EIA(RS)485 is polarity sensitive, with pin 4 positive (+) and pin 7 negative (-).</p> <p>The K-Bus protocol cannot be connected to a PC.</p> <p>It is recommended that a 2-core screened cable be used. To avoid exceeding the second communications port flash clearances it is recommended that the length of cable between the port and the communications equipment should be less than 300 m. This length can be increased to 1000 m or 200nF total cable capacitance if the communications cable is not laid in close proximity to high current carrying conductors. The cable screen should be earthed at one end only.</p>	

Table 6 - Pin connections for K-bus or IEC 60870-5-2 over EIA(RS)485

A typical cable specification would be:

Each core:	16/0.2mm copper conductors. PVC insulated
Nominal conductor area:	0.5mm ² per core
Screen:	Overall braid, PVC sheathed

4.11 Earth Connection (Protective Conductor)

Every relay must be connected to the local earth bar using the M4 earth studs in the bottom left hand corner of the relay case. The minimum recommended wire size is 2.5mm² and should have a ring terminal at the relay end.

Due to the limitations of the ring terminal, the maximum wire size that can be used for any of the medium or heavy duty terminals is 6.0mm² per wire. If a greater cross-sectional area is required, two parallel connected wires, each terminated in a separate ring terminal at the relay, or a metal earth bar could be used.

Note

To prevent any possibility of electrolytic action between brass or copper earth conductors and the rear panel of the relay, precautions should be taken to isolate them from one another. This could be achieved in a number of ways, including placing a nickel-plated or insulating washer between the conductor and the relay case, or using tinned ring terminals.



Warning

Before carrying out any work on the equipment, you should be familiar with the contents of the Safety Information chapter/Safety Guide SFTY/5L M/L11 or later issue, the Technical Data chapter and the ratings on the equipment rating label.

5. CASE DIMENSIONS

The MiCOM range of products are available in a series of different case sizes.

The case sizes available for each product are shown here:

Range	Case Size		
	40TE	60TE	80TE
P14x	P141, P142	P143, P145	P143
P24x	P241	P242	P243
P34x	P341, P342	P341, P342, P343	P343, P344, P345
P441	P441		
P44x		P442	P444
P44y			P443, P446
P445	P445	P445	
P541	P541		
P542		P542	
P54x		P543, P544	P545, P546
P547			P547
P64x	P642	P643, P645	P645
P74x	P742	P743	P741
P746			P746
P841		P841	P841
P849			P849

Table 7 - Products and case sizes

5.1 40TE Case Dimensions

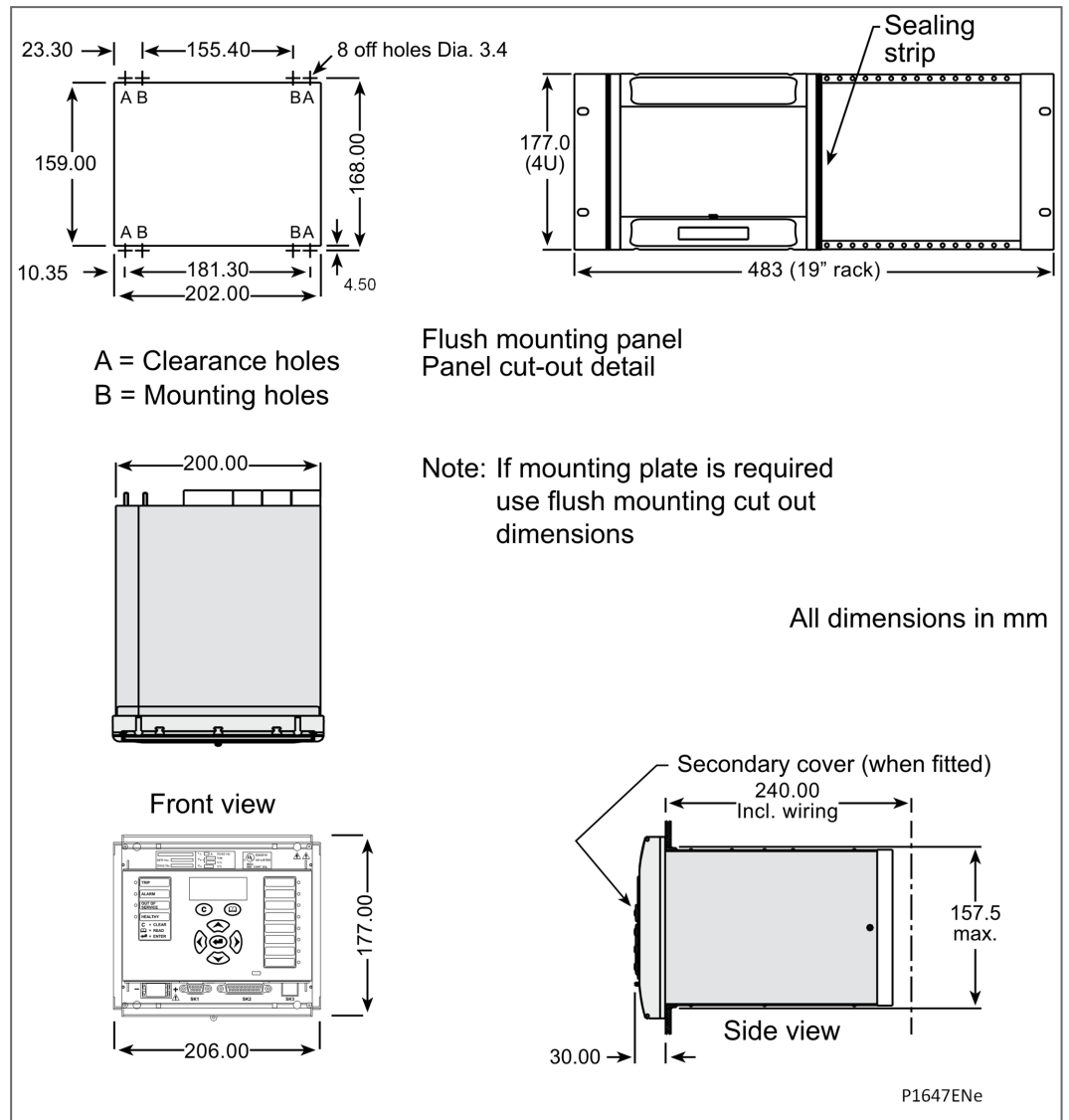

Figure 3 - 40TE Case Dimensions

5.2 60TE Case Dimensions

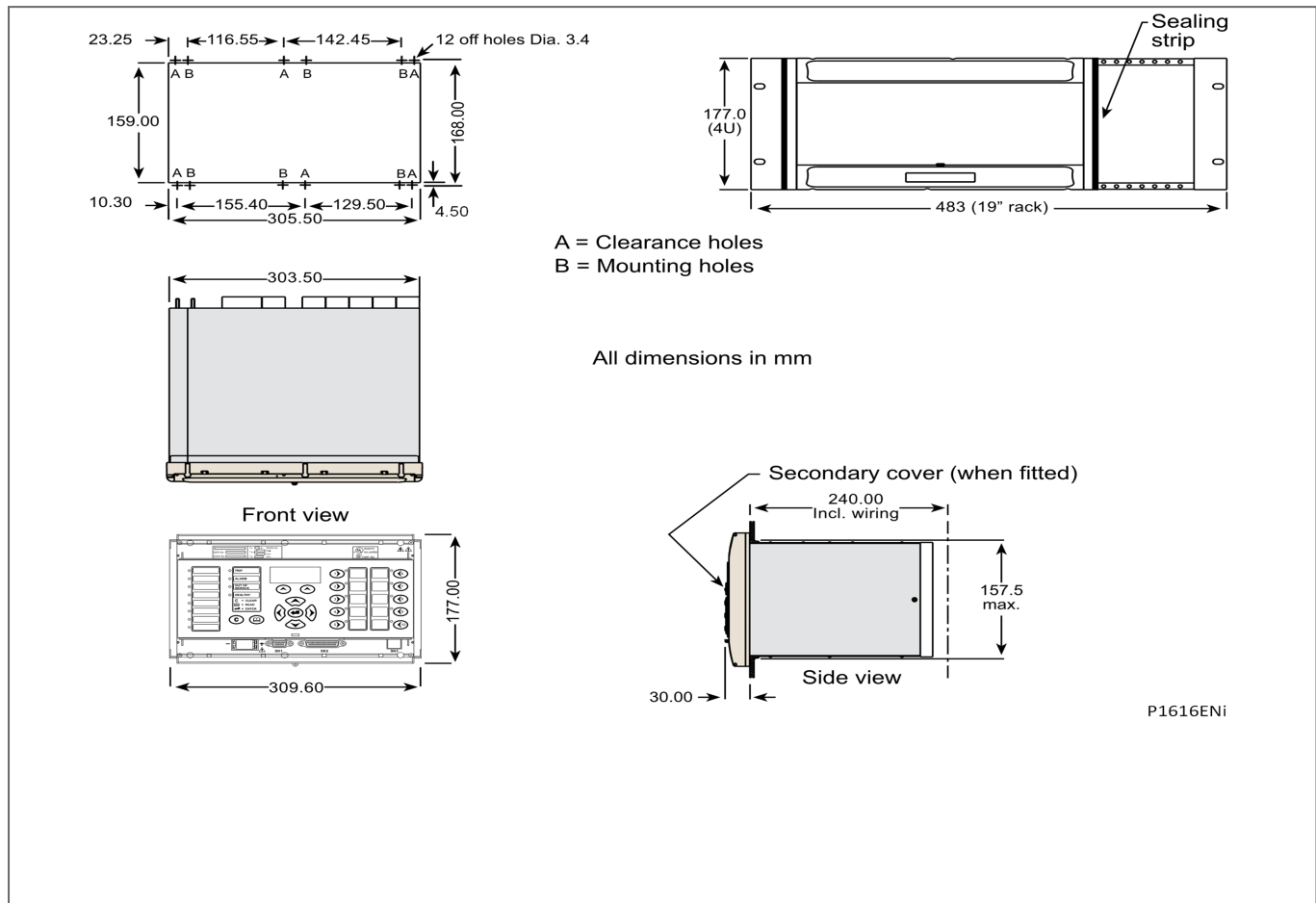

Figure 4 - 60TE Case Dimensions

5.3 80TE Case Dimensions

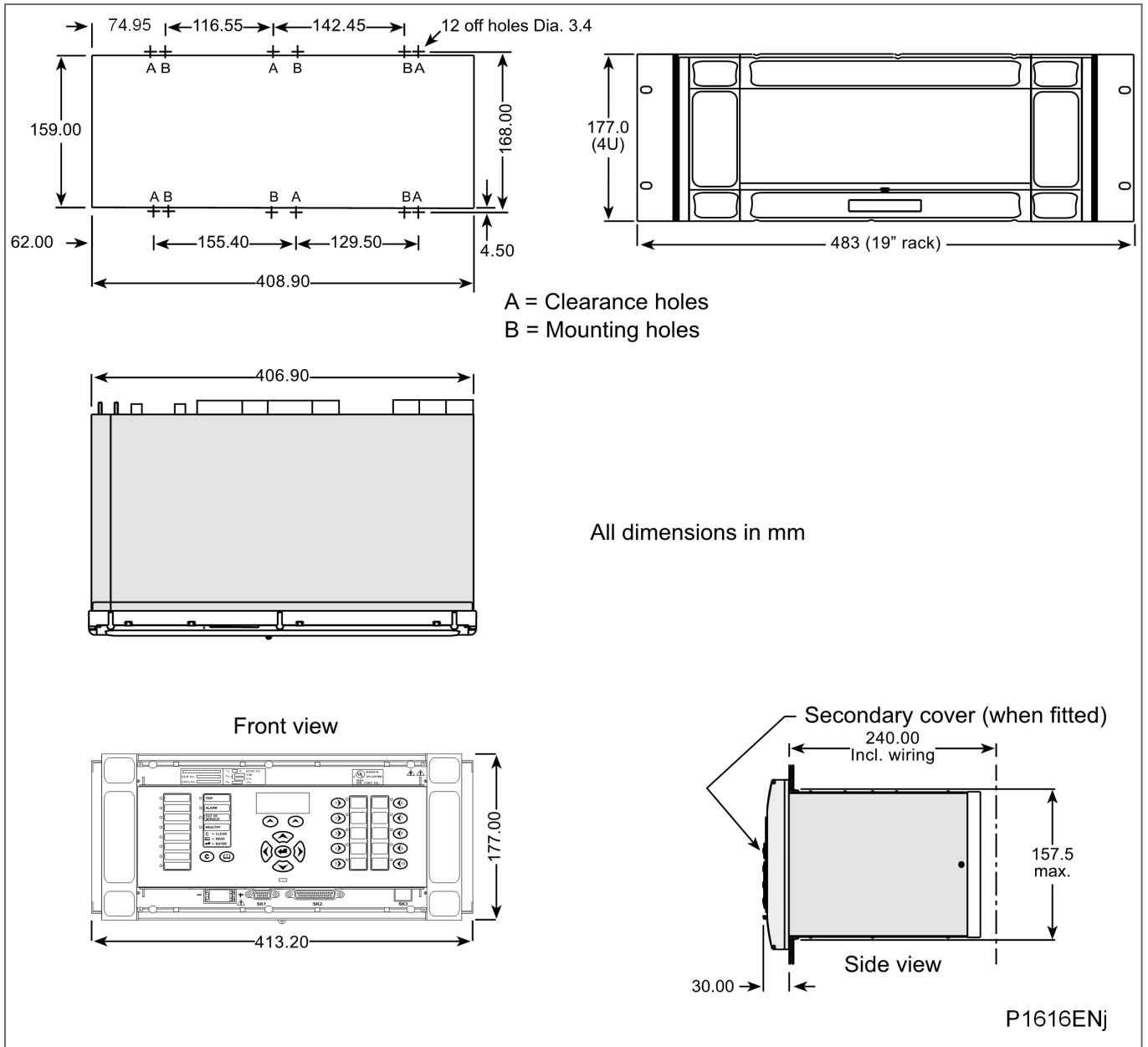

Figure 5 - 80TE Case Dimensions

Notes:

CONNECTION DIAGRAMS

CHAPTER 17

Applicability

Date: 02/2024

Products covered by this chapter:

This chapter covers the specific versions of the MiCOM products listed below. This includes **only** the following combinations of Software Version and Hardware Suffix.

Hardware Suffix:

MiCOM P54x (P543, P544, P545 and P546)	M (P543, P544, P545 and P546)
--	-------------------------------

Software Version:

MiCOM P54x (P543, P544, P545 and P546)	K6
--	----

Connection Diagrams: This chapter list the connection diagram for the product:

P54x (P543, P544, P545 & P546):	10P54302 (SH 1 to 2) 10P54303 (SH 1 to 2) 10P54304 (SH 1 to 2) 10P54400 10P54404 (SH 1 to 2) 10P54405 (SH 1 to 2) 10P54502 (SH 1 to 2) 10P54503 (SH 1 to 2) 10P54504 (SH 1 to 2) 10P54600 10P54604 (SH 1 to 2) 10P54605 (SH 1 to 2) 10P54606 (SH 1 to 2)
---------------------------------	--

CONTENTS

1. Introduction to the Connection Diagrams..... 5

2. Communication Options MiCOM Px40 Platform..... 6

3. External Connection Diagrams..... 8

3.1 P543 Connection Diagrams..... 9

3.2 P544 Connection Diagrams..... 16

3.3 P545 Connection Diagrams..... 22

3.4 P546 Connection Diagrams..... 29

FIGURES

Figure 1 - Communications Options MiCOM Px40 platform..... 6

Figure 2 - External communications option MiCOM Px40 platform..... 7

Figure 3 - P543 - external connection diagram – 16 inputs/14 standard outputs..... 10

Figure 4 - P543 – 16 inputs/14 standard outputs default mapping..... 11

Figure 5 - P543 – external connection diagram – 16 inputs/7 standard and 4 high break outputs..... 12

Figure 6 - P543 – 16 inputs/7 standard and 4 high-break outputs default mapping..... 13

Figure 7 - P543 – external connection diagram – 16 inputs/24 standard outputs default mapping..... 14

Figure 8 - P543 – 16 inputs/24 standard outputs default mapping..... 15

Figure 9 - P544 - external connection diagram - standard outputs..... 17

Figure 10 - P544 - 16 inputs/outputs default mapping - 14 standard outputs..... 18

Figure 11 - P544 - 16 inputs/outputs default mapping - 14 standard outputs..... 19

Figure 12 - P544 - 16 inputs/outputs default mapping - 7 standard and 4 high-break outputs..... 20

Figure 13 - P544 - 16 inputs/outputs default mapping - 7 standard and 4 high-break outputs..... 21

Figure 14 - P545 - external connection diagram - standard outputs..... 23

Figure 15 - P545 - inputs/outputs default mapping - standard outputs..... 24

Figure 16 - P545 - 16 standard and 8 high-break outputs..... 25

Figure 17 - P545 - 24 inputs/outputs default mapping - 16 standard and 8 high-break outputs..... 26

Figure 18 - P545 - 32 optos, 32 relays, Distance, 1 or 3 Pole Tripping, Auto-Reclose and Chk Sync Sheet 1..... 27

Figure 19 - P545 - 32 optos, 32 relays, Distance, 1 or 3 Pole Tripping, Auto-Reclose and Chk Sync Sheet 2..... 28

Figure 20 - P546 - external connection diagram - standard outputs..... 30

Figure 21 - P546 - 24 inputs/32 outputs default mapping - standard and high-break outputs..... 31

Figure 22 - P546 - 24 opto inputs/32 outputs default mapping - standard and high-break outputs..... 32

Figure 23 - P546 - 24 inputs/outputs default mapping – 16 standard and 8 high-break outputs..... 33

Figure 24 - P546 - 24 inputs/outputs default mapping – 16 standard and 8 high-break outputs..... 34

Figure 25 - P546 - 24 inputs/outputs default mapping – 8 Standard and 12 high-break outputs..... 35

Figure 26 - P546 - 24 inputs/outputs default mapping – 8 Standard and 12 high-break outputs..... 36

Figure 27 - P546 Final assembly drawing..... 37

Notes:

1. INTRODUCTION TO THE CONNECTION DIAGRAMS

The Installation chapter contains general information about the MiCOM unit. The Installation chapter covers many MiCOM P40 products. It includes items such as:

- Receiving, Handling, Storing and Unpacking the Relays
- Mounting the Relay
- Wiring the Relay
- Case Dimensions

This Connection Diagrams chapter is specific to this particular relay, and includes the detailed wiring diagrams which relate only to this particular relay.

Important:

You must be familiar with the contents of the Installation chapter, before using the information in this Connection Diagrams chapter.

2. COMMUNICATION OPTIONS MICOM PX40 PLATFORM

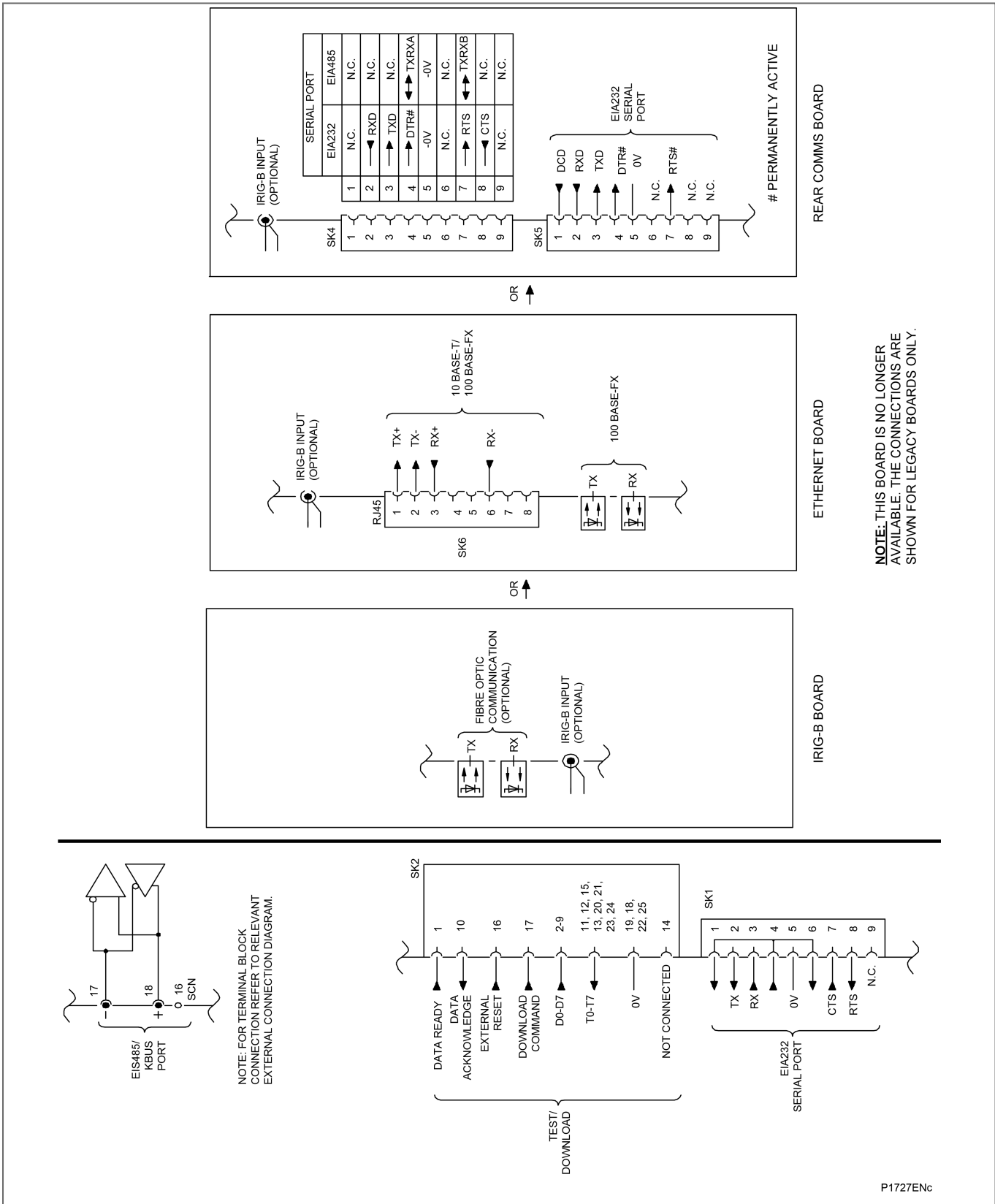

Figure 1 - Communications Options MiCOM Px40 platform

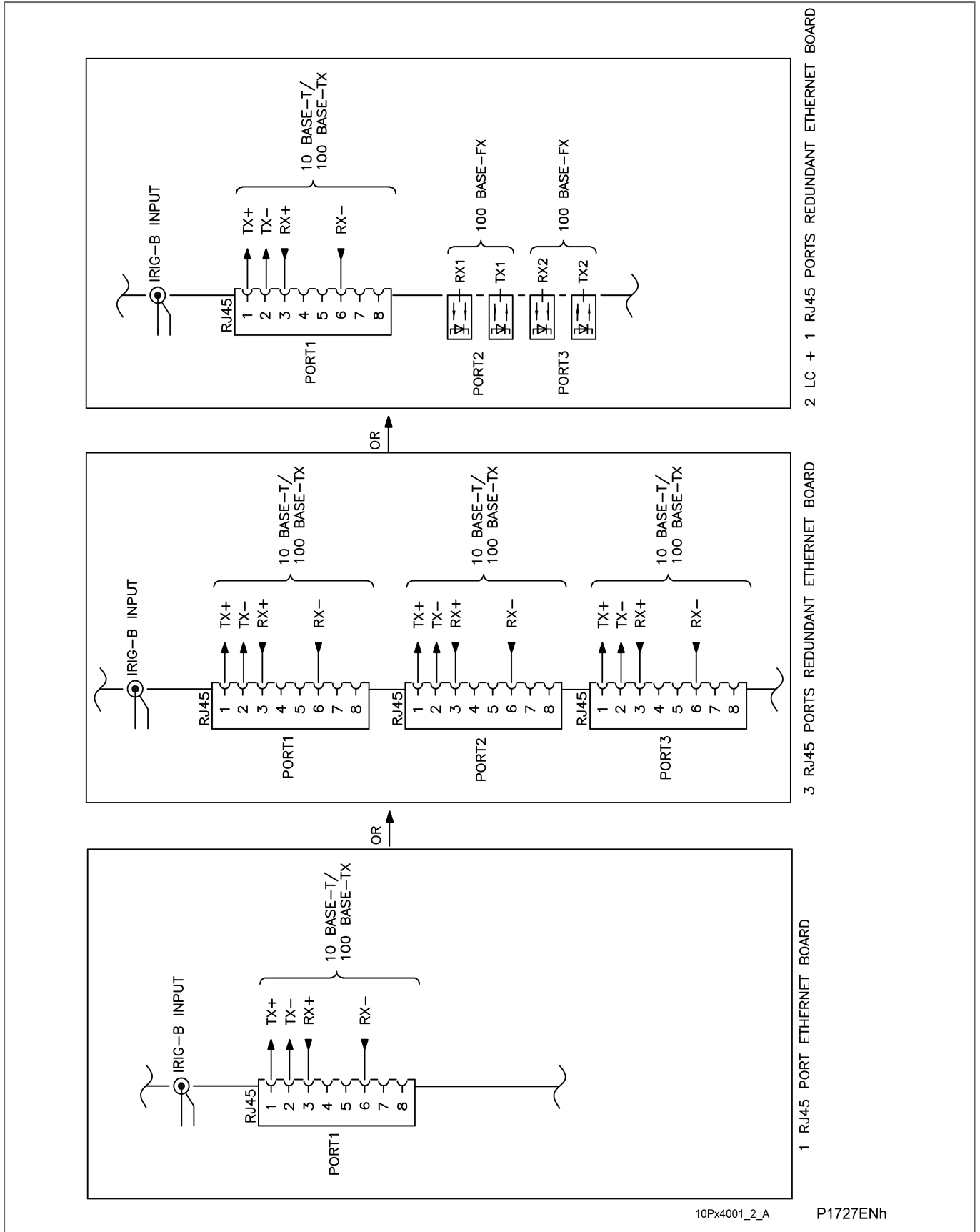

Figure 2 - External communications option MiCOM Px40 platform

3. EXTERNAL CONNECTION DIAGRAMS

In this section, the figures may use these abbreviations:

- I/P = Input
- O/P = Output
- HB = High Break
- D/P = Directional Phase
- O/C = Overcurrent
- EF = Earth Fault
- SEF = Sensitive Earth Fault
- AR = Auto-reclose
- CS = Check Synchronizing
- RVI = Residual Voltage Input

3.1 P543 Connection Diagrams

This section includes the following diagrams:

- Figure 1 - P543 - external connection diagram – 16 inputs/14 standard outputs
- Figure 4 - P543 – 16 inputs/14 standard outputs default mapping
- Figure 1 - P543 – external connection diagram – 16 inputs/7 standard and 4 high break outputs
- Figure 6 - P543 – 16 inputs/7 standard and 4 high-break outputs default mapping
- Figure 1 - P543 – external connection diagram – 16 inputs/24 standard outputs default mapping
- Figure 8 - P543 – 16 inputs/24 standard outputs default mapping

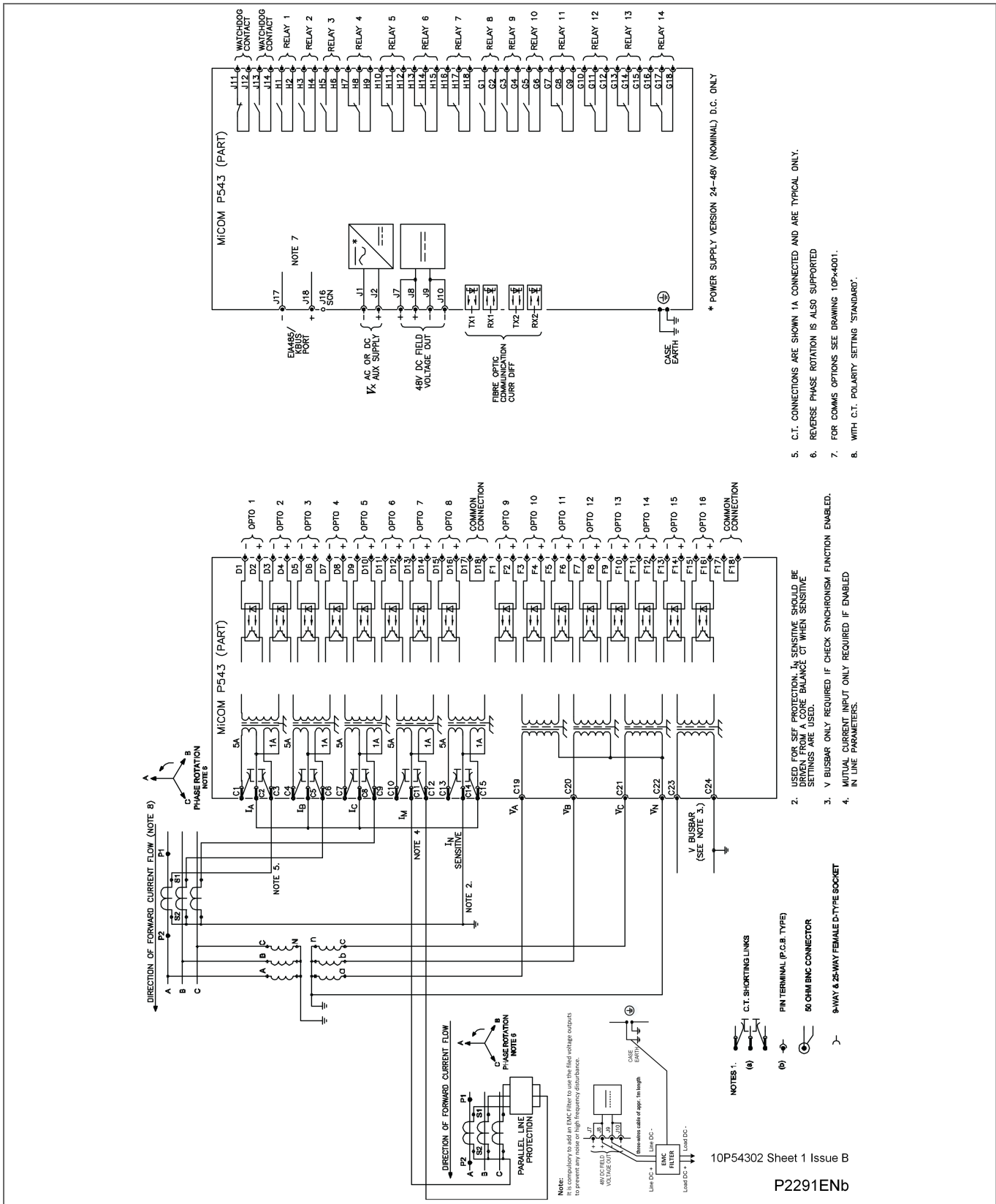

Figure 3 - P543 - external connection diagram – 16 inputs/14 standard outputs

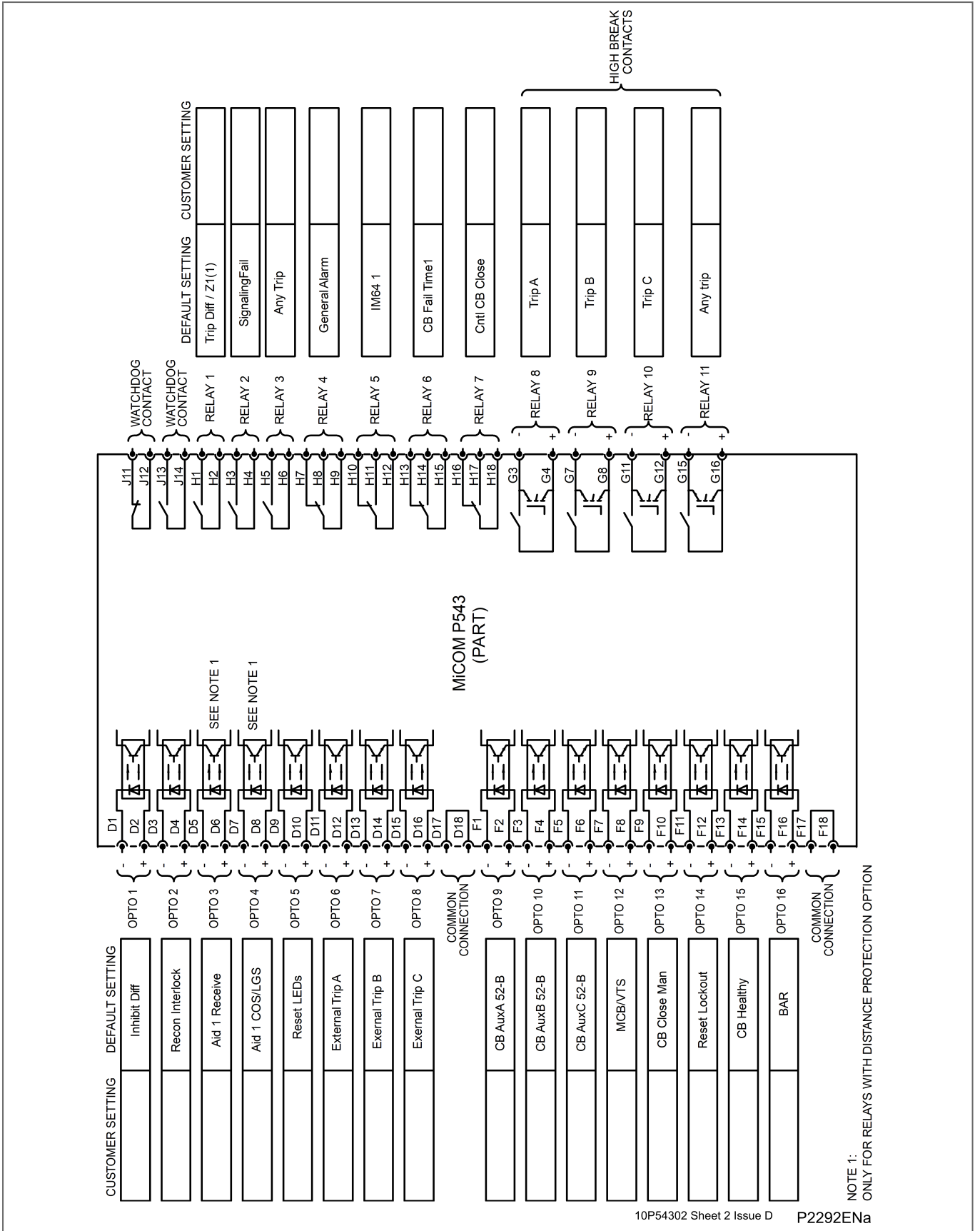

Figure 4 - P543 - 16 inputs/14 standard outputs default mapping

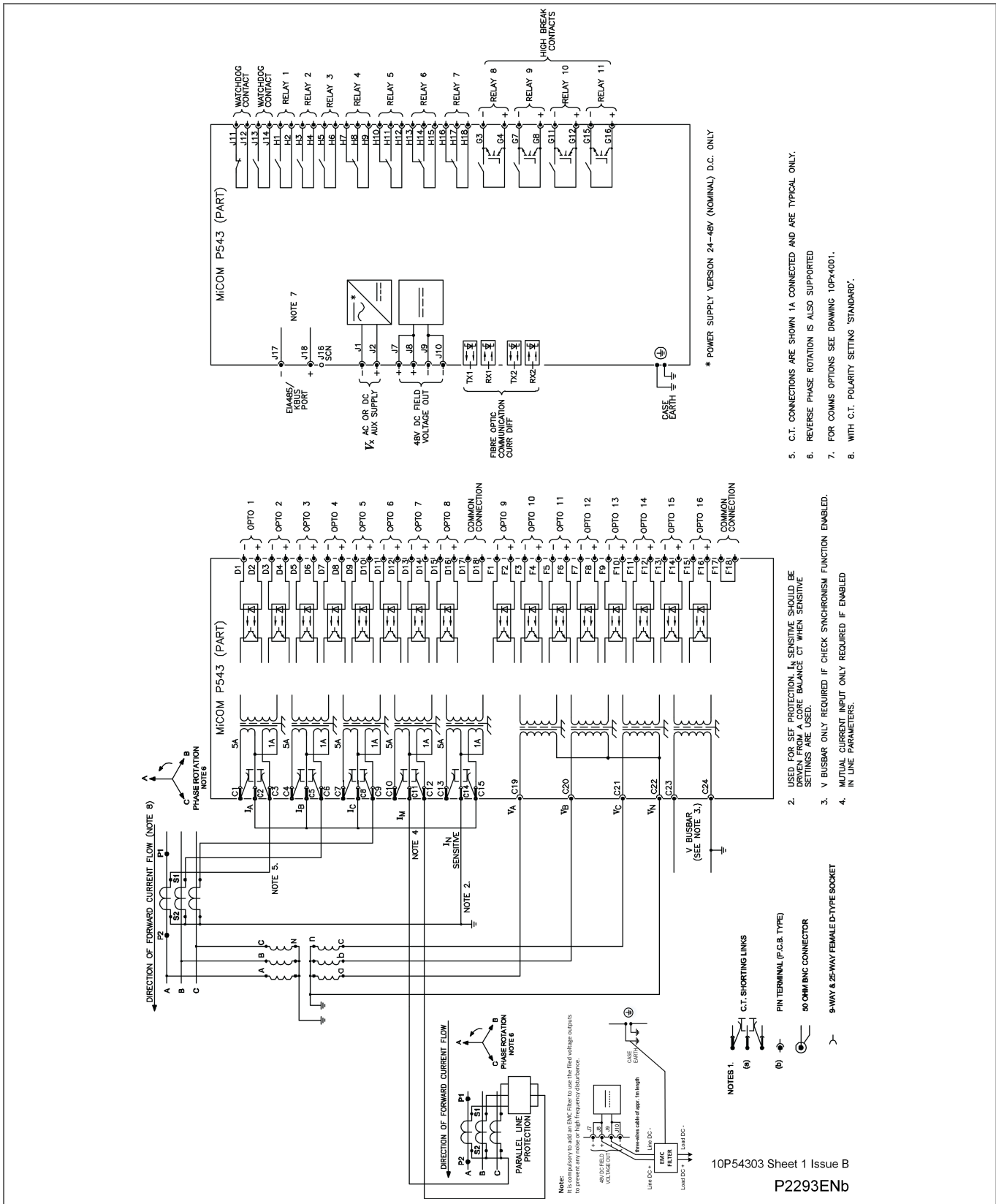

Figure 5 - P543 – external connection diagram – 16 inputs/7 standard and 4 high break outputs

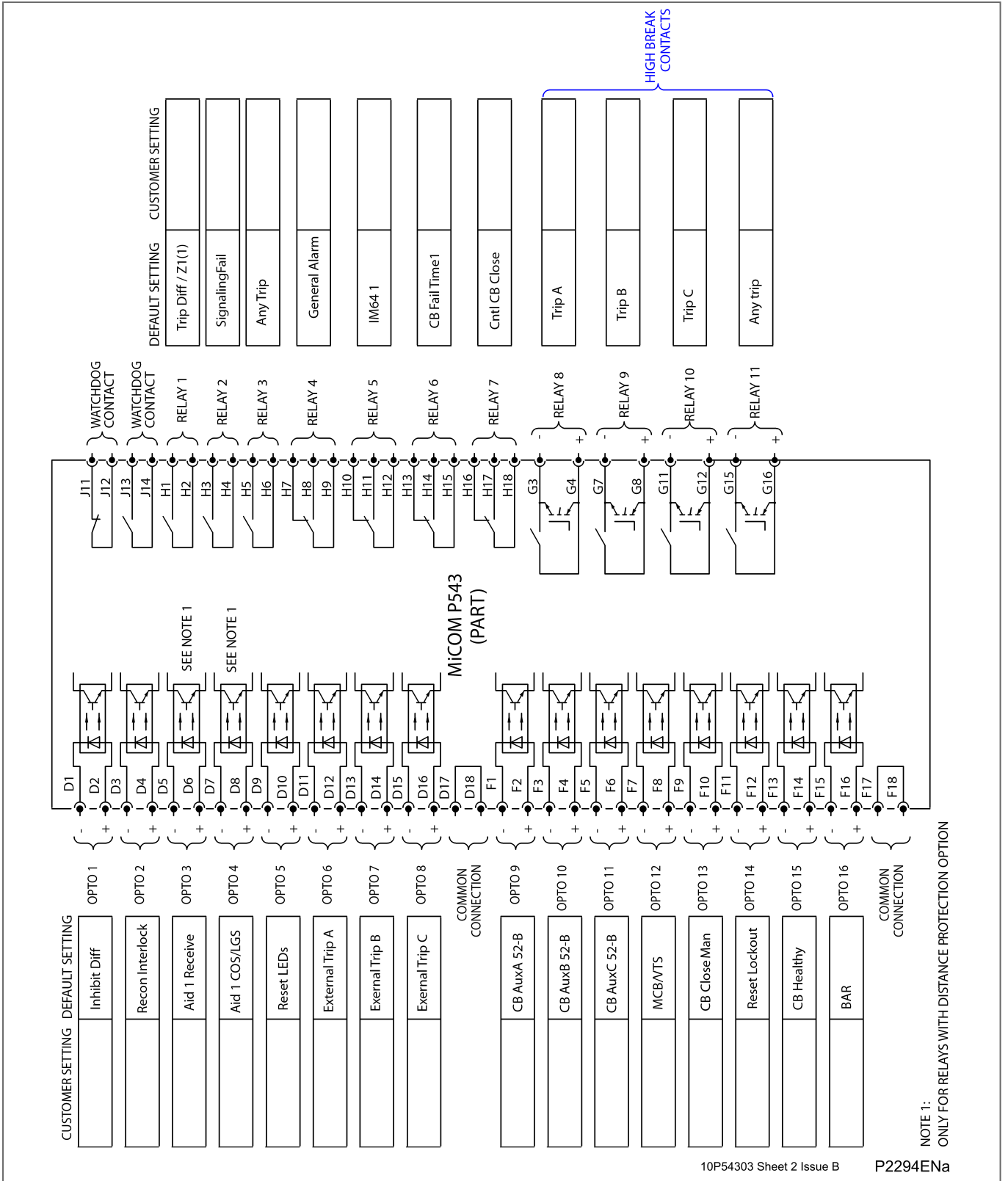

Figure 6 - P543 – 16 inputs/7 standard and 4 high-break outputs default mapping

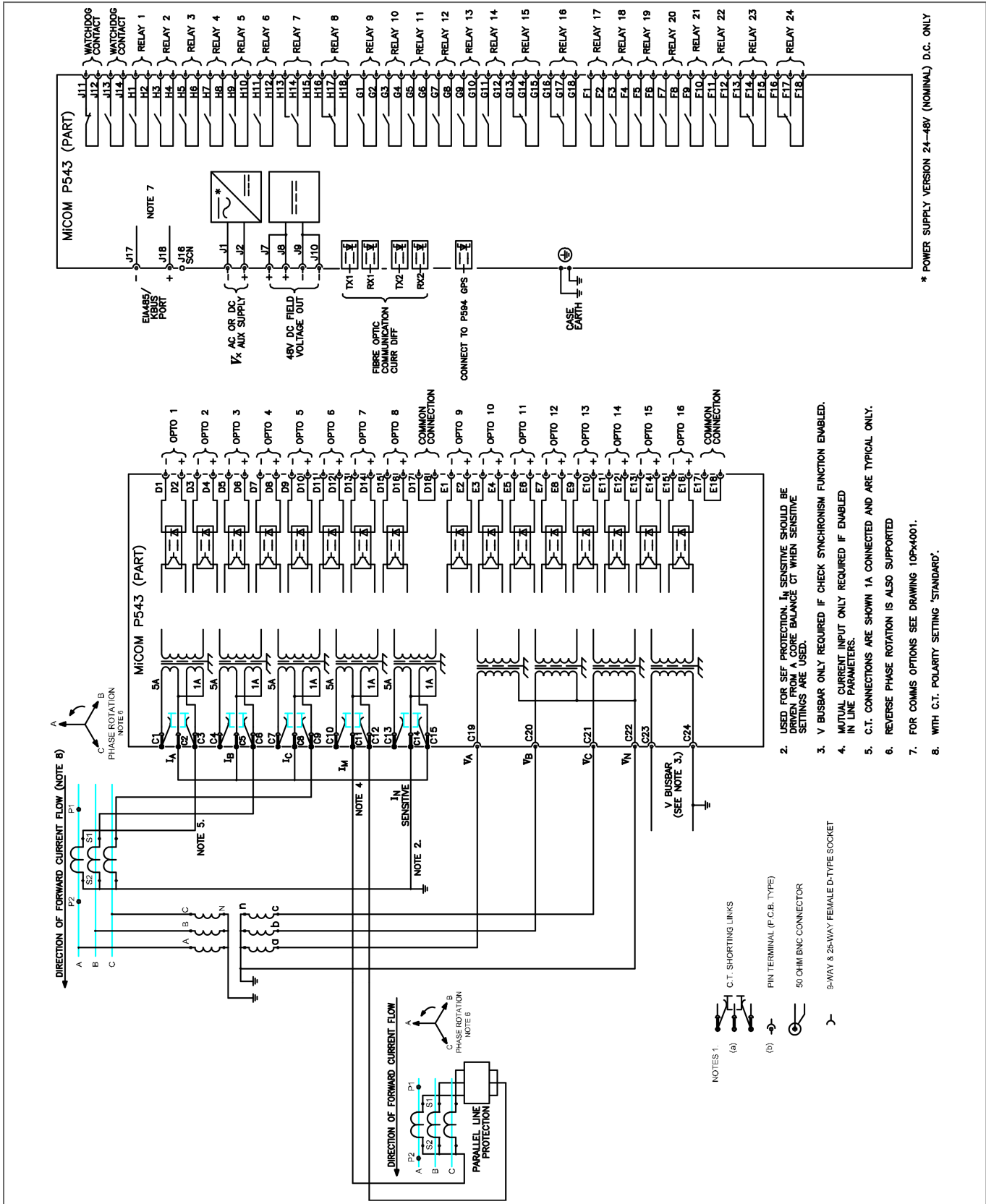

Figure 7 - P543 – external connection diagram – 16 inputs/24 standard outputs default mapping

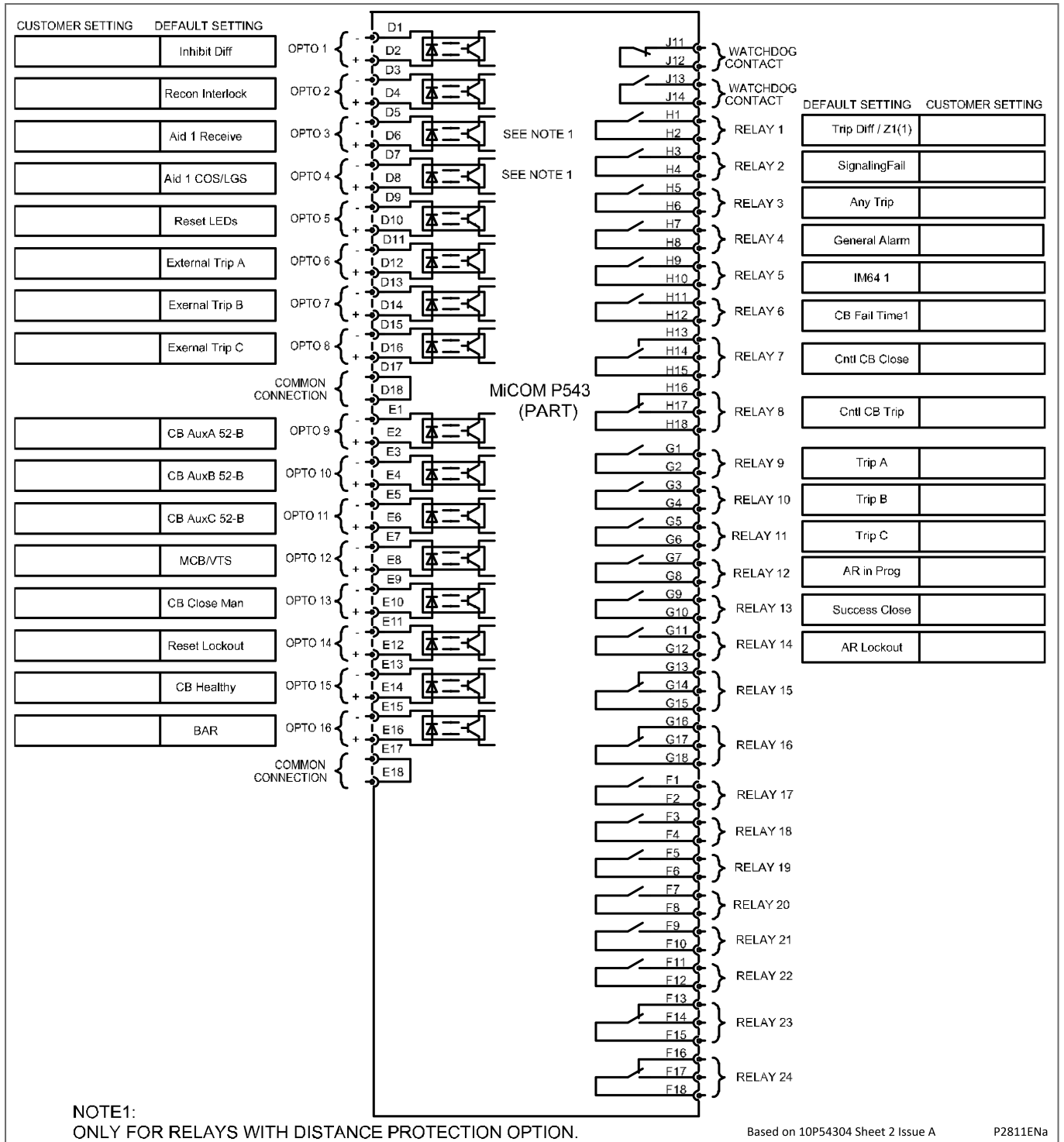

Figure 8 - P543 – 16 inputs/24 standard outputs default mapping

3.2 P544 Connection Diagrams

This section includes the following diagrams:

- Figure 1 - P544 - external connection diagram - standard outputs
- Figure 1 - P544 - 16 inputs/outputs default mapping - 14 standard outputs
- Figure 11 - P544 - 16 inputs/outputs default mapping - 14 standard outputs
- Figure 1 - P544 - 16 inputs/outputs default mapping - 7 standard and 4 high-break outputs
- Figure 13 - P544 - 16 inputs/outputs default mapping - 7 standard and 4 high-break outputs

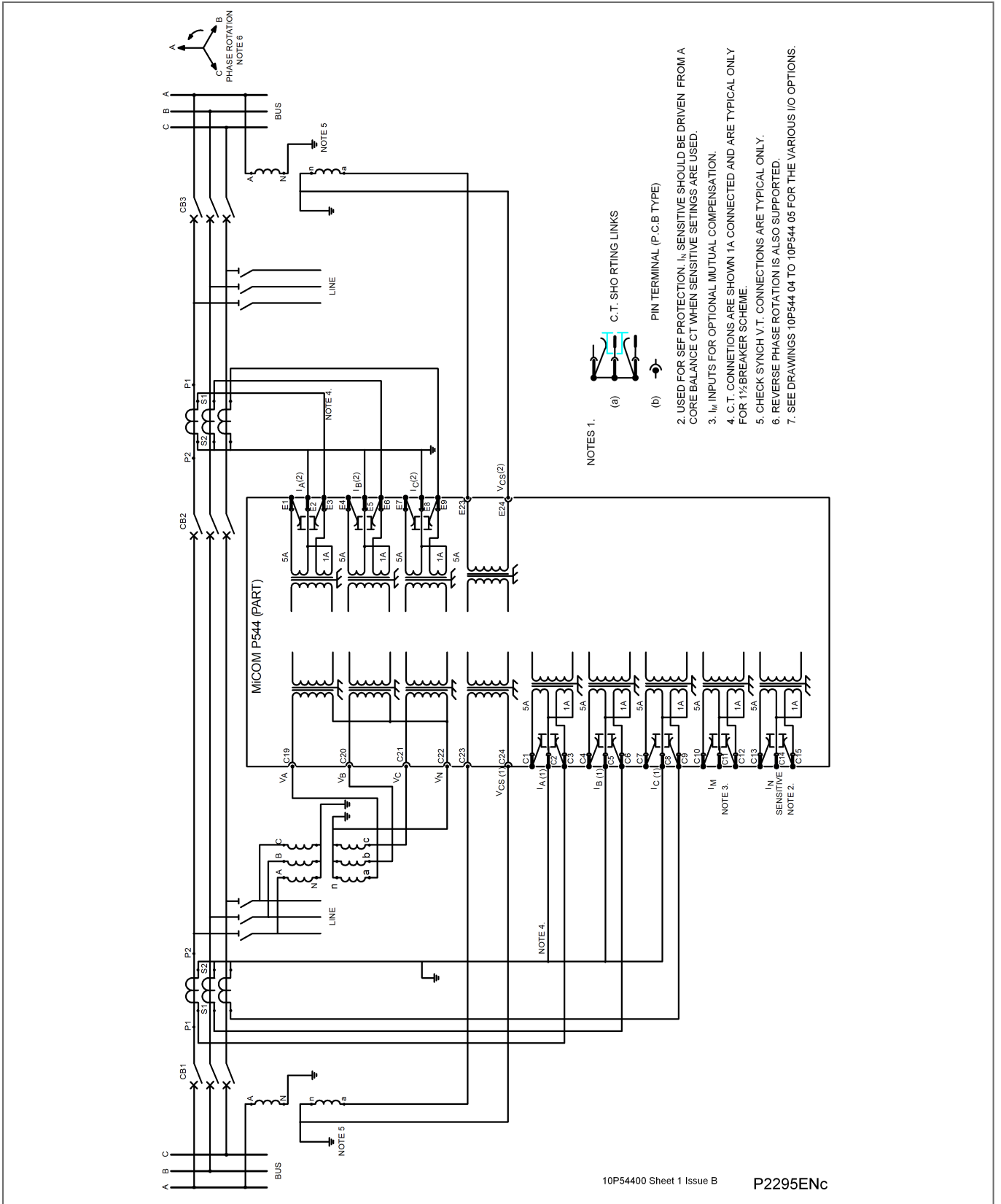

Figure 9 - P544 - external connection diagram - standard outputs

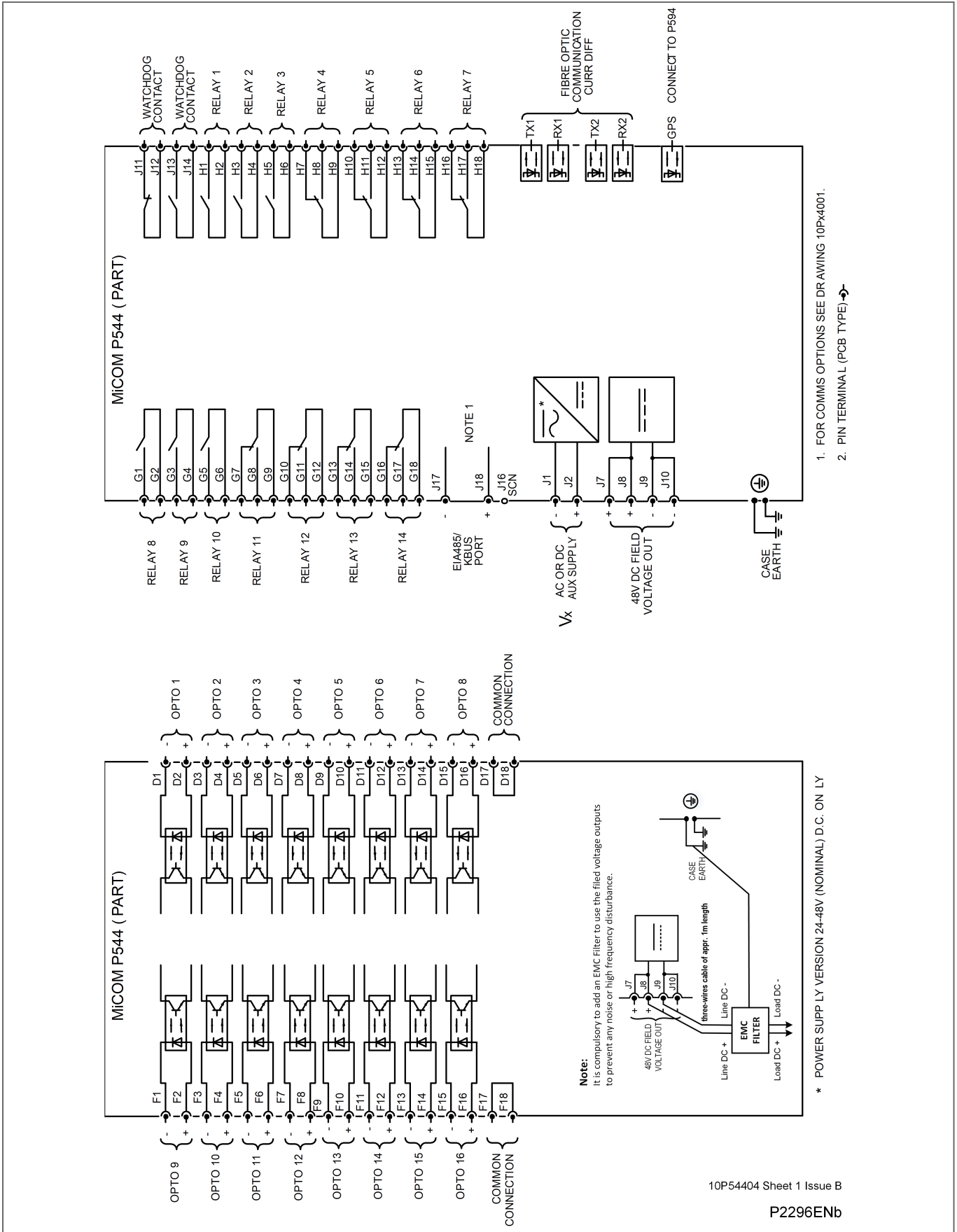

Figure 10 - P544 - 16 inputs/outputs default mapping - 14 standard outputs

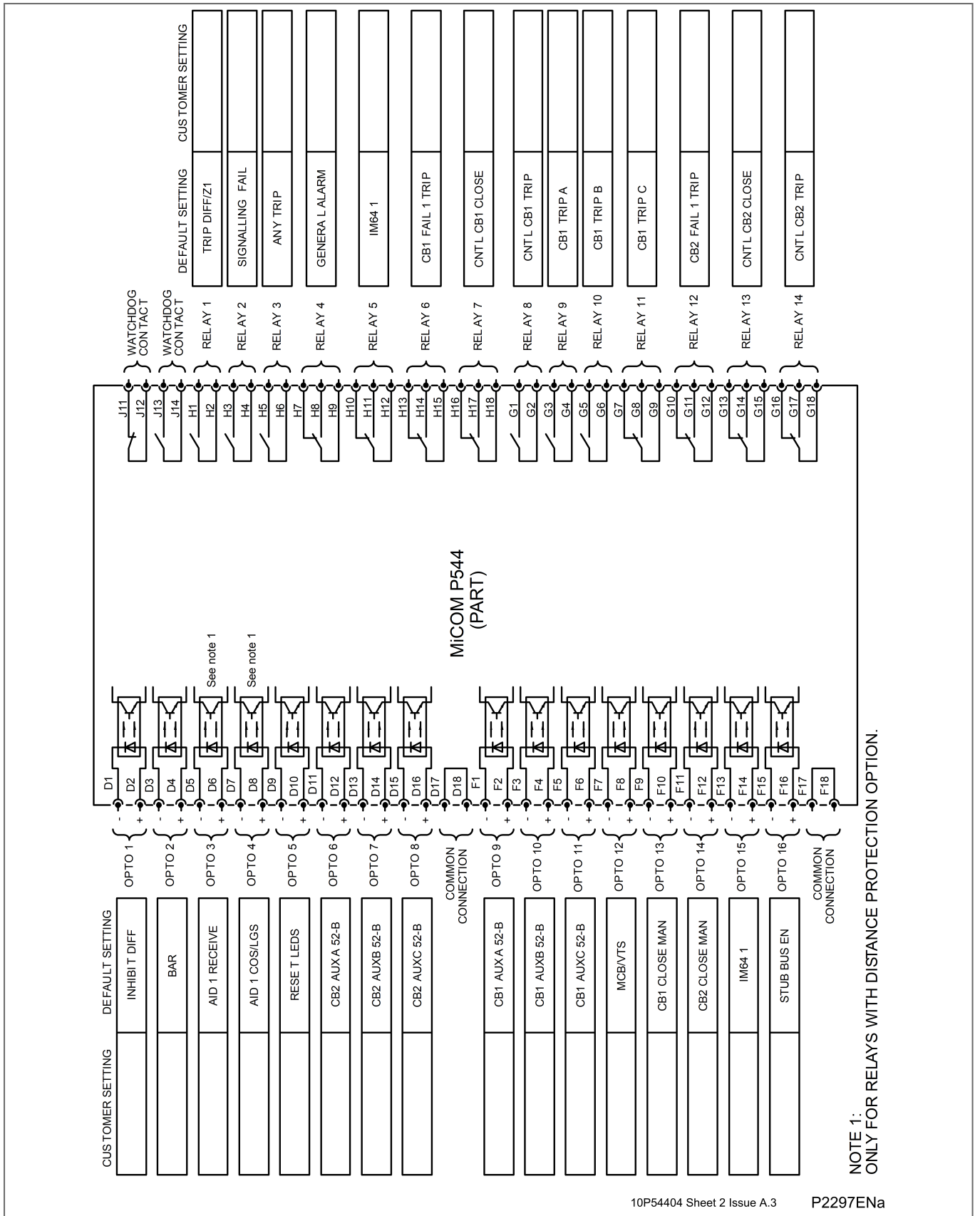

Figure 11 - P544 - 16 inputs/outputs default mapping - 14 standard outputs

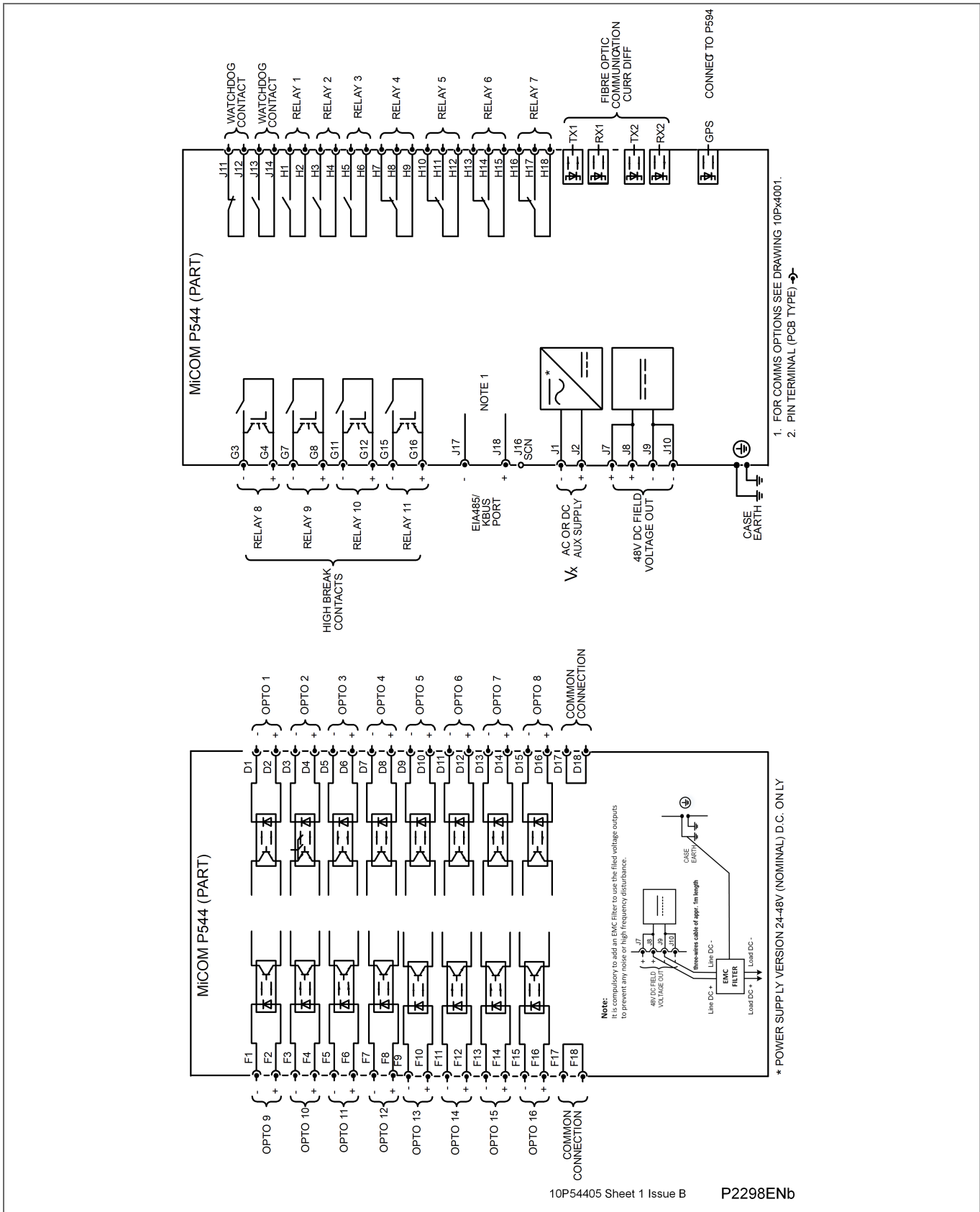

Figure 12 - P544 - 16 inputs/outputs default mapping - 7 standard and 4 high-break outputs

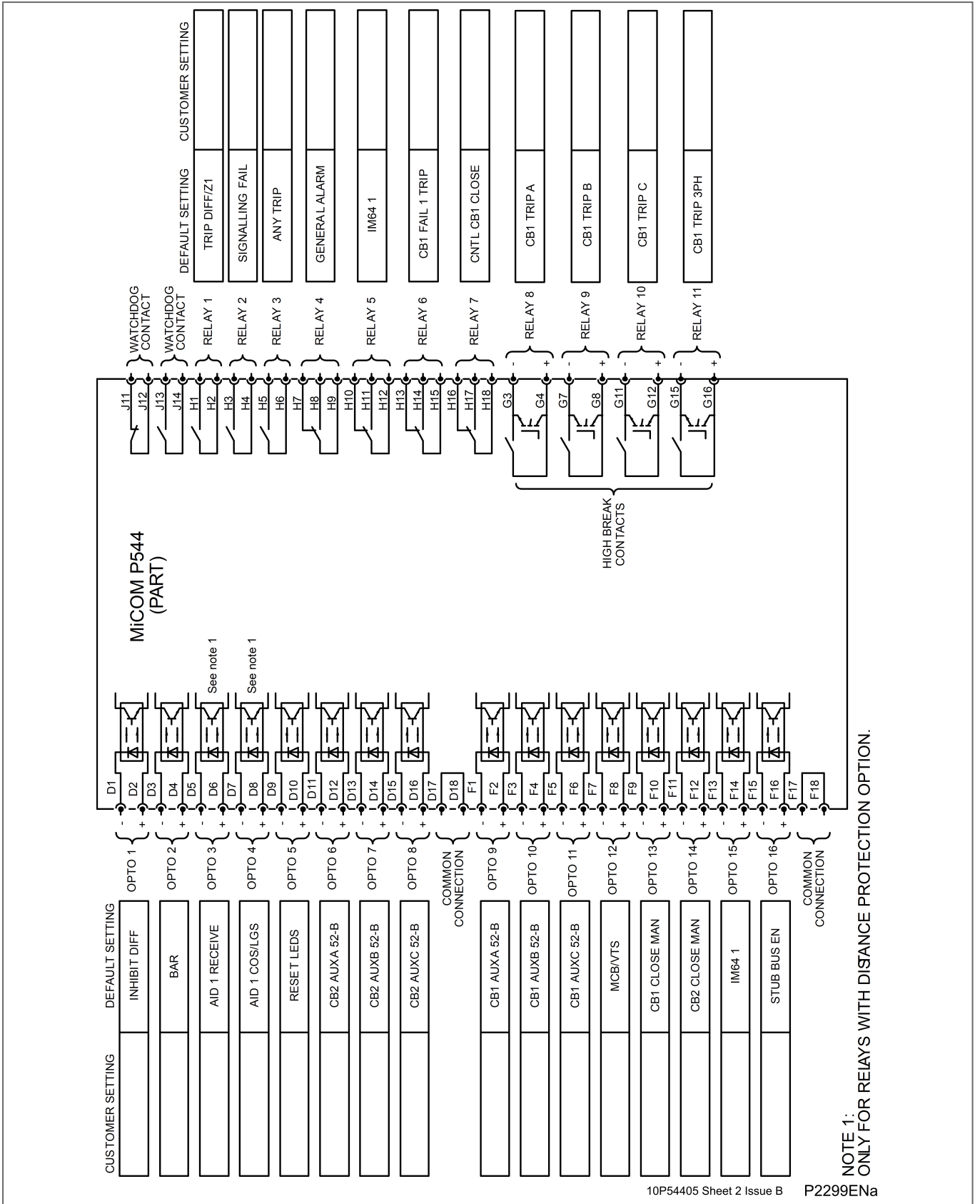

Figure 13 - P544 - 16 inputs/outputs default mapping - 7 standard and 4 high-break outputs

3.3 P545 Connection Diagrams

This section includes the following diagrams:

- Figure 1 - P545 - external connection diagram - standard outputs
- Figure 15 - P545 - inputs/outputs default mapping - standard outputs
- Figure 1 - P545 - 16 standard and 8 high-break outputs
- Figure 17 - P545 - 24 inputs/outputs default mapping - 16 standard and 8 high-break outputs
- Figure 1 - P545 - 32 optos, 32 relays, Distance, 1 or 3 Pole Tripping, Auto-Reclose and Chk Sync Sheet 1
- Figure 19 - P545 - 32 optos, 32 relays, Distance, 1 or 3 Pole Tripping, Auto-Reclose and Chk Sync Sheet 2

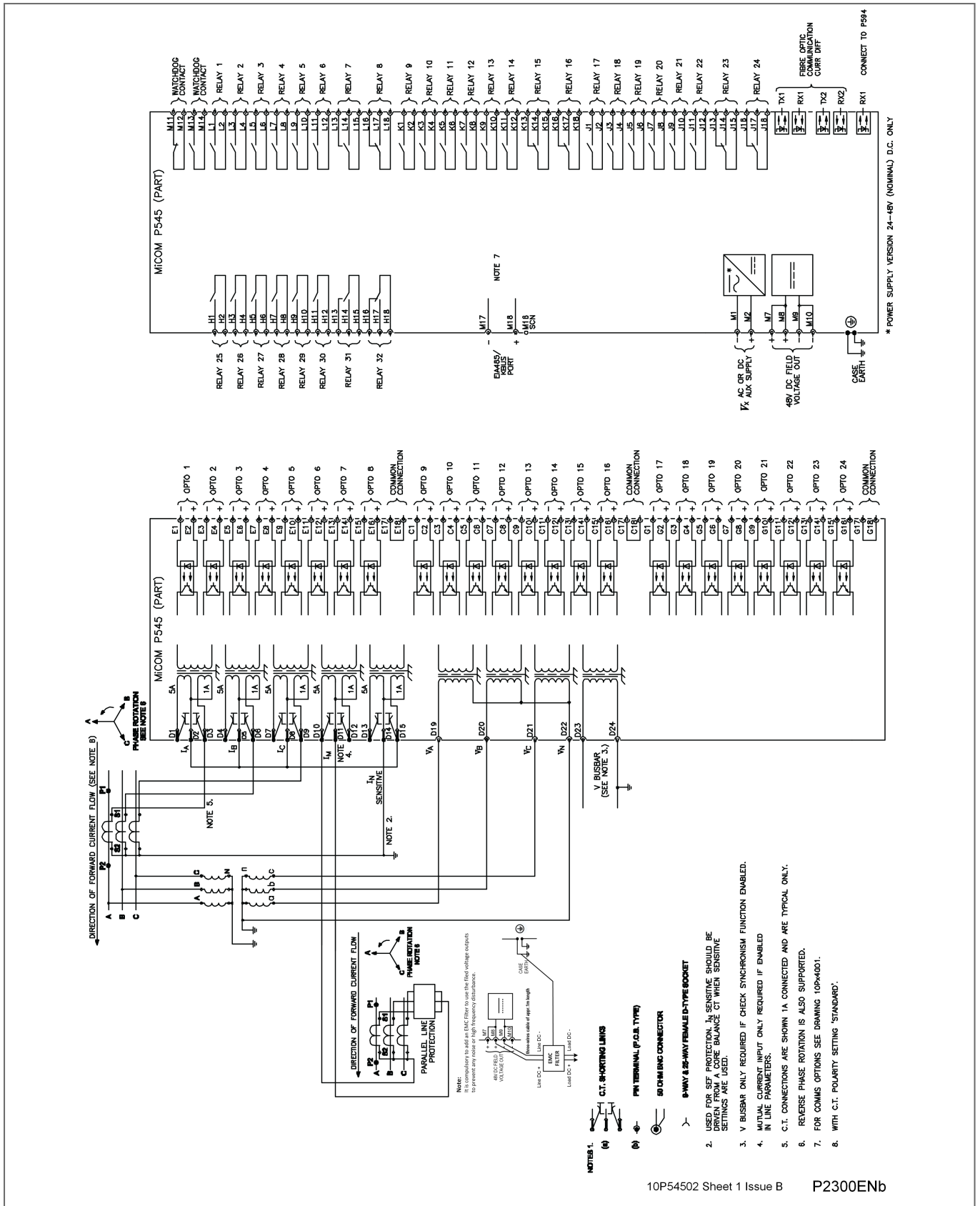

Figure 14 - P545 - external connection diagram - standard outputs

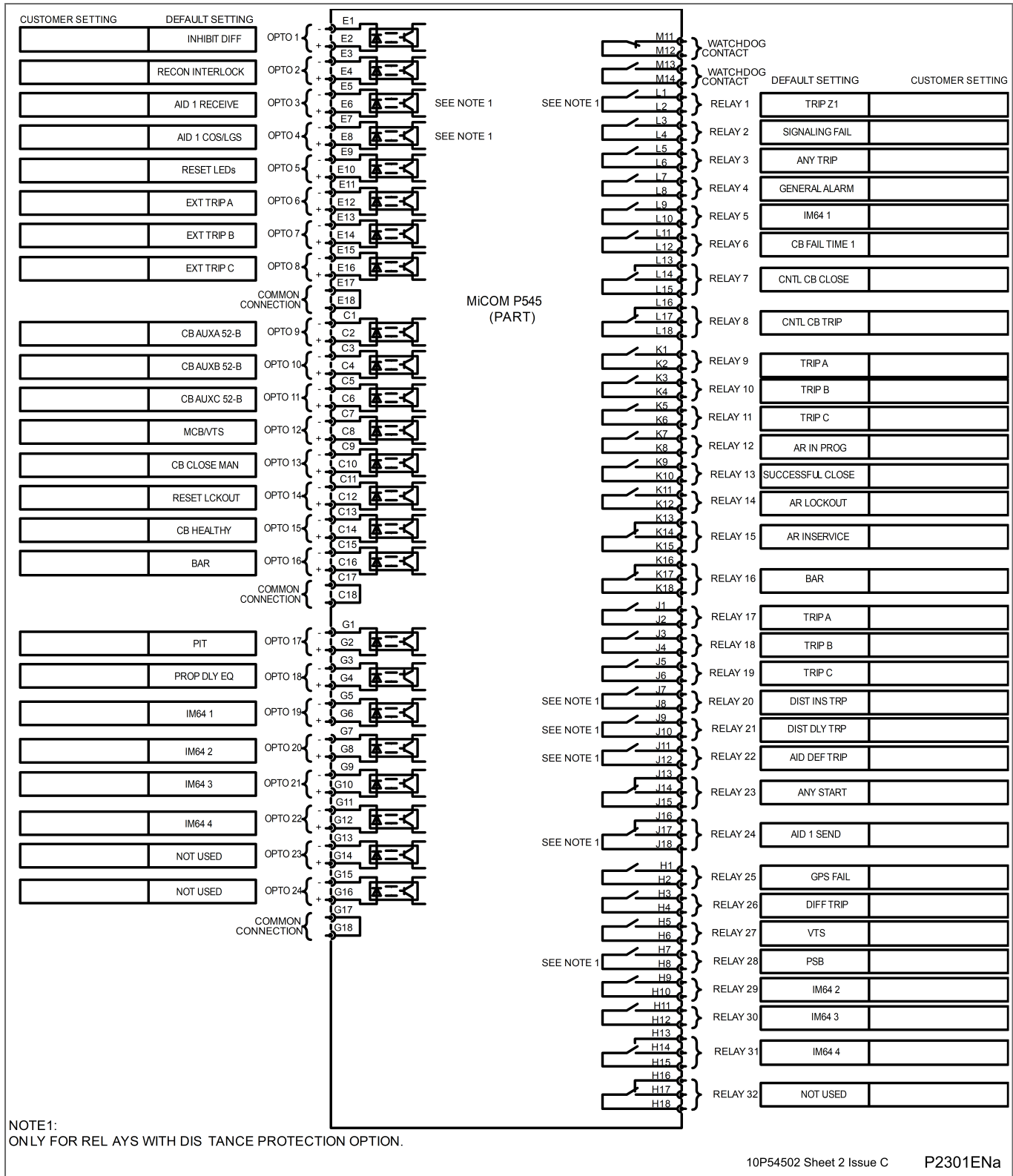

Figure 15 - P545 - inputs/outputs default mapping - standard outputs

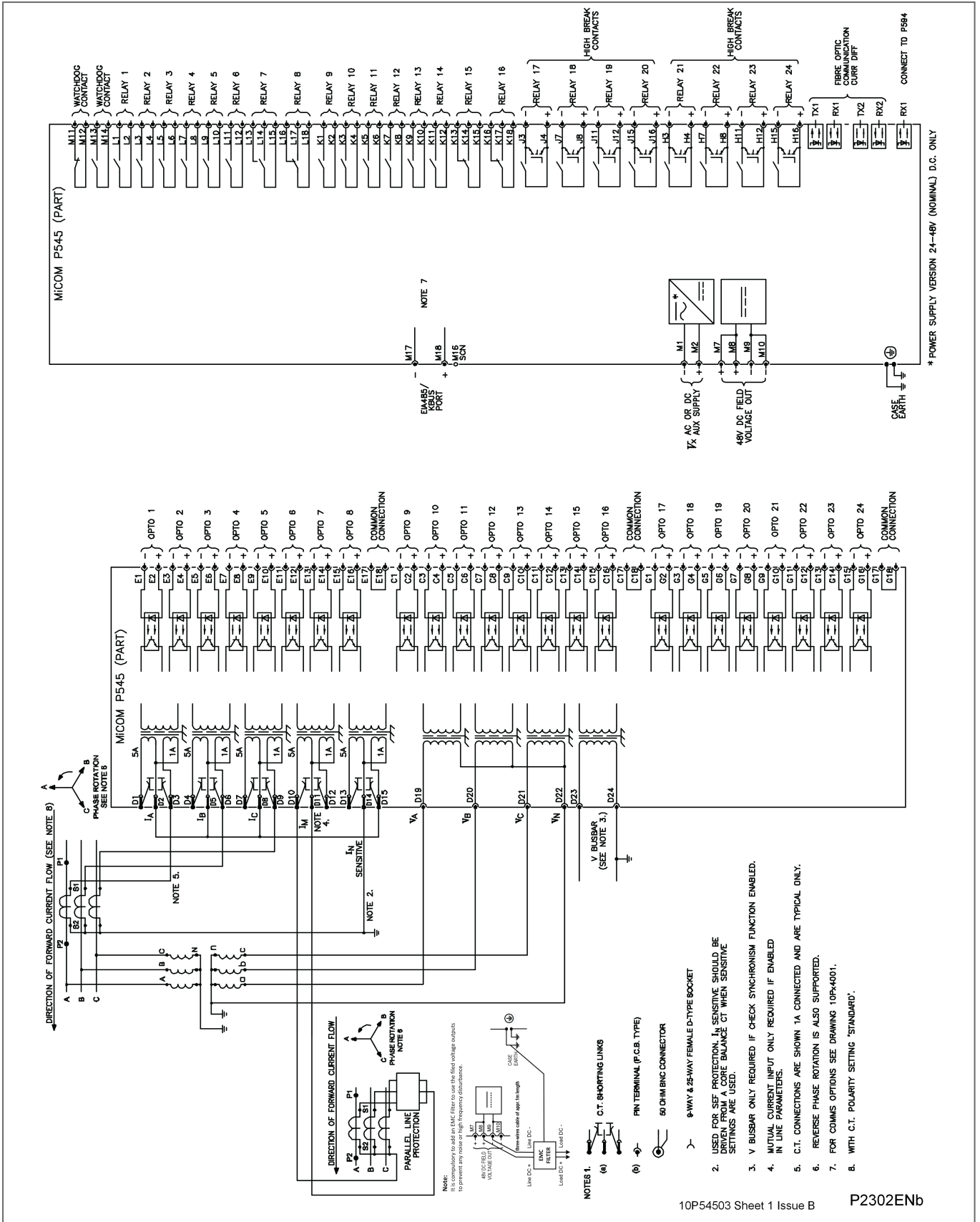

Figure 16 - P545 - 16 standard and 8 high-break outputs

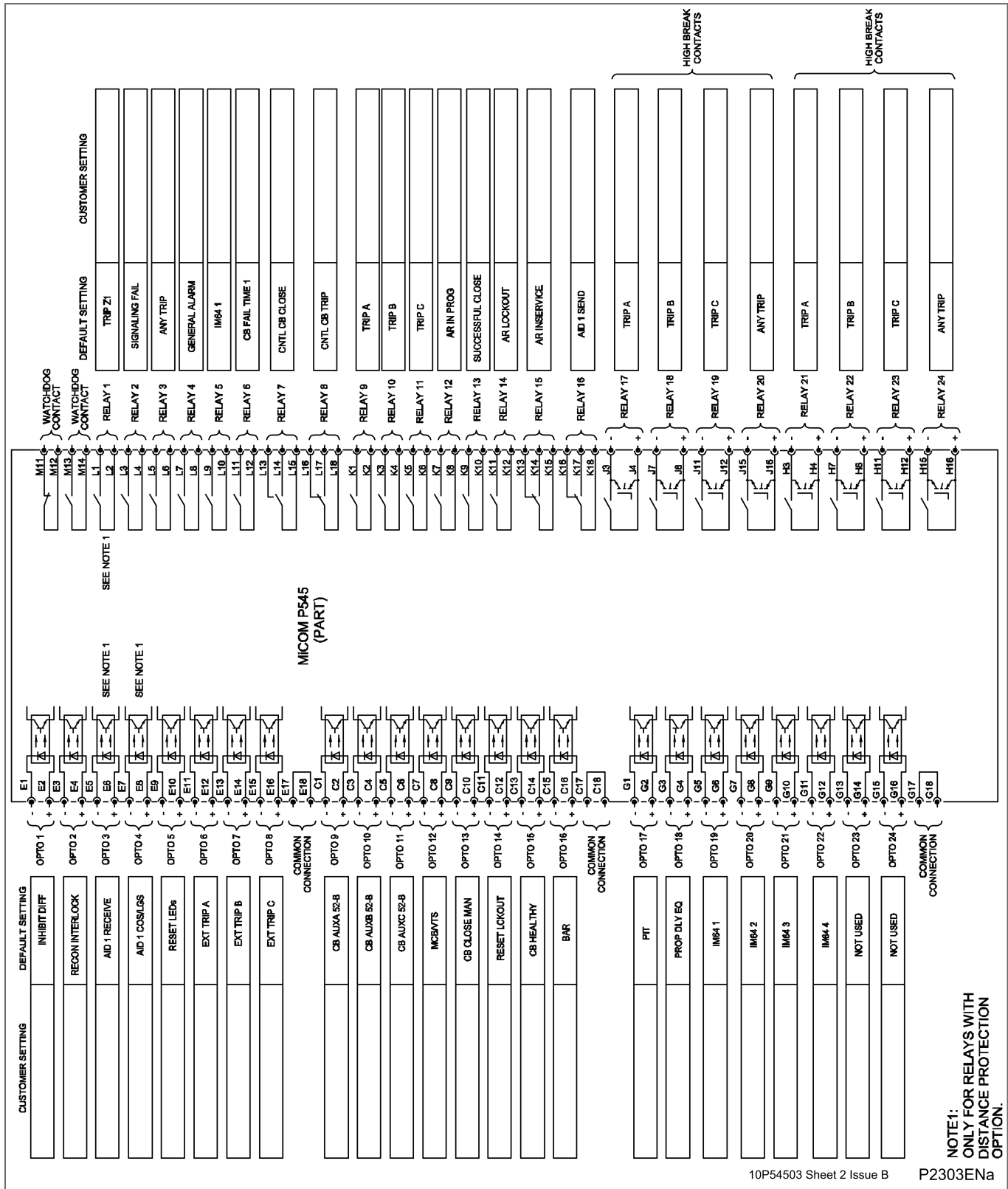

Figure 17 - P545 - 24 inputs/outputs default mapping - 16 standard and 8 high-break outputs

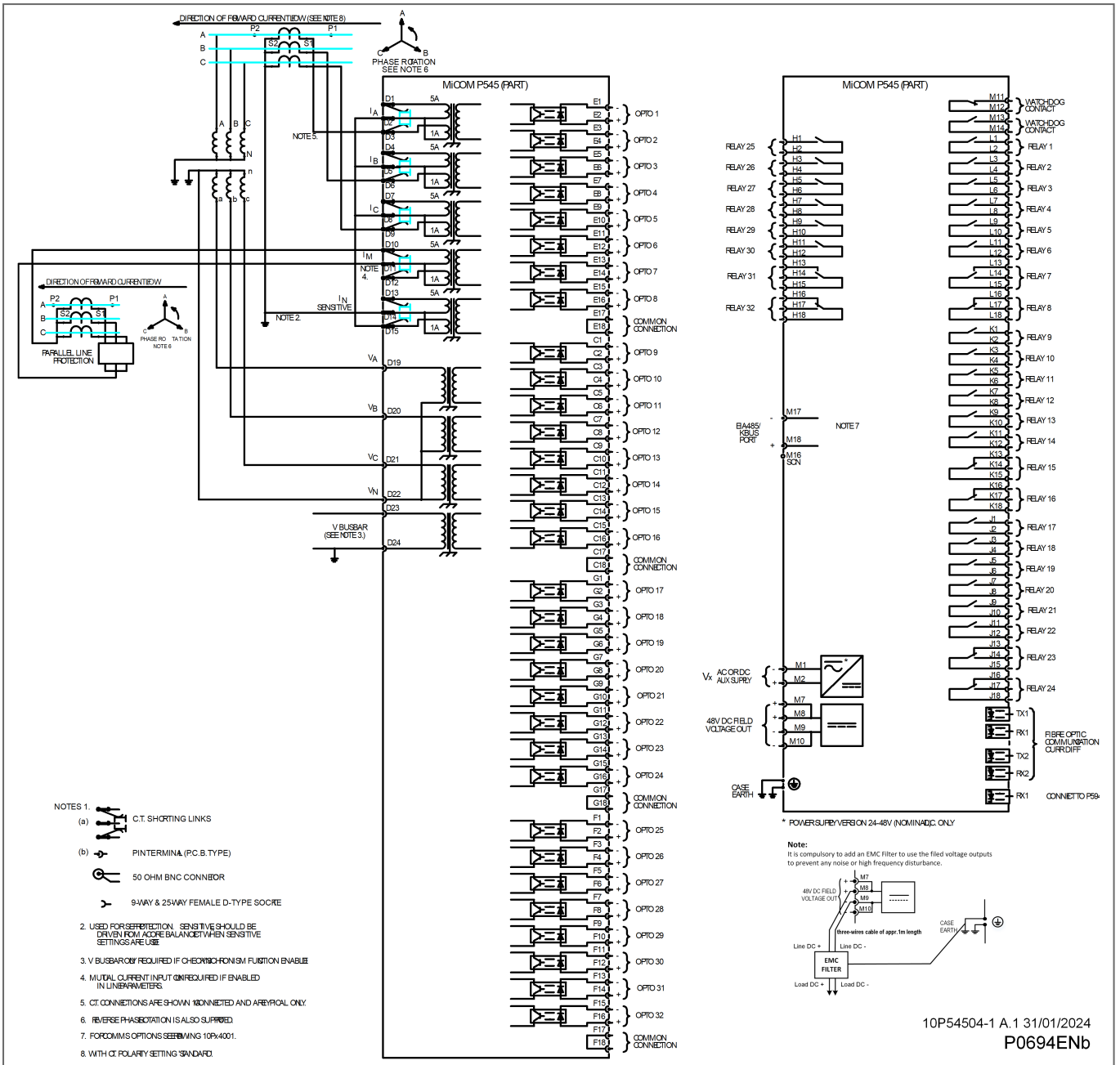

Figure 18 - P545 - 32 optos, 32 relays, Distance, 1 or 3 Pole Tripping, Auto-Reclose and Chk Sync Sheet 1

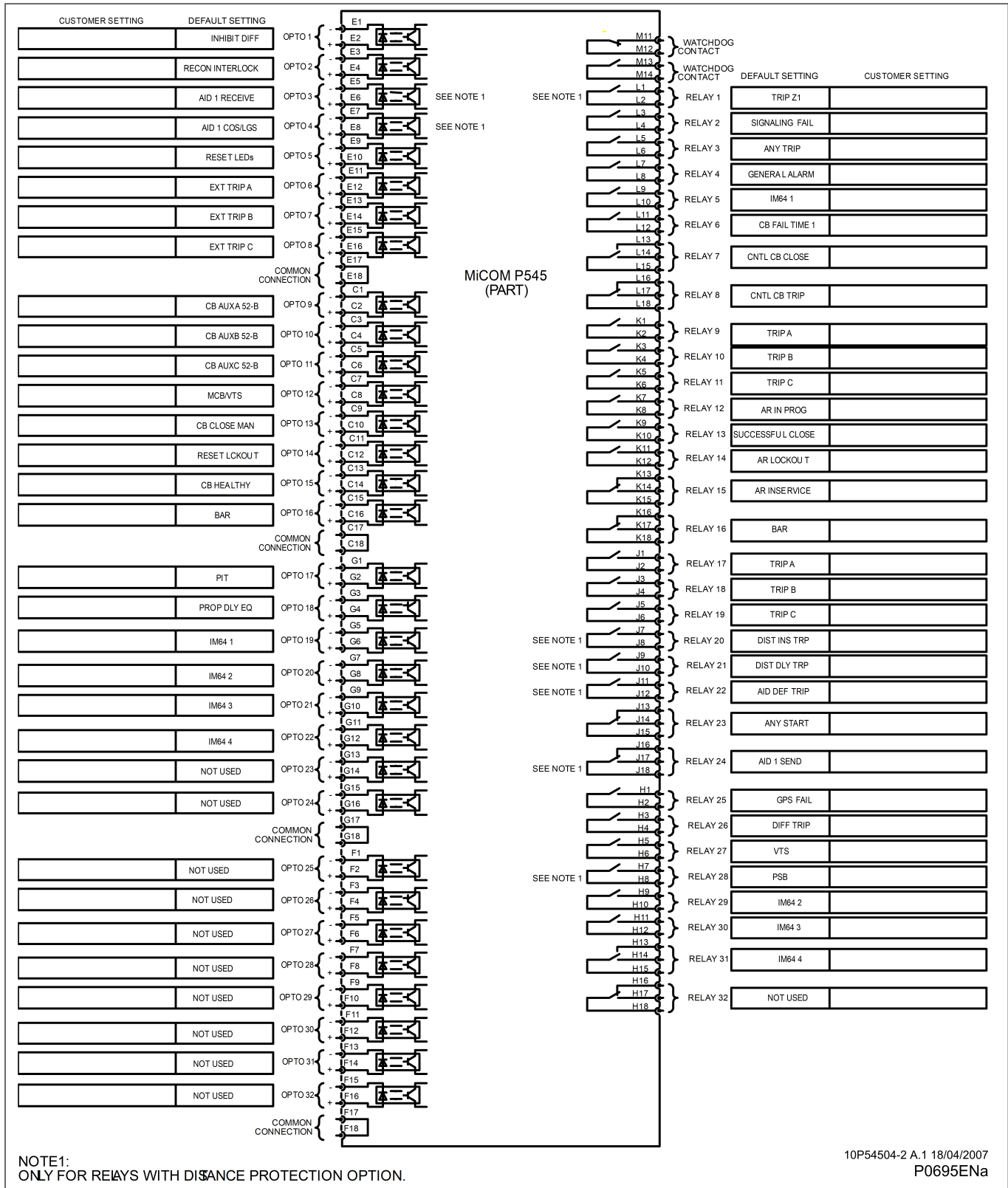
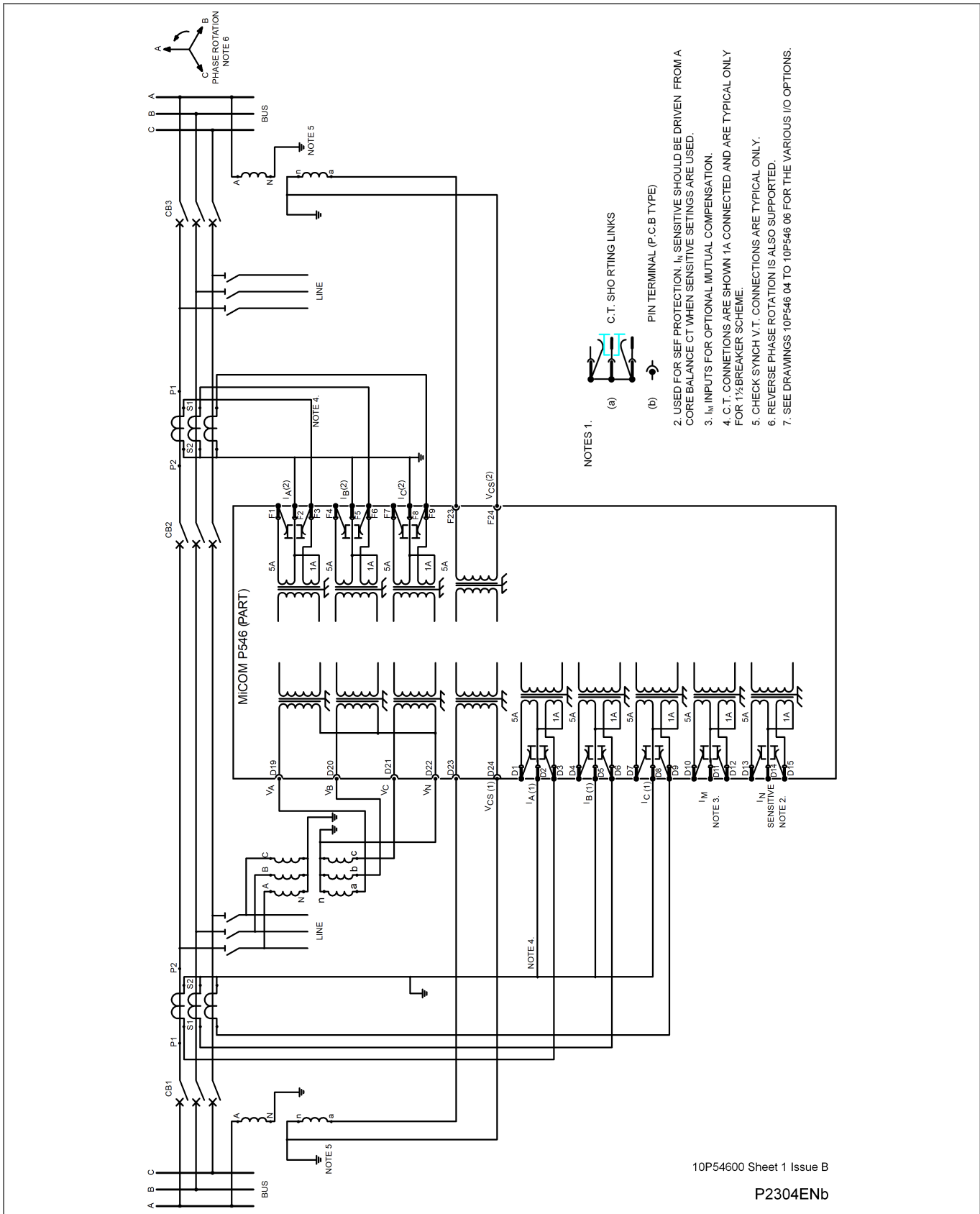

Figure 19 - P545 - 32 optos, 32 relays, Distance, 1 or 3 Pole Tripping, Auto-Reclose and Chk Sync Sheet 2

3.4 P546 Connection Diagrams

This section includes the following diagrams:

- Figure 1 - P546 - external connection diagram - standard outputs
- Figure 1 - P546 - 24 inputs/32 outputs default mapping - standard and high-break outputs
- Figure 22 - P546 - 24 opto inputs/32 outputs default mapping - standard and high-break outputs
- Figure 23 - P546 - 24 inputs/outputs default mapping – 16 standard and 8 high-break outputs
- Figure 24 - P546 - 24 inputs/outputs default mapping – 16 standard and 8 high-break outputs
- Figure 1 - P546 - 24 inputs/outputs default mapping – 8 Standard and 12 high-break outputs
- Figure 26 - P546 - 24 inputs/outputs default mapping – 8 Standard and 12 high-break outputs
- Figure 27 - P546 Final assembly drawing



10P54600 Sheet 1 Issue B

P2304ENb

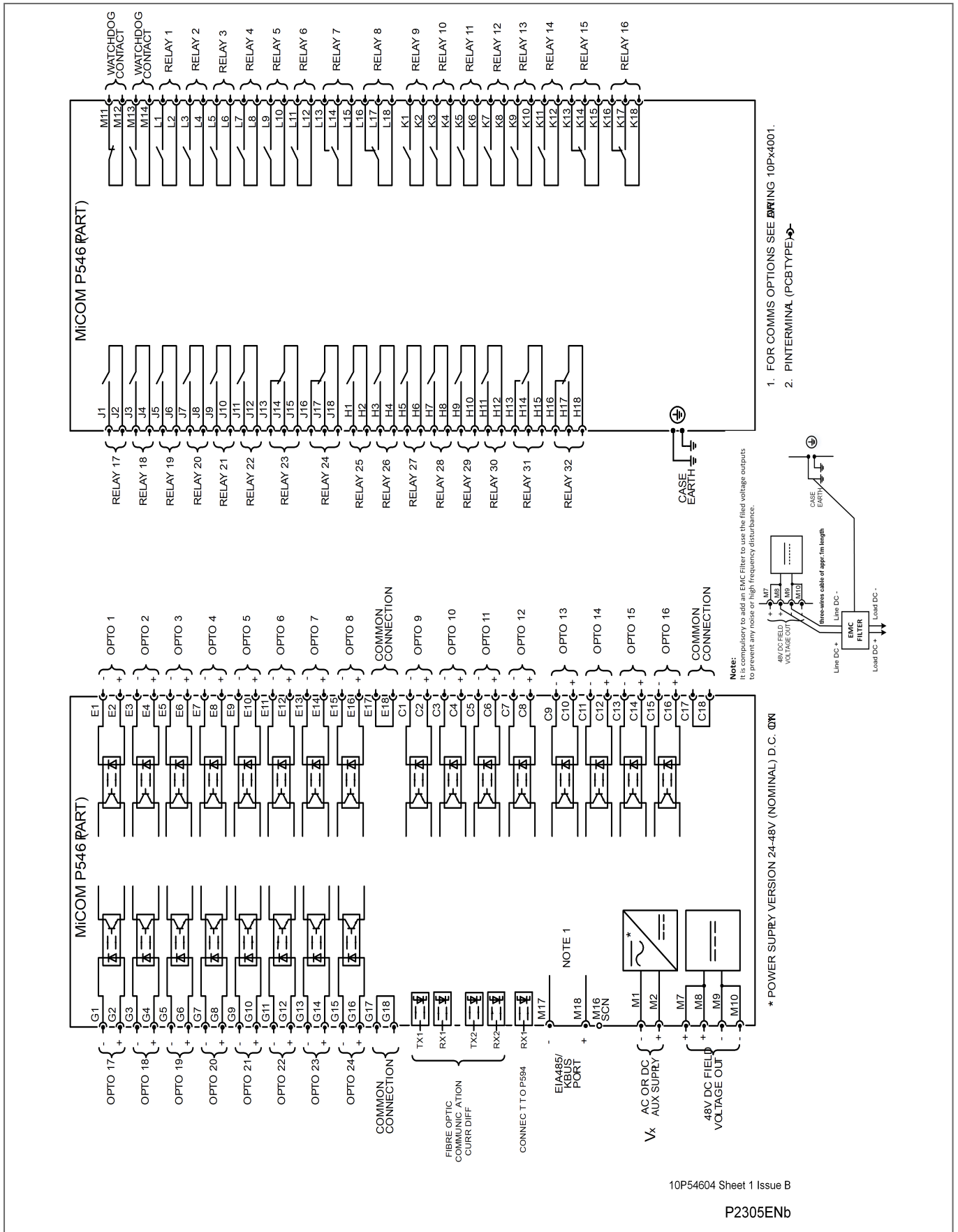

Figure 21 - P546 - 24 inputs/32 outputs default mapping - standard and high-break outputs

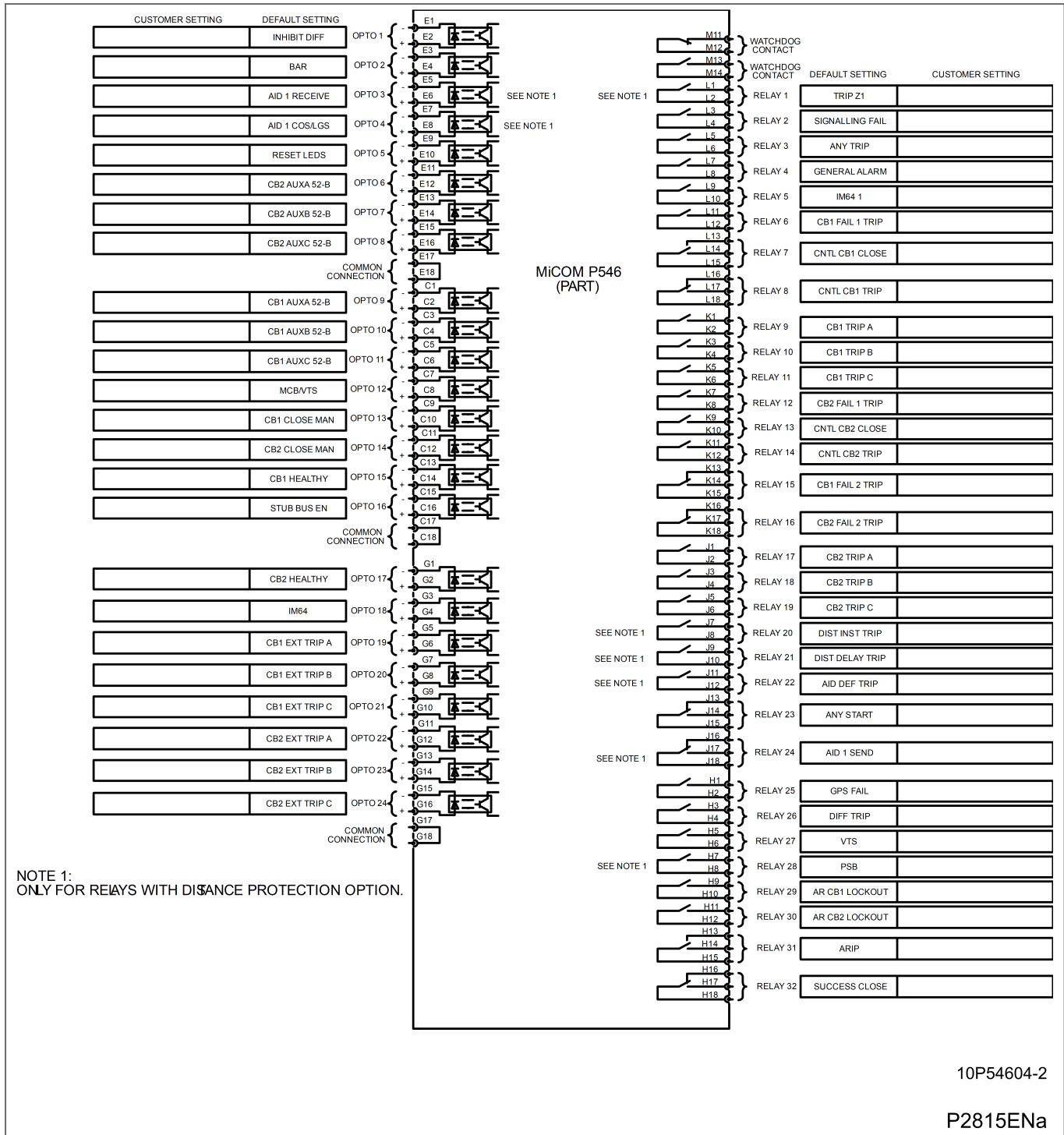

Figure 22 - P546 - 24 opto inputs/32 outputs default mapping - standard and high-break outputs

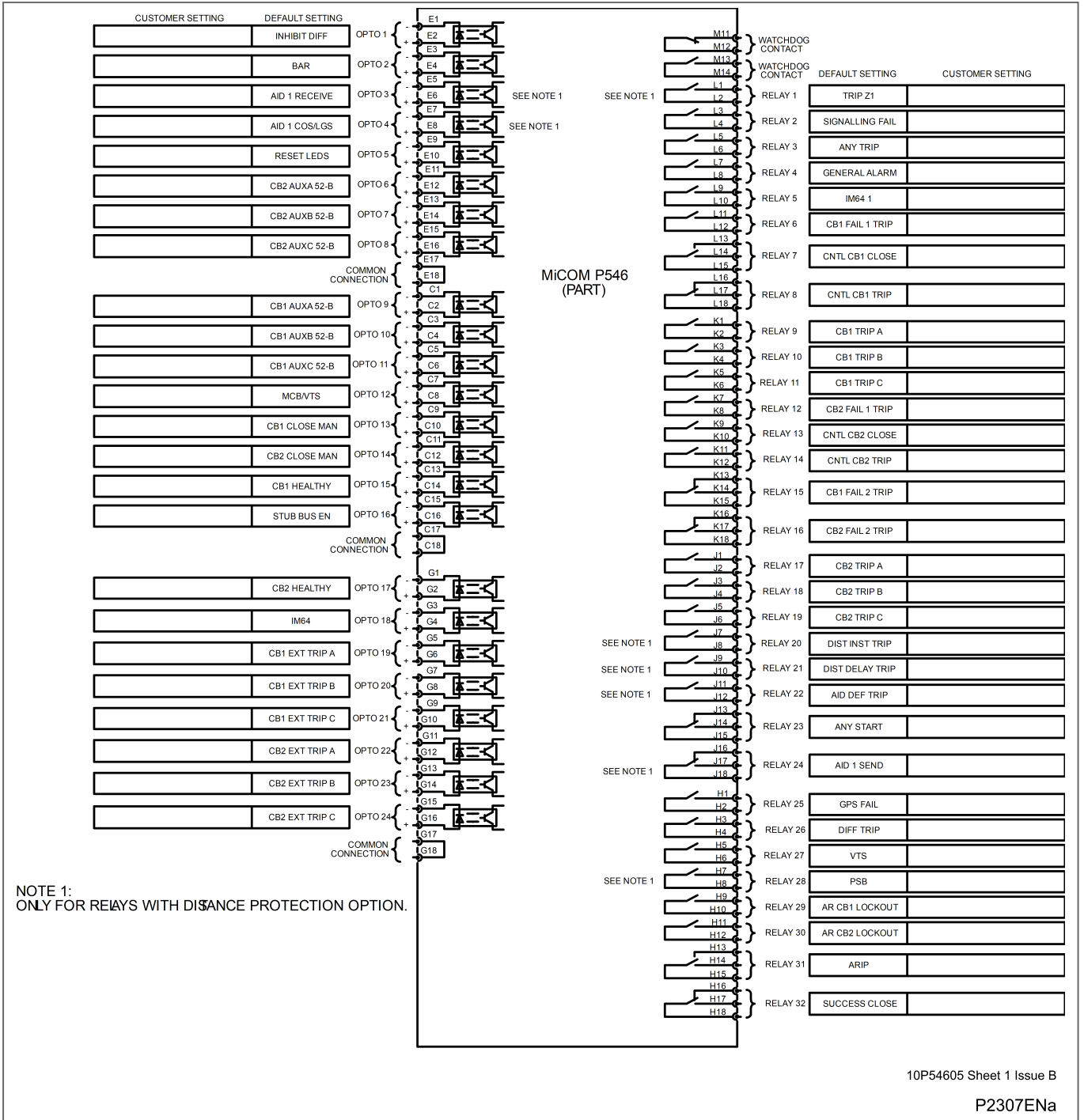

Figure 23 - P546 - 24 inputs/outputs default mapping – 16 standard and 8 high-break outputs

10P54605 Sheet 1 Issue B
P2307ENa

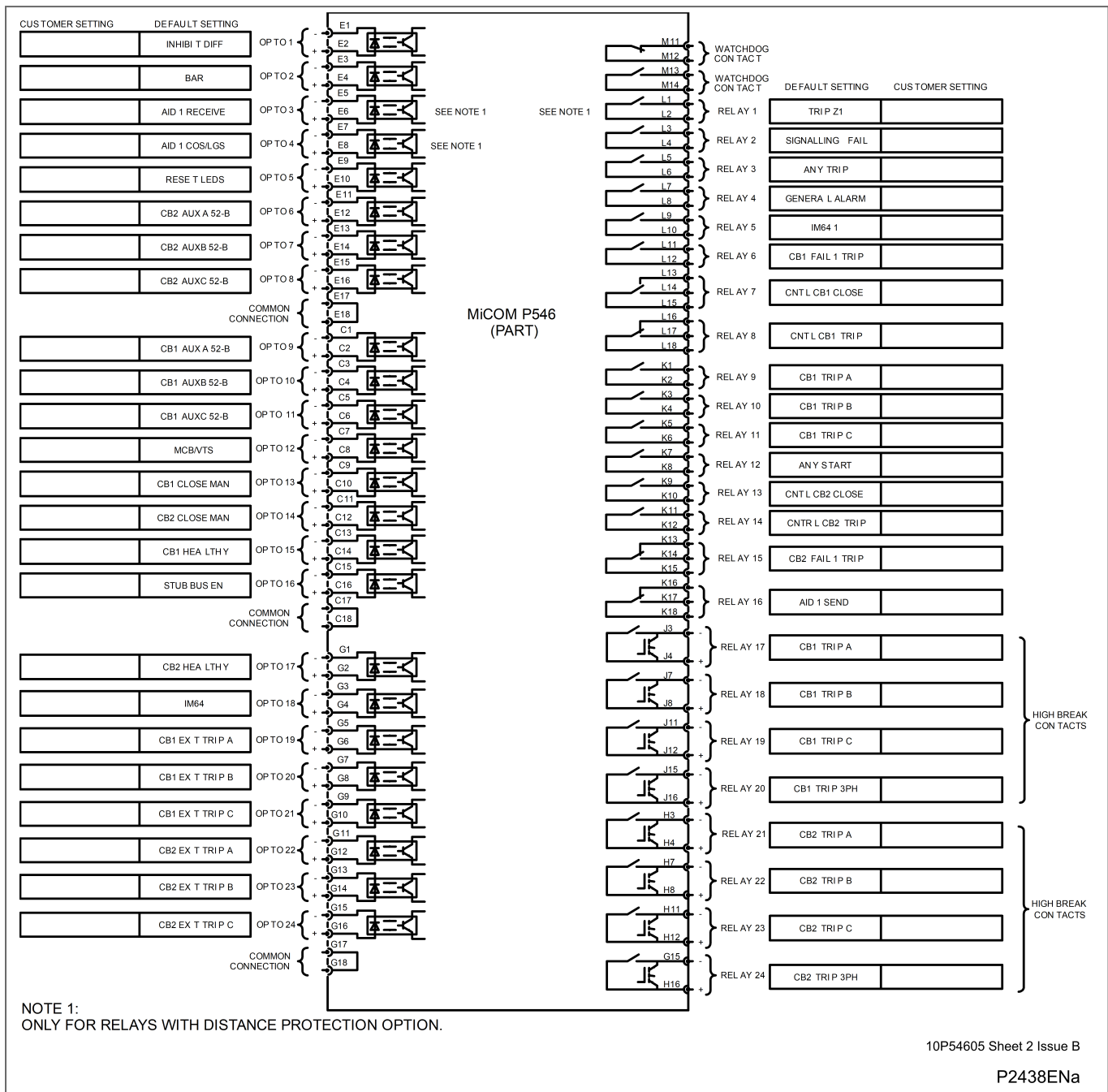

Figure 24 - P546 - 24 inputs/outputs default mapping – 16 standard and 8 high-break outputs

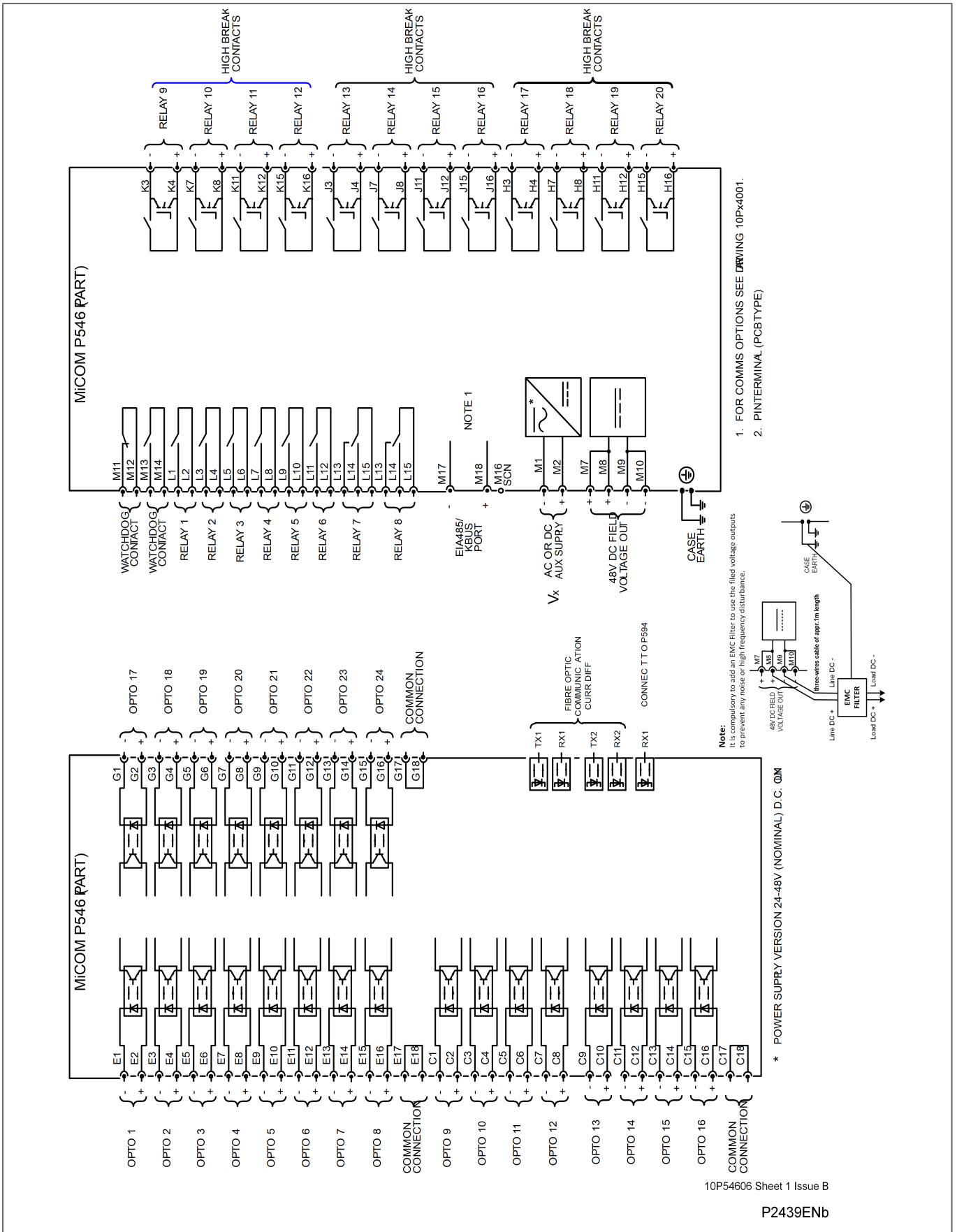

Figure 25 - P546 - 24 inputs/outputs default mapping – 8 Standard and 12 high-break outputs

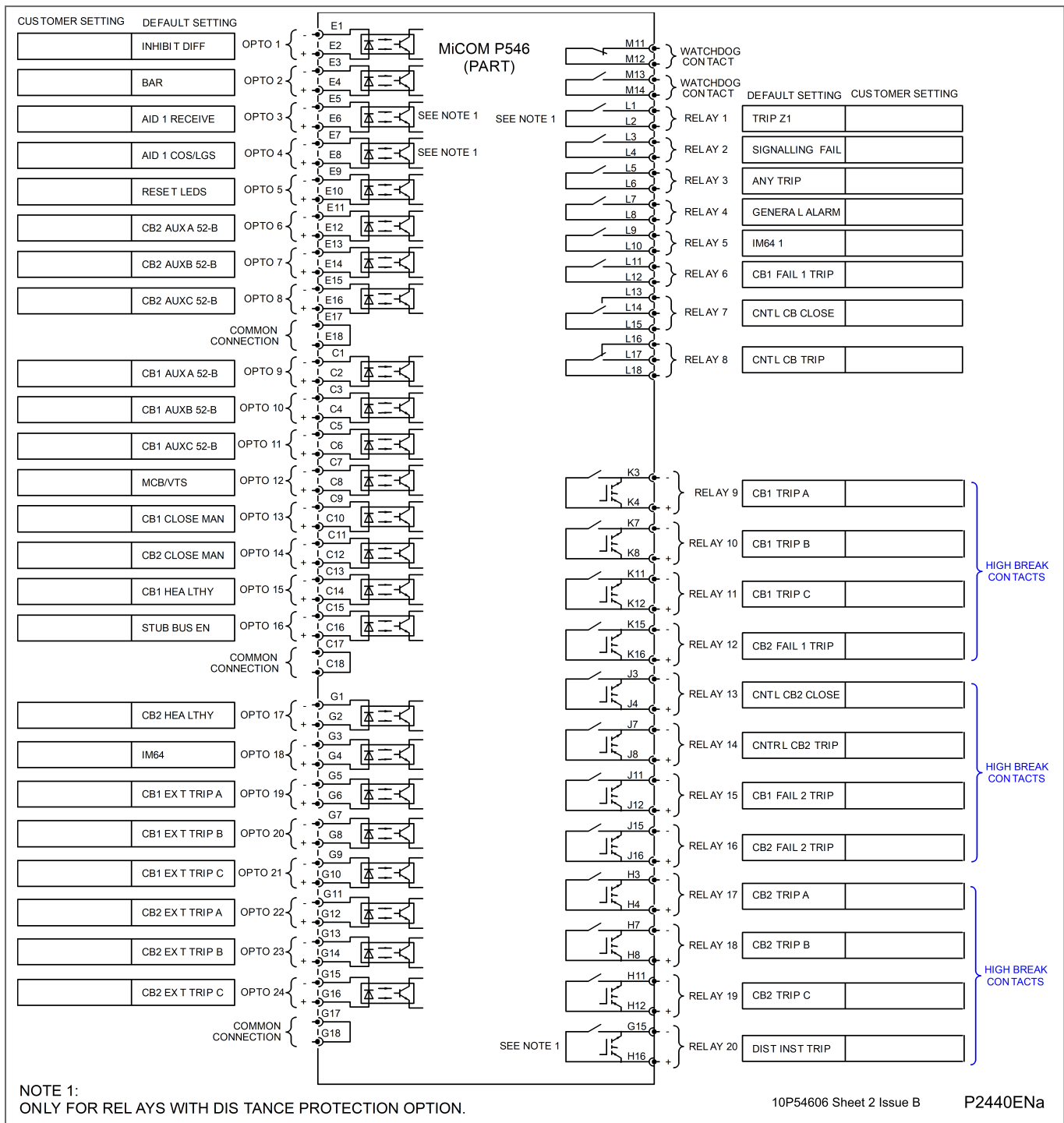

Figure 26 - P546 - 24 inputs/outputs default mapping – 8 Standard and 12 high-break outputs

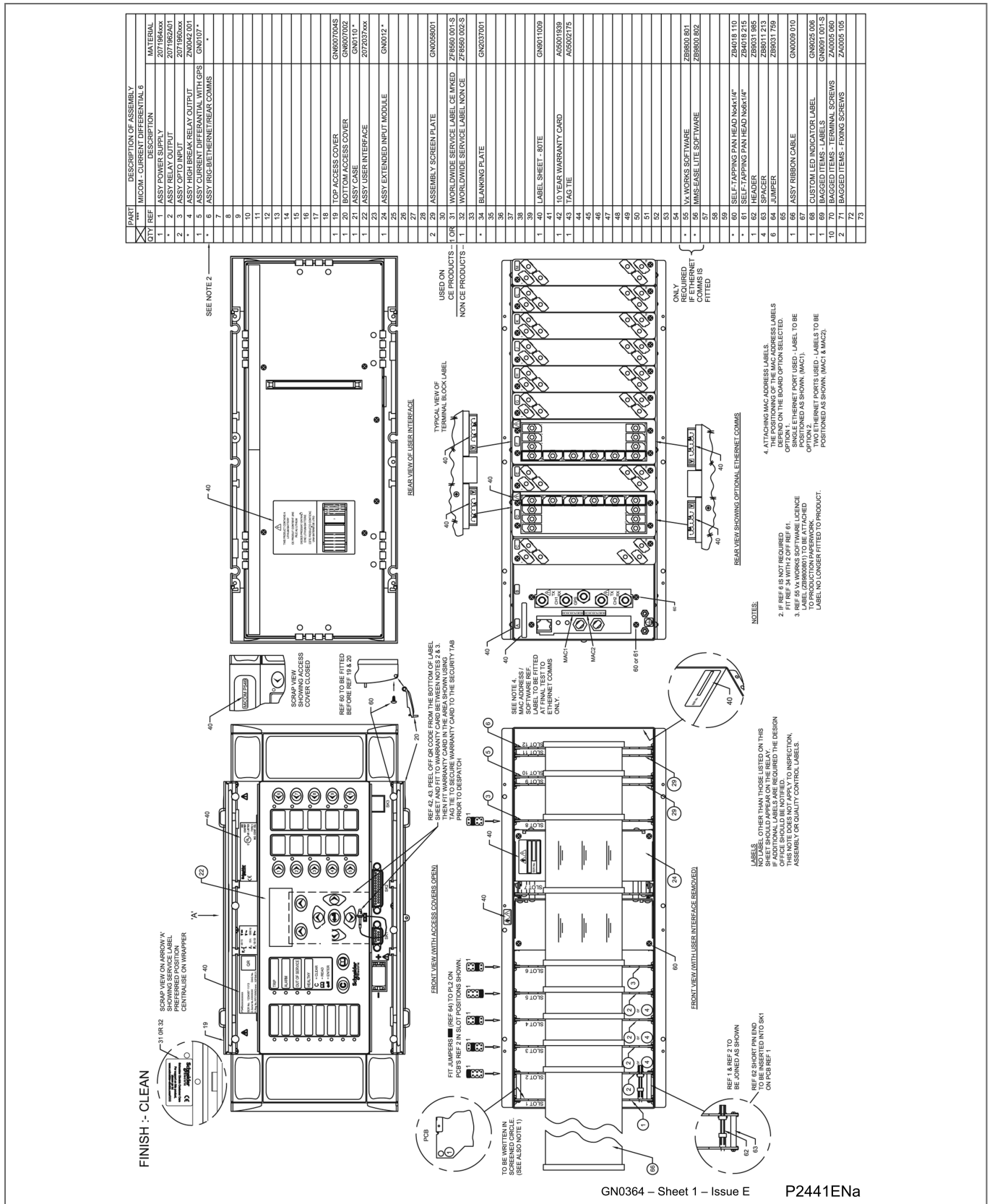

Figure 27 - P546 Final assembly drawing

Notes:

CYBER SECURITY

CHAPTER 18

Applicability

Date:	10/2022
--------------	---------

Products covered by this chapter:

This chapter covers the specific versions of the MiCOM products listed below. This includes **only** the following combinations of Software Version and Hardware Suffix.

Hardware Suffix:

P141/P142/P143	L or later
P145	M or later
P241	L or later
P242/P243	M or later
P341	L or later
P342	L or later
P343/P344/P345	M or later
P391	A or later
P445	L or later
P44x (P442/P444)	M or later
P44y (P443/P446)	M or later
P54x (P543/P544/P545/P546)	M or later
P642	L or later
P643/P645	M or later
P742	L or later
P741/P743	M or later
P746	M or later
P841A (one circuit breaker)	M or later
P841B (two circuit breakers)	M or later
P849	M or later

Software Version:

P14x (P141/P142/P143/P145)	B5 or later
P24x (P241/P242/P243)	D2 or later
P341	B3/E3 or later
P34x (P342/P343/P344/P345/P391)	B3 or later
P44x (P442/P444)	E3 or later
P44y (P443/P446)	K1 or later
P445	K1 or later
P54x (P543/P544/P545/P546)	K1 or later
P64x (P642/P643/P645)	B4 or later
P74x (P741/P742/P743)	B1 or later
P746	B5/C5 or later
P841A (one circuit breaker)	L1 or later
P841B (two circuit breakers)	K1 or later
P849	B2 or later

Connection Diagrams: This chapter list the connection diagram for the product:	
P14x (P141, P142, P143 & P145):	10P141xx (xx = 01 to 02) 10P142xx (xx = 01 to 05) 10P143xx (xx = 01 to 11) 10P145xx (xx = 01 to 11)
P445:	10P445xx (xx = 01 to 04)
P44x (P442 & P444):	10P44201 (SH 1 & 2) 10P44202 (SH 1) 10P44203 (SH 1 & 2) 10P44401 (SH 1) 10P44402 (SH 1) 10P44403 (SH 1 & 2) 10P44404 (SH 1) 10P44405 (SH 1) 10P44407 (SH 1 & 2)
P44y:	10P44303 (SH 01 and 03) 10P44304 (SH 01 and 03) 10P44305 (SH 01 and 03) 10P44306 (SH 01 and 03) 10P44600 10P44601 (SH 1 to 2) 10P44602 (SH 1 to 2) 10P44603 (SH 1 to 2)
P54x (P543, P544, P545 & P546):	10P54302 (SH 1 to 2) 10P54303 (SH 1 to 2) 10P54304 (SH 1 to 2) 10P54400 10P54404 (SH 1 to 2) 10P54405 (SH 1 to 2) 10P54502 (SH 1 to 2) 10P54503 (SH 1 to 2) 10P54504 (SH 1 to 2) 10P54600 10P54604 (SH 1 to 2) 10P54605 (SH 1 to 2) 10P54606 (SH 1 to 2)
P64x (P642, P643 & P645):	10P642xx (xx = 1 to 10) 10P643xx (xx = 1 to 6) 10P645xx (xx = 1 to 9)
P746:	10P746xx (xx = 00 to 21)
P841:	10P84100 10P84101 (SH 1 to 2) 10P84102 (SH 1 to 2) 10P84103 (SH 1 to 2) 10P84104 (SH 1 to 2) 10P84105 (SH 1 to 2)
P849:	10P849xx (xx = 01 to 06)

Notes:

CONTENTS

1. Overview	7
1.1 Definition	7
1.2 Introduction to Cyber Security	7
1.3 Roles, Rights and relationship between IEC62351 and MiCOM Px4x	8
1.3.1 Role Based Access Control (RBAC).....	8
1.3.2 User Roles.....	9
1.3.3 Rights.....	10
1.3.4 Roles and their Access Rights.....	12
1.4 Cybersecurity Admin Expert (CAE) Software	12
2. MiCOM Px4x Cyber Security Implementation	15
2.1 MiCOM Px4x with CSL1 - Advanced Cyber Security	15
2.1.1 Password Management (via the CAE).....	16
2.1.2 RBAC Management (via the CAE).....	17
2.1.3 User Locking.....	17
2.1.4 Inactivity Timer.....	18
2.1.5 RBAC Recovery.....	18
2.1.5.1 Generate Security Code.....	18
2.1.5.2 Entry of the Recovery Password.....	19
2.1.6 Port Disabling (Equipment Hardening).....	19
2.1.7 Physical Security.....	20
2.1.8 Security Logs.....	20
2.1.9 Common Cyber Security Settings.....	21
2.1.10 Local Default Access.....	22
2.2 MiCOM Px4x with CSL0 - Simple Password Management	23
2.2.1 Password Management.....	23
2.2.2 Fixed Factory RBAC.....	23
2.2.3 Security Logs Service.....	24
2.2.4 Cyber Security Settings.....	24
2.2.5 Disable/Blank Password.....	24
3. How to Use Cyber Security Features	25
3.1 How to Login	25
3.1.1 Local Default Access.....	25
3.1.2 Auto Login.....	25
3.1.3 Login with Prompt User List.....	25
3.2 How to Logout	26
3.2.1 How to Logout at the IED.....	26
3.2.2 How to Logout at Easergy Studio.....	26
3.3 How to Disable a Physical Port	26
3.4 How to Disable a Logical Port	26
3.5 How to Secure a Function Key (when available)	27

4. Glossary for Cyber Security.....28

TABLES

Table 1 - RBAC object, subject, rights and roles definitions.....	9
Table 2 - RBAC permission and authorization rules.....	9
Table 3 - Default user roles summary for MiCOM Px4x.....	10
Table 4 - Pre-defined rights for IEC 62351-8.....	11
Table 5 - Specific rights for MiCOM Px4x.....	12
Table 6 - Pre-defined roles (and rights) for IEC 62351-8 and MiCOM Px4x.....	12
Table 7 - Main CAE user functions.....	14
Table 8 - MiCOM Px4x protocol options for cyber security options.....	15
Table 9 - Factory RBAC.....	17
Table 10 - Port hardening settings.....	19
Table 11 - Security logs recorded.....	21
Table 12 - Configurable cyber security settings.....	22
Table 13 - Un-configurable cyber security settings.....	22
Table 14 - Auto Login process.....	25
Table 15 - Glossary for cyber security.....	28

FIGURES

Figure 1 - Associated topics.....	7
Figure 2 - Continuous improvement process.....	8
Figure 3 - RBAC role structure.....	9

1. OVERVIEW

1.1 Definition

Cyber security is a domain that addresses attacks on or by computer systems and through computer networks that can result in accidental or intentional disruptions.

Cyber security addresses not only deliberate attacks, such as from disgruntled employees, industrial espionage, and terrorists, but also inadvertent compromises of the information infrastructure due to user errors, equipment failures, and natural disasters.

1.2 Introduction to Cyber Security

The objective of cyber security is to provide increased levels of protection for information and physical assets from theft, corruption, misuse, or accidents while maintaining access for their intended users.

To achieve this objective the owner of the grid must take into account Cyber Security at every level of his organization by the management of an ongoing process that encompasses procedures, policies, technical (software, and hardware asset) and regulatory constraints.

The following diagram outlines some of the associated topics.

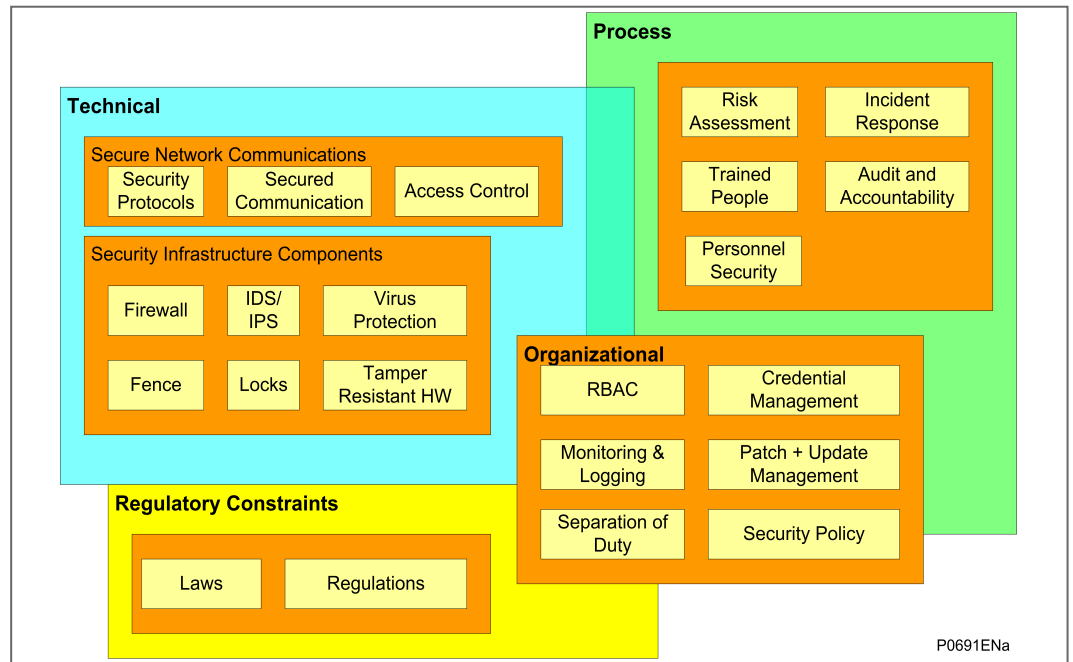

Figure 1 - Associated topics

The asset owner needs to run a continuous improvement process as outlined here:

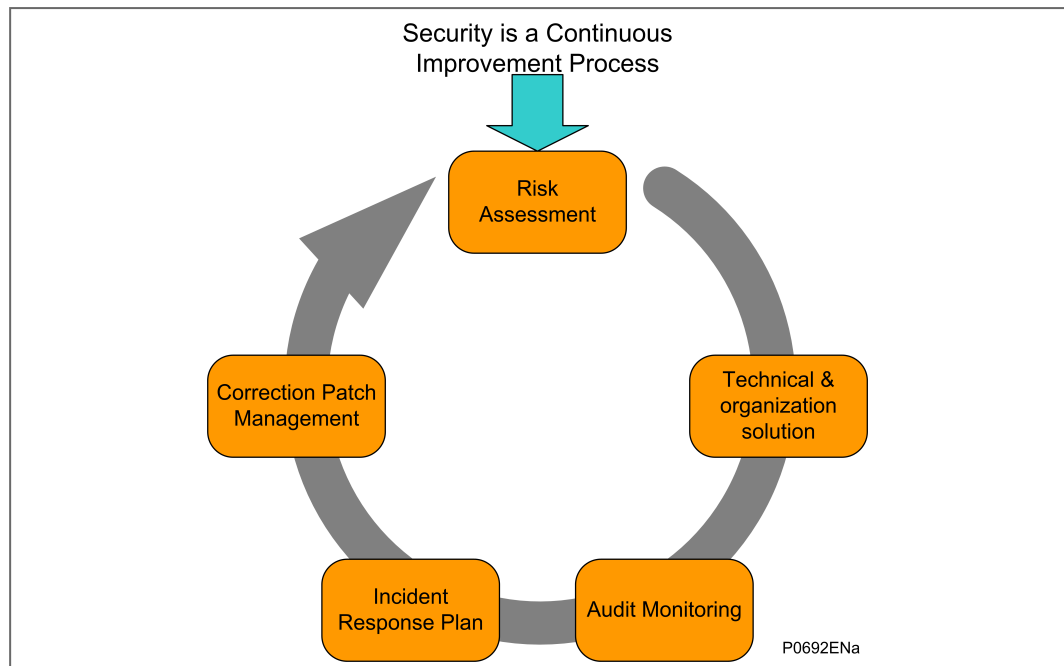

Figure 2 - Continuous improvement process

No single solution can provide adequate protection against all cyber attacks on the control network. Schneider Electric recommends employing a “defense in depth” approach using multiple security techniques to help mitigate risk.

A secured system is to offer:

- **Detective controls:** Monitor and record specific types of events: Security logs, Intrusion, detection systems, Video Surveillance etc.
- **Preventive controls:** Help blocking or controlling specific event: Antivirus, White listing, Firewall etc.
- **Recovery controls:** Help achieve Business continuity and Disaster recovery planning objectives in case of an incident: Backup and Restore solution.

As protective relay vendor, Schneider Electric helps the grid owner to achieve by providing technical features inside the IED, described in the next chapters.

Important

This product contains a cyber-security function, which manages the encryption of the data exchanged through some of the communication channels. The aim is to protect the data (configuration and process data) from any corruption, malice, attack. Subsequently, this product might be subject to control from customs authorities. It might be necessary to request special authorization from these customs authorities before any export/import operation. For any technical question relating to the characteristics of this encryption please contact your Customer Care Centre - www.schneider-electric.com/ccc.

1.3 Roles, Rights and relationship between IEC62351 and MiCOM Px4x

1.3.1 Role Based Access Control (RBAC)

The Role Based Access Control (RBAC) is a method to restrict resource access to authorized users. RBAC is an alternative to traditional Mandatory Access Control (MAC) and Discretionary Access Control (DAC).

A key feature of RBAC model is that all access is through roles. A role is essentially a collection of permissions, and all users receive permissions only through the roles to which they are assigned, or through roles they inherit through the role hierarchy.

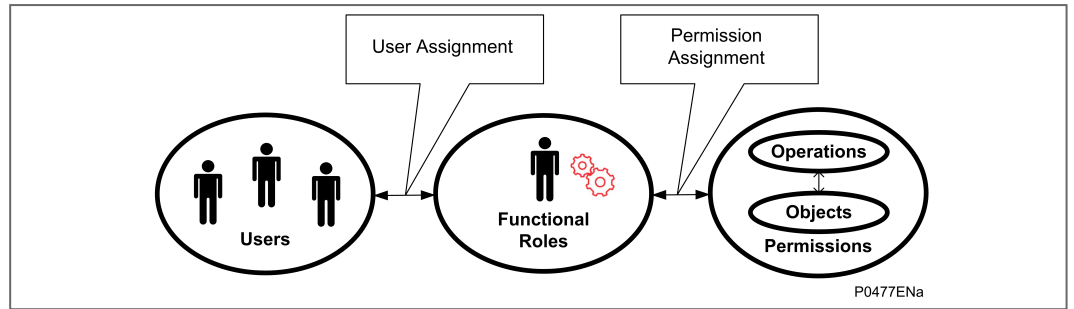

Figure 3 - RBAC role structure

Roles are created for various job activities. The **Permissions**, to perform certain operations, are assigned to specific roles. **Users** are assigned particular roles, and through those role assignments acquire the computer permissions to perform particular computer-system functions. Since users are not assigned permissions directly, but only acquire them through their role (or roles), management of individual user rights becomes a matter of simply assigning appropriate roles to the user’s account; this simplifies common operations, such as adding a user, or changing user’s account.

RBAC defines four different concepts:

RBAC Standard Definition	Description
Object	An object can represent information containers (e.g. files, directories in an operating system, tables and views in a database management system) or device resources, such as IEDs.
Subject	A subject is a user of the system. Note that a subject can be a person, or an automated agent / device.
Right	A right is the ability to access an object in order to perform certain operations (e.g. setting a data or reading a file)
Role	A role defines a certain authority level in the system. Rights are assigned to roles.

Table 1 - RBAC object, subject, rights and roles definitions

RBAC defines three primary rules:

RBAC Rule	Description
Role assignment	A subject can exercise a permission only if the subject has selected or been assigned a role.
Role authorization	A subject’s active role must be authorized for the subject. With rule 1 above, this rule ensures that users can take on only roles for which they are authorized.
Permission authorization	A subject can exercise permission only if the permission is authorized for the subject’s active role. With rules 1 and 2, this rule ensures that users can exercise only permissions for which they are authorized.

Table 2 - RBAC permission and authorization rules

1.3.2 User Roles

Different named roles are associated with different access rights. Roles and Rights are setup in a pre-defined arrangement, according to the IEC62351 standard, but customized to the MiCOM Px4x equipment.

When the user tries to access an IED, they need to login using their own username and their own password. The username/password combination is then checked against the records stored on the IED. If they are allowed to login, a message appears which shows them what Role they have been assigned to. It is the role that defines their access to the relevant parts of the system.

The default user roles for MiCOM Px4x are shown here:

Role	Description
VIEWER	Can View what objects are present within a Logical-Device by presenting the type ID of those objects.
OPERATOR	An Operator can view what objects and values are present within a Logical-Device by presenting the type ID of those objects as well as perform control actions.
ENGINEER	An Engineer can view what objects and values are present within a Logical-Device by presenting the type ID of those objects. Moreover, an engineer has full access to Datasets and Files and can configure the server locally or remotely.
SECADM	Security Administrator can change subject-to-role assignments (outside the device) and role-to-right assignment (inside the device) and security policy setting; change security setting such as certificates for subject authentication and access token verification.
SECAUD	Security Auditor can view audit logs

Table 3 - Default user roles summary for MiCOM Px4x

Each authorized user must be placed into at least ONE of these roles that most suits their job description. It is possible to assign a user into a different role; and/or to change the rights associated with a particular role. This means that the administrator can change the access rights for one role; and this will affect ALL the users who are assigned to that role.

It is possible for MiCOM Px4x to create the customized user roles.

1.3.3 Rights

In a similar way in which a set of pre-defined Roles have been created, a pre-defined set of Rights have been created.

These Rights give different permissions to look at what devices may be present, what those devices may contain, manage data within those devices (directly or by using files) and configure rights for other people.

A list of the pre-defined Rights for IEC 62351-8 is given here:

Right	Description
VIEW	Allows the subject/role to discover what objects are present within a Logical- Device by presenting the type ID of those objects. If this right is not granted to a subject/role, the Logical-Device for which the View right has not been granted shall not appear
READ	Allows the subject/role to obtain all or some of the values in addition to the type and ID of objects that are present within a Logical-Device
DATASET	Allows the subject/role to have full management rights for both permanent and non-permanent Datasets
REPORTING	Allows a subject/role to use buffered reporting as well as un-buffered reporting
FILEREAD	Allows the subject/role to have read rights for file objects
FILEWRITE	Allows the subject/role to have write rights for file objects. This right includes the FILEREAD right

Right	Description
CONTROL	allows a subject to perform control operations
CONFIG	Allows a subject to locally or remotely configure certain aspects of the server
SETTINGGROUP	Allows a subject to remotely configure Settings Groups
FILEMNGT	Allows the role to transfer files to the Logical-Device, as well as delete existing files on the Logical-Device.
SECURITY	Allows a subject/role to perform security functions at both a Server/Service Access Point and Logical-Device basis. To add Information about the concept of Rights.

Table 4 - Pre-defined rights for IEC 62351-8

The specific Rights for MiCOM Px4x are listed below. These are dependent on the IED data type. Please refer to each product MD file (Menu Database) for the IED data type.

Rights	Authorized Actions to IED	IED_DESC	IED_DATA	DISPLAY	IED_CONFIG	PROT_CONFIG	IEC_COMMAND	AUDIT	IED_FN_KEY	IED_CLEAR
Read Only (CAE default_access_right)	Read	x	x	x	x		x			
	Write	x								
IED Configuration (CAE configuration_right)	Read / Write / Upload / Download				x					
HMI Display Settings (CAE display_action_right)	Read / Write / Select			x						
Protection Configuration (CAE protection_configuration_right)	Read / Write					x				
IED Commands (CAE control_right)	Read / Write / Clear / Reset / Select						x			
Reading of Records & Events (CAE audit_read_right)	Read / Select / Upload							x		
Extraction of Records and Events (CAE audit_write_right)	Send / Accept							x		
IED Function Key (CAE fn_key_access_right)	Write								x	

Rights	Authorized Actions to IED	IED_DESC	IED_DATA	DISPLAY	IED_CONFIG	PROT_CONFIG	IEC_COMMAND	AUDIT	IED_FN_KEY	IED_CLEAR
IED Records Clear (CAE clear_right)	Read / Write / Clear									X

Table 5 - Specific rights for MiCOM Px4x

1.3.4 Roles and their Access Rights

A complete list of the Roles and their access Rights is shown in this table:

Rights		Roles				
		VIEWER	OPERATOR	ENGINEER	SECADM	SECAUD
Pre-defined Rights for IEC 62351	VIEW	X	X	X	X	X
	READ		X	X	X	X
	DATASET			X		
	REPORTING	X	X	X		X
	FILEREAD					X
	FILEWRITE			X	X	
	FILEMNGT			X	X	
	CONTROL		X		X	
	CONFIG			X	X	
	SETTINGGROUP				X	
	LOGS				X	X
SECURITY				X		
Specific Rights for MiCOM Px4x	Read Only	X	X	X		X
	IED Configuration			X		
	HMI Display Settings		X	X		
	Protection Configuration			X		
	IED Commands		X	X		
	Reading of Records and Events	X	X	X		X
	Extraction of Records and Events		X	X		X
	IED Function Key		X	X		
IED Clear			X			

Table 6 - Pre-defined roles (and rights) for IEC 62351-8 and MiCOM Px4x

Important

The reason why these are described as Default, is that it is possible to change the definitions of Roles and Rights, using the full version of the CAE software. Depending on the work done by the system administrator, it is possible that your own situation may vary from these initial recommendations.

1.4 Cybersecurity Admin Expert (CAE) Software

Important

This can only be used with Px4x relays with cyber security CSL1 features.

Important

For Dual Ethernet cards the CAE functionality is available from communication interface 1. The connection to the CAE would be available from interface 2 only when interface 1 is disconnected from the network.

The Cybersecurity Admin Expert (CAE) is the security configuration tool of MiCOM Px4x equipment. It allows the security administrator to define the security policy to the IEDs.

The Security Administrator manages RBAC and security policies data. Security Administrator defines needs to protect devices in accordance with user privileges. Thus, the system security can be configured easily and precisely.

The CAE is used by the Security Administrator to manage the system's security database and deploys security configurations to IED(s).

The CAE allows to Manage User Accounts, Roles, Permission, Elements to Secure (ETS) and Security Server parameters without connection with devices. Information is store on the MS SQL database. This is the Offline mode. CAE allows devices management connected on network. This is the online mode.

The Role Based Access Control (RBAC) is a method to restrict resource access to authorized users. Please refer to the "[System RBAC Management](#)" section for more details.

The following table contains the main user functions of the CAE:

Category	User Function	Note
Offline General Administration	User Accounts Management	User Account Functions: * Creation * Edition * Suppress * Viewing * Sorting * Filtering
	Server Configuration	
	Users Accounts & Roles association Management	Associate a role to the user account
Offline Advanced Administration	Roles Management	Roles Functions: * Creation * Edition * Suppress * Viewing * Sorting
	Element To Secure (ETS) Management	Define ETS which are in fact the PACiS assets present in the project (C264, PACiS Gateway, ECOSUI, IED and SAM). Add, Suppress and Sort permissions associated with the ETS.
	Global Security Management	The Global Security allows scope(s) and associate or disassociate role(s) management for each user account. The security administrator manages the current scope by the Roles: * View Roles List, User Account List and associations User-Roles or Role-Users * Associate / dissociate role(s) for each User

Category	User Function	Note
		Account * Add / Suppress User account(s) for each Role
	Permission access	Define parameters: * Password validity * Inactivity period * Automatic logout period * Maximum attempts of login and lockout period
Communication	Refresh IED list	
	Display IED Logs	
	Display SAM Logs	
	Push RBAC and Security Policies	Send Security Configuration to all Devices integrating Security features.

Table 7 - Main CAE user functions

The details of how to use the CAE are provided in the CAE documentation:

CAE (Cybersecurity Admin Expert) Documentation - User Guide

This is available from the Schneider Electric website: www.schneider-electric.com.

2. MICOM PX4X CYBER SECURITY IMPLEMENTATION

Considered some users may not want to use the cyber security, Schneider Electric offers MiCOM Px4x relays with CSL0 and CSL1 as below:

CSL0: Simple password management, No CAE required.

CSL1: Advanced cyber security, CAE required.

This depends on the model number, as CSL1 is depend on the Ethernet communication. Hence if the IED if supports only legacy protocol this will be CLS0 default as. The digit position number 9 (protocol options) in the Cortec / model number is used to distinguish it.

Protocol Option Number	Protocol Options	Cyber Security Options
1	K-Bus/Courier	CSL0
2	Modbus	CSL0
3	IEC 60870 -5 - 103	CSL0
4	DNP3.0	CSL0
6	IEC 61850 Edition 1 / 2 and Courier via rear K-Bus/RS485	CSL0
7	IEC 61850 Edition 1 / 2 and CS103 via rear port RS485	CSL0
B	IEC 61850 Edition 1 / 2 and DNP3oE and DNP Serial	CSL0
G	IEC 61850 Edition 1 / 2 and Courier via rear K-Bus/RS485	CSL1
H	IEC 61850 Edition 1 / 2 and CS103 via rear port RS485	CSL1
L	IEC 61850 Edition 1 / 2 and DNP3oE and DNP3 serial	CSL1

Table 8 - MiCOM Px4x protocol options for cyber security options

Important
 Except for Courier tunneling via secured communication (TLS), the device does not have the capability to transmit data encrypted using the following protocols: IEC 61850, DNP3 over Ethernet, Courier serial, Modbus serial, IEC60870-5-103 serial, and DNP3 serial.
 If other users gained access to your network, transmitted information can be disclosed or subject to tampering.
 For transmitting data over an internal network, physically or logically segment the network and restrict access using standard controls such as firewalls and other relevant features supported by your device such as IPTable whitelisting.
 For transmitting data over an external network, encrypt protocol transmissions over all external connections using an encrypted tunnel, TLS wrapper or a similar solution.

2.1 MiCOM Px4x with CSL1 - Advanced Cyber Security

For MiCOM Px4x IEDs which support CSL1, this means the IED supports advanced user account right management. Moreover, the IED supports security logs/events and secure administration capability.

If you want to use cyber security, you need to order the IED that supports CSL1. In this case, the Cybersecurity Admin Expert (CAE) is required for RBAC configuration.

At the IED level, these cyber security features have been implemented:

- Passwords management (via the CAE)
- RBAC Management (via the CAE)
- User Locking
- Inactivity Timer
- RBAC recovery
- Port Disablement (via Easergy Studio or the front panel)
- Security Logs

2.1.1 Password Management (via the CAE)

For the IED if CSL1 supported, there are two types of password possible for the IED access: alphanumeric password or Arrow Key password.

The alphanumeric password is only settable via the CAE:

- Passwords may be any length between 1 and 32 characters long
- Passwords may contain any ASCII character in the range ASCII code 33 (21 Hex) to ASCII code 122 (7A Hex) inclusive
- Passwords may or may not be NERC/IEEE 1686 compliant
- The alphanumeric password will be used for courier client access

For more details about NERC/IEEE 1686 password compliant, please check the standard.

The Arrow Key password is only settable via the CAE:

- The Arrow Key password is a combination of the four arrow keys on the front panel
- The Arrow Key password may be any length between 1 and 8 arrow keys long
- The Arrow Key password can only be used in the front panel
- The user also can disable the Arrow Key password by not setting it

Important

If the Arrow Key password is not configured, the alphanumeric password will be used for the front panel access. In this case, alphanumeric passwords longer than 16 characters are not allowed.

Easergy Studio and the front panel are not allowed to change the password.

Important
 The Schneider Electric password policy is one of the key elements of the Cyber Security Policy.
 Good practice to improve the Password definition:

- Use common Cyber Security Good Practice for password complexity definition by using strong passwords.
- Change All Passwords from their default value when taking the protection device into use. (User must change password after first login).
- Change Passwords regularly. (User must update password after a certain period of time).
- Use NERC Compliant password as much as possible.
- Enforce the use of strong and complexes Password as : Caps characters + Lowercases characters + Numbers + Special characters in one password.
- Set the minimum password length to 10 characters.
- Switch off all Comm port not use on the device, if possible.
- Do not reuse old passwords.
- All P40 relays installed before January 2020 should be checked separately case by case to confirm the Cyber Security conformity to Standard/country law.

All user must be aware of best practice concerning passwords, these include:

- Not Sharing personal passwords.
- Not displaying passwords during password entry.
- Not transmitting passwords in email or by other means.
- Not saving the passwords on PC's or other devices.
- Not written password on any supports.
- Regularly reminding users about best practices concerning password.

2.1.2 RBAC Management (via the CAE)

By default, the IED includes a factory RBAC which has three users, and for each user, the Rights depend on the user Role. Please refer to the **Roles and their Access Rights** section for more details.

Username	Role	Default password
SecurityAdmin	SECADM	AAAAAAAA
EngineerLevel	ENGINEER	AAAA
OperatorLevel	OPERATOR	AAAA

Table 9 - Factory RBAC

A Local Default Access function also available for the default RBAC, with the VIEWER role, which allows everyone login the IED in the front panel with VIEWER role. For more details about the Local Default Access function, please refer to the **Local Default Access** section.

For more information about how the CAE management the RBAC and cyber security policies, please see the 1.4 - Cybersecurity Admin Expert (CAE) Software section.

2.1.3 User Locking

The user is locked out temporarily, after a defined number of failed password entry attempts.

Important
 If a user is locked out, the block is applied to that named user and to the all IED interfaces. The blocking of one user, does not apply blocks to others.
 If the user entry is blocked, recover the RBAC or push a new RBAC will not reset the blocked user entry, but IED reboot will reset the blocking time and attempts count, so the user entry will be unblocked.

An invalid password entry will display a 'Login Failed PW Incorrect' message for 2s. It also reduces the Attempts Remaining Counter (Attempts Remain) by 1 and it remains at this level

until the interface inactivity timer expires (CSL0 models) or until the Password Attempts Timer configured in CAE expires (CSL1 models) or another password entry is made. If Attempts Remain equals 1 then a '1 Attempt Left' warning will also be issued for 2s. When Attempts Remain equals 0 then a 'USER LOCKED OUT' warning is displayed for 2s and access for that user is blocked. If the Blocking Timer expires, or the correct password is entered before Attempts Remain reaches zero, then the Attempts Remain is reset to the Attempts Limit.

Once the user entry is blocked, the Blocking Timer is initiated. If the locked out user is selected whilst the Attempts Remain is zero a 'USER LOCKED OUT' error message is displayed.

2.1.4 Inactivity Timer

The MiCOM device runs an inactivity timer, which means that it records the last time an action was taken by a user who was logged in.

If the user does not perform an action within a pre-defined interval, the user will be logged off. This is to reduce the risk that a device can accidentally be left open to access by unauthorized people.

The inactivity timer is separate for each interface.

The inactivity timer is configurable by using the CAE.

Important
In case of a connection through an Ethernet interface, the actual inactive time depends on the setting value of both "Minimum inactivity period" & "[0E A7] ETH Tunl Timeout", the smaller value of both timers will be applied.

Refer to the 2.1.9 - Common Cyber Security Settings section for more details.

2.1.5 RBAC Recovery

RBAC recovery is the means by which the device can be reset to the factory RBAC settings if required. To obtain the recovery password, the customer must go to www.schneider-electric.com/ccs to raise a recovery password request and supply the IED Security Code.

Caution
The "recovery" password gives you access to the Factory RBAC Configuration. This action deletes all existing users (and their passwords), and restores to Factory RBAC Configuration. Recover the RBAC does not affect relay proper settings and does not provoke reboot of the relay - the protection functions of the relay are always maintained.

2.1.5.1 Generate Security Code

The security code is a 16-character ASCII string. It is a read-only parameter. The IED generates its own random security code. This is when a new code is generated:

- On power up
- On expiry of validity timer (see below)
- When the recovery password is entered

As soon as the security code is first displayed on the LCD display, a validity timer is started. This validity timer is set to 120 hours and is not configurable. The validity timer is not reset if you request a subsequent code within the 120 hour period.

To prevent accidental reading of the IED security code the cell will initially display a warning message on the front panel of the IED:

PRESS ENTER TO
READ SEC. COD

The security code will be displayed on confirmation, whereupon the validity timer will be started. Note that the security code can only be read from the front panel.

Important
The recover password will be invalid once the new Security Code is generated, so please make sure the IED is always powered on before you get the recover password, and make sure you input the recover password within 120 hours.

2.1.5.2 Entry of the Recovery Password

The “recovery” password is intended for recovery only. It is not a replacement password that can be used continually. It can only be used once – for password recovery.

Entry of the recovery password is done at the local front panel and it causes the IED to reset the RBAC back to default.

On this action, the following message is displayed on the front panel of the IED:

RBAC reset done
 Press any key

2.1.6 Port Disabling (Equipment Hardening)

The availability of unused ports could provide a security risk. Hence, unused ports can be disabled (also known as equipment hardening) – either via the front panel or by Easergy Studio software. An Engineer role is needed to perform this action.

These physical ports and logical ports can be enabled/disabled:

Port Types	Menu Text	Col	Row	Default Setting	Available Value
Physical Ports	Front Port	25	05	Enable	Enable/Disable
	Rear Port 1	25	06	Enable	Enable/Disable
	Rear Port 2	25	07	Enable	Enable/Disable
	Ethernet Port 1	25	08	Enable	Enable/Disable
	Ethernet Port 1/2	25	09	Enable	Enable/Disable
	Ethernet Port 2/3	25	0A	Enable	Enable/Disable
	Ethernet Port 3	25	0B	Enable	Enable/Disable
Logical Ports	Courier Tunnel	25	0C	Enable	Enable/Disable
	IEC61850	25	0D	Enable	Enable/Disable
	DNP3oE	25	0E	Enable	Enable/Disable

Table 10 - Port hardening settings

Note
 The port disabling setting cells are not provided in the settings file. In addition, it is not possible to disable simultaneously more than one physical port or Logical port. New redundant Ethernet boards have three physical ports but total two interfaces. The actual disabled physical port is depended on the redundant communication mode (PRP, HSR, RSTP or Dual IP). Refer to the Dual Redundant Ethernet Board (Upgrade) (DREB) chapter (Px4x/EN EB) for more details.

When the Ethernet board related physical ports or logical ports are disabled or enabled, the Ethernet card will reboot. The status of the ports will be available after reboot of the Ethernet board.

For more details about how to disable/enable the unused ports, please see sections:

- 3.3 - How to Disable a Physical Port
- 3.4 - How to Disable a Logical Port

2.1.7 Physical Security

MiCOM Px4x IED protects its front EIA(RS) - 232 serial (9 pin) and parallel (25 pin) ports with a sealable flip cover.

These two ports are normally NOT needed during device normal operation:

- The serial port is used for setting/events/records downloading and extraction during commissioning or post-fault analysis which can be done also via rear RS485 ports and Ethernet ports during normal operation.
- The parallel port is dedicated for firmware upgrade.

Thus, it is highly recommended to seal the flip cover during the normal operation to avoid exploiting those two ports by unauthorized personnel.

2.1.8 Security Logs

The Security Logs need to store logs from each item of equipment. These logs are generated by the system, and cannot be edited by the user. A variety of different items are recorded, including: bad/faulty access attempts, login attempts, authentication errors, changes to roles, users and access control lists, network backup and configuration changes, communication failures and so on.

Security logs emissions depend on the security standards that are configurable by the CAE.

The security logs will push to a Syslog server if the Syslog server IP address and Syslog server IP port are configured and connected.

CAE also can be used to explore the security logs but Easergy studio is not supported.

The settings for the security log standards and Syslog server IP address and ports are listed in the Configurable cyber security settings table. For more detail about the security log configuration, please refer to the CAE documentation.

Note

The Security logs time stamp may be time shifted by several milliseconds compared with local event log. The security logs will not be generated if the Ethernet card is starting up. If the Syslog server is unavailable, the new logs will be stored and overwriting the oldest logs.

This table lists the security logs categories available for each standard.

Log ID	Additional field	Explanation	Level	Standards					
				BDEW	E3	NERC CIP	IEEE 1686	IEC 62351	CS Phase 1
CONNECTION_SUCCESS	The additional field will contain the issuer of the connection: LOCAL or NETWORK	Successful connection	INFO	x	x	x	x		x
CONNECTION_FAILURE		Failed connection (wrong credentials)	WARNING	x	x	x	x		x
CONNECTION_FAILURE_AND_BLOCK		Failed connection (wrong credentials) triggering the blocking of the account on the IED	DANGER	x	x	x	x		x
CONNECTION_FAILURE_ALREADY_BLOCKED		Failed connection because of a blocked userID on this IED	DANGER	x	x	x	x		x
DISCONNECTION		Disconnection triggered by the peer /user	INFO	x	x	x	x		x

Log ID	Additional field	Explanation	Level	Standards					
				BDEW	E3	NERC CIP	IEEE 1686	IEC 62351	CS Phase 1
DISCONNECTION_TIMEOUT		Disconnection triggered by a timeout	INFO	x	x	x	x		x
CONTROL_OPERATION	Type & Data associated to the control	Trace and control / override of real data from a peer	INFO				x		
CONFIGURATION_DOWNLOAD	Version	Download of the configuration file from the device - Files include PSL, Courier setting, DNP setting, MCL/CID and user curves (crv)	INFO				x		
CONFIGURATION_UPLOAD	Version	Upload of a new configuration file into the device - Files include PSL, Courier setting, DNP setting, MCL and user curves (crv)	INFO				x		
RBAC_UPDATE	Version	Update of the RBAC cache in the IED	INFO				x		x
SEC_LOGS_RETRIEVAL	Version	Retrieval of the security logs of the IED	INFO				x		
TIME_CHANGE	New & Old time	Modification of the time of the IED	INFO				x		
REBOOT_ORDER	None	Reboot order sent to the IED / IED start up	DANGER				x		x
PORT_MANAGEMENT	Port, action (enable / disable)	Any comms port enabled / disabled	INFO						x
AUTHORIZATION_REQ	Action, object	Any authorization request sent to the CS brick	INFO			x		x	x

Table 11 - Security logs recorded

2.1.9 Common Cyber Security Settings

The System Administrator can customize the cyber security settings at the CAE. The following table shows the common cyber security settings. Parts of settings also are visible on the IED with specific Courier cells but not editable in IED or Easergy Studio. These are shown in the right-hand columns of this table:

Setting in CAE	Default Setting	Available Value	Menu in IED	Col	Row
Minimum inactivity period	15	1 to 99 Minutes	-	-	-
If the user does not perform any action within this interval, the user will be logged off.					
Allow user locking	Yes	Yes/No	-	-	-
Option allows user account locking					
Maximum login attempts	5	1 to 99	Attempts Limit	25	02
The maximum failed password entry attempts, the user will lock once the attempts reached.					
Password attempts timer	3	1 to 30 Minutes	Attempts timer	25	03
The time for reset the attempts count to 0. The user got to maximum login attempts.					
Automatic user account unlocking	Yes	Yes/No	-	-	-
Enable/disable the attempts times aromatic reset function.					
Locking period duration	240	1 to 86400 Seconds	Blocking timer	25	04
The Locking period duration (seconds)					
Password Complexity	None	None / IEEE1686/ NERC	-	-	-
Set the password compliant standard.					
Log and monitoring standard	BDEW	BDEW / E3 / NERC-CIP / IEE1686 / IEC62351/ CS_PH1	-	-	-
Setup security log emission standard					
Syslog server IP address	0.0.0.0		-	-	-
Syslog server IP address					
Syslog server IP port	601	1 to 65535	-	-	-
Syslog server IP port					

Table 12 - Configurable cyber security settings

These settings show some common information about cyber security, which are not configurable whether by CAE, or Easergy Studio or the front panel.

Menu in IED	Col	Row	Description
User Banner	25	01	Show user banner information: ACCESS ONLY FOR AUTHORISED USERS.
Attempts remain	25	11	Show the remains attempt times for user login
Blk time remain	25	12	Show the remains time for blocked user to unlock
User Name	25	21-2F	Configured user name (in CAE)
Security Code	25	FE	The security code used to recovery the password.
RBAC Password	25	FF	Enter 16 characters recover password to recovery password

Table 13 - Un-configurable cyber security settings

2.1.10 Local Default Access

Local Default Access function can be disabled/enabled in the CAE.

The intention for Local Default Access function is to allow the user easy to access the IED from the front panel and without any authorization required. This means if the Local Default Access function is enabled, everyone will be authorized to access the front panel with associated Rights.

By default, the Local Default Access has the VIEWER role, it is also possible to associate the other Roles to the Local Default Access, which is configurable in the CAE.

Local Default Access function is only available in the front panel.

The Local Default Access login/logout process is invisible for the user.

2.2 MiCOM Px4x with CSL0 - Simple Password Management

For MiCOM Px4x IED with CSL0, as the Cybersecurity Admin Expert (CAE) is not supported, all the cyber security features which need CAE support will not be available.

This section describes the different implementations by comparing with CLS1.

The cyber security features that are not mentioned in this section will default to be the same as CSL1.

2.2.1 Password Management

For MiCOM Px4x IED with CSL0, CAE is not supported for the configuration, so only the alphanumeric password can be used.

- The alphanumeric password is settable via Easergy Studio and the Front panel
- Passwords may be any length between 1 and 16 characters long
- Passwords may contain any ASCII character in the range ASCII code 33 (21 Hex) to ASCII code 122 (7A Hex) inclusive
- No password compliance is required
- The alphanumeric password will be used for Courier access and the front panel access

Arrow key password is not available for IED with CSL0.

Important

The Schneider Electric password policy is one of the key elements of the Cyber Security Policy.

Good practice to improve the Password definition:

- Use common Cyber Security Good Practice for password complexity definition by using strong passwords.
 - Change All Passwords from their default value when taking the protection device into use. (User must change password after first login).
 - Change Passwords regularly. (User must update password after a certain period of time).
 - Use NERC Compliant password as much as possible.
 - Enforce the use of strong and complex Password as : Caps characters + Lowercases characters + Numbers + Special characters in one password.
 - Set the minimum password length to 10 characters.
 - Switch off all Comm port not use on the device, if possible.
 - Do not reuse old passwords.
 - All P40 relays installed before January 2020 should be checked separately case by case to confirm the Cyber Security conformity to Standard/country law.
- All user must be aware of best practice concerning passwords, these include:**
- Not Sharing personal passwords.
 - Not displaying passwords during password entry.
 - Not transmitting passwords in email or by other means.
 - Not saving the passwords on PC's or other devices.
 - Not written password on any supports.
 - Regularly reminding users about best practices concerning password.

2.2.2 Fixed Factory RBAC

For MiCOM Px4x IED with CSL0, the user list and its role/right will be fixed as factory RBAC and not configurable. Refer to the *Factory RBAC* table for more details.

2.2.3 Security Logs Service

The security logs services are not available for MiCOM Px4x IED with CSL0.

2.2.4 Cyber Security Settings

For MiCOM Px4x IED with CSL0, all cyber security settings are fixed as default setting and un-configurable. Refer to the *Configurable cyber security settings* table for the default settings.

2.2.5 Disable/Blank Password

For MiCOM Px4x IED with CSL0, it is possible to remove the user password. In MiCOM S1 Studio, this is achieved by click the BOX "Disable the password". In the IED, this is achieved by setting the password as blank.

Once the password is disabled/blank, the user can login to the IED directly and there is no need to enter the password.

3. HOW TO USE CYBER SECURITY FEATURES

These sections shows the most common tasks associated with Cyber Security features. For many of these tasks, the steps you take are the same as you have performed previously; with the main changes being in the steps you use to login and/or logout.

3.1 How to Login

3.1.1 Local Default Access

If the Local Default Access is enabled, the user may login to the front panel with associated roles.

3.1.2 Auto Login

Auto login means the user will login the IED automatically and no need to select the user name and enter the password. In this case, the user will be authorized with relevant rights. The auto login will be applied in these cases:

CS Version	Interface	RBAC/PW Cases	Login Process
CSL1	Front panel	Factory RBAC	Auto login with EngineerLevel
		Customized RBAC	Local Default Access Enabled: Login with Local Default Access Local Default Access Disabled: Login with Prompt User List
	Courier Interface	All cases	Login with Prompt User List
CSL0	Front panel	Factory RBAC	Auto login with EngineerLevel
		Password changed	EngineerLevel password is "AAAA" or is disabled/blank: Auto login with EngineerLevel . OperatorLevel password is "AAAA" or is disabled/blank: Auto login with OperatorLevel . EngineerLevel and OperatorLevel password changed: Auto login with ViewerLevel Access
	Courier Interface	Factory RBAC	Auto login with EngineerLevel
		Password changed	EngineerLevel password is "AAAA" or is disabled/blank: Auto login with EngineerLevel . OperatorLevel password is "AAAA" or is disabled/blank: Auto login with OperatorLevel . EngineerLevel and OperatorLevel password changed: Login with Prompt User List

Table 14 - Auto Login process

For more details about the Factory RBAC, please refer to the 2.1.2 - RBAC Management (via the CAE) section.

3.1.3 Login with Prompt User List

This login process will happen if:

- The Auto login process is not applied.
- Or high authorization is required for the current operation.

In this case, the IED will prompt the user list, and the user needs to select proper user name and enter the password to login.

3.2 How to Logout

3.2.1 How to Logout at the IED

For security consideration, it would be better to “logout” the IED once the configuration done. You can do this by going up to the default display. When you are at the default display and you press the ‘Cancel’ button, you may be prompted to log out with the following display:

```
ENTER TO LOGOUT  
CLEAR TO CANCEL
```

You will be asked this question if you are logged in.

If you confirm, the following message is displayed for 2 seconds:

```
LOGGED OUT  
UserName
```

If you decide not to log out (i.e. you cancel), the following message is displayed for 2 seconds.

```
LOGOUT_CANCELLED  
UserName
```

Note

The MiCOM IED runs a timer, which logs the user out after a period of inactivity. For more details, refer to the [Inactivity Timer](#) section.

3.2.2 How to Logout at Easergy Studio

- Right-click on the device name and select Log Off.
- In the Log Off confirmation dialog click Yes.

3.3 How to Disable a Physical Port

Using Easergy Studio or the front panel it is possible to disable unused physical ports. This can not be done by the CAE. By default, an Engineer-role is needed to perform this action.

To prevent accidental disabling of a port, a warning message is displayed according to whichever port is required to be disabled. For example if rear port 1 is to be disabled, the following message appears:

```
REAR PORT 1 TO BE  
DISABLED.CONFIRM
```

There are between two and four ports eligible for disablement:

- Front port
- Rear port 1
- Rear port 2 (available in the specific models)
- Ethernet port (available in the specific models)

Important

It is not possible to disable a port from which the disabling port command originates.

3.4 How to Disable a Logical Port

Using Easergy Studio or the front panel it is possible to disable unused logical ports. This can't be done by the CAE. An Engineer-role is needed to perform this action.

**Caution****Disabling the Ethernet port will disable all Ethernet based communications.**

If it is not desirable to disable the Ethernet port, it is possible to disable selected protocols on the Ethernet card and leave others functioning.

These protocols can be disabled:

- IEC61850 (available in the specific models)
- Courier Tunnelling (available in the specific models)
- IEC61850 + DNPoE (available in the specific models)

Note

It is strongly recommended to disable the protocols which are not needed or when they are no longer needed to reduce attack surface to the MiCOM Px4x IED.

3.5 How to Secure a Function Key (when available)

In cyber security implementation, this function has been linked to the front panel authorization.

- When the function key pressed, if there is no user login in the front panel or the logged-in user is not authorized, a prompt message will be raised in the front panel to ask the user to login. Once the user is logged-in, they need to press the function key again to execute the command.
- If the user is already logged in and the authorization is OK, the command will be executed immediately.
- By default, the OPERATOR or ENGINEER Roles are able to operate the function keys.
- The function key will be executed immediately if the auto login process is applied and the user is authorized.
- If unauthorized users press the Function Key during the setting change, they need to commit the changes first then login with authorized user to operate the function key.

4. GLOSSARY FOR CYBER SECURITY

Term	Meaning
CAE	Cybersecurity Admin Expert TSF based application used to define and create security configuration
CIP Standards	Critical Infrastructure Protection standards. NERC CIP standards have been given the force of law by the Federal Energy Regulatory Commission (FERC)
DCS	Distributed Control System
HMI	Human Machine Interface
IED	Intelligent Electronic Device. It is a power industry term to describe microprocessor-based controllers of power system equipments (e.g. Circuit breaker, transformer, etc)
LOGS	All the operations related to the security (connection, configuration...) are automatically caught in events that are logged in order to provide a good visibility of the previous actions to the security administrators.
MIB	Management Information Base
NERC	North American Electric Reliability Corporation
RBAC	Role Based Access Control. Authentication and authorization mechanism based on roles granted to a user. Roles are made of rights, themselves being actions that can be applied on objects. Each user's action is authorized or not based on his roles
Roles	A role is a logical representation of a person activity. This activity authorizes or forbids operations within the tool suite thanks to permissions that are associated to the role. A role needs to be attached to a user account to have a real purpose.
SAM	Security Administration Module. Device in charge of security management on an IP-over-Ethernet network.
Secured IED	Devices embedding security mechanisms defined in the security architecture document
Security Administrator	A user of the system granted to manage its security
TAT	Transfer Administration Tool
Unsecured IED	Relay/IEDs with no security mechanisms.

Table 15 - Glossary for cyber security

DUAL REDUNDANT ETHERNET BOARD

CHAPTER 19

Applicability**Date:** 09/2022**Products covered by this chapter:**

This chapter covers the specific versions of the MiCOM products listed below.
This includes **only** the following combinations of Software Version and Hardware Suffix.

Hardware Suffix:

P141/P142/P143	L or later
P145	M or later
P445	L or later
P44x (P442/P444)	M or later
P44y (P443/P446)	M or later
P54x (P543/P544/P545/P546)	M or later
P746	M or later
P841A (one circuit breaker)	M or later
P841B (two circuit breakers)	M or later
P342	L or later
P343 / P344 / P345	M or later
P341	L or later
P849	M or later

Software Version:

P14x (P141/P142/P143/P145)	B5 or later
P445	K1 or later
P44x (P442/P444)	E3 or later
P44y (P443/P446)	K1 or later
P54x (P543/P544/P545/P546)	K1 or later
P746	B5/C5 or later
P841A (one circuit breaker)	L1 or later
P841B (two circuit breakers)	K1 or later
P341	B1/E1 or later
P342 / P343 / P344 / P345	B0/B1 or later
P849	B4 or later

Connection Diagrams: This chapter list the connection diagram for the product:

P14x (P141, P142, P143 & P145):	10P141xx (xx = 01 to 02) 10P142xx (xx = 01 to 05) 10P143xx (xx = 01 to 11) 10P145xx (xx = 01 to 11)
P44x (P442 & P444):	10P44201 (SH 1 & 2) 10P44202 (SH 1) 10P44203 (SH 1 & 2) 10P44401 (SH 1) 10P44402 (SH 1) 10P44403 (SH 1 & 2)

	10P44404 (SH 1) 10P44405 (SH 1) 10P44407 (SH 1 & 2)
P44y:	10P44303 (SH 01 and 03) 10P44304 (SH 01 and 03) 10P44305 (SH 01 and 03) 10P44306 (SH 01 and 03) 10P44600 10P44601 (SH 1 to 2) 10P44602 (SH 1 to 2) 10P44603 (SH 1 to 2)
P445:	10P445xx (xx = 01 to 04)
P54x (P543, P544, P545 & P546):	10P54302 (SH 1 to 2) 10P54303 (SH 1 to 2) 10P54304 (SH 1 to 2) 10P54400 10P54404 (SH 1 to 2) 10P54405 (SH 1 to 2) 10P54502 (SH 1 to 2) 10P54503 (SH 1 to 2) 10P54504 (SH 1 to 2) 10P54600 10P54604 (SH 1 to 2) 10P54605 (SH 1 to 2) 10P54606 (SH 1 to 2)
P64x (P642, P643 & P645):	10P642xx (xx = 1 to 10) 10P643xx (xx = 1 to 6) 10P645xx (xx = 1 to 9)
P746:	10P746xx (xx = 00 to 21)
P841:	10P84100 10P84101 (SH 1 to 2) 10P84102 (SH 1 to 2) 10P84103 (SH 1 to 2) 10P84104 (SH 1 to 2) 10P84105 (SH 1 to 2)
P849:	10P849xx (xx = 01 to 06)

Notes:

CONTENTS

1. Introduction	9
1.1 Standard Safety Statements	9
2. Hardware Description	10
2.1 IRIG-B Connector	11
2.2 LEDs	11
2.3 Optical Fibre Connectors	11
3. Redundancy Protocols	13
3.1 Parallel Redundancy Protocol (PRP)	13
3.1.1 PRP Network Structure.....	13
3.1.2 Example PRP Configuration.....	14
3.2 High-availability Seamless Redundancy (HSR)	14
3.2.1 HSR Network Structure.....	15
3.2.2 Example HSR Configuration.....	17
3.3 Rapid Spanning Tree Protocol (RSTP)	17
3.3.1 RSTP Network Structure.....	17
3.3.2 Example RSTP Configuration.....	17
3.4 Generic Functions for all Redundant Ethernet Boards (REBs)	18
3.4.1 Priority Tagging.....	18
3.4.2 Simple Network Time Protocol (SNTP).....	18
3.4.3 Dual Ethernet Communication (Dual IPs).....	18
3.4.3.1 Dual IP Introduction.....	18
3.4.3.2 Dual IP in MiCOM.....	18
3.4.3.3 Typical User Cases.....	19
3.4.4 Precision Time Protocol (PTP).....	20
3.4.4.1 Introduction to the IEEE1588 Standard.....	20
3.4.4.2 PTP Implementation.....	20
3.4.4.3 PTP Settings.....	20
3.4.4.4 IEC61850-9-3 PICS.....	20
4. Configuration	22
4.1 Configuring Ethernet Communication Mode	22
4.2 Configuring the IED Communication Parameters	22
4.3 Configuring GOOSE Publish Parameters	23
5. Commissioning	24
5.1 PRP Star Connection	24
5.2 HSR Ring Connection	24
5.3 RSTP Ring Connection	25
5.4 RSTP Star Connection	26
5.5 Large RSTP Networks combining Star and Ring	27

6. Technical Data	29
6.1 Board Hardware	29
6.1.1 100 Base TX Communications Interface	29
6.1.2 100 Base FX Communications Interface	29
6.1.3 Transmitter Optical Characteristics	29
6.1.4 Receiver Optical Characteristics	29
6.1.5 IRIG-B and Real-Time Clock	30
6.1.5.1 Performance	30
6.1.5.2 Features	30
6.1.5.3 Self-adapted Rear IRIG-B Interface (Modulated or Unmodulated)	30
6.2 Type Tests	30
6.2.1 Insulation	30
6.2.2 Creepage Distances and Clearances	30
6.2.3 High Voltage (Dielectric) Withstand	30
6.2.4 Impulse Voltage Withstand Test	31
6.3 ElectroMagnetic Compatibility (EMC)	31
6.3.1 1 MHz Burst High Frequency Disturbance Test	31
6.3.2 100 kHz and 1MHz Damped Oscillatory Test	31
6.3.3 Immunity to Electrostatic Discharge	31
6.3.4 Electrical Fast Transient or Burst Requirements	31
6.3.5 Surge Withstand Capability	32
6.3.6 Surge Immunity Test	32
6.3.7 Conducted/Radiated Immunity	32
6.3.8 Immunity to Radiated Electromagnetic Energy	32
6.3.9 Radiated Immunity from Digital Communications	32
6.3.10 Radiated Immunity from Digital Radio Telephones	32
6.3.11 Immunity to Conducted Disturbances Induced by Radio Frequency Fields	32
6.3.12 Power Frequency Magnetic Field Immunity	32
6.3.13 Conducted Emissions	32
6.3.14 Radiated Emissions	33
6.4 Environmental Conditions	33
6.4.1 Ambient Temperature Range	33
6.4.2 Ambient Humidity Range	33
6.4.3 Corrosive Environments	33
6.5 EU Directives	33
6.5.1 EMC Compliance	33
6.5.2 Product Safety	33
6.5.3 R&TTE Compliance	34
6.5.4 ATEX Compliance	34
6.5.5 UKCA Compliance	34
6.6 Mechanical Robustness	34
6.6.1 Vibration Test	34
6.6.2 Shock and Bump	34
6.6.3 Seismic Test	34
7. Cortec	35

TABLES

Table 1 - LED functionality.....	11
Table 2 - Optical fiber connector functionality.....	12
Table 3 - Ethernet ports operation mode.....	18
Table 4 - PTP Settings, Values and Descriptions.....	20
Table 5 - PICS Proforma Reference, Capability, Base and Support.....	21
Table 6 - Ethernet communication mode setting.....	22
Table 7 - First three bytes for default IP address.....	22
Table 8 - 100 Base TX interface.....	29
Table 9 - 100 Base FX interface.....	29
Table 10 - Tx optical characteristics.....	29
Table 11 - Rx optical characteristics.....	30
Table 12 - Cortec for Redundant Ethernet models.....	36

FIGURES

Figure 1 - Ethernet board connectors (3 RJ45 or 2 LC + RJ45 or 1 RJ45).....	11
Figure 2 - PRP example of general redundant network.....	14
Figure 3 - PRP Relay Configuration.....	14
Figure 4 - HSR example of ring configuration for multicast traffic.....	15
Figure 5 - HSR example of ring configuration for unicast traffic.....	16
Figure 6 - HSR Relay Configuration.....	17
Figure 7 - Px4x attached to a redundant Ethernet star or ring circuit.....	17
Figure 8 - PRP + Dual IP (Ethernet Mode PRP).....	19
Figure 9 - HSR + Dual IP (Ethernet Mode HSR).....	19
Figure 10 - Dual IP (Ethernet Mode Dual IP).....	19
Figure 11 - Communication Parameters for two Interfaces.....	22
Figure 12 - Goose Publish Parameters for two Interfaces.....	23
Figure 13 - PRP star connection.....	24
Figure 14 - HSR ring topology.....	25
Figure 15 - Dual Ethernet ring topology.....	26
Figure 16 - Dual Ethernet star topology.....	27
Figure 17 - Combined RSTP star and ring topology.....	28

Notes:

1. INTRODUCTION

The redundant Ethernet board assures redundancy at IED level. It is fitted into the following MiCOM IEDs from Schneider Electric.

- P14x = P141, P142, P143, P145
- P34x = P341, P342, P343, P344, P345
- P44x = P442, P444
- P44y = P443, P446
- P445
- P54x = P543, P544, P545, P546
- P64x = P642, P643, P645
- P746
- P841
- P849

1.1 Standard Safety Statements

For safety information please see the Safety Information chapter of the relevant Px4x Technical Manual.

2. HARDWARE DESCRIPTION

IEC 61850 works over Ethernet. Three boards are available:

- 1RJ45 Port Ethernet Board
- 3RJ45 Ports Redundant Ethernet Board
- 2LC+1RJ45 Ports Redundant Ethernet Board.

All are required for communications but 3RJ45 Ports and 2LC+1RJ45 Ports Redundant Ethernet Board allow an alternative path to be always available, providing bumpless redundancy.

Industrial network failure can be disastrous. Redundancy provides increased security and reliability, but also devices can be added to or removed from the network without network downtime.

The following list shows Schneider Electric's implementation of Ethernet redundancy, which has two variants with embedded IEC 61850 over Ethernet, plus PRP, HSR and RSTP redundancy protocols.

- Parallel Redundancy Protocol (PRP)/High-availability Seamless Redundancy (HSR)/Rapid Spanning Tree Protocol (RSTP) with 1310 nm multi mode 100BaseFx fiber optic Ethernet ports (LC connector) and modulated/un-modulated IRIG-B input. Part number 2072069A01.

Note

The board offers compatibility with any PRP/HSR/RSTP device.

- Parallel Redundancy Protocol (PRP)/High-availability Seamless Redundancy (HSR)/Rapid Spanning Tree Protocol(RSTP) with 100BaseTx Ethernet ports (RJ45) and modulated/un-modulated IRIG-B input. Part number 2072071A01.

Note

The board offers compatibility with any PRP/HSR/RSTP device.

The redundant Ethernet board is fitted into Slot A of the IED, which is the optional communications slot. Each Ethernet board has three MAC addresses for two groups, one group (PORT 1) including one host MAC address, the other group (PORT 2 & 3) used for redundant application, including one host MAC address and one redundant agency device MAC address. Two host MAC addresses of the IED are printed on the rear panel of the IED.

In addition above for HSR/PRP/RSTP redundant protocols, the redundant Ethernet board also can operate on Dual IP mode. In this case, each Ethernet board has two host MAC addresses.

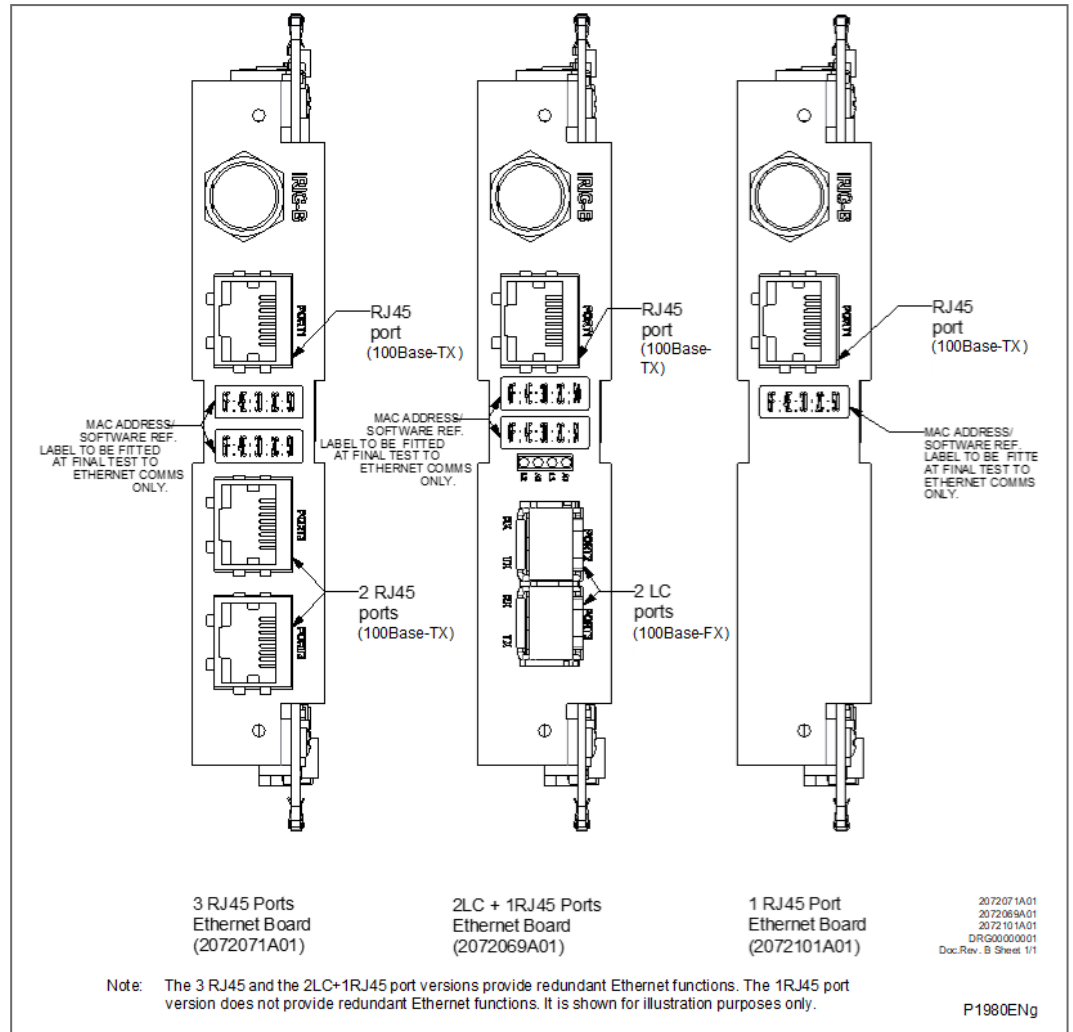

Figure 1 - Ethernet board connectors (3 RJ45 or 2 LC + RJ45 or 1 RJ45)

2.1 IRIG-B Connector

This is available as a modulated/un-modulated input.
See the 6.1 - Board Hardware section.

2.2 LEDs

LED	Function	On	Off	Flashing
Green	Link	Link ok	Link broken	
Yellow	Activity			Traffic activity

Table 1 - LED functionality

2.3 Optical Fibre Connectors

Use 1310 nm multi mode 100BaseFx and LC connectors.
See Figure 1 - Ethernet board connectors (3 RJ45 or 2 LC + RJ45 or 1 RJ45) and the 6.1 - Board Hardware section.

Connector	PRP	HSR	RSTP
2	Rx	Rx	Rx

Connector	PRP	HSR	RSTP
2	Tx	Tx	Tx
3	Rx	Rx	Rx
3	Tx	Tx	Tx

Table 2 - Optical fiber connector functionality

3. REDUNDANCY PROTOCOLS

These redundancy protocols are available:

- PRP (Parallel Redundancy Protocol)
- HSR (High-availability Seamless Redundancy)
- RSTP (Rapid Spanning Tree Protocol)

3.1 Parallel Redundancy Protocol (PRP)

When the upper protocol layers send a data packet, the PRP interface creates a “twin packet” from this. The PRP interface then transmits redundant data packet of the twin pair to each participating LAN simultaneously. As they are transmitted via different LANs, the data packets may have different run times.

The receiving PRP interface forwards the first packet of a pair towards the upper protocol layers and discards the second packet. When viewed from the application, a PRP interface functions like a standard Ethernet interface.

The PRP interface or a Redundancy Box (RedBox) injects a Redundancy Control Trailer (RCT) into each packet. The RCT is a 48-bit identification field and is responsible for the identification of duplicates. This field contains, LAN identification (LAN A or B), information about the length of the payload, and a 16-bit sequence number. The PRP interface increments the sequence number for each packet sent. Using the unique attributes included in each packet, such as Physical MAC source address and sequence number, the receiving RedBox or Double Attached Node (DAN) interface identifies and discards duplicates.

Depending on the packet size, with PRP it attains a throughput of 93 to 99% of the available bandwidth.

3.1.1 PRP Network Structure

PRP uses two independent LANs. The topology of each of these LANs is arbitrary, and ring, star, bus and meshed topologies are possible.

The main advantage of PRP is loss-free data transmission with an active (transit) LAN. When the terminal device receives no packets from one of the LANs, the second (transit) LAN maintains the connection. As long as 1 (transit) LAN is available, repairs and maintenance on the other (transit) LAN have no impact on the data packet transmission.

The elementary devices of a PRP network are known as RedBox (Redundancy Box) and DANP (Double Attached Node implementing PRP).

Both devices have one connection each to the (transit) LANs.

The devices in the (transit) LAN are conventional switches that do not require any PRP support. The devices transmit PRP data packets transparently, without evaluating the RCT information.

Terminal devices that are connected directly to a device in the (transit) LAN are known as SAN (Single Attached Node). If there is an interruption, these terminal devices cannot be reached via the redundant line. To use the uninterruptible redundancy of the PRP network, you integrate your device into the PRP network via a RedBox.

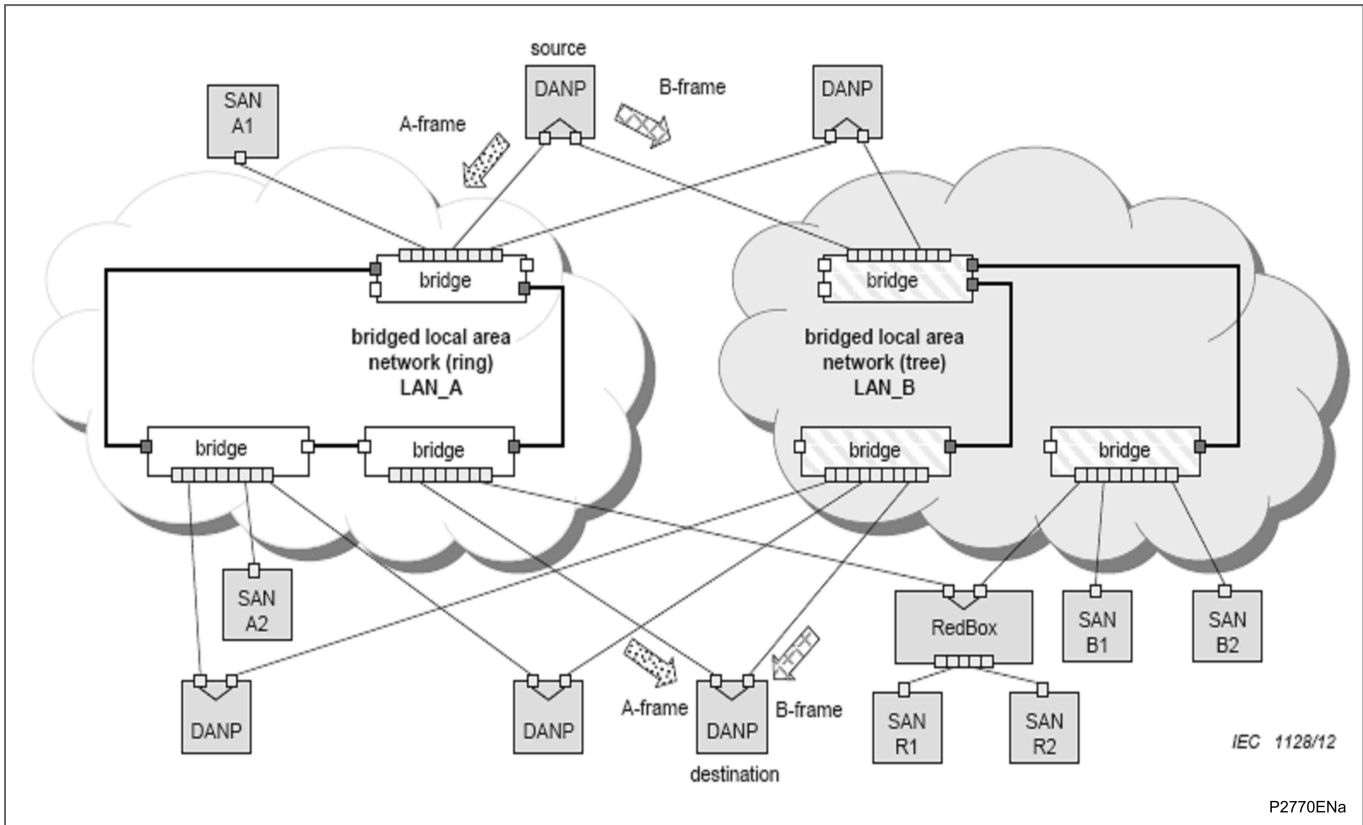

Figure 2 - PRP example of general redundant network

3.1.2 Example PRP Configuration

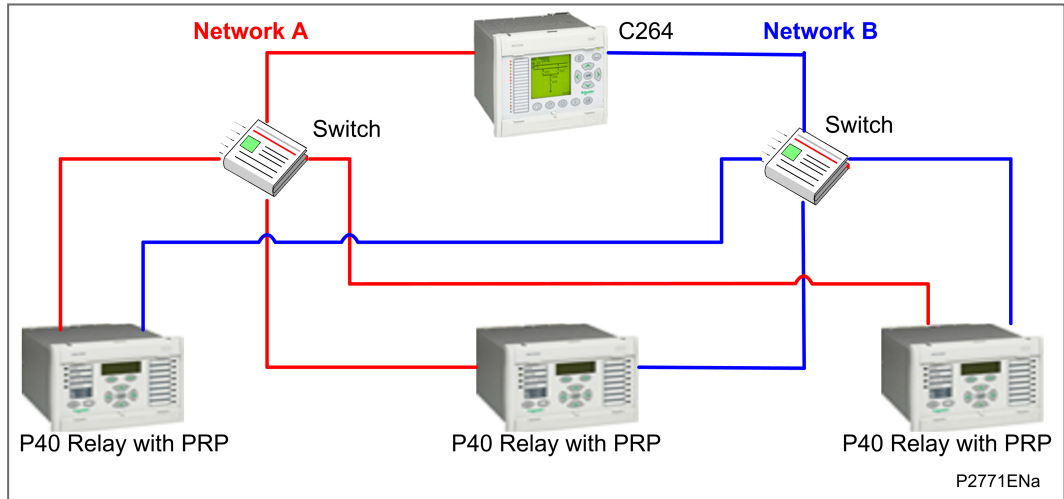

Figure 3 - PRP Relay Configuration

3.2 High-availability Seamless Redundancy (HSR)

High-availability Seamless Redundancy (HSR) can only be used in a ring topology, This section describes the application of the PRP principles (IEC 62439-3- Clause 4) to implement a High-availability Seamless Redundancy (HSR), retaining the PRP property of zero recovery time, applicable to rings. With respect to PRP, HSR allows you to greatly reduce the network infrastructure. With respect to rings based on IEEE 802.1D (RSTP), IEC 62439-2 (MRP), IEC 62439-6 (DRP) or IEC 62439-7 (RRP), the available network bandwidth for network traffic is somewhat reduced depending on the type of traffic. Nodes within the ring are restricted to be HSR-capable bridging nodes, thus avoiding the use of dedicated bridges.

Singly Attached Nodes (SANs) such as laptops or printers cannot be attached directly to the ring, but need attachment through a RedBox (redundancy box).

3.2.1 HSR Network Structure

As in PRP, a node has two ports operated in parallel; it is a DANH (Doubly Attached Node with HSR protocol).

A simple HSR network consists of doubly-attached bridging nodes, each having two ring ports, interconnected by full-duplex links, as shown in these examples for a ring topology:

- Figure 4 - HSR example of ring configuration for multicast traffic
- Figure 5 - HSR example of ring configuration for unicast traffic

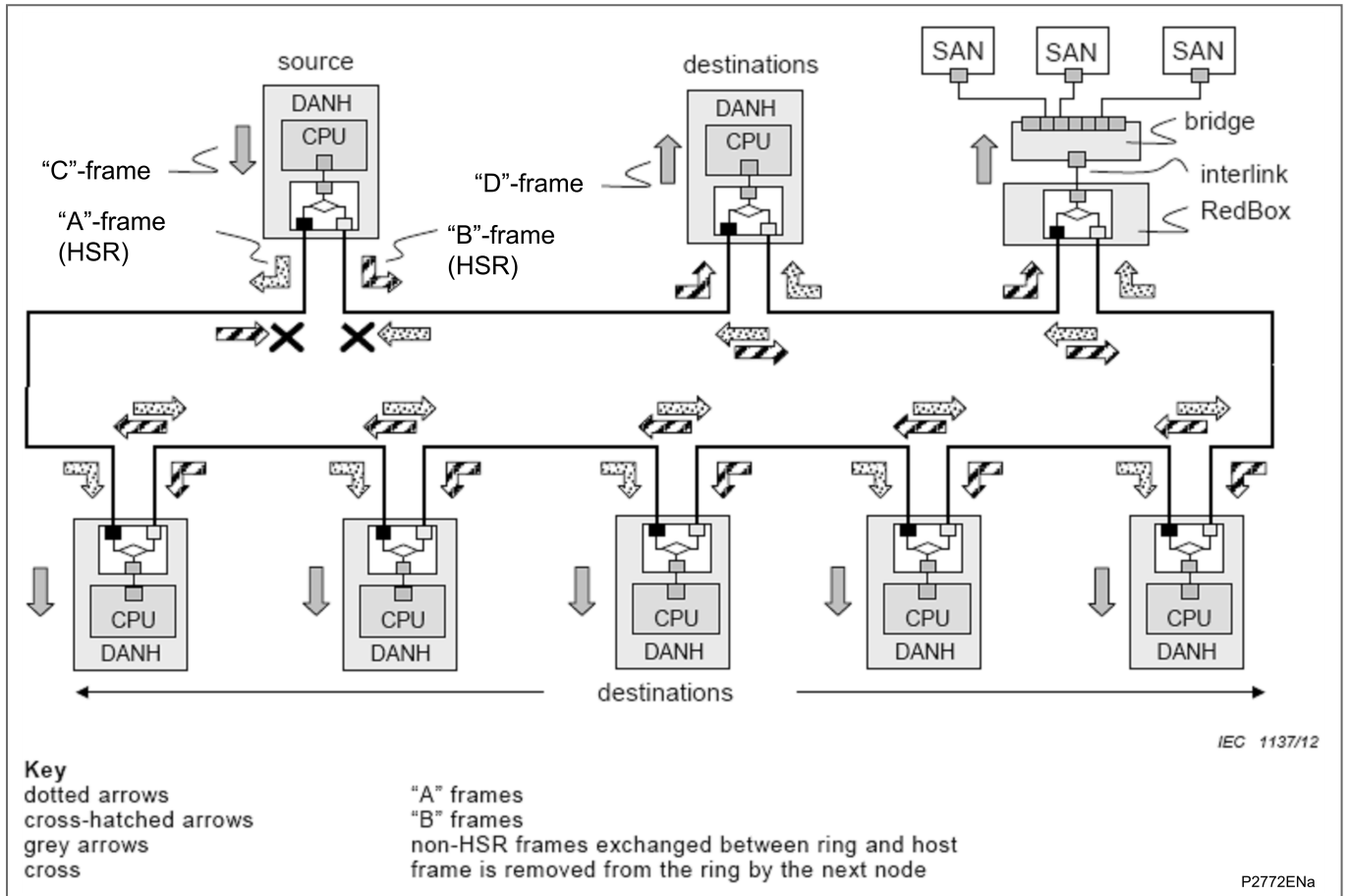

Figure 4 - HSR example of ring configuration for multicast traffic

A source DANH sends a frame passed from its upper layers ("C" frame), prefixes it by an HSR tag to identify frame duplicates and sends the frame over each port ("A"-frame and "B"-frame). A destination DANH receives, in the fault-free state, two identical frames from each port within a certain interval, removes the HSR tag of the first frame before passing it to its upper layers ("D"-frame) and discards any duplicate.

The nodes support the IEEE 802.1D bridge functionality and forward frames from one port to the other, except if they already sent the same frame in that same direction.

In particular, the node will not forward a frame that it injected into the ring.

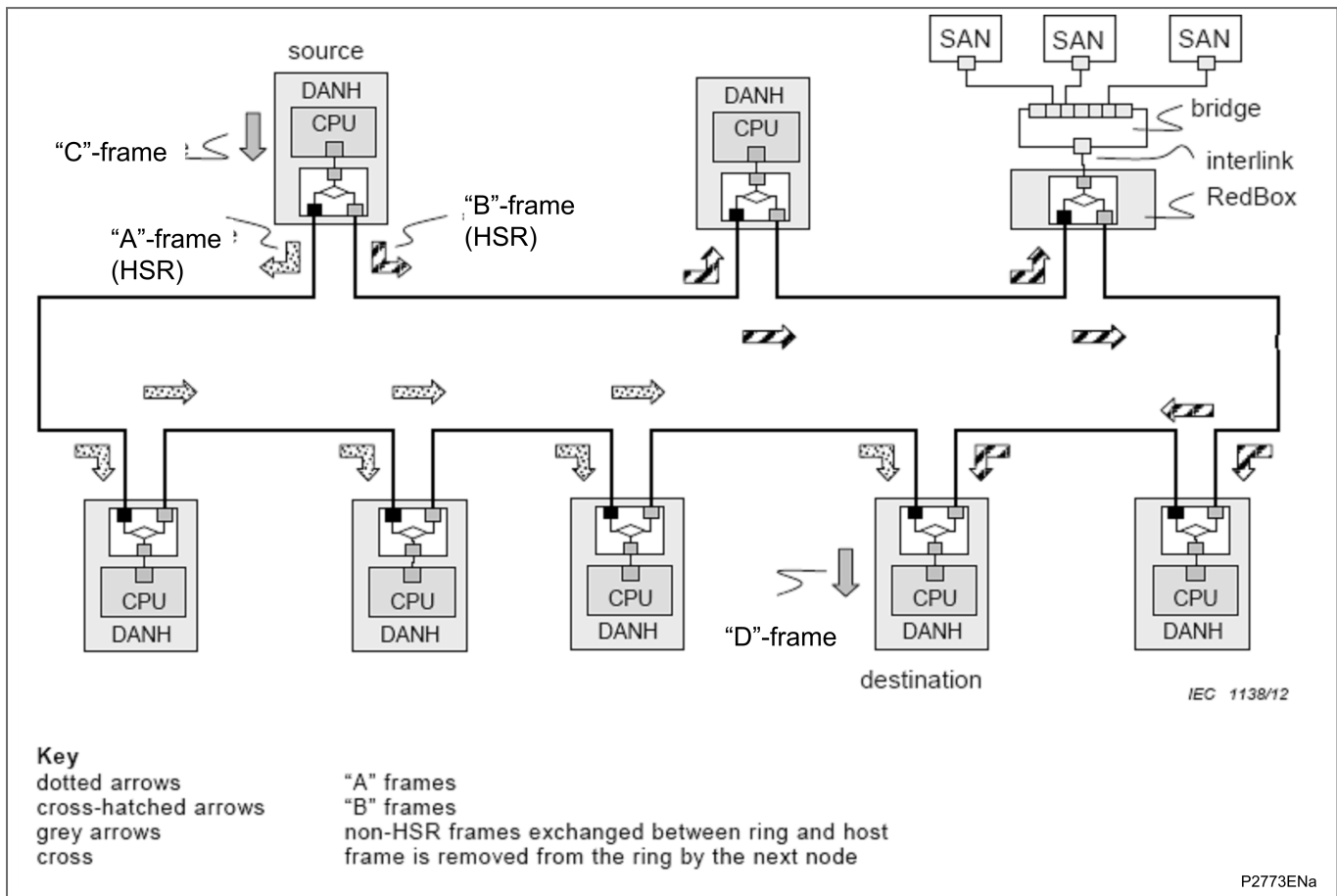

Figure 5 - HSR example of ring configuration for unicast traffic

A destination node of a unicast frame does not forward a frame for which it is the only destination, except for testing.

Frames circulating in the ring carry the HSR tag inserted by the source, which contains a sequence number. The doublet {source MAC address, sequence number} uniquely identifies copies of the same frame.

Singly Attached Nodes (SANs), for instance maintenance laptops or printers cannot be inserted directly into the ring since they have only one port and cannot interpret the HSR tag in the frames. SANs communicate with ring devices through a RedBox (redundancy box) that acts as a proxy for the SANs attached to it, as shown in the diagram. Connecting non-HSR nodes to ring ports, breaking the ring, is allowed to enable configuration. Non-HSR traffic within the closed ring is supported in an optional mode.

3.2.2 Example HSR Configuration

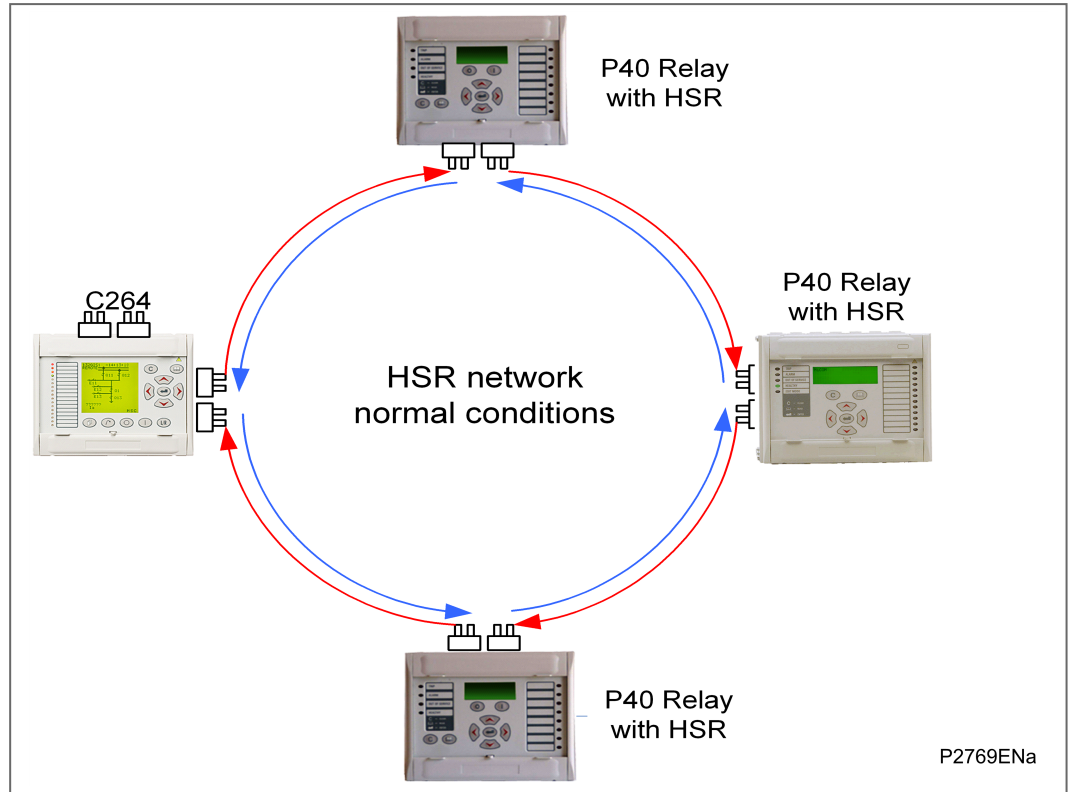

Figure 6 - HSR Relay Configuration

3.3 Rapid Spanning Tree Protocol (RSTP)

3.3.1 RSTP Network Structure

RSTP is a standard used to quickly reconnect a network fault by finding an alternative path, allowing loop-free network topology. Although RSTP can recover network faults quickly, the fault recovery time depends on the number of devices and the topology. The recovery time also depends on the time taken by the devices to determine the root bridge and compute the port roles (discarding, learning, forwarding). The devices do this by exchanging Bridge Protocol Data Units (BPDUs) containing information about bridge IDs and root path costs. See the IEEE 802.1D 2004 standard for further information.

3.3.2 Example RSTP Configuration

The Px4x redundant Ethernet board uses the RSTP protocol (802.1w), so a Px4x can attach onto a network as shown below:

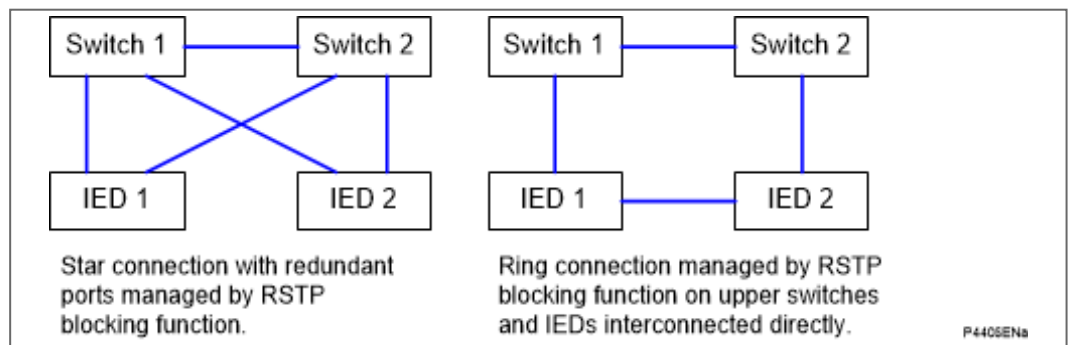

Figure 7 - Px4x attached to a redundant Ethernet star or ring circuit

The RSTP solution is based on open standards. It is therefore compatible with other manufacturers' IEDs that use the RSTP protocol. The RSTP recovery time is typically 300ms but it increases with network size.

3.4 Generic Functions for all Redundant Ethernet Boards (REBs)

The following apply to the redundant Ethernet protocols (PRP, HSR).

3.4.1 Priority Tagging

802.1p priority is enabled on all ports.

3.4.2 Simple Network Time Protocol (SNTP)

Simple Network Time Protocol (SNTP) is supported by both the IED and the redundant Ethernet switch. SNTP is used to synchronize the clocks of computer systems over packet-switched, variable-latency data networks. A jitter buffer is used to reduce the effects of variable latency introduced by queuing in packet switched networks, ensuring a continuous data stream over the network.

The IED receives the synchronization from the SNTP server. This is done using the IP address of the SNTP server entered into the IED from the IED Configurator software.

3.4.3 Dual Ethernet Communication (Dual IPs)

3.4.3.1 Dual IP Introduction

Dual IP means the IED provides two independent IEC 61850 interfaces, and both these interfaces support MMS and GOOSE message.

The IED which supports Dual IP can provide the customer with more flexible network connections: two fully segregated Station BUS networks, or one Station Bus and one Process Bus (for GOOSE message transmission).

Dual IP is not mutually exclusive with PRP/HSR/RSTP - Dual IP is automatically supported even if the IED is operate under PRP/HSR/RSTP mode.

3.4.3.2 Dual IP in MiCOM

Dual IP is only supported for devices with the new Ethernet board assembly. This is shown by the model number, where the 7th digit is either hardware option Q or R. These boards have three Ethernet ports, as shown in the Ethernet Board Connectors diagram.

A setting is provided in the HMI to switch the operation mode between PRP / HSR / RSTP / Dual IP.

Operation mode	Port 1	Port 2	Port 3
PRP	Interface 1	Interface 2 (PRP)	Interface 2 (PRP)
HSR	Interface 1	Interface 2 (HSR)	Interface 2 (HSR)
RSTP	Interface 1	Interface 2 (HSR)	Interface 2 (HSR)
Dual IP	* Interface 1 on Port 1 or Port 2		Interface 2
Note *			
In Dual IP mode, interface 1 can be available on port 1 or port 2.			
If both of port 1 and port 2 are connected, only port 1 will work.			

Table 3 - Ethernet ports operation mode

For each interface, the fully IEC 61850 functions (GOOSE and MMS services) are supported independently.

For outgoing GOOSE messages, you need to configure whether a message is to be transmitted across one or both Ethernet connections. You also need to configure the destination parameters such as multicast MAC address, ApplID, VLAN, etc.

Two communication parameters also need to be configured for each interface (IP address, MAC address, subnet mask). For the CID which is exported from SCD file, the second interface communication parameters are not configured. This needs to be done by manually editing in the IED configurator (this being invisible by the SCD file). This process needs to be completed before the exported CID file is downloaded to the IED. (this being invisible by the SCD file).

3.4.3.3 Typical User Cases

Below for Interface 1 and Interface 2, from a functional point of view it is same. The customer has flexibility to define the functionality according their requirements.

- Both for Station Bus to have duplicated network for DCS.
- One for Station Bus and one for process bus (Goose message)

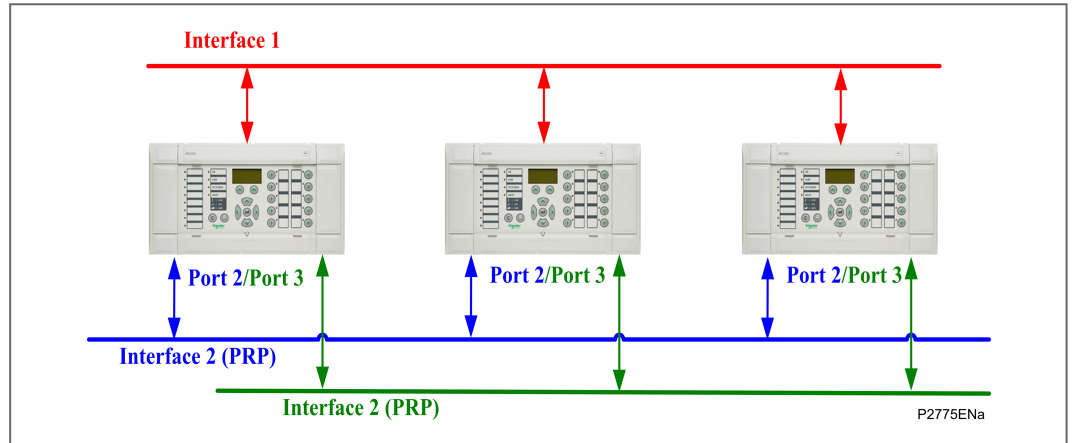

Figure 8 - PRP + Dual IP (Ethernet Mode PRP)

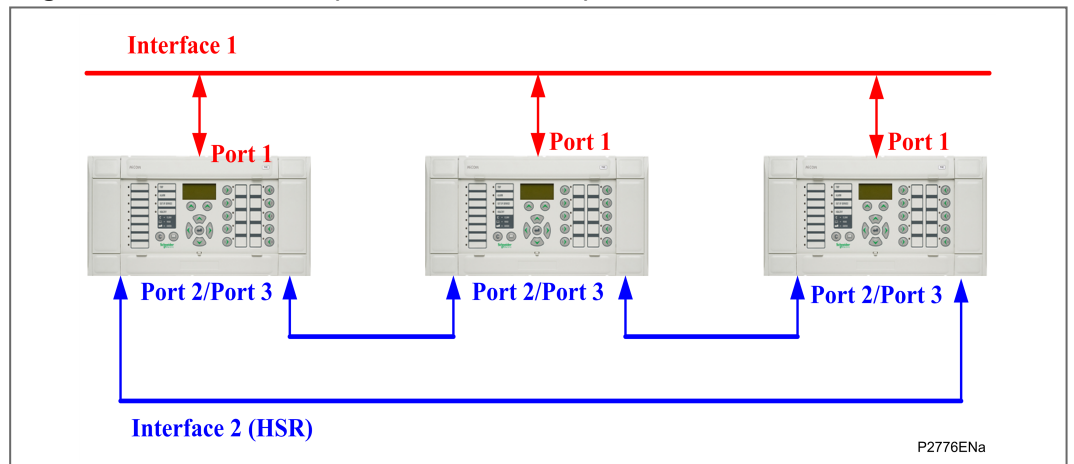

Figure 9 - HSR + Dual IP (Ethernet Mode HSR)

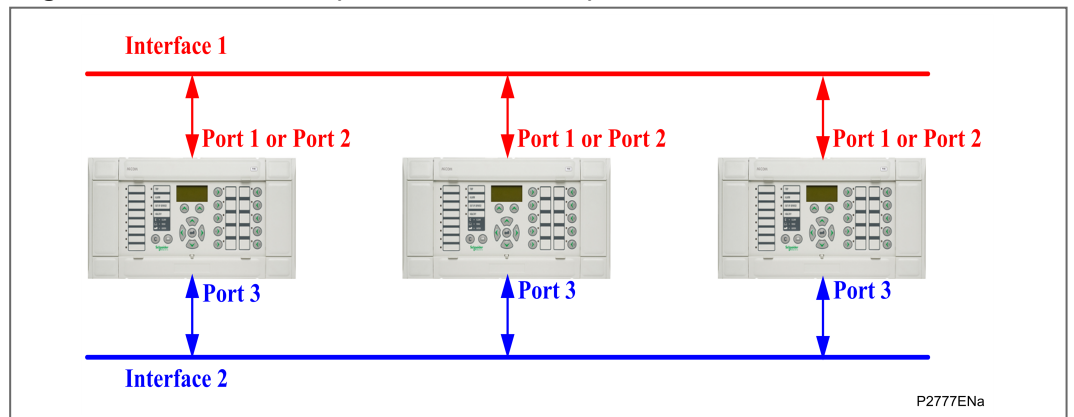

Figure 10 - Dual IP (Ethernet Mode Dual IP)

3.4.4 Precision Time Protocol (PTP)

Precision Time Protocol (PTP) provides higher time accuracy (500us) than IRIG-B.

PTP communication uses the IEEE 802.3 protocol.

3.4.4.1 Introduction to the IEEE1588 Standard

A protocol is provided in this standard that enables precise synchronization of clocks in measurement and control systems implemented with technologies such as network communication, local computing, and distributed objects. The protocol is applicable to systems communicating via packet networks. Heterogeneous systems are enabled that include clocks of various inherent precision, resolution, and stability to synchronize. System-wide synchronization accuracy and precision in the sub-microsecond range are supported with minimal network and local clock computing resources. Simple systems are installed and operated without requiring the management attention of users because the default behaviour of the protocol allows for it.

3.4.4.2 PTP Implementation

PTP implementation is compliant with IEC61850-9-3.

PTP communication is supported in all Ethernet interfaces (redundant ports or single port) with communication protocols (PRP/HSR).

A Slave only Ordinary Clock (OC) is supported by the single port of the Ethernet boards. A Transparent Clock (TC) is supported on the HSR ring.

Peer-to-Peer mode and Best Master Clock algorithm (BMCA) are supported.

The priority of time synchronization is PTP then, if not provided IRIG-B then, if not provided SNTP.

PTP is only supported by the model number, where the 7th digit is Q, R or S.

3.4.4.3 PTP Settings

PTP Settings	Value	Description
DATE AND TIME		
1588 Sync	0: Disabled 1: Interface1 Enabled 2: Interface2 Enabled 3: Interface1&2 Enabled	For Q or R board, the setting value can be 0,1,2,3. For S board, the setting value can be 0, 1. If the setting value is 0, PTP communication is disabled.
1588 DomainNum	[0, 255]	Define the permitted domainNumber of master clock. If the domainNumber in received PTP message header is different from the configuration parameter, the message will be rejected.
1588 PdelInterv	[0, 5]	Define the PDelay interval (20~25) sent by IED.

Table 4 - PTP Settings, Values and Descriptions

PTP is linked with Interface 2 configuration. If there is no IP configured for Interface 2, PTP on interface 2 will not work.

3.4.4.4 IEC61850-9-3 PICS

PICS proforma reference	Capability	Base	Support
CLOCK_TYPE_OC	clock is OC according to this base	m	True
CLOCK_TYPE_TC	clock is TC according to this base	m	True

PICS proforma reference	Capability	Base	Support
CLOCK_TYPE_BC	clock is BC according to this base	m	False
NR_PORTS	number of clock ports (total)	m	2
PORTS_STEP	1: all ports support 1- step on egress 2: all ports support 2- step on egress 3: all ports support both 1 - step and 2.	m	{1 or 2} For PRP/HSR/RSTP mode: - Port1 support 2 step on egress. - Port2&3 support 1 step on egress For Dual IP mode: - Port1&2 support 2 step on egress - Port3 support 1 step on egress
SLAVE_ONLY	all ports of the clock are slave - only	m	True
TIME_TRACEABLE	connectable to a time reference outside of PTP (e.g. GPS)	m	
FREQ_TRACEABLE	connectable to a frequency reference outside of PTP (e.g. GPS)	m	
DAC	doubly attached OC	o	True (in HSR,PRP or RSTP mode)
PORTS_PAISED	paired clock ports for redundancy (e.g. {3-4})	o	{0,1} 0=A, 1=B
REDBOX_DATC	RedBox as TC	o	
REDBOX_SLTC	RedBox as Stateless TC	o	
REDBOX_TWBC	RedBox as three-way BC	o	
REDBOX_DABC	Redbox as DAC BC	o	
MIB_SNMP	supports MIB of IEC 2439-3 :2015, Annex E	m	False
MIB_61850	supports IEC 6 1859- 90- 4 Clock Objects	m	False
MIB_OTHER	clock supports fixed values or a mechanism defined by the manufacturer (If True, this list is appended to this PICS)	m	True Some management requests for time synchronization information are supported in PTP protocol. The following lists the supported datasets. CURRENT_DATA_SET - stepsRemoved - offsetFromMaster - meanPathDelay PORT_DATA_SET - portIdentity - portState - logMinDelayReqInterval - peerMeanPathDelay - logAnnounceInterval - announceReceiptTimeout - logSyncInterval - delayMechanism - logMinPdelayReqInterval - versionNumber

Table 5 - PICS Proforma Reference, Capability, Base and Support

4. CONFIGURATION

The new redundant Ethernet board supports three communication operation modes. These can be achieved by change the setting in HMI. It is not necessary to flash the firmware.

Also for the two interfaces, the communication parameters need to be configured. These include the IP address, MAC address, and subnet mask, etc.

For redundant protocols, the communication parameters for redundant agency device also need to be configured.

4.1 Configuring Ethernet Communication Mode

Menu Text	Cell Add.	Default Setting	Available Setting
ETH COMM Mode	0016	Dual IP	Dual IP, PRP, HSR or RSTP
Sets the redundancy protocol. This setting can only be changed via the UI. The setting is linked with Interface2. If there is no IP configured for Interface 2, the setting is not configurable. By default, this setting is configurable thanks to the default IP.			

Table 6 - Ethernet communication mode setting

4.2 Configuring the IED Communication Parameters

The communication parameter for each interface is configured using the IED Configurator software in MiCOM S1 Studio. **Customers can configure these parameters according to their needs, but the IP address for these two interfaces should not be in the same subnet.**

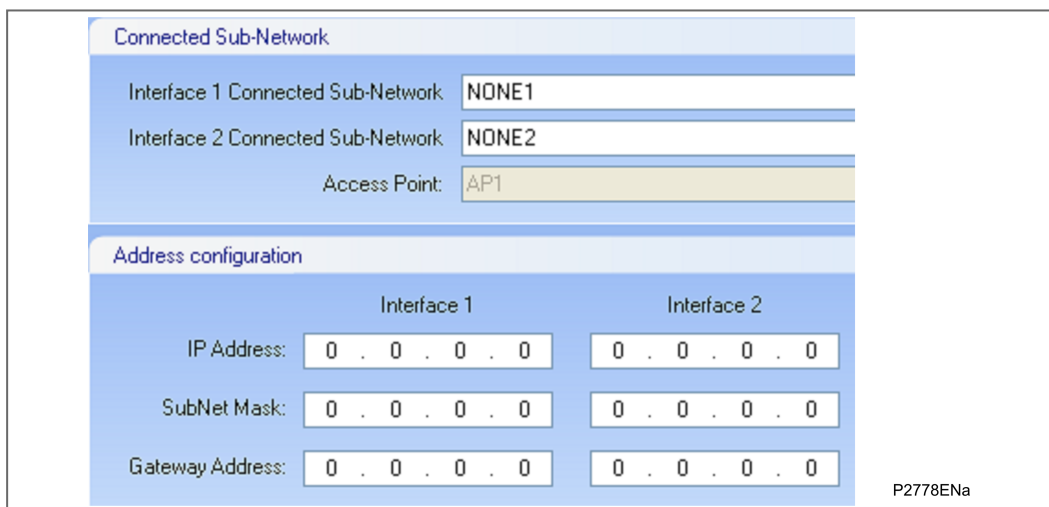

Figure 11 - Communication Parameters for two Interfaces

To use the device configuration with Courier Tunneling, for each interface, a default IP address has been applied. The default IP address for the first three bytes is fixed for each interface as below:

Interface	First three Bytes for IP address
Interface 1	169.254.0.xxx
Interface 2	169.254.1.yyy
Note xxx = Mod (the last byte MAC1 address, 128) + 1 yyy = Mod (the last byte MAC2 address, 128) + 1	

Table 7 - First three bytes for default IP address

The default IP address can be found in the IED CONFIGURATOR column. Also, you can also calculate it according the MAC address label which is mounted on the rear panel of the Ethernet card.

The default IP address is 169.254.2.zzz.

zzz = Mod (The last byte MAC3 address, 128) + 1

4.3 Configuring GOOSE Publish Parameters

For outgoing GOOSE messages, you need to configure whether a message is to be transmitted over one Ethernet connection. You also need to configure the destination parameters including multicast MAC address, AppID, VLAN, etc.

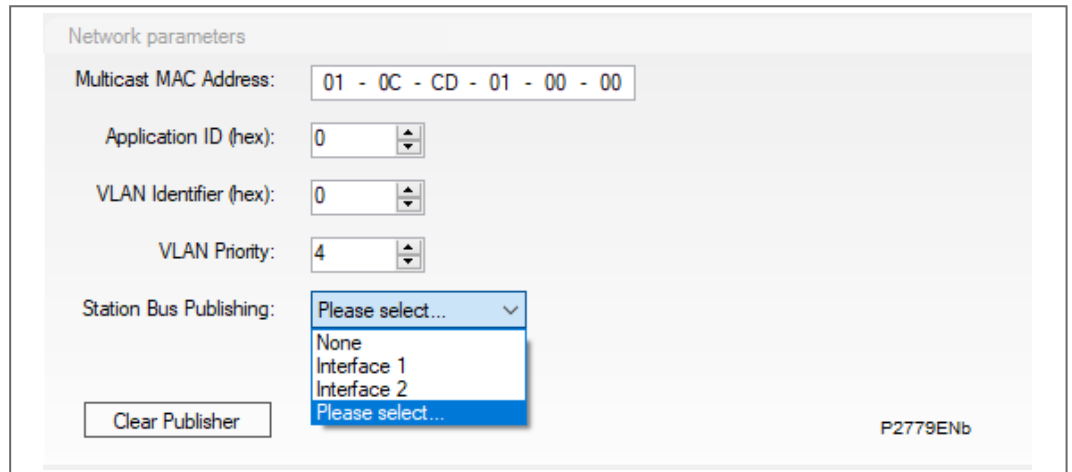

The screenshot shows a configuration window titled "Network parameters". It contains the following fields and controls:

- Multicast MAC Address:** A text input field containing "01 - 0C - CD - 01 - 00 - 00".
- Application ID (hex):** A spin box with the value "0".
- VLAN Identifier (hex):** A spin box with the value "0".
- VLAN Priority:** A spin box with the value "4".
- Station Bus Publishing:** A dropdown menu currently showing "Please select...". The dropdown list is open, showing options: "None", "Interface 1", "Interface 2", and "Please select...".
- Clear Publisher:** A button located at the bottom left of the configuration area.
- P2779ENb:** A small text label at the bottom right of the configuration area.

Figure 12 - Goose Publish Parameters for two Interfaces

5. COMMISSIONING

5.1 PRP Star Connection

The following diagram shows the Px4x IEDs with the PRP variant of Redundant Ethernet boards connected in a STAR topology. The STAR topology can have one or more high-end PRP-enabled Ethernet switches to interface with another network. The Ethernet switch is an HSR-enabled switch with a higher number of ports, which should be configured as the root bridge.

The number of IEDs that can be connected in the STAR can be up to 128.

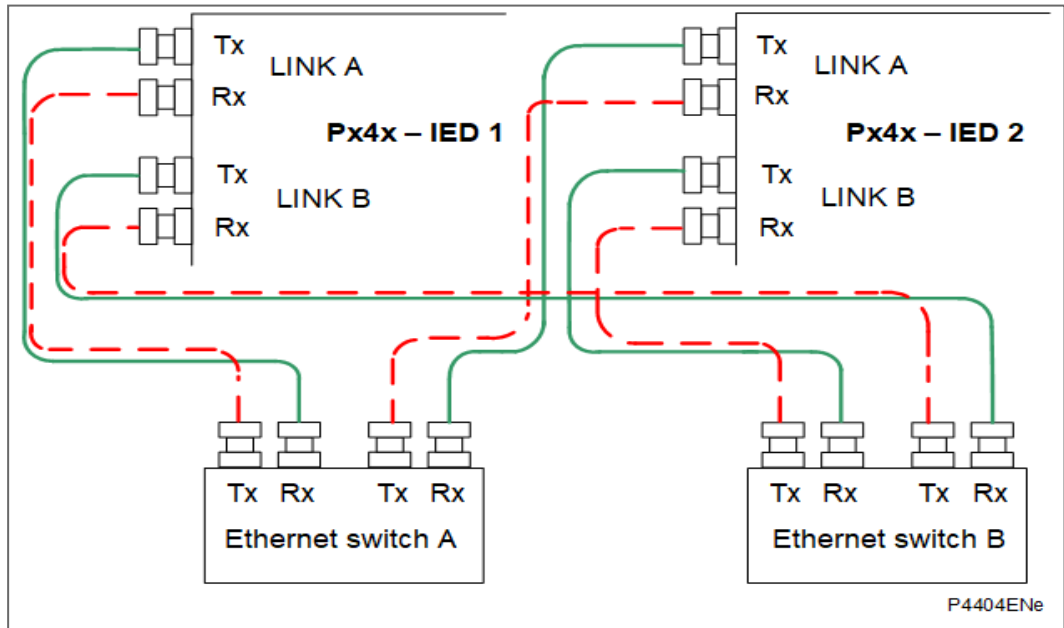

Figure 13 - PRP star connection

5.2 HSR Ring Connection

The following diagram shows the Px4x IEDs (Px4x - IED 1 to IED N) with the HSR variant of redundant Ethernet boards connected in a ring topology. The ring topology can have one or more high-end HSR-enabled Ethernet switches to interface with another network or a control center.

The Ethernet switch is an HSR enabled switch with a higher number of ports. The Ethernet switch, which is connected to the controlling PC, should be configured as the root bridge.

The number of IEDs that can be connected in the ring can be up to 128.

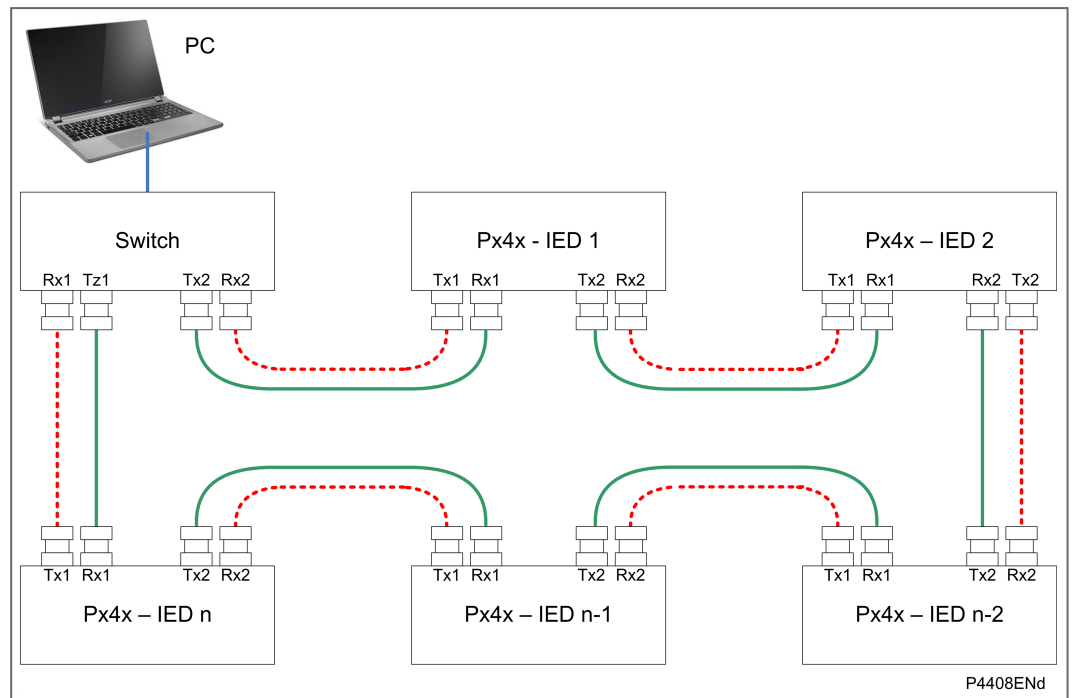

Figure 14 - HSR ring topology

5.3 RSTP Ring Connection

The next diagram shows the Px4x IEDs (Px4x – IED 1 to IED N) with the RSTP variant of redundant Ethernet boards connected in a ring topology. The ring topology can have one or more high-end RSTP-enabled Ethernet switches to interface with another network or control center.

The Ethernet switch is an RSTP enabled switch with a higher number of ports.

The Ethernet switch, which is connected to the controlling PC, should be configured as the root bridge. The bridge priority of the Ethernet switch should be configured to the minimum value in the network shown in the next diagram.

The maximum number of IEDs that can be connected in the ring network depends on the Max Age parameter configured in the root bridge, see the *Combined RSTP star and ring topology* diagram.

The Max Age parameter can be varied from 6 to 40 seconds.

If Max Age = 6 seconds, the maximum number of IEDs in the ring is $6 - 1 = 5$.

If Max Age = 40 seconds, the maximum number of IEDs in the ring is $40 - 1 = 39$.

Therefore, the number of IEDs that can be connected in the ring can vary from 5 to 39.

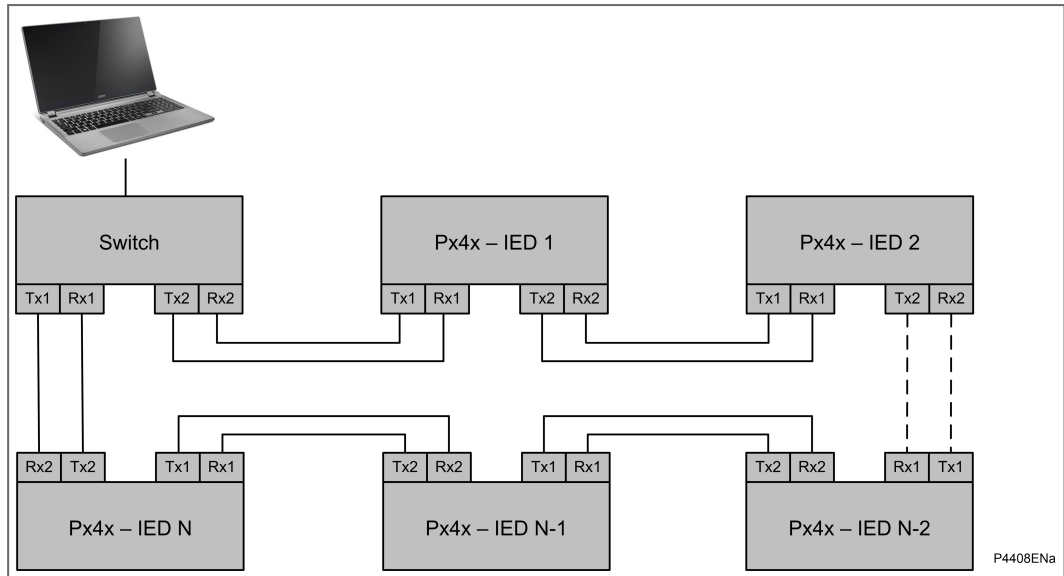

Figure 15 - Dual Ethernet ring topology

5.4 RSTP Star Connection

The next diagram shows the Px4x IEDs (Px4x – IED 1 to IED N) with the RSTP variant of redundant Ethernet boards connected in a star topology. The star topology can have one or more high-end RSTP-enabled Ethernet switches to interface with other networks, control centers, or Px4x IEDs.

The Ethernet switch is an RSTP enabled switch with a greater number of ports. The Ethernet switch, which is connected to the controlling PC, should be configured as the root bridge. The bridge priority of the Ethernet switch should be configured to the minimum value in the network shown below.

The Px4x IEDs are placed at two hop distance from the root bridge, therefore the Max Age meter has no impact on star topology.

The maximum number of IEDs that can be connected in the star network depends on the number of ports available in the Ethernet switch, provided that the hop count from the root bridge is less than the Max Age parameter.

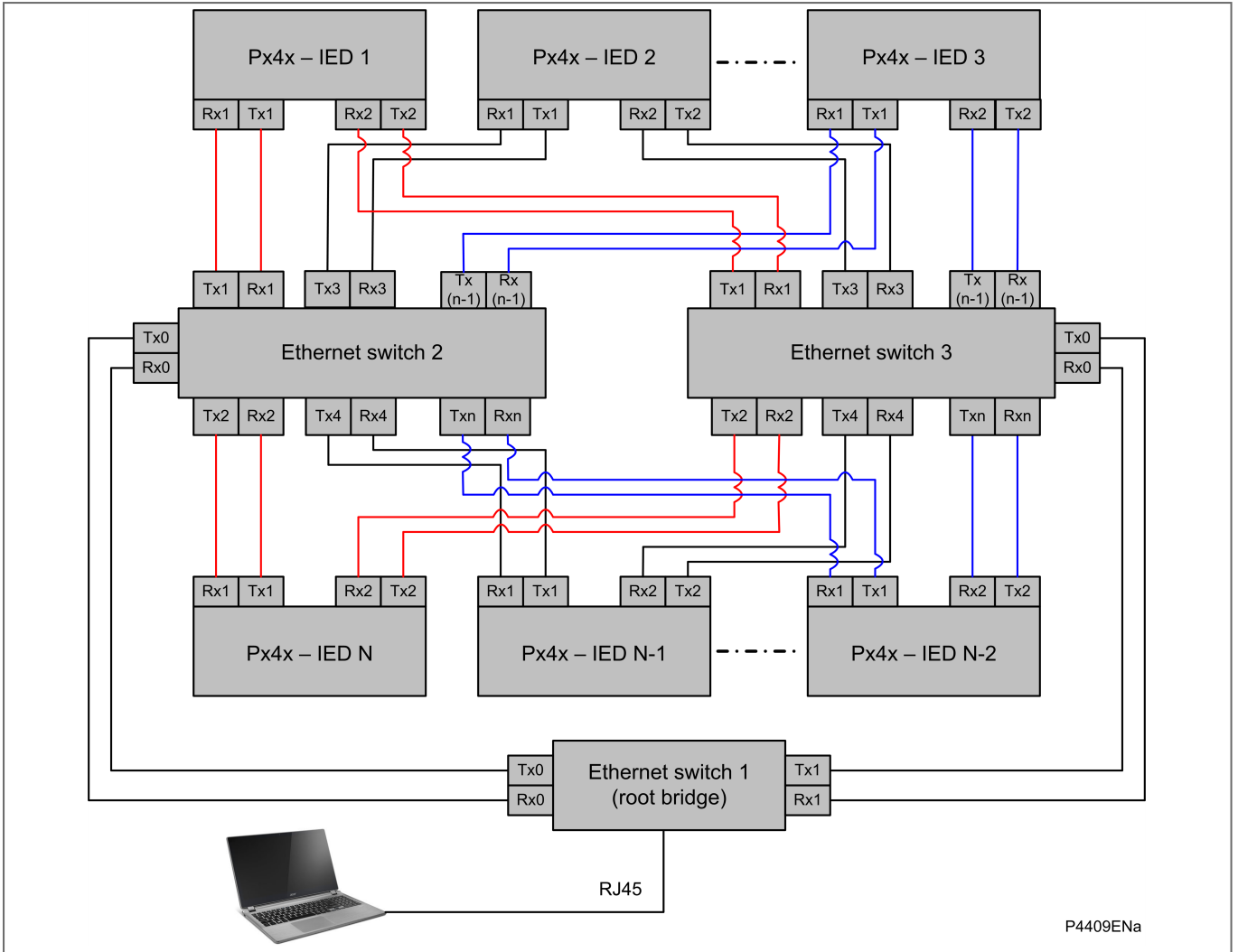

Figure 16 - Dual Ethernet star topology

5.5 Large RSTP Networks combining Star and Ring

The next diagram shows a star of four rings. Each ring is connected to the root bridge. The root bridge is a high-end RSTP enabled bridge with the maximum number of ports as required.

The devices A1, A2...Anmax, B1, B2...Bnmax, C1, C2...Cnmax, D1, D2...Dnmax, represent the RSTP variant of redundant Ethernet boards.

The maximum number of boards that can be connected in single ring in an RSTP-enabled network depends on the Max Age parameter. The hop count from the root bridge cannot be greater than the Max Age parameter.

The maximum number of RSTP bridges in a ring is given by:

$$N_{max} = (Max\ Age - 1)$$

Where:

N_{max} = maximum number of devices in a ring

Max Age = Max Age value configured in the root bridge

Assuming the default value of Max Age as 20 seconds in the topology shown 0, the maximum number of devices that can be connected in ring A is 19.

If Max Age is configured as 40 seconds, the maximum number of IEDs that can be connected in the network is $(40-1) = 39$. According to the IEEE 802.1D 2004 standard, the

maximum value for the Max Age parameter is limited to 40. To use the maximum number of IEDs in the ring, the following configuration should be used.

Max Age = 40 seconds

Forward Delay = 30 seconds

Hello Time = 2 seconds

Bridge Priority = As required by the end user

The IEEE 802.1D 2004 standard defines the relation between Max Age and Forward Delay as:

$$2 * (\text{Forward Delay} - 1.0 \text{ seconds}) \geq \text{Max Age}$$

To have the maximum number of nodes in the RSTP network, the number of rings can be increased, depending on the number of ports available in the root bridge.

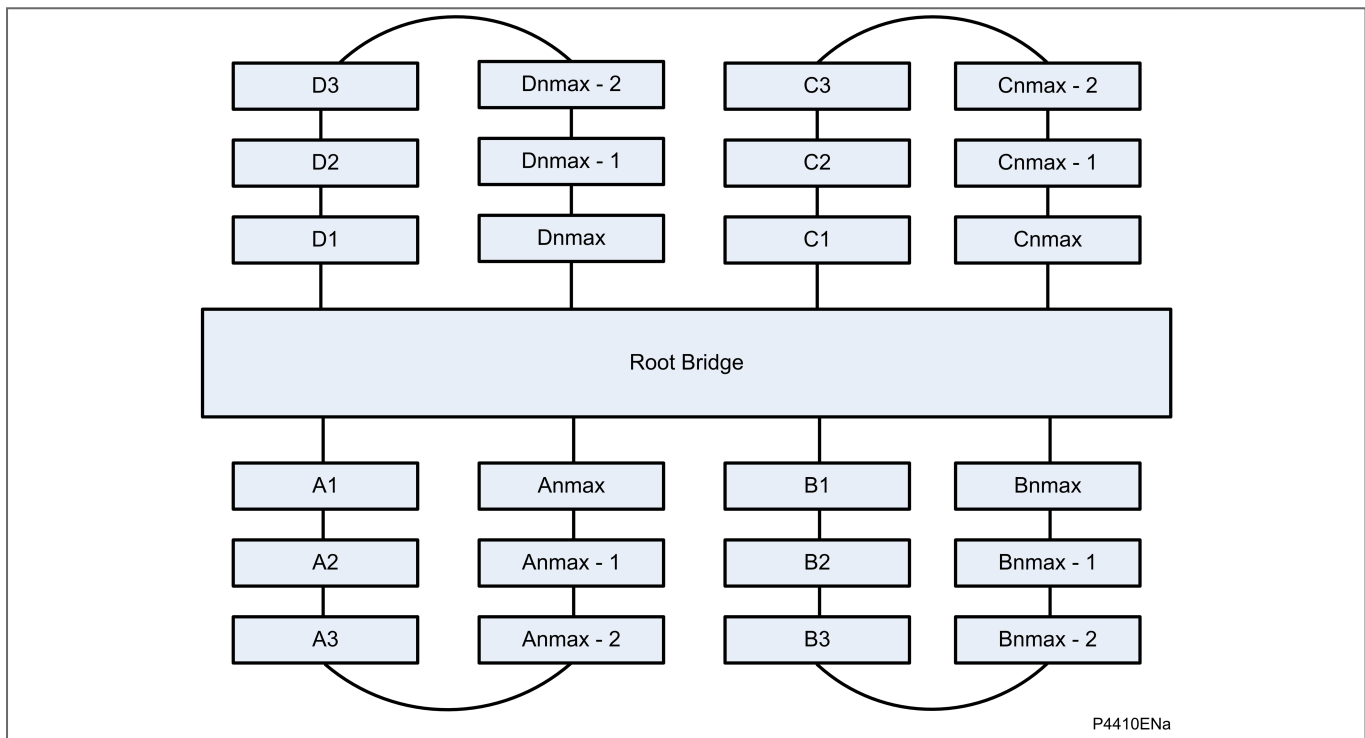

Figure 17 - Combined RSTP star and ring topology

6. TECHNICAL DATA

The redundant Ethernet board assures redundancy at IED level. It is fitted into the following MiCOM IEDs from Schneider Electric.

- P14x = P141, P142, P143, P145
- P34x = P341, P342, P343, P344, P345
- P44x = P442, P444
- P44y = P443, P446
- P445
- P54x = P543, P544, P545, P546
- P64x = P642, P643, P645
- P746
- P841
- P849

6.1 Board Hardware

6.1.1 100 Base TX Communications Interface

Cable type	Screened Twisted Pair (STP)
Connector type	RJ45
Maximum distance	100m
Full Duplex	100 Mbps

Table 8 - 100 Base TX interface

6.1.2 100 Base FX Communications Interface

Optical fiber cable	Multi-mode 50/125 μm or 62.5/125 μm
Center wavelength	1300 nm
Connector type	LC
Maximum distance	2 km
Full Duplex	100 Mbps

Table 9 - 100 Base FX interface

6.1.3 Transmitter Optical Characteristics

(TA = -40° C to 85° C)

Parameter	Sym	Min.	Typ.	Max.	Unit
Output Optical Power 62.5/125 μm , NA = 0.275 Fiber	PO	-20	-17.0	-14	dBm avg
Output Optical Power 50/125 μm , NA = 0.20 Fiber	PO	-23.5	-20.0	-14	dBm avg
Optical Extinction Ratio				10	dB
Output Optical Power at Logic "0" State	PO ("0")			-45	dBm avg

Table 10 - Tx optical characteristics

6.1.4 Receiver Optical Characteristics

(TA = -40° C to 85° C)

Parameter	Sym	Min.	Typ.	Max.	Unit
Input Optical Power	PIN	-31		-14	dBm avg

Table 11 - Rx optical characteristics

6.1.5 IRIG-B and Real-Time Clock

6.1.5.1 Performance

Year 2000: Compliant
 Real time accuracy: < ± 2 second / day
 External clock synchronisation: Conforms to IRIG standard 200-98, format B

6.1.5.2 Features

Real time 24 hour clock settable in hours, minutes and seconds
 Calendar settable from January 1994 to December 2092
 Clock and calendar maintained via battery after loss of auxiliary supply
 Internal clock synchronization using IRIG-B Interface for IRIG-B signal is BNC

6.1.5.3 Self-adapted Rear IRIG-B Interface (Modulated or Unmodulated)

BNC plug
 Isolation to SELV level.
 50 ohm coaxial cable.

6.2 Type Tests

6.2.1 Insulation

Per EN / IEC 60255-27:
 Insulation resistance > 100 M Ω at 500 Vdc
 (Using only electronic/brushless insulation tester).

6.2.2 Creepage Distances and Clearances

Per EN / IEC 60255-27:
 Pollution degree 2, Overvoltage category III,

6.2.3 High Voltage (Dielectric) Withstand

(EIA RS-232 ports excepted and normally-open contacts of output relays excepted).

(i) As for EN / IEC 60255-27:

2 kV rms AC, 1 minute:

Between all independent circuits.

Between independent circuits and case earth (ground).

1 kV rms AC for 1 minute, across open watchdog contacts.

1 kV rms AC for 1 minute, across open contacts of changeover output relays (not applicable for high break contacts due to electronics presence across the contact).

1 kV rms AC for 1 minute for all D-type EIA(RS)-232 or EIA(RS)-485 ports between the communications port terminals and protective (earth) conductor terminal.

1 kV rms AC for 1 minute between RJ45 ports and the case earth (ground).

1 kV rms AC for 1 minute between RJ45 ports and other independent circuits.

(ii) As for ANSI/IEEE C37.90:

1.5 kV rms AC for 1 minute, across open contacts of normally open output relays.

1 kV rms AC for 1 minute, across open watchdog contacts.

1 kV rms AC for 1 minute, across open contacts of changeover output relays (not applicable for high break contacts due to electronics presence across the contact).

6.2.4 Impulse Voltage Withstand Test

As for EN / IEC 60255-27:

(i) Front time: 1.2 μ s, Time to half-value: 50 μ s,

Peak value: 1.5kV, 0.5 J

Between RJ45 ports and the case earth (ground).

Between RJ45 ports and other independent circuits.

EIA(RS)-232 & EIA(RS)-485 ports and normally open contacts of output relays excepted.

(ii) Front time: 1.2 μ s, Time to half-value: 50 μ s,

Peak value: 5 kV, 0.5 J

Between all independent circuits.

Between independent circuits and case earth ground.

6.3 ElectroMagnetic Compatibility (EMC)

6.3.1 1 MHz Burst High Frequency Disturbance Test

As for EN / IEC 60255-22-1, Class III,

Common-mode test voltage: 2.5 kV,

Differential test voltage: 1.0 kV,

Test duration: 2 s,

Source impedance: 200 Ω

(EIA(RS)-232 ports excepted).

6.3.2 100 kHz and 1MHz Damped Oscillatory Test

EN / IEC 61000-4-18: Level 3

Common mode test voltage: 2.5 kV

Differential mode test voltage: 1 kV

6.3.3 Immunity to Electrostatic Discharge

As for EN / IEC 60255-22-2, EN / IEC 61000-4-2:

15kV discharge in air to user interface, display, communication ports and exposed metalwork.

6kV contact discharge to the screws on the front of the front communication ports.

8kV point contact discharge to any part of the front of the product.

6.3.4 Electrical Fast Transient or Burst Requirements

As for EN / IEC 60255-22-4, Class B:

\pm 4.0 kV, 5kHz and 100kHz applied to all inputs / outputs excluding communication ports

\pm 2.0 kV, 5kHz and 100kHz applied to all communication ports

As for EN / IEC 61000-4-4, severity level 4:

\pm 2.0 kV, 5kHz and 100kHz applied to all inputs / outputs and communication ports excluding power supply and earth.

\pm 4.0 kV, 5kHz and 100kHz applied to all power supply and earth port

Rise time of one pulse: 5 ns

Impulse duration (50% value): 50 ns

Burst duration: 15 ms or 0.75ms

Burst cycle: 300 ms

Source impedance: 50 Ω

6.3.5 Surge Withstand Capability

As for IEEE/ANSI C37.90.1:

4 kV fast transient and 2.5 kV oscillatory

applied directly across each output contact, optically isolated input, and power supply circuit.

6.3.6 Surge Immunity Test

As for EN / IEC 61000-4-5, EN / IEC 60255-26:

Time to half-value: 1.2 to 50 μ s,

Amplitude: 4 kV between all groups and case earth (ground),

Amplitude: 2 kV between terminals of each group.

Amplitude: 1kV for LAN ports

6.3.7 Conducted/Radiated Immunity

For RTDs used for tripping applications the conducted and radiated immunity performance is guaranteed only when using totally shielded RTD cables (twisted leads).

6.3.8 Immunity to Radiated Electromagnetic Energy

Per EN / IEC 61000-4-3 and EN / IEC 60255-22-3, Class 3

Test field strength, frequency band 80 to 1000 MHz and 1.4 GHz to 2.7GHz: 10 V/m,

Test using AM: 1 kHz / 80%

Spot tests at: 80, 160, 450, 900, 1850, 2150 MHz

Per IEEE/ANSI C37.90.2:

80MHz to 1000MHz, zero and 100% square wave modulated.

Field strength of 35V/m.

6.3.9 Radiated Immunity from Digital Communications

As for EN / IEC61000-4-3, Level 4:

Test field strength, frequency band 800 to 960 MHz,

and 1.4 to 2.0 GHz: 30 V/m, Test using AM: 1 kHz/80%.

6.3.10 Radiated Immunity from Digital Radio Telephones

As for EN / IEC 61000-4-3: 10 V/m, 900 MHz and 1.89 GHz.

6.3.11 Immunity to Conducted Disturbances Induced by Radio Frequency Fields

As for EN / IEC 61000-4-6, Level 3, Disturbing test voltage: 10 V.

6.3.12 Power Frequency Magnetic Field Immunity

As for EN / IEC 61000-4-8, Level 5,

100 A/m applied continuously, 1000 A/m applied for 3 s.

As for EN / IEC 61000-4-9, Level 5,

1000 A/m applied in all planes.

As for EN / IEC 61000-4-10, Level 5,

100 A/m applied in all planes at 100 kHz and 1 MHz with a burst duration of 2 s.

6.3.13 Conducted Emissions

As for CISPR 22 Class A:

Power supply:

0.15 - 0.5 MHz, 79 dB μ V (quasi peak) 66 dB μ V (average)

0.5 - 30 MHz, 73 dB μ V (quasi peak) 60 dB μ V (average)

Permanently connected communications ports:

0.15 - 0.5MHz, 97dB μ V (quasi peak) 84dB μ V (average)
 0.5 - 30MHz, 87dB μ V (quasi peak) 74dB μ V (average)

6.3.14 Radiated Emissions

As for CISPR 22 Class A:

30 to 230 MHz, 40 dB μ V/m at 10m measurement distance.

230 to 1 GHz, 47 dB μ V/m at 10 m measurement distance.

1 – 3GHz, 76dB μ V/m (peak), 56dB μ V/m (average) at 3m measurement distance.

3 – 5GHz, 80dB μ V/m (peak), 60dB μ V/m (average) at 3m measurement distance.

6.4 Environmental Conditions

6.4.1 Ambient Temperature Range

Per EN 60068-2-1 & EN / IEC 60068-2-2

Operating temperature range: -25°C to +55°C (or -13°F to +131°F)

Storage and transit: -25°C to +70°C (or -13°F to +158°F)

6.4.2 Ambient Humidity Range

Per EN / IEC 60068-2-78:

56 days at 93% relative humidity and +40 °C

Per EN / IEC 60068-2-14

5 cycles, -25°C to +55 °C

1°C / min rate of change

Per EN / IEC 60068-2-30

Damp heat cyclic, six (12 + 12) hour cycles, +25 to +55°C

6.4.3 Corrosive Environments

Per EN / IEC 60068-2-60, Part 2, Test Ke, Method (class) 3

Industrial corrosive environment/poor environmental control, mixed gas flow test.

21 days at 75% relative humidity and +30°C

Exposure to elevated concentrations of H₂S, (100 ppb), NO₂, (200 ppb) & Cl₂ (20 ppb).

Per EN / IEC 60068-2-52 Salt mist (7 days)

Per EN / IEC 60068-2-43 for H₂S (21 days), 15 ppm

Per EN / IEC 60068-2-42 for SO₂ (21 days), 25 ppm

6.5 EU Directives

6.5.1 EMC Compliance

As for 2004/108/EC:

Compliance to the European Commission Directive on EMC is demonstrated using a Technical File. Product Specific Standards were used to establish conformity:

EN 60255-26

6.5.2 Product Safety

Per 2006/95/EC:

Compliance to the European Commission Low Voltage Directive (LVD) is demonstrated using a Technical File. A product-specific standard was used to establish conformity.

 EN 60255-27

6.5.3 R&TTE Compliance

Radio and Telecommunications Terminal Equipment (R&TTE) directive 99/5/EC.
Compliance demonstrated by compliance to both the EMC directive and the Low voltage directive, down to zero volts.
Applicable to rear communications ports.
Compliance demonstrated by Notified Body certificates of compliance.

6.5.4 ATEX Compliance

ATEX is the Potentially Explosive Atmospheres directive 94/9/EC.
Compliance with Article 1 of European directive 2014/34/EU.

6.5.5 UKCA Compliance

UK Type Examination regulation of the equipment.
Compliance with Article 3 of the UK directive SI 2016 No.1107.
For other approvals such as UL/CUL/CSA, consult Schneider Electric.

6.6 Mechanical Robustness

6.6.1 Vibration Test

Per EN / IEC 60255-21-1
Response Class 2
Endurance Class 2

6.6.2 Shock and Bump

Per EN / IEC 60255-21-2
Shock response Class 2
Shock withstand Class 1
Bump Class 1

6.6.3 Seismic Test

Per EN / IEC 60255-21-3: Class 2

7. CORTEC

This is a generic Cortec to cover all IEDs using the **Redundant Ethernet** boards. It does not necessarily include all the possible options for all products in the MiCOM Px4x range. Likewise, it is possible that options shown in this list, may not be available for all products.

Note: IEC-60870-5-103, DNP3.0 and MODBUS are not supported in P74x.

Variants	Order Number	1	2	3	4	5	6	7	8	9	10	11	12	13	14	15
MiCOM Protection	P															
Application/Platform																
Feeder Management		1	4	*												
Motor Protection		2	4	*												
Generator Protection Relay		3	4	*												
Distance Protection Relay		4	4	*												
Current Differential		5	4	*												
Transformer		6	4	*												
Busbar		7	4	*												
Breaker Fail		8	4	*												
Vx Aux Rating:																
24 - 32 Vdc						9										
48 - 110 Vdc						2										
110 - 250 Vdc (100 - 240 Vac)						3										
In/Vn Rating (model dependent):																
Product Dependent							*									
Communications Options (model dependent):																
Standard - no options								1								
IRIG-B only (modulated)								2								
Fibre optic converter only								3								
IRIG-B (modulated) & fibre optic converte								4								
Ethernet with 100Mits/s fibre-optic port								6								
Second Rear Comms Port (Courier EIA232/EIA485/k-bus)								7								
Second Rear Comms Port + IRIG-B (modulated) (Courier EIA232/EIA485/k-bus)								8								
InterMiCOM + Courier Rear Port								E								
InterMiCOM + Courier Rear Port + IRIG-B modulated								F								
Redundant Ethernet RSTP, 2 multi-mode fibre ports + Modulated IRIG-B								J								
Redundant Ethernet RSTP, 2 multi-mode fibre ports + Unmodulated IRIG-B								K								
Redundant Ethernet (100Mbit/s) PRP or HSR or RSTP and Dual IP, 2 LC ports + 1 RJ45 port + Modulated/Un-modulated IRIG-B + 1588								Q								
Redundant Ethernet (100Mbit/s) PRP or HSR or RSTP and Dual IP, 3 RJ45 ports + Modulated/Un-modulated IRIG-B + 1588								R								
Ethernet (100Mbit/s), 1 RJ45 port + Modulated/Un-modulated IRIG-B + 1588								S								
Product Specific Options (model dependent):																

Variants	Order Number	1	2	3	4	5	6	7	8	9	10	11	12	13	14	15
MiCOM Protection	P															
Product Dependent									*							
Protocol Options:																
K-Bus/Courier										1						
Modbus										2						
IEC60870-5-103 (VDEW)										3						
DNP3.0										4						
IEC 61850 over Ethernet and Courier via rear K-Bus/RS485 OR IEC 61850 Edition 1 and Edition 2 and Courier via rear K-Bus/RS485										6						
IEC 61850 over ethernet with CS103 rear port RS485 protocol OR IEC 61850 Edition 1 and Edition 2 and CS103 via rear port RS485										7						
IEC 61850 Edition 1 / 2 and DNPoE and DNP3 Serial with simple password management - (CSL0)										B						
IEC 61850 Edition 1 / 2 and Courier via rear K-Bus/RS485 with advanced Cyber Security - CSL1 - Cybersecurity Admin Expert (CAE) required										G						
IEC 61850 Edition 1 / 2 and CS103 via rear port RS485 with advanced Cyber Security - CSL1 - Cybersecurity Admin Expert (CAE) required										H						
IEC 61850 Edition 1 / 2 and DNPoE and DNP3 Serial with advanced Cyber Security - CSL1 - Cybersecurity Admin Expert (CAE) required										L						
Mounting Options:																
Flush Panel Mounting											M					
Rack Mounting (80TE only)											N					
Language Options:																
English, French, German, Spanish											0					
English, French, German, Russian											5					
Chinese, English or French via HMI, with English or French only via Communications port C											C					
Software Version:																
													*	*		
Customisation:																
Default																8
Customer Specific																9
Design Suffix:																
Phase 3 CPU																L
Extended Phase 3 CPU																M

Table 12 - Cortec for Redundant Ethernet models

PARALLEL REDUNDANCY PROTOCOL (PRP) NOTES

CHAPTER 20

Applicability**Date:** 10/2022**Products covered by this chapter:**

This chapter covers the specific versions of the MiCOM products listed below. This includes **only** the following combinations of Software Version and Hardware Suffix.

Hardware Suffix:

P141/P142/P143	L or later
P145	M or later
P241	L or later
P242 / P243	M or later
P341	L or later
P342	L or later
P343 / P344 / P345	M or later
P391	A or later
P44x (P442 / P444)	M or later
P44y (P443/P446)	M or later
P445	L or later
P54x (P543 / P544 / P545 / P546)	M or later
P642	L or later
P643 / P645	M or later
P741 / P743	M or later
P742	L or later
P746	M or later
P841	M or later
P849	M or later

Software Version:

P14x (P141/P142/P143/P145)	B5 or later
P24x (P241 / P242 / P243)	D1 or later
P341	B3 / E3 or later
P342 / P343 / P344 / P345 / P391	B3 or later
P445	K1 or later
P44x (P442 / P444)	E3 or later
P44y (P443/P446)	K1 or later
P54x (P543/P544/P545/P546)	K1 or later
P64x (P642 / P643 / P645)	B4 or later
P74x (P741 / P742 / P743)	B1 or later
P746_1 / P746_2	B5 / C5 or later
P841A / P841B	L1 / K1 or later
P849	B2 or later

Connection Diagrams: This chapter list the connection diagram for the product:

P14x (P141, P142, P143 & P145):	10P141xx (xx = 01 to 02) 10P142xx (xx = 01 to 05) 10P143xx (xx = 01 to 11) 10P145xx (xx = 01 to 11)
P24x (P241, P242 & P243):	10P241xx (xx = 01 to 02) 10P242xx (xx = 01) 10P243xx (xx = 01)
P34x (P342, P343, P344, P345 & P391)	10P342xx (xx = 01 to 17) 10P343xx (xx = 01 to 19) 10P344xx (xx = 01 to 12) 10P345xx (xx = 01 to 07) 10P391xx (xx = 01 to 02)
P445:	10P445xx (xx = 01 to 04)
P44x (P442 & P444):	10P44201 (SH 1 & 2) 10P44202 (SH 1) 10P44203 (SH 1 & 2) 10P44401 (SH 1) 10P44402 (SH 1) 10P44403 (SH 1 & 2) 10P44404 (SH 1) 10P44405 (SH 1) 10P44407 (SH 1 & 2)
P44y:	10P44303 (SH 01 and 03) 10P44304 (SH 01 and 03) 10P44305 (SH 01 and 03) 10P44306 (SH 01 and 03) 10P44600 10P44601 (SH 1 to 2) 10P44602 (SH 1 to 2) 10P44603 (SH 1 to 2)
P54x (P543, P544, P545 & P546):	10P54302 (SH 1 to 2) 10P54303 (SH 1 to 2) 10P54304 (SH 1 to 2) 10P54400 10P54404 (SH 1 to 2) 10P54405 (SH 1 to 2) 10P54502 (SH 1 to 2) 10P54503 (SH 1 to 2) 10P54504 (SH 1 to 2) 10P54600 10P54604 (SH 1 to 2) 10P54605 (SH 1 to 2) 10P54606 (SH 1 to 2)
P547:	10P54702xx (xx = 01 to 02) 10P54703xx (xx = 01 to 02) 10P54704xx (xx = 01 to 02) 10P54705xx (xx = 01 to 02)
P64x (P642, P643 & P645):	10P642xx (xx = 1 to 10) 10P643xx (xx = 1 to 6) 10P645xx (xx = 1 to 9)
P74x:	10P740xx (xx = 01 to 07)

P746:	10P746xx (xx = 00 to 21)
P841:	10P84100 10P84101 (SH 1 to 2) 10P84102 (SH 1 to 2) 10P84103 (SH 1 to 2) 10P84104 (SH 1 to 2) 10P84105 (SH 1 to 2)
P849:	10P849xx (xx = 01 to 06)

CONTENTS

1. Parallel Redundancy Protocol (PRP) Notes	7
1.1 Introduction to PRP.....	7
1.2 Protocols.....	7
1.3 PRP Summary (IEC 62439-3 Clause 4).....	7
1.4 Example of a PRP Network.....	7
1.5 PRP Network Structure.....	8
1.6 Structure of a DAN.....	9
1.7 Communication between SANs and DANs.....	10
1.8 PRP Technical Data.....	12
2. PRP and MiCOM Functions	13
2.1 MiCOM Products and PRP.....	13
2.2 Easergy Studio and the PRP Function.....	13
2.3 MiCOM Relay Configuration and the PRP Function.....	13
2.4 Hardware Changes for PRP Protocol.....	13
2.5 PRP Parameters.....	14
2.6 Product Implementation Features.....	14
2.7 Abbreviations and Acronyms.....	15

TABLES

Table 1 - Hardware option numbers for PRP options.....	13
Table 2 - PRP parameter values (for PRP Protocol Version 1).....	14

FIGURES

Figure 1 - PRP Redundancy Network.....	8
Figure 2 - PRP example of general redundant network.....	9
Figure 3 - Communication between two DANs (in PRP).....	10
Figure 4 - Frames (basic, extended by an RCT and a VLAN tagged frame extended by RCT).....	12

Notes:

1. PARALLEL REDUNDANCY PROTOCOL (PRP) NOTES

1.1 Introduction to PRP

This section gives an introduction to the Parallel Redundancy Protocol (PRP); and how it is implemented on MiCOM-based products manufactured by Schneider Electric.

1.2 Protocols

Industrial real-time Ethernets typically need much better levels of availability and uninterrupted operation than normal office-type Ethernet solutions. For power networks, even a short loss of connectivity may result in a significant loss of functionality or impaired safety. To recover from a network failure, various redundancy schemes have been considered, including Parallel Redundancy Protocol (**PRP**). The key properties of this protocol are as follows:

PRP

This does not change the active topology as it uses two independent networks. Each message is replicated and sent over both networks. The first network node to receive it acts on it, with all later copies of the message being discarded. Importantly, these details are controlled by the low-level PRP layer of the network architecture, with the two networks being hidden from the higher level layers. Consequently, PRP-based networks are continuously available.

Power networks need to be able to respond to problems very quickly (typically in less than 10ms), and this is an available protocol which is robust enough to achieve this. This protocol is used in the MiCOM relay/IED and is defined in the IEC62439-3 (2016) standard and is configured using the existing redundant Ethernet card(s).

1.3 PRP Summary (IEC 62439-3 Clause 4)

A summary of the main PRP features is given below:

- Ethernet redundancy method independent of any industrial Ethernet protocol and typically used in a ring topology
 - Seamless switchover and recovery in case of failure, which supports real-time communication
 - Supervises redundancy continuously for better management of network devices
 - Suitable for hot swap, 24 hour/365 day operation in substations
 - Allows laptops and workstations to be connected to the network with standard Ethernet adapters (on double or single attached nodes)
 - Particularly suited for substation automation, high-speed drives and transportation
-

1.4 Example of a PRP Network

Essentially a PRP network is a pair of similar Local Area Networks (LANs) which can be any topology (tree, ring or mesh). An example of a PRP network is shown in this diagram:

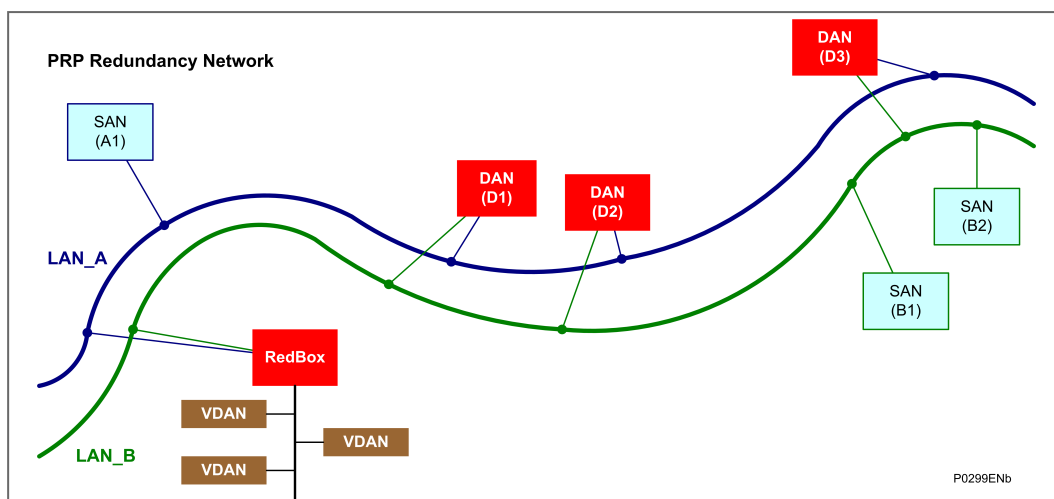

Figure 1 - PRP Redundancy Network

This shows two similar Local Area Networks (LANs) which have various Nodes in common. The key features of these networks include:

- With the exception of a RedBox (see below), no direct cable connections can be made between the two LANs.
- Each of these LANs can have one or more Single Attached Nodes (SANs). These are normally non-critical devices that are attached only to a single network. SANs can talk to one another, but only if they are on the same LAN.
- Matched pairs of devices which are critical to the operation of the overall scheme are connected one to each network as Doubly Attached Nodes (DANs).
- To be sure that network messages (also known as frames) are transferred correctly to each DAN, each DAN must have the same Media Access Control (MAC) code and Internet Protocol (IP) address. This will also mean that TCP/IP traffic will automatically communicate with both of the paired devices, so it will be unaware of any two-layer redundancy or frame duplication issues.
- A Redundancy Box (RedBox) is used when a single interface node has to be connected to both networks. The RedBox can talk to all other nodes. So far as other nodes are concerned, the RedBox behaves like a DAN, so a SAN that is connected through a RedBox is also called a Virtual Doubly Attached Node (VDAN). The RedBox must have its own unique IP address.
- Transmission delays can be different between related Nodes of the two LANs.
- Each LAN (i.e. LAN_A and LAN_B) must be powered from a different power source and must be failure independent.

The two LANs can differ in terms of performance and topology. The redundant Ethernet interface can be made using an optical fiber connection with an LC or ST connector type or with RJ45 copper connector type. There is no need for an optical interface away from the relay.

1.5 PRP Network Structure

PRP uses two independent LANs. The topology of each of these LANs is arbitrary, and ring, star, bus and meshed topologies are possible.

The main advantage of PRP is loss-free data transmission with an active (transit) LAN. When the terminal device receives no packets from one of the LANs, the second (transit) LAN maintains the connection. As long as 1 (transit) LAN is available, repairs and maintenance on the other (transit) LAN have no impact on the data packet transmission.

The elementary devices of a PRP network are known as RedBox (Redundancy Box) and DANP (Double Attached Node implementing PRP).

Both devices have one connection each to the (transit) LANs.

The devices in the (transit) LAN are conventional switches that do not require any PRP support. The devices transmit PRP data packets transparently, without evaluating the RCT information.

Terminal devices that are connected directly to a device in the (transit) LAN are known as SAN (Single Attached Node). If there is an interruption, these terminal devices cannot be reached via the redundant line. To use the uninterruptible redundancy of the PRP network, you integrate your device into the PRP network via a RedBox.

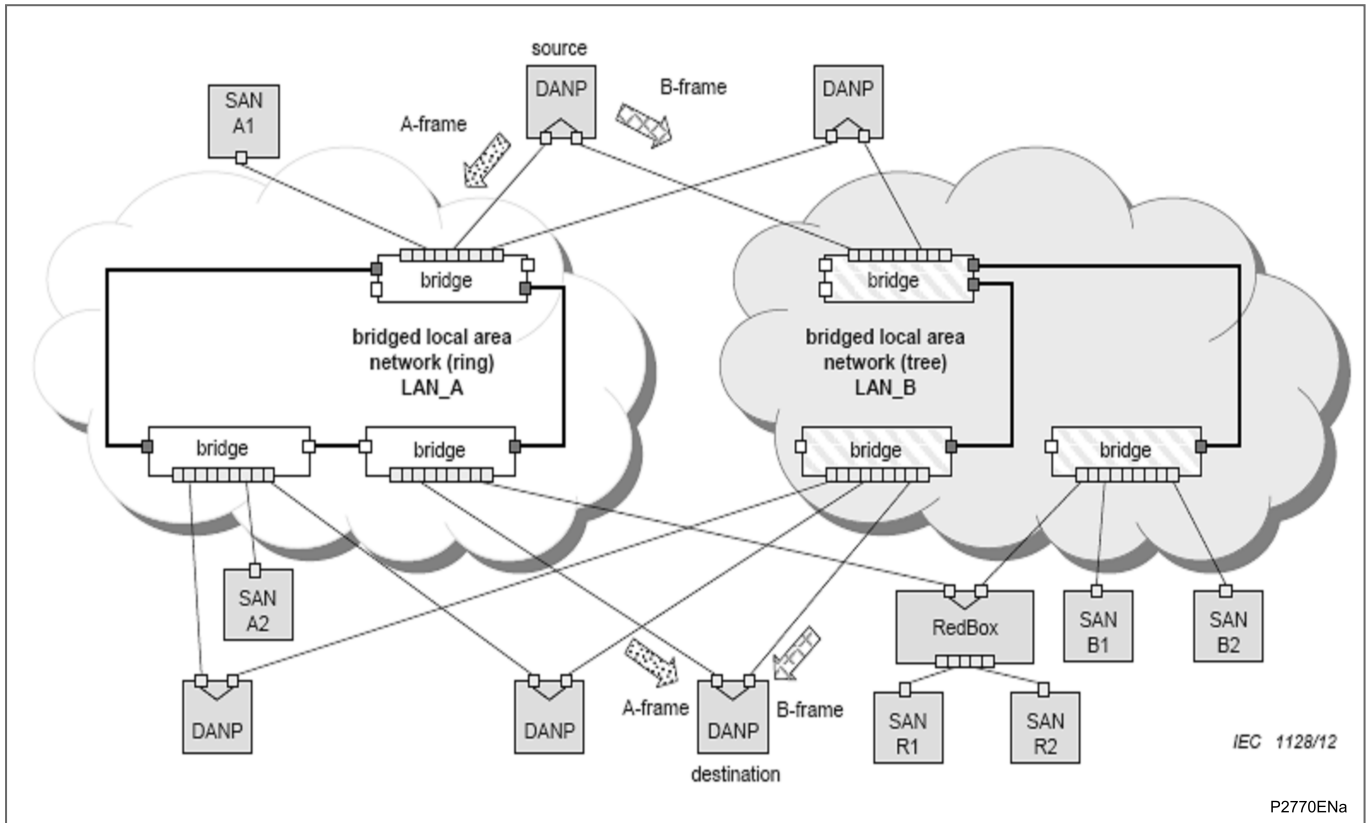

Figure 2 - PRP example of general redundant network

1.6 Structure of a DAN

A MiCOM P40 relay working in PRP Mode works as a DAN within the overall network topology. Each DAN has two ports that operate in parallel. They are attached to the upper layers of the communications stack through the Link Redundancy Entity (LRE) as shown here:

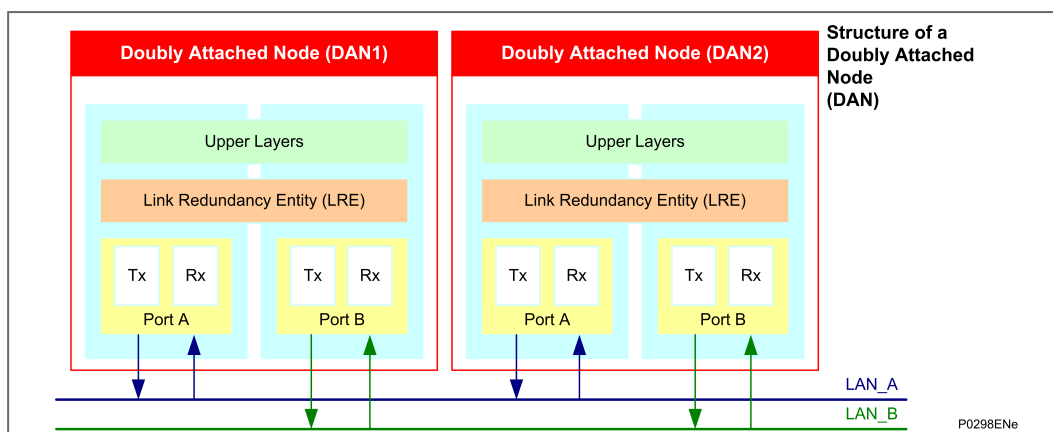

Figure 3 - Communication between two DANs (in PRP)

The LRE has two main tasks:

- handling message frames and
- management of redundancy

When an upper layer sends a frame to the LRE, the LRE replicates the frame and sends it through both its ports at nearly the same time. The two frames move through the two LANs with slightly different delays, ideally arriving at the destination node within a small time window.

When receiving frames, the LRE forwards the first frame it received to its upper layers and then discards the duplicate.

As both DAN nodes have the same MAC and IP addresses, this makes redundancy transparent to the upper layers. This allows the Address Resolution Protocol (ARP) to work in the same way as with a SAN. Accordingly, to the upper layers of a DAN, the LRE layer shows the same interface as the network adapter of a non-redundant adapter.

To manage redundancy, the LRE:

- Adds a 32-bit Redundancy Check Tag (RCT) to each frame it sends and
- Removes the RCT from each frame it receives

1.7 Communication between SANs and DANs

A SAN can be connected to any LAN and can communicate with any other SAN on the same LAN or any DAN. However, a SAN which connected to one LAN can not communicate directly to a SAN which is connected to the other LAN.

A DAN is connected to both LANs and can communicate with any RedBox or any other DANs or any SANs on either network. For communication purposes, a DAN “views” a SAN connected through a RedBox as a VDAN.

When a SAN generates a basic frame, it sends the frame only onto the LAN to which it is connected.

Originating at the SAN, a typical frame contains these parameters:

- dest_addr = Destination Address
- src_addr = Source Address
- type = Type
- data
- fcs = Frame Check Sequence (i.e. extra checksum characters added to allow error detection and correction)

The frame from the SAN is then received by the DAN; which sends the frame to its upper layers, which act accordingly.

When a DAN generates a frame, it needs to send the frame onto both of the LANs to which it is connected. When it does this, it extends the frame by adding the 48-bit Redundancy Control Trailer (RCT) into the frame.

The RCT consists of these parameters:

- 16-bit Sequence Number
- 4-bit LAN identifier, 1010 (0xA) for LAN_A and 1011 (0xB) for LAN_B
- 12-bit frame size
- PRP suffix

Note

The Sequence number is a measure of the number of messages which have been sent since the last system reset. Each time the link layer sends a frame to a particular destination the sender increases the sequence number corresponding to that destination and sends the (nearly) identical frames over both LANs.

Accordingly, originating at the DAN, a typical frame then contains these parameters:

- dest_addr = Destination Address
- src_addr = Source Address
- type = Type
- lsd_u = Link Service Data Unit
- Padding = if needed
- RCT data:
 - 16-bit sequence number:
 - 4-bit LAN identifier
 - 12-bit frame size
 - 16-bit PRP suffix (0X88 0XFB)
- fcs Frame Check Sequence

LSDU

The Link Service Data Unit (LSDU) data allows PRP frames to be distinguished from none-PRP frames.

Padding

After the LSDU data, there may be some data padding. This is added to frames which would otherwise be too short for conventional network traffic (minimum frame size is 64 octets).

Size

The frame size will vary depending on the contents of the frame and how it has been tagged by the various SANs and DANs. In VLANs, frame tags may be added or removed during transit through a switch. To make the length field independent of tagging, only the LSDU and the RCT are considered in the size.

The following diagrams shows the frame types with different types of data.

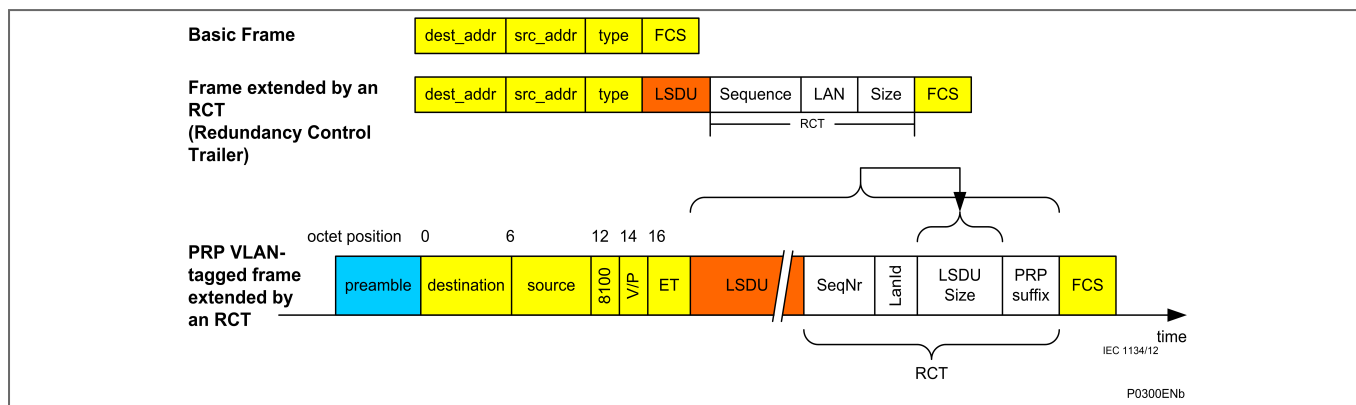

Figure 4 - Frames (basic, extended by an RCT and a VLAN tagged frame extended by RCT)

The key points about these differing frame structures is that:

- SANs do not implement any redundancy features, so they generate basic frames which SANs and DANs can understand.
- SANs can still understand the frames that come from DANs, as SANs ignore the RCT components in frames which come from DANs (a SAN cannot distinguish the RCT from the IEEE802.3 padding)
- If a DAN receives a frame which does not include the RCT component, it sends a single copy of the frame to its upper layers.
- If a DAN receives a frame which does include the RCT component, it does not send a duplicate copy of the frame to its upper layers.
- If a DANP cannot identify that the remote Node is a DAN, it inserts no RCT.

When using a Single Attached Nodes connected to the IED, a redbox is suggested to handle the case when the TPDU size for the client has been set above than 1024.

1.8 PRP Technical Data

- One VLAN tag supported
- Up to 128 devices supported
- Up to 100Mbit/s full duplex Ethernet
- Dynamic frame memory allocation (page manager)
- Configurable duplicate detection
- Wishbone interface for configuration and status registers
- CPU port interface - Ethernet or Wishbone
- Support for link-local protocols - CPU may send to specific ports only - CPU knows receive port
- Configurable frame memory and queue length
- Duplicate detection with configurable size and aging time
- MAC address filtering (8 filter masks for interlink port, 6 for CPU port)
- Support for interfaces with or without Ethernet preamble

Maximum Transmission Unit

According to the IEC 8802-3, the MTU (Ethernet maximum packet size) is:

- 1518 bytes without VLAN and without PRP
- 1522 bytes with VLAN and without PRP
- 1524 bytes without VLAN and with PRP
- 1528 bytes with VLAN and with PRP

Note

Check that the LAN switches setting for the MTU is at least 1528 bytes

2. PRP AND MICOM FUNCTIONS

2.1 MiCOM Products and PRP

The PRP functions being introduced as part of the overall MiCOM product range provide additional functionality, which is backwards compatible with existing Schneider Electric MiCOM equipment. This means that existing MiCOM relays/IEDs can be used on networks, which use PRP functions, with no changes being made to those relays/IEDs.

The new MiCOM products that use the PRP, will interrogate other equipment to determine the equipment model number, and then use the model number to decide (at runtime), whether that particular item of equipment can support PRP or not.

MiCOM models which include the following Ethernet board assembly provide the possibility of PRP function support. This is denoted by Digit 7 where the Hardware option is N, P, Q or R, as shown below:

Hardware Option	Type	Model No format
“N” at Digit No 7	2 ST ports redundant Ethernet board (Modulated IRIG-B)	Px4xxxNx6Mxxx8M
“P” at Digit No 7	2 ST ports redundant Ethernet board (Un-modulated IRIG-B)	Px4xxxPx6Mxxx8M
“Q” at Digit No 7	2 LC + 1 RJ45 ports redundant Ethernet board (Modulated/Un-modulated IRIG-B)	Px4xxxQx6Mxxx8M
“R” at Digit No 7	3 RJ45 ports redundant Ethernet board (Modulated/Un-modulated IRIG-B)	Px4xxxRx6Mxxx8M

Table 1 - Hardware option numbers for PRP options

The MiCOM relay/IED firmware has been modified to allow the PRP options to be accepted for the power-up tests in addition to the implementation of the supervision frame transmission.

2.2 Easergy Studio and the PRP Function

The addition of this function has no impact of the Easergy Studio support files so there is no need to upgrade any Easergy Studio software.

2.3 MiCOM Relay Configuration and the PRP Function

There is no need to change the configuration of any relay (as relays which include support for this function will be able to recognize other devices which support it).

2.4 Hardware Changes for PRP Protocol

This protocol is implemented using the existing redundant Ethernet and dual redundant Ethernet card as a starting point. The Frame management is achieved by re-programming the Field-Programmable Gate Array (FPGA).

The low-level management of the redundant frames is performed within the FPGA; this being defined as the Link Redundancy Entity (LRE). This will involve the addition of the Redundancy Check Tag (RCT) to a frame to be transmitted; this identifies the LAN and the sequence number of the message over the two networks. The FPGA is also responsible for the stripping of the RCT from received frames and discarding the duplicated messages such that only a single application frame is received by the Ethernet processor.

The LRE functionality of the supervision frame transmission is performed by the Ethernet processor card.

2.5 PRP Parameters

The Redundant Ethernet standard (IEC 62439-3:2012/FDIS) defines several parameters for the PRP protocol; these being fixed at a default value within this release. The following values are set:

Parameter	Value	Description
Supervision Frame Multicast Address	01-15-4E-00-01-00	Target MAC Address for multicast supervision frame.
Life Check Interval	2 seconds	Period between transmission of supervision frames.
PRP Mode	Duplicate Discard	This is normal PRP mode, Duplicate address will not be supported.
Node Forget Time	60 s	This is the time after which a node entry is cleared.
Entry Forget Time	400 ms	Duration that the received message Sequence number will be held to discard a duplicate message.
Node Reboot Interval	500ms	Duration following reboot for which no PRP frames should be transmitted

Table 2 - PRP parameter values (for PRP Protocol Version 1)

2.6 Product Implementation Features

Here is a list of the main Product Requirements for MiCOM products which support PRP:

- The MiCOM relay/IED provides two redundant Ethernet ports using PRP.
- The MiCOM relay/IED must be connected to the redundant Ethernet network as a Double Attached Node (DAN) using PRP (DAN using PRP is known as DANP)
- The redundant Ethernet interface can be made using an RJ45 or an optical fibre connection with an LC or ST connector type (Ethernet card dependent).
- The management of the PRP redundancy is transparent to the application data provided via the Ethernet interface.
- The PRP option is available with any of the existing protocol options via the Ethernet Interface (IEC61850 and/or DNPoE)
- Loss of one of the LAN connections to the device does not cause any loss or degradation to the Application data over the Ethernet interface.
- The MiCOM relay/IED supports the transmission of the PRP Supervision frame at a fixed time period (LifeCheckInterval) of 2s (+/- 100ms)
- Each supervision frame includes a sequence number as defined in the IEC 62439-3:2012 specification. This is incremented for each supervision message and the value starts from zero following a system restart.
- The MiCOM relay/IED does not process received supervision frames to provide supervision of the redundant network.
- The MiCOM relay/IED does not provide for the PRP management to be configured (via either the MiCOM relay/IED HMI or the Ethernet interface). Accordingly, the default values (as defined within this document) are used for all PRP parameters.
- The performance of the Ethernet Interface is not degraded by using the PRP interface.

2.7 Abbreviations and Acronyms

Abbreviations / Acronyms	Meaning
BPDU	Bridge Protocol Data Unit
CRC	Cyclic Redundancy Check
DAN	Doubly Attached Nodes
DANH	Doubly Attached Node implementing HSR
DANP	Doubly Attached Node implementing PRP
FPGA	Field-Programmable Gate Array
HMI	Human Machine Interface
HSR	High-availability Seamless Redundancy
IED	Intelligent Electronic Devices
IP	Internet Protocol
LAN	Local Area Network
LRE	Link Redundancy Entity
MAC	Media Access Control
MRP	Media Redundancy Protocol
PRP	Parallel Redundancy Protocol
RCT	Redundancy Check Tag
RedBox	Redundancy Box
RST BPDU	Rapid Spanning Tree BPDU
RSTP	Rapid Spanning Tree Protocol
SAN	Singly Attached Node
TCP	Transmission Control Protocol
VDAN	Virtual Doubly Attached Node

Notes:

HIGH-AVAILABILITY SEAMLESS REDUNDANCY (HSR) NOTES

CHAPTER 21

Applicability**Date:** 10/2022**Products covered by this chapter:**

This chapter covers the specific versions of the MiCOM products listed below. This includes **only** the following combinations of Software Version and Hardware Suffix.

Hardware Suffix:

P141/P142/P143	L or later
P145	M or later
P241	L or later
P242 / P243	M or later
P341	L or later
P342	L or later
P343 / P344 / P345	M or later
P391	A or later
P44x (P442 / P444)	M or later
P44y (P443/P446)	M or later
P445	L or later
P54x (P543 / P544 / P545 / P546)	M or later
P642	L or later
P643 / P645	M or later
P741 / P743	M or later
P742	L or later
P746	M or later
P841	M or later
P849	M or later

Software Version:

P14x (P141/P142/P143/P145)	B5 or later
P24x (P241 / P242 / P243)	D1 or later
P341	B3 / E3 or later
P342 / P343 / P344 / P345 / P391	B3 or later
P445	K1 or later
P44x (P442 / P444)	E3 or later
P44y (P443/P446)	K1 or later
P54x (P543/P544/P545/P546)	K1 or later
P64x (P642 / P643 / P645)	B4 or later
P74x (P741 / P742 / P743)	B1 or later
P746_1 / P746_2	B5 / C5 or later
P841A / P841B	L1 / K1 or later
P849	B2 or later

Connection Diagrams: This chapter list the connection diagram for the product:

P14x (P141, P142, P143 & P145):	10P141xx (xx = 01 to 02) 10P142xx (xx = 01 to 05) 10P143xx (xx = 01 to 11) 10P145xx (xx = 01 to 11)
P24x (P241, P242 & P243):	10P241xx (xx = 01 to 02) 10P242xx (xx = 01) 10P243xx (xx = 01)
P34x (P342, P343, P344, P345 & P391)	10P342xx (xx = 01 to 17) 10P343xx (xx = 01 to 19) 10P344xx (xx = 01 to 12) 10P345xx (xx = 01 to 07) 10P391xx (xx = 01 to 02)
P445:	10P445xx (xx = 01 to 04)
P44x (P442 & P444):	10P44201 (SH 1 & 2) 10P44202 (SH 1) 10P44203 (SH 1 & 2) 10P44401 (SH 1) 10P44402 (SH 1) 10P44403 (SH 1 & 2) 10P44404 (SH 1) 10P44405 (SH 1) 10P44407 (SH 1 & 2)
P44y:	10P44303 (SH 01 and 03) 10P44304 (SH 01 and 03) 10P44305 (SH 01 and 03) 10P44306 (SH 01 and 03) 10P44600 10P44601 (SH 1 to 2) 10P44602 (SH 1 to 2) 10P44603 (SH 1 to 2)
P54x (P543, P544, P545 & P546):	10P54302 (SH 1 to 2) 10P54303 (SH 1 to 2) 10P54304 (SH 1 to 2) 10P54400 10P54404 (SH 1 to 2) 10P54405 (SH 1 to 2) 10P54502 (SH 1 to 2) 10P54503 (SH 1 to 2) 10P54504 (SH 1 to 2) 10P54600 10P54604 (SH 1 to 2) 10P54605 (SH 1 to 2) 10P54606 (SH 1 to 2)
P547:	10P54702xx (xx = 01 to 02) 10P54703xx (xx = 01 to 02) 10P54704xx (xx = 01 to 02) 10P54705xx (xx = 01 to 02)
P64x (P642, P643 & P645):	10P642xx (xx = 1 to 10) 10P643xx (xx = 1 to 6) 10P645xx (xx = 1 to 9)
P74x:	10P740xx (xx = 01 to 07)

P746:	10P746xx (xx = 00 to 21)
P841:	10P84100 10P84101 (SH 1 to 2) 10P84102 (SH 1 to 2) 10P84103 (SH 1 to 2) 10P84104 (SH 1 to 2) 10P84105 (SH 1 to 2)
P849:	10P849xx (xx = 01 to 06)

CONTENTS

1. Introduction to HSR	7
1.1 Introduction to High-Availability Seamless Redundancy (HSR)	7
1.2 Protocols	7
1.3 HSR Summary (IEC 62439-3 Clause 5)	7
1.4 Example of an HSR Network	7
1.5 Structure of a DAN	8
1.6 Structure of a RedBox	9
1.7 Communication between SANs, DANs and RedBoxes	9
1.8 HSR Technical Data	11
2. HSR and MiCOM Functions	13
2.1 MiCOM Products and HSR	13
2.2 Easergy Studio and the HSR Function	13
2.3 MiCOM Relay Configuration and the HSR Function	13
2.4 Hardware Changes for HSR Protocol	13
2.5 HSR Parameters	13
2.6 Product Implementation Features	14
2.7 Abbreviations and Acronyms	14

TABLES

Table 1 - Hardware option numbers with HSR functions	13
Table 2 - HSR parameter values.....	14

FIGURES

Figure 1 - HSR Redundancy Network.....	8
Figure 2 - DAN communication between two paths (in HSR).....	9
Figure 3 - HSR frame without a VLAN tag.....	11
Figure 4 - HSR frame with VLAN tag.....	11

Notes:

1. INTRODUCTION TO HSR

1.1 Introduction to High-Availability Seamless Redundancy (HSR)

This section gives an introduction to the High-availability Seamless Redundancy (HSR); and how it is implemented on MiCOM-based products manufactured by Schneider Electric.

1.2 Protocols

Industrial real-time Ethernets typically need much better levels of availability and uninterrupted operation than normal office-type Ethernet solutions. For power networks, even a short loss of connectivity may result in a significant loss of functionality or impaired safety. To recover from a network failure, various redundancy schemes have been considered, including High-availability Seamless Redundancy (**HSR**). The key properties of this protocol are as follows:

HSR

HSR basically uses ring topology, This Clause describes the application of the HSR principles (Clause 5) to implement a High-availability Seamless Redundancy (HSR), retaining the PRP property of zero recovery time, applicable to any topology, in particular rings and rings of rings. With respect to PRP, HSR allows to roughly halve the network infrastructure. With respect to rings based on IEEE 802.1D (RSTP), IEC 62439-2 (MRP), IEC 62439-6 (DRP) or IEC 62439-7 (RRP), the available network bandwidth for network traffic is somewhat reduced depending on the type of traffic. Nodes within the ring are restricted to be HSR-capable bridging nodes, thus avoiding the use of dedicated bridges. Singly Attached Nodes (SANs) such as laptops or printers cannot be attached directly to the ring, but need attachment through a RedBox (redundancy box).

Power networks need to be able to respond to problems very quickly (typically in less than 10ms), and this is an available protocol which is robust enough to achieve this. This protocol is used in the MiCOM relay/IED and is defined in the IEC62439-3 (2016) standard and is configured using the existing redundant Ethernet card(s).

1.3 HSR Summary (IEC 62439-3 Clause 5)

A summary of the main HSR features is given below:

- HSR Ethernet redundancy method independent of any industrial Ethernet protocol and typically used in a ring topology
 - Seamless switchover and recovery in case of failure, which supports real-time communication
 - Supervises redundancy continuously for better management of network devices
 - Suitable for hot swap, 24 hour/365 day operation in substations
 - Allows laptops and workstations to be connected to the network with HSR Redbox
 - Particularly suited for substation automation, high-speed drives and transportation
-

1.4 Example of an HSR Network

Essentially an HSR network is a ring topology. An example of an HSR network is shown in this diagram. This shows typical ring networks that have various Nodes in common.

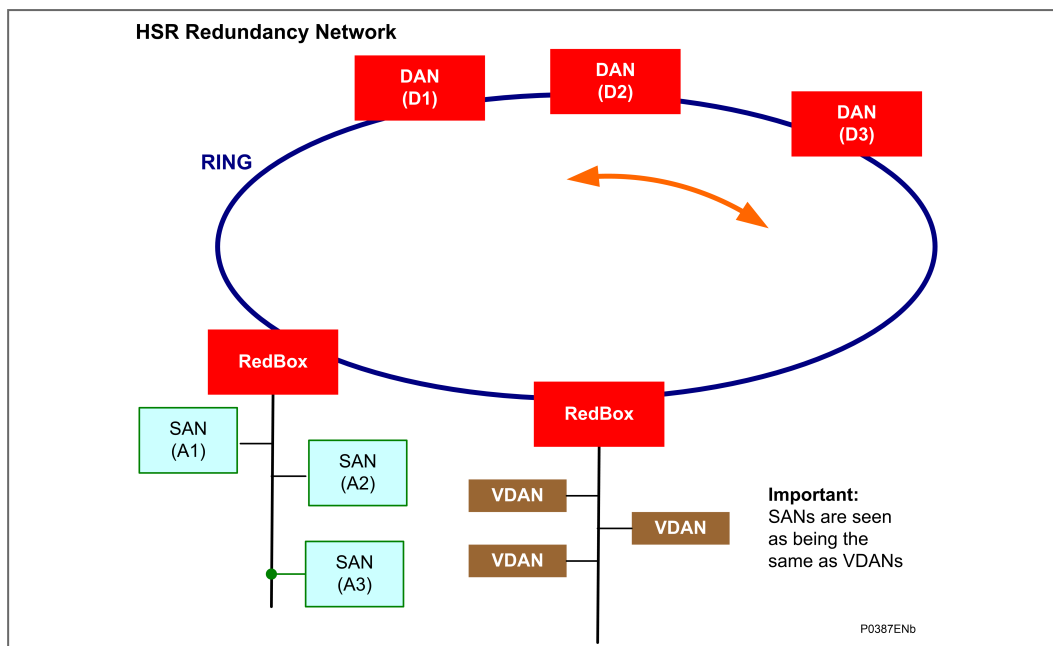

Figure 1 - HSR Redundancy Network

The key features of the network include:

- Nodes within the ring are restricted to be HSR-capable bridging nodes, thus avoiding the use of dedicated bridges
- Singly Attached Nodes (SANs) such as laptops or printers cannot be attached directly to the ring, but need attachment through a RedBox (redundancy box)
- A simple HSR network consists of doubly attached bridging nodes, each having two ports, interconnected by full-duplex link
- A source DANH sends a frame passed from its upper layers, prefixes it by an HSR tag to identify frame duplicates and sends the frame over each port
- A destination DANH receives, in the fault-free state, two identical frames from each port within a certain interval, if it is a multicast frame, it instantaneously forwards it on the ring (see Note *), removes the HSR tag of the first frame before passing it to its upper layers and discards any duplicate.

Note *

In particular, the node will not forward a frame that it injected into the ring.

Note *

A destination node of a unicast frame does not forward a frame for which it is the only destination, except for testing.

1.5 Structure of a DAN

A MiCOM P40 relay working in HSR Mode works as a DAN within the overall network topology. Each DAN has two ports that operate in parallel. As in the next diagram, the two HSR ports A and B and the device port C are connected by the LRE, which includes a switching matrix allowing to forward frames from one port to the other. The switching matrix allows cut-through bridging. The Link Redundancy Entity (LRE) presents to the higher layers the same interface as a standard Ethernet transceiver would do.

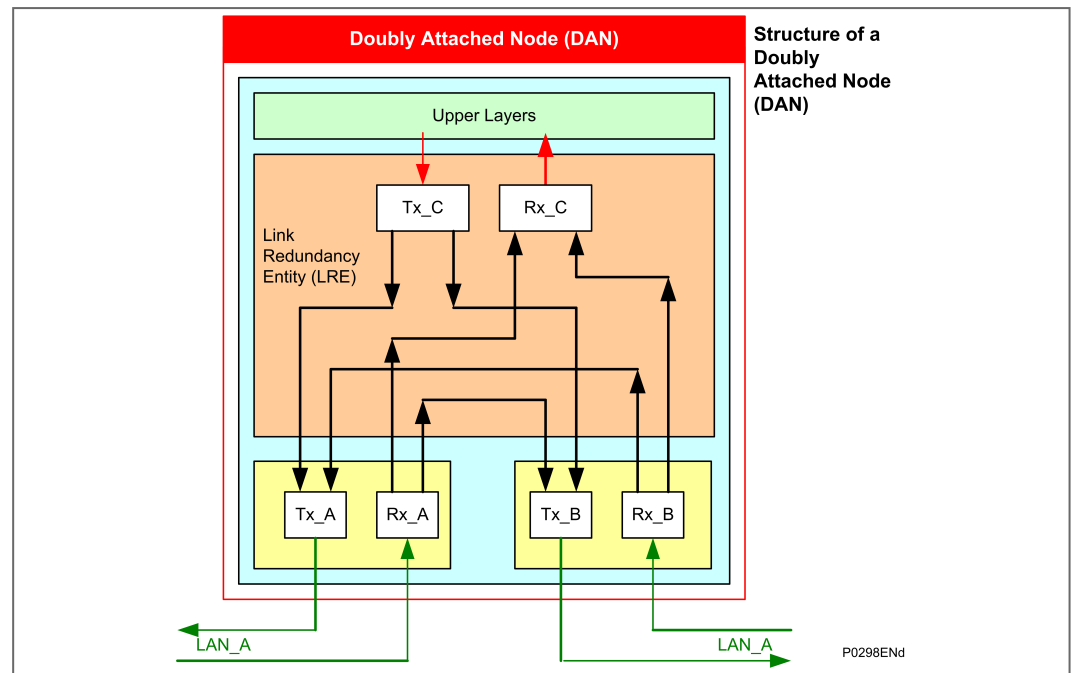

Figure 2 - DAN communication between two paths (in HSR)

DAN node is operable in HSR-tagged forwarding mode, the DAN inserts the HSR tag on behalf of its host and forwards the ring traffic, except for frames sent by the node itself. Duplicate frames and frames where the node is the unicast destination is not forwarded.

1.6 Structure of a RedBox

The RedBox has a LRE that performs the duties of the HSR protocol, in particular:

- forwards the frames received from one HSR port to the other HSR port, unless the frame receives frames addressed to its own upper protocols
- prefixes the frames sent by its own upper layers with the corresponding HSR tag before sending two copies over its HSR ports

The switching logic is incorporated into the RedBox, so interlink becomes an internal connection.

A simple RedBox is present in every node, since the LRE makes a transition to a single non-HSR host. In addition, it is usual to have more than one host in a node, since a port for maintenance often exists.

A node does not send over a port a frame that is a duplicate of a frame previously sent over that port in that same direction.

For the purpose of Duplicate Discard, a frame is identified by:

- its source MAC address;
- its sequence number.

The Duplicate Discard method forgets an entry identified by <Source MAC Address><Sequence number> after a time EntryForgetTime.

1.7 Communication between SANs, DANs and RedBoxes

Singly Attached Nodes (SANs), for instance maintenance laptops or printers cannot be inserted directly into the ring since they have only one port and cannot interpret the HSR tag in the frames. SANs communicate with ring devices through a RedBox (Redundancy Box) that acts as a proxy for the SANs attached to it.

A source DANH sends a frame passed from its upper layers, and prefixes it by an HSR tag to identify frame duplicates and sends the frame over both ports.

A destination DANH receives, in the fault-free state, two identical frames from each port within a certain interval, if it is a multicast frame, it instantaneously forwards it on the ring*, removes the HSR tag of the first frame before passing it to its upper layers ("D"-frame) and discards any duplicate.

A typical frame contains these parameters:

- dest_addr = Destination Address
- src_addr = Source Address
- type = Type
- data
- fcs = Frame Check Sequence (i.e. extra checksum characters added to allow error detection and correction)

HSR frames are identified uniquely by their HSR tag.

The HSR tag consists of these parameters:

- 16-bit Ethertype (HSR_EtherType = 0x892F)
- 4-bit path identifier (PathId), 0000 for both HSR nodes A and B, and 0010-1111 for one of 7 PRP networks (A/B).
- 12-bit frame size (LSDUsize)
- 16-bit Sequence Number (SeqNr)

Accordingly, a typical HSR frame then contains these parameters:

- dest_addr = Destination Address
- src_addr = Source Address
- HSR tag data:
 - 16-bit Ethertype (HSR_EtherType = 0x892F)
 - 4-bit path identifier
 - 12-bit frame size
 - 16-bit sequence number:
- type = Type
- payload = Payload
- Padding = if needed
- fcs = Frame Check Sequence

Padding
After the payload data, there may be some data padding. This is added to frames which would otherwise be too short for conventional network traffic (minimum frame size is 70 octets).

Size
The frame size will vary depending on the contents of the frame and how it has been tagged by the various SANs and DANs. In VLANs, frame tags may be added or removed during transit through a switch. To make the length field independent of tagging, only the original LPDU and the HSR tag are considered in the size.

The following diagrams shows the frame types with different types of data.

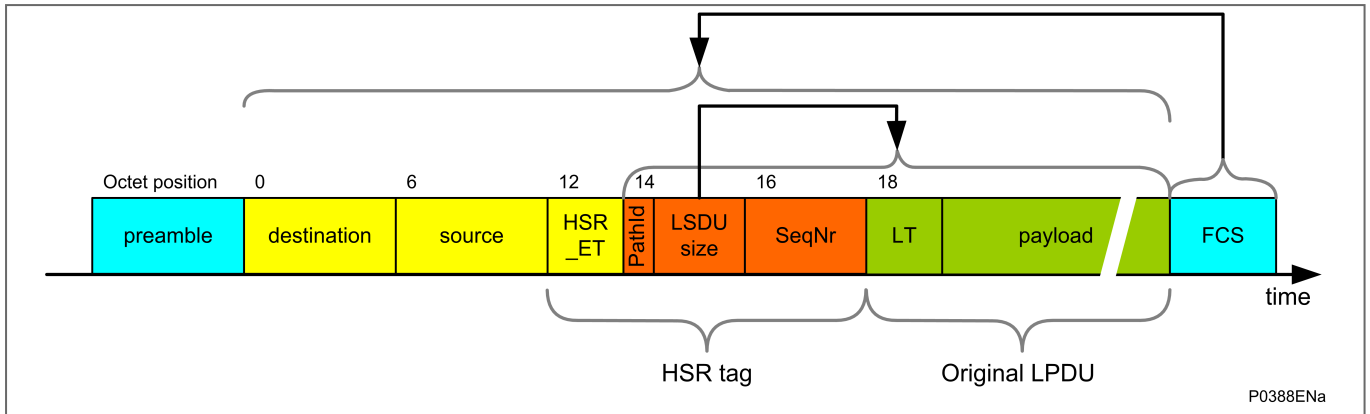

Figure 3 - HSR frame without a VLAN tag

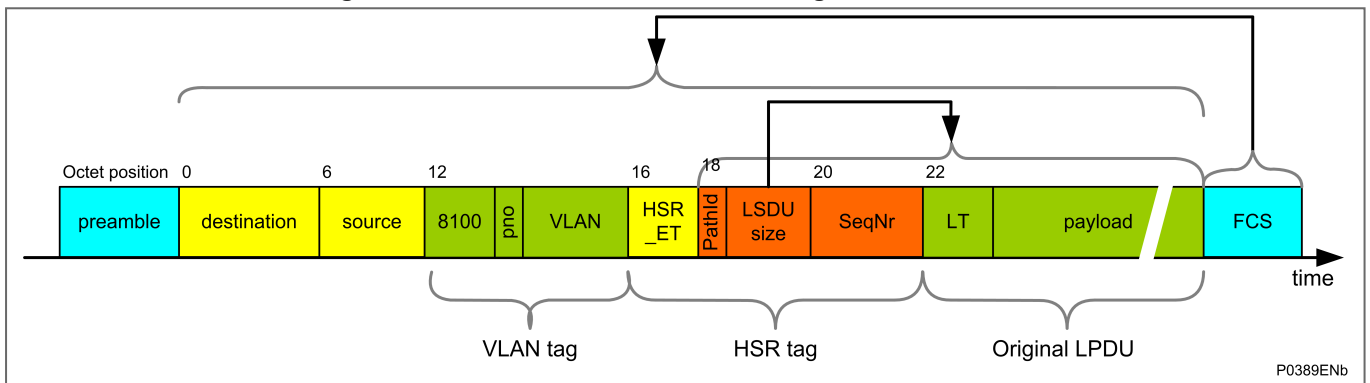

Figure 4 - HSR frame with VLAN tag

The key points about these differing frame structures are that:

- Unlike PRP, SANs cannot be attached directly to such a duplicated network unless they are able to interpret the HSR tag.
- In particular, the node will not forward a frame that it injected into the ring.
- A destination node of a unicast frame does not forward a frame for which it is the only destination, except for testing.]
- DANH receiving from an HSR port, if this frame is not HSR-tagged and is a link local traffic, consume the frame and do not forward it.
- DANH receiving from an HSR port, if this frame is HSR-tagged and this node is not a destination, do not pass the frame to the link layer interface.
- A node accepts an HSR tagged frame also if the LanId does not correspond to the PortId and if the LSDUsize does not match the frame size.

1.8 HSR Technical Data

- One VLAN tag supported
- Up to 128 devices supported
- Up to 100Mbit/s full duplex Ethernet
- Dynamic frame memory allocation (page manager)
- Configurable duplicate detection
- Wishbone interface for configuration and status registers
- CPU port interface - Ethernet or Wishbone
- Support for link-local protocols - CPU may send to specific ports only - CPU knows receive port
- Configurable frame memory and queue length
- Duplicate detection with configurable size and aging time

- MAC address filtering (8 filter masks for interlink port, 6 for CPU port)
- Support for interfaces with or without Ethernet preamble

Limitations:

Number of IEDs on a same ring at 100Mbit/s:

Each hop (IED or RedBox) not only carries its own messages but also all the other IED messages thus the bandwidth used is proportional to the number of IEDs.

The maximum number of hops is around 20 when the GOOSE messages are highly used or 40 if the number and importance of GOOSE messages is not high.

When Precision Time Protocol («IEEE1588/IEC 61588») is used:

As the GPS receiver inaccuracy is 200ns and as each hop (IED or RedBox) can add a 50ns inaccuracy, the maximum number of hops is 16 if 1 μ s accuracy is required (PMU application or Process Bus)

2. HSR AND MICOM FUNCTIONS

2.1 MiCOM Products and HSR

The HSR functions being introduced as part of the overall MiCOM product range provide additional functionality, which is backwards compatible with existing Schneider Electric MiCOM equipment. This means that existing MiCOM relays/IEDs can be used on networks, which use HSR functions, with no changes being made to those relays/IEDs.

The new MiCOM products that use the HSR, will interrogate other equipment to determine the equipment model number, and then use the model number to decide (at runtime), whether that particular item of equipment can support HSR or not. MiCOM models which include the following Ethernet board assembly provide the possibility of HSR function support. This is denoted by Digit 7 where the Hardware option is Q or R, as shown below:

Hardware Option	Type	Model No format
“Q” at Digit No 7	2 LC + 1 RJ45 ports redundant Ethernet board (Modulated/ Un-modulated IRIG-B)	Px4xxxQx6Mxxx8M
“R” at Digit No 7	3 RJ45 ports redundant Ethernet board (Modulated/ Un-modulated IRIG-B)	Px4xxxRx6Mxxx8M

Table 1 - Hardware option numbers with HSR functions

The MiCOM relay/IED firmware has been modified to allow the HSR options to be accepted for the power-up tests in addition to the implementation of the supervision frame transmission.

2.2 Easergy Studio and the HSR Function

The addition of this function has no impact of the Easergy Studio support files so there is no need to upgrade any Easergy Studio software.

2.3 MiCOM Relay Configuration and the HSR Function

There is no need to change the configuration of any relay (as relays which include support for this function will be able to recognize other devices which support it).

2.4 Hardware Changes for HSR Protocol

This protocol is implemented using the redundant Ethernet card as a starting point. The Frame management is achieved by programming the Field-Programmable Gate Array (FPGA).

The low-level management of the redundant frames is performed within the FPGA; this being defined as the Link Redundancy Entity (LRE). This will add the HSR tag to a frame to be transmitted. The FPGA is also responsible for the stripping of the HSR tag from received frames and discarding the duplicated messages so that only a single application frame is received by the Ethernet processor.

The LRE functionality of the supervision frame transmission is performed by the NIOS II.

The new version of the redundant Ethernet card is based on the 2072069A01 and 2072071A01 (both have modulated and un-modulated IRIG-B).

2.5 HSR Parameters

The Redundant Ethernet standard (IEC 62439-3:2012/FDIS) defines several parameters for the HSR protocol; these being fixed at a default value within this release. The following

values are set:

Parameter	Value	Description
Supervision Frame Multicast Address	01-15-4E-00-01-00	Target MAC Address for multicast supervision frame.
Life Check Interval	2 seconds	Period between transmission of supervision frames.
HSR Mode	Duplicate Discard	This is normal HSR mode, Duplicate address will not be supported.
Node Forget Time	60 s	This is the time after which a node entry is cleared.
Entry Forget Time	400 ms	Duration that the received message Sequence number will be held to discard a duplicate message.
Node Reboot Interval	500ms	Duration following reboot for which no HSR frames should be transmitted
MulticastFilterSize	16	Number of multicast addresses to be filtered

Table 2 - HSR parameter values

2.6 Product Implementation Features

Here is a list of the main Product Requirements for MiCOM products that support HSR:

- The MiCOM relay/IED provides two redundant Ethernet ports using HSR.
- The MiCOM relay/IED must be connected to the redundant Ethernet network as a Double Attached Node (DAN) using HSR (DAN using HSR is known as DANH)
- The redundant Ethernet interface can be made using an RJ45 or an optical fibre connection with an LC connector type.
- The management of the HSR redundancy is transparent to the application data provided via the Ethernet interface.
- The HSR option is available with any of the existing protocol options via the Ethernet Interface (IEC61850)
- Loss of one of the Node connections to the device does not cause any loss or degradation to the Application data over the Ethernet interface.
- The MiCOM relay/IED supports the transmission of the HSR Supervision frame at a fixed time period (LifeCheckInterval) of 2s (+/- 100ms)
- Each supervision frame includes a sequence number as defined in the IEC 62439-3:2012/FDIS specification. This will be incremented for each supervision message and the value will start from zero following a system restart.
- The MiCOM relay/IED does not provide for the HSR management to be configured (via either the MiCOM relay/IED HMI or the Ethernet interface). Accordingly, the default values (as defined within this document) are used for all HSR parameters.
- The performance of the Ethernet Interface is not degraded by using the HSR interface.

2.7 Abbreviations and Acronyms

Abbreviations / Acronyms	Meaning
BPDU	Bridge Protocol Data Unit
CRC	Cyclic Redundancy Check
DAN	Doubly Attached Nodes

Abbreviations / Acronyms	Meaning
DANH	Doubly Attached Node implementing HSR
DANP	Doubly Attached Node implementing PRP
FPGA	Field-Programmable Gate Array
HMI	Human Machine Interface
HSR	High-availability Seamless Redundancy
IED	Intelligent Electronic Devices
IP	Internet Protocol
LAN	Local Area Network
LRE	Link Redundancy Entity
MAC	Media Access Control
MRP	Media Redundancy Protocol
PRP	Parallel Redundancy Protocol
RCT	Redundancy Check Tag
RedBox	Redundancy Box
RST BPDU	Rapid Spanning Tree BPDU
RSTP	Rapid Spanning Tree Protocol
SAN	Singly Attached Node
TCP	Transmission Control Protocol
VDAN	Virtual Doubly Attached Node

Notes:

RAPID SPANNING TREE PROTOCOL (RSTP) NOTES

CHAPTER 22

Applicability**Date:** 10/2022**Products covered by this chapter:**

This chapter covers the specific versions of the MiCOM products listed below. This includes **only** the following combinations of Software Version and Hardware Suffix.

Hardware Suffix:

P141/P142/P143	L or later
P145	M or later
P445	L or later
P44x (P442/P444)	M or later
P44y (P443/P446)	M or later
P54x (P543/P544/P545/P546)	M or later
P642	L or later
P643/P645	M or later
P746	M or later
P841A (one circuit breaker)	M or later
P841B (two circuit breakers)	M or later
P342	L or later
P343/P344/P345	M or later
P849	M or later

Software Version:

P14x (P141/P142/P143/P145)	B5 or later
P445	K1 or later
P44x (P442/P444)	E3 or later
P44y (P443/P446)	K1 or later
P54x (P543/P544/P545/P546)	K1 or later
P64x (B642/P643/P645)	B4 or later
P746	B5/C5 or later
P841A (one circuit breaker)	L1 or later
P841B (two circuit breakers)	K1 or later
P342/P343/P344/P345	B5 or later
P849	B4 or later

Connection Diagrams: This chapter list the connection diagram for the product:

P14x (P141, P142, P143 & P145):	10P141xx (xx = 01 to 02) 10P142xx (xx = 01 to 05) 10P143xx (xx = 01 to 11) 10P145xx (xx = 01 to 11)
P445:	10P445xx (xx = 01 to 04)
P44x (P442 & P444):	10P44201 (SH 1 & 2) 10P44202 (SH 1)

	10P44203 (SH 1 & 2) 10P44401 (SH 1) 10P44402 (SH 1) 10P44403 (SH 1 & 2) 10P44404 (SH 1) 10P44405 (SH 1) 10P44407 (SH 1 & 2)
P44y:	10P44303 (SH 01 and 03) 10P44304 (SH 01 and 03) 10P44305 (SH 01 and 03) 10P44306 (SH 01 and 03) 10P44600 10P44601 (SH 1 to 2) 10P44602 (SH 1 to 2) 10P44603 (SH 1 to 2)
P54x (P543, P544, P545 & P546):	10P54302 (SH 1 to 2) 10P54303 (SH 1 to 2) 10P54304 (SH 1 to 2) 10P54400 10P54404 (SH 1 to 2) 10P54405 (SH 1 to 2) 10P54502 (SH 1 to 2) 10P54503 (SH 1 to 2) 10P54504 (SH 1 to 2) 10P54600 10P54604 (SH 1 to 2) 10P54605 (SH 1 to 2) 10P54606 (SH 1 to 2)
P547:	10P54702xx (xx = 01 to 02) 10P54703xx (xx = 01 to 02) 10P54704xx (xx = 01 to 02) 10P54705xx (xx = 01 to 02)
P64x (P642, P643 & P645):	10P642xx (xx = 1 to 10) 10P643xx (xx = 1 to 6) 10P645xx (xx = 1 to 9)
P746:	10P746xx (xx = 00 to 21)
P841:	10P84100 10P84101 (SH 1 to 2) 10P84102 (SH 1 to 2) 10P84103 (SH 1 to 2) 10P84104 (SH 1 to 2) 10P84105 (SH 1 to 2)
P34x (P342, P343, P344, P345 & P391)	10P342xx (xx = 01 to 17) 10P343xx (xx = 01 to 19) 10P344xx (xx = 01 to 12) 10P345xx (xx = 01 to 07) 10P391xx (xx = 01 to 02)
P849:	10P849xx (xx = 01 to 06)

Notes:

CONTENTS

1. Rapid Spanning Tree Protocol (RSTP) Notes	7
1.1 Introduction to RSTP.....	7
1.2 Protocols.....	7
1.3 Example of an RSTP Network.....	7
2. RSTP and MiCOM Functions	8
2.1 MiCOM Products and RSTP.....	8
2.2 Easergy Studio and the RSTP Function.....	8
2.3 MiCOM Relay Configuration and the RSTP Function.....	8
2.4 Hardware Changes for RSTP Protocol.....	8
2.5 RSTP Parameters.....	8
2.6 Product Implementation Features.....	9
2.7 Abbreviations and Acronyms.....	10

TABLES

Table 1 - Hardware option numbers with RSTP functions	8
---	---

FIGURES

Figure 1 - Px4x attached to a redundant Ethernet star or ring circuit	7
---	---

Notes:

1. RAPID SPANNING TREE PROTOCOL (RSTP) NOTES

1.1 Introduction to RSTP

This section gives an introduction to the Rapid Spanning Tree Protocol (RSTP); and how it is implemented on MiCOM-based products manufactured by Schneider Electric.

1.2 Protocols

Industrial real-time Ethernets typically need much better levels of availability and uninterrupted operation than normal office-type Ethernet solutions. For power networks, even a short loss of connectivity may result in a significant loss of functionality or impaired safety. To recover from a network failure, various redundancy schemes have been considered, including Rapid Spanning Tree Protocol (**RSTP**). The key properties of this protocol are as follows:

RSTP

This uses mesh-based topologies or ring topology and computes a tree, based on path costs and priorities. In case of network failure, a typical reset time for RSTP-based system is normally a few seconds.

Power networks need to be able to respond to problems very quickly (typically in less than 10ms), and this is an available protocol which is robust enough to achieve this. This protocol is used in the MiCOM relay/IED and is defined in the IEC62439-3 (2016) standard and is configured using the existing redundant Ethernet card(s).

1.3 Example of an RSTP Network

The Px4x Redundant Ethernet board uses the RSTP protocol (IEEE 802.1D-2004, chapter 17), so a Px4x can attach onto a network as shown in this diagram.

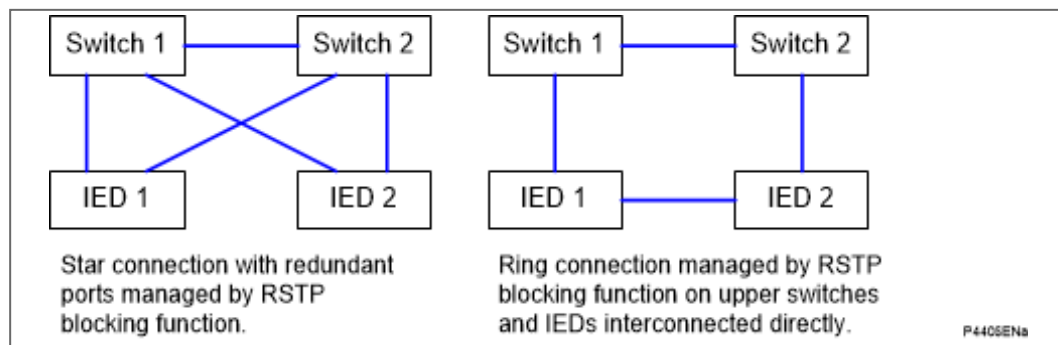

Figure 1 - Px4x attached to a redundant Ethernet star or ring circuit

The RSTP solution is based on open standards. It is therefore compatible with other manufacturers' IEDs that use the RSTP protocol. The RSTP recovery time is some tenth of ms in case of physical link failure (depend of network size and topology) and 3 HelloTime (usually 3x2s) in case of fault without link failure, but it increases with network size.

2. RSTP AND MICOM FUNCTIONS

2.1 MiCOM Products and RSTP

The RSTP functions being introduced as part of the overall MiCOM product range provide additional functionality, which is backwards compatible with existing Schneider Electric MiCOM equipment. This means that existing MiCOM relays/IEDS can be used on networks, which use RSTP functions, with no changes being made to those relays/IEDS.

The new MiCOM products that use the RSTP, will interrogate other equipment to determine the equipment model number, and then use the model number to decide (at runtime), whether that particular item of equipment can support RSTP or not. MiCOM models which include the following Ethernet board assembly provide the possibility of RSTP function support. This is denoted by Digit 7 where the Hardware option is Q or R, as shown below:

Hardware Option	Type	Model No format
“Q” at Digit No 7	2 LC + 1 RJ45 ports redundant Ethernet board (Modulated/ Un-modulated IRIG-B)	Px4xxx Q x6Mxxx8M
“R” at Digit No 7	3 RJ45 ports redundant Ethernet board (Modulated/ Un-modulated IRIG-B)	Px4xxx R x6Mxxx8M

Table 1 - Hardware option numbers with RSTP functions

The MiCOM relay/IED firmware has been modified to allow the RSTP options to be accepted for the power-up tests in addition to the implementation of the supervision frame transmission.

2.2 Easergy Studio and the RSTP Function

The addition of this function has no impact of the Easergy Studio support files so there is no need to upgrade any Easergy Studio software.

2.3 MiCOM Relay Configuration and the RSTP Function

There is no need to change the configuration of any relay (as relays which include support for this function will be able to recognize other devices which support it).

2.4 Hardware Changes for RSTP Protocol

This protocol is implemented using the redundant Ethernet card as a starting point. The Frame management is achieved by programming the Field-Programmable Gate Array (FPGA).

RSTP doesn't add a tag to the frame (unlike HSR or PRP), but uses low-level peer-to-peer dialog (RST BPDU) to enable or not a point-to-point link, so that there is no loop inside the network.

There is no supervision frame in RSTP, but there is a dedicated peer-to-peer dialog between ethernet ports.

The new version of the redundant Ethernet card is based on the 2072069A01 and 2072071A01 (both have modulated and un-modulated IRIG-B).

2.5 RSTP Parameters

You can use the following settings to configure the RSTP function. The IEEE 802.1D 2004 standard defines the relation between Max Age and Forward Delay as:

$$2 * (\text{Forward Delay} - 1.0 \text{ seconds}) \geq \text{Max Age}$$

RSTP Settings

RSTP Settings	Value	Description
COMMUNICATIONS		
RSTPPriority	0 to 61440 with step 4096	Bridge Priority
RSTPMaxAge	6.0 to 40.0 with step 0.1	The max age time of RSTP
RSTPForwardDelay	4.0 to 30.0 with step 0.1	The timer of the RSTP forward delay
RSTPHelloTime	1.0 to 2.0 with step 0.1	The RSTP hello time settings

RSTP Status

RSTP Status	Value	Description
COMMUNICATIONS		
RSTPPortAStatus	FORWARDING, DISCARDING, DISABLED	The status RSTP Port A
RSTPPortBStatus	FORWARDING, DISCARDING, DISABLED	The status RSTP Port B

Notes

These two parameters are only visible on front panel (HMI).
The following relays do not use any independent RSTP Configuration tool:
P14x (Software Version B4 and later)
P44x (Software Version E3 and later)
P445 (Software Version J9 and later)
P44y (Software Version H9 and later)
P54x (Software Version H9 and later)
P841 (Software Version G9 (P841A) & H9 (P841B) and later)
P64x (Software Version B4 and later)
P746 (Software Version B5/C5 and later)
All the RSTP parameters are configured via HMI and Easergy S1 Studio.

2.6 Product Implementation Features

Here is a list of the main Product Requirements for MiCOM products that support RSTP:

- The MiCOM relay/IED provides two redundant Ethernet ports using RSTP.
- The redundant Ethernet interface can be made using an RJ 45 or an optical fibre connection with an LC connector type.
- The management of the RSTP is transparent to the application data provided via the Ethernet interface.
- The RSTP option is available with any of the existing protocol options via the Ethernet Interface (IEC61850 and/or DNPoE)
- Loss of one of the Node connections to the device does not cause any loss or degradation to the Application data over the Ethernet interface.
- The MiCOM relay/IED supports the transmission of the RSTP RST BPDU at a fixed time interval.
- The MiCOM relay/IED provide for the RSTP management to be configured and RSTP status to be monitored via either the MiCOM relay or IED HMI.

- The performance of the Ethernet Interface is not degraded by using the RSTP interface.

2.7 Abbreviations and Acronyms

Abbreviations / Acronyms	Meaning
BPDU	Bridge Protocol Data Unit
CRC	Cyclic Redundancy Check
DAN	Doubly Attached Nodes
DANH	Doubly Attached Node implementing HSR
DANP	Doubly Attached Node implementing PRP
FPGA	Field-Programmable Gate Array
HMI	Human Machine Interface
HSR	High-availability Seamless Redundancy
IED	Intelligent Electronic Devices
IP	Internet Protocol
LAN	Local Area Network
LRE	Link Redundancy Entity
MAC	Media Access Control
MRP	Media Redundancy Protocol
PRP	Parallel Redundancy Protocol
RCT	Redundancy Check Tag
RedBox	Redundancy Box
RST BPDU	Rapid Spanning Tree BPDU
RSTP	Rapid Spanning Tree Protocol
SAN	Singly Attached Node
TCP	Transmission Control Protocol
VDAN	Virtual Doubly Attached Node

Notes:

PROCESS BUS NOTES

CHAPTER 23

Applicability

Date:	11/2023
--------------	---------

Products covered by this chapter:

This chapter covers the specific versions of the MiCOM products listed below. This includes **only** the following combinations of Software Version and Hardware Suffix.

Hardware Suffix:

P145	M or later
P442	M or later
P44y (P443/P446)	M or later
P543/P546	M or later
P643/P645	M or later
P746	M or later
P841A (one circuit breaker)	M or later
P841B (two circuit breakers)	M or later

Software Version:

P145	B5 or later
P442	E3 or later
P44y (P443/P446)	K1 or later
P543/P546	K1 or later
P643/P645	B4 or later
P746	B5/C5 or later
P841A (one circuit breaker)	L1 or later
P841B (two circuit breakers)	K1 or later

Connection Diagrams: This chapter list the connection diagram for the product:

All Models	10PX002 10PX003
------------	--------------------

CONTENTS

1. Process Bus Safety Information	7
1.1 Risk of Electric Shock using RJ45 cables	7
2. Process Bus Introduction	9
3. Process Bus Hardware Description	11
3.1 Relay Rear Panel	11
3.1.1 Relay with Process Bus.....	11
4. Process Bus Operation	12
4.1 Process Bus Initialization	12
4.2 Single Merging Unit (MU) Configuration	12
4.2.1 SV Configuration Example.....	13
4.3 Multiple Merging Unit (MU) Configuration	13
4.3.1 SV Configuration.....	14
4.4 Multiple Relays	14
4.5 Data Resampling	15
5. Process Bus Configuration	16
5.1 Settings	16
5.2 Process Bus Communication mode (for redundant option)	17
5.2.1 GOOSE.....	17
5.2.2 Sampled Values.....	17
5.3 DDB Signals for Process Bus Relays	17
5.3.1 DDB Signals for Process Bus for P145.....	18
5.3.2 DDB Signals for Process Bus for P442.....	19
5.3.3 DDB Signals for Process Bus for P443 and P446.....	19
5.3.4 DDB Signals for Process Bus for P543 and P546.....	21
5.3.5 DDB Signals for Process Bus for P643 and P645.....	22
5.3.6 DDB Signals for Process Bus for P746.....	23
5.3.7 DDB Signals for Process Bus for P841A and P841B.....	24
5.4 Setting Guide	25
5.4.1 Anti-Alias Filter.....	25
5.4.2 MUs Delay Offset.....	25
5.4.3 Synchro Mode.....	26
5.4.4 Data Quality.....	26
5.4.5 Analogue Channel Groups.....	27
5.4.5.1 Products with one set of CT, P145.....	27
5.4.5.2 Products with one set of CT, P443, P543, P841A.....	28
5.4.5.3 Products with two sets of CT, P446, P546, P841B.....	29
5.4.5.4 Products with three sets of CT, P643.....	29
5.4.5.5 Products with five sets of CT, P645.....	30
5.4.5.6 Products with two sets of CT, P442.....	31

5.4.5.7 Products with seven sets of CT, P746.....	31
5.5 Simulation SV.....	31
5.6 Merging Unit (MU) Out-Of-Service (OOS) Configuration.....	32
5.7 Analogue Channel Switching.....	32
5.7.1 Switch Check Synchronizing Voltage Channel.....	32
5.7.2 Switch Other Analogue Channels.....	34
5.8 Measurement Operation.....	34
5.8.1 Measurement Addition Operation.....	34
5.8.2 Measurement Subtraction Operation.....	34
5.9 IEC61850 Enhanced Features.....	35
5.9.1 Two Dedicated GOOSE Control Blocks.....	35
5.9.2 GOOSE VIP.....	35
5.10 Current Differential Function.....	35
5.11 Configuration Examples.....	37
5.11.1 Example 1 - Line Protection.....	38
5.11.2 Example 2 - Line Protection with Mutual Coupling.....	39
5.11.3 Example 3 - Line protection with Check Synch.....	40
5.11.4 Example 4 - Double Bus Line Protection with Check Synch.....	41
5.11.5 Example 5 - Breaker and a Half with Mutual Coupling and Check Synch.....	42
6. Process Bus Commissioning.....	43
6.1 Product Checks for IEDs which use the Process Bus Interface.....	43
6.1.1 IED Configured with One Merging Unit (MU).....	43
6.1.2 IED Configured with Two or More Merging Units (MUs).....	43
6.2 GPS Synchronization for IEDs which use the Process Bus Interface.....	44
6.3 Commissioning Mode for P54x Relay with Process Bus.....	44
6.4 Commissioning Mode.....	44
7. Process Bus Connection Diagrams.....	46

TABLES

Table 1 - Column 00 Settings for Process Bus Devices.....	16
Table 2 - Column 18 Settings for Process Bus Devices.....	17
Table 3 - DDB Signals for Process Bus for P145.....	18
Table 4 - DDB Signals for Process Bus for P442.....	19
Table 5 - DDB Signals for Process Bus for P443 and P446.....	20
Table 6 - DDB Signals for Process Bus for P543 and P546.....	21
Table 7 - DDB Signals for Process Bus for P643 and P645.....	23
Table 8 - DDB Signals for Process Bus for P746.....	24
Table 9 - DDB Signals for Process Bus for P841A and P841B.....	25
Table 10 - How sample quality impacts protection (P145).....	28
Table 11 - How sample quality impacts protection (P443, P543, P841A).....	28

Table 12 - How sample quality impacts protection (P446, P546, P841B).....	29
Table 13 - How sample quality impacts protection (P643).....	30
Table 14 - How sample quality impacts protection (P645).....	31
Table 15 - How sample quality impacts protection (P442).....	31
Table 16 - How sample quality impacts protection (P746).....	31
Table 17 - PSL configuration and logic.....	34
Table 18 - Switching logic.....	34

FIGURES

Figure 1 - Connecting a Px40 device to a SAMU.....	7
Figure 2 - RJ45 connection electric shock risk.....	7
Figure 3 - Process Bus principle.....	9
Figure 4 - Rear view of the process bus device.....	11
Figure 5 - Single Merging Unit (MU) configuration.....	13
Figure 6 - CID configuration for one Merging Unit (MU).....	13
Figure 7 - Multiple Merging Unit (MU) configuration.....	14
Figure 8 - CID configuration for four Merging Units (MUs).....	14
Figure 9 - Data sampling using CTs/VTs and an input board.....	15
Figure 10 - Data sampling using Process Bus interface.....	15
Figure 11 - Different MU Delay Offset for 4000Hz Sample Rate.....	26
Figure 12 - A typical P543 application.....	33
Figure 13 - One CB and a half application.....	33
Figure 14 - IED configurator.....	33
Figure 15 - PSL configuration and logic.....	33
Figure 16 - OR Operation.....	34
Figure 17 - Configure analogue channel for addition.....	34
Figure 18 - Configure analogue channel for subtraction.....	34
Figure 19 - Two-ended P54x scheme with Process Bus IEDs at both ends.....	36
Figure 20 - P54x PB IED scheme and conventional P54x IED combined in a current differential scheme.....	36
Figure 21 - Measured currents/voltages and transmitted signal.....	37
Figure 22 - Connection.....	38
Figure 23 - CID configuration.....	38
Figure 24 - Connection.....	39
Figure 25 - CID configuration.....	39
Figure 26 - Connection.....	40
Figure 27 - CID configuration.....	40
Figure 28 - Connection.....	41
Figure 29 - CID configuration.....	41
Figure 30 - Connection.....	42
Figure 31 - CID configuration.....	42
Figure 32 - MiCOM Px40 process bus – rear view.....	46
Figure 33 - External communications option MiCOM Px40 platform.....	47
Figure 34 - Ethernet Communications option MiCOM Px40 process bus platform.....	48

Figure 35 - MiCOM Px40 process bus 8 I/P 8 O/P or 16 O/P (+ CILO & RDT)..... 49

1. PROCESS BUS SAFETY INFORMATION

The Safety Information differs slightly, depending on whether the relay uses the Process Bus Interface or not. The relevant details are shown in the Safety Information chapter. The Process Bus details are also copied here for easy reference.

Caution
 Before the **OUT OF SERVICE LED** is extinguished and the status of **DDB Prot'n Disabled** is **FALSE**, user should not put the Process Bus relay into operation.

1.1 Risk of Electric Shock using RJ45 cables

This diagram shows how a P40 IED could be connected to a Stand Alone Merging Unit (SAMU), using either an optical or an RJ45 cable. When connecting devices using RJ45 wired network cables, precautions for cabling must be taken to avoid any risk of electrical shock.

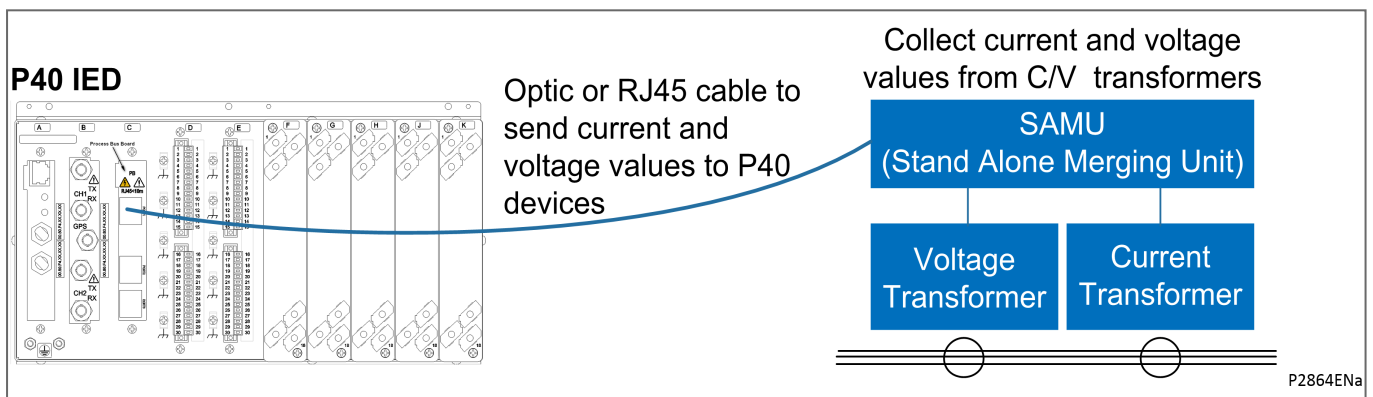

Figure 1 - Connecting a Px40 device to a SAMU

The risk arises due to the widely separated equipment having a different earth potential; and/or faults being propagated on the RJ45 cable. This diagram shows the possible risk:

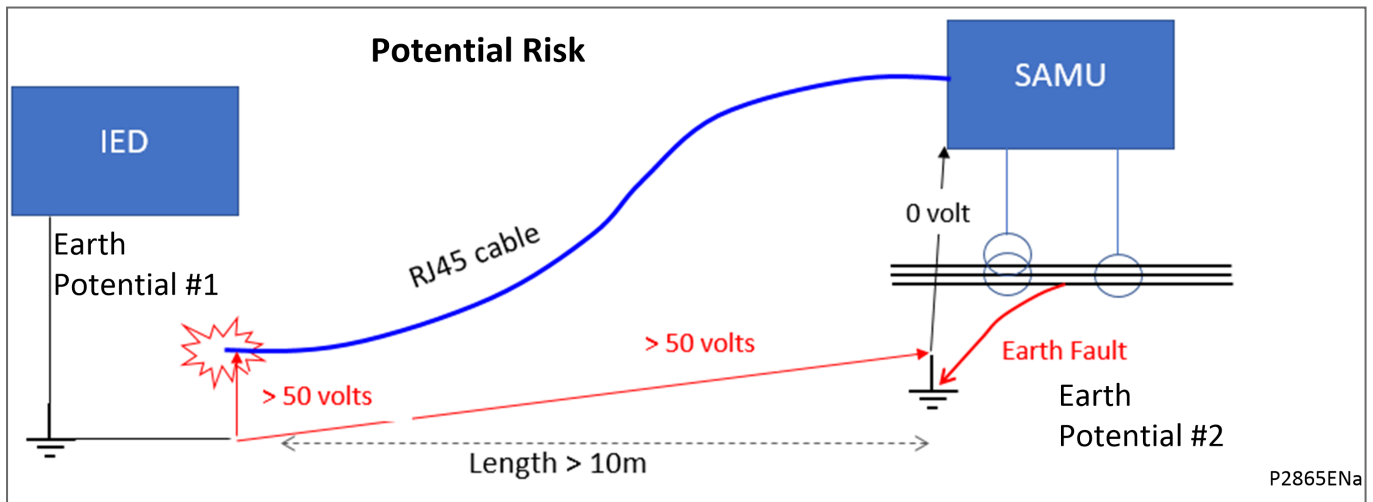

Figure 2 - RJ45 connection electric shock risk

The connection between the IED and the SAMU is done using a RJ45 cable. An electric shock could occur if:

- A fault occurs on SAMU/Voltage Transformer/Current Transformer side
- There is an earth potential difference between the two locations
- An RJ45 cable is used instead of an optical cable, so that the earth potential difference and/or the fault is propagated along the RJ45 cable

- The distance from the P40 IED (or a switch) to the SAMU is greater than 10m, so that there is a risk of electrical shock for someone who comes into electrical contact with the other end of the RJ45 cable (when it is disconnected from P40 device)

The latest advice for connecting a Low Power Instrument Transformer (LPIT) or a Stand Alone Merging Unit (SAMU) to an IED/switch is, if the distance from the IED/switch is:

- greater than 10m: you must only use a fiber optic cable
- less than 10m: you can use fiber optic or RJ45 cable

When a connection to a LPIT or SAMU is made with the RJ45 cable, this RJ45 cable must not be longer than 10 meters.

The reason is that, during a ground fault, the ground potential of the LPIT or the SAMU rises and is transmitted by the RJ45 cable. If someone was touching the conductive sleeve at the other end of the cable, they could be electrocuted or seriously injured.



DANGER

If you connect items of equipment with different earth potentials with an RJ45 cable, there is a risk of electric shock, explosion or arc flash.



DANGER

Do not use RJ45 cable longer than 10 meters. Failure to do this may result in death or serious injury.

2. PROCESS BUS INTRODUCTION

The Process Bus board interfaces to IEC 61850-9-2LE and IEC61869-9 compliant Merging Units (MU). The Process Bus board replaces the conventional analogue inputs (analogue module) and is available in these Easergy protection relays:

- P145 (feeder protection)
- P442, P443 and P446 (distance protection)
- P543 and P546 (line differential protection)
- P643 and P645 (transformer protection)
- P746 (busbar protection)
- P841(multifunction line terminal IED)

Process bus is mainly used to communicate the primary values of current and voltage to a protection relay via an Ethernet network. Merging Units form the data acquisition layer in the network. They connect to the primary sensor, determining the instantaneous primary measurements and publishing them on the process bus.

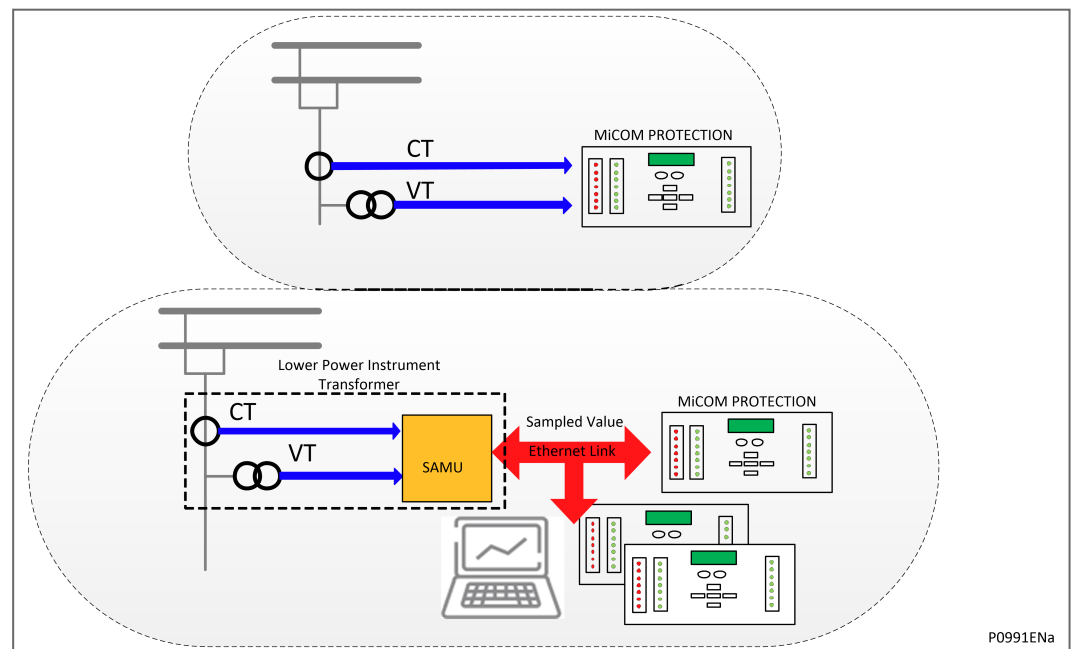

Figure 3 - Process Bus principle

The Process Bus philosophy is to enable isolating the primary interfaces (CTs or VTs) from the secondary system such as protection or control IEDs. The principle consists of interposing new primary equipment called Low Power Instrument Transformers (LPIT) or Stand Alone Merging Units (SAMU). Note that LPIT was previously known as Non-Conventional Instrument Transformers (NCIT)

The Stand Alone Merging Unit (SAMU) converts 1/5A and 100/110V signals to process bus measurements (called Sampled Values). One feature that is mandatory for the Merging Unit is a very accurate clock source. Time is unique and common in the "analogue world" but is not in the digital world. Sampled values must be synchronized via IEC61850-9-3 (refer to IEC 61588/IEEE1588 Precision Time Protocol) or 1 Pulse Per Second (PPS) signal. The measurement values provided must be suitable for the protection application. This performance is ensured by the selection of primary sensors meeting the CT requirements of the protection application. These requirements must now be met by both the primary CT and the Merging Unit.

An IMU can embed other digital functionality, sending information such as position of breaker and isolators and receiving digital information such as close, open, trip or reclose commands over the process bus.

The process bus links allow multiple measurement streams as well as the digital information to be sent over common Ethernet link which potentially could reduce the need to install secondary wiring. Also, the same stream can be used by multiple relays reducing the number of primary sensors required. This does, however, expose the system to a greater outage due to a link or switch failure. In most cases, redundancy such as IEC62439 PRP will be required to ensure system availability.

The protection tripping time in a Process Bus scheme is 4ms plus the MU delay offset setting, up to 7ms slower than in conventional one.

3. PROCESS BUS HARDWARE DESCRIPTION

3.1 Relay Rear Panel

3.1.1 Relay with Process Bus

The Process Bus board provides a IEC61850-9-2LE (80 samples/cycle) or IEC61869 (F4800S2liUu where i+u<24) Ethernet link and IEC61850-8-1 (GOOSE).

The board fits into a dedicated slot of the Easergy P40 protection. The board can be connected to the network using:

- For the 3 RJ45 connectors board, either the top or both the bottom RJ45 connectors or
- For the 1 RJ45 connector and two optical fibre connectors board, either the top RJ45 connector or both the bottom LC connectors

Optical fiber connectors

- 1300nm multimode 100BaseFx LC® connectors

RJ45 connection

- 100BaseTx RJ45 connector

Case size

- The case size of all Easergy MiCOM P40 Process Bus relays is fixed at 60TE

Board Location

- The Process Bus board is fitted in slot C

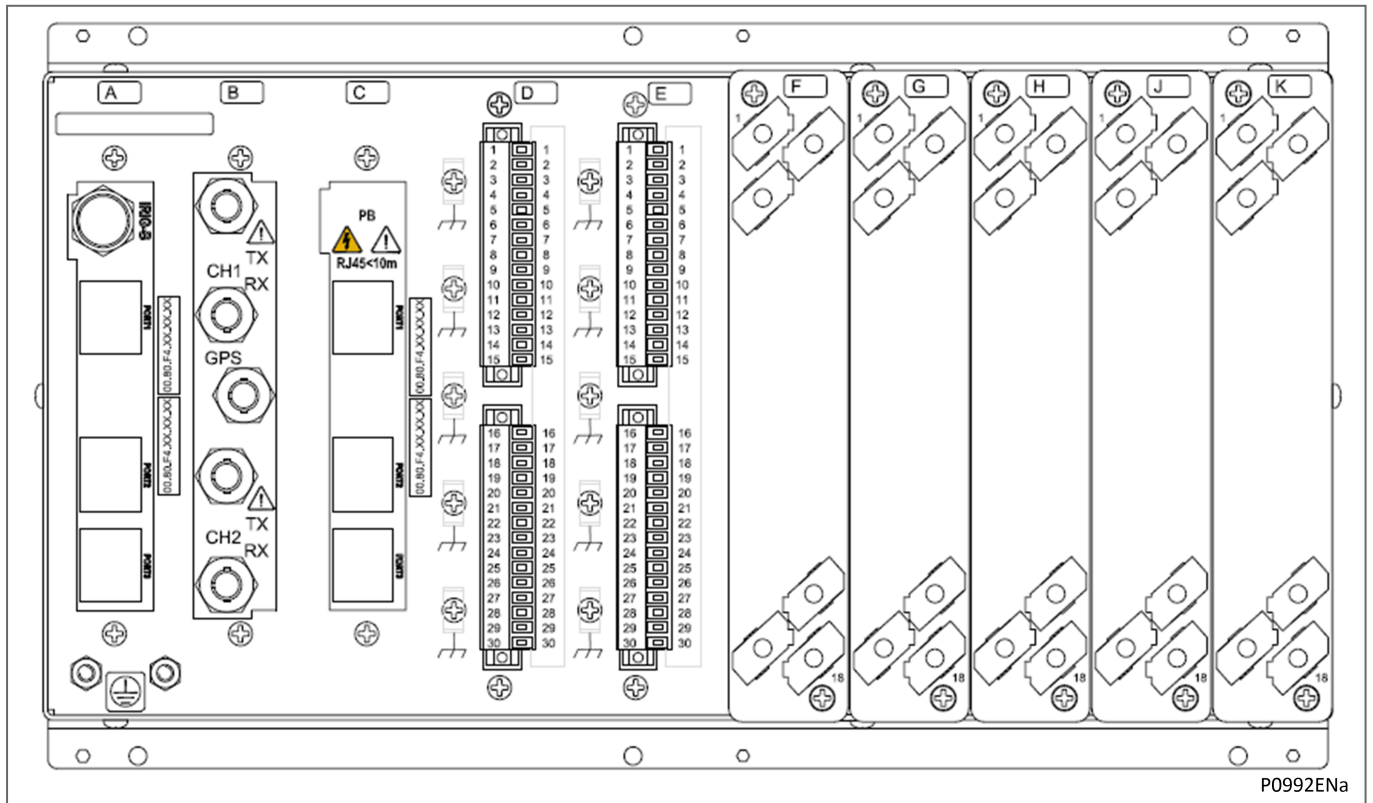

Figure 4 - Rear view of the process bus device

P0992ENa

4. PROCESS BUS OPERATION

When fitted, the Process Bus board replaces the analogue module board(s) with conventional CTs and VTs. In this case, the Process Bus board resamples the IEC 61850-9-2LE or IEC 61869 samples received from the process bus network and transforms them to the same format sent by the analogue module. According to the application, Merging Units (MUs) are:

- MUs included in LPITs
- SAMUs, connected to Conventional CTs and/or VTs

Depending on the products, up to 6 or 7 MUs can be simultaneously subscribed by one Easergy P40 protection relay (for P746, the maximum number is 7, for other P40 relays, the maximum number is 6).

The protection algorithms are unchanged, they are the same for the Process Bus board and the analogue module(s).

The number of MUs varies depending upon the product, the Sampled Values (SV) configuration is flexible to support different kinds of products and application.

Note the derived quality bit introduced in IEC61850-9-2LE (no longer used in IEC61869) is ignored by the relay.

4.1 Process Bus Initialization

During Process Bus (PB) initialization, the **Out of Service** LED in front panel will be on and the DDB signal **Prot'n Disabled** will be set to TRUE associated with the **Prot'n Disabled** alarm appearance on the HMI.

Once the PB board has booted up and is ready to receive Sampled Values (SV), the *Out of Service* LED in the front panel will be extinguished automatically. The DDB signal *Prot'n Disabled* will be set to FALSE associated with the disappearance of the *Prot'n Disabled* alarm from HMI.

The *Out of Service* LED and the *Prot'n Disabled* alarm will not extinguish if any of these conditions are met:

- no CID is configured or
- an invalid CID is configured or
- the CID is valid but Sampled Value is not configured in the CID

If need be, users can map the DDB signal *Prot'n Disabled* to a relay output in the PSL for a remote indication that the PB board is not ready to receive SV. This will be applied in these cases:

- During PB board booting up stage after a power on
- After a restore all command is executed
- During PB board rebooting due to PB Comm. Mode switching (PRP and Dual IP) or CID bank

4.2 Single Merging Unit (MU) Configuration

A single MU can be directly connected to the process bus card on a dedicated Ethernet link allowing process bus to be used without any additional network components.

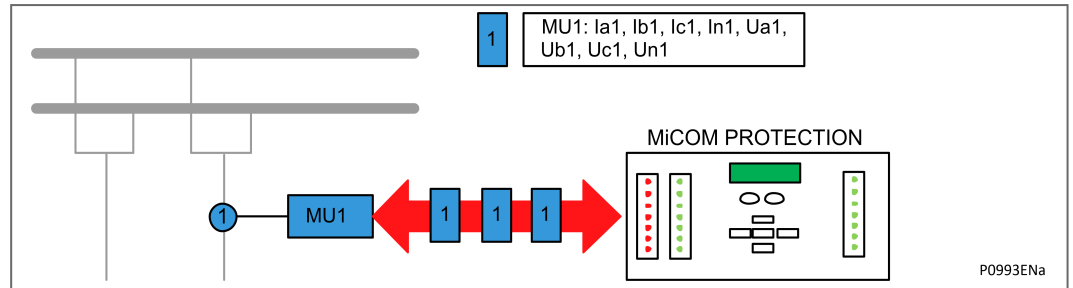

Figure 5 - Single Merging Unit (MU) configuration

4.2.1 SV Configuration Example

Analog channel parameters					
	MU No.	Index	Operation	MU No.	Index
Element Name:Ua	MU1	5	N/A	N/A	0
Element Name:Ub	MU1	6	N/A	N/A	0
Element Name:Uc	MU1	7	N/A	N/A	0
Element Name:Ubus	MU1	8	N/A	N/A	0
Element Name:Ia	MU1	1	N/A	N/A	0
Element Name:Ib	MU1	2	N/A	N/A	0
Element Name:Ic	MU1	3	N/A	N/A	0
Element Name:Im	MU1	4	N/A	N/A	0

P0994ENa

Figure 6 - CID configuration for one Merging Unit (MU)

In the above example the wiring normally brought to the relay has been connected to the merging unit. The check synch voltage input and mutual current input would normally require access to additional streams, however, in this case they have been wired to the neutral inputs of the MU. Since the relay inputs are configured by index it is then possible to allocate these channels to the appropriate analogue input.

4.3 Multiple Merging Unit (MU) Configuration

When the relay requires SV streams from multiple MUs an Ethernet network is required to provide the required streams to the relay. An example of a double bus application is shown below. In this case local synchronization is required for the check synch and mutual coupling functions.

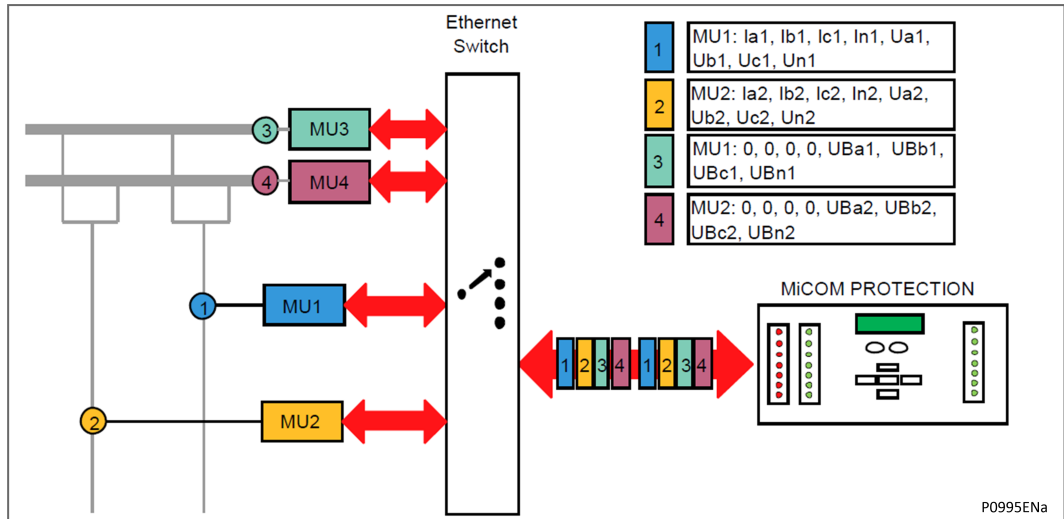

Figure 7 - Multiple Merging Unit (MU) configuration

The analogue channels are:

- MU1 = "Ia1, Ib1, Ic1, In1, Ua1, Ub1, Uc1, Un1"
- MU2 = "Ia2, Ib2, Ic2, In2, Ua2, Ub2, Uc2, Un2"
- MU3 = "0, 0, 0, 0, UBa1, UBb1, UBc1, UBn1"
- MU4 = "0, 0, 0, 0, UBa2, UBb2, UBc2, UBn2"

4.3.1 SV Configuration

Analog channel parameters						
	MU No.	Index	Operation	MU No.	Index	
Element Name:Ua	MU1	5	N/A	N/A	0	
Element Name:Ub	MU1	6	N/A	N/A	0	
Element Name:Uc	MU1	7	N/A	N/A	0	
Element Name:Ubus	MU3	5	OR	MU4	5	
Element Name:Ia	MU1	1	N/A	N/A	0	
Element Name:Ib	MU1	2	N/A	N/A	0	
Element Name:Ic	MU1	3	N/A	N/A	0	
Element Name:Im	MU2	4	N/A	N/A	0	
Element Name:Is	MU1	4	N/A	N/A	0	

Figure 8 - CID configuration for four Merging Units (MUs)

In this example the main currents and voltages are provided by MU1. MU2 provides its neutral current to the mutual coupling input. The A phase voltage is used from MU3 or MU4 for the check synch input. The correct stream to use will depend upon which primary isolators are closed. The second bus isolator status is connected to the "Check Synch Alt1" DDB in the relay PSL to select MU4 for check synch when feeder is connected to the second bus. If this signal is low then the Check Synch input will come from MU3.

4.4 Multiple Relays

Since the SV streams are Ethernet signals they can be simultaneously used by multiple relays. In the example above, the feeder currents could also be used by a busbar protection

and the busbar voltages would likely be used by other feeder protections. Care must be taken with sharing to avoid overloading the process bus network. VLANs are normally used to control the traffic to ensure that each IED only receives the SVs it uses ensuring no link is overloaded.

4.5 Data Resampling

The Process Bus relay receives 80 Sampled Values per cycle (4000 Sampled Values per second at 50Hz) or 4800 Sampled Values per second from the Merging Unit depending upon whether IEC61850-9-2LE or IEC61869 mode is used. The Process Bus board then resamples these Sampled Values and divides the values received by the input CT/VT ratio to make the data appear the same to the IED as analogue signals would do on its normal inputs from CTs and VTs. When a SAMU is used the ratios should match the primary CT/VT values. If a LPIT is used then the nominal switchgear ratings would normally be used to set the CT/VT ratios.

Caution

The CT and VT ratios must be set to suitable values to ensure the relay has correct measuring and setting ranges

The resampling frequency depends on the IED:

- P543, P546, P442, P443, P446, P841 - 48 samples/cycle
- P145, P643, P645, P746 - 24 samples/cycle

Note

The relay uses frequency tracking to follow the supply frequency, changing the number of samples per second when the frequency changes, where the process bus samples are fixed at 4000 samples/sec (50Hz) or 4800 samples/sec per different standard edition.

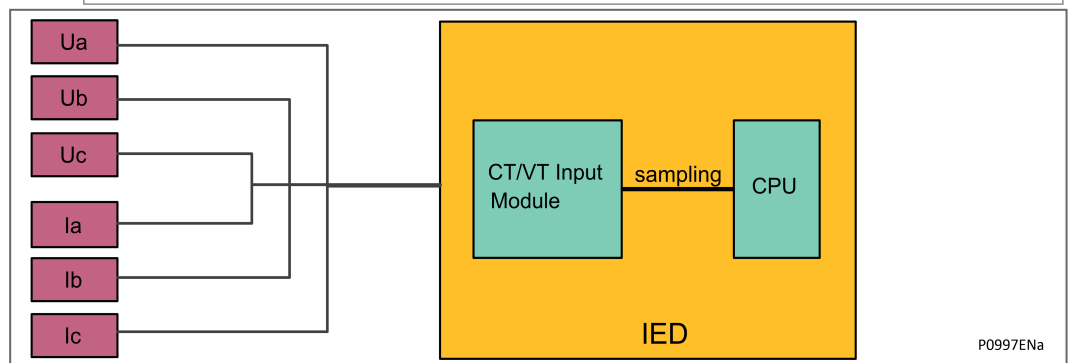

Figure 9 - Data sampling using CTs/VTs and an input board

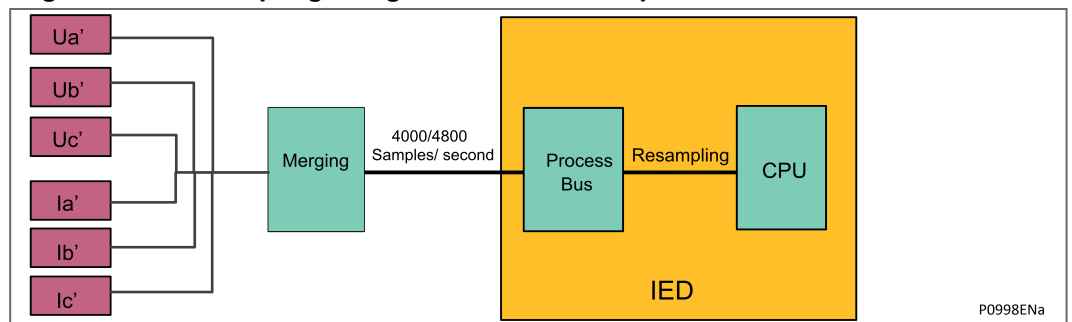

Figure 10 - Data sampling using Process Bus interface

5. PROCESS BUS CONFIGURATION

5.1 Settings

The Process Bus board must be configured to the system and application by means of appropriate settings. The sequence in which the settings are listed and described in this section will be the **PB CONFIG** submenu in the IED submenu.

Col	Row	Menu Text	Default Setting	Available Setting
00	13	Software Ref. 3	<Software Ref. 3>	Not settable
Relay Process Bus card software reference. Visible when Process Bus card fitted.				
00	15	IEC61850 Edition	Ed2	Not settable
This cell displays the supported IEC61850 Edition, only Ed2 is supported in Process Bus relays.				
00	17	PB COMM Mode	Dual IP	Dual IP, PRP
Sets the redundancy protocol of Process Bus board. This setting can only be changed via the UI and will cause the Process Bus board to reboot.				

Table 1 - Column 00 Settings for Process Bus Devices

Col	Row	Menu Text	Default Setting	Available Setting
18	00	PB CONFIG	Column Heading	
This column contains settings and status parameters relative to process bus				
18	01	MU OOS Config	00000000(bin)	
Used to set one or more Merging Units to be run in Out of Service mode.				
18	02	AntiAlias Filter	Disabled	0 = Disabled, 1 = Enabled
This cell activates or deactivates the anti-aliasing filter, which conditions the Sampled Values from the Process Bus network.				
18	03	SMV Version	IEC61850-9-2LE	0=IEC61850-9-2LE, 1 = IEC61869
This cell selects which version of sampled values are used, if it is set to IEC61850-9-2LE, the relay will subscribe the sampled value compliant with IEC61850-9-2LE, otherwise, device will subscribe the sampled value compliant with IEC61869.				
18	04	MUs Delay Offset	0s	From 0s to 3ms step 250us
This cell adjusts the maximum time-delay offset starting at the reception of the Ethernet message from the "first" Merging Unit (MU) to the reception of the Ethernet message from the "last" Merging Unit (MU). This time-delay should be adjusted to ensure all MU samples for the same time instant are received before sending to the relay processor.				
18	05	Mon Delay Offset	No	0 = No, 1 = Yes
When sampled values are received at the IED from different Merging Units, they do not arrive simultaneously due to differences in Merging Unit performance or different network path delays. After this setting is set to Yes, a command to monitor the maximum time-delay will be sent to Process Bus board. After Process Bus board has calculated a delay, it will send the delay time to main board for users to set a proper MUs Delay Offset.				
18	06	Max Delay Offset		Not Settable
This setting specifies the maximum time-delay supervised, supervision starting at the reception of the sampled value frame from the "first" Merging Unit to the reception of the sampled value frame from the last Merging Unit for each sample count. If >3ms, a -1 will be displayed.				
18	30	Synchro Mode	No SYNC CLK	0 = No SYNC CLK, 1 = Local Clock, 2 = Global Clock
This setting specifies the type of Sampled Value synchronization expected by the IED, depending on the application. Global Clock: The Sampled Values are synchronized with a global area clock (GPS like clock). Local Clock: The Sampled Values are synchronized with a local area clock signal at the substation. Sampled Value frames received with Global or Local synchronization are acceptable with this setting. No SYNC CLK: The Sampled Values do not need to be synchronized. With this setting the IED ignores the synchronization flag in the Sampled Value frames				

Col	Row	Menu Text	Default Setting	Available Setting
18	31	SV Absence Alm		Not Settable
<p>This is a data cell with 8 binary flags. It indicates the presence or absence of Sampled Values from each of the Merging Units the IED is communicating with. The cell data for each Merging Unit is continuously refreshed. Unused MUs will indicate a 0.</p> <p>0: Sampled Values being received from the Merging Unit. 1: No Sampled Values being received from the Merging Unit.</p>				
18	32	SV SmpSynch Alm		Not Settable
<p>This is a data cell with 8 binary flags. It indicates the healthiness of the Sampled Values being received from each of the Merging Units configured.</p> <p>0: Sampled Values received are synchronized. 1: Sampled Values received are not synchronized.</p>				
18	33	SV Test Alm		Not Settable
<p>This is a data cell with a binary flag for each of the analogue groups within the relay. It indicates that the publisher is in 'Test Mode'. Normal channels are only valid when 'Test Mode' is Disabled and will have associated functions blocked. Test channels are only valid when 'Test Mode' is not Disabled.</p>				
18	34	SV Invalid Alm		Not Settable
<p>This is a data cell with a binary flag for each of the analogue groups within the relay. It indicates the status of the IEC 61850 Quality attribute 'Invalid' in the Sampled Value frame used for that channel. If a channel is marked Invalid then functions associated with that channel are blocked.</p>				
18	35	SV Quest Alm		Not Settable
<p>This is a data cell with a binary flag for each of the analogue groups within the relay. It indicates the status of the IEC 61850 Quality attribute 'Questionable' in the Sampled Value frame used for that channel. If a channel is marked Questionable then functions associated with that channel are blocked.</p>				

Table 2 - Column 18 Settings for Process Bus Devices

5.2 Process Bus Communication mode (for redundant option)

5.2.1 GOOSE

Any of the 3 ports can be used for GOOSE communication.

When the PB Comm. mode is set to "Dual IP", either PORT 1 or PORT 2 is linked to interface 1 and PORT 3 is linked to interface 2.

When the PB Comm. mode is set to "PRP", PORT 1 is linked to interface 1 and PORT 2 and PORT 3 are linked to interface 2.

5.2.2 Sampled Values

When the PB Comm. mode is set to "Dual IP", either PORT 1 or PORT 2 is ready for SV subscription. PORT 3 doesn't support SV subscription.

When the PB Comm. mode is set to "PRP", PORT 1 doesn't support SV subscription. PORT 2 and PORT 3 is ready (PRP mode) for SV subscription.

5.3 DDB Signals for Process Bus Relays

The meaning of the DDB signals for Process Bus Relays. The relevant DDB signals are shown in these sections:

- 5.3.1 - DDB Signals for Process Bus for P145
- 5.3.2 - DDB Signals for Process Bus for P442
- 5.3.3 - DDB Signals for Process Bus for P443 and P446
- 5.3.4 - DDB Signals for Process Bus for P543 and P546
- 5.3.5 - DDB Signals for Process Bus for P643 and P645

- 5.3.6 - DDB Signals for Process Bus for P746
- 5.3.7 - DDB Signals for Process Bus for P841A and P841B

5.3.1 DDB Signals for Process Bus for P145

DDB No	Source	Description	English Text	P145
314	SW	IEC 61850 accept simulated GOOSE and SV alarm	Sim.Signal Alm	*
778	SW	MU OOS Alarm	MU OOS Alarm	*
792	SW	Invalid IEC 61850 Configuration Alarm for PB	Invalid SV conf.	*
793	SW	SV Absence Alm	SV Absence Alm	*
794	SW	SV SmpSynch alarm	SV SmpSynch Alm	*
795	SW	SV Test alarm	SV Test Alm	*
796	SW	SV Invalid alarm	SV Invalid Alm	*
797	SW	SV Questionable alarm	SV Quest Alm	*
1214	SW	Process Bus Network Interface link 1 fail indication	PB Link 1 Fail	*
1215	SW	Process Bus Network Interface link 2 fail indication	PB Link 2 Fail	*
1216	SW	Process Bus Network Interface link 3 fail indication	PB Link 3 Fail	*
1217	SW	DDB_MU1_ABSENCE	MU1 Absence	*
1218	SW	DDB_MU2_ABSENCE	MU2 Absence	*
1219	SW	DDB_MU3_ABSENCE	MU3 Absence	*
1220	SW	DDB_MU4_ABSENCE	MU4 Absence	*
1221	SW	DDB_MU5_ABSENCE	MU5 Absence	*
1222	SW	DDB_MU6_ABSENCE	MU6 Absence	*
1223	SW	DDB_MU7_ABSENCE	MU7 Absence	*
1224	SW	DDB_MU8_ABSENCE	MU8 Absence	*
1225	SW	Main VT Inhibit	Main VT Inhibit	*
1226	SW	CS VT Inhibit	CS VT Inhibit	*
1227	SW	Phs CT Inhibit	Phs CT Inhibit	*
1228	SW	In CT Inhibit	In CT Inhibit	*
1229	SW	SEF CT Inhibit	SEF CT Inhibit	*
1230	SW	Main VT Synch alarm	Main VT Synch alarm	*
1231	SW	CS VT Synch alarm	CS VT Synch alarm	*
1232	SW	Phs CT Synch alarm	Phs CT Synch alarm	*
1233	SW	In CT Synch alarm	In CT Synch alarm	*
1234	SW	SEF CT Synch alarm	SEF CT Synch alarm	*
1914	PSL	Alternate other analogue channels	Channel Alt	*
1915	PSL	Signal used to alternate VCS 1	Check SyncAlt1	*

Table 3 - DDB Signals for Process Bus for P145

5.3.2 DDB Signals for Process Bus for P442

DDB No	Source	Description	English Text	P442
477	SW	MU OOS Alarm	MU OOS Alarm	*
478	SW	Invalid IEC 61850 Configuration Alarm for PB	Invalid SV conf.	*
479	SW	SV Absence Alm	SV Absence Alm	*
496	SW	IEC 61850 accept simulated GOOSE and SV alarm	Sim.Signal Alm	*
497	SW	SV SmpSynch alarm	SV SmpSynch Alm	*
498	SW	SV Test alarm	SV Test Alm	*
499	SW	SV Invalid alarm	SV Invalid Alm	*
500	SW	SV Questionable alarm	SV Quest Alm	*
545	SW	Process Bus Network Interface link 1 fail indication	PB Link 1 Fail	*
546	SW	Process Bus Network Interface link 2 fail indication	PB Link 2 Fail	*
547	SW	Process Bus Network Interface link 3 fail indication	PB Link 3 Fail	*
548	SW	DDB_MU1_ABSENCE	MU1 Absence	*
549	SW	DDB_MU2_ABSENCE	MU2 Absence	*
550	SW	DDB_MU3_ABSENCE	MU3 Absence	*
551	SW	DDB_MU4_ABSENCE	MU4 Absence	*
552	SW	DDB_MU5_ABSENCE	MU5 Absence	*
553	SW	DDB_MU6_ABSENCE	MU6 Absence	*
554	SW	DDB_MU7_ABSENCE	MU7 Absence	*
555	SW	DDB_MU8_ABSENCE	MU8 Absence	*
556	SW	Main VT Inhibit	Main VT Inhibit	*
557	SW	CS VT Inhibit	CS VT Inhibit	*
558	SW	Phase CT Inhibit	Phase CT Inhibit	*
559	SW	MCOMP CT Inhibit	MCOMP CT Inhibit	*
560	SW	Main VT Synch alarm	Main VT Synch alarm	*
561	SW	CS VT Synch alarm	CS VT Synch alarm	*
562	SW	Phs CT Synch alarm	Phase CT Synch alarm	*
563	SW	MCOMP CT Synch alarm	MCOMP CT Synch alarm	*
564	PSL	Alternate other analogue channels	Channel Alt	*
565	PSL	Signal used to alternate VCS1	Check Sync Alt1	*

Table 4 - DDB Signals for Process Bus for P442

5.3.3 DDB Signals for Process Bus for P443 and P446

DDB No	Source	Description	English Text	P443	P446
360	SW	MU OOS alarm	MU OOS Alarm	*	*
361	SW	Invalid IEC 61850 Configuration alarm for PB	Invalid SV conf.	*	*
362	SW	SV Absence alarm	SV Absence Alm	*	*

DDB No	Source	Description	English Text	P443	P446
379	SW	Accept simulated GOOSE and SV alarm	Sim.Signal Alm	*	*
380	SW	SV Synchronization alarm	SV SmpSynch Alm	*	*
381	SW	SV Test alarm	SV Test Alm	*	*
382	SW	SV Invalid alarm	SV Invalid Alm	*	*
383	SW	SV Questionable alarm	SV Quest Alm	*	*
1914	PSL	Signal used to alternate analogue channels except check synchronization voltages	Channel Alt	*	*
1915	PSL	Signal used to alternate VCS 1	Check Sync Alt1	*	*
1916	PSL	Signal used to alternate VCS 2	Check Sync Alt2		*
1917	SW	Process Bus Ethernet port 1 link fail indication	PB Link 1 Fail	*	*
1918	SW	Process Bus Ethernet port 2 link fail indication	PB Link 2 Fail	*	*
1919	SW	Process Bus Ethernet port 3 link fail indication	PB Link 3 Fail	*	*
1920	SW	MU1 Absence indication	MU1 Absence	*	*
1921	SW	MU2 Absence indication	MU2 Absence	*	*
1922	SW	MU3 Absence indication	MU3 Absence	*	*
1923	SW	MU4 Absence indication	MU4 Absence	*	*
1924	SW	MU5 Absence indication	MU5 Absence	*	*
1925	SW	MU6 Absence indication	MU6 Absence	*	*
1926	SW	MU7 Absence indication	MU7 Absence	*	*
1927	SW	MU8 Absence indication	MU8 Absence	*	*
1928	SW	Main VT inhibit indication	Main VT Inhibit	*	*
1929	SW	CS VT1 inhibit indication	CS VT1 Inhibit	*	*
1930	SW	Phs CT1 inhibit indication	Phs CT1 Inhibit	*	*
1931	SW	Mcomp CT inhibit indication	Mcomp CT Inhibit	*	*
1932	SW	SEF CT inhibit indication	SEF CT Inhibit	*	*
1933	SW	Phs CT2 inhibit indication	Phs CT2 Inhibit		*
1934	SW	CS VT2 inhibit indication	CS VT2 Inhibit		*
1935	SW	Main VT synchronization alarm	Main VT Sync Alm	*	*
1936	SW	CS VT1 synchronization alarm	CS VT1 Sync Alm	*	*
1937	SW	Phs CT1 synchronization alarm	Phs CT1 Sync Alm	*	*
1938	SW	Mcomp CT synchronization alarm	McompCT Sync Alm	*	*
1939	SW	SEF CT synchronization alarm	SEF CT Sync Alm	*	*
1940	SW	Phs CT2 synchronization alarm	Phs CT2 Sync Alm		*
1941	SW	CS VT2 synchronization alarm	CS VT2 Sync Alm		*

Table 5 - DDB Signals for Process Bus for P443 and P446

5.3.4 DDB Signals for Process Bus for P543 and P546

DDB No	Source	Description	English Text	P543	P546
360	SW	MU OOS alarm	MU OOS Alarm	*	*
361	SW	Invalid IEC 61850 Configuration alarm for PB	Invalid SV conf.	*	*
362	SW	SV Absence alarm	SV Absence Alm	*	*
379	SW	Accept simulated GOOSE and SV alarm	Sim.Signal Alm	*	*
380	SW	SV Synchronization alarm	SV SmpSynch Alm	*	*
381	SW	SV Test alarm	SV Test Alm	*	*
382	SW	SV Invalid alarm	SV Invalid Alm	*	*
383	SW	SV Questionable alarm	SV Quest Alm	*	*
1914	PSL	Signal used to alternate analogue channels except check synchronization voltages	Channel Alt	*	*
1915	PSL	Signal used to alternate VCS 1	Check SyncAlt1	*	*
1916	PSL	Signal used to alternate VCS 2	Check SyncAlt2		*
1917	SW	Process Bus Ethernet port 1 link fail indication	PB Link 1 Fail	*	*
1918	SW	Process Bus Ethernet port 2 link fail indication	PB Link 2 Fail	*	*
1919	SW	Process Bus Ethernet port 3 link fail indication	PB Link 3 Fail	*	*
1920	SW	MU1 Absence indication	MU1 Absence	*	*
1921	SW	MU2 Absence indication	MU2 Absence	*	*
1922	SW	MU3 Absence indication	MU3 Absence	*	*
1923	SW	MU4 Absence indication	MU4 Absence	*	*
1924	SW	MU5 Absence indication	MU5 Absence	*	*
1925	SW	MU6 Absence indication	MU6 Absence	*	*
1926	SW	MU7 Absence indication	MU7 Absence	*	*
1927	SW	MU8 Absence indication	MU8 Absence	*	*
1928	SW	Main VT inhibit indication	Main VT Inhibit	*	*
1929	SW	CS VT1 inhibit indication	CS VT1 Inhibit	*	*
1930	SW	Phs CT1 inhibit indication	Phs CT1 Inhibit	*	*
1931	SW	Mcomp CT inhibit indication	Mcomp CT Inhibit	*	*
1932	SW	SEF CT inhibit indication	SEF CT Inhibit	*	*
1933	SW	Phs CT2 inhibit indication	Phs CT2 Inhibit		*
1934	SW	CS VT2 inhibit indication	CS VT2 Inhibit		*
1935	SW	Main VT synchronization alarm	Main VT Sync Alm	*	*
1936	SW	CS VT1 synchronization alarm	CS VT1 Sync Alm	*	*
1937	SW	Phs CT1 synchronization alarm	Phs CT1 Sync Alm	*	*
1938	SW	Mcomp CT synchronization alarm	McompCT Sync Alm	*	*
1939	SW	SEF CT synchronization alarm	SEF CT Sync Alm	*	*
1940	SW	Phs CT2 synchronization alarm	Phs CT2 Sync Alm		*
1941	SW	CS VT2 synchronization alarm	CS VT2 Sync Alm		*

Table 6 - DDB Signals for Process Bus for P543 and P546

5.3.5 DDB Signals for Process Bus for P643 and P645

DDB No	Source	Description	English Text	P643	P645
520	SW	MU OOS alarm	MU OOS Alarm	*	*
521	SW	Invalid IEC 61850 Configuration alarm for PB	Invalid SV conf.	*	*
522	SW	SV Absence alarm	SV Absence Alm	*	*
539	SW	Accept simulated GOOSE and SV alarm	Sim.Signal Alm	*	*
540	SW	SV Synchronization alarm	SV SmpSynch Alm	*	*
541	SW	SV Test alarm	SV Test Alm	*	*
542	SW	SV Invalid alarm	SV Invalid Alm	*	*
543	SW	SV Questionable alarm	SV Quest Alm	*	*
1267	PSL	Signal used to alternate analogue channels except check synchronization voltages	Channel Alt	*	*
1268	SW	Process Bus Ethernet port 1 link fail indication	PB Link 1 Fail	*	*
1269	SW	Process Bus Ethernet port 2 link fail indication	PB Link 2 Fail	*	*
1270	SW	Process Bus Ethernet port 3 link fail indication	PB Link 3 Fail	*	*
1271	SW	MU1 Absence indication	MU1 Absence	*	*
1272	SW	MU2 Absence indication	MU2 Absence	*	*
1273	SW	MU3 Absence indication	MU3 Absence	*	*
1274	SW	MU4 Absence indication	MU4 Absence	*	*
1275	SW	MU5 Absence indication	MU5 Absence	*	*
1276	SW	MU6 Absence indication	MU6 Absence	*	*
1277	SW	MU7 Absence indication	MU7 Absence	*	*
1278	SW	MU8 Absence indication	MU8 Absence	*	*
1279	SW	Main VT inhibit indication	Main VT Inhibit	*	*
1280	SW	AUX VT Inhibit indication	Aux VT Inhibit	*	*
1281	SW	CT1 Inhibit indication	Phs CT1 Inhibit	*	*
1282	SW	CT2 Inhibit indication	Phs CT2 Inhibit	*	*
1283	SW	CT3 Inhibit indication	Phs CT3 Inhibit	*	*
1284	SW	CT4 Inhibit indication	Phs CT4 Inhibit		*
1285	SW	CT5 Inhibit indication	Phs CT5 Inhibit		*
1286	SW	TN1 Inhibit indication	IN T1 Inhibit	*	*
1287	SW	TN2 Inhibit indication	IN T2 Inhibit	*	*
1288	SW	TN3 Inhibit indication	IN T3 Inhibit	*	*
1289	SW	Main VT synchronization alarm	Main VT Sync Alm	*	*
1290	SW	AUX VT synchronization alarm	Aux VT Sync Alm	*	*
1291	SW	CT1 synchronization alarm	Phs CT1 Sync Alm	*	*
1292	SW	CT2 synchronization alarm	Phs CT2 Sync Alm	*	*
1293	SW	CT3 synchronization alarm	Phs CT3 Sync Alm	*	*
1294	SW	CT4 synchronization alarm	Phs CT4 Sync Alm		*

DDB No	Source	Description	English Text	P643	P645
1295	SW	CT5 synchronization alarm	Phs CT5 Sync Alm		*
1296	SW	TN1 synchronization alarm	IN T1 Sync Alm	*	*
1297	SW	TN2 synchronization alarm	IN T2 Sync Alm	*	*
1298	SW	TN3 synchronization alarm	IN T3 Sync Alm	*	*

Table 7 - DDB Signals for Process Bus for P643 and P645

5.3.6 DDB Signals for Process Bus for P746

DDB No	Source	Description	English Text	P746_1	P746_2
520	SW	MU OOS Alarm	MU OOS Alarm	*	*
521	SW	Invalid IEC 61850 Configuration Alarm for PB	Invalid SV conf.	*	*
522	SW	SV Absence Alm	SV Absence Alm	*	*
539	SW	IEC 61850 accept simulated GOOSE and SV alarm	Sim.Signal Alm	*	*
540	SW	SV SmpSynch alarm	SV SmpSynch Alm	*	*
541	SW	SV Test alarm	SV Test Alm	*	*
542	SW	SV Invalid alarm	SV Invalid Alm	*	*
543	SW	SV Questionable alarm	SV Quest Alm	*	*
589	PSL	Alternate other analogue channels	Channel Alt	*	*
590	SW	Process Bus Network Interface link 1 fail indication	PB Link 1 Fail	*	*
591	SW	Process Bus Network Interface link 2 fail indication	PB Link 2 Fail	*	*
592	SW	Process Bus Network Interface link 3 fail indication	PB Link 3 Fail	*	*
982	SW	DDB_MU1_ABSENCE	MU1 Absence	*	*
983	SW	DDB_MU2_ABSENCE	MU2 Absence	*	*
984	SW	DDB_MU3_ABSENCE	MU3 Absence	*	*
985	SW	DDB_MU4_ABSENCE	MU4 Absence	*	*
986	SW	DDB_MU5_ABSENCE	MU5 Absence	*	*
987	SW	DDB_MU6_ABSENCE	MU6 Absence	*	*
988	SW	DDB_MU7_ABSENCE	MU7 Absence	*	*
989	SW	DDB_MU8_ABSENCE	MU8 Absence	*	*
990	SW	Main VT Inhibit	Main VT Inhibit	*	
991	SW	CT1 Inhibit	Phs CT1 Inhibit	*	*
992	SW	CT2 Inhibit	Phs CT2 Inhibit	*	*
993	SW	CT3 Inhibit	Phs CT3 Inhibit	*	*
994	SW	CT4 Inhibit	Phs CT4 Inhibit	*	*
995	SW	CT5 Inhibit	Phs CT5 Inhibit	*	*
996	SW	CT6 Inhibit	Phs CT6 Inhibit	*	*
997	SW	CT7 Inhibit	Phs CT7 Inhibit		*
998	SW	Main VT Sync Alm	Main VT Sync Alm	*	
999	SW	CT1 Sync Alm	CT1 Sync Alm	*	*

DDB No	Source	Description	English Text	P746_1	P746_2
1000	SW	CT2 Sync Alm	CT2 Sync Alm	*	*
1001	SW	CT3 Sync Alm	CT3 Sync Alm	*	*
1002	SW	CT4 Sync Alm	CT4 Sync Alm	*	*
1003	SW	CT5 Sync Alm	CT5 Sync Alm	*	*
1004	SW	CT6 Sync Alm	CT6 Sync Alm	*	*
1005	SW	CT7 Sync Alm	CT7 Sync Alm		*

Table 8 - DDB Signals for Process Bus for P746

5.3.7 DDB Signals for Process Bus for P841A and P841B

DDB No	Source	Description	English Text	P841A	P841B
360	SW	MU OOS alarm	MU OOS Alarm	*	*
361	SW	Invalid IEC 61850 Configuration alarm for PB	Invalid SV conf.	*	*
362	SW	SV Absence alarm	SV Absence Alm	*	*
379	SW	Accept simulated GOOSE and SV alarm	Sim.Signal Alm	*	*
380	SW	SV Synchronization alarm	SV SmpSynch Alm	*	*
381	SW	SV Test alarm	SV Test Alm	*	*
382	SW	SV Invalid alarm	SV Invalid Alm	*	*
383	SW	SV Questionable alarm	SV Quest Alm	*	*
1914	PSL	Signal used to alternate analogue channels except check synchronization voltages	Channel Alt	*	*
1915	PSL	Signal used to alternate VCS 1	Check Sync Alt1	*	*
1916	PSL	Signal used to alternate VCS 2	Check Sync Alt2		*
1917	SW	Process Bus Ethernet port 1 link fail indication	PB Link 1 Fail	*	*
1918	SW	Process Bus Ethernet port 2 link fail indication	PB Link 2 Fail	*	*
1919	SW	Process Bus Ethernet port 3 link fail indication	PB Link 3 Fail	*	*
1920	SW	MU1 Absence indication	MU1 Absence	*	*
1921	SW	MU2 Absence indication	MU2 Absence	*	*
1922	SW	MU3 Absence indication	MU3 Absence	*	*
1923	SW	MU4 Absence indication	MU4 Absence	*	*
1924	SW	MU5 Absence indication	MU5 Absence	*	*
1925	SW	MU6 Absence indication	MU6 Absence	*	*
1926	SW	MU7 Absence indication	MU7 Absence	*	*
1927	SW	MU8 Absence indication	MU8 Absence	*	*
1928	SW	Main VT inhibit indication	Main VT Inhibit	*	*
1929	SW	CS VT1 inhibit indication	CS VT1 Inhibit	*	*
1930	SW	Phs CT1 inhibit indication	Phs CT1 Inhibit	*	*
1931	SW	Mcomp CT inhibit indication	Mcomp CT Inhibit	*	*
1932	SW	SEF CT inhibit indication	SEF CT Inhibit	*	*

DDB No	Source	Description	English Text	P841A	P841B
1933	SW	Phs CT2 inhibit indication	Phs CT2 Inhibit		*
1934	SW	CS VT2 inhibit indication	CS VT2 Inhibit		*
1935	SW	Main VT synchronization alarm	Main VT Sync Alm	*	*
1936	SW	CS VT1 synchronization alarm	CS VT1 Sync Alm	*	*
1937	SW	Phs CT1 synchronization alarm	Phs CT1 Sync Alm	*	*
1938	SW	Mcomp CT synchronization alarm	McompCT Sync Alm	*	*
1939	SW	SEF CT synchronization alarm	SEF CT Sync Alm	*	*
1940	SW	Phs CT2 synchronization alarm	Phs CT2 Sync Alm		*
1941	SW	CS VT2 synchronization alarm	CS VT2 Sync Alm		*

Table 9 - DDB Signals for Process Bus for P841A and P841B

5.4 Setting Guide

This section details non-protection functions in addition to where and how they may be applied. It provides some worked examples on how the settings are applied to the relay.

5.4.1 Anti-Alias Filter

The Anti-Aliasing filter prevents high frequency noise from being sampled by the process bus board. Except for some special applications, where very high-speed processing is required, always enable this setting. For these special applications, the frequency response of the Merging Unit needs to be checked to ensure aliasing does not occur at the relays internal sampling rate.

5.4.2 MUs Delay Offset

When Sampled Value frames come from different Merging Units (MUs) on the Process Bus network, they do not arrive at the same time at the IED. The transmission delay depends on the background Ethernet traffic and how many switches are used in the Process Bus network.

Transmission delays do not usually matter for functions such as three-phase overcurrent protection where current signals are all received in a single frame. However, a function such as distance protection uses voltage and current signals which may be from different MUs with different transmission delays. The Process Bus board synchronizes the voltage and current samples that are sent to the IEDs distance protection function. The IED then uses the **MUs Delay Offset** setting, which is set to the maximum expected delay between the first and last Sampled Value of the same count.

The following examples show how you would need to set the delay.

- If the IED subscribes to SV from one MU only, no delay is needed so it operates correctly with a **MUs Delay Offset** setting of '0ms'.
- If the IED subscribes to SVs from several MUs which arrive within the period of two consecutive SV frames, no delay is needed so it operates correctly with a **Merging Unit Delay** setting of '0ms'.
- If the IED subscribes to SVs from several MUs but the streams do not arrive within the period of two consecutive SV frames, set the **MUs Delay Offset** to an appropriate value for the IED to operate correctly.

To set the MU delay during commissioning, set **Mon Delay Offset** to **Yes**. The IED then monitors the Sampled Value frames received for the next one second and displays the maximum delay between identical time tagged samples (SmpCnt).

The setting will directly impact protection performance, as shown in this diagram:



Figure 11 - Different MU Delay Offset for 4000Hz Sample Rate

5.4.3 Synchro Mode

To process algorithms that need synchronized samples (for example distance with multiple MUs) coming from several Merging Units, we need to differentiate if the Sample Values (SV) are:

- not synchronized (one Merging Unit),
- synchronized with a local area clock (substation),
- synchronized with a global area clock (GPS...)

Three values are available:

- Global Clock
The relay will generate an alarm if MU synchronization is not “global area synchronization”
- Local Clock
The relay will generate an alarm if the MU synchronization is not global or local synchronization
- No SYNC CLK
The relay will not generate a synchronization alarm

With the exception of current differential, the loss of synchronization does not automatically block functions using these inputs. Whether a function needs to be blocked will depend on whether it uses signals from separate MUs. This will vary by application and affected functions should be blocked by linking the Synch Alarm to the affected function block input in the PSL.

5.4.4 Data Quality

Any degradation in the measurement or transmission of Sampled Values means that the protection function of the IED may not operate correctly. Therefore, to be able to detect invalid or questionable data, the IEC 61850 protocol assigns quality flags to each channel in the Sampled Value frame.

Data frames from a typical MU with, for example, four voltages and four currents [VA, VB, VC, VN, IA, IB, IC, IN] have quality flags for each of the channels. The IED adapts the behaviour of protection functions according to the quality flags. See the examples in the *Analogue Channel Groups* section.

The front panel of the IED shows the quality flags for each of the analogue channel groups configured. The number of analogue channel groups depends on the IED type.

To make protection functions work correctly, the Sampled Values arriving at the IED should have Good quality, as defined by the IEC 61850 or IEC61869 standards. Samples that have an Invalid or Questionable quality could result in unacceptable performance from the protection functions.

A protection function operates normally when all the necessary Sampled Value inputs are available and have a Good quality flag. When the flag for one or more of the Sampled Value inputs changes to Invalid or Questionable, the protection function is temporarily inhibited. The protection function returns to normal state when the quality flags for all the necessary Sampled Value inputs are Good. The quality flags can change with each sample, therefore there is a one-cycle transition delay between the Normal and Inhibit states for each protection function.

5.4.5 Analogue Channel Groups

The following tables shows how Sampled Value errors affect protection functions in the IED in different products.

Note

The quality for analogue groups is commoned. For example, if one CT channel has poor quality, all channels in the CT group are given poor quality. When the P746 is used in 3 box mode the same quality is given to each group of 3 current channels.

For example, overcurrent protection can be configured as directional, in which case the voltage inputs have an impact on the function. In another case, the quality of the voltage input is not important if the overcurrent is non-directional. The meanings are shown here:

- = the SMV quality affects inhibit states of the protection function.
- = the protection function is affected where configured to work with this input.
- = the frequency protection operates if any input has good quality.
- = the protection operates if configured to work with this input and it has good quality.

The possible options are in these sections:

- 5.4.5.1 - Products with one set of CT, P145
- 5.4.5.2 - Products with one set of CT, P443, P543, P841A
- 5.4.5.3 - Products with two sets of CT, P446, P546, P841B
- 5.4.5.4 - Products with three sets of CT, P643
- 5.4.5.5 - Products with five sets of CT, P645
- 5.4.5.6 - Products with two sets of CT, P442
- 5.4.5.7 - Products with seven sets of CT, P746

5.4.5.1 Products with one set of CT, P145

Protection for Products with one set of CT, P145	Groups					Comments
	CT	VT	CS VT	IN CT	SEN CT	
Overcurrent Protection	●	○				
Negative Sequence	●	○				
Broken Conductor	●					
Earth Fault 1 Protection		○		●		

Protection for Products with one set of CT, P145	Groups					Comments
	CT	VT	CS VT	IN CT	SEN CT	
Earth Fault 2 Protection	●	○				
REF Protection	○			○	○	
SEF Protection		○			●	
Residual Overvoltage		●				
Voltage Protection		●				
System check		●	○			
Thermal Overload	●					
Admit Protection		●		○	○	
Power Protection	●	●				
Sensitive Power Protection		●			●	
VTS	●	●				
CTS	●	●				
CB Fail	■			■	■	
Frequency Protection	■	■				

Table 10 - How sample quality impacts protection (P145)

5.4.5.2 Products with one set of CT, P443, P543, P841A

Protection for Products with one set of CT, P443, P543, P841A	Groups					Comments
	CT1	Mutual CT	VT	CS VT1	Sen CT	
Differential Protection	●		○			
Distance Protection	●	○	●			
Directional Earth Fault	●		●			
Overcurrent Protection	●		○			
Negative Sequence	●		○			
Broken Conductor	●					
Earth Fault Protection	●		○			
REF Protection					●	
SEF Protection			○		●	
Residual Overvoltage			●			
Voltage Protection			●			
Check Sync			●	●		
Loss of Load	●					
Thermal Overload	●					
VTS	●				●	
CTS	●				○	
CB Fail	■				■	
Frequency Protection	■		■			

Table 11 - How sample quality impacts protection (P443, P543, P841A)

5.4.5.3 Products with two sets of CT, P446, P546, P841B

Protection for Products with two sets of CT, P446, P546, P841B	Groups							Comments
	CT1	CT2	Mutual VT	VT	CS VT1	CS VT2	SEN CT	
Differential Protection	●	●		○				
Distance Protection	●	●	○	●				
Directional Earth Fault	●	●		●				
Overcurrent Protection	○	○		○				
Negative Sequence	●	●		○				
Broken Conductor	●	●						
Earth Fault Protection	●	●		○				
REF Protection							●	
SEF Protection				○			●	
Residual Overvoltage				●				
Voltage Protection				●				
Check Sync				●	○	○		
Loss of Load	●	●						
Thermal Overload	●	●						
VTS	●	●		○				
CTS	●	●		○				
CB1 Fail	■						■	
CB2 Fail		■					■	
Frequency Protection	■	■		■				

Table 12 - How sample quality impacts protection (P446, P546, P841B)

If only one CT is configured the first table would apply to whichever CT is configured.

When both CTs are configured within IED configurator the second table would apply.

5.4.5.4 Products with three sets of CT, P643

Protection for Products with three sets of CT, P643	Groups								Comments
	CT1	CT2	CT3	TN1	TN2	TN3	Main VT	Aux CT	
Overcurrent protection	○	○	○				○		
Negative phase sequence overcurrent	○	○	○				○		
Earth Fault protection (Derived)	○	○	○						
Earth Fault protection (Measured)				○	○	○			
REF protection (REF HV)	○			●					
REF protection (REF LV)			○		●				
REF protection (REF TV)		○				●			
Residual overvoltage							●		
Thermal overload (HV)	●								
Thermal overload (LV)			●						
Thermal overload (TV)		●							
Thermal overload (Bias)	●		●						

Protection for Products with three sets of CT, P643	Groups								Comments
	CT1	CT2	CT3	TN1	TN2	TN3	Main VT	Aux CT	
Overtoltage protection							•		
Undervoltage protection							•		
Negative sequence overvoltage							•		
Differential protection	•	•	•						
Overfluxing protection							•		
Through fault (HV)	•								
Through fault (LV)			•						
Through fault (TV)		•							
VTS							•		
CTS	•	•	•						
Frequency protection	■	■	■	■	■	■	■	■	

Table 13 - How sample quality impacts protection (P643)

5.4.5.5 Products with five sets of CT, P645

Protection for Products with five sets of CT, P645	Groups										Comments
	CT1	CT2	CT3	CT4	CT5	TN1	TN2	TN3	Main VT	Aux VT	
Overcurrent protection	○	○	○	○	○				○		
Negative phase sequence overcurrent	○	○	○	○	○				○		
Earth Fault protection (Derived)	○	○	○	○	○						
Earth Fault protection (Measured)						○	○	○			
REF protection (REF HV)	○	○	○	○	○	•					
REF protection (REF LV)		○	○	○	○		•				
REF protection (REF TV)		○	○	○				•			
Residual overvoltage									•		
Thermal overload (HV)	•	○	○	○							
Thermal overload (LV)		○	○	○	•						
Thermal overload (TV)		○	•	○							
Thermal overload (Bias)	•	○	○	○	•						
Overtoltage protection									•		
Undervoltage protection									•		
Negative sequence overvoltage									•		
Differential protection	•	○	○	○	•						
Overfluxing protection									•		
Through fault (HV)	•	○	○	○							
Through fault (LV)		○	○	○	•						
Through fault (TV)		○	•	○							
VTS									•		
CTS	•	○	•	○	•						
Frequency protection	■	■	■	■	■	■	■	■	■	■	

Table 14 - How sample quality impacts protection (P645)

5.4.5.6 Products with two sets of CT, P442

Protection for Products with two sets of CT, P442	Groups				Comments
	Main VT	CS VT	Phase CT	Mcomp CT	
Distance Protection	●		●	○	
Directional and Non-Directional Overcurrent	○		●		
Negative Sequence Overcurrent	○		●		
Under current Protection			●		
Directional and Non-Directional Earth Fault Protection	○		●		
Aided Directional Earth Fault Protection	○		●		
Thermal Overload			●		
Broken Conductor Detection			●		
Over voltage	●				
Residual Overvoltage	●				
Under voltage	●				
Frequency protection	■		■		
VTS	●		●		
CVTS	●				
CTS	●		●		
System Checks	●	●			

Table 15 - How sample quality impacts protection (P442)

5.4.5.7 Products with seven sets of CT, P746

Protection for Products with seven sets of CT, P746	Groups								Comments
	VT (see Note 1)	CT1	CT2	CT3	CT4	CT5	CT6	CT7 (see Note 2)	
Diff protection		●	●	●	●	●	●	●	
Dead Zone OC		●	●	●	●	●	●	●	
Phase Comp		●	●	●	●	●	●	●	
Over Current	○	●	●	●	●	●	●	●	
Earth Fault		●	●	●	●	●	●	●	
Cct fail		●	●	●	●	●	●	●	
VTS		●							
CTS		●	●	●	●	●	●	●	

Note 1 VT is only for P746 B5A or later.

Note 2 CT7 is only for P746 C5A or later.

Table 16 - How sample quality impacts protection (P746)

5.5 Simulation SV

Process Bus relays can be configured to subscribe to normal or simulation SVs. This is achieved by modifying the setting cell **Sub.Sim.Signal** in **IED Configurator** menu. The setting can be set to Yes or No.

In the data package of the SV frame, one bit is used to indicate the SV is 'Simulated' SV or normal SV. When **Sub.Sim.Signal** is set to No, only normal SV will be subscribed. When **Sub.Sim.Signal** is set to Yes, an alarm "Sim.Signal Alm" will be raised, the behaviour of the relay is the same as handling simulation GOOSE. The relay will subscribe normal SV until it finds a corresponding simulation SV. It will then subscribe to the simulation SV.

Warning

The Sub.Sim. Signal must be disabled after testing.

5.6 Merging Unit (MU) Out-Of-Service (OOS) Configuration

Primary plant and its associated Merging Unit (MU) may be placed out of service but require the protection to remain in service. For example, a tie breaker on a breaker-and-a-half scheme may be taken Out Of Service (OOS) for maintenance. During this time the feeder is still in service being fed from the other breaker, therefore the protection needs to be active. If the MU stream is missing, has bad quality or is in test mode the protection would normally be disabled. To enable the relay to operate under these conditions a setting **MU OOS Config** is implemented to set one or more MUs to be run in OOS mode. When a MU is set to OOS, no matter what the actual Sampled Value is, the process bus board will set the analogue value and the quality of the MU to 0 with good synchronization. When one or more MU are set to OOS mode, an alarm "MU OOS Alarm" will be raised.

5.7 Analogue Channel Switching

The analogue channels may need to be switched from one CT/VT to another CT/VT during operation. The analogue channels switching function is setup in the CID configuration. The PSL is then used to energize one or more dedicated DDB signals to switch the streams.

The relay allows the user to switch all main CT and VT analogue channels input between two independent Sampled Value frames while the IED is in service. This may correspond to two separate CT or VT in the primary system. The single-phase check synchronizing voltages is also allowed to be selected from two independent Sampled Value frames.

Every check synchronizing voltage channel is controlled by a DDB, but different products may have different number of check synchronizing voltage channels. For example, P543 only has one such channel (Vcs1), while P546 has two channels (Vcs1 and Vcs2). Vcs1 switching is always controlled by DDB_VCS1_ALT, Vcs2 switching is always controlled by DDB_VCS2_ALT. All other analogue channels are controlled by another DDB, which is DDB_CHAN_ALT. If a product does not have check synchronizing, it will only have one dedicated DDB to be used to control channel switching.

It can take up to 100ms for the relay to switch channels. This is normally performed when the affected function is off-line (e.g. check synch input is not switched at the same time as synch check is being performed). A switching transient may be produced, particularly if there is a phase difference between the signals. This transient could appear as a frequency change or current/voltage delta. If on line switching is to be used this may require elements to be blocked to ensure the transients do not affect connected functions.

5.7.1 Switch Check Synchronizing Voltage Channel

Assume we are using a P543 relay which only has Vline and Vcs1 which are compared for the check synch function. If the line is connected to B-I the relay needs to compare Vline vs VT B-I but if the line is connected to B-II the relay needs to compare VLine vs VT B-II. In process bus application VT B-I and VT B-II can be provided by 1 or 2 different Merging Units. The measured value of VT B-I and VT B-II will be published and the relay needs to be able to subscribe the appropriate stream based on the position of busbar isolators.

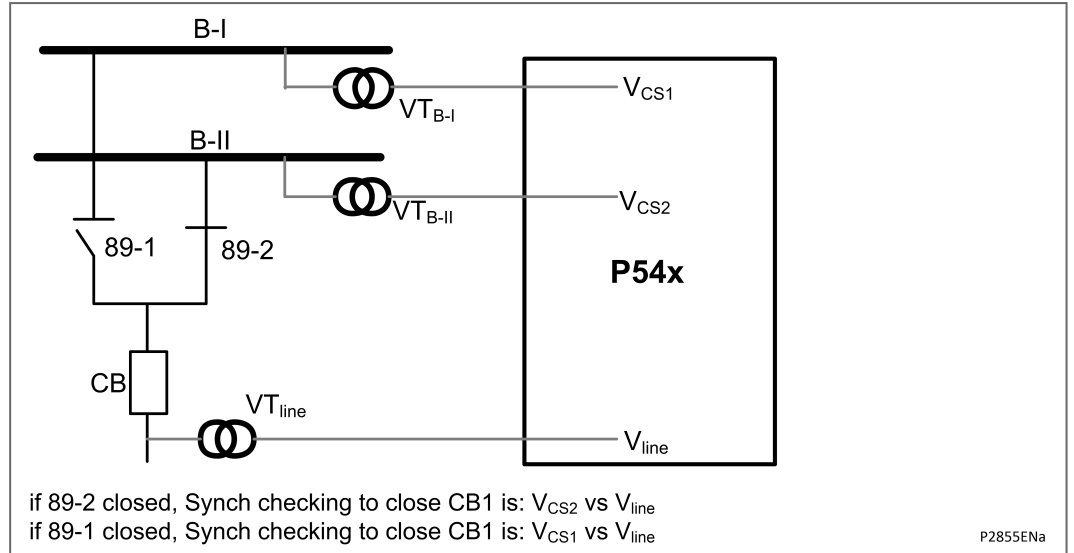

Figure 12 - A typical P543 application

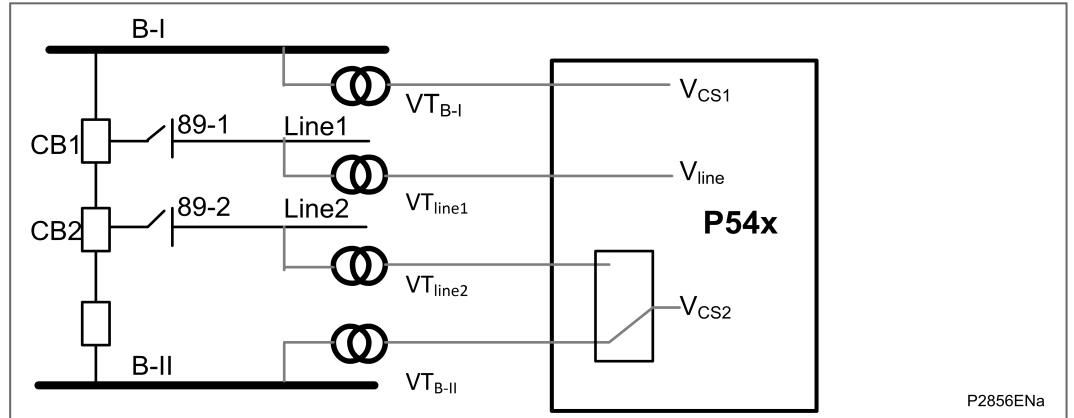

Figure 13 - One CB and a half application

As it can be seen in one-and-a-half breaker configuration, up to 4 VT measurements may be required. Therefore, the PB application requires access to the same measurements. In a traditional scheme the Vcs2 is fed from an external voltage selection scheme based on isolator positions. To replicate this functionality in PB we need to replace the voltage selection by stream switching based on the same logic used to operate the traditional voltage selection scheme.

To switch a check synchronizing channel, configure an OR operator using IED configurator as shown below:



Figure 14 - IED configurator

The switching is controlled by the status of the DDB_VCS1_ALT. The PSL configuration and the logic is shown in the following table. When Opto Input 1 is energized, DDB_VCS1_ALT becomes TRUE, and then Ubus is switched from the 8th channel of MU1 to the 8th channel of MU2.

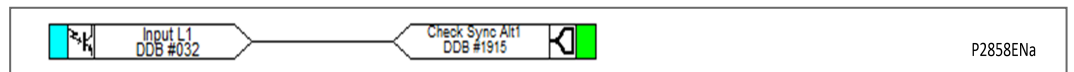

Figure 15 - PSL configuration and logic

DDB_VCS1_ALT Status	Check Sync Voltage Source
0	Check synchronizing voltage frames of MU1

DDB_VCS1_ALT Status	Check Sync Voltage Source
1	Check synchronizing voltage frames of MU2

Table 17 - PSL configuration and logic

5.7.2 Switch Other Analogue Channels

To switch the three-phase voltage configure the CID as shown below:

Analog channel parameters

	MU No.	Index	Operation	MU No.	Index
Element Name:Ua	MU1	5	OR	MU2	5
Element Name:Ub	MU1	6	OR	MU2	6
Element Name:Uc	MU1	7	OR	MU2	7

P2859ENa

Figure 16 - OR Operation

The switching is controlled by the status of the DDB_CHAN_ALT. The logic is shown in the following table.

DDB_CHAN_ALT Status	Three Phase-Voltage Source
0	Voltage frames of MU 1
1	Voltage frames of MU2

Table 18 - Switching logic

5.8 Measurement Operation

Besides analogue channel switching, the relay also provides two Sampled Value operations for all channels, the two operations are plus and minus.

5.8.1 Measurement Addition Operation

An analogue channel can be configured to give the Sampled Value addition from two separate SVs.

Element Name:Im MU1 4 + MU2 4

Figure 17 - Configure analogue channel for addition

If Sampled Value addition operation is configured for Im, the actual value of Im will be the Sampled Value summation of the 4th data channel of MU1 and the 4th data channel of MU2.

5.8.2 Measurement Subtraction Operation

An analogue channel can be configured to give the Sampled Value difference result from two separate SVs.

Element Name:Ia MU1 1 - MU2 1

Figure 18 - Configure analogue channel for subtraction

If Sampled Value plus operation is configured for Ia, the actual value of Ia will be the Sampled Value difference of the 1st data channel of MU1 and the 1st data channel of MU2.

5.9 IEC61850 Enhanced Features

5.9.1 Two Dedicated GOOSE Control Blocks

In addition to the existing 16 GOOSE control blocks, the Process Bus relays provide two dedicated GOOSE Control Blocks, GCB17 and GCB18. Only these two GCBs can be published via the Process Bus board. The existing 16 GCBs can only be published via the Station Bus board.

Caution

Only GOOSE VOP information can be published via Process Bus GOOSE control blocks.

5.9.2 GOOSE VIP

All GOOSE VIP signals will be detected by both Station Bus and Process Bus boards, which means different VIP signals should be used in different networks, Station Bus network or Process Bus network.

If a GOOSE is published to both Station Bus network and Process Bus network, both Station Bus board and Process Bus board will subscribe to the GOOSE.

Caution

The Station Bus and Process Bus boards should not be connected to the same network to avoid bandwidth and quality of service issues.

5.10 Current Differential Function

The feeder differential function uses a P543 or P546 at each end of the protected circuit which can be a two ended or three-ended scheme depending on the application. The IEDs send local current information to the remote ends. The decisions whether to trip are made locally after calculating the bias and differential currents based on the received currents.

For the current differential function to work correctly, Sampled Values from each end of the feeder must be synchronized to correspond to the same time instant. This also applies to any other quantities derived from samples such as Fourier values. This is essential to properly evaluate bias and differential currents and if not synchronized could result in false differential currents and unwanted operation of the differential scheme.

In a differential scheme with conventional P543 or P546 IEDs, either:

- time stamps plus current information is exchanged between the IEDs
- all the IEDs in the scheme are synchronized to 1 PPS GPS inputs.

When the IEDs in the scheme have a Process Bus interface, the synchronization must account for delays in receiving Sampled Values over the Process Bus network. This is not important for conventional IEDs where the primary CTs are directly wired to the IED's analogue inputs. The following diagram shows P546 IEDs at both line ends with Process Bus. The Merging Units and the Sampled Value distribution networks at End A and End B are independent of each other. Therefore, the Sampled Values may arrive at the P546 IEDs with different delays.

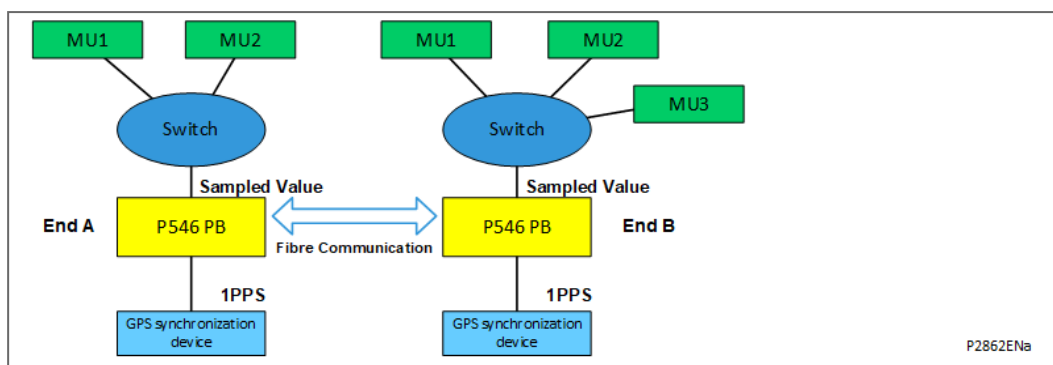

Figure 19 - Two-ended P54x scheme with Process Bus IEDs at both ends

To synchronize the Sampled Values across multiple P546 IEDs with Process Bus interfaces, all must be synchronized using a 1 PPS GPS signal from a GPS synchronization device. This applies for all IEDs in the scheme when one or more of the feeder ends uses Sampled Value inputs.

These conditions are also needed for the feeder differential function to work correctly:

- All P54x IEDs in the scheme must work in GPS Synchronized mode and must have 1PPS GPS inputs from the GPS synchronization device.
- At all line ends, the Merging Units in the feeder differential scheme must use a reference time clock for synchronization. For example, IEEE 1588 or GPS synchronized 1PPS.
- The GPS sources for the P54x IEDs and the Merging Units must be synchronized as they may not be common.
- The first Sampled Value frame from the Merging Units for each second has a sequence count of 0. This corresponds to a zero-time offset from the start of the second.

The P54x uses the sample count in the Sampled Value frames, plus its own 1PPS GPS synchronization input, to calculate delays between 1PPS trigger and the time when coprocessor board has detected the current sample is calculated based on the sample with SmpCnt 0. The P54x then time-aligns them before performing bias and differential currents calculations. The delay is recalculated every second to adapt to any changes in the Process Bus, enhancing the security of the protection scheme.

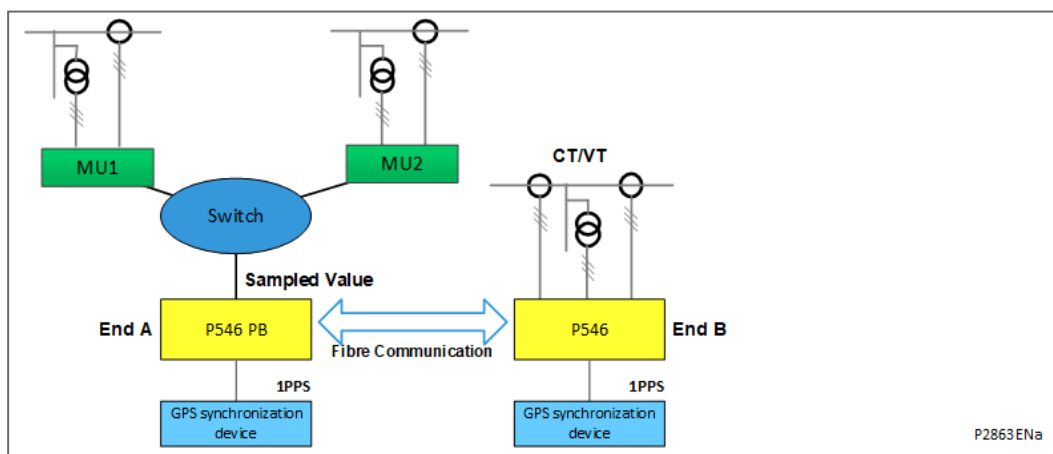

Figure 20 - P54x PB IED scheme and conventional P54x IED combined in a current differential scheme

The current differential scheme is inhibited at all feeder ends if any of the following conditions occur:

- The Sampled Value frames received at the P54x are not synchronized.
- The 1PPS input to the P54x is not GPS synchronized.

- The setting **PB CONFIG->Synchro Mode** is set to **No_SYNC_CLK**.
- There is a delay of 10 ms or more between the receipt of a Sampled Value frame with SmpCnt 0, and the 1 PPS input pulse to the P54x indicating the start of the second.

When the GPS synchronization recovers in any of these cases, the current differential scheme inhibit is removed on the next occurrence of the 'SmpCnt 0' in the Sampled Value frames.

Note

Dual Redundant scheme is not supported when P54x Process Bus IEDs and conventional P54x IEDs are combined in a current differential scheme.

Note

It is not allowed that PROT COMMS/IM64 -> GPS Sync is set to GPS Disabled when P54x Process Bus IEDs are in the scheme. It might cause current differential mal-operation.

Note

When P54x Process Bus IEDs are in the current differential scheme, Rx Propagation Delay and Tx Propagation Delay can't be calculated separately, it is an average value.

Note

When PB CONFIG -> Synchro Mode is set to Local, all Merging Units and the relay 1PPS sources in the scheme must be connected to the same time source.

5.11 Configuration Examples

In this section, some configuration and connection examples will be displayed as references. In the following diagrams, the Merging Units (MU) are illustrated as follows:

- The first line contains the measured currents and voltages
- The second line contains the Merging Unit reference
- The third line illustrates the dataset elements used by the Process Bus board

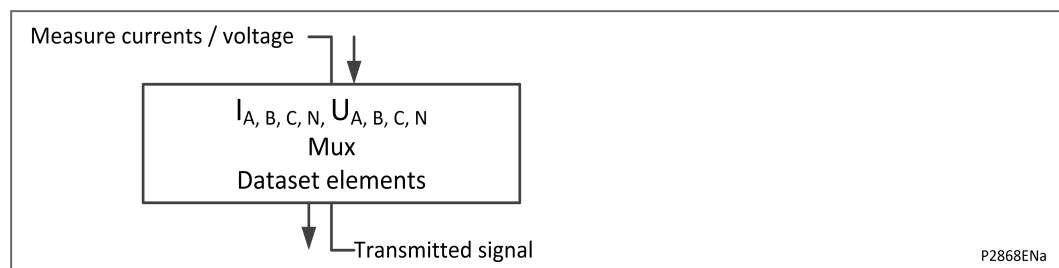

Figure 21 - Measured currents/voltages and transmitted signal

Note the standard inputs and outputs defined by PhsMeas1 have been used in these examples. In IEC61850-9LE this structure is fixed, however, the MU will send whatever signal is applied to the physical input on the corresponding channel. For example, a check synch voltage could be applied to the U_N input and the MU would send this value as U_N in the SV stream. Since the P40 relays allow flexible channel allocation the U_N element can be assigned to the check synch voltage input. This also applies to IEC61869, however, it also supports other PhsMeasx datasets allowing custom datasets to also be used. The flexible channel allocation can then be used to assign any relay input to the appropriate channel.

The examples given here include:

- 5.11.1 - Example 1 - Line Protection
- 5.11.2 - Example 2 - Line Protection with Mutual Coupling
- 5.11.3 - Example 3 - Line protection with Check Synch
- 5.11.4 - Example 4 - Double Bus Line Protection with Check Synch
- 5.11.5 - Example 5 - Breaker and a Half with Mutual Coupling and Check Synch

5.11.1 Example 1 - Line Protection

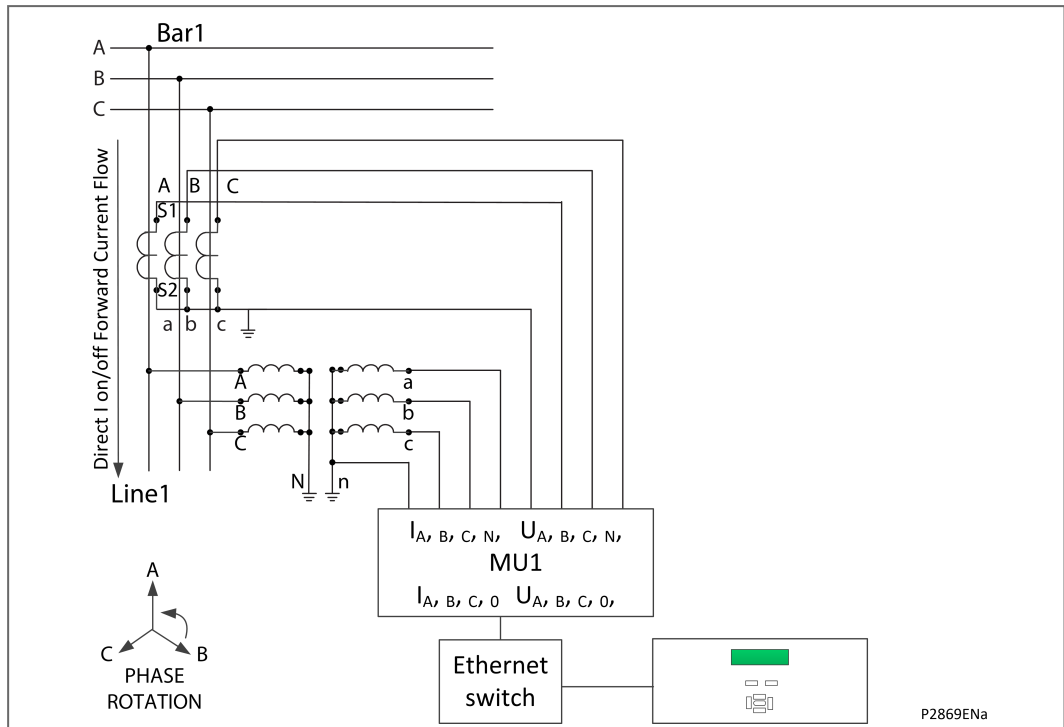

Figure 22 - Connection

Analog channel parameters

	MU No.	Index	Operation	MU No.	Index
Element Name:Ua	MU1	5	N/A	0	0
Element Name:Ub	MU1	6	N/A	0	0
Element Name:Uc	MU1	7	N/A	0	0
Element Name:Ubus	0	0	N/A	0	0
Element Name:ia	MU1	1	N/A	0	0
Element Name:ib	MU1	2	N/A	0	0
Element Name:ic	MU1	3	N/A	0	0

P2870ENa

Figure 23 - CID configuration

5.11.2 Example 2 - Line Protection with Mutual Coupling

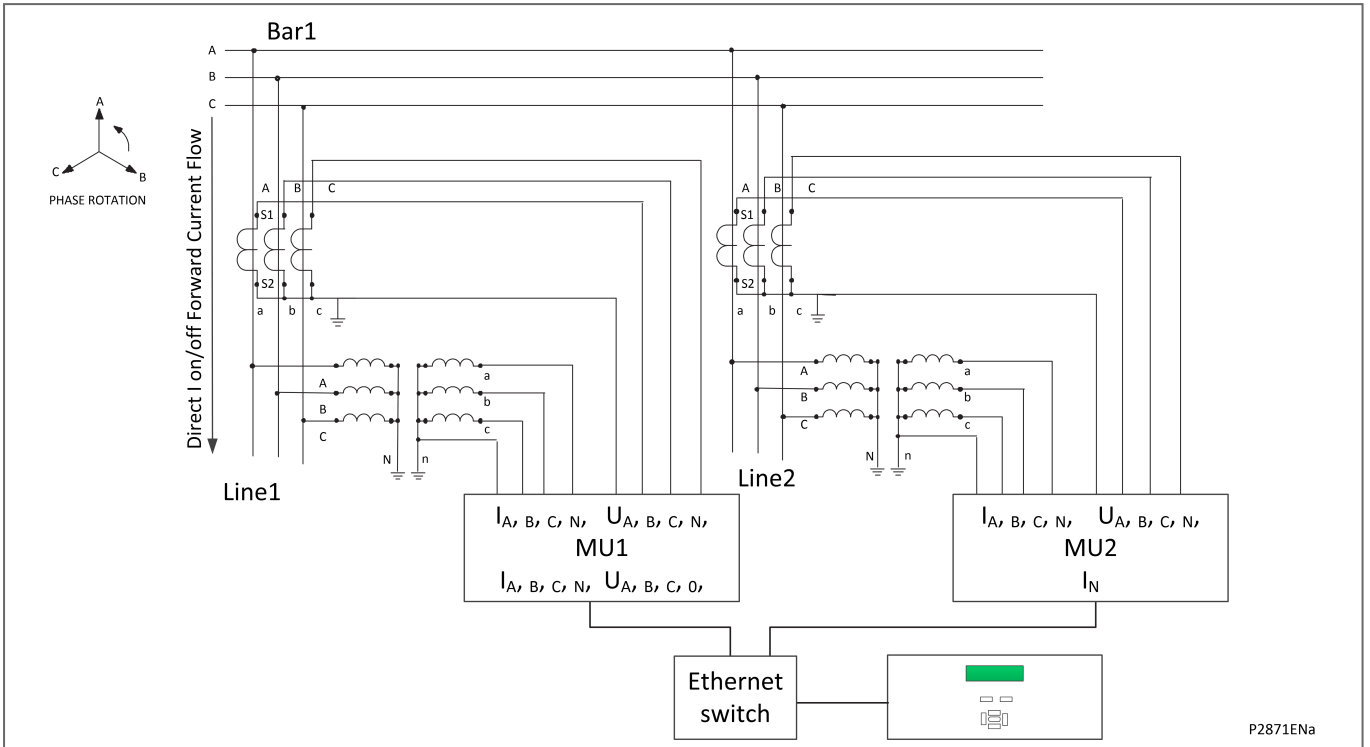

Figure 24 - Connection

Analog channel parameters

	MU No.	Index	Operation	MU No.	Index
Element Name:Ua	MU1	5	N/A	0	0
Element Name:Ub	MU1	6	N/A	0	0
Element Name:Uc	MU1	7	N/A	0	0
Element Name:Ubus	0	0	N/A	0	0
Element Name:ia	MU1	1	N/A	0	0
Element Name:ib	MU1	2	N/A	0	0
Element Name:ic	MU1	3	N/A	0	0
Element Name:im	MU2	4	N/A	0	0
Element Name:is	MU1	4	N/A	0	0

P2872ENa

Figure 25 - CID configuration

5.11.3 Example 3 - Line protection with Check Synch

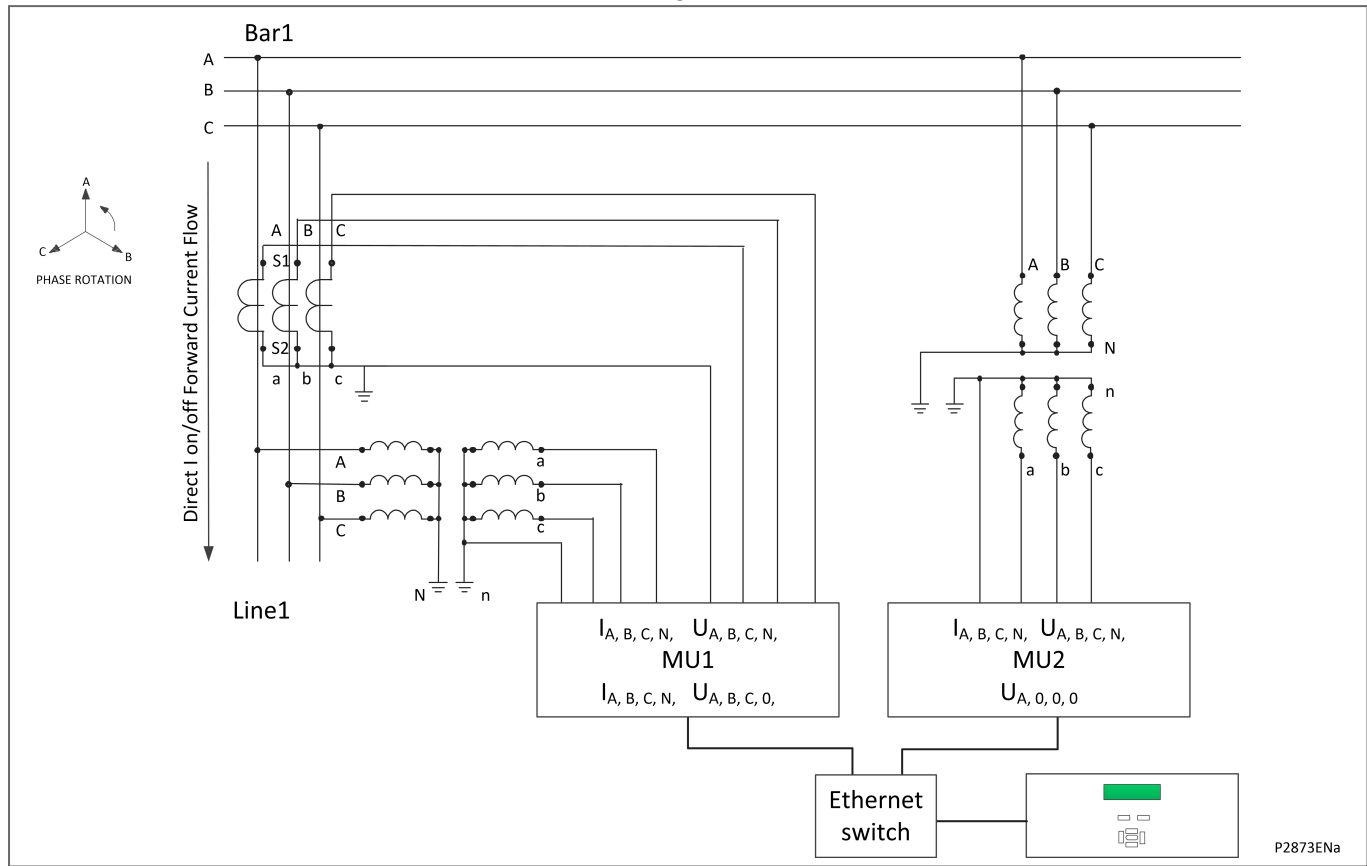

Figure 26 - Connection

Analog channel parameters

	MU No.	Index	Operation	MU No.	Index
Element Name:Ua	MU1	5	N/A	0	0
Element Name:Ub	MU1	6	N/A	0	0
Element Name:Uc	MU1	7	N/A	0	0
Element Name:Ubus	MU2	5	N/A	0	0
Element Name:Ia	MU1	1	N/A	0	0
Element Name:Ib	MU1	2	N/A	0	0
Element Name:Ic	MU1	3	N/A	0	0
Element Name:Im	0	0	N/A	0	0
Element Name:Is	MU1	4	N/A	0	0

P2874ENa

Figure 27 - CID configuration

5.11.4 Example 4 - Double Bus Line Protection with Check Synch

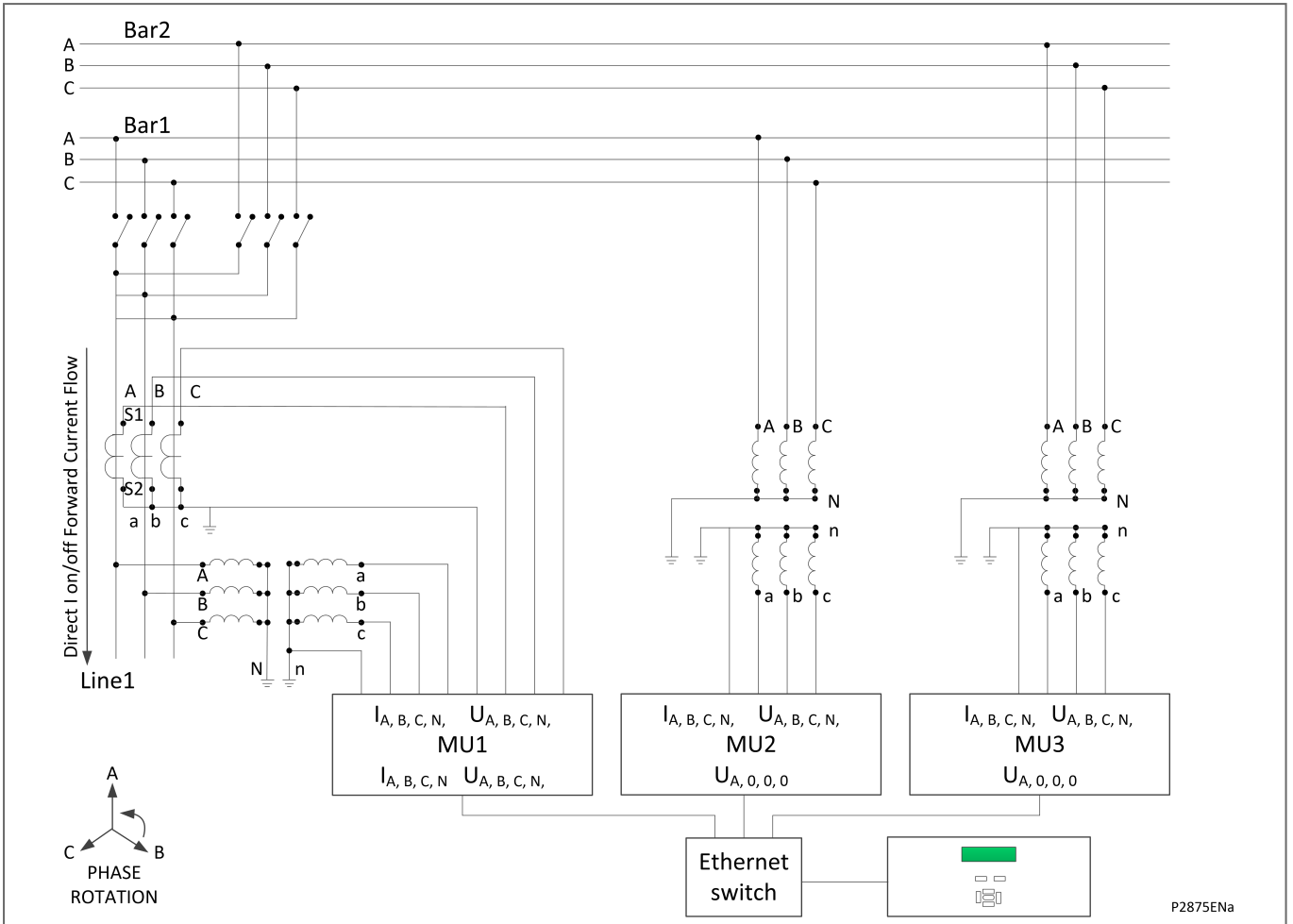

Figure 28 - Connection

Analog channel parameters

	MU No.	Index	Operation	MU No.	Index
Element Name:Ua	MU1	5	N/A	0	0
Element Name:Ub	MU1	6	N/A	0	0
Element Name:Uc	MU1	7	N/A	0	0
Element Name:Ubus	MU2	5	OR	MU3	5
Element Name:la	MU1	1	N/A	0	0
Element Name:lb	MU1	2	N/A	0	0
Element Name:lc	MU1	3	N/A	0	0
Element Name:lm	0	0	N/A	0	0
Element Name:ls	MU1	4	N/A	0	0

Figure 29 - CID configuration

5.11.5 Example 5 - Breaker and a Half with Mutual Coupling and Check Synch

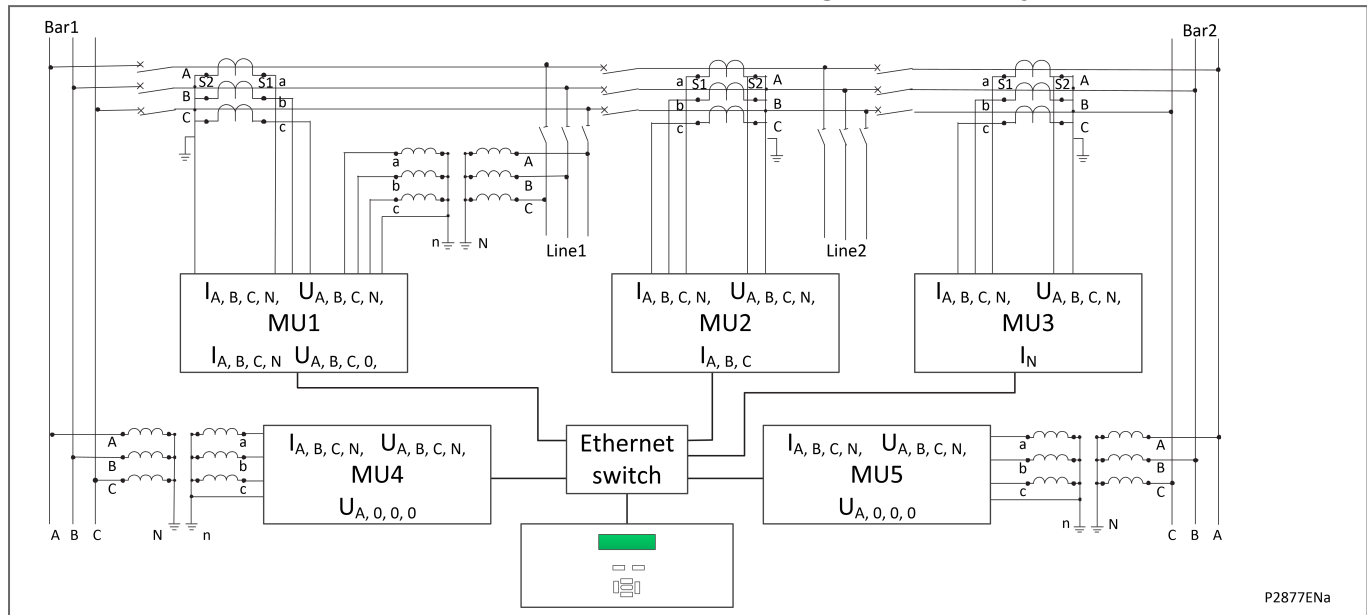

Figure 30 - Connection

Analog channel parameters

	MU No.	Index	Operation	MU No.	Index
Element Name:Ua	MU1	5	N/A	0	0
Element Name:Ub	MU1	6	N/A	0	0
Element Name:Uc	MU1	7	N/A	0	0
Element Name:Ubus	MU4	5	N/A	0	0
Element Name:la	MU1	1	N/A	0	0
Element Name:lb	MU1	2	N/A	0	0
Element Name:lc	MU1	3	N/A	0	0
Element Name:lm	MU3	4	-	MU2	4
Element Name:ls	MU1	4	+	MU2	4
Element Name:la2	MU2	1	N/A	0	0
Element Name:lb2	MU2	2	N/A	0	0
Element Name:lc2	MU2	3	N/A	0	0
Element Name:Ubus2	MU5	5	N/A	0	0

Figure 31 - CID configuration

6. PROCESS BUS COMMISSIONING

Commissioning methods differ slightly, depending on whether the relay uses the Process Bus Interface or not. The relevant details are shown in the **Commissioning** chapter.

CAUTION

When connecting devices using RJ45 wired network cables, precautions for cabling must be taken in order to avoid any risk of electrical shock, please refer to Process Bus Safety Information.

6.1 Product Checks for IEDs which use the Process Bus Interface

6.1.1 IED Configured with One Merging Unit (MU)

The settings for the Process Bus interface are in the IED menu **IED Config**. See the Settings chapter.

1. If necessary, isolate or block any outgoing trips from the IED. If physical contacts from the IED are wired in the scheme, in **COMMISSION TESTS** menu, set **Test Mode** to **Contacts Blocked** if operation of the contacts is not desired. If GOOSE outputs are used, from the main IED menu COMMISSIONING TEST column select **Test Mode**.
2. Connect the IEDs Ethernet port on the Process Bus board to the Sampled Value source. If necessary this can be routed through an Ethernet switch.
3. Make a valid SV configuration (a CID file via **IED Configurator**) and download it to relay and activate the configuration bank.
4. Check that the MU configuration in the CID file matches the actual Sampled Value source (test kit or Merging Unit). Make any changes in the source Sampled Value configuration. This prevents mismatches in Sampled Value when the IED is put into service when testing existing schemes.
5. Set the IED **Synchro Mode** to **No SYNC CLK** so the IED accepts Sampled Value frames with or without synchronization.
6. Generate Sampled Value frames with the rated current and voltage as required in the IED's Sampled Value configuration.
7. In the **MEASUREMENTS** menu, check the magnitudes and phase angles are displayed correctly. The display may be in primary or secondary values. Also, the IED's CT ratio or VT ratio settings affect the display. A typical accuracy of 1% can be expected for magnitudes.
8. Change the SV configuration configured in the test kit or Merging Unit to mismatch the Sampled Value configuration of the relay. Check the data cell **SV Absence Alm** displays '*****1' (where * is a don't care state for this test, normally its value is 0) for the Merging Unit configured in the CID. Check that all **MEASUREMENTS** displays for voltage or current are zero.
9. Depending on the scheme, if Merging Unit is configured to publish SV in IEC61869 format, set **SMV Version** to IEC61869, if Merging Unit is configured to publish SV in IEC61850-9-2LE compatible format, set **SMV Version** to **IEC61850-9-2LE**.

6.1.2 IED Configured with Two or More Merging Units (MUs)

The settings for the IEC61850-9-2LE or IEC61869 interface are in the IED menu **PB CONFIG**.

1. If necessary, isolate or block any outgoing trips from the IED. If physical contacts from the IED are wired in the scheme, in **COMMISSION TESTS** menu, set **Test Mode** to **Contacts Blocked** if operation of the contacts is not desired. If GOOSE outputs are used, from the main IED menu COMMISSIONING TEST column select **Test Mode**.

2. Connect the IEDs Ethernet port on Process Bus board to an Ethernet switch, which is connected to the Sampled Value sources. If necessary this can be routed through an Ethernet switch.
3. Make a valid SV configuration (a CID file via **IED Configurator**) and download it to relay and activate the configuration bank.
4. Check that the MU configuration in the CID file matches the actual Sampled Value source (test kit or Merging Unit). Make any changes in the source Sampled Value configuration. This prevents mismatches in Sampled Value when the IED is put into service when testing existing schemes.
5. Set the IED Synchro Alarm to 'Local Clock' so the IED accepts Sampled Value frames with local or global synchronization.
6. Check that the Sampled Value source (test kit or Merging Unit) is GPS synchronized.
7. Check the receipt of Sampled Value frames one by one for each Logical Node configured in the IED.

Repeat the following steps for each Merging Unit, configuring them one by one in the Sampled Value source(s).

1. Generate Sampled Value frames with the rated current and voltage as required in the IED's Logical Node configuration. You can check the receipt of Sampled Value frames for the configured Logical Node.
2. In the **MEASUREMENTS** menu, check the magnitudes and phase angles are displayed correctly. The display may be in primary or secondary values. Also, the IED's CT ratio or VT ratio settings affect the display. A typical accuracy of 1% can be expected for magnitudes.
3. Change the SV configuration configured in the test kit or Merging Unit to mismatch the Sampled Value configuration of the relay. Check the data cell **SV Absence Alm** displays '00000001' (where * is a don't care state for this test, normally its value is 0) for the first Merging Unit configured in the CID, or '*****1*' (where * is a don't care state for this test, normally its value is 0) for the second Merging Unit configured in the CID. Check that all **MEASUREMENTS** displays for voltage or current are zero.

6.2 GPS Synchronization for IEDs which use the Process Bus Interface

The P54x has a feature whereby the timing information used to align the local and remote current vectors used in the phase differential algorithm can be very accurately synchronized via the Global Positioning Satellite (GPS) system. If specified, a GPS synchronizing unit is employed to decipher GPS signals and provide the P54x relay with a suitable synchronizing signal.

If the P54x is using GPS synchronization to enhance the phase current differential protection, then the associated GPS synchronization device unit will need to be commissioned in accordance with the relevant commissioning instructions. Please refer to GPS synchronization device manual.

6.3 Commissioning Mode for P54x Relay with Process Bus

The P54x needs a 1PPS GPS input to function correctly. See the IED manual for GPS synchronization tests.

6.4 Commissioning Mode

Global synchronization is needed for a current differential scheme to function correctly. The protection function is inhibited if global synchronization is not present. As IED test kits may not be able to generate Sampled Value frames with global synchronization, the IED has a commissioning mode which allows the differential function to be tested with local synchronization alone.

1. In the **PB CONFIG** menu, set **Synchro Mode** to *Local Clock*. The current differential protection function then executed for Sampled Value frames received with either Local Clock or Global Clock synchronization. But if Merging Unit is not synchronized with global 1 PPS signal, the differential current will be compared to actual differential current, the value only can be used as a reference due to the phase rotation basis is not established.
2. Test the current differential protection function using a test kit synchronized to GPS, publishing Sampled Value frames with Local Clock synchronization.
3. When the commissioning tests are complete, set the **Synchro Mode** to *Global Clock* before the IED is returned to service. The current differential protection operates only with Global 1 PPS synchronization.
4. Check the Merging Unit's maximum delay and if necessary adjust the **MUs Delay Offset** setting. If the monitored maximum delay offset is -1, it means the time difference of different SV arrived at device is longer than 3ms, which cannot meet the protection running condition, the whole network needs to be reconfigured to find why there is such a huge transmission delay for some Merging Units.

7. PROCESS BUS CONNECTION DIAGRAMS

Some of the Connection Diagrams differ slightly, depending on whether the relay uses the Process Bus Interface or not. The relevant details are shown in the *Connection Diagrams* chapter.

CAUTION
When connecting devices using RJ45 wired network cables, precautions for cabling must be taken in order to avoid any risk of electrical shock, please refer to *Process Bus Safety Information*.

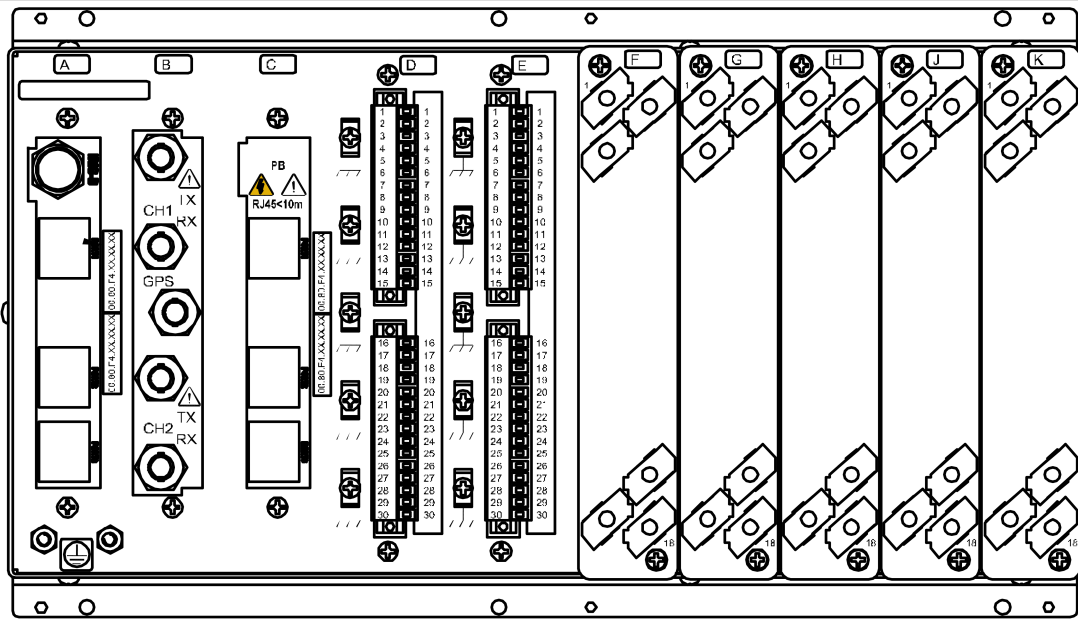

Based on A05002142_Issue B P2921ENa

Code	Board
A	Ethernet Board
B	Coprocessor board*
C	Process Bus Board
D	RTD Board *
E	CILO Board*

Code	Board
F	Opto input board *
G	Opto input board
H	Output Relay Board *
J	Output relay board
K	Power Supply board

Where * means that this board is optional. Whether it is present or not depends on the model.

Figure 32 - MiCOM Px40 process bus – rear view

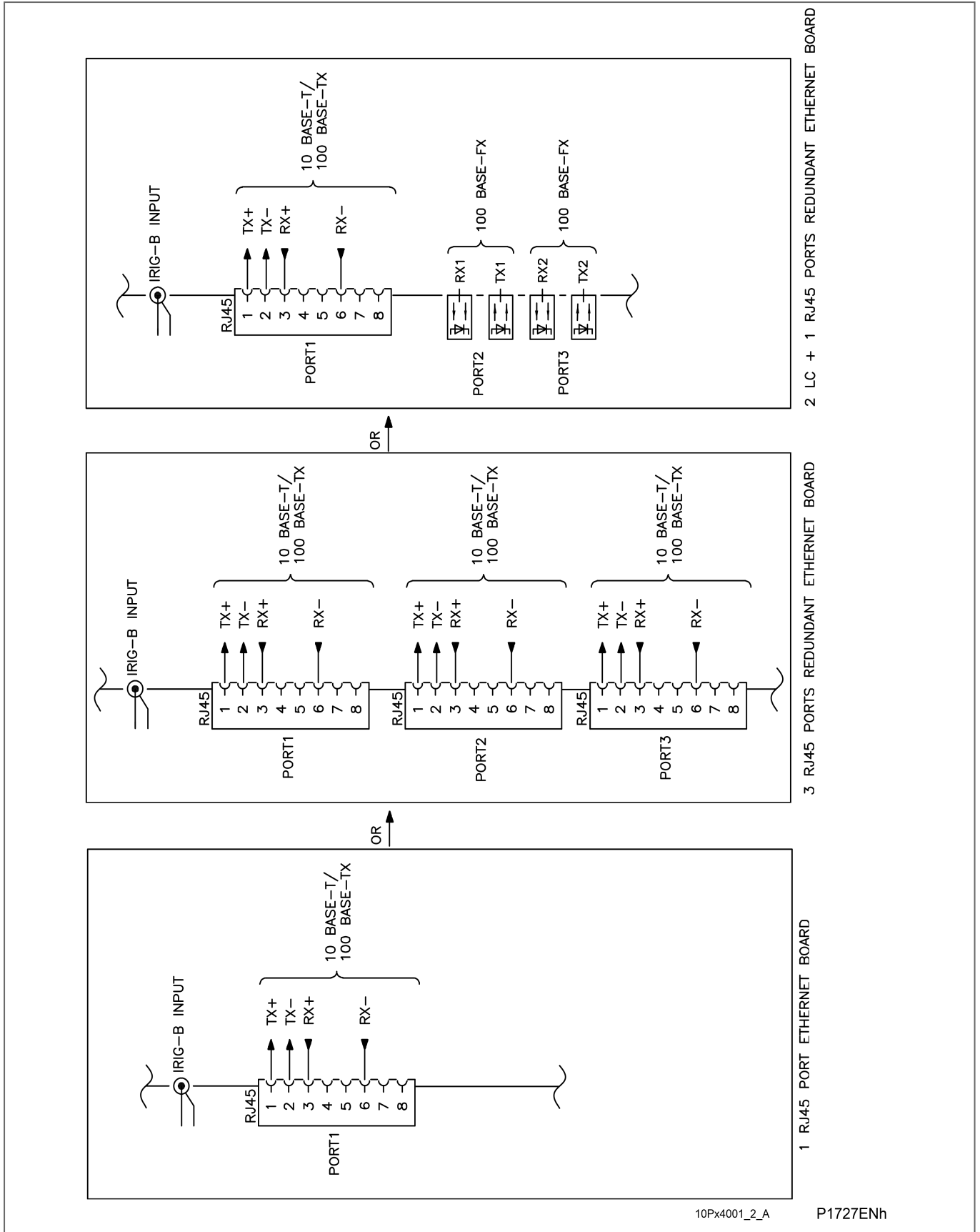

Figure 33 - External communications option MiCOM Px40 platform

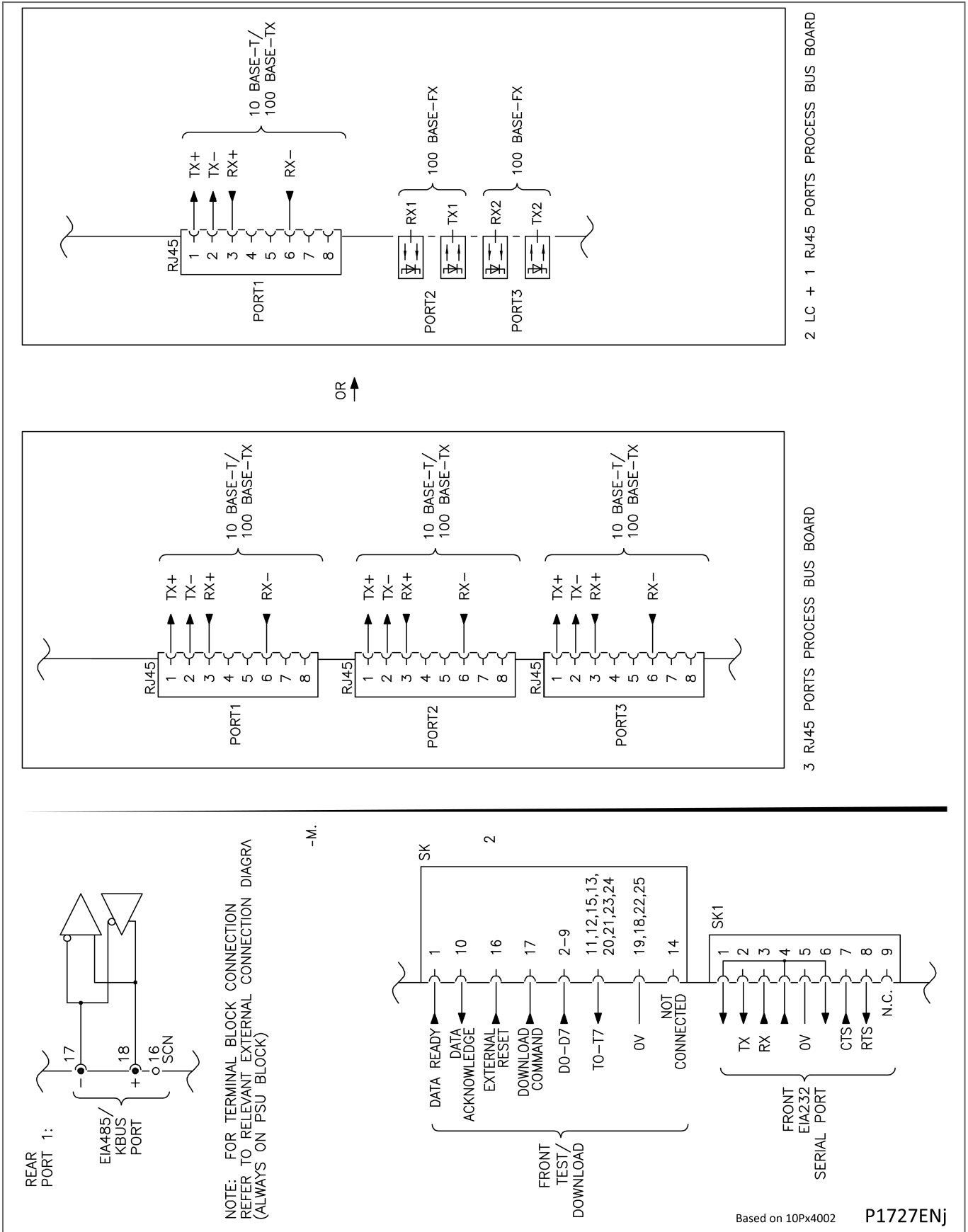

Figure 34 - Ethernet Communications option MiCOM Px40 process bus platform

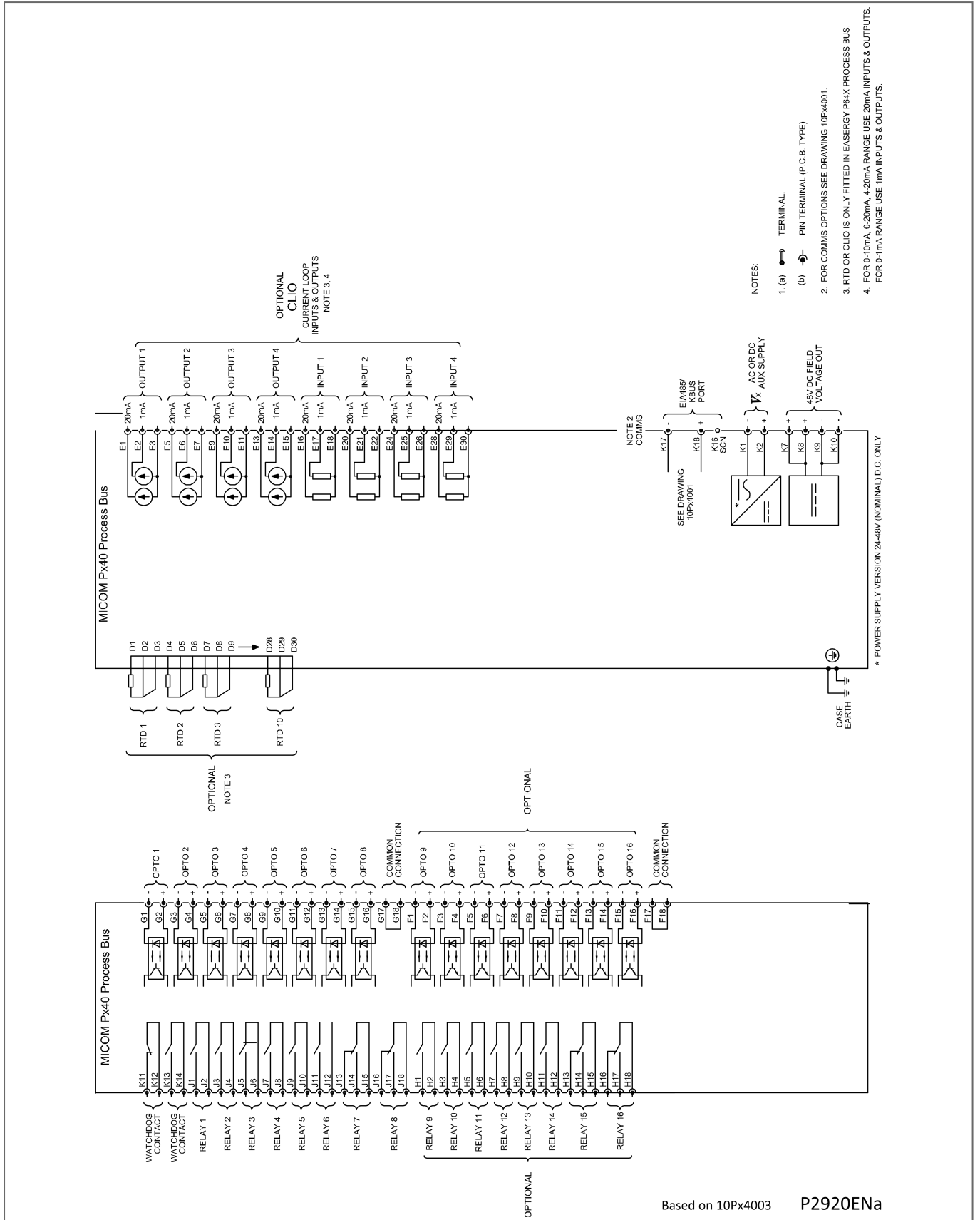

Figure 35 - MiCOM Px40 process bus 8 I/P 8 O/P or 16 O/P (+ CILO & RDT)

Notes:

VERSION HISTORY

CHAPTER 24

Date:	08/2023
Products covered by this chapter:	This chapter covers the specific versions of the MiCOM products listed below. This includes only the following combinations of Software Version and Hardware Suffix.
Hardware suffix:	M
Software version:	K6
Connection diagrams:	10P54302 (SH 1 to 2) 10P54303 (SH 1 to 2) 10P54304 (SH 1 to 2) 10P54400 10P54404 (SH 1 to 2) 10P54405 (SH 1 to 2) 10P54502 (SH 1 to 2) 10P54503 (SH 1 to 2) 10P54504 (SH 1 to 2) 10P54600 10P54604 (SH 1 to 2) 10P54605 (SH 1 to 2) 10P54606 (SH 1 to 2)

CONTENTS

Page (VH) 24-

1	Version History	5
2	Setting File and Relay Software	59
3	PSL File and Relay Software	61
4	Menu Text and Relay Software	63

TABLES

Page (VH) 24-

Table 1 - Software and Hardware Versions	58
Table 2 - Setting file and relay software versions	60
Table 3 - PSL file and relay software versions	62
Table 4 - Menu text and relay software versions	64

Notes:

1 VERSION HISTORY

The Easergy Studio software is updated periodically. These updates provide support for new features (such as allowing you to manage new MiCOM products, as well as using new software releases and hardware suffixes). The updates may also include fixes. **Accordingly, we strongly advise customers to use the latest Schneider Electric version of Easergy Studio.** This table shows the earliest version of the software which lets you use that feature. Unless otherwise stated in the Studio software, the latest version lets you to use all the features of previous versions. If you need more information regarding bug fixes, please contact your **Schneider Electric** local support.

This table shows the Software Version together with the Hardware Suffix the particular software runs on. The changes introduced by each Software Version are shown with each change on one row.

Software version		Hardware suffix	Original date of issue	Description of changes	Easergy Studio compatibility	Technical documentation
Major	Minor					
01	A	A	Feb 2000	First release to production	V1.07 or Later	TG8613A
02	A	A	Mar 2000	PSB. Three settings added to set zone 6 to increase flexibility.	V1.08 or Later	TG8613B
				Protection address. Universal address added.		
				SEF & EF. Polarizing voltage setting range increased.		
				Thermal. Setting range increased.		
				Trip conversion logic. 3 DDB signals added to simplify logic for users.		
				Distance. Min polarizing voltage increased to prevent tripping for close up three phase faults.		
				Check sync. angle measurement improved.		
				PSB. Text for power swing indication improved.		
				Include pole discrepancy logic to P543.		
				Susceptance setting corrected		
03	A	A	May 2000	German text changed.	V1.09 or Later	TG8613B
				Spanish text changed.		
				Changes to DDB names & properties.		
				Improvements in auto-reclose and reset from lockout code.		
				Changes to pole dead & trip conversion logic.		
				Changes to P544 circuit breaker fail logic.		
				Added DDB for CS103 test mode.		
				Recommend upgrading to 03B software or later		
03	B	A	Feb 2002	All builds released for maintenance upgrades.	V1.09 or Later	TG8613B
				Resolved possible reboot caused by disturbance recorder.		
				Resolved possible reboot caused by invalid MODBUS requests.		
				Resolved a loss of measurements (column 3 & 4) problem that can occur in 3 terminal applications.		
				Problem whereby MiCOM S1 could only set group 1 line length corrected.		
				Fixed capacitive charging current compensation in P544.		
				Corrected P544 display of phase C current phase angle.		
				IDMT curves improvements.		
				Removed rounding error in calculation of tp.		
				Menu dependence using ripple bit corrected.		

Software version		Hardware suffix	Original date of issue	Description of changes	Easergy Studio compatibility	Technical documentation
Major	Minor					
				Directional/non-direction earth fault fixed.		
				Battery fail alarm improvements.		
				Power measurements read over MODBUS may be incorrect.		
				Resolved problem caused by rapid changing self resetting alarm resetting the relay when read key pressed.		
				Prevented software errors from clearing event log		
04	A	A	Aug 2000	Trip conversion logic moved from internal fixed logic to PSL	V1.10 or Later	TG8613B
04	B	A	Mar 2001	Only P543 CS103 builds released.	V1.10 or Later	TG8613B
				Improvements to the CS103 time synchronization		
04	C	A	Jun 2001	Only P543 CS103 builds released. Based on 04B.	V1.10 or Later	TG8613B
				Resolved a loss of measurements (columns 3 & 4) problem that can occur in 3 terminal applications		
04	D	A	Jun 2001	Only P543 CS103 build released. Based on 04C.	V1.10 or Later	TG8613B
				Prevents a reboot on power-up when battery is removed		
05	A	A	Sep 2000	Internal release for validation only.	V2.0 or Later	TG8613B
				Includes DNP3.0.		
				Courier bay module compatibility modification.		
				MODBUS bay module compatibility modification.		
				Distance - Z3 selectable forward/reverse.		
				Spanish text corrected.		
				Menu dependence using ripple bit corrected.		
				MODBUS problem reading negative values of fault location corrected.		
				RDF file modified.		
				Directional/non-direction earth fault fixed.		
				Battery fail alarm corrected.		
				Very low fault location could be shown incorrectly as negative.		
				Some MODBUS address changed		
05	B	A	Oct 2000	Released to production.	V2.0 or Later	TG8613B
				Includes all of 05A changes.		
				Requirement to use relays 8, 9 & 10 for Trip A, B & C removed.		
				MODBUS communication problem when used with P140 fixed.		
				Power measurements read over MODBUS may be incorrect.		
				MODBUS status register reports disturbance records incorrectly following power cycle		
05	C	A	Mar 2001	Only P543 & P544 builds released for customer tests.	V2.0 or Later	TG8613B
				PSB now works with single pole open		
05	D	A	May 2001	Only P543 & P544 builds released for customer tests.	New PSL will be required	-

Software version		Hardware suffix	Original date of issue	Description of changes	Easergy Studio compatibility	Technical documentation
Major	Minor					
				Distance directional line fixed at -30°.		
				PSB block issued when impedance passes into any Z1, Z2 or Z3.		
				PSB unblock via negative sequence current now done via PSL		
05	E	A	Jun 2001	All builds released to production. Based on 05B software.	V2.0 or Later	TG8613B
				Resolved a loss of measurements (column 3 & 4) problem that can occur in 3 terminal applications.		
				Recommended upgrading to 05K or later		
05	F	A	Sep 2001	All builds released to production. Based on 05E software.	V2.0 or Later	TG8613B
				Problem whereby MiCOM S1 could only set group 1 line length corrected.		
				Fixed capacitive charging current compensation in P544.		
				Corrected P544 display of phase C current phase angle.		
				IDMT curves improvements.		
				Removed rounding error in calculation of tp.		
				Fixed problems caused by changes to DNP3.0 address.		
				Recommended upgrading to 05K or later		
05	G	A	Jan 2002	All builds except MODBUS released to production. Based on 05F software.	V2.0 or Later	TG8613B
				Resolved possible reboot caused by disturbance recorder.		
				Problem in MODBUS build which can cause a reboot.		
				Recommended upgrading to 05K or later		
05	H	A	Jan 2002	All builds released to production. Based on 05G software.	V2.0 or Later	TG8613B
				Resolved possible reboot caused by invalid MODBUS requests.		
				Recommended upgrading to 05K or later		
05	I	A	Oct 2002	Limited release - not released to production. Based on 05H software.	V2.0 or Later	TG8613B
				Correct the format used to display frequency over the MODBUS interface.		
				Recommended upgrading to 05K or later		
05	J	A	Nov 2002	All builds released to production. Based on 05I software.	V2.0 or Later	TG8613B
				Resolved incorrect operation of C diff failure alarm in 3 terminal schemes.		
				Correct operation of capacitive charging current compensation in 3 terminal schemes.		
				Resolved problem which caused short duration current differential trips in some applications.		
				Recommended upgrading to 05K or later		
05	K	A	Feb 2003	All builds released to production. Based on 05I software.	V2.0 or Later	TG8613B
				Resolved problem with IEC 60870-5-103 time synchronization		
05	L	A	Jan 2004	Maintenance release based on 05K (not formally released).	V2.0 or Later	TG8613B
				Prevents compressed disturbance recorder stalling.		

Software version		Hardware suffix	Original date of issue	Description of changes	Easergy Studio compatibility	Technical documentation
Major	Minor					
				Prevent a maintenance record when reading from an inaccessible MODBUS register		
05	M	A	Jun 2004	Maintenance release based on 05L.	V2.0 or Later	TG8613B
				Improved self-checking of analogue data acquisition.		
				Improved self checking of SRAM.		
				Reception of MODBUS frame improved.		
				Rejection of spurious messages injected onto RS485 network improved.		
				Permissive intertrip in dual redundant schemes corrected		
05	N	A	Jun 2005	Maintenance release based on 05M.	V2.0 or Later	TG8613B
				Changed MODBUS driver		
06	A	A	May 2001	Internal Release for validation only - runs on phase 1 hardware with an old co-processor board.	-	-
				In non GPS mode the char modification timer has been made visible in P545/P546.		
				The char modification timer setting was not being seen by the co-processor board.		
				GPS detected flag was not cleared when switching from GPS to non GPS mode.		
				Equal prop delay command was not resetting inhibit following a comms. switch.		
				Problem displaying Rx & Tx when comms. path was short fixed.		
				Note: Non of the above are relevant to software in production		
06	B	A	Jun 2001	Internal release for validation only - runs on phase 1 hardware with an old co-processor board.	-	-
				Prevent loss of measurements in 3 ended schemes.		
				Added a 1s drop off timer to C diff inhibit.		
				Changed max value of char mod timer to 2s.		
				Increased number of PSL timers to 16 (all models).		
				Corrected PSL default reference.		
				Added a setting to P543/5 AR to select which edge of trip initiates AR.		
				Added 3 DDB signals to block distance.		
				Removed force 3 pole trip DDB.		
				Note: Non of the above are relevant to software in production		
07	A	A	Feb 2002	Limited release (P543 only) - not released to production. Based on 05K software.	V2.08 or Later	-
				Additional check sync signals added to PSL		
10	A	B	Feb 2001	Internal release for validation only - runs on phase 1 hardware with a modified co-processor board to accept a 1pps input.	No official release to support this version. Will need V2 to extract PSL files	-
				GPS synchronization.		
				Flexible intertripping.		

Software version		Hardware suffix	Original date of issue	Description of changes	Easergy Studio compatibility	Technical documentation
Major	Minor					
				Signaling message format changed.		
				Models 5 & 6 (but limited to 16 optos & 14 relays).		
				Remains of neutral C diff removed.		
				Event optimization & filtering.		
				Watt hour measurement correction.		
				Addition of digital opto filtering control.		
				Changes & additions to error codes.		
				Increase in protection signaling address.		
				DDB increased in size to 1022 and also support functions changed.		
				Support for universal optos (model number suffix B).		
				Support for new output relays added		
10	A	B	Feb 2001	Internal loopback setting added (not full functional).	No official release to support this version. Will need V2 to extract PSL files	-
				PSL references added.		
				Reset LEDs DDB name change.		
				Text for cells 0F20 - 0F2F changed.		
				Problem whereby MiCOM S1 could only set group 1 line length corrected.		
				Control inputs added.		
				Restore defaults now restores DNP3.0 cells correctly.		
				Prevent non DNP3.0 builds generating fatal error when S1 request DNP3.0 upload.		
				MODBUS enabling/disabling of IRIG-B now works.		
				Courier/MODBUS event bit functionality corrected.		
				DNP3.0 & MODBUS address are compatible but there are several new ones.		
				Software is not compatible with previous software (signaling message)		
10	B	B	Apr 2001	Internal release for validation only - runs on phase 1 hardware with a modified co-processor board to accept a 1pps input.	As per 10A	-
				Fixed a reset indications problem in CS103 build.		
				Fixed a problem with P544 display of phase C current phase angle.		
				Setting relay address via rear port corrupted other setting ranges		
10	C	B	May 2001	Internal release for validation only - runs on phase 2 hardware with a new co-processor board.	As per 10A	-
				Support for new co-processor board added.		
				In non GPS mode the char modification timer has been made visible in P545/P546.		
				The char modification timer setting was not being seen by the co-processor board.		
				GPS detected flag was not cleared when switching from GPS to non GPS mode.		

Software version		Hard-ware suffix	Original date of issue	Description of changes	Easergy Studio compatibility	Technical document-ation
Major	Minor					
				Equal prop delay command was not resetting inhibit following a comms. switch.		
				Problem displaying Rx & Tx when comms. path was short fixed.		
				Opto filtering corrected.		
				Note: Non of the above are relevant to software in production		
10	D	B	Jun 2001	Internal release for validation only - runs on phase 2 hardware with a new co-processor board.	V2.01b (not issued)	-
				Prevent loss of measurements in 3 ended schemes.		
				Added a 1s drop off timer to C diff inhibit.		
				Changed max value of char mod timer to 2s.		
				Increased number of PSL timers to 16 (all models).		
				Corrected PSL default reference.		
				Added a setting to P543/5 AR to select which edge of trip initiates AR.		
				Added 3 DDB signals to block distance.		
				Removed force 3 pole trip DDB.		
				Resolved problem caused by rapid changing self resetting alarm resetting the relay when read key pressed.		
				Note: None of the above are relevant to software in production		
10.	E	B	Jul 2001	Internal release for validation only - runs on phase 2 hardware with a new co-processor board.	V2.01b (not issued)	-
				Fixed capacitive charging current compensation in P544 & P546.		
				Fixed fast operating times for IDMT at a particular multiply of setting.		
				Added MODBUS control of opto filter cell.		
				Removed the quick start up for GPS because it was causing general startup problems.		
				Fixed the GPS inhibit in dual redundant mode.		
				Fixed an error in GPS synchronization when a timer wraps round.		
				Fixed comms. delay equal command in 3 terminal schemes.		
				CS103 time sync modified not to generate courier events.		
				Note: Non of the above are relevant to software in production		
10	F	B		Internal release for validation only - runs on phase 2 hardware with a new co-processor board.	V2.01b (not issued)	-
				Added CS103 private codes.		
				Added uncompressed disturbance recorder to CS103 build.		
				Added translations for filter control.		
				Fixed the GI list for P545 & P546.		
				Fixed the incorrect response in three terminal mode with GPS present and running on a split path followed by a power cycle at one end.		
				Fixed the occasional incorrect calculation of tp being caused by rounding errors.		
				Fixed the incorrect response in dual redundant schemes with GPS failure followed by a switch to a split path on one channel and a comms. failure on the other.		
				Prevented software errors from clearing event log.		

Software version		Hardware suffix	Original date of issue	Description of changes	Easergy Studio compatibility	Technical documentation
Major	Minor					
				Unextracted disturbance records now set the courier status flag on power up.		
				Added support for MODBUS function code 7.		
				Corrected the MODBUS status bit 0.		
				Corrected the OTEV bit in the status of fault in IEC60870-5-103.		
				Menu text files do not contain the additional translations.		
				Note: Non of the above are relevant to software in production		
11	A	B	Sep 2001	First phase 2 release to production.	V2.03 or Later	P54x/EN T/D11
				Includes all of 10F.		
				Added CS103 monitor/command blocking.		
				PSB now uses 6 comparators.		
				Distance directional line fixed at -30°.		
				PSB block issued when impedance passes into any Z1, Z2 or Z3.		
				PSB unblock via negative sequence current now done via PSL.		
				Modified co-processor initiation to run on 1 wait state (memory access problem).		
				Fixed a problem with P545 & P546 opto & relay labels in disturbance record.		
				Fixed the GPS inhibit.		
				Recommended upgrading to 11G or later		
11	B	B	Oct 2001	All builds released to production. Based on 11A software.	V2.03 or Later	P54x/EN T/D11
				Modified the co-processor start-up routine to work with alternative types of SRAM.		
				Improved response to a CS103 poll class 1 when monitor blocked was active.		
				Resolved a time alignment problem which resulted in C diff failure alarms being raised.		
				Corrected some MODBUS address for P545 & P546.		
				Fixed a problem with the relays response to MODBUS commands read coils and read inputs.		
				Fixed an incorrect response to a DNP3.0 command.		
				Recommended upgrading to 11G or later		
11.	C	B	Dec 2001	All builds released to production. Based on 11B software.	V2.03 or Later	P54x/EN T/D11
				Fixed a problem in P541 & P542 CS103 builds where the voltage and power measurements were not being marked as invalid.		
				Fixed a problem in P544 & P546 where the SEF current measurement was incorrect when set to 1A & 60 Hz.		
				Recommended upgrading to 11G or later		
11	D	B	Jan 2002	All builds released to production. Based on 11C software.	V2.03 or Later	P54x/EN T/D11
				Resolved possible reboot caused by disturbance recorder.		
				Resolved possible reboot caused by invalid MODBUS requests.		
				Resolved problem when internal loopback was selected with external clocks.		

Software version		Hardware suffix	Original date of issue	Description of changes	Easergy Studio compatibility	Technical documentation
Major	Minor					
				Resolved a problem which caused the loss of IEC 60870-5-103 class 1 messages.		
				Recommended upgrading to 11G or later		
11	E	B	Oct 2002	All builds released to production. Based on 11D software.	V2.03 or Later	P54x/EN T/D11
				Resolved incorrect operation of C diff failure alarm in 3 terminal schemes.		
				Correct operation of capacitive charging current compensation in 3 terminal schemes.		
				Resolved problem which caused short duration GPS failure alarms.		
				Recommended upgrading to 11G or later		
11	F	B	Feb 2003	All builds ready. Based on 11E software.	V2.03 or Later	P54x/EN T/D11
				Resolved several problems related to the IEC 60870-5-103 protocol.		
				Resolved problem which may cause short duration current differential trips.		
				Corrected the format used to display frequency over the MODBUS interface.		
				Recommended upgrading to 11G or later		
11	G	B	May 2003	All builds ready. Based on 11F software.	V2.03 or Later	P54x/EN T/D11
				Changes to clock recovery circuits to improve operation with multiplexers.		
				PSL logic for user defined intertrips corrected P545 & P546.		
				Permissive intertrip in dual redundant schemes corrected.		
				Prevented unwanted comms. delay alarms		
11	H	B	Sept 2003	All builds ready. Based on 11G software.	V2.03 or Later	P54x/EN T/D11
				Prevents compressed disturbance recorder stalling.		
				Prevents CS103 reporting more non-compressed disturbance records than actually present		
11	I	B	Oct 2004	All builds released to production. Based on 11G software.	V2.03 or Later	P54x/EN T/D11
				Improved self-checking of analogue data acquisition.		
				Differential intertrip in IEC 60870-5-103 reported with correct FAN.		
				SRAM self checking added to co-processor board.		
				Reception of MODBUS frame improved.		
				Rejection of spurious messages injected onto RS485 network improved.		
				Improved self checking of SRAM.		
				Fixed an incorrect response of the summertime time bit in IEC 60870-5-103 protocol.		
				Prevented incorrect behavior of P545/P546 when one relay is energized when there is noise on the signaling channel.		
				Status of local GPS reported incorrectly in dual redundant schemes.		
				Setting "Char Mod Time" was missing on P541 - P544.		
				Prevent a maintenance record when reading from an inaccessible MODBUS register.		

Software version		Hardware suffix	Original date of issue	Description of changes	Easergy Studio compatibility	Technical documentation
Major	Minor					
				Prevents relay crashing when phase 2 software used with phase 1 optos.		
				Cell 0709 now replies OK change		
11	J	B	Jul 2005	All builds released to production. Based on 11I software.	V2.03 or Later	P54x/EN T/D11
				Changed MODBUS driver		
12	A	B	Mar 2002	Released for validation testing only.	V2.05 or Later	P54x/EN T/E21
				2nd rear comms. added.		
				Alarms increased to 64 with user programmable alarms.		
				Enhancements and corrections to CS103.		
				Prevented additional events being generated on power up.		
				French language text improvements.		
				Prevent a maintenance record when reading from an inaccessible MODBUS register.		
				Setting "Char Mod Time" was missing on P541 - P544.		
				Prevents relay crashing when phase 2 software used with phase 1 optos.		
				Cell 0709 now replies OK change.		
				Maximum pre-trigger time for disturbance recorder in IEC 870-103-5 builds reduced to allow extraction via rear port		
12	B	B	Nov 2002	All builds released to production. Based on 12A software.	V2.05 or Later	P54x/EN T/E21
				Resolved incorrect operation of C diff failure alarm in 3 terminal schemes.		
				Correct operation of capacitive charging current compensation in 3 terminal schemes.		
				Resolved problem which caused short duration GPS failure alarms.		
				Resolved problem selecting setting group via optos.		
				Resolved a circuit breaker lockout problem.		
				Corrected the thermal measurement displayed when thermal protection is disabled.		
				Spanish text for user defined alarms contained an extra letter.		
				Blocked overcurrent elements now generate events.		
				Correct DNP3.0 operation of object 10		
12	B	B	Nov 2002	Resolved problem with P541 & P542 IEC 60870-5-103 builds not running.	V2.05 or Later	P54x/EN T/E21
				Resolved a problem with IEC 60870-5-103 class 1 polling.		
				Resolved a problem with IEC 60870-5-103 ASDU2 events which occurred prior to a start event.		
				Correct the format used to display frequency over the MODBUS interface.		
				Resolved problem related to incorrect CB trip/close commands via MODBUS.		
				Resolved problem related to CB trip/close commands via MODBUS being accepted when not selected.		
				Resolved a problem which prevented protection setting being saved after control and support setting had been saved.		

Software version		Hardware suffix	Original date of issue	Description of changes	Easergy Studio compatibility	Technical documentation
Major	Minor					
				Corrected the saving of fault locator settings in groups 2, 3, 7 & 4 when made via user interface.		
				Added object 10 to DNP3.0 class 0 poll.		
				Corrected the way DNP3.0 handled the season bit in the time & date.		
				Recommended upgrading to 12D or later		
12	C	B	Mar 2003	All builds released to production. Based on 12B software.	V2.05 or Later	P54x/EN T/E21
				Resolved several problems related to the IEC 60870-5-103 protocol.		
				Resolved problem which may cause short duration current differential trips.		
				Improved self diagnostics relating to input module clock.		
				Modified courier block transfer mechanism so it can handle more than 255 blocks.		
				Intermittent loss of data from 2nd rear comms. port corrected.		
				PSL logic for user defined intertrips corrected P545 & P546.		
				Permissive intertrip in dual redundant schemes corrected.		
				Recommended upgrading to 12D or later		
12	D	B	Jun 2003	All builds released to production. Based on 12C software.	V2.05 or later	P54x/EN T/E21
				Changes to clock recovery circuits to improve operation with multiplexers.		
				Prevented unwanted comms. delay alarms		
12	E	B	Sept 2003	All builds released to production. Based on 12D software.	V2.05 or later	P54x/EN T/E21
				Prevents compressed disturbance recorder stalling.		
				Correction to operation of reset relays/LEDs opto.		
				Prevents CS103 reporting more non-compressed disturbance records than actually present		
12	F	B	Jun 2004	Not released to production. Supplied to one customer. Based on 12E software.	V2.05 or Later	P54x/EN T/E21
				Improved self-checking of analogue data acquisition.		
				Differential intertrip in IEC 60870-5-103 reported with correct FAN		
12	G	B	Oct 2004	All builds released to production. Based on 12E software.	V2.05 or Later	P54x/EN T/E21
				Improved self-checking of analogue data acquisition.		
				Differential intertrip in IEC 60870-5-103 reported with correct FAN.		
				SRAM self checking added to co-processor board.		
				Reception of MODBUS frame improved.		
				Rejection of spurious messages injected onto RS485 network improved.		
				Improved self checking of SRAM.		
				Fixed an incorrect response of the summertime time bit in IEC 60870-5-103 protocol.		
				Prevented incorrect behavior of P545/P546 when one relay is energized when there is noise on the signaling channel.		
				Status of local GPS reported incorrectly in dual redundant schemes		

Software version		Hardware suffix	Original date of issue	Description of changes	Easergy Studio compatibility	Technical documentation
Major	Minor					
12	H	B	May 2005	All builds released to production. Based on 12G software. Changed MODBUS driver	V2.05 or Later	P54x/EN T/E21
12	I	B	May 2006	All builds released to production. Based on 12G software. Improvements to the distance protection	V2.05 or Later	P54x/EN T/E21
13	A	B	Apr 2004	All builds released to production. Based on 12E software. Control inputs enhancements including non-volatile, latched, pulsed and support for DNP3.0 pulsed. Enhanced DNP3.0. Distance Residual compensation angle range extended. Display of number of good messages via MODBUS is corrected. Prevented DNP3.0 time sync causes relay to reboot when IRIG-B is active. Improved self-checking of analogue data acquisition. Improved self checking of SRAM. Added TRIP & ALARM to MODBUS status word. Addition of MODBUS only setting to allow transmission of IEC time format in reverse IEC byte order. Reception of MODBUS frame improved. Rejection of spurious messages injected onto RS485 network improved. Handling of FAN in IEC 60870-5-103 improved. Differential intertrip in IEC 60870-5-103 reported with correct FAN	V2.10 or later	P54x/EN T/E21
13	B	B	Aug 2004	All builds released to production. Based on 13A software. SRAM self checking added to co-processor board. Fault location & cumulative broken current measurements reported over DNP3.0. Accuracy of MODBUS time sync improved. Invalid MODBUS register 4x00966 removed. Reception of MODBUS frame improved	V2.10 or Later (DNP3.0 files) different to 13A	P54x/EN T/E21
13	C	B	Oct 2004	All builds released to production. Based on 13B software. Resolved a problem relating to co-processor SRAM checking. Fixed an incorrect response of the summertime time bit in IEC 60870-5-103 protocol. Prevented incorrect behavior of P545/P546 when one relay is energized when there is noise on the signaling channel. Status of local GPS reported incorrectly in dual redundant schemes	V2.10 or Later (DNP3.0 files) different to 13A	P54x/EN T/E21

Software version		Hardware suffix	Original date of issue	Description of changes	Easergy Studio compatibility	Technical documentation
Major	Minor					
13	D	B	Mar 2005	All builds released to production. Based on 13C software.	V2.10 or Later (DNP3.0 files) different to 13A	P54x/ENT/E21
				Correction to single pole auto-reclose.		
				Remapped fun/inf. 192/130 in P543 & P545.		
				Display of no. valid messages on LCD corrected.		
				DNP3.0 improved binary scanning.		
				Operation of CB maintenance alarm corrected.		
				Corrections to allow extended courier characters to be used in string setting cells for courier and MODBUS.		
				Corrected default display of neutral current for 5A CTs.		
				Prevented a reboot for DNP3.0 versions when control & support settings are changed rapidly.		
				Changes to co-processor start-up to eliminate a timing problem		
13	E	B	Apr 2005	All builds released to production. Based on 13D software.	V2.10 or Later (DNP3.0 files) different to 13A	P54x/ENT/E21
				Changed MODBUS driver		
13	F	B	Jun 2006	All builds released to production. Based on 13E software.	V2.10 or Later (DNP3.0 files) different to 13A	P54x/ENT/E21
				Improvements to the distance protection.		
				Add interframe gap to DNP3.0.		
				Corrections to IRIG-B.		
				Vector group compensations for YY2 and YY10 corrected.		
				Corrected reporting of distance & C diff stars over CS103.		
				Reports the correct COT for reset LEDs command sent via S1.		
				Corrected a problem which occurs when two relays power up when one is configured out		
13	G	B	Nov 2007	P543 DNP3 released to a customer. Based on Version 13F. Improvements to DNP3	V2.10 or Later (DNP3 files different to 13A)	P54x/EN x/E21
13	H	B	Dec 2007	All builds released to production. Based on 13F software.	V2.10 or Later (DNP3 files different to 13A)	P54x/EN x/E21
				Improvements to DNP3.		
				Fixed autoreclose problem.		
				Resolved a problem relating to CT Ratio's not being restored when restoring default settings.		

Software version		Hardware suffix	Original date of issue	Description of changes	Easergy Studio compatibility	Technical documentation
Major	Minor					
				Resolved a problem with the Disturbance Recorder which saturates for High current levels into 5A CT.		
				Resolved problem with relay recognising non zero entry in 14th position of model number.		
				Only P545 builds released to production. Based on 13H software. Resolved Autoreclose problems.		
13	I	B	Oct 2008	Only P545 builds released to production. Based on 13H software. Resolved Autoreclose problems	V2.10 or Later (DNP3 files different to 13A)	P54x/EN x/E21
14	A	B	Nov 2003	Released for China only.	V2.10 or Later	
				Current transformer Supervision added.		
				A number of bugs have been fixed.		
14	B	B	Oct 2004	Released to China only. Based on 14A software.	V2.10 or Later	
				Improved Self-checking of Analogue data acquisition.		
				Differential Intertrip in IEC60870-5-103 reported with correct FAN.		
				Corrected a CTS setting when 5A inputs selected.		
				SRAM self checking added to co-processor board.		
				Reception of modbus frame improved.		
				Rejection of spurious messages injected onto RS485 network improved.		
				Improved self checking of SRAM.		
				Fixed an incorrect response of the summertime time bit in IEC60870-5-103 protocol.		
				Prevented incorrect behaviour of P545/P546 when one relay is energised when there is noise on the signalling channel.		
				Status of local GPS reported incorrectly in dual redundant schemes.		
14	C	B	Jun 2005	Released to China only. Based on 14B software.	V2.10 or Later	
				Changed modbus driver.		
15	A	B	Mar 2004	Released for China only.	V2.10 or Later	
				Removal of Distance Protection.		
				Corrected a CTS setting when 5A inputs selected.		
				CT ratio correction setting moved into setting groups.		
				Default setting for measurements and settings changed to secondary.		
				Bug fixes.		
15	B	B	July 2004	Released for China only.	V2.10 or Later	
				Correction to CTS for 5A applications.		
				Improved self checking of SRAM.		
				Reception of modbus frame improved.		
				Corrected VTS setting which was only actioned on power up.		
15	C	B	Aug 2004	Released for China only.	V2.10 or Later	

Software version		Hardware suffix	Original date of issue	Description of changes	Easergy Studio compatibility	Technical documentation
Major	Minor					
				Modbus protocol added.		
				SRAM self checking added to co-processor board.		
				Fixed an incorrect response of the summertime time bit in IEC60870-5-103 protocol.		
				Status of local GPS reported incorrectly in dual redundant schemes.		
				Prevented incorrect behaviour of P545/P546 when one relay is energised when there is noise on the signalling channel		
15	D	B	Nov 2005	Released for China only.	V2.10 or Later	
				Migration of Platform from version C4.2 to C4.7.		
				Display of good messages could go negative corrected.		
				Corrected wrong display of number of good messages via Modbus.		
				Resolved changing settings on a DNP3 relay rapidly sometimes causing a reboot. It appeared the problem occurred if 4 or more control & support settings were sent in quick succession.		
				Resolved attempts to set the data cell [04 20] Thermal State, returning 'Local Access in Progress' instead of 'Remote Access Denied'.		
				Resolved CTS Block operating transiently when modbus communications were running		
16	A	B	Jul 2006	Release of P543 CS103 for Germany only. Based on 13F.	Patch for V2.12	P54x/EN T/E21
				CS103/Auto-reclose modifications		
16	B	B	Dec 2006	Release of P543 CS103 for Germany only. Based on 16A.	Patch for V2.12	P54x/EN T/E21
				Corrected some German text.		
				Generated events for main starts.		
				Added some DDB to disturbance recorder.		
20	A	G	Nov 2002	Internal release for validation only - runs on phase 2 processor board. Based on 12B.	-	-
				UCA2 option added.		
				Russian text added (not complete).		
				Added fault location to for IEC 60870-5-103.		
				Added TRIP & ALARM to MODBUS status word.		
				Distance direction setting added.		
				Distance residual compensation angle range extended.		
				Indication of password status on DDB (code added but not run).		
				Improvements to auto-reclose.		
				Alarms increased to 96.		
				Corrected the response to courier SEND EVENT.		
				Improved self diagnostics relating to input module clock.		
				Removed the setting for IEC 60870-5-103 over fiber when hardware not present.		
				Resolved problem related to CB trip/close commands via MODBUS being accepted when not selected.		
				Corrected the saving of fault locator settings in groups 2, 3 & 4 when made via user interface.		
				Added object 10 to DNP3.0 class 0 poll.		

Software version		Hardware suffix	Original date of issue	Description of changes	Easergy Studio compatibility	Technical documentation
Major	Minor					
				Corrected the way DNP3.0 handled the season bit in the time & date		
20	B	G	Apr 2003	Internal release for validation only. Based on 20A.	-	-
				Enhanced check synchronization feature.		
				Control inputs enhancements including non-volatile, latched, pulsed and support for DNP3.0 pulsed.		
				BBRAM used in disturbance recorder optimized.		
				Resolved several problems related to the IEC 60870-5-103 protocol.		
				Resolved problem which may cause short duration current differential trips.		
				Improved self diagnostics relating to input module clock.		
				Modified courier block transfer mechanism so it can handle more than 255 blocks		
20	B	G	Apr 2003	PSL logic for user defined intertrips corrected P545 & P546.	-	-
				Permissive intertrip in dual redundant schemes corrected.		
				Operation of manual reset alarms corrected.		
				Bug fixes relating to CPU2		
20	C	G	Apr 2003	Internal release for validation only. Based on 20B.	-	-
				CB control via hot keys.		
				Bug fixes relating to CPU2		
20	D	G	Jul 2003	Internal release for validation only. Based on 20C.	V2.09 or Later	P54x/EN T/F32
				Changes to clock recovery circuits to improve operation with multiplexers.		
				Prevented unwanted comms. delay alarms.		
				Enhanced auto-reclose feature added.		
				Alarms handled better in CS103 GI.		
				Time synchronization via opto added.		
				Platform alarms copied to DDB.		
				Correction to operation of reset relays/LEDs opto.		
				Backup protection run if co-processor fails to start up on power on.		
				Correction to cell 0B25.		
				Bug fixes relating to CPU2		
20	E	G	Oct 2003	Limited release for NiCAP + selected others.	V2.09 or Later	P54x/EN T/F32
				Extraction of disturbance recorder over MODBUS added.		
				Resolve nucleus missing HISR problems.		
				Enhancements to IDMT curves.		
				Display of number of good messages via MODBUS is corrected.		
				Bug fixes relating to CPU2		
20	F	G	Feb 2004	Release to production.	V2.09 or Later	P54x/EN T/F32
				UCA2: Increase max. pending requests & max. connected clients.		
				Enhanced DNP3.0.		
				Prevented DNP3.0 time sync causes relay to reboot when IRIG-B is active.		

Software version		Hardware suffix	Original date of issue	Description of changes	Easergy Studio compatibility	Technical documentation
Major	Minor					
				Corrected cause of transmission which may be returned for "Fault Location".		
				Prevents relay rebooting during EMC ANSI fast transient and IEC high frequency.		
				Bug fixes relating to CPU2		
20	G	G	Jun 2004	Release to production. Based on 20F software.	V2.09 or Later	P54x/EN T/G42
				Prevented repeated downloads of GSL files without Ethernet card restart rebooting Ethernet card.		
				Correction to uploading of disturbance records over UCA2.		
				Corrected operation of Ethernet card link LED for 10 Base-FL.		
				Closed UCA2 association after "dirty" client disconnection.		
				Made UCA2 disturbance record directory service compatible with PACiS.		
				Corrected under and over voltage blocking of check sync.		
				Improved self-checking of analogue data acquisition.		
				Handling of FAN in IEC 60870-5-103 improved.		
				Differential intertrip in IEC 60870-5-103 reported with correct FAN.		
				Prevented C diff fail alarm occurs before signaling fail alarm for loss of communications.		
				Improved self checking of SRAM		
20	H	G	Oct 2004	Release to production. Based on 20G software.	V2.09 or Later	P54x/EN T/G42
				SRAM self checking added to co-processor board.		
				Fixed an incorrect response of the summertime time bit in IEC 60870-5-103 protocol.		
				Prevented incorrect behavior of P545/P546 when one relay is energized when there is noise on the signaling channel.		
				Status of local GPS reported incorrectly in dual redundant schemes.		
				Accuracy of MODBUS time sync improved.		
				Fixed an incorrect response of the summertime time bit in IEC 60870-5-103 protocol.		
				Prevented Ethernet card restarting after approximately 20 hours when no connection made.		
				Improvements to time sync for courier, CS103 and DNP3.0.		
				Invalid MODBUS register 4x00966 removed		
20	I	G	Nov 2004	Release to production. Based on 20G software.	V2.09 or Later	P54x/EN T/G42
				Display of no. valid messages on LCD corrected.		
				Operation of CB maintenance alarm corrected.		
				Corrections to allow extended courier characters to be used in string setting cells for courier and MODBUS.		
				Corrected default display of neutral current for 5A CTs.		
				Prevented a reboot for MODBUS versions during event extraction when messages were close together.		
				Correction to prevent the 2nd rear comms. locking up		
20	J	G	Apr 2006	Release to production. Based on 20G software.	V2.09 or Later	P54x/EN T/G42

Software version		Hardware suffix	Original date of issue	Description of changes	Easergy Studio compatibility	Technical documentation
Major	Minor					
				Correction to IEEE/US inverse reset setting.		
				Changes to co-processor start-up to eliminate a timing problem		
20	K	G	Apr 2006	Release to production. Based on 20G software.	V2.09 or Later	P54x/EN T/G42
				Improvements to the distance protection.		
				Add interframe gap to DNP3.0.		
				Corrections to IRIG-B.		
				Vector group compensations for YY2 and YY10 corrected.		
				Corrected reporting of distance & C diff stars over CS103.		
				Reports the correct COT for reset LEDs command sent via S1.		
				Corrected a problem which occurs when two relays power up when one is configured out		
20	L	G		P545 Release to Production. Based on 20K software.	V2.09 or Later	P54x/EN T/G42
				Resolved a problem which interrupted the UCA2 communications periodically.		
				Resolved a problem relating to CT Ratio's not being restored when restoring default settings.		
				Resolved a problem with the Disturbance Recorder which saturates for High current levels into 5A CT.		
				Resolved problem with relay recognising non zero entry in 14th position of model number		
20	M	G	Nov 2009	Release to Production. Based on 20L software.	V2.09 or Later	P54x/EN T/G42
				Improvements to the GPS code.		
				Improvements in the clock recover circuits used by the Differential Comms.		
				Correction to the way latched LED/Relays are cleared.		
				Correction to autoreclose operation for switch on to fault condition.		
				Prevented CB Operating Time displaying 4.295Ms.		
				Bug Fixes		
20	N	G		Release to Production. Based on 20M software.	V2.09 or Later	P54x/EN T/G42
				Prevented the Differential protection inhibiting in three terminal schemes when GPS is enabled and loopback mode selected.		
				Fault locator measurements in ohms corrected when 5A CT used or displayed in primary.		
30	A	J	Sep 2004	Released to selected customers only. Based on 20G.	V2.09 or Later (No language file support)	P54x/EN T/G42
				Interface to optical multiplexer (IEEE standard C37.94).		
				SRAM checking in co-processor.		
				Dual range optos.		
				AREVA livery & software changes.		
				Extended residual angle in fault locator to match distance.		
				Rename GOOSE signals in line with P443.		

Software version		Hardware suffix	Original date of issue	Description of changes	Easergy Studio compatibility	Technical documentation
Major	Minor					
				Add virtual signals, control inputs & user alarms to DR in line with P443.		
				Relay settings shall be stored in FLASH EEPROM instead of EEPROM memory.		
				Extend range of time dial to line up with P140.		
				Accuracy of MODBUS time sync improved.		
				Invalid MODBUS register 4x00966 removed.		
				Improvements to time sync for courier, CS103 and DNP3.0.		
				Addition of MODBUS only time and date format setting to common courier settings for access from the other interfaces.		
				Vector group compensations for YY2 and YY10 corrected.		
				Prevented Ethernet card restarting after approximately 20 hours when no connection made.		
				Prevented incorrect behavior of P545/P546 when one relay is energized when there is noise on the signaling channel		
30	B	J	Nov 2004	Released to production but held. Based on 30A.	V2.11 or Later	P54x/EN T/H53
				Courier, MODBUS & DNP3.0 communications over Fiber added		
30	C	J	Nov 2004	Released to production. Based on 30B.	V2.11 or Later	P54x/EN T/H53
				Correction to prevent the 2nd rear comms. locking up.		
				Correction to prevent the front panel UI and comms. lockup after continued operation.		
				Changes to co-processor start-up to eliminate a timing problem		
30	D	J	Dec 2004	Released to production. Based on 30C.	V2.11 or Later	P54x/EN T/H53
				Improvements to operation when subjected to multiple communication switches when operating in non-GPS mode		
30	E	J	Jan 2005	Released to production. Based on 30D.	V2.11 or Later	P54x/EN T/H53
				VTS enhanced to restore 3 software version 20 performance for three pole tripping whilst keeping the improvements for 1 pole tripping added at 30B		
30	F	J	Mar 2005	Released to production. Based on 30E.	V2.11 or Later	P54x/EN T/H53
				Enhancements to the current differential performance under switched communication channels.		
				Correction to the CS103 mapping for platform alarms		
30	G	J	Apr 2006	Released to production. Based on 30E. Correction to IEEE/US Inverse reset setting	V2.11 or Later	P54x/EN T/H53
30	H	J	Apr 2006	Limited release P542 DNP3.0 to a customer. Add interframe gap to DNP3.0	V2.11 or Later	P54x/EN T/H53
30	I	J	May 2005	Released to production. Based on 30G.	V2.11 or Later	P54x/EN T/H53
				Improvements to the distance protection.		
				Add interframe gap to DNP3.0.		
				Corrections to IRIG-B.		
				Vector group compensations for YY2 and YY10 corrected.		
				Corrected reporting of distance & C diff stars over CS103.		

Software version		Hardware suffix	Original date of issue	Description of changes	Easergy Studio compatibility	Technical documentation
Major	Minor					
				Reports the correct COT for reset LEDs command sent via S1.		
				Corrected a problem which occurs when two relays power up when one is configured out.		
				Modification to allow individual MODBUS register access		
40	A	K	May 2006	Release of P543, P544, P545 & P546 without distance protection. CTS.	Patch for V2.12	P54x/EN M/I64
				Definitive time directional negative sequence overcurrent I2>.		
				GPS synchronization of current differential in all models.		
				P543 and P545 now facilitate in zone transformer-feeder applications.		
				All models support ABC and ACB phase rotation.		
				Standard and Inverted CT polarity setting for each set of CTs in the relay.		
				User interface with tri colored LED and function keys.		
				InterMiCOM64.		
				Voltage protection.		
				Backwards compatibility mode		
41	C	K	Jul 2006	Release of P543, P544, P545 & P546 without distance protection based on 40A.	Patch for V2.12	P54x/EN M/J74
				IEC 61850-8-1.		
				High break options.		
				Unmodulated IRIG-B options.		
				Reduction of distance minimum reach settings to 0.05 ohm.		
				Permissive trip reinforcement.		
				Poledead modifications for Hydro Quebec.		
				CS103/auto-reclose modifications		
41	D	K	Aug 2006	Release of P543, P544, P545 & P546 without distance protection based on 41C.	Patch for V2.12	P54x/EN M/J74
				Prevents a possible reboot 15 minutes after browsing the front courier port but not making a setting change i.e. browsing using PAS&T.		
				Extended GOOSE Enrolment Capability.		
				Correction to ICD files, Enumeration (value) and Fixed data Mapping		
41	E	K	Nov 2006	Release of P543, P544, P545 & P546 without distance protection based on 41D.	Patch for V2.12	P54x/EN M/J74
				Prevent a reboot in 61850 builds when NIC link is inactive and avalanche of DDB activity.		
				Correctly report a fatal error generated by the sampling call-back.		
				Correct the operation of the GOOSE messaging and a problem with the download of an IED Configuration file.		
				Correct the operation of the check sync.		
				Correct the operation of the overcurrent reset curves.		
				Removed check on the 14th position of model number.		
				Fixed Telegrams for public inf 64-67.		
				SOTF can operate even when it is disabled		
41	F	K	May 2007	Release of P543, P544, P545 & P546 without distance protection based on 41E.	Patch for V2.12	P54x/EN M/J74

Software version		Hardware suffix	Original date of issue	Description of changes	Easergy Studio compatibility	Technical documentation
Major	Minor					
				Prevent a fatal error from an incorrect DNP address in not using DNP evolutions platform.		
				Default setting for 450B 'I< Current Set' reduced to 50mA.		
				French Translations for DDBs 1368-1371 corrected.		
				Fun & INF values related to CS103 Command Blocking corrected.		
				Angle for negative sequence phase overcurrent setting corrected.		
				Corrected operation when using MiCOM S1 is used to activate Settings group by right clicking on the group.		
				Corrected the latching of Function Key DDB signals on relay power up.		
				Corrected Disturbance recorder scaling to prevent high current levels into 5A CT causing the Disturbance Recorder to saturate.		
				Restricting defaults appears not to change the 1/5A CT selection.		
				Corrected the performance of the IM64 Direct mode.		
				CB control via Direct access does not work with 2CB versions of P540D.		
				Autoreclose dead time/close cycle continues even if AR switched out of service.		
				Ch2 Statistics may not be displayed		
41	G	K		P543, P544, P545 & P546 non-61850 builds without distance protection based on 41F was approved for release but withdrawn before release.	Patch for V2.12	P54x/EN M/J74
				Corrections to enable/disable of Autoreclose		
41	H	K	May 2007	Release of P543, P544, P545 & P546 without distance protection based on 41G.	Patch for V2.12	P54x/EN M/J74
				Corrections to enable/disable of Autoreclose		
41	I	K	Jan 2010	Release of P543, P544, P545 & P546 non 61850 builds without distance protection based on 41H.	Patch for V2.12	P54x/EN M/J74
				Prevented the Differential protection inhibiting in three terminal schemes when GPS is enabled and loopback mode selected.		
				Improvements to the GPS code.		
				Improvements in the clock recover circuits used by the Differential Comms.		
				Correction to P545/P541 compatibility when used in transformer compensation mode.		
				Correction to the way latched LED/Relays are cleared.		
				Corrections to the Current Differential Inhibit when the GPS synchronisation is disabled.		
				Corrections to menu text.		
				Correction to autoreclose operation for switch on to fault condition.		
				Corrected some French and German text.		
				Prevented CB Operating Time displaying 4.295Ms.		
				Fixed Inhibit CB Fail Protection in P544/P546.		
				Improved co-processor error reporting.		
				Fixed a SOTF problem.		
41	J	K	Oct 2010	Release of P543, P544, P545 & P546 non-61850 builds without distance protection based on 41J.	Patch for V2.12	P54x/EN M/J74

Software version		Hardware suffix	Original date of issue	Description of changes	Easergy Studio compatibility	Technical documentation
Major	Minor					
				Fixed a problem with the co-processor stack check which could cause a re-boot		
42	A	K	Feb 2007	Release of P543, P544, P545 & P546 without distance protection.	Patch for V2.12	P54x/EN M/J74 + P54x/EN AD/J84
				Chinese interface.		
				Replacing the existing DNP3 with the DNP3 evolutions.		
				Replacement of existing negative sequence overcurrent with multi stage (2 IDMT + 2 DT) negative sequence overcurrent..		
				Addition of IDG curve, commonly used in Sweden, to Earth Fault & Sensitive Earth Fault (involves moving settings).		
				Reduction of all TMS step sizes to 0.005.		
				Addition of Channel propagation delay Statistics and Alarms.		
				Changes to CTS so both techniques can be selected together.		
				Regrouping of CTS settings.		
				Addition of four stages of under frequency protection and two stages of		
				Overfrequency protection.		
				Addition of df/dt protection.		
				Changes to Under and Overvoltage to enable each stage to be independently set.		
				Extensions to the checksync VT position setting.		
				Changes to Permissive Inter Trip (PIT) logic to enable the user to select either local or remote current to be used.		
				Includes local time zone settings for Date & Time.		
				Reduced minimum setting for IN> I2pol Set.		
				Addition of propagation delay times to Fault Record.		
				Default setting for 450B 'I< Current Set' reduced to 50mA.		
				Enhancement to self checking of output relays.		
				Change tunnelled courier address to follow the 1st Rear Port's KBUS or CS103 address.		
42	B	K	July 2007	Release of P543, P544, P545 & P546 without distance protection based on 42A.	Patch for V2.12	P54x/EN M/J74 + P54x/EN AD/J84
				Improvements to VTS.		
				Corrections to enable/disable of Autoreclose.		
				Resolved a problem relating to CT Ratio's not being restored when restoring default settings.		
				Resolved a problem with the Disturbance Recorder which saturates for High current levels into 5A CT.		
42	D	K	Dec 2007	Release of P543, P544, P545 & P546 without distance protection based on 42B.	Patch for V2.12	P54x/EN M/J74 + P54x/EN AD/J84
				Fixed a number of 61850/Goose problems.		
				Minor correction to fault record.		
				Corrections to over voltage stage 2 inhibit.		

Software version		Hardware suffix	Original date of issue	Description of changes	Easergy Studio compatibility	Technical documentation
Major	Minor					
				Fixed the max prop alarm.		
				Corrected some DDB German text		
42	E	K	May 2008	Release of P543, P544, P545 & P546 without distance protection based on 42D.	Patch for V2.12	P54x/EN M/J74 + P54x/EN AD/J84
				Fixed a number of 61850 problems.		
				Improved co-processor error reporting.		
				Fixed Inhibit CB Fail Protection in P544/P546		
42	F	K		Not released to production. Based on 42E.	Patch for V2.12	P54x/EN M/J74 + P54x/EN AD/J84
				Correction to autoreclose operation for switch on to fault condition.		
				Prevented CB Operating Time displaying 4.295Ms.		
				Bug fixes		
42	G	K	Oct 2008	Release of P543, P544, P545 & P546 without distance protection based on 42F.	Patch for V2.12	P54x/EN M/J74 + P54x/EN AD/J84
				Correction to the distance cross polarising when the memory expires		
42	H	K	Sept 2009	Release of P543, P544, P545 & P546 without distance protection based on 42G.	Patch for V2.12	P54x/EN M/J74 + P54x/EN AD/J84
				Corrected some menu translations.		
				Corrected Breaker Fail - WI Aided1 trips so they can be disabled via setting "WI Prot Reset".		
				Timestamp in fault record adjusted for the local time setting.		
				Corrected P543 default PSL.		
				Corrections to the Current Differential Inhibit when the GPS synchronisation is disabled.		
				Corrected Thermal State measurement via DNP3.		
				Correction to the way latched LED/Relays are cleared.		
				Correction to Negative sequence overcurrent settings when 5A input used.		
				Correction to P545/P541 compatibility when used in transformer compensation mode.		
				Improvements to the GPS code.		
				Prevented CTS generating events when CTS is disabled.		
				Fixed problem which prevented residual overvoltage from initiating CB Fail.		
				Various improvements to DNP, CS103 & IEC61850 protocols.		
				Bug fixes		
44	A	K	Mar 2008	Release of P543, P544, P545 & P546 without distance protection based on 42D.	Patch for V2.14 First release of Studio	P54x/EN M/J74 + P54x/EN AD/J94
				Positional information added to PSL.		

Software version		Hardware suffix	Original date of issue	Description of changes	Easergy Studio compatibility	Technical documentation
Major	Minor					
				DNP 3.0 Over Ethernet protocol added.		
				Extended I/O – status inputs increased from 24 to 32.		
				Compensated overvoltage protection added.		
				IEC-103 Generic Services Measurements added.		
				Set/Reset Latch Logic Gates added to PSL.		
				Fault record to include current differential currents recorded at the time of the current differential trip in addition to the existing data from 1 cycle later.		
				Fault record increased max number of fault records to 15.		
				GPS Alarm modifications.		
				DNP enhancements for SSE.		
				Bug fixes		
44	B	K	Jun 2008	Release of P543, P544, P545 & P546 without distance protection based on 44A.	Patch for V2.14 First release of Studio	P54x/EN M/J74 + P54x/EN AD/J94
				Fixed a number of 61850 problems.		
				Improved co-processor error reporting.		
				Fixed Inhibit CB Fail Protection in P544/P546.		
				Corrected some French and German text.		
				Prevented CB Operating Time displaying 4.295Ms.		
				Fixed a problem which prevented extraction of dnp3 setting files from dnp3 over Ethernet variants.		
44	D	K	Jan 2009	Release of P543, P544, P545 & P546 without distance protection based on 44B.	Patch for V2.14 First release of Studio	P54x/EN M/J74 + P54x/EN AD/J94
				Corrections to the Current Differential Inhibit when the GPS synchronization is disabled.		
				Corrected Thermal State measurement via DNP3.		
				Timestamp in fault record adjusted for the local time setting.		
				Corrected Breaker Fail - WI Aided1 trips so they can be disabled via setting "WI Prot Reset"		
44	E	K	Mar 2009	Release of P543, P544, P545 & P546 without distance protection based on 44D.	Patch for V2.14 First release of Studio	P54x/EN M/J74 + P54x/EN AD/J94
				Prevents the loss of IEC61850 messages and fixed the handling of the ACD flag during Gl.		
				Improved the Ethernet card boot code		
44	F	K	Sept 2009	Release of P543, P544, P545 & P546 without distance protection based on 44E.	Patch for V2.14 First release of Studio	P54x/EN M/J74 + P54x/EN AD/J94
				Corrected some menu translations.		
				Corrected P543 default PSL.		

Software version		Hardware suffix	Original date of issue	Description of changes	Easergy Studio compatibility	Technical documentation
Major	Minor					
				Correction to the way latched LED/Relays are cleared.		
				Correction to Negative sequence overcurrent settings when 5A input used.		
				Correction to P545/P541 compatibility when used in transformer compensation mode.		
				Improvements to the GPS code.		
				Prevented CTS generating events when CTS is disabled.		
				Fixed problem which prevented residual overvoltage from initiating CB Fail.		
				Various improvements to DNP, CS103 & IEC61850 protocols.		
				Bug fixes		
44	G	K	Oct 2010	Release of P543, P544, P545 & P546 without distance protection based on 44F.	Patch for V2.14 First release of Studio	P54x/EN M/J74 + P54x/EN AD/J94
				Fixed a 61850 issue which blocked clients when one was disconnected.		
				Improvements to Fault record display over Courier and DNP3.		
				Bug fixes		
44	U	K	Apr 2011	Release of P543, P544, P545 & P546 without distance protection based on 44G.	Patch for V2.14 First release of Studio	P54x/EN M/J74 + P54x/EN AD/J94 P54x/EN AD/K94
				Rebranded as Schneider Electric.		
				Minor change to software number plus changes to 61850 (New ICD files required).		
				Additional CB Monitoring data provided over CS103.		
				Bug Fixes		
44	V	K	Dec 2011	Release of P543, P544, P545 & P546 without distance protection based on 44U.	Patch for V2.14 First release of Studio	P54x/EN M/J74 + P54x/EN AD/J94 P54x/EN AD/K94
				Improved IEC61850 Status reporting of DDB signal changes.		
				Protection communications Invalid Message Format Alarm Implementation corrected.		
				The default PSL of P546 with 12 high break outputs could not upload from relay correctly. The options with 20 relays outputs associate the default PSL with 32 relays outputs.		
				Bug Fixes		
44	U/V/W/X	K	June 2012	Release of P54x (P543/P54/P545/P546) based on 44/54G.	Patch for V2.12	P54x/EN M/Ka4
				CS103 for CB Monitor functions (CB1 only).		
				Software re-branded from Areva to Schneider Electric.		

Software version		Hardware suffix	Original date of issue	Description of changes	Easergy Studio compatibility	Technical documentation
Major	Minor					
45	B	K	Mar 2009	Release of P543, P544, P545 & P546 without distance protection based on 44E.	Patch for V2.14 Studio ftp server	P54x/EN M/KA4
				Autoreclose, Check Sync and CB Monitoring added to P544 & P546		
45	C	K	May 2009	Release of P543, P544, P545 & P546 without distance protection based on 45B.	Patch for V2.14 Studio ftp server	P54x/EN M/KA4
				Improvements to the Ethernet card startup and configuration.		
				Correction to Negative sequence overcurrent settings when 5A input used.		
				Correction to P545/P541 compatibility when used in transformer compensation mode.		
				Correction to the way latched LED/Relays are cleared.		
				Corrections to menu text.		
				Improvements to the GPS code.		
				Bug Fixes		
45	D	K	Oct 2009	Release of P543, P544, P545 & P546 without distance protection based on 45C.	Patch for V2.14 Studio ftp server	P54x/EN M/KA4
				Improvements to the GPS code.		
				Improvements in the clock recover circuits used by the Differential Comms.		
				Bug Fixes		
47	A	K	Dec 2009	Release of P543, P544, P545 & P546 without distance protection based on 45D.	Patch for V2.14 Studio ftp server	P54x/EN M/KA4 + P54x/EN AD/KB4
				IEC-61850 phase 2 and 2.1 implemented.		
				Application for Inzone Transformers (2nd and 5th Harmonic Blocking/restraint).		
				Differential Highset can be disabled when Inrush protection is enabled.		
				Restricted Earth Fault Protection (REF).		
				Modification to Char Mod timer functionality.		
				Separate measurements for each set of CT's.		
				Interrupt Driven InterMiCOM in all models.		
				Read Only Mode		
47	B	K	Jan 2010	Release of P543, P544, P545 & P546 without distance protection based on 47A.	Patch for V2.14 Studio ftp server	P54x/EN M/KA4 + P54x/EN AD/KB4
				Prevented the Differential protection inhibiting in three terminal schemes when GPS is enabled and loopback mode selected.		
				Fault locator measurements in ohms corrected when 5A CT used or displayed in primary.		
				Frequency measurement in DNP3 fault record corrected		

Software version		Hardware suffix	Original date of issue	Description of changes	Easergy Studio compatibility	Technical documentation
Major	Minor					
47	D	K	Oct 2010	Release of P543, P544, P545 & P546 without distance protection based on 47B.	Patch for V2.14 Studio ftp server	P54x/EN M/KA4 + P54x/EN AD/KB4
				Enhancement to GOOSE performance.		
				Fixes to 61850.		
				Fixed Protection comms address problem in three ended scheme selected.		
				Fixed dnp3 control of CB2.		
				Incorrect mapping of XCBR(n).CBOpCap.stVal data attribute corrected.		
				Improvements to Fault record display over courier and DNP3.		
47	U	K	Feb 2011	Release of P543, P544, P545 & P546 without distance protection based on 47D.	Studio ftp server	P54x/EN M/KA4 + P54x/EN AD/KB5 P54x/EN AD/LC4
				Rebranded as Schneider Electric.		
				Minor change to software number.		
				Changes to 61850 (New ICD files required). Changes to improve IEC61850 reporting on rapidly toggling status. Corrections to IEC61850 datamodel.		
				Improvements to processing of GOOSE messages when using managed Ethernet switch parameterised for VLAN.		
				Improvements to PSL Operation when non-latched and latched LEDs are used together.		
				Improvements to copro configuration (settings) failure detection.		
				P543 Software Version 47 only - Corrected PSL Reference Cell in the PSL DATA menu column.		
				Bug Fixes.		
47	V	K	17/06/2011	Release of P54x (P543/P54/P545/P546) based on 47/57U.	Patch for V2.14 Studio ftp server	P54x/EN M/Ka4
				CB Fail reset time on fault clearance improvement.		
				CB Status monitoring improvement		
47	W	K	27/12/2011	Release of P543, P544, P545 & P546 without distance protection based on 47V	Patch for V2.14 Studio ftp server	P54x/EN M/KA4 + P54x/EN AD/LC4
				Status report over IEC61850 not in line with DDB signals		
				Protection communications Invalid Message Format Alarm Implementation corrected.		
				Directional negative sequence overcurrent will only reset from the tripped state by loss of current and not incorrect direction.		
				Improved IEC61850 Status reporting of DDB signal changes.		
				The default PSL of P546 with 12 high break outputs could not upload from relay correctly. The options with 20 relays outputs associate the default PSL with 32 relays outputs.		

Software version		Hardware suffix	Original date of issue	Description of changes	Easergy Studio compatibility	Technical documentation
Major	Minor					
				P544/P546 57V IEC61850 + CS103 variant Download: Relay does not occasionally re-boot with error code 0X351f03f5.		
				BugFixes		
47	X	K	15/05/2012	Release of P543, P544, P545 & P546 without distance protection based on 57W	Patch for V2.14 Studio ftp server	P54x/EN M/KA4 + P54x/EN AD/LC4
				Improved IEC61850 Goose Performance		
				Improvements to IEC61850.		
				Bug Fixes.		
48	C	K		Restricted Release of P545 (Courier / IEC61850 Comms only) without distance protection based on 45C.	Patch for V2.14 First release of Studio	
				Replace the conventional analogue input module with the 9-2 LE NCIT module.		
				Support P545 CIT/NCIT 2-ended schema with the introduction of current adjust algorithm		
48	F	K		Restricted Release of P546 (Courier / IEC61850 Comms only) without distance protection based on 47B and 48C.	Patch for V2.14 First release of Studio	
				Include v47 Functionality.		
				Replace the conventional analogue input module with the 9-2 LE NCIT module.		
				Support P545 CIT/NCIT 2-ended schema with the introduction of current adjust algorithm		
50	A	K	May 2006	Release of P543, P544, P545 & P546 with distance protection.	Patch for V2.12	P54x/EN M/I64
				Distance protection from P443.		
				DEF from P443.		
				Aided distance & DEF schemes from P443.		
				CTS		
50	A	K	May 2006	Definitive time directional negative sequence overcurrent I2>.	Patch for V2.12	P54x/EN M/I64
				GPS synchronization of current differential in all models.		
				P543 and P545 now facilitate in zone transformer-feeder applications.		
				All models support ABC and ACB phase rotation.		
				Standard and inverted CT polarity setting for each set of CTs in the relay.		
				User interface with tri colored LED and function keys.		
				InterMiCOM64.		
				Voltage protection.		
				Backwards compatibility mode		
51	C	K	Jul 2006	Release of P543, P544, P545 & P546 with distance protection based on 50A. IEC 61850-8-1.	Patch for V2.12	P54x/EN M/J74

Software version		Hardware suffix	Original date of issue	Description of changes	Easergy Studio compatibility	Technical documentation
Major	Minor					
				High break options.		
				Unmodulated IRIG-B options.		
				Reduction of distance minimum reach settings to 0.05 ohm.		
				Permissive trip reinforcement.		
				Poledead modifications for Hydro Quebec.		
				CS103/auto-reclose modifications.		
				Out of step tripping		
51	D	K	Aug 2006	Release of P543, P544, P545 & P546 with distance protection based on 51C.	Patch for V2.12 V2.13 or Later	P54x/EN M/J74
				Prevents a possible reboot 15 minutes after browsing the front courier port but not making a setting change i.e. browsing using PAS&T.		
				Extended GOOSE Enrolment Capability.		
				Correction to ICD files, Enumeration (value) and Fixed data Mapping		
51	E	K	Nov 2006	Release of P543, P544, P545 & P546 with distance protection based on 51D.	Patch for V2.12 V2.13 or Later	P54x/EN M/J74
				Prevent a reboot in 61850 builds when NIC link is inactive and avalanche of DDB activity.		
				Correctly report a fatal error generated by the sampling call-back.		
				Correct the operation of the GOOSE messaging and a problem with the download of an IED Configuration file.		
				Correct the operation of the check sync.		
				Correct the operation of the overcurrent reset curves.		
				Removed check on the 14th position of model number.		
				Fixed Telegrams for public inf 64-67.		
				SOTF can operate even when it is disabled		
51	F	K	May 2007	Release of P543, P544, P545 & P546 non 61850 builds with distance protection based on 51E.	Patch for V2.12 V2.13 or Later	P54x/EN M/J74
				Prevent a fatal error from an incorrect DNP address in not using DNP evolutions platform.		
				Default setting for 450B 'I< Current Set' reduced to 50 mA.		
				French Translations for DDBs 1368-1371 corrected.		
				Dependencies for cells 3242 & 3245 corrected.		
				Fun & INF values related to CS103 Command Blocking corrected.		
				Angle for negative sequence phase overcurrent setting corrected.		
				Corrected operation when using MICOM S1 is used to activate Settings group by right clicking on the group.		
				Corrected the latching of Function Key DDB signals on relay power up.		
				Corrected Disturbance recorder scaling to prevent high current levels into 5A CT causing the Disturbance Recorder to saturate.		
				Restricting defaults appears not to change the 1/5A CT selection.		
				Corrected the performance of the IM64 Direct mode.		

Software version		Hardware suffix	Original date of issue	Description of changes	Easergy Studio compatibility	Technical documentation
Major	Minor					
				CB control via Direct access does not work with 2CB versions of P540D.		
				Autoreclose dead time/close cycle continues even if AR switched out of service.		
				Distance setting are not updated in simple setting mode in setting groups other than the active one.		
				Ch2 Statistics may not be displayed		
51	G	K		P543, P544, P545 & P546 non 61850 builds with distance protection based on 51F was approved for release but withdrawn before release.	Patch for V2.12	P54x/EN M/J74
				Corrections to enable/disable of Autoreclose		
51	H	K	July 2007	Release of P543, P544, P545 & P546 non 61850 builds with distance protection based on 51G.	Patch for V2.12	P54x/EN M/J74
				Corrected power swing detection when both distance and current differential enabled.		
				Corrections to enable/disable of Autoreclose		
51	I	K	Jan 2010	Release of P543, P544, P545 & P546 non 61850 builds with distance protection based on 51H.	Patch for V2.12	P54x/EN M/J74
				Prevented the Differential protection inhibiting in three terminal schemes when GPS is enabled and loopback mode selected.		
				Improvements to the GPS code.		
				Improvements in the clock recover circuits used by the Differential Comms.		
				Correction to P545/P541 compatibility when used in transformer compensation mode.		
				Correction to the way latched LED/Relays are cleared.		
				Corrections to the Current Differential Inhibit when the GPS synchronisation is disabled.		
				Correction to the distance cross polarising when the memory expires.		
				Corrections to menu text.		
				Correction to autoreclose operation for switch on to fault condition.		
				Fix for DEF reverse operation.		
				Corrected some French and German text.		
				Prevented CB Operating Time displaying 4.295Ms.		
				Fix to Blocking scheme.		
				Fixed Inhibit CB Fail Protection in P544/P546.		
				Improved co-processor error reporting.		
				Fixed a SOTF problem.		
51	J	K	Oct 2010	Release of P543, P544, P545 & P546 non 61850 builds with distance protection based on 51J.	Patch for V2.12	P54x/EN M/J74
				Fixed a problem with the co-processor stack check which could cause a re-boot.		
				Enhanced the OST feature to make it more stable when currents are low.		
				Improved the distance performance for 2ph-g and also cross country faults.		

Software version		Hardware suffix	Original date of issue	Description of changes	Easergy Studio compatibility	Technical documentation
Major	Minor					
51	U	K	Aug 2012	Special software release for P546 (Australia only). Based on 51J.	Patch for V2.14	P54x/EN M/J74 + P54x/EN AD/J84
				Rebranded as Schneider Electric (Minor change to software number)		
				Protection communications Invalid Message Format Alarm Implementation corrected..		
				Relay may reboot with errorcode 39170000 when an incorrect DNP3 address is received.		
52	A	K	Feb 2007	Release of P543, P544, P545 & P546 with distance protection. Chinese interface.	Patch for V2.14	P54x/EN M/J74 + P54x/EN AD/J84
				Replacing the existing DNP3 with the DNP3 evolutions.		
				Addition of a current but no volts trip option to Switch on to Fault and Trip on Reclose feature (SOTF/TOR).		
				Replacement of existing negative sequence overcurrent with multi stage (2 IDMT + 2 DT) negative sequence overcurrent.		
				Addition of IDG curve, commonly used in Sweden, to Earth Fault & Sensitive Earth Fault (involves moving settings).		
				Reduction of all TMS step sizes to 0.005.		
				Addition of Channel propagation delay Statistics and Alarms.		
				Changes to CTS so both techniques can be selected together.		
				Regrouping of CTS settings.		
				Addition of four stages of under frequency protection and two stages of Overfrequency protection.		
				Addition of df/dt protection.		
				Changes to Under and Overvoltage to enable each stage to be independently set.		
				Extensions to the checksync VT position setting.		
				Replacing fixed Trip on Close (TOC) Delay with a setting.		
				Improvements to slow power swing detection.		
				Changes to distance count strategy to restore the same operating time when phase differential protection is enabled.		
				Changes to Permissive Inter Trip (PIT) logic to enable the user to select either local or remote current to be used.		
				Includes local time zone settings for Date & Time		
				Addition of flexible settings for distance quadrilateral top line.		
				Reduced minimum setting for IN> I2pol Set.		
				Addition of propagation delay times to Fault Record.		
				Default setting for 450B 'I< Current Set' reduced to 50mA.		
				Enhancement to self checking of output relays.		
				Change tunnelled courier address to follow the 1st Rear Port's KBUS or CS103 address.		
52	B	K	July 2007	Release of P543, P544, P545 & P546 with distance protection based on 52A.		P54x/EN AD/J84
				Phase comparison protection P547 added to range.		
				Improvements to VTS.		
				Improvements to slow power swing detection.		

Software version		Hardware suffix	Original date of issue	Description of changes	Easergy Studio compatibility	Technical documentation
Major	Minor					
				Corrected power swing detecting when both distance and current differential enabled.		
				Corrections to enable/disable of Autoreclose.		
				Resolved a problem relating to CT Ratio's not being restored when restoring default settings.		
				Resolved a problem with the Disturbance Recorder which saturates for High current levels into 5A CT.		
52	C	K	July 2007	Release of P543, P544, P545 & P546 with distance protection based on 52B.	Patch for V2.14	P54x/EN M/J74 + P54x/EN AD/J84
				Tilt angle of ground quadrilateral Characteristic corrected.		
				Minor correction to fault record.		
				Corrections to over voltage stage 2 inhibit		
52	D	K	Dec 2007	Release of P543, P544, P545 & P546 with distance protection based on 52C.	Patch for V2.14	P54x/EN M/J74 + P54x/EN AD/J84
				Fixed a number of 61850/Goose problems.		
				Fixed a problem in P547 related o the transient starters.		
				Fixed the max prop alarm.		
				Corrected some DDB German text.		
				Fixed a problem with week infeed inhibit.		
				Fixed a SOTF problem when there is a short duration pre-fault.		
				Fixed a primary scaling issue relating to Zone 5 & 6		
52	E	K	May 2008	Release of P543, P544, P545 & P546 with distance protection based on 52D.	Patch for V2.14	P54x/EN M/J74 + P54x/EN AD/J84
				Fixed a number of 61850 problems.		
				Improved co-processor error reporting.		
				Fix to Blocking scheme.		
				Fixed Inhibit CB Fail Protection in P544/P546		
52	F	K		Not released to production. Based on 52E.	Patch for V2.14	P54x/EN M/J74 + P54x/EN AD/J84
				Correction to autoreclose operation for switch on to fault condition.		
				Prevented CB Operating Time displaying 4.295Ms.		
				Bug fixes		
52	G	K	Oct 2008	Release of P543, P544, P545 & P546 with distance protection based on 52F.	Patch for V2.14	P54x/EN M/J74 + P54x/EN AD/J84
				Correction to the distance cross polarising when the memory expires		
52	H	K	Sept 2009	Release of P543, P544, P545 & P546 with distance protection based on 52G.	Patch for V2.14	P54x/EN M/J74 + P54x/EN AD/J84
				Corrected some menu translations.		

Software version		Hardware suffix	Original date of issue	Description of changes	Easergy Studio compatibility	Technical documentation
Major	Minor					
				Corrected Breaker Fail - WI Aided1 trips so they can be disabled via setting "WI Prot Reset".		
				Timestamp in fault record adjusted for the local time setting.		
				Corrections to the Current Differential Inhibit when the GPS synchronisation is disabled.		
				Corrected Thermal State measurement via DNP3.		
				Correction to the way latched LED/Relays are cleared.		
				Correction to Negative sequence overcurrent settings when 5A input used.		
				Correction to P545/P541 compatibility when used in transformer compensation mode.		
				Improvements to the GPS code.		
				Prevented CTS generating events when CTS is disabled.		
				Prevent Z5 from setting slow swing when PSB is disabled.		
				Resolved problem in P543/P545 which prevent correct reporting of fault record over 61850.		
				Fixed problem which prevented residual overvoltage from initiating CB Fail.		
				Various improvements to DNP, CS103 & IEC61850 protocols.		
				Bug fixes		
52	U	K	May 2012	Restricted Release of P546 IEC61850 Only with distance protection based on 52H. Supplied to North China Grid (NCGC).	Patch for V2.14 First release of Studio	P54x/EN M/J74 + P54x/EN AD/J84
				Rebranded as Schneider Electric.		
				Minor change to software number plus changes to 61850 (New ICD files required).		
				Protection communications Invalid Message Format Alarm Implementation corrected.		
				Bug fixes.		
52	V	K	Nov 2013	Restricted Release of P543 and P545 with distance protection DNP3 (comms Protocol 4) based on 52H and 52U. Supplied to Transpower (New Zealand).	Patch for V2.14 First release of Studio	P54x/EN M/J74 + P54x/EN AD/J84
				Rebranded as Schneider Electric. Minor change to software number plus changes to 61850 (New ICD files required).		
				Protection communications Invalid Message Format Alarm Implementation corrected.		
				GPS / Protection communications drop-out improvements (when operating with some Multiplexer / radio links).		
53	A	K	01/08/2007	Restricted Release of P545 (CS103 Comms only) with distance protection based on 52C.	Patch for V2.14 First release of Studio	P54x/EN M/J74 + P54x/EN AD/J94
				Extended I/O – status inputs increased from 24 to 32.		
				Positional information added to PSL.		
				Bug fixes		

Software version		Hardware suffix	Original date of issue	Description of changes	Easergy Studio compatibility	Technical documentation
Major	Minor					
53	B	K	24/08/2007	Restricted Release of P545 (CS103 Comms only) with distance protection based on 53A.	Patch for V2.14 First release of Studio	P54x/EN M/J74 + P54x/EN AD/J94
				Tilt angle of ground quadrilateral Characteristic corrected		
				Minor correction to fault record		
				Corrections to over voltage stage 2 inhibit		
54	A	K	Mar 2008	Release of P543, P544, P545 & P546 with distance protection based on 52D.	Patch for V2.14 First release of Studio	P54x/EN M/J74 + P54x/EN AD/J94
				Positional information added to PSL.		
				DNP 3.0 Over Ethernet protocol added.		
				Extended I/O – status inputs increased from 24 to 32.		
				Compensated overvoltage protection added.		
				IEC-103 Generic Services Measurements added.		
				Set/Reset Latch Logic Gates added to PSL.		
				Improved Sensitivity Range for DEF.		
				Fault record to include current differential currents recorded at the time of the current differential trip in addition to the existing data from 1 cycle later.		
				Fault record increased max number of fault records to 15.		
				GPS Alarm modifications.		
				Scheme Delta from P443 included.		
				DNP enhancements for SSE.		
				Bug fixes		
54	B	K	June 2008	Release of P543, P544, P545 & P546 with distance protection based on 54A.	Patch for V2.14 First release of Studio	P54x/EN M/J74 + P54x/EN AD/J94
				Fixed a number of 61850 problems.		
				Improved co-processor error reporting.		
				Fix to Blocking scheme.		
				Fix for DEF reverse operation.		
				Fixed Inhibit CB Fail Protection in P544/P546.		
				Corrected some French and German text.		
				Prevented CB Operating Time displaying 4.295Ms.		
				Fixed a problem which prevented extraction of dnp3 setting files from dnp3 over Ethernet variants.		
				Bug fixes		
54	C	K	June 2008	Release of P543 & P545 with distance protection based on 54B.	Patch for V2.14 First release of Studio	P54x/EN M/J74 + P54x/EN AD/J94
				Correction to autoreclose operation for switch on to fault condition		

Software version		Hardware suffix	Original date of issue	Description of changes	Easergy Studio compatibility	Technical documentation
Major	Minor					
54	D	K	Jan 2009	Release of P543, P544, P545 & P546 with distance protection based on 54C.	Patch for V2.14 First release of Studio	P54x/EN M/J74 + P54x/EN AD/J94
				Correction to the distance cross polarizing when the memory expires.		
				Corrections to the Current Differential Inhibit when the GPS synchronization is disabled.		
				Corrected Thermal State measurement via DNP3.		
				Timestamp in fault record adjusted for the local time setting.		
				Corrected Breaker Fail - WI Aided1 trips so they can be disabled via setting "WI Prot Reset"		
54	E	K	20/03/2009	Release of P543, P544, P545 & P546 with distance protection based on 54D.	Patch for V2.14 First release of Studio	P54x/EN M/J74 + P54x/EN AD/J94
				Prevents the loss of IEC61850 messages and fixed the handling of the ACD flag during GI.		
				Improved the Ethernet card boot code		
54	F	K	21/09/2009	Release of P543, P544, P545 & P546 with distance protection based on 54E.	Patch for V2.14 First release of Studio	P54x/EN M/J74 + P54x/EN AD/J94
				Corrected some menu translations.		
				Correction to the way latched LED/Relays are cleared.		
				Correction to Negative sequence overcurrent settings when 5A input used.		
				Correction to P545/P541 compatibility when used in transformer compensation mode.		
				Improvements to the GPS code.		
				Prevented CTS generating events when CTS is disabled.		
				Prevent Z5 from setting slow swing when PSB is disabled.		
				Resolved problem in P543/P545 which prevent correct reporting of fault record over 61850.		
				Fixed problem which prevented residual overvoltage from initiating CB Fail.		
				Various improvements to DNP, CS103 & IEC61850 protocols.		
				Bug fixes		
54	G	K	19/10/2010	Release of P543, P544, P545 & P546 with distance protection based on 54F.	Patch for V2.14 First release of Studio	P54x/EN M/J74 + P54x/EN AD/J94
				Time stamping and status of IEC61850 Data attribute sofPSOF1.ST.general.Op improved		
				Fixed a 61850 issue which blocked clients when one was disconnected		
				Enhanced the OST feature to make it more stable when currents are low		

Software version		Hardware suffix	Original date of issue	Description of changes	Easergy Studio compatibility	Technical documentation
Major	Minor					
				Improved the distance performance for cross country faults		
				Improvements to Fault record display over courier and dnp3		
				Bug fixes		
54	U	K	18/04/2011	Release of P543, P544, P545 & P546 with distance protection based on 54G.	Patch for V2.14 First release of Studio	P54x/EN M/J74 + P54x/EN AD/J94 P54x/EN AD/K94
				Rebranded as Schneider Electric.		
				Minor change to software number plus changes to 61850 (New ICD files required).		
				Additional CB Monitoring data provided over CS103		
				OST sensitivity now 60mA (was previously 180mA).		
				DEF Aided and Delta Aided setting 3 pole / 1 and 3 pole visibility corrected.		
				Bug Fixes		
54	V	K	15/12/2011	Release of P543, P544, P545 & P546 with distance protection based on 54U.	Patch for V2.14 First release of Studio	P54x/EN M/J74 + P54x/EN AD/J94 P54x/EN AD/K94
				Improved IEC61850 Status reporting of DDB signal changes.		
				Protection communications Invalid Message Format Alarm Implementation corrected.		
				The default PSL of P546 with 12 high break outputs could not upload from relay correctly. The options with 20 relays outputs associate the default PSL with 32 relays outputs.		
				Bug Fixes		
54	W	K	20/11/2013	Restricted release of P544 & P546 with distance protection DNP3 (Protocol 4) and IEC61850+Courier (protocol 6) variant for Manitoba Hydro based on 54V	Patch for V2.14 First release of Studio	P54x/EN M/J74 + P54x/EN AD/J94 P54x/EN AD/K94
				Dual CB Variants (P446/P544/P546/P841B) - Aided Scheme Echo on dual CB variants.		
				Software re-branded from Areva to Schneider Electric.		
55	B	K	March 2009	Release of P543, P544, P545 & P546 with distance protection based on 54E.	Patch for V2.14 Studio ftp server	P54x/EN M/KA4
				Autoreclose, Check Sync and CB Monitoring added to P544 & P546		
55	C	K	15/05/2009	Release of P543, P544, P545 & P546 with distance protection based on 55B.	Patch for V2.14 Studio ftp server	P54x/EN M/KA4
				Improvements to the Ethernet card startup and configuration.		
				Correction to Negative sequence overcurrent settings when 5A input used.		

Software version		Hardware suffix	Original date of issue	Description of changes	Easergy Studio compatibility	Technical documentation
Major	Minor					
				Correction to P545/P541 compatibility when used in transformer compensation mode.		
				Correction to the way latched LED/Relays are cleared.		
				Corrections to menu text.		
				Improvements to the GPS code.		
				Bug Fixes		
55	D	K	28/10/2009	Release of P543, P544, P545 & P546 with distance protection based on 55C.	Patch for V2.14 Studio ftp server	P54x/EN M/KA4
				Improvements to the GPS code.		
				Correction to slow power swing configuration.		
				Improvements in the clock recover circuits used by the Differential Comms.		
				Prevent Z5 from setting slow swing when PSB is disabled.		
				Bug Fixes		
56	A	K	03/04/2008	Restricted Release of P546 (CS103 Comms only) with distance protection based on 54A.	Patch for V2.14 First release of Studio	P54x/EN M/J74
				Read Only Mode.		
				Fix to Blocking scheme.		
				Bug fixes		
57	A	K	10/12/2009	Limited Release of P543, P544, P545 & P546 with distance protection based on 55D.	Patch for V2.14 Studio ftp server	P54x/EN M/KA4 + P54x/EN AD/KB4
				IEC-61850 phase 2 and 2.1 implemented.		
				Application for Inzone Transformers (2nd and 5th Harmonic Blocking/restraint).		
				Differential Highset can be disabled when Inrush protection is enabled.		
				Restricted Earth Fault Protection (REF).		
				Modification to Char Mod timer functionality.		
				Separate measurements for each set of CT's.		
				Interrupt Driven InterMiCOM in all models.		
				Read Only Mode		
57	B	K	10/02/2010	Release of P543, P544, P545 & P546 with distance protection based on 57A.	Patch for V2.14 Studio ftp server	P54x/EN M/KA4 + P54x/EN AD/KB4
				Prevented the Differential protection inhibiting in three terminal schemes when GPS is enabled and loopback mode selected.		
				Fault locator measurements in ohms corrected when 5A CT used or displayed in primary.		
				Frequency measurement in DNP3 fault record corrected		

Software version		Hardware suffix	Original date of issue	Description of changes	Easergy Studio compatibility	Technical documentation
Major	Minor					
57	C	K	05/05/2010	Release of P543 61850 with distance protection based on 57B	Patch for V2.14 Studio ftp server	P54x/EN M/KA4 + P54x/EN AD/KB4
				Enhancement to GOOSE performance		
				Fixes to 61850.		
				Fixed Protection comms address problem in three ended scheme selected		
				Fixed dnp3 control of CB2		
				Fixed a small issue with the detection of slow swings		
57	D	K	15/10/2010	Release of P543, P544, P545 & P546 with distance protection based on 57B	Patch for V2.14 Studio ftp server	P54x/EN M/KA4 + P54x/EN AD/KB4
				Enhancement to GOOSE performance		
				Fixes to 61850.		
				Fixed Protection comms address problem in three ended scheme selected		
				Fixed dnp3 control of CB2		
				Fixed a small issue with the detection of slow swings		
				Incorrect mapping of XCBR(n).CBOpCap.stVal data attribute corrected		
				Time stamping and status of IEC61850 Data attribute sofPSOF1.ST.general.Op improved		
				Enhanced the OST feature to make it more stable when currents are low		
				Improved the distance performance for cross country faults		
				Improvements to Fault record display over courier and dnp3		
57	U	K	23/02/2011	Release of P543, P544, P545 & P546 with distance protection based on 57D	Patch for V2.14 Studio ftp server	P54x/EN M/KA4 + P54x/EN AD/KB4
				Rebranded as Schneider Electric.		
				Minor change to software number.		
				Changes to 61850 (New ICD files required). Changes to improve IEC61850 reporting on rapidly toggling status. Corrections to IEC61850 datamodel.		
				Improvements to processing of GOOSE messages when using managed Ethernet switch parameterised for VLAN.		
				Improvements to PSL Operation when non-latched and latched LEDs are used together.		
				Improvements to copro configuration (settings) failure detection.		
				Improvements to Zone 1 Extension Reset.		
				P543 Software Version 47 only - Corrected PSL Reference Cell in the PSL DATA menu column.		
				Bug Fixes.		
57	V	K	17/06/2011	Release of P543, P544, P545 & P546 with distance protection based on 57U	Patch for V2.14 Studio ftp server	P54x/EN M/KA4 + P54x/EN AD/LC4

Software version		Hardware suffix	Original date of issue	Description of changes	Easergy Studio compatibility	Technical documentation
Major	Minor					
				CB Fail reset time on fault clearance improvement.		
				CB Status monitoring improvement		
57	W	K	27/12/2011	Release of P543, P544, P545 & P546 with distance protection based on 57V	Patch for V2.14 Studio ftp server	P54x/EN M/KA4 + P54x/EN AD/LC4
				Status report over IEC61850 not in line with DDB signals		
				OST sensitivity now 60mA (was previously 180mA).		
				Protection communications Invalid Message Format Alarm Implementation corrected.		
				Directional negative sequence overcurrent will only reset from the tripped state by loss of current and not incorrect direction.		
				Improved IEC61850 Status reporting of DDB signal changes.		
				The default PSL of P546 with 12 high break outputs could not upload from relay correctly. The options with 20 relays outputs associate the default PSL with 32 relays outputs.		
				P544/P546 57V IEC61850 + CS103 variant Download: Relay does not occasionally re-boot with error code 0X351f03f5.		
				BugFixes		
57	X	K	15/05/2012	Release of P543, P544, P545 & P546 with distance protection based on 57W	Patch for V2.14 Studio ftp server	P54x/EN M/KA4 + P54x/EN AD/LC4
				Improved IEC61850 Goose Performance		
				Distance zone 1 may mal-trip when simulated three-phase VT fail condition is applied.		
				Improvements to IEC61850.		
				Bug Fixes.		
57	Y	K	12/03/2014	Restricted release of P543 & P545 with distance protection IEC61850+Courier (protocol 6) variant for PetroBras based on 57X	Patch for V2.14 Studio ftp server	P54x/EN M/KA4 + P54x/EN AD/LC4
				Improved IEC61850 Goose Performance - During IEC61850 testing on P64x 04 software, buffered events cannot be sent to the client before GI reports (MMSLITE_V5.1001i replaces MMSLITE_V5.1001D)		
				The high traffic of unicast (eventually multicast with the same MAC address as the goose subscription) frames leads to blocking of the GOOSE subscription by the Px4 relays. GOOSE publishing and MMS services remains working correctly.		
				P54x Power Factor measurement can be displayed as greater than 1.000		
				Bug fixes		
58	C	K	08/03/2010	Restricted Release of P545 (Courier / IEC61850 Comms only) with distance protection based on 55C.	Patch for V2.14 Studio ftp server	
				Replace the conventional analogue input module with the 9-2 LE NCIT module		
				Support P545 CIT/NCIT 2-ended schema with the introduction of current adjust algorithm		

Software version		Hardware suffix	Original date of issue	Description of changes	Easergy Studio compatibility	Technical documentation
Major	Minor					
58	F	K	04/06/2010	Restricted Release of P545 & P546 (Courier / IEC61850 Comms only) with distance protection based on 57B and 58C.	Patch for V2.14 Studio ftp server	
				Include v57 Functionality		
				Replace the conventional analogue input module with the 9-2 LE NCIT module		
				Support P545 CIT/NCIT 2-ended schema with the introduction of current adjust algorithm		
70	A	M	01/02/2011	Restricted Release of Cyber Security P546 IEC61850 variant with distance protection based on 57D.	Studio ftp server	P54x/EN M/J74 + P54x/EN AD/J84
				Cyber Security included.		
70	U	M	24/04/2012	Restricted Release of P546 IEC61850 Only with distance protection based on 70A.	Studio ftp server	P54x/EN M/J74 + P54x/EN AD/J84
				Rebranded as Schneider Electric. Minor change to software number plus changes to 61850 (New ICD files required).		
				Improved IEC61850 Goose Performance		
				Changes to improve IEC61850 reporting on rapidly toggling status. Corrections to IEC61850 datamodel.		
				Status report over IEC61850 not in line with DDB signals		
				Improvements to IEC61850.		
				Protection communications Invalid Message Format Alarm Implementation corrected.		
				OST sensitivity now 60mA (was previously 180mA).		
				Improvements to PSL Operation when non-latched and latched LEDs are used together.		
				Improvements to copro configuration (settings) failure detection.		
				Improvements in PSL data models.		
				Improvements to processing of GOOSE messages when using managed Ethernet switch parameterised for VLAN.		
				Minor bug fixes to distance protection.		
				Bug fixes		
A0	A	K	09/11/2011	Release of P543, P544, P545 & P546 without distance protection based on 57U (Courier, CS103 and IEC61850+Courier Comms protocols only).	MiCOM S1 Studio v3.0.0	P54x/EN M/KA4 + P54x/EN AD/KB5
				Change to Schneider-Electric Major release (alpha) software number plus changes to 61850 (New ICD files required). Changes to improve IEC61850 reporting on rapidly toggling status. Corrections to IEC61850 datamodel.		
				CB Fail reset time on fault clearance improvement.		
				Enhanced Disturbance Recorder - 20 Analog / 128 Digital Channels. Additional Differential, Max Bias and 2nd Harmonic current data.		
				CT Ratio Enhancements (P544/P546 allow use of different CT1 and CT2 Ratios).		
				Additional CB Monitoring data provided over CS103		

Software version		Hardware suffix	Original date of issue	Description of changes	Easergy Studio compatibility	Technical documentation
Major	Minor					
				Protection communications Invalid Message Format Alarm Implementation corrected.		
				Language Text for "IED CONFIGURATOR" menu column header uses selected language (previously only English).		
				Bug Fixes		
A0	B	K	31/05/2012	Release of P543, P544, P545 & P546 without distance protection based on A0A	MiCOM S1 Studio v3.5.2	P54x/EN M/KA4 + P54x/EN AD/J84 P54x/EN AD/KB5 P54x/EN AD/LC4
				DR code optimize to release additional memory for DR pre-trigger time		
				Additional protocols release (DNP3, DNP3OE, IEC61850+IEC103) by compare with A0/B0A		
				Improved IEC61850 Goose Performance		
				Changes to improve IEC61850 reporting on rapidly toggling status. Corrections to IEC61850 datamodel.		
				Improvements to IEC61850.		
				Status report over IEC61850 not in line with DDB signals		
				Reset improvements (Amplitude or Direction) to directional neg. seq. overcurrent.		
				Schneider use alpha character for software release version. Major version is not compatible with letters of cs103 protocol, both IED code and tools.		
				P544/P546 57V IEC61850 + CS103 variant Download: Relay does not occasionally re-boot with error code 0X351f03f5.		
				Improvements in PSL data models.		
				Bug Fixes		
A0	D	K	02/07/2015	Release of P543, P544, P545 & P546 without distance protection based on A0B and B0C	Easergy Studio v8.0.0	P54x/EN M/KA4 + P54x/EN AD/KB5 P54x/EN AD/LC4
				Correction in DNP3 OE TCP slave regarding event management.		
				IEC61850 minor bug corrections		
				The TrgOps GI is set by default after start-up		
				IED Subscribe GOOSE with inconformity ApplID should be discarded.		
				IEC61850 corrections related to OrdRunGGIO LN.		
				3600001 and 3600002: Bug Fix / Improvements in setting BufTm		
				Better GOOSE performance in case of high traffic of unicast (eventually multicast with the same MAC address as the goose subscription) frames.		
				IEC61850 minor bug corrections in control model.		
				Improvements in IEC61850 data included in reports managing.		
				IEC61850 minor bug corrections in GOOSE model.		
				Minor DNP3 corrections regarding units of analogue values.		

Software version		Hardware suffix	Original date of issue	Description of changes	Easergy Studio compatibility	Technical documentation
Major	Minor					
				Corrections in DR checksum calculation.		
				IEC61850 minor corrections related to BCR (Binary Counter Reading).		
				Corrections in logical note of OptGGIO1.ST.		
				Corrections in IEC61850 related to deadbands.		
				Minor corrections related to units of analogue values shown in DR.		
				"GosGGIO1\$DC" is readable when configure many datasets in IED dataset definitions.		
				Corrections in IEC61850 related to LN XCBR.POS.stVal.		
				Improvements in POR combined with Weak Infeed.		
				Bug fix related to C Diff failure alarm.		
				Bug fix related to Weak infeed detection function reduces ground fault current sensitivity/		
				IEC61850 interlocking control correction.		
				Corrections related to the manual close delay.		
				IEC61850 bug fixes related to intermediate state.		
				Bug Fix: Max. value of power factor fixed to 1		
				All relevant Changes in version B0C		
				Bug Fixes		
B0	A	K	09/11/2011	Release of P543, P544, P545 & P546 with distance protection based on 57U (Courier, CS103 and IEC61850+Courier Comms protocols only).	MiCOM S1 Studio v3.0.0	
				Change to Schneider-Electric Major release (alpha) software number plus changes to 61850 (New ICD files required). Changes to improve IEC61850 reporting on rapidly toggling status. Corrections to IEC61850 datamodel.		
				CB Fail reset time on fault clearance improvement.		
				Enhanced Disturbance Recorder - 20 Analog / 128 Digital Channels. Additional Differential, Max Bias and 2nd Harmonic current data.		
				CT Ratio Enhancements (P544/P546 allow use of different CT1 and CT2 Ratios).		
				Additional CB Monitoring data provided over CS103		
				OST sensitivity now 60mA (was previously 180mA).		
				Protection communications Invalid Message Format Alarm Implementation corrected.		
				Language Text for "IED CONFIGURATOR" menu column header uses selected language (previously only English).		
				Bug Fixes		
B0	B	K	31/05/2012	Release of P543, P544, P545 & P546 with distance protection based on B0A	MiCOM S1 Studio v3.0.0	
				DR code optimize to release additional memory for DR pre-trigger time		
				Additional protocols release (DNP3, DNP3OE, IEC61850+IEC103) by compare with A0/B0A		
				Improved IEC61850 Goose Performance		
				Changes to improve IEC61850 reporting on rapidly toggling status. Corrections to IEC61850 datamodel.		
				Improvements to IEC61850.		

Software version		Hardware suffix	Original date of issue	Description of changes	Easergy Studio compatibility	Technical documentation
Major	Minor					
				Status report over IEC61850 not in line with DDB signals		
				Directional negative sequence overcurrent will only reset from the tripped state by loss of current and not incorrect direction.		
				Minor bug fixes to distance protection.		
				P544/P546 57V IEC61850 + CS103 variant Download: Relay does not occasionally re-boot with error code 0X351f03f5.		
				Improvements in PSL data models.		
				Bug Fixes		
B0	C	K	20/11/2013	Restricted release of P544 & P546 with distance protection DNP3 (Protocol 4) and IEC61850+Courier (protocol 6) variant based on B0B.	MiCOM S1 Studio v5.0.0	
				Improved IEC61850 Goose Performance.		
				Improvements regarding the MMS communication of IEC61850.		
				Corrections in IEC61850 related to LN XCBR.POS.stVal		
				Dual CB Variants (P446/P544/P546/P841B) - Aided Scheme Echo on dual CB variants.		
				General IEC61850 Improvements		
				IEC61850 Data Model Changes		
				Bug Fixes		
B0	D	K	02/07/2015	Release of P543, P544, P545 & P546 with distance protection based on B0B and B0C	Easergy Studio v8.0.0	
				Correction in DNP3 OE TCP slave regarding event management		
				IEC61850 minor bug corrections		
				The TrgOps GI is set by default after start-up		
				IED Subscribe GOOSE with inconformity ApplID should be discarded.		
				IEC61850 corrections related to OrdRunGGIO LN.		
				A number 3600001 can be successfully set to BufTm.		
				Better GOOSE performance in case of high traffic of unicast (eventually multicast with the same MAC address as the goose subscription) frames.		
				IEC61850 minor bug corrections in control model.		
				Improvements in IEC61850 data included in reports managing.		
				IEC61850 minor bug corrections in GOOSE model.		
				Minor DNP3 corrections regarding units of analogue values.		
				Corrections in DR checksum calculation.		
				IEC61850 minor corrections related to BCR (Binary Counter Reading).		
				Corrections in logical note of OptGGIO1.ST.		
				Corrections in IEC61850 related to deadbands.		
				Minor corrections related to units of analogue values shown in DR.		
				"GosGGIO1\$DC" is readable when configure many datasets in IED dataset definitions.		
				Corrections in IEC61850 related to LN XCBR.POS.stVal.		
				Improvements in POR combined with Weak Infeed.		
				Bug fix related to C Diff failure alarm.		

Software version		Hardware suffix	Original date of issue	Description of changes	Easergy Studio compatibility	Technical documentation
Major	Minor					
				Bug fix related to Weak infeed detection function reduces ground fault current sensitivity.		
				IEC61850 interlocking control correction.		
				Corrections related to the manual close delay.		
				IEC61850 bug fixes related to intermediate state.		
				The maximum range of power factor in phase C is 660		
				P54x Power Factor greater than 1.000.		
				All Changes in version B0C		
				Bug Fixes		
C0	A	M	13/06/2012	Cyber Security Release of P543, P544, P545 & P546 without distance protection based on 70A (also 70U and A0A/A0B)	Easergy Studio v8.0.0	P54x/EN M/Mc5
				Change to Schneider-Electric Major release (alpha) software number plus changes to 61850 (New ICD files required). Changes to improve IEC61850 reporting on rapidly toggling status. Corrections to IEC61850 datamodel.		
				Improved IEC61850 Goose Performance		
				Status report over IEC61850 not in line with DDB signals		
				CB Fail reset time on fault clearance improvement.		
				Enhanced Disturbance Recorder - 20 Analog / 128 Digital Channels. Additional Differential, Max Bias and 2nd Harmonic current data.		
				CT Ratio Enhancements (P544/P546 allow use of different CT1 and CT2 Ratios).		
				Additional CB Monitoring data provided over CS103		
				Protection communications Invalid Message Format Alarm Implementation corrected.		
				Language Text for "IED CONFIGURATOR" menu column header uses selected language (previously only English).		
				Improvements to processing of GOOSE messages when using managed Ethernet switch parameterised for VLAN.		
				Some new Cyber Security Cells (BF15, 00E1) needs to be accessible even if read only mode is enabled.		
				Improvements in PSL data models.		
				Improvements to PSL Operation when non-latched and latched LEDs are used together.		
				Bug Fixes		
C0	B	M	17/04/2013	Release of P543, P544, P545 & P546 without distance protection based on C0A	MiCOM S1 Studio v5.0.0	P54x/EN M/Mc5
				Ethernet Parallel Redundancy Protocol (PRP) Functionality		
				Delta-V, Delta-f and Delta-phi Check Synch Measurements		
				IEC61850 bug fix related to buffered reports.		
				Minor IEC61850 bug fix related to "Quality" DO.		
				Minor bug correction related to the Logical Node System/ploGGIO1.		
				Corrections in default PSL Reference text string is not correct.		
				Bug fix related to IM64 Communications Max propagation delay.		
				Bug fixes related to the MiCOM S1 Language text files (.lng).		
				Bug Fixes		

Software version		Hardware suffix	Original date of issue	Description of changes	Easergy Studio compatibility	Technical documentation
Major	Minor					
C0	D	M	20/08/2015	Release of P543, P544, P545 & P546 without distance protection based on C0B and D0C	Easergy Studio v8.0.0	P54x/EN M/Mc5
				Improvements to Firmware download		
				"GosGGIO1\$DC" is readable when configure many datasets in IED dataset definitions		
				Corrections in IEC61850 related to LN XCBR.POS.stVal.		
				IEC61850 correction related to deadband.		
				Correction in DNP3 OE TCP slave regarding event management		
				The TrgOps GI is set by default after start-up		
				IED Subscribe GOOSE with inconformity ApplD should be discarded.		
				IEC61850 corrections related to OrdRunGGIO LN.		
				A number 3600001 can be successfully set to BufTm.		
				IEC61850 minor bug corrections in control model.		
				Edit password level 2, 3, when input blank password, Chinese HMI display wrong langtxt.		
				IEC61850 minor bug corrections in GOOSE model.		
				Minor DNP3 corrections regarding units of analogue values.		
				Corrections in DR checksum calculation.		
				IEC61850 minor corrections related to BCR (Binary Counter Reading).		
				Improvements in IEC61850 data included in reports managing.		
				Improvements in POR combined with Weak Infeed.		
				Bug fix related to C Diff failure alarm.		
				Bug fix related to IM64 Communications Max propagation delay.		
				Bug fix related to Weak infeed detection function reduces ground fault current sensitivity/		
				IEC61850 interlocking control correction.		
				IEC61850 bug fixes related to intermediate state.		
				The maximum range of power factor in phase C is 660		
				All relevant changes in version D0C		
				Bug Fixes		
C0	E	M	29/02/2016	Restricted release of P545 without distance protection based on C0D	Easergy Studio v8.0.0	P54x/EN M/Mc5
				Added LN RFRE in Logic device Records.		
				Added DO SumSwARs in LN XCBR.		
				Bug fix related to DR list.		
				Bug fix related to The 'orCat' and 'orIdent' value of the PloGGIO1 in the urcb,brcb and GOOSE.		
				Bug fix related to trigger time is not extracted correctly via CS103 in the configuration file.		
				Minor bug correction related to the Logical Node System/ploGGIO1.		
				IED with 128 digital features. DR files extracted by IEC61850 are not the same with which extracted by MiCOM S1 studio.		

Software version		Hardware suffix	Original date of issue	Description of changes	Easergy Studio compatibility	Technical documentation
Major	Minor					
				Bug fix related to stateNumber increased even there is no status change after IED rebooting/ MCL downloading.		
				Deadband read via DNP3 corrected to uint32.		
				IEC 61850 can read the current SGCB.actVal when selecting setting group via Opto.		
				Several IEC61850 minor bug fixes related to GOOSE and control model.		
				Bug fix related to MiCOM S1 Language text files (.lng)		
				Bug Fixes		
C0	F	M	21/02/2017	Release of P543, P544, P545 & P546 without distance protection based on C0D. Occasionally the GOOSE absent alarm can not be reset when the IEC61850 communications is functioning correctly. Where an Ethernet gateway is connected to the relay, if the gateway reboots sometimes the P546 will also reboot (when communicating via DNP3OE). While extracting DNP3 configure file from relay, the relay reboots. Communication interrupt of iec61850 (bug fix). Bug Fixes.	Easergy Studio v8.0.0	
				Occasionally the GOOSE absent alarm can not be reset when the IEC61850 communications is functioning correctly.		
				Where an Ethernet gateway is connected to the relay, if the gateway reboots sometimes the P546 will also reboot (when communicating via DNP3OE).		
				While extracting DNP3 configure file from relay, the relay reboots.		
				Communication interrupt of iec61850 (bug fix).		
				Bug Fixes		
D0	A	M	13/06/2012	Cyber Security Release of P543, P544, P545 & P546 with distance protection based on 70A (also 70U and B0A/B0B)	MiCOM S1 Studio v3.5.2	P54x/EN M/Mc5
				Change to Schneider-Electric Major release (alpha) software number plus changes to 61850 (New ICD files required). Changes to improve IEC61850 reporting on rapidly toggling status. Corrections to IEC61850 datamodel.		
				Improved IEC61850 Goose Performance		
				Status report over IEC61850 not in line with DDB signals		
				CB Fail reset time on fault clearance improvement.		
				Enhanced Disturbance Recorder - 20 Analog / 128 Digital Channels. Additional Differential, Max Bias and 2nd Harmonic current data.		
				CT Ratio Enhancements (P544/P546 allow use of different CT1 and CT2 Ratios).		
				Additional CB Monitoring data provided over CS103		
				OST sensitivity now 60mA (was previously 180mA).		
				Protection communications Invalid Message Format Alarm Implementation corrected.		
				Language Text for "IED CONFIGURATOR" menu column header uses selected language (previously only English).		
				Improvements to processing of GOOSE messages when using managed Ethernet switch parameterised for VLAN.		
				Some new Cyber Security Cells (BF15, 00E1) needs to be accessible even if read only mode is enabled.		

Software version		Hardware suffix	Original date of issue	Description of changes	Easergy Studio compatibility	Technical documentation
Major	Minor					
				Improvements in PSL data models.		
				Improvements to PSL Operation when non-latched and latched LEDs are used together.		
				Bug Fixes		
D0	B	M	17/04/2013	Release of P543, P544, P545 & P546 with distance protection based on D0A	MiCOM S1 Studio v5.0.0	P54x/EN M/Mc5
				Ethernet Parallel Redundancy Protocol (PRP) Functionality		
				Delta-V, Delta-f and Delta-phi Check Synch Measurements		
				Minor IEC61850 bug fix related to "Quality" Data Object (DO).		
				Minor bug correction related to the Logical Node System/ploGGIO1.		
				Bug fix related to IM64 Communications Max propagation delay.		
				Bug fixes related to the MiCOM S1 Language text files (.Ing).		
				Bug Fixes		
D0	C	M	12/04/2014	Restricted release of P544 & P546 with distance protection IEC61850+Courier (protocol 6) based on D0B	MiCOM S1 Studio v5.1.0	P54x/EN M/Mc5
				Better GOOSE performance in case of high traffic of unicast (eventually multicast with the same MAC address as the goose subscription) frames.		
				P54x Power Factor measurement can be displayed as greater than 1.000		
				Dual CB Variants (P446/P544/P546/P841B) - Aided Scheme Echo on dual CB variants.		
				Bug Fixes		
D0	D	M	20/08/2015	Release of P543, P544, P545 & P546 with distance protection based on D0B and D0C	Easergy Studio v8.0.0	P54x/EN M/Mc5
				Downloaded the P546 version 57V IEC61850+CS103 variant to a relay, occasionally the relay re-boot with error code 0x351f03f5.		
				"GosGGIO1\$DC" is readable when configure many datasets in IED dataset definitions		
				Corrections in IEC61850 related to LN XCBR.POS.stVal		
				IEC61850 correction related to deadband.		
				Correction in DNP3 OE TCP slave regarding event management		
				The TrgOps GI is set by default after start-up		
				IED Subscribe GOOSE with inconformity ApplD should be discard.		
				IEC61850 corrections related to OrdRunGGIO LN.		
				A number 3600001 can be successfully set to BufTm.		
				IEC61850 minor bug corrections in control model.		
				All question mark "?" is messy code in HMI, when language is Chinese.		
				Edit password level 2, 3, when input blank password, Chinese HMI display wrong langtxt.		
				IEC61850 minor bug corrections in GOOSE model.		
				Minor DNP3 corrections regarding units of analogue values.		
				Corrections in DR checksum calculation.		

Software version		Hardware suffix	Original date of issue	Description of changes	Easergy Studio compatibility	Technical documentation
Major	Minor					
				IEC61850 minor corrections related to BCR (Binary Counter Reading).		
				Improvements in IEC61850 data included in reports managing.		
				Improvements in POR combined with Weak Infeed.		
				Bug fix related to C Diff failure alarm.		
				Bug fix related to IM64 Communications Max propagation delay.		
				Bug fix related to Weak infeed detection function reduces ground fault current sensitivity/		
				IEC61850 interlocking control correction.		
				The solution of CTCSE10202 will make four mandatory cases of IEC61850 conformance test fail, because of missing intermediate state.		
				The maximum range of power factor in phase C is 660.		
				All Changes in version D0C.		
				Bug Fixes		
D0	E	M	29/02/2016	Restricted release of P545 with distance protection based on D0D	Easergy Studio v8.0.0	P54x/EN M/Mc5
				Added LN RFRE in Logic device Records.		
				Added DO SumSwARs in LN XCBR.		
				Bug fix related to DR list.		
				Bug fix related to The 'orCat' and 'orIdent' value of the PloGGIO1 in the urcb,brcb and GOOSE.		
				Bug fix related to trigger time is not extracted correctly via CS103 in the configuration file.		
				Minor bug correction related to the Logical Node System/ploGGIO1.		
				IED with 128 digital features. DR files extracted by IEC61850 are not the same with which extracted by MiCOM S1 studio.		
				Bug fix related to stateNumber increased even there is no status change after IED rebooting/ MCL downloading		
				Deadband read via DNP3 corrected to uint32."		
				IEC 61850 can read the current SGCB.actVal when selecting setting group via Opto		
				Several IEC61850 minor bug fixes related to GOOSE and control model.		
				Bug fix related to MiCOM S1 Language text files (.lng)		
				Bug Fixes		
D0	F	M	21/02/2017	Release of P543, P544, P545 & P546 with distance protection based on D0D.	Easergy Studio v8.0.0	
				Occasionally the GOOSE absent alarm can not be reset when the IEC61850 communications is functioning correctly.		
				Where an Ethernet gateway is connected to the relay, if the gateway reboots sometimes the P546 will also reboot (when communicating via DNP3OE).		
				While extracting DNP3 configure file from relay, the relay reboots.		
				Communication interrupt of iec61850 (bug fix).		
				Bug Fixes		

Software version		Hardware suffix	Original date of issue	Description of changes	Easergy Studio compatibility	Technical documentation
Major	Minor					
D1	A	M	31/08/2014	Restricted release of P443, P543 & P545 with distance protection and additional IEC61850+DNP3 (protocol 9) variant based on D0B/D0C	MiCOM S1 Studio v5.1.0	P54x/EN M/Mc5
				User Settable Labels for Virtual I/O		
				Lower CT Requirements for Line Diff (87L)		
				Line Differential (Function 87L) Intertrip feature selected by user		
				Setting File (Control) Inputs		
				DR- Force Disturbance Record		
				New Settings and DDB for check synchronism (25)		
				External DDB Reset for CB Fail Function		
				Line Differential (Function 87L) conditioned to OC (Function 50) release.		
				Overcurrent (50) enabled on additional conditions as backup to Line Differential (87L).		
				Tripping Mode Selection for all Distance Zones (21)		
				DR-Customised Labels for digital channels		
				SEF Enhancement of setting range (stage 3 and 4 max current is 2.0A) – Requested for P841, but added across P540D range (now consistent with P14x).		
				IEC-103 (VDEW) Protocol New Signals (Protection Enable)		
				Increase the number of timers in the PSL (from 16 to 32)		
				IRIG-B Status in DDB & SCADA (VDEW)		
				Autoreclose Skip Shot 1 Functionality (DDB)		
				Slow operation of Reverse DEF element can lead to weak infeed echo for external faults		
				GPS / Protection communications drop-out improvements (when operating with some Multiplexer / radio links)		
				Better GOOSE performance in case of high traffic of unicast (eventually multicast with the same MAC address as the goose subscription) frames		
				Improved IEC61850 Goose Performance		
				Bug fixed related to MMS communication of IEC61850 of device may get lost after perform control operations (Control\XCBR1\Pos) for several times.		
				Bug fix related to XCBR1.POS.stVal reports unexpected status change during CB status change		
				Dual CB Variants (P446/P544/P546/P841B) - Aided Scheme Echo on dual CB variants.		
				General IEC61850 Improvements		
				IEC61850 Data Model Changes		
				P54x Power Factor measurement can be displayed as greater than 1.000		
				Bug Fixes		
				An additional four DDB Group Nodes can be mapped to individual or multiple DDBs in the PSL. These can be set to trigger the DR via the Disturbance Record menu.		
D1	B	M	09/01/2015	Release of P543, P544, P545 & P546 with distance protection based on D1A and D0B/D0C	Easergy Studio v8.0.0	P54x/EN M/Nd5

Software version		Hardware suffix	Original date of issue	Description of changes	Easergy Studio compatibility	Technical documentation
Major	Minor					
				Check Synch Adaptive mode should close as close to 0 Degrees as possible		
				Missing IEC61850 reports for short duration trips		
				Circuit Breaker Control (IEC61850), error report on IEC61850 after changing CB position		
				Improvements to default PSL - Mapping of I Diff >> Start B (DDB 1439) and I Diff >> Start C(DDB 1440) to started Phase "B" (DDB 957) and Started Phase "C" (DDB 958) in Default P545 PSLs		
				Bug Fixes		
D1	C	M	05/02/2015	Restricted release of P545 (Comms protocol 9 - IEC61850+Serial DNP3 Only) with distance protection based on D1B	Easergy Studio v8.0.0	P54x/EN M/Mc5
				Bug fix related to C Diff failure alarm.		
D1	D	M	24/12/2015	Release of P543, P544, P545 & P546 with distance protection based on D1B and D1C	Easergy Studio v8.0.0	P54x/EN M/Mc5
				Bug fix related to DR list.		
				Bug fix related to the 'orCat' and 'orIdent' value of the PloGGIO1 in the urcb,brcb and GOOSE.		
				Bug fix related to trigger time is not extracted correctly via CS103 in the configuration file.		
				Minor bug correction related to the Logical Node System/ploGGIO1		
				IED with 128 digital features. DR files extracted by IEC61850 are not the same with which extracted by MiCOM S1 studio.		
				Deadband read via DNP3 corrected to uint32."		
				Virtual Input/Output Labels are available for non IEC61850 variants.		
				Enhancements for IEC 61850		
				Corrections in IEC61850 related to LN XCBR.POS.stVal		
				IEC61850 interlocking control correction.		
				Bug fix related to Weak infeed detection function reduces ground fault current sensitivity/		
				Corrections made for range of power factors		
				Improvements for mms service under high load situations		
				All Changes in version D1C		
				Bug Fixes		
D1	E	M	30/05/2016	Release of P543, P544, P545 & P546 with distance protection based on D1D.	Easergy Studio v8.0.0	
				Time detected in IED Event list (P545) is not the same as time of signals packed in Report and sent via Network to IEC 61850 Client by MMS (i.e. SCADA servers, Gateways, IED scouts).		
				Ethernet Tunnel communication between MiCOM S1 and relays may become unreliable after several days to several months.		
				When the user attempts to read the "CT mismatch alarm" from HMI, the IED reboots with error code "0x0600012A".		
				IED can sometimes reboot with error code: 0x070A032F, when writing "control 10" to control input 33 to 48 in quick succession via dnp3 serial or dnp3 ethernet.		
				Menu cell "RP2 Read Only" is not visible for some protocol options.		

Software version		Hardware suffix	Original date of issue	Description of changes	Easergy Studio compatibility	Technical documentation
Major	Minor					
				When IEC61850 client try to select or operate a SPC/DPC with the parameter 'Orldent' as '00', Then Check ST of PlogGGIO. The 'Orldent' value of PlogGGIO is " (or NULL), not '00'.		
				Whenever a ClearAllDisturbance command is executed, a DR_MEMORY_FULL_ALARM event is recorded.		
				Upgrade TPCL from 1.7 to 1.8.		
				Wrong value of menu cell "> Blocking" is displayed on the HMI. It is necessary to press the enter key to visualise the real settings for >Blocking in the relay display.		
				For IEC6150 Edition 1, Dbpos is a basic type, so the enumeration should be removed from ICD file.		
				IEC61850 - CDC mismatch in Logical Node ThmPTTR : Data Attribute AlmThm is now SPS (previously incorrectly specified as ACT).		
				The communication between the IED and CET SCADA system may be interrupted after operating correctly for several days and will only resume after rebooting the relay.		
				Correction to Control Inputs 33 to 48 event file textual descriptions.		
				Extraction of Group 1 PSL will generate two different events (PSL Config Upload by FP Group1 and PSL Config Upload By FP Group2).		
				When downloading a DNP setting to the relay, the event list incorrectly displays a new event "DNP Stng D/Load by DNP".		
				Occasionally, the GOOSE Absent alarm can not be reset when the IEC61850 communications is functioning correctly.		
				The IEC61850 energy measurement values were not consistent with the values displayed on User Interface.		
				MTRRs control response corrected.		
				Thermal State and Energy Measurement could not be reset by IEC61850 client in ED1.		
				Changed to the value of the Primary/Secondary Setting Values menu cell [092E] apply to all interfaces (Internet, front courier/HMI, Rear RS485).		
				Remove readonly references to Software Reference cells [0011] and [0012] from system data in MiCOM S1.		
				Unlike the Ctrl Setg Input lables and Virtual Input/Output labels, Control Input labels are not associated to the IEC61850 communication logic nodes PIOGGIOx.		
				Adaptive check synch is incorrectly blocked by CS1 under some conditions.		
				Phase selector does not adapt correctly to some evolving faults.		
				Status of PriMMTR1/MTRRs.ST of PriMMTR1/MTRRs is not consistent with Set (control) value when Measurements/PriMMTR1/MTRRs are configured for direct control mode in the mcl file.		
				The user alarm label in the event file is not correct.		
				Bug Fixes.		
D2	A	M	19/04/2016	Release of P543, P544, P545 & P546 with distance protection based on D1D.	Easergy Studio v8.0.0	P54x/EN M/Mc5
				Add DDB (361) for BBRAM failure indicator		
				Bug fix related to the same data set being used in a RCB and GOCB.		

Software version		Hardware suffix	Original date of issue	Description of changes	Easergy Studio compatibility	Technical documentation
Major	Minor					
				Bug fix related to time detected in IED Event list and IEC61850		
				Menu cell "RP2 Read Only" is visible for all protocol options		
				Bug fix related to DR_MEMORY_FULL_ALARM event is recorded.		
				Bug fixing HMI issue for "I>Blocking" value.		
				Bug fix related to CBF function starts/trips even if the protection element is not mapped in psl to the corresponding trip DDB signal.		
				Add DDB (1893) to configure the non-current protection triggering CB failure logic		
				Improvements for Check Sync.		
				Enhancements for IEC61850		
				Add Hysteresis to the UnderCurrent element. Fixed hysteresis threshold: 1.2		
				Correction to communication interrupt of IEC61850		
				Bug fix to CDC mismatch in LN PTTR		
				Bug Fixes		
D2	B	M	10/08/2016	Release of P543, P544, P545 & P546 with distance protection based on D2A. Correction to Control Inputs 33 to 48 event file textual descriptions.	Easergy Studio v8.0.0	
				IEC61850 - CDC mismatch in Logical Node ThmPTTR: Data Attribute AlmThm is now SPS (previously incorrectly specified as ACT).		
				Unlike the Ctrl Setg Input labels and Virtual Input/Output labels, Control Input labels are not associated to the IEC61850 communication logic nodes PIOGGIOx.		
				Extraction of Group 1 PSL will generate two different events (PSL Config Upload By FP Group 1 and PSL Config Upload By FP Group 2).		
				When downloading a DNP setting to the relay, the event list incorrectly displays a new event "DNP Stng D/Load by DNP".		
				Occasionally, the GOOSE Absent alarm can not be reset when the IEC61850 communications is functioning correctly.		
				The IEC61850 energy measurement values were not consistent with the values displayed on User Interface.		
				MTRRs control response corrected.		
				Thermal State and Energy Measurement could not be reset by IEC61850 client in ED1.		
				Adaptive check synch is incorrectly blocked by CS1 under some conditions.		
				Status of PriMMTR1/MTRRs.ST of PriMMTR1/MTRRs is not consistent with Set (control) value when Measurements/PriMMTR1/MTRRs are configured for direct control mode in the mcl file.		
				The user alarm label in the event file is not correct.		
				The initial value of CIO.Mod.ctlModel in ICD template shall be 'status-only'. bType of stVal in DOType - INC_CTRL_D_PRIV (CDC:INC) shall be Enum not "INT32" dataNs and lnNs format is not correct.		
				IEC61850 Mapping error of P445 Control\AscRSYNx\Mod.		
				Circuit Breaker position could not be read by 61850 client in P54x version D1E and D2A.		

Software version		Hardware suffix	Original date of issue	Description of changes	Easergy Studio compatibility	Technical documentation
Major	Minor					
				For IEC6150 Edition 1, Dbpos is a basic type, so the enumeration should be removed from ICD file.		
				Minor Corrections to ICD file as a result of the IEC61850 changes.		
				Bug Fixes.		
D3	A	M	11/02/2017	Software release to meet Brazil customer requirement (AR15258) to expand the setting range of R5, R5' and R6, R6' in power swing function. Based on the previous D2B. Include some of the outstanding DTS issues.	Easergy Studio v8.0.0	P54x/EN M/Mc5
H4	B	M	July 2016	Release with rejuvenated Ethernet card, IEC61850 Edition 2 + CS3. Based on D1B, P544/P546 Version H1 and P545 Version H3.	Easergy Studio v8.0.0	P54x/EN M/Nd5
				Virtual Input and Virtual Output labels included in all protocol options.		
				Protection performance – the frequency operating range is now up to 70 Hz Distance protection protection will operate up to 65Hz. Line Differential protection will operate up to 66Hz. Backup functions (Volt, Current and Frequency) will operate up to 70Hz.		
				Protection Function Trip Supervision/Fault Detector Element available.		
				In-Zone transformer feature (from the P543/P545) is now included in P544/P546.		
				Improvements in Zone 1 distance tripping time.		
				New distance zone Q available. New distance mode of operation available, new timers available.		
				Correction in the distance directional top line of P54x.		
				Distance phase selector correction.		
				"Is1 Step Size" setting range increased.		
				"PSB Unblock Dly" setting range increased.		
				For a pair of P546 units, one Phase Overcurrent and one Neutral Overcurrent stage can now be associated with CT1 and CT2. New settings options mean that the overcurrent stages can not take into account each of the CT inputs; and not just the summation of both of them.		
				The pole discrepancy logic timer used to be fixed at 0.04s for all MiCOM P54x relays. It is now configurable in the range 0s to 10s with a step of 0.01s for P546 relays only.		
				Protocols Mapping has been changed in this release. Details of the protocols used for each product are shown in the SCADA Communications chapter.		
				Product Ordering options have been changed for this release. For more details, see the Introduction chapter.		

Software version		Hardware suffix	Original date of issue	Description of changes	Easergy Studio compatibility	Technical documentation
Major	Minor					
				The rejuvenated Ethernet board as well as the Px40 rejuvenation project features (such as PRP/HSR/RSTP, IEC61850 Ed2, Dual IP and Cyber Security) have been included in this release. This includes new or replacement chapters for: Installation Cyber Security Dual Redundant Ethernet Board Parallel Redundancy Protocol (PRP) Notes High-availability Seamless Redundancy (HSR)		
				Some of the DDBs have been changed in order to show the Status of Auto-Reclose (AR) (1P, 3P) in the MiCOM P54x relays.		
				Enhancement of Setting Ranges in Stage 3 and Stage 4 Current settings. The Maximum Current in Stage 3 and Stage 4 Overcurrent settings has been changed, the range now being from 0.005 A to 2.00A.		
				GPS / Protection communications drop-out improvements (when operating with some Multiplexer / radio links).		
				Improvements in Check Sync Adaptive Mode.		
				In zone transformer application now supported in P544 and P546 devices.		
				New Setting No BF if L No CS available.		
H5	B	M	January 2017	This is based on Software H4B and is only available for a specific customer and it only applies to P544 and P546. These new features include:	v7.0.0	P54x/EN M/Pe5
				VTS logic changed to improve operation on lightly loaded lines.		
				Check synchronisation enhancement for dual CB models P544 and P546.		
				Additional CS103 (VDEW) signals to be included in General Interrogation.		
				Modified (increased) setting range of Line Differential "k1" parameter.		
				Modified (increased) setting range of "Max Iload/Inom" parameter.		
				CB Monitoring information (signals) modelled in IEC61850 protocol.		
				DTS Fixes.		
H6	A	M	January 2017	This is based on version H4B, with the addition of new protocol IEC61850 Edition 1 / 2 and DNPoE and DNP3 Serial.	v7.0.0	P54x/EN M/Pe5
				Courier Tunneling via Secured Communications.		
				Extended Fault Record added to DNP Measurements.		
				Latest Fault Record via IEC61850.		
				New DDB: Logic 0 and Simul. GOOSE Alm		
				Bug fixes.		
H7	A	M	August 2017	Merge of H5B and H6A features. DNP3 unsolicited messages feature supported. New P543 variant with 16l and 24O created. Resistive reach of Power Swing Zones has been increased. Step size of parameter UVD>Threshold has been modified. Setting Value consistency (primary/secondary values) in all ports can be configurable now. Bug fixes.	V8.0.0	P54x/EN M/Qf5
H7	B	M	August 2018	Bug fix, only P543 protocol L.	V8.0.0 or later	P54x/EN M/Qf5

Software version		Hardware suffix	Original date of issue	Description of changes	Easergy Studio compatibility	Technical documentation
Major	Minor					
H7	C	M	March 2019	Bug fix, only P543 protocol 6 & G.	V8.0.0 or later	P54x/EN M/Qf5
H7	D	M	January 2020	Bug fix, only P543 protocol 6 & L.	V8.0.0 or later	P54x/EN M/Qf5
H7	E	M	March 2020	Bug fix, only P544 protocol 7.	V8.0.0 or later	P54x/EN M/Qf5
H8	A	M	Not released			
H9	A	M	September 2018	PTP and RSTP has been added. SNMP has been removed. Pre-configured dataset High Performance GOOSE is removed.	V8.1.0	P54x/EN M/Sh5
H9	B	M	March 2019	Bug fix.	V8.1.1	P54x/EN M/Sh5
H9	C	M	August 2019	Bug fix.	V8.1.1 or later	P54x/EN M/Sh5
K1	A	M	August 2019	Independent initiation for external CBF. Independent current setting function for CBF and pole dead detection is added. Setting range of 59N is changed.	V8.1.1	P54x/EN M/TI5
K2	A	M	January 2020	Adding timer to check Synchro 1, 2 for reclose; Adding Main VT Location; Change step size of voltage protection to 0.1V in secondary;	V9.0.0	P54x/EN M/Uj5
K3	A	M	December 2020	Adding OCD> and UVD> Hold Timer; Adding 54 output DDBs for Trip Supervision elements.	V9.2.1	P54x/EN M/Vk5
K4	A	M	July 2021	For P543 and P546 only: Process Bus is supported. Bug fix.	V9.3.1	P54x/EN M/WI5
K5	B	M	Jun 2022	Support two gateways communication for two interfaces. DNP client number modified from 6 to 3. Bug fix.	V9.3.2 or later	P54x/EN M/Xm5
K6	A	M	Oct 2022	Add service tracking (BrCb.Trk & UrCb.Trk) Bug fix.	V9.3.2 or later	P54x/EN M/Yn5
K6	B	M	Aug 2023	Correction of Analog channel primary, secondary in COMTRADE File .cfg, for IEC61850 (Ed1 and Ed2) or DNP3oE or CS103 when CT is 5A or VT is 440V. Easergy Studio update for DR files extraction via Courier. Correction of SR gate resetting when navigation keys are used. Correction to pass Nessus Scan test.	V9.3.5 or later	P54x/EN M/Yn5

The Easergy Studio software is updated periodically. These updates provide support for new features (such as allowing you to manage new MiCOM products, as well as using new software releases and hardware suffixes). The updates may also include fixes. **Accordingly, we strongly advise customers to use the latest Schneider Electric version of Easergy Studio.** This table shows the earliest version of the software which lets you use that feature. Unless otherwise stated in the Studio software, the latest version lets you to use all the features of previous versions. If you need more information regarding bug fixes, please contact your **Schneider Electric** local support.

This table shows the Software Version together with the Hardware Suffix the particular software runs on. The changes introduced by each Software Version are shown with each change on one row.

Table 1 - Software and Hardware Versions

2 SETTING FILE AND RELAY SOFTWARE

To enhance readability, this table has been split over two pages. The columns are shown on adjacent pages:

		Relay Software Version																								
		01	02	03	04	05	07	11	12	13	14	15	20	30	32	40	41	42	44	45	47	48	50	51	52	
Setting File Software Version	01	✓	x	x	x	x	x	x	x	x	x	x	x	x	x	x	x	x	x	x	x	x	x	x	x	
	02	x	✓	x	x	x	x	x	x	x	x	x	x	x	x	x	x	x	x	x	x	x	x	x	x	x
	03	x	x	✓	1	x	x	x	x	x	x	x	x	x	x	x	x	x	x	x	x	x	x	x	x	x
	04	x	x	x	✓	2	2	x	x	x	x	x	x	x	x	x	x	x	x	x	x	x	x	x	x	x
	05	x	x	x	x	✓	✓	x	x	x	x	x	x	x	x	x	x	x	x	x	x	x	x	x	x	x
	07	x	x	x	x	✓	✓	x	x	x	x	x	x	x	x	x	x	x	x	x	x	x	x	x	x	x
	11	x	x	x	x	x	x	✓	✓	2	2	x	2	x	x	x	x	x	x	x	x	x	x	x	x	x
	12	x	x	x	x	x	x	✓	✓	2	2	x	2	x	x	x	x	x	x	x	x	x	x	x	x	x
	13	x	x	x	x	x	x	✓	✓	✓	2	x	2	x	x	x	x	x	x	x	x	x	x	x	x	x
	14	x	x	x	x	x	x	x	x	x	✓	x	x	x	x	x	x	x	x	x	x	x	x	x	x	x
	15	x	x	x	x	x	x	x	x	x	x	✓	x	x	x	x	x	x	x	x	x	x	x	x	x	x
	20	x	x	x	x	x	x	x	x	x	x	x	✓	3	3	x	x	x	x	x	x	x	x	x	x	x
	30	x	x	x	x	x	x	x	x	x	x	x	x	✓	x	x	x	x	x	x	x	x	x	x	x	x
	32	x	x	x	x	x	x	x	x	x	x	x	x	x	✓	x	x	x	x	x	x	x	x	x	x	x
	40	x	x	x	x	x	x	x	x	x	x	x	x	x	x	✓	x	x	x	x	x	x	x	4	x	x
	41	x	x	x	x	x	x	x	x	x	x	x	x	x	x	x	✓	x	x	x	x	x	x	x	4	x
	42	x	x	x	x	x	x	x	x	x	x	x	x	x	x	x	x	✓	3	x	x	x	x	x	x	4
	44	x	x	x	x	x	x	x	x	x	x	x	x	x	x	x	x	x	✓	x	x	x	x	x	x	x
	45	x	x	x	x	x	x	x	x	x	x	x	x	x	x	x	x	x	x	✓	x	x	x	x	x	x
	47	x	x	x	x	x	x	x	x	x	x	x	x	x	x	x	x	x	x	x	✓	x	x	x	x	x
	48	x	x	x	x	x	x	x	x	x	x	x	x	x	x	x	x	x	x	x	x	✓	x	x	x	x
	50	x	x	x	x	x	x	x	x	x	x	x	x	x	x	5	x	x	x	x	x	x	x	✓	x	x
	51	x	x	x	x	x	x	x	x	x	x	x	x	x	x	x	5	x	x	x	x	x	x	x	✓	x
	52	x	x	x	x	x	x	x	x	x	x	x	x	x	x	x	x	5	x	x	x	x	x	x	✓	x
	53	x	x	x	x	x	x	x	x	x	x	x	x	x	x	x	x	x	5	x	x	x	x	x	x	x
	54	x	x	x	x	x	x	x	x	x	x	x	x	x	x	x	x	x	x	5	x	x	x	x	x	x
	55	x	x	x	x	x	x	x	x	x	x	x	x	x	x	x	x	x	x	x	5	x	x	x	x	x
	56	x	x	x	x	x	x	x	x	x	x	x	x	x	x	x	x	x	x	x	x	5	x	x	x	x
	57	x	x	x	x	x	x	x	x	x	x	x	x	x	x	x	x	x	x	x	x	5	x	x	x	x
	58	x	x	x	x	x	x	x	x	x	x	x	x	x	x	x	x	x	x	x	x	x	5	x	x	x
A0	x	x	x	x	x	x	x	x	x	x	x	x	x	x	x	x	x	x	x	x	x	x	x	x	x	
B0	x	x	x	x	x	x	x	x	x	x	x	x	x	x	x	x	x	x	x	x	x	x	x	x	x	
C0	x	x	x	x	x	x	x	x	x	x	x	x	x	x	x	x	x	x	x	x	x	x	x	x	x	
D0	x	x	x	x	x	x	x	x	x	x	x	x	x	x	x	x	x	x	x	x	x	x	x	x	x	
D1	x	x	x	x	x	x	x	x	x	x	x	x	x	x	x	x	x	x	x	x	x	x	x	x	x	
D2	x	x	x	x	x	x	x	x	x	x	x	x	x	x	x	x	x	x	x	x	x	x	x	x	x	
H4	x	x	x	x	x	x	x	x	x	x	x	x	x	x	x	x	x	x	x	x	x	x	x	x	x	
H5	x	x	x	x	x	x	x	x	x	x	x	x	x	x	x	x	x	x	x	x	x	x	x	x	x	
H6	x	x	x	x	x	x	x	x	x	x	x	x	x	x	x	x	x	x	x	x	x	x	x	x	x	
H7	x	x	x	x	x	x	x	x	x	x	x	x	x	x	x	x	x	x	x	x	x	x	x	x	x	
H8	x	x	x	x	x	x	x	x	x	x	x	x	x	x	x	x	x	x	x	x	x	x	x	x	x	
H9	x	x	x	x	x	x	x	x	x	x	x	x	x	x	x	x	x	x	x	x	x	x	x	x	x	
K1	x	x	x	x	x	x	x	x	x	x	x	x	x	x	x	x	x	x	x	x	x	x	x	x	x	
K2	x	x	x	x	x	x	x	x	x	x	x	x	x	x	x	x	x	x	x	x	x	x	x	x	x	
K3	x	x	x	x	x	x	x	x	x	x	x	x	x	x	x	x	x	x	x	x	x	x	x	x	x	
K4	x	x	x	x	x	x	x	x	x	x	x	x	x	x	x	x	x	x	x	x	x	x	x	x	x	
K5	x	x	x	x	x	x	x	x	x	x	x	x	x	x	x	x	x	x	x	x	x	x	x	x	x	
K6	x	x	x	x	x	x	x	x	x	x	x	x	x	x	x	x	x	x	x	x	x	x	x	x	x	

- Notes:
- Compatible except for Disturbance recorder digital channel selection
 - Additional functionality added such that setting files from earlier software versions will need additional settings to be made
 - Compatible except for Disturbance recorder digital channel selection & settings for additional functionality will be missing
 - Compatible except for the Disturbance recorder digital channel selection and the distance settings
 - Compatible except for Disturbance recorder digital channel selection & the setting file contains a large number of Distance setting which will each produce an error on download

Important: The second set of columns are shown on the following page.

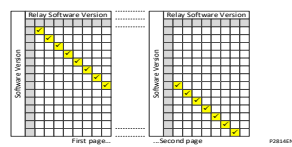

Important: The first set of columns are shown on the previous page.

		Relay Software Version																							
		53	54	55	56	57	58	A0	B0	C0	D0	D1	D2	H4	H5	H6	H7	H8	H9	K1	K2	K3	K4	K5	K6
Setting File Software Version	01	x	x	x	x	x	x	x	x	x	x	x	x	x	x	x	x	x	x	x	x	x	x	x	x
	02	x	x	x	x	x	x	x	x	x	x	x	x	x	x	x	x	x	x	x	x	x	x	x	x
	03	x	x	x	x	x	x	x	x	x	x	x	x	x	x	x	x	x	x	x	x	x	x	x	x
	04	x	x	x	x	x	x	x	x	x	x	x	x	x	x	x	x	x	x	x	x	x	x	x	x
	05	x	x	x	x	x	x	x	x	x	x	x	x	x	x	x	x	x	x	x	x	x	x	x	x
	07	x	x	x	x	x	x	x	x	x	x	x	x	x	x	x	x	x	x	x	x	x	x	x	x
	11	x	x	x	x	x	x	x	x	x	x	x	x	x	x	x	x	x	x	x	x	x	x	x	x
	12	x	x	x	x	x	x	x	x	x	x	x	x	x	x	x	x	x	x	x	x	x	x	x	x
	13	x	x	x	x	x	x	x	x	x	x	x	x	x	x	x	x	x	x	x	x	x	x	x	x
	14	x	x	x	x	x	x	x	x	x	x	x	x	x	x	x	x	x	x	x	x	x	x	x	x
	15	x	x	x	x	x	x	x	x	x	x	x	x	x	x	x	x	x	x	x	x	x	x	x	x
	20	x	x	x	x	x	x	x	x	x	x	x	x	x	x	x	x	x	x	x	x	x	x	x	x
	30	x	x	x	x	x	x	x	x	x	x	x	x	x	x	x	x	x	x	x	x	x	x	x	x
	32	x	x	x	x	x	x	x	x	x	x	x	x	x	x	x	x	x	x	x	x	x	x	x	x
	40	x	x	x	x	x	x	x	x	x	x	x	x	x	x	x	x	x	x	x	x	x	x	x	x
	41	x	x	x	x	x	x	x	x	x	x	x	x	x	x	x	x	x	x	x	x	x	x	x	x
	42	x	x	x	x	x	x	x	x	x	x	x	x	x	x	x	x	x	x	x	x	x	x	x	x
	44	x	4	x	x	x	x	x	x	x	x	x	x	x	x	x	x	x	x	x	x	x	x	x	x
	45	x	x	4	x	x	x	x	x	x	x	x	x	x	x	x	x	x	x	x	x	x	x	x	x
	47	x	x	x	x	4	x	x	x	x	x	x	x	x	x	x	x	x	x	x	x	x	x	x	x
	48	x	x	x	x	x	4	x	x	x	x	x	x	x	x	x	x	x	x	x	x	x	x	x	x
	50	x	x	x	x	x	x	x	x	x	x	x	x	x	x	x	x	x	x	x	x	x	x	x	x
	51	x	x	x	x	x	x	x	x	x	x	x	x	x	x	x	x	x	x	x	x	x	x	x	x
	52	x	3	x	x	x	x	x	x	x	x	x	x	x	x	x	x	x	x	x	x	x	x	x	x
	53	✓	x	x	x	x	x	x	x	x	x	x	x	x	x	x	x	x	x	x	x	x	x	x	x
	54	x	✓	x	x	x	x	x	x	x	x	x	x	x	x	x	x	x	x	x	x	x	x	x	x
55	x	x	✓	x	x	x	x	x	x	x	x	x	x	x	x	x	x	x	x	x	x	x	x	x	
56	x	x	x	✓	x	x	x	x	x	x	x	x	x	x	x	x	x	x	x	x	x	x	x	x	
57	x	x	x	x	✓	x	x	x	x	x	x	x	x	x	x	x	x	x	x	x	x	x	x	x	
58	x	x	x	x	x	✓	x	x	x	x	x	x	x	x	x	x	x	x	x	x	x	x	x	x	
A0	x	x	x	x	x	x	✓	4	x	x	x	x	x	x	x	x	x	x	x	x	x	x	x	x	
B0	x	x	x	x	x	x	5	✓	x	x	x	x	x	x	x	x	x	x	x	x	x	x	x	x	
C0	x	x	x	x	x	x	x	x	✓	4	x	x	x	x	x	x	x	x	x	x	x	x	x	x	
D0	x	x	x	x	x	x	x	5	✓	x	x	x	x	x	x	x	x	x	x	x	x	x	x	x	
D1	x	x	x	x	x	x	x	x	x	x	✓	x	x	x	x	x	x	x	x	x	x	x	x	x	
D2	x	x	x	x	x	x	x	x	x	x	x	✓	x	x	x	x	x	x	x	x	x	x	x	x	
H4	x	x	x	x	x	x	x	x	x	x	x	x	✓	x	x	x	x	x	x	x	x	x	x	x	
H5	x	x	x	x	x	x	x	x	x	x	x	x	x	✓	x	x	x	x	x	x	x	x	x	x	
H6	x	x	x	x	x	x	x	x	x	x	x	x	x	x	✓	x	x	x	x	x	x	x	x	x	
H7	x	x	x	x	x	x	x	x	x	x	x	x	x	x	x	✓	x	x	x	x	x	x	x	x	
H8	x	x	x	x	x	x	x	x	x	x	x	x	x	x	x	x	✓	x	x	x	x	x	x	x	
H9	x	x	x	x	x	x	x	x	x	x	x	x	x	x	x	x	x	✓	x	x	x	x	x	x	
K1	x	x	x	x	x	x	x	x	x	x	x	x	x	x	x	x	x	x	✓	x	x	x	x	x	
K2	x	x	x	x	x	x	x	x	x	x	x	x	x	x	x	x	x	x	x	✓	x	x	x	x	
K3	x	x	x	x	x	x	x	x	x	x	x	x	x	x	x	x	x	x	x	x	✓	x	x	x	
K4	x	x	x	x	x	x	x	x	x	x	x	x	x	x	x	x	x	x	x	x	x	✓	x	x	
K5	x	x	x	x	x	x	x	x	x	x	x	x	x	x	x	x	x	x	x	x	x	x	✓	x	
K6	x	x	x	x	x	x	x	x	x	x	x	x	x	x	x	x	x	x	x	x	x	x	x	✓	

Notes:

1. Compatible except for Disturbance recorder digital channel selection
2. Additional functionality added such that setting files from earlier software versions will need additional settings to be made
3. Compatible except for Disturbance recorder digital channel selection & settings for additional functionality will be missing
4. Compatible except for the Disturbance recorder digital channel selection and the distance settings
5. Compatible except for Disturbance recorder digital channel selection & the setting file contains a large number of Distance setting which will each produce an error on download

Table 2 - Setting file and relay software versions

3 PSL FILE AND RELAY SOFTWARE

To enhance readability, this table has been split over two pages. The columns are shown on adjacent pages:

		Relay Software Version																							
		01	02	03	04	05	07	11	12	13	14	15	20	30	32	40	41	42	44	45	47	48	50	51	52
PSL File Software Version	01	✓	x	x	x	x	x	x	x	x	x	x	x	x	x	x	x	x	x	x	x	x	x	x	x
	02	x	✓	x	x	x	x	x	x	x	x	x	x	x	x	x	x	x	x	x	x	x	x	x	x
	03	x	x	✓	x	x	x	x	x	x	x	x	x	x	x	x	x	x	x	x	x	x	x	x	x
	04	x	x	x	✓	x	x	x	x	x	x	x	x	x	x	x	x	x	x	x	x	x	x	x	x
	05	x	x	x	x	✓	1	x	x	x	x	x	x	x	x	x	x	x	x	x	x	x	x	x	x
	07	x	x	x	x	x	✓	x	x	x	x	x	x	x	x	x	x	x	x	x	x	x	x	x	x
	11	x	x	x	x	x	x	✓	✓	✓	x	x	1	1	1	x	x	x	x	x	x	x	x	x	x
	12	x	x	x	x	x	x	x	✓	✓	x	x	1	1	1	x	x	x	x	x	x	x	x	x	x
	13	x	x	x	x	x	x	x	x	✓	x	x	1	1	1	x	x	x	x	x	x	x	x	x	x
	14	x	x	x	x	x	x	x	x	x	✓	x	x	x	x	x	x	x	x	x	x	x	x	x	x
	15	x	x	x	x	x	x	x	x	x	x	✓	x	x	x	x	x	x	x	x	x	x	x	x	x
	20	x	x	x	x	x	x	x	x	x	x	x	✓	1	x	x	x	x	x	x	x	x	x	x	x
	30	x	x	x	x	x	x	x	x	x	x	x	x	✓	x	x	x	x	x	x	x	x	x	x	x
	32	x	x	x	x	x	x	x	x	x	x	x	x	x	✓	x	x	x	x	x	x	x	x	x	x
	40	x	x	x	x	x	x	x	x	x	x	x	x	x	x	✓	x	x	x	x	x	x	x	2	x
	41	x	x	x	x	x	x	x	x	x	x	x	x	x	x	x	✓	x	x	x	x	x	x	x	2
	42	x	x	x	x	x	x	x	x	x	x	x	x	x	x	x	x	✓	x	x	x	x	x	x	2
	44	x	x	x	x	x	x	x	x	x	x	x	x	x	x	x	x	x	✓	x	x	x	x	x	x
	45	x	x	x	x	x	x	x	x	x	x	x	x	x	x	x	x	x	x	✓	x	x	x	x	x
	47	x	x	x	x	x	x	x	x	x	x	x	x	x	x	x	x	x	x	x	✓	x	x	x	x
	48	x	x	x	x	x	x	x	x	x	x	x	x	x	x	x	x	x	x	x	x	✓	x	x	x
	50	x	x	x	x	x	x	x	x	x	x	x	x	x	x	x	x	x	x	x	x	x	✓	x	x
	51	x	x	x	x	x	x	x	x	x	x	x	x	x	x	x	x	x	x	x	x	x	x	✓	x
	52	x	x	x	x	x	x	x	x	x	x	x	x	x	x	x	x	x	x	x	x	x	x	x	✓
	53	x	x	x	x	x	x	x	x	x	x	x	x	x	x	x	x	x	x	x	x	x	x	x	x
	54	x	x	x	x	x	x	x	x	x	x	x	x	x	x	x	x	x	x	x	x	x	x	x	x
55	x	x	x	x	x	x	x	x	x	x	x	x	x	x	x	x	x	x	x	x	x	x	x	x	
56	x	x	x	x	x	x	x	x	x	x	x	x	x	x	x	x	x	x	x	x	x	x	x	x	
57	x	x	x	x	x	x	x	x	x	x	x	x	x	x	x	x	x	x	x	x	x	x	x	x	
58	x	x	x	x	x	x	x	x	x	x	x	x	x	x	x	x	x	x	x	x	x	x	x	x	
A0	x	x	x	x	x	x	x	x	x	x	x	x	x	x	x	x	x	x	x	x	x	x	x	x	
B0	x	x	x	x	x	x	x	x	x	x	x	x	x	x	x	x	x	x	x	x	x	x	x	x	
C0	x	x	x	x	x	x	x	x	x	x	x	x	x	x	x	x	x	x	x	x	x	x	x	x	
D0	x	x	x	x	x	x	x	x	x	x	x	x	x	x	x	x	x	x	x	x	x	x	x	x	
D1	x	x	x	x	x	x	x	x	x	x	x	x	x	x	x	x	x	x	x	x	x	x	x	x	
D2	x	x	x	x	x	x	x	x	x	x	x	x	x	x	x	x	x	x	x	x	x	x	x	x	
H4	x	x	x	x	x	x	x	x	x	x	x	x	x	x	x	x	x	x	x	x	x	x	x	x	
H5	x	x	x	x	x	x	x	x	x	x	x	x	x	x	x	x	x	x	x	x	x	x	x	x	
H6	x	x	x	x	x	x	x	x	x	x	x	x	x	x	x	x	x	x	x	x	x	x	x	x	
H7	x	x	x	x	x	x	x	x	x	x	x	x	x	x	x	x	x	x	x	x	x	x	x	x	
H8	x	x	x	x	x	x	x	x	x	x	x	x	x	x	x	x	x	x	x	x	x	x	x	x	
H9	x	x	x	x	x	x	x	x	x	x	x	x	x	x	x	x	x	x	x	x	x	x	x	x	
K1	x	x	x	x	x	x	x	x	x	x	x	x	x	x	x	x	x	x	x	x	x	x	x	x	
K2	x	x	x	x	x	x	x	x	x	x	x	x	x	x	x	x	x	x	x	x	x	x	x	x	
K3	x	x	x	x	x	x	x	x	x	x	x	x	x	x	x	x	x	x	x	x	x	x	x	x	
K4	x	x	x	x	x	x	x	x	x	x	x	x	x	x	x	x	x	x	x	x	x	x	x	x	
K5	x	x	x	x	x	x	x	x	x	x	x	x	x	x	x	x	x	x	x	x	x	x	x	x	
K6	x	x	x	x	x	x	x	x	x	x	x	x	x	x	x	x	x	x	x	x	x	x	x	x	

Notes:
 1. Additional DDBs were added such that PSL files from earlier software versions will not be able to access them
 2. Additional DDB for the Distance protection will not be included

Important: The second set of columns are shown on the following page.

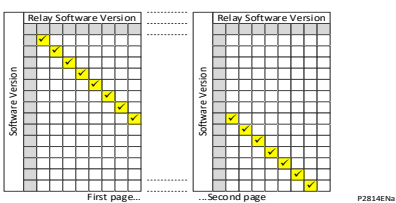

Important: The first set of columns are shown on the previous page.

		Relay Software Version																							
		53	54	55	56	57	58	A0	B0	C0	D0	D1	D2	H4	H5	H6	H7	H8	H9	K1	K2	K3	K4	K5	K6
PSL File Software Version	01	x	x	x	x	x	x	x	x	x	x	x	x	x	x	x	x	x	x	x	x	x	x	x	x
	02	x	x	x	x	x	x	x	x	x	x	x	x	x	x	x	x	x	x	x	x	x	x	x	x
	03	x	x	x	x	x	x	x	x	x	x	x	x	x	x	x	x	x	x	x	x	x	x	x	x
	04	x	x	x	x	x	x	x	x	x	x	x	x	x	x	x	x	x	x	x	x	x	x	x	x
	05	x	x	x	x	x	x	x	x	x	x	x	x	x	x	x	x	x	x	x	x	x	x	x	x
	07	x	x	x	x	x	x	x	x	x	x	x	x	x	x	x	x	x	x	x	x	x	x	x	x
	11	x	x	x	x	x	x	x	x	x	x	x	x	x	x	x	x	x	x	x	x	x	x	x	x
	12	x	x	x	x	x	x	x	x	x	x	x	x	x	x	x	x	x	x	x	x	x	x	x	x
	13	x	x	x	x	x	x	x	x	x	x	x	x	x	x	x	x	x	x	x	x	x	x	x	x
	14	x	x	x	x	x	x	x	x	x	x	x	x	x	x	x	x	x	x	x	x	x	x	x	x
	15	x	x	x	x	x	x	x	x	x	x	x	x	x	x	x	x	x	x	x	x	x	x	x	x
	20	x	x	x	x	x	x	x	x	x	x	x	x	x	x	x	x	x	x	x	x	x	x	x	x
	30	x	x	x	x	x	x	x	x	x	x	x	x	x	x	x	x	x	x	x	x	x	x	x	x
	32	x	x	x	x	x	x	x	x	x	x	x	x	x	x	x	x	x	x	x	x	x	x	x	x
	40	x	x	x	x	x	x	x	x	x	x	x	x	x	x	x	x	x	x	x	x	x	x	x	x
	41	x	x	x	x	x	x	x	x	x	x	x	x	x	x	x	x	x	x	x	x	x	x	x	x
	42	x	2	x	x	x	x	x	x	x	x	x	x	x	x	x	x	x	x	x	x	x	x	x	x
	44	x	2	x	x	x	x	x	x	x	x	x	x	x	x	x	x	x	x	x	x	x	x	x	x
	45	x	x	2	2	x	x	x	x	x	x	x	x	x	x	x	x	x	x	x	x	x	x	x	x
	47	x	x	x	x	2	2	x	x	x	x	x	x	x	x	x	x	x	x	x	x	x	x	x	x
	48	x	x	x	x	2	2	x	x	x	x	x	x	x	x	x	x	x	x	x	x	x	x	x	x
	50	x	x	x	x	x	x	x	x	x	x	x	x	x	x	x	x	x	x	x	x	x	x	x	x
	51	x	x	x	x	x	x	x	x	x	x	x	x	x	x	x	x	x	x	x	x	x	x	x	x
	52	x	x	x	x	x	x	x	x	x	x	x	x	x	x	x	x	x	x	x	x	x	x	x	x
	53	x	✓	x	x	x	x	x	x	x	x	x	x	x	x	x	x	x	x	x	x	x	x	x	x
	54	x	✓	x	x	x	x	x	x	x	x	x	x	x	x	x	x	x	x	x	x	x	x	x	x
	55	x	x	✓	x	x	x	x	x	x	x	x	x	x	x	x	x	x	x	x	x	x	x	x	x
	56	x	x	x	✓	x	x	x	x	x	x	x	x	x	x	x	x	x	x	x	x	x	x	x	x
	57	x	x	x	x	✓	x	x	x	x	x	x	x	x	x	x	x	x	x	x	x	x	x	x	x
	58	x	x	x	x	x	✓	x	x	x	x	x	x	x	x	x	x	x	x	x	x	x	x	x	x
A0	x	x	x	x	x	x	✓	2	x	x	x	x	x	x	x	x	x	x	x	x	x	x	x	x	
B0	x	x	x	x	x	x	x	✓	x	x	x	x	x	x	x	x	x	x	x	x	x	x	x	x	
C0	x	x	x	x	x	x	x	x	✓	2	x	x	x	x	x	x	x	x	x	x	x	x	x	x	
D0	x	x	x	x	x	x	x	x	x	x	✓	x	x	x	x	x	x	x	x	x	x	x	x	x	
D1	x	x	x	x	x	x	x	x	x	x	x	✓	x	x	x	x	x	x	x	x	x	x	x	x	
D2	x	x	x	x	x	x	x	x	x	x	x	x	✓	x	x	x	x	x	x	x	x	x	x	x	
H4	x	x	x	x	x	x	x	x	x	x	x	x	x	✓	x	x	x	x	x	x	x	x	x	x	
H5	x	x	x	x	x	x	x	x	x	x	x	x	x	x	✓	x	x	x	x	x	x	x	x	x	
H6	x	x	x	x	x	x	x	x	x	x	x	x	x	x	x	✓	x	x	x	x	x	x	x	x	
H7	x	x	x	x	x	x	x	x	x	x	x	x	x	x	x	x	✓	x	x	x	x	x	x	x	
H8	x	x	x	x	x	x	x	x	x	x	x	x	x	x	x	x	x	✓	x	x	x	x	x	x	
H9	x	x	x	x	x	x	x	x	x	x	x	x	x	x	x	x	x	x	✓	x	x	x	x	x	
K1	x	x	x	x	x	x	x	x	x	x	x	x	x	x	x	x	x	x	x	✓	x	x	x	x	
K2	x	x	x	x	x	x	x	x	x	x	x	x	x	x	x	x	x	x	x	x	✓	x	x	x	
K3	x	x	x	x	x	x	x	x	x	x	x	x	x	x	x	x	x	x	x	x	x	✓	x	x	
K4	x	x	x	x	x	x	x	x	x	x	x	x	x	x	x	x	x	x	x	x	x	x	✓	x	
K5	x	x	x	x	x	x	x	x	x	x	x	x	x	x	x	x	x	x	x	x	x	x	x	✓	
K6	x	x	x	x	x	x	x	x	x	x	x	x	x	x	x	x	x	x	x	x	x	x	x	✓	

Notes:
 1. Additional DDBs were added such that PSL files from earlier software versions will not be able to access them
 2. Additional DDB for the Distance protection will not be included

Table 3 - PSL file and relay software versions

4 MENU TEXT AND RELAY SOFTWARE

To enhance readability, this table has been split over two pages. The columns are shown on adjacent pages:

		Relay Software Version																								
		01	02	03	04	05	07	11	12	13	14	15	20	30	32	40	41	42	44	45	47	48	50	51	52	
Menu Text Software Version	01	✓	x	x	x	x	x	x	x	x	x	x	x	x	x	x	x	x	x	x	x	x	x	x	x	
	02	x	✓	x	x	x	x	x	x	x	x	x	x	x	x	x	x	x	x	x	x	x	x	x	x	
	03	x	x	✓	x	x	x	x	x	x	x	x	x	x	x	x	x	x	x	x	x	x	x	x	x	
	04	x	x	x	✓	x	x	x	x	x	x	x	x	x	x	x	x	x	x	x	x	x	x	x	x	
	05	x	x	x	x	✓	✓	x	x	x	x	x	x	x	x	x	x	x	x	x	x	x	x	x	x	
	07	x	x	x	x	✓	✓	x	x	x	x	x	x	x	x	x	x	x	x	x	x	x	x	x	x	
	11	x	x	x	x	x	x	✓	x	x	x	x	x	x	x	x	x	x	x	x	x	x	x	x	x	
	12	x	x	x	x	x	x	x	✓	x	x	x	x	x	x	x	x	x	x	x	x	x	x	x	x	
	13	x	x	x	x	x	x	x	x	✓	x	x	x	x	x	x	x	x	x	x	x	x	x	x	x	
	14	x	x	x	x	x	x	x	x	x	✓	x	x	x	x	x	x	x	x	x	x	x	x	x	x	
	15	x	x	x	x	x	x	x	x	x	x	✓	x	x	x	x	x	x	x	x	x	x	x	x	x	
	20	x	x	x	x	x	x	x	x	x	x	x	✓	x	x	x	x	x	x	x	x	x	x	x	x	
	30	x	x	x	x	x	x	x	x	x	x	x	x	✓	x	x	x	x	x	x	x	x	x	x	x	
	32	x	x	x	x	x	x	x	x	x	x	x	x	x	✓	x	x	x	x	x	x	x	x	x	x	
	40	x	x	x	x	x	x	x	x	x	x	x	x	x	x	✓	x	x	x	x	x	x	x	x	x	
	41	x	x	x	x	x	x	x	x	x	x	x	x	x	x	x	✓	x	x	x	x	x	x	x	x	
	42	x	x	x	x	x	x	x	x	x	x	x	x	x	x	x	x	✓	x	x	x	x	x	x	x	
	44	x	x	x	x	x	x	x	x	x	x	x	x	x	x	x	x	x	✓	x	x	x	x	x	x	
	45	x	x	x	x	x	x	x	x	x	x	x	x	x	x	x	x	x	x	✓	x	x	x	x	x	
	47	x	x	x	x	x	x	x	x	x	x	x	x	x	x	x	x	x	x	x	✓	x	x	x	x	
	48	x	x	x	x	x	x	x	x	x	x	x	x	x	x	x	x	x	x	x	x	✓	x	x	x	
	50	x	x	x	x	x	x	x	x	x	x	x	x	x	x	x	x	x	x	x	x	x	✓	x	x	
	51	x	x	x	x	x	x	x	x	x	x	x	x	x	x	x	x	x	x	x	x	x	x	✓	x	
	52	x	x	x	x	x	x	x	x	x	x	x	x	x	x	x	x	x	x	x	x	x	x	x	✓	
	53	x	x	x	x	x	x	x	x	x	x	x	x	x	x	x	x	x	x	x	x	x	x	x	x	
	54	x	x	x	x	x	x	x	x	x	x	x	x	x	x	x	x	x	x	x	x	x	x	x	x	
	55	x	x	x	x	x	x	x	x	x	x	x	x	x	x	x	x	x	x	x	x	x	x	x	x	
	56	x	x	x	x	x	x	x	x	x	x	x	x	x	x	x	x	x	x	x	x	x	x	x	x	
	57	x	x	x	x	x	x	x	x	x	x	x	x	x	x	x	x	x	x	x	x	x	x	x	x	
	58	x	x	x	x	x	x	x	x	x	x	x	x	x	x	x	x	x	x	x	x	x	x	x	x	
	A0	x	x	x	x	x	x	x	x	x	x	x	x	x	x	x	x	x	x	x	x	x	x	x	x	
	B0	x	x	x	x	x	x	x	x	x	x	x	x	x	x	x	x	x	x	x	x	x	x	x	x	
	C0	x	x	x	x	x	x	x	x	x	x	x	x	x	x	x	x	x	x	x	x	x	x	x	x	
	D0	x	x	x	x	x	x	x	x	x	x	x	x	x	x	x	x	x	x	x	x	x	x	x	x	
	D1	x	x	x	x	x	x	x	x	x	x	x	x	x	x	x	x	x	x	x	x	x	x	x	x	
D2	x	x	x	x	x	x	x	x	x	x	x	x	x	x	x	x	x	x	x	x	x	x	x	x		
H4	x	x	x	x	x	x	x	x	x	x	x	x	x	x	x	x	x	x	x	x	x	x	x	x		
H5	x	x	x	x	x	x	x	x	x	x	x	x	x	x	x	x	x	x	x	x	x	x	x	x		
H6	x	x	x	x	x	x	x	x	x	x	x	x	x	x	x	x	x	x	x	x	x	x	x	x		
H7	x	x	x	x	x	x	x	x	x	x	x	x	x	x	x	x	x	x	x	x	x	x	x	x		
H8	x	x	x	x	x	x	x	x	x	x	x	x	x	x	x	x	x	x	x	x	x	x	x	x		
H9	x	x	x	x	x	x	x	x	x	x	x	x	x	x	x	x	x	x	x	x	x	x	x	x		
K1	x	x	x	x	x	x	x	x	x	x	x	x	x	x	x	x	x	x	x	x	x	x	x	x		
K2	x	x	x	x	x	x	x	x	x	x	x	x	x	x	x	x	x	x	x	x	x	x	x	x		
K3	x	x	x	x	x	x	x	x	x	x	x	x	x	x	x	x	x	x	x	x	x	x	x	x		
K4	x	x	x	x	x	x	x	x	x	x	x	x	x	x	x	x	x	x	x	x	x	x	x	x		
K5	x	x	x	x	x	x	x	x	x	x	x	x	x	x	x	x	x	x	x	x	x	x	x	x		
K6	x	x	x	x	x	x	x	x	x	x	x	x	x	x	x	x	x	x	x	x	x	x	x	x		

Important: The second set of columns are shown on the following page.

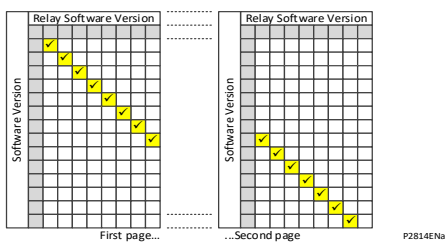

Important: The first set of columns are shown on the previous page.

		Relay Software Version																							
		53	54	55	56	57	58	A0	B0	C0	D0	D1	D2	H4	H5	H6	H7	H8	H9	K1	K2	K3	K4	K5	K6
Menu Text Software Version	01	x	x	x	x	x	x	x	x	x	x	x	x	x	x	x	x	x	x	x	x	x	x	x	x
	02	x	x	x	x	x	x	x	x	x	x	x	x	x	x	x	x	x	x	x	x	x	x	x	x
	03	x	x	x	x	x	x	x	x	x	x	x	x	x	x	x	x	x	x	x	x	x	x	x	x
	04	x	x	x	x	x	x	x	x	x	x	x	x	x	x	x	x	x	x	x	x	x	x	x	x
	05	x	x	x	x	x	x	x	x	x	x	x	x	x	x	x	x	x	x	x	x	x	x	x	x
	07	x	x	x	x	x	x	x	x	x	x	x	x	x	x	x	x	x	x	x	x	x	x	x	x
	11	x	x	x	x	x	x	x	x	x	x	x	x	x	x	x	x	x	x	x	x	x	x	x	x
	12	x	x	x	x	x	x	x	x	x	x	x	x	x	x	x	x	x	x	x	x	x	x	x	x
	13	x	x	x	x	x	x	x	x	x	x	x	x	x	x	x	x	x	x	x	x	x	x	x	x
	14	x	x	x	x	x	x	x	x	x	x	x	x	x	x	x	x	x	x	x	x	x	x	x	x
	15	x	x	x	x	x	x	x	x	x	x	x	x	x	x	x	x	x	x	x	x	x	x	x	x
	20	x	x	x	x	x	x	x	x	x	x	x	x	x	x	x	x	x	x	x	x	x	x	x	x
	30	x	x	x	x	x	x	x	x	x	x	x	x	x	x	x	x	x	x	x	x	x	x	x	x
	32	x	x	x	x	x	x	x	x	x	x	x	x	x	x	x	x	x	x	x	x	x	x	x	x
	40	x	x	x	x	x	x	x	x	x	x	x	x	x	x	x	x	x	x	x	x	x	x	x	x
	41	x	x	x	x	x	x	x	x	x	x	x	x	x	x	x	x	x	x	x	x	x	x	x	x
	42	x	x	x	x	x	x	x	x	x	x	x	x	x	x	x	x	x	x	x	x	x	x	x	x
	44	x	x	x	x	x	x	x	x	x	x	x	x	x	x	x	x	x	x	x	x	x	x	x	x
	45	x	x	x	x	x	x	x	x	x	x	x	x	x	x	x	x	x	x	x	x	x	x	x	x
	47	x	x	x	x	x	x	x	x	x	x	x	x	x	x	x	x	x	x	x	x	x	x	x	x
	48	x	x	x	x	x	x	x	x	x	x	x	x	x	x	x	x	x	x	x	x	x	x	x	x
	50	x	x	x	x	x	x	x	x	x	x	x	x	x	x	x	x	x	x	x	x	x	x	x	x
	51	x	x	x	x	x	x	x	x	x	x	x	x	x	x	x	x	x	x	x	x	x	x	x	x
	52	x	x	x	x	x	x	x	x	x	x	x	x	x	x	x	x	x	x	x	x	x	x	x	x
	53	x	✓	x	x	x	x	x	x	x	x	x	x	x	x	x	x	x	x	x	x	x	x	x	x
	54	x	x	✓	x	x	x	x	x	x	x	x	x	x	x	x	x	x	x	x	x	x	x	x	x
	55	x	x	x	✓	x	x	x	x	x	x	x	x	x	x	x	x	x	x	x	x	x	x	x	x
	56	x	x	x	x	✓	x	x	x	x	x	x	x	x	x	x	x	x	x	x	x	x	x	x	x
57	x	x	x	x	x	✓	x	x	x	x	x	x	x	x	x	x	x	x	x	x	x	x	x	x	
58	x	x	x	x	x	x	✓	x	x	x	x	x	x	x	x	x	x	x	x	x	x	x	x	x	
A0	x	x	x	x	x	x	x	✓	x	x	x	x	x	x	x	x	x	x	x	x	x	x	x	x	
B0	x	x	x	x	x	x	x	x	✓	x	x	x	x	x	x	x	x	x	x	x	x	x	x	x	
C0	x	x	x	x	x	x	x	x	x	✓	x	x	x	x	x	x	x	x	x	x	x	x	x	x	
D0	x	x	x	x	x	x	x	x	x	x	✓	x	x	x	x	x	x	x	x	x	x	x	x	x	
D1	x	x	x	x	x	x	x	x	x	x	x	✓	x	x	x	x	x	x	x	x	x	x	x	x	
D2	x	x	x	x	x	x	x	x	x	x	x	x	✓	x	x	x	x	x	x	x	x	x	x	x	
H4	x	x	x	x	x	x	x	x	x	x	x	x	x	✓	x	x	x	x	x	x	x	x	x	x	
H5	x	x	x	x	x	x	x	x	x	x	x	x	x	x	✓	x	x	x	x	x	x	x	x	x	
H6	x	x	x	x	x	x	x	x	x	x	x	x	x	x	x	✓	x	x	x	x	x	x	x	x	
H7	x	x	x	x	x	x	x	x	x	x	x	x	x	x	x	x	✓	x	x	x	x	x	x	x	
H8	x	x	x	x	x	x	x	x	x	x	x	x	x	x	x	x	x	✓	x	x	x	x	x	x	
H9	x	x	x	x	x	x	x	x	x	x	x	x	x	x	x	x	x	x	✓	x	x	x	x	x	
K1	x	x	x	x	x	x	x	x	x	x	x	x	x	x	x	x	x	x	x	✓	x	x	x	x	
K2	x	x	x	x	x	x	x	x	x	x	x	x	x	x	x	x	x	x	x	x	✓	x	x	x	
K3	x	x	x	x	x	x	x	x	x	x	x	x	x	x	x	x	x	x	x	x	x	✓	x	x	
K4	x	x	x	x	x	x	x	x	x	x	x	x	x	x	x	x	x	x	x	x	x	x	✓	x	
K5	x	x	x	x	x	x	x	x	x	x	x	x	x	x	x	x	x	x	x	x	x	x	x	✓	
K6	x	x	x	x	x	x	x	x	x	x	x	x	x	x	x	x	x	x	x	x	x	x	x	✓	

Table 4 - Menu text and relay software versions

SYMBOLS AND GLOSSARY

CHAPTER SG

Applicability	
Date:	11/2023
Products covered by this chapter:	
This chapter covers the specific versions of the MiCOM products listed below. This includes only the following combinations of Software Version and Hardware Suffix.	
Hardware Suffix:	
MiCOM Px4x	All
Software Version:	
MiCOM Px4x	All
Connection Diagrams:	
This chapter list the connection diagram for the product:	
P14x (P141, P142, P143 & P145):	10P141xx (xx = 01 to 02) 10P142xx (xx = 01 to 05) 10P143xx (xx = 01 to 11) 10P145xx (xx = 01 to 11)
P24x (P241, P242 & P243):	10P241xx (xx = 01 to 02) 10P242xx (xx = 01) 10P243xx (xx = 01)
P34x (P342, P343, P344, P345 & P391)	10P342xx (xx = 01 to 17) 10P343xx (xx = 01 to 19) 10P344xx (xx = 01 to 12) 10P345xx (xx = 01 to 07) 10P391xx (xx = 01 to 02)
P445:	10P445xx (xx = 01 to 04)
P44x (P442 & P444):	10P44101 (SH 1 & 2) 10P44201 (SH 1 & 2) 10P44202 (SH 1) 10P44203 (SH 1 & 2) 10P44401 (SH 1) 10P44402 (SH 1) 10P44403 (SH 1 & 2) 10P44404 (SH 1) 10P44405 (SH 1) 10P44407 (SH 1 & 2)
P44x (P442 & P444):	10P44201 (SH 1 & 2) 10P44202 (SH 1) 10P44203 (SH 1 & 2) 10P44401 (SH 1) 10P44402 (SH 1) 10P44403 (SH 1 & 2) 10P44404 (SH 1) 10P44405 (SH 1) 10P44407 (SH 1 & 2)
P44y:	10P44303 (SH 01 and 03) 10P44304 (SH 01 and 03) 10P44305 (SH 01 and 03) 10P44306 (SH 01 and 03)

	<p>10P44600 10P44601 (SH 1 to 2) 10P44602 (SH 1 to 2) 10P44603 (SH 1 to 2)</p>
P54x (P543, P544, P545 & P546):	<p>10P54302 (SH 1 to 2) 10P54303 (SH 1 to 2) 10P54304 (SH 1 to 2) 10P54400 10P54404 (SH 1 to 2) 10P54405 (SH 1 to 2) 10P54502 (SH 1 to 2) 10P54503 (SH 1 to 2) 10P54504 (SH 1 to 2) 10P54600 10P54604 (SH 1 to 2) 10P54605 (SH 1 to 2) 10P54606 (SH 1 to 2)</p>
P547:	<p>10P54702xx (xx = 01 to 02) 10P54703xx (xx = 01 to 02) 10P54704xx (xx = 01 to 02) 10P54705xx (xx = 01 to 02)</p>
P64x (P642, P643 & P645):	<p>10P642xx (xx = 1 to 10) 10P643xx (xx = 1 to 6) 10P645xx (xx = 1 to 9)</p>
P74x:	<p>10P740xx (xx = 01 to 07)</p>
P746:	<p>10P746xx (xx = 00 to 21)</p>
P841:	<p>10P84100 10P84101 (SH 1 to 2) 10P84102 (SH 1 to 2) 10P84103 (SH 1 to 2) 10P84104 (SH 1 to 2) 10P84105 (SH 1 to 2)</p>
P849:	<p>10P849xx (xx = 01 to 06)</p>

Notes:

CONTENTS

1. Acronyms and Abbreviations	7
2. Company Proprietary Terms	16
3. ANSI Terms	17
4. Concatenated Terms	21
5. Units for Digital Communications	22
6. American vs British English Terminology	23
7. Logic Symbols and Terms	24
8. Logic Timers	29
9. Logic Gates	31

TABLES

Table 1 - Acronyms and abbreviations.....	15
Table 2 - Company-proprietary terms.....	16
Table 3 - ANSI Abbreviations.....	17
Table 4 - ANSI Descriptions.....	20
Table 5 - Concatenated Terms.....	21
Table 6 - Units for Digital Communications.....	22
Table 7 - American vs British English terminology.....	23
Table 8 - Logic Symbols and Terms.....	28
Table 9 - Logic Timers.....	30

FIGURES

Figure 1 - Logic Gates - AND Gate.....	31
Figure 2 - Logic Gates - OR Gate.....	31
Figure 3 - Logic Gates - R-S Flip-Flop Gate.....	31
Figure 4 - Logic Gates - Exclusive OR Gate.....	31
Figure 5 - Logic Gates - Programmable Gate.....	32
Figure 6 - Logic Gates - NOT Gate.....	32

Notes:

1. ACRONYMS AND ABBREVIATIONS

Term	Description
<	Less than: Used to indicate an "under" threshold, such as undercurrent (current dropout).
>	Greater than: Used to indicate an "over" threshold, such as overcurrent (current overload)
A	Ampere
AA	Application Association
AC / ac	Alternating Current
ACSI	Abstract Communication Service Interface
ACSR	Aluminum Conductor Steel Reinforced
ALF	Accuracy Limit Factor
AM	Amplitude Modulation
ANSI	American National Standards Institute
AR	Auto-Reclose
ARIP	Auto-Reclose In Progress
ASCII	American Standard Code for Information Interchange
ATEX	ATEX is the Potentially Explosive Atmospheres directive 94/9/EC
AUX / Aux	Auxiliary
AWG	American Wire Gauge
BAR	Block Auto-Reclose signal
BCD	Binary Coded Decimal
BCR	Binary Counter Reading
BDEW	Bundesverband der Energie- und Wasserwirtschaft Startseite (i.e. German Association of Energy and Water Industries)
BIED	Breaker IED
BMP	BitMaP – a file format for a computer graphic
BN>	Neutral over susceptance protection element: Reactive component of admittance calculation from neutral current and residual voltage.
BOP	Blocking Overreach Protection - a blocking aided-channel scheme.
BPDU	Bridge Protocol Data Unit
BRCB	Buffered Report Control Block
BRP	Beacon Redundancy Protocol
BU	Backup: Typically a back-up protection element
C264	MiCOM C264 is the latest generation of modular substation computers. In addition to the traditional input/output (I/O) management, MiCOM C264 acts as a powerful communication gateway, an advanced measurement center and a fast automation processor. As a remote terminal unit, bay controller or protocol converter, MiCOM C264 is the compact solution to countless applications installed in demanding electromagnetic conditions.
C/O	A ChangeOver contact having normally-closed and normally-open connections: Often called a "form C" contact.
CB	Circuit Breaker
CB Aux.	Circuit Breaker auxiliary contacts: Indication of the breaker open/closed status.
CBF	Circuit Breaker Failure protection
CDC	Common Data Class

Term	Description
CF	Control Function
Ch	Channel: usually a communications or signaling channel
Check Synch	Check Synchronizing function
CLIO	Current Loop Input Output: 0-1 mA/0-10 mA/0-20 mA/4-20 mA transducer inputs and outputs CLI = current loop input - 0-1 mA/0-10 mA/0-20 mA/4-20 mA transducer input CLIO = current loop output - 0-1 mA/0-10 mA/0-20 mA/4-20 mA transducer output
CID	Configured IED Description
CIP	Critical Infrastructure Protection standards
CLK / Clk	Clock
CIs	Close - generally used in the context of close functions in circuit breaker control.
CMV	Complex Measured Value
CNV	Current No Volts
COMFEDE	Common Format for Event Data Exchange
CPNI	Centre for the Protection of National Infrastructure
CRC	Cyclic Redundancy Check
CRP	Cross-network Redundancy Protocol
CRV	Curve (file format for curve information)
CRx	Channel Receive: Typically used to indicate a teleprotection signal received.
CS	Cyber Security or Check Synchronism.
CSV	Comma Separated Values (a file format for database information)
CT	Current Transformer
CTRL	Control - as used for the Control Inputs function
CTS	Current Transformer Supervision: To detect CT input failure.
CTx	Channel Transmit: Typically used to indicate a teleprotection signal send.
CUL	Canadian Underwriters Laboratory
CVT	Capacitor-coupled Voltage Transformer - equivalent to terminology CCVT.
CZ	Abbreviation of "Check Zone": Zone taking into account only the feeders.
DA	Data Attribute
DAU	Data Acquisition Unit
DC	Data Concentrator
DC / dc	Direct Current
DCC	An Omicron compatible format
DCE	Data Communication Equipment
DDB	Digital Data Bus within the programmable scheme logic: A logic point that has a zero or 1 status. DDB signals are mapped in logic to customize the relay's operation.
DDR	Dynamic Disturbance Recorder
DEF	Directional Earth Fault protection: A directionalized ground fault aided scheme.
df/dt	Rate of Change of Frequency
df/dt>1	First stage of df/dt protection
DFT	Discrete Fourier Transform

Term	Description
DG	Distributed Generation
DHCP	Dynamic Host Configuration Protocol
DHM	Dual Homing Manager
DHP	Dual Homing Protocol
DHS	Dual Homing Star: Ethernet protocol allowing bumpless redundancy. Used with Redundant Ethernet board with dual homing protocol
Diff	Differential protection.
DIN	Deutsches Institut für Normung (German standards body)
Dist	Distance protection.
DITA	Darwinian Information Typing Architecture
DLDB	Dead-Line Dead-Bus : In system synchronism check, indication that both the line and bus are de-energised.
DLLB	Dead-Line Live-Bus : In system synchronism check, indication that the line is de-energised whilst the bus is energised.
DLR	Dynamic Line Rating
DLY / Dly	Time Delay
DMT	Definite Minimum Time
DNP	Distributed Network Protocol
DO	Data Object
DPWS	Device Profile for Web Services
DR	Disturbance Record
DSP	Digital Signal Processor
DST	Daylight Saving Time
DT	Definite Time: in the context of protection elements: An element which always responds with the same constant time delay on operation. Abbreviation of "Dead Time" in the context of auto-reclose:
DTD	Document Type Definition
DTOC	Definite Time Overcurrent
DTS	Date and Time Stamp
DVC	Direct Variable Cost
DZ	Abbreviation of "Dead Zone": Area between a CT and an open breaker or an open isolator.
EF or E/F	Earth Fault (directly equivalent to Ground Fault)
EIA	Electronic Industries Alliance
ELR	Environmental Lapse Rate
EMC	ElectroMagnetic Compatibility
ENA	Energy Networks Association
ER	Engineering Recommendation
ESD	ElectroStatic Discharge
FAA	Ageing Acceleration Factor: Used by Loss of Life (LOL) element
FFail	A field failure (loss of excitation) element: Could be labeled 40 in ANSI terminology.
FFT	Fast Fourier Transform

Term	Description
FIR	Finite Impulse Response
FLC	Full load current: The nominal rated current for the circuit.
FLT / Fit	Fault - typically used to indicate faulted phase selection.
Fn or FN	Function
FPGA	Field Programmable Gate Array
FPS	Frames Per Second
FTP	File Transfer Protocol or Foil Twisted Pair
FWD, Fwd or Fwd.	Indicates an element responding to a flow in the "Forward" direction
Gen Diff	A generator differential element: Could be labeled 87G in ANSI terminology.
Gen-Xformer Diff	A generator-transformer differential element: Could be labeled 87GT in ANSI terminology.
GI	General Interrogation
GIF	Graphic Interchange Format – a file format for a computer graphic
GN>	Neutral over conductance protection element: Real component of admittance calculation from neutral current and residual voltage.
GND / Gnd	Ground: used in distance settings to identify settings that relate to ground (earth) faults.
GoCB	GOOSE Control Block
GOOSE	Generic Object Oriented Substation Event
GPS	Global Positioning System
GRP / Grp	Group. Typically an alternative setting group.
GSE	General Substation Event
GSSE	Generic Substation Status Event
GUESS	Generator Unintentional Energization at StandStill.
GUI	Graphical User Interface
HMI	Human Machine Interface
HSR	High-Availability Seamless Ring or High Availability Seamless Redundancy
HTML	Hypertext Markup Language
I	Current
I/O	Input/Output
I/P	Input
IANA	Internet Assigned Numbers Authority
ICAO	International Civil Aviation Organization
ICD	IED Capability Description
ID	Identifier or Identification. Often a label used to track a software version installed.
IDMT	Inverse Definite Minimum Time. A characteristic whose trip time depends on the measured input (e.g. current) according to an inverse-time curve.
IEC	International Electro-technical Commission
IED	Intelligent Electronic Device - a term used to describe microprocessor-based controllers of power system equipment. Common types of IEDs include protective relaying devices, load tap changer controllers, circuit breaker controllers, capacitor bank switches, recloser controllers, voltage regulators, etc.

Term	Description
IEEE	Institute of Electrical and Electronics Engineers
IETF	Internet Engineering Task Force
IID	Instantiated/Individual IED Description
IIR	Infinite Impulse Response
IMU	Integrated MU
Inh	An Inhibit signal
Inst	An element with Instantaneous operation: i.e. having no deliberate time delay.
IP	Internet Protocol
IRIG	InterRange Instrumentation Group
ISA	International Standard Atmosphere
ISA	Instrumentation Systems and Automation Society
ISO	International Standards Organization
JPEF	Joint Photographic Experts Group – a file format for a computer graphic
L	Live
LAN	Local Area Network
LCB	Log Control Block
LCD	Liquid Crystal Display: The front-panel text display on the relay.
LD	Level Detector: An element responding to a current or voltage below its set threshold. or Logical Device
LDOV	Level Detector for OverVoltage
LDUV	Level Detector for UnderVoltage
LED	Light Emitting Diode: Red or green indicator on the front-panel.
LLDB	Live-Line Dead-Bus : In system synchronism check, indication that the line is energized whilst the bus is de-energized.
Ln	Natural logarithm
LN	Logical Node
LoL	A Loss of Load scheme, providing a fast distance trip without needing a signaling channel.
LPDU	Link Protocol Data Unit
LPHD	Logical Physical Device
LPIT	Low Power Instrument Transformers
MC	MultiCast
MCB	Miniature Circuit Breaker
MIB	Management Information Base
MICS	Model Implementation Conformance Statement
MIDOS	Modular Integrated DrawOut System
MMF	Magneto-Motive Force
MMS	Manufacturing Message Specification
MRP	Media Redundancy Protocol
MU	Merging Unit
MV	Measured Value
N	Neutral

Term	Description
N/A	Not Applicable
N/C	A Normally Closed or "break" contact: Often called a "form B" contact.
N/O	A Normally Open or "make" contact: Often called a "form A" contact.
NCIT	Non-Conventional Instrument Transformer
NERC	North American Reliability Corporation
NIC	Network Interface Card: i.e. the Ethernet card of the IED
NIST	National Institute of Standards and Technology
NPS	Negative Phase Sequence
NVD	Neutral Voltage Displacement: Equivalent to residual overvoltage protection.
NXT	Abbreviation of "Next": In connection with hotkey menu navigation.
°	A small circle on the input or output of a logic gate: Indicates a NOT (invert) function.
OC	Ordinary clock: A clock that has a single Precision Time Protocol (PTP) port in a domain and maintains the timescale used in the domain. It may serve as a source of time, i.e., be a master clock, or may synchronize to another clock, i.e., be a slave clock.
O/C	Overcurrent
O/P	Output
OCB	Oil Circuit Breaker
OID	Object IDentifier
Opto	An Optically coupled logic input. Alternative terminology: binary input.
OSI	Open Systems Interconnection
PCB	Printed Circuit Board
PCT	Protective Conductor Terminal (Ground)
PDC	Phasor Data Concentrator
Ph	Phase - used in distance settings to identify settings that relate to phase-phase faults.
PICS	Protocol Implementation Conformance Statement
PMU	Phasor Measurement Unit
PNG	Portable Network Graphics – a file format for a computer graphic
Pol	Polarize - typically the polarizing voltage used in making directional decisions.
POR	A Permissive OverReaching transfer trip scheme (alternative terminology: POTT).
PPS	Pulse Per Second
PRP	Parallel Redundancy Protocol
PSB	Power Swing Blocking, to detect power swing/out of step functions (ANSI 78).
PSL	Programmable Scheme Logic: The part of the relay's logic configuration that can be modified by the user, using the graphical editor within MiCOM S1 Studio software.
PSlip	A Pole slip (out of step - OOS) element: could be labeled 78 in ANSI terminology.
PT	Power Transformer
PTP	Precision Time Protocol
PUR	A Permissive UnderReaching transfer trip scheme (alternative terminology: PUTT).
Q	Quantity defined as per unit value
Qx	Isolator number x (from 1 to 6).
R	Resistance
R&TTE	Radio and Telecommunications Terminal Equipment

Term	Description
RBAC	Role Based Access Control
RBN	Lead burden for the neutral.
RBPh	Lead burden for the phases.
RCA	Relay Characteristic Angle - The center of the directional characteristic.
RCB	Report Control Block
REB	Redundant Ethernet Board
REF	Restricted Earth Fault
Rev.	Indicates an element responding to a flow in the "reverse" direction
RMS / rms	Root mean square. The equivalent a.c. current: Taking into account the fundamental, plus the equivalent heating effect of any harmonics.
RP	Rear Port: The communication ports on the rear of the IED
RS232	A common serial communications standard defined by the EIA
RS485	A common serial communications standard defined by the EIA (multi-drop)
RST or Rst	Reset generally used in the context of reset functions in circuit breaker control.
RSTP	Rapid Spanning Tree Protocol. Ethernet protocol allowing bumpless redundancy. Used with Redundant Ethernet board.
RTD	Resistance Temperature Device
RTU	Remote Terminal Unit
Rx	Receive: Typically used to indicate a communication transmit line/pin.
SBS	Straight Binary Second
SC	Synch-Check or system Synchronism Check.
SCADA	Supervisory Control and Data Acquisition
SCD	Substation Configuration Description
SCL	Substation Configuration Language. In IEC 61850, the definition of the configuration files.
SCSM	Specific Communication Service Mappings: In IEC 61850, the SCSMs define the actual information exchange mechanisms currently used (e.g. MMS).
SCU	Substation Control Unit
SDEF	Sensitive Differential Earth Fault Protection
SEF	Sensitive Earth Fault Protection
Sen	Sensitive
SGCB	Setting Group Control Block
SHM	Self-Healing Manager
SHP	Self Healing Protocol
SHR	Self Healing Ring: Ethernet protocol allowing bumpless redundancy. Used with Redundant Ethernet board with self-healing protocol.
SIED	Switch IED
SIR	Source Impedance Ratio
SLA	Service Level Agreement
SMV	Sampled Measured Values
SNTP	Simple Network Time Protocol

Term	Description
SOA	Service Oriented Architecture
SOAP	Simple Object Access Protocol
SOC	Second of Century
SOTF	Switch on to Fault protection. Modified protection on manual closure of the circuit breaker.
SP	Single pole.
SPAR	Single pole auto-reclose.
SPC	Single Point Controllable
SPDT	Single Pole Dead Time. The dead time used in single pole auto-reclose cycles.
SPS	Single Point Status
SQRT	Square Root
SSD	Solid State Device
SSL	Source Impedance Ratio
STP	Shielded Twisted Pair or Spanning Tree Protocol
SV	Sampled Values
SVC	Sampled Value Model
SVM	Sampled Value Model
TAF	Turbine Abnormal Frequency
TC	Transparent Clock: A device that measures the time taken for a Precision Time Protocol (PTP) event message to transit the device and provides this information to clocks receiving this PTP event message. See also: end-to-end transparent clock; peer-to-peer transparent clock.
TCP	Transmission Control Protocol
TCS	Second of Century
TCS	Trip Circuit Supervision
TD	Time Dial. The time dial multiplier setting: Applied to inverse-time curves (ANSI/IEEE).
TE	Unit for case measurements: One inch = 5TE units
THD	Total Harmonic Distortion
TICS	Technical Issues Conformance Statement
TIFF	Tagged Image File Format – a file format for a computer graphic
TLS	Transport Layer Security protocol
TMS	Time Multiplier Setting: Applied to inverse-time curves (IEC)
TOC	Trip On Close ("line check") protection. Offers SOTF and TOR functionality.
TOR	Trip On Reclose protection. Modified protection on autoreclosure of the circuit breaker.
TP	Two-Part
TS	Trip Supervision
TUC	Timed UnderCurrent
TVE	Total Vector Error
Tx	Transmit
UDP	User Datagram Protocol
UKCA	UK Type Examination regulation of the equipment
UL	Underwriters Laboratory
UPCT	User Programmable Curve Tool

Term	Description
UTC	Universal Time Coordinated
V	Voltage
VA	Phase A voltage: Sometimes L1, or red phase
VB	Phase B voltage: Sometimes L2, or yellow phase
VC	Phase C voltage: Sometimes L3, or blue phase
VCO	Voltage Controlled Overcurrent element
VDEP OC>	A voltage dependent overcurrent element: could be a voltage controlled or voltage restrained overcurrent element and could be labeled 51V in ANSI terminology.
VDR	Voltage Dependent Resistor
V/Hz	An overfluxing element, flux is proportional to voltage/frequency: could be labeled 24 in ANSI terminology.
VIP	Virtual Input
Vk	IEC knee point voltage of a current transformer.
VOP	Virtual Output
VT	Voltage Transformer
VTS	Voltage Transformer Supervision: To detect VT input failure.
WAN	Wide Area Network
Xformer	Transformer
XML	Extensible Markup Language
XSD	XML Schema Definition

Table 1 - Acronyms and abbreviations

2. COMPANY PROPRIETARY TERMS

Symbol	Description
Courier	Schneider Electric's proprietary SCADA communications protocol
Metrosil	Brand of non-linear resistor produced by M&I Materials Ltd.
MiCOM	Schneider Electric's brand of protection relays

Table 2 - Company-proprietary terms

3. ANSI TERMS

ANSI No.	Description
3PAR	Three pole auto-reclose.
3PDT	Three pole dead time. The dead time used in three pole auto-reclose cycles.
52a	A circuit breaker closed auxiliary contact: The contact is in the same state as the breaker primary contacts
52b	A circuit breaker open auxiliary contact: The contact is in the opposite state to the breaker primary contacts
64R	Rotor earth fault protection
64S	100% stator earth (ground) fault protection using a low frequency injection method.
89a	An Isolator closed auxiliary contact: The contact is in the same state as the breaker primary contacts.
89b	An Isolator open auxiliary contact: The contact is in the opposite state to the breaker primary contacts.

Table 3 - ANSI Abbreviations

ANSI No.	Function	Description
Current Protection Functions		
50/51	Phase overcurrent	Three-phase protection against overloads and phase-to-phase short-circuits.
50N/51N	Earth fault	Earth fault protection based on measured or calculated residual current values: <ul style="list-style-type: none"> • 50N/51N: residual current calculated or measured by 3 phase current sensors
50G/51G	Sensitive earth fault	Sensitive earth fault protection based on measured residual current values: <ul style="list-style-type: none"> • 50G/51G: residual current measured directly by a specific sensor such as a core balance CT
50BF	Breaker failure	If a breaker fails to be triggered by a tripping order, as detected by the non-extinction of the fault current, this backup protection sends a tripping order to the upstream or adjacent breakers.
46	Negative sequence / unbalance	Protection against phase unbalance, detected by the measurement of negative sequence current: <ul style="list-style-type: none"> • sensitive protection to detect 2-phase faults at the ends of long lines • protection of equipment against temperature build-up, caused by an unbalanced power supply, phase inversion or loss of phase, and against phase current unbalance
46BC	Broken conductor protection	Protection against phase imbalance, detected by measurement of I2/I1.
49RMS	Thermal overload	Protection against thermal damage caused by overloads on machines (transformers, motors or generators). The thermal capacity used is calculated according to a mathematical model which takes into account: <ul style="list-style-type: none"> • current RMS values • ambient temperature • negative sequence current, a cause of motor rotor temperature rise
Re-Closer		
79	Recloser	Automation device used to limit down time after tripping due to transient or semipermanent faults on overhead lines. The recloser orders automatic reclosing of the breaking device after the time delay required to restore the insulation has elapsed. Recloser operation is easy to adapt for different operating modes by parameter setting.

ANSI No.	Function	Description
Directional Current Protection		
67N/67NC type 1 and 67	Directional phase overcurrent	Phase-to-phase short-circuit protection, with selective tripping according to fault current direction. It comprises a phase overcurrent function associated with direction detection, and picks up if the phase overcurrent function in the chosen direction (line or busbar) is activated for at least one of the three phases.
67N/67NC	Directional earth fault	Earth fault protection, with selective tripping according to fault current direction. Three types of operation: <ul style="list-style-type: none"> • Type 1: the protection function uses the projection of the I0 vector • Type 2: the protection function uses the I0 vector magnitude with half-plane tripping zone • Type 3: the protection function uses the I0 vector magnitude with angular sector tripping zone
67N/67NC type 1	Directional current protection	Directional earth fault protection for impedant, isolated or compensated neutral systems, based on the projection of measured residual current.
67N/67NC type 2	Directional current protection	Directional overcurrent protection for impedance and solidly earthed systems, based on measured or calculated residual current. It comprises an earth fault function associated with direction detection, and picks up if the earth fault function in the chosen direction (line or busbar) is activated.
67N/67NC type 3	Directional current protection	Directional overcurrent protection for distribution networks in which the neutral earthing system varies according to the operating mode, based on measured residual current. It comprises an earth fault function associated with direction detection (angular sector tripping zone defined by 2 adjustable angles), and picks up if the earth fault function in the chosen direction (line or busbar) is activated.
Directional Power Protection Functions		
32P	Directional active overpower	Two-way protection based on calculated active power, for the following applications: <ul style="list-style-type: none"> • active overpower protection to detect overloads and allow load shedding • reverse active power protection: <ul style="list-style-type: none"> • against generators running like motors when the generators consume active power • against motors running like generators when the motors supply active power
32Q/40	Directional reactive overpower	Two-way protection based on calculated reactive power to detect field loss on synchronous machines: <ul style="list-style-type: none"> • reactive overpower protection for motors which consume more reactive power with field loss • reverse reactive overpower protection for generators which consume reactive power with field loss.
Machine Protection Functions		
37	Phase undercurrent	Protection of pumps against the consequences of a loss of priming by the detection of motor no-load operation. It is sensitive to a minimum of current in phase 1, remains stable during breaker tripping and may be inhibited by a logic input.
48/51LR/14	Locked rotor / excessive starting time	Protection of motors against overheating caused by: <ul style="list-style-type: none"> • excessive motor starting time due to overloads (e.g. conveyor) or insufficient supply voltage. The reacceleration of a motor that is not shut down, indicated by a logic input, may be considered as starting. <ul style="list-style-type: none"> • locked rotor due to motor load (e.g. crusher): <ul style="list-style-type: none"> • in normal operation, after a normal start • directly upon starting, before the detection of excessive starting time, with

ANSI No.	Function	Description
		detection of locked rotor by a zero speed detector connected to a logic input, or by the underspeed function.
66	Starts per hour	Protection against motor overheating caused by: <ul style="list-style-type: none"> • too frequent starts: motor energizing is inhibited when the maximum allowable number of starts is reached, after counting of: • starts per hour (or adjustable period) • consecutive motor hot or cold starts (reacceleration of a motor that is not shut down, indicated by a logic input, may be counted as a start) • starts too close together in time: motor re-energizing after a shutdown is only allowed after an adjustable waiting time.
50V/51V	Voltage-restrained overcurrent	Phase-to-phase short-circuit protection, for generators. The current tripping set point is voltage-adjusted in order to be sensitive to faults close to the generator which cause voltage drops and lowers the short-circuit current.
26/63	Thermostat / Buchholz	Protection of transformers against temperature rise and internal faults via logic inputs linked to devices integrated in the transformer.
38/49T	Temperature monitoring	Protection that detects abnormal temperature build-up by measuring the temperature inside equipment fitted with sensors: <ul style="list-style-type: none"> • transformer: protection of primary and secondary windings • motor and generator: protection of stator windings and bearings.
Voltage Protection Functions		
27D	Positive sequence undervoltage	Protection of motors against faulty operation due to insufficient or unbalanced network voltage, and detection of reverse rotation direction.
27R	Remanent undervoltage	Protection used to check that remanent voltage sustained by rotating machines has been cleared before allowing the busbar supplying the machines to be re-energized, to avoid electrical and mechanical transients.
27	Undervoltage	Protection of motors against voltage sags or detection of abnormally low network voltage to trigger automatic load shedding or source transfer. Works with phase-to-phase voltage.
59	Oversvoltage	Detection of abnormally high network voltage or checking for sufficient voltage to enable source transfer. Works with phase-to-phase or phase-to-neutral voltage, each voltage being monitored separately.
59N	Neutral voltage displacement	Detection of insulation faults by measuring residual voltage in isolated neutral systems.
47	Negative sequence overvoltage	Protection against phase unbalance resulting from phase inversion, unbalanced supply or distant fault, detected by the measurement of negative sequence voltage.
Frequency Protection Functions		
81O	Overfrequency	Detection of abnormally high frequency compared to the rated frequency, to monitor power supply quality. Other organizations may use 81H instead of 81O.
81U	Underfrequency	Detection of abnormally low frequency compared to the rated frequency, to monitor power supply quality. The protection may be used for overall tripping or load shedding. Protection stability is ensured in the event of the loss of the main source and presence of remanent voltage by a restraint in the event of a continuous decrease of the frequency, which is activated by parameter setting. Other organizations may use 81L instead of 81U.
81R	Rate of change of frequency	Protection function used for fast disconnection of a generator or load shedding control. Based on the calculation of the frequency variation, it is insensitive to transient voltage disturbances and therefore more stable than a phase-shift protection function.

ANSI No.	Function	Description
		<p>Disconnection In installations with autonomous production means connected to a utility, the “rate of change of frequency” protection function is used to detect loss of the main system in view of opening the incoming circuit breaker to:</p> <ul style="list-style-type: none"> • protect the generators from a reconnection without checking synchronization • avoid supplying loads outside the installation. <p>Load shedding The “rate of change of frequency” protection function is used for load shedding in combination with the underfrequency protection to:</p> <ul style="list-style-type: none"> • either accelerate shedding in the event of a large overload • or inhibit shedding following a sudden drop in frequency due to a problem that should not be solved by shedding.
Dynamic Line Rating (DLR) Protection Functions		
49DLR	Dynamic line rating (DLR)	<p>Protection of overhead lines based on calculation of rating or ampacity to dynamically take into account the effect of prevailing weather conditions as monitored by external sensors for:</p> <ul style="list-style-type: none"> • Ambient Temperature • Wind Velocity • Wind Direction • Solar Radiation

Table 4 - ANSI Descriptions

4. CONCATENATED TERMS

Term
Undercurrent
Overcurrent
Underfrequency
Overfrequency
Undervoltage
Overvoltage

Table 5 - Concatenated Terms

5. UNITS FOR DIGITAL COMMUNICATIONS

Unit	Description
b	bit
B	Byte
kB	Kilobit(s)
kbps	Kilobits per second
kB	Kilobyte(s)
Mb	Megabit(s)
Mbps	Megabits per second
MB	Megabyte(s)
Gb	Gigabit(s)
Gbps	Gigabits per second
GB	Gigabyte(s)
Tb	Terabit(s)
Tbps	Terabits per second
TB	Terabyte(s)

Table 6 - Units for Digital Communications

6. AMERICAN VS BRITISH ENGLISH TERMINOLOGY

British English	American English
...ae...	...e...
...ence	...ense
...ise	...ize
...oe...	...e...
...ogue	...og
...our	...or
...ourite	...orite
...que	...ck
...re	...er
...yse	...yze
Aluminium	Aluminum
Centre	Center
Earth	Ground
Fibre	Fiber
Ground	Earth
Speciality	Specialty

Table 7 - American vs British English terminology

7. LOGIC SYMBOLS AND TERMS

Symbol	Description	Units
&	Logical "AND": Used in logic diagrams to show an AND-gate function.	
Σ	"Sigma": Used to indicate a summation, such as cumulative current interrupted.	
τ	"Tau": Used to indicate a time constant, often associated with thermal characteristics.	
ω	System angular frequency	rad
<	Less than: Used to indicate an "under" threshold, such as undercurrent (current dropout).	
>	Greater than: Used to indicate an "over" threshold, such as overcurrent (current overload)	
o	A small circle on the input or output of a logic gate: Indicates a NOT (invert) function.	
1	Logical "OR": Used in logic diagrams to show an OR-gate function.	
ABC	Clockwise phase rotation.	
ACB	Anti-Clockwise phase rotation.	
C	Capacitance	A
df/dt	Rate of Change of Frequency protection	Hz/s
df/dt>1	First stage of df/dt protection	Hz/s
F<	Underfrequency protection: Could be labeled 81-U in ANSI terminology.	Hz
F>	Overfrequency protection: Could be labeled 81-O in ANSI terminology.	Hz
F<1	First stage of under frequency protection: Could be labeled 81-U in ANSI terminology.	Hz
F>1	First stage of over frequency protection: Could be labeled 81-O in ANSI terminology.	Hz
f _{max}	Maximum required operating frequency	Hz
f _{min}	Minimum required operating frequency	Hz
f _n	Nominal operating frequency	Hz
I	Current	A
I [^]	Current raised to a power: Such as when breaker statistics monitor the square of ruptured current squared (^ power = 2).	An
I ^{'f}	Maximum internal secondary fault current (may also be expressed as a multiple of I _n)	A
I<	An undercurrent element: Responds to current dropout.	A
I>>	Current setting of short circuit element	In
I>	A phase overcurrent protection: Could be labeled 50/51 in ANSI terminology.	A
I>1	First stage of phase overcurrent protection: Could be labeled 51-1 in ANSI terminology.	A
I>2	Second stage of phase overcurrent protection: Could be labeled 51-2 in ANSI terminology.	A
I>3	Third stage of phase overcurrent protection: Could be labeled 51-3 in ANSI terminology.	A
I>4	Fourth stage of phase overcurrent protection: Could be labeled 51-4 in ANSI terminology.	A
I>BB	Minimum pick-up phase threshold for the local trip order confirmation.	A
I>DZ	Minimum pick-up phase threshold for the Dead Zone protection.	A
I ₀	Earth fault current setting Zero sequence current: Equals one third of the measured neutral/residual current.	A
I ₁	Positive sequence current.	A
I ₂	Negative sequence current.	A
I ₂ >	Negative sequence overcurrent protection (NPS element).	A
I _{2pol}	Negative sequence polarizing current.	A

Symbol	Description	Units
I2therm>	A negative sequence thermal element: Could be labeled 46T in ANSI terminology.	A
IA	Phase A current: Might be phase L1, red phase.. or other, in customer terminology.	A
IB	Phase B current: Might be phase L2, yellow phase.. or other, in customer terminology.	A
IbiasPh> Cur.	SDEF blocking bias current threshold.	
IC	Phase C current: Might be phase L3, blue phase.. or other, in customer terminology.	A
ID>1	Minimum pick-up phase circuitry fault threshold.	
ID>2	Minimum pick-up differential phase element for all the zones.	
IDCZ>2	Minimum pick-up differential phase element for the Check Zone.	
Idiff	Current setting of biased differential element	A
IDN>1	Minimum pick-up neutral circuitry fault threshold.	
IDN>2	Minimum pick-up differential neutral element for all the zones.	
IDNCZ>2	Minimum pick-up differential neutral element for the Check Zone.	
IDZ	Minimum pick-up differential neutral element for the Check Zone.	
If	Maximum secondary through-fault current	A
If max	Maximum secondary fault current (same for all feeders)	A
If max int	Maximum secondary contribution from a feeder to an internal fault	A
If Z1	Maximum secondary phase fault current at Zone 1 reach point	A
Ife	Maximum secondary through fault earth current	A
IfeZ1	Maximum secondary earth fault current at Zone 1 reach point	A
Ifn	Maximum prospective secondary earth fault current or $31 \times I >$ setting (whichever is lowest)	A
Ifp	Maximum prospective secondary phase fault current or $31 \times I >$ setting (whichever is lowest)	A
Im	Mutual current	A
IM64	InterMiCOM64.	
IMx	InterMiCOM64 bit (x=1 to 16)	
In	Current transformer nominal secondary current. The rated nominal current of the relay: Software selectable as 1 amp or 5 amp to match the line CT input.	A
IN	Neutral current, or residual current: This results from an internal summation of the three measured phase currents.	A
IN>	A neutral (residual) overcurrent element: Detects earth/ground faults.	A
IN>1	First stage of ground overcurrent protection: Could be labeled 51N-1 in ANSI terminology.	A
IN>2	Second stage of ground overcurrent protection: Could be labeled 51N-2 in ANSI terminology.	A
IN>BB	Minimum pick-up neutral threshold for the local trip order confirmation.	
IN>DZ	Minimum pick-up neutral threshold for the Dead Zone protection.	
Inst	An element with "instantaneous" operation: i.e. having no deliberate time delay.	
I/O	Inputs and Outputs - used in connection with the number of optocoupled inputs and output contacts within the relay.	
I/P	Input	
Iref	Reference current of P63x calculated from the reference power and nominal voltage	A
IREF>	A Restricted Earth Fault overcurrent element: Detects earth (ground) faults. Could be labeled 64 in ANSI terminology.	A

Symbol	Description	Units
IRm2	Second knee-point bias current threshold setting of P63x biased differential element	A
Is	Value of stabilizing current	A
IS1	Differential current pick-up setting of biased differential element	A
IS2	Bias current threshold setting of biased differential element	A
ISEF>	Sensitive Earth Fault overcurrent element.	A
Isn	Rated secondary current (I secondary nominal)	A
Isp	Stage 2 and 3 setting	A
Ist	Motor start up current referred to CT secondary side	A
K	Dimensioning factor	
K1	Lower bias slope setting of biased differential element	%
K2	Higher bias slope setting of biased differential element	%
KCZ	Slope of the differential phase element for the Check Zone.	
Ke	Dimensioning factor for earth fault	
km	Distance in kilometers	
Kmax	Maximum dimensioning factor	
KNCZ	Slope of the differential neutral element for the Check Zone.	
Krpa	Dimensioning factor for reach point accuracy	
Ks	Dimensioning factor dependent upon through fault current	
Kssc	Rated symmetrical short-circuit current factor or ALF	
Kt	Dimensioning factor dependent upon operating time	
kZm	The mutual compensation factor (mutual compensation of distance elements and fault locator for parallel line coupling effects).	
kZN	The residual compensation factor: Ensuring correct reach for ground distance elements.	
L	Inductance A	A
m1	Lower bias slope setting of P63x biased differential element	None
m2	Higher bias slope setting of P63x biased differential element	None
mi	Distance in miles.	
N	Indication of "Neutral" involvement in a fault: i.e. a ground (earth) fault.	
-P>	A reverse power (W) element: could be labeled 32R in ANSI terminology.	
P>	An overpower (W) element: could be labeled 32O in ANSI terminology.	
P<	A low forward power (W) element: could be labeled 32L in ANSI terminology.	
P1	Used in IEC terminology to identify the primary CT terminal polarity: Replace by a dot when using ANSI standards.	
P2	Used in IEC terminology to identify the primary CT terminal polarity: The non-dot terminal.	
Pn	Rotating plant rated single phase power W	W
PN>	Wattmetric earth fault protection: Calculated using residual voltage and current quantities.	
Q<	A reactive under power (VAr) element	
R	Resistance (Ohms)	Ohms
R< or 64S R<	A 100% stator earth (ground) fault via low frequency injection under resistance element: could be labeled 64S in ANSI terminology.	
R Gnd.	A distance zone resistive reach setting: Used for ground (earth) faults.	
R Ph	A distance zone resistive reach setting used for Phase-Phase faults.	

Symbol	Description	Units
Rct	Secondary winding resistance	Ω
RCT	Current transformer secondary resistance	Ohms
RI	Resistance of single lead from relay to current transformer	Ohms
Rr	Resistance of any other protective relays sharing the current transformer	Ohms
Rm	Resistance of relay neutral current input	Ohms
Rrp	Resistance of relay phase current input	Ohms
Rs	Value of stabilizing resistor	Ohms
Rx	Receive: typically used to indicate a communication receive line/pin.	
S<	An apparent under power (VA) element	
S1	Used in IEC terminology to identify the secondary CT terminal polarity: Replace by a dot when using ANSI standards.	
S2	Used in IEC terminology to identify the secondary CT terminal polarity: The non-dot terminal. Also used to signify negative sequence apparent power, $S2 = V2 \times I2$.	
S2>	A negative sequence apparent power element, $S2 = V2 \times I2$.	
t	A time delay.	
t'	Duration of first current flow during auto-reclose cycle	s
T1	Primary system time constant	s
TF	Through Fault monitoring	
tfr	Auto-reclose dead time	s
Thermal I>	A stator thermal overload element: could be labeled 49 in ANSI terminology.	
Thru/TF	Through Fault monitoring	
tldiff	Current differential operating time s	s
Ts	Secondary system time constant s	s
Tx	Transmit: typically used to indicate a communication transmit line/pin.	
V	Voltage	V
V<	An undervoltage element: could be labeled 27 in ANSI terminology	V
V<1	First stage of undervoltage protection: Could be labeled 27-1 in ANSI terminology.	V
V<2	Second stage of undervoltage protection: Could be labeled 27-2 in ANSI terminology.	V
V<3	Third stage of undervoltage protection: Could be labeled 27-3 in ANSI terminology.	V
V>	An overvoltage element: could be labeled 59 in ANSI terminology	V
V>1	First stage of overvoltage protection: Could be labeled 59-1 in ANSI terminology.	V
V>2	Second stage of overvoltage protection: Could be labeled 59-2 in ANSI terminology.	V
V>3	Third stage of overvoltage protection: Could be labeled 59-3 in ANSI terminology.	V
V0	Zero sequence voltage: Equals one third of the measured neutral/residual voltage.	V
V1	Positive sequence voltage.	V
V2	Negative sequence voltage.	V
V2>	A negative phase sequence (NPS) overvoltage element: could be labeled 47 in ANSI terminology.	
V2pol	Negative sequence polarizing voltage.	V
VA	Phase A voltage: Might be phase L1, red phase.. or other, in customer terminology. V	V
VB	Phase B voltage: Might be phase L2, yellow phase.. or other, in customer terminology. V	V
VC	Phase C voltage: Might be phase L3, blue phase.. or other, in customer terminology.	V

Symbol	Description	Units
Vf	Theoretical maximum voltage produced if CT saturation did not occur	V
Vin	Input voltage e.g. to an opto-input	V
Vk	Required CT knee-point voltage. IEC knee point voltage of a current transformer.	V
VN	Neutral voltage displacement, or residual voltage.	V
VN>	A residual (neutral) overvoltage element: could be labeled 59N in ANSI terminology.	V
Vn	Nominal voltage	V
Vn	The rated nominal voltage of the relay: To match the line VT input.	V
VN>1	First stage of residual (neutral) overvoltage protection.	V
VN>2	Second stage of residual (neutral) overvoltage protection.	V
VN>3	Third stage of residual (neutral) overvoltage protection.	V
VN3H>	A 100% stator earth (ground) fault 3rd harmonic residual (neutral) overvoltage element: could be labeled 59TN in ANSI terminology.	
VN3H<	A 100% stator earth (ground) fault 3rd harmonic residual (neutral) undervoltage element: could be labeled 27TN in ANSI terminology.	
Vres.	Neutral voltage displacement, or residual voltage.	V
Vs	Value of stabilizing voltage	V
Vx	An auxiliary supply voltage: Typically the substation battery voltage used to power the relay.	V
WI	Weak Infeed logic used in teleprotection schemes.	
X	Reactance	None
X/R	Primary system reactance/resistance ratio	None
Xe/Re	Primary system reactance/resistance ratio for earth loop	None
Xt	Transformer reactance (per unit)	p.u.
Y	Admittance	p.u.
YN>	Neutral overadmittance protection element: Non-directional neutral admittance protection calculated from neutral current and residual voltage.	
Z	Impedance	p.u.
Z<	An under impedance element: could be labeled 21 in ANSI terminology.	
Z0	Zero sequence impedance.	
Z1	Positive sequence impedance.	
Z1	Zone 1 distance protection.	
Z1X	Reach-stepped Zone 1X, for zone extension schemes used with auto-reclosure.	
Z2	Negative sequence impedance.	
Z2	Zone 2 distance protection.	
ZP	Programmable distance zone that can be set forward or reverse looking.	
Zs	Used to signify the source impedance behind the relay location.	
Φal	Accuracy limit flux	Wb
Ψr	Remanent flux	Wb
Ψs	Saturation flux	Wb

Table 8 - Logic Symbols and Terms

8. LOGIC TIMERS

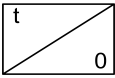
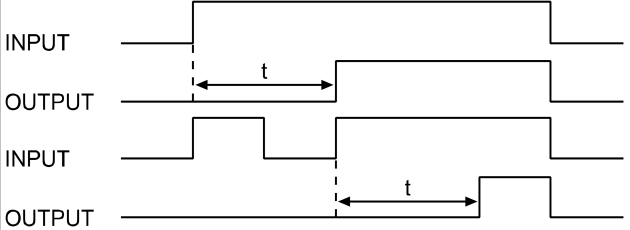
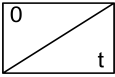
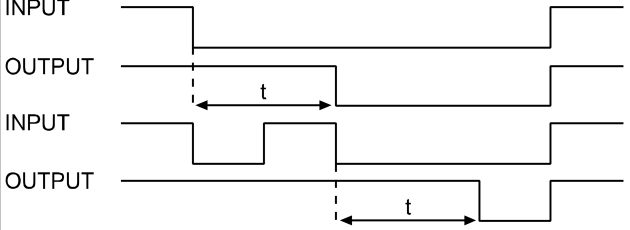
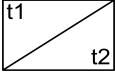
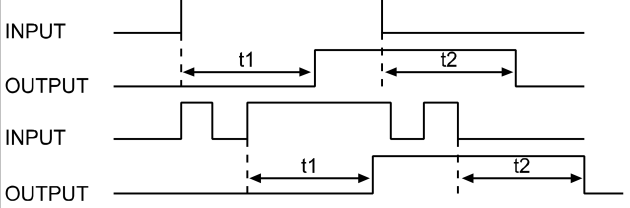
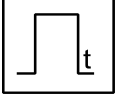
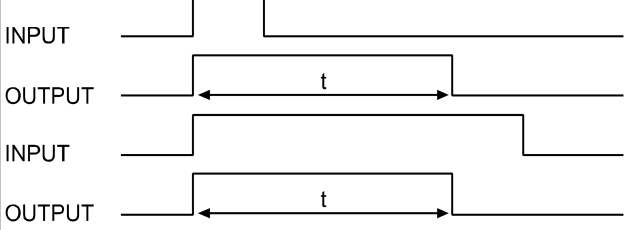
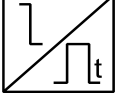
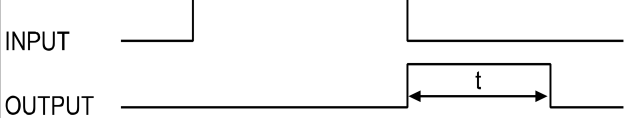
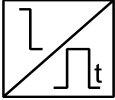
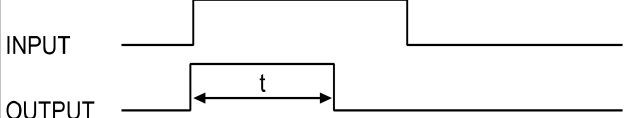
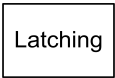
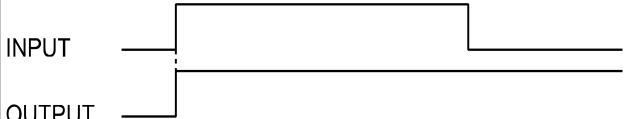
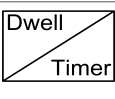
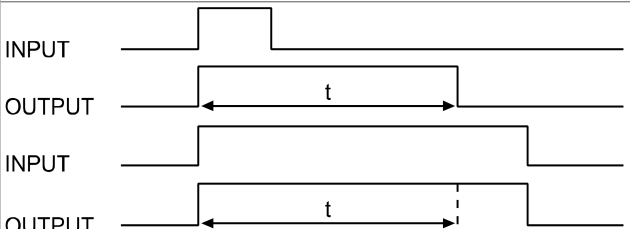
Logic symbols	Explanation	Time Chart
	Delay in pick-up timer, t	
	Delay on drop-off timer, t	
	Delay on pick-up/drop-off timer	
	Pulse timer	
	Pulse pick-up falling edge	
	Pulse pick-up raising edge	
	Latching	
	Dwell timer	



Logic symbols	Explanation	Time Chart
	Straight (non latching): Hold value until input reset signal	

Table 9 - Logic Timers

9. LOGIC GATES

AND GATE																																																											
Symbol	Truth Table	Symbol	Truth Table	Symbol	Truth Table																																																						
	<table border="1" style="margin: auto;"> <thead> <tr><th colspan="2">IN</th><th>OUT</th></tr> <tr><th>A</th><th>B</th><th>Y</th></tr> </thead> <tbody> <tr><td>0</td><td>0</td><td>0</td></tr> <tr><td>0</td><td>1</td><td>0</td></tr> <tr><td>1</td><td>0</td><td>0</td></tr> <tr><td>1</td><td>1</td><td>1</td></tr> </tbody> </table>	IN		OUT	A	B	Y	0	0	0	0	1	0	1	0	0	1	1	1		<table border="1" style="margin: auto;"> <thead> <tr><th colspan="2">IN</th><th>OUT</th></tr> <tr><th>A</th><th>B</th><th>Y</th></tr> </thead> <tbody> <tr><td>0</td><td>0</td><td>0</td></tr> <tr><td>0</td><td>1</td><td>1</td></tr> <tr><td>1</td><td>0</td><td>0</td></tr> <tr><td>1</td><td>1</td><td>0</td></tr> </tbody> </table>	IN		OUT	A	B	Y	0	0	0	0	1	1	1	0	0	1	1	0		<table border="1" style="margin: auto;"> <thead> <tr><th colspan="2">IN</th><th>OUT</th></tr> <tr><th>A</th><th>B</th><th>Y</th></tr> </thead> <tbody> <tr><td>0</td><td>0</td><td>1</td></tr> <tr><td>0</td><td>1</td><td>1</td></tr> <tr><td>1</td><td>0</td><td>1</td></tr> <tr><td>1</td><td>1</td><td>0</td></tr> </tbody> </table>	IN		OUT	A	B	Y	0	0	1	0	1	1	1	0	1	1	1	0
IN		OUT																																																									
A	B	Y																																																									
0	0	0																																																									
0	1	0																																																									
1	0	0																																																									
1	1	1																																																									
IN		OUT																																																									
A	B	Y																																																									
0	0	0																																																									
0	1	1																																																									
1	0	0																																																									
1	1	0																																																									
IN		OUT																																																									
A	B	Y																																																									
0	0	1																																																									
0	1	1																																																									
1	0	1																																																									
1	1	0																																																									

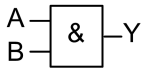
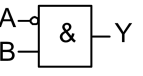
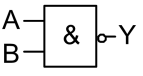

P4424ENb

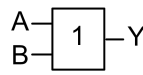
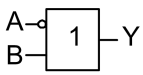
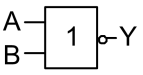
Figure 1 - Logic Gates - AND Gate

OR GATE																																																											
Symbol	Truth Table	Symbol	Truth Table	Symbol	Truth Table																																																						
	<table border="1" style="margin: auto;"> <thead> <tr><th colspan="2">IN</th><th>OUT</th></tr> <tr><th>A</th><th>B</th><th>Y</th></tr> </thead> <tbody> <tr><td>0</td><td>0</td><td>0</td></tr> <tr><td>0</td><td>1</td><td>1</td></tr> <tr><td>1</td><td>0</td><td>1</td></tr> <tr><td>1</td><td>1</td><td>1</td></tr> </tbody> </table>	IN		OUT	A	B	Y	0	0	0	0	1	1	1	0	1	1	1	1		<table border="1" style="margin: auto;"> <thead> <tr><th colspan="2">IN</th><th>OUT</th></tr> <tr><th>A</th><th>B</th><th>Y</th></tr> </thead> <tbody> <tr><td>0</td><td>0</td><td>1</td></tr> <tr><td>0</td><td>1</td><td>1</td></tr> <tr><td>1</td><td>0</td><td>0</td></tr> <tr><td>1</td><td>1</td><td>1</td></tr> </tbody> </table>	IN		OUT	A	B	Y	0	0	1	0	1	1	1	0	0	1	1	1		<table border="1" style="margin: auto;"> <thead> <tr><th colspan="2">IN</th><th>OUT</th></tr> <tr><th>A</th><th>B</th><th>Y</th></tr> </thead> <tbody> <tr><td>0</td><td>0</td><td>1</td></tr> <tr><td>0</td><td>1</td><td>0</td></tr> <tr><td>1</td><td>0</td><td>0</td></tr> <tr><td>1</td><td>1</td><td>0</td></tr> </tbody> </table>	IN		OUT	A	B	Y	0	0	1	0	1	0	1	0	0	1	1	0
IN		OUT																																																									
A	B	Y																																																									
0	0	0																																																									
0	1	1																																																									
1	0	1																																																									
1	1	1																																																									
IN		OUT																																																									
A	B	Y																																																									
0	0	1																																																									
0	1	1																																																									
1	0	0																																																									
1	1	1																																																									
IN		OUT																																																									
A	B	Y																																																									
0	0	1																																																									
0	1	0																																																									
1	0	0																																																									
1	1	0																																																									

P4424ENc

Figure 2 - Logic Gates - OR Gate

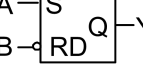
R – S FLIP-FLOP																																																																																																									
Symbol	Truth Table	Symbol	Truth Table	Symbol	Truth Table																																																																																																				
	<table border="1" style="margin: auto;"> <thead> <tr><th>A</th><th>B</th><th>QN</th><th>QN+</th><th>Active Mode</th></tr> </thead> <tbody> <tr><td>0</td><td>0</td><td></td><td></td><td>Hold Mode</td></tr> <tr><td>0</td><td>1</td><td>0</td><td></td><td>Hold Mode</td></tr> <tr><td></td><td>1</td><td>0</td><td>Reset</td><td>Reset</td></tr> <tr><td></td><td>0</td><td>1</td><td>Set</td><td>Set</td></tr> <tr><td>1</td><td>0</td><td>1</td><td></td><td>Hold Mode</td></tr> <tr><td>0</td><td>0</td><td>-</td><td>-</td><td>Inhibit Mode</td></tr> </tbody> </table>	A	B	QN	QN+	Active Mode	0	0			Hold Mode	0	1	0		Hold Mode		1	0	Reset	Reset		0	1	Set	Set	1	0	1		Hold Mode	0	0	-	-	Inhibit Mode		<table border="1" style="margin: auto;"> <thead> <tr><th>A</th><th>B</th><th>QN</th><th>QN+</th><th>Active Mode</th></tr> </thead> <tbody> <tr><td>0</td><td>0</td><td>0</td><td></td><td>Hold Mode</td></tr> <tr><td></td><td>1</td><td>0</td><td>Reset</td><td>Reset</td></tr> <tr><td>0</td><td>1</td><td></td><td></td><td>Hold Mode</td></tr> <tr><td>1</td><td>0</td><td>-</td><td>-</td><td>Inhibit Mode</td></tr> <tr><td></td><td>0</td><td>1</td><td>Set</td><td>Set</td></tr> <tr><td>0</td><td>1</td><td>1</td><td></td><td>Hold Mode</td></tr> </tbody> </table>	A	B	QN	QN+	Active Mode	0	0	0		Hold Mode		1	0	Reset	Reset	0	1			Hold Mode	1	0	-	-	Inhibit Mode		0	1	Set	Set	0	1	1		Hold Mode		<table border="1" style="margin: auto;"> <thead> <tr><th>A</th><th>B</th><th>QN</th><th>QN+</th><th>Active Mode</th></tr> </thead> <tbody> <tr><td>0</td><td>0</td><td></td><td></td><td>Hold Mode</td></tr> <tr><td>0</td><td>1</td><td></td><td></td><td>0</td></tr> <tr><td></td><td>0</td><td>1</td><td>Set</td><td>Set</td></tr> <tr><td>1</td><td>0</td><td>1</td><td></td><td>Hold Mode</td></tr> <tr><td>1</td><td>1</td><td></td><td></td><td>0</td></tr> </tbody> </table> <p style="font-size: small;">* RD = Reset Dominant</p>	A	B	QN	QN+	Active Mode	0	0			Hold Mode	0	1			0		0	1	Set	Set	1	0	1		Hold Mode	1	1			0
A	B	QN	QN+	Active Mode																																																																																																					
0	0			Hold Mode																																																																																																					
0	1	0		Hold Mode																																																																																																					
	1	0	Reset	Reset																																																																																																					
	0	1	Set	Set																																																																																																					
1	0	1		Hold Mode																																																																																																					
0	0	-	-	Inhibit Mode																																																																																																					
A	B	QN	QN+	Active Mode																																																																																																					
0	0	0		Hold Mode																																																																																																					
	1	0	Reset	Reset																																																																																																					
0	1			Hold Mode																																																																																																					
1	0	-	-	Inhibit Mode																																																																																																					
	0	1	Set	Set																																																																																																					
0	1	1		Hold Mode																																																																																																					
A	B	QN	QN+	Active Mode																																																																																																					
0	0			Hold Mode																																																																																																					
0	1			0																																																																																																					
	0	1	Set	Set																																																																																																					
1	0	1		Hold Mode																																																																																																					
1	1			0																																																																																																					

P4424ENd

Figure 3 - Logic Gates - R-S Flip-Flop Gate

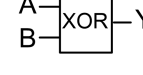
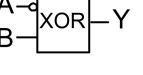
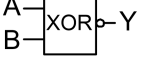
EXCLUSIVE OR GATE																																																											
Symbol	Truth Table	Symbol	Truth Table	Symbol	Truth Table																																																						
	<table border="1" style="margin: auto;"> <thead> <tr><th colspan="2">IN</th><th>OUT</th></tr> <tr><th>A</th><th>B</th><th>Y</th></tr> </thead> <tbody> <tr><td>0</td><td>0</td><td>0</td></tr> <tr><td>0</td><td>1</td><td>1</td></tr> <tr><td>1</td><td>0</td><td>1</td></tr> <tr><td>1</td><td>1</td><td>0</td></tr> </tbody> </table>	IN		OUT	A	B	Y	0	0	0	0	1	1	1	0	1	1	1	0		<table border="1" style="margin: auto;"> <thead> <tr><th colspan="2">IN</th><th>OUT</th></tr> <tr><th>A</th><th>B</th><th>Y</th></tr> </thead> <tbody> <tr><td>0</td><td>0</td><td>1</td></tr> <tr><td>0</td><td>1</td><td>1</td></tr> <tr><td>1</td><td>0</td><td>0</td></tr> <tr><td>1</td><td>1</td><td>1</td></tr> </tbody> </table>	IN		OUT	A	B	Y	0	0	1	0	1	1	1	0	0	1	1	1		<table border="1" style="margin: auto;"> <thead> <tr><th colspan="2">IN</th><th>OUT</th></tr> <tr><th>A</th><th>B</th><th>Y</th></tr> </thead> <tbody> <tr><td>0</td><td>0</td><td>1</td></tr> <tr><td>0</td><td>1</td><td>0</td></tr> <tr><td>1</td><td>0</td><td>0</td></tr> <tr><td>1</td><td>1</td><td>1</td></tr> </tbody> </table>	IN		OUT	A	B	Y	0	0	1	0	1	0	1	0	0	1	1	1
IN		OUT																																																									
A	B	Y																																																									
0	0	0																																																									
0	1	1																																																									
1	0	1																																																									
1	1	0																																																									
IN		OUT																																																									
A	B	Y																																																									
0	0	1																																																									
0	1	1																																																									
1	0	0																																																									
1	1	1																																																									
IN		OUT																																																									
A	B	Y																																																									
0	0	1																																																									
0	1	0																																																									
1	0	0																																																									
1	1	1																																																									

P4424ENe

Figure 4 - Logic Gates - Exclusive OR Gate

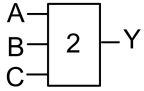
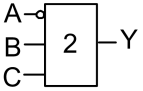
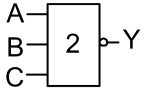
PROGRAMMABLE GATE																																																																																																																													
Symbol	Truth Table	Symbol	Truth Table	Symbol	Truth Table																																																																																																																								
	<table border="1" style="margin: auto;"> <thead> <tr> <th colspan="3">IN</th> <th>OUT</th> </tr> <tr> <th>A</th> <th>B</th> <th>C</th> <th>Y</th> </tr> </thead> <tbody> <tr><td>0</td><td>0</td><td>0</td><td>0</td></tr> <tr><td>0</td><td>0</td><td>1</td><td>0</td></tr> <tr><td>0</td><td>1</td><td>0</td><td>0</td></tr> <tr><td>0</td><td>1</td><td>1</td><td>1</td></tr> <tr><td>1</td><td>0</td><td>0</td><td>0</td></tr> <tr><td>1</td><td>0</td><td>1</td><td>1</td></tr> <tr><td>1</td><td>1</td><td>0</td><td>1</td></tr> <tr><td>1</td><td>1</td><td>1</td><td>1</td></tr> </tbody> </table>	IN			OUT	A	B	C	Y	0	0	0	0	0	0	1	0	0	1	0	0	0	1	1	1	1	0	0	0	1	0	1	1	1	1	0	1	1	1	1	1		<table border="1" style="margin: auto;"> <thead> <tr> <th colspan="3">IN</th> <th>OUT</th> </tr> <tr> <th>A</th> <th>B</th> <th>C</th> <th>Y</th> </tr> </thead> <tbody> <tr><td>0</td><td>0</td><td>0</td><td>0</td></tr> <tr><td>0</td><td>0</td><td>1</td><td>1</td></tr> <tr><td>0</td><td>1</td><td>0</td><td>1</td></tr> <tr><td>0</td><td>1</td><td>1</td><td>1</td></tr> <tr><td>1</td><td>0</td><td>0</td><td>0</td></tr> <tr><td>1</td><td>0</td><td>1</td><td>0</td></tr> <tr><td>1</td><td>1</td><td>0</td><td>0</td></tr> <tr><td>1</td><td>1</td><td>1</td><td>1</td></tr> </tbody> </table>	IN			OUT	A	B	C	Y	0	0	0	0	0	0	1	1	0	1	0	1	0	1	1	1	1	0	0	0	1	0	1	0	1	1	0	0	1	1	1	1		<table border="1" style="margin: auto;"> <thead> <tr> <th colspan="3">IN</th> <th>OUT</th> </tr> <tr> <th>A</th> <th>B</th> <th>C</th> <th>Y</th> </tr> </thead> <tbody> <tr><td>0</td><td>0</td><td>0</td><td>1</td></tr> <tr><td>0</td><td>0</td><td>1</td><td>1</td></tr> <tr><td>0</td><td>1</td><td>0</td><td>1</td></tr> <tr><td>0</td><td>1</td><td>1</td><td>0</td></tr> <tr><td>1</td><td>0</td><td>0</td><td>1</td></tr> <tr><td>1</td><td>0</td><td>1</td><td>0</td></tr> <tr><td>1</td><td>1</td><td>0</td><td>0</td></tr> <tr><td>1</td><td>1</td><td>1</td><td>0</td></tr> </tbody> </table>	IN			OUT	A	B	C	Y	0	0	0	1	0	0	1	1	0	1	0	1	0	1	1	0	1	0	0	1	1	0	1	0	1	1	0	0	1	1	1	0
IN			OUT																																																																																																																										
A	B	C	Y																																																																																																																										
0	0	0	0																																																																																																																										
0	0	1	0																																																																																																																										
0	1	0	0																																																																																																																										
0	1	1	1																																																																																																																										
1	0	0	0																																																																																																																										
1	0	1	1																																																																																																																										
1	1	0	1																																																																																																																										
1	1	1	1																																																																																																																										
IN			OUT																																																																																																																										
A	B	C	Y																																																																																																																										
0	0	0	0																																																																																																																										
0	0	1	1																																																																																																																										
0	1	0	1																																																																																																																										
0	1	1	1																																																																																																																										
1	0	0	0																																																																																																																										
1	0	1	0																																																																																																																										
1	1	0	0																																																																																																																										
1	1	1	1																																																																																																																										
IN			OUT																																																																																																																										
A	B	C	Y																																																																																																																										
0	0	0	1																																																																																																																										
0	0	1	1																																																																																																																										
0	1	0	1																																																																																																																										
0	1	1	0																																																																																																																										
1	0	0	1																																																																																																																										
1	0	1	0																																																																																																																										
1	1	0	0																																																																																																																										
1	1	1	0																																																																																																																										

P4424ENf

Figure 5 - Logic Gates - Programmable Gate

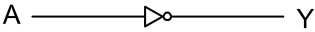
NOT GATE									
Symbol	Truth Table								
 <p>Inverter (NOT)</p>	<table border="1" style="margin: auto;"> <thead> <tr> <th>IN</th> <th>OUT</th> </tr> <tr> <th>A</th> <th>Y</th> </tr> </thead> <tbody> <tr><td>0</td><td>1</td></tr> <tr><td>1</td><td>0</td></tr> </tbody> </table>	IN	OUT	A	Y	0	1	1	0
IN	OUT								
A	Y								
0	1								
1	0								

P4424ENg

Figure 6 - Logic Gates - NOT Gate



Customer Care Centre

<http://www.se.com/cc>

Schneider Electric

35 rue Joseph Monier
92506 Rueil-Malmaison
FRANCE

Phone: +33 (0) 1 41 29 70 00
Fax: +33 (0) 1 41 29 71 00

www.se.com

Publisher: Schneider Electric

Publication:

Easergy MiCOM P54x/EN M/Yn5 Current Differential Protection Relay Software Version: K6 Hardware Suffix: M 02/2024