

Easergy MiCOM P445

Fast Multifunction Distance Protection Relay

P445/EN M/Og2

Software Version	K6
Hardware Suffix	L
Date	02/2024

Technical Manual

Note The technical manual for this device gives instructions for its installation, commissioning, and operation. However, the manual cannot cover all conceivable circumstances or include detailed information on all topics. In the event of questions or specific problems, do not take any action without proper authorization. Contact the appropriate Schneider Electric technical sales office and request the necessary information.

Any agreements, commitments, and legal relationships and any obligations on the part of Schneider Electric including settlements of warranties, result solely from the applicable purchase contract, which is not affected by the contents of the technical manual.

This device **MUST NOT** be modified. If any modification is made without the express permission of Schneider Electric, it will invalidate the warranty, and may render the product unsafe.

Easergy MiCOM and the Schneider Electric logo and any alternative version thereof are trademarks and service marks of Schneider Electric.

All trade names or trademarks mentioned herein whether registered or not, are the property of their owners.

This manual is provided for informational use only and is subject to change without notice.

© 2024, Schneider Electric. All rights reserved.

CONTENTS

Chapter	Description	Document ID
SI	Safety Information	Px4x/EN SI/R14
Chapter 1	Introduction	P445/EN IT/Og2
Chapter 2	Technical Data	P445/EN TD/Og2
Chapter 3	Getting Started	P445/EN GS/Og2
Chapter 4	Settings	P445/EN ST/Og2
Chapter 5	Operation	P445/EN OP/Og2
Chapter 6	Application Notes	P445/EN AP/Og2
Chapter 7	Using the PSL Editor	Px4x/EN SE/I22
Chapter 8	Programmable Logic	P445/EN PL/Og2
Chapter 9	Measurements and Recording	P445/EN MR/Og2
Chapter 10	Product Design	Px4x/EN PD/C24
Chapter 11	Commissioning	P445/EN CM/Og2
Chapter 12	Test and Setting Records	P445/EN RC/Og2
Chapter 13	Maintenance	Px4x/EN MT/H53
Chapter 14	Troubleshooting	Px4x/EN TS/If9
Chapter 15	SCADA Communications	Px4x/EN SC/Og2
Chapter 16	Installation	Px4x/EN IN/A05
Chapter 17	Connection Diagrams	P445/EN CD/Og2
Chapter 18	Cyber Security	Px4x/EN CS/F34
Chapter 19	Dual Redundant Ethernet Board	Px4x/EN REB/K56
Chapter 20	Parallel Redundancy Protocol (PRP) Notes	Px4x/EN PR/F34
Chapter 21	High-availability Seamless Redundancy (HSR)	Px4x/EN HS/C33
Chapter 22	Rapid Spanning Tree Protocol (RSTP) Notes	Px4x/EN TP/B23
Chapter 23	Firmware and Service Manual Version History	P445/EN VH/Og2
SG	Symbols and Glossary	Px4x/EN SG/E51

Date:	11/2022
Products covered by this chapter:	This chapter covers the specific versions of the MiCOM products listed below. This includes only the following combinations of Software Version and Hardware Suffix.
Hardware Suffix:	L
Software Version:	K6
Connection Diagrams:	10P445xx (xx = 01 to 04)

SAFETY INFORMATION

Chapter Applicability	
Date:	02/2024
Products covered by this chapter:	
This chapter covers the specific versions of the Easergy MiCOM products listed below. This includes only the following combinations of Software Version and Hardware Suffix.	
Hardware Suffix:	All PowerLogic P1, Easergy MiCOM P10, P20, P30, P40, P90 and C264 products
Software Version:	All PowerLogic P1, Easergy MiCOM P10, P20, P30, P40, P90 and C264 products
Connection Diagrams:	This chapter may use any of these connection diagrams:
P14x (P141, P142, P143 & P145):	10P141xx (xx = 01 to 02) 10P142xx (xx = 01 to 05) 10P143xx (xx = 01 to 11) 10P145xx (xx = 01 to 11)
P24x (P241, P242 & P243):	10P241xx (xx = 01 to 02) 10P242xx (xx = 01) 10P243xx (xx = 01)
P445:	10P445xx (xx = 01 to 04)
P34x (P342, P343, P344, P345 & P391):	10P342xx (xx = 01 to 17) 10P343xx (xx = 01 to 19) 10P344xx (xx = 01 to 12) 10P345xx (xx = 01 to 07) 10P391xx (xx = 01 to 02)
P44x (P442 & P444):	10P44101 (SH 1 & 2) 10P44201 (SH 1 & 2) 10P44202 (SH 1) 10P44203 (SH 1 & 2) 10P44401 (SH 1) 10P44402 (SH 1) 10P44403 (SH 1 & 2) 10P44404 (SH 1) 10P44405 (SH 1) 10P44407 (SH 1 & 2)
P44y (P443 & P446):	10P44303 (SH 01 and 03) 10P44304 (SH 01 and 03) 10P44305 (SH 01 and 03) 10P44306 (SH 01 and 03) 10P44600 10P44601 (SH 1 to 2) 10P44602 (SH 1 to 2) 10P44603 (SH 1 to 2)
P54x (P543, P544, P545 & P546):	10P54302 (SH 1 to 2) 10P54303 (SH 1 to 2) 10P54400 10P54404 (SH 1 to 2) 10P54405 (SH 1 to 2) 10P54502 (SH 1 to 2) 10P54503 (SH 1 to 2) 10P54600 10P54604 (SH 1 to 2)

	10P54605 (SH 1 to 2) 10P54606 (SH 1 to 2)
P547:	10P54702xx (xx = 01 to 02) 10P54703xx (xx = 01 to 02) 10P54704xx (xx = 01 to 02) 10P54705xx (xx = 01 to 02)
P64x (P642, P643 & P645):	10P642xx (xx = 1 to 10) 10P643xx (xx = 1 to 6) 10P645xx (xx = 1 to 9)
P74x (P741, P742 & P743):	10P740xx (xx = 01 to 07)
P746:	10P746xx (xx = 00 to 21)
P841:	10P84100 10P84101 (SH 1 to 2) 10P84102 (SH 1 to 2) 10P84103 (SH 1 to 2) 10P84104 (SH 1 to 2) 10P84105 (SH 1 to 2)
P849:	10P849xx (xx = 01 to 06)

Notes:

CONTENTS

	Page-
1. Safety Information	7
2. Introduction	8
3. Health and Safety	9
4. Symbols and Labels on the Equipment	11
4.1 Symbols.....	11
4.2 Labels.....	11
5. Installing, Commissioning and Servicing	12
5.1 Risk of Electric Shock using RJ45 Cables.....	15
6. De-Commissioning and Disposal	17
7. Equipment which includes Electromechanical Elements	18
8. Technical Specifications for Safety	19
8.1 Protective Fuse Rating.....	19
8.2 Protective Class.....	19
8.3 Installation Category.....	19
8.4 Environment.....	19
8.5 Humidity During Storage.....	19
9. Technical Specification for Functional Safety	21
9.1 Technical Specification for Functional Safety.....	21
9.2 General Conditions or Restrictions for use in SIL Applications.....	21
9.3 Proof Testing.....	21
9.4 Functional Safety Parameters.....	21
9.5 Random Hardware Failures (h-1).....	22
9.6 Parameters Common to All Products in Scope.....	23
9.7 Maintaining Systemic Safety Integrity.....	23
9.8 Safety Function End of Life.....	24
9.9 Fault Reporting.....	24
10. Compliance Marking for Applicable European Directives and UK Regulations	25
11. Requirements for the USA and Canada	27
11.1 Recognized and Listed Marks for North America.....	27
11.2 Information for MiCOM Relays Complying with USA & Canadian.....	27

Requirements	
11.2.1 Typical Equipment Marking.....	27
11.2.2 Rack and Panel Mounted Equipment.....	27
11.2.3 Operating Temperature.....	27
11.2.4 External Branch Circuit Protection.....	27
11.2.5 Wire Terminations (Field Wiring) - Power and Signal Circuits.....	27
11.2.6 M4 Terminal Screw Torque.....	28
11.2.7 Output Relay Ratings.....	28
11.2.8 Output Relay Contact Symbols.....	28

12. Typical Labels	29
12.1 Typical Compliance Label	29

1. SAFETY INFORMATION

Important Information

Read these instructions carefully and look at the equipment to become familiar with the device before trying to install, operate, service, or maintain it. The following special messages may appear throughout this documentation or on the equipment to warn of potential hazards or to call attention to information that clarifies or simplifies a procedure.



The addition of this symbol to a Danger or Warning safety label indicates that an electrical hazard exists, which will result in death or serious injury if the instructions are not followed.



This is the safety alert symbol. It is used to alert you to potential personal injury hazards. Obey all safety messages that follow this symbol to avoid possible injury or death.

DANGER

DANGER indicates a hazardous situation which, if not avoided, **will result in** death or serious injury.

WARNING

WARNING indicates a hazardous situation which, if not avoided, **could result in** death or serious injury.

CAUTION

CAUTION indicates a hazardous situation which, if not avoided, **could result in** minor or moderate injury.

NOTICE

NOTICE is used to address practices not related to physical injury.

Please Note

Electrical equipment should be installed, operated, serviced, and maintained only by qualified personnel. No responsibility is assumed by Schneider Electric for any consequences arising out of the use of this material.

A qualified person is one who has skills and knowledge related to the construction, installation, and operation of electrical equipment and has received safety training to recognize and avoid the hazards involved.

2. INTRODUCTION

This document and the relevant equipment documentation provide full information on safe handling, installation, testing, commissioning and operation of this equipment. This document also includes reference to typical equipment label markings.

Documentation for equipment ordered from Schneider Electric is dispatched separately from manufactured goods and may not be received at the same time as the equipment. Therefore this guide is provided to ensure that printed information which may be present on the equipment is fully understood by the recipient.

The technical data in this document provides typical information and advice, which covers a variety of different products. You must also refer to the Technical Data section of the relevant product publication(s) as this includes additional information which is specific to particular equipment.

DANGER

HAZARD OF ELECTRIC SHOCK, EXPLOSION, OR ARC FLASH

- Only qualified personnel, trained, authorized and familiar with the contents of the latest issue of the Safety Guide, Safety Information, Technical Data chapters and the equipment rating label(s) shall work on installation, connection, commissioning, maintenance or servicing of the equipment.

Failure to follow these instructions will result in death or serious injury.

You also need to make reference to the external connection diagram(s) before the equipment is installed, commissioned or serviced.

Language-specific, self-adhesive User Interface labels are provided in a bag for some equipment.

3. HEALTH AND SAFETY

The information in this part of the equipment documentation is intended to ensure that equipment is properly installed and handled in order to maintain it in a safe condition.

People

Receipt, Handling, Storage and Unpacking Relays

Although relays are of a robust construction, we recommend that you become familiar with the Installation chapter, as this describes important issues associated with receiving, handling, storage and unpacking relays.

Planning

Live and Stored Voltages

When electrical equipment is in operation, dangerous voltages will be present in certain parts of the equipment. Even if electrical power is no longer being supplied, some items of equipment may retain enough electrical energy inside them to pose a potentially serious risk of electrocution or damage to other equipment.

NOTICE

HAZARD OF EQUIPMENT DAMAGE

- Remember that placing equipment in a “test” position does not normally isolate it from the power supply or discharge any stored electrical energy.

Failure to follow these instructions could result in equipment damage.

Warnings and Barricades

Everyone must observe all warning notices. This is because the incorrect use of equipment, or improper use may endanger personnel and equipment and also cause personal injury or physical damage.

Unauthorized entry should also be prevented with suitably marked fixed barricades which will notify people of any dangers and screen off work areas.

People should not enter electrical equipment cubicles or cable troughs until it has been confirmed that all equipment/cables have been isolated and de-energised.

Electrical Isolation

Before working in the terminal strip area, all equipment which has the potential to provide damaging or unsafe levels of electrical energy must be isolated. You will need to isolate and de-energize the specific item of equipment which is being worked on.

Depending on the location, you may also need to isolate and de-energize other items which are electrically connected to it as well as those which are close enough to pose a risk of electrocution in the event of accidental physical or electrical contact.

Remember too that, where necessary, both load and line sides should be de-energized.

Before you make contact with any equipment use an approved voltage detection device to reduce the risk of electric shock.

Risk of Accidental Contact or Arc Flash

Be aware of the risk of accidental contact with hands, long hair, tools or other equipment; and be aware of the possibility of the increased risk of arc flash from areas of high voltage.

Always wear appropriate shock and arc flash personal protective equipment while isolating and de-energizing electrical equipment and until a de-energized state is confirmed.

Temporary Protection

Consider the use of temporary protective Earthing Clamps. This is required to establish and maintain de-energization when electrical equipment operates at greater than 1000 volts or there is potential for back-feed at any voltage.

Temporary protective earthing can be accomplished by installing cables designed for that purpose or by the use of intrinsic earthing clamp equipment. Temporary protective earthing clamp equipment must be able to carry maximum fault current available and have an impedance low enough to cause the applicable protective device to operate.

Restoring Power

To reduce the risks, the work plan should have a check list of things which must be completed and checks made before electrical power can be restored.

Be aware of the risk that electrical systems may have power restored to them at a remote location (possibly by the customer or a utility company). You should consider the use of lockouts so that the electrical system can be restored only when you unlock it. In any event, you should be aware of and be part of the process which determines when electrical power can be restored; and that people working on the system have control over when power is restored.

Inspect and test the electrical equipment to ensure it has been restored to a “safe” condition prior re-energizing. Replace all devices, doors and covers before turning on the power to any device.

Qualified Personnel

Proper and safe operation of the equipment depends on appropriate shipping and handling, proper storage, installation and commissioning, and on careful operation, maintenance and servicing. For this reason only qualified personnel may work on or operate the equipment.

Qualified personnel are individuals who:

- Are familiar with the installation, commissioning, and operation of the equipment and of the system to which it is being connected
- Are able to safely perform switching operations in accordance with accepted safety engineering practices and are authorized to energize and de-energize equipment and to isolate, ground, and label it
- Are trained in the care and use of safety apparatus in accordance with safety engineering practices
- Are trained in emergency procedures (first aid)

Documentation

The equipment documentation gives instructions for its installation, commissioning, and operation. However, the manuals cannot cover all conceivable circumstances or include detailed information on all topics. In the event of questions or specific problems, do not take any action without proper authorization. Contact the appropriate Schneider Electric technical sales office and request the necessary information.

4. SYMBOLS AND LABELS ON THE EQUIPMENT

For safety reasons the following symbols and external labels, which may be used on the equipment or referred to in the equipment documentation, should be understood before the equipment is installed or commissioned.

4.1 Symbols



Caution

Refer to equipment documentation



Caution

Risk of electric shock



Protective Conductor (*Earth) terminal



Functional/Protective Conductor (*Earth) terminal

Note

This symbol may also be used for a Protective Conductor (Earth) Terminal if that terminal is part of a terminal block or sub-assembly e.g. power supply.



HAZARD OF INJURY OR EQUIPMENT DAMAGE

- The term "Earth" used throughout this technical manual is the direct equivalent of the North American term "Ground".

Failure to follow these instructions could result in injury or equipment damage.

4.2 Labels

See the Typical Labels section for equipment labelling information.

5. INSTALLING, COMMISSIONING AND SERVICING



Manual Handling

Plan carefully, identify any possible hazards and determine whether the load needs to be moved at all. Look at other ways of moving the load to avoid manual handling. Use the correct lifting techniques and Personal Protective Equipment to reduce the risk of injury.

Many injuries are caused by:

- Lifting heavy objects
- Lifting things incorrectly
- Pushing or pulling heavy objects
- Using the same muscles repetitively

Follow European directives 89/654 EU, 89/655 EU, 89/656 EU, 90/269 EU and 90/270 EU for safety and health at work (EU-OSHA), the Health and Safety at Work, etc Act 1974, and the Management of Health and Safety at Work Regulations 1999.



Equipment Connections

Personnel undertaking installation, commissioning or servicing work for this equipment should be aware of the correct working procedures to ensure safety.

The equipment documentation should be consulted before installing, commissioning, or servicing the equipment.

Terminals exposed during installation, commissioning and maintenance may present a hazardous voltage unless the equipment is electrically isolated.

The clamping screws of all terminal block connectors, for field wiring, using M4 screws shall be tightened to a nominal torque of 1.3 Nm.

Equipment intended for rack or panel mounting is for use on a flat surface of a Type 1 enclosure, as defined by Underwriters Laboratories (UL).

Any disassembly of the equipment may expose parts at hazardous voltage, also electronic parts may be damaged if suitable ElectroStatic voltage Discharge (ESD) precautions are not taken.

If there is unlocked access to the rear of the equipment, care should be taken by all personnel to avoid electric shock or energy hazards.

CAUTION

HAZARD OF INJURY OR EQUIPMENT DAMAGE

- Voltage and current connections shall be made using insulated crimp terminations to ensure that terminal block insulation requirements are maintained for safety.

Failure to follow these instructions could result in injury or equipment damage.

Watchdog (self-monitoring) contacts are provided in numerical relays to indicate the health of the device. Schneider Electric strongly recommends that these contacts are hardwired into the substation's automation system, for alarm purposes.

To ensure that wires are correctly terminated the correct crimp terminal and tool for the wire size should be used.

This equipment must be connected in accordance with the appropriate connection diagram.



Protection Class I Equipment

- Before energizing the equipment it must be earthed using the protective conductor terminal, if provided, or the appropriate termination of the supply plug in the case of plug connected equipment.

- The protective conductor (earth) connection must not be removed since the protection against electric shock provided by the equipment would be lost.
- When the protective (earth) conductor terminal (PCT) is also used to terminate cable screens, etc., it is essential that the integrity of the protective (earth) conductor is checked after the addition or removal of such functional earth connections. For M4 stud PCTs the integrity of the protective (earth) connections should be ensured by use of a locknut or similar.

The recommended minimum protective conductor (earth) wire size is 2.5 mm² (AWG 14) (3.3 mm² (AWG 12) for North America) unless otherwise stated in the technical data section of the equipment documentation, or otherwise required by local or country wiring regulations.

The protective conductor (earth) connection must be low-inductance and as short as possible.

All connections to the equipment must have a defined potential. Connections that are pre-wired, but not used, should preferably be grounded when binary inputs and output relays are isolated. When binary inputs and output relays are connected to common potential, the pre-wired but unused connections should be connected to the common potential of the grouped connections.



Pre-Energization Checklist

Before energizing the equipment, the following should be checked:

- Voltage rating/polarity (rating label/equipment documentation)
- Current Transformer (CT) circuit rating (rating label) and integrity of connections
- Protective fuse rating
- Integrity of the protective conductor (earth) connection (where applicable)
- Voltage and current rating of external wiring, applicable to the application



Accidental Touching of Exposed Terminals

If working in an area of restricted space, such as a cubicle, where there is a risk of electric shock due to accidental touching of terminals which do not comply with IP20 rating, then a suitable protective barrier should be provided.



Equipment Use

If the equipment is used in a manner not specified by the manufacturer, the protection provided by the equipment may be impaired.



Removal of the Equipment Front Panel/Cover

Removal of the equipment front panel/cover may expose hazardous live parts, which must not be touched until the electrical power is removed.



UL and CSA/CUL Listed or Recognized Equipment

To maintain UL and CSA/CUL Listing/Recognized status for North America the equipment should be installed using UL or CSA Listed or Recognized parts for the following items: connection cables, protective fuses/fuseholders or circuit breakers, insulation crimp terminals and replacement internal battery, as specified in the equipment documentation.

For external protective fuses a UL or CSA Listed fuse shall be used. The Listed type shall be a Class J time delay fuse, with a maximum current rating of 15 A and a minimum DC rating of 250 V DC, for example type AJT15.

Where UL or CSA Listing of the equipment is not required, a high rupture capacity (HRC) fuse type with a maximum current rating of 16 A and a minimum DC rating of 250 V DC may be used, for example Red Spot type NIT or TIA.



Equipment Operating Conditions

The equipment should be operated within the specified electrical and environmental limits. This includes humidity as well as temperature limits.

**Current Transformer (CT) Circuits**

Do not open the secondary circuit of a live CT since the high voltage produced may be lethal to personnel and could damage insulation. Generally, for safety, the secondary of the line CT must be shorted before opening any connections to it.

For most equipment with ring-terminal connections, the threaded terminal block for current transformer termination has automatic CT shorting on removal of the module. Therefore external shorting of the CTs may not be required, the equipment documentation should be checked to see if this applies.

For equipment with pin-terminal connections, the threaded terminal block for current transformer termination does NOT have automatic CT shorting on removal of the module.

**External Resistors, including Voltage Dependent Resistors (VDRs)**

Where external resistors, including Voltage Dependent Resistors (VDRs), are fitted to the equipment, these may present a risk of electric shock or burns, if touched.

**Battery Replacement**

Where internal batteries are fitted they should be replaced with the recommended type and be installed with the correct polarity to avoid possible damage to the equipment, buildings and persons.

**Insulation and Dielectric Strength Testing**

Insulation testing may leave capacitors charged up to a hazardous voltage. At the end of each part of the test, the voltage should be gradually reduced to zero, to discharge capacitors, before the test leads are disconnected.

**Insertion of Modules and PCB Cards**

Modules and PCB cards must not be inserted into or withdrawn from the equipment whilst it is energized, since this may result in damage.

**Insertion and Withdrawal of Extender Cards**

Extender cards are available for some equipment. If an extender card is used, this should not be inserted or withdrawn from the equipment whilst it is energized. This is to avoid possible shock or damage hazards. Hazardous live voltages may be accessible on the extender card.

**External Test Blocks and Test Plugs**

Great care should be taken when using external test blocks and test plugs such as the Easergy Test Block, Easergy Test Plug and MiCOM P99x types, as hazardous voltages may be accessible when using these. CT shorting links must be in place before the insertion or removal of Easergy test plugs, to avoid potentially lethal voltages.

NOTICE**HAZARD OF EQUIPMENT DAMAGE**

- When a MiCOM P992 Test Plug is inserted into the MiCOM P991 Test Block, the secondaries of the line CTs are automatically shorted.

Failure to follow these instructions could result in equipment damage.

**Fiber Optic Communication**

Where fiber optic communication devices are fitted, these use laser light. These laser-light sources should not be viewed directly, as they can cause permanent damage to eyesight. Optical power meters should be used to determine the operation or signal level of the device.



RJ45 Cable – Electric Shock Risk / Maximum Cable Length

Do not use an RJ45 cable which is longer than 10 m (32.8 ft).

This is because the ground potential may be different for the equipment at each end of the RJ45 cable. If someone was touching a conductive part of the sleeve at the other end of the cable, they could be electrocuted (which could result in death or serious injury). It is recommended that you use optical fiber cables instead of RJ45.



Product Configuration

After any modifications or download of any of the configuration files, it is the user's duty to define the list of tests to be performed before putting the relay back in service. These tests should be comprehensive enough to ensure the application of the product will not result in any unexpected behavior.

The tests to be performed will be dependent on the nature of the changes but could range from:

- A simple file comparison between application-specific settings applied to the relay and the original written application-specific setting record.

to

- Commissioning tests of the complete protection relay and functions.



Cleaning

The equipment may be cleaned using a lint free cloth dampened with clean water, when no connections are energized. Contact fingers of test plugs are normally protected by petroleum jelly, which should not be removed.

5.1 Risk of Electric Shock using RJ45 Cables

This diagram shows how a MiCOM P40 protection relay could be connected to a Stand Alone Merging Unit (SAMU), using either an optical or an RJ45 cable. When connecting devices using RJ45 wired network cables, precautions for cabling must be taken to avoid any risk of electrical shock.

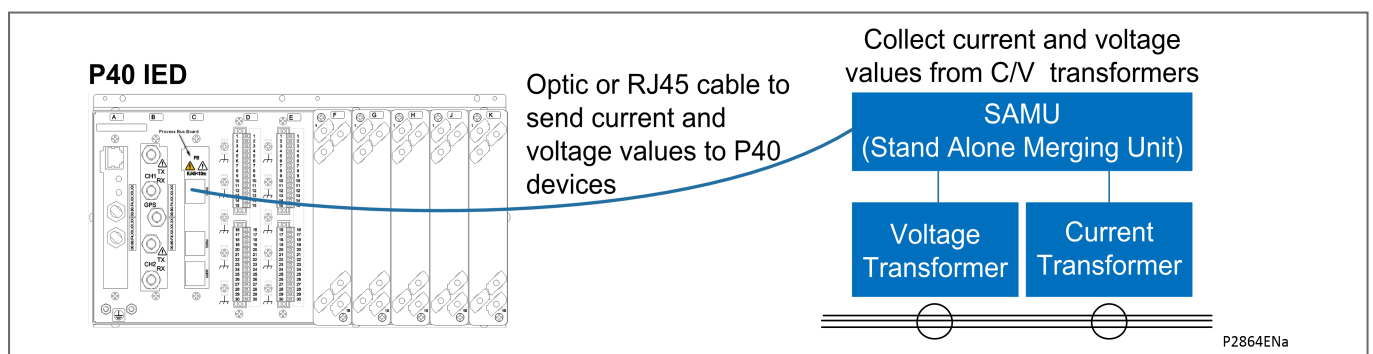

Figure 1 - Connecting a MiCOM P40 device to a SAMU

The risk arises due to the widely separated equipment having a different earth potential; and/or faults being propagated on the RJ45 cable. This diagram shows the possible risk:

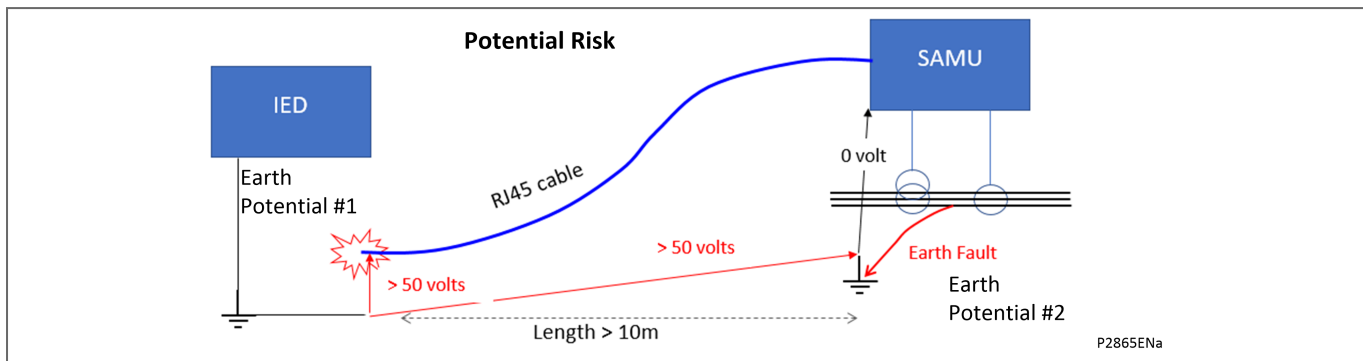

Figure 2 - RJ45 connection electric shock risk

The connection between the device and the SAMU is done using a RJ45 cable. An electric shock could occur if:

- A fault occurs on SAMU/Voltage Transformer/Current Transformer side
- There is an earth potential difference between the two locations
- An RJ45 cable is used instead of an optical cable, so that the earth potential difference and/or the fault is propagated along the RJ45 cable
- The distance from the MiCOM P40 protection relay (or a switch) to the SAMU is greater than 10 m (32.8 ft), so that there is a risk of electrical shock for someone who comes into electrical contact with the other end of the RJ45 cable (when it is disconnected from MiCOM P40 protection relay)

The latest advice for connecting a Low Power Instrument Transformer (LPIT) or a Stand Alone Merging Unit (SAMU) to an protection relay/switch is, if the distance from the protection relay/switch is:

- greater than 10 m: you must only use a fiber optic cable
- less than 10 m: you can use fiber optic or RJ45 cable

When a connection to a LPIT or SAMU is made with the RJ45 cable, this RJ45 cable must not be longer than 10 m (32.8 ft).

The reason is that, during a ground fault, the ground potential of the LPIT or the SAMU rises and is transmitted by the RJ45 cable. If someone was touching the conductive sleeve at the other end of the cable, they could be electrocuted or seriously injured.

⚡ ⚠ DANGER

HAZARD OF ELECTRIC SHOCK, EXPLOSION, OR ARC FLASH

- Do not connect items of equipment with different earth potentials with an RJ45 cable.
- Do not use RJ45 cable longer than 10 m (32.8 ft).

Failure to follow these instructions will result in death or serious injury.

6. DE-COMMISSIONING AND DISPOSAL



De-Commissioning

The supply input (auxiliary) for the equipment may include capacitors across the supply or to earth. To avoid electric shock or energy hazards, after completely isolating the supplies to the equipment (both poles of any DC supply), the capacitors should be safely discharged via the external terminals prior to de-commissioning.



Disposal

It is recommended that incineration and disposal to water courses is avoided. The equipment should be disposed of in a safe manner. Any equipment containing batteries should have them removed before disposal, taking precautions to avoid short circuits. Particular regulations within the country of operation, may apply to the disposal of the equipment.

7. EQUIPMENT WHICH INCLUDES ELECTROMECHANICAL ELEMENTS



Electrical Adjustments

It is possible to change current or voltage settings on some equipment by direct physical adjustment e.g. adjustment of a plug-bridge setting. The electrical power should be removed before making any change, to avoid the risk of electric shock.



Exposure of Live Parts

Removal of the cover may expose hazardous live parts such as relay contacts, these should not be touched before removing the electrical power.

8. TECHNICAL SPECIFICATIONS FOR SAFETY

Unless otherwise stated in the equipment technical manual, the following data is applicable.

8.1 Protective Fuse Rating

The recommended maximum rating of the external protective fuse for equipments is 16A, High Rupture Capacity (HRC) Red Spot type NIT, or TIA, or equivalent. Unless otherwise stated in equipment technical manual, the following data is applicable. The protective fuse should be located as close to the unit as possible.

 **DANGER**

HAZARD OF ELECTRIC SHOCK, EXPLOSION, OR ARC FLASH

- CTs must NOT be fused since open circuiting them may produce lethal hazardous voltages.

Failure to follow these instructions will result in death or serious injury.

8.2 Protective Class

IEC 60255-27: 2013 EN 60255-27: 2014 BS EN 60255-27: 2014	Class I (unless otherwise specified in the equipment documentation). This equipment requires a protective conductor (earth) connection to ensure user safety.
---	---

8.3 Installation Category

IEC 60255-27: 2013 EN 60255-27: 2014 BS EN 60255-27: 2014	Installation Category III (Overvoltage Category III) Distribution level, fixed installation.
---	---

Equipment in this category is qualification tested at 5 kV peak, 1.2/50 μ s, 500 Ω , 0.5 J, between all supply circuits and earth and also between independent circuits.

8.4 Environment

The equipment is intended for indoor installation and use only. If it is required for use in an outdoor environment then it must be mounted in a specific cabinet or housing which will enable it to meet the requirements of IEC 60529 with the classification of degree of protection IP54 (dust and splashing water protected).

Pollution Degree	Pollution Degree 2 Compliance is demonstrated by reference to safety standards.
------------------	---

Altitude	Operation up to 2000 m (6561 ft)
----------	----------------------------------

IEC 60255-27: 2013 EN 60255-27: 2014 BS EN 60255-27: 2014

8.5 Humidity During Storage

Sustained exposure to high humidity during storage may cause damage to electronics and reduce the lifetime of the equipment.

We recommend that storage humidity shall not exceed 50% relative humidity.

Once the MiCOM products have been unpacked, we recommend that they are energized within the three following months.

Where electrical equipment is being installed, sufficient time should be allowed for acclimatization to the ambient temperature of the environment, before energization.

9. TECHNICAL SPECIFICATION FOR FUNCTIONAL SAFETY

9.1 Technical Specification for Functional Safety

The following information is applicable when the MiCOM P130C, P132, P139, P141, P142, P143, P144, P145, P241, P242, P243, P341, P342, P343, P344 and P345 is used as an element in an automated safety function that is specified to achieve a Safety Integrity Level (SIL).

The reliability of the MiCOM P130C, P132, P139, P14x, P24x, P34x has been analysed in accordance with IEC 61508 for use in SIL applications.

The information in this Safety Guide is intended to support the safety system integration phase in accordance with IEC 61508 (and to be available to those performing the system 'lifecycle phases' that follow) to enable the safety function(s) achieve the specified SIL. The information only applies to the specified products; the actual SIL achieved will depend on many system considerations that are outside the scope of this safety manual.

9.2 General Conditions or Restrictions for use in SIL Applications

1. Safety functions are intended to be automated. Any non-specified manual interaction that could interfere with the safety function during operation should be protected from inadvertent use.
2. The MiCOM P130C, P132, P139, P14x, P24x, P34x are not to be used in environments beyond claimed specification.
3. The instructions contained in this Safety Guide (or referred to in associated user documentation) should be strictly complied with to provide the correct level of systematic safety integrity.
4. Failure modes of the MiCOM P130C, P132, P139, P14x, P24x, P34x that are classified as 'dangerous detected' (quantified by the value λ_{DD}) shall result in a safe action with respect to the hazard(s) being controlled or be repaired within the time assumed in the PFD calculations.

9.3 Proof Testing

The MiCOM P130C, P132, P139, P14x, P24x, P34x shall be periodically proof tested, preferably in the installation, by a qualified person familiar with the operation of the device, to verify all aspects of the functional specification required for the application when it is used in 'low demand' safety functions. Low demand is defined in IEC 61508-4 as a demand to act less frequently than once a year.

A suitable proof test interval (T_i) should be used to achieve the required average probability of failure on demand (PFD_{AVG}). A nominal interval of 8,760 hrs (1 year) and Mean Time To Repair (MTTR) of 8 hours has been used in the calculations for PFD_{AVG} illustration purposes.

9.4 Functional Safety Parameters

The MiCOM P130C, P132, P139, P14x, P24x, P34x have been assessed by CML B.V. (Notified Body number 2776) and by CMLEx (approved body number 2503) and found to comply with the functional safety requirements of IEC 61508-2:2010 clause 7.4.4.1.3 (Route 2H) and 7.4.10 (Route 2S / 'proven in use') for use in SIL 1 safety functions. This was done in accordance with the article 1(b) of ATEX Directive 2014/34/EU and with the Article 3 (b) part I of the UK regulation SI 2016 No. 1107 (as amended by UKSI 2019:696) for an intended use outside potentially explosive atmospheres. These are required for, or contributing to, the safe functioning of equipment and protective systems with respect to the risks of explosion, when used in accordance with the user documentation and subject to special conditions for safe

use specified in Section 14 of EU Type Examination Certificate CML 18ATEX3008X and in the Section 14 of UK Type Examination Certificate CML 21UKEX31194X.

Feeder management and Bay Control relays:	P130C, P132, P139	All versions since 2011
Feeder management relays:	P141, P142, P143, P144, P145	All versions since 2011
Motor protection relays:	P241, P242, P243 All versions since 2011	All versions since 2011
Generator protection relays:	P341, P342, P343, P344, P345	All versions since 2011

Element safety function (common to all relays):	To monitor the current supplied to electrical equipment in a hazardous area and isolate the equipment if a fault condition occurs that may lead to an ignition source.
--	--

Product specification:	Refer to Technical Manual for each product type.
-------------------------------	--

Random hardware failures:	The assessment confirms the following quantitative reliability data (failure rates in h^{-1})
----------------------------------	--

9.5 Random Hardware Failures (h^{-1})

Product [Note 1]	Dangerous failure rate λ_D [Note 2]	Diagnostic coverage [Note 3]	Dangerous Undetected failure rate λ_{DU}	Dangerous Detected failure rate λ_{DD}	PFD _{AVG} [Note 4]	PFD _{AVG} [Note 5]	ATEX	SIL1
P130C	$7.87 E^{-07}$	60%	$3.15 E^{-07}$	$4.72 E^{-07}$	$4.00 E^{-03}$	$6.48 E^{-03}$	Yes	Yes
P132	$6.67 E^{-07}$	60%	$2.67 E^{-07}$	$4.00 E^{-07}$	$3.39 E^{-03}$	$5.50 E^{-03}$	Yes	Yes
P139	$1.18 E^{-06}$	60%	$4.74 E^{-07}$	$7.10 E^{-07}$	$6.02 E^{-03}$	$9.75 E^{-03}$	Yes	Yes
P14x	$4.28 E^{-07}$	60%	$1.71 E^{-07}$	$2.57 E^{-07}$	$2.18 E^{-03}$	$3.53 E^{-03}$	Yes	Yes
P24x	$4.82 E^{-07}$	60%	$1.93 E^{-07}$	$2.89 E^{-07}$	$2.45 E^{-03}$	$3.97 E^{-03}$	Yes	Yes
P34x	$5.31 E^{-07}$	60%	$2.12 E^{-07}$	$3.18 E^{-07}$	$2.70 E^{-03}$	$4.37 E^{-03}$	Yes	Yes

Note 1
Refer to full list of products ('Product Identification' above) in scope where "x" appears

Note 2
Worst case assumptions have been used to classify a "dangerous failure"

Note 3
Diagnostic coverage is conservatively estimated by analysis of the design

Note 4
Calculated assuming proof test interval 8,760 hours and MTTR 8 hours

Note 5
Calculated assuming proof test interval 8,760 hours and MTTR 8 hours and proof test coverage factor of 90%, mission time 20 years

9.6 Parameters Common to All Products in Scope

Safe failure fraction (SFF):	Not assessed. The SFF parameter is not required for the 'Route 2H' compliance option in IEC 61508-2
Diagnostic coverage (DC):	60% (proportion of dangerous failures in the product that are self-diagnosed)
Type classification (A/B):	'Type B' in accordance with IEC 61508-2, 7.4.4.1.3 (contains some complex components whose fault behavior cannot be completely determined)
Architectural constraints:	SIL 1 in accordance with the Route 2H method with a hardware fault tolerance (HFT) = 0
Systematic capability:	SC 1 which limits an application that uses this product to no higher than SIL 1
Demand mode:	Safety function applications are expected to be low demand (greater than 1 year between demands)
Restrictions, conditions and general information:	<ul style="list-style-type: none"> Refer to information in this Safety Guide and the relevant product Technical Manual for all conditions, restrictions in use, installation, maintenance, test and all other functional safety related information. It is the responsibility of the system designer, installer and end user to ensure a specified safety integrity level (SIL) is achieved by reference to the data in this document and adhering to all the conditions and restrictions herein. Use of this data to ensure safety functions meet a specified SIL should only be made by persons who are competent in the functional safety activities they are performing. Cyclic diagnostic test intervals assume the process safety time is 50ms (although in some cases trip time can increase due to intentional time delays within the protection function). The watchdog relay is energized during normal operation and is de-energized with its contacts closed (for monitoring by the SCADA system) in the event of a fault.
Restrictions when using the MiCOM P30 and P40 in hazardous area applications:	<ul style="list-style-type: none"> No use shall be made of binary inputs to ensure the safety function is not interfered with. No reliance of data from communication interfaces shall be made to perform the safety function. Tripping of the circuit breaker shall be made directly using an output contact from the protection relay. (As contact allocation is configurable it is possible to assign multiple contacts to this tripping function to mitigate risk of contact failure as the external contact operation is not directly able to be monitored). Unauthorized access to the device configuration shall be prevented through the use of physical protection and/or password control. Protection functions using data from thermal or other sensors are not considered as safety functions. (RTD or CLIO inputs).

9.7 Maintaining Systemic Safety Integrity

The systematic safety integrity of MiCOM products listed in this section meet the requirements of SIL1 when the products are installed, used and maintained in accordance with the product and safety manuals.

To maintain functional safety and systematic safety integrity a suitable proof testing interval; 8,760 operational hours has been used for calculation, should be used. In view of the critical nature of protective and control equipment, and their infrequent operation, it is desirable to confirm that the equipment is operating correctly at regular interval periods following installation. Although MiCOM relays are self-supervising and therefore require less maintenance than earlier designs, periodic checks are necessary to ensure the equipment is functioning correctly and to ensure external wiring to the equipment remains intact. It is

particularly important to check the equipment for alarms, the functionality of opto-isolated inputs and relay outputs and measurement accuracy to prove the product calibration is maintained.

The product specific commissioning and maintenance guides should be followed to confirm that equipment is operating within specification. The maintenance results should be assessed against the original commissioning results (or previous maintenance results), any deviation outside tolerance should result in appropriate corrective action being taken.

Equipment repair or replacement should follow the recommendation of the maintenance chapter found in the specific product manual.

9.8 Safety Function End of Life

When a product has reached the end of its useful service life, a mission time of 20 years has been used for the purposes of calculation, the product must be disposed according to the legislation of the local country. MiCOM products are in the scope of European Union Directive 2012/19/EU on Waste Electrical and Electronic Equipment (WEEE) Regulations 2013. For Product End of Life Instructions, the documentation found on the Schneider Electric web site should be followed.

9.9 Fault Reporting

Any goods returned to Schneider Electric will require an RMA number which can be initiated by contacting a Technical Support Representative or the local country Sales Representative.

If a fault has been determined with a product the following details are required by Technical Support

- Contact name, email address and phone number
- Company name
- Serial number of unit(s)
- Model number of unit(s)
- Brief description of the problem(s)
- Invoice address
- Shipping address (if it is not the same as above)

A form with the assigned RMA number, along with details of the problem will be emailed to the contact email provided. All information on the form should be verified, the form should be included with the product(s) being returned. The RMA number must be marked on the outside of the box.

Schneider Electric warranty does not cover failures due to incorrect installation, misuse, abnormal operating conditions or lack of routine maintenance.

10. COMPLIANCE MARKING FOR APPLICABLE EUROPEAN DIRECTIVES AND UK REGULATIONS

The following European directives may be applicable to the equipment, if so it will carry the relevant marking(s) shown below:



For the Low Voltage Directive (LVD) 2014/35/EU, the following product specific harmonized standard was used to establish product safety compliance:

EN 60255-27:2014

For the Electromagnetic Compatibility Directive (EMCD) 2014/30/EU, the following product specific harmonized standard was used to establish the EMC compliance:

EN 60255-26:2013

For the restriction of the use of certain hazardous substances in electrical and electronic equipment (ROHS) Directive 2015/863/EU, the following harmonized standard was used to establish ROHS compliance:

EN IEC 63000:2018

The compliance is demonstrated via Technical Files, with reference to product safety and EMC standards.

Where applicable:

Equipment and protective systems intended for use in potentially explosive atmospheres European directive 2014/34/EU and UK regulations SI 2016 No. 1107 (as amended by SI 2019:696)

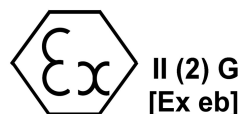

The equipment is compliant with Article 1(b) of ATEX Directive 2014/34/EU and with Article 3 (b) part I of the UK regulation SI 2016 No. 1107, amended by SI 2019 No. 696. It is approved for use outside potentially explosive atmospheres. It is required for the safe operation of 'Increased Safety - Ex eb' protected electrical machines, when used in accordance with the user documentation and subject to special conditions for safe use specified in Section 14 of EU Type Examination Certificate CML 18ATEX3008X and in the Section 14 of UK Type Examination Certificate CML 21UKEX31194X.

The following UK regulations may be applicable to the equipment, if so it will carry the relevant marking(s) shown below:



For the electrical equipment (safety) regulations SI 2016 No. 1101, the following product specific designated standards were used to establish product safety compliance:

BS EN 60255-27:2014

For the Electromagnetic Compatibility regulations SI 2016 No. 1091, the following product specific designated standard was used to establish the EMC compliance:

BS EN 60255-26:2013

For the restriction of the use of certain hazardous substances in electrical and electronic equipment (ROHS) regulations, SI 2012 No. 3032, the following standard was used to establish ROHS compliance:

BS EN IEC 63000:2018



HAZARD OF INJURY OR EQUIPMENT DAMAGE

- Equipment with this marking is not itself suitable for operation within a potentially explosive atmosphere.

Failure to follow these instructions could result in injury or equipment damage.

Compliance demonstrated through the following documents:

- EN 50495:2010 / BS EN 50495:2010
- EN 60079-7:2015 / BS EN 60079-7:2015+A1:2018
- EN 60079-14:2003 / BS EN 60079-14:2014
- EN ISO/IEC 80079-34:2018 / BS EN ISO/IEC 80079-34:2020
- EU Type Examination Certificate CML 18ATEX3008X
- UK Type Examination Certificate CML 21UKEX31194X

Equipment and Protective Systems Intended for Use in Potentially Explosive Atmospheres Classification:

Group II - equipment intended for use in potentially explosive atmospheres, except in mines.

(2) - Category 2 equipment intended for use in areas in which potentially explosive atmospheres are likely to occur. The number shown in brackets means that the equipment is approved for use outside potentially explosive atmospheres but are required for or contributing to the safe functioning of equipment and protective systems with respect to the risks of explosion.

G - equipment contributing to the safe functioning of equipment and protective systems with respect to the risks of explosion in gas zones 1 and 2.

[Ex eb] – Increased Safety electrical machines - additional measures are applied and employed so as to give increased security against the possibility of excessive temperatures and of the occurrence of arcs and sparks in normal service or under specified abnormal conditions.

For more information regarding CE documentation, please contact:



Schneider Electric Industries SAS

35 rue Joseph Monier
92500 Rueil-Malmaison
FRANCE

For more information regarding UKCA documentation, please contact:



Schneider Electric Limited

Stafford Park 5
Telford, TF3 3BL
UNITED KINGDOM

11. REQUIREMENTS FOR THE USA AND CANADA

11.1 Recognized and Listed Marks for North America

CSA	Canadian Standards Association
UL	Underwriters Laboratory of America

If applicable, the following marks will be present on the equipment:

	UL Recognized to UL (USA) requirements
	UL Recognized to UL (USA) and CSA (Canada) requirements
	UL Listed to UL (USA) requirements
	UL Listed to UL (USA) and CSA (Canada) requirements
	Certified to CSA (Canada) requirements

11.2 Information for MiCOM Relays Complying with USA & Canadian Requirements

11.2.1 Typical Equipment Marking

	Listed by UL for compliance with USA and Canadian requirements. UL = Underwriters Laboratories Inc.
---	--

11.2.2 Rack and Panel Mounted Equipment

The MiCOM protection relay ranges are intended for use on a flat surface of a Type 1 enclosure, as defined by Underwriters Laboratories Inc. (UL).

11.2.3 Operating Temperature

The maximum rated continuous operating temperature, in surrounding air, of the equipment is 55 °C (131 °F).

Pollution Degree – Pollution Degree 2

11.2.4 External Branch Circuit Protection

For external protective fuses a UL or CSA Listed or Recognized fuse and fuseholder shall be used. The fuse type shall be a Class J time delay fuse, with a maximum current rating of 15 A and a minimum rating of 250 V DC and 250 V AC, for example type AJT15.

Where UL or CSA Listing of the equipment is not required, a high rupture capacity (HRC) fuse type with a maximum current rating of 16 A and a minimum DC rating of 250 V DC and 250 V AC may be used, for example Red Spot type NIT or TIA.

11.2.5 Wire Terminations (Field Wiring) - Power and Signal Circuits

Equipment wire terminations for power circuits shall be made using UL/CSA Listed wire and suitable insulated pressure/crimp terminals or terminal kits only.

These shall have a minimum temperature rating of 75 °C (167 °F).

The minimum wire size used shall be:

Relay Protective Ground/Earth Conductor:	AWG 12 (3.3 mm ²) for North America, AWG 14 (2.5 mm ²) elsewhere
Current Transformers (CTs):	AWG 12 (3.3 mm ²) for North America, AWG 14 (2.5 mm ²) elsewhere
Auxiliary Supply, Vx:	AWG 16 (1.5 mm ²)
EIA (RS) 485 Port (See Note 1):	AWG 22 (0.25 mm ²)
Low voltage signal circuits (e.g. RTD) (See Note 2)	AWG 22 (0.25 mm ²) using screw clamp connectors
Other Circuits (See Note 3):	AWG 18 (1.0 mm ²)

Note 1
Pressure/crimp push-on or ring or pin terminals may be used for communication circuit connections.

Note 2
Low voltage signal circuits using screw clamp connectors, wire may be clamped directly or terminated in a pressure/crimp pin terminal and clamped.

Note 3
Only insulated pressure/crimp ring terminals shall be used for connections to other circuits.

11.2.6 M4 Terminal Screw Torque

The terminal screws of all connector blocks, for field wiring, using M4 screws shall be tightened to a nominal torque of 1.3 Nm.

11.2.7 Output Relay Ratings

MiCOM Px4x relays:

Standard output relay (Make and carry):	5 A, 250 Vac
High Break - Make 30 A, carry 30 A for 0.2 s, 250Vac/Vdc, 15 s cycle as per ANSI C37.90 including break 30 A.	Continuous 10A, 250 Vac.

11.2.8 Output Relay Contact Symbols

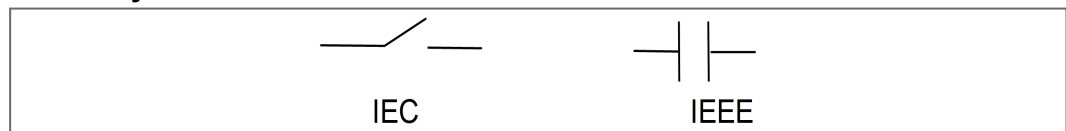

12. TYPICAL LABELS

12.1 Typical Compliance Label

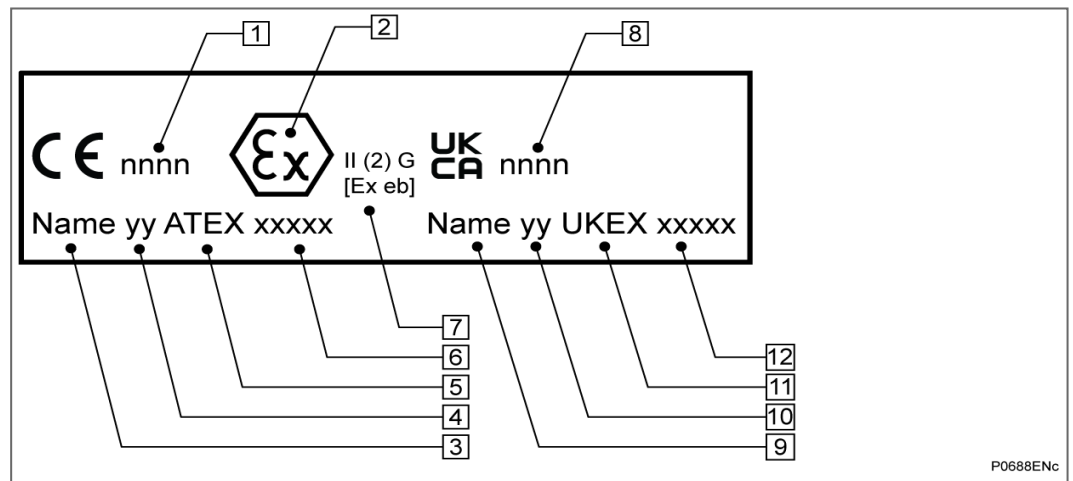

- [1] nnnn - identifying number of the Notified Body which demonstrated manufacturing Quality Assurance compliance to EN 80079-34:2018, e.g. 0891.
- [2] Ex logo - signifies compliance with the European directive 2014/34/EU and with the UK regulation SI 2016 No. 1107, amended by SI 2019 No. 696.
- [3] Name - Notified Body which carried out the EU Type Examination of the equipment design and construction, e.g. CML.
- [4] yy - year certificate issued e.g. 18 for 2018.
- [5] Compliance with European ATEX directive 2014/34/EU.
- [6] xxxxx - approval number given by the Notified Body for the Type Examination of the equipment, e.g. 3008X.
- [7] The equipment is compliant with Article 1(b) of ATEX Directive 2014/34/EU and with Article 3 (b) part I of the UK regulation SI 2016 No. 1107, amended by SI 2019 No. 696. It is approved for use outside potentially explosive atmospheres. It is required for the safe operation of 'Increased Safety - Ex eb' protected electrical machines, when used in accordance with the user documentation and subject to special conditions for safe use specified in Section 14 of EU Type Examination Certificate CML 18ATEX3008X and in the Section 14 of UK Type Examination Certificate CML 21UKEX31194X.
- [8] nnnn - identifying number of the Approval Body which demonstrated manufacturing Quality Assurance compliance to BS EN ISO/IEC 80079-34:2018, e.g. 0891.
- [9] Name - Approval Body which carried out the UK Type Examination of the equipment design and construction, e.g. CML.
- [10] yy - year certificate issued for compliance with UK regulation SI 2016 No. 1107, e.g. 21 for 2021.
- [11] Compliance with UK regulation SI 2016 No. 1107.
- [12] xxxxx - approval number given by the Approval Body for the UK Type Examination of the equipment, e.g. 31194X.

Notes:

INTRODUCTION

CHAPTER 1

Date:	11/2022
Products covered by this chapter:	This chapter covers the specific versions of the MiCOM products listed below. This includes only the following combinations of Software Version and Hardware Suffix.
Hardware Suffix:	L
Software Version:	K6
Connection Diagrams:	10P445xx (xx = 01 to 04)

CONTENTS

		Page (IT) 1-
1	Documentation Structure	5
2	Introduction to MiCOM	7
3	Product Scope	8
3.1	Functional Overview	8
3.2	Application Overview	10
4	Ordering Options	11
4.1	P445 Order Options	12

FIGURES

		Page (IT) 1-
	Figure 1 - Functional diagram	10

TABLES

		Page (IT) 1-
	Table 1 - Functional overview	9

Notes:

1 DOCUMENTATION STRUCTURE

This manual provides a functional and technical description of this MiCOM device, and gives a comprehensive set of instructions for its use and application. A summary of the different chapters of this manual is given here:

	Description	Chapter Code
SI	Safety Information A guide to the safe handling, commissioning and testing of equipment. This provides typical information and advice which covers a range of MiCOM Px4x products. It explains how to work with equipment safely.	Px4x/EN SI
1	Introduction A guide to the MiCOM range of relays and the documentation structure. General safety aspects of handling Electronic Equipment are discussed with particular reference to relay safety symbols. Also a general functional overview of the relay and brief application summary is given.	P445/EN IT
2	Technical Data Technical data including setting ranges, accuracy limits, recommended operating conditions, ratings and performance data. Compliance with norms and international standards is quoted where appropriate.	P445/EN TD
3	Getting Started A guide to the different user interfaces of the IED describing how to start using it. This chapter provides detailed information regarding the communication interfaces of the IED, including a detailed description of how to access the settings database stored within the IED.	P445/EN GS
4	Settings List of all relay settings, including ranges, step sizes and defaults, together with a brief explanation of each setting.	P445/EN ST
5	Operation A comprehensive and detailed functional description of all protection and non-protection functions.	P445/EN OP
6	Application Notes This section includes a description of common power system applications of the relay, calculation of suitable settings, some typical worked examples, and how to apply the settings to the relay.	P445/EN AP
7	Using the PSL Editor This provides a short introduction to using the PSL Editor application.	Px4x/EN SE
8	Programmable Logic Overview of the Programmable Scheme Logic (PSL) and a description of each logical node. This chapter includes the factory default and an explanation of typical applications.	P445/EN PL
9	Measurements and Recording Detailed description of the relays recording and measurements functions including the configuration of the event and disturbance recorder and measurement functions.	P445/EN MR
10	Product Design Overview of the operation of the relay's hardware and software. This chapter includes information on the self-checking features and diagnostics of the relay.	P540d/EN PD
11	Commissioning Instructions on how to commission the relay, comprising checks on the calibration and functionality of the relay.	P445/EN CM
12	Test and Setting Records This is a list of the tests made and the settings stored on the MiCOM IED.	P445/EN RC
13	Maintenance A general maintenance policy for the relay is outlined.	Px4x/EN MT

	Description	Chapter Code
14	Troubleshooting Advice on how to recognize failure modes and the recommended course of action. Includes guidance on whom within Schneider Electric to contact for advice.	Px4x/EN TS
15	SCADA Communications This chapter provides an overview regarding the SCADA communication interfaces of the relay. Detailed protocol mappings, semantics, profiles and interoperability tables are not provided within this manual. Separate documents are available per protocol, available for download from our website.	P540d/EN SC
16	Installation Recommendations on unpacking, handling, inspection and storage of the relay. A guide to the mechanical and electrical installation of the relay is provided, incorporating earthing recommendations.	Px4x/EN IN
17	Connection Diagrams A list of connection diagrams, which show the relevant wiring details for this relay.	P445/EN CD
18	Cyber Security An overview of cyber security protection (to secure communication and equipment within a substation environment). Relevant cyber security standards and implementation are described too.	Px4x/EN CS
19	Dual Redundant Ethernet Board Information about how MiCOM products can be equipped with Dual Redundant Ethernet Boards (DREBs) and the different protocols which are available. Also covers how to configure and commission these types of boards.	Px4x/EN REB
20	Parallel Redundancy Protocol (PRP) Notes Includes an introduction to Parallel Redundancy Protocols (PRP) and the different networks PRP can be used with. Also includes details of PRP and MiCOM functions.	Px4x/EN PR
21	High-availability Seamless Redundancy (HSR) Introduction to the High-availability Seamless Redundancy (HSR); and how it is implemented on MiCOM-based products manufactured by Schneider Electric.	Px4x/EN HS
22	Rapid Spanning Tree Protocol (RSTP) This section gives an introduction to the Rapid Spanning Tree Protocol (RSTP); and how it is implemented on MiCOM-based products manufactured by Schneider Electric.	Px4x/EN TP
23	Version History (of Firmware and Service Manual) This is a history of all hardware and software releases for this product.	P445/EN VH
SG	Symbols and Glossary List of common technical terms, abbreviations and symbols found in this documentation.	P445/EN SG

Some of these chapters are *Specific* to a particular MiCOM product. Others are *Generic* – meaning that they cover more than one MiCOM product. The generic chapters have a Chapter Code which starts with Px4x.

2 INTRODUCTION TO MiCOM

About MiCOM Range

MiCOM is a comprehensive solution capable of meeting all electricity supply requirements. It comprises a range of components, systems and services from Schneider Electric.

Central to the MiCOM concept is flexibility. MiCOM provides the ability to define an application solution and, through extensive communication capabilities, integrate it with your power supply control system.

The components within MiCOM are:

- P range protection relays
- C range control products
- M range measurement products for accurate metering and monitoring
- S range versatile PC support and substation control packages

MiCOM products include extensive facilities for recording information on the state and behaviour of the power system using disturbance and fault records. They can also provide measurements of the system at regular intervals to a control centre enabling remote monitoring and control to take place.

For up-to-date information, please see:

www.schneider-electric.com

<i>Note</i>	<i>During 2011, the International Electrotechnical Commission classified the voltages into different levels (IEC 60038). The IEC defined LV, MV, HV and EHV as follows: LV is up to 1000V. MV is from 1000V up to 35 kV. HV is from 110 kV or 230 kV. EHV is above 230 KV. There is still ambiguity about where each band starts and ends. A voltage level defined as LV in one country or sector, may be described as MV in a different country or sector. Accordingly, LV, MV, HV and EHV suggests a possible range, rather than a fixed band. Please refer to your local Schneider Electric office for more guidance.</i>
-------------	--

3 PRODUCT SCOPE

MiCOM distance protection has been designed for the protection of all overhead lines and underground cables where the network is solidly/effectively grounded. (For insulated neutral, or Petersen coil earthing, use the MiCOM P433/P435 protection or P439 protection and control relays).

The P445 is a high-performance relay targeted mainly for sub-transmission and distribution applications. Tripping is 3-pole, with a typical operating time 1...1.3 cycles. The P445 is delivered in a 40TE or 60TE case according to the model selected to allow easy retrofitting.

3.1 Functional Overview

The P445 distance relay contains a wide variety of protection functions. The protection features are summarized below:

The P445 has 4 models available. All models have the same basic (and optional) functionality, with the difference between models being restricted to the digital (opto) inputs, and the relay outputs available:

- P445 Model A has 8 inputs and 8 standard outputs
- P445 Model B has 12 inputs and 12 standard outputs
- P445 Model C has 16 inputs and 16 standard outputs
- P445 Model D has 16 inputs, 8 standard outputs, and 4 high break outputs

Refer to *P445/EN TD* for the contact ratings for the two types of output. Note that the high break outputs are polarity sensitive, and the external wiring must respect the convention described in the external connection diagram, for correct operation.

ANSI	FEATURE		P445
	Dual rated 1 A and 5 A CT inputs		Yes
	Tripping mode		3 phase
	ABC and ACB phase rotation		Yes
21P/21G	Distance zones, full-scheme protection		6
	Characteristic	Phase elements:	Mho
		Ground elements:	Mho and Quadrilateral
	CVT transient overreach elimination		Yes
	Load blinder		Yes
	Easy setting mode		Yes
85	Communication-aided schemes, PUTT, POTT, Blocking, Weak Infeed		Yes
	Accelerated tripping - loss of load and Z1 extension		Yes
50/27	Switch on to fault and trip on re-close - elements for fast fault clearance upon breaker closure		Yes
68	Power swing blocking		Yes
67N	Directional Earth Fault (DEF) unit protection		Yes
50/51/67	Phase overcurrent stages, with optional directionality		4
50N/51N/67N	Earth/ground overcurrent stages, with optional directionality		4
	Sensitive Earth Fault (SEF), with optional directionality		Yes
	High-impedance Restricted Earth Fault (REF)		Yes
67/46	Negative sequence overcurrent, with optional directionality		Yes
46BC	Broken conductor (open jumper), used to detect open circuit faults		Yes
49	Thermal overload protection		Yes
27	Undervoltage protection stages		2
59	Overvoltage protection stages		2

ANSI	FEATURE	P445
59N	Residual voltage protection stages (neutral displacement)	2
50BF	High speed breaker fail. Two-stage, suitable for re-tripping and backtripping	Yes
CTS/VTS	Current Transformer Supervision (CTS) and Voltage Transformer Supervision (VTS)	Yes
79	Auto-reclose - shots supported	4
25	Check synchronism, 2 stages	Yes
	Alternative setting groups	4
FL	Fault locator	Yes
	SOE event records	1024
	Disturbance recorder, samples per cycle. For waveform capture	48
	Circuit breaker condition monitoring	Yes
	Graphical Programmable Scheme Logic (PSL)	Yes
	IRIG-B time synchronism	Optional
	Second rear communication port	Optional
	InterMiCOM teleprotection for direct relay-relay communication. Two scheme types exist, including EIA(RS)232 for MODEM links up to 19.2 kbit/s, and InterMiCOM ⁶⁴ 56/64 kbit/s. The latter can be used over direct fiber, or interfaces readily to G.703, V.35, X.21 and IEEE C37.94 multiplexers.	Optional
	High break (HB) output contacts	Optional

Table 1 - Functional overview

The relay supports these relay management functions as well as the ones shown above.

- Measurement of all instantaneous & integrated values
- Circuit breaker, status & condition monitoring
- Programmable Scheme Logic (PSL)
- Trip circuit and coil supervision (using PSL)
- Alternative setting groups
- Control inputs
- Programmable allocation of digital inputs and outputs
- Sequence of event recording
- Comprehensive disturbance recording (waveform capture)
- Fault recording
- Fully customizable menu texts
- Power-up diagnostics and continuous self-monitoring of relay
- Commissioning test facilities
- Real time clock/time synchronization - time synchronization possible from IRIG-B input, opto input or communications
- Simple password management:
CSL0 - No Security Administration Tool (SAT) required
- Advanced Cyber Security:
CSL1 - Security Administration Tool (SAT) required
- Read only mode

3.2 Application Overview

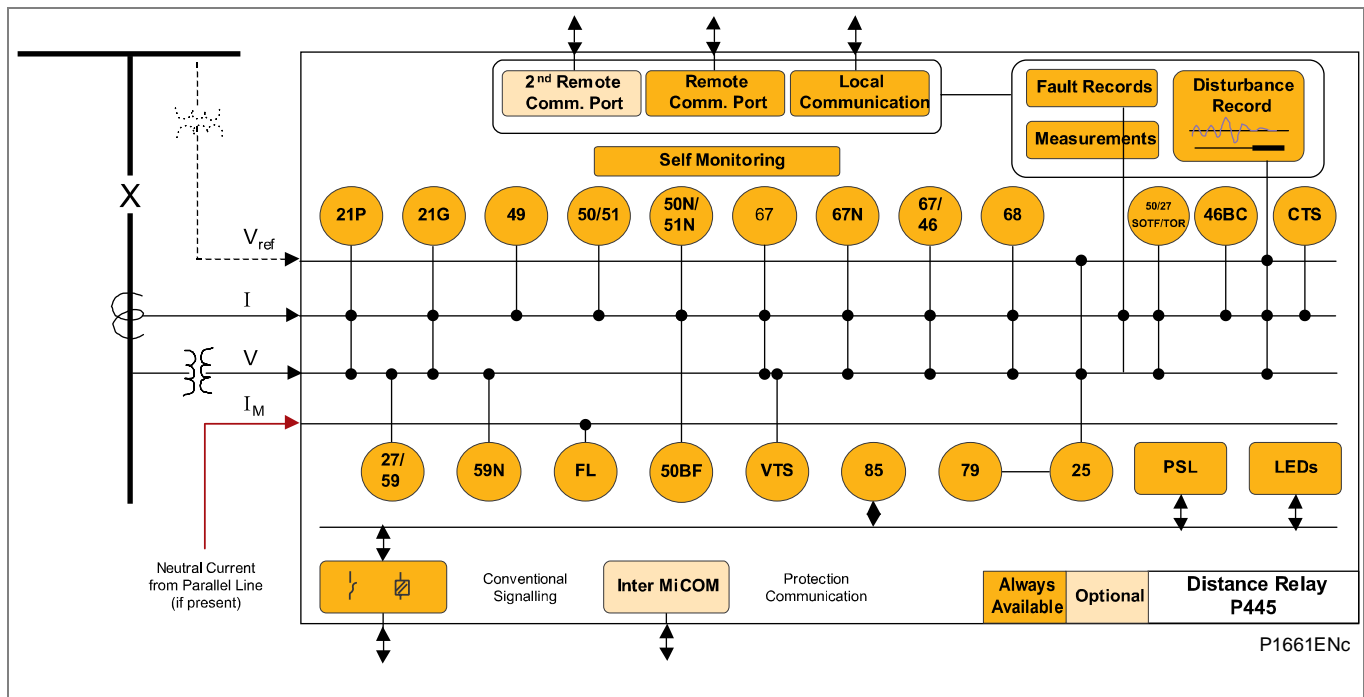

Figure 1 - Functional diagram

4 ORDERING OPTIONS

For each product there are range of ordering options. The options vary from one product to another, and from one Software Version to another.

The information required with your order is given in these sections:

- P445 Order Options

Note The Cortec table(s) list the options available as of the date of this documentation. The most up-to-date versions of these tables can be found on our web site (www.schneider-electric.com). It may not be possible to select ALL of the options shown here within a single item of equipment.

4.1 P445 Order Options

Order form	MiCOM P445									
Distance Protection 3 Pole tripping/reclosing MHO/Quad Distance with product options	P445	1				M				
Nominal auxiliary voltage										
24 - 32 Vdc		9								
48 - 110 Vdc		2								
110 - 250 Vdc (100 - 240 Vac)		3								
In/Vn rating										
Dual rated CT (1 & 5A : 100 - 120V)		1								
Hardware options										
Standard Version						1				
IRIG-Input						2				
Ethernet (100Mbit/s) plus IRIG-B (De-modulated)						B				
InterMiCOM + Courier Rear Port						E				
InterMiCOM + Courier Rear Port + IRIG-B modulated						F				
Redundant Ethernet RSTP, 2 multi-mode ST fibre ports + Modulated IRIG-B						J				
Redundant Ethernet RSTP, 2 multi-mode ST fibre ports + Un-modulated IRIG-B						K				
Redundant Ethernet (100Mbit/s) PRP or HSR or RSTP and Dual IP, 2 LC ports + 1 RJ45 port + Modulated/Un-modulated IRIG-B + IEEE1588						Q				
Redundant Ethernet (100Mbit/s) PRP or HSR or RSTP and Dual IP, 3 RJ45 ports + Modulated/Un-modulated IRIG-B + IEEE1588						R				
Ethernet (100Mbit/s), 1 RJ45 port + Modulated/Un-modulated IRIG-B + IEEE1588						S				
Product Options										
3 Pole tripping/reclosing MHO/Quad Distance with 8 Inputs & 8 Outputs (40TE)						A				
3 Pole tripping/reclosing MHO/Quad Distance with 12 Inputs & 12 Outputs (60TE)						B				
3 Pole tripping/reclosing MHO/Quad Distance with 16 Inputs & 16 Outputs (60TE)						C				
3 Pole tripping/reclosing MHO/Quad Distance with 16 Inputs, 8 Outputs & 4 High Break (60TE)						D				
As A with 820nm dual channel fibre interface						E				
As B with 820nm dual channel fibre interface						F				
As C with 820nm dual channel fibre interface						G				
As D with 820nm dual channel fibre interface						H				
As A with 1310nm single mode, single channel fibre interface						I				
As B with 1310nm single mode, single channel fibre interface						J				
As C with 1310nm single mode, single channel fibre interface						K				
As D with 1310nm single mode, single channel fibre interface						L				
As A with 1310nm single mode, dual channel fibre interface						M				
As B with 1310nm single mode, dual channel fibre interface						N				
As C with 1310nm single mode, dual channel fibre interface						O				
As D with 1310nm single mode, dual channel fibre interface						P				
As A with 1300nm multi mode, dual channel fibre interface						U				
As B with 1300nm multi mode, dual channel fibre interface						V				
As C with 1300nm multi mode, dual channel fibre interface						W				

Order form	MiCOM P445									
Distance Protection 3 Pole tripping/reclosing MHO/Quad Distance with product options	P445		1				M			
As D with 1300nm multi mode, dual channel fibre interface					X					
Protocol options										
K-Bus with simple password management - CSL0						1				
IEC 60870-5-103 (VDEW) with simple password management - CSL0						3				
DNP3.0 serial via rear RS485 with simple password management - CSL0						4				
IEC61850 Edition 1 / 2 and Courier via rear K-Bus/RS485 with simple password management - CSL0						6				
IEC 61850 Edition 1 / 2 and CS103 via rear port RS485 with simple password management - CSL0						7				
DNP3 over Ethernet with Courier rear port K-Bus/RS485 protocol with simple password management - CSL0						8				
IEC61850 Edition 1 / 2 and DNP3 serial with simple password management - CSL0						9				
IEC61850 Edition 1 / 2 and DNP3 and DNPoE serial with simple password management - CSL0						B				
IEC61850 Edition 1 / 2 and Courier via rear K-Bus/RS485 with advanced Cyber Security - CSL1 - Security Administration Tool (SAT) Required						G				
IEC61850 Edition 1 / 2 and CS103 via rear port RS485 with advanced Cyber Security - CSL1 - Security Administration Tool (SAT) Required						H				
IEC61850 Edition 1 / 2 and DNP3 serial with advanced Cyber Security - CSL1 - Security Administration Tool (SAT) Required						J				
IEC61850 Edition 1 / 2 and DNPoE and DNP3 serial with advanced Cyber Security - CSL1 - Security Administration Tool (SAT) Required						L				
Mounting										
Flush / Panel mounting							M			
Language										
English, French, German, Spanish								0		
English, French, German, Russian								5		
Chinese, English or French via HMI, with English or French only via Communications port								C		
Software version										
									**	
Customer specific options										
Default										8
Customer Specific										9
Hardware version										
Phase 3 CPU										L

Notes:

TECHNICAL DATA

CHAPTER 2

Date:	01/2024
Products covered by this chapter:	This chapter covers the specific versions of the MiCOM products listed below. This includes only the following combinations of Software Version and Hardware Suffix.
Hardware Suffix:	L
Software Version:	K6
Connection Diagrams:	10P445xx (xx = 01 to 04)

CONTENTS

Page (TD) 2-

1	Mechanical Specifications	11
1.1	Design	11
1.2	Enclosure Protection	11
1.3	Weight	11
2	Terminals	12
2.1	AC Current and Voltage Measuring Inputs	12
2.2	General Input/Output Terminals	12
2.3	Case Protective Earth Connection	12
2.4	Front Port Serial PC Interface	12
2.5	Front Download/Monitor Port	12
2.6	Rear Serial Communications Port	12
2.7	Optional Second Rear Communications Port	12
2.8	Optional Rear IRIG-B Interface Modulated or Un-modulated	12
2.9	IRIG-B Interface	13
2.9.1	IRIG-B 12X Interface (Modulated)	13
2.9.2	IRIG-B 00X Interface (Unmodulated)	13
2.10	Optional Rear Fiber Connection for SCADA/DCS	13
2.11	Optional Rear Ethernet Connection for IEC 61850 or DNP3.0	13
2.11.1	Optional Redundant Rear Ethernet Connection	13
3	Ratings	14
3.1	AC Measuring Inputs	14
3.2	AC Current	14
3.3	AC Voltage	14
4	Power Supply	15
4.1	Auxiliary Voltage (Vx)	15
4.2	Operating Range	15
4.3	Nominal Burden	15
4.4	Power-up Time	15
4.5	Power Supply Interruption	15
4.6	Battery Backup	15
4.7	Field Voltage Output	15
4.8	Digital (“Opto”) Inputs	16
5	Output Contacts	17

5.1	Standard Contacts	17
5.2	High Break Contacts (Model D Only)	17
5.3	Watchdog Contacts	18
<hr/>		
6	Environmental Conditions	19
6.1	Ambient Temperature Range	19
6.2	Ambient Humidity Range	19
6.3	Corrosive Environments	19
<hr/>		
7	Type Tests	20
7.1	Insulation	20
7.2	Creepage Distances and Clearances	20
7.3	High Voltage (Dielectric) Withstand	20
7.4	Impulse Voltage Withstand Test	20
<hr/>		
8	Electromagnetic Compatibility (EMC)	21
8.1	1 MHz Burst High Frequency Disturbance Test	21
8.2	100 kHz Damped Oscillatory Test	21
8.3	Immunity to Electrostatic Discharge	21
8.4	Electrical Fast Transient or Burst Requirements	21
8.5	Surge Withstand Capability	21
8.6	Surge Immunity Test	21
8.7	Immunity to Radiated Electromagnetic Energy	22
8.8	Radiated Immunity from Digital Communications	22
8.9	Radiated Immunity from Digital Radio Telephones	22
8.10	Immunity to Conducted Disturbances Induced by Radio Frequency Fields	22
8.11	Power Frequency Magnetic Field Immunity	22
8.12	Conducted Emissions	22
8.13	Radiated Emissions	22
<hr/>		
9	EU Directives	23
9.1	EMC Compliance	23
9.2	Product Safety	23
9.3	ATEX Compliance	23
9.4	UKCA Compliance	23
<hr/>		
10	Mechanical Robustness	24
10.1	Vibration Test	24
10.2	Shock and Bump	24
10.3	Seismic Test	24

11	Px40 Third Party Compliances	25
11.1	Underwriters Laboratory (UL)	25
11.2	Energy Networks Association (ENA)	25
12	Protection Functions	26
12.1	Performance Data	26
12.2	Distance Protection	26
12.3	Phase and Ground (Earth) Overcurrent	27
12.4	Sensitive Earth Fault (SEF)	27
12.5	Wattmetric SEF	27
12.6	Polarizing Quantities	27
12.7	Negative Sequence Overcurrent	28
12.8	Undervoltage	28
12.9	Overvoltage	28
12.10	Neutral Displacement / Residual Overvoltage	28
12.11	Underfrequency Protection	28
12.12	Overfrequency Protection	29
12.13	Circuit Breaker Fail and Undercurrent	29
12.14	Broken Conductor Logic	29
12.15	Thermal Overload	29
12.16	Voltage Transformer Supervision	29
12.17	Current Transformer Supervision	29
12.18	CB State Monitoring and Condition Monitoring	29
12.19	Programmable Scheme Logic	30
12.20	Auto-Reclose and Check Synchronism	30
12.21	Measurements and Recording Facilities	30
12.22	Real Time Clock	30
12.23	Enhanced Disturbance Records	31
12.24	Fault Locator	31
12.25	Event, Fault & Maintenance Records	31
12.26	Plant Supervision	31
12.27	Timer	31
12.28	Undercurrent	31
12.29	InterMiCOM64 Fiber Optic Teleprotection	32
12.30	Ethernet Data (where applicable)	32
12.30.1	100 Base FX Interface	32
13	Settings List	33
13.1	Global Settings (System Data)	33

13.2	Circuit Breaker Control (CB Control)	33
13.3	Date and Time	33
13.4	Configuration	33
13.5	CT and VT Ratios	34
13.6	Sequence of Event Recorder (Record Control)	35
13.7	Oscillography (Disturb Recorder)	35
13.8	Measured Operating Data (Measure't Setup)	35
13.9	Communications	35
13.9.1	Courier Protocol	35
13.9.2	IEC60870-5-103 Protocol	36
13.9.3	MODBUS Protocol	36
13.9.4	DNP3.0 Protocol (Serial)	36
13.9.5	Ethernet Port, IEC61850 Protocol	36
13.9.6	Ethernet Port, DNP3.0 Protocol	36
13.10	Optional Additional Second Rear Communication (Rear Port2 (RP2))	37
13.11	Commission Tests	37
13.12	Circuit Breaker Condition Monitoring (CB Monitor Setup)	37
13.13	Optocoupled Binary Inputs (Opto Config.)	38
13.14	Settable Control Inputs (Control Inputs)	38
13.15	EIA(RS)232 Teleprotection (INTERMiCOM Comms.)	38
13.16	INTERMiCOM CONF	38
13.17	IED Configurator	38
13.18	PROT COMMS./IM64	38
13.19	Security Config	39
14	Protection Functions (in Multiple Groups)	40
14.1	Line Parameters	40
14.2	Distance Setup	40
14.3	Phase Distance	40
14.4	Ground Distance	40
14.5	Delta Direction	41
14.6	Phase Distance Parameters	41
14.7	Ground Distance Parameters	41
14.8	Scheme Logic	42
14.8.1	Basic Scheme	42
14.8.2	Aided Scheme 1	43
14.8.3	Aided Scheme 2	43
14.9	Trip on Close	43
14.10	Z1 Extension	43
14.11	Loss of Load	43

14.12	Phase Overcurrent	44
14.13	Negative Sequence Overcurrent (Neg Seq O/C)	44
14.14	Broken Conductor	45
14.15	Ground Overcurrent (Earth Fault)	45
14.16	Directional Aided Schemes - DEF Settings	45
14.17	Sensitive Earth Fault (SEF)	46
14.17.1	Wattmetric SEF	46
14.18	Neutral Voltage Displacement (Residual O/V NVD)	46
14.19	Thermal Overload	46
14.20	Power Swing/Out Of Step	47
14.21	Undervoltage Protection	47
14.22	Overvoltage Protection	47
14.23	Underfrequency Protection	47
14.24	Overfrequency Protection	48
14.25	Rate-of-Change of Frequency Protection ($\Delta f/\Delta t$ Protection)	48
14.26	Circuit Breaker Fail and Pole Dead Logic (CB Fail and P.Dead)	48
<hr/>		
15	Supervision Functions (in Multiple Groups)	49
15.1	Voltage Transformer Supervision (VTS)	49
15.1.1	Inrush Detection	49
15.1.2	Weak Infeed Blk	49
15.2	Current Transformer Supervision (CTS)	49
15.2.1	Inrush Detection	49
15.2.2	Weak Infeed Blk	49
15.3	Trip Supervision (TS) or Fault Detector	50
15.4	Bus-Line Synchronism and Voltage Checks (System Checks)	50
15.5	Auto-Reclose	51
<hr/>		
16	Labels	52
16.1	Opto Input Labels	52
16.2	Opto Output Labels	52
16.3	Disturbance Recorder Channel Labels (DR Chan Labels)	52
16.4	Virtual Input Labels (VIR I/P Labels)	52
16.5	Virtual Output Labels (VIR O/P Labels)	52
16.6	SR/MR User Alarm Labels (USR Alarm Labels)	52
16.7	Control Input Labels	52
<hr/>		
17	Measurements List	53
17.1	Measurements 1	53
17.2	Measurements 2	54
17.3	Measurements 4	54

17.4	Circuit Breaker Monitoring Statistics	55
17.5	Fault Record Proforma	55

Notes:

1 MECHANICAL SPECIFICATIONS

1.1 Design

Modular MiCOM Px40 platform relay, 40 TE or 60 TE, front of panel flush mounting.

1.2 Enclosure Protection

Per IEC 60529:

- IP 52 Protection (front panel) against dust and dripping water.
- IP 50 Protection for the rear and sides of the case against dust.
- IP 10 Product safety protection for the rear due to live connections on the terminal block.

1.3 Weight

Approx. 11 kg

2 TERMINALS

2.1 AC Current and Voltage Measuring Inputs

Located on heavy duty (black) terminal block:
Threaded M4 terminals, for ring terminal connection.
CT inputs have integral safety shorting, upon removal of the terminal block.

2.2 General Input/Output Terminals

For power supply, opto inputs, output contacts and RP1, COM1 and optional COM2 rear communications.
Located on general purpose (grey) blocks:
Threaded M4 terminals, for ring lug/terminal connection.

2.3 Case Protective Earth Connection

Two rear stud connections, threaded M4.
Must be earthed (grounded) using the protective (earth) conductor for safety, minimum earth wire size 2.5mm².

2.4 Front Port Serial PC Interface

EIA(RS)-232 DCE, 9 pin D-type female connector Socket SK1.
Courier protocol for interface to MiCOM S1 Studio software.
Isolation to SELV/ELV (Safety/Extra Low Voltage) level / PEB (Protective Equipotential Bonded).
Maximum cable length 15m.

2.5 Front Download/Monitor Port

EIA(RS)-232, 25 pin D-type female connector Socket SK2.
For firmware and menu text downloads.
Isolation to SELV/PEB level.

2.6 Rear Serial Communications Port

EIA(RS)-485 signal levels, two wire connections located on general purpose block, M4 screw.
For screened twisted pair cable, multidrop, 1000 m max.
For Courier (K-Bus), IEC-60870-5-103 or DNP3.0 protocol (ordering option).
Isolation to SELV (Safety Extra Low Voltage) level.

2.7 Optional Second Rear Communications Port

EIA(RS)-232, 9 pin D-type female connector, socket SK4.
Courier protocol: K-Bus, EIA(RS)-232, or EIA(RS)485 connection.
Isolation to SELV level.
Maximum cable length 15m.

2.8 Optional Rear IRIG-B Interface Modulated or Un-modulated

BNC plug
Isolation to SELV level.
50 Ohm coaxial cable.

2.9 IRIG-B Interface**2.9.1 IRIG-B 12X Interface (Modulated)**

External clock synchronization to IRIG standard 200-98, format B12x
Input impedance 6 k Ω at 1000 Hz
Modulation ratio: 3:1 to 6:1
Input signal, peak-peak: 200 mV to 20 V
A DDB point is available to indicate the IRIG-B signal is valid.

2.9.2 IRIG-B 00X Interface (Unmodulated)

External clock synchronization to IRIG standard 200-98, format B00X.
Input signal TTL level
Input impedance at dc 10 k Ω
A DDB point is available to indicate the IRIG-B signal is valid.

2.10 Optional Rear Fiber Connection for SCADA/DCS

BFOC 2.5 -(ST)-interface for multi-mode glass fiber type 62.5/125 μm , as for IEC 874-10.
850nm short-haul fibers, one Tx and one Rx. For Courier, IEC-60870-5-103 or DNP3.0
(see different ordering options for each model).

2.11 Optional Rear Ethernet Connection for IEC 61850 or DNP3.0**100Base-TX Communications**

Interface in accordance with IEEE802.3 and IEC 61850
Isolation: 1.5 kV
Connector type: RJ45
Cable type: Screened Twisted Pair (STP)
Max. cable length: 100 m

2.11.1 Optional Redundant Rear Ethernet Connection

Above copper port plus two copper or two fiber ports.

100Base-TX Communications

Interface in accordance with IEEE802.3 and IEC 61850
Isolation: 1.5 kV
Connector type: RJ45
Cable type: Screened Twisted Pair (STP)
Max. cable length: 100 m

100Base-FX Interface

Interface in accordance with IEEE802.3 and IEC 61850
Wavelength: 1300 nm
Fiber: multi-mode 50/125 μm or 62.5/125 μm
Connector type: LC Connector Optical Interface

3 RATINGS

3.1 AC Measuring Inputs

Nominal frequency: 50 and 60 Hz (settable)
Operating range: 45 to 66.3 Hz
Phase rotation: ABC or ACB

3.2 AC Current

Nominal current (In): 1 and 5 A dual rated. (1A and 5A inputs use different transformer tap Connections, check correct terminals are wired).

Nominal burden per phase: < 0.2 VA at In
Thermal withstand: continuous 4 In for 10 s: 30 In
for 1 s; 100 In

Linear to 64 In (non-offset AC current).

3.3 AC Voltage

Nominal voltage (Vn): 100 to 120 V phase-phase.
Nominal burden per phase: < 0.02 VA at Vn.
Thermal withstand: continuous 2 Vn for 10 s: 2.6 Vn

4 POWER SUPPLY

4.1 Auxiliary Voltage (Vx)

Three ordering options:

- (i) Vx: 24 to 32 Vdc
- (ii) Vx: 48 to 110 Vdc,
- (iii) Vx: 110 to 250 Vdc, and 100 to 240 Vac (rms).

4.2 Operating Range

- (i) 19 to 38V (dc only for this variant)
- (ii) 37 to 150V (dc only for this variant) for classic relay
43 to 150V (dc only for this variant) for Process Bus relay
- (iii) 87 to 300V (dc), 80 to 265V (ac).

With a tolerable ac ripple of up to 15% for a dc supply, per EN/IEC 60255-11, EN/IEC 60255-26.

4.3 Nominal Burden

Quiescent burden (DC): 15 W (Extra 1.25 W when fitted with second rear Courier)
Quiescent burden (AC): 28 VA (Extra 1.25 W when fitted with second rear Courier)

Additions for energized binary inputs/outputs:

Per opto input:	0.09 W	(24 to 54 V)
	0.12 W	(110/125 V)
	0.19 W	(220/250 V)

Per energized output relay: 0.13 W

4.4 Power-up Time

Main Processor including User Interface and front access port < 25 s.
Ethernet Communications <120 s.

4.5 Power Supply Interruption

Per IEC60255-26: 2013

The relay will withstand a 20 ms interruption in the DC auxiliary supply, without deenergizing except process bus relays operating between 37 and 43V which have a 10 ms withstand.

The relay will withstand a 20 ms interruption in an AC auxiliary supply, without deenergizing.

4.6 Battery Backup

Front panel mounted.

Type ½ AA, 3.6 V Lithium Thionyl Chloride (SAFT advanced battery reference LS14250).
Battery life (assuming relay energized for 90% time) >10 years.

4.7 Field Voltage* Output

Regulated 48 Vdc

Current limited at 112 mA maximum output

*** Note**

It is compulsory to add an EMC Filter to use the field voltage outputs to prevent any noise or high frequency disturbance.

The EMC Filter must be connected to the protection relay with a **three-wires cable** of appr. 1m length.

The earth port of the EMC filter must **only** be connected to the earth terminal of Px4x; the metal housing of the filter **should** not be connected to the ground plane.

Proposal:

Schaffner EMC Filter (FN2010-1-06, 1A max - 250V), or equivalent

**4.8****Digital (“Opto”) Inputs**

Universal opto inputs with programmable voltage thresholds (24/27, 30/34, 48/54, 110/125, 220/250 V). May be energized from the 48 V field voltage, or the external battery supply.

Rated nominal voltage: 24 to 250 Vdc

Operating range: 19 to 265 Vdc

Withstand: 300 Vdc, 300 Vrms.

Peak current of opto input when energized is 3.5 mA (0-300 V)

Nominal pick-up and reset thresholds:

Nominal battery 24/27:	60 - 80% DO/PU
(logic 0) <16.2	(logic 1) >19.2

Nominal battery 24/27:	50 - 70% DO/PU
(logic 0) <12.0	(logic 1) >16.8

Nominal battery 30/34:	60 - 80% DO/PU
(logic 0) <20.4	(logic 1) >24.0

Nominal battery 30/34:	50 - 70% DO/PU
(logic 0) <15.0	(logic 1) >21.0

Nominal battery 48/54:	60 - 80% DO/PU
(logic 0) <32.4	(logic 1) >38.4

Nominal battery 48/54:	50 - 70% DO/PU
(logic 0) <24.0	(logic 1) >33.6

Nominal battery 110/125:	60 - 80% DO/PU
(logic 0) <75.0	(logic 1) >88.0

Nominal battery 110/125:	50 - 70% DO/PU
(logic 0) <55.0	(logic 1) >77.0

Nominal battery 220/250:	60 - 80% DO/PU
(logic 0) <150.0	(logic 1) >176.0

Nominal battery 220/250:	50 - 70% DO/PU
(logic 0) <110	(logic 1) >154

Recognition time:

<2 ms with filter removed.

<12 ms with half cycle ac immunity filter on.

5 OUTPUT CONTACTS

5.1

Standard Contacts

General purpose relay outputs for signaling, tripping and alarming:

Continuous Carry Ratings (Not Switched):

Maximum continuous current:	10 A (UL: 8 A)
Short duration withstand carry:	30 A for 3 s or 250A for 30ms
Rated voltage:	300 V

Make & Break Capacity:

DC:	50 W resistive	
DC:	62.5 W inductive	(L/R = 50 ms)
AC:	2500 VA resistive	(cos ϕ = unity)
AC:	2500 VA inductive	(cos ϕ = 0.7)

Make, Carry:

30 A for 3 secs, dc resistive.

10,000 operations (subject to the above limits of make/break capacity and rated voltage).

Make, Carry & Break:

30 A for 200 ms, ac resistive.

2,000 operations (subject to the above limits of make/break capacity & rated voltage).

4A for 1.5 secs, dc resistive.

10,000 operations (subject to the above limits of make/break capacity & rated voltage).

0.5 A for 1 sec, dc inductive.

10,000 operations (subject to the above limits of make/break capacity & rated voltage).

10 A for 1.5 secs, ac resistive/inductive.

10,000 operations (subject to the above limits of make/break capacity & rated voltage).

Durability:

Loaded contact:	10,000 operations minimum
Unloaded contact:	100,000 operations minimum
Operate Time	Less than 5 ms
Reset Time	Less than 5 ms

5.2

High Break Contacts (Model D Only)

Continuous Carry Ratings (Not Switched):

Maximum continuous current:	10 A dc
Short duration withstand carry:	30 A dc for 3 s 250A dc for 30ms
Rated voltage:	300 V

Make & Break Capacity:

DC:	7500 W resistive	
DC:	2500 W inductive	(L/R = 50 ms)

Make, Carry:

30 A for 3 secs, dc resistive.

10,000 operations (subject to the above limits of make/break capacity & rated voltage).

Make, Carry & Break:

30 A for 3 secs, dc resistive.

5,000 operations (subject to the above limits of make/break capacity & rated voltage).

30 A for 200 ms, dc resistive.

10,000 operations (subject to the above limits of make/break capacity & rated voltage).

10 A (*), dc inductive.

10,000 operations (subject to the above limits of make/break capacity & rated voltage).

*Typical for repetitive shots - 2 minutes idle for thermal dissipation

Voltage	Current	L/R	No. of Shots in 1 sec
65 V	10 A	40 ms	5
150 V	10 A	40 ms	4
250 V	10 A	40 ms	2
250 V	10 A	20 ms	4

MOV protection: Max Voltage 330 V dc

Durability:

Loaded contact: 10,000 operations minimum

Unloaded contact: 100,000 operations minimum

Operate Time: Less than 0.2 ms

Reset Time: Less than 8 ms

5.3**Watchdog Contacts**

Non-programmable contacts for relay healthy or relay fail indication:

Breaking capacity: DC: 30 W resistive
 DC: 15 W inductive (L/R = 40 ms)
 AC: 375 VA inductive (cos ϕ = 0.7)

6 ENVIRONMENTAL CONDITIONS

6.1 Ambient Temperature Range

Per IEC 60255-1: 2009

Operating temperature range: -25°C to +55°C (or -13°F to +131°F).

Storage and transit: -25°C to +70°C (or -13°F to +158°F).

6.2 Ambient Humidity Range

Per IEC 60068-2-78: 2012:

56 days at 93% relative humidity and +40°C

Per IEC 60068-2-30: 2009:

Damp heat cyclic, six (12 + 12) hour cycles, 93% RH, +25 to +55°C

6.3 Corrosive Environments

Per IEC 60068-2-60: 1995, Part 2, Test Ke, Method (class) 3

Industrial corrosive environment/poor environmental control, mixed gas flow test.

21 days at 75% relative humidity and +30°C

Exposure to elevated concentrations of H₂S, NO₂, Cl₂ and SO₂.

7 TYPE TESTS

7.1 Insulation

As for IEC 60255-27: 2005 (incorporating corrigendum March 2007):
Insulation resistance > 100 MΩ at 500 Vdc
(Using only electronic/brushless insulation tester).

7.2 Creepage Distances and Clearances

IEC 60255-27: 2005 (incorporating corrigendum March 2007)
Pollution degree 2, Overvoltage category III
Impulse test voltage 5 kV.

7.3 High Voltage (Dielectric) Withstand

(EIA RS-232 ports excepted).

(i) As for EN / IEC 60255-27:

2 kV rms AC, 1 minute:

Between all independent circuits.

Between independent circuits and case earth (ground).

1 kV rms AC for 1 minute, across open watchdog contacts.

1 kV rms AC for 1 minute, across open contacts of changeover output relays (not applicable for high break contacts due to electronics presence across the contact).

1 kV rms AC for 1 minute for all D-type EIA(RS)-232 or EIA(RS)-485 ports between the communications port terminals and protective (earth) conductor terminal.

1 kV rms AC for 1 minute between RJ45 ports and the case earth (ground).

1 kV rms AC for 1 minute between RJ45 ports and other independent circuits.

(ii) As for ANSI/IEEE C37.90:

1.5 kV rms AC for 1 minute, across open contacts of normally open output relays.

1 kV rms AC for 1 minute, across open watchdog contacts.

1 kV rms AC for 1 minute, across open contacts of changeover output relays (not applicable for high break contacts due to electronics presence across the contact).

7.4 Impulse Voltage Withstand Test

As for EN / IEC 60255-27:

(i) Front time: 1.2 μs, Time to half-value: 50 μs,

Peak value: 1.5 kV, 0.5 J

Between RJ45 ports and the case earth (ground).

Between RJ45 ports and other independent circuits.

EIA(RS)-232 & EIA(RS)-485 ports and normally open contacts of output relays excepted.

(ii) Front time: 1.2 μs, Time to half-value: 50 μs,

Peak value: 5 kV, 0.5 J

Between all independent circuits.

Between independent circuits and the case earth (ground).

8 ELECTROMAGNETIC COMPATIBILITY (EMC)

8.1 1 MHz Burst High Frequency Disturbance Test

As for EN / IEC 60255-22-1, Class III,
Common-mode test voltage: 2.5 kV,
Differential test voltage: 1.0 kV,
Test duration: 2 s,
Source impedance: 200 Ω
(EIA(RS)-232 ports excepted).

8.2 100 kHz Damped Oscillatory Test

Per EN61000-4-18: 2006 Level 3
2.5 kV peak between independent circuits and case earth.
1.0 kV peak across terminal of the same circuit.

8.3 Immunity to Electrostatic Discharge

Per IEC 60255-22-2: 1996, Class 4,
15 kV discharge in air to user interface, display, and exposed metalwork.
Per IEC 60255-22-2: 1996, Class 3,
8 kV discharge in air to all communication ports.
6 kV point contact discharge to any part of the front of the product.

8.4 Electrical Fast Transient or Burst Requirements

Per IEC 60255-22-4: 2002.
Test severity: Class III and IV:
Amplitude: 2 kV, burst frequency 5 kHz (Class III),
Amplitude: 4 kV, burst frequency 2.5 kHz (Class IV).
Applied directly to auxiliary supply, and applied to all other inputs. EIA(RS)232 ports excepted.

8.5 Surge Withstand Capability

IEEE/ANSI C37.90.1:2002:
4 kV fast transient and 2.5 kV oscillatory applied common mode and differential mode to opto inputs (filtered), output relays, CTs, VTs, power supply, field voltage.
4 kV fast transient and 2.5 kV oscillatory applied common mode to communications, IRIG- B.

8.6 Surge Immunity Test

EIA(RS)232 ports excepted.
Per IEC 61000-4-5: 2005 Level 4.
Time to half-value: 1.2/50 μ s.
Amplitude: 4 kV between all groups and protective (earth) conductor terminal.
Amplitude: 2 kV between terminals of each group.

-
- 8.7 Immunity to Radiated Electromagnetic Energy**
IEC 60255-22-3: 2000, Class III:
Test field strength, frequency band 80 to 1000 MHz: 10 V/m,
Test using AM: 1 kHz / 80%,
Spot tests at: 80, 160, 450, 900 MHz
IEEE/ANSI C37.90.2: 1995:
25 MHz to 1000 MHz, zero and 100% square wave modulated.
Field strength of 35 V/m.
-
- 8.8 Radiated Immunity from Digital Communications**
EN61000-4-3: 2002, Level 4:
Test field strength, frequency band 800 to 960 MHz, and 1.4 to 2.0 GHz: 30 V/m,
Test using AM: 1 kHz / 80%.
-
- 8.9 Radiated Immunity from Digital Radio Telephones**
ENV 50204: 1995 10 V/m, 900 MHz and 1.89 GHz.
-
- 8.10 Immunity to Conducted Disturbances Induced by Radio Frequency Fields**
IEC 61000-4-6: 1996, Level 3, Disturbing test voltage: 10 V
-
- 8.11 Power Frequency Magnetic Field Immunity**
IEC 61000-4-8: 1994, Level 5: 100 A/m applied continuously,
1000 A/m applied for 3 s.
IEC 61000-4-9: 1993, Level 5: 1000 A/m applied in all planes.
IEC 61000-4-10: 1993, Level 5:
100 A/m applied in all planes at 100 kHz/1MHz with a burst duration of 2 s.
-
- 8.12 Conducted Emissions**
EN 55022: 1998: Class A:
0.15 - 0.5 MHz, 79 dB μ V (quasi peak) 66 dB μ V (average)
0.5 – 30 MHz, 73 dB μ V (quasi peak) 60 dB μ V (average).
-
- 8.13 Radiated Emissions**
EN 55022: 1998: Class A:
30 – 230 MHz, 40 dB μ V/m at 10 m measurement distance
230 – 1 GHz, 47 dB μ V/m at 10 m measurement distance.

9 EU DIRECTIVES

9.1 EMC Compliance

2004/30/EU:

Compliance to the European Commission Directive on EMC is claimed via the Technical Construction File route. Product Specific Standards were used to establish conformity: EN 60255-26

9.2 Product Safety

2014/35/EU:

Compliance to the European Commission Low Voltage Directive (LVD) is demonstrated using a Technical File. A product-specific standard was used to establish conformity.



EN 60255-27

9.3 ATEX Compliance

ATEX Potentially Explosive Atmospheres directive 2014/34/EU, for equipment.

The equipment is compliant with Article 1 of European directive 2014/34/EU.

It is approved for operation outside an ATEX hazardous area. It is however approved for connection to Increased Safety, "Ex e", motors with rated ATEX protection, Equipment Category 2, to ensure their safe operation in gas Zones 1 and 2 hazardous areas.

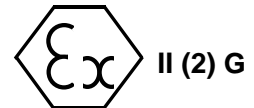

Caution

Equipment with this marking is not itself suitable for operation within a potentially explosive atmosphere.

Compliance demonstrated by Notified Body certificates of compliance.

9.4 UKCA Compliance

SI 2016 No.1107:

UK Type Examination regulation of the equipment.

The equipment is compliant with Article 3 (b) part I of the UK regulation SI 2016 No. 1107, amended by SI 2019 No. 696.



BS EN 60255-27

11 PX40 THIRD PARTY COMPLIANCES

11.1 Underwriters Laboratory (UL)

File Number: E202519
(Complies with Canadian and US requirements).
Issue Date 21-04-2005

11.2 Energy Networks Association (ENA)

Certificate Number: 142 Issue 1
Assessment Date: 02-08-2007

12 PROTECTION FUNCTIONS

12.1 Performance Data

12.2 Distance Protection

From version H4 the operating times for off-angle faults have been improved to an average of 30-35ms in all zone 1 (for f = 50Hz). Faults at the zone boundary will be cleared in higher times (10-20% of zone 1 area). Sub cycle operation is maintained for faults close to the relay characteristic up to 75% of zone reach setting.

All quoted operating times include the closure of the trip output contact.

The *Operating Time v Reach % at 50 Hz* diagram and the *Operating Time v Reach % at 60 Hz* diagram shows Operating Time versus Reach Percentage, for faults close to line angle.

50 Hz Operation

Minimum tripping time:	19 ms	(SIR = 5)
Typical tripping time:	23 ms	(SIR = 5)
	24.5 ms	(SIR = 30)

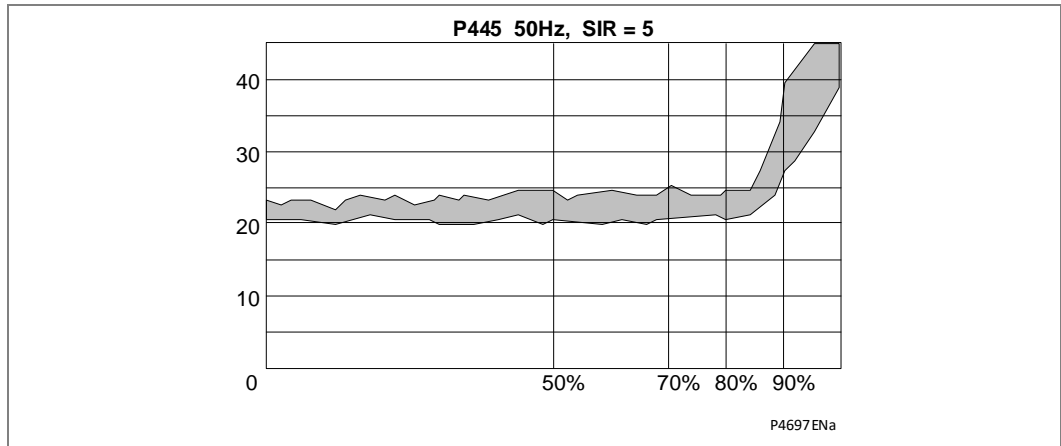

Figure 1 - Operating Time vs Reach % at 50 Hz

60 Hz Operation

Minimum tripping time:	18 ms	(SIR = 5)
Typical tripping time:	19 ms	(SIR = 5)
	20 ms	(SIR = 30)

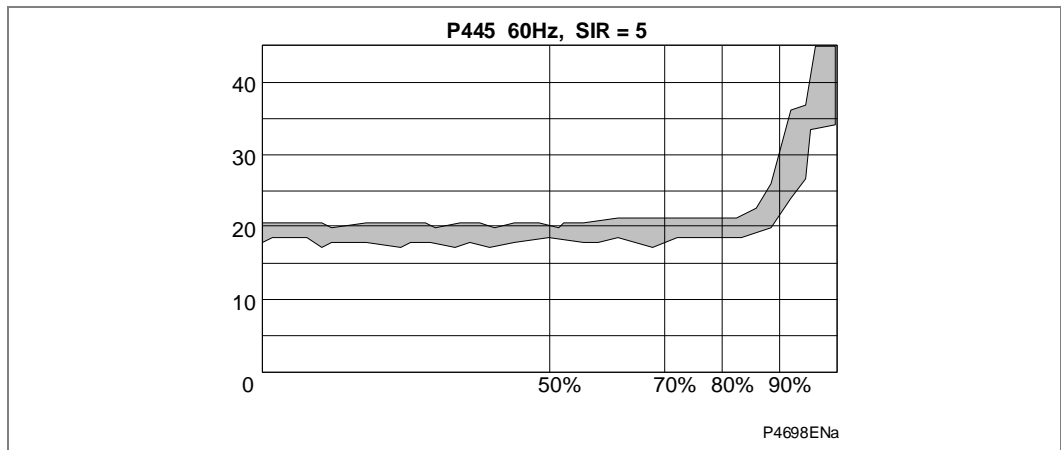

Figure 2 - Operating Time vs Reach % at 60 Hz

Accuracy

Characteristic shape, up to SIR = 30: $\pm 5\%$ for on-angle fault (the set line angle)
 $\pm 10\%$ off-angle

(Example: For a 70 degree set line angle, injection testing at 40 degrees would be referred to as "off-angle").

Zone time delay deviations: ± 20 ms or 2%, whichever is greater.

Sensitivity

Settings $< 5/I_n \Omega$: $(0.05 I_n * 5 / (\text{setting} * I_n)) \pm 5\%$

Settings $> 5/I_n \Omega$: $0.05 I_n \pm 5\%$

12.3**Phase and Ground (Earth) Overcurrent****Accuracy**

DT Pick-up: Setting $\pm 5\%$

Minimum IDMT trip level: $1.05 \times \text{setting} \pm 5\%$

Drop-off: $0.95 \times \text{setting} \pm 5\%$

IDMT shape: $\pm 5\%$ or 40 ms whichever is greater

IEEE reset: $\pm 5\%$ or 50 ms whichever is greater

DT operation: $\pm 2\%$ or 50 ms, whichever is greater

DT reset: $\pm 5\%$

Directional boundary (RCA $\pm 90\%$): $\pm 2^\circ$ hysteresis $< 3^\circ$

Characteristic: UK curves IEC 60255-3 ... 1998

US curves: IEEE C37.112... 1996

Reference conditions TMS = 1, TD = 1 and $I >$ setting of 1 A operating range 2-20 In

Additional tolerance due to increasing X/R ratios: $\pm 5\%$ over the X/R ratio from 1 to 90

Overshoot of overcurrent elements: < 30 ms

12.4**Sensitive Earth Fault (SEF)**

Pick-up: Setting $\pm 5\%$

Minimum IDMT Trip level: $1.05 \times \text{Setting} \pm 5\%$

Drop-off: $0.95 \times \text{Setting} \pm 5\%$

IDMT shape: $\pm 5\%$ or 40 ms whichever is greater

IEEE reset: $\pm 17.5\%$ or 60 ms whichever is greater

DT operation: $\pm 2\%$ or 50 ms whichever is greater

DT reset: $\pm 5\%$

Repeatability: $\pm 5\%$

Reference conditions TMS = 1, TD = 1 and ISEF $>$ setting of 1A, operating range 2-0 In

12.5**Wattmetric SEF**

Pick-up P=0W: ISEF $>$ $\pm 5\%$ or 5 mA

Pick-up P>0W: P $>$ $\pm 5\%$

Drop-off P=0W: $(0.95 \times \text{ISEF } >) \pm 5\%$ or 5 mA

Drop-off P>0W: $0.9 \times P > \pm 5\%$

Boundary accuracy: $\pm 5^\circ$ with 1° hysteresis

Repeatability: 1%

12.6**Polarizing Quantities**

VN $>$ and V2 $>$ Level detectors: Pick-up: $\pm 10\%$
 Resetting ratio: 0.9

I2 $>$ Level detector: Pick-up: $\pm 10\%$
 Resetting ratio: 0.9

12.7 Negative Sequence Overcurrent**Accuracy**

Pick-up:	Setting $\pm 5\%$
Drop-off:	0.95 x setting
Definite time operation:	± 60 ms or 2%, whichever is greater
Repeatability:	1%
Directional boundary accuracy:	$\pm 2^\circ$ with hysteresis $< 1^\circ$
Reset:	< 35 ms

12.8 Undervoltage**Accuracy**

Definite time operation:	± 40 ms or 2%, whichever is greater
Repeatability:	1%
IDMT characteristic shape:	± 40 ms or 2%, whichever is greater
Reset:	< 75 ms

12.9 Overvoltage**Accuracy**

DT Pick-up:	Setting $\pm 1\%$
IDMT Pick-up:	1.02 x setting $\pm 2\%$
Drop-off:	0.98 x setting $\pm 2\%$
Definite time operation:	± 40 ms or 2%, whichever is greater
Repeatability:	1%
IDMT characteristic shape:	± 40 ms or 2%, whichever is greater
Reset:	< 75 ms

12.10 Neutral Displacement / Residual Overvoltage**Accuracy**

DT Pick-up:	Setting $\pm 5\%$
IDMT Pick-up:	1.05 x setting $\pm 5\%$
Drop-off:	0.95 x setting $\pm 5\%$
Definite time operation:	± 20 ms or 2%, whichever is greater
Instantaneous operation:	< 50 ms
Repeatability:	10%
IDMT characteristic shape:	± 60 ms or 5%, whichever is greater
Reset:	< 35 ms

12.11 Underfrequency Protection**Accuracy**

Pick-up:	Setting ± 0.025 Hz
Drop-off:	1.05 x Setting ± 0.025 Hz
DT operation:	$\pm 2\%$ or 50 ms whichever is greater *

* The operating time will also include a time for the relay to frequency tracking (20 Hz/second)

12.12 Overfrequency Protection**Accuracy**

Pick-up:	Setting ± 0.025 Hz
Drop-off:	$0.95 \times$ Setting ± 0.025 Hz
DT operation:	$\pm 2\%$ or 50 ms whichever is greater *

* The operating will also include a time for the relay to frequency tracking (20 Hz/ second)

12.13 Circuit Breaker Fail and Undercurrent

Pick-up:	$\pm 10\%$ or $0.025 I_n$, whichever is greater
Operating time:	<12 ms
Timers:	2 ms or 2%, whichever is greater
Reset:	<15 ms

12.14 Broken Conductor Logic**Accuracy**

Pick-up:	Setting $\pm 2.5\%$
Drop-off:	$0.95 \times$ setting $\pm 2.5\%$
Definite time operation:	± 50 ms or 2%, whichever is greater
Reset:	<25 ms

12.15 Thermal Overload**Accuracy**

Thermal alarm pick-up:	Calculated trip time $\pm 10\%$
Thermal overload pick-up:	Calculated trip time $\pm 10\%$
Cooling time accuracy:	$\pm 15\%$ of theoretical
Repeatability:	<5%

Operating time measured with applied current of 20% above thermal setting.

12.16 Voltage Transformer Supervision**Accuracy**

Fast block operation:	<1 cycle
Fast block reset:	<1.5 cycles
Time delay:	± 20 ms or 2%, whichever is greater

12.17 Current Transformer Supervision**Accuracy**

In> Pick-up:	Setting $\pm 5\%$
VN< Pick-up:	Setting $\pm 5\%$
In> Drop-off:	$0.9 \times$ Setting $\pm 5\%$
VN< Drop-off:	$1.05 \times$ Setting $\pm 5\%$ or 1 V whichever is greater
Time delay operation:	Setting $\pm 2\%$ or 20 ms whichever is greater
CTS block operation:	<1 cycle
CTS reset:	<35 ms

12.18 CB State Monitoring and Condition Monitoring**Accuracy**

Timers:	$\pm 2\%$ or 20 ms whichever is greater
Broken current accuracy:	$\pm 5\%$

12.19 Programmable Scheme Logic

Output conditioner timer: Setting $\pm 2\%$ or 20 ms whichever is greater
 Dwell conditioner timer: Setting $\pm 2\%$ or 20 ms whichever is greater
 Pulse conditioner timer: Setting $\pm 2\%$ or 20 ms whichever is greater
 No of PSL Timers: 32

Control Inputs into PSL (Ctrl. I/P config.)

Hotkey Enabled: Binary function link string, selecting which of the control inputs are driven from Hotkeys.
 Control Input 1: Latched/Pulsed
 (up to):
 Control Input 32:
 Ctrl Command 1: ON/OFF / SET/RESET / IN/OUT / ENALBED/DISABLED
 (up to):
 Ctrl Command 32:

PSL Signal Grouping Nodes

For Software Version D1a and later, these DDB "Group" Nodes can be mapped to individual or multiple DDBs in the PSL:

PSL Group Sig 1
 PSL Group Sig 2
 PSL Group Sig 3
 PSL Group Sig 4

12.20 Auto-Reclose and Check Synchronism**Accuracy**

Timers: Setting ± 20 ms or 2%, whichever is greater

12.21 Measurements and Recording Facilities**Accuracy**

Typically $\pm 1\%$, but $\pm 0.5\%$ between 0.2-2 In/Vn
 Current: 0.05... 3 In
 Accuracy: $\pm 1.0\%$ of reading
 Voltage: 0.05...2 Vn
 Accuracy: $\pm 1.0\%$ of reading
 Power (W): 0.2...2 Vn 0.05...3 In
 Accuracy: $\pm 5.0\%$ of reading at unity power factor
 Reactive Power (Vars): 0.2...2 Vn, 0.05...3 In
 Accuracy: $\pm 5.0\%$ of reading at zero power factor
 Apparent Power (VA): 0.2...2 Vn 0.05...3 In
 Accuracy: $\pm 5\%$ of reading
 Energy (Wh): 0.2...2 Vn 0.2...3 In
 Accuracy: $\pm 5\%$ of reading at unity power factor
 Energy (Varh): 0.2...2 Vn 0.2...3 In
 Accuracy: $\pm 5\%$ of reading at zero power factor
 Phase accuracy: $0^\circ \dots 360^\circ$
 Accuracy: $\pm 0.5^\circ$
 Frequency: 45...65 Hz
 Accuracy: ± 0.025 Hz

12.22 Real Time Clock

Real time clock accuracy: $< \pm 2$ seconds/day

12.23 Enhanced Disturbance Records

Maximum record duration: 3 seconds
 Maximum pre-trigger time 500 ms (see Note below)
 Extracted over: CS103, IEC61850 and COURIER

<i>Note</i>	<i>As from Software Version H4, in DNP3 the maximum DR pre-trigger time is around 140 ms (50Hz) and 120 ms (60 Hz).</i>
-------------	---

<i>Note</i>	<i>As from Software Version H6, in DNP3 and CS103 the maximum DR pre-trigger time is around 500 ms (50Hz) and 420 ms (60 Hz).</i>
-------------	---

Accuracy

Magnitude and relative phases: $\pm 5\%$ of applied quantities
 Duration: $\pm 2\%$
 Trigger position: $\pm 2\%$ (minimum Trigger 100 ms)

12.24 Fault Locator**Accuracy**

Fault location: $\pm 2\%$ of line length
 Reference conditions solid fault applied on line

12.25 Event, Fault & Maintenance Records

The most recent records are stored in battery-backed memory, and can be extracted via the communication port or be viewed on the front panel display.

No of Event Records: Up to 1024 time tagged event records
 No of Fault Records: Up to 15
 No of Maintenance Records: Up to 10

12.26 Plant Supervision**Accuracy**

Broken current accuracy: $\pm 5\%$

Timer Accuracy

Timers: $\pm 2\%$ or 40 ms whichever is greater
 Reset time: < 30 ms
 Pick-up: $\pm 10\%$ or 25 mA whichever is greater
 Operating time: < 20 ms
 Reset: < 25 ms

12.27 Timer

Timers: $\pm 2\%$ or 40 ms whichever is greater
 Reset time: < 30 ms

12.28 Undercurrent**Accuracy**

Pick-up: $\pm 10\%$ or 25 mA whichever is greater
 Operating time: < 20 ms
 Reset: < 25 ms

12.29 InterMiCOM64 Fiber Optic Teleprotection

End-end operation. The table below shows the bit transfer time.

For multiplexed links, 'MUX' denotes the multiplexer delay.

IM64 Cmd	Applic.	Typical Delay (ms)	Max. (ms)	Note
Permissive	Direct Fiber	3 to 7	9	No Noise
	via MUX	5 to 8 + MUX	12 + MUX	BER ≤10 ⁻³
Dir. Intertrip	Direct Fiber	4 to 8	10	No Noise
	via MUX	6 to 8 + MUX	13 + MUX	BER ≤10 ⁻³

BER = Bit error rate for channel

12.30 Ethernet Data (where applicable)**12.30.1 100 Base FX Interface****Transmitter Optical Characteristics**

Parameter	Sym	Min.	Typ.	Max	Unit
Output Optical Power BOL: 62.5/125 μm, NA = 0.275 Fiber EOL	P _{OUT}	-19 -20	-16.8	-14	dBm avg.
Output Optical Power BOL: 50/125 μm, NA = 0.20 Fiber EOL	P _{OUT}	-22.5 -23.5	-20.3	-14	dBm avg.
Optical Extinction Ratio				10 -10	% dB
Output Optical Power at Logic "0" State	P _{OUT} ("0")			-45	dBm avg.

BOL – Beginning of life EOL – End of life NA – Numerical Aperture

Table 1 - Transmitter optical characteristics

Receiver Optical Characteristics

Parameter	Sym	Min.	Typ.	Max.	Unit
Input Optical Power Minimum at Window Edge	P _{IN} Min. (W)		-33.5	-31	dBm avg.
Input Optical Power Minimum at Eye Center	P _{IN} Min. (C)		-34.5	-31.8	dBm avg.
Input Optical Power Maximum	P _{IN} Max.	-14	-11.8		dBm avg.

Table 2 - Receiver optical characteristics

13 SETTINGS LIST

13.1 Global Settings (System Data)

Language:	English/French/German/Spanish English/French/German/Russian Chinese/English/French
Frequency:	50/60 Hz
IEC61850 Edition	1 or 2
ETH COMM Mode	Dual IP, PRP, HSR or RSTP

13.2 Circuit Breaker Control (CB Control)

CB Control by:	Disabled, Local, Remote, Local+remote, Opto, Opto+local, Opto+Remote, Opto+Rem+Local
Close pulse time:	0.10...10.00s
Trip pulse time:	0.10...5.00s
Man close t max:	0.01...9999.00s
Man close delay:	0.01...600.00s
CB healthy time:	0.01...9999.00s
Check sync time:	0.01...9999.00s
Reset lockout by:	User interface/CB close
Man close RstDly:	0.10...600.00 s
Three pole A/R:	Disabled/Enabled
CB Status Input:	None / 52A 3 pole / 52B 3 pole / 52A & 52B 3 pole

13.3 Date and Time

IRIG-B Sync:	Disabled/Enabled
Battery Alarm:	Disabled/Enabled
LocalTime Enable:	Disabled/Fixed/Flexible
LocalTime Offset:	-720 min...720 min
DST Enable:	Disabled/Enabled
DST Offset:	30 min...60 min
DST Start:	First/Second/Third/Fourth/Last
DST Start Day:	Sun/Mon/Tues/Wed/Thurs/Fri/Sat
DST Start Month:	Jan/Feb/Mar/Apr/May/June/Jul/Aug/Sept/Oct/Nov/Dec
DST Start Mins:	0 min...1425 min
DST End:	First/Second/Third/Fourth/Last
DST End Day:	Sun/Mon/Tues/Wed/Thurs/Fri/Sat
DST End Month:	Jan/Feb/Mar/Apr/May/June/Jul/Aug/Sept/Oct/Nov/Dec
DST End Mins:	0 min...1425 min
RP1 Time Zone:	UTC/Local
RP2 Time Zone:	UTC/Local
Tunnel Time Zone:	UTC/Local
DNPOE Time Zone:	UTC or Local

13.4 Configuration

Setting Group:	Select via Menu or Select via PSL
Active Settings:	Group 1/2/3/4
Setting Group 1:	Disabled/Enabled
Setting Group 2:	Disabled/Enabled
Setting Group 3:	Disabled/Enabled
Setting Group 4:	Disabled/Enabled
Distance:	Disabled/Enabled
Directional E/F:	Disabled/Enabled

Overcurrent:	Disabled/Enabled
Neg Sequence O/C:	Disabled/Enabled
Broken Conductor:	Disabled/Enabled
Earth Fault:	Disabled/Enabled
SEF/REF Prot'n:	Disabled/Enabled
Residual O/V NVD:	Disabled/Enabled
Thermal Overload:	Disabled/Enabled
Power Swing Block:	Disabled/Enabled (not P841)
Volt Protection:	Disabled/Enabled
Freq Protection:	Disabled/Enabled
df/dt Protection:	Disabled/Enabled
CB Fail:	Disabled/Enabled
Supervision:	Disabled/Enabled
System Checks:	Disabled/Enabled
Auto-Reclose:	Disabled/Enabled
Input Labels:	Invisible/Visible
Output Labels:	Invisible/Visible
CT & VT Ratios:	Invisible/Visible
Record Control:	Invisible/Visible
Disturb Recorder:	Invisible/Visible
Measure't Setup:	Invisible/Visible
Comms Settings:	Invisible/Visible
Commission Tests:	Invisible/Visible
Setting Values:	Primary/Secondary
Control Inputs:	Invisible/Visible
Timer Settable:	Invisible/Visible
Ctrl I/P Config:	Invisible/Visible
Ctrl I/P Labels:	Invisible/Visible
PB Config:	Invisible/Visible
Direct Access:	Disabled/Enabled
InterMiCOM:	Disabled/Enabled
Function Key:	Invisible/Visible
VIR I/P Labels	Invisible/Visible
VIR O/P Labels	Invisible/Visible
Usr Alarm Labels	Invisible/Visible
SettingValueBeh.	Independent/Locked Mode
RP1 Read Only:	Disabled/Enabled
RP2 Read Only:	Disabled/Enabled
NIC Read Only:	Disabled/Enabled
LCD Contrast:	(Factory pre-set)

13.5**CT and VT Ratios**

Main VT Primary:	100 V...1 MV
Main VT Sec'y:	80...140 V
CS VT Primary:	100 V...1 MV
CS VT Secondary:	80...140 V
Phase CT Primary:	1 A...30 kA
Phase CT Sec'y:	1 A/5 A
SEF CT Primary:	1 A...30 kA
SEF CT Sec'y:	1 A/5 A
CS Input:	A-N, B-N, C-N, A-B, B-C, C-A
Main VT Location:	Line/Bus
CT Polarity:	Standard /Inverted
SEF CT Polarity:	Standard /Inverted
CS VT PhShft:	-180...+180 deg
CS VT Mag:	0.2...3

13.6 Sequence of Event Recorder (Record Control)

Alarm Event:	Disabled/Enabled
Relay O/P Event:	Disabled/Enabled
Opto Input Event:	Disabled/Enabled
General Event:	Disabled/Enabled
Fault Rec Event:	Disabled/Enabled
Maint Rec Event:	Disabled/Enabled
Protection Event:	Disabled/Enabled
Security Event:	Disabled/Enabled
Flt Rec Extended:	Disabled/Enabled (where available)
DDB 31 - 0:	(up to):
DDB 1791 - 1760:	Binary function link strings, selecting which DDB signals will be stored as events, and which will be filtered out.

13.7 Oscillography (Disturb Recorder)

Duration:	0.10...10.50s
Trigger Position:	0.0...100.0%
Trigger Mode:	Single/Extended
Analog Channel 1: (up to):	Analog Channel 12:
Disturbance channels selected from:	
IA, IB, IC, IN, IN Sensitive, VA, VB, VC, V CheckSync	
Digital Input 1: (up to):	Digital Input 32:
Selected binary channel assignment from any DDB status point within the relay (opto input, output contact, alarms, starts, trips, controls, logic...).	
Input 1 Trigger: (up to):	No Trigger or
Input 32 Trigger:	Trigger L/H (Low to High) or
	Trigger H/L (High to Low)

13.8 Measured Operating Data (Measure't Setup)

Default Display:	Banner / 3Ph + N Current / 3Ph Voltage / Power / Date and Time / Description / Plant Reference / Frequency / Access Level
Local Values:	Primary/Secondary
Remote Values:	Primary/Secondary
Measurement Ref:	VA/VB/VC/IA/IB/IC
Measurement Mode:	0/1/2/3
Fix Dem. Period:	1...99 mins
Roll Sub Period:	1...99 mins
Num. Sub Periods:	1...15
Distance Unit:	Miles/Kilometers
Fault Location:	Distance Ohms % of Line
Remote2 Values:	Primary/Secondary

13.9 Communications**13.9.1 Courier Protocol**

Courier protocol:	Protocol and RP1 Card Status indicated
RP1 Address:	0 to 255 (step 1)
RP1 Inactiv timer:	1min to 30 mins (step 1min)
RP1 Physical link:	Copper/Fibre optic
RP1 Port configuration:	K-Bus/EIA485 (RS485)
RP1 comms mode:	IEC60870 FT1.2/10-Bit No Parity
RP1 Baud Rate:	9600/19200/38400 bits/s

13.9.2 IEC60870-5-103 Protocol

IEC60870-5-103 protocol:	Protocol indicated
RP1 Address:	1 to 254 (step 1)
RP1 Inactiv timer:	1min to 30 mins (step 1min)
RP1 Baud Rate:	9600/19200 bits/s
RP1 Measurement period:	1s to 60s (step 1s)
RP1 Physical link:	Copper/Fibre optic
CS103 blocking:	Disabled/Monitor blocking/Command blocking

13.9.3 MODBUS Protocol

Modbus protocol:	Protocol indicated
RP1 Address:	1 to 247 (step 1)
RP1 Inactiv timer:	1min to 30 mins (step 1min)
RP1 Baud Rate:	9600/19200/38400 bits/s
RP1 Parity:	Odd/Even/None
RP1 Physical link:	Copper/Fibre optic
Modbus IEC Time:	Standard/Reverse

13.9.4 DNP3.0 Protocol (Serial)

DNP3.0 protocol:	Protocol indicated
RP1 Address:	1 to 65519 (step 1)
RP1 Baud Rate:	1200/2400/4800/9600/19200/38400 bits/s
RP1 Parity:	Odd/Even/None
RP1 Physical link:	RS485/Fibre optic
DNP Time Sync:	Disabled/Enabled
Meas scaling:	Primary/Secondary/Normalised
Message gap:	0ms to 50ms (step 1ms)
DNP Need Time:	1min to 30mins (step 1min)
DNP Application fragment size:	100 to 2048 (step 1)
DNP Application fragment timeout:	1s to 120s (step 1s)
DNP SBO timeout:	1s to 10s (step 1s)
DNP link timeout:	0s to 120s (step 1s)

13.9.5 Ethernet Port, IEC61850 Protocol

Ethernet port, IEC61850 Protocol:	Protocol, NIC MAC address(es), Redundancy IP address, Subnet mask and Gateway address indicated
ETH tunnel timeout:	1min to 30min (step 1min)

13.9.6 Ethernet Port, DNP3.0 Protocol

Ethernet port, DNP3.0 protocol:	Protocol, NIC MAC address(es), Redundancy IP address, Subnet mask and Gateway address indicated
DNP Time Sync:	Disabled/Enabled
Meas scaling:	Primary/Secondary/Normalised
DNP need time:	1min to 30mins (step 1min)
DNP Application Fragment size:	100 to 2048 (step 1)
DNP Application fragment timeout:	1s to 120s (step 1s)
DNP SBO timeout:	1s to 10s (step 1s)
DNP Link timeout:	0s to 120s (step 1s)
ETH tunnel timeout:	1min to 30mins (step 1min)

13.10 Optional Additional Second Rear Communication (Rear Port2 (RP2))

RP2 Protocol:	Courier (fixed)
RP2 Port Config:	Courier over EIA(RS)232 or Courier over EIA(RS)485 or K-Bus
RP2 Comms. Mode:	IEC60870 FT1.2 Frame 10-Bit NoParity
RP2 Address:	0...255
RP2 InactivTimer:	1...30mins
RP2 Baud Rate:	9600 or 19200 or 38400 bits/s

13.11 Commission Tests

Monitor bit 1: (up to):	Selects which DDB signals have their status visible in the Test Port Status.
Monitor bit 8:	
Test Mode:	Disabled / Enabled / Contacts Blocked
Test Pattern:	Configuration of which output contacts are to be energized when the contact test is applied
Contact test:	No operation/Apply test/Remove test
Test LEDs:	No operation/Apply test
Test Autoreclose:	No operation/Trip 3-pole/ Trip Pole A/Trip Pole B/Trip Pole C
Static Test:	Disabled/Enabled
Test Loopback:	Disabled, External, Internal
Loopback Mode:	Disabled, External, Internal
IM64 TestPattern:	Configuration of which InterMiCOM64 commands are to be set high or low for a loopback test.
IM64 Test Mode	Enabled/Disabled

13.12 Circuit Breaker Condition Monitoring (CB Monitor Setup)

Broken I ^Δ :	1.0...2.0
I ^Δ Maintenance:	Alarm Disabled/Enabled
I ^Δ Maintenance:	1...25000
I ^Δ Lockout:	Alarm Disabled/Enabled
I ^Δ Lockout:	1...25000
No. CB Ops Maint:	Alarm Disabled/Enabled
No. CB Ops Maint:	1...10000
No. CB Ops Lock:	Alarm Disabled/Enabled
No. CB Ops Lock:	1...10000
CB Time Maint:	Alarm Disabled/Enabled
CB Time Maint:	0.005...0.500s
CB Time Lockout:	Alarm Disabled/Enabled
CB Time Lockout:	0.005...0.500s
Fault Freq. Lock:	Alarm Disabled/Enabled
Fault Freq. Count:	1...9999
Fault Freq. Time:	0...9999s

13.13	Optocoupled Binary Inputs (Opto Config.)
Global Nominal V:	24 – 27 V / 30 – 34 V / 48 – 54 V / 110 – 125 V / 220 – 250 V / Custom
Opto Input 1 (up to):	
Opto Input #. (# = max. opto no. fitted):	Custom options allow independent thresholds to be set for each opto, from the same range as above.
Opto Filter Control:	Binary function link string, selecting which optos have an extra 1/2 cycle noise filter, and which do not.
Characteristics:	Standard 60% - 80% / 50% - 70%
Time stamping accuracy:	±1 msec

13.14	Settable Control Inputs (Control Inputs)
--------------	---

Ctrl Setg I/P 33:	Disabled/Enabled
(up to)	
Ctrl Steg I/P 48:	Disabled/Enabled

13.15	EIA(RS)232 Teleprotection (INTERMiCOM Comms.)
--------------	--

Source Address:	1...10
Received Address:	1...10
Data Rate:	600 / 1200 / 2400 / 4800 / 9600 / 19200 baud
Loopback Mode:	Disabled/Internal/External
Test Pattern:	Configuration of which InterMiCOM signals are to be energized when the loopback test is applied.

13.16	INTERMiCOM CONF
--------------	------------------------

IM Msg Alarm Lvl:	0.1...100.0%
IM1 Cmd Type:	(up to):
IM4 Cmd Type:	Disabled/Direct/Blocking
IM5 Cmd Type:	(up to):
IM8 Cmd Type:	Disabled/Permissive/ Direct
IM1 FallBackMode:	(up to):
IM8 FallBackMode:	Default/Latched
IM1 DefaultValue:	(up to):
IM8 DefaultValue:	0/1
IM1 FrameSyncTim:	(up to):
IM8 FrameSyncTim:	1 ms...1 s

13.17	IED Configurator
--------------	-------------------------

GoEna:	0000000000000000(bin)... 1111111111111111(bin)
Pub.Simul.Goose:	0000000000000000(bin)... 1111111111111111(bin)
Sub.Simul.Goose:	No/Yes

13.18	PROT COMMS./IM64
--------------	-------------------------

Scheme Setup:	2 Terminal/Dual Redundant/3 Terminal
Address:	0-0, 1-A...20-A, 1-B...20-B
Address:	0-0, 1-A...20-A, 1-B...20-B, 1-C...20-C
Comm Mode:	Standard/IEEE C37.94
Baud Rate Ch 1:	56kbits/s or 64kbits/s
Baud Rate Ch 2:	56kbits/s or 64kbits/s
Clock Source Ch1:	Internal or External
Clock Source Ch2:	Internal or External
Ch1 N*64kbits/s:	Auto, 1, 2, 3... 12
Ch2 N*64kbits/s:	Auto, 1, 2, 3... 12

Comm Delay Tol:	0.001 s...0.00005 s
Comm Fail Timer:	0.1 s...600 s
Comm Fail Mode:	Ch 1 Failure/Ch 2 Failure/Ch 1 or Ch 2 Fail/Ch 1 and Ch 2 Fail
GPS Sync:	GPS Disabled, GPS→Standard, GPS→Inhibit, GPS→Restrain
Prop Delay Equal:	No operation/Restore CDiff
Re-Configuration:	Three Ended/Two Ended (R1&R2)/ Two Ended (L&R2)/Two Ended (L&R1)
Alarm Level:	0%...100%
Prop Delay Stats:	Disabled or Enabled
MaxCh 1 PropDelay:	1 m...50 ms
MaxCh 2 PropDelay:	1 m...50 ms
TxRx Delay Stats:	Disabled or Enabled
MaxCh1 Tx-RxTime:	1 m...50 ms
MaxCh2 Tx-RxTime:	1 m...50 ms
GPS Fail Timer:	0...9999 s
GPS Trans Fail:	Disabled or Enabled
GPS Trans Count:	1...100 s
GPS Trans Timer:	0...9999 s
GPS Sync los Dly:	0...100s
IMx Cmd Type:	Direct or Permissive
IMx FallBackMode:	Default or Latched
IMxDefaultValue:	0 or 1

(x=1 to 8). The IM1 – IM8 settings are common to both Ch1 and Ch2 (i.e. if IM1
DefaultValue is set to 0, it will be 0 on Ch1 and on Ch2)

13.19**Security Config**

Front Port:	Disabled/Enabled
Rear Port 1:	Disabled/Enabled
Rear Port 2:	Disabled/Enabled
ETH Port 1:	Disabled/Enabled
ETH Port 1/2:	Disabled/Enabled
ETH Port 2/3:	Disabled/Enabled
ETH Port 3:	Disabled/Enabled

14 PROTECTION FUNCTIONS (IN MULTIPLE GROUPS)

14.1 Line Parameters

Line Length (km):	0.30...1000.00 km
Line Length (miles):	0.20...625.00 mi
Line Impedance:	0.05...500.00/In Ω
Line Angle:	20...90°
kZN Res Comp.:	0.00...10.00
kZN Res Angle:	-180...90°
Phase Sequence:	Standard ABC or Reverse ACB
CB Tripping Mode:	3 Pole or 1 and 3 Pole
Line Charging Y:	0.00...10.00 ms

14.2 Distance Setup

Setting Mode:	Simple/Advanced
---------------	-----------------

14.3 Phase Distance

Zone 1 Ph Status:	Disabled/Enabled
Zone 1 Ph Reach:	10...1000% of line
Zone 2 Ph Status:	Disabled/Enabled
Zone 2 Ph Reach:	10...1000% of line
Zone 3 Ph Status:	Disabled/Enabled
Zone 3 Ph Reach:	10...1000% of line
Zone 3 Ph Offset:	Disabled/Enabled
Zone 3 Ph Rev Reach:	10...1000% of line
Zone P Ph Status:	Disabled/Enabled
Zone P Ph Dir.:	Forward/Reverse
Zone P Ph Reach:	10...1000% of line
Zone 4 Ph Status:	Disabled/Enabled
Zone 4 Ph Reach:	10...1000% of line
Zone Q Ph Status:	Disabled/Enabled
Zone Q Ph Dir.:	Forward/Reverse
Zone Q Ph Reach:	0.05...500.00/In Ω

14.4 Ground Distance

Ground Chars.:	Disabled/Mho/Quadrilateral
Quad Resistance:	Common/Proportional
Fault Resistance:	0.05...500.00/In Ω
Zone1 Gnd Status:	Disabled/Enabled
Zone1 Gnd Reach:	10...1000% of line
Zone2 Gnd Status:	Disabled/Enabled
Zone2 Gnd Reach:	10...1000% of line
Zone3 Gnd Status:	Disabled/Enabled
Zone3 Gnd Reach:	10...1000% of line
Zone3 Gnd Offset:	Disabled/Enabled
Z3Gnd Rev Reach:	10...1000% of line
ZoneP Gnd Status:	Disabled/Enabled
ZoneP Gnd Direction:	Forward/Reverse
ZoneP Gnd Reach:	10...1000% of line
Zone4 Gnd Status:	Disabled/Enabled
Zone4 Gnd Reach:	10...1000% of line
ZoneQ Gnd Status:	Disabled/Enabled
ZoneQ Gnd Direction:	Forward/Reverse
ZoneQ Gnd Reach:	0.05...500.00/In Ω
Digital Filter:	Standard / Special Applies

CVT Filters:	Disabled / Passive / Active
SIR Setting: (for CVT):	5...60
Load Blinders:	Disabled/Enabled
Load/B Impedance:	0.10...500.00/In Ω
Load/B Angle:	15...65°
Load Blinder V<:	1.0...70.0V (ph-g)
Distance Polarizing:	0.2...5.0

14.5 Delta Direction

Delta Status	Disabled/Enabled
Delta Char Angle:	0°...90°

14.6 Phase Distance Parameters

Z1 Ph. Reach:	0.05...500.00/In Ω
Z1 Ph. Angle:	20...90°
Z1 Ph. Sensit. Iph>1:	0.050...2.000 In
Z2 Ph. Reach:	0.05...500.00/In Ω
Z2 Ph. Angle:	20...90°
Z2 Ph Resistive:	0.05...500.00/In Ω
Z3 Ph. Reach:	0.05...500.00/In Ω
Z3 Ph. Angle:	20...90°
Z3' Ph Rev Reach:	0.05...500.00/In Ω
Z3 Ph. Sensit. Iph>3:	0.050...2.000 In
ZP Ph. Reach:	0.05...500.00/In Ω
ZP Ph. Angle:	20...90°
ZP Ph. Sensit. Iph>P:	0.050...2.000In
Z4 Ph. Reach:	0.05...500.00/In Ω
Z4 Ph. Angle:	20...90°
Z4 Ph. Sensit. Iph>4:	0.050...2.000 In
ZQ Ph. Reach:	0.05...500.00/In Ω
ZQ Ph. Angle:	20...90°
ZQ Ph. Sensit. Iph>Q:	0.050...2.000 In

14.7 Ground Distance Parameters

Z1 Gnd. Reach:	0.05...500.00/In Ω
Z1 Gnd. Angle:	20...90°
Z1 Dynamic Tilt:	Disabled or Enabled
Z1 Tilt top line:	-30°...30°
kZN1 Res. Comp.:	0.00...10.00
kZN1 Res. Angle:	-180...90°
R1 Gnd. Resistive:	0.05...500.00/In Ω
Z1 Sensit I _{gnd} >1:	0.050...2.000 In
Z2 Gnd. Reach:	0.05...500.00/In Ω
Z2 Gnd. Angle:	20...90°
Z2 Dynamic Tilt:	Disabled or Enabled
Z2 Tilt top line:	-30°...30°
kZN2 Res. Comp.:	0.00...10.00
kZN2 Res. Angle:	-180...90°
R2 Gnd Resistive:	0.05...500.00/In Ω
Z2 Sensit I _{gnd} >2:	0.050...2.000 In
Z3 Gnd. Reach:	0.05...500.00/In Ω
Z3 Gnd. Angle:	20...90°
Z3' Gnd Rev Rch:	0.05...500.00/In Ω
Z3 Dynamic Tilt:	Disabled or Enabled
Z3 Tilt top line:	-30°...30°

kZN3 Res. Comp.:	0.00...10.00
kZN3 Res. Angle:	-180...90°
R3 Gnd Res. Fwd:	0.05...500.00/In Ω
R3' Gnd Res. Rev:	0.05...500.00/In Ω
Z3 Sensit Ignd>3:	0.050...2.000 In
ZP Ground Reach:	0.05...500.00/In Ω
ZP Ground Angle:	20...90°
ZP Dynamic Tilt:	Disabled or Enabled
ZP Tilt top line:	-30°...30°
kZNP Res. Comp.:	0.00...10.00
kZNP Res. Angle:	-180...90°
RP Gnd Resistive:	0.05...500.00/In Ω
ZP Sensit Ignd>P:	0.050...2.000 In
Z4 Gnd. Reach:	0.05...500.00/In Ω
Z4 Gnd. Angle:	20...90°
Z4 Dynamic Tilt:	Disabled or Enabled
Z4 Tilt top line:	-30°...30°
kZN4 Res. Comp.:	0.00...10.00
kZN4 Res. Angle:	-180...90°
R4 Gnd. Resistive:	0.05...500.00/In Ω
Z4 Gnd Sensitivity:	0.050...2.000 In
Zone Q Grid Reach:	0.05...500.00/In Ω
ZQ Ground Angle:	20...90°
ZQ Dynamic Tilt:	Disabled or Enabled
ZQ Tilt top line:	-30°...30°
kZNP Res. Comp.:	0.00...10.00
kZNP Res. Angle:	-180...90°
RQ Gnd Resistive:	0.05...500.00/In Ω
ZQ Sensit Ignd>Q:	0.050...000 In

14.8 Scheme Logic

14.8.1 Basic Scheme

Zone 1 Tripping:	Disabled/Phase only/Ground only/Phase and Ground
tZ1 Ph. Delay:	s...10s
tZ1 Gnd. Delay:	0s...10s
Zone 2 Tripping:	Disabled/Phase only/Ground only/Phase and Ground
tZ2 Ph. Delay:	s...10s
tZ2 Gnd. Delay:	0s...10s
Zone 3 Tripping:	Disabled/Phase only/Ground only/Phase and Ground
tZ3 Ph. Delay:	s...10s
tZ2 Gnd. Delay:	0s...10s
Zone P Tripping:	Disabled/Phase only/Ground only/Phase and Ground
tZP Ph. Delay:	0s...10s
tZP Gnd. Delay:	0s...10s
Zone 4 Tripping:	Disabled/Phase only/Ground only/Phase and Ground
tZ4 Ph. Delay:	s...10s
tZ4 Gnd. Delay:	0s...10s
Zone Q Tripping:	Disabled/Phase only/Ground only/Phase and Ground
tZQ Ph. Delay:	0s...10s
tZQ Gnd. Delay:	0s...10s

14.8.2**Aided Scheme 1**

Aid 1 Selection:	Disabled / PUR / PUR / Unblocking / POR / POR / Unblocking / Blocking 1 / Blocking 2 / Prog Unblocking / Programmable
Aid 1 Distance:	Disabled / Phase Only / Ground only / Phase and Ground
Aid 1 Dist. Dly:	0 s...1 s
Unblocking Delay:	0 s...0.1 s
Aid 1 DEF:	Disabled / Enabled
Aid 1 DEF Dly:	0 s...1 s
tREV Guard:	0 s...0.15 s
Unblocking Delay:	0 s...0.1 s
Send on Trip:	Aided/Z1, Any Trip or None
Weak Infeed:	Disabled / Echo / Echo and Trip
WI V< Thresh:	10 V...70 V
WI Trip Delay:	0 s...1 s
Custom Send Mask:	Bit 0 = Z1 Gnd / Bit 1 = Z2 Gnd / Bit 2 = Z4 Gnd / Bit 3 = Z1 Ph / Bit 4 = Z2 Ph / Bit 5 = Z4 Ph / Bit 6 = DEF Fwd / Bit 7 = DEF Rev / Bit
Custom Time PU:	0 s...1 s
Custom Time DO:	0 s...1 s

14.8.3**Aided Scheme 2**

(As per aided scheme 1)

14.9**Trip on Close**

SOTF Status:	Disabled/Enabled Pole Dead/Enabled ExtPulse/En Pdead + Pulse
SOTF Delay:	0.2s...1000s
SOTF Tripping:	Bit 00 = Zone 1 / Bit 01 = Zone 2 / Bit 02 = Zone 3 / Bit 03 = Zone P / Bit 04 = Zone 4 / Bit 05 = Zone Q / Bit 06 = Current No Volts
TOR Status	Disabled/Enabled
TOR Tripping:	Bit 00 = Zone 1 / Bit 01 = Zone 2 / Bit 02 = Zone 3 / Bit 03 = Zone P / Bit 04 = Zone 4 / Bit 05 = Zone Q / Bit 06 = Current No Volts
TOC Reset Delay:	0.1s...2s
TOC Delay	0.05s...0.2s
SOTF Pulse:	0.1s...10s

14.10**Z1 Extension**

Z1 Ext Scheme:	Disabled/Enabled/En. On Ch1 Fail/En. On Ch2 Fail/En All Ch Fail/En. anyCh Fail
Z1 Ext Ph:	100%...200%
Z1 Ext Gnd:	100%...200%

14.11**Loss of Load**

LOL Scheme:	Disabled/Enabled/En. On Ch1 Fail/En. On Ch2 Fail/En All Ch Fail/En. Any Ch Fail
LOL <l:	0.05 x In...1 x In
LOL Window:	0.01s 0.1s Phase

14.12**Phase Overcurrent**

I>1 Status:	Disabled, Enabled or Enabled VTS
I>1 Function:	DT / IEC S Inverse / IEC V Inverse / IEC E Inverse / UK LT Inverse / IEEE M Inverse / IEEE V Inverse / IEEE E Inverse / US Inverse / US ST Inverse
I>1 Directional:	Non-Directional / Directional Fwd / Directional Rev
I>1 Current Set:	0.08...4.00 In
I>1 Time Delay:	0.00...100.00 s
I>1 TMS:	0.025...1.200
I>1 Time Dial:	0.01...100.00
I>1 Reset Char:	DT/Inverse
I>1 tRESET:	0.00...100.00 s
I>2 Status (up to):	
I>2 tRESET	All settings and options chosen from the same ranges as per the first stage overcurrent, I>1.
I>3 Status:	Disabled, Enabled or Enabled VTS
I>3 Directional:	Non-Directional, Directional Fwd or Directional Rev
I>3 Current Set:	0.08...32.00 In
I>3 Time Delay:	0.00...100.00 s
I>4 Status (up to):	
I>4 Time Delay	All settings and options chosen from the same ranges as per the third stage overcurrent, I>3.
I> Char Angle:	-95...95°
I> Blocking:	Binary function link string, selecting which overcurrent elements (stages 1 to 4) will be blocked if VTS detection of fuse failure occurs.

14.13**Negative Sequence Overcurrent (Neg Seq O/C)**

I2>1 Status:	Enabled/Disabled
I2>1 Function:	Disabled / DT / IEC S Inverse / IEC V Inverse / IEC E Inverse / UK LT Inverse / IEEE M Inverse / IEEE V Inverse / IEEE E Inverse / US Inverse / US ST Inverse
I2>1 Direction:	Non-Directional / Directional Fwd / Directional Rev
I2>1 Current Set:	0.08...4.00 In
I2>1 Time Delay:	0.00...100.00 s
I2>1 TMS:	0.025...1.200
I2>1 Time Dial:	0.01...100.00
I2>1 Reset Char.:	DT/Inverse
I2>1 tRESET:	0.00...100.00 s
I2>2 Status (up to):	
I2>2 tRESET	All settings and options chosen from the same ranges as per the first stage overcurrent, I2>1.
I2>3 Status:	Disabled or Enabled
I2>3 Direction:	Non-Directional / Directional Fwd / Directional Rev
I2>3 Current Set:	0.08...32.00 In
I2>3 Time Delay:	0.00...100.00 s
I2>4 Status (up to):	
I2>4 Time Delay	All settings and options chosen from the same ranges as per the third stage overcurrent, I2>3.
I2> VTS Blocking:	Binary function link string, selecting which Neg. Seq. O/C elements (stages 1 to 4) will be blocked if VTS detection of fuse failure occurs
I2> Char Angle:	-95...95°
I2> V2pol Set:	0.5...25.0 (100 – 110 V)

14.14 Broken Conductor

Broken Conductor: Disabled/Enabled
 I2/I1 Setting: 0.20...1.00
 I2/I1 Time Delay: 0.0...100.0 s

14.15 Ground Overcurrent (Earth Fault)

IN>1 Status: Disabled / Enabled / Enabled VTS / Enabled Ch Fail /
 En VTSorCh Fail / En VTSandCh Fail / Enabled CTS /
 En VTSorCTS / En Ch FailorCTS / En VTSorCHForCTS /
 En VTSandCTS / En Ch FailandCTS / En VTS CHF CTS

IN>1 Function: DT / IEC S Inverse/IEC V Inverse/IEC E Inverse/
 UK LT Inverse/IEEE M Inverse/IEEE V Inverse/IEEE E Inverse/
 US Inverse/US ST Inverse / IDG

IN>1 Directional: Non-Directional/Directional Fwd/Directional Rev

IN>1 Current Set: 0.08...4.00 In

IN>1 IDG Is: 1...4

IN>1 IDG Time: 1...2

IN>1 Time Delay: 0.00...200.00 s

IN>1 TMS: 0.025...1.200

IN>1 Time Dial: 0.01...100.00

IN>1 Reset Char: DT/Inverse

IN>1 tRESET: 0.00...100.00 s

IN>2 Status *(up to):*

IN>2 tRESET All settings and options chosen from the same ranges as per
 the first stage ground overcurrent, IN>1.

IN>3 Status: Disabled / Enabled / Enabled VTS / Enabled Ch Fail /
 En VTSorCh Fail / En VTSandCh Fail / Enabled CTS /
 En VTSorCTS / En Ch FailorCTS / En VTSorCHForCTS /
 En VTSandCTS / En Ch FailandCTS / En VTS CHF CTS

IN>3 Directional: Non-Directional/Directional Fwd /Directional Rev

IN>3 Current Set: 0.08...32.00 In

IN>3 Time Delay: 0.00...200.00 s

IN>4 Status *(up to):*

IN>4 Time Delay All settings and options chosen from the same ranges as per
 the third stage ground overcurrent, IN>3.

IN> Blocking: Binary function link string, selecting which ground overcurrent
 elements (stages 1 to 4) will be blocked if VTS detection of
 fuse failure occurs.

IN> DIRECTIONAL

IN> Char Angle: -95...95°

IN> Polarization: Zero or Neg Sequence

IN> VNpol Set: 0.5...40.0 V

IN> V2pol Set: 0.5...25.0 V

IN> I2pol Set: 0.02...1.00 In

14.16 Directional Aided Schemes - DEF Settings

DEF Status: Disabled/Enabled

DEF Polarizing: Zero Sequence (virtual current pol) or Neg Sequence

DEF Char Angle: -95...95°

DEF VNpol Set: 0.5...40.0V

DEF V2pol Set: 0.5...25.0V

DEF Fwd Set: 0.08...1.00 In

DEF Rev Set: 0.04...1.00 In

14.17	Sensitive Earth Fault (SEF)
SEF/REF Options:	SEF Enabled / Wattmetric SEF, HI Z REF
SEF>1 Function:	Disabled / DT / IEC S Inverse / IEC V Inverse / IEC E Inverse / UK LT Inverse / IEEE M Inverse / IEEE V Inverse / IEEE E Inverse / US Inverse / US ST Inverse / IDG
ISEF>1 Directional:	Non-Directional / Directional Fwd / Directional Rev
ISEF>1 Current Set:	0.005...0.1 In _{SEF}
ISEF>1 IDG Is:	1...4
ISEF>1 IDG Time:	1...2 s
ISEF>1 Time Delay:	0 s...200 s
ISEF>1 TMS:	0.025...1.2
ISEF>1 Time Dial:	0.01...100
ISEF>1 Reset Char:	DT/Inverse
ISEF>1 tRESET:	0 s-100 s
ISEF>2 as ISEF>1	
ISEF>3 Status:	Disabled / Enabled
ISEF>3 Directional:	Non-Directional / Directional Fwd / Directional Rev
ISEF>3 Current Set:	0.05...2.00 In _{SEF}
ISEF>3 Time Delay:	0 s...200s
ISEF>3 Intertrip:	Enabled/Disabled
ISEF>4 as ISEF>3	
ISEF> Blocking	Bit 00 VTS Blks ISEF>1 Bit 01 VTS Blks ISEF>2 Bit 02 VTS Blks ISEF>3 Bit 03 VTS Blks ISEF>4 Bit 04 Not Used Bit 05 Not Used
ISEF> Directional	
ISEF> Char Angle:	-95°...95° deg
ISEF> VNpol Set:	0.5...80 V

14.17.1	Wattmetric SEF
PN> Setting:	0...20 In _{SEF} W

14.18	Neutral Voltage Displacement (Residual O/V NVD)
VN>1 Function:	Disabled / DT / IDMT
VN>1 Voltage Set:	1...200 V
VN>1 Time Delay:	0.00...100.00 s
VN>1 TMS:	0.5...100.0
VN>1 tReset:	0.00...100.00 s
VN>2 Status:	Disabled/Enabled
VN>2 Voltage Set:	1...200 V
VN>2 Time Delay:	0.00...100.00 s

14.19	Thermal Overload
Characteristic:	Disabled / Single / Dual
Thermal Trip:	0.08...4.00 In
Thermal Alarm:	50...100%
Time Constant 1:	1...200 mins
Time Constant 2:	1...200 mins

14.20 Power Swing/Out Of Step

Power Swing:	Blocking, Indication
PSB Reset Delay:	0.05...2.00s
Zone 1 Ph PSB:	(up to):
Zone 4 Ph PSB:	Blocking/Allow Trip
Zone 1 Gnd PSB:	(up to):
Zone 4 Gnd PSB:	Blocking/Allow Trip
PSB Unblocking:	Disabled/Enabled
PSB Unblock Delay:	0.1...20.0s
PSB Reset Delay:	0.5...2.0s

14.21 Undervoltage Protection

V< Measur't Mode:	V<1 & V<2 Ph-Ph / V<1 & V<2 Ph-N / V<1Ph-Ph V<2Ph-N / V<1Ph-N V<2Ph-Ph
V< Operate Mode:	V<1 & V<2 Any Ph / V<1 & V<2 3Phase / V<1AnyPh V<2 3Ph / V<1 3Ph V<2AnyPh
V<1 Function:	Disabled / DT / IDMT
V<1 Voltage Set:	10...120 V
V<1 Time Delay:	0.00...100.00 s
V<1 TMS:	0.5...100.0
V<1 Poledead Inh:	Disabled/Enabled
V<2 Status:	Disabled/Enabled
V<2 Voltage Set:	10...120 V
V<2 Time Delay:	0.00...100.00 s
V<2 Poledead Inh:	Disabled/Enabled

14.22 Overvoltage Protection

V> Measur't Mode:	V>1 & V>2 Ph-Ph / V>1 & V>2 Ph-N / V>1Ph-Ph V>2Ph-N / V>1Ph-N V>2Ph-Ph
V> Operate Mode:	V>1 & V>2 Any Ph / V>1 & V>2 3Phase / V>1AnyPh V>2 3Ph / V>1 3Ph V>2AnyPh
V>1 Function:	Disabled / DT / IDMT
V>1 Voltage Set:	60...185 V
V>1 Time Delay:	0.00...100.00 s
V>1 TMS:	0.5...100.0
V>2 Status:	Disabled/Enabled
V>2 Voltage Set:	60...185 V
V>2 Time Delay:	0.00...100.00 s
V1>1 Cmp Funct:	Disabled / DT / IDMT
V1>1 Cmp Vlt Set:	60...110 V
V1>1 Cmp Tim Dly:	0.00...100.00 s
V1>1 CmpTMS:	0.5...100.0
V1>2 Cmp Status:	Disabled/Enabled
V1>2 Vlt Set:	60...110 V
V1>2 CmpTim Dly:	0.00...100.00 s

14.23 Underfrequency Protection

F<1 Status:	Disabled/Enabled
F<1 Setting:	45.00...65.00 Hz
F<1 Time Delay:	0.00...100.00 s
F<2 Status (up to):	F<4 Time Delay
All settings and options chosen from the same ranges as per the 1st stage.	
F> Blocking:	Binary function link string, selecting which frequency elements (stages 1 to 4) will be blocked by the pole-dead logic.

14.24 Overfrequency Protection

F>1 Status:	Disabled/Enabled
F>1 Setting:	45.00...65.00 Hz
F>1 Time Delay:	0.00...100.00 s
F>2 Status (up to):	All settings and options chosen from the same ranges
F>2 Time Delay	as per the 1st stage.

14.25 Rate-of-Change of Frequency Protection ($\Delta f/\Delta t$ Protection)

$\Delta f/\Delta t$ Avg. Cycles:	6...12
$\Delta f/\Delta t > 1$ Status:	Disabled/Enabled
$\Delta f/\Delta t > 1$ Setting:	0.1...10.0 Hz
$\Delta f/\Delta t > 1$ Dir'n.:	Negative/Positive/Both
$\Delta f/\Delta t > 1$ Time:	0.00...100.00 s
$\Delta f/\Delta t > 2$ Status: (up to):	
$\Delta f/\Delta t > 4$ Time	All settings and options chosen from the same ranges as per the 1st stage.

14.26 Circuit Breaker Fail and Pole Dead Logic (CB Fail and P.Dead)

CB Fail 1 Status:	Disabled/Enabled
CB Fail 1 Timer:	0.00...10.00 s
CB Fail 2 Status:	Disabled/Enabled
CB Fail 2 Timer:	0.00...10.00 s
Volt Prot. Reset:	I< Only / CB Open & I< / Prot. Reset & I<
Ext Prot. Reset:	I< Only / CB Open & I< / Prot. Reset & I<
WI Prot Reset:	Disabled / Enabled
CB1 I< Current Set:	0.02...3.20 In
CB2 I<Current:	0.02...3.20 In
ISEF< Current Set:	0.001...0.8 In _{SEF}
Poledead V<:	10...40 V
Poledead I<:	0.02...3.20 In
I< Current Set:	0.02...3.20 In
I _{SEF} < Current Set:	0.001...0.8 In _{SEF}
CB2 CB Fail1 Status:	All settings and options chosen from the same ranges as per (up to) the first CB above
CB2 Ext Prot Rst:	

Note	I< Current Set and I_{SEF}< Current Set are applicable for 1CB product P443/P445/P543/P545/P841A; CB1 I< Current Set , CB2 I<Current Set and I_{SEF}< Current Set are applicable for 2CB product P446/P544/P546/P841B.
------	--

15 SUPERVISION FUNCTIONS (IN MULTIPLE GROUPS)

15.1 Voltage Transformer Supervision (VTS)

VTS Mode:	Measured + MCB, Measured Only or MCB Only
VTS Status:	Disabled/Blocking/Indication
VTS Reset Mode:	Manual/Auto
VTS Time Delay:	1 s...10 s
VTS I> Inhibit:	0.08...32 x In
VTS I2> Inhibit:	0.05...0.5 x In

15.1.1 Inrush Detection

Inrush Detection:	Disabled/Enabled
I> 2nd Harmonic:	10%...100%

15.1.2 Weak Infeed Blk

WI Inhibit:	Disabled/Enabled
I0/I2 Setting:	2...3

15.2 Current Transformer Supervision (CTS)

CTS Mode:	Disabled / Standard / I Diff / Idiff + Std
CTS Status:	Restrain / Indication
CTS Reset Mode:	Manual / Auto
CTS Time Delay:	0...10 s
CTS VN< Inhibit:	0.5...22 V
CTS IN> Set:	0.08...4.00 In
CTS i1>:	0.05...4.0 In
CTS i2/i1>:	0.05...1
CTS i2/i1>>:	0.05...1

15.2.1 Inrush Detection

I> 2nd Harmonic:	10%...100%
------------------	------------

15.2.2 Weak Infeed Blk

WI Inhibit:	Disabled/Enabled
I0/I2 Setting:	2...3

15.3 Trip Supervision (TS) or Fault Detector

Stage 1 Trip Supervision (TS):

Stage 1 TS:	Enabled / Disabled
I>Threshold:	0.08... 4In,
I>TS Elements	Bit 00 Zone 1 Bit 01 Zone 2 Bit 02 Zone 3 Bit 03 Zone P Bit 04 Zone 4 Bit 05 Zone Q Bit 06 Aided Dist Bit 07 Current Diff
IN>Threshold:	0.08... 4In,
IN>TS Elements:	same as I> TS Elements
OCD>Threshold:	0.05... 0.2In,
OCD>TS Elements:	same as I> TS Elements
Vpp<Threshold:	10... 120 V
Vpp<TS Elements:	same as I> TS Elements
Vpn<Threshold:	10... 120 V
Vpn<TS Elements:	same as I> TS Elements
UVD>Threshold:	1... 20 V
UVD>TS Elements:	same as I> TS Elements
OCD>Hold Timer:	0...10 s
UVD>Hold Timer:	0...10 s

Stage 2 Trip Supervision (TS)

same as Stage 1 TS

Stage 3 Trip Supervision (TS)

same as Stage 1 TS

15.4 Bus-Line Synchronism and Voltage Checks (System Checks)

Voltage Monitors:

Live Line:	5...132 V
Dead Line:	5...132 V
Live Bus:	5...132 V
Dead Bus:	5...132 V
CS UV:	5...120 V
CS OV:	60...200 V

Synchrocheck (Check Synch)

CS1 Status:	Enabled/Disabled
CS1 Angle:	0...90°
CS1 Vdiff:	1...120 V
CS1 SlipCtrl:	None, Timer, Frequency, Both
CS1 Slip Freq:	5 mHz...2 Hz
CS1 Slip Timer:	0.00...99.00 s
CS2 Status:	Enabled/Disabled
CS2 Angle:	0...90°
CS2 Vdiff:	1...120 V
CS2 SlipCtrl:	None, Timer, Frequency, Timer+Freq, Freq+CB Comp
CS2 Slip Freq:	5 mHz...2 Hz
CS2 Slip Timer:	0.0...99.0 s
CI Time:	10.0 ms...0.5 s
CS Voltage Block:	V< / V> / Vdiff.> / V< and V> / V< and Vdiff> / V> and Vdiff> / V< V> and Vdiff> / None

15.5**Auto-Reclose**

Single Pole Shot:	1/2/3/4
Three Pole Shot:	1/2/3/4
1 Pole Dead Time:	0.05...5.00s
Dead Time 1:	0.05...100.00s
Dead Time 2:	1...1800s
Dead Time 3:	1...3600s
Dead Time 4:	1...3600s
CB Healthy Time:	1...3600s
Reclaim Time:	1...600s
AR Inhibit Time:	0.01...600.00s
Check Sync Time:	0.01...9999.00s
Z2T AR:	(up to):
Z4T AR:	No Action, Initiate AR or Block AR

All time-delayed distance zones can be independently set not to act upon AR logic, to initiate a cycle, or to block.

DEF Aided AR:	No Action or Initiate AR or Block AR
TOR:	No Action or Initiate AR or Block AR
I>1 AR to I>4 AR:	No action, Block AR, Initiate AR

All overcurrent stages can be independently set not to act upon AR logic, to initiate a cycle, or to block.

IN>1 AR to IN>4 AR:	No action, Block AR, Initiate AR
---------------------	----------------------------------

All ground/earth overcurrent stages can be independently set not to act upon AR logic, to initiate a cycle, or to block.

ISEF>1 AR to ISEF>4 AR:	No action, Block AR, Initiate AR
-------------------------	----------------------------------

All ground/earth overcurrent stages can be independently set not to act upon AR logic, to initiate a cycle, or to block.

Mult Phase AR:	Allow Autoclose, BAR 2 and 3Ph or BAR 3 Phase
Dead Time Start:	Protection Op or Protection Reset
Discrim Time:	0.10...5.00s

Auto-Reclose System Checks

CheckSync1 Close:	Disabled/Enabled
CheckSync2 Close:	Disabled/Enabled
LiveLine/DeadBus:	Disabled/Enabled
DeadLine/LiveBus:	Disabled/Enabled
DeadLine/DeadBus:	Disabled/Enabled
CS AR Immediate:	Disabled/Enabled
SysChk on Shot 1:	Disabled/Enabled
SPDT Ext Time:	0...300.00 s
CB1 Pole Dis. Tm:	0...10.00s
CB2 Pole Dis. Tm:	0...10.00s

16 LABELS

16.1 Opto Input Labels

Opto Input 1: (up to): Opto Input 24:
User defined text string to describe the function of the particular opto input.

16.2 Opto Output Labels

Relay 1 to 32: Output R1 to Output R32
User-defined text string to describe the function of the particular relay output contact.

16.3 Disturbance Recorder Channel Labels (DR Chan Labels)

If the first character of the label is a space the default DDB naming is used.
Digital Input 1: (up to): Digital Input 128:
User defined text string to describe the function of the particular digital input.

16.4 Virtual Input Labels (VIR I/P Labels)

Virtual Input 1 to Virtual Input 32.
User-defined text string to describe the function of the particular virtual input.

16.5 Virtual Output Labels (VIR O/P Labels)

Virtual Output 1 to Virtual Output 32.
User-defined text string to describe the function of the particular virtual output.

16.6 SR/MR User Alarm Labels (USR Alarm Labels)

SR User Alarm 1 to SR User Alarm 4:
User-defined text string to describe the function of the particular self-reset user alarm.
MR User Alarm 5 to MR User Alarm 8:
User-defined text string to describe the function of the particular manual reset user alarm.

16.7 Control Input Labels

Control Input 1 (up to):	User defined text string to describe the function of the particular control input.
Control Input 32:	
Settable Control Input 33 (up to):	User defined text string to describe the function of the particular settable control input.
Settable Control Input 48:	

17 MEASUREMENTS LIST

17.1

Measurements 1

I_{φ} Magnitude
 I_{φ} Phase Angle Per phase ($\varphi = A, B, C$)
 Current Measurements
 IN derived Mag
 IN derived Angle
 ISEF Mag
 ISEF Angle
 I1 Magnitude
 I2 Magnitude
 I0 Magnitude
 I_{φ} RMS Per phase ($\varphi = A, B, C$)
 RMS Current Measurements
 IN RMS
 $V_{\varphi-\varphi}$ Magnitude
 $V_{\varphi-\varphi}$ Phase Angle
 V_{φ} Magnitude
 V_{φ} Phase Angle All phase-phase and phase-neutral voltages ($\varphi = A, B, C$).
 V1 Magnitude
 V2 Magnitude
 V0 Magnitude
 V_{φ} RMS
 $V_{\varphi-\varphi}$ RMS All phase-phase and phase-neutral voltages ($\varphi = A, B, C$).
 Frequency
 C/S Voltage Mag. (P143 and P145)
 C/S Voltage Ang. (P143 and P145)
 C/S Bus-line Ang. (P143 and P145)
 Slip Frequency (P143 and P145)
 I1 Magnitude
 I1 Phase Angle
 I2 Magnitude
 I2 Phase Angle
 I0 Magnitude
 I0 Phase Angle
 V1 Magnitude
 V1 Phase Angle
 V2 Magnitude
 V2 Phase Angle
 V0 Magnitude
 V0 Phase Angle
 V1 Rem Magnitude V1 Rem Phase Ang

17.2**Measurements 2**

φ Phase Watts	
φ Phase VArS	
φ Phase VA	All phase segregated power measurements, real, reactive and apparent ($\varphi = A, B, C$).
3 Phase Watts	
3 Phase VArS	
3 Phase VA	
Zero Seq Power	
3Ph Power Factor	
φ Ph Power Factor	Independent power factor measurements for all three phases ($\varphi = A, B, C$).
3Ph WHours Fwd	
3Ph WHours Rev	
3Ph VArHours Fwd	
3Ph VArHours Rev	
3Ph W Fix Demand	
3Ph VArS Fix Dem	
$I\varphi$ Fixed Demand	Maximum demand currents measured on a per phase basis ($\varphi = A, B, C$).
3Ph W Roll Dem	
3Ph VArS Roll Dem	
$I\varphi$ Roll Demand	Maximum demand currents measured on a per phase basis ($\varphi = A, B, C$).
3Ph W Peak Dem	
3Ph VAr Peak Dem	
$I\varphi$ Peak Demand	Maximum demand currents measured on a per phase basis ($\varphi = A, B, C$).
Thermal State	

17.3**Measurements 4**

Ch 1 Prop Delay	
Ch 2 Prop Delay	
Channel 1 Status	
Channel 2 Status	
Channel Status:	
Bit 0-3: =	Not Used
Bit 4 =	Mux Clk F Error
Bit 5 =	Signal Lost
Bit 6 =	Path Yellow
Bit 7 =	Mismatch RxN
Bit 8 =	Timeout
Bit 9 =	Message Level
Bit 10 =	Passthrough
Bit 11 =	Reserved
Bit 12 =	Max Prop Delay
	Binary function link strings denoting channel errors, and when self-healing has been initiated in 3-terminal applications.
IM64 Rx Status	
Statistics	
Last Reset on	
Date/Time	

Ch1 No. Vald Mess
 Ch1 No. Err Mess
 Ch1 No. Errored s
 Ch1 No. Sev Err s
 Ch1 No. Dgraded m
 Ch2 No. Vald Mess
 Ch2 No. Err Mess
 Ch2 No. Errored s
 Ch2 No. Sev Err s
 Ch2 No. Dgraded m
 Max Ch 1 Prop Delay
 Max Ch 2 Prop Delay
 Clear Statistics

17.4 Circuit Breaker Monitoring Statistics

CB Operations
 CB φ Operations
 Total I φ Broken
 CB Operate Time
 CB CONTROL
 Total Reclosures

Circuit breaker operation counters on a per phase basis ($\varphi = A, B, C$).

Cumulative breaker interruption duty on a per phase basis ($\varphi = A, B, C$).

17.5 Fault Record Proforma

The following data is recorded for any relevant elements that operated during a fault, and can be viewed in each fault record.

Time & Date
 Model Number:
 Address:
 Event Type: Fault record
 Event Value
 Faulted Phase: Binary data strings for fast polling of which phase elements started or tripped for the fault recorded.
 Start Elements
 Trip Elements Binary data strings for fast polling of which protection elements started or tripped for the fault recorded.
 Fault Alarms Binary data strings for fast polling of alarms for the fault recorded.
 Fault Time
 Active Group: 1/2/3/4
 System Frequency: Hz
 Fault Duration: s
 CB Operate Time: s
 Relay Trip Time: s
 Fault Location: km/miles/ Ω /%

I φ Pre Flt
 I φ Angle Pre Flt Per phase record of the current magnitudes and phase angles stored before the fault inception.

IN Prefault Mag
 IN Prefault Ang
 IM Prefault Mag
 IM Prefault Ang

V ϕ Prefault Mag	Per phase record of the voltage magnitudes and phase angles stored before the fault inception.
V ϕ Prefault Ang	
VN Prefault Mag	
VN Prefault Ang	
I ϕ Fault Mag	Per phase record of the current magnitudes and phase angles during the fault.
I ϕ Fault Ang	
IN Fault Mag	
IN Fault Ang	
IM Fault Mag	
IM Fault Ang	
V ϕ Fault Mag	Per phase record of the voltage magnitudes and phase angles during the fault.
V ϕ Fault Ang	
VN Fault Mag	
VN Fault Ang	

GETTING STARTED

CHAPTER 3

Applicability

Date:	11/2022
--------------	---------

Products covered by this chapter:

This chapter covers the specific versions of the MiCOM products listed below. This includes **only** the following combinations of Software Version and Hardware Suffix.

Hardware Suffix:

MiCOM P445	L
------------	---

Software Version:

MiCOM P445	K6
------------	----

Connection Diagrams: This chapter list the connection diagram for the product:

P445:	10P445xx (xx = 01 to 04)
-------	--------------------------

CONTENTS

1. Introduction to the Relay	5
1.1 User Interfaces and Menu Structure	5
1.2 Front Panel	5
1.3 LED Indications	6
1.3.1 Fixed Function.....	6
1.3.2 Programmable LEDs.....	6
1.4 Relay Rear Panel	7
1.5 Connection and Power-Up	7
2. User Interfaces and Setting Options	9
3. Menu Structure	10
3.1 Protection Settings	10
3.2 Disturbance Recorder Settings	11
3.3 Control and Support Settings	11
4. Cyber Security	12
4.1 Cyber Security Settings	12
4.2 Products with Cyber Security Settings	12
4.3 Password Management	13
5. Relay Configuration	14
6. Front Panel User Interface (Keypad and LCD)	15
6.1 Default Display and Menu Time-Out	15
6.2 Navigating Menus and Browsing Settings	16
6.3 Navigating the Hotkey Menu	16
6.3.1 Setting Group Selection.....	16
6.3.2 Control Inputs - User Assignable Functions.....	17
6.3.3 CB Control.....	17
6.4 How to Login	17
6.4.1 Local Default Access.....	17
6.4.2 Auto Login.....	17
6.4.3 Login with Prompt User List.....	18
6.5 Reading and Clearing of Alarm Messages and Fault Records	18
6.6 Setting Changes	19
6.7 How to Logout	19
6.7.1 How to Logout at the IED.....	19
6.7.2 How to Logout at Easergy Studio.....	20
7. Front Communication Port User Interface	21

7.1 Relay Front Port Settings.....	22
7.2 Front Courier Port.....	22

8. Easergy Studio Communications Basics.....	24
8.1 PC Requirements.....	24
8.2 Connecting to the Relay using Easergy Studio.....	25
8.3 Off-Line use of Easergy Studio.....	25

TABLES

Table 1 - P445 LED assignments.....	6
Table 2 - Nominal and Operative dc and ac Ranges.....	8
Table 3 - Measurement information and relay settings.....	9
Table 4 - Access Levels (with cyber security features).....	13
Table 5 - Auto Login process.....	18
Table 6 - Relay Serial Port Connections.....	21
Table 7 - PC Serial Port Connections.....	21
Table 8 - Communication settings for front port.....	22
Table 9 - Minimum requirements.....	24
Table 10 - Recommended requirements.....	24
Table 11 - Easergy Studio Additional Components.....	25

FIGURES

Figure 1 - Relay front view (40TE case for).....	5
Figure 2 - P445 relay rear view (40TE).....	7
Figure 3 - Menu structure.....	10
Figure 4 - Front panel user interface.....	15
Figure 5 - Hotkey menu navigation.....	17
Figure 6 - Front port connection.....	21
Figure 7 - PC - relay signal connection.....	22

1. INTRODUCTION TO THE RELAY



Warning

Before carrying out any work on the equipment, you should be familiar with the contents of the Safety Information chapter/Safety Guide SFTY/5L M/L11 or later issue, the Technical Data chapter and the ratings on the equipment rating label.

1.1 User Interfaces and Menu Structure

The settings and functions of the MiCOM protection relay can be accessed both from the front panel keypad and LCD, and via the front and rear communication ports. Information on each of these methods is given in this section to describe how to start using the relay.

1.2 Front Panel

The following figure shows the front panel of the relay; the hinged covers at the top and bottom of the front panel are shown open. An optional transparent front cover physically protects the front panel. With the cover in place, access to the user interface is read-only. Removing the cover allows access to the relay settings and does not compromise the protection of the product from the environment. When editing relay settings, full access to the relay keypad is needed. To remove the front cover:

1. Open the top and bottom covers, then unclip and remove the transparent cover. If the lower cover is secured with a wire seal, remove the seal.
2. Using the side flanges of the transparent cover, pull the bottom edge away from the relay front panel until it is clear of the seal tab.
3. Move the cover vertically down to release the two fixing lugs from their recesses in the front panel.

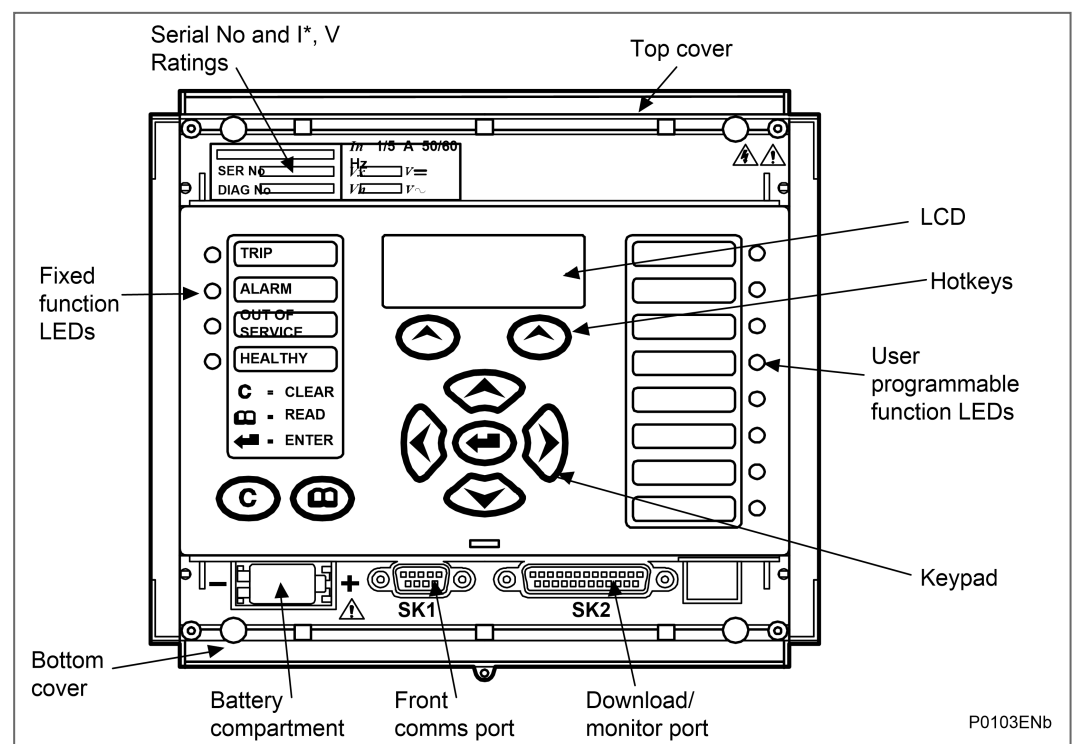

Figure 1 - Relay front view (40TE case for)

The front panel of the relay includes the following, as shown in the previous figure:

- a 16-character by 3-line alphanumeric Liquid Crystal Display (LCD)
- a 9-key keypad with 4 arrow keys (←, →, ↑, ↓), an enter key (↵), a clear key (⌫), a read key (🔍) and 2 hot keys (◆)
- 12 LEDs; 4 fixed function LEDs on the left hand side of the front panel and 8 programmable function LEDs on the right hand side.

Under the top hinged cover:

- The relay serial number, and the relay’s current and voltage rating information

Under the bottom hinged cover:

- Battery compartment to hold the 1/2 AA size battery which is used for memory back-up for the real time clock, event, fault and disturbance records
- A 9-pin female D-type front port for communication with a PC locally to the relay (up to 15m distance) via an EIA(RS)232 serial data connection
- A 25-pin female D-type port providing internal signal monitoring and high speed local downloading of software and language text via a parallel data connection

1.3 LED Indications

1.3.1 Fixed Function

The Fixed Function LEDs on the left-hand side of the front panel show these conditions:

- **Trip (Red)** indicates that the relay has issued a trip signal. It is reset when the associated fault record is cleared from the front display.
- **Alarm (Yellow)** flashes when the relay has registered an alarm. This may be triggered by a fault, event or maintenance record. The LED will flash until the alarms have been accepted (read), after which the LED will change to constant illumination, and will extinguish, when the alarms have been cleared.
- **Out of Service (Yellow)** is ON when the relay is not fully operational.
- **Healthy (Green)** indicates that the relay is in correct working order, and should be on at all times. It will be extinguished if the relay’s self-test facilities show that there is an error with the relay’s hardware or software. The state of the healthy LED is reflected by the watchdog contact at the back of the relay.

To improve the visibility of the settings via the front panel, the LCD contrast can be adjusted using the “LCD Contrast” setting in the CONFIGURATION column. This should only be necessary in very hot or cold ambient temperatures.

1.3.2 Programmable LEDs

The 8 programmable LEDs on the right-hand side are suitable for alarm and trip indications as required by the user. Their functionality is assigned in the Programmable Scheme Logic (PSL) of the relay and can be latched or self-resetting. All of these LEDs are red when energized. The following table shows the default mapping for the P445 relays.

LED No	Assignment for P445
1	Zone 1 or Aided Trip Indication
2	Z2 Trip Indication
3	Zone 3 Trip Indication
4	Zone 4 Trip Indication
5	Aided DEF Trip Indication
6	AR 3ph in Progress
7	AR Lockout
8	Not used

Table 1 - P445 LED assignments

1.4 Relay Rear Panel

Examples of the rear panel of the relay are shown in the following figure. All current and voltage signals, digital logic input signals and output contacts are connected at the rear of the relay. Also connected at the rear is the twisted pair wiring for the rear EIA(RS)485 communication port; the IRIG-B time synchronising input is optional, the Ethernet rear communication board with copper and fiber optic connections or the second communication are optional.

Refer to the wiring diagrams in the 'Connection Diagrams' chapter for further details.

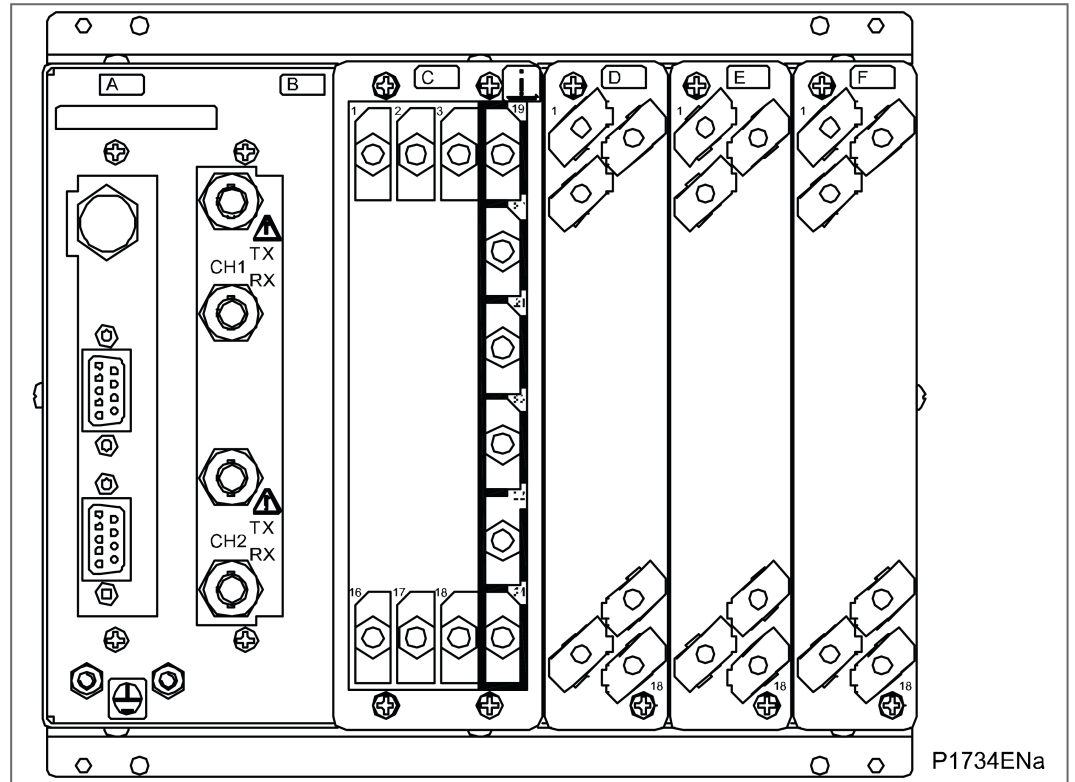

Slot Reference	Board Function
A	Optional IRIG-B and/or Communications board
B	InterMiCOM ⁶⁴ Fiber Communication Board (optional)
C	Analog (VT) Input Board
D	Opto-isolated Inputs (L1 - L8)
E	Relay Output Contacts (R1 - R8)
F	Power Supply and EIA(RS)485 Communications

Figure 2 - P445 relay rear view (40TE)

Note
 This diagram shows the P445 40TE case layout. The exact layout depends on the model configuration and case size.

1.5 Connection and Power-Up

Before powering-up the relay, confirm that the relay power supply voltage and nominal ac signal magnitudes are appropriate for your application. The relay serial number, and the relay's current and voltage rating, power rating information can be viewed under the top hinged cover. The relay is available in the auxiliary voltage versions shown in this table:

Nominal Ranges		Operative Ranges	
dc	ac	dc	ac
24 – 32 V dc	-	19 - 38 V dc	-
48 – 110 V dc	-	37 - 150 V dc	-
110 – 250 V dc **	100 – 240 V ac rms **	87 - 300 V dc	80 - 265 V ac

** rated for ac or dc operation

Table 2 - Nominal and Operative dc and ac Ranges

Please note that the label does not specify the logic input ratings. These relays are fitted with universal opto isolated logic inputs that can be programmed for the nominal battery voltage of the circuit of which they are a part. See 'Universal Opto input' in the **Product Design** chapter for more information on logic input specifications.

Note

The opto inputs have a maximum input voltage rating of 300V dc at any setting.

Once the ratings have been verified for the application, connect external power capable of delivering the power requirements specified on the label to perform the relay familiarization procedures. Previous diagrams show the location of the power supply terminals - please refer to the **Installation** and **Connection Diagrams** chapters for all the details, ensuring that the correct polarities are observed in the case of dc supply.

2. USER INTERFACES AND SETTING OPTIONS

The relay has three user interfaces:

- front panel user interface via the LCD and keypad
- front port which supports Courier communication
- rear port which supports:
 - K-Bus or
 - DNP3.0 or
 - IEC 60870-5-103 or
 - IEC 61850 + Courier through the rear EIA(RS)485 port or
 - IEC 61850 + IEC 60870-5-103 through the rear EIA(RS)485 port.

The protocol for the rear port must be specified when the IED is ordered.

	Keypad or LCD	Courier	MODBUS	IEC870-5-103	DNP3.0	IEC61850
Display & modification of all settings	Yes	Yes				
Digital I/O signal status	Yes	Yes		Yes	Yes	Yes
Display/extraction of measurements	Yes	Yes		Yes	Yes	Yes
Display/extraction of fault records	Yes	Yes		Yes	Yes	Yes
Extraction of disturbance records		Yes		Yes		Yes
Programmable scheme logic settings		Yes				
Reset of fault & alarm records	Yes	Yes		Yes	Yes	Yes
Clear event, fault & disturbance records	Yes	Yes			Yes	
Time synchronization		Yes		Yes	Yes	Yes
Control commands	Yes	Yes		Yes	Yes	Yes

Table 3 - Measurement information and relay settings

3. MENU STRUCTURE

The relay's menu is arranged in a table. Each setting in the menu is referred to as a cell, and each cell in the menu may be accessed using a row and column address. The settings are arranged so that each column contains related settings, for example all the disturbance recorder settings are contained within the same column. As shown in the following diagram, the top row of each column contains the heading that describes the settings contained within that column. Movement between the columns of the menu can only be made at the column heading level.

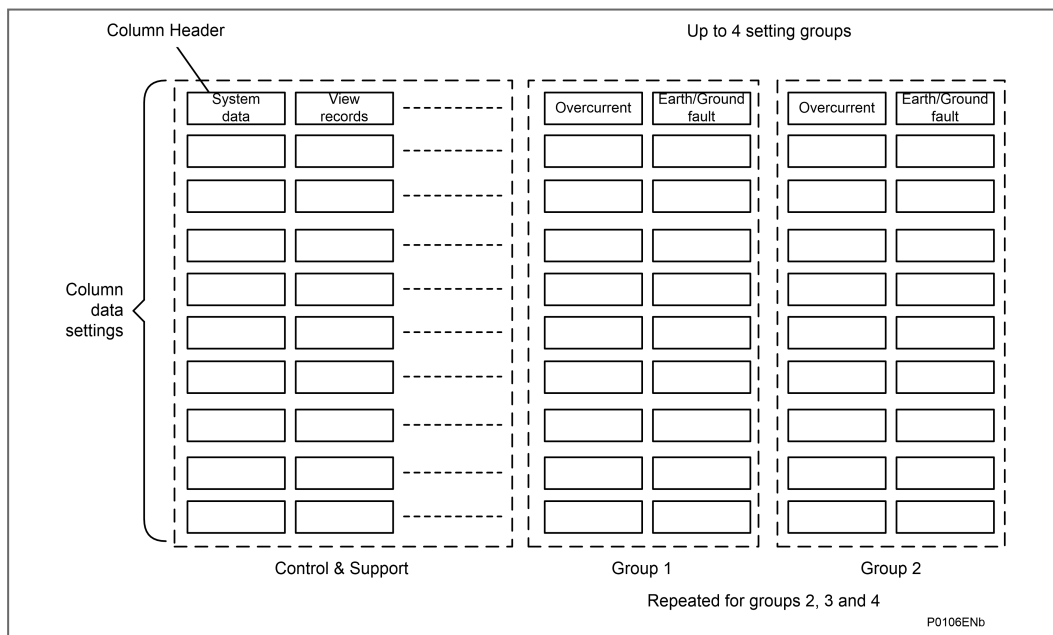

Figure 3 - Menu structure

The settings in the menu fall into one of these categories:

- Protection Settings
- Disturbance Recorder settings
- Control and Support (C&S) settings.

Different methods are used to change a setting depending on which category the setting falls into

- C&S settings are stored and used by the relay immediately after they are entered.
- For either protection settings or disturbance recorder settings, the relay stores the new setting values in a temporary 'scratchpad'. It activates all the new settings together, but only after it has been confirmed that the new settings are to be adopted. This technique is employed to provide extra security, and so that several setting changes that are made within a group of protection settings will all take effect at the same time.

3.1 Protection Settings

The protection settings include the following items:

- Protection element settings
- Scheme logic settings

There are four groups of protection settings, with each group containing the same setting cells. One group of protection settings is selected as the active group, and is used by the protection elements.

3.2 Disturbance Recorder Settings

The Disturbance Recorder (DR) settings include the record duration and trigger position, selection of analogue and digital signals to record, and the signal sources that trigger the recording.

There are now four additional **DDB Group Sig x** Nodes that can be mapped to individual or multiple DDBs in the PSL. These can then be set to trigger the DR via the DISTURBANCE RECORD menu.

These "Nodes" are general and can also be used to group signals together in the PSL for any other reason. These four nodes are available in each of the four PSL setting groups.

1. For a control input, the DR can be triggered directly by triggering directly from the Individual Control Input (e.g. Low to High (L to H) change)
2. For an input that cannot be triggered directly, or where any one of a number of DDBs are required to trigger a DR, map the DDBs to the new PSL Group sig n and then trigger the DR on this.

e.g. in the PSL:

In the DR Settings:

- Digital Input 1 is triggered by the PSL Group Sig 1 (L to H)
- Digital Input 2 is triggered by Control Input 1 (L to H)

If triggering on both edges is required map another DR channel to the H/L as well

Digital Input 4 is triggered by the PSL Group Sig 1 (H to L)

Digital Input 5 is triggered by Control Input 1 (H to L)

3.3 Control and Support Settings

The control and support settings include:

- Relay configuration settings
- Open/close circuit breaker (may vary according to relay type or model)
- CT & VT ratio settings
- Reset LEDs
- Active protection setting group
- Password & language settings
- Communications settings
- Measurement settings
- Event & fault record settings
- User interface settings
- Commissioning settings
- Circuit breaker control & monitoring settings (may vary according to relay type or model)

4. CYBER SECURITY

4.1 Cyber Security Settings

A detailed description of Schneider Electric Cyber Security features is provided in the *Cyber Security* chapter.

Important

We would strongly recommend that you understand the contents of the *Cyber Security* chapter before you use any cyber security features or make any changes to the settings.

Each MiCOM P40 IED includes a large number of possible settings. These settings are very important in determining how the device works.

4.2 Products with Cyber Security Settings

For products with cyber security features, the menu structure contains four levels of access, three of which are password-protected. These are summarized below:

Level	Meaning	Read Operation	Write Operation
0	Read Some Write Minimal	SYSTEM DATA column: Description Plant Reference Model Number Serial Number S/W Ref. Access Level Security Feature SECURITY CONFIG column: User Banner Attempts Remain Blk Time Remain Fallback PW level Security Code (UI only)	Password Entry LCD Contrast (UI only)
1	Read All Write Few	All data and settings are readable. Poll Measurements	All items writeable at level 0. Level 1 Password setting Select Event, Main and Fault (upload) Extract Events (e.g. via Easergy Studio)
2	Read All Write Some	All data and settings are readable. Poll Measurements	All items writeable at level 1. Setting Cells that change visibility (Visible/Invisible). Setting Values (Primary/Secondary) selector Commands: Reset Indication Reset Demand Reset Statistics Reset CB Data / counters Level 2 Password setting
3	Read All Write All	All data and settings are readable. Poll Measurements	All items writeable at level 2. Change all Setting cells Operations: Extract and download Setting file.

Level	Meaning	Read Operation	Write Operation
			Extract and download PSL Extract and download MCL61850 (IED Config - IEC61850) Extraction of Disturbance Recorder Courier/Modbus Accept Event (auto event extraction, e.g. via A2R) Commands: Change Active Group setting Close / Open CB Change Comms device address. Set Date & Time Switch MCL banks / Switch Conf. Bank in UI (IED Config - IEC61850) Enable / Disable Device ports (in SECURITY CONFIG column) Level 3 password setting

Table 4 - Access Levels (with cyber security features)

Note

Applicable to Software Versions prior to H1. For further details, see the Cyber Security chapter.

4.3 Password Management

Level management, including password description, management and recovery, is fully described in the *Cyber Security* chapter.

Each of the Password may be any length between 0 and 8 characters long which can contain any ASCII character in the range ASCII code 33 (21 Hex) to ASCII code 122 (7A Hex) inclusive. The factory default passwords are blank for Level 1 and AAAA for Levels 2 and 3. Each password is user-changeable once it has been correctly entered. Entry of the password is achieved either by a prompt when a setting change is attempted, or by moving to the 'Password' cell in the 'System data' column of the menu. The level of access is independently enabled for each interface, that is to say if level 2 access is enabled for the rear communication port, the front panel access will remain at level 0 unless the relevant password is entered at the front panel. The access level enabled by the password entry will time-out independently for each interface after a period of inactivity and revert to the default level. If the passwords are lost an emergency password can be supplied - contact Schneider Electric with the relay's serial number and security code (relays with Cyber Security features). The current level of access enabled for an interface can be determined by examining the 'Access level' cell in the 'System data' column, the access level for the front panel User Interface (UI), can also be found as one of the default display options.

5. RELAY CONFIGURATION

The relay is a multi-function device that supports numerous different protection, control and communication features. To simplify the setting of the relay, there is a configuration settings column which can be used to enable or disable many of the functions of the relay. The settings associated with any function that is disabled are made invisible, i.e. they are not shown in the menu. To disable a function change the relevant cell in the '**Configuration**' column from '**Enabled**' to '**Disabled**'.

The configuration column controls which of the protection settings groups is selected as active through the '**Active settings**' cell. A protection setting group can also be disabled in the configuration column, provided it is not the present active group. Similarly, a disabled setting group cannot be set as the active group.



The column also allows all of the setting values in one group of protection settings to be copied to another group.

To do this firstly set the 'Copy from' cell to the protection setting group to be copied, then set the 'Copy to' cell to the protection group where the copy is to be placed. The copied settings are initially placed in the temporary scratchpad and will only be used by the relay following confirmation.

To restore the default values to the settings in any protection settings group, set the 'Restore defaults' cell to the relevant group number. Alternatively, it is possible to set the 'Restore defaults' cell to 'All settings' to restore the default values to all of the relay's settings, not just the protection groups' settings. The default settings will initially be placed in the scratchpad and will only be used by the relay after they have been confirmed. Note that restoring defaults to all settings includes the rear communication port settings, which may result in communication via the rear port being disrupted if the new (default) settings do not match those of the master station.

6. FRONT PANEL USER INTERFACE (KEYPAD AND LCD)

When the keypad is exposed it provides full access to the menu options of the relay, with the information displayed on the LCD.

The  and  keys which are used for menu navigation and setting value changes include an auto-repeat function that comes into operation if any of these keys are held continually pressed. This can speed up both setting value changes and menu navigation; the longer the key is held depressed, the faster the rate of change or movement becomes.

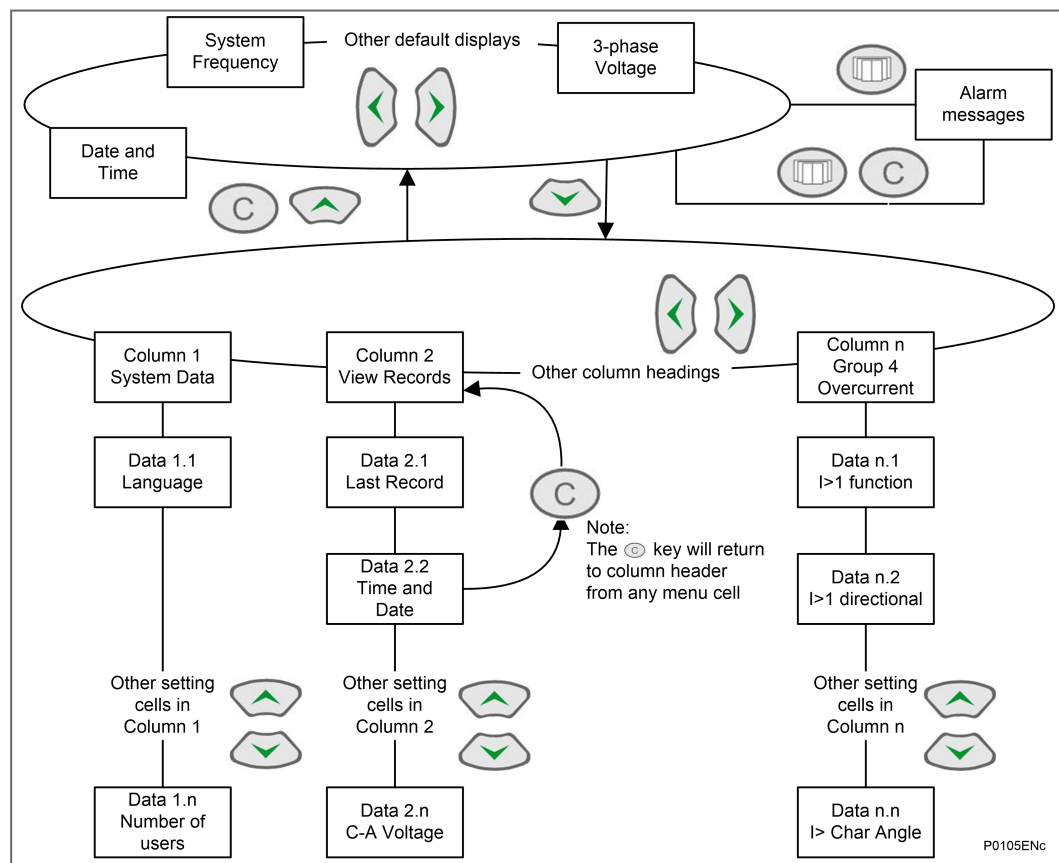



Figure 4 - Front panel user interface

6.1 Default Display and Menu Time-Out

The front panel menu has a default display. To change it, the Engineer Role will be required and the following items can be selected:

- Banner
- 3-phase and neutral current
- 3-phase voltage
- Power
- Date and time
- Description (user defined)
- Plant Reference (user defined)
- Frequency
- Access level

From the default display, the user can switch the default display to other default display items using the  and  keys. The default display will be saved as the last viewed items

automatically. If the user tries to change the default display, Engineer Role will be requested (if the current access role is not that of an Engineer).

When user is browsing the relay menu structure with default access right, if there is no keypad activity for the 15 minutes (i.e. the timeout period), the default display will revert from the last viewed menu structure (can be any location from the menu structure) and the LCD backlight will turn off.

When user is logged in with Engineer Role, the menu timeout time may be shorter than 15 minutes. This depends on the value of inactive timer (e.g. if the inactive timer is set to shorter than 15 minutes). If menu timeout happens, any setting changes that have not been confirmed will be lost and the original setting values maintained.

Whenever there is an uncleared alarm present in the relay (e.g. fault record, protection alarm, control alarm etc.) the default display will be replaced by:

Alarms/Faults Present

Enter the menu structure of the relay from the default display, even if the display shows the **Alarms/Faults Present** message.

6.2 Navigating Menus and Browsing Settings

Use the four arrow keys to browse the menu, following the menu structure shown above.

1. Starting at the default display, press the **Left** key to show the first column heading.
2. Use the **Up** and **Down** keys to select the required column heading.
3. Use the **Left** and **Right** keys to view the setting data in the column.
4. To return to the column header, either hold the **Right** key down or press the clear key **Clear** once. It is only possible to move across columns at the column heading level.
5. To return to the default display, press the **Right** key or the clear key **Clear** from any of the column headings. If you use the auto-repeat function of the **Right** key, you cannot go straight to the default display from one of the column cells because the auto-repeat stops at the column heading.
6. Press the **Right** key again to go to the default display.

6.3 Navigating the Hotkey Menu

To access the hotkey menu from the default display:

1. Press the key directly below the **HOTKEY** text on the LCD.
2. Once in the hotkey menu, use the **Up** and **Down** keys to scroll between the available options, then use the hotkeys to control the function currently displayed. If neither the **Up** or **Down** keys are pressed within 20 seconds of entering a hotkey sub menu, the relay reverts to the default display.
3. Press the clear key **Clear** to return to the default menu from any page of the hotkey menu.

The layout of a typical page of the hotkey menu is as follows:

- The top line shows the contents of the previous and next cells for easy menu navigation
- The center line shows the function
- The bottom line shows the options assigned to the direct access keys

The functions available in the hotkey menu are listed in the following sections.

6.3.1 Setting Group Selection

The user can either scroll using <<NXT GRP>> through the available setting groups or <<SELECT>> the setting group that is currently displayed.

When the SELECT button is pressed a screen confirming the current setting group is displayed for 2 seconds before the user is prompted with the <<NXT GRP>> or <<SELECT>> options again. The user can exit the sub menu by using the left and right arrow keys.

For more information on setting group selection refer to “Setting group selection” section in the Operation chapter.

6.3.2 Control Inputs - User Assignable Functions

The number of control inputs (user assignable functions – USR ASS) represented in the hotkey menu is user configurable in the “CTRL I/P CONFIG” column. The chosen inputs can be SET/RESET using the hotkey menu.

For more information refer to the “Control Inputs” section in the Operation chapter.

6.3.3 CB Control

The CB control functionality varies from one Px40 relay to another. For a detailed description of the CB control via the hotkey menu refer to the “Circuit Breaker Control” section of the Setting chapter.

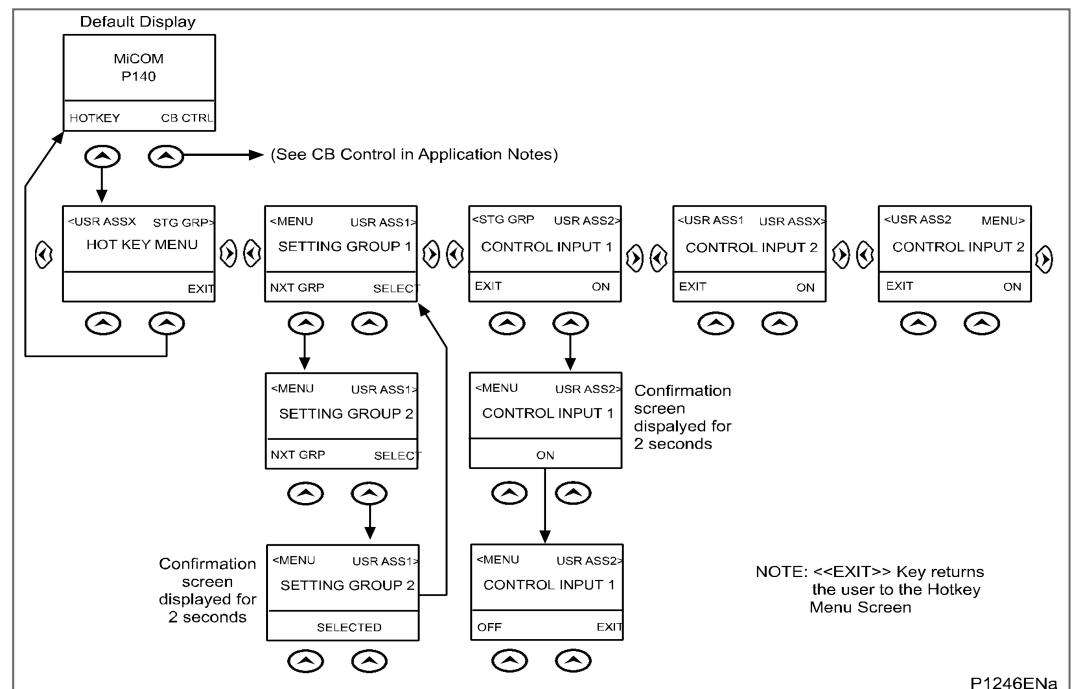

Figure 5 - Hotkey menu navigation

6.4 How to Login

The password entry method varies slightly between CSL0 and CSL1 Versions.

6.4.1 Local Default Access

In CSL0 models the user can access the relay menu without the need to login.

In CSL1 models this can be enabled/disabled using CAE.

If the Local Default Access is enabled, the user may login to the front panel with associated roles.

6.4.2 Auto Login

Auto login means the user will login the IED automatically and no need to select the user name and enter the password. In this case, the user will be authorized with relevant rights.

The auto login will be applied in these cases:

CS Version	Interface	RBAC/PW Cases	Login Process
CSL1	Front Panel	Factory RBAC	Auto login with EngineerLevel
		Customised RBAC	Local Default Access Enabled: Login with Local Default Access Local Default Access Disabled: Login with Prompt User List
	Courier Interface	All Cases	Login with Prompt User List
CSL0	Front Panel	Factory RBAC	Auto login with EngineerLevel
		Password changed	EngineerLevel password is "AAAA" or is disabled/blank: Auto login with EngineerLevel OperatorLevel password is "AAAA" or is disabled/blank: Auto login with OperatorLevel EngineerLevel and OperatorLevel password changed: Auto login with ViewerLevel Access
	Courier Interface	Factory RBAC	Auto login with EngineerLevel
		Password changed	EngineerLevel password is "AAAA" or is disabled/blank: Auto login with EngineerLevel OperatorLevel password is "AAAA" or is disabled/blank: Auto login with OperatorLevel EngineerLevel and OperatorLevel password changed: Login with Prompt User List

Table 5 - Auto Login process

For more details about the Factory RBAC, please refer to the **Cyber Security** chapter.

6.4.3 Login with Prompt User List



This login process will happen if:

- The Auto login process is not applied.
- Or high authorization is required for the current operation.

In this case, the IED will prompt the user list, and the user needs to select proper user name and enter the password to login.

6.5 Reading and Clearing of Alarm Messages and Fault Records

One or more alarm messages appear on the default display and the yellow alarm LED flashes. The alarm messages can either be self-resetting or latched, in which case they must be cleared manually.

1. To view the alarm messages, press the read key . When all alarms have been viewed but not cleared, the alarm LED change from flashing to constantly ON and the latest fault record appears (if there is one).
2. Scroll through the pages of the latest fault record, using the  key. When all pages of the fault record have been viewed, the following prompt appears.

Press clear to
reset alarms

3. To clear all alarm messages, press To return to the display showing alarms or faults present, and leave the alarms uncleared, press
4. Depending on the password configuration settings, you may need to enter a password before the alarm messages can be cleared. See the **How to Access the IED/Relay** section.
5. When all alarms are cleared, the yellow alarm LED switches OFF; also the red trip LED switches OFF if it was switched ON after a trip.
6. To speed up the procedure, enter the alarm viewer using the key, then press the key. This goes straight to the fault record display. Press again to move straight to the alarm reset prompt, then press again to clear all alarms.

6.6 Setting Changes

1. To change the value of a setting, go to the relevant cell in the menu, then press the enter key to change the cell value. A flashing cursor on the LCD shows the value can be changed. If a password is required to edit the cell value, a password prompt appears.
2. To change the setting value, press the or keys. If the setting to be changed is a binary value or a text string, select the required bit or character to be changed using the and keys.
3. Press to confirm the new setting value or the clear key to discard it. The new setting is automatically discarded if it is not confirmed in 15 minutes.
4. For protection group settings and disturbance recorder settings, the changes must be confirmed before they are used by the relay.
5. To do this, when all required changes have been entered, return to the column heading level and press the key. Before returning to the default display, the following prompt appears.

Update settings?
Enter or clear

6. Press to accept the new settings or press to discard the new settings.

Note

If the menu time-out occurs before the setting changes have been confirmed, the setting values are also discarded.

Control and support settings are updated immediately after they are entered, without the **Update settings?** prompt.

6.7 How to Logout

6.7.1 How to Logout at the IED

For security consideration, it would be better to 'logout' the IED once the configuration done. You can do this by going up to the default display. When you are at the default display and you press the 'Cancel' button, you may be prompted to log out with the following display:

ENTER TO LOGOUT
CLEAR TO CANCEL

You will be asked this question if you are logged in.

If you confirm, the following message is displayed for 2 seconds:

LOGGED OUT
UserName

If you decide not to log out (i.e. you cancel), the following message is displayed for 2 seconds.

```
LOGOUT_CANCELLED  
UserName
```

Note
The MiCOM IED runs a timer, which logs the user out after a period of inactivity. For more details, refer to the [Inactivity Timer](#) section.

6.7.2 How to Logout at Easergy Studio

- Right-click on the device name and select Log Off.
- In the Log Off confirmation dialog click Yes.

7. FRONT COMMUNICATION PORT USER INTERFACE

The front communication port is provided by a 9-pin female D-type connector located under the bottom hinged cover. It provides EIA(RS)232 serial data communication and is intended for use with a PC locally to the relay (up to 15m distance) as shown in the following diagram. This port supports the Courier communication protocol only. Courier is the communication language developed by Schneider Electric to allow communication with its range of protection relays. The front port is particularly designed for use with the relay settings program Easergy Studio.

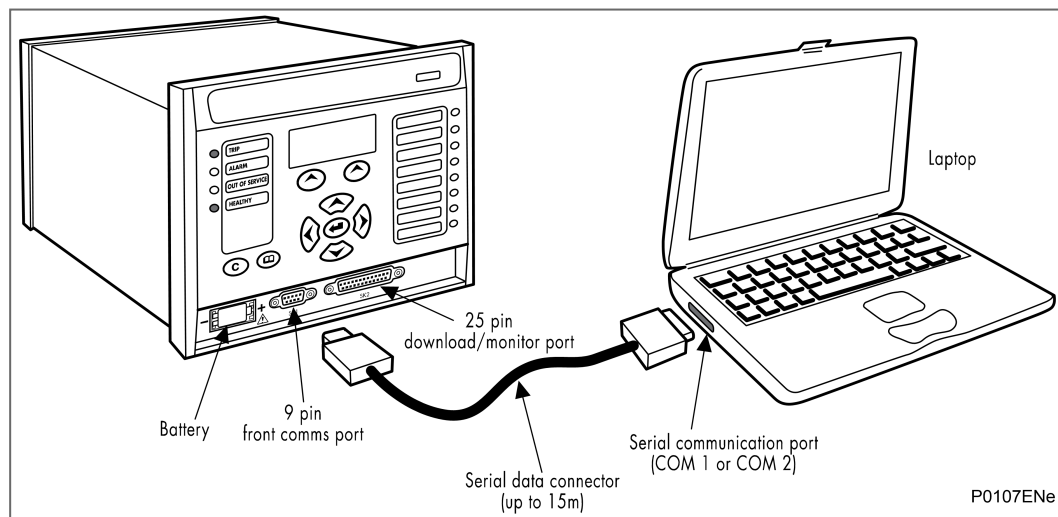

Figure 6 - Front port connection

The IED is a Data Communication Equipment (DCE) device. The pin connections of the 9-pin front port are as follows:

Pin no.	Description
2	Tx Transmit data
3	Rx Receive data
5	0V Zero volts common

Table 6 - Relay Serial Port Connections

None of the other pins are connected in the relay. The relay should be connected to the serial port of a PC, usually called COM1 or COM2. PCs are normally Data Terminal Equipment (DTE) devices which have a serial port pin connection as below (if in doubt check your PC manual):

Pin	25 Way	9 Way	Description
Pin no. 2	3	2	Rx Receive data
Pin no. 3	2	3	Tx Transmit data
Pin no. 5	7	5	0V Zero volts common

Table 7 - PC Serial Port Connections

For successful data communication, the Tx pin on the relay must be connected to the Rx pin on the PC, and the Rx pin on the relay must be connected to the Tx pin on the PC, as shown in the diagram. Therefore, providing that the PC is a DTE with pin connections as given above, a 'straight through' serial connector is required, i.e. one that connects pin 2 to pin 2, pin 3 to pin 3, and pin 5 to pin 5.

Note

A common cause of difficulty with serial data communication is connecting Tx to Tx and Rx to Rx. This could happen if a 'cross-over' serial connector is used, i.e. one that connects pin 2 to pin 3, and pin 3 to pin 2, or if the PC has the same pin configuration as the relay.

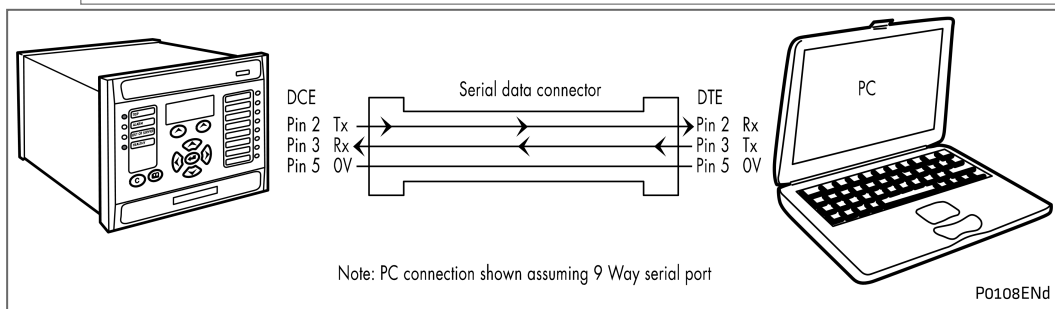

Figure 7 - PC - relay signal connection

Having made the physical connection from the relay to the PC, the PC's communication settings must be configured to match those of the relay. The relay's communication settings for the front port are fixed as shown below:

Protocol	Baud rate	Courier address	Message format
Courier	19,200 bits/s	1	11 bit - 1 start bit, 8 data bits, 1 parity bit (even parity), 1 stop bit

Table 8 - Communication settings for front port

7.1 Relay Front Port Settings

The inactivity timer for the front port is set at 15 minutes. This controls how long the relay will maintain its password access on the front port. If no messages are received on the front port for 15 minutes then any password access that has been enabled will be revoked.

7.2 Front Courier Port

The front EIA(RS)232 9-pin port supports the Courier protocol for one to one communication.

Note

The front port is actually compliant to EIA(RS)574; the 9-pin version of EIA(RS)232, see www.tiaonline.org.

The front port is designed for use during installation and commissioning/maintenance and is not suitable for permanent connection. Since this interface will not be used to link the relay to a substation communication system, some of the features of Courier are not implemented. These are as follows:

- Automatic Extraction of Event Records:
 - Courier Status byte does not support the Event flag
 - Send Event/Accept Event commands are not implemented
- Automatic Extraction of Disturbance Records:
 - Courier Status byte does not support the Disturbance flag
- Busy Response Layer:
 - Courier Status byte does not support the Busy flag, the only response to a request will be the final data
- Fixed Address:
 - The address of the front courier port is always 1, the Change Device address command is not supported.

- Fixed Baud Rate:
 - 19200 bps

Note

Although automatic extraction of event and disturbance records is not supported, this data can be manually accessed using the front port.

8. EASERGY STUDIO COMMUNICATIONS BASICS

The EIA(RS)232 front communication port is particularly designed for use with the relay settings program Easergy Studio. Easergy Studio is the universal MiCOM IED Support Software and provide users a direct and convenient access to all stored data in any MiCOM IED using the EIA(RS)232 front communication port.

Easergy Studio provides full access to MiCOM Px10, Px20, Px30, Px40 and Mx20 measurements units.

8.1 PC Requirements

The minimum and recommended hardware requirements for Easergy Studio (v7.0.0) are shown below. These include the Studio application and other tools which are included: UPCT, P746 RHMI, P74x Topology Tool:

Minimum requirements				
Platform	Processor	RAM	HDD (Note 1 & 3)	HDD (Note 2 & 3)
Windows XP x86	1 GHz	512 MB	900 MB	1.5 GB
Windows 7 x86	1 GHz	1 GB	900 MB	1.9 GB
Windows 7 x64	1 GHz	2 GB	900 MB	2.1 GB
Windows Server 2008 x86 Sp1	1 GHz	512 MB	900 MB	1.7 GB

Table 9 - Minimum requirements

Recommended requirements				
Platform	Processor	RAM	HDD (Note 1 & 3)	HDD (Note 2 & 3)
Windows XP x86	1 GHz	1 GB	900 MB	1.5 GB
Windows 7 x86	1 GHz	2 GB	900 MB	1.9 GB
Windows 7 x64	1 GHz	4 GB	900 MB	2.1 GB
Windows Server 2008 x86 Sp1	1 GHz	4 GB	900 MB	1.7 GB

Table 10 - Recommended requirements

Note 1

Operating system with Windows Updates updated on 2015/05.

Note 2

Operating system without Windows Updates installed.

Note 3

Both configurations do not include Data Models HDD requirements. Data Models typically need from 1 GB to 15 GB of hard disk space.

Screen resolution for minimum requirements: Super VGA (800 x 600).

Screen resolution for recommended requirements: XGA (1024x768) and higher.

Easergy Studio must be started with Administrator privileges.

Easergy Studio Additional components

The following components are required to run Easergy Studio and are installed by its installation package.

Component Type	Component
Package	Package .NET Framework 2.0 SP 1 (x64)

Component Type	Component
Package	Package .NET Framework 2.0 SP 1 (x86)
Package	Package .NET Framework 4.0 Client (x64)
Package	Package .NET Framework 4.0 Client (x86)
Package	Package Visual C++ 2005 SP1 Redistributable Package (x86)
Package	Package Visual C++ 2008 SP1 Redistributable Package (x86)
Merge modules	DAO 3.50
Merge modules	MFC 6.0 Merge modules MFC Unicode 6.0
Merge modules	Microsoft C Runtime Library 6.0
Merge modules	Microsoft C++ Runtime Library 6.0
Merge modules	Microsoft Component Category Manager Library
Merge modules	Microsoft Data Access Components 2.8 (English)
Merge modules	Microsoft Jet Database Engine 3.51 (English)
Merge modules	Microsoft OLE 2.40 for Windows NT and Windows 95
Merge modules	Microsoft Visual Basic Virtual Machine 6.0
Merge modules	MSXML 4.0 - Windows 9x and later
Merge modules	MSXML 4.0 - Windows XP and later
Merge modules	Visual C++ 8.0 MFC (x86) WinSXS MSM
Merge modules	Visual C++ 8.0 MFC.Policy (x86) WinSXS MSM

Table 11 - Easergy Studio Additional Components

8.2 Connecting to the Relay using Easergy Studio

This section is a quick start guide to using Easergy Studio and assumes this is installed on your PC. See the Easergy Studio program online help for more detailed information.

1. Make sure the EIA(RS)232 serial cable is properly connected between the port on the front panel of the relay and the PC.
2. To start Easergy Studio, select **Start > All Apps > Schneider Electric > Easergy Studio**.
3. Click the **Quick Connect** tab and select **Create a New System**.
4. Check the **Path to System file** is correct, then enter the name of the system in the **Name** field. To add a description of the system, use the **Comment** field.
5. Click **OK**.
6. Select the device type.
7. Select the communications port, and open a connection with the device.
8. Once connected, select the language for the settings file, the device name, then click **Finish**. The configuration is updated.
9. In the **Studio Explorer** window, select **Device > Supervise Device...** to control the relay directly. (User Login necessary)

8.3 Off-Line use of Easergy Studio

Easergy Studio can also be used as an off-line tool to prepare settings, without access to the relay.

1. If creating a new system, in the Studio Explorer, select **create new** system. Then right-click the new system and select **New substation**.
2. Right-click the new substation and select **New voltage level**.

3. Then right-click the new voltage level and select **New bay**.
4. Then right-click the new bay and select **New device**.
You can add a device at any level, whether it is a system, substation, voltage or bay.
5. Select a device type from the list, then enter the relay type. Click **Next**.
6. Enter the full model number and click **Next**.
7. Select the **Language** and **Model**, then click **Next**.
8. If the IEC61850 protocol is selected, and an Ethernet board with hardware option Q, R or S is selected, select IEC 61850 Edition:
IEC 61850 Edition 2 Mode or
IEC 61850 Edition 1 Compatible Mode.
9. Enter a unique device name, then click **Finish**.
10. Right-click the **Settings** folder and select **New File**. A default file **000** is added.
11. Right-click file **000** and select click **Open**. You can then edit the settings.
See the Easergy Studio program online help for more information.

SETTINGS

CHAPTER 4

Date:	11/2022
Products covered by this chapter:	This chapter covers the specific versions of the MiCOM products listed below. This includes only the following combinations of Software Version and Hardware Suffix.
Hardware Suffix:	L
Software Version:	K6
Connection Diagrams:	10P445xx (xx = 01 to 04)

CONTENTS

Page (ST) 4-

1	Introduction	7
1.1	Making Changes to the Settings	7
1.2	Relay Settings	7
1.3	Default Settings Restore	7
2	Configuration Settings	8
3	Group Settings	12
3.1	Line Parameters	12
3.2	Distance Setup	13
3.3	Distance Elements	17
3.4	Scheme Logic (Basic and Aided Scheme Logic)	21
3.5	Power Swing Blocking	27
3.6	Phase Overcurrent Protection	29
3.7	Negative Sequence Overcurrent	31
3.8	Broken Conductor	33
3.9	Earth Fault	33
3.10	Aided DEF	36
3.11	Sensitive Earth Fault (SEF)	37
3.12	Residual Overvoltage (Neutral Voltage Displacement)	39
3.13	Thermal Overload	40
3.14	Voltage Protection	40
3.15	Frequency Protection	43
3.16	Independent Rate of Change of Frequency Protection	44
3.17	Circuit Breaker (CB) Fail and Pole Dead Detection Function	45
3.18	Supervision (VTS, CTS, Inrush Detection, Special Weak Infeed Blocking and Trip Supervision)	46
3.19	System Checks (Check Sync. Function)	51
3.20	Auto-Reclose Function	54
3.21	Input Labels	57
3.22	Virtual Input Labels	58
3.23	Output Labels	60
3.24	Virtual Output Labels	61
3.25	DR Chan Labels	63
3.26	SR/MR User Alarm Labels	69
3.27	EIA(RS)232 InterMiCOM Communications	70

3.28	EIA(RS)232 InterMiCOM Conf 56/64 kbit/s Fiber Teleprotection – InterMiCOM 64	72
4	Control and Support Settings	75
4.1	System Data	75
4.2	Circuit Breaker Control	77
4.3	Date and Time	79
4.4	CT/VT Ratios	82
4.5	Record Control	83
4.6	Disturbance Recorder Settings (Oscillography)	89
4.7	Measurements	103
4.8	Communications Settings	104
4.9	Commissioning Tests	107
4.10	Circuit Breaker Condition Monitor Setup	112
4.11	Opto Configuration	113
4.12	Control Inputs	115
4.13	Control Input Configuration	118
4.14	PB Config	122
4.15	IED Configurator (for IEC 61850 Configuration)	124
4.16	56/64 kbit/s Fiber Teleprotection - InterMiCOM ⁶⁴	126
4.17	Control Input Labels	129
4.18	Direct Access (Breaker Control and Hotkeys)	132

TABLES

	Page (ST) 4-
Table 1 - Configuration settings	11
Table 2 - Line parameters	13
Table 3 - Group x distance setup	17
Table 4 - Group x distance elements	21
Table 5 - Group x scheme logic	26
Table 6 - Group x power swing blk	29
Table 7 - Phase overcurrent protection	31
Table 8 - Negative sequence overcurrent	33
Table 9 - Broken conductor	33
Table 10 - Earth fault	36
Table 11 - Group x aided DEF	36
Table 12 - Sensitive earth fault	39
Table 13 - Residual overvoltage (neutral voltage displacement)	40

Table 14 - Thermal overload	40
Table 15 - Voltage protection	43
Table 16 - Frequency protection	44
Table 17 - DF/DT protection	45
Table 18 - Circuit breaker fail and pole dead detection function	46
Table 19 - Supervision	51
Table 20 - System checks (check sync. function)	53
Table 21 - Auto-reclose function	57
Table 22 - Input labels	58
Table 23 - Virtual Input labels	60
Table 24 - Output labels	61
Table 25 - Virtual Output labels	63
Table 26 - DR Chan labels	69
Table 27 - SR/MR User Alarm labels	69
Table 28 - InterMiCOM comms	71
Table 29 - INTERMiCOM conf	74
Table 30 - System data	77
Table 31 - Circuit breaker control	79
Table 32 - Date and time	82
Table 33 - CT/VT ratios	83
Table 34 - Record control	89
Table 35 - Disturbance recorder	103
Table 36 - Measurements	104
Table 37 - Communications settings	107
Table 38 - Commissioning tests	112
Table 39 - Circuit breaker condition monitor setup	113
Table 40 - Opto configuration	115
Table 41 - Control inputs	117
Table 42 - Control input configuration	122
Table 43 - PB Config	124
Table 44 - IED configurator (for IEC 61850 configuration)	126
Table 45 - Prot comms/IM64	128
Table 46 - Control input labels	132
Table 47 - Direct access (breaker control and “hotkeys”)	135

Notes:

1 INTRODUCTION

1.1 Making Changes to the Settings

The relay is supplied with a factory-set configuration of default settings. Before being put into service, it must be configured to the system and the application by means of appropriate settings.

Because of the complex functionality of the device, it contains a large number of settings. These settings are arranged in a menu structure to facilitate clarity of presentation. The ways in which individual settings can be changed is described in the Getting Started section of this manual.

When configuring the functionality to the system application, the structure of the settings can be considered in three parts:

- Configuration Settings
- Group Settings
- Control and Support Settings

The sequence in which the settings are listed and described in this chapter reflects this structure.

1.2 Relay Settings

The IED is a multi-function device that supports numerous different control and communication features. The settings associated with any function that is disabled are made invisible; i.e. they are not shown in the menu. To disable a function change the relevant cell in the **'Configuration'** column from **'Enabled'** to **'Disabled'**.

To simplify the setting of the IED, there is a configuration settings column, used to enable or disable many of the IED functions. The aim of the configuration column is to allow general configuration from a single point in the menu.

The configuration column controls which of the four settings groups is selected as active through the **'Active settings'** cell. A setting group can also be disabled in the configuration column, provided it is not the present active group. Similarly, a disabled setting group cannot be set as the active group.

The column also allows all of the setting values in one group of settings to be copied to another group.

To do this firstly set the **'Copy from'** cell to the setting group to be copied, then set the **'Copy to'** cell to the group where the copy is to be placed. The copied settings are initially placed in the temporary scratchpad, and will only be used by the IED following confirmation.

1.3 Default Settings Restore

To restore the default values to the settings in any protection settings group, set the 'restore defaults' cell to the relevant group number. Alternatively, it is possible to set the 'restore defaults' cell to 'all settings' to restore the default values to all of the IEDs settings, not just the protection groups' settings. The default settings will initially be placed in the scratchpad and will only be used by the IED after they have been confirmed.

Important

Restoring defaults to all settings includes the rear communication port settings, which may result in communication via the rear port being disrupted if the new (default) settings do not match those of the master station.

2 CONFIGURATION SETTINGS

To simplify the setting of the relay, there is a configuration settings column which is used to enable or disable many of the functions. If a function is disabled, the settings associated with that function are not shown in the menu. To disable a function, change the relevant cell in the Configuration column from Enabled to Disabled.

The **Active settings** cell of the configuration column controls which of the application setting groups is used by the relay.

The configuration column can also be used to copy the contents of one of the setting Groups to that of another Group.

To do this, firstly set the **Copy from** cell to the protection setting group to be copied, then set the **copy to** cell to the protection group where the copy is to be placed. The copied settings are initially placed in the temporary scratchpad, and will only be used by the IED following confirmation.

The settings of the configuration column are detailed below.

Col	Row	Menu Text	Default Setting	Available Setting
Description				
09	00	CONFIGURATION	0	
This column contains all the general configuration options				
09	01	Restore Defaults	No Operation	0 = No Operation, 1 = All Settings, 2 = Setting Group 1, 3 = Setting Group 2, 4 = Setting Group 3, 5 = Setting Group 4
Setting to restore a setting group to factory default settings. To restore the default values to the settings in any Group settings, set the 'restore defaults' cell to the relevant Group number. Alternatively it is possible to set the 'restore defaults' cell to 'all settings' to restore the default values to all of the IED's settings, not just the Group settings. The default settings will initially be placed in the scratchpad and will only be used by the relay after they have been confirmed by the user. Note: Restoring defaults to all settings includes the rear communication port settings, which may result in communication via the rear port being disrupted if the new (default) settings do not match those of the master station.				
09	02	Setting Group	Select via Menu	0 = Select via Menu or 1 = Select via PSL
Allows setting group changes to be initiated via Opto Input or via Menu				
09	03	Active Settings	Group 1	0 = Group 1, 1 = Group 2, 2 = Group 3, 3 = Group 4
Selects the active setting group.				
09	04	Save Changes	No Operation	0 = No Operation, 1 = Save, 2 = Abort
Saves all relay settings.				
09	05	Copy From	Group 1	0 = Group 1, 1 = Group 2, 2 = Group 3, 3 = Group 4
Allows displayed settings to be copied from a selected setting group				
09	06	Copy To	No Operation	0 = No Operation, 1 = Group 1, 2 = Group 2, 3 = Group 3
Allows displayed settings to be copied to a selected setting group (ready to paste).				
09	07	Setting Group 1	Enabled	0 = Disabled or 1 = Enabled
Settings Group 1. If the setting group is disabled from the configuration, then all associated settings and signals are hidden, with the exception of this setting (paste).				
09	08	Setting Group 2	Disabled	0 = Disabled or 1 = Enabled
Settings Group 2. If the setting group is disabled from the configuration, then all associated settings and signals are hidden, with the exception of this setting (paste).				
09	09	Setting Group 3	Disabled	0 = Disabled or 1 = Enabled

Col	Row	Menu Text	Default Setting	Available Setting
Description				
Settings Group 3. If the setting group is disabled from the configuration, then all associated settings and signals are hidden, with the exception of this setting (paste).				
09	0A	Setting Group 4	Disabled	0 = Disabled or 1 = Enabled
Settings Group 4. If the setting group is disabled from the configuration, then all associated settings and signals are hidden, with the exception of this setting (paste).				
09	0B	Distance	Enabled	0 = Disabled or 1 = Enabled
Only in models with Distance option. To enable (activate) or disable (turn off) the Distance Protection: ANSI 21P/21G.				
09	0C	Directional E/F	Enabled	0 = Disabled or 1 = Enabled
Only in models with Distance option. To enable (activate) or disable (turn off) the Directional Earth Fault (DEF) Protection used in a pilot aided scheme: ANSI 67N. This protection is independent from back up Earth fault protection described below.				
09	10	Overcurrent	Disabled	0 = Disabled or 1 = Enabled
To enable (activate) or disable (turn off) the Phase Overcurrent Protection function. I> stages: ANSI 50/51/67P				
09	11	Neg Sequence O/C	Disabled	0 = Disabled or 1 = Enabled
To enable (activate) or disable (turn off) the Negative Sequence Overcurrent Protection function. I2> stages: ANSI 46/67				
09	12	Broken Conductor	Disabled	0 = Disabled or 1 = Enabled
To enable (activate) or disable (turn off) the Broken Conductor function. I2/I1> stage: ANSI 46BC				
09	13	Earth Fault	Disabled	0 = Disabled or 1 = Enabled
To enable (activate) or disable (turn off) the back up Earth Fault Protection function. IN >stages: ANSI 50/51/67N				
09	15	SEF/REF Prot'n	Disabled	0 = Disabled or 1 = Enabled
To enable (activate) or disable (turn off) the Sensitive Earth Fault/Restricted Earth fault Protection function. ISEF >stages: ANSI 50/51/67N. IREF>stage: ANSI 64.				
09	16	Residual O/V NVD	Disabled	0 = Disabled or 1 = Enabled
To enable (activate) or disable (turn off) the Residual Overvoltage Protection function. VN>stages: ANSI 59N				
09	17	Thermal Overload	Disabled	0 = Disabled or 1 = Enabled
To enable (activate) or disable (turn off) the Thermal Overload Protection function. ANSI 49.				
09	18	PowerSwing Block	Enabled	0 = Disabled or 1 = Enabled
Only in models with Distance option. To enable (activate) or disable (turn off) the power swing blocking/out of step: ANSI 68/78.				
09	1D	Volt Protection	Disabled	0 = Disabled or 1 = Enabled
To enable (activate) or disable (turn off) the Voltage Protection (under/overvoltage) function. V<, V> stages: ANSI 27/59.				
09	1E	Freq Protection	Disabled	0 = Disabled or 1 = Enabled
To enable (activate) or disable (turn off) the Frequency Protection (under/over frequency) function. F<, F> stages: ANSI 81O/U.				
09	1F	df/dt Protection	Disabled	0 = Disabled or 1 = Enabled
To enable (activate) or disable (turn off) the Rate of change of Frequency Protection function. df/dt> stages: ANSI 81R.				
09	20	CB Fail	Disabled	0 = Disabled or 1 = Enabled
To enable (activate) or disable (turn off) the Circuit Breaker Fail Protection function. ANSI 50BF.				
09	21	Supervision	Enabled	0 = Disabled or 1 = Enabled
To enable (activate) or disable (turn off) the Supervision (VTS & CTS) functions. ANSI VTS/CTS.				
09	23	System Checks	Disabled	0 = Disabled or 1 = Enabled
To enable (activate) or disable (turn off) the System Checks (Check Sync. and Voltage Monitor) function: ANSI 25.				
09	24	Auto-Reclose	Disabled	0 = Disabled or 1 = Enabled
To enable (activate) or disable (turn off) the Auto-reclose function. ANSI 79.				
09	25	Input Labels	Visible	0 = Invisible or 1 = Visible
Sets the Input Labels menu visible further on in the relay settings menu.				
09	26	Output Labels	Visible	0 = Invisible or 1 = Visible

Col	Row	Menu Text	Default Setting	Available Setting
Description				
Sets the Output Labels menu visible further on in the relay settings menu.				
09	28	CT & VT Ratios	Visible	0 = Invisible or 1 = Visible
Sets the Current & Voltage Transformer Ratios menu visible further on in the relay settings menu.				
09	29	Record Control	Visible	0 = Invisible or 1 = Visible
Sets the Record Control menu visible further on in the relay settings menu.				
09	2A	Disturb Recorder	Visible	0 = Invisible or 1 = Visible
Sets the Disturbance Recorder menu visible further on in the relay settings menu.				
09	2B	Measure't Setup	Visible	0 = Invisible or 1 = Visible
Sets the Measurement Setup menu visible further on in the relay settings menu.				
09	2C	Comms Settings	Visible	0 = Invisible or 1 = Visible
Sets the Communications Settings menu visible further on in the relay settings menu. These are the settings associated with the 2nd rear communications ports.				
09	2D	Commission Tests	Visible	0 = Invisible or 1 = Visible
Sets the Commissioning Tests menu visible further on in the relay settings menu.				
09	2E	Setting Values	Primary	0 = Primary or 1 = Secondary
This affects all protection settings that are dependent upon CT and VT ratios. All subsequent settings input must be based in terms of this reference.				
09	2F	Control Inputs	Visible	0 = Invisible or 1 = Visible
Activates the Control Input status and operation menu further on in the relay setting menu.				
09	35	Control I/P Config	Visible	0 = Invisible or 1 = Visible
Sets the Control Input Configuration menu visible further on in the relay setting menu.				
09	36	Ctrl I/P Labels	Visible	0 = Invisible or 1 = Visible
Sets the Control Input Labels menu visible further on in the relay setting menu.				
09	39	Direct Access	Enabled	0= Disabled, 1 = Enabled, 2 = Hotkey Only, or 3 = CB Ctrl Only
Defines what CB control direct access is allowed. The front direct access keys that are used as a short cut function of the menu may be: Disabled – No function visible on the LCD. Enabled – All control functions mapped to the Hotkeys and Control Trip/Close are available. Hotkey Only – Only control functions mapped to the Hotkeys are available on the LCD. CB Ctrl Only – Only Control Trip/Control Close command will appear on the relay's LCD. Not available on Chinese version relays (P54??????C??M)				
09	40	InterMiCOM	Disabled	0 = Disabled or 1 = Enabled
To enable (activate) or disable (turn off) EIA (RS) 232 InterMiCOM (integrated teleprotection).				
09	41	InterMiCOM 64	Disabled	0 = Disabled or 1 = Enabled
To enable (activate) or disable (turn off) InterMiCOM64 (integrated 56/64kbit/s teleprotection). Note that Phase Diff setting and InterMiCOM64 Fiber setting are mutually exclusive as with Phase Diff enabled, the digital message exchanged has the structure of the differential message (i.e. currents are sent to the remote end, etc) and with InterMiCOM64 Fiber the digital message exchanged has the structure and properties of the InterMiCOM64 Fiber.				
9	48	PB CONFIG	Visible	0 = Invisible or 1 = Visible
Sets the PB CONFIG menu visible in the relay setting menu.				
09	70	VIR I/P Labels	Invisible	0 = Invisible or 1 = Visible
VIR I/P Labels Visible/Invisible				
09	80	VIR O/P Labels	Invisible	0 = Invisible or 1 = Visible
VIR O/P Labels Visible/Invisible				
09	90	Usr Alarm Labels	Invisible	0 = Invisible or 1 = Visible
USR Alarm Labels Visible/Invisible				

Col	Row	Menu Text	Default Setting	Available Setting
Description				
09	FB	RP1 Read Only	Disabled	0 = Disabled or 1 = Enabled
To enable (activate) or disable (turn off) Read Only Mode of Rear Port 1.				
09	FC	RP2 Read Only	Disabled	0 = Disabled or 1 = Enabled
To enable (activate) or disable (turn off) Read Only Mode of Rear Port 2.				
09	FD	NIC Read Only	Disabled	0 = Disabled or 1 = Enabled
Ethernet versions only. To enable (activate) or disable (turn off) Read Only Mode of Network Interface Card.				
9	FE	SettingValueBeh.	Independent	0 = Independent or 1 = Locked Mode
Independent: cell [092E] Setting Values will be independent in each interfaces Locked Mode: cell [092E] Setting Values are locked to the same value for all interfaces				
09	FF	LCD Contrast	11	0 to 31 step 1
Sets the LCD contrast.				

Table 1 - Configuration settings

“SettingValue” and “SettingValueBeh.” (09FE) Notes

A new setting [09FE] SettingValueBeh has been added:

Cell	Menu Text	Data Type	Strings	Default Setting	Available Setting
09FE	SettingValueBeh.	Indexed string	G263	Independent	0 = Independent 1 = Locked Mode

When [09FE] = Independent, the IED will behave as the original design. That means the [092E] Setting Values are independent for each interface. For example:

Interface	[092E]	Protect Setting Display as
Local	Primary	Primary
Remote 1	Secondary	Secondary
Remote 2	Secondary	Secondary
LPM	Primary	Primary

When [09FE] = Locked Mode, the IED will behave this way, [092E] Setting Values are locked to the same value for each interface:

- When the [092E] Setting Value = Primary, the protection settings are entered in Primary terms on all interfaces; and the value of this cell is equal to Primary on all interfaces.
- When the [092E] Setting Value = Secondary, the protection settings are entered in Secondary terms on all interfaces; and the value of this cell is equal to Secondary on all interfaces.

Note When [09FE] is changed to Locked Mode, all interfaces will apply to the current selection for the interface that is changing this setting.

For example, the Front Port is Secondary and Rear Port 1 is Primary. When [09FE] is changed to Locked Mode on the HMI, all interfaces should apply Secondary to [092E]; if it is changed from the Rear Port then we should apply Primary.

3 GROUP SETTINGS

The relay has four application settings groups to enable adaptive behaviour to changing system conditions. The Group settings contain the settings associated with the main application functions and include the following items that become active once enabled in the configuration column of the relay menu database:

- Protection element settings
- Programmable Scheme Logic (PSL) settings
- Auto-reclose and check synchronization settings
- Fault locator settings.

Those setting cells that are enabled in the configuration column are visible in each Group setting. One group of settings is selected as the active group, and those Group settings are then used by the appropriate application elements.

The settings for group 1 are described below. The settings are discussed in the same order in which they are displayed in the menu.

3.1 Line Parameters

The column **GROUP x LINE PARAMETERS** is used to enter the characteristics of the protected line or cable. These settings are used by the fault locator as the base data for input to the distance to fault algorithm, and also as the reference for all distance zones when the Distance set up is preferred in the 'Simple' setting mode. It also accommodates the system phase rotation (phase sequence) and defines the single or three pole tripping mode.

Col	Row	MENU TEXT	Default Setting	Available Setting
Description				
30	00	GROUP 1 LINE PARAMETERS	0	
This column contains settings for Line Parameters				
30	01	Line Length (metres)	100000m	From 300m to 1000Km step 10m
Setting of the protected line/cable length in km. This setting is available if MEASURE'T SETUP column is selected as 'Visible' in the CONFIGURATION column and if 'Distance unit' in the MEASURE'T SETUP column is selected as 'kilometers'.				
30	02	Line Length (miles)	62.1mi	From 0.005mi to 621mi step 0.005mi
Setting of the protected line/cable length in miles. This setting is available if MEASURE'T SETUP column is selected as 'Visible' in the CONFIGURATION column and if 'Distance unit' in the MEASURE'T SETUP column is selected as 'miles'. Dual step size is provided, for cables/short lines up to 10 miles the step size is 0.005 miles, 0.01 miles otherwise.				
30	03	Line Impedance	10*V1/I1Ω	From 0.05*V1/I1Ω to 500*V1/I1Ω step 0.01*V1/I1Ω
Setting for protected line/cable positive sequence impedance in either primary or secondary terms, depending on the Setting Values reference chosen in the CONFIGURATION column. The set value is used for Fault locator, and for all distance zone reaches calculation if 'Simple' setting mode under GROUP x DISTANCE SETUP is selected.				
30	04	Line Angle	70°	From 20° to 90° step 1°
Setting of the line angle (line positive sequence impedance angle).				
30	05	Residual Comp	1	0 to 10 step 0.01

Col	Row	MENU TEXT	Default Setting	Available Setting
Description				
Setting of the residual compensation factor magnitude, used to extend the ground loop reach by a multiplication factor of (1+kZN), is calculated as ratio: $ kZN = (Z0 - Z1)/3Z1$ where, Z1 = positive sequence impedance for the protected line or cable. Z0 = zero sequence impedance for the protected line or cable. Setting of the residual compensation factor magnitude, used to extend the ground loop reach by a multiplication factor of (1+kZN), is calculated as ratio: $ kZN = (Z0 - Z1)/3Z1$ where, Z1 = positive sequence impedance for the protected line or cable. Z0 = zero sequence impedance for the protected line or cable. This setting is a used for Distance protection (when set to simple mode) . If Distance protection is set to Advanced mode, there are individual settings per Zone in the GROUP x DISTANCE ELEMENTS settings.				
30	06	kZN Res Angle	0°	From -180° to 90° step 1°
Setting of the residual compensation factor angle (in degrees) is calculated as: $\angle kZN = \angle (Z0 - Z1)/3Z1$ where, Z1 = positive sequence impedance for the protected line or cable. Z0 = zero sequence impedance for the protected line or cable. This setting is a used for Distance protection (when set to simple mode) . If Distance protection is set to Advanced mode, there are individual settings per Zone in the GROUP x DISTANCE ELEMENTS settings.				
30	0B	Phase Sequence	Standard ABC	0 = Standard ABC or 1 = Reverse ACB
This setting is used to select whether the 3 phase quantities (V and I) are rotating in the standard ABC sequence, or whether the rotation is in reverse ACB order. The appropriate selection is required to ensure that all derived sequence components and faulted phase flagging/targeting are correct.				
30	10	Line Charging Y	0.002*11/V1 S	From 0 S to 0.01*11/V1 S step 0.0001*11/V1 S
Setting for protected lines' total susceptance in either primary or secondary terms, depending on the Setting Values reference chosen in the CONFIGURATION column. The set value is used to calculate the compensated overvoltage if 'V1>1 Cmp Funct' setting is enabled under GROUP x VOLT PROTECTION.				

Table 2 - Line parameters

3.2 Distance Setup

The column **GROUP x DISTANCE SETUP** is used to:

- Select the Distance setting mode (Simple or Advanced)
- Select the operating characteristic (Mho or Quad) for phase and ground measuring loops independently
- Enable or Disable each phase and ground zone independently
- Define the reach (in Ohms) for each phase and ground zone independently by simply setting the percentage required reach with reference to the line impedance (taken as the 100% reference basis)
- Other settings related to application of the "Basic" distance scheme

Col	Row	MENU TEXT	Default Setting	Available Setting
Description				
31	00	GROUP 1 DISTANCE SETUP	0	
This column contains settings for Distance Setup				
31	0C	Setting Mode	Simple	0 = Simple or 1 = Advanced

Col	Row	MENU TEXT	Default Setting	Available Setting
Description				
Setting to select setting mode for Distance protection, depending on type of application and user preferences. 'Simple' mode: 'Simple' setting mode is the default setting mode, suitable for the majority of applications. Instead of entering distance zone impedance reaches in ohms, zone settings are simply entered in terms of percentage of the protected line data specified in the 'GROUP x LINE PARAMETERS/Line Impedance' setting. The setting assumes that the residual compensation factor is equal for all zones. The relay auto calculates the required reaches from the percentages. The calculated zone reaches are available for viewing but a user can not alter/change the value as long as 'Simple' mode setting remains active. Advanced setting mode: 'Advanced' setting mode allows individual distance ohmic reaches and residual compensation factors to be entered for each zone. When 'Advanced' mode is selected, all 'percentage' settings that are associated to 'Simple' setting mode in the column GROUP x DISTANCE SETUP will be hidden and the Distance zone settings need to be entered for each zone in the 'GROUP x DIST. ELEMENTS' column.				
31	0D	Distance Setup	Zone Starting	0 = Zone Starting or 1 = Gen Starting
Setting to select distance timers start option after fault finding. 'Zone Start' setting is default setting configure the device functionality comparable with existing solution where zone timers starts individually in which zone, the fault found. 'Gen Start' setting configures the device to start all distance zone timers irrespective of the fault finding zone. this triggers quick trip.				
31	10	PHASE DISTANCE	0	
0				
31	11	Phase Chars.	Mho	0 = Disabled, 1 = Mho, 2 = Quadrilateral
Setting to disable (turn off) phase distance protection or to set Mho or Quad operating characteristic: ANSI 21P. The chosen setting is applicable to all phase distance zones.				
31	20	Zone 1 Ph Status	Enabled	0 = Disabled or 1 = Enabled, 2 = Enabled on Ch Fail
To enable (activate) or disable (turn off) or enable (only in the case that differential protection communication channel is lost) Z1 for phase faults. This setting is invisible if 'Phase Char.' is disabled.				
31	21	Zone 1 Ph Reach	0.8	From 10% to 1000% step 1%
Setting entry as percentage of the line impedance that sets Zone 1 reach in ohms.				
31	30	Zone 2 Ph Status	Enabled	0 = Disabled or 1 = Enabled, 2 = Enabled on Ch Fail
To enable (activate) or disable (turn off) or enable (only in the case that differential protection communication channel is lost) Z2 for phase faults. This setting is invisible if 'Phase Char.' is disabled.				
31	31	Zone 2 Ph Reach	1.5	From 10% to 1000% step 1%
Setting entry as percentage of the line impedance that sets Zone 2 reach in ohms.				
31	40	Zone 3 Ph Status	Enabled	0 = Disabled or 1 = Enabled, 2 = Enabled on Ch Fail
To enable (activate) or disable (turn off) or enable (only in the case that differential protection communication channel is lost) Z3 for phase faults. This setting is invisible if 'Phase Char.' is disabled.				
31	41	Zone 3 Ph Reach	2.5	From 10% to 1000% step 1%
Setting entry as percentage of the line impedance that sets Zone 3 forward reach in ohms.				
31	42	Zone 3 Ph Offset	Enabled	0 = Disabled or 1 = Enabled
To enable (activate) or disable (turn off) or enable (only in the case that differential protection communication channel is lost) Zone 3 offset reach for phase faults. By default, Z3 Mho phase characteristic is offset (partly reverse directional), thus not memory/cross polarized. 'If Z3 Gnd Offset' is disabled, Z3 Mho characteristic becomes memory/cross polarized like all other zones.				
31	43	Z3Ph Rev Reach	0.1	From 10% to 1000% step 1%
Setting entry as percentage of the line impedance that sets Zone 3 reverse reach in ohms.				
31	50	Zone P Ph Status	Disabled	0 = Disabled or 1 = Enabled, 2 = Enabled on Ch Fail
To enable (activate) or disable (turn off) or enable (only in the case that differential protection communication channel is lost) ZP for phase faults. This setting is invisible if 'Phase Char.' is disabled.				
31	51	Zone P Ph Dir.	Forward	0 = Forward or 1 = Reverse

Col	Row	MENU TEXT	Default Setting	Available Setting
Description				
To directionalize Zone P forward or reverse.				
31	52	Zone P Ph Reach	2	From 10% to 1000% step 1%
Setting entry as percentage of the line impedance that sets Zone P forward or reverse reach in ohms.				
31	60	Zone 4 Ph Status	Enabled	0 = Disabled or 1 = Enabled, 2 = Enabled on Ch Fail
To enable (activate) or disable (turn off) or enable (only in the case that differential protection communication channel is lost) Z4 for phase faults. This setting is invisible if 'Phase Char.' is disabled.				
31	61	Zone 4 Ph Reach	1.5	From 10% to 1000% step 1%
Setting entry as percentage of the line impedance that sets reverse Zone 4 reach in ohms.				
31	65	Zone Q Ph Status	Enabled	0 = Disabled or 1 = Enabled, 2 = Enabled on Ch Fail
To enable (activate) or disable (turn off) or enable (only in the case that differential protection communication channel is lost) ZQ for phase faults. This setting is invisible if 'Phase Char.' is disabled.				
31	66	Zone Q Ph Dir.	Reverse	0 = Forward or 1 = Reverse
To directionalize Zone Q forward or reverse.				
31	67	Zone Q Ph Reach	2	From 10% to 1000% step 1%
Setting entry as percentage of the line impedance that sets reverse Zone Q reach in ohms.				
31	70	GROUND DISTANCE	0	
0				
31	71	Ground Chars.	Mho	0 = Disabled, 1 = Mho, 2 = Quadrilateral
Setting to disable (turn off) ground distance protection or to set Mho or Quad operating characteristic: ANSI 21G. The chosen setting is applicable to all ground distance zones.				
31	72	Quad Resistance	Proportional	0 = Common or 1 = Proportional
Setting to define the mode of resistive reach coverage. If 'Common' mode is selected, all ground distance zones will have the equal resistive coverage. If 'Proportional' mode is selected, the zones will have resistive coverage according to the % reach set for the zone, multiplied by the 'Fault Resistance' RG setting. This setting is visible only when 'Simple' setting mode and quad characteristic are set.				
31	73	Fault Resistance	$10 \cdot V1/I1\Omega$	From $0.1 \cdot V1/I1\Omega$ to $500 \cdot V1/I1\Omega$ step $0.01 \cdot V1/I1\Omega$
Setting used to specify the fault arc resistance that can be detected for faults phase - ground. The set value determines the right hand side of the quadrilaterals. This setting is visible only when 'Simple' setting mode and quad characteristic are set.				
31	75	Dynamic Top Tilt	45	From 5° to 45° step 1°
Maximum tilt angle limit during dynamical tilting of phase - ground quadrilateral characteristic. This setting is visible when 'Advanced' setting mode and Quad characteristic are set				
31	80	Zone 1 Gnd Stat.	Enabled	0 = Disabled or 1 = Enabled, 2 = Enabled on Ch Fail
To enable (activate) or disable (turn off) or enable (only in the case that differential protection communication channel is lost) Zone 1 for ground faults. This setting is invisible if 'Ground Char.' is disabled.				
31	81	Zone 1 Gnd Reach	0.8	From 10% to 1000% step 1%
Setting entry as percentage of the line impedance that sets Zone 1 reach in ohms.				
31	90	Zone 2 Gnd Stat.	Enabled	0 = Disabled or 1 = Enabled, 2 = Enabled on Ch Fail
To enable (activate) or disable (turn off) or enable (only in the case that differential protection communication channel is lost) Zone 2 for ground faults. This setting is invisible if 'Ground Char.' is disabled.				
31	91	Zone 2 Gnd Reach	1.5	From 10% to 1000% step 1%
Setting entry as percentage of the line impedance that sets Zone 2 reach in ohms.				
31	A0	Zone 3 Gnd Stat.	Enabled	0 = Disabled or 1 = Enabled, 2 = Enabled on Ch Fail

Col	Row	MENU TEXT	Default Setting	Available Setting
Description				
To enable (activate) or disable (turn off) or enable (only in the case that differential protection communication channel is lost) Zone 3 for ground faults. This setting is invisible if 'Ground Char.' is disabled.				
31	A1	Zone 3 Gnd Reach	2.5	From 10% to 1000% step 1%
Setting entry as percentage of the line impedance that sets Zone 3 forward reach in ohms.				
31	A2	Zone3 Gnd Offset	Enabled	0 = Disabled or 1 = Enabled
To enable (activate) or disable (turn off) or enable (only in the case that differential protection communication channel is lost) Zone 3 offset reach for ground faults. By default, Z3 Mho ground characteristic is offset (partly reverse directional), thus not memory/cross polarized. 'If Z3 Gnd Offset' is disabled, Z3 Mho characteristic becomes memory/cross polarized like all other zones.				
31	A3	Z3Gnd Rev Reach	0.1	From 10% to 1000% step 1%
Setting entry as percentage of the line impedance that sets Zone 3 reverse reach in ohms.				
31	B0	Zone P Gnd Stat.	Disabled	0 = Disabled or 1 = Enabled, 2 = Enabled on Ch Fail
To enable (activate) or disable (turn off) or enable (only in the case that differential protection communication channel is lost) Zone P for ground faults. This setting is invisible if 'Ground Char.' is disabled.				
31	B1	Zone P Gnd Dir.	Forward	0 = Forward or 1 = Reverse
To directionalize ZP forward or reverse.				
31	B2	Zone P Gnd Reach	2	From 10% to 1000% step 1%
Setting entry as percentage of the line impedance that sets Zone P forward or reverse reach in ohms.				
31	C0	Zone 4 Gnd Stat.	Enabled	0 = Disabled or 1 = Enabled, 2 = Enabled on Ch Fail
To enable (activate) or disable (turn off) or enable (only in the case that differential protection communication channel is lost) Zone 4 for ground faults. This setting is invisible if 'Ground Char.' is disabled.				
31	C1	Zone 4 Gnd Reach	1.5	From 10% to 1000% step 1%
Setting entry as percentage of the line impedance that sets reverse Zone 4 reach in ohms.				
31	C5	Zone Q Gnd Stat.	Enabled	0 = Disabled or 1 = Enabled, 2 = Enabled on Ch Fail
To enable (activate) or disable (turn off) or enable (only in the case that differential protection communication channel is lost) Zone Q for ground faults. This setting is invisible if 'Ground Char.' is disabled.				
31	C6	Zone Q Gnd Dir.	Reverse	0 = Forward or 1 = Reverse
To directionalize ZQ forward or reverse.				
31	C7	Zone Q Gnd Reach	2	From 10% to 1000% step 1%
Setting entry as percentage of the line impedance that sets reverse Zone Q reach in ohms.				
31	D0	Digital Filter	Standard	0 = Standard or 1 = Special Applies.
Setting to enable (activate) 'Standard' or 'Special Application' filters. 'Standard' filters are the default setting and should be applied in the majority of applications. It is only the case when the fault currents and voltages may become very distorted by non-fundamental harmonics that extra filtering is necessary to avoid transient over-reach. In such system conditions the 'Special Applications' setting should be applied.				
31	D1	CVT Filters	Disabled	0 = Disabled, 1 = Passive, 2 = Active
Setting that accommodates the type of voltage transformer being used to prevent transient over-reach and preserve sub-cycle operating time whenever possible. In case of conventional wound VTs, the transients due to voltage collapse during faults are very small and no extra filtering is required, therefore the setting should be 'Disabled' as per default. For a CVT with active Ferro resonance damping, the voltage distortions may be severe and risk transient over-reach. For that reason, the 'CVT Filters' should be set to 'Active'. Trip times increase proportionally (subcycle up to SIR = 2, gradually lengthening for SIR up to 30). For a CVT with passive Ferro resonance damping, the voltage distortions are generally small up to SIR of 30. For such applications, 'CVT Filters' should be set 'Passive'. The relay calculates the SIR and will take marginally longer to trip if the infeed is weak (exceeds the relay's SIR setting).				

Col	Row	MENU TEXT	Default Setting	Available Setting
Description				
31	D2	SIR Setting	30	5 to 60 step 1
Setting that determines when extra filtering will be applied. If on fault inception the calculated SIR exceeds the 'SIR Setting' the relay will marginally slow down, as otherwise there would be a risk of over-reach. This setting is visible only when 'CVT Filters' is set to 'Passive'.				
31	D3	Load Blinders	Disabled	0 = Disabled or 1 = Enabled
Setting used to activate (enable) or turn off (disable) load blinders. Load blinders, when enabled, have two main purposes: to prevent tripping due to load encroachment under heavy load condition and detect very slow moving power swings.				
31	D4	Z< Blinder Imp	15*V1/I1Ω	From 0.1*V1/I1Ω to 500*V1/I1Ω step 0.01*V1/I1Ω
Setting of radius of under-impedance circle.				
31	D5	Load/B Angle	45	From 15° to 65° step 1°
Angle setting for the two blinder lines boundary with the gradient of the rise or fall with respect to the resistive axis.				
31	D6	Load Blinder V<	15*V1	From 1*V1 to 70*V1 step 0.5*V1
Load blinder phase to ground under-voltage setting that overrides the blinder if the measured voltage in the affected phase falls below setting. Also overrides blinding of phase-phase loops where the phase-phase voltage falls below $\sqrt{3} \times (V< \text{setting})$.				
31	D7	Distance Polarising	1	0.2 to 5 step 0.1
The setting defines the composition of polarizing voltage as a mixture of 'Self' and 'Memory' polarizing voltage. 'Self' polarized voltage is fixed to 1pu and could be mixed with 'Memory' polarizing voltage ranging from 0.2pu up to 5pu. The default setting of 1 means that half of the polarizing voltage is made up from 'Self' and the other half from clean 'Memory' voltage. Adding more 'Memory' voltage will enhance the resistive coverage of Mho characteristics, whose expansion is defined as: Mho expansion = [(Dist. Polarizing)/ (Dist. Polarizing + 1)] x Zs Where Zs is the source impedance.				
31	E0	DELTADIRECTIONAL	0	
0				
31	E1	Dir. Status	Enabled	0 = Disabled or 1 = Enabled
Setting used to enable or disable Delta Direction ($\Delta I/\Delta V$). To enable or disable the delta direction decision used by distance elements. If disabled, the relay uses conventional (non delta) directional lines.				
31	E3	Dir. Char Angle	60	From 0° to 90° step 1°
Setting for the relay characteristic angle used for the delta directional decision.				

Table 3 - Group x distance setup

3.3 Distance Elements

The column **GROUP x DISTANCE ELEMENTS** is used to individually set reaches, line angles, neutral compensation factors, minimum current operating levels and line tilting for resistive phase faults for each zone if the setting mode is set to 'Advanced'. In 'Simple' setting mode, 'Distance Elements' setting can be **viewed**, but not edited here.

Col	Row	MENU TEXT	Default Setting	Available Setting
Description				
32	00	GROUP 1 DIST. ELEMENTS	0	
This column contains settings for Distance Elements				
32	01	PHASE DISTANCE	0	
0				
32	02	Z1 Ph. Reach	8*V1/I1Ω	From 0.05*V1/I1Ω to 500*V1/I1Ω step 0.01*V1/I1Ω
Setting for Z1 reach.				

Col	Row	MENU TEXT	Default Setting	Available Setting
Description				
32	03	Z1 Ph. Angle	70	From 20° to 90° step 1°
Setting of line angle for zone 1.				
32	09	Z1 Sensit. Iph>1	0.075*11 A	From 0.05*11 A to 2*11 A step 0.005*11 A
Current sensitivity setting for Z1 that must be exceeded in faulted phases if Z1 is to operate.				
32	10	Z2 Ph. Reach	15*V1/I1Ω	From 0.05*V1/I1Ω to 500*V1/I1Ω step 0.01*V1/I1Ω
Setting for Z2 reach.				
32	11	Z2 Ph. Angle	70	From 20° to 90° step 1°
Setting of line angle for zone 2.				
32	17	Z2 Sensit. Iph>2	0.075*11 A	From 0.05*11 A to 2*11 A step 0.005*11 A
Zone 2 current sensitivity.				
32	20	Z3 Ph. Reach	25*V1/I1Ω	From 0.05*V1/I1Ω to 500*V1/I1Ω step 0.01*V1/I1Ω
Setting for Z3 reach.				
32	21	Z3 Ph. Angle	70	From 20° to 90° step 1°
Setting of line angle for zone 3.				
32	22	Z3' Ph Rev Reach	1*V1/I1Ω	From 0.05*V1/I1Ω to 500*V1/I1Ω step 0.01*V1/I1Ω
Setting for Z3 offset (reverse) reach. This setting is only visible if 'Z3 Offset' is enabled in 'GROUP x DISTANCE SETUP'.				
32	28	Z3 Sensit. Iph>3	0.05*11 A	From 0.05*11 A to 2*11 A step 0.005*11 A
Zone 3 current sensitivity.				
32	30	ZP Ph. Reach	20*V1/I1Ω	From 0.05*V1/I1Ω to 500*V1/I1Ω step 0.01*V1/I1Ω
Setting for ZP reach.				
32	31	ZP Ph. Angle	70	From 20° to 90° step 1°
Setting of line angle for zone P.				
32	37	ZP Sensit. Iph>P	0.05*11 A	From 0.05*11 A to 2*11 A step 0.005*11 A
Zone P current sensitivity.				
32	40	Z4 Ph. Reach	15*V1/I1Ω	From 0.05*V1/I1Ω to 500*V1/I1Ω step 0.01*V1/I1Ω
Setting for Z4 reach. This is a common setting for Z4 time delayed and Z4 high speed elements used in blocking schemes and for current reversal guard.				
32	41	Z4 Ph. Angle	70	From 20° to 90° step 1°
Setting of line angle for zone 4.				
32	46	Z4 Sensit. Iph>4	0.05*11 A	From 0.05*11 A to 2*11 A step 0.005*11 A
Zone P current sensitivity.				
32	49	ZQ Ph. Reach	20*V1/I1Ω	From 0.05*V1/I1Ω to 500*V1/I1Ω step 0.01*V1/I1Ω
Setting for ZQ reach. This is a common setting for ZQ time delayed and ZQ high speed elements used in blocking schemes and for current reversal guard.				
32	4A	ZQ Ph. Angle	70	From 20° to 90° step 1°
Setting of line angle for zone Q.				
32	4D	ZQ Sensit. Iph>Q	0.05*11 A	From 0.05*11 A to 2*11 A step 0.005*11 A
Zone Q current sensitivity.				
32	50	GROUND DISTANCE	0	
0				
32	51	Z1 Gnd. Reach	8*V1/I1Ω	From 0.05*V1/I1Ω to 500*V1/I1Ω step 0.01*V1/I1Ω
Setting for Z1 reach.				
32	52	Z1 Gnd. Angle	70	From 20° to 90° step 1°

Col	Row	MENU TEXT	Default Setting	Available Setting
Description				
Setting of line angle (positive sequence) for zone 1.				
32	53	Z1 Dynamic Tilt	Enabled	0 = Disabled or 1 = Enabled
Setting that enables or disables zone 1 top reactance line dynamic tilting. If set enabled, the top line angle will be automatically shifted by the angle difference between the fault current and negative sequence current, starting from the 'Z1 Tilt top line' angle setting – see the next cell. The zone 1 is allowed only to tilt down. If Dynamic tilting is disabled, the top line will be shifted by the 'Z1 Tilt top line' setting (Predetermined tilting by fixed angle). This setting is visible only when ground characteristic is set to 'Quad'.				
32	54	Z1 Tilt Top Line	-3	From -30° to 30° step 1°
Setting of the zone 1 tilt angle. Minus angle tilts the reactance line downwards This setting is visible only when the above setting is visible.				
32	55	kZN1 Res. Comp.	1	0 to 10 step 0.01
Setting of Z1 residual compensation magnitude.				
32	56	kZN1 Res. Angle	0	From -180° to 90° step 0.1°
Setting of Z1 residual compensation angle.				
32	59	R1 Gnd Resistive	8*V1/I1Ω	From 0.05*V1/I1Ω to 500*V1/I1Ω step 0.01*V1/I1Ω
Setting for Z1 ground resistive reach. This setting is only visible if Quad is selected.				
32	5B	Z1 Sensit Ignd>1	0.075*I1 A	From 0.05*I1 A to 2*I1 A step 0.005*I1 A
Current sensitivity setting for Z1 that must be exceeded in faulted phase and the neutral if Z1 is to operate.				
32	60	Z2 Gnd. Reach	15*V1/I1Ω	From 0.05*V1/I1Ω to 500*V1/I1Ω step 0.01*V1/I1Ω
Setting for Z2 reach.				
32	61	Z2 Gnd. Angle	70	From 20° to 90° step 1°
Setting of line angle (positive sequence) for zone 2.				
32	63	Z2 Dynamic Tilt	Enabled	0 = Disabled or 1 = Enabled
Setting that enables or disables zone 2 top reactance line dynamic tilting. If set enabled, the top line angle will be automatically shifted by the angle difference between the fault current and negative sequence current, starting from the 'Z2 Tilt top line' angle setting – see the next cell. The zone 2, as over-reaching zone, is allowed only to tilt up. If Dynamic tilting is disabled, the top line will be shifted by the 'Z2 Tilt top line' setting (Predetermined tilting by fixed angle). This setting is visible only when ground characteristic is set to 'Quad'.				
32	64	Z2 Tilt Top Line	-3	From -30° to 30° step 1°
Setting of the zone 2 tilt angle. Minus angle tilts the reactance line downwards This setting is visible only when the above setting is visible.				
32	65	kZN2 Res. Comp.	1	0 to 10 step 0.01
Setting of Z2 residual compensation magnitude.				
32	66	kZN2 Res. Angle	0	From -180° to 90° step 0.1°
Setting of Z2 residual compensation angle.				
32	69	R2 Gnd Resistive	15*V1/I1Ω	From 0.05*V1/I1Ω to 500*V1/I1Ω step 0.01*V1/I1Ω
Setting for Z2 ground resistive reach.				
32	6B	Z2 Sensit Ignd>2	0.075*I1 A	From 0.05*I1 A to 2*I1 A step 0.005*I1 A
Zone 2 current sensitivity.				
32	70	Z3 Gnd. Reach	25*V1/I1Ω	From 0.05*V1/I1Ω to 500*V1/I1Ω step 0.01*V1/I1Ω
Setting for Z3 reach.				
32	71	Z3 Gnd. Angle	70	From 20° to 90° step 1°
Setting of line angle (positive sequence) for zone 3.				
32	72	Z3' Gnd Rev Rch	1*V1/I1Ω	From 0.05*V1/I1Ω to 500*V1/I1Ω step 0.01*V1/I1Ω
Setting for Z3 offset (reverse) reach. This setting is only visible if 'Z3 Offset' is enabled in 'GROUP x DISTANCE SETUP'.				
32	73	Z3 Dynamic Tilt	Enabled	0 = Disabled or 1 = Enabled

Col	Row	MENU TEXT	Default Setting	Available Setting
Description				
Setting that enables or disables Z3 top reactance line dynamic tilting. If set enabled, the top line angle will be automatically shifted by the angle difference between the fault current and negative sequence current, starting from the 'Z3 Tilt top line' angle setting – see the next cell. The ZP, as over-reaching zone, is allowed only to tilt up. If Dynamic tilting is disabled, the top line will be shifted by the 'ZP Tilt top line' setting (Predetermined tilting by fixed angle). This setting is visible only when ground characteristic is set to 'Quad' and Z3 offset disabled.				
32	74	Z3 Tilt Top Line	-3	From -30° to 30° step 1°
Setting of the Z3 tilt angle. Minus angle tilts the reactance line downwards This setting is visible only when the above setting is visible.				
32	75	kZN3 Res. Comp.	1	0 to 10 step 0.01
Setting of Z3 residual compensation magnitude.				
32	76	kZN3 Res. Angle	0	From -180° to 90° step 0.1°
Setting of Z3 residual compensation angle.				
32	79	R3 Gnd. Res. Fwd	25*V1/I1Ω	From 0.05*V1/I1Ω to 500*V1/I1Ω step 0.01*V1/I1Ω
Setting for Z3 resistive reach that defines Quad's right hand line.				
32	7A	R3' Gnd Res. Rev	1*V1/I1Ω	From 0.05*V1/I1Ω to 500*V1/I1Ω step 0.01*V1/I1Ω
Setting for Z3 resistive reach that defines Quad's left hand line. This is settable only if Ground Chars. is Quad and Z3 offset is enabled otherwise is fixed to 25% of the right hand blinder.				
32	7C	Z3 Sensit Ignd>3	0.05*I1 A	From 0.05*I1 A to 2*I1 A step 0.005*I1 A
Zone 3 current sensitivity.				
32	80	ZP Gnd. Reach	20*V1/I1Ω	From 0.05*V1/I1Ω to 500*V1/I1Ω step 0.01*V1/I1Ω
Setting for ZP reach.				
32	81	ZP Gnd. Angle	70	From 20° to 90° step 1°
Setting of line angle (positive sequence) for zone P.				
32	83	ZP Dynamic Tilt	Enabled	0 = Disabled or 1 = Enabled
Setting that enables or disables ZP top reactance line dynamic tilting. If set enabled, the top line angle will be automatically shifted by the angle difference between the fault current and negative sequence current, starting from the 'ZP Tilt top line' angle setting – see the next cell. The ZP, as over-reaching zone, is allowed only to tilt up. If Dynamic tilting is disabled, the top line will be shifted by the 'ZP Tilt top line' setting (Predetermined tilting by fixed angle). This setting is visible only when ground characteristic is set to 'Quad'.				
32	84	ZP Tilt Top Line	-3	From -30° to 30° step 1°
Setting of the ZP tilt angle. Minus angle tilts the reactance line downwards This setting is visible only when the above setting is visible.				
32	85	kZNP Res. Comp.	1	0 to 10 step 0.01
Setting of ZP residual compensation magnitude.				
32	86	kZNP Res. Angle	0	From -180° to 90° step 0.1°
Setting of ZP residual compensation angle.				
32	89	RP Gnd Resistive	20*V1/I1Ω	From 0.05*V1/I1Ω to 500*V1/I1Ω step 0.01*V1/I1Ω
Setting for ZP ground resistive reach.				
32	8B	ZP Sensit Ignd>P	0.05*I1 A	From 0.05*I1 A to 2*I1 A step 0.005*I1 A
Zone P current sensitivity.				
32	90	Z4 Gnd. Reach	15*V1/I1Ω	From 0.05*V1/I1Ω to 500*V1/I1Ω step 0.01*V1/I1Ω
Setting for Z4 reach. This is a common setting for Z4 time delayed and Z4 high speed elements used in blocking schemes and for current reversal guard.				
32	91	Z4 Gnd. Angle	70	From 20° to 90° step 1°
Setting of line angle (positive sequence) for zone 4.				
32	93	Z4 Dynamic Tilt	Enabled	0 = Disabled or 1 = Enabled

Col	Row	MENU TEXT	Default Setting	Available Setting
Description				
Setting that enables or disables Z4 top reactance line dynamic tilting. If set enabled, the top line angle will be automatically shifted by the angle difference between the fault current and negative sequence current, starting from the 'Z4 Tilt top line' angle setting – see the next cell. The Z4, as over-reaching zone, is allowed only to tilt up. If Dynamic tilting is disabled, the top line will be shifted by the 'Z4 Tilt top line' setting (Predetermined tilting by fixed angle). This setting is visible only when ground characteristic is set to 'Quad'.				
32	94	Z4 Tilt Top Line	-3	From -30° to 30° step 1°
Setting of the Z4 tilt angle. Minus angle tilts the reactance line downwards This setting is visible only when the above setting is visible.				
32	95	kZN4 Res. Comp.	1	0 to 10 step 0.01
Setting of Z4 residual compensation magnitude.				
32	96	kZN4 Res. Angle	0	From -180° to 90° step 0.1°
Setting of Z4 residual compensation angle.				
32	99	R4 Gnd Resistive	15*V1/I1Ω	From 0.05*V1/I1Ω to 500*V1/I1Ω step 0.01*V1/I1Ω
Setting for Z4 ground resistive reach.				
32	9B	Z4 Sensit Ignd>4	0.05*I1 A	From 0.05*I1 A to 2*I1 A step 0.005*I1 A
Zone 4 current sensitivity.				
32	A0	ZQ Gnd. Reach	20*V1/I1Ω	From 0.05*V1/I1Ω to 500*V1/I1Ω step 0.01*V1/I1Ω
Setting for ZQ reach. This is a common setting for ZQ time delayed and ZQ high speed elements used in blocking schemes and for current reversal guard.				
32	A1	ZQ Gnd. Angle	70	From 20° to 90° step 1°
Setting of line angle (positive sequence) for zone Q.				
32	A3	ZQ Dynamic Tilt	Enabled	0 = Disabled or 1 = Enabled
Setting that enables or disables ZQ top reactance line dynamic tilting. If set enabled, the top line angle will be automatically shifted by the angle difference between the fault current and negative sequence current, starting from the 'ZQ Tilt top line' angle setting – see the next cell. The ZQ, as over-reaching zone, is allowed only to tilt up. If Dynamic tilting is disabled, the top line will be shifted by the 'ZQ Tilt top line' setting (Predetermined tilting by fixed angle). This setting is visible only when ground characteristic is set to 'Quad'.				
32	A4	ZQ Tilt Top Line	-3	From -30° to 30° step 1°
Setting of the ZQ tilt angle. Minus angle tilts the reactance line downwards This setting is visible only when the above setting is visible.				
32	A5	kZQNQ Res. Comp.	1	0 to 10 step 0.01
Setting of ZQ residual compensation magnitude.				
32	A6	kZQNQ Res. Angle	0	From -180° to 90° step 0.1°
Setting of ZQ residual compensation angle.				
32	A9	RQ Gnd Resistive	20*V1/I1Ω	From 0.05*V1/I1Ω to 500*V1/I1Ω step 0.01*V1/I1Ω
Setting for ZQ ground resistive reach.				
32	AB	ZQ Sensit Ignd>Q	0.05*I1 A	From 0.05*I1 A to 2*I1 A step 0.005*I1 A
Zone Q current sensitivity.				

Table 4 - Group x distance elements

3.4

Scheme Logic (Basic and Aided Scheme Logic)

The column **GROUP x SCHEME LOGIC** is used to:

- Set operating mode and associated timers for each distance zone when distance operates in the Basic scheme
- Select aided schemes via one or two available signaling channels
- Define operating zones during Trip On Close (TOC)

Col	Row	MENU TEXT	Default Setting	Available Setting
Description				
34	00	GROUP 1 SCHEME LOGIC	0	
This column contains settings for Distance and Aided DEF Scheme Logic				
34	01	BASIC SCHEME	0	
0				
34	08	Zone 1 Tripping	Phase And Ground	0 = Disabled, 1 = Phase only, 2 = Ground only, 3 = Phase And Ground
Setting to select for which types of fault Zone 1 elements will be applied.				
34	09	tZ1 Ph. Delay	0s	From 0s to 10s step 10ms
Time delay for Z1 phase element.				
34	0A	tZ1 Gnd. Delay	0s	From 0s to 10s step 10ms
Time delay for Z1 ground element.				
34	10	Zone 2 Tripping	Phase And Ground	0 = Disabled, 1 = Phase only, 2 = Ground only, 3 = Phase And Ground
Setting to select for which types of fault Zone 2 elements will be applied.				
34	11	tZ2 Ph. Delay	200ms	From 0s to 10s step 10ms
Time delay for Z2 phase element.				
34	12	tZ2 Gnd. Delay	200ms	From 0s to 10s step 10ms
Time delay for Z2 ground element.				
34	18	Zone 3 Tripping	Phase And Ground	0 = Disabled, 1 = Phase only, 2 = Ground only, 3 = Phase And Ground
Setting to select for which types of fault Zone 3 elements will be applied.				
34	19	tZ3 Ph. Delay	600ms	From 0s to 10s step 10ms
Time delay for Z3 phase element.				
34	1A	tZ3 Gnd. Delay	600ms	From 0s to 10s step 10ms
Time delay for Z3 ground element.				
34	20	Zone P Tripping	Phase And Ground	0 = Disabled, 1 = Phase only, 2 = Ground only, 3 = Phase And Ground
Setting to select for which types of fault Zone P elements will be applied.				
34	21	tZP Ph. Delay	400ms	From 0s to 10s step 10ms
Time delay for ZP phase element.				
34	22	tZP Gnd. Delay	400ms	From 0s to 10s step 10ms
Time delay for ZP ground element.				
34	28	Zone 4 Tripping	Phase And Ground	0 = Disabled, 1 = Phase only, 2 = Ground only, 3 = Phase And Ground
Setting to select for which types of fault Zone 4 elements will be applied.				
34	29	tZ4 Ph. Delay	1s	From 0s to 10s step 10ms
Time delay for Z4 phase element.				
34	2A	tZ4 Gnd. Delay	1s	From 0s to 10s step 10ms
Time delay for Z4 ground element.				
34	30	Zone Q Tripping	Phase And Ground	0 = Disabled, 1 = Phase only, 2 = Ground only, 3 = Phase And Ground
Setting to select for which types of fault Zone Q elements will be applied.				
34	31	tZQ Ph. Delay	1s	From 0s to 10s step 10ms

Col	Row	MENU TEXT	Default Setting	Available Setting
Description				
Time delay for ZQ phase element.				
34	32	tZQ Gnd. Delay	1s	From 0s to 10s step 10ms
Time delay for ZQ ground element.				
34	35	Dist tEnd Dir	Non Directional	0 = Non-Directional, 1 = Directional Fwd, 2 = Directional Rev
Setting to select the direction that directional end timer should elapse				
34	36	ZDir tEnd	1s	From 0s to 10s step 10ms
Time delay for distance directional end timer				
34	37	ZNonDir tEnd	1s	From 0s to 10s step 10ms
Time delay for distance non directional end timer				
34	40	AIDED SCHEME 1	0	
0				
34	41	Aid. 1 Selection	Disabled	0 = Disabled, 1 = PUR, 2 = PUR Unblocking, 3 = POR, 4 = POR Unblocking, 5 = Blocking 1, 6 = Blocking 2, 7 = Prog. Unblocking, 8 = Programmable
Selection of the generic scheme type for aided channel 1. Note: POR is equivalent to POTT (permissive overreach transfer trip), PUR is equivalent to PUTT (permissive underreach transfer trip).				
34	42	Aid 1 Distance	Phase And Ground	0 = Disabled, 1 = Phase only, 2 = Ground only, 3 = Phase And Ground
Setting to select whether distance elements should key the scheme selected as per the previous setting. If set to Disabled, no distance zones interact with this aided scheme, and basic scheme tripping only applies.				
34	43	Aid.1 Dist. Dly	0s	From 0s to 1s step 2ms
Trip time delay for Aided 1 Distance schemes.				
34	44	Aid. 1 DEF	Disabled	0 = Disabled or 1 = Enabled
Setting to select whether a DEF scheme should be mapped to Aided scheme 1. (Not applicable where a Permissive Underreaching scheme selection has been made).				
34	45	Aid. 1 DEF Dly.	0s	From 0s to 1s step 2ms
Time delay for Aided 1 DEF tripping.				
34	4A	tRev. Guard	20ms	From 0s to 150ms step 2ms
Setting for the current reversal guard timer. Intended to keep stability on a healthy line, whilst breakers open on a faulted parallel line to clear the fault. This setting is visible only when over-reaching or Blocking schemes are selected.				
34	4B	Unblocking Delay	50ms	From 0s to 100ms step 2ms
Time delay after Loss of Guard until unblocking occurs. After the set delay, the relay will respond as though an aided signal has been received from the remote end. This setting is visible only when PUR Unblocking, POR Unblocking or Programmable Unblocking schemes are chosen.				
34	4C	Send On Trip	Aided / Z1	0 = Aided / Z1, 1 = Any Trip, 2 = None
Setting that defines the reinforced trip signal for POR Aided 1 scheme. If selected to: None: No reinforced signal is issued Aided/Z1: The reinforced signal is issued with aided trip or with Z1 if aided distance scheme is enabled Any Trip: Signal is reinforced with Any trip (DDB 522)				
34	50	Weak Infeed	Disabled	0 = Disabled, 1 = Echo, 2 = Echo and Trip
Setting that defines Aided 1 scheme operation in case of weak infeed conditions, where no protection elements detect the fault at the local end, but an aided channel has been received from the remote end. Setting "Echo" will allow the received signal to be returned to the remote relay, "Trip" will allow local end tripping after a set delay.				
34	52	WI V< Threshold	45*V1	From 10*V1 to 70*V1 step 5*V1

Col	Row	MENU TEXT	Default Setting	Available Setting
Description				
Setting of Weak Infeed level detector. If phase - ground voltage in any phase drops below the threshold and with insufficient phase current for the protection to operate, the end is declared as a weak infeed terminal.				
34	53	WI Trip Delay	60ms	From 0s to 1s step 2ms
Setting for the weak infeed trip time delay.				
34	58	Custom Send Mask	000000001(bin)	Bit 00 = Z1 Gnd., Bit 01 = Z2 Gnd., Bit 02 = Z4 Gnd., Bit 03 = Z1 Ph., Bit 04 = Z2 Ph., Bit 05 = Z4 Ph., Bit 06 = DEF Fwd., Bit 07 = DEF Rev., Bit 08 = Dir Comp Fwd., Bit 09 = Dir Comp Rev.
Logic Settings that determine the element or group of elements that are sending a permissive signal to the other line end. For the signal to be sent, the element must operate and a corresponding bit in the matrix must be set to 1 (High). The above mapping is part of a custom made Aided 1 scheme, and unlike all other schemes that are factory tested, the customer must take the responsibility for testing and the operation of the scheme. This setting is visible only if a Programmable or Prog. Unblocking scheme is selected.				
34	59	Custom Time PU	0s	0
Pick up time delay of DDB signal 'Aid1 CustomT in', available in the PSL logic. Once the time delay elapses, the DDB signal 'Aid1 CustomT out' will become high.				
34	5A	Custom Time DO	0s	DEF Fwd., Bit 07 = DEF Rev., Bit 08 = Dir Comp Fwd., Bit 09 = Dir Comp Rev.
Drop off time delay of DDB signal 'Aid1 CustomT in'. Once the time delay elapses, the DDB signal 'Aid1 CustomT out' will become low. Note: The timer is a combined hard coded PU/DO timer for Custom Aided scheme 1.				
34	60	AIDED SCHEME 2	0	
0				
34	61	Aid. 2 Selection	Disabled	0 = Disabled, 1 = PUR, 2 = PUR Unblocking, 3 = POR, 4 = POR Unblocking, 5 = Blocking 1, 6 = Blocking 2, 7 = Prog. Unblocking, 8 = Programmable
Selection of the generic scheme type for aided channel 2. Note: POR is equivalent to POTT (permissive overreach transfer trip), PUR is equivalent to PUTT (permissive underreach transfer trip).				
34	62	Aid 2 Distance	Disabled	0 = Disabled, 1 = Phase only, 2 = Ground only, 3 = Phase And Ground
Setting to select whether distance elements should key the scheme selected as per the previous setting. If set to Disabled, no distance zones interact with this aided scheme, and basic scheme tripping only applies.				
34	63	Aid.2 Dist. Dly	20ms	From 0s to 1s step 2ms
Trip time delay for Aided 2 Distance schemes.				
34	64	Aid. 2 DEF	Enabled	0 = Disabled or 1 = Enabled
Setting to select whether a DEF scheme should be mapped to Aided scheme 2. (Not applicable where a Permissive Underreaching scheme selection has been made).				
34	65	Aid. 2 DEF Dly.	20ms	From 0s to 1s step 2ms
Time delay for Aided 2 DEF tripping.				
34	6A	tRev. Guard	20ms	From 0s to 150ms step 2ms
Setting for the current reversal guard timer. Intended to keep stability on a healthy line, whilst breakers open on a faulted parallel line to clear the fault. This setting is visible only when over-reaching or Blocking schemes are selected.				
34	6B	Unblocking Delay	50ms	From 0s to 100ms step 2ms
Time delay after Loss of Guard until unblocking occurs. After the set delay, the relay will respond as though an aided signal has been received from the remote end. This setting is visible only when PUR Unblocking, POR Unblocking or Programmable Unblocking schemes are chosen.				
34	6C	Send On Trip	Aided / Z1	0 = Aided / Z1, 1 = Any Trip, 2 = None

Col	Row	MENU TEXT	Default Setting	Available Setting
Description				
<p>Setting that defines the reinforced trip signal for POR Aided 2 scheme. If selected to: None: No reinforced signal is issued Aided/Z1: The reinforced signal is issued with aided trip or with Z1 if aided distance scheme is enabled Any Trip: Signal is reinforced with Any trip (DDB 522)</p>				
34	70	Weak Infeed	Disabled	0 = Disabled, 1 = Echo, 2 = Echo and Trip
<p>Setting that defines Aided 2 scheme operation in case of weak infeed conditions, where no protection elements detect the fault at the local end, but an aided channel has been received from the remote end. Setting "Echo" will allow the received signal to be returned to the remote relay, "Trip" will allow local end tripping after a set delay.</p>				
34	72	WI V< Threshold	45*V1	From 10*V1 to 70*V1 step 5*V1
<p>Setting of Weak Infeed level detector. If phase - ground voltage in any phase drops below the threshold and with insufficient phase current for the protection to operate, the end is declared as a weak infeed terminal.</p>				
34	73	WI Trip Delay	60ms	From 0s to 1s step 2ms
<p>Setting for the weak infeed trip time delay.</p>				
34	78	Custom Send Mask	0000000001(bin)	Bit 00 = Z1 Gnd., Bit 01 = Z2 Gnd., Bit 02 = Z4 Gnd., Bit 03 = Z1 Ph., Bit 04 = Z2 Ph., Bit 05 = Z4 Ph., Bit 06 = DEF Fwd., Bit 07 = DEF Rev., Bit 08 = Dir Comp Fwd., Bit 09 = Dir Comp Rev.
<p>Logic Settings that determine the element or group of elements that are sending a permissive signal to the other line end. For the signal to be sent, the element must operate and a corresponding bit in the matrix must be set to 1 (High). The above mapping is part of a custom made Aided 2 scheme, and unlike all other schemes that are factory tested, the customer must take the responsibility for testing and the operation of the scheme. This setting is visible only if a Programmable or Prog. Unblocking scheme is selected.</p>				
34	79	Custom Time PU	0s	From 0s to 1s step 2ms
<p>Pick up time delay of DDB signal 'Aid2 CustomT in', available in the PSL logic. Once the time delay elapses, the DDB signal 'Aid2 CustomT out' will become high.</p>				
34	7A	Custom Time DO	0s	From 0s to 1s step 2ms
<p>Drop off time delay of DDB signal 'Aid2 CustomT in'. Once the time delay elapses, the DDB signal 'Aid2 CustomT out' will become low. Note: The timer is a combined hard coded PU/DO timer for Custom Aided scheme 2.</p>				
34	80	Trip on Close	0	
0				
34	81	SOTF Status	Enabled PoleDead	0 = Disabled, 1 = Enabled PoleDead, 2 = Enabled ExtPulse, 3 = En Pdead + Pulse
<p>Setting that enables note (turns on) or disables (turns off) a special protection logic which can apply upon line energization. SOTF = Switch on to Fault. Note: SOTF can be enabled in three different manners: 1. Enabled Pole Dead. By using pole dead logic detection logic 2. Enabled ExtPulse. By using an external pulse 3. En Pdead + Pulse. By using both</p>				
34	82	SOTF Delay	110s	From 0.2s to 1000s step 0.2s
<p>The SOTF Delay is a pick up time delay that starts after opening all 3 poles of a CB. If the CB is then closed after the set time delay has expired, SOTF protection will be active. SOTF provides enhanced protection for manual closure of the breaker (not for auto-reclosure). This setting is visible only if Pole Dead or Pdead + Pulse are selected to enable SOTF.</p>				
34	83	SOTF Tripping	0000001(bin)	Bit 00 = Zone 1, Bit 01 = Zone 2, Bit 02 = Zone 3, Bit 03 = Zone P, Bit 04 = Zone 4, Bit 05 = Zone Q or Bit 06 = Current No Volts
<p>Logic Settings that determine the Distance zones that are allowed to operate instantaneously upon line energization. If, for example, Bit 1 is set to 1 (High), Z2 will operate without waiting for the usual tZ2 time delay should a fault lie within Z2 upon CB closure. It also allows a user to map 'Currents No Volt' option for fast fault clearance upon line energization. SOTF tripping is 3 phase and auto-reclose will be blocked.</p>				
34	84	TOR Status	Enabled	0 = Disabled or 1 = Enabled

Col	Row	MENU TEXT	Default Setting	Available Setting
Description				
Setting that enables (turns on) or disables (turns off) special protection following auto-reclosure. When set Enabled, TOR will be activated after the 'TOC Delay' has expired, ready for application when an auto-reclose shot occurs. TOR = Trip on (auto)Reclose.				
34	85	TOR Tripping	0000001(bin)	Bit 00 = Zone 1, Bit 01 = Zone 2, Bit 02 = Zone 3, Bit 03 = Zone P, Bit 04 = Zone 4, Bit 05 = Zone Q or Bit 06 = Current No Volts
Logic Settings that determine the Distance zones that are allowed to operate instantaneously upon line energization. If, for example, Bit 1 is set to 1 (High), Z2 will operate without waiting for the usual tZ2 time delay should a fault lie within Z2 upon CB closure. It also allows a user to map 'Currents No Volt' option for fast fault clearance upon line reclosure on a permanent fault. TOR tripping is 3 phase and auto-reclose will be blocked.				
34	86	TOC Reset Delay	500ms	From 100ms to 2s step 100ms
The TOC Reset Delay is a user settable time window during which TOC protection is available. The time window starts timing upon CB closure and it is common for SOTF and TOR protection. Once this timer expires after a successful (re)closure, all protection reverts to normal.				
34	87	SOTF Pulse	500ms	From 100ms to 10s step 10ms
The SOTF Pulse is a user settable time window during which the SOTF protection is available. This setting is visible only if ExtPulse or Pdead + Pulse are selected to enable SOTF				
34	88	TOC Delay	200ms	From 50ms to 200ms step 10ms
The TOC Delay is a user settable time delay following the CB opening after which the TOR becomes active (enabled). The time must be set in conjunction with the Dead Time setting of the Auto-reclose so that the setting must not exceed the minimum Dead Time setting since both timers start instantaneously.				
34	B0	Zone 1 Extension	0	
0				
34	B1	Z1 Ext Scheme	Disabled	0 = Disabled, 1 = Enabled, 2 = En. on Ch1 Fail, 3 = En. on Ch2 Fail, 4 = En. All Ch Fail, 5 = En. Any Ch Fail
Setting that enables (turns on) or disables (turns off) the Zone 1 Extension scheme. When Enabled, extended Zone 1 will apply unless the Reset Zone 1 Extension DDB signal is energized. Otherwise, it is possible to enable Z1X when aided scheme channel(s) fail.				
34	B2	Z1 Ext Ph	1.5	From 100% to 200% step 1%
Extended Z1X phase reach as a percentage of the Z1 phase reach. (Phase resistive reach for Z1X is the same as for Zone 1.)				
34	B3	Z1 Ext Gnd	1.5	From 100% to 200% step 1%
Extended Z1X ground reach as a percentage of Z1 ground reach. (Ground resistive reach and residual compensation for Z1X is the same as for Zone 1.)				
34	C0	Loss of Load	0	
0				
34	C1	LOL Scheme	Disabled	0 = Disabled, 1 = Enabled, 2 = En. on Ch1 Fail, 3 = En. on Ch2 Fail, 4 = En. All Ch Fail, 5 = En. Any Ch Fail
Setting that enables (turns on) or disables (turns off) the Loss of Load scheme. When Enabled, accelerated tripping can apply as the remote end opens (3-pole trip applications only). Otherwise, it is possible to enable Z1X when aided scheme channel(s) fail.				
34	C3	LOL <l	0.5*11 A	From 0.05*11 A to 1*11 A step 0.05*11 A
LOL undercurrent detector that indicates a loss of load condition on the unfaulted phases, indicating that the remote end has just opened.				
34	C4	LOL Window	40ms	From 10ms to 100s step 10ms
Length of LOL window - the time window in which Zone 2 accelerated tripping can occur following LOL undercurrent detector operation.				

Table 5 - Group x scheme logic

3.5 Power Swing Blocking

The column **GROUP x POWER SWING Blk.** is used to set either blocking or indication for out of step conditions. If blocking mode is selected, a user can individually select for each zone to be either blocked or allow tripping.

The power swing detection is based on superimposed current, and is essentially “settings free”.

Col	Row	MENU TEXT	Default Setting	Available Setting
Description				
3D	00	GROUP 1 POWER SWING BLK.	0	
This column contains settings for Power Swing Blocking/Out of Step Tripping				
3D	01	PSB Status	Blocking	0 = Blocking or 1 = Indication
To enable (activate) Indication or Blocking mode. This setting is invisible if disabled in 'CONFIGURATION' column. If Indication status is selected, the alarm will be issued but tripping by distance protection will be unaffected. When Blocking status is selected, the user is presented with further options as to which zones do/do not require blocking.				
3D	03	Zone 1 Ph. PSB	Blocking	0 = Allow Trip, 1 = Blocking, 2 = Delayed Unblock
Setting that defines the Z1 phase element operation should any swing impedance enter and remains inside the Z1 phase characteristic for more then 'tZ1 Ph. Delay'. If Blocking is selected, the Z1 phase element operation will be disabled for the duration of the swing. If Unblocking is chosen, the Z1 phase element block will be removed after drop off timer 'PSB Unblocking Dly' has expired, even if the swing is still present. This allows system separation when swings fail to stabilize. In 'Allow trip' mode, the Z1 phase element is unaffected by PSB detection.				
3D	05	Zone 2 Ph. PSB	Blocking	1 = Allow Trip, 1 = Blocking, 2 = Delayed Unblock
Setting that defines the Z2 phase element operation should any swing impedance enter and remains inside the Z2 phase characteristic for more then 'tZ2 Ph. Delay'. If Blocking is selected, the Z2 phase element operation will be disabled for the duration of the swing. If Unblocking is chosen, the Z2 phase element block will be removed after drop off timer 'PSB Unblocking Dly' has expired, even if the swing is still present. This allows system separation when swings fail to stabilize. In 'Allow trip' mode, the Z2 phase element is unaffected by PSB detection.				
3D	07	Zone 3 Ph. PSB	Blocking	2 = Allow Trip, 1 = Blocking, 2 = Delayed Unblock
Setting that defines the Z3 phase element operation should any swing impedance enter and remains inside the Z3 phase characteristic for more then 'tZ3 Ph. Delay'. If Blocking is selected, the Z3 phase element operation will be disabled for the duration of the swing. If Unblocking is chosen, the Z3 phase element block will be removed after drop off timer 'PSB Unblocking Dly' has expired, even if the swing is still present. This allows system separation when swings fail to stabilize. In 'Allow trip' mode, the Z3 phase element is unaffected by PSB detection.				
3D	09	Zone P Ph. PSB	Blocking	3 = Allow Trip, 1 = Blocking, 2 = Delayed Unblock
Setting that defines the ZP phase element operation should any swing impedance enter and remains inside the ZP phase characteristic for more then 'tZP Ph. Delay'. If Blocking is selected, the ZP phase element operation will be disabled for the duration of the swing. If Unblocking is chosen, the ZP phase element block will be removed after drop off timer 'PSB Unblocking Dly' has expired, even if the swing is still present. This allows system separation when swings fail to stabilize. In 'Allow trip' mode, the ZP phase element is unaffected by PSB detection.				
3D	0B	Zone 4 Ph. PSB	Blocking	4 = Allow Trip, 1 = Blocking, 2 = Delayed Unblock
Setting that defines the Z4 phase element operation should any swing impedance enter and remains inside the Z4 phase characteristic for more then 'tZ4 Ph. Delay'. If Blocking is selected, the Z4 phase element operation will be disabled for the duration of the swing. If Unblocking is chosen, the Z4 phase element block will be removed after drop off timer 'PSB Unblocking Dly' has expired, even if the swing is still present. This allows system separation when swings fail to stabilize. In 'Allow trip' mode, the Z4 phase element is unaffected by PSB detection.				
3D	0C	Zone Q Ph. PSB	Blocking	4 = Allow Trip, 1 = Blocking, 2 = Delayed Unblock

Col	Row	MENU TEXT	Default Setting	Available Setting
Description				
<p>Setting that defines the ZQ phase element operation should any swing impedance enter and remains inside the ZQ phase characteristic for more then 'tZQ Ph. Delay'.</p> <p>If Blocking is selected, the ZQ phase element operation will be disabled for the duration of the swing.</p> <p>If Unblocking is chosen, the Z4 phase element block will be removed after drop off timer 'PSB Unblocking Dly' has expired, even if the swing is still present. This allows system separation when swings fail to stabilize.</p> <p>In 'Allow trip' mode, the Z4 phase element is unaffected by PSB detection.</p>				
3D	0D	Zone 1 Gnd. PSB	Blocking	5 = Allow Trip, 1 = Blocking, 2 = Delayed Unblock
<p>Setting that defines the Z1 ground element operation should any swing impedance enter and remains inside the Z1 ground characteristic for more then 'tZ1 Gnd. Delay'.</p> <p>If Blocking is selected, the Z1 ground element operation will be disabled for the duration of the swing.</p> <p>If Unblocking is chosen, the Z1 ground element block will be removed after drop off timer 'PSB Unblocking Dly' has expired, even if the swing is still present. This allows system separation when swings fail to stabilize.</p> <p>In 'Allow trip' mode, the Z1 ground element is unaffected by PSB detection.</p>				
3D	0F	Zone 2 Gnd. PSB	Blocking	6 = Allow Trip, 1 = Blocking, 2 = Delayed Unblock
<p>Setting that defines the Z2 ground element operation should any swing impedance enter and remains inside the Z2 ground characteristic for more then 'tZ2 Gnd. Delay'.</p> <p>If Blocking is selected, the Z2 ground element operation will be disabled for the duration of the swing.</p> <p>If Unblocking is chosen, the Z2 ground element block will be removed after drop off timer 'PSB Unblocking Dly' has expired, even if the swing is still present. This allows system separation when swings fail to stabilize.</p> <p>In 'Allow trip' mode, the Z2 ground element is unaffected by PSB detection.</p>				
3D	11	Zone 3 Gnd. PSB	Blocking	7 = Allow Trip, 1 = Blocking, 2 = Delayed Unblock
<p>Setting that defines the Z3 ground element operation should any swing impedance enter and remains inside the Z3 ground characteristic for more then 'tZ3 Gnd. Delay'.</p> <p>If Blocking is selected, the Z3 ground element operation will be disabled for the duration of the swing.</p> <p>If Unblocking is chosen, the Z3 ground element block will be removed after drop off timer 'PSB Unblocking Dly' has expired, even if the swing is still present. This allows system separation when swings fail to stabilize.</p> <p>In 'Allow trip' mode, the Z3 ground element is unaffected by PSB detection.</p>				
3D	13	Zone P Gnd. PSB	Blocking	8 = Allow Trip, 1 = Blocking, 2 = Delayed Unblock
<p>Setting that defines the ZP ground element operation should any swing impedance enter and remains inside the ZP ground characteristic for more then 'tZP Gnd. Delay'.</p> <p>If Blocking is selected, the ZP ground element operation will be disabled for the duration of the swing.</p> <p>If Unblocking is chosen, the ZP ground element block will be removed after drop off timer 'PSB Unblocking Dly' has expired, even if the swing is still present. This allows system separation when swings fail to stabilize.</p> <p>In 'Allow trip' mode, the ZP ground element is unaffected by PSB detection.</p>				
3D	15	Zone 4 Gnd. PSB	Blocking	9 = Allow Trip, 1 = Blocking, 2 = Delayed Unblock
<p>Setting that defines the Z4 ground element operation should any swing impedance enter and remains inside the Z4 ground characteristic for more then 'tZ4 Gnd. Delay'.</p> <p>If Blocking is selected, the Z4 ground element operation will be disabled for the duration of the swing.</p> <p>If Unblocking is chosen, the Z4 ground element block will be removed after drop off timer 'PSB Unblocking Dly' has expired, even if the swing is still present. This allows system separation when swings fail to stabilize.</p> <p>In 'Allow trip' mode, the Z4 ground element is unaffected by PSB detection.</p>				
3D	17	Zone Q Gnd. PSB	Blocking	9 = Allow Trip, 1 = Blocking, 2 = Delayed Unblock
<p>Setting that defines the ZQ ground element operation should any swing impedance enter and remains inside the ZQ ground characteristic for more then 'tZQ Gnd. Delay'.</p> <p>If Blocking is selected, the ZQ ground element operation will be disabled for the duration of the swing.</p> <p>If Unblocking is chosen, the Z4 ground element block will be removed after drop off timer 'PSB Unblocking Dly' has expired, even if the swing is still present. This allows system separation when swings fail to stabilize.</p> <p>In 'Allow trip' mode, the Z4 ground element is unaffected by PSB detection.</p>				
3D	20	PSB Unblocking	Disabled	0 = Disabled or 1 = Enabled
<p>To enable (activate) or disable (turn off) the PSB Unblocking delay timer.</p> <p>This setting is common to all zones and it is visible if any distance zone is set to 'PSB Unblocking Dly'. For swing durations longer than this setting, blocking can be selectively removed.</p>				
3D	21	PSB Unblock dly	2s	From 100ms to 20s step 100ms
Unblock timer setting - on expiry, power swing blocking can optionally be removed.				

Col	Row	MENU TEXT	Default Setting	Available Setting
Description				
3D	22	PSB Reset Delay	200ms	From 50ms to 2s step 50ms
Setting to maintain the power swing detection for a period after the delta current detection has reset. ΔI will naturally reset momentarily twice in each swing cycle, and a short setting ensures continued PSB pick-up, to ride through the gaps.				
3D	24	Z5	30*V1/I1Ω	From 0.1*V1/I1Ω to 500*V1/I1Ω step 0.01*V1/I1Ω
Setting for Z5 forward reactance reach.				
3D	26	Z5'	-30*V1/I1Ω	From -500*V1/I1Ω to -0.1*V1/I1Ω step 0.01*V1/I1Ω
Setting for Z5 reverse reactance reach.				
3D	28	R5	20*V1/I1Ω	From 0.1*V1/I1Ω to 500*V1/I1Ω step 0.01*V1/I1Ω
Setting for Z5 positive resistive reach.				
3D	2A	R5'	-20*V1/I1Ω	From -0.1*V1/I1Ω to -500*V1/I1Ω step 0.01*V1/I1Ω
Setting for Z5 negative resistive reach.				
3D	2C	Blinder Angle	80	From 20° to 90° step 1°
Setting of blinder angle, common for both Z5 and Z6.				

Table 6 - Group x power swing blk

3.6 Phase Overcurrent Protection

The phase overcurrent protection included in the relay provides four-stage non-directional/directional phase-segregated overcurrent protection with independent time delay characteristics. All overcurrent and directional settings apply to each phase but are independent for each of the four stages. To arrange a single pole tripping by overcurrent protection, the default PSL needs to be checked (and possibly modified).

The first two stages of overcurrent protection have time-delayed characteristics which are selectable between Inverse Definite Minimum Time (IDMT), or Definite Time (DT). The third and fourth stages have DT characteristics only.

Col	Row	MENU TEXT	Default Setting	Available Setting
Description				
35	00	GROUP 1 OVERCURRENT	0	
This column contains settings for Overcurrent				
35	01	I>1 Status	Enabled	0 = Disabled, 1 = Enabled, 2 = Enabled VTS
Setting that defines first stage overcurrent operating status. I>1 can be disabled or enabled permanently or in case of Voltage Transformer Supervision (VTS) operation.				
35	02	I>1 Function	IEC S Inverse	0 = DT, 2 = IEC V Inverse, 4 = UK LT Inverse, 6 = IEEE V Inverse, 8 = US Inverse, 1 = IEC S Inverse, 3 = IEC E Inverse, 5 = IEEE M Inverse, 7 = IEEE E Inverse, 9 = US ST Inverse
Setting for the tripping characteristic for the first stage overcurrent element.				
35	03	I>1 Directional	Non-Directional	0 = Non-Directional, 1 = Directional Fwd, 2 = Directional Rev
This setting determines the direction of measurement for first stage element.				
35	04	I>1 Current Set	1*I1 A	From 0.08*I1 A to 4.0*I1 A step 0.01*I1 A
Pick-up setting for first stage overcurrent element.				
35	05	I>1 Time Delay	1s	From 0s to 100s step 10ms
Setting for the time-delay for the definite time setting if selected for first stage element. The setting is visible only when DT function is selected.				

Col	Row	MENU TEXT	Default Setting	Available Setting
Description				
35	06	I>1 TMS	1	0.025 to 1.2 step 0.005
Setting for the time multiplier setting to adjust the operating time of the IEC IDMT characteristic.				
35	07	I>1 Time Dial	1	0.01 to 100 step 0.01
Setting for the time multiplier setting to adjust the operating time of the IEEE/US IDMT curves. The Time Dial (TD) is a multiplier on the standard curve equation, in order to achieve the required tripping time. The reference curve is based on TD = 1. Care: Certain manufacturer's use a mid-range value of TD = 5 or 7, so it may be necessary to divide by 5 or 7 to achieve parity.				
35	08	I>1 Reset Char	DT	0 = DT or 1 = Inverse
Setting to determine the type of reset/release characteristic of the IEEE/US curves.				
35	09	I>1 tRESET	0s	From 0s to 100s step 10ms
Setting that determines the reset/release time for definite time reset characteristic				
35	10	I>2 Status	Disabled	0 = Disabled, 1 = Enabled, 2 = Enabled VTS
Setting that defines first stage overcurrent operating status. I>2 can be disabled or enabled permanently or in case of Voltage Transformer Supervision (VTS) operation.				
35	11	I>2 Function	IEC S Inverse	0 = DT, 1 = IEC S Inverse, 2 = IEC V Inverse, 3 = IEC E Inverse, 4 = UK LT Inverse, 5 = IEEE M Inverse, 6 = IEEE V Inverse, 7 = IEEE E Inverse, 8 = US Inverse, 9 = US ST Inverse
Setting for the tripping characteristic for the second stage overcurrent element.				
35	12	I>2 Directional	Non-Directional	0 = Non-Directional, 1 = Directional Fwd, 2 = Directional Rev
This setting determines the direction of measurement for second stage element.				
35	13	I>2 Current Set	1*11 A	From 0.08*11 A to 4.0*11 A step 0.01*11 A
Pick-up setting for second stage overcurrent element.				
35	14	I>2 Time Delay	1s	From 0s to 100s step 10ms
Setting for the time-delay for the definite time setting if selected for second stage element. The setting is visible only when DT function is selected.				
35	15	I>2 TMS	1	0.025 to 1.2 step 0.005
Setting for the time multiplier setting to adjust the operating time of the IEC IDMT characteristic.				
35	16	I>2 Time Dial	1	0.01 to 100 step 0.01
Setting for the time multiplier setting to adjust the operating time of the IEEE/US IDMT curves. The Time Dial (TD) is a multiplier on the standard curve equation, in order to achieve the required tripping time. The reference curve is based on TD = 1. Care: Certain manufacturer's use a mid-range value of TD = 5 or 7, so it may be necessary to divide by 5 or 7 to achieve parity.				
35	17	I>2 Reset Char	DT	0 = DT or 1 = Inverse
Setting to determine the type of reset/release characteristic of the IEEE/US curves.				
35	18	I>2 tRESET	0s	From 0s to 100s step 10ms
Setting that determines the reset/release time for definite time reset characteristic				
35	20	I>3 Status	Disabled	0 = Disabled, 1 = Enabled, 2 = Enabled VTS
Setting that defines first stage overcurrent operating status. I>3 can be disabled or enabled permanently or in case of Voltage Transformer Supervision (VTS) operation.				
35	21	I>3 Directional	Directional Fwd	0 = Non-Directional, 1 = Directional Fwd, 2 = Directional Rev
This setting determines the direction of measurement for the third stage overcurrent element.				
35	22	I>3 Current Set	10*11 A	From 0.08*11 A to 32*11 A step 0.01*11 A
Pick-up setting for third stage overcurrent element.				
35	23	I>3 Time Delay	0s	From 0s to 100s step 10ms
Setting for the operating time-delay for third stage overcurrent element.				

Col	Row	MENU TEXT	Default Setting	Available Setting
Description				
35	30	I>4 Status	Disabled	0 = Disabled, 1 = Enabled, 2 = Enabled VTS
Setting that defines first stage overcurrent operating status. I>4 can be disabled or enabled permanently or in case of Voltage Transformer Supervision (VTS) operation.				
35	31	I>4 Directional	Non-Directional	0 = Non-Directional, 1 = Directional Fwd, 2 = Directional Rev
This setting determines the direction of measurement for the fourth stage overcurrent element.				
35	32	I>4 Current Set	10*I1 A	From 0.08*I1 A to 32*I1 A step 0.01*I1 A
Pick-up setting for fourth stage overcurrent element.				
35	33	I>4 Time Delay	0s	From 0s to 100s step 10ms
Setting for the operating time-delay for fourth stage overcurrent element.				
35	40	I> Char Angle	30	From -95° to 95° step 1°
Setting for the relay characteristic angle used for the directional decision. The setting is visible only when 'Directional Fwd' or 'Directional Rev' is set.				
35	41	I> Blocking	001111(bin)	Bit 00 = VTS Blocks I>1, Bit 01 = VTS Blocks I>2, Bit 02 = VTS Blocks I>3, Bit 03 = VTS Blocks I>4, Bit 04 = Not Used, Bit 05 = Not Used
Logic Settings that determine whether blocking signals from VT supervision affect certain overcurrent stages. VTS Block – only affects directional overcurrent protection. With the relevant bit set to 1, operation of the Voltage Transformer Supervision (VTS), will block the stage. When set to 0, the stage will revert to Non-directional upon operation of the VTS. If I> Status is set 'Enabled VTS', no blocking should be selected in order to provide fault clearance by overcurrent protection during the VTS condition.				

Table 7 - Phase overcurrent protection

3.7 Negative Sequence Overcurrent

The negative sequence overcurrent protection included in the relay provides four-stage non-directional/directional phase segregated negative sequence overcurrent protection with independent time delay characteristics.

The first two stages of negative sequence overcurrent protection have time-delayed characteristics which are selectable between Inverse Definite Minimum Time (IDMT), or Definite Time (DT). The third and fourth stages have DT characteristics only.

Col	Row	MENU TEXT	Default Setting	Available Setting
Description				
36	00	GROUP 1 NEG SEQ O/C	0	
This column contains settings for Negative Sequence Overcurrent				
36	10	I2>1 Status	Disabled	0 = Disabled or 1 = Enabled
Setting to enable or disable the first stage negative sequence element.				
36	11	I2>1 Function	DT	0 = DT, 1 = IEC S Inverse, 2 = IEC V Inverse, 3 = IEC E Inverse, 4 = UK LT Inverse, 5 = IEEE M Inverse, 6 = IEEE V Inverse, 7 = IEEE E Inverse, 8 = US Inverse or 9 = US ST Inverse
Setting for the tripping characteristic for the first stage negative sequence overcurrent element.				
36	12	I2>1 Directional	Non-Directional	0 = Non-Directional, 1 = Directional Fwd, 2 = Directional Rev
This setting determines the direction of measurement for this element.				
36	15	I2>1 Current Set	0.2*I1 A	From 0.08*I1 A to 4.0*I1 A step 0.01*I1 A
Pick-up setting for the first stage negative sequence overcurrent element.				
36	17	I2>1 Time Delay	10s	From 0s to 100s step 10ms

Col	Row	MENU TEXT	Default Setting	Available Setting
Description				
Setting for the operating time-delay for the first stage negative sequence overcurrent element.				
36	18	I2>1 TMS	1	From 0.025 to 1.2 step 0.005
Setting for the time multiplier setting to adjust the operating time of the IEC IDMT characteristic.				
36	19	I2>1 Time Dial	1	0.01 to 100 step 0.01
Setting for the time multiplier setting to adjust the operating time of the IEEE/US IDMT curves.				
36	1C	I2>1 Reset Char	DT	0 = DT or 1 = Inverse
Setting to determine the type of reset/release characteristic of the IEEE/US curves.				
36	1D	I2>1 tRESET	0s	From 0s to 100s step 10ms
Setting that determines the reset/release time for definite time reset characteristic.				
36	20	I2>2 Status	Disabled	0 = Disabled or 1 = Enabled
Setting to enable or disable the second stage negative sequence element.				
36	21	I2>2 Function	DT	0 = DT, 1 = IEC S Inverse, 2 = IEC V Inverse, 3 = IEC E Inverse, 4 = UK LT Inverse, 5 = IEEE M Inverse, 6 = IEEE V Inverse, 7 = IEEE E Inverse, 8 = US Inverse or 9 = US ST Inverse
Setting for the tripping characteristic for the second stage negative sequence overcurrent element.				
36	22	I2>2 Directional	Non-Directional	0 = Non-Directional, 1 = Directional Fwd, 2 = Directional Rev
This setting determines the direction of measurement for this element.				
36	25	I2>2 Current Set	0.2*11 A	From 0.08*11 A to 4.0*11 A step 0.01*11 A
Pick-up setting for the second stage negative sequence overcurrent element.				
36	27	I2>2 Time Delay	10s	From 0s to 100s step 10ms
Setting for the operating time-delay for the second stage negative sequence overcurrent element.				
36	28	I2>2 TMS	1	From 0.025 to 1.2 step 0.005
Setting for the time multiplier setting to adjust the operating time of the IEC IDMT characteristic.				
36	29	I2>2 Time Dial	1	0.01 to 100 step 0.01
Setting for the time multiplier setting to adjust the operating time of the IEEE/US IDMT curves.				
36	2C	I2>2 Reset Char	DT	0 = DT or 1 = Inverse
Setting to determine the type of reset/release characteristic of the IEEE/US curves.				
36	2D	I2>2 tRESET	0s	From 0s to 100s step 10ms
Setting that determines the reset/release time for definite time reset characteristic.				
36	30	I2>3 Status	Disabled	0 = Disabled or 1 = Enabled
Setting to enable or disable the third stage negative sequence element.				
36	32	I2>3 Directional	Non-Directional	0 = Non-Directional, 1 = Directional Fwd, 2 = Directional Rev
This setting determines the direction of measurement for this element.				
36	35	I2>3 Current Set	0.2*11 A	From 0.08*11 A to 32*11 A step 0.01*11 A
Pick-up setting for the third stage negative sequence overcurrent element.				
36	37	I2>3 Time Delay	10s	From 0s to 100s step 10ms
Setting for the operating time-delay for the third stage negative sequence overcurrent element.				
36	40	I2>4 Status	Disabled	0 = Disabled or 1 = Enabled
Setting to enable or disable the fourth stage negative sequence element.				
36	42	I2>4 Directional	Non-Directional	0 = Non-Directional, 1 = Directional Fwd, 2 = Directional Rev
This setting determines the direction of measurement for this element.				
36	45	I2>4 Current Set	0.2*11 A	From 0.08*11 A to 32*11 A step 0.01*11 A
Pick-up setting for the fourth stage negative sequence overcurrent element.				

Col	Row	MENU TEXT	Default Setting	Available Setting
Description				
36	47	I2>4 Time Delay	10s	From 0s to 100s step 10ms
Setting for the operating time-delay for the fourth stage negative sequence overcurrent element.				
36	50	I2> VTS Blocking	1111(bin)	0 = VTS Blocks I2>1, 2 = VTS Blocks I2>3, 1 = VTS Blocks I2>2, 3 = VTS Blocks I2>4
Logic settings that determine whether VT supervision blocks selected negative sequence overcurrent stages. Setting '0' will permit continued non-directional operation.				
36	51	I2> Char Angle	-60	From -95° to 95° step 1°
Setting for the relay characteristic angle used for the directional decision.				
36	52	I2> V2pol Set	5*V1	From 0.5*V1 to 25*V1 step 0.5*V1
Setting determines the minimum negative sequence voltage threshold that must be present to determine directionality.				

Table 8 - Negative sequence overcurrent

3.8 Broken Conductor

Col	Row	MENU TEXT	Default Setting	Available Setting
Description				
37	00	GROUP 1 BROKEN CONDUCTOR	0	
This column contains settings for Broken Conductor				
37	01	Broken Conductor	Disabled	0 = Disabled or 1 = Enabled
Enables or disables the broken conductor function.				
37	02	I2/I1 Setting	0.2	0.2 to 1 step 0.01
Setting to determine the pick- up level of the negative to positive sequence current ratio.				
37	03	I2/I1 Time Delay	60s	From 0s to 100s step 100ms
Setting for the function operating time delay.				

Table 9 - Broken conductor

3.9 Earth Fault

The back-up earth fault overcurrent protection included in the relay provides four-stage non-directional/directional three-phase overcurrent protection with independent time delay characteristics. All earth fault overcurrent and directional settings apply to all three phases but are independent for each of the four stages.

The first two stages of earth fault overcurrent protection have time-delayed characteristics which are selectable between Inverse Definite Minimum Time (IDMT), or Definite Time (DT). The third and fourth stages have DT characteristics only.

Col	Row	MENU TEXT	Default Setting	Available Setting
Description				
38	00	GROUP 1 EARTH FAULT	0	
This column contains settings for Earth Fault				
38	01	IN>1 Status	Enabled	0 = Disabled, 1 = Enabled, 2 = Enabled VTS
Setting that defines first stage overcurrent operating status. IN>1 can be disabled or enabled permanently or in case of Voltage Transformer Supervision (VTS) operation.				

Col	Row	MENU TEXT	Default Setting	Available Setting
Description				
38	25	IN>1 Function	IEC S Inverse	0 = DT, 1 = IEC S Inverse, 2 = IEC V Inverse, 3 = IEC E Inverse, 4 = UK LT Inverse, 5 = IEEEE M Inverse, 6 = IEEEE V Inverse, 7 = IEEEE E Inverse, 8 = US Inverse, 9 = US ST Inverse or 10 = IDG
Setting for the tripping characteristic for the first stage earth fault overcurrent element.				
38	26	IN>1 Directional	Non-Directional	0 = Non-Directional, 1 = Directional Fwd, 2 = Directional Rev
This setting determines the direction of measurement for first stage element.				
38	29	IN>1 Current Set	0.2*I1 A	From 0.08*I1 A to 4.0*I1 A step 0.01*I1 A
Pick-up setting for first stage overcurrent element				
38	2A	IN1>1 IDG Is	1.5	1 to 4 step 0.1
This setting is set as a multiple of "IN>" setting for the IDG curve (Scandinavian) and determines the actual relay current threshold at which the element starts.				
38	2C	IN>1 Time Delay	1s	From 0s to 100s step 10ms
Setting for the time-delay for the definite time setting if selected for first stage element. The setting is available only when DT function is selected.				
38	2D	IN>1 TMS	1	From 0.025 to 1.2 step 0.005
Setting for the time multiplier setting to adjust the operating time of the IEC IDMT characteristic.				
38	2E	IN>1 Time Dial	1	0.01 to 100 step 0.01
Setting for the time multiplier setting to adjust the operating time of the IEEEE/US IDMT curves. The Time Dial (TD) is a multiplier on the standard curve equation, in order to achieve the required tripping time. The reference curve is based on TD = 1. Care: Certain manufacturer's use a mid-range value of TD = 5 or 7, so it may be necessary to divide by 5 or 7 to achieve parity.				
38	30	IN1>1 IDG Time	1.2s	From 1s to 2s step 10ms
Setting for the IDG curve used to set the minimum operating time at high levels of fault current.				
38	32	IN>1 Reset Char	DT	0 = DT or 1 = Inverse
Setting to determine the type of reset/release characteristic of the IEEEE/US curves.				
38	33	IN>1 tRESET	0s	From 10ms to 100s step 10ms
Setting that determines the reset/release time for definite time reset characteristic.				
38	35	IN>2 Status	Disabled	0 = Disabled, 1 = Enabled, 2 = Enabled VTS
Setting that defines first stage overcurrent operating status. IN>2 can be disabled or enabled permanently or in case of Voltage Transformer Supervision (VTS) operation.				
38	36	IN>2 Function	IEC S Inverse	0 = DT, 1 = IEC S Inverse, 2 = IEC V Inverse, 3 = IEC E Inverse, 4 = UK LT Inverse, 5 = IEEEE M Inverse, 6 = IEEEE V Inverse, 7 = IEEEE E Inverse, 8 = US Inverse, 9 = US ST Inverse or 10 = IDG
Setting for the tripping characteristic for the second stage earth fault overcurrent element.				
38	37	IN>2 Directional	Non-Directional	0 = Non-Directional, 1 = Directional Fwd, 2 = Directional Rev
This setting determines the direction of measurement for first stage element.				
38	3A	IN>2 Current Set	0.2*I1 A	From 0.08*I1 A to 4.0*I1 A step 0.01*I1 A
Pick-up setting for second stage overcurrent element				
38	3B	IN2>1 IDG Is	1.5	1 to 4 step 0.1
This setting is set as a multiple of "IN>" setting for the IDG curve (Scandinavian) and determines the actual relay current threshold at which the element starts.				
38	3D	IN>2 Time Delay	1s	From 0s to 200s step 10ms
Setting for the time-delay for the definite time setting if selected for second stage element. The setting is available only when DT function is selected.				
38	3E	IN>2 TMS	1	From 0.025 to 1.2 step 0.005
Setting for the time multiplier setting to adjust the operating time of the IEC IDMT characteristic.				

Col	Row	MENU TEXT	Default Setting	Available Setting
Description				
38	3F	IN>2 Time Dial	1	0.01 to 100 step 0.01
Setting for the time multiplier setting to adjust the operating time of the IEEE/US IDMT curves. The Time Dial (TD) is a multiplier on the standard curve equation, in order to achieve the required tripping time. The reference curve is based on TD = 1. Care: Certain manufacturer's use a mid-range value of TD = 5 or 7, so it may be necessary to divide by 5 or 7 to achieve parity.				
38	41	IN2>1 IDG Time	1.2s	From 1s to 2s step 10ms
Setting for the IDG curve used to set the minimum operating time at high levels of fault current.				
38	43	IN>2 Reset Char	DT	0 = DT or 1 = Inverse
Setting to determine the type of reset/release characteristic of the IEEE/US curves.				
38	44	IN>2 tRESET	0s	From 0s to 100s step 10ms
Setting that determines the reset/release time for definite time reset characteristic.				
38	46	IN>3 Status	Disabled	0 = Disabled, 1 = Enabled, 2 = Enabled VTS
Setting that defines first stage overcurrent operating status. IN>3 can be disabled or enabled permanently or in case of Voltage Transformer Supervision (VTS) operation.				
38	47	IN>3 Directional	Directional Fwd	0 = Non-Directional, 1 = Directional Fwd, 2 = Directional Rev
This setting determines the direction of measurement for the earth fault overcurrent element.				
38	4A	IN>3 Current Set	10*I1 A	From 0.08*I1 A to 32*I1 A step 0.01*I1 A
Pick-up setting for third stage earth fault overcurrent element.				
38	4B	IN>3 Time Delay	0s	From 0s to 200s step 10ms
Setting for the operating time-delay for third stage earth fault overcurrent element.				
38	4D	IN>4 Status	Disabled	0 = Disabled, 1 = Enabled, 2 = Enabled VTS
Setting that defines fourth stage overcurrent operating status. IN>3 can be disabled or enabled permanently or in case of Voltage Transformer Supervision (VTS) operation.				
38	4E	IN>4 Directional	Non-Directional	0 = Non-Directional, 1 = Directional Fwd, 2 = Directional Rev
This setting determines the direction of measurement for the earth fault overcurrent element.				
38	51	IN>4 Current Set	10*I1 A	From 0.08*I1 A to 32*I1 A step 0.01*I1 A
Pick-up setting for fourth stage earth fault overcurrent element.				
38	52	IN>4 Time Delay	0s	From 0s to 200s step 10ms
Setting for the operating time-delay for fourth stage earth fault overcurrent element.				
38	54	IN> Blocking	001111(bin)	Bit 00 = VTS Blocks IN>1, Bit 01 = VTS Blocks IN>2, Bit 02 = VTS Blocks IN>3, Bit 03 = VTS Blocks IN>4, Bit 04 = Not Used, Bit 05 = Not Used
Logic Settings that determine whether blocking signals from VT supervision affect certain earth fault overcurrent stages. VTS Block - only affects directional earth fault overcurrent protection. With the relevant bit set to 1, operation of the Voltage Transformer Supervision (VTS), will block the stage. When set to 0, the stage will revert to Non-directional upon operation of the VTS. If IN> Status is set 'Enabled VTS', no blocking should be selected in order to provide earth fault clearance by earth fault overcurrent protection during VTS condition.				
38	55	IN> DIRECTIONAL	0	
0				
38	56	IN> Char Angle	-60	From -95° to 95° step 1°
Setting for the relay characteristic angle used for the directional decision. The setting is visible only when 'Directional Fwd' or 'Directional Rev' is set.				
38	57	IN> Polarisation	Zero Sequence	0 = Zero Sequence or 1 = Neg Sequence
Setting that determines whether the directional function uses zero sequence or negative sequence voltage polarizing.				
38	59	IN> VNpol Set	1*V1	From 0.5*V1 to 40*V1 step 0.5*V1
Setting for the minimum zero sequence voltage polarizing quantity for directional decision. Setting is visible only when 'Zero Sequence' polarization is set.				

Col	Row	MENU TEXT	Default Setting	Available Setting
Description				
38	5A	IN> V2pol Set	1*V1	From 0.5*V1 to 25*V1 step 0.5*V1
Setting for the minimum negative sequence voltage polarizing quantity for directional decision. Setting is visible only when 'Negative Sequence' polarization is set.				
38	5B	IN> I2pol Set	0.08*I1 A	From 0.08*I1 A to 1.0*I1 A step 0.01*I1 A
Setting for the minimum negative sequence current polarizing quantity for directional decision. Setting is visible only when 'Negative Sequence' polarization is set.				

Table 10 - Earth fault

3.10 Aided DEF

The column **GROUP x AIDED DEF** is used to set all parameters for operation of DEF (Directional Earth Fault aided scheme thresholds). As this configuration merely assigns pick up at the local end only, they need to be further configured to a selected Aided channel scheme under **GROUP x SCHEME LOGIC** to provide unit protection.

Col	Row	Menu Text	Default Setting	Available Setting
Description				
39	00	GROUP 1 AIDED DEF	0	
This column contains settings for Aided DEF				
39	02	DEF Status	Enabled	0 = Disabled or 1 = Enabled
To enable (activate) or disable (turn off) the Directional Earth Fault element that is used in an aided scheme (= ground overcurrent pilot scheme). This setting is invisible if disabled in 'CONFIGURATION' column.				
39	03	DEF Polarizing	Zero Sequence	0 = Zero Sequence or 1 = Neg Sequence
Setting that defines the method of DEF polarization. Either zero, or negative sequence voltage can be taken as the directional reference. When Zero Sequence is selected, this arms the Virtual Current Polarizing.				
39	04	DEF Char Angle	-60	From -95° to 95° step 1°
Setting for the relay characteristic angle used for the directional decision.				
39	05	DEF VNpol Set	1*V1	From 0.5*V1 to 40*V1 step 0.5*V1
Setting that must be exceeded by generated neutral displacement voltage VN (= 3.Vo) in order for the DEF function to be operational. As Virtual Current Polarizing will be in force when Zero sequence polarizing is used, this setting will normally have no relevance. If the relay phase selector (delta sensitivity typically 4% In) detects the faulted phase, this will artificially generate a large VNpol, typically equal to Vn (phase-ground). Only if the phase selector cannot phase select will this setting be relevant, as VNpol will then measure true VN. The setting is invisible if 'Neg. Sequence' polarization is set.				
39	06	DEF V2pol Set	1*V1	From 0.5*V1 to 25*V1 step 0.5*V1
Setting that must be exceeded by generated negative sequence voltage V2 in order for the DEF function to be operational. The setting is invisible if 'Zero Sequence' polarization is set.				
39	07	DEF FWD Set	0.08*I1 A	From 0.05*I1 A to 1.0*I1 A step 0.01*I1 A
Setting the forward pickup current sensitivity for residual current (= 3.Io).				
39	08	DEF REV Set	0.04*I1 A	From 0.03*I1 A to 1.0*I1 A step 0.01*I1 A
Setting the reverse pickup current sensitivity for residual current (= 3.Io).				
39	09	Virtual I Pol	Enabled	0 = Disabled or 1 = Enabled
Setting to Enable/Disable virtual current polarizing				

Table 11 - Group x aided DEF

3.11 Sensitive Earth Fault (SEF)

If a system is earthed through a high impedance, or is subject to high ground fault resistance, the earth fault level will be severely limited. Consequently, the applied earth fault protection requires both an appropriate characteristic and a suitably sensitive setting range in order to be effective. A separate four-stage sensitive earth fault element is provided within the relay for this purpose, which has a dedicated input.

Col	Row	MENU TEXT	Default Setting	Available Setting
Description				
3A	00	GROUP 1 SEF/REF PROT'N	0	
This column contains settings for SEF/REF				
3A	01	SEF/REF Options	SEF Enabled	0 = SEF Enabled, 1 = Wattmetric SEF, 2 = Hi Z REF
Setting to select the type of sensitive earth fault protection function and the type of high-impedance function to be used.				
3A	2A	ISEF>1 Function	DT	0 = Disabled, 1 = DT, 2 = IEC S Inverse, 3 = IEC V Inverse, 4 = IEC E Inverse, 5 = UK LT Inverse, 6 = IEEE M Inverse, 7 = IEEE V Inverse, 8 = IEEE E Inverse, 9 = US Inverse, 10 = US ST Inverse or 11 = IDG
Setting for the tripping characteristic for the first stage sensitive earth fault element.				
3A	2B	ISEF>1 Direction	Non-Directional	0 = Non-Directional, 1 = Directional Fwd, 2 = Directional Rev
This setting determines the direction of measurement for the first stage sensitive earth fault element.				
3A	2E	ISEF>1 Current	0.05*I3 A	From 0.005*I3 A to 0.1*I3 A step 0.00025*I3 A
Pick-up setting for the first stage sensitive earth fault element.				
3A	2F	ISEF>1 IDG Is	1.5	1 to 4 step 0.1
This setting is set as a multiple of ISEF> setting for the IDG curve (Scandinavian) and determines the actual relay current threshold at which the element starts.				
3A	31	ISEF>1 Delay	1s	From 0s to 200s step 10ms
Setting for the time delay for the first stage definite time element.				
3A	32	ISEF>1 TMS	1	From 0.025 to 1.2 step 0.005
Setting for the time multiplier to adjust the operating time of the IEC IDMT characteristic.				
3A	33	ISEF>1 Time Dial	1	From 0.01 to 100 step 0.01
Setting for the time multiplier to adjust the operating time of the IEEE/US IDMT curves.				
3A	34	ISEF>1 IDG Time	1.2s	From 1s to 2s step 10ms
Setting for the IDG curve used to set the minimum operating time at high levels of fault current.				
3A	36	ISEF>1 Reset Chr	DT	0 = DT or 1 = Inverse
Setting to determine the type of reset/release characteristic of the IEEE/US curves.				
3A	37	ISEF>1 tRESET	0s	From 10ms to 100s step 10ms
Setting to determine the reset/release time for definite time reset characteristic.				
3A	3A	ISEF>2 Function	Disabled	0 = Disabled, 1 = DT, 2 = IEC S Inverse, 3 = IEC V Inverse, 4 = IEC E Inverse, 5 = UK LT Inverse, 6 = IEEE M Inverse, 7 = IEEE V Inverse, 8 = IEEE E Inverse, 9 = US Inverse, 10 = US ST Inverse or 11 = IDG
Setting for the tripping characteristic for the second stage sensitive earth fault element.				
3A	3B	ISEF>2 Direction	Non-Directional	0 = Non-Directional, 1 = Directional Fwd, 2 = Directional Rev
This setting determines the direction of measurement for the second stage sensitive earth fault element.				
3A	3E	ISEF>2 Current	0.05*I3 A	From 0.005*I3 A to 0.1*I3 A step 0.00025*I3 A
Pick-up setting for the second stage sensitive earth fault element.				
3A	3F	ISEF>2 IDG Is	1.5	From 1 to 4 step 0.1

Col	Row	MENU TEXT	Default Setting	Available Setting
Description				
This setting is set as a multiple of ISEF> setting for the IDG curve (Scandinavian) and determines the actual relay current threshold at which the element starts.				
3A	41	ISEF>2 Delay	1s	From 0s to 200s step 10ms
Setting for the time delay for the second stage definite time element.				
3A	42	ISEF>2 TMS	1	From 0.025 to 1.2 step 0.005
Setting for the time multiplier to adjust the operating time of the IEC IDMT characteristic.				
3A	43	ISEF>2 Time Dial	1	From 0.01 to 100 step 0.01
Setting for the time multiplier to adjust the operating time of the IEEE/US IDMT curves.				
3A	44	ISEF>2 IDG Time	1.2s	From 1s to 2s step 10ms
Setting for the IDG curve used to set the minimum operating time at high levels of fault current.				
3A	46	ISEF>2 Reset Chr	DT	0 = DT or 1 = Inverse
Setting to determine the type of reset/release characteristic of the IEEE/US curves.				
3A	47	ISEF>2 tRESET	0s	From 10ms to 100s step 10ms
Setting to determine the reset/release time for definite time reset characteristic.				
3A	49	ISEF>3 Status	Disabled	0 = Disabled or 1 = Enabled
Setting to enable or disable the third stage definite time sensitive earth fault element.				
3A	4A	ISEF>3 Direction	Non-Directional	0 = Non-Directional, 1 = Directional Fwd, 2 = Directional Rev
This setting determines the direction of measurement for the third stage element.				
3A	4D	ISEF>3 Current	0.4*I3 A	From 0.005*I3 A to 2.0*I3 A step 0.001*I3 A
Pick-up setting for the third stage sensitive earth fault element.				
3A	4E	ISEF>3 Delay	500ms	From 0s to 200s step 10ms
Setting for the operating time delay for third stage sensitive earth fault element.				
3A	50	ISEF>4 Status	Disabled	0 = Disabled or 1 = Enabled
Setting to enable or disable the fourth stage definite time sensitive earth fault element.				
3A	51	ISEF>4 Direction	Non-Directional	0 = Non-Directional, 1 = Directional Fwd, 2 = Directional Rev
This setting determines the direction of measurement for the fourth stage element.				
3A	54	ISEF>4 Current	0.6*I3 A	From 0.005*I3 A to 2.0*I3 A step 0.001*I3 A
Pick-up setting for the fourth stage sensitive earth fault element.				
3A	55	ISEF>4 Delay	250ms	From 0s to 200s step 10ms
Setting for the operating time delay for fourth stage sensitive earth fault element.				
3A	57	ISEF> Blocking	001111(bin)	Bit 00 = VTS Blks ISEF>1, Bit 01 = VTS Blks ISEF>2, Bit 02 = VTS Blks ISEF>3, Bit 03 = VTS Blks ISEF>4, Bit 04 = Not Used, Bit 05 = Not Used
Logic Settings that determine whether blocking signals from VT supervision affect certain earth fault overcurrent stages. VTS Block - only affects sensitive earth fault protection. With the relevant bit set to 1, operation of the Voltage Transformer Supervision (VTS), will block the stage. When set to 0, the stage will revert to Non-directional upon operation of the VTS.				
3A	58	ISEF DIRECTIONAL	0	
0				
3A	59	ISEF> Char Angle	90	From -95° to 95° step 1°
Setting for the relay characteristic angle used for the directional decision.				
3A	5B	ISEF> VNpol Set	5*V1	From 0.5*V1 to 88*V1 step 0.5*V1
Setting for the minimum zero sequence voltage polarizing quantity required for directional decision.				
3A	5D	Wattmetric SEF	0	0
0				
3A	5E	PN> Setting	9*V1*I3	From 0.0*V1*I3 to 20*V1*I3 step 0.05*V1*I3

Col	Row	MENU TEXT	Default Setting	Available Setting
Description				
Setting for the threshold for the wattmetric component of zero sequence power. The power calculation is as follows: The PN> setting corresponds to: $V_{res} \times I_{res} \times \cos(\varphi - \varphi_c) = 9 \times V_0 \times I_0 \times \cos(\varphi - \varphi_c)$ Where; φ = Angle between the Polarizing Voltage (-V _{res}) and the Residual Current φ_c = Relay Characteristic Angle (RCA) Setting (ISEF> Char Angle) V _{res} = Residual Voltage I _{res} = Residual Current V ₀ = Zero Sequence Voltage I ₀ = Zero Sequence Current				
3A	60	RESTRICTED E/F	0	0
0				
3A	65	IREF> Is	0.2*I3 A	From 0.05*I1 A to 1.0*I3 A step 0.01*I3 A
Pick-up setting for the High Impedance restricted earth fault element.				

Table 12 - Sensitive earth fault

3.12 Residual Overvoltage (Neutral Voltage Displacement)

The Neutral Voltage Displacement (NVD) element within the relay is of two-stage design, each stage having separate voltage and time delay settings. Stage 1 may be set to operate on either an IDMT or DT characteristic, whilst stage 2 may be set to DT only.

Col	Row	MENU TEXT	Default Setting	Available Setting
Description				
3B	00	GROUP 1 RESIDUAL O/V NVD	0	
This column contains settings for Residual Overcurrent				
3B	01	VN Input	Derived	Not Settable
Data cell indicating the VN Input is always derived from the 3 phase voltages				
3B	02	VN>1 Function	DT	0 = Disabled, 1 = DT or 2 = IDMT
Setting for the tripping characteristic of the first stage residual overvoltage element.				
3B	03	VN>1 Voltage Set	5*V1	From 1*V1 to 200*V1 step 1*V1
Pick-up setting for the first stage residual overvoltage characteristic.				
3B	04	VN>1 Time Delay	5s	From 0s to 100s step 10ms
Operating time delay setting for the first stage definite time residual overvoltage element.				
3B	05	VN>1 TMS	1	0.5 to 100 step 0.5
Setting for the time multiplier setting to adjust the operating time of the IDMT characteristic. The characteristic is defined as follows: $t = K / (M - 1)$ Where: K = Time multiplier setting t = Operating time in seconds M = Derived residual voltage/relay setting voltage (VN> Voltage Set)				
3B	06	VN>1 tReset	0s	From 0s to 100s step 10ms
Setting to determine the reset/release definite time for the first stage characteristic				
3B	07	VN>2 Status	Disabled	0 = Disabled or 1 = Enabled
Setting to enable or disable the second stage definite time residual overvoltage element.				
3B	08	VN>2 Voltage Set	10*V1	From 1*V1 to 200*V1 step 1*V1
Pick-up setting for the second stage residual overvoltage element.				

Col	Row	MENU TEXT	Default Setting	Available Setting
Description				
3B	09	VN>2 Time Delay	10s	From 0s to 100s step 10ms
Operating time delay for the second stage residual overvoltage element.				

Table 13 - Residual overvoltage (neutral voltage displacement)

3.13 Thermal Overload

The thermal overload function within the relay can be selected as a single time constant or dual time constant characteristic, dependent on the type of plant to be protected.

Col	Row	MENU TEXT	Default Setting	Available Setting
Description				
3C	00	GROUP 1 THERMAL OVERLOAD	0	
This column contains settings for Thermal Overload				
3C	01	Characteristic	Single	0 = Disabled, 1 = Single, 2 = Dual
Setting for the operating characteristic of the thermal overload element.				
3C	02	Thermal Trip	1*11 A	From 0.08*11 A to 4.0*11 A step 0.01*11 A
Sets the maximum full load current allowed and the pick-up threshold of the thermal characteristic.				
3C	03	Thermal Alarm	0.7	From 50% to 100% step 1%
Setting for the thermal state threshold corresponding to a percentage of the trip threshold at which an alarm will be generated.				
3C	04	Time Constant 1	10min	From 1min to 200min step 1min
Setting for the thermal time constant for a single time constant characteristic or the first time constant for the dual time constant characteristic.				
3C	05	Time Constant 2	5min	From 1min to 200min step 1min
Setting for the second thermal time constant for the dual time constant characteristic.				

Table 14 - Thermal overload

3.14 Voltage Protection

Under and overvoltage protection included within the relay consists of two independent stages. The measuring mode (ph-N or ph-ph) and operating mode (any phase or 3 phase) are configurable as a combination between Stage 1 and Stage 2, therefore allowing completely independent operation for each stage.

Stage 1 may be selected as IDMT, DT or Disabled, within the **V<1 function** cell.

Stage 2 is DT only and is enabled/disabled in the **V<2 status** cell.

Two stages are included to provide both alarm and trip stages, where required.

Col	Row	MENU TEXT	Default Setting	Available Setting
Description				
42	00	GROUP 1 VOLT PROTECTION	0	
This column contains settings for Voltage Protection				
42	01	UNDER VOLTAGE	0	
0				

Col	Row	MENU TEXT	Default Setting	Available Setting
Description				
42	02	V< Measur't Mode	V<1 & V<2 Ph-Ph	0 = V<1 & V<2 Ph-Ph, 1 = V<1 & V<2 Ph-N, 2 = V<1Ph-Ph V<2Ph-N, 3 = V<1Ph-N V<2Ph-Ph
Sets the combination of measured input voltage that will be used for the undervoltage elements. Note: If any stage is disabled, the associated text in the setting menu cell setting will remain visible but will not affect the operation of the stage that is enabled.				
42	03	V< Operate Mode	V<1 & V<2 Any Ph	0 = V<1 & V<2 Any Ph, 1 = V<1 & V<2 3Phase, 2 = V<1AnyPh V<2 3Ph, 3 = V<1 3Ph V<2AnyPh
Setting that determines whether any phase or all three phases has to satisfy the undervoltage criteria before a decision is made. Note: If any stage is disabled, the associated text in the setting menu cell setting will remain visible but will not affect the operation of the stage that is enabled.				
42	04	V<1 Function	DT	0 = Disabled, 1 = DT or 2 = IDMT
Tripping characteristic for the first stage undervoltage function. The IDMT characteristic available on the first stage is defined by the following formula: $t = K / (1 - M)$ Where: K = Time multiplier setting t = Operating time in seconds M = Measured voltage/relay setting voltage (V< Voltage Set)				
42	05	V<1 Voltage Set	80*V1	From 10*V1 to 120*V1 step 0.1*V1
Sets the pick-up setting for first stage undervoltage element.				
42	06	V<1 Time Delay	10s	From 0s to 100s step 10ms
Setting for the operating time-delay for the first stage definite time undervoltage element.				
42	07	V<1 TMS	1	0.5 to 100 step 0.5
Setting for the time multiplier setting to adjust the operating time of the IDMT characteristic.				
42	08	V<1 Poledead Inh	Enabled	0 = Disabled or 1 = Enabled
If the cell is enabled, the relevant stage will become inhibited by the pole dead logic. This logic produces an output when it detects either an open circuit breaker via auxiliary contacts feeding the relay opto inputs or it detects a combination of both undercurrent and undervoltage on any one phase. It allows the undervoltage protection to reset when the circuit breaker opens to cater for line or bus side VT applications.				
42	09	V<2 Status	Disabled	0 = Disabled or 1 = Enabled
Setting to enable or disable the second stage undervoltage element.				
42	0A	V<2 Voltage Set	60*V1	From 10*V1 to 120*V1 step 0.1*V1
This setting determines the pick-up setting for second stage undervoltage element.				
42	0B	V<2 Time Delay	5s	From 0s to 100s step 10ms
Setting for the operating time-delay for the second stage definite time undervoltage element.				
42	0C	V<2 Poledead Inh	Enabled	0 = Disabled or 1 = Enabled
Similar function to V<1 Poledead Inhibit.				
42	0D	OVERVOLTAGE	0	
0				
42	0E	V> Measur't Mode	V>1 & V>2 Ph-Ph	0 = V>1 & V>2 Ph-Ph, 1 = V>1 & V>2 Ph-N, 2 = V>1Ph-Ph V>2Ph-N, 3 = V>1Ph-N V>2Ph-Ph
Sets the combination of measured input voltage that will be used for the overvoltage elements. Note: If any stage is disabled, the associated text in the setting menu cell setting will remain visible but will not affect the operation of the stage that is enabled.				

Col	Row	MENU TEXT	Default Setting	Available Setting
Description				
42	0F	V> Operate Mode	V>1 & V>2 Any Ph	0 = V>1 & V>2 Any Ph, 1 = V>1 & V>2 3Phase, 2 = V>1AnyPh V>2 3Ph, 3 = V>1 3Ph V>2AnyPh
Setting that determines whether any phase or all three phases has to satisfy the overvoltage criteria before a decision is made. Note: If any stage is disabled, the associated text in the setting menu cell setting will remain visible but will not affect the operation of the stage that is enabled.				
42	10	V>1 Function	DT	0 = Disabled, 1 = DT or 2 = IDMT
Tripping characteristic setting for the first stage overvoltage element. The IDMT characteristic available on the first stage is defined by the following formula: $t = K/(M - 1)$ Where: K = Time multiplier setting t = Operating time in seconds M = Measured voltage/relay setting voltage (V<>Voltage Set)				
42	11	V>1 Voltage Set	130*V1	From 60*V1 to 185*V1 step 0.1*V1
Sets the pick-up setting for first stage overvoltage element.				
42	12	V>1 Time Delay	10s	From 0s to 100s step 10ms
Setting for the operating time-delay for the first stage definite time overvoltage element.				
42	13	V>1 TMS	1	0.5 to 100 step 0.5
Setting for the time multiplier setting to adjust the operating time of the IDMT characteristic.				
42	14	V>2 Status	Disabled	0 = Disabled or 1 = Enabled
Setting to enable or disable the second stage overvoltage element.				
42	15	V>2 Voltage Set	150*V1	From 60*V1 to 185*V1 step 0.1*V1
This setting determines the pick-up setting for the second stage overvoltage element.				
42	16	V>2 Time Delay	500ms	From 0s to 100s step 10ms
Setting for the operating time-delay for the second stage definite time overvoltage element.				
42	20	COMP OVERVOLTAGE	0	0
0				
42	23	V1>1 Cmp Funct	Disabled	0 = Disabled, 1 = DT or 2 = IDMT
Tripping characteristic setting for the first stage compensated overvoltage element. The IDMT characteristic available on the first stage is defined by the following formula: $t = K/(M - 1)$ Where: K = Time multiplier setting t = Operating time in seconds M = Remote calculated voltage/relay setting voltage (V<>Voltage Set)				
42	24	V1>1 Cmp Vlt Set	75*V1	From 60*V1 to 110*V1 step 0.1*V1
Sets the pick-up setting for first stage overvoltage element. This is set in terms of the phase to neutral voltage.				
42	25	V1>1 Cmp Tim Dly	10s	From 0s to 100s step 10ms
Setting for the operating time-delay for the first stage definite time compensated overvoltage element.				
42	26	V1>1 Cmp TMS	1	0.5 to 100 step 0.5
Setting for the time multiplier setting to adjust the operating time of the IDMT characteristic.				
42	27	V1>2 Cmp Status	Disabled	0 = Disabled or 1 = Enabled
Setting to enable or disable the second stage compensated overvoltage element.				
42	28	V1>2 Cmp Vlt Set	85*V1	From 60*V1 to 110*V1 step 0.1*V1
This setting determines the pick-up setting for the second stage overvoltage element.				
42	29	V1>2 Cmp Tim Dly	500ms	From 0s to 100s step 10ms

Col	Row	MENU TEXT	Default Setting	Available Setting
Description				
Setting for the operating time-delay for the second stage definite time compensated overvoltage element.				

Table 15 - Voltage protection

3.15 Frequency Protection

The relay includes four stages of underfrequency and two stages of overfrequency protection to facilitate load shedding and subsequent restoration. The underfrequency stages may be optionally blocked by a pole dead (CB Open) condition.

Col	Row	MENU TEXT	Default Setting	Available Setting
Description				
43	00	GROUP 1 FREQ PROTECTION	0	
This column contains settings for Frequency				
43	01	UNDER FREQUENCY	0	0
0				
43	02	F<1 Status	Enabled	0 = Disabled or 1 = Enabled
Setting to enable or disable the first stage underfrequency element.				
43	03	F<1 Setting	49.5Hz	From 45Hz to 66.3Hz step 0.01Hz
Setting that determines the pick-up threshold for the first stage underfrequency element.				
43	04	F<1 Time Delay	4s	From 0s to 100s step 10ms
Setting that determines the minimum operating time-delay for the first stage underfrequency element.				
43	05	F<2 Status	Disabled	0 = Disabled or 1 = Enabled
Setting to enable or disable the second stage underfrequency element.				
43	06	F<2 Setting	49Hz	From 45Hz to 66.3Hz step 0.01Hz
Setting that determines the pick-up threshold for the second stage underfrequency element.				
43	07	F<2 Time Delay	3s	From 0s to 100s step 10ms
Setting that determines the minimum operating time-delay for the second stage underfrequency element.				
43	08	F<3 Status	Disabled	0 = Disabled or 1 = Enabled
Setting to enable or disable the third stage underfrequency element.				
43	09	F<3 Setting	48.5Hz	From 45Hz to 66.3Hz step 0.01Hz
Setting that determines the pick-up threshold for the third stage underfrequency element.				
43	0A	F<3 Time Delay	2s	From 0s to 100s step 10ms
Setting that determines the minimum operating time-delay for the third stage underfrequency element.				
43	0B	F<4 Status	Disabled	0 = Disabled or 1 = Enabled
Setting to enable or disable the fourth stage underfrequency element.				
43	0C	F<4 Setting	48Hz	From 45Hz to 66.3Hz step 0.01Hz
Setting that determines the pick-up threshold for the fourth stage underfrequency element.				
43	0D	F<4 Time Delay	1s	From 0s to 100s step 10ms
Setting that determines the minimum operating time-delay for the fourth stage underfrequency element.				
43	0E	F< Function Link	0000(bin)	Bit 00 = F<1 Poledead Blk, Bit 01 = F<2 Poledead Blk, Bit 02 = F<3 Poledead Blk, Bit 03 = F<4 Poledead Blk
Settings that determines whether undervoltage level (setting CB FAIL & P.DEAD/POLEDEAD VOLTAGE/V<) signal block the underfrequency elements.				

Col	Row	MENU TEXT	Default Setting	Available Setting
Description				
43	0F	OVER FREQUENCY	0	0
0				
43	10	F>1 Status	Enabled	0 = Disabled or 1 = Enabled
Setting to enable or disable the first stage overfrequency element.				
43	11	F>1 Setting	50.5Hz	From 45Hz to 66.3Hz step 0.01Hz
Setting that determines the pick-up threshold for the first stage overfrequency element.				
43	12	F>1 Time Delay	2s	From 0s to 100s step 10ms
Setting that determines the minimum operating time-delay for the first stage overfrequency element.				
43	13	F>2 Status	Disabled	0 = Disabled or 1 = Enabled
Setting to enable or disable the second stage overfrequency element.				
43	14	F>2 Setting	51Hz	From 45Hz to 66.3Hz step 0.01Hz
Setting that determines the pick-up threshold for the second stage overfrequency element.				
43	15	F>2 Time Delay	1s	From 0s to 100s step 10ms
Setting that determines the minimum operating time-delay for the second stage overfrequency element.				

Table 16 - Frequency protection

3.16 Independent Rate of Change of Frequency Protection

The relay provides four independent stages of rate of change of frequency protection (df/dt+t). Depending upon whether the rate of change of frequency setting is set positive or negative, the element will react to rising or falling frequency conditions respectively, with an incorrect setting being indicated if the threshold is set to zero.

Col	Row	MENU TEXT	Default Setting	Available Setting
Description				
44	00	GROUP 1 DF/DT PROTECTION	0	
This column contains settings for DF/DT Protection				
44	01	df/dt Avg.Cycles	6	6 to 12 step 6
This setting is available for calculating the rate of change of frequency measurement over a fixed period of either 6 or 12 cycles.				
44	04	df/dt>1 Status	Enabled	0 = Disabled or 1 = Enabled
Setting to enable or disable the first stage df/dt element.				
44	05	df/dt>1 Setting	2Hz/s	From 0.1Hz/s to 10Hz/s step 0.1Hz/s
Pick-up setting for the first stage df/dt element.				
44	06	df/dt>1 Dir'n	Negative	0 = Negative, 1 = Positive, 2 = Both
This setting determines whether the element will react to rising or falling frequency conditions respectively, with an incorrect setting being indicated if the threshold is set to zero.				
44	07	df/dt>1 Time	500ms	From 0s to 100s step 10ms
Minimum operating time-delay setting for the first stage df/dt element.				
44	0B	df/dt>2 Status	Enabled	0 = Disabled or 1 = Enabled
Setting to enable or disable the second stage df/dt element.				
44	0C	df/dt>2 Setting	2Hz/s	From 0.1Hz/s to 10Hz/s step 0.1Hz/s
Pick-up setting for the second stage df/dt element.				
44	0D	df/dt>2 Dir'n	Negative	0 = Negative, 1 = Positive, 2 = Both

Col	Row	MENU TEXT	Default Setting	Available Setting
Description				
This setting determines whether the element will react to rising or falling frequency conditions respectively, with an incorrect setting being indicated if the threshold is set to zero.				
44	0E	df/dt>2 Time	1s	From 0s to 100s step 10ms
Minimum operating time-delay setting for the second stage df/dt element.				
44	12	df/dt>3 Status	Enabled	0 = Disabled or 1 = Enabled
Setting to enable or disable the third stage df/dt element.				
44	13	df/dt>3 Setting	2Hz/s	From 0.1Hz/s to 10Hz/s step 0.1Hz/s
Pick-up setting for the third stage df/dt element.				
44	14	df/dt>3 Dir'n	Negative	0 = Negative, 1 = Positive, 2 = Both
This setting determines whether the element will react to rising or falling frequency conditions respectively, with an incorrect setting being indicated if the threshold is set to zero.				
44	15	df/dt>3 Time	2s	From 0s to 100s step 10ms
Minimum operating time-delay setting for the third stage df/dt element.				
44	19	df/dt>4 Status	Enabled	0 = Disabled or 1 = Enabled
Setting to enable or disable the fourth stage df/dt element.				
44	1A	df/dt>4 Setting	2Hz/s	From 0.1Hz/s to 10Hz/s step 0.1Hz/s
Pick-up setting for the fourth stage df/dt element.				
44	1B	df/dt>4 Dir'n	Negative	0 = Negative, 1 = Positive, 2 = Both
This setting determines whether the element will react to rising or falling frequency conditions respectively, with an incorrect setting being indicated if the threshold is set to zero.				
44	1C	df/dt>4 Time	3s	From 0s to 100s step 10ms
Minimum operating time-delay setting for the fourth stage df/dt element.				

Table 17 - DF/DT protection**3.17****Circuit Breaker (CB) Fail and Pole Dead Detection Function****CB Fail**

This function consists of a two-stage Circuit Breaker (CB) fail function initiated by:

- Current-based or Voltage-based protection elements
- External protection elements.

For current-based protection, the reset condition is based on undercurrent operation to determine that the CB has opened. For the non-current based protection, the reset criteria may be selected by means of a setting for determining a CB Failure condition.

It is common practice to use low set undercurrent elements in protection relays to indicate that circuit breaker poles have interrupted the fault or load current, as required.

Pole Dead

The Pole Dead Detection consists of a two user-settable level detectors:

- Undercurrent
- Undervoltage

Both, undercurrent and undervoltage settings are also used for CNV (Current No Volt) function in TOC protection.

Col	Row	MENU TEXT	Default Setting	Available Setting
Description				
45	00	GROUP1 CB FAIL & P.DEAD	0	

Col	Row	MENU TEXT	Default Setting	Available Setting
Description				
This column contains settings for Circuit Breaker Fail and Pole Dead detection				
45	01	BREAKER FAIL	0	0
0				
45	02	CB Fail 1 Status	Enabled	0 = Disabled or 1 = Enabled
Setting to enable or disable the first stage of the circuit breaker function.				
45	03	CB Fail 1 Timer	200ms	From 0s to 100s step 10ms
Setting for the circuit breaker fail timer stage 1, during which breaker opening must be detected. There are timers per phase to cope with evolving faults, but the timer setting is common.				
45	04	CB Fail 2 Status	Disabled	0 = Disabled or 1 = Enabled
Setting to enable or disable the second stage of the circuit breaker function.				
45	05	CB Fail 2 Timer	400ms	From 0s to 100s step 10ms
Setting for the circuit breaker fail timer stage 2, during which breaker opening must be detected.				
45	06	Volt Prot Reset	Prot Reset & I<	0 = I< Only, 1 = CB Open & I<, 2 = Prot Reset & I<
Setting which determines the elements that will reset the circuit breaker fail time for voltage protection function initiated circuit breaker fail conditions.				
45	07	Ext Prot Reset	Prot Reset & I<	0 = I< Only, 1 = CB Open & I<, 2 = Prot Reset & I<
Setting which determines the elements that will reset the circuit breaker fail time for external protection function initiated circuit breaker fail conditions.				
45	08	WI Prot Reset	Disabled	0 = Disabled or 1 = Enabled
When Enabled, CB Fail timers will be reset by drop off of a weak infeed trip condition, providing that WI trip logic is activated.				
45	0A	UNDER CURRENT	0	0
0				
45	0B	I< Current Set	0.05*I1 A	From 0.02*I1 A to 3.2*I1 A step 0.01*I1 A
Setting that determines the circuit breaker fail timer reset current for overcurrent based protection circuit breaker fail initiation.				
45	0D	ISEF< Current	0.02*I3 A	From 0.001*I3 A to 0.8*I3 A step 0.0005*I3 A
Setting that determines the circuit breaker fail timer reset current for Sensitive earth fault (SEF) protection circuit breaker fail initiation.				
45	0E	POLEDEAD	0	0
0				
45	10	V<	38.1*V1	From 10*V1 to 40*V1 step 0.1*V1
Under voltage level detector for pole dead detection				
45	11	I<	0.05*I1 A	From 0.02*I1 A to 3.2*I1 A step 0.01*I1 A
Under current level detector for pole dead detection				

Table 18 - Circuit breaker fail and pole dead detection function

3.18 Supervision (VTS, CTS, Inrush Detection, Special Weak Infeed Blocking and Trip Supervision)

The VTS feature within the relay operates on detection of Negative Phase Sequence (NPS) voltage without the presence of NPS current.

The CT Supervision (CTS) feature operates on detection of derived zero sequence current, in the absence of corresponding derived zero sequence voltage that would normally accompany it.

The Trip supervision (TS) feature relates to using fault detectors to supervise the trip signals.

The Special Weak Infeed Blocking is not normally applied, and is described in detail later in this service manual.

Col	Row	MENU TEXT	Default Setting	Available Setting
Description				
46	00	GROUP 1 SUPERVISION	0	
This column contains settings for Voltage and Current Transformer Supervision				
46	01	VTS Mode	Measured + MCB	0 = Measured + MCB, 1 = Measured Only, 2 = MCB Only
Setting that determines the method to be used to declare VT failure.				
46	02	VTS Status	Blocking	0 = Disabled, 1 = Blocking, 2 = Indication
This setting determines whether the following operations will occur upon detection of VTS. <ul style="list-style-type: none"> • VTS set to provide alarm indication only. • Optional blocking of voltage dependent protection elements. • Optional conversion of directional overcurrent elements to non-directional protection (available when set to blocking mode only). These settings are found in the function links cell of the relevant protection element columns in the menu. 				
46	03	VTS Reset Mode	Auto	0 = Manual or 1 = Auto
The VTS block will be latched after a user settable time delay 'VTS Time Delay'. Once the signal has latched then two methods of resetting are available. The first is manually via the front panel interface (or remote communications) and secondly, when in 'Auto' mode, provided the VTS condition has been removed and the 3 phase voltages have been restored above the phase level detector settings for more than 240 ms.				
46	04	VTS Time Delay	5s	From 1s to 10s step 100ms
Setting that determines the operating time-delay of the element upon detection of a voltage supervision condition.				
46	05	VTS I> Inhibit	10*11 A	From 0.08*11 A to 32*11 A step 0.01*11 A
The setting is used to override a voltage supervision block in the event of a phase fault occurring on the system that could trigger the voltage supervision logic.				
46	06	VTS I2> Inhibit	0.05*11 A	From 0.05*11 A to 0.5*11 A step 0.01*11 A
The setting is used to override a voltage supervision block in the event of a fault occurring on the system with negative sequence current above this setting which could trigger the voltage supervision logic.				
46	0E	Inrush Detection	Disabled	0 = Disabled or 1 = Enabled
This setting is to enable/disable the Inrush Detection used for the Distance protection.				
46	0F	I>2nd Harmonic	0.35	From 10% to 100% step 5%
If the level of second harmonic in any phase current or neutral current exceeds the setting, inrush conditions will be recognized by changing the status of four DDB signals from low to high in the Programmable Scheme Logic (PSL). The user then has a choice to use them further in the PSL in accordance with the application.				
46	10	WEAK INFEED BLK	0	
0				
46	11	WI Inhibit	Enabled	0 = Disabled or 1 = Enabled
This setting enables (turns on) or disables (turns off) a special feature to cover scenarios when there is a very weak positive or negative sequence source behind the relay, but the zero sequence infeed is large. Special to stub-end transformer feeding, where the stub end has no generation, but has solid earthing at a Yd transformer neutral.				
46	12	I0/I2 Setting	3	2 to 3 step 0.2
If the ratio of zero sequence current to negative sequence current exceeds the setting, all protection elements such as Distance, DEF and Delta that could potentially operate during a genuine weak infeed condition will be inhibited. This setting will be visible only if 'WI Inhibit' is enabled.				
46	30	CT SUPERVISION	0	
0				
46	31	CTS Mode	Disabled	0 = Disabled or 1 = Enabled
Setting to disable, enable the standard (voltage dependant) CTS element				

Col	Row	MENU TEXT	Default Setting	Available Setting
Description				
46	32	CTS Status	Restrain	0 = Restrain or 1 = Indication
<p>This setting determines whether the following operations will occur upon detection of CTS.</p> <ul style="list-style-type: none"> • CTS set to provide alarm indication only. • CTS set to restrain local protection <p>The settings are visible if CTS Mode is not disabled.</p>				
46	33	CTS Reset Mode	Manual	0 = Manual, 1 = Auto
<p>The CTS block will be latched after a user settable time delay 'CTS Time Delay'. Once the signal has latched then two methods of resetting are available. The first is manually via the front panel interface (or remote communications) and secondly, when in 'Auto' mode, provided the CTS condition has been removed. The setting is visible if CTS Mode is not disabled.</p>				
46	34	CTS Time Delay	5s	From 0s to 10s step 10ms
<p>Setting that determines the operating time-delay of the element upon detection of a current transformer supervision condition. The setting is visible if CTS Mode is not disabled</p>				
46	35	CTS VN< Inhibit	5*V1	From 0.5*V1 to 22*V1 step 0.5*V1
<p>This setting is used to inhibit the current transformer supervision element should the zero sequence voltage exceed this setting. The setting is visible if CTS Mode is not disabled</p>				
46	36	CTS IN> Set	0.1*11 A	From 0.08*11 A to 4*11 A step 0.01*11 A
<p>This setting determines the level of zero sequence current that must be present for a valid current transformer supervision condition. The setting is visible if CTS Mode is not disabled</p>				
46	60	Trip Supervision	0	
0				
46	61	Stage 1 TS	Disabled	0 = Disabled or 1 = Enabled
Setting to enable/disable the first stage of supervision				
46	62	I> Threshold	1*11 A	From 0.08*11 A to 4*11 A step 0.01*11 A
Threshold of Over-current supervision element				
46	63	I> TS Elements	00000000(bin)	Bit 00 = Zone 1, Bit 01 = Zone 2, Bit 02 = Zone 3, Bit 03 = Zone P, Bit 04 = Zone 4, Bit 05 = Zone Q, Bit 06 = Aided Dist, Bit 07 = Current Diff
<p>A binary flag cell with bits for each of the distance zone functions, one bit for the Aided Scheme trip and one bit for Line Differential function. If the flag is set to 1, the function will be allowed to trip if the current is above the threshold. If set to 0, the element will have no influence on the function</p>				
46	64	IN> Threshold	0.2*11 A	From 0.008*11 A to 4*11 A step 0.001*11 A
Threshold of Earth Fault over-current supervision element				
46	65	IN> TS Elements	00000000(bin)	Bit 00 = Zone 1, Bit 01 = Zone 2, Bit 02 = Zone 3, Bit 03 = Zone P, Bit 04 = Zone 4, Bit 05 = Zone Q, Bit 06 = Aided Dist, Bit 07 = Current Diff
<p>A binary flag cell with bits for each of the distance zone functions, one bit for the Aided Scheme trip and one bit for Line Differential function. If the flag is set to 1, the function will be allowed to trip if the neutral current is above the threshold. If set to 0, the element will have no influence on the function</p>				
46	66	OCD> Threshold	0.08*11 A	From 0.005*11 A to 0.2*11 A step 0.001*11 A
Threshold for the delta over-current supervision element.				
46	67	OCD> TS Elements	00000000(bin)	Bit 00 = Zone 1, Bit 01 = Zone 2, Bit 02 = Zone 3, Bit 03 = Zone P, Bit 04 = Zone 4, Bit 05 = Zone Q, Bit 06 = Aided Dist, Bit 07 = Current Diff
<p>A binary flag cell with bits for each of the distance zone functions, one bit for the Aided Scheme trip and one bit for Line Differential function. If the flag is set to 1, the function will be allowed to trip if the delta current is above the threshold. If set to 0, the element will have no influence on the function</p>				
46	68	Vpp< Threshold	80.00V	From 10*V1 to 120*V1 step 1*V1
Threshold for the under phase-to-phase voltage supervision element.				

Col	Row	MENU TEXT	Default Setting	Available Setting
Description				
46	69	V _{pp} < TS Elements	00000000(bin)	Bit 00 = Zone 1, Bit 01 = Zone 2, Bit 02 = Zone 3, Bit 03 = Zone P, Bit 04 = Zone 4, Bit 05 = Zone Q, Bit 06 = Aided Dist, Bit 07 = Current Diff
A binary flag cell with bits for each of the distance zone functions, one bit for the Aided Scheme trip and one bit for Line Differential function. If the flag is set to 1, the function will be allowed to trip if the phase-to-phase voltage is below the threshold. If set to 0, the element will have no influence on the function				
46	6A	V _{pn} < Threshold	80.00V	From 10*V1 to 120*V1 step 1*V1
Threshold for the under phase-neutral voltage supervision element.				
46	6B	V _{pn} < TS Elements	00000000(bin)	Bit 00 = Zone 1, Bit 01 = Zone 2, Bit 02 = Zone 3, Bit 03 = Zone P, Bit 04 = Zone 4, Bit 05 = Zone Q, Bit 06 = Aided Dist, Bit 07 = Current Diff
A binary flag cell with bits for each of the distance zone functions, one bit for the Aided Scheme trip and one bit for Line Differential function. If the flag is set to 1, the function will be allowed to trip if the phase-neutral voltage is below the threshold. If set to 0, the element will have no influence on the function				
46	6C	UVD< Threshold	5.00V	From 1*V1 to 20*V1 step 1*V1
Threshold for the delta phase-neutral voltage supervision element.				
46	6D	UVD< TS Elements	00000000(bin)	Bit 00 = Zone 1, Bit 01 = Zone 2, Bit 02 = Zone 3, Bit 03 = Zone P, Bit 04 = Zone 4, Bit 05 = Zone Q, Bit 06 = Aided Dist, Bit 07 = Current Diff
A binary flag cell with bits for each of the distance zone functions, one bit for the Aided Scheme trip and one bit for Line Differential function. If the flag is set to 1, the function will be allowed to trip if the delta phase-neutral voltage is over the threshold. If set to 0, the element will have no influence on the function				
46	6E	UVD>Hold Timer	0s	From 0s to 10s step 10ms
Setting that determines the operating time-delay of the trip supervision element upon detection of a UVD> drop-off.				
46	6F	OCD>Hold Timer	0s	From 0s to 10s step 10ms
Setting that determines the operating time-delay of the trip supervision element upon detection of an OCD> drop-off.				
46	70	Stage 2 TS	Disabled	0 = Disabled or 1 = Enabled
Setting to enable/disable the second stage of supervision				
46	71	I> Threshold	1*I1 A	From 0.008*I1 A to 4*I1 A step 0.001*I1 A
Threshold of Over-current supervision element				
46	72	I> TS Elements	00000000(bin)	Bit 00 = Zone 1, Bit 01 = Zone 2, Bit 02 = Zone 3, Bit 03 = Zone P, Bit 04 = Zone 4, Bit 05 = Zone Q, Bit 06 = Aided Dist, Bit 07 = Current Diff
A binary flag cell with bits for each of the distance zone functions, one bit for the Aided Scheme trip and one bit for Line Differential function. If the flag is set to 1, the function will be allowed to trip if the current is above the threshold. If set to 0, the element will have no influence on the function				
46	73	IN> Threshold	0.2*I1 A	From 0.008*I1 A to 4*I1 A step 0.001*I1 A
Threshold of Earth Fault over-current supervision element				
46	74	IN> TS Elements	00000000(bin)	Bit 00 = Zone 1, Bit 01 = Zone 2, Bit 02 = Zone 3, Bit 03 = Zone P, Bit 04 = Zone 4, Bit 05 = Zone Q, Bit 06 = Aided Dist, Bit 07 = Current Diff
A binary flag cell with bits for each of the distance zone functions, one bit for the Aided Scheme trip and one bit for Line Differential function. If the flag is set to 1, the function will be allowed to trip if the neutral current is above the threshold. If set to 0, the element will have no influence on the function				
46	75	OCD> Threshold	0.08*I1 A	From 0.005*I1 A to 0.2*I1 A step 0.001*I1 A
Threshold for the delta over-current supervision element.				
46	76	OCD> TS Elements	00000000(bin)	Bit 00 = Zone 1, Bit 01 = Zone 2, Bit 02 = Zone 3, Bit 03 = Zone P, Bit 04 = Zone 4, Bit 05 = Zone Q, Bit 06 = Aided Dist, Bit 07 = Current Diff

Col	Row	MENU TEXT	Default Setting	Available Setting
Description				
A binary flag cell with bits for each of the distance zone functions, one bit for the Aided Scheme trip and one bit for Line Differential function. If the flag is set to 1, the function will be allowed to trip if the delta current is above the threshold. If set to 0, the element will have no influence on the function				
46	77	Vpp< Threshold	80.00V	From 10*V1 to 120*V1 step 1*V1
Threshold for the under phase-to-phase voltage supervision element.				
46	78	Vpp< TS Elements	00000000(bin)	Bit 00 = Zone 1, Bit 01 = Zone 2, Bit 02 = Zone 3, Bit 03 = Zone P, Bit 04 = Zone 4, Bit 05 = Zone Q, Bit 06 = Aided Dist, Bit 07 = Current Diff
A binary flag cell with bits for each of the distance zone functions, one bit for the Aided Scheme trip and one bit for Line Differential function. If the flag is set to 1, the function will be allowed to trip if the phase-to-phase voltage is below the threshold. If set to 0, the element will have no influence on the function				
46	79	Vpn< Threshold	80.00V	From 10*V1 to 120*V1 step 1*V1
Threshold for the under phase-neutral voltage supervision element.				
46	7A	Vpn< TS Elements	00000000(bin)	Bit 00 = Zone 1, Bit 01 = Zone 2, Bit 02 = Zone 3, Bit 03 = Zone P, Bit 04 = Zone 4, Bit 05 = Zone Q, Bit 06 = Aided Dist, Bit 07 = Current Diff
A binary flag cell with bits for each of the distance zone functions, one bit for the Aided Scheme trip and one bit for Line Differential function. If the flag is set to 1, the function will be allowed to trip if the phase-neutral voltage is below the threshold. If set to 0, the element will have no influence on the function				
46	7B	UVD> Threshold	5.00V	From 1*V1 to 20*V1 step 1*V1
Threshold for the delta phase-neutral voltage supervision element.				
46	7C	UVD> TS Elements	00000000(bin)	Bit 00 = Zone 1, Bit 01 = Zone 2, Bit 02 = Zone 3, Bit 03 = Zone P, Bit 04 = Zone 4, Bit 05 = Zone Q, Bit 06 = Aided Dist, Bit 07 = Current Diff
A binary flag cell with bits for each of the distance zone functions, one bit for the Aided Scheme trip and one bit for Line Differential function. If the flag is set to 1, the function will be allowed to trip if the delta phase-neutral voltage is over the threshold. If set to 0, the element will have no influence on the function				
46	7D	UVD>Hold Timer	0s	From 0s to 10s step 10ms
Setting that determines the operating time-delay of the trip supervision element upon detection of a UVD> drop-off.				
46	7E	OCD>Hold Timer	0s	From 0s to 10s step 10ms
Setting that determines the operating time-delay of the trip supervision element upon detection of an OCD> drop-off.				
46	80	Stage 3 TS	Disabled	0 = Disabled or 1 = Enabled
Setting to enable/disable the third stage of supervision				
46	81	I> Threshold	1*I1 A	From 0.008*I1 A to 4*I1 A step 0.001*I1 A
Threshold of Over-current supervision element				
46	82	I> TS Elements	00000000(bin)	Bit 00 = Zone 1, Bit 01 = Zone 2, Bit 02 = Zone 3, Bit 03 = Zone P, Bit 04 = Zone 4, Bit 05 = Zone Q, Bit 06 = Aided Dist, Bit 07 = Current Diff
A binary flag cell with bits for each of the distance zone functions, one bit for the Aided Scheme trip and one bit for Line Differential function. If the flag is set to 1, the function will be allowed to trip if the current is above the threshold. If set to 0, the element will have no influence on the function				
46	83	IN> Threshold	0.2*I1 A	From 0.008*I1 A to 4*I1 A step 0.001*I1 A
Threshold of Earth Fault over-current supervision element				
46	84	IN> TS Elements	00000000(bin)	Bit 00 = Zone 1, Bit 01 = Zone 2, Bit 02 = Zone 3, Bit 03 = Zone P, Bit 04 = Zone 4, Bit 05 = Zone Q, Bit 06 = Aided Dist, Bit 07 = Current Diff
A binary flag cell with bits for each of the distance zone functions, one bit for the Aided Scheme trip and one bit for Line Differential function. If the flag is set to 1, the function will be allowed to trip if the neutral current is above the threshold. If set to 0, the element will have no influence on the function				
46	85	OCD> Threshold	0.08*I1 A	From 0.005*I1 A to 0.2*I1 A step 0.001*I1 A

Col	Row	MENU TEXT	Default Setting	Available Setting
Description				
Threshold for the delta over-current supervision element.				
46	86	OCD> TS Elements	00000000(bin)	Bit 00 = Zone 1, Bit 01 = Zone 2, Bit 02 = Zone 3, Bit 03 = Zone P, Bit 04 = Zone 4, Bit 05 = Zone Q, Bit 06 = Aided Dist, Bit 07 = Current Diff
A binary flag cell with bits for each of the distance zone functions, one bit for the Aided Scheme trip and one bit for Line Differential function. If the flag is set to 1, the function will be allowed to trip if the delta current is above the threshold. If set to 0, the element will have no influence on the function				
46	87	Vpp< Threshold	80.00V	From 10*V1 to 120*V1 step 1*V1
Threshold for the under phase-to-phase voltage supervision element.				
46	88	Vpp< TS Elements	00000000(bin)	Bit 00 = Zone 1, Bit 01 = Zone 2, Bit 02 = Zone 3, Bit 03 = Zone P, Bit 04 = Zone 4, Bit 05 = Zone Q, Bit 06 = Aided Dist, Bit 07 = Current Diff
A binary flag cell with bits for each of the distance zone functions, one bit for the Aided Scheme trip and one bit for Line Differential function. If the flag is set to 1, the function will be allowed to trip if the phase-to-phase voltage is below the threshold. If set to 0, the element will have no influence on the function				
46	89	Vpn< Threshold	80.00V	From 10*V1 to 120*V1 step 1*V1
Threshold for the under phase-neutral voltage supervision element.				
46	8A	Vpn< TS Elements	00000000(bin)	Bit 00 = Zone 1, Bit 01 = Zone 2, Bit 02 = Zone 3, Bit 03 = Zone P, Bit 04 = Zone 4, Bit 05 = Zone Q, Bit 06 = Aided Dist, Bit 07 = Current Diff
A binary flag cell with bits for each of the distance zone functions, one bit for the Aided Scheme trip and one bit for Line Differential function. If the flag is set to 1, the function will be allowed to trip if the phase-neutral voltage is below the threshold. If set to 0, the element will have no influence on the function				
46	8B	UVD> Threshold	5.00V	From 1*V1 to 20*V1 step 1*V1
Threshold for the delta phase-neutral voltage supervision element.				
46	8C	UVD> TS Elements	00000000(bin)	Bit 00 = Zone 1, Bit 01 = Zone 2, Bit 02 = Zone 3, Bit 03 = Zone P, Bit 04 = Zone 4, Bit 05 = Zone Q, Bit 06 = Aided Dist, Bit 07 = Current Diff
A binary flag cell with bits for each of the distance zone functions, one bit for the Aided Scheme trip and one bit for Line Differential function. If the flag is set to 1, the function will be allowed to trip if the delta phase-neutral voltage is over the threshold. If set to 0, the element will have no influence on the function				
46	8D	UVD>Hold Timer	0s	From 0s to 10s step 10ms
Setting that determines the operating time-delay of the trip supervision element upon detection of a UVD> drop-off.				
46	8E	OCD>Hold Timer	0s	From 0s to 10s step 10ms
Setting that determines the operating time-delay of the trip supervision element upon detection of an OCD> drop-off.				

Table 19 - Supervision

3.19 System Checks (Check Sync. Function)

The relay has a two-stage Check Synchronization function that can be set independently.

Col	Row	MENU TEXT	Default Setting	Available Setting
Description				
48	00	GROUP 1 SYSTEM CHECKS	0	
This column contains settings for System Checks				
48	14	VOLTAGE MONITORS	0	
0				

Col	Row	MENU TEXT	Default Setting	Available Setting
Description				
48	85	Live Line	32	From 5 to 132 step 0.5
Line is considered Live with voltage above this setting.				
48	86	Dead Line	13	From 5 to 132 step 0.5
Line is considered Dead with voltage below this setting.				
48	87	Live Bus 1	32	From 5 to 132 step 0.5
Bus 1 is considered Live with voltage above this setting.				
48	88	Dead Bus 1	13	From 5 to 132 step 0.5
Bus 1 is considered Dead with voltage below this setting.				
48	8B	CS UV	54	From 5 to 120 step 0.5
Check Synch Undervoltage setting decides that System Check Synchronism logic for CB1 will be blocked if V< is one of the selected options in setting CB1 CS Volt.Blk (48 8 E), and either line or bus voltage is below this setting. System Check Synchronism for CB2 will be blocked if V< is one of the selected options in setting CB2 CS Volt. Blk (48 9 C), and either line or bus voltage is below this setting.				
48	8C	CS OV	130	From 60 to 200 step 0.5
Check Synch Overvoltage setting decides that System Check Synchronism logic for CB1 is blocked if V> is one of the selected options in setting CB1 CS Volt.Blk (48 8 E), and either line or bus voltage is above this setting. System Check Synchronism for CB2 is blocked if V> is one of the selected options in setting CB2 CS Volt. Blk (48 9 C), and either line or bus voltage is above this setting.				
48	8D	System Checks	Disabled	0 = Disabled or 1 = Enabled
Setting to enable or disable both stages of system checks for reclosing. If System Checks is set to Disabled, all other menu settings associated with synchronism checks become invisible, and a DDB (880) signal SysChks Inactive is set.				
48	8E	CS Voltage Block	V<	0 = None, 1 = V<, 2 = V>, 3 = Vdiff>, 4 = V< and V>, 5 = V< and Vdiff>, 6 = V> and Vdiff>, 7 = V< V> and Vdiff>
Setting to determine which, if any, conditions should block synchronism check (undervoltage V<, overvoltage V>, and/or voltage differential Vdiff etc) for the line and bus voltages.				
48	8F	CS1 Status	Enabled	0 = Disabled or 1 = Enabled
Setting to enable or disable the stage 1 synchronism check elements for auto-reclosing and manual closing of CB.				
48	90	CS1 Angle	20	From 0° to 90° step 1°
Maximum permitted phase angle between Line and Bus 1 voltages for first stage synchronism check element to reclose CB.				
48	91	CS1 VDiff	6.5	From 1 to 120 step 0.5
Check Synch Voltage differential setting decides that stage 1 System Check Synchronism logic is blocked if Vdiff> is one of the selected options in setting CS Voltage Block (48 8 E), and voltage magnitude difference between line and bus 1 voltage is above this setting.				
48	92	CS1 Slip Ctrl	Frequency	From None to Both step 1
Setting to enable or disable blocking of synchronism check stage 1 for reclosing CB by excessive frequency difference or inadequate time slip.				
48	93	CS1 Slip Freq	50mHz	From 5mHz to 2Hz step 5mHz
If CS1 Slip Ctrl is enabled for frequency, synchronism check stage 1 is blocked for reclosing CB if measured frequency difference between line and bus voltages is greater than this setting.				
48	94	CS1 Slip Timer	1s	From 0 to 99s step 10ms
If CS1 Slip Ctrl is enabled for timer, synchronism check stage 1 is blocked for reclosing CB if time slip is smaller than this setting.				
48	95	CS2 Status	Disabled	0 = Disabled or 1 = Enabled

Col	Row	MENU TEXT	Default Setting	Available Setting
Description				
Setting to enable or disable the stage 2 synchronism check elements for auto-reclosing and manual closing CB.				
48	96	CS2 Angle	20	From 0° to 90° step 1°
Maximum permitted phase angle between Line and Bus 1 voltages for second stage synchronism check element to reclose CB				
48	97	CS2 VDiff	6.5V	From 1 to 120 step 0.5
Check Synch Voltage differential setting decides that stage 2 System Check Synchronism logic is blocked if Vdiff> is one of the selected options in setting CS Voltage Block (48 8 E), and voltage magnitude difference between line and bus 1 voltage is above this setting.				
48	98	CS2 Slip Ctrl	Frequency	From None to Both step 1
Setting to enable or disable blocking of synchronism check stage 2 for reclosing CB by excessive frequency difference or inadequate time slip.				
48	99	CS2 Slip Freq	50mHz	From 5mHz to 2Hz step 5mHz
If CS2 Slip Ctrl is enabled for frequency, synchronism check stage 2 is blocked for reclosing CB if measured frequency difference between line and bus voltages is greater than this setting.				
48	9A	CS2 Slip Timer	1s	From 0 to 99s step 10ms
If CS2 Slip Ctrl is enabled for timer, synchronism check stage 2 is blocked for reclosing CB if time slip is smaller than this setting.				
48	9B	CB1 CI Time	50ms	From 10ms to 500ms step 1ms
This sets CB1 closing time, from receipt of CB1 close command until main contacts touch				
48	B0	MAN SYS CHECKS	0	0
0				
48	B2	CBM SC required	Disabled	0 = Disabled or 1 = Enabled
This setting determines whether a system check (e.g. live bus / dead line etc) is required for any manual (operator-controlled) closure of CB. If Enabled, system check is required for closure. If Disabled, system check is not required.				
48	B3	CBM SC CS1	Disabled	0 = Disabled or 1 = Enabled
This setting enables CB to close by manual control when the system satisfies all the System Check Synchronism Stage 1 conditions as listed under the setting CS1 Status in the SYSTEM CHECKS column.				
48	B4	CBM SC CS2	Disabled	0 = Disabled or 1 = Enabled
This setting enables CB1 to close by manual control when the system satisfies all the System Check Synchronism Stage 2 conditions as listed under the setting CS2 Status in the SYSTEM CHECKS column.				
48	B5	CBM SC DLLB	Disabled	0 = Disabled or 1 = Enabled
This setting enables CB to close by manual control when the dead line & live bus1 conditions are satisfied as set in the SYSTEM CHECKS column.				
48	B6	CBM SC LLDB	Disabled	0 = Disabled or 1 = Enabled
This setting enables CB to close by manual control when the live line & dead bus1 conditions are satisfied as set in the SYSTEM CHECKS column.				
48	B7	CBM SC DLDB	Disabled	0 = Disabled or 1 = Enabled
This setting enables CB to close by manual control when the dead line & dead bus1 conditions are satisfied as set in the SYSTEM CHECKS column.				

Table 20 - System checks (check sync. function)

3.20 Auto-Reclose Function

The relay will initiate auto-reclose for fault clearances by any instantaneous trip allocated in the PSL to the Any Trip signal. The default PSL includes Zone 1 trip and aided trips. In addition, other distance zones, Aided DEF, phase and earth overcurrent protection and Trip On Reclose (TOR) may be set to initiate auto-reclose, when required. This is done in the settings (shown below). Protection such as voltage, frequency, thermal etc. will block auto-reclose.

The following shows the relay settings for the auto-reclose function, which must be set in conjunction with the Circuit Breaker Control settings under main Menu. The available setting ranges and factory defaults are shown.

Col	Row	MENU TEXT	Default Setting	Available Setting
Description				
49	00	GROUP 1 AUTORECLOSE	0	
This column contains settings for Autoreclose				
49	51	AR Mode	AR 3P	0 = 1P, 1 = 1/3P, 2 = 3P or 3 = AR Opto
This setting determines which auto-reclose modes are permitted for the circuit breaker : single phase (AR 1P) only, both single phase and three phase (AR 1/3P), three phase only (AR 3P), or the auto-reclosing mode is controlled by opto input signals (AR Opto) mapped via DDBs (1497) AR Mode 1P and (1498) AR Mode 3P.				
49	59	AR Shots	1	1 to 4 step 1
This setting determines how many reclose attempts (shots) are permitted for any single fault incident before it is treated as persistent and auto-reclosing is locked out. For example if AR Shots = 2, a second reclose attempt is initiated if the protection retrips during the reclaim time following one reclose attempt, but locks out if the protection retrips during the reclaim time after a second reclose attempt.				
49	5A	AR Skip Shot 1	Disable	0 = Disabled or 1 = Enabled
If Enabled then the first shot can be skipped by setting the AR Skip Shot1 DDB high in the PSL				
49	5C	Multi Phase AR	Allow AR	0 = Allow Autoclose, 1 = BAR 2 and 3Ph, 2 = BAR 3 Phase
This setting determines whether auto-reclosing is permitted or blocked for two phase or three phase faults.				
49	5D	Discrim Time	100ms	From 5ms to 5s step 5ms
Discrim Time = Discriminating Time. This is a setting which determines whether a fault on another phase (evolving or developing fault) after single phase trip and auto-reclose has been initiated by a single phase fault stops the single phase cycle and starts a three phase auto-reclose cycle provided this second fault (evolving fault) occurs BEFORE the Discrimination Time elapsed. It forces a lockout if second fault (evolving fault) occurs AFTER Discrimination Time has elapsed but before Single Phase Dead Time elapses.				
49	5E	CB IS LL Check	Disabled	0 = Disabled or 1 = Enabled
CB IS LL Check = CB In Service Live Line Check. If Enabled the Live Line status is held for a selectable memory time.				
49	5F	CB L Memory Time	200ms	From 10ms to 10s step 10ms
CB L Memory Time is a timer setting which allows the Live Line state to be remembered for a short period. Visible if CB IS LL Check is Enabled				
49	60	CB IS Time	5s	From 10ms to 200s step 100ms
CB IS Time = CB In Service Time. This is a timer setting for which a CB must remain closed (and optionally the line be live) before it is considered to be In Service.				
49	61	CB IS MemoryTime	500ms	From 10ms to 1s step 10ms
CB IS Memory Time is a timer setting which allows a CB In Service state to be remembered for a short period following changeover of the CB auxiliary switch contacts to a CB Open state. This may occasionally be necessary for a few types of CB with exceptionally fast acting auxiliary switch contacts which allow the auto-reclose scheme logic to detect the CB opening before it detects an associated protection operation.				
49	62	DT Start by Prot	Prot Res	0 = Prot Res, 1 = Prot Op or 2 = Disabled

Col	Row	MENU TEXT	Default Setting	Available Setting
Description				
DT Start by Prot = Dead Time Start By Protection action. If DT Start by Prot is set to Disable, a dead time start is not directly affected by protection operation or reset, but is enabled by other conditions or events (see settings: 3PDTStart WhenLD and DTStart by CB Op).				
If DT Start by Prot is set to Protection Op, the dead time starting is enabled when the auto-reclose initiation signal is received from the protection. If DT Start by Prot is set to Protection Reset, the dead time starting is inhibited until the auto-reclose initiation signal from the protection resets.				
49	63	3PDTStart WhenLD	Disabled	0 = Disabled or 1 = Enabled
3PDTStart When LD = three phase auto-reclose dead time starts when the line has gone dead. If Enabled, the line is required to go dead before a 3 phase auto-reclose dead time can start. If Disabled, dead time can start when other selected conditions are satisfied, irrespective of line volts.				
49	64	DTStart by CB Op	Disabled	0 = Disabled or 1 = Enabled
If Enabled, a dead time start is permitted only when the CB has tripped. If Disabled, a dead time start is permitted when other selected conditions are satisfied, irrespective of the CB position.				
49	66	Dead Line Time	5s	From 1s to 9999s step 1s
When 3PDTStart When LD is Enabled, and the line does not go dead within the set Dead Line Time period, then the logic will force the auto-reclose sequence to lockout after expiry of this time.				
49	67	SP AR Dead Time	500ms	From 0s to 10s step 10ms
Dead time setting for single phase auto-reclose.				
49	68	3P AR DT Shot 1	300ms	From 10ms to 300s step 10ms
Dead time setting for three phase auto-reclose (first shot).				
49	69	3P AR DT Shot 2	60s	From 1s to 9999s step 1s
Dead time setting for three phase auto-reclose (2nd shot).				
49	6A	3P AR DT Shot 3	60s	From 1s to 9999s step 1s
Dead time setting for three phase auto-reclose (3rd shot).				
49	6B	3P AR DT Shot 4	60s	From 1s to 9999s step 1s
Dead time setting for three phase auto-reclose (4th shot).				
49	6D	SPAR ReclaimTime	60s	From 1s to 600s step 1s
Reclaim time setting following single phase auto-reclosure.				
49	6E	3PAR ReclaimTime	180s	From 1s to 600s step 1s
Reclaim time setting following three phase auto-reclosure.				
49	6F	AR CBHealthyTime	5s	From 10ms to 9999s step 10ms
Maximum waiting time to enable CB Closing by auto-reclose. Input DDB (436) CB Healthy CB Close by auto-reclose. If the set time runs out with the input DDB: CB Healthy low (= 0), alarm AR CB Unhealthy (DDB307) is set and the auto-reclose sequence is cancelled.				
49	70	AR CheckSyncTime	5s	From 10ms to 9999s step 10ms
Maximum waiting time for relevant signal CB SCOK from system check logic, to enable CB Close by auto-reclose. If the set time runs out with the input signal CB SCOK low (= 0), System Check Synchronization fail alarm AR CB NO C/S (DDB 308) is set and the auto-reclose sequence is cancelled.				
49	72	Z1 AR	Initiate AR	0 = Initiate AR or 1 = Block AR
Setting that determines impact of instantaneous zone 1 on AR operation. (Only in models with distance option)				
49	74	Dist Aided AR	Initiate AR	0 = Initiate AR or 1 = Block AR
Setting that determines impact of the aided distance schemes tripping on AR operation. (Only in models with distance option)				
49	75	Z2T AR	Block AR	0 = No Action, 1 = Initiate AR or 2 = Block AR

Col	Row	MENU TEXT	Default Setting	Available Setting
Description				
Setting that determines impact of time delayed zone 2 on AR operation. Set Initiate AR if the trip should initiate a cycle, and Block AR if a time delayed trip should cause lockout. Set No action if Zone 2 tripping should exert no specific logic control on the recloser. (Only in models with distance option)				
49	76	Z3T AR	Block AR	0 = No Action, 1 = Initiate AR or 2 = Block AR
Similar application to Z3T AR. Selection for Zone 3 trips. (Only in models with distance option)				
49	77	ZPT AR	Block AR	0 = No Action, 1 = Initiate AR or 2 = Block AR
Similar application to ZPT AR. Selection for Zone 3 trips. (Only in models with distance option)				
49	78	Z4T AR	Block AR	0 = No Action, 1 = Initiate AR or 2 = Block AR
Similar application to Z4T AR. Selection for Zone 4 trips. (Only in models with distance option)				
49	79	DEF Aided AR	Block AR	0 = Initiate AR or 1 = Block AR
Setting that determines impact of aided Directional Earth Fault protection (DEF) on AR operation. (Only in models with distance option)				
49	7A	Dir. Comp AR	Block AR	0 = Initiate AR or 1 = Block AR
Setting that determines impact of aided Directional Comparison protection (DEF) on AR operation. (Only in models with distance option)				
49	7B	TOR AR	Block AR	0 = Initiate AR or 1 = Block AR
Setting that determines impact of Trip On Reclose (TOR) on AR operation. (Only in models with distance option)				
49	7C	I>1 AR	No Action	0 = No Action, 1 = Initiate AR or 2 = Block AR
Setting that determines impact of the first stage overcurrent protection on AR operation.				
49	7D	I>2 AR	No Action	0 = No Action, 1 = Initiate AR or 2 = Block AR
Setting that determines impact of the second stage overcurrent protection on AR operation.				
49	7E	I>3 AR	No Action	0 = No Action, 1 = Initiate AR or 2 = Block AR
Setting that determines impact of the third stage overcurrent protection on AR operation.				
49	7F	I>4 AR	No Action	0 = No Action, 1 = Initiate AR or 2 = Block AR
Setting that determines impact of the fourth stage overcurrent protection on AR operation.				
49	80	IN>1 AR	No Action	0 = No Action, 1 = Initiate AR or 2 = Block AR
Setting that determines impact of the first stage earth fault overcurrent protection on AR operation.				
49	81	IN>2 AR	No Action	0 = No Action, 1 = Initiate AR or 2 = Block AR
Setting that determines impact of the second stage earth fault overcurrent protection on AR operation.				
49	82	IN>3 AR	No Action	0 = No Action, 1 = Initiate AR or 2 = Block AR
Setting that determines impact of the third stage earth fault overcurrent protection on AR operation.				
49	83	IN>4 AR	No Action	0 = No Action, 1 = Initiate AR or 2 = Block AR
Setting that determines impact of the fourth stage earth fault overcurrent protection on AR operation.				
49	84	ISEF>1 AR	No Action	0 = No Action, 1 = Initiate AR or 2 = Block AR
Setting that determines impact of the first stage sensitive earth fault overcurrent protection on AR operation.				
49	85	ISEF>2 AR	No Action	0 = No Action, 1 = Initiate AR or 2 = Block AR
Setting that determines impact of the second stage sensitive earth fault overcurrent protection on AR operation.				
49	86	ISEF>3 AR	No Action	0 = No Action, 1 = Initiate AR or 2 = Block AR
Setting that determines impact of the third stage sensitive earth fault overcurrent protection on AR operation.				
49	87	ISEF>4 AR	No Action	0 = No Action, 1 = Initiate AR or 2 = Block AR
Setting that determines impact of the fourth stage sensitive earth fault overcurrent protection on AR operation.				

Col	Row	MENU TEXT	Default Setting	Available Setting
Description				
49	88	ZQT AR	Block AR	0 = No Action, 1 = Initiate AR or 2 = Block AR
Setting that determines impact of time delayed zone Q on AR operation. Set Initiate AR if the trip should initiate a cycle, and Block AR if a time delayed trip should cause lockout. Set No action if Zone Q tripping should exert no specific logic control on the re-closer. (Only in models with distance option)				
49	A5	AR SYS CHECKS	0	0
0				
49	A6	CB SC all	Disabled	0 = Disabled or 1 = Enabled
This setting determines whether a system check (e.g. live bus / dead line etc) is required for any auto-reclose of CB. If Enabled, system check is required for some or all reclosures. If Disabled, system check is not required for any reclosures.				
49	A7	CB SC Shot 1	Disabled	0 = Disabled or 1 = Enabled
This setting determines whether a system check (e.g. live bus / dead line etc) is required for the first shot reclosure of CB. If Enabled, system check is required for the first shot reclosure. If Disabled, system check is not required for the first shot reclosure.				
49	A8	CB SC ClsNoDly	Disabled	0 = Disabled or 1 = Enabled
If CB SC ClsNoDly is Enabled, CB can reclose as leader as soon as the synchro check conditions are satisfied, without waiting for the dead time to elapse. This option is sometimes required for the second line end to reclose onto a line with delayed auto-reclosing (typical cycle: first line end recloses after the dead time with live bus & dead line, then the second line end recloses immediately with live bus & live line in synchronism).				
49	A9	CB SC CS1	Disabled	0 = Disabled or 1 = Enabled
This setting enables CB to auto-reclose as leader when the system satisfies all the System Check Synchronism Stage 1 criteria as defined under CB CS1 Status settings in the SYSTEM CHECKS column.				
49	AA	CB SC CS2	Disabled	0 = Disabled or 1 = Enabled
This setting enables CB to auto-reclose as leader when the system satisfies all the System Check Synchronism Stage 2 criteria as defined under the setting CB CS2 Status in the SYSTEM CHECKS column.				
49	AB	CB SC DLLB	Disabled	0 = Disabled or 1 = Enabled
This setting enables CB to auto-reclose as leader when the dead line & live bus1 conditions are satisfied as set in the SYSTEM CHECKS column.				
49	AC	CB SC LLDB	Disabled	0 = Disabled or 1 = Enabled
This setting enables CB to auto-reclose as leader when the live line & dead bus1 conditions are satisfied as set in the SYSTEM CHECKS column.				
49	AD	CB SC DLDB	Disabled	0 = Disabled or 1 = Enabled
This setting enables CB to auto-reclose as leader when the dead line & dead bus1 conditions are satisfied as set in the SYSTEM CHECKS column.				
49	E0	SPDT Ext Time	10ms	From 0s to 300s step 10ms
This setting sets the extended time for SPDT mode				
49	E1	3PDT Ext Time	10ms	From 0s to 300s step 10ms
This setting sets the extended time for 3PDT mode				
49	EA	CB1 Pole Dis. Tm	40ms	From 0s to 10s step 10ms
This setting sets pole discrepancy time for CB1				

Table 21 - Auto-reclose function

3.21

Input Labels

The column **GROUP x INPUT LABELS** is used to individually label each opto input that is available in the relay. The text is restricted to 16 characters and is available if 'Input Labels' are set visible under CONFIGURATION column.

Col	Row	MENU TEXT	Default Setting	Available Setting
Description				
4A	00	GROUP 1 INPUT LABELS	0	
This column contains settings for Input Labels				
4A	01	Opto Input 1	Input L1	From 32 to 234 step 1
Label for Opto Input 1				
4A	02	Opto Input 2	Input L2	From 32 to 234 step 1
Label for Opto Input 2				
4A	03	Opto Input 3	Input L3	From 32 to 234 step 1
Label for Opto Input 3				
4A	04	Opto Input 4	Input L4	From 32 to 234 step 1
Label for Opto Input 4				
4A	05	Opto Input 5	Input L5	From 32 to 234 step 1
Label for Opto Input 5				
4A	06	Opto Input 6	Input L6	From 32 to 234 step 1
Label for Opto Input 6				
4A	07	Opto Input 7	Input L7	From 32 to 234 step 1
Label for Opto Input 7				
4A	08	Opto Input 8	Input L8	From 32 to 234 step 1
Label for Opto Input 8				
4A	09	Opto Input 9	Input L9	From 32 to 234 step 1
Label for Opto Input 9				
4A	0A	Opto Input 10	Input L10	From 32 to 234 step 1
Label for Opto Input 10				
4A	0B	Opto Input 11	Input L11	From 32 to 234 step 1
Label for Opto Input 11				
4A	0C	Opto Input 12	Input L12	From 32 to 234 step 1
Label for Opto Input 12				
4A	0D	Opto Input 13	Input L13	From 32 to 234 step 1
Label for Opto Input 13				
4A	0E	Opto Input 14	Input L14	From 32 to 234 step 1
Label for Opto Input 14				
4A	0F	Opto Input 15	Input L15	From 32 to 234 step 1
Label for Opto Input 15				
4A	10	Opto Input 16	Input L16	From 32 to 234 step 1
Label for Opto Input 16				

Table 22 - Input labels**3.22 Virtual Input Labels**

Col	Row	MENU TEXT	Default Setting	Available Setting
Description				
26	00	VIR I/P LABELS	0	0
This column contains settings for Virtual Input Labels				

Col	Row	MENU TEXT	Default Setting	Available Setting
Description				
26	01	Virtual Input 1	Virtual Input 1	From 32 to 234 step 1
Text label to describe each individual Virtual Input.				
26	02	Virtual Input 2	Virtual Input 2	From 32 to 234 step 1
Text label to describe each individual Virtual Input.				
26	03	Virtual Input 3	Virtual Input 3	From 32 to 234 step 1
Text label to describe each individual Virtual Input.				
26	04	Virtual Input 4	Virtual Input 4	From 32 to 234 step 1
Text label to describe each individual Virtual Input.				
26	05	Virtual Input 5	Virtual Input 5	From 32 to 234 step 1
Text label to describe each individual Virtual Input.				
26	06	Virtual Input 6	Virtual Input 6	From 32 to 234 step 1
Text label to describe each individual Virtual Input.				
26	07	Virtual Input 7	Virtual Input 7	From 32 to 234 step 1
Text label to describe each individual Virtual Input.				
26	08	Virtual Input 8	Virtual Input 8	From 32 to 234 step 1
Text label to describe each individual Virtual Input.				
26	09	Virtual Input 9	Virtual Input 9	From 32 to 234 step 1
Text label to describe each individual Virtual Input.				
26	0A	Virtual Input 10	Virtual Input 10	From 32 to 234 step 1
Text label to describe each individual Virtual Input.				
26	0B	Virtual Input 11	Virtual Input 11	From 32 to 234 step 1
Text label to describe each individual Virtual Input.				
26	0C	Virtual Input 12	Virtual Input 12	From 32 to 234 step 1
Text label to describe each individual Virtual Input.				
26	0D	Virtual Input 13	Virtual Input 13	From 32 to 234 step 1
Text label to describe each individual Virtual Input.				
26	0E	Virtual Input 14	Virtual Input 14	From 32 to 234 step 1
Text label to describe each individual Virtual Input.				
26	0F	Virtual Input 15	Virtual Input 15	From 32 to 234 step 1
Text label to describe each individual Virtual Input.				
26	10	Virtual Input 16	Virtual Input 16	From 32 to 234 step 1
Text label to describe each individual Virtual Input.				
26	11	Virtual Input 17	Virtual Input 17	From 32 to 234 step 1
Text label to describe each individual Virtual Input.				
26	12	Virtual Input 18	Virtual Input 18	From 32 to 234 step 1
Text label to describe each individual Virtual Input.				
26	13	Virtual Input 19	Virtual Input 19	From 32 to 234 step 1
Text label to describe each individual Virtual Input.				
26	14	Virtual Input 20	Virtual Input 20	From 32 to 234 step 1
Text label to describe each individual Virtual Input.				
26	15	Virtual Input 21	Virtual Input 21	From 32 to 234 step 1
Text label to describe each individual Virtual Input.				

Col	Row	MENU TEXT	Default Setting	Available Setting
Description				
26	16	Virtual Input 22	Virtual Input 22	From 32 to 234 step 1
Text label to describe each individual Virtual Input.				
26	17	Virtual Input 23	Virtual Input 23	From 32 to 234 step 1
Text label to describe each individual Virtual Input.				
26	18	Virtual Input 24	Virtual Input 24	From 32 to 234 step 1
Text label to describe each individual Virtual Input.				
26	19	Virtual Input 25	Virtual Input 25	From 32 to 234 step 1
Text label to describe each individual Virtual Input.				
26	1A	Virtual Input 26	Virtual Input 26	From 32 to 234 step 1
Text label to describe each individual Virtual Input.				
26	1B	Virtual Input 27	Virtual Input 27	From 32 to 234 step 1
Text label to describe each individual Virtual Input.				
26	1C	Virtual Input 28	Virtual Input 28	From 32 to 234 step 1
Text label to describe each individual Virtual Input.				
26	1D	Virtual Input 29	Virtual Input 29	From 32 to 234 step 1
Text label to describe each individual Virtual Input.				
26	1E	Virtual Input 30	Virtual Input 30	From 32 to 234 step 1
Text label to describe each individual Virtual Input.				
26	1F	Virtual Input 31	Virtual Input 31	From 32 to 234 step 1
Text label to describe each individual Virtual Input.				
26	20	Virtual Input 32	Virtual Input 32	From 32 to 234 step 1
Text label to describe each individual Virtual Input.				

Table 23 - Virtual Input labels

3.23 Output Labels

The column **GROUP x OUTPUT LABELS** is used to individually label each output relay that is available in the relay. The text is restricted to 16 characters and is available if 'Output Labels' are set visible under CONFIGURATION column.

Col	Row	MENU TEXT	Default Setting	Available Setting
Description				
4B	00	GROUP 1 OUTPUT LABELS	0	
This column contains settings for Output Relay Labels				
4B	01	Relay 1	Output R1	From 32 to 234 step 1
Label for Output Relay 1				
4B	02	Relay 2	Output R2	From 32 to 234 step 1
Label for Output Relay 2				
4B	03	Relay 3	Output R3	From 32 to 234 step 1
Label for Output Relay 3				
4B	04	Relay 4	Output R4	From 32 to 234 step 1
Label for Output Relay 4				
4B	05	Relay 5	Output R5	From 32 to 234 step 1

Col	Row	MENU TEXT	Default Setting	Available Setting
Description				
Label for Output Relay 5				
4B	06	Relay 6	Output R6	From 32 to 234 step 1
Label for Output Relay 6				
4B	07	Relay 7	Output R7	From 32 to 234 step 1
Label for Output Relay 7				
4B	08	Relay 8	Output R8	From 32 to 234 step 1
Label for Output Relay 8				
4B	09	Relay 9	Output R9	From 32 to 234 step 1
Label for Output Relay 9				
4B	0A	Relay 10	Output R10	From 32 to 234 step 1
Label for Output Relay 10				
4B	0B	Relay 11	Output R11	From 32 to 234 step 1
Label for Output Relay 11				
4B	0C	Relay 12	Output R12	From 32 to 234 step 1
Label for Output Relay 12				
4B	0D	Relay 13	Output R13	From 32 to 234 step 1
Label for Output Relay 13				
4B	0E	Relay 14	Output R14	From 32 to 234 step 1
Label for Output Relay 14				

Table 24 - Output labels

3.24 Virtual Output Labels

Col	Row	MENU TEXT	Default Setting	Available Setting
Description				
27	00	VIR O/P LABELS	0	0
This column contains settings for Virtual Output Labels				
27	01	Virtual Output 1	Virtual Output 1	From 32 to 234 step 1
Text label to describe each individual Virtual Output.				
27	02	Virtual Output 2	Virtual Output 2	From 32 to 234 step 1
Text label to describe each individual Virtual Output.				
27	03	Virtual Output 3	Virtual Output 3	From 32 to 234 step 1
Text label to describe each individual Virtual Output.				
27	04	Virtual Output 4	Virtual Output 4	From 32 to 234 step 1
Text label to describe each individual Virtual Output.				
27	05	Virtual Output 5	Virtual Output 5	From 32 to 234 step 1
Text label to describe each individual Virtual Output.				
27	06	Virtual Output 6	Virtual Output 6	From 32 to 234 step 1
Text label to describe each individual Virtual Output.				
27	07	Virtual Output 7	Virtual Output 7	From 32 to 234 step 1
Text label to describe each individual Virtual Output.				
27	08	Virtual Output 8	Virtual Output 8	From 32 to 234 step 1
Text label to describe each individual Virtual Output.				

Col	Row	MENU TEXT	Default Setting	Available Setting
Description				
27	09	Virtual Output 9	Virtual Output 9	From 32 to 234 step 1
Text label to describe each individual Virtual Output.				
27	0A	Virtual Output 10	Virtual Output10	From 32 to 234 step 1
Text label to describe each individual Virtual Output.				
27	0B	Virtual Output 11	Virtual Output11	From 32 to 234 step 1
Text label to describe each individual Virtual Output.				
27	0C	Virtual Output 12	Virtual Output12	From 32 to 234 step 1
Text label to describe each individual Virtual Output.				
27	0D	Virtual Output 13	Virtual Output13	From 32 to 234 step 1
Text label to describe each individual Virtual Output.				
27	0E	Virtual Output 14	Virtual Output14	From 32 to 234 step 1
Text label to describe each individual Virtual Output.				
27	0F	Virtual Output 15	Virtual Output15	From 32 to 234 step 1
Text label to describe each individual Virtual Output.				
27	10	Virtual Output 16	Virtual Output16	From 32 to 234 step 1
Text label to describe each individual Virtual Output.				
27	11	Virtual Output 17	Virtual Output17	From 32 to 234 step 1
Text label to describe each individual Virtual Output.				
27	12	Virtual Output 18	Virtual Output18	From 32 to 234 step 1
Text label to describe each individual Virtual Output.				
27	13	Virtual Output 19	Virtual Output19	From 32 to 234 step 1
Text label to describe each individual Virtual Output.				
27	14	Virtual Output 20	Virtual Output20	From 32 to 234 step 1
Text label to describe each individual Virtual Output.				
27	15	Virtual Output 21	Virtual Output21	From 32 to 234 step 1
Text label to describe each individual Virtual Output.				
27	16	Virtual Output 22	Virtual Output22	From 32 to 234 step 1
Text label to describe each individual Virtual Output.				
27	17	Virtual Output 23	Virtual Output23	From 32 to 234 step 1
Text label to describe each individual Virtual Output.				
27	18	Virtual Output 24	Virtual Output24	From 32 to 234 step 1
Text label to describe each individual Virtual Output.				
27	19	Virtual Output 25	Virtual Output25	From 32 to 234 step 1
Text label to describe each individual Virtual Output.				
27	1A	Virtual Output 26	Virtual Output26	From 32 to 234 step 1
Text label to describe each individual Virtual Output.				
27	1B	Virtual Output 27	Virtual Output27	From 32 to 234 step 1
Text label to describe each individual Virtual Output.				
27	1C	Virtual Output 28	Virtual Output28	From 32 to 234 step 1
Text label to describe each individual Virtual Output.				
27	1D	Virtual Output 29	Virtual Output29	From 32 to 234 step 1
Text label to describe each individual Virtual Output.				
27	1E	Virtual Output 30	Virtual Output30	From 32 to 234 step 1

Col	Row	MENU TEXT	Default Setting	Available Setting
Description				
Text label to describe each individual Virtual Output.				
27	1F	Virtual Output 31	Virtual Output31	From 32 to 234 step 1
Text label to describe each individual Virtual Output.				
27	20	Virtual Output 32	Virtual Output32	From 32 to 234 step 1
Text label to describe each individual Virtual Output.				

Table 25 - Virtual Output labels**3.25 DR Chan Labels**

Col	Row	MENU TEXT	Default Setting	Available Setting
Description				
2A	00	DR CHAN LABELS	0	0
This column contains settings for Disturbance Record Channel Labels				
2A	01	Digital Input 1	Digital I/P 1	From 32 to 234 step 1
Text label to describe each individual Disturbance Record channel				
2A	02	Digital Input 2	Digital I/P 2	From 32 to 234 step 1
Text label to describe each individual Disturbance Record channel				
2A	03	Digital Input 3	Digital I/P 3	From 32 to 234 step 1
Text label to describe each individual Disturbance Record channel				
2A	04	Digital Input 4	Digital I/P 4	From 32 to 234 step 1
Text label to describe each individual Disturbance Record channel				
2A	05	Digital Input 5	Digital I/P 5	From 32 to 234 step 1
Text label to describe each individual Disturbance Record channel				
2A	06	Digital Input 6	Digital I/P 6	From 32 to 234 step 1
Text label to describe each individual Disturbance Record channel				
2A	07	Digital Input 7	Digital I/P 7	From 32 to 234 step 1
Text label to describe each individual Disturbance Record channel				
2A	08	Digital Input 8	Digital I/P 8	From 32 to 234 step 1
Text label to describe each individual Disturbance Record channel				
2A	09	Digital Input 9	Digital I/P 9	From 32 to 234 step 1
Text label to describe each individual Disturbance Record channel				
2A	0A	Digital Input 10	Digital I/P 10	From 32 to 234 step 1
Text label to describe each individual Disturbance Record channel				
2A	0B	Digital Input 11	Digital I/P 11	From 32 to 234 step 1
Text label to describe each individual Disturbance Record channel				
2A	0C	Digital Input 12	Digital I/P 12	From 32 to 234 step 1
Text label to describe each individual Disturbance Record channel				
2A	0D	Digital Input 13	Digital I/P 13	From 32 to 234 step 1
Text label to describe each individual Disturbance Record channel				
2A	0E	Digital Input 14	Digital I/P 14	From 32 to 234 step 1
Text label to describe each individual Disturbance Record channel				
2A	0F	Digital Input 15	Digital I/P 15	From 32 to 234 step 1

Col	Row	MENU TEXT	Default Setting	Available Setting
Description				
Text label to describe each individual Disturbance Record channel				
2A	10	Digital Input 16	Digital I/P 16	From 32 to 234 step 1
Text label to describe each individual Disturbance Record channel				
2A	11	Digital Input 17	Digital I/P 17	From 32 to 234 step 1
Text label to describe each individual Disturbance Record channel				
2A	12	Digital Input 18	Digital I/P 18	From 32 to 234 step 1
Text label to describe each individual Disturbance Record channel				
2A	13	Digital Input 19	Digital I/P 19	From 32 to 234 step 1
Text label to describe each individual Disturbance Record channel				
2A	14	Digital Input 20	Digital I/P 20	From 32 to 234 step 1
Text label to describe each individual Disturbance Record channel				
2A	15	Digital Input 21	Digital I/P 21	From 32 to 234 step 1
Text label to describe each individual Disturbance Record channel				
2A	16	Digital Input 22	Digital I/P 22	From 32 to 234 step 1
Text label to describe each individual Disturbance Record channel				
2A	17	Digital Input 23	Digital I/P 23	From 32 to 234 step 1
Text label to describe each individual Disturbance Record channel				
2A	18	Digital Input 24	Digital I/P 24	From 32 to 234 step 1
Text label to describe each individual Disturbance Record channel				
2A	19	Digital Input 25	Digital I/P 25	From 32 to 234 step 1
Text label to describe each individual Disturbance Record channel				
2A	1A	Digital Input 26	Digital I/P 26	From 32 to 234 step 1
Text label to describe each individual Disturbance Record channel				
2A	1B	Digital Input 27	Digital I/P 27	From 32 to 234 step 1
Text label to describe each individual Disturbance Record channel				
2A	1C	Digital Input 28	Digital I/P 28	From 32 to 234 step 1
Text label to describe each individual Disturbance Record channel				
2A	1D	Digital Input 29	Digital I/P 29	From 32 to 234 step 1
Text label to describe each individual Disturbance Record channel				
2A	1E	Digital Input 30	Digital I/P 30	From 32 to 234 step 1
Text label to describe each individual Disturbance Record channel				
2A	1F	Digital Input 31	Digital I/P 31	From 32 to 234 step 1
Text label to describe each individual Disturbance Record channel				
2A	20	Digital Input 32	Digital I/P 32	From 32 to 234 step 1
Text label to describe each individual Disturbance Record channel				
2A	21	Digital Input 33	Digital I/P 33	From 32 to 234 step 1
Text label to describe each individual Disturbance Record channel				
2A	22	Digital Input 34	Digital I/P 34	From 32 to 234 step 1
Text label to describe each individual Disturbance Record channel				
2A	23	Digital Input 35	Digital I/P 35	From 32 to 234 step 1
Text label to describe each individual Disturbance Record channel				
2A	24	Digital Input 36	Digital I/P 36	From 32 to 234 step 1
Text label to describe each individual Disturbance Record channel				

Col	Row	MENU TEXT	Default Setting	Available Setting
Description				
2A	25	Digital Input 37	Digital I/P 37	From 32 to 234 step 1
Text label to describe each individual Disturbance Record channel				
2A	26	Digital Input 38	Digital I/P 38	From 32 to 234 step 1
Text label to describe each individual Disturbance Record channel				
2A	27	Digital Input 39	Digital I/P 39	From 32 to 234 step 1
Text label to describe each individual Disturbance Record channel				
2A	28	Digital Input 40	Digital I/P 40	From 32 to 234 step 1
Text label to describe each individual Disturbance Record channel				
2A	29	Digital Input 41	Digital I/P 41	From 32 to 234 step 1
Text label to describe each individual Disturbance Record channel				
2A	2A	Digital Input 42	Digital I/P 42	From 32 to 234 step 1
Text label to describe each individual Disturbance Record channel				
2A	2B	Digital Input 43	Digital I/P 43	From 32 to 234 step 1
Text label to describe each individual Disturbance Record channel				
2A	2C	Digital Input 44	Digital I/P 44	From 32 to 234 step 1
Text label to describe each individual Disturbance Record channel				
2A	2D	Digital Input 45	Digital I/P 45	From 32 to 234 step 1
Text label to describe each individual Disturbance Record channel				
2A	2E	Digital Input 46	Digital I/P 46	From 32 to 234 step 1
Text label to describe each individual Disturbance Record channel				
2A	2F	Digital Input 47	Digital I/P 47	From 32 to 234 step 1
Text label to describe each individual Disturbance Record channel				
2A	30	Digital Input 48	Digital I/P 48	From 32 to 234 step 1
Text label to describe each individual Disturbance Record channel				
2A	31	Digital Input 49	Digital I/P 49	From 32 to 234 step 1
Text label to describe each individual Disturbance Record channel				
2A	32	Digital Input 50	Digital I/P 50	From 32 to 234 step 1
Text label to describe each individual Disturbance Record channel				
2A	33	Digital Input 51	Digital I/P 51	From 32 to 234 step 1
Text label to describe each individual Disturbance Record channel				
2A	34	Digital Input 52	Digital I/P 52	From 32 to 234 step 1
Text label to describe each individual Disturbance Record channel				
2A	35	Digital Input 53	Digital I/P 53	From 32 to 234 step 1
Text label to describe each individual Disturbance Record channel				
2A	36	Digital Input 54	Digital I/P 54	From 32 to 234 step 1
Text label to describe each individual Disturbance Record channel				
2A	37	Digital Input 55	Digital I/P 55	From 32 to 234 step 1
Text label to describe each individual Disturbance Record channel				
2A	38	Digital Input 56	Digital I/P 56	From 32 to 234 step 1
Text label to describe each individual Disturbance Record channel				
2A	39	Digital Input 57	Digital I/P 57	From 32 to 234 step 1
Text label to describe each individual Disturbance Record channel				
2A	3A	Digital Input 58	Digital I/P 58	From 32 to 234 step 1

Col	Row	MENU TEXT	Default Setting	Available Setting
Description				
Text label to describe each individual Disturbance Record channel				
2A	3B	Digital Input 59	Digital I/P 59	From 32 to 234 step 1
Text label to describe each individual Disturbance Record channel				
2A	3C	Digital Input 60	Digital I/P 60	From 32 to 234 step 1
Text label to describe each individual Disturbance Record channel				
2A	3D	Digital Input 61	Digital I/P 61	From 32 to 234 step 1
Text label to describe each individual Disturbance Record channel				
2A	3E	Digital Input 62	Digital I/P 62	From 32 to 234 step 1
Text label to describe each individual Disturbance Record channel				
2A	3F	Digital Input 63	Digital I/P 63	From 32 to 234 step 1
Text label to describe each individual Disturbance Record channel				
2A	40	Digital Input 64	Digital I/P 64	From 32 to 234 step 1
Text label to describe each individual Disturbance Record channel				
2A	41	Digital Input 65	Digital I/P 65	From 32 to 234 step 1
Text label to describe each individual Disturbance Record channel				
2A	42	Digital Input 66	Digital I/P 66	From 32 to 234 step 1
Text label to describe each individual Disturbance Record channel				
2A	43	Digital Input 67	Digital I/P 67	From 32 to 234 step 1
Text label to describe each individual Disturbance Record channel				
2A	44	Digital Input 68	Digital I/P 68	From 32 to 234 step 1
Text label to describe each individual Disturbance Record channel				
2A	45	Digital Input 69	Digital I/P 69	From 32 to 234 step 1
Text label to describe each individual Disturbance Record channel				
2A	46	Digital Input 70	Digital I/P 70	From 32 to 234 step 1
Text label to describe each individual Disturbance Record channel				
2A	47	Digital Input 71	Digital I/P 71	From 32 to 234 step 1
Text label to describe each individual Disturbance Record channel				
2A	48	Digital Input 72	Digital I/P 72	From 32 to 234 step 1
Text label to describe each individual Disturbance Record channel				
2A	49	Digital Input 73	Digital I/P 73	From 32 to 234 step 1
Text label to describe each individual Disturbance Record channel				
2A	4A	Digital Input 74	Digital I/P 74	From 32 to 234 step 1
Text label to describe each individual Disturbance Record channel				
2A	4B	Digital Input 75	Digital I/P 75	From 32 to 234 step 1
Text label to describe each individual Disturbance Record channel				
2A	4C	Digital Input 76	Digital I/P 76	From 32 to 234 step 1
Text label to describe each individual Disturbance Record channel				
2A	4D	Digital Input 77	Digital I/P 77	From 32 to 234 step 1
Text label to describe each individual Disturbance Record channel				
2A	4E	Digital Input 78	Digital I/P 78	From 32 to 234 step 1
Text label to describe each individual Disturbance Record channel				
2A	4F	Digital Input 79	Digital I/P 79	From 32 to 234 step 1
Text label to describe each individual Disturbance Record channel				

Col	Row	MENU TEXT	Default Setting	Available Setting
Description				
2A	50	Digital Input 80	Digital I/P 80	From 32 to 234 step 1
Text label to describe each individual Disturbance Record channel				
2A	51	Digital Input 81	Digital I/P 81	From 32 to 234 step 1
Text label to describe each individual Disturbance Record channel				
2A	52	Digital Input 82	Digital I/P 82	From 32 to 234 step 1
Text label to describe each individual Disturbance Record channel				
2A	53	Digital Input 83	Digital I/P 83	From 32 to 234 step 1
Text label to describe each individual Disturbance Record channel				
2A	54	Digital Input 84	Digital I/P 84	From 32 to 234 step 1
Text label to describe each individual Disturbance Record channel				
2A	55	Digital Input 85	Digital I/P 85	From 32 to 234 step 1
Text label to describe each individual Disturbance Record channel				
2A	56	Digital Input 86	Digital I/P 86	From 32 to 234 step 1
Text label to describe each individual Disturbance Record channel				
2A	57	Digital Input 87	Digital I/P 87	From 32 to 234 step 1
Text label to describe each individual Disturbance Record channel				
2A	58	Digital Input 88	Digital I/P 88	From 32 to 234 step 1
Text label to describe each individual Disturbance Record channel				
2A	59	Digital Input 89	Digital I/P 89	From 32 to 234 step 1
Text label to describe each individual Disturbance Record channel				
2A	5A	Digital Input 90	Digital I/P 90	From 32 to 234 step 1
Text label to describe each individual Disturbance Record channel				
2A	5B	Digital Input 91	Digital I/P 91	From 32 to 234 step 1
Text label to describe each individual Disturbance Record channel				
2A	5C	Digital Input 92	Digital I/P 92	From 32 to 234 step 1
Text label to describe each individual Disturbance Record channel				
2A	5D	Digital Input 93	Digital I/P 93	From 32 to 234 step 1
Text label to describe each individual Disturbance Record channel				
2A	5E	Digital Input 94	Digital I/P 94	From 32 to 234 step 1
Text label to describe each individual Disturbance Record channel				
2A	5F	Digital Input 95	Digital I/P 95	From 32 to 234 step 1
Text label to describe each individual Disturbance Record channel				
2A	60	Digital Input 96	Digital I/P 96	From 32 to 234 step 1
Text label to describe each individual Disturbance Record channel				
2A	61	Digital Input 97	Digital I/P 97	From 32 to 234 step 1
Text label to describe each individual Disturbance Record channel				
2A	62	Digital Input 98	Digital I/P 98	From 32 to 234 step 1
Text label to describe each individual Disturbance Record channel				
2A	63	Digital Input 99	Digital I/P 99	From 32 to 234 step 1
Text label to describe each individual Disturbance Record channel				
2A	64	Digital Input 100	Digital I/P 100	From 32 to 234 step 1
Text label to describe each individual Disturbance Record channel				
2A	65	Digital Input 101	Digital I/P 101	From 32 to 234 step 1

Col	Row	MENU TEXT	Default Setting	Available Setting
Description				
Text label to describe each individual Disturbance Record channel				
2A	66	Digital Input 102	Digital I/P 102	From 32 to 234 step 1
Text label to describe each individual Disturbance Record channel				
2A	67	Digital Input 103	Digital I/P 103	From 32 to 234 step 1
Text label to describe each individual Disturbance Record channel				
2A	68	Digital Input 104	Digital I/P 104	From 32 to 234 step 1
Text label to describe each individual Disturbance Record channel				
2A	69	Digital Input 105	Digital I/P 105	From 32 to 234 step 1
Text label to describe each individual Disturbance Record channel				
2A	6A	Digital Input 106	Digital I/P 106	From 32 to 234 step 1
Text label to describe each individual Disturbance Record channel				
2A	6B	Digital Input 107	Digital I/P 107	From 32 to 234 step 1
Text label to describe each individual Disturbance Record channel				
2A	6C	Digital Input 108	Digital I/P 108	From 32 to 234 step 1
Text label to describe each individual Disturbance Record channel				
2A	6D	Digital Input 109	Digital I/P 109	From 32 to 234 step 1
Text label to describe each individual Disturbance Record channel				
2A	6E	Digital Input 110	Digital I/P 110	From 32 to 234 step 1
Text label to describe each individual Disturbance Record channel				
2A	6F	Digital Input 111	Digital I/P 111	From 32 to 234 step 1
Text label to describe each individual Disturbance Record channel				
2A	70	Digital Input 112	Digital I/P 112	From 32 to 234 step 1
Text label to describe each individual Disturbance Record channel				
2A	71	Digital Input 113	Digital I/P 113	From 32 to 234 step 1
Text label to describe each individual Disturbance Record channel				
2A	72	Digital Input 114	Digital I/P 114	From 32 to 234 step 1
Text label to describe each individual Disturbance Record channel				
2A	73	Digital Input 115	Digital I/P 115	From 32 to 234 step 1
Text label to describe each individual Disturbance Record channel				
2A	74	Digital Input 116	Digital I/P 116	From 32 to 234 step 1
Text label to describe each individual Disturbance Record channel				
2A	75	Digital Input 117	Digital I/P 117	From 32 to 234 step 1
Text label to describe each individual Disturbance Record channel				
2A	76	Digital Input 118	Digital I/P 118	From 32 to 234 step 1
Text label to describe each individual Disturbance Record channel				
2A	77	Digital Input 119	Digital I/P 119	From 32 to 234 step 1
Text label to describe each individual Disturbance Record channel				
2A	78	Digital Input 120	Digital I/P 120	From 32 to 234 step 1
Text label to describe each individual Disturbance Record channel				
2A	79	Digital Input 121	Digital I/P 121	From 32 to 234 step 1
Text label to describe each individual Disturbance Record channel				
2A	7A	Digital Input 122	Digital I/P 122	From 32 to 234 step 1
Text label to describe each individual Disturbance Record channel				

Col	Row	MENU TEXT	Default Setting	Available Setting
Description				
2A	7B	Digital Input 123	Digital I/P 123	From 32 to 234 step 1
Text label to describe each individual Disturbance Record channel				
2A	7C	Digital Input 124	Digital I/P 124	From 32 to 234 step 1
Text label to describe each individual Disturbance Record channel				
2A	7D	Digital Input 125	Digital I/P 125	From 32 to 234 step 1
Text label to describe each individual Disturbance Record channel				
2A	7E	Digital Input 126	Digital I/P 126	From 32 to 234 step 1
Text label to describe each individual Disturbance Record channel				
2A	7F	Digital Input 127	Digital I/P 127	From 32 to 234 step 1
Text label to describe each individual Disturbance Record channel				
2A	80	Digital Input 128	Digital I/P 128	From 32 to 234 step 1
Text label to describe each individual Disturbance Record channel				

Table 26 - DR Chan labels

3.26 SR/MR User Alarm Labels

Col	Row	MENU TEXT	Default Setting	Available Setting
Description				
28	00	USR ALARM LABELS	0	0
This column contains settings for Virtual Input Labels				
28	01	SR User Alarm 1	SR User Alarm 1	From 32 to 234 step 1
Text label to describe each individual User Alarm.				
28	02	SR User Alarm 2	SR User Alarm 2	From 32 to 234 step 1
Text label to describe each individual User Alarm.				
28	03	SR User Alarm 3	SR User Alarm 3	From 32 to 234 step 1
Text label to describe each individual User Alarm.				
28	04	SR User Alarm 4	SR User Alarm 4	From 32 to 234 step 1
Text label to describe each individual User Alarm.				
28	05	MR User Alarm 1	MR User Alarm 1	From 32 to 234 step 1
Text label to describe each individual User Alarm.				
28	06	MR User Alarm 2	MR User Alarm 2	From 32 to 234 step 1
Text label to describe each individual User Alarm.				
28	07	MR User Alarm 3	MR User Alarm 3	From 32 to 234 step 1
Text label to describe each individual User Alarm.				
28	08	MR User Alarm 4	MR User Alarm 4	From 32 to 234 step 1
Text label to describe each individual User Alarm.				

Table 27 - SR/MR User Alarm labels

3.27 EIA(RS)232 InterMiCOM Communications

'InterMiCOM' operates via an EIA(RS)232 physical output on the back of the 2nd rear communication board. It provides 8 independently settable digital signals that can be conveyed between line ends. The InterMiCOM teleprotection is restricted to 2 ends. InterMiCOM input and output mapping has to be done in the Programmable Scheme Logic (PSL).

Col	Row	MENU TEXT	Default Setting	Available Setting
Description				
15	00	INTERMiCOM COMMS	0	
This column is only visible if the model number supports InterMiCOM and second rear comms board is fitted.				
15	01	IM Input Status	0	Not Settable
Displays the status of each InterMiCOM input signal, with IM1 signal starting from the right. When loop back mode is set, all bits will display zero.				
15	02	IM Ouput Status	0	Not Settable
Displays the status of each InterMiCOM output signal.				
15	10	Source Address	1	0 to 10 step 1
Setting for the unique relay address that is encoded in the InterMiCOM sent message.				
15	11	Receive Address	2	0 to 10 step 1
The aim of setting addresses is to establish pairs of relays which will only communicate with each other. Should an inadvertent channel misrouting or spurious loopback occur, an error will be logged, and the erroneous received data will be rejected. As an example, in a 2 ended scheme the following address setting would be correct: Local relay: Source Address = 1, Receive Address = 2 Remote relay: Source Address = 2, Receive Address = 1				
15	12	Baud Rate	9600	0 = 600, 1 = 1200, 2 = 2400, 3 = 4800, 4 = 9600 or 5 = 19200
Setting of the signalling speed in terms of number of bits per second. The speed will match the capability of the MODEM or other characteristics of the channel provided.				
15	20	Ch Statistics	Invisible	0 = Invisible, 1 = Visible
Settings that makes visible or invisible Channel Statistics on the LCD. The statistic is reset by either relay's powering down or using the 'Reset Statistics' cell.				
15	21	Rx Direct Count	0	Not Settable
Displays the number of valid Direct Tripping messages since last counter reset.				
15	22	Rx Perm Count	0	Not Settable
Displays the number of valid Permissive Tripping messages since last counter reset.				
15	23	Rx Block Count	0	Not Settable
Displays the number of valid Blocking messages since last counter reset.				
15	24	Rx NewData Count	0	Not Settable
Displays the number of different messages (change events) since last counter reset.				
15	25	Rx Errored Count	0	Not Settable
Displays the number of invalid received messages since last counter reset.				
15	26	Lost Messages	0	Not Settable
Displays the difference between the number of messages that were supposed to be received (based on set Baud Rate) and actual valid received messages since last reset.				
15	30	Elapsed Time	0	Not Settable
Displays the time in seconds since last counter reset.				
15	31	Reset Statistics	No	0 = No, 1 = Yes
Command that allows all Statistics and Channel Diagnostics to be reset.				

Col	Row	MENU TEXT	Default Setting	Available Setting
Description				
15	40	Ch Diagnostics	Invisible	0 = Invisible, 1 = Visible
Setting that makes visible or invisible Channel Diagnostics on the LCD. The diagnostic is reset by either relay's powering down or using the 'Reset Statistics' cell.				
15	41	Data CD Status	0	Not Settable
Indicates when the DCD line (pin 1 on EIA232 Connector) is energized. OK = DCD is energized FAIL = DCD is de-energized Absent = 2nd Rear port board is not fitted				
15	42	FrameSync Status	0	Not Settable
Indicates when the message structure and synchronization is valid. OK = Valid message structure and synchronization FAIL = Synchronization has been lost Absent = 2nd Rear port board is not fitted Unavailable = Hardware error present				
15	43	Message Status	0	Not Settable
Indicates when the percentage of received valid messages has fallen below the 'IM Msg Alarm Lvl' setting within the alarm time period. OK = Acceptable ratio of lost messages FAIL = Unacceptable ratio of lost messages Absent = 2nd Rear port board is not fitted Unavailable = Hardware error present				
15	44	Channel Status	0	Not Settable
Indicates the state of the InterMiCOM communication channel. OK = Channel healthy FAIL = Channel failure Absent = 2nd Rear port board is not fitted Unavailable = Hardware error present				
15	45	IM H/W Status	0	Not Settable
Indicates the state of InterMiCOM hardware OK = InterMiCOM hardware healthy Read or Write Error = InterMiCOM failure Absent = 2nd Rear port is not fitted or failed to initialize.				
15	50	Loopback Mode	Disabled	0 = Disabled, 1 = Internal or 2 = External
Setting to allow testing of the InterMiCOM channel. When 'Internal' is selected, only the local InterMiCOM software functionality is tested, whereby the relay will receive its own sent data. 'External' setting allows a hardware and software check, with an external link required to jumper the sent data onto the receive channel. During normal service condition Loopback mode must be disabled.				
15	51	Test Pattern	11111111(bin)	Bit 00=InterMiCOM 1 to Bit 07=InterMiCOM 8
Allows specific bit statuses to be inserted directly into the InterMiCOM message, to substitute real data. This is used for testing purposes.				
15	52	Loopback Status	0	Not Settable
Indicates the status of the InterMiCOM loopback mode OK = Loopback software (and hardware) is working correctly FAIL = Loopback mode failure Unavailable = Hardware error present.				

Table 28 - InterMiCOM comms

3.28 EIA(RS)232 InterMiCOM Conf 56/64 kbit/s Fiber Teleprotection – InterMiCOM 64

Col	Row	MENU TEXT	Default Setting	Available Setting
Description				
16	00	INTERMiCOM CONF	0	
This column is only visible if the model number supports InterMiCOM and second rear comms board is fitted.				
16	01	IM Msg Alarm Lvl	0.25	From 0% to 100% step 0.1%
Setting that is used to alarm for poor channel quality. If during the fixed 1.6s window the ratio of invalid messages to the total number of messages that should be received (based upon the 'Baud Rate' setting) exceeds the above threshold, a 'Message Fail' alarm will be issued.				
16	10	IM1 Cmd Type	Blocking	0 = Disabled, 1 = Direct, 2 = Permissive or 3 = Blocking
Setting that defines the operative mode of the InterMiCOM_1 signal. Selecting the channel response for this bit to Blocking allows fastest signalling, whereas setting to Direct offers higher security at the expense of speed. Selecting the channel response for this bit to Permissive offers higher dependability				
16	11	IM1 FallBackMode	Default	0 = Default or 1 = Latched
Setting that defines the status of IM1 signal in case of heavy noise and message synchronization being lost. If set to 'Latching' the last valid IM1 status will be maintained until the new valid message is received. If set to 'Default', the IM1 status, pre-defined by the user in 'IM1 DefaultValue' cell will be set. A new valid message will replace 'IM1 DefaultValue', once the channel recovers.				
16	12	IM1 DefaultValue	1	0 to 1 step 1
Setting that defines the IM1 fallback status.				
16	13	IM1 FrameSyncTim	1.5s	From 10ms to 1.5s step 10ms
Time delay after which 'IM1 DefaultValue' is applied, providing that no valid message is received in the meantime.				
16	18	IM2 Cmd Type	Blocking	0 = Disabled, 1 = Direct, 2 = Permissive or 3 = Blocking
Setting that defines the operative mode of the InterMiCOM_2 signal. Selecting the channel response for this bit to Blocking allows fastest signalling, whereas setting to Direct offers higher security at the expense of speed. Selecting the channel response for this bit to Permissive offers higher dependability				
16	19	IM2 FallBackMode	Default	0 = Default or 1 = Latched
Setting that defines the status of IM2 signal in case of heavy noise and message synchronization being lost. If set to 'Latching' the last valid IM2 status will be maintained until the new valid message is received. If set to 'Default', the IM2 status, pre-defined by the user in 'IM2 DefaultValue' cell will be set. A new valid message will replace 'IM2 DefaultValue', once the channel recovers.				
16	1A	IM2 DefaultValue	1	0 to 1 step 1
Setting that defines the IM2 fallback status.				
16	1B	IM2 FrameSyncTim	1.5s	From 10ms to 1.5s step 10ms
Time delay after which 'IM2 DefaultValue' is applied, providing that no valid message is received in the meantime.				
16	20	IM3 Cmd Type	Blocking	0 = Disabled, 1 = Direct, 2 = Permissive or 3 = Blocking
Setting that defines the operative mode of the InterMiCOM_3 signal. Selecting the channel response for this bit to Blocking allows fastest signalling, whereas setting to Direct offers higher security at the expense of speed. Selecting the channel response for this bit to Permissive offers higher dependability				
16	21	IM3 FallBackMode	Default	0 = Default or 1 = Latched
Setting that defines the status of IM3 signal in case of heavy noise and message synchronization being lost. If set to 'Latching' the last valid IM3 status will be maintained until the new valid message is received. If set to 'Default', the IM3 status, pre-defined by the user in 'IM3 DefaultValue' cell will be set. A new valid message will replace 'IM3 DefaultValue', once the channel recovers.				
16	22	IM3 DefaultValue	1	0 to 1 step 1
Setting that defines the IM3 fallback status.				

Col	Row	MENU TEXT	Default Setting	Available Setting
Description				
16	23	IM3 FrameSyncTim	1.5s	From 10ms to 1.5s step 10ms
Time delay after which 'IM3 DefaultValue' is applied, providing that no valid message is received in the meantime.				
16	28	IM4 Cmd Type	Blocking	0 = Disabled, 1 = Direct, 2 = Permissive or 3 = Blocking
Setting that defines the operative mode of the InterMiCOM_4 signal. Selecting the channel response for this bit to Blocking allows fastest signalling, whereas setting to Direct offers higher security at the expense of speed. Selecting the channel response for this bit to Permissive offers higher dependability				
16	29	IM4 FallBackMode	Default	0 = Default or 1 = Latched
Setting that defines the status of IM4 signal in case of heavy noise and message synchronization being lost. If set to 'Latching' the last valid IM4 status will be maintained until the new valid message is received. If set to 'Default', the IM4 status, pre-defined by the user in 'IM4 DefaultValue' cell will be set. A new valid message will replace 'IM4 DefaultValue', once the channel recovers.				
16	2A	IM4 DefaultValue	1	0 to 1 step 1
Setting that defines the IM4 fallback status.				
16	2B	IM4 FrameSyncTim	1.5s	From 10ms to 1.5s step 10ms
Time delay after which 'IM4 DefaultValue' is applied, providing that no valid message is received in the meantime.				
16	30	IM5 Cmd Type	Direct	0 = Disabled, 1 = Direct, 2 = Permissive or 3 = Blocking
Setting that defines the operative mode of the InterMiCOM_5 signal. Selecting the channel response for this bit to Blocking allows fastest signalling, whereas setting to Direct offers higher security at the expense of speed. Selecting the channel response for this bit to Permissive offers higher dependability				
16	31	IM5 FallBackMode	Default	0 = Default or 1 = Latched
Setting that defines the status of IM5 signal in case of heavy noise and message synchronization being lost. If set to 'Latching' the last valid IM5 status will be maintained until the new valid message is received. If set to 'Default', the IM5 status, pre-defined by the user in 'IM5 DefaultValue' cell will be set. A new valid message will replace 'IM5 DefaultValue', once the channel recovers.				
16	32	IM5 DefaultValue	0	0 to 1 step 1
Setting that defines the IM5 fallback status.				
16	33	IM5 FrameSyncTim	1.5s	From 10ms to 1.5s step 10ms
Time delay after which 'IM5 DefaultValue' is applied.				
16	38	IM6 Cmd Type	Direct	0 = Disabled, 1 = Direct, 2 = Permissive or 3 = Blocking
Setting that defines the operative mode of the InterMiCOM_6 signal. Selecting the channel response for this bit to Blocking allows fastest signalling, whereas setting to Direct offers higher security at the expense of speed. Selecting the channel response for this bit to Permissive offers higher dependability				
16	39	IM6 FallBackMode	Default	0 = Default or 1 = Latched
Setting that defines the status of IM6 signal in case of heavy noise and message synchronization being lost. If set to 'Latching' the last valid IM6 status will be maintained until the new valid message is received. If set to 'Default', the IM6 status, pre-defined by the user in 'IM6 DefaultValue' cell will be set. A new valid message will replace 'IM6 DefaultValue', once the channel recovers.				
16	3A	IM6 DefaultValue	0	0 to 1 step 1
Setting that defines the IM6 fallback status.				
16	3B	IM6 FrameSyncTim	1.5s	From 10ms to 1.5s step 10ms
Time delay after which 'IM6 DefaultValue' is applied.				
16	40	IM7 Cmd Type	Direct	0 = Disabled, 1 = Direct, 2 = Permissive or 3 = Blocking
Setting that defines the operative mode of the InterMiCOM_7 signal. Selecting the channel response for this bit to Blocking allows fastest signalling, whereas setting to Direct offers higher security at the expense of speed. Selecting the channel response for this bit to Permissive offers higher dependability				
16	41	IM7 FallBackMode	Default	0 = Default or 1 = Latched

Col	Row	MENU TEXT	Default Setting	Available Setting
Description				
Setting that defines the status of IM7 signal in case of heavy noise and message synchronization being lost. If set to 'Latching' the last valid IM7 status will be maintained until the new valid message is received. If set to 'Default', the IM7 status, pre-defined by the user in 'IM7 DefaultValue' cell will be set. A new valid message will replace 'IM7 DefaultValue', once the channel recovers.				
16	42	IM7 DefaultValue	0	0 to 1 step 1
Setting that defines the IM7 fallback status.				
16	43	IM7 FrameSyncTim	1.5s	From 10ms to 1.5s step 10ms
Time delay after which 'IM7 DefaultValue' is applied.				
16	48	IM8 Cmd Type	Direct	0 = Disabled, 1 = Direct, 2 = Permissive or 3 = Blocking
Setting that defines the operative mode of the InterMiCOM_8 signal. Selecting the channel response for this bit to Blocking allows fastest signalling, whereas setting to Direct offers higher security at the expense of speed. Selecting the channel response for this bit to Permissive offers higher dependability				
16	49	IM8 FallBackMode	Default	0 = Default or 1 = Latched
Setting that defines the status of IM8 signal in case of heavy noise and message synchronization being lost. If set to 'Latching' the last valid IM8 status will be maintained until the new valid message is received. If set to 'Default', the IM8 status, pre-defined by the user in 'IM8 DefaultValue' cell will be set. A new valid message will replace 'IM8 DefaultValue', once the channel recovers.				
16	4A	IM8 DefaultValue	0	0 to 1 step 1
Setting that defines the IM8 fallback status.				
16	4B	IM8 FrameSyncTim	1.5s	From 10ms to 1.5s step 10ms
Time delay after which 'IM8 DefaultValue' is applied.				

Table 29 - INTERMiCOM conf

4 CONTROL AND SUPPORT SETTINGS

These settings exist outside the Group settings, and are used to configure the control and support features that do not need to adapt according to changing system conditions. These settings are used to configure system data, date and time, CT/VT ratios, SCADA type communications interfaces, input conditioners, etc. They also used to control CB operation, measurements and recording functions.

The control and support settings are part of the main menu and are used to configure the global configuration for the relay. It includes submenu settings as shown here.

The control and support settings include:

- Relay configuration settings
- Open/close circuit breaker (may vary according to relay type or model)
- CT & VT ratio settings
- Reset LEDs
- Active protection setting group
- Password & language settings
- Communications settings
- Measurement settings
- Event & fault record settings
- User interface settings
- Commissioning settings
- Circuit breaker control & monitoring settings (may vary according to relay type or model)

4.1 System Data

This menu provides information for the device and general status of the relay.

Col	Row	Menu Text	Default Setting	Available Setting
Description				
00	00	SYSTEM DATA	0	
This column contains general system settings				
00	01	Language	English	English / Français / Deutsche / Español 中文(Chinese)
The default language used by the device. Selectable as English, French, German, Spanish, Russian or Chinese. Available languages selected model.				
00	03	Sys Fn Links	0(bin)	Bit 0 = Trip led self reset (1 = enable self reset) Bit 1 = Not Used, Bit 2 = Not Used, Bit 3 = Not Used Bit 4 = Not Used, Bit 5 = Not Used, Bit 6 = Not Used
Setting to allow the fixed function trip LED to be self resetting (set to 1 to extinguish the LED after a period of healthy restoration of load)				
00	04	Description	MiCOM P54x	From 32 to 234 step 1
16 character relay description. Can be edited.				
00	05	Plant Reference	MiCOM	From 32 to 234 step 1
Associated plant description and can be edited.				
00	06	Model Number	Model Number	<Model number>
Relay model number. This display cannot be altered.				
00	08	Serial Number	Serial Number	<Serial number>
Relay model number. This display cannot be altered.				
00	09	Frequency	50 Hz	50 Hz or 60 Hz

Col	Row	Menu Text	Default Setting	Available Setting
Description				
Relay set frequency. Settable either 50 or 60 Hz				
00	0A	Comms Level	2	<conformance level displayed>
Displays the conformance of the relay to the Courier Level 2 comms.				
00	0B	Relay Address	255 1 1	0 to 255 step 1 (Courier) 0 to 254 step 1 (CS103) 0 to 65519 step 1 (DNP3)
Set the first rear port relay address. Build = Courier (Address available via LCD) Build = CS103 (Address available via LCD) Build = DNP3.0 (Address available via LCD)				
00	0C	Plant Status	0	Not Settable
Displays the circuit breaker plant status.				
00	0D	Control Status	0	Not Settable
Not used				
00	0E	Active Group	0	Not Settable
Displays the active settings group				
00	10	CB Trip/Close	No Operation	0 = No Operation, 1 = Trip, 2 = Close
Supports trip and close commands if enabled in the Circuit Breaker Control menu.				
00	10	CB Trip/Close	No Operation	0 = No Operation, 1 = Trip, 2 = Close
Supports trip and close commands if enabled in the Circuit Breaker Control menu.				
00	11	Software Ref. 1	0	<Software Ref. 1>
Displays the relay software version including protocol and relay model.				
00	12	Software Ref. 2	0	<Software Ref. 2>
Relay Ethernet card software reference. Visible when Ethernet card fitted.				
00	13	Software Ref. 3	0	<Software Ref. 3>
Relay Process Bus card software reference. Visible when Process Bus card fitted.				
00	14	NIC Platform Ref	0	<NIC platform reference>
Displays the relay NIC platform reference. Visible when Ethernet card fitted.				
00	15	IEC61850 Edition	2	Edition 1, Edition 2
This cell displays the supported IEC61850 Edition, only Ed2 is supported in Process Bus devices.				
00	16	ETH COMM Mode	Dual IP	Dual IP, PRP, HSR, RSTP
Sets the redundancy protocol. This setting can only be changed via the UI and the changes will cause the Ethernet board to reboot.				
00	17	PB COMM Mode	Dual IP	Dual IP, PRP
Sets the redundancy protocol of Process Bus board. This setting can only be changed via the UI and will cause the Process Bus board to reboot.				
00	20	Opto I/P Status	0	Not Settable
Display the status of the available opto inputs fitted.				
00	21	Relay O/P Status	0	Not Settable
Displays the status of all available output relays fitted. Not Valid if Contacts Blocked.				
00	22	Alarm Status 1	0	Not Settable
Displays the status of the first 32 alarms as a binary string.				
00	50	Alarm Status 1	0	Not Settable
Displays the status of the first 32 alarms as a binary string.				
00	51	Alarm Status 2	0	Not Settable
Displays the status of the next 32 alarms as a binary string. Includes fixed and user settable alarms.				
00	52	Alarm Status 3	0	Not Settable

Col	Row	Menu Text	Default Setting	Available Setting
Description				
Displays the status of the next 32 alarms as a binary string.				
00	D0	Access Level	ENGINEER	<Role>
Display the Role(s) of the current logged in user. Fixed as ENGINEER, OPERATOR or VIEWER for CSL0 models. SAT can configure Roles and will show NONE when no user has logged in.				
00	D3	New Eng.Level PW	0	ASCII 33 to 122
Allows user to change password for EngineerLevel on CSL0 models. Visible on UI only.				
00	D4	New Op.Level PW	0	ASCII 33 to 122
Allows user to change password for OperatorLevel on CSL0 models. Visible on UI only.				
00	DF	Security Feature	3	Not Settable
Displays the level of cyber security implemented				
00	E1	Password	0	<Password>
Used to send encrypted password. Not visible on UI.				
00	F2	Number of users	2	Special cell, not settable except for CSL1 models
Shows the number of users configured within the relays RBAC. Fixed at 2 (EngineerLevel and OperatorLevel) for CSL0 models. SAT can set 15 for CSL1 models.				

Table 30 - System data

4.2 Circuit Breaker Control

The IED/relay includes the following options for control of a single circuit breaker:

- Local tripping and closing, via the relay menu or hotkeys
- Local tripping and closing, via relay opto-isolated inputs
- Remote tripping and closing, using the relay communications

Col	Row	MENU TEXT	Default Setting	Available Setting
Description				
07	00	CB CONTROL	0	
This column controls the circuit Breaker Control configuration				
07	01	CB Control by	Disabled	0 = Disabled, 1 = Local, 2 = Remote, 3 = Local+Remote, 4 = Opto, 5 = Opto+local, 6 = Opto+Remote, 7 = Opto+Rem+local
Selects the type of circuit breaker control to be used				
07	02	Close Pulse Time	500ms	From 100ms to 10s step 10ms
Set period during which the CB should close when a CB close command is issued.				
07	03	Trip Pulse Time	500ms	From 100ms to 5s step 10ms
Set period during which the CB should trip when a CB trip command is issued.				
07	05	Man Close Delay	10s	From 10ms to 600s step 10ms
Set delay after operator controlled CB close sequence is initiated, before a CB close output can be issued. (Allows operator to retire to a place of safety before the CB close command is issued).				
07	06	CB Healthy Time	5s	From 10ms to 9999s step 10ms
Maximum waiting time for input DDB: CB1 Healthy (= gas pressure OK, spring charged etc) to enable CB1 Close by manual control. Same setting applies to DDB: CB2 Healthy to enable CB2 Close by manual control. If set time runs out with input DDB: CBx Healthy low (= 0), alarm Control CBx Unhealthy is set and CB close sequence is cancelled.				
07	07	Check Sync Time	5s	From 10ms to 9999s step 10ms

Col	Row	MENU TEXT	Default Setting	Available Setting
Description				
Maximum waiting time for input signal CB1MSCOK from system check logic, to enable CB1 Close by manual control. Same setting applies to input signal CB2MSCOK to enable CB2 Close by manual control. If set time runs out with input signal CBxMSCOK low (= 0), alarm Control CBx NoChSync is set and CB close sequence is cancelled.				
07	08	Lockout Reset	No	0 = No or 1 = Yes
Command to reset the Lockout Alarm				
07	09	Reset Lockout by	CB Close	0 = User Interface or 1 = CB Close
Setting that determines if a lockout condition will be reset by a manual circuit breaker close command or via the user interface.				
07	0A	Man Close RstDly	5s	From 100ms to 600s step 10ms
If Reset Lockout by is set to CB close then Man Close RstDly timer allows reset of Lockout state after set time delay				
07	0B	Autoreclose Mode	No Operation	0 = No Operation, 1 = In Service, 2 = Out of Service
Command to changes state of Auto-Reclose				
07	0D	Three Pole A/R	Enabled	0 = Disabled or 1 = Enabled
Enable or disable AR for multi-phase faults.				
07	0E	AR Status	0	Not Settable
Displays the Auto Reclose Status: Out of Service or In Service				
07	0F	Total Reclosures	0	Not Settable
Displays the number of successful re-closures.				
07	10	Reset Total A/R	No	0 = No or 1 = Yes
Allows user to reset the auto-reclose counters.				
07	11	CB Status Input	52B 3 pole	0 = None 1 = 52A 3 pole 2 = 52B 3 pole 3 = 52A & 52B 3 pole
Setting to define the type of circuit breaker contacts that will be used for the circuit breaker control logic. Form A contacts match the status of the circuit breaker primary contacts, form B are opposite to the breaker status.				
07	7F	CB Status Time	5s	From 0.1s to 5s step 10ms
Under healthy conditions the circuit breaker auxiliary contacts will be in opposite states. Should both sets of contacts be open or closed, it indicates that either the contacts, or the wiring, or the circuit breaker are defective and an alarm will be issued after CB Status Time delay. The time delay is set to avoid unwanted operation during normal switching duties.				
07	82	Reset AROK Ind	No	0 = No or 1 = Yes
If Res AROK by UI is set to Enabled, this command provides a pulse to reset the successful AR indication for both CB's				
07	83	Reset CB LO	No	0 = No or 1 = Yes
If Res LO by UI is set to Enabled, this command provides a pulse to reset the lockout for CB. Note: This requires the condition that caused the lockout to have been cleared.				
07	85	CB Total Shots	0	Not Settable
Indicates the total number of CB reclosures				
07	86	CB SUCC SPAR	0	Not Settable
Indicates the total number of CB successful 1 pole reclosures				
07	87	CB SUCC3PARShot1	0	Not Settable
Indicates the total number of CB successful 3 pole reclosures at 1st shot				
07	88	CB SUCC3PARShot2	0	Not Settable
Indicates the total number of CB successful 3 pole reclosures at 2nd shot				
07	89	CB SUCC3PARShot3	0	Not Settable
Indicates the total number of CB successful 3 pole reclosures at 3rd shot				
07	8A	CB SUCC3PARShot4	0	Not Settable
Indicates the total number of CB successful 3 pole reclosures at 4th shot				
07	8B	CB Failed Shots	0	Not Settable

Col	Row	MENU TEXT	Default Setting	Available Setting
Description				
Indicates the total number of CB failed reclose cycles				
07	8C	Reset CB Shots	No	0 = No or 1 = Yes
This command resets all CB shots counters to zero				
07	96	Res AROK by UI	Enabled	0 = Disabled or 1 = Enabled
If Enabled, this allows the successful auto-reclose signal to be reset by user interface command Reset AROK Ind.				
07	97	Res AROK by NoAR	Disabled	0 = Disabled or 1 = Enabled
if Enabled, allows "successful autoreclose" signal reset by selecting CB autoreclosing disabled				
07	98	Res AROK by Ext	Disabled	0 = Disabled or 1 = Enabled
If Enabled, allows "successful autoreclose" signal reset by external DDB input				
07	99	Res AROK by TDly	Disabled	0 = Disabled or 1 = Enabled
if Enabled, allows "successful autoreclose" signal to reset after time AROK Reset Time				
07	9A	Res AROK by TDly	1s	From 1s to 9999s step 1s
Reset time for "successful autoreclose" signal if Res AROK by TDly is set to Enabled				
07	9B	Res LO by CB IS	Enabled	0 = Disabled or 1 = Enabled
if Enabled, allows reset of CB lockout state when CB is "In Service" (= closed for t > CBIS Time)				
07	9C	Res LO by UI	Enabled	0 = Disabled or 1 = Enabled
if Enabled, allows reset of CB lockout state by UI command				
07	9D	Res LO by NoAR	Disabled	0 = Disabled or 1 = Enabled
if Enabled, allows reset of CB lockout state by selecting CB autoreclosing disabled				
07	9E	Res LO by ExtDDB	Disabled	0 = Disabled or 1 = Enabled
if Enabled, allows reset of CB lockout state by external DDB input				
07	9F	Res LO by TDelay	Disabled	0 = Disabled or 1 = Enabled
if Enabled, allows reset of CB lockout state after time LO Reset Time				
07	A0	LO Reset Time	1s	From 1s to 9999s step 1s
CB lockout reset time if Res LO by TDelay is set to Enabled				

Table 31 - Circuit breaker control

4.3 Date and Time

Displays the date and time as well as the battery condition.

Col	Row	Menu Text	Default Setting	Available Setting
Description				
08	00	DATE AND TIME	0	
This column contains Date and Time settings				
08	01	Date/Time	0	<Date/Time>
Displays the relay's current date and time.				
08	02	Date	0	<Date>
Displays the date. Front Panel Menu only				
08	03	Time	0	<Time>
Displays the time. Front Panel Menu only				
08	04	IRIG-B Sync	Disabled	0 = Disabled or 1 = Enabled
Enable IRIG-B time synchronization.				

Col	Row	Menu Text	Default Setting	Available Setting
Description				
08	05	IRIG-B Status	0	Not Settable
Displays the status of IRIG-B: Card Not Fitted, Card Failed, Signal Healthy or No Signal				
08	06	Battery Status	0	Not Settable
Displays whether the battery is Healthy or Dead				
08	07	Battery Alarm	Enabled	0 = Disabled or 1 = Enabled
Setting that determines whether an unhealthy relay battery condition is alarmed or not				
08	13	SNTP Status	0	Not Settable
Ethernet versions only. Displays information about the SNTP time synchronization status: Disabled, Trying Server 1, Trying Server 2, Server 1 OK, Server 2 OK, No response or No valid clock.				
08	20	LocalTime Enable	Flexible	0 = Disabled, 1 = Fixed or 2 = Flexible
Setting to turn on/off local time adjustments. Disabled - No local time zone will be maintained. Time synchronization from any interface will be used to directly set the master clock and all displayed (or read) times on all interfaces will be based on the master clock with no adjustment. Fixed - A local time zone adjustment can be defined using the LocalTime offset setting and all interfaces will use local time except SNTP time synchronization and IEC 61850 timestamps. Flexible - A local time zone adjustment can be defined using the LocalTime offset setting and each interface can be assigned to the UTC zone or local time zone with the exception of the local interfaces which will always be in the local time zone and IEC 61850/SNTP which will always be in the UTC zone.				
08	21	LocalTime Offset	0min	From -720min to 720min step 15min
Setting to specify an offset of -12 to +12 hrs in 15 minute intervals for local time zone. This adjustment is applied to the time based on the master clock which is UTC/GMT				
08	22	DST Enable	Enabled	0 = Disabled or 1 = Enabled
Setting to turn on/off daylight saving time adjustment to local time.				
08	23	DST Offset	60min	From 30min to 60min step 30min
Setting to specify daylight saving offset which will be used for the time adjustment to local time.				
08	24	DST Start	Last	0 = First, 1 = Second, 2 = Third, 3 = Fourth or 4 = Last
Setting to specify the week of the month in which daylight saving time adjustment starts				
08	25	DST Start Day	Sunday	0 = Sunday, 1 = Monday, 2 = Tuesday, 3 = Wednesday, 4 = Thursday, 5 = Friday or 6 = Saturday
Setting to specify the day of the week in which daylight saving time adjustment starts				
08	26	DST Start Month	March	0 = January, 1 = February, 2 = March, 3 = April, 4 = May, 5 = June, 6 = July, 7 = August, 8 = September, 9 = October, 10 = November or 11 = December
Setting to specify the month in which daylight saving time adjustment starts				
08	27	DST Start Mins	60min	From 0min to 1425min step 15min
Setting to specify the time of day in which daylight saving time adjustment starts. This is set relative to 00:00 hrs on the selected day when time adjustment is to start				
08	28	DST End	Last	0 = First, 1 = Second, 2 = Third, 3 = Fourth or 4 = Last
Setting to specify the week of the month in which daylight saving time adjustment ends				
08	29	DST End Day	Sunday	0 = Sunday, 1 = Monday, 2 = Tuesday, 3 = Wednesday, 4 = Thursday, 5 = Friday or 6 = Saturday
Setting to specify the day of the week in which daylight saving time adjustment ends				

Col	Row	Menu Text	Default Setting	Available Setting
Description				
08	2A	DST End Month	October	0 = January, 1 = February, 2 = March, 3 = April, 4 = May, 5 = June, 6 = July, 7 = August, 8 = September, 9 = October, 10 = November or 11 = December
Setting to specify the month in which daylight saving time adjustment ends				
08	2B	DST End Mins	60min	From 0min to 1425min step 15min
Setting to specify the time of day in which daylight saving time adjustment ends. This is set relative to 00:00 hrs on the selected day when time adjustment is to end				
08	30	RP1 Time Zone	UTC	0 = UTC or 1 = Local
Setting for the rear port 1 interface to specify if time synchronization received will be local or universal time co-ordinated				
08	31	RP2 Time Zone	UTC	0 = UTC or 1 = Local
Setting for the rear port 2 interface to specify if time synchronization received will be local or universal time co-ordinated				
08	32	DNPOE Time Zone	UTC	0 = UTC or 1 = Local
DNP3.0 over Ethernet versions only. Setting to specify if time synchronisation received will be local or universal time co-ordinate.				
08	33	Tunnel Time Zone	UTC	0 = UTC or 1 = Local
Ethernet versions only for tunnelled courier. Setting to specify if time synchronization received will be local or universal time co-ordinate				
08	40	1588 Sync	DISABLE	0 = Disabled or 1 = Intfc 1 Enabled or 2 = Intfc 2 Enabled or 3 = Intfc 1 & 2 Enabled
The setting that indicate the 1588 enable or the Intfc 1,Intfc 2 OR Both.				
08	41	1588 DomainNum	0	0 to 255 step 1
The domain number of 1588 which define the scope of PTP message communication, state, operations, data sets, and timescale.				
08	42	1588 PdelInterv	0	From 0 to 5 step 1
The initialization value is implementation-specific consistent				
08	50	1588 Status	0	Not Settable
Indication the status of 1588				
08	51	InterfaceNum	0	Not Settable
The value of the port number				
08	52	OffsetFromMaster	0	Not Settable
An implementation-specific representation of the current value of the time difference between a master and a slave as computed by the slave				
08	53	PeerMeanPDelay	0	Not Settable
An estimate of the current one-way propagation delay on the link				
08	54	StepsRemoved	0	Not Settable
The number of communication paths traversed between the local clock and the grandmaster clock.				
08	55	ParentClockId	0	Not Settable
The clock clockIdentity of the parent clock.				
08	56	ParentPortNum	0	Not Settable
The value of parent port number				
08	57	ParentClockClass	0	Not Settable
The parent clock class which is the attribute defining a clock's TAI traceability				
08	58	ParentClockAcc	0	Not Settable
The parent clock accuracy which is the attribute defining the accuracy of a clock				

Col	Row	Menu Text	Default Setting	Available Setting
Description				
08	59	ParentClockVar	0	Not Settable
The parent clock variance which is the attribute defining the stability of a clock				
08	5A	ParentPriority1	0	Not Settable
A user configurable designation that a clock belongs to an ordered set of clocks from which a master is selected				
08	5B	ParentPriority2	0	Not Settable
A user configurable designation that provides finer grained ordering among otherwise equivalent clocks				

Table 32 - Date and time

4.4 CT/VT Ratios

Col	Row	MENU TEXT	Default Setting	Available Setting
Description				
0A	00	CT AND VT RATIOS	0	
This column contains settings for Current and Voltage Transformer ratios				
0A	01	Main VT Primary	110V	From 100V to 1MV step 1V
Sets the main voltage transformer input primary voltage. V1=1 for Vn=100-120				
0A	02	Main VT Sec'y	110V	From 80V to 140V step 1V
Sets the main voltage transformer input secondary voltage.				
0A	03	CS VT Primary	110V	From 100V to 1MV step 1V
Sets the check sync. voltage transformer input primary voltage. V2=1 for Vn=100-120				
0A	04	CS VT Secondary	110V	From 80V to 140V step 1V
Sets the check sync. voltage transformer input secondary voltage.				
0A	07	Phase CT Primary	1A	From 1A to 30kA step 1A
Sets the phase current transformer input primary current rating. I1=Phase CT secondary rating				
0A	08	Phase CT Sec'y	1A	From 1A to 5A step 4A
Sets the phase current transformer input secondary current rating.				
0A	0B	SEF CT Primary	1	From 1A to 30kA step 1A
Sets the sensitive earth fault current transformer input primary current rating. I3=SEF CT secondary rating				
0A	0C	SEF CT Secondary	1	From 1A to 5A step 4A
Sets the sensitive earth fault current transformer input secondary current rating.				
0A	0F	CS Input	AN	0 = AN, 1 = BN, 2 = CN, 3 = AB, 4 = BC, 5 = CA, 6 = AN / 1.732, 7 = BN / 1.732, 8 = CN / 1.732
Selects the System Check Synchronism Input voltage measurement.				
0A	10	Main VT Location	Line	0 = Line or 1 = Bus
Selects the main voltage transformer location.				
0A	11	CT Polarity or CT1 Polarity	Standard	0 = Standard or 1 = Inverted

Col	Row	MENU TEXT	Default Setting	Available Setting
Description				
To invert polarity (180 °) of the CT				
0A	13	SEF CT Polarity	Standard	0 = Standard or 1 = Inverted
To invert polarity (180 °) of the SEF CT				
0A	21	CS VT Ph Shift	0	From -180° to 180° step 5°
Phase angle difference between selected phase ("C/S Input" 0A 0F) of Line VT input and applied "CB CS" VT input voltage under healthy system conditions				
0A	22	CS VT Mag	1	0.2 to 3 step 0.01
Ratio of voltage magnitudes of selected phase ("C/S Input" 0A 0F) of Line VT input and applied "CB CS" VT input voltage under healthy system conditions				

Table 33 - CT/VT ratios

4.5 Record Control

It is possible to disable the reporting of events from all interfaces that support setting changes. The settings that control the various types of events are in the Record Control column. The effect of setting each to disabled is as follows:

Col	Row	MENU TEXT	Default Setting	Available Setting
Description				
0B	00	RECORD CONTROL	0	
This column contains settings for Record Controls				
0B	01	Clear Events	No	0 = No or 1 = Yes
Clear Event records				
0B	02	Clear Faults	No	0 = No or 1 = Yes
Clear Fault records				
0B	03	Clear Maint	No	0 = No or 1 = Yes
Clear Maintenance records				
0B	04	Alarm Event	Enabled	0 = Disabled or 1 = Enabled
Disabling this setting means that all the occurrences that produce an alarm will result in no event being generated.				
0B	05	Relay O/P Event	Enabled	0 = Disabled or 1 = Enabled
Disabling this setting means that no event will be generated for any change in logic state.				
0B	06	Opto Input Event	Enabled	0 = Disabled or 1 = Enabled
Disabling this setting means that no event will be generated for any change in logic input state.				
0B	07	General Event	Enabled	0 = Disabled or 1 = Enabled
Disabling this setting means that no General Events will be generated				
0B	08	Fault Rec Event	Enabled	0 = Disabled or 1 = Enabled
Disabling this setting means that no event will be generated for any fault that produces a fault record				
0B	09	Maint Rec Event	Enabled	0 = Disabled or 1 = Enabled
Disabling this setting means that no event will be generated for any occurrence that produces a maintenance record.				
0B	0A	Protection Event	Enabled	0 = Disabled or 1 = Enabled
Disabling this setting means that any operation of protection elements will not be logged as an event				
0B	30	Clear Dist Recs	No	0 = No or 1 = Yes
Clear Disturbance records				
0B	31	Security Event	Enabled	0 = Disabled or 1 = Enabled

Col	Row	MENU TEXT	Default Setting	Available Setting
Description				
Disabling this setting means that any operation of security elements will not be logged as an event				
0B	40	DDB 31 - 0	11111111111111111111111111111111(bin)	32-bit binary setting: 1 = event recording Enabled, 0 = event recording Disabled
Chooses whether any individual DDBs should be deselected as a stored event, by setting the relevant bit to 0 (zero). Typically used for repetitive recurrent changes such as an Opto input assigned for Minute Pulse clock synchronizing.				
0B	41	DDB 63 - 32	11111111111111111111111111111111(bin)	32-bit binary setting: 1 = event recording Enabled, 0 = event recording Disabled
Chooses whether any individual DDBs should be deselected as a stored event, by setting the relevant bit to 0 (zero). Typically used for repetitive recurrent changes such as an Opto input assigned for Minute Pulse clock synchronizing.				
0B	42	DDB 95 - 64	11111111111111111111111111111111(bin)	32-bit binary setting: 1 = event recording Enabled, 0 = event recording Disabled
Chooses whether any individual DDBs should be deselected as a stored event, by setting the relevant bit to 0 (zero). Typically used for repetitive recurrent changes such as an Opto input assigned for Minute Pulse clock synchronizing.				
0B	43	DDB 127 - 96	11111111111111111111111111111111(bin)	32-bit binary setting: 1 = event recording Enabled, 0 = event recording Disabled
Chooses whether any individual DDBs should be deselected as a stored event, by setting the relevant bit to 0 (zero). Typically used for repetitive recurrent changes such as an Opto input assigned for Minute Pulse clock synchronizing.				
0B	44	DDB 159 - 128	11111111111111111111111111111111(bin)	32-bit binary setting: 1 = event recording Enabled, 0 = event recording Disabled
Chooses whether any individual DDBs should be deselected as a stored event, by setting the relevant bit to 0 (zero). Typically used for repetitive recurrent changes such as an Opto input assigned for Minute Pulse clock synchronizing.				
0B	45	DDB 191 - 160	11111111111111111111111111111111(bin)	32-bit binary setting: 1 = event recording Enabled, 0 = event recording Disabled
Chooses whether any individual DDBs should be deselected as a stored event, by setting the relevant bit to 0 (zero). Typically used for repetitive recurrent changes such as an Opto input assigned for Minute Pulse clock synchronizing.				
0B	46	DDB 223 - 192	11111111111111111111111111111111(bin)	32-bit binary setting: 1 = event recording Enabled, 0 = event recording Disabled
Chooses whether any individual DDBs should be deselected as a stored event, by setting the relevant bit to 0 (zero). Typically used for repetitive recurrent changes such as an Opto input assigned for Minute Pulse clock synchronizing.				
0B	47	DDB 255 - 224	11111111111111111111111111111111(bin)	32-bit binary setting: 1 = event recording Enabled, 0 = event recording Disabled
Chooses whether any individual DDBs should be deselected as a stored event, by setting the relevant bit to 0 (zero). Typically used for repetitive recurrent changes such as an Opto input assigned for Minute Pulse clock synchronizing.				
0B	48	DDB 287 - 256	11111111111111111111111111111111(bin)	32-bit binary setting: 1 = event recording Enabled, 0 = event recording Disabled
Chooses whether any individual DDBs should be deselected as a stored event, by setting the relevant bit to 0 (zero). Typically used for repetitive recurrent changes such as an Opto input assigned for Minute Pulse clock synchronizing.				
0B	49	DDB 319 - 288	11111111111111111111111111111111(bin)	32-bit binary setting: 1 = event recording Enabled, 0 = event recording Disabled
Chooses whether any individual DDBs should be deselected as a stored event, by setting the relevant bit to 0 (zero). Typically used for repetitive recurrent changes such as an Opto input assigned for Minute Pulse clock synchronizing.				
0B	4A	DDB 351 - 320	11111111111111111111111111111111(bin)	32-bit binary setting: 1 = event recording Enabled, 0 = event recording Disabled
Chooses whether any individual DDBs should be deselected as a stored event, by setting the relevant bit to 0 (zero). Typically used for repetitive recurrent changes such as an Opto input assigned for Minute Pulse clock synchronizing.				
0B	4B	DDB 383 - 352	11111111111111111111111111111111(bin)	32-bit binary setting: 1 = event recording Enabled, 0 = event recording Disabled
Chooses whether any individual DDBs should be deselected as a stored event, by setting the relevant bit to 0 (zero). Typically used for repetitive recurrent changes such as an Opto input assigned for Minute Pulse clock synchronizing.				
0B	4C	DDB 415 - 384	11111111111111111111111111111111(bin)	32-bit binary setting: 1 = event recording Enabled, 0 = event recording Disabled

Col	Row	MENU TEXT	Default Setting	Available Setting
Description				
Chooses whether any individual DDBs should be deselected as a stored event, by setting the relevant bit to 0 (zero). Typically used for repetitive recurrent changes such as an Opto input assigned for Minute Pulse clock synchronizing.				
0B	4D	DDB 447 - 416	11111111111111111111111111111111(bin)	32-bit binary setting: 1 = event recording Enabled, 0 = event recording Disabled
Chooses whether any individual DDBs should be deselected as a stored event, by setting the relevant bit to 0 (zero). Typically used for repetitive recurrent changes such as an Opto input assigned for Minute Pulse clock synchronizing.				
0B	4E	DDB 479 - 448	11111111111111111111111111111111(bin)	32-bit binary setting: 1 = event recording Enabled, 0 = event recording Disabled
Chooses whether any individual DDBs should be deselected as a stored event, by setting the relevant bit to 0 (zero). Typically used for repetitive recurrent changes such as an Opto input assigned for Minute Pulse clock synchronizing.				
0B	4F	DDB 511 - 480	11111111111111111111111111111111(bin)	32-bit binary setting: 1 = event recording Enabled, 0 = event recording Disabled
Chooses whether any individual DDBs should be deselected as a stored event, by setting the relevant bit to 0 (zero). Typically used for repetitive recurrent changes such as an Opto input assigned for Minute Pulse clock synchronizing.				
0B	50	DDB 543 - 512	11111111111111111111111111111111(bin)	32-bit binary setting: 1 = event recording Enabled, 0 = event recording Disabled
Chooses whether any individual DDBs should be deselected as a stored event, by setting the relevant bit to 0 (zero). Typically used for repetitive recurrent changes such as an Opto input assigned for Minute Pulse clock synchronizing.				
0B	51	DDB 575 - 544	11111111111111111111111111111111(bin)	32-bit binary setting: 1 = event recording Enabled, 0 = event recording Disabled
Chooses whether any individual DDBs should be deselected as a stored event, by setting the relevant bit to 0 (zero). Typically used for repetitive recurrent changes such as an Opto input assigned for Minute Pulse clock synchronizing.				
0B	52	DDB 607 - 576	11111111111111111111111111111111(bin)	32-bit binary setting: 1 = event recording Enabled, 0 = event recording Disabled
Chooses whether any individual DDBs should be deselected as a stored event, by setting the relevant bit to 0 (zero). Typically used for repetitive recurrent changes such as an Opto input assigned for Minute Pulse clock synchronizing.				
0B	53	DDB 639 - 608	11111111111111111111111111111111(bin)	32-bit binary setting: 1 = event recording Enabled, 0 = event recording Disabled
Chooses whether any individual DDBs should be deselected as a stored event, by setting the relevant bit to 0 (zero). Typically used for repetitive recurrent changes such as an Opto input assigned for Minute Pulse clock synchronizing.				
0B	54	DDB 671 - 640	11111111111111111111111111111111(bin)	32-bit binary setting: 1 = event recording Enabled, 0 = event recording Disabled
Chooses whether any individual DDBs should be deselected as a stored event, by setting the relevant bit to 0 (zero). Typically used for repetitive recurrent changes such as an Opto input assigned for Minute Pulse clock synchronizing.				
0B	55	DDB 703 - 672	11111111111111111111111111111111(bin)	32-bit binary setting: 1 = event recording Enabled, 0 = event recording Disabled
Chooses whether any individual DDBs should be deselected as a stored event, by setting the relevant bit to 0 (zero). Typically used for repetitive recurrent changes such as an Opto input assigned for Minute Pulse clock synchronizing.				
0B	56	DDB 735 - 704	11111111111111111111111111111111(bin)	32-bit binary setting: 1 = event recording Enabled, 0 = event recording Disabled
Chooses whether any individual DDBs should be deselected as a stored event, by setting the relevant bit to 0 (zero). Typically used for repetitive recurrent changes such as an Opto input assigned for Minute Pulse clock synchronizing.				
0B	57	DDB 767 - 736	11111111111111111111111111111111(bin)	32-bit binary setting: 1 = event recording Enabled, 0 = event recording Disabled
Chooses whether any individual DDBs should be deselected as a stored event, by setting the relevant bit to 0 (zero). Typically used for repetitive recurrent changes such as an Opto input assigned for Minute Pulse clock synchronizing.				
0B	58	DDB 799 - 768	11111111111111111111111111111111(bin)	32-bit binary setting: 1 = event recording Enabled, 0 = event recording Disabled
Chooses whether any individual DDBs should be deselected as a stored event, by setting the relevant bit to 0 (zero). Typically used for repetitive recurrent changes such as an Opto input assigned for Minute Pulse clock synchronizing.				

Col	Row	MENU TEXT	Default Setting	Available Setting
Description				
0B	59	DDB 831 - 800	11111111111111111111111111111111(bin)	32-bit binary setting: 1 = event recording Enabled, 0 = event recording Disabled
Chooses whether any individual DDBs should be deselected as a stored event, by setting the relevant bit to 0 (zero). Typically used for repetitive recurrent changes such as an Opto input assigned for Minute Pulse clock synchronizing.				
0B	5A	DDB 863 - 832	11111111111111111111111111111111(bin)	32-bit binary setting: 1 = event recording Enabled, 0 = event recording Disabled
Chooses whether any individual DDBs should be deselected as a stored event, by setting the relevant bit to 0 (zero). Typically used for repetitive recurrent changes such as an Opto input assigned for Minute Pulse clock synchronizing.				
0B	5B	DDB 895 - 864	11111111111111111111111111111111(bin)	32-bit binary setting: 1 = event recording Enabled, 0 = event recording Disabled
Chooses whether any individual DDBs should be deselected as a stored event, by setting the relevant bit to 0 (zero). Typically used for repetitive recurrent changes such as an Opto input assigned for Minute Pulse clock synchronizing.				
0B	5C	DDB 927 - 896	11111111111111111111111111111111(bin)	32-bit binary setting: 1 = event recording Enabled, 0 = event recording Disabled
Chooses whether any individual DDBs should be deselected as a stored event, by setting the relevant bit to 0 (zero). Typically used for repetitive recurrent changes such as an Opto input assigned for Minute Pulse clock synchronizing.				
0B	5D	DDB 959 - 928	11111111111111111111111111111111(bin)	32-bit binary setting: 1 = event recording Enabled, 0 = event recording Disabled
Chooses whether any individual DDBs should be deselected as a stored event, by setting the relevant bit to 0 (zero). Typically used for repetitive recurrent changes such as an Opto input assigned for Minute Pulse clock synchronizing.				
0B	5E	DDB 991 - 960	11111111111111111111111111111111(bin)	32-bit binary setting: 1 = event recording Enabled, 0 = event recording Disabled
Chooses whether any individual DDBs should be deselected as a stored event, by setting the relevant bit to 0 (zero). Typically used for repetitive recurrent changes such as an Opto input assigned for Minute Pulse clock synchronizing.				
0B	5F	DDB 1023 - 992	11111111111111111111111111111111(bin)	32-bit binary setting: 1 = event recording Enabled, 0 = event recording Disabled
Chooses whether any individual DDBs should be deselected as a stored event, by setting the relevant bit to 0 (zero). Typically used for repetitive recurrent changes such as an Opto input assigned for Minute Pulse clock synchronizing.				
0B	60	DDB 1055 - 1024	11111111111111111111111111111111(bin)	32-bit binary setting: 1 = event recording Enabled, 0 = event recording Disabled
Chooses whether any individual DDBs should be deselected as a stored event, by setting the relevant bit to 0 (zero). Typically used for repetitive recurrent changes such as an Opto input assigned for Minute Pulse clock synchronizing.				
0B	61	DDB 1087 - 1056	11111111111111111111111111111111(bin)	32-bit binary setting: 1 = event recording Enabled, 0 = event recording Disabled
Chooses whether any individual DDBs should be deselected as a stored event, by setting the relevant bit to 0 (zero). Typically used for repetitive recurrent changes such as an Opto input assigned for Minute Pulse clock synchronizing.				
0B	62	DDB 1119 - 1088	11111111111111111111111111111111(bin)	32-bit binary setting: 1 = event recording Enabled, 0 = event recording Disabled
Chooses whether any individual DDBs should be deselected as a stored event, by setting the relevant bit to 0 (zero). Typically used for repetitive recurrent changes such as an Opto input assigned for Minute Pulse clock synchronizing.				
0B	63	DDB 1151 - 1120	11111111111111111111111111111111(bin)	32-bit binary setting: 1 = event recording Enabled, 0 = event recording Disabled
Chooses whether any individual DDBs should be deselected as a stored event, by setting the relevant bit to 0 (zero). Typically used for repetitive recurrent changes such as an Opto input assigned for Minute Pulse clock synchronizing.				
0B	64	DDB 1183 - 1152	11111111111111111111111111111111(bin)	32-bit binary setting: 1 = event recording Enabled, 0 = event recording Disabled
Chooses whether any individual DDBs should be deselected as a stored event, by setting the relevant bit to 0 (zero). Typically used for repetitive recurrent changes such as an Opto input assigned for Minute Pulse clock synchronizing.				
0B	65	DDB 1215 - 1184	11111111111111111111111111111111(bin)	32-bit binary setting: 1 = event recording Enabled, 0 = event recording Disabled

Col	Row	MENU TEXT	Default Setting	Available Setting
Description				
Chooses whether any individual DDBs should be deselected as a stored event, by setting the relevant bit to 0 (zero). Typically used for repetitive recurrent changes such as an Opto input assigned for Minute Pulse clock synchronizing.				
0B	66	DDB 1247 - 1216	11111111111111111111111111111111(bin)	32-bit binary setting: 1 = event recording Enabled, 0 = event recording Disabled
Chooses whether any individual DDBs should be deselected as a stored event, by setting the relevant bit to 0 (zero). Typically used for repetitive recurrent changes such as an Opto input assigned for Minute Pulse clock synchronizing.				
0B	67	DDB 1279 - 1248	11111111111111111111111111111111(bin)	32-bit binary setting: 1 = event recording Enabled, 0 = event recording Disabled
Chooses whether any individual DDBs should be deselected as a stored event, by setting the relevant bit to 0 (zero). Typically used for repetitive recurrent changes such as an Opto input assigned for Minute Pulse clock synchronizing.				
0B	68	DDB 1311 - 1280	11111111111111111111111111111111(bin)	32-bit binary setting: 1 = event recording Enabled, 0 = event recording Disabled
Chooses whether any individual DDBs should be deselected as a stored event, by setting the relevant bit to 0 (zero). Typically used for repetitive recurrent changes such as an Opto input assigned for Minute Pulse clock synchronizing.				
0B	69	DDB 1343 - 1312	11111111111111111111111111111111(bin)	32-bit binary setting: 1 = event recording Enabled, 0 = event recording Disabled
Chooses whether any individual DDBs should be deselected as a stored event, by setting the relevant bit to 0 (zero). Typically used for repetitive recurrent changes such as an Opto input assigned for Minute Pulse clock synchronizing.				
0B	6A	DDB 1375 - 1344	11111111111111111111111111111111(bin)	32-bit binary setting: 1 = event recording Enabled, 0 = event recording Disabled
Chooses whether any individual DDBs should be deselected as a stored event, by setting the relevant bit to 0 (zero). Typically used for repetitive recurrent changes such as an Opto input assigned for Minute Pulse clock synchronizing.				
0B	6B	DDB 1407 - 1376	11111111111111111111111111111111(bin)	32-bit binary setting: 1 = event recording Enabled, 0 = event recording Disabled
Chooses whether any individual DDBs should be deselected as a stored event, by setting the relevant bit to 0 (zero). Typically used for repetitive recurrent changes such as an Opto input assigned for Minute Pulse clock synchronizing.				
0B	6C	DDB 1439 - 1408	11111111111111111111111111111111(bin)	32-bit binary setting: 1 = event recording Enabled, 0 = event recording Disabled
Chooses whether any individual DDBs should be deselected as a stored event, by setting the relevant bit to 0 (zero). Typically used for repetitive recurrent changes such as an Opto input assigned for Minute Pulse clock synchronizing.				
0B	6D	DDB 1471 - 1440	11111111111111111111111111111111(bin)	32-bit binary setting: 1 = event recording Enabled, 0 = event recording Disabled
Chooses whether any individual DDBs should be deselected as a stored event, by setting the relevant bit to 0 (zero). Typically used for repetitive recurrent changes such as an Opto input assigned for Minute Pulse clock synchronizing.				
0B	6E	DDB 1503 - 1472	11111111111111111111111111111111(bin)	32-bit binary setting: 1 = event recording Enabled, 0 = event recording Disabled
Chooses whether any individual DDBs should be deselected as a stored event, by setting the relevant bit to 0 (zero). Typically used for repetitive recurrent changes such as an Opto input assigned for Minute Pulse clock synchronizing.				
0B	6F	DDB 1535 - 1504	11111111111111111111111111111111(bin)	32-bit binary setting: 1 = event recording Enabled, 0 = event recording Disabled
Chooses whether any individual DDBs should be deselected as a stored event, by setting the relevant bit to 0 (zero). Typically used for repetitive recurrent changes such as an Opto input assigned for Minute Pulse clock synchronizing.				
0B	70	DDB 1567 - 1536	11111111111111111111111111111111(bin)	32-bit binary setting: 1 = event recording Enabled, 0 = event recording Disabled
Chooses whether any individual DDBs should be deselected as a stored event, by setting the relevant bit to 0 (zero). Typically used for repetitive recurrent changes such as an Opto input assigned for Minute Pulse clock synchronizing.				
0B	71	DDB 1599 - 1568	11111111111111111111111111111111(bin)	32-bit binary setting: 1 = event recording Enabled, 0 = event recording Disabled
Chooses whether any individual DDBs should be deselected as a stored event, by setting the relevant bit to 0 (zero). Typically used for repetitive recurrent changes such as an Opto input assigned for Minute Pulse clock synchronizing.				

Col	Row	MENU TEXT	Default Setting	Available Setting
Description				
0B	72	DDB 1631 - 1600	11111111111111111111111111111111(bin)	32-bit binary setting: 1 = event recording Enabled, 0 = event recording Disabled
Chooses whether any individual DDBs should be deselected as a stored event, by setting the relevant bit to 0 (zero). Typically used for repetitive recurrent changes such as an Opto input assigned for Minute Pulse clock synchronizing.				
0B	73	DDB 1663 - 1632	11111111111111111111111111111111(bin)	32-bit binary setting: 1 = event recording Enabled, 0 = event recording Disabled
Chooses whether any individual DDBs should be deselected as a stored event, by setting the relevant bit to 0 (zero). Typically used for repetitive recurrent changes such as an Opto input assigned for Minute Pulse clock synchronizing.				
0B	74	DDB 1695 - 1664	11111111111111111111111111111111(bin)	32-bit binary setting: 1 = event recording Enabled, 0 = event recording Disabled
Chooses whether any individual DDBs should be deselected as a stored event, by setting the relevant bit to 0 (zero). Typically used for repetitive recurrent changes such as an Opto input assigned for Minute Pulse clock synchronizing.				
0B	75	DDB 1727 - 1696	11111111111111111111111111111111(bin)	32-bit binary setting: 1 = event recording Enabled, 0 = event recording Disabled
Chooses whether any individual DDBs should be deselected as a stored event, by setting the relevant bit to 0 (zero). Typically used for repetitive recurrent changes such as an Opto input assigned for Minute Pulse clock synchronizing.				
0B	76	DDB 1759 - 1728	11111111111111111111111111111111(bin)	32-bit binary setting: 1 = event recording Enabled, 0 = event recording Disabled
Chooses whether any individual DDBs should be deselected as a stored event, by setting the relevant bit to 0 (zero). Typically used for repetitive recurrent changes such as an Opto input assigned for Minute Pulse clock synchronizing.				
0B	77	DDB 1760 - 1791	11111111111111111111111111111111(bin)	32-bit binary setting: 1 = event recording Enabled, 0 = event recording Disabled
Chooses whether any individual DDBs should be deselected as a stored event, by setting the relevant bit to 0 (zero). Typically used for repetitive recurrent changes such as an Opto input assigned for Minute Pulse clock synchronizing.				
0B	78	DDB 1792 - 1823	11111111111111111111111111111111(bin)	32-bit binary setting: 1 = event recording Enabled, 0 = event recording Disabled
Chooses whether any individual DDBs should be deselected as a stored event, by setting the relevant bit to 0 (zero). Typically used for repetitive recurrent changes such as an Opto input assigned for Minute Pulse clock synchronizing.				
0B	79	DDB 1824 - 1855	11111111111111111111111111111111(bin)	32-bit binary setting: 1 = event recording Enabled, 0 = event recording Disabled
Chooses whether any individual DDBs should be deselected as a stored event, by setting the relevant bit to 0 (zero). Typically used for repetitive recurrent changes such as an Opto input assigned for Minute Pulse clock synchronizing.				
0B	7A	DDB 1856 - 1887	11111111111111111111111111111111(bin)	32-bit binary setting: 1 = event recording Enabled, 0 = event recording Disabled
Chooses whether any individual DDBs should be deselected as a stored event, by setting the relevant bit to 0 (zero). Typically used for repetitive recurrent changes such as an Opto input assigned for Minute Pulse clock synchronizing.				
0B	7B	DDB 1888 - 1919	11111111111111111111111111111111(bin)	32-bit binary setting: 1 = event recording Enabled, 0 = event recording Disabled
Chooses whether any individual DDBs should be deselected as a stored event, by setting the relevant bit to 0 (zero). Typically used for repetitive recurrent changes such as an Opto input assigned for Minute Pulse clock synchronizing.				
0B	7C	DDB 1920 - 1951	11111111111111111111111111111111(bin)	32-bit binary setting: 1 = event recording Enabled, 0 = event recording Disabled
Chooses whether any individual DDBs should be deselected as a stored event, by setting the relevant bit to 0 (zero). Typically used for repetitive recurrent changes such as an Opto input assigned for Minute Pulse clock synchronizing.				
0B	7D	DDB 1952 - 1983	11111111111111111111111111111111(bin)	32-bit binary setting: 1 = event recording Enabled, 0 = event recording Disabled
Chooses whether any individual DDBs should be deselected as a stored event, by setting the relevant bit to 0 (zero). Typically used for repetitive recurrent changes such as an Opto input assigned for Minute Pulse clock synchronizing.				
0B	7E	DDB 1984 - 2015	11111111111111111111111111111111(bin)	32-bit binary setting: 1 = event recording Enabled, 0 = event recording Disabled

Col	Row	MENU TEXT	Default Setting	Available Setting
Description				
Chooses whether any individual DDBs should be deselected as a stored event, by setting the relevant bit to 0 (zero). Typically used for repetitive recurrent changes such as an Opto input assigned for Minute Pulse clock synchronizing.				
0B	7F	DDB 2016 - 2047	11111111111111111111111111111111(bin)	32-bit binary setting: 1 = event recording Enabled, 0 = event recording Disabled
Chooses whether any individual DDBs should be deselected as a stored event, by setting the relevant bit to 0 (zero). Typically used for repetitive recurrent changes such as an Opto input assigned for Minute Pulse clock synchronizing.				

Table 34 - Record control

4.6 Disturbance Recorder Settings (Oscillography)

The disturbance recorder settings include the record duration and trigger position, selection of analog and digital signals to record, and the signal sources that trigger the recording.

The precise event recorder column ("Disturb. Recorder" menu) is visible when the "Disturb recorder" setting ("Configuration" column) = "visible".

Important In the following table there are rows which may appear to be duplicated. The convention here is that the:

- First line applies to single breaker variants (e.g. P443, P445, P543, P544 and P841A).
- Second line applies to dual circuit breaker versions (e.g. P446, P544, P546 and P841B).

Col	Row	MENU TEXT	Default Setting	Available Setting
Description				
0C	00	DISTURB RECORDER	0	
This column contains settings for the Disturbance Recorder				
0C	01	Duration	1.5s	From 100ms to 10.5s step 10ms
This sets the overall recording time.				
0C	02	Trigger Position	33.30%	From 0% to 100% step 0.1%
This sets the trigger point as a percentage of the duration. For example, the default settings show that the overall recording time is set to 1.5 s with the trigger point being at 33.3% of this, giving 0.5 s pre-fault and 1s post fault recording times.				
0C	03	Trigger Mode	Single	0 = Single or 1 = Extended
If set to single mode, if a further trigger occurs whilst a recording is taking place, the recorder will ignore the trigger. However, if this has been set to Extended, the post trigger timer will be reset to zero, thereby extending the recording time.				
0C	04	Analog Channel 1	VA	A - Available settings 0 = IA, 1 = IB, 2 = IC, 3 = IN, 4 = IN Sensitive, 5 = VA, 6 = VB, 7 = VC, 8 = IM, 9 = V Checksync, 10 = Unused
Selects any available analogue input to be assigned to this channel (including derived IN residual current).				
0C	04	Analog Channel 1	VA	0 = IA, 1 = IB, 2 = IC, 3 = IN, 4 = IN Sensitive, 5 = VA, 6 = VB, 7 = VC, 8 = IM, 9 = V Checksync, 10 = IA2, 11 = IB2, 12 = IC2, 13 = IN2, 14 = V Checksync2, 15 = Unused
Selects any available analogue input to be assigned to this channel (including derived IN residual current).				
0C	05	Analog Channel 2	VA	A - Available settings 0 = IA, 1 = IB, 2 = IC, 3 = IN, 4 = IN Sensitive, 5 = VA, 6 = VB, 7 = VC, 8 = IM, 9 = V Checksync, 10 = Unused
Selects any available analogue input to be assigned to this channel (including derived IN residual current).				

Col	Row	MENU TEXT	Default Setting	Available Setting
Description				
0C	05	Analog Channel 2	VA	0 = IA, 1 = IB, 2 = IC, 3 = IN, 4 = IN Sensitive, 5 = VA, 6 = VB, 7 = VC, 8 = IM, 9 = V Checksync, 10 = IA2, 11 = IB2, 12 = IC2, 13 = IN2, 14 = V Checksync2, 15 = Unused
Selects any available analogue input to be assigned to this channel (including derived IN residual current).				
0C	06	Analog Channel 3	VA	A - Available settings 0 = IA, 1 = IB, 2 = IC, 3 = IN, 4 = IN Sensitive, 5 = VA, 6 = VB, 7 = VC, 8 = IM, 9 = V Checksync, 10 = Unused
Selects any available analogue input to be assigned to this channel (including derived IN residual current).				
0C	06	Analog Channel 3	VA	0 = IA, 1 = IB, 2 = IC, 3 = IN, 4 = IN Sensitive, 5 = VA, 6 = VB, 7 = VC, 8 = IM, 9 = V Checksync, 10 = IA2, 11 = IB2, 12 = IC2, 13 = IN2, 14 = V Checksync2, 15 = Unused
Selects any available analogue input to be assigned to this channel (including derived IN residual current).				
0C	07	Analog Channel 4	VA	A - Available settings 0 = IA, 1 = IB, 2 = IC, 3 = IN, 4 = IN Sensitive, 5 = VA, 6 = VB, 7 = VC, 8 = IM, 9 = V Checksync, 10 = Unused
Selects any available analogue input to be assigned to this channel (including derived IN residual current).				
0C	07	Analog Channel 4	VA	0 = IA, 1 = IB, 2 = IC, 3 = IN, 4 = IN Sensitive, 5 = VA, 6 = VB, 7 = VC, 8 = IM, 9 = V Checksync, 10 = IA2, 11 = IB2, 12 = IC2, 13 = IN2, 14 = V Checksync2, 15 = Unused
Selects any available analogue input to be assigned to this channel (including derived IN residual current).				
0C	08	Analog Channel 5	VA	A - Available settings 0 = IA, 1 = IB, 2 = IC, 3 = IN, 4 = IN Sensitive, 5 = VA, 6 = VB, 7 = VC, 8 = IM, 9 = V Checksync, 10 = Unused
Selects any available analogue input to be assigned to this channel (including derived IN residual current).				
0C	08	Analog Channel 5	VA	0 = IA, 1 = IB, 2 = IC, 3 = IN, 4 = IN Sensitive, 5 = VA, 6 = VB, 7 = VC, 8 = IM, 9 = V Checksync, 10 = IA2, 11 = IB2, 12 = IC2, 13 = IN2, 14 = V Checksync2, 15 = Unused
Selects any available analogue input to be assigned to this channel (including derived IN residual current).				
0C	09	Analog Channel 6	VA	A - Available settings 0 = IA, 1 = IB, 2 = IC, 3 = IN, 4 = IN Sensitive, 5 = VA, 6 = VB, 7 = VC, 8 = IM, 9 = V Checksync, 10 = Unused
Selects any available analogue input to be assigned to this channel (including derived IN residual current).				
0C	09	Analog Channel 6	VA	0 = IA, 1 = IB, 2 = IC, 3 = IN, 4 = IN Sensitive, 5 = VA, 6 = VB, 7 = VC, 8 = IM, 9 = V Checksync, 10 = IA2, 11 = IB2, 12 = IC2, 13 = IN2, 14 = V Checksync2, 15 = Unused
Selects any available analogue input to be assigned to this channel (including derived IN residual current).				
0C	0A	Analog Channel 7	VA	A - Available settings 0 = IA, 1 = IB, 2 = IC, 3 = IN, 4 = IN Sensitive, 5 = VA, 6 = VB, 7 = VC, 8 = IM, 9 = V Checksync, 10 = Unused
Selects any available analogue input to be assigned to this channel (including derived IN residual current).				
0C	0A	Analog Channel 7	VA	0 = IA, 1 = IB, 2 = IC, 3 = IN, 4 = IN Sensitive, 5 = VA, 6 = VB, 7 = VC, 8 = IM, 9 = V Checksync, 10 = IA2, 11 = IB2, 12 = IC2, 13 = IN2, 14 = V Checksync2, 15 = Unused
Selects any available analogue input to be assigned to this channel (including derived IN residual current).				
0C	0B	Analog Channel 8	VA	A - Available settings 0 = IA, 1 = IB, 2 = IC, 3 = IN, 4 = IN Sensitive, 5 = VA, 6 = VB, 7 = VC, 8 = IM, 9 = V Checksync, 10 = Unused
Selects any available analogue input to be assigned to this channel (including derived IN residual current).				
0C	0B	Analog Channel 8	VA	0 = IA, 1 = IB, 2 = IC, 3 = IN, 4 = IN Sensitive, 5 = VA, 6 = VB, 7 = VC, 8 = IM, 9 = V Checksync, 10 = IA2, 11 = IB2, 12 = IC2, 13 = IN2, 14 = V Checksync2, 15 = Unused

Col	Row	MENU TEXT	Default Setting	Available Setting
Description				
Selects any available analogue input to be assigned to this channel (including derived IN residual current).				
0C	0C	Digital Input 1	Output R1	See Data Types - G32
The digital channels may monitor any of the opto isolated inputs or output contacts, in addition to a number of internal relay digital signals, such as protection starts, LEDs etc.				
0C	0D	Input 1 Trigger	No Trigger	0 = No Trigger, 1 = Trigger L/H, 2 = Trigger H/L
Any of the digital channels may be selected to trigger the disturbance recorder on either a low to high or a high to low transition.				
0C	0E	Digital Input 2	Output R2	See Data Types - G32
The digital channels may monitor any of the opto isolated inputs or output contacts, in addition to a number of internal relay digital signals, such as protection starts, LEDs etc.				
0C	0F	Input 2 Trigger	No Trigger	0 = No Trigger, 1 = Trigger L/H, 2 = Trigger H/L
Any of the digital channels may be selected to trigger the disturbance recorder on either a low to high or a high to low transition.				
0C	10	Digital Input 3	Output R3	See Data Types - G32
The digital channels may monitor any of the opto isolated inputs or output contacts, in addition to a number of internal relay digital signals, such as protection starts, LEDs etc.				
0C	11	Input 3 Trigger	Trigger L/H	0 = No Trigger, 1 = Trigger L/H, 2 = Trigger H/L
Any of the digital channels may be selected to trigger the disturbance recorder on either a low to high or a high to low transition.				
0C	12	Digital Input 4	Output R4	See Data Types - G32
The digital channels may monitor any of the opto isolated inputs or output contacts, in addition to a number of internal relay digital signals, such as protection starts, LEDs etc.				
0C	13	Input 4 Trigger	No Trigger	0 = No Trigger, 1 = Trigger L/H, 2 = Trigger H/L
Any of the digital channels may be selected to trigger the disturbance recorder on either a low to high or a high to low transition.				
0C	14	Digital Input 5	Output R5	See Data Types - G32
The digital channels may monitor any of the opto isolated inputs or output contacts, in addition to a number of internal relay digital signals, such as protection starts, LEDs etc.				
0C	15	Input 5 Trigger	No Trigger	0 = No Trigger, 1 = Trigger L/H, 2 = Trigger H/L
Any of the digital channels may be selected to trigger the disturbance recorder on either a low to high or a high to low transition.				
0C	16	Digital Input 6	Output R6	See Data Types - G32
The digital channels may monitor any of the opto isolated inputs or output contacts, in addition to a number of internal relay digital signals, such as protection starts, LEDs etc.				
0C	17	Input 6 Trigger	No Trigger	0 = No Trigger, 1 = Trigger L/H, 2 = Trigger H/L
Any of the digital channels may be selected to trigger the disturbance recorder on either a low to high or a high to low transition.				
0C	18	Digital Input 7	Output R7	See Data Types - G32
The digital channels may monitor any of the opto isolated inputs or output contacts, in addition to a number of internal relay digital signals, such as protection starts, LEDs etc.				
0C	19	Input 7 Trigger	No Trigger	0 = No Trigger, 1 = Trigger L/H, 2 = Trigger H/L
Any of the digital channels may be selected to trigger the disturbance recorder on either a low to high or a high to low transition.				
0C	1A	Digital Input 8	Output R8	See Data Types - G32
The digital channels may monitor any of the opto isolated inputs or output contacts, in addition to a number of internal relay digital signals, such as protection starts, LEDs etc.				
0C	1B	Input 8 Trigger	No Trigger	0 = No Trigger, 1 = Trigger L/H, 2 = Trigger H/L
Any of the digital channels may be selected to trigger the disturbance recorder on either a low to high or a high to low transition.				
0C	1C	Digital Input 9	Output R9	See Data Types - G32
The digital channels may monitor any of the opto isolated inputs or output contacts, in addition to a number of internal relay digital signals, such as protection starts, LEDs etc.				
0C	1D	Input 9 Trigger	No Trigger	0 = No Trigger, 1 = Trigger L/H, 2 = Trigger H/L
Any of the digital channels may be selected to trigger the disturbance recorder on either a low to high or a high to low transition.				

Col	Row	MENU TEXT	Default Setting	Available Setting
Description				
0C	1E	Digital Input 10	Output R10	See Data Types - G32
The digital channels may monitor any of the opto isolated inputs or output contacts, in addition to a number of internal relay digital signals, such as protection starts, LEDs etc.				
0C	1F	Input 10 Trigger	No Trigger	0 = No Trigger, 1 = Trigger L/H, 2 = Trigger H/L
Any of the digital channels may be selected to trigger the disturbance recorder on either a low to high or a high to low transition.				
0C	20	Digital Input 11	Output R11	See Data Types - G32
The digital channels may monitor any of the opto isolated inputs or output contacts, in addition to a number of internal relay digital signals, such as protection starts, LEDs etc.				
0C	21	Input 11 Trigger	No Trigger	0 = No Trigger, 1 = Trigger L/H, 2 = Trigger H/L
Any of the digital channels may be selected to trigger the disturbance recorder on either a low to high or a high to low transition.				
0C	22	Digital Input 12	Output R12	See Data Types - G32
The digital channels may monitor any of the opto isolated inputs or output contacts, in addition to a number of internal relay digital signals, such as protection starts, LEDs etc.				
0C	23	Input 12 Trigger	No Trigger	0 = No Trigger, 1 = Trigger L/H, 2 = Trigger H/L
Any of the digital channels may be selected to trigger the disturbance recorder on either a low to high or a high to low transition.				
0C	24	Digital Input 13	Output R13	See Data Types - G32
The digital channels may monitor any of the opto isolated inputs or output contacts, in addition to a number of internal relay digital signals, such as protection starts, LEDs etc.				
0C	25	Input 13 Trigger	No Trigger	0 = No Trigger, 1 = Trigger L/H, 2 = Trigger H/L
Any of the digital channels may be selected to trigger the disturbance recorder on either a low to high or a high to low transition.				
0C	26	Digital Input 14	Output R14	See Data Types - G32
The digital channels may monitor any of the opto isolated inputs or output contacts, in addition to a number of internal relay digital signals, such as protection starts, LEDs etc.				
0C	27	Input 14 Trigger	No Trigger	0 = No Trigger, 1 = Trigger L/H, 2 = Trigger H/L
Any of the digital channels may be selected to trigger the disturbance recorder on either a low to high or a high to low transition.				
0C	28	Digital Input 15	Output R15	See Data Types - G32
The digital channels may monitor any of the opto isolated inputs or output contacts, in addition to a number of internal relay digital signals, such as protection starts, LEDs etc.				
0C	29	Input 15 Trigger	No Trigger	0 = No Trigger, 1 = Trigger L/H, 2 = Trigger H/L
Any of the digital channels may be selected to trigger the disturbance recorder on either a low to high or a high to low transition.				
0C	2A	Digital Input 16	Output R16	See Data Types - G32
The digital channels may monitor any of the opto isolated inputs or output contacts, in addition to a number of internal relay digital signals, such as protection starts, LEDs etc.				
0C	2B	Input 16 Trigger	No Trigger	0 = No Trigger, 1 = Trigger L/H, 2 = Trigger H/L
Any of the digital channels may be selected to trigger the disturbance recorder on either a low to high or a high to low transition.				
0C	2C	Digital Input 17	Input L1	See Data Types - G32
The digital channels may monitor any of the opto isolated inputs or output contacts, in addition to a number of internal relay digital signals, such as protection starts, LEDs etc.				
0C	2D	Input 17 Trigger	No Trigger	0 = No Trigger, 1 = Trigger L/H, 2 = Trigger H/L
Any of the digital channels may be selected to trigger the disturbance recorder on either a low to high or a high to low transition.				
0C	2E	Digital Input 18	Input L2	See Data Types - G32
The digital channels may monitor any of the opto isolated inputs or output contacts, in addition to a number of internal relay digital signals, such as protection starts, LEDs etc.				
0C	2F	Input 18 Trigger	No Trigger	0 = No Trigger, 1 = Trigger L/H, 2 = Trigger H/L
Any of the digital channels may be selected to trigger the disturbance recorder on either a low to high or a high to low transition.				
0C	30	Digital Input 19	Input L3	See Data Types - G32

Col	Row	MENU TEXT	Default Setting	Available Setting
Description				
The digital channels may monitor any of the opto isolated inputs or output contacts, in addition to a number of internal relay digital signals, such as protection starts, LEDs etc.				
0C	31	Input 19 Trigger	No Trigger	0 = No Trigger, 1 = Trigger L/H, 2 = Trigger H/L
Any of the digital channels may be selected to trigger the disturbance recorder on either a low to high or a high to low transition.				
0C	32	Digital Input 20	Input L4	See Data Types - G32
The digital channels may monitor any of the opto isolated inputs or output contacts, in addition to a number of internal relay digital signals, such as protection starts, LEDs etc.				
0C	33	Input 20 Trigger	No Trigger	0 = No Trigger, 1 = Trigger L/H, 2 = Trigger H/L
Any of the digital channels may be selected to trigger the disturbance recorder on either a low to high or a high to low transition.				
0C	34	Digital Input 21	Input L5	See Data Types - G32
The digital channels may monitor any of the opto isolated inputs or output contacts, in addition to a number of internal relay digital signals, such as protection starts, LEDs etc.				
0C	35	Input 21 Trigger	No Trigger	0 = No Trigger, 1 = Trigger L/H, 2 = Trigger H/L
Any of the digital channels may be selected to trigger the disturbance recorder on either a low to high or a high to low transition.				
0C	36	Digital Input 22	Input L6	See Data Types - G32
The digital channels may monitor any of the opto isolated inputs or output contacts, in addition to a number of internal relay digital signals, such as protection starts, LEDs etc.				
0C	37	Input 22 Trigger	No Trigger	0 = No Trigger, 1 = Trigger L/H, 2 = Trigger H/L
Any of the digital channels may be selected to trigger the disturbance recorder on either a low to high or a high to low transition.				
0C	38	Digital Input 23	Input L7	See Data Types - G32
The digital channels may monitor any of the opto isolated inputs or output contacts, in addition to a number of internal relay digital signals, such as protection starts, LEDs etc.				
0C	39	Input 23 Trigger	No Trigger	0 = No Trigger, 1 = Trigger L/H, 2 = Trigger H/L
Any of the digital channels may be selected to trigger the disturbance recorder on either a low to high or a high to low transition.				
0C	3A	Digital Input 24	Input L8	See Data Types - G32
The digital channels may monitor any of the opto isolated inputs or output contacts, in addition to a number of internal relay digital signals, such as protection starts, LEDs etc.				
0C	3B	Input 24 Trigger	No Trigger	0 = No Trigger, 1 = Trigger L/H, 2 = Trigger H/L
Any of the digital channels may be selected to trigger the disturbance recorder on either a low to high or a high to low transition.				
0C	3C	Digital Input 25	Input L9	See Data Types - G32
The digital channels may monitor any of the opto isolated inputs or output contacts, in addition to a number of internal relay digital signals, such as protection starts, LEDs etc.				
0C	3D	Input 25 Trigger	No Trigger	0 = No Trigger, 1 = Trigger L/H, 2 = Trigger H/L
Any of the digital channels may be selected to trigger the disturbance recorder on either a low to high or a high to low transition.				
0C	3E	Digital Input 26	Input L10	See Data Types - G32
The digital channels may monitor any of the opto isolated inputs or output contacts, in addition to a number of internal relay digital signals, such as protection starts, LEDs etc.				
0C	3F	Input 26 Trigger	No Trigger	0 = No Trigger, 1 = Trigger L/H, 2 = Trigger H/L
Any of the digital channels may be selected to trigger the disturbance recorder on either a low to high or a high to low transition.				
0C	40	Digital Input 27	Input L11	See Data Types - G32
The digital channels may monitor any of the opto isolated inputs or output contacts, in addition to a number of internal relay digital signals, such as protection starts, LEDs etc.				
0C	41	Input 27 Trigger	No Trigger	0 = No Trigger, 1 = Trigger L/H, 2 = Trigger H/L
Any of the digital channels may be selected to trigger the disturbance recorder on either a low to high or a high to low transition.				
0C	42	Digital Input 28	Input L12	See Data Types - G32

Col	Row	MENU TEXT	Default Setting	Available Setting
Description				
The digital channels may monitor any of the opto isolated inputs or output contacts, in addition to a number of internal relay digital signals, such as protection starts, LEDs etc.				
0C	43	Input 28 Trigger	No Trigger	0 = No Trigger, 1 = Trigger L/H, 2 = Trigger H/L
Any of the digital channels may be selected to trigger the disturbance recorder on either a low to high or a high to low transition.				
0C	44	Digital Input 29	Input L13	See Data Types - G32
The digital channels may monitor any of the opto isolated inputs or output contacts, in addition to a number of internal relay digital signals, such as protection starts, LEDs etc.				
0C	45	Input 29 Trigger	No Trigger	0 = No Trigger, 1 = Trigger L/H, 2 = Trigger H/L
Any of the digital channels may be selected to trigger the disturbance recorder on either a low to high or a high to low transition.				
0C	46	Digital Input 30	Input L14	See Data Types - G32
The digital channels may monitor any of the opto isolated inputs or output contacts, in addition to a number of internal relay digital signals, such as protection starts, LEDs etc.				
0C	47	Input 30 Trigger	No Trigger	0 = No Trigger, 1 = Trigger L/H, 2 = Trigger H/L
Any of the digital channels may be selected to trigger the disturbance recorder on either a low to high or a high to low transition.				
0C	48	Digital Input 31	Input L15	See Data Types - G32
The digital channels may monitor any of the opto isolated inputs or output contacts, in addition to a number of internal relay digital signals, such as protection starts, LEDs etc.				
0C	49	Input 31 Trigger	No Trigger	0 = No Trigger, 1 = Trigger L/H, 2 = Trigger H/L
Any of the digital channels may be selected to trigger the disturbance recorder on either a low to high or a high to low transition.				
0C	4A	Digital Input 32	Input L16	See Data Types - G32
The digital channels may monitor any of the opto isolated inputs or output contacts, in addition to a number of internal relay digital signals, such as protection starts, LEDs etc.				
0C	4B	Input 32 Trigger	No Trigger	0 = No Trigger, 1 = Trigger L/H, 2 = Trigger H/L
Any of the digital channels may be selected to trigger the disturbance recorder on either a low to high or a high to low transition.				
0C	50	Analog Channel 9	VA	A - Available settings 0 = IA, 1 = IB, 2 = IC, 3 = IN, 4 = IN Sensitive, 5 = VA, 6 = VB, 7 = VC, 8 = IM, 9 = V Checksync, 10 = Unused
Selects any available analogue input to be assigned to this channel (including derived IN residual current).				
0C	50	Analog Channel 9	VA	0 = IA, 1 = IB, 2 = IC, 3 = IN, 4 = IN Sensitive, 5 = VA, 6 = VB, 7 = VC, 8 = IM, 9 = V Checksync, 10 = IA2, 11 = IB2, 12 = IC2, 13 = IN2, 14 = V Checksync2, 15 = Unused
Selects any available analogue input to be assigned to this channel (including derived IN residual current).				
0C	51	Analog Channel 10	VA	A - Available settings 0 = IA, 1 = IB, 2 = IC, 3 = IN, 4 = IN Sensitive, 5 = VA, 6 = VB, 7 = VC, 8 = IM, 9 = V Checksync, 10 = Unused
Selects any available analogue input to be assigned to this channel (including derived IN residual current).				
0C	51	Analog Channel 10	VA	0 = IA, 1 = IB, 2 = IC, 3 = IN, 4 = IN Sensitive, 5 = VA, 6 = VB, 7 = VC, 8 = IM, 9 = V Checksync, 10 = IA2, 11 = IB2, 12 = IC2, 13 = IN2, 14 = V Checksync2, 15 = Unused
Selects any available analogue input to be assigned to this channel (including derived IN residual current).				
0C	52	Analog Channel 11	VA	A - Available settings 0 = IA, 1 = IB, 2 = IC, 3 = IN, 4 = IN Sensitive, 5 = VA, 6 = VB, 7 = VC, 8 = IM, 9 = V Checksync, 10 = Unused
Selects any available analogue input to be assigned to this channel (including derived IN residual current).				
0C	52	Analog Channel 11	VA	0 = IA, 1 = IB, 2 = IC, 3 = IN, 4 = IN Sensitive, 5 = VA, 6 = VB, 7 = VC, 8 = IM, 9 = V Checksync, 10 = IA2, 11 = IB2, 12 = IC2, 13 = IN2, 14 = V Checksync2, 15 = Unused
Selects any available analogue input to be assigned to this channel (including derived IN residual current).				

Col	Row	MENU TEXT	Default Setting	Available Setting
Description				
0C	53	Analog Channel 12	VA	A - Available settings 0 = IA, 1 = IB, 2 = IC, 3 = IN, 4 = IN Sensitive, 5 = VA, 6 = VB, 7 = VC, 8 = IM, 9 = V Checksync, 10 = Unused
Selects any available analogue input to be assigned to this channel (including derived IN residual current).				
0C	53	Analog Channel 12	VA	0 = IA, 1 = IB, 2 = IC, 3 = IN, 4 = IN Sensitive, 5 = VA, 6 = VB, 7 = VC, 8 = IM, 9 = V Checksync, 10 = IA2, 11 = IB2, 12 = IC2, 13 = IN2, 14 = V Checksync2, 15 = Unused
Selects any available analogue input to be assigned to this channel (including derived IN residual current).				
0C	54	Analog Channel 13	Unused	0 = IA, 1 = IB, 2 = IC, 3 = IN, 4 = IN Sensitive, 5 = VA, 6 = VB, 7 = VC, 8 = IM, 9 = V Checksync, 10 = IA DIFF, 11 = IB DIFF, 12 = IC DIFF, 13 = I BIAS MAX, 14 = I H2 MAX or 15 = Unused
Selects any available analogue input to be assigned to this channel (including derived IN residual current).				
0C	54	Analog Channel 13	VA	A - Available settings 0 = IA, 1 = IB, 2 = IC, 3 = IN, 4 = IN Sensitive, 5 = VA, 6 = VB, 7 = VC, 8 = IM, 9 = V Checksync, 10 = Unused
Selects any available analogue input to be assigned to this channel (including derived IN residual current).				
0C	54	Analog Channel 13	VA	0 = IA, 1 = IB, 2 = IC, 3 = IN, 4 = IN Sensitive, 5 = VA, 6 = VB, 7 = VC, 8 = IM, 9 = V Checksync, 10 = IA2, 11 = IB2, 12 = IC2, 13 = IN2, 14 = V Checksync2, 15 = Unused
Selects any available analogue input to be assigned to this channel (including derived IN residual current).				
0C	55	Analog Channel 14	Unused	0 = IA, 1 = IB, 2 = IC, 3 = IN, 4 = IN Sensitive, 5 = VA, 6 = VB, 7 = VC, 8 = IM, 9 = V Checksync, 10 = IA DIFF, 11 = IB DIFF, 12 = IC DIFF, 13 = I BIAS MAX, 14 = I H2 MAX or 15 = Unused
Selects any available analogue input to be assigned to this channel (including derived IN residual current).				
0C	55	Analog Channel 14	VA	A - Available settings 0 = IA, 1 = IB, 2 = IC, 3 = IN, 4 = IN Sensitive, 5 = VA, 6 = VB, 7 = VC, 8 = IM, 9 = V Checksync, 10 = Unused
Selects any available analogue input to be assigned to this channel (including derived IN residual current).				
0C	55	Analog Channel 14	VA	0 = IA, 1 = IB, 2 = IC, 3 = IN, 4 = IN Sensitive, 5 = VA, 6 = VB, 7 = VC, 8 = IM, 9 = V Checksync, 10 = IA2, 11 = IB2, 12 = IC2, 13 = IN2, 14 = V Checksync2, 15 = Unused
Selects any available analogue input to be assigned to this channel (including derived IN residual current).				
0C	56	Analog Channel 15	Unused	0 = IA, 1 = IB, 2 = IC, 3 = IN, 4 = IN Sensitive, 5 = VA, 6 = VB, 7 = VC, 8 = IM, 9 = V Checksync, 10 = IA DIFF, 11 = IB DIFF, 12 = IC DIFF, 13 = I BIAS MAX, 14 = I H2 MAX or 15 = Unused
Selects any available analogue input to be assigned to this channel (including derived IN residual current).				
0C	56	Analog Channel 15	VA	A - Available settings 0 = IA, 1 = IB, 2 = IC, 3 = IN, 4 = IN Sensitive, 5 = VA, 6 = VB, 7 = VC, 8 = IM, 9 = V Checksync, 10 = Unused
Selects any available analogue input to be assigned to this channel (including derived IN residual current).				
0C	56	Analog Channel 15	VA	0 = IA, 1 = IB, 2 = IC, 3 = IN, 4 = IN Sensitive, 5 = VA, 6 = VB, 7 = VC, 8 = IM, 9 = V Checksync, 10 = IA2, 11 = IB2, 12 = IC2, 13 = IN2, 14 = V Checksync2, 15 = Unused
Selects any available analogue input to be assigned to this channel (including derived IN residual current).				
0C	57	Analog Channel 16	Unused	0 = IA, 1 = IB, 2 = IC, 3 = IN, 4 = IN Sensitive, 5 = VA, 6 = VB, 7 = VC, 8 = IM, 9 = V Checksync, 10 = IA DIFF, 11 = IB DIFF, 12 = IC DIFF, 13 = I BIAS MAX, 14 = I H2 MAX or 15 = Unused
Selects any available analogue input to be assigned to this channel (including derived IN residual current).				

Col	Row	MENU TEXT	Default Setting	Available Setting
Description				
0C	57	Analog Channel 16	VA	A - Available settings 0 = IA, 1 = IB, 2 = IC, 3 = IN, 4 = IN Sensitive, 5 = VA, 6 = VB, 7 = VC, 8 = IM, 9 = V Checksync, 10 = Unused
Selects any available analogue input to be assigned to this channel (including derived IN residual current).				
0C	57	Analog Channel 16	VA	0 = IA, 1 = IB, 2 = IC, 3 = IN, 4 = IN Sensitive, 5 = VA, 6 = VB, 7 = VC, 8 = IM, 9 = V Checksync, 10 = IA2, 11 = IB2, 12 = IC2, 13 = IN2, 14 = V Checksync2, 15 = Unused
Selects any available analogue input to be assigned to this channel (including derived IN residual current).				
0C	58	Analog Channel 17	Unused	0 = IA, 1 = IB, 2 = IC, 3 = IN, 4 = IN Sensitive, 5 = VA, 6 = VB, 7 = VC, 8 = IM, 9 = V Checksync, 10 = IA DIFF, 11 = IB DIFF, 12 = IC DIFF, 13 = I BIAS MAX, 14 = I H2 MAX or 15 = Unused
Selects any available analogue input to be assigned to this channel (including derived IN residual current).				
0C	58	Analog Channel 17	VA	A - Available settings 0 = IA, 1 = IB, 2 = IC, 3 = IN, 4 = IN Sensitive, 5 = VA, 6 = VB, 7 = VC, 8 = IM, 9 = V Checksync, 10 = Unused
Selects any available analogue input to be assigned to this channel (including derived IN residual current).				
0C	58	Analog Channel 17	VA	0 = IA, 1 = IB, 2 = IC, 3 = IN, 4 = IN Sensitive, 5 = VA, 6 = VB, 7 = VC, 8 = IM, 9 = V Checksync, 10 = IA2, 11 = IB2, 12 = IC2, 13 = IN2, 14 = V Checksync2, 15 = Unused
Selects any available analogue input to be assigned to this channel (including derived IN residual current).				
0C	59	Analog Channel 18	Unused	0 = IA, 1 = IB, 2 = IC, 3 = IN, 4 = IN Sensitive, 5 = VA, 6 = VB, 7 = VC, 8 = IM, 9 = V Checksync, 10 = IA DIFF, 11 = IB DIFF, 12 = IC DIFF, 13 = I BIAS MAX, 14 = I H2 MAX or 15 = Unused
Selects any available analogue input to be assigned to this channel (including derived IN residual current).				
0C	59	Analog Channel 18	VA	A - Available settings 0 = IA, 1 = IB, 2 = IC, 3 = IN, 4 = IN Sensitive, 5 = VA, 6 = VB, 7 = VC, 8 = IM, 9 = V Checksync, 10 = Unused
Selects any available analogue input to be assigned to this channel (including derived IN residual current).				
0C	59	Analog Channel 18	VA	0 = IA, 1 = IB, 2 = IC, 3 = IN, 4 = IN Sensitive, 5 = VA, 6 = VB, 7 = VC, 8 = IM, 9 = V Checksync, 10 = IA2, 11 = IB2, 12 = IC2, 13 = IN2, 14 = V Checksync2, 15 = Unused
Selects any available analogue input to be assigned to this channel (including derived IN residual current).				
0C	5A	Analog Channel 19	Unused	0 = IA, 1 = IB, 2 = IC, 3 = IN, 4 = IN Sensitive, 5 = VA, 6 = VB, 7 = VC, 8 = IM, 9 = V Checksync, 10 = IA DIFF, 11 = IB DIFF, 12 = IC DIFF, 13 = I BIAS MAX, 14 = I H2 MAX or 15 = Unused
Selects any available analogue input to be assigned to this channel (including derived IN residual current).				
0C	5A	Analog Channel 19	VA	A - Available settings 0 = IA, 1 = IB, 2 = IC, 3 = IN, 4 = IN Sensitive, 5 = VA, 6 = VB, 7 = VC, 8 = IM, 9 = V Checksync, 10 = Unused
Selects any available analogue input to be assigned to this channel (including derived IN residual current).				
0C	5A	Analog Channel 19	VA	0 = IA, 1 = IB, 2 = IC, 3 = IN, 4 = IN Sensitive, 5 = VA, 6 = VB, 7 = VC, 8 = IM, 9 = V Checksync, 10 = IA2, 11 = IB2, 12 = IC2, 13 = IN2, 14 = V Checksync2, 15 = Unused
Selects any available analogue input to be assigned to this channel (including derived IN residual current).				
0C	5B	Analog Channel 20	Unused	0 = IA, 1 = IB, 2 = IC, 3 = IN, 4 = IN Sensitive, 5 = VA, 6 = VB, 7 = VC, 8 = IM, 9 = V Checksync, 10 = IA DIFF, 11 = IB DIFF, 12 = IC DIFF, 13 = I BIAS MAX, 14 = I H2 MAX or 15 = Unused
Selects any available analogue input to be assigned to this channel (including derived IN residual current).				

Col	Row	MENU TEXT	Default Setting	Available Setting
Description				
0C	5B	Analog Channel 20	VA	A - Available settings 0 = IA, 1 = IB, 2 = IC, 3 = IN, 4 = IN Sensitive, 5 = VA, 6 = VB, 7 = VC, 8 = IM, 9 = V Checksync, 10 = Unused
Selects any available analogue input to be assigned to this channel (including derived IN residual current).				
0C	5B	Analog Channel 20	VA	0 = IA, 1 = IB, 2 = IC, 3 = IN, 4 = IN Sensitive, 5 = VA, 6 = VB, 7 = VC, 8 = IM, 9 = V Checksync, 10 = IA2, 11 = IB2, 12 = IC2, 13 = IN2, 14 = V Checksync2, 15 = Unused
Selects any available analogue input to be assigned to this channel (including derived IN residual current).				
0C	70	Digital Input 33	Unused	See Data Types - G32
The digital channels may monitor any of the opto isolated inputs or output contacts, in addition to a number of internal relay digital signals, such as protection starts, LEDs etc.				
0C	71	Digital Input 34	Unused	See Data Types - G32
The digital channels may monitor any of the opto isolated inputs or output contacts, in addition to a number of internal relay digital signals, such as protection starts, LEDs etc.				
0C	72	Digital Input 35	Unused	See Data Types - G32
The digital channels may monitor any of the opto isolated inputs or output contacts, in addition to a number of internal relay digital signals, such as protection starts, LEDs etc.				
0C	73	Digital Input 36	Unused	See Data Types - G32
The digital channels may monitor any of the opto isolated inputs or output contacts, in addition to a number of internal relay digital signals, such as protection starts, LEDs etc.				
0C	74	Digital Input 37	Unused	See Data Types - G32
The digital channels may monitor any of the opto isolated inputs or output contacts, in addition to a number of internal relay digital signals, such as protection starts, LEDs etc.				
0C	75	Digital Input 38	Unused	See Data Types - G32
The digital channels may monitor any of the opto isolated inputs or output contacts, in addition to a number of internal relay digital signals, such as protection starts, LEDs etc.				
0C	76	Digital Input 39	Unused	See Data Types - G32
The digital channels may monitor any of the opto isolated inputs or output contacts, in addition to a number of internal relay digital signals, such as protection starts, LEDs etc.				
0C	77	Digital Input 40	Unused	See Data Types - G32
The digital channels may monitor any of the opto isolated inputs or output contacts, in addition to a number of internal relay digital signals, such as protection starts, LEDs etc.				
0C	78	Digital Input 41	Unused	See Data Types - G32
The digital channels may monitor any of the opto isolated inputs or output contacts, in addition to a number of internal relay digital signals, such as protection starts, LEDs etc.				
0C	79	Digital Input 42	Unused	See Data Types - G32
The digital channels may monitor any of the opto isolated inputs or output contacts, in addition to a number of internal relay digital signals, such as protection starts, LEDs etc.				
0C	7A	Digital Input 43	Unused	See Data Types - G32
The digital channels may monitor any of the opto isolated inputs or output contacts, in addition to a number of internal relay digital signals, such as protection starts, LEDs etc.				
0C	7B	Digital Input 44	Unused	See Data Types - G32
The digital channels may monitor any of the opto isolated inputs or output contacts, in addition to a number of internal relay digital signals, such as protection starts, LEDs etc.				
0C	7C	Digital Input 45	Unused	See Data Types - G32
The digital channels may monitor any of the opto isolated inputs or output contacts, in addition to a number of internal relay digital signals, such as protection starts, LEDs etc.				
0C	7D	Digital Input 46	Unused	See Data Types - G32

Col	Row	MENU TEXT	Default Setting	Available Setting
Description				
The digital channels may monitor any of the opto isolated inputs or output contacts, in addition to a number of internal relay digital signals, such as protection starts, LEDs etc.				
0C	7E	Digital Input 47	Unused	See Data Types - G32
The digital channels may monitor any of the opto isolated inputs or output contacts, in addition to a number of internal relay digital signals, such as protection starts, LEDs etc.				
0C	7F	Digital Input 48	Unused	See Data Types - G32
The digital channels may monitor any of the opto isolated inputs or output contacts, in addition to a number of internal relay digital signals, such as protection starts, LEDs etc.				
0C	80	Digital Input 49	Unused	See Data Types - G32
The digital channels may monitor any of the opto isolated inputs or output contacts, in addition to a number of internal relay digital signals, such as protection starts, LEDs etc.				
0C	81	Digital Input 50	Unused	See Data Types - G32
The digital channels may monitor any of the opto isolated inputs or output contacts, in addition to a number of internal relay digital signals, such as protection starts, LEDs etc.				
0C	82	Digital Input 51	Unused	See Data Types - G32
The digital channels may monitor any of the opto isolated inputs or output contacts, in addition to a number of internal relay digital signals, such as protection starts, LEDs etc.				
0C	83	Digital Input 52	Unused	See Data Types - G32
The digital channels may monitor any of the opto isolated inputs or output contacts, in addition to a number of internal relay digital signals, such as protection starts, LEDs etc.				
0C	84	Digital Input 53	Unused	See Data Types - G32
The digital channels may monitor any of the opto isolated inputs or output contacts, in addition to a number of internal relay digital signals, such as protection starts, LEDs etc.				
0C	85	Digital Input 54	Unused	See Data Types - G32
The digital channels may monitor any of the opto isolated inputs or output contacts, in addition to a number of internal relay digital signals, such as protection starts, LEDs etc.				
0C	86	Digital Input 55	Unused	See Data Types - G32
The digital channels may monitor any of the opto isolated inputs or output contacts, in addition to a number of internal relay digital signals, such as protection starts, LEDs etc.				
0C	87	Digital Input 56	Unused	See Data Types - G32
The digital channels may monitor any of the opto isolated inputs or output contacts, in addition to a number of internal relay digital signals, such as protection starts, LEDs etc.				
0C	88	Digital Input 57	Unused	See Data Types - G32
The digital channels may monitor any of the opto isolated inputs or output contacts, in addition to a number of internal relay digital signals, such as protection starts, LEDs etc.				
0C	89	Digital Input 58	Unused	See Data Types - G32
The digital channels may monitor any of the opto isolated inputs or output contacts, in addition to a number of internal relay digital signals, such as protection starts, LEDs etc.				
0C	8A	Digital Input 59	Unused	See Data Types - G32
The digital channels may monitor any of the opto isolated inputs or output contacts, in addition to a number of internal relay digital signals, such as protection starts, LEDs etc.				
0C	8B	Digital Input 60	Unused	See Data Types - G32
The digital channels may monitor any of the opto isolated inputs or output contacts, in addition to a number of internal relay digital signals, such as protection starts, LEDs etc.				
0C	8C	Digital Input 61	Unused	See Data Types - G32
The digital channels may monitor any of the opto isolated inputs or output contacts, in addition to a number of internal relay digital signals, such as protection starts, LEDs etc.				
0C	8D	Digital Input 62	Unused	See Data Types - G32

Col	Row	MENU TEXT	Default Setting	Available Setting
Description				
The digital channels may monitor any of the opto isolated inputs or output contacts, in addition to a number of internal relay digital signals, such as protection starts, LEDs etc.				
0C	8E	Digital Input 63	Unused	See Data Types - G32
The digital channels may monitor any of the opto isolated inputs or output contacts, in addition to a number of internal relay digital signals, such as protection starts, LEDs etc.				
0C	8F	Digital Input 64	Unused	See Data Types - G32
The digital channels may monitor any of the opto isolated inputs or output contacts, in addition to a number of internal relay digital signals, such as protection starts, LEDs etc.				
0C	90	Digital Input 65	Unused	See Data Types - G32
The digital channels may monitor any of the opto isolated inputs or output contacts, in addition to a number of internal relay digital signals, such as protection starts, LEDs etc.				
0C	91	Digital Input 66	Unused	See Data Types - G32
The digital channels may monitor any of the opto isolated inputs or output contacts, in addition to a number of internal relay digital signals, such as protection starts, LEDs etc.				
0C	92	Digital Input 67	Unused	See Data Types - G32
The digital channels may monitor any of the opto isolated inputs or output contacts, in addition to a number of internal relay digital signals, such as protection starts, LEDs etc.				
0C	93	Digital Input 68	Unused	See Data Types - G32
The digital channels may monitor any of the opto isolated inputs or output contacts, in addition to a number of internal relay digital signals, such as protection starts, LEDs etc.				
0C	94	Digital Input 69	Unused	See Data Types - G32
The digital channels may monitor any of the opto isolated inputs or output contacts, in addition to a number of internal relay digital signals, such as protection starts, LEDs etc.				
0C	95	Digital Input 70	Unused	See Data Types - G32
The digital channels may monitor any of the opto isolated inputs or output contacts, in addition to a number of internal relay digital signals, such as protection starts, LEDs etc.				
0C	96	Digital Input 71	Unused	See Data Types - G32
The digital channels may monitor any of the opto isolated inputs or output contacts, in addition to a number of internal relay digital signals, such as protection starts, LEDs etc.				
0C	97	Digital Input 72	Unused	See Data Types - G32
The digital channels may monitor any of the opto isolated inputs or output contacts, in addition to a number of internal relay digital signals, such as protection starts, LEDs etc.				
0C	98	Digital Input 73	Unused	See Data Types - G32
The digital channels may monitor any of the opto isolated inputs or output contacts, in addition to a number of internal relay digital signals, such as protection starts, LEDs etc.				
0C	99	Digital Input 74	Unused	See Data Types - G32
The digital channels may monitor any of the opto isolated inputs or output contacts, in addition to a number of internal relay digital signals, such as protection starts, LEDs etc.				
0C	9A	Digital Input 75	Unused	See Data Types - G32
The digital channels may monitor any of the opto isolated inputs or output contacts, in addition to a number of internal relay digital signals, such as protection starts, LEDs etc.				
0C	9B	Digital Input 76	Unused	See Data Types - G32
The digital channels may monitor any of the opto isolated inputs or output contacts, in addition to a number of internal relay digital signals, such as protection starts, LEDs etc.				
0C	9C	Digital Input 77	Unused	See Data Types - G32
The digital channels may monitor any of the opto isolated inputs or output contacts, in addition to a number of internal relay digital signals, such as protection starts, LEDs etc.				
0C	9D	Digital Input 78	Unused	See Data Types - G32

Col	Row	MENU TEXT	Default Setting	Available Setting
Description				
The digital channels may monitor any of the opto isolated inputs or output contacts, in addition to a number of internal relay digital signals, such as protection starts, LEDs etc.				
0C	9E	Digital Input 79	Unused	See Data Types - G32
The digital channels may monitor any of the opto isolated inputs or output contacts, in addition to a number of internal relay digital signals, such as protection starts, LEDs etc.				
0C	9F	Digital Input 80	Unused	See Data Types - G32
The digital channels may monitor any of the opto isolated inputs or output contacts, in addition to a number of internal relay digital signals, such as protection starts, LEDs etc.				
0C	A0	Digital Input 81	Unused	See Data Types - G32
The digital channels may monitor any of the opto isolated inputs or output contacts, in addition to a number of internal relay digital signals, such as protection starts, LEDs etc.				
0C	A1	Digital Input 82	Unused	See Data Types - G32
The digital channels may monitor any of the opto isolated inputs or output contacts, in addition to a number of internal relay digital signals, such as protection starts, LEDs etc.				
0C	A2	Digital Input 83	Unused	See Data Types - G32
The digital channels may monitor any of the opto isolated inputs or output contacts, in addition to a number of internal relay digital signals, such as protection starts, LEDs etc.				
0C	A3	Digital Input 84	Unused	See Data Types - G32
The digital channels may monitor any of the opto isolated inputs or output contacts, in addition to a number of internal relay digital signals, such as protection starts, LEDs etc.				
0C	A4	Digital Input 85	Unused	See Data Types - G32
The digital channels may monitor any of the opto isolated inputs or output contacts, in addition to a number of internal relay digital signals, such as protection starts, LEDs etc.				
0C	A5	Digital Input 86	Unused	See Data Types - G32
The digital channels may monitor any of the opto isolated inputs or output contacts, in addition to a number of internal relay digital signals, such as protection starts, LEDs etc.				
0C	A6	Digital Input 87	Unused	See Data Types - G32
The digital channels may monitor any of the opto isolated inputs or output contacts, in addition to a number of internal relay digital signals, such as protection starts, LEDs etc.				
0C	A7	Digital Input 88	Unused	See Data Types - G32
The digital channels may monitor any of the opto isolated inputs or output contacts, in addition to a number of internal relay digital signals, such as protection starts, LEDs etc.				
0C	A8	Digital Input 89	Unused	See Data Types - G32
The digital channels may monitor any of the opto isolated inputs or output contacts, in addition to a number of internal relay digital signals, such as protection starts, LEDs etc.				
0C	A9	Digital Input 90	Unused	See Data Types - G32
The digital channels may monitor any of the opto isolated inputs or output contacts, in addition to a number of internal relay digital signals, such as protection starts, LEDs etc.				
0C	AA	Digital Input 91	Unused	See Data Types - G32
The digital channels may monitor any of the opto isolated inputs or output contacts, in addition to a number of internal relay digital signals, such as protection starts, LEDs etc.				
0C	AB	Digital Input 92	Unused	See Data Types - G32
The digital channels may monitor any of the opto isolated inputs or output contacts, in addition to a number of internal relay digital signals, such as protection starts, LEDs etc.				
0C	AC	Digital Input 93	Unused	See Data Types - G32
The digital channels may monitor any of the opto isolated inputs or output contacts, in addition to a number of internal relay digital signals, such as protection starts, LEDs etc.				
0C	AD	Digital Input 94	Unused	See Data Types - G32

Col	Row	MENU TEXT	Default Setting	Available Setting
Description				
The digital channels may monitor any of the opto isolated inputs or output contacts, in addition to a number of internal relay digital signals, such as protection starts, LEDs etc.				
0C	AE	Digital Input 95	Unused	See Data Types - G32
The digital channels may monitor any of the opto isolated inputs or output contacts, in addition to a number of internal relay digital signals, such as protection starts, LEDs etc.				
0C	AF	Digital Input 96	Unused	See Data Types - G32
The digital channels may monitor any of the opto isolated inputs or output contacts, in addition to a number of internal relay digital signals, such as protection starts, LEDs etc.				
0C	B0	Digital Input 97	Unused	See Data Types - G32
The digital channels may monitor any of the opto isolated inputs or output contacts, in addition to a number of internal relay digital signals, such as protection starts, LEDs etc.				
0C	B1	Digital Input 98	Unused	See Data Types - G32
The digital channels may monitor any of the opto isolated inputs or output contacts, in addition to a number of internal relay digital signals, such as protection starts, LEDs etc.				
0C	B2	Digital Input 99	Unused	See Data Types - G32
The digital channels may monitor any of the opto isolated inputs or output contacts, in addition to a number of internal relay digital signals, such as protection starts, LEDs etc.				
0C	B3	Digital Input 100	Unused	See Data Types - G32
The digital channels may monitor any of the opto isolated inputs or output contacts, in addition to a number of internal relay digital signals, such as protection starts, LEDs etc.				
0C	B4	Digital Input 101	Unused	See Data Types - G32
The digital channels may monitor any of the opto isolated inputs or output contacts, in addition to a number of internal relay digital signals, such as protection starts, LEDs etc.				
0C	B5	Digital Input 102	Unused	See Data Types - G32
The digital channels may monitor any of the opto isolated inputs or output contacts, in addition to a number of internal relay digital signals, such as protection starts, LEDs etc.				
0C	B6	Digital Input 103	Unused	See Data Types - G32
The digital channels may monitor any of the opto isolated inputs or output contacts, in addition to a number of internal relay digital signals, such as protection starts, LEDs etc.				
0C	B7	Digital Input 104	Unused	See Data Types - G32
The digital channels may monitor any of the opto isolated inputs or output contacts, in addition to a number of internal relay digital signals, such as protection starts, LEDs etc.				
0C	B8	Digital Input 105	Unused	See Data Types - G32
The digital channels may monitor any of the opto isolated inputs or output contacts, in addition to a number of internal relay digital signals, such as protection starts, LEDs etc.				
0C	B9	Digital Input 106	Unused	See Data Types - G32
The digital channels may monitor any of the opto isolated inputs or output contacts, in addition to a number of internal relay digital signals, such as protection starts, LEDs etc.				
0C	BA	Digital Input 107	Unused	See Data Types - G32
The digital channels may monitor any of the opto isolated inputs or output contacts, in addition to a number of internal relay digital signals, such as protection starts, LEDs etc.				
0C	BB	Digital Input 108	Unused	See Data Types - G32
The digital channels may monitor any of the opto isolated inputs or output contacts, in addition to a number of internal relay digital signals, such as protection starts, LEDs etc.				
0C	BC	Digital Input 109	Unused	See Data Types - G32
The digital channels may monitor any of the opto isolated inputs or output contacts, in addition to a number of internal relay digital signals, such as protection starts, LEDs etc.				
0C	BD	Digital Input 110	Unused	See Data Types - G32

Col	Row	MENU TEXT	Default Setting	Available Setting
Description				
The digital channels may monitor any of the opto isolated inputs or output contacts, in addition to a number of internal relay digital signals, such as protection starts, LEDs etc.				
0C	BE	Digital Input 111	Unused	See Data Types - G32
The digital channels may monitor any of the opto isolated inputs or output contacts, in addition to a number of internal relay digital signals, such as protection starts, LEDs etc.				
0C	BF	Digital Input 112	Unused	See Data Types - G32
The digital channels may monitor any of the opto isolated inputs or output contacts, in addition to a number of internal relay digital signals, such as protection starts, LEDs etc.				
0C	C0	Digital Input 113	Unused	See Data Types - G32
The digital channels may monitor any of the opto isolated inputs or output contacts, in addition to a number of internal relay digital signals, such as protection starts, LEDs etc.				
0C	C1	Digital Input 114	Unused	See Data Types - G32
The digital channels may monitor any of the opto isolated inputs or output contacts, in addition to a number of internal relay digital signals, such as protection starts, LEDs etc.				
0C	C2	Digital Input 115	Unused	See Data Types - G32
The digital channels may monitor any of the opto isolated inputs or output contacts, in addition to a number of internal relay digital signals, such as protection starts, LEDs etc.				
0C	C3	Digital Input 116	Unused	See Data Types - G32
The digital channels may monitor any of the opto isolated inputs or output contacts, in addition to a number of internal relay digital signals, such as protection starts, LEDs etc.				
0C	C4	Digital Input 117	Unused	See Data Types - G32
The digital channels may monitor any of the opto isolated inputs or output contacts, in addition to a number of internal relay digital signals, such as protection starts, LEDs etc.				
0C	C5	Digital Input 118	Unused	See Data Types - G32
The digital channels may monitor any of the opto isolated inputs or output contacts, in addition to a number of internal relay digital signals, such as protection starts, LEDs etc.				
0C	C6	Digital Input 119	Unused	See Data Types - G32
The digital channels may monitor any of the opto isolated inputs or output contacts, in addition to a number of internal relay digital signals, such as protection starts, LEDs etc.				
0C	C7	Digital Input 120	Unused	See Data Types - G32
The digital channels may monitor any of the opto isolated inputs or output contacts, in addition to a number of internal relay digital signals, such as protection starts, LEDs etc.				
0C	C8	Digital Input 121	Unused	See Data Types - G32
The digital channels may monitor any of the opto isolated inputs or output contacts, in addition to a number of internal relay digital signals, such as protection starts, LEDs etc.				
0C	C9	Digital Input 122	Unused	See Data Types - G32
The digital channels may monitor any of the opto isolated inputs or output contacts, in addition to a number of internal relay digital signals, such as protection starts, LEDs etc.				
0C	CA	Digital Input 123	Unused	See Data Types - G32
The digital channels may monitor any of the opto isolated inputs or output contacts, in addition to a number of internal relay digital signals, such as protection starts, LEDs etc.				
0C	CB	Digital Input 124	Unused	See Data Types - G32
The digital channels may monitor any of the opto isolated inputs or output contacts, in addition to a number of internal relay digital signals, such as protection starts, LEDs etc.				
0C	CC	Digital Input 125	Unused	See Data Types - G32
The digital channels may monitor any of the opto isolated inputs or output contacts, in addition to a number of internal relay digital signals, such as protection starts, LEDs etc.				
0C	CD	Digital Input 126	Unused	See Data Types - G32

Col	Row	MENU TEXT	Default Setting	Available Setting
Description				
The digital channels may monitor any of the opto isolated inputs or output contacts, in addition to a number of internal relay digital signals, such as protection starts, LEDs etc.				
0C	CE	Digital Input 127	Unused	See Data Types - G32
The digital channels may monitor any of the opto isolated inputs or output contacts, in addition to a number of internal relay digital signals, such as protection starts, LEDs etc.				
0C	CF	Digital Input 128	Unused	See Data Types - G32
The digital channels may monitor any of the opto isolated inputs or output contacts, in addition to a number of internal relay digital signals, such as protection starts, LEDs etc.				

Table 35 - Disturbance recorder

4.7 Measurements

Col	Row	MENU TEXT	Default Setting	Available Setting
Description				
0D	00	MEASURE'T SETUP	0	
This column contains settings for the measurement setup				
0D	01	Default Display	Banner	0 = Banner, 1 = 3Ph + N Current, 2 = 3Ph Voltage , 3 = Power , 4 =Date and Time, 5 = Description, 6 = Plant Reference, 7 = Frequency, 8 = Access Level
This indicates the default display which can only be changed whilst at the default display using the arrow keys for operator or higher level roles. Only visible on UI.				
0D	02	Local Values	Primary	0 = Primary or 1 = Secondary
This setting controls whether measured values via the front panel user interface and the front courier port are displayed as primary or secondary quantities.				
0D	03	Remote Values	Primary	0 = Primary or 1 = Secondary
This setting controls whether measured values via the rear communication port are displayed as primary or secondary quantities.				
0D	04	Measurement Ref	VA	0 = VA, 1 = VB, 2 = VC, 3 = IA, 4 = IB, 5 = IC
Using this setting the phase reference for all angular measurements by the relay can be selected. This reference is for Measurements 1. Measurements 3 uses always IA local as a reference				
0D	05	Measurement Mode	0	0 to 3 step 1
This setting is used to control the signing of the real and reactive power quantities; the signing convention used is defined in the Measurements and Recording chapter (P54x/EN MR).				
0D	06	Fix Dem Period	30min	From 1min to 99min step 1min
This setting defines the length of the fixed demand window				
0D	07	Roll Sub Period	30min	From 1min to 99min step 1min
These two settings are used to set the length of the window used for the calculation of rolling demand quantities				
0D	08	Num Sub Periods	1	1 to 15 step 1
This setting is used to set the resolution of the rolling sub window				
0D	09	Distance Unit	Miles	0 = Kilometres or 1 = Miles
This setting is used to select the unit of distance for fault location purposes, note that the length of the line is preserved when converting from km to miles and vice versa				
0D	0A	Fault Location	Distance	0 = Distance, 1 = Ohms, 2 = % of Line
The calculated fault location can be displayed using one of several options selected using this setting				
0D	0B	Remote2 Values	Primary	0 = Primary or 1 = Secondary

Col	Row	MENU TEXT	Default Setting	Available Setting
Description				
The setting defines whether the values measured via the 2nd Rear Communication port are displayed in primary or secondary terms.				

Table 36 - Measurements

4.8 Communications Settings

The communications settings apply to the rear communications ports only and will depend upon the particular protocol being used. Further details are given in the SCADA Communications chapter.

Depending on the values stored, the available settings may change too. The applicability of each setting is given in the description or available setting cell. These settings are available in the menu '**Communications**' column and are displayed.

These settings potentially cover a variety of different protocols and ports, including:

Col	Row	Menu Text	Default Setting	Available Setting
Description				
0E	00	COMMUNICATIONS	0	
This column contains general communications settings				
0E	01	RP1 Protocol	0	Not Settable
Indicates the communications protocol that will be used on the rear communications port. Ordering option: Courier, IEC870-5-103 or DNP 3.0				
0E	02	RP1 Address	255 1 1	0 to 255 step 1 (Courier) 0 to 254 step 1 (CS103) 0 to 65519 step 1 (DNP3)
Rear Port 1 Protocol device address. This cell sets the unique address for the relay such that only one relay is accessed by master station software.				
0E	03	RP1 InactivTimer	15min	From 1min to 30min step 1min
Rear Port 1 Protocol inactivity timer. This cell controls how long the relay will wait without receiving any messages on the rear port before it reverts to its default state, including resetting any password access that was enabled.				
0E	04	RP1 Baud Rate	19200 bits/s	0=9600 bits/s 1=19200 bits/s (CS103) 0=1200 bits/s 1=2400 bits/s 2=4800 bits/s 3=9600 bits/s 4=19200 bits/s 5=38400 bits/s (DNP3)
Rear Port 1 Protocol serial bit/ baud rate. This cell controls the communication speed between IED and master station. It is important that both IED and master station are set at the same speed setting.				
0E	05	RP1 Parity	None	0 = Odd, 1 = Even, 2 = None
Rear Port 1 Modbus/DNP3 Protocol parity. This cell controls the parity format used in the data frames. It is important that both IED and master station are set with the same parity setting.				
0E	06	RP1 Meas Period	10s	From 1s to 60s step 1s
Rear Port 1 IEC60870-5-103 Protocol measurement period. IEC60870-5-103 versions only. This cell controls the time interval that the IED will use between sending measurement data to the master station.				
0E	07	RP1 PhysicalLink	Copper	0 = Copper or 1 = Fibre Optic
Rear Port 1 Physical link selector. This cell defines whether an electrical EIA(RS) 485 or fiber optic connection is being used for communication between the master station and IED. This cell is only visible if a fibre optic board is fitted.				
0E	08	DNP Time Sync	Disabled	0 = Disabled or 1 = Enabled
Rear Port 1 DNP 3.0 Protocol time sync configuration. Enables or disables the relay requesting time sync. from the master via IIN bit 4 word 1.				

Col	Row	Menu Text	Default Setting	Available Setting
Description				
0E	0A	RP1 CS103Blcking	Disabled	0 = Disabled, 1 = Monitor blocking or 2 = Command blocking
IEC60870-5-103 versions only. There are three settings associated with this cell: Disabled - No blocking selected. Monitor Blocking - When the monitor blocking DDB Signal is active high, either by energizing an opto input or control input, reading of the status information and disturbance records is not permitted. When in this mode the relay returns a "termination of general interrogation" message to the master station. Command Blocking - When the command blocking DDB signal is active high, either by energizing an opto input or control input, all remote commands will be ignored (i.e. CB Trip/Close, change setting group etc.). When in this mode the relay returns a "negative acknowledgement of command" message to the master station.				
0E	0B	RP1 Card Status	0	Not Settable
Displays the status of the card in RP1				
0E	0C	RP1 Port Config	K Bus	0 = K Bus or 1 = EIA485 (RS485)
Courier versions only. This cell defines whether an electrical KBus or EIA(RS)485 is being used for communication between the master station and relay.				
0E	0D	RP1 Comms Mode	IEC60870 FT1.2	0 = IEC60870 FT1.2 or 1 = 10-bit No Parity
Courier versions only. The choice is either IEC 60870 FT1.2 for normal operation with 11-bit modems, or 10-bit no parity.				
0E	0E	RP1 Baud Rate	19200 bits/s	0 = 9600 bits/s, 1 = 19200 bits/s, 2 = 38400 bits/s
Courier versions only. This cell controls the communication speed between relay and master station. It is important that both relay and master station are set at the same speed setting.				
0E	0F	Meas Scaling	Primary	0 = Normalised, 1 = Primary, 2 = Secondary
DNP 3.0 and IEC61850+DNP3OE only. Setting to report analogue values in terms of primary, secondary or normalized (with respect to the CT/VT ratio setting) values.				
0E	10	Message Gap (ms)	0	0 to 50 step 1
DNP 3.0 and IEC61850+DNP3OE only. This setting allows the master station to have an interframe gap.				
0E	11	DNP Need Time	10min	From 1min to 30min step 1min
DNP 3.0 and IEC61850+DNP3OE only. The duration of time waited before requesting another time sync from the master. Change this setting needs to reboot relay to take effect.				
0E	12	DNP App Fragment	2048	100 to 2048 step 1
DNP 3.0 and IEC61850+DNP3OE only. The maximum message length (application fragment size) transmitted by the IED. Change this setting needs to reboot relay to take effect.				
0E	13	DNP App Timeout	2s	From 1s to 120s step 1s
DNP 3.0 and IEC61850+DNP3OE only. Duration of time waited, after sending a message fragment and awaiting a confirmation from the master. Change this setting needs to reboot relay to take effect.				
0E	14	DNP SBO Timeout	10s	From 1s to 10s step 1s
DNP 3.0 and IEC61850+DNP3OE only. Duration of time waited, after receiving a select command and awaiting an operate confirmation from the master. Change this setting needs to reboot relay to take effect.				
0E	15	DNP Link Timeout	0s	From 0s to 120s step 1s
DNP 3.0 and IEC61850+DNP3OE only. Duration of time that the IED will wait for a Data Link Confirmation from the master. A value of 0 means data link support disabled and 1 to 120 seconds is the timeout setting. Change this setting needs to reboot relay to take effect.				
0E	1F	ETH Protocol	0	Not Settable
Visible when Ethernet card fitted. Indicates the protocol used on the Network Interface Card: IEC61850 or IEC61850+DNP3				
0E	22	ETH MAC Addr1	0	Not Settable
Shows the MAC address of the 1st Ethernet port. Visible when Ethernet card fitted.				
0E	23	ETH MAC Addr2	0	Not Settable

Col	Row	Menu Text	Default Setting	Available Setting
Description				
Shows the MAC address of the 2nd Ethernet port. Visible when Ethernet card fitted.				
0E	24	PB MAC Addr1	0	Not Settable
Shows the MAC address of the 1st Process Bus Ethernet port. Visible when Process Bus card fitted.				
0E	25	PB MAC Addr2	0	Not Settable
Shows the MAC address of the 2nd Process Bus Ethernet port. Visible when Process Bus card fitted.				
0E	64	ETH Tunl Timeout	15min	From 1min to 30min step 1min
Duration of time to wait before an inactive tunnel to MiCOM S1 Studio is reset. Visible when Ethernet card fitted.				
0E	70	Redundancy Conf	0	0
NIOS PARAMETERS. The redundant agency device configuration is used for SNMP server. This does not affect IEC61850 communications. Visible when redundant Ethernet card fitted and Comm Mode=PRP or HSR				
0E	71	MAC Address	0	Not Settable
MAC address for the NIOS. The redundant agency device configuration is used for SNMP server. The MAC address is MAC2+1. This does not affect IEC61850 communications. Visible when redundant Ethernet card fitted and Comm Mode=PRP or HSR				
0E	72	IP Address	000.000.000.000	000.000.000.000 to 255.255.255.255
The redundant agency device configuration is used for SNMP server. This does not affect IEC61850 communications. Visible when redundant Ethernet card fitted and Comm Mode=PRP or HSR.				
0E	73	Subnet Mask	000.000.000.000	000.000.000.000 to 255.255.255.255
Subnet Mask for the NIOS. The redundant agency device configuration is used for SNMP server. This does not affect IEC61850 communications. Visible when redundant Ethernet card fitted and Comm Mode=PRP or HSR				
0E	74	Gateway	000.000.000.000	000.000.000.000 to 255.255.255.255
Gateway for the NIOS. The redundant agency device configuration is used for SNMP server. This does not affect IEC61850 communications. Visible when redundant Ethernet card fitted and Comm Mode=PRP or HSR				
0E	75	RSTPPriority	32768	From 0 to 61440 step 4096
The manageable component of the Bridge Identifier, also known as the Bridge Priority				
0E	76	RSTPMaxAge	20	From 6 to 40 step 1
The maximum age of the information transmitted by the Bridge when it is the Root Bridge. In 802.1D-2004 standard (RSTP), chap 17.14, a Bridge shall enforce the following relationships: "2 × (RSTPForwardDelay – 1.0 seconds) >= RSTPMaxAge".				
0E	77	RSTPFwdDelay	15	From 4 to 30 step 1
The delay used by STP Bridges to transition Root and Designated Ports to Forwarding. In 802.1D-2004 standard (RSTP), chap 17.14, a Bridge shall enforce the following relationships: "2 × (RSTPForwardDelay – 1.0 seconds) >= RSTPMaxAge".				
0E	78	RSTPHelloTime	2	From 1 to 2 step 1
The interval between periodic transmissions of Configuration Messages by Designated Ports				
0E	7E	RSTPPortAStatus	0	Not Settable
Indication the status of port A.				
0E	7F	RSTPPortBStatus	0	Not Settable
Indication the status of port B.				
0E	80	REAR PORT2 (RP2)	0	0
RP2 versions only.				
0E	81	RP2 Protocol	Courier	Not Settable
RP2 versions only. Indicates the communications protocol that will be used on the rear communications port.				
0E	84	RP2 Card Status	0	Not Settable

Col	Row	Menu Text	Default Setting	Available Setting
Description				
RP2 versions only. Displays the status of the card in RP2: Unsupported, Card Not Fitted, EIA232 OK, EIA485 OK or K Bus OK				
0E	88	RP2 Port Config	EIA232 (RS232)	0 = EIA232 (RS232), 1 = EIA485 (RS485), 2 = K-Bus
RP2 versions only. This cell defines whether an electrical EIA(RS)232, EIA(RS)485 or KBus is being used for communication.				
0E	8A	RP2 Comms Mode	IEC60870 FT1.2	0 = IEC60870 FT1.2 Frame or 1 = 10-bit no parity
RP2 versions only. The choice is either IEC 60870 FT1.2 for normal operation with 11-bit modems, or 10-bit no parity.				
0E	90	RP2 Address	255	0 to 255 step 1
RP2 versions only. This cell sets the unique address for the relay such that only one relay is accessed by master station software.				
0E	92	RP2 InactivTimer	15min	From 1min to 30min step 1min
RP2 versions only. This cell controls how long the relay will wait without receiving any messages on the rear port before it reverts to its default state, including resetting any password access that was enabled.				
0E	94	RP2 Baud Rate	19200 bits/s	0 = 9600 bits/s, 1 = 19200 bits/s, 2 = 38400 bits/s
RP2 versions only. This cell controls the communication speed between relay and master station. It is important that both relay and master station are set at the same speed setting.				

Table 37 - Communications settings

4.9 Commissioning Tests

To help minimising the time required to test MiCOM relays the relay provides several test facilities under the 'COMMISSION TESTS' menu heading.

There are menu cells which allow the status of the opto-isolated inputs, output relay contacts, internal Digital Data Bus (DDB) signals and user-programmable LEDs to be monitored. Additionally there are cells to test the operation of the output contacts, user-programmable LEDs.

This column is visible when the "Commission tests" setting ("Configuration" column) = "visible".

There are also cells to test the operation of, where available, the auto-reclose cycles.

Col	Row	MENU TEXT	Default Setting	Available Setting
Description				
0F	00	COMMISSION TESTS	0	
This column contains commissioning test settings				
0F	01	Opto I/P Status	0	Not Settable
This menu cell displays the status of the available relay's opto-isolated inputs as a binary string, a '1' indicating an energized opto-isolated input and a '0' a de-energized one.				
0F	02	Relay O/P Status	0	Not Settable
Displays the status of all available output relays fitted. Not Valid if Contacts Blocked.				
0F	03	Test Port Status	0	Not Settable
This menu cell displays the status of the eight digital data bus (DDB) signals that have been allocated in the 'Monitor Bit' cells.				
0F	04	LED Status	0	Not Settable
This cell is an eight bit binary string that indicates which of the user-programmable LEDs on the relay are illuminated, a '1' indicating a particular LED is lit and a '0' not lit.				
0F	05	Monitor Bit 1	1070	0 to 2047 step 1

Col	Row	MENU TEXT	Default Setting	Available Setting
Description				
The eight 'Monitor Bit' cells allow the user to select the status of which digital data bus signals can be observed in the 'Test Port Status' cell or via the monitor/download port.				
0F	06	Monitor Bit 2	1071	0 to 2047 step 1
The eight 'Monitor Bit' cells allow the user to select the status of which digital data bus signals can be observed in the 'Test Port Status' cell or via the monitor/download port.				
0F	07	Monitor Bit 3	1072	0 to 2047 step 1
The eight 'Monitor Bit' cells allow the user to select the status of which digital data bus signals can be observed in the 'Test Port Status' cell or via the monitor/download port.				
0F	08	Monitor Bit 4	1073	0 to 2047 step 1
The eight 'Monitor Bit' cells allow the user to select the status of which digital data bus signals can be observed in the 'Test Port Status' cell or via the monitor/download port.				
0F	09	Monitor Bit 5	1074	0 to 2047 step 1
The eight 'Monitor Bit' cells allow the user to select the status of which digital data bus signals can be observed in the 'Test Port Status' cell or via the monitor/download port.				
0F	0A	Monitor Bit 6	1075	0 to 2047 step 1
The eight 'Monitor Bit' cells allow the user to select the status of which digital data bus signals can be observed in the 'Test Port Status' cell or via the monitor/download port.				
0F	0B	Monitor Bit 7	1076	0 to 2047 step 1
The eight 'Monitor Bit' cells allow the user to select the status of which digital data bus signals can be observed in the 'Test Port Status' cell or via the monitor/download port.				
0F	0C	Monitor Bit 8	1077	0 to 2047 step 1
The eight 'Monitor Bit' cells allow the user to select the status of which digital data bus signals can be observed in the 'Test Port Status' cell or via the monitor/download port.				
0F	0D	Test Mode	Disabled	0 = Disabled, 1 = Test Mode, 2 = Contacts Blocked
The Test Mode menu cell is used to allow secondary injection testing to be performed on the IED without operation of the trip contacts. It also enables a facility to directly test the output contacts by applying menu controlled test signals. To select test mode the Test Mode menu cell should be set to 'Test Mode', which causes an alarm condition to be recorded with message "Test mode Alm". In IEC 60870-5-103 builds changes the Cause of Transmission, COT, to Test Mode. To enable testing of output contacts the Test Mode cell should be set to Contacts Blocked which causes an alarm condition to be recorded with message "Contacts Blk Alm" and the yellow 'Out of Service' LED to illuminate. This blocks the protection from operating the contacts and enables the test pattern and contact test functions which can be used to manually operate the output contacts. This mode also blocks maintenance, counters and freezes any information stored in the Circuit Breaker Condition column. Also in IEC 60870-5-103 builds changes the Cause of Transmission, COT, to Test Mode. Once testing is complete the cell must be set back to 'Disabled' to restore the IED back to service.				
0F	0E	Test Pattern	0000000000000000(bin)	0=Not Operated or 1=Operated
This cell is used to select the output relay contacts that will be operated when the 'Contact Test' cell is set to 'Apply Test'.				
0F	0F	Contact Test	No Operation	0 = No Operation, 1 = Apply Test, 2 = Remove Test
When the 'Apply Test' command in this cell is issued the contacts set for operation (set to '1') in the 'Test Pattern' cell are energised. After the test has been applied the command text on the LCD will change to 'No Operation' and the contacts will remain in the Test State until reset issuing the 'Remove Test' command. The command text on the LCD will again revert to 'No Operation' after the 'Remove Test' command has been issued.				
Note: When the 'Test Mode' cell is set to 'Contacts Blocked' the 'Relay O/P Status' cell does not show the current status of the output relays and hence can not be used to confirm operation of the output relays. Therefore it will be necessary to physically monitor the state of each contact in turn.				
0F	10	Test LEDs	No Operation	0 = No Operation or 1 = Apply Test
When the 'Apply Test' command in this cell is issued the eighteen user-programmable LEDs will illuminate for approximately 2 seconds before they extinguish and the command text on the LCD reverts to 'No Operation'.				
0F	11	Test Autoreclose	No Operation	0 = No Operation, 1 = Trip 3 Pole, 2 = Trip Pole A, 3 = Trip Pole B, 4 = Trip Pole C
This is a command used to simulate a single pole or three phase tripping in order to test Auto-reclose cycle.				

Col	Row	MENU TEXT	Default Setting	Available Setting
Description				
0F	12	Static Test	Disabled	0 = Disabled or 1 = Enabled
When Static test is Enabled, delta phase selectors and the delta directional line are bypassed to allow the user to test the relay with older injection test sets that are incapable of simulating real dynamic step changes in current and voltage. Resulting trip times will be slower, as extra filtering of distance comparators is also switched-in.				
0F	13	Test Loopback	Disabled	0 = Disabled, 1 = External, 2 = Internal
Setting that allows communication loopback testing.				
0F	14	IM64 TestPattern	0000000000000000(bin)	Bit 00=IM64 Ch1 Output1 to Bit 07=IM64 Ch1 Output8, Bit 08=IM64 Ch2 Output1 to Bit 0F=IM64 Ch2 Output8
This cell is used to set the DDB signals included in the User Defined Inter-Relay Commands IM64 when the 'IM64 Test Mode' cell is set to 'Enable'.				
0F	15	IM64 Test Mode	Disabled	0 = Disabled or 1 = Enabled
When the Enable command in this cell is issued the DDB set for operation (set to '1') in the 'Test Pattern' cell change state.				
0F	20	DDB 31 - 0	0	Not Settable
Displays the status of DDB signals				
0F	21	DDB 63 - 32	0	Not Settable
Displays the status of DDB signals				
0F	22	DDB 95 - 64	0	Not Settable
Displays the status of DDB signals				
0F	23	DDB 127 - 96	0	Not Settable
Displays the status of DDB signals				
0F	24	DDB 159 - 128	0	Not Settable
Displays the status of DDB signals				
0F	25	DDB 191 - 160	0	Not Settable
Displays the status of DDB signals				
0F	26	DDB 223 - 192	0	Not Settable
Displays the status of DDB signals				
0F	27	DDB 255 - 224	0	Not Settable
Displays the status of DDB signals				
0F	28	DDB 287 - 256	0	Not Settable
Displays the status of DDB signals				
0F	29	DDB 319 - 288	0	Not Settable
Displays the status of DDB signals				
0F	2A	DDB 351 - 320	0	Not Settable
Displays the status of DDB signals				
0F	2B	DDB 383 - 352	0	Not Settable
Displays the status of DDB signals				
0F	2C	DDB 415 - 384	0	Not Settable
Displays the status of DDB signals				
0F	2D	DDB 447 - 416	0	Not Settable
Displays the status of DDB signals				
0F	2E	DDB 479 - 448	0	Not Settable
Displays the status of DDB signals				
0F	2F	DDB 511 - 480	0	Not Settable
Displays the status of DDB signals				

Col	Row	MENU TEXT	Default Setting	Available Setting
Description				
0F	30	DDB 543 - 512	0	Not Settable
Displays the status of DDB signals				
0F	31	DDB 575 - 544	0	Not Settable
Displays the status of DDB signals				
0F	32	DDB 607 - 576	0	Not Settable
Displays the status of DDB signals				
0F	33	DDB 639 - 608	0	Not Settable
Displays the status of DDB signals				
0F	34	DDB 671 - 640	0	Not Settable
Displays the status of DDB signals				
0F	35	DDB 703 - 672	0	Not Settable
Displays the status of DDB signals				
0F	36	DDB 735 - 704	0	Not Settable
Displays the status of DDB signals				
0F	37	DDB 767 - 736	0	Not Settable
Displays the status of DDB signals				
0F	38	DDB 799 - 768	0	Not Settable
Displays the status of DDB signals				
0F	39	DDB 831 - 800	0	Not Settable
Displays the status of DDB signals				
0F	3A	DDB 863 - 832	0	Not Settable
Displays the status of DDB signals				
0F	3B	DDB 895 - 864	0	Not Settable
Displays the status of DDB signals				
0F	3C	DDB 927 - 896	0	Not Settable
Displays the status of DDB signals				
0F	3D	DDB 959 - 928	0	Not Settable
Displays the status of DDB signals				
0F	3E	DDB 991 - 960	0	Not Settable
Displays the status of DDB signals				
0F	3F	DDB 1023 - 992	0	Not Settable
Displays the status of DDB signals				
0F	40	DDB 1055 - 1024	0	Not Settable
Displays the status of DDB signals				
0F	41	DDB 1087 - 1056	0	Not Settable
Displays the status of DDB signals				
0F	42	DDB 1119 - 1088	0	Not Settable
Displays the status of DDB signals				
0F	43	DDB 1151 - 1120	0	Not Settable
Displays the status of DDB signals				
0F	44	DDB 1183 - 1152	0	Not Settable
Displays the status of DDB signals				
0F	45	DDB 1215 - 1184	0	Not Settable

Col	Row	MENU TEXT	Default Setting	Available Setting
Description				
Displays the status of DDB signals				
0F	46	DDB 1247 - 1216	0	Not Settable
Displays the status of DDB signals				
0F	47	DDB 1279 - 1248	0	Not Settable
Displays the status of DDB signals				
0F	48	DDB 1311 - 1280	0	Not Settable
Displays the status of DDB signals				
0F	49	DDB 1343 - 1312	0	Not Settable
Displays the status of DDB signals				
0F	4A	DDB 1375 - 1344	0	Not Settable
Displays the status of DDB signals				
0F	4B	DDB 1407 - 1376	0	Not Settable
Displays the status of DDB signals				
0F	4C	DDB 1439 - 1408	0	Not Settable
Displays the status of DDB signals				
0F	4D	DDB 1471 - 1440	0	Not Settable
Displays the status of DDB signals				
0F	4E	DDB 1503 - 1472	0	Not Settable
Displays the status of DDB signals				
0F	4F	DDB 1535 - 1504	0	Not Settable
Displays the status of DDB signals				
0F	50	DDB 1567 - 1536	0	Not Settable
Displays the status of DDB signals				
0F	51	DDB 1599 - 1568	0	Not Settable
Displays the status of DDB signals				
0F	52	DDB 1631 - 1600	0	Not Settable
Displays the status of DDB signals				
0F	53	DDB 1663 - 1632	0	Not Settable
Displays the status of DDB signals				
0F	54	DDB 1695 - 1664	0	Not Settable
Displays the status of DDB signals				
0F	55	DDB 1727 - 1696	0	Not Settable
Displays the status of DDB signals				
0F	56	DDB 1759 - 1728	0	Not Settable
Displays the status of DDB signals				
0F	57	DDB 1791 - 1760	0	Not Settable
Displays the status of DDB signals				
0F	58	DDB 1823 - 1792	0	Not Settable
Displays the status of DDB signals				
0F	59	DDB 1855 - 1824	0	Not Settable
Displays the status of DDB signals				
0F	5A	DDB 1887 - 1856	0	Not Settable
Displays the status of DDB signals				

Col	Row	MENU TEXT	Default Setting	Available Setting
Description				
0F	5B	DDB 1919 - 1888	0	Not Settable
Displays the status of DDB signals				
0F	5C	DDB 1951 - 1920	0	Not Settable
Displays the status of DDB signals				
0F	5D	DDB 1983 - 1952	0	Not Settable
Displays the status of DDB signals				
0F	5E	DDB 2015 - 1984	0	Not Settable
Displays the status of DDB signals				
0F	5F	DDB 2047 - 2016	0	Not Settable
Displays the status of DDB signals				

Table 38 - Commissioning tests

4.10 Circuit Breaker Condition Monitor Setup

The following table, detailing the options available for the Circuit Breaker condition monitoring, is taken from the relay menu. It includes the setup of the current broken facility and those features that can be set to raise an alarm or Circuit Breaker lockout.

Col	Row	MENU TEXT	Default Setting	Available Setting
Description				
10	00	CB MONITOR SETUP	0	
This column contains Circuit Breaker monitoring parameters				
10	01	Broken I [^]	2	1 to 2 step 0.1
This sets the factor to be used for the cumulative I [^] counter calculation that monitors the cumulative severity of the duty placed on the interrupter. This factor is set according to the type of Circuit Breaker used				
10	02	I [^] Maintenance	Alarm Disabled	0 = Alarm Disabled or 1 = Alarm Enabled
Setting which determines if an alarm will be raised or not when the cumulative I [^] maintenance counter threshold is exceeded.				
10	03	I [^] Maintenance	1000	From 1A to 25kA step 1A
Setting that determines the threshold for the cumulative I [^] maintenance counter monitors.				
10	04	I [^] Lockout	Alarm Disabled	0 = Alarm Disabled or 1 = Alarm Enabled
Setting which determines if an alarm will be raised or not when the cumulative I [^] lockout counter threshold is exceeded.				
10	05	I [^] Lockout	2000	From 1A to 25kA step 1A
Setting that determines the threshold for the cumulative I [^] lockout counter monitor. Set that should maintenance not be carried out, the relay can be set to lockout the auto-reclose function on reaching a second operations threshold.				
10	06	No. CB Ops Maint	Alarm Disabled	0 = Alarm Disabled or 1 = Alarm Enabled
Setting to activate the number of circuit breaker operations maintenance alarm.				
10	07	No. CB Ops Maint	10	1 to 10000 step 1
Sets the threshold for number of circuit breaker operations maintenance alarm, indicating when preventative maintenance is due.				
10	08	No. CB Ops Lock	Alarm Disabled	0 = Alarm Disabled or 1 = Alarm Enabled
Setting to activate the number of circuit breaker operations lockout alarm.				
10	09	No. CB Ops Lock	20	1 to 10000 step 1
Sets the threshold for number of circuit breaker operations lockout. The relay can be set to lockout the auto-reclose function on reaching a second operations threshold.				

Col	Row	MENU TEXT	Default Setting	Available Setting
Description				
10	0A	CB Time Maint	Alarm Disabled	0 = Alarm Disabled or 1 = Alarm Enabled
Setting to activate the circuit breaker operating time maintenance alarm.				
10	0B	CB Time Maint	100ms	From 5ms to 500ms step 1ms
Setting for the circuit operating time threshold which is set in relation to the specified interrupting time of the circuit breaker.				
10	0C	CB Time Lockout	Alarm Disabled	0 = Alarm Disabled or 1 = Alarm Enabled
Setting to activate the circuit breaker operating time lockout alarm.				
10	0D	CB Time Lockout	200ms	From 5ms to 500ms step 1ms
Setting for the circuit breaker operating time threshold which is set in relation to the specified interrupting time of the circuit breaker. The relay can be set to lockout the auto-reclose function on reaching a second operations threshold.				
10	0E	Fault Freq Lock	Alarm Disabled	0 = Alarm Disabled or 1 = Alarm Enabled
Enables the excessive fault frequency alarm.				
10	0F	Fault Freq Count	10	1 to 9999 step 1
Sets a circuit breaker frequent operations counter that monitors the number of operations over a set time period				
10	10	Fault Freq Time	3600s	From 0s to 9999s step 1s
Sets the time period over which the circuit breaker operations are to be monitored. Should the set number of trip operations be accumulated within this time period, an alarm can be raised. Excessive fault frequency/trips can be used to indicate that the circuit may need maintenance attention (e.g. Tree-felling or insulator cleaning).				

Table 39 - Circuit breaker condition monitor setup

4.11 Opto Configuration

Col	Row	MENU TEXT	Default Setting	Available Setting
Description				
11	00	OPTO CONFIG	0	
This column contains opto-input configuration settings				
11	01	Global Nominal V	24/27V	0 = 24-27V, 1 = 30-34V, 2 = 48-54V, 3 = 110-125V, 4 = 220-250V or 5 = Custom
Sets the nominal battery voltage for all opto inputs by selecting one of the five standard ratings in the Global Nominal V settings. If Custom is selected then each opto input can individually be set to a nominal voltage value.				
11	02	Opto Input 1	24/27V	0 = 24/27V, 1 = 30/34V, 2 = 48/54V, 3 = 110/125V or 4 = 220/250V
Each opto input can individually be set to a nominal voltage value if custom is selected for the global setting.				
11	03	Opto Input 2	24/27V	0 = 24/27V, 1 = 30/34V, 2 = 48/54V, 3 = 110/125V or 4 = 220/250V
Each opto input can individually be set to a nominal voltage value if custom is selected for the global setting. The number of inputs may be up to 32, depending on MiCOM P54x model and I/O configuration.				
11	04	Opto Input 3	24/27V	0 = 24/27V, 1 = 30/34V, 2 = 48/54V, 3 = 110/125V or 4 = 220/250V
Each opto input can individually be set to a nominal voltage value if custom is selected for the global setting. The number of inputs may be up to 32, depending on MiCOM P54x model and I/O configuration.				
11	05	Opto Input 4	24/27V	0 = 24/27V, 1 = 30/34V, 2 = 48/54V, 3 = 110/125V or 4 = 220/250V
Each opto input can individually be set to a nominal voltage value if custom is selected for the global setting. The number of inputs may be up to 32, depending on MiCOM P54x model and I/O configuration.				

Col	Row	MENU TEXT	Default Setting	Available Setting
Description				
11	06	Opto Input 5	24/27V	0 = 24/27V, 1 = 30/34V, 2 = 48/54V, 3 = 110/125V or 4 = 220/250V
Each opto input can individually be set to a nominal voltage value if custom is selected for the global setting. The number of inputs may be up to 32, depending on MiCOM P54x model and I/O configuration.				
11	07	Opto Input 6	24/27V	0 = 24/27V, 1 = 30/34V, 2 = 48/54V, 3 = 110/125V or 4 = 220/250V
Each opto input can individually be set to a nominal voltage value if custom is selected for the global setting. The number of inputs may be up to 32, depending on MiCOM P54x model and I/O configuration.				
11	08	Opto Input 7	24/27V	0 = 24/27V, 1 = 30/34V, 2 = 48/54V, 3 = 110/125V or 4 = 220/250V
Each opto input can individually be set to a nominal voltage value if custom is selected for the global setting. The number of inputs may be up to 32, depending on MiCOM P54x model and I/O configuration.				
11	09	Opto Input 8	24/27V	0 = 24/27V, 1 = 30/34V, 2 = 48/54V, 3 = 110/125V or 4 = 220/250V
Each opto input can individually be set to a nominal voltage value if custom is selected for the global setting. The number of inputs may be up to 32, depending on MiCOM P54x model and I/O configuration.				
11	0A	Opto Input 9	24/27V	0 = 24/27V, 1 = 30/34V, 2 = 48/54V, 3 = 110/125V or 4 = 220/250V
Each opto input can individually be set to a nominal voltage value if custom is selected for the global setting. The number of inputs may be up to 32, depending on MiCOM P54x model and I/O configuration.				
11	0B	Opto Input 10	24/27V	0 = 24/27V, 1 = 30/34V, 2 = 48/54V, 3 = 110/125V or 4 = 220/250V
Each opto input can individually be set to a nominal voltage value if custom is selected for the global setting. The number of inputs may be up to 32, depending on MiCOM P54x model and I/O configuration.				
11	0C	Opto Input 11	24/27V	0 = 24/27V, 1 = 30/34V, 2 = 48/54V, 3 = 110/125V or 4 = 220/250V
Each opto input can individually be set to a nominal voltage value if custom is selected for the global setting. The number of inputs may be up to 32, depending on MiCOM P54x model and I/O configuration.				
11	0D	Opto Input 12	24/27V	0 = 24/27V, 1 = 30/34V, 2 = 48/54V, 3 = 110/125V or 4 = 220/250V
Each opto input can individually be set to a nominal voltage value if custom is selected for the global setting. The number of inputs may be up to 32, depending on MiCOM P54x model and I/O configuration.				
11	0E	Opto Input 13	24/27V	0 = 24/27V, 1 = 30/34V, 2 = 48/54V, 3 = 110/125V or 4 = 220/250V
Each opto input can individually be set to a nominal voltage value if custom is selected for the global setting. The number of inputs may be up to 32, depending on MiCOM P54x model and I/O configuration.				
11	0F	Opto Input 14	24/27V	0 = 24/27V, 1 = 30/34V, 2 = 48/54V, 3 = 110/125V or 4 = 220/250V
Each opto input can individually be set to a nominal voltage value if custom is selected for the global setting. The number of inputs may be up to 32, depending on MiCOM P54x model and I/O configuration.				
11	10	Opto Input 15	24/27V	0 = 24/27V, 1 = 30/34V, 2 = 48/54V, 3 = 110/125V or 4 = 220/250V
Each opto input can individually be set to a nominal voltage value if custom is selected for the global setting. The number of inputs may be up to 32, depending on MiCOM P54x model and I/O configuration.				
11	11	Opto Input 16	24/27V	0 = 24/27V, 1 = 30/34V, 2 = 48/54V, 3 = 110/125V or 4 = 220/250V
Each opto input can individually be set to a nominal voltage value if custom is selected for the global setting. The number of inputs may be up to 32, depending on MiCOM P54x model and I/O configuration.				
11	60	Opto Filter Cntl	1111110101101111111011 (bin)	32-bit binary setting: 0=disable filtering or 1=enable filtering

Col	Row	MENU TEXT	Default Setting	Available Setting
Description				
12	0B	Control Input 10	No Operation	0 = No Operation, 1 = SET , 2 = RESET
Setting to allow Control Inputs 10 set/ reset.				
12	0C	Control Input 11	No Operation	0 = No Operation, 1 = SET , 2 = RESET
Setting to allow Control Inputs 11 set/ reset.				
12	0D	Control Input 12	No Operation	0 = No Operation, 1 = SET , 2 = RESET
Setting to allow Control Inputs 12 set/ reset.				
12	0E	Control Input 13	No Operation	0 = No Operation, 1 = SET , 2 = RESET
Setting to allow Control Inputs 13 set/ reset.				
12	0F	Control Input 14	No Operation	0 = No Operation, 1 = SET , 2 = RESET
Setting to allow Control Inputs 14 set/ reset.				
12	10	Control Input 15	No Operation	0 = No Operation, 1 = SET , 2 = RESET
Setting to allow Control Inputs 15 set/ reset.				
12	11	Control Input 16	No Operation	0 = No Operation, 1 = SET , 2 = RESET
Setting to allow Control Inputs 16 set/ reset.				
12	12	Control Input 17	No Operation	0 = No Operation, 1 = SET , 2 = RESET
Setting to allow Control Inputs 17 set/ reset.				
12	13	Control Input 18	No Operation	0 = No Operation, 1 = SET , 2 = RESET
Setting to allow Control Inputs 18 set/ reset.				
12	14	Control Input 19	No Operation	0 = No Operation, 1 = SET , 2 = RESET
Setting to allow Control Inputs 19 set/ reset.				
12	15	Control Input 20	No Operation	0 = No Operation, 1 = SET , 2 = RESET
Setting to allow Control Inputs 20 set/ reset.				
12	16	Control Input 21	No Operation	0 = No Operation, 1 = SET , 2 = RESET
Setting to allow Control Inputs 21 set/ reset.				
12	17	Control Input 22	No Operation	0 = No Operation, 1 = SET , 2 = RESET
Setting to allow Control Inputs 22 set/ reset.				
12	18	Control Input 23	No Operation	0 = No Operation, 1 = SET , 2 = RESET
Setting to allow Control Inputs 23 set/ reset.				
12	19	Control Input 24	No Operation	0 = No Operation, 1 = SET , 2 = RESET
Setting to allow Control Inputs 24 set/ reset.				
12	1A	Control Input 25	No Operation	0 = No Operation, 1 = SET , 2 = RESET
Setting to allow Control Inputs 25 set/ reset.				
12	1B	Control Input 26	No Operation	0 = No Operation, 1 = SET , 2 = RESET
Setting to allow Control Inputs 26 set/ reset.				
12	1C	Control Input 27	No Operation	0 = No Operation, 1 = SET , 2 = RESET
Setting to allow Control Inputs 27 set/ reset.				
12	1D	Control Input 28	No Operation	0 = No Operation, 1 = SET , 2 = RESET
Setting to allow Control Inputs 28 set/ reset.				
12	1E	Control Input 29	No Operation	0 = No Operation, 1 = SET , 2 = RESET
Setting to allow Control Inputs 29 set/ reset.				
12	1F	Control Input 30	No Operation	0 = No Operation, 1 = SET , 2 = RESET
Setting to allow Control Inputs 30 set/ reset.				
12	20	Control Input 31	No Operation	0 = No Operation, 1 = SET , 2 = RESET

Col	Row	MENU TEXT	Default Setting	Available Setting
Description				
Setting to allow Control Inputs 31 set/ reset.				
12	21	Control Input 32	No Operation	0 = No Operation, 1 = SET , 2 = RESET
Setting to allow Control Inputs 32 set/ reset.				
12	22	Ctrl Stg I/P Stat	0000000000000000(bin)	Binary Flag (16 bits) Indexed String (0 = Disabled, 1 = Enabled)
Cell that is used to set (1) and reset (0) the selected Setting Input by simply scrolling and changing the status of selected bits. This command will be then recognized and executed in the PSL. Alternatively, each of the 32 Setting input can also be enabled and disabled using the individual menu setting cells as follows:				
12	23	Ctrl Setg I/P 33	Disabled	0 = Disabled, 1 = Enabled
Setting to allow Setting Input 33 enable/Disable.				
12	24	Ctrl Setg I/P 34	Disabled	0 = Disabled, 1 = Enabled
Setting to allow Setting Input 33 enable/Disable.				
12	25	Ctrl Setg I/P 35	Disabled	0 = Disabled, 1 = Enabled
Setting to allow Setting Input 33 enable/Disable.				
12	26	Ctrl Setg I/P 36	Disabled	0 = Disabled, 1 = Enabled
Setting to allow Setting Input 33 enable/Disable.				
12	27	Ctrl Setg I/P 37	Disabled	0 = Disabled, 1 = Enabled
Setting to allow Setting Input 33 enable/Disable.				
12	28	Ctrl Setg I/P 38	Disabled	0 = Disabled, 1 = Enabled
Setting to allow Setting Input 33 enable/Disable.				
12	29	Ctrl Setg I/P 39	Disabled	0 = Disabled, 1 = Enabled
Setting to allow Setting Input 33 enable/Disable.				
12	2A	Ctrl Setg I/P 40	Disabled	0 = Disabled, 1 = Enabled
Setting to allow Setting Input 33 enable/Disable.				
12	2B	Ctrl Setg I/P 41	Disabled	0 = Disabled, 1 = Enabled
Setting to allow Setting Input 33 enable/Disable.				
12	2C	Ctrl Setg I/P 42	Disabled	0 = Disabled, 1 = Enabled
Setting to allow Setting Input 33 enable/Disable.				
12	2D	Ctrl Setg I/P 43	Disabled	0 = Disabled, 1 = Enabled
Setting to allow Setting Input 33 enable/Disable.				
12	2E	Ctrl Setg I/P 44	Disabled	0 = Disabled, 1 = Enabled
Setting to allow Setting Input 33 enable/Disable.				
12	2F	Ctrl Setg I/P 45	Disabled	0 = Disabled, 1 = Enabled
Setting to allow Setting Input 33 enable/Disable.				
12	30	Ctrl Setg I/P 46	Disabled	0 = Disabled, 1 = Enabled
Setting to allow Setting Input 33 enable/Disable.				
12	31	Ctrl Setg I/P 47	Disabled	0 = Disabled, 1 = Enabled
Setting to allow Setting Input 33 enable/Disable.				
12	32	Ctrl Setg I/P 48	Disabled	0 = Disabled, 1 = Enabled
Setting to allow Setting Input 33 enable/Disable.				

Table 41 - Control inputs

Col	Row	MENU TEXT	Default Setting	Available Setting
Description				
13	21	Ctrl Command 5	SET/RESET	0 = ON/OFF, 1 = SET/RESET, 2 = IN/OUT, 3 = ENABLED/DISABLED
Allows the SET / RESET text, displayed in the hotkey menu, to be changed to something more suitable for the application of an individual control input, such as ON / OFF, IN / OUT etc.				
13	24	Control Input 6	Latched	0 = Latched or 1 = Pulsed
Configures the control inputs as either 'latched' or 'pulsed'.				
13	25	Ctrl Command 6	SET/RESET	0 = ON/OFF, 1 = SET/RESET, 2 = IN/OUT, 3 = ENABLED/DISABLED
Allows the SET / RESET text, displayed in the hotkey menu, to be changed to something more suitable for the application of an individual control input, such as ON / OFF, IN / OUT etc.				
13	28	Control Input 7	Latched	0 = Latched or 1 = Pulsed
Configures the control inputs as either 'latched' or 'pulsed'.				
13	29	Ctrl Command 7	SET/RESET	0 = ON/OFF, 1 = SET/RESET, 2 = IN/OUT, 3 = ENABLED/DISABLED
Allows the SET / RESET text, displayed in the hotkey menu, to be changed to something more suitable for the application of an individual control input, such as ON / OFF, IN / OUT etc.				
13	2C	Control Input 8	Latched	0 = Latched or 1 = Pulsed
Configures the control inputs as either 'latched' or 'pulsed'.				
13	2D	Ctrl Command 8	SET/RESET	0 = ON/OFF, 1 = SET/RESET, 2 = IN/OUT, 3 = ENABLED/DISABLED
Allows the SET / RESET text, displayed in the hotkey menu, to be changed to something more suitable for the application of an individual control input, such as ON / OFF, IN / OUT etc.				
13	30	Control Input 9	Latched	0 = Latched or 1 = Pulsed
Configures the control inputs as either 'latched' or 'pulsed'.				
13	31	Ctrl Command 9	SET/RESET	0 = ON/OFF, 1 = SET/RESET, 2 = IN/OUT, 3 = ENABLED/DISABLED
Allows the SET / RESET text, displayed in the hotkey menu, to be changed to something more suitable for the application of an individual control input, such as ON / OFF, IN / OUT etc.				
13	34	Control Input 10	Latched	0 = Latched or 1 = Pulsed
Configures the control inputs as either 'latched' or 'pulsed'.				
13	35	Ctrl Command 10	SET/RESET	0 = ON/OFF, 1 = SET/RESET, 2 = IN/OUT, 3 = ENABLED/DISABLED
Allows the SET / RESET text, displayed in the hotkey menu, to be changed to something more suitable for the application of an individual control input, such as ON / OFF, IN / OUT etc.				
13	38	Control Input 11	Latched	0 = Latched or 1 = Pulsed
Configures the control inputs as either 'latched' or 'pulsed'.				
13	39	Ctrl Command 11	SET/RESET	0 = ON/OFF, 1 = SET/RESET, 2 = IN/OUT, 3 = ENABLED/DISABLED
Allows the SET / RESET text, displayed in the hotkey menu, to be changed to something more suitable for the application of an individual control input, such as ON / OFF, IN / OUT etc.				
13	3C	Control Input 12	Latched	0 = Latched or 1 = Pulsed
Configures the control inputs as either 'latched' or 'pulsed'.				
13	3D	Ctrl Command 12	SET/RESET	0 = ON/OFF, 1 = SET/RESET, 2 = IN/OUT, 3 = ENABLED/DISABLED
Allows the SET / RESET text, displayed in the hotkey menu, to be changed to something more suitable for the application of an individual control input, such as ON / OFF, IN / OUT etc.				

Col	Row	MENU TEXT	Default Setting	Available Setting
Description				
13	40	Control Input 13	Latched	0 = Latched or 1 = Pulsed
Configures the control inputs as either 'latched' or 'pulsed'.				
13	41	Ctrl Command 13	SET/RESET	0 = ON/OFF, 1 = SET/RESET, 2 = IN/OUT, 3 = ENABLED/DISABLED
Allows the SET / RESET text, displayed in the hotkey menu, to be changed to something more suitable for the application of an individual control input, such as ON / OFF, IN / OUT etc.				
13	44	Control Input 14	Latched	0 = Latched or 1 = Pulsed
Configures the control inputs as either 'latched' or 'pulsed'.				
13	45	Ctrl Command 14	SET/RESET	0 = ON/OFF, 1 = SET/RESET, 2 = IN/OUT, 3 = ENABLED/DISABLED
Allows the SET / RESET text, displayed in the hotkey menu, to be changed to something more suitable for the application of an individual control input, such as ON / OFF, IN / OUT etc.				
13	48	Control Input 15	Latched	0 = Latched or 1 = Pulsed
Configures the control inputs as either 'latched' or 'pulsed'.				
13	49	Ctrl Command 15	SET/RESET	0 = ON/OFF, 1 = SET/RESET, 2 = IN/OUT, 3 = ENABLED/DISABLED
Allows the SET / RESET text, displayed in the hotkey menu, to be changed to something more suitable for the application of an individual control input, such as ON / OFF, IN / OUT etc.				
13	4C	Control Input 16	Latched	0 = Latched or 1 = Pulsed
Configures the control inputs as either 'latched' or 'pulsed'.				
13	4D	Ctrl Command 16	SET/RESET	0 = ON/OFF, 1 = SET/RESET, 2 = IN/OUT, 3 = ENABLED/DISABLED
Allows the SET / RESET text, displayed in the hotkey menu, to be changed to something more suitable for the application of an individual control input, such as ON / OFF, IN / OUT etc.				
13	50	Control Input 17	Latched	0 = Latched or 1 = Pulsed
Configures the control inputs as either 'latched' or 'pulsed'.				
13	51	Ctrl Command 17	SET/RESET	0 = ON/OFF, 1 = SET/RESET, 2 = IN/OUT, 3 = ENABLED/DISABLED
Allows the SET / RESET text, displayed in the hotkey menu, to be changed to something more suitable for the application of an individual control input, such as ON / OFF, IN / OUT etc.				
13	54	Control Input 18	Latched	0 = Latched or 1 = Pulsed
Configures the control inputs as either 'latched' or 'pulsed'.				
13	55	Ctrl Command 18	SET/RESET	0 = ON/OFF, 1 = SET/RESET, 2 = IN/OUT, 3 = ENABLED/DISABLED
Allows the SET / RESET text, displayed in the hotkey menu, to be changed to something more suitable for the application of an individual control input, such as ON / OFF, IN / OUT etc.				
13	58	Control Input 19	Latched	0 = Latched or 1 = Pulsed
Configures the control inputs as either 'latched' or 'pulsed'.				
13	59	Ctrl Command 19	SET/RESET	0 = ON/OFF, 1 = SET/RESET, 2 = IN/OUT, 3 = ENABLED/DISABLED
Allows the SET / RESET text, displayed in the hotkey menu, to be changed to something more suitable for the application of an individual control input, such as ON / OFF, IN / OUT etc.				

Col	Row	MENU TEXT	Default Setting	Available Setting
Description				
13	5C	Control Input 20	Latched	0 = Latched or 1 = Pulsed
Configures the control inputs as either 'latched' or 'pulsed'.				
13	5D	Ctrl Command 20	SET/RESET	0 = ON/OFF, 1 = SET/RESET, 2 = IN/OUT, 3 = ENABLED/DISABLED
Allows the SET / RESET text, displayed in the hotkey menu, to be changed to something more suitable for the application of an individual control input, such as ON / OFF, IN / OUT etc.				
13	60	Control Input 21	Latched	0 = Latched or 1 = Pulsed
Configures the control inputs as either 'latched' or 'pulsed'.				
13	61	Ctrl Command 21	SET/RESET	0 = ON/OFF, 1 = SET/RESET, 2 = IN/OUT, 3 = ENABLED/DISABLED
Allows the SET / RESET text, displayed in the hotkey menu, to be changed to something more suitable for the application of an individual control input, such as ON / OFF, IN / OUT etc.				
13	64	Control Input 22	Latched	0 = Latched or 1 = Pulsed
Configures the control inputs as either 'latched' or 'pulsed'.				
13	65	Ctrl Command 22	SET/RESET	0 = ON/OFF, 1 = SET/RESET, 2 = IN/OUT, 3 = ENABLED/DISABLED
Allows the SET / RESET text, displayed in the hotkey menu, to be changed to something more suitable for the application of an individual control input, such as ON / OFF, IN / OUT etc.				
13	68	Control Input 23	Latched	0 = Latched or 1 = Pulsed
Configures the control inputs as either 'latched' or 'pulsed'.				
13	69	Ctrl Command 23	SET/RESET	0 = ON/OFF, 1 = SET/RESET, 2 = IN/OUT, 3 = ENABLED/DISABLED
Allows the SET / RESET text, displayed in the hotkey menu, to be changed to something more suitable for the application of an individual control input, such as ON / OFF, IN / OUT etc.				
13	6C	Control Input 24	Latched	0 = Latched or 1 = Pulsed
Configures the control inputs as either 'latched' or 'pulsed'.				
13	6D	Ctrl Command 24	SET/RESET	0 = ON/OFF, 1 = SET/RESET, 2 = IN/OUT, 3 = ENABLED/DISABLED
Allows the SET / RESET text, displayed in the hotkey menu, to be changed to something more suitable for the application of an individual control input, such as ON / OFF, IN / OUT etc.				
13	70	Control Input 25	Latched	0 = Latched or 1 = Pulsed
Configures the control inputs as either 'latched' or 'pulsed'.				
13	71	Ctrl Command 25	SET/RESET	0 = ON/OFF, 1 = SET/RESET, 2 = IN/OUT, 3 = ENABLED/DISABLED
Allows the SET / RESET text, displayed in the hotkey menu, to be changed to something more suitable for the application of an individual control input, such as ON / OFF, IN / OUT etc.				
13	74	Control Input 26	Latched	0 = Latched or 1 = Pulsed
Configures the control inputs as either 'latched' or 'pulsed'.				
13	75	Ctrl Command 26	SET/RESET	0 = ON/OFF, 1 = SET/RESET, 2 = IN/OUT, 3 = ENABLED/DISABLED
Allows the SET / RESET text, displayed in the hotkey menu, to be changed to something more suitable for the application of an individual control input, such as ON / OFF, IN / OUT etc.				

Col	Row	MENU TEXT	Default Setting	Available Setting
Description				
13	78	Control Input 27	Latched	0 = Latched or 1 = Pulsed
Configures the control inputs as either 'latched' or 'pulsed'.				
13	79	Ctrl Command 27	SET/RESET	0 = ON/OFF, 1 = SET/RESET, 2 = IN/OUT, 3 = ENABLED/DISABLED
Allows the SET / RESET text, displayed in the hotkey menu, to be changed to something more suitable for the application of an individual control input, such as ON / OFF, IN / OUT etc.				
13	7C	Control Input 28	Latched	0 = Latched or 1 = Pulsed
Configures the control inputs as either 'latched' or 'pulsed'.				
13	7D	Ctrl Command 28	SET/RESET	0 = ON/OFF, 1 = SET/RESET, 2 = IN/OUT, 3 = ENABLED/DISABLED
Allows the SET / RESET text, displayed in the hotkey menu, to be changed to something more suitable for the application of an individual control input, such as ON / OFF, IN / OUT etc.				
13	80	Control Input 29	Latched	0 = Latched or 1 = Pulsed
Configures the control inputs as either 'latched' or 'pulsed'.				
13	81	Ctrl Command 29	SET/RESET	0 = ON/OFF, 1 = SET/RESET, 2 = IN/OUT, 3 = ENABLED/DISABLED
Allows the SET / RESET text, displayed in the hotkey menu, to be changed to something more suitable for the application of an individual control input, such as ON / OFF, IN / OUT etc.				
13	84	Control Input 30	Latched	0 = Latched or 1 = Pulsed
Configures the control inputs as either 'latched' or 'pulsed'.				
13	85	Ctrl Command 30	SET/RESET	0 = ON/OFF, 1 = SET/RESET, 2 = IN/OUT, 3 = ENABLED/DISABLED
Allows the SET / RESET text, displayed in the hotkey menu, to be changed to something more suitable for the application of an individual control input, such as ON / OFF, IN / OUT etc.				
13	88	Control Input 31	Latched	0 = Latched or 1 = Pulsed
Configures the control inputs as either 'latched' or 'pulsed'.				
13	89	Ctrl Command 31	SET/RESET	0 = ON/OFF, 1 = SET/RESET, 2 = IN/OUT, 3 = ENABLED/DISABLED
Allows the SET / RESET text, displayed in the hotkey menu, to be changed to something more suitable for the application of an individual control input, such as ON / OFF, IN / OUT etc.				
13	8C	Control Input 32	Latched	0 = Latched or 1 = Pulsed
Configures the control inputs as either 'latched' or 'pulsed'.				
13	8D	Ctrl Command 32	SET/RESET	0 = ON/OFF, 1 = SET/RESET, 2 = IN/OUT, 3 = ENABLED/DISABLED
Allows the SET / RESET text, displayed in the hotkey menu, to be changed to something more suitable for the application of an individual control input, such as ON / OFF, IN / OUT etc.				

Table 42 - Control input configuration**4.14****PB Config**

The Process Bus board must be configured to the system and application by means of appropriate settings. The sequence in which the settings are listed and described in this section will be the **PB CONFIG** submenu in the IED submenu.

Col	Row	Menu Text	Default Setting	Available Setting
Description				
18	00	PB CONFIG	0	0
This column contains settings and status parameters relative to process bus				
18	1	MU OOS CONFIG	00000000(bin)	8 bits setting, 0 = MU OOS Disabled, 1 = MU OOS Enabled
Used to set one or more Merging Units to be run in Out of Service mode .				
18	02	AntiAlais Filter	Disabled	0 = Disabled, 1 = Enabled
This cell activates or deactivates the anti-aliasing filter, which conditions the Sampled Values from the Process Bus network.				
18	03	SMV Version	IEC61850=9-2LE	0=IEC61850=9-2LE, 1 = IEC61869
This cell selects which version of sampled values are used, if it is set to IEC61850-9-2LE, device will subscribe the sampled value compliant with IEC61850-9-2LE, otherwise, device will subscribe the sampled value compliant with IEC61869. If the MU device is configured to published IEC61850-9-2 compatible frames, the setting should be set to IEC61850-9-2LE.				
18	04	MUs Delay Offset	0s	From 0s to 3ms step 250us
This cell adjusts the maximum time-delay offset starting at the reception of the Ethernet message from the "first" Merging Unit (MU) to the reception of the Ethernet message from the "last" Merging Unit (MU). This time-delay should be adjusted to ensure all MU samples for the same time instant are received before sending to the relay processor.				
18	05	Mon Delay Offset	No	0 = No, 1 = Yes
When sampled values are received at the IED from different Merging Units, they do not arrive simultaneously due to differences in Merging Unit performance or different network path delays. After this setting is set to Yes, a command to monitor the maximum time-delay will be sent to Process Bus board. After Process Bus board has calculated a delay, it will send the delay time to main board for users to set a proper MUs Delay Offset.				
18	06	Max Delay Offset	0	0
This setting specifies the maximum time-delay supervised, supervision starting at the reception of the sampled value frame from the "first" Merging Unit to the reception of the sampled value frame from the last Merging Unit for each sample count. If >3ms, a -1 will be displayed.				
18	30	Synchro Mode	No SYNC CLK	0 = No SYNC CLK, 1 = Local Clock, 2 = Global Clock
This setting specifies the type of Sampled Value synchronization expected by the IED, depending on the application. Global Clock: The Sampled Values are synchronized with a global area clock (GPS like clock). Local Clock: The Sampled Values are synchronized with a local area clock signal at the substation. Sampled Value frames received with Global or Local synchronization are acceptable with this setting. No SYNC CLK: The Sampled Values do not need to be synchronized. With this setting the IED ignores the synchronization flag in the Sampled Value frames.				
18	31	SV Absence Alm	0	0
This is a data cell with 8 binary flags. It indicates the presence or absence of Sampled Values from each of the Merging Units the IED is communicating with. The cell data for each Merging Unit is continuously refreshed. Unused MUs will indicate a 0. 0: Sampled Values being received from the Merging Unit. 1: No Sampled Values being received from the Merging Unit.				
18	32	SV SmpSynch Alm	0	0
This is a data cell with 8 binary flags. It indicates whether the Sampled Values being received from each of the Merging Units has the Synchro as required by 1830 above. Unused MUs will indicate a 0 0: Sampled Values received are synchronized. 1: Sampled Values received are not synchronized.				
18	33	SV Test Alm	0	0
This is a data cell with a binary flag for each of the analogue groups within the relays. It indicates the status of the IEC 61850 Quality attribute 'Test' in the Sampled Value frame used for that channel. If a channel is marked Test then functions associated with that channel are blocked unless the relay is in 'Test Mode' or 'Contacts Blocked'				
18	34	SV Invalid Alm	0	0
This is a data cell with a binary flag for each of the analogue groups within the relay. It indicates the status of the IEC 61850 Quality attribute 'Invalid' in the Sampled Value frame used for that channel. If a channel is marked Invalid then functions associated with that channel are blocked.				

Col	Row	Menu Text	Default Setting	Available Setting
Description				
18	35	SV Quest Alm	0	0
This is a data cell with a binary flag for each of the analogue groups within the relay. It indicates the status of the IEC 61850 Quality attribute 'Questionable' in the Sampled Value frame used for that channel. If a channel is marked Questionable then functions associated with that channel are blocked.				

Table 43 - PB Config

4.15 IED Configurator (for IEC 61850 Configuration)

The contents of the IED CONFIGURATOR column (for IEC 61850 configuration) are mostly data cells, displayed for information but not editable. To edit the configuration, you need to use the IED (Intelligent Electronic Device) configurator tool within the Schneider Electric MiCOM S1 Studio software.

Col	Row	Menu Text	Default Setting	Available Setting
Description				
19	00	IED CONFIGURATOR	0	
This column contains settings for IED Configurator settings (IEC61850 builds)				
19	05	Switch Conf.Bank	No action	0 = No action or 1 = Switch banks
Setting which allows the user to switch between the current configuration, held in the Active Memory Bank (and partly displayed below), to the configuration sent to and held in the Inactive Memory Bank.				
19	0A	Restore Conf.	No action	0 = No action or 1 = Restore Conf.
Used to restore data from MCL(MiCOM Configuration Language)/CID (Configured IED Descriptor) file. This file is specific, containing a single devices IEC61850 configuration information, and used for transferring data to/from the MiCOM IED.				
19	10	Active Conf.Name	0	Not Settable
IEC61850 versions only. The name of the configuration in the Active Memory Bank, usually taken from the SCL file.				
19	11	Active Conf.Rev	0	Not Settable
IEC61850 versions only. Configuration Revision number of the configuration in the Active Memory Bank, usually taken from the SCL file.				
19	20	Inact.Conf.Name	0	Not Settable
IEC61850 versions only. The name of the configuration in the Inactive Memory Bank, usually taken from the SCL file.				
19	21	Inact.Conf.Rev	0	Not Settable
IEC61850 versions only. Configuration Revision number of the configuration in the Inactive Memory Bank, usually taken from the SCL file.				
19	30	IP PARAMETERS	0	0
IP PARAMETERS				
19	31	IP Address 1	0	Not Settable
IEC61850 versions only. Displays the unique network IP address that identifies the relay on interface 1. A default IP address is encoded from MAC address 169.254.0.xxx, xxx = mod (The last byte of MAC1, 128) + 1.				
19	32	Subnet mask 1	0	Not Settable
IEC61850 versions only. Displays the sub-network mask for interface 1.				
19	33	Gateway 1	0	Not Settable
IEC61850 versions only. Displays the IP address of the gateway (proxy) that interface 1 is connected to.				
19	34	IP Address 2	0	Not Settable
Displays the unique network IP address that identifies the relay on interface 2. A default IP address is encoded from MAC address 169.254.0.xxx, xxx = mod (The last byte of MAC2, 128) + 1. Visible when redundant Ethernet card fitted.				
19	35	Subnet mask 2	0	Not Settable

Col	Row	Menu Text	Default Setting	Available Setting
Description				
Displays the sub-network mask for interface 2.				
19	36	Gateway 2	0	Not Settable
Displays the IP address of the gateway (proxy) that interface 2 is connected to.				
19	40	SNTP PARAMETERS	0	0
SNTP PARAMETERS				
19	41	SNTP Server 1	0	Not Settable
Displays the IP address of the primary SNTP server. Ethernet card fitted.				
19	42	SNTP Server 2	0	Not Settable
Displays the IP address of the secondary SNTP server. Ethernet card fitted.				
19	43	ROUTE RULE GTW 1		
IEC61850 versions only.				
19	44	Dest. Network 1	0.0.0.0	<IP address of relay>
IEC61850 versions only. Displays the destination network address of the first route rule for gateway 1, if any.				
19	45	Subnet Mask 1	0.0.0.0	<Subnet mask of relay>
IEC61850 versions only. Displays the subnet mask of the first route rule for gateway 1, if any.				
19	46	Dest. Network 2	255.255.255.255	<IP address of relay>
IEC61850 versions only. Displays the destination network address of the second route rule for gateway 1, if any.				
19	47	Subnet Mask 2	255.255.255.255	<Subnet mask of relay>
IEC61850 versions only. Displays the subnet mask of the second route rule for gateway 1, if any.				
19	48	ROUTE RULE GTW 2		
IEC61850 versions only.				
19	49	Dest. Network 1	0.0.0.0	<IP address of relay>
IEC61850 versions only. Displays the destination network address of the first route rule for gateway 2, if any.				
19	4A	Subnet Mask 1	0.0.0.0	<Subnet mask of relay>
IEC61850 versions only. Displays the subnet mask of the first route rule for gateway 2, if any.				
19	4B	Dest. Network 2	255.255.255.255	<IP address of relay>
IEC61850 versions only. Displays the destination network address of the second route rule for gateway 2, if any.				
19	4C	Subnet Mask 2	255.255.255.255	<Subnet mask of relay>
IEC61850 versions only. Displays the subnet mask of the second route rule for gateway 2, if any.				
19	4D	Act. Route Rule	No	0 = No or 1 = Yes
IEC61850 versions only. Active the route rules of gateways, if any.				
19	50	IEC 61850 SCL	0	0
IEC 61850 SCL				
19	51	IED Name	0	Not Settable
IED name, which is the unique name on the IEC 61850 network for the IED, usually taken from the SCL (Substation Configuration Language for XML) file.				
19	60	IEC 61850 GOOSE	0	0
IEC 61850 GOOSE				
19	70	GoEna	0000000000000000(bin)	Bit 00=gcb01 GoEna to Bit 0F=gcb16 GoEna
Setting to Disable (0) or Enable (1) the publishing of a GOOSE Control Block. Ethernet card fitted.				
19	71	Pub.simul.GOOSE	0000000000000000(bin)	Bit 00=gcb01 Sim Mode to Bit 0F=gcb16 Sim Mode

Col	Row	Menu Text	Default Setting	Available Setting
Description				
The Pub.Simul.GOOSE cell controls whether GOOSE are sent as Normal (0) or Simulated (1) GOOSE. When a GOOSE control block is set to Sim Mode its GOOSE is published as simulated. Simulated GOOSE are usually published by test equipment and this setting allows a test IED to be set up to simulate the IEDs in a substation.				
19	73	Sub.Siml.Signal	No	0 = No or 1 = Yes
In edition 2 mode when Sub.Sim.Signal is set to Yes the relay will look for simulated GOOSE or SV. If a simulated GOOSE or SV is found the relay will subscribe to it and will not respond to its normal GOOSE or SV until Sub.Siml.Signal is set to No. Other GOOSE or SV signals that are not being simulated will remain subscribing to normal GOOSE or SV. In edition 1 mode the relay will respond to both normal and test GOOSE.				

Table 44 - IED configurator (for IEC 61850 configuration)

4.16 56/64 kbit/s Fiber Teleprotection - InterMiCOM⁶⁴

InterMiCOM⁶⁴ is a fiber-optic based teleprotection scheme, described in detail in the Operation and Application chapters of this manual. Only relays ordered with fiber ports support this feature. The communication uses 56 or 64 kbit/s channels.

In the settings listed here, Channel1 and Channel2 refer to the communications channels, and are associated with configuring the communications ports fitted to the co-processor board.

Each setting below that refers to Channel 2 is associated with the communications setting of the second communications channel (where fitted) and is visible only when 3 Terminal or Dual redundant teleprotection configuration is set.

Note InterMiCOM⁶⁴ provides 2 groups of 8 InterMiCOM⁶⁴ commands. These are referenced as Channel 1 / Channel 2. They have a subtly different meaning and should not be confused with communications channels 1 / 2.

InterMiCOM⁶⁴ input and output mapping has to be done in the Programmable Scheme Logic (PSL).

Col	Row	MENU TEXT	Default Setting	Available Setting
P443				
20	00	PROT COMMS/ IM64	0	
*				
20	01	Scheme Setup	2 Terminal	0 = 3 Terminal, 1 = 2 Terminal, 2 = Dual Redundant
*				
20	02	Address	0-0	0=0-0, 1=1-A, 2=2-A, 3=3-A, 4=4-A, 5=5-A, 6=6-A, 7=7-A, 8=8-A, 9=9-A, 10=10-A, 11=11-A, 12=12-A, 13=13-A, 14=14-A, 15=15-A, 16=16-A, 17=17-A, 18=18-A, 19=19-A, 20=20-A, 21=1-B, 22=2-B, 23=3-B, 24=4-B, 25=5-B, 26=6-B, 27=7-B, 28=8-B, 29=9-B, 30=10-B, 31=11-B, 32=12-B, 33=13-B, 34=14-B, 35=15-B, 36=16-B, 37=17-B, 38=18-B, 39=19-B, 40=20-B, 41=1-C, 42=2-C, 43=3-C, 44=4-C, 45=5-C, 46=6-C, 47=7-C, 48=8-C, 49=9-C, 50=10-C, 51=11-C, 52=12-C, 53=13-C, 54=14-C, 55=15-C, 56=16-C, 57=17-C, 58=18-C, 59=19-C, 60=20-C
*				
20	03	Address	0-0	0=0-0, 1=1-A, 2=2-A, 3=3-A, 4=4-A, 5=5-A, 6=6-A, 7=7-A, 8=8-A, 9=9-A, 10=10-A, 11=11-A, 12=12-A, 13=13-A, 14=14-A, 15=15-A, 16=16-A, 17=17-A, 18=18-A, 19=19-A, 20=20-A, 21=1-B, 22=2-B, 23=3-B, 24=4-B, 25=5-B, 26=6-B, 27=7-B, 28=8-B, 29=9-B, 30=10-B, 31=11-B, 32=12-B, 33=13-B, 34=14-B, 35=15-B, 36=16-B, 37=17-B, 38=18-B, 39=19-B, 40=20-B
*				

Col	Row	MENU TEXT	Default Setting	Available Setting
P443				
20	10	Comms Mode	Standard	0 = Standard or 1 = IEEE C37.94
*				
20	11	Baud Rate Ch1	64kbits/s	0 = 64kbits/s or 1 = 56kbits/s
*				
20	12	Baud Rate Ch2	64kbits/s	0 = 64kbits/s or 1 = 56kbits/s
*				
20	13	Clock Source Ch1	Internal	0 = Internal or 1 = External
*				
20	14	Clock Source Ch2	Internal	0 = Internal or 1 = External
*				
20	15	Ch1 N*64kbits/s	1	0 = Auto, 1 = 1, 2 = 2, 3 = 3, 4 = 4, 5 = 5, 6 = 6, 7 = 7, 8 = 8, 9 = 9, 10 = 10, 11 = 11 or 12 = 12
*				
20	16	Ch2 N*64kbits/s	1	0 = Auto, 1 = 1, 2 = 2, 3 = 3, 4 = 4, 5 = 5, 6 = 6, 7 = 7, 8 = 8, 9 = 9, 10 = 10, 11 = 11 or 12 = 12
*				
20	18	Comm Fail Timer	10s	From 100ms to 600s step 100ms
*				
20	19	Comm Fail Mode	Ch 1 or 2 Fail	0 = Ch 1 Failure 2 = Ch 1 or 2 Fail 1 = Ch 2 Failure 3 = Ch 1 and 2 Fail
*				
20	1E	Channel Timeout	100ms	From 100ms to 10s step 100ms
*				
20	1F	Alarm Level	0.25	From 0% to 100% step 0.1%
*				
20	20	Prop Delay Stats	Enabled	0 = Disabled or 1 = Enabled
*				
20	21	MaxCh1 PropDelay	15ms	From 1ms to 50ms step 1ms
*				
20	22	MaxCh2 PropDelay	15ms	From 1ms to 50ms step 1ms
*				
20	30	IM1 Cmd Type	Permissive	0 = Direct or 1 = Permissive
*				
20	31	IM1 FallBackMode	Default	0 = Default or 1 = Latched
*				
20	32	IM1 DefaultValue	0	0 to 1 step 1
*				
20	34	IM2 Cmd Type	Permissive	0 = Direct or 1 = Permissive
*				
20	35	IM2 FallBackMode	Default	0 = Default or 1 = Latched
*				
20	36	IM2 DefaultValue	0	0 to 1 step 1
*				
20	38	IM3 Cmd Type	Permissive	0 = Direct or 1 = Permissive

Col	Row	MENU TEXT	Default Setting	Available Setting
P443				
*				
20	39	IM3 FallBackMode	Default	0 = Default or 1 = Latched
*				
20	3A	IM3 DefaultValue	0	0 to 1 step 1
*				
20	3C	IM4 Cmd Type	Permissive	0 = Direct or 1 = Permissive
*				
20	3D	IM4 FallBackMode	Default	0 = Default or 1 = Latched
*				
20	3E	IM4 DefaultValue	0	0 to 1 step 1
*				
20	40	IM5 Cmd Type	Permissive	0 = Direct or 1 = Permissive
*				
20	41	IM5 FallBackMode	Default	0 = Default or 1 = Latched
*				
20	42	IM5 DefaultValue	0	0 to 1 step 1
*				
20	44	IM6 Cmd Type	Permissive	0 = Direct or 1 = Permissive
*				
20	45	IM6 FallBackMode	Default	0 = Default or 1 = Latched
*				
20	46	IM6 DefaultValue	0	0 to 1 step 1
*				
20	48	IM7 Cmd Type	Permissive	0 = Direct or 1 = Permissive
*				
20	49	IM7 FallBackMode	Default	0 = Default or 1 = Latched
*				
20	4A	IM7 DefaultValue	0	0 to 1 step 1
*				
20	4C	IM8 Cmd Type	Permissive	0 = Direct or 1 = Permissive
*				
20	4D	IM8 FallBackMode	Default	0 = Default or 1 = Latched
*				
20	4E	IM8 DefaultValue	0	0 to 1 step 1
*				

Table 45 - Prot comms/IM64*Note*

The IM1 – IM8 settings in the table above are applied the same to the 8 InterMiCOM⁶⁴ commands grouped as Channel 1 as to the 8 InterMiCOM⁶⁴ commands grouped as Channel 2. If IM1 Default Value is set to 0, then IM1 Channel 1, and IM1 Channel 2 will both default to 0.

4.17 Control Input Labels

Col	Row	MENU TEXT	Default Setting	Available Setting
Description				
29	00	CTRL I/P LABELS	0	
This column contains settings for Control Input Labels				
29	01	Control Input 1	Control Input 1	From 32 to 234 step 1
Text label to describe each individual control input. This text is displayed when a control input is accessed by the hotkey menu. It is displayed in the programmable scheme logic description of the control input				
29	02	Control Input 2	Control Input 2	From 32 to 234 step 1
Text label to describe each individual control input. This text is displayed when a control input is accessed by the hotkey menu. It is displayed in the programmable scheme logic description of the control input				
29	03	Control Input 3	Control Input 3	From 32 to 234 step 1
Text label to describe each individual control input. This text is displayed when a control input is accessed by the hotkey menu. It is displayed in the programmable scheme logic description of the control input				
29	04	Control Input 4	Control Input 4	From 32 to 234 step 1
Text label to describe each individual control input. This text is displayed when a control input is accessed by the hotkey menu. It is displayed in the programmable scheme logic description of the control input				
29	05	Control Input 5	Control Input 5	From 32 to 234 step 1
Text label to describe each individual control input. This text is displayed when a control input is accessed by the hotkey menu. It is displayed in the programmable scheme logic description of the control input				
29	06	Control Input 6	Control Input 6	From 32 to 234 step 1
Text label to describe each individual control input. This text is displayed when a control input is accessed by the hotkey menu. It is displayed in the programmable scheme logic description of the control input				
29	07	Control Input 7	Control Input 7	From 32 to 234 step 1
Text label to describe each individual control input. This text is displayed when a control input is accessed by the hotkey menu. It is displayed in the programmable scheme logic description of the control input				
29	08	Control Input 8	Control Input 8	From 32 to 234 step 1
Text label to describe each individual control input. This text is displayed when a control input is accessed by the hotkey menu. It is displayed in the programmable scheme logic description of the control input				
29	09	Control Input 9	Control Input 9	From 32 to 234 step 1
Text label to describe each individual control input. This text is displayed when a control input is accessed by the hotkey menu. It is displayed in the programmable scheme logic description of the control input				
29	0A	Control Input 10	Control Input 10	From 32 to 234 step 1
Text label to describe each individual control input. This text is displayed when a control input is accessed by the hotkey menu. It is displayed in the programmable scheme logic description of the control input				
29	0B	Control Input 11	Control Input 11	From 32 to 234 step 1
Text label to describe each individual control input. This text is displayed when a control input is accessed by the hotkey menu. It is displayed in the programmable scheme logic description of the control input				
29	0C	Control Input 12	Control Input 12	From 32 to 234 step 1
Text label to describe each individual control input. This text is displayed when a control input is accessed by the hotkey menu. It is displayed in the programmable scheme logic description of the control input				
29	0D	Control Input 13	Control Input 13	From 32 to 234 step 1
Text label to describe each individual control input. This text is displayed when a control input is accessed by the hotkey menu. It is displayed in the programmable scheme logic description of the control input				
29	0E	Control Input 14	Control Input 14	From 32 to 234 step 1
Text label to describe each individual control input. This text is displayed when a control input is accessed by the hotkey menu. It is displayed in the programmable scheme logic description of the control input				
29	0F	Control Input 15	Control Input 15	From 32 to 234 step 1

Col	Row	MENU TEXT	Default Setting	Available Setting
Description				
Text label to describe each individual control input. This text is displayed when a control input is accessed by the hotkey menu. It is displayed in the programmable scheme logic description of the control input				
29	30	Setting Input 48	Ctrl Setg I/P 48	From 32 to 234 step 1
Text label to describe each individual control input. This text is displayed when a control input is accessed by the hotkey menu. It is displayed in the programmable scheme logic description of the control input				

Table 46 - Control input labels

4.18 Direct Access (Breaker Control and Hotkeys)

The Direct Access keys are the **0** and **1** keys situated directly below the LCD display. The user may assign the function of these two keys, to signal direct commands into the PSL logic. Two modes of use exist:

- Tripping and Closing commands to the circuit breaker
- **Hotkey** functions, whereby a mini menu of frequently required commands and operations is accessed. Operators can then easily access the required command, without needing to navigate the full relay menu.

Col	Row	MENU TEXT	Default Setting	Available Setting
Description				
09	00	CONFIGURATION	0	
This column contains all the general configuration options				
09	01	Restore Defaults	No Operation	0 = No Operation, 1 = All Settings, 2 = Setting Group 1, 3 = Setting Group 2, 4 = Setting Group 3, 5 = Setting Group 4
Setting to restore a setting group to factory default settings. To restore the default values to the settings in any Group settings, set the 'restore defaults' cell to the relevant Group number. Alternatively it is possible to set the 'restore defaults' cell to 'all settings' to restore the default values to all of the IED's settings, not just the Group settings. The default settings will initially be placed in the scratchpad and will only be used by the relay after they have been confirmed by the user. Note: Restoring defaults to all settings includes the rear communication port settings, which may result in communication via the rear port being disrupted if the new (default) settings do not match those of the master station.				
09	02	Setting Group	Select via Menu	0 = Select via Menu or 1 = Select via PSL
Allows setting group changes to be initiated via Opto Input or via Menu				
09	03	Active Settings	Group 1	0 = Group 1, 1 = Group 2, 2 = Group 3, 3 = Group 4
Selects the active setting group.				
09	04	Save Changes	No Operation	0 = No Operation, 1 = Save, 2 = Abort
Saves all relay settings.				
09	05	Copy From	Group 1	0 = Group 1, 1 = Group 2, 2 = Group 3, 3 = Group 4
Allows displayed settings to be copied from a selected setting group				
09	06	Copy To	No Operation	0 = No Operation, 1 = Group 1, 2 = Group 2, 3 = Group 3
Allows displayed settings to be copied to a selected setting group (ready to paste).				
09	07	Setting Group 1	Enabled	0 = Disabled or 1 = Enabled
Settings Group 1. If the setting group is disabled from the configuration, then all associated settings and signals are hidden, with the exception of this setting (paste).				
09	08	Setting Group 2	Disabled	0 = Disabled or 1 = Enabled
Settings Group 2. If the setting group is disabled from the configuration, then all associated settings and signals are hidden, with the exception of this setting (paste).				
09	09	Setting Group 3	Disabled	0 = Disabled or 1 = Enabled

Col	Row	MENU TEXT	Default Setting	Available Setting
Description				
Settings Group 3. If the setting group is disabled from the configuration, then all associated settings and signals are hidden, with the exception of this setting (paste).				
09	0A	Setting Group 4	Disabled	0 = Disabled or 1 = Enabled
Settings Group 4. If the setting group is disabled from the configuration, then all associated settings and signals are hidden, with the exception of this setting (paste).				
09	0B	Distance	Enabled	0 = Disabled or 1 = Enabled
Only in models with Distance option. To enable (activate) or disable (turn off) the Distance Protection: ANSI 21P/21G.				
09	0C	Directional E/F	Enabled	0 = Disabled or 1 = Enabled
Only in models with Distance option. To enable (activate) or disable (turn off) the Directional Earth Fault (DEF) Protection used in a pilot aided scheme: ANSI 67N. This protection is independent from back up Earth fault protection described below.				
09	10	Overcurrent	Disabled	0 = Disabled or 1 = Enabled
To enable (activate) or disable (turn off) the Phase Overcurrent Protection function. I> stages: ANSI 50/51/67P				
09	11	Neg Sequence O/C	Disabled	0 = Disabled or 1 = Enabled
To enable (activate) or disable (turn off) the Negative Sequence Overcurrent Protection function. I2> stages: ANSI 46/67				
09	12	Broken Conductor	Disabled	0 = Disabled or 1 = Enabled
To enable (activate) or disable (turn off) the Broken Conductor function. I2/I1> stage: ANSI 46BC				
09	13	Earth Fault	Disabled	0 = Disabled or 1 = Enabled
To enable (activate) or disable (turn off) the back up Earth Fault Protection function. IN >stages: ANSI 50/51/67N				
09	15	SEF/REF Prot'n	Disabled	0 = Disabled or 1 = Enabled
To enable (activate) or disable (turn off) the Sensitive Earth Fault/Restricted Earth fault Protection function. ISEF >stages: ANSI 50/51/67N. IREF>stage: ANSI 64.				
09	16	Residual O/V NVD	Disabled	0 = Disabled or 1 = Enabled
To enable (activate) or disable (turn off) the Residual Overvoltage Protection function. VN>stages: ANSI 59N				
09	17	Thermal Overload	Disabled	0 = Disabled or 1 = Enabled
To enable (activate) or disable (turn off) the Thermal Overload Protection function. ANSI 49.				
09	18	PowerSwing Block	Enabled	0 = Disabled or 1 = Enabled
Only in models with Distance option. To enable (activate) or disable (turn off) the power swing blocking/out of step: ANSI 68/78.				
09	1D	Volt Protection	Disabled	0 = Disabled or 1 = Enabled
To enable (activate) or disable (turn off) the Voltage Protection (under/overvoltage) function. V<, V> stages: ANSI 27/59.				
09	1E	Freq Protection	Disabled	0 = Disabled or 1 = Enabled
To enable (activate) or disable (turn off) the Frequency Protection (under/over frequency) function. F<, F> stages: ANSI 81O/U.				
09	1F	df/dt Protection	Disabled	0 = Disabled or 1 = Enabled
To enable (activate) or disable (turn off) the Rate of change of Frequency Protection function. df/dt> stages: ANSI 81R.				
09	20	CB Fail	Disabled	0 = Disabled or 1 = Enabled
To enable (activate) or disable (turn off) the Circuit Breaker Fail Protection function. ANSI 50BF.				
09	21	Supervision	Enabled	0 = Disabled or 1 = Enabled
To enable (activate) or disable (turn off) the Supervision (VTS & CTS) functions. ANSI VTS/CTS.				
09	23	System Checks	Disabled	0 = Disabled or 1 = Enabled
To enable (activate) or disable (turn off) the System Checks (Check Sync. and Voltage Monitor) function: ANSI 25.				
09	24	Auto-Reclose	Disabled	0 = Disabled or 1 = Enabled
To enable (activate) or disable (turn off) the Auto-reclose function. ANSI 79.				
09	25	Input Labels	Visible	0 = Invisible or 1 = Visible
Sets the Input Labels menu visible further on in the relay settings menu.				
09	26	Output Labels	Visible	0 = Invisible or 1 = Visible

Col	Row	MENU TEXT	Default Setting	Available Setting
Description				
Sets the Output Labels menu visible further on in the relay settings menu.				
09	28	CT & VT Ratios	Visible	0 = Invisible or 1 = Visible
Sets the Current & Voltage Transformer Ratios menu visible further on in the relay settings menu.				
09	29	Record Control	Visible	0 = Invisible or 1 = Visible
Sets the Record Control menu visible further on in the relay settings menu.				
09	2A	Disturb Recorder	Visible	0 = Invisible or 1 = Visible
Sets the Disturbance Recorder menu visible further on in the relay settings menu.				
09	2B	Measure't Setup	Visible	0 = Invisible or 1 = Visible
Sets the Measurement Setup menu visible further on in the relay settings menu.				
09	2C	Comms Settings	Visible	0 = Invisible or 1 = Visible
Sets the Communications Settings menu visible further on in the relay settings menu. These are the settings associated with the 2nd rear communications ports.				
09	2D	Commission Tests	Visible	0 = Invisible or 1 = Visible
Sets the Commissioning Tests menu visible further on in the relay settings menu.				
09	2E	Setting Values	Primary	0 = Primary or 1 = Secondary
This affects all protection settings that are dependent upon CT and VT ratios. All subsequent settings input must be based in terms of this reference.				
09	2F	Control Inputs	Visible	0 = Invisible or 1 = Visible
Activates the Control Input status and operation menu further on in the relay setting menu.				
09	35	Control I/P Config	Visible	0 = Invisible or 1 = Visible
Sets the Control Input Configuration menu visible further on in the relay setting menu.				
09	36	Ctrl I/P Labels	Visible	0 = Invisible or 1 = Visible
Sets the Control Input Labels menu visible further on in the relay setting menu.				
09	39	Direct Access	Enabled	0= Disabled, 1 = Enabled, 2 = Hotkey Only, or 3 = CB Ctrl Only
Defines what CB control direct access is allowed. The front direct access keys that are used as a short cut function of the menu may be: Disabled – No function visible on the LCD. Enabled – All control functions mapped to the Hotkeys and Control Trip/Close are available. Hotkey Only – Only control functions mapped to the Hotkeys are available on the LCD. CB Ctrl Only – Only Control Trip/Control Close command will appear on the relay's LCD. Not available on Chinese version relays (P54??????C??M)				
09	40	InterMiCOM	Disabled	0 = Disabled or 1 = Enabled
To enable (activate) or disable (turn off) EIA (RS) 232 InterMiCOM (integrated teleprotection).				
09	41	InterMiCOM 64	Disabled	0 = Disabled or 1 = Enabled
To enable (activate) or disable (turn off) InterMiCOM64 (integrated 56/64kbit/s teleprotection). Note that Phase Diff setting and InterMiCOM64 Fiber setting are mutually exclusive as with Phase Diff enabled, the digital message exchanged has the structure of the differential message (i.e. currents are sent to the remote end, etc) and with InterMiCOM64 Fiber the digital message exchanged has the structure and properties of the InterMiCOM64 Fiber.				
09	70	VIR I/P Labels	Invisible	0 = Invisible or 1 = Visible
VIR I/P Labels Visible/Invisible				
09	80	VIR O/P Labels	Invisible	0 = Invisible or 1 = Visible
VIR O/P Labels Visible/Invisible				
09	90	Usr Alarm Labels	Invisible	0 = Invisible or 1 = Visible
USR Alarm Labels Visible/Invisible				
09	FB	RP1 Read Only	Disabled	0 = Disabled or 1 = Enabled
To enable (activate) or disable (turn off) Read Only Mode of Rear Port 1.				
09	FC	RP2 Read Only	Disabled	0 = Disabled or 1 = Enabled

Col	Row	MENU TEXT	Default Setting	Available Setting
Description				
To enable (activate) or disable (turn off) Read Only Mode of Rear Port 2.				
09	FD	NIC Read Only	Disabled	0 = Disabled or 1 = Enabled
Ethernet versions only. To enable (activate) or disable (turn off) Read Only Mode of Network Interface Card.				
09	FF	LCD Contrast	11	0 to 31 step 1
Sets the LCD contrast.				

Table 47 - Direct access (breaker control and “hotkeys”)

Notes:

OPERATION

CHAPTER 5

Date:	08/2023
Products covered by this chapter:	This chapter covers the specific versions of the MiCOM products listed below. This includes only the following combinations of Software Version and Hardware Suffix.
Hardware Suffix:	L
Software Version:	K6
Connection Diagrams:	10P445xx (xx = 01 to 04)

CONTENTS

Page (OP) 5-

1	Operation of Individual Protection Functions	11
1.1	Phase Fault Distance Protection (for Software Versions BEFORE H3a)	11
1.2	Phase Fault Distance Protection (for Software Version H3a and Later)	11
1.3	Earth Fault Distance Protection (for Software Versions BEFORE H3a)	11
1.4	Phase Fault Distance Protection (for Software Version H3a and Later)	12
1.5	Distance Protection Starting	13
1.6	Distance Protection Tripping Decision	14
1.7	Phase Selection	14
1.7.1	Theory of Operation	15
1.8	Mho Element Polarization and Expansion	16
1.8.1	Switch on to Fault Action for Zone 1	17
1.8.2	Offset Mho	17
1.9	Quadrilateral Elements	17
1.9.1	Directional Quadrilateral	18
1.9.2	Offset Quadrilateral	18
1.9.3	Reactance Line - Top Line of Quadrilateral	18
1.9.4	Right Hand Resistive Reach Line	20
1.10	Quadrilateral Ground Resistive Reaches	20
1.11	Line Parameters Settings	21
1.11.1	Phase Rotation	21
1.11.2	Trip Mode	21
1.11.3	Pole Dead Logic	21
1.11.4	Residual Compensation for Earth/Ground Faults	22
1.12	Advanced Distance Elements Zone Settings	22
1.12.1	Phase Fault Zone Settings	22
1.12.2	Ground Fault Zone Settings	22
1.12.3	Distance Zone Sensitivities	23
1.13	Conventional Voltage Transformer and Capacitor VT Applications	24
1.13.1	CVTs with Passive Suppression of Ferroresonance	24
1.13.2	CVTs with Active Suppression of Ferroresonance	24
1.14	Load Blinding (Load Avoidance)	25
1.15	Distance Elements Basic Scheme Setting	25
1.16	Power Swing Detection, Alarming and Blocking	27
1.16.1	Detection of Power Swings	27
1.16.2	Actions Upon Power Swing Detection	27
1.16.3	Detection of a Fault During a Power Swing	28
1.16.4	Actions Upon Detection of a Fault During a Power Swing	28
1.16.5	Power Swing Settings	28

1.17	Switch On To Fault (SOTF) and Trip On Reclose (TOR)	29
1.17.1	Switch OnTo Fault (SOTF) Mode	31
1.17.2	Trip On Reclose (TOR) Mode	31
1.17.3	Polarization during Circuit Energization	32
1.18	Directional Function - Setup of DEF	32
1.18.1	DEF Zero Sequence Polarization with “Virtual Current Polarizing”	32
1.18.2	DEF Negative Sequence Polarization	33
1.18.3	Delta Directionalizing Comparison Principle and Setup	34
1.18.4	Delta Directional Decision	35
1.19	Channel Aided Schemes	35
1.19.1	Distance Scheme Permissive UnderReach (PUR) Transfer Trip	38
1.19.2	Distance Scheme Permissive OverReach (POR) Transfer Trip	39
1.19.3	Permissive Overreach Trip Reinforcement	42
1.19.4	Permissive Overreach Scheme Weak Infeed Features	42
1.19.5	Permissive Scheme Unblocking Logic - Loss of Guard	43
1.19.6	Distance Scheme Blocking	44
1.19.7	Distance Schemes Current Reversal Guard Logic	45
1.19.8	Permissive Overreach Schemes Current Reversal Guard	46
1.19.9	Blocking Scheme 1 and 2 Current Reversal Guard	46
1.19.10	Aided DEF Ground Fault Scheme - Permissive Overreach	47
1.19.11	Aided DEF Ground Fault Scheme - Blocking	47
1.20	Zone 1 Extension and Loss of Load Schemes	48
1.20.1	Zone 1 Extension Scheme	48
1.20.2	Loss of Load (LoL) Accelerated Tripping	49
1.21	InterMiCOM	51
1.21.1	Protection Signaling	51
1.21.2	InterMiCOM Variants	52
1.21.3	InterMiCOM Features	52
1.21.4	Definition of Teleprotection Commands	52
1.22	MODEM InterMiCOM EIA(RS)232 InterMiCOM, or Copper InterMiCOM	54
1.22.1	Communications Media	54
1.22.2	General Features and Implementation	54
1.22.3	EIA(RS)232 Physical Connections	55
1.22.4	Direct Connection	55
1.22.5	EIA(RS)232 Modem Connection	56
1.22.6	RS422 Connection	56
1.22.7	Fiber Optic Connection	57
1.22.8	InterMiCOM Functional Assignment	57
1.22.9	InterMiCOM Statistics and Diagnostics	58
1.23	InterMiCOM⁶⁴ (fiber InterMiCOM)	58
1.23.1	General Features and Implementation	58
1.23.2	Configuring InterMiCOM ⁶⁴	58
1.23.2.1	InterMiCOM ⁶⁴ Scheme Setup – Application	59
1.23.2.2	InterMiCOM ⁶⁴ Protection Communications Address	60
1.23.2.3	InterMiCOM ⁶⁴ Communications Mode Setup	61

1.23.2.4	InterMiCOM ⁶⁴ Communications Baud Rate	61
1.23.2.5	InterMiCOM ⁶⁴ Communications Clock Source	61
1.23.2.6	InterMiCOM ⁶⁴ IEEE C37.94 Channel Selection	61
1.23.2.7	InterMiCOM ⁶⁴ Communications Fail Timer	62
1.23.2.8	InterMiCOM ⁶⁴ Communications Failure Mode	62
1.23.2.9	InterMiCOM ⁶⁴ Channel Timeout	62
1.23.2.10	InterMiCOM ⁶⁴ Propagation Delay Statistics	62
1.23.2.11	InterMiCOM ⁶⁴ Command Type	62
1.23.2.12	InterMiCOM ⁶⁴ Fallback Mode	62
1.23.3	InterMiCOM ⁶⁴ Communications Alarm Management	62
1.23.3.1	InterMiCOM ⁶⁴ DDB Signal List	63
1.23.3.2	InterMiCOM ⁶⁴ Communications Alarm Logic	65
1.23.3.3	InterMiCOM ⁶⁴ Two Ended Scheme Extended Supervision	66
1.23.3.4	InterMiCOM ⁶⁴ Three Ended Scheme Extended Supervision	67
1.23.4	InterMiCOM ⁶⁴ Communications Link Options	68
1.23.4.1	InterMiCOM ⁶⁴ Optical Fiber Communications Link Options	68
1.23.4.2	InterMiCOM ⁶⁴ Connection via P-2M-L Series Optical Fiber to Electrical Interface Units	69
1.23.4.3	InterMiCOM ⁶⁴ Connection Over Unconditioned Pilot Wires	70
1.24	Phase Fault Overcurrent Protection	71
1.24.1	Reset Characteristics for Overcurrent Elements	72
1.24.2	Directional Overcurrent Protection	72
1.25	Synchronous Polarization	73
1.26	Thermal Overload Protection	74
1.26.1	Single Time Constant Characteristic	74
1.26.2	Dual Time Constant Characteristic (typically not Applied for MiCOM P445)	75
1.27	Earth Fault (Ground Overcurrent) and Sensitive Earth Fault (SEF) Protection	76
1.27.1	IDG Curve	76
1.28	Directional Earth Fault (DEF) Protection	77
1.29	Residual Voltage Polarization	77
1.29.1	Negative Sequence Polarization (Not for SEF)	78
1.30	Negative Phase Sequence (NPS) Overcurrent Protection	79
1.30.1	Directionalizing the Negative Phase Sequence Overcurrent Element	80
1.31	Undervoltage Protection	81
1.32	Overvoltage Protection	82
1.32.1	Compensated Overvoltage	83
1.33	Residual Overvoltage (Neutral Displacement) Protection	84
1.34	Circuit Breaker Fail (CBF) Protection	85
1.34.1	Reset Mechanisms for Breaker Fail Timers	86
1.35	Broken Conductor Detection	88
1.36	Frequency Protection	89
1.37	Independent Rate of Change of Frequency Protection [81R]	90
1.37.1	Basic Functionality	91
1.38	Special Weak Infeed Logic for Stub End Transformer Terminals	92

2	Operation of Non-Protection Functions	93
2.1	Auto-Reclosing	93
2.1.1	Time Delayed and High Speed Auto-Reclosing	93
2.1.2	Auto-Reclose Logic Inputs	93
2.1.2.1	CB Healthy	93
2.1.2.2	BAR	93
2.1.2.3	Reset Lockout	93
2.1.2.4	Enable 3 Pole AR	93
2.1.2.5	External Trip	94
2.1.3	Internal Signals	94
2.1.3.1	Trip Initiate Signals	94
2.1.3.2	Circuit Breaker Status	94
2.1.3.3	Check Synch OK and System Check OK	94
2.1.4	Auto-Reclose Logic Outputs	94
2.1.4.1	AR 3 Pole In Progress	94
2.1.4.2	Successful Close	94
2.1.4.3	AR Status	94
2.1.4.4	Auto Close	94
2.1.5	Auto-Reclose Alarms	94
2.1.5.1	AR No Checksync (Latched)	94
2.1.5.2	AR CB Unhealthy (Latched)	95
2.1.5.3	AR Lockout (Self Reset)	95
2.1.6	Auto-Reclose Logic Operating Sequence	95
2.1.7	Main Operating Features	96
2.1.7.1	Auto-Reclose Modes	98
2.1.7.2	Auto-Reclose Initiation	98
2.1.7.3	Auto-Reclose Inhibit following Manual Close	98
2.1.7.4	Auto-Reclose Lockout	98
2.1.7.5	Reset from Lockout	98
2.1.7.6	System Check on Shot 1	99
2.1.7.7	Immediate Auto-Reclose with Check Synchronism	99
2.1.8	Auto-Reclose Logic Diagrams	99
2.2	System Checks (including Check Synchronizer)	104
2.2.1	Overview	104
2.2.2	VT Selection	104
2.2.3	Basic Functionality	105
2.2.4	System Check Logic Outputs	105
2.2.5	Check Sync 2 and System Split	105
2.2.6	Synchronism Check	106
2.2.7	Slip Control by Timer	106
2.3	Auto-Reclose/Check Synchronization Interface	107
2.4	Voltage Transformer Supervision (VTS) - Fuse Fail	108
2.4.1	Loss of One or Two Phase Voltages	108
2.4.2	Loss of all Three Phase Voltages Under Load Conditions	108
2.4.3	Absence of Three Phase Voltages Upon Line Energization	109
2.4.4	VTS Logic	109
2.5	Current Transformer Supervision (CTS)	111

2.6	Transformer Magnetizing Inrush Detector	111
2.7	Circuit Breaker State Monitoring	112
2.7.1	Circuit Breaker State Monitoring Features	112
2.8	Circuit Breaker Condition Monitoring	113
2.8.1	Circuit Breaker Condition Monitoring Features	113
2.9	Circuit Breaker Control	115
2.9.1	CB Control using Hotkeys	118
2.10	Setting Groups Selection	119
2.11	Control Inputs	120
2.12	Real Time Clock Synchronization via Opto-Inputs	121
2.13	Fault Locator	122
2.13.1	Data Acquisition and Buffer Processing	122
2.13.2	Faulted Phase Selection	122
2.13.3	The Fault Location Calculation	122
2.13.4	Obtaining the Vectors	122
2.13.5	Solving the Equation for the Fault Location	123

FIGURES

	Page (OP) 5-
Figure 1 - Phase fault Mho characteristics	11
Figure 2 - Earth fault quadrilateral characteristics	12
Figure 3 - General starting logic and end timers	13
Figure 4 - Phase-to-phase currents showing change for CN fault	15
Figure 5 - Expansion of zone 1 for the default polarizing setting $V_{pol}=1$	16
Figure 6 - Quadrilateral characteristics (directional line shown simplified)	18
Figure 7 - Offset quadrilateral for zone 3	18
Figure 8 - Reactance line - top line of quadrilateral	19
Figure 9 - Resistive reach line (load blinder)	20
Figure 10 - Pole dead logic	21
Figure 11 - Load blinder characteristics	25
Figure 12 - Basic scheme delayed trip	26
Figure 13 - Power swing detected for 3 cycles continuous ΔI	27
Figure 14 - Power swing blocking	29
Figure 15 - Trip on close	30
Figure 16 - Trip on close based on CNV level detectors	31
Figure 17 - Sequence networks connection for an internal A-N fault	34
Figure 18 - Aided scheme logic overview	36
Figure 19 - Send logic	37
Figure 20 - Receive logic	37
Figure 21 - Aided tripping logic	38

Figure 22 - Permissive underreach transfer trip scheme (PUR)	39
Figure 23 - PUR	39
Figure 24 - Permissive OverReach (POR) transfer trip scheme	41
Figure 25 - POR	42
Figure 26 - Distance blocking scheme (BOP)	45
Figure 27 - Example of fault current reverse of direction	46
Figure 28 - Blocking 1	46
Figure 29 - Blocking 2	46
Figure 30 - The DEF permissive scheme	47
Figure 31 - Aided DEF (ground) permissive scheme logic	47
Figure 32 - The DEF blocking scheme	48
Figure 33 - Aided DEF (ground) blocking scheme logic	48
Figure 34 - Zone 1 extension scheme	48
Figure 35 - Zone 1 extension	49
Figure 36 - Loss of load accelerated trip scheme	50
Figure 37 - Loss of load	51
Figure 38 - Pictorial comparison of operating modes	53
Figure 39 - Direct connection within the local substation	56
Figure 40 - InterMiCOM teleprotection via a MODEM link	56
Figure 41 - MODEM InterMiCOM teleprotection via a RS422 protocol	56
Figure 42 - MODEM InterMiCOM teleprotection via fiber optic	57
Figure 43 - Example assignment of signals within the PSL	57
Figure 44 - Triangulated InterMiCOM⁶⁴ Application	59
Figure 45 - InterMiCOM⁶⁴ channel fail and scheme fail conceptual logic	65
Figure 46 - InterMiCOM⁶⁴ general alarm signals (conceptual logic)	66
Figure 47 - InterMiCOM⁶⁴ communications mode and IEEE C37.94 alarm signals	66
Figure 48 - InterMiCOM⁶⁴ two ended scheme extended supervision	67
Figure 49 - Triangulated InterMiCOM⁶⁴ application	67
Figure 50 - Directional overcurrent logic	73
Figure 51 - Thermal overload protection logic diagram	75
Figure 52 - IDG characteristic	77
Figure 53 - Directional EF with neutral voltage polarization (single stage)	78
Figure 54 - Directional EF with negative sequence polarization (single stage)	78
Figure 55 - Negative sequence overcurrent non-directional operation	80
Figure 56 - Directionalizing the negative phase sequence overcurrent element	80
Figure 57 - Directionalizing the negative phase sequence overcurrent element	80
Figure 58 - Undervoltage - single and three phase tripping mode (single stage)	82
Figure 59 - Overvoltage - single and three phase tripping mode (single stage)	83
Figure 60 - Residual overvoltage logic (single stage)	84
Figure 61 - Decaying dc component	85
Figure 62 - Calculating a Zero Cross Detection Point using sample values	86
Figure 63 - CB failure for MiCOM P445	88
Figure 64 - Broken conductor logic	88

Figure 65 - Underfrequency logic (single stage)	89
Figure 66 - Overfrequency logic (single stage)	89
Figure 67 - Rate of change of frequency protection	91
Figure 68 - Weak infeed configuration on stub-fed radial circuit (parallel line is out of service)	92
Figure 69 - Auto-reclose timing diagram - single fault	96
Figure 70 - Auto-reclose timing diagram - repeated fault inception	96
Figure 71 - Auto-reclose timing diagram - fault with system synchronism	96
Figure 72 - Auto-reclose timing diagram - lockout for no checksynch	96
Figure 73 - Auto-reclose enable logic	99
Figure 74 - Auto-reclose tripping	99
Figure 75 - Auto-reclose inhibit sequence count	100
Figure 76 - Auto-reclose cycles	101
Figure 77 - Auto-reclose close	102
Figure 78 - Auto-reclose lockout logic	103
Figure 79 - Auto-reclose close notify	103
Figure 80 - Auto-reclose/check sync interface	107
Figure 81 - VTS logic	110
Figure 82 - Voltage dependant CTS	111
Figure 83 - Circuit breaker state monitor	113
Figure 84 - Circuit breaker condition monitoring - broken current	114
Figure 85 - Circuit breaker condition monitoring - operation time	114
Figure 86 - CB monitoring	115
Figure 87 - Remote control of circuit breaker	116
Figure 88 - Circuit breaker control	118
Figure 89 - CB control hotkey menu	119
Figure 90 - Fault locator selection of fault current zero	123

TABLES

	Page (OP) 5-
Table 1 - Signals, Zones and DDB Numbers	26
Table 2 - Phase Selector Pickup and VNpol	33
Table 3 - Function logic	43
Table 4 - Time delays associated with extended zone Z1X	49
Table 5 - Pins, Acronyms and InterMiCOM usage	55
Table 6 - Address groups for a two-terminal or dual redundant scheme	60
Table 7 - Address groups for a three-terminal scheme	61
Table 8 - InterMiCOM DDB Signal List	64
Table 9 – IDMT curve descriptions, standards and constants	71
Table 10 - IDMT curve descriptions, standards and constants	72

Table 11 - Phases, operating currents and polarizing voltages	72
Table 12 - Functions, DDB numbers and descriptions	79
Table 13 - Initiation (menu selectable) and CB fail timer reset mechanism	87
Table 14 - Functions, DDB numbers and descriptions	90
Table 15 - Functions, DDB numbers and descriptions	91
Table 16 - Contact positions, states detected and actions	112
Table 17 - CB operations Min/Max values	113
Table 18 - DDB signals and active setting groups	119
Table 19 - Control inputs	120
Table 20 - Ctrl. I/P config	120
Table 21 - Ctrl. I/P labels	120
Table 22 - Time of “sync. pulse” and corrected time	121
Table 23 - Record control settings	121

1 OPERATION OF INDIVIDUAL PROTECTION FUNCTIONS

The following sections detail the individual protection functions.

Note Although the MiCOM P445 provides only three-pole tripping, much of the fault evaluation process, etc., is performed on a phase-by-phase basis and is, therefore, described in that context.

1.1 Phase Fault Distance Protection (for Software Versions BEFORE H3a)

The MiCOM P445 has five zones of phase fault protection. These are configured as mho circle characteristics. Each zone can be set independently to be permanently disabled or permanently enabled. The impedance plot (shown in the *Phase fault Mho characteristics impedance plot* diagram) shows the characteristic when set for mho operation. The characteristic drawn for illustration is based on the default distance settings without dynamic expansion.

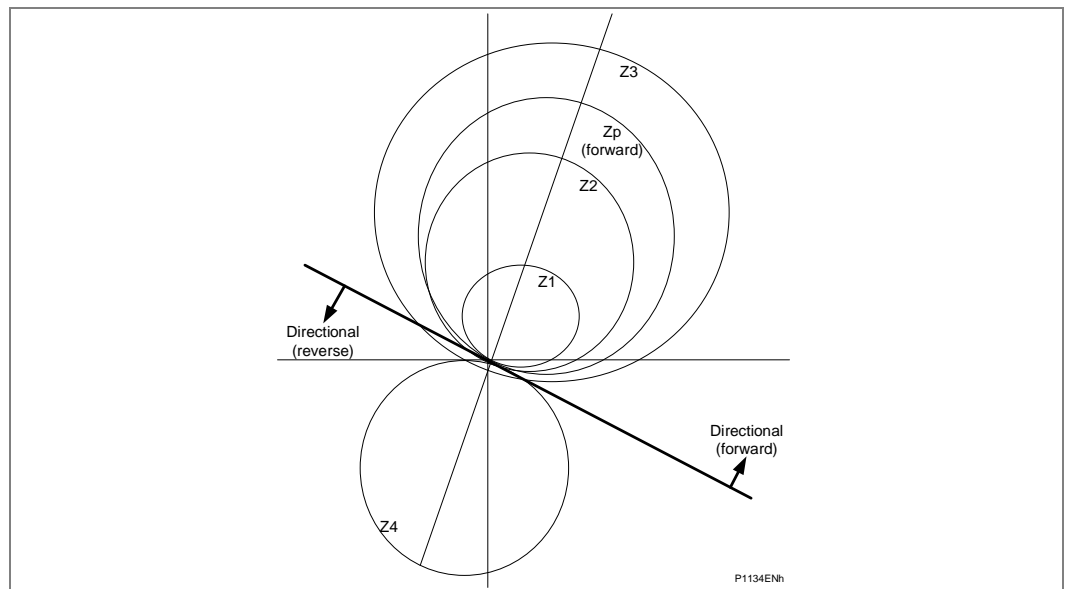

Figure 1 - Phase fault Mho characteristics

The protection elements are directionalized as follows:

- Zones 1, 2 and 3 - Directional forward zones, as used in conventional three zone distance schemes. Note that Zone 1 can be extended to Zone 1X when required in zone 1 extension schemes.
- Zone P - Programmable directionality. Selectable as a directional forward or reverse zone.
- Zone 4 - Directional reverse zone.

1.2 Phase Fault Distance Protection (for Software Version H3a and Later)

The Distance Protection function has been modified in Software Version H3a. For more details, please refer to the **Distance Protection Zone and Timer Start Enhancements** section in the **Application Notes** chapter.

1.3 Earth Fault Distance Protection (for Software Versions BEFORE H3a)

The MiCOM P445 has five zones of earth (ground) fault protection. It is possible to set all zones either with quadrilateral characteristics, or with mho circles. Each zone can be set independently to be permanently disabled or permanently enabled.

All earth fault distance elements are directionalized as per the phase fault elements, and use residual compensation of the corresponding phase fault reach. The impedance plot shown in the *Earth fault quadrilateral characteristics* diagram adds the characteristics when set for quadrilateral operation.

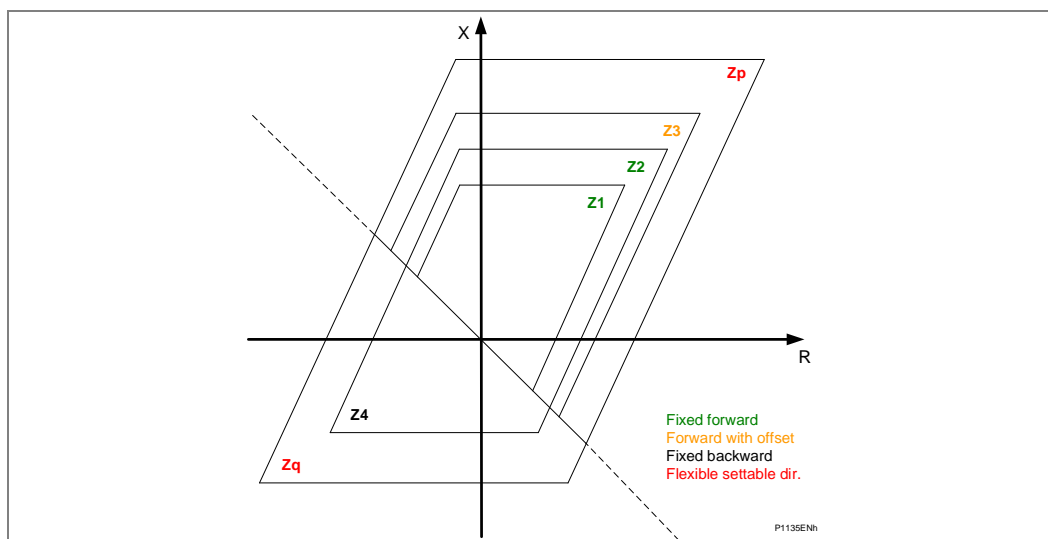

Figure 2 - Earth fault quadrilateral characteristics

1.4

Phase Fault Distance Protection (for Software Version H3a and Later)

The Distance Protection function has been modified in Software Version H3a. For more details, please refer to the *Distance Protection Zone and Timer Start Enhancements* section in the *Application Notes* chapter.

1.5 Distance Protection Starting

With Software H3 and later the zone timer starting is selectable either 'Zone Start' (default) or 'General Start'. Before Software H3 only the 'Zone Start' behaviour is implemented. This section describes how both options will operate.

The MiCOM P44y/P54x distance protection provides several starting elements (with dedicated DDBs):

- Zone 1 Ph starting ... Zone Q Ph starting
- Zone 1 Gnd starting ... Zone Q Gnd starting
- Delta Directional starting

Zone Start (Default)

In this operation mode the dedicated timers for each zone $t_{Z1} \dots t_{ZQ}$ are started individually with the measured impedance entering the zone and the correct phase selection (see also the Phase Selector section). This may result in different starting times for the zones and a longer tripping time in case the apparent impedance trajectory moves to smaller impedances. Each zone timer will stop individually if the measured impedance gets out of the zone reaches.

General Start

In this operation mode all zone timers $t_{Z1} \dots t_{ZQ}$ are started instantaneously with the first zone starting or delta starting as shown in the **General starting logic and end timers** diagram. The General Start signal will reset in case all zone and delta directional startings have reset.

In addition to the General Start signal two End Timers are available:

- Directional End Timer (**ZDir tEnd**) with directional setting **Dist tEnd Dir** (Forward, Reverse or Non-Directional)
- Non-Directional End Timer (**ZNonDir tEnd**)

The end timers can be used for Distance protection backup tripping e. g. in combination with a high reach setting for the used zones.

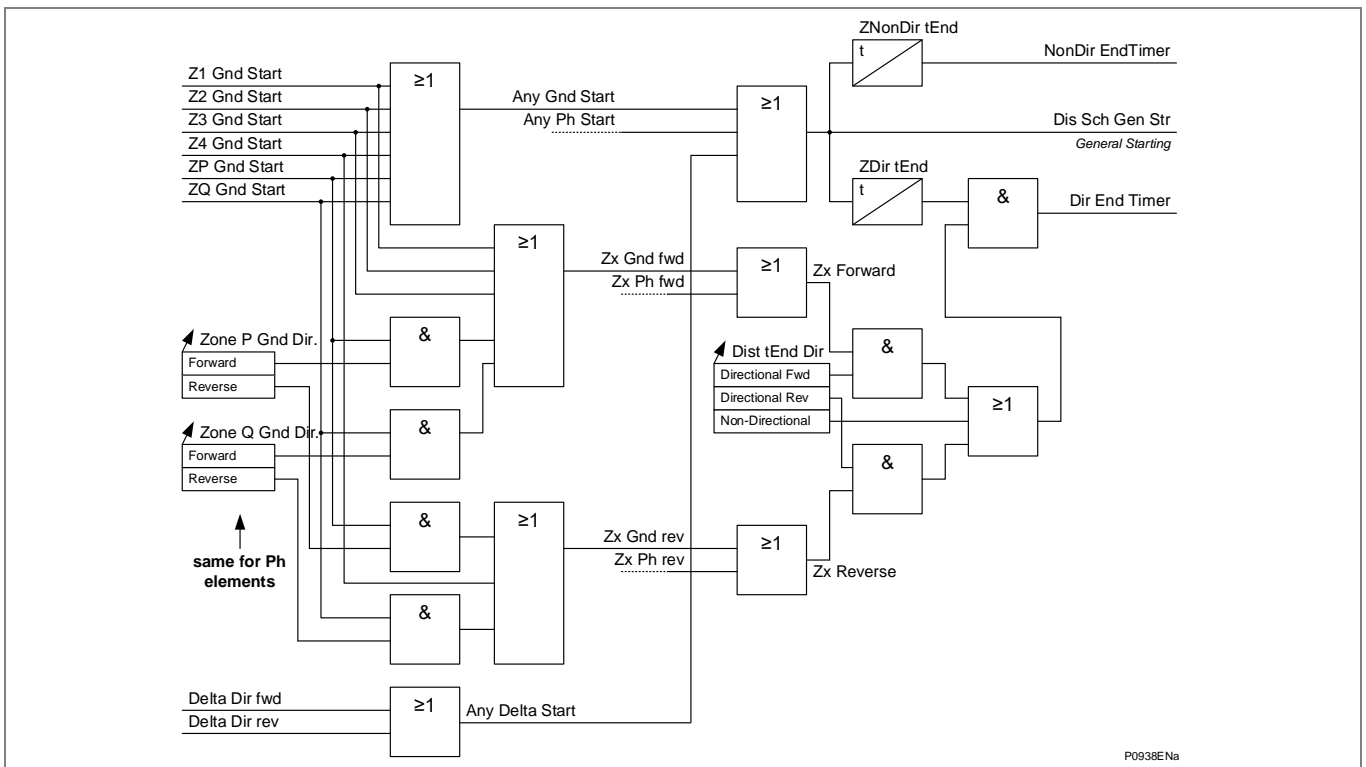

Figure 3 - General starting logic and end timers

1.6 Distance Protection Tripping Decision

For the MiCOM relay, five conditions would generally need to be satisfied for a correct relay trip to result. These are:

- The phase selector needs to identify the faulted phases, and ensure that only the correct distance measuring zones may proceed to issue a trip. Possible phase selections are AN, BN, CN, AB, BC, CA, ABC. For double phase to ground faults, the selection is AB, BC or CA, with N (neutral) just for indication only.
- The loop current for the selected phase-ground or phase-phase loop must exceed the minimum sensitivity for the tripping zone. By default, this sensitivity is 5%In for ground faults, and both the faulted phases must exceed 5%In for phase-phase faults. The user may raise this minimum sensitivity if required, but this is not normally done.
- The faulted phase impedance must appear within a tripping (measuring) zone, corresponding to the phase selection. Five independent zones of protection are provided. The tripping zones are fixed as mho circles for the phase fault elements. For ground fault elements, they may be selected as mho or quadrilateral. The ground fault distance elements require compensation for the return impedance, this residual compensation modifies the replica impedance for each zone. The reach setting Z for ground fault mho and quadrilateral elements is determined as follows:

$$Z = Z_1 + [(I_{res} / IP) \times Z_{res}]$$

Where:

Z_1 is the positive sequence reach setting

IP is the current in the faulted phase

I_{res} is the residual current (= $I_a + I_b + I_c$)

Z_{res} is the residual impedance (= $(Z_0 - Z_1)/3 = K_{res} \times Z_1$)

- For directional zones within the relay (Zone 1, P, 2, 4 and Z3 if set directional), the directional line must be in agreement with the tripping zone. For example, zone 1 is a forward directional zone, and must not trip for reverse faults behind the relay location. A zone 1 trip will only be permitted if the directional line issues a "forward" decision. The converse will be true for zone 4, which is reverse-looking and this needs a reverse decision by the directional line.
- The set time delay for the measuring zone must expire, with the fault impedance measured inside the zone characteristic for the duration. In general, Zone 1 has no time delay ("instantaneous"), all other zones have time delays. Where channel-aided distance schemes are used, the time delay tZ2 for overreaching Zone 2 may be bypassed under certain conditions.

To achieve fast, sub-cycle operation, the phase selection, measuring zones and directional line algorithms run in parallel, with their outputs gated in an AND configuration. This avoids sequential measurement which would slow the operation of the relay.

From version H4 the operating times for off-angle faults have been improved to an average of 30-35ms in all zone 1 (for $f = 50\text{Hz}$). Faults at the zone boundary will be cleared in higher times (10-20% of zone 1 area). Sub cycle operation is maintained for faults close to the relay characteristic up to 75% of zone reach setting.

1.7 Phase Selection

Phase selection is the means by which the relay is able to identify exactly which phase are involved in the fault and allow the correct measuring zones to trip.

Operation of the distance elements, is controlled by the Superimposed Current Phase Selector. Only elements associated with the fault type selected by the phase selector are allowed to operate during a period of two cycles following the phase selection. If no such element operates, all elements are enabled for the following 5 cycles, before the phase selector returns to its quiescent state.

Operation of an enabled distance element, during the 2-cycle or 5-cycle period, causes the phase selector state to be maintained until the element resets. The one exception to this is when the phase selector decision changes while an element is operated. Here the selected elements are reset and the 2-cycle period re-starts with the new selection.

Note Any existing trip decision is not reset under this condition. After the first cycle following a selection, the phase selector is only permitted to change to a selection involving additional phases.

On double phase-to-ground faults, only the appropriate phase-phase elements are enabled. The indication of the involvement of ground is by operation of a biased neutral current level detector.

1.7.1

Theory of Operation

Selection of the faulted phase(s) is performed by comparing the magnitudes of the three-phase-to-phase superimposed currents. A single-phase-to-ground fault produces the same superimposed current on two of these signals and zero on the third. A phase-to-phase or double phase-to-ground fault produces one signal which is larger than the other two. A three-phase fault produces three superimposed currents which are the same size. Refer to the *Phase-to-phase currents showing change for CN fault* diagram to see how the change in current can be used to select the faulted phases for a CN fault.

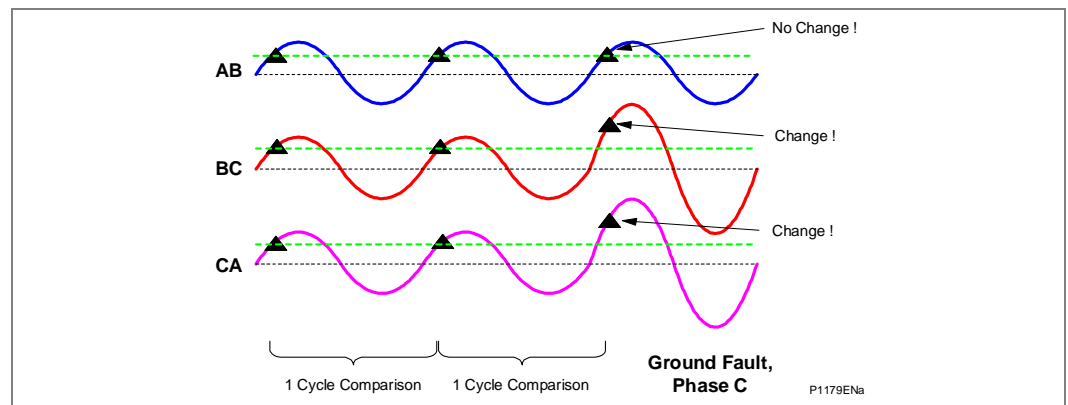

Figure 4 - Phase-to-phase currents showing change for CN fault

A superimposed current is deemed to be large enough to be included in the selection if it is greater than 80% of the largest superimposed current.

A controlled decay of the superimposed threshold ensures that the phase selector resets correctly on fault clearance.

Phase selection can only be made when any superimposed current exceeds 4% of nominal current (I_n) as a default value.

Under normal power system conditions, the superimposed currents are made by subtracting the phase-phase current sample taken 96 samples (2 cycles) earlier from the present sample.

When a fault is detected, resulting in a phase selection being made, the “previous” memorized sample used in the superimposed current calculation is taken from a recycled buffer of “previous” samples. This ensures that, if the fault develops to include other phases, the original selection is not lost. The re-cycling of the pre-fault buffers is continued until the phase selector resets, either because the fault is cleared or when the 5-cycle period has expired and no element has operated.

Under conditions on load with high levels of sub-synchronous frequencies, it is necessary to increase the ΔI phase selector threshold from its default (4% I_n) to prevent sporadic operation. This is automatically performed by the relay, which will self-adjust the threshold to prevent operation upon the noise signals, whilst still maintaining a high sensitivity to faults.

To facilitate testing of the Distance elements using test sets which do not provide a dynamic model to generate true fault delta conditions, a Static Test Mode setting is provided. This setting is found in the COMMISSIONING TESTS menu column. When set, this disables phase selector control and forces the relay to use a conventional (non-delta) directional line.

1.8

Mho Element Polarization and Expansion

To ensure coverage for close-up faults, distance protection always includes a proportion of voltage memory. Therefore, when each zone characteristic is determined, the phase comparator used in the zone decision will use a mix of vectors "V" (the directly measured phase/line voltage), "IZ" (a voltage constructed from the fault current and zone impedance reach setting) and "Vpol" (a polarizing voltage). The MiCOM relay allows the user to specify the composition of Vpol, deciding on how to mix the proportion of two voltage selections:

- The amount of directly measured ("self") polarizing in the mix
- The amount of clean memory stored from before the fault inception

One of the additional benefits in adding memory into the polarizing mix is that mho characteristics will offer dynamic expansion in the event of a forward fault. This phenomenon is shown in the *Expansion of zone 1 for the default polarizing setting Vpol=1 (Distance option only)* diagram for the default setting Vpol=1, where a Zone 1 characteristic with reach Z will grow to cover 50% of Zs to cover more fault arc resistance.

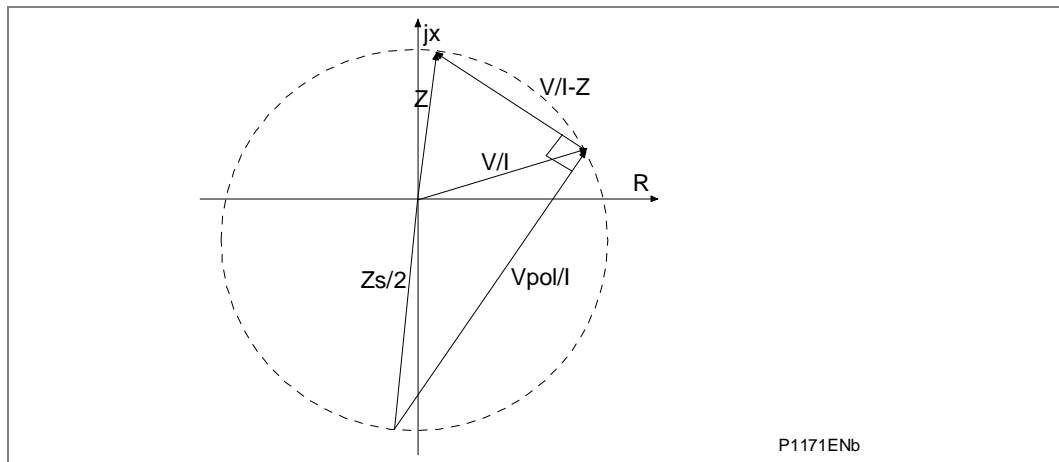

Figure 5 - Expansion of zone 1 for the default polarizing setting Vpol=1

Key: Z_s = Source impedance behind the relay location

The MiCOM relay does not allow the polarizing to be selected as entirely self polarized, or entirely memory polarized. Vpol always contains the directly measured self-polarized voltage, onto which a percentage of the pre-fault memory voltage can be added. The percentage memory addition is settable within the range 0.2 (20%) to 5 (500%).

Setting 20% means that most of the polarizing will be self-polarizing, with minimal mho circle expansion, and just enough memory to counteract any CVT transients. Setting 500% means that in the overall polarizing mix the ratio would be 1-part self polarizing to 5-parts memory. Such a high memory content would offer large dynamic expansion, covering 83% of the source impedance (Z_s) behind the relay.

Mho expansion = $[(\text{Polarizing Setting})/(\text{Setting} + 1)] \cdot Z_s$

This characteristic is used for Zones 1, P (optionally reversed), 2, 4 and Zone 3 if the offset is disabled.

The characteristic is generated by a phase comparison between $V/I-Z$ and the polarizing signal Vpol

Where:

- V is the fault voltage
- V_{pol} is a user selected mix of the fault voltage and pre-fault memory
- I is the fault current
- Z is the zone reach setting (including residual compensation for ground fault elements)
- Z_s is the source impedance (included in the *Expansion of zone 1 for the default polarizing setting V_{pol}=1 (Distance option only)* diagram to show the position of the V_{pol} phasor)

The polarizing signal V_{pol} is a combination of the fault voltage and the stored vector taken from 2 cycles before the fault, which is a representation of the volts at the source.

$$V_{pol} = IZ_s + V \quad \text{or} \quad V_{pol}/I = Z_s + V/I$$

Operation occurs when the angle between the signals is greater than 90°, which is for faults inside the circle.

The validity of the voltage memory in the MiCOM relay extends to 16 cycles after loss of the VT input voltage. If no memory is available, the polarizing signal is substituted by cross polarizing from the unfaulted phase(s). For example if V_{mem} is unavailable, the voltages measured on phases B and C now are used, phase-shifted as necessary.

To produce the reversed zones (Zone 4 and, optionally, Zone P), the impedance Z is automatically set to a negative value.

1.8.1 Switch on to Fault Action for Zone 1

Operation of the distance elements is generally prevented if the polarizing signal magnitude is insufficient (less than 1V). The exception is for Zone 1, which following breaker closure is allowed to operate with a small (10%) reverse offset. This is to ensure operation when closing on to a close-up three-phase fault (Scenario: earthing/ground clamps inadvertently left in position).

In addition Z₄ reverse operation is held if it operates in memory.

Other zones may have their zone time delays bypassed for SOTF/TOR, as detailed in the Application Notes chapter.

1.8.2 Offset Mho

If the Zone 3 offset is enabled then it uses no memory polarizing and has a fixed reverse offset from the origin of a distance polar diagram. Characteristic angle and residual compensation are as per the forward settings.

1.9 Quadrilateral Elements

The quadrilateral elements are made from combinations of reactance lines, directional lines and load blinders.

A counter, similar to that used for the mho element, is incremented when all the relevant phase comparisons indicate operation. A fast up-count of 6 is issued when the fault is within 80% of the reach of the zone, and well within the resistive reach boundary. Elsewhere, the increment is always 1 but a fast decrement (6) is used when the faulted phase current is less than half the minimum operating current setting. Therefore, an area of fast operation for faults near the characteristic angle is always available, whether mho or quadrilateral characteristics are applied.

- 1.9.1 Directional Quadrilateral**
- This characteristic is used for Zones 1, P (optionally reversed), 2 and 4 (reversed). It is formed from two parallel reactance lines, two parallel resistive reach blinders and controlled by the delta or conventional directional line. The bottom reactance line (not shown on in the following diagram) and the left-hand reach blinder are automatically set to 25% of the reactance reach and the right-hand blinder, respectively. The reactance line is arranged to operate for faults below the line, the blinders for faults within the resistive reach limits, and the delta directional line for forward faults. The counter increments when all these conditions are satisfied.

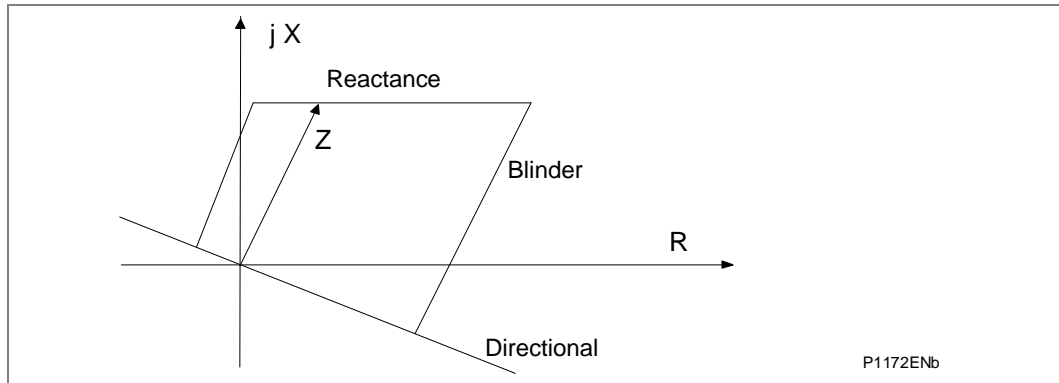

Figure 6 - Quadrilateral characteristics (directional line shown simplified)

- 1.9.2 Offset Quadrilateral**
- This characteristic is used for Zone 3 when the offset is enabled. It is formed from two reactance lines and two resistive reach blinders. The upper reactance line is arranged to operate for faults below it and the lower for fault above it. The right hand blinder is arranged to operate for faults to its left and the left hand blinder for faults to its right. The counter increments when all these conditions are satisfied.

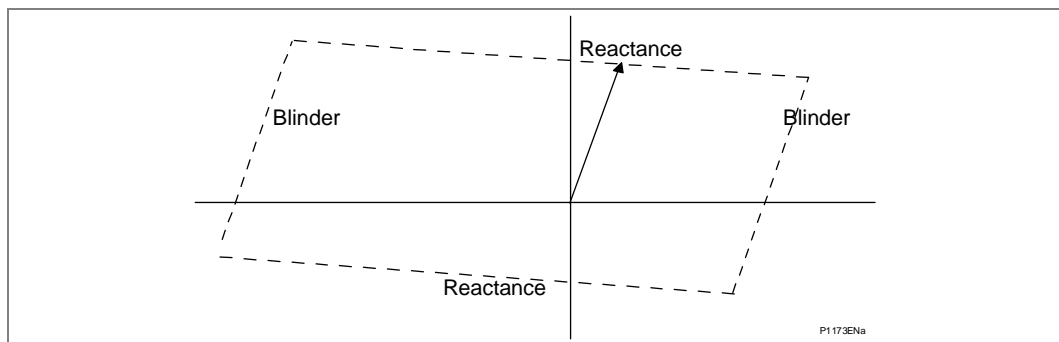

Figure 7 - Offset quadrilateral for zone 3

<i>Note</i>	<i>When Zone 3 is set offset in simple setting mode, the left-hand blinder and lower reactance line equal the offset percentage setting of the line impedance and fault resistance respectively. In the advanced setting mode, both lines can be set independently.</i>
-------------	---

- 1.9.3 Reactance Line - Top Line of Quadrilateral**
- The relay provides a flexible user settable top reactance line tilting mode:
1. Dynamic (self adaptive) tilt angle - applicable to ground distance only
 2. Fixed tilt angle - applicable to phase distance and ground distance if Dynamic tilting is disabled

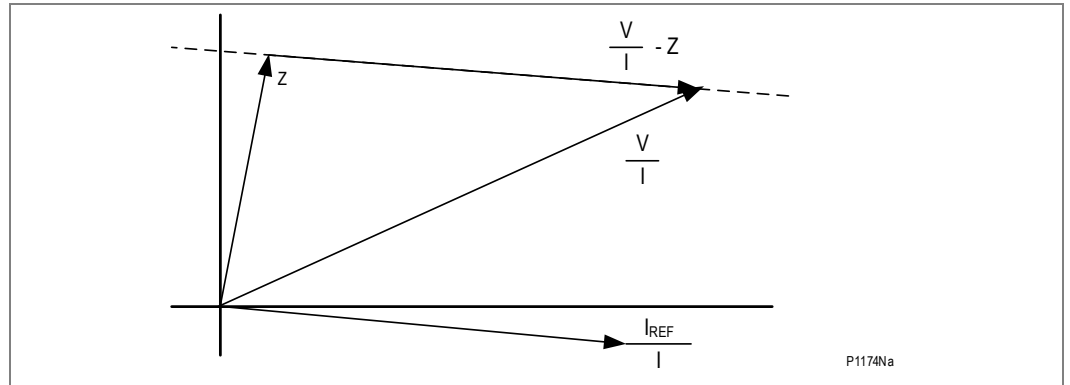

Figure 8 - Reactance line - top line of quadrilateral

A reactance line is formed by the phase comparison between an operating signal $V/I - Z$, which is the same as that used for the equivalent mho element, and a polarizing signal I_{ref}/I .

Where:

V is the fault voltage

I is the fault current (always presented at zero degree)

Z is the zone reach setting, including residual compensation

I_{ref} is the negative sequence current for dynamic tilting or phase current for the fixed angle tilting that includes the initial tilt angle setting (set to -3° as default).

Dynamic Tilting:

When the Dynamic tilting is selected by a user, the top line of the ground distance quadrilateral characteristic will **start** tilting from the user settable angle (default angle is -3°) and tilt further for the angle difference between the fault current and the negative sequence current so that an overall tilt angle with the reference to fault (phase) current 'I' will be:

$$\text{Tilt angle} = \angle I_{ref}/I = \text{setting} + \angle(I_{ph}-I_2)$$

Operation occurs when the operating signal lags the polarizing signal.

The default starting (initial) tilt angle of -3° is introduced to reduce the possibility of overreach caused by any small differences between the negative sequence source impedances, and general CT/VT angle tolerances.

Negative sequence current is used for ground fault I_{ref} since it provides a better estimate of the current in the fault than either the faulted phase current or zero sequence current. As a result, the reactance line follows the fault resistance impedance and tilts up or down (depending on the load direction) starting from the set initial tilt angle to avoid underreach or overreach.

These additional constraints also exist to ensure that the top line does not tilt too far:

- The Zone 1 reactance (top) line can only stay at set initial tilt angle (-3° default) compared to the resistive axis, or can tilt down by $\angle(I_{ph}-I_2)$. The top line may never tilt up from set tilting angle, to ensure that Zone 1 does not overreach. This maintains grading/selectivity with downstream protection.
- The Zone 2 reactance (top) line can only ever stay at set tilt angle (-3° default) compared to the resistive axis, or can tilt up by $\angle(I_{ph}-I_2)$. The top line may never tilt down, to ensure that Zone 2 does not underreach. This is particularly important when Zone 2 is used to key channel-aided distance schemes.
- The maximum permissible tilt is $\pm 45^\circ$ either side of the set initial tilt angle (-3° default)

When one circuit breaker pole is open, during a single pole reclose sequence, the polarizing signal is replaced by the fault current with a -7° phase shift, allowing the protection of the remaining phases, even though the negative sequence current is not available. The additional phase shift is provided to reduce the possibility of overreach caused by the faulted phase as the reference.

Predetermined (Fixed Angle) Tilting:

For the ground quadrilateral characteristics when Dynamic tilting is disabled, the fix angle setting settable by a user applies. Each zone has an independent tilt angle setting. The total tilting angle with the reference to fault current 'I' is equal to the set angle:

Tilt angle = $\angle I_{ref}/I = \text{setting}$

Note *A minus angle is used to set a downwards tilt gradient, and a positive angle to tilt upwards.*

Operation occurs when the operating signal lags the polarizing signal. The setting range is $\pm 30^\circ$.

1.9.4

Right Hand Resistive Reach Line

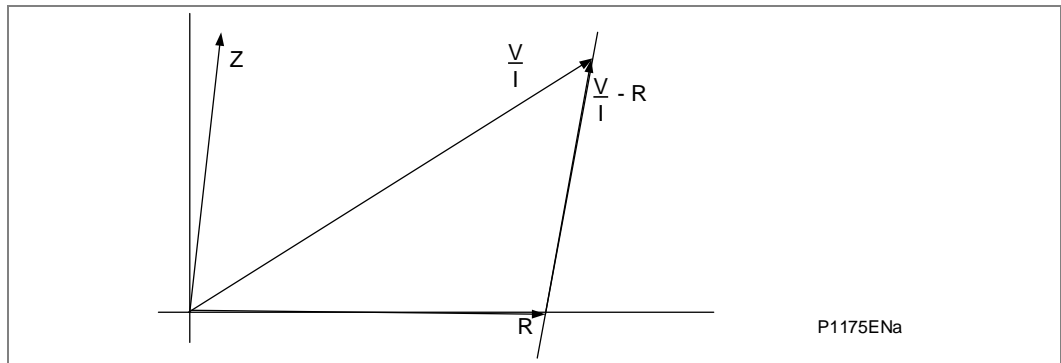

Figure 9 - Resistive reach line (load blinder)

A load blinder is formed by the phase comparison between an operating signal V/I and a polarizing signal Z

Where:

V is the fault voltage

I is the fault current

R is the resistive reach of the blinder

Z zone reach setting (including neutral compensation for ground distance)

Operation occurs when the operating signal leads the polarizing signal.

1.10

Quadrilateral Ground Resistive Reaches

The resistive reach setting is used to select the resistive intercept of the quadrilaterals – the right-hand side of the zone. Note that the RG setting applied defines the fault arc resistance that can be detected for a single-phase-ground fault. For such a fault, the fault resistance appears in the out and return total fault loop, in which the line impedance is $Z_1 \times (1 + kZ_N)$. Therefore, as most injection test sets will plot impedance characteristics in positive sequence terms, the right-hand intercept will be found at less than setting applied ($= RG/[1+kZ_N]$).

1.11 Line Parameters Settings

1.11.1 Phase Rotation

A setting is used to select whether the 3-phase voltage set is rotating in the standard ABC sequence, or whether the rotation is in reverse ACB order. The appropriate selection is required to ensure that all sequence components and faulted phase flagging/targeting is correct.

1.11.2 Trip Mode

The P445 is always configured for three pole tripping.

1.11.3 Pole Dead Logic

Pole dead logic is used by the relay to determine when the circuit breaker poles are open ("pole dead"). This indication may be forced, by means of status indication from CB auxiliary contacts (52a or 52b), or internally determined by the relay. When no auxiliary contacts are available, the relay uses an undercurrent level detector (ranged from 20mA to 3.2A, drop-off value=1.1*pick-up value), and an undervoltage level detector (ranged from 10V to 40V, drop-off value=1.15*pick-up value) to declare a "pole dead".

Note If the VT is connected at the busbar side, auxiliary contacts (52a or 52b) must be connected to the relay for a correct pole dead indication. The Pole dead logic for MiCOM P445 diagrams show the details:

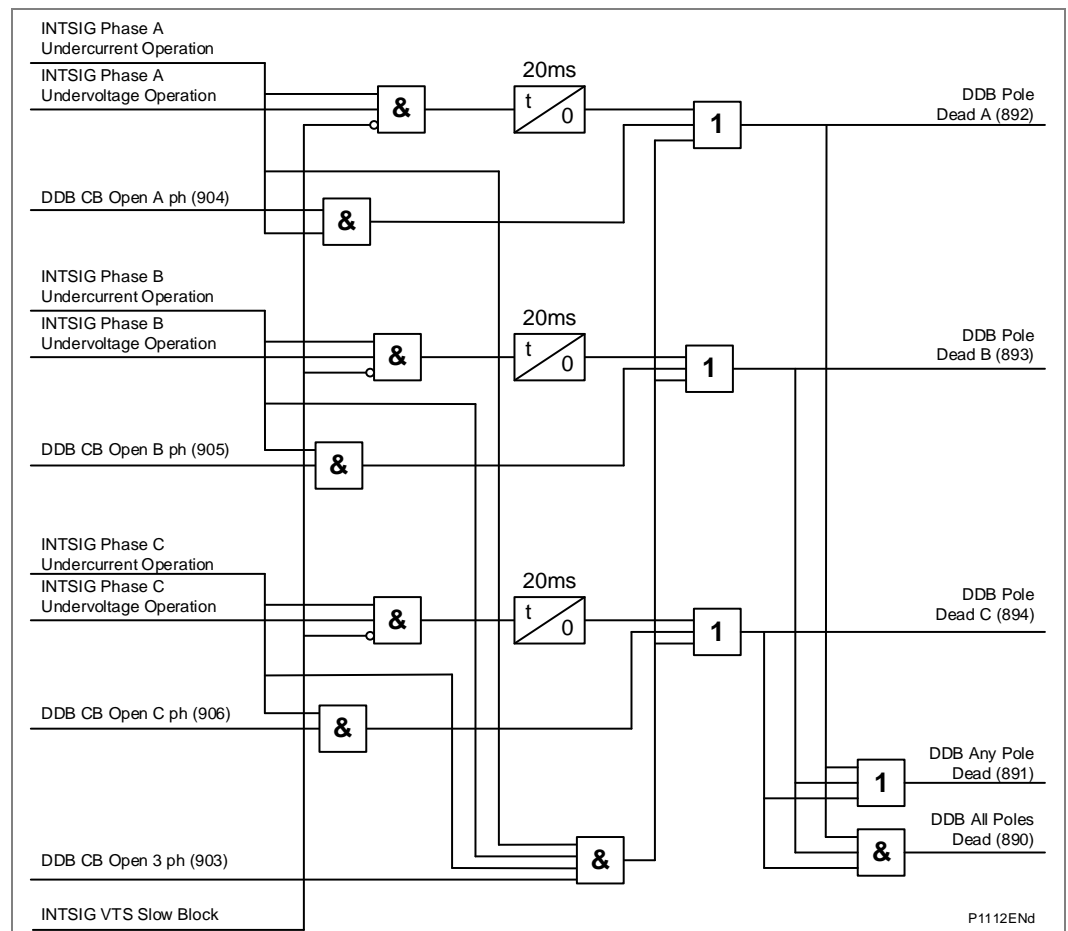

Figure 10 - Pole dead logic

1.11.4

Residual Compensation for Earth/Ground Faults

For earth faults, residual current (derived as the vector sum of phase current inputs (Ia + Ib + Ic) is assumed to flow in the residual path of the earth loop circuit. Hence, the earth loop reach of any zone must be extended by a multiplication factor of (1 + kZN) compared to the positive sequence reach for the corresponding phase fault element.



Caution

The kZN Angle is different than previous LFZP, SHNB, and LFZR relays: When importing settings from these older products, subtract angle $\angle Z1$.

1.12

Advanced Distance Elements Zone Settings

For most applications the user will configure the relay in “Simple” setting mode, whereby all zone reaches are based on the protected line impedance, scaled by a reach percentage. In such a case there is then no need to set the individual zone ohmic reaches and compensation factors, because the automatic calculation will already have determined these settings. Therefore with Simple settings, the menu column GROUP x DISTANCE ELEMENTS will merely be a list of what settings have been automatically calculated and applied. This list is useful as a reference when commissioning and periodic injection testing.

Using the **Advanced** setting mode, the user has decided to set all the zones him/herself, and must complete all the reach and residual compensation settings on a per zone basis.

Note Distance zones are directionalized by default by a delta directional decision. The characteristic angle for this decision is set along with the Delta Directional configuration, in the **GROUP x DIRECTIONAL FN** menu column. The default setting is 60°. If the delta directional decision is disabled, or cannot calculate a decision, a conventional directional element is automatically used.

1.12.1

Phase Fault Zone Settings

It can be noted that each phase zone has one additional setting that is not accessible in the Simple set mode:

- A minimum current sensitivity setting

The current *Sensitivity* setting for each zone is used to set the minimum current that must be flowing in each of the faulted phases before a trip can occur. If for example a phase A-B line fault is present, the relay must measure both currents Ia and Ib above the minimum set sensitivity. The default setting is 7.5% In for Zones 1 and 2, 5% In for other zones, ensuring that distance element operation is not constrained, right through to an SIR ratio of 60.

1.12.2

Ground Fault Zone Settings

It should be noted that the Ground reach settings (Reach and Angle) are set according to the **positive sequence line impedance**, and so will generally be identical to the Phase reach settings.

The Top Line of ground quadrilateral characteristics is not fixed as a horizontal reactance line. To account for phase angle tolerances in the line CT, VT and relay itself, the line is tilted downwards, at a “droop” of -3°. This tilt down helps to prevent zone 1 overreach. However, to further improve performance this line incorporates an additional dynamic tilt, which will change according to the phase angle between the faulted phase current and the negative sequence current:

- Zone 1 can tilt down to avoid overreaching for pre-fault power export
- Zones 2 and 3 can tilt up to avoid underreaching for pre-fault power import

As the tilt is dynamic, this is why ground fault elements do not have a setting for the angle.

The current Sensitivity setting for each zone is used to set the minimum current that must be flowing in the faulted phase and the neutral before a trip can occur. If for example an A-ground fault is present, the relay must measure both currents I_a and $I_{residual}$ above the minimum set sensitivity.

The default setting is 7.5% I_n for Zones 1 and 2, 5% I_n for other zones, ensuring that distance element operation is not constrained, right through to an SIR ratio of 60.

1.12.3

Distance Zone Sensitivities

When the Simple setting mode is selected, the minimum current sensitivity still applies, but the value is automatically calculated and applied based on the data entered into the simple settings fields. The criteria used to calculate the setting value is required to satisfy a minimum value of current flowing in the faulted loop and a requirement on the Zone reach point voltage. For Zones 3, P, and 4, the requirements are that the minimum current must be greater than 5% of rated current, and that the minimum voltage at the Zone reach point is 0.25 V. The current equating to the reach point criteria can be expressed as 0.25/Zone reach, and the sensitivity can be expressed as:

$$\text{Sensitivity (Z3, ZP, Z4)} = \max(5\%I_n, (0.25/\text{Zone reach}))$$

For Zones 1 and 2, the sensitivity is further qualified to ensure that they are set less sensitive than the reverse Zone 4. This is designed to ensure stability of the relay where applied with either an overreaching, or a blocking scheme. For Zones 1 and 2, the same criteria as for Zones 3, P, and 4 are applied, but in addition a minimum sensitivity criterion dependent upon the Zone 4 sensitivity is applied: the sensitivity must also exceed 1.5 x Zone 4 sensitivity. The sensitivity can be expressed as:

$$\begin{aligned} \text{Sensitivity (Z1, Z2)} &= \max(5\%I_n, (0.25/\text{Zone reach}), (1.5 \times \text{Zone 4 sensitivity})) \text{ OR} \\ \text{Sensitivity (Z1, Z2)} &= \max(5\%I_n, (0.25/\text{Zone reach}), (1.5 \times (0.25/\text{Zone 4 reach}))) \end{aligned}$$

Note 1 The dependency on the Zone 4 element always applies, even if Zone 4 is disabled.

Note 2 The default reach setting for Zones 1, 2, and 4 are 80%, 120%, and 150% respectively and for these settings, the "Zone dependent" terms can be reduced to:

$$\begin{aligned} 0.25/\text{Zone 1 reach} &= 0.25/(0.8 \times \text{line impedance}) \\ 0.25/\text{Zone 2 reach} &= 0.25/(1.2 \times \text{line impedance}) \\ 1.5 \times (0.25/\text{Zone 4 reach}) &= 0.25/\text{line impedance} \end{aligned}$$

In such cases, for Zone 1, the dominant Zone reach term will be that of Zone 1 and the equation can be reduced to:

$$\text{Sensitivity (Z1)} = \max(5\%I_n, (0.25/(0.8 \times \text{line impedance})))$$

And it can be shown that for lines with an impedance less than 6.25 Ω the Zone 1 reach term will dominate and the sensitivity will be greater than 5% I_n . Above this line impedance the sensitivity will be 5% I_n .

Similarly, for Zone 2, the dominant Zone reach term will be that of Zone 4 and the equation can be reduced to:

$$\text{Sensitivity (Z2)} = \max(5\%I_n, (0.25/\text{line impedance}))$$

For lines with an impedance less than 5 Ω , the Zone reach term will dominate and the sensitivity will be greater than 5% I_n . Above this line impedance the sensitivity will be 5% I_n .

In **Advanced** mode the same restrictions as minimum sensitivity should be applied to ensure distance element accuracy.

1.13 Conventional Voltage Transformer and Capacitor VT Applications

The MiCOM relay achieves fast trip times due an optimized counting strategy. For faults on angle and up to 80% of the set reach of the zone, a counter increments quickly to reach the level at which a trip is issued. Near the characteristic boundary, the count increments slower to avoid transient overreach, and to ensure boundary accuracy. This strategy is entirely sufficient where conventional wound voltage transformers are used. Thus, where Capacitor-coupled Voltage Transformers (CVT) are not employed, the setting “**CVT Filters**” can be set to Disabled.

Where capacitor-coupled voltage transformers are employed, then for a close-up fault the transient component can be very large in relation to the fundamental component of fault voltage. The relay has setting options available to allow additional filtering to be switched-in when required, and the filter options to use depend on the likely severity of the CVT transient. The two filtering methods are explained below.

1.13.1 CVTs with Passive Suppression of Ferroresonance

Passive suppression employs an anti-resonance design, and the resulting transient/distortion is fairly small. Sometimes such suppression is classed as a “**type 2**” CVT. In passive CVT applications, the affect on characteristic accuracy is generally negligible for source to line impedance ratios of less than 30 ($SIR < 30$). However, at high SIRs it is advisable to use the slower count strategy. This is achieved by setting “**CVT Filters**” to “**Passive**”.

It is important to note that by enabling this filter, the relay will not be slowed unless the SIR is above that set. If the line terminal has an SIR below the setting, the relay can still trip subcycle. It is only if the SIR is estimated higher than the setting that the instantaneous operating time will be increased by about a quarter of a power frequency cycle. The relay estimates the SIR as the ratio of nominal rated voltage V_n to the size of the comparator vector I_Z (in volts):

$$SIR = V_n / I_Z$$

Where:

V_n = Nominal phase to neutral voltage

I = Fault current

Z = Reach setting for the zone concerned

Thus for slower counting “**I**” would need to be low, as restricted by a relatively weak infeed, and “**Z**” would need to be small as per a short line.

1.13.2 CVTs with Active Suppression of Ferroresonance

Active suppression employs a tuned L-C circuit within the CVT. The damping of transients is not as efficient as for the passive designs, and such suppression is often termed as being a **Type 1** CVT. In active CVT applications, to ensure reach point accuracy the setting **CVT Filters** is set to **Active**. The relay then varies the count strategy according to the calculated SIR ($= V_n / I_Z$). Subcycle tripping is maintained for lower SIRs, up to a ratio of 2, with the instantaneous operating time increasing by about a quarter of a power frequency cycle at higher SIRs.

Transients caused by voltage dips, however severe, will not have an impact on the relay's directional measurement as the MiCOM relay uses voltage memory.

1.14 Load Blinding (Load Avoidance)

Load blinders are provided for both phase and ground fault distance elements, to prevent misoperation (mal-tripping) for heavy load flow. The purpose is to configure a blinder envelope which surrounds the expected worst case load limits, and to block tripping for any impedance measured within the blinded region. Only a fault impedance which is outside of the load area will be allowed to cause a trip. The blinder characteristics are shown in the *Load blinder characteristics* diagram.

In the diagram:

- Z denotes the Load/B Impedance setting. This sets the radius of the underimpedance circle.
- β denotes the Load/B Angle setting. This sets the angle of the two blinder boundary lines - the gradient of the rise or fall with respect to the resistive axis.

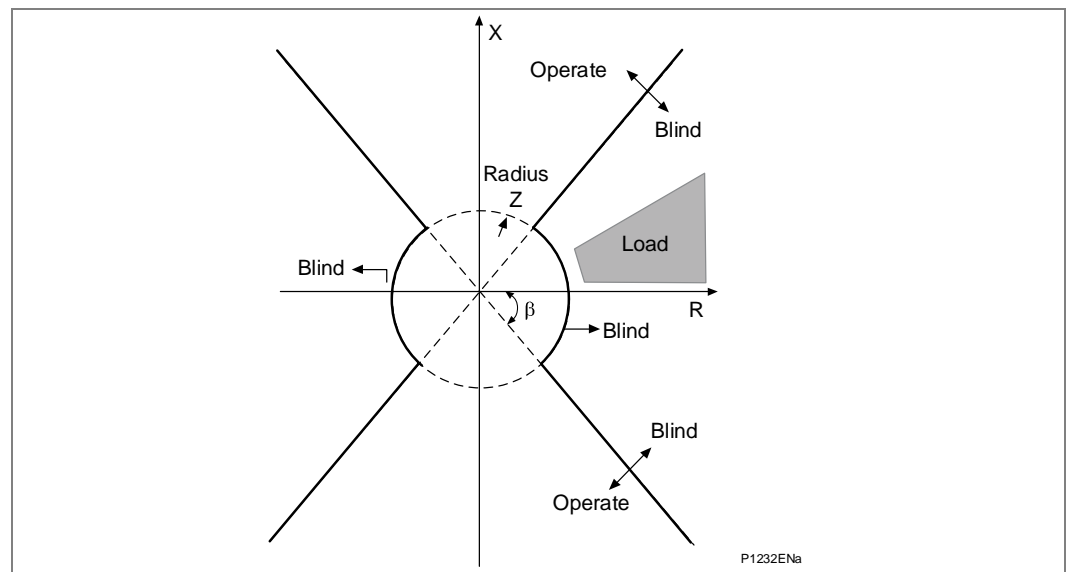

Figure 11 - Load blinder characteristics

The MiCOM relay has a facility to allow the load blinder to be bypassed any time the measured voltage for the phase in question falls below an undervoltage $V <$ setting. Under such circumstances, the low voltage could not be explained by normal voltage excursion tolerances on-load. A fault is definitely present on the phase in question, and it is acceptable to override the blinder action and allow the distance zones to trip according to the entire zone shape. The benefit is that the resistive coverage for faults near to the relay location can be higher.

1.15 Distance Elements Basic Scheme Setting

Configuration of which zones will trip, and the zone time delays is set in the menu column **GROUP x SCHEME LOGIC** (where x is the setting group). Phase and ground elements may have different time delays if required. Operation of distance zones according to their set time delays is termed the **Basic Scheme**, and is shown in the Basic scheme delayed trip diagram. The basic scheme always runs, regardless of any channel-aided acceleration schemes which may be enabled (see later).

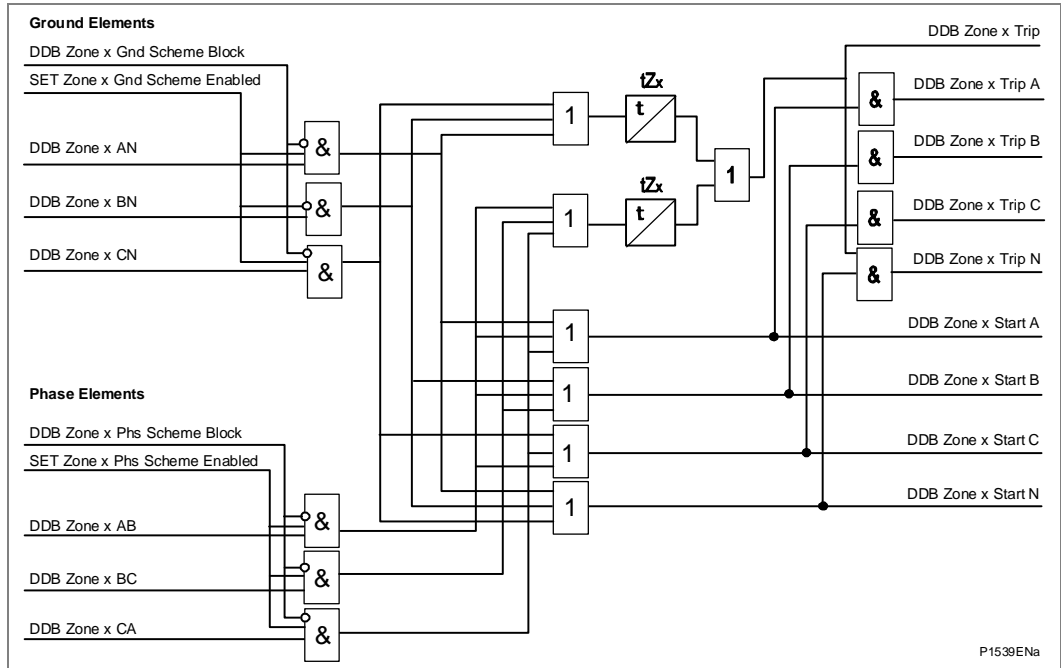

Figure 12 - Basic scheme delayed trip

Signal	Zone 1	Zone 2	Zone 3	Zone P	Zone 4
Zone x Ground Block	384	386	388	390	392
Zone x Phase Block	385	387	389	391	393
Zone x AN	960	966	972	978	984
Zone x BN	961	967	973	979	985
Zone x CN	962	968	974	980	986
Zone x AB	963	969	975	981	987
Zone x BC	964	970	976	982	988
Zone x CA	965	971	977	983	989
Zone x Trip	608	613	618	623	628
Zone x Trip A	609	614	619	624	629
Zone x Trip B	610	615	620	625	630
Zone x Trip C	611	616	621	626	631
Zone x Trip N	612	617	622	627	632
Zone x Start A	741	745	749	753	757
Zone x Start B	742	746	750	754	758
Zone x Start C	743	747	751	755	759
Zone x Start N	744	748	752	756	760

Note The numbers in the table represent the DDB signals available in the PSL.

Table 1 - Signals, Zones and DDB Numbers

1.16 Power Swing Detection, Alarming and Blocking

1.16.1 Detection of Power Swings

A power swing may cause the impedance presented to a distance relay to move away from the normal load area and into one or more of its tripping characteristics. In the case of a stable power swing it is important that the relay should not trip. The relay should also not trip during loss of stability since there may be a utility strategy for controlled system break up during such an event.

The power swing detection in the MiCOM relay is an advanced technique that uses superimposed current (ΔI) detector similar to the phase selection principle described above. However, for the power swing detector the current is always compared to that 2 cycles previous. For a fault condition this power swing detector (PSD) will reset after 2 cycles as no superimposed current is detected.

For a power swing, PSD will measure superimposed current for longer than 2 cycles, and it is the length of time for which the superimposed current persists that is used to distinguish between a fault and a power swing. A power swing is deemed to be in progress if a 3-phase selection, or a phase to phase selection when one pole is open, produced in this way is retained for more than 3 cycles, as shown in the following diagram. At this point the required distance zones can be blocked, to avoid tripping should the swing impedances cross into a tripping zone.

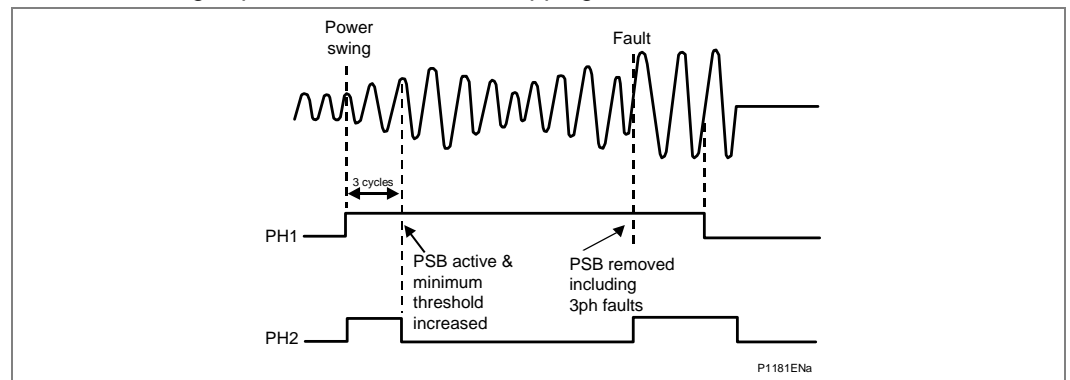

Figure 13 - Power swing detected for 3 cycles continuous ΔI

To detect slow power swings, when the superimposed current remains below the minimum threshold ($5\%I_n$), a complementary method of detection could be used. This method requires zone 5 to be set. For the zone 5 setting, no system study is required, it is only needed to set the R5 and R5' reach below the minimum possible load impedance, (see the Application Notes chapter). If the fault impedance remains within a zone 5 for at least 1 cycle without phase selection operation, the slow swing is declared. This complementary method works in parallel to the automatic, setting free technique explained above.

1.16.2 Actions Upon Power Swing Detection

Once a power swing is detected, the following actions occur:

- Distance elements are blocked on selected zones providing blocking is enabled
- All zones are switched to self polarized mho characteristics for maximum stability during the swing
- A power swing block alarm is issued when the swing impedance enters a distance zone. The condition of entering an impedance zone avoids alarming for low current momentary swings that settle quickly
- When a power swing is in progress, the minimum threshold used by the phase selector is increased to twice the maximum superimposed current prevailing in the swing. Therefore, the phase selector resets once a power swing is detected. It can then be used to detect a fault during a power swing.

1.16.3 Detection of a Fault During a Power Swing

A fault is detected during a swing when the phase selector operates, based on its increased threshold. Therefore, any operation of the phase selector will cause PSB unblocking, and allow a trip. Example scenarios are:

- A fault causes the delta current measured to increase above twice that stored during the swing (a step change in delta I rather than the expected gradual transition in a power swing).

1.16.4 Actions Upon Detection of a Fault During a Power Swing

The block signal is only removed from zones that start within 2 cycles of a fault being detected. This improves stability for external faults during power swings. Any measuring zone that was detecting an impedance within its characteristic before the phase selector detected the fault will remain blocked. This minimizes the risk of tripping for a swing impedance that may naturally be passing through Zone 1, and could otherwise cause a spurious trip if all zones were unblocked on fault inception. Any measuring zone that picks up beyond the 2-cycle window will remain blocked. This minimizes the risk of tripping for a continued swing that may pass through Zone 1, and could otherwise cause a spurious trip if all zones were allowed to unblock together.

1.16.5 Power Swing Settings

The power swing detection is setting free aided with slow swing detection that uses zone 5 and does not require any system study. The only setting available to a user, apart from zone 5, is to decide whether a zone should be blocked or allowed to trip after a power swing is detected. Zone by zone, it is possible to select one mode from the following:

Allow Trip	should a power swing locus remain within a trip zone characteristic for a duration equal to the zone time delay, the trip will be allowed to happen
Blocking	to keep stability for that zone, even if a power swing locus should enter it
Delayed Unblock	maintains the block for a set duration. If the swing is still present after the PSB Timeout Set window has expired, tripping is allowed as normal

Other setting possibilities are:

- Selection of PSB as "Indication" only will raise an alarm, without blocking any zones
- The *PSB Unblock Dly* function allows for any power swing block to be removed after a set period. For a persistent swing that does not stabilize, any blocked zones will be made free to trip once the timer has elapsed. In setting which relays will unblock, the user should consider which relay locations are natural split points for islanding the power system.
- The *PSB Reset Delay* is a time delay on drop-off timer, which maintains the PSB detection even after the swing has apparently stabilized. It is used to ensure that where the swing current passes through a natural minimum and delta I detection might reset, that the detection does not drop out/chatter. It can therefore be used to ensure a continual Power Swing indication when pole slipping (an unstable out of step condition) is in progress.

The following is a simplified logic diagram showing operation of the power swing blocking.

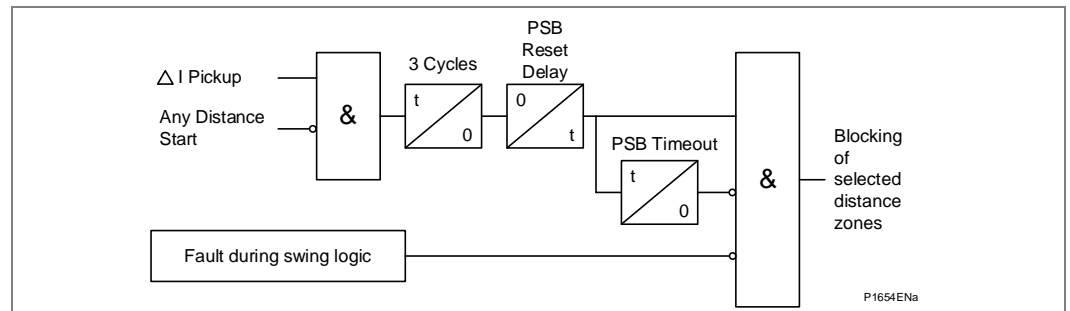

Figure 14 - Power swing blocking

1.17

Switch On To Fault (SOTF) and Trip On Reclose (TOR)

The settings for SOTF and TOR are included in the menu column “TRIP ON CLOSE” (TOC) within the MiCOM relay. The settings are designed to deal with two different scenarios.

- SOTF is designed to provide instantaneous operation of selected elements for a fault present on manual closure of the circuit breaker
- TOR is designed to provide instantaneous operation of selected elements for a persistent fault present on auto-reclosing of the circuit breaker

The SOTF and TOR functions are communally termed “Trip on Close” logic. The operation of these features is split into two Figures for clarity:

The *Trip on close* diagram shows Trip On Close function in relation with the Distance zones whilst the *Trip on close based on CNV level detectors* diagram presents Trip On Close driven by ‘Current No Volt’ level detectors. Both methods operate in parallel if mapped to the SOTF and TOR Tripping matrix in the setting file.

The ‘Current No Volt’ (CNV) level detectors are user settable in the ‘GROUP X CB FAIL & P. Dead’ column. The same setting is used for pole dead logic detection - see Settings Section for more details. The 20ms time delay in the *Trip on close based on CNV level detectors* diagram is to avoid a possible race between very fast overvoltage and undercurrent level detectors.

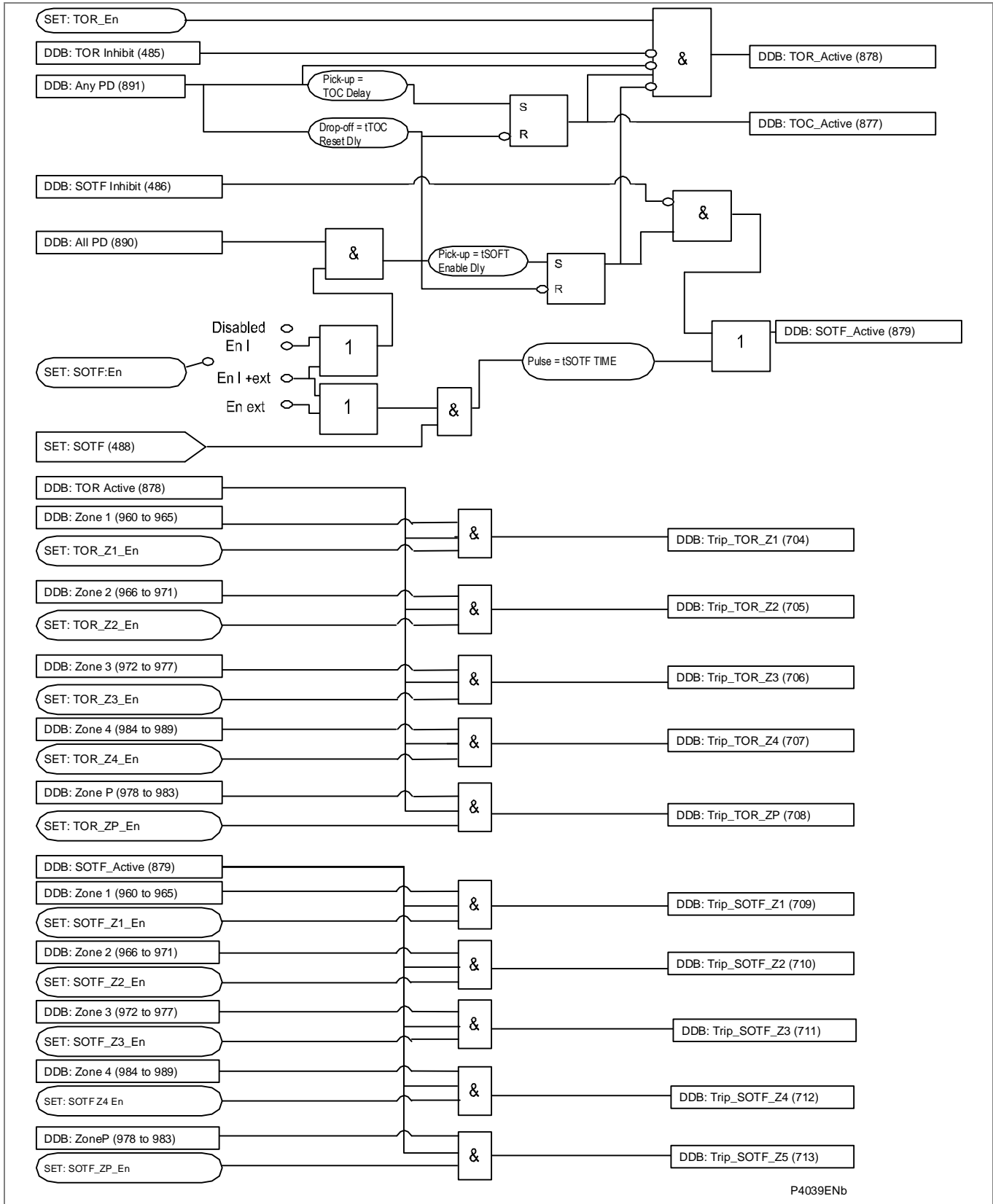

Figure 15 - Trip on close

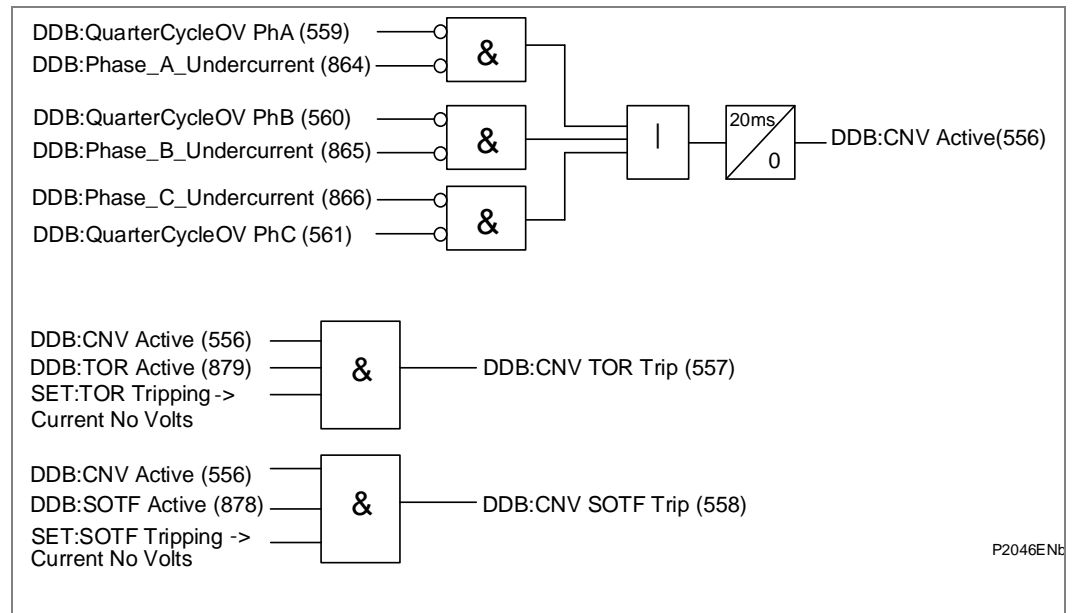

Figure 16 - Trip on close based on CNV level detectors

1.17.1

Switch OnTo Fault (SOTF) Mode

The settings applied are as follows:

SOTF Status SOTF can be activated in three different ways:

1. Enabled by using pole dead logic detection logic. A *SOTF Delay* timer starts if “all pole dead” condition is detected. Once this timer expires, SOTF becomes enabled and remains active during the period set on “TOC Reset Delay” setting.
2. Enabled by an external pulse. SOTF becomes enabled after an external pulse (as a circuit breaker close command for example) linked to DDB “Set SOTF” (DDB 488) is ON. The function remains active for the duration of the “SOTF Pulse” setting.
3. Enabled by using the two previous methods.
 With this feature *Enabled*, the relay operates in *Switch on to Fault* mode. Three pole instantaneous tripping (and auto-reclose blocking) occurs for any fault detected by the selected zones or/and **Current No Volt** level detectors when in Switch on to Fault mode. Whether this feature is enabled or disabled, the normal time delayed elements or aided channel scheme continues to function and can operate to trip the circuit.

TOC Reset Delay The SOTF (when enabled by pole dead detection logic) and TOR features remain in-service for the duration of the TOC reset delay once the circuit is energized.

SOTF Tripping Link While the Switch on to Fault Mode is active. The MiCOM relay will trip instantaneously for pick up of any zone selected in these links. To operate for faults on the entire circuit length it is recommended that at least Zone 1 and Zone 2 are selected. If no elements are selected then the normal time delayed elements and aided scheme provide the protection.

1.17.2

Trip On Reclose (TOR) Mode

The settings applied are as follows:

TOR Status With this feature Enabled, for a period following circuit breaker closure, the relay operates in Trip on Re-close mode. Three pole instantaneous tripping occurs for any fault detected by the selected zones or/and 'Current No Volt' level detectors. Whether this feature is enabled or disabled, the normal time delayed elements or aided channel scheme continue to function and can operate to trip the circuit.

TOC Reset Delay The SOTF and TOR features remain in-service for the duration of the TOC reset delay once the circuit is energized.

TOC Delay Is a user settable time delay that starts upon opening the CB after which the 'TOR' becomes active (enabled). The time delay must not exceed the minimum Dead Time setting as both times start simultaneously and TOR protection must be ready by the time of CB closing on potentially persistent faults.

TOR Tripping Links While the Trip on Re-close Mode is active, the MiCOM relay will trip instantaneously for pick up of or/and 'Current No Volt' level detectors any zone selected in these links. To operate for faults on the entire circuit length it is recommended that at least Zone 1 and Zone 2 are selected. If no elements are selected then the normal time delayed elements and aided scheme provide the protection.

1.17.3 Polarization during Circuit Energization

While the Switch on to Fault and Trip on Re-close modes are active, the directionalized distance elements are partially cross polarized from other phases. The same proportion of healthy phase to faulted phase voltage as given by the Distance Polarizing setting in the DISTANCE SETUP menu is used.

Partial cross polarization is thus used in substitute for the normal memory polarizing, for the duration of the TOC window. If insufficient polarizing voltage is available, a slight reverse offset (10% of the forward reach) is included in the zone 1 characteristic to enable fast clearance of close-up 3-phase faults. Therefore, the mapping of CNV function to the SOTF tripping matrix is not essential.

1.18 Directional Function - Setup of DEF

The MiCOM P445 has an additional aided channel ("pilot") scheme that can be used to supplement the distance protection.

- DEF Directional Earth (Ground) Fault Protection
- Any of the following conditions will block Aided DEF scheme:
- Phase selector picking up on either 2 or 3 phases.
 - Assertion of "Any Trip" signal.

DEF FWD signal will be blocked in case of any or all pole dead conditions.

1.18.1 DEF Zero Sequence Polarization with "Virtual Current Polarizing"

With earth fault protection, the polarizing (directional reference) signal requires to be representative of the earth fault condition. As residual voltage is generated during earth fault conditions, this quantity is commonly used to polarize the directional decision of DEF elements. The relay internally derives this voltage from the 3-phase voltage input which must be supplied from either a 5-limb or three single-phase VTs. These types of VT design allow the passage of residual flux and consequently permit the relay to derive the required residual voltage. In addition, the primary star point of the VT must be earthed. A three-limb VT has no path for residual flux and, is therefore unsuitable to supply the relay. It is possible that small levels of residual voltage will be present under normal system conditions due to system imbalances, VT inaccuracies, relay tolerances etc. Hence, the relay includes a user settable threshold (DEF VNPOL Set) which must be exceeded for the DEF function to be operational. Note that residual voltage is nominally 180° out of phase with residual current. Consequently, the DEF relays are polarized from the '-Vres' quantity. This 180° phase shift is automatically introduced within the relay.

A distinct advantage is that the MiCOM relay can trip by this method of polarizing, even if VNpol is less than the set threshold. Provided that the superimposed current phase selector has identified the faulted phase (suppose phase A), it will remove that phase from the residual calculation $V_a + V_b + V_c$, leaving only $V_b + V_c$. The resultant polarizing voltage will have a large magnitude, and will be in the same direction as $-V_{res}$. This allows the relay to be applied even where very solid earthing behind the relay prevents residual voltage from being developed.

This technique of subtracting the faulted phase is given the description “virtual current polarizing” as it removes the need to use current polarizing from a CT in a transformer star (wye)-ground connection behind the relay. This would have been necessary with traditional relays.

The directional criteria with zero sequence (virtual current) polarization are given below:

Directional forward $-90^\circ < (\text{angle}(I_N) - \text{angle}(V_{Npol}+180^\circ) - RCA) < 90^\circ$

Directional reverse $-90^\circ > (\text{angle}(I_N) - \text{angle}(V_{Npol}+180^\circ) - RCA) > 90^\circ$

Where VNpol is as per the table below:

Phase selector pickup	VNpol
A Phase Fault	$V_B + V_C$
B Phase Fault	$V_A + V_C$
C Phase Fault	$V_A + V_B$
No Selection	$V_N = V_A + V_B + V_C$

Table 2 - Phase Selector Pickup and VNpol

1.18.2

DEF Negative Sequence Polarization

In certain applications, the use of residual voltage polarization of DEF may either be not possible to achieve, or problematic. An example of the former case would be where a suitable type of VT was unavailable, for example if only a three-limb VT was fitted. An example of the latter case would be an HV/EHV parallel line application where problems with zero sequence mutual coupling may exist.

In either of these situations, the problem may be solved by the use of Negative Phase Sequence (NPS) quantities for polarization. This method determines the fault direction by comparison of NPS voltage with NPS current. The operate quantity, however, is still residual current (3I0). It requires a suitable voltage threshold to be set in cell **DEF 3V2pol Set**.

The directional criteria with negative sequence polarization are given below:

Directional forward $-90^\circ < (\text{angle}(3I_2) - \text{angle}(3V_2+180^\circ) - RCA) < 90^\circ$

Directional reverse $-90^\circ > (\text{angle}(3I_2) - \text{angle}(3V_2+180^\circ) - RCA) > 90^\circ$

Attention: In configuring V2 threshold (cell 39.06)
 With firmware versions previous to version K5, the menu text shows: DEF V2pol Set
 Starting with firmware version K5 and above, the menu text will show: DEF 3V2pol Set

3V2 is the polarizing quantity used in the firmware design since the product launch. So at all case
 The V2 polarization threshold to be set at 3 times the required V2 to achieve correct operation.

For example: If the required V2 threshold is 500V, cell 39.06 has to be set at 1500V, irrespective
 of menu text DEF V2pol Set in firmware’s previous to K5.

1.18.3

Delta Directionalizing Comparison Principle and Setup

Delta directional comparison looks at the relative phase angle of the superimposed current ΔI compared to the superimposed voltage ΔV , at the instant of fault inception. The delta is only present when a fault occurs and a step change from the pre-fault steady-state load is generated by the fault itself. The element will issue a forward or reverse decision, which can be used to input into an aided channel unit protection scheme.

Under healthy network conditions, the system voltage will be close to V_n nominal, and load current will be flowing. Under such steady-state conditions, if the voltage measured on each phase now is compared with a stored memory from exactly two power system cycles previously (equal to 96 samples), the difference between them will be zero. Zero change equals zero "delta" ($\Delta V = 0$). The same will be generally true for the current ($\Delta I = 0$), except when there are changes in load current etc.

When a fault occurs on the system, the delta changes measured will be:

$$\Delta V = \text{fault voltage (time "t")} - \text{prefault healthy voltage (t-96 samples)}$$

$$\Delta I = \text{fault current (time "t")} - \text{prefault load current (t-96 samples)}$$

The delta measurements are a vector difference, resulting in a delta magnitude and angle. Under healthy system conditions, the pre-fault values will be those measured 2 cycles earlier, but when a fault is detected, the pre-fault values will be retained for the duration of the fault.

The changes in magnitude are used to detect the presence of the fault, and the angles are used to determine whether the fault is in the Forward or Reverse direction.

Consider a single-phase to ground fault as shown in the *Sequence networks connection for an internal A-N fault* diagram below.

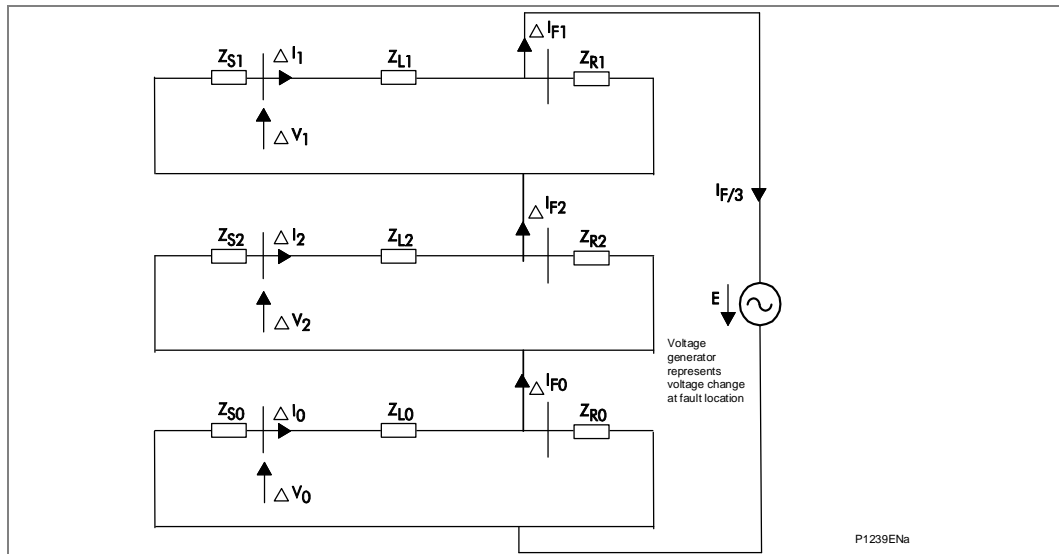

Figure 17 - Sequence networks connection for an internal A-N fault

The fault is shown near to the busbar at end R of the line, and results in a connection of the positive, negative, and zero sequence networks in series. Drawing the delta diagram, it is seen that any fault is effectively a generator of Δ , connected at the location of fault inception. The characteristics are:

1. The ΔI generated by the fault is equal to the total fault arc current;
2. The ΔI will split into parallel paths, with part contribution from source "S", and part from remote end "R" of the line. Therefore, each relay will measure a lower proportion of delta I;
3. The ΔV generated by the fault is equal to the fault arc voltage minus the pre-fault voltage (and so will be in antiphase with the pre-fault voltage);
4. The ΔV will generally be smaller as measured at the relay location, due to the voltage collapse being smaller near to the source than at the fault itself. The delta V measured by a relay is effectively the voltage drop across the source impedance behind the relay location.

If a fault were to occur at any point on the protected line, the resulting ΔI and ΔV as measured at the relay location must be greater than the Delta I Fwd and Delta V Fwd settings, in order that the fault can be detected. (Scenarios (2) and (4) above must be verified for all fault types: Ph-G, Ph-Ph, Ph-Ph-G, and 3-phase).

1.18.4

Delta Directional Decision

On fault inception, delta quantities are generated, and it is then simple for the relay to determine the direction of the fault:

Forward fault Delta V is a decrease in voltage, and so is in the negative sense; whereas delta I is a forward current flow and so is in the positive sense. Where delta I and delta V are approximately in antiphase, the fault is forward.

The exact angle relationship for the forward fault is:

$$\Delta V / \Delta I = - (\text{Source impedance, } Z_s)$$

Reverse fault Delta V is a decrease in voltage, and so is in the negative sense; delta I is an outfeed flowing in the reverse direction, so that too is in the negative sense. Where delta I and delta V are approximately in phase, the fault is reverse.

The exact angle relationship for the reverse fault is:

$$\Delta V / \Delta I = (\text{Remote Source impedance } Z_s' + Z_L)$$

Where Z_L is protected line impedance and Z_s' source impedance behind the relay. An RCA angle setting in the relay allows the user to set the center of the directional characteristic, according to the amount the current will nominally lag the reference delta voltage. The characteristic boundary will then be ± 90 degrees either side of the set center.



Note The internal thresholds used by the delta directional element are fixed at: $\Delta V=0.5V$ and $\Delta I=4\%I_n$. In distance applications, if the fault ΔV is below the threshold of 0.5V, a conventional distance line ensures correct forward/reverse polarizing.

The directional criteria for delta directional decisions are given below:

Directional forward $-90^\circ < (\text{angle}(\Delta I) - \text{angle}(\Delta V + 180^\circ) - \text{RCA}) < 90^\circ$

Directional reverse $-90^\circ > (\text{angle}(\Delta I) - \text{angle}(\Delta V + 180^\circ) - \text{RCA}) > 90^\circ$

For the delta directionalizing elements, the operating thresholds for the changes in voltage and current are fixed at $\Delta V=0.5 V$ and $\Delta I=4\%I_n$. If the fault ΔV is below the threshold of 0.5 V, a conventional distance directional line is used to ensure correct forward/reverse polarizing.

To facilitate testing of the Distance elements using test sets which do not provide a dynamic model to generate true fault delta conditions, a Static Test Mode setting is provided. This setting is found in the COMMISSIONING TESTS menu column. When set, this disables phase selector control and forces the relay to use a conventional (non-delta) directional line.

1.19

Channel Aided Schemes

The MiCOM relay offers two sets of aided channel (“pilot”) schemes, which may be operated in parallel.

Aided Scheme 1 May be keyed by distance and/or DEF protection

Aided Scheme 2 May be keyed by distance and/or DEF protection

The provision of two discrete channel selections would allow the following to be implemented, as an example:

- Distance POR with DEF POR scheme operating over a common shared channel... Select both in AIDED SCHEME 1 only, with AIDED SCHEME 2 Disabled.
- Distance PUR with DEF BLOCKING operating over separate channels due to the dissimilar scheme types. Assign Distance to AIDED SCHEME 1, and DEF to AIDED SCHEME 2.

Note *Where schemes share a common channel, the signal send and signal receive logic operates in a logical "OR" mode.*

Aided Scheme 1 and Aided Scheme 2 are two instances of the same logic. Each of these schemes provides the same options and can be independently applied. The scheme logic is split into three sections defined in the following diagram: send logic, receive logic, and aided tripping logic, as shown in the *Aided scheme logic overview* diagram. Detailed scheme descriptions follow later. As there are two instances of the aided scheme, any internal logic signals which are specific to the instance of the scheme are shown in the diagrams with two DDB numbers relating to the first and second instance, respectively.

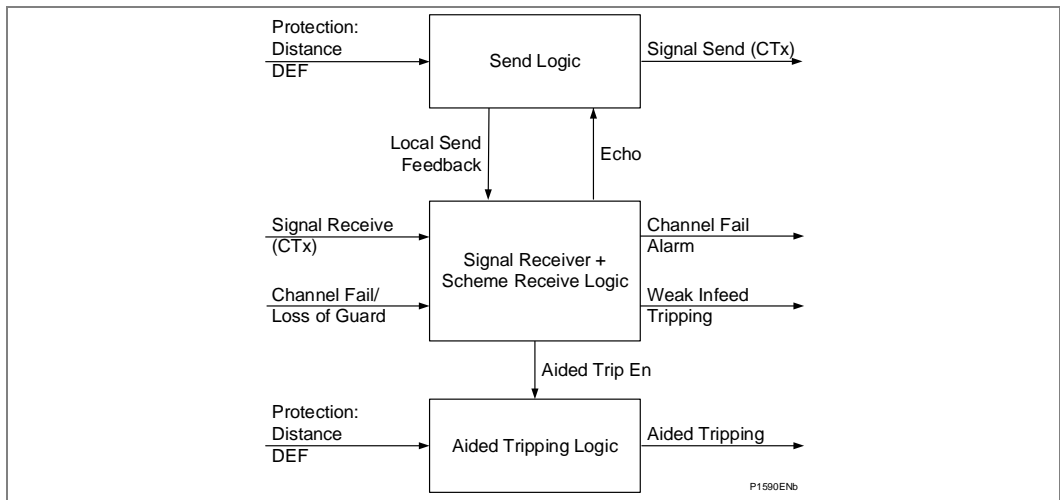

Figure 18 - Aided scheme logic overview

The full Logic Diagrams of the Send, Receive and Aided Trip Logic are now attached here, for reference. It is not necessary to understand the entire logic in order to apply any scheme, as in later sections abbreviated scheme diagrams are available.

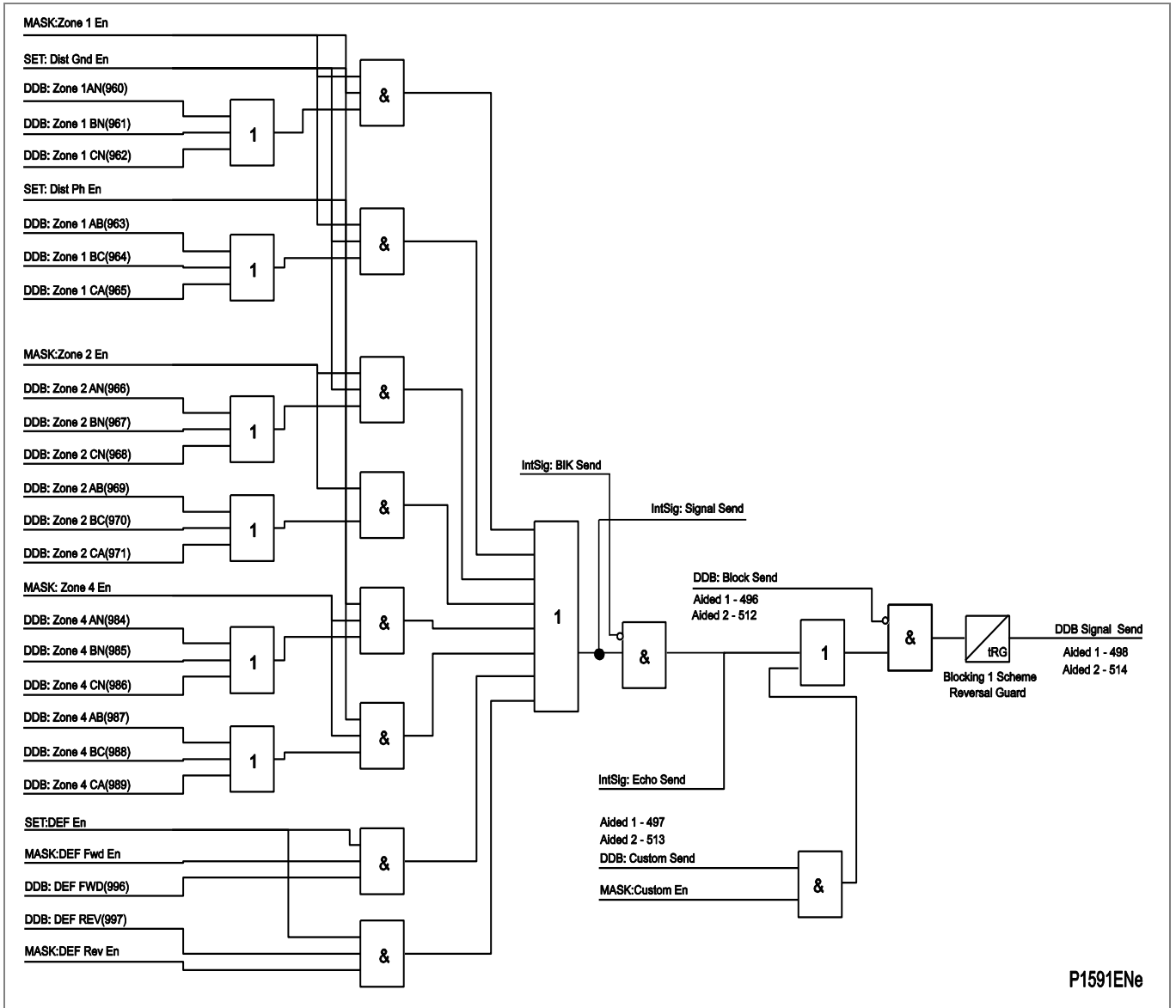

Figure 19 - Send logic

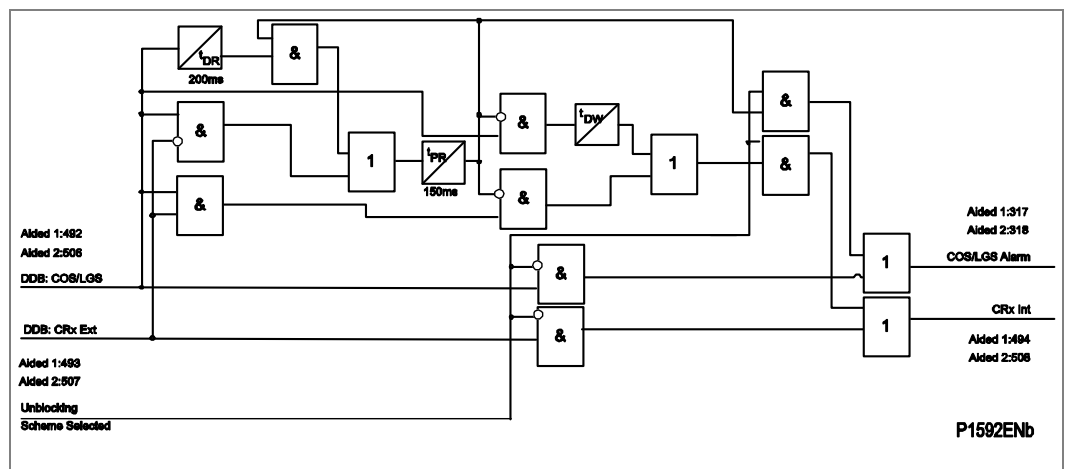

Figure 20 - Receive logic

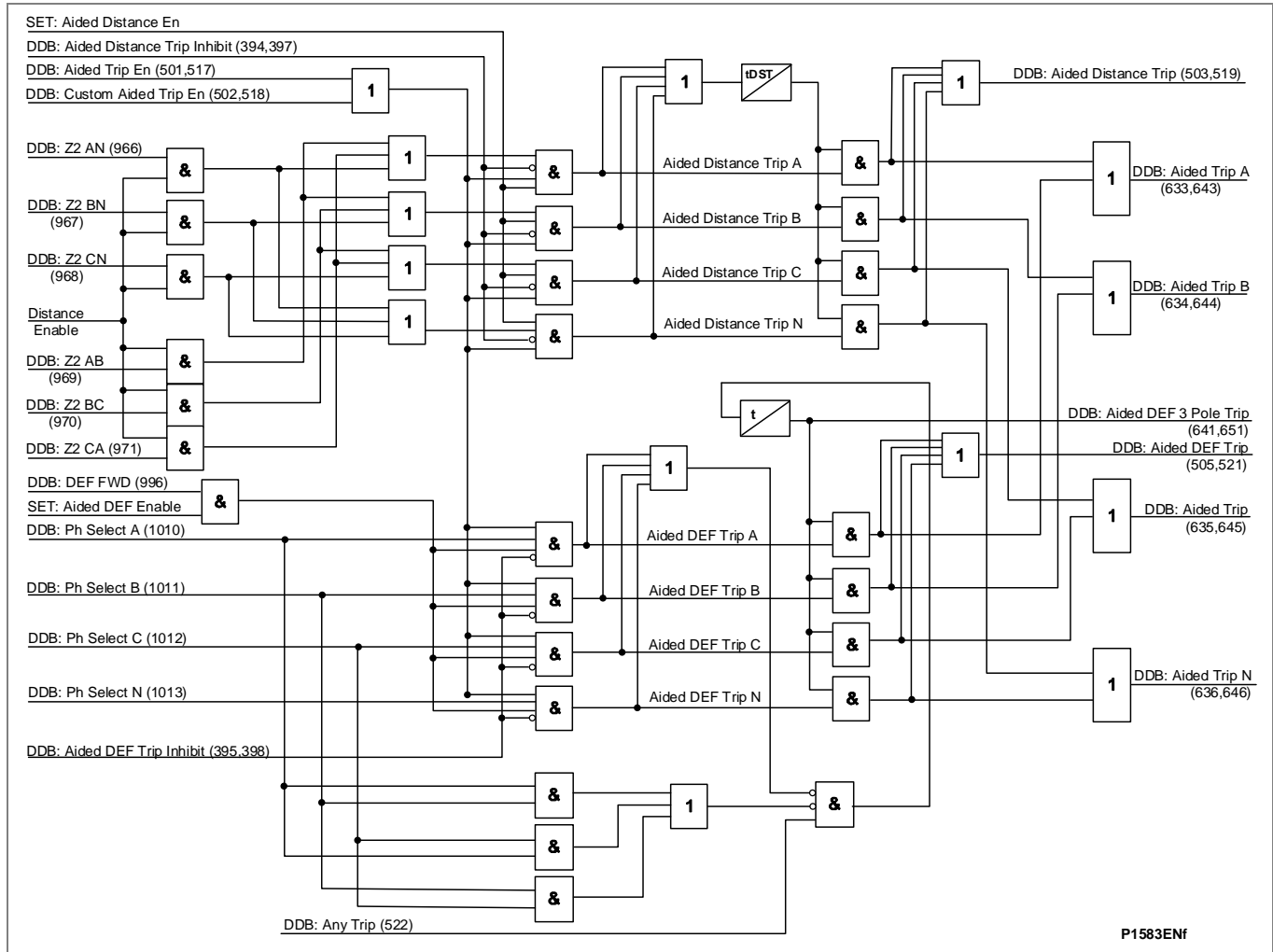

Figure 21 - Aided tripping logic

1.19.1 Distance Scheme Permissive UnderReach (PUR) Transfer Trip

To provide fast fault clearance for all faults, both transient and permanent, along the length of the protected circuit, it is necessary to use a signal aided tripping scheme. The simplest of these is the Permissive UnderReach (PUR) protection scheme. The channel for a PUR scheme is keyed by operation of the underreaching zone 1 elements of the relay. If the remote relay has detected a forward fault upon receipt of this signal, the relay will operate with no additional delay. Faults in the last 20% (Note 1) of the protected line are therefore cleared with no intentional time delay.

Note 1 Assuming a 20% typical "end-zone" when Zone 1 is set to 80% of the protected line.

Some of the main features/requirements for a permissive underreaching scheme are:

- Only a simplex signaling channel is required
- The scheme has a high degree of security since the signaling channel is only keyed for faults within the protected line
- If the remote terminal of a line is open then faults in the remote 20% of the line will be cleared via the zone 2 time delay of the local relay
- If there is a weak or zero infeed from the remote line end, (i.e. current below the relay sensitivity), then faults in the remote 20% of the line will be cleared via the zone 2 time delay of the local relay
- If the signaling channel fails, Basic distance scheme tripping will be available

The *Permissive underreach transfer trip scheme (PUR)* diagram shows the simplified scheme logic.

Send logic: Zone 1
 Permissive trip logic: Zone 2 plus Channel Received

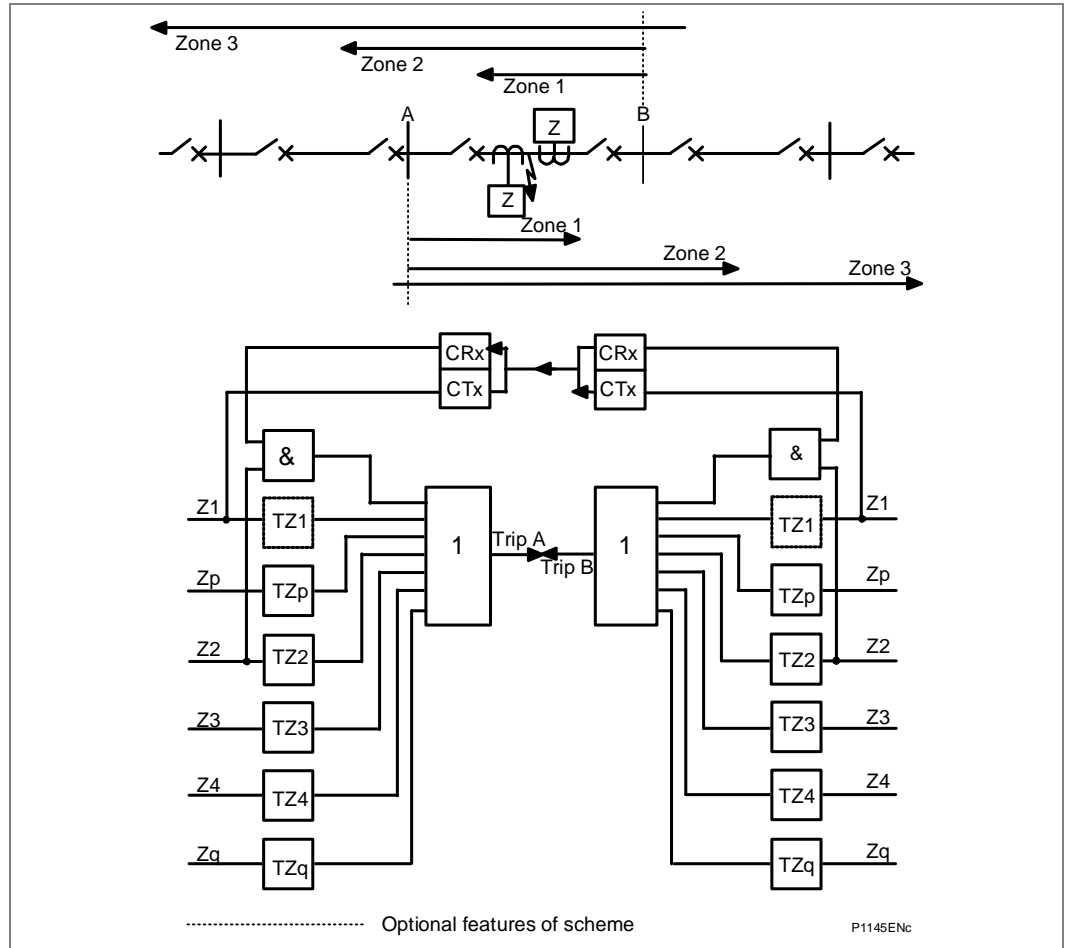

Figure 22 - Permissive underreach transfer trip scheme (PUR)

Detailed logic is shown in in the following PUR (Distance option only) diagram:

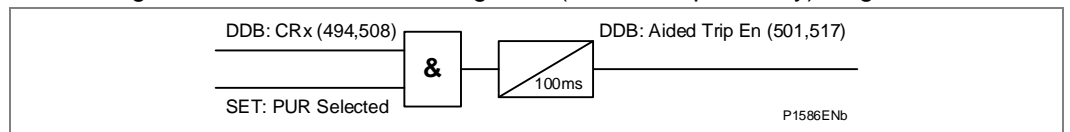

Figure 23 - PUR

1.19.2

Distance Scheme Permissive OverReach (POR) Transfer Trip

The channel for a POR scheme is keyed by operation of the overreaching zone 2 elements of the relay. If the remote relay has detected a forward fault upon receipt of this signal, the relay will operate with no additional delay. Faults in the last 20% (Note 1) of the protected line are therefore cleared with no intentional time delay.

Note 1 Assuming a 20% typical “end-zone” when Zone 1 is set to 80% of the protected line.

Listed below are some of the main features/requirements for a permissive overreaching scheme:

- The scheme requires a duplex signaling channel to prevent possible relay maloperation due to spurious keying of the signaling equipment. This is needed because the signaling channel is keyed for faults external to the protected line.

- The POR scheme may be more advantageous than permissive underreach schemes for the protection of short transmission lines, since the resistive coverage of the Zone 2 elements may be greater than that of the Zone 1 elements.
- Current reversal guard logic is used to prevent healthy line protection maloperation for the high speed current reversals experienced in double circuit lines, caused by sequential opening of circuit breakers.
- If the signaling channel fails, Basic distance scheme tripping will be available.

<i>Note</i>	<i>The POR scheme also uses the reverse looking zone 4 of the relay as a reverse fault detector. This is used in the current reversal logic and in the optional weak infeed echo feature, shown dotted in the Permissive overreach transfer trip scheme (POR) diagram.</i>
-------------	---

Send logic: Zone 2

Permissive trip logic: Zone 2 plus Channel Received

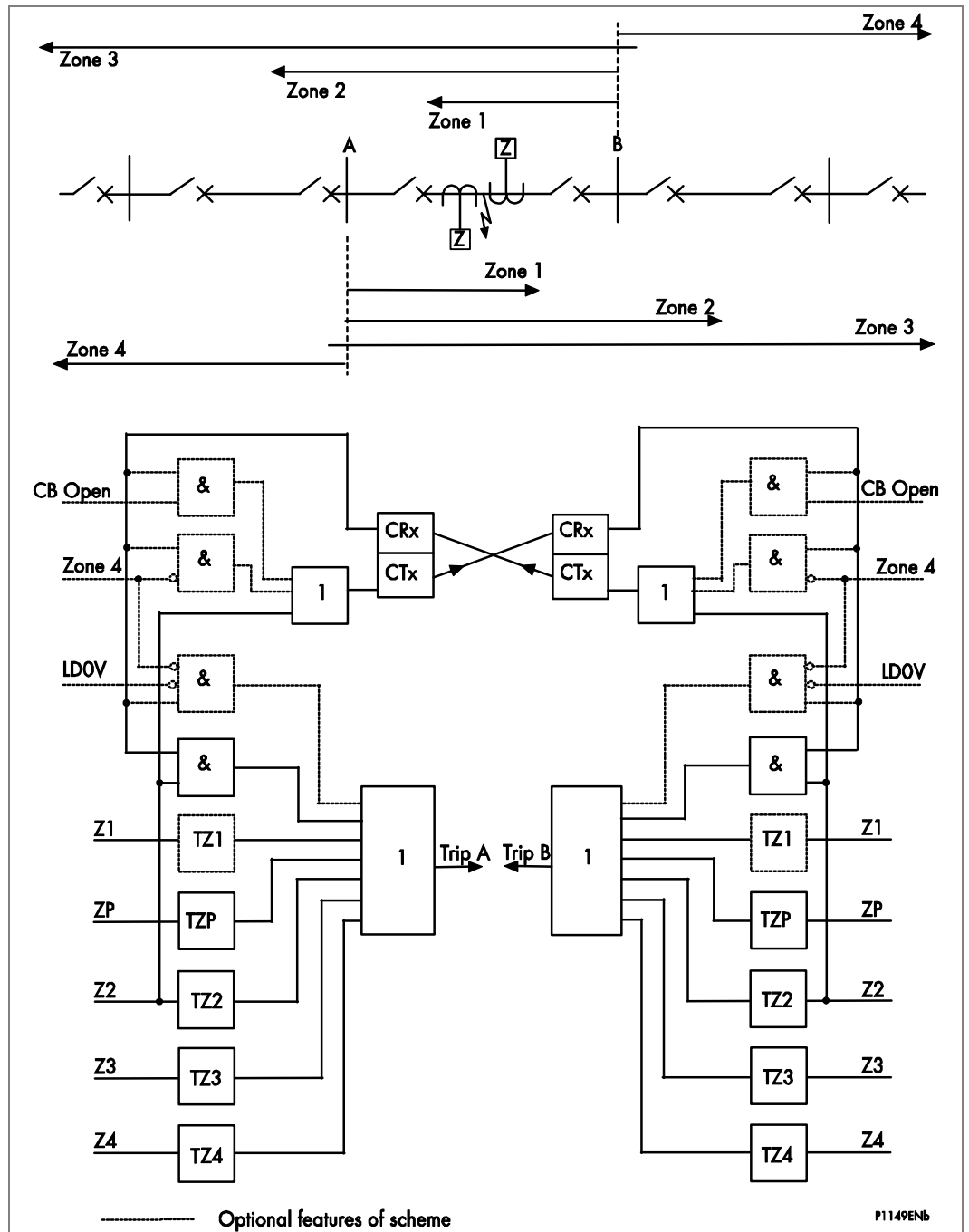

Figure 24 - Permissive OverReach (POR) transfer trip scheme

Detailed logic is shown in the following *POR Permissive OverReach* diagram:

Note The DDB Any Trip (522) feeds into a 100 ms delay on drop-off timer, which in turn leads to signal sending. This is a principle similar to the logic which results in a signal send for weak infeed and breaker open echoing.

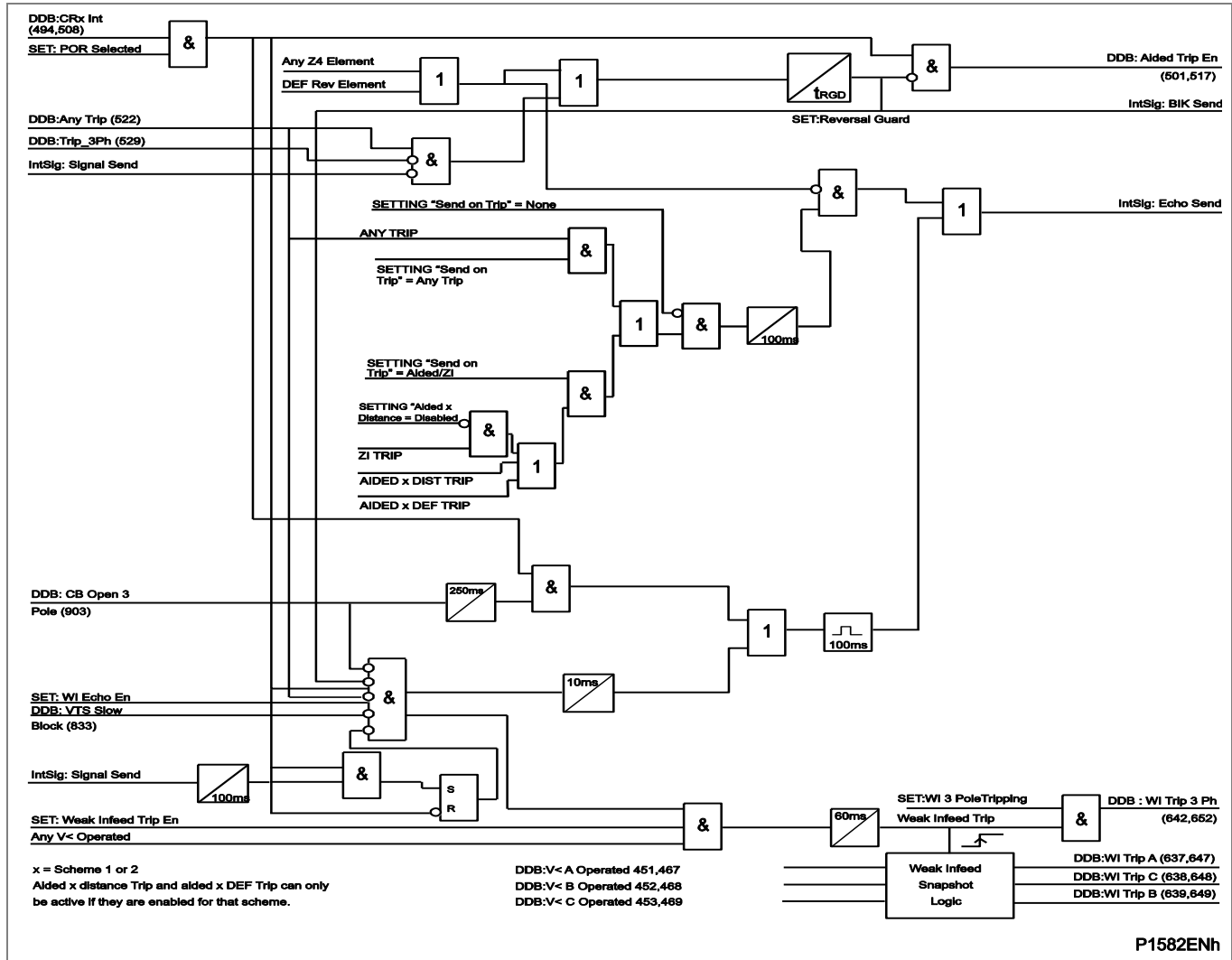

Figure 25 - POR

1.19.3 Permissive Overreach Trip Reinforcement

The send logic in the POR scheme is done in such a way that for any trip command at the local end, the relay sends a channel signal to the remote end(s) in order to maximize the chances for the fault to be isolated at all ends. It should be noted that the send signal that is generated by the 'Any trip' command is sent on both channels, Ch1 and Ch2, if more than one channel is in use. This feature is termed permissive trip reinforcement, and is a deliberate attempt to ensure that synchronous tripping occurs at all line ends.

1.19.4 Permissive Overreach Scheme Weak Infeed Features

Weak infeed logic can be enabled to run in parallel with the POR schemes. Two options are available: WI Echo, and WI Tripping.

Note Special stub-end transformer Weak Infeed is covered in the **Frequency Protection** section.

Weak Infeed Echo For permissive schemes, a signal would only be sent if the required signal send zone were to detect a fault. However, the fault current infeed at one line end may be so low as to be insufficient to operate any distance zones, and risks a failure to send the signal. Also, if one circuit breaker had already been left open, the current infeed would be zero. These are termed weak infeed conditions, and may result in slow fault clearance at the strong infeed line end (tripping after time t_{Z2}). To avoid this slow tripping, the weak infeed relay can be set to “echo” back any channel received to the strong infeed relay (i.e. to immediately send a signal once a signal has been received). This allows the strong infeed relay to trip instantaneously in its permissive trip zone.

The additional signal send logic is:

Echo Send No Distance Zone Operation, plus Channel Received.

Weak Infeed Tripping Weak infeed echo logic ensures an aided trip at the strong infeed terminal but not at the weak infeed. The MiCOM P54x also has a setting option to allow tripping of the weak infeed circuit breaker of a faulted line. Three undervoltage elements, $V_{a<}$, $V_{b<}$ and $V_{c<}$ are used to detect the line fault at the weak infeed terminal. This voltage check prevents tripping during spurious operations of the channel or during channel testing.

The additional weak infeed trip logic is:

Weak Infeed Trip No Distance Zone Operation, plus $V_{c<}$, plus Channel Received.

Weak infeed tripping is time delayed according to the WI Trip Delay value. Due to the use of phase segregated undervoltage elements, single pole tripping can be enabled for WI trips if required. If single pole tripping is disabled a three pole trip will result after the time delay.

1.19.5

Permissive Scheme Unblocking Logic - Loss of Guard

This mode is designed for use with Frequency Shift Keyed (FSK) Power Line Carrier (PLC) communications. When the protected line is healthy a guard frequency is sent between line ends, to verify that the channel is in service. However, when a line fault occurs and a permissive trip signal must be sent over the line, the power line carrier frequency is shifted to a new (trip) frequency. Therefore, distance relays should receive either the guard, or trip frequency, but not both together. With any permissive scheme, the PLC communications are transmitted over the power line which may contain a fault. So, for certain fault types the line fault can attenuate the PLC signals, so that the permissive signal is lost and not received at the other line end. To overcome this problem, when the guard is lost and no “trip” frequency is received, the relay opens a window of time during which the permissive scheme logic acts as though a “trip” signal had been received. Two opto inputs to the relay need to be assigned, one is the Channel Receive opto, the second is designated Loss of Guard (the inverse function to guard received). The function logic is summarized in the table below.

System condition	Permissive channel received	Loss of guard	Permissive trip allowed	Alarm generated
Healthy Line	No	No	No	No
Internal Line Fault	Yes	Yes	Yes	No
Unblock	No	Yes	Yes, during a 150 ms window	Yes, delayed on pickup by 150 ms
Signaling Anomaly	Yes	No	No	Yes, delayed on pickup by 150 ms

Table 3 - Function logic

The window of time during which the unblocking logic is enabled starts 10 ms after the guard signal is lost, and continues for 150 ms. The 10 ms delay gives time for the signaling equipment to change frequency as in normal operation. For the duration of any alarm condition, zone 1 extension logic will be invoked if the option Z1 Ext on Chan. Fail has been Enabled.

1.19.6**Distance Scheme Blocking**

The signaling channel is keyed from operation of the reverse zone 4 elements of the relay. If the remote relay has picked up in zone 2, then it will operate after the trip delay if no block is received. Listed below are some of the main features/requirements for a Blocking scheme:

- Blocking schemes require only a simplex signaling channel
- Reverse looking Zone 4 is used to send a blocking signal to the remote end to prevent unwanted tripping
- When a simplex channel is used, a Blocking scheme can easily be applied to a multi-terminal line provided that outfeed does not occur for any internal faults
- The blocking signal is transmitted over a healthy line, and so there are no problems associated with power line carrier signaling equipment
- Blocking schemes provides similar resistive coverage to the permissive overreach schemes
- Fast tripping will occur at a strong source line end, for faults along the protected line section, even if there is weak or zero infeed at the other end of the protected line
- If a line terminal is open, fast tripping will still occur for faults along the whole of the protected line length
- If the signaling channel fails to send a blocking signal during a fault, fast tripping will occur for faults along the whole of the protected line, but also for some faults within the next line section
- If the signaling channel is taken out of service, the relay will operate in the conventional basic mode
- A current reversal guard timer is included in the signal send logic to prevent unwanted trips of the relay on the healthy circuit, during current reversal situations on a parallel circuit

The *Distance blocking scheme (BOP)* diagram shows the simplified scheme logic.

Send logic: Reverse Zone 4

Trip logic: Zone 2, plus Channel NOT Received, delayed by Tp

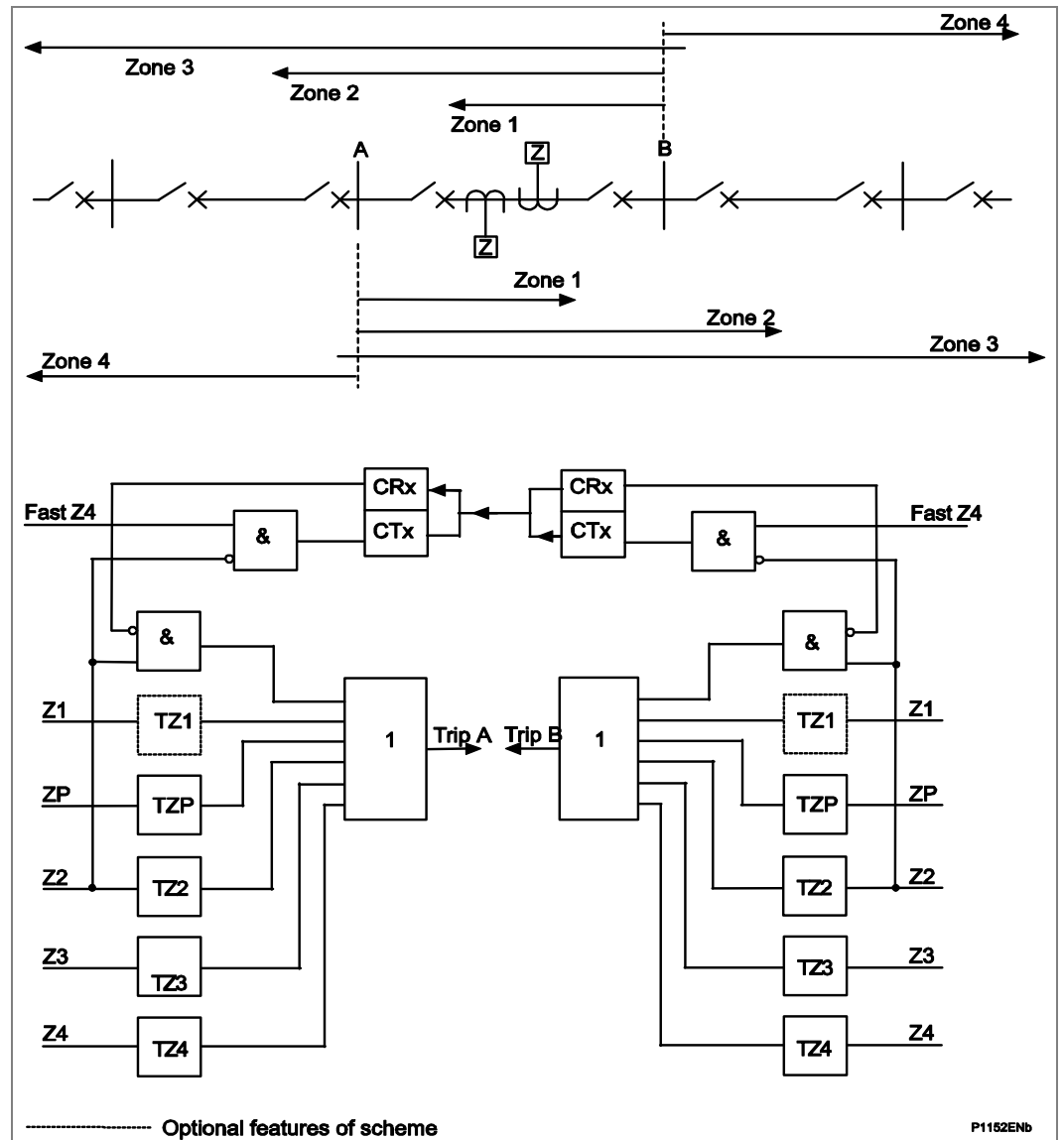

Figure 26 - Distance blocking scheme (BOP)

1.19.7

Distance Schemes Current Reversal Guard Logic

For double circuit lines, the fault current direction can change in one circuit when circuit breakers open sequentially to clear the fault on the parallel circuit. The change in current direction causes the overreaching distance elements to see the fault in the opposite direction to the direction in which the fault was initially detected (settings of these elements exceed 150% of the line impedance at each terminal). The race between operation and resetting of the overreaching distance elements at each line terminal can cause the Permissive Overreach, and Blocking schemes to trip the healthy line. A system configuration that could result in current reversals is shown in the *Example of fault current reverse of direction* diagram. For a fault on line L1 close to circuit breaker B, as circuit breaker B trips it causes the direction of current flow in line L2 to reverse.

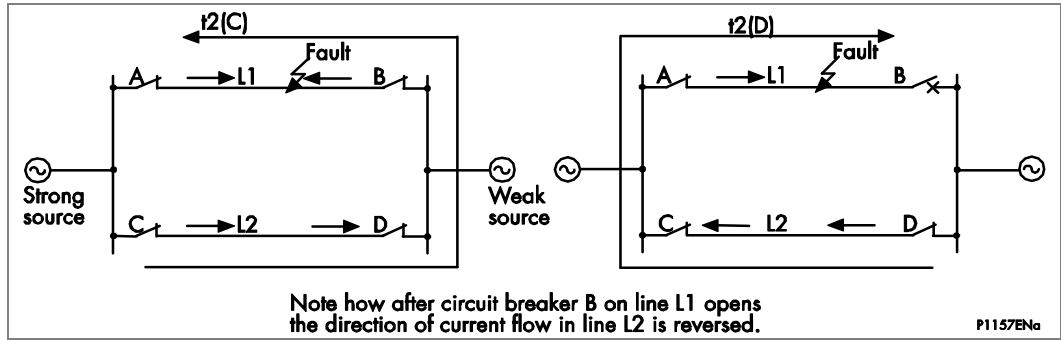

Figure 27 - Example of fault current reverse of direction

1.19.8

Permissive Overreach Schemes Current Reversal Guard

The current reversal guard incorporated in the POR scheme logic is initiated when the reverse looking Zone 4 elements operate on a healthy line. Once the reverse looking Zone 4 elements have operated, the relay's permissive trip logic and signal send logic are inhibited at substation D. The reset of the current reversal guard timer is initiated when the reverse looking Zone 4 resets. A time delay $t_{REVERSAL\ GUARD}$ is required in case the overreaching trip element at end D operates before the signal send from the relay at end C has reset. Otherwise this would cause the relay at D to over trip. Permissive tripping for the relays at D and C substations is enabled again, once the faulted line is isolated and the current reversal guard time has expired.

1.19.9

Blocking Scheme 1 and 2 Current Reversal Guard

The current reversal guard incorporated in the Blocking scheme logic is initiated when a blocking element picks-up to inhibit the channel-aided trip. When the current reverses and the reverse looking Zone 4 elements reset, the blocking signal is maintained by the timer $t_{REVERSAL\ GUARD}$. Therefore, the relays in the healthy line are prevented from over tripping due to the sequential opening of the circuit breakers in the faulted line. After the faulted line is isolated, the reverse-looking Zone 4 elements at substation C and the forward-looking elements at substation D will reset.

Two variants of Blocking scheme exist, Blocking 1, and Blocking 2. The only difference in functionality is:

- Blocking 1 - The Reversal Guard is applied to the Signal Send
- Blocking 2 - The Reversal Guard is applied to the Signal Receive

The difference in the receive logic is shown in the Logic Diagrams, *Blocking 1 (Distance option only)* and *Blocking 1 (Distance option only)* below:

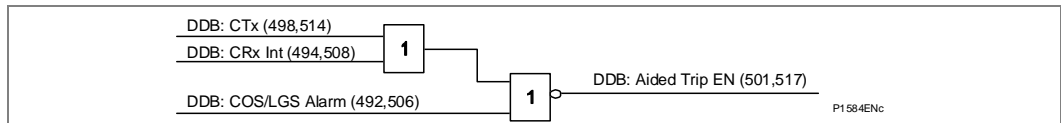

Figure 28 - Blocking 1

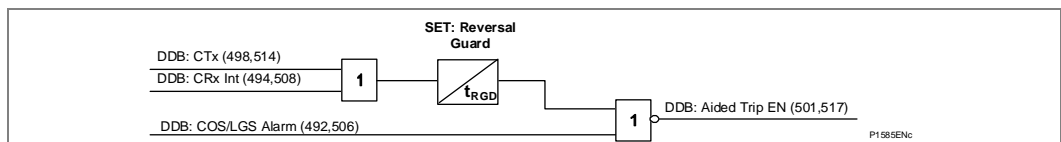

Figure 29 - Blocking 2

The relative merits of Blocking 1 and Blocking 2 are discussed in the Application Notes chapter.

1.19.10

Aided DEF Ground Fault Scheme - Permissive Overreach

The DEF *permissive scheme* diagram shows the element reaches, and the *Aided DEF (ground) permissive scheme logic* diagram the simplified scheme logic. The signaling channel is keyed from operation of the forward IN> DEF element of the relay. If the remote relay has also detected a forward fault, then it will operate with no additional delay upon receipt of this signal.

Send logic: IN> Forward pickup

Permissive trip logic: IN> Forward plus Channel Received

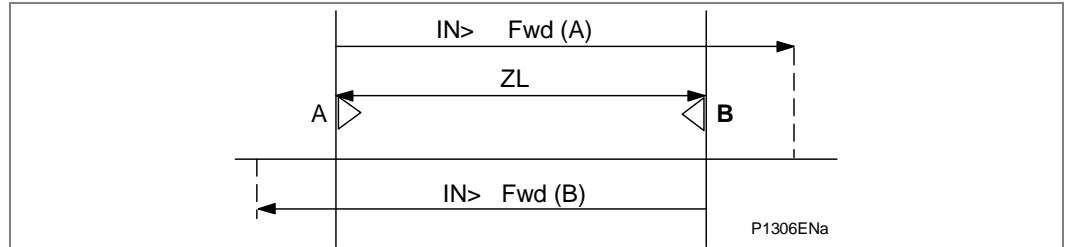

Figure 30 - The DEF permissive scheme

The scheme has the same features/requirements as the corresponding distance scheme and provides sensitive protection for high resistance earth faults.

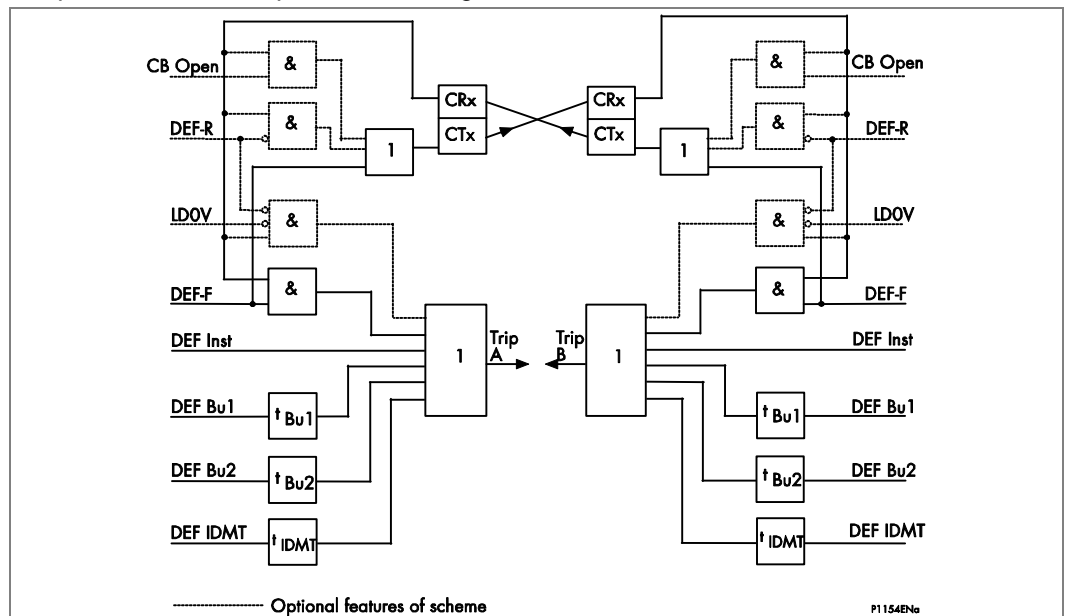

Figure 31 - Aided DEF (ground) permissive scheme logic

1.19.11

Aided DEF Ground Fault Scheme - Blocking

The DEF *blocking scheme* diagram shows the element reaches, and *Aided DEF (ground) blocking scheme logic* diagram the simplified scheme logic. The signaling channel is keyed from operation of the reverse DEF element of the relay. If the remote relay forward IN> element has picked up, then it will operate after the set Time Delay if no block is received.

Send logic: DEF Reverse

Trip logic: IN> Forward, plus Channel NOT Received, with small set delay

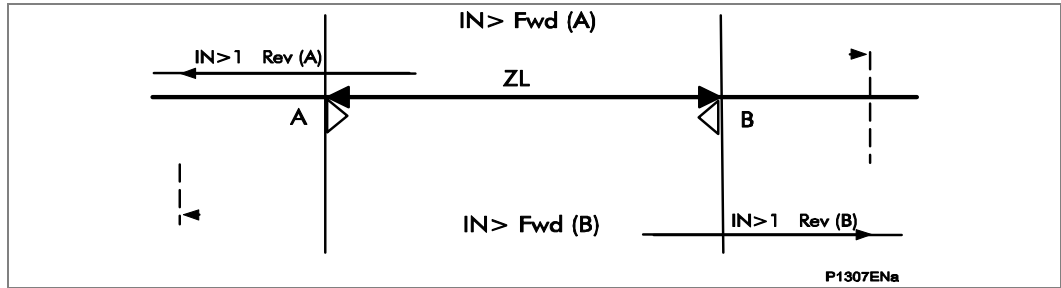

Figure 32 - The DEF blocking scheme

The scheme has the same features/requirements as the corresponding distance scheme and provides sensitive protection for high resistance earth faults.

Where t is shown in the diagram this signifies the time delay associated with an element. To allow time for a blocking signal to arrive, a short time delay on aided tripping must be used.

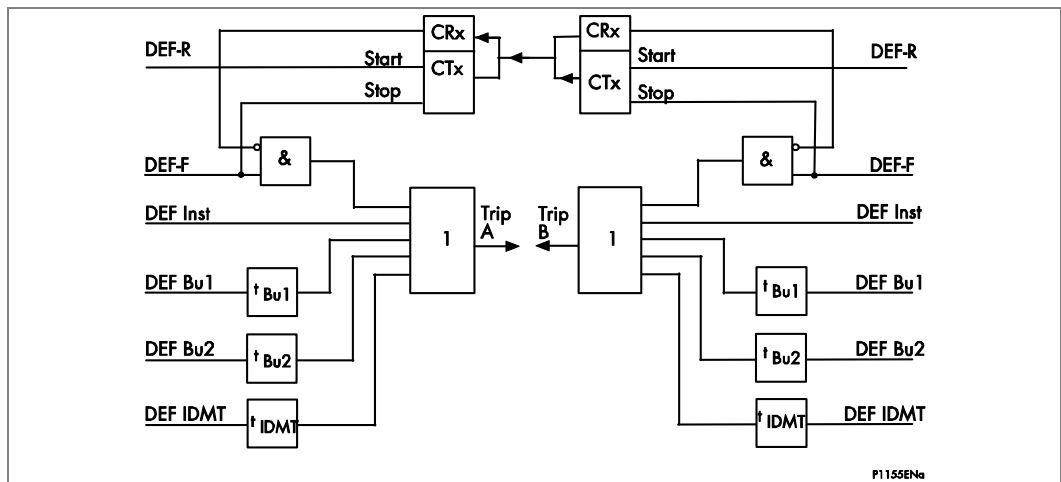

Figure 33 - Aided DEF (ground) blocking scheme logic

1.20 Zone 1 Extension and Loss of Load Schemes

The MiCOM relay offers additional non-channel distance schemes, notably Zone 1 extension, and loss of load.

1.20.1 Zone 1 Extension Scheme

Auto-reclosure is widely used on radial overhead line circuits to re-establish supply following a transient fault. A Zone 1 extension scheme may therefore be applied to a radial overhead feeder to provide high speed protection for transient faults along the whole of the protected line. The *Zone 1 extension scheme* diagram shows the alternative reach selections for zone 1: Z1 or the extended reach Z1X.

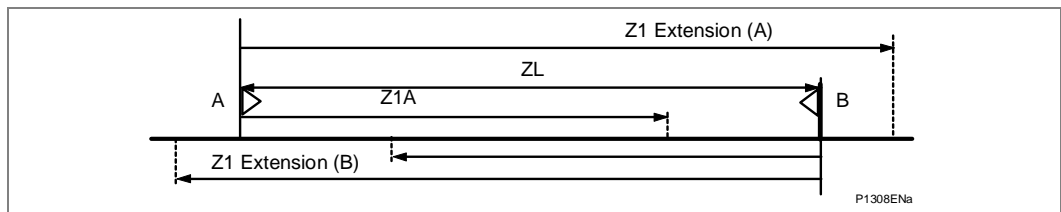

Figure 34 - Zone 1 extension scheme

In this scheme, Zone 1X is enabled and set to overreach the protected line. A fault on the line, including one in the end 20% not covered by zone 1, will now result in instantaneous tripping followed by auto-reclosure. Zone 1X has resistive reaches and residual compensation similar to Zone 1. The auto-recloser in the relay is used to inhibit tripping from zone 1X such that upon reclosure the relay will operate with Basic scheme logic only, to co-ordinate with downstream protection for permanent faults. Thus, transient faults on the line will be cleared instantaneously, which will reduce the probability of a transient fault becoming permanent. The scheme can, however, operate for some faults on an adjacent line, although this will be followed by auto-reclosure with correct protection discrimination. Increased circuit breaker operations would occur, together with transient loss of supply to a substation.

The time delays associated with extended zone Z1X are shown in the table below:

Scenario	Z1X Time Delay
First fault trip	= tZ1
Fault trip for persistent fault on auto-reclose	= tZ2

Table 4 - Time delays associated with extended zone Z1X

The Zone 1X reach is set as a percentage of the Zone 1 reach, i.e. as a reach multiplier.

Note The Zone 1 extension scheme can be “Disabled”, permanently “Enabled” or just brought into service when the distance communication channel fails and the aided scheme would be inoperative. A selection of which out of the two channels available in The MiCOM relay is monitored, is provided, with selections from Channel 1 and Channel 2 in any combination. The Logic Diagram is attached as the **Zone 1 extension** diagram:

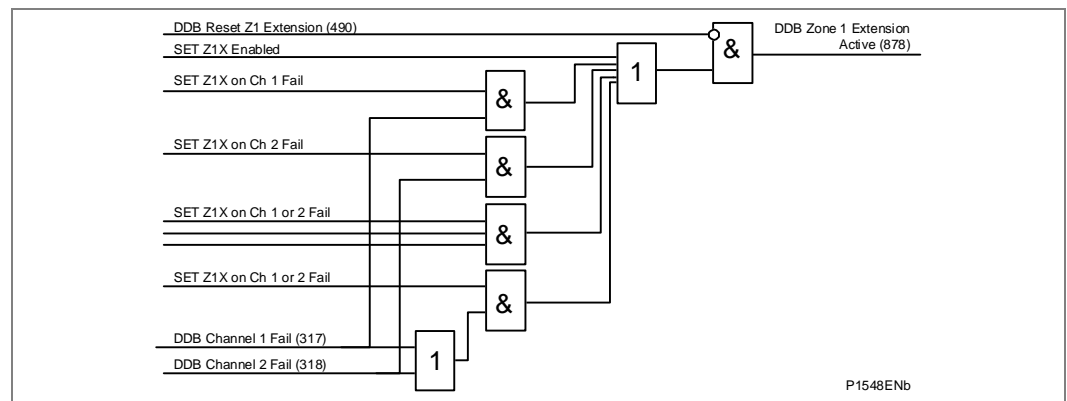

Figure 35 - Zone 1 extension

1.20.2

Loss of Load (LoL) Accelerated Tripping

The loss of load accelerated trip logic is shown in abbreviated form in the *Loss of load accelerated trip scheme* diagram. The loss of load logic provides fast fault clearance for faults over the whole of a double end fed protected circuit for all types of fault, except three phase. The scheme has the advantage of not requiring a signaling channel. Alternatively, the logic can be chosen to be enabled when the channel associated with an aided scheme has failed. This failure is detected by permissive scheme unblocking logic, or a Channel Out of Service (COS) opto input. A selection of which out of the two channels available in the MiCOM relay is monitored, is provided, with selections from Channel 1 and Channel 2 in any combination.

Any fault located within the reach of Zone 1 will result in fast tripping of the local circuit breaker. For an end zone fault with remote infeed, the remote breaker will be tripped in Zone 1 by the remote relay and the local relay can recognize this by detecting the loss of load current in the healthy phases. This, coupled with operation of a Zone 2 comparator causes tripping of the local circuit breaker.

Before an accelerated trip can occur, load current must have been detected prior to the fault. The loss of load current opens a window during which time a trip will occur if a Zone 2 comparator operates. A typical setting for this window is 40 ms as shown in the *Loss of load* diagram, although this can be altered in the menu LoL Window cell. The accelerated trip is delayed by 18 ms to prevent initiation of a loss of load trip due to circuit breaker pole discrepancy occurring for clearance of an external fault. The local fault clearance time can be deduced as follows:

$$t = Z1d + 2CB + LDr + 18ms$$

Where:

Z1d = Maximum downstream zone 1 trip time

CB = Breaker operating time

LDr = Upstream level detector (LoL: I<) reset time

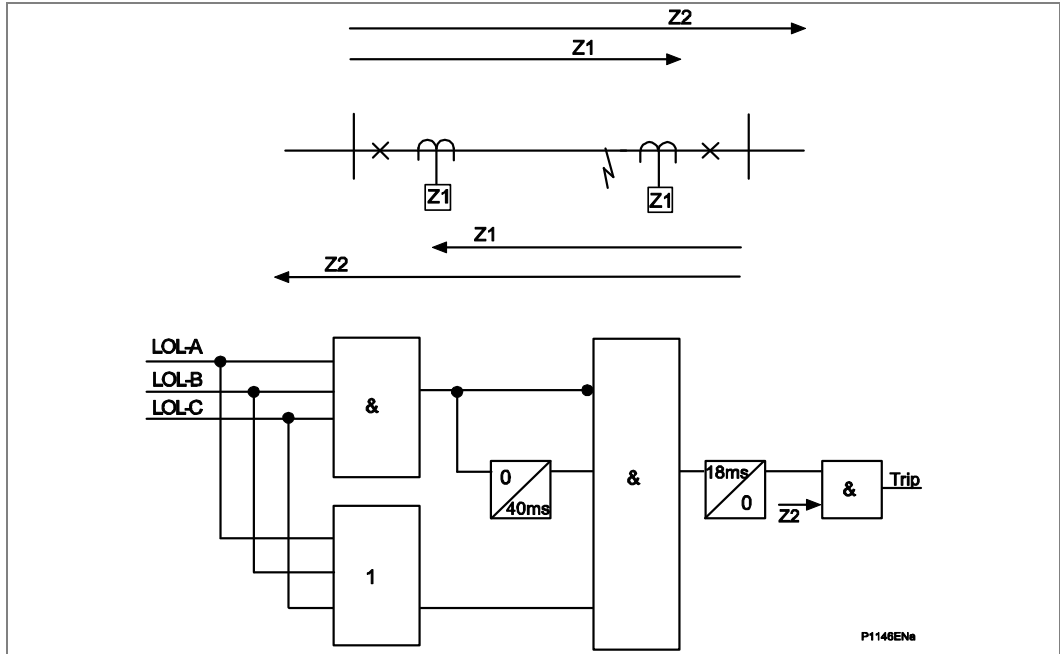

Figure 36 - Loss of load accelerated trip scheme

For circuits with load tapped off the protected line, care must be taken in setting the loss of load feature to ensure that the I< level detector setting is above the tapped load current. When selected, the loss of load feature operates in conjunction with the main distance scheme that is selected. In this way it provides high speed clearance for end zone faults when the Basic scheme is selected or, with permissive signal aided tripping schemes, it provides high speed back-up clearance for end zone faults if the channel fails.

Note *Loss of load tripping is only available where 3 pole tripping is used. The detailed logic follows in the **Loss of load** diagram.*

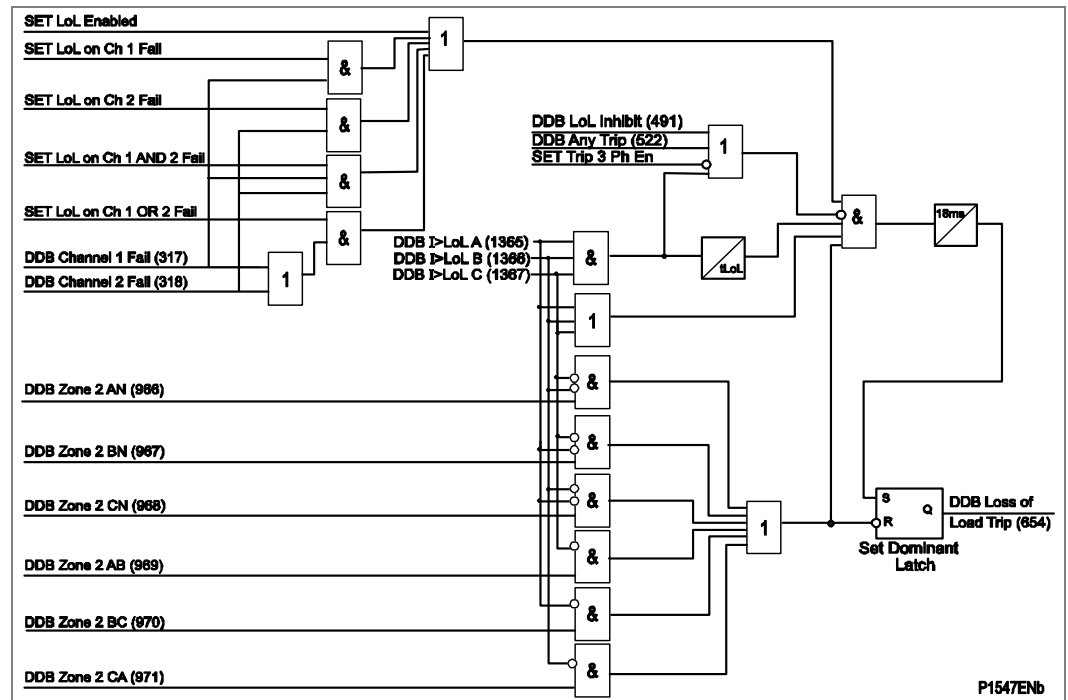

Figure 37 - Loss of load

1.21

InterMiCOM

1.21.1

Protection Signaling

To achieve fast fault clearance and correct discrimination for faults anywhere in a high voltage power network, it is necessary to signal between the points at which protection relays are connected. The following two distinct types of protection signaling can be identified.

Unit protection schemes:

In these schemes the signaling channel is used to convey analog data representative of the power system between relays. Typically current magnitude and/or phase information is communicated between line ends to enable a unit protection scheme to be implemented. These unit protection schemes are not covered by InterMiCOM or InterMiCOM⁶⁴. Instead, the MiCOM P44y, P52x, P54x and P841 range of current differential and phase comparison relays are available for unit applications.

Teleprotection - channel aided schemes

In channel-aided schemes the signaling channel is used to convey simple ON/OFF commands from a local protection device to a remote device to provide some additional information to be used in the protection scheme operation. The commands can be used to accelerate in-zone fault clearance or to prevent out-of-zone tripping, or both.

The InterMiCOM application is an effective replacement to the traditional hardwired logic and communication schemes used by protection relays for such teleprotection signaling. The MiCOM Px4x series products have a grouping of internal digital signals known as the digital data bus, DDB, that are used to implement the protection scheme logic. A number of these DDB signals are reserved as inputs and outputs for the InterMiCOM application. These are mapped using the Programmable Scheme Logic (PSL) support tool. The InterMiCOM application provides a means of transferring the status of these mapped DDB signals between the protection relays using dedicated full-duplex communications channels.

1.21.2**InterMiCOM Variants**

There are two different types of integrated InterMiCOM teleprotection available in the MiCOM relays:

- An optical fiber implementation, InterMiCOM⁶⁴ - designed, primarily, to work over fiber optic and multiplexed digital communications channels with data rates of 56/64kbit/s. A total of 16 InterMiCOM⁶⁴ commands (16 inputs and 16 outputs) are available in the P443/P445/P446/P54x. These are arranged as two groups of 8 bits each, and are referred to as Channel 1 and Channel 2. Three InterMiCOM⁶⁴ scheme arrangements are possible:
- Two-terminal with a single communications link
- Two-terminal with a dual redundant communications link (sometimes referred to as 'hot standby')
- Three terminal (or triangulated) scheme
- An electrical implementation of InterMiCOM, realised over an EIA(RS)232 medium typically for MODEM applications and referred to as MODEM InterMiCOM for ease of differentiation with InterMiCOM⁶⁴. MODEM InterMiCOM supports two-terminal applications with a single communications channel. Eight MODEM InterMiCOM commands can be transmitted between the line ends.

Provided the correct hardware options have been specified, it is possible to configure the P443/P445/P446/P54x to operate using either InterMiCOM⁶⁴ or MODEM InterMiCOM, or both. The selection is made under the CONFIGURATION column of the menu software. It should be noted, however, that although both hardware options can be fitted and the software supports both forms of InterMiCOM as standard, only one type may be operational at any one time.

1.21.3**InterMiCOM Features**

The different requirements of applications that use teleprotection signaling for direct acting, permissive, or blocking schemes are all catered for by InterMiCOM. Communications are supervised and alarms and signal defaults can be defined to give controlled actions in the event of communications signals being distorted or unavailable. Communications statistics and loopback features are available to help with commissioning and testing purposes. Both, InterMiCOM⁶⁴ and MODEM InterMiCOM teleprotection provide the ideal means to configure the schemes in the MiCOM relay. The selection between the two will generally depend on communications media availability, system configuration, distances, cost issues and utility practice.

1.21.4**Definition of Teleprotection Commands**

Three generic types of teleprotection command can be defined. These are Intertripping, Permissive signaling, and Blocking. All teleprotection signals are initiated in a transmitting relay but, according to the application, the receiving relay may condition the signal according to the scheme requirements:

The decision to send a command is made by a local protective relay operation, and three generic types of InterMiCOM signal are available:

Intertripping In intertripping (direct or transfer tripping applications), the command is not supervised at the receiving end by any protection relay and simply causes CB operation. Since no checking of the received signal by another protection device is performed, it is absolutely essential that any noise on the signaling channel isn't seen as being a valid signal. In other words, an intertripping channel must be very secure.

Permissive In permissive applications, tripping is only permitted when the command coincides with a protection operation at the receiving end. Since this applies a second, independent check before tripping, the signaling channel for permissive schemes do not have to be as secure as for intertripping channels.

Blocking In blocking applications, tripping is only permitted when no signal is received but a protection operation has occurred. In other words, when a command is transmitted, the receiving end device is blocked from operating even if a protection operation occurs. Since the signal is used to prevent tripping, it is imperative that a signal is received whenever possible and as quickly as possible. In other words, a blocking channel must be fast and dependable.

The requirements for the three channel types are shown in the *Pictorial comparison of operating modes* diagram. This diagram shows that a blocking signal should be fast and dependable; a direct intertrip signal should be very secure and a permissive signal is an intermediate compromise of speed, security and dependability. In MODEM applications, all three modes can be applied to selected signaling bits within each message.

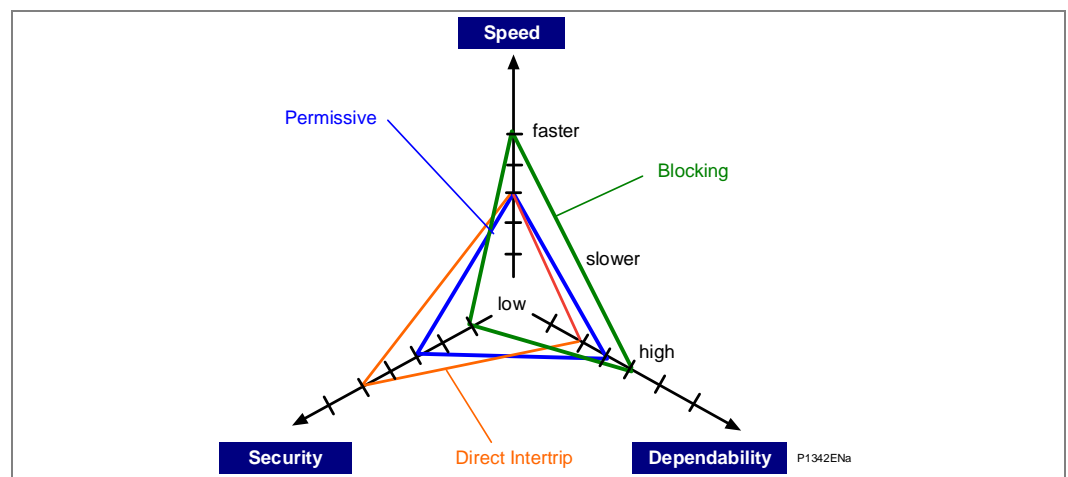

Figure 38 - Pictorial comparison of operating modes

In MODEM InterMiCOM applications, selected signaling bits within each message can be conditioned to provide optimal characteristics for each of the three teleprotection command types.

In InterMiCOM⁶⁴ applications, the framing and error checking of a single command message is sufficient to meet the security of a permissive application, while the speed is sufficiently fast to meet the needs of a blocking scheme. Accordingly in InterMiCOM⁶⁴ applications, there is no differentiation between blocking commands or permissive commands, so that only signals being used for direct intertripping with higher security requirements need to be differentiated from those in permissive (or blocking) schemes.

1.22 MODEM InterMiCOM EIA(RS)232 InterMiCOM, or Copper InterMiCOM

1.22.1 Communications Media

InterMiCOM can transfer up to eight commands over one communication channel. Due to recent expansions in communication networks, most signaling channels are now digital schemes using multiplexed fiber optics. For this reason, InterMiCOM provides a standard EIA(RS)232 output using digital signaling techniques. This digital signal can be converted using suitable devices to any communications media as required. The EIA(RS)232 output may alternatively be connected to a MODEM link.

Regardless of whether analogue or digital systems are being used, all the requirements of teleprotection commands are governed by an international standard IEC60834-1:1999 and InterMiCOM is compliant with the essential requirements of this standard. This standard governs the speed requirements of the commands as well as the probability of unwanted commands being received (security) and the probability of missing commands (dependability).

Additional security can now be achieved by using Cyber Security settings. This is now an option for products which use Software Release D0 and later.

1.22.2 General Features and Implementation

InterMiCOM provides eight commands over a single communications link, with the mode of operation of each command being individually selectable within the **IM# Cmd Type** cell. **Blocking** mode provides the fastest signaling speed (available on commands 1 - 4), **Direct Intertrip** mode provides the most secure signaling (available on commands 1 - 8) and **Permissive** mode provides the most dependable signaling (available on commands 5 - 8). Each command can also be disabled so that it has no effect in the logic of the relay.

Since many applications will involve the commands being sent over a multiplexed communications channel, it is necessary to ensure that only data from the correct relay is used. Both relays in the scheme must be programmed with a unique pair of addresses that correspond with each other in the **Source Address** and **Receive Address** cells. For example, at the local end relay if we set the **Source Address** to 1, the **Receive Address** at the remote end relay must also be set to 1. Similarly, if the remote end relay has a **Source Address** set to 2, the **Receive Address** at the local end must also be set to 2. All four addresses must not be set identical in any given relay scheme if the possibility of incorrect signaling is to be avoided.

In particular, the two pairs of addresses should be set to be different in any scheme to avoid the possibility of incorrect operation during inadvertent loopback connections, and any schemes sharing the same communications services should be set to have different address pairs in order to avoid any problems caused by inadvertent cross-channel connections.

Noise in the communications channel should not be interpreted as valid messages by the relay. For this reason, InterMiCOM uses a combination of unique pair addressing described above, basic signal format checking and for **Direct Intertrip** commands an 8-bit Cyclic Redundancy Check (CRC) is also performed. This CRC calculation is performed at both the sending and receiving end relay for each message and then compared to maximize the security of the **Direct Intertrip** commands.

An alarm is provided if noise on the communications channel becomes excessive. During periods of excessive noise, it is possible that the synchronization of the message structure will be lost and accurate decoding of the messages may not be possible. Predictable operation of InterMiCOM is assured during such noisy periods by means of the **IM# FallBackMode** cell. The status of the last received valid command can be maintained until a new valid message is received by setting the **IM# FallBackMode** cell to **Latched**. Alternatively, a known fallback state can be assigned to the command by setting the **IM# FallBackMode** cell to **Default**. In this latter case, the time period between communication disruption and the default state being restored will need to be set in the **IM# FrameSynTim** cell and the default value will need to be set in **IM# DefaultValue** cell. Upon subsequent receipt of a valid message, all the timer periods will be reset and the new valid command states will be used.

If there is a total communications failure, the relay will use the fallback (failsafe) strategy as described above. Total failure of the channel is considered when no message data is received for four power system cycles or if there is a loss of the DCD line.

1.22.3

EIA(RS)232 Physical Connections

InterMiCOM on the Px40 relays is implemented using a 9-pin 'D' type female connector (labeled SK5) located at the bottom of the 2nd Rear communication board. This connector on the Px40 relay is wired in DTE (Data Terminating Equipment) mode, as shown in the *EIA(RS)232 Physical Connections* table:

Pin	Acronym	InterMiCOM Usage
1	DCD	"Data Carrier Detect" is only used when connecting to modems otherwise this should be tied high by connecting to terminal 4.
2	RxD	"Receive Data"
3	TxD	"Transmit Data"
4	DTR	"Data Terminal Ready" is permanently tied high by the hardware since InterMiCOM requires a permanently open communication channel.
5	GND	"Signal Ground"
6	Not used	-
7	RTS	"Ready To Send" is permanently tied high by the hardware since InterMiCOM requires a permanently open communication channel.
8	Not used	-
9	Not used	-

Table 5 - Pins, Acronyms and InterMiCOM usage

Depending upon whether a direct or modem connection between the two relays in the scheme is being used, the required pin connections are described below.

1.22.4

Direct Connection

The EIA(RS)232 protocol only allows for short transmission distances due to the signalling levels used and therefore the connection shown below is limited to less than 15m. However, this may be extended by introducing suitable EIA(RS)232 to fiber optic convertors, such as the CILI 204. Depending upon the type of convertor and fiber used, direct communication over a few kilometres can easily be achieved.

This type of connection should also be used when connecting to multiplexers that have no ability to control the DCD line.

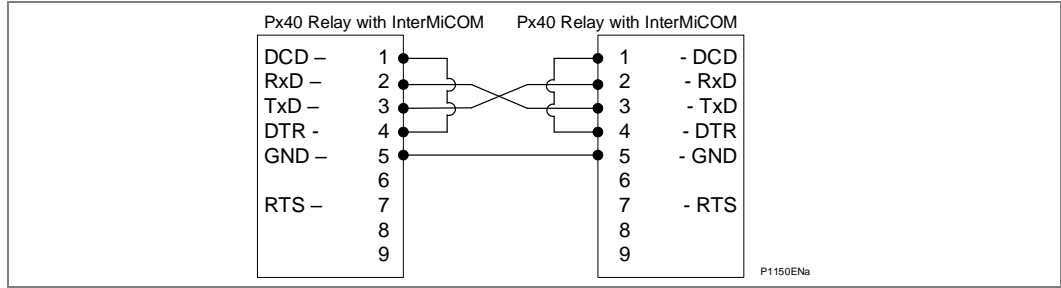

Figure 39 - Direct connection within the local substation

1.22.5

EIA(RS)232 Modem Connection

For long distance communication, modems may be used in which the case the following connections should be made.

This type of connection should also be used when connecting to multiplexers that have the ability to control the DCD line. With this type of connection it should be noted that the maximum distance between the Px40 relay and the modem should be 15m, and that a baud rate suitable for the communications path used should be selected.

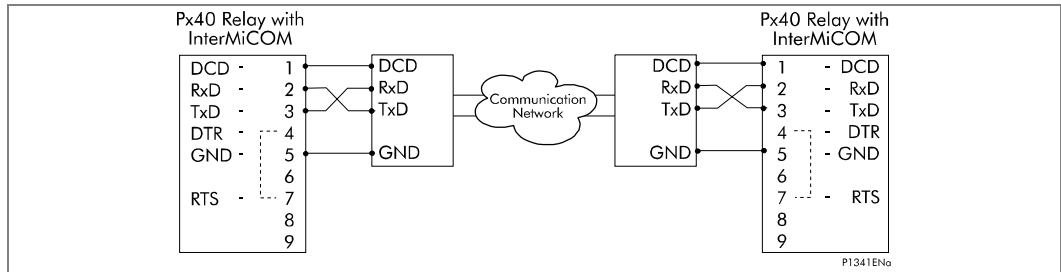

Figure 40 - InterMiCOM teleprotection via a MODEM link

1.22.6

RS422 Connection

RS232 to RS422 converter such as Schneider Electric CK212 may also be used for a longer distance application; it can be formed as shown in the *InterMiCOM teleprotection via a RS422 protocol* diagram:

With this type of connection, the maximum distance between the Px40 relay and the converter should be 15m.

Up to 1.2km length can be achieved with this type of protocol, depending on the converter performance.

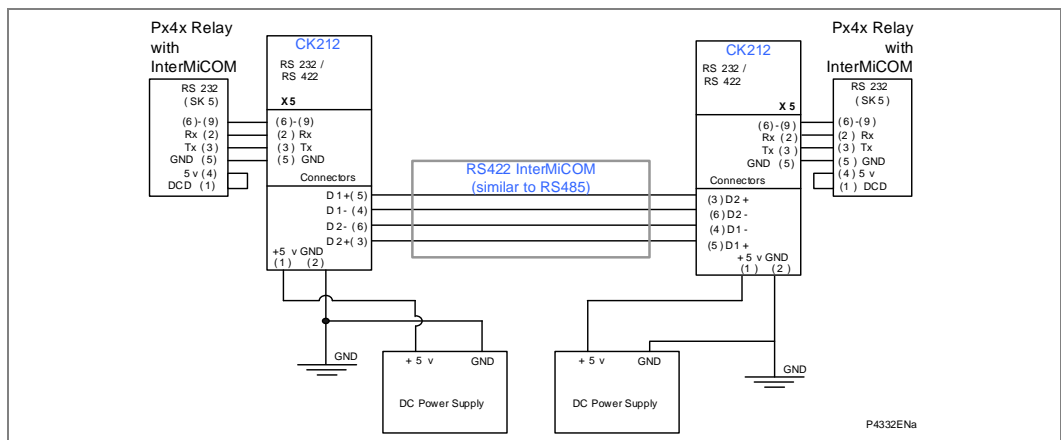

Figure 41 - MODEM InterMiCOM teleprotection via a RS422 protocol

1.22.7 Fiber Optic Connection

For long distance communication, a fiber optic converter may be used connected as shown in the *InterMiCOM teleprotection via fiber optic* diagram. With this type of connection, the maximum distance between the Px40 relay and the converter should be 15m. The length that can be achieved is depending on the converter performance.

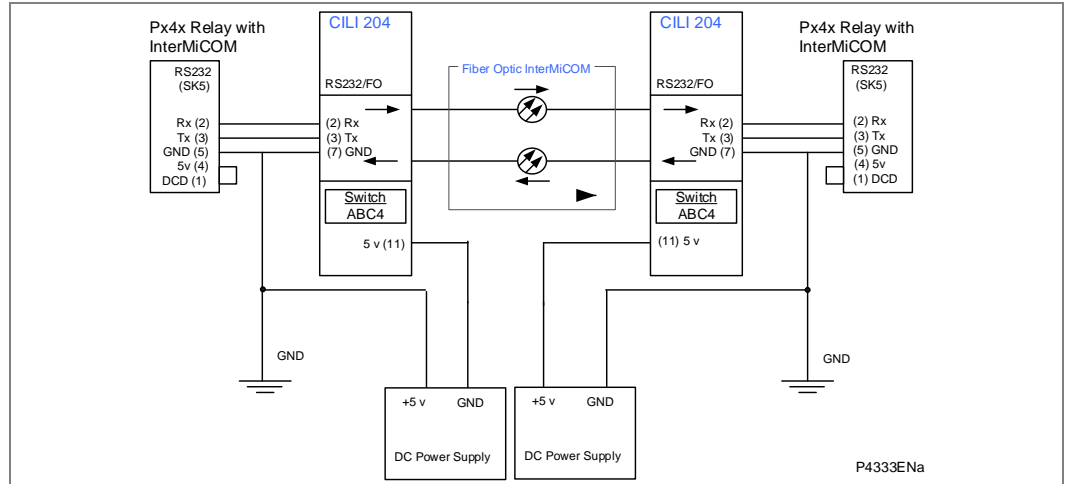

Figure 42 - MODEM InterMiCOM teleprotection via fiber optic

1.22.8 InterMiCOM Functional Assignment

Even though settings are made on the relay to control the mode of the intertrip signals, it is necessary to assign InterMiCOM input and output signals in the relay Programmable Scheme Logic (PSL) if InterMiCOM is to be successfully implemented. Two icons are provided on the PSL editor of MiCOM S1 for “Integral tripping In” and “Integral tripping out” which can be used to assign the eight intertripping commands. The example shown in the *Example assignment of signals within the PSL* diagram shows a “Control Input_1” connected to the “Intertrip O/P1” signal which would then be transmitted to the remote end. At the remote end, the “Intertrip I/P1” signal could then be assigned within the PSL. In this example, we can see that when intertrip signal 1 is received from the remote relay, the local end relay would operate an output contact, R1.

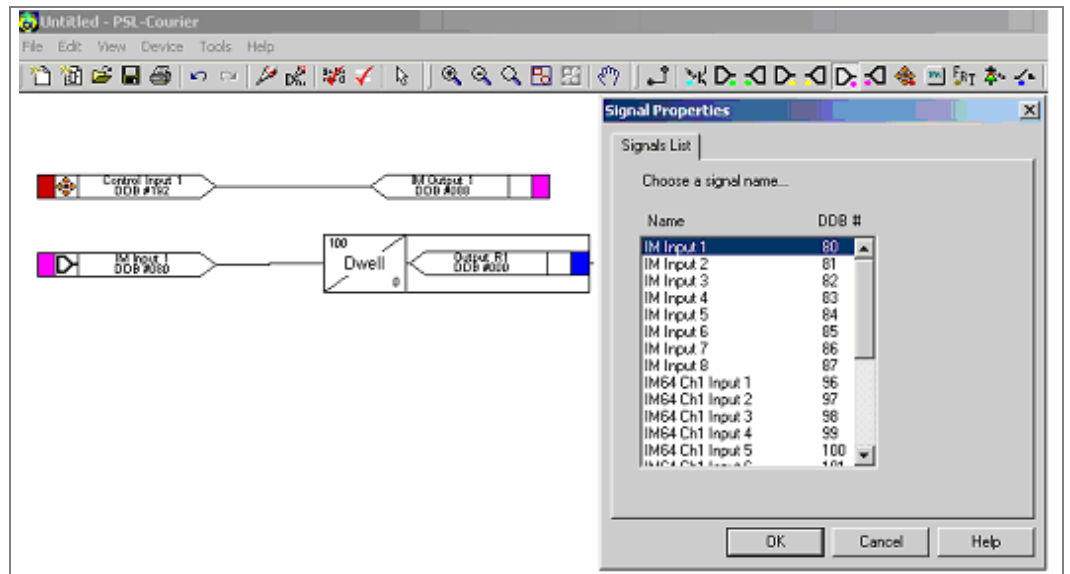

Figure 43 - Example assignment of signals within the PSL

It should be noted that when an InterMiCOM signal is sent from the local relay, only the remote end relay will react to this command. The local end relay will only react to InterMiCOM commands initiated at the remote end. InterMiCOM is thus suitable for teleprotection schemes requiring Duplex signaling.

1.22.9 InterMiCOM Statistics and Diagnostics

It is possible to hide the channel diagnostics and statistics from view by setting the “**Ch Statistics**” and/or “**Ch Diagnostics**” cells to “**Invisible**”. All channel statistics are reset when the relay is powered up, or by user selection using the “**Reset Statistics**” cell.

1.23 InterMiCOM⁶⁴ (fiber InterMiCOM)

1.23.1 General Features and Implementation

InterMiCOM⁶⁴ is an optional feature, offering very fast fault clearance in distance aided schemes with a typical end-end delay of 5ms for Permissive/Blocking signals and around 6ms for Intertripping (adding the channel time delay where multiplexers are used).

InterMiCOM⁶⁴ provides a direct fiber output from the relay’s co-processor board that can be connected either directly to the protection at the remote end(s) or via appropriate interfaces and multiplexed communications channels, similar to MiCOM P52x and P54x line differential relays. InterMiCOM⁶⁴ can use two channels for communication. The second channel is used in dual redundant two-terminal scheme or three-terminal scheme configurations. (Sometimes such schemes are termed “**hot standby**” and “**triangulated**” schemes, respectively).

InterMiCOM⁶⁴ is designed, primarily, to work over fiber optic and multiplexed digital communications channels. A total of sixteen InterMiCOM⁶⁴ commands (16 inputs and 16 outputs) are available in the MiCOM P443/P445/P446. These are arranged as two groups of 8 bits each, and are referenced as Channel 1 and Channel 2.

<i>Note</i>	<i>InterMiCOM⁶⁴ Channel 1 and 2 references are not the same as references to communications Channels 1 and 2 and this can cause some confusion.</i>
-------------	--

InterMiCOM⁶⁴ communications can run using two different user settable Baud rates: 56 and 64kbits/s, for ease of interfacing with standard public and private telecommunication networks.

InterMiCOM⁶⁴ also supports the IEEE C37.94 standard for direct optical fiber connection to appropriately equipped multiplexers. In this case the data rate is matched to one of the Nx64 channels supported by the multiplexer.

1.23.2 Configuring InterMiCOM⁶⁴

InterMiCOM⁶⁴ provides two groups of eight InterMiCOM⁶⁴ commands. These groups of InterMiCOM⁶⁴ commands are referenced as Channel 1 and Channel 2. The mapping of the InterMiCOM⁶⁴ command signals is performed using the programmable scheme logic (PSL) editor (which is part of the MiCOM S1/S1 Studio support tool) in a manner similar to that described in the *InterMiCOM Functional Assignment* section.

In addition to mapping the commands with the PSL editor, it is also necessary to configure the InterMiCOM⁶⁴ communications scheme. This configuration is made using the settings found in the PROT COMMS/IM⁶⁴ column of the menu software. These settings are described in detail in the Settings (ST) chapter of this manual, but in order to facilitate understanding of InterMiCOM⁶⁴ operation, they are also presented in the following sections.

The MiCOM P443/P445/P446 can be equipped with either one or two fiber communications ports to support InterMiCOM⁶⁴. For the purposes of setting, labeling, etc., these communications ports are referenced as protection communications Channels 1 and 2. Although there is some association of the InterMiCOM⁶⁴ signal groupings referenced Channels 1 and 2, with communications Channels 1 and 2, they have subtly different meanings and care needs to be taken to avoid confusion.

1.23.2.1

InterMiCOM⁶⁴ Scheme Setup – Application

Three InterMiCOM⁶⁴ scheme arrangements are possible:

- Two-terminal with a single communications link
- Two-terminal with a dual redundant communications link (sometimes referred to as 'hot standby')
- Three terminal (or triangulated) scheme

The selection is made using the Scheme Setup setting.

In the two-terminal configurations, the 8 InterMiCOM⁶⁴ commands of both channel 1 and channel 2 (i.e. all 16 commands) can be freely assigned within the scheme logic of the two relays. So long as a communications link between the two terminals is functioning, all 16 commands are usable. The advantage of a dual redundant scheme is the fact that scheme integrity can be maintained in the event of a failure of one of the communications links.

The triangulated scheme is designed such that the InterMiCOM⁶⁴ communications can self-heal in the event of a failure of a communication link between any two terminals. It achieves this by routing the 8 InterMiCOM⁶⁴ commands on Channel 1 for use by the relay connected to communications channel 1 (remote 1), and the 8 InterMiCOM⁶⁴ commands on Channel 2 for use by the relay connected to communications channel 2 (remote 2). In the event of a failure of communications between say the local relay and remote 1, remote 2 will pass on the 8 InterMiCOM⁶⁴ commands intended from local to remote1 using the second communications channel.

The recommended InterMiCOM⁶⁴ connection for a three ended application is shown below.

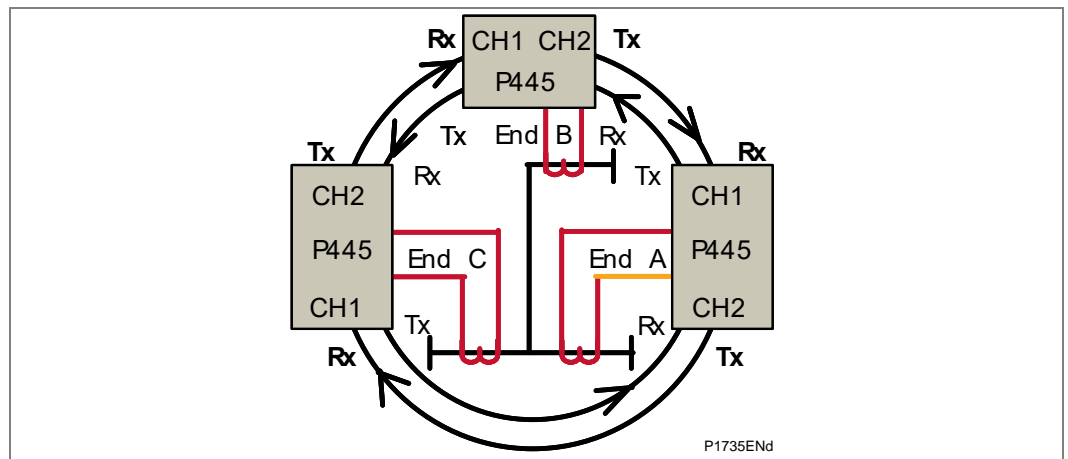

Figure 44 - Triangulated InterMiCOM⁶⁴ Application

If one leg of the communication triangle fails, for example, channel A-C becomes unavailable, the InterMiCOM⁶⁴ will continue to provide the full teleprotection scheme between all three ends in a degraded chain topology because of the way the 8 Channel 2 InterMiCOM⁶⁴ commands are passed on via the scheme logic. In this degraded 'Chain' topology, relays A and C will receive and transmit teleprotection commands via relay B. The retransmitting done by relay B (A-B-C and C-B-A) provides the self-healing for the lost links A-C and C-A).

This Chain topology may be employed as a means to save cost in implementing a three-terminal scheme, since two legs may be cheaper to install than full triangulation, or if a suitable communication link is not available between two of the line ends. It should be noted, however, that the operating speed of teleprotection commands will increase by approximately 7ms (plus communications channel signaling delay) when retransmitted in Chain topology, due to the extended path length.

1.23.2.2

InterMiCOM⁶⁴ Protection Communications Address

The InterMiCOM⁶⁴ communication messages include an address field to ensure correct scheme connection. There are twenty one address group selections available. These addresses are provided to ensure that commands are communicated only between the particular relays in the scheme. The address patterns are carefully designed to provide maximum security for the application, and within the ranges given, they are freely assignable.

The Universal Address can be useful during testing, but in deployment it should be avoided to prevent the possibility of incorrect operation during inadvertent loopback connections. In addition, and any schemes sharing the same communications services should be set to have different address patterns to avoid any problems caused by inadvertent cross-channel connection.

The groups of addresses available when a two-terminal or dual redundant InterMiCOM⁶⁴ scheme is selected are as follows:

Address	Relay A	Relay B	Address	Relay A	Relay B
Universal Address	0-0	0-0			
Address Group 1	1-A	1-B	Address Group 11	11-A	11-B
Address Group 2	2-A	2-B	Address Group 12	12-A	12-B
Address Group 3	3-A	3-B	Address Group 13	13-A	13-B
Address Group 4	4-A	4-B	Address Group 14	14-A	14-B
Address Group 5	5-A	5-B	Address Group 15	15-A	15-B
Address Group 6	6-A	6-B	Address Group 16	16-A	16-B
Address Group 7	7-A	7-B	Address Group 17	17-A	17-B
Address Group 8	8-A	8-B	Address Group 18	18-A	18-B
Address Group 9	9-A	9-B	Address Group 19	19-A	19-B
Address Group 10	10-A	10-B	Address Group 20	20-A	20-B

Table 6 - Address groups for a two-terminal or dual redundant scheme

For two relays to communicate with one another, their addresses need to be in the same address group. One relay should be assigned with address A and the other with address B. For example, if the group 1 address is used, one relay should be given the address 1-A, and the other relay should be given the address 1-B. The relay with address 1-A will only accept messages with the 1-A address and will send out messages carrying address 1-B. The relay assigned with address 1-B will only accept messages with address 1-B and will send out messages carrying address 1-A.

The groups of addresses available when a three-terminal InterMiCOM⁶⁴ scheme is selected are as follows:

Address	Relay A	Relay B	Relay C	Address	Relay A	Relay B	Relay C
Address Group 1	1-A	1-B	1-C	Address Group 11	11-A	11-B	11-C
Address Group 2	2-A	2-B	2-C	Address Group 12	12-A	12-B	12-C
Address Group 3	3-A	3-B	3-C	Address Group 13	13-A	13-B	13-C
Address Group 4	4-A	4-B	4-C	Address Group 14	14-A	14-B	14-C
Address Group 5	5-A	5-B	5-C	Address Group 15	15-A	15-B	15-C
Address Group 6	6-A	6-B	6-C	Address Group 16	16-A	16-B	16-C
Address Group 7	7-A	7-B	7-C	Address Group 17	17-A	17-B	17-C
Address Group 8	8-A	8-B	8-C	Address Group 18	18-A	18-B	18-C
Address Group 9	9-A	9-B	9-C	Address Group 19	19-A	19-B	19-C
Address Group 10	10-A	10-B	10-C	Address Group 20	20-A	20-B	20-C

Table 7 - Address groups for a three-terminal scheme

For three relays to work together as a protection system, their addresses must be in the same group and they should be assigned separately with addresses A, B and C. They must also have a fixed connection configuration, in which channel 1 of one relay is connected to channel 2 of another relay.

For example, if the group 1 address is used, addresses 1-A, 1-B and 1-C should be assigned to relays A, B and C respectively. Relay A will only accept messages with address 1-A and will send messages carrying addresses 1-B and 1-C to channel 1 and channel 2 respectively. Relay B will only accept messages with address 1-B and will send messages carrying addresses 1-C and 1-A to channel 1 and to channel 2 respectively. Similarly relay C will only accept messages with address 1-C and will send messages carrying addresses 1-A and 1-B to channel 1 and to channel 2 respectively.

1.23.2.3

InterMiCOM⁶⁴ Communications Mode Setup

The Communications Mode setup configures the optical fiber ports either as “**standard**”, or as “**IEEE C37.94**”. If connection is to be made to a multiplexer that supports the IEEE C37.94 interface, then “**IEEE C37.94**” should be selected otherwise the selection should be “**standard**”. This setting applies to both communications channels - they cannot be set independently. If this setting is changed, the relay must be power cycled before it will take effect.

1.23.2.4

InterMiCOM⁶⁴ Communications Baud Rate

The baud rate for communication over channel 1 (and channel 2 where fitted) can be selected (independently) between 56kbits/s and 64kbits/s. For direct fiber connection 64kbits/s should be selected. If P-2M-L units are being used to interface to a telecommunications network, the setting will be dictated by the network. This setting is hidden if the IEEE C37.94 mode has been selected.

1.23.2.5

InterMiCOM⁶⁴ Communications Clock Source

The clock source for communication channel 1 (and channel 2 where fitted) can be selected (independently) between “**internal**” and “**external**”. For direct fiber connection “**internal**” should be selected. If P-2M-L units are being used to interface to a telecommunications network, the setting will be dictated by the network. In general, the “**external**” setting will be used when connecting to a telecommunications network, since the network will normally provide a clock master. This setting is hidden if the IEEE C37.94 mode has been selected.

1.23.2.6

InterMiCOM⁶⁴ IEEE C37.94 Channel Selection

This setting is only visible if the IEEE C37.94 mode has been selected. It allows the channels to be assigned to a particular channel presented by the interface. Setting it to Auto enables the relay to configure itself to match the multiplexer.

1.23.2.7 InterMiCOM⁶⁴ Communications Fail Timer

The “**Comm Fail Timer**” sets how long after a communications failure the alarm will be issued. In this context, a communications failure is defined as no messages received during the channel timeout period, or the alarm level being exceeded.

1.23.2.8 InterMiCOM⁶⁴ Communications Failure Mode

The “**Comm Fail Mode**” setting applies only to relays configured for dual redundant or three-terminal configuration. It prescribes what combination of failures on the two communications channels is used to flag an alarm.

1.23.2.9 InterMiCOM⁶⁴ Channel Timeout

If an InterMiCOM⁶⁴ command has been set to revert to a default value after a communications failure, this timer sets how long will elapse before the defaults are applied.

1.23.2.10 InterMiCOM⁶⁴ Propagation Delay Statistics

The “**Prop Delay Stats**” setting can be either enabled or disabled. When enabled The “**Max Ch Prop Delay**” settings for communications channel 1 (and 2 if fitted) become visible. These are settings whereby, if InterMiCOM⁶⁴ messages take longer to be received than the setting value, the message can be rejected.

1.23.2.11 InterMiCOM⁶⁴ Command Type

Each of the InterMiCOM⁶⁴ commands can be set via the “**IMn Cmd Type**” setting (n=1-8) to be conditioned for either direct transfer tripping (setting = “**Direct**”) or for use in a blocking or permissive scheme (setting = “**Permissive**”).

<i>Note</i>	<i>There are 8 of these settings, one for each of eight InterMiCOM⁶⁴ commands. The 8 settings are applied the same to the 8 InterMiCOM⁶⁴ commands on Channel 1 as to the 8 InterMiCOM⁶⁴ commands on Channel 2, so that if “IM1 Cmd Type” is set to “Direct”, then IM1 channel 1 and IM1 channel2 with both be conditioned for direct transfer tripping.</i>
-------------	--

1.23.2.12 InterMiCOM⁶⁴ Fallback Mode

Each of the InterMiCOM⁶⁴ command can be set via the “**IMn FallBackMode**” setting (n=1-8) to define its behavior under communications failure conditions. They can be programmed to either latch the state of the last good command received, or they can revert to a default state (either 1 or 0) defined in the “**IMn DefaultValue**” setting (n=1-8).

<i>Note</i>	<i>There are 8 of each of these settings, one for each of eight InterMiCOM⁶⁴ commands. The 8 settings are applied the same to the 8 InterMiCOM⁶⁴ commands on Channel 1 as to the 8 InterMiCOM⁶⁴ commands on Channel 2.</i>
-------------	---

1.23.3 InterMiCOM⁶⁴ Communications Alarm Management

Due to the criticality of InterMiCOM⁶⁴ communications for correct scheme performance, there is an extensive regime to monitor signal quality and integrity, generate and report alarms. For most applications, the alarming supplied as standard should satisfy the needs of the scheme. For some applications, however, it may be necessary to provide additional qualifications using the programmable scheme logic. To do this, it is necessary to understand the concepts behind the alarm signals and their implementation in the MiCOM P443/P445/P446 relay.

Fundamental to the implementation of scheme logic in the MiCOM Px4x series of relays is the concept of the DDB introduced earlier. The complete list of DDB signals applicable to InterMiCOM⁶⁴ communications are described in the *InterMiCOM⁶⁴ DDB Signal List* section below.

1.23.3.1

InterMiCOM⁶⁴ DDB Signal List

The DDB signals applicable to the optional InterMiCOM⁶⁴ feature are tabulated below. (For a complete list of all DDB signals applicable to the relay please refer to the Programmable Logic (PL) section of this Technical Guide).

DDB No.	English text	Description
291	Test Loopback	Indicates that the local relay has been selected to Loopback mode (internal or external) in the Commission Tests options.
292	Test IM64	Indicates that the local relay has been selected to Test mode in the Commission Tests options.
311	Signaling Fail	Indicates when the local receive signal is totally lost, or exceeds the alarm threshold, on either channel 1 or channel 2
337	Comms Changed	Indicates that the Comms Mode setting has been changed between Standard and IEEEC37.94 or vice versa. The relay must be power-cycled to remove this alarm and activate the new communication mode.
315	IEEE C37.94	Indicates that one or more IEEE C37.94 communication alarms are currently active. (IEEE C37.94 alarms are DDB # 1123 - 1126 and DDB # 1133 - 1136. This signal is only used when the Comms Mode is selected to IEEE C37.94
314	IM64 Scheme Fail	Indicates when the communications between the relays has been compromised and therefore IM64 doesn't work. For 2-ended schemes, this is functionally identical to the Signaling Fail DDB signal (DDB # 285). For 3-ended schemes, this is only active when it is no longer possible to provide communications even allowing for pass through mode i.e. more than one link has failed.
96	IM64 Ch1 Input 1	Input DDB signal used in the PSL which is the receive signal for Channel 1, bit 1.
97 - 103	IM64 Ch1 Input 2 ... 8	Input DDB signal used in the PSL which is the receive signal for Channel 1, bit 2 to 8.
104	IM64 Ch2 Input 1	Input DDB signal used in the PSL which is the receive signal for Channel 2, bit 1.
105 - 111	IM64 Ch2 Input 2 ... 8	Input DDB signal used in the PSL which is the receive signal for Channel 2, bit 2 to 8.
112	IM64 Ch1 Output1	Output DDB signal used in the PSL which is the transmit signal for Channel 1, bit 1.
113 - 119	IM64 Ch1 Output2 ... 8	Output DDB signal used in the PSL which is the transmit signal for Channel 1, bit 2 to 8.
120	IM64 Ch2 Output1	Output DDB signal used in the PSL which is the transmit signal for Channel 2, bit 1.
121 - 127	IM64 Ch2 Output 2 ... 8	Output DDB signal used in the PSL which is the transmit signal for Channel 2, bits 2 to 8.
1123	Ch1 Mux Clk	Output DDB signal used to indicate that the frequency of the signal on Channel 1 is outside the frequency expected by the multiplexer. This signal is only used when the Comms Mode is selected to IEEE C37.94
1124	Ch1 Signal Lost	Output DDB signal used to indicate that the multiplexer has lost the signal over channel 1. i.e no receive information on Channel 1. This signal is only used when the Comms Mode is selected to IEEE C37.94
1125	Ch1 Path Yellow	Output DDB signal used to indicate that the multiplexer has detected one way communication on Channel 1. i.e the transmit information is not being received by the remote end on Channel 1. This signal is only used when the Comms Mode is selected to IEEE C37.94

DDB No.	English text	Description
1126	Ch1 Mismatch RxN	Output DDB signal used to indicate that there is a mismatch between the communication settings on the InterMiCOM ⁶⁴ Channel 1 and the multiplexer. This signal is only used when the Comms Mode is selected to IEEE C37.94
1127	Ch1 Timeout	Output DDB signal used in the PSL to indicate that no valid messages have been received on Channel 1 during the Channel Timeout period (settable).
1128	Ch1 Degraded	Output DDB signal used in the PSL to indicate poor channel quality on Channel 1. This is determined by the percentage of bad messages received on Channel 1 exceeding the IM Msg Alarm Lvl setting during the previous 100 ms.
1129	Ch1 Passthrough	Output DDB signal used in the PSL to indicate when the Channel 1 signaling bits have been received through Channel 2 because of failure of channel 1. This signal is only relevant for 3 ended signaling schemes and is part of the self-healing capability.
1133	Ch2 Mux Clk	Output DDB signal used to indicate that the frequency of the signal on Channel 2 is outside the frequency expected by the multiplexer. This signal is only used when the Comms Mode is selected to IEEE C37.94
1134	Ch2 Signal Lost	Output DDB signal used to indicate that the multiplexer has lost the signal over channel 2. i.e no receive information on Channel 2. This signal is only used when the Comms Mode is selected to IEEE C37.94
1135	Ch2 Path Yellow	Output DDB signal used to indicate that the multiplexer has detected one way communication on Channel 2. i.e the transmit information is not being received by the remote end on Channel 2. This signal is only used when the Comms Mode is selected to IEEE C37.94
1136	Ch2 Mismatch RxN	Output DDB signal used to indicate that there is a mismatch between the communication settings on the InterMiCOM ⁶⁴ Channel 2 and the multiplexer. This signal is only used when the Comms Mode is selected to IEEE C37.94
1137	Ch2 Timeout	Output DDB signal used in the PSL to indicate that no valid messages have been received on Channel 2 during the Channel Timeout period (settable).
1138	Ch2 Degraded	Output DDB signal used in the PSL to indicate poor channel quality on Channel 2. This is determined by the percentage of bad messages received on Channel 2 exceeding the IM Msg Alarm Lvl setting during the previous 100 ms.
1139	Ch2 Passthrough	Output DDB signal used in the PSL to indicate when the Channel 2 signaling bits have been received through Channel 1 because of failure of channel 2. This signal is only relevant for 3 ended signaling schemes and is part of the self-healing capability.
338	Max Prop Alarm	Output DDB set if the communications propagation delay on either channel 1 or channel 2 exceeds its setting.
1386	Max Ch1 PropDelay	Output DDB set if the communications propagation delay on channel 1 exceeds its setting.
1387	Max Ch2 PropDelay	Output DDB set if the communications propagation delay on channel 2 exceeds its setting.

Table 8 - InterMiCOM DDB Signal List

1.23.3.2

InterMiCOM⁶⁴ Communications Alarm Logic

The operation of the main alarm DDB signals associated with InterMiCOM⁶⁴ are shown in the conceptual diagrams (*InterMiCOM⁶⁴ channel fail and scheme fail conceptual logic* and *InterMiCOM⁶⁴ general alarm signals (conceptual logic)*). It should be recognized that some of the signals are setting/hardware dependent (for example, Channel 2 alarms will not be available on a simple 2-terminal single communications link application).

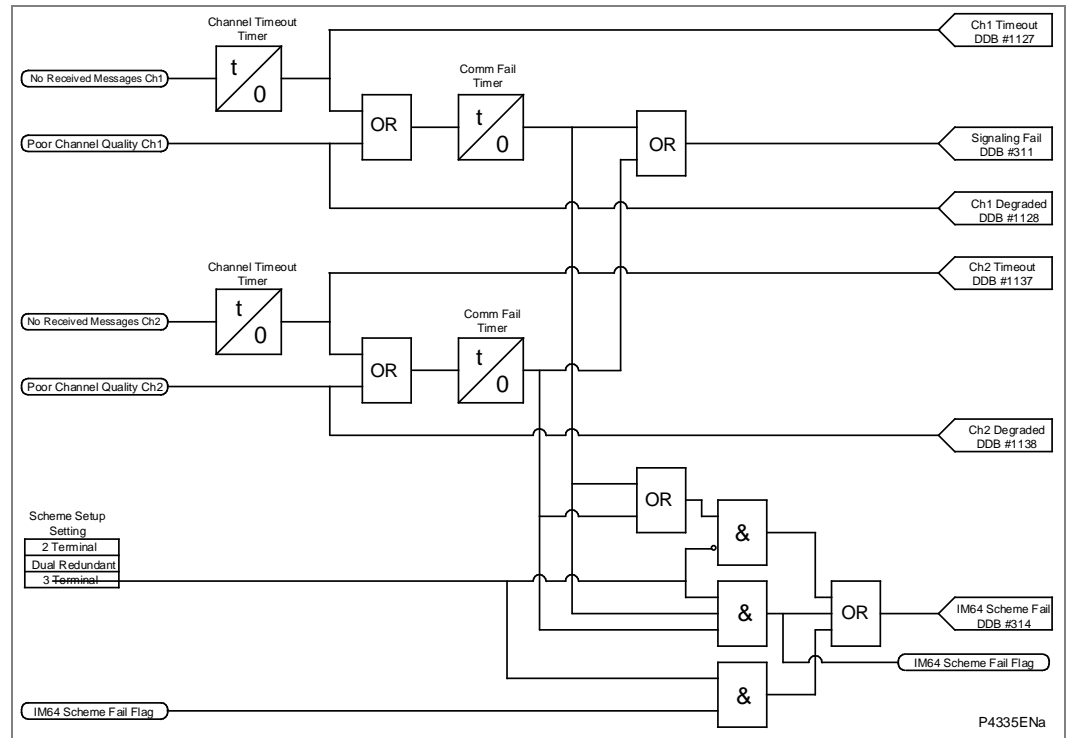

Figure 45 - InterMiCOM⁶⁴ channel fail and scheme fail conceptual logic

The messages received on each channel are individually assessed for quality to ensure that the InterMiCOM⁶⁴ signaling scheme is available for use. In the event of no messages being received for a period equal to the “**Channel Timeout**” setting, or the signal quality falling below a defined value then DDB signals will be activated as shown in the figure. Poor quality is indicated if the percentage of incomplete messages exceeds the “**IM Msg Alarm Lvl**” setting within a 100ms period (rolling window), or if the communications propagation time of the InterMiCOM⁶⁴ message exceeds the “**Ch Max PropDelay**” (if the “**Prop DelayStats**” setting is enabled), or if (in IEEE C37.94 configuration only, and not shown on the diagram) the “**Ch Mux Clk**” flag is set to indicate an incorrect baud rate. If either the “**Ch Timeout**”, or the “**Ch Degraded**” signal persists in the alarmed state for more than the duration of the “**Comm Fail Timer**” setting, then the “**Signaling Fail**” signal will be raised and indicated on the relay according to the conditions set in the “**Comm Fail Mode**” setting of the relay.

In the case of two-ended schemes (including dual redundant schemes), the “**IM64 Scheme Fail**” signal will be generated at the same time as the “**Signaling Fail**” signal. However, for three-terminal applications, the “**IM64 Scheme Fail**” signal gives an indication of when the full set of signaling bits cannot be processed by the scheme. Due to the self-healing nature of the three-terminal application, this occurs when both channels at any one end are not receiving good signals. This will generate a flag within the InterMiCOM⁶⁴ message structure which is passed to both remote ends, as well as generating the local “**IM64 Scheme Fail**” signal. By this method, in three-terminal applications the scheme fail indication will be raised at all three ends.

The scheme fail signaling is generated by the inability of the relays to receive messages through communication failure. That is to say that a transmitting relay will only know that its communication to a remote relay is in a failed state if it receives notification from the remote relay that that is the case. If a relay in the scheme is put into test mode, the communication failure information is not passed on to the remote ends. In this instance then it might be that the communications are in a failed state, but that there is no indication to the remote relays that this is the case. Should this cause operational issues then it may be necessary to include other signals to enable more precise indication of scheme failure, as described in the Application Notes (AP) chapter of this Technical Guide.

In addition to the main InterMiCOM⁶⁴ channel fail and scheme fail conceptual logic in the figure above, there are number of additional alarm DDB signals associated with test modes, reconfiguration for 3-terminal schemes, and the communication mode (standard vs IEEE C37.94). These are outlined in the two figures below:

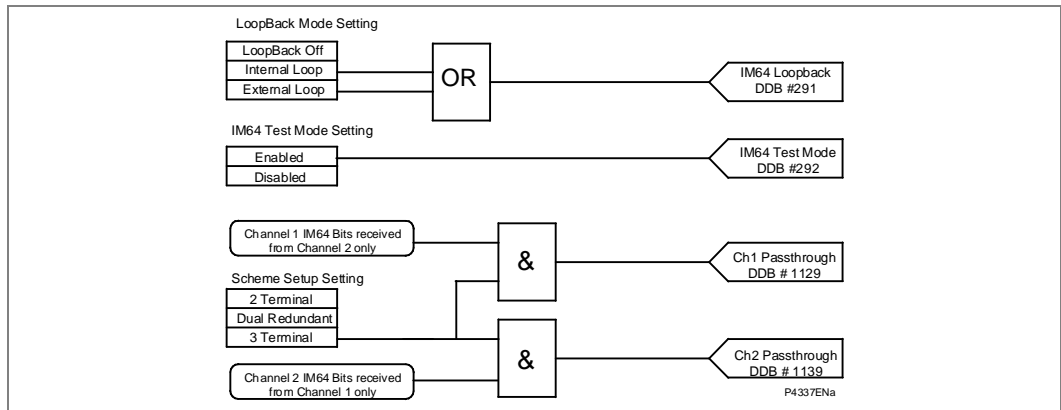

Figure 46 - InterMiCOM⁶⁴ general alarm signals (conceptual logic)

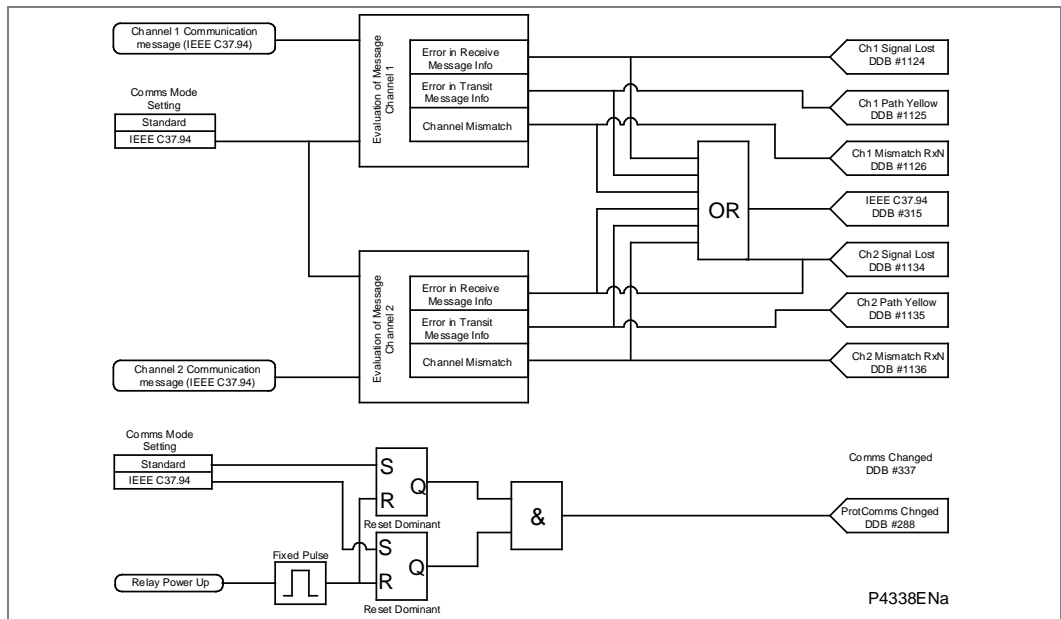

Figure 47 - InterMiCOM⁶⁴ communications mode and IEEE C37.94 alarm signals

1.23.3.3

InterMiCOM⁶⁴ Two Ended Scheme Extended Supervision

Referring to the logic of the *InterMiCOM64 Communications Alarm Logic* section, it may be seen that for two-ended applications, the “**Signaling Fail**” and “**IM64 Scheme Fail**” signals operate together. As such, the basic indications available on each relay should be considered as local-end indications only. If remote indication is needed to assure scheme functionality, it is necessary to use additional signals to communicate the status to the remote end. One method of performing this is shown in below:

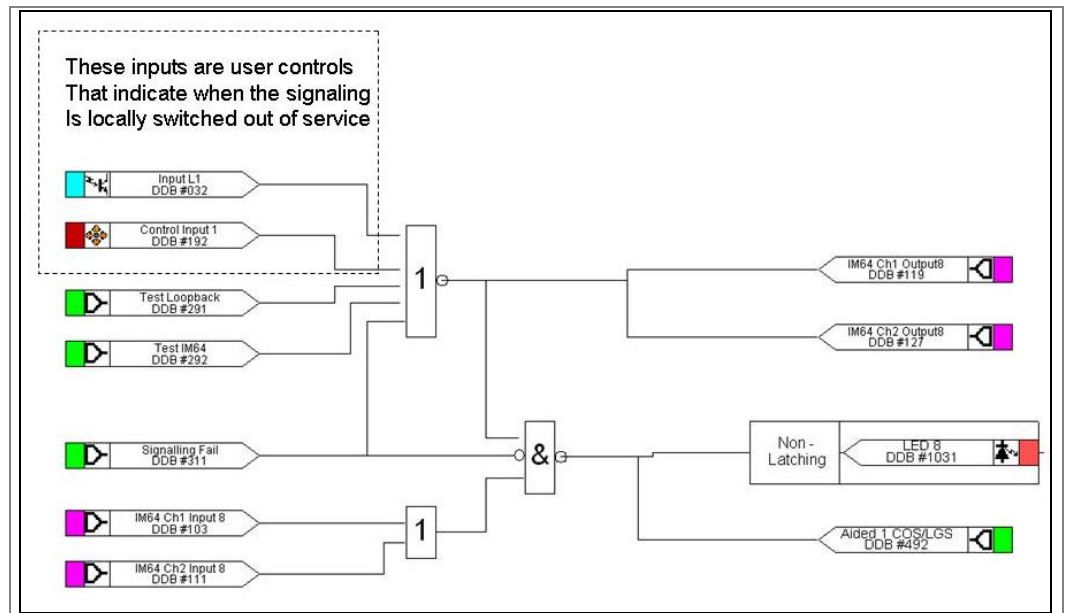

Figure 48 - InterMiCOM⁶⁴ two ended scheme extended supervision

In this example scheme, a number of signals are used to permanently pass an InterMiCOM⁶⁴ signal to the remote end. These signals take account of the local ability to receive InterMiCOM⁶⁴ messages, local test/loopback modes and any other external methods of switching the signaling scheme out of service. If any of these driving signals are energized, then the InterMiCOM⁶⁴ message is reset (a “0” sent on InterMiCOM⁶⁴ bit 8), causing both ends to raise an alarm (LED 8) and/or switch the aided scheme out of service due to loss of channel.

It should be noted that the logic presented above is intended only as an example. It is likely that some customization would be required to suit actual application requirements.

1.23.3.4

InterMiCOM⁶⁴ Three Ended Scheme Extended Supervision

The example scheme shown in the *InterMiCOM⁶⁴ Two Ended Scheme Extended Supervision* section can be extended to cover 3-terminal applications. In this case the “IM64 Scheme Fail” signal that is automatically communicated to all ends of the scheme is incorporated rather than the “Signaling Fail” of the previous example.

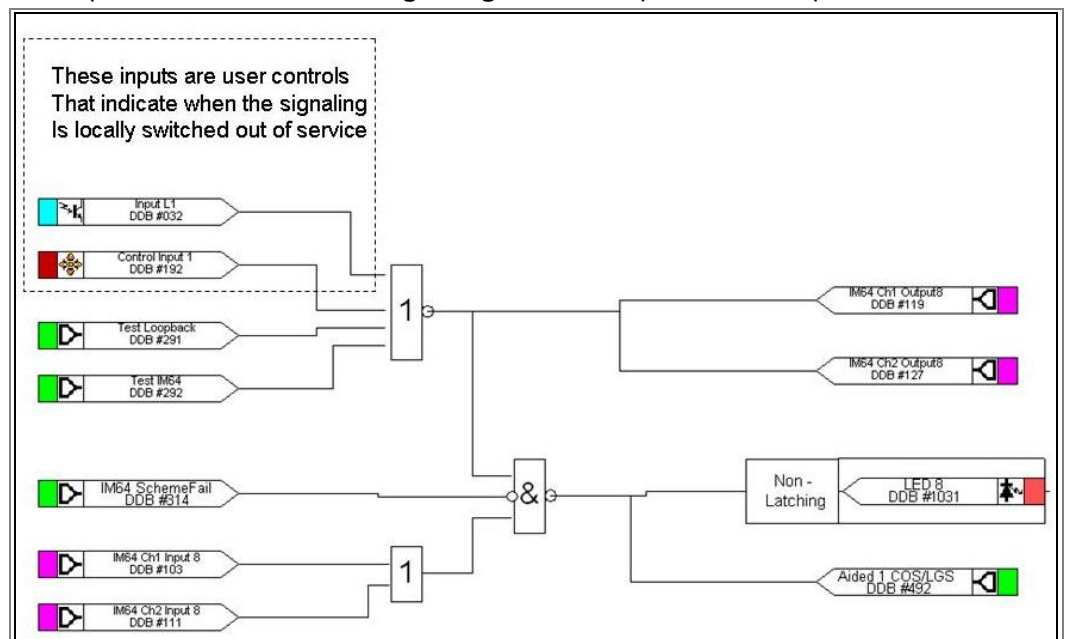

Figure 49 - Triangulated InterMiCOM⁶⁴ application

In this example if both channels at any one end fail to receive information, then this will be communicated to the other ends with an alarm raised and aided scheme switched out of service. The example above takes into account the test modes and local switching, such that the scheme will be signaled out of service at all ends if one end is locally disabled.

Again, it should be noted that the logic presented above is intended only as an example. It is likely that some customization would be required to suit actual application requirements.

1.23.4 InterMiCOM⁶⁴ Communications Link Options

A number of communications options are available, for the communication channels between MiCOM P443/P445/P446 system ends. The various connection options are shown below. Choosing between each of these options will depend on the type of communications equipment that is available.

- Where existing suitable multiplexer communication equipment is installed for other communication between substations, the 850nm option together with an appropriate ITU-T compatible electrical interface (P-2M-L series unit) should be selected to match the existing multiplexer equipment. Where an IEEE C37.94 compatible multiplexer is installed the 850nm option should be configured to interface directly to the multiplexer.
- Where no multiplexer is installed, a direct 1300nm optical fiber connection can be used. The type of fiber used (multi-mode or single-mode) will be determined by the distance between the ends of the MiCOM P443/P445/P446 relay scheme.

In any configuration, except the IEEE C37.94, the data rate may be selected as either 64kbit/sec or 56kbit/sec.

1.23.4.1 InterMiCOM⁶⁴ Optical Fiber Communications Link Options

The list of all available fiber channel options is:

- 850 nm multi-mode always two channels supplied as standard
- 1300 nm multi-mode one channel only
- 1300 nm multi-mode both channels (CH1 and CH2)
- 1310 nm single-mode one channel only
- 1310 nm single-mode both channels (CH1 and CH2)

Direct Optical Fiber Link, 850nm Multi-Mode Fiber

It is possible to connect two MiCOM P443/P445/P446 relays using 850nm multi-mode fiber but since the above configuration is typically suitable for connection only up to 1km, it is unlikely that this application will ever be applied in practical applications. This interface is, however, the most commonly supplied, since it is suitable for connection using the P-2M-L series of interface units and/or an interface compliant with the IEEE C37.94 standard described later.

Direct Optical Fiber Link, 1300nm Multi-Mode Fiber

The relays are connected directly using two 1300nm multi-mode fibers for each signaling channel. Multi-mode fiber type 50/125µm or 62.5/125µm is suitable. BFOC/2.5 type fiber optic connectors are used.

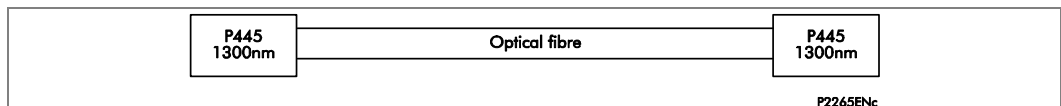

This is typically suitable for connection up to approximately 50km (from April 2008). Pre-April 2008 relays were suitable for connection up to approximately 30km.

Direct Optical Fiber Link, 1310nm Single-Mode Fiber

The relays are connected directly using two 1310nm single-mode fibers, type 9/125µm for each signaling channel. BFOC/2.5 type fiber optic connectors are used.

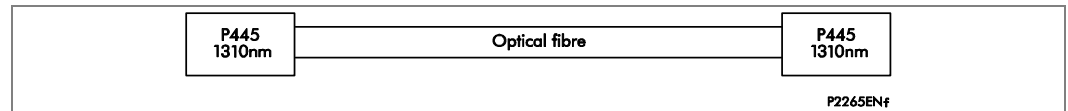

This is typically suitable for connection up to approximately 100km (from April 2008). Pre-April 2008 relays were suitable for connection up to approximately 60km.

IEEE C37.94 Interface to Multiplexer

A relay with 850nm short haul optical interface is connected directly to the multiplexer by 850nm multi-mode optical fiber. Multi-mode fiber type 50/125µm or 62.5/125µm is suitable. BFOC/2.5 type fiber optic connectors are used.

The setting Comms Mode should be set to IEEE C37.94.

Note The relay must be powered off and on before this setting change becomes effective. The IEEE C37.94 standard defines an N*64kbits/s standard where N can be 1 - 12. N can be selected on the relay or alternatively set to Auto in which case the relay will configure itself to match the multiplexer.

1.23.4.2

InterMiCOM⁶⁴ Connection via P-2M-L Series Optical Fiber to Electrical Interface Units

In order to connect the relays via a pulse code modulation (PCM) multiplexer network or digital communication channel, Type P-2M-L type interface units are required. The following interface units are available:

- P-2M-L interface to multiplexing equipment supporting ITU-T (formerly CCITT) Recommendation G.703 co-directional electrical interface

The data rate for each unit can be 56kbits/s or 64kbits/s as required for the data communications link.

One P-2M-L unit is required per relay per data channel (i.e. for each transmit and receive signal pair). It provides optical to electrical and electrical to optical signal conversion between the MiCOM P443/P446 relay and the multiplexer. The interface unit should be located as close to the PCM multiplexer as possible, to minimize any effects on the data of electromagnetic noise or interference. The units are housed in a 20TE MiCOM case.

Fiber optic connections to the unit are made through BFOC/2.5 type connectors, more commonly known as 'ST' connectors. The optical characteristics are similar to the MiCOM P443/P446 850nm multi-mode fiber optic interface.

Multiplexer Link with G.703 using Type P-2M-L Interface

A relay with 850nm short haul optical interface is connected to a P-2M-L unit by two cores of 850nm multi-mode optical fiber. Multi-mode fiber type 50/125µm or 62.5/125µm is suitable. BFOC/2.5 type fiber optic connectors are used. The P-2M-L unit converts the data between optical fiber and ITU-T compatible G.703 co-directional electrical interface. The G.703 output must be connected to an ITU-T compatible G.703 co-directional channel on the multiplexer.

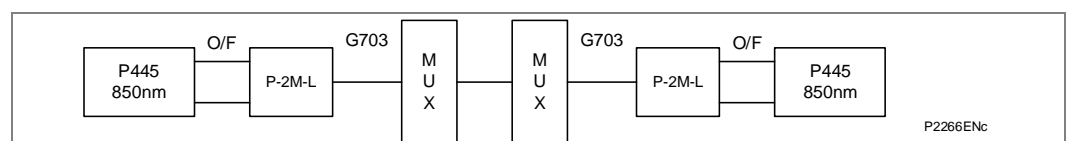

The G.703 signals are isolated by pulse transformers to 1kV.

Since the G.703 signals are only of ±1V magnitude, the cable connecting the P-2M-L unit and the multiplexer must be properly screened against electromagnetic noise and interference. The interface cable should consist of twisted pairs of 24AWG, overall shielded, and have a characteristic impedance of about 120Ω. It is generally recommended that the interface cable shield should be connected to the multiplexer frame ground only. The choice of grounding depends however on local codes and practices.

Electrical connections to the P-2M-L unit are made via a standard 28-way Midos connector. Please refer to Connection Diagrams chapter for the external wiring diagrams. The MiCOM P443/P445/P446 must be set with Clock Source as 'External'.

1.23.4.3

InterMiCOM⁶⁴ Connection Over Unconditioned Pilot Wires

It is possible to deploy InterMiCOM⁶⁴ on certain circuits where unconditioned 2-wire or 4-wire pilots are available for communication. To achieve this requires a combination of P-2M-L series optical fiber to electrical interface units together with third-party baseband modems. The application will be restricted by the length and quality of the pilots, with maximum pilot lengths restricted to less than 20km.

When considering applying a scheme based on InterMiCOM⁶⁴, P-2M-L, and baseband modems, the impact of the modem retrain time on the application needs to be understood before making the decision. Unconditioned 2-wire and 4-wire pilots are generally routed in proximity to the electrical power transmission and distribution feeders that they are helping to protect. As such, they are partial to electro-magnetic interference during switching or fault conditions on the power system. The induced interference on the pilots can cause disruption of the communications signals, and if this is sufficient to cause the synchronization of the communications to be lost, then the modems will have to re-synchronize, or retrain.

Note If the possibility of communications breaks of up to 10 seconds during switching or fault conditions on the power system cannot be tolerated by the InterMiCOM⁶⁴ application, then the decision to implement a scheme using pilot wire circuits should be reviewed.

Pilot Isolation

During primary earth faults, the strong magnetic field generated can induce a significant voltage between the pilots and ground (longitudinal voltage). To prevent damage to any equipment connected to the pilot circuit, it must be ensured that the modem can provide an adequate isolation barrier between the pilot itself and all other electrically isolated circuits. Although it may be difficult to accurately predict the induced pilot voltage during an earth fault, the following equations can be used to give an approximation:

Induced voltage for un-screened pilots ≈ 0.3 x I_F x L

Induced voltage for screened pilots ≈ 0.1 x I_F x L

Where:

I_F = Maximum prospective earth fault current in amperes

L = Length of pilot circuit in miles

In cases where the calculated voltage exceeds, typically 60% of the relay/modem isolation level, additional isolation must be added. Schneider Electric offer the PCM-FLÜ 10kV or 20kV isolating transformers for use in conjunction with such baseband modems. The choice of 10kV or 20kV will depend upon the predicted magnitude of the induced voltage.

Note The PCM-FLÜ isolating transformer has "a", "m" and "b" taps on both primary and secondary windings. For all InterMiCOM⁶⁴ applications, connection must be made between taps 'a' and 'm', since the frequency range of this winding extends to 2MHz. Connection between 'a' and 'b' may result in unreliable communications as the maximum frequency for this tap configuration is 6kHz. Connection to 'a' and 'm' taps must be adhered to on both primary and secondary so as to maintain a 1:1 ratio.

1.24

Phase Fault Overcurrent Protection

Phase fault overcurrent protection is a form of back-up protection that could be:

- Permanently disabled
- Permanently enabled
- Enabled only in case of VT fuse/MCB failure

In addition, each stage may be disabled by a DDB (463,464,465 or 466) Inhibit I > x (x = 1, 2, 3 or 4)

It should be noted that phase overcurrent protection is phase segregated, but the operation of any phase is mapped to 3-phase tripping in the default PSL.

The VTS element of the relay can be selected to either block the directional element or simply remove the directional control.

The first two stages can be set either inverse time or definite time only. The third and fourth stages have a DT characteristic only. Each stage can be configured to be directional forward, directional reverse or non-directional.

For the IDMT characteristics the following options are available.

The IEC/UK IDMT curves conform to this formula:

$$t = T \times \left(\frac{\beta}{(I/I_s)^\alpha - 1} + L \right)$$

The IEEE/US IDMT curves conform to this formula:

$$t = TD \times \left(\frac{\beta}{(I/I_s)^\alpha - 1} + L \right)$$

- t = Operation time
- β = Constant
- I = Measured current
- I_s = Current threshold setting
- α = Constant
- L = ANSI/IEEE constant (zero for IEC curves)
- T = Time multiplier setting for IEC/UK curves
- TD = Time multiplier setting for IEEE/US curves

IDMT Curve description	Standard	β Constant	α Constant	L Constant	I/I _s Limit
Standard Inverse	IEC	0.14	0.02	0	30
Very Inverse	IEC	13.5	1	0	30
Extremely Inverse	IEC	80	2	0	20
Long Time Inverse	UK	120	1	0	30
Moderately Inverse	IEEE	0.0515	0.02	0.114	80
Very Inverse	IEEE	19.61	2	0.491	60
Extremely Inverse	IEEE	28.2	2	0.1217	40
Inverse	US-C08	5.95	2	0.18	30
Short Time Inverse	US	0.16758	0.02	0.11858	80

Note For currents above I/I_s Limit the tripping time is fixed at the I/I_s Limit trip time.

Table 9 – IDMT curve descriptions, standards and constants

Note: The IEEE and US curves are set differently to the IEC/UK curves, with regard to the time setting. A time multiplier setting (TMS) is used to adjust the operating time of the IEC curves, whereas a time dial setting is employed for the IEEE/US curves. The menu is arranged such that if an IEC/UK curve is selected, the '> Time Dial' cell is not visible and vice versa for the TMS setting.

1.24.1

Reset Characteristics for Overcurrent Elements

The IEC/UK inverse characteristics can be used with a definite time reset characteristic, however, the IEEE/US curves may have an inverse or definite time reset characteristic. The following equation can be used to calculate the inverse reset time for IEEE/US curves:

$$t_{\text{RESET}} = \frac{\text{TD} \times \text{S}}{(1 - M^2)} \text{ in seconds}$$

Where:

TD = Time dial setting for IEEE curves
 S = Constant
 M = I / I_s

Curve description	Standard	S constant
Moderately Inverse	IEEE	4.85
Very Inverse	IEEE	21.6
Extremely Inverse	IEEE	29.1
Inverse	US	5.95
Short Time Inverse	US	2.261

Table 10 - IDMT curve descriptions, standards and constants

1.24.2

Directional Overcurrent Protection

The phase fault elements of the MiCOM P34x/P44y/P445/P54x/P841 relays are internally polarized by the quadrature phase-phase voltages, as shown in following *Phase, Operating Current and Polarizing Voltages* table.

Phase of Protection	Operate Current	Polarizing Voltage
A Phase	IA	VBC
B Phase	IB	VCA
C Phase	IC	VAB

Table 11 - Phases, operating currents and polarizing voltages

Under system fault conditions, the fault current vector will lag its nominal phase voltage by an angle dependent upon the system X/R ratio. It is therefore a requirement that the relay operates with maximum sensitivity for currents lying in this region. This is achieved by means of the relay characteristic angle (RCA) setting; this defines the angle by which the current applied to the relay must be displaced from the voltage applied to the relay to obtain maximum relay sensitivity. This is set in cell "**I>Char Angle**" in the overcurrent menu. On the relays, it is possible to set characteristic angles anywhere in the range -95° to $+95^\circ$.

The functional logic block diagram for directional overcurrent is shown in the following *Directional overcurrent logic* diagram.

The overcurrent block is a level detector that detects that the current magnitude is above the threshold and together with the respective polarizing voltage, a directional check is performed based on the following criteria:

Directional forward $-90^\circ < (\text{angle}(I) - \text{angle}(V) - \text{RCA}) < 90^\circ$
 Directional reverse $-90^\circ > (\text{angle}(I) - \text{angle}(V) - \text{RCA}) > 90^\circ$

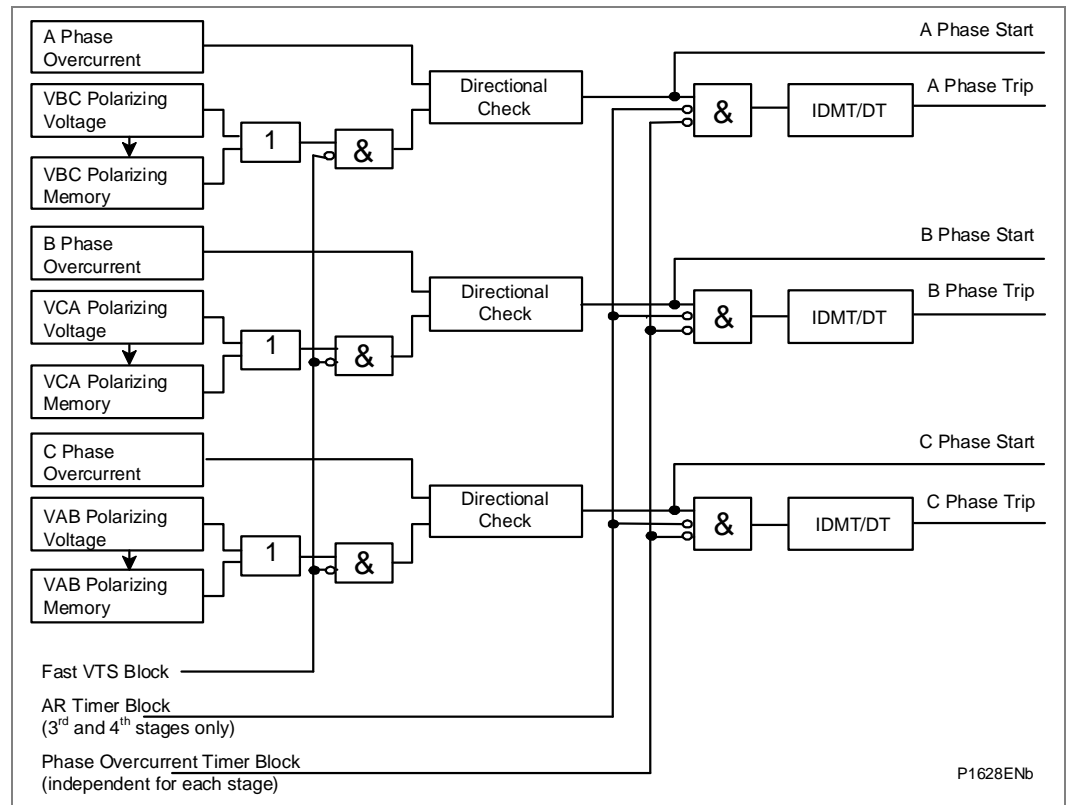

Figure 50 - Directional overcurrent logic

Any of the four overcurrent stages may be configured to be directional noting that IDMT characteristics are only selectable on the first two stages. When the element is selected as directional, a VTS Block option is available in the **I> Function Link** setting. When the relevant bit is set to 1, operation of the Voltage Transformer Supervision (VTS), will block the stage if directionalized. When set to 0, the stage will revert to non-directional upon operation of the VTS.

1.25

Synchronous Polarization

For a close-up 3-phase fault, all three voltages will collapse to zero and no healthy phase voltages will be present. For this reason, the MiCOM relays include a synchronous polarization feature that stores the pre-fault voltage information and continues to apply it to the Directional Overcurrent (DOC) elements for a period of 3.2 seconds. This ensures that either instantaneous or time-delayed directional overcurrent elements will be allowed to operate, even with a 3-phase voltage collapse.

1.26 Thermal Overload Protection

The relay incorporates a current based thermal replica, using rms load current to model heating and cooling of the protected plant. The element can be set with both alarm and trip stages.

The heat generated within an item of plant, such as a cable or a transformer, is the resistive loss (I²R x t). Thus, heating is directly proportional to current squared. The thermal time characteristic used in the relay is therefore based on current squared, integrated over time. The relay automatically uses the largest phase current for input to the thermal model.

Equipment is designed to operate continuously at a temperature corresponding to its full load rating, where heat generated is balanced with heat dissipated by radiation etc. Over-temperature conditions therefore occur when currents in excess of rating are allowed to flow for a period of time. It can be shown that temperatures during heating follow exponential time constants and a similar exponential decrease of temperature occurs during cooling.

The relay provides two characteristics that may be selected according to the application. Thermal overload protection may be disabled by DDB 478 Inhibit Thermal > .

1.26.1 Single Time Constant Characteristic

This characteristic is used to protect cables, dry type transformers (e.g. type AN), and capacitor banks.

The thermal time characteristic is given by:

t = -τ log_e ((I² - (K.I_FLC)²) / (I² - I_p²))

Where:

t = Time to trip, following application of the overload current, I

τ = Heating and cooling time constant of the protected plant

I = Largest phase current

I_FLC = Full load current rating (relay setting 'Thermal Trip')

k = 1.05 constant, allows continuous operation up to <1.05 I_FLC

I_p = Steady state pre-loading before application of the overload

The time to trip varies depending on the load current carried before application of the overload, i.e. whether the overload was applied from 'hot' or 'cold'.

The thermal time constant characteristic may be rewritten as:

e^(-t/τ) = ((θ - θ_p) / (θ - 1))

Where:

θ = I²/k² I_FLC²

and

θ_p = I_p²/k² I_FLC²

Where θ is the thermal state and is θ_p the pre-fault thermal state.

Note A current of 105%Is (kI_FLC) has to be applied for several time constants to cause a thermal state measurement of 100%

1.26.2

Dual Time Constant Characteristic (typically not Applied for MiCOM P445)

This characteristic is used to protect oil-filled transformers with natural air cooling (e.g. type ONAN). The thermal model is similar to that with the single time constant, except that two timer constants must be set.

For marginal overloading, heat will flow from the windings into the bulk of the insulating oil. Thus, at low current, the replica curve is dominated by the long time constant for the oil. This provides protection against a general rise in oil temperature.

For severe overloading, heat accumulates in the transformer windings, with little opportunity for dissipation into the surrounding insulating oil. Thus, at high current, the replica curve is dominated by the short time constant for the windings. This provides protection against hot spots developing within the transformer windings.

Overall, the dual time constant characteristic provided within the relay serves to protect the winding insulation from ageing, and to minimize gas production by overheated oil. Note, however, that the thermal model does not compensate for the effects of ambient temperature change.

The thermal curve is defined as:

$$0.4e^{(-t/\tau_1)} + 0.6e^{(-t/\tau_2)} = \frac{I^2 - (k.I_{FLC})^2}{I^2 - I_p^2}$$

Where:

- τ_1 = Heating and cooling time constant of the transformer windings
- τ_2 = Heating and cooling time constant for the insulating oil

In practice, it is difficult to solve this equation to give the operating time (t), therefore a graphical solution, using a spreadsheet package, is recommended. The spreadsheet can be arranged to calculate the current that will give a chosen operating time. The equation to calculate the current is defined as:

Equation 1:

$$I = \sqrt{\frac{0.4I_p^2 \cdot e^{(-t/\tau_1)} + 0.6I_p^2 \cdot e^{(-t/\tau_2)} - k^2 \cdot I_{FLC}^2}{0.4 e^{(-t/\tau_1)} + 0.6 e^{(-t/\tau_2)} - 1}}$$

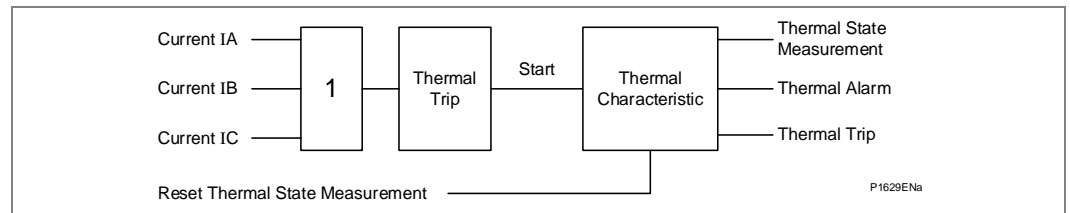

Figure 51 - Thermal overload protection logic diagram

The functional block diagram for the thermal overload protection is shown in the above diagram.

The magnitudes of the three phase input currents are compared and the largest magnitude taken as the input to the thermal overload function. If this current exceeds the thermal trip threshold setting a start condition is asserted.

1.27 Earth Fault (Ground Overcurrent) and Sensitive Earth Fault (SEF) Protection

The MiCOM P445 relay includes backup earth fault protection. Two elements are available; a derived earth fault element (where the residual current to operate the element is derived from the addition of the three line CT currents) and a sensitive earth fault element where low current settings are required. The sensitive earth fault element has a separate CT input and would normally be connected to a core balance CT. The derived and sensitive earth fault elements both have four stages of protection. The first two stages can be set either inverse time or definite time only. Each stage can be configured to be directional forward, directional reverse or non-directional.

Earth fault Overcurrent IN> (not applicable to SEF and REF Functions) can be set to:

- Permanently disabled
- Permanently enabled
- Enabled only in case of VT fuse/MCB failure

In addition, each stage (not for SEF/REF) may be disabled by a DDB (467,468,469 and 470) **Inhibit IN > x** (x = 1, 2, 3 or 4).

The VTS element of the relay can be selected to either block the directional element or simply remove the directional control.

The IN> and ISEF> Function Links settings have the following effect:

- VTS Block - When the relevant is set to 1, operation of the Voltage Transformer Supervision (VTS) will block the stage if it is directionalized. When set to 0 the stage will revert to non-directional upon operation of the VTS.

The inverse time characteristics available for the earth fault protection are the same as those for the phase overcurrent elements, but with the addition of an IDG curve characteristic.

Details of the IDG curve are provided below:

1.27.1 IDG Curve

The IDG curve is commonly used for time delayed earth fault protection in the Swedish market. This curve is available in stages 1 and 2 of Earth Fault 1, Earth Fault 2 and Sensitive Earth Fault protections.

The IDG curve is represented by the following equation:

$$t = 5.8 - 1.35 \log_e \left(\frac{I}{IN > \text{Setting}} \right) \text{ in seconds}$$

Where:

I	=	Measured current
IN>Setting	=	An adjustable setting which defines the start point of the characteristic

Although the start point of the characteristic is defined by the "IN>" setting, the actual relay current threshold is a different setting called "IDG Is". The "IDG Is" setting is set as a multiple of "IN>".

An additional setting "IDG Time" is also used to set the minimum operating time at high levels of fault current.

The following *IDG characteristic* diagram shows how the IDG characteristic is implemented.

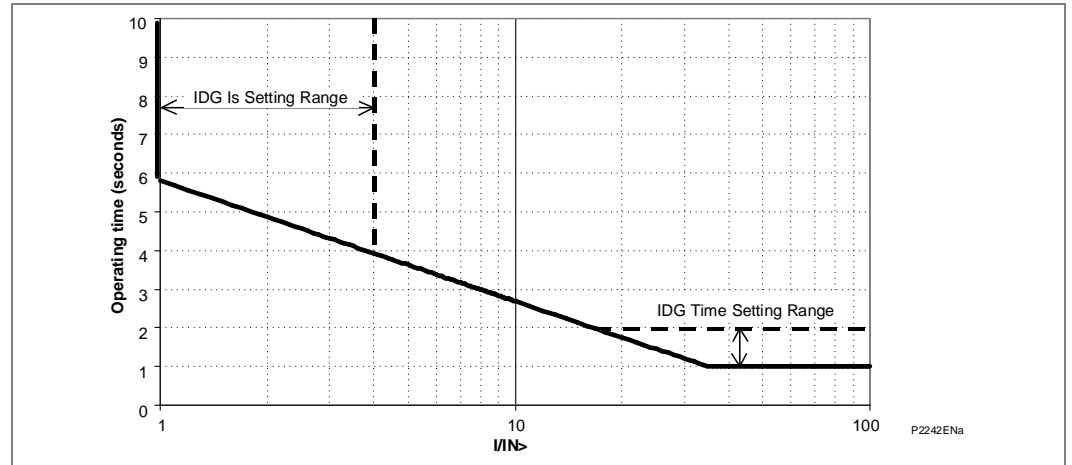

Figure 52 - IDG characteristic

1.28 Directional Earth Fault (DEF) Protection

As stated in the previous sections, each of the four stages of earth fault protection may be set to directional if required. Consequently, as with the application of directional overcurrent protection, a suitable voltage supply is required by the relay to provide the necessary polarization. Two options are available for polarization: Residual Voltage or Negative Sequence.

1.29 Residual Voltage Polarization

With earth fault protection, the polarizing signal requires to be representative of the earth fault condition. As residual voltage is generated during earth fault conditions, this quantity is commonly used to polarize DEF elements. The relay internally derives this voltage from the 3-phase voltage input which must be supplied from either a 5-limb or three single-phase VTs. These types of VT design allow the passage of residual flux and consequently permit the relay to derive the required residual voltage. In addition, the primary star point of the VT must be earthed. A three-limb VT has no path for residual flux and is therefore unsuitable to supply the relay.

Note *Residual voltage is nominally 180° out of phase with residual current. Consequently, the DEF elements are polarized from the "-Vres" quantity. This 180° phase shift is automatically introduced within the relay.*

The directional criteria with zero sequence (residual voltage) polarization are given below:

- Directional forward $-90^\circ < (\text{angle}(IN) - \text{angle}(VN+180^\circ) - \text{RCA}) < 90^\circ$
- Directional reverse $-90^\circ > (\text{angle}(IN) - \text{angle}(VN+180^\circ) - \text{RCA}) > 90^\circ$

The virtual current polarizing feature is not available for use with the backup earth fault elements - that is used exclusively in DEF aided schemes only.

The logic diagram for directional earth fault overcurrent with neutral voltage polarization is shown below.

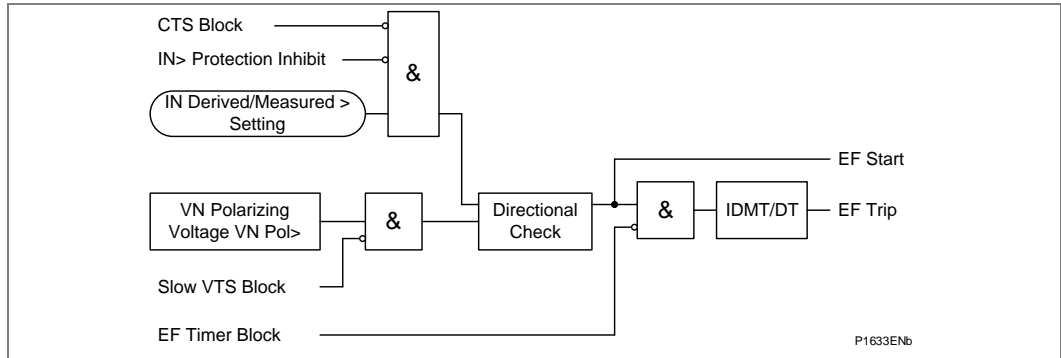

Figure 53 - Directional EF with neutral voltage polarization (single stage)

1.29.1

Negative Sequence Polarization (Not for SEF)

In certain applications, the use of residual voltage polarization of DEF may either be not possible to achieve, or problematic. An example of the former case would be where a suitable type of VT was unavailable, for example if only a three limb VT was fitted. An example of the latter case would be an HV/EHV parallel line application where problems with zero sequence mutual coupling may exist.

In either of these situations, the problem may be solved by using Negative Phase Sequence (NPS) quantities for polarization. This method determines the fault direction by comparison of NPS voltage with NPS current. The operate quantity, however, is still residual current.

This is available for selection on both the derived and measured standard earth fault elements (EF1 and EF2) but not on the SEF protection. It requires a suitable voltage and current threshold to be set in cells "IN>V2pol set" and "IN>I2pol set", respectively.

Negative sequence polarizing is not recommended for impedance earthed systems regardless of the type of VT feeding the relay. This is due to the reduced earth fault current limiting the voltage drop across the negative phase sequence source impedance (V2pol) to negligible levels. If this voltage is less than 0.5 volts the relay will cease to provide DEF.

The logic diagram for Directional Earth Fault (DEF) overcurrent with negative sequence polarization is shown in this diagram.

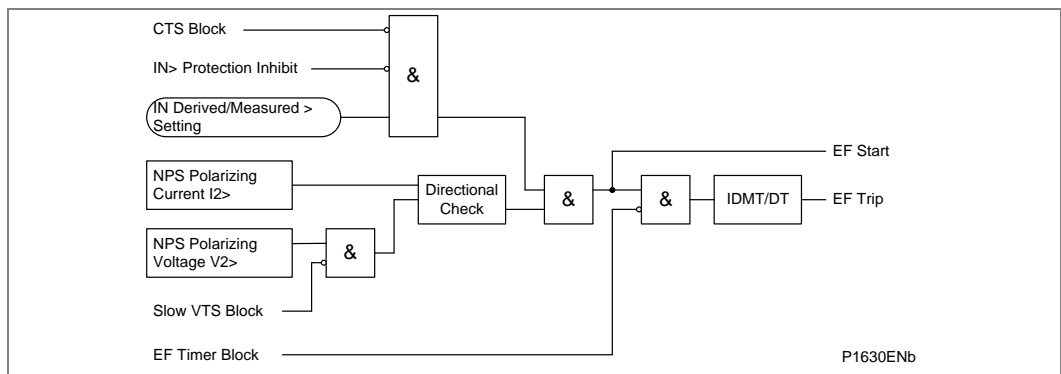

Figure 54 - Directional EF with negative sequence polarization (single stage)

The directional criteria with negative sequence polarization is given below:

- Directional forward $-90^\circ < (\text{angle}(I2) - \text{angle}(V2 + 180^\circ) - \text{RCA}) < 90^\circ$
- Directional reverse $-90^\circ > (\text{angle}(I2) - \text{angle}(V2 + 180^\circ) - \text{RCA}) > 90^\circ$

1.30 Negative Phase Sequence (NPS) Overcurrent Protection

The Negative Phase Sequence (NPS) overcurrent protection included in the P445/P54x/P841 relays provides four-stage non-directional/directional overcurrent protection with independent time delay characteristics. The first two stages of overcurrent protection have time-delayed characteristics which are selectable between Inverse Definite Minimum Time (IDMT), or Definite Time (DT). The third and fourth stages have definite time characteristics only. The inverse time delayed characteristics support both IEC and IEEE curves and please refer to the *Phase Fault Overcurrent Protection* section for a detailed description. The user may choose to directionalize operation of the elements, for either forward or reverse fault protection for which a suitable relay characteristic angle may be set. Alternatively, the elements may be set as non-directional.

For the NPS directional elements to operate, the relay must detect a polarizing voltage above a minimum threshold, "**I2> V2pol Set**".

When the element is selected as directional, a VTS Block option is available. When the relevant bit is set to 1, operation of the Voltage Transformer Supervision (VTS), will block the stage if directionalized. When set to 0, the stage will revert to non-directional upon operation of the VTS.

When enabled, the following signals are set by the negative sequence O/C logic according to the status of the monitored function.

Function	DDB	Description
I2> Inhibit	(DDB 562)	Inhibit all 4 stages when high
I2>1 Tmr. Block	(DDB 563)	Block timer on 1st stage when high
I2>2 Tmr. Block	(DDB 564)	Block timer on 1st stage when high
I2>3 Tmr. Block	(DDB 565)	Block timer on 1st stage when high
I2>4 Tmr. Block	(DDB 566)	Block timer on 1st stage when high
I2>1 Start	(DDB 567)	1st stage started when high
I2>2 Start	(DDB 568)	2nd stage started when high
I2>3 Start	(DDB 569)	3rd stage started when high
I2>4 Start	(DDB 570)	4th stage started when high
I2>1 Trip	(DDB 571)	1st stage tripped when high
I2>2 Trip	(DDB 572)	2nd stage tripped when high
I2>3 Trip	(DDB 573)	3rd stage tripped when high
I2>4 Trip	(DDB 574)	4th stage tripped when high

Table 12 - Functions, DDB numbers and descriptions

All the above signals are available as DDB signals for mapping in Programmable Scheme Logic (PSL). In addition the negative sequence overcurrent protection trips 1/2/3/4 are mapped internally to the block auto-reclose logic.

Negative sequence overcurrent protection starts 1/2/3/4 are mapped internally to the ANY START DDB signal – DDB 736.

The non-directional and directional operation is shown in these diagrams:

- Negative sequence overcurrent non-directional operation
- Directionalizing the negative phase sequence overcurrent element

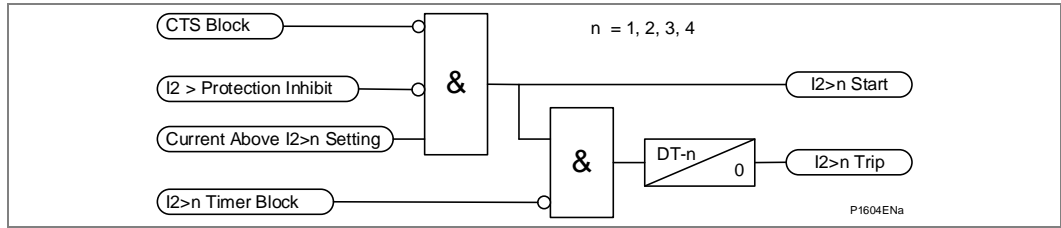

Figure 55 - Negative sequence overcurrent non-directional operation

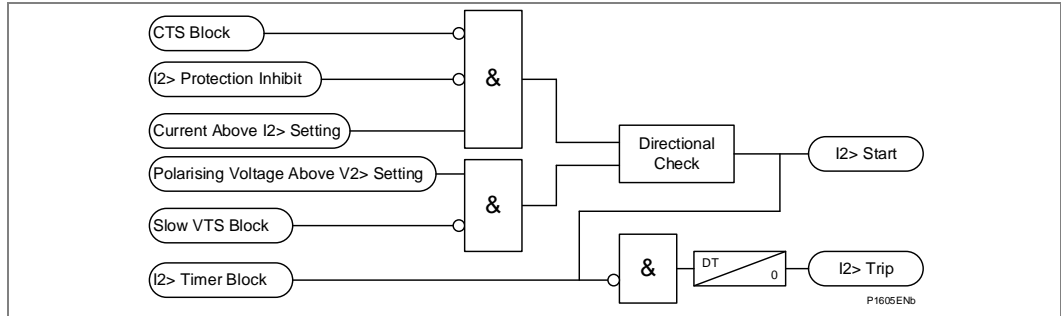

Figure 56 - Directionalizing the negative phase sequence overcurrent element

1.30.1

Directionalizing the Negative Phase Sequence Overcurrent Element

Directionality is achieved by comparison of the angle between the negative phase sequence voltage and the negative phase sequence current. It may be selected to operate in either the forward or reverse direction.

A suitable relay characteristic angle setting (**I2> Char Angle**) is chosen to provide optimum performance. This setting should be set equal to the phase angle of the negative sequence current with respect to the inverted negative sequence voltage ($-V_2$), in order to be at the centre of the directional characteristic.

For the negative phase sequence directional elements to operate, the relay must detect a polarizing voltage above a minimum threshold, **I2> V2pol Set**. The logic diagram for negative sequence overcurrent protection (shown with directional operation) is attached as the *Directionalizing the negative phase sequence overcurrent element* diagram below.

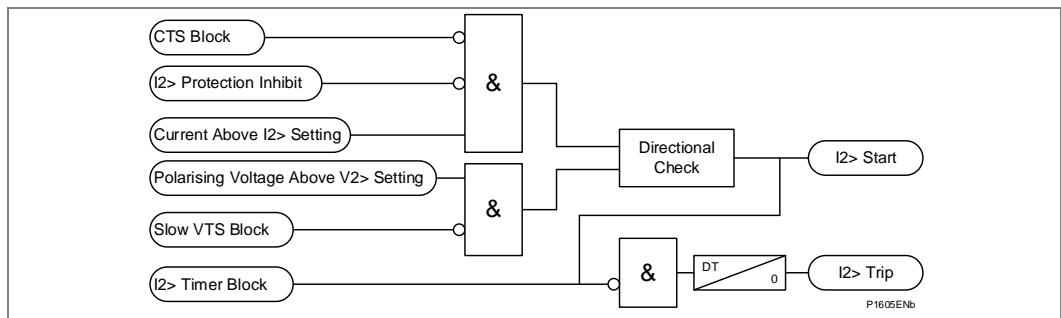

Figure 57 - Directionalizing the negative phase sequence overcurrent element

1.31 Undervoltage Protection

Both the under and overvoltage protection functions can be found in the relay menu **Volt Protection**. The measuring mode (ph-N or ph-ph) and operating mode (single phase or 3 phase) for both stages are independently settable.

Stage 1 may be selected as either IDMT, DT or Disabled, within the **V<1 function** cell. Stage 2 is DT only and is enabled/disabled in the **V<2 status** cell.

Two stages are included to provide both alarm and trip stages, where required. Alternatively, different time settings may be required depending upon the severity of the voltage dip.

Outputs are available for single or three phase conditions via the **V<Operate Mode** cell.

When the protected feeder is de-energized, or the circuit breaker is opened, an undervoltage condition would be detected. Therefore, the **V<Polehead Inh** cell is included for each of the two stages to block the undervoltage protection from operating for this condition. If the cell is enabled, the relevant stage will become inhibited by the inbuilt pole dead logic within the relay. This logic produces an output when it detects either an open circuit breaker via auxiliary contacts feeding the relay opto inputs or it detects a combination of both undercurrent and undervoltage on any one phase.

The IDMT characteristic available on the first stage is defined by the formula:

$$t = K/(1 - M)$$

Where:

K = Time multiplier setting

t = Operating time in seconds

M = Measured voltage/relay setting voltage (V< Voltage Set)

The logic diagram for the first stage undervoltage function is shown in the following *Undervoltage - single and three-phase tripping mode (single stage)* diagram.

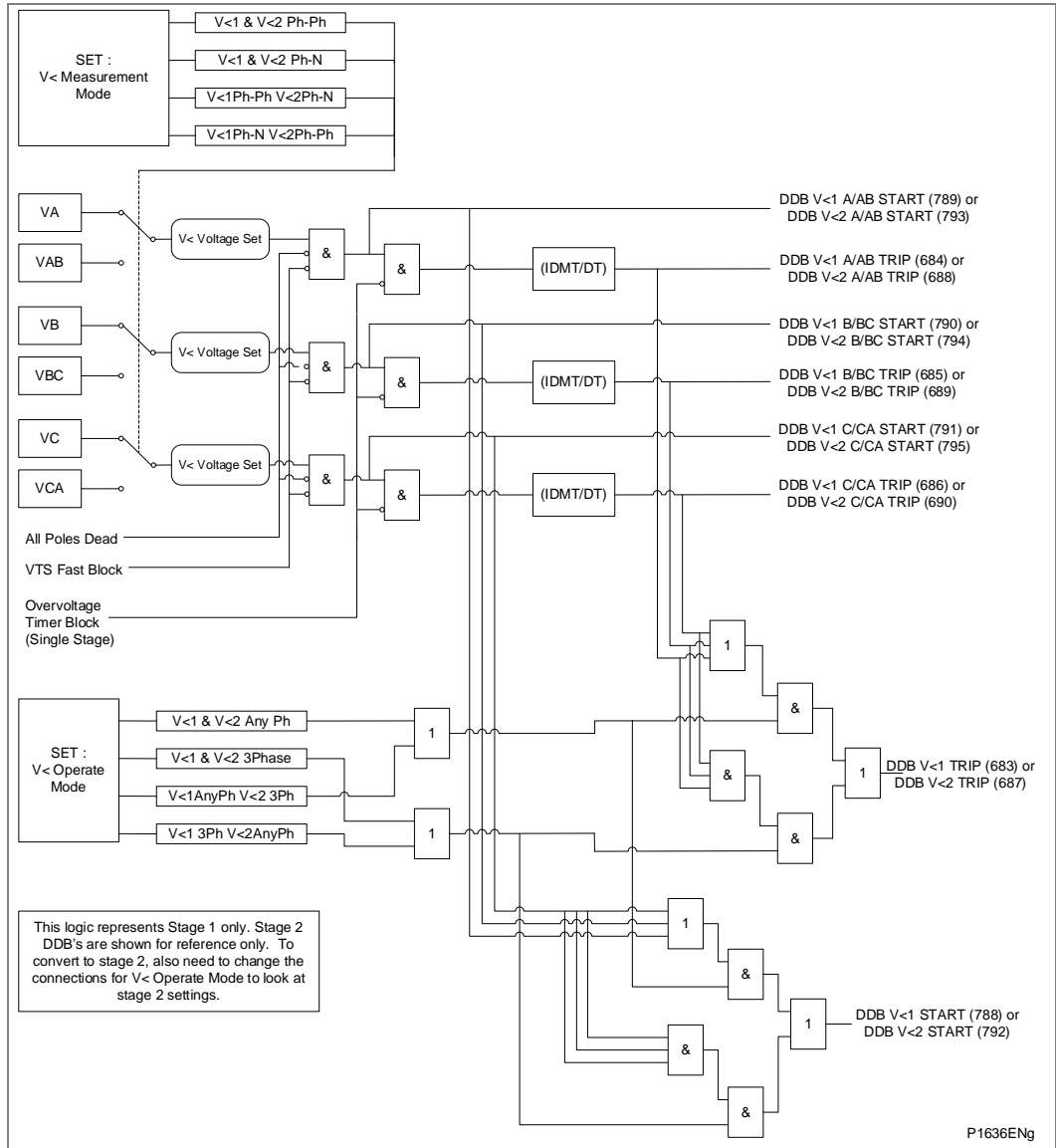

Figure 58 - Undervoltage - single and three phase tripping mode (single stage)

Note Undervoltage protection is phase segregated, but the operation of any phase is mapped to 3-phase tripping in the default PSL.

Each stage of Undervoltage protection may be disabled by a DDB (471 or 472) Inhibit Vx<.

1.32 Overvoltage Protection

Both the over and undervoltage protection functions can be found in the relay menu **Volt Protection**. The measuring mode (ph-N or ph-ph) is settable.

The IDMT characteristic available on the first stage is defined by the following formula:

$$t = K/(M - 1)$$

Where:

- K = Time Multiplier Setting (TMS)
- t = Operating Time in seconds
- M = Measured voltage / relay setting voltage (V> Voltage Set)

The logic diagram of the first stage overvoltage function is shown in this diagram. Each stage of Overvoltage protection may be disabled by a DDB (473 or 474) Inhibit Vx> (x = 1, 2).

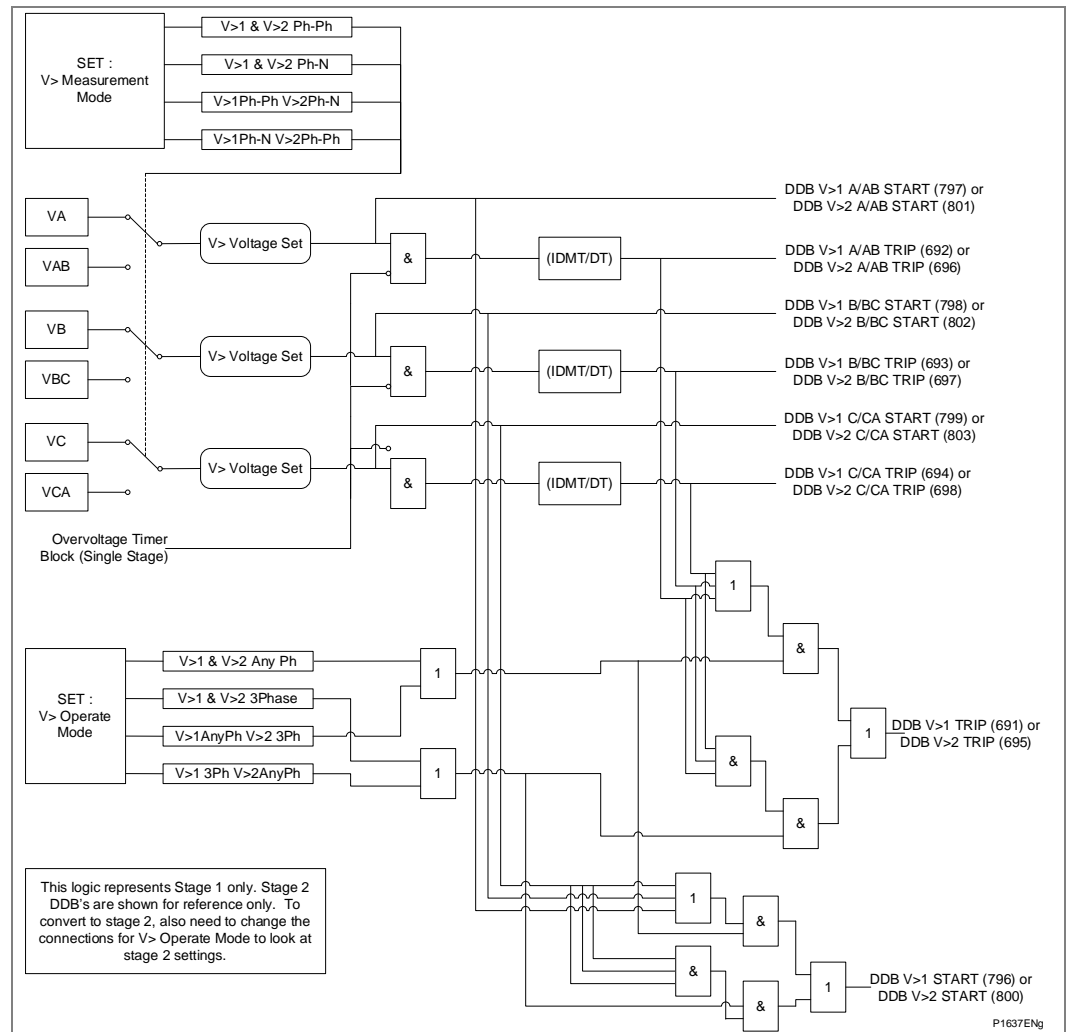

Figure 59 - Overvoltage - single and three phase tripping mode (single stage)

1.32.1

Compensated Overvoltage

The Compensated Overvoltage function calculates the positive sequence voltage at the remote terminal using the positive sequence local current and voltage and the line impedance and susceptance. This can be used on long transmission lines where Ferranti Overvoltages can develop under remote circuit breaker open conditions.

The Compensated overvoltage protection function can be found in the relay menu Volt Protection. The line impedance settings together with the line charging admittance in relay menu Line Parameters is used to calculate the remote voltage.

The relay uses the [A,B,C,D] transmission line equivalent model given these parameters:

Total Impedance:

$$Z = z \angle \theta \Omega \text{ and}$$

Total Susceptance:

$$Y = y \angle -90 \Omega \text{ and}$$

Line Length l

The remote voltage is calculated using the following equations:

$$\begin{bmatrix} \bar{V}_r \\ \bar{I}_r \end{bmatrix} = \begin{bmatrix} D & -C \\ -B & A \end{bmatrix} \times \begin{bmatrix} \bar{V}_s \\ \bar{I}_s \end{bmatrix}$$

Where:

V_r, I_r - Voltage and Current at the receiving end.

V_s, I_s - Measured (relay) Voltage and Current at the sending end.

$$A = D = \cosh(\gamma \times l)$$

$$B = Z_c \times \sinh(\gamma \times l)$$

$$C = Y_c \times \sinh(\gamma \times l)$$

$$\gamma \times l = \sqrt{ZY}$$

$$Z_c = \frac{1}{Y_c} = \sqrt{\frac{Z}{Y}}$$

Y = Total Line Capacitive Charging Susceptance

Z_c = Characteristic Impedance of the line (Surge Impedance).

Two stages are included to provide both alarm and trip stages, where required.

Both stages are independently settable where Stage 1 may be selected as either IDMT, DT or Disabled, within the V1>1 Cmp Funct cell. Stage 2 is DT only and is enabled/disabled in the V1>Cmp Status cell.

The IDMT characteristic available on the first stage is defined by the formula:

$$t = K/(1 - M)$$

Where:

K = Time multiplier setting

t = Operating time in seconds

M = Remote Calculated voltage / relay setting voltage (PH-)

1.33

Residual Overvoltage (Neutral Displacement) Protection

The NVD element within the MiCOM P445/P44y/P54x/P841 is of two stage design, each stage having separate voltage and time delay settings. Stage 1 may be set to operate on either an IDMT or DT characteristic, whilst stage 2 may be set to DT only. Two stages are included for the NVD protection to account for applications which require both alarm and trip stages.

The relay internally derives the NVD voltage from the 3 input phases which must be supplied from either a 5-limb or three single-phase VTs. These types of VT design allow the passage of residual flux and consequently permit the relay to derive the required residual voltage. In addition, the primary star point of the VT must be earthed. A three limb VT has no path for residual flux and is therefore unsuitable to supply the relay.

The IDMT characteristic available on the first stage is defined by the formula:

$$t = K/(M - 1)$$

Where:

K = Time multiplier setting

t = Operating time in seconds

M = Derived residual voltage/relay setting voltage (V_N> Voltage Set)

The functional block diagram of the first stage residual overvoltage is shown below:

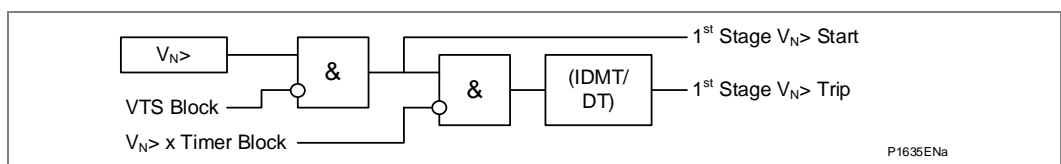

Figure 60 - Residual overvoltage logic (single stage)

Each stage of Residual Overvoltage protection may be disabled by a DDB (475 or 476) Inhibit VN>x (x = 1, 2).

1.34

Circuit Breaker Fail (CBF) Protection

The CBF protection incorporates two timers, 'CB Fail 1 Timer' and 'CB Fail 2 Timer', allowing configuration for the following scenarios:

- Simple CBF, where only CB Fail 1 Timer is enabled. For any protection trip, the CB Fail 1 Timer is started, and normally reset when the circuit breaker opens to isolate the fault. If breaker opening is not detected, CB Fail 1 Timer times out and closes an output contact assigned to breaker fail (using the programmable scheme logic). This contact is used to backtrip upstream switchgear, generally tripping all infeeds connected to the same busbar section.
- A re-tripping scheme, plus delayed backtripping. Here, CB Fail 1 Timer is used to route a trip to a second trip circuit of the same circuit breaker. This requires duplicated circuit breaker trip coils, and is known as re-tripping. Should re-tripping fail to open the circuit breaker, a backtrip may be issued following an additional time delay. The backtrip uses CB Fail 2 Timer, which is also started at the instant of the initial protection element trip.
- CBF elements CB Fail 1 Timer and CB Fail 2 Timer can be configured to operate for trips triggered by protection elements within the relay or via an external protection trip. The latter is achieved by allocating one of the relay opto-isolated inputs to CBF External Initiation using the programmable scheme logic.

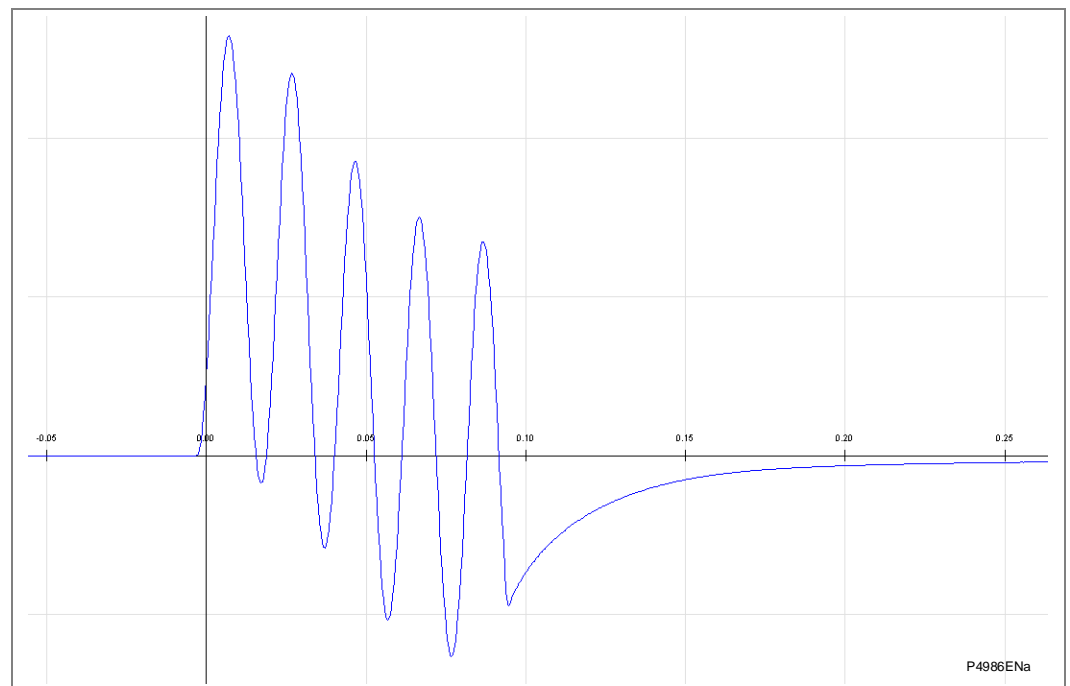

Figure 61 - Decaying dc component

The length of the operating time is primarily related to the usage of the combination of Fourier magnitudes and the 3-sample interpolation method used for the undercurrent reset algorithm. In some applications, a 160ms reset time is too slow.

We have introduced a Zero Cross Detector (ZCD) to shorten the reset time. In some cases, it is preferable to record measured sample values of a variable waveform. However, we have found it acceptable to record the magnitude of the waveform. For example, see the *Calculating a Zero Cross Detection Point using sample values* diagram below.

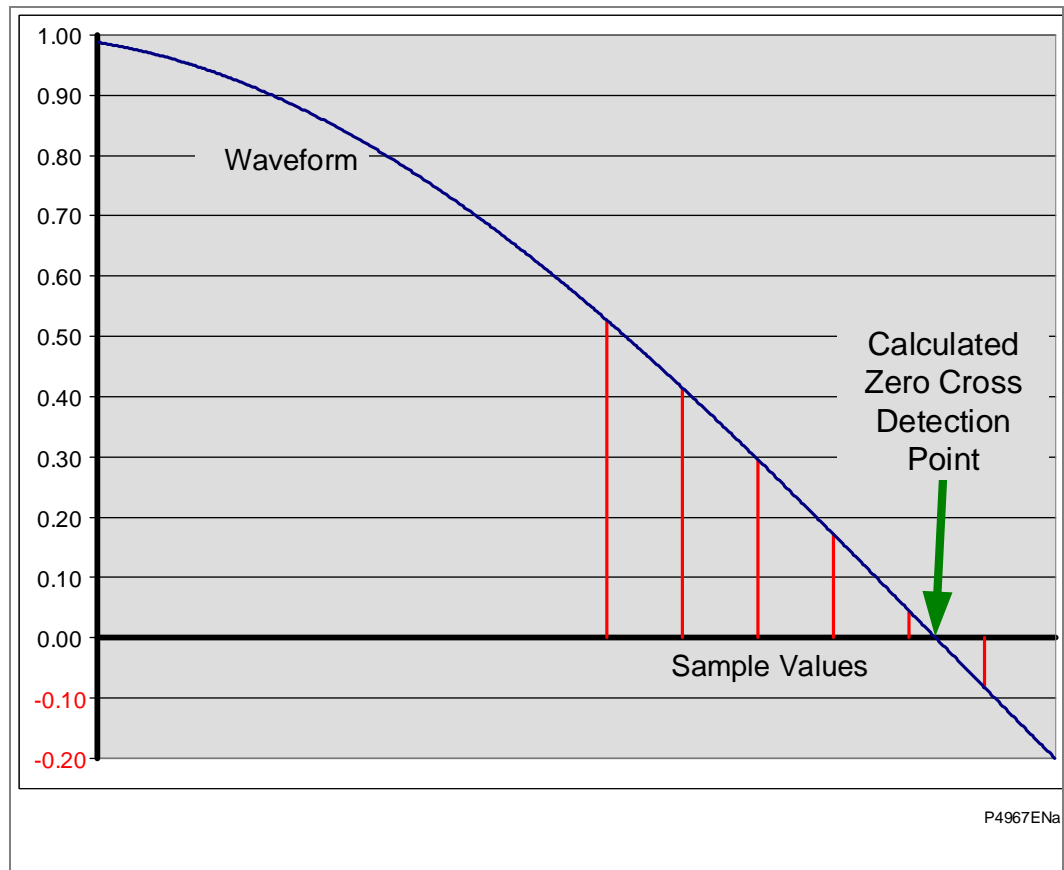

Figure 62 - Calculating a Zero Cross Detection Point using sample values

We have modified the CB Fail logic to incorporate the addition of ZCD signals with a time delayed drop off of 1/2 a cycle for each phase current and the SEF current. These are logically combined with the output of the breaker fail timers to determine breaker fail trip operation.

The objective of this software release is to improve the reset performance of the CB Fail. The target reset time is $\frac{3}{4}$ cycle (i.e. 15ms for a 50Hz signal).

The CBF timer settings have the same setting range as the existing design but the step size has been reduced from 10ms to 1ms.

1.34.1

Reset Mechanisms for Breaker Fail Timers

It is common practice to use low set undercurrent elements in protection relays to indicate that Circuit Breaker (CB) poles have interrupted the fault or load current, as required. This covers the following situations:

- Where CB auxiliary contacts are defective, or cannot be relied on to definitely indicate that the CB has tripped.
- Where a CB has started to open but has become jammed. This may result in continued arcing at the primary contacts, with an additional arcing resistance in the fault current path. Should this resistance severely limit fault current, the initiating protection element may reset. Therefore reset of the element may not give a reliable indication that the CB has opened fully.

For any protection function requiring current to operate, the relay uses operation of undercurrent elements (I<) to detect that the necessary circuit breaker poles have tripped and reset the CB fail timers. However, the undercurrent elements may not be reliable methods of resetting circuit breaker fail in all applications. For example:

- Where non-current operated protection, such as under/overvoltage derives measurements from a line connected voltage transformer. Here, I< only gives a reliable reset method if the protected circuit would always have load current flowing. Detecting drop-off of the initiating protection element might be a more reliable method.
- Similarly, where the distance scheme includes Weak Infeed (“WI”) trip logic, the reset of the WI trip condition should be used in addition to the undercurrent check. Set: **WI Prot Rese’** = Enabled.
- Where non-current operated protection, such as under/overvoltage derives measurements from a busbar connected voltage transformer. Again using I< would rely **upon the feeder normally being loaded. Also, tripping the circuit breaker may not remove the initiating condition from the busbar, and hence drop-off of the protection element may not occur. In such cases, the position of the circuit breaker auxiliary contacts may give the best reset method.**

Resetting of the CBF is possible from a breaker open indication (from the relay’s pole dead logic) or from a protection reset. In these cases, resetting is only allowed provided the undercurrent elements have also reset. The resetting options are summarized in the *Initiation (menu selectable) and CB fail timer reset mechanism* table.

Initiation (menu selectable)	CB fail timer reset mechanism
Current based protection (e.g. 50/51/46/21/67)	The resetting mechanism is fixed [IA< operates] & [IB< operates] & [IC< operates] & [IN< operates]
Non-current based protection (e.g. 27/59)	Three options are available. The user can Select from the following options: [All I< and IN< elements operate] [Protection element reset] AND [All I< and N< elements operate] CB open (all 3 poles) AND [All I< and IN< elements operate]
External protection	Three options are available: The user can select any or all of the options. [All I< and IN< elements operate] [External trip reset] AND [All I< and IN< elements operate] CB open (all 3 poles) AND [All I< and IN< elements operate]

Table 13 - Initiation (menu selectable) and CB fail timer reset mechanism

The complete breaker fail logic is shown in these diagrams:

- CB1 failure logic - Part 1 of 2 (for MiCOM P443 and P446)
- CB1 failure logic - Part 2 of 2 (for MiCOM P443 and P446)
- CB2 failure (for MiCOM P446)

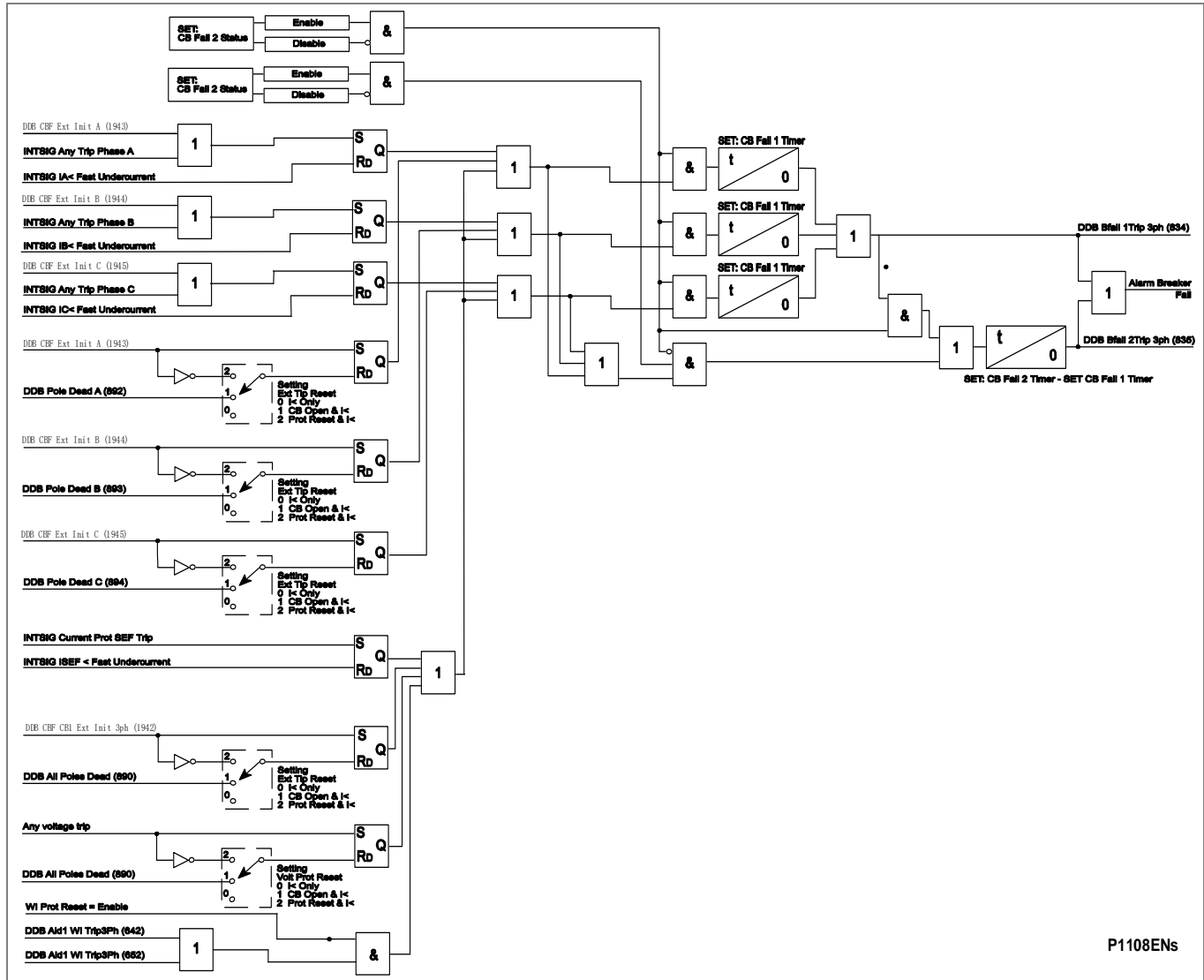

Figure 63 - CB failure for MiCOM P445

1.35 Broken Conductor Detection

The relay incorporates an element which measures the ratio of negative to positive phase sequence current (I_2/I_1). This will be affected to a lesser extent than the measurement of negative sequence current alone, since the ratio is approximately constant with variations in load current. Hence, a more sensitive setting may be achieved.

The *Broken conductor logic* diagram is as shown below. The ratio of I_2/I_1 is calculated and is compared with the threshold and if the threshold is exceeded then the delay timer is initiated. The CTS block signal is used to block the operation of the delay timer.

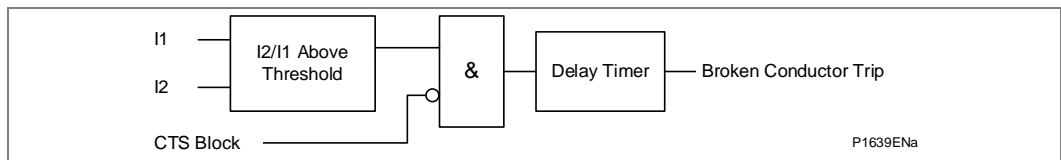

Figure 64 - Broken conductor logic

1.36 Frequency Protection

The P14x/P341/P34x/P391/P445/P44y/P54x/P64x/P841 feeder relay includes 4 stages of underfrequency and 2 stages of overfrequency protection to facilitate load shedding and subsequent restoration. The underfrequency stages may be optionally blocked by a pole dead (CB Open) condition. All the stages may be enabled/disabled in the "**F<n Status**" or "**F>n Status**" cell depending on which element is selected.

The logic diagram for the underfrequency logic is as shown in the following *Underfrequency logic (single stage)* diagram. Only a single stage is shown. The other three stages are identical in functionality.

If the frequency is below the setting and not blocked the DT timer is started. Blocking may come from the All_Poledead signal (selectively enabled for each stage) or the underfrequency timer block.

If the frequency cannot be determined, the function is also blocked.

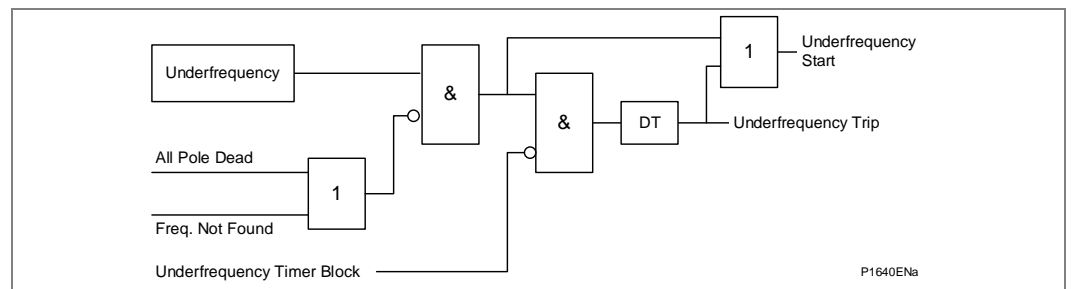

Figure 65 - Underfrequency logic (single stage)

The functional logic for the overfrequency function as shown in the *Overfrequency logic (single stage)* diagram. Only a single stage is shown as the other stages are functionally identical. If the frequency is above the setting and not blocked the DT timer is started and after this has timed out the trip is produced. Blocking may come from the All_Poledead signal (selectively enabled for each stage) or the overfrequency timer block.

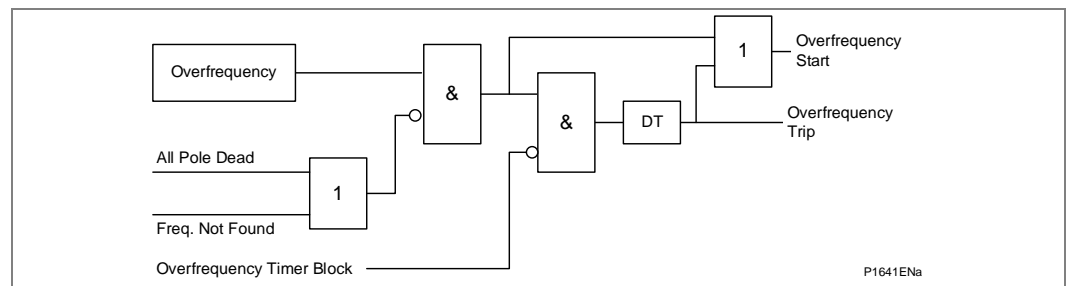

Figure 66 - Overfrequency logic (single stage)

When enabled, the following signals are set by the under/overfrequency logic according to the status of the monitored functions.

Function	DDB	Description	Function	DDB	Description
F<1 Timer Block	(DDB 1149)	Block Underfrequency Stage 1 Timer	F<1 Trip	(DDB 1161)	Underfrequency Stage 1 Trip
F<2 Timer Block	(DDB 1150)	Block Underfrequency Stage 2 Timer	F<2 Trip	(DDB 1162)	Underfrequency Stage 2 Trip
F<3 Timer Block	(DDB 1151)	Block Underfrequency Stage 3 Timer	F<3 Trip	(DDB 1163)	Underfrequency Stage 3 Trip
F<4 Timer Block	(DDB 1152)	Block Underfrequency Stage 4 Timer	F<4 Trip	(DDB 1164)	Underfrequency Stage 4 Trip
F>1 Timer Block	(DDB 1153)	Block Overfrequency Stage 1 Timer	F>1 Trip	(DDB 1165)	Overfrequency Stage 1 Trip
F>2 Timer Block	(DDB 1154)	Block Overfrequency Stage 2 Timer	F>2 Trip	(DDB 1166)	Overfrequency Stage 2 Trip
F<1 Start	(DDB 1155)	Underfrequency Stage 1 Start	Inhibit F<1	(DDB 1167)	Inhibit stage 1 Under frequency protection
F<2 Start	(DDB 1156)	Underfrequency Stage 2 Start	Inhibit F<2	(DDB 1168)	Inhibit stage 2 Under frequency protection
F<3 Start	(DDB 1157)	Underfrequency Stage 3 Start	Inhibit F<3	(DDB 1169)	Inhibit stage 3 Under frequency protection
F<4 Start	(DDB 1158)	Underfrequency Stage 4 Start	Inhibit F<4	(DDB 1170)	Inhibit stage 4 Under frequency protection
F>1 Start	(DDB 1159)	Overfrequency Stage 1 Start	Inhibit F>1	(DDB 1171)	Inhibit stage 1 Over frequency protection
F>2 Start	(DDB 1160)	Overfrequency Stage 2 Start	Inhibit F>2	(DDB 1172)	Inhibit stage 2 Over frequency protection

Table 14 - Functions, DDB numbers and descriptions

1.37 Independent Rate of Change of Frequency Protection [81R]

In the load shedding scheme below, it is assumed under falling frequency conditions that by shedding a stage of load, the system can be stabilized at frequency f_2 . For slow rates of decay, this can be achieved using the underfrequency protection element set at frequency f_1 with a suitable time delay. However, if the generation deficit is substantial, the frequency will rapidly decrease and it is possible that the time delay imposed by the underfrequency protection will not allow for frequency stabilization. In this case, the chance of system recovery will be enhanced by disconnecting the load stage based upon a measurement of rate of change of frequency and bypassing the time delay.

Considerable care should be taken when setting this element because it is not supervised by a frequency setting. Setting of the time delay or increasing the number of df/dt averaging cycles will lead to a more stable element but this should be considered against the loss of fast tripping capability as the tripping time is extended. However, a timer is included to provide a time delayed operation. The time delay will lead to a more stable element but this should be considered against the loss of fast tripping capability as the tripping time is extended. The use of time delay settings of 100ms or less with df/dt rates of less than 0.4Hz/s is not recommended as system frequency oscillations or voltage selection transients will likely cause instability. The element can be utilized to provide extra flexibility to a load shedding scheme in dealing with severe load to generation imbalances.

Since the rate of change monitoring is independent of frequency, the element can identify frequency variations occurring close to nominal frequency and therefore provide early warning to the operator on a developing frequency problem. Additionally, the element could also be used as an alarm to warn operators of unusually high system frequency variations.

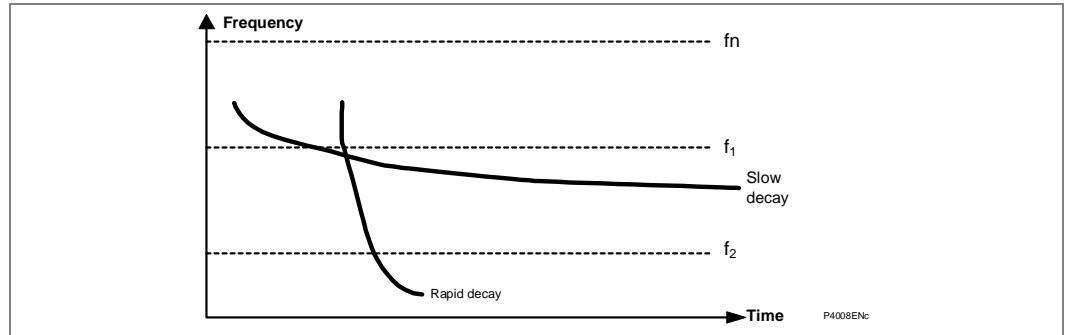

Figure 67 - Rate of change of frequency protection

1.37.1

Basic Functionality

The relay provides four independent stages of rate of change of frequency protection (df/dt+t). Depending upon whether the rate of change of frequency setting is set positive or negative, the element will react to rising or falling frequency conditions respectively, with an incorrect setting being indicated if the threshold is set to zero. The output of the element would normally be given a user-selectable time delay, although it is possible to set this to zero and create an instantaneous element.

An Independent setting is available for calculating the rate of change of frequency measurement, df/dt Avg. Cycles over a fixed period of either 6 or 12 cycles. This provides the ability to de-sensitize the frequency based protection element against oscillations in the power system frequency or voltage selection transients. The 12-cycle averaging window setting improves measurement accuracy, but slows down the protection start time following fault inception. The maximum fault detection start time following fault inception can be approximated as:

$$\text{Fault Detection Delay Time (cycles)} = 2 \times M + 1$$

Where M = No. of frequency averaging cycles df/dt.Av. Cycles

When enabled, the following signals are set by the df/dt logic according to the status of the monitored function.

Function	DDB	Description
df/dt> Inhibit	(DDB 592)	Inhibit all 4 stages when high
df/dt>1 Tmr. Block	(DDB 593)	Block timer on 1st stage when high
df/dt>2 Tmr. Block	(DDB 594)	Block timer on 2nd stage when high
df/dt>3 Tmr. Block	(DDB 595)	Block timer on 3rd stage when high
df/dt>4 Tmr. Block	(DDB 596)	Block timer on 4th stage when high
df/dt>1 Start	(DDB 597)	1st stage started when high
df/dt>2 Start	(DDB 598)	2nd stage started when high
df/dt>3 Start	(DDB 599)	3rd stage started when high
df/dt>4 Start	(DDB 600)	4th stage started when high
df/dt>1 Trip	(DDB 601)	1st stage tripped when high
df/dt>2 Trip	(DDB 602)	2nd stage tripped when high
df/dt>3 Trip	(DDB 603)	3rd stage tripped when high
df/dt>4 Trip	(DDB 604)	4th stage tripped when high

Table 15 - Functions, DDB numbers and descriptions

All the above signals are available as DDB signals for mapping in Programmable Scheme Logic (PSL).

1.38 Special Weak Infeed Logic for Stub End Transformer Terminals

The true weak infeed condition is when no current based protection element is sensitive enough to operate. This is the case when zero or minimal generation is connected at that terminal, and the prospective level of fault current flowing through the CT is insufficient for any forward/reverse protection operation. In such cases, the fault will be cleared using either POR or Blocking schemes and enabling WI Echo + Trip.

However, there could be a specific configuration as shown in the *Weak infeed configuration on stub-fed radial circuit (parallel line is out of service)* diagram that may not be detected by relay as a weak infeed condition, even if there is no generation at that end (left side - relay R2).

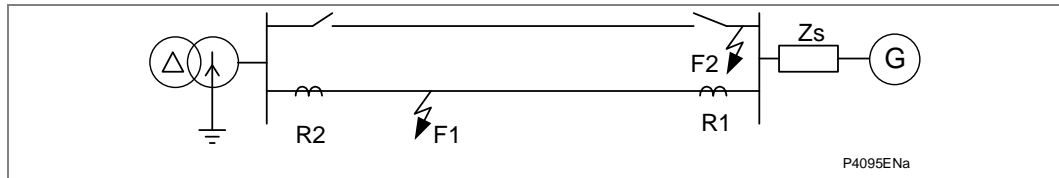

Figure 68 - Weak infeed configuration on stub-fed radial circuit (parallel line is out of service)

The reason is a star earthed transformer which, in case of phase to ground and double phase to ground faults, imposes a very low zero sequence impedance and almost infinite positive and negative sequence impedance, i.e. behaving as a source of zero sequence current only. In such a case, the zero sequence current I_0 will dominate over I_1 and I_2 at the weak end, where all three-phase currents will approximately equal I_0 (all in phase and equal in magnitude). This is true for F1 earth faults at R2, and for F2 earth faults at R1 and R2. The phase currents will be sufficient to pickup current level detectors in the MiCOM P44/P44y/P54x, and a true weak infeed condition will not be seen as such by the relay.

In such a stub-end feeding case, relay R2 may experience some overreach in the case of double-phase to ground faults. This is caused by the unusual current distribution making the MiCOM P445/P44y/P54x detect a single-phase fault condition (and potential single pole tripping only in single pole tripping applications).

For this unusual feeding arrangement, the MiCOM P445/P44y/P54x makes available a Zero sequence stabilizing feature, that measures the dominance of zero sequence current over negative sequence current (I_0/I_2). It promotes stability by forcing the relay to recognize the above configuration as a WI condition. It then blocks all distance elements, once the measured I_0/I_2 ratio exceeds the setting.

2 OPERATION OF NON-PROTECTION FUNCTIONS

2.1 Auto-Reclosing

2.1.1 Time Delayed and High Speed Auto-Reclosing

The MiCOM P445 will initiate auto-reclosure following any Zone 1, or distance-aided scheme trips which occur. In addition, the user can selectively decide to auto-reclose for trips from time-delayed distance zones, overcurrent and earth (ground) elements, and DEF aided schemes.

The auto-reclose function offers multi-shot auto-reclose control, selectable to perform up to a four shot cycle. Dead times (Note 1) for all shots (Note 2) are independently adjustable. Should the CB close successfully at the end of the dead time, a Reclaim Time starts. If the circuit breaker does not trip again, the auto-reclose function resets at the end of the reclaim time. If the protection trips again during the reclaim time the relay advances to the next shot in the programmed cycle, or, if all programmed reclose attempts have been made, goes to lockout.

Note **Dead Time** denotes the open (dead) interval delay of the CB.

Note 2 A **Shot** is a reclosure attempt.

Logic diagrams to explain the operation of the auto-reclose feature are grouped together at the end of this section.

2.1.2 Auto-Reclose Logic Inputs

The auto-reclose function uses inputs in the logic, which can be assigned and activated from any of the opto-isolated inputs on the relay via the Programmable Scheme Logic (PSL). Contacts from external equipment may be used to influence the auto-recloser via the optos, noting that the CB Status (open/closed) must also be available via auxiliary contact inputs to the relay.

These logic inputs can also be assigned and activated from other sources. The function of these inputs is described below, identified by their DDB signal text. The inputs can be selected to accept either a normally open or a normally closed contact, programmable via the PSL editor.

2.1.2.1 CB Healthy

The majority of Circuit Breakers (CBs) are only capable of providing one trip-close-trip cycle. Following this, it is necessary to re-establish sufficient energy in the CB before the CB can be reclosed. The CB Healthy input is used to ensure that there is sufficient energy available to close and trip the CB before initiating a CB close command. If on completion of the dead time, sufficient energy is not detected by the relay from the CB Healthy input for a period given by the CB Healthy time timer, lockout will result and the CB will remain open.

2.1.2.2 BAR

The BAR input will block auto-reclose and cause a lockout if auto-reclose is in progress. It can be used when protection operation without auto-reclose is required.

2.1.2.3 Reset Lockout

The Reset Lockout input can be used to reset the auto-reclose function following lockout and reset any auto-reclose alarms, provided that the signals which initiated the lockout have been removed.

2.1.2.4 Enable 3 Pole AR

The En 3-pole Reclose input is used to select the three-phase auto-reclose operating mode.

2.1.2.5**External Trip**

The External Trip 3Ph input and the External Trip A, External Trip B and External Trip C inputs can be used to initiate three or single-phase auto-reclose.

<i>Note</i>	<i>These signals are not used to trip the CB but do initiate auto-reclose. To trip the CB directly they could be assigned to the trip contacts of the relay in the PSL.</i>
-------------	---

2.1.3**Internal Signals****2.1.3.1****Trip Initiate Signals**

The auto-reclose can be initiated by any of the instantaneous tripping elements.

2.1.3.2**Circuit Breaker Status**

The **CB Open 3 ph**, "signal is used to indicate if a CB is open. This is driven from the internal pole dead logic and the CB auxiliary inputs.

2.1.3.3**Check Synch OK and System Check OK**

Internal signals generated from the internal system check function and external system check equipment are used by the internal auto-reclose logic to permit auto-reclosure.

2.1.4**Auto-Reclose Logic Outputs**

The following DDB signals can be masked to a relay contact in the PSL or assigned to a Monitor Bit in Commissioning Tests, to provide information about the status of the auto-reclose cycle. These are described below, identified by their DDB signal text.

2.1.4.1**AR 3 Pole In Progress**

The AR 3-pole in Progress output indicates that three pole auto-reclose is in progress. The output is on from protection initiation to the end of the three pole dead time, 'Dead Time 1, 2, 3, 4'.

2.1.4.2**Successful Close**

The AR Successful Reclose output indicates that an auto-reclose cycle has been successfully completed. A successful auto-reclose signal is given after the CB has tripped from the protection and reclosed whereupon the fault has been cleared and the reclaim time has expired resetting the auto-reclose cycle. The successful auto-reclose output is reset at the next CB trip or from one of the reset lockout methods; see the 'Reset from lockout' section.

2.1.4.3**AR Status**

The **A/R In Status 3P** output indicates that the relay is in the three phase auto-reclose mode.

2.1.4.4**Auto Close**

The Auto Close output indicates that the auto-reclose logic has issued a close signal to the CB. This output feeds a signal to the control close pulse timer and remains on until the CB has closed. This signal may be useful during relay commissioning to check the operation of the auto-reclose cycle. This signal is combined with the manual close signal to produce the signal Control Close which should be mapped to an output contact.

2.1.5**Auto-Reclose Alarms**

The following DDB signals will produce a relay alarm. These are described below, identified by their DDB signal text.

2.1.5.1**AR No Checksync (Latched)**

The AR No Checksync alarm indicates that the system voltages were not in synchronism at the end of the Check Sync Time, leading to a lockout condition. This alarm can be reset using one of the reset lockout methods; see the 'Reset from lockout' section.

2.1.5.2 AR CB Unhealthy (Latched)

The AR CB Unhealthy alarm indicates that the CB Healthy input was not energized at the end of the CB Healthy Time, leading to a lockout condition. The CB Healthy input is used to indicate that there is sufficient energy in the CB operating mechanism to close and trip the CB at the end of the dead time. This alarm can be reset using one of the reset lockout methods; see the *Reset from Lockout* section.

2.1.5.3 AR Lockout (Self Reset)

The AR Lockout alarm indicates that the relay is in a lockout state and that further reclose attempts will not be made; see the *Reset from Lockout* section for more details. This alarm can be reset using one of the reset lockout methods; see the *Reset from Lockout* section.

2.1.6 Auto-Reclose Logic Operating Sequence

An auto-reclose cycle can be internally initiated by operation of a protection element, provided the circuit breaker is closed until the instant of protection operation. The user can, via a setting, determine if the auto-reclose shall be initiated on the rising edge of the protection trip (Protection Op) or on the falling edge (Protection Reset).

If three pole auto-reclose [A/R Status 3P] only is enabled then for any fault the three pole dead time ("Dead Time 1, Dead Time 2, Dead Time 3, Dead Time 4") [Dead Time 1, 2, 3, 4] and three pole auto-reclose in progress [AR 3pole in prog] starts on the rising or falling edge (according to the setting) of the three-phase trip. The logic forces a 3-pole trip [Force 3-pole AR] for any single-phase fault if three pole auto-reclose [A/R Status 3P] only is enabled.

If three pole auto-reclose [A/R Status 3P] is enabled then for any fault the three pole dead time ("Dead Time 1, Dead Time 2, Dead Time 3, Dead Time 4") [Dead Time 1, 2, 3, 4] and three pole auto-reclose in progress [AR 3pole in prog] starts on the rising or falling edge (according to the setting) of the trip.

At the end of the relevant dead time, the auto-reclose in progress signal is reset and a CB close signal is given, provided system conditions are suitable. The system conditions to be met for closing are that the system voltages are in synchronism or dead line/live bus or live line/dead bus conditions exist, indicated by the internal check synchronizing element and that the circuit breaker closing spring, or other energy source, is fully charged indicated from the **CB Healthy** input. The CB close signal is cut-off when the circuit breaker closes.

When the CB has closed the reclaim time ("Reclaim Time") starts. If the circuit breaker does not trip again, the auto-reclose function resets at the end of the reclaim time. If the protection operates during the reclaim time the relay either advances to the next shot in the programmed auto-reclose cycle, or, if all programmed reclose attempts have been made, goes to lockout.

Every time the relay trips the sequence counter is incremented by 1. The relay compares the counter value to the sequence count. If the sequence count is greater than the setting then the relay will lockout.

The total number of auto-reclosures is shown in the CB Control menu under Total Reclosures. This value can be reset to zero with the Reset Total A/R command.

The selection of which protection is used to initiate auto-reclose can be made using the settings Initiate AR, No Action or Block AR for the protection functions listed in the auto-reclose menu. See the *Auto-reclose Initiation* section for more details.

For multi-phase faults the auto-reclose logic can be set to allow auto-reclose block for 2 and 3-phase faults or to block auto-reclose for 3-phase faults only using the setting Multi Phase AR - Allow AR/BAR 2 & 3 Phase/BAR 3 Phase in the Auto-reclose settings.

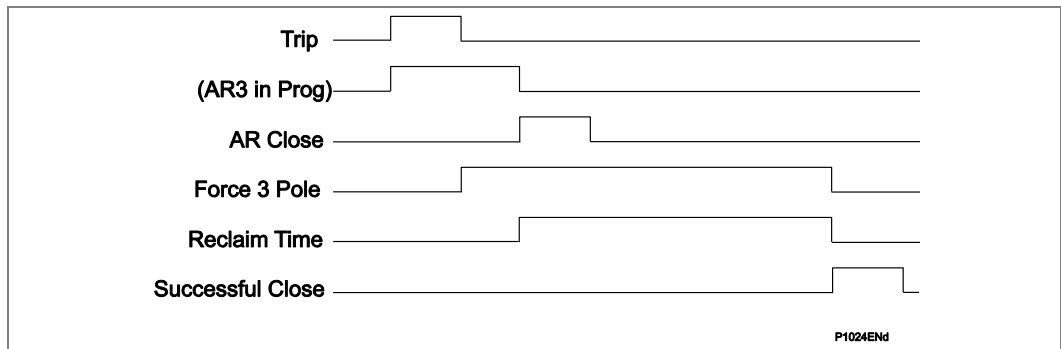

Figure 69 - Auto-reclose timing diagram - single fault

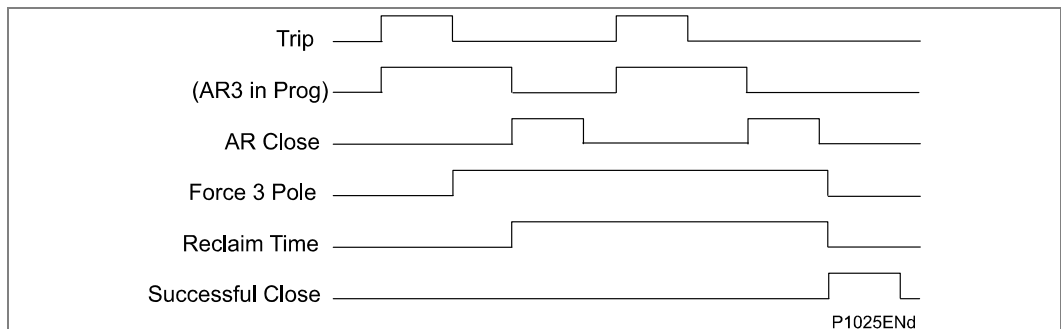

Figure 70 - Auto-reclose timing diagram - repeated fault inception

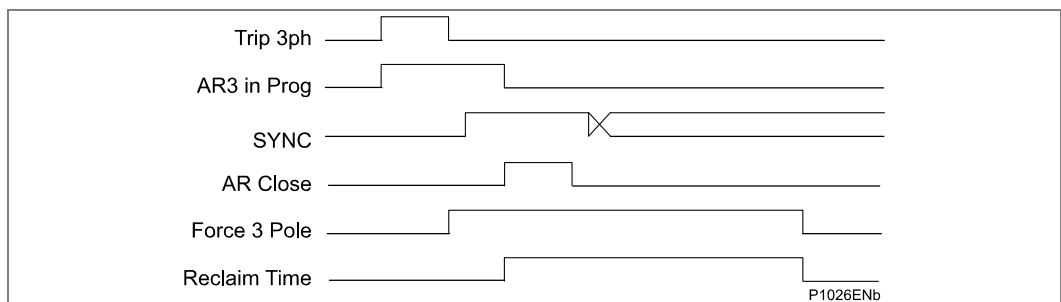

Figure 71 - Auto-reclose timing diagram - fault with system synchronism

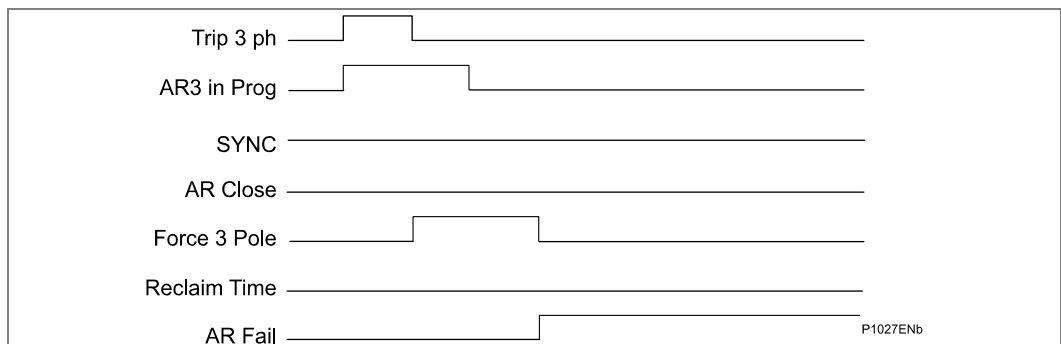

Figure 72 - Auto-reclose timing diagram - lockout for no checksynch

2.1.7

Main Operating Features

The Auto-Reclose function as modified in Software Version C1/D1/F1/G4/H4/J4 so this it works as follows:

This is an Output signal available in the PSL, which can be mapped to an opto status input to enable the autoreclose as long as the below conditions are satisfied.

Autoreclose can be Enabled or Disabled. This is done using a combination of Setting changes, starting with DDB 1384 (AR Enable) operation. Here is what is needed to Enable or Disable the Autoreclose:

AR Enabled = Autoreclose Enabled (0924 = 1) AND

(AR Telecontrol In Service (070B = 1) OR AR Enable DDB active (DDB 1384 = 1)) AND

(AR Enable CB1 DDB Active (DDB 1609 = 1) OR AR Enable CB2 DDB Active (DDB 1605 = 1))

AR Disabled = Autoreclose Enabled (0924 = 0) OR

(AR Telecontrol Out of Service (070B = 2) AND AR Enable DDB active (DDB 1384 = 0)) OR

(AR Enable CB1 DDB Active (DDB 1609 = 1) AND AR Enable CB2 DDB Active (DDB 1605 = 1))

Note More details are provided in the **Auto-Reclose Skip Shot 1 (P543/P545)** and the **Auto-Reclose (P544/P546)** sections.

Here is the new description of DDB 1384:

DDB No	Text	Description
DDB 1384	AR Enable	External input via DDB mapped in PSL to enable AR, but ONLY if “Enable AR CB1” DDB or “Enable AR CB2” DDB is set and “Auto-Reclose” Configuration setting is enabled.

As from Software Version H4, the possible statuses of the Auto-Reclose function have changed. The new method means that the function now works in the same way across the whole P54x range. It does this because of the following DDB Numbers.

DDB Numbers 856, 857, 1532 and 1533

DDB Nos 856 and 857 have never been included in the MiCOM P544/P546 products.

In the MiCOM P543/P545 (running on Software Version 57), DDB Nos 856 and 857 were available to show the mode (3P, 1P) for the Auto-Reclose (AR) function.

In the MiCOM P543/P545 (running on Software Version D1), DDB Nos 856 and 857 were removed.

As from Software Version H4a, the following situation applies:

DDB No	Source	Element Name	Description
856	Autoreclose	DDB_AR_IN_SERVICE_3P	3 Pole auto-recloser in service – the auto-reclose function has been enabled either in the relay menu, or by an auto input.
857	Autoreclose	DDB_AR_IN_SERVICE_1P	Single pole auto-recloser in service – the auto-reclose function has been enabled either in the relay menu, or by an auto input.
1532	Autoreclose	DDB_AR_IN_SERVICE_3P_FOLLOWER	Follower 3 Pole auto-recloser in service – the auto-reclose function has been enabled either in the relay menu, or by an auto input.
1533	Autoreclose	DDB_AR_IN_SERVICE_1P_FOLLOWER	Follower Single pole auto-recloser in service – the auto-reclose function has been enabled either in the relay menu, or by an auto input.

- For MiCOM P44y/P54x products with a single CB application (P543/P545), DDB Nos 856 and 857 again show the mode (3P, 1P).
- For MiCOM P44y/P54x products with a dual CB application (P544/P546), DDB Nos 856 and 857 again show the mode (3P, 1P) for the leader CB.
- For MiCOM P44y/P54x products with a dual CB application (P544/P546), DDB Nos 1532 and 1533 show the mode (3P, 1P) for the follower CB.

2.1.7.1 Auto-Reclose Modes

Three-pole auto-reclose is supported.

2.1.7.2 Auto-Reclose Initiation

Auto-reclose is initiated from the internal protection of the relay:

The distance zones, DEF aided, overcurrent and earth fault protection can be selected to “**Initiate AR, No Action or Block AR**” in the Auto-reclose settings.

- By default, all **instantaneous** schemes will initiate auto-reclose, Zone 1 distance, Aided Scheme 1, and Aided Scheme 2 will all initiate AR.
- For these instantaneous tripping elements, it is possible to override initiation for user set combinations of multi-phase faults if required, by use of the 'Multi Phase AR' Block setting. This will prevent auto-reclose initiation, and drive the sequence to lockout.

2.1.7.3 Auto-Reclose Inhibit following Manual Close

The AR Inhibit Time setting can be used to prevent auto-reclose being initiated when the CB is manually closed onto a fault. Auto-reclose is disabled for the AR Inhibit Time following manual CB closure.

2.1.7.4 Auto-Reclose Lockout

If protection operates during the reclaim time, following the final reclose attempt, the relay will be driven to lockout and the auto-reclose function will be disabled until the lockout condition is reset. This will produce an alarm, AR Lockout.

The block auto-reclose logic in the relay will also cause an auto-reclose lockout if auto-reclose is in progress. The **BAR** input assigned to an opto input will block auto-reclose and cause a lockout if auto-reclose is in progress. The auto-reclose logic can also be set to block auto-reclose for 2 and 3-phase faults or to block auto-reclose for 3-phase faults only using the setting **Multi Phase AR - Allow AR/BAR 2&3 Phase/BAR 3 Phase** in the Auto-reclose menu. Also, the protection functions can be individually selected to block auto-reclose using the settings, **Initiate AR, No Action** or **Block AR** in the Auto-reclose menu.

Auto-reclose lockout can also be caused by the CB failing to close because the CB springs are not charged/low gas pressure or there is no synchronism between the system voltages indicated by the **AR CB Unhealthy** and **AR No Checksync** alarms.

An auto-reclose lockout is also given if the CB is open at the end of the reclaim time.

*Note CB Lockout, can also be caused by the CB condition monitoring functions maintenance lockout, excessive fault frequency lockout, broken current lockout, CB failed to trip and CB failed to close and manual close - no check synchronism and CB unhealthy. These lockout alarms are mapped to a composite signal **CB Lockout Alarm**.*

2.1.7.5 Reset from Lockout

The **Reset Lockout** input assigned to an opto input can be used to reset the auto-reclose function following lockout and reset any auto-reclose alarms, provided that the signals which initiated the lockout have been removed. Lockout can also be reset from the clear key or the CB CONTROL command **Lockout Reset**.

The **Reset Lockout** by setting, **CB Close/User interface** in CB CONTROL is used to enable/ disable reset of lockout automatically from a manual close after the manual close time **AR Inhibit Time**.

2.1.7.6

System Check on Shot 1

The SysChk on Shot 1 setting is used to Enable/Disable system checks for the first reclose after a 3-pole trip in an auto-reclose cycle. When the SysChk on Shot 1 is set to Disabled no system checks are required for the first reclose which may be preferred when high speed auto-reclose is applied to avoid the extra time for a system check. Subsequent reclose attempts in a multi-shot cycle will still require a system check.

2.1.7.7

Immediate Auto-Reclose with Check Synchronism

The CS AR Immediate setting allows immediate auto-reclosure without waiting for the expiry of the settable dead time, provided the check synchronism conditions are met and a fault is not detected. The intention is to allow the local end to reclose immediately if the remote end has already reclosed successfully and the synchronizing conditions are met.

This feature applies when the setting is enabled. It applies to all dead times, just for three pole auto-reclose and just for Live Line-Live Bus condition (plus other check synchronizing conditions of phase angle, frequency etc).

When set to disabled the relay will wait for the relevant dead time.

2.1.8

Auto-Reclose Logic Diagrams

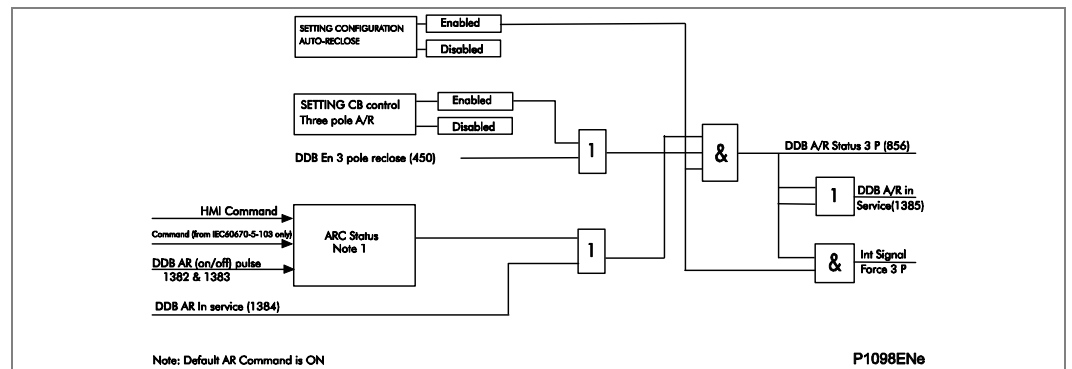

Figure 73 - Auto-reclose enable logic

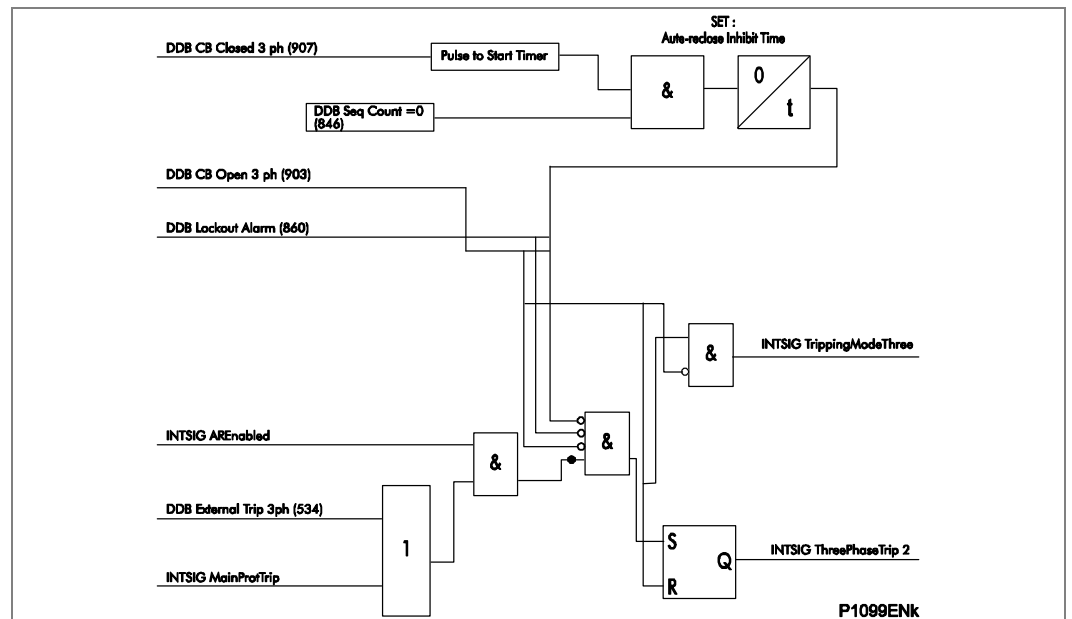

Figure 74 - Auto-reclose tripping

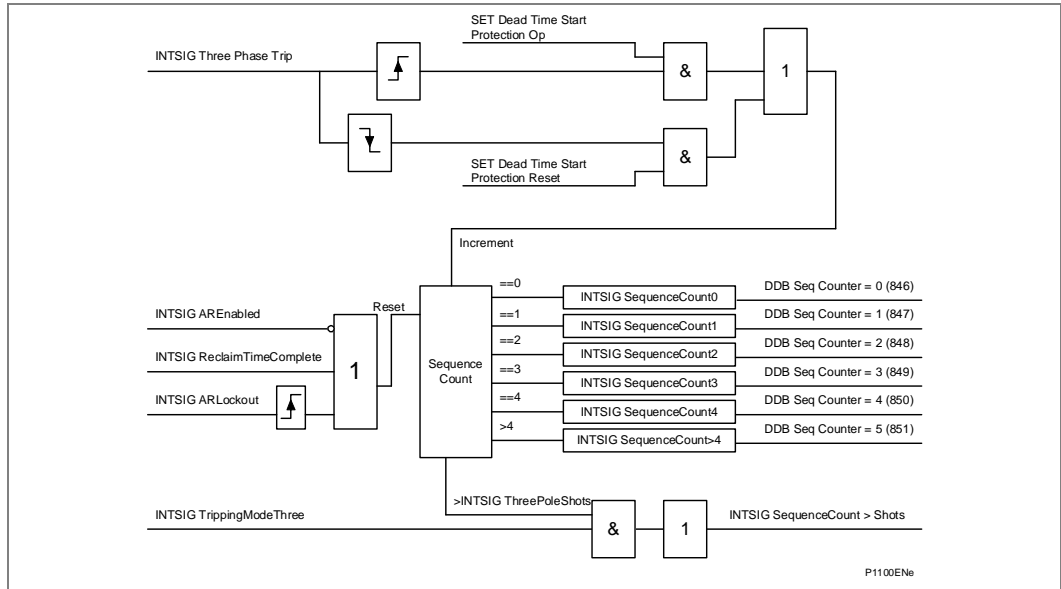

Figure 75 - Auto-reclose inhibit sequence count

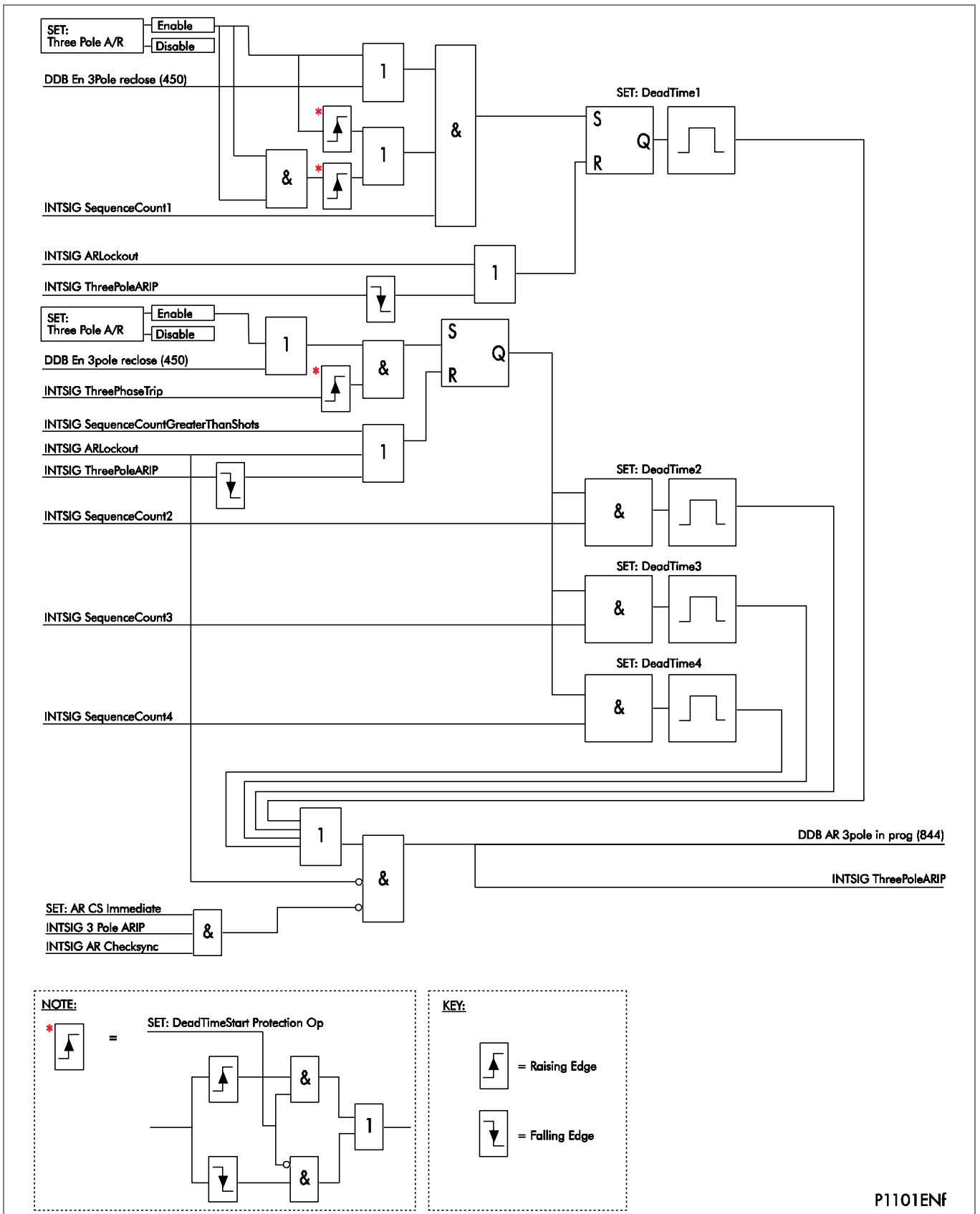

Figure 76 - Auto-reclose cycles

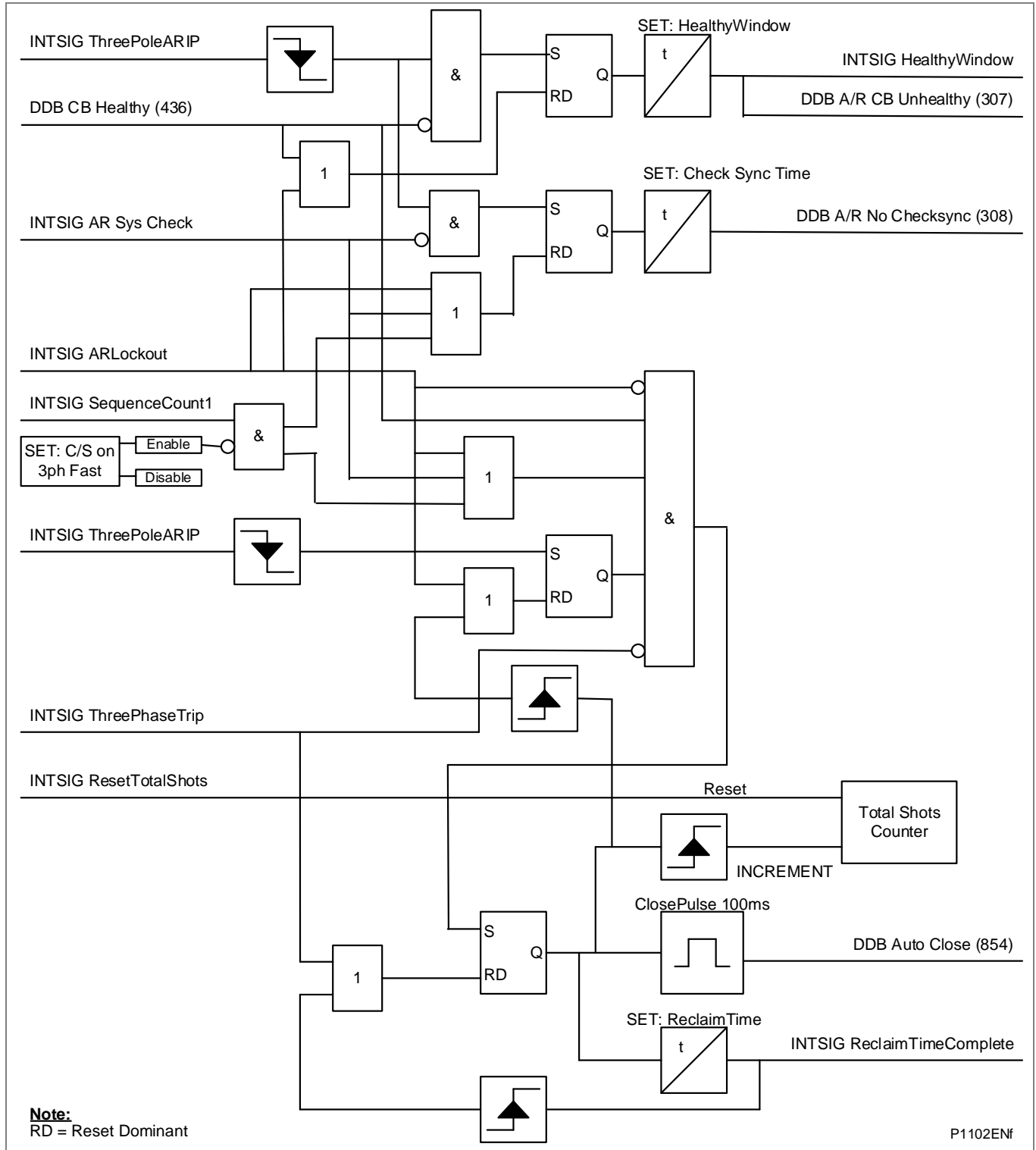

Figure 77 - Auto-reclose close

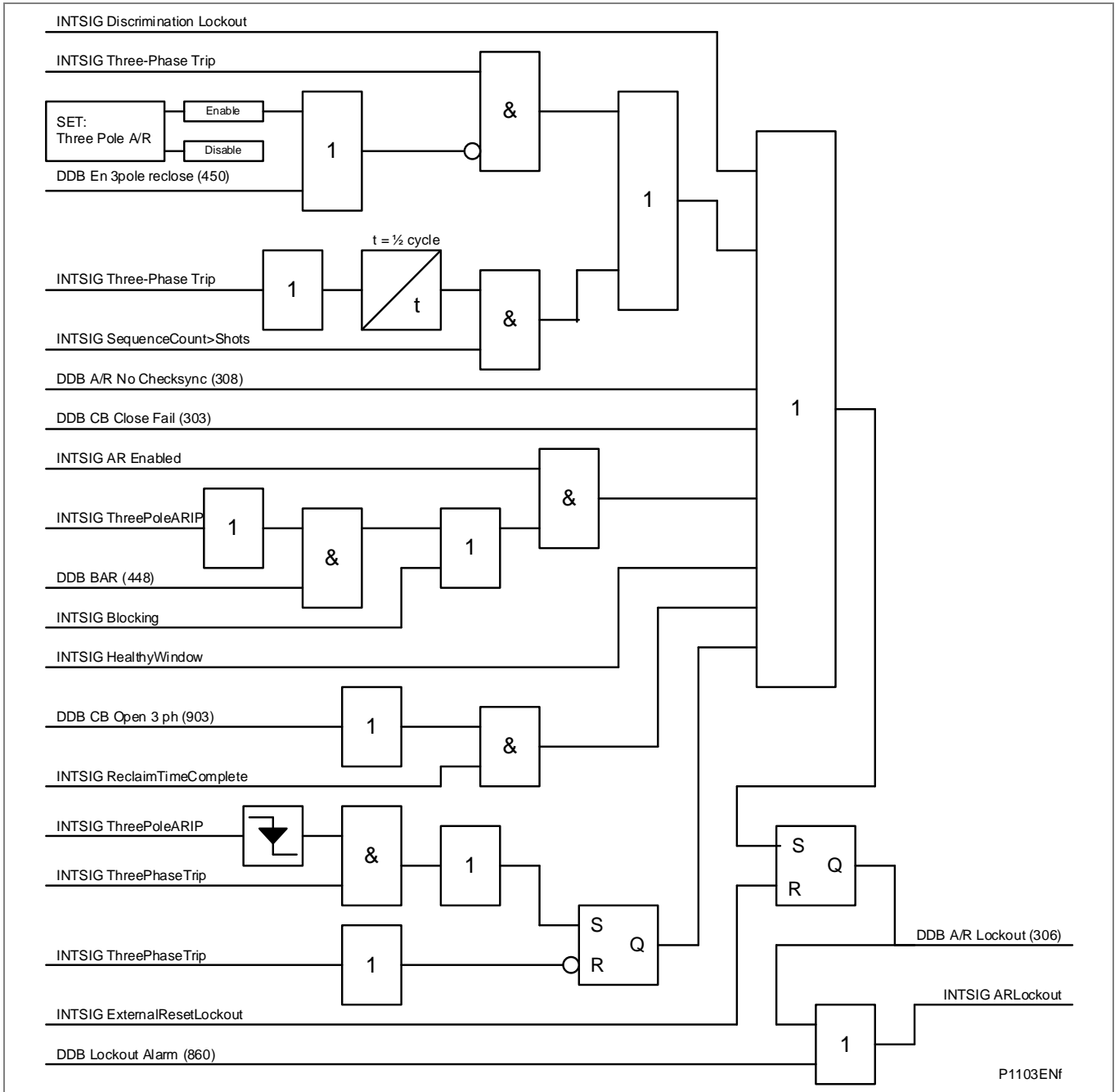

Figure 78 - Auto-reclose lockout logic

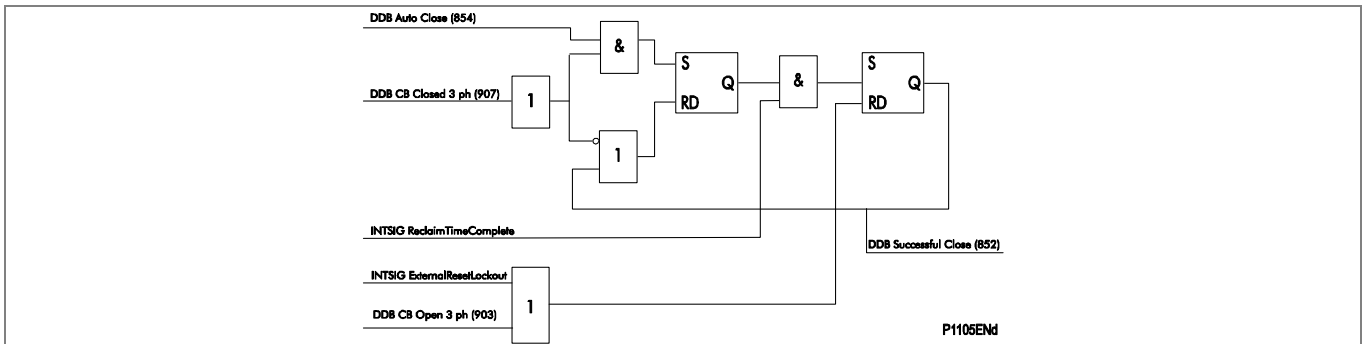

Figure 79 - Auto-reclose close notify

2.2 System Checks (including Check Synchronizer)

2.2.1 Overview

In some situations it is possible for both “bus” and “line” sides of a Circuit Breaker (CB) to be live when the CB is open, for example at the ends of a feeder which has a power source at each end. Therefore, when closing the CB, it is normally necessary to check that the network conditions on both sides are suitable, before giving a CB Close command. This applies to both manual CB closing and auto-reclosure. If a CB is closed when the line and bus voltages are both live, with a large phase angle, frequency or magnitude difference between them, the system could be subjected to an unacceptable shock, resulting in loss of stability, and possible damage to connected machines.

System checks involve monitoring the voltages on both sides of a circuit breaker, and, if both sides are live, performing a synchronism check to determine whether the phase angle, frequency and voltage magnitude differences between the voltage vectors, are within permitted limits.

The pre-closing system conditions for a given Circuit Breaker (CB) depend on the system configuration and, for auto-reclosing, on the selected auto-reclose program. For example, on a feeder with delayed auto-reclosing, the CBs at the two line ends are normally arranged to close at different times. The first line end to close usually has a live bus and a dead line immediately before reclosing, and charges the line (dead line charge) when the CB closes. The second line end CB sees live bus and live line after the first CB has reclosed. If there is a parallel connection between the ends of the tripped feeder, they are unlikely to go out of synchronism, i.e. the frequencies will be the same, but the increased impedance could cause the phase angle between the two voltages to increase. Therefore the second CB to close might need a synchronism check, to ensure that the phase angle has not increased to a level which would cause unacceptable shock to the system when the CB closes.

If there are no parallel interconnections between the ends of the tripped feeder, the two systems could lose synchronism, and the frequency at one end could “slip” relative to the other end. In this situation, the second line end would require a synchronism check comprising both phase angle and slip frequency checks.

If the second line end busbar has no power source other than the feeder which has tripped, the circuit breaker will see a live line and dead bus assuming the first circuit breaker has reclosed. When the second line end circuit breaker closes the bus will charge from the live line (dead bus charge).

2.2.2 VT Selection

The MiCOM P443/P445/P543/P545 has a three-phase **Main VT** input and a single-phase **Check Sync VT** input. Depending on the primary system arrangement, the main three-phase VT for the relay may be located on either the busbar side or the line side of the circuit breaker, with the check sync VT being located on the other side. Hence, the relay has to be programmed with the location of the Main VT. This is done using the **Main VT Location** setting in the CT & VT RATIOS menu.

The Check Sync VT may be connected to either a phase to phase or phase to neutral voltage, and for correct synchronism check operation, the relay has to be programmed with the required connection. The C/S Input setting in the CT & VT RATIOS menu should be set to A-N, B-N, C-N, A-B, B-C or C-A A-N/1.732, B-N/1.732 or C-N/1.732 as appropriate.

2.2.3 Basic Functionality

System check logic is collectively enabled or disabled as required, by setting **System Checks** in the CONFIGURATION menu. The associated settings are available in SYSTEM CHECKS, sub-menus VOLTAGE MONITORS, CHECK SYNC and SYSTEM SPLIT. If **System Checks** is selected to Disabled, the associated SYSTEM CHECKS menu becomes invisible, and a Sys checks Inactive DDB signal is set.

In most situations where synchronism check is required, the Check Sync 1 function alone will provide the necessary functionality, and the Check Sync 2 and System Split signals can be ignored.

2.2.4 System Check Logic Outputs

When enabled, the MiCOM P443/P445/P543/P545 system check logic sets signals as listed below, according to the status of the monitored voltages.

Line Live	If the Line voltage magnitude is not less than VOLTAGE MONITORS - Live Voltage setting
Line Dead	If the Line voltage magnitude is less than VOLTAGE MONITORS - Dead Voltage setting
Bus Live	If the Bus voltage magnitude is not less than VOLTAGE MONITORS - Live Voltage setting
Bus Dead	If the Bus voltage magnitude is less than VOLTAGE MONITORS - Dead Voltage setting
Check Sync 1 OK	If Check Sync 1 Status is Enabled, the Line and Bus voltages are both live, and the parameters meet the CHECK SYNC - Check Sync 1 ---- settings
Check Sync 2 OK	If Check Sync 2 Status is Enabled, the Line and Bus voltages are both live, and the parameters meet the CHECK SYNC - Check Sync 2 ---- settings
System Split	If SS Status is Enabled, the Line and Bus voltages are both live, and the measured phase angle between the voltage vectors is greater than SYSTEM SPLIT - SS Phase Angle setting

All the above signals are available as DDB signals for mapping in Programmable Scheme Logic (PSL). In addition, the Checksync 1 & 2 signals are "hard coded" into the auto-reclose logic.

2.2.5 Check Sync 2 and System Split

Check Sync 2 and System Split functions are included for situations where the maximum permitted slip frequency and phase angle for synchronism check can change according to actual system conditions. A typical application is on a closely interconnected system, where synchronism is normally retained when a given feeder is tripped, but under some circumstances, with parallel interconnections out of service, the feeder ends can drift out of synchronism when the feeder is tripped. Depending on the system and machine characteristics, the conditions for safe circuit breaker closing could be, for example:

Condition 1: for synchronized systems, with zero or very small slip:

slip * 50 mHz; phase angle <30°

Condition 2: for unsynchronized systems, with significant slip:

slip * 250 mHz; phase angle <10° and decreasing

By enabling both Check Sync 1, set for condition 1, and Check Sync 2, set for condition 2, the relay can be configured to allow CB closure if either of the two conditions is detected.

For manual circuit breaker closing with synchro check, some utilities might prefer to arrange the logic to check initially for condition 1 only. However, if a System Split is detected before the condition 1 parameters are satisfied, the relay will switch to checking for condition 2 parameters instead, based upon the assumption that a significant degree of slip must be present when system split conditions are detected. This can be arranged by suitable PSL logic, using the system check DDB signals.

2.2.6 Synchronism Check

Check Sync 1 and Check Sync 2 are two synchro check logic modules with similar functionality, but independent settings.

For "CS1 OK" DDB to be set, the following conditions are necessary:

- Settings "System Checks" and "CS1 Status" must **both** be Enabled; AND
- "Live Line" and "Live Bus 1" signals are both set; AND
- None of the selected "CS1 Volt. Blk" conditions (V<, V>, VDiff) are true; AND
- The measured phase angle magnitude is less than the "CS1 Angle" setting; AND
- If "CS1 SlipCtrl" is set to Frequency or Timer+Freq, the measured slip frequency between the line VT and Bus1 VT is less than the "CS1 SlipFreq" setting, OR If "CS1 SlipCtrl" is set to Timer or Timer+Freq, the above conditions have been true for a time more than or equal to the "CS1 SlipTimer" setting.

For signal "CS2 OK" DDB to be set, these conditions are necessary:

- Settings "System Checks" and "CS2 Status" must **both** be Enabled; AND
- "Live Line" and "Live Bus 1" signals are both set; AND
- None of the selected "CS2 Volt. Blk" conditions (V<, V>, VDiff) are true; AND
- If "CS2 SlipCtrl" is set to Frequency or Timer+Freq, the measured slip frequency between the line VT and Bus1 VT is less than the "CS2 SlipFreq" setting, OR If "CS2 SlipCtrl" is set to Timer or Timer+Freq, the above conditions have been true for a time more than or equal to the "CS2 SlipTimer" setting; AND
- The measured phase angle magnitude is decreasing; AND
- If "CS2 SlipCtrl" is NOT set to Freq+CB Comp, OR "ADAPTIVE_CHECKSYNC" is NOT defined, the measured phase angle magnitude is less than the "CS2 Angle" setting; OR If "CS2 SlipCtrl" is set to Freq+CB Comp, AND "ADAPTIVE_CHECKSYNC" is defined, AND if the predicted phase angle is less than the "CS2 Angle" setting AND as close as possible to zero AND still decreasing in magnitude.

Note Live Line/Dead Bus and Dead Bus/Line functionality is provided as part of the default PSL.

2.2.7 Slip Control by Timer

If Slip Control by Timer or Frequency + Timer is selected, the combination of Phase Angle and Timer settings determines an effective maximum slip frequency, calculated as:

$$\frac{2 \times A}{T \times 360} \text{ Hz. for Check Sync 1}$$

or

$$\frac{A}{T \times 360} \text{ Hz. for Check Sync 2}$$

Where:

- A = Phase Angle setting (°)
- T = Slip Timer setting (seconds)

For example, with Check Sync 1 Phase Angle setting 30° and Timer setting 3.3 sec, the “slipping” vector has to remain within ±30° of the reference vector for at least 3.3 seconds. Therefore a synchro check output will not be given if the slip is greater than 2 x 30° in 3.3 seconds. Using the formula: $2 \times 30 \div (3.3 \times 360) = 0.0505 \text{ Hz}$ (50.5 mHz).

For Check Sync 2, with Phase Angle setting 10° and Timer setting 0.1 sec, the slipping vector has to remain within 10° of the reference vector, with the angle decreasing, for 0.1 sec. When the angle passes through zero and starts to increase, the synchro check output is blocked. Therefore an output will not be given if slip is greater than 10° in 0.1 second. Using the formula: $10 \div (0.1 \times 360) = 0.278 \text{ Hz}$ (278 mHz).

Slip control by Timer is not practical for “large slip / small phase angle” applications, because the timer settings required are very small, sometimes < 0.1 s. For these situations, slip control by frequency is recommended.

If Slip Control by Frequency + Timer is selected, for an output to be given, the slip frequency must be less than BOTH the set Slip Freq value and the value determined by the Phase Angle and Timer settings.

2.3

Auto-Reclose/Check Synchronization Interface

Output signals from the internal system check function and signals from an external system check device are combined and made available as two internal inputs to the auto-reclose function. One internal input permits auto-reclose based on system check conditions being met. The other internal input permits immediate auto-reclose based on check synchronism conditions being met, if this feature is enabled (CS AR Immediate).

The logic diagram for the interaction between the auto-reclose and system checks is shown below.

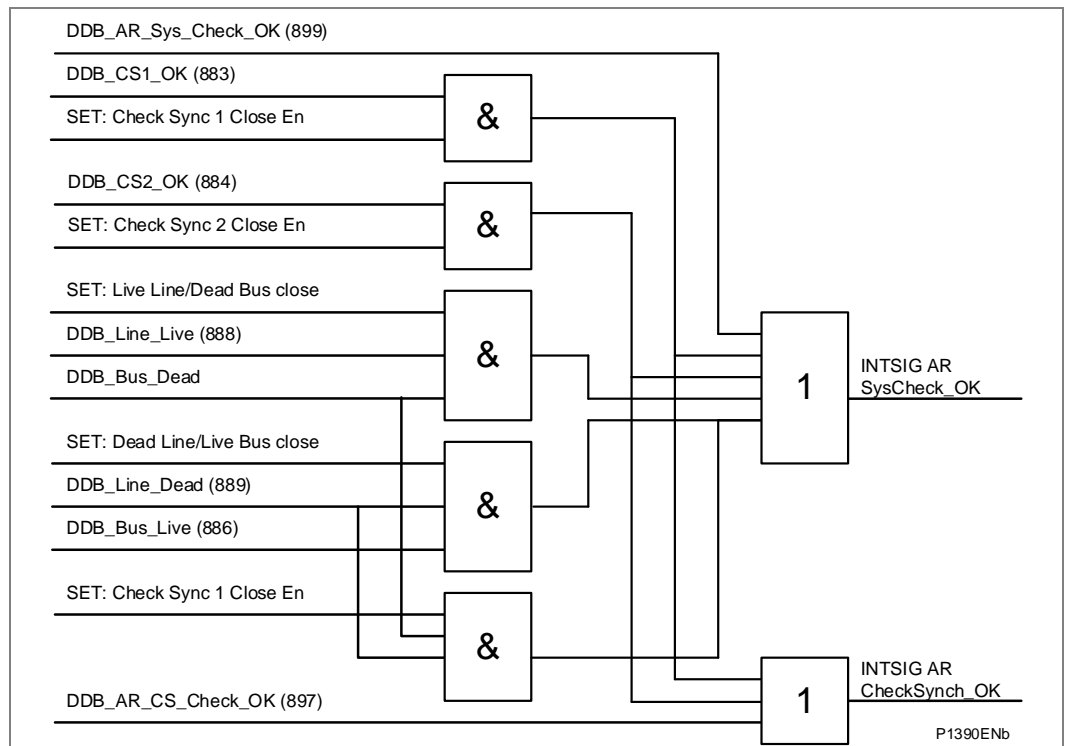

Figure 80 - Auto-reclose/check sync interface

If an external system check device is to be used with the internal auto-reclose function then logic inputs are available for the purpose and can be assigned to opto-isolated inputs using the PSL. These logic inputs are.

- AR Check Synch OK
- AR System Check OK/SYNC

2.4 Voltage Transformer Supervision (VTS) - Fuse Fail

The Voltage Transformer Supervision (VTS) feature is used to detect failure of the ac voltage inputs to the relay. This may be caused by internal voltage transformer faults, overloading, or faults on the interconnecting wiring to relays. This usually results in one or more VT fuses blowing. Following a failure of the ac voltage input there would be a misrepresentation of the phase voltages on the power system, as measured by the relay, which may result in maloperation.

The VTS logic in the relay is designed to detect the voltage failure, and automatically adjust the configuration of protection elements whose stability would otherwise be compromised. A time-delayed alarm output is also available.

VTS can be declared by a Miniature Circuit Breaker (MCB) status input, by an internal logic using relay measurement or both. A setting VTS Mode (Measured + MCB /Measured Only/MCB Only) is available to select the method to declare VT failure.

For the measured method, there are three main aspects to consider regarding the failure of the VT supply. These are defined below:

- Loss of one or two-phase voltages
- Loss of all three-phase voltages under load conditions
- Absence of three-phase voltages upon line energization

2.4.1 Loss of One or Two Phase Voltages

If one or two phase voltages drop below the fixed 10V level detectors a VTS will be initiated. In addition, the VTS feature within the relay operates on detection of Negative Phase Sequence (NPS) voltage without the presence of NPS current. This gives operation for the loss of one or two phase voltages. Stability of the VTS function is assured during system fault conditions, by the presence of NPS current. The use of negative sequence quantities ensures correct operation even where three-limb or 'V' connected (open delta) VTs are used.

Negative Sequence VTS Element:

The negative sequence thresholds used by the element are $V_2 = 10 \text{ V}$ and $I_2 = 0.05$ to 0.5 In settable (defaulted to 0.05 In).

2.4.2 Loss of all Three Phase Voltages Under Load Conditions

Under the loss of all three phase voltages to the relay, there will be no negative phase sequence quantities present to operate the VTS function. However, under such circumstances, a collapse of the three phase voltages will occur. If this is detected without a corresponding change in any of the phase current signals (which would be indicative of a fault), a VTS condition will be raised. In practice, the relay detects the presence of superimposed current signals, which are changes in the current applied to the relay. These signals are generated by comparison of the present value of the current with that exactly one cycle previously. Under normal load conditions, the value of superimposed current should therefore be zero. Under a fault condition a superimposed current signal will be generated which will prevent operation of the VTS.

The phase voltage level detectors are fixed and will drop off at 10 V and pickup at 30 V.

The sensitivity of the superimposed current elements is fixed at 0.1 In .

2.4.3

Absence of Three Phase Voltages Upon Line Energization

If a VT were inadvertently left isolated prior to line energization, incorrect operation of voltage dependent elements could result. The previous VTS element detected 3-phase VT failure by absence of all 3-phase voltages with no corresponding change in current. On line energization there will, however, be a change in current (as a result of load or line charging current for example). An alternative method of detecting 3-phase VT failure is therefore required on-line energization.

The absence of measured voltage on all three-phases on line energization can be due to:

- A three-phase VT failure
- A close-up 3-phase fault

The first condition would require blocking of the voltage dependent function and the second would require tripping.

To differentiate between these two conditions an overcurrent level detector (**VTS I> Inhibit**) is used which will prevent a VTS block from being issued if it operates. This element should be set in excess of any non-fault based currents on line energization (load, line charging current, transformer inrush current if applicable) but below the level of current produced by a close-up 3-phase fault. If the line is now closed where a 3-phase VT failure is present the overcurrent detector will not operate and a VTS block will be applied. Closing onto a 3-phase fault will result in operation of the overcurrent detector and prevent a VTS block being applied.

This logic will only be enabled during a live line condition (as indicated by the relays pole dead logic) to prevent operation under dead system conditions, where no voltage will be present and the **VTS I> Inhibit** overcurrent element will not be picked up.

Note *VTS I> Inhibit logic is equally applicable for the situation where loss of all three-phase voltages occurs under load conditions (refer the **Loss of all Three Phase Voltages Under Load Conditions** section). If the setting of VTS I> Inhibit is less than the load current and if three-phase VT fails during normal load, VTS block will not be applied. Hence it is important that the VTS I> Inhibit is always set above the expected load current.*

2.4.4

VTS Logic

The relay may respond as follows, on operation of any VTS element:

- VTS set to provide alarm indication only;
- Optional blocking of voltage dependent protection elements;
- Optional conversion of directional overcurrent elements to non-directional protection (available when set to Blocking mode only). These settings are found in the Function Links cell of the relevant protection element columns in the menu.

The VTS I> Inhibit or VTS I2> Inhibit elements are used to override a VTS block in event of a fault occurring on the system which could trigger the VTS logic. Once the VTS block has been established, however, then it would be undesirable for subsequent system faults to override the block. The VTS block will therefore be latched after a user settable time delay 'VTS Time Delay'. Once the signal has latched then two methods of resetting are available. The first is manually via the front panel interface (or remote communications) provided the VTS condition has been removed and secondly, when in 'Auto' mode, by the restoration of the 3-phase voltages above the phase level detector settings mentioned previously.

A VTS indication will be given after the VTS Time Delay has expired. In the case where the VTS is set to indicate only the relay may potentially maloperate, depending on which protection elements are enabled. In this case the VTS indication will be given prior to the VTS time delay expiring if a trip signal is given.

The VTS can be inhibited by connecting a signal to the "Inhibit VTS" input in the PSL. When using single pole tripping this should be active during pole open conditions when a line VT is used to prevent VTS operation on reclose preventing distance operation.

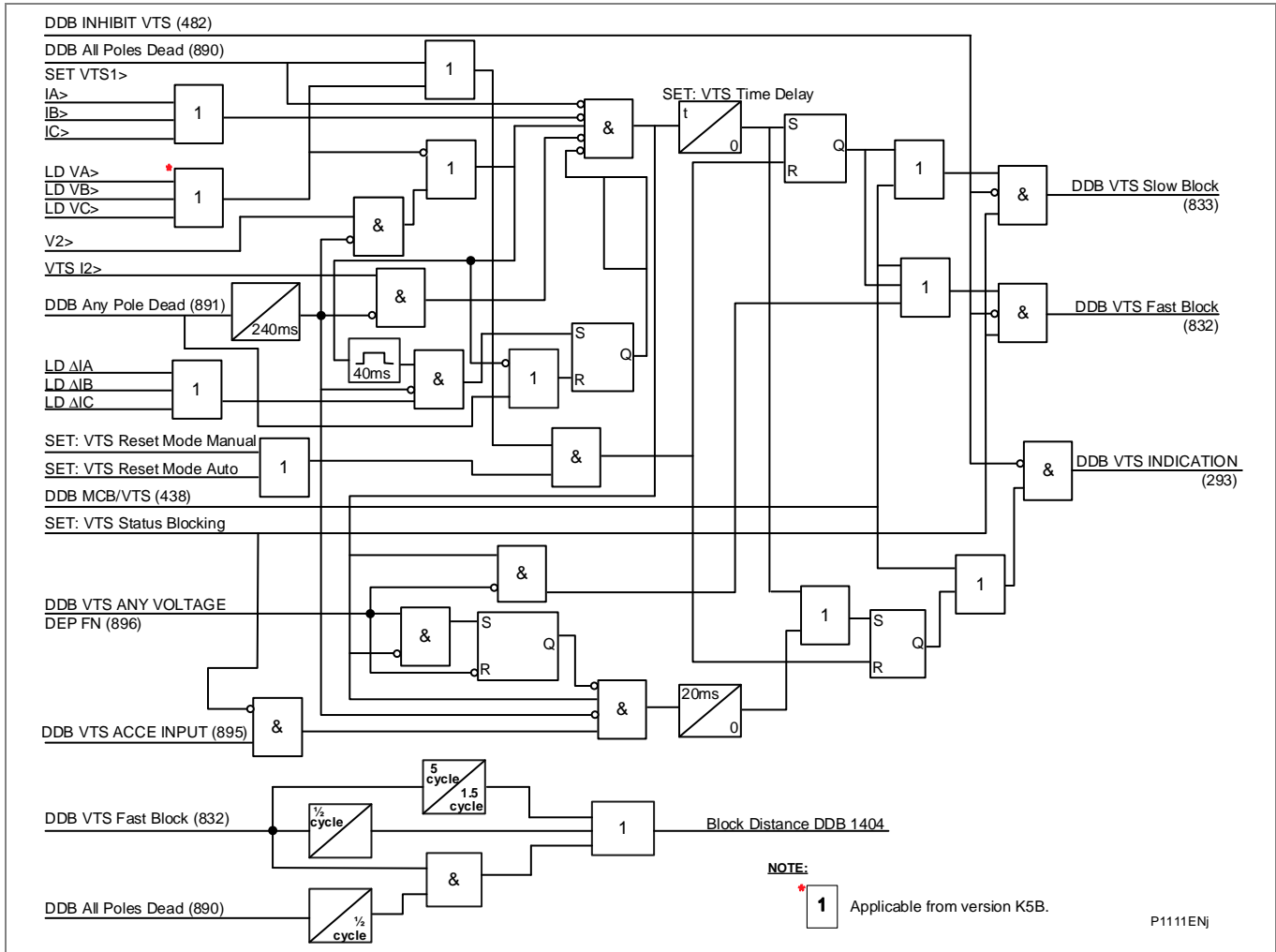

Figure 81 - VTS logic

This scheme is also able to correctly operate under very low load or even no load conditions, by the combination of time delayed signals derived from the DDB signals **VTS Fast block** and **All Poles Dead**, to generate the **Block Distance DDB**.

Note All non-distance elements are blocked by the “VTS Fast Block” DDB.

Where a Miniature Circuit Breaker (MCB) is used to protect the voltage transformer ac output circuits, it is common to use MCB auxiliary contacts to indicate a three-phase output disconnection. As previously described, it is possible for the VTS logic to operate correctly without this input. However, this facility has been provided for compatibility with various utilities current practices. Energizing an opto-isolated input assigned to **DDB: MCB/VTS** on the relay will therefore provide the necessary block.

2.5

Current Transformer Supervision (CTS)

The Current Transformer Supervision (CTS) feature is used to detect failure of one or more of the ac phase current inputs to the relay. Failure of a phase CT or an open circuit of the interconnecting wiring can result in incorrect operation of any current operated element. Additionally, interruption in the ac current circuits risks dangerous CT secondary voltages being generated.

The CT Supervision (CTS) feature operates on detection of derived zero sequence current, in the absence of a corresponding derived zero sequence voltage that would normally accompany it. The voltage transformer connection used must be able to refer zero sequence voltages from the primary to the secondary side. Thus, this element should only be enabled where the VT is of five limb construction, or comprises three single phase units, and has the primary star point earthed.

Operation of the element will produce a time-delayed alarm visible on the LCD, an event record and a DDB 294: CT Fail Alarm, with an instantaneous block (DDB 928: CTS Block) for inhibition of protection elements. Protection elements operating from derived quantities (Broken Conductor, DEF, Earth Fault, Neg Seq O/C) are always blocked on operation of the CT supervision element; other protection can be selectively blocked by customizing the PSL, gating DDB: CTS Block with the protection function logic.

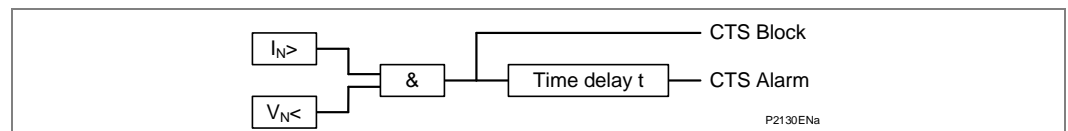

Figure 82 - Voltage dependant CTS

2.6

Transformer Magnetizing Inrush Detector

The MiCOM P443/P445/P54x distance protection has been designed as a fast protection relay. It is therefore not desirable that distance zones should be slowed by forcing them to wait for a detection/no detection of transformer inrush current (in general applications). For this reason, the relay has no second harmonic blocking of the distance elements in the standard protection algorithms.

However, should a user wish to employ, for example, a long Zone 1 reach through a transformer, it is possible to implement harmonic blocking for magnetizing inrush current. Provided that the Inrush Detection is **Enabled**, the user can then pick up the output of the I(2)/I(1) detectors in the Programmable Scheme Logic (PSL). The user can then assign blocking functions in the PSL as necessary, because as stated above this detector does not directly route into the relay's fixed logic.

2.7 Circuit Breaker State Monitoring

The relay incorporates circuit breaker state monitoring, giving an indication of the position of the circuit breaker, or, if the state is unknown, an alarm is raised.

2.7.1 Circuit Breaker State Monitoring Features

MiCOM relays can be set to monitor Normally Open (52a) and Normally Closed (52b) auxiliary contacts of the circuit breaker. Under healthy conditions, these contacts will be in opposite states. Should both sets of contacts be open, this would indicate one of the following conditions:

- Auxiliary contacts/wiring defective
- Circuit Breaker (CB) is defective
- CB is in isolated position

Should both sets of contacts be closed, only one of these conditions would apply:

- Auxiliary contacts / wiring defective
- Circuit Breaker (CB) is defective

If any of the above conditions exist, an alarm will be issued after the time delay set in the PSL. A normally open / normally closed output contact can be assigned to this function via the Programmable Scheme Logic (PSL). The time delay is set to avoid unwanted operation during normal switching duties.

Note *If the Circuit Breaker is under "not ready" status, the relay will not send any trip order to the Circuit Breaker.*

In the CB CONTROL column of the relay menu there is a setting called **CB Status Input**. This cell can be set at one of these options:

- None
- 52 A 3 pole
- 52 B 3 pole
- 52 A & 52 B 3 pole

Where **None** is selected no CB status will be available. This will directly affect any function within the relay that requires this signal, for example CB control, auto-reclose, etc. Where only 52 A is used on its own then the relay will assume a 52 B signal from the absence of the 52 A signal. Circuit breaker status information will be available in this case but no discrepancy alarm will be available. The above is also true where only a 52 B is used. If both 52 A and 52 B are used then status information will be available and in addition a discrepancy alarm will be possible, according to the following table. 52 A and 52 B inputs are assigned to relay opto-isolated inputs via the PSL.

Auxiliary Contact Position		CB State Detected	Action
52A	52B		
Open	Closed	Breaker Open	Circuit breaker healthy
Closed	Open	Breaker Closed	Circuit breaker healthy
Closed	Closed	State Unknown	Alarm raised if the condition persists for longer than "CB supervision timer" delay time setting
Open	Open	State Unknown	Alarm raised if the condition persists for longer than "CB supervision timer" delay time setting

Table 16 - Contact positions, states detected and actions

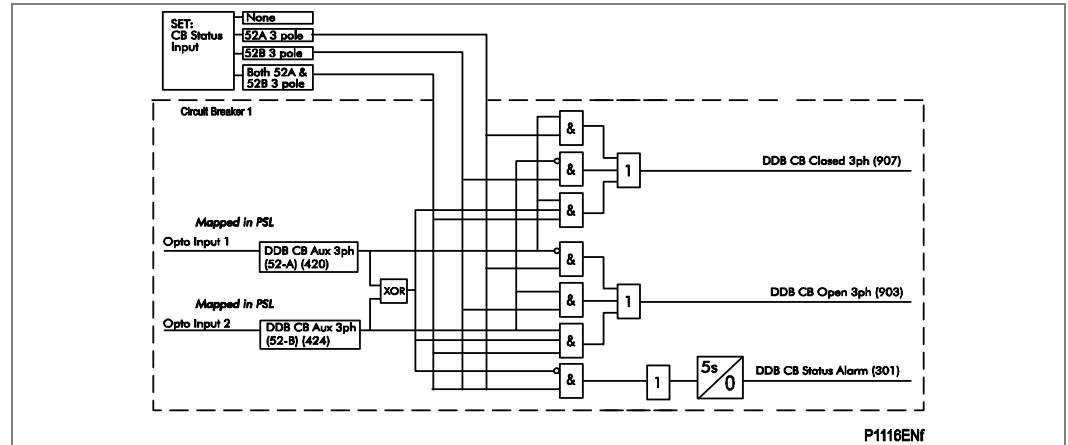

Figure 83 - Circuit breaker state monitor

2.8

Circuit Breaker Condition Monitoring

Periodic maintenance of circuit breakers is needed to ensure that the trip circuit and mechanism operate correctly and also that the interrupting capability has not been compromised due to previous fault interruptions. Generally, such maintenance is based on a fixed time interval or a fixed number of fault current interruptions. These methods of monitoring circuit breaker condition give a rough guide only and can lead to excessive maintenance. The circuit breaker monitoring features of the MiCOM relay can help with more efficient maintenance regimes.

2.8.1

Circuit Breaker Condition Monitoring Features

For each circuit breaker trip operation the relay records statistics as shown in the following table taken from the relay menu. The menu cells shown are counter values only. The Min./Max. values in this case show the range of the counter values. These cells can not be set:

Menu text	Default	Setting		Step size
		Min.	Max.	
CB Operations	0	0	10000	1
Displays the total number of 3 pole trips issued by the relay.				
Total IA Broken	0	0	25000 In [^]	1
Displays the total fault current interrupted by the relay for the A phase.				
Total IB Broken	0	0	25000 In [^]	1
Displays the total fault current interrupted by the relay for the B phase.				
Total IC Broken	0	0	25000 In [^]	1 In [^]
Displays the total fault current interrupted by the relay for the C phase.				
CB Operate Time	0	0	0.5 s	0.001
Displays the calculated CB operating time.				
Reset CB Data	No		Yes, No	
Reset the CB condition counters.				

Table 17 - CB operations Min/Max values

The above counters may be reset to zero, for example, following a maintenance inspection and overhaul.

The circuit breaker condition monitoring counters will be updated every time the relay issues a trip command. In cases where the breaker is tripped by an external protection device it is also possible to update the CB condition monitoring. This is achieved by allocating one of the relays opto-isolated inputs (using the programmable scheme logic) to accept a trigger from an external device. The signal that is mapped to the opto is called **External Trip**, DDB 115.

Note When in **Commissioning Test Mode** the CB condition monitoring counters will not be updated.

The measurement of circuit breaker operating time, broken current and the overall CB Monitoring logic are shown in the following diagrams.

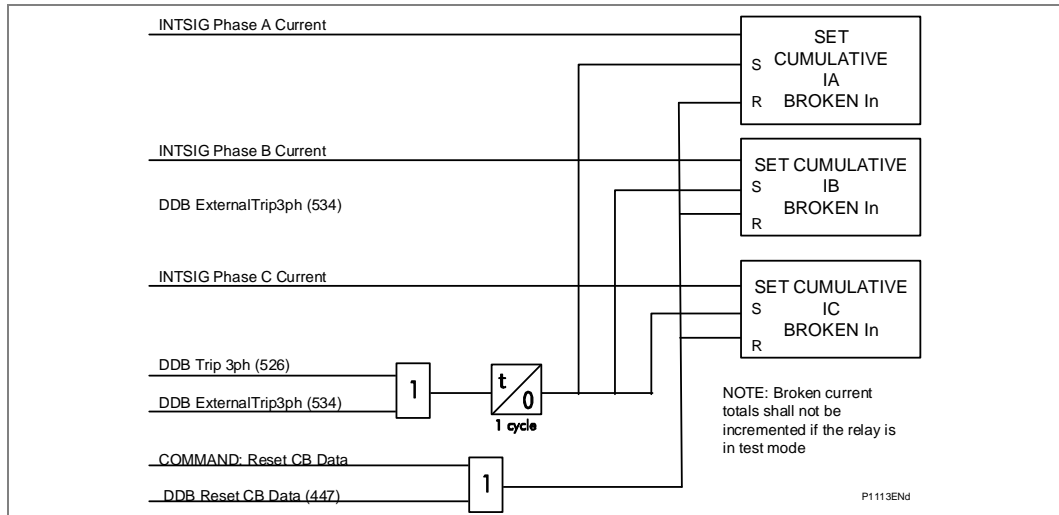

Figure 84 - Circuit breaker condition monitoring - broken current

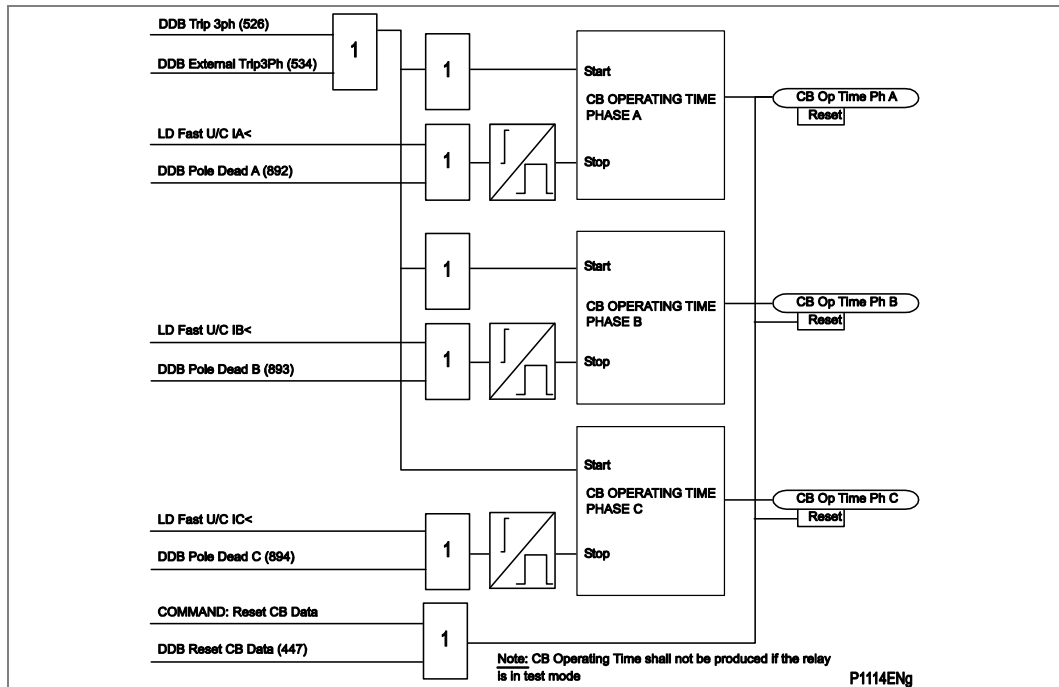

Figure 85 - Circuit breaker condition monitoring - operation time

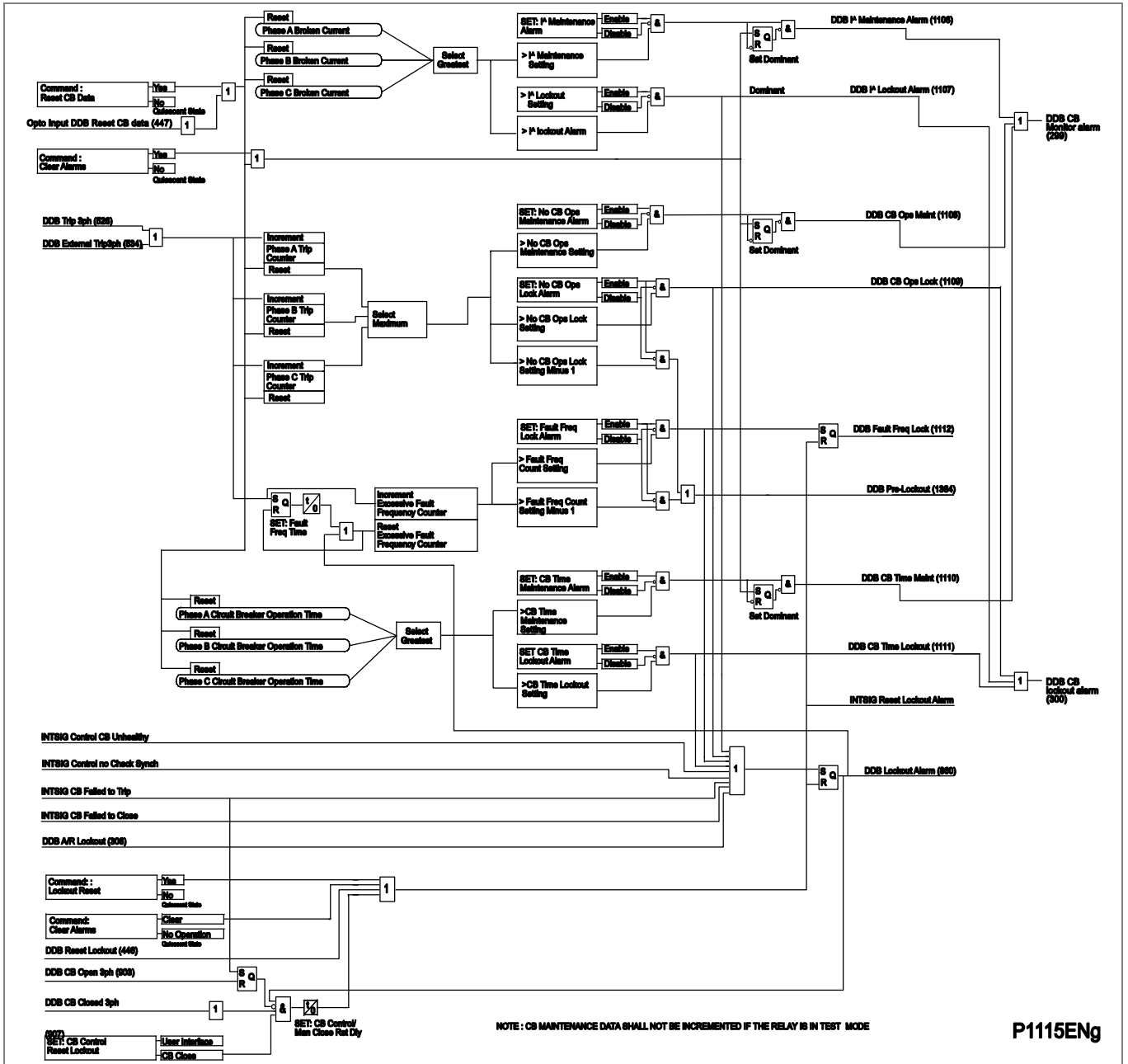

Figure 86 - CB monitoring

2.9 Circuit Breaker Control

The relay includes the following options for control of a single circuit breaker:

- Local tripping and closing, via the relay menu
- Local tripping and closing, via relay opto-isolated inputs
- Remote tripping and closing, using the relay communications

It is recommended that separate relay output contacts are allocated for remote circuit breaker control and protection tripping. This enables the control outputs to be selected via a local/remote selector switch. Where this feature is not required the same output contact(s) can be used for both protection and remote tripping.

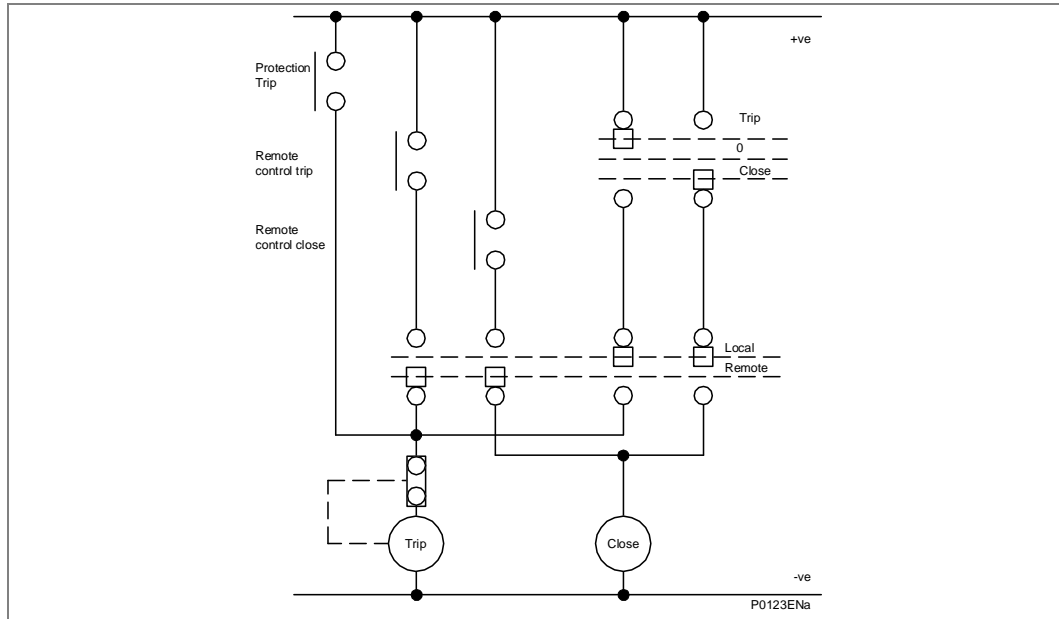

Figure 87 - Remote control of circuit breaker

A manual trip will be possible if the circuit breaker is closed. Likewise, a close command can only be issued if the CB is initially open.

Therefore, it will be necessary to use the breaker 52A and/or 52B contacts (the different selection options are given from the 'CB Status Input' cell above). If no CB auxiliary contacts are available then this cell should be set to None. Under these circumstances no CB control (manual or auto) will be possible.

A circuit breaker close command **CB Close** will initiate closing of the circuit breaker. The output contact, however, can be set to operate following a user defined time delay (**Man Close Delay**). This is designed to give personnel time to retreat from the circuit breaker following the close command. This time delay applies to all manual circuit breaker close commands.

The control close cycle can be cancelled at any time before the output contact operates by any appropriate trip signal, or by activating DDB443: **Reset Close Delay**.

An **Auto Close CB** signal from the **Auto close** logic bypasses the **Man Close Delay** time, and the **CB Close** output operate immediately to close the circuit breaker.

The length of the trip or close control pulse is set via the **Trip Pulse Time** and **Close Pulse Time** settings respectively. These should be set long enough to ensure the breaker has completed its open or close cycle before the pulse has elapsed.

<i>Note</i>	<i>The manual trip and close commands are found in the SYSTEM DATA column and the hotkey menu.</i>
-------------	--

If an attempt to close the breaker is being made, and a protection trip signal is generated, the protection trip command overrides the close command.

When the check synchronisation function ('**System check**' menu) is enabled, it can be used to control manual circuit breaker close commands. When the check synchronism criteria are satisfied, '**CBC Close**' pulse is emitted. The '**C/S Window**' time delay is used to set manual closure according to system check logic. If the system check criteria are not satisfied before that time-delay elapses, the relay will lockout and issue alarm.

In addition, a CB Healthy information (from the CB), connected to one of the relay's opto-isolators, will indicate the circuit breaker condition for closing availability. When "CB Healthy input" (DDB: '**CB Healthy**') is used, the '**Healthy Window**' time-delay can be set to adjust the manual close of the CB. If the CB does not indicate a healthy condition during this time-delay period, the relay will lockout and issue an alarm.

Where auto-reclose is used it may be desirable to block its operation when performing a manual close. In general, the majority of faults following a manual closure will be permanent faults and it will be undesirable to auto-reclose.

The 'AR Inhibit Time' setting can be used to prevent auto-reclose being initiated when the CB is manually closed onto a fault. Auto-reclose is disabled for the AR Inhibit Time following manual CB closure.

If the CB fails to respond to the control command (indicated by no change in the state of CB Status inputs) a 'CB Failed to Trip' or 'CB Failed to Close' alarm will be generated after the relevant trip or close pulses have expired. These alarms can be viewed on the relay LCD display, remotely via the relay communications, or can be assigned to operate output contacts for annunciation using the relays Programmable Scheme Logic (PSL).

Important	The 'Healthy Window' and 'C/S Window' time-delay settings are applicable <u>to manual circuit breaker operations only</u>. These are duplicated in the Auto-reclose menu for Auto-reclose applications.
------------------	--

The 'Lockout Reset' and 'Reset Lockout by' setting cells in the menu are applicable to CB Lockouts associated with manual circuit breaker closure, CB Condition monitoring (Number of circuit breaker operations, for example) and auto-reclose lockouts.

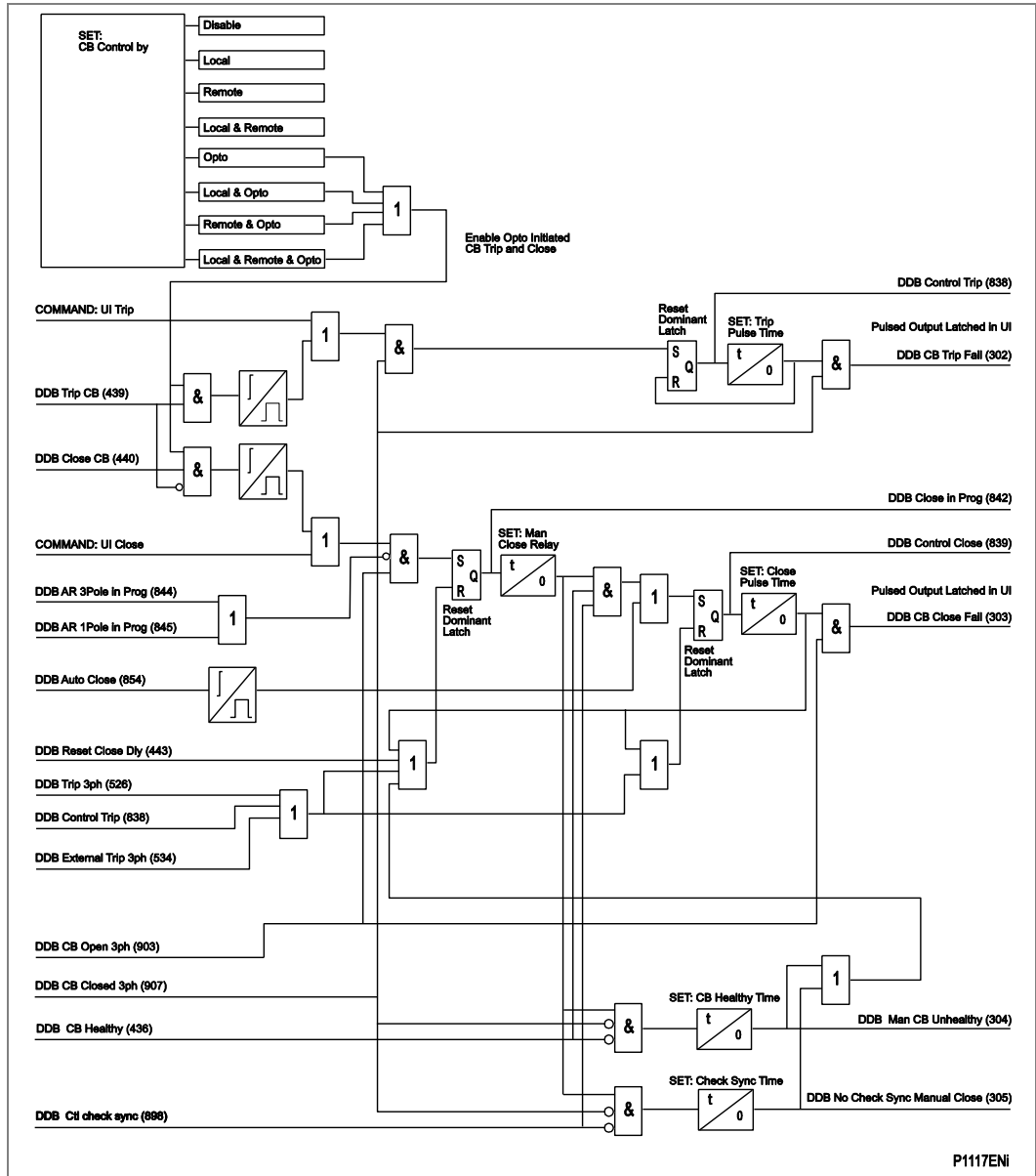

Figure 88 - Circuit breaker control

2.9.1

CB Control using Hotkeys

The hotkeys allow direct access to the manual trip and close commands without the need to use the SYSTEM DATA menu column. Red or green color coding can be applied when used in circuit breaker control applications.

IF <<TRIP>> or <<CLOSE>> is selected the user is prompted to confirm the execution of the relevant command. If a trip is executed, a screen displaying the circuit breaker status will be displayed once the command has been completed. If a close is executed a screen with a timing bar will appear while the command is being executed. This screen has the option to cancel or restart the close procedure. The timer used is taken from the manual close delay timer setting in the CB CONTROL menu. If the command has been executed, a screen confirming the present status of the circuit breaker will be displayed. The user is then prompted to select the next appropriate command or to exit - this will return to the default relay screen.

If no keys are pressed for a period of 25 seconds whilst the P445/P44y/P54x/P74x/P841 is waiting for the command confirmation, the P445/P44y/P54x/P74x/P841 will revert to showing the circuit breaker status. If no key presses are made for a period of 25 seconds whilst the P445/P44y/P54x/P74x/P841 is displaying the circuit breaker status screen, the P445/P44y/P54x/P74x/P841 will revert to the default relay screen. The *Circuit breaker control hotkey menu* diagram shows the hotkey menu associated with circuit breaker control functionality.

To avoid accidental operation of the trip and close functionality, the hotkey circuit breaker control commands are disabled for 10 seconds after exiting the hotkey menu.

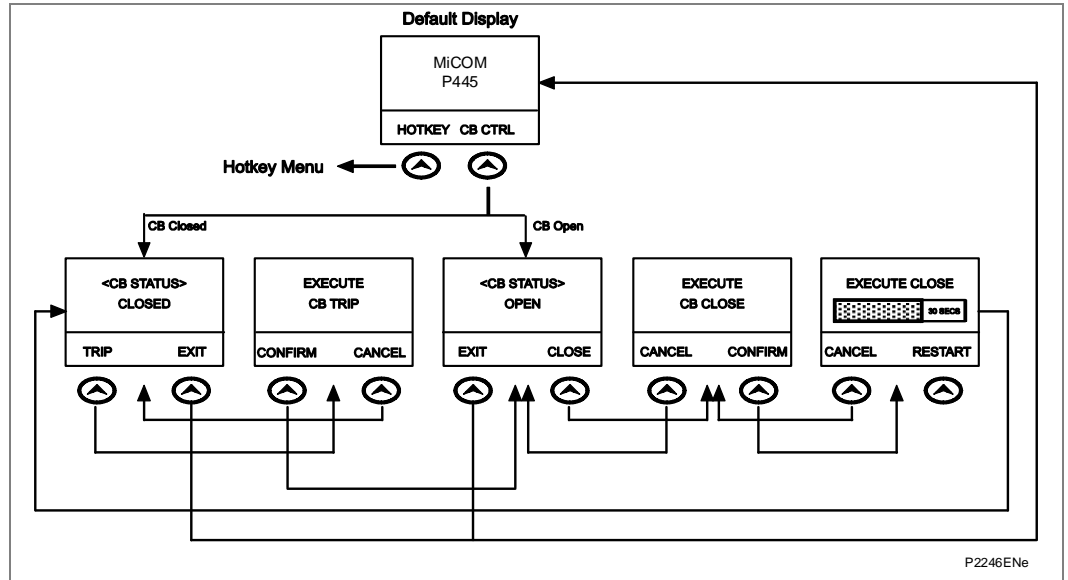

Figure 89 - CB control hotkey menu

2.10

Setting Groups Selection

The setting groups can be changed either via opto inputs, via a menu selection or via the hotkey menu. In the Configuration column if 'Setting Group - select via optos' is selected then any opto input or function key can be programmed in PSL to select the setting group as shown in the table below. If 'Setting Group - select via menu' is selected, then in the Configuration column the 'Active Settings - Group1/2/3/4' can be used to select the setting group.

The setting group can be changed via the hotkey menu providing 'Setting Group select via menu' is chosen.

Two DDB signals are available in PSL for selecting a setting group via an opto input or function key selection. The following table illustrates the setting group that is active on activation of the relevant DDB signals.

DDB 542 SG select x1	DDB 543 SG select 1x	Selected setting group
0	0	1
1	0	2
0	1	3
1	1	4

Note Each setting group has its own PSL. Once a PSL has been designed it can be sent to any one of 4 setting groups within the relay. When downloading a PSL to the relay the user will be prompted to enter the desired setting group to which it will be sent. This is also the case when extracting a PSL from the relay.

Table 18 - DDB signals and active setting groups

2.11 Control Inputs

As from Software Versions C1/D1/F1/G4/H4/J4, there are now 32 Standard Control Inputs and 16 additional Settable Control Inputs available. These are settable via the "CONTROL INPUTS" folder and are located after the standard "Control Input" labels in the relevant settings file.

The control inputs function as software switches that can be set or reset either locally or remotely. These inputs can be used to trigger any function that they are connected to as part of the PSL. There are three setting columns associated with the control inputs that are: "CONTROL INPUTS", "CTRL. I/P CONFIG." and "CTRL. I/P LABELS". The function of these columns is described below:

Menu Text	Default Setting	Setting Range	Step Size
CONTROL INPUTS			
Ctrl I/P Status	00000000000000000000000000000000		
Control Input 1	No Operation	No Operation, Set, Reset	
Control Input 2 to 32	No Operation	No Operation, Set, Reset	

Table 19 - Control inputs

The Control Input commands can be found in the **Control Input** menu. In the **Ctrl. I/P status** menu cell there is a 32-bit word which represent the 32 control input commands. The status of the 32 control inputs can be read from this 32-bit word. The 32 control inputs can also be set and reset from this cell by setting a 1 to set or 0 to reset a particular control input. Alternatively, each of the 32 Control Inputs can be set and reset using the individual menu setting cells **Control Input 1, 2, 3** etc. The Control Inputs are available through the relay menu as described above and also via the rear communications.

In the programmable scheme logic editor 32 Control Input signals which can be set to a logic 1 or On state, as described above, are available to perform control functions defined by the user.

In the PSL editor 32 Control Input signals, use DDB 191 – 223.

Menu Text	Default Setting	Setting Range	Step Size
CTRL. I/P CONFIG.			
Hotkey Enabled	11111111111111111111111111111111		
Control Input 1	Latched	Latched, Pulsed	
Ctrl Command 1	Set/Reset	Set/Reset, In/Out, Enabled/Disabled, On/Off	
Control Input 2 to 32	Latched	Latched, Pulsed	
Ctrl Command 2 to 32	Set/Reset	Set/Reset, In/Out, Enabled/Disabled, On/Off	

Table 20 - Ctrl. I/P config

Menu Text	Default Setting	Setting Range	Step Size
CTRL. I/P LABELS			
Control Input 1	Control Input 1	16 character text	
Control Input 2 to 32	Control Input 2 to 32	16 character text	

Table 21 - Ctrl. I/P labels

The **CTRL. I/P CONFIG.** column has several functions one of which allows the user to configure the control inputs as either **latched** or **pulsed**. A latched control input will remain in the set state until a reset command is given, either by the menu or the serial communications. A pulsed control input, however, will remain energized for 10ms after the set command is given and will then reset automatically (i.e. no reset command required).

In addition to the latched/pulsed option this column also allows the control inputs to be individually assigned to the **Hotkey** menu by setting **1** in the appropriate bit in the **Hotkey Enabled** cell. The hotkey menu allows the control inputs to be set, reset or pulsed without the need to enter the **CONTROL INPUTS** column. The **Ctrl. Command** cell also allows the SET/RESET text, displayed in the hotkey menu, to be changed to something more suitable for the application of an individual control input, such as **ON/OFF, IN/OUT** etc.

The **CTRL. I/P LABELS** column makes it possible to change the text associated with each individual control input. This text will be displayed when a control input is accessed by the hotkey menu, or it can be displayed in the PSL.

Note *Apart from pulsed operation, the status of the control inputs is stored in battery backed memory. If the auxiliary supply is interrupted the status of all the inputs will be recorded. Following the restoration of the auxiliary supply the status of the control inputs, prior to supply failure, will be reinstated. If the battery is missing or flat the control inputs will set to logic 0 once the auxiliary supply is restored.*

2.12

Real Time Clock Synchronization via Opto-Inputs

In modern protective schemes it is often desirable to synchronize the relays real time clock so that events from different relays can be placed in chronological order. This can be done using the IRIG-B input, if fitted, or via the communication interface connected to the substation control system. In addition to these methods, the relay offers the facility to synchronize via an opto-input by routing it in PSL to DDB 400 (Time Sync.). Pulsing this input will result in the real time clock snapping to the nearest minute if the pulse input is ± 3 s of the relay clock time. If the real time clock is within 3 s of the pulse the relay clock will crawl (the clock will slow down or get faster over a short period) to the correct time. The recommended pulse duration is 20 ms to be repeated no more than once per minute. An example of the time sync function is shown below:

Time of "Sync. Pulse"	Corrected time
19:47:00 to 19:47:29	19:47:00 This assumes a time format of hh:mm:ss
19:47:30 to 19:47:59	19:48:00

Table 22 - Time of "sync. pulse" and corrected time

To avoid the event buffer from being filled with unnecessary time sync. events, it is possible to ignore any event that generated by the time sync. opto input. This can be done by applying the following settings:

Menu text	Value
RECORD CONTROL	
Opto Input Event	Enabled
Protection Event	Enabled
DDB 062 - 032 (Opto Inputs)	Set "Time Sync." associated opto to 0

Table 23 - Record control settings

To improve the recognition time of the time sync. opto input by approximately 10 ms, the opto input filtering could be disabled. This is achieved by setting the appropriate bit to 0 in the **Opto Filter Cntl** cell in the **OPTO CONFIG** column.

Disabling the filtering may make the opto input more susceptible to induced noise. Fortunately the effects of induced noise can be minimized by using the methods described in the *Product Design* chapter.

2.13 Fault Locator

The relay has an integral fault locator that uses information from the current and voltage inputs to provide a distance to fault location. The sampled data from the analog input circuits is written to a cyclic buffer until a fault condition is detected. The data in the input buffer is then held to allow the fault calculation to be made. When the fault calculation is complete the fault location information is available in the relay fault record.

2.13.1 Data Acquisition and Buffer Processing

The fault locator stores the sampled data within a 12 cycle cyclic buffer at a resolution of 48 samples per cycle. When the fault recorder is triggered the data in the buffer is frozen such that the buffer contains 6 cycles of pre-trigger data and 6 cycles of post-trigger data. Fault calculation commences shortly after this trigger point.

The trigger for the fault recorder is user selectable via the PSL.

The fault locator can store data for up to four faults. This ensures that fault location can be calculated for all shots on a typical multiple reclose sequence.

2.13.2 Faulted Phase Selection

Phase selection is derived from the current differential protection or the superimposed current phase selector.

Phase selection and fault location calculations can only be made if the current change exceeds 5% I_n .

2.13.3 The Fault Location Calculation

This works by:

1. First obtaining the vectors
2. Selecting the faulted phase(s)
3. Estimating the phase of the fault current, I_f , for the faulted phase(s)
4. Solving the *Fault Location* equation for the fault location m at the instant of time where $I_f = 0$

2.13.4 Obtaining the Vectors

Different sets of vectors are chosen depending on the type of fault identified by the phase selection algorithm. The calculation using the *Fault Location* equation is applied for either a phase-to-ground fault or a phase-to-phase fault.

Thus for an A-phase to ground fault:

Equation 2: A-phase to ground fault

$$\begin{aligned} I_p Z_r &= I_a Z_{Line} + I_n Z_{Line} k Z_N \\ \text{And} \\ V_p &= V_A \end{aligned}$$

For an A-phase to B-phase fault:

Equation 3: A-phase to B-phase fault

$$\begin{aligned} I_p Z_r &= I_a Z_{Line} - I_b Z_{Line} \\ \text{And} \\ V_p &= V_A - V_B \end{aligned}$$

For a Ground fault:

The calculation for a ground fault is modified when mutual compensation is used:

Equation 4: ground fault

$$I_p Z_r = I_a Z_{Line} + I_n Z_{Line} k Z_N + I_m Z_{Line} k Z_m$$

2.13.5

Solving the Equation for the Fault Location

As the sine wave of I_f passes through zero, the instantaneous values of the sine waves V_p and I_p can be used to solve the *Fault Location* equation for the fault location m . (The term $I_f R_f$ being zero.)

This is determined by shifting the calculated vectors of V_p and $I_p Z_r$ by the angle $(90^\circ - \text{angle of fault current})$ and then dividing the real component of V_p by the real component of $I_p Z_r$. See the *Fault locator selection of fault current zero* diagram below.

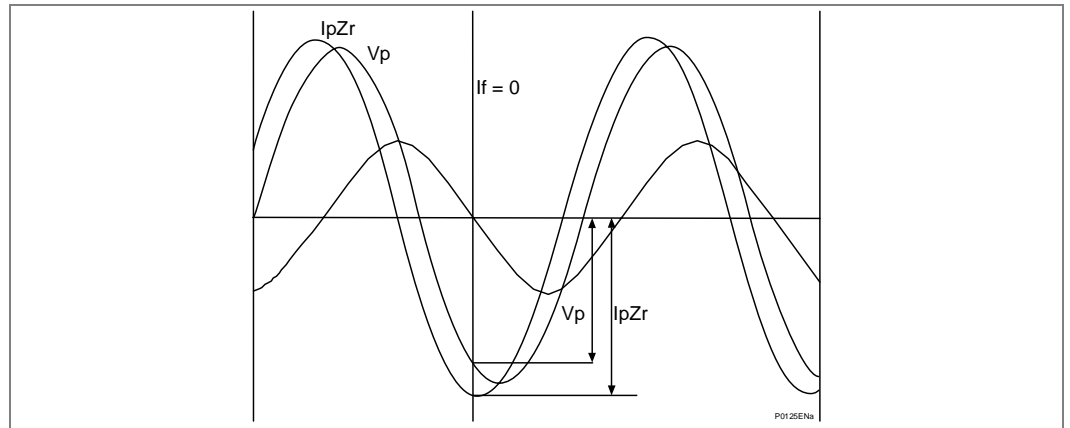

Figure 90 - Fault locator selection of fault current zero

i.e.:

Phase advanced vector V_p

$$V_p = |V_p| (\cos(s) + j\sin(s)) * (\sin(d) + j\cos(d))$$

$$V_p = |V_p| [-\sin(s-d) + j\cos(s-d)]$$

Phase advanced vector $I_p Z_r$

$$I_p Z_r = |I_p Z_r| (\cos(e) + j\sin(e)) * (\sin(d) + j\cos(d))$$

$$I_p Z_r = |I_p Z_r| [-\sin(e-d) + j\cos(e-d)]$$

Therefore from the *Fault Location* equation:

$$m = V_p \div (I_p * Z_r) \text{ at } I_f = 0$$

$$m = V_p \sin(s-d) / (I_p Z_r * \sin(e-d))$$

Where:

$$d = \text{angle of fault current } I_f$$

$$s = \text{angle of } V_p$$

$$e = \text{angle of } I_p Z_r$$

Hence, the relay evaluates m which is the fault location as a percentage of the fault locator line impedance setting and then calculates the output fault location by multiplying this by the line length setting. When calculated, the fault location can be found in the fault record under the "VIEW RECORDS" column in the Fault Location cells. Distance to fault is available in kilometers, miles, impedance or percentage of line length.

Notes:

APPLICATION NOTES

CHAPTER 6

Date:	11/2022
Products covered by this chapter:	This chapter covers the specific versions of the MiCOM products listed below. This includes only the following combinations of Software Version and Hardware Suffix.
Hardware Suffix:	L
Software Version:	K6
Connection Diagrams:	10P445xx (xx = 01 to 04)

CONTENTS

Page (AP) 6-

1	Introduction	10
1.1	Protection of Overhead Line, Cable, and Hybrid Circuits	10
2	Application of Individual Protection Functions	11
2.1	Simple and Advanced Setting Mode	11
2.2	Line Parameters Settings	11
2.2.1	Residual Compensation for Earth/Ground Faults	11
2.2.2	Selection of Starting Behaviour	12
2.3	Selection of Distance Operating Characteristic	14
2.3.1	Phase Characteristic	14
2.3.2	Ground Characteristics	14
2.4	Zone Reaches - Recommended Settings	15
2.5	Quadrilateral Ground Resistive Reaches and Tilting	16
2.5.1	Dynamic Tilting	17
2.5.2	Distance Directional Principle and Setup	19
2.5.3	Delta Directional - Selection of RCA	19
2.6	Distance Protection Zone and Timer Start Enhancements (for Software Version H3a and later)	19
2.7	Distance Setup - Filtering, Load Blinding and Polarizing	22
2.7.1	Digital Filtering	22
2.7.1.1	CVTs with Passive Suppression of Ferroresonance	22
2.7.1.2	CVTs with Active Suppression Of Ferroresonance	23
2.7.2	Load Blinding (Load Avoidance)	23
2.7.3	Recommended Polarizing Settings	23
2.8	Distance Elements Basic Scheme Setting	24
2.9	Power Swing Alarming and Blocking	25
2.10	Switch On To Fault (SOTF) and Trip On Reclose (TOR)	27
2.10.1	Switch On To Fault (SOTF) Mode	27
2.10.2	Trip on Reclose Mode	27
2.11	Directional Function - Setup of DEF Element	27
2.11.1	DEF Zero Sequence Polarization	27
2.11.2	DEF Negative Sequence Polarization	27
2.11.3	General Setting Guidelines for DEF (Directional Ground Overcurrent)	28
2.12	Distance Protection Application for Series Compensated Lines	29
2.12.1	Series Capacitor Protection	29
2.12.2	Transient Effects in Case of Line Faults	29
2.12.2.1	Reduced Apparent Fault Impedance	29
2.12.2.2	Sub-Synchronous Resonances	30
2.12.2.3	Voltage Reversal	31

2.12.2.4	Current Reversal	31
2.12.3	Distance Protection Settings Guidelines	31
2.13	Channel Aided Schemes	32
2.13.1	Distance Scheme PUR - Permissive Underreach Transfer Trip	32
2.13.2	Distance Scheme POR - Permissive Overreach Transfer Trip	32
2.13.3	Permissive Overreach Trip Reinforcement	33
2.13.4	Permissive Overreach Scheme Weak Infeed Features	33
2.13.5	Distance Scheme Blocking	33
2.13.6	Permissive Overreach Schemes Current Reversal Guard	33
2.13.7	Blocking Scheme Current Reversal Guard	33
2.13.8	Aided DEF Ground Fault Scheme - Permissive Overreach	33
2.13.9	Aided DEF Ground Fault Scheme - Blocking	34
2.14	Loss of Load (LoL) Accelerated Tripping	34
2.15	Integral Intertripping	34
2.15.1	EIA(RS)232 InterMiCOM ("Modem InterMiCOM")	35
2.15.2	InterMiCOM ⁶⁴ ("Fiber InterMiCOM")	36
2.15.2.1	Optical Budgets	36
2.15.2.2	Clock Source Setting	37
2.15.2.3	Data Rate	38
2.15.2.4	IMx Command Type	38
2.15.2.5	IMx Fallback Mode	39
2.16	Phase Fault Overcurrent Protection	39
2.16.1	Directional Overcurrent Characteristic Angle Settings	39
2.17	Thermal Overload Protection	39
2.17.1	Single Time Constant Characteristic	40
2.17.2	Dual Time Constant Characteristic	40
2.18	Earth Fault (Ground Overcurrent) and Sensitive Earth Fault (SEF) Protection	40
2.18.1	Directional Earth Fault Protection	41
2.18.1.1	Residual Voltage Polarization	41
2.18.2	General Setting Guidelines for Directional Earth Fault (Ground Overcurrent) Protection	41
2.18.3	Sensitive Earth Fault (SEF) Protection Element	41
2.19	Negative Phase Sequence (NPS) Overcurrent Protection	42
2.19.1	Negative Phase Sequence (NPS) Current Threshold, 'I ₂ > Current Set'	43
2.19.2	Time Delay for the NPS Overcurrent Element, 'I ₂ > Time Delay'	43
2.19.3	Directionalizing the Negative Phase Sequence Overcurrent Element	43
2.20	Undervoltage Protection	43
2.21	Overvoltage Protection	44
2.22	Compensated Overvoltage Protection	44
2.23	Residual Overvoltage (Neutral Displacement) Protection	45
2.23.1	Setting Guidelines	46
2.24	Circuit Breaker Fail (CBF) Protection	47
2.24.1	Breaker Fail Timer Settings	47
2.24.2	Breaker Fail Undercurrent Settings	47

2.25	Broken Conductor Detection	47
2.25.1	Setting Guidelines	48
3	Worked Example and Other Protection Tips	49
3.1	Distance Protection Setting Example	49
3.1.1	Objective	49
3.1.2	System Data	49
3.1.3	Relay Settings	49
3.1.4	Line Impedance	50
3.1.5	Residual Compensation for Ground Fault Elements	50
3.1.6	Zone 1 Phase and Ground Reach Settings	50
3.1.7	Zone 2 Phase and Ground Reach Settings	51
3.1.8	Zone 3 Phase and Ground Reach Settings	51
3.1.9	Zone 3 Reverse Reach	51
3.1.10	Zone 4 Reverse Settings with POR and BLOCKING schemes	51
3.1.11	Load Avoidance	52
3.1.12	Additional Settings for Quadrilateral Applications	52
3.1.12.1	Ground Fault Resistive Reaches (RGnd)	52
3.2	Teed Feeder Protection	53
3.2.1	The Apparent Impedance seen by the Distance Elements	53
3.2.2	Permissive Overreach (POR) Schemes	53
3.2.3	Permissive Underreach (PUR) Schemes	54
3.2.4	Blocking Schemes	55
3.3	VT Connections	56
3.3.1	Open Delta (Vee Connected) VT's	56
3.3.2	VT Single Point Earthing	56
3.4	Trip Circuit Supervision (TCS)	57
3.4.1	TCS Scheme 1	57
3.4.1.1	Scheme Description	57
3.4.1.2	Scheme 1 PSL	58
3.4.2	TCS Scheme 2a	59
3.4.2.1	Scheme Description	59
3.4.2.2	Scheme 2a PSL	59
3.4.3	TCS Scheme 2b	60
3.4.3.1	Scheme Description	60
3.4.3.2	Scheme 2b PSL	60
3.4.4	TCS Scheme 3	61
3.4.4.1	Scheme Description	61
3.4.4.2	Scheme 3 PSL	61
3.5	Fault Detector / Trip Supervision	62
3.6	Intermicom⁶⁴ Application Example	65
3.6.1	InterMiCOM ⁶⁴ Mapping for Three Ended Application – Blocking or PUR Example	65
3.6.2	Intermicom ⁶⁴ Application Example General Advice	66
3.6.3	Three-Ended Applications	66
3.6.4	Intermicom ⁶⁴ Application Example Scheme Description	67
3.6.5	Intermicom ⁶⁴ Application Example Channel Supervision	67

3.6.6	Intermicom ⁶⁴ Application Example Transfer Trip	68
3.6.7	InterMiCOM ⁶⁴ Application Example - Mapping for Two Ended Application	68
3.6.8	Intermicom ⁶⁴ Application Example - Dual Redundant Communications Channels	68
3.6.9	Intermicom ⁶⁴ Application example - Scheme Co-Ordination Timers	68
3.6.9.1	InterMiCOM ⁶⁴ Application Example - Distance PUR Permissive Underreach	68
3.6.9.2	InterMiCOM ⁶⁴ Application Example - Distance POR Permissive Overreach	68
3.6.9.3	InterMiCOM ⁶⁴ Application Example - Distance Blocking	68
3.6.9.4	InterMiCOM ⁶⁴ Application Example - Directional Earth Fault (DEF) POR Permissive Overreach	69
3.6.9.5	InterMiCOM ⁶⁴ Application Example - Directional Earth Fault (DEF) Blocking	69
3.6.10	Fallback Mode for InterMiCOM ⁶⁴ Bits	69
4	Application of Non-Protection Functions	70
4.1	Auto-Reclosing	70
4.1.1	Time Delayed and High Speed Auto-Reclosing	70
4.1.2	Auto-Reclose Logic Operating Sequence	70
4.1.3	Setting Guidelines	70
4.1.3.1	CB Healthy	70
4.1.3.2	Number of Shots	70
4.1.3.3	Dead Timer Setting	71
4.1.3.4	De-Ionizing Time	71
4.1.3.5	Example Minimum Dead Time Calculation	71
4.1.3.6	Reclaim Timer Setting	72
4.2	Current Transformer Supervision (CTS)	72
4.3	Circuit Breaker Condition Monitoring	72
4.3.1	Setting the Total Fault Current Broken Thresholds	72
4.3.2	Setting the Number of Operations Thresholds	73
4.3.3	Setting the Operating Time Thresholds	73
4.3.4	Setting the Excessive Fault Frequency Thresholds	73
4.3.5	Read Only Mode	73
5	Current Transformer (CT) Requirements	74
5.1	Zone 1 Reach Point Accuracy (RPA)	74
5.2	Zone 1 Close-Up Fault Operation	74
5.3	Recommended CT Classes (British and IEC)	74
5.4	Determining V_k for an IEEE "C" Class CT	74
6	High Break Output Contacts	75
7	Auxiliary Supply Fuse Rating	76

FIGURES

	Page (AP) 6-
Figure 1 - Zone reach setting with load blinders and underimpedance starting for application example	13
Figure 2 - Settings required to apply a Mho zone	14
Figure 3 - Settings required to apply a quadrilateral zone	15
Figure 4 - Example of high resistive zone 1 fault that falls outside zone 1 characteristic when the starting tilt angle of -3° is set (over-tilting effect)	18
Figure 5 - Distance protection zones	19
Figure 6 - Logical OR Gate	20
Figure 7 - Non-directional timer fixed logic	21
Figure 8 - Distance protection logic	22
Figure 9 - Basic time stepped distance scheme	25
Figure 10 - Overvoltage protection for series compensation (simplified)	29
Figure 11 - Effect of series capacitor location to apparent impedance for faults along the line A-B	30
Figure 12 - Apparent impedance with sub-synchronous oscillations effecting zone 1 operation (simulated data)	31
Figure 13 - Positioning of core balance current transformers	42
Figure 14 - Calculated Ferranti voltage rise on 345 kV and 765 kV lines	44
Figure 15 - Residual voltage, solidly earthed system	45
Figure 16 - Residual voltage, resistance earthed system	46
Figure 17 - System assumed for worked example	49
Figure 18 - Teed feeder application - apparent impedances seen by relay	53
Figure 19 - Teed feeder applications	54
Figure 20 - TCS scheme 1	57
Figure 21 - PSL for TCS schemes 1 and 3	58
Figure 22 - TCS scheme 2a	59
Figure 23 - PSL for TCS schemes 2a	59
Figure 24 - TCS scheme 2b	60
Figure 25 - PSL for TCS schemes 2b	60
Figure 26 - TCS scheme 3	61
Figure 27 - InterMiCOM ⁶⁴ mapping in a three ended application	65

TABLES

	Page (AP) 6-
Table 1 - Degree of compensation and resonant frequency	30
Table 2 - Recommended IM# FrameSyncTim settings	36
Table 3 - Optical budgets of the available communications interfaces	37

Table 4 - Optical budgets and maximum transmission distances for Pre-April 2008 relays	37
Table 5 - Typical operating times	38
Table 6 - Typical time constant values	40
Table 7 - Typical time constants	40
Table 8 - Typical timer settings	47
Table 9 - Resistor values for TCS scheme 1	58
Table 10 - Resistor values for TCS scheme 3	61
Table 11 - Phase Association Logic	62
Table 12 - DNP3 Mapping	64
Table 13 - Minimum Fault Arc De-Ionizing Time (Three Pole Tripping)	71

Notes:

1 INTRODUCTION

1.1 Protection of Overhead Line, Cable, and Hybrid Circuits

Transmission and distribution systems are essential to route power from the point of generation to the region(s) of demand. The means of transport is generally via overhead lines, which must have maximum in-service availability. The exposed nature of overhead lines make them fault-prone, and protection devices must trip to initiate isolation of any faulted circuit.

Most of the faults that occur on overhead lines, however, are transient or semi-permanent in nature and are cleared simply by the act of isolating the circuit. Once the fault is cleared, system stability and availability can be addressed by auto-reclosing the circuit to bring it back into service. For distribution systems, continuity of supply is of paramount importance.

In addition to fast fault clearance to prevent plant damage, the requirements for a transmission network must also take into account system stability. Where systems are not highly interconnected the use of single phase tripping and high-speed multi-shot auto-reclosure is often required. This in turn dictates the need for very high-speed protection to reduce overall fault clearance times.

Physical distance must be taken into account. Some EHV transmission lines can be up to several hundred kilometers in length. If high speed, discriminative protection is to be applied, it will be necessary to transfer information between line ends. This not only puts the onus on the security of signaling equipment but also on the protection in the event of loss of this signal.

Back-up protection is also an important feature of any protection scheme. In the event of equipment failure, such as signaling equipment or switchgear, for example, it is necessary to provide alternative forms of fault clearance. It is desirable to provide back-up protection which can operate with minimum time delay and yet discriminate with both the main protection and protection elsewhere on the system.

Distance protection on the MiCOM IED offers advanced load blinding and disturbance detection techniques such as power swing blocking to ensure stability when no tripping is required. Selectable mho and quadrilateral (polygon) characteristics allow versatile deployment as main protection for all effectively-earthed transmission and distribution circuits, whether lines, cables or hybrid (a mix of part cable, part overhead line).

Comprehensive back-up protection and control functions are also included. A choice between two integrated teleprotection schemes secures fast fault clearance over the whole length of protected lines and reduces the overall scheme cost.

The relay offers powerful recording and monitoring features, to assist with power system diagnosis and fault analysis.

2 APPLICATION OF INDIVIDUAL PROTECTION FUNCTIONS

These sections detail the individual protection functions in addition to where and how they may be applied. Worked examples show how the settings are applied to the relay. The MiCOM IED has, by ordering option, a comprehensive integrated distance protection package. This consists of:

- Phase fault distance protection
- Earth/ground fault distance protection
- Power sing detection, alarm, and blocking
- Out-of-step detection and tripping
- Switch On To Fault (SOTF) and Trip On Reclose (TOR)
- Directional Schemes
- Aided schemes

These are described in the following sections and are marked as being applicable to the distance option only. If the distance option is not specified, the following features will not be applicable.

Note *The Zone Q and General Starting features were introduced in Software H3.*

2.1 Simple and Advanced Setting Mode

The relay has two setting modes for distance protection: “**Simple**” and “**Advanced**”.

In the majority of cases, “**Simple**” setting is recommended, and allows the user merely to enter the line parameters such as length, impedances and residual compensation. Then, instead of entering distance zone impedance reaches in ohms, zone settings are entered in terms of **percentage of the protected line**. This makes the relay particularly suited to use along with any installed LFZP Optimho relays, as the reduced number of settings mimics the Autocalc facility within Opticom software.

The “**Advanced**” setting mode is recommended for the networks where the protected and adjacent lines are of dissimilar construction, requiring independent zone characteristic angles and residual compensation. In this setting mode all individual distance ohmic reach and residual compensation settings and operating current thresholds per each zone are accessible. This makes the relay adaptable to any specific application.

2.2 Line Parameters Settings

It is essential (especially when using the **simple** setting mode) that the data relating to 100% of the protected line is entered here. Take care to input the Line Impedance that correctly corresponds to either Primary or Secondary, whichever has been chosen as the basis for Settings Values in the Configuration column.

2.2.1 Residual Compensation for Earth/Ground Faults

For earth faults, residual current (derived as the vector sum of phase current inputs ($I_a + I_b + I_c$) is assumed to flow in the residual path of the earth loop circuit. Thus, the earth loop reach of any zone must generally be extended by a multiplication factor of $(1 + kZN)$ compared to the positive sequence reach for the corresponding phase fault element.



Caution

The kZN Angle is different than previous LFZP, SHNB, and LFZR relays: When importing settings from these older products, subtract. angle $\angle Z_1$.

2.2.2**Selection of Starting Behaviour**

With Software H3 and later the zone timer starting is selectable either 'Zone Start' (default) and 'General Start'. Before Software H3 only the 'Zone Start' behaviour is implemented.

The choice of the starting behaviour will be defined by the transmission or distribution system operator's philosophy. Zone starting is commonly used in English distance philosophy regions (for example, the UK, Spain and South America) while general starting is mainly used in German speaking countries and Poland.

The advantage of using 'General Starting' is a shorter fault clearance time in the case of evolving faults. If all timer stages run in parallel and the detected fault moves from an "outer zone" (e.g. zone 3) into an "inner zone" (e.g. Zone 2), the timer for the inner zone must not be started or re-started. A potential disadvantage of this selection is that fault clearance times may end up being too short to fit into the installed base.

End Timers

End timers by origin principle in mechanical relays were independent from distance zone measuring elements, to operate independently from these complex mechanics which might fail to operate. They were solely depending on general starting and directional relays. In numerical design, we have no "mechanical" (or electronic) independence, but the back-up protection philosophy of these end-timers is maintained (e.g. to avoid non-operation due to too narrow zone settings).

Application Example for an Underimpedance Starting Scheme (Software H3 and later)

For a distance protection application 3 zones in forward direction and 2 zones in reverse direction are requested. In addition a non-directional and a directional backup protection using End timers are needed. A polygonal characteristic shall be used.

The application can be solved in P44y/P54x using all six zones (see figure below):

- Polygonal tripping zones
 - Zone 1, 2 and P in forward direction
 - Zone 4 and Q in reverse direction
- Underimpedance starting (non-directional)
 - Zone 3 with offset enabled covering all other zones (highest zone reach)
 - Zone 3 tripping disabled
 - Load blinder settings effecting Zones 3
- Starting behaviour is 'General Start' using both End Timers (Non-directional and directional)

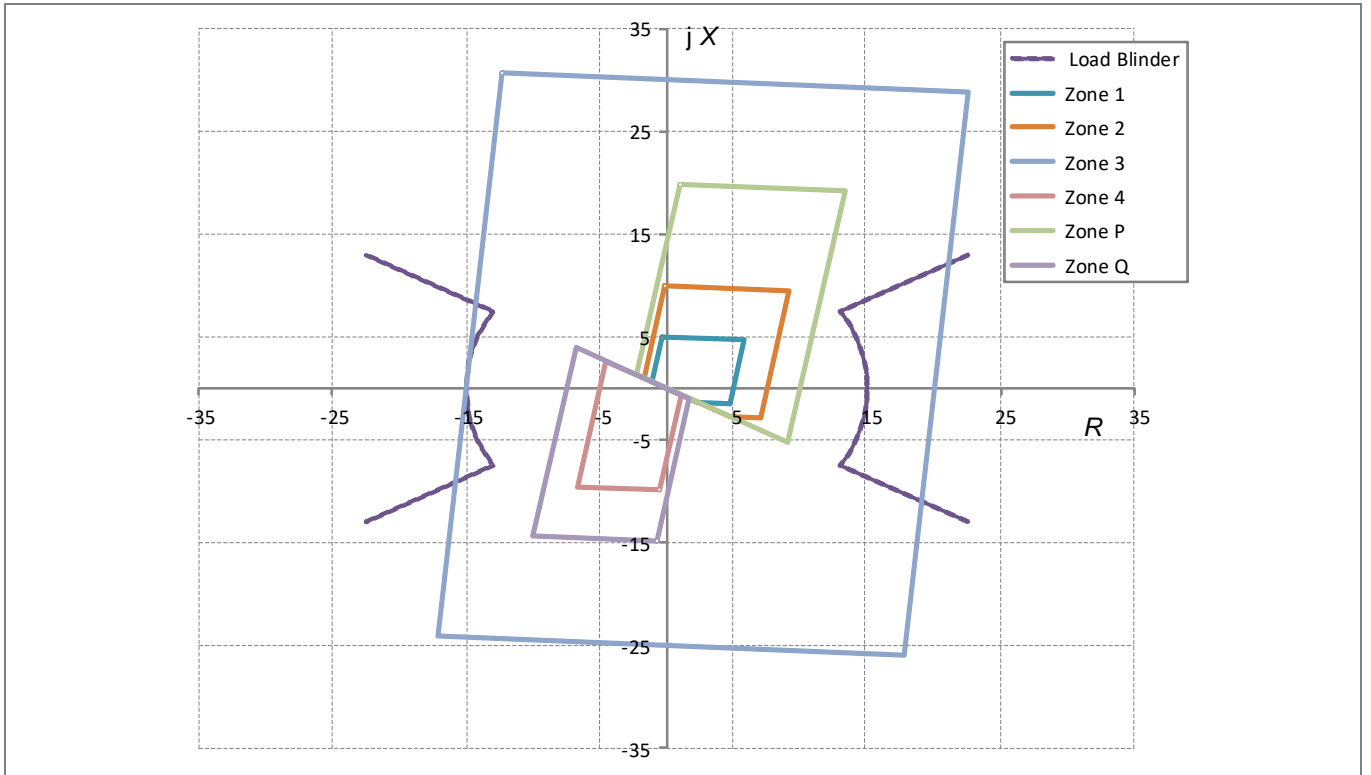

Figure 1 - Zone reach setting with load blinders and underimpedance starting for application example

2.3 Selection of Distance Operating Characteristic

In general, the following characteristics are recommended:

- Short line applications: Mho phase fault and quadrilateral earth fault zones.
- Open delta (vee-connected) VT applications: Mho phase fault, with earth fault distance **disabled**, and directional earth fault only used for earth fault protection.
- Series compensated lines: Recommend **always** to use mho characteristics for both phase and earth faults.

2.3.1 Phase Characteristic

This phase characteristics provided by the MiCOM P445 are Mhos.

The following figure shows the basic settings needed to configure a forward-looking mho zone, assuming that the load blinder is enabled.

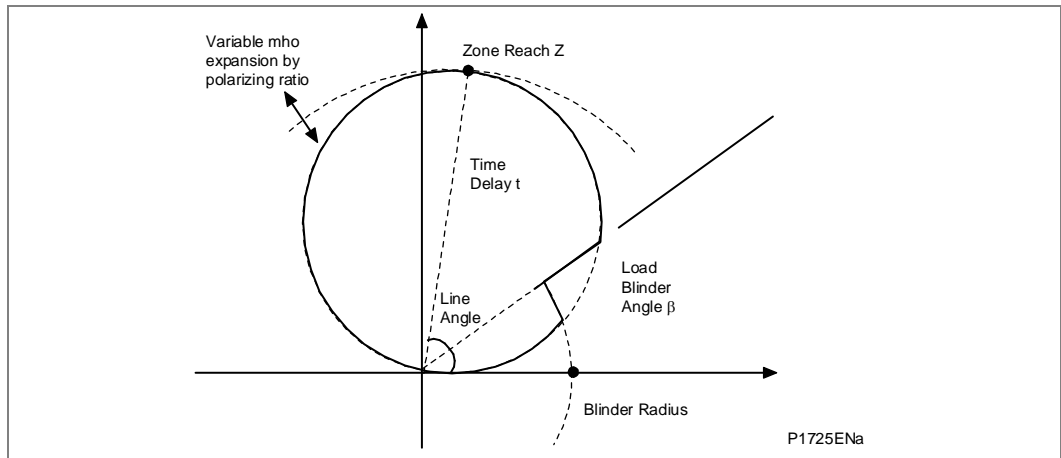

Figure 2 - Settings required to apply a Mho zone

2.3.2 Ground Characteristics

The ground characteristic selection is common to all zones, allowing mho or quadrilateral selection. Generally, the characteristic chosen will match the utility practice. If applied for line protection similarly to LFZP Optimho, LFZR, SHNB Micromho or SHPM Quadramho models in the Schneider Electric range, a mho selection is recommended. For cable applications, or to set similarly to the MiCOM P441/P442/P444 models, a quadrilateral selection is recommended.

Quadrilateral ground characteristics are recommended for all lines shorter than 10 miles (16 km). This is to ensure that the resistive fault arc coverage is not dependent on mho circle dynamic expansion, but will be a known set value.

The following figure shows the basic settings needed to configure a forward-looking quadrilateral zone (blinder not shown).

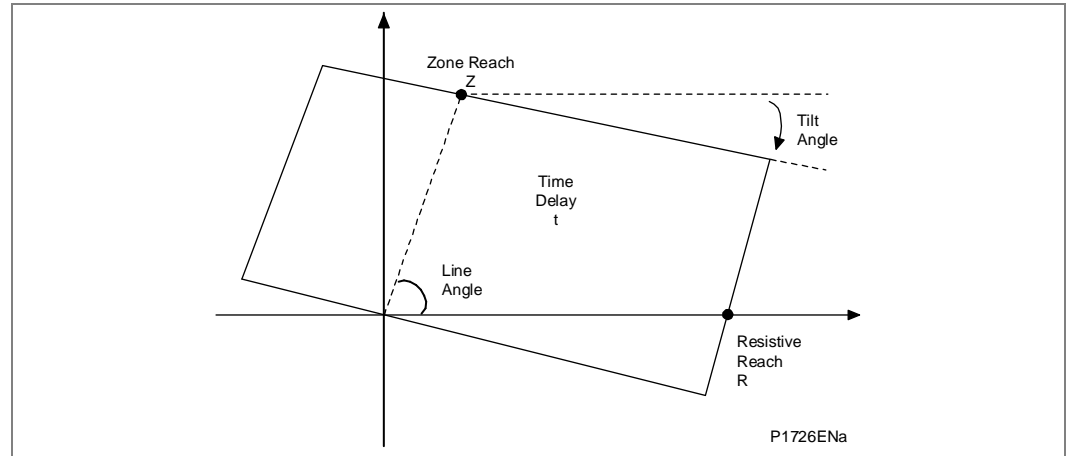

Figure 3 - Settings required to apply a quadrilateral zone

2.4

Zone Reaches - Recommended Settings

The **Zone 1** elements of a distance relay should be set to cover as much of the protected line as possible, allowing instantaneous tripping for as many faults as possible. In most applications the zone 1 reach (Z1) should not be able to respond to faults beyond the protected line. For an underreaching application the zone 1 reach must therefore be set to account for any possible overreaching errors. These errors come from the relay, the VTs and CTs and inaccurate line impedance data. It is therefore recommended that the reach of the zone 1 distance elements is restricted to 80% of the protected line impedance (positive phase sequence line impedance), with zone 2 elements set to cover the final 20% of the line.

The **Zone 2** elements should be set to cover the 20% of the line not covered by zone 1. Allowing for underreaching errors, the zone 2 reach (Z2) should be set in excess of 120% of the protected line impedance for all fault conditions. Where aided tripping schemes are used; fast operation of the zone 2 elements is required. It is therefore beneficial to set zone 2 to reach as far as possible, such that faults on the protected line are well within reach. A constraining requirement is that, where possible, zone 2 does not reach beyond the zone 1 reach of adjacent line protection. For this reason the zone 2 reach should be set to cover $\leq 50\%$ of the shortest adjacent line impedance, if possible.

The **Zone 3** elements would usually be used to provide overall back-up protection for adjacent circuits. The zone 3 reach (Z3) is therefore set to approximately 120% of the combined impedance of the protected line plus the longest adjacent line. A higher apparent impedance of the adjacent line may need to be allowed where fault current can be fed from multiple sources or flow via parallel paths.

Zone 3 may also be programmed with a slight reverse ("rev") offset, in which case its reach in the reverse direction is set as a percentage of the protected line impedance too. This would typically provide back-up protection for the local busbar, where the offset reach is set to 20% for short lines (<30 km) or 10% for longer lines.

Zone P is a reversible directional zone. The setting chosen for Zone P, if used at all, will depend upon its application. Typical applications include its use as an additional time delayed zone or as a reverse back-up protection zone for busbars and transformers. Use of zone P as an additional forward zone of protection may be required by some users to line up with any existing practice of using more than three forward zones of distance protection.

The **Zone 4** elements may also provide back-up protection for the local busbar. Where zone 4 is used to provide reverse directional decisions for Blocking or Permissive Overreach schemes, zone 4 must reach further behind the relay than zone 2 for the remote end relay. In such cases the reverse reach should be as below (depends on characteristic used):

Mho: $Z4 \geq ((\text{Remote zone 2 reach}) \times 120\%)$

Quadrilateral: $Z4 \geq ((\text{Remote zone 2 reach}) \times 120\%)$ minus the protected line impedance

Note In the case of the mho, the line impedance is not subtracted. This ensures that whatever the amount of dynamic expansion of the circle, the reverse looking zone will always detect all solid and resistive faults capable of detection by zone 2 at the remote line end.

Note Each zone has additional settings that are not accessible in the Simple set mode. For all types of characteristic, a minimum current sensitivity setting is provided in the advanced set mode.

The current sensitivity setting for each zone is used to set the minimum current that must be flowing in each of the faulted phases before a trip can occur. It is recommended to leave these settings at their default. The exception is where the relay is made more insensitive to match the lesser sensitivity of older relays existing on the power system, or to grade with the pickup setting of any ground overcurrent protection for tee-off circuits.

2.5

Quadrilateral Ground Resistive Reaches and Tilting

Two setting modes are possible for resistive reach coverage:

Common In this mode, all zones share one common fault resistive reach setting

Proportional With this mode, the aspect ratio of (zone reach): (resistive reach) is the same for all zones. The "Fault Resistance" defines a reference fault at the remote end of the line, and depending on the zone reach percentage setting, the resistive reach will be at that same percentage of the Fault Resistance set. For example, if the zone 1 reach is 80% of the protected line, its resistive reach will be 80% of the reference "Fault Resistance".

Proportional setting is used to mimic Germanic protection practice, and to avoid zones being excessively broad (large resistive reach width compared to zone reach length). In general, for easiest injection testing, the aspect ratio of any zone is best within the 1:15 range:

$$1/15 \leq Z \text{ reach} / R \text{ reach setting} \leq 15$$

The resistive reach settings (RPh and RG) should be selected according to the utility practice. If no such guidance exists, a starting point for Zone 1 is:

Cables Choose Resistive Reach = 3 x Zone 1 reach

Overhead lines Choose Resistive Reach according to the following formula:

$$\text{Resistive reach} = [2.3 - 0.0045 \times \text{Line length (km)}] \times \text{Zone 1 reach}$$

Lines longer than 400 km Choose: 0.5 x Zone 1 reach

Note Because the fault current for a ground fault may be limited by tower footing resistance, high soil resistivity, and weak infeeding, any arcing resistance is often higher than for a corresponding phase fault at the same location. It may be necessary to set the RG ground resistive settings to be higher than the RPh phase setting (i.e. boosted higher than the rule of thumb described previously). A setting of RG three times that of RPh is not uncommon.

The P443/P446/P54x/P547 allows two different methods of tilting the top reactance line:

- Automatic adjustment of the top reactance line angle
- Fix setting of the top line that will over-ride dynamic tilting

Both methods are detailed in the Operation chapter.

2.5.1

Dynamic Tilting**Medium/ Long Lines:**

In the case of medium and long line applications where Quad distance ground characteristic is used, the recommended setting is 'Dynamic tilt' enabled at starting tilt angle of -3° (as per default settings). The -3° is set to compensate for possible CT/VT and line data errors.

For high resistive faults during power exporting, the under-reaching zone 1 is only allowed to tilt down by the angle difference between the faulted phase and negative sequence current $\angle(I_{ph-I2})$ starting from the -3° set angle. This ensures stability of zone 1 for high resistance faults beyond the zone 1 reach even during heavy load conditions (high load angle between two voltage sources) and sufficient sensitivity for high resistance internal faults. The tilt angle for all other zones (that are by nature over-reaching zones) will remain at -3 deg.

In the case of power importing, zone 1 will remain at -3° whilst all other zones will be allowed to tilt up by the $\angle(I_{ph-I2})$ angle difference, starting from -3° . This will increase the zone 2 and zone 4 resistive reaches and secure correct operation in POR and blocking type schemes.

Short Lines:

For very short lines, typically below 10 Miles (16 km), the ratio of resistive to reactance reach setting (R/X) could easily exceed 10. For such applications the geometrical shape of the Quad characteristic could be such that the top reactance line is close or even crosses the resistive axis as shown below:

The below illustration shows an example of high resistive zone 1 fault that falls outside zone 1 characteristic when the starting tilt angle of -3° is set (over-tilting effect). (Distance option only)

In the case of high resistance external faults on a short line, particularly under heavy power exporting conditions, zone 1 will remain stable due to dynamic downwards tilting of the top line as explained earlier but the detection of high resistance internal faults especially towards the end of the line needs consideration. In such applications a user has a choice to either detect high resistance faults using highly sensitive Aided DEF or Delta Directional schemes or to clear the fault with distance ground protection. If distance is to operate, it is necessary to eliminate over-tilting for internal faults by reducing the initial -3° tilting angle to zero so that the overall top line tilt will equal to $\angle(I_{ph-I2})$ angle only.

As shown in the above illustration, the internal resistive fault will then fall in the zone 1 operating characteristic. However, it should be noted that for short lines the load angle is relatively low when compared to long transmission lines for the same transfer capacity and therefore the top line dynamic tilting may be moderate. Therefore it may be necessary to reduce the zone one reach to guarantee zone 1 stability. This is particularly recommended if distance is operating in an aided scheme. To summarize, for very short lines with large R/X setting ratios, it is recommended to set the initial tilt angle to zero and zone 1 reach to 70-75% of the line impedance.

Note

The above discussion assumes homogenous networks where the angle of the negative sequence current derived at relaying point is very close to the total fault current angle. If the network is non-homogenous, there will be a difference in angle that will cause inaccurate dynamic tilting, hence in such networks either quad with fixed tilt angle or even Mho characteristic should be considered in order to avoid zone 1 over-reach.

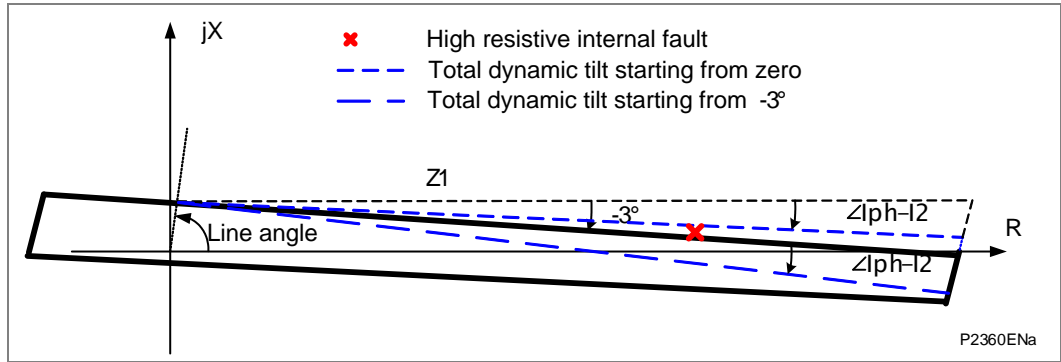

Figure 4 - Example of high resistive zone 1 fault that falls outside zone 1 characteristic when the starting tilt angle of -3° is set (over-tilting effect)

Fixed Tilt Angle:

As an alternative to Dynamic tilting, a user can set a fixed tilt angle. This is applicable to applications where the power flow direction is unidirectional.

Exporting End:

To secure stability, the tilt angle of zone 1 at exporting end has to be set negative and above the maximum angle difference between sources feeding the resistive faults. This data should be known from load flow study, but if unavailable, the minimum recommended setting would be the angle difference between voltage and current measured at local end during the heaviest load condition coupled with reduced zone 1 reach of 70-75% of the line impedance.

Note The previous illustration of a high resistive zone 1 fault shows that at sharp fixed tilt angle, the effective resistive coverage would be significantly reduced, and therefore for the short lines the dynamic tilting (with variable tilt angle depending on fault resistance and location) is preferred. For all other over-reaching zones set tilting angle to zero.

Importing End:

Set zone 1 tilt angle to zero and for all other zones the typical setting should be positive and between +(5-10)°.

Note The setting accuracy for over-reaching zones is not crucial because it will not pose a risk for relay's maloperation, the purpose is only to boost zone 2 and zone 4 reach and improve distance aided schemes.

2.5.2 Distance Directional Principle and Setup

2.5.3 Delta Directional - Selection of RCA

Distance zones are directionalized by the delta decision. For delta directional decisions, the RCA settings must be based on the average source + line impedance angle for a fault anywhere internal or external to the line. Typically, the **Delta Char Angle** is set to 60° , as it is not essential for this setting to be precise. When a fault occurs, the delta current will never be close to the characteristic boundary, so an approximate setting is good enough.

The 60° angle is associated with mainly inductive sources and will work perfectly well for most applications. However, in series compensated line applications where the capacitor is physically located behind the line VT the Delta directional characteristic angle needs adjusting. In such applications the capacitor is included in the equivalent source impedance and the overall source impedance as seen by the relay will become predominantly capacitive if the inductance of the source (normally strong source) is less than the capacitor value. In this case, the calculated operating angle during an internal fault may not fall within the default 60° delta directional line operating boundary and that could potentially lead to an incorrect (reverse) directional decision. A zero degree shift will be most suitable for such a fault, but the constraining factor is the case of external faults for which the source is always inductive regardless of the degree of compensation and for which the 60° shift is most appropriate. To ensure correct, reliable and fast operation for both fault locations in case of predominantly capacitive source, a **Delta Char Angle setting of 30° is strongly recommended.**

2.6 Distance Protection Zone and Timer Start Enhancements (for Software Version H3a and later)

Software Version H3a has modified how the Distance Protection Zone and the Timer Start functions work. This section describes how these new functions can be applied.

For the MiCOM P443/P54x, there is now enhanced distance protection which includes the ability to start all timer stages with a general starting signal. This covers a distance protection application with six different distance zones, three zones in the forward direction, two programmable zones and one zone in the backward direction. The timer stages are defined for each zone (e.g. t1, t2, t3, tP and t4), and run in parallel with the two backup timer stages (directional and non-directional end timers) t5 and t6.

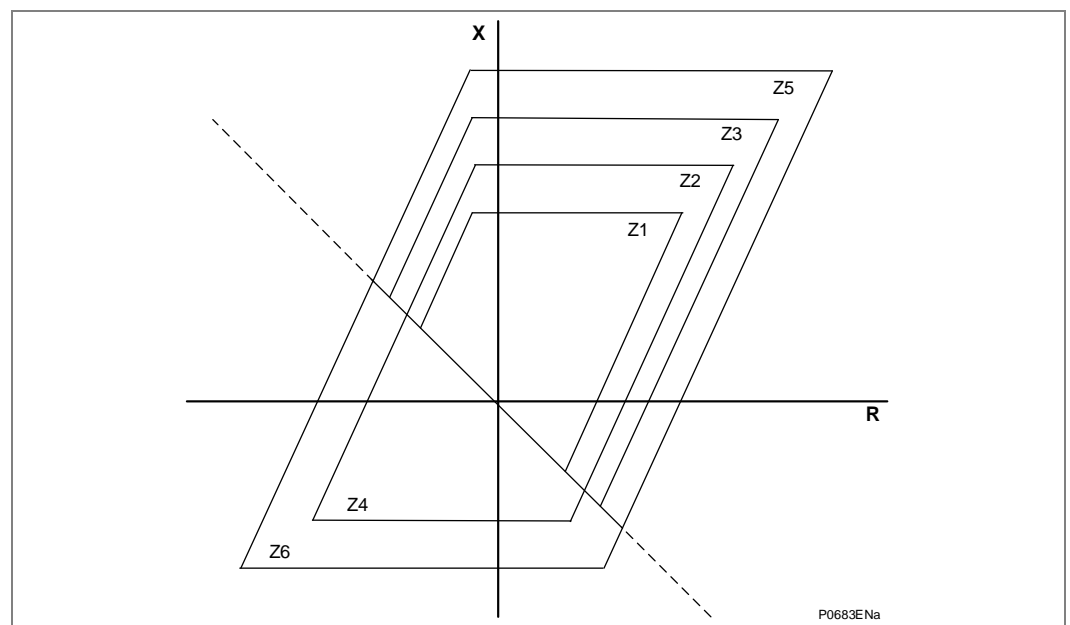

Figure 5 - Distance protection zones

This feature implements a distance zone ZQ. This ZQ zone uses the same parameters as the distance zone ZP.

To fulfill the requirements for the application these zones are required:

- Zone Z1 MiCOM P443/MiCOM P540 zone 1
- Zone Z2 MiCOM P443/MiCOM P540 zone 2
- Zone Z3 MiCOM P443/MiCOM P540 zone P
- Zone Z4 MiCOM P443/MiCOM P540 zone Q
- Zone Z5 MiCOM P443/MiCOM P540 zone 3 without configured offset
- Zone Z6 MiCOM P443/MiCOM P540 zone 4

Distance Starting Elements

The MiCOM P443/MiCOM P540 are provided with these distance starting elements:

- DELTA starting
- Zone 3 starting
- Zone 4 starting

Each of the starting elements has its own DDB numbers. This means that these can use special logical schemes (using GOOSE traffic or IM64 signal exchange) or simple signaling via PSL.

In addition to these starting DDBs, common starting information is also part of the fixed distance protection logic. Again, this common starting element has its own DDB to fulfill the specification mentioned before. This common starting information is created as a logical OR-gate, as shown in the drawing below:

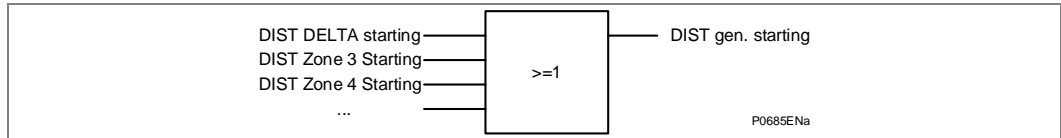

Figure 6 - Logical OR Gate

The core requirement is that the DIST General Starting picks up each time, if any of the distance function elements start. Therefore this should be the OR-combination of all DELTA and distance zone starting signals. Such solution avoids potential trouble, if the scheme has been set e.g. zone Zp reach bigger than Z3 reach.

In distance timer operating mode “with general starting“, the zone 3 and zone 4 together are used as “impedance starting zone“. In this application, the scheme settings are defined so that these zones are reaching clearly beyond any other distance zones (Z1, Z2, Zp, Zq). Also, in this scheme, their timers t3 and t4 won’t be used, but the end timers that are used are explained below.

Operating Mode “Timer Starting”

As already available in MiCOM P437 a special mode for the distance timer starting is part of the global distance settings. Two different timer modes can be configured:

- Distance Zone Starting
- Distance Gen. Starting

Within MiCOM S1 Studio, the settings are located in the Group 1 > Group 1 Distance Setup section.

Distance Timer Starting using the Operating Mode

With configured DISTANCE GEN. STARTING the distance protection timer(s) is started with the active “DIST gen. starting” signal, independent from the zone starting information. In principle, one timer may be sufficient, but when using an existing device environment it is possible to start individual zone timers in parallel.

If a timer relating to a dedicated distance zone has elapsed, the distance protection checks whether the fault is inside this zone or not. If the fault is in this zone and the related timer has elapsed, the distance protection trips (with additional info that this zone tripped). If the zone timer has elapsed and the fault impedance “moves” into this zone (e.g. because of remote CB opening), the distance protection trips too. This functionality has been implemented for each of the 6 distance zones (including the new ZQ zone).

All timers are started when distance general starting picks up, and all timers are stopped and reset to zero when general starting resets. These timers are all independent from trip decisions.

Note The advantage of this functionality is a shorter fault clearance time in the case of evolving faults. If all timer stages run in parallel and the detected fault moves from an “outer zone” (e.g. zone 3) into an “inner zone” (e.g. Zone P), the timer for the inner zone must not be started or re-started.

Note A potential disadvantage of this functionality is that fault clearance times may end up being too short to fit into the installed base.

End Timers

As described previously, the highest distance zones (for MiCOM P443/MiCOM P54x Zone 3 and Zone 4) are used for backup functionality, and the zone timers are defined as end timers. Both of them are defined for a protection direction. So the timer for the zone in forward direction (zone 3) is defined as the directional (forward) end timer, a comparable definition can be created for the zone in backward direction.

However, in some locations schemes are expected to have a dedicated non-directional end timer. This non-directional end timer has an internal fixed logic, as shown here:

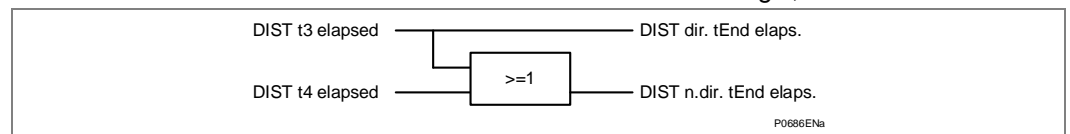

Figure 7 - Non-directional timer fixed logic

The above solution is very specific. It is preferable to implement the end timers as follows.

End timers by origin principle in mechanical relays were independent from distance zone measuring elements, to operate independently from these complex mechanics which might fail to operate. They were solely depending on general starting and directional relays. In numerical design, we have no “mechanical” (or electronic) independence, but the back-up protection philosophy of these end-timers is maintained (e.g. to avoid non-operation due to too narrow zone settings).

What is needed is:

- General fault direction information (forward or backward).
It is not specified how the direction is determined, it could be DELTA or impedance based. Notably end timers are in the order of 1...3 s, so “slow” steady state based methods are suitable.
This direction information is generalized and not measurement loop selective. This means that any loop (impedance) measurement provides “fault impedance in forward zone”, the fault direction is “forward”. By this definition, “forward” and “backward” directions could be present at the same time in case of e.g. cross-country faults or intersystem faults on double-circuit lines.
- One setting to determine the directional sense of the directional end timer.
- Two end timer settings (0-10 s in steps of 0.1 s or smaller, and “blocked” setting)
- Two signals indicating that the end timers elapsed. If such timer elapses, the DIST general trip signal shall be raised.

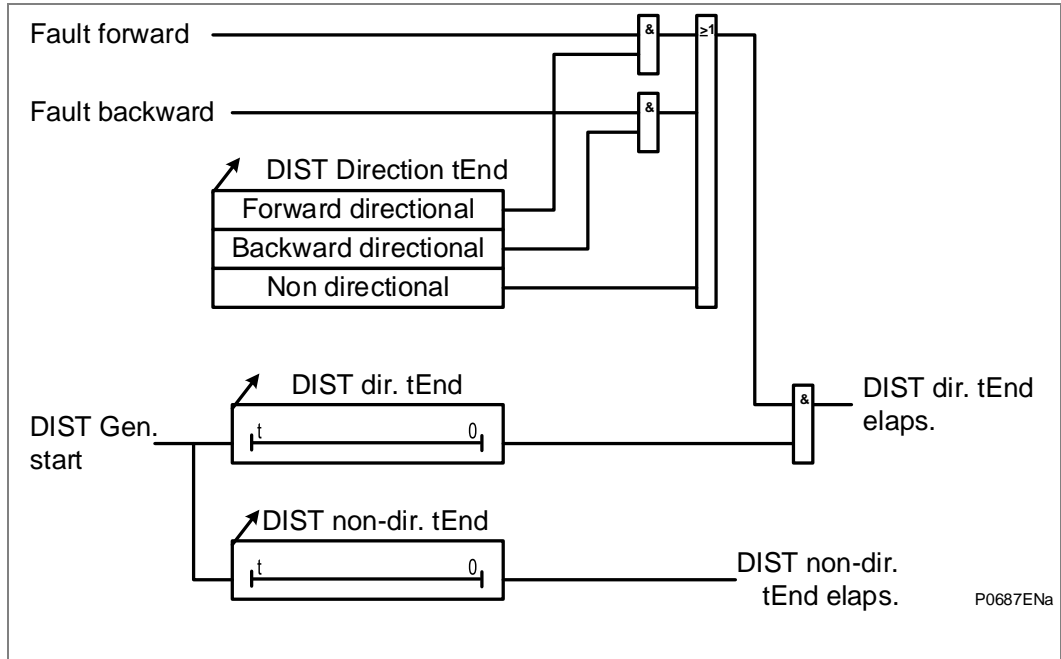

Figure 8 - Distance protection logic

Distance Timer Stage Handling

In parallel to the existing distance protection trip signals each of the elapsed timer information has its own DDB numbers. It uses this information in special logical schemes (using GOOSE traffic or IM64 signal exchange) or for simple signaling via PSL.

Distance Information

The elapsed timer information is checked to make sure it complies with communication standards.

The minimum requirement is related to the new distance zone ZQ. All zone information (starting, trip, timer elapsed ...) is provided for the communication protocols, mainly for the communication based on IEC 60870 and IEC 61850.

2.7 Distance Setup - Filtering, Load Blinding and Polarizing

2.7.1 Digital Filtering

In most applications, it is recommended that Standard filtering is used. This will ensure that the relay offers fast, sub-cycle tripping. In certain rare cases, such as where lines are immediately adjacent to High Voltage DC (HVDC) transmission, the current and voltage inputs may be severely distorted under fault conditions. The resulting non-fundamental harmonics could affect the reach point accuracy of the relay. To prevent the relay being affected, a Special set of filters are available.

Note When using the long line filter the instantaneous operating time is increased by about a quarter of a power frequency cycle.

2.7.1.1 CVTs with Passive Suppression of Ferroresonance

Set a Passive CVT filter for any type 2 CVT (those with an anti-resonance design). An SIR cutoff setting needs to be applied, above which the relay operation is deliberately slowed by a quarter of a cycle. A typical setting is SIR = 30, below which the relay will trip sub-cycle, and if the infeed is weak the CVT filter adapts to slow the relay and prevent transient overreach.

2.7.1.2 CVTs with Active Suppression Of Ferroresonance

Set an **Active** CVT filter for any type 1 CVT.

2.7.2 Load Blinding (Load Avoidance)

For security, it is highly recommended that the blinder is Enabled, especially for lines above 150 km (90 miles), to prevent non-harmonic low-frequency transients causing load encroachment problems, and for any networks where power swings might be experienced.

The impedance radius must be set lower than the worst-case loading, and this is often taken as 120% overloading in one line, multiplied by two to account for increased loading during outages or fault clearance in an adjacent parallel circuit. Then an additional allowance for measuring tolerances results in a recommended setting typically 1/3rd (or even 1/4th in some countries such as UK) of the rated full load current:

$$Z \leq (\text{Rated phase voltage } V_n) / (I_{FLC} \times 3)$$

When the load is at the worst-case power factor, it should remain below the beta setting. So, if we assume a typical worst-case 0.85 power factor, then:

$$\beta \geq \text{Cos-1 (0.85) plus } 15^\circ \text{ margin} \geq 47^\circ$$

And, to ensure that line faults are detected, $\beta \leq (\text{Line Angle} - 15^\circ)$.

In practice, an angle half way between the worst-case leading load angle, and the protected line impedance angle, is often used.

The MiCOM P443/P445/P446/P54x/P547 has a facility to allow the load blinder to be bypassed any time the measured voltage for the phase in question falls below an undervoltage V< setting. Under such circumstances, the low voltage could not be explained by normal voltage excursion tolerances on-load. A fault is definitely present on the phase in question, and it is acceptable to override the blinder action and allow the distance zones to trip according to the entire zone shape. The benefit is that the resistive coverage for faults near to the relay location can be higher.

The undervoltage setting must be lower than the lowest phase-neutral voltage under heavy load flow and depressed system voltage conditions. The typical maximum V< setting is **70% V_n**.

2.7.3 Recommended Polarizing Settings

Cable applications	In line with LFZP123 or LFZR applications for cable feeders, use only minimum 20% (0.2) memory, which results in minimum mho expansion. This keeps the protected line section well within the expanded mho, thereby ensuring better accuracies and faster operating times for close-up faults.
Series compensated lines	Use a mho with maximum memory polarizing (setting = 5). The large memory content will ensure correct operation even with the negative reactance effects of the compensation capacitors seen either within Z _s , or within the line impedance.
Short lines	For lines shorter than 10 miles (16 km), or with an SIR higher than 15, use maximum memory polarizing (setting = 5). This ensures sufficient characteristic expansion to cover fault arc resistance.
General line applications	Use any setting between 0.2 and 1.

2.8 Distance Elements Basic Scheme Setting

The **Zone 1** time delay (tZ1) is generally set to zero, giving instantaneous operation.

The **Zone 2** time delay (tZ2) is set to co-ordinate with zone 1 fault clearance time for adjacent lines. The total fault clearance time will consist of the downstream zone 1 operating time plus the associated breaker operating time. Allowance must also be made for the zone 2 elements to reset following clearance of an adjacent line fault and also for a safety margin. A typical minimum zone 2 time delay is of the order of 200 ms.

The **Zone 3** time delay (tZ3) is typically set with the same considerations made for the zone 2 time delay, except that the delay needs to co-ordinate with the downstream zone 2 fault clearance. A typical minimum zone 3 operating time would be in the region of 400 ms.

The **Zone 4** time delay (tZ4) needs to co-ordinate with any protection for adjacent lines in the relay's reverse direction.

Note (1)	<i>The MiCOM P443/P445/P446/P54x/P547 allows separate time delays to be applied to both phase and ground fault zones, for example where ground fault delays are set longer to time grade with external ground/earth overcurrent protection.</i>
Note (2)	<i>Any zone (“#”) which may reach through a power transformer reactance, and measure secondary side faults within that impedance zone should have a small time delay applied. This is to avoid tripping on the inrush current when energizing the transformer. As a general rule, if: Z# Reach setting > 50% XT transformer reactance, set: tZ# ≥ 100 ms. Alternatively, the 2nd harmonic detector that is available in the Programmable Scheme Logic may be used to block zones that may be at risk of tripping on inrush current. Settings for the inrush detector are found in the SUPERVISION menu column.</i>

Figure 9 shows the typical application of the Basic scheme.

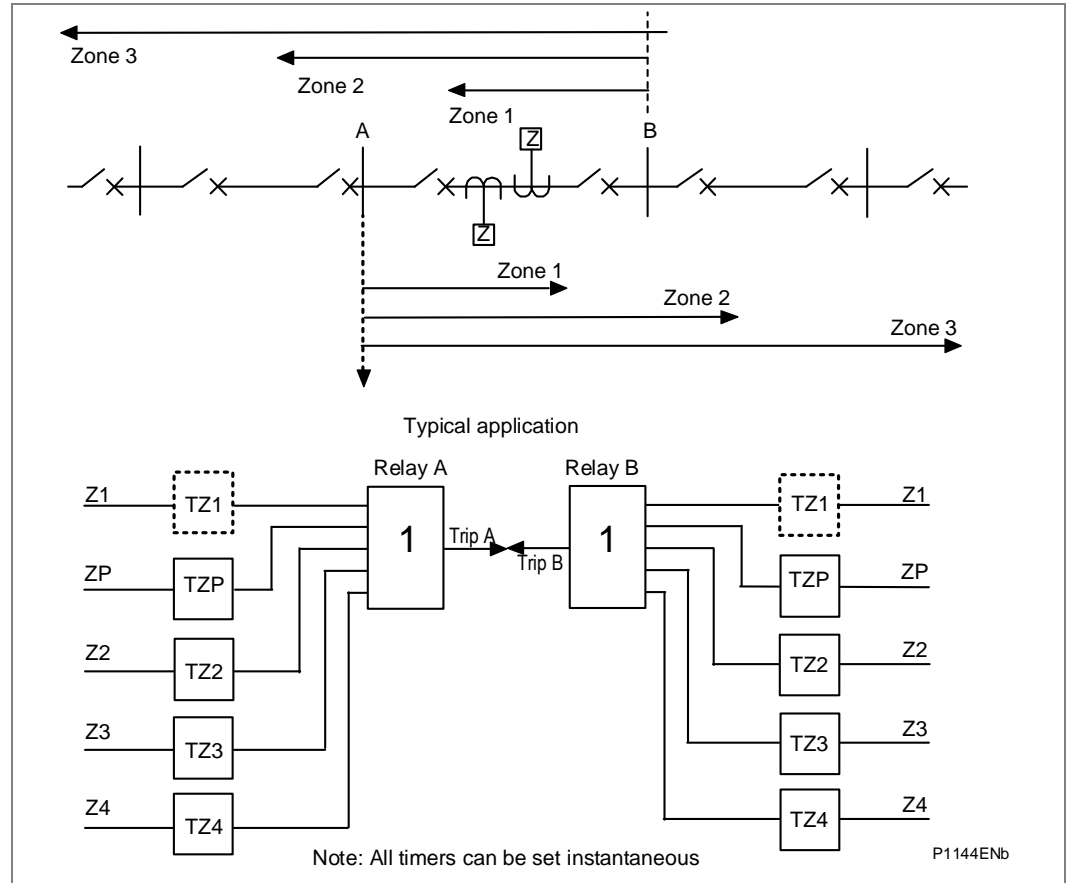

Figure 9 - Basic time stepped distance scheme

2.9

Power Swing Alarming and Blocking

Power Swing Blocking (PSB) is used to set either blocking or indication for out-of-step conditions. If blocking mode is selected, a user can individually select for each zone to be either blocked or allow tripping. The power swing detection is based on superimposed current, and is largely settings free.

The *PSB Unblock Dly* function allows any power swing block to be removed after a set period of time. For a persistent swing that does not stabilize, any blocked zones will be made free to trip once the timer has elapsed. In setting which relays will unblock, the user should consider which relay locations are natural split points for islanding the power system.

The PSB technique employed in the MiCOM P443/P445/P446/P54x/P547 has the significant advantage that it is adaptive and requires no user-set thresholds in order to detect swings faster than 0.5 Hz. The PSB relies on the delta techniques internal to the relay, which automatically detect swings. During the power oscillations slower than 0.5 Hz the continuous ΔI phase current integral to the detection technique for swing conditions may fall below the sensitive threshold of $\Delta I = 0.05 I_n$ therefore may not operate. These slow swings will usually occur following sudden load changes or single pole tripping on the weaker systems where the displacement of initial power transfer is not severe. The slow swings of up to 1 Hz are by its nature recoverable swings but the swing impedance may stay longer inside the distance characteristics until the oscillations are damped by the power system. Therefore, to guarantee system stability during very slow swings it is recommended to set a blinder to complement the automatic, setting free detection algorithm. Zone 5 is used as a blinder for slow swing detection as well as for the Out-of-Step (OST) protection described in the next section. Zone 5 settings are therefore visible even if OST protection is disabled. The slow swing condition will be declared if positive sequence impedance is detected inside zone 5 for more than a cycle without phase selection operation. The slow swing detection operates in parallel to automatic swing detection mechanism.

No system calculation is needed for zone 5 setting, it is only important to set zone 5 smaller than the minimum possible load impedance with a security margin:

In case the OST is enabled the R5, R5', Z5 and Z5' settings will be adequate for very slow swing detection. If, however, the OST protection is disabled, set:

$$R5 = R5' = 0.85 \times Z_{<}$$

$$Z5 = Z5' = 2 \times Z_{line}$$

where $Z_{<}$ is load blinder radius determined in the Load Blinding (Load Avoidance) section.

The user decides which zones are required to be blocked.

Two timers are available:

- The **PSB Reset Delay** is used to maintain the PSB status when ΔI naturally is low during the swing cycle (near the current maxima and minima in the swing envelope). A typical setting of 0.2s is used to seal-in the detection until ΔI has chance to appear again.
- The **PSB Unblock Dly** is used to time the duration for which the swing is present. The intention is to allow the distinction between a stable and an unstable swing. If after the timeout period the swing has still not stabilized, the block for selected zones can be released ("unblocking"), giving the opportunity to split the system. If no unblocking is required at the location of this relay, set to maximum.

The maximum value of the PSB Unblock Dly setting has been increased from 10 seconds to 20 seconds.

PSB can be disabled on distribution systems, where power swings would not normally be experienced.

2.10 Switch On To Fault (SOTF) and Trip On Reclose (TOR)

2.10.1 Switch On To Fault (SOTF) Mode

To ensure fast isolation of faults (for example a closed three phase earth/grounding switch) upon energization, it is recommended this feature is enabled with appropriate zones and/or 'Current No Volt' (CNV) level detectors, depend on utility practices.

When busbar VTs are used, 'Pole Dead' signal will not be produced and a user has to connect circuit breaker auxiliary contacts for correct operation. This is not necessary if the SOTF is activated by an external pulse.

SOTF delay	The time chosen should be longer than the slowest delayed-auto-reclose dead time, but shorter than the time in which the system operator might re-energize a circuit once it had opened/tripped. 110 seconds is recommended as a typical setting.
SOTF pulse	Typically this could be set to at 500 ms. This time is enough to establish completely the voltage memory of distance protection.
TOC reset delay	500 ms is recommended as a typical setting (chosen to be in excess of the 16 cycles length of memory polarizing, allowing full memory charging before normal protection resumes).

2.10.2 Trip on Reclose Mode

To ensure fast isolation of all persistent faults following the circuit breaker reclosure. It is recommended this feature is enabled with appropriate zones selected and/or 'Current No Volt' (CNV) level detectors.

TOC Delay	The TOR is activated after 'TOC Delay' has expired. The setting must not exceed the minimum AR Dead Time setting to make sure that the TOR is active immediately upon reclose command.
TOC reset delay	500 ms is recommended as a typical setting (as per SOTF).

2.11 Directional Function - Setup of DEF Element

2.11.1 DEF Zero Sequence Polarization

In practice, the typical zero sequence voltage on a healthy system can be as high as 1% (i.e.: 3% residual), and the VT error could be 1% per phase. A VNpol Set setting between 1% and 4%.Vn is typical, to avoid spurious detection on standing signals. The residual voltage measurement provided in the **Measurements** column of the menu may assist in determining the required threshold setting during commissioning, as this will indicate the level of standing residual voltage present. The Virtual Current Polarizing feature will create a VNpol which is always large, regardless of whether actual VN is present.

With DEF, the residual current under fault conditions lies at an angle lagging the polarizing voltage. Hence, negative characteristic angle settings are required for DEF applications. This is set in cell 'DEF Char Angle' in the relevant earth fault menu.

The following angle settings are recommended for a residual voltage polarized relay:

- Distribution systems (solidly earthed) ⇒ -45°
- Transmissions systems (solidly earthed) ⇒ -60°

2.11.2 DEF Negative Sequence Polarization

For negative sequence polarization, the RCA settings must be based on the angle of the upstream negative phase sequence source impedance. A typical setting is -60°.

2.11.3**General Setting Guidelines for DEF (Directional Ground Overcurrent)**

DEF forward threshold	This setting determines the current sensitivity (trip sensitivity) of the DEF aided scheme. This setting must be set higher than any standing residual current unbalance. A typical setting will be between 10 and 20% I_n .
DEF reverse threshold	This setting determines the current sensitivity for the reverse ground fault. The setting must always be below the DEF forward threshold for correct operation of Blocking scheme and to provide stability for current reversal in parallel line applications. The recommended setting is $2/3$ of DEF forward setting. This setting has to be above the maximum steady state residual current unbalance.

2.12 Distance Protection Application for Series Compensated Lines

Series compensation is applied to long transmission lines to increase the loadability (i.e. maximum electrical power transfer) of the line. The compensation is done by a series connected capacitor $X_C = -1/(\omega C)$ which reduces the effective reactance of the line $X = X_L + X_C = \omega L - 1/(\omega C)$. The degree of compensation is specified as $k_C = X_C/X_L$ and can typically reach values up to 70 % (some lines are being trialed with >100% compensation which are not discussed here). The location of the series capacitor is a matter of network planning, eventually of installation logistics, available space and costs. Therefore is typically at one line end but can be at both line ends or somewhere in the middle of the line.

2.12.1 Series Capacitor Protection

To protect the capacitor from transient overvoltages a parallel connected metal-oxide varistor (MOV) and/or spark gap are used. The spark gap is designed to bypass the capacitor in case of overvoltages caused by fault currents higher than $2 \dots 3 I_{Load}$. Depending on the overvoltage the spark gap will operate in a few milliseconds. The MOV will reduce the voltage in cases of smaller (external) fault currents. A sensitive overcurrent element detects the operated spark gap and will bypass the capacitor for the duration of the fault current using a bypass circuit breaker.

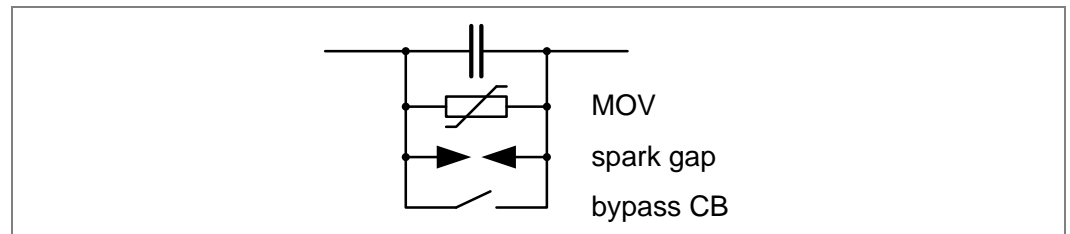

Figure 10 - Overvoltage protection for series compensation (simplified)

In case of high fault currents the spark gap will operate and the capacitor is shorted. In this case the impedance measurements and directional decision are the same as a normal line. In case of small fault currents the spark gap might not operate and the series capacitor will influence the distance protection measurements at the line ends. This effect will depend upon the capacitors location.

2.12.2 Transient Effects in Case of Line Faults

The following fault situations compare the impedance depending upon the spark gap operation.

2.12.2.1 Reduced Apparent Fault Impedance

The series compensation reduces the electrical length of the line. In Figure 11 the impedance seen by a distance relay is shown for the same line length and degree of compensation.

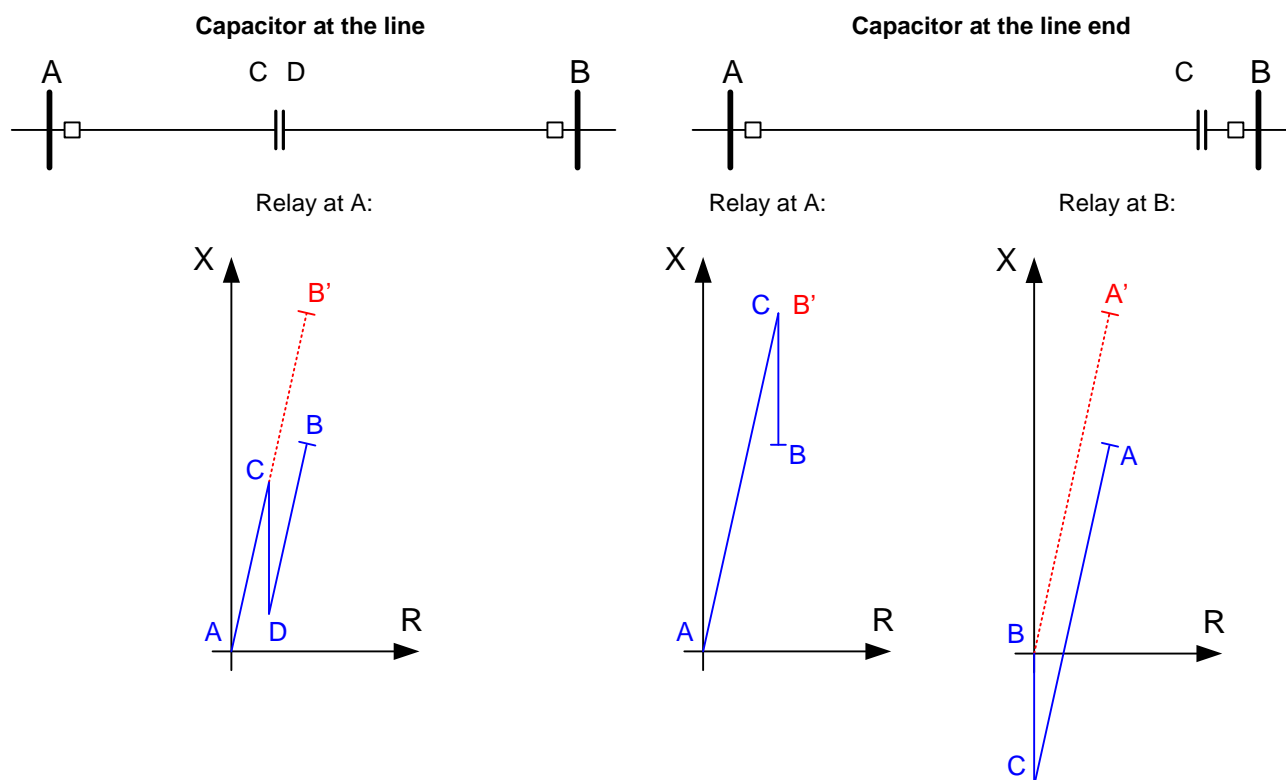

Figure 11 - Effect of series capacitor location to apparent impedance for faults along the line A-B

Depending upon the spark gap operation (solid line – capacitor active; dashed line – capacitor bypassed) a fault at the remote line end will be seen with different reaches. In case the capacitor is at the line end and in front of the relay, the apparent impedance becomes negative for close faults.

2.12.2.2

Sub-Synchronous Resonances

The line impedance and the series capacitor form an oscillating circuit R-L-C. The resonant frequency f_0 depends on the degree of compensation k_c and network frequency f_N :

degree of compensation k_c	resonant frequency f_0 for $f_N = 50$ Hz
10 %	16 Hz
30 %	27 Hz
50 %	35 Hz
70 %	42 Hz

Table 1 - Degree of compensation and resonant frequency

These oscillations overlay the fault current and voltages measured by the relay and therefore impact the apparent impedance. The damping of this sub-synchronous oscillation will depend on the network topology.

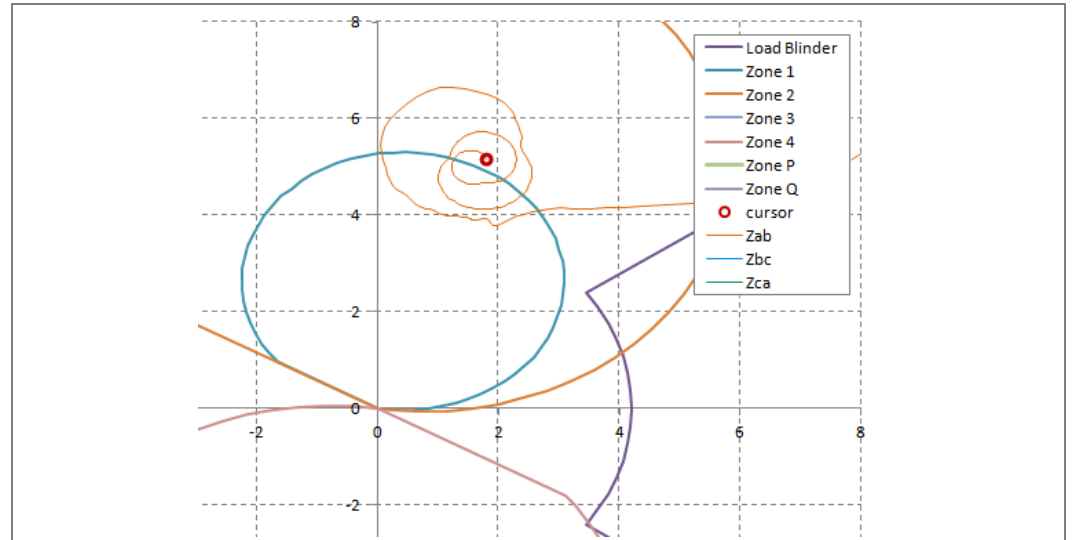

Figure 12 - Apparent impedance with sub-synchronous oscillations effecting zone 1 operation (simulated data)

In Figure 12 the apparent impedance seen by a relay using Fourier filters is plotted for sub-synchronous oscillations effecting the voltages and currents for an external fault. The trajectory crosses several times the zone 1 MHO characteristic. An overreach is likely to occur.

2.12.2.3

Voltage Reversal

If the apparent fault reactance is negative ($X = f \cdot X_L + X_C < 0$) and the total fault loop impedance (including the source reactance X_{src}) is still positive, the measured voltage will lag behind the current. The directional decision will be faulty in cases where the polarizing voltage is made up on the phase voltages only. Incorporating memorized voltages will ensure correct directional decisions. A MHO relay with a high proportion of memory polarization will dynamically expand and detect the fault correctly. Therefore a MHO characteristic with a high amount of memorized voltage is required.

2.12.2.4

Current Reversal

In extreme cases the effective fault current loop reactance becomes negative ($X = X_{src} + f \cdot X_L + X_C < 0$) – this might be the case for a high degree of compensation and faults in close-up range – a capacitive fault current will flow. In such situations the directional decision (based on a voltage memory) will not be correct. Delta-Directional principles (i.e. directional evaluation based on ΔU and ΔI quantities) will perform better under such conditions and should be preferred. Also line differential protection will not operate for internal faults due to the current reversal. Typically faults close to the relay will result in high fault currents which will trigger the spark gap and current reversal will not occur.

2.12.3

Distance Protection Settings Guidelines

Due to the transient effects it is recommended to perform a network study if distance protection is applied for series compensated lines. Also the impact of series compensation on adjacent lines needs to be considered.

The traditional approach of setting zone 1 reach at about 80% of the line impedance does not work for series compensated lines due to the reduced apparent impedance and sub-synchronous oscillations explained above. The zone 1 will overreach the series compensated line in case the spark gap does not bypass the capacitor and will trip the line for external faults, which is commonly not accepted.

A common approach for zone 1 reach setting is:

$$X_1 = k_{trans} \cdot k_{st}(X_L + X_C)$$

with:

$X_L = \omega L$ line reactance,
 $X_C = -1/(\omega C)$ series capacitor reactance,
 k_{st} reach grading factor (around 0.8),
 k_{trans} transient factor considering the sub-synchronous oscillations
 (based on system studies)

Zone 2 reach setting is chosen as for non-compensated lines (considering the capacitor is bypassed). This approach will lead to a potential overreach in case the capacitor is not bypassed. It can be accepted as the zone 2 operation is typically just a backup to the unit protection with line differential and signaling scheme. Cross polarized MHO characteristic with a high amount of memorized voltage is recommended.

Example

Series compensated line with grading factor $k_{st} = 0.85$, transient factor $k_{trans} = 0.7$, degree of compensation $k_C = 50\%$:

$$X_1 = 0.7 \cdot 0.85(X_L - 0.5 \cdot X_L) = 0.3X_L$$

That means only 30 % of the series compensated line is protected in zone 1 (instantaneous tripping). Distance aided schemes (e.g. POR) are therefore highly recommended for full line protection with fast tripping.

2.13 Channel Aided Schemes

The MiCOM P443/P445/P446/P54x/P547 offers two sets of aided channel (“pilot”) schemes, which may be operated in parallel.

Aided Scheme 1 May be keyed by distance and/or DEF and/ or delta directional comparison

Aided Scheme 2 May be keyed by distance and/or DEF and/ or delta directional comparison

When schemes share the same channel, the same generic scheme type will be applied - i.e. ALL Permissive Overreach, or ALL Blocking.

2.13.1 Distance Scheme PUR - Permissive Underreach Transfer Trip

This scheme is similar to that used in the MiCOM P44x (see note) distance relays. It allows an instantaneous Z2 trip on receipt of the signal from the remote end protection.

Note Matches PUP Z2 mode in P44x (P442/P444).

Send logic: Zone 1
 Permissive trip logic: Zone 2 plus Channel Received

The “Dist dly” trip time setting should be set to Zero, for fast fault clearance.

2.13.2 Distance Scheme POR - Permissive Overreach Transfer Trip

This scheme is similar to that used in the MiCOM P44x (see note) distance relays. The POR scheme also uses the reverse looking zone 4 of the relay as a reverse fault detector. This is used in the current reversal logic and in the optional weak infeed echo feature.

Note Matches POP Z2 mode in P44x (P442/P444).

Send logic: Zone 2
 Permissive trip logic: Zone 2 plus Channel Received

The “Dist dly” trip time setting should be set to Zero, for fast fault clearance.

2.13.3 Permissive Overreach Trip Reinforcement

The send logic in the POR scheme is done in such a way that for any trip command at the local end, the relay sends a channel signal to the remote end(s) in order to maximize the chances for the fault to be isolated at all ends.

Note The send signal is generated by the '**Any trip**' command and is sent on both channels, Ch1 and Ch2, if more than one channel is in use. This feature is termed **permissive trip reinforcement**, and is a deliberate attempt to ensure that synchronous tripping occurs at all line ends.

2.13.4 Permissive Overreach Scheme Weak Infeed Features

Where weak infeed tripping is employed, a typical voltage setting is 70% of rated phase-neutral voltage. Weak infeed tripping is time delayed according to the **WI Trip Delay** value, usually set at 60 ms.

2.13.5 Distance Scheme Blocking

To allow time for a blocking signal to arrive, a short time delay on aided tripping, "**Dist dly**", must be used, as follows:

Recommended Dly setting = Max. Signaling channel operating time + 1 power frequency cycle.

This scheme is similar to that used in the LFZP Optimho, SHNB Micromho, LFZR, and MICOM P44x (see note) distance relays.

Note Matches BOP Z2 mode in P441/P442/P444.

Send logic: Reverse Zone 4

Trip logic: Zone 2, plus Channel NOT Received, delayed by Tp

Note Two variants of a Blocking scheme are provided, Blocking 1 and Blocking 2. Both schemes operate identically, except that the reversal guard timer location in the logic changes. Blocking 2 may sometimes allow faster unblocking when a fault evolves from external to internal, and hence a faster trip.

2.13.6 Permissive Overreach Schemes Current Reversal Guard

The recommended setting is:

tREVERSAL GUARD = Maximum signaling channel reset time + 35 ms.

2.13.7 Blocking Scheme Current Reversal Guard

The recommended setting is:

- Where Duplex signaling channels are used:
tREVERSAL GUARD = Maximum signaling channel operating time + 20 ms.
- Where Simplex signaling channels are used:
tREVERSAL GUARD = Maximum signaling channel operating time - minimum signaling channel reset time + 20 ms.

2.13.8 Aided DEF Ground Fault Scheme - Permissive Overreach

This POR scheme is similar to that used in all other Schneider Electric relays.

Send logic: IN> Forward pickup

Permissive trip logic: IN> Forward plus Channel Received

Note The Time Delay for a permissive scheme aided trip would normally be set to zero.

2.13.9 Aided DEF Ground Fault Scheme - Blocking

This scheme is similar to that used in all other Schneider Electric relays.

Send logic: DEF Reverse

Trip logic: IN> Forward, plus Channel NOT Received, with a small set delay

To allow time for a blocking signal to arrive, a short time delay on aided tripping must be used.

The recommended

Time Delay setting = max. Signaling channel operating time + 20 ms.

2.14 Loss of Load (LoL) Accelerated Tripping

For circuits with load tapped off the protected line, care must be taken in setting the Loss of Load (LoL) feature to ensure that the I< level detector setting is above the tapped load current. When selected, the LoL feature operates in conjunction with the main distance scheme that is selected. In this way it provides high speed clearance for end zone faults when the Basic scheme is selected or, with permissive signal aided tripping schemes, it provides high speed back-up clearance for end zone faults if the channel fails.

2.15 Integral Intertripping

MiCOM P443/P445/P446/P54x devices support integral intertripping in the form of InterMiCOM.

InterMiCOM can use an auxiliary EIA(RS)232 connection (MODEM InterMiCOM), or it can be realised by means of an integral optical fiber communication connection (fiber InterMiCOM, or InterMiCOM⁶⁴). An EIA(RS)232 (MODEM) InterMiCOM provides a single, full duplex communication channel, suitable for connection between two MiCOM P443/P445/P446/P54x relays. The fiber InterMiCOM (InterMiCOM⁶⁴) can provide up to two full-duplex communications channels. It can be used to connect two MiCOM P443/P445/P446/P54x relays using a single channel, or redundancy can be added by using dual communications. Alternatively, InterMiCOM⁶⁴ can be used to connect three MiCOM P443/P445/P446/P54x devices in a triangulated scheme for the protection of Teed feeders. MODEM InterMiCOM and InterMiCOM⁶⁴ are completely independent. They have separate settings, are described by separate DDB signals.

As a general rule, where possible, InterMiCOM⁶⁴ would be preferable from an application point of view since it is faster, and based on optical fibers it has high immunity to electromagnetic interference. If the high speed communication channel requirement of InterMiCOM⁶⁴ cannot be provided, EIA(RS)232 provides a cost effective alternative.

Because of the differences between the implementation of EIA(RS)232 InterMiCOM and InterMiCOM⁶⁴, the settings associated with each implementation are different. Refer to the Settings chapter for details. It can be seen that there are settings to prevent inadvertent cross-connection or loopback of communications channels (address settings), settings to accommodate different channel requirements (baud rate, clock source, channel selection) as well as the different settings used for channel quality monitoring and signal management actions in the event of channel failures.

The received InterMiCOM signals are continually monitored for quality and availability. In the event of quality or availability of the received signals falling below set levels, then an alarm can be raised.

Note

An alarm indicating the signaling has failed, refers only to the incoming signals. The remote relay will monitor the other direction of the communications link for quality of transmission. If indication of the quality of the signal transmitted from the local relay for reception at the remote relay is required, then one of the InterMiCOM command channels can be used to reflect this back.

2.15.1

EIA(RS)232 InterMiCOM (“Modem InterMiCOM”)

The settings needed for the implementation of MODEM InterMiCOM are stored in two columns of the menu structure. The first column entitled **INTERMICOM COMMS** contains all the information to configure the communication channel and also contains the channel statistics and diagnostic facilities. The second column entitled **INTERMICOM CONF** selects the format of each signal and its fallback operation mode.

The settings needed for the InterMiCOM signaling are largely dependant on whether a direct or indirect (modem/multiplexed) connection between the scheme ends is used.

Direct connections will either be short metallic or dedicated fiber optic based (by means of suitable EIA(RS)232 to optical fiber converters) and hence can be set to have the highest signaling speed of 19200b/s. Due to this high signaling rate, the difference in operating speed between the direct, permissive and blocking type signals is so small that the most secure signaling (direct intertrip) can be selected without any significant loss of speed. In turn, since the direct intertrip signaling requires the full checking of the message frame structure and CRC checks, it would seem prudent that the **IM# Fallback Mode** be set to Default with a minimal intentional delay by setting **IM# FrameSyncTim** to 10 msec. In other words, whenever two consecutive messages have an invalid structure, the relay will immediately revert to the default value until a new valid message is received.

For indirect connections, the settings that can be applied will become more application and communication media dependent. As for the direct connections, consider only the fastest baud rate but this will usually increase the cost of the necessary modem/multiplexer. In addition, devices operating at these high baud rates may suffer from **data jams** during periods of interference and in the event of communication interruptions, may require longer re-synchronization periods. Both of these factors will reduce the effective communication speed thereby leading to a recommended baud rate setting of 9.6 kbit/s. As the baud rate decreases, the communications will become more robust with fewer interruptions, but the overall signaling times will increase.

Since it is likely that slower baud rates will be selected, the choice of signaling mode becomes significant. However, once the signaling mode has been chosen it is necessary to consider what should happen during periods of noise when message structure and content can be lost. If **Blocking** mode is selected, only a small amount of the total message is actually used to provide the signal, which means that in a noisy environment there is still a good likelihood of receiving a valid message. In this case, it is recommended that the **IM# Fallback Mode** is set to **Default** with a reasonably long **IM# FrameSyncTim**. A typical default selection of Default = 1 (blocking received substitute) would generally apply as the failsafe assignment for blocking schemes.

If **Direct Intertrip** mode is selected, the whole message structure must be valid and checked to provide the signal, which means that in a very noisy environment the chances of receiving a valid message are quite small. In this case, it is recommended that the **IM# Fallback Mode** is set to **Default** with a minimum **IM# FrameSyncTim** setting i.e. whenever a non-valid message is received, InterMiCOM will use the set default value. A typical default selection of Default = 0 (intertrip NOT received substitute) would generally apply as the failsafe assignment for intertripping schemes.

If **Permissive** mode is selected, the chances of receiving a valid message is between that of the **Blocking** and **Direct Intertrip** modes. In this case, it is possible that the **IM# Fallback Mode** is set to **Latched**. The table below highlights the recommended **IM# FrameSyncTim** settings for the different signaling modes and baud rates:

Baud rate	Minimum recommended "IM# FrameSyncTim" Setting		Minimum setting (ms)	Maximum setting (ms)
	Direct intertrip mode	Blocking mode		
600	100	250	100	1500
1200	50	130	50	1500
2400	30	70	30	1500
4800	20	40	20	1500
9600	10	20	10	1500
19200	10	10	10	1500

Note No recommended setting is given for the Permissive mode since it is anticipated that **Latched** operation will be selected. If **Default mode** is selected, the **IM# FrameSyncTim** setting should be set greater than the minimum settings listed above. If the **IM# FrameSyncTim** setting is set lower than the minimum setting listed above, there is a danger that the relay will monitor a correct change in message as a corrupted message.

A setting of 25% is recommended for the communications failure alarm.

Table 2 - Recommended IM# FrameSyncTim settings**2.15.2****InterMiCOM⁶⁴ ("Fiber InterMiCOM")****2.15.2.1****Optical Budgets****Optical Budgets**

InterMiCOM⁶⁴ supports teleprotection schemes using optical fiber communications. The optical fiber communications may connect directly between line ends of the MiCOM scheme, or they may use digital data channels provided by some form of telecommunications multiplexing equipment. Some multiplexers support direct optical fiber connection as described in the IEEE C37.94 standard. Some multiplexers will require connection using an electrical interface. InterMiCOM⁶⁴ has a number of different optical fiber configurations to allow direct electrical connection between line ends, direct multiplexer connection to IEEE 37.94, or, by means of associated P-2M-L interface units, indirect (electrical) multiplexer connections (to G.703).

When applying any of the InterMiCOM⁶⁴ teleprotection schemes, it is important to select the appropriate communications interface. This will depend on the fiber used and distance between devices. The following table shows the optical budgets of the available communications interfaces.

From April 2008	850nm Multi Mode	1300nm Multi Mode	1310nm Single Mode
Min. transmit output level (average power)	-19.8dBm	-6dBm	-6dBm
Receiver sensitivity (average power)	-25.4dBm	-49dBm	-49dBm
Optical budget	5.6dB	43.0dB	43.0dB
Less safety margin (3dB)	2.6dB	40.0dB	40.0dB
Typical cable loss	2.6dB/km	0.8dB/km	0.4dB/km
Max. transmission distance	1km	50.0km	100.0km

Note From April 2008, the optical budgets and hence also the maximum transmission distances of the 1300nm multi-mode and 1310nm single-mode fiber interfaces have been increased, to the values shown in the table above.

Table 3 - Optical budgets of the available communications interfaces

The new interface cards are identified by “43dB” marked in the centre of the back-plate, visible from the rear of the relay. These new fiber interfaces are fully backward-compatible with the original equivalent interface. However, to achieve the increased distance, both/all ends of the P443/P445 scheme would need to use the new interface. Pre-April 2008 relays will have the original optical budgets and maximum transmission distances, as shown below.

Pre-April 2008	850nm Multi Mode	1300nm Multi Mode	1310nm Single Mode
Min. transmit output level (average power)	-19.8dBm	-10dBm	-10dBm
Receiver sensitivity (average power)	-25.4dBm	-37dBm	-37dBm
Optical budget	5.6dB	27.0dB	27.0dB
Less safety margin (3dB)	2.6dB	24.0dB	24.0dB
Typical cable loss	2.6dB/km	0.8dB/km	0.4dB/km
Max. transmission distance	1km	30.0km	60.0km

Table 4 - Optical budgets and maximum transmission distances for Pre-April 2008 relays

The total optical budget is given by transmitter output level minus the receiver sensitivity and will indicate the total allowable losses that can be tolerated between devices. A safety margin of 3dB is also included in the above table. This allows for degradation of the fiber as a result of ageing and any losses in cable joints. The remainder of the losses will come from the fiber itself. The figures given are typical only and should only be used as a guide.

In general, the 1300nm and 1310nm interfaces will be used for direct connections between relays. The 850nm would be used where multiplexing equipment is employed.

2.15.2.2

Clock Source Setting

Clock Source Setting

A clock source is required to synchronize data transmissions between the system ends. This may be provided either by the MiCOM relays (internal) or may be a function of the telecommunications equipment (external). The relays have a setting for each of Channel 1 and Channel 2 to set the Clock Source to either “**Internal**” or “**External**” according to the communications system configuration.

This setting is not applicable if IEEE C37.94 mode selected.

The Clock Source should be set to “**Internal**” at all system ends, where they are connected by direct optical fiber, as the MiCOM P443/P445/P446 at each end has to supply the clock.

The Clock Source should be set to “**External**” at all system ends, where the ends are connected by multiplexer equipment which is receiving a master clock signal from the multiplexer network. It is important that there is a single master clock source on the multiplexer network and that the multiplexer equipment at each end is synchronized to this clock.

<i>Note</i>	<i>This setting is not applicable if IEEE C37.94 mode selected.</i>
-------------	---

2.15.2.3 Data Rate

Data Rate

The data rate for signaling between the two or three ends may be set to either 64kbit/sec or 56kbit/sec as appropriate.

If there is a direct fiber connection between the ends, the data rate would usually be set to 64kbit/sec, as this gives a slightly faster trip time.

If there is a multiplexer network between the ends, then this will determine the data rate to be used by the MiCOM P443/P445/P446/P54x system. The electrical interface to the multiplexer (G.703 co-directional) will be provided on either a 64kbit/sec or 56kbit/sec channel, and the MiCOM P443/P445/P446/P54x at each end must be set to match this data rate.

Generally, North American multiplexer networks are based on 56kbit/sec (and multiples thereof) channels, whereas multiplexer networks in the rest of the world are based on 64kbit/sec (and multiples thereof) channels.

This setting is not applicable if IEEE C37.94 mode selected.

2.15.2.4

IMx Command Type

IMx Command Type

Many of the same application considerations as per MODEM InterMiCOM apply equally for InterMiCOM⁶⁴. However, as the data rate is much faster (56 or 64 kbit/s), only the comments relating to fast fiber channels are relevant. Due to the fast data rate, there is not so much difference in real performance between the three generic modes of teleprotection (Direct Intertrip, Permissive and Blocking), so only two are implemented for InterMiCOM⁶⁴. Direct Intertripping is available, with the second mode a combined mode for Permissive/Blocking (the latter is named as '**Permissive**' in the menu). To increase the security for Intertripping (Direct transfer tripping), the InterMiCOM⁶⁴ Direct command is issued only when 2 valid consecutive messages are received. The recommended setting is:

- For Blocking schemes set Permissive
- For Permissive scheme set Permissive
- For Transfer (inter)tripping set Direct

The setting files provide independent setting for each of the first 8 commands. It should be noted that the remaining 8 commands will have the same settings respectively, i.e. if the IM1 is set to '**Direct**' the same signaling mode will apply to Channel 1 and Channel 2. Due to the fast data rate, there will be minimal speed difference between the two mode options. Both will give a typical operating time (PSL trigger at the send relay, to PSL state change at the receive relay) as shown below:

Channel Mode Setting	Application	Typical Delay (ms)	Maximum (ms)	Comments
Permissive	Direct Fiber	3 to 7	9	Assuming no repeaters (no source of digital noise).
	Multiplexed Link	5 to 8 + MUX	12 + MUX	For channel bit error rate up to 1×10^{-3} .
Direct Intertrip	Direct Fiber	4 to 8	10	Assuming no repeaters (no source of digital noise).
	Multiplexed Link	6 to 8 + MUX	13 + MUX	For channel bit error rate up to 1×10^{-3} .

Table 5 - Typical operating times

When using InterMiCOM⁶⁴ to implement Aided Scheme 1 or Aided Scheme 2, it is suggested to assume a conservative worst-case channel delay of 15ms (pickup and reset delay), for the purposes of blocking and reversal guard calculations. The delay of the multiplexer should be added if applicable, taking into account longer standby path re-routings which might be experienced in the event of self-healing in a SONET/SDH telecomms network.

In 3-terminal applications, where fallback to “**chain**” topology is possible in the event of failure of one communications leg in the triangle, longer times may be experienced. In fallback mode, retransmission of the messages occurs so the path length is doubled. Overall command times to the final end can be doubled.

2.15.2.5

IMx Fallback Mode

IMx Fallback Mode

When the ‘**Default**’ setting is selected, the following ‘**IMx Default Value**’ settings are recommended: For Intertripping schemes set **0**, for Blocking schemes set **1**. In Permissive applications, the user may prefer to latch the last healthy received state

2.16

Phase Fault Overcurrent Protection

Settings for the time delayed overcurrent element should be selected to ensure discrimination with surrounding protection. Setting examples for phase fault overcurrent protection can be found in the Network Protection and Automation Guide (NPAG), a comprehensive reference textbook available from Schneider Electric.



Caution

The IEEE C.37.112 standard for IDMT curves permits some freedom to manufacturers at which Time Dial (TD) value the reference curve applies. Rather than pick a mid-range value, for the MiCOM device the reference curve norm applies at a time dial of 1. The TD is a multiplier on the reference curve, used to achieve the desired tripping time. Take care when working with other suppliers' relays which may take TD = 5, or TD = 7 as a mid-range value to define the IDMT curve. The equivalent MiCOM device setting to match those relays is achieved by dividing the imported setting by 5 or 7. This caution applies to the MiCOM P443 / P445 / P446 / P54x / P841.

2.16.1

Directional Overcurrent Characteristic Angle Settings

The relay uses a 90° connection angle for the directional overcurrent elements. The relay characteristic angles in this case are nominally set to:

- +30° Plain feeders, zero sequence source behind relay
- +45° Transformer feeder, zero sequence source in front of relay

It is possible to set the RCA to match the system fault angle exactly, but we recommend that these figures are followed, as these provide satisfactory performance and stability under a wide range of system conditions.

2.17

Thermal Overload Protection

Thermal overload protection can be used to prevent electrical plant from operating at temperatures higher than the designed maximum withstand. Prolonged overloading causes excessive heating, which may result in premature ageing of the insulation, or in extreme cases, insulation failure.

2.17.1 Single Time Constant Characteristic

The current setting is calculated as:

Thermal Trip = Permissible continuous loading of the plant item/CT ratio.

Typical time constant values are given in the following table. The relay setting, 'Time Constant 1', is in minutes.

An alarm can be raised on reaching a thermal state corresponding to a percentage of the trip threshold. A typical setting might be 'Thermal Alarm' = 70% of thermal capacity.

	Time constant τ (minutes)	Limits
Air-core reactors	40	
Capacitor banks	10	
Overhead lines	10	Cross section $\geq 100 \text{ mm}^2$ Cu or 150 mm^2 Al
Cables	60 - 90	Typical, at 66 kV and above
Busbars	60	

Table 6 - Typical time constant values

2.17.2 Dual Time Constant Characteristic

The current setting is calculated as:

Thermal Trip = Permissible continuous loading of the transformer / CT ratio.

Typical time constant values are shown in the following table:

An alarm can be raised on reaching a thermal state corresponding to a percentage of the trip threshold. A typical setting might be 'Thermal Alarm' = 70% of thermal capacity.

<i>Note</i>	<i>The thermal time constants given in the above tables are typical only. Reference should always be made to the plant manufacturer for accurate information.</i>
-------------	---

	τ_1 (minutes)	τ_2 (minutes)	Limits
Oil-filled transformer	5	120	Rating 400 - 1600 kVA

Table 7 - Typical time constants

2.18 Earth Fault (Ground Overcurrent) and Sensitive Earth Fault (SEF) Protection



Caution The IEEE C.37.112 standard for IDMT curves permits some freedom to manufacturers at which Time Dial (TD) value the reference curve applies. Rather than pick a mid-range value, for the MiCOM device the reference curve norm applies at a time dial of 1. The TD is a multiplier on the reference curve, used to achieve the desired tripping time. Take care when working with other suppliers' relays which may take TD = 5, or TD = 7 as a mid-range value to define the IDMT curve. The equivalent MiCOM device setting to match those relays is achieved by dividing the imported setting by 5 or 7. This caution applies to the MiCOM P443 / P445 / P446 / P54x / P841.

2.18.1 Directional Earth Fault Protection

2.18.1.1 Residual Voltage Polarization

It is possible that small levels of residual voltage will be present under normal system conditions due to system imbalances, VT inaccuracies, relay tolerances etc. Hence, the relay includes a user settable threshold (**IN>VNPoI Set**) which must be exceeded in order for the DEF function to be operational. In practice, the typical zero sequence voltage on a healthy system can be as high as 1% (i.e.: 3% residual), and the VT error could be 1% per phase. A setting between 1% and 4% is typical. The residual voltage measurement provided in the **Measurements** column of the menu may assist in determining the required threshold setting during commissioning, as this will indicate the level of standing residual voltage present.

2.18.2 General Setting Guidelines for Directional Earth Fault (Ground Overcurrent) Protection

When setting the Relay Characteristic Angle (RCA) for the Directional Earth Fault (DEF) element, a positive angle setting was specified. This was due to the fact that the quadrature polarizing voltage lagged the nominal phase current by 90°; i.e. the position of the current under fault conditions was leading the polarizing voltage and hence a positive RCA was required. With DEF, the residual current under fault conditions lies at an angle lagging the polarizing voltage. Hence, negative RCA settings are required for DEF applications. This is set in cell '**I>N**' in the relevant earth fault menu.

The following angle settings are recommended for a residual voltage polarized relay:

- Distribution systems (solidly earthed) -45°
- Transmissions systems (solidly earthed) -60°

For negative sequence polarization, the RCA settings must be based on the angle of the upstream negative phase sequence source impedance.

2.18.3 Sensitive Earth Fault (SEF) Protection Element

Sensitive Earth Fault (SEF) would normally be fed from a Core Balance Current Transformer (CBCT) mounted around the three phases of the feeder cable. However, care must be taken in the positioning of the CT with respect to the earthing of the cable sheath. See below.

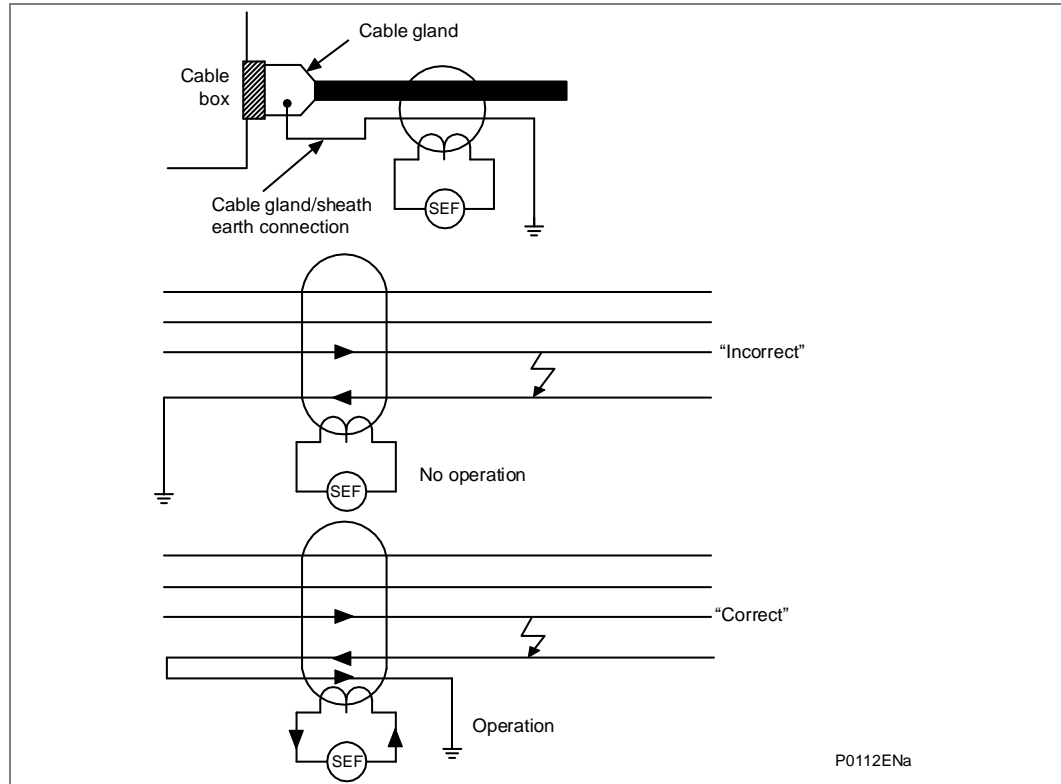

Figure 13 - Positioning of core balance current transformers

As can be seen from the above illustration, if the cable sheath is terminated at the cable gland and earthed directly at that point, a cable fault (from phase to sheath) will not result in any unbalance current in the core balance CT. Hence, prior to earthing, the connection must be brought back through the CBCT and earthed on the feeder side. This then ensures correct relay operation during earth fault conditions.

2.19

Negative Phase Sequence (NPS) Overcurrent Protection

The following section describes how Negative Phase Sequence (NPS) overcurrent protection may be applied in conjunction with standard overcurrent and earth fault protection to alleviate some less common application difficulties:

- NPS overcurrent elements give greater sensitivity to resistive phase-to-phase faults, where phase overcurrent elements may not operate.
- In certain applications, residual current may not be detected by an earth fault relay due to the system configuration. For example, an earth fault relay applied on the delta side of a Dy (delta-wye) transformer is unable to detect earth faults on the star (wye) side. However, negative sequence current will be present on both sides of the transformer for any fault condition, irrespective of the transformer configuration. Therefore, a NPS overcurrent element may be employed to provide time-delayed back-up protection for any uncleared asymmetrical faults downstream.
- It may be required to simply alarm for the presence of negative phase sequence currents on the system. Operators may then investigate the cause of the unbalance.

2.19.1 Negative Phase Sequence (NPS) Current Threshold, 'I2> Current Set'

The current pick-up threshold must be set higher than the NPS current due to the maximum normal load unbalance on the system. This can be set practically at the commissioning stage, making use of the relay measurement function to display the standing NPS current, and setting at least 20% above this figure.

Where the NPS element is required to operate for specific uncleared asymmetric faults, a precise threshold setting would have to be based upon an individual fault analysis for that particular system due to the complexities involved. However, to ensure operation of the protection, the current pick-up setting must be set approximately 20% below the lowest calculated NPS fault current contribution to a specific remote fault condition.

2.19.2 Time Delay for the NPS Overcurrent Element, 'I2> Time Delay'

As stated above, correct setting of the time delay for this function is vital. It should also be noted that this element is applied primarily to provide back-up protection to other protective devices or to provide an alarm. Hence, in practice, it would be associated with a long time delay.

It must be ensured that the time delay is set greater than the operating time of any other protective device (at minimum fault level) on the system which may respond to unbalanced faults.

2.19.3 Directionalizing the Negative Phase Sequence Overcurrent Element

Where NPS current may flow in either direction through a relay location, such as parallel lines, directional control of the element should be employed. Directionality is achieved by comparison of the angle between the NPS voltage and the NPS current and the element may be selected to operate in either the forward or reverse direction. A suitable relay characteristic angle setting (I2> Char Angle) is chosen to provide optimum performance. This setting should be set equal to the phase angle of the negative sequence current with respect to the inverted negative sequence voltage ($-V_2$), in order to be at the center of the directional characteristic.

The angle that occurs between V_2 and I_2 under fault conditions is directly dependent upon the negative sequence source impedance of the system. However, typical settings for the element are as follows;

- For a transmission system the RCA should be set equal to -60°
- For a distribution system the RCA should be set equal to -45°

For the NPS directional elements to operate, the relay must detect a polarizing voltage above a minimum threshold, **I2> V2pol Set**. This must be set in excess of any steady state NPS voltage. This may be determined during the commissioning stage by viewing the NPS measurements in the relay.

2.20 Undervoltage Protection

In most applications, undervoltage protection is not required to operate during system earth (ground) fault conditions. If this is the case, the element should be selected in the menu to operate from a phase to phase voltage measurement, as this quantity is less affected by single phase voltage depressions due to earth faults. The measuring mode (ph-N or ph-ph) and operating mode (single phase or 3 phase) for both stages are independently settable.

The voltage threshold setting for the undervoltage protection should be set at some value below the voltage excursions which may be expected under normal system operating conditions. This threshold is dependent upon the system in question but typical healthy system voltage excursions may be in the order of -10% of nominal value.

Similar comments apply with regard to a time setting for this element, i.e. the required time delay is dependent upon the time for which the system is able to withstand a depressed voltage.

2.21 Overvoltage Protection

The inclusion of the two stages and their respective operating characteristics allows for a number of possible applications;

- Use of the IDMT characteristic gives the option of a longer time delay if the overvoltage condition is only slight but results in a fast trip for a severe overvoltage. As the voltage settings for both of the stages are independent, the second stage could then be set lower than the first to provide a time delayed alarm stage if required.
- Alternatively, if preferred, both stages could be set to definite time and configured to provide the required alarm and trip stages.
- If only one stage of overvoltage protection is required, or if the element is required to provide an alarm only, the remaining stage may be disabled within the relay menu.

This type of protection must be co-ordinated with any other overvoltage relays at other locations on the system. This should be carried out in a similar manner to that used for grading current operated devices. The measuring mode (ph-N or ph-ph) and operating mode (single phase or 3 phase) for both stages are independently settable.

2.22 Compensated Overvoltage Protection

Temporary overvoltages in the order of seconds (even minutes) which may originate from switching or load rejection may damage primary plant equipment. In particular, this type of overvoltage protection is applied to protect long transmission lines against Ferranti effect overvoltages where the transmission line is energized from one end only. The following figure shows the Ferranti overvoltages calculated for a 345 kV and 765 kV transmission line for different line lengths based on the formulas as in the Operation chapter.

The two stage compensated overvoltage element can be applied as alarming or trip elements. Both stages' time delays should be set not to pick-up for transient overvoltages in the system with a typical time delays of 1-2 seconds upwards being adequate for most applications. In the example above for a 345 kV transmission line of 400 km line length, the alarm threshold (stage 1) can be set to 105% and the trip threshold set to 110% for example.

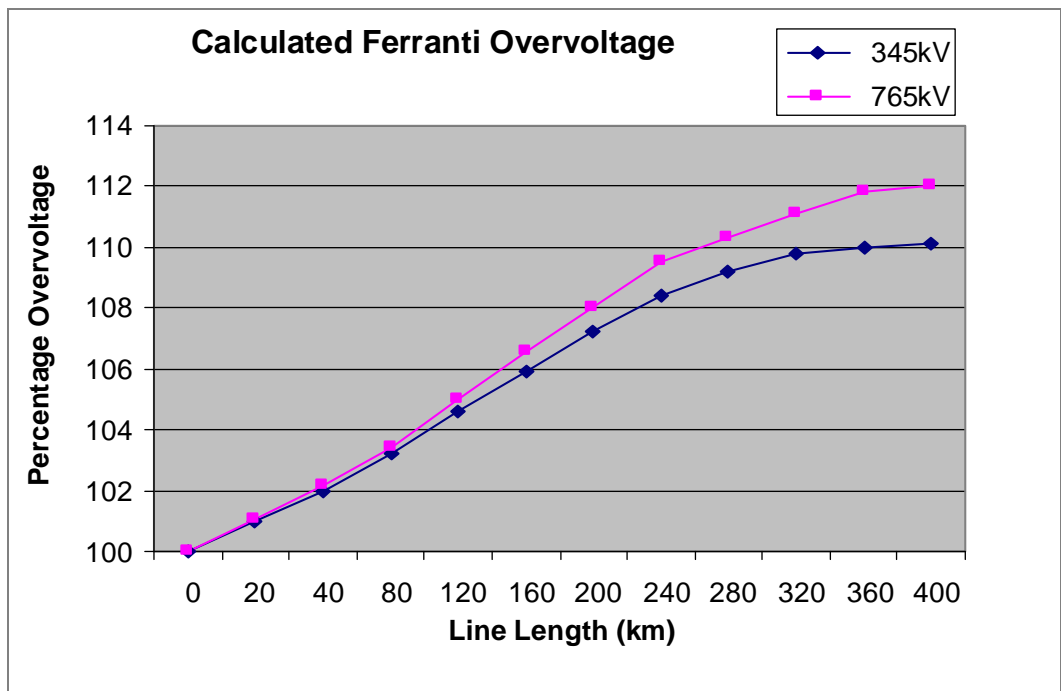

Figure 14 - Calculated Ferranti voltage rise on 345 kV and 765 kV lines

P4094ENa

2.23 Residual Overvoltage (Neutral Displacement) Protection

On a healthy three phase power system, the addition of each of the three phase to earth voltages is nominally zero, as it is the vector addition of three balanced vectors at 120° to one another. However, when an earth (ground) fault occurs on the primary system this balance is upset and a 'residual' voltage is produced.

Note This condition causes a rise in the neutral voltage with respect to earth which is commonly referred to as **neutral voltage displacement** or **NVD**.

The following figure shows the residual voltages that are produced during earth fault conditions occurring on a solidly earthed power system.

As shown in below the residual voltage measured by a relay for an earth fault on a solidly earthed system is solely dependent upon the ratio of source impedance behind the relay to line impedance in front of the relay, up to the point of fault. For a remote fault, the Z_s/Z_l ratio will be small, resulting in a correspondingly small residual voltage. As such, depending upon the relay setting, such a relay would only operate for faults up to a certain distance along the system. The value of residual voltage generated for an earth fault condition is given by the general formula shown.

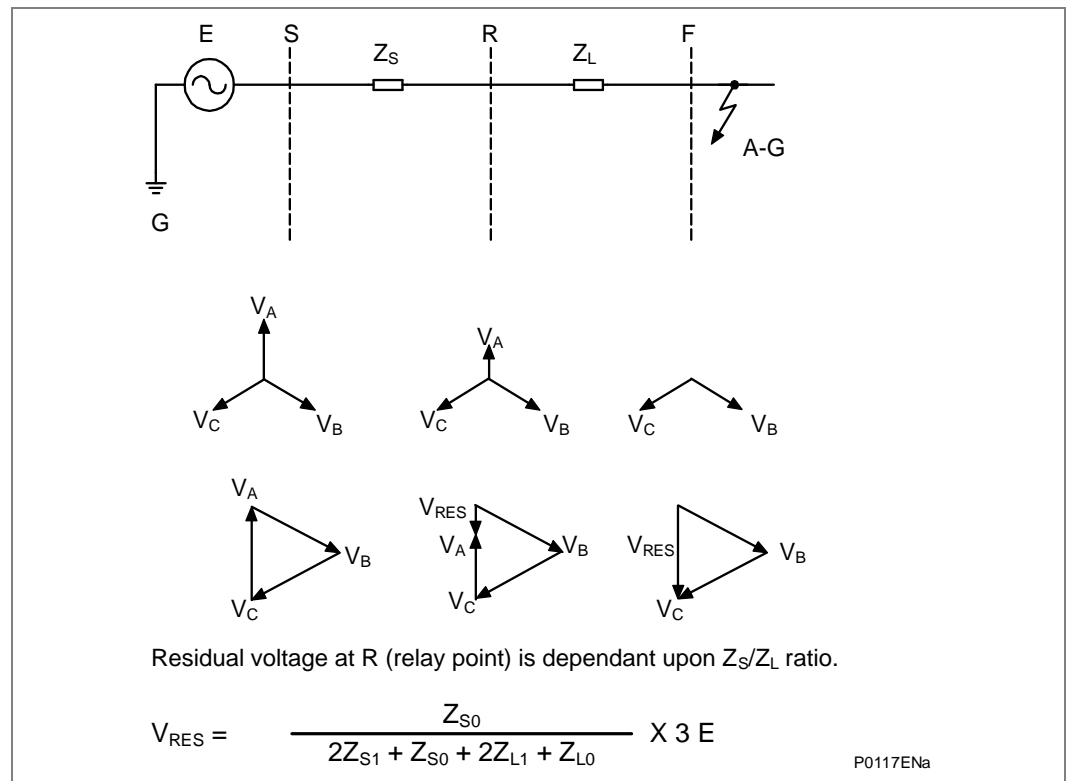

Figure 15 - Residual voltage, solidly earthed system

The following figure shows the residual voltages that are produced during earth fault conditions occurring on an impedance earthed power system.

This shows that a resistance earthed system will always generate a relatively large degree of residual voltage, as the zero sequence source impedance now includes the earthing impedance. It follows then, that the residual voltage generated by an earth fault on an insulated system will be the highest possible value (3 x phase-neutral voltage), as the zero sequence source impedance is infinite.

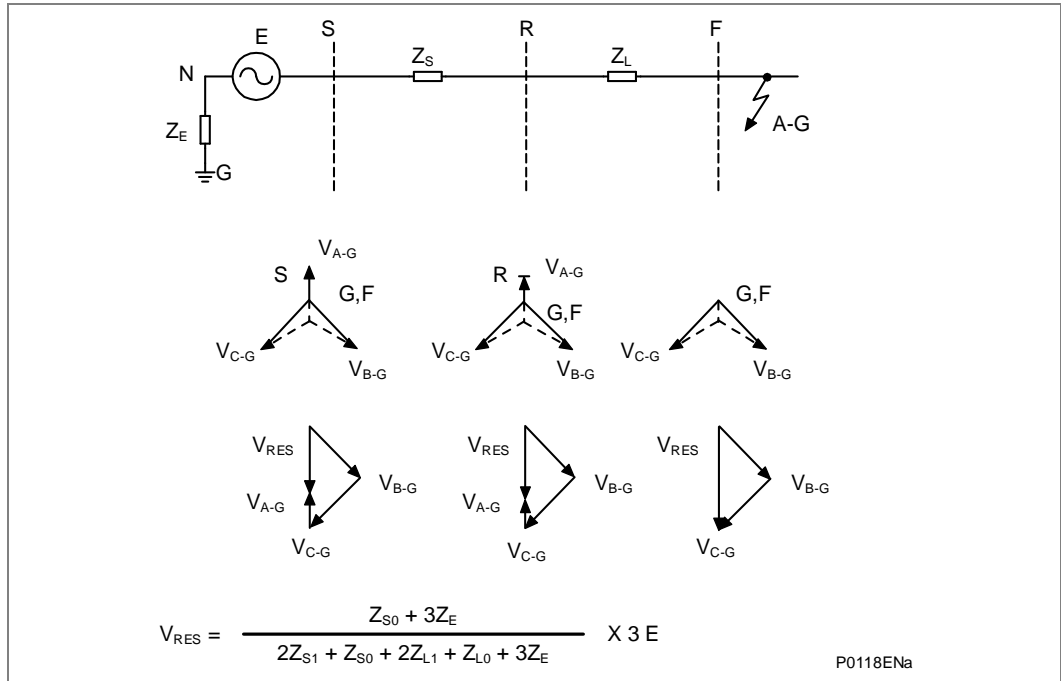

Figure 16 - Residual voltage, resistance earthed system

The detection of a residual overvoltage condition is an alternative means of earth fault detection, which does not require any measurement of zero sequence current. This may be particularly advantageous at a tee terminal where the infeed is from a delta winding of a transformer (and the delta acts as a zero-sequence current trap).

Note Where residual overvoltage protection is applied, such a voltage will be generated for a fault occurring anywhere on that section of the system and hence the NVD protection must co-ordinate with other earth/ground fault protection.

2.23.1

Setting Guidelines

The voltage setting applied to the elements depends on the magnitude of residual voltage that is expected to occur during the earth fault condition. This in turn is dependent on the method of system earthing employed and may be calculated by using the formulae previously given in the previous diagrams. It must also be ensured that the relay is set above any standing level of residual voltage that is present on the system.

Note IDMT characteristics are selectable on the first stage of NVD so that elements located at various points on the system may be time graded with one another.

2.24 Circuit Breaker Fail (CBF) Protection

2.24.1 Breaker Fail Timer Settings

Typical timer settings to use are as follows:

CB fail reset mechanism	tBF time delay	Typical delay for 2 ½ cycle circuit breaker
Initiating element reset	CB interrupting time + element reset time (max.) + error in tBF timer + safety margin	50 + 45 + 10 + 50 = 155 ms
CB open	CB auxiliary contacts opening/closing time (max.) + error in tBF timer + safety margin	50 + 10 + 50 = 110 ms
Undercurrent elements	CB interrupting time + undercurrent element (max.) + safety margin	50 + 25 + 50 = 125 ms
<p><i>Note</i> All CB Fail resetting involves the operation of the undercurrent elements. Where element reset or CB open resetting is used the undercurrent time setting should still be used if this proves to be the worst case.</p>		
<p>The examples above consider direct tripping of a 2½ cycle circuit breaker.</p>		
<p><i>Note</i> Where auxiliary tripping relays are used, an additional 10-15 ms must be added to allow for trip relay operation.</p>		

Table 8 - Typical timer settings

2.24.2 Breaker Fail Undercurrent Settings

The phase undercurrent settings ($I_{<}$) must be set less than load current, to ensure that $I_{<}$ operation indicates that the circuit breaker pole is open. A typical setting for overhead line or cable circuits is 20% I_n , reduced to 10% or 5% where the infeed has a high SIR ratio (e.g. at a spur terminal with embedded generation infeed).

The sensitive earth fault protection (SEF) undercurrent element must be set less than the respective trip setting, typically as follows:

$$I_{SEF<} = (I_{SEF>} \text{ trip}) / 2$$

2.25 Broken Conductor Detection

The majority of faults on a power system occur between one phase and ground or two phases and ground. These are known as shunt faults and arise from lightning discharges and other overvoltages which initiate flashovers. Alternatively, they may arise from other causes such as birds on overhead lines or mechanical damage to cables etc. Such faults result in an appreciable increase in current and hence in the majority of applications are easily detectable.

Another type of unbalanced fault that can occur on the system is the series or open circuit fault. These can arise from broken conductors, maloperation of single phase switchgear, or single-phasing of fuses. Series faults will not cause an increase in phase current on the system and hence are not readily detectable by standard protection. However, they will produce an unbalance and a resultant level of negative phase sequence current, which can be detected.

It is possible to apply a negative phase sequence overcurrent relay to detect the above condition. However, on a lightly loaded line, the negative sequence current resulting from a series fault condition may be very close to, or less than, the full load steady state unbalance arising from CT errors, load unbalance etc. A negative sequence element therefore would not operate at low load levels.

2.25.1

Setting Guidelines

For a broken conductor affecting a single point earthed power system, there will be little zero sequence current flow and the ratio of I2/I1 that flows in the protected circuit will approach 100%. In the case of a multiple earthed power system (assuming equal impedances in each sequence network), the ratio I2/I1 will be 50%.

In practice, the levels of standing negative phase sequence current present on the system govern this minimum setting. This can be determined from a system study, or by making use of the relay measurement facilities at the commissioning stage. If the latter method is adopted, it is important to take the measurements during maximum system load conditions, to ensure that all single-phase loads are accounted for.

Note *A minimum value of 8% negative phase sequence current is required for successful relay operation.*

As sensitive settings have been employed, it can be expected that the element will operate for any unbalance condition occurring on the system (for example, during a single pole auto-reclose cycle). Hence, a long time delay is needed to ensure co-ordination with other protective devices. A 60 second time delay setting may be typical. For example, this information was recorded by the relay during commissioning;

$$\begin{aligned} I_{full\ load} &= 500\ A \\ I_2 &= 50\ A \end{aligned}$$

Therefore, the quiescent I2/I1 ratio is given by:

$$I_2/I_1 = 50/500 = 0.1$$

To allow for tolerances and load variations a setting of 20% of this value may be typical: Therefore, set I2/I1 = 0.2

In a double circuit (parallel line) application, using a 40% setting will ensure that the broken conductor protection will operate only for the circuit that is affected. Setting 0.4 results in no pick-up for the parallel healthy circuit.

Set I2/I1 Time Delay = 60 s to allow adequate time for short circuit fault clearance by time delayed protections.

3 WORKED EXAMPLE AND OTHER PROTECTION TIPS

3.1 Distance Protection Setting Example

3.1.1 Objective

To protect the 100 km double circuit line between Green Valley and Blue River substations using a MiCOM P445/P54x in distance POR Permissive Overreach mode and to set the relay at Green Valley substation, shown in the following diagram. It is assumed that mho characteristics will be used.

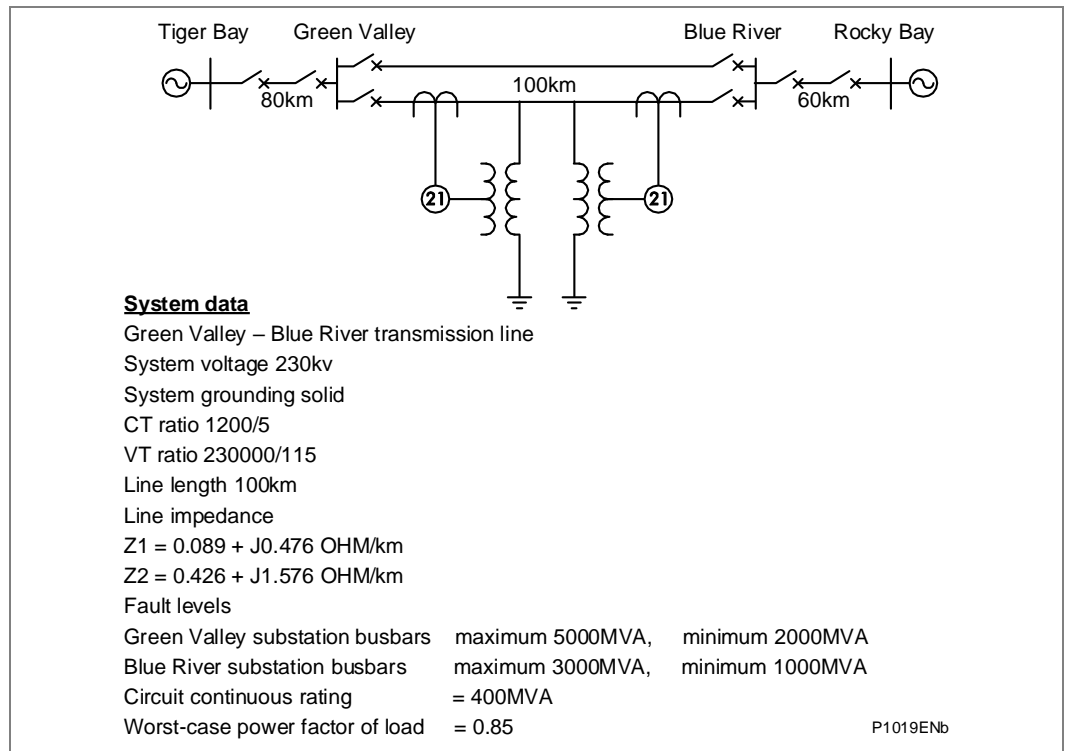

Figure 17 - System assumed for worked example

3.1.2 System Data

Line length: 100 km
 Line impedances: $Z1 = 0.089 + j0.476 = 0.484 \angle 79.4^\circ \text{ } \Omega/\text{km}$
 $Z0 = 0.426 + j1.576 = 1.632 \angle 74.8^\circ \text{ } \Omega/\text{km}$
 $Z0/Z1 = 3.372 \angle -4.6^\circ$
 CT ratio: 1 200/5
 VT ratio: 230 000/115

3.1.3 Relay Settings

It is assumed that Zone 1 Extension is not used and that only three forward zones are required. Settings on the relay can be performed in primary or secondary quantities and impedances can be expressed as either polar or rectangular quantities (menu selectable). For the purposes of this example, secondary quantities are used.

3.1.4 Line Impedance

$$\text{Ratio of secondary to primary impedance} = \frac{1200 / 5}{230000 / 115} = 0.12$$

$$\text{Line impedance secondary} = \text{ratio CT/VT} \times \text{line impedance primary.}$$

$$\begin{aligned} \text{Line Impedance} &= 100 \times 0.484 \angle 79.4^\circ \text{ (primary)} \times 0.124 \\ &= 5.81 \angle 79.4^\circ \Omega \text{ secondary.} \end{aligned}$$

$$\text{Select Line Angle} = 80^\circ \text{ for convenience.}$$

$$\text{Therefore set Line Impedance and Line Angle:} = 5.81 \angle 80^\circ \Omega \text{ secondary.}$$

3.1.5 Residual Compensation for Ground Fault Elements

The residual compensation factor can be applied independently to certain zones if required. This feature is useful where line impedance characteristics change between sections or where hybrid circuits are used. In this example, the line impedance characteristics do not change and as such a common KZN factor can be applied to each zone. This is set as a ratio **kZN Res. Comp**, and an angle **kZN Angle**:

$$\begin{aligned} \text{kZN Res. Comp,} \quad |kZN| &= (Z_0 - Z_1) / 3Z_1 \quad \text{i.e.: As a ratio} \\ \text{kZN Angle,} \quad \angle kZN &= \angle (Z_0 - Z_1) / 3Z_1 \quad \text{Set in degrees} \\ ZL_0 - ZL_1 &= (0.426 + j1.576) - (0.089 + j0.476) \\ &= 0.337 + j1.1 \\ &= 1.15 \angle 72.9^\circ \end{aligned}$$

$$kZN = \frac{1.15 \angle 72.9^\circ}{3 \times 0.484 \angle 79.4^\circ} = 0.79 \angle -6.5^\circ$$

Therefore, select:

$$\text{kZN Res. Comp} = 0.7$$

$$\text{kZN Angle} = -6.5^\circ$$

3.1.6 Zone 1 Phase and Ground Reach Settings

Required Zone 1 reach is to be 80% of the line impedance between Green Valley and Blue River substations.

Setting the Relay in the SIMPLE setting mode (recommended):

- Set Zone 1 Ph and Zone 1 Gnd reach = 80%

From this the relay will automatically calculate the required ohmic reaches, or they can be entered manually in the ADVANCED mode, as follows:

$$\text{Required Zone 1 reach} = 0.8 \times 100 \times 0.484 \angle 79.4^\circ \times 0.12$$

$$Z1 = 4.64 \angle 79.4^\circ \Omega \text{ secondary}$$

$$\text{The Line Angle} = 80^\circ$$

$$\text{Therefore actual Zone 1 reach, Z1} = 4.64 \angle 80^\circ \Omega \text{ secondary.}$$

3.1.7 Zone 2 Phase and Ground Reach Settings

Required Zone 2 impedance = (Green Valley-Blue River) line impedance + 50% (Blue River-Rocky Bay) line impedance

$$Z2 = (100+30) \times 0.484 \angle 79.4^\circ \times 0.12 = 7.56 \angle 79.4^\circ \Omega \text{ secondary.}$$

$$\text{The Line Angle} = 80^\circ$$

$$\text{Actual Zone 2 reach setting} = 7.56 \angle 80^\circ \Omega \text{ secondary}$$

Alternatively, in SIMPLE setting mode, this reach can be set as a percentage of the protected line. Typically a figure of at least 120% is used.

3.1.8 Zone 3 Phase and Ground Reach Settings

Required Zone 3 forward reach = (Green Valley-Blue River + Blue River-Rocky Bay) x 1.2

$$= (100+60) \times 1.2 \times 0.484 \angle 79.4^\circ \times 0.12$$

$$Z3 = 11.15 \angle 79.4^\circ \text{ ohms secondary}$$

$$\text{Actual Zone 3 forward reach setting} = 11.16 \angle 80^\circ \text{ ohms secondary}$$

Alternatively, in SIMPLE setting mode, this reach can be set as a percentage of the protected line.

3.1.9 Zone 3 Reverse Reach

In the absence of other special requirements, Zone 3 can be given a small reverse reach setting, of $Z3' = 10\%$. This is acceptable because the protected line length is $> 30\text{km}$.

3.1.10 Zone 4 Reverse Settings with POR and BLOCKING schemes

Where zone 4 is used to provide reverse directional decisions for Blocking or Permissive Overreach schemes, zone 4 must reach further behind the relay than zone 2 for the remote relay. This can be achieved by setting: $Z4 \geq ((\text{Remote zone 2 reach}) \times 120\%)$, where mho characteristics are used.

Remote Zone 2 reach = (Blue River-Green Valley) line impedance + 50% (Green Valley-Tiger Bay) line impedance

$$= (100+40) \times 0.484 \angle 79.4^\circ \times 0.12$$

$$= 8.13 \angle 79.4^\circ \Omega \text{ secondary}$$

$$Z4 \geq ((8.13 \angle 79.4^\circ) \times 120\%) - (5.81 \angle 79.4^\circ)$$

$$= 3.95 \angle 79.4^\circ$$

$$\text{Minimum zone 4 reverse reach setting} = 3.96 \angle 80^\circ \text{ ohms secondary}$$

3.1.11**Load Avoidance**

The maximum full load current of the line can be determined from the calculation:

$$I_{FLC} = \frac{[(\text{Rated MVA}_{FLC}) / (\sqrt{3} \times \text{Line kV})]}{1}$$

In practice, relay settings must allow for a level of overloading, typically a maximum current of 120% I_{FLC} prevailing on the system transmission lines. Also, for a double circuit line, during the auto-reclose dead time of fault clearance on the adjacent circuit, twice this level of current may flow on the healthy line for a short period of time. Therefore the circuit current loading could be $2.4 \times I_{FLC}$.

With such a heavy load flow, the system voltage may be depressed, typically with phase voltages down to 90% of V_n nominal.

Allowing for a tolerance in the measuring circuit inputs (line CT error, VT error, relay tolerance, and safety margin), this results in a load impedance which might be 3 times the expected "rating".

To avoid the load, the blinder impedance needs to be set:

$$\begin{aligned} Z &\leq (\text{Rated phase-ground voltage } V_n) / (I_{FLC} \times 3) \\ &= (115/\sqrt{3}) / (I_{FLC} \times 3) \end{aligned}$$

Set the $V <$ Blinder voltage threshold at the recommended 70% of $V_n = 66.4 \times 0.7 = 45 \text{ V}$.

3.1.12**Additional Settings for Quadrilateral Applications****3.1.12.1****Ground Fault Resistive Reaches (RGnd)**

Fault resistance would comprise arc-resistance and tower footing resistance. A typical resistive reach coverage setting would be 40Ω on the primary system.

For high resistance earth faults, the situation may arise where no distance elements could operate. In this case it will be necessary to provide supplementary earth fault protection, for example using the relay Channel Aided DEF protection. In such cases it is not essential to set large resistive reaches for ground distance, and then RGnd can be set according to the rule of thumb formula in the Quadrilateral Ground Resistive Reaches and Tilting section earlier in this chapter.

3.2 Teed Feeder Protection

The application of distance relays to three terminal lines is fairly common. However, several problems arise when applying distance protection to three terminal lines.

3.2.1 The Apparent Impedance seen by the Distance Elements

The following illustration shows a typical three terminal line arrangement. For a fault at the busbars of terminal B the impedance seen by a relay at terminal A will be equal to:

$$Z_a = Z_{at} + Z_{bt} + [Z_{bt} \cdot (I_c/I_a)]$$

Relay A will underreach for faults beyond the tee-point with infeed from terminal C. When terminal C is a relatively strong source, the underreaching effect can be substantial. For a zone 2 element set to 120% of the protected line, this effect may result in non-operation of the element for internal faults. This not only effects time delayed zone 2 tripping but also channel-aided schemes. Where infeed is present, it will be necessary for Zone 2 elements at all line terminals to overreach both remote terminals with allowance for the effect of tee-point infeed. Zone 1 elements must be set to underreach the true impedance to the nearest terminal without infeed. Both these requirements can be met through use of the alternative setting groups.

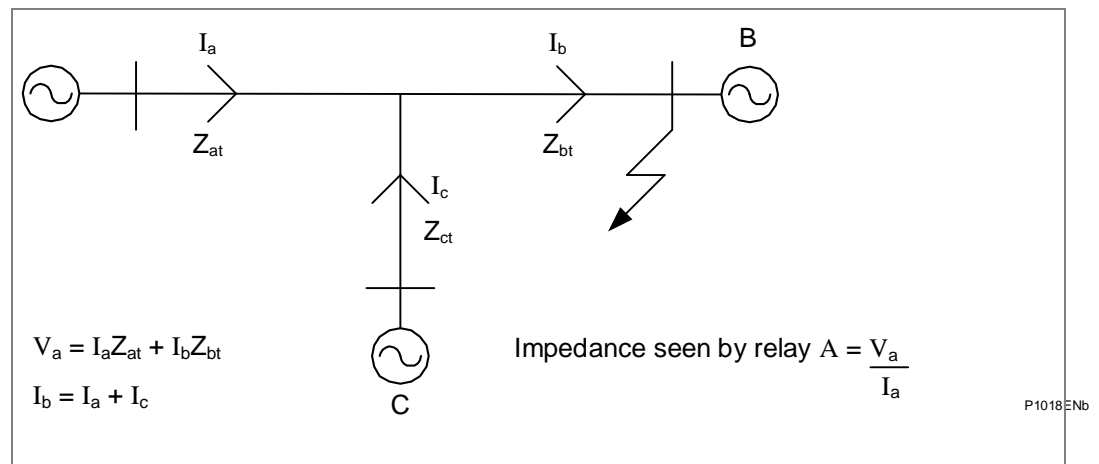

Figure 18 - Teed feeder application - apparent impedances seen by relay

3.2.2 Permissive Overreach (POR) Schemes

To ensure operation for internal faults in a POR scheme, the relays at the three terminals should be able to see a fault at any point within the protected feeder. This may demand very large zone 2 reach settings to deal with the apparent impedances seen by the relays.

A POR scheme requires the use of two signaling channels. A permissive trip can only be issued upon operation of zone 2 and receipt of a signal from both remote line ends. The requirement for an 'AND' function of received signals must be realized through use of contact logic external to the relay, or the internal Programmable Scheme Logic (PSL). Although a POR scheme can be applied to a three terminal line, the signaling requirements make its use unattractive.

3.2.3 Permissive Underreach (PUR) Schemes

For a PUR scheme, the signaling channel is only keyed for internal faults. Permissive tripping is allowed for operation of zone 2 plus receipt of a signal from either remote line end. This makes the signaling channel requirements for a PUR less demanding than for a POR. A common Power Line Carrier (PLC) signaling channel or a triangulated signaling arrangement can be used. This makes a PUR for a teed feeder attractive than a POR. The channel is keyed from operation of zone 1 tripping elements. Provided at least one zone 1 element can see an internal fault then aided tripping will occur at the other terminals if the overreaching zone 2 setting requirement has been met. There are however two cases where this is not possible:

The following figure is divided into three parts: (i), (ii) and (iii).

- (i) shows where a short tee is connected close to another terminal. Here zone 1 elements set to 80% of the shortest relative feeder length do not overlap. This leaves a section not covered by any zone 1 element. Any fault in this section would result in zone 2 time-delayed tripping.
- (ii) shows where terminal 'C' has no infeed. Faults close to this terminal will not operate the relay at 'C' and hence the fault will be cleared by the zone 2 time-delayed elements of the relays at 'A' and 'B'.
- (iii) shows a further difficulty for a PUR scheme. Here current is outfed from terminal 'C' for an internal fault. The relay at 'C' will see the fault as reverse and not operate until the breaker at 'B' has opened; i.e. sequential tripping will occur.

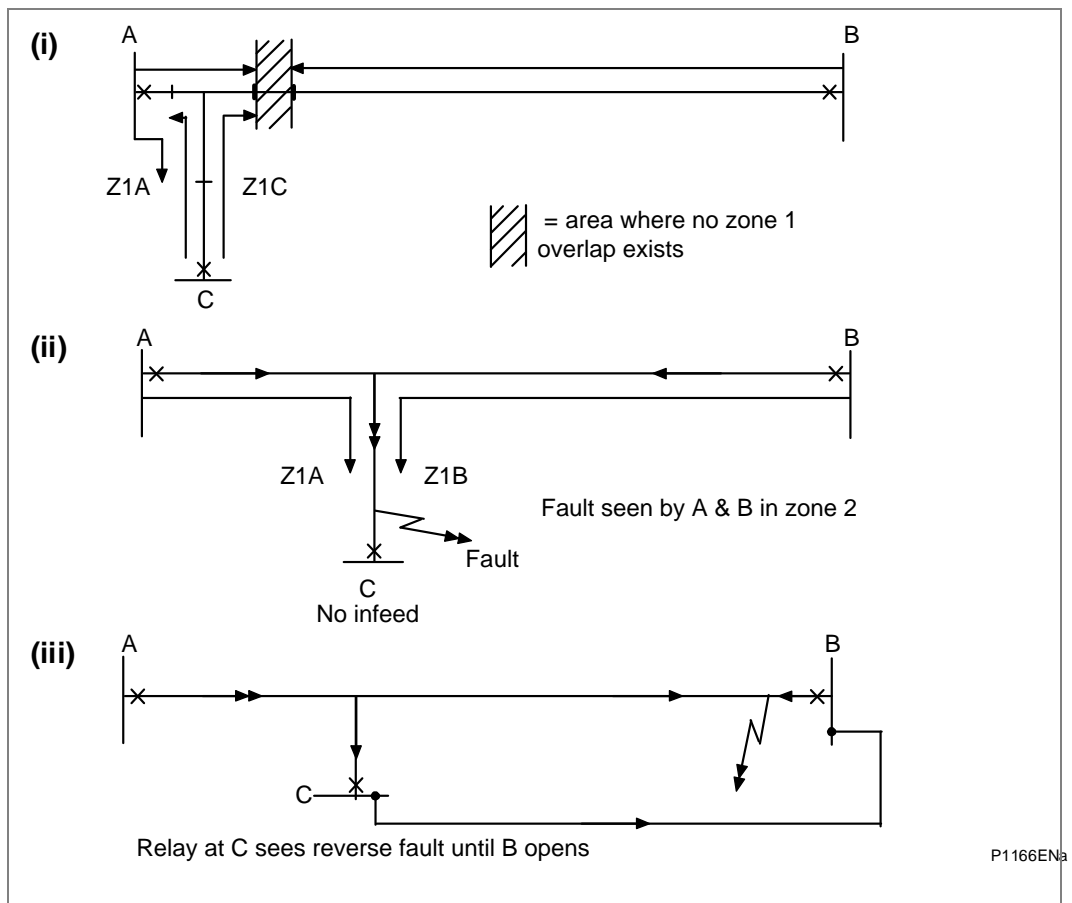

Figure 19 - Teed feeder applications

3.2.4**Blocking Schemes**

Blocking schemes are particularly suited to the protection of teed feeders, since high speed operation can be achieved where there is no current infeed from one or more terminals. The scheme also has the advantage that only a common simplex channel or a triangulated simplex channel is required.

The major disadvantage of blocking schemes is highlighted in section (iii) of the previous figure where fault current is outfed from a terminal for an internal fault condition. Relay 'C' sees a reverse fault condition. This results in a blocking signal being sent to the two remote line ends, preventing tripping until the normal zone 2 time delay has expired.

3.3 VT Connections

3.3.1 Open Delta (Vee Connected) VT's

MiCOM relays can be used with V-connected VTs by connecting the VT secondaries to:

- C19, C20 and C21 input terminals, with the C22 input left unconnected for P14x, P341, P342, P343, P344, P345, P443, P445, P543, P544 and P841A
- D19, D20 and D21 input terminals, with the D22 input left unconnected for P446, P545, P546, P547 and P841B
- C2, C4 and E2 input terminals, with the Vn input left unconnected for P64x (P642, P643 & P645)

For more details, see the *Connection Diagrams* chapter.

This type of VT arrangement cannot pass zero-sequence (residual) voltage to the relay, or provide any phase to neutral voltage quantities. Therefore any protection that is dependent upon phase to neutral voltage measurements should be disabled.

The ground directional comparison elements, ground distance elements, neutral voltage displacement (residual overvoltage) and CT supervision all use phase-to-neutral voltage signals for their operation and should be disabled. The DEF elements should be selected for negative sequence polarization to avoid the use of phase-to-neutral voltages. Under and over voltage protection can be set as phase-to-phase measuring elements, whereas all other protection elements should remain operational.

The accuracy of the single phase voltage measurements can be impaired when using vee connected VT's. The relay attempts to derive the phase to neutral voltages from the phase to phase voltage vectors. If the impedance of the voltage inputs were perfectly matched the phase to neutral voltage measurements would be correct, provided the phase to phase voltage vectors were balanced. However, in practice there are small differences in the impedance of the voltage inputs, which can cause small errors in the phase to neutral voltage measurements. This may give rise to an apparent residual voltage. This problem also extends to single phase power measurements that are also dependent upon their respective single phase voltages.

The phase to neutral voltage measurement accuracy can be improved by connecting three, well-matched, load resistors between the relevant phase voltage inputs and neutral thus creating a 'virtual' neutral point. The load resistor values must be chosen so that their power consumption is within the limits of the VT. It is recommended that $10\text{ k}\Omega \pm 1\%$ (6 W) resistors are used for the 110 V (Vn) rated relay, assuming the VT can supply this burden.

The connections are as follows for different MiCOM relays:

Phase Voltage Inputs	Neutral	MiCOM IEDs
C19, C20, C21	C22	P14x, P341, P342, P343, P344, P345, P443, P445, P446, P543, P544, P841A
D19, D20, D21	D22	P545, P546, P841B

3.3.2 VT Single Point Earthing

The MiCOM P14x/P341/P34x/P391/P443/P445/P446/P54x/P547/P64x/P841 will function correctly with conventional 3-phase VTs earthed at any one point on the VT secondary circuit. Typical earthing examples being neutral earthing, or B-phase (UK: "**yellow phase**" earthing).

3.4 Trip Circuit Supervision (TCS)

The trip circuit, in most protective schemes, extends beyond the IED enclosure and passes through components such as fuses, links, relay contacts, auxiliary switches and other terminal boards. This complex arrangement, coupled with the importance of the trip circuit, has led to dedicated schemes for its supervision.

Several Trip Circuit Supervision (TCS) scheme variants are offered. Although there are no dedicated settings for TCS, the following schemes can be produced using the Programmable Scheme Logic (PSL).

A user alarm is used in the PSL to issue an alarm message on the relay front display. If necessary, the user alarm can be re-named using the menu text editor to indicate that there is a fault with the trip circuit.

3.4.1 TCS Scheme 1

3.4.1.1 Scheme Description

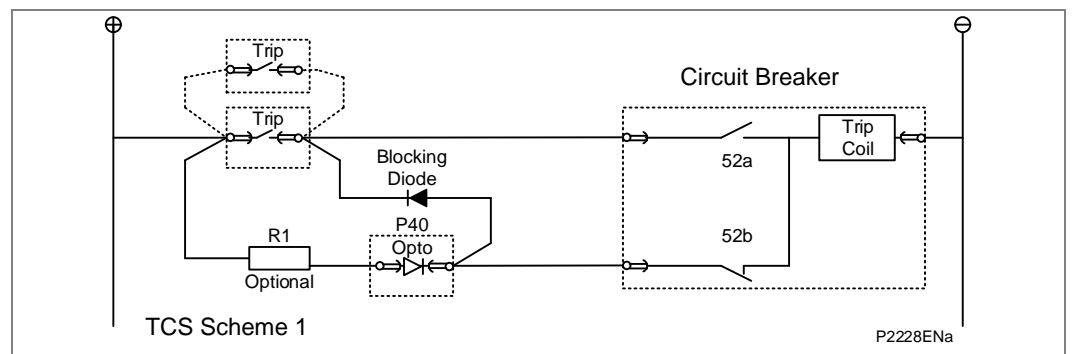

Figure 20 - TCS scheme 1

This scheme provides supervision of the trip coil with the breaker open or closed, however, pre-closing supervision is not provided. This scheme is also incompatible with latched trip contacts, as a latched contact will short out the opto for greater than the recommended DDO timer setting of 400ms. If breaker status monitoring is required a further 1 or 2 opto inputs must be used.

Note A 52a CB auxiliary contact follows the CB position and a 52b contact is the opposite.

When the breaker is closed, supervision current passes through the opto input, blocking diode and trip coil. When the breaker is open current still flows through the opto input and into the trip coil via the 52b auxiliary contact. Hence, no supervision of the trip path is provided whilst the breaker is open. Any fault in the trip path will only be detected on CB closing, after a 400ms delay.

Resistor R1 is an optional resistor that can be fitted to prevent maloperation of the circuit breaker if the opto input is inadvertently shorted, by limiting the current to <60mA. The resistor should not be fitted for auxiliary voltage ranges of 30/34 volts or less, as satisfactory operation can no longer be guaranteed. The table below shows the appropriate resistor value and voltage setting (Opto Config. menu) for this scheme. This TCS scheme will function correctly even without resistor R1, since the opto input automatically limits the supervision current to less than 10mA. However, if the opto is accidentally shorted the circuit breaker may trip.

Auxiliary Voltage (Vx)	Resistor R1 (ohms)	Opto Voltage Setting with R1 Fitted
24/27	-	-
30/34	-	-
48/54	1.2k	24/27
110/125	2.5k	48/54
220/250	5.0k	110/125

Note When R1 is not fitted the opto voltage setting must be set equal to supply voltage of the supervision circuit.

Table 9 - Resistor values for TCS scheme 1

3.4.1.2

Scheme 1 PSL

The next figure shows the scheme logic diagram for the TCS scheme 1. Any of the available opto inputs can be used to show whether or not the trip circuit is healthy. The delay on drop off timer operates as soon as the opto is energized, but will take 400ms to drop off/reset in the event of a trip circuit failure. The 400ms delay prevents a false alarm due to voltage dips caused by faults in other circuits or during normal tripping operation when the opto input is shorted by a self-reset trip contact. When the timer is operated the NC (normally closed) output relay opens and the LED and user alarms are reset.

The 50ms delay on pick-up timer prevents false LED and user alarm indications during the relay power up time, following an auxiliary supply interruption.

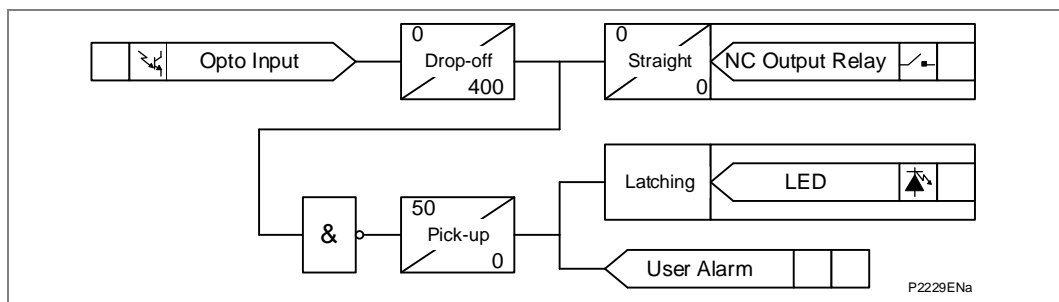

Figure 21 - PSL for TCS schemes 1 and 3

3.4.2 TCS Scheme 2a

3.4.2.1 Scheme Description

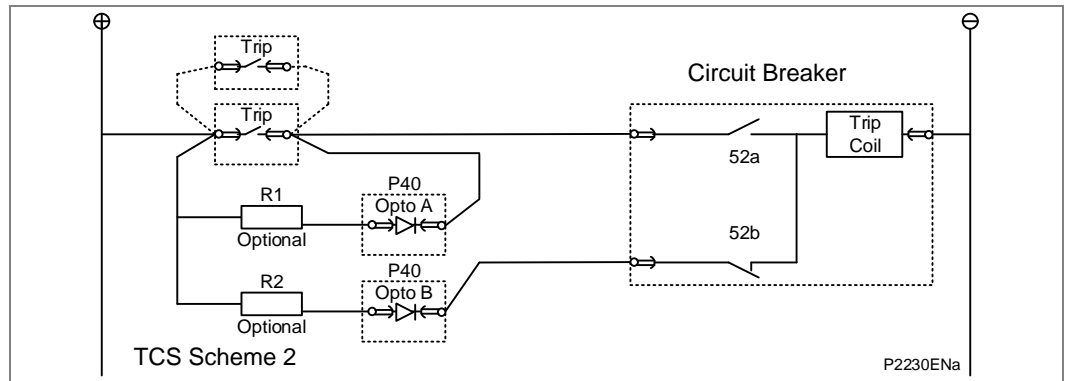

Figure 22 - TCS scheme 2a

Much like scheme 1, this scheme provides supervision of the trip coil with the breaker open or closed and also does not provide pre-closing supervision. However, using two opto inputs allows the relay to correctly monitor the circuit breaker status since they are connected in series with the CB auxiliary contacts. This is achieved by assigning Opto A to the 52a contact and Opto B to the 52b contact. Provided the **Circuit Breaker Status** is set to **52a and 52b** (CB CONTROL column) the relay will correctly monitor the status of the breaker. This scheme is also fully compatible with latched contacts as the supervision current will be maintained through the 52b contact when the trip contact is closed.

When the breaker is closed, supervision current passes through opto input A and the trip coil. When the breaker is open current flows through opto input B and the trip coil. As with scheme 1, no supervision of the trip path is provided whilst the breaker is open. Any fault in the trip path will only be detected on CB closing, after a 400 ms delay.

As with scheme 1, optional resistors R1 and R2 can be added to prevent tripping of the CB if either opto is shorted. The resistor values of R1 and R2 are equal and can be set the same as R1 in scheme 1.

3.4.2.2 Scheme 2a PSL

The PSL for this scheme is practically the same as that of scheme 1. The main difference being that both opto inputs must be off before a trip circuit fail alarm is given.

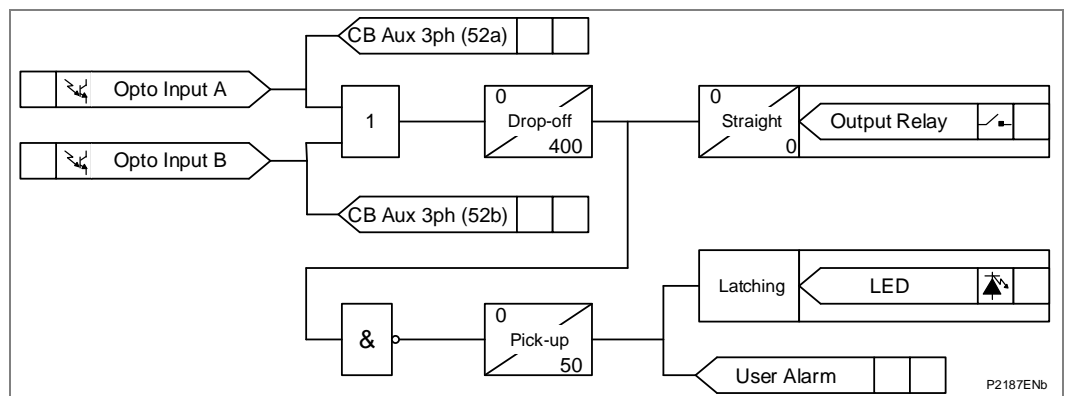

Figure 23 - PSL for TCS schemes 2a

3.4.4

TCS Scheme 3

3.4.4.1

Scheme Description

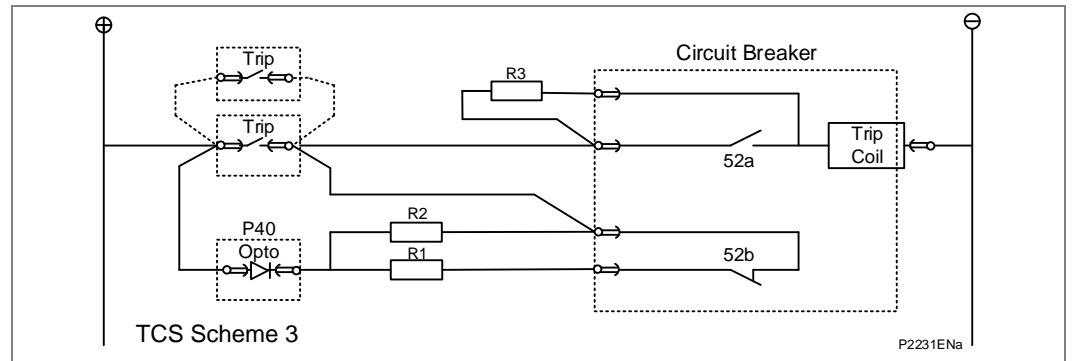

Figure 26 - TCS scheme 3

Scheme 3 is designed to provide supervision of the trip coil with the breaker open or closed, but unlike schemes 1 and 2, it also provides pre-closing supervision. Since only one opto input is used, this scheme is not compatible with latched trip contacts. If circuit breaker status monitoring is required a further 1 or 2 opto inputs must be used.

When the breaker is closed, supervision current passes through the opto input, resistor R2 and the trip coil. When the breaker is open current flows through the opto input, resistors R1 and R2 (in parallel), resistor R3 and the trip coil. Unlike schemes 1 and 2, supervision current is maintained through the trip path with the breaker in either state, thus giving pre-closing supervision.

As with schemes 1 and 2, resistors R1 and R2 are used to prevent false tripping, if the opto-input is accidentally shorted. However, unlike the other two schemes, this scheme is dependent upon the position and value of these resistors. Removing them would result in incomplete trip circuit monitoring. The table below shows the resistor values and voltage settings required for satisfactory operation.

Auxiliary Voltage (Vx)	Resistor R1 & R2 (ohms)	Resistor R3 (ohms)	Opto Voltage Setting
24/27	-	-	-
30/34	-	-	-
48/54	1.2k	0.6k	24/27
110/125	2.5k	1.2k	48/54
220/250	5.0k	2.5k	110/125

Note Scheme 3 is not compatible with auxiliary supply voltages of 30/34 volts and below.

Table 10 - Resistor values for TCS scheme 3

3.4.4.2

Scheme 3 PSL

The PSL for scheme 3 is identical to that of scheme 1.

3.5

Fault Detector / Trip Supervision**Trip Supervision**

The following features were introduced in these software releases:

- P445 = J4

The Under delta Voltage and Over delta current supervision elements require that Distance protection is enabled. If these are required to supervise a Differential scheme where Distance protection is not required, then the Distance protection must be enabled, but the individual Distance protection zones (e.g. Z1, Z2, Z3, Z4, ZP, ZQ and aided schemes etc) should be disabled.

Phase Associated Logic

This table lists the phase relationships between the protection and supervision elements:

Supervision Elements	I>			IN>	OCD>			Vpp<			Vpn<			UVD>		
Protection element phases	A	B	C	N	A	B	C	AB	BC	CA	A	B	C	A	B	C
A	X			X	X			X		X	X			X		
B		X		X		X		X	X			X			X	
C			X	X			X		X	X			X			X

Table 11 - Phase Association Logic

Menu Cells

The Settings associated with these new functions are given in the GROUP 1 SUPERVISION part of the main Settings table (Column 46, from Row No 60 through to 8C).

For more details, please refer to the Supervision (VTS, CTS, Inrush Detection and Special Weak Infeed Blocking) section in the Settings chapter.

DDB Changes

Several DDB numbers have been modified, including:

P443, P445 and P446 = 1881 to 1888

P543, P544, P545 & P546 = 1889 to 1892

DDB No (Ordinal)	English Definition	Description
1881	TS Dist. Z1 Blk	Provides an indication that Distance Zone 1 is blocked by the trip supervision elements. Set to one when any of the supervising elements is enabled for the Distance Zone 1 function but none of the elements has met the criteria and the trip signal is high.
1882	TS Dist. Z2 Blk	Provides an indication that Distance Zone 2 is blocked by the trip supervision elements. Set to one when any of the supervising elements is enabled for the Distance Zone 2 function but none of the elements has met the criteria and the trip signal is high.
1883	TS Dist. Z3 Blk	Provides an indication that Distance Zone 3 is blocked by the trip supervision elements. Set to one when any of the supervising elements is enabled for the Distance Zone 3 function but none of the elements has met the criteria and the trip signal is high.
1884	TS Dist. Z4 Blk	Provides an indication that Distance Zone 4 is blocked by the trip supervision elements. Set to one when any of the supervising elements is enabled for the Distance Zone 4 function but none of the elements has met the criteria and the trip signal is high.
1885	TS Dist. ZP Blk	Provides an indication that Distance Zone P is blocked by the trip supervision elements. Set to one when any of the supervising elements is enabled for the Distance Zone P function but none of the elements has met the criteria and the trip signal is high.
1886	TS Dist. ZQ Blk	Provides an indication that Distance Zone Q is blocked by the trip supervision elements. Set to one when any of the supervising elements is enabled for the Distance Zone Q function but none of the elements has met the criteria and the trip signal is high.
1887	TS Aided1 Z Blk	Provides an indication that Distance Aided Scheme 1 is blocked by the trip supervision elements. Set to one when any of the supervising elements is enabled for the Aided Scheme function but none of the elements has met the criteria and the trip signal is high.
1888	TS Aided2 Z Blk	Provides an indication that Distance Aided Scheme 2 is blocked by the trip supervision elements. Set to one when any of the supervising elements is enabled for the Aided Scheme function but none of the elements has met the criteria and the trip signal is high.
1889	TS IDiff. Blk	Provides an indication that Line Differential is blocked by the trip supervision elements. Set to one when any of the supervising elements is enabled for the Line Differential function but none of the elements has met the criteria and the trip signal is high.
1890	CdiffTripA Blk	Current Diff Trip A Block by Trip Supervision
1891	CdiffTripB Blk	Current Diff Trip B Block by Trip Supervision
1892	CdiffTripC Blk	Current Diff Trip C Block by Trip Supervision
<div style="border: 1px solid black; padding: 5px; display: inline-block;"> <i>Note The Programming Scheme Logic chapter contains details of these DDB Nos.</i> </div>		

Monitor points with INF numbers 86 to 93 are available in P443, P445, P446, P543, P544, P545 & P546.

Monitor points with INF numbers 86 to 93 are available in P543, P544, P545 & P546 only.

See IEC870 Monitor sheet of the Menu Database for further details.

COT	Diff Primary		Distance Primary		AR Primary		Description
	FUN	INF	FUN	INF	FUN	INF	
	202	86	138	86	170	86	Supervision block on Z1 Trip
	202	87	138	87	170	87	Supervision block on Z2 Trip
	202	88	138	88	170	88	Supervision block on Z3 Trip
	202	89	138	89	170	89	Supervision block on Z4 Trip
	202	90	138	90	170	90	Supervision block on ZP Trip
	202	91	138	91	170	91	Supervision block on ZQ Trip
	202	92	138	92	170	92	Supervision block on aided1 Z Trip
	202	93	138	93	170	93	Supervision block on aided2 Z Trip
	202	94	138	94	170	94	Supervision block on IDiff Trip

All the below Binary Input points except “TS IDiff.Blk” are available in P443, P445, P446, P543, P544, P545 and P546. Binary Input point “TS IDiff.Blk” is available in P543, P544, P545 and P546 only.

See DNPEV Binary Inputs sheet of the Manu Database for further details.

P443	P445	P446	P543 / P545 No Distance	P544 / P546 No Distance	P543 / P545	P544 / P546	P547	P841 A	P841 B	Name / Description	DDB No.
611	573	712			662	764				TS Dist. Z1 Blk	1881
612	574	713			663	765				TS Dist. Z2 Blk	1882
613	575	714			664	766				TS Dist. Z3 Blk	1883
614	576	715			665	767				TS Dist. Z4 Blk	1884
615	577	716			666	768				TS Dist. ZP Blk	1885
616	578	717			667	769				TS Dist. ZQ Blk	1886
618	579	718			668	770				TS Aided1 Z Blk	1887
619	580	719			669	771				TS Aided2 Z Blk	1888
					670	772				TS IDiff. Blk	1889

Table 12 - DNP3 Mapping

These points are not mapped in IEC61850.

3.6 Intermicom⁶⁴ Application Example

An example of how to apply the InterMiCOM⁶⁴ scheme is given below. This example should be read in conjunction with the InterMiCOM⁶⁴ section of the Operation (OP) chapter in this Technical Manual.

3.6.1 InterMiCOM⁶⁴ Mapping for Three Ended Application – Blocking or PUR Example

The following figure shows a suggested InterMiCOM⁶⁴ mapping:

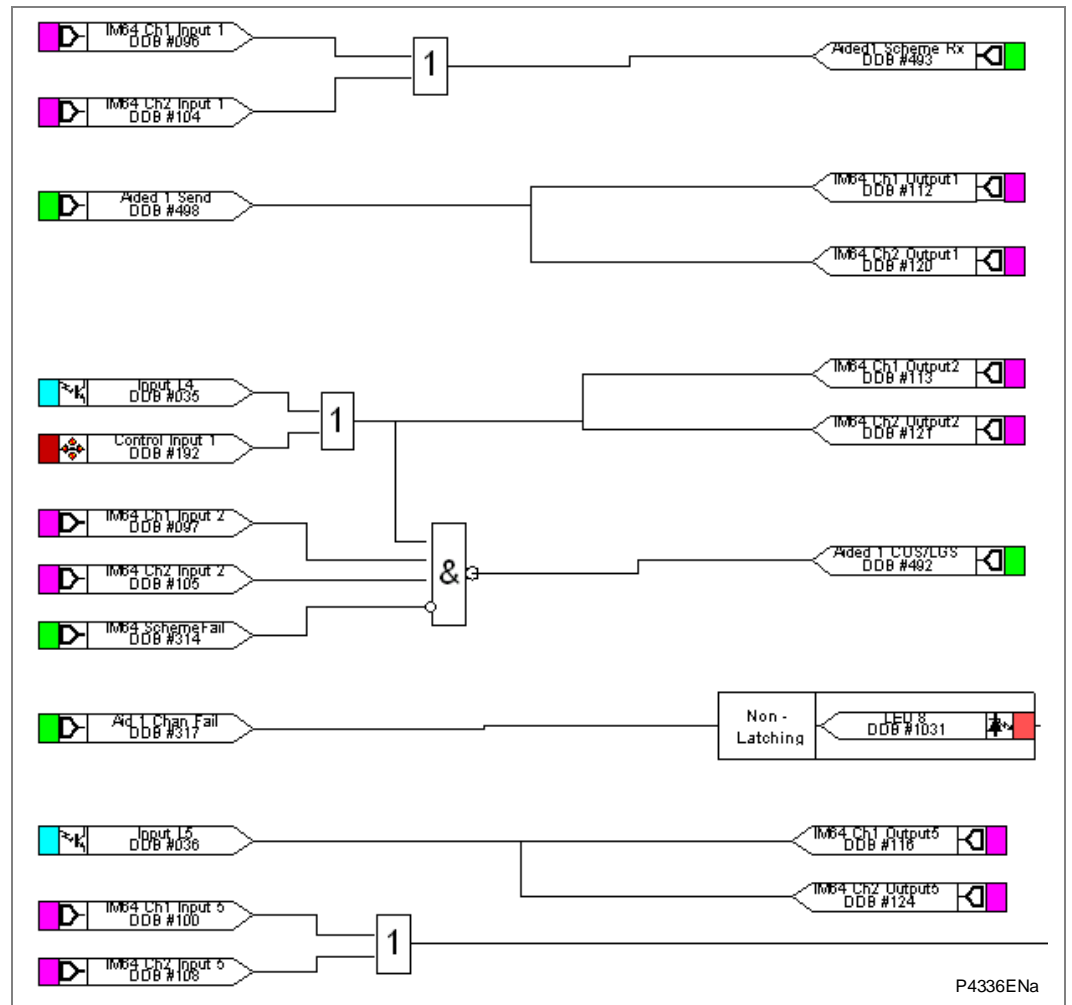

Figure 27 - InterMiCOM⁶⁴ mapping in a three ended application

3.6.2 Intermicom⁶⁴ Application Example General Advice

MiCOM relays have standard, pre-configured aided scheme logic internal to each relay. Thus, it is not necessary to draw the zone logic for Permissive Underreach, Permissive Overreach or Blocking schemes within the PSL. To gain the benefit of selecting a proven and tested scheme, the standard “**Aided**” scheme logic should be used.

When InterMiCOM⁶⁴ is being used as the transmission medium for the aided channel signal(s), all that is required is to create one-to-one mapping between the Aided scheme logic, and the InterMiCOM⁶⁴ (IM64) signals to be used. The PSL editor is used to perform the simple mapping required.

To configure the signal SEND logic:

- Route the required Aided send DDB signal to the IM64 Output to be used

To configure the signal RECEIVE logic:

- Route the required IM64 Input signal to the Aided scheme Rx DDB input

3.6.3 Three-Ended Applications

The example in the “InterMiCOM⁶⁴ Application Example General Advice” section shows a three terminal application, in this case in a BLOCKING or PUR scheme mode.

Note: This breaks with the rule of the one-to-one mapping as described in the InterMiCOM⁶⁴ Application Example General Advice section. In three terminal schemes, the input to the Aided scheme is some kind of logic combination of the signals received from the two remote ends:

- BLOCKING schemes are recommended to take a logical OR of the incoming IM64 signals, before being mapped to Aided scheme Rx. This is to ensure that if the fault is declared as external at any line end, Zone 2 accelerated tripping at the local end is blocked.
- PERMISSIVE UNDERREACH schemes are recommended to take a logical OR of the incoming IM64 signals, before being mapped to Aided scheme Rx. Thus, if the fault is declared as internal at any remote line end, Zone 2 accelerated tripping at the local end is allowed. As Zone 1 is an underreaching element, it can only key the channel for an internal fault, so there is no need for AND logic.
- PERMISSIVE OVERREACH schemes are recommended to take a logical AND of the incoming IM64 signals, before being mapped to Aided scheme Rx. This is to ensure that the fault must be seen as forward from both remote ends before Zone 2 accelerated tripping at the local end is allowed. As Zone 2 keys the channel, confirmation of a forward decision at all three line ends must be confirmed before aided scheme tripping is permitted.

In all three terminal schemes, the send logic is a one-to-many mapping. The Aided send is mapped to the IM64 signals which transmit to both remote ends. The connection to Ch1 (channel 1), and Ch2 (channel 2) ensures communication to the two remote ends. In case of channel failure between any two relays, the ‘**Aided 1 COS/LGS**’ signal will become high in the relay that is not receiving and activate the FallBackMode. Therefore, to preserve the stability in 3-ended blocking scheme, the corresponding ‘**IM_X DefaultValue**’ in the setting file must be set high. It should be noted that in the PUR and POR schemes such a precaution is not necessary since the aided signal can not be sent via broken communications.

3.6.4

Intermicom⁶⁴ Application Example Scheme Description

The scheme in the InterMiCOM⁶⁴ mapping in a three ended application diagram is assumed as a case study. The top half of the page shows the mapping of the send and receive logic as already described. It can be seen that the first InterMiCOM bit (Input 1) is being used for the purposes of Aided scheme 1.

Notes Two Aided schemes are available, Aided 1 and Aided 2. This allows for example an independent Distance aided scheme, and a DEF aided scheme to be configured. Whether Aided 1 is used alone, or Aided 2 is used too will depend on the utility preference. Further detail is available in the MiCOM Technical Manual.

The InterMiCOM⁶⁴ bits are duplex in nature, in other words InterMiCOM⁶⁴ bit 1 between the relay at line end A and B is completely independent from the same bit traveling from end B to A.

For simplicity, it is recommended that Aided scheme 1 is mapped to IM64 bit 1.

Likewise, where Aided scheme 2 is applied, it is more logical to assign IM64 bit 2, providing that it is not already used in the PSL for some other function.

3.6.5

Intermicom⁶⁴ Application Example Channel Supervision

For teleprotection schemes, it is commonplace to configure alarming in the event of channel failure. The third dotted box on the case study provides full monitoring of the scheme in three ended applications. Here, IM64 bit 2 is permanently energized when the channel is healthy. The OR gate shows how an opto input (L4) and a Control Input might be used as prerequisites for healthy signaling:

- The use of an opto input allows a check that correct DC battery voltages are present for local teleprotection purposes, or perhaps that a selector switch has not taken the scheme out of service.
- The use of a Control Input allows switching in or out of the teleprotection via menu commands on the relay concerned. This provides convenient in-out switching of the entire teleprotection scheme by visiting/addressing just one line end relay.

The exact logic condition to declare the local “**signaling healthy**” condition will be chosen such as to reflect the utility’s practices. In the example shown, this logical condition is then mapped to IM64 Output 2 (bit 2), for transmitting to the two remote line ends.

In order to declare that the signaling scheme is healthy, bit 2 (the assigned health-check bit) must be received from both remote ends. This can be combined with a general check on InterMiCOM⁶⁴ messaging, DDB#314. The AND gate shows that signaling is only healthy if:

- The local DC battery voltage/control state is set to allow teleprotection operation,
- The remote end health-check bits are both received successfully,
- The scheme alarms have not detected messaging failures (IM64 Scheme Fail).

A logical “**AND**” combination is used, with the gate output inverted to feed into the aided scheme logic. This scheme failure output then feeds the standard “**Channel out of Service**” (COS) logic.

The fourth dotted box illustrates how the same scheme failure alarm (COS) can then be simply mapped to any LED indication, or output contact for alarming.

Note If a simpler scheme is preferred, it is not necessary to assign a health-check bit. In such instances, the IM64 Scheme Fail alarm alone can be used to drive COS. However, if a test mode selection were to disable the aided scheme at one end, the other line ends would have no indication of the depleted operation.

For this reason, the use of the health-check bit is recommended.

3.6.6 Intermicom⁶⁴ Application Example Transfer Trip

The case study scheme shows a suggested Transfer Trip (“**Intertrip**”) in the lower dotted box area. This is an optional addition (or alternative) with any aided scheme. The example shows an opto input (L5) which is being used to initiate the intertrip, mapped to send IM64 bit 5 to both remote ends. On receipt of the intertrip bit from any remote line end, the OR gate is used to map the received intertrip to whichever output relay trips the local breaker. In the diagram, relay 3 is shown as an example.

Again it can be seen that the PSL is the means by which the InterMiCOM⁶⁴ signals are driven, and to where any received bits are routed too.

3.6.7 InterMiCOM⁶⁴ Application Example - Mapping for Two Ended Application

The same scheme principle as shown in the InterMiCOM⁶⁴ mapping in a three-ended application diagram applies in a two-ended application. The scheme will be simplified, whereby Aided Send signals are mapped directly to IM64 bits, on a one-to-one mapping. The IM64 bit received from the remote end is also mapped directly to the Aided Scheme Rx signal, requiring no AND or OR logic combination.

3.6.8 Intermicom⁶⁴ Application Example - Dual Redundant Communications Channels

In dual redundant operation, the user has the option to send end-end signals via two paths. The two paths (channels) are defined as Ch1 and Ch2. Several factors can be taken into account when using this mode:

- The assignment of IM64 bits is completely independent, per channel. For example if all 8 possible bits per channel are assigned to discrete functions, this allows a total of 16 end-end signals.
- The receive logic should employ AND (“**both**”) or OR (“**any**”) logic gate functions to combine the dual redundant signals, as appropriate to the desired operation.

3.6.9 Intermicom⁶⁴ Application example - Scheme Co-Ordination Timers

Distance and DEF and delta directional aided schemes use scheme co-ordination timers to ensure correct operation. The function of these is documented in the Operation chapter of the Technical Manual. However, when using InterMiCOM⁶⁴ as the teleprotection channel, the time delays applied can be different to those used for traditional channels. This is due, mainly, to the fact that the response time of opto inputs and output contacts is bypassed. An output contact will take typically 3 to 5ms to close, and an opto input will take 1 to 2ms to recognize a change of state. Thus, using InterMiCOM⁶⁴ will save around 5-6ms for I/O response time.

The new time delays appropriate for Dist dly and Current Reversal Guard timers are as listed in the following sections. Where direct fiber connections are used for InterMiCOM⁶⁴, ignore the + MUX addition. Where a multiplexed link is used, the + MUX figure should account for the multiplexer response time. If this is unknown, it can be obtained for the specific installation using the appropriate measurement in the MEASUREMENTS 4 menu column.

3.6.9.1 InterMiCOM⁶⁴ Application Example - Distance PUR Permissive Underreach

- Dist dly = zero

3.6.9.2 InterMiCOM⁶⁴ Application Example - Distance POR Permissive Overreach

- Dist dly = zero
- tREV. Guard = 40ms + MUX

3.6.9.3 InterMiCOM⁶⁴ Application Example - Distance Blocking

- Dist dly (50Hz) = 25ms + MUX
- Dist dly (60Hz) = 22ms + MUX
- tREV. Guard = 25ms + MUX

3.6.9.4 InterMiCOM64 Application Example - Directional Earth Fault (DEF) POR Permissive Overreach

- DEF dly = zero
- tREV. Guard = 50ms + MUX

3.6.9.5 InterMiCOM64 Application Example - Directional Earth Fault (DEF) Blocking

- DEF dly = 25ms + MUX
- tREV. Guard = 35ms + MUX

<i>Note</i>	<i>When adding any multiplexer delays, the maximum response time of the multiplexed link should be assumed. This should include any addition for rerouting in self-healing networks.</i>
-------------	--

3.6.10 Fallback Mode for InterMiCOM⁶⁴ Bits

On temporary loss of the InterMiCOM⁶⁴ channel, the user may select to latch the last healthy signal for a period of time, or to fallback to a chosen default value.

- For Intertripping schemes, reverting to a default state of 0 is recommended;
- For Blocking schemes set, reverting to a default state of 1 is recommended;
- For Permissive applications, latching the last healthy received state is recommended.

4 APPLICATION OF NON-PROTECTION FUNCTIONS

4.1 Auto-Reclosing

4.1.1 Time Delayed and High Speed Auto-Reclosing

An analysis of faults on any overhead line network has shown that 80-90% are transient in nature.

In the majority of fault incidents, if the faulty line is immediately tripped out, and time is allowed for the fault arc to de-ionize, reclosure of the circuit breakers will result in the line being successfully re-energized. Auto-reclose schemes are employed to automatically reclose a switching device a set time after it has been opened due to operation of protection, where transient and semi-permanent faults are prevalent.

The principal benefit gained by the application of auto-reclosing to overhead line feeders is improved supply continuity and possibly reduced costs since fewer personnel may be required. On some systems the application of high speed auto-reclose may permit a higher level of power transfer while retaining transient stability for most faults which are likely to occur. High speed single phase auto-reclosure can offer increased benefits over high speed three phase auto-reclosure in terms of a higher power transfer limit and reduced stress on reclosing.

4.1.2 Auto-Reclose Logic Operating Sequence

The standard scheme logic is configured to permit control of one circuit breaker.

Auto-reclosure of two circuit breakers in a 1½ circuit breaker scheme is not supported by the standard logic (although PSL schemes to allow such operations do exist - contact your local Schneider Electric Applications support team for advice).

For high speed auto-reclose only the instantaneous protection would normally be set to initiate auto-reclose. This is because for best results when applying high speed auto-reclose to improve a system stability limit, it is important that the fault should be cleared as quickly as possible from both line ends.

4.1.3 Setting Guidelines

4.1.3.1 CB Healthy

This check can be disabled by not allocating an opto input to this function, and deliberate application of a logic 1 onto this DDB signal within the PSL. Assigning a PSL gate with no inputs and an inverted output will mean that the signal is always high, and the circuit breaker deemed to be **healthy**. Alternatively, it is possible to energize the CB healthy opto input from a circuit breaker open auxiliary contact (52b).

4.1.3.2 Number of Shots

An important consideration is the ability of the circuit breaker to perform several trip close operations in quick succession and the effect of these operations on the maintenance period.

The fact that 80 - 90% of faults are transient highlights the advantage of single shot schemes. If statistical information for the power system shows that a moderate percentage of faults are semi-permanent, further Delayed Auto-Reclose (DAR) shots may be used provided that system stability is not threatened.

<i>Note</i>	<i>DAR shots will always be three pole.</i>
-------------	---

4.1.3.3

Dead Timer Setting

High speed auto-reclose may be required to maintain stability on a network with two or more power sources. For high speed auto-reclose the system disturbance time should be minimized by using fast protection, <30 ms, such as distance or feeder differential protection (for P54x/P841) or distance or phase comparison (for P547) and fast circuit breakers <60 ms. For stability between two sources a system dead time of ≤300 ms may typically be required. The minimum system dead time considering just the CB is the trip mechanism reset time plus the CB closing time.

Minimum relay dead time settings are governed primarily by two factors:

- Time taken for de-ionization of the fault path
- Circuit breaker characteristics

Also it is essential that the protection fully resets during the dead time, so that correct time discrimination will be maintained after reclosure onto a fault. For high speed auto-reclose instantaneous reset of protection is required.

4.1.3.4

De-ionizing Time

The de-ionization time of a fault arc depends on circuit voltage, conductor spacing, fault current and duration, wind speed and capacitive coupling from adjacent conductors. As circuit voltage is generally the most significant, minimum de-ionizing times can be specified as in the table below.

Note For single pole high-speed auto-reclose, the capacitive current induced from the healthy phases can increase the time taken to de-ionize fault arcs.

Line voltage (kV)	Minimum de-energization time (s)
66	0.1
110	0.15
132	0.17
220	0.28
275	0.3
400	0.5

Table 13 - Minimum Fault Arc De-ionizing Time (Three Pole Tripping)

4.1.3.5

Example Minimum Dead Time Calculation

The following circuit breaker and system characteristics are to be used:

CB Operating time (Trip coil energized → Arc interruption): 50 ms (a);

CB Opening + Reset time (Trip coil energized → Trip mechanism reset): 200 ms (b);

Protection reset time: < 80 ms (c);

CB Closing time (Close command → Contacts make): 85 ms (d).

De-ionizing time for 220 kV line:

280 ms (e) for a three-phase trip. (560 ms for a single pole trip).

The minimum relay dead time setting is the greater of:

(a) + (c) = 50 + 80 = 130 ms, to allow protection reset;

(a) + (e) - (d) = 50 + 280 - 85 = 245 ms, to allow de-ionizing (three pole);

= 50 + 560 - 85 = 525 ms, to allow de-ionizing (single pole).

In practice a few additional cycles would be added to allow for tolerances, so **3P - Dead Time 1** could be chosen as ≥ 300 ms, and **1P - Dead Time** could be chosen as ≥ 600 ms. The overall system dead time is found by adding (d) to the chosen settings, and then subtracting (a). (This gives 335 ms and 635 ms respectively here).

4.1.3.6

Reclaim Timer Setting

A number of factors influence the choice of the reclaim timer, such as;

- Fault incidence/Past experience - Small reclaim times may be required where there is a high incidence of recurrent lightning strikes to prevent unnecessary lockout for transient faults
- Spring charging time - For high speed auto-reclose the reclaim time may be set longer than the spring charging time. A minimum reclaim time of >5 s may be needed to allow the CB time to recover after a trip and close before it can perform another trip-close-trip cycle. This time will depend on the duty (rating) of the CB. For delayed auto-reclose there is no need as the dead time can be extended by an extra CB healthy check AR Inhibit Time window time if there is insufficient energy in the CB
- Switchgear Maintenance - Excessive operation resulting from short reclaim times can mean shorter maintenance intervals
- The Reclaim Time setting is generally set greater than the tZ2 distance zone delay

4.2

Current Transformer Supervision (CTS)

The residual voltage setting, **CTS Vn< Inhibit** and the residual current setting, **CTS In> set**, should be set to avoid unwanted operation during healthy system conditions. For example **CTS Vn< Inhibit** should be set to at least 120% of the maximum steady state residual voltage. The **CTS In> set** will typically be set below minimum load current. The time-delayed alarm, **CTS Time Delay**, is generally set to 5 seconds.

Where the magnitude of residual voltage during a ground/earth fault is unpredictable, the element can be disabled to prevent protection elements being blocked during fault conditions.

4.3

Circuit Breaker Condition Monitoring

4.3.1

Setting the Total Fault Current Broken Thresholds

i.e. Setting the ΣI^{\wedge} Thresholds

Where overhead lines are prone to frequent faults and are protected by Oil Circuit Breakers (OCBs), oil changes account for a large proportion of the life cycle cost of the switchgear. Generally, oil changes are performed at a fixed interval of circuit breaker fault operations. However, this may result in premature maintenance where fault currents tend to be low, and hence oil degradation is slower than expected. The ΣI^{\wedge} counter monitors the cumulative severity of the duty placed on the interrupter allowing a more accurate assessment of the circuit breaker condition to be made.

For OCBs, the dielectric withstand of the oil generally decreases as a function of ΣI^2t . This is where 'I' is the fault current broken, and 't' is the arcing time within the interrupter tank (not the interrupting time). As the arcing time cannot be determined accurately, the relay would normally be set to monitor the sum of the broken current squared, by setting 'Broken I[^]' = 2.

For other types of circuit breaker, especially those operating on higher voltage systems, practical evidence suggests that the value of 'Broken I[^]' = 2 may be inappropriate. In such applications 'Broken I[^]' may be set lower, typically 1.4 or 1.5. An alarm in this instance may be indicative of the need for gas/vacuum interrupter HV pressure testing, for example. The setting range for 'Broken I[^]' is variable between 1.0 and 2.0 in 0.1 steps. It is imperative that any maintenance program must be fully compliant with the switchgear manufacturer's instructions.

4.3.2 **Setting the Number of Operations Thresholds**

Every operation of a circuit breaker results in some degree of wear for its components. Therefore, routine maintenance, such as oiling of mechanisms, may be based upon the number of operations. Suitable setting of the maintenance threshold will allow an alarm to be raised, indicating when preventative maintenance is due. Should maintenance not be carried out, the relay can be set to lockout the auto-reclose function on reaching a second operations threshold. This prevents further reclosure when the circuit breaker has not been maintained to the standard demanded by the switchgear manufacturer's maintenance instructions.

Certain circuit breakers, such as Oil Circuit Breakers (OCBs) can only perform a certain number of fault interruptions before requiring maintenance attention. This is because each fault interruption causes carbonizing of the oil, degrading its dielectric properties. The maintenance alarm threshold **No CB Ops. Maint.** may be set to indicate the requirement for oil sampling for dielectric testing, or for more comprehensive maintenance. Again, the lockout threshold **No CB Ops. Lock** may be set to disable auto-reclosure when repeated further fault interruptions could not be guaranteed. This minimizes the risk of oil fires or explosion.

4.3.3 **Setting the Operating Time Thresholds**

Slow CB operation is also indicative of the need for mechanism maintenance. Therefore, alarm and lockout thresholds (CB Time Maint./CB Time Lockout) are provided and are settable in the range of 5 to 500 ms. This time is set in relation to the specified interrupting time of the circuit breaker.

4.3.4 **Setting the Excessive Fault Frequency Thresholds**

Persistent faults will generally cause auto-reclose lockout, with subsequent maintenance attention. Intermittent faults such as clashing vegetation may repeat outside of any reclaim time, and the common cause might never be investigated. For this reason it is possible to set a frequent operations counter on the relay which allows the number of operations **Fault Freq. Count** over a set time period **Fault Freq. Time** to be monitored. A separate alarm and lockout threshold can be set.

4.3.5 **Read Only Mode**

With IEC 61850 and Ethernet/Internet communication capabilities, security has become a pressing issue. The Px40 IED provides a facility to allow the user to enable or disable the change in configuration remotely.

Read Only mode can be enabled/disabled for the following rear ports:

- Rear Port 1 - IEC 60870-5-103 and Courier protocols
- Rear Port 2 (if fitted) - Courier protocol
- Ethernet Port (if fitted) - Courier protocol (**tunnelled**)

5 CURRENT TRANSFORMER (CT) REQUIREMENTS

5.1 Zone 1 Reach Point Accuracy (RPA)

$$V_k \geq K_{RPA} \times I_{F Z1} \times (1 + X/R) \cdot (R_{CT} + R_L)$$

Where:

V_k = Required CT knee point voltage (volts)

K_{RPA} = Fixed dimensioning factor = **always 0.6**

$I_{F Z1}$ = Max. secondary phase fault current at Zone 1 reach point (A)

X/R = Primary system reactance/resistance ratio

R_{CT} = CT secondary winding resistance (Ω)

R_L = Single lead resistance from CT to relay (Ω)

5.2 Zone 1 Close-Up Fault Operation

An additional calculation must be performed for all cables, and any lines where the source impedance ratio might be less than $SIR = 2$.

$$V_k \geq K_{max} \times I_{F max} \times (R_{CT} + R_L)$$

Where:

K_{max} = Fixed dimensioning factor = **always 1.4**

$I_{F max}$ = Max. secondary phase fault current (A).

Then, the highest of the two calculated knee points must be used.

Note It is not necessary to repeat the calculation for earth faults, as the phase reach calculation (3 ϕ) is the worst-case for CT dimensioning.

5.3 Recommended CT Classes (British and IEC)

Class PX current transformers with a knee point voltage greater or equal than that calculated can be used.

Class 5P protection CTs can be used, noting that the knee point voltage equivalent these offer can be approximated from:

$$V_k = (VA \times ALF) / I_n + (R_{CT} \times ALF \times I_n)$$

Where:

VA = Voltampere burden rating

ALF = Accuracy limit factor

I_n = CT nominal secondary current

5.4 Determining V_k for an IEEE "C" Class CT

Where American/IEEE standards are used to specify CTs, the C class voltage rating can be checked to determine the equivalent V_k (knee point voltage according to IEC). The equivalence formula is:

$$V_k = [(C \text{ rating in volts}) \times 1.05] + [100 \times R_{CT}]$$

6 HIGH BREAK OUTPUT CONTACTS

The high break contacts allow the elimination of auxiliary relays. This in turn helps in the provision of cost effective solutions, minimizing space, wiring, commissioning time, etc. According to the model selected, in addition to standard output relay boards, one or two 'high break' output relay boards can be fitted. Each houses four normally open output contacts suitable for breaking loads higher than can be broken with the standard contacts. The performance and possible application scenarios of these contacts are described in the Technical Data (TD) and Product Design (PD) chapters of this manual.

Note For the P445 relay it is only the model "D" which has a 'high break' output relay board fitted.

7 AUXILIARY SUPPLY FUSE RATING

In the Safety Information part of this manual, the maximum allowable fuse rating of 16A is quoted. To allow time grading with fuses upstream, a lower fuselink current rating is often preferable. Use of standard ratings of between 6A and 16A is recommended. Low voltage fuselinks, rated at 250V minimum and compliant with IEC60269-2 general application type gG are acceptable, with high rupturing capacity. This gives equivalent characteristics to HRC "red spot" fuses type NIT/TIA often specified historically.

The table below recommends advisory limits on relays connected per fused spur. This applies to MiCOM Px40 series devices with hardware suffix C and higher, as these have inrush current limitation on switch-on, to conserve the fuse-link.

Maximum Number of MiCOM Px40 Relays Recommended Per Fuse				
Battery Nominal Voltage	6A	10A Fuse	15 or 16A Fuse	Fuse Rating > 16A
24 to 54V	2	4	6	Not permitted
60 to 125V	4	8	12	Not permitted
138 to 250V	6	10	16	Not permitted
Alternatively, Miniature Circuit Breakers (MCBs) may be used to protect the auxiliary supply circuits.				

USING THE PSL EDITOR

CHAPTER 7

Chapter Applicability	
Date:	08/2017
Products covered by this chapter:	This chapter covers the specific versions of the MiCOM products listed below. This includes only the following combinations of Software Version and Hardware Suffix.
Hardware Suffix:	All MiCOM Px4x products
Software Version:	All MiCOM Px4x products
Connection Diagrams:	This chapter may use any of these connection diagrams:
P14x (P141, P142, P143 & P145):	10P141xx (xx = 01 to 02) 10P142xx (xx = 01 to 05) 10P143xx (xx = 01 to 11) 10P145xx (xx = 01 to 11)
P24x (P241, P242 & P243):	10P241xx (xx = 01 to 02) 10P242xx (xx = 01) 10P243xx (xx = 01)
P34x (P342, P343, P344, P345 & P391):	10P342xx (xx = 01 to 17) 10P343xx (xx = 01 to 19) 10P344xx (xx = 01 to 12) 10P345xx (xx = 01 to 07) 10P391xx (xx = 01 to 02)
P341:	10P341xx (xx = 01 to 12)
P445:	10P445xx (xx = 01 to 04)
P44x (P442 & P444):	10P44101 (SH 1 & 2) 10P44201 (SH 1 & 2) 10P44202 (SH 1) 10P44203 (SH 1 & 2) 10P44401 (SH 1) 10P44402 (SH 1) 10P44403 (SH 1 & 2) 10P44404 (SH 1) 10P44405 (SH 1) 10P44407 (SH 1 & 2)
P44y (P443 & P446):	10P44303 (SH 01 and 03) 10P44304 (SH 01 and 03) 10P44305 (SH 01 and 03) 10P44306 (SH 01 and 03) 10P44600 10P44601 (SH 1 to 2) 10P44602 (SH 1 to 2) 10P44603 (SH 1 to 2)
P54x (P543, P544, P545 & P546):	10P54302 (SH 1 to 2) 10P54303 (SH 1 to 2) 10P54400 10P54404 (SH 1 to 2) 10P54405 (SH 1 to 2) 10P54502 (SH 1 to 2) 10P54503 (SH 1 to 2) 10P54600 10P54604 (SH 1 to 2)

	10P54605 (SH 1 to 2) 10P54606 (SH 1 to 2)
P547:	10P54702xx (xx = 01 to 02) 10P54703xx (xx = 01 to 02) 10P54704xx (xx = 01 to 02) 10P54705xx (xx = 01 to 02)
P64x (P642, P643 & P645):	10P642xx (xx = 1 to 10) 10P643xx (xx = 1 to 6) 10P645xx (xx = 1 to 9)
P74x (P741, P742 & P743):	10P740xx (xx = 01 to 07)
P746:	10P746xx (xx = 00 to 21)
P841:	10P84100 10P84101 (SH 1 to 2) 10P84102 (SH 1 to 2) 10P84103 (SH 1 to 2) 10P84104 (SH 1 to 2) 10P84105 (SH 1 to 2)
P849:	10P849xx (xx = 01 to 06)

Notes:

CONTENTS

1. Overview	9
2. Easergy Studio PSL Editor	10
2.1 How to Obtain Easergy Studio.....	10
2.2 To Start Easergy Studio.....	10
2.3 To Open a Pre-Existing System.....	10
2.4 To Start the PSL Editor.....	10
2.5 How to use MiCOM PSL Editor.....	11
2.6 Warnings.....	11
3. Toolbar and Commands	13
3.1 Standard Tools.....	13
3.2 Alignment Tools.....	13
3.3 Drawing Tools.....	14
3.4 Nudge Tools.....	14
3.5 Rotation Tools.....	15
3.6 Structure Tools.....	15
3.7 Zoom and Pan Tools.....	15
3.8 Logic Symbols.....	16
4. PSL Logic Signals Properties	18
4.1 Signal Properties Menu.....	18
4.2 Link Properties.....	18
4.2.1 Rules for Linking Symbols.....	18
4.3 Opto Signal Properties.....	19
4.4 Input Signal Properties.....	19
4.5 Output Signal Properties.....	19
4.6 GOOSE Input Signal Properties.....	19
4.7 GOOSE Output Signal Properties.....	20
4.8 Control In Signal Properties.....	20
4.9 InterMiCOM Output Commands Properties.....	20
4.10 InterMiCOM Input Commands Properties.....	20
4.11 Function Key Properties.....	21
4.12 Fault Recorder Trigger Properties.....	21
4.13 LED Signal Properties.....	21
4.14 Contact Signal Properties.....	21
4.15 LED Conditioner Properties.....	21
4.16 Contact Conditioner Properties.....	22
4.17 Timer Properties.....	22

4.18 Gate Properties.....	23
4.19 SR Programmable Gate Properties.....	23
4.20 PSL Signal Grouping Modes.....	24
<hr/>	
5. Specific Tasks.....	26
5.1 Digital Input Label Operation (P44y, P54x, P445 & P841 only).....	26
5.2 Virtual Input Label Operation.....	26
5.3 Virtual Output Label Operation.....	27
5.4 SR/MR User Alarm Label Operation.....	27
5.5 Settable Control Input Operation (P14x, P44y, P54x, P445 & P841 only).....	28
5.6 Settable Control Setg I/P Label Operation (P14x, P44y, P54x, P445 & P841 only).....	29
<hr/>	
6. Making a Record of MiCOM Px40 Device Settings.....	31
6.1 Using Easergy Studio to Manage Device Settings.....	31
6.2 Extract Settings from a MiCOM Px40 Device.....	31
6.3 Send Settings to a MiCOM Px40 Device.....	31

FIGURES

Figure 1 - Example of a PSL Editor Module.....	11
Figure 2 - Link Properties.....	18
Figure 3 - Red, green and yellow LED outputs.....	22
Figure 4 - Contact conditioner settings.....	22
Figure 5 - Timer Settings.....	23
Figure 6 - Gate properties.....	23
Figure 7 - SR latch component properties.....	24
Figure 8 - PSL diagram.....	25
Figure 9 - Easergy Studio Disturb Recorder table diagram.....	25
Figure 10 - DR Chan Labels tree.....	26
Figure 11 - Digital Input 1 dialog box.....	26
Figure 12 - DR Chan Labels tree.....	26
Figure 13 - Easergy StudioVIR I/P Labels Tree.....	26
Figure 14 - Virtual Input 1 dialog box.....	27
Figure 15 - Easergy Studio VIR I/P Labels Tree.....	27
Figure 16 - Easergy Studio VIR O/P Labels Tree.....	27
Figure 17 - Easergy Studio USR Labels Tree.....	28
Figure 18 - User Alarm dialog box.....	28
Figure 19 - Virtual Input 1 settings.....	28
Figure 20 - Easergy Studio Control Inputs tree.....	28
Figure 21 - Ctrl Setg I/P 33 dialog box.....	29
Figure 22 - Easergy Studio Control Inputs (Ctl Setg I/P 33) tree.....	29
Figure 23 - Ctrl Stg I/P Stat dialog box.....	29
Figure 24 - Easergy Studio Control I/P Labels (Ctl Setg I/P 33) tree.....	29

Figure 25 - Ctrl Setg I/P 33 dialog box 30
 Figure 26 - Easergy Studio Control I/P Labels (Ctl Setg I/P 33) tree 30

TABLES

Table 1 - SR programmable gate properties 24

Notes:

1. OVERVIEW

The purpose of the Programmable Scheme Logic (PSL) is to allow the relay user to configure an individual protection scheme to suit their own particular application. This is achieved through the use of programmable logic gates and delay timers.

The input to the PSL is any combination of the status of opto inputs. It is also used to assign the mapping of functions to the opto inputs and output contacts, the outputs of the protection elements, e.g. protection starts and trips, and the outputs of the fixed protection scheme logic. The fixed scheme logic provides the relay's standard protection schemes.

The PSL itself consists of software logic gates and timers. The logic gates can be programmed to perform a range of different logic functions and can accept any number of inputs. The timers are used either to create a programmable delay, and/or to condition the logic outputs, e.g. to create a pulse of fixed duration on the output regardless of the length of the pulse on the input. The outputs of the PSL are the LEDs on the front panel of the relay and the output contacts at the rear.

The execution of the PSL logic is event driven; the logic is processed whenever any of its inputs change, for example as a result of a change in one of the digital input signals or a trip output from a protection element. Also, only the part of the PSL logic that is affected by the particular input change that has occurred is processed. This reduces the amount of processing time that is used by the PSL; even with large, complex PSL schemes the relay trip time will not lengthen.

This system provides flexibility for the user to create their own scheme logic design. However, it also means that the PSL can be configured into a very complex system; hence setting of the PSL is implemented through the PC support package Easergy Studio.

Note

MiCOM S1 Studio has been renamed as Easergy Studio.

2. EASERGY STUDIO PSL EDITOR

Note

MiCOM S1 Studio has been renamed as Easergy Studio.

The PSL Editor can be used inside Easergy Studio or directly.

This chapter assumes that you are using the PSL Editor from within Easergy Studio.

If you use it from Easergy Studio, the Studio software will be locked whilst you are using the PSL editor software. The Studio software will be unlocked when you close the PSL Editor software.

The Easergy Studio product is updated periodically. These updates provide support for new features (such as allowing you to manage new MiCOM products, as well as using new software releases and hardware suffixes). The updates may also include fixes.

Accordingly, we strongly advise customers to use the latest Schneider Electric version of Easergy Studio.

2.1 How to Obtain Easergy Studio

Easergy Studio is available from the Schneider Electric website:

- www.schneider-electric.com

2.2 To Start Easergy Studio

To Start the Easergy Studio software, click the **Start > Programs > Schneider Electric > Easergy Studio > Easergy Studio** menu option.

2.3 To Open a Pre-Existing System

Within Easergy Studio, click the **File + Open System** menu option.

Navigate to where the scheme is stored, then double-click to open the scheme.

2.4 To Start the PSL Editor

The PSL editor lets you connect to any MiCOM device front port, retrieve and edit its PSL files and send the modified file back to a suitable MiCOM device.

Px30 and Px40 products are edited different versions of the PSL Editor. There is one link to the Px30 editor and one link to the Px40 editor.

To start the PSL editor for Px40 products:

Highlight the PSL file you wish to edit, and then either:

Double-click the highlighted PSL file,

Click the open icon or

In the Easergy Studio main menu, select **Tools > PSL PSL editor (Px40)** menu.

The PSL Editor will then start, and show you the relevant PSL Diagram(s) for the file you have opened. An example of such a PSL diagram is shown in the [Example of a PSL editor module](#) diagram.

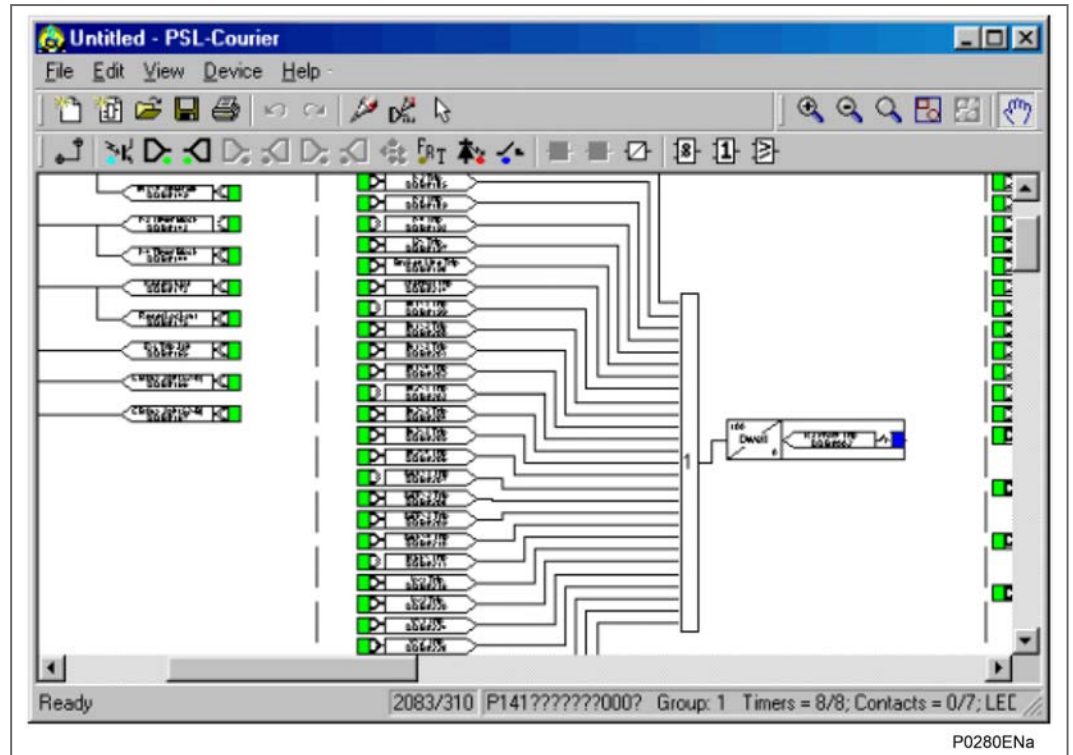

Figure 1 - Example of a PSL Editor Module

2.5 How to use MiCOM PSL Editor

The MiCOM PSL editor lets you:

- Start a new PSL diagram
- Extract a PSL file from a MiCOM Px40 IED
- Open a diagram from a PSL file
- Add logic components to a PSL file
- Move components in a PSL file
- Edit link of a PSL file
- Add link to a PSL file
- Highlight path in a PSL file
- Use a conditioner output to control logic
- Download PSL file to a MiCOM Px40 IED
- Print PSL files

For a detailed discussion on how to use these functions, please refer to the Easergy Studio help file.

2.6 Warnings

Before the scheme is sent to the relay checks are done. Various warning messages may be displayed as a result of these checks.

The Editor first reads in the model number of the connected relay, then compares it with the stored model number. A "wildcard" comparison is used. If a model mismatch occurs, a warning is generated before sending starts. Both the stored model number and the number read from the relay are displayed with the warning. However, the user must decide if the settings to be sent are compatible with the relay that is connected. Ignoring the warning could lead to undesired behavior of the relay.

If there are any potential problems of an obvious nature then a list will be generated. The types of potential problems that the program attempts to detect are:

- One or more gates, LED signals, contact signals, and/or timers have their outputs linked directly back to their inputs. An erroneous link of this sort could lock up the relay, or cause other more subtle problems to arise.
- Inputs to Trigger (ITT) exceeds the number of inputs. If a programmable gate has its ITT value set to greater than the number of actual inputs; the gate can never activate. There is no lower ITT value check. A 0-value does not generate a warning.
- Too many gates. There is a theoretical upper limit of 256 gates in a scheme, but the practical limit is determined by the complexity of the logic. In practice the scheme would have to be very complex, and this error is unlikely to occur.
- Too many links. There is no fixed upper limit to the number of links in a scheme. However, as with the maximum number of gates, the practical limit is determined by the complexity of the logic. In practice the scheme would have to be very complex, and this error is unlikely to occur.













3. TOOLBAR AND COMMANDS

There are a number of toolbars available for easy navigation and editing of PSL.

3.1 Standard Tools



For file management and printing.







	Blank Scheme	Create a blank scheme based on a relay model.
	Default Configuration	Create a default scheme based on a relay model.
	Open	Open an existing diagram.
	Save	Save the active diagram.
	Print	Display the Windows Print dialog, enabling you to print the current diagram.
	Undo	Undo the last action.
	Redo	Redo the previously undone action.
	Re-Draw	Redraw the diagram.
	No of DDBs	Display the DDB numbers of the links.
	Calculate CRC	Calculate unique number based on both the function and layout of the logic.
	Compare Files	Compare current file with another stored on disk.
	Select	Enable the select function. While this button is active, the mouse pointer is displayed as an arrow. This is the default mouse pointer. It is sometimes referred to as the selection pointer.

Point to a component and click the left mouse button to select it. Several components may be selected by clicking the left mouse button on the diagram and dragging the pointer to create a rectangular selection area.

3.2 Alignment Tools

To align logic elements horizontally or vertically into groups.



	Align Top	Align all selected components so the top of each is level with the others.
	Align Middle	Align all selected components so the middle of each is level with the others.
	Align Bottom	Align all selected components so the bottom of each is level with the others.
	Align Left	Align all selected components so the leftmost point of each is level with the others.
	Align Centre	Align all selected components so the centre of each is level with the others.
	Align Right	Align all selected components so the rightmost point of each is level with the others.

3.3 Drawing Tools

To add text comments and other annotations, for easier reading of PSL schemes.



	Rectangle	When selected, move the mouse pointer to where you want one of the corners to be hold down the left mouse button and move it to where you want the diagonally opposite corner to be. Release the button. To draw a square hold down the SHIFT key to ensure height and width remain the same.
	Ellipse	When selected, move the mouse pointer to where you want one of the corners to be hold down the left mouse button and move until the ellipse is the size you want it to be. Release the button. To draw a circle hold down the SHIFT key to ensure height and width remain the same.
	Line	When selected, move the mouse pointer to where you want the line to start, hold down left mouse, move to the position of the end of the line and release button. To draw horizontal or vertical lines only hold down the SHIFT key.
	Polyline	When selected, move the mouse pointer to where you want the polyline to start and click the left mouse button. Now move to the next point on the line and click the left button. Double click to indicate the final point in the polyline.
	Curve	When selected, move the mouse pointer to where you want the polycurve to start and click the left mouse button. Each time you click the button after this a line will be drawn, each line bisects its associated curve. Double click to end. The straight lines will disappear leaving the polycurve. Note: whilst drawing the lines associated with the polycurve, a curve will not be displayed until either three lines in succession have been drawn or the polycurve line is complete.
	Text	When selected, move the mouse pointer to where you want the text to begin and click the left mouse button. To change the font, size or colour, or text attributes select Properties from the right mouse button menu.
	Image	When selected, the Open dialog is displayed, enabling you to select a bitmap or icon file. Click Open, position the mouse pointer where you want the image to be and click the left mouse button.

3.4 Nudge Tools



To move logic elements.



The nudge tool buttons enable you to shift a selected component a single unit in the selected direction, or five pixels if the SHIFT key is held down.

As well as using the tool buttons, single unit nudge actions on the selected components can be achieved using the arrow keys on the keyboard.





	Nudge Up	Shift the selected component(s) upwards by one unit. Holding down the SHIFT key while clicking on this button will shift the component five units upwards.
---	----------	--

	Nudge Down	Shift the selected component(s) downwards by one unit. Holding down the SHIFT key while clicking on this button will shift the component five units downwards.
	Nudge Left	Shift the selected component(s) to the left by one unit. Holding down the SHIFT key while clicking on this button will shift the component five units to the left.
	Nudge Right	Shift the selected component(s) to the right by one unit. Holding down the SHIFT key while clicking on this button will shift the component five units to the right.

3.5 Rotation Tools

To spin, mirror and flip.







	Free Rotate	Enable the rotation function. While rotation is active components may be rotated as required. Press the ESC key or click on the diagram to disable the function.
	Rotate Left	Rotate the selected component 90 degrees to the left.
	Rotate Right	Rotate the selected component 90 degrees to the right.
	Flip Horizontal	Flip the component horizontally.
	Flip Vertical	Flip the component vertically.

3.6 Structure Tools

To change the stacking order of logic components.









	Bring to Front	Bring the selected components in front of all other components.
	Send to Back	Bring the selected components behind all other components.
	Bring Forward	Bring the selected component forward one layer.
	Send Backward	Send the selected component backwards one layer.

3.7 Zoom and Pan Tools

For scaling the displayed screen size, viewing the entire PSL, or zooming to a selection.

















	Zoom In	Increases the Zoom magnification by 25%.
	Zoom Out	Decreases the Zoom magnification by 25%.
	Zoom	Enable the zoom function. While this button is active, the mouse pointer is displayed as a magnifying glass. Right-clicking will zoom out and left-clicking will zoom in. Press the ESC key to return to the selection pointer. Click and drag to zoom in to an area.







	Zoom to Fit	Display at the highest magnification that will show all the diagram's components.
	Zoom to Selection	Display at the highest magnification that will show the selected component(s).
	Pan	Enable the pan function. While this button is active, the mouse pointer is displayed as a hand. Hold down the left mouse button and drag the pointer across the diagram to pan. Press the ESC key to return to the selection pointer.

3.8 Logic Symbols

This toolbar provides icons to place each type of logic element into the scheme diagram. Not all elements are available in all devices. Icons will only be displayed for those elements available in the selected device. Depending on the device, the toolbar may not include Function key or coloured LED conditioner/signal or Contact conditioner or SR Gate icons.



Link Create a link between two logic symbols.	
Opto Signal Create an opto signal.	
Input Signal Create an input signal.	
Output Signal Create an output signal.	
GOOSE In Create an input signal to logic to receive a UCA2.0 or IEC 61850 GOOSE message transmitted from another IED.	
GOOSE Out Create an output signal from logic to transmit a UCA2.0 or IEC 61850 GOOSE message to another IED.	
Control In Create an input signal to logic that can be operated from an external command.	
Integral Intertripping In/InterMiCOM In Create an input signal to logic to receive a MiCOM command transmitted from another IED. InterMiCOM is not available for all products.	
Integral Intertripping Out/InterMiCOM Out Create an output signal from logic to transmit a MiCOM command to another IED. InterMiCOM is not available for all products.	
Function Key Create a function key input signal.	
Trigger Signal Create a fault record trigger.	
LED Signal Create an LED input signal that repeats the status of the LED. The icon colour shows whether the product uses mono-colour or tri-color LEDs.	
Contact Signal Create a contact signal.	
LED Conditioner Create a LED conditioner. The icon colour shows whether the product uses mono-colour or tri-color LEDs.	

Contact Conditioner Create a contact conditioner. Contact conditioning is not available for all products.	
Timer Create a timer.	
AND Gate Create an AND Gate.	
OR Gate Create an OR Gate.	
Programmable Gate Create a programmable gate.	
SR gate Create an SR gate.	

4. PSL LOGIC SIGNALS PROPERTIES

The logic signal toolbar is used for the selection of logic signals.

This allows you to link signals together to program the PSL. A number of different properties are associated with each signal. In the following sections, these are characterized by the use of an icon from the toolbar; together with a signal name and a DDB number. The name and DDB number are shown in a pointed rectangular block, which includes a colour code, the icon, the name, DDB No and a directional pointer. One example of such a block (for P54x for Opto Signal 1 DDB No #032) is shown below:

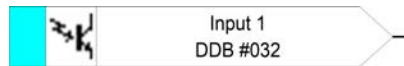

More examples of these are shown in the following properties sections.

Important

The DDB Numbers vary according to the particular product and the particular name, so that Opto Signal 1 may not be DDB No #032 for all products. The various names and DDB numbers illustrated below are provided as an example. You need to look up the DDB numbers for the signal and the specific MiCOM product you are working on in the relevant DDB table for your chosen product. Available functions will depend on model/firmware version.

4.1 Signal Properties Menu

The logic signal toolbar is used for the selection of logic signals. To use this:

- Use the logic toolbar to select logic signals.
 - This is enabled by default but to hide or show it, select **View > Logic Toolbar**.
- Zoom in or out of a logic diagram using the toolbar icon or select **View > Zoom Percent**.
- Right-click any logic signal and a context-sensitive menu appears.
- Certain logic elements show the **Properties...** option. Select this and a **Component Properties** window appears. The Component Properties window and the signals listed vary depending on the logic symbol selected.

The following subsections describe each of the available logic symbols.

4.2 Link Properties

Links form the logical link between the output of a signal, gate or condition and the input to any element.

Any link that is connected to the input of a gate can be inverted. Right-click the input and select **Properties...** The **Link Properties** window appears.



Figure 2 - Link Properties

4.2.1 Rules for Linking Symbols

An inverted link is shown with a small circle on the input to a gate. A link must be connected to the input of a gate to be inverted.

Links can only be started from the output of a signal, gate, or conditioner, and can only be ended at an input to any element.

Signals can only be an input or an output. To follow the convention for gates and conditioners, input signals are connected from the left and output signals to the right. The Editor automatically enforces this convention.

A link is refused for the following reasons:

- An attempt to connect to a signal that is already driven. The reason for the refusal may not be obvious because the signal symbol may appear elsewhere in the diagram. Right-click the link and select Highlight to find the other signal. Click anywhere on the diagram to disable the highlight.
- An attempt is made to repeat a link between two symbols. The reason for the refusal may not be obvious because the existing link may be represented elsewhere in the diagram.

4.3 Opto Signal Properties

Each opto input can be selected and used for programming in PSL. Activation of the opto input drives an associated DDB signal.

For example, activating opto Input L1 asserts DDB 032 in the PSL for the P14x, P34x, P44y, P445, P54x, P547, P74x, P746, P841, P849 products.



DDB Nos

“Input 1 DDB #064” applies to: P24x, P64x.

“Opto Label DDB #064” applies to: P44x.

4.4 Input Signal Properties

Relay logic functions provide logic output signals that can be used for programming in PSL. Depending on the relay functionality, operation of an active relay function drives an associated DDB signal in PSL.

For example, DDB 671 is asserted in the PSL for the P44y, P547 & P841 product if the active earth fault 1, stage 1 protection operate/trip.



4.5 Output Signal Properties

Relay logic functions provide logic input signals that can be used for programming in PSL. Depending on the relay functionality, activation of the output signal will drive an associated DDB signal in PSL and cause an associated response to the relay function.

For example, if DDB 409 is asserted in the PSL for the P44y, P54x, P547 and P841 product, it will block the sensitive earth function stage 1 timer.



4.6 GOOSE Input Signal Properties

The PSL interfaces with the GOOSE Scheme Logic using virtual inputs. The Virtual Inputs can be used in much the same way as the Opto Input signals.

The logic that drives each of the Virtual Inputs is contained within the relay's GOOSE Scheme Logic file. It is possible to map any number of bit-pairs, from any enrolled device, using logic gates onto a Virtual Input (see MiCOM S1 StudioEasergy Studio help file for more details). The number of available GOOSE virtual inputs is shown in the Programmable Logic chapter.

For example DDB 224 will be asserted in PSL for the P44y, P54x, P547 & P841 product should virtual input 1 operate.

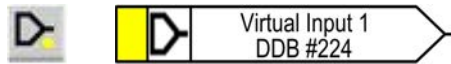

4.7 GOOSE Output Signal Properties

The PSL interfaces with the GOOSE Scheme Logic using 32 virtual outputs. Virtual outputs can be mapped to bit-pairs for transmitting to any enrolled devices.

For example if DDB 256 is asserted in PSL for the P44y, P54x, P547 and P841 product, Virtual Output 32 and its associated mappings will operate.

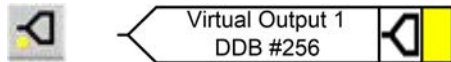

4.8 Control In Signal Properties

There are 32 control inputs which can be activated via the relay menu, 'hotkeys' or via rear communications. Depending on the programmed setting i.e. latched or pulsed, an associated DDB signal will be activated in PSL when a control input is operated.

For example, when operated control input 1 will assert DDB 192 in the PSL for the P44y, P54x, P547 and P841 products.



4.9 InterMiCOM Output Commands Properties

There are 16 InterMiCOM outputs that could be selected and use for teleprotection, remote commands, etc. "InterMiCOM Out" is a send command to a remote end that could be mapped to any logic output or opto input. This will be transmitted to the remote end as corresponding "InterMiCOM In" command for the P14x, P44y, P445 & P54x products.

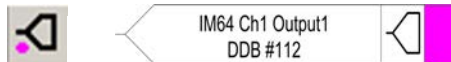

4.10 InterMiCOM Input Commands Properties

There are 16 InterMiCOM inputs that could be selected and use for teleprotection, remote commands, etc. "InterMiCOM In" is a received signal from remote end that could be mapped to a selected output relay or logic input.



Example:

Relay End A

At end A, InterMiCOM Output 1 is mapped to the command indication "Clear Statistics" (issued at end A).

Relay End B

At end B, InterMiCOM Input 1 is mapped to the command "Clear Statistics".

Upon receive of IM64 1 from relay at end A, the relay at end B will reset its statistics.



4.11 Function Key Properties

Each function key can be selected and used for programming in PSL. Activation of the function key will drive an associated DDB signal and the DDB signal will remain active depending on the programmed setting i.e. toggled or normal. Toggled mode means the DDB signal will remain latched or unlatched on key press and normal means the DDB will only be active for the duration of the key press.



For example, operate function key 1 to assert DDB 1096 in the PSL for the P44y, P54x, P547 or P841 products.

4.12 Fault Recorder Trigger Properties

The fault recording facility can be activated by driving the fault recorder trigger DDB signal. For example assert DDB 702 to activate the fault recording in the PSL for the P44y, P54x, P547 or P841 product.



4.13 LED Signal Properties

All programmable LEDs will drive associated DDB signal when the LED is activated. For example DDB 1036 will be asserted when LED 7 is activated for the P44y, P54x, P547 or P841 product.

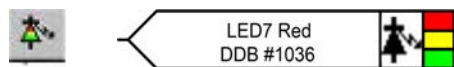

4.14 Contact Signal Properties

All relay output contacts will drive associated DDB signal when the output contact is activated.

For example, DDB 009 will be asserted when output R10 is activated for all products.

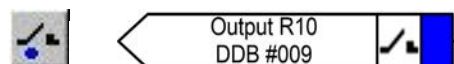

4.15 LED Conditioner Properties

1. Select the LED name from the list (only shown when inserting a new symbol).
2. Configure the LED output to be Red, Yellow or Green.

Configure a Green LED by driving the Green DDB input.

Configure a RED LED by driving the RED DDB input.

Configure a Yellow LED by driving the RED and GREEN DDB inputs simultaneously.

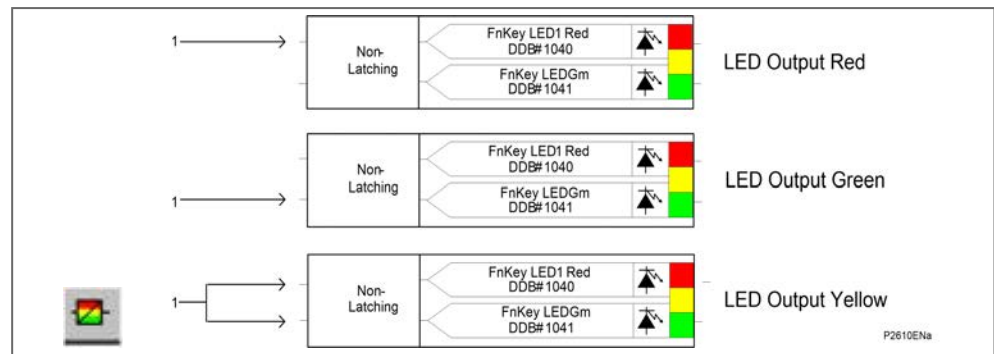

Figure 3 - Red, green and yellow LED outputs

- 3. Configure the LED output to be latching or non-latching.

DDB #642 and DDB #643 applies to these products: P14x, P44x, P74x, P746 and P849.

DDB #1040 and DDB #1041 applies to these products: P24x, P34x, P44y, P54x, P547, P64x and P841.

4.16 Contact Conditioner Properties

Each contact can be conditioned with an associated timer that can be selected for pick up, drop off, dwell, pulse, pick-up/drop-off, straight-through, or latching operation.

Straight-through means it is not conditioned in any way whereas **Latching** is used to create a sealed-in or lockout type function.

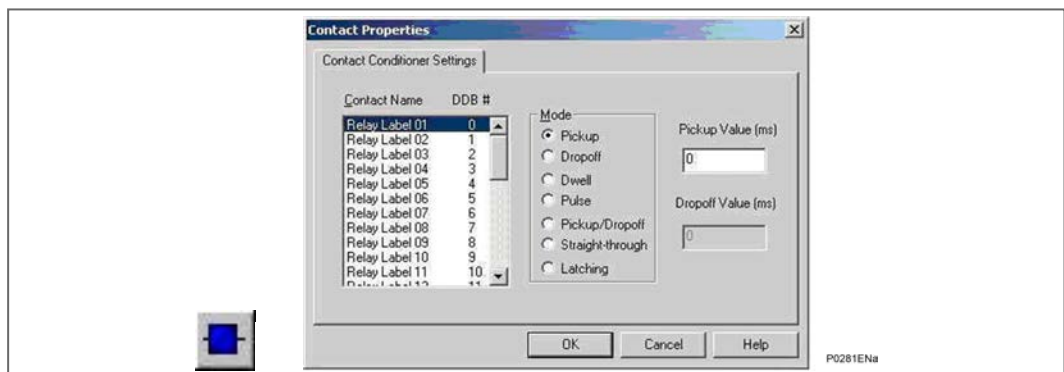

Figure 4 - Contact conditioner settings

- 1. Select the contact name from the **Contact Name** list (only shown when inserting a new symbol).
- 2. Choose the conditioner type required in the **Mode** tick list.
- 3. Set the **Pick-up** Time (in milliseconds), if required.
- 4. Set the **Drop-off** Time (in milliseconds), if required.

4.17 Timer Properties

Each timer can be selected for pick up, drop off, dwell, pulse or pick-up/drop-off operation.

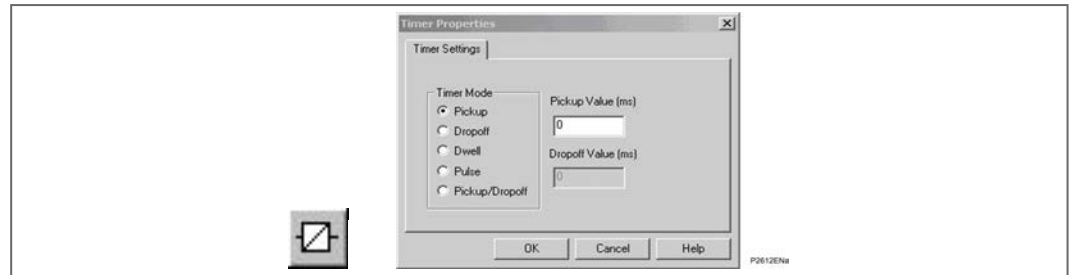

Figure 5 - Timer Settings

1. Choose the operation mode from the **Timer Mode** tick list.
2. Set the Pick-up Time (in milliseconds), if required.
3. Set the Drop-off Time (in milliseconds), if required.

4.18 Gate Properties

A Gate may be an AND, OR, or programmable gate.



An AND gate requires that all inputs are TRUE for the output to be TRUE.



An OR gate requires that one or more input is TRUE for the output to be TRUE.



A Programmable gate requires that the number of inputs that are TRUE is equal to or greater than its 'Inputs to Trigger' setting for the output to be TRUE.

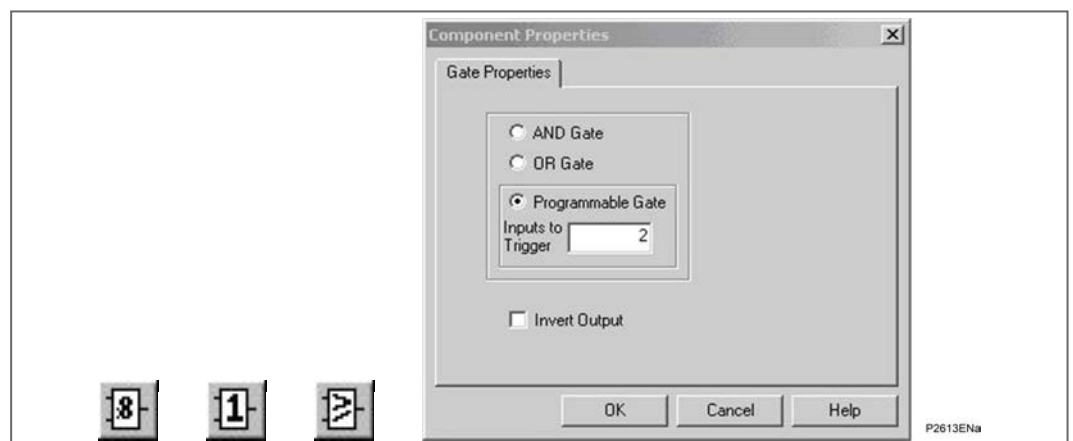

Figure 6 - Gate properties

1. Select the Gate type AND, OR, or Programmable.
2. Set the number of inputs to trigger when Programmable is selected.
3. Select if the output of the gate should be inverted using the Invert Output check box. An inverted output is indicated with a "bubble" on the gate output.

4.19 SR Programmable Gate Properties

For many products a number of programmable SR Latches are added. They are configured by an appropriate version of PSL Editor (S1v2.14 version 5.0.0 or greater) where an SRQ icon features on the toolbar.

Each SR latch has a Q output. The Q output may be inverted in the PSL Editor under the SR Latch component properties window. The SR Latches may be configured as Standard (no input dominant), Set Dominant or Reset Dominant in the PSL Editor under the SR Latch component properties window. The truth table for the SR Latches is given below.

A Programmable SR gate can be selected to operate with these latch properties:

S input	R input	O - Standard	O – Set input dominant	O – Reset input dominant
0	0	0	0	0
0	1	0	0	0
1	0	1	1	1
1	1	0	1	0

Table 1 - SR programmable gate properties

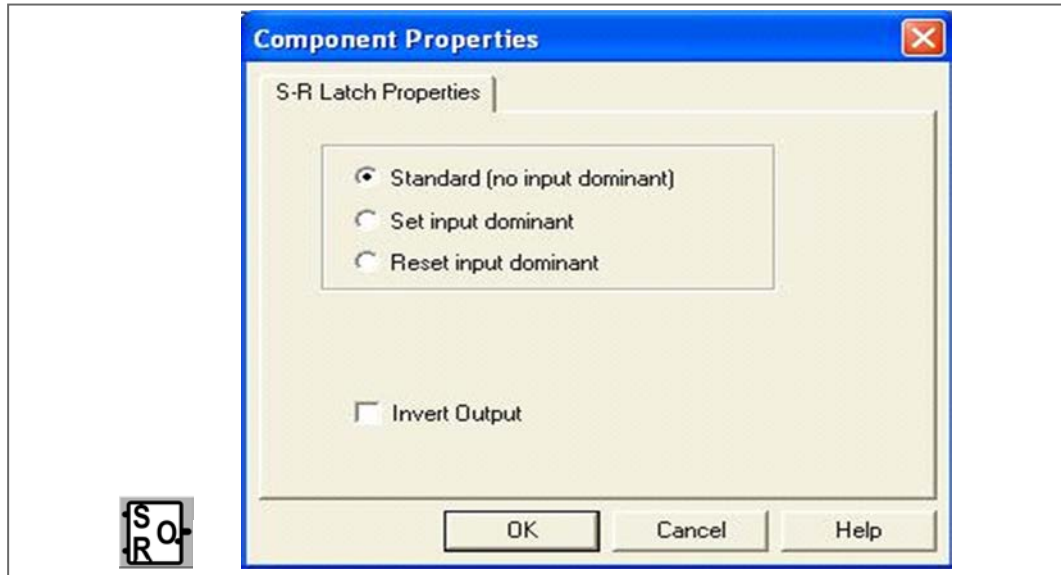

Figure 7 - SR latch component properties

Select if the output of the gate should be inverted using the Invert Output check box. An inverted output is indicated with a "bubble" on the gate output.

4.20 PSL Signal Grouping Modes

PSL Signal Grouping Nodes

For Software Version D1a and later, these DDB "Group" Nodes can be mapped to individual or multiple DDBs in the PSL:

- PSL Group Sig 1
- PSL Group Sig 2
- PSL Group Sig 3
- PSL Group Sig 4

There are now four additional DDB Group Sig x Nodes that can be mapped to individual or multiple DDBs in the PSL. These can then be set to trigger the DR via the DISTURBANCE RECORD menu.

These "Nodes" are general and can also be used to group signals together in the PSL for any other reason. These four nodes are available in each of the four PSL setting groups.

Number	PSL Group Sig
992	PSL Group Sig 1
993	PSL Group Sig 2
994	PSL Group Sig 3
995	PSL Group Sig 4

1. For a control input, the DR can be triggered directly by triggering directly from the Individual Control Input (e.g. Low to High (L to H) change)
2. For an input that cannot be triggered directly, or where any one of a number of DDBs are required to trigger a DR, map the DDBs to the new PSL Group signal and then trigger the DR on this.

e.g. in the PSL:

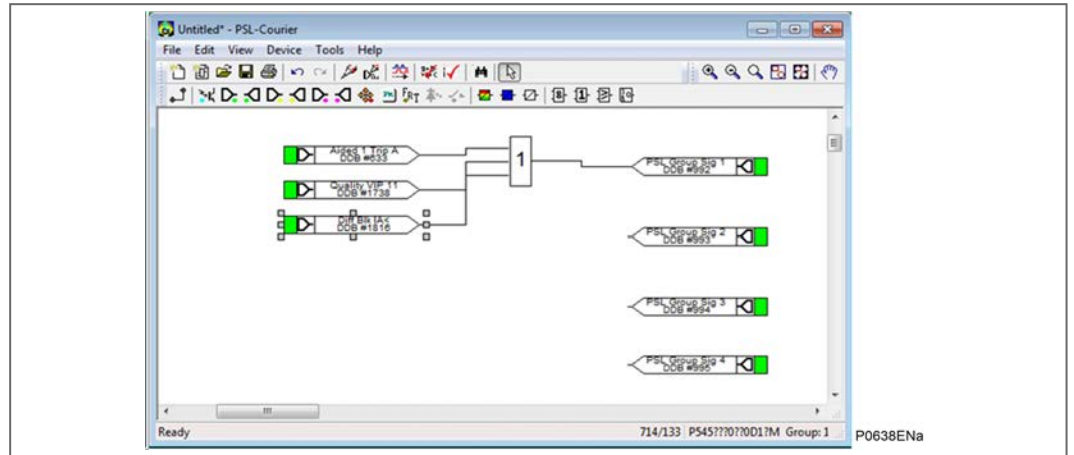

Figure 8 - PSL diagram

In the DR Settings:

- Digital Input 1 is triggered by the PSL Group Sig 1 (L to H)
- Digital Input 2 is triggered by Control Input 1 (L to H)

Name	Value	Address (C.R)
CT AND VT RATIOS		
RECORD CONTROL		
DISTURB RECORDER		
Duration	1.500 s	0C.01
Trigger Position	33.30 %	0C.02
Trigger Mode	Single	0C.03
Analog Channel 1	VA	0C.04
Analog Channel 2	VB	0C.05
Analog Channel 3	VC	0C.06
Analog Channel 4	IA	0C.07
Analog Channel 5	IB	0C.08
Analog Channel 6	IC	0C.09
Analog Channel 7	IN	0C.0A
Analog Channel 8	IN Sensitive	0C.0B
Digital Input 1	PSL Group Sig 1	0C.0C
Input 1 Trigger	Trigger L/H	0C.0D
Digital Input 2	Control Input 1	0C.0E
Input 2 Trigger	Trigger L/H	0C.0F
Digital Input 3	Relay 3	0C.10
Input 3 Trigger	Trigger L/H	0C.11
Digital Input 4	PSL Group Sig 1	0C.12
Input 4 Trigger	Trigger H/L	0C.13
Digital Input 5	Control Input 1	0C.14
Input 5 Trigger	Trigger H/L	0C.15
Digital Input 6	Relay 6	0C.16
Input 6 Trigger	No Trigger	0C.17
Digital Input 7	Relay 7	0C.18
Input 7 Trigger	No Trigger	0C.19
Digital Input 8	Relay 8	0C.1A

Figure 9 - Easergy Studio Disturb Recorder table diagram

If triggering on both edges is required map another DR channel to the H/L as well:

- Digital Input 4 is triggered by the PSL Group Sig 1 (H to L)
- Digital Input 5 is triggered by Control Input 1 (H to L)

5. SPECIFIC TASKS

Note

MiCOM S1 Studio has been renamed as Easergy Studio.

5.1 Digital Input Label Operation (P44y, P54x, P445 & P841 only)

The digital input labels can be modified via the MiCOM Px40 user interface or Easergy Studio. The following example is using Version 5.0.0.

The digital input labels are available in the “DR CHAN LABELS” folder in the settings file as shown below:

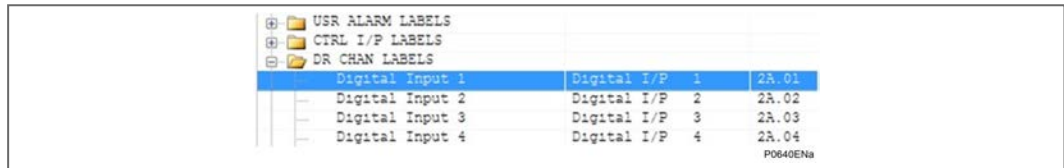

Figure 10 - DR Chan Labels tree

Easergy Studio removes leading spaces from the value field so making the ‘D’ look as if it’s the 1st character in the label. The default values above in fact have a leading space which is used to switch off the use of the label as show below in the change settings view.

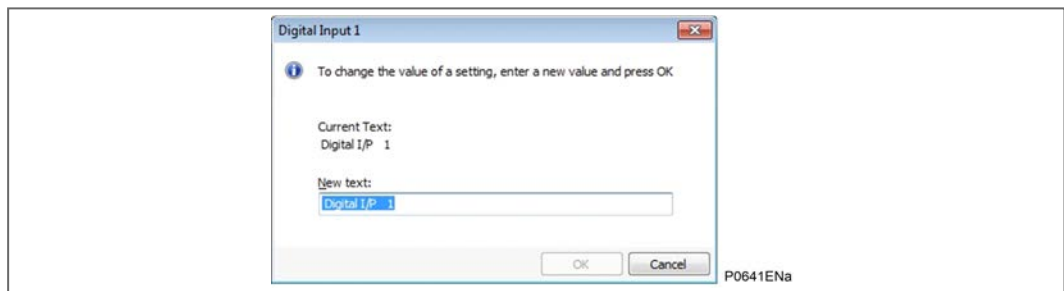

Figure 11 - Digital Input 1 dialog box

Pressing OK will save the setting and return to the settings page as follows:

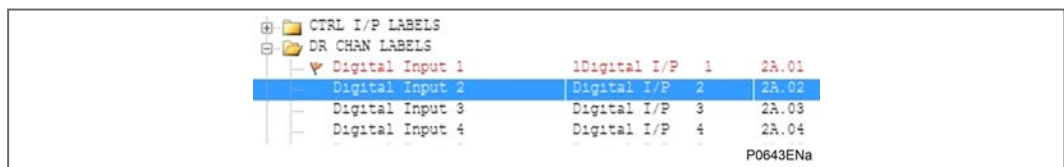

Figure 12 - DR Chan Labels tree

Digital Input 1 label will now be used in the Disturbance Record when the settings file is downloaded to the relay.

5.2 Virtual Input Label Operation

The Virtual Input labels can be modified via the MiCOM Px40 user interface or Easergy Studio. The following example is using Version 5.0.0.

The default labels are available in the “VIR I/P LABELS” (or “VIRT I/P LABELS”) folder in the settings file as shown below:

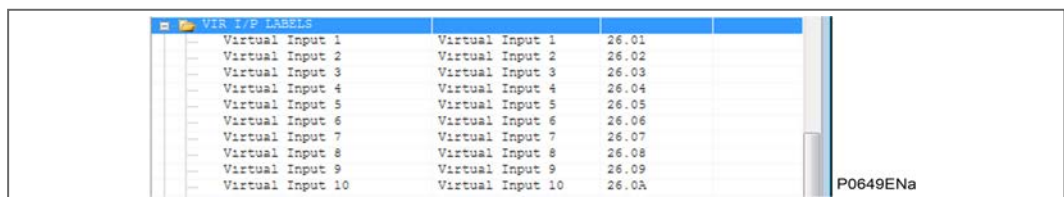

Figure 13 - Easergy StudioVIR I/P Labels Tree

The default “Virtual Input” labels can be changed to suit the customer requirements. For example, to change default text from “Virtual Input 1” to “Customer Func 1” open the Virtual Input 1 dialog box, and change “Virtual Input 1” in the New Text: text box to be “Customer Func 1”, as follows:

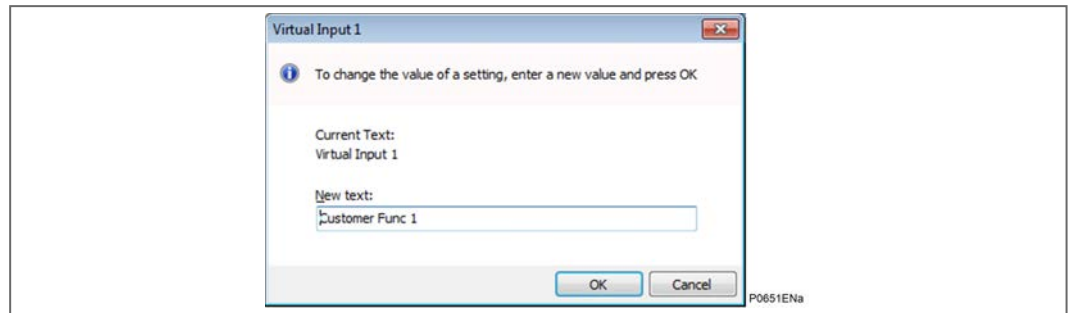

Figure 14 - Virtual Input 1 dialog box

Pressing OK will save the setting and return to the settings page as follows: The above “Customer Func 1” label text will now be used in place of “Virtual Input 1” in the Disturbance / Event Records after the settings file is downloaded to the relay.

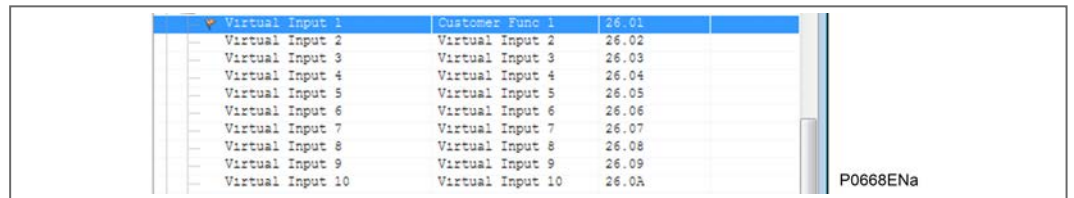

Figure 15 - Easergy Studio VIR I/P Labels Tree

The above “Customer Func 1” label text will now be used in place of “Virtual Input 1” in the Disturbance / Event Records after the settings file is downloaded to the relay.

5.3 Virtual Output Label Operation

The Virtual Output labels can be modified via the MiCOM Px40 user interface or Easergy Studio. The following example is using Version 5.0.0.

The virtual Output labels are available in the “VIR O/P LABELS” (or “VIRT O/P LABELS”) folder in the settings file as shown below:

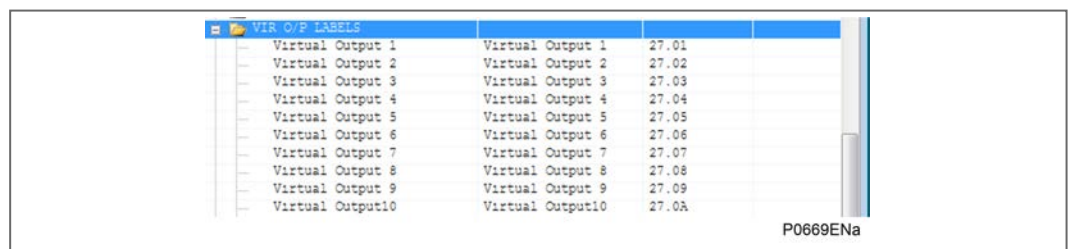

Figure 16 - Easergy Studio VIR O/P Labels Tree

The default “Virtual Output Labels” can be changed to suit the customer requirements. The process is identical to the previously described procedure for the Virtual Input Labels.

5.4 SR/MR User Alarm Label Operation

The SR/MR User Alarm input labels can be modified via the MiCOM Px40 user interface or Easergy Studio. This example is using Version 5.0.0.

The default “SR User Alarm” and “MR User Alarm” labels can be changed to suit the customer requirements. For example, to change default text from “SR User Alarm 1” to “Customer Alarm 1” open the SR User Alarm 1 dialog box and change “SR User Alarm 1” in the New Text: Text box to be “Customer Alarm 1”.

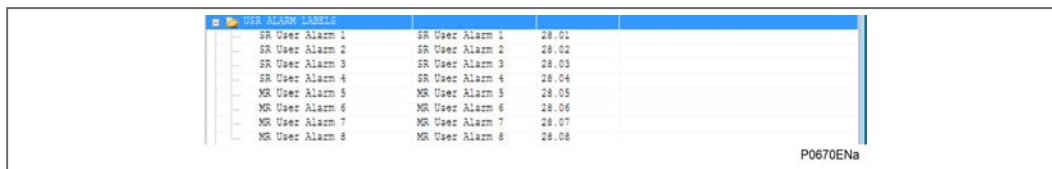

Figure 17 - Easergy Studio USR Labels Tree

The default “SR User Alarm” and “MR User Alarm” labels can be changed to suit the customer requirements. For example, to change default text from “SR User Alarm 1” to “Customer Alarm 1” open the SR User Alarm 1 dialog box and change “SR User Alarm 1” in the New Text: Text box to be “Customer Alarm 1”.

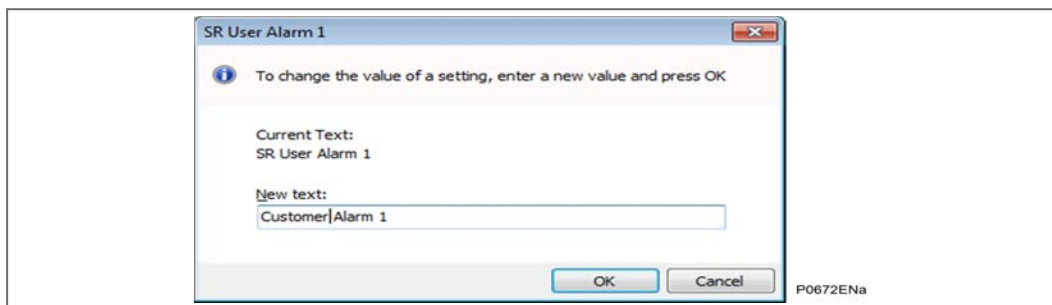

Figure 18 - User Alarm dialog box

Pressing OK will save the setting and return to the settings page as follows:

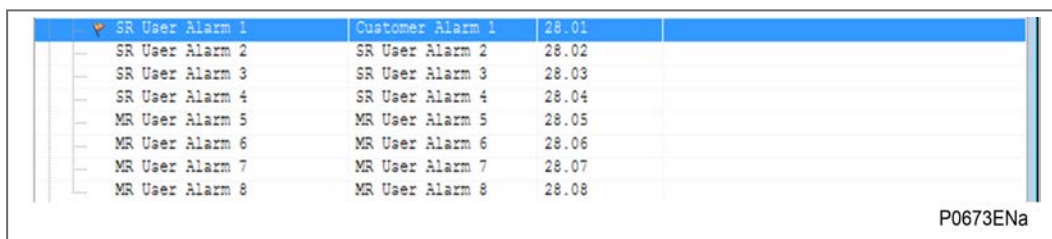

Figure 19 - Virtual Input 1 settings

The above “Customer Alarm 1” label text will now be used in place of “SR User Alarm 1” in the Disturbance / Event Records after the settings file is downloaded to the relay.

5.5 Settable Control Input Operation (P14x, P44y, P54x, P445 & P841 only)

The settings should be applied to all relays in the current differential protection scheme. As from Software Versions C1/D1/F1/G4/H4/J4, there are now 32 Standard Control Inputs and 16 additional Settable Control Inputs available. These are settable via the “CONTROL INPUTS” folder and are located after the standard “Control Input” labels in the relevant settings file.

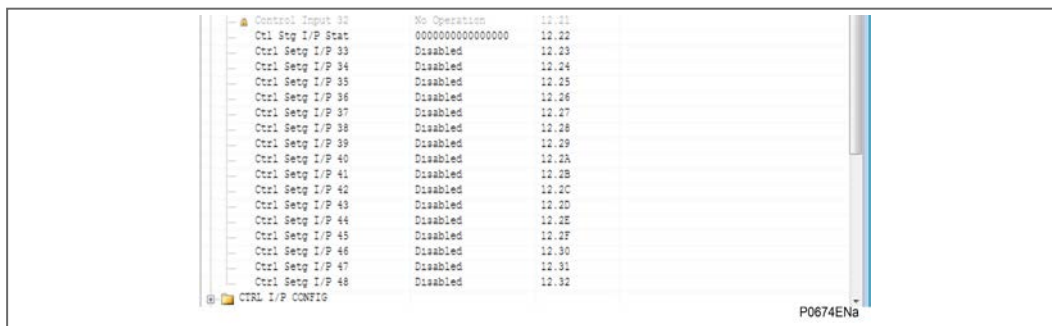

Figure 20 - Easergy Studio Control Inputs tree

Each Settable control Input “Ctrl Setg I/P xx” can be controlled using Enable / Disable settings. To change from (the default) Disabled to Enabled, open the Ctrl Setg I/P xx dialog box, then change Disabled to Enabled in the New Setting drop-down list box:

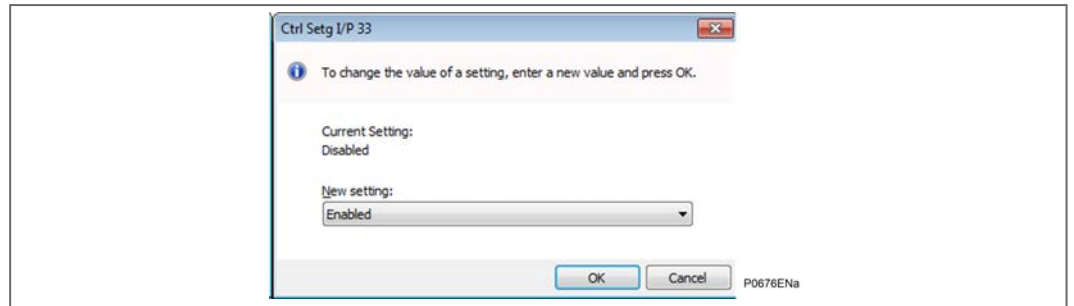

Figure 21 - Ctrl Stg I/P 33 dialog box

Pressing OK will save the setting and return to the settings page as follows:

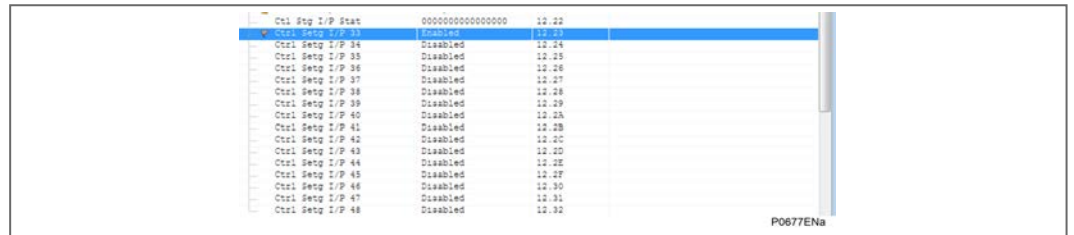

Figure 22 - Easergy Studio Control Inputs (Ctl Stg I/P 33) tree

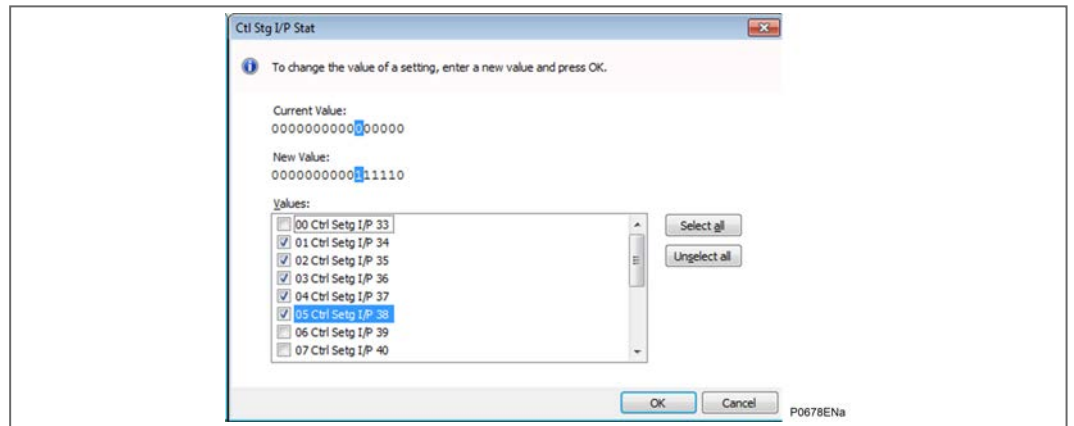

Figure 23 - Ctrl Stg I/P Stat dialog box

The setting “Ctl Stg I/P Stat” can be used to control multiple “Ctrl Stg I/P” at the same time, e.g. clear Ctrl Stg I/P 33 and set Ctrl Stg I/P 34 to 38, but please note that the status will not be reflected in the individual inputs settings or vice versa.

This cell may be hidden in the Easergy Studio files.

5.6 Settable Control Stg I/P Label Operation (P14x, P44y, P54x, P445 & P841 only)

The default labels are available in the “CTRL I/P LABELS” folder and are located after the standard “Control Input” labels in the settings file as shown below:

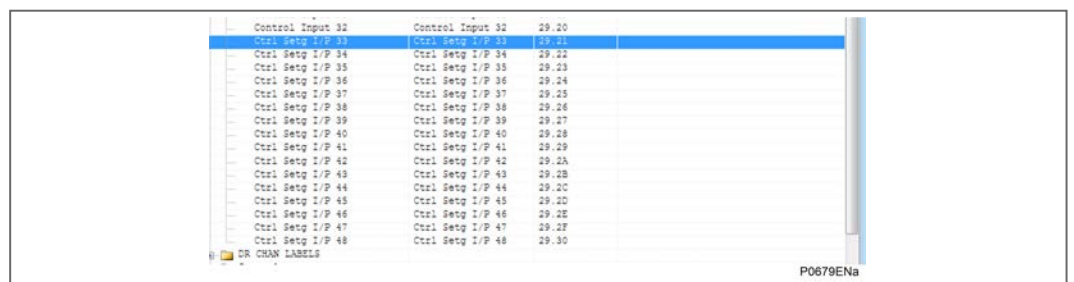

Figure 24 - Easergy Studio Control I/P Labels (Ctl Stg I/P 33) tree

The default “Ctrl Stg I/P” labels can be changed to suit the customer requirements using the same procedure as for the standard “Control Inputs”. For example to change the default text

from “Ctrl Setg I/P 33” to “Custom Ctrl Sg 1” open the Ctrl Setg I/P 33 dialog box, then change “Ctrl Setg I/P 33” in the New Text: box to be “Custom Ctrl Sg 1”.

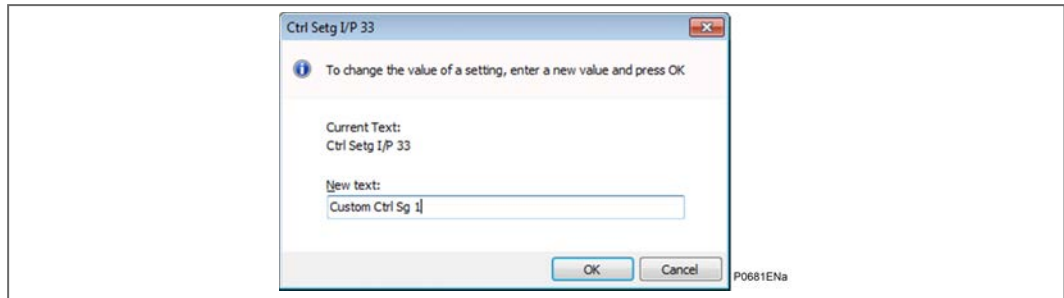

Figure 25 - Ctrl Setg I/P 33 dialog box

Pressing OK will save the setting and return to the settings page as follows:

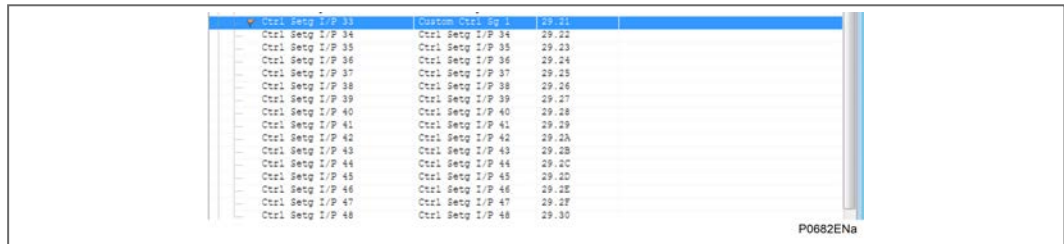

Figure 26 - Easergy Studio Control I/P Labels (Ctl Setg I/P 33) tree

The above “Custom Ctrl Sg 1” label text will now be used in place of “Ctrl Setg I/P 33” in the Disturbance / Event Records after the settings file is downloaded to the relay.

6. MAKING A RECORD OF MICOM PX40 DEVICE SETTINGS

6.1 Using Easergy Studio to Manage Device Settings

An engineer often needs to create a record of what settings have been applied to a device. In the past, they could have used paper printouts of all the available settings, and mark up the ones they had used. Keeping such a paper-based Settings Records could be time-consuming and prone to error (e.g. due to being settings written down incorrectly).

The MiCOM S1 StudioEasergy Studio software lets you read from or write to MiCOM devices.

- **Extract** lets you download all the settings from a MiCOM Px40 device. A summary is given in the [Extract Settings from a MiCOM Px40 Device](#) section.
- **Send** lets you send the settings you currently have open in Easergy Studio. A summary is given in the [Send Settings to a MiCOM Px40 Device](#) section.

In most cases, it will be quicker and less error prone to extract settings electronically and store them in a settings file on a memory stick. In this way, there will be a digital record which is certain to be accurate. It is also possible to archive these settings files in a repository; so they can be used again or adapted for another use.

Full details of how to do this is provided in the Easergy Studio help.

A quick summary of the main steps is given here. In each case, you need to make sure that:

- Your computer includes the Easergy Studio software.
- Your computer and the MiCOM device are powered on.
- You have used a suitable cable to connect your computer to the MiCOM device (Front Port, Rear Port, Ethernet port or Modem as available).

6.2 Extract Settings from a MiCOM Px40 Device

Full details of how to do this is provided in the Easergy Studio help.

As a quick guide, you need to do the following:

1. In Easergy Studio, click the **Quick Connect...** button.
2. Select the relevant **Device Type** in the **Quick Connect** dialog box.
3. Click the relevant port in the **Port Selection** dialog box.
4. Enter the relevant connection parameters in the **Connection Parameters** dialog box and click the **Finish** button
5. Studio will try to communicate with the Px40 device. It will display a **connected** message if the connection attempt is successful.
6. The device will appear in the **Studio Explorer** pane on the top-left hand side of the interface.
7. Click the **+** button to expand the options for the device, then click on the **Settings** folder.
8. Right-click on **Settings** and select the **Extract Settings** link to read the settings on the device and store them on your computer or a memory stick attached to your computer.
9. After retrieving the settings file, close the dialog box by clicking the **Close** button.

6.3 Send Settings to a MiCOM Px40 Device

Full details of how to do this is provided in the Easergy Studio help.

As a quick guide, you need to do the following:

1. In Easergy Studio, click the **Quick Connect...** button.
2. Select the relevant **Device Type** in the **Quick Connect** dialog box.

3. Click the relevant **port** in the **Port Selection** dialog box.
4. Enter the relevant **connection parameters** in the **Connection Parameters** dialog box and click the **Finish** button
5. Studio will try to communicate with the Px40 device. It will display a **connected** message if the connection attempt is successful.
6. The device will appear in the **Studio Explorer** pane on the top-left hand side of the interface.
7. Click the **+** button to expand the options for the device, then click on the **Settings link**.
8. Right-click on the **device name** and select the **Send link**.

Note

When you send settings to a MiCOM Px40 device, the data is stored in a temporary location at first. This temporary data is tested to make sure it is complete. If the temporary data is complete, it will be programmed into the MiCOM Px40 device. This avoids the risk of a device being programmed with incomplete or corrupt settings.

9. In the **Send To** dialog box, select the settings file(s) you wish to send, then click the **Send** button.
10. Close the the **Send To** dialog box by clicking the **Close** button.

PROGRAMMABLE LOGIC

CHAPTER 8

Date:	11/2022
Products covered by this chapter:	This chapter covers the specific versions of the MiCOM products listed below. This includes only the following combinations of Software Version and Hardware Suffix.
Hardware Suffix:	L
Software Version:	K6
Connection Diagrams:	10P445xx (xx = 01 to 04)

CONTENTS

Page (PL) 8-

1	Overview	5
2	Description of the Digital Database (DDB)	6
3	Factory Default Programmable Scheme Logic (PSL) Schemes	70
4	Logic Input and Output Mappings	71
4.1	Logic Input Mappings	71
4.2	Standard Relay Output Contact Mappings	72
4.3	Optional High Break Relay Output Contact Mappings (P445 model D)	73
4.4	Programmable LED Output Mappings	74
4.5	Fault Recorder Start Mappings	74
4.6	PSL Data Column	74
4.7	PSL Signal Grouping Modes	74
5	Viewing and Printing Default PSL Diagrams	76
5.1	Typical Mappings	76
5.2	Download and Print PSL Diagrams	76
6	P445 with Standard Contacts PSL	77
6.1	Opto Input Mappings	77
6.2	Output Contacts	78
6.3	LEDs	81
6.4	Start Phase Mappings	82

TABLES

	Page (PL) 8-
Table 1 - Digital database point list sorted by DDB number	69
Table 2 - Factory default PSL settings	70
Table 3 - Default opto-isolated input mappings	71
Table 4 - Default relay output contact mappings for P445	72
Table 5 - Default standard and high break output contact mappings for P445 Model D 73	
Table 6 - Default mappings for programmable LEDs	74
Table 7 - Fault recorder start mappings	74

1 OVERVIEW

The purpose of the Programmable Scheme Logic (PSL) is to allow the user to configure an individual protection scheme to suit their own particular application. This is achieved through the use of programmable logic gates and delay timers.

The input to the PSL is any combination of the status of opto inputs. It is also used to assign the mapping of functions to the opto inputs and output contacts, the outputs of the protection elements, e.g. protection starts and trips, and the outputs of the fixed protection scheme logic. The fixed scheme logic provides the relay's standard protection schemes.

The PSL itself consists of software logic gates and timers. The logic gates can be programmed to perform a range of different logic functions and can accept any number of inputs. The timers are used either to create a programmable delay, and/or to condition the logic outputs, e.g. to create a pulse of fixed duration on the output regardless of the length of the pulse on the input. The outputs of the PSL are the LEDs on the front panel of the relay and the output contacts at the rear.

The execution of the PSL logic is event driven; the logic is processed whenever any of its inputs change, for example as a result of a change in one of the digital input signals. Also, only the part of the PSL logic that is affected by the particular input change that has occurred is processed. This reduces the amount of processing time that is used by the PSL. This means that even with large, complex PSL schemes the device trip time will not lengthen.

This system provides flexibility for the user to create their own scheme logic design. It also means that the PSL can be configured into a very complex system, hence setting of the PSL is implemented through the PC support package MiCOM S1 Studio.

How to edit the PSL schemes is described in the "Using the PSL Editor" chapter.

This chapter contains details of the logic nodes which are specific to this product, together with any PSL diagrams which we have published for this product.

2 DESCRIPTION OF THE DIGITAL DATABASE (DDB)

The following table shows the available DDB Numbers, a Description of what they are and which products they apply to. Where a range of DDB Numbers apply to a consecutively-numbered range of related items, the DDB Number range is shown. For example, DDB No 0 to 11 to cover Output Relay 1 to Output Relay 11; or 2nd Harmonic A to C to cover 2nd Harmonic A, 2nd Harmonic B and 2nd Harmonic C. If a DDB Number is not shown, it is not used in this range of products.

Note Where applicable. Not all nodes appear in every product variant.

DDB No	Source	Element Name	Description	English Text
0	Output conditioner	DDB_OUTPUT_RELAY_1	Programmable Output Relay 1 is energized. Not valid if Contacts Blocked	Relay 1
1	Output conditioner	DDB_OUTPUT_RELAY_2	Programmable Output Relay 2 is energized. Not valid if Contacts Blocked	Relay 2
2	Output conditioner	DDB_OUTPUT_RELAY_3	Programmable Output Relay 3 is energized. Not valid if Contacts Blocked	Relay 3
3	Output conditioner	DDB_OUTPUT_RELAY_4	Programmable Output Relay 4 is energized. Not valid if Contacts Blocked	Relay 4
4	Output conditioner	DDB_OUTPUT_RELAY_5	Programmable Output Relay 5 is energized. Not valid if Contacts Blocked	Relay 5
5	Output conditioner	DDB_OUTPUT_RELAY_6	Programmable Output Relay 6 is energized. Not valid if Contacts Blocked	Relay 6
6	Output conditioner	DDB_OUTPUT_RELAY_7	Programmable Output Relay 7 is energized. Not valid if Contacts Blocked	Relay 7
7	Output conditioner	DDB_OUTPUT_RELAY_8	Programmable Output Relay 8 is energized. Not valid if Contacts Blocked	Relay 8
8	Output conditioner	DDB_OUTPUT_RELAY_9	Programmable Output Relay 9 is energized. Not valid if Contacts Blocked	Relay 9
9	Output conditioner	DDB_OUTPUT_RELAY_10	Programmable Output Relay 10 is energized. Not valid if Contacts Blocked	Relay 10
10	Output conditioner	DDB_OUTPUT_RELAY_11	Programmable Output Relay 11 is energized. Not valid if Contacts Blocked	Relay 11
11	Output conditioner	DDB_OUTPUT_RELAY_12	Programmable Output Relay 12 is energized. Not valid if Contacts Blocked	Relay 12
12	Output conditioner	DDB_OUTPUT_RELAY_13	Programmable Output Relay 13 is energized. Not valid if Contacts Blocked	Relay 13
13	Output conditioner	DDB_OUTPUT_RELAY_14	Programmable Output Relay 14 is energized. Not valid if Contacts Blocked	Relay 14
14	Output conditioner	DDB_OUTPUT_RELAY_15	Programmable Output Relay 15 is energized. Not valid if Contacts Blocked	Relay 15
15	Output conditioner	DDB_OUTPUT_RELAY_16	Programmable Output Relay 16 is energized. Not valid if Contacts Blocked	Relay 16
16	Output conditioner	DDB_OUTPUT_RELAY_17	Programmable Output Relay 17 is energized. Not valid if Contacts Blocked	Relay 17
17	Output conditioner	DDB_OUTPUT_RELAY_18	Programmable Output Relay 18 is energized. Not valid if Contacts Blocked	Relay 18
18	Output conditioner	DDB_OUTPUT_RELAY_19	Programmable Output Relay 19 is energized. Not valid if Contacts Blocked	Relay 19
19	Output conditioner	DDB_OUTPUT_RELAY_20	Programmable Output Relay 20 is energized. Not valid if Contacts Blocked	Relay 20
20	Output conditioner	DDB_OUTPUT_RELAY_21	Programmable Output Relay 21 is energized. Not valid if Contacts Blocked	Relay 21

DDB No	Source	Element Name	Description	English Text
21	Output conditioner	DDB_OUTPUT_RELAY_22	Programmable Output Relay 22 is energized. Not valid if Contacts Blocked	Relay 22
22	Output conditioner	DDB_OUTPUT_RELAY_23	Programmable Output Relay 23 is energized. Not valid if Contacts Blocked	Relay 23
23	Output conditioner	DDB_OUTPUT_RELAY_24	Programmable Output Relay 24 is energized. Not valid if Contacts Blocked	Relay 24
24	Output conditioner	DDB_OUTPUT_RELAY_25	Programmable Output Relay 25 is energized. Not valid if Contacts Blocked	Relay 25
25	Output conditioner	DDB_OUTPUT_RELAY_26	Programmable Output Relay 26 is energized. Not valid if Contacts Blocked	Relay 26
26	Output conditioner	DDB_OUTPUT_RELAY_27	Programmable Output Relay 27 is energized. Not valid if Contacts Blocked	Relay 27
27	Output conditioner	DDB_OUTPUT_RELAY_28	Programmable Output Relay 28 is energized. Not valid if Contacts Blocked	Relay 28
28	Output conditioner	DDB_OUTPUT_RELAY_29	Programmable Output Relay 29 is energized. Not valid if Contacts Blocked	Relay 29
29	Output conditioner	DDB_OUTPUT_RELAY_30	Programmable Output Relay 30 is energized. Not valid if Contacts Blocked	Relay 30
30	Output conditioner	DDB_OUTPUT_RELAY_31	Programmable Output Relay 31 is energized. Not valid if Contacts Blocked	Relay 31
31	Output conditioner	DDB_OUTPUT_RELAY_32	Programmable Output Relay 32 is energized. Not valid if Contacts Blocked	Relay 32
32	Opto Input	DDB_OPTO_ISOLATOR_1	From opto input 1 - when opto energized	Opto 1
33	Opto Input	DDB_OPTO_ISOLATOR_2	From opto input 2 - when opto energized	Opto 2
34	Opto Input	DDB_OPTO_ISOLATOR_3	From opto input 3 - when opto energized	Opto 3
35	Opto Input	DDB_OPTO_ISOLATOR_4	From opto input 4 - when opto energized	Opto 4
36	Opto Input	DDB_OPTO_ISOLATOR_5	From opto input 5 - when opto energized	Opto 5
37	Opto Input	DDB_OPTO_ISOLATOR_6	From opto input 6 - when opto energized	Opto 6
38	Opto Input	DDB_OPTO_ISOLATOR_7	From opto input 7 - when opto energized	Opto 7
39	Opto Input	DDB_OPTO_ISOLATOR_8	From opto input 8 - when opto energized	Opto 8
40	Opto Input	DDB_OPTO_ISOLATOR_9	From opto input 9 - when opto energized	Opto 9
41	Opto Input	DDB_OPTO_ISOLATOR_10	From opto input 10 - when opto energized	Opto 10
42	Opto Input	DDB_OPTO_ISOLATOR_11	From opto input 11 - when opto energized	Opto 11
43	Opto Input	DDB_OPTO_ISOLATOR_12	From opto input 12 - when opto energized	Opto 12
44	Opto Input	DDB_OPTO_ISOLATOR_13	From opto input 13 - when opto energized	Opto 13
45	Opto Input	DDB_OPTO_ISOLATOR_14	From opto input 14 - when opto energized	Opto 14
46	Opto Input	DDB_OPTO_ISOLATOR_15	From opto input 15 - when opto energized	Opto 15
47	Opto Input	DDB_OPTO_ISOLATOR_16	From opto input 16 - when opto energized	Opto 16
48	Opto Input	DDB_OPTO_ISOLATOR_17	From opto input 17 - when opto energized	Opto 17
49	Opto Input	DDB_OPTO_ISOLATOR_18	From opto input 18 - when opto energized	Opto 18
50	Opto Input	DDB_OPTO_ISOLATOR_19	From opto input 19 - when opto energized	Opto 19
51	Opto Input	DDB_OPTO_ISOLATOR_20	From opto input 20 - when opto energized	Opto 20
52	Opto Input	DDB_OPTO_ISOLATOR_21	From opto input 21 - when opto energized	Opto 21
53	Opto Input	DDB_OPTO_ISOLATOR_22	From opto input 22 - when opto energized	Opto 22
54	Opto Input	DDB_OPTO_ISOLATOR_23	From opto input 23 - when opto energized	Opto 23
55	Opto Input	DDB_OPTO_ISOLATOR_24	From opto input 24 - when opto energized	Opto 24
56	Opto Input	DDB_OPTO_ISOLATOR_25	Unused	Unused

DDB No	Source	Element Name	Description	English Text
57	Opto Input	DDB_OPTO_ISOLATOR_26	Unused	Unused
58	Opto Input	DDB_OPTO_ISOLATOR_27	Unused	Unused
59	Opto Input	DDB_OPTO_ISOLATOR_28	Unused	Unused
60	Opto Input	DDB_OPTO_ISOLATOR_29	Unused	Unused
61	Opto Input	DDB_OPTO_ISOLATOR_30	Unused	Unused
62	Opto Input	DDB_OPTO_ISOLATOR_31	Unused	Unused
63	Opto Input	DDB_OPTO_ISOLATOR_32	Unused	Unused
64		DDB_UNUSED_64	Unused	Unused
65		DDB_UNUSED_65	Unused	Unused
66		DDB_UNUSED_66	Unused	Unused
67		DDB_UNUSED_67	Unused	Unused
68		DDB_UNUSED_68	Unused	Unused
69		DDB_UNUSED_69	Unused	Unused
70		DDB_UNUSED_70	Unused	Unused
71		DDB_UNUSED_71	Unused	Unused
72		DDB_UNUSED_72	Unused	Unused
73		DDB_UNUSED_73	Unused	Unused
74		DDB_UNUSED_74	Unused	Unused
75		DDB_UNUSED_75	Unused	Unused
76		DDB_UNUSED_76	Unused	Unused
77		DDB_UNUSED_77	Unused	Unused
78		DDB_UNUSED_78	Unused	Unused
79		DDB_UNUSED_79	Unused	Unused
80	InterMiCOM	DDB_INTERIN_1	InterMiCOM Input 1 - is driven by a message from the remote line end	IM Input 1
81	InterMiCOM	DDB_INTERIN_2	InterMiCOM Input 2 - is driven by a message from the remote line end	IM Input 2
82	InterMiCOM	DDB_INTERIN_3	InterMiCOM Input 3 - is driven by a message from the remote line end	IM Input 3
83	InterMiCOM	DDB_INTERIN_4	InterMiCOM Input 4 - is driven by a message from the remote line end	IM Input 4
84	InterMiCOM	DDB_INTERIN_5	InterMiCOM Input 5 - is driven by a message from the remote line end	IM Input 5
85	InterMiCOM	DDB_INTERIN_6	InterMiCOM Input 6 - is driven by a message from the remote line end	IM Input 6
86	InterMiCOM	DDB_INTERIN_7	InterMiCOM Input 7 - is driven by a message from the remote line end	IM Input 7
87	InterMiCOM	DDB_INTERIN_8	InterMiCOM Input 8 - is driven by a message from the remote line end	IM Input 8
88	PSL	DDB_INTEROUT_1	InterMiCOM Output 1 - is an output to the remote line end	IM Output 1
89	PSL	DDB_INTEROUT_2	InterMiCOM Output 2 - is an output to the remote line end	IM Output 2
90	PSL	DDB_INTEROUT_3	InterMiCOM Output 3 - is an output to the remote line end	IM Output 3
91	PSL	DDB_INTEROUT_4	InterMiCOM Output 4 - is an output to the remote line end	IM Output 4

DDB No	Source	Element Name	Description	English Text
92	PSL	DDB_INTEROUT_5	InterMiCOM Output 5 - is an output to the remote line end	IM Output 5
93	PSL	DDB_INTEROUT_6	InterMiCOM Output 6 - is an output to the remote line end	IM Output 6
94	PSL	DDB_INTEROUT_7	InterMiCOM Output 7 - is an output to the remote line end	IM Output 7
95	PSL	DDB_INTEROUT_8	InterMiCOM Output 8 - is an output to the remote line end	IM Output 8
96	IM64	DDB_IM64_CH1_1_IN	IM64 Ch1 input 1 - is driven by a message from the remote line end	IM64 Ch1 Input 1
97	IM64	DDB_IM64_CH1_2_IN	IM64 Ch1 input 2 - is driven by a message from the remote line end	IM64 Ch1 Input 2
98	IM64	DDB_IM64_CH1_3_IN	IM64 Ch1 input 3 - is driven by a message from the remote line end	IM64 Ch1 Input 3
99	IM64	DDB_IM64_CH1_4_IN	IM64 Ch1 input 4 - is driven by a message from the remote line end	IM64 Ch1 Input 4
100	IM64	DDB_IM64_CH1_5_IN	IM64 Ch1 input 5 - is driven by a message from the remote line end	IM64 Ch1 Input 5
101	IM64	DDB_IM64_CH1_6_IN	IM64 Ch1 input 6 - is driven by a message from the remote line end	IM64 Ch1 Input 6
102	IM64	DDB_IM64_CH1_7_IN	IM64 Ch1 input 7 - is driven by a message from the remote line end	IM64 Ch1 Input 7
103	IM64	DDB_IM64_CH1_8_IN	IM64 Ch1 input 8 - is driven by a message from the remote line end	IM64 Ch1 Input 8
104	IM64	DDB_IM64_CH2_1_IN	IM64 Ch2 input 1 - is driven by a message from the remote line end	IM64 Ch2 Input 1
105	IM64	DDB_IM64_CH2_2_IN	IM64 Ch2 input 2 - is driven by a message from the remote line end	IM64 Ch2 Input 2
106	IM64	DDB_IM64_CH2_3_IN	IM64 Ch2 input 3 - is driven by a message from the remote line end	IM64 Ch2 Input 3
107	IM64	DDB_IM64_CH2_4_IN	IM64 Ch2 input 4 - is driven by a message from the remote line end	IM64 Ch2 Input 4
108	IM64	DDB_IM64_CH2_5_IN	IM64 Ch2 input 5 - is driven by a message from the remote line end	IM64 Ch2 Input 5
109	IM64	DDB_IM64_CH2_6_IN	IM64 Ch2 input 6 - is driven by a message from the remote line end	IM64 Ch2 Input 6
110	IM64	DDB_IM64_CH2_7_IN	IM64 Ch2 input 7 - is driven by a message from the remote line end	IM64 Ch2 Input 7
111	IM64	DDB_IM64_CH2_8_IN	IM64 Ch2 input 8 - is driven by a message from the remote line end	IM64 Ch2 Input 8
112	PSL	DDB_IM64_CH1_1_OUT	IM64 Ch1 output 1 - mapping what will be sent to the remote line end	IM64 Ch1 Output1
113	PSL	DDB_IM64_CH1_2_OUT	IM64 Ch1 output 2 - mapping what will be sent to the remote line end	IM64 Ch1 Output2
114	PSL	DDB_IM64_CH1_3_OUT	IM64 Ch1 output 3 - mapping what will be sent to the remote line end	IM64 Ch1 Output3
115	PSL	DDB_IM64_CH1_4_OUT	IM64 Ch1 output 4 - mapping what will be sent to the remote line end	IM64 Ch1 Output4
116	PSL	DDB_IM64_CH1_5_OUT	IM64 Ch1 output 5 - mapping what will be sent to the remote line end	IM64 Ch1 Output5
117	PSL	DDB_IM64_CH1_6_OUT	IM64 Ch1 output 6 - mapping what will be sent to the remote line end	IM64 Ch1 Output6

DDB No	Source	Element Name	Description	English Text
118	PSL	DDB_IM64_CH1_7_OUT	IM64 Ch1 output 7 - mapping what will be sent to the remote line end	IM64 Ch1 Output7
119	PSL	DDB_IM64_CH1_8_OUT	IM64 Ch1 output 8 - mapping what will be sent to the remote line end	IM64 Ch1 Output8
120	PSL	DDB_IM64_CH2_1_OUT	IM64 Ch2 output 1 - mapping what will be sent to the remote line end	IM64 Ch2 Output1
121	PSL	DDB_IM64_CH2_2_OUT	IM64 Ch2 output 2 - mapping what will be sent to the remote line end	IM64 Ch2 Output2
122	PSL	DDB_IM64_CH2_3_OUT	IM64 Ch2 output 3 - mapping what will be sent to the remote line end	IM64 Ch2 Output3
123	PSL	DDB_IM64_CH2_4_OUT	IM64 Ch2 output 4 - mapping what will be sent to the remote line end	IM64 Ch2 Output4
124	PSL	DDB_IM64_CH2_5_OUT	IM64 Ch2 output 5 - mapping what will be sent to the remote line end	IM64 Ch2 Output5
125	PSL	DDB_IM64_CH2_6_OUT	IM64 Ch2 output 6 - mapping what will be sent to the remote line end	IM64 Ch2 Output6
126	PSL	DDB_IM64_CH2_7_OUT	IM64 Ch2 output 7 - mapping what will be sent to the remote line end	IM64 Ch2 Output7
127	PSL	DDB_IM64_CH2_8_OUT	IM64 Ch2 output 8 - mapping what will be sent to the remote line end	IM64 Ch2 Output8
128	PSL	DDB_OUTPUT_CON_1	Input to relay 1 output conditioner	Relay Cond 1
129	PSL	DDB_OUTPUT_CON_2	Input to relay 2 output conditioner	Relay Cond 2
130	PSL	DDB_OUTPUT_CON_3	Input to relay 3 output conditioner	Relay Cond 3
131	PSL	DDB_OUTPUT_CON_4	Input to relay 4 output conditioner	Relay Cond 4
132	PSL	DDB_OUTPUT_CON_5	Input to relay 5 output conditioner	Relay Cond 5
133	PSL	DDB_OUTPUT_CON_6	Input to relay 6 output conditioner	Relay Cond 6
134	PSL	DDB_OUTPUT_CON_7	Input to relay 7 output conditioner	Relay Cond 7
135	PSL	DDB_OUTPUT_CON_8	Input to relay 8 output conditioner	Relay Cond 8
136	PSL	DDB_OUTPUT_CON_9	Input to relay 9 output conditioner	Relay Cond 9
137	PSL	DDB_OUTPUT_CON_10	Input to relay 10 output conditioner	Relay Cond 10
138	PSL	DDB_OUTPUT_CON_11	Input to relay 11 output conditioner	Relay Cond 11
139	PSL	DDB_OUTPUT_CON_12	Input to relay 12 output conditioner	Relay Cond 12
140	PSL	DDB_OUTPUT_CON_13	Input to relay 13 output conditioner	Relay Cond 13
141	PSL	DDB_OUTPUT_CON_14	Input to relay 14 output conditioner	Relay Cond 14
142	PSL	DDB_OUTPUT_CON_15	Input to relay 15 output conditioner	Relay Cond 15
143	PSL	DDB_OUTPUT_CON_16	Input to relay 16 output conditioner	Relay Cond 16
144	PSL	DDB_OUTPUT_CON_17	Input to relay 17 output conditioner	Relay Cond 17
145	PSL	DDB_OUTPUT_CON_18	Input to relay 18 output conditioner	Relay Cond 18
146	PSL	DDB_OUTPUT_CON_19	Input to relay 19 output conditioner	Relay Cond 19
147	PSL	DDB_OUTPUT_CON_20	Input to relay 20 output conditioner	Relay Cond 20
148	PSL	DDB_OUTPUT_CON_21	Input to relay 21 output conditioner	Relay Cond 21
149	PSL	DDB_OUTPUT_CON_22	Input to relay 22 output conditioner	Relay Cond 22
150	PSL	DDB_OUTPUT_CON_23	Input to relay 23 output conditioner	Relay Cond 23
151	PSL	DDB_OUTPUT_CON_24	Input to relay 24 output conditioner	Relay Cond 24
152	PSL	DDB_OUTPUT_CON_25	Input to relay 25 output conditioner	Relay Cond 25
153	PSL	DDB_OUTPUT_CON_26	Input to relay 26 output conditioner	Relay Cond 26
154	PSL	DDB_OUTPUT_CON_27	Input to relay 27 output conditioner	Relay Cond 27

DDB No	Source	Element Name	Description	English Text
155	PSL	DDB_OUTPUT_CON_28	Input to relay 28 output conditioner	Relay Cond 28
156	PSL	DDB_OUTPUT_CON_29	Input to relay 29 output conditioner	Relay Cond 29
157	PSL	DDB_OUTPUT_CON_30	Input to relay 30 output conditioner	Relay Cond 30
158	PSL	DDB_OUTPUT_CON_31	Input to relay 31 output conditioner	Relay Cond 31
159	PSL	DDB_OUTPUT_CON_32	Input to relay 32 output conditioner	Relay Cond 32
160		DDB_UNUSED_160	Unused	Unused
161		DDB_UNUSED_161	Unused	Unused
162		DDB_UNUSED_162	Unused	Unused
163		DDB_UNUSED_163	Unused	Unused
164		DDB_UNUSED_164	Unused	Unused
165		DDB_UNUSED_165	Unused	Unused
166		DDB_UNUSED_166	Unused	Unused
167		DDB_UNUSED_167	Unused	Unused
168		DDB_UNUSED_168	Unused	Unused
169		DDB_UNUSED_169	Unused	Unused
170		DDB_UNUSED_170	Unused	Unused
171		DDB_UNUSED_171	Unused	Unused
172		DDB_UNUSED_172	Unused	Unused
173		DDB_UNUSED_173	Unused	Unused
174		DDB_UNUSED_174	Unused	Unused
175		DDB_UNUSED_175	Unused	Unused
176		DDB_UNUSED_176	Unused	Unused
177		DDB_UNUSED_177	Unused	Unused
178		DDB_UNUSED_178	Unused	Unused
179		DDB_UNUSED_179	Unused	Unused
180		DDB_UNUSED_180	Unused	Unused
181		DDB_UNUSED_181	Unused	Unused
182		DDB_UNUSED_182	Unused	Unused
183		DDB_UNUSED_183	Unused	Unused
184		DDB_UNUSED_184	Unused	Unused
185		DDB_UNUSED_185	Unused	Unused
186		DDB_UNUSED_186	Unused	Unused
187		DDB_UNUSED_187	Unused	Unused
188		DDB_UNUSED_188	Unused	Unused
189		DDB_UNUSED_189	Unused	Unused
190		DDB_UNUSED_190	Unused	Unused
191		DDB_UNUSED_191	Unused	Unused
192	Virtual Input Command	DDB_CONTROL_1	Control input 1 - for SCADA and menu commands into PSL	Control Input 1
193	Virtual Input Command	DDB_CONTROL_2	Control input 2 - for SCADA and menu commands into PSL	Control Input 2
194	Virtual Input Command	DDB_CONTROL_3	Control input 3 - for SCADA and menu commands into PSL	Control Input 3
195	Virtual Input Command	DDB_CONTROL_4	Control input 4 - for SCADA and menu commands into PSL	Control Input 4

DDB No	Source	Element Name	Description	English Text
196	Virtual Input Command	DDB_CONTROL_5	Control input 5 - for SCADA and menu commands into PSL	Control Input 5
197	Virtual Input Command	DDB_CONTROL_6	Control input 6 - for SCADA and menu commands into PSL	Control Input 6
198	Virtual Input Command	DDB_CONTROL_7	Control input 7 - for SCADA and menu commands into PSL	Control Input 7
199	Virtual Input Command	DDB_CONTROL_8	Control input 8 - for SCADA and menu commands into PSL	Control Input 8
200	Virtual Input Command	DDB_CONTROL_9	Control input 9 - for SCADA and menu commands into PSL	Control Input 9
201	Virtual Input Command	DDB_CONTROL_10	Control input 10 - for SCADA and menu commands into PSL	Control Input 10
202	Virtual Input Command	DDB_CONTROL_11	Control input 11 - for SCADA and menu commands into PSL	Control Input 11
203	Virtual Input Command	DDB_CONTROL_12	Control input 12 - for SCADA and menu commands into PSL	Control Input 12
204	Virtual Input Command	DDB_CONTROL_13	Control input 13 - for SCADA and menu commands into PSL	Control Input 13
205	Virtual Input Command	DDB_CONTROL_14	Control input 14 - for SCADA and menu commands into PSL	Control Input 14
206	Virtual Input Command	DDB_CONTROL_15	Control input 15 - for SCADA and menu commands into PSL	Control Input 15
207	Virtual Input Command	DDB_CONTROL_16	Control input 16 - for SCADA and menu commands into PSL	Control Input 16
208	Virtual Input Command	DDB_CONTROL_17	Control input 17 - for SCADA and menu commands into PSL	Control Input 17
209	Virtual Input Command	DDB_CONTROL_18	Control input 18 - for SCADA and menu commands into PSL	Control Input 18
210	Virtual Input Command	DDB_CONTROL_19	Control input 19 - for SCADA and menu commands into PSL	Control Input 19
211	Virtual Input Command	DDB_CONTROL_20	Control input 20 - for SCADA and menu commands into PSL	Control Input 20
212	Virtual Input Command	DDB_CONTROL_21	Control input 21 - for SCADA and menu commands into PSL	Control Input 21
213	Virtual Input Command	DDB_CONTROL_22	Control input 22 - for SCADA and menu commands into PSL	Control Input 22
214	Virtual Input Command	DDB_CONTROL_23	Control input 23 - for SCADA and menu commands into PSL	Control Input 23
215	Virtual Input Command	DDB_CONTROL_24	Control input 24 - for SCADA and menu commands into PSL	Control Input 24
216	Virtual Input Command	DDB_CONTROL_25	Control input 25 - for SCADA and menu commands into PSL	Control Input 25
217	Virtual Input Command	DDB_CONTROL_26	Control input 26 - for SCADA and menu commands into PSL	Control Input 26
218	Virtual Input Command	DDB_CONTROL_27	Control input 27 - for SCADA and menu commands into PSL	Control Input 27
219	Virtual Input Command	DDB_CONTROL_28	Control input 28 - for SCADA and menu commands into PSL	Control Input 28
220	Virtual Input Command	DDB_CONTROL_29	Control input 29- for SCADA and menu commands into PSL	Control Input 29
221	Virtual Input Command	DDB_CONTROL_30	Control input 30 - for SCADA and menu commands into PSL	Control Input 30

DDB No	Source	Element Name	Description	English Text
222	Virtual Input Command	DDB_CONTROL_31	Control input 31 - for SCADA and menu commands into PSL	Control Input 31
223	Virtual Input Command	DDB_CONTROL_32	Control input 32 - for SCADA and menu commands into PSL	Control Input 32
224	GOOSE Input Command	DDB_GOOSEIN_1	Virtual Input 1 - received from GOOSE message	Virtual Input 1
225	GOOSE Input Command	DDB_GOOSEIN_2	Virtual Input 2 - received from GOOSE message	Virtual Input 2
226	GOOSE Input Command	DDB_GOOSEIN_3	Virtual Input 3 - received from GOOSE message	Virtual Input 3
227	GOOSE Input Command	DDB_GOOSEIN_4	Virtual Input 4 - received from GOOSE message	Virtual Input 4
228	GOOSE Input Command	DDB_GOOSEIN_5	Virtual Input 5 - received from GOOSE message	Virtual Input 5
229	GOOSE Input Command	DDB_GOOSEIN_6	Virtual Input 6 - received from GOOSE message	Virtual Input 6
230	GOOSE Input Command	DDB_GOOSEIN_7	Virtual Input 7 - received from GOOSE message	Virtual Input 7
231	GOOSE Input Command	DDB_GOOSEIN_8	Virtual Input 8 - received from GOOSE message	Virtual Input 8
232	GOOSE Input Command	DDB_GOOSEIN_9	Virtual Input 9 - received from GOOSE message	Virtual Input 9
233	GOOSE Input Command	DDB_GOOSEIN_10	Virtual Input 10 - received from GOOSE message	Virtual Input 10
234	GOOSE Input Command	DDB_GOOSEIN_11	Virtual Input 11 - received from GOOSE message	Virtual Input 11
235	GOOSE Input Command	DDB_GOOSEIN_12	Virtual Input 12 - received from GOOSE message	Virtual Input 12
236	GOOSE Input Command	DDB_GOOSEIN_13	Virtual Input 13 - received from GOOSE message	Virtual Input 13
237	GOOSE Input Command	DDB_GOOSEIN_14	Virtual Input 14 - received from GOOSE message	Virtual Input 14
238	GOOSE Input Command	DDB_GOOSEIN_15	Virtual Input 15 - received from GOOSE message	Virtual Input 15
239	GOOSE Input Command	DDB_GOOSEIN_16	Virtual Input 16 - received from GOOSE message	Virtual Input 16
240	GOOSE Input Command	DDB_GOOSEIN_17	Virtual Input 17 - received from GOOSE message	Virtual Input 17
241	GOOSE Input Command	DDB_GOOSEIN_18	Virtual Input 18 - received from GOOSE message	Virtual Input 18
242	GOOSE Input Command	DDB_GOOSEIN_19	Virtual Input 19 - received from GOOSE message	Virtual Input 19
243	GOOSE Input Command	DDB_GOOSEIN_20	Virtual Input 20 - received from GOOSE message	Virtual Input 20
244	GOOSE Input Command	DDB_GOOSEIN_21	Virtual Input 21 - received from GOOSE message	Virtual Input 21
245	GOOSE Input Command	DDB_GOOSEIN_22	Virtual Input 22 - received from GOOSE message	Virtual Input 22
246	GOOSE Input Command	DDB_GOOSEIN_23	Virtual Input 23 - received from GOOSE message	Virtual Input 23
247	GOOSE Input Command	DDB_GOOSEIN_24	Virtual Input 24 - received from GOOSE message	Virtual Input 24

DDB No	Source	Element Name	Description	English Text
248	GOOSE Input Command	DDB_GOOSEIN_25	Virtual Input 25 - received from GOOSE message	Virtual Input 25
249	GOOSE Input Command	DDB_GOOSEIN_26	Virtual Input 26 - received from GOOSE message	Virtual Input 26
250	GOOSE Input Command	DDB_GOOSEIN_27	Virtual Input 27 - received from GOOSE message	Virtual Input 27
251	GOOSE Input Command	DDB_GOOSEIN_28	Virtual Input 28 - received from GOOSE message	Virtual Input 28
252	GOOSE Input Command	DDB_GOOSEIN_29	Virtual Input 29 - received from GOOSE message	Virtual Input 29
253	GOOSE Input Command	DDB_GOOSEIN_30	Virtual Input 30 - received from GOOSE message	Virtual Input 30
254	GOOSE Input Command	DDB_GOOSEIN_31	Virtual Input 31 - received from GOOSE message	Virtual Input 31
255	GOOSE Input Command	DDB_GOOSEIN_32	Virtual Input 32 - received from GOOSE message	Virtual Input 32
256	PSL	DDB_GOOSEOUT_1	Virtual output 1 - allows user to control a binary signal which can be mapped via SCADA protocol output to other devices	Virtual Output 1
257	PSL	DDB_GOOSEOUT_2	Virtual output 2 - allows user to control a binary signal which can be mapped via SCADA protocol output to other devices	Virtual Output 2
258	PSL	DDB_GOOSEOUT_3	Virtual output 3 - allows user to control a binary signal which can be mapped via SCADA protocol output to other devices	Virtual Output 3
259	PSL	DDB_GOOSEOUT_4	Virtual output 4 - allows user to control a binary signal which can be mapped via SCADA protocol output to other devices	Virtual Output 4
260	PSL	DDB_GOOSEOUT_5	Virtual output 5 - allows user to control a binary signal which can be mapped via SCADA protocol output to other devices	Virtual Output 5
261	PSL	DDB_GOOSEOUT_6	Virtual output 6 - allows user to control a binary signal which can be mapped via SCADA protocol output to other devices	Virtual Output 6
262	PSL	DDB_GOOSEOUT_7	Virtual output 7 - allows user to control a binary signal which can be mapped via SCADA protocol output to other devices	Virtual Output 7
263	PSL	DDB_GOOSEOUT_8	Virtual output 8 - allows user to control a binary signal which can be mapped via SCADA protocol output to other devices	Virtual Output 8
264	PSL	DDB_GOOSEOUT_9	Virtual output 9 - allows user to control a binary signal which can be mapped via SCADA protocol output to other devices	Virtual Output 9
265	PSL	DDB_GOOSEOUT_10	Virtual output 10 - allows user to control a binary signal which can be mapped via SCADA protocol output to other devices	Virtual Output10
266	PSL	DDB_GOOSEOUT_11	Virtual output 11 - allows user to control a binary signal which can be mapped via SCADA protocol output to other devices	Virtual Output11
267	PSL	DDB_GOOSEOUT_12	Virtual output 12 - allows user to control a binary signal which can be mapped via SCADA protocol output to other devices	Virtual Output12

DDB No	Source	Element Name	Description	English Text
268	PSL	DDB_GOOSEOUT_13	Virtual output 13 - allows user to control a binary signal which can be mapped via SCADA protocol output to other devices	Virtual Output13
269	PSL	DDB_GOOSEOUT_14	Virtual output 14 - allows user to control a binary signal which can be mapped via SCADA protocol output to other devices	Virtual Output14
270	PSL	DDB_GOOSEOUT_15	Virtual output 15 - allows user to control a binary signal which can be mapped via SCADA protocol output to other devices	Virtual Output15
271	PSL	DDB_GOOSEOUT_16	Virtual output 16 - allows user to control a binary signal which can be mapped via SCADA protocol output to other devices	Virtual Output16
272	PSL	DDB_GOOSEOUT_17	Virtual output 17 - allows user to control a binary signal which can be mapped via SCADA protocol output to other devices	Virtual Output17
273	PSL	DDB_GOOSEOUT_18	Virtual output 18 - allows user to control a binary signal which can be mapped via SCADA protocol output to other devices	Virtual Output18
274	PSL	DDB_GOOSEOUT_19	Virtual output 19 - allows user to control a binary signal which can be mapped via SCADA protocol output to other devices	Virtual Output19
275	PSL	DDB_GOOSEOUT_20	Virtual output 20 - allows user to control a binary signal which can be mapped via SCADA protocol output to other devices	Virtual Output20
276	PSL	DDB_GOOSEOUT_21	Virtual output 21 - allows user to control a binary signal which can be mapped via SCADA protocol output to other devices	Virtual Output21
277	PSL	DDB_GOOSEOUT_22	Virtual output 22 - allows user to control a binary signal which can be mapped via SCADA protocol output to other devices	Virtual Output22
278	PSL	DDB_GOOSEOUT_23	Virtual output 23 - allows user to control a binary signal which can be mapped via SCADA protocol output to other devices	Virtual Output23
279	PSL	DDB_GOOSEOUT_24	Virtual output 24 - allows user to control a binary signal which can be mapped via SCADA protocol output to other devices	Virtual Output24
280	PSL	DDB_GOOSEOUT_25	Virtual output 25 - allows user to control a binary signal which can be mapped via SCADA protocol output to other devices	Virtual Output25
281	PSL	DDB_GOOSEOUT_26	Virtual output 26 - allows user to control a binary signal which can be mapped via SCADA protocol output to other devices	Virtual Output26
282	PSL	DDB_GOOSEOUT_27	Virtual output 27 - allows user to control a binary signal which can be mapped via SCADA protocol output to other devices	Virtual Output27
283	PSL	DDB_GOOSEOUT_28	Virtual output 28 - allows user to control a binary signal which can be mapped via SCADA protocol output to other devices	Virtual Output28
284	PSL	DDB_GOOSEOUT_29	Virtual output 29 - allows user to control a binary signal which can be mapped via SCADA protocol output to other devices	Virtual Output29
285	PSL	DDB_GOOSEOUT_30	Virtual output 30 - allows user to control a binary signal which can be mapped via SCADA protocol output to other devices	Virtual Output30

DDB No	Source	Element Name	Description	English Text
286	PSL	DDB_GOOSEOUT_31	Virtual output 31 - allows user to control a binary signal which can be mapped via SCADA protocol output to other devices	Virtual Output31
287	PSL	DDB_GOOSEOUT_32	Virtual output 32 - allows user to control a binary signal which can be mapped via SCADA protocol output to other devices	Virtual Output32
288	Group Selection	DDB_ILLEGAL_OPTO_SETTINGS_GROUP	Setting group selection opto inputs have detected an invalid (disabled) settings group	SG-opto Invalid
289	Commissioning Test	DDB_OOS_ALARM	Protection disabled - typically out of service due to test mode	Prot'n Disabled
290	Commissioning Test	DDB_STATIC_TEST_MODE	Static test mode option bypasses the delta phase selectors, power swing detection and reverts to conventional directional line and cross polarization to allow testing with test sets that can not simulate a real fault	Static Test Mode
291	C Diff	DDB_LOOPBACK_TEST	Loopback test in service (external or internal)	Test Loopback
292	C Diff	DDB_IM64_TEST_MODE	Indication that relay is in test mode	Test IM64
293	VT Supervision	DDB_VTS_INDICATION	VTS indication alarm- failed VT (fuse blow) detected by VT supervision	VT Fail Alarm
294	CT Supervision	DDB_CTS_INDICATION	CTS indication alarm (CT supervision alarm)	CT Fail Alarm
295	CT Supervision	DDB_CT2S_INDICATION	Unused	Reserved
296	CT Supervision	DDB_REMOTE_CTS_INDICATION	Unused	Reserved
297	Powerswing Blocking	DDB_PSB_ALARM	Powerswing blocking will block any distance zone selected in the setting file	Power Swing
298	CB Fail	DDB_BREAKER_FAIL_ALARM	Circuit breaker fail alarm	CB Fail Alarm
299	CB Monitoring	DDB_CB_MONITOR_ALARM	This alarm indicates that DDB I ^ Maint. Alarm (1106) or DDB CB OPs Maint. (1108) or DDB CB Time Maint. (1110)	CB Monitor Alarm
300	CB Monitoring	DDB_CB_MONITOR_LOCKOUT	This alarm indicates that DDB I ^ Lockout Alarm (1107) or DDB CB Ops Lock (1109) or DDB CB Time lockout (1111)	CB Lockout Alarm
301	CB Status	DDB_CB_STATUS_ALARM	Indication of problems by circuit breaker state monitoring - example defective auxiliary contacts	CB Status Alarm
302	CB Control	DDB_CB_FAILED_TO_TRIP	Circuit breaker failed to trip (after a manual/operator) trip command	CB Trip Fail
303	CB Control	DDB_CB_FAILED_TO_CLOSE	Circuit breaker failed to close (after a manual/operator or auto-reclose close command)	CB Close Fail
304	CB Control	DDB_CONTROL_CB_UNHEALTHY	Manual circuit breaker unhealthy output signal indicating that the circuit breaker has not closed successfully after a manual close command. (A successful close also requires The circuit breaker healthy signal to reappear within the "healthy window" timeout)	Man CB Unhealthy
305	CB Control	DDB_CONTROL_NO_CHECK_SYNC	Indicates that the check synchronism signal has failed to appear for a manual close	No C/S Man Close
306	Autoreclose	DDB_AR_LOCKOUT	Indicates an auto-reclose lockout condition - no further auto-reclosures possible until resetting	A/R Lockout
307	Autoreclose	DDB_AR_CB_UNHEALTHY	Auto-reclose circuit breaker unhealthy signal, output from auto-reclose logic. Indicates during auto-reclose in progress, if the circuit breaker has to become healthy within the circuit breaker healthy time window	A/R CB Unhealthy

DDB No	Source	Element Name	Description	English Text
308	Autoreclose	DDB_AR_NO_CHECK_SYNC	Indicates during auto-reclose in progress, if system checks have not been satisfied within the check synchronizing time window	A/R No Checksync
309	Check sync	DDB_SYSTEM_SPLIT_ALARM	Unused	Reserved
310	C Diff	DDB_LOCAL_GPS_FAIL	Unused	Reserved
311	C Diff	DDB_SIGNALLING_FAILURE	If a differential protection communication path has remained failed for a period which is longer than the "Comms Fail Timer", this alarm is ON	Signalling Fail
312	C Diff	DDB_PROPAGATION_DELAY_FAILURE	Unused	Reserved
313	C Diff	DDB_PROTECTION_FAILURE	Unused	Reserved
314		DDB_FIB_IM_SCHEME_FAIL	It indicates that communications between relays are completely lost and therefore IM64 does not work	IM64 SchemeFail
315	C Diff	DDB_IEEE_37_94	t will appear in case of at least one of the following: CH1 (or CH2) loss of signal, CH1 (or CH2) PATH_YELLOW or CH1 (or CH2) BAD_RX_N	IEEE C37.94 Fail
316	C Diff	DDB_INHIBIT_CD_PROTECTION	Unused	Reserved
317	PSL	DDB_AIDED1_LGS_ALARM	Aided channel scheme 1 - channel out of service indication, indicating channel failure	Aid 1 Chan Fail
318	PSL	DDB_AIDED2_LGS_ALARM	Aided channel scheme 2 - channel out of service indication, indicating channel failure	Aid 2 Chan Fail
319	Frequency Tracking	DDB_FREQ_ALARM	Frequency out of range alarm	F out of Range
320	CB2 Fail	DDB_BREAKER_FAIL_ALARM_2	Unused	Reserved
321	CB Monitoring	DDB_CB2_MONITOR_ALARM	Unused	Reserved
322	CB Monitoring	DDB_CB2_MONITOR_LOCKOUT	Unused	Reserved
323	CB2 Status	DDB_CB2_STATUS_ALARM	Unused	Reserved
324	CB2 Control	DDB_CB2_FAILED_TO_TRIP	Unused	Reserved
325	CB2 Control	DDB_CB2_FAILED_TO_CLOSE	Unused	Reserved
326	CB2 Control	DDB_CONTROL_CB2_UNHEALTHY	Unused	Reserved
327	CB2 Control	DDB_CONTROL_NO_CHECK_SYNC_2	Unused	Reserved
328	Autoreclose	DDB_AR_LOCKOUT_2	Unused	Reserved
329	Autoreclose	DDB_AR_CB2_UNHEALTHY	Unused	Reserved
330	Autoreclose	DDB_AR_NO_CHECK_SYNC_2	Unused	Reserved
331	Autoreclose	DDB_INVALID_AR_MODE	Unused	Reserved
332	C Diff	DDB_IN_COMPATABLE_RELAYS	Unused	Reserved
333	C Diff	DDB_MESSAGE_FORMAT_FAIL	Invalid Message Format	InValid Mesg Fmt
334	Co-processor interface	DDB_MAIN_PROTECTION_FAIL	Indicates a failure in differential or distance or DEF	Main Prot. Fail
335	C Diff	DDB_CONFIGURATION_ERROR	Unused	Reserved
336	C Diff	DDB_RE_CONFIGURATION_ERROR	Unused	Reserved
337	C Diff	DDB_PROT_COMMS_MODE	This is an alarm which indicates that C3794 comms have been changed to standard or vice versa and relay must be rebooted	Comms Changed
338	C Diff	DDB_MAX_PROP_DELAY_ALARM	Maximum Propagation Delay Alarm	Max Prop. Alarm
339	CT Setting	DDB_CT_MISMATCH_ALARM	Unused	Reserved
340		DDB_ALARM_52	Unused	Reserved
341		DDB_ALARM_53	Unused	Reserved

DDB No	Source	Element Name	Description	English Text
342		DDB_ALARM_54	Unused	Reserved
343		DDB_ALARM_55	Unused	Reserved
344	PSL	DDB_ALARM_56	Triggers user alarm 1 message to be alarmed on LCD display (self-resetting)	SR User Alarm 1
345	PSL	DDB_ALARM_57	Triggers user alarm 2 message to be alarmed on LCD display (self-resetting)	SR User Alarm 2
346	PSL	DDB_ALARM_58	Triggers user alarm 3 message to be alarmed on LCD display (self-resetting)	SR User Alarm 3
347	PSL	DDB_ALARM_59	Triggers user alarm 4 message to be alarmed on LCD display (self-resetting)	SR User Alarm 4
348	PSL	DDB_ALARM_60	Triggers user alarm 5 message to be alarmed on LCD display (manual-resetting)	MR User Alarm 5
349	PSL	DDB_ALARM_61	Triggers user alarm 6 message to be alarmed on LCD display (manual-resetting)	MR User Alarm 6
350	PSL	DDB_ALARM_62	Triggers user alarm 7 message to be alarmed on LCD display (manual-resetting)	MR User Alarm 7
351	PSL	DDB_ALARM_63	Triggers user alarm 8 message to be alarmed on LCD display (manual-resetting)	MR User Alarm 8
352	Self monitoring	DDB_BATTERY_FAIL	Front panel miniature battery failure - either battery removed from slot, or low voltage	Battery Fail
353	Self monitoring	DDB_FIELD_VOLTS_FAIL	48V field voltage failure	Field Volts Fail
354	Self monitoring	DDB_REAR_COMMS_FAIL	Comm2 hardware failure - second rear communications board	Rear Comm 2 Fail
355	Ethernet Interface	DDB_GOOSE_MISSING_IED	The IED is not subscribed to a publishing IED in the current scheme	GOOSE IED Absent
356	Ethernet Interface	DDB_ECARD_NOT_FITTED	Ethernet board not fitted	NIC Not Fitted
357	Ethernet Interface	DDB_NIC_NOT_RESPONDING	Ethernet board not responding	NIC No Response
358	Ethernet Interface	DDB_NIC_FATAL_ERROR	Ethernet board unrecoverable error	NIC Fatal Error
359	Ethernet Interface	DDB_NIC_SOFTWARE_RELOAD	Ethernet problem	NIC Soft. Reload
360	SW	DDB_MU_OOS_ALARM	MU OOS Alarm	MU OOS Alarm
361	SW	DDB_INVALID_SV_CONFIG_ALARM	Invalid IEC 61850 Configuration Alarm for PB	Invalid SV conf.
362	SW	DDB_SV_ABSENCE_ALARM	SV Absence Alarm	SV Absence Alm
363	Ethernet Interface	DDB_SW_MISMATCH_ALARM	Ethernet board software not compatible with main CPU	NIC SW Mis-Match
364	Ethernet Interface	DDB_NIC_IP_ADDRESS_CONFLICT	The IP address of the IED is already used by another IED	IP Addr Conflict
365	InterMiCOM	DDB_INTERMICOM_LOOPBACK	EIA(RS)232 InterMiCOM indication that Loopback testing is in progress	IM Loopback
366	InterMiCOM	DDB_INTERMICOM_MESSAGE	EIA(RS)232 InterMiCOM Message Failure alarm. Setting that is used to alarm for poor channel quality. If during the fixed 1.6 s rolling window the ratio of invalid messages to the total number of messages that should be received (based upon the 'Baud Rate' setting) exceeds the above threshold, a 'Message Fail' alarm will be issued	IM Message Fail
367	InterMiCOM	DDB_INTERMICOM_DCD	EIA(RS)232 InterMiCOM Data Channel Detect Fail i.e. modem failure	IM Data CD Fail
368	InterMiCOM	DDB_INTERMICOM_CHANNEL	EIA(RS)232 InterMiCOM Channel Failure alarm. No messages were received during the alarm time setting	IM Channel Fail

DDB No	Source	Element Name	Description	English Text
369	Self monitoring	DDB_BACKUP_DATA_IN_USE	This is an alarm that is ON if any setting fail during the setting changing process. If this happens, the relay will use the last known good setting	Backup Setting
370		DDB_PLATFORM_ALARM_19	Platform Alarm 19	Reserved
371		DDB_PLATFORM_ALARM_20	Platform Alarm 20	Reserved
372	SW	DDB_BBRAM_TEST_FAIL_ALARM	BBRAM Failure Alarm	BBRAM Failure
373	SW	DDB_INVALID_DNPOE_IP_ALARM	Invalid DNPOE IP Configuration Alarm	Invalid DNPOE IP
374	SW	DDB_INVALID_CONFIG_ALARM	Invalid IEC 61850 Configuration Alarm	Invalid Config.
375	SW	DDB_TEST_MODE_ALARM	Test Mode Activated Alarm	Test Mode Alm
376	SW	DDB_CONT_BLK_ALARM	Contacts Blocked Alarm	Contacts Blk Alm
377	SW	DDB_HW_MISMATCH_ALARM	Main card/Ethernet card hw option mismatch Alarm	NIC HW Mismatch
378	SW	DDB_IEC61850_VER_MISMATCH_ALARM	Main card/Ethernet card IEC61850 ver mismatch Alarm	NIC APP Mismatch
379	SW	DDB_ACCEPT_SIMULATED_ALM	IEC 61850 accept simulated GOOSE and SV alarm	Sim.Signal Alm
380	SW	DDB_SV_SMPSYNCH_ALARM	SV SmpSynch alarm	SV SmpSynch Alm
381	SW	DDB_SV_TEST_ALARM	SV Test alarm	SV Test Alm
382	SW	DDB_SV_INVALID_ALARM	SV Invalid alarm	SV Invalid Alm
383	SW	DDB_SV_QUESTIONABLE_ALARM	SV Questionable alarm	SV Quest Alm
384	PSL	DDB_ZONE_1_GND_BLOCK	Zone 1 ground basic scheme blocking	Block Zone 1 Gnd
385	PSL	DDB_ZONE_1_PHS_BLOCK	Zone 1 phase basic scheme blocking	Block Zone 1 Phs
386	PSL	DDB_ZONE_2_GND_BLOCK	Zone 2 ground basic scheme blocking	Block Zone 2 Gnd
387	PSL	DDB_ZONE_2_PHS_BLOCK	Zone 2 phase basic scheme blocking	Block Zone 2 Phs
388	PSL	DDB_ZONE_3_GND_BLOCK	Zone 3 ground basic scheme blocking	Block Zone 3 Gnd
389	PSL	DDB_ZONE_3_PHS_BLOCK	Zone 3 phase basic scheme blocking	Block Zone 3 Phs
390	PSL	DDB_ZONE_P_GND_BLOCK	Zone P ground basic scheme blocking	Block Zone P Gnd
391	PSL	DDB_ZONE_P_PHS_BLOCK	Zone P phase basic scheme blocking	Block Zone P Phs
392	PSL	DDB_ZONE_4_GND_BLOCK	Zone 4 ground basic scheme blocking	Block Zone 4 Gnd
393	PSL	DDB_ZONE_4_PHS_BLOCK	Zone 4 phase basic scheme blocking	Block Zone 4 Phs
394	PSL	DDB_AIDED1_DIST_TRIP_INHIBIT	Block distance aided scheme 1 tripping	Aid1 InhibitDist
395	PSL	DDB_AIDED1_DEF_TRIP_INHIBIT	Block DEF aided scheme 1 tripping	Aid1 Inhibit DEF
396	PSL	DDB_AIDED1_DIR_TRIP_INHIBIT	Unused	Unused
397	PSL	DDB_AIDED2_DIST_TRIP_INHIBIT	Block distance aided scheme 2 tripping	Aid2 InhibitDist
398	PSL	DDB_AIDED2_DEF_TRIP_INHIBIT	Block DEF aided scheme 2 tripping	Aid2 Inhibit DEF
399	PSL	DDB_AIDED2_DIR_TRIP_INHIBIT	Unused	Unused
400	PSL	DDB_TIMESYNC	Time synchronism by opto pulse	Time Synch
401	PSL	DDB_POC_1_TIMER_BLOCK	Block phase overcurrent stage 1 time delayed tripped trip	I>1 Timer Block
402	PSL	DDB_POC_2_TIMER_BLOCK	Block phase overcurrent stage 2 time delayed tripped trip	I>2 Timer Block
403	PSL	DDB_POC_3_TIMER_BLOCK	Block phase overcurrent stage 3 time delayed trip	I>3 Timer Block
404	PSL	DDB_POC_4_TIMER_BLOCK	Block phase overcurrent stage 4 time delayed trip	I>4 Timer Block

DDB No	Source	Element Name	Description	English Text
405	PSL	DDB_EF1_1_TIMER_BLOCK	Block standby earth fault stage 1 time delayed trip	IN>1 Timer Block
406	PSL	DDB_EF1_2_TIMER_BLOCK	Block standby earth fault stage 2 time delayed trip	IN>2 Timer Block
407	PSL	DDB_EF1_3_TIMER_BLOCK	Block standby earth fault stage 3 time delayed trip	IN>3 Timer Block
408	PSL	DDB_EF1_4_TIMER_BLOCK	Block standby earth fault stage 4 time delayed trip	IN>4 Timer Block
409	PSL	DDB_SEF_1_TIMER_BLOCK	Block sensitive earth fault stage 1 time delayed trip	ISEF>1 Timer Blk
410	PSL	DDB_SEF_2_TIMER_BLOCK	Block sensitive earth fault stage 2 time delayed trip	ISEF>2 Timer Blk
411	PSL	DDB_SEF_3_TIMER_BLOCK	Block sensitive earth fault stage 3 time delayed trip	ISEF>3 Timer Blk
412	PSL	DDB_SEF_4_TIMER_BLOCK	Block sensitive earth fault stage 4 time delayed trip	ISEF>4 Timer Blk
413	PSL	DDB_NEGSEQOC_TIMER_BLOCK	Unused	Unused
414	PSL	DDB_PUV_1_TIMER_BLOCK	Block phase undervoltage stage 1 time delayed trip	V<1 Timer Block
415	PSL	DDB_PUV_2_TIMER_BLOCK	Block phase undervoltage stage 2 time delayed trip	V<2 Timer Block
416	PSL	DDB_POV_1_TIMER_BLOCK	Block phase overvoltage stage 1 time delayed trip	V>1 Timer Block
417	PSL	DDB_POV_2_TIMER_BLOCK	Block phase overvoltage stage 2 time delayed trip	V>2 Timer Block
418	PSL	DDB_RESOV_1_TIMER_BLOCK	Block residual overvoltage stage 1 time delayed trip	VN>1 Timer Blk
419	PSL	DDB_RESOV_2_TIMER_BLOCK	Block residual overvoltage stage 2 time delayed trip	VN>2 Timer Blk
420	PSL	DDB_CB_THREE_PHASE_52A	52-A (CB closed) CB auxiliary input (3 phase)	CB Aux 3ph(52-A)
421	PSL	DDB_CB_PHASE_A_52A	Unused	Unused
422	PSL	DDB_CB_PHASE_B_52A	Unused	Unused
423	PSL	DDB_CB_PHASE_C_52A	Unused	Unused
424	PSL	DDB_CB_THREE_PHASE_52B	52-B (CB open) CB auxiliary input (3 phase)	CB Aux 3ph(52-B)
425	PSL	DDB_CB_PHASE_A_52B	Unused	Unused
426	PSL	DDB_CB_PHASE_B_52B	Unused	Unused
427	PSL	DDB_CB_PHASE_C_52B	Unused	Unused
428	PSL	DDB_CB2_THREE_PHASE_52A	Unused	Unused
429	PSL	DDB_CB2_PHASE_A_52A	Unused	Unused
430	PSL	DDB_CB2_PHASE_B_52A	Unused	Unused
431	PSL	DDB_CB2_PHASE_C_52A	Unused	Unused
432	PSL	DDB_CB2_THREE_PHASE_52B	Unused	Unused
433	PSL	DDB_CB2_PHASE_A_52B	Unused	Unused
434	PSL	DDB_CB2_PHASE_B_52B	Unused	Unused
435	PSL	DDB_CB2_PHASE_C_52B	Unused	Unused
436	PSL	DDB_CB_HEALTHY	Circuit breaker healthy (input to auto-recloser - that the CB has enough energy to allow re-closing)	CB Healthy
437	PSL	DDB_CB2_HEALTHY	Unused	Unused

DDB No	Source	Element Name	Description	English Text
438	PSL	DDB_VTS_MCB_OPTO	VT supervision input - signal from external miniature circuit breaker showing MCB tripped	MCB/VTS
439	PSL	DDB_LOGIC_INPUT_TRIP	Initiate tripping of circuit breaker from a manual command	Init Trip CB
440	PSL	DDB_LOGIC_INPUT_CLOSE	Initiate closing of circuit breaker from a manual command	Init Close CB
441	PSL	DDB_LOGIC_INPUT_TRIP_2	Unused	Unused
442	PSL	DDB_LOGIC_INPUT_CLOSE_2	Unused	Unused
443	PSL	DDB_RESET_CB_CLOSE_DELAY	Reset Manual CB Close Timer Delay (stop & reset Manual Close Delay time for closing CB).	Reset Close Dly
444	PSL	DDB_RESET_RELAYS_LEDS	Reset latched relays & LEDs (manual reset of any lockout trip contacts, auto-reclose lockout, and LEDs)	Reset Relays/LED
445	PSL	DDB_RESET_THERMAL	Reset thermal state to 0%	Reset Thermal
446	PSL	DDB_RESET_LOCKOUT	Manual control to reset auto-recloser from lockout	Reset Lockout
447	PSL	DDB_RESET_ALL_VALUES	Reset circuit breaker maintenance values	Reset CB Data
448	PSL	DDB_BLOCK_AR	DDB mapped in PSL from opto or comms input. External signal to force CB autoreclose to lockout.	Block CB AR
449	PSL	DDB_INP_SPAR	Unused	Unused
450	PSL	DDB_INP_TPAR	Unused	Unused
451	PSL	DDB_INP_TR2P	Pole discrepancy (from external detector) - input used to force a 2nd single pole trip to move to a 3 pole auto-reclose cycle	Pole Discrepancy
452	PSL	DDB_INTERNAL_LOOPBACK	To enable loopback mode via opto input	Loopback Mode
453		DDB_PERMISSIVE_INTERTRIP_OPTO	Unused	Unused
454		DDB_STUB_BUS_ENABLED	Unused	Unused
455		DDB_INHIBIT_CURRENT_DIFF_OPTO	Unused	Unused
456		DDB_RECONFIGURATION_INTERLOCK	Unused	Unused
457	PSL	DDB_OVERRIDE_INHIBIT	Unused	Unused
458	PSL	DDB_INHIBIT_WI	Inhibit weak infeed aided scheme logic	Inhibit WI
459	PSL	DDB_TEST_MODE	Commissioning tests - automatically places relay in test mode	Test Mode
460	PSL	DDB_COMMAND_BLOCKING	For IEC-870-5-103 protocol only, used for "Command Blocking" (relay ignores SCADA commands)	103 CommandBlock
461	PSL	DDB_MONITOR_BLOCKING	For IEC-870-5-103 protocol only, used for "Monitor Blocking" (relay is quiet - issues no messages via SCADA port)	103 MonitorBlock
462		DDB_UNUSED_462	Unused	Unused
463	PSL	DDB_INHIBIT_POC1	Inhibit stage 1 overcurrent protection	Inhibit I>1
464	PSL	DDB_INHIBIT_POC2	Inhibit stage 2 overcurrent protection	Inhibit I>2
465	PSL	DDB_INHIBIT_POC3	Inhibit stage 3 overcurrent protection	Inhibit I>3
466	PSL	DDB_INHIBIT_POC4	Inhibit stage 4 overcurrent protection	Inhibit I>4
467	PSL	DDB_INHIBIT_EF1	Inhibit stage 1 earth fault protection	Inhibit IN>1
468	PSL	DDB_INHIBIT_EF2	Inhibit stage 2 earth fault protection	Inhibit IN>2
469	PSL	DDB_INHIBIT_EF3	Inhibit stage 3 earth fault protection	Inhibit IN>3
470	PSL	DDB_INHIBIT_EF4	Inhibit stage 4 earth fault protection	Inhibit IN>4

DDB No	Source	Element Name	Description	English Text
471	PSL	DDB_INHIBIT_UV1	Inhibit stage 1 undervoltage protection	Inhibit V<1
472	PSL	DDB_INHIBIT_UV2	Inhibit stage 2 undervoltage protection	Inhibit V<2
473	PSL	DDB_INHIBIT_OV1	Inhibit stage 1 overvoltage protection	Inhibit V>1
474	PSL	DDB_INHIBIT_OV2	Inhibit stage 2 overvoltage protection	Inhibit V>2
475	PSL	DDB_INHIBIT_RESOV1	Inhibit stage 2 overvoltage protection	Inhibit VN>1
476	PSL	DDB_INHIBIT_RESOV2	Inhibit stage 2 residual overvoltage protection	Inhibit VN>2
477	PSL	DDB_INHIBIT_NPS	Unused	Unused
478	PSL	DDB_INHIBIT_THERMAL	Inhibit thermal overload protection	Inhibit Thermal
479	PSL	DDB_INHIBIT_CBS	Inhibit circuit breaker state monitoring (no alarm for defective/stuck auxiliary contact)	InhibitCB Status
480	PSL	DDB_INHIBIT_CBF	Inhibit circuit breaker fail protection	Inhibit CB Fail
481	PSL	DDB_INHIBIT_BCL	Broken conductor protection	Inhibit OpenLine
482	PSL	DDB_INHIBIT_VTS	Inhibit VT supervision (including turn OFF MCB's) via PSL	Inhibit VTS
483	PSL	DDB_INHIBIT_CTS	Inhibit CT supervision (both differential and standard CTS) via PSL	Inhibit CTS
484	PSL	DDB_INHIBIT_CHKSYN	Inhibit checksync. (Both stages and for each CB)	InhibitChecksync
485	PSL	DDB_INHIBIT_TOR	Inhibit trip on reclose (TOR)	Inhibit TOR
486	PSL	DDB_INHIBIT_SOTF	Inhibit switch onto fault (SOTF)	Inhibit SOTF
487	PSL	DDB_DISABLE_CTS	Unused	Unused
488	PSL	DDB_SET_SOTF	To enable SOTF logic by an external pulse. When this input is energized by an external pulse, SOTF becomes enabled during "SOTF Pulse" time setting	Set SOTF
489	Zone 1 Extension Scheme	DDB_RESET_Z1_EXT	AR reset Z1X reach back to Z1 reach in Z1 extension scheme	AR Reset Z1 EXT
490	PSL	DDB_RESET_ZONE1_EXT	Reset zone Z1X back to Z1 reach using logic input (i.e. case when external AR and Z1 extension scheme are used)	Reset Zone 1 Ext
491	PSL	DDB_INHIBIT_LOL	Inhibit Loss of Load scheme function	Inhibit LoL
492	PSL	DDB_AIDED1_COS_LGS	Aided 1 channel out of service signal (COS) or loss of guard signal (LGS) in distance unblocking schemes. This signal is normally driven from an opto input on conventional channels or from InterMiCOM	Aided 1 COS/LGS
493	PSL	DDB_AIDED1_CRX_EXT	Aided channel 1 - external signal received, for input to distance fixed scheme logic	Aided1 Scheme Rx
494	Aided Scheme Logic	DDB_AIDED1_CRX_INT	Aided channel 1 - internal signal received generated in the signal receive logic	Aided 1 Receive
495		DDB_UNUSED_495	Unused	Unused
496	PSL	DDB_AIDED1_BLOCK_SEND	Prevent sending by customized logic - aided scheme 1	Aid1 Block Send
497	PSL	DDB_AIDED1_PROGRAM_SEND	Programmable send logic for special customized scheme (aided channel 1)	Aid1 Custom Send
498	Aided Scheme Logic	DDB_AIDED1_SEND	Aided channel 1 send - internal send signal generated in signal send logic	Aided 1 Send
499	PSL	DDB_AIDED1_CUSTOM_TIMER_IN	When using a custom programmable aided scheme 1, the user is able to include a current reversal guard timer. Energizing this DDB will additionally start this timer, from PSL	Aid1 Custom T In

DDB No	Source	Element Name	Description	English Text
500	Aided Scheme Logic	DDB_AIDED1_CUSTOM_TIMER_OUT	When using customized aided scheme 1, this signal is used to indicate any additional condition that should be treated as permission for an aided trip (for example a permissive signal received could be connected, or a blocking signal could be inverted and then connected)	Aid1 CustomT Out
501	Aided Scheme Logic	DDB_AIDED1_TRIP_ENABLE	Aided scheme 1 trip enable - this is a permissive signal used to accelerate zone 2, or a blocking signal which has been inverted. It is a signal output, part-way through the internal fixed logic of aided schemes	Aid1 Trip Enable
502	PSL	DDB_AIDED1_CUSTOM_TRIP_ENABLE	Aid1 custom trip enable	Aid1 Custom Trip
503	Aided Scheme Logic	DDB_AIDED1_DIST_TRIP	Aided scheme 1 distance trip command (output from aided tripping logic)	Aid 1 Dist Trip
504	Aided Scheme Logic	DDB_AIDED1_DIR_TRIP	Unused	Unused
505	Aided Scheme Logic	DDB_AIDED1_DEF_TRIP	Aided scheme 1 DEF trip command (output from aided tripping logic)	Aid 1 DEF Trip
506	PSL	DDB_AIDED2_COS_LGS	Aided 2 channel out of service signal (COS) or loss of guard signal (LGS) in distance unblocking schemes. This signal is normally driven from an opto input on conventional channels or from InterMiCOM	Aided 2 COS/LGS
507	PSL	DDB_AIDED2_CRX_EXT	Aided channel 2 - external signal received, for input to distance fixed scheme logic	Aided2 Scheme Rx
508	Aided Scheme Logic	DDB_AIDED2_CRX_INT	Aided channel 2 - internal signal received generated in the signal receive logic	Aided 2 Receive
509	RP1 Read Only	DDB_REMOTEREADONLY_RP1	RP1 Read Only DDB	RP1 Read Only
510	RP2 Read Only	DDB_REMOTEREADONLY_RP2	RP2 Read Only DDB	RP2 Read Only
511	NIC Read Only	DDB_REMOTEREADONLY_NIC	NIC Read Only DDB	NIC Read Only
512	PSL	DDB_AIDED2_BLOCK_SEND	Prevent sending by customized logic - aided scheme 2	Aid2 Block Send
513	PSL	DDB_AIDED2_PROGRAM_SEND	Programmable send logic for special customized scheme (aided channel 2)	Aid2 Custom Send
514	Aided Scheme Logic	DDB_AIDED2_SEND	Aided channel 2 send - internal send signal generated in signal send logic	Aided 2 Send
515	PSL	DDB_AIDED2_CUSTOM_TIMER_IN	When using a custom programmable aided scheme 2, the user is able to include a current reversal guard timer. Energizing this DDB will additionally start this timer, from PSL	Aid2 Custom T In
516	Aided Scheme Logic	DDB_AIDED2_CUSTOM_TIMER_OUT	When using customized aided scheme 2, this signal is used to indicate any additional condition that should be treated as permission for an aided trip (for example a permissive signal received could be connected, or a blocking signal could be inverted and then connected)	Aid2 CustomT Out
517	Aided Scheme Logic	DDB_AIDED2_TRIP_ENABLE	Aided scheme 2 trip enable - this is a permissive signal used to accelerate zone 2, or a blocking signal which has been inverted. It is a signal output, part-way through the internal fixed logic of aided schemes	Aid2 Trip Enable
518	PSL	DDB_AIDED2_CUSTOM_TRIP_ENABLE	Aid2 custom trip enable	Aid2 Custom Trip
519	Aided Scheme Logic	DDB_AIDED2_DIST_TRIP	Aided scheme 2 distance trip command (output from aided tripping logic)	Aid 2 Dist Trip

DDB No	Source	Element Name	Description	English Text
520	Aided Scheme Logic	DDB_AIDED2_DIR_TRIP	Unused	Unused
521	Aided Scheme Logic	DDB_AIDED2_DEF_TRIP	Aided scheme 2 DEF trip command (output from aided tripping logic)	Aid 2 DEF Trip
522	Trip Conversion Logic	DDB_ANY_TRIP	Any trip signal - can be used as the trip command in three-pole tripping applications	Any Trip
523	Trip Conversion Logic	DDB_TRIP_A_PHASE	Unused	Unused
524	Trip Conversion Logic	DDB_TRIP_B_PHASE	Unused	Unused
525	Trip Conversion Logic	DDB_TRIP_C_PHASE	Unused	Unused
526	Trip Conversion Logic	DDB_TRIP_3PH	Trip signal for 3ph - used as a command to drive trip 3ph output contact(s). Takes the output from the internal trip conversion logic	Trip 3ph
527	Trip Conversion Logic	DDB_TR_23_PHASE_FAULT	2 or 3 phase fault indication - used to flag whether the fault is polyphase. Typically used to control auto-reclose logic, where auto-reclosing is allowed only for single phase faults	2/3 Ph Fault
528	Trip Conversion Logic	DDB_TR_3_PHASE_FAULT	3 phase fault indication. Typically used to control auto-reclose logic, where auto-reclosing is blocked for faults affecting all three phases together	3 Ph Fault
529	PSL	DDB_TR_3_PHASE	Trip 3 phase - input to trip latching logic	Trip Inputs 3Ph
530	PSL	DDB_TR_A_PHASE	A phase trip - input to trip conversion logic. Essential to ensure correct single or three pole trip command results (e.g. converts a 2 pole trip to 3 phase)	Trip Inputs A
531	PSL	DDB_TR_B_PHASE	B phase trip - input to trip conversion logic. Essential to ensure correct single or three pole trip command results (e.g. converts a 2 pole trip to 3 phase)	Trip Inputs B
532	PSL	DDB_TR_C_PHASE	C phase trip - input to trip conversion logic. Essential to ensure correct single or three pole trip command results (e.g. converts a 2 pole trip to 3 phase)	Trip Inputs C
533	PSL	DDB_FORCE_3_POLE_TRIP	Force any trip which is issued to always be 3 pole (trip conversion - used in single pole trip applications, to signal when single pole tripping and re-closing is either unwanted, or impossible)	Force 3Pole Trip
534	PSL	DDB_EXTERNAL_TRIP_3PH	External trip 3 phase - allows external protection to initiate breaker fail, circuit breaker condition monitoring statistics, and internal auto-reclose (if enabled)	External Trip3ph
535	PSL	DDB_EXTERNAL_TRIP_A	Unused	Unused
536	PSL	DDB_EXTERNAL_TRIP_B	Unused	Unused
537	PSL	DDB_EXTERNAL_TRIP_C	Unused	Unused
538		DDB_CB2_EXTERNAL_TRIP_3PH	Unused	Unused
539		DDB_CB2_EXTERNAL_TRIP_A	Unused	Unused
540		DDB_CB2_EXTERNAL_TRIP_B	Unused	Unused
541		DDB_CB2_EXTERNAL_TRIP_C	Unused	Unused

DDB No	Source	Element Name	Description	English Text
542		DDB_SG_SELECTOR_X1	Setting group selector X1 (low bit)-selects SG2 if only DDB 542 signal is active. SG1 is active if both DDB 542 & DDB 543=0 SG4 is active if both DDB 542 & DDB 543=1	SG Select x1
543		DDB_SG_SELECTOR_1X	Setting group selector 1X (high bit)-selects SG3 if only DDB 543 is active. SG1 is active if both DDB 542 & DDB 543=0 SG4 is active if both DDB 542 & DDB 543=1	SG Select 1x
544	PSL	DDB_CLEAR_STATISTICS	To reset all statistics values cumulated on the relay. If mapped, the input for this signal could come from a command of the remote end (DDB 1020 - clear stats cmd -) via IM64	Clear Statistics
545	Stability test	DDB_STAB_TEST_PASS	Unused	Unused
546	Phase Comparison	DDB_BLOCK_DELTA	Unused	Unused
547	Phase Comparison	DDB_BLOCK_PHASE_COMP	Unused	Unused
548	Phase Comparison	DDB_BLOCK_START_I2	Unused	Unused
549	Phase Comparison	DDB_SET_TRANS_START	Unused	Unused
550	Out Of Step Tripping	DDB_INHIBIT_PREDICTIVE_OST_TRIP	Unused	Unused
551	Out Of Step Tripping	DDB_PREDICTIVE_OST_TRIP	Unused	Unused
552	Out Of Step Tripping	DDB_INHIBIT_OST_TRIP	Unused	Unused
553	Out Of Step Tripping	DDB_OST_TRIP	Unused	Unused
554	Out Of Step Tripping	DDB_START_Z5	Positive sequence impedance is detected in Z5	Start Z5
555	Out Of Step Tripping	DDB_START_Z6	Unused	Unused
556	Distance Basic Scheme	DDB_CNV_ACTIVE	Level detector Current No Volts (CNV) exceeded	CNV ACTIVE
557	Distance Basic Scheme	DDB_CNV_TOR_TRIP	Trip on Reclose trip due to Current No Volts (CNV) level detectors	TOR Trip CNV
558	Distance Basic Scheme	DDB_CNV_SOTF_TRIP	Switch on to Fault trip due to Current No Volts (CNV) level detectors	SOTF Trip CNV
559	Distance Basic Scheme	DDB_QUARTER_CYCLE_OV_PHA	Phase A Fast Overvoltage level detector used by Current No Volts (CNV)	Fast OV PHA
560	Distance Basic Scheme	DDB_QUARTER_CYCLE_OV_PHB	Phase B Fast Overvoltage level detector used by Current No Volts (CNV)	Fast OV PHB
561	Distance Basic Scheme	DDB_QUARTER_CYCLE_OV_PHC	Phase C Fast Overvoltage level detector used by Current No Volts (CNV)	Fast OV PHC
562	PSL	DDB_NPSOC_INHIBIT	Inhibit Neg Sequence overcurrent protection	I2> Inhibit
563	PSL	DDB_NPSOC_1_TIMER_BLOCK	Block Neg Sequence overcurrent stage 1 time delayed trip	I2>1 Tmr Blk
564	PSL	DDB_NPSOC_2_TIMER_BLOCK	Block Neg Sequence overcurrent stage 2 time delayed trip	I2>2 Tmr Blk
565	PSL	DDB_NPSOC_3_TIMER_BLOCK	Block Neg Sequence overcurrent stage 3 time delayed trip	I2>3 Tmr Blk
566	PSL	DDB_NPSOC_4_TIMER_BLOCK	Block Neg Sequence overcurrent stage 4 time delayed trip	I2>4 Tmr Blk
567	Neg Sequence overcurrent	DDB_NPSOC_1_START	1st stage Neg Sequence overcurrent start	I2>1 Start

DDB No	Source	Element Name	Description	English Text
568	Neg Sequence overcurrent	DDB_NPSOC_2_START	2nd stage Neg Sequence overcurrent start	I2>2 Start
569	Neg Sequence overcurrent	DDB_NPSOC_3_START	3rd stage Neg Sequence overcurrent start	I2>3 Start
570	Neg Sequence overcurrent	DDB_NPSOC_4_START	4th stage Neg Sequence overcurrent start	I2>4 Start
571	Neg Sequence overcurrent	DDB_NPSOC_1_TRIP	1st stage Neg Sequence overcurrent trip	I2>1 Trip
572	Neg Sequence overcurrent	DDB_NPSOC_2_TRIP	2nd stage Neg Sequence overcurrent trip	I2>2 Trip
573	Neg Sequence overcurrent	DDB_NPSOC_3_TRIP	3rd stage Neg Sequence overcurrent trip	I2>3 Trip
574	Neg Sequence overcurrent	DDB_NPSOC_4_TRIP	4th stage Neg Sequence overcurrent trip	I2>4 Trip
575	Phase comparison	DDB_ICAP_MODE_SECURE	Unused	Unused
576	Commissioning Test	DDB_AR_TRIP_TEST	Auto-reclose trip test cycle in progress. Indication that a manually-initiated test cycle is in progress	AR Trip Test
577	Commissioning Test	DDB_AR_TRIP_TEST_A	Unused	Unused
578	Commissioning Test	DDB_AR_TRIP_TEST_B	Unused	Unused
579	Commissioning Test	DDB_AR_TRIP_TEST_C	Unused	Unused
580	Autoreclose	DDB_AR_INIT_3PH	Initiate 3 phase auto-reclose (signal to an external re-closer)	AR Init 3Ph
581	Autoreclose	DDB_AR_BLOCK_AR	Block Autoreclose	Block AR
582	SW	DDB_DIFFERENTIAL_TRIP	Unused	Unused
583	SW	DDB_DIFFERENTIAL_TRIP_A	Unused	Unused
584	SW	DDB_DIFFERENTIAL_TRIP_B	Unused	Unused
585	SW	DDB_DIFFERENTIAL_TRIP_C	Unused	Unused
586	SW	DDB_DIFFERENTIAL_INTERTRIP	Unused	Unused
587	SW	DDB_DIFFERENTIAL_INTERTRIP_A	Unused	Unused
588	SW	DDB_DIFFERENTIAL_INTERTRIP_B	Unused	Unused
589	SW	DDB_DIFFERENTIAL_INTERTRIP_C	Unused	Unused
590	SW	DDB_PERMISSIVE_INTERTRIP	Unused	Unused
591	SW	DDB_STUB_BUS_TRIP	Unused	Unused
592	PSL	DDB_DFDT_INHIBIT	Inhibit df/dt protection	df/dt> Inhibit
593	PSL	DDB_DFDT_1_TIMER_BLOCK	Block df/dt Stage 1 Timer	df/dt>1 Tmr Blk
594	PSL	DDB_DFDT_2_TIMER_BLOCK	Block df/dt Stage 2 Timer	df/dt>2 Tmr Blk
595	PSL	DDB_DFDT_3_TIMER_BLOCK	Block df/dt Stage 3 Timer	df/dt>3 Tmr Blk
596	PSL	DDB_DFDT_4_TIMER_BLOCK	Block df/dt Stage 4 Timer	df/dt>4 Tmr Blk
597	df/dt protection	DDB_DFDT_1_START	df/dt Stage 1 Start	df/dt>1 Start
598	df/dt protection	DDB_DFDT_2_START	df/dt Stage 2 Start	df/dt>2 Start
599	df/dt protection	DDB_DFDT_3_START	df/dt Stage 3 Start	df/dt>3 Start
600	df/dt protection	DDB_DFDT_4_START	df/dt Stage 4 Start	df/dt>4 Start
601	df/dt protection	DDB_DFDT_1_TRIP	df/dt Stage 1 Trip	df/dt>1 Trip
602	df/dt protection	DDB_DFDT_2_TRIP	df/dt Stage 2 Trip	df/dt>2 Trip

DDB No	Source	Element Name	Description	English Text
603	df/dt protection	DDB_DFDT_3_TRIP	df/dt Stage 3 Trip	df/dt>3 Trip
604	df/dt protection	DDB_DFDT_4_TRIP	df/dt Stage 4 Trip	df/dt>4 Trip
605		DDB_UNUSED_605	Unused	Unused
606		DDB_UNUSED_606	Unused	Unused
607		DDB_UNUSED_607	Unused	Unused
608	Distance Basic Scheme	DDB_ZONE_1_TRIP	Zone 1 Trip	Zone 1 Trip
609	Distance Basic Scheme	DDB_ZONE_1_TRIP_A	Zone 1 A Phase Trip	Zone 1 A Trip
610	Distance Basic Scheme	DDB_ZONE_1_TRIP_B	Zone 1 B Phase Trip	Zone 1 B Trip
611	Distance Basic Scheme	DDB_ZONE_1_TRIP_C	Zone 1 C Phase Trip	Zone 1 C Trip
612	Distance Basic Scheme	DDB_ZONE_1_TRIP_N	Zone 1 N Trip	Zone 1 N Trip
613	Distance Basic Scheme	DDB_ZONE_2_TRIP	Zone 2 Trip	Zone 2 Trip
614	Distance Basic Scheme	DDB_ZONE_2_TRIP_A	Zone 2 A Phase Trip	Zone 2 A Trip
615	Distance Basic Scheme	DDB_ZONE_2_TRIP_B	Zone 2 B Phase Trip	Zone 2 B Trip
616	Distance Basic Scheme	DDB_ZONE_2_TRIP_C	Zone 2 C Phase Trip	Zone 2 C Trip
617	Distance Basic Scheme	DDB_ZONE_2_TRIP_N	Zone 2 N Trip	Zone 2 N Trip
618	Distance Basic Scheme	DDB_ZONE_3_TRIP	Zone 3 Trip	Zone 3 Trip
619	Distance Basic Scheme	DDB_ZONE_3_TRIP_A	Zone 3 A Phase Trip	Zone 3 A Trip
620	Distance Basic Scheme	DDB_ZONE_3_TRIP_B	Zone 3 B Phase Trip	Zone 3 B Trip
621	Distance Basic Scheme	DDB_ZONE_3_TRIP_C	Zone 3 C Phase Trip	Zone 3 C Trip
622	Distance Basic Scheme	DDB_ZONE_3_TRIP_N	Zone 3 N Trip	Zone 3 N Trip
623	Distance Basic Scheme	DDB_ZONE_P_TRIP	Zone P Trip	Zone P Trip
624	Distance Basic Scheme	DDB_ZONE_P_TRIP_A	Zone P A Phase Trip	Zone P A Trip
625	Distance Basic Scheme	DDB_ZONE_P_TRIP_B	Zone P B Phase Trip	Zone P B Trip
626	Distance Basic Scheme	DDB_ZONE_P_TRIP_C	Zone P C Phase Trip	Zone P C Trip
627	Distance Basic Scheme	DDB_ZONE_P_TRIP_N	Zone P N Trip	Zone P N Trip
628	Distance Basic Scheme	DDB_ZONE_4_TRIP	Zone 4 Trip	Zone 4 Trip
629	Distance Basic Scheme	DDB_ZONE_4_TRIP_A	Zone 4 A Phase Trip	Zone 4 A Trip
630	Distance Basic Scheme	DDB_ZONE_4_TRIP_B	Zone 4 B Phase Trip	Zone 4 B Trip

DDB No	Source	Element Name	Description	English Text
631	Distance Basic Scheme	DDB_ZONE_4_TRIP_C	Zone 4 C Phase Trip	Zone 4 C Trip
632	Distance Basic Scheme	DDB_ZONE_4_TRIP_N	Zone 4 N Phase Trip	Zone 4 N Trip
633	Aided Scheme Logic	DDB_AIDED1_TRIP_A	Aided channel scheme 1 trip A phase	Aided 1 Trip A
634	Aided Scheme Logic	DDB_AIDED1_TRIP_B	Aided channel scheme 1 trip B phase	Aided 1 Trip B
635	Aided Scheme Logic	DDB_AIDED1_TRIP_C	Aided channel scheme 1 trip C phase	Aided 1 Trip C
636	Aided Scheme Logic	DDB_AIDED1_TRIP_N	Aided channel scheme 1 trip involving ground (N)	Aided 1 Trip N
637	Aided Scheme Logic	DDB_AIDED1_WI_TRIP_A	Aided scheme 1 weak infeed trip phase A	Aid 1 WI Trip A
638	Aided Scheme Logic	DDB_AIDED1_WI_TRIP_B	Aided scheme 1 weak infeed trip phase B	Aid 1 WI Trip B
639	Aided Scheme Logic	DDB_AIDED1_WI_TRIP_C	Aided scheme 1 weak infeed trip phase C	Aid 1 WI Trip C
640	Aided Scheme Logic	DDB_AIDED1_DIR_3P_TRIP	Unused	Unused
641	Aided Scheme Logic	DDB_AIDED1_DEF_3P_TRIP	Aided 1 directional earth fault scheme trip 3 phase	Aid1 DEF Trip3Ph
642	Aided Scheme Logic	DDB_AIDED1_WI_3P_TRIP	Aided channel scheme 1 - weak infeed logic trip 3 phase	Aid1 WI Trip 3Ph
643	Aided Scheme Logic	DDB_AIDED2_TRIP_A	Aided channel scheme 2 trip A phase	Aided 2 Trip A
644	Aided Scheme Logic	DDB_AIDED2_TRIP_B	Aided channel scheme 2 trip B phase	Aided 2 Trip B
645	Aided Scheme Logic	DDB_AIDED2_TRIP_C	Aided channel scheme 2 trip C phase	Aided 2 Trip C
646	Aided Scheme Logic	DDB_AIDED2_TRIP_N	Aided channel scheme 2 trip involving ground (N)	Aided 2 Trip N
647	Aided Scheme Logic	DDB_AIDED2_WI_TRIP_A	Aided scheme 2 weak infeed trip phase A	Aid 2 WI Trip A
648	Aided Scheme Logic	DDB_AIDED2_WI_TRIP_B	Aided scheme 2 weak infeed trip phase B	Aid 2 WI Trip B
649	Aided Scheme Logic	DDB_AIDED2_WI_TRIP_C	Aided scheme 2 weak infeed trip phase C	Aid 2 WI Trip C
650	Aided Scheme Logic	DDB_AIDED2_DIR_3P_TRIP	Unused	Unused
651	Aided Scheme Logic	DDB_AIDED2_DEF_3P_TRIP	Aided 2 directional earth fault scheme trip 3 phase	Aid2 DEF Trip3Ph
652	Aided Scheme Logic	DDB_AIDED2_WI_3P_TRIP	Aided channel scheme 2 - weak infeed logic trip 3 phase	Aid2 WI Trip 3Ph
653	PTP	DDB_1588_STATUS	IEEE1588 Status Signal Valid	1588 Status
654	Loss of Load Logic	DDB_LOL_TRIP	Loss of Load Trip	Loss of Load Trip
655	Overcurrent	DDB_POC_1_3PH_TRIP	1st stage phase overcurrent trip 3 phase	I>1 Trip
656	Overcurrent	DDB_POC_1_PH_A_TRIP	1st stage phase overcurrent trip phase A	I>1 Trip A
657	Overcurrent	DDB_POC_1_PH_B_TRIP	1st stage phase overcurrent trip phase B	I>1 Trip B
658	Overcurrent	DDB_POC_1_PH_C_TRIP	1st stage phase overcurrent trip phase C	I>1 Trip C

DDB No	Source	Element Name	Description	English Text
659	Overcurrent	DDB_POC_2_3PH_TRIP	2nd stage phase overcurrent trip 3 phase	I>2 Trip
660	Overcurrent	DDB_POC_2_PH_A_TRIP	2nd stage phase overcurrent trip phase A	I>2 Trip A
661	Overcurrent	DDB_POC_2_PH_B_TRIP	2nd stage phase overcurrent trip phase B	I>2 Trip B
662	Overcurrent	DDB_POC_2_PH_C_TRIP	2nd stage phase overcurrent trip phase C	I>2 Trip C
663	Overcurrent	DDB_POC_3_3PH_TRIP	3rd stage phase overcurrent trip 3 phase	I>3 Trip
664	Overcurrent	DDB_POC_3_PH_A_TRIP	3rd stage phase overcurrent trip phase A	I>3 Trip A
665	Overcurrent	DDB_POC_3_PH_B_TRIP	3rd stage phase overcurrent trip phase B	I>3 Trip B
666	Overcurrent	DDB_POC_3_PH_C_TRIP	3rd stage phase overcurrent trip phase C	I>3 Trip C
667	Overcurrent	DDB_POC_4_3PH_TRIP	4th stage phase overcurrent trip 3 phase	I>4 Trip
668	Overcurrent	DDB_POC_4_PH_A_TRIP	4th stage phase overcurrent trip phase A	I>4 Trip A
669	Overcurrent	DDB_POC_4_PH_B_TRIP	4th stage phase overcurrent trip phase B	I>4 Trip B
670	Overcurrent	DDB_POC_4_PH_C_TRIP	4th stage phase overcurrent trip phase C	I>4 Trip C
671	Earth Fault	DDB_EF1_1_TRIP	1st stage stand by earth fault (SBEF) protection trip	IN>1 Trip
672	Earth Fault	DDB_EF1_2_TRIP	2nd stage stand by earth fault (SBEF) protection trip	IN>2 Trip
673	Earth Fault	DDB_EF1_3_TRIP	3rd stage stand by earth fault (SBEF) protection trip	IN>3 Trip
674	Earth Fault	DDB_EF1_4_TRIP	4th stage stand by earth fault (SBEF) protection trip	IN>4 Trip
675	SEF	DDB_SEF_1_TRIP	1st stage sensitive earth fault (SEF) protection trip	ISEF>1 Trip
676	SEF	DDB_SEF_2_TRIP	2nd stage sensitive earth fault (SEF) protection trip	ISEF>2 Trip
677	SEF	DDB_SEF_3_TRIP	3rd stage sensitive earth fault (SEF) protection trip	ISEF>3 Trip
678	SEF	DDB_SEF_4_TRIP	4th stage sensitive earth fault (SEF) protection trip	ISEF>4 Trip
679	Broken Conductor	DDB_BROKEN_CONDUCTOR_TRIP	Broken Conductor Trip	Broken Wire Trip
680	Thermal overload	DDB_THERMAL_TRIP	Thermal Overload Trip	Thermal Trip
681		DDB_BLOCK_GND_ZP_START	Unused	Unused
682	SEF	DDB_REF_TRIP	Restricted earth fault (REF) protection trip	IREF> Trip
683	Undervoltage	DDB_PUV_1_3PH_TRIP	Undervoltage stage 1, three phase trip	V<1 Trip
684	Undervoltage	DDB_PUV_1_PH_A_TRIP	Undervoltage stage 1 A/AB phase trip	V<1 Trip A/AB
685	Undervoltage	DDB_PUV_1_PH_B_TRIP	Undervoltage stage 1 B/BC phase trip	V<1 Trip B/BC
686	Undervoltage	DDB_PUV_1_PH_C_TRIP	Undervoltage stage 1 C/CA phase trip	V<1 Trip C/CA
687	Undervoltage	DDB_PUV_2_3PH_TRIP	Undervoltage stage 2, three phase trip	V<2 Trip
688	Undervoltage	DDB_PUV_2_PH_A_TRIP	Undervoltage stage 2 A/AB phase trip	V<2 Trip A/AB
689	Undervoltage	DDB_PUV_2_PH_B_TRIP	Undervoltage stage 2 B/BC phase trip	V<2 Trip B/BC
690	Undervoltage	DDB_PUV_2_PH_C_TRIP	Undervoltage stage 2 C/CA phase trip	V<2 Trip C/CA
691	Overvoltage	DDB_POV_1_3PH_TRIP	Overvoltage stage 1, three phase trip	V>1 Trip
692	Overvoltage	DDB_POV_1_PH_A_TRIP	Overvoltage stage 1 A/AB phase trip	V>1 Trip A/AB
693	Overvoltage	DDB_POV_1_PH_B_TRIP	Overvoltage stage 1 B/BC phase trip	V>1 Trip B/BC
694	Overvoltage	DDB_POV_1_PH_C_TRIP	Overvoltage stage 1 C/CA phase trip	V>1 Trip C/CA
695	Overvoltage	DDB_POV_2_3PH_TRIP	Overvoltage stage 2, three phase trip	V>2 Trip
696	Overvoltage	DDB_POV_2_PH_A_TRIP	Overvoltage stage 2 A/AB phase trip	V>2 Trip A/AB

DDB No	Source	Element Name	Description	English Text
697	Overvoltage	DDB_POV_2_PH_B_TRIP	Overvoltage stage 2 B/BC phase trip	V>2 Trip B/BC
698	Overvoltage	DDB_POV_2_PH_C_TRIP	Overvoltage stage 2 C/CA phase trip	V>2 Trip C/CA
699	Pole discrepancy	DDB_POLE_DISCREPENCE_TRIP	Pole discrepancy signal to force a three pole trip conversion, if the relay detects one pole dead, and no auto-reclose in progress	Pole Discrepancy
700	Residual overvoltage	DDB_RESOV_1_TRIP	Residual overvoltage stage 1 trip	VN>1 Trip
701	Residual overvoltage	DDB_RESOV_2_TRIP	Residual overvoltage stage 2 trip	VN>2 Trip
702	PSL	DDB_FAULT_RECORDER_START	Trigger for Fault Recorder	Fault REC TRIG
703	Neg Sequence overcurrent	DDB_NEGSEQOC_TRIP	Unused	Unused
704	Trip on Close	DDB_ZONE_1_TOR_TRIP	TOR trip zone 1 (trip on reclose)	TOR Trip Zone 1
705	Trip on Close	DDB_ZONE_2_TOR_TRIP	TOR Trip Zone 2	TOR Trip Zone 2
706	Trip on Close	DDB_ZONE_3_TOR_TRIP	TOR Trip Zone 3	TOR Trip Zone 3
707	Trip on Close	DDB_ZONE_4_TOR_TRIP	TOR Trip Zone 4	TOR Trip Zone 4
708	Trip on Close	DDB_ZONE_P_TOR_TRIP	TOR Trip Zone P	TOR Trip Zone P
709	Trip on Close	DDB_ZONE_1_SOTF_TRIP	SOTF trip zone 1 (switch on to fault)	SOTF Trip Zone 1
710	Trip on Close	DDB_ZONE_2_SOTF_TRIP	SOTF Trip Zone 2	SOTF Trip Zone 2
711	Trip on Close	DDB_ZONE_3_SOTF_TRIP	SOTF Trip Zone 3	SOTF Trip Zone 3
712	Trip on Close	DDB_ZONE_4_SOTF_TRIP	SOTF Trip Zone 4	SOTF Trip Zone 4
713	Trip on Close	DDB_ZONE_P_SOTF_TRIP	SOTF Trip Zone P	SOTF Trip Zone P
714	SW	DDB_CH_TEST_COMPLETED	Unused	Unused
715	SW	DDB_CH_TEST_START	Unused	Unused
716	Phase comparison	DDB_UNSTABALISING	Unused	Unused
717	SW	DDB_BLOCK_CHANNEL_TEST	Unused	Unused
718	SW	DDB_CLP_INITIATE	Unused	Unused
719	SW	DDB_CLP_OPERATION	Unused	Unused
720		DDB_UNUSED_720	Unused	Unused
721	PSL	DDB_CONT_MAN_TEST	Unused	Unused
722	PSL	DDB_BLOCK_PLC	Unused	Unused
723	Phase Comparison	DDB_PHASE_COMP_TRIP	Unused	Unused
724	Phase comparison	DDB_PHASE_COMP_TRIP_A	Unused	Unused
725	Phase comparison	DDB_PHASE_COMP_TRIP_B	Unused	Unused
726	Phase comparison	DDB_PHASE_COMP_TRIP_C	Unused	Unused
727	Phase comparison	DDB_PHASE_COMP_TRIP_3PH	Unused	Unused
728	SW	DDB_TRANS_START_ENABLED	Unused	Unused
729	SW	DDB_BLOCK_PH_Z2_START	Unused	Unused
730	SW	DDB_BLOCK_PH_Z3_START	Unused	Unused
731	SW	DDB_BLOCK_PH_Z4_START	Unused	Unused
732	SW	DDB_BLOCK_PH_ZP_START	Unused	Unused
733	SW	DDB_BLOCK_GND_Z2_START	Unused	Unused
734	SW	DDB_BLOCK_GND_Z3_START	Unused	Unused
735	SW	DDB_BLOCK_GND_Z4_START	Unused	Unused
736	PSL	DDB_ANY_START	Any Start	Any Start

DDB No	Source	Element Name	Description	English Text
737	SW	DDB_DIFFERENTIAL_START	Unused	Unused
738	SW	DDB_DIFFERENTIAL_START_A	Unused	Unused
739	SW	DDB_DIFFERENTIAL_START_B	Unused	Unused
740	SW	DDB_DIFFERENTIAL_START_C	Unused	Unused
741	Distance Basic Scheme	DDB_ZONE_1_START_A	Zone 1 A Phase Start	Zone 1 A Start
742	Distance Basic Scheme	DDB_ZONE_1_START_B	Zone 1 B Phase Start	Zone 1 B Start
743	Distance Basic Scheme	DDB_ZONE_1_START_C	Zone 1 C Phase Start	Zone 1 C Start
744	Distance Basic Scheme	DDB_ZONE_1_START_N	Zone 1 ground element start	Zone 1 N Start
745	Distance Basic Scheme	DDB_ZONE_2_START_A	Zone 2 A Phase Start	Zone 2 A Start
746	Distance Basic Scheme	DDB_ZONE_2_START_B	Zone 2 B Phase Start	Zone 2 B Start
747	Distance Basic Scheme	DDB_ZONE_2_START_C	Zone 2 C Phase Start	Zone 2 C Start
748	Distance Basic Scheme	DDB_ZONE_2_START_N	Zone 2 ground element start	Zone 2 N Start
749	Distance Basic Scheme	DDB_ZONE_3_START_A	Zone 3 A Phase Start	Zone 3 A Start
750	Distance Basic Scheme	DDB_ZONE_3_START_B	Zone 3 B Phase Start	Zone 3 B Start
751	Distance Basic Scheme	DDB_ZONE_3_START_C	Zone 3 C Phase Start	Zone 3 C Start
752	Distance Basic Scheme	DDB_ZONE_3_START_N	Zone 3 N Start	Zone 3 N Start
753	Distance Basic Scheme	DDB_ZONE_P_START_A	Zone P A Phase Start	Zone P A Start
754	Distance Basic Scheme	DDB_ZONE_P_START_B	Zone P B Phase Start	Zone P B Start
755	Distance Basic Scheme	DDB_ZONE_P_START_C	Zone P C Phase Start	Zone P C Start
756	Distance Basic Scheme	DDB_ZONE_P_START_N	Zone P N Start	Zone P N Start
757	Distance Basic Scheme	DDB_ZONE_4_START_A	Zone 4 A Phase Start	Zone 4 A Start
758	Distance Basic Scheme	DDB_ZONE_4_START_B	Zone 4 B Phase Start	Zone 4 B Start
759	Distance Basic Scheme	DDB_ZONE_4_START_C	Zone 4 C Phase Start	Zone 4 C Start
760	Distance Basic Scheme	DDB_ZONE_4_START_N	Zone 4 N Start	Zone 4 N Start
761	Overcurrent	DDB_POC_1_3PH_START	1st stage overcurrent start 3 phase	I>1 Start
762	Overcurrent	DDB_POC_1_PH_A_START	1st stage overcurrent start phase A	I>1 Start A
763	Overcurrent	DDB_POC_1_PH_B_START	1st stage overcurrent start phase B	I>1 Start B
764	Overcurrent	DDB_POC_1_PH_C_START	1st stage overcurrent start phase C	I>1 Start C
765	Overcurrent	DDB_POC_2_3PH_START	2nd stage overcurrent start 3 phase	I>2 Start
766	Overcurrent	DDB_POC_2_PH_A_START	2nd stage overcurrent start phase A	I>2 Start A

DDB No	Source	Element Name	Description	English Text
767	Overcurrent	DDB_POC_2_PH_B_START	2nd stage overcurrent start phase B	I>2 Start B
768	Overcurrent	DDB_POC_2_PH_C_START	2nd stage overcurrent start phase C	I>2 Start C
769	Overcurrent	DDB_POC_3_3PH_START	3rd stage overcurrent start 3 phase	I>3 Start
770	Overcurrent	DDB_POC_3_PH_A_START	3rd stage overcurrent start phase A	I>3 Start A
771	Overcurrent	DDB_POC_3_PH_B_START	3rd stage overcurrent start phase B	I>3 Start B
772	Overcurrent	DDB_POC_3_PH_C_START	3rd stage overcurrent start phase C	I>3 Start C
773	Overcurrent	DDB_POC_4_3PH_START	4th stage overcurrent start 3 phase	I>4 Start
774	Overcurrent	DDB_POC_4_PH_A_START	4th stage overcurrent start phase A	I>4 Start A
775	Overcurrent	DDB_POC_4_PH_B_START	4th stage overcurrent start phase B	I>4 Start B
776	Overcurrent	DDB_POC_4_PH_C_START	4th Stage overcurrent start phase C	I>4 Start C
777	Earth Fault	DDB_EF1_1_START	1st stage stand by earth fault (SBEF) overcurrent start	IN>1 Start
778	Earth Fault	DDB_EF1_2_START	2nd stage stand by earth fault (SBEF) overcurrent start	IN>2 Start
779	Earth Fault	DDB_EF1_3_START	3rd stage stand by earth fault (SBEF) overcurrent start	IN>3 Start
780	Earth Fault	DDB_EF1_4_START	4th stage stand by earth fault (SBEF) overcurrent start	IN>4 Start
781	SW	DDB_SEF_1_START	1st stage sensitive earth fault (SEF) overcurrent start	ISEF>1 Start
782	SW	DDB_SEF_2_START	2nd stage sensitive earth fault (SEF) overcurrent start	ISEF>2 Start
783	SW	DDB_SEF_3_START	3rd stage sensitive earth fault (SEF) overcurrent start	ISEF>3 Start
784	SW	DDB_SEF_4_START	4th stage sensitive earth fault (SEF) overcurrent start	ISEF>4 Start
785	Thermal overload	DDB_THERMAL_ALARM	Thermal Overload Alarm	Thermal Alarm
786		DDB_PH_BLOCKED_OC_START	Unused	Unused
787		DDB_N_BLOCKED_OC_START	Unused	Unused
788	Undervoltage	DDB_PUV_1_3PH_START	Undervoltage stage 1, three phase start	V<1 Start
789	Undervoltage	DDB_PUV_1_PH_A_START	Undervoltage stage 1, A phase start	V<1 Start A/AB
790	Undervoltage	DDB_PUV_1_PH_B_START	Undervoltage stage 1, B phase start	V<1 Start B/BC
791	Undervoltage	DDB_PUV_1_PH_C_START	Undervoltage stage 1, C phase start	V<1 Start C/CA
792	Undervoltage	DDB_PUV_2_3PH_START	Undervoltage stage 2, three phase start	V<2 Start
793	Undervoltage	DDB_PUV_2_PH_A_START	Undervoltage stage 2, A phase start	V<2 Start A/AB
794	Undervoltage	DDB_PUV_2_PH_B_START	Undervoltage stage 2, B phase start	V<2 Start B/BC
795	Undervoltage	DDB_PUV_2_PH_C_START	Undervoltage stage 2, C phase start	V<2 Start C/CA
796	Overvoltage	DDB_POV_1_3PH_START	Overvoltage stage 1, three phase start	V>1 Start
797	Overvoltage	DDB_POV_1_PH_A_START	Overvoltage stage 1, A phase start	V>1 Start A/AB
798	Overvoltage	DDB_POV_1_PH_B_START	Overvoltage stage 1, B phase start	V>1 Start B/BC
799	Overvoltage	DDB_POV_1_PH_C_START	Overvoltage stage 1, C phase start	V>1 Start C/CA
800	Overvoltage	DDB_POV_2_3PH_START	Overvoltage stage 1, C phase start	V>2 Start
801	Overvoltage	DDB_POV_2_PH_A_START	Overvoltage stage 2, A phase start	V>2 Start A/AB
802	Overvoltage	DDB_POV_2_PH_B_START	Overvoltage stage 2, B phase start	V>2 Start B/BC
803	Overvoltage	DDB_POV_2_PH_C_START	Overvoltage stage 2, C phase start	V>2 Start C/CA

DDB No	Source	Element Name	Description	English Text
804	Residual overvoltage	DDB_RESOV_1_START	Residual overvoltage stage 1 start	VN>1 Start
805	Residual overvoltage	DDB_RESOV_2_START	Residual overvoltage stage 2 start	VN>2 Start
806	Neg Sequence overcurrent	DDB_NEGSEQOC_START	Unused	Unused
807	Phase Comparison	DDB_DELTA_I2_LOW	Unused	Unused
808	Phase Comparison	DDB_DELTA_I2_HIGH	Unused	Unused
809	Phase Comparison	DDB_DELTA_I1_LOW	Unused	Unused
810	Phase Comparison	DDB_DELTA_I1_HIGH	Unused	Unused
811	Phase Comparison	DDB_START_I2_LOW	Unused	Unused
812	Phase Comparison	DDB_START_I2_HIGH	Unused	Unused
813	Phase Comparison	DDB_START_I1_LOW	Unused	Unused
814	Phase Comparison	DDB_START_I1_HIGH	Unused	Unused
815	Phase Comparison	DDB_START_V2_LOW	Unused	Unused
816	Phase Comparison	DDB_START_V2_HIGH	Unused	Unused
817	Phase Comparison	DDB_PH_Z2_LOW	Unused	Unused
818	Phase Comparison	DDB_PH_Z2_HIGH	Unused	Unused
819	Phase Comparison	DDB_PH_Z3_LOW	Unused	Unused
820	Phase Comparison	DDB_PH_Z3_HIGH	Unused	Unused
821	Phase Comparison	DDB_PH_Z4_LOW	Unused	Unused
822	Phase Comparison	DDB_PH_Z4_HIGH	Unused	Unused
823	Phase Comparison	DDB_PH_ZP_LOW	Unused	Unused
824	Phase Comparison	DDB_PH_ZP_HIGH	Unused	Unused
825	Phase Comparison	DDB_ANY_DELTA_START	Unused	Unused
826	Phase Comparison	DDB_ANY_THRESH_START	Unused	Unused
827	Phase Comparison	DDB_ANY_LOW_SET	Unused	Unused
828	Phase Comparison	DDB_ANY_HI_SET	Unused	Unused
829	Poledead	DDB_PHASE_A_UNDERVOLTAGE	Phase A undervoltage level detector used in the pole dead logic. Detectors have a fixed threshold: undervoltage pickup 38.1 V–drop off 43.8 V	VA< start
830	Poledead	DDB_PHASE_B_UNDERVOLTAGE	Phase B undervoltage level detector used in the pole dead logic. Detectors have a fixed threshold: undervoltage pickup 38.1 V–drop off 43.8 V	VB< start
831	Poledead	DDB_PHASE_C_UNDERVOLTAGE	Phase C undervoltage level detector used in the pole dead logic. Detectors have a fixed threshold: undervoltage pickup 38.1 V–drop off 43.8 V	VC< start

DDB No	Source	Element Name	Description	English Text
832	VT Supervision	DDB_VTS_FAST_BLOCK	VT supervision fast block - blocks elements which would otherwise maloperate immediately a fuse failure event occurs	VTS Fast Block
833	VT Supervision	DDB_VTS_SLOW_BLOCK	VT supervision slow block - blocks elements which would otherwise maloperate some time after a fuse failure event occurs	VTS Slow Block
834	CB Fail	DDB_CBF1_TRIP_3PH	tBF1 trip 3Ph - three phase output from circuit breaker failure logic, stage 1	CBfail1 Trip 3ph
835	CB Fail	DDB_CBF2_TRIP_3PH	tBF2 trip 3Ph - three phase output from circuit breaker failure logic, stage 2	CBfail2 Trip 3ph
836	CB Fail	DDB_CB2F1_TRIP_3PH	Unused	Unused
837	CB Fail	DDB_CB2F2_TRIP_3PH	Unused	Unused
838	CB Control	DDB_CONTROL_TRIP	Control trip - operator trip instruction to the circuit breaker, via menu, or SCADA. (Does not operate for protection element trips)	Control Trip
839	CB Control	DDB_CONTROL_CLOSE	Control close command to the circuit breaker. Operates for a manual close command (menu, SCADA), and additionally is driven by the auto-reclose close command	Control Close
840	CB Control	DDB_CONTROL_TRIP_2	Unused	Unused
841	CB Control	DDB_CONTROL_CLOSE_2	Unused	Unused
842	CB Control	DDB_CONTROL_CLOSE_IN_PROGRESS	Control close in progress - the relay has been given an instruction to close the circuit breaker, but the manual close timer delay has not yet finished timing out	Close in Prog
843	Autoreclose	DDB_AR_BLOCK_MAIN_PROTECTION	AR Block Main Protection. In P841 etc, there is no specific output DDB to block selected protection functions. If such a feature is required for a particular application, appropriate mapping should be created in PSL, using output DDBs from sequence counter, single phase dead time and three phase dead time logic as required.	Block Main Prot
844	Autoreclose	DDB_AR_3_POLE_IN_PROGRESS	Auto-reclose 3 pole in progress (dead time is running)	AR 3pole in prog
845	Autoreclose	DDB_AR_1_POLE_IN_PROGRESS	Unused	Unused
846	Autoreclose	DDB_SEQ_COUNT_0	Auto-reclose sequence counter is at zero - no previous faults have been cleared within recent history. The sequence count is at zero because no reclaim times are timing out, and the auto-recloser is not locked out. The recloser is awaiting the first protection trip, and all programmed cycles are free to follow	Seq Counter = 0
847	Autoreclose	DDB_SEQ_COUNT_1	The first fault trip has happened in a new auto-reclose sequence. Dead time 1, or reclaim time 1 are in the process of timing out	Seq Counter = 1
848	Autoreclose	DDB_SEQ_COUNT_2	Auto-reclose sequence counter is at 2. This means that the initial fault trip happened, and then another trip followed, moving the counter on to 2	Seq Counter = 2
849	Autoreclose	DDB_SEQ_COUNT_3	Auto-reclose sequence counter is at 3. This means that the initial fault trip happened, and then 2 trips followed, moving the counter on to 3	Seq Counter = 3
850	Autoreclose	DDB_SEQ_COUNT_4	Auto-reclose sequence counter is at 4. This means that the initial fault trip happened, and then 3 trips followed, moving the counter on to 4	Seq Counter = 4

DDB No	Source	Element Name	Description	English Text
851	Autoreclose	DDB_SEQ_COUNT_5	Seq Counter = 5 (In 2CB AR, there is no output specifically for seq counter = 5. However there is a DDB output for Seq Counter > 4. may need a different allocation for DDB#851 in 2CB AR scheme.	Seq Counter = 5
852	Autoreclose	DDB_AR_SUCCESSFUL_RECLOSE	This signal is set when CB has successfully completed a three phase autoreclose cycle.	CB Succ 3P AR
853	Autoreclose	DDB_DEAD_TIME_IN_PROGRESS	Unused	Unused
854	Autoreclose	DDB_AUTO_CLOSE	Auto-reclose command to the circuit breaker	Auto Close
855	Autoreclose	DDB_UNUSED_855	Unused	Unused
856	Autoreclose	DDB_AR_IN_SERVICE_3P	3 Pole auto-recloser in service - the auto-reclose function has been enabled either in the relay menu, or by an opto input	A/R Status 3P
857	Autoreclose	DDB_AR_IN_SERVICE_1P	Unused	Unused
858	Autoreclose	DDB_AR_FORCE_3_POLE_TRIPS	Unused	Unused
859	Autoreclose	DDB_AR_BLOCKED	It indicates that AR has been blocked (ex. from external input BAR)	AR Blocked
860	CB Control	DDB_CB_LOCKOUT_ALARM	Composite lockout alarm - circuit breaker locked out due to auto-recloser, or condition monitoring reasons	Lockout Alarm
861	C Diff	DDB_LOCAL_GPS_FAIL_INST	Unused	Unused
862	IRIG-B Inmon	DDB_IRIGB_SIGNAL_VALID	IRIG-B Status Signal Valid	IRIG-B Valid
863	SW	DDB_LOGIC_0	Logic 0 for use in PSL. This can be used to force a DDB, contact, LED, InterMiCOM or Virtual Output low (or high by using an inversion gate)	Logic 0 Ref.
864	Undercurrent	DDB_PHASE_A_UNDERCURRENT	A phase undercurrent level detector pickup (detects low current). It is used for breaker failure in models with one CT input and also it is used for fault record reset (as the sum CTs in models with two CTs)	IA< Start
865	Undercurrent	DDB_PHASE_B_UNDERCURRENT	B phase undercurrent level detector pickup (detects low current). It is used for breaker failure in models with one CT input and also it is used for fault record reset (as the sum CTs in models with two CTs)	IB< Start
866	Undercurrent	DDB_PHASE_C_UNDERCURRENT	C phase undercurrent level detector pickup (detects low current). It is used for breaker failure in models with one CT input and also it is used for fault record reset (as the sum CTs in models with two CTs)	IC< Start
867	Undercurrent	DDB_PHASE_A_UNDERCURRENT_CB1	Unused	Unused
868	Undercurrent	DDB_PHASE_B_UNDERCURRENT_CB1	Unused	Unused
869	Undercurrent	DDB_PHASE_C_UNDERCURRENT_CB1	Unused	Unused
870	Undercurrent	DDB_PHASE_A_UNDERCURRENT_CB2	Unused	Unused
871	Undercurrent	DDB_PHASE_B_UNDERCURRENT_CB2	Unused	Unused
872	Undercurrent	DDB_PHASE_C_UNDERCURRENT_CB2	Unused	Unused
873	Undercurrent	DDB_SEF_UNDERCURRENT	SEF undercurrent level detector pickup (detects low current in CT SEF)	ISEF< Start
874	Undercurrent	DDB_UNUSED_874	Unused	Unused
875	Undercurrent	DDB_UNUSED_875	Unused	Unused
876	Zone 1 Extension Scheme	DDB_ZONE1_EXT_ACTIVE	Zone 1 extension active - zone 1 is operating in its reach extended mode	Z1X Active

DDB No	Source	Element Name	Description	English Text
877	Trip on Close	DDB_TOC_ACTIVE	Trip on close functions (either SOTF or TOR) active. These elements are in-service for a period of time following circuit breaker closure	TOC Active
878	Trip on Close	DDB_TOR_ACTIVE	Trip on re-close protection is active - indicated TOC delay timer has elapsed after circuit breaker opening, and remains in-service on auto-reclosure for the duration of the trip on close window	TOR Active
879	Trip on Close	DDB_SOTF_ACTIVE	Switch on to fault protection is active - in service on manual breaker closure, and then remains in-service for the duration of the trip on close window	SOTF Active
880	Check sync	DDB_SYSCHECKS_INACTIVE	System checks inactive (output from the check synchronism, and other voltage checks)	SysChks Inactive
881	PSL	DDB_CHECKSYNC_1_ENABLED	Check sync. stage 1 enabled	CS1 Enabled
882	PSL	DDB_CHECKSYNC_2_ENABLED	Check sync. stage 2 enabled	CS2 Enabled
883	Check sync	DDB_CHECKSYNC_1_OK	Check sync. stage 1 OK	Check Sync 1 OK
884	Check sync	DDB_CHECKSYNC_2_OK	Check sync. stage 2 OK	Check Sync 2 OK
885	PSL	DDB_SYSTEM_SPLIT_ENABLED	Unused	Unused
886	Voltage Monitoring	DDB_SYSCHECKS_BUS_LIVE	Indicates live bus condition is detected	Live Bus
887	Voltage Monitoring	DDB_SYSCHECKS_BUS_DEAD	Indicates dead bus condition is detected	Dead Bus
888	Voltage Monitoring	DDB_SYSCHECKS_LINE_LIVE	Indicates live line condition is detected	Live Line
889	Voltage Monitoring	DDB_SYSCHECKS_LINE_DEAD	Indicates dead line condition is detected	Dead Line
890	Poledead logic	DDB_ALL_POLEDEAD	Pole dead logic detects 3 phase breaker open	All Poles Dead
891	Poledead logic	DDB_ANY_POLEDEAD	Pole dead logic detects at least one breaker pole open	Any Pole Dead
892	Poledead logic	DDB_PHASE_A_POLEDEAD	Phase A Pole Dead	Pole Dead A
893	Poledead logic	DDB_PHASE_B_POLEDEAD	Phase B Pole Dead	Pole Dead B
894	Poledead logic	DDB_PHASE_C_POLEDEAD	Phase C Pole Dead	Pole Dead C
895	Fixed Logic	DDB_VTS_ACCELERATE_INPUT	Accelerate Ind	VTS Acc Ind
896	Fixed Logic	DDB_VTS_ANY_VOLTAGE_DEP_FN	Any Voltage Dependent	VTS Volt Dep
897	PSL	DDB_SYNC_AR_CS_CHECK_OK	Input to the auto-reclose logic to indicate system in synchronism	AR Check Sync OK
898	PSL	DDB_SYNC_CTRL_SYS_CHECK_OK	Input to the circuit breaker control logic to indicate manual check synchronization conditions are satisfied	Ctl Check Sync
899	PSL	DDB_SYNC_AR_SYS_CHECK_OK	Input to the auto-reclose logic to indicate system checks conditions are satisfied	AR Sys Checks OK
900	PSL	DDB_CB1_EXT_CS_OK	External check-sync is OK for CB1	CB1 Ext CS OK
901	PSL	DDB_CB2_EXT_CS_OK	Unused	Unused
902	PSL	DDB_UNUSED_902	Unused	Unused
903	CB Status	DDB_CB_OPEN	Circuit breaker is open, all three phases	CB Open 3 ph
904	CB Status	DDB_CB_PHASE_A_OPEN	Unused	Unused
905	CB Status	DDB_CB_PHASE_B_OPEN	Unused	Unused
906	CB Status	DDB_CB_PHASE_C_OPEN	Unused	Unused
907	CB Status	DDB_CB_CLOSED	Circuit breaker is closed, all three phases	CB Closed 3 ph
908	CB Status	DDB_CB_PHASE_A_CLOSED	Unused	Unused
909	CB Status	DDB_CB_PHASE_B_CLOSED	Unused	Unused

DDB No	Source	Element Name	Description	English Text
910	CB Status	DDB_CB_PHASE_C_CLOSED	Unused	Unused
911		DDB_CB2_OPEN	Unused	Unused
912		DDB_CB2_PHASE_A_OPEN	Unused	Unused
913		DDB_CB2_PHASE_B_OPEN	Unused	Unused
914		DDB_CB2_PHASE_C_OPEN	Unused	Unused
915		DDB_CB2_CLOSED	Unused	Unused
916		DDB_CB2_PHASE_A_CLOSED	Unused	Unused
917		DDB_CB2_PHASE_B_CLOSED	Unused	Unused
918		DDB_CB2_PHASE_C_CLOSED	Unused	Unused
919	PSL	DDB_INHIBIT_COMP_OV1	Inhibit the first stage compensated overvoltage element	Inhibit Cmp V1>1
920	PSL	DDB_INHIBIT_COMP_OV2	Inhibit the second stage compensated overvoltage element	Inhibit Cmp V1>2
921	PSL	DDB_PCOV_1_TIMER_BLOCK	Block the first stage compensated overvoltage element	Cmp V1>1 Tim Blk
922	PSL	DDB_PCOV_2_TIMER_BLOCK	Block the second stage compensated overvoltage element	Cmp V1>2 Tim Blk
923	Overvoltage	DDB_PCOV_1_3PH_START	1st stage compensated overvoltage start signal	V1>1 Cmp Start
924	Overvoltage	DDB_PCOV_2_3PH_START	2nd stage compensated overvoltage start signal	V1>2 Cmp Start
925	Overvoltage	DDB_PCOV_1_3PH_TRIP	1st stage compensated overvoltage trip signal	V1>1 Cmp Trip
926	Overvoltage	DDB_PCOV_2_3PH_TRIP	2nd stage compensated overvoltage trip signal	V1>2 Cmp Trip
927		DDB_UNUSED_927	Unused	Unused
928		DDB_CTS_BLOCK	Standard or differential CT supervision block (current transformer supervision)	CTS Block
929	CT Supervision	DDB_CTS_BLOCK_DIFF	Unused	Unused
930	CT Supervision	DDB_CTS_RESTRAIN	Unused	Unused
931	CT Supervision	DDB_CTS_L1_I1	Unused	Unused
932	CT Supervision	DDB_CTS_L2_I1	Unused	Unused
933	CT Supervision	DDB_CTS_R1_1_I1	Unused	Unused
934	CT Supervision	DDB_CTS_R1_2_I1	Unused	Unused
935	CT Supervision	DDB_CTS_R2_1_I1	Unused	Unused
936	CT Supervision	DDB_CTS_R2_2_I1	Unused	Unused
937	CT Supervision	DDB_CTS_L1_I2I1_L	Unused	Unused
938	CT Supervision	DDB_CTS_L2_I2I1_L	Unused	Unused
939	CT Supervision	DDB_CTS_R1_1_I2I1_L	Unused	Unused
940	CT Supervision	DDB_CTS_R1_2_I2I1_L	Unused	Unused
941	CT Supervision	DDB_CTS_R2_1_I2I1_L	Unused	Unused
942	CT Supervision	DDB_CTS_R2_2_I2I1_L	Unused	Unused
943	CT Supervision	DDB_CTS_L1_I2I1_H	Unused	Unused
944	CT Supervision	DDB_CTS_L2_I2I1_H	Unused	Unused
945	CT Supervision	DDB_CTS_R1_1_I2I1_H	Unused	Unused
946	CT Supervision	DDB_CTS_R1_2_I2I1_H	Unused	Unused
947	CT Supervision	DDB_CTS_R2_1_I2I1_H	Unused	Unused
948	CT Supervision	DDB_CTS_R2_2_I2I1_H	Unused	Unused
949		DDB_UNUSED_949	Unused	Unused

DDB No	Source	Element Name	Description	English Text
950		DDB_UNUSED_950	Unused	Unused
951		DDB_UNUSED_951	Unused	Unused
952	PSL	DDB_FLTREC_FLT_A	Faulted phase A - must be assigned, as this sets the start flag used in records, and on the LCD display	Faulted Phase A
953	PSL	DDB_FLTREC_FLT_B	Faulted phase B - must be assigned, as this sets the start flag used in records, and on the LCD display	Faulted Phase B
954	PSL	DDB_FLTREC_FLT_C	Faulted phase C - must be assigned, as this sets the start flag used in records, and on the LCD display	Faulted Phase C
955	PSL	DDB_FLTREC_FLT_N	Faulted phase N (fault involves ground) - must be assigned, as this sets the start flag used in records, and on the LCD display	Faulted Phase N
956	PSL	DDB_FLTREC_STRT_A	Started phase A - must be assigned, as this sets the start flag used in records, and on the LCD display	Started Phase A
957	PSL	DDB_FLTREC_STRT_B	Started phase B - must be assigned, as this sets the start flag used in records, and on the LCD display	Started Phase B
958	PSL	DDB_FLTREC_STRT_C	Started phase C - must be assigned, as this sets the start flag used in records, and on the LCD display	Started Phase C
959	PSL	DDB_FLTREC_STRT_N	Started phase N (fault involves ground) - must be assigned, as this sets the start flag used in records, and on the LCD display	Started Phase N
960	Distance Elements	DDB_ZONE_1_AN	Zone 1 AN ground fault element	Zone1 AN Element
961	Distance Elements	DDB_ZONE_1_BN	Zone 1 BN ground fault element	Zone1 BN Element
962	Distance Elements	DDB_ZONE_1_CN	Zone 1 CN ground fault element	Zone1 CN Element
963	Distance Elements	DDB_ZONE_1_AB	Zone 1 AB phase fault element	Zone1 AB Element
964	Distance Elements	DDB_ZONE_1_BC	Zone 1 BC phase fault element	Zone1 BC Element
965	Distance Elements	DDB_ZONE_1_CA	Zone 1 CA phase fault element	Zone1 CA Element
966	Distance Elements	DDB_ZONE_2_AN	Zone 2 AN ground fault element	Zone2 AN Element
967	Distance Elements	DDB_ZONE_2_BN	Zone 2 BN ground fault element	Zone2 BN Element
968	Distance Elements	DDB_ZONE_2_CN	Zone 2 CN ground fault element	Zone2 CN Element
969	Distance Elements	DDB_ZONE_2_AB	Zone 2 AB phase fault element	Zone2 AB Element
970	Distance Elements	DDB_ZONE_2_BC	Zone 2 BC phase fault element	Zone2 BC Element
971	Distance Elements	DDB_ZONE_2_CA	Zone 2 CA phase fault element	Zone2 CA Element
972	Distance Elements	DDB_ZONE_3_AN	Zone 3 AN ground fault element	Zone3 AN Element
973	Distance Elements	DDB_ZONE_3_BN	Zone 3 BN ground fault element	Zone3 BN Element
974	Distance Elements	DDB_ZONE_3_CN	Zone 3 CN ground fault element	Zone3 CN Element
975	Distance Elements	DDB_ZONE_3_AB	Zone 3 AB phase fault element	Zone3 AB Element
976	Distance Elements	DDB_ZONE_3_BC	Zone 3 BC phase fault element	Zone3 BC Element
977	Distance Elements	DDB_ZONE_3_CA	Zone 3 CA phase fault element	Zone3 CA Element
978	Distance Elements	DDB_ZONE_P_AN	Zone P AN ground fault element	ZoneP AN Element
979	Distance Elements	DDB_ZONE_P_BN	Zone P BN ground fault element	ZoneP BN Element
980	Distance Elements	DDB_ZONE_P_CN	Zone P CN ground fault element	ZoneP CN Element
981	Distance Elements	DDB_ZONE_P_AB	Zone P AB phase fault element	ZoneP AB Element
982	Distance Elements	DDB_ZONE_P_BC	Zone P BC phase fault element	ZoneP BC Element

DDB No	Source	Element Name	Description	English Text
983	Distance Elements	DDB_ZONE_P_CA	Zone P CA phase fault element	ZoneP CA Element
984	Distance Elements	DDB_ZONE_4_AN	Zone 4 AN ground fault element	Zone4 AN Element
985	Distance Elements	DDB_ZONE_4_BN	Zone 4 BN ground fault element	Zone4 BN Element
986	Distance Elements	DDB_ZONE_4_CN	Zone 4 CN ground fault element	Zone4 CN Element
987	Distance Elements	DDB_ZONE_4_AB	Zone 4 AB phase fault element	Zone4 AB Element
988	Distance Elements	DDB_ZONE_4_BC	Zone 4 BC phase fault element	Zone4 BC Element
989	Distance Elements	DDB_ZONE_4_CA	Zone 4 CA phase fault element	Zone4 CA Element
990		DDB_UNUSED_990	Unused	Unused
991		DDB_UNUSED_991	Unused	Unused
992	PSL	DDB_TRIGGER_NODE_1	PSL Group Sig. 1	PSL Group Sig 1
993	PSL	DDB_TRIGGER_NODE_2	PSL Group Sig. 2	PSL Group Sig 2
994	PSL	DDB_TRIGGER_NODE_3	PSL Group Sig. 3	PSL Group Sig 3
995	PSL	DDB_TRIGGER_NODE_4	PSL Group Sig. 4	PSL Group Sig 4
996	Directional Earth Fault	DDB_DEF_FWD	DEF forward (directional earth fault aided scheme detector)	DEF Forward
997	Directional Earth Fault	DDB_DEF_REV	DEF reverse (directional earth fault aided scheme detector)	DEF Reverse
998	Delta directional Element	DDB_DELTA_DIR_FWD_AN	Unused	Unused
999	Delta directional Element	DDB_DELTA_DIR_FWD_BN	Unused	Unused
1000	Delta directional Element	DDB_DELTA_DIR_FWD_CN	Unused	Unused
1001	Delta directional Element	DDB_DELTA_DIR_FWD_AB	Unused	Unused
1002	Delta directional Element	DDB_DELTA_DIR_FWD_BC	Unused	Unused
1003	Delta directional Element	DDB_DELTA_DIR_FWD_CA	Unused	Unused
1004	Delta directional Element	DDB_DELTA_DIR_REV_AN	Unused	Unused
1005	Delta directional Element	DDB_DELTA_DIR_REV_BN	Unused	Unused
1006	Delta directional Element	DDB_DELTA_DIR_REV_CN	Unused	Unused
1007	Delta directional Element	DDB_DELTA_DIR_REV_AB	Unused	Unused
1008	Delta directional Element	DDB_DELTA_DIR_REV_BC	Unused	Unused
1009	Delta directional Element	DDB_DELTA_DIR_REV_CA	Unused	Unused
1010	Phase Selector	DDB_PHS_SEL_A	Phase selector - phase A pickup	Phase Select A
1011	Phase Selector	DDB_PHS_SEL_B	Phase selector - phase B pickup	Phase Select B
1012	Phase Selector	DDB_PHS_SEL_C	Phase selector - phase C pickup	Phase Select C
1013	Phase Selector	DDB_PHS_SEL_N	Phase selector - neutral indication	Phase Select N
1014	Powerswing Blocking	DDB_PSB_DETECTED	Power swing detected	P Swing Detector
1015	Powerswing Blocking	DDB_PSB_FAULT	Power swing block fault	PSB Fault

DDB No	Source	Element Name	Description	English Text
1016	Inrush Detector	DDB_HARMONIC_2_A	2nd harmonic current ratio exceeds threshold on phase A (may be used to block any instantaneous distance elements that reach through the reactance of a power transformer)	lh(2) Loc Blk A
1017	Inrush Detector	DDB_HARMONIC_2_B	2nd harmonic current ratio exceeds threshold on phase B (may be used to block any instantaneous distance elements that reach through the reactance of a power transformer)	lh(2) Loc Blk B
1018	Inrush Detector	DDB_HARMONIC_2_C	2nd harmonic current ratio exceeds threshold on phase C (may be used to block any instantaneous distance elements that reach through the reactance of a power transformer)	lh(2) Loc Blk C
1019	Inrush Detector	DDB_HARMONIC_2_N	2nd harmonic current ratio exceeds threshold on neutral current measurement (may be used to block any instantaneous distance elements that reach through the reactance of a power transformer)	lh(2) Loc Blk N
1020	SW	DDB_UNUSED_1020	Unused	Unused
1021	SW	DDB_HARMONIC_2_REM_BLOCK_A	Unused	Unused
1022	SW	DDB_HARMONIC_2_REM_BLOCK_B	Unused	Unused
1023	SW	DDB_HARMONIC_2_REM_BLOCK_C	Unused	Unused
1024	LED Conditioner	DDB_OUTPUT_LED_1	Programmable LED 1	LED 1
1025	LED Conditioner	DDB_OUTPUT_LED_2	Programmable LED 2	LED 2
1026	LED Conditioner	DDB_OUTPUT_LED_3	Programmable LED 3	LED 3
1027	LED Conditioner	DDB_OUTPUT_LED_4	Programmable LED 4	LED 4
1028	LED Conditioner	DDB_OUTPUT_LED_5	Programmable LED 5	LED 5
1029	LED Conditioner	DDB_OUTPUT_LED_6	Programmable LED 6	LED 6
1030	LED Conditioner	DDB_OUTPUT_LED_7	Programmable LED 7	LED 7
1031	LED Conditioner	DDB_OUTPUT_LED_8	Programmable LED 8	LED 8
1032		DDB_UNUSED_1032	Unused	Unused
1033		DDB_UNUSED_1033	Unused	Unused
1034		DDB_UNUSED_1034	Unused	Unused
1035		DDB_UNUSED_1035	Unused	Unused
1036		DDB_UNUSED_1036	Unused	Unused
1037		DDB_UNUSED_1037	Unused	Unused
1038		DDB_UNUSED_1038	Unused	Unused
1039		DDB_UNUSED_1039	Unused	Unused
1040		DDB_UNUSED_1040	Unused	Unused
1041		DDB_UNUSED_1041	Unused	Unused
1042		DDB_UNUSED_1042	Unused	Unused
1043		DDB_UNUSED_1043	Unused	Unused
1044		DDB_UNUSED_1044	Unused	Unused
1045		DDB_UNUSED_1045	Unused	Unused
1046		DDB_UNUSED_1046	Unused	Unused
1047		DDB_UNUSED_1047	Unused	Unused
1048		DDB_UNUSED_1048	Unused	Unused
1049		DDB_UNUSED_1049	Unused	Unused
1050		DDB_UNUSED_1050	Unused	Unused

DDB No	Source	Element Name	Description	English Text
1051		DDB_UNUSED_1051	Unused	Unused
1052		DDB_UNUSED_1052	Unused	Unused
1053		DDB_UNUSED_1053	Unused	Unused
1054		DDB_UNUSED_1054	Unused	Unused
1055		DDB_UNUSED_1055	Unused	Unused
1056		DDB_UNUSED_1056	Unused	Unused
1057		DDB_UNUSED_1057	Unused	Unused
1058		DDB_UNUSED_1058	Unused	Unused
1059		DDB_UNUSED_1059	Unused	Unused
1060		DDB_UNUSED_1060	Unused	Unused
1061		DDB_UNUSED_1061	Unused	Unused
1062		DDB_UNUSED_1062	Unused	Unused
1063		DDB_UNUSED_1063	Unused	Unused
1064		DDB_UNUSED_1064	Unused	Unused
1065		DDB_UNUSED_1065	Unused	Unused
1066		DDB_UNUSED_1066	Unused	Unused
1067		DDB_UNUSED_1067	Unused	Unused
1068		DDB_UNUSED_1068	Unused	Unused
1069		DDB_UNUSED_1069	Unused	Unused
1070	PSL	DDB_LED_CON_1	Input to LED Output Condition	LED Cond IN 1
1071	PSL	DDB_LED_CON_2	Input to LED Output Condition	LED Cond IN 2
1072	PSL	DDB_LED_CON_3	Input to LED Output Condition	LED Cond IN 3
1073	PSL	DDB_LED_CON_4	Input to LED Output Condition	LED Cond IN 4
1074	PSL	DDB_LED_CON_5	Input to LED Output Condition	LED Cond IN 5
1075	PSL	DDB_LED_CON_6	Input to LED Output Condition	LED Cond IN 6
1076	PSL	DDB_LED_CON_7	Input to LED Output Condition	LED Cond IN 7
1077	PSL	DDB_LED_CON_8	Input to LED Output Condition	LED Cond IN 8
1078		DDB_UNUSED_1078	Unused	Unused
1079		DDB_UNUSED_1079	Unused	Unused
1080		DDB_UNUSED_1080	Unused	Unused
1081		DDB_UNUSED_1081	Unused	Unused
1082		DDB_UNUSED_1082	Unused	Unused
1083		DDB_UNUSED_1083	Unused	Unused
1084		DDB_UNUSED_1084	Unused	Unused
1085		DDB_UNUSED_1085	Unused	Unused
1086		DDB_UNUSED_1086	Unused	Unused
1087		DDB_UNUSED_1087	Unused	Unused
1088		DDB_UNUSED_1088	Unused	Unused
1089		DDB_UNUSED_1089	Unused	Unused
1090		DDB_UNUSED_1090	Unused	Unused
1091		DDB_UNUSED_1091	Unused	Unused
1092		DDB_UNUSED_1092	Unused	Unused
1093		DDB_UNUSED_1093	Unused	Unused
1094		DDB_UNUSED_1094	Unused	Unused

DDB No	Source	Element Name	Description	English Text
1095		DDB_UNUSED_1095	Unused	Unused
1096		DDB_UNUSED_1096	Unused	Unused
1097		DDB_UNUSED_1097	Unused	Unused
1098		DDB_UNUSED_1098	Unused	Unused
1099		DDB_UNUSED_1099	Unused	Unused
1100		DDB_UNUSED_1100	Unused	Unused
1101		DDB_UNUSED_1101	Unused	Unused
1102		DDB_UNUSED_1102	Unused	Unused
1103		DDB_UNUSED_1103	Unused	Unused
1104		DDB_UNUSED_1104	Unused	Unused
1105		DDB_UNUSED_1105	Unused	Unused
1106	CB Monitoring	DDB_BROKEN_CURRENT_ALARM	Broken current maintenance alarm - circuit breaker cumulative duty alarm set-point	CB I ^A Maint
1107	CB Monitoring	DDB_BROKEN_CURRENT_LOCKOUT	Broken current lockout alarm - circuit breaker cumulative duty has been exceeded	CB I ^A Lockout
1108	CB Monitoring	DDB_MAINTENANCE_ALARM	No of circuit breaker operations maintenance alarm - indicated due to circuit breaker trip operations threshold	No.CB OPs Maint
1109	CB Monitoring	DDB_MAINTENANCE_LOCKOUT	No of circuit breaker operations maintenance lockout - excessive number of circuit breaker trip operations, safety lockout	No.CB OPs Lock
1110	CB Monitoring	DDB_EXCESSIVE_OP_TIME_ALARM	Excessive circuit breaker operating time maintenance alarm - excessive operation time alarm for the circuit breaker (slow interruption time)	CB Time Maint
1111	CB Monitoring	DDB_EXCESSIVE_OP_TIME_LOCKOUT	Excessive circuit breaker operating time lockout alarm - excessive operation time alarm for the circuit breaker (too slow interruption)	CB Time Lockout
1112	CB Monitoring	DDB_EFF_LOCKOUT	Excessive fault frequency lockout alarm	CB FaultFreqLock
1113	CB2 Monitoring	DDB_BROKEN_CURRENT_ALARM_2	Unused	Unused
1114	CB2 Monitoring	DDB_BROKEN_CURRENT_LOCKOUT_2	Unused	Unused
1115	CB2 Monitoring	DDB_MAINTENANCE_ALARM_2	Unused	Unused
1116	CB2 Monitoring	DDB_MAINTENANCE_LOCKOUT_2	Unused	Unused
1117	CB2 Monitoring	DDB_EXCESSIVE_OP_TIME_ALARM_2	Unused	Unused
1118	CB2 Monitoring	DDB_EXCESSIVE_OP_TIME_LOCKOUT_2	Unused	Unused
1119	CB2 Monitoring	DDB_EFF_LOCKOUT_2	Unused	Unused
1120	C Diff	DDB_SIGNALLING_FAIL_CH1_RX	Unused	Unused
1121	C Diff	DDB_SIGNALLING_FAIL_CH1_TX	Unused	Unused
1122	C Diff	DDB_REMOTE_1_GPS_FAIL	Unused	Unused
1123	Fibre Monitor Bits	DDB_MUX_CLK_ERROR_CH1	This is an alarm that appears if the channel 1 baud rate is outside the limits 52 kbits/s or 70 Kbits/s	Ch1 Mux Clk
1124	Fibre Monitor Bits	DDB_IEEE37_94_CH1_LOSS_OF_SIG	Mux indicates signal lost over channel 1	Ch1 Signal Lost
1125	Fibre Monitor Bits	DDB_IEEE37_94_CH1_PATH_YELLOW	One way communication. Local relay that is sending over Ch1 indicates that remote end is not receiving	Ch1 Path Yellow
1126	Fibre Monitor Bits	DDB_IEEE37_94_CH1_BAD_RX_N	Indication of mismatch between Ch1 N*64kbits/s setting and Mux	Ch1 Mismatch RxN

DDB No	Source	Element Name	Description	English Text
1127	Fibre Monitor Bits	DDB_CH1_TIMEOUT	Indication that no valid message is received over channel 1 during 'Channel Timeout' window	Ch1 Timeout
1128	Fibre Monitor Bits	DDB_CH1_MESS_LEVEL	Indicates poor channel 1 quality	Ch1 Degraded
1129	Fibre Monitor Bits	DDB_CH1_PASSTHROUGH	Ch1 data received via Ch 2 in 3 ended configuration - self healing indication -	Ch1 Passthrough
1130	C Diff	DDB_SIGNALLING_FAIL_CH2_RX	Unused	Unused
1131	C Diff	DDB_SIGNALLING_FAIL_CH2_TX	Unused	Unused
1132	C Diff	DDB_REMOTE_2_GPS_FAIL	Unused	Unused
1133	Fibre Monitor Bits	DDB_MUX_CLK_ERROR_CH2	This is an alarm that appears if the channel 2 baud rate is outside the limits 52kbits/s or 70 kbits/s	Ch2 Mux Clk
1134	Fibre Monitor Bits	DDB_IEEE37_94_CH2_LOSS_OF_SIG	Mux indicates signal lost over channel 2	Ch2 Signal Lost
1135	Fibre Monitor Bits	DDB_IEEE37_94_CH2_PATH_YELLOW	One way communication. Local relay that is sending over Ch2 indicates that remote end is not receiving	Ch2 Path Yellow
1136	Fibre Monitor Bits	DDB_IEEE37_94_CH2_BAD_RX_N	Indication of mismatch between InterMiCOM64 Ch 2 setting and Mux	Ch2 Mismatch RxN
1137	Fibre Monitor Bits	DDB_CH2_TIMEOUT	Indication that no valid message is received over channel 2 during 'Channel Timeout' window	Ch2 Timeout
1138	Fibre Monitor Bits	DDB_CH2_MESS_LEVEL	Indicates poor channel 2 quality	Ch2 Degraded
1139	Fibre Monitor Bits	DDB_CH2_PASSTHROUGH	Ch2 data received via Ch 1 in 3 ended configuration - self healing indication -	Ch2 Passthrough
1140		DDB_CONFIGURED	Unused	Unused
1141		DDB_RECONFIGURE_OK	Unused	Unused
1142		DDB_RECONFIGURE_FAIL	Unused	Unused
1143		DDB_RESTORE_OK	Unused	Unused
1144		DDB_RESTORE_FAIL	Unused	Unused
1145		DDB_INHIBIT_CURRENT_DIFF	Unused	Unused
1146		DDB_BACKUP_IN	Unused	Unused
1147		DDB_FL_CURRENT_PROT_SEF_TRIP	SEF Trip	SEF Trip
1148		DDB_CURRENT_PROT_SEF_TRIP	Current Prot SEF Trip	B Fail SEF Trip
1149	PSL	DDB_UFREQ_1_TIMER_BLOCK	Block Underfrequency Stage 1 Timer	F<1 Timer Block
1150	PSL	DDB_UFREQ_2_TIMER_BLOCK	Block Underfrequency Stage 2 Timer	F<2 Timer Block
1151	PSL	DDB_UFREQ_3_TIMER_BLOCK	Block Underfrequency Stage 3 Timer	F<3 Timer Block
1152	PSL	DDB_UFREQ_4_TIMER_BLOCK	Block Underfrequency Stage 4 Timer	F<4 Timer Block
1153	PSL	DDB_OFREQ_1_TIMER_BLOCK	Block Overfrequency Stage 1 Timer	F>1 Timer Block
1154	PSL	DDB_OFREQ_2_TIMER_BLOCK	Block Overfrequency Stage 2 Timer	F>2 Timer Block
1155	Frequency Protection	DDB_UFREQ_1_START	Under frequency Stage 1 start	F<1 Start
1156	Frequency Protection	DDB_UFREQ_2_START	Under frequency Stage 2 start	F<2 Start
1157	Frequency Protection	DDB_UFREQ_3_START	Under frequency Stage 3 start	F<3 Start
1158	Frequency Protection	DDB_UFREQ_4_START	Under frequency Stage 4 start	F<4 Start
1159	Frequency Protection	DDB_OFREQ_1_START	Over frequency Stage 1 start	F>1 Start

DDB No	Source	Element Name	Description	English Text
1160	Frequency Protection	DDB_OFREQ_2_START	Over frequency Stage 2 start	F>2 Start
1161	Frequency Protection	DDB_UFREQ_1_TRIP	Under frequency Stage 1 trip	F<1 Trip
1162	Frequency Protection	DDB_UFREQ_2_TRIP	Under frequency Stage 2 trip	F<2 Trip
1163	Frequency Protection	DDB_UFREQ_3_TRIP	Under frequency Stage 3 trip	F<3 Trip
1164	Frequency Protection	DDB_UFREQ_4_TRIP	Under frequency Stage 4 trip	F<4 Trip
1165	Frequency Protection	DDB_OFREQ_1_TRIP	Over frequency Stage 1 Trip	F>1 Trip
1166	Frequency Protection	DDB_OFREQ_2_TRIP	Over frequency Stage 2 Trip	F>2 Trip
1167	PSL	DDB_INHIBIT_UF1	Inhibit Stage 1 Underfrequency protection	Inhibit F<1
1168	PSL	DDB_INHIBIT_UF2	Inhibit Stage 2 Underfrequency protection	Inhibit F<2
1169	PSL	DDB_INHIBIT_UF3	Inhibit Stage 3 Underfrequency protection	Inhibit F<3
1170	PSL	DDB_INHIBIT_UF4	Inhibit Stage 4 Underfrequency protection	Inhibit F<4
1171	PSL	DDB_INHIBIT_OF1	Inhibit Stage 1 Overfrequency protection	Inhibit F>1
1172	PSL	DDB_INHIBIT_OF2	Inhibit Stage 2 Overfrequency protection	Inhibit F>2
1173	SW	DDB_NIC_LINK_1_FAIL	Network Interface Card link 1 fail indication	ETH Link 1 Fail
1174	SW	DDB_NIC_LINK_2_FAIL	Network Interface Card link 2 fail indication	ETH Link 2 Fail
1175	SW	DDB_NIC_LINK_3_FAIL	Network Interface Card link 3 fail indication	ETH Link 3 Fail
1176	SW	DDB_UI_LOGGEDIN	User logged into UI	Logged into UI
1177	SW	DDB_FCUR_LOGGEDIN	User logged into front port courier	Logged into FP
1178	SW	DDB_RP1_LOGGEDIN	User logged into Rear Port1 courier	Logged into RP1
1179	SW	DDB_RP2_LOGGEDIN	User logged into Rear Port2 courier	Logged into RP2
1180	SW	DDB_TNL_LOGGEDIN	User logged into turnneled courier	Logged into TNL
1181	SW	DDB_CPR_LOGGEDIN	User logged into co-processor courier	Logged into CPR
1182	SW	DDB_DST_STATUS	If this location DST is in effect now	DST status
1183		DDB_UNUSED_1183	Unused	Unused
1184	Commissioning Test	DDB_MONITOR_PORT_1	Monitor port signal 1 - allows mapped monitor signals to be mapped to disturbance recorder or contacts	Monitor Bit 1
1185	Commissioning Test	DDB_MONITOR_PORT_2	Monitor port signal 2 - allows mapped monitor signals to be mapped to disturbance recorder or contacts	Monitor Bit 2
1186	Commissioning Test	DDB_MONITOR_PORT_3	Monitor port signal 3 - allows mapped monitor signals to be mapped to disturbance recorder or contacts	Monitor Bit 3
1187	Commissioning Test	DDB_MONITOR_PORT_4	Monitor port signal 4 - allows mapped monitor signals to be mapped to disturbance recorder or contacts	Monitor Bit 4
1188	Commissioning Test	DDB_MONITOR_PORT_5	Monitor port signal 5 - allows mapped monitor signals to be mapped to disturbance recorder or contacts	Monitor Bit 5
1189	Commissioning Test	DDB_MONITOR_PORT_6	Monitor port signal 6 - allows mapped monitor signals to be mapped to disturbance recorder or contacts	Monitor Bit 6

DDB No	Source	Element Name	Description	English Text
1190	Commissioning Test	DDB_MONITOR_PORT_7	Monitor port signal 7 - allows mapped monitor signals to be mapped to disturbance recorder or contacts	Monitor Bit 7
1191	Commissioning Test	DDB_MONITOR_PORT_8	Monitor port signal 8 - allows mapped monitor signals to be mapped to disturbance recorder or contacts	Monitor Bit 8
1192	Fault recorder	DDB_NEW_FAULT_REC	New Fault Record	New Fault Record
1193	PSL	DDB_UNUSED_DR	Unused	Unused
1194	PSL	DDB_PSLINT_1	PSL Internal Node	PSL Int 1
1195	PSL	DDB_PSLINT_2	PSL Internal Node	PSL Int 2
1196	PSL	DDB_PSLINT_3	PSL Internal Node	PSL Int 3
1197	PSL	DDB_PSLINT_4	PSL Internal Node	PSL Int 4
1198	PSL	DDB_PSLINT_5	PSL Internal Node	PSL Int 5
1199	PSL	DDB_PSLINT_6	PSL Internal Node	PSL Int 6
1200	PSL	DDB_PSLINT_7	PSL Internal Node	PSL Int 7
1201	PSL	DDB_PSLINT_8	PSL Internal Node	PSL Int 8
1202	PSL	DDB_PSLINT_9	PSL Internal Node	PSL Int 9
1203	PSL	DDB_PSLINT_10	PSL Internal Node	PSL Int 10
1204	PSL	DDB_PSLINT_11	PSL Internal Node	PSL Int 11
1205	PSL	DDB_PSLINT_12	PSL Internal Node	PSL Int 12
1206	PSL	DDB_PSLINT_13	PSL Internal Node	PSL Int 13
1207	PSL	DDB_PSLINT_14	PSL Internal Node	PSL Int 14
1208	PSL	DDB_PSLINT_15	PSL Internal Node	PSL Int 15
1209	PSL	DDB_PSLINT_16	PSL Internal Node	PSL Int 16
1210	PSL	DDB_PSLINT_17	PSL Internal Node	PSL Int 17
1211	PSL	DDB_PSLINT_18	PSL Internal Node	PSL Int 18
1212	PSL	DDB_PSLINT_19	PSL Internal Node	PSL Int 19
1213	PSL	DDB_PSLINT_20	PSL Internal Node	PSL Int 20
1214	PSL	DDB_PSLINT_21	PSL Internal Node	PSL Int 21
1215	PSL	DDB_PSLINT_22	PSL Internal Node	PSL Int 22
1216	PSL	DDB_PSLINT_23	PSL Internal Node	PSL Int 23
1217	PSL	DDB_PSLINT_24	PSL Internal Node	PSL Int 24
1218	PSL	DDB_PSLINT_25	PSL Internal Node	PSL Int 25
1219	PSL	DDB_PSLINT_26	PSL Internal Node	PSL Int 26
1220	PSL	DDB_PSLINT_27	PSL Internal Node	PSL Int 27
1221	PSL	DDB_PSLINT_28	PSL Internal Node	PSL Int 28
1222	PSL	DDB_PSLINT_29	PSL Internal Node	PSL Int 29
1223	PSL	DDB_PSLINT_30	PSL Internal Node	PSL Int 30
1224	PSL	DDB_PSLINT_31	PSL Internal Node	PSL Int 31
1225	PSL	DDB_PSLINT_32	PSL Internal Node	PSL Int 32
1226	PSL	DDB_PSLINT_33	PSL Internal Node	PSL Int 33
1227	PSL	DDB_PSLINT_34	PSL Internal Node	PSL Int 34
1228	PSL	DDB_PSLINT_35	PSL Internal Node	PSL Int 35
1229	PSL	DDB_PSLINT_36	PSL Internal Node	PSL Int 36
1230	PSL	DDB_PSLINT_37	PSL Internal Node	PSL Int 37

DDB No	Source	Element Name	Description	English Text
1231	PSL	DDB_PSLINT_38	PSL Internal Node	PSL Int 38
1232	PSL	DDB_PSLINT_39	PSL Internal Node	PSL Int 39
1233	PSL	DDB_PSLINT_40	PSL Internal Node	PSL Int 40
1234	PSL	DDB_PSLINT_41	PSL Internal Node	PSL Int 41
1235	PSL	DDB_PSLINT_42	PSL Internal Node	PSL Int 42
1236	PSL	DDB_PSLINT_43	PSL Internal Node	PSL Int 43
1237	PSL	DDB_PSLINT_44	PSL Internal Node	PSL Int 44
1238	PSL	DDB_PSLINT_45	PSL Internal Node	PSL Int 45
1239	PSL	DDB_PSLINT_46	PSL Internal Node	PSL Int 46
1240	PSL	DDB_PSLINT_47	PSL Internal Node	PSL Int 47
1241	PSL	DDB_PSLINT_48	PSL Internal Node	PSL Int 48
1242	PSL	DDB_PSLINT_49	PSL Internal Node	PSL Int 49
1243	PSL	DDB_PSLINT_50	PSL Internal Node	PSL Int 50
1244	PSL	DDB_PSLINT_51	PSL Internal Node	PSL Int 51
1245	PSL	DDB_PSLINT_52	PSL Internal Node	PSL Int 52
1246	PSL	DDB_PSLINT_53	PSL Internal Node	PSL Int 53
1247	PSL	DDB_PSLINT_54	PSL Internal Node	PSL Int 54
1248	PSL	DDB_PSLINT_55	PSL Internal Node	PSL Int 55
1249	PSL	DDB_PSLINT_56	PSL Internal Node	PSL Int 56
1250	PSL	DDB_PSLINT_57	PSL Internal Node	PSL Int 57
1251	PSL	DDB_PSLINT_58	PSL Internal Node	PSL Int 58
1252	PSL	DDB_PSLINT_59	PSL Internal Node	PSL Int 59
1253	PSL	DDB_PSLINT_60	PSL Internal Node	PSL Int 60
1254	PSL	DDB_PSLINT_61	PSL Internal Node	PSL Int 61
1255	PSL	DDB_PSLINT_62	PSL Internal Node	PSL Int 62
1256	PSL	DDB_PSLINT_63	PSL Internal Node	PSL Int 63
1257	PSL	DDB_PSLINT_64	PSL Internal Node	PSL Int 64
1258	PSL	DDB_PSLINT_65	PSL Internal Node	PSL Int 65
1259	PSL	DDB_PSLINT_66	PSL Internal Node	PSL Int 66
1260	PSL	DDB_PSLINT_67	PSL Internal Node	PSL Int 67
1261	PSL	DDB_PSLINT_68	PSL Internal Node	PSL Int 68
1262	PSL	DDB_PSLINT_69	PSL Internal Node	PSL Int 69
1263	PSL	DDB_PSLINT_70	PSL Internal Node	PSL Int 70
1264	PSL	DDB_PSLINT_71	PSL Internal Node	PSL Int 71
1265	PSL	DDB_PSLINT_72	PSL Internal Node	PSL Int 72
1266	PSL	DDB_PSLINT_73	PSL Internal Node	PSL Int 73
1267	PSL	DDB_PSLINT_74	PSL Internal Node	PSL Int 74
1268	PSL	DDB_PSLINT_75	PSL Internal Node	PSL Int 75
1269	PSL	DDB_PSLINT_76	PSL Internal Node	PSL Int 76
1270	PSL	DDB_PSLINT_77	PSL Internal Node	PSL Int 77
1271	PSL	DDB_PSLINT_78	PSL Internal Node	PSL Int 78
1272	PSL	DDB_PSLINT_79	PSL Internal Node	PSL Int 79
1273	PSL	DDB_PSLINT_80	PSL Internal Node	PSL Int 80
1274	PSL	DDB_PSLINT_81	PSL Internal Node	PSL Int 81

DDB No	Source	Element Name	Description	English Text
1275	PSL	DDB_PSLINT_82	PSL Internal Node	PSL Int 82
1276	PSL	DDB_PSLINT_83	PSL Internal Node	PSL Int 83
1277	PSL	DDB_PSLINT_84	PSL Internal Node	PSL Int 84
1278	PSL	DDB_PSLINT_85	PSL Internal Node	PSL Int 85
1279	PSL	DDB_PSLINT_86	PSL Internal Node	PSL Int 86
1280	PSL	DDB_PSLINT_87	PSL Internal Node	PSL Int 87
1281	PSL	DDB_PSLINT_88	PSL Internal Node	PSL Int 88
1282	PSL	DDB_PSLINT_89	PSL Internal Node	PSL Int 89
1283	PSL	DDB_PSLINT_90	PSL Internal Node	PSL Int 90
1284	PSL	DDB_PSLINT_91	PSL Internal Node	PSL Int 91
1285	PSL	DDB_PSLINT_92	PSL Internal Node	PSL Int 92
1286	PSL	DDB_PSLINT_93	PSL Internal Node	PSL Int 93
1287	PSL	DDB_PSLINT_94	PSL Internal Node	PSL Int 94
1288	PSL	DDB_PSLINT_95	PSL Internal Node	PSL Int 95
1289	PSL	DDB_PSLINT_96	PSL Internal Node	PSL Int 96
1290	PSL	DDB_PSLINT_97	PSL Internal Node	PSL Int 97
1291	PSL	DDB_PSLINT_98	PSL Internal Node	PSL Int 98
1292	PSL	DDB_PSLINT_99	PSL Internal Node	PSL Int 99
1293	PSL	DDB_PSLINT_100	PSL Internal Node	PSL Int 100
1294	VT Supervision	DDB_VTS_IA_OPERATED	"VTS I> Inhibit " setting has been exceeded in phase a	VTS Ia>
1295	VT Supervision	DDB_VTS_IB_OPERATED	"VTS I> Inhibit " setting has been exceeded in phase b	VTS Ib>
1296	VT Supervision	DDB_VTS_IC_OPERATED	"VTS I> Inhibit " setting has been exceeded in phase c	VTS Ic>
1297	VT Supervision	DDB_VTS_VA_OPERATED	Va has exceed 30 volts (drop off at 10 volts)	VTS Va>
1298	VT Supervision	DDB_VTS_VB_OPERATED	Vb has exceed 30 volts (drop off at 10 volts)	VTS Vb>
1299	VT Supervision	DDB_VTS_VC_OPERATED	Vc has exceed 30 volts (drop off at 10 volts)	VTS Vc>
1300	VT Supervision	DDB_VTS_I2_OPERATED	"VTS I2> Inhibit " setting has been exceeded	VTS I2>
1301	VT Supervision	DDB_VTS_V2_OPERATED	V2 has exceed 10 volts	VTS V2>
1302	VT Supervision	DDB_VTS_DELTA_IA_OPERATED	Superimposed phase a current has exceed 0.1In	VTS Ia delta>
1303	VT Supervision	DDB_VTS_DELTA_IB_OPERATED	Superimposed phase b current has exceed 0.1In	VTS Ib delta>
1304	VT Supervision	DDB_VTS_DELTA_IC_OPERATED	Superimposed phase c current has exceed 0.1In	VTS Ic delta>
1305	Distance diagnostic	DDB_ZONE_1_AN_RAW	Z1 AN Comparator	Z1 AN Comparator
1306	Distance diagnostic	DDB_ZONE_1_BN_RAW	Z1 BN Comparator	Z1 BN Comparator
1307	Distance diagnostic	DDB_ZONE_1_CN_RAW	Z1 CN Comparator	Z1 CN Comparator
1308	Distance diagnostic	DDB_ZONE_1_AB_RAW	Z1 AB Comparator	Z1 AB Comparator
1309	Distance diagnostic	DDB_ZONE_1_BC_RAW	Z1 BC Comparator	Z1 BC Comparator
1310	Distance diagnostic	DDB_ZONE_1_CA_RAW	Z1 CA Comparator	Z1 CA Comparator
1311	Distance diagnostic	DDB_ZONE_2_AN_RAW	Z2 AN Comparator	Z2 AN Comparator
1312	Distance diagnostic	DDB_ZONE_2_BN_RAW	Z2 BN Comparator	Z2 BN Comparator
1313	Distance diagnostic	DDB_ZONE_2_CN_RAW	Z2 CN Comparator	Z2 CN Comparator
1314	Distance diagnostic	DDB_ZONE_2_AB_RAW	Z2 AB Comparator	Z2 AB Comparator
1315	Distance diagnostic	DDB_ZONE_2_BC_RAW	Z2 BC Comparator	Z2 BC Comparator
1316	Distance diagnostic	DDB_ZONE_2_CA_RAW	Z2 CA Comparator	Z2 CA Comparator

DDB No	Source	Element Name	Description	English Text
1317	Distance diagnostic	DDB_ZONE_3_AN_RAW	Z3 AN Comparator	Z3 AN Comparator
1318	Distance diagnostic	DDB_ZONE_3_BN_RAW	Z3 BN Comparator	Z3 BN Comparator
1319	Distance diagnostic	DDB_ZONE_3_CN_RAW	Z3 CN Comparator	Z3 CN Comparator
1320	Distance diagnostic	DDB_ZONE_3_AB_RAW	Z3 AB Comparator	Z3 AB Comparator
1321	Distance diagnostic	DDB_ZONE_3_BC_RAW	Z3 BC Comparator	Z3 BC Comparator
1322	Distance diagnostic	DDB_ZONE_3_CA_RAW	Z3 CA Comparator	Z3 CA Comparator
1323	Distance diagnostic	DDB_ZONE_P_AN_RAW	ZP AN Comparator	ZP AN Comparator
1324	Distance diagnostic	DDB_ZONE_P_BN_RAW	ZP BN Comparator	ZP BN Comparator
1325	Distance diagnostic	DDB_ZONE_P_CN_RAW	ZP CN Comparator	ZP CN Comparator
1326	Distance diagnostic	DDB_ZONE_P_AB_RAW	ZP AB Comparator	ZP AB Comparator
1327	Distance diagnostic	DDB_ZONE_P_BC_RAW	ZP BC Comparator	ZP BC Comparator
1328	Distance diagnostic	DDB_ZONE_P_CA_RAW	ZP CA Comparator	ZP CA Comparator
1329	Distance diagnostic	DDB_ZONE_4_AN_RAW	Z4 AN Comparator	Z4 AN Comparator
1330	Distance diagnostic	DDB_ZONE_4_BN_RAW	Z4 BN Comparator	Z4 BN Comparator
1331	Distance diagnostic	DDB_ZONE_4_CN_RAW	Z4 CN Comparator	Z4 CN Comparator
1332	Distance diagnostic	DDB_ZONE_4_AB_RAW	Z4 AB Comparator	Z4 AB Comparator
1333	Distance diagnostic	DDB_ZONE_4_BC_RAW	Z4 BC Comparator	Z4 BC Comparator
1334	Distance diagnostic	DDB_ZONE_4_CA_RAW	Z4 CA Comparator	Z4 CA Comparator
1335	Distance diagnostic	DDB_LDBN	IN> Bias	IN> Bias
1336		DDB_WI_I0_I2	WI Detect I0/I2	WI Detect I0/I2
1337	Delta directional Diagnostic	DDB_DELTA_DIR_FWD_AN_RAW	Unused	Unused
1338	Delta directional Diagnostic	DDB_DELTA_DIR_FWD_BN_RAW	Unused	Unused
1339	Delta directional Diagnostic	DDB_DELTA_DIR_FWD_CN_RAW	Unused	Unused
1340	Delta directional Diagnostic	DDB_DELTA_DIR_FWD_AB_RAW	Unused	Unused
1341	Delta directional Diagnostic	DDB_DELTA_DIR_FWD_BC_RAW	Unused	Unused
1342	Delta directional Diagnostic	DDB_DELTA_DIR_FWD_CA_RAW	Unused	Unused
1343	Delta directional Diagnostic	DDB_DELTA_DIR_REV_AN_RAW	Unused	Unused
1344	Delta directional Diagnostic	DDB_DELTA_DIR_REV_BN_RAW	Unused	Unused
1345	Delta directional Diagnostic	DDB_DELTA_DIR_REV_CN_RAW	Unused	Unused
1346	Delta directional Diagnostic	DDB_DELTA_DIR_REV_AB_RAW	Unused	Unused
1347	Delta directional Diagnostic	DDB_DELTA_DIR_REV_BC_RAW	Unused	Unused
1348	Delta directional Diagnostic	DDB_DELTA_DIR_REV_CA_RAW	Unused	Unused
1349	Distance diagnostic	DDB_ZONE_1_BLOCKED	Zone 1 Blocked by PSB	Zone 1 Blocked
1350	Distance diagnostic	DDB_ZONE_2_BLOCKED	Zone 2 Blocked by PSB	Zone 2 Blocked
1351	Distance diagnostic	DDB_ZONE_3_BLOCKED	Zone 3 Blocked by PSB	Zone 3 Blocked

DDB No	Source	Element Name	Description	English Text
1352	Distance diagnostic	DDB_ZONE_P_BLOCKED	Zone P Blocked by PSB	Zone P Blocked
1353	Distance diagnostic	DDB_ZONE_4_BLOCKED	Zone 4 Blocked by PSB	Zone 4 Blocked
1354	Distance diagnostic	DDB_MEM_VALID	Memory Valid	Mem. Valid
1355	Phase Selector	DDB_PH_TWO_CYCLE	Phase Sel Two Cycle	Ph Two Cycle
1356	Phase Selector	DDB_PH_FIVE_CYCLE	Phase Sel Five Cycle	Ph Five Cycle
1357	Phase Selector	DDB_FROZEN	Buffer Frozen	Ph Frozen
1358	Aided Scheme Logic	DDB_AIDED1_WI_LEVEL_DETECT_A	Aided 1 WI V< A	Aided 1 WI V< A
1359	Aided Scheme Logic	DDB_AIDED1_WI_LEVEL_DETECT_B	Aided 1 WI V< B	Aided 1 WI V< B
1360	Aided Scheme Logic	DDB_AIDED1_WI_LEVEL_DETECT_C	Aided 1 WI V< C	Aided 1 WI V< C
1361	Aided Scheme Logic	DDB_AIDED2_WI_LEVEL_DETECT_A	Aided 2 WI V< A	Aided 2 WI V< A
1362	Aided Scheme Logic	DDB_AIDED2_WI_LEVEL_DETECT_B	Aided 2 WI V< B	Aided 2 WI V< B
1363	Aided Scheme Logic	DDB_AIDED2_WI_LEVEL_DETECT_C	Aided 2 WI V< C	Aided 2 WI V< C
1364	CB Control	DDB_CB_PRE_LOCKOUT	Pre-Lockout	Pre-Lockout
1365	Loss of Load logic	DDB_LOL_LEVEL_DETECT_A	Loss of Load level detector A	I> LoL A
1366	Loss of Load logic	DDB_LOL_LEVEL_DETECT_B	Loss of Load level detector B	I> LoL B
1367	Loss of Load logic	DDB_LOL_LEVEL_DETECT_C	Loss of Load level detector C	I> LoL C
1368	Frequency Tracking	DDB_FREQ_ABOVE_RANGE_LIMIT	Freq High	Freq High
1369	Frequency Tracking	DDB_FREQ_BELOW_RANGE_LIMIT	Freq Low	Freq Low
1370	Frequency Tracking	DDB_FREQ_NOT_FOUND	Freq Not found	Freq Not found
1371	Frequency Tracking	DDB_FREQ_STOP_TRACK	Stop Freq Track	Stop Freq Track
1372	3d/4th Harmonic Restraint A Phase	DDB_FOURTH_HARM_A	3rd/4th Harmonic Restraint A Phase	3d/4th HarmonicA
1373	3d/4th Harmonic Restraint B Phase	DDB_FOURTH_HARM_B	3rd/4th Harmonic Restraint B Phase	3d/4th HarmonicB
1374	3d/4th Harmonic Restraint C Phase	DDB_FOURTH_HARM_C	3rd/4th Harmonic Restraint C Phase	3d/4th HarmonicC
1375		DDB_TELEPROTECTION_DISTURBED	This is an output signal available in the PSL, that could be mapped to "C Diff Failure" for IEC870-5-103	Teleprot Disturb
1376		DDB_BACK_UP_SUPERVISION	This applies only if distance primary FUN is selected (in IEC870-5-103) This signal is ON if an overcurrent stage is selected to be enabled on VTS and distance is blocked by VTS	I>> Backup Super
1377		DDB_POC_TRIP_BY_VTS	This applies only if distance primary FUN is selected (in IEC870-5-103) This signal is ON if DDB 1376 is ON and one of the overcurrent stages set to be enabled on VTS condition trips	I> Trip by VTS
1378		DDB_TELEPROTECTION_SENT	This applies only if distance primary FUN is selected (in IEC870-5-103) This is an output signal available in the PSL, which could be mapped to a signal send of one of the two teleprotection channels	Teleprot Tx

DDB No	Source	Element Name	Description	English Text
1379		DDB_TELEPROTECTION_RECEIVED	This applies only if distance primary FUN is selected (in IEC870-5-103) This is an output signal available in the PSL, which could be mapped to a signal receive of one of the two teleprotection channels	Teleprot Rx
1380		DDB_GROUP_WARNING	This is an output signal available in the PSL, which can be mapped in IEC870-5-103 to a minor defect which does not shut down the main protection	Group Warning
1381		DDB_GROUP_ALARM	This is an output signal available in the PSL, which can be mapped in IEC870-5-103 to a major problem normally linked to the watchdog	Group Alarm
1382		DDB_AR_ON_PULSE	This is an output signal available in the PSL, which can be mapped to enable AR via pulse	AR On Pulse
1383		DDB_AR_OFF_PULSE	This is an output signal available in the PSL, which can be mapped to disable AR via pulse	AR Off Pulse
1384		DDB_AR_ENABLE	External input via DDB mapped in PSL to enable AR if Enable AR CB1 or Enable AR CB2 is set and AR Configuration setting is enabled	AR Enable
1385		DDB_AR_IN_SERVICE	Auto-reclose in service	AR In Service
1386		DDB_MAX_CH1_PROP_DELAY	Setting MaxCh 1 PropDelay has been exceeded	MaxCh1 PropDelay
1387		DDB_MAX_CH2_PROP_DELAY	Setting MaxCh 2 PropDelay has been exceeded	MaxCh2 PropDelay
1388		DDB_MAX_CH1_TXRX_TIME	Unused	Unused
1389		DDB_MAX_CH2_TXRX_TIME	Unused	Unused
1390	Distance diagnostic	DDB_ZONE_V_AN_RAW	ZV AN Comparator	ZV AN Comparator
1391	Distance diagnostic	DDB_ZONE_V_BN_RAW	ZV BN Comparator	ZV BN Comparator
1392	Distance diagnostic	DDB_ZONE_V_CN_RAW	ZV CN Comparator	ZV CN Comparator
1393	Distance diagnostic	DDB_ZONE_V_AB_RAW	ZV AB Comparator	ZV AB Comparator
1394	Distance diagnostic	DDB_ZONE_V_BC_RAW	ZV BC Comparator	ZV BC Comparator
1395	Distance diagnostic	DDB_ZONE_V_CA_RAW	ZV CA Comparator	ZV CA Comparator
1396		DDB_GND_Z2_LOW	Unused	Unused
1397		DDB_GND_Z2_HIGH	Unused	Unused
1398		DDB_GND_Z3_LOW	Unused	Unused
1399		DDB_GND_Z3_HIGH	Unused	Unused
1400		DDB_GND_Z4_LOW	Unused	Unused
1401		DDB_GND_Z4_HIGH	Unused	Unused
1402		DDB_GND_ZP_LOW	Unused	Unused
1403		DDB_GND_ZP_HIGH	Unused	Unused
1404	Transfer	DDB_VTS_BLOCK_DIST	Signal from the VTS logic that can be used to block operation of the distance elements	VTS Blk Distance
1405		DDB_UNUSED_1405	Unused	Unused
1406		DDB_UNUSED_1406	Unused	Unused
1407		DDB_UNUSED_1407	Unused	Unused
1408		DDB_CB2_LEAD	Unused	Unused
1409		DDB_FOLLOW_AR_SP	Unused	Unused
1410		DDB_FOLLOW_AR_3P	Unused	Unused
1411		DDB_UNUSED_1411	Unused	Unused
1412		DDB_EN_CB2_INDEPENDENT	Unused	Unused

DDB No	Source	Element Name	Description	English Text
1413		DDB_CB2_SPDT_EXTERNAL	Unused	Unused
1414		DDB_CB2_3PDT_EXTERNAL	Unused	Unused
1415		DDB_CB2_ARPERMIT	Unused	Unused
1416		DDB_CB2_AR_STOP	Unused	Unused
1417		DDB_EXTERNAL_RES_CB2_AROK	Unused	Unused
1418		DDB_EXTERNAL_RES_CB2_SHOTS	Unused	Unused
1419		DDB_RESET_CB2_CLOSE_DELAY	Unused	Unused
1420	PSL	DDB_INHIBIT_AR	DDB mapped in PSL from opto or comms input. External signal to inhibit autoreclose.	Inhibit AR
1421		DDB_BLOCK_CB2_AR	Unused	Unused
1422		DDB_RESET_CB2_LOCKOUT	Unused	Unused
1423		DDB_MCB_VTS_CS2	Unused	Unused
1424		DDB_INHIBIT_LIVE_BUS2	Unused	Unused
1425		DDB_INHIBIT_DEAD_BUS2	Unused	Unused
1426		DDB_CHECKSYNC2_1_ENABLED	Unused	Unused
1427		DDB_CHECKSYNC2_2_ENABLED	Unused	Unused
1428		DDB_CB2_IN_SERVICE	Unused	Unused
1429		DDB_CB2_NO_AR	Unused	Unused
1430		DDB_UNUSED_1430	Unused	Unused
1431		DDB_LEAD_CB2	Unused	Unused
1432		DDB_FOLLOW_CB	Unused	Unused
1433		DDB_FOLLOW_CB2	Unused	Unused
1434		DDB_CB2_AR_INIT	Unused	Unused
1435		DDB_CB2_AR_INPROGRESS	Unused	Unused
1436		DDB_CB2_IND_AR_INPROGRESS	Unused	Unused
1437	SW	DDB_DIFFERENTIAL_HIGHSTART	Unused	Unused
1438	SW	DDB_DIFFERENTIAL_HIGHSTART_A	Unused	Unused
1439	SW	DDB_DIFFERENTIAL_HIGHSTART_B	Unused	Unused
1440	SW	DDB_DIFFERENTIAL_HIGHSTART_C	Unused	Unused
1441		DDB_CB2_FAIL_AR	Unused	Unused
1442		DDB_DEAD_TIME_OK_CB2LSP	Unused	Unused
1443		DDB_DEAD_TIME_OK_CB2L3P	Unused	Unused
1444		DDB_CB2_3POLE_DEAD_TIME	Unused	Unused
1445		DDB_ENABLE_CB2_FOLLOWER	Unused	Unused
1446		DDB_SPOLE_FOLLOWER_TIME	Unused	Unused
1447		DDB_3POLE_FOLLOWER_TIME	Unused	Unused
1448		DDB_CB2_AUTO_CLOSE	Unused	Unused
1449		DDB_SET_CB2_CLOSE	Unused	Unused
1450		DDB_CB2_CONTROL	Unused	Unused
1451		DDB_CB2_SUCCESSFUL_SPAR	Unused	Unused
1452		DDB_CB2_SUCCESSFUL_3PAR	Unused	Unused
1453		DDB_CB2_CTRL_CLOSE_IN_PROGRESS	Unused	Unused
1454		DDB_CB2_FAST_SYSTEM_CHECK_OK	Unused	Unused
1455		DDB_CB2_LEADER_SYSTEM_CHECK_OK	Unused	Unused

DDB No	Source	Element Name	Description	English Text
1456		DDB_CB2_FOLLOWER_SYSTEM_CHECK_OK	Unused	Unused
1457		DDB_CB2_IND_SYSTEM_CHECK_OK	Unused	Unused
1458		DDB_CB2_MANUAL_SYSTEM_CHECK_OK	Unused	Unused
1459		DDB_CB2_FAIL_PROTECTION_TRIP	Unused	Unused
1460		DDB_CB2_LOCKOUT	Unused	Unused
1461		DDB_SYSCHECKS_BUS2_LIVE	Unused	Unused
1462		DDB_SYSCHECKS_BUS2_DEAD	Unused	Unused
1463		DDB_CHECKSYNC2_2_OK	Unused	Unused
1464		DDB_CS2_SLIP_O	Line-Bus 1 slip freq > setting [48 98] (frequency difference (slip) between line voltage and bus 1 voltage is greater than maximum slip permitted for CB synchronism check type 2)	CS2 SlipF>
1465		DDB_CS2_SLIP_U	Line-Bus 1 slip freq < setting [48 98] (frequency difference (slip) between line voltage and bus voltage is within the permitted range for CB synchronism check type 2)	CS2 SlipF<
1466		DDB_CS2_1_SLIP_O	Unused	Unused
1467		DDB_CS2_1_SLIP_U	Unused	Unused
1468		DDB_CS2_2_SLIP_O	Unused	Unused
1469		DDB_CS2_2_SLIP_U	Unused	Unused
1470		DDB_SYSCHECKS2_1_VLINE_DIFF_HIGH	Unused	Unused
1471		DDB_SYSCHECKS2_2_VLINE_DIFF_HIGH	Unused	Unused
1472		DDB_SYSCHECKS2_1_VBUS_DIFF_HIGH	Unused	Unused
1473		DDB_SYSCHECKS2_2_VBUS_DIFF_HIGH	Unused	Unused
1474		DDB_CS2_1_LINE_FREQ_GT_BUS_FREQ	Unused	Unused
1475		DDB_CS2_2_LINE_FREQ_GT_BUS_FREQ	Unused	Unused
1476		DDB_CS2_1_LINE_FREQ_LT_BUS_FREQ	Unused	Unused
1477		DDB_CS2_2_LINE_FREQ_LT_BUS_FREQ	Unused	Unused
1478		DDB_CS2_1_ANGLE_NOT_OK_POS	Unused	Unused
1479		DDB_CS2_1_ANGLE_NOT_OK_NEG	Unused	Unused
1480		DDB_CS2_2_ANGLE_NOT_OK_POS	Unused	Unused
1481		DDB_CS2_2_ANGLE_NOT_OK_NEG	Unused	Unused
1482		DDB_SYSCHECKS2_ANGLE_ACW	Unused	Unused
1483		DDB_SYSCHECKS2_ANGLE_CW	Unused	Unused
1484		DDB_SYSCHECKS_INACTIVE2	Unused	Unused
1485		DDB_AR_FORCE_3_POLE_TRIPS_CB2	Unused	Unused
1486		DDB_UNUSED_1486	Unused	Unused
1487		DDB_CB_IND_AR_INPROGRESS	Unused	Unused
1488		DDB_ENABLE_CB_FOLLOWER	Unused	Unused
1489		DDB_SPOLE_INDEPENDENT_TIME	Unused	Unused
1490		DDB_3POLE_INDEPENDENT_TIME	Unused	Unused
1491		DDB_CB_FOLLOWR_SYSTEM_CHECK_OK	Unused	Unused
1492		DDB_CB_IND_SYSTEM_CHECK_OK	Unused	Unused
1493		DDB_CS2_LINE_FREQ_GT_BUS_FREQ	Frequency difference between Line V and Bus1 V is greater than setting [48 98] (line freq > Bus freq)	CS2 FL>FB

DDB No	Source	Element Name	Description	English Text
1494		DDB_CS2_LINE_FREQ_LT_BUS_FREQ	Frequency difference between Line V and Bus1 V is greater than setting [48 98] (line freq < Bus freq)	CS2 FL<FB
1495		DDB_CS2_ANGLE_NOT_OK_POS	Line/Bus1 phase angle in range: setting [48 95] to +180deg (anticlockwise from Vbus)	CS2 AngHigh+
1496		DDB_CS2_ANGLE_NOT_OK_NEG	Line/Bus1 phase angle in range: setting [48 95] to -180deg (clockwise from Vbus)	CS2 AngHigh-
1497	PSL	DDB_LEAD_AR_SP	If setting "Lead AR Mode" = Opto, then if input DDB "AR Mode 1P" is high, the leader CB is enabled for single phase autoreclose, if "AR Mode 1P" is low, the leader CB is NOT enabled for single phase autoreclose.	AR Mode 1P
1498	PSL	DDB_LEAD_AR_3P	If setting "Lead AR Mode" = Opto, then if input DDB "AR Mode 3P" is high, the leader CB is enabled for three phase autoreclose, if "AR Mode 3P" is low, the leader CB is NOT enabled for three phase autoreclose.	AR Mode 3P
1499		DDB_CB2_TRIP_AR_MEMORY_A	Unused	Unused
1500		DDB_CB2_TRIP_AR_MEMORY_B	Unused	Unused
1501		DDB_CB2_TRIP_AR_MEMORY_C	Unused	Unused
1502		DDB_UNUSED_1502	Unused	Unused
1503		DDB_EN_CB_INDEPENDENT	Unused	Unused
1504	PSL	DDB_INIT_APH_AR_TEST	DDB mapped in PSL from opto or comms input. Input high-low operation will initiate APh test trip & autoreclose cycle	Init APh AR Test
1505	PSL	DDB_INIT_BPH_AR_TEST	DDB mapped in PSL from opto or comms input. Input high-low operation will initiate BPh test trip & autoreclose cycle	Init BPh AR Test
1506	PSL	DDB_INIT_CPH_AR_TEST	DDB mapped in PSL from opto or comms input. Input high-low operation will initiate CPh test trip & autoreclose cycle	Init CPh AR Test
1507	PSL	DDB_INIT_3PH_AR_TEST	DDB mapped in PSL from opto or comms input. Input high-low operation will initiate 3Ph test trip & autoreclose cycle	Init 3P AR Test
1508	PSL	DDB_EXTERNAL_FAULT_A	DDB mapped in PSL from opto or comms input: indicates external protection operated for fault involving A phase	Ext Fault APh
1509	PSL	DDB_EXTERNAL_FAULT_B	DDB mapped in PSL from opto or comms input: indicates external protection operated for fault involving C phase	Ext Fault BPh
1510	PSL	DDB_EXTERNAL_FAULT_C	DDB mapped in PSL from opto or comms input: indicates external protection operated for fault involving C phase	Ext Fault CPh
1511	PSL	DDB_AR_SKIP_SHOT1	DDB mapped in PSL from opto or comms input: if setting "AR Skip Shot 1" = Enable and this input is high when a protection operation initiates an autoreclose cycle, then the sequence counter advances directly to SC:COUNT = 2 so the autoreclose cycle skips (omits) Shot 1 and instead starts at Dead Time 2 for the first reclose attempt.	AR Skip Shot1
1512	PSL	DDB_CB_SPDT_EXTERNAL	Unused	Unused
1513	PSL	DDB_CB_3PDT_EXTERNAL	Unused	Unused
1514	PSL	DDB_CB_ARPERMIT	Unused	Unused

DDB No	Source	Element Name	Description	English Text
1515	PSL	DDB_CB_AR_STOP	Unused	Unused
1516	PSL	DDB_EXTERNAL_RECLAIM_TIME	Unused	Unused
1517	PSL	DDB_EXTERNAL_RES_CB_AROK	DDB mapped in PSL from opto or comms input. This input DDB is used when required to reset any CB "Successful Autoreclose" signal.	Ext Rst AROK
1518	PSL	DDB_EXTERNAL_RES_CB_SHOTS	DDB mapped in PSL from opto or comms input. This input DDB is used when required to reset the CB cumulative "Shots" counters.	Ext Rst CB Shots
1519	PSL	DDB_UNUSED_1519	Unused	Unused
1520	PSL	DDB_UNUSED_1520	Unused	Unused
1521	PSL	DDB_MCB_VTS_CS1	DDB mapped in PSL from opto input (Bus1 VT secondary MCB tripped or VT fail detected by external VTS scheme), or signal from host relay VTS scheme	MCB/VTS CB1 CS
1522	PSL	DDB_INHIBIT_LIVE_LINE	DDB mapped in PSL from opto input (external signal to inhibit Live Line function)	Inhibit LL
1523	PSL	DDB_INHIBIT_DEAD_LINE	DDB mapped in PSL from opto input (external signal to inhibit Dead Line function)	Inhibit DL
1524	PSL	DDB_INHIBIT_LIVE_BUS1	DDB mapped in PSL from opto input (external signal to inhibit Live Bus function)	Inhibit LB
1525	PSL	DDB_INHIBIT_DEAD_BUS1	DDB mapped in PSL from opto input (external signal to inhibit Dead Bus function)	Inhibit DB
1526		DDB_CB1_IN_SERVICE	CB In Service (can be initiated for autoreclose)	CB In Service
1527		DDB_UNUSED_1527	Unused	Unused
1528		DDB_CB_NO_AR	Unused	Unused
1529		DDB_UNUSED_1529	Unused	Unused
1530		DDB_LEAD_CB	Unused	Unused
1531		DDB_UNUSED_1531	Unused	Unused
1532		DDB_UNUSED_1532	Unused	Unused
1533		DDB_UNUSED_1533	Unused	Unused
1534		DDB_UNUSED_1534	Unused	Unused
1535		DDB_TRIP_AR_MEMORY_A	A Ph trip & AR initiation memory	Trip AR MemA
1536		DDB_TRIP_AR_MEMORY_B	B Ph trip & AR initiation memory	Trip AR MemB
1537		DDB_TRIP_AR_MEMORY_C	C Ph trip & AR initiation memory	Trip AR MemC
1538	SW	DDB_TS_OC_A_S1	Trip supervision: l> phaseA stage1	TS l> pH A s1
1539	SW	DDB_TS_OC_A_S2	Trip supervision: l> phaseA stage2	TS l> pH A s2
1540	SW	DDB_TS_OC_A_S3	Trip supervision: l> phaseA stage3	TS l> pH A s3
1541	Autoreclose	DDB_AR_START	Any AR initiation signal present	AR Start
1542	Autoreclose	DDB_AR_IN_PROGRESS	Any AR cycle in progress	ARIP
1543	Autoreclose	DDB_CB_AR_INIT	CB AR cycle initiation	AR Initiation
1544	Autoreclose	DDB_CB_AR_INPROGRESS	CB AR cycle in progress	CB ARIP
1545	SW	DDB_TS_OC_B_S1	Trip supervision: l> phaseB stage1	TS l> pH B s1
1546		DDB_SEQ_COUNT_GREATER_THAN_SHOTS	Sequence counts greater than shots	Seq Counter>Set
1547		DDB_EVOLVE_3PHASE	Convert SPAR to 3PAR. DDB mapped to give 100ms pulse to CB1 Trip 3Ph and CB2 Trip 3Ph outputs	Evolve 3Ph
1548	SW	DDB_TS_OC_B_S2	Trip supervision: l> phaseB stage2	TS l> pH B s2
1549	SW	DDB_TS_OC_B_S3	Trip supervision: l> phaseB stage3	TS l> pH B s3

DDB No	Source	Element Name	Description	English Text
1550		DDB_CB_FAIL_AR	CB AR failed due to persistent fault	CB Failed AR
1551		DDB_DEADTIME_OK_ALL	Enabling condition for any dead time	DTOK All
1552		DDB_DEAD_TIME_OK_CB1LSP	required for CB SPAR D Time	DTOK CB 1P
1553		DDB_DEAD_TIME_OK_CB1L3P	required for CB 3PAR D Time	DTOK CB 3P
1554		DDB_SPDT_IN_PROGRESS	Single pole dead time in progress	1P DTime
1555		DDB_OK_TIME_3POLE	OK to start 3PAR dead time	OK Time 3P
1556		DDB_3POLE_DEAD_TIME1	3Phase dead time 1 running	3P DTime1
1557		DDB_3POLE_DEAD_TIME2	3Phase dead time 2 running	3P DTime2
1558		DDB_3POLE_DEAD_TIME3	3Phase dead time 3 running	3P DTime3
1559		DDB_3POLE_DEAD_TIME4	3Phase dead time 4 running	3P DTime4
1560		DDB_CB_3POLE_DEAD_TIME	CB 3PAR dead time running	3P Dtime
1561		DDB_SPOLE_FT_COMPLETE	Unused	Unused
1562		DDB_3POLE_FT_COMPLETE	Unused	Unused
1563		DDB_IND_SPOLE_FT_COMPLETE	Unused	Unused
1564		DDB_IND_3POLE_FT_COMPLETE	Unused	Unused
1565		DDB_SET_CB_CLOSE	DDB (Optional PSL mapping to indication)	Set CB Close
1566		DDB_CB_CONTROL	Inhibits CB reclose by adjacent scheme	CB Control
1567		DDB_SP_RECLAIM_TIME	Single Ph AR reclaim time running	1P Reclaim Time
1568		DDB_SP_RECLAIM_TIME_COMPLETE	Single Ph AR reclaim time complete	1P Reclaim TComp
1569		DDB_TP_RECLAIM_TIME	Three Ph AR reclaim time running	3P Reclaim Time
1570		DDB_TP_RECLAIM_TIME_COMPLETE	Three Ph AR reclaim time complete	3P Reclaim TComp
1571		DDB_CB_SUCCESSFUL_SPAR	CB successful single phase AR	CB Succ 1P AR
1572		DDB_CB_FAST_SYSTEM_CHECK_OK	OK to reclose CB with sync check without waiting for dead time to complete	CB Fast SCOK
1573		DDB_CB_LEADER_SYSTEM_CHECK_OK	System conditions OK to reclose CB when dead time complete	CB SCOK
1574		DDB_CB_MANUAL_SYSTEM_CHECK_OK	System conditions OK to manually close CB	CB Man SCOK
1575		DDB_CB_FAIL_PROTECTION_TRIP	signal to force CB AR lockout	CB Fail Pr Trip
1576		DDB_CB_LOCKOUT	Unused	Unused
1577		DDB_CHECKSYNC2_1_OK	Unused	Unused
1578		DDB_CS1_SLIP_O	Line-Bus slip freq > setting [48 93] (frequency difference (slip) between line voltage and bus voltage is greater than maximum slip permitted for CB synchronism check type 1)	CS1 SlipF>
1579		DDB_CS1_SLIP_U	Line-Bus slip freq < setting [48 93] (frequency difference (slip) between line voltage and bus voltage is greater than maximum slip permitted for CB synchronism check type 1)	CS1 SlipF<
1580		DDB_SYSCHECKS_VLINE_U	Line Volts < setting [48 8B]	CS VLine<
1581		DDB_SYSCHECKS_VLINE_O	Line Volts > setting [48 8C]	CS VLine>
1582		DDB_SYSCHECKS_VBUS_U	Bus Volts < setting [48 8B]	CS VBus<
1583		DDB_SYSCHECKS_VBUS_O	Bus Volts > setting [48 8C]	CS VBus>
1584		DDB_SYSCHECKS_VBUS2_U	Unused	Unused
1585		DDB_SYSCHECKS_VBUS2_O	Unused	Unused
1586		DDB_SYSCHECKS_VLINE_DIFF_HIGH	Voltage magnitude difference between Line V and Bus V is greater than setting [48 91] (line V > Bus V)	CS1 VL>VB

DDB No	Source	Element Name	Description	English Text
1587		DDB_SYSCHECKS1_2_VLINE_DIFF_HIGH	Voltage magnitude difference between Line V and Bus V is greater than setting [48 96] (line V > Bus V)	CS2 VL>VB
1588		DDB_SYSCHECKS_VBUS_DIFF_HIGH	Voltage magnitude difference between Line V and Bus V is greater than setting [48 91] (line V < Bus V)	CS1 VL<VB
1589		DDB_SYSCHECKS1_2_VBUS_DIFF_HIGH	Voltage magnitude difference between Line V and Bus V is greater than setting [48 96] (line V < Bus V)	CS2 VL<VB
1590		DDB_CS1_LINE_FREQ_GT_BUS_FREQ	Frequency difference between Line V and Bus V is greater than setting [48 93] (line freq > Bus freq)	CS1 FL>FB
1591		DDB_CS1_LINE_FREQ_LT_BUS_FREQ	Frequency difference between Line V and Bus V is greater than setting [48 93] (line freq < Bus freq)	CS1 FL<FB
1592		DDB_CS1_ANGLE_NOT_OK_POS	Line/Bus phase angle in range: setting [48 90] to +180deg (anticlockwise from Vbus)	CS1 AngHigh+
1593		DDB_CS1_ANGLE_NOT_OK_NEG	Line/Bus phase angle in range: setting [48 90] to -180deg (anticlockwise from Vbus)	CS1 AngHigh-
1594		DDB_SYSCHECKS_ANGLE_ACW	Line freq > (Bus freq + 0.001Hz) (Line voltage vector rotating anticlockwise relative to VBus1)	CS AngRotACW
1595		DDB_SYSCHECKS_ANGLE_CW	Bus freq > (Line freq + 0.001Hz) (Line voltage vector rotating clockwise relative to VBus1)	CS AngRotCW
1596		DDB_UNUSED_1596	Unused	Unused
1597		DDB_RESET_ALL_VALUES_2	Unused	Unused
1598		DDB_CB2_PRE_LOCKOUT	Unused	Unused
1599		DDB_CB2_LOCKOUT_ALARM	Unused	Unused
1600	Trip Conversion Logic	DDB_TRIP_3PH_2	Unused	Unused
1601	Trip Conversion Logic	DDB_TRIP_A_PHASE_2	Unused	Unused
1602	Trip Conversion Logic	DDB_TRIP_B_PHASE_2	Unused	Unused
1603	Trip Conversion Logic	DDB_TRIP_C_PHASE_2	Unused	Unused
1604	PSL	DDB_FORCE_3_POLE_TRIP_2	Unused	Unused
1605		DDB_AR_ENABLE_CB2	Unused	Unused
1606		DDB_INP_TR2P_2	Unused	Unused
1607	Pole discrepancy	DDB_POLE_DISCREPENCE_TRIP_2	Unused	Unused
1608	PSL	DDB_TR_3_PHASE_CB2	Unused	Unused
1609		DDB_AR_ENABLE_CB1	External input via DDB mapped in PSL to enable CB, if "in service", to be initiated for autoreclosing by an AR initiation signal from protection. DDB input defaults to high if not mapped in PSL, so CB AR initiation is permitted.	AR Enable CB
1610		DDB_CB1_INDEPENDENT_INIT_A_PHASE	Unused	Unused
1611		DDB_CB1_INDEPENDENT_INIT_B_PHASE	Unused	Unused
1612		DDB_CB1_INDEPENDENT_INIT_C_PHASE	Unused	Unused
1613		DDB_CB2_INDEPENDENT_INIT_A_PHASE	Unused	Unused
1614		DDB_CB2_INDEPENDENT_INIT_B_PHASE	Unused	Unused

DDB No	Source	Element Name	Description	English Text
1615		DDB_CB2_INDEPENDENT_INIT_C_PHASE	Unused	Unused
1616	PSL	DDB_PSLINT_101	PSL Internal Node	PSL Int 101
1617	PSL	DDB_PSLINT_102	PSL Internal Node	PSL Int 102
1618	PSL	DDB_PSLINT_103	PSL Internal Node	PSL Int 103
1619	PSL	DDB_PSLINT_104	PSL Internal Node	PSL Int 104
1620	PSL	DDB_PSLINT_105	PSL Internal Node	PSL Int 105
1621	PSL	DDB_PSLINT_106	PSL Internal Node	PSL Int 106
1622	PSL	DDB_PSLINT_107	PSL Internal Node	PSL Int 107
1623	PSL	DDB_PSLINT_108	PSL Internal Node	PSL Int 108
1624	PSL	DDB_PSLINT_109	PSL Internal Node	PSL Int 109
1625	PSL	DDB_PSLINT_110	PSL Internal Node	PSL Int 110
1626	PSL	DDB_PSLINT_111	PSL Internal Node	PSL Int 111
1627	PSL	DDB_PSLINT_112	PSL Internal Node	PSL Int 112
1628	PSL	DDB_PSLINT_113	PSL Internal Node	PSL Int 113
1629	PSL	DDB_PSLINT_114	PSL Internal Node	PSL Int 114
1630	PSL	DDB_PSLINT_115	PSL Internal Node	PSL Int 115
1631	PSL	DDB_PSLINT_116	PSL Internal Node	PSL Int 116
1632	PSL	DDB_PSLINT_117	PSL Internal Node	PSL Int 117
1633	PSL	DDB_PSLINT_118	PSL Internal Node	PSL Int 118
1634	PSL	DDB_PSLINT_119	PSL Internal Node	PSL Int 119
1635	PSL	DDB_PSLINT_120	PSL Internal Node	PSL Int 120
1636	PSL	DDB_PSLINT_121	PSL Internal Node	PSL Int 121
1637	PSL	DDB_PSLINT_122	PSL Internal Node	PSL Int 122
1638	PSL	DDB_PSLINT_123	PSL Internal Node	PSL Int 123
1639	PSL	DDB_PSLINT_124	PSL Internal Node	PSL Int 124
1640	PSL	DDB_PSLINT_125	PSL Internal Node	PSL Int 125
1641	PSL	DDB_PSLINT_126	PSL Internal Node	PSL Int 126
1642	PSL	DDB_PSLINT_127	PSL Internal Node	PSL Int 127
1643	PSL	DDB_PSLINT_128	PSL Internal Node	PSL Int 128
1644	PSL	DDB_PSLINT_129	PSL Internal Node	PSL Int 129
1645	PSL	DDB_PSLINT_130	PSL Internal Node	PSL Int 130
1646	PSL	DDB_PSLINT_131	PSL Internal Node	PSL Int 131
1647	PSL	DDB_PSLINT_132	PSL Internal Node	PSL Int 132
1648	PSL	DDB_PSLINT_133	PSL Internal Node	PSL Int 133
1649	PSL	DDB_PSLINT_134	PSL Internal Node	PSL Int 134
1650	PSL	DDB_PSLINT_135	PSL Internal Node	PSL Int 135
1651	PSL	DDB_PSLINT_136	PSL Internal Node	PSL Int 136
1652	PSL	DDB_PSLINT_137	PSL Internal Node	PSL Int 137
1653	PSL	DDB_PSLINT_138	PSL Internal Node	PSL Int 138
1654	PSL	DDB_PSLINT_139	PSL Internal Node	PSL Int 139
1655	PSL	DDB_PSLINT_140	PSL Internal Node	PSL Int 140
1656	PSL	DDB_PSLINT_141	PSL Internal Node	PSL Int 141
1657	PSL	DDB_PSLINT_142	PSL Internal Node	PSL Int 142
1658	PSL	DDB_PSLINT_143	PSL Internal Node	PSL Int 143

DDB No	Source	Element Name	Description	English Text
1659	PSL	DDB_PSLINT_144	PSL Internal Node	PSL Int 144
1660	PSL	DDB_PSLINT_145	PSL Internal Node	PSL Int 145
1661	PSL	DDB_PSLINT_146	PSL Internal Node	PSL Int 146
1662	PSL	DDB_PSLINT_147	PSL Internal Node	PSL Int 147
1663	PSL	DDB_PSLINT_148	PSL Internal Node	PSL Int 148
1664	PSL	DDB_PSLINT_149	PSL Internal Node	PSL Int 149
1665	PSL	DDB_PSLINT_150	PSL Internal Node	PSL Int 150
1666		DDB_HARMONIC_5_A	Unused	Unused
1667		DDB_HARMONIC_5_B	Unused	Unused
1668		DDB_HARMONIC_5_C	Unused	Unused
1669		DDB_HARMONIC_5_REM_BLOCK_A	Unused	Unused
1670		DDB_HARMONIC_5_REM_BLOCK_B	Unused	Unused
1671		DDB_HARMONIC_5_REM_BLOCK_C	Unused	Unused
1672	SW	DDB_CB_PHASE_A_RETRIP	tBF1 trip phase A for CB	CB Fail1 Trip A
1673	SW	DDB_CB_PHASE_A_BKTRIP	tBF2 trip phase A for CB	CB Fail2 Trip A
1674	SW	DDB_CB_PHASE_B_RETRIP	tBF1 trip phase B for CB	CB Fail1 Trip B
1675	SW	DDB_CB_PHASE_B_BKTRIP	tBF2 trip phase B for CB	CB Fail2 Trip B
1676	SW	DDB_CB_PHASE_C_RETRIP	tBF1 trip phase C for CB	CB Fail1 Trip C
1677	SW	DDB_CB_PHASE_C_BKTRIP	tBF2 trip phase C for CB	CB Fail2 Trip C
1678	SW	DDB_CB2_PHASE_A_RETRIP	Unused	Unused
1679	SW	DDB_CB2_PHASE_A_BKTRIP	Unused	Unused
1680	SW	DDB_CB2_PHASE_B_RETRIP	Unused	Unused
1681	SW	DDB_CB2_PHASE_B_BKTRIP	Unused	Unused
1682	SW	DDB_CB2_PHASE_C_RETRIP	Unused	Unused
1683	SW	DDB_CB2_PHASE_C_BKTRIP	Unused	Unused
1684	SW	DDB_CT_PHASE_A_ZCD	CT phase A Zero Cross Detector	CT A ZCD
1685	SW	DDB_CT_PHASE_B_ZCD	CT phase B Zero Cross Detector	CT B ZCD
1686	SW	DDB_CT_PHASE_C_ZCD	CT phase C Zero Cross Detector	CT C ZCD
1687	SW	DDB_CT2_PHASE_A_ZCD	Unused	Unused
1688	SW	DDB_CT2_PHASE_B_ZCD	Unused	Unused
1689	SW	DDB_CT2_PHASE_C_ZCD	Unused	Unused
1690	SW	DDB_CT_IN_ZCD	CT1 and CT2 Zero Cross Detector	CT IN ZCD
1691		DDB_UNUSED_1691	Unused	Unused
1692		DDB_UNUSED_1692	Unused	Unused
1693		DDB_UNUSED_1693	Unused	Unused
1694		DDB_UNUSED_1694	Unused	Unused
1695		DDB_UNUSED_1695	Unused	Unused
1696	PSL	DDB_IEC_USR_OPN_1	IEC61850 User Dual Point Status 1 Open	IEC Usr 01 Open
1697	PSL	DDB_IEC_USR_CLS_1	IEC61850 User Dual Point Status 1 Closed	IEC Usr 01 Close
1698	PSL	DDB_IEC_USR_OPN_2	IEC61850 User Dual Point Status 2 Open	IEC Usr 02 Open
1699	PSL	DDB_IEC_USR_CLS_2	IEC61850 User Dual Point Status 2 Closed	IEC Usr 02 Close
1700	PSL	DDB_IEC_USR_OPN_3	IEC61850 User Dual Point Status 3 Open	IEC Usr 03 Open
1701	PSL	DDB_IEC_USR_CLS_3	IEC61850 User Dual Point Status 3 Closed	IEC Usr 03 Close
1702	PSL	DDB_IEC_USR_OPN_4	IEC61850 User Dual Point Status 4 Open	IEC Usr 04 Open

DDB No	Source	Element Name	Description	English Text
1703	PSL	DDB_IEC_USR_CLS_4	IEC61850 User Dual Point Status 4 Closed	IEC Usr 04 Close
1704	PSL	DDB_IEC_USR_OPN_5	IEC61850 User Dual Point Status 5 Opened	IEC Usr 05 Open
1705	PSL	DDB_IEC_USR_CLS_5	IEC61850 User Dual Point Status 5 Closed	IEC Usr 05 Close
1706	PSL	DDB_IEC_USR_OPN_6	IEC61850 User Dual Point Status 6 Open	IEC Usr 06 Open
1707	PSL	DDB_IEC_USR_CLS_6	IEC61850 User Dual Point Status 6 Closed	IEC Usr 06 Close
1708	PSL	DDB_IEC_USR_OPN_7	IEC61850 User Dual Point Status 7 Open	IEC Usr 07 Open
1709	PSL	DDB_IEC_USR_CLS_7	IEC61850 User Dual Point Status 7 Closed	IEC Usr 07 Close
1710	PSL	DDB_IEC_USR_OPN_8	IEC61850 User Dual Point Status 8 Open	IEC Usr 08 Open
1711	PSL	DDB_IEC_USR_CLS_8	IEC61850 User Dual Point Status 8 Closed	IEC Usr 08 Close
1712	SW	DDB_TS_OC_C_S1	Trip supervision: I> phaseC stage1	TS I> pHc s1
1713	SW	DDB_TS_OC_C_S2	Trip supervision: I> phaseC stage2	TS I> pHc s2
1714	SW	DDB_TS_OC_C_S3	Trip supervision: I> phaseC stage3	TS I> pHc s3
1715	PSL	DDB_EXT_RESET_CB_FAIL_3PH	External Reset for CB 3 phase fail	Ext Rst CBF
1716	PSL	DDB_EXT_RESET_CB_FAIL_A	External Reset for CB A phase fail	Ext Rst CBF A
1717	PSL	DDB_EXT_RESET_CB_FAIL_B	External Reset for CB B phase fail	Ext Rst CBF B
1718	PSL	DDB_EXT_RESET_CB_FAIL_C	External Reset for CB C phase fail	Ext Rst CBF C
1719	PSL	DDB_EXT_RESET_CB_FAIL_SEF	External Reset for SEF CB fail	Ext Rst SEF CBF
1720		DDB_UNUSED_1720	Unused	Unused
1721		DDB_UNUSED_1721	Unused	Unused
1722		DDB_UNUSED_1722	Unused	Unused
1723		DDB_UNUSED_1723	Unused	Unused
1724		DDB_UNUSED_1724	Unused	Unused
1725	SW	DDB_TS_OCN_A_S1	Trip supervision: IN> phaseA stage1	TS IN> pHa s1
1726	SW	DDB_TS_OCN_A_S2	Trip supervision: IN> phaseA stage2	TS IN> pHa s2
1727	SW	DDB_TS_OCN_A_S3	Trip supervision: IN> phaseA stage3	TS IN> pHa s3
1728	GOOSE Input Command	DDB_VIP_QUALITY_1	GOOSE virtual input 1 - provides the Quality attributes of any data object in an incoming GOOSE message	Quality VIP 1
1729	GOOSE Input Command	DDB_VIP_QUALITY_2	GOOSE virtual input 2 - provides the Quality attributes of any data object in an incoming GOOSE message	Quality VIP 2
1730	GOOSE Input Command	DDB_VIP_QUALITY_3	GOOSE virtual input 3 - provides the Quality attributes of any data object in an incoming GOOSE message	Quality VIP 3
1731	GOOSE Input Command	DDB_VIP_QUALITY_4	GOOSE virtual input 4 - provides the Quality attributes of any data object in an incoming GOOSE message	Quality VIP 4
1732	GOOSE Input Command	DDB_VIP_QUALITY_5	GOOSE virtual input 5 - provides the Quality attributes of any data object in an incoming GOOSE message	Quality VIP 5
1733	GOOSE Input Command	DDB_VIP_QUALITY_6	GOOSE virtual input 6 - provides the Quality attributes of any data object in an incoming GOOSE message	Quality VIP 6
1734	GOOSE Input Command	DDB_VIP_QUALITY_7	GOOSE virtual input 7 - provides the Quality attributes of any data object in an incoming GOOSE message	Quality VIP 7
1735	GOOSE Input Command	DDB_VIP_QUALITY_8	GOOSE virtual input 8 - provides the Quality attributes of any data object in an incoming GOOSE message	Quality VIP 8

DDB No	Source	Element Name	Description	English Text
1736	GOOSE Input Command	DDB_VIP_QUALITY_9	GOOSE virtual input 9 - provides the Quality attributes of any data object in an incoming GOOSE message	Quality VIP 9
1737	GOOSE Input Command	DDB_VIP_QUALITY_10	GOOSE virtual input 10 - provides the Quality attributes of any data object in an incoming GOOSE message	Quality VIP 10
1738	GOOSE Input Command	DDB_VIP_QUALITY_11	GOOSE virtual input 11 - provides the Quality attributes of any data object in an incoming GOOSE message	Quality VIP 11
1739	GOOSE Input Command	DDB_VIP_QUALITY_12	GOOSE virtual input 12 - provides the Quality attributes of any data object in an incoming GOOSE message	Quality VIP 12
1740	GOOSE Input Command	DDB_VIP_QUALITY_13	GOOSE virtual input 13 - provides the Quality attributes of any data object in an incoming GOOSE message	Quality VIP 13
1741	GOOSE Input Command	DDB_VIP_QUALITY_14	GOOSE virtual input 14 - provides the Quality attributes of any data object in an incoming GOOSE message	Quality VIP 14
1742	GOOSE Input Command	DDB_VIP_QUALITY_15	GOOSE virtual input 15 - provides the Quality attributes of any data object in an incoming GOOSE message	Quality VIP 15
1743	GOOSE Input Command	DDB_VIP_QUALITY_16	GOOSE virtual input 16 - provides the Quality attributes of any data object in an incoming GOOSE message	Quality VIP 16
1744	GOOSE Input Command	DDB_VIP_QUALITY_17	GOOSE virtual input 17 - provides the Quality attributes of any data object in an incoming GOOSE message	Quality VIP 17
1745	GOOSE Input Command	DDB_VIP_QUALITY_18	GOOSE virtual input 18 - provides the Quality attributes of any data object in an incoming GOOSE message	Quality VIP 18
1746	GOOSE Input Command	DDB_VIP_QUALITY_19	GOOSE virtual input 19 - provides the Quality attributes of any data object in an incoming GOOSE message	Quality VIP 19
1747	GOOSE Input Command	DDB_VIP_QUALITY_20	GOOSE virtual input 20 - provides the Quality attributes of any data object in an incoming GOOSE message	Quality VIP 20
1748	GOOSE Input Command	DDB_VIP_QUALITY_21	GOOSE virtual input 21 - provides the Quality attributes of any data object in an incoming GOOSE message	Quality VIP 21
1749	GOOSE Input Command	DDB_VIP_QUALITY_22	GOOSE virtual input 22 - provides the Quality attributes of any data object in an incoming GOOSE message	Quality VIP 22
1750	GOOSE Input Command	DDB_VIP_QUALITY_23	GOOSE virtual input 23 - provides the Quality attributes of any data object in an incoming GOOSE message	Quality VIP 23
1751	GOOSE Input Command	DDB_VIP_QUALITY_24	GOOSE virtual input 24 - provides the Quality attributes of any data object in an incoming GOOSE message	Quality VIP 24
1752	GOOSE Input Command	DDB_VIP_QUALITY_25	GOOSE virtual input 25 - provides the Quality attributes of any data object in an incoming GOOSE message	Quality VIP 25
1753	GOOSE Input Command	DDB_VIP_QUALITY_26	GOOSE virtual input 26 - provides the Quality attributes of any data object in an incoming GOOSE message	Quality VIP 26

DDB No	Source	Element Name	Description	English Text
1754	GOOSE Input Command	DDB_VIP_QUALITY_27	GOOSE virtual input 27 - provides the Quality attributes of any data object in an incoming GOOSE message	Quality VIP 27
1755	GOOSE Input Command	DDB_VIP_QUALITY_28	GOOSE virtual input 28 - provides the Quality attributes of any data object in an incoming GOOSE message	Quality VIP 28
1756	GOOSE Input Command	DDB_VIP_QUALITY_29	GOOSE virtual input 29 - provides the Quality attributes of any data object in an incoming GOOSE message	Quality VIP 29
1757	GOOSE Input Command	DDB_VIP_QUALITY_30	GOOSE virtual input 30 - provides the Quality attributes of any data object in an incoming GOOSE message	Quality VIP 30
1758	GOOSE Input Command	DDB_VIP_QUALITY_31	GOOSE virtual input 31 - provides the Quality attributes of any data object in an incoming GOOSE message	Quality VIP 31
1759	GOOSE Input Command	DDB_VIP_QUALITY_32	GOOSE virtual input 32 - provides the Quality attributes of any data object in an incoming GOOSE message	Quality VIP 32
1760	GOOSE Input Command	DDB_VIP_PUB_PRES_1	GOOSE virtual input 1- indicates if the GOOSE publisher responsible for publishing the data that derives a virtual input is present.	PubPres VIP 1
1761	GOOSE Input Command	DDB_VIP_PUB_PRES_2	GOOSE virtual input 2- indicates if the GOOSE publisher responsible for publishing the data that derives a virtual input is present.	PubPres VIP 2
1762	GOOSE Input Command	DDB_VIP_PUB_PRES_3	GOOSE virtual input 3- indicates if the GOOSE publisher responsible for publishing the data that derives a virtual input is present.	PubPres VIP 3
1763	GOOSE Input Command	DDB_VIP_PUB_PRES_4	GOOSE virtual input 4- indicates if the GOOSE publisher responsible for publishing the data that derives a virtual input is present.	PubPres VIP 4
1764	GOOSE Input Command	DDB_VIP_PUB_PRES_5	GOOSE virtual input 5- indicates if the GOOSE publisher responsible for publishing the data that derives a virtual input is present.	PubPres VIP 5
1765	GOOSE Input Command	DDB_VIP_PUB_PRES_6	GOOSE virtual input 6- indicates if the GOOSE publisher responsible for publishing the data that derives a virtual input is present.	PubPres VIP 6
1766	GOOSE Input Command	DDB_VIP_PUB_PRES_7	GOOSE virtual input 7- indicates if the GOOSE publisher responsible for publishing the data that derives a virtual input is present.	PubPres VIP 7
1767	GOOSE Input Command	DDB_VIP_PUB_PRES_8	GOOSE virtual input 8- indicates if the GOOSE publisher responsible for publishing the data that derives a virtual input is present.	PubPres VIP 8
1768	GOOSE Input Command	DDB_VIP_PUB_PRES_9	GOOSE virtual input 9- indicates if the GOOSE publisher responsible for publishing the data that derives a virtual input is present.	PubPres VIP 9
1769	GOOSE Input Command	DDB_VIP_PUB_PRES_10	GOOSE virtual input 10- indicates if the GOOSE publisher responsible for publishing the data that derives a virtual input is present.	PubPres VIP 10
1770	GOOSE Input Command	DDB_VIP_PUB_PRES_11	GOOSE virtual input 11- indicates if the GOOSE publisher responsible for publishing the data that derives a virtual input is present.	PubPres VIP 11
1771	GOOSE Input Command	DDB_VIP_PUB_PRES_12	GOOSE virtual input 12- indicates if the GOOSE publisher responsible for publishing the data that derives a virtual input is present.	PubPres VIP 12

DDB No	Source	Element Name	Description	English Text
1772	GOOSE Input Command	DDB_VIP_PUB_PRES_13	GOOSE virtual input 13- indicates if the GOOSE publisher responsible for publishing the data that derives a virtual input is present.	PubPres VIP 13
1773	GOOSE Input Command	DDB_VIP_PUB_PRES_14	GOOSE virtual input 14- indicates if the GOOSE publisher responsible for publishing the data that derives a virtual input is present.	PubPres VIP 14
1774	GOOSE Input Command	DDB_VIP_PUB_PRES_15	GOOSE virtual input 15- indicates if the GOOSE publisher responsible for publishing the data that derives a virtual input is present.	PubPres VIP 15
1775	GOOSE Input Command	DDB_VIP_PUB_PRES_16	GOOSE virtual input 16- indicates if the GOOSE publisher responsible for publishing the data that derives a virtual input is present.	PubPres VIP 16
1776	GOOSE Input Command	DDB_VIP_PUB_PRES_17	GOOSE virtual input 17- indicates if the GOOSE publisher responsible for publishing the data that derives a virtual input is present.	PubPres VIP 17
1777	GOOSE Input Command	DDB_VIP_PUB_PRES_18	GOOSE virtual input 18- indicates if the GOOSE publisher responsible for publishing the data that derives a virtual input is present.	PubPres VIP 18
1778	GOOSE Input Command	DDB_VIP_PUB_PRES_19	GOOSE virtual input 19- indicates if the GOOSE publisher responsible for publishing the data that derives a virtual input is present.	PubPres VIP 19
1779	GOOSE Input Command	DDB_VIP_PUB_PRES_20	GOOSE virtual input 20- indicates if the GOOSE publisher responsible for publishing the data that derives a virtual input is present.	PubPres VIP 20
1780	GOOSE Input Command	DDB_VIP_PUB_PRES_21	GOOSE virtual input 21- indicates if the GOOSE publisher responsible for publishing the data that derives a virtual input is present.	PubPres VIP 21
1781	GOOSE Input Command	DDB_VIP_PUB_PRES_22	GOOSE virtual input 22- indicates if the GOOSE publisher responsible for publishing the data that derives a virtual input is present.	PubPres VIP 22
1782	GOOSE Input Command	DDB_VIP_PUB_PRES_23	GOOSE virtual input 23- indicates if the GOOSE publisher responsible for publishing the data that derives a virtual input is present.	PubPres VIP 23
1783	GOOSE Input Command	DDB_VIP_PUB_PRES_24	GOOSE virtual input 24- indicates if the GOOSE publisher responsible for publishing the data that derives a virtual input is present.	PubPres VIP 24
1784	GOOSE Input Command	DDB_VIP_PUB_PRES_25	GOOSE virtual input 25- indicates if the GOOSE publisher responsible for publishing the data that derives a virtual input is present.	PubPres VIP 25
1785	GOOSE Input Command	DDB_VIP_PUB_PRES_26	GOOSE virtual input 26- indicates if the GOOSE publisher responsible for publishing the data that derives a virtual input is present.	PubPres VIP 26
1786	GOOSE Input Command	DDB_VIP_PUB_PRES_27	GOOSE virtual input 27- indicates if the GOOSE publisher responsible for publishing the data that derives a virtual input is present.	PubPres VIP 27
1787	GOOSE Input Command	DDB_VIP_PUB_PRES_28	GOOSE virtual input 28- indicates if the GOOSE publisher responsible for publishing the data that derives a virtual input is present.	PubPres VIP 28
1788	GOOSE Input Command	DDB_VIP_PUB_PRES_29	GOOSE virtual input 29- indicates if the GOOSE publisher responsible for publishing the data that derives a virtual input is present.	PubPres VIP 29
1789	GOOSE Input Command	DDB_VIP_PUB_PRES_30	GOOSE virtual input 30- indicates if the GOOSE publisher responsible for publishing the data that derives a virtual input is present.	PubPres VIP 30

DDB No	Source	Element Name	Description	English Text
1790	GOOSE Input Command	DDB_VIP_PUB_PRES_31	GOOSE virtual input 31- indicates if the GOOSE publisher responsible for publishing the data that derives a virtual input is present.	PubPres VIP 31
1791	GOOSE Input Command	DDB_VIP_PUB_PRES_32	GOOSE virtual input 32- indicates if the GOOSE publisher responsible for publishing the data that derives a virtual input is present.	PubPres VIP 32
1792		DDB_UNUSED_1792	Unused	Unused
1793		DDB_UNUSED_1793	Unused	Unused
1794		DDB_UNUSED_1794	Unused	Unused
1795		DDB_UNUSED_1795	Unused	Unused
1796	IEC 103	DDB_DIST_PROT_ENABLED	Distance protection function enabled in configuration settings	Distance Enabled
1797	IEC 103	DDB_DEF_PROT_ENABLED	Directional Earth Fault protection function enabled in configuration settings	DEF Enabled
1798		DDB_UNUSED_1798	Unused	Unused
1799		DDB_UNUSED_1799	Unused	Unused
1800	IEC 103	DDB_OVERCURRENT_PROT_ENABLED	Overcurrent function enabled in configuration settings	OC Enabled
1801	IEC 103	DDB_NEG_SEQ_OC_PROT_ENABLED	Negative Sequence Overcurrent function enabled in configuration settings	Neg OC Enabled
1802	IEC 103	DDB_BROKEN_COND_PROT_ENABLED	Broken conductor protection function enabled in configuration settings	Broke cond Enab
1803	IEC 103	DDB_EARTH_FAULT_PROT_ENABLED	Earth Fault protection function enabled in configuration settings	EF Enabled
1804	IEC 103	DDB_SEF_REF_PROT_ENABLED	SEF/REF protection function enabled in configuration settings	SEF/REF Enabled
1805	IEC 103	DDB_RESIDUAL_OV_NVD_PROT_ENABLED	Residual OV NVD protection function enabled in configuration settings	Res OV NVD Enab
1806	IEC 103	DDB_THERMAL_OL_PROT_ENABLED	Thermal overload protection function enabled in configuration settings	Therm OL Enabled
1807	IEC 103	DDB_PSB_PROT_ENABLED	Power swing block protection function enabled in configuration settings	PSB Enabled
1808		DDB_UNUSED_1808	Unused	Unused
1809	IEC 103	DDB_VOLTAGE_PROT_ENABLED	Voltage protection function enabled in configuration settings	Volt Prt Enabled
1810	IEC 103	DDB_FREQ_PROT_ENABLED	Frequency protection function enabled in configuration settings	Freq Prt Enabled
1811	IEC 103	DDB_DFDT_PROT_ENABLED	df/dt function enabled in configuration settings	dfdt Enabled
1812	IEC 103	DDB_CBFail_PROT_ENABLED	CBFail protection function enabled in configuration settings	CBFail Enabled
1813	IEC 103	DDB_SUPERVISION_PROT_ENABLED	Supervision protection function enabled in configuration setting	SuperVis Enabled
1814	IEC 103	DDB_SYS_CHECKS_PROT_ENABLED	System checks function enabled in configuration settings	SysChk Enabled
1815	IEC 103	DDB_AUTO_RECLOSE_PROT_ENABLED	Auto reclose protection function enabled in configuration settings	AutoRec Enabled
1816		DDB_UNUSED_1816	Unused	Unused
1817		DDB_UNUSED_1817	Unused	Unused
1818		DDB_UNUSED_1818	Unused	Unused
1819	SW	DDB_SETTING_INPUT_33	setting input 33 menu settings into PSL	Ctrl Setg I/P 33

DDB No	Source	Element Name	Description	English Text
1820	SW	DDB_SETTING_INPUT_34	setting input 34 menu settings into PSL	Ctrl Setg I/P 34
1821	SW	DDB_SETTING_INPUT_35	setting input 35 menu settings into PSL	Ctrl Setg I/P 35
1822	SW	DDB_SETTING_INPUT_36	setting input 36 menu settings into PSL	Ctrl Setg I/P 36
1823	SW	DDB_SETTING_INPUT_37	setting input 37 menu settings into PSL	Ctrl Setg I/P 37
1824	SW	DDB_SETTING_INPUT_38	setting input 38 menu settings into PSL	Ctrl Setg I/P 38
1825	SW	DDB_SETTING_INPUT_39	setting input 39 menu settings into PSL	Ctrl Setg I/P 39
1826	SW	DDB_SETTING_INPUT_40	setting input 40 menu settings into PSL	Ctrl Setg I/P 40
1827	SW	DDB_SETTING_INPUT_41	setting input 41 menu settings into PSL	Ctrl Setg I/P 41
1828	SW	DDB_SETTING_INPUT_42	setting input 42 menu settings into PSL	Ctrl Setg I/P 42
1829	SW	DDB_SETTING_INPUT_43	setting input 43 menu settings into PSL	Ctrl Setg I/P 43
1830	SW	DDB_SETTING_INPUT_44	setting input 44 menu settings into PSL	Ctrl Setg I/P 44
1831	SW	DDB_SETTING_INPUT_45	setting input 45 menu settings into PSL	Ctrl Setg I/P 45
1832	SW	DDB_SETTING_INPUT_46	setting input 46 menu settings into PSL	Ctrl Setg I/P 46
1833	SW	DDB_SETTING_INPUT_47	setting input 47 menu settings into PSL	Ctrl Setg I/P 47
1834	SW	DDB_SETTING_INPUT_48	setting input 48 menu settings into PSL	Ctrl Setg I/P 48
1835	PSL	DDB_ZONE_Q_GND_BLOCK	Zone Q ground basic scheme blocking	Block Zone Q Gnd
1836	PSL	DDB_ZONE_Q_PHS_BLOCK	Zone Q phase basic scheme blocking	Block Zone Q Phs
1837	Distance Basic Scheme	DDB_ZONE_Q_TRIP	Zone Q Trip	Zone Q Trip
1838	Distance Basic Scheme	DDB_ZONE_Q_TRIP_A	Zone Q A Phase Trip	Zone Q A Trip
1839	Distance Basic Scheme	DDB_ZONE_Q_TRIP_B	Zone Q B Phase Trip	Zone Q B Trip
1840	Distance Basic Scheme	DDB_ZONE_Q_TRIP_C	Zone Q C Phase Trip	Zone Q C Trip
1841	Distance Basic Scheme	DDB_ZONE_Q_TRIP_N	Zone Q N Phase Trip	Zone Q N Trip
1842	Trip on Close	DDB_ZONE_Q_TOR_TRIP	TOR Trip Zone Q	TOR Trip Zone Q
1843	Trip on Close	DDB_ZONE_Q_SOTF_TRIP	SOTF Trip Zone Q	SOTF Trip Zone Q
1844		DDB_BLOCK_PH_ZQ_START	Unused	Unused
1845		DDB_BLOCK_GND_ZQ_START	Unused	Unused
1846	Distance Basic Scheme	DDB_ZONE_Q_START_A	Zone Q A Phase Start	Zone Q A Start
1847	Distance Basic Scheme	DDB_ZONE_Q_START_B	Zone Q B Phase Start	Zone Q B Start
1848	Distance Basic Scheme	DDB_ZONE_Q_START_C	Zone Q C Phase Start	Zone Q C Start
1849	Distance Basic Scheme	DDB_ZONE_Q_START_N	Zone Q N Start	Zone Q N Start
1850	Distance Elements	DDB_ZONE_Q_AN	Zone Q AN ground fault element	ZoneQ AN Element
1851	Distance Elements	DDB_ZONE_Q_BN	Zone Q BN ground fault element	ZoneQ BN Element
1852	Distance Elements	DDB_ZONE_Q_CN	Zone Q CN ground fault element	ZoneQ CN Element
1853	Distance Elements	DDB_ZONE_Q_AB	Zone Q AB phase fault element	ZoneQ AB Element
1854	Distance Elements	DDB_ZONE_Q_BC	Zone Q BC phase fault element	ZoneQ BC Element
1855	Distance Elements	DDB_ZONE_Q_CA	Zone Q CA phase fault element	ZoneQ CA Element
1856	Distance diagnostic	DDB_ZONE_Q_AN_RAW	ZQ AN Comparator	ZQ AN Comparator

DDB No	Source	Element Name	Description	English Text
1857	Distance diagnostic	DDB_ZONE_Q_BN_RAW	ZQ BN Comparator	ZQ BN Comparator
1858	Distance diagnostic	DDB_ZONE_Q_CN_RAW	ZQ CN Comparator	ZQ CN Comparator
1859	Distance diagnostic	DDB_ZONE_Q_AB_RAW	ZQ AB Comparator	ZQ AB Comparator
1860	Distance diagnostic	DDB_ZONE_Q_BC_RAW	ZQ BC Comparator	ZQ BC Comparator
1861	Distance diagnostic	DDB_ZONE_Q_CA_RAW	ZQ CA Comparator	ZQ CA Comparator
1862	Distance diagnostic	DDB_ZONE_Q_BLOCKED	Zone Q Blocked by PSB	Zone Q Blocked
1863		DDB_PH_ZQ_LOW	Unused	Unused
1864		DDB_PH_ZQ_HIGH	Unused	Unused
1865		DDB_GND_ZQ_LOW	Unused	Unused
1866		DDB_GND_ZQ_HIGH	Unused	Unused
1867	SW	DDB_TS_OCN_B_S1	Trip supervision: IN> phaseB stage1	TS IN> phB s1
1868	SW	DDB_TS_OCN_B_S2	Trip supervision: IN> phaseB stage2	TS IN> phB s2
1869	SW	DDB_TS_OCN_B_S3	Trip supervision: IN> phaseB stage3	TS IN> phB s3
1870		DDB_UNUSED_1870	Unused	Unused
1871	SW	DDB_DIST_SCHEME_GENERAL_START	Distance Scheme General Start	Dis Sch Gen Str
1872	SW	DDB_DIST_DIR_TEND_ELAPSE	Directional end timer elapse	Dir End Timer
1873	SW	DDB_DIST_NON_DIR_TEND_ELAPSE	Non Directional end timer elapse	NonDir EndTimer
1874	SW	DDB_TS_OCN_C_S1	Trip supervision: IN> phaseC stage1	TS IN> phC s1
1875	SW	DDB_TS_OCN_C_S2	Trip supervision: IN> phaseC stage2	TS IN> phC s2
1876	SW	DDB_TS_OCN_C_S3	Trip supervision: IN> phaseC stage3	TS IN> phC s3
1877	SW	DDB_TS_UVPP_A_S1	Trip supervision: Vpp< phaseA stage1	TS Vpp< phA s1
1878	SW	DDB_TS_UVPP_A_S2	Trip supervision: Vpp< phaseA stage2	TS Vpp< phA s2
1879	SW	DDB_TS_UVPP_A_S3	Trip supervision: Vpp< phaseA stage3	TS Vpp< phA s3
1880		DDB_UNUSED_1880	Unused	Unused
1881	SW	DDB_Z1_TRIP_SUPERVISION_BLOCK	Supervision block on Z1 Trip	TS Dist. Z1 Blk
1882	SW	DDB_Z2_TRIP_SUPERVISION_BLOCK	Supervision block on Z2 Trip	TS Dist. Z2 Blk
1883	SW	DDB_Z3_TRIP_SUPERVISION_BLOCK	Supervision block on Z3 Trip	TS Dist. Z3 Blk
1884	SW	DDB_Z4_TRIP_SUPERVISION_BLOCK	Supervision block on Z4 Trip	TS Dist. Z4 Blk
1885	SW	DDB_ZP_TRIP_SUPERVISION_BLOCK	Supervision block on ZP Trip	TS Dist. ZP Blk
1886	SW	DDB_ZQ_TRIP_SUPERVISION_BLOCK	Supervision block on ZQ Trip	TS Dist. ZQ Blk
1887	SW	DDB_AIDED1_DIST_TRIP_SUPER_BLOCK	Supervision block on aided1 Z Trip	TS Aided1 Z Blk
1888	SW	DDB_AIDED2_DIST_TRIP_SUPER_BLOCK	Supervision block on aided2 Z Trip	TS Aided2 Z Blk
1889		DDB_IDIFF_TRIP_SUPERVISION_BLOCK	Unused	Unused
1890		DDB_TS_CDIFF_ALLOW_TRIP_A	Unused	Unused
1891		DDB_TS_CDIFF_ALLOW_TRIP_B	Unused	Unused
1892		DDB_TS_CDIFF_ALLOW_TRIP_C	Unused	Unused
1893	PSL	DDB_CBF_NONITRIP	CB Fail Non current trip	CBFNonITrip
1894	SW	DDB_TS_UVPP_B_S1	Trip supervision: Vpp< phaseB stage1	TS Vpp< phB s1
1895	SW	DDB_TS_UVPP_B_S2	Trip supervision: Vpp< phaseB stage2	TS Vpp< phB s2
1896	SW	DDB_TS_UVPP_B_S3	Trip supervision: Vpp< phaseB stage3	TS Vpp< phB s3
1897		DDB_UNUSED_1897	Unused	Unused
1898		DDB_UNUSED_1898	Unused	Unused
1899		DDB_UNUSED_1899	Unused	Unused
1900		DDB_UNUSED_1900	Unused	Unused

DDB No	Source	Element Name	Description	English Text
1901		DDB_UNUSED_1901	Unused	Unused
1902		DDB_UNUSED_1902	Unused	Unused
1903		DDB_UNUSED_1903	Unused	Unused
1904		DDB_UNUSED_1904	Unused	Unused
1905		DDB_UNUSED_1905	Unused	Unused
1906		DDB_UNUSED_1906	Unused	Unused
1907		DDB_UNUSED_1907	Unused	Unused
1908		DDB_UNUSED_1908	Unused	Unused
1909		DDB_UNUSED_1909	Unused	Unused
1910		DDB_UNUSED_1910	Unused	Unused
1911	SW	DDB_TS_UVPP_C_S1	Trip supervision: Vpp< phaseC stage1	TS Vpp< pHC s1
1912	SW	DDB_TS_UVPP_C_S2	Trip supervision: Vpp< phaseC stage2	TS Vpp< pHC s2
1913	SW	DDB_TS_UVPP_C_S3	Trip supervision: Vpp< phaseC stage3	TS Vpp< pHC s3
1914	PSL	DDB_CHAN_ALT	Alternate other analogue channels	Channel Alt
1915	PSL	DDB_VCS1_ALT	Alternate VCS 1	Check Sync Alt1
1916		DDB_UNUSED_1916	Unused	Unused
1917	SW	DDB_PB_LINK_1_FAIL	Process Bus Network Interface link 1 fail indication	PB Link 1 Fail
1918	SW	DDB_PB_LINK_2_FAIL	Process Bus Network Interface link 2 fail indication	PB Link 2 Fail
1919	SW	DDB_PB_LINK_3_FAIL	Process Bus Network Interface link 3 fail indication	PB Link 3 Fail
1920	SW	DDB_MU1_ABSENCE	MU1 Absence	MU1 Absence
1921	SW	DDB_MU2_ABSENCE	MU2 Absence	MU2 Absence
1922	SW	DDB_MU3_ABSENCE	MU3 Absence	MU3 Absence
1923	SW	DDB_MU4_ABSENCE	MU4 Absence	MU4 Absence
1924	SW	DDB_MU5_ABSENCE	MU5 Absence	MU5 Absence
1925	SW	DDB_MU6_ABSENCE	MU6 Absence	MU6 Absence
1926	SW	DDB_MU7_ABSENCE	MU7 Absence	MU7 Absence
1927	SW	DDB_MU8_ABSENCE	MU8 Absence	MU8 Absence
1928	SW	DDB_MAIN_VT_INHIBIT	Main VT Inhibit	Main VT Inhibit
1929	SW	DDB_CS_VT1_INHIBIT	CS VT1 Inhibit	CS VT1 Inhibit
1930	SW	DDB_PHASE_CT1_INHIBIT	Phs CT1 Inhibit	Phs CT1 Inhibit
1931		DDB_UNUSED_1931	Unused	Unused
1932	SW	DDB_SEF_CT_INHIBIT	SEF CT Inhibit	SEF CT Inhibit
1933		DDB_UNUSED_1933	Unused	Unused
1934		DDB_UNUSED_1934	Unused	Unused
1935	SW	DDB_MAIN_VT_SYNC_ALM	Main VT Synch alarm	Main VT Sync Alm
1936	SW	DDB_CS_VT1_SYNC_ALM	CS VT1 Synch alarm	CS VT1 Sync Alm
1937	SW	DDB_PHASE_CT1_SYNC_ALM	Phs CT1 Synch alarm	Phs CT1 Sync Alm
1938		DDB_UNUSED_1938	Unused	Unused
1939	SW	DDB_SEF_CT_SYNC_ALM	SEF CT Synch alarm	SEF CT Sync Alm
1940		DDB_UNUSED_1940	Unused	Unused
1941	PSL	DDB_INT_CBF_INIT_3PH	CBF Internal Initialization trip 3 phase	CBF Int Init 3ph
1942	PSL	DDB_EXT_CBF_INIT_3PH	CBF External Initialization trip 3 phase	CBF Ext Init 3ph

DDB No	Source	Element Name	Description	English Text
1943	PSL	DDB_EXT_CBF_INIT_A	Unused	Unused
1944	PSL	DDB_EXT_CBF_INIT_B	Unused	Unused
1945	PSL	DDB_EXT_CBF_INIT_C	Unused	Unused
1946	PSL	DDB_EXT_CBF_INIT_3PH_CB2	Unused	Unused
1947	PSL	DDB_EXT_CBF_INIT_A_CB2	Unused	Unused
1948	PSL	DDB_EXT_CBF_INIT_B_CB2	Unused	Unused
1949	PSL	DDB_EXT_CBF_INIT_C_CB2	Unused	Unused
1950	PSL	DDB_INT_CBF_INIT_A	Unused	Unused
1951	PSL	DDB_INT_CBF_INIT_B	Unused	Unused
1952	PSL	DDB_INT_CBF_INIT_C	Unused	Unused
1953	PSL	DDB_INT_CBF_INIT_A_CB2	Unused	Unused
1954	PSL	DDB_INT_CBF_INIT_B_CB2	Unused	Unused
1955	PSL	DDB_INT_CBF_INIT_C_CB2	Unused	Unused
1956	SW	DDB_TS_UVPN_A_S1	Trip supervision: Vpn< phaseA stage1	TS Vpn< pH A s1
1957	SW	DDB_TS_UVPN_A_S2	Trip supervision: Vpn< phaseA stage2	TS Vpn< pH A s2
1958	SW	DDB_TS_UVPN_A_S3	Trip supervision: Vpn< phaseA stage3	TS Vpn< pH A s3
1959	SW	DDB_TS_UVPN_B_S1	Trip supervision: Vpn< phaseB stage1	TS Vpn< pH B s1
1960	SW	DDB_TS_UVPN_B_S2	Trip supervision: Vpn< phaseB stage2	TS Vpn< pH B s2
1961	SW	DDB_TS_UVPN_B_S3	Trip supervision: Vpn< phaseB stage3	TS Vpn< pH B s3
1962	SW	DDB_TS_UVPN_C_S1	Trip supervision: Vpn< phaseC stage1	TS Vpn< pH C s1
1963	SW	DDB_TS_UVPN_C_S2	Trip supervision: Vpn< phaseC stage2	TS Vpn< pH C s2
1964	SW	DDB_TS_UVPN_C_S3	Trip supervision: Vpn< phaseC stage3	TS Vpn< pH C s3
1965	SW	DDB_TS_OCD_A_S1	Trip supervision: OCD> phaseA stage1	TS OCD> pH A s1
1966	SW	DDB_TS_OCD_A_S2	Trip supervision: OCD> phaseA stage2	TS OCD> pH A s2
1967	SW	DDB_TS_OCD_A_S3	Trip supervision: OCD> phaseA stage3	TS OCD> pH A s3
1968	SW	DDB_TS_OCD_B_S1	Trip supervision: OCD> phaseB stage1	TS OCD> pH B s1
1969	SW	DDB_TS_OCD_B_S2	Trip supervision: OCD> phaseB stage2	TS OCD> pH B s2
1970	SW	DDB_TS_OCD_B_S3	Trip supervision: OCD> phaseB stage3	TS OCD> pH B s3
1971	SW	DDB_TS_OCD_C_S1	Trip supervision: OCD> phaseC stage1	TS OCD> pH C s1
1972	SW	DDB_TS_OCD_C_S2	Trip supervision: OCD> phaseC stage2	TS OCD> pH C s2
1973	SW	DDB_TS_OCD_C_S3	Trip supervision: OCD> phaseC stage3	TS OCD> pH C s3
1974	SW	DDB_TS_UVD_A_S1	Trip supervision: UVD> phaseA stage1	TS UVD> pH A s1
1975	SW	DDB_TS_UVD_A_S2	Trip supervision: UVD> phaseA stage2	TS UVD> pH A s2
1976	SW	DDB_TS_UVD_A_S3	Trip supervision: UVD> phaseA stage3	TS UVD> pH A s3
1977	SW	DDB_TS_UVD_B_S1	Trip supervision: UVD> phaseB stage1	TS UVD> pH B s1
1978	SW	DDB_TS_UVD_B_S2	Trip supervision: UVD> phaseB stage2	TS UVD> pH B s2
1979	SW	DDB_TS_UVD_B_S3	Trip supervision: UVD> phaseB stage3	TS UVD> pH B s3
1980	SW	DDB_TS_UVD_C_S1	Trip supervision: UVD> phaseC stage1	TS UVD> pH C s1
1981	SW	DDB_TS_UVD_C_S2	Trip supervision: UVD> phaseC stage2	TS UVD> pH C s2
1982	SW	DDB_TS_UVD_C_S3	Trip supervision: UVD> phaseC stage3	TS UVD> pH C s3
1983		DDB_UNUSED_1983	Unused	Unused
1984	PSL	DDB_TIMERIN_1	Input to auxiliary timer 1	Timer in 1
1985	PSL	DDB_TIMERIN_2	Input to auxiliary timer 2	Timer in 2
1986	PSL	DDB_TIMERIN_3	Input to auxiliary timer 3	Timer in 3

DDB No	Source	Element Name	Description	English Text
1987	PSL	DDB_TIMERIN_4	Input to auxiliary timer 4	Timer in 4
1988	PSL	DDB_TIMERIN_5	Input to auxiliary timer 5	Timer in 5
1989	PSL	DDB_TIMERIN_6	Input to auxiliary timer 6	Timer in 6
1990	PSL	DDB_TIMERIN_7	Input to auxiliary timer 7	Timer in 7
1991	PSL	DDB_TIMERIN_8	Input to auxiliary timer 8	Timer in 8
1992	PSL	DDB_TIMERIN_9	Input to auxiliary timer 9	Timer in 9
1993	PSL	DDB_TIMERIN_10	Input to auxiliary timer 10	Timer in 10
1994	PSL	DDB_TIMERIN_11	Input to auxiliary timer 11	Timer in 11
1995	PSL	DDB_TIMERIN_12	Input to auxiliary timer 12	Timer in 12
1996	PSL	DDB_TIMERIN_13	Input to auxiliary timer 13	Timer in 13
1997	PSL	DDB_TIMERIN_14	Input to auxiliary timer 14	Timer in 14
1998	PSL	DDB_TIMERIN_15	Input to auxiliary timer 15	Timer in 15
1999	PSL	DDB_TIMERIN_16	Input to auxiliary timer 16	Timer in 16
2000	PSL	DDB_TIMERIN_17	Input to auxiliary timer 17	Timer in 17
2001	PSL	DDB_TIMERIN_18	Input to auxiliary timer 18	Timer in 18
2002	PSL	DDB_TIMERIN_19	Input to auxiliary timer 19	Timer in 19
2003	PSL	DDB_TIMERIN_20	Input to auxiliary timer 20	Timer in 20
2004	PSL	DDB_TIMERIN_21	Input to auxiliary timer 21	Timer in 21
2005	PSL	DDB_TIMERIN_22	Input to auxiliary timer 22	Timer in 22
2006	PSL	DDB_TIMERIN_23	Input to auxiliary timer 23	Timer in 23
2007	PSL	DDB_TIMERIN_24	Input to auxiliary timer 24	Timer in 24
2008	PSL	DDB_TIMERIN_25	Input to auxiliary timer 25	Timer in 25
2009	PSL	DDB_TIMERIN_26	Input to auxiliary timer 26	Timer in 26
2010	PSL	DDB_TIMERIN_27	Input to auxiliary timer 27	Timer in 27
2011	PSL	DDB_TIMERIN_28	Input to auxiliary timer 28	Timer in 28
2012	PSL	DDB_TIMERIN_29	Input to auxiliary timer 29	Timer in 29
2013	PSL	DDB_TIMERIN_30	Input to auxiliary timer 30	Timer in 30
2014	PSL	DDB_TIMERIN_31	Input to auxiliary timer 31	Timer in 31
2015	PSL	DDB_TIMERIN_32	Input to auxiliary timer 32	Timer in 32
2016	Auxiliary Timer	DDB_TIMEROUT_1	Output from auxiliary timer 1	Timer out 1
2017	Auxiliary Timer	DDB_TIMEROUT_2	Output from auxiliary timer 2	Timer out 2
2018	Auxiliary Timer	DDB_TIMEROUT_3	Output from auxiliary timer 3	Timer out 3
2019	Auxiliary Timer	DDB_TIMEROUT_4	Output from auxiliary timer 4	Timer out 4
2020	Auxiliary Timer	DDB_TIMEROUT_5	Output from auxiliary timer 5	Timer out 5
2021	Auxiliary Timer	DDB_TIMEROUT_6	Output from auxiliary timer 6	Timer out 6
2022	Auxiliary Timer	DDB_TIMEROUT_7	Output from auxiliary timer 7	Timer out 7
2023	Auxiliary Timer	DDB_TIMEROUT_8	Output from auxiliary timer 8	Timer out 8
2024	Auxiliary Timer	DDB_TIMEROUT_9	Output from auxiliary timer 9	Timer out 9
2025	Auxiliary Timer	DDB_TIMEROUT_10	Output from auxiliary timer 10	Timer out 10
2026	Auxiliary Timer	DDB_TIMEROUT_11	Output from auxiliary timer 11	Timer out 11
2027	Auxiliary Timer	DDB_TIMEROUT_12	Output from auxiliary timer 12	Timer out 12
2028	Auxiliary Timer	DDB_TIMEROUT_13	Output from auxiliary timer 13	Timer out 13
2029	Auxiliary Timer	DDB_TIMEROUT_14	Output from auxiliary timer 14	Timer out 14
2030	Auxiliary Timer	DDB_TIMEROUT_15	Output from auxiliary timer 15	Timer out 15

DDB No	Source	Element Name	Description	English Text
2031	Auxiliary Timer	DDB_TIMEROUT_16	Output from auxiliary timer 16	Timer out 16
2032	Auxiliary Timer	DDB_TIMEROUT_17	Output from auxiliary timer 17	Timer out 17
2033	Auxiliary Timer	DDB_TIMEROUT_18	Output from auxiliary timer 18	Timer out 18
2034	Auxiliary Timer	DDB_TIMEROUT_19	Output from auxiliary timer 19	Timer out 19
2035	Auxiliary Timer	DDB_TIMEROUT_20	Output from auxiliary timer 20	Timer out 20
2036	Auxiliary Timer	DDB_TIMEROUT_21	Output from auxiliary timer 21	Timer out 21
2037	Auxiliary Timer	DDB_TIMEROUT_22	Output from auxiliary timer 22	Timer out 22
2038	Auxiliary Timer	DDB_TIMEROUT_23	Output from auxiliary timer 23	Timer out 23
2039	Auxiliary Timer	DDB_TIMEROUT_24	Output from auxiliary timer 24	Timer out 24
2040	Auxiliary Timer	DDB_TIMEROUT_25	Output from auxiliary timer 25	Timer out 25
2041	Auxiliary Timer	DDB_TIMEROUT_26	Output from auxiliary timer 26	Timer out 26
2042	Auxiliary Timer	DDB_TIMEROUT_27	Output from auxiliary timer 27	Timer out 27
2043	Auxiliary Timer	DDB_TIMEROUT_28	Output from auxiliary timer 28	Timer out 28
2044	Auxiliary Timer	DDB_TIMEROUT_29	Output from auxiliary timer 29	Timer out 29
2045	Auxiliary Timer	DDB_TIMEROUT_30	Output from auxiliary timer 30	Timer out 30
2046	Auxiliary Timer	DDB_TIMEROUT_31	Output from auxiliary timer 31	Timer out 31
2047	Auxiliary Timer	DDB_TIMEROUT_32	Output from auxiliary timer 32	Timer out 32

Table 1 - Digital database point list sorted by DDB number

3 FACTORY DEFAULT PROGRAMMABLE SCHEME LOGIC (PSL) SCHEMES

The following section details the default settings of the PSL.

The P445 model options are as follows:

Model	Opto inputs	Relay outputs
P445xxxAxxxxxxK	8	8 standard
P445xxxBxxxxxxK	12	12 standard
P445xxxCxxxxxxK	16	16 standard
P445xxxDxxxxxxK	16	8 standard and 4 high break

Table 2 - Factory default PSL settings

4 LOGIC INPUT AND OUTPUT MAPPINGS

4.1 Logic Input Mappings

The default mappings for each of the opto-isolated inputs are as shown in this table:

Opto-input No	P445 relay text	Function
1	Input L1	Setting Group selection
2	Input L2	Setting Group selection
3	Input L3	Aided 1 Scheme Rx
4	Input L4	Aided 1 COS/LGS
5	Input L5	External indication reset
6	Input L6	External Trip3ph
7	Input L7	MCB (miniature CB) aux. contact input
8	Input L8	CB Aux 3ph(52-B)
9	L9 Not Mapped	L9 Not Mapped
10	L10 Not Mapped	L10 Not Mapped
11	L11 Not Mapped	L11 Not Mapped
12	L12 Not Mapped	L12 Not Mapped
13	L13 Not Mapped	L13 Not Mapped
14	L14 Not Mapped	L14 Not Mapped
15	L15 Not Mapped	L15 Not Mapped
16	L16 Not Mapped	L16 Not Mapped

Note If the **Setting Group** cell in the **CONFIGURATION** column is set to **Select via Opto**, the opto's that are used for changing setting groups are always opto's 1 and 2. This mapping is effectively hardwired and does not therefore need to be mapped within the PSL.

Note Model A has eight inputs, model B has 12, and models C and D have 16. Ignore those that are not applicable to the particular model in question.

Table 3 - Default opto-isolated input mappings

4.2 Standard Relay Output Contact Mappings

The default mappings for each of the relay output contacts for P445 models A, B, and C are as shown in the following table:

Relay contact No	P445 (A, B, or C) relay text	P445 relay conditioner	Function
1	Output R1	Dwell 100 ms	Any Trip
2	Output R2	Straight	Any Start indication
3	Output R3	Dwell 100 ms	Any Trip
4	Output R4	Dwell 500 ms	General Alarm indication
5	Output R5	Straight	Control Close command
6	Output R6	Straight	Control Trip command
7	Output R7	Straight	Aided 1 Send
8	Output R8	Straight	Block AR indication
9	Output R9	Not Mapped	R9 Not Mapped
10	Output R10	Not Mapped	R10 Not Mapped
11	Output R11	Not Mapped	R11 Not Mapped
12	Output R12	Not Mapped	R12 Not Mapped
13	Output R13	Not Mapped	R13 Not Mapped
14	Output R14	Not Mapped	R14 Not Mapped
15	Output R15	Not Mapped	R15 Not Mapped
16	Output R16	Not Mapped	R16 Not Mapped

Note A fault record can be generated by connecting one or a number of contacts to the Fault Record Trigger in PSL. It is recommended that the triggering contact be 'self reset' and not a latching. If a latching contact were chosen the fault record would not be generated until the contact had fully reset.



Note It is essential that Relay 3 is used for tripping purposes as this output drives the trip LED on the frontplate. It also feeds into other logic sections that require CB trip information such as the CB fail, auto-reclose, condition monitoring etc.

Note Model A has eight inputs, model B has 12, and models C and D have 16. Ignore those that are not applicable to the particular model in question.

Table 4 - Default relay output contact mappings for P445

4.3

Optional High Break Relay Output Contact Mappings (P445 model D)

The default mappings for each of the standard and high break relay output contacts for the P445 model D are as shown in this table:

Relay contact No	Relay Text	Relay Conditioner	Function	High break contacts
1	Output R1	Dwell 100 ms	Any Trip	
2	Output R2	Straight	Any Start indication	
3	Output R3	Dwell 100 ms	Any Trip	
4	Output R4	Dwell 500 ms	General Alarm indication	
5	Output R5	Straight	Control Close command	
6	Output R6	Straight	Control Trip command	
7	Output R7	Straight	Aided 1 Send	
8	Output R8	Straight	Block AR indication	
9	Output R9	Dwell 100 ms	Any Trip	Yes
10	Output R10	Dwell 100 ms	Any Trip	Yes
11	Output R11	Dwell 100 ms	Any Trip	Yes
12	Output R12	Dwell 100 ms	Any Trip	Yes

Table 5 - Default standard and high break output contact mappings for P445 Model D

4.4 Programmable LED Output Mappings

The default mappings for each of the programmable LEDs are as shown in this table:

LED No	Latched	P445 LED function indication
1	Yes	Zone 1 or Aided Trip Indication
2	Yes	Z2 Trip indication
3	Yes	Zone 3 Trip indication
4	Yes	Zone 4 Trip indication
5	Yes	Aided DEF Trip indication
6	No	AR 3ph in progress
7	No	AR Lockout
8	No	AR Status 3p indication

Table 6 - Default mappings for programmable LEDs

4.5 Fault Recorder Start Mappings

The default mappings for the signal which initiates a fault record is as shown below:

Initiating Signal	Fault Trigger
DDB Any Trip (522)	Initiate fault recording from main protection trip

Table 7 - Fault recorder start mappings

4.6 PSL Data Column

The relay contains a PSL DATA column that can be used to track PSL modifications. A total of 12 cells are contained in the PSL DATA column, 3 for each setting group. The function for each cell is shown below:

Grp PSL Ref

When downloading a PSL to the relay, the user will be prompted to enter which groups the PSL is for and a reference ID. The first 32 characters of the reference ID will be displayed in this cell.

The 4 and 6 keys can be used to scroll through 32 characters as only 16 can be displayed at any one time.

18 Nov 2002 08:59:32.047

This cell displays the date and time when the PSL was down loaded to the relay.

Grp 1 PSL ID - 2062813232

This is a unique number for the PSL that has been entered. Any change in the PSL will result in a different number being displayed.

<i>Note</i> <i>The above cells are repeated for each setting group.</i>

4.7 PSL Signal Grouping Modes

There are now four additional **DDB Group Sig x** Nodes that can be mapped to individual or multiple DDBs in the PSL. These can then be set to trigger the DR via the DISTURBANCE RECORD menu.

These "Nodes" are general and can also be used to group signals together in the PSL for any other reason. These four nodes are available in each of the four PSL setting groups.

Number	PSL Group Sig
992	PSL Group Sig 1
993	PSL Group Sig 2
994	PSL Group Sig 3
995	PSL Group Sig 4

1. For a control input, the DR can be triggered directly by triggering directly from the Individual Control Input (e.g. Low to High (L to H) change)
2. For an input that cannot be triggered directly, or where any one of a number of DDBs are required to trigger a DR, map the DDBs to the new PSL Group sig n and then trigger the DR on this.

e.g. in the PSL:

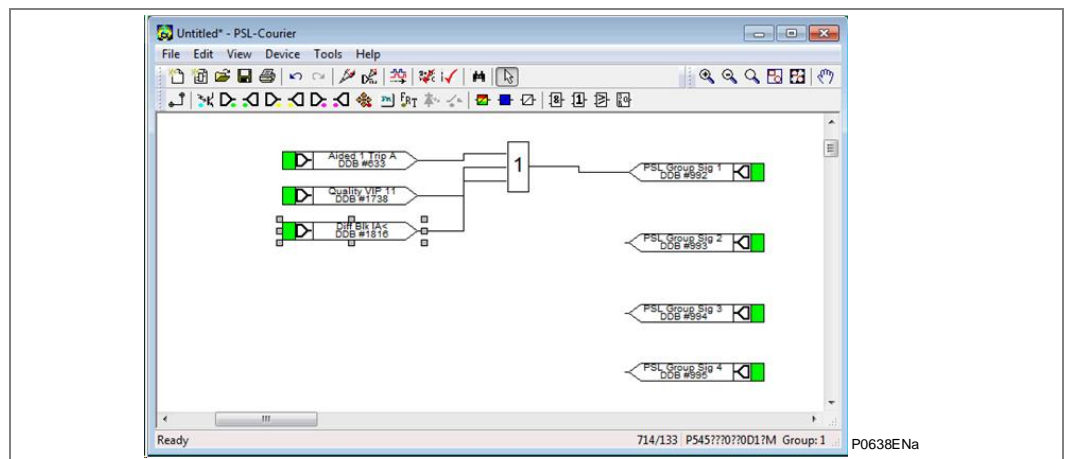

In the DR Settings:

- Digital Input 1 is triggered by the PSL Group Sig 1 (L to H)
- Digital Input 2 is triggered by Control Input 1 (L to H)

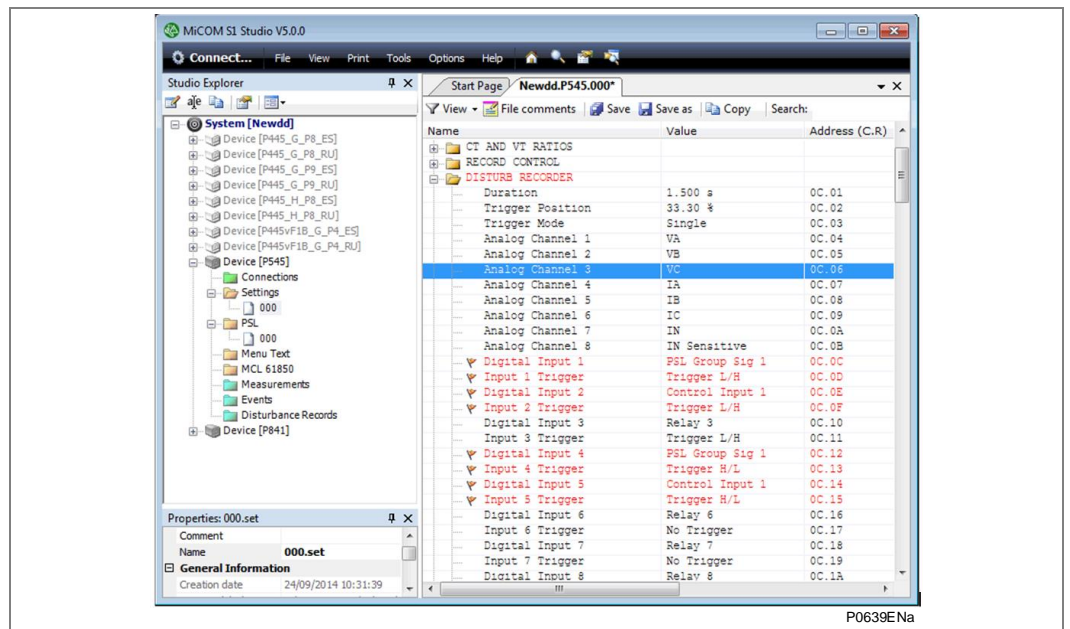

If triggering on both edges is required map another DR channel to the H/L as well

Digital Input 4 is triggered by the PSL Group Sig 1 (H to L)

Digital Input 5 is triggered by Control Input 1 (H to L)

5 VIEWING AND PRINTING DEFAULT PSL DIAGRAMS

5.1 Typical Mappings

It is possible to view and print the default PSL diagrams for the device. Typically, these diagrams allow you to see these mappings:

- Opto Input Mappings
- Output Relay Mappings
- LED Mappings
- Start Indications
- Phase Trip Mappings
- System Check Mapping

Important

The following PSL diagrams show the DDB numbers for a specific MiCOM product, with a specific software version to run on a specific hardware platform. Descriptions, DDB Numbers, Inputs and Outputs may vary for different products, software or hardware.

5.2 Download and Print PSL Diagrams

To download and print the default PSL diagrams for the device:

1. Close Easergy Studio.
2. Select **Programs** > then navigate through to > **Easergy Studio** > **Data Model Manager**.
3. Click **Add** then **Next**.
4. Click **Internet** then **Next**.
5. Select your language then click **Next**.
6. From the tree view, select the model and software version.
7. Click **Install**. When complete click **OK**.
8. Close the Data Model Manager and start Easergy Studio.
9. Select Tools > PSL Editor (Px40).
10. In the PSL Editor select **File** > **Open**. The downloaded PSL files are in C:\Program Files\ directory located in the \Easergy Studio\Courier\PSL\Defaults sub-directory.
11. Highlight the required PSL diagram and select **File** > **Print**.

6 P445 WITH STANDARD CONTACTS PSL

6.1 Opto Input Mappings

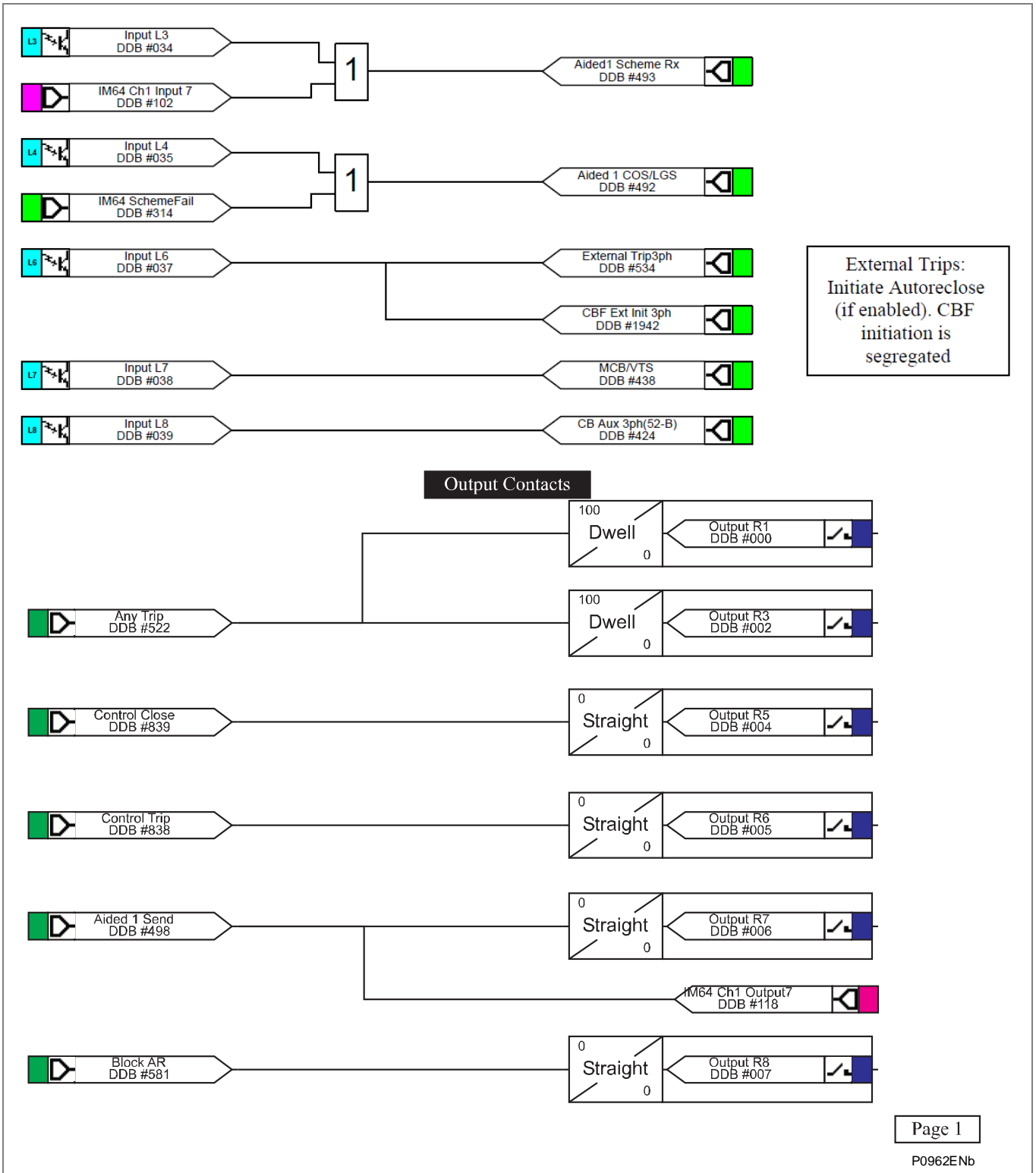

6.2 Output Contacts

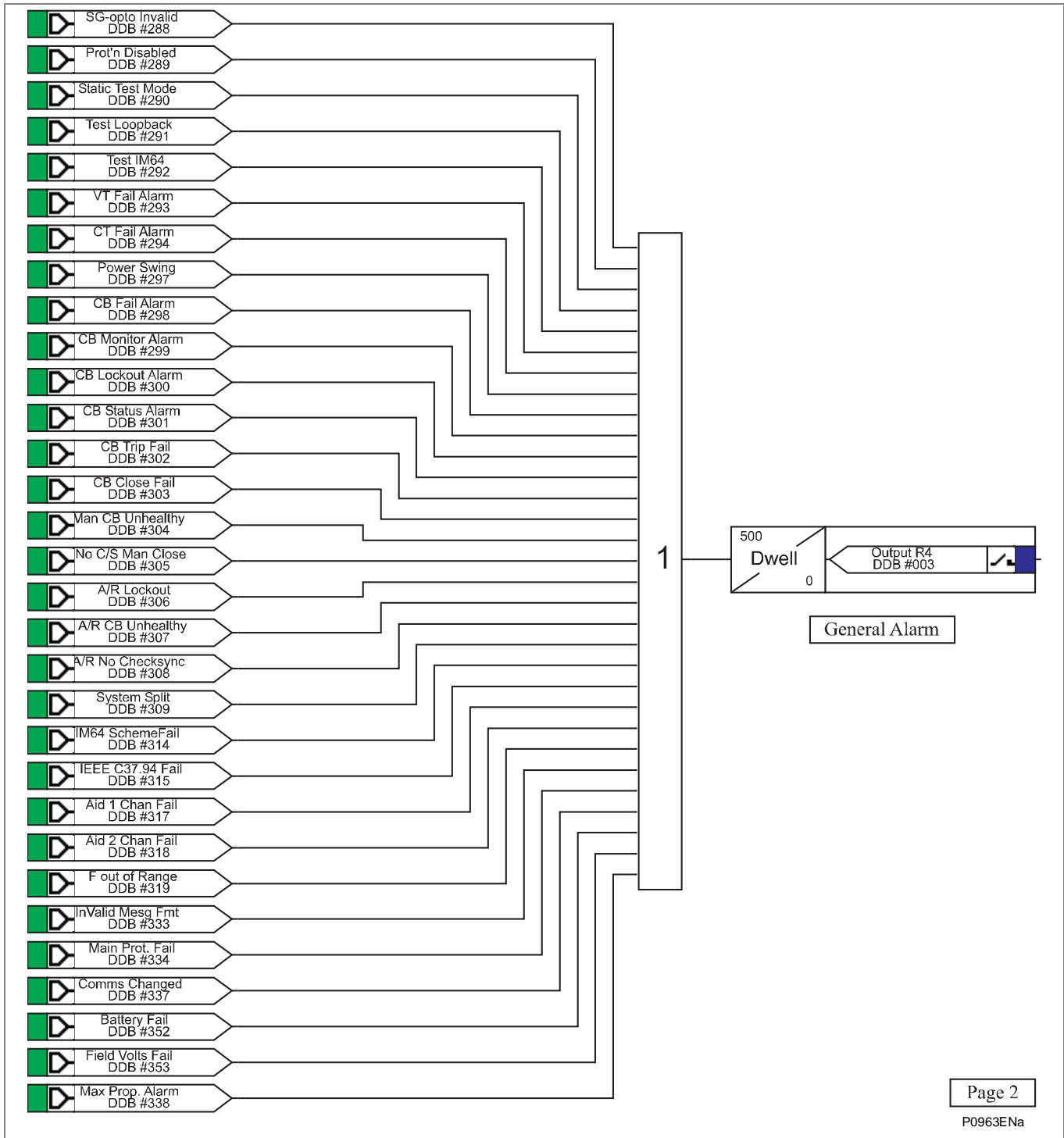

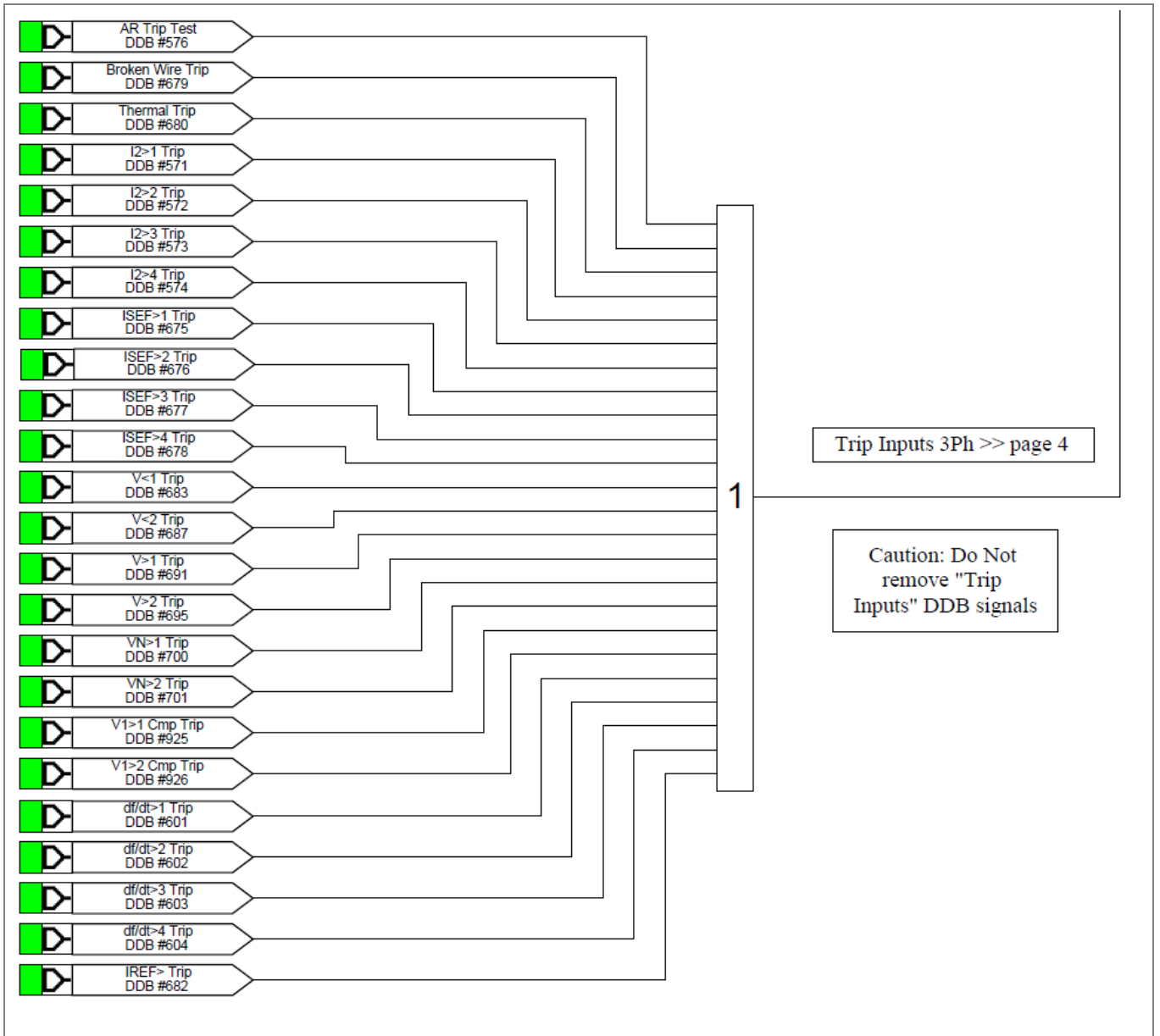

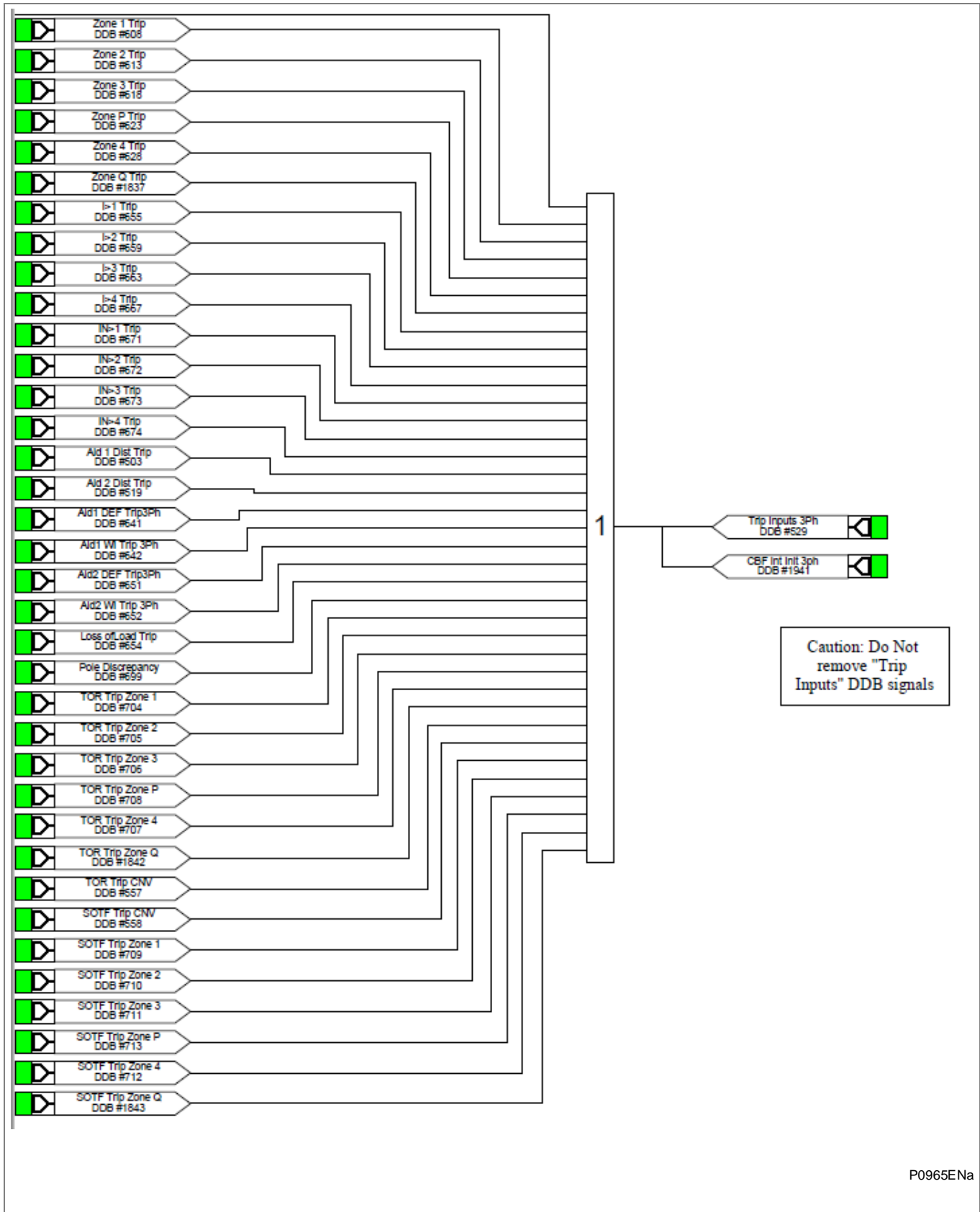

6.3 LEDs

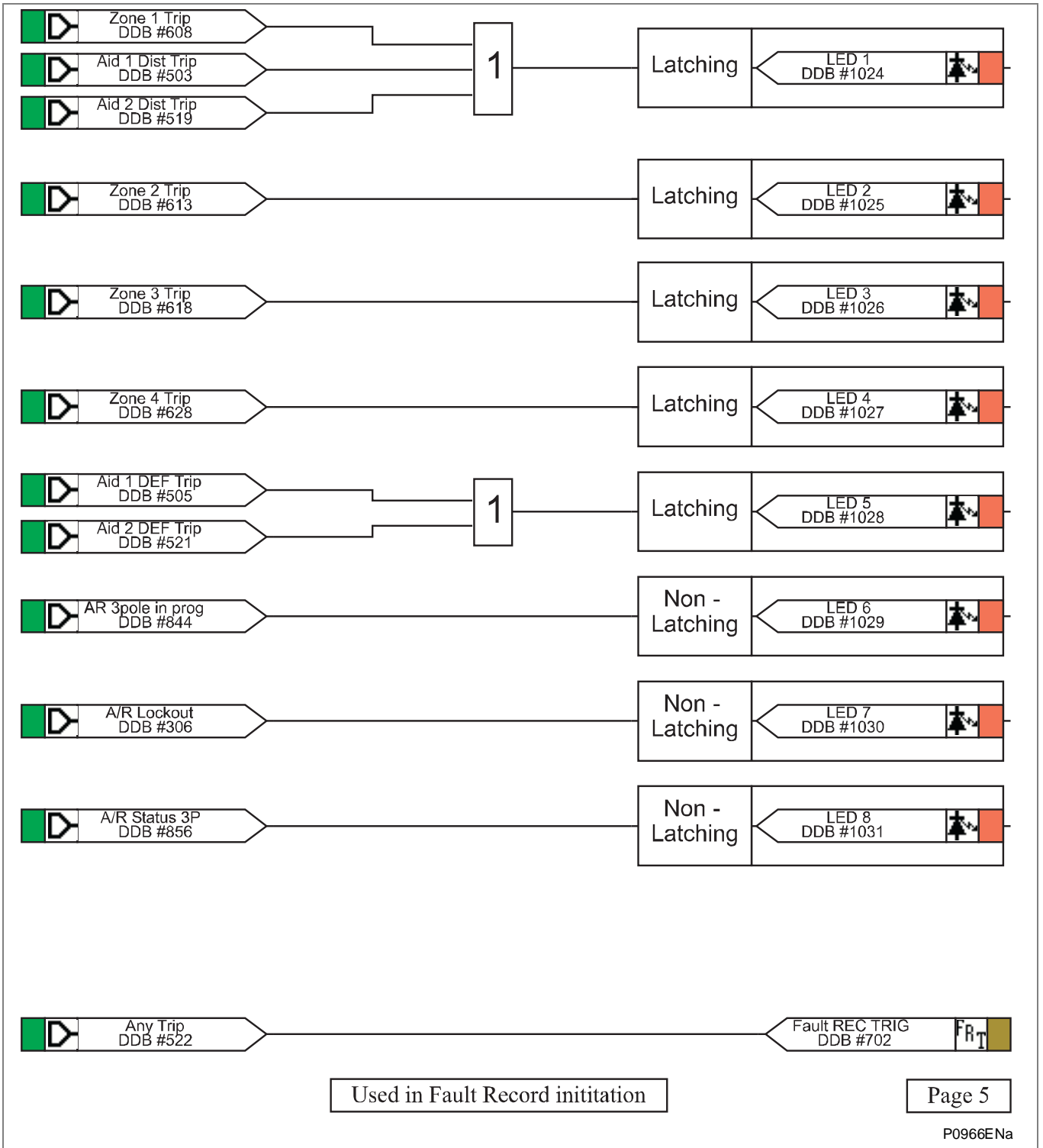

6.4 Start Phase Mappings

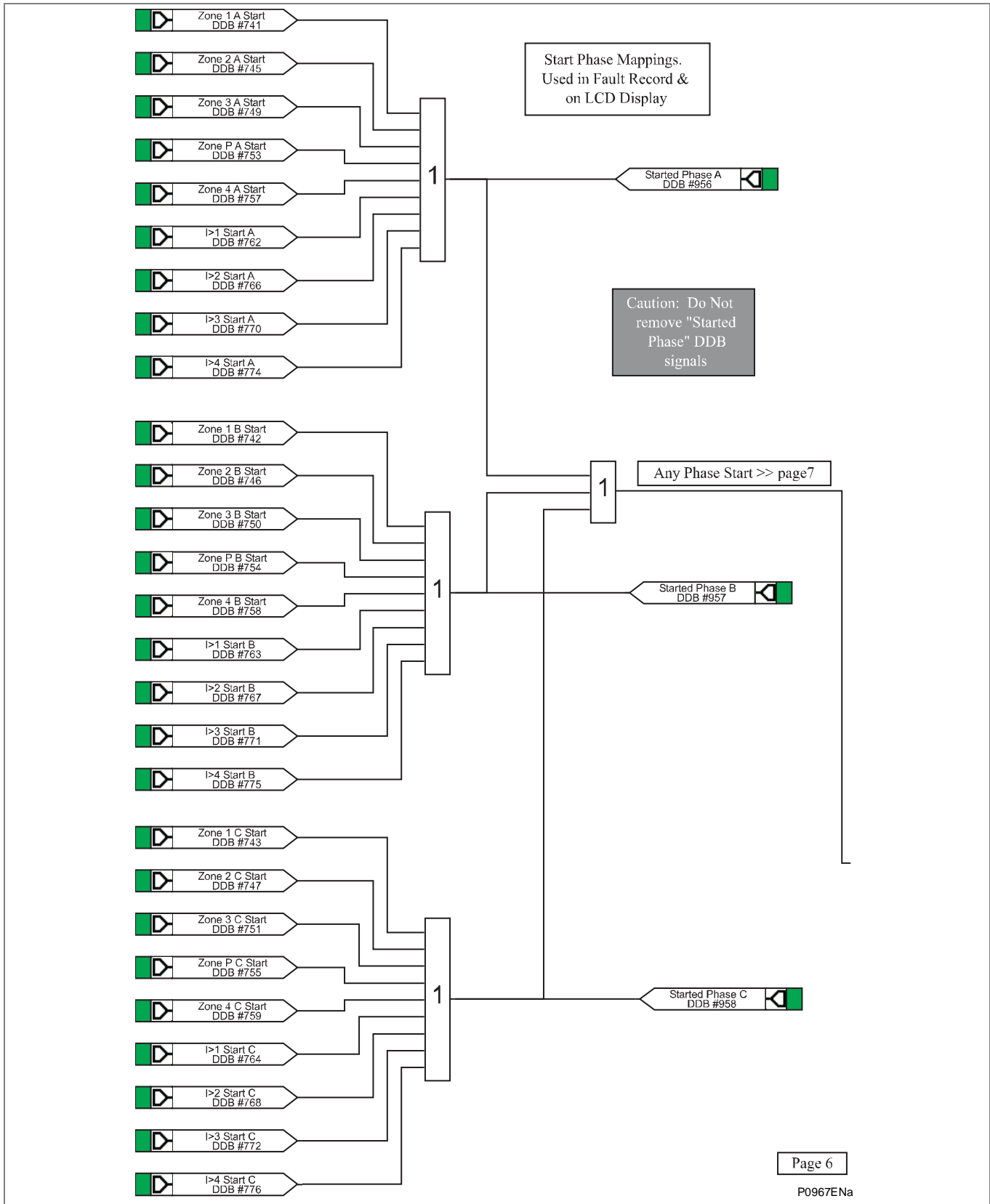

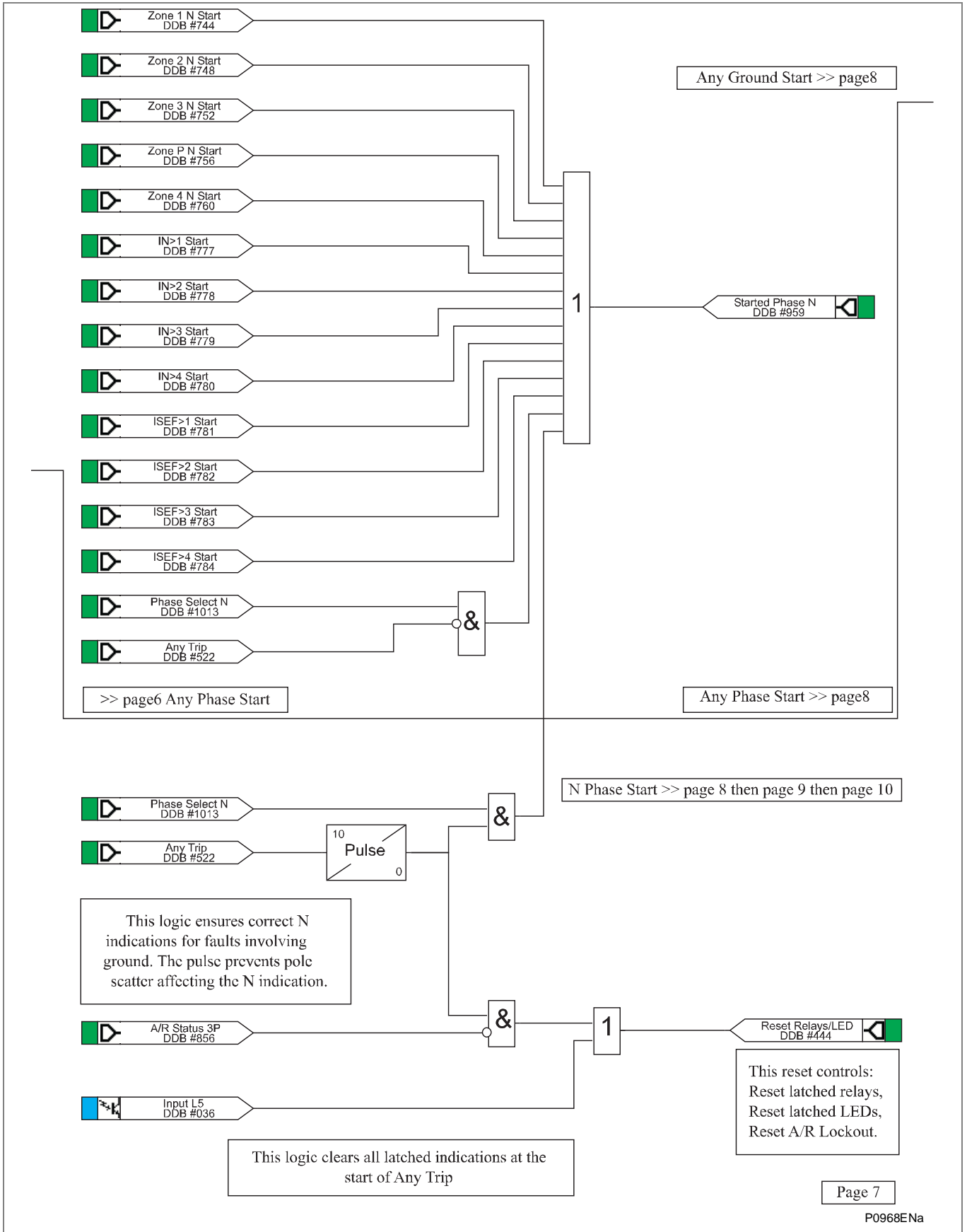

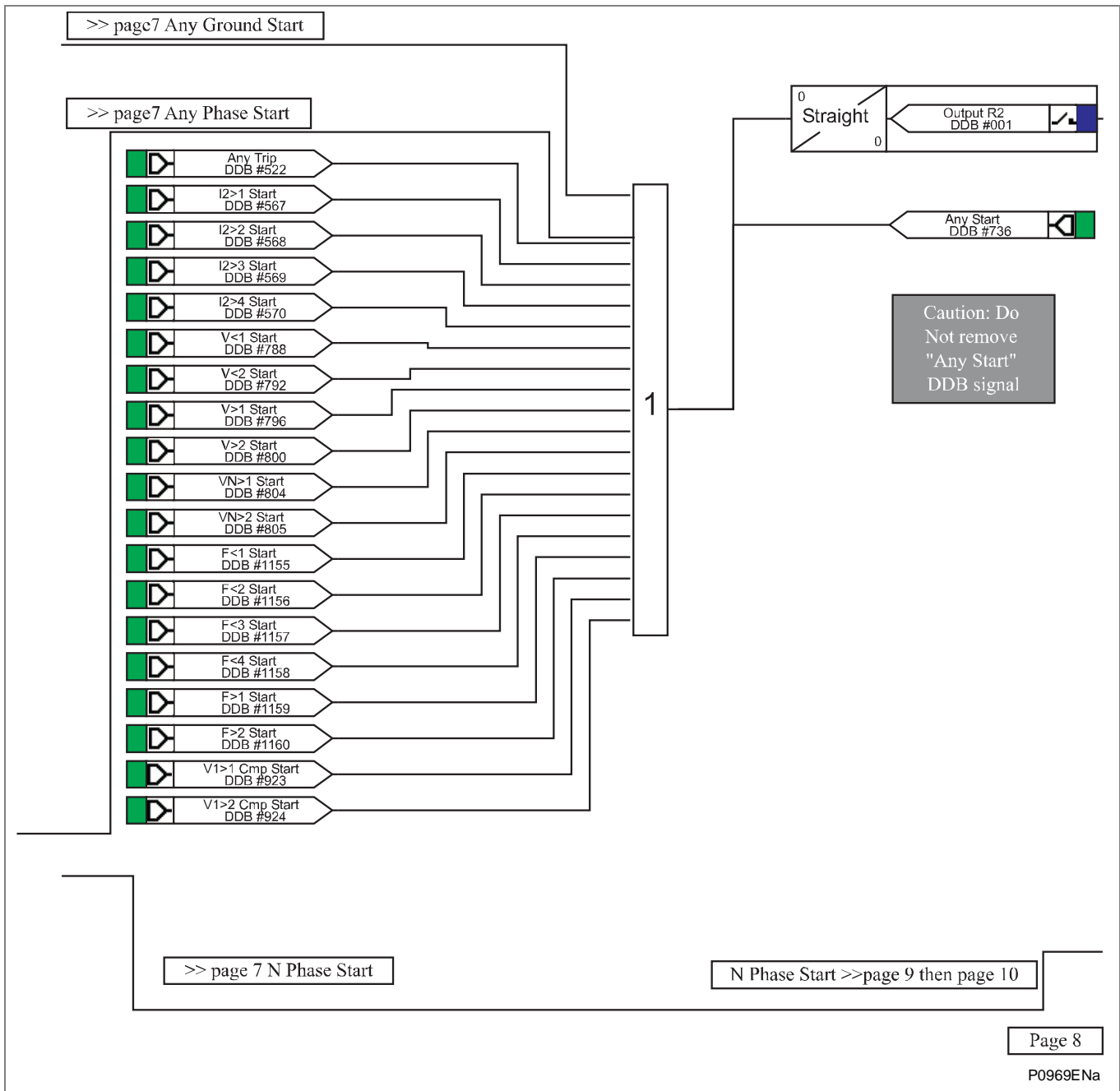

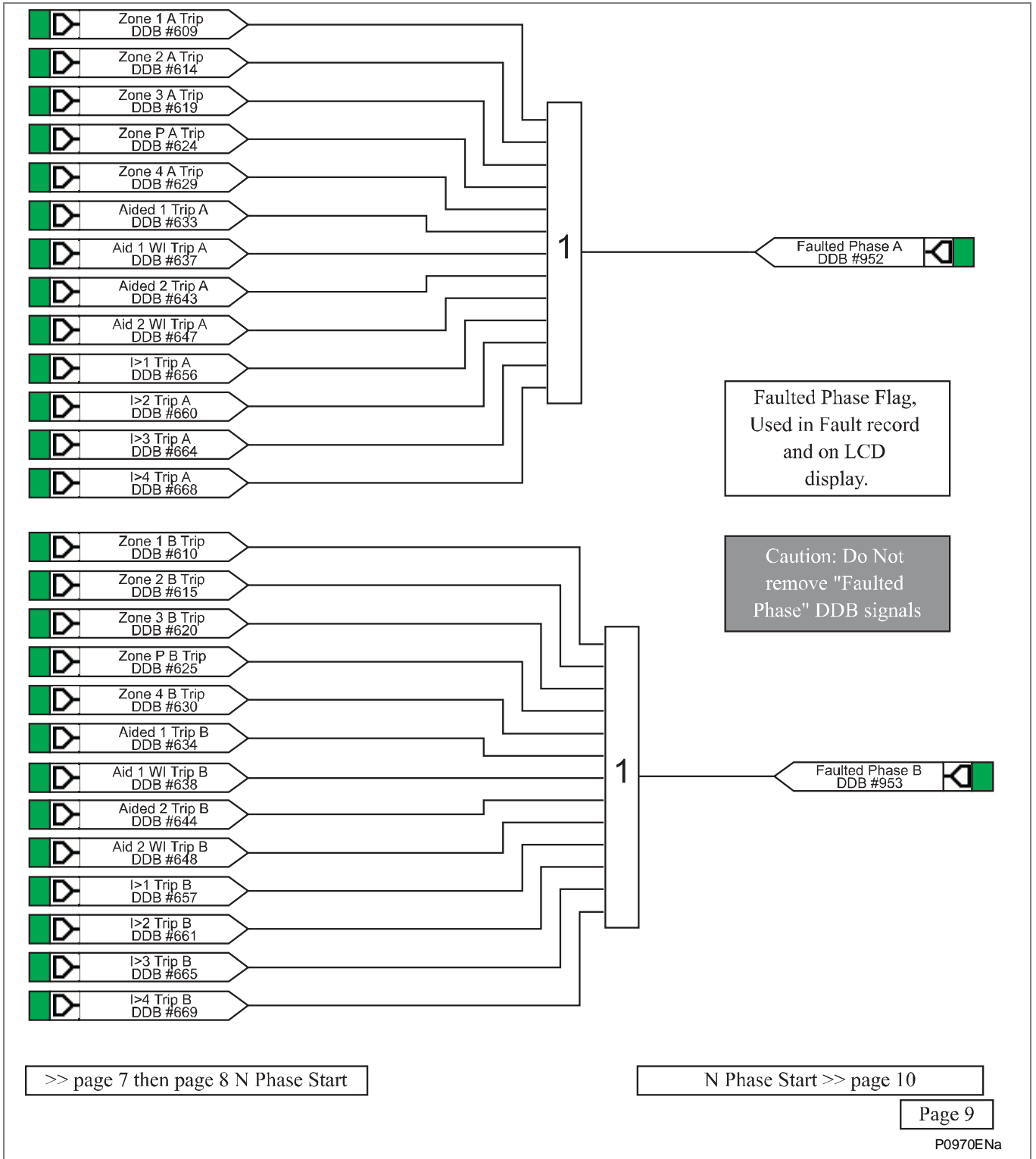

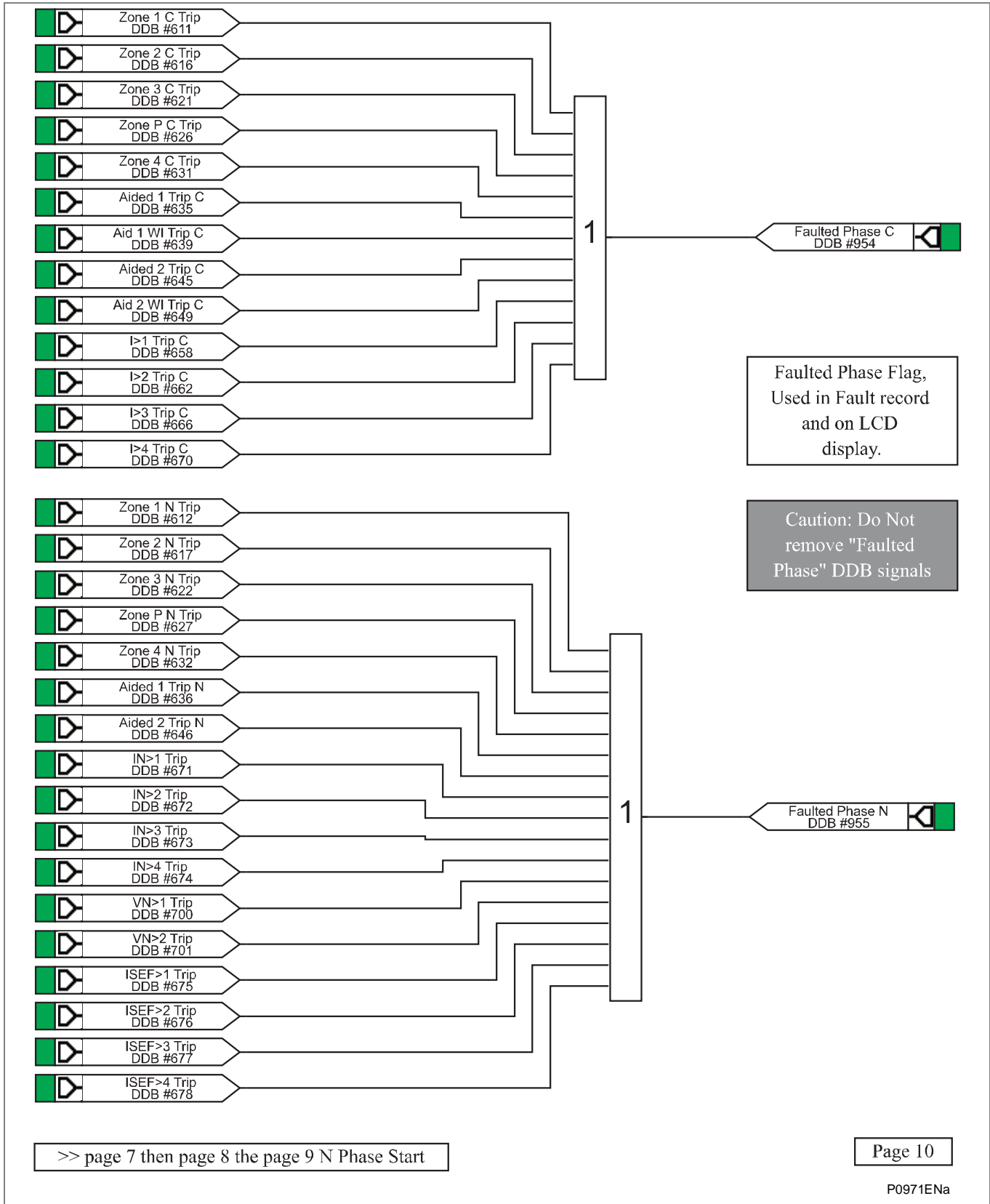

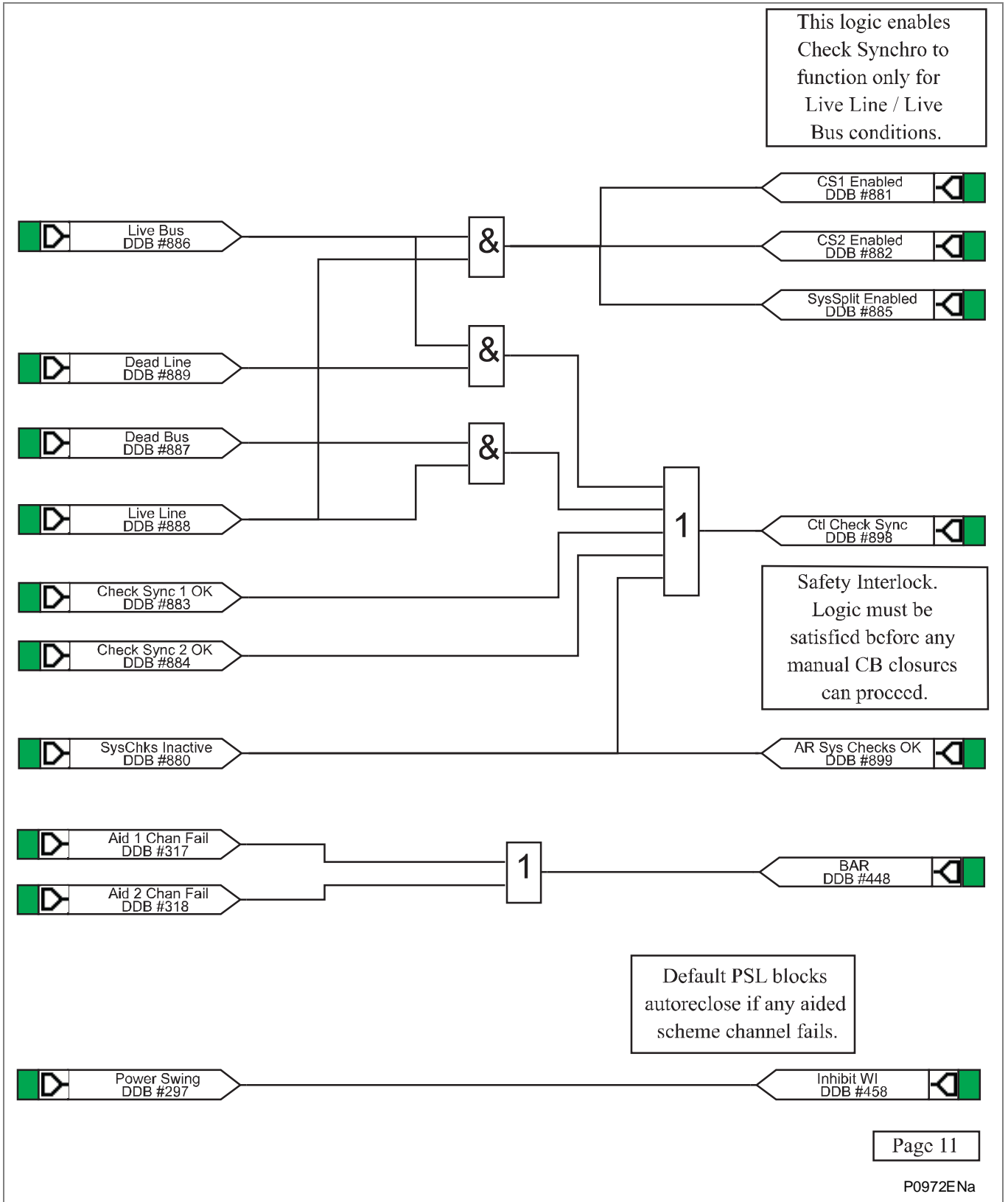

Notes:

MEASUREMENTS AND RECORDING

CHAPTER 9

Date:	11/2022
Products covered by this chapter:	This chapter covers the specific versions of the MiCOM products listed below. This includes only the following combinations of Software Version and Hardware Suffix.
Hardware Suffix:	L
Software Version:	K6
Connection Diagrams:	10P445xx (xx = 01 to 04)

CONTENTS

Page (MR) 9-

1	Introduction	5
2	Event & Fault Records	6
2.1	View Records Column	6
2.2	Types of Event	6
2.3	Change of State of Opto-Isolated Inputs	7
2.4	Change of State of One or More Output Relay Contacts	7
2.5	Relay Alarm Conditions	7
2.6	Protection Element Starts and Trips	8
2.7	General Events	9
2.8	Fault Records	9
2.9	Maintenance Reports	9
2.10	Setting Changes	10
2.11	Resetting of Event/Fault Records	10
2.12	Viewing Event Records via Easergy Studio Support Software	10
2.13	Event Filtering	11
3	Disturbance Recorder	17
4	Measurements	32
4.1	Measured Voltages and Currents	32
4.2	Sequence Voltages and Currents	32
4.3	Slip Frequency	32
4.4	Power and Energy Quantities	32
4.5	RMS. Voltages and Currents	33
4.6	Demand Values	33
4.6.1	Fixed Demand Values	33
4.6.2	Rolling Demand Values	33
4.6.3	Peak Demand Values	33
4.7	Settings	33
4.8	Measurement Display Quantities	35
4.9	Measurements 4 Column	36

TABLES

	Page (MR) 9-
Table 1 - View records	6
Table 2 - Alarm conditions and event text/values	8
Table 3 - Event filtering	16
Table 4 - Disturbance recorder settings	30
Table 5 - Measurement setup	34
Table 6 - Measurements 1, 2 and 4	36

1 INTRODUCTION

The relay is equipped with integral measurements, event, fault and disturbance recording facilities suitable for analysis of complex system disturbances.

The relay is flexible enough to allow for the programming of these facilities to specific user application requirements. These requirements are discussed in the sections which follow.

2 EVENT & FAULT RECORDS

The relay records and time tags up to 250 or 512 events (only up to 250 events in the P24x and P44x) and stores them in non-volatile (battery-backed up) memory. This lets the system operator establish the sequence of events that occurred in the relay following a particular power system condition or switching sequence. When the available space is used up, the oldest event is automatically overwritten by the new one (i.e. first in, first out).

The relay's real-time clock provides the time tag to each event, to a resolution of 1 ms. The event records can be viewed either from the front plate LCD or remotely using the communications ports (using any available protocols, such as Courier or MODBUS).

For local viewing on the LCD of event, fault and maintenance records, select the **VIEW RECORDS** menu column.

For extraction from a remote source using communications, see the *SCADA Communications* chapter or the MiCOM S1 Studio instructions.

For a full list of all the event types and the meaning of their values, see the Menu Database document.

2.1 View Records Column

VIEW RECORDS	
LCD reference	Description
Select Event	Setting range from 0 to 1023. This selects the required event record from the possible 1024 that may be stored. A value of 0 corresponds to the latest event and so on.
Time & Date	Time & Date Stamp for the event given by the internal Real Time Clock.
Event Text	Up to 32 Character description of the Event (refer to following sections).
Event Value	Up to 32 Bit Binary Flag or integer representative of the Event (refer to following sections).
Select Fault	Setting range from 0 to 14. This selects the required fault record from the possible 15 that may be stored. A value of 0 corresponds to the latest fault and so on.
	The following cells show all the fault flags, protection starts, protection trips, fault location, measurements etc. associated with the fault, i.e. the complete fault record.
Select Maint.	Setting range from 0 to 9. This selects the required maintenance report from the possible 10 that may be stored. A value of 0 corresponds to the latest report and so on.
Maint. Text	Up to 16 Character description of the occurrence (refer to following sections).
Maint. Type/Main Data	These cells are numbers representative of the occurrence. They form a specific error code which should be quoted in any related correspondence to Report Data.
Reset Indication	Either Yes or No. This serves to reset the trip LED indications provided that the relevant protection element has reset.

Table 1 - View records

2.2 Types of Event

An event may be a change of state of a control input or output relay, an alarm condition, or a setting change. The following sections show the various items that constitute an event:

2.3 Change of State of Opto-Isolated Inputs

If one or more of the opto (logic) inputs has changed state since the last time the protection algorithm ran, the new status is logged as an event. When this event is selected to be viewed on the LCD, three cells appear, as in shown here:

Time & date of event "LOGIC INPUTS1" "Event Value 0101010101010101"

The Event Value is a multi-bit word (see note) showing the status of the opto inputs, where the least significant bit (extreme right) corresponds to opto input 1. The same information is present if the event is extracted and viewed using a PC.

<i>Note</i>	<i>For P24x or P44x the Event Value is an 8 or 16 bit word.</i> <i>For P34x or P64x it is an 8, 12, 16, 24 or 32-bit word.</i> <i>For P445 it is an 8, 12 or 16-bit word.</i> <i>For P44y, P54x, P547 or P841, it is an 8, 12, 16 or 24-bit word.</i> <i>For P74x it is a 12, 16, 24 or 32-bit word.</i> <i>For P746 or P849 it is a 32-bit word.</i>
-------------	--

2.4 Change of State of One or More Output Relay Contacts

If one or more of the output relay contacts have changed state since the last time the protection algorithm ran, the new status is logged as an event. When this event is selected to be viewed on the LCD, three cells appear, as shown here:

Time and Date of Event Output Contacts Event Value 0101010101010101010
--

The Event Value is a multi-bit word (see Note) showing the status of the output contacts, where the least significant bit (extreme right) corresponds to output contact 1, etc. The same information is present if the event is extracted and viewed using a PC.

<i>Note</i>	<i>For P24x the Event Value is is a 7 or 16-bit word.</i> <i>For P34x or P64x it is an 7, 11, 14, 15, 16, 22, 24 or 32-bit word.</i> <i>For P445 it is an 8, 12 or 16-bit word.</i> <i>For P44x it is a 7, 14 or 21 bit word.</i> <i>For P44y, P54x, P547 or P841, it is an 8, 12, 16, 24 or 32 bit word.</i> <i>For P74x it is a 12, 16, 24 or 32 bit word.</i> <i>For P746 or P849 it is a 24-bit word.</i>
-------------	---

2.5 Relay Alarm Conditions

Any alarm conditions generated by the relays are logged as individual events. This table shows examples of some of the alarm conditions and how they appear in the event list:

Alarm Status 1		Alarm Status 2		Alarm Status 3	
Bit	Text	Bit	Text	Bit	Text
0	SG-opto Invalid	0	CB2 Fail Alarm	0	Battery Fail
1	Prot'n Disabled	1	CB2 Monitor Alm	1	Field Volt Fail
2	Static Test Mode	2	CB2 Mon LO Alarm	2	Comm2 H/W FAIL
3	Test Loopback	3	CB2 Status Alm	3	GOOSE IED Absent
4	Test IM64	4	CB2 Trip Fail	4	NIC Not Fitted
5	VT Fail Alarm	5	CB2 Close Fail	5	NIC No Response
6	CT Fail Alarm	6	ManCB2 Unhealthy	6	NIC Fatal Error
7	CT2 Fail Alarm	7	NoCS CB2ManClose	7	Unused
8	Remote CT Alarm	8	CB2 AR Lockout	8	Unused
9	Power Swing	9	AR CB2 Unhealthy	9	Unused
10	CB Fail Alarm	10	AR CB2 No C/S	10	Unused
11	CB Monitor Alarm	11	Invalid AR Mode	11	NIC SW Mis-Match
12	CB Lockout Alarm	12	Incompatible Rly	12	IP Addr Conflict
13	CB Status Alarm	13	InValid Mesg Fmt	13	IM Loopback
14	CB Trip Fail	14	Main Prot. Fail	14	IM Message Fail
15	CB Close Fail	15	Config Error	15	IM Data CD Fail
16	Man CB Unhealthy	16	Re-Config Error	16	IM Channel Fail
17	No CS ManClose	17	Comms Changed	17	Backup Setting
18	A/R Lockout	18	Max Prop. Alarm	18	Bad DNP Settings
19	A/R CB Unhealthy	19	Ct para mismatch	19	Unused
20	A/R No Checksync	20	Reserved	20	Unused
21	Reserved	21	Reserved	21	Invalid DNPoE IP
22	GPS Alarm	22	Reserved	22	Invalid Config.
23	Signalling Fail	23	Reserved	23	Test Mode Alm
24	Comm Delay Alarm	24	SR User Alarm 1	24	Contacts Blk Alm
25	C Diff Failure	25	SR User Alarm 2	25	NIC H/W Mismatch
26	IM64 SchemeFail	26	SR User Alarm 3	26	NIC APP Mismatch
27	IEEE C37.94 Fail	27	SR User Alarm 4	27	Simul. GOOSE Alm
28	C Diff Inhibited	28	MR User Alarm 5	28	Unused
29	Aid 1 Chan Fail	29	MR User Alarm 6	29	Unused
30	Aid 2 Chan Fail	30	MR User Alarm 7	30	Unused
31	F out of Range	31	MR User Alarm 8	31	Unused

Table 2 - Alarm conditions and event text/values

The previous table shows the abbreviated description given to the various alarm conditions and a corresponding value between 0 and 31. This value is appended to each alarm event in a similar way to the input and output events described previously. It is used by the event extraction software, such as MiCOM S1 Studio, to identify the alarm and is therefore invisible if the event is viewed on the LCD. ON or OFF is shown after the description to signify whether the particular condition has become operated or has reset.

2.6

Protection Element Starts and Trips

Any operation of protection elements, (either a start or a trip condition) is logged as an event record, consisting of a text string indicating the operated element and an event value. This value is intended for use by the event extraction software, such as MiCOM S1 Studio, rather than for the user, and is invisible when the event is viewed on the LCD.

2.7**General Events**

Several events come under the heading of **General Events**. An example appears here.

Nature of event	Displayed text in event record	Displayed value
Password modified, either from the front or the rear port.	PW modified F, R or R2	0 F=11, R=16, R2=38.

A complete list of the General Events is in the Relay Menu Database document. This is a separate document, for each MiCOM Px4x product or product range. They are normally available for download from www.schneider-electric.com

2.8**Fault Records**

Each time a fault record is generated, an event is also created. The event states that a fault record was generated, with a corresponding time stamp.

Further down the **VIEW RECORDS** column, select the Select Fault cell to view the actual fault record, which is selectable from up to 15 records. These records consist of fault flags, fault location, fault measurements, etc. The time stamp given in the fault record is more accurate than the corresponding stamp given in the event record as the event is logged some time after the actual fault record is generated.

The latest fault record can also be retrieved over DNP3.0 and IEC61850, please refer to the Object 30 Analog Input section in the SCADA Communications chapter as well as the IEC 61850 in MiCOM Relays section for detailed information.

The fault record is triggered from the **Fault REC. TRIG.** signal assigned in the default programmable scheme logic. Normally this is assigned to relay 3, protection trip, but in the P746 it is assigned to Any Start or Any Trip. The fault measurements in the fault record are given at the time of the protection start.

The fault recorder does not stop recording until any start or relay 3 (protection trip) resets in order to record all the protection flags during the fault.

It is recommended that the triggering contact (relay 3 for example) be 'self reset' and not latching. If a latching contact were chosen the fault record would not be generated until the contact had fully reset.

2.9**Maintenance Reports**

Internal failures detected by the self-monitoring circuitry, such as watchdog failure, field voltage failure etc. are logged into a maintenance report. The maintenance report holds up to 10 such **Events** and is accessed from the **Select Maint** cell at the bottom of the **VIEW RECORDS** column.

Each entry consists of a self explanatory text string and a **Type** and **Data** cell, which are explained in the menu extract at the beginning of this section.

Each time a Maintenance Report is generated, an event is also created. The event simply states that a report was generated, with a corresponding time stamp.

2.10 Setting Changes

Changes to any setting in the relay are logged as an event. For example:

Type of setting change	Displayed text in event record	Displayed value
Control/Support Setting	C & S Changed	22
Group # Change	Group # Changed	#
Where # = 1 to 4		
<div style="border: 1px solid black; padding: 5px;"> <p><i>Note</i> <i>Control/Support settings are communications, measurement, CT/VT ratio settings etc, which are not duplicated in the setting groups. When any of these settings are changed, the event record is created simultaneously. Changes to protection or disturbance recorder settings only generate an event once the settings have been confirmed at the 'setting trap'.</i></p> </div>		

2.11 Resetting of Event/Fault Records

To delete the event, fault or maintenance reports, use the **RECORD CONTROL** column.

2.12 Viewing Event Records via Easergy Studio Support Software

When the event records are extracted and viewed on a PC they look slightly different than when viewed on the LCD. The following shows an example of how various events appear when displayed using Easergy Studio:

```

Friday 03 March 2017 15:32:49 GMT I>1 Start ON
MiCOM : MiCOM P445
Model Number: P445218A1M0350J
Address: 001 Column: 00 Row: 23
Event Type: Protection operation
Friday 03 March 2017 15:32:52 GMT Fault Recorded
MiCOM : MiCOM P445
Model Number: P445218A1M0350J
Address: 001 Column: 01 Row: 00
Event Type: Fault record
Friday 03 March 2017 15:33:11 GMT Logic Inputs
MiCOM : MiCOM P445
Model Number: P445218A1M0350J
Address: 001 Column: 00 Row: 20
Event Type: Logic input changed state
Friday 03 March 2017 15:34:54 GMT Output Contacts
MiCOM : MiCOM P445
Model Number: P445218A1M0350J
Address: 001 Column: 00 Row: 21
Event Type: Relay output changed state
Friday 03 March 2017 15:35:55 GMT A/R Lockout ON
MiCOM : MiCOM P445
Model Number: P445218A1M0350J
Address: 001 Column: 00 Row: 22
Event Type: Alarm event
Tuesday 04 March 2017 20:18:22.988 GMT Zone 1 Trip ON
MiCOM : MiCOM P445
Model Number: P445218A1M0350J
Address: 001 Column: 0F Row: 30
Event Type: Setting event

```

The first line gives the description and time stamp for the event, while the additional information displayed below may be collapsed using the +/- symbol.

For further information regarding events and their specific meaning, refer to the *Menu Database* document. This standalone document not included in this manual.

2.13 Event Filtering

Event reporting can be disabled from all interfaces that support setting changes. The settings that control the various types of events are in the RECORD CONTROL column. The effect of setting each to disabled is shown in the following table:

Note Some occurrences can result in more than one type of event, e.g. a battery failure will produce an alarm event and a maintenance record event.

If the Protection Event setting is Enabled, a further set of settings is revealed which allow the event generation by individual DDB signals to be enabled or disabled.

For further information on events and their specific meaning, see the *Relay Menu Database* document.

Col	Row	MENU TEXT	Default Setting	Available Setting
Description				
0B	00	RECORD CONTROL	0	
This column contains settings for Record Controls				
0B	01	Clear Events	No	0 = No or 1 = Yes
Clear Event records				
0B	02	Clear Faults	No	0 = No or 1 = Yes
Clear Fault records				
0B	03	Clear Maint	No	0 = No or 1 = Yes
Clear Maintenance records				
0B	04	Alarm Event	Enabled	0 = Disabled or 1 = Enabled
Disabling this setting means that all the occurrences that produce an alarm will result in no event being generated.				
0B	05	Relay O/P Event	Enabled	0 = Disabled or 1 = Enabled
Disabling this setting means that no event will be generated for any change in logic state.				
0B	06	Opto Input Event	Enabled	0 = Disabled or 1 = Enabled
Disabling this setting means that no event will be generated for any change in logic input state.				
0B	07	General Event	Enabled	0 = Disabled or 1 = Enabled
Disabling this setting means that no General Events will be generated				
0B	08	Fault Rec Event	Enabled	0 = Disabled or 1 = Enabled
Disabling this setting means that no event will be generated for any fault that produces a fault record				
0B	09	Maint Rec Event	Enabled	0 = Disabled or 1 = Enabled
Disabling this setting means that no event will be generated for any occurrence that produces a maintenance record.				
0B	0A	Protection Event	Enabled	0 = Disabled or 1 = Enabled
Disabling this setting means that any operation of protection elements will not be logged as an event				
0B	30	Clear Dist Recs	No	0 = No or 1 = Yes
Clear Disturbance records				
0B	31	Security Event	Enabled	0 = Disabled or 1 = Enabled
Disabling this setting means that any operation of security elements will not be logged as an event				
0B	40	DDB 31 - 0	11111111111111111111111111111111(bin)	32-bit binary setting: 1 = event recording Enabled, 0 = event recording Disabled
Chooses whether any individual DDBs should be deselected as a stored event, by setting the relevant bit to 0 (zero). Typically used for repetitive recurrent changes such as an Opto input assigned for Minute Pulse clock synchronizing.				
0B	41	DDB 63 - 32	11111111111111111111111111111111(bin)	32-bit binary setting: 1 = event recording Enabled, 0 = event recording Disabled

Col	Row	MENU TEXT	Default Setting	Available Setting
Description				
Chooses whether any individual DDBs should be deselected as a stored event, by setting the relevant bit to 0 (zero). Typically used for repetitive recurrent changes such as an Opto input assigned for Minute Pulse clock synchronizing.				
0B	42	DDB 95 - 64	11111111111111111111111111111111(bin)	32-bit binary setting: 1 = event recording Enabled, 0 = event recording Disabled
Chooses whether any individual DDBs should be deselected as a stored event, by setting the relevant bit to 0 (zero). Typically used for repetitive recurrent changes such as an Opto input assigned for Minute Pulse clock synchronizing.				
0B	43	DDB 127 - 96	11111111111111111111111111111111(bin)	32-bit binary setting: 1 = event recording Enabled, 0 = event recording Disabled
Chooses whether any individual DDBs should be deselected as a stored event, by setting the relevant bit to 0 (zero). Typically used for repetitive recurrent changes such as an Opto input assigned for Minute Pulse clock synchronizing.				
0B	44	DDB 159 - 128	11111111111111111111111111111111(bin)	32-bit binary setting: 1 = event recording Enabled, 0 = event recording Disabled
Chooses whether any individual DDBs should be deselected as a stored event, by setting the relevant bit to 0 (zero). Typically used for repetitive recurrent changes such as an Opto input assigned for Minute Pulse clock synchronizing.				
0B	45	DDB 191 - 160	11111111111111111111111111111111(bin)	32-bit binary setting: 1 = event recording Enabled, 0 = event recording Disabled
Chooses whether any individual DDBs should be deselected as a stored event, by setting the relevant bit to 0 (zero). Typically used for repetitive recurrent changes such as an Opto input assigned for Minute Pulse clock synchronizing.				
0B	46	DDB 223 - 192	11111111111111111111111111111111(bin)	32-bit binary setting: 1 = event recording Enabled, 0 = event recording Disabled
Chooses whether any individual DDBs should be deselected as a stored event, by setting the relevant bit to 0 (zero). Typically used for repetitive recurrent changes such as an Opto input assigned for Minute Pulse clock synchronizing.				
0B	47	DDB 255 - 224	11111111111111111111111111111111(bin)	32-bit binary setting: 1 = event recording Enabled, 0 = event recording Disabled
Chooses whether any individual DDBs should be deselected as a stored event, by setting the relevant bit to 0 (zero). Typically used for repetitive recurrent changes such as an Opto input assigned for Minute Pulse clock synchronizing.				
0B	48	DDB 287 - 256	11111111111111111111111111111111(bin)	32-bit binary setting: 1 = event recording Enabled, 0 = event recording Disabled
Chooses whether any individual DDBs should be deselected as a stored event, by setting the relevant bit to 0 (zero). Typically used for repetitive recurrent changes such as an Opto input assigned for Minute Pulse clock synchronizing.				
0B	49	DDB 319 - 288	11111111111111111111111111111111(bin)	32-bit binary setting: 1 = event recording Enabled, 0 = event recording Disabled
Chooses whether any individual DDBs should be deselected as a stored event, by setting the relevant bit to 0 (zero). Typically used for repetitive recurrent changes such as an Opto input assigned for Minute Pulse clock synchronizing.				
0B	4A	DDB 351 - 320	11111111111111111111111111111111(bin)	32-bit binary setting: 1 = event recording Enabled, 0 = event recording Disabled
Chooses whether any individual DDBs should be deselected as a stored event, by setting the relevant bit to 0 (zero). Typically used for repetitive recurrent changes such as an Opto input assigned for Minute Pulse clock synchronizing.				
0B	4B	DDB 383 - 352	11111111111111111111111111111111(bin)	32-bit binary setting: 1 = event recording Enabled, 0 = event recording Disabled
Chooses whether any individual DDBs should be deselected as a stored event, by setting the relevant bit to 0 (zero). Typically used for repetitive recurrent changes such as an Opto input assigned for Minute Pulse clock synchronizing.				
0B	4C	DDB 415 - 384	11111111111111111111111111111111(bin)	32-bit binary setting: 1 = event recording Enabled, 0 = event recording Disabled
Chooses whether any individual DDBs should be deselected as a stored event, by setting the relevant bit to 0 (zero). Typically used for repetitive recurrent changes such as an Opto input assigned for Minute Pulse clock synchronizing.				
0B	4D	DDB 447 - 416	11111111111111111111111111111111(bin)	32-bit binary setting: 1 = event recording Enabled, 0 = event recording Disabled
Chooses whether any individual DDBs should be deselected as a stored event, by setting the relevant bit to 0 (zero). Typically used for repetitive recurrent changes such as an Opto input assigned for Minute Pulse clock synchronizing.				

Col	Row	MENU TEXT	Default Setting	Available Setting
Description				
0B	4E	DDB 479 - 448	11111111111111111111111111111111(bin)	32-bit binary setting: 1 = event recording Enabled, 0 = event recording Disabled
Chooses whether any individual DDBs should be deselected as a stored event, by setting the relevant bit to 0 (zero). Typically used for repetitive recurrent changes such as an Opto input assigned for Minute Pulse clock synchronizing.				
0B	4F	DDB 511 - 480	11111111111111111111111111111111(bin)	32-bit binary setting: 1 = event recording Enabled, 0 = event recording Disabled
Chooses whether any individual DDBs should be deselected as a stored event, by setting the relevant bit to 0 (zero). Typically used for repetitive recurrent changes such as an Opto input assigned for Minute Pulse clock synchronizing.				
0B	50	DDB 543 - 512	11111111111111111111111111111111(bin)	32-bit binary setting: 1 = event recording Enabled, 0 = event recording Disabled
Chooses whether any individual DDBs should be deselected as a stored event, by setting the relevant bit to 0 (zero). Typically used for repetitive recurrent changes such as an Opto input assigned for Minute Pulse clock synchronizing.				
0B	51	DDB 575 - 544	11111111111111111111111111111111(bin)	32-bit binary setting: 1 = event recording Enabled, 0 = event recording Disabled
Chooses whether any individual DDBs should be deselected as a stored event, by setting the relevant bit to 0 (zero). Typically used for repetitive recurrent changes such as an Opto input assigned for Minute Pulse clock synchronizing.				
0B	52	DDB 607 - 576	11111111111111111111111111111111(bin)	32-bit binary setting: 1 = event recording Enabled, 0 = event recording Disabled
Chooses whether any individual DDBs should be deselected as a stored event, by setting the relevant bit to 0 (zero). Typically used for repetitive recurrent changes such as an Opto input assigned for Minute Pulse clock synchronizing.				
0B	53	DDB 639 - 608	11111111111111111111111111111111(bin)	32-bit binary setting: 1 = event recording Enabled, 0 = event recording Disabled
Chooses whether any individual DDBs should be deselected as a stored event, by setting the relevant bit to 0 (zero). Typically used for repetitive recurrent changes such as an Opto input assigned for Minute Pulse clock synchronizing.				
0B	54	DDB 671 - 640	11111111111111111111111111111111(bin)	32-bit binary setting: 1 = event recording Enabled, 0 = event recording Disabled
Chooses whether any individual DDBs should be deselected as a stored event, by setting the relevant bit to 0 (zero). Typically used for repetitive recurrent changes such as an Opto input assigned for Minute Pulse clock synchronizing.				
0B	55	DDB 703 - 672	11111111111111111111111111111111(bin)	32-bit binary setting: 1 = event recording Enabled, 0 = event recording Disabled
Chooses whether any individual DDBs should be deselected as a stored event, by setting the relevant bit to 0 (zero). Typically used for repetitive recurrent changes such as an Opto input assigned for Minute Pulse clock synchronizing.				
0B	56	DDB 735 - 704	11111111111111111111111111111111(bin)	32-bit binary setting: 1 = event recording Enabled, 0 = event recording Disabled
Chooses whether any individual DDBs should be deselected as a stored event, by setting the relevant bit to 0 (zero). Typically used for repetitive recurrent changes such as an Opto input assigned for Minute Pulse clock synchronizing.				
0B	57	DDB 767 - 736	11111111111111111111111111111111(bin)	32-bit binary setting: 1 = event recording Enabled, 0 = event recording Disabled
Chooses whether any individual DDBs should be deselected as a stored event, by setting the relevant bit to 0 (zero). Typically used for repetitive recurrent changes such as an Opto input assigned for Minute Pulse clock synchronizing.				
0B	58	DDB 799 - 768	11111111111111111111111111111111(bin)	32-bit binary setting: 1 = event recording Enabled, 0 = event recording Disabled
Chooses whether any individual DDBs should be deselected as a stored event, by setting the relevant bit to 0 (zero). Typically used for repetitive recurrent changes such as an Opto input assigned for Minute Pulse clock synchronizing.				
0B	59	DDB 831 - 800	11111111111111111111111111111111(bin)	32-bit binary setting: 1 = event recording Enabled, 0 = event recording Disabled
Chooses whether any individual DDBs should be deselected as a stored event, by setting the relevant bit to 0 (zero). Typically used for repetitive recurrent changes such as an Opto input assigned for Minute Pulse clock synchronizing.				
0B	5A	DDB 863 - 832	11111111111111111111111111111111(bin)	32-bit binary setting: 1 = event recording Enabled, 0 = event recording Disabled

Col	Row	MENU TEXT	Default Setting	Available Setting
Description				
Chooses whether any individual DDBs should be deselected as a stored event, by setting the relevant bit to 0 (zero). Typically used for repetitive recurrent changes such as an Opto input assigned for Minute Pulse clock synchronizing.				
0B	5B	DDB 895 - 864	11111111111111111111111111111111(bin)	32-bit binary setting: 1 = event recording Enabled, 0 = event recording Disabled
Chooses whether any individual DDBs should be deselected as a stored event, by setting the relevant bit to 0 (zero). Typically used for repetitive recurrent changes such as an Opto input assigned for Minute Pulse clock synchronizing.				
0B	5C	DDB 927 - 896	11111111111111111111111111111111(bin)	32-bit binary setting: 1 = event recording Enabled, 0 = event recording Disabled
Chooses whether any individual DDBs should be deselected as a stored event, by setting the relevant bit to 0 (zero). Typically used for repetitive recurrent changes such as an Opto input assigned for Minute Pulse clock synchronizing.				
0B	5D	DDB 959 - 928	11111111111111111111111111111111(bin)	32-bit binary setting: 1 = event recording Enabled, 0 = event recording Disabled
Chooses whether any individual DDBs should be deselected as a stored event, by setting the relevant bit to 0 (zero). Typically used for repetitive recurrent changes such as an Opto input assigned for Minute Pulse clock synchronizing.				
0B	5E	DDB 991 - 960	11111111111111111111111111111111(bin)	32-bit binary setting: 1 = event recording Enabled, 0 = event recording Disabled
Chooses whether any individual DDBs should be deselected as a stored event, by setting the relevant bit to 0 (zero). Typically used for repetitive recurrent changes such as an Opto input assigned for Minute Pulse clock synchronizing.				
0B	5F	DDB 1023 - 992	11111111111111111111111111111111(bin)	32-bit binary setting: 1 = event recording Enabled, 0 = event recording Disabled
Chooses whether any individual DDBs should be deselected as a stored event, by setting the relevant bit to 0 (zero). Typically used for repetitive recurrent changes such as an Opto input assigned for Minute Pulse clock synchronizing.				
0B	60	DDB 1055 - 1024	11111111111111111111111111111111(bin)	32-bit binary setting: 1 = event recording Enabled, 0 = event recording Disabled
Chooses whether any individual DDBs should be deselected as a stored event, by setting the relevant bit to 0 (zero). Typically used for repetitive recurrent changes such as an Opto input assigned for Minute Pulse clock synchronizing.				
0B	61	DDB 1087 - 1056	11111111111111111111111111111111(bin)	32-bit binary setting: 1 = event recording Enabled, 0 = event recording Disabled
Chooses whether any individual DDBs should be deselected as a stored event, by setting the relevant bit to 0 (zero). Typically used for repetitive recurrent changes such as an Opto input assigned for Minute Pulse clock synchronizing.				
0B	62	DDB 1119 - 1088	11111111111111111111111111111111(bin)	32-bit binary setting: 1 = event recording Enabled, 0 = event recording Disabled
Chooses whether any individual DDBs should be deselected as a stored event, by setting the relevant bit to 0 (zero). Typically used for repetitive recurrent changes such as an Opto input assigned for Minute Pulse clock synchronizing.				
0B	63	DDB 1151 - 1120	11111111111111111111111111111111(bin)	32-bit binary setting: 1 = event recording Enabled, 0 = event recording Disabled
Chooses whether any individual DDBs should be deselected as a stored event, by setting the relevant bit to 0 (zero). Typically used for repetitive recurrent changes such as an Opto input assigned for Minute Pulse clock synchronizing.				
0B	64	DDB 1183 - 1152	11111111111111111111111111111111(bin)	32-bit binary setting: 1 = event recording Enabled, 0 = event recording Disabled
Chooses whether any individual DDBs should be deselected as a stored event, by setting the relevant bit to 0 (zero). Typically used for repetitive recurrent changes such as an Opto input assigned for Minute Pulse clock synchronizing.				
0B	65	DDB 1215 - 1184	11111111111111111111111111111111(bin)	32-bit binary setting: 1 = event recording Enabled, 0 = event recording Disabled
Chooses whether any individual DDBs should be deselected as a stored event, by setting the relevant bit to 0 (zero). Typically used for repetitive recurrent changes such as an Opto input assigned for Minute Pulse clock synchronizing.				
0B	66	DDB 1247 - 1216	11111111111111111111111111111111(bin)	32-bit binary setting: 1 = event recording Enabled, 0 = event recording Disabled
Chooses whether any individual DDBs should be deselected as a stored event, by setting the relevant bit to 0 (zero). Typically used for repetitive recurrent changes such as an Opto input assigned for Minute Pulse clock synchronizing.				

Col	Row	MENU TEXT	Default Setting	Available Setting
Description				
0B	67	DDB 1279 - 1248	11111111111111111111111111111111(bin)	32-bit binary setting: 1 = event recording Enabled, 0 = event recording Disabled
Chooses whether any individual DDBs should be deselected as a stored event, by setting the relevant bit to 0 (zero). Typically used for repetitive recurrent changes such as an Opto input assigned for Minute Pulse clock synchronizing.				
0B	68	DDB 1311 - 1280	11111111111111111111111111111111(bin)	32-bit binary setting: 1 = event recording Enabled, 0 = event recording Disabled
Chooses whether any individual DDBs should be deselected as a stored event, by setting the relevant bit to 0 (zero). Typically used for repetitive recurrent changes such as an Opto input assigned for Minute Pulse clock synchronizing.				
0B	69	DDB 1343 - 1312	11111111111111111111111111111111(bin)	32-bit binary setting: 1 = event recording Enabled, 0 = event recording Disabled
Chooses whether any individual DDBs should be deselected as a stored event, by setting the relevant bit to 0 (zero). Typically used for repetitive recurrent changes such as an Opto input assigned for Minute Pulse clock synchronizing.				
0B	6A	DDB 1375 - 1344	11111111111111111111111111111111(bin)	32-bit binary setting: 1 = event recording Enabled, 0 = event recording Disabled
Chooses whether any individual DDBs should be deselected as a stored event, by setting the relevant bit to 0 (zero). Typically used for repetitive recurrent changes such as an Opto input assigned for Minute Pulse clock synchronizing.				
0B	6B	DDB 1407 - 1376	11111111111111111111111111111111(bin)	32-bit binary setting: 1 = event recording Enabled, 0 = event recording Disabled
Chooses whether any individual DDBs should be deselected as a stored event, by setting the relevant bit to 0 (zero). Typically used for repetitive recurrent changes such as an Opto input assigned for Minute Pulse clock synchronizing.				
0B	6C	DDB 1439 - 1408	11111111111111111111111111111111(bin)	32-bit binary setting: 1 = event recording Enabled, 0 = event recording Disabled
Chooses whether any individual DDBs should be deselected as a stored event, by setting the relevant bit to 0 (zero). Typically used for repetitive recurrent changes such as an Opto input assigned for Minute Pulse clock synchronizing.				
0B	6D	DDB 1471 - 1440	11111111111111111111111111111111(bin)	32-bit binary setting: 1 = event recording Enabled, 0 = event recording Disabled
Chooses whether any individual DDBs should be deselected as a stored event, by setting the relevant bit to 0 (zero). Typically used for repetitive recurrent changes such as an Opto input assigned for Minute Pulse clock synchronizing.				
0B	6E	DDB 1503 - 1472	11111111111111111111111111111111(bin)	32-bit binary setting: 1 = event recording Enabled, 0 = event recording Disabled
Chooses whether any individual DDBs should be deselected as a stored event, by setting the relevant bit to 0 (zero). Typically used for repetitive recurrent changes such as an Opto input assigned for Minute Pulse clock synchronizing.				
0B	6F	DDB 1535 - 1504	11111111111111111111111111111111(bin)	32-bit binary setting: 1 = event recording Enabled, 0 = event recording Disabled
Chooses whether any individual DDBs should be deselected as a stored event, by setting the relevant bit to 0 (zero). Typically used for repetitive recurrent changes such as an Opto input assigned for Minute Pulse clock synchronizing.				
0B	70	DDB 1567 - 1536	11111111111111111111111111111111(bin)	32-bit binary setting: 1 = event recording Enabled, 0 = event recording Disabled
Chooses whether any individual DDBs should be deselected as a stored event, by setting the relevant bit to 0 (zero). Typically used for repetitive recurrent changes such as an Opto input assigned for Minute Pulse clock synchronizing.				
0B	71	DDB 1599 - 1568	11111111111111111111111111111111(bin)	32-bit binary setting: 1 = event recording Enabled, 0 = event recording Disabled
Chooses whether any individual DDBs should be deselected as a stored event, by setting the relevant bit to 0 (zero). Typically used for repetitive recurrent changes such as an Opto input assigned for Minute Pulse clock synchronizing.				
0B	72	DDB 1631 - 1600	11111111111111111111111111111111(bin)	32-bit binary setting: 1 = event recording Enabled, 0 = event recording Disabled
Chooses whether any individual DDBs should be deselected as a stored event, by setting the relevant bit to 0 (zero). Typically used for repetitive recurrent changes such as an Opto input assigned for Minute Pulse clock synchronizing.				
0B	73	DDB 1663 - 1632	11111111111111111111111111111111(bin)	32-bit binary setting: 1 = event recording Enabled, 0 = event recording Disabled

Col	Row	MENU TEXT	Default Setting	Available Setting
Description				
Chooses whether any individual DDBs should be deselected as a stored event, by setting the relevant bit to 0 (zero). Typically used for repetitive recurrent changes such as an Opto input assigned for Minute Pulse clock synchronizing.				
0B	74	DDB 1695 - 1664	11111111111111111111111111111111(bin)	32-bit binary setting: 1 = event recording Enabled, 0 = event recording Disabled
Chooses whether any individual DDBs should be deselected as a stored event, by setting the relevant bit to 0 (zero). Typically used for repetitive recurrent changes such as an Opto input assigned for Minute Pulse clock synchronizing.				
0B	75	DDB 1727 - 1696	11111111111111111111111111111111(bin)	32-bit binary setting: 1 = event recording Enabled, 0 = event recording Disabled
Chooses whether any individual DDBs should be deselected as a stored event, by setting the relevant bit to 0 (zero). Typically used for repetitive recurrent changes such as an Opto input assigned for Minute Pulse clock synchronizing.				
0B	76	DDB 1759 - 1728	11111111111111111111111111111111(bin)	32-bit binary setting: 1 = event recording Enabled, 0 = event recording Disabled
Chooses whether any individual DDBs should be deselected as a stored event, by setting the relevant bit to 0 (zero). Typically used for repetitive recurrent changes such as an Opto input assigned for Minute Pulse clock synchronizing.				
0B	77	DDB 1760 - 1791	11111111111111111111111111111111(bin)	32-bit binary setting: 1 = event recording Enabled, 0 = event recording Disabled
Chooses whether any individual DDBs should be deselected as a stored event, by setting the relevant bit to 0 (zero). Typically used for repetitive recurrent changes such as an Opto input assigned for Minute Pulse clock synchronizing.				
0B	78	DDB 1792 - 1823	11111111111111111111111111111111(bin)	32-bit binary setting: 1 = event recording Enabled, 0 = event recording Disabled
Chooses whether any individual DDBs should be deselected as a stored event, by setting the relevant bit to 0 (zero). Typically used for repetitive recurrent changes such as an Opto input assigned for Minute Pulse clock synchronizing.				
0B	79	DDB 1824 - 1855	11111111111111111111111111111111(bin)	32-bit binary setting: 1 = event recording Enabled, 0 = event recording Disabled
Chooses whether any individual DDBs should be deselected as a stored event, by setting the relevant bit to 0 (zero). Typically used for repetitive recurrent changes such as an Opto input assigned for Minute Pulse clock synchronizing.				
0B	7A	DDB 1856 - 1887	11111111111111111111111111111111(bin)	32-bit binary setting: 1 = event recording Enabled, 0 = event recording Disabled
Chooses whether any individual DDBs should be deselected as a stored event, by setting the relevant bit to 0 (zero). Typically used for repetitive recurrent changes such as an Opto input assigned for Minute Pulse clock synchronizing.				
0B	7B	DDB 1888 - 1919	11111111111111111111111111111111(bin)	32-bit binary setting: 1 = event recording Enabled, 0 = event recording Disabled
Chooses whether any individual DDBs should be deselected as a stored event, by setting the relevant bit to 0 (zero). Typically used for repetitive recurrent changes such as an Opto input assigned for Minute Pulse clock synchronizing.				
0B	7C	DDB 1920 - 1951	11111111111111111111111111111111(bin)	32-bit binary setting: 1 = event recording Enabled, 0 = event recording Disabled
Chooses whether any individual DDBs should be deselected as a stored event, by setting the relevant bit to 0 (zero). Typically used for repetitive recurrent changes such as an Opto input assigned for Minute Pulse clock synchronizing.				
0B	7D	DDB 1952 - 1983	11111111111111111111111111111111(bin)	32-bit binary setting: 1 = event recording Enabled, 0 = event recording Disabled
Chooses whether any individual DDBs should be deselected as a stored event, by setting the relevant bit to 0 (zero). Typically used for repetitive recurrent changes such as an Opto input assigned for Minute Pulse clock synchronizing.				
0B	7E	DDB 1984 - 2015	11111111111111111111111111111111(bin)	32-bit binary setting: 1 = event recording Enabled, 0 = event recording Disabled
Chooses whether any individual DDBs should be deselected as a stored event, by setting the relevant bit to 0 (zero). Typically used for repetitive recurrent changes such as an Opto input assigned for Minute Pulse clock synchronizing.				
0B	7F	DDB 2016 - 2047	11111111111111111111111111111111(bin)	32-bit binary setting: 1 = event recording Enabled, 0 = event recording Disabled
Chooses whether any individual DDBs should be deselected as a stored event, by setting the relevant bit to 0 (zero). Typically used for repetitive recurrent changes such as an Opto input assigned for Minute Pulse clock synchronizing.				

Table 3 - Event filtering

3 DISTURBANCE RECORDER

The integral enhanced disturbance recorder has an area of memory specifically set aside for record storage. The number of records that may be stored by the relay is dependent on the selected recording duration and the installed software release.

The relay can typically store a pre-set minimum number of records, each of a pre-set duration. These may vary between different MiCOM products.

Disturbance records continue to be recorded until the available memory is exhausted, at which time the oldest record(s) are overwritten to make space for the newest one.

The recorder stores actual samples that are taken at a rate of pre-defined number of samples per cycle. Again, this may vary between different MiCOM products.

Each disturbance record consists of a number of analog data channels and digital data channels.

The relevant CT and VT ratios for the analog channels are also extracted to enable scaling to primary quantities. If a CT ratio is set less than unity, the relay will choose a scaling factor of zero for the appropriate channel.

This relay can typically store a minimum of 15 records each of 1.5 seconds duration. However, IEC 60870-5 CS 103 relays have the same total record length but the VDEW protocol dictates that only 8 records (of 3 seconds duration) can be extracted via the rear port.

The record stores samples taken at 48 samples per cycle.

Each disturbance record consists of 12 analog data channels and 32 digital data channels.

There are now four additional **DDB Group Sig x** Nodes that can be mapped to individual or multiple DDBs in the PSL. These can then be set to trigger the DR via the DISTURBANCE RECORD menu.

These "Nodes" are general and can also be used to group signals together in the PSL for any other reason. These four nodes are available in each of the four PSL setting groups.

1. For a control input, the DR can be triggered directly by triggering directly from the Individual Control Input (e.g. Low to High (L to H) change)
2. For an input that cannot be triggered directly, or where any one of a number of DDBs are required to trigger a DR, map the DDBs to the new PSL Group sig n and then trigger the DR on this.

e.g. in the PSL:

In the DR Settings:

- Digital Input 1 is triggered by the PSL Group Sig 1 (L to H)
- Digital Input 2 is triggered by Control Input 1 (L to H)

If triggering on both edges is required map another DR channel to the H/L as well

Digital Input 4 is triggered by the PSL Group Sig 1 (H to L)

Digital Input 5 is triggered by Control Input 1 (H to L)

Col	Row	MENU TEXT	Default Setting	Available Setting
Description				
0C	00	DISTURB RECORDER	0	
This column contains settings for the Disturbance Recorder				
0C	01	Duration	1.5s	From 100ms to 10.5s step 10ms
This sets the overall recording time.				
0C	02	Trigger Position	33.30%	From 0% to 100% step 0.1%
This sets the trigger point as a percentage of the duration. For example, the default settings show that the overall recording time is set to 1.5 s with the trigger point being at 33.3% of this, giving 0.5 s pre-fault and 1s post fault recording times.				
0C	03	Trigger Mode	Single	0 = Single or 1 = Extended

Col	Row	MENU TEXT	Default Setting	Available Setting
Description				
If set to single mode, if a further trigger occurs whilst a recording is taking place, the recorder will ignore the trigger. However, if this has been set to Extended, the post trigger timer will be reset to zero, thereby extending the recording time.				
0C	04	Analog Channel 1	VA	A - Available settings 0 = IA, 1 = IB, 2 = IC, 3 = IN, 4 = IN Sensitive, 5 = VA, 6 = VB, 7 = VC, 8 = IM, 9 = V Checksync, 10 = Unused
Selects any available analogue input to be assigned to this channel (including derived IN residual current).				
0C	04	Analog Channel 1	VA	0 = IA, 1 = IB, 2 = IC, 3 = IN, 4 = IN Sensitive, 5 = VA, 6 = VB, 7 = VC, 8 = IM, 9 = V Checksync, 10 = IA2, 11 = IB2, 12 = IC2, 13 = IN2, 14 = V Checksync2, 15 = Unused
Selects any available analogue input to be assigned to this channel (including derived IN residual current).				
0C	05	Analog Channel 2	VA	A - Available settings 0 = IA, 1 = IB, 2 = IC, 3 = IN, 4 = IN Sensitive, 5 = VA, 6 = VB, 7 = VC, 8 = IM, 9 = V Checksync, 10 = Unused
Selects any available analogue input to be assigned to this channel (including derived IN residual current).				
0C	05	Analog Channel 2	VA	0 = IA, 1 = IB, 2 = IC, 3 = IN, 4 = IN Sensitive, 5 = VA, 6 = VB, 7 = VC, 8 = IM, 9 = V Checksync, 10 = IA2, 11 = IB2, 12 = IC2, 13 = IN2, 14 = V Checksync2, 15 = Unused
Selects any available analogue input to be assigned to this channel (including derived IN residual current).				
0C	06	Analog Channel 3	VA	A - Available settings 0 = IA, 1 = IB, 2 = IC, 3 = IN, 4 = IN Sensitive, 5 = VA, 6 = VB, 7 = VC, 8 = IM, 9 = V Checksync, 10 = Unused
Selects any available analogue input to be assigned to this channel (including derived IN residual current).				
0C	06	Analog Channel 3	VA	0 = IA, 1 = IB, 2 = IC, 3 = IN, 4 = IN Sensitive, 5 = VA, 6 = VB, 7 = VC, 8 = IM, 9 = V Checksync, 10 = IA2, 11 = IB2, 12 = IC2, 13 = IN2, 14 = V Checksync2, 15 = Unused
Selects any available analogue input to be assigned to this channel (including derived IN residual current).				
0C	07	Analog Channel 4	VA	A - Available settings 0 = IA, 1 = IB, 2 = IC, 3 = IN, 4 = IN Sensitive, 5 = VA, 6 = VB, 7 = VC, 8 = IM, 9 = V Checksync, 10 = Unused
Selects any available analogue input to be assigned to this channel (including derived IN residual current).				
0C	07	Analog Channel 4	VA	0 = IA, 1 = IB, 2 = IC, 3 = IN, 4 = IN Sensitive, 5 = VA, 6 = VB, 7 = VC, 8 = IM, 9 = V Checksync, 10 = IA2, 11 = IB2, 12 = IC2, 13 = IN2, 14 = V Checksync2, 15 = Unused
Selects any available analogue input to be assigned to this channel (including derived IN residual current).				
0C	08	Analog Channel 5	VA	A - Available settings 0 = IA, 1 = IB, 2 = IC, 3 = IN, 4 = IN Sensitive, 5 = VA, 6 = VB, 7 = VC, 8 = IM, 9 = V Checksync, 10 = Unused
Selects any available analogue input to be assigned to this channel (including derived IN residual current).				
0C	08	Analog Channel 5	VA	0 = IA, 1 = IB, 2 = IC, 3 = IN, 4 = IN Sensitive, 5 = VA, 6 = VB, 7 = VC, 8 = IM, 9 = V Checksync, 10 = IA2, 11 = IB2, 12 = IC2, 13 = IN2, 14 = V Checksync2, 15 = Unused
Selects any available analogue input to be assigned to this channel (including derived IN residual current).				
0C	09	Analog Channel 6	VA	A - Available settings 0 = IA, 1 = IB, 2 = IC, 3 = IN, 4 = IN Sensitive, 5 = VA, 6 = VB, 7 = VC, 8 = IM, 9 = V Checksync, 10 = Unused
Selects any available analogue input to be assigned to this channel (including derived IN residual current).				
0C	09	Analog Channel 6	VA	0 = IA, 1 = IB, 2 = IC, 3 = IN, 4 = IN Sensitive, 5 = VA, 6 = VB, 7 = VC, 8 = IM, 9 = V Checksync, 10 = IA2, 11 = IB2, 12 = IC2, 13 = IN2, 14 = V Checksync2, 15 = Unused
Selects any available analogue input to be assigned to this channel (including derived IN residual current).				
0C	0A	Analog Channel 7	VA	A - Available settings 0 = IA, 1 = IB, 2 = IC, 3 = IN, 4 = IN Sensitive, 5 = VA, 6 = VB, 7 = VC, 8 = IM, 9 = V Checksync, 10 = Unused
Selects any available analogue input to be assigned to this channel (including derived IN residual current).				
0C	0A	Analog Channel 7	VA	0 = IA, 1 = IB, 2 = IC, 3 = IN, 4 = IN Sensitive, 5 = VA, 6 = VB, 7 = VC, 8 = IM, 9 = V Checksync, 10 = IA2, 11 = IB2, 12 = IC2, 13 = IN2, 14 = V Checksync2, 15 = Unused

Col	Row	MENU TEXT	Default Setting	Available Setting
Description				
Selects any available analogue input to be assigned to this channel (including derived IN residual current).				
0C	0B	Analog Channel 8	VA	A - Available settings 0 = IA, 1 = IB, 2 = IC, 3 = IN, 4 = IN Sensitive, 5 = VA, 6 = VB, 7 = VC, 8 = IM, 9 = V Checksync, 10 = Unused
Selects any available analogue input to be assigned to this channel (including derived IN residual current).				
0C	0B	Analog Channel 8	VA	0 = IA, 1 = IB, 2 = IC, 3 = IN, 4 = IN Sensitive, 5 = VA, 6 = VB, 7 = VC, 8 = IM, 9 = V Checksync, 10 = IA2, 11 = IB2, 12 = IC2, 13 = IN2, 14 = V Checksync2, 15 = Unused
Selects any available analogue input to be assigned to this channel (including derived IN residual current).				
0C	0C	Digital Input 1	Output R1	See Data Types - G32
The digital channels may monitor any of the opto isolated inputs or output contacts, in addition to a number of internal relay digital signals, such as protection starts, LEDs etc.				
0C	0D	Input 1 Trigger	No Trigger	0 = No Trigger, 1 = Trigger L/H, 2 = Trigger H/L
Any of the digital channels may be selected to trigger the disturbance recorder on either a low to high or a high to low transition.				
0C	0E	Digital Input 2	Output R2	See Data Types - G32
The digital channels may monitor any of the opto isolated inputs or output contacts, in addition to a number of internal relay digital signals, such as protection starts, LEDs etc.				
0C	0F	Input 2 Trigger	No Trigger	0 = No Trigger, 1 = Trigger L/H, 2 = Trigger H/L
Any of the digital channels may be selected to trigger the disturbance recorder on either a low to high or a high to low transition.				
0C	10	Digital Input 3	Output R3	See Data Types - G32
The digital channels may monitor any of the opto isolated inputs or output contacts, in addition to a number of internal relay digital signals, such as protection starts, LEDs etc.				
0C	11	Input 3 Trigger	Trigger L/H	0 = No Trigger, 1 = Trigger L/H, 2 = Trigger H/L
Any of the digital channels may be selected to trigger the disturbance recorder on either a low to high or a high to low transition.				
0C	12	Digital Input 4	Output R4	See Data Types - G32
The digital channels may monitor any of the opto isolated inputs or output contacts, in addition to a number of internal relay digital signals, such as protection starts, LEDs etc.				
0C	13	Input 4 Trigger	No Trigger	0 = No Trigger, 1 = Trigger L/H, 2 = Trigger H/L
Any of the digital channels may be selected to trigger the disturbance recorder on either a low to high or a high to low transition.				
0C	14	Digital Input 5	Output R5	See Data Types - G32
The digital channels may monitor any of the opto isolated inputs or output contacts, in addition to a number of internal relay digital signals, such as protection starts, LEDs etc.				
0C	15	Input 5 Trigger	No Trigger	0 = No Trigger, 1 = Trigger L/H, 2 = Trigger H/L
Any of the digital channels may be selected to trigger the disturbance recorder on either a low to high or a high to low transition.				
0C	16	Digital Input 6	Output R6	See Data Types - G32
The digital channels may monitor any of the opto isolated inputs or output contacts, in addition to a number of internal relay digital signals, such as protection starts, LEDs etc.				
0C	17	Input 6 Trigger	No Trigger	0 = No Trigger, 1 = Trigger L/H, 2 = Trigger H/L
Any of the digital channels may be selected to trigger the disturbance recorder on either a low to high or a high to low transition.				
0C	18	Digital Input 7	Output R7	See Data Types - G32
The digital channels may monitor any of the opto isolated inputs or output contacts, in addition to a number of internal relay digital signals, such as protection starts, LEDs etc.				
0C	19	Input 7 Trigger	No Trigger	0 = No Trigger, 1 = Trigger L/H, 2 = Trigger H/L
Any of the digital channels may be selected to trigger the disturbance recorder on either a low to high or a high to low transition.				
0C	1A	Digital Input 8	Output R8	See Data Types - G32
The digital channels may monitor any of the opto isolated inputs or output contacts, in addition to a number of internal relay digital signals, such as protection starts, LEDs etc.				
0C	1B	Input 8 Trigger	No Trigger	0 = No Trigger, 1 = Trigger L/H, 2 = Trigger H/L

Col	Row	MENU TEXT	Default Setting	Available Setting
Description				
Any of the digital channels may be selected to trigger the disturbance recorder on either a low to high or a high to low transition.				
0C	1C	Digital Input 9	Output R9	See Data Types - G32
The digital channels may monitor any of the opto isolated inputs or output contacts, in addition to a number of internal relay digital signals, such as protection starts, LEDs etc.				
0C	1D	Input 9 Trigger	No Trigger	0 = No Trigger, 1 = Trigger L/H, 2 = Trigger H/L
Any of the digital channels may be selected to trigger the disturbance recorder on either a low to high or a high to low transition.				
0C	1E	Digital Input 10	Output R10	See Data Types - G32
The digital channels may monitor any of the opto isolated inputs or output contacts, in addition to a number of internal relay digital signals, such as protection starts, LEDs etc.				
0C	1F	Input 10 Trigger	No Trigger	0 = No Trigger, 1 = Trigger L/H, 2 = Trigger H/L
Any of the digital channels may be selected to trigger the disturbance recorder on either a low to high or a high to low transition.				
0C	20	Digital Input 11	Output R11	See Data Types - G32
The digital channels may monitor any of the opto isolated inputs or output contacts, in addition to a number of internal relay digital signals, such as protection starts, LEDs etc.				
0C	21	Input 11 Trigger	No Trigger	0 = No Trigger, 1 = Trigger L/H, 2 = Trigger H/L
Any of the digital channels may be selected to trigger the disturbance recorder on either a low to high or a high to low transition.				
0C	22	Digital Input 12	Output R12	See Data Types - G32
The digital channels may monitor any of the opto isolated inputs or output contacts, in addition to a number of internal relay digital signals, such as protection starts, LEDs etc.				
0C	23	Input 12 Trigger	No Trigger	0 = No Trigger, 1 = Trigger L/H, 2 = Trigger H/L
Any of the digital channels may be selected to trigger the disturbance recorder on either a low to high or a high to low transition.				
0C	24	Digital Input 13	Output R13	See Data Types - G32
The digital channels may monitor any of the opto isolated inputs or output contacts, in addition to a number of internal relay digital signals, such as protection starts, LEDs etc.				
0C	25	Input 13 Trigger	No Trigger	0 = No Trigger, 1 = Trigger L/H, 2 = Trigger H/L
Any of the digital channels may be selected to trigger the disturbance recorder on either a low to high or a high to low transition.				
0C	26	Digital Input 14	Output R14	See Data Types - G32
The digital channels may monitor any of the opto isolated inputs or output contacts, in addition to a number of internal relay digital signals, such as protection starts, LEDs etc.				
0C	27	Input 14 Trigger	No Trigger	0 = No Trigger, 1 = Trigger L/H, 2 = Trigger H/L
Any of the digital channels may be selected to trigger the disturbance recorder on either a low to high or a high to low transition.				
0C	28	Digital Input 15	Output R15	See Data Types - G32
The digital channels may monitor any of the opto isolated inputs or output contacts, in addition to a number of internal relay digital signals, such as protection starts, LEDs etc.				
0C	29	Input 15 Trigger	No Trigger	0 = No Trigger, 1 = Trigger L/H, 2 = Trigger H/L
Any of the digital channels may be selected to trigger the disturbance recorder on either a low to high or a high to low transition.				
0C	2A	Digital Input 16	Output R16	See Data Types - G32
The digital channels may monitor any of the opto isolated inputs or output contacts, in addition to a number of internal relay digital signals, such as protection starts, LEDs etc.				
0C	2B	Input 16 Trigger	No Trigger	0 = No Trigger, 1 = Trigger L/H, 2 = Trigger H/L
Any of the digital channels may be selected to trigger the disturbance recorder on either a low to high or a high to low transition.				
0C	2C	Digital Input 17	Input L1	See Data Types - G32
The digital channels may monitor any of the opto isolated inputs or output contacts, in addition to a number of internal relay digital signals, such as protection starts, LEDs etc.				
0C	2D	Input 17 Trigger	No Trigger	0 = No Trigger, 1 = Trigger L/H, 2 = Trigger H/L
Any of the digital channels may be selected to trigger the disturbance recorder on either a low to high or a high to low transition.				

Col	Row	MENU TEXT	Default Setting	Available Setting
Description				
0C	2E	Digital Input 18	Input L2	See Data Types - G32
The digital channels may monitor any of the opto isolated inputs or output contacts, in addition to a number of internal relay digital signals, such as protection starts, LEDs etc.				
0C	2F	Input 18 Trigger	No Trigger	0 = No Trigger, 1 = Trigger L/H, 2 = Trigger H/L
Any of the digital channels may be selected to trigger the disturbance recorder on either a low to high or a high to low transition.				
0C	30	Digital Input 19	Input L3	See Data Types - G32
The digital channels may monitor any of the opto isolated inputs or output contacts, in addition to a number of internal relay digital signals, such as protection starts, LEDs etc.				
0C	31	Input 19 Trigger	No Trigger	0 = No Trigger, 1 = Trigger L/H, 2 = Trigger H/L
Any of the digital channels may be selected to trigger the disturbance recorder on either a low to high or a high to low transition.				
0C	32	Digital Input 20	Input L4	See Data Types - G32
The digital channels may monitor any of the opto isolated inputs or output contacts, in addition to a number of internal relay digital signals, such as protection starts, LEDs etc.				
0C	33	Input 20 Trigger	No Trigger	0 = No Trigger, 1 = Trigger L/H, 2 = Trigger H/L
Any of the digital channels may be selected to trigger the disturbance recorder on either a low to high or a high to low transition.				
0C	34	Digital Input 21	Input L5	See Data Types - G32
The digital channels may monitor any of the opto isolated inputs or output contacts, in addition to a number of internal relay digital signals, such as protection starts, LEDs etc.				
0C	35	Input 21 Trigger	No Trigger	0 = No Trigger, 1 = Trigger L/H, 2 = Trigger H/L
Any of the digital channels may be selected to trigger the disturbance recorder on either a low to high or a high to low transition.				
0C	36	Digital Input 22	Input L6	See Data Types - G32
The digital channels may monitor any of the opto isolated inputs or output contacts, in addition to a number of internal relay digital signals, such as protection starts, LEDs etc.				
0C	37	Input 22 Trigger	No Trigger	0 = No Trigger, 1 = Trigger L/H, 2 = Trigger H/L
Any of the digital channels may be selected to trigger the disturbance recorder on either a low to high or a high to low transition.				
0C	38	Digital Input 23	Input L7	See Data Types - G32
The digital channels may monitor any of the opto isolated inputs or output contacts, in addition to a number of internal relay digital signals, such as protection starts, LEDs etc.				
0C	39	Input 23 Trigger	No Trigger	0 = No Trigger, 1 = Trigger L/H, 2 = Trigger H/L
Any of the digital channels may be selected to trigger the disturbance recorder on either a low to high or a high to low transition.				
0C	3A	Digital Input 24	Input L8	See Data Types - G32
The digital channels may monitor any of the opto isolated inputs or output contacts, in addition to a number of internal relay digital signals, such as protection starts, LEDs etc.				
0C	3B	Input 24 Trigger	No Trigger	0 = No Trigger, 1 = Trigger L/H, 2 = Trigger H/L
Any of the digital channels may be selected to trigger the disturbance recorder on either a low to high or a high to low transition.				
0C	3C	Digital Input 25	Input L9	See Data Types - G32
The digital channels may monitor any of the opto isolated inputs or output contacts, in addition to a number of internal relay digital signals, such as protection starts, LEDs etc.				
0C	3D	Input 25 Trigger	No Trigger	0 = No Trigger, 1 = Trigger L/H, 2 = Trigger H/L
Any of the digital channels may be selected to trigger the disturbance recorder on either a low to high or a high to low transition.				
0C	3E	Digital Input 26	Input L10	See Data Types - G32
The digital channels may monitor any of the opto isolated inputs or output contacts, in addition to a number of internal relay digital signals, such as protection starts, LEDs etc.				
0C	3F	Input 26 Trigger	No Trigger	0 = No Trigger, 1 = Trigger L/H, 2 = Trigger H/L
Any of the digital channels may be selected to trigger the disturbance recorder on either a low to high or a high to low transition.				
0C	40	Digital Input 27	Input L11	See Data Types - G32

Col	Row	MENU TEXT	Default Setting	Available Setting
Description				
The digital channels may monitor any of the opto isolated inputs or output contacts, in addition to a number of internal relay digital signals, such as protection starts, LEDs etc.				
0C	41	Input 27 Trigger	No Trigger	0 = No Trigger, 1 = Trigger L/H, 2 = Trigger H/L
Any of the digital channels may be selected to trigger the disturbance recorder on either a low to high or a high to low transition.				
0C	42	Digital Input 28	Input L12	See Data Types - G32
The digital channels may monitor any of the opto isolated inputs or output contacts, in addition to a number of internal relay digital signals, such as protection starts, LEDs etc.				
0C	43	Input 28 Trigger	No Trigger	0 = No Trigger, 1 = Trigger L/H, 2 = Trigger H/L
Any of the digital channels may be selected to trigger the disturbance recorder on either a low to high or a high to low transition.				
0C	44	Digital Input 29	Input L13	See Data Types - G32
The digital channels may monitor any of the opto isolated inputs or output contacts, in addition to a number of internal relay digital signals, such as protection starts, LEDs etc.				
0C	45	Input 29 Trigger	No Trigger	0 = No Trigger, 1 = Trigger L/H, 2 = Trigger H/L
Any of the digital channels may be selected to trigger the disturbance recorder on either a low to high or a high to low transition.				
0C	46	Digital Input 30	Input L14	See Data Types - G32
The digital channels may monitor any of the opto isolated inputs or output contacts, in addition to a number of internal relay digital signals, such as protection starts, LEDs etc.				
0C	47	Input 30 Trigger	No Trigger	0 = No Trigger, 1 = Trigger L/H, 2 = Trigger H/L
Any of the digital channels may be selected to trigger the disturbance recorder on either a low to high or a high to low transition.				
0C	48	Digital Input 31	Input L15	See Data Types - G32
The digital channels may monitor any of the opto isolated inputs or output contacts, in addition to a number of internal relay digital signals, such as protection starts, LEDs etc.				
0C	49	Input 31 Trigger	No Trigger	0 = No Trigger, 1 = Trigger L/H, 2 = Trigger H/L
Any of the digital channels may be selected to trigger the disturbance recorder on either a low to high or a high to low transition.				
0C	4A	Digital Input 32	Input L16	See Data Types - G32
The digital channels may monitor any of the opto isolated inputs or output contacts, in addition to a number of internal relay digital signals, such as protection starts, LEDs etc.				
0C	4B	Input 32 Trigger	No Trigger	0 = No Trigger, 1 = Trigger L/H, 2 = Trigger H/L
Any of the digital channels may be selected to trigger the disturbance recorder on either a low to high or a high to low transition.				
0C	50	Analog Channel 9	VA	A - Available settings 0 = IA, 1 = IB, 2 = IC, 3 = IN, 4 = IN Sensitive, 5 = VA, 6 = VB, 7 = VC, 8 = IM, 9 = V Checksync, 10 = Unused
Selects any available analogue input to be assigned to this channel (including derived IN residual current).				
0C	50	Analog Channel 9	VA	0 = IA, 1 = IB, 2 = IC, 3 = IN, 4 = IN Sensitive, 5 = VA, 6 = VB, 7 = VC, 8 = IM, 9 = V Checksync, 10 = IA2, 11 = IB2, 12 = IC2, 13 = IN2, 14 = V Checksync2, 15 = Unused
Selects any available analogue input to be assigned to this channel (including derived IN residual current).				
0C	51	Analog Channel 10	VA	A - Available settings 0 = IA, 1 = IB, 2 = IC, 3 = IN, 4 = IN Sensitive, 5 = VA, 6 = VB, 7 = VC, 8 = IM, 9 = V Checksync, 10 = Unused
Selects any available analogue input to be assigned to this channel (including derived IN residual current).				
0C	51	Analog Channel 10	VA	0 = IA, 1 = IB, 2 = IC, 3 = IN, 4 = IN Sensitive, 5 = VA, 6 = VB, 7 = VC, 8 = IM, 9 = V Checksync, 10 = IA2, 11 = IB2, 12 = IC2, 13 = IN2, 14 = V Checksync2, 15 = Unused
Selects any available analogue input to be assigned to this channel (including derived IN residual current).				
0C	52	Analog Channel 11	VA	A - Available settings 0 = IA, 1 = IB, 2 = IC, 3 = IN, 4 = IN Sensitive, 5 = VA, 6 = VB, 7 = VC, 8 = IM, 9 = V Checksync, 10 = Unused
Selects any available analogue input to be assigned to this channel (including derived IN residual current).				

Col	Row	MENU TEXT	Default Setting	Available Setting
Description				
0C	52	Analog Channel 11	VA	0 = IA, 1 = IB, 2 = IC, 3 = IN, 4 = IN Sensitive, 5 = VA, 6 = VB, 7 = VC, 8 = IM, 9 = V Checksync, 10 = IA2, 11 = IB2, 12 = IC2, 13 = IN2, 14 = V Checksync2, 15 = Unused
Selects any available analogue input to be assigned to this channel (including derived IN residual current).				
0C	53	Analog Channel 12	VA	A - Available settings 0 = IA, 1 = IB, 2 = IC, 3 = IN, 4 = IN Sensitive, 5 = VA, 6 = VB, 7 = VC, 8 = IM, 9 = V Checksync, 10 = Unused
Selects any available analogue input to be assigned to this channel (including derived IN residual current).				
0C	53	Analog Channel 12	VA	0 = IA, 1 = IB, 2 = IC, 3 = IN, 4 = IN Sensitive, 5 = VA, 6 = VB, 7 = VC, 8 = IM, 9 = V Checksync, 10 = IA2, 11 = IB2, 12 = IC2, 13 = IN2, 14 = V Checksync2, 15 = Unused
Selects any available analogue input to be assigned to this channel (including derived IN residual current).				
0C	54	Analog Channel 13	Unused	0 = IA, 1 = IB, 2 = IC, 3 = IN, 4 = IN Sensitive, 5 = VA, 6 = VB, 7 = VC, 8 = IM, 9 = V Checksync, 10 = IA DIFF, 11 = IB DIFF, 12 = IC DIFF, 13 = I BIAS MAX, 14 = I H2 MAX or 15 = Unused
Selects any available analogue input to be assigned to this channel (including derived IN residual current).				
0C	54	Analog Channel 13	VA	A - Available settings 0 = IA, 1 = IB, 2 = IC, 3 = IN, 4 = IN Sensitive, 5 = VA, 6 = VB, 7 = VC, 8 = IM, 9 = V Checksync, 10 = Unused
Selects any available analogue input to be assigned to this channel (including derived IN residual current).				
0C	54	Analog Channel 13	VA	0 = IA, 1 = IB, 2 = IC, 3 = IN, 4 = IN Sensitive, 5 = VA, 6 = VB, 7 = VC, 8 = IM, 9 = V Checksync, 10 = IA2, 11 = IB2, 12 = IC2, 13 = IN2, 14 = V Checksync2, 15 = Unused
Selects any available analogue input to be assigned to this channel (including derived IN residual current).				
0C	55	Analog Channel 14	Unused	0 = IA, 1 = IB, 2 = IC, 3 = IN, 4 = IN Sensitive, 5 = VA, 6 = VB, 7 = VC, 8 = IM, 9 = V Checksync, 10 = IA DIFF, 11 = IB DIFF, 12 = IC DIFF, 13 = I BIAS MAX, 14 = I H2 MAX or 15 = Unused
Selects any available analogue input to be assigned to this channel (including derived IN residual current).				
0C	55	Analog Channel 14	VA	A - Available settings 0 = IA, 1 = IB, 2 = IC, 3 = IN, 4 = IN Sensitive, 5 = VA, 6 = VB, 7 = VC, 8 = IM, 9 = V Checksync, 10 = Unused
Selects any available analogue input to be assigned to this channel (including derived IN residual current).				
0C	55	Analog Channel 14	VA	0 = IA, 1 = IB, 2 = IC, 3 = IN, 4 = IN Sensitive, 5 = VA, 6 = VB, 7 = VC, 8 = IM, 9 = V Checksync, 10 = IA2, 11 = IB2, 12 = IC2, 13 = IN2, 14 = V Checksync2, 15 = Unused
Selects any available analogue input to be assigned to this channel (including derived IN residual current).				
0C	56	Analog Channel 15	Unused	0 = IA, 1 = IB, 2 = IC, 3 = IN, 4 = IN Sensitive, 5 = VA, 6 = VB, 7 = VC, 8 = IM, 9 = V Checksync, 10 = IA DIFF, 11 = IB DIFF, 12 = IC DIFF, 13 = I BIAS MAX, 14 = I H2 MAX or 15 = Unused
Selects any available analogue input to be assigned to this channel (including derived IN residual current).				
0C	56	Analog Channel 15	VA	A - Available settings 0 = IA, 1 = IB, 2 = IC, 3 = IN, 4 = IN Sensitive, 5 = VA, 6 = VB, 7 = VC, 8 = IM, 9 = V Checksync, 10 = Unused
Selects any available analogue input to be assigned to this channel (including derived IN residual current).				
0C	56	Analog Channel 15	VA	0 = IA, 1 = IB, 2 = IC, 3 = IN, 4 = IN Sensitive, 5 = VA, 6 = VB, 7 = VC, 8 = IM, 9 = V Checksync, 10 = IA2, 11 = IB2, 12 = IC2, 13 = IN2, 14 = V Checksync2, 15 = Unused
Selects any available analogue input to be assigned to this channel (including derived IN residual current).				
0C	57	Analog Channel 16	Unused	0 = IA, 1 = IB, 2 = IC, 3 = IN, 4 = IN Sensitive, 5 = VA, 6 = VB, 7 = VC, 8 = IM, 9 = V Checksync, 10 = IA DIFF, 11 = IB DIFF, 12 = IC DIFF, 13 = I BIAS MAX, 14 = I H2 MAX or 15 = Unused
Selects any available analogue input to be assigned to this channel (including derived IN residual current).				
0C	57	Analog Channel 16	VA	A - Available settings 0 = IA, 1 = IB, 2 = IC, 3 = IN, 4 = IN Sensitive, 5 = VA, 6 = VB, 7 = VC, 8 = IM, 9 = V Checksync, 10 = Unused

Col	Row	MENU TEXT	Default Setting	Available Setting
Description				
Selects any available analogue input to be assigned to this channel (including derived IN residual current).				
0C	57	Analog Channel 16	VA	0 = IA, 1 = IB, 2 = IC, 3 = IN, 4 = IN Sensitive, 5 = VA, 6 = VB, 7 = VC, 8 = IM, 9 = V Checksync, 10 = IA2, 11 = IB2, 12 = IC2, 13 = IN2, 14 = V Checksync2, 15 = Unused
Selects any available analogue input to be assigned to this channel (including derived IN residual current).				
0C	58	Analog Channel 17	Unused	0 = IA, 1 = IB, 2 = IC, 3 = IN, 4 = IN Sensitive, 5 = VA, 6 = VB, 7 = VC, 8 = IM, 9 = V Checksync, 10 = IA DIFF, 11 = IB DIFF, 12 = IC DIFF, 13 = I BIAS MAX, 14 = I H2 MAX or 15 = Unused
Selects any available analogue input to be assigned to this channel (including derived IN residual current).				
0C	58	Analog Channel 17	VA	A - Available settings 0 = IA, 1 = IB, 2 = IC, 3 = IN, 4 = IN Sensitive, 5 = VA, 6 = VB, 7 = VC, 8 = IM, 9 = V Checksync, 10 = Unused
Selects any available analogue input to be assigned to this channel (including derived IN residual current).				
0C	58	Analog Channel 17	VA	0 = IA, 1 = IB, 2 = IC, 3 = IN, 4 = IN Sensitive, 5 = VA, 6 = VB, 7 = VC, 8 = IM, 9 = V Checksync, 10 = IA2, 11 = IB2, 12 = IC2, 13 = IN2, 14 = V Checksync2, 15 = Unused
Selects any available analogue input to be assigned to this channel (including derived IN residual current).				
0C	59	Analog Channel 18	Unused	0 = IA, 1 = IB, 2 = IC, 3 = IN, 4 = IN Sensitive, 5 = VA, 6 = VB, 7 = VC, 8 = IM, 9 = V Checksync, 10 = IA DIFF, 11 = IB DIFF, 12 = IC DIFF, 13 = I BIAS MAX, 14 = I H2 MAX or 15 = Unused
Selects any available analogue input to be assigned to this channel (including derived IN residual current).				
0C	59	Analog Channel 18	VA	A - Available settings 0 = IA, 1 = IB, 2 = IC, 3 = IN, 4 = IN Sensitive, 5 = VA, 6 = VB, 7 = VC, 8 = IM, 9 = V Checksync, 10 = Unused
Selects any available analogue input to be assigned to this channel (including derived IN residual current).				
0C	59	Analog Channel 18	VA	0 = IA, 1 = IB, 2 = IC, 3 = IN, 4 = IN Sensitive, 5 = VA, 6 = VB, 7 = VC, 8 = IM, 9 = V Checksync, 10 = IA2, 11 = IB2, 12 = IC2, 13 = IN2, 14 = V Checksync2, 15 = Unused
Selects any available analogue input to be assigned to this channel (including derived IN residual current).				
0C	5A	Analog Channel 19	Unused	0 = IA, 1 = IB, 2 = IC, 3 = IN, 4 = IN Sensitive, 5 = VA, 6 = VB, 7 = VC, 8 = IM, 9 = V Checksync, 10 = IA DIFF, 11 = IB DIFF, 12 = IC DIFF, 13 = I BIAS MAX, 14 = I H2 MAX or 15 = Unused
Selects any available analogue input to be assigned to this channel (including derived IN residual current).				
0C	5A	Analog Channel 19	VA	A - Available settings 0 = IA, 1 = IB, 2 = IC, 3 = IN, 4 = IN Sensitive, 5 = VA, 6 = VB, 7 = VC, 8 = IM, 9 = V Checksync, 10 = Unused
Selects any available analogue input to be assigned to this channel (including derived IN residual current).				
0C	5A	Analog Channel 19	VA	0 = IA, 1 = IB, 2 = IC, 3 = IN, 4 = IN Sensitive, 5 = VA, 6 = VB, 7 = VC, 8 = IM, 9 = V Checksync, 10 = IA2, 11 = IB2, 12 = IC2, 13 = IN2, 14 = V Checksync2, 15 = Unused
Selects any available analogue input to be assigned to this channel (including derived IN residual current).				
0C	5B	Analog Channel 20	Unused	0 = IA, 1 = IB, 2 = IC, 3 = IN, 4 = IN Sensitive, 5 = VA, 6 = VB, 7 = VC, 8 = IM, 9 = V Checksync, 10 = IA DIFF, 11 = IB DIFF, 12 = IC DIFF, 13 = I BIAS MAX, 14 = I H2 MAX or 15 = Unused
Selects any available analogue input to be assigned to this channel (including derived IN residual current).				
0C	5B	Analog Channel 20	VA	A - Available settings 0 = IA, 1 = IB, 2 = IC, 3 = IN, 4 = IN Sensitive, 5 = VA, 6 = VB, 7 = VC, 8 = IM, 9 = V Checksync, 10 = Unused
Selects any available analogue input to be assigned to this channel (including derived IN residual current).				
0C	5B	Analog Channel 20	VA	0 = IA, 1 = IB, 2 = IC, 3 = IN, 4 = IN Sensitive, 5 = VA, 6 = VB, 7 = VC, 8 = IM, 9 = V Checksync, 10 = IA2, 11 = IB2, 12 = IC2, 13 = IN2, 14 = V Checksync2, 15 = Unused
Selects any available analogue input to be assigned to this channel (including derived IN residual current).				
0C	70	Digital Input 33	Unused	See Data Types - G32

Col	Row	MENU TEXT	Default Setting	Available Setting
Description				
The digital channels may monitor any of the opto isolated inputs or output contacts, in addition to a number of internal relay digital signals, such as protection starts, LEDs etc.				
0C	71	Digital Input 34	Unused	See Data Types - G32
The digital channels may monitor any of the opto isolated inputs or output contacts, in addition to a number of internal relay digital signals, such as protection starts, LEDs etc.				
0C	72	Digital Input 35	Unused	See Data Types - G32
The digital channels may monitor any of the opto isolated inputs or output contacts, in addition to a number of internal relay digital signals, such as protection starts, LEDs etc.				
0C	73	Digital Input 36	Unused	See Data Types - G32
The digital channels may monitor any of the opto isolated inputs or output contacts, in addition to a number of internal relay digital signals, such as protection starts, LEDs etc.				
0C	74	Digital Input 37	Unused	See Data Types - G32
The digital channels may monitor any of the opto isolated inputs or output contacts, in addition to a number of internal relay digital signals, such as protection starts, LEDs etc.				
0C	75	Digital Input 38	Unused	See Data Types - G32
The digital channels may monitor any of the opto isolated inputs or output contacts, in addition to a number of internal relay digital signals, such as protection starts, LEDs etc.				
0C	76	Digital Input 39	Unused	See Data Types - G32
The digital channels may monitor any of the opto isolated inputs or output contacts, in addition to a number of internal relay digital signals, such as protection starts, LEDs etc.				
0C	77	Digital Input 40	Unused	See Data Types - G32
The digital channels may monitor any of the opto isolated inputs or output contacts, in addition to a number of internal relay digital signals, such as protection starts, LEDs etc.				
0C	78	Digital Input 41	Unused	See Data Types - G32
The digital channels may monitor any of the opto isolated inputs or output contacts, in addition to a number of internal relay digital signals, such as protection starts, LEDs etc.				
0C	79	Digital Input 42	Unused	See Data Types - G32
The digital channels may monitor any of the opto isolated inputs or output contacts, in addition to a number of internal relay digital signals, such as protection starts, LEDs etc.				
0C	7A	Digital Input 43	Unused	See Data Types - G32
The digital channels may monitor any of the opto isolated inputs or output contacts, in addition to a number of internal relay digital signals, such as protection starts, LEDs etc.				
0C	7B	Digital Input 44	Unused	See Data Types - G32
The digital channels may monitor any of the opto isolated inputs or output contacts, in addition to a number of internal relay digital signals, such as protection starts, LEDs etc.				
0C	7C	Digital Input 45	Unused	See Data Types - G32
The digital channels may monitor any of the opto isolated inputs or output contacts, in addition to a number of internal relay digital signals, such as protection starts, LEDs etc.				
0C	7D	Digital Input 46	Unused	See Data Types - G32
The digital channels may monitor any of the opto isolated inputs or output contacts, in addition to a number of internal relay digital signals, such as protection starts, LEDs etc.				
0C	7E	Digital Input 47	Unused	See Data Types - G32
The digital channels may monitor any of the opto isolated inputs or output contacts, in addition to a number of internal relay digital signals, such as protection starts, LEDs etc.				
0C	7F	Digital Input 48	Unused	See Data Types - G32
The digital channels may monitor any of the opto isolated inputs or output contacts, in addition to a number of internal relay digital signals, such as protection starts, LEDs etc.				
0C	80	Digital Input 49	Unused	See Data Types - G32

Col	Row	MENU TEXT	Default Setting	Available Setting
Description				
The digital channels may monitor any of the opto isolated inputs or output contacts, in addition to a number of internal relay digital signals, such as protection starts, LEDs etc.				
0C	81	Digital Input 50	Unused	See Data Types - G32
The digital channels may monitor any of the opto isolated inputs or output contacts, in addition to a number of internal relay digital signals, such as protection starts, LEDs etc.				
0C	82	Digital Input 51	Unused	See Data Types - G32
The digital channels may monitor any of the opto isolated inputs or output contacts, in addition to a number of internal relay digital signals, such as protection starts, LEDs etc.				
0C	83	Digital Input 52	Unused	See Data Types - G32
The digital channels may monitor any of the opto isolated inputs or output contacts, in addition to a number of internal relay digital signals, such as protection starts, LEDs etc.				
0C	84	Digital Input 53	Unused	See Data Types - G32
The digital channels may monitor any of the opto isolated inputs or output contacts, in addition to a number of internal relay digital signals, such as protection starts, LEDs etc.				
0C	85	Digital Input 54	Unused	See Data Types - G32
The digital channels may monitor any of the opto isolated inputs or output contacts, in addition to a number of internal relay digital signals, such as protection starts, LEDs etc.				
0C	86	Digital Input 55	Unused	See Data Types - G32
The digital channels may monitor any of the opto isolated inputs or output contacts, in addition to a number of internal relay digital signals, such as protection starts, LEDs etc.				
0C	87	Digital Input 56	Unused	See Data Types - G32
The digital channels may monitor any of the opto isolated inputs or output contacts, in addition to a number of internal relay digital signals, such as protection starts, LEDs etc.				
0C	88	Digital Input 57	Unused	See Data Types - G32
The digital channels may monitor any of the opto isolated inputs or output contacts, in addition to a number of internal relay digital signals, such as protection starts, LEDs etc.				
0C	89	Digital Input 58	Unused	See Data Types - G32
The digital channels may monitor any of the opto isolated inputs or output contacts, in addition to a number of internal relay digital signals, such as protection starts, LEDs etc.				
0C	8A	Digital Input 59	Unused	See Data Types - G32
The digital channels may monitor any of the opto isolated inputs or output contacts, in addition to a number of internal relay digital signals, such as protection starts, LEDs etc.				
0C	8B	Digital Input 60	Unused	See Data Types - G32
The digital channels may monitor any of the opto isolated inputs or output contacts, in addition to a number of internal relay digital signals, such as protection starts, LEDs etc.				
0C	8C	Digital Input 61	Unused	See Data Types - G32
The digital channels may monitor any of the opto isolated inputs or output contacts, in addition to a number of internal relay digital signals, such as protection starts, LEDs etc.				
0C	8D	Digital Input 62	Unused	See Data Types - G32
The digital channels may monitor any of the opto isolated inputs or output contacts, in addition to a number of internal relay digital signals, such as protection starts, LEDs etc.				
0C	8E	Digital Input 63	Unused	See Data Types - G32
The digital channels may monitor any of the opto isolated inputs or output contacts, in addition to a number of internal relay digital signals, such as protection starts, LEDs etc.				
0C	8F	Digital Input 64	Unused	See Data Types - G32
The digital channels may monitor any of the opto isolated inputs or output contacts, in addition to a number of internal relay digital signals, such as protection starts, LEDs etc.				
0C	90	Digital Input 65	Unused	See Data Types - G32

Col	Row	MENU TEXT	Default Setting	Available Setting
Description				
The digital channels may monitor any of the opto isolated inputs or output contacts, in addition to a number of internal relay digital signals, such as protection starts, LEDs etc.				
0C	91	Digital Input 66	Unused	See Data Types - G32
The digital channels may monitor any of the opto isolated inputs or output contacts, in addition to a number of internal relay digital signals, such as protection starts, LEDs etc.				
0C	92	Digital Input 67	Unused	See Data Types - G32
The digital channels may monitor any of the opto isolated inputs or output contacts, in addition to a number of internal relay digital signals, such as protection starts, LEDs etc.				
0C	93	Digital Input 68	Unused	See Data Types - G32
The digital channels may monitor any of the opto isolated inputs or output contacts, in addition to a number of internal relay digital signals, such as protection starts, LEDs etc.				
0C	94	Digital Input 69	Unused	See Data Types - G32
The digital channels may monitor any of the opto isolated inputs or output contacts, in addition to a number of internal relay digital signals, such as protection starts, LEDs etc.				
0C	95	Digital Input 70	Unused	See Data Types - G32
The digital channels may monitor any of the opto isolated inputs or output contacts, in addition to a number of internal relay digital signals, such as protection starts, LEDs etc.				
0C	96	Digital Input 71	Unused	See Data Types - G32
The digital channels may monitor any of the opto isolated inputs or output contacts, in addition to a number of internal relay digital signals, such as protection starts, LEDs etc.				
0C	97	Digital Input 72	Unused	See Data Types - G32
The digital channels may monitor any of the opto isolated inputs or output contacts, in addition to a number of internal relay digital signals, such as protection starts, LEDs etc.				
0C	98	Digital Input 73	Unused	See Data Types - G32
The digital channels may monitor any of the opto isolated inputs or output contacts, in addition to a number of internal relay digital signals, such as protection starts, LEDs etc.				
0C	99	Digital Input 74	Unused	See Data Types - G32
The digital channels may monitor any of the opto isolated inputs or output contacts, in addition to a number of internal relay digital signals, such as protection starts, LEDs etc.				
0C	9A	Digital Input 75	Unused	See Data Types - G32
The digital channels may monitor any of the opto isolated inputs or output contacts, in addition to a number of internal relay digital signals, such as protection starts, LEDs etc.				
0C	9B	Digital Input 76	Unused	See Data Types - G32
The digital channels may monitor any of the opto isolated inputs or output contacts, in addition to a number of internal relay digital signals, such as protection starts, LEDs etc.				
0C	9C	Digital Input 77	Unused	See Data Types - G32
The digital channels may monitor any of the opto isolated inputs or output contacts, in addition to a number of internal relay digital signals, such as protection starts, LEDs etc.				
0C	9D	Digital Input 78	Unused	See Data Types - G32
The digital channels may monitor any of the opto isolated inputs or output contacts, in addition to a number of internal relay digital signals, such as protection starts, LEDs etc.				
0C	9E	Digital Input 79	Unused	See Data Types - G32
The digital channels may monitor any of the opto isolated inputs or output contacts, in addition to a number of internal relay digital signals, such as protection starts, LEDs etc.				
0C	9F	Digital Input 80	Unused	See Data Types - G32
The digital channels may monitor any of the opto isolated inputs or output contacts, in addition to a number of internal relay digital signals, such as protection starts, LEDs etc.				
0C	A0	Digital Input 81	Unused	See Data Types - G32

Col	Row	MENU TEXT	Default Setting	Available Setting
Description				
The digital channels may monitor any of the opto isolated inputs or output contacts, in addition to a number of internal relay digital signals, such as protection starts, LEDs etc.				
0C	A1	Digital Input 82	Unused	See Data Types - G32
The digital channels may monitor any of the opto isolated inputs or output contacts, in addition to a number of internal relay digital signals, such as protection starts, LEDs etc.				
0C	A2	Digital Input 83	Unused	See Data Types - G32
The digital channels may monitor any of the opto isolated inputs or output contacts, in addition to a number of internal relay digital signals, such as protection starts, LEDs etc.				
0C	A3	Digital Input 84	Unused	See Data Types - G32
The digital channels may monitor any of the opto isolated inputs or output contacts, in addition to a number of internal relay digital signals, such as protection starts, LEDs etc.				
0C	A4	Digital Input 85	Unused	See Data Types - G32
The digital channels may monitor any of the opto isolated inputs or output contacts, in addition to a number of internal relay digital signals, such as protection starts, LEDs etc.				
0C	A5	Digital Input 86	Unused	See Data Types - G32
The digital channels may monitor any of the opto isolated inputs or output contacts, in addition to a number of internal relay digital signals, such as protection starts, LEDs etc.				
0C	A6	Digital Input 87	Unused	See Data Types - G32
The digital channels may monitor any of the opto isolated inputs or output contacts, in addition to a number of internal relay digital signals, such as protection starts, LEDs etc.				
0C	A7	Digital Input 88	Unused	See Data Types - G32
The digital channels may monitor any of the opto isolated inputs or output contacts, in addition to a number of internal relay digital signals, such as protection starts, LEDs etc.				
0C	A8	Digital Input 89	Unused	See Data Types - G32
The digital channels may monitor any of the opto isolated inputs or output contacts, in addition to a number of internal relay digital signals, such as protection starts, LEDs etc.				
0C	A9	Digital Input 90	Unused	See Data Types - G32
The digital channels may monitor any of the opto isolated inputs or output contacts, in addition to a number of internal relay digital signals, such as protection starts, LEDs etc.				
0C	AA	Digital Input 91	Unused	See Data Types - G32
The digital channels may monitor any of the opto isolated inputs or output contacts, in addition to a number of internal relay digital signals, such as protection starts, LEDs etc.				
0C	AB	Digital Input 92	Unused	See Data Types - G32
The digital channels may monitor any of the opto isolated inputs or output contacts, in addition to a number of internal relay digital signals, such as protection starts, LEDs etc.				
0C	AC	Digital Input 93	Unused	See Data Types - G32
The digital channels may monitor any of the opto isolated inputs or output contacts, in addition to a number of internal relay digital signals, such as protection starts, LEDs etc.				
0C	AD	Digital Input 94	Unused	See Data Types - G32
The digital channels may monitor any of the opto isolated inputs or output contacts, in addition to a number of internal relay digital signals, such as protection starts, LEDs etc.				
0C	AE	Digital Input 95	Unused	See Data Types - G32
The digital channels may monitor any of the opto isolated inputs or output contacts, in addition to a number of internal relay digital signals, such as protection starts, LEDs etc.				
0C	AF	Digital Input 96	Unused	See Data Types - G32
The digital channels may monitor any of the opto isolated inputs or output contacts, in addition to a number of internal relay digital signals, such as protection starts, LEDs etc.				
0C	B0	Digital Input 97	Unused	See Data Types - G32

Col	Row	MENU TEXT	Default Setting	Available Setting
Description				
The digital channels may monitor any of the opto isolated inputs or output contacts, in addition to a number of internal relay digital signals, such as protection starts, LEDs etc.				
0C	B1	Digital Input 98	Unused	See Data Types - G32
The digital channels may monitor any of the opto isolated inputs or output contacts, in addition to a number of internal relay digital signals, such as protection starts, LEDs etc.				
0C	B2	Digital Input 99	Unused	See Data Types - G32
The digital channels may monitor any of the opto isolated inputs or output contacts, in addition to a number of internal relay digital signals, such as protection starts, LEDs etc.				
0C	B3	Digital Input 100	Unused	See Data Types - G32
The digital channels may monitor any of the opto isolated inputs or output contacts, in addition to a number of internal relay digital signals, such as protection starts, LEDs etc.				
0C	B4	Digital Input 101	Unused	See Data Types - G32
The digital channels may monitor any of the opto isolated inputs or output contacts, in addition to a number of internal relay digital signals, such as protection starts, LEDs etc.				
0C	B5	Digital Input 102	Unused	See Data Types - G32
The digital channels may monitor any of the opto isolated inputs or output contacts, in addition to a number of internal relay digital signals, such as protection starts, LEDs etc.				
0C	B6	Digital Input 103	Unused	See Data Types - G32
The digital channels may monitor any of the opto isolated inputs or output contacts, in addition to a number of internal relay digital signals, such as protection starts, LEDs etc.				
0C	B7	Digital Input 104	Unused	See Data Types - G32
The digital channels may monitor any of the opto isolated inputs or output contacts, in addition to a number of internal relay digital signals, such as protection starts, LEDs etc.				
0C	B8	Digital Input 105	Unused	See Data Types - G32
The digital channels may monitor any of the opto isolated inputs or output contacts, in addition to a number of internal relay digital signals, such as protection starts, LEDs etc.				
0C	B9	Digital Input 106	Unused	See Data Types - G32
The digital channels may monitor any of the opto isolated inputs or output contacts, in addition to a number of internal relay digital signals, such as protection starts, LEDs etc.				
0C	BA	Digital Input 107	Unused	See Data Types - G32
The digital channels may monitor any of the opto isolated inputs or output contacts, in addition to a number of internal relay digital signals, such as protection starts, LEDs etc.				
0C	BB	Digital Input 108	Unused	See Data Types - G32
The digital channels may monitor any of the opto isolated inputs or output contacts, in addition to a number of internal relay digital signals, such as protection starts, LEDs etc.				
0C	BC	Digital Input 109	Unused	See Data Types - G32
The digital channels may monitor any of the opto isolated inputs or output contacts, in addition to a number of internal relay digital signals, such as protection starts, LEDs etc.				
0C	BD	Digital Input 110	Unused	See Data Types - G32
The digital channels may monitor any of the opto isolated inputs or output contacts, in addition to a number of internal relay digital signals, such as protection starts, LEDs etc.				
0C	BE	Digital Input 111	Unused	See Data Types - G32
The digital channels may monitor any of the opto isolated inputs or output contacts, in addition to a number of internal relay digital signals, such as protection starts, LEDs etc.				
0C	BF	Digital Input 112	Unused	See Data Types - G32
The digital channels may monitor any of the opto isolated inputs or output contacts, in addition to a number of internal relay digital signals, such as protection starts, LEDs etc.				
0C	C0	Digital Input 113	Unused	See Data Types - G32

Col	Row	MENU TEXT	Default Setting	Available Setting
Description				
The digital channels may monitor any of the opto isolated inputs or output contacts, in addition to a number of internal relay digital signals, such as protection starts, LEDs etc.				
0C	C1	Digital Input 114	Unused	See Data Types - G32
The digital channels may monitor any of the opto isolated inputs or output contacts, in addition to a number of internal relay digital signals, such as protection starts, LEDs etc.				
0C	C2	Digital Input 115	Unused	See Data Types - G32
The digital channels may monitor any of the opto isolated inputs or output contacts, in addition to a number of internal relay digital signals, such as protection starts, LEDs etc.				
0C	C3	Digital Input 116	Unused	See Data Types - G32
The digital channels may monitor any of the opto isolated inputs or output contacts, in addition to a number of internal relay digital signals, such as protection starts, LEDs etc.				
0C	C4	Digital Input 117	Unused	See Data Types - G32
The digital channels may monitor any of the opto isolated inputs or output contacts, in addition to a number of internal relay digital signals, such as protection starts, LEDs etc.				
0C	C5	Digital Input 118	Unused	See Data Types - G32
The digital channels may monitor any of the opto isolated inputs or output contacts, in addition to a number of internal relay digital signals, such as protection starts, LEDs etc.				
0C	C6	Digital Input 119	Unused	See Data Types - G32
The digital channels may monitor any of the opto isolated inputs or output contacts, in addition to a number of internal relay digital signals, such as protection starts, LEDs etc.				
0C	C7	Digital Input 120	Unused	See Data Types - G32
The digital channels may monitor any of the opto isolated inputs or output contacts, in addition to a number of internal relay digital signals, such as protection starts, LEDs etc.				
0C	C8	Digital Input 121	Unused	See Data Types - G32
The digital channels may monitor any of the opto isolated inputs or output contacts, in addition to a number of internal relay digital signals, such as protection starts, LEDs etc.				
0C	C9	Digital Input 122	Unused	See Data Types - G32
The digital channels may monitor any of the opto isolated inputs or output contacts, in addition to a number of internal relay digital signals, such as protection starts, LEDs etc.				
0C	CA	Digital Input 123	Unused	See Data Types - G32
The digital channels may monitor any of the opto isolated inputs or output contacts, in addition to a number of internal relay digital signals, such as protection starts, LEDs etc.				
0C	CB	Digital Input 124	Unused	See Data Types - G32
The digital channels may monitor any of the opto isolated inputs or output contacts, in addition to a number of internal relay digital signals, such as protection starts, LEDs etc.				
0C	CC	Digital Input 125	Unused	See Data Types - G32
The digital channels may monitor any of the opto isolated inputs or output contacts, in addition to a number of internal relay digital signals, such as protection starts, LEDs etc.				
0C	CD	Digital Input 126	Unused	See Data Types - G32
The digital channels may monitor any of the opto isolated inputs or output contacts, in addition to a number of internal relay digital signals, such as protection starts, LEDs etc.				
0C	CE	Digital Input 127	Unused	See Data Types - G32
The digital channels may monitor any of the opto isolated inputs or output contacts, in addition to a number of internal relay digital signals, such as protection starts, LEDs etc.				
0C	CF	Digital Input 128	Unused	See Data Types - G32
The digital channels may monitor any of the opto isolated inputs or output contacts, in addition to a number of internal relay digital signals, such as protection starts, LEDs etc.				

Table 4 - Disturbance recorder settings

The pre and post fault recording times are set by a combination of the **Duration** and **Trigger Position** cells. **Duration** sets the overall recording time and the **Trigger Position** sets the trigger point as a percentage of the duration.

- For example, the default settings show that the overall recording time is set to 1.5 s with the trigger point being at 33.3% of this, giving 0.5 s pre-fault and 1 s post-fault recording times.

If a further trigger occurs while a recording is taking place, the recorder ignores the trigger if the **Trigger Mode** is set to **Single**. However, if this is set to **Extended**, the post-trigger timer is reset to zero, extending the recording time.

As can be seen from the menu, each of the analog channels is selectable from the available analog inputs to the relay. The digital channels may be mapped to any of the opto isolated inputs or output contacts, in addition to several internal relay digital signals, such as protection starts and LEDs. The complete list of these signals may be found by viewing the available settings in the relay menu or using a setting file in MiCOM S1 Studio. Any of the digital channels may be selected to trigger the disturbance recorder on either a low-to-high or a high-to-low transition, using the **Input Trigger** cell. The default trigger settings are that any dedicated trip output contacts, such as relay 3, trigger the recorder.

It is not possible to view the disturbance records locally using the LCD; they must be extracted using suitable software such as MiCOM S1 Studio. This process is fully explained in the *SCADA Communications* chapter.

4 MEASUREMENTS

The relay produces a variety of both directly measured and calculated power system quantities. These measurement values are updated every second and can be viewed in the **Measurements** columns (up to three) of the relay or using the MiCOM S1 Studio Measurement viewer.

The relay can measure and display these quantities:

- Phase Voltages and Currents
- Phase to Phase Voltages and Currents
- Sequence Voltages and Currents
- Slip Frequency
- Power and Energy Quantities
- Rms. Voltages and Currents
- Peak, Fixed and Rolling Demand Values

There are also measured values from the protection functions, which are also displayed under the measurement columns of the menu; these are described in the section on the relevant protection function.

4.1 Measured Voltages and Currents

The relay produces both phase-to-ground and phase-to-phase voltage and current values. They are produced directly from the Discrete Fourier Transform (DFT) used by the relay protection functions and present both magnitude and phase angle measurement.

4.2 Sequence Voltages and Currents

Sequence quantities are produced by the relay from the measured Fourier values; these are displayed as magnitude and phase angle values.

4.3 Slip Frequency

The relay produces a slip frequency measurement by measuring the rate of change of phase angle, between the bus and line voltages, over a one-cycle period. The slip frequency measurement assumes the bus voltage to be the reference phasor.

4.4 Power and Energy Quantities

Using the measured voltages and currents the relay calculates the apparent, real and reactive power quantities. These are produced phase-by-phase. Three-phase values are based on the sum of the three individual phase values. The signing of the real and reactive power measurements can be controlled using the measurement mode setting. The options are as follows.

Measurement mode	Parameter	Signing
0 (Default)	Export Power	+
	Import Power	-
	Lagging Vars	+
	Leading VArS	-
1	Export Power	-
	Import Power	+
	Lagging Vars	+
	Leading VArS	-
2	Export Power	+
	Import Power	-
	Lagging Vars	-
	Leading VArS	+
3	Export Power	-
	Import Power	+
	Lagging Vars	-
	Leading VArS	+

In addition to the measured power quantities, the relay calculates the power factor phase-by-phase, in addition to a three-phase power factor.

These power values are also used to increment the total real and reactive energy measurements. Separate energy measurements are maintained for the total exported and imported energy. The energy measurements are incremented up to maximum values of 1000 GWhr or 1000 GVARhr, at which point they reset to zero. It is also possible to reset these values using the menu or remote interfaces using the **Reset Demand** cell.

4.5 RMS. Voltages and Currents

RMS phase voltage and current values are calculated by the relay using the sum of the samples squared over a cycle of sampled data.

4.6 Demand Values

The relay produces fixed, rolling and peak demand values. Using the reset demand menu cell it is possible to reset these quantities from the user interface or the remote communications.

4.6.1 Fixed Demand Values

The fixed demand value is the average value of a quantity over the specified interval; values are produced for each phase current and for three-phase real and reactive power. The fixed demand values displayed by the relay are those for the previous interval. The values are updated at the end of the fixed demand period.

4.6.2 Rolling Demand Values

The rolling demand values are similar to the fixed demand values, the difference being that a sliding window is used. The rolling demand window consists of several smaller sub-periods. The resolution of the sliding window is the sub-period length, with the displayed values updated at the end of each of the sub-periods.

4.6.3 Peak Demand Values

Peak demand values are produced for each phase current and the real and reactive power quantities. These display the maximum value of the measured quantity since the last reset of the demand values.

4.7 Settings

The settings shown under the heading **MEASURE'T SETUP** can be used to configure the relay measurement function. See the following Measurements table for more details:

MENU TEXT	Col	Row	Default Setting	Available Setting
Description				
MEASURE'T SETUP	0D	0	0	
This column contains settings for the measurement setup				
Default Display	0D	1	Description	0 = User Banner, 1 = 3Ph + N Current, 2 = 3Ph Voltage, 3 = Power, 4 = Date and Time, 5 = Description, 6 = Plant Reference, 7 = Frequency, 8 = Access Level
This setting can be used to select the default display from a range of options, note that it is also possible to view the other default displays whilst at the default level using the 4 and 6 keys. However once the 15 minute timeout elapses the default display will revert to that selected by this setting.				
Local Values	0D	2	Primary	0 = Primary or 1 = Secondary
This setting controls whether measured values via the front panel user interface and the front courier port are displayed as primary or secondary quantities.				
Remote Values	0D	3	Primary	0 = Primary or 1 = Secondary
This setting controls whether measured values via the rear communication port are displayed as primary or secondary quantities.				
Measurement Ref	0D	4	VA	0 = VA, 1 = VB, 2 = VC, 3 = IA, 4 = IB, 5 = IC
Using this setting the phase reference for all angular measurements by the relay can be selected. This reference is for Measurements 1. Measurements 3 uses always IA local as a reference				
Measurement Mode	0D	5	0	0 to 3 step 1
This setting is used to control the signing of the real and reactive power quantities; the signing convention used is defined in the Measurements and Recording chapter (P54x/EN MR).				
Fix Dem Period	0D	6	30	1 to 99 step 1
This setting defines the length of the fixed demand window				
Roll Sub Period	0D	7	30	1 to 99 step 1
These two settings are used to set the length of the window used for the calculation of rolling demand quantities				
Num Sub Periods	0D	8	1	1 to 15 step 1
This setting is used to set the resolution of the rolling sub window				
Distance Unit	0D	9	Miles	0 = Kilometres or 1 = Miles
This setting is used to select the unit of distance for fault location purposes, note that the length of the line is preserved when converting from km to miles and vice versa				
Fault Location	0D	0A	Distance	0 = Distance, 1 = Ohms, 2 = % of Line
The calculated fault location can be displayed using one of several options selected using this setting				
Remote 2 Values	0D	0B	Primary	0 = Primary or 1 = Secondary
The setting defines whether the values measured via the 2nd Rear Communication port are displayed in primary or secondary terms.				

Table 5 - Measurement setup

4.8 Measurement Display Quantities

The relay has Measurement columns for viewing measurement quantities. These can also be viewed with MiCOM S1 Studio and are shown below.

MEASUREMENTS 1		MEASUREMENTS 2		MEASUREMENTS 4	
IA Magnitude	0 A	A Phase Watts	0 W	Ch 1 Prop Delay	
IA Phase Angle	0 deg	B Phase Watts	0 W	Ch 2 Prop Delay	
IB Magnitude	0 A	C Phase Watts	0 W	Channel 1 Status	
IB Phase Angle	0 deg	A Phase VArS	0 Var	Channel 2 Status	
IC Magnitude	0 A	B Phase VArS	0 Var	IM64 Rx Status	
IC Phase Angle	0 deg	C Phase VArS	0 Var	STATISTICS	
IN Derived Mag.	0 A	A Phase VA	0 VA	Last Reset on	
IN Derived Angle	0 deg	B Phase VA	0 VA	Date/Time	
ISEF Magnitude	0 A	C Phase VA	0 VA	Ch1 No.Vald Mess	
ISEF Angle	0 deg	3 Phase Watts	0 W	Ch1 No.Err Mess	
I1 Magnitude	0 A	3 Phase VArS	0 VAr	Ch1 No.Errorred s	
I2 Magnitude	0 A	3 Phase VA	0 VA	Ch1 No.Sev Err s	
I0 Magnitude	0 A	3Ph Power Factor	0	Ch1 No.Dgraded m	
IA RMS	0 A	A Ph Power Factor	0	Ch2 No.Vald Mess	
IB RMS	0 A	B Ph Power Factor	0	Ch2 No.Err Mess	
IC RMS	0 A	C Ph Power Factor	0	Ch2 No.Errorred s	
IN RMS	0 A	3Ph WHours Fwd	0 Wh	Ch2 No.Sev Err s	
VAB Magnitude	0 V	3Ph WHours Rev	0 Wh	Ch2 No.Dgraded m	
VAB Phase Angle	0 deg	3Ph VArHours Fwd	0 VArh	Max Ch 1 Prop Delay	
VBC Magnitude	0 V	3Ph VArHours Rev	0 VArh	Max Ch 2 Prop Delay	
VBC Phase Angle	0 deg	3Ph W Fix Demand	0 W	Clear Statistics	
VCA Magnitude	0 V	3Ph VArS Fix Dem.	0 VAr		
VCA Phase Angle	0 deg	IA Fixed Demand	0 A		
VAN Magnitude	0 V	IB Fixed Demand	0 A		
VAN Phase Angle	0 deg	IC Fixed Demand	0 A		
VBN Magnitude	0 V	3 Ph W Roll Dem.	0 W		
VBN Phase Angle	0 deg	3Ph VArS Roll Dem.	0 VAr		
VCN Magnitude	0 V	IA Roll Demand	0 A		
VCN Phase Angle	0 deg	IB Roll Demand	0 A		
V1 Magnitude	0 V	IC Roll Demand	0 A		
V2 Magnitude	0 V	3Ph W Peak Dem.	0 W		
V0 Magnitude	0 V	3Ph VAr Peak Dem.	0 VAr		
VAN RMS	0 V	IA Peak Demand	0 A		
VBN RMS	0 V	IB Peak Demand	0 A		
VCN RMS	0 V	IC Peak Demand	0 A		
VAB RMS	0 V	Reset Demand	No		
VBC RMS	0 V				
VCA RMS	0 V				
Frequency					
C/S Voltage Mag.	0 V				

MEASUREMENTS 1		MEASUREMENTS 2		MEASUREMENTS 4	
C/S Voltage Ang.	0 deg				
C/S Bus-Line Ang.	0 deg				
Slip Frequency					
I1 Magnitude	0 A				
I1 Phase Angle	0 deg				
I2 Magnitude	0 A				
I2 Phase Angle	0 deg				
I0 Magnitude	0 A				
I0 Phase Angle	0 deg				
V1 Magnitude	0 V				
V1 Phase Angle	0 deg				
V2 Magnitude	0 V				
V2 Phase Angle	0 deg				
V0 Magnitude	0 V				
V0 Phase Angle	0 deg				
VRem Magnitude	0 V				
VRem Phase Ang	0 deg				

Table 6 - Measurements 1, 2 and 4

4.9

Measurements 4 Column

The contents of the Measurements 4 column are associated with the InterMiCOM⁶⁴ feature. Two InterMiCOM⁶⁴ channels can be supported referred to as Channel1 (Ch1) and Channel2 (Ch2)

Channel 1 and Channel 2 propagation times are displayed in seconds. The time represents the time from the start of transmission of an InterMiCOM⁶⁴ message to the completion of its reception by the remote device.

'Channel Status 1' is a diagnostics flag associated with each channel. The bits associated with the Channel 1 condition are described below (Channel 2 is similar).

- Bit "Max Prop Delay" If the "Prop Delay Stats" is enabled, this bit indicates that the propagation delay time is above the setting.
- Bit "Passthrough" This indicates that, in a three-terminal configuration, Ch1 data has been received on Ch2 via the self healing ring mechanism.
- Bit "Message Level" Is indicative of the quality of the signal on Channel 1
- Bit "Timeout" Indication that no valid messages are received over Channel 1 during the 'Channel Timeout' window
- Bit "Mismatch Rxn" Indication of mismatch between the InterMiCOM⁶⁴ Ch1 setting and that of the associated multiplexer
- Bit "Path Yellow" An indication of one way communication. The local relay is being informed by the remote connected relay that the remote connected relay is not receiving messages from the local one
- Bit "Signal Lost" An indication from the associated multiplexer that Channel1 signals are being lost
- Bit "Mux Clk F Error" This is an alarm that appears if the Channel 1 baud rate is outside the limits 52 Kbis/s or 70 Kbits/s
- Bit "Tx" Indication of transmission on Channel 1
- Bit "Rx" Indication of reception on Channel 1

'IM64 Rx Status' is a 16 bit word that displays the status of received commands as "1" or "0".

'Last Reset on' displays the time and date of last statistics reset.

'Ch1/Ch2 No. of valid messages' displays the number of received valid messages over channel 1/2 since last statistics reset.

'Ch1/Ch2 No. of Errored messages' displays the number of invalid messages over channel 1/Ch 2 since last statistics reset.

The number of errored messages complies with ITU- G8.21 and is as follows:

'Ch1/Ch2 No. Errored seconds' displays the number of seconds containing 1 or more errored or lost messages

'Ch1/Ch2 No. Severely Errored seconds' displays the number of seconds containing 31 or more errored or lost messages (see Note 1).

<i>Note 1</i>	<i>Any severely errored seconds are ignored when working out the minutes intervals</i>
---------------	--

'Ch1/Ch2 No. Degraded minutes' displays the number of minutes containing 2 or more errored or lost messages.

The number of lost messages recorded is intended as an indicator for noises under normal communication conditions and not for recording long communication breaks. The lost message count is accumulated by incrementing a counter when a message is rejected by the Error code check, message length check and the sequential time tag check.

'Max Ch 1/2 Prop Delay' displays the maximum value of the overall propagation delay divided by 2 when the protection communications are enabled.

The error statistics are automatically cleared on power-up. They can also be cleared using the Clear Statistics setting in Measurements column of the menu.

<i>Note</i>	<i>MEASUREMENT 3 column is intentionally blank (reserved for future use)</i>
-------------	--

Notes:

PRODUCT DESIGN

CHAPTER 10

Applicability**Date:** 01/2024**Products covered by this chapter:**

This chapter covers the specific versions of the MiCOM products listed below.
This includes **only** the following combinations of Software Version and Hardware Suffix.

Hardware Suffix:

Product	Hardware Suffix
P141 / P142 / P143	L or later
P145	M or later
P241	L or later
P242 / P243	M or later
P341	L or later
P342	L or later
P343 / P344 / P345	M or later
P391	A or later
P44x (P442 / P444)	M or later
P44y (P443 / P446)	M or later
P445	L or later
P54x (P543 / P544 / P545 / P546)	M or later
P642	L or later
P643 / P645	M or later
P741 / P743	M or later
P742	L or later
P746	M or later
P841 (P841A / P841B)	M or later
P849	M or later

Software Version:

Product	Software Version
P14x (P141 / P142 / P143 / P145)	B5 or later
P24x (P241 / P242 / P243)	D1 or later
P341	B3 / E3 or later
P342 / P343 / P344 / P345 / P391	B3 or later
P445	K1 or later
P44x (P442 / P444)	E3 or later
P44y (P443 / P446)	K1 or later
P54x (P543 / P544 / P545 / P546)	K1 or later
P64x (P642 / P643 / P645)	B4 or later
P74x (P741 / P742 / P743)	B1 or later
P746_1 / P746_2	B5 / C5 or later
P841A / P841B	L1 / K1 or later
P849	B2 or later

Connection Diagrams: This chapter list the connection diagram for the product:	
P14x (P141, P142, P143 & P145):	10P141xx (xx = 01 to 02) 10P142xx (xx = 01 to 05) 10P143xx (xx = 01 to 11) 10P145xx (xx = 01 to 11)
P24x (P241, P242 & P243):	10P241xx (xx = 01 to 02) 10P242xx (xx = 01) 10P243xx (xx = 01)
P34x (P342, P343, P344, P345 & P391)	10P342xx (xx = 01 to 17) 10P343xx (xx = 01 to 19) 10P344xx (xx = 01 to 12) 10P345xx (xx = 01 to 07) 10P391xx (xx = 01 to 02)
P445:	10P445xx (xx = 01 to 04)
P44x (P442 & P444):	10P44101 (SH 1 & 2) 10P44201 (SH 1 & 2) 10P44202 (SH 1) 10P44203 (SH 1 & 2) 10P44401 (SH 1) 10P44402 (SH 1) 10P44403 (SH 1 & 2) 10P44404 (SH 1) 10P44405 (SH 1) 10P44407 (SH 1 & 2)
P44y:	10P44303 (SH 01 and 03) 10P44304 (SH 01 and 03) 10P44305 (SH 01 and 03) 10P44306 (SH 01 and 03) 10P44600 10P44601 (SH 1 to 2) 10P44602 (SH 1 to 2) 10P44603 (SH 1 to 2)
P54x (P543, P544, P545 & P546):	10P54302 (SH 1 to 2) 10P54303 (SH 1 to 2) 10P54304 (SH 1 to 2) 10P54400 10P54404 (SH 1 to 2) 10P54405 (SH 1 to 2) 10P54502 (SH 1 to 2) 10P54503 (SH 1 to 2) 10P54504 (SH 1 to 2) 10P54600 10P54604 (SH 1 to 2) 10P54605 (SH 1 to 2) 10P54606 (SH 1 to 2)
P547:	10P54702xx (xx = 01 to 02) 10P54703xx (xx = 01 to 02) 10P54704xx (xx = 01 to 02) 10P54705xx (xx = 01 to 02)
P64x (P642, P643 & P645):	10P642xx (xx = 1 to 10)

	10P643xx (xx = 1 to 6) 10P645xx (xx = 1 to 9)
P74x:	10P740xx (xx = 01 to 07)
P746:	10P746xx (xx = 00 to 21)
P841:	10P84100 10P84101 (SH 1 to 2) 10P84102 (SH 1 to 2) 10P84103 (SH 1 to 2) 10P84104 (SH 1 to 2) 10P84105 (SH 1 to 2)
P849:	10P849xx (xx = 01 to 06)

CONTENTS

1. Relay System Overview	9
1.1 Hardware Overview	9
1.2 Mechanical Layout	10
1.3 Processor Board	10
1.4 Internal Communication Buses	10
1.4.1 Co-Processor Board (optionally with InterMiCOM64 Fiber Teleprotection).....	11
1.5 Input Module	11
1.5.1 Transformer Board.....	12
1.5.2 Input Board.....	12
1.5.3 Universal Opto Isolated Logic Inputs.....	14
1.6 Power Supply Module (including Output relays)	16
1.6.1 Power Supply Board (including EIA(RS)485 Communication Interface).....	16
1.6.2 Output Relay Board.....	17
1.6.3 High Break Relay Board.....	18
1.6.3.1 High Break Contact Applications.....	19
1.6.4 Input/Output (4+4) Relay Board.....	20
1.7 Product Specific Options	20
1.8 Current Loop Input Output (CLIO) Board	20
1.9 IRIG-B Modulated and/or Un-modulated Board (Optional)	22
1.10 Resistance Temperature Detector (RTD) Board (Optional)	22
1.11 Second Rear Communications Board (Optional)	22
1.11.1 Rear Communications and InterMiCOM (P445 Model D, P741 & P743 only).....	23
1.12 Ethernet Board (Optional)	23
2. Relay Software	26
2.1 Real-Time Operating System	26
2.2 System Services Software	27
2.3 Platform Software	27
2.3.1 Record Logging.....	27
2.3.2 Settings Database.....	28
2.3.3 Database Interface.....	28
2.4 Protection and Control Software	28
2.4.1 Sample Acquisition without a Co-Processor (P14x, P64x, P841).....	29
2.4.2 Sample Acquisition with a Co-Processor (P54x, P44y & P445 Model D).....	29
2.4.3 Signal Processing.....	29
2.4.4 Main Protection Digital Filtering - Co-Processor Board.....	29
2.4.4.1 Differential Protection (P54x only).....	29
2.4.4.2 Distance Protection Filters (P44y and P54x).....	30
2.4.6 Frequency Response.....	30
2.4.6.1 Fourier Filtering.....	32
2.4.7 Programmable Scheme Logic (PSL).....	32

2.4.7.1 PSL Data	32
2.4.8 Function Key Interface	33
2.4.9 Event, Fault and Maintenance Recording	33
2.5 Disturbance Recorder	34
2.6 Communication Software for P74x	34

3. Fault Locator	36
3.1 Basic Theory for Ground Faults (for P14x)	36
3.2 Data Acquisition and Buffer Processing (for P14x)	36
3.3 Faulted Phase Selection (for P14x)	36
3.4 Fault Location Calculation (for P14x)	37
3.4.1 Obtaining the Vectors (for P14x)	37
3.4.2 Solving the Equation for the Fault Location (for P14x)	37

4. Self Testing and Diagnostics	39
4.1 Startup Self-Testing	39
4.1.1 System Boot	39
4.1.2 Initialization Software	39
4.1.3 Platform Software Initialization and Monitoring	40
4.2 Continuous Self-Testing	40

TABLES

Table 1 - PCBs and voltage/current inputs for different relay types	12
Table 2 - Threshold levels	15
Table 3 - Numbers of opto inputs for different models	16
Table 4 - Power supply options	16
Table 5 - Numbers of relay contacts for different models	18
Table 6 - Numbers of boards and relay outputs for different models	19
Table 7 - Numbers of alarms, event records, fault records and maintenance records for different software versions	28
Table 8 - Disturbance recorder channels, signals, times and records for different models	34

FIGURES

Figure 1 - Relay modules and information flow diagram	9
Figure 2 - Main input board diagram	13
Figure 3 - Main input module diagram	14
Figure 4 - High break contact operation diagram	19
Figure 5 - Current loop input output board diagram	22
Figure 6 - Rear communications port diagram	23
Figure 7 - Ethernet board connectors (3 RJ45 or 2 LC + RJ45 or 1 RJ45)	25

Figure 8 - Relay software structure diagram.....	26
Figure 9 - Frequency response (for P14x, P24x, P341, P34x and P64x) diagram.....	31
Figure 10 - Frequency response (for P44y, P54x and P445) diagram.....	31
Figure 11 - Frequency response (for P841) diagram.....	31
Figure 12 - System overview diagram.....	35
Figure 13 - Two machine equivalent circuit diagram.....	36
Figure 14 - Fault locator selection of fault current zero diagram.....	38
Figure 15 - Start-up self-testing logic diagram.....	42
Figure 16 - Continuous self-testing logic diagram.....	43

Notes:

1. RELAY SYSTEM OVERVIEW

1.1 Hardware Overview

The relay is based on a modular hardware design where each module performs a separate function. This section describes the functional operation of the various hardware modules. Some modules are essential while others are optional depending on the user's requirements (see 1.7 - Product Specific Options and 1.12 - Ethernet Board (Optional)).

All modules are connected by a parallel data and address bus which allows the processor board to send and receive information to and from the other modules as required.

There is also a separate serial data bus for transferring sample data from the input module to the processor. See the Figure 1 - Relay modules and information flow diagram.

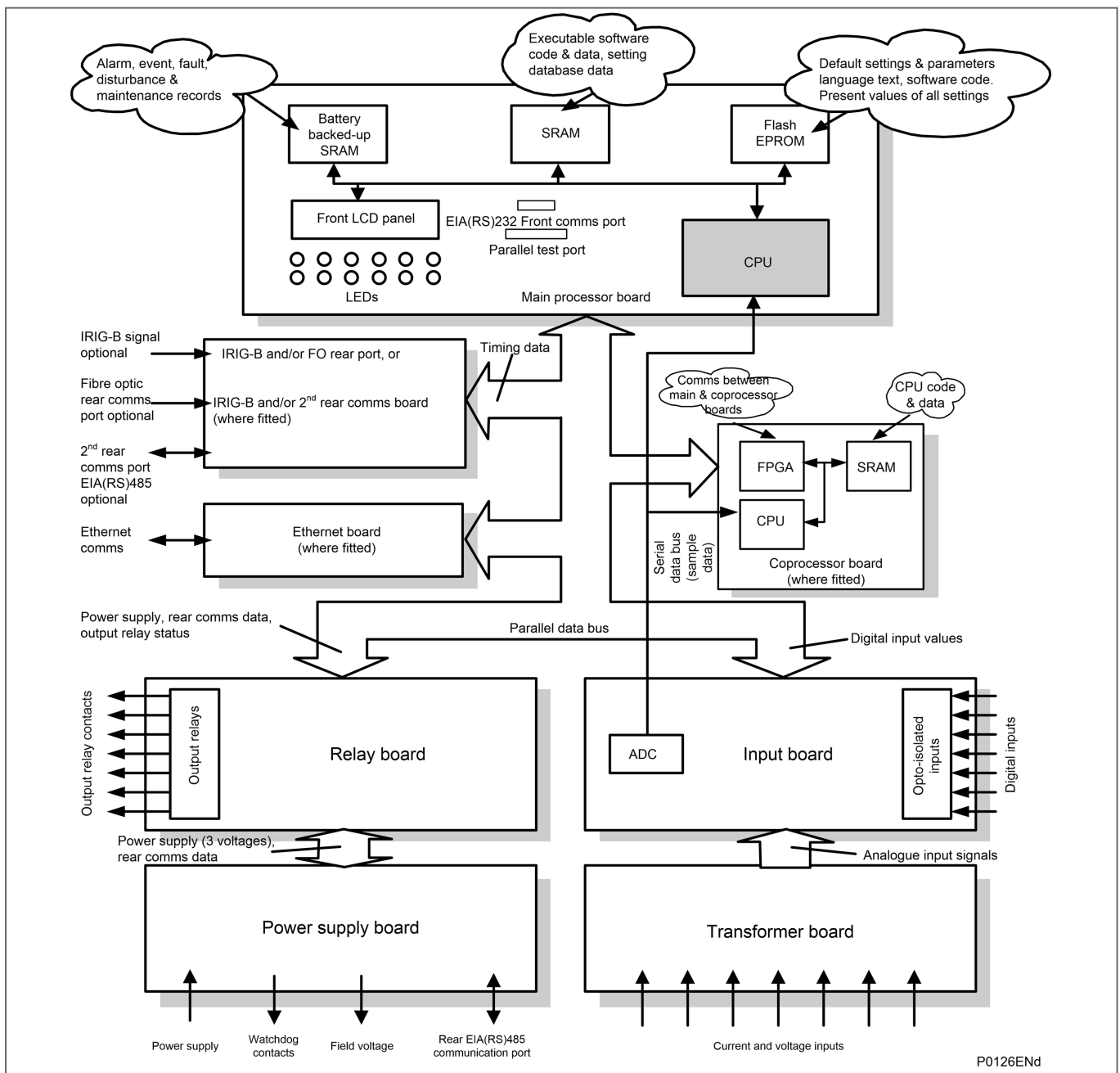

Figure 1 - Relay modules and information flow diagram

1.2 Mechanical Layout

The relay case is pre-finished steel with a conductive covering of aluminum and zinc. This provides good earthing at all joints with a low impedance path to earth that is essential for shielding from external noise. The boards and modules use multi-point grounding (earthing) to improve immunity to external noise and minimize the effect of circuit noise. Ground planes are used on boards to reduce impedance paths and spring clips are used to ground the module metalwork.

Heavy duty terminal blocks are used at the rear of the relay for the current and voltage signal connections. Medium duty terminal blocks are used for the digital logic input signals, output relay contacts, power supply and rear communication port. A BNC connector is used for the optional IRIG-B signal. 9-pin and 25-pin female D-connectors are used at the front of the relay for data communication.

Inside the relay the boards plug into the connector blocks at the rear, and can be removed from the front of the relay only. The connector blocks to the relay's CT inputs have internal shorting links inside the relay. These automatically short the current transformer circuits before they are broken when the board is removed.

The front panel consists of a membrane keypad with tactile dome keys, an LCD and 12 or 22 LEDs (depending on the model) mounted on an aluminum backing plate.

1.3 Processor Board

The processor board performs all calculations for the relay and controls the operation of all other modules in the relay. The processor board also contains and controls the user interfaces (LCD, LEDs, keypad and communication interfaces).

The relay is based around a TMS320VC33-150MHz (peak speed), floating-point, 32-bit Digital Signal Processor (DSP) operating at a clock frequency of half this speed. This processor performs all the calculations for the relay, including the protection functions, control of the data communication and user interfaces including the operation of the LCD, keypad and LEDs.

The processor board is directly behind the relay's front panel. This allows the LCD and LEDs and front panel communication ports to be mounted on the processor board. These ports are:

- The 9-pin D-connector for EIA(RS)232 serial communications used for Easergy Studio and Courier communications.
- The 25-pin D-connector relay test port for parallel communication.

All serial communication is handled using a Field Programmable Gate Array (FPGA). The main processor board has:

- 8 MB SRAM for the working area. This is fast access (zero wait state) volatile memory used to temporarily store and execute the processor software.
- 8 MB flash ROM to store the software code, text, configuration data, default settings, and present settings.
- 4 MB battery-backed SRAM to store disturbance, event, fault and maintenance records.

1.4 Internal Communication Buses

The relay has two internal buses for the communication of data between different modules. The main bus is a parallel link that is part of a 64-way ribbon cable. The ribbon cable carries the data and address bus signals in addition to control signals and all power supply lines. Operation of the bus is driven by the main processor board that operates as a master while all other modules in the relay are slaves.

The second bus is a serial link that is used exclusively for communicating the digital sample values from the input module to the main processor board. The DSP has a built-in serial port that is used to read the sample data from the serial bus. The serial bus is also carried on the 64-way ribbon cable.

1.4.1 Co-Processor Board (optionally with InterMiCOM⁶⁴ Fiber Teleprotection)

Important

The Co-processor board is not present in the P14x, P341, P34x, P44x, P64x, P746, P841 or P849 relays.

A co-processor board is used to process the distance protection and delta directional algorithms. It contains the optical fiber transmit and receive hardware and serial data communication controller for the InterMiCOM⁶⁴ teleprotection. InterMiCOM⁶⁴ is an extra cost ordering option.

A second processor board is used in the relay for the processing of the distance and delta protection algorithms. The processor used on the second board is the same as that used on the main processor board. The second processor board has provision for fast access (zero wait state) SRAM for use with both program and data memory storage. This memory can be accessed by the main processor board via the parallel bus, and this route is used at power-on to download the software for the second processor from the flash memory on the main processor board. Further communication between the two processor boards is achieved via interrupts and the shared SRAM. The serial bus carrying the sample data is also connected to the co-processor board, using the processor's built-in serial port, as on the main processor board.

The co-processor board also handles any communication with the remote differential relay(s). This is achieved via BFOC 2.5 - ST optical fiber connections at the rear and hence the co-processor board holds the optical modules to transmit and receive data over the fiber links. One or two channels will be provided, each comprising a Rx (receive) and a Tx (transmit) fiber as a pair. The channels, when fitted according to an ordering option, are labeled Ch1 and Ch2.

1.5 Input Module

The input module provides the interface between the relay processor board(s) and the analog and digital signals coming into the relay. The input module consists of the main 1.5.2 - Input Board and the 1.5.1 - Transformer Board.

Model	Input Boards	Transformer Boards	Voltage Inputs	Current Inputs	Notes
P14x	1	1	4	5	
P241	1	1	3	4	
P242	1	1	3	4	
P243	1	2	3	7	
P342	1	1	3	5	
P343	1	2	4/5/6	8/9	
P344	1	2	4/5/6	8/9	P344 input module is the same as P343 but with an additional voltage input, providing 5 voltage inputs and 8 current inputs
P345	1	2	4/5/6	8/9	P345 input module is the same as P344 but with an additional 20 Hz current and 20 Hz voltage input for 100% stator earth fault protection
P442	1	1	4	5	

Model	Input Boards	Transformer Boards	Voltage Inputs	Current Inputs	Notes
P443	1	1	4	5	
P444	1	1	4	5	
P445	1	1	4	4	
P446	1	2	5	8	
P543	1	1	4	5	
P544	1	2	5	8	
P545	1	1	4	5	
P546	1	2	5	8	
P642	1	1	1 or 2	8	
P643	1	1	2	3 or 9	
P645	1	1	2	9	
P741	0	0	0	0	
P742	1	1	0	4	
P743	1	1	3	4	
P746_1	1	1	3	18	
P746_2	1	1	-	21	
P841A	1	1	4	5	
P841B	1	2	5	8	
P849	1	1	-	-	

Table 1 - PCBs and voltage/current inputs for different relay types

1.5.1 Transformer Board

The transformer board holds a number of Voltage Transformers (VTs) and Current Transformers (CTs). Some model/options may also have an auxiliary transformer board which can provide more VTs and CTs.

The current inputs will accept either 1A or 5A nominal current (observe menu and wiring options) and the voltage inputs can be specified for either 110V or 440V nominal voltage (order option). The transformers are used both to step-down the currents and voltages to levels appropriate to the relay's electronic circuitry and to provide effective isolation between the relay and the power system. The connection arrangements of both the current and voltage transformer secondary's provide differential input signals to the main input board to reduce noise.

1.5.2 Input Board

The main input board is shown as a block diagram in the Figure 2 - Main input board diagram. It provides the circuitry for the digital input signals and the Analog-to-Digital (A-D) conversion for the analog signals. It takes the differential analog signals from the CTs and VTs on the transformer board(s), converts these to digital samples and transmits the samples to the main processor board through the serial data bus. On the input board, the analog signals are converted using a dedicated sigma-delta A-D convertor for each channel. This allows all of the channels to be sampled concurrently with no sampling skew between channels. The digital input signals are opto isolated on this board to prevent excessive voltages on these inputs causing damage to the relay's internal circuitry. The sampled signals are then digitally filtered prior to the data being sent to the main processor via the serial link.

In models using the second transformer board, a second input board is also fitted to provide the A-D conversion for the additional channels

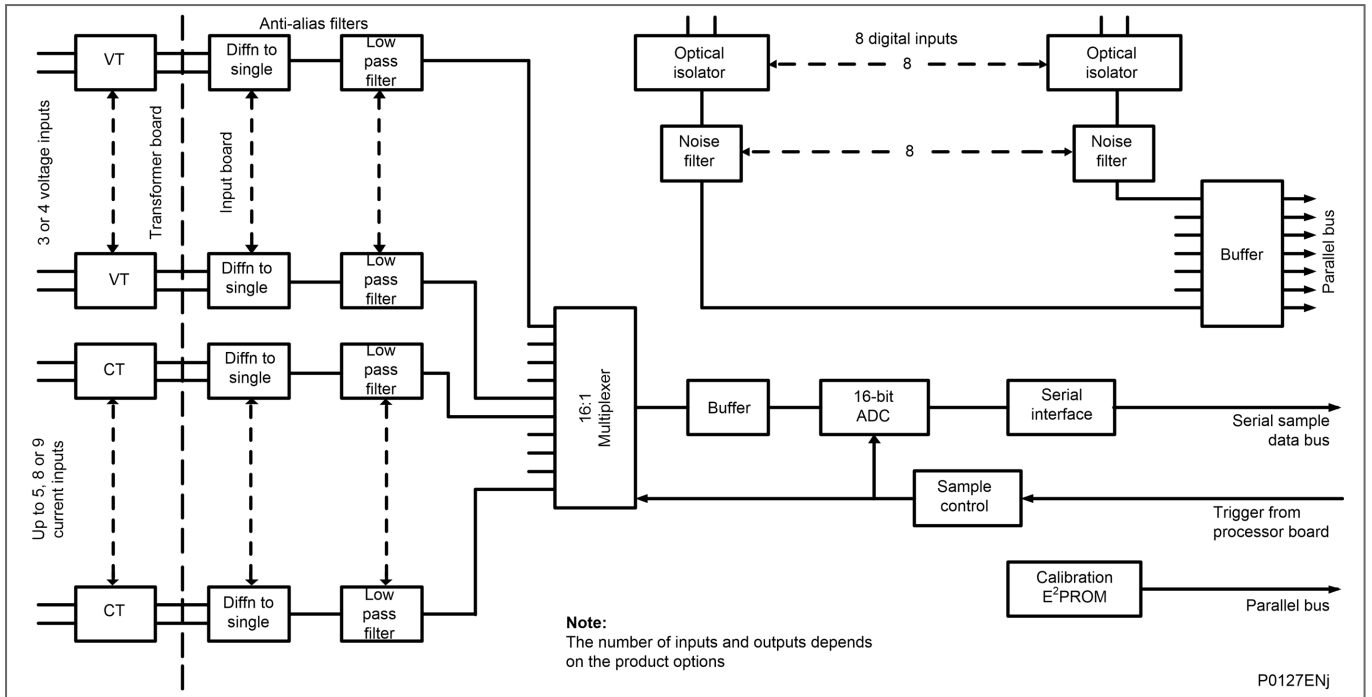

Figure 2 - Main input board diagram

Three spare channels are used to sample three different reference voltages for continually checking the operation of the multiplexer and the accuracy of the A-D converter. Generally, with a 2.4kHz sample frequency, the sample rate is maintained at 48 samples per cycle at 50Hz (or 40 samples per cycle @ 60Hz) of the power waveform by a logic control circuit which is driven by the frequency tracking function on the main processor board.

Note

For the P14x, P24x & P64x, the sample rate is 24 samples per cycle.

The calibration non-volatile memory holds the calibration coefficients which are used by the processor board to correct for any amplitude or phase errors introduced by the transformers and analog circuitry.

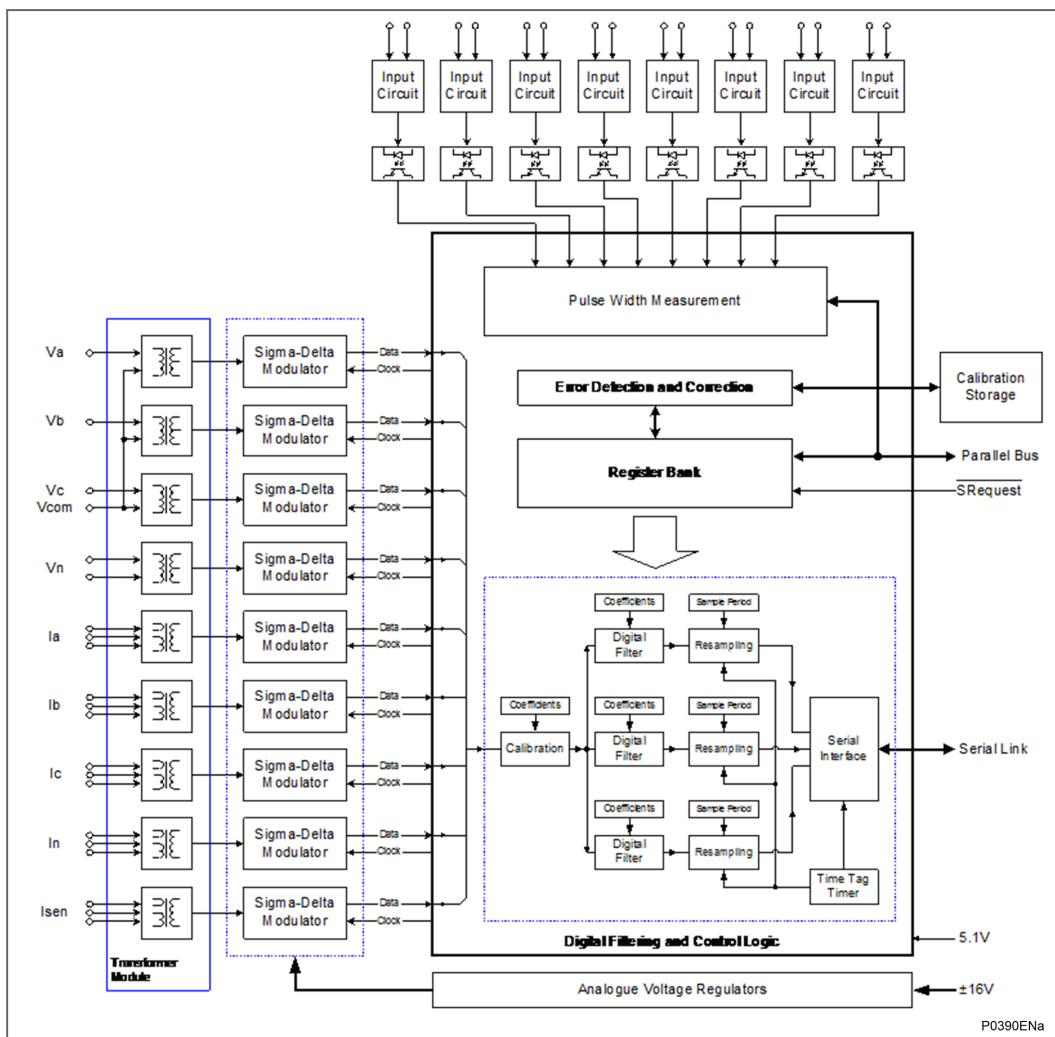

Figure 3 - Main input module diagram

The other function of the input board is to read the signals on the digital inputs and send them through the parallel data bus to the processor board. The input board holds eight optical isolators for connecting up to eight digital input signals. Opto-isolators are used with digital signals for the same reason as transformers are used with analog signals: to isolate the relay’s electronics from the power system environment. The input board has hardware filters to remove noise from the digital signals. The digital signals are then buffered so they can be read on the parallel data bus. Depending on the relay model, more than eight digital input signals can be accepted by the relay. This is done using an additional opto-board that contains the same provision for eight isolated digital inputs as the main input board, but does not contain any of the circuits for analog signals which are provided on the main input board.

1.5.3 Universal Opto Isolated Logic Inputs

This series of relays have universal opto-isolated logic inputs that can be programmed for the nominal battery voltage of the circuit of which they are a part. This allows different voltages for different circuits such as signaling and tripping. They can also be programmed as Standard 60% - 80% or 50% - 70% to satisfy different operating constraints.

Threshold levels are shown in this table:

Nominal battery voltage (Vdc)	Standard 60% - 80%		50% - 70%	
	No operation (Logic 0) Vdc	Operation (Logic 1) Vdc	No operation (Logic 0) Vdc	Operation (Logic 1) Vdc
24/27	<16.2	>19.2	<12.0	>16.8

Nominal battery voltage (Vdc)	Standard 60% - 80%		50% - 70%	
	No operation (Logic 0) Vdc	Operation (Logic 1) Vdc	No operation (Logic 0) Vdc	Operation (Logic 1) Vdc
30/34	<20.4	>24.0	<15.0	>21.0
48/54	<32.4	>38.4	<24.0	>33.6
110/125	<75.0	>88.0	<55.0	>77.0
220/250	<150.0	>176.0	<110.0	>154.0

Table 2 - Threshold levels

This lower value eliminates fleeting pick-ups that may occur during a battery earth fault, when stray capacitance may present up to 50% of battery voltage across an input.

Each input also has selectable filtering. This allows a pre-set ½ cycle filter to be used to prevent induced noise on the wiring. However, although the ½ cycle filter is secure it can be slow, particularly for intertripping. If the ½ cycle filter is switched off to improve speed, double pole switching or screened twisted cable may be needed on the input to reduce ac noise.

The first method is to use double pole switching on the input, the second is to use screened twisted cable on the input circuit.

Model	Opto Inputs	Notes
P14x	32	achieved by the inclusion of three opto-input cards that will increase the total number of opto-inputs to 32
P241	8	
P242 / P243	16	
P442	16	
P443 A / C	16	
P443 B / D	24	
P443 Y	32	
P444	24	
P445 A	8	
P445 B	12	achieved by the inclusion of a special combined input output board which has 4 inputs and 4 outputs
P445 C / D	16	
P446	24	
P543 / P544	16	
P545	24	Or 32 by certain ordering options
P546	24	
P642	12	
P643 / P645	24	
P741	8	
P742xxxA	16	
P742xxxB	8	
P743xxxA	24	
P743xxxB	16	
P743xxxC	24	
P743xxxD	16	

Model	Opto Inputs	Notes
P841 A	16	
P841 B	24	

Table 3 - Numbers of opto inputs for different models

1.6 Power Supply Module (including Output relays)

The power supply module contains two boards, one for the power supply unit and the other for the output relays. It provides power to all of the other modules in the relay, as well as the EIA (RS)485 electrical connection for the rear communication port. The second board of the power supply module contains the relays that provide the output contacts.

1.6.1 Power Supply Board (including EIA(RS)485 Communication Interface)

The power supply module also provides a 48V external field supply output to drive the opto isolated digital inputs (or the substation battery may be used to drive the optos).

One of three different configurations of the power supply board can be fitted to the relay. This is specified at the time of order and depends on the nature of the supply voltage that will be connected to the relay. The options are shown in this table:

Nominal dc range	Nominal ac range
24 - 32 V dc	dc only
48 - 110 V dc	dc only
110 - 250 V dc	100 - 240 V ac rms

Table 4 - Power supply options

The output from all versions of the power supply module are used to provide isolated power supply rails to all of the other modules in the relay. Three voltage levels are used in the relay: 5.1 V for all of the digital circuits, ±16 V for the analog electronics such as on the input board, and 22 V for driving the output relay coils and the RTD board if fitted. All power supply voltages including the 0 V earth line are distributed around the relay through the 64-way ribbon cable. The power supply board also provides the 48 V field voltage*. This is brought out to terminals on the back of the relay so that it can be used to drive the optically-isolated digital inputs.

* Note
 It is compulsory to add an EMC Filter to use the field voltage outputs to prevent any noise or high frequency disturbance.
 The EMC Filter must be connected to the protection relay with a three-wires cable of appr. 1m length.
 The earth port of the EMC filter must only be connected to the earth terminal of Px4x; the metal housing of the filter should not be connected to the ground plane.
 Proposal:
 Schaffner EMC Filter (FN2010-1-06, 1A max - 250V), or equivalent



Important
MiCOM P44y (P443 & P446), P445, P54x (P543, P544, P545 & P546), P74x (P741, P742 & P743) and P841 relays do not support MODBUS.

The two other functions provided by the power supply board are the EIA(RS)485 communications interface and the watchdog contacts for the relay. The EIA(RS)485 interface is used with the relay's rear communication port to provide communication using one of either Courier, MODBUS, IEC60870-5-103, or DNP3.0 protocols. The EIA(RS)485 hardware supports half-duplex communication and provides optical isolation of the serial data that is transmitted and received. All internal communication of data from the power supply board is through the output relay board connected to the parallel bus.

The watchdog facility has two output relay contacts, one Normally Open (N/O) and one Normally Closed (N/C). These are driven by the main processor board and indicate that the relay is in a healthy state.

The power supply board incorporates inrush current limiting. This limits the peak inrush current, during energization, to approximately 10 A.

1.6.2 Output Relay Board

The standard output relay boards hold different numbers of relays with Normally Open (N/O) contacts and with ChangeOver (C/O) contacts. The relevant numbers are as follows:

There are two versions of the output relay board:

- one with seven relays, three Normally Open (N/O) contacts and four Changeover (C/O) contacts and
- one with eight relays, six N/O contacts and two C/O contacts.

For relay models with Hardware Suffix A, only the seven-output relay boards were available. For equivalent relay models in Hardware Suffix B or greater the base numbers of output contacts, using the seven-output relay boards, is being maintained for compatibility. The eight-output relay board is only used for new relay models or existing relay models available in new case sizes or to provide additional output contacts to existing models for Hardware Suffix B or greater.

Model	Relay Contacts	Normally Open Contacts	Changeover Contacts	Notes
P14x	8	6	2	For the P145, up to 32 output contacts using up to four standard output relay boards
P24x	7 / 8	3 / 6	4 / 2	
P442	7 / 8	3 / 6	4 /	Up to three boards depending on model
P443	8	6	2	Up to four boards depending on model
P444	7 / 8	3 / 6	2	Up to three boards depending on model
P445	8	6	4 / 2	In a 40TE case only 1 output board can be fitted In the 60TE case 2 boards are an option
P446	8	6	2	Up to four boards depending on model
P543 / P544	7	3	2	Up to 32 outputs using one or two standard output relay boards
P545 / P546	8	6	4	Up to 32 outputs using up to four standard output relay boards
P642	8	6	2	Up to 12 outputs using up to one standard output relay boards
P643 / P645	8	6	2	Up to 24 outputs using up to two standard output relay boards
P741	8	6	2	
P742xxxA	16	6	2	

Model	Relay Contacts	Normally Open Contacts	Changeover Contacts	Notes
P742xxxB	8	6	2	
P743xxxA	24	14	2	
P743xxxB	16	12	4	
P743xxxC	24	6	2	
P743xxxD	16	6	2	
P841 A	7	3	4	In a standard configuration, this uses two output relay boards
P841 B	8	6	2	In a standard configuration, this uses four output relay boards

Table 5 - Numbers of relay contacts for different models

The relays are driven from the 22 V power supply line. The relays' state is written to or read from using the parallel data bus. Depending on the relay model, more than seven output contacts may be provided, through the use of up to three extra relay boards. Each additional relay board provides a further seven or eight output relays.

1.6.3 High Break Relay Board

All the relays are driven from the 22 V power supply line. The state of the relay is written to or read from using the parallel data bus.

A 'high break' output relay board is fitted in addition to a standard output relay board. This houses four normally-open (N/O) output contacts suitable for breaking loads higher than can be broken with the standard contacts. These boards are arranged as follows:

Relay Model	No of high break output relay boards	Total standard relay outputs	Total high break relay outputs
P142	1	15	4
P143 / P145	1 or 2	32	8
P24x	3		
P442	3		
P443 C	1	16	4
P443 D	2	16	8
P444	3		
P445 D	1	8	4
P446 B	3	8	12
P446 C	2	16	8
P543 / P544	1 (to replace a standard board)	7	4
P545	2 (to replace standard boards)	16	8
P546 A	2 (to replace standard boards)	16	8
P546 B	3 (to replace standard boards)	8	12
P642		12	4
P643 / P645		24	8
P74x		4	
P746		32	16
P841 A		7	4

Relay Model	No of high break output relay boards	Total standard relay outputs	Total high break relay outputs
P841 B		16	8
P841 C		8	12
P841 D		16	8
P841 E		8	12

Table 6 - Numbers of boards and relay outputs for different models

Important
These relay contacts are polarity-sensitive. External wiring must comply with the polarity requirements described in the external connection diagram to ensure correct operation.

This board uses a hybrid of MOSFET Solid State Devices (SSD) in parallel with high capacity relay output contacts. The MOSFET has a varistor across it to provide protection which is required when switching off inductive loads because the stored energy in the inductor causes a reverse high voltage which could damage the MOSFET.

When there is a control input command to operate an output contact, the miniature relay is operated at the same time as the SSD. The miniature relay contact closes in nominally 3.5 ms and is used to carry the continuous load current; the SSD operates in <0.2 ms and is switched off after 7.5 ms. When the control input resets to open the contacts, the SSD is again turned on for 7.5 ms. The miniature relay resets in nominally 3.5 ms before the SSD so the SSD is used to break the load. The SSD absorbs the energy when breaking inductive loads and so limits the resulting voltage surge. This contact arrangement is for switching dc circuits only. As the SSD comes on very fast (<0.2 ms) these high break output contacts have the added advantage of being very fast operating. See the Figure 4 - High break contact operation diagram.

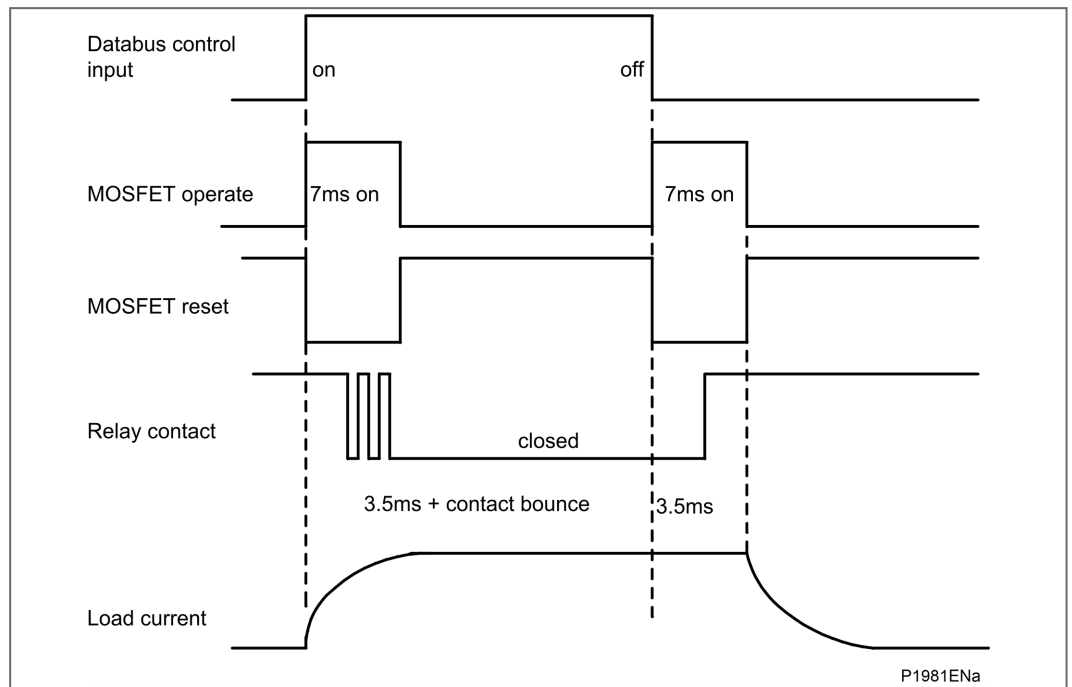

Figure 4 - High break contact operation diagram

1.6.3.1 High Break Contact Applications

1. Efficient Scheme Engineering

In traditional hardwired scheme designs, high break capability could only be achieved using external electromechanical trip relays. External tripping relays

can be used or the high break contacts inside MiCOM relays can be used, reducing panel space.

2. Accessibility of CB Auxiliary Contacts

Common practice is to use circuit breaker 52a (CB Closed) auxiliary contacts to break the trip coil current on breaker opening, easing the duty on the protection contacts. In cases such as operation of disconnectors, or retrofitting, 52a contacts may be unavailable or unreliable. High break contacts can be used to break the trip coil current in these applications.

3. Breaker Fail

The technique to use 52a contacts in trip circuits was described above. However, in the event of failure of the local circuit breaker (stuck breaker), or defective auxiliary contacts (stuck contacts), the 52a contact action is incorrect. The interrupting duty at the local breaker then falls on the relay output contacts which may not be rated to perform this duty. MiCOM high break contacts will avoid the risk of burnt relay contacts.

4. Initiation of Teleprotection

The MiCOM high break contacts also offer fast making, which can provide faster tripping. Also fast keying of teleprotection is a benefit. Fast keying bypasses the usual contact operation time so that permissive, blocking and intertrip commands can be routed faster.

1.6.4 Input/Output (4+4) Relay Board

The input/output relay board has four isolated digital inputs and four output relays. Two of the relays have normally open contacts and two have changeover contacts. The output relays are driven from the 22 V power supply line. The relays' state is written to or read from using the parallel data bus.

This is used with variants of:

- P142 relay that has 12 opto inputs and 11 output contacts.
- P145 (B model) that has 12 opto inputs and 12 output contacts.
- P642 relay option that has 12 opto inputs and 12 output relay contacts.

1.7 Product Specific Options

Product Specific Options may mean that an additional board may be present if it was specified when the relay was ordered. The product specific options commonly allow a choice of RTD, CLIO, different numbers of Optos, Relays (including High Break relays). These options are shown in the *Ordering Options* section in *Chapter 1 – Introduction*.

- 1.8 - Current Loop Input Output (CLIO) Board
- 1.9 - IRIG-B Modulated and/or Un-modulated Board (Optional)
- 1.10 - Resistance Temperature Detector (RTD) Board (Optional)
- 1.11 - Second Rear Communications Board (Optional)
- 1.12 - Ethernet Board (Optional)

1.8 Current Loop Input Output (CLIO) Board

The Current Loop Input Output (CLIO) board is an order option. The CLIO board is powered from the 22 V power rail that is used to drive the output relays.

Four analog (or current loop) inputs are provided for transducers with ranges of 0 to 1 mA, 0 to 10 mA, 0 to 20 mA or 4 to 20 mA. The input current data is read by the processor through the parallel data bus, and is used to provide measurements from various transducers such as vibration monitors, tachometers and pressure transducers.

For each of the four current loop inputs there are two separate input circuits, 0 to 1 mA and 0 to 20 mA. The latter is also used for 0 to 10 mA and 4 to 20 mA transducer inputs. The anti-alias filters have a nominal cut-off frequency (3 dB point) of 23 Hz to reduce power system interference from the incoming signals. Four analog current outputs are provided with ranges of 0 to 1 mA, 0 to 10 mA, 0 to 20 mA or 4 to 20 mA which can alleviate the need for separate transducers. These may be used to feed standard moving coil ammeters for analog indication of certain measured quantities or into a SCADA using an existing analog RTU.

Each of the four current loop outputs provides one 0 to 1 mA output, one 0 to 20 mA output and one common return. Suitable software scaling of the value written to the board allows the 0 to 20 mA output to also provide 0 to 10 mA and 4 to 20 mA. Screened leads are recommended for use on the current loop output circuits.

The refresh interval for the outputs is nominally 50 ms. Any measurements that do not fit this timing are updated once every second.

All external connections to the current loop I/O board are made using the same 15-way light duty I/O connector SL3.5/15/90F used on the RTD board. Two such connectors are used, one for the current loop outputs and one for the current loop inputs.

The I/O connectors accommodate wire sizes in the range 1/0.85 mm (0.57 mm²) to 1/1.38 mm (1.5 mm²) and their multiple conductor equivalents. The use of screened cable is recommended. The screen terminations should be connected to the case earth of the relay.

Basic Insulation (300 V) is provided between analog inputs or outputs and earth, and between analog inputs and outputs. However, there is no insulation between one input and another or one output and another.

Connection	IO Blocks	Connection
Outputs		
Screen channel 1		0 - 10/0 - 20/4 - 20 mA channel 1 0 - 1 mA channel 1 Common return channel 1
Screen channel 2		0 - 10/0 - 20/4 - 20 mA channel 2 0 - 1 mA channel 2 Common return channel 2
Screen channel 3		0 - 10/0 - 20/4 - 20 mA channel 3 0 - 1 mA channel 3 Common return channel 3
Screen channel 4		0 - 10/0 - 20/4 - 20 mA channel 4 0 - 1 mA channel 4 Common return channel 4
Inputs		

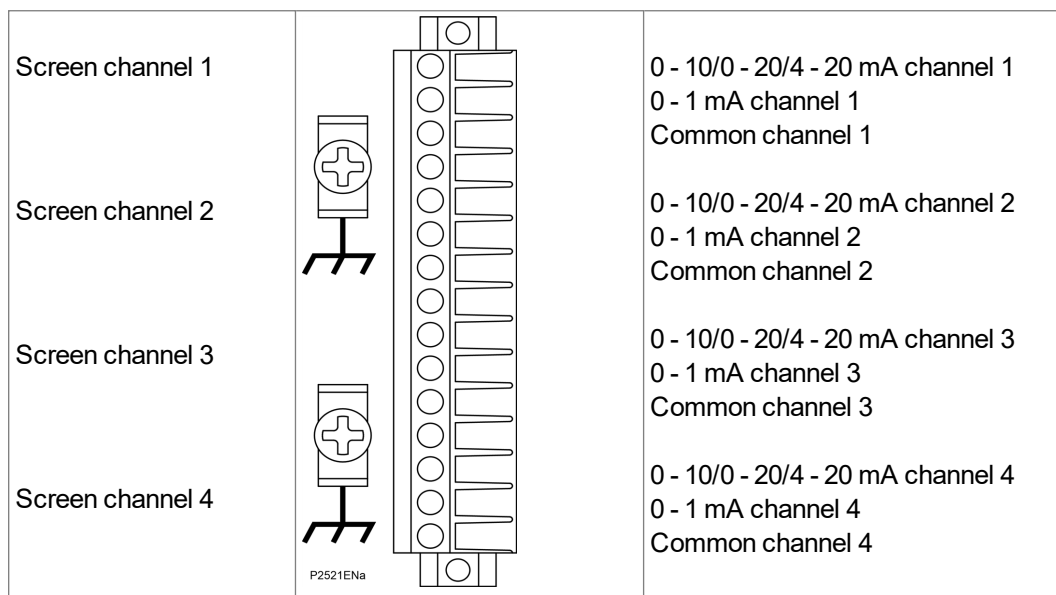

Figure 5 - Current loop input output board diagram

1.9 IRIG-B Modulated and/or Un-modulated Board (Optional)

The optional IRIG-B board is an order option that can be fitted to provide an accurate timing reference for the relay. This can be used wherever an IRIG-B signal is available. The IRIG-B signal is connected to the board with a BNC connector on the back of the relay. The timing information is used to synchronize the relay's internal real-time clock to an accuracy of 1 ms. The internal clock is then used for the time tagging of the event, fault maintenance and disturbance records.

Modulated IRIG-B is available on its own or with any of the other communications options. Un-modulated is only available on the optional Ethernet boards

1.10 Resistance Temperature Detector (RTD) Board (Optional)

The optional Resistance Temperature Detectors (RTD) board is used to monitor the winding and ambient temperature readings from up to ten PT100 RTD that are each connected using a 3-wire connection. The board is powered from the 22 V power rail that is used to drive the output relays. The RTD board includes two redundant channels that are connected to high stability resistors to provide reference readings. These are used to check the operation of the RTD board. The temperature data is read by the processor through the parallel data bus, and is used to provide thermal protection of the windings.

1.11 Second Rear Communications Board (Optional)

Important

MiCOM P44y (P443 & P446), P445, P54x (P543, P544, P545 & P546), P74x (P741, P742 & P743) and P841 relays do not support MODBUS.

For relays with Courier, MODBUS, IEC60870-5-103 or DNP3.0 protocol on the first rear communications port there is the hardware option of a second rear communications port, which runs the Courier language. This can be used over one of three physical links: twisted pair K-BUS (non-polarity sensitive), twisted pair EIA(RS)485 (connection polarity sensitive) or EIA(RS)232.

This optional second rear port is designed typically for dial-up modem access by protection engineers and operators, when the main port is reserved for SCADA traffic.

The port supports full local or remote protection and control access by Easergy Studio software. The second rear port is also available with an on board IRIG-B input.

The second rear communications board, Ethernet and IRIG-B boards are mutually exclusive since they use the same hardware slot. Two versions of second rear communications board are available; with and without modulated IRIG-B. The second rear communications board is shown in the Figure 6 - Rear communications port diagram.

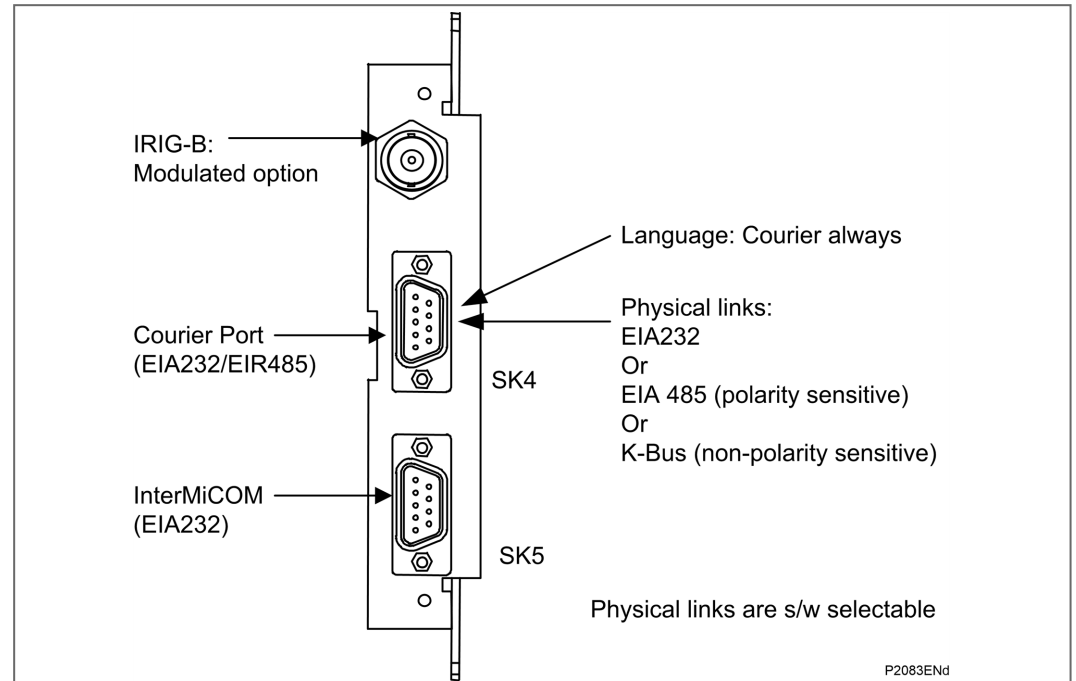

Figure 6 - Rear communications port diagram

1.11.1 Rear Communications and InterMiCOM (P445 Model D, P741 & P743 only)

On ordering this board within a relay, both 2nd rear communications and InterMiCOM will become connection and setting options. The user may then enable either one, or both, as demanded by the installation.

SK4: The second rear communications port runs the Courier language. This can be used over one of three physical links: twisted pair K-Bus (non polarity sensitive), twisted pair EIA (RS)485 (connection polarity sensitive) or EIA(RS)232.

SK5: The InterMiCOM board is used to connect to an EIA(RS)232 link, allowing up to eight programmable signaling bits to be transferred from/to the remote line end relay. A suitable EIA(RS)232 link must exist between the two line ends, for example a MODEM, or via a compatible multiplexer (check compatibility before ordering the relay).

1.12 Ethernet Board (Optional)

This is a mandatory board for IEC 61850 enabled relays. It provides network connectivity through either copper or fiber media at rates of 10Mb/s (copper only) or 100Mb/s. There is also an option on this board to specify IRIG-B board port (modulated and/or un-modulated). This board, the IRIG-B board mentioned in the Hardware Communications Options section and second rear comms. board mentioned in the IRIG-B Board section are mutually exclusive as they all use slot A within the relay case.

All modules are connected by a parallel data and address bus that allows the processor board to send and receive information to and from the other modules as required. There is also a separate serial data bus for conveying sample data from the input module to the processor. The relay modules and information flow diagram shows the modules of the relay and the flow of information between them.

This optional board is required for providing network connectivity using IEC 61850 and/or DNP3oE. There are a variety of different boards which provide Ethernet connectivity.

Important
The choice of communication board options varies according to the Hardware Suffix and the Software Version of the MiCOM product. These are shown in the Ordering Options section in Chapter 1 – Introduction.

By way of example, the board options may include:

- single-port Ethernet boards (which use 100 Mbits/s Copper and modulated/unmodulated IRIG-B connectivity)
- Redundant Ethernet with PRP/HSR/RSTP/Dual IP and a mixture of LC/RJ45 ports and modulated/unmodulated IRIG-B connectivity

These options are mutually exclusive as they all use slot A in the relay case.

Note
Each Ethernet board has a unique MAC address used for each Ethernet communication interface. The MAC address is printed on the rear of the board, next to the Ethernet sockets.

Note
The 100 Mbits/s Fiber Optic ports use LC type connectors and are suitable for 1300 nm multi-mode fiber type.

Copper ports use RJ45 type connectors. When using copper Ethernet, it is important to use Shielded Twisted Pair (STP) or Foil Twisted Pair (FTP) cables, to shield the IEC 61850 communications against electromagnetic interference. The RJ45 connector at each end of the cable must be shielded, and the cable shield must be connected to this RJ45 connector shield, so that the shield is grounded to the relay case. Both the cable and the RJ45 connector at each end of the cable must be Category 5 minimum, as specified by the IEC 61850 standard.

It is recommended that each copper Ethernet cable is limited to a maximum length of 3 m and confined to one bay or cubicle.

When using IEC61850 communications through the Ethernet board, the rear EIA(RS)485 and front EIA(RS)232 ports are available for simultaneous use. The front port always uses the Courier protocol. The rear port protocol depends upon the protocol option selected.

One example of an Ethernet board is shown in this Figure 7 - Ethernet board connectors (3 RJ45 or 2 LC + RJ45 or 1 RJ45):

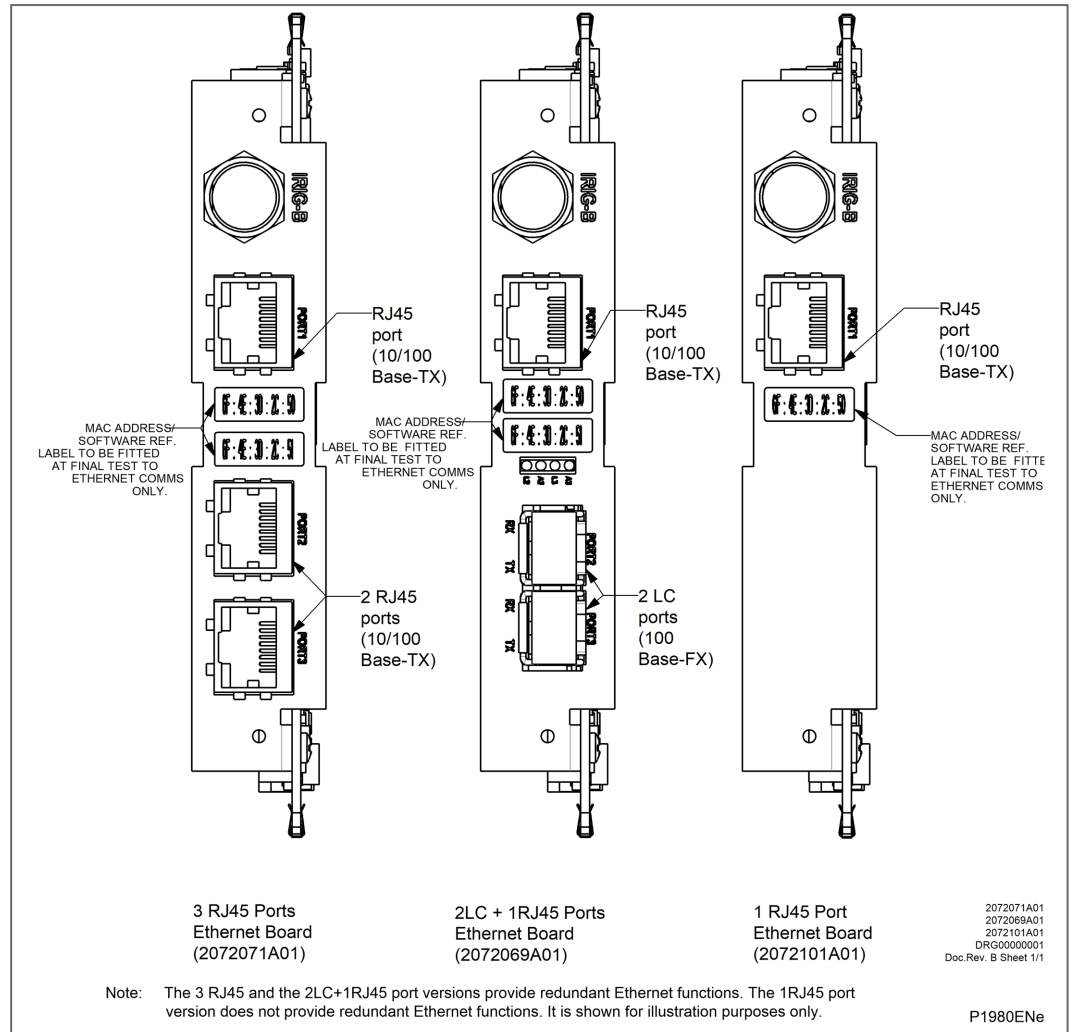

Figure 7 - Ethernet board connectors (3 RJ45 or 2 LC + RJ45 or 1 RJ45)

2. RELAY SOFTWARE

The relay software was introduced in the overview of the relay at the start of this chapter. The software can be considered to be made up of these sections:

- 2.1 - Real-Time Operating System
- 2.2 - System Services Software
- 2.3 - Platform Software
- 2.4 - Protection and Control Software

These four elements are all processed by the same processor board. This section describes in detail the platform software and the protection and control software, which between them control the functional behavior of the relay. The following Figure 8 - Relay software structure diagram shows the structure of the relay software.

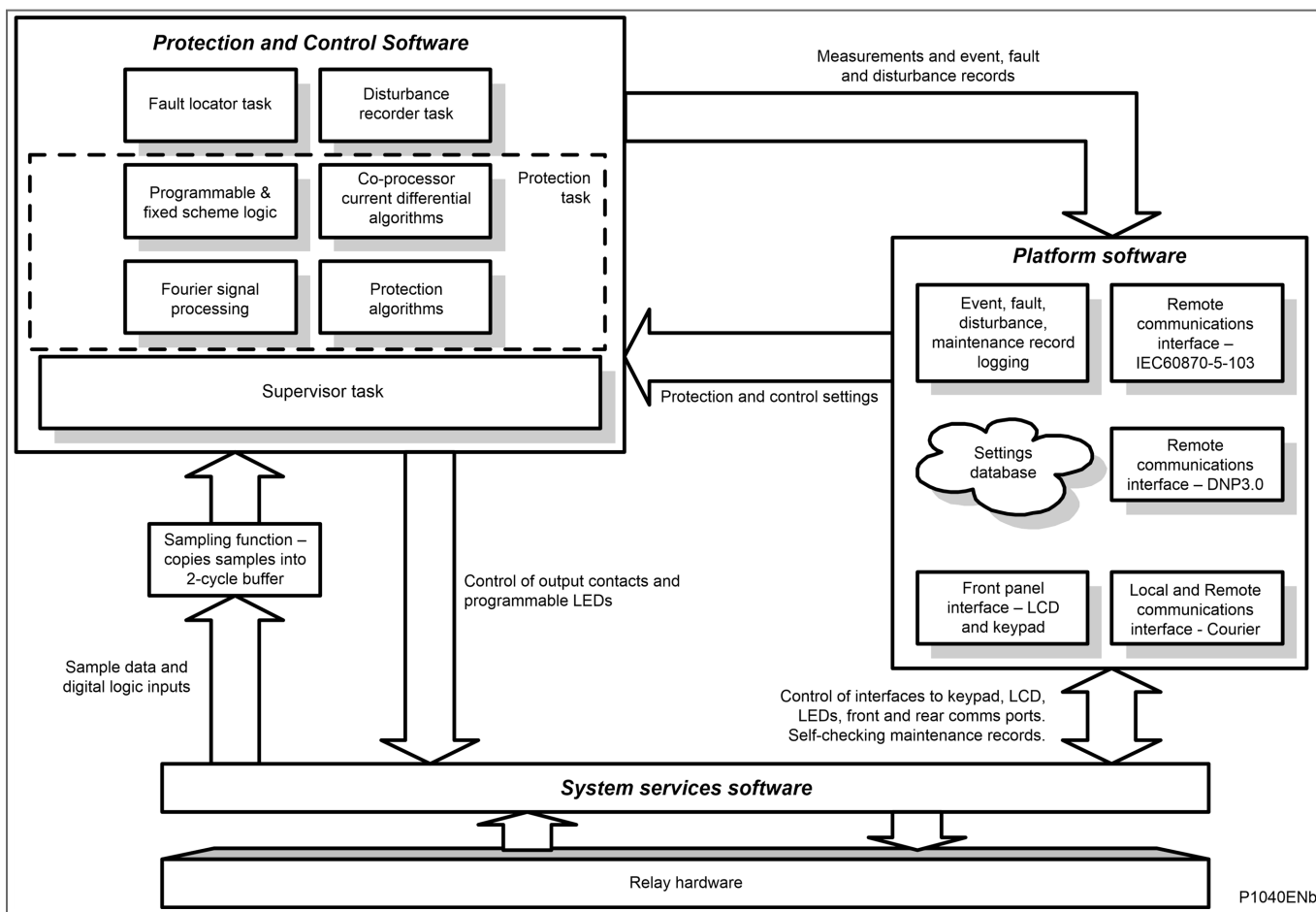

Figure 8 - Relay software structure diagram

2.1 Real-Time Operating System

As explained in the hardware overview, each relay contains one main board and one coprocessor board. These two boards use two different operating systems:

- For main board software: a real time operating system provides a framework for the different parts of the relay's software to operate within. To this end, the software is split into tasks. The real-time operating system is responsible for scheduling the processing of these tasks such that they are carried out in the time available and in the desired order of priority.

- For coprocessor board software: a sequencer manages all the functions implemented on the coprocessor board. Each function is executed at a fixed frequency. Consequently the CPU load of the coprocessor is fixed and independent of the network's frequency.

The real-time operating system is responsible for scheduling the processing of these tasks such that they are carried out in the time available and in the desired order of priority. The operating system is also responsible for the exchange of information between tasks, in the form of messages.

2.2 System Services Software

As shown in the Figure 8 - Relay software structure diagram, the system services software provides the low-level control of the relay hardware. It also provides the interface between the relay's hardware and the higher-level functionality of the platform software and the protection and control software.

For example, the system services software provides drivers for items such as the LCD display, the keypad and the remote communication ports. It also controls the boot of the processor and downloading of the processor code into SRAM from non-volatile flash EPROM at power up.

2.3 Platform Software

Important

MiCOM P44y (P443 & P446), P445, P54x (P543, P544, P545 & P546), P74x (P741, P742 & P743) and P841 relays do not support MODBUS.

The platform software has these main functions:

- To deal with the management of the relay settings.
- To control the logging of all records that are generated by the protection software, including alarms and event, fault, disturbance and maintenance records.
- To store and maintain a database of all of the relay's settings in non-volatile memory.
- To provide the internal interface between the settings database and each of the relay's user interfaces. These interfaces are the front panel interface and the front and rear communication ports, using whichever communication protocol has been specified (Courier, MODBUS, IEC60870-5-103 and DNP3.0). The platform software converts the information from the database into the format required.

The platform software notifies the protection and control software of all settings changes and logs data as specified by the protection and control software.

2.3.1 Record Logging

The logging function is provided to store all alarms, events, faults and maintenance records. The records for all these incidents are logged in battery backed-up SRAM to provide a non-volatile log of what has happened. The relay maintains four logs: one each for alarms, event records, fault records and maintenance records. The logs are maintained such that the oldest record is overwritten with the newest record.

The maximum number of alarms, event records, fault records and maintenance records varies depending on the product, the software and the model options, as shown below:

Software	Versions prior to 41/51	Versions 41/51 to A0/B0	Versions H1 and later
Alarms (maximum)	96	96	96
Events Records	512 (0 - 511)	1024 (0 - 1023)	1024 (0 - 1023)
Fault Records	5 (0 - 4)	10 (0 - 9)	15 (0 - 14)
Maintenance Records	5 (0 - 4)	10 (0 - 9)	10 (0 - 9)

Table 7 - Numbers of alarms, event records, fault records and maintenance records for different software versions

The logging function can be initiated from the protection software or the platform software, and is responsible for logging of a maintenance record in the event of a relay failure. This includes errors that have been detected by the platform software itself or error that are detected by either the system services or the protection software functions. See also 4 - Self Testing and Diagnostics.

2.3.2 Settings Database

The settings database contains all of the settings and data for the relay, including the protection, disturbance recorder and control and support settings. The settings are maintained in non-volatile memory. The platform software's management of the settings database make sure that only one user interface modifies the database settings at any one time. This feature is used to avoid confusion between different parts of the software during a setting change. For changes to protection settings and disturbance recorder settings, the platform software operates a 'scratchpad' in SRAM memory. This allows a number of setting changes to be made in any order but applied to the protection elements, disturbance recorder and saved in the database in non-volatile memory, at the same time. If a setting change affects the protection and control task, the database advises it of the new values.

The database is directly compatible with Courier communications.

2.3.3 Database Interface

The other function of the platform software is to implement the relay's internal interface between the database and each of the relay's user interfaces. The database of settings and measurements must be accessible from all the relay's user interfaces to allow read and modify operations. The platform software presents the data in the appropriate format for each user interface.

2.4 Protection and Control Software

The protection and control software interfaces with the platform software for settings changes and logging of records, and with the system services software for acquisition of sample data and access to output relays and digital opto-isolated inputs. It also performs the calculations for all of the protection algorithms of the relay. This includes digital signal processing such as Fourier filtering and ancillary tasks such as the disturbance recorder.

The protection and control software task processes all of the protection elements and measurement functions of the relay. It has to communicate with both the system services software and the platform software, and organize its own operations. The protection software has the highest priority of any of the software tasks in the relay, to provide the fastest possible protection response. It also has a supervisor task that controls the start-up of the task and deals with the exchange of messages between the task and the platform software.

After initialization at start-up, the protection & control task waits until there are enough samples to process. The sampling function is called by the system services software and takes each set of new samples from the input module and stores them in a two-cycle buffer. The protection & control software resumes execution when the number of unprocessed samples in the buffer reaches a certain number. However, the protection elements are split into groups so that different elements are processed each time, with every element being processed at least once per cycle. The protection and control software is suspended again when all of its processing on a set of samples is complete. This allows operations by other software tasks to take place.

2.4.1 Sample Acquisition without a Co-Processor (P14x, P64x, P841)

The acquisition of samples on the main processor board is controlled by a 'sampling function' which is called by the system services software and takes each set of new samples from the input module and stores them in a two-cycle buffer. The scheduling of the sampling function dictates the scheduling of the protection and control tasks.

2.4.2 Sample Acquisition with a Co-Processor (P54x, P44y & P445 Model D)

After initialization at start-up, the protection and control task on the main processor board is suspended until the co-processor board re-starts via an interrupt. Where the co-processor board has failed, the protection task will automatically start after six analog samples have been received. In normal operation the task will be re-started by the co-processor 16 times per cycle. The acquisition of samples on the main processor board is controlled by a 'sampling function' which is called by the system services software and takes each set of new samples from the input module and stores them in a two-cycle buffer, these samples are also stored concurrently by the co-processor.

2.4.3 Signal Processing

The sampling function filters the digital input signals from the opto-isolators and tracks the frequency of the analog signals. The digital inputs are checked against their previous value over a period of half a cycle. Therefore a change in the state of one of the inputs must be maintained over at least half a cycle before it is registered with the protection and control software.

The frequency tracking of the analog input signals is achieved by a recursive Fourier algorithm which is applied to one of the input signals, and works by detecting a change in the measured signal's phase angle. The calculated value of the frequency is used to modify the sample rate being used by the input module to achieve a constant sample rate of 24 or 48 samples per cycle of the power waveform. The value of the frequency is also stored for use by the protection and control task.

When the protection and control task is re-started by the sampling function, it calculates the Fourier components for the analog signals. The Fourier components are calculated using a one-cycle, 24 or 48-sample Discrete Fourier Transform (DFT). The DFT is always calculated using the last cycle of samples from the 2-cycle buffer, which is the most recent data. Used in this way, the DFT extracts the power frequency fundamental component from the signal and produces the magnitude and phase angle of the fundamental in rectangular component format. The DFT provides an accurate measurement of the fundamental frequency component, and effective filtering of harmonic frequencies and noise. This performance is achieved with the relay input module which provides hardware anti-alias filtering to attenuate frequencies above the half sample rate, and frequency tracking to maintain a sample rate of 24 samples per cycle. The Fourier components of the input current and voltage signals are stored in memory so they can be accessed by all of the protection elements' algorithms. The samples from the input module are also used in an unprocessed form by the disturbance recorder for waveform recording and to calculate true RMS values of current, voltage and power for metering purposes.

2.4.4 Main Protection Digital Filtering - Co-Processor Board

2.4.4.1 Differential Protection (P54x only)

The differential protection is based on the relays at the line ends exchanging data messages four times per cycle. To achieve this the co-processor takes the frequency-tracked samples at 48 samples per cycle from the input board and converts these to 8 samples per cycle based on the nominal frequency (i.e. not frequency tracked). The co-processor calculates the Fourier transform of the fixed rate samples after every sample, using a one-cycle window.

This generates current measurements eight times per cycle which are used for the differential

protection algorithm and transmitted to the remote relay(s) using the HDLC (High-level Data Link Control) communication protocol.

The co-processor is also responsible for managing intertripping commands via the communication link, and re-configuration instigated from the remote relay(s). Data exchange between the co-processor board and the main processor board is achieved through the use of shared memory on the co-processor board. When the main processor accesses this memory, the co-processor is temporarily halted. After the co-processor code has been copied onto the board at initialization, the main traffic between the two boards consists of setting change information, commands from the main processor, differential protection measurements and output data.

2.4.5 Distance Protection Filters (P44y and P54x)

Important
This applies to the MiCOM P44y/P54x products which include distance protection options. More recent Software (such as D1 and H4) includes distance protection options, but exclude non-distance variants. Depending on the specific model and the options, older software (such as 41, 42, 44, 45, 47, A0 and C0) may not include distance protection.

The current and voltage inputs are filtered, using Finite Impulse Response (FIR) digital filters to reduce the effects of non-power frequency components in the input signals, such as DC offsets in current waveforms, and Capacitor Voltage Transformer (CVT) transients in the voltages.

- The P44y/P54x uses a combination of a ¼-cycle filter using 12 coefficients, a ½-cycle filter using 24 coefficients, and a one-cycle filter using 48 coefficients.

The relay automatically performs intelligent switching in the application of the filters, to select the best balance of removal of transients with fast response.

Note
 The protection elements themselves then perform additional filtering, for example implemented by the trip count strategy.

2.4.6 Frequency Response

Important
This applies to the MiCOM P44y/P54x products which include distance protection options. More recent Software (such as D1 and H4) includes distance protection options, but exclude non-distance variants. Depending on the specific model and the options, older software (such as 41, 42, 44, 45, 47, A0 and C0) may not include distance protection.

With the exception of the RMS measurements, all other measurements and protection functions are based on the Fourier-derived fundamental component. The fundamental component is extracted by using a 24-sample DFT. This gives good harmonic rejection for frequencies up to the 23rd harmonic. The 23rd is the first predominant harmonic that is not attenuated by the Fourier filter and this is known as an 'Alias'. However, the Alias is attenuated by approximately 85% by an additional, analog, 'anti-aliasing' filter (low pass filter). The combined effect of the anti-aliasing and Fourier filters is shown in the Figure 9 - Frequency response (for P14x, P24x, P341, P34x and P64x) diagram:

The combined effect of the anti-aliasing and Fourier filters is shown in the following Figure 10 - Frequency response (for P44y, P54x and P445) diagram. This shows the frequency response of the 12, 24 and 48 coefficient filters, noting that all have a gain of unity at the fundamental.

For the P841, the combined effect of the anti-aliasing and Fourier filters is shown in the following Figure 11 - Frequency response (for P841) diagram. This shows the frequency

response of the coefficient filter, noting the gain of unity at the fundamental. Unlike some other products, only the full cycle filter response applies to the P841.

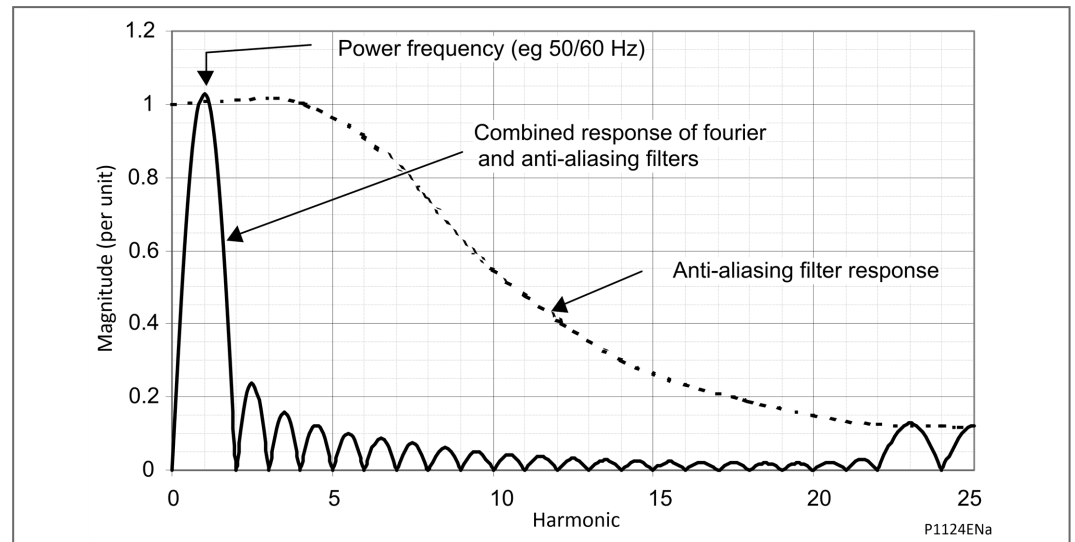

Figure 9 - Frequency response (for P14x, P24x, P341, P34x and P64x) diagram

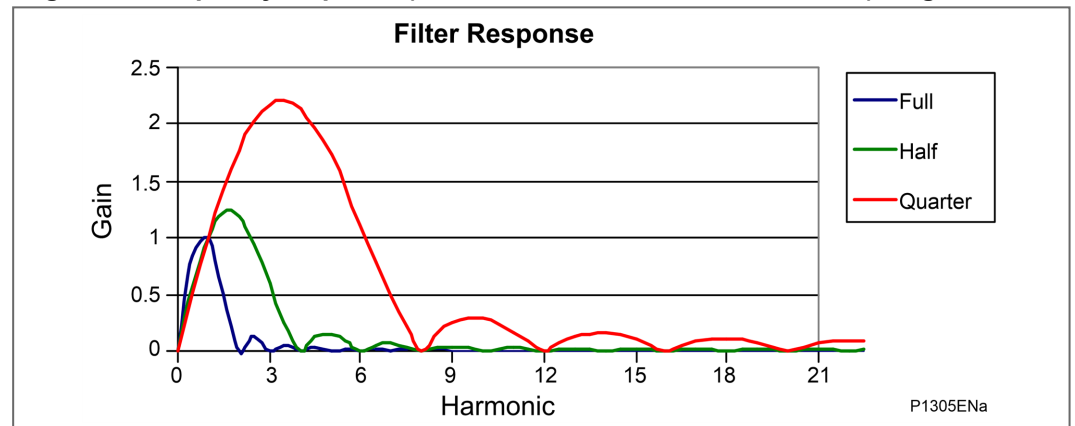

Figure 10 - Frequency response (for P44y, P54x and P445) diagram

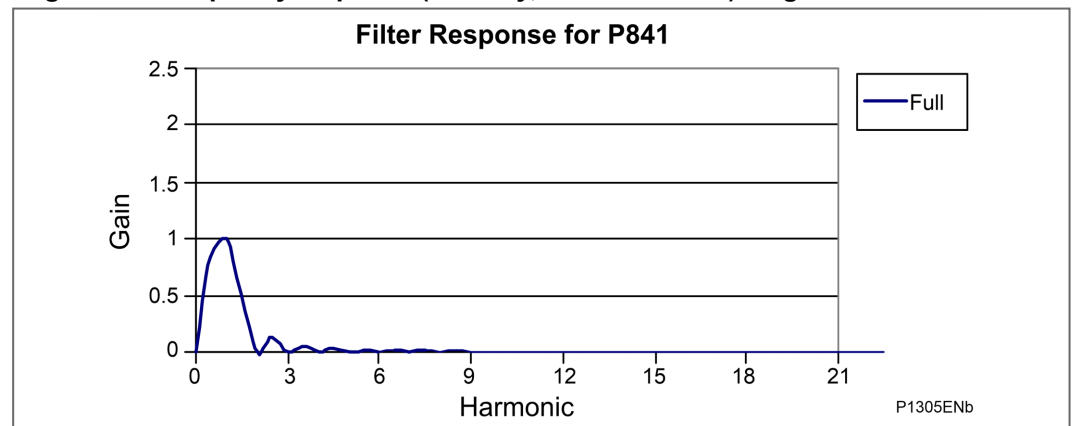

Figure 11 - Frequency response (for P841) diagram

For power frequencies that are not equal to the selected rated frequency, the harmonics are attenuated to zero amplitude. For small deviations of $\pm 1\text{Hz}$, this is not a problem but to allow for larger deviations, frequency tracking is used.

Frequency tracking automatically adjusts the sampling rate of the analog to digital conversion to match the applied signal. In the absence of a suitable signal to amplitude track, the sample rate defaults to the selected rated frequency (F_n). If the a signal is in the tracking range of 45 to 66 Hz (40 to 70 Hz for P341 and P34x), the relay locks onto the signal and the measured

frequency coincides with the power frequency as shown in the above *Frequency response* diagrams. The outputs for harmonics up to the 23rd are zero. The relay frequency tracks off any voltage or current in the order VA/VB/VC/IA/IB/IC down to 10% Vn for voltage and 5%In for current.

2.4.6.1 Fourier Filtering

All backup protection and measurement functions use one-cycle Fourier digital filtering to extract the power frequency component. This filtering is performed on the main processor board.

2.4.7 Programmable Scheme Logic (PSL)

The Programmable Scheme Logic (PSL) allows the relay user to configure an individual protection scheme to suit their own particular application. This is done with programmable logic gates and delay timers.

The input to the PSL is any combination of the status of the digital input signals from the opto-isolators on the input board, the outputs of the protection elements such as protection starts and trips, and the outputs of the fixed PSL. The fixed PSL provides the relay's standard protection schemes. The PSL consists of software logic gates and timers. The logic gates can be programmed to perform a range of different logic functions and can accept any number of inputs. The timers are used either to create a programmable delay or to condition the logic outputs, such as to create a pulse of fixed duration on the output, regardless of the length of the pulse on the input. The outputs of the PSL are the LEDs on the front panel of the relay and the output contacts at the rear.

The execution of the PSL logic is event driven: the logic is processed whenever any of its inputs change, for example as a result of a change in one of the digital input signals or a trip output from a protection element. Also, only the part of the PSL logic that is affected by the particular input change that has occurred is processed. This reduces the amount of processing time that is used by the PSL. The protection and control software updates the logic delay timers and checks for a change in the PSL input signals every time it runs.

This system provides flexibility for the user to create their own scheme logic design. However, it also means that the PSL can be configured into a very complex system, and because of this setting of the PSL is implemented through the PC support package Easergy Studio Studio.

2.4.7.1 PSL Data

In the PSL editor in Easergy Studio, when a PSL file is downloaded to the relay the user can specify the group to download the file and a 32 character PSL reference description. This PSL reference is shown in the **Grp. 1/2/3/4 PSL Ref.** cell in the **PSL DATA** menu in the relay. The download date and time and file checksum for each group's PSL file is also shown in the **PSL DATA** menu in cells **Date/Time** and **Grp. 1/2/3/4 PSL ID**. The PSL data can be used to show if a PSL has been changed and can be useful in providing information for version control of PSL files.

The default PSL Reference description is **Default PSL** followed by the model number, for example, **Default PSL Pxxx?????0yy0?** where Pxxx refers to the model such as P54x, P44y, P445, P746 or P841 and yy refers to the software version such as 05. This is the same for all protection setting groups (since the default PSL is the same for all groups). Since the LCD display (bottom line) only has space for 16 characters, the display must be scrolled to see all 32 characters of the PSL Reference description.

The default date and time is the date and time when the defaults were loaded.

Note

The PSL DATA column information is only supported by Courier and MODBUS, but not DNP3.0 or IEC60870-5-103.

Note

The PSL DATA column information is visible via the relay front panel interface or over the Courier communications protocol.

2.4.8 Function Key Interface

The ten function keys interface directly into the PSL as digital input signals and are processed based on the PSLs event-driven execution. However, a change of state is only recognized when a key press is executed, on average for longer than 200 ms. The time to register a change of state depends on whether the function key press is executed at the start or the end of a protection task cycle, with the additional hardware and software scan time included. A function key press can provide a latched (toggled mode) or output on key press only (normal mode) depending on how it is programmed and can be configured to individual protection scheme requirements. The latched state signal for each function key is written to non-volatile memory and read from non-volatile memory during relay power up, allowing the function key state to be reinstated after power-up if the relay power is lost.

2.4.9 Event, Fault and Maintenance Recording

A change in any digital input signal or protection element output signal is used to indicate that an event has taken place. When this happens, the protection and control task sends a message to the supervisor task to show that an event is available to be processed. The protection and control task writes the event data to a fast buffer in SRAM that is controlled by the supervisor task. When the supervisor task receives either an event or fault record message, it instructs the platform software to create the appropriate log in battery backed-up SRAM. The supervisor's buffer is faster than battery backed-up SRAM, therefore the protection software is not delayed waiting for the records to be logged by the platform software. However, if a large number of records to be logged are created in a short time, some may be lost if the supervisor's buffer is full before the platform software is able to create a new log in battery backed-up SRAM. If this occurs, an event is logged to indicate this loss of information.

Maintenance records are created in a similar manner with the supervisor task instructing the platform software to log a record when it receives a maintenance record message. However, it is possible that a maintenance record may be triggered by a fatal error in the relay, in which case it may not be possible to successfully store a maintenance record, depending on the nature of the problem. See 4 - Self Testing and Diagnostics.

Fault records are stored in the sequence of events. They can be viewed locally or remotely and include:

- Faulty phase(s)
- Protection Tripped
- Protection Started
- Fault Alarms
- Fault Date and Time
- Active Group
- Frequency
- Fault duration
- CB operating time
- Relay operating time
- Fault Location
- Primary or Secondary magnitude and phase of prefault phase, neutral and mutual currents
- Primary or Secondary magnitude and phase of fault phase, neutral and mutual currents
- Primary or Secondary magnitude of local and remote currents

- Primary or Secondary magnitude of differential and bias currents
- Communication measurements

2.5 Disturbance Recorder

The analog values and logic signals are routed from the protection and control software to the disturbance recorder software. The platform software interfaces with the disturbance recorder to allow the stored records to be extracted.

The enhanced disturbance recording is started from any relay start or trip, or any specific opto-isolator input or internal information. The recording time is user selectable up to a *Maximum Recording Time*.

The disturbance recorder operates as a separate task to the protection and control task. It can record the waveforms for *Maximum Calibrated Analog Channels* and the values for *Maximum Digital Signals*. Additional calculated analogue channels are also available and can be added up to a maximum of 20 channels in total. The *Minimum No of Records* and *Maximum No of Records* varies from one product to another as shown here:

Product	Maximum calibrated analog channels	Maximum digital signals	Maximum Recording Time	Minimum No of Records	Maximum No of Records
P14x	9	128	10.5		
P24x	8	32	10		
P341	9	128	10.5		
P342, P343, P344, P345 & P391	9	128	10.5		
P44x	8	32	10		
P44y	13	128	50	5 records of 10 secs each	50 records of 10 secs each
P445	8	128	10.5		
P54x	13	128	50	5 records of 10 secs each	50 records of 10 secs each
P64x	21	32	10		
P74x	8	32	10		
P746	21; 27 (B6/C6)	32; 80 (B6/C6)	10		
P841	8	128	10		
P849	8	32	10		

Table 8 - Disturbance recorder channels, signals, times and records for different models

The enhanced disturbance recorder is supplied with data once per cycle by the protection and control task. The enhanced disturbance recorder collates the data that it receives into the required length disturbance record. The enhanced disturbance records that can also store the data in COMTRADE format can be extracted using Easergy Studio, allowing the use of other packages to view the recorded data.

2.6 Communication Software for P74x

The communication software manages optical fibre communication between the central unit and the peripheral units. This includes the control of data exchanged transmitted and the

synchronisation of peripheral units. With this object, the communication software interfaces with the sequencer used in co-processors boards.

In accordance with sequencer used in coprocessor board, the communication software sends frames at fixed frequency equal to 2400Hz. Likewise the contents of the frames is independent of the frequency and of the status of the protections. The frames are split in fixed parts according to the priority of each application. For example trip order and current sample are respectively transmitted at 2400Hz and 1200Hz whereas the internal courier communication or date & time are exchange at low frequency.

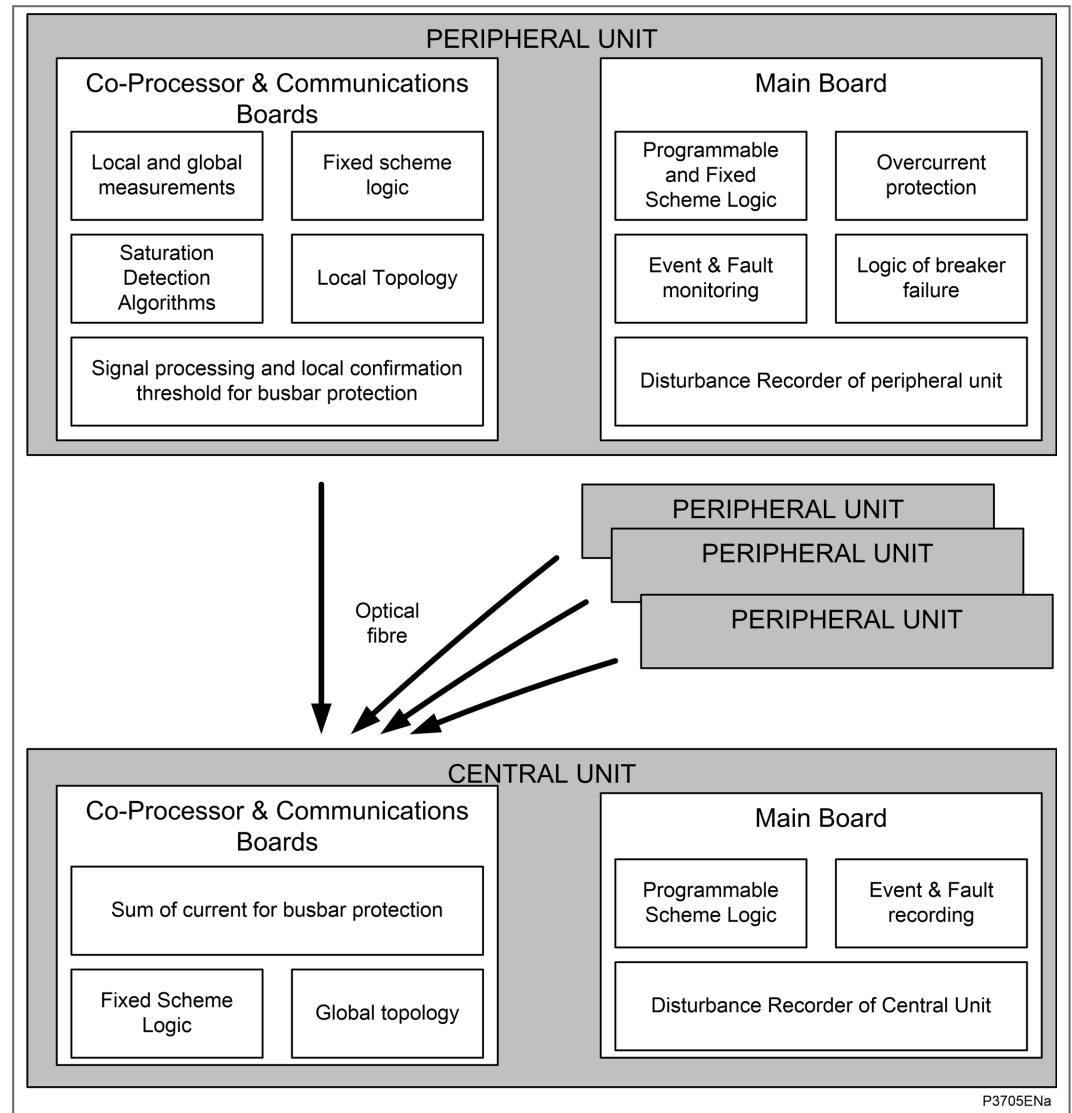

Figure 12 - System overview diagram

3. FAULT LOCATOR

The relay has an integral fault locator (which is separate from the protection and control task). The fault locator samples data from analog current and voltage inputs and writes it to a cyclic 12-cycle buffer until a fault condition is detected. It then uses this data to provide a distance to fault location feature.

The data in the input buffer is then held to allow the fault calculation to be made and to calculate a distance to fault location. The calculated location of the fault is sent to the protection and control task which includes it in the fault record for the fault. When the fault record is complete (i.e. includes the fault location), the protection and control task can send a message to the supervisor task to log the fault record.

3.1 Basic Theory for Ground Faults (for P14x)

A two-machine equivalent circuit of a faulted power system is shown below.

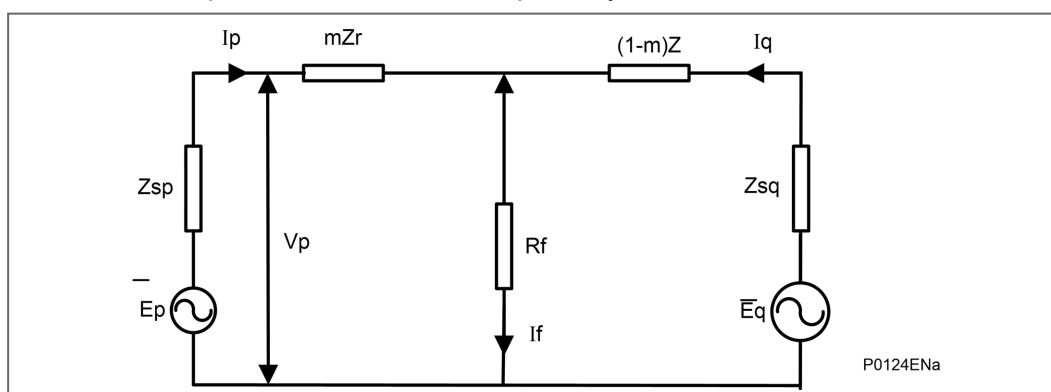

Figure 13 - Two machine equivalent circuit diagram

From this diagram, the fault location (m) can be found by estimating I_f and solving the following **Fault Location** equation.

Equation 1 - Fault Location

$$V_p = mI_p Z_r + I_f R_f$$

3.2 Data Acquisition and Buffer Processing (for P14x)

The fault locator stores the sampled data within a 12 cycle cyclic buffer at a resolution of 24 samples per cycle. When the fault recorder is triggered the data in the buffer is frozen such that the buffer contains 6 cycles of pre-trigger data and 6 cycles of post trigger data. Fault calculation commences shortly after this trigger point.

The trigger for the fault locator is user selectable via the PSL.

The fault locator can store data for up to four faults. This ensures that fault location can be calculated for all shots on a typical multiple re-close sequence.

3.3 Faulted Phase Selection (for P14x)

Selection of the faulted phase(s) is performed by comparing the magnitude of the pre fault and post fault values of the three phase-to-phase currents. A single phase-to-ground fault produces the same change on two of these signals and zero on the third. A phase-to-phase or double phase-to-ground fault produces one signal that is larger than the other two. A three-phase fault produces the same change on all 3 currents.

Current changes are considered to be the same if they are within 20% of each other. Phase selection and fault location calculation can only be made if the current change exceeds 5% I_n .

3.4 Fault Location Calculation (for P14x)

This works by:

1. First obtaining the vectors
2. Selecting the faulted phase(s)
3. Estimating the phase of the fault current, I_f , for the faulted phase(s)
4. Solving the Fault Location equation for the fault location m at the instant of time where $I_f = 0$

3.4.1 Obtaining the Vectors (for P14x)

Different sets of vectors are chosen depending on the type of fault identified by the phase selection algorithm. The calculation using the **Fault Location** equation is applied for either a phase-to-ground fault or a phase-to-phase fault. Thus:

For an A-phase to ground fault:

Equation 2 - A-phase to ground fault

$$I_p Z_r = I_a (Z_{line} / \theta_{line}) + I_n (Z_{residual} / \theta_{residual})$$

And

$$V_p = V_A$$

For an A-phase to B-phase fault:

Equation 3 - A-phase to B-phase fault

$$I_p Z_r = I_a (Z_{line} / \theta_{line}) - I_b (Z_{residual} / \theta_{residual})$$

And

$$V_p = V_A - V_B$$

3.4.2 Solving the Equation for the Fault Location (for P14x)

As the sine wave of I_f passes through zero, the instantaneous values of the sine waves V_p and I_p can be used to solve the *Fault Location* equation for the fault location m . (The term $I_f R_f$ being zero.)

This is determined by shifting the calculated vectors of V_p and $I_p Z_r$ by the angle (90° - angle of fault current) and then dividing the real component of V_p by the real component of $I_p Z_r$. See the Figure 14 - Fault locator selection of fault current zero diagram.

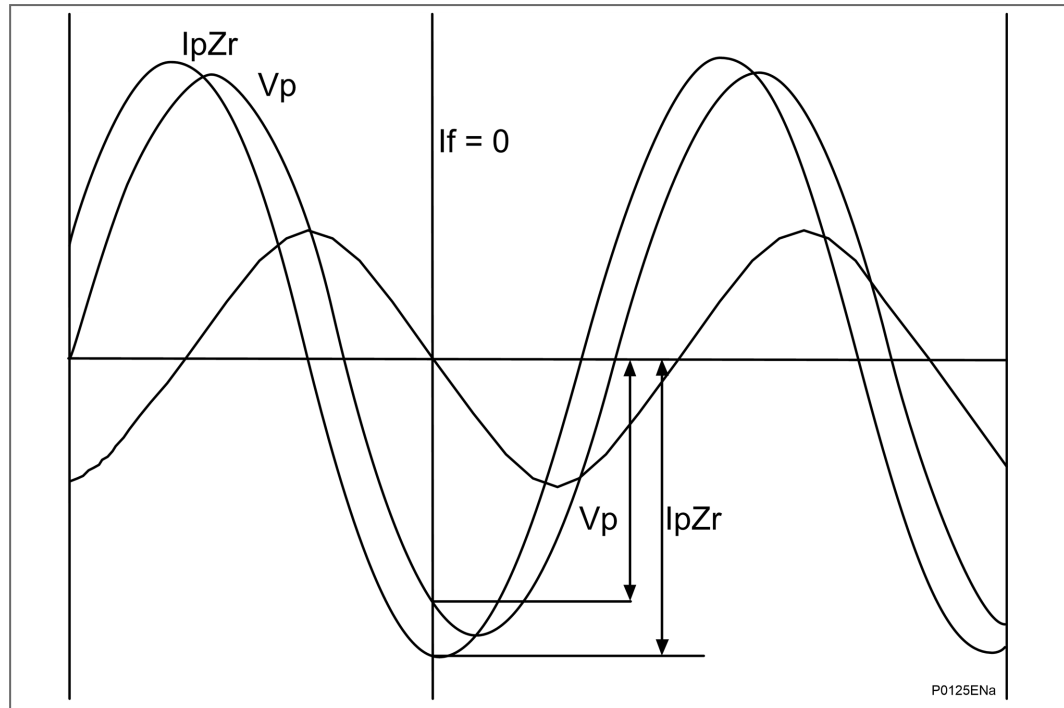

Figure 14 - Fault locator selection of fault current zero diagram
i.e.:

Phase advanced vector V_p

$$V_p = |V_p| (\cos(s) + j\sin(s)) * (\sin(d) + j\cos(d))$$

$$V_p = |V_p| [-\sin(s-d) + j\cos(s-d)]$$

Phase advanced vector $I_p Z_r$

$$I_p Z_r = |I_p Z_r| (\cos(e) + j\sin(e)) * (\sin(d) + j\cos(d))$$

$$I_p Z_r = |I_p Z_r| [-\sin(e-d) + j\cos(e-d)]$$

Therefore from the Fault Location equation:

$$m = V_p \div (I_p * Z_r) \text{ at } I_f = 0$$

$$m = V_p \sin(s-d) / (I_p Z_r * \sin(e-d))$$

Where:

d = angle of fault current I_f

s = angle of V_p

e = angle of $I_p Z_r$

Hence, the relay evaluates m which is the fault location as a percentage of the fault locator line impedance setting and then calculates the output fault location by multiplying this by the line length setting. When calculated, the fault location can be found in the fault record under the **VIEW RECORDS** column in the Fault Location cells. Distance to fault is available in kilometers, miles, impedance or percentage of line length.

4. SELF TESTING AND DIAGNOSTICS

The relay includes several self-monitoring functions to check the operation of its hardware and software when it is in service. These are included so that if an error or fault occurs in the relay's hardware or software, the relay is able to detect and report the problem and attempt to resolve it by performing a reboot. The relay must therefore be out of service for a short time, during which the **Healthy** LED on the front of the relay is OFF and, the watchdog contact at the rear is ON. If the reboot fails to resolve the problem, the relay takes itself permanently out of service; the **Healthy** LED stays OFF and watchdog contact stays ON.

If a problem is detected by the self-monitoring functions, the relay stores a maintenance record in battery backed-up SRAM.

The self-monitoring is implemented in two stages:

- firstly a thorough diagnostic check that is performed when the relay is booted-up
- secondly a continuous self-checking operation that checks the operation of the relay's critical functions while it is in service.

4.1 Startup Self-Testing

The self-testing that is carried out when the relay is started takes a few seconds to complete, during which time the relay's protection is unavailable. This is shown by the **Healthy** LED on the front of the relay which is ON when the relay has passed all tests and entered operation. If the tests detect a problem, the relay remains out of service until it is manually restored to working order.

The operations that are performed at start-up are:

- 4.1.1 - System Boot
- 4.1.2 - Initialization Software
- 4.1.3 - Platform Software Initialization and Monitoring

4.1.1 System Boot

The integrity of the flash memory is verified using a checksum before the program code and data are copied into SRAM and executed by the processor. When the copy is complete the data then held in SRAM is checked against that in flash memory to ensure they are the same and that no errors have occurred in the transfer of data from flash memory to SRAM. The entry point of the software code in SRAM is then called which is the relay initialization code.

4.1.2 Initialization Software

The initialization process includes the operations of initializing the processor registers and interrupts, starting the watchdog timers (used by the hardware to determine whether the software is still running), starting the real-time operating system and creating and starting the supervisor task.

In the initialization process the relay checks the following.

- The status of the battery
- The integrity of the battery backed-up SRAM that stores event, fault and disturbance records
- The voltage level of the field voltage supply that drives the opto-isolated inputs
- The operation of the LCD controller
- The watchdog operation

When the initialization software routine is complete, the supervisor task starts the platform software.

If the startup follows a watchdog reboot due to BBRAM memory corruption, the relay will raise the BBRAM failure indication DDB which is available for mapping in the PSL.

At the conclusion of the initialization software the supervisor task begins the process of starting the platform software. The checking that is made in the process of starting the co-processor board is as follows:

- A check is made for the presence of, and a valid response from, the co-processor board
- The SRAM on the co-processor board is checked with a test bit pattern before the co-processor code is transferred from the flash EPROM

Any of these checks which produces an error results in the co-processor board being left out of service and the relay relying on the other protection functions which are provided by the main processor board.

If the startup follows a watchdog reboot due to memory corruption, the relay will raise the BBRAM failure indication DDB which is available for mapping in the PSL.

4.1.3 Platform Software Initialization and Monitoring

In starting the platform software, the relay checks the integrity of the data held in non-volatile memory with a checksum, the operation of the real-time clock, and the IRIG-B board if fitted. The final test that is made concerns the input and output of data; the presence and healthy condition of the input board is checked and the analog data acquisition system is checked through sampling the reference voltage.

At the successful conclusion of all of these tests the relay is entered into service and the protection started-up.

4.2 Continuous Self-Testing

When the relay is in service, it continually checks the operation of the critical parts of its hardware and software. The checking is carried out by the 2.2 - System Services Software and the results reported to the 2.3 - Platform Software.

The functions that are checked are as follows:

- The flash EPROM containing all program code and language text is verified by a checksum
- The SRAM containing all data other than the code and constant data is verified with a checksum
- The non-volatile memory containing setting values is verified by a checksum, whenever its data is accessed
- The battery status
- The level of the field voltage
- The integrity of the digital signal I/O data from the opto-isolated inputs and the relay contacts, is checked by the data acquisition function every time it is executed. The operation of the analog data acquisition system is checked by the acquisition function every time it is executed. This is done by sampling the reference voltage on a spare multiplexed channel
- The operation of the IRIG-B board is checked, where it is fitted, by the software that reads the time and date from the board

If the Ethernet board is fitted, it is checked by the software on the main processor board. If the Ethernet board fails to respond, an alarm is raised and the board is reset in an attempt to resolve the problem.

In addition, the following checks may be made too:

- The correct operation of the CLIO board is checked (where fitted)
- The operation of the Ethernet board is checked (where fitted), by the software on the main processor card. If the Ethernet board fails to respond an alarm is raised and the card is reset to try to resolve the problem

In the unlikely event that one of the checks detects an error in the relay's subsystems, the platform software is notified and it will attempt to log a maintenance record in battery backed-up SRAM. If the problem is with the battery status or the IRIG B board, the relay continues in operation. However, for problems detected in any other area the relay shuts down and reboots. This results in a period of up to 5 seconds when protection is unavailable, but the complete restart of the relay including all initializations should clear most problems that could occur. An integral part of the start-up procedure is a thorough diagnostic self-check. If this detects the same problem that caused the relay to restart, the restart has not cleared the problem and the relay takes itself permanently out of service. This is indicated by the **Healthy** LED on the front of the relay which goes OFF, and the watchdog contact that goes ON.

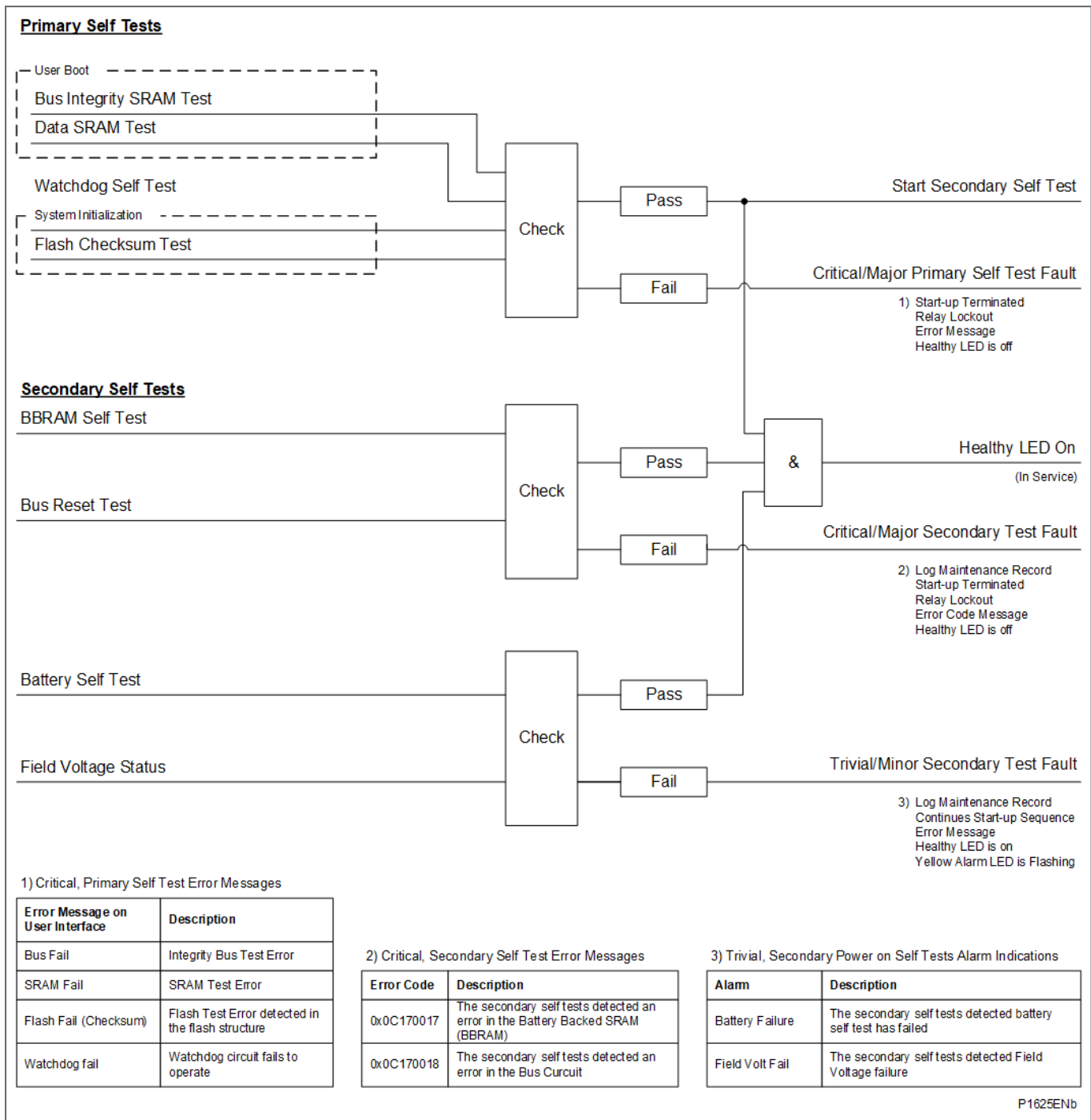

Figure 15 - Start-up self-testing logic diagram

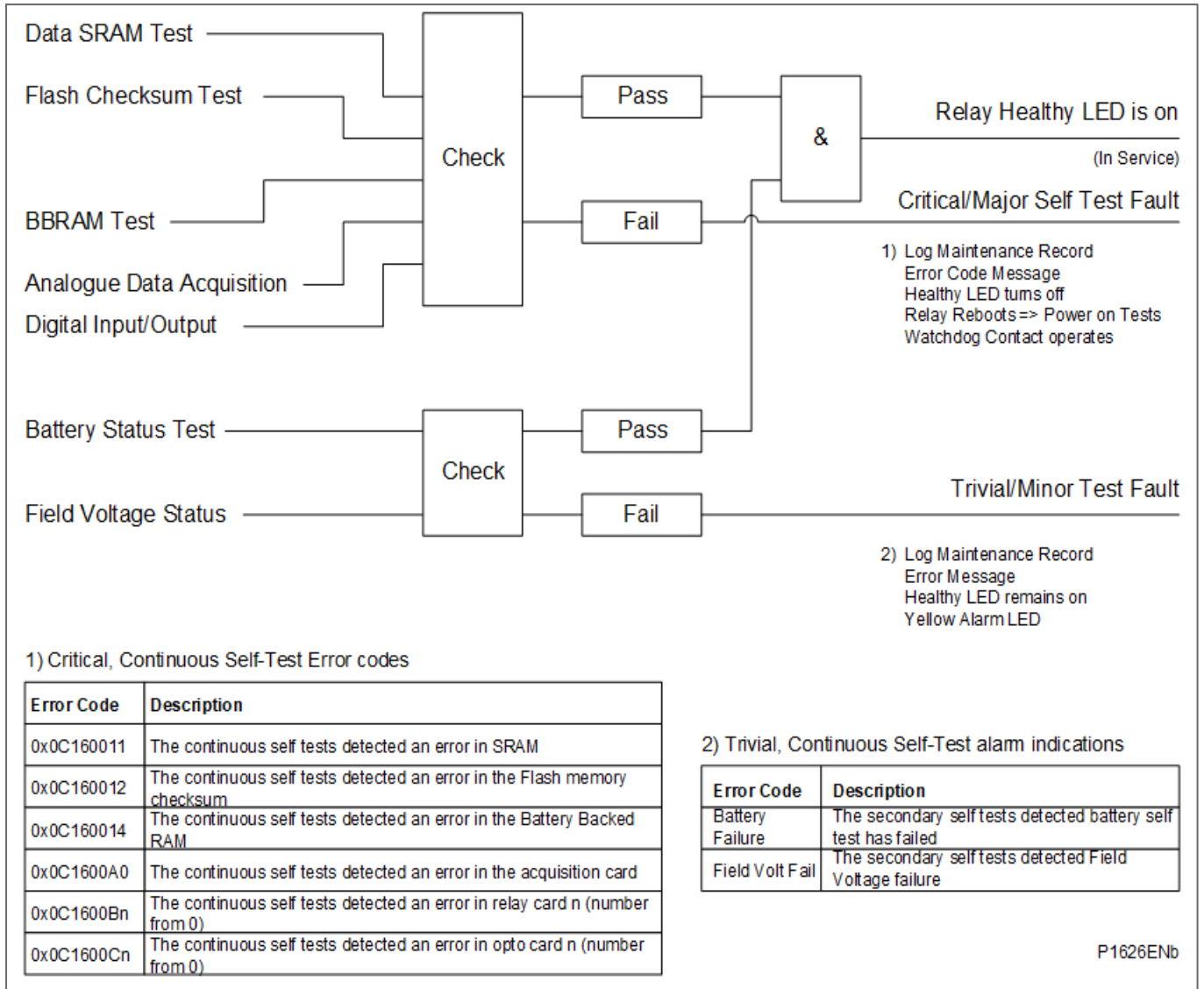

Figure 16 - Continuous self-testing logic diagram

COMMISSIONING

CHAPTER 11

Date:	01/2024
Products covered by this chapter:	This chapter covers the specific versions of the MiCOM products listed below. This includes only the following combinations of Software Version and Hardware Suffix.
Hardware suffix:	L
Software versions:	K6
Connection diagrams:	10P445xx (xx = 01 to 04)

CONTENTS

Page (CM) 11-

1	Introduction	9
2	Commissioning Tests	10
2.1	Opto I/P Status	10
2.2	Relay O/P Status	11
2.3	Test Port Status	11
2.4	LED Status	11
2.5	Monitor Bits 1 to 8	11
2.6	Test Mode	12
2.7	Test Pattern	12
2.8	Contact Test	12
2.9	Test LEDs	12
2.10	Test Auto-Reclose	13
2.11	Static Test Mode	13
2.12	InterMiCOM Loopback Mode	14
2.12.1	EIA(RS)232 InterMiCOM Loopback	14
2.12.2	Fiber InterMiCOM ⁶⁴ Loopback	14
2.13	InterMiCOM Test Pattern	14
2.13.1	EIA(RS)232 InterMiCOM Test Pattern	14
2.13.2	Fiber InterMiCOM ⁶⁴ Test Pattern	15
2.13.3	Fiber InterMiCOM ⁶⁴ Test Mode	15
2.14	Using a Monitor/Download Port Test Box	15
3	Setting Familiarization	16
4	Equipment Required for Commissioning	17
4.1	Minimum Equipment Required	17
4.2	Optional Equipment	17
5	Product Checks	18
5.1	Introduction to Product Checks	18
5.2	With the Relay De-Energized	19
5.2.1	Visual Inspection	19
5.2.2	Current Transformer Shorting Contacts (Optional Check)	19
5.2.3	Insulation	21
5.2.4	External Wiring	21
5.2.5	Watchdog Contacts	22
5.2.6	Auxiliary Supply	22
5.3	With the Relay Energized	22

5.3.1	Watchdog Contacts	23
5.3.2	LCD Front Panel Display	23
5.3.3	Date and Time	23
5.3.3.1	With an IRIG-B Signal	24
5.3.3.2	Without an IRIG-B Signal	24
5.3.4	Light Emitting Diodes (LEDs)	24
5.3.4.1	Testing the Alarm and Out Of Service LEDs	24
5.3.4.2	Testing the Trip LED	25
5.3.4.3	Testing the User-Programmable LEDs	25
5.3.5	Field Voltage Supply	25
5.3.6	Input Opto-Isolators	25
5.3.7	Output Relays	26
5.3.8	Rear Communications Port	27
5.3.8.1	Courier Communications	27
5.3.8.2	IEC 60870-5-103 (VDEW) Communications	28
5.3.8.3	DNP3.0 Communications Interface	28
5.3.9	Second Rear Communications Port	28
5.3.9.1	K-Bus Configuration	28
5.3.9.2	EIA(RS)485 Configuration	29
5.3.9.3	EIA(RS)232 Configuration	29
5.3.10	Current Inputs	30
5.3.11	Voltage Inputs	31
5.4	IEDs which use the Process Bus Interface	32
5.4.1	IED Configured with One Merging Unit (MU)	32
5.4.2	IED Configured with Two or More Merging Units (MUs)	33
6	InterMiCOM Communications Loopback	34
6.1	EIA(RS)232 InterMiCOM Communications	34
6.1.1	Modem InterMiCOM Loopback Testing & Diagnostics	34
6.1.1.1	MODEM InterMiCOM Command Bits	35
6.1.1.2	MODEM InterMiCOM Channel Diagnostics	35
6.1.1.3	MODEM InterMiCOM Channel Failure	35
6.2	InterMiCOM64 Fiber Communications	35
6.2.1	Communications Loopback Setting	36
6.2.1.1	Channel 1 Transmit Power Level	36
6.2.1.2	Channel 2 Transmit Power Level	37
6.2.2	Loopback Communications Configuration	37
6.2.3	Fiber Connection	37
6.2.4	Communications using P-2M-L interface units (G.703)	37
6.2.4.1	P-2M-L Visual Inspection	37
6.2.4.2	P-2M-L Insulation	37
6.2.4.3	P-2M-L External Wiring	37
6.2.4.4	P-2M-L Auxiliary Supply	37
6.2.4.5	P-2M-L Light Emitting Diode (LED)	37
6.2.4.6	P-2M-L Optical Received Signal Level	37
6.2.4.7	P-2M-L Loopback	37
6.2.4.8	P-2M-L Optical Transmitter Signal Level	38
6.2.4.9	MiCOM Optical Received Signal Level From P-2M-L	38

6.2.5	Loopback Test	38
7	Setting Checks	39
7.1	Apply Application-Specific Settings	39
7.1.1	InterMiCOM Loopback	39
7.1.2	Reset Statistics	40
7.2	Demonstrate Correct Relay Operation	40
7.2.1	Distance Protection Single-End Testing	40
7.2.1.1	Connection and Preliminaries	40
7.2.1.2	Zone 1 Reach Check	41
7.2.1.3	Zone 2 Reach Check	41
7.2.1.4	Zone 3 Reach Check	41
7.2.1.5	Zone 4 Reach Check (if Enabled)	41
7.2.1.6	Zone P Reach Check (if Enabled)	42
7.2.1.7	Resistive Reach (Quadrilateral Characteristics Only)	42
7.2.1.8	Load Blinder	42
7.2.2	Distance Protection Operation and Contact Assignment	42
7.2.2.1	Phase A	42
7.2.2.2	Phase B	42
7.2.2.3	Phase C	42
7.2.2.4	Time Delay Settings $t_{Z1 Ph}$, and $t_{Z2} - t_{Z4}$	42
7.2.3	Distance Protection Scheme Testing	43
7.2.3.1	Scheme Trip Test for Zone 1 Extension Only	44
7.2.3.2	Scheme Trip Tests for Permissive Schemes (PUR/POR Only)	44
7.2.3.3	Scheme Trip Tests for Blocking Scheme Only	44
7.2.3.4	Signal Send Test for Permissive Schemes (PUR/POR Only)	44
7.2.3.5	Signal Send Test for Blocking Scheme Only	45
7.2.4	Scheme Timer Settings	45
7.2.5	Directional Earth Fault Aided Scheme (Ground Current Pilot Scheme)	45
7.2.5.1	Connect the Test Circuit	46
7.2.5.2	DEF Aided Scheme - Forward Fault Trip Test	46
7.2.6	DEF Aided Scheme - Scheme Testing	46
7.2.6.1	Signal Send Test for Permissive Schemes (POR/POTT Only)	46
7.2.6.2	Signal Send Test for Blocking Schemes Only	47
7.2.7	Backup Phase Overcurrent Protection	47
7.2.7.1	Connect the Test Circuit	47
7.2.7.2	Perform the Test	47
7.2.7.3	Check the Operating Time	48
7.3	Check Trip and Auto-Reclose Cycle	48
8	End to End Communication Tests (InterMiCOM Only)	49
8.1	MODEM InterMiCOM	49
8.1.1	Local End Configuration	49
8.1.2	Remote End Configuration	49
8.1.3	Verify End-To-End Communication	49
8.1.3.1	Verify Operational Link	49
8.1.3.2	Verify Pattern Transmission	49
8.1.3.3	Check Data Received Counters	50

8.1.3.4	Statistics Check	50
8.2	Fiber InterMiCOM64	50
8.2.1	Remove Local Loopbacks	50
8.2.1.1	Direct Fiber and C37.94 Connections	50
8.2.1.2	Communications using P-2M-L Interface Units	51
8.2.2	Remote Loopback Removal	51
8.2.2.1	Remove Loopbacks at Remote Terminal Connected to Channel 1	51
8.2.2.2	Remove Loopbacks at Remote Terminal Connected to Channel 2	51
8.2.3	Verify Communications Between Relays	51
9	End-to-End Scheme Tests	53
9.1	Signaling Channel Check	53
9.1.1	Aided Scheme 1	53
9.1.1.1	Remote End Preparation to Observe Channel Arrival	53
9.1.1.2	Application of the Test	53
9.1.1.3	Channel Check in the Opposite Direction	54
9.1.2	Aided Scheme 2	54
10	Modem InterMiCOM Scheme Testing	55
11	On-load Checks	56
11.1	Confirm Current and Voltage Transformer Wiring	56
11.1.1	Voltage Connections	56
11.1.2	Current Connections	57
11.2	On Load Directional Test	57
11.3	Signaling Channel Check (if Not Already Completed)	57
12	Final Checks	58

FIGURES

	Page (CM) 11-
Figure 1 - Rear terminal blocks on size 40TE case	20
Figure 2 - Location of securing screws for heavy duty terminal blocks	21
Figure 3 - Example connections for InterMiCOM communications loopback	35

TABLES

	Page (CM) 11-
Table 1 - Commission tests	10
Table 2 - Current transformer shorting contact locations	20

Table 3 - Watchdog contact status	22
Table 4 - Operational range of auxiliary supply Vx	22
Table 5 - Field voltage terminals	25
Table 6 - Output relays	26
Table 7 - EIA(RS)485 terminals	27
Table 8 - 2nd rear communications port K-Bus terminals	28
Table 9 - Second rear communications port EIA(RS)232 terminals	29
Table 10 - Current transformer shorting contact locations	30
Table 11 - CT ratio settings	30
Table 12 - Voltage input terminals	31
Table 13 - Voltage ratio settings	31
Table 14 - Record the transmit power level.	37
Table 15 - Characteristic operating times for I>1	48
Table 16 - Measured voltages and VT ratio settings	56

Notes:

1 INTRODUCTION

MiCOM P40 relays are fully numerical in their design, implementing all protection and non-protection functions in software. The relays use a high degree of self-checking and give an alarm in the unlikely event of a failure. Therefore, the commissioning tests do not need to be as extensive as with non-numeric electronic or electro-mechanical relays.

To commission numeric relays, you only need to verify that the hardware is functioning correctly and the application-specific software settings have been applied to the relay. You don't need to test every function of the relay if the settings have been verified by one of these methods:

- Extracting the settings applied to the relay using appropriate setting software (preferred method)
- Using the operator interface

To confirm that the product is operating correctly once the application-specific settings have been applied, perform a test on a single protection element.

Unless previously agreed to the contrary, the customer is responsible for determining the application-specific settings to be applied to the relay and for testing any scheme logic applied by external wiring or configuration of the relay's internal Programmable Scheme Logic (PSL).

Blank commissioning test and setting records are available for completion as needed.

As the relay's menu language is user-selectable, the Commissioning Engineer can change it to allow accurate testing as long as the menu is restored to the customer's preferred language on completion.

To simplify the specifying of menu cell locations in these Commissioning Instructions, they are given in the form [courier reference: COLUMN HEADING, Cell Text]. For example, the cell for selecting the menu language (first cell under the column heading) is in the System Data column (column 00) so it is given as [0001: SYSTEM DATA, Language].



Warning

Before carrying out any work on the equipment, you should be familiar with the contents of the latest issue of the Safety Guide, Safety Information and Technical Data chapters and the equipment rating label(s).



Caution

The relay must not be disassembled in any way during commissioning.

2 COMMISSIONING TESTS

To help minimize the time needed to test MiCOM relays the relay provides several test facilities under the '**COMMISSION TESTS**' menu heading. There are menu cells which allow the status of the opto-isolated inputs, output relay contacts, internal Digital Data Bus (DDB) signals and user-programmable LEDs to be monitored. Additionally there are cells to test the operation of the output contacts, user-programmable LEDs and, where available, the auto-reclose cycles.

The following table shows the relay menu of commissioning tests, including the available setting ranges and factory defaults. Each of the main menu tests are described in more detail in the following sections.

COMMISSION TESTS for P445		
Menu Text	Default Setting	Settings
Opto I/P Status	-	-
Relay O/P Status	-	-
Test Port Status	-	-
LED Status	-	-
Monitor Bit 1	1070 : LED Cond In 1	0 to 1791
Monitor Bit 2	1071 : LED Cond In 2	0 to 1791
Monitor Bit 3	1072 : LED Cond In 3	0 to 1791
Monitor Bit 4	1073 : LED Cond In 4	0 to 1791
Monitor Bit 5	1074 : LED Cond In 5	-
Monitor Bit 6	1075 : LED Cond In 6	-
Monitor Bit 7	1076 : LED Cond In 7	-
Monitor Bit 8	1077 : LED Cond In 8	-
Test Mode	Disabled	Disabled, Test Mode, Contacts Blocked
Test Pattern	All bits set to 0	0 = Not Operated, 1 = Operated
Contact Test	No Operation	No Operation, Apply Test, Remove Test
Test LEDs	No Operation	No Operation, Apply Test
Test Auto-reclose	No Operation	No Operation, 3 Pole Test
Red LED Status	-	-
Green LED Status	-	-
<i>Note See Relay Menu Database for details of DDB signals</i>		

Table 1 - Commission tests

2.1

Opto I/P Status

This menu cell displays the status of the relay's opto-isolated inputs as a binary string, a '1' indicating an energized opto-isolated input and a '0' a de-energized one. If the cursor is moved along the binary numbers the corresponding label text will be displayed for each logic input.

It can be used during commissioning or routine testing to monitor the status of the opto-isolated inputs whilst they are sequentially energized with a suitable dc voltage.

2.2 Relay O/P Status

This menu cell displays the status of the Digital Data Bus (DDB) signals that result in energization of the output relays as a binary string, a '1' indicating an operated state and '0' a non-operated state. If the cursor is moved along the binary numbers the corresponding label text will be displayed for each relay output.

The information displayed can be used during commissioning or routine testing to indicate the status of the output relays when the relay is 'in service'. Additionally fault finding for output relay damage can be performed by comparing the status of the output contact under investigation with it's associated bit.

Note When the 'Test Mode' cell is set to 'Enabled' this cell will continue to indicate which contacts would operate if the relay was in-service, it does not show the actual status of the output relays.

2.3 Test Port Status

This menu cell displays the status of the eight Digital Data Bus (DDB) signals that have been allocated in the 'Monitor Bit' cells. If the cursor is moved along the binary numbers the corresponding DDB signal text string will be displayed for each monitor bit.

By using this cell with suitable monitor bit settings, the state of the DDB signals can be displayed as various operating conditions or sequences are applied to the relay. Thus the Programmable Scheme Logic (PSL) can be tested.

2.4 LED Status

The 'LED Status' is an eight bit binary strings that indicate which of the user-programmable LEDs on the relay are illuminated when accessing the relay from a remote location, a '1' indicating a particular LED is lit and a '0' not lit.

2.5 Monitor Bits 1 to 8

The eight 'Monitor Bit' cells allow the user to select the status of which digital data bus signals can be observed in the 'Test Port Status' cell or via the monitor/download port. Each 'Monitor Bit' is set by entering the required Digital Data Bus (DDB) signal number from the list of available DDB signals in the Programmable Logic chapter. The pins of the monitor/download port used for monitor bits are given in the following table. The signal ground is available on pins 18, 19, 22 and 25.

Monitor bit	1	2	3	4	5	6	7	8
Monitor/download port pin	11	12	15	13	20	21	23	24

The required DDB signal numbers are 0 – 1791.



Warning

The monitor/download port is not electrically isolated against induced voltages on the communications channel. It should therefore only be used for local communications.

2.6 Test Mode

The **Test Mode** menu cell (in the **COMMISSION TESTS** column) is used to allow secondary injection testing to be performed on the relay.

To select test mode set the Test Mode menu cell to '**Test Mode**'. It causes an alarm condition to be recorded, the yellow ALARM LED to light and an alarm message '**Test Mode Alm**' to be generated.

Test Mode freezes any information stored in the **CB CONDITION** column and (in IEC60870-5-103 builds) changes the Cause Of Transmission (COT) to Test Mode. For relays supporting IEC 61850 Edition 2, the test bit for data quality attribute shall set to TRUE, and the Logical Device Mode will set to test.

Test mode can also be enabled by energizing an opto mapped to the **Test Mode** signal.

To enable testing of output contacts set the **Test Mode** cell to **Contacts Blocked**. It causes an alarm condition to be recorded, the yellow ALARM LED to light and an alarm message '**Contacts Blk Alm**' to be generated.

In **Contact Blocked** mode, the protection function still works but the contacts will not operate. Also the **test pattern** and contact test functions are visible, which can be used to manually operate the output contacts. For relays supporting IEC 61850 Edition 2, the test bit for data quality attribute shall set to TRUE, and the Logical Device Mode will set to test/blocked.

Contacts Blocked can also be enabled by energizing an opto mapped to the **Contacts Blocked** signal.

Once testing is complete the cell must be set back to '**Disabled**' to restore the relay back to service.



WARNING If you use or enable Test Mode, you must disable Test Mode before putting the relay back into active service. IT IS POTENTIALLY EXTREMELY UNSAFE TO ATTEMPT TO USE ANY RELAY WHICH IS STILL IN TEST MODE IN ACTIVE SERVICE.

2.7 Test Pattern

The '**Test Pattern**' cell is used to select the output relay contacts that will be tested when the '**Contact Test**' cell is set to '**Apply Test**'. The cell has a binary string with one bit for each user-configurable output contact which can be set to '1' to operate the output under test conditions and '0' to not operate it.

2.8 Contact Test

When the '**Apply Test**' command in this cell is issued the contacts set for operation (set to '1') in the '**Test Pattern**' cell change state. After the test has been applied the command text on the LCD will change to '**No Operation**' and the contacts will remain in the Test State until reset issuing the '**Remove Test**' command. The command text on the LCD will again revert to '**No Operation**' after the '**Remove Test**' command has been issued.

Note When the '**Test Mode**' cell is set to '**Enabled**' the '**Relay O/P Status**' cell does not show the current status of the output relays and hence can not be used to confirm operation of the output relays. Therefore it will be necessary to monitor the state of each contact in turn.

2.9 Test LEDs

When the '**Apply Test**' command in this cell is issued the eight/eighteen user-programmable LEDs will illuminate for approximately 2 seconds before they extinguish and the command text on the LCD reverts to '**No Operation**'.

2.10 Test Auto-Reclose

Where the relay provides an auto-reclose function, this cell will be available for testing the sequence of circuit breaker trip and auto-reclose cycles with the settings applied.

Issuing the command '**3 Pole Trip**' will cause the relay to perform the first three-phase trip/reclose cycle so that associated output contacts can be checked for operation at the correct times during the cycle. Once the trip output has operated the command text will revert to '**No Operation**' whilst the rest of the auto-reclose cycle is performed. To test subsequent three-phase auto-reclose cycles repeat the '**3 Pole Trip**' command.

<i>Note</i>	<i>The factory settings for the relay's Programmable Scheme Logic (PSL) has the 'AR Trip Test' signal mapped to relay 3. If the PSL has been changed, it is essential that this signal remains mapped to relay 3 for the 'Test Auto-reclose' facility to work.</i>
-------------	--

2.11 Static Test Mode

Modern dynamic secondary injection test sets are able to accurately mimic real power system faults. The test sets mimic an instantaneous fault "shot", with the real rate of rise of current, and any decaying DC exponential component, according to the point on (voltage) wave of fault inception. Injections for all three phases provide a six signal set of analog inputs: Va, Vb, Vc, Ia, Ib, Ic. Such injection test sets can be used with the P44y (P443/P446), P445, P54x, with no special testing limitations.

Conversely, older test sets may not properly simulate:

- A healthy prefault voltage memory
- A real fault shot (instead a gradually varying current or voltage may be used)
- The rate of rise of current and DC components
- A six signal set of analog inputs (instead, these may offer for example: Va, Vb, Ia, Ib only, to test for an A-B injection)

Such injection sets may be referred to as "*Static*" simulators.

As the P44y (P443/P446), P445 and P54x relies on voltage memories and delta step changes as would happen on a real power system, certain functions within the relay must be disabled or bypassed to allow injection testing. Selecting the **Static Mode** test option serves to bypass the delta phase selectors, and power swing detection.

For the tests, the delta directional line is also replaced by a conventional distance directional line, and the digital filtering slows to use a fixed one cycle window. Memory polarizing is replaced by cross-polarizing from unfaulted phases.

The Static Test mode allows older injection test sets to be retained, and used to commission and test the P44y, P445 & P54x.

<i>Note</i>	<i>Trip times may be up to ½ cycle longer when tested in the static mode, due to the nature of the test voltage and current, and the slower filtering. This is normal, and perfectly acceptable.</i>
-------------	--

2.12 InterMiCOM Loopback Mode

The loopback test facilities lets you check the operation of the local InterMiCOM signaling (if fitted). This lets you verify the wiring between the relay communications port and any communications converter units before commissioning the communications channel.

InterMiCOM exists in two different forms on the MiCOM relay. One version is presented on an electrical (EIA(RS)232) interface, designed primarily for use with modems, and is referred to as EIA(RS)232 InterMiCOM or MODEM InterMiCOM. The other uses faster signaling speeds, is presented on an optical fiber interface as is referred to as fiber InterMiCOM or InterMiCOM⁶⁴.

EIA(RS)232 InterMiCOM presents 8 command signaling bits over one communications channel. Fiber InterMiCOM⁶⁴ presents 8 command signaling bits on one or two communications channels according to the application.

A test mode and test pattern facility is provided to help with testing. The functionality of these features differs subtly in the two forms of InterMiCOM and is explained below.

2.12.1 EIA(RS)232 InterMiCOM Loopback

The Loopback Mode setting for EIA(RS)232 InterMiCOM is found in the INTERMICOM COMMS column of the menu.

<i>Note</i>	<i>By selecting the [1550 Loopback Mode] to “Internal” only the internal software of the relay is checked, and is useful for testing functionality if no communications connections are made, whereas “External” will check both the software and hardware used by InterMiCOM and is the preferred option during commissioning. When relay is switched into either ‘Loopback Mode’ the relay will automatically use generic addresses and will inhibit the InterMiCOM messages to the PSL by setting all eight InterMiCOM message command states to zero.</i>
-------------	---

2.12.2 Fiber InterMiCOM⁶⁴ Loopback

The Test Loopback setting for the InterMiCOM⁶⁴ is found in the COMMISSION TESTS column of the menu. So by selecting the [0F13 Test Loopback] to **Internal** only the internal software of the relay is checked, and is useful for testing functionality if no communications connections are made, whereas **External** will check both the software and hardware and is the preferred option during commissioning. When the relay is switched into either **Loopback Mode**, the relay will automatically use generic addresses (address 0-0) and will respond as if it is connected to a remote relay. The signals sent and received over the InterMiCOM⁶⁴ channel continue to be routed to and from the signals defined in the programmable logic.

2.13 InterMiCOM Test Pattern

Test patterns can be set to confirm transmission of commands by the InterMiCOM channels and to exercise any associated logic. For EIA(RS)232 InterMiCOM the test pattern cell is found in the INTERMICOM COMMS column of the menu software. For the fiber InterMiCOM⁶⁴, the test pattern is found in the COMMISSION TESTS column of the menu.

2.13.1 EIA(RS)232 InterMiCOM Test Pattern

When the Loopback Mode setting for EIA(RS)232 InterMiCOM [1550 Loopback Mode] is set to **Internal** or **External**, all 8 InterMiCOM commands input to the PSL [1501 IM Input status] are set to zero. The InterMiCOM test pattern [1551 Test Pattern] can be used to test any of the 8 individual bits in the InterMiCOM messages by setting them to one and checking for correct reception in the [1502 IM Output status] register.

2.13.2 Fiber InterMiCOM⁶⁴ Test Pattern

The [0F14 IM64Test Pattern] cell is used in conjunction with the [IM64 Test Mode] cell to set a 16-bit pattern (8 bits per channel) that is transmitted by the InterMiCOM⁶⁴ message whilst ever the 'IM64 Test Mode' cell is set to 'Enable'. The 'IM64 Test Pattern' cell has a binary string with one bit for each User Defined Inter-Relay Commands which can be set to '1' to operate the IM64 output under test conditions and '0' to not operate it.

2.13.3 Fiber InterMiCOM⁶⁴ Test Mode

When the **Enable** command in this cell [0F15] is issued, the InterMiCOM⁶⁴ commands change to reflect the state to the values set in the 'IM64 Test Pattern' cell. If set to 'Disable', the InterMiCOM⁶⁴ commands reflect the state of the signals generated by the protection and control functionality of the relay.

2.14 Using a Monitor/Download Port Test Box

A monitor/download port test box containing 8 LEDs and a switchable audible indicator is available from Schneider Electric, or one of their regional sales offices. It is housed in a small plastic box with a 25-pin male D-connector that plugs directly into the relay's monitor/download port. There is also a 25-pin female D-connector which allows other connections to be made to the monitor/download port whilst the monitor/download port test box is in place.

Each LED corresponds to one of the monitor bit pins on the monitor/download port with '**Monitor Bit 1**' being on the left hand side when viewing from the front of the relay. The audible indicator can either be selected to sound if a voltage appears on any of the eight monitor pins or remain silent so that indication of state is by LED alone.

3 SETTING FAMILIARIZATION

When first commissioning a relay, allow sufficient time to become familiar with how to apply the settings.

The *Menu Database document* and the *Introduction* or *Settings* chapters contain a detailed description of the menu structure of Schneider Electric relays. The menu database is a separate document which can be downloaded from our website:

www.schneider-electric.com

With the secondary front cover in place, all keys except the 5 key are accessible. All menu cells can be read. LEDs and alarms can be reset. However, no protection or configuration settings can be changed, or fault and event records cleared.

Removing the secondary front cover allows access to all keys so that settings can be changed, LEDs and alarms reset, and fault and event records cleared. However, to make changes to menu cells, the appropriate user role and password is needed.

Alternatively, if a portable PC with suitable setting software is available (such as Easergy Studio), the menu can be viewed one page at a time, to display a full column of data and text. This PC software also allows settings to be entered more easily, saved to a file for future reference, or printed to produce a settings record. Refer to the PC software user manual for details. If the software is being used for the first time, allow sufficient time to become familiar with its operation.

4 EQUIPMENT REQUIRED FOR COMMISSIONING

4.1 Minimum Equipment Required

The minimum equipment needed varies slightly, depending on the features provided by each type of MiCOM product. The list of minimum equipment is given below:

- Multifunctional dynamic current and voltage injection test set.
- Multimeter with suitable ac current range, and ac and dc voltage ranges of 0 - 440V and 0 - 250V respectively.
- Continuity tester (if not included in multimeter).
- Phase angle meter.
- Phase rotation meter.

<i>Note</i>	<i>Modern test equipment may contain many of the above features in one unit.</i>
-------------	--

- Fiber optic power meter.
- Fiber optic test leads (type and number according to application).
- Please refer to GPS synchronization device manual.
- Overcurrent test set with interval timer
- 110 V ac voltage supply (if stage 1 of the overcurrent function is set directional)
- 100 Ω precision wire wound or metal film resistor, 0.1% tolerance ($0^{\circ}\text{C} \pm 2^{\circ}\text{C}$)

Additional equipment is needed for relays which use the Process Bus interface. This is a typical list of equipment required for testing the Process Bus interface in the IED.

- IED test kit (such as Omicron) capable of generating IEC61850-9-2LE or IEC61869 Sampled Values. Multiple streams may be required depending upon the application.
- Ethernet switch(es)
- Fibre optic cables or RJ45 ethernet wires

Specific requirement for P54x devices are listed below:

- GPS synchronization on the IED test kit which can generate Sampled Value frames with Global 1 PPS

4.2 Optional Equipment

- Multi-finger test plug type Easergy test plug (if Easergy test block type is installed)
- An electronic or brushless insulation tester with a dc output not exceeding 500 V (for insulation resistance testing when required)
- A portable PC, with an RS232 port as well as appropriate software. This allows the rear communications port to be tested. If this is used, and it can save considerable time during commissioning.
- K-Bus to EIA(RS)232 protocol converter (if the first rear EIA(RS)485 K-Bus port or second rear port configured for K-Bus is being tested and one is not already installed)
- EIA(RS)485 to EIA(RS)232 converter (if first rear EIA(RS)485 port or second rear port configured for EIA(RS)485 is being tested)
- A printer, for printing a setting record from the portable PC

5 PRODUCT CHECKS

5.1 Introduction to Product Checks

These product checks cover all aspects of the relay that need to be checked to ensure:

- that it has not been physically damaged before commissioning
- that it is functioning correctly and
- that all input quantity measurements are within the stated tolerances

If the application-specific settings have been applied to the relay before commissioning, it is advisable to make a copy of the settings to allow their restoration later.

If Programmable Scheme Logic (PSL) (other than the default settings with which the relay was supplied) has been applied, the default settings should be restored before commissioning. This can be done by:

- Obtaining a setting file from the customer. This requires a portable PC with appropriate setting software for transferring the settings from the PC to the relay.
- Extracting the settings from the relay itself. This requires a portable PC with appropriate setting software.
- Manually creating a setting record. This could be done by stepping through the front panel menu using the front panel user interface.



Warning

Before carrying out any work on the equipment, you should be familiar with the contents of the latest issue of the Safety Guide, Safety Information and Technical Data chapters and the equipment rating label(s).

Connect the device to the network. Check the Link and Activity LEDs are functioning. This section shows typical network connections.

If the default RBAC has been changed then a username/password combination must be provided to allow access to change relay settings.

Note

If the password has been lost, a recovery password can be obtained from Schneider Electric.

5.2

With the Relay De-Energized

The following group of tests should be carried out without the auxiliary supply applied to the relay and with the trip circuit isolated.

Before inserting the test plug, refer to the scheme diagram to ensure this will not cause damage or a safety hazard. For example, the test block may be associated with protection current transformer circuits. Before the test plug is inserted into the test block, make sure the sockets in the test plug which correspond to the current transformer secondary windings are linked.

**Warning**

The current and voltage transformer connections must be isolated from the relay for these checks. If a MiCOM P991 or an Easergy test block is provided, insert the Easergy or MiCOM P992 test plug, which open-circuits all wiring routed through the test block.

**Danger**

Never open-circuit the secondary circuit of a current transformer because the high voltage produced may be lethal. It could also damage insulation.

If a test block is not provided, isolate the voltage transformer supply to the relay using the panel links or connecting blocks. Short-circuit and disconnect the line current transformers from the relay terminals. Where means of isolating the auxiliary supply and trip circuit (such as isolation links, fuses and MCB) are provided, these should be used. If this is impossible, the wiring to these circuits must be disconnected and the exposed ends suitably terminated to prevent them from being a safety hazard.

5.2.1

Visual Inspection**Caution**

Check the rating information under the top access cover on the front of the relay. Check that the relay being tested is correct for the protected line or circuit. Ensure that the circuit reference and system details are entered onto the setting record sheet. Double-check the CT secondary current rating, and be sure to record the actual CT tap which is in use.

1. De-energize the IED.
2. Visually inspect the connectors and check the external wiring is correct. Carefully examine the relay to see that no physical damage has occurred since installation.

Ensure that the case earthing connections, at the bottom left-hand corner at the rear of the relay case, are used to connect the relay to a local earth bar using an adequate conductor.

5.2.2

Current Transformer Shorting Contacts (Optional Check)

If needed, the current transformer shorting contacts can be checked to ensure they close when the heavy-duty terminal block shown in the following figure is disconnected from the current input PCB. The heavy-duty terminal block location depends on the relay model.

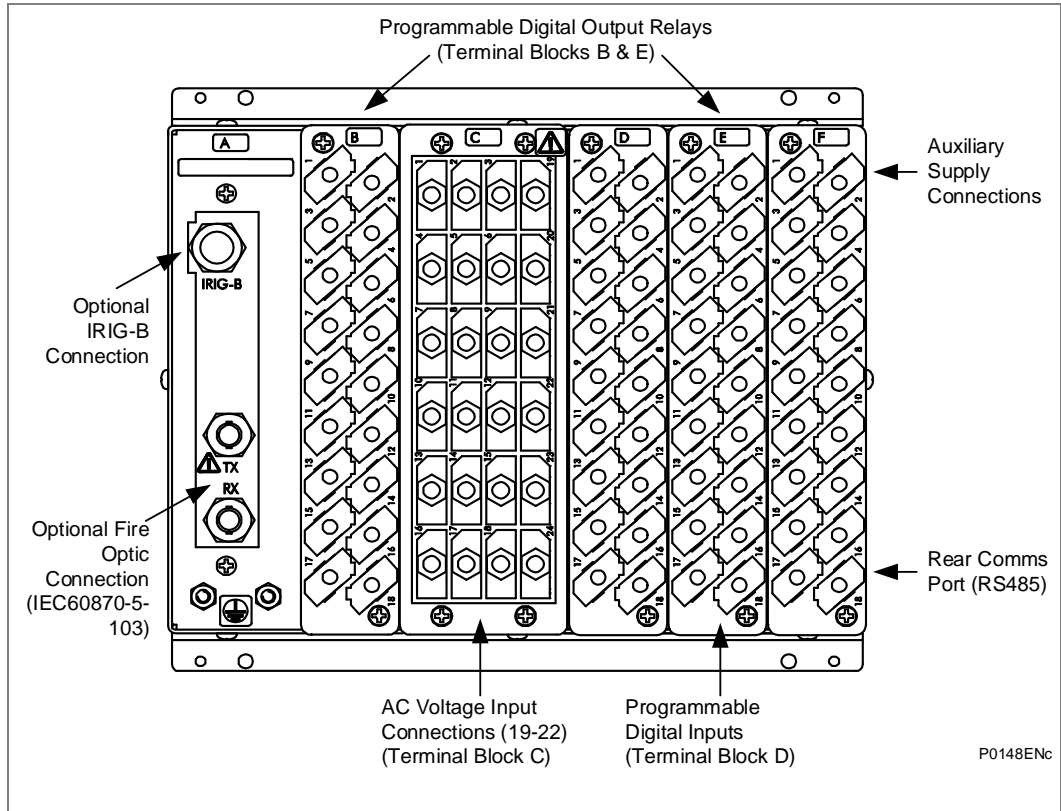

Figure 1 - Rear terminal blocks on size 40TE case

Heavy duty terminal blocks are fastened to the rear panel using four Pozidriv or PZ1 screws. These are at the top and bottom between the first and second, and third and fourth, columns of terminals (see the *Location of Securing Screws for Terminal Blocks* diagram below).

Note Use a magnetic-bladed screwdriver to avoid losing screws or leaving them in the terminal block.

Pull the terminal block away from the rear of the case and check with a continuity tester that all the shorting switches being used are closed. The following table(s) shows the terminals between which shorting contacts are fitted.

Current input	Shorting contact between terminals 1 A - Common – 5 A MiCOM P445
I _A	C3 - C2 - C1
I _B	C6 - C5 - C4
I _C	C9 - C8 - C7

Table 2 - Current transformer shorting contact locations

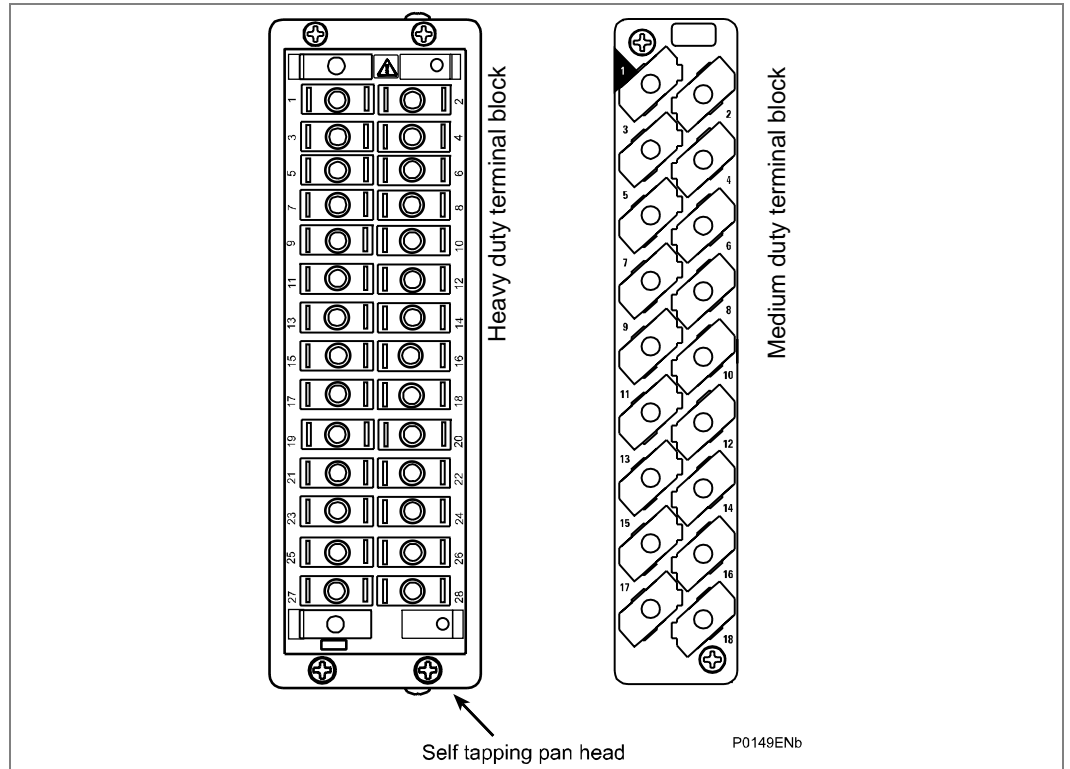

Figure 2 - Location of securing screws for heavy duty terminal blocks

5.2.3

Insulation

Insulation resistance tests are only necessary during commissioning if it is required for them to be done and they haven't been performed during installation.

Isolate all wiring from the earth and test the insulation with an electronic or brushless insulation tester at a dc voltage not exceeding 500 V. Terminals of the same circuits should be temporarily connected together.

The main groups of relay terminals are:

- a) Voltage transformer circuits
- b) Current transformer circuits
- c) Auxiliary voltage supply
- d) Field voltage output and opto-isolated control inputs
- e) Relay contacts
- f) EIA(RS)485 communication port
- g) Case earth

The insulation resistance should be greater than 100 MΩ at 500 V.

On completion of the insulation resistance tests, ensure all external wiring is correctly reconnected to the unit.

5.2.4

External Wiring



Caution

Check that the external wiring is correct to the relevant relay diagram and scheme diagram. Ensure as far as practical that phasing/phase rotation appears to be as expected. The relay diagram number appears on the rating label under the top access cover on the front of the relay.

Schneider Electric supply the corresponding connection diagram with the order acknowledgement for the relay.

If a MiCOM P991 or an Easergy test block is provided, check the connections against the wiring diagram. It is recommended that the supply connections are to the live side of the test block (colored orange with the odd numbered terminals 1, 3, 5, 7, and so on). The auxiliary supply is normally routed through terminals 13 (supply positive) and 15 (supply negative), with terminals 14 and 16 connected to the relay’s positive and negative auxiliary supply terminals respectively. However, check the wiring against the schematic diagram for the installation to ensure compliance with the customer’s normal practice.

5.2.5 Watchdog Contacts

Using a continuity tester, check that the watchdog contacts are in the states shown in the Watchdog contact status table for a de-energized relay.

Terminals		Contact state	
		Relay de-energised	Relay energised
F11 - F12	P445 model A	Closed	Open
F13 - F14	P445 model A	Closed	Open
J11 - J12	P445 models B, C & D	Open	Closed
J13 - J14	P445 models B, C & D	Open	Closed

Table 3 - Watchdog contact status

5.2.6 Auxiliary Supply



Caution	<i>The relay can be operated from either a dc only or an ac/dc auxiliary supply depending on the relay’s nominal supply rating. The incoming voltage must be within the operating range specified in the following table.</i>
----------------	--

Without energizing the relay, measure the auxiliary supply to ensure it is within the operating range.

<i>Note</i>	<i>The relay can withstand an ac ripple of up to 12% of the upper rated voltage on the dc auxiliary supply.</i>
-------------	---

Nominal Supply Rating		Operating Ranges	
dc	ac	dc	ac
24 - 32V dc	-	19 - 38V dc	-
48 - 110V dc	-	37 - 150V dc	-
110 - 250V dc	100 - 240V ac rms	87 - 300V dc	80 - 265V ac

Table 4 - Operational range of auxiliary supply Vx



Caution	<i>Do not energize the relay using the battery charger with the battery disconnected as this can irreparably damage the relay’s power supply circuitry.</i>
----------------	--



Caution	Energize the relay only if the auxiliary supply is within the operating range. If a test block is provided, it may be necessary to link across the front of the test plug to connect the auxiliary supply to the relay.
----------------	--

5.3 With the Relay Energized

The following group of tests verify that the relay hardware and software is functioning correctly and should be carried out with the auxiliary supply applied to the relay.

**Caution**

The current and voltage transformer connections must remain isolated from the relay for these checks. The trip circuit should also remain isolated to prevent accidental operation of the associated circuit breaker.

**Caution**

The InterMiCOM64 communication channel (when fitted) should be disconnected to prevent the remote end relay being affected during the tests.

5.3.1**Watchdog Contacts**

Using a continuity tester, check that the watchdog contacts are in the states shown in the *Watchdog contact status* table for an energized relay.

5.3.2**LCD Front Panel Display**

The Liquid Crystal Display (LCD) is designed to operate in a wide range of substation ambient temperatures. For this purpose, the Px40 relays have an **LCD Contrast** setting. This allows the user to adjust the lightness or darkness of the displayed characters. The contrast is factory preset to account for a standard room temperature, however it may be necessary to adjust the contrast to give the best in-service display. To change the contrast, at the bottom of the **CONFIGURATION** column, use cell [09FF: LCD Contrast] to increment (darker) or decrement (lighter), as required.

**Important**

Before applying a contrast setting, ensure that it does not make the display too light or dark so the menu text becomes unreadable. If this happens, it is possible to restore the display by downloading an Easergy Studio setting file, with the LCD Contrast set in the typical range of 7 to 11.

5.3.3**Date and Time**

Before setting the date and time, ensure that the factory-fitted battery isolation strip that prevents battery drain during transportation and storage has been removed. With the lower access cover open, the presence of the battery isolation strip can be checked by a red tab protruding from the positive side of the battery compartment. Lightly pressing the battery to prevent it falling out of the battery compartment, pull the red tab to remove the isolation strip.

The data and time should now be set to the correct values. The method of setting depends on whether accuracy is being maintained through the optional Inter-Range Instrumentation Group standard B (IRIG-B) port on the rear of the relay or by using IEEE1588 and SNTP via Ethernet.

5.3.3.1

With an IRIG-B Signal

If a satellite time clock signal conforming to IRIG-B is provided and the relay has the optional IRIG-B port fitted, the satellite clock equipment should be energized.

To allow the relay's time and date to be maintained from an external IRIG-B source cell [DATE and TIME, IRIG-B Sync.] must be set to **Enabled**.

Ensure the relay is receiving the IRIG-B signal by checking that cell [DATE and TIME, IRIG-B Status] reads **Active**.

Once the IRIG-B signal is active, adjust the time offset of the universal coordinated time (satellite clock time) on the satellite clock equipment so that local time is displayed.

Check the time, date and month are correct in cell [0801: DATE and TIME, Date/Time]. The IRIG-B signal does not contain the current year so needs to be set manually in this cell.

If the auxiliary supply fails, with a battery fitted in the compartment behind the bottom access cover, the time and date is maintained. Therefore, when the auxiliary supply is restored, the time and date are correct and need not be set again.

To test this, remove the IRIG-B signal, then remove the auxiliary supply from the relay. Leave the relay de-energized for approximately 30 seconds. On re-energization, the time in cell [DATE and TIME, Date/Time] should be correct. Then reconnect the IRIG-B signal.

5.3.3.2

Without an IRIG-B Signal

<i>Note</i>	<i>For P741 the IRIG-B signal may not apply to the Central Unit only. For the P742/P743 it may apply to the Peripheral Unit only.</i>
-------------	---

If the time and date is not being maintained by an IRIG-B signal, ensure that cell [0804: DATE and TIME, IRIG-B Sync.] is set to **Disabled**.

Set the date and time to the correct local time and date using cell [0801: DATE and TIME, Date/Time].

If the auxiliary supply fails, with a battery fitted in the compartment behind the bottom access cover, the time and date are maintained. Therefore when the auxiliary supply is restored, the time and date are correct and need not be set again.

To test this, remove the auxiliary supply from the relay for approximately 30 seconds. On re-energization, the time in cell [0801: DATE and TIME, Date/Time] should be correct.

5.3.4

Light Emitting Diodes (LEDs)

On power-up, the green LED should switch on and stay on, indicating that the relay is healthy. The relay has non-volatile memory which stores the state (on or off) of the alarm, trip and, if configured to latch, user-programmable LED indicators when the relay was last energized from an auxiliary supply. Therefore, these indicators may also switch on when the auxiliary supply is applied.

If any of these LEDs are on, reset them before proceeding with further testing. If the LED successfully resets (the LED switches off), there is no testing required for that LED because it is known to be operational.

<i>Note</i>	<i>It is likely that alarms related to the communications channels will not reset at this stage.</i>
-------------	--

5.3.4.1

Testing the Alarm and Out Of Service LEDs

The alarm and out of service LEDs can be tested using the **COMMISSIONING TESTS** menu column. Set cell [0F0D: COMMISSIONING TESTS, Test Mode] to **Contacts Blocked**. Check that the out of service LED is on continuously and the alarm LED flashes.

It is not necessary to return cell [0F0D: COMMISSIONING TESTS, Test Mode] to **Disabled** at this stage because the test mode will be required for later tests.

5.3.4.2 Testing the Trip LED

The trip LED can be tested by initiating a manual circuit breaker trip from the relay. However, the trip LED will operate during the setting checks performed later. Therefore, no further testing of the trip LED is required at this stage.

5.3.4.3 Testing the User-Programmable LEDs

To test the user-programmable LEDs set cell [0F10: COMMISSIONING TESTS, Test LEDs] to **Apply Test**. Check that all the programmable LEDs on the relay switch on.

5.3.5 Field Voltage* Supply

The relay generates a field voltage of nominally 48 V that can be used to energize the opto-isolated inputs (alternatively the substation battery may be used). Measure the field voltage across terminals 7 and 9 on the terminal block shown in the following table. Check that the field voltage is in the range 40 V to 60 V when no load is connected and that the polarity is correct.

Repeat for terminals 8 and 10

Supply rail	Terminals	
	P445 model A	P445 models B & C
+ve	F7 & F8	J7 & J8
-ve	F9 & F10	J9 & J10

Table 5 - Field voltage terminals

* Note *It is compulsory to add an EMC Filter to use the field voltage outputs to prevent any noise or high frequency disturbance.*

*The EMC Filter must be connected to the protection relay with a **three-wires cable** of appr. 1m length.*

*The earth port of the EMC filter must **only** be connected to the earth terminal of Px4x; the metal housing of the filter **should** not be connected to the ground plane.*

Proposal:
Schaffner EMC Filter (FN2010-1-06, 1A max - 250V), or equivalent



5.3.6 Input Opto-Isolators

This test checks that all the opto-isolated inputs on the relay are functioning correctly.

Model	Outputs
P441	14
P442	21
P443 option "A" (model no. begins: P443xxxA..)	24
P443 option "B" (model no. begins: P443xxxB..)	32
P443 option "C" (model no. begins: P443xxxC..)	16 + 4 High-Break
P443 option "D" (model no. begins: P443xxxD..)	16 + 8 High-Break
P444	32
P445 with I/O option "A" (model no. begins: P445xxxA..)	8
P445 with I/O option "B" (model no. begins: P445xxxB..)	12
P445 with I/O option "C" (model no. begins: P445xxxC..)	16
P445 with I/O option "D" (model no. begins: P445xxxD..)	8 + 4 High-Break
P446 option "A" (model no. begins: P446xxxA..)	32
P446 option "B" (model no. begins: P446xxxB..)	8 + 12 High-Break
P446 option "C" (model no. begins: P446xxxC..)	16 + 8 High-Break

Note *The high break output contacts fitted to I/O options "C" and "D" are polarity sensitive. External wiring should, wherever possible, be verified against polarity requirements described in the external connection diagram to ensure correct high break operation when in service.*

Energize the opto-isolated inputs one at a time; see the external connection diagrams in the *Connection Diagrams* chapter for terminal numbers. Ensure that the correct opto input nominal voltage is set in the **Opto Config**. Menu. Ensure correct polarity and connect the field supply voltage to the appropriate terminals for the input being tested. Each opto input also has selectable filtering. This allows use of a pre-set filter of ½ cycle that renders the input immune to induced noise on the wiring.

Note *The opto-isolated inputs may be energized from an external dc auxiliary supply (such as the station battery) in some installations. Check that this is not the case before connecting the field voltage, otherwise damage to the relay may result. If an external 24/27 V, 30/34 V, 48/54 V, 110/125 V, 220/250 V supply is being used it will be connected to the relay's optically isolated inputs directly. If an external supply is used it must be energized for this test, but only after confirming that it is suitably rated, with less than 12% ac ripple.*

The status of each opto-isolated input can be viewed using either cell [0020: SYSTEM DATA, Opto I/P Status] or [0F01: COMMISSIONING TESTS, Opto I/P Status], a **1** indicating an energized input and a **0** indicating a de-energized input. When each opto-isolated input is energized, one of the characters on the bottom line of the display changes, to indicate the new state of the inputs.

5.3.7

Output Relays

This test checks that all the output relays are functioning correctly.

Model	Outputs
P445 with I/O option "A" (model no. begins: P445xxxA..)	8
P445 with I/O option "B" (model no. begins: P445xxxB..)	12
P445 with I/O option "C" (model no. begins: P445xxxC..)	16
P445 with I/O option "D" (model no. begins: P445xxxD..)	8 + 4 High-Break

Table 6 - Output relays

Note *The High-Break contacts are polarity sensitive. External wiring should, wherever possible, be verified against polarity requirements described in the external connection diagram to ensure correct high-break operation when in service.*

Ensure that the cell [0F0D: COMMISSIONING TESTS, Test Mode] is set to **Contacts Blocked**.

The output relays should be energized one at a time. To select output relay 1 for testing, set cell [0F0E: COMMISSIONING TESTS, Test Pattern] to 00000000000000000000000000000001.

Connect a continuity tester across the terminals corresponding to output relay 1 as shown in the relevant external connection diagram in the *Connection Diagrams* chapter.

To operate the output relay, set cell [0F0F: COMMISSIONING TESTS, Contact Test] to **Apply Test**. Operation is confirmed by the continuity tester operating for a normally open contact and ceasing to operate for a normally closed contact. Measure the resistance of the contacts in the closed state.

Reset the output relay by setting cell [0F0F: COMMISSIONING TESTS, Contact Test] to **Remove Test**.

Note *Ensure that the thermal ratings of anything connected to the output relays during the contact test procedure are not exceeded by the associated output relay being operated for too long. Keep the time between application and removal of contact test to a minimum.*

Repeat the test for the rest of the relays (the numbers depend on the model).

Return the relay to service by setting cell [0F0D: COMMISSIONING TESTS, Test Mode] to **Disabled**.

5.3.8 Rear Communications Port

This test should only be performed where the relay is to be accessed from a remote location and varies depending on the communications standard adopted.

It is not the intention of the test to verify the operation of the complete system from the relay to the remote location, just the relay’s rear communications port and any protocol converter necessary.

A variety of communications protocols may be available. For further details, please see whichever of these sections are relevant for the device you are commissioning:

5.3.8.1 Courier Communications

It is possible to connect the PC to the relay installed. The terminal numbers for the relay’s first rear K-Bus, RS485 port are shown in the following table. However, as the installed protocol converter is not being used in the test, only the correct operation of the relay’s K-Bus port will be confirmed.

Connection		Terminal	
RS485	IEC 60870-5-103 or DNP3.0	P445 model A	P445 models B, C & D
Screen	Screen	F16	J16
1	+ve	F17	J17
2	-ve	F18	J18

Table 7 - EIA(RS)485 terminals

Ensure that the communications baud rate and parity settings in the application software are set the same as those on the protocol. The relay’s Courier address in cell [0E02: COMMUNICATIONS, Remote Address] must be set to a value between 1 and 254.

Check that communications can be established with this relay using the portable PC.

5.3.8.2 IEC 60870-5-103 (VDEW) Communications

If the relay has the optional fiber optic communications port fitted, the port to be used should be selected by setting cell [0E07: COMMUNICATIONS, Physical Link] to **Fiber Optic** or **EIA(RS)485**.

IEC60870-5-103/VDEW communication systems are designed to have a local Master Station and this should be used to verify that the relay's rear fiber optic or EIA(RS)485 port, as appropriate, is working.

Ensure that the relay address and baud rate settings in the application software are set the same as those in cells [0E02: COMMUNICATIONS, Remote Address] and [0E04: COMMUNICATIONS, Baud Rate] of the relay.

Check, using the Master Station, that communications with the relay can be established.

5.3.8.3 DNP3.0 Communications Interface

Connect a portable PC running the appropriate DNP3.0 Master Station Software to the relay's first rear EIA(RS)485 port using an EIA(RS)485 to EIA(RS)232 interface converter. The terminal numbers for the relay's EIA(RS)485 port are shown in the *EIA(RS)485 terminals* table.

Ensure that the relay address, baud rate and parity settings in the application software are set the same as those in cells [0E02: COMMUNICATIONS, Remote address], [0E04: COMMUNICATIONS, Baud Rate] and [0E05: COMMUNICATIONS, Parity] of the relay.

Check that communications with this relay can be established.

If the relay has the optional fiber optic communications port fitted, the port to be used should be selected by setting cell [0E07: COMMUNICATIONS, Physical Link] to **Fiber Optic**. Ensure that the relay address and baud rate settings in the application software are set the same as those in cell [0E04: COMMUNICATIONS, Baud Rate] of the relay. Check that, using the Master Station, communications with the relay can be established.

5.3.9 Second Rear Communications Port

This test should only be performed where the relay is to be accessed from a remote location and varies depending on the communications standard being adopted.

It is not the intention of the test to verify the operation of the complete system from the relay to the remote location, just the relay's rear communications port and any protocol converter necessary.

The second rear communications port uses Courier communications allowing remote engineering access with Easergy MiCOM Studio.

5.3.9.1 K-Bus Configuration

It is possible to connect the PC to the relay installed. The terminal numbers for the relay's K-Bus port are shown in the following table. However, as the installed protocol converter is not being used in the test, only the correct operation of the relay's K-Bus port is confirmed.

Pin*	Connection
4	EIA(RS)485 - 1 (+ ve)
7	EIA(RS)485 - 2 (- ve)
* All other pins unconnected.	

Table 8 - 2nd rear communications port K-Bus terminals

Ensure that the communications baud rate and parity settings in the application software are set the same as those on the protocol converter. The relay's Courier address in cell [0E90: COMMUNICATIONS, RP2 Address] must be set to a value between 1 and 254. The second rear communication's port configuration [0E88: COMMUNICATIONS RP2 Port Config.] must be set to K-Bus.

Check that communications can be established with this relay using the portable PC.

5.3.9.2**EIA(RS)485 Configuration**

If an EIA(RS)485 to EIA(RS)232 converter (Schneider Electric CK222) is installed, connect a portable PC running the appropriate software (Easergy Studio) to the EIA(RS)232 side of the converter and the second rear communications port of the relay to the EIA(RS)485 side of the converter.

The terminal numbers for the relay's EIA(RS)485 port are shown in the *Second rear communications port K-Bus terminals* table.

Ensure that the communications baud rate and parity settings in the application software are the same as those in the relay. The relay's Courier address in cell [0E90: COMMUNICATIONS, RP2 Address] must be set to a value between 1 and 254. The second rear communications port's configuration [0E88: COMMUNICATIONS RP2 Port Config.] must be set to EIA(RS)485.

Check that communications can be established with this relay using the portable PC.

5.3.9.3**EIA(RS)232 Configuration**

Connect a portable PC running the appropriate software (Easergy Studio) to the rear EIA(RS)232 port of the relay. This port is compliant with EIA(RS)574; the 9-pin version of EIA(RS)232, see www.tiaonline.org.

The second rear communications port connects using the 9-way female D-type connector (SK4). The connection is compliant with EIA(RS)574.

Pin	Connection
1	No Connection
2	RxD
3	TxD
4	DTR#
5	Ground
6	No Connection
7	RTS#
8	CTS#
9	No Connection

These pins are control lines for use with a modem.

Table 9 - Second rear communications port EIA(RS)232 terminals

Connections to the second rear port configured for EIA(RS)232 operation can be made using a screened multi-core communication cable up to 15 m long, or a total capacitance of 2500 pF. Terminate the cable at the relay end with a 9-way, metal-shelled, D-type male plug. The terminal numbers for the relay's EIA(RS)232 port are shown in the previous table.

Ensure that the communications baud rate and parity settings in the application software are set the same as those in the relay. The relay's Courier address in cell [0E90: COMMUNICATIONS, RP2 Address] must be set to a value between 1 and 254. The second rear communication's port configuration [0E88: COMMUNICATIONS RP2 Port Config] must be set to EIA(RS)232.

Check that communications can be established with this relay using the portable PC.

5.3.10

Current Inputs

This test verifies that the accuracy of current measurement is within acceptable tolerances.

All relays leave the factory set for operation at a system frequency of 50 Hz. If operation at 60 Hz is required, this must be set in cell [0009: SYSTEM DATA, Frequency].

Caution *To avoid spurious operation of protection elements during injection testing, ensure that current operated elements are disabled.*

Apply current equal to the line current transformer secondary winding rating to each current transformer input of the corresponding rating in turn, checking its magnitude using a multimeter. Refer to the *Current input terminals* table for the corresponding reading in the relay's **MEASUREMENTS 1** columns, as appropriate, and record the value displayed. The measured current values displayed on the relay LCD, or on a portable PC connected to the front communication port, are either in primary or secondary Amperes. If cell [0D02: MEASURE'T SETUP, Local Values] is set to **Primary**, the values displayed should be equal to the applied current multiplied by the corresponding current transformer ratio set in the **CT and VT RATIOS** menu column (see the *CT ratio settings* table). If cell [0D02: MEASURE'T SETUP, Local Values] is set to **Secondary**, the value displayed should be equal to the applied current.

Note *If a PC connected to the relay's rear communications port is used to display the measured current, the process is similar. However, the setting of cell [0D03: MEASURE'T SETUP, Remote Values] determines whether the displayed values are in primary or secondary Amperes.*

The measurement accuracy of the relay is ±1% (5% for P741/P742/P743/P746). However, an additional allowance must be made for the accuracy of the test equipment being used.

	P443	P445	P446
Current Input	Shorting Contact Between Terminals 1A - Common - 5A		
I _A	C3 - C2 - C1	C3 - C2 - C1	D3 - D2 - D1
I _B	C6 - C5 - C4	C6 - C5 - C4	D6 - D5 - D4
I _C	C9 - C8 - C7	C9 - C8 - C7	D9 - D8 - D7
I _M	C12 - C11 - C10		D12 - D11 - D10
I _{SEF}	C15 - C14 - C13	C15 - C14 - C13	D15 - D14 - D13
I _{A2}			F3 - F2 - F1
I _{B2}			F6 - F5 - F4
I _{C2}			F9 - F8 - F7

Table 10 - Current transformer shorting contact locations

	P445
Cell in MEASUREMENTS 1 column (02)	Corresponding CT Ratio (in 'CT and VT RATIOS' column(0A) of menu)
[0201: IA Magnitude] [0203: IB Magnitude [0205: IC Magnitude]	$\frac{[0A07 : Phase CT Primary]}{[0A08 : Phase CT Secondary]}$
[020B: ISEF Magnitude]	$\frac{[0A0B : SEF amp CT Primary]}{[0A0C : SEF amp CT Secondary]}$

Table 11 - CT ratio settings

5.3.11

Voltage Inputs

This test verifies the accuracy of voltage measurement is within the acceptable tolerances.

Apply rated voltage to each voltage transformer input in turn, checking its magnitude using a multimeter. Refer to the *Voltage Input Terminals* table for the corresponding reading in the relay's **MEASUREMENTS 1** column and record the value displayed.

Cell in Measurements 1 Column (02)	Voltage applied to P445
[021A: VAN Magnitude]	C19 - C22
[021C: VBN Magnitude]	C20 - C22
[021E: VCN Magnitude]	C21 - C22
[022E: (CB1) CS Volt Mag]	C23 - C24

Table 12 - Voltage input terminals

The measured voltage values displayed on the relay LCD or a portable PC connected to the front communication port are either in primary or secondary volts. If cell [0D02: MEASURE'T SETUP, Local Values] is set to **Primary**, the values displayed should be equal to the applied voltage multiplied by the corresponding voltage transformer ratio set in the **VT and CT RATIOS** menu column (see the following *VT ratio settings* table). If cell [0D02: MEASURE'T SETUP, Local Values] is set to **Secondary**, the value displayed should be equal to the applied voltage.

<i>Note</i>	<i>If a PC connected to the relay's rear communications port is used to display the measured voltage, the process is similar. However, the setting of cell [0D03: MEASURE'T SETUP, Remote Values] determines whether the displayed values are in primary or secondary volts.</i>
-------------	--

The measurement accuracy of the relay is $\pm 1\%$. However, an additional allowance must be made for the accuracy of the test equipment being used.

Cell in MEASUREMENTS 1 column (02)	Corresponding CT ratio (in 'CT and VT RATIOS' column (0A) of menu) for P445
[021A: VAN Magnitude] [021C: VBN Magnitude] [021E: VCN Magnitude]	<u>[0A01 : Main CT Primary]</u> <u>[0A02 : Main CT Secondary]</u>
[022E: Voltage Mag]	<u>[0A03 : C/S VT Primary]</u> <u>[0A04 : C/S VT Secondary]</u>

Table 13 - Voltage ratio settings

5.4 IEDs which use the Process Bus Interface

5.4.1 IED Configured with One Merging Unit (MU)

The settings for the Process Bus interface are in the IED menu **IED Config**. See the Settings chapter.

1. If necessary, isolate or block any outgoing trips from the IED. If physical contacts from the IED are wired in the scheme, in **COMMISSION TESTS** menu, set **Test Mode** to **Contacts Blocked** if operation of the contacts is not desired. If GOOSE outputs are used, from the main IED menu COMMISSIONING TEST column select **Test Mode**.
2. Connect the IEDs Ethernet port on the Process Bus board to the Sampled Value source. If necessary this can be routed through an Ethernet switch.
3. Make a valid SV configuration (a CID file via **IED Configurator**) and download it to relay and activate the configuration bank.
4. Check that the MU configuration in the CID file matches the actual Sampled Value source (test kit or Merging Unit). Make any changes in the source Sampled Value configuration. This prevents mismatches in Sampled Value when the IED is put into service when testing existing schemes.
5. Set the IED **Synchro Mode** to **No SYNC CLK** so the IED accepts Sampled Value frames with or without synchronization.
6. Generate Sampled Value frames with the rated current and voltage as required in the IED's Sampled Value configuration.
7. In the **MEASUREMENTS** menu, check the magnitudes and phase angles are displayed correctly. The display may be in primary or secondary values. Also, the IED's CT ratio or VT ratio settings affect the display. A typical accuracy of 1% can be expected for magnitudes.
8. Change the SV configuration configured in the test kit or Merging Unit to mismatch the Sampled Value configuration of the relay. Check the data cell **SV Absence Alm** displays '*****1' (where * is a don't care state for this test, normally its value is 0) for the Merging Unit configured in the CID. Check that all **MEASUREMENTS** displays for voltage or current are zero.
9. Depending on the scheme, if Merging Unit is configured to publish SV in IEC61869 format, set **SMV Version** to **IEC61869**, if Merging Unit is configured to publish SV in IEC61850-9-2LE compatible format, set **SMV Version** to **IEC61850-9-2LE**.

5.4.2

IED Configured with Two or More Merging Units (MUs)

The settings for the IEC61850-9-2LE or IEC61869 interface are in the IED menu **PB CONFIG**.

1. If necessary, isolate or block any outgoing trips from the IED. If physical contacts from the IED are wired in the scheme, in **COMMISSION TESTS** menu, set **Test Mode** to **Contacts Blocked** if operation of the contacts is not desired. If GOOSE outputs are used, from the main IED menu COMMISSIONING TEST column select **Test Mode**.
2. Connect the IEDs Ethernet port on Process Bus board to an Ethernet switch, which is connected to the Sampled Value sources. If necessary this can be routed through an Ethernet switch.
3. Make a valid SV configuration (a CID file via **IED Configurator**) and download it to relay and activate the configuration bank.
4. Check that the MU configuration in the CID file matches the actual Sampled Value source (test kit or Merging Unit). Make any changes in the source Sampled Value configuration. This prevents mismatches in Sampled Value when the IED is put into service when testing existing schemes.
5. Set the IED Synchro Alarm to 'Local Clock' so the IED accepts Sampled Value frames with local or global synchronization.
6. Check that the Sampled Value source (test kit or Merging Unit) is GPS synchronized.
7. Check the receipt of Sampled Value frames one by one for each Logical Node configured in the IED.

Repeat the following steps for each Merging Unit, configuring them one by one in the Sampled Value source(s).

1. Generate Sampled Value frames with the rated current and voltage as required in the IED's Logical Node configuration. You can check the receipt of Sampled Value frames for the configured Logical Node.
2. In the **MEASUREMENTS** menu, check the magnitudes and phase angles are displayed correctly. The display may be in primary or secondary values. Also, the IED's CT ratio or VT ratio settings affect the display. A typical accuracy of 1% can be expected for magnitudes.
3. Change the SV configuration configured in the test kit or Merging Unit to mismatch the Sampled Value configuration of the relay. Check the data cell **SV Absence Alm** displays '00000001' (where * is a don't care state for this test, normally its value is 0) for the first Merging Unit configured in the CID, or '*****1*' (where * is a don't care state for this test, normally its value is 0) for the second Merging Unit configured in the CID. Check that all **MEASUREMENTS** displays for voltage or current are zero.

6 INTERMICOM COMMUNICATIONS LOOPBACK

If the MiCOM relay is being used in a scheme with phase differential or InterMiCOM⁶⁴ communications it will be necessary to configure a loopback on the communications. If this is not the case, skip to the *Setting Checks* section.

Unless direct fiber optic communications are being used, the loopback should be made as close as possible to where the communication link leaves the substation such that as much of the wiring as possible and all associated communication signal converters are included in the test.

InterMiCOM exists in two different forms on the MiCOM relay. One version is presented on an electrical (EIA(RS)232) interface and is referred to as EIA(RS)232 InterMiCOM or MODEM InterMiCOM; the other is presented on an optical fiber interface as is referred to as fiber InterMiCOM or InterMiCOM⁶⁴.

It is possible for a relay to have both MODEM InterMiCOM and InterMiCOM⁶⁴ fitted, and both can be operational at the same time. If both are fitted, both should be tested even if one appears not to be used, since it may be that a future upgrade of communications services is envisaged that will see a migration from one implementation to the other. If only InterMiCOM⁶⁴ is fitted, skip to the Protection Communications section.

6.1 EIA(RS)232 InterMiCOM Communications

Using the relay menu structure, ensure that the InterMiCOM communications is enabled using the [0940 InterMiCOM] cell in the [09 CONFIGURATION] column.

Set the [1520 Ch Statistics] and [1540 Ch Diagnostics] cells to visible.

Check that the InterMiCOM hardware is fitted and initialized by checking that the [1545 IM HW Status] cell displays 'OK'.

6.1.1 Modem InterMiCOM Loopback Testing & Diagnostics

The MODEM InterMiCOM “**Loopback**” test facilities, located within the [15 INTERMICOM COMMS] column of the relay menu, provide a user with the ability to check the InterMiCOM signaling.

<i>Note</i>	<i>By selecting the [1550 Loopback Mode] to “Internal”, only the internal software of the relay is checked. This is useful for testing functionality if no communications connections are made, whereas “External” will check both the software and hardware used by InterMiCOM and is the preferred option during commissioning. When the relay is switched into either ‘Loopback Mode’ the relay will automatically use generic addresses and will inhibit the InterMiCOM messages to the PSL by setting all eight InterMiCOM message command states to zero.</i>
-------------	--

Set the [1550 Loopback Mode] cell to ‘**External**’ and form a communications loopback by connecting the transmit and receive signals together. In its simplest form, this is done by connecting the transmit and receive pins together (pins 2 and 3) as the diagram below.

<i>Note</i>	<i>The DCD signal must be held high (connect pin 1 and pin 4 together) if any connected equipment does not support DCD. In practice, it is likely that some form of communications converter will have been employed (refer to the operations (OP) section of this manual for examples), and the loopback will not be at the InterMiCOM connector as it should be made as far into the communications channel as possible so that as much wiring as possible, and as many ancillary communication components (converters, associated power supplies, etc.) as possible are included in the test.</i>
-------------	--

The loopback mode will be indicated on the relay frontplate by the amber Alarm LED being illuminated and a LCD alarm message, “**IM Loopback**”. See the connections shown in the *Example connections for InterMiCOM communications loopback* diagram.

Providing all connections are correct and the software is working correctly, observe that the [1552 Loopback Status] cell that is located within the INTERMICOM COMMS column of the relay menu displays “**OK**”.

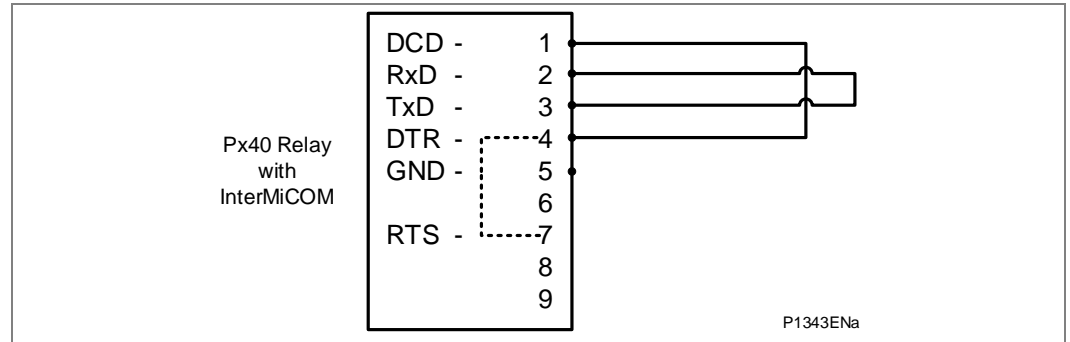

Figure 3 - Example connections for InterMiCOM communications loopback

6.1.1.1

MODEM InterMiCOM Command Bits

To test the InterMiCOM command bits, enter any test pattern in the [1551 Test Pattern] cell by scrolling through and changing selected bits between “1” and “0”. The entered pattern will be transmitted through the loopback. Check that the [1502 IM Output Status] cell matches with the applied ‘Test Pattern’. Also check that all 8 bits in the [1501 IM Input Status] cell are zero.

6.1.1.2

MODEM InterMiCOM Channel Diagnostics

Check that the Channel Diagnostics status is displaying:

[1541 Data CD Status]	OK
[1542 FrameSync Status]	OK
[1543 Message Status]	OK
[1544 Channel Status]	OK

6.1.1.3

MODEM InterMiCOM Channel Failure

Simulate a failure of the communications link by breaking a connection and checking that some of these cells indicate ‘fail’.

Note *Some or all of these cells will indicate ‘fail’ according to the communications configuration and the manner in which the link has been failed.*

Restore the communications loopback and ensure that the four diagnostic cells display ‘OK’.

6.2

InterMiCOM64 Fiber Communications

This test verifies that the relay’s fiber optic protection signaling ports together with any associated P-2M-L interface units are operating correctly.

A number of different fiber-optic interfaces are available. These are described in detail in the Operations (OP) and Application Notes (AP) sections of this manual. In general, 1300nm multi-mode fiber optics, 1310nm single-mode fiber optics and 1550nm single-mode fiber optics are used for direct fiber optic connections. 850nm multi-mode fiber optic connections are employed in conjunction with multiplexing telecommunications equipment. It is important that any optical fibers used for testing are correct for the interface(s) specified. Optical fibers should be terminated with BFOC2.5 (ST2.5) connectors. For multi-mode applications the use of 50/125µm cored fiber is recommended. Any fiber-optic test leads used for measurements should be sufficiently long to assure mode stripping, and a minimum length of 10m (30ft) is recommended to achieve this.

A P-2M-L unit will be situated near the multiplexer in applications where communications between P54x relays is via multiplexed electrical communication channels and the PCM multiplexer is installed remote from the relay room. This unit provides bi-directional optical to electrical signal conversion between the cross-site optical fiber from the relay and the electrical interface of the multiplexer.

Using the relay menu structure, ensure either:

- The current differential protection is enabled by setting the [090F Phase Diff] cell in the configuration column, or if the current differential protection is not being used,
- The InterMiCOM⁶⁴ communications is enabled by setting the [0941 InterMiCOM64] cell in the configuration column,

The method of testing is similar whether communications between relays is via dedicated optical fibers, using a P-2M-L unit to interface the relay’s fiber optic communications channel to a multiplexer, or direct fiber connection to a multiplexer supporting the IEEE C37.94 standard. However, where P-2M-L interface units are being used, there are a number of extra tests on the P-2M-L units that need to be performed refer to the following section:

- 6.2.4 - Communications using P-2M-L interface units (G.703)

If the relay is to be connected to a multiplexer supporting the IEEE C37.94 standard, the loopback testing is performed exactly the same as for a direct fiber connection described in the *Loopback Communications Configuration* section.

<i>Note</i>	<i>It is possible that two channels may have different implementations and the sections describing the commissioning of the interfaces and the loopback tests should be used as relevant to each channel.</i>
-------------	---

Caution	When connecting or disconnecting optical fibers care should be taken not to look directly into the transmit port or end of the optical fiber.
----------------	--

6.2.1 Communications Loopback Setting

The loopback test can be used to establish correct operation of the local communication interface.



Caution	In loopback mode the signals sent & received via the communications interface continue to be routed to & from the signals defined in the programmable logic. If InterMiCOM⁶⁴ is enabled, the same applies, but in this case, if the IM64 Test Mode is set to ‘Enabled’, a test pattern, IM64 Test Pattern is transmitted instead. This can be useful for testing.
----------------	---

Set cell [0F13 Test Loopback] to ‘External’.

6.2.1.1 Channel 1 Transmit Power Level

Using an appropriate fiber optic cable, connect the Channel 1 transmitter (TX1) to an optical power meter. Check the average power transmitted is in the range in the following table.

Relays manufactured pre April 2008	850 nm multi-mode	1300 nm multi-mode	1310 nm single-mode
Maximum transmitter power (average value)	-19.8 dBm	-7 dBm	-7 dBm
Minimum transmitter power (average value)	-22.8 dBm	-13 dBm	-13 dBm
Relays manufactured post April 2008	850 nm multi-mode	1300 nm multi-mode	1310 nm single-mode
Maximum transmitter power (average value)	-19.8 dBm	-3 dBm	-3 dBm
Minimum transmitter power (average value)	-22.8 dBm	-9 dBm	-9 dBm

Table 14 - Record the transmit power level.**6.2.1.2 Channel 2 Transmit Power Level**

Repeat section 6.2.1.1 - Channel 1 Transmit Power Level for channel 2 (if fitted).

6.2.2 Loopback Communications Configuration

A communications loopback will need to be made on the protection signaling communications. Either one or two channels will be fitted according to specification. A combination of direct fiber connection or multiplexed (using P-2M-L units) connection can be used on each of the channels. The following sections describe how the various loopbacks are made:

- Fiber Connection
- Communications using P-2M-L interface units (G.703)

They should be followed as appropriate to configure the loopback on channel 1 and the loopback on channel 2 (if fitted), before proceeding to the loopback test described in the *Loopback Test* section.

If the communications is being realized using P-2M-L interface units, then start by connecting the appropriate optical fiber(s) between the channel transmitter(s) on the P54x that will be used to make connection to the P-2M-L optical receiver(s) and then proceed to the relevant sections below that describe the commissioning of the P-2M-L interface units.

6.2.3 Fiber Connection

Where direct fiber connections are being used (or where multiplexer channels conforming to the IEEE C37.94 standard are being used), using an appropriate optical fiber cable, connect the channel transmitter to the channel receiver port on the rear of the relay.

6.2.4 Communications using P-2M-L interface units (G.703)**6.2.4.1 P-2M-L Visual Inspection**

Please operate as P-2M-L manual.

6.2.4.2 P-2M-L Insulation

Please operate as P-2M-L manual.

6.2.4.3 P-2M-L External Wiring

Please operate as P-2M-L manual.

6.2.4.4 P-2M-L Auxiliary Supply

Please operate as P-2M-L manual.

6.2.4.5 P-2M-L Light Emitting Diode (LED)

Please operate as P-2M-L manual.

6.2.4.6 P-2M-L Optical Received Signal Level

Please operate as P-2M-L manual.

6.2.4.7 P-2M-L Loopback

Please operate as P-2M-L manual.

6.2.4.8 P-2M-L Optical Transmitter Signal Level

Please operate as P-2M-L manual.

6.2.4.9 MiCOM Optical Received Signal Level From P-2M-L

Please operate as P-2M-L manual.

6.2.5 Loopback Test

Please operate as P-2M-L manual.



Note For P44y and P445, the propagation delay measurement will not be valid in this mode of operation. The relay will now respond as if it is connected to a remote relay. The relay will indicate a loopback alarm which can only be cleared by setting the 'Test Loopback' to disabled.



Note In loopback mode the signals sent and received via the protection communications / InterMiCOM64 interface continue to be routed to and from the signals defined in the programmable logic.



Note A test pattern can be also sent to the remote end in order to test the whole InterMiCOM communication path by enabling (OF14 IM64 Test Mode) and connecting two ends. If such a test is performed, special care has to be taken as the test pattern will be executed via PSL at the remote end.

7 SETTING CHECKS

The setting checks ensure that all of the application-specific relay settings (both the relay's function and Programmable Scheme Logic (PSL) settings) for the particular installation have been correctly applied to the relay.

If the application-specific settings are not available, ignore sections 7.1 and 7.2.



Caution **The trip circuit should remain isolated during these checks to prevent accidental operation of the associated circuit breaker.**

7.1 Apply Application-Specific Settings

There are different methods of applying the settings:

- Transferring settings from a pre-prepared setting file to the relay using a laptop PC running the appropriate software (such as Easergy Studio). Use the front EIA(RS)232 port (under the bottom access cover), or the first rear communications port (Courier protocol with a protocol converter connected), or the second rear communications port. This is the preferred method for transferring function settings as it is much faster and there is less margin for error. If PSL other than the default settings with which the relay is supplied is used, this is the only way of changing the settings.

If a setting file has been created for the particular application and provided on a memory device, the commissioning time is further reduced, especially if application-specific PSL is applied to the relay.

- Enter the settings manually using the relay's operator interface. This method is not suitable for changing the PSL.



Caution ***When the installation needs application-specific Programmable Scheme Logic (PSL), it is essential that the appropriate .psl file is downloaded (sent) to the relay, for each setting group that will be used. If the user fails to download the required .psl file to any setting group that may be brought into service, the factory default PSL will still be resident. This may have severe operational and safety consequences.***

Note *If, as a result of applying the application settings, the communication mode [2010 Comms Mode] has been changed, then a 'comms changed' alarm will be raised on the user interface. This alarm can only be cleared by power cycling the relay. If the alarm appears, remove and then re-apply the auxiliary supply to the relay.*

7.1.1 InterMiCOM Loopback

If either MODEM InterMiCOM, or Fiber InterMiCOM⁶⁴ is being used for the signaling channel, the communication loopbacks that were tested earlier need to be maintained whilst scheme testing is being performed.

For InterMiCOM⁶⁴ cell [0F13 Test Loopback] should be set to '**External**', the contents of cell [0F15 IM64 TestPattern] should have all bits set to '**0**' initially, and cell [0F15 IM64 Test Mode] should be set to '**Enabled**'.

For MODEM InterMiCOM, cell [1550 Loopback Mode] should be set to '**External**' and the test pattern should have all bits set to '**0**' initially.

7.1.2 **Reset Statistics**

The protection communications / InterMiCOM communications statistics should be reset at this point. For MODEM InterMiCOM the [1531 Reset Statistics] in the InterMiCOM COMMS column of the menu is used. For InterMiCOM⁶⁴ the [0530 Clear Statistics] cell in the MEASUREMENTS 4 column should be used.

7.2 **Demonstrate Correct Relay Operation**

The *Current Inputs* and *Voltage Inputs* tests have already demonstrated that the relay is within calibration, thus the purpose of these tests is as follows:

- To determine that the primary protection function of the relay, distance (or delta directional comparison) can trip according to the correct application settings.
- To verify correct setting of any aided scheme DEF (ground overcurrent) protection.

7.2.1 **Distance Protection Single-End Testing**

If the distance protection function is being used, the reaches and time delays should be tested. If not, skip to the *Scheme Timer Settings* section.

To avoid spurious operation of any delta directional, overcurrent, DEF/earth fault or breaker fail elements, these should be disabled for the duration of the distance element tests. This is done in the relay's CONFIGURATION column. Ensure that cells [090C: Directional E/F DEF], [0910: Overcurrent], [0913: Earth Fault] and [0920: CB Fail] are all set to "Disabled". Make a note of which elements need to be re-enabled after testing.

7.2.1.1 **Connection and Preliminaries**

The relay should now be connected to equipment able to supply phase-phase and phase-neutral volts with current in the correct phase relation for a particular type of fault on the selected relay characteristic angle. The facility for altering the loop impedance (phase-to-ground fault or phase-phase) presented to the relay is essential.

It is recommended that a 3-phase digital/electronic injection test set is used for ease of commissioning. If this is not available, two setting changes may need to be made on the relay, for the duration of testing:



Caution 1	To facilitate testing of the Distance elements using test sets which do not provide a dynamic model to generate true fault delta conditions, a Static Test Mode setting is provided. This setting is found in the <i>Commissioning Tests</i> menu column. When set, this disables phase selector control and forces the relay to use a conventional (non-delta) directional line.
------------------	--



Caution 2	For lower specification test equipment that cannot apply a full three-phase set of healthy simulated pre-fault voltages, the VT supervision may need to be disabled to avoid spurious pickup. This is achieved in the CONFIGURATION column, by setting cell [0921: Supervision] to Disabled.
------------------	---

Connect the test equipment to the relay via the test block(s) taking care not to open-circuit any CT secondary. If Easergy test blocks are used, the live side of the test plug **must** be provided with shorting links before it is inserted into the test block.

7.2.1.2**Zone 1 Reach Check**

The zone 1 element is set to be directional forward.

Apply a dynamic A phase to neutral fault, slightly in excess of the expected reach. The duration of the injection should be in excess of the tZ1 timer setting, but less than tZ2 (settings found in the DISTANCE menu column). Observe that no trip should occur, and the red Trip LED remains extinguished.

Reduce the impedance and reapply this to the relay. This procedure should be repeated until a trip occurs. The display will show Alarms/Faults present and the Alarm and Trip LEDs will illuminate. To view the alarm message press the read key 1, repeat presses of this key should be used to verify that phase A was the "Start Element". Keep pressing the 1 key until the yellow alarm LED changes from flashing to being steadily on. To reset the alarms press the **C** key. This will clear the fault record from the display.

Record the impedance at which the relay tripped. The measured impedance should be within +/- 10% of the expected reach.

Modern injection test sets usually calculate the expected fault loop impedance from the relay settings, for those that do not:

- Connections for an A-N fault. The appropriate loop impedance is given by the vector sum:
- $Z1 + Z1 \text{ residual} = Z1 + (Z1 \times kZN \text{ Res Comp} \angle kZN \text{ Angle}) \Omega$.

7.2.1.3**Zone 2 Reach Check**

The zone 2 element is set to be directional forward.

Apply a dynamic B-C fault, slightly in excess of the expected reach. The duration of the injection should be in excess of the tZ2 timer setting, but less than tZ3. Repeat as in the *Zone 1 Reach Check* section to find the zone reach.

Record the impedance at which the relay tripped. The measured impedance should be within +/- 10% of the expected reach. Read and reset the alarms.

Modern injection test sets usually calculate the expected fault loop impedance from the relay settings, for those that do not:

Connections for a B-C fault. The reach for phase-phase should be checked and the operation of the appropriate contacts confirmed. The appropriate loop impedance is now given by:

$$2 \times Z2 \Omega$$

7.2.1.4**Zone 3 Reach Check**

The zone 3 element is set to be directional forward.

Apply a dynamic C-A fault, slightly in excess of the expected reach. The duration of the injection should be in excess of the tZ3 timer setting (typically tZ3 + 100ms). Repeat as in the *Zone 1 Reach Check* section to find the zone reach.

Record the impedance at which the relay tripped. The measured impedance should be within +/- 10% of the expected reach. Read and reset the alarms.

Only a visual check that the correct reverse offset (Z3') has been applied is needed. The setting is found in cell [3143: Z3' Ph Rev Reach] and [31A3: Z3' Gnd Rev Reach].

7.2.1.5**Zone 4 Reach Check (if Enabled)**

The zone 4 element is set to be directional reverse.

Apply a dynamic B-N fault, slightly in excess of the expected reach. The duration of the injection should be in excess of the tZ4 timer setting (typically tZ4 + 100 ms). Repeat as in the *Zone 1 Reach Check* section to find the zone reach.

Record the impedance at which the relay tripped. The measured impedance should be within +/- 10% of the expected reach. Read and reset the alarms.

7.2.1.6 Zone P Reach Check (if Enabled)

The zone P element can be set to be forward or reverse directional. The current injected must be in the appropriate direction to match the setting in the “**DISTANCE SETUP**” menu column (cells [3151] and [31B1]).

Apply a dynamic C-N fault, slightly in excess of the expected reach. The duration of the injection should be in excess of the tZP timer setting (typically tZP + 100ms). Repeat as in the *Zone 1 Reach Check* section to find the zone reach.

Record the impedance at which the relay tripped. The measured impedance should be within +/- 10% of the expected reach. Read and reset the alarms.

7.2.1.7 Resistive Reach (Quadrilateral Characteristics Only)

Only a visual check that the correct settings for ground element resistive reaches have been applied is needed. The relevant settings are R1Gnd, R2Gnd, R3Gnd, R3Gnd reverse, R4Gnd and RP Gnd for ground fault zones.

Note *Zone 3 has an independent setting for the forward resistance reach (right-hand resistive reach line), and the reverse resistance reach (left-hand resistive reach line).*

7.2.1.8 Load Blinder

Only a visual check that the correct settings for the load blinder have been applied is needed. The settings are found at the end of the DISTANCE SETUP menu column, cells [31D4] to [31D6]. It must be verified that [31D5: Load B/Angle] is set at least 10 degrees less than the [3004: Line Angle] setting in the LINE PARAMETERS menu column.

7.2.2 Distance Protection Operation and Contact Assignment**7.2.2.1 Phase A**

Prepare a dynamic A phase to neutral fault, at half the Zone 1 reach. Connect a timer to start when the fault injection is applied, and to stop when the Any Trip contact closure occurs. Apply the fault and record the phase A trip time. Switch **OFF** the ac supply and reset the alarms.

7.2.2.2 Phase B

Reconfigure to test a B phase fault. Repeat the test in Phase A. Record the phase B trip time. Switch **OFF** the ac supply and reset the alarms.

7.2.2.3 Phase C

Repeat Phase B for the C phase.

The average of the recorded operating times for the three phases should typically be less than 25 ms for 50 Hz, and less than 20 ms for 60 Hz when set for instantaneous operation. Switch OFF the ac supply and reset the alarms.

- Where a non-zero tZ1 Gnd time delay is set in the DISTANCE menu column, the expected operating time is typically within +/- 5% of the tZ1 setting plus the “instantaneous” delay quoted above.

7.2.2.4 Time Delay Settings tZ1 Ph, and tZ2 - tZ4

Only a visual check that the correct time delay settings have been applied is needed. The relevant settings in the SCHEME LOGIC column are:

[3409: tZ1 Ph Time Delay]
 [3411: tZ2 Ph Time Delay] and [3412: tZ2 Gnd Time Delay]
 [3419: tZ3 Ph Time Delay] and [341A: tZ3 Gnd Time Delay]
 [3421: tZP Ph Time Delay] and [3422: tZP Gnd Time Delay]
 [3429: tZ4 Ph Time Delay] and [342A: tZ4 Gnd Time Delay]

Note *The P445 allows separate time delay settings for phase (“Ph”) and ground (“Gnd”) fault elements. BOTH must be checked to ensure that they have been set correctly.*

7.2.3

Distance Protection Scheme Testing

The relay will be tested for its response to internal and external fault simulations, but the engineer must note that the response will depend upon the aided channel (pilot) scheme that is selected. For a conventional signaling scheme, the table overleaf indicates the expected response for various test scenarios, according to the scheme selection, and status of the opto-input that is assigned to the “**Aided Receive Ext**” channel receive for the distance scheme. The response to the “**Reset Z1 Extension**” opto is shown in the case of a Zone 1 Extension scheme.

Scheme testing of the MiCOM relay is detailed in the case of conventional scheme implementation. In the case where an InterMiCOM scheme is being employed to provide the signalling, it may be that the scheme logic does not use opto-inputs for the aided scheme implementation and that internal logic signals (DDBs) will need to be set/reset in order to test the operation of the protection scheme. With InterMiCOM⁶⁴, it should be possible to use the IM64 Test Mode in conjunction with the IM64 Test Pattern to assert/monitor the relevant signal. With MODEM InterMiCOM, it may be more difficult due to the different way that the Test Pattern is implemented such that, in MODEM InterMiCOM applications, it may be that the scheme testing has to be delayed until the end-to-end tests can be performed.

Ensure that the injection test set timer is still connected to measure the time taken for the relay to trip. A series of fault injections will be applied, with a Zone 1, end-of-line, or Zone 4 fault simulated. At this stage, merely note the method in which each fault will be applied, but do not inject yet:

- Zone 1 fault A dynamic forward A-B fault at half the Zone 1 reach will be simulated.
- End of line fault A dynamic forward A-B fault at the remote end of the line will be simulated. The fault impedance simulated should match the [3003: Line Impedance] setting in the LINE PARAMETERS menu column.
- Zone 4 fault A dynamic reverse A-B fault at half the Zone 4 reach will be simulated.

Fault Type Simulated	RELAY RESPONSE					
	Forward Fault in Zone 1		Forward Fault at End of Line (Within Z1X/Z2)		Reverse Fault in Zone 4	
Signal Receive Opto	ON	OFF	ON	OFF	ON	OFF
Zone 1 Extension	Trip	Trip	No trip	Trip	No trip	No trip
Blocking Scheme	Trip, No signal send	Trip, No signal send	No trip, No signal send	Trip, No signal send	No trip, Signal send	No trip, Signal send
Permissive Scheme (PUR/PUTT)	Trip, Signal send	Trip, Signal send	Trip, No signal send	Trip, No signal send	No trip, No signal send	No trip, No signal send
Permissive Scheme (POR/POTT)	Trip, Signal send	Trip, Signal send	Trip, Signal send	No trip, Signal send	No trip, No signal send	No trip, No signal send

7.2.3.1 Scheme Trip Test for Zone 1 Extension Only

The Reset Zone 1 Extension opto input should first be ON (energized). This should be performed by applying a continuous DC voltage onto the required opto input, either from the test set, station battery, or relay field voltage (commissioning engineer to ascertain the best method).

With the opto energized, inject an end of line fault. The duration of injection should be set to 100 ms. No Trip should occur.

De-energize the Reset Z1X opto (remove the temporary energization link, to turn it OFF). Repeat the test injection, and record the operating time. This should typically be less than 25 ms for 50 Hz, and less than 20 ms for 60 Hz when set for instantaneous operation. Switch OFF the ac supply and reset the alarms.

- Where a non-zero tZ1 Ph time delay is set in the DISTANCE menu column, the expected operating time is typically within +/- 5% of the tZ1 setting plus the “instantaneous” delay quoted above.

7.2.3.2 Scheme Trip Tests for Permissive Schemes (PUR/POR Only)

This test applies to both Permissive Underreach, and Permissive Overreach aided scheme applications.

As in the table, for a Permissive scheme the Signal Receive opto input will need to be ON (energized). This should be performed by applying a continuous DC voltage onto the required opto input, either from the test set, station battery, or relay field voltage (commissioning engineer to ascertain the best method).

With the opto energized, inject an end of line fault, and record the operating time. The measured operating time should typically be less than 25 ms for 50 Hz, and less than 20 ms for 60 Hz when set for instantaneous operation. Switch OFF the ac supply and reset the alarms.

- Where a non-zero Distance Dly time delay is set in the DISTANCE menu column, the expected operating time is typically within +/- 5% of the tZ1 setting plus the “instantaneous” delay quoted above.

De-energize the channel received opto (remove the temporary energization link, to turn it OFF).

7.2.3.3 Scheme Trip Tests for Blocking Scheme Only

The Signal Receive opto input should first be ON (energized). This should be performed by applying a continuous DC voltage onto the required opto input, either from the test set, station battery, or relay field voltage (commissioning engineer to ascertain the best method).

With the opto energized, inject an end of line fault. The duration of injection should be set to 100ms. No trip should occur.

De-energize the channel received opto (remove the temporary energization link, to turn it OFF).

Repeat the test injection, and record the operating time. Switch OFF the ac supply and reset the alarms.

- For blocking schemes, a non-zero Distance Dly time delay is set, so the expected operating time is typically within +/- 5% of the delay setting plus the P445 “instantaneous” operating delay. The Trip time should thus be less than 25 ms for 50 Hz, and less than 20 ms for 60 Hz, plus 1.05 x Delay setting.

7.2.3.4 Signal Send Test for Permissive Schemes (PUR/POR Only)

This test applies to both Permissive Underreach, and Permissive Overreach scheme applications.

Firstly, reconnect the test set so that the timer is no longer stopped by the Trip contact, but is now stopped by the **Signal Send contact** (the contact that would normally be connected to the pilot/signaling channel).

Inject a Zone 1 fault, and record the signal send contact operating time. The measured operating time should typically be less than 25 ms for 50 Hz, and less than 20 ms for 60 Hz applications. Switch OFF the ac supply and reset the alarms.

7.2.3.5

Signal Send Test for Blocking Scheme Only

Firstly, reconnect the test set so that the timer is no longer stopped by the Trip contact, but is now stopped by the **Signal Send contact** (the contact that would normally be connected to the pilot/signaling channel).

Inject a Zone 4 fault, and record the signal send contact operating time. The measured operating time should typically be less than 25 ms for 50 Hz, and less than 20 ms for 60 Hz applications. Switch OFF the ac supply and reset the alarms.

7.2.4

Scheme Timer Settings

Only a visual check that the correct time delay settings have been applied is needed. The relevant settings in the AIDED SCHEMES column are:

- [344A: tRev. Guard] if applicable/visible
- [344B: Unblocking Delay] if applicable/visible
- [3453: WI Trip Delay] if applicable/visible



Caution

On completion of the tests any delta directional, DEF, overcurrent, earth fault, breaker fail or supervision elements which were disabled for testing purposes must have their original settings restored in the CONFIGURATION column.

Ensure that the Static Test Mode has been left *Disabled*. Ensure that any wires/leads temporarily fitted to energize the channel receive opto input have been removed.

7.2.5

Directional Earth Fault Aided Scheme (Ground Current Pilot Scheme)

If the Aided DEF protection function is being used, it should be tested.

If not, skip to the *Backup Phase Overcurrent Protection* section.

To avoid spurious operation of any distance, overcurrent, earth fault or breaker fail elements, these should be disabled for the duration of the DEF tests. This is done in the relay's CONFIGURATION column. Make a note of which elements need to be re-enabled after testing.

DEF testing of the MiCOM relay is detailed in the case of conventional scheme implementation. In the case where an InterMiCOM scheme is being employed to provide the signaling, it may be that the scheme logic does not use opto-inputs for the aided scheme implementation and that internal logic signals (DDBs) will need to be set/reset in order to test the operation of the protection scheme. With InterMICOM⁶⁴, it should be possible to use the IM64 Test Mode in conjunction with the IM64 Test Pattern to assert/monitor the relevant signal. With MODEM InterMiCOM, it may be more difficult due to the different way that the Test Pattern is implemented such that, in MODEM InterMiCOM applications, it may be that the scheme testing has to be delayed until the end-to-end tests can be performed.

This set of injection tests aims to determine that a single relay, at one end of the scheme is performing correctly. The relay is tested in isolation, with the communications channel to the remote line terminal disconnected. Verify that the relay cannot send or receive channel scheme signals to/from the remote line end.

7.2.5.1

Connect the Test Circuit

Determine which output relay(s) has/have been selected to operate when a DEF Trip occurs by viewing the relay’s programmable scheme logic.

Connect the output relay so that its operation will Trip the test set and stop the timer.

Connect the current output of the test set to the ‘A’ phase current transformer input of the relay. Connect, all three phase voltages to the relay Va, Vb, and Vc. Ensure that the timer will start when the current is applied to the relay.



Ensure that the timer is reset, and prepare the test shot below:

- Simulate a forward fault on the A-phase. The A-phase voltage must be simulated to drop by 4 times the [3905] or [3906] : “DEF Vpol” setting, i.e.:

$$V_a = V_n - (4 \times \text{DEF Vpol})$$

The fault current on the A-phase should be set to 2 times the [3907: DEF Threshold] setting, and in the forward direction. For a forward fault, the current Ia should lag the voltage Va by the “DEF Char Angle” setting, i.e.:

$$I_a = 2 \times I_{N \text{ DEF Threshold}} \angle \theta_{\text{DEF}}$$

Phases B and C should retain their healthy prefault voltage, and no current. The duration of the injection should be in excess of the **DEF Delay** setting (typically tDEF Delay + 100 ms).

Direction of Fault Test Injection	RELAY RESPONSE			
	Forward fault		Reverse fault	
Signal Receive Opto	ON	OFF	ON	OFF
Blocking Scheme	No trip, No signal send	Trip, No signal send	No trip, Signal send	No trip, Signal send
Permissive Scheme (POR/POTT)	Trip, Signal send	No trip, Signal send	No trip, No signal send	No trip, No signal send

A forward fault will be injected as described, with the intention to cause a scheme Trip. As in the table, for a Permissive scheme the Signal Receive opto input will need to be ON (energized). This should be performed by applying a continuous DC voltage onto the required opto input, either from the test set, station battery, or relay field voltage (commissioning engineer to ascertain the best method).

For a blocking scheme, the opto should remain de-energized (“OFF”).

7.2.5.2

DEF Aided Scheme - Forward Fault Trip Test

Apply the fault and record the (phase A) Trip time. Switch OFF the ac supply and reset the alarms.

- The aided ground fault (DEF) scheme Trip time for POR schemes should be less than 40 ms
- For blocking schemes, where a non-zero DEF Dly time delay is set, the expected operating time is typically within +/- 5% of the delay setting plus the “instantaneous” (40 ms) delay quoted above.
- There is no need to repeat the test for phases B and C, as these Trip assignments have already been proven by the distance/delta Trip tests.

7.2.6

DEF Aided Scheme - Scheme Testing

7.2.6.1

Signal Send Test for Permissive Schemes (POR/POTT Only)

Firstly, reconnect the test set so that the timer is no longer stopped by the Trip contact, but is now stopped by the **Signal Send contact** (the contact that would normally be connected to the pilot/signaling channel).

Repeat the **forward** fault injection, and record the signal send contact operating time. The measured operating time should typically be less than 40 ms. Switch OFF the ac supply and reset the alarms.

7.2.6.2

Signal Send Test for Blocking Schemes Only

Firstly, reconnect the test set so that the timer is no longer stopped by the Trip contact, but is now stopped by the **Signal Send contact** (the contact that would normally be connected to the pilot/signaling channel).

Secondly, reverse the current flow direction on the “A” phase, to simulate a **reverse** fault. Perform the reverse fault injection, and record the signal send contact operating time. The measured operating time should typically be less than 40 ms. Switch OFF the ac supply and reset the alarms.



Caution

On completion of the tests any distance, overcurrent, earth fault, breaker fail or supervision elements which were disabled for testing purposes must have their original settings restored in the CONFIGURATION column. Ensure that any wires/leads temporarily fitted to energize the channel receive opto input have been removed.

7.2.7

Backup Phase Overcurrent Protection

If the overcurrent protection function is being used, the I>1 element should be tested. If not, skip to the *Check Trip and Auto-Reclose Cycle* section.

To avoid spurious operation of any distance, DEF, earth fault or breaker fail elements, these should be disabled for the duration of the overcurrent tests. This is done in the relay's CONFIGURATION column. Make a note of which elements need to be re-enabled after testing.

7.2.7.1

Connect the Test Circuit

Determine which output relay has been selected to operate when an I>1 Trip occurs by viewing the relay's Programmable Scheme Logic (PSL).

Stage 1 should be mapped directly to an output relay in the programmable scheme logic. If default PSL is used, Relay 3 can be used as I1> is mapped to Any Trip (DDB 522) mapped to relay 3.

Connect the output relay so that its operation will Trip the test set and stop the timer.

Connect the current output of the test set to the 'A' phase current transformer input of the relay (terminals C3 and C2 where 1 A current transformers are being used and terminals C1 and C2 for 5 A current transformers).



If [3503: GROUP 1 OVERCURRENT, I>1 Directional] is set to **Directional Fwd**, the current should flow out of terminal C2 but into C2 if set to **Directional Rev**.

If cell [3503: GROUP 1 OVERCURRENT, I>1 Directional] has been set to **Directional Fwd** or **Directional Rev** then rated voltage should be applied to terminals C20 and C21. Ensure that the timer will start when the current is applied to the relay.

Note

If the timer does not stop when the current is applied and stage 1 has been set for directional operation, the connections may be incorrect for the direction of operation set. Try again with the current connections reversed.

7.2.7.2

Perform the Test

Ensure that the timer is reset.

Apply a current of twice the setting in cell [3504: GROUP 1 OVERCURRENT, I>1 Current Set] to the relay and note the time displayed when the timer stops.

Check that the red Trip LED has illuminated.

7.2.7.3

Check the Operating Time

Check that the operating time recorded by the timer is within the range shown in the following **Characteristic operating times for I>1** table.

Note *Except for the definite time characteristic, the operating times given in the table are for a time multiplier or time dial setting of 1. Therefore, to obtain the operating time at other time multiplier or time dial settings, the time given in the table must be multiplied by the setting of cell [3506: GROUP 1 OVERCURRENT, I>1 TMS] for IEC and UK characteristics or cell [3507: GROUP 1 OVERCURRENT, Time Dial] for IEEE and US characteristics.*

In addition, for definite time and inverse characteristics there is an additional delay of up to 0.02 second and 0.08 second respectively that may need to be added to the relay's acceptable range of operating times.

For all characteristics, allowance must be made for the accuracy of the test equipment being used.

Characteristic	Operating time at twice current setting and time multiplier/ time dial setting of 1.0	
	Nominal (seconds)	Range (seconds)
DT	[3505: I>1 Time Delay] setting	Setting $\pm 2\%$
IEC S Inverse	10.03	9.53 - 10.53
IEC V Inverse	13.50	12.83 - 14.18
IEC E Inverse	26.67	24.67 - 28.67
UK LT Inverse	120.00	114.00 - 126.00
IEEE M Inverse	3.8	3.61 - 4.0
IEEE V Inverse	7.03	6.68 - 7.38
IEEE E Inverse	9.50	9.02 - 9.97
US Inverse	2.16	2.05 - 2.27
US ST Inverse	12.12	11.51 - 12.73

Table 15 - Characteristic operating times for I>1



Caution **On completion of the tests any distance, overcurrent, earth fault, breaker fail or supervision elements which were disabled for testing purposes must have their original settings restored in the CONFIGURATION column.**

7.3

Check Trip and Auto-Reclose Cycle

If the auto-reclose function is being used, the circuit breaker trip and auto-reclose cycle can be tested automatically at the application-specific settings.

In order to test the trip and close operation without operating the breaker, the following criterion must be satisfied:

- The "CB Healthy" DDB should not be mapped, or if it is mapped, it must be asserted high.
- The CB status inputs (52 A, etc.) should not be mapped, or if they are mapped, they should be activated so as to mimic the circuit breaker operation.

To test the first three-phase auto-reclose cycle, set cell [0F11: COMMISSION TESTS, Test Auto-reclose] to '3 Pole Test'. The relay will perform a trip/reclose cycle. Repeat this operation to test the subsequent three-phase auto-reclose cycles.

Check all output relays used for circuit breaker tripping and closing, blocking other devices, etc. operate at the correct times during the trip/close cycle.

8 END TO END COMMUNICATION TESTS (INTERMICOM ONLY)

If InterMiCOM protection is being used, the end-to-end tests must be performed.

If not, skip to the *End-to-End Scheme Tests* section.

In the *Communications Loopback* section, InterMiCOM communications loopbacks were applied to enable completion of the local end tests. In this section any loopbacks are removed and, if possible, satisfactory communications between line ends of the MiCOM relays in the scheme will be confirmed.

Note End-to-end communication requires the provision of a working telecommunication channel between line ends (which may be a multiplexed link or may be a direct connection). If the telecommunication channel is not available, it will not be possible to establish end-to-end communication. Nonetheless unless otherwise directed by local operational practice, the instructions in the **End-To-End Protection Communications Tests** section should be followed such that the scheme is ready for full operation when the telecommunications channels becomes available.

Note The trip circuit should remain isolated during these checks to prevent accidental operation of the associated circuit breaker.

8.1 MODEM InterMiCOM

If MODEM InterMiCOM is being used, the end-to-end tests need to be performed.

If not, skip to the *Fiber InterMiCOM*⁶⁴ section.

8.1.1 Local End Configuration

Check that the [1520 Ch Statistics] and [1540 Ch Diagnostics] cells are set to visible. Use the statistics and diagnostics cells to check that the loopback communication remained healthy throughout the testing and that good messages are being received.

Check that the [1510 Source Address] and the [1511 Receive Address] are different, corresponding to the complimentary pair at the remote end as required by the application. Set the [1550 Loopback Mode] to disabled. The InterMiCOM communications should fail.

Remove the physical loopback connection that was made in the *Modem InterMiCOM Loopback Testing & Diagnostics* section and restore the communications link to its operational connection.

Observe that the LCD alarm message, “**IM Loopback**” and corresponding amber Alarm LED indication are not present.

8.1.2 Remote End Configuration

Repeat the steps taken in the previous *Local End Configuration* section at the remote end (if not already done). If the remote end is not actively communicating, then a comprehensive test cannot be performed until the two ended system is established.

8.1.3 Verify End-To-End Communication

8.1.3.1 Verify Operational Link

If the communications link is operational then at either end the channel diagnostics (cells 1541 - 1545) should indicate ‘OK’.

8.1.3.2 Verify Pattern Transmission

Check that the [1502 IM Output Status] cell pattern at the local relay matches with the [1501 IM Input Status] at the remote end and vice versa.

8.1.3.3 Check Data Received Counters

The Rx count for Direct, Permissive and Blocking signals (subject to setting) will rise rapidly in proportion to Baud rate setting, whilst the Rx count for “**NewData**” and “**Errored**” and the percentage of “**Lost Messages**” must remain close to zero.

8.1.3.4 Statistics Check

Reset the InterMiCOM statistics [1531 Reset Statistics] and record the number of good messages (Direct, Permissive, Blocking) and the number of errored messages (NewData, Errored, Lost Messages) after a minimum period of 1 hour. Check that the ratio of errored/good messages is better than 10^{-4} .

8.2 Fiber InterMiCOM64

If InterMiCOM protection is being used, the end-to-end tests must be performed. If not, skip to the *End-to-End Scheme Tests* section.

8.2.1 Remove Local Loopbacks

As well as removing the loopback test, this section checks that all wiring and optical fibers are reconnected. If interface units are installed the application-specific settings will also be applied.

Check the alarm records to ensure that no communications failure alarms have occurred whilst the loopback test has been in progress.

Note *If it was necessary to ‘fail’ the communications whilst testing the non-current differential elements, it may be prudent to observe the communications behavior for a few minutes before proceeding to remove the loopbacks.*

Set cell [0F15 Test Mode] to **Disabled**.

Set cell [0F13 Loopback Mode] to **Disabled**.

Restore the communications channels as per the appropriate sub-section below.

8.2.1.1 Direct Fiber and C37.94 Connections

In the *InterMiCOM64 Fiber Communications* section, most of the required optical signal power levels were measurements were taken. If all signaling uses P-2M-L interface units, then no further measurements are required. If direct fiber or C37.94 communications are used then it will be necessary to make further measurements.

8.2.1.1.1 Direct Fiber Connections

It is necessary to check the optical power level received from the remote relay(s).

Remove the loopback test fiber(s) and at both ends of each channel used, reconnect the fiber optic cables for communications between relays, ensuring correct placement.



Caution *When connecting or disconnecting optical fibres care should be taken not to look directly into the transmit port or end of the optical fibre.*

For each channel fitted, in turn, remove the fiber connecting to the optical receiver (RX) and, using an optical power meter measure the strength of the signal received from the remote relay. The measurements should be within the values shown in the tables below:

Relays Manufactured Pre April 2008	850nm multi-mode	1300nm multi-mode	1310nm single-mode
Maximum Transmitter Power (Average Value)	-16.8dBm	-6dBm	-6dBm
Minimum Transmitter Power (Average Value)	-25.4dBm	-49dBm	-49dBm

Relays Manufactured Post April 2008	850nm multi-mode	1300nm multi-mode	1310nm single-mode
Maximum Transmitter Power (Average Value)	-16.8dBm	-7dBm	-7dBm
Minimum Transmitter Power (Average Value)	-25.4dBm	-37dBm	-37dBm

Record the received power level(s).

Reconnect the fiber(s) to the MiCOM receiver(s).

8.2.1.1.2

Fiber Connections to C37.94

It is necessary to check the optical power level received from the MiCOM at the C37.94 multiplexer, as well as that received by the MiCOM from the C37.94 multiplexer.

Remove the loopback test fibers and at both ends of each channel used, reconnect the fiber optic cables for communications between relays and the C37.94 compatible multiplexer, ensuring correct placement.



Caution

When connecting or disconnecting optical fibres care should be taken not to look directly into the transmit port or end of the optical fibre.

In a similar manner to that described in the *Direct Fiber Connections* section, check that the value received from the MiCOM at the C37.94 multiplexer, as well as that received by the MiCOM from the C37.94 multiplexer are in the range presented in the table below:

Maximum Transmitter Power (Average Value)	-16.8dBm
Minimum Transmitter Power (Average Value)	-25.4dBm

Record the received power level(s).

Reconnect the fiber(s).

8.2.1.2

Communications using P-2M-L Interface Units

Return to the P-2M-L units.



Warning

Ensure that all external wiring that has been removed to facilitate testing is replaced in accordance with the relevant connection diagram or scheme diagram.

If applicable, replace the secondary front cover on the P-2M-L units.

8.2.2

Remote Loopback Removal

8.2.2.1

Remove Loopbacks at Remote Terminal Connected to Channel 1

Repeat the following sections as needed at the remote end relay connected to channel 1.

- Direct Fiber and C37.94 Connections
- Communications using P-2M-L Interface Units

8.2.2.2

Remove Loopbacks at Remote Terminal Connected to Channel 2

Repeat the following sections as needed at the remote end relay connected to channel 2.

- Direct Fiber and C37.94 Connections
- Communications using P-2M-L Interface Units

8.2.3

Verify Communications Between Relays

Reset any alarm indications and check that no further communications failure alarms are raised. Using the following cells in the [MEASUREMENTS 4] to check that the communications channel(s) is(are) working correctly:

[0513 Ch1 No. Vald Mess] should be incrementing for healthy channel 1
[0514 Ch1 No. Err Mess] should be zero healthy channel 1
[0518 Ch2 No. Vald Mess] should be incrementing for healthy channel 2
[0519 Ch2 No. Err Mess] should be zero for healthy channel 2

Clear the statistics and record the number of valid messages and the number of errored messages after a minimum period of 1 hour. Check that the ratio of errored/good messages is better than 10^{-4} . Record the measured message propagation delays for channel 1, and channel 2 (if fitted).

9 END-TO-END SCHEME TESTS

If an external signalling channel is being employed to provide aided scheme signaling (i.e. an aided protection scheme is being realised without InterMiCOM protection signaling, it should be tested. If only basic schemes are being used, or if InterMiCOM is being used to realise the schemes, skip to the *Modem InterMiCOM Scheme Testing* section.

9.1 Signaling Channel Check

This section aims to check that the signaling channel is able to transmit the ON/OFF signals used in aided schemes between the remote line ends. Before testing, check that the channel is healthy (for example, if a power line carrier link is being used, it may not be possible to perform the tests until the protected circuit is live and has in-service). If the channel tests must be postponed, make a note to perform them as described in the *On-Load Checks* section.

9.1.1 Aided Scheme 1

If Aided Scheme 1 is enabled, it must be tested. This is achieved by operating output contacts as in the *Output Relays* section to mimic the relay sending an aided channel signal.

Put the relay in test mode by setting cell [0F0D: COMMISSION TESTS, Test Mode] to **Blocked**.

Record which contact is assigned as the *Signal Send 1* output. Select this output contact as the one to test. And advise the remote end engineer that the contact is about to be tested.

9.1.1.1 Remote End Preparation to Observe Channel Arrival

At the remote end, the engineer must confirm the assignment of the Monitor Bits in the COMMISSION TESTS column in the menu, in order to be able to see the aided channel on arrival. Scroll down and ensure cells are set: [0F05: Monitor Bit 1] to 493, and [0F09: Monitor Bit 5] to 507. In doing so, cell [0F03: Test Port Status] will appropriately set or reset the bits that now represent Aided 1 Scheme Receive (DDB #493), and Aided 2 Scheme Receive (DDB #507), with the rightmost bit representing Aided Channel 1. From now on the remote end engineer should monitor the indication of [0F03: Test Port Status].

9.1.1.2 Application of the Test

At the local end, to operate the output relay set cell [0F0F: COMMISSION TESTS, Contact Test] to **Apply Test**.

Reset the output relay by setting cell [0F0F: COMMISSION TESTS, Contact Test] to **Remove Test**.

Note It should be ensured that thermal ratings of anything connected to the output relays during the contact test procedure are not exceeded by the associated output relay being operated for too long. It is therefore advised that the time between application and removal of the contact test is kept to the minimum.

Check with the engineer at the remote end that the Aided Channel 1 signal did change state as expected. The Test Port Status should have responded as in the table below:

DDB No.				507				493
Monitor Bit	8	7	6	5	4	3	2	1
Contact Test OFF	X	X	X	X	X	X	X	0
Contact Test Applied (ON)	X	X	X	X	X	X	X	1
Test OFF	X	X	X	X	X	X	X	0

Note "x" = Wildcard/denotes don't care

Return the relay to service by setting cell [0F0D: COMMISSION TESTS, Test Mode] to 'Disabled'.

9.1.1.3**Channel Check in the Opposite Direction**

Repeat the aided scheme 1 test procedure, but this time to check that the channel responds correctly when keyed from the remote end. The remote end commissioning engineer should perform the contact test, with the Monitor Option observed at the local end.

9.1.2**Aided Scheme 2**

If applicable, now repeat the test for Aided Channel 2. Repeat as per the *Channel Check in the Opposite Direction* section above, checking that Monitor Bit 5 responds correctly for channel transmission in both directions (from the local end to the remote end, and vice versa).

Return the relay to service by setting cell [0F0D: COMMISSION TESTS, Test Mode] to **Disabled**.

10**MODEM INTERMICOM SCHEME TESTING**

If the aided scheme tests described in the *Demonstrate Correct Relay Operation* section could not be carried out for a scheme using MODEM InterMiCOM signaling due to lack of access to the internal signal, they will need to be checked here.

The principles are the same as those described in these sections:

- Distance Protection Scheme Testing
- DEF Aided Scheme - Scheme Testing

However, in order to generate the correct conditions to stimulate the appropriate signaling commands and responses, synchronous generation of the fault scenarios at each end of the protected line will be required.

11 ON-LOAD CHECKS

The objectives of the on-load checks are to:

- Confirm the external wiring to the current and voltage inputs is correct
- Check the polarity of the line current transformers at each end is consistent
- Directionality check for distance (or delta directional) elements

However, these checks can only be carried out if there are no restrictions preventing the energization of the plant being protected and the other P443/P445/P446 relays in the group have been commissioned.



Caution Remove all test leads and temporary shorting leads, and replace any external wiring that was removed to allow testing.



Caution If any of the external wiring was disconnected from the relay to run any tests, make sure that all connections are restored according to the external connection or scheme diagram.

11.1 Confirm Current and Voltage Transformer Wiring

11.1.1 Voltage Connections



Caution Using a multimeter, measure the voltage transformer secondary voltages to ensure they are correctly rated. Check that the system phase rotation is correct using a phase rotation meter.

Compare the values of the secondary phase voltages with the relay’s measured values, which can be found in the **MEASUREMENTS 1** menu column.

If cell [0D02: MEASURE’T SETUP, Local Values] is set to **Secondary**, the values displayed on the relay LCD or a portable PC connected to the front EIA(RS)232 communication port should be equal to the applied secondary voltage. The values should be within 1% of the applied secondary voltages/currents (5% for P74x). However, an additional allowance must be made for the accuracy of the test equipment being used.

If cell [0D02: MEASURE’T SETUP, Local Values] is set to **Primary**, the values displayed should be equal to the applied secondary voltage multiplied the corresponding voltage transformer ratio set in the **CT and VT RATIOS** menu column (see the following table). Again, the values should be within 1% of the expected value (5% for P74x), plus an additional allowance for the accuracy of the test equipment being used.

Voltage	Cell in MEASUREMENTS 1 Column (02)	Corresponding VT Ratio in ‘VT and CT RATIO’ Column (0A) of Menu
V _{AB} V _{BC} V _{CA} V _{AN} V _{BN} V _{CN}	[0214: V _{AB} Magnitude] [0216: V _{BC} Magnitude] [0218: V _{CA} Magnitude] [021A: V _{AN} Magnitude] [021C: V _{BN} Magnitude] [021E: V _{CN} Magnitude]	[0A01 : Main VT Primary] [0A02 : Main VT Secondary]
V _{CHECKSYNC.}	[022E: CB1 CS Volt Mag.]	[0A03 : (CB1) CS VT Prim’y] [0A04 : (CB1) CS VT Sec’y]
V _{CHECKSYNC2} (NOT P445/P841 A)	[024C: CB2 CS2 Volt Mag] (NOT P443/P445)	[0A05 : CB2 CS VT Prim’y] [0A06 : CB2 CS VT Sec’y]

Table 16 - Measured voltages and VT ratio settings

11.1.2

Current Connections

**Caution**

Measure the current transformer secondary values for each input using a multimeter connected in series with corresponding relay current input.

Check that the current transformer polarities are correct by measuring the phase angle between the current and voltage, either against a phase meter already installed on site and known to be correct or by determining the direction of power flow by contacting the system control center.

Caution

Ensure the current flowing in the neutral circuit of the current transformers is negligible.

Compare the values of the secondary phase currents (and any phase angle) with the relay's measured values, which can be found in the **MEASUREMENTS 1** menu column. If cell [0D02: MEASURE'T SETUP, Local Values] is set to **Secondary**, the current displayed on the relay LCD or a portable PC connected to the front EIA(RS)232 communication port should be equal to the applied secondary current. The values should be within 1% of the applied secondary currents. However, an additional allowance must be made for the accuracy of the test equipment being used.

If cell [0D02: MEASURE'T SETUP, Local Values] is set to **Primary**, the current displayed should be equal to the applied secondary current multiplied by the corresponding current transformer ratio set in the **CT & VT RATIOS** menu column (see the *Measured Voltages and VT Ratio Settings* table). Again the values should be within 1% of the expected value, plus an additional allowance for the accuracy of the test equipment being used.

11.2

On Load Directional Test

This test is important to ensure that directionalized overcurrent and fault locator functions have the correct forward/reverse response to fault and load conditions.

Firstly the actual direction of power flow on the system must be ascertained, using adjacent instrumentation or protection already in-service, or a knowledge of the prevailing network operation conditions.

- For load current flowing in the Forward direction - i.e. power export to the remote line end, cell [0301: MEASUREMENTS 2, A Phase Watts] should show **positive** power signing
- For load current flowing in the Reverse direction - i.e. power import from the remote line end, cell [0301: MEASUREMENTS 2, A Phase Watts] should show **negative** power signing

Note

The check above applies only for Measurement Modes 0 (default), and 2. This should be checked in [0D05: MEASURE'T. SETUP, Measurement Mode = 0 or 2]. If measurement modes 1 or 3 are used, the expected power flow signing would be opposite to that shown in the bullets above.

In the event of any uncertainty, check the phase angle of the phase currents with respect to their phase voltage.

11.3

Signaling Channel Check (if Not Already Completed)

If the aided scheme signaling channel(s) was/were not tested already in the *Signalling Channel Check* section they should be tested now. This test may be avoided only with the agreement of the customer, or if only the basic scheme is used.

12 FINAL CHECKS

The tests are now complete.

**Caution**

Remove all test or temporary shorting leads. If it has been necessary to disconnect any of the external wiring from the relay to perform the wiring verification tests, make sure all connections are replaced according to the relevant external connection or scheme diagram.

Ensure that the relay is restored to service by checking that cell [0F0D: COMMISSIONING TESTS, Test Mode] and [0F12: COMMISSION TESTS, Static Test] are set to 'Disabled'.

The settings applied should be carefully checked against the required application-specific settings to ensure that they are correct, and have not been mistakenly altered during testing.

There are two methods of checking the settings:

- Extract the settings from the relay using a portable PC running the appropriate software via the front EIA(RS)232 port, located under the bottom access cover, or rear communications port. Compare the settings transferred from the relay with the original written application-specific setting record. (For cases where the customer has only provided a printed copy of the required settings but a portable PC is available).
- Step through the settings using the relay's operator interface and compare them with the original application-specific setting record. Ensure that all protection elements required have been ENABLED in the CONFIGURATION column.

If the relay is in a new installation or the circuit breaker has just been maintained, the circuit breaker maintenance and current counters should be zero. These counters can be reset using cell [0609: CB CONDITION, Reset All Values]. If the required access level is not active, the relay will prompt for a password to be entered so that the setting change can be made.

If the menu language was changed to allow accurate testing, it must now be restored to the customer's preferred language.

If a MiCOM P991 or Easergy test block is installed, remove the MiCOM P992 or Easergy test plug and replace the test block cover so that the protection is put into service.

Ensure that all event records, fault records, disturbance records, alarms and LEDs have been reset before leaving the relay.

If applicable, replace the secondary front cover on the relay.

TEST AND SETTING RECORDS

CHAPTER 12

Applicability

Date: 11/2022

Products covered by this chapter:

This chapter covers the specific versions of the MiCOM products listed below. This includes **only** the following combinations of Software Version and Hardware Suffix.

Hardware Suffix:

MiCOM P445 | L

Software Version:

MiCOM P445 | K6

Connection Diagrams: This chapter list the connection diagram for the product:

P445: | 10P445xx (xx = 01 to 04)

CONTENTS

1. Test Record	5
1.1 About this Chapter	5
1.2 Date	5
1.3 Front Plate Information	5
1.4 Test Equipment Used	5
1.5 Checklist	6
1.6 Engineer Details	20
<hr/>	
2. Creating a Setting Record	21
2.1 Extract Settings from a MiCOM Px40 Device	21
2.2 Send Settings to a MiCOM Px40 Device	22

Notes:

1. TEST RECORD

1.1 About this Chapter

The Commissioning chapter provides instructions on how to commission the relay – including how to calibrate it and how to establish that it is functioning as intended.

This chapter provides you with a series of templates. You can use this to record the tests which have been made and the settings which have been used. You should use this chapter in conjunction with the Commissioning chapter and any work instructions you have as to what functionality and settings the relay should use.

1.2 Date

Date:

Station:
VT Ratio: / V

Engineer:
Circuit:
System Frequency: Hz
CT Ratio (tap in use): /A

1.3 Front Plate Information

Relay type	MiCOM P445
Model number	
Serial number	
Rated current I _n	
Rated voltage V _n	
Auxiliary voltage V _x	

1.4 Test Equipment Used

This section should be completed to allow future identification of protective devices that have been commissioned using equipment that is later found to be defective or incompatible but may not be detected during the commissioning procedure.

Overcurrent test set	Model: Serial No:	
Injection test set	Model: Serial No:	
Phase angle meter	Model: Serial No:	
Phase rotation meter	Model: Serial No:	
Optical power meter	Model: Serial No:	
Insulation tester	Model: Serial No:	
Setting software:	Type: Version:	

1.5 Checklist



Have all relevant safety instructions been followed?

Yes	<input type="checkbox"/>	No	<input type="checkbox"/>
-----	--------------------------	----	--------------------------

Explanatory Notes

In the following pages you need to complete or delete the entries as appropriate.
 na or N/A means Not Applicable.
 nm or N/M means Not Measured.
 N/O means Normally Open and N/C means Normally Closed; and is shown in the relevant diagram in the Connection Diagrams chapter.
 The numbers in **bold** on the left-hand side represent the relevant Section number in the Commissioning chapter.

5.	PRODUCT CHECKS					
5.1	With the relay de-energized					
5.1.1	Visual inspection					
	Relay damaged?	Yes	<input type="checkbox"/>	No	<input type="checkbox"/>	
	Rating information correct for installation?	Yes	<input type="checkbox"/>	No	<input type="checkbox"/>	
	Case earth installed?	Yes	<input type="checkbox"/>	No	<input type="checkbox"/>	
5.1.2	Current transformer shorting contacts close?	Yes	<input type="checkbox"/>	No	<input type="checkbox"/>	N/M <input type="checkbox"/>
5.1.3	Insulation resistance >100 MΩ at 500 V dc	Yes	<input type="checkbox"/>	No	<input type="checkbox"/>	N/M <input type="checkbox"/>
5.1.4	External wiring					
	Wiring checked against diagram?	Yes	<input type="checkbox"/>	No	<input type="checkbox"/>	
	Test block connections checked?	Yes	<input type="checkbox"/>	No	<input type="checkbox"/>	N/A <input type="checkbox"/>
5.1.5	Watchdog Contacts (Auxiliary Supply Off)					
	Terminals 11 and 12	Contact closed?	Yes	<input type="checkbox"/>	No	<input type="checkbox"/>
		Contact resistance		Ω	N/M	<input type="checkbox"/>
	Terminals 13 and 14	Contact open?	Yes	<input type="checkbox"/>	No	<input type="checkbox"/>
5.1.6	Measured auxiliary supply				V ac/dc	
5.2	With the relay energized					
5.2.1	Watchdog contacts (auxiliary supply on)					
	Terminals 11 and 12	Contact open?	Yes	<input type="checkbox"/>	No	<input type="checkbox"/>
	Terminals 13 and 14	Contact closed?	Yes	<input type="checkbox"/>	No	<input type="checkbox"/>
		Contact resistance		Ω	N/M	<input type="checkbox"/>
5.2.2	LCD front panel display					
	LCD contrast setting used					
5.2.3	Date and Time					
	Clock set to local Time?	Yes	<input type="checkbox"/>	No	<input type="checkbox"/>	
	Time maintained when auxiliary supply removed?	Yes	<input type="checkbox"/>	No	<input type="checkbox"/>	
5.2.4	Light Emitting Diodes (LEDs)					
	Relay healthy (green) LED working?	Yes	<input type="checkbox"/>	No	<input type="checkbox"/>	
	Alarm (yellow) LED working?	Yes	<input type="checkbox"/>	No	<input type="checkbox"/>	

	Out of service (yellow) LED working?	Yes	<input type="checkbox"/>	No	<input type="checkbox"/>
	Trip (red) LED working?	Yes	<input type="checkbox"/>	No	<input type="checkbox"/>
	All programmable LEDs working? (may be 8 or 18 depending on the model)	Yes	<input type="checkbox"/>	No	<input type="checkbox"/>

5.2.5	Field Supply Voltage				
	Value measured between terminals 7 and 9				V dc
	Value measured between terminals 8 and 10				V dc

5.2.6	Input opto-isolators (numbers vary depending on the product)						
	Opto input 1	Working?	Yes	<input type="checkbox"/>	No	<input type="checkbox"/>	
	Opto input 2	Working?	Yes	<input type="checkbox"/>	No	<input type="checkbox"/>	
	Opto input 3	Working?	Yes	<input type="checkbox"/>	No	<input type="checkbox"/>	
	Opto input 4	Working?	Yes	<input type="checkbox"/>	No	<input type="checkbox"/>	
	Opto input 5	Working?	Yes	<input type="checkbox"/>	No	<input type="checkbox"/>	
	Opto input 6	Working?	Yes	<input type="checkbox"/>	No	<input type="checkbox"/>	
	Opto input 7	Working?	Yes	<input type="checkbox"/>	No	<input type="checkbox"/>	
	Opto input 8	Working?	Yes	<input type="checkbox"/>	No	<input type="checkbox"/>	
	Opto input 9	Working?	Yes	<input type="checkbox"/>	No	<input type="checkbox"/>	N/A <input type="checkbox"/>
	Opto input 10	Working?	Yes	<input type="checkbox"/>	No	<input type="checkbox"/>	N/A <input type="checkbox"/>
	Opto input 11	Working?	Yes	<input type="checkbox"/>	No	<input type="checkbox"/>	N/A <input type="checkbox"/>
	Opto input 12	Working?	Yes	<input type="checkbox"/>	No	<input type="checkbox"/>	N/A <input type="checkbox"/>
	Opto input 13	Working?	Yes	<input type="checkbox"/>	No	<input type="checkbox"/>	N/A <input type="checkbox"/>
	Opto input 14	Working?	Yes	<input type="checkbox"/>	No	<input type="checkbox"/>	N/A <input type="checkbox"/>
	Opto input 15	Working?	Yes	<input type="checkbox"/>	No	<input type="checkbox"/>	N/A <input type="checkbox"/>
	Opto input 16	Working?	Yes	<input type="checkbox"/>	No	<input type="checkbox"/>	N/A <input type="checkbox"/>

5.2.7	Output Relays						
	Relay 1	working?	Yes	<input type="checkbox"/>	No	<input type="checkbox"/>	
	Relay 2	working?	Yes	<input type="checkbox"/>	No	<input type="checkbox"/>	
	Relay 3	working?	Yes	<input type="checkbox"/>	No	<input type="checkbox"/>	
	Relay 4	working?	Yes	<input type="checkbox"/>	No	<input type="checkbox"/>	
	Relay 5	working?	Yes	<input type="checkbox"/>	No	<input type="checkbox"/>	
	Relay 6	working?	Yes	<input type="checkbox"/>	No	<input type="checkbox"/>	
	Relay 7	working?	Yes	<input type="checkbox"/>	No	<input type="checkbox"/>	
	Relay 8	working?	Yes	<input type="checkbox"/>	No	<input type="checkbox"/>	
	Relay 9	working?	Yes	<input type="checkbox"/>	No	<input type="checkbox"/>	N/A <input type="checkbox"/>
	Relay 10	working?	Yes	<input type="checkbox"/>	No	<input type="checkbox"/>	N/A <input type="checkbox"/>
	Relay 11	working?	Yes	<input type="checkbox"/>	No	<input type="checkbox"/>	N/A <input type="checkbox"/>
	Relay 12	working?	Yes	<input type="checkbox"/>	No	<input type="checkbox"/>	N/A <input type="checkbox"/>
	Relay 13	working?	Yes	<input type="checkbox"/>	No	<input type="checkbox"/>	N/A <input type="checkbox"/>
	Relay 14	working?	Yes	<input type="checkbox"/>	No	<input type="checkbox"/>	N/A <input type="checkbox"/>
	Relay 15	working?	Yes	<input type="checkbox"/>	No	<input type="checkbox"/>	N/A <input type="checkbox"/>
	Relay 16	working?	Yes	<input type="checkbox"/>	No	<input type="checkbox"/>	N/A <input type="checkbox"/>

	High break Relay 9	External wiring polarity check?	Yes	<input type="checkbox"/>	No	<input type="checkbox"/>	N/A	<input type="checkbox"/>
	High break Relay 10	External wiring polarity check?	Yes	<input type="checkbox"/>	No	<input type="checkbox"/>	N/A	<input type="checkbox"/>
	High break Relay 11	External wiring polarity check?	Yes	<input type="checkbox"/>	No	<input type="checkbox"/>	N/A	<input type="checkbox"/>
	High break Relay 12	External wiring polarity check?	Yes	<input type="checkbox"/>	No	<input type="checkbox"/>	N/A	<input type="checkbox"/>

5.2.9	Second Rear Communications Port							
	Communication port configuration	K-Bus	<input type="checkbox"/>					
		EIA(RS)232	<input type="checkbox"/>					
		EIA(RS)485	<input type="checkbox"/>					
		IEC61850	<input type="checkbox"/>					
		DNPoE	<input type="checkbox"/>					
		IEC61850+DNPoE	<input type="checkbox"/>					
		Ethernet	<input type="checkbox"/>					
	Communications Established?	Yes	<input type="checkbox"/>	No	<input type="checkbox"/>			
	Protocol Converter tested?	Yes	<input type="checkbox"/>	No	<input type="checkbox"/>	N/A	<input type="checkbox"/>	

5.2.10	Current Inputs							
	Displayed Current		Primary	<input type="checkbox"/>	Secondary	<input type="checkbox"/>		
	Earth Fault CT Ratio	$\frac{[E/F CT Primary]}{[E/F CT Sec'y]}$		A	N/A	<input type="checkbox"/>		
	Phase CT Ratio			%	N/A	<input type="checkbox"/>		

	Input CT	Applied Value			Displayed Value		
	IA	A	N/A	<input type="checkbox"/>	A	N/A	<input type="checkbox"/>
	IB	A	N/A	<input type="checkbox"/>	A	N/A	<input type="checkbox"/>
	IC	A	N/A	<input type="checkbox"/>	A	N/A	<input type="checkbox"/>
	IN Sensitive/ISEF	A	N/A	<input type="checkbox"/>	A	N/A	<input type="checkbox"/>

5.2.14	Voltage Inputs							
	Displayed Voltage		Primary	<input type="checkbox"/>	Secondary	<input type="checkbox"/>		
	Main VT Ratio	$\frac{[Main VT Primary]}{[Main VT Sec'y]}$		V	N/A	<input type="checkbox"/>		
	VN VT Ratio	$\frac{[VN VT Primary]}{[VN VT Secondary]}$		V	N/A	<input type="checkbox"/>		
	VN2 VTRatio	$\frac{[VN2 VT Primary]}{[VN2 VT Secondary]}$		V	N/A	<input type="checkbox"/>		
	C/S VT Ratio	$\frac{[C/S VT Prim'y]}{[C/S VT Sec'y]}$		V	N/A	<input type="checkbox"/>		

5.2.11	Voltage Inputs							
	Displayed Voltage		Primary	<input type="checkbox"/>	Secondary	<input type="checkbox"/>		
	Main VT Ratio			V	N/A	<input type="checkbox"/>		
	C/S VT Ratio			V	N/A	<input type="checkbox"/>		

	Input VT	Applied Value			Displayed Value		
--	----------	---------------	--	--	-----------------	--	--

	VAN		V		V	
	VBN		V		V	
	VCN		V		V	
	VN2 (P344/P345 only)		V	N/A	<input type="checkbox"/>	V
	C/S Voltage (P345 only)		V	N/A	<input type="checkbox"/>	V
	CB1 CS Voltage		V	N/A	<input type="checkbox"/>	V
	CB2 CS Voltage		V	N/A	<input type="checkbox"/>	V

6.	InterMiCOM Communications Loopback							
6.1	MODEM InterMiCOM							
	InterMiCOM hardware status OK?	Yes	<input type="checkbox"/>	No	<input type="checkbox"/>			
6.1.1	Loopback Mode set to External?	Yes	<input type="checkbox"/>	No	<input type="checkbox"/>			
	Loopback connection made?	Yes	<input type="checkbox"/>	No	<input type="checkbox"/>			
	Loopback connection location							
	IM Loopback message and LED indication?	Yes	<input type="checkbox"/>	No	<input type="checkbox"/>			
	IM Loopback status OK?	Yes	<input type="checkbox"/>	No	<input type="checkbox"/>			
6.1.1.1	Test Pattern set							
	IM Output Status received							
	IM Input Status all zero?	Yes	<input type="checkbox"/>	No	<input type="checkbox"/>			
6.1.1.2	InterMiCOM channel diagnostics							
	Data CD Status OK?	Yes	<input type="checkbox"/>	No	<input type="checkbox"/>			
	Frame Sync Status OK?	Yes	<input type="checkbox"/>	No	<input type="checkbox"/>			
	Message Status OK?	Yes	<input type="checkbox"/>	No	<input type="checkbox"/>			
	Channel Status OK?	Yes	<input type="checkbox"/>	No	<input type="checkbox"/>			
6.1.1.3	Channel failure indication for broken channel?	Yes	<input type="checkbox"/>	No	<input type="checkbox"/>			
	Channel Status OK for restored loopback?	Yes	<input type="checkbox"/>	No	<input type="checkbox"/>			
6.2	InterMiCOM ⁶⁴ Fiber Communications							
6.2.1	Test Loopback set to External?	Yes	<input type="checkbox"/>					
6.2.1.1	Channel 1 transmit power level			dBm				
6.2.1.2	Channel 2 transmit power level			dBm	N/A	<input type="checkbox"/>		
6.2.2	Fiber Optic Configuration							
	Type of fiber optic connection for channel 1	Direct	<input type="checkbox"/>	C37.94	<input type="checkbox"/>	N/A	<input type="checkbox"/>	
		P-2M-L	<input type="checkbox"/>		<input type="checkbox"/>		<input type="checkbox"/>	
	Fiber connections made with P-2M-L unit on Ch 1?	Yes	<input type="checkbox"/>	N/A	<input type="checkbox"/>			
	Type of fiber optic connection for channel 2	Direct	<input type="checkbox"/>	C37.94	<input type="checkbox"/>	N/A	<input type="checkbox"/>	
		P-2M-L	<input type="checkbox"/>		<input type="checkbox"/>		<input type="checkbox"/>	
	Fiber connections made with P-2M-L unit on Ch 2?	Yes	<input type="checkbox"/>	N/A	<input type="checkbox"/>			
6.2.3	Fiber loopback connection made for 'Direct' or 'C37.94' on Ch 1?	Yes	<input type="checkbox"/>	N/A	<input type="checkbox"/>			
	Fiber loopback connection made for 'Direct' or 'C37.94' on Ch 2?	Yes	<input type="checkbox"/>	N/A	<input type="checkbox"/>			
6.2.n	Communications using P-2M-L units: n=4 for P-2M-L Apply to MiCOM Ch1 and/or Ch2 as appropriate							
6.2.n.1	Visual inspection (P-2M-L units only) Ch1							
	Ch 1 unit damaged?	Yes	<input type="checkbox"/>	No	<input type="checkbox"/>	N/A	<input type="checkbox"/>	
	Ch 1 rating information correct?	Yes	<input type="checkbox"/>	No	<input type="checkbox"/>	N/A	<input type="checkbox"/>	
	Ch 1 earthed?	Yes	<input type="checkbox"/>	No	<input type="checkbox"/>	N/A	<input type="checkbox"/>	
6.2.n.2	Insulation resistance (P-2M-L units only)							
	Ch 1 unit	Yes	<input type="checkbox"/>	No	<input type="checkbox"/>	N/T	<input type="checkbox"/>	N/A <input type="checkbox"/>
6.2.n.3	External wiring (P-2M-L units only)							

	Ch 1 unit checked against diagram?	Yes	<input type="checkbox"/>	No	<input type="checkbox"/>	N/A	<input type="checkbox"/>
6.2.n.4	Measured auxiliary supply (P-2M-L units only)						
	Ch 1 unit				V dc/ac	N/A	<input type="checkbox"/>
6.2.n.5	Light emitting diodes (P-2M-L units only)						
	Ch 1 unit LEDs working?	Yes	<input type="checkbox"/>	No	<input type="checkbox"/>	N/A	<input type="checkbox"/>
6.2.n.6	P-2M-L optical received signal level						
	Signal strength received by P-2M-L connected to Ch 1				dBm	N/A	<input type="checkbox"/>
6.2.n.7	P-2M-L loopback configured?	Yes	<input type="checkbox"/>		<input type="checkbox"/>	N/A	<input type="checkbox"/>
	Signal strength received by P-2M-L connected to Ch 1				dBm	N/A	<input type="checkbox"/>
6.2.n.8	Signal strength transmitted by P-2M-L on Ch 1				dBm	N/A	<input type="checkbox"/>
6.2.n.9	MiCOM optical received signal level Ch 1 from P-2M-L				dBm	N/A	<input type="checkbox"/>
6.2.n.1	Visual inspection (P-2M-L units only) Ch2						
	Ch 2 unit damaged?	Yes	<input type="checkbox"/>	No	<input type="checkbox"/>	N/A	<input type="checkbox"/>
	Ch 2 rating information correct?	Yes	<input type="checkbox"/>	No	<input type="checkbox"/>	N/A	<input type="checkbox"/>
	Ch 2 earthed?	Yes	<input type="checkbox"/>	No	<input type="checkbox"/>	N/A	<input type="checkbox"/>
6.2.n.2	Insulation resistance (P-2M-L units only)						
	Ch 2 unit	Yes	<input type="checkbox"/>	No	<input type="checkbox"/>	N/T	<input type="checkbox"/>
6.2.n.3	External wiring (P-2M-L units only)						
	Ch 2 unit checked against diagram?	Yes	<input type="checkbox"/>	No	<input type="checkbox"/>	N/A	<input type="checkbox"/>
6.2.n.4	Measured auxiliary supply P-2M-L units only)						
	Ch 2 unit				V dc/ac	N/A	<input type="checkbox"/>
6.2.n.5	Light emitting diodes (P-2M-L units only)						
	Ch 2 unit LEDs working?	Yes	<input type="checkbox"/>	No	<input type="checkbox"/>	N/A	<input type="checkbox"/>
6.2.n.6	P-2M-L optical received signal level						
	Signal strength received by P-2M-L connected to Ch 2				dBm	N/A	<input type="checkbox"/>
6.2.n.7	P-2M-L loopback configured?	Yes	<input type="checkbox"/>		<input type="checkbox"/>	N/A	<input type="checkbox"/>
	Signal strength received by P-2M-L connected to Ch 2				dBm	N/A	<input type="checkbox"/>
6.2.n.8	Signal strength transmitted by P-2M-L on Ch 2				dBm	N/A	<input type="checkbox"/>
6.2.n.9	MiCOM optical received signal level Ch 2 from P-2M-L				dBm	N/A	<input type="checkbox"/>
6.2.7	IM64 loopback test						
	IM64 test pattern set						
	IM64 Rx status observed						

7.		SETTING CHECKS					
7.1	Application-specific function settings applied?	Yes	<input type="checkbox"/>	No	<input type="checkbox"/>		
	Application-specific programmable scheme logic settings applied?	Yes	<input type="checkbox"/>	No	<input type="checkbox"/>	N/A	<input type="checkbox"/>
	Relay power-off and on if IM64 Comms Mode changed?	Yes	<input type="checkbox"/>	N/A	<input type="checkbox"/>		
7.1.1	InterMiCOM Loopback Mode and Test Pattern configured?	Yes	<input type="checkbox"/>	N/A	<input type="checkbox"/>		
7.1.2	InterMiCOM statistics reset?	Yes	<input type="checkbox"/>	N/A	<input type="checkbox"/>		
7.2	Injection testing - distance zones						
7.2.1	Elements to be re-enabled after testing (mark any that have been temporarily disabled)	Earth Fault				<input type="checkbox"/>	
		Overcurrent				<input type="checkbox"/>	
		DEF				<input type="checkbox"/>	
		CB Fail				<input type="checkbox"/>	
		N/A				<input type="checkbox"/>	
7.2.1.2	Zone 1 reach check - impedance at trip		Ω	N/M	<input type="checkbox"/>		
7.2.1.3	Zone 2 reach check - impedance at trip		Ω	N/M	<input type="checkbox"/>		
7.2.1.4	Zone 3 reach check - impedance at trip		Ω	N/M	<input type="checkbox"/>		
7.2.1.5	Zone 4 reach check - impedance at trip		Ω	N/M	<input type="checkbox"/>		
7.2.1.6	Zone P reach check - impedance at trip		Ω	N/M	<input type="checkbox"/>		
7.2.1.7	Resistive reach						
	Visual inspection						
	Phase & ground element resistive reach settings are correct?	Yes	<input type="checkbox"/>	No	<input type="checkbox"/>		
7.2.1.8	Load Blinder						
	Visual inspection						
	Load blinder settings are correct?	Yes	<input type="checkbox"/>	No	<input type="checkbox"/>	N/A	<input type="checkbox"/>
	Load blinder angle applied	Yes	<input type="checkbox"/>	No	<input type="checkbox"/>	N/A	<input type="checkbox"/>
7.2.2.1	Distance phase A trip time		ms				
7.2.2.2	Distance phase B trip time		ms				
7.2.2.3	Distance phase C trip time		ms				
	Average trip time, phases A, B and C		ms				
7.2.2.4	Time delay settings tZ1 Ph, and tZ2 - tZ4						
	Visual inspection						
	Time delay settings are correct?	Yes	<input type="checkbox"/>	No	<input type="checkbox"/>		
7.2.3	Distance protection scheme testing						
7.2.3.1	Scheme trip zone 1 extension scheme						
	No trip for fault with reset Z1X energized	Yes	<input type="checkbox"/>	No	<input type="checkbox"/>		
	Trip time with reset Z1X de-energized		ms				
7.2.3.2	Scheme trip permissive schemes (PUR/POR)						
	Trip time with signal receive energized	Yes	<input type="checkbox"/>	No	<input type="checkbox"/>		
7.2.3.3	Scheme trip blocking scheme						
	No trip for fault with signal receive energized	Yes	<input type="checkbox"/>	No	<input type="checkbox"/>		
	Trip time with signal receive de-energized		ms				

7.2.3.4	Signal send test for permissive schemes				
	Signal send operate time				ms
7.2.3.5	Signal send blocking schemes				
	Signal send operate time				ms
7.2.4	Scheme timer settings				
	Visual inspection				
	Time delays settings are correct?	Yes	<input type="checkbox"/>	No	<input type="checkbox"/>
	All disabled elements which were noted/circled previously are restored?	Yes	<input type="checkbox"/>	No	<input type="checkbox"/>
	Injection testing - DEF Aided Scheme				
	Elements to be re-enabled after testing (mark any that have been temporarily disabled)			Distance	<input type="checkbox"/>
				Earth Fault	<input type="checkbox"/>
				Overcurrent	<input type="checkbox"/>
				CB Fail	<input type="checkbox"/>
				N/A	<input type="checkbox"/>
	DEF aided scheme trip time				ms
	DEF signal send time permissive scheme				ms
	DEF signal send time blocking scheme				ms
	All disabled elements which were noted/circled previously are restored?	Yes	<input type="checkbox"/>	No	<input type="checkbox"/>
	Backup phase overcurrent protection				
	Elements to be re-enabled after testing (mark any that have been temporarily disabled)			Distance	<input type="checkbox"/>
				Earth Fault	<input type="checkbox"/>
				DEF	<input type="checkbox"/>
				CB Fail	<input type="checkbox"/>
				N/A	<input type="checkbox"/>
	Overcurrent type (set in call [>1 Direction])	Directional	<input type="checkbox"/>	Non-Directional	<input type="checkbox"/>
	Applied Voltage				V/na
	Applied Current				A
	Expected operating time				s
	Measure operating time				s
	All disabled elements which were noted/circled previously are restored?	Yes	<input type="checkbox"/>	No	<input type="checkbox"/>
	Trip and auto-reclose cycle checked				
	3 pole cycle tested?	Yes	<input type="checkbox"/>	No	<input type="checkbox"/>
				N/A	<input type="checkbox"/>

8.	END-TO-END COMMUNICATION TESTS (InterMiCOM only)					
8.1	MODEM InterMiCOM					
8.1.1	Local channel statistics and channel diagnostics visible?	Yes	<input type="checkbox"/>	No	<input type="checkbox"/>	N/A <input type="checkbox"/>
	Local source address and receive address correct?	Yes	<input type="checkbox"/>	No	<input type="checkbox"/>	N/A <input type="checkbox"/>
	Local operational connection restored?	Yes	<input type="checkbox"/>	No	<input type="checkbox"/>	N/A <input type="checkbox"/>
	Local loopback indication absent?	Yes	<input type="checkbox"/>	No	<input type="checkbox"/>	N/A <input type="checkbox"/>
8.1.2	Remote channel statistics and channel diagnostics visible?	Yes	<input type="checkbox"/>	No	<input type="checkbox"/>	N/A <input type="checkbox"/>
	Remote source address and receive address correct?	Yes	<input type="checkbox"/>	No	<input type="checkbox"/>	N/A <input type="checkbox"/>
	Remote operational connection restored?	Yes	<input type="checkbox"/>	No	<input type="checkbox"/>	N/A <input type="checkbox"/>
	Remote loopback indication absent?	Yes	<input type="checkbox"/>	No	<input type="checkbox"/>	N/A <input type="checkbox"/>
8.1.3	Verify end-to-end communications					
8.1.3.1	Local channel diagnostics OK?					
	Remote channel diagnostics OK?					
8.1.3.2	Local IM Output Status pattern					
	Remote IM Input Status Pattern					
	Pattern match?	Yes	<input type="checkbox"/>	No	<input type="checkbox"/>	N/A <input type="checkbox"/>
	Remote IM Output Status pattern					
	Local IM Input Status Pattern					
	Pattern match?	Yes	<input type="checkbox"/>	No	<input type="checkbox"/>	N/A <input type="checkbox"/>
8.1.3.3	Received data/error counters OK					
8.1.3.4	Statistics reset at (time)	HH:MM:SS				
	Statistics measured at (reset time + 1 hr minimum)	HH:MM:SS				
	Statistics measurements					
		Direct				
		Permissive				
		Blocking				
		NewData				
		Errored				
		Lost Messages				
		Ratio: errored/good				
8.2	Fiber InterMiCOM					
	Any Ch1 communication alarm?	Yes	<input type="checkbox"/>	No	<input type="checkbox"/>	
	Any Ch2 communication alarm?	Yes	<input type="checkbox"/>	No	<input type="checkbox"/>	N/A <input type="checkbox"/>
	Restore Communication Channels					
8.2.1.1.1	Direct fiber connection					
	Optical received signal level Ch 1			dBm	N/A	<input type="checkbox"/>
	Optical received signal level Ch 2			dBm	N/A	<input type="checkbox"/>
8.2.1.1.2	Fiber connections to C37.94					
	Optical received signal level from C37.94 Ch 1			dBm	N/A	<input type="checkbox"/>
	Optical received signal level at C37.94 Ch 1			dBm	N/A	<input type="checkbox"/>

	Optical received signal level from C37.94 Ch 1		dBm	N/A	<input type="checkbox"/>
	Optical received signal level at C37.94 Ch		dBm	N/A	<input type="checkbox"/>
8.2.1.1 - 8.2.1.4	All local connections restored?				
	Local Ch 1	Yes <input type="checkbox"/>	No <input type="checkbox"/>		
	Local Ch 2	Yes <input type="checkbox"/>	No <input type="checkbox"/>	N/A	<input type="checkbox"/>
	Cover replaced? (P-2M-L only)				
	Local Ch 1	Yes <input type="checkbox"/>	No <input type="checkbox"/>	N/A	<input type="checkbox"/>
	Local Ch 2	Yes <input type="checkbox"/>	No <input type="checkbox"/>	N/A	<input type="checkbox"/>
8.2.2.1	All connections restored at relay connected to Ch1?	Yes <input type="checkbox"/>	No <input type="checkbox"/>	N/A	<input type="checkbox"/>
8.2.2.2	All connections restored at relay connected to Ch2?	Yes <input type="checkbox"/>	No <input type="checkbox"/>	N/A	<input type="checkbox"/>
8.2.3	Verify communications between relays				
	Alarms reset?	Yes <input type="checkbox"/>	No <input type="checkbox"/>		
	Ch 1 propagation time delay				ms
	Ch 2 propagation time delay		ms	N/A	<input type="checkbox"/>
	Channel 1 valid message incrementing and errored messages zero?				
	Channel 2 valid message incrementing and errored messages zero?				
	Statistics reset at (time)	HH:MM:SS			
	Statistics measured at (reset time + 1 hr minimum)	HH:MM:SS			
	Statistics measurements				
		Ch 1 No. valid messages	No <input type="checkbox"/>	N/A	<input type="checkbox"/>
		Ch 1 No. err messages	No <input type="checkbox"/>	N/A	<input type="checkbox"/>
		Ch 1 errored/valid	No <input type="checkbox"/>	N/A	<input type="checkbox"/>
		Ch 1 errored/valid < 10 ⁻⁴	No <input type="checkbox"/>	N/A	<input type="checkbox"/>
		Ch 2 No. valid messages	No <input type="checkbox"/>	N/A	<input type="checkbox"/>
		Ch 2 No. err messages	No <input type="checkbox"/>	N/A	<input type="checkbox"/>
		Ch 2 errored/valid >	No <input type="checkbox"/>	N/A	<input type="checkbox"/>
		Ch 2 errored/valid < 10 ⁻⁴	No <input type="checkbox"/>	N/A	<input type="checkbox"/>

9.	END-TO-END SCHEME TESTS						
9.1	Signaling channel check						
9.1.1	Aided scheme 1 signaling channel test						
9.1.1.2	Local - remote end signal received	Yes	<input type="checkbox"/>	No	<input type="checkbox"/>	N/A	<input type="checkbox"/>
9.1.1.3	Remote - local end signal received	Yes	<input type="checkbox"/>	No	<input type="checkbox"/>	N/A	<input type="checkbox"/>
9.1.2	Aided scheme 2 signaling channel test						
9.1.2.1	Local - remote end signal received	Yes	<input type="checkbox"/>	No	<input type="checkbox"/>	N/A	<input type="checkbox"/>
9.1.2.2	Remote - local end signal received	Yes	<input type="checkbox"/>	No	<input type="checkbox"/>	N/A	<input type="checkbox"/>

10.	MODEM InterMiCOM Scheme Testing
	If applicable, provide details of scheme tests undertaken and results obtained.

11.	ON-LOAD CHECKS						
	Test wiring removed?	Yes	<input type="checkbox"/>	No	<input type="checkbox"/>		
11.1.1	Voltage inputs and phase rotation OK?	Yes	<input type="checkbox"/>	No	<input type="checkbox"/>		
11.1.2	Current inputs and polarities OK?	Yes	<input type="checkbox"/>	No	<input type="checkbox"/>		
	Capacitive Charging Current Checked??	Yes	<input type="checkbox"/>	No	<input type="checkbox"/>	N/A	<input type="checkbox"/>
	CT Polarity Consistency Checked??	Yes	<input type="checkbox"/>	No	<input type="checkbox"/>	N/A	<input type="checkbox"/>
11.2	On-load test performed? (If "No", give reason why) ...	Yes	<input type="checkbox"/>	No	<input type="checkbox"/>		
	Relay is correctly directionalized?	Yes	<input type="checkbox"/>	No	<input type="checkbox"/>	N/A	<input type="checkbox"/>
11.3	Signaling channel check	Yes	<input type="checkbox"/>	Tested in	<input type="checkbox"/>	N/A	<input type="checkbox"/>

12.	FINAL CHECKS					
	All Test equipment, leads, shorts, test blocks and other test wiring removed?	Yes	<input type="checkbox"/>	No	<input type="checkbox"/>	N/A <input type="checkbox"/>
	Disturbed customer wiring re-checked?	Yes	<input type="checkbox"/>	No	<input type="checkbox"/>	N/A <input type="checkbox"/>
	All commissioning tests disabled?	Yes	<input type="checkbox"/>	No	<input type="checkbox"/>	
	Test mode disabled?	Yes	<input type="checkbox"/>	No	<input type="checkbox"/>	
	Application Settings Checked?	Yes	<input type="checkbox"/>	No	<input type="checkbox"/>	
	Circuit breaker operations counter reset?	Yes	<input type="checkbox"/>	No	<input type="checkbox"/>	N/A <input type="checkbox"/>
	Current counters reset?	Yes	<input type="checkbox"/>	No	<input type="checkbox"/>	N/A <input type="checkbox"/>
	Event records reset?	Yes	<input type="checkbox"/>	No	<input type="checkbox"/>	
	Fault records reset?	Yes	<input type="checkbox"/>	No	<input type="checkbox"/>	
	Disturbance records reset?	Yes	<input type="checkbox"/>	No	<input type="checkbox"/>	
	Alarms reset?	Yes	<input type="checkbox"/>	No	<input type="checkbox"/>	
	LEDs reset?	Yes	<input type="checkbox"/>	No	<input type="checkbox"/>	
	Communications statistics reset?	Yes	<input type="checkbox"/>	No	<input type="checkbox"/>	
	Secondary front cover replaced?	Yes	<input type="checkbox"/>	No	<input type="checkbox"/>	N/A <input type="checkbox"/>

1.6 Engineer Details

COMMENTS #

(# Optional, for site observations or utility-specific notes).

Commissioning Engineer:
Date:

Customer Witness:
Date:

2. CREATING A SETTING RECORD

You often need to create a record of what settings have been applied to a device. In the past, you could have used paper printouts of all the available settings, and mark up the ones you had used. Keeping such a paper-based Settings Records can be time consuming and prone to error (e.g. due to being settings written down incorrectly).

The Easergy Studio software lets you read/write MiCOM devices.

- **Extract** lets you download all the settings from a MiCOM Px40 device. A summary is given in Extract Settings from a MiCOM Px40 Device below.
- **Send** lets you send the settings you currently have open in the Easergy Studio software. A summary is given in Send Settings to a MiCOM Px40 Device below.

The Easergy Studio product is updated periodically. These updates provide support for new features (such as allowing you to manage new MiCOM products, as well as using new software releases and hardware suffixes). The updates may also include fixes.

Accordingly, we strongly advise customers to use the latest Schneider Electric version of Easergy Studio.

In most cases, it will be quicker and less error prone to extract settings electronically and store them in a settings file on a memory stick. In this way, there will be a digital record which is certain to be accurate. It is also possible to archive these settings files in a repository; so they can be used again or adapted for another use.

Full details of how to do these tasks is provided in the Easergy Studio help.

A quick summary of the main steps is given below. In each case you need to make sure that:

- Your computer includes the Easergy Studio software.
- Your computer and the MiCOM device are powered on.
- You have used a suitable cable to connect your computer to the MiCOM device (Front Port, Rear Port, Ethernet port or Modem as available).

2.1 Extract Settings from a MiCOM Px40 Device

Full details of how to do this is provided in the Easergy Studio help.

As a quick guide, you need to do the following:

1. In **Easergy Studio**, click the **Quick Connect...** button.
2. Select the relevant **Device Type** in the **Quick Connect** dialog box.
3. Click the relevant **port** in the **Port Selection** dialog box.
4. Enter the relevant **connection parameters** in the **Connection Parameters** dialog box and click the **Finish** button
5. Easergy Studio will try to communicate with the Px40 device. It will display a **Connected** message if the connection attempt is successful.
6. The **device** will appear in the Studio Explorer pane on the top-left of the interface.
7. Click the **+** button to expand the **options** for the device, then click on the **Settings** folder.
8. Right-click on **Settings** and select the **Extract Settings** link to read the settings on the device and store them on your computer or a memory stick.
9. After retrieving the settings file, close the dialog box by clicking the **Close** button.

2.2 Send Settings to a MiCOM Px40 Device

Full details of how to do this is provided in the Easergy Studio help.

As a quick guide, you need to do the following:

1. In **Easergy Studio**, click the **Quick Connect...** button.
2. Select the relevant **Device Type** in the **Quick Connect** dialog box.
3. Click the relevant **port** in the **Port Selection** dialog box.
4. Enter the relevant **connection parameters** in the **Connection Parameters** dialog box and click the **Finish** button
5. Easergy Studio will try to communicate with the Px40 device. It will display a **connected** message if the connection attempt is successful.
6. The device will appear in the Studio Explorer pane on the top-left hand side of the interface.
7. Click the **+** button to **expand** the options for the device and then right-click on the **Settings** link.
8. To **add** an existing file, right-click the **settings** folder and choose **Add Existing File**.
9. To **create** a new file, right-click the **settings** folder and select **Add**. A file with the next sequential number will be created. **Double-click the file to edit**.
10. Right-click on the **device name** and select the **Send** link.

Note

When you send settings to a MiCOM Px40 device, the data is stored in a temporary location at first. This temporary data is tested to make sure it is complete. If the temporary data is complete, it will be programmed into the MiCOM Px40 device. This avoids the risk of a device being programmed with incomplete or corrupt settings.

11. In the **Send To** dialog box, select the **settings file(s)** you wish to send, then click the **Send** button.
12. Close the **Send To dialog box** by clicking the **Close** button.

MAINTENANCE

CHAPTER 13

Chapter Applicability	
Date:	09/2016
Products covered by this chapter:	
This chapter covers the specific versions of the MiCOM products listed below. This includes only the following combinations of Software Version and Hardware Suffix.	
Hardware Suffix:	All MiCOM Px4x products
Software Version:	All MiCOM Px4x products
Connection Diagrams:	This chapter may use any of these connection diagrams:
P14x (P141, P142, P143 & P145):	10P141xx (xx = 01 to 02) 10P142xx (xx = 01 to 05) 10P143xx (xx = 01 to 11) 10P145xx (xx = 01 to 11)
P24x (P241, P242 & P243):	10P241xx (xx = 01 to 02) 10P242xx (xx = 01) 10P243xx (xx = 01)
P34x (P342, P343, P344, P345 & P391):	10P342xx (xx = 01 to 17) 10P343xx (xx = 01 to 19) 10P344xx (xx = 01 to 12) 10P345xx (xx = 01 to 07) 10P391xx (xx = 01 to 02)
P445:	10P445xx (xx = 01 to 04)
P44x (P442 & P444):	10P44101 (SH 1 & 2) 10P44201 (SH 1 & 2) 10P44202 (SH 1) 10P44203 (SH 1 & 2) 10P44401 (SH 1) 10P44402 (SH 1) 10P44403 (SH 1 & 2) 10P44404 (SH 1) 10P44405 (SH 1) 10P44407 (SH 1 & 2)
P44y (P443 & P446):	10P44303 (SH 01 and 03) 10P44304 (SH 01 and 03) 10P44305 (SH 01 and 03) 10P44306 (SH 01 and 03) 10P44600 10P44601 (SH 1 to 2) 10P44602 (SH 1 to 2) 10P44603 (SH 1 to 2)
P54x (P543, P544, P545 & P546):	10P54302 (SH 1 to 2) 10P54303 (SH 1 to 2) 10P54400 10P54404 (SH 1 to 2) 10P54405 (SH 1 to 2) 10P54502 (SH 1 to 2) 10P54503 (SH 1 to 2) 10P54600 10P54604 (SH 1 to 2)

	10P54605 (SH 1 to 2) 10P54606 (SH 1 to 2)
P547:	10P54702xx (xx = 01 to 02) 10P54703xx (xx = 01 to 02) 10P54704xx (xx = 01 to 02) 10P54705xx (xx = 01 to 02)
P64x (P642, P643 & P645):	10P642xx (xx = 1 to 10) 10P643xx (xx = 1 to 6) 10P645xx (xx = 1 to 9)
P74x (P741, P742 & P743):	10P740xx (xx = 01 to 07)
P746:	10P746xx (xx = 00 to 21)
P841:	10P84100 10P84101 (SH 1 to 2) 10P84102 (SH 1 to 2) 10P84103 (SH 1 to 2) 10P84104 (SH 1 to 2) 10P84105 (SH 1 to 2)
P849:	10P849xx (xx = 01 to 06)

Notes:

CONTENTS

1. Maintenance Period	7
2. Maintenance Checks	8
2.1 Alarms.....	8
2.2 Opto-Isolators.....	8
2.3 Output Relays.....	8
2.4 Measurement Accuracy.....	8
3. Method of Repair	9
3.1 Replacing the Complete Equipment IED/Relay.....	9
3.2 Replacing a PCB.....	10
4. Re-Calibration	11
5. Changing the Battery	12
5.1 Instructions for Replacing the Battery.....	12
5.2 Post Modification Tests.....	12
5.3 Battery Disposal.....	12
6. Cleaning	13

Notes:

1. MAINTENANCE PERIOD



Warning

Before inspecting any wiring, performing any tests or carrying out any work on the equipment, you should be familiar with the contents of the Safety Information and Technical Data sections and the information on the equipment's rating label.

It is recommended that products supplied by Schneider Electric receive periodic monitoring after installation. In view of the critical nature of protective and control equipment, and their infrequent operation, it is desirable to confirm that they are operating correctly at regular intervals.

Schneider Electric protection and control equipment is designed for a life in excess of 20 years.

MiCOM relays are self-supervising and so require less maintenance than earlier designs. Most problems will result in an alarm so that remedial action can be taken. However, some periodic tests should be done to ensure that the equipment is functioning correctly and the external wiring is intact.

If the customer's organization has a preventative maintenance policy, the recommended product checks should be included in the regular program. Maintenance periods depend on many factors, such as:

- The operating environment
- The accessibility of the site
- The amount of available manpower
- The importance of the installation in the power system
- The consequences of failure

2. MAINTENANCE CHECKS

Although some functionality checks can be performed from a remote location by using the communications ability of the equipment, these are predominantly restricted to checking that the equipment, is measuring the applied currents and voltages accurately, and checking the circuit breaker maintenance counters. Therefore, it is recommended that maintenance checks are performed locally (i.e. at the equipment itself).

**Warning**

Before carrying out any work on the equipment, you should be familiar with the contents of the Safety Information chapter/Safety Guide SFTY/5L M/L11 or later issue, the Technical Data chapter and the ratings on the equipment rating label.

**Warning**

If a P391 is used, you should also be familiar with the ratings and warning statements in the P391 technical manual.

2.1 Alarms

The alarm status LED should first be checked to identify if any alarm conditions exist. If so, press the read key (Ⓜ) repeatedly to step through the alarms.

Clear the alarms to extinguish the LED.

2.2 Opto-Isolators

The opto-isolated inputs can be checked to ensure that the equipment responds to energization by repeating the commissioning test detailed in the Commissioning chapter.

2.3 Output Relays

The output relays can be checked to ensure that they operate by repeating the commissioning test detailed in the Commissioning chapter.

2.4 Measurement Accuracy

If the power system is energized, the values measured by the equipment can be compared with known system values to check that they are in the approximate range that is expected. If they are, the analog/digital conversion and calculations are being performed correctly by the relay. Suitable test methods can be found in the Commissioning chapter.

Alternatively, the values measured by the equipment can be checked against known values injected via the test block, if fitted, or injected directly into the equipment terminals. Suitable test methods can be found in the Commissioning chapter. These tests will prove the calibration accuracy is being maintained.

3. METHOD OF REPAIR

If the equipment should develop a fault whilst in service, depending on the nature of the fault, the watchdog contacts will change state and an alarm condition will be flagged. Due to the extensive use of surface-mount components, faulty Printed Circuit Boards (PCBs) should be replaced, as it is not possible to perform repairs on damaged PCBs. Therefore, either the complete equipment module or just the faulty PCB (as identified by the in-built diagnostic software), can be replaced. Advice about identifying the faulty PCB can be found in the Troubleshooting chapter.

The preferred method is to replace the complete equipment module as it ensures that the internal circuitry is protected against electrostatic discharge and physical damage at all times and overcomes the possibility of incompatibility between replacement PCBs. However, it may be difficult to remove installed equipment due to limited access in the back of the cubicle and the rigidity of the scheme wiring.

Replacing PCBs can reduce transport costs but requires clean, dry conditions on site and higher skills from the person performing the repair. If the repair is not performed by an approved service center, the warranty will be invalidated.



Warning

Before carrying out any work on the equipment, you should be familiar with the contents of the Safety Information chapter/Safety Guide SFTY/5L M/L11 or later issue, the Technical Data chapter and the ratings on the equipment rating label.

This should ensure that no damage is caused by incorrect handling of the electronic components.

3.1 Replacing the Complete Equipment IED/Relay

The case and rear terminal blocks have been designed to facilitate removal of the IED/relay should replacement or repair become necessary without having to disconnect the scheme wiring.



Warning

Before working at the rear of the equipment, isolate all voltage and current supplies to the equipment.

Note

The MiCOM range has integral current transformer shorting switches which will close when the heavy duty terminal block is removed.

1. Disconnect the equipment's earth, IRIG-B and fiber optic connections, as appropriate, from the rear of the device.

There are two types of terminal block used on the equipment, medium and heavy duty, which are fastened to the rear panel using Pozidriv or PZ1 screws. The P24x/P34x/P64x ranges also includes an RTD/CLIO terminal block option. These block types are shown in the Commissioning chapter.

Important

The use of a magnetic bladed screwdriver is recommended to minimize the risk of the screws being left in the terminal block or lost.

2. Without exerting excessive force or damaging the scheme wiring, pull the terminal blocks away from their internal connectors.
3. Remove the screws used to fasten the equipment to the panel, rack, etc. These are the screws with the larger diameter heads that are accessible when the access covers are fitted and open.

**Warning**

If the top and bottom access covers have been removed, do not remove the screws with the smaller diameter heads which are accessible. These screws secure the front panel to the equipment.

4. Withdraw the equipment carefully from the panel, rack, etc. because it will be heavy due to the internal transformers.

To reinstall the repaired or replacement equipment, follow the above instructions in reverse, ensuring that each terminal block is relocated in the correct position and the case earth, IRIG-B and fiber optic connections are replaced. To facilitate easy identification of each terminal block, they are labeled alphabetically with 'A' on the left-hand side when viewed from the rear.

Once reinstallation is complete, the equipment should be re-commissioned using the instructions in the Commissioning chapter.

3.2 Replacing a PCB

Replacing PCBs and other internal components must be undertaken only by Service Centers approved by Schneider Electric. Failure to obtain the authorization of Schneider Electric after sales engineers prior to commencing work may invalidate the product warranty.

**Warning**

Before removing the front panel to replace a PCB, remove the auxiliary supply and wait at least 30 seconds for the capacitors to discharge. We strongly recommend that the voltage and current transformer connections and trip circuit are isolated.

Schneider Electric support teams are available world-wide. We strongly recommend that any repairs be entrusted to those trained personnel. For this reason, details on product disassembly and re-assembly are not included here.

4. RE-CALIBRATION

Re-calibration is not required when a PCB is replaced unless it happens to be one of the boards in the input module; the replacement of either directly affects the calibration.

**Warning**

Although it is possible to carry out re-calibration on site, this requires test equipment with suitable accuracy and a special calibration program to run on a PC. It is therefore recommended that the work be carried out by the manufacturer, or entrusted to an approved service center.

5. CHANGING THE BATTERY

Each relay/IED has a battery to maintain status data and the correct time when the auxiliary supply voltage fails. The data maintained includes event, fault and disturbance records and the thermal state at the time of failure.

This battery will periodically need changing, although an alarm will be given as part of the relay's/IEDs continuous self-monitoring in the event of a low battery condition.

If the battery-backed facilities are not required to be maintained during an interruption of the auxiliary supply, the steps below can be followed to remove the battery, but do not replace with a new battery.



Warning

Before carrying out any work on the equipment, you should be familiar with the contents of the Safety Information chapter/Safety Guide SFTY/5L M/L11 or later issue, the Technical Data chapter and the ratings on the equipment rating label.

5.1 Instructions for Replacing the Battery

1. Open the bottom access cover on the front of the equipment.
2. Gently extract the battery from its socket. If necessary, use a small, insulated screwdriver to prize the battery free.
3. Ensure that the metal terminals in the battery socket are free from corrosion, grease and dust.
4. The replacement battery should be removed from its packaging and placed into the battery holder, taking care to ensure that the polarity markings on the battery agree with those adjacent to the socket.



Note

Only use a type ½AA Lithium battery with a nominal voltage of 3.6 V and safety approvals such as UL (Underwriters Laboratory), CSA (Canadian Standards Association) or VDE (Vereinigung Deutscher Elektrizitätswerke).

5. Ensure that the battery is securely held in its socket and that the battery terminals are making good contact with the metal terminals of the socket.
6. Close the bottom access cover.

5.2 Post Modification Tests

To ensure that the replacement battery will maintain the time and status data if the auxiliary supply fails, check cell [0806: DATE and TIME, Battery Status] reads 'Healthy'.

If further confirmation that the replacement battery is installed correctly is required, the commissioning test is described in the Commissioning chapter, 'Date and Time', can be performed.

5.3 Battery Disposal

The battery that has been removed should be disposed of in accordance with the disposal procedure for Lithium batteries in the country in which the equipment is installed.

6. CLEANING

**Warning**

Before cleaning the equipment ensure that all ac and dc supplies, current transformer and voltage transformer connections are isolated to prevent any chance of an electric shock whilst cleaning.

The equipment may be cleaned using a lint-free cloth moistened with clean water. The use of detergents, solvents or abrasive cleaners is not recommended as they may damage the relay's surface and leave a conductive residue.

Notes:

TROUBLESHOOTING

CHAPTER 14

Applicability	
Date:	12/2021
Products covered by this chapter:	
This chapter covers the specific versions of the MiCOM products listed below. This includes only the following combinations of Software Version and Hardware Suffix.	
Hardware Suffix:	
MiCOM Px4x	All
Software Version:	
MiCOM Px4x	All
Connection Diagrams:	
This chapter list the connection diagram for the product:	
P14x (P141, P142, P143 & P145):	10P141xx (xx = 01 to 02) 10P142xx (xx = 01 to 05) 10P143xx (xx = 01 to 11) 10P145xx (xx = 01 to 11)
P24x (P241, P242 & P243):	10P241xx (xx = 01 to 02) 10P242xx (xx = 01) 10P243xx (xx = 01)
P34x (P342, P343, P344, P345 & P391)	10P342xx (xx = 01 to 17) 10P343xx (xx = 01 to 19) 10P344xx (xx = 01 to 12) 10P345xx (xx = 01 to 07) 10P391xx (xx = 01 to 02)
P445:	10P445xx (xx = 01 to 04)
P44x (P442 & P444):	10P44101 (SH 1 & 2) 10P44201 (SH 1 & 2) 10P44202 (SH 1) 10P44203 (SH 1 & 2) 10P44401 (SH 1) 10P44402 (SH 1) 10P44403 (SH 1 & 2) 10P44404 (SH 1) 10P44405 (SH 1) 10P44407 (SH 1 & 2)
P44y:	10P44303 (SH 01 and 03) 10P44304 (SH 01 and 03) 10P44305 (SH 01 and 03) 10P44306 (SH 01 and 03) 10P44600 10P44601 (SH 1 to 2) 10P44602 (SH 1 to 2) 10P44603 (SH 1 to 2)
P54x (P543, P544, P545 & P546):	10P54302 (SH 1 to 2) 10P54303 (SH 1 to 2) 10P54304 (SH 1 to 2) 10P54400 10P54404 (SH 1 to 2)

	10P54405 (SH 1 to 2) 10P54502 (SH 1 to 2) 10P54503 (SH 1 to 2) 10P54504 (SH 1 to 2) 10P54600 10P54604 (SH 1 to 2) 10P54605 (SH 1 to 2) 10P54606 (SH 1 to 2)
P547:	10P54702xx (xx = 01 to 02) 10P54703xx (xx = 01 to 02) 10P54704xx (xx = 01 to 02) 10P54705xx (xx = 01 to 02)
P64x (P642, P643 & P645):	10P642xx (xx = 1 to 10) 10P643xx (xx = 1 to 6) 10P645xx (xx = 1 to 9)
P74x:	10P740xx (xx = 01 to 07)
P746:	10P746xx (xx = 00 to 21)
P841:	10P84100 10P84101 (SH 1 to 2) 10P84102 (SH 1 to 2) 10P84103 (SH 1 to 2) 10P84104 (SH 1 to 2) 10P84105 (SH 1 to 2)
P849:	10P849xx (xx = 01 to 06)

Notes:

CONTENTS

1. Introduction	7
2. Initial Problem Identification	8
3. Power Up Errors	9
4. Error Message/Code on Power-up	10
5. Out of Service LED Illuminated on Power Up	11
6. Error Code during Operation	12
7. Mal-Operation of the Relay during Testing	13
7.1 Failure of Output Contacts	13
7.2 Failure of Opto-Isolated Inputs	13
7.3 Incorrect Analog Signals	14
7.4 PSL Editor Troubleshooting	14
7.4.1 Diagram Reconstruction after Recover from Relay.....	14
7.4.2 PSL Version Check.....	14
8. Repair and Modification Procedure	15
9. Repair / Modification Return Authorization Form	16

TABLES

Table 1 - Problem identification.....	8
Table 2 - Failure of relay to power up.....	9
Table 3 - Power-up self-test error.....	10
Table 4 - Out-of-Service LED illuminated.....	11
Table 5 - Failure of output contacts.....	13

Notes:

1. INTRODUCTION

**Warning**

Before carrying out any work on the equipment, you should be familiar with the contents of the Safety Information chapter/Safety Guide SFTY/5L M/L11 or later issue, the Technical Data chapter and the ratings on the equipment rating label.

The purpose of this chapter of the service manual is to allow an error condition on the relay to be identified so that appropriate corrective action can be taken.

If the relay has developed a fault, it should be possible in most cases to identify which relay module requires attention. The Maintenance chapter advises on the recommended method of repair where faulty modules need replacing. It is not possible to perform an on-site repair to a faulted module.

In cases where a faulty relay/module is being returned to the manufacturer or one of their approved service centers, a completed copy of the [Repair/Modification Return Authorization Form](#) located at the end of this chapter should be included.

2. INITIAL PROBLEM IDENTIFICATION

Consult the following table to find the description that best matches the problem experienced, then consult the section referenced to perform a more detailed analysis of the problem.

Symptom	Refer To
Relay fails to power up	Power-Up Errors section
Relay powers up - but indicates error and halts during power-up sequence	Error Message/Code On Power-Up section
Relay Powers up but Out of Service LED is illuminated	Out of Service LED illuminated on Power Up section
Error during normal operation	Error Code During Operation section
Mal-operation of the relay during testing	Mal-Operation of the Relay during Testing section

Table 1 - Problem identification

3. POWER UP ERRORS

If the relay does not appear to power up then the following procedure can be used to determine whether the fault is in the external wiring, auxiliary fuse, power supply module of the relay or the relay front panel.

Test	Check	Action
1	1 Measure auxiliary voltage on terminals 1 and 2; verify voltage level and polarity against rating the label on front. Terminal 1 is -dc, 2 is +dc	If auxiliary voltage is present and correct, then proceed to test 2. Otherwise the wiring/fuses in auxiliary supply should be checked.
2	Do LEDs/and LCD backlight illuminate on power-up, also check the N/O watchdog contact for closing.	If they illuminate or the contact closes and no error code is displayed then error is probably in the main processor board (front panel). If they do not illuminate and the contact does not close then proceed to test 3.
3	Check Field voltage output (nominally 48V DC)	If field voltage is not present then the fault is probably in the relay power supply module.

Table 2 - Failure of relay to power up

4. ERROR MESSAGE/CODE ON POWER-UP

During the power-up sequence of the relay self-testing is performed as indicated by the messages displayed on the LCD. If an error is detected by the relay during these self-tests, an error message will be displayed and the power-up sequence will be halted. If the error occurs when the relay application software is executing, a maintenance record will be created and the relay will reboot.

Test	Check	Action										
1	Is an error message or code permanently displayed during power up?	If relay locks up and displays an error code permanently then proceed to Test 2. If the relay prompts for input by the user proceed to Test 4. If the relay re-boots automatically then proceed to Test 5.										
2	Record displayed error, then remove and re-apply relay auxiliary supply.	Record whether the same error code is displayed when the relay is rebooted. If no error code is displayed then contact the local service center stating the error code and relay information. If the same code is displayed proceed to Test 3.										
3	<p>Error code Identification</p> <p>Following text messages (in English) will be displayed if a fundamental problem is detected preventing the system from booting:</p> <table border="0"> <tr> <td>Bus Fail</td> <td>address lines</td> </tr> <tr> <td>SRAM Fail</td> <td>data lines</td> </tr> <tr> <td>FLASH Fail</td> <td>format error</td> </tr> <tr> <td>FLASH Fail</td> <td>checksum</td> </tr> <tr> <td>Code Verify</td> <td>Fail</td> </tr> </table> <p>These hex error codes relate to errors detected in specific relay modules:</p>	Bus Fail	address lines	SRAM Fail	data lines	FLASH Fail	format error	FLASH Fail	checksum	Code Verify	Fail	<p>These messages indicate that a problem has been detected on the main processor board of the relay (located in the front panel).</p>
Bus Fail	address lines											
SRAM Fail	data lines											
FLASH Fail	format error											
FLASH Fail	checksum											
Code Verify	Fail											
	0c140005/0c0d0000	Input Module (inc. Opto-isolated inputs)										
	0c140006/0c0e0000	Output Relay Cards										
	Last 4 digits provide details on the actual error	Other error codes relate to problems within the main processor board hardware or software. It will be necessary to contact Schneider Electric with details of the problem for a full analysis.										
4	Relay displays message for corrupt settings and prompts for restoration of defaults to the affected settings.	The power up tests have detected corrupted relay settings, it is possible to restore defaults to allow the power-up to be completed. It will then be necessary to re-apply the application-specific settings.										

Table 3 - Power-up self-test error

5. OUT OF SERVICE LED ILLUMINATED ON POWER UP

Test	Check	Action	
1	Using the relay menu confirm whether the Commission Test/Test Mode setting is Contact Blocked. Otherwise proceed to test 2.	If the setting is Contact Blocked then disable the test mode and, verify that the Out of Service LED is extinguished.	
2	Select and view the last maintenance record from the menu (in the View Records).	Check for H/W Verify Fail this indicates a discrepancy between the relay model number and the hardware; examine the "Maint. Data", this indicates the causes of the failure using bit fields:	
		Bit	Meaning
		0	The application type field in the model number does not match the software ID
		1	The application field in the model number does not match the software ID
		2	The variant 1 field in the model number does not match the software ID
		3	The variant 2 field in the model number does not match the software ID
		4	The protocol field in the model number does not match the software ID
		5	The language field in the model number does not match the software ID
		6	The VT type field in the model number is incorrect (110V VTs fitted)
		7	The VT type field in the model number is incorrect (440V VTs fitted)
		8	The VT type field in the model number is incorrect (no VTs fitted)

Table 4 - Out-of-Service LED illuminated

6. ERROR CODE DURING OPERATION

The relay performs continuous self-checking, if an error is detected then an error message will be displayed, a maintenance record will be logged and the relay will reset (after a 1.6 second delay). A permanent problem (for example due to a hardware fault) will generally be detected on the power up sequence, following which the relay will display an error code and halt. If the problem was transient in nature then the relay should reboot correctly and continue in operation. The nature of the detected fault can be determined by examination of the maintenance record logged.

There are also two cases where a maintenance record will be logged due to a detected error where the relay will not reset. These are detection of a failure of either the field voltage or the lithium battery, in these cases the failure is indicated by an alarm message, however the relay will continue to operate.

If the field voltage is detected to have failed (the voltage level has dropped below threshold), then a scheme logic signal is also set. This allows the scheme logic to be adapted in the case of this failure (for example if a blocking scheme is being used).

In the case of a battery failure it is possible to prevent the relay from issuing an alarm using the setting under the Date and Time section of the menu. This setting 'Battery Alarm' can be set to 'Disabled' to allow the relay to be used without a battery, without an alarm message being displayed.

In the case of an RTD board failure, an alarm "RTD board fail" message is displayed, the RTD protection is disabled, but the operation of the rest of the relay functionality is unaffected.

7. MAL-OPERATION OF THE RELAY DURING TESTING

7.1 Failure of Output Contacts

An apparent failure of the relay output contacts may be caused by the relay configuration; the following tests should be performed to identify the real cause of the failure.

Note

The relay self-tests verify that the coil of the contact has been energized, an error will be displayed if there is a fault in the output relay board.

Test	Check	Action
1	Is the Out of Service LED illuminated?	Illumination of this LED may indicate that the relay is Contact Blocked or that the protection has been disabled due to a hardware verify error (see the Out of service LED illuminated table.
2	Examine the Contact status in the Commissioning section of the menu.	If the relevant bits of the contact status are operated, proceed to test 4, if not proceed to test 3.
3	Verify by examination of the fault record or by using the test port whether the protection element is operating correctly. If the protection element does not operate verify whether the test is being correctly applied.	If the protection element does operate, it will be necessary to check the PSL to ensure that the mapping of the protection element to the contacts is correct.
4	Using the Commissioning/Test mode function apply a test pattern to the relevant relay output contacts and verify whether they operate (note the correct external connection diagram should be consulted). A continuity tester can be used at the rear of the relay for this purpose.	If the output relay does operate, the problem must be in the external wiring to the relay. If the output relay does not operate this could indicate a failure of the output relay contacts (note that the self-tests verify that the relay coil is being energized). Ensure that the closed resistance is not too high for the continuity tester to detect.

Table 5 - Failure of output contacts

7.2 Failure of Opto-Isolated Inputs

The opto-isolated inputs are mapped onto the relay internal signals using the PSL. If an input does not appear to be recognized by the relay scheme logic the Commission Tests/Opto Status menu option can be used to verify whether the problem is in the opto-isolated input itself or the mapping of its signal to the scheme logic functions. If the opto-isolated input does appear to be read correctly then it will be necessary to examine its mapping within the PSL.

Ensure the voltage rating for the opto inputs has been configured correctly with applied voltage. If the opto-isolated input state is not being correctly read by the relay the applied signal should be tested. Verify the connections to the opto-isolated input using the correct wiring diagram and the correct nominal voltage settings in any standard or custom menu settings. Next, using a voltmeter verify that 80% opto setting voltage is present on the terminals of the opto-isolated input in the energized state. If the signal is being correctly applied to the relay then the failure may be on the input card itself. Depending on which opto-isolated input has failed this may require replacement of either the complete analog input module (the board within this module cannot be individually replaced without re-calibration of the relay) or a separate opto board.

7.3 Incorrect Analog Signals

The measurements may be configured in primary or secondary to assist. If it is suspected that the analog quantities being measured by the relay are not correct then the measurement function of the relay can be used to verify the nature of the problem. The measured values displayed by the relay should be compared with the actual magnitudes at the relay terminals. Verify that the correct terminals are being used (in particular the dual rated CT inputs) and that the CT and VT ratios set on the relay are correct. The correct 120 degree displacement of the phase measurements should be used to confirm that the inputs have been correctly connected.

7.4 PSL Editor Troubleshooting

A failure to open a connection could be because of one or more of the following:

- The relay address is not valid (note: this address is always 1 for the front port).
- Password is not valid
- Communication Set-up - COM port, Baud rate, or Framing - is not correct
- Transaction values are not suitable for the relay and/or the type of connection
- Modem configuration is not valid. Changes may be necessary when using a modem
- The connection cable is not wired correctly or broken. See MiCOM S1 connection configurations

7.4.1 Diagram Reconstruction after Recover from Relay

Although the extraction of a scheme from a relay is supported, the facility is provided as a way of recovering a scheme in the event that the original file is unobtainable.

The recovered scheme will be logically correct, but much of the original graphical information is lost. Many signals will be drawn in a vertical line down the left side of the canvas. Links are drawn orthogonally using the shortest path from A to B.

Any annotation added to the original diagram (titles, notes, etc.) are lost.

Sometimes a gate type may not be what was expected, e.g. a 1-input AND gate in the original scheme will appear as an OR gate when uploaded. Programmable gates with an inputs-to-trigger value of 1 will also appear as OR gates.

7.4.2 PSL Version Check

The PSL is saved with a version reference, time stamp and CRC check. This gives a visual check whether the default PSL is in place or whether a new application has been downloaded.

8. REPAIR AND MODIFICATION PROCEDURE

Please follow these steps to return an Automation product to us:

1. Get the Repair and Modification Authorization Form (RMA).
A copy of the RMA form is shown at the end of this section.
2. Fill in the RMA form.
Fill in only the white part of the form.
Please ensure that all fields marked **(M)** are completed such as:
 - Equipment model
 - Model No. and Serial No.
 - Description of failure or modification required (please be specific)
 - Value for customs (in case the product requires export)
 - Delivery and invoice addresses
 - Contact details
3. Receive from local service contact, the information required to ship the product.
Your local service contact will provide you with all the information:
 - Pricing details
 - RMA No
 - Repair center address
If required, an acceptance of the quote must be delivered before going to next stage.
4. Send the product to the repair center.
Address the shipment to the repair center specified by your local contact.
Ensure all items are protected by appropriate packaging: anti-static bag and foam protection.
Ensure a copy of the import invoice is attached with the unit being returned.
Ensure a copy of the RMA form is attached with the unit being returned.
E-mail or fax a copy of the import invoice and airway bill document to your local contact.

9. REPAIR / MODIFICATION RETURN AUTHORIZATION FORM

FIELDS IN GREY TO BE FILLED IN BY SCHNEIDER ELECTRIC PERSONNEL ONLY

Reference RMA:		Date:	
Repair Center Address: (for shipping)	Service Type:		LSC PO No.:
	<input type="checkbox"/>	Retrofit	
	<input type="checkbox"/>	Warranty	
	<input type="checkbox"/>	Paid service	
	<input type="checkbox"/>	Under repair contract	
<input type="checkbox"/>	Wrong supply		
Schneider Electric - Local Contact Details:			
Name:		Telephone No.:	
E-mail:		Fax No.:	

IDENTIFICATION OF UNIT

Fields marked **(M)** are mandatory, delays in return will occur if not completed.

Model No./Part No.: (M)	Site Name/Project:		
Manufacturer Reference: (M)	Commissioning Date:		
Serial No.: (M)	Under Warranty:	<input type="checkbox"/>	Yes <input type="checkbox"/> No
Software Version:	Additional Information:		
Quantity:	Customer P.O (if paid):		

FAULT INFORMATION

Type of Failure		Found Defective	
Hardware fail	<input type="checkbox"/>	During FAT/inspection	<input type="checkbox"/>
Mechanical fail/visible defect	<input type="checkbox"/>	On receipt	<input type="checkbox"/>
Software fail	<input type="checkbox"/>	During installation/commissioning	<input type="checkbox"/>
Other:	<input type="checkbox"/>	During operation	<input type="checkbox"/>
		Other:	<input type="checkbox"/>
Fault Reproducibility			
Fault persists after removing, checking on test bench	<input type="checkbox"/>		
Fault persists after re-energization	<input type="checkbox"/>		
Intermittent fault	<input type="checkbox"/>		

Description of Failure Observed or Modification Required
Please be specific(M)

FOR REPAIRS ONLY

Would you like us to install an updated firmware version after repair?	<input type="checkbox"/>	Yes	<input type="checkbox"/>	No
--	--------------------------	-----	--------------------------	----

CUSTOMS & INVOICING INFORMATION (required to allow return of repaired items)

Value for Customs (M)				
Customer Invoice Address ((M) if paid)	Customer Return Delivery Address (full street address) (M)			
	Part shipment accepted	<input type="checkbox"/>	Yes	<input type="checkbox"/> No
	OR Full shipment required	<input type="checkbox"/>	Yes	<input type="checkbox"/> No
Contact Name:	Contact Name:			
Telephone No.:	Telephone No.:			
Fax No.:	Fax No.:			
E-mail:	E-mail:			

REPAIR TERMS

1	Please ensure that a copy of the import invoice is attached with the returned unit, together with the airway bill document. Please fax/e-mail a copy of the appropriate documentation (M).
2	Please ensure the Purchase Order is released, for paid service, to allow the unit to be shipped.
3	Submission of equipment to Schneider Electric is deemed as authorization to repair and acceptance of quote.
4	Please ensure all items returned are marked as Returned for 'Repair/Modification' and protected by appropriate packaging (anti-static bag for each board and foam protection).

Notes:

SCADA COMMUNICATIONS

CHAPTER 15

Applicability

Date: 11/2022

Products covered by this chapter:

This chapter covers the specific versions of the MiCOM products listed below. This includes **only** the following combinations of Software Version and Hardware Suffix.

Hardware Suffix:

P445 L or later

Software Suffix:

P445 K1 or later

Connection Diagrams: This chapter list the connection diagram for the product:

P445: 10P445xx (xx = 01 to 04)

CONTENTS

1. Introduction	7
1.1 Read Only Mode (Command Blocking)	7
2. Connections to the Communications Ports	9
2.1 Front Port	9
2.2 Rear Communication Port - EIA(RS)-485	9
2.3 Second Rear Communications Port (RP2) (Courier)	9
2.3.1 Courier Protocol.....	10
2.3.1.1 Event Extraction.....	10
2.3.1.2 Disturbance Record Extraction.....	10
2.3.2 Connection to the Second Rear Port.....	10
2.4 EIA(RS)-485 Bus	11
2.4.1 EIA(RS)-485 Bus Termination.....	11
2.4.2 EIA(RS)-485 Bus Connections & Topologies.....	11
2.4.3 EIA(RS)-485 Biasing.....	11
2.4.4 K-Bus Connections.....	12
2.4.5 Courier Communications.....	12
2.4.6 IEC 60870-5 CS 103 Communications.....	12
2.4.7 DNP3.0 Communication.....	13
3. Configuring the Communications Ports	14
3.1 Introduction	14
3.2 Configuring the Front Courier Port	14
3.3 Configuring the First Rear Courier Port (RP1)	14
3.4 Configuring the IEC 60870-5 CS 103 Rear Port, RP1	16
3.5 Configuring DNP3.0 Communications Rear Port RP1	17
3.6 Configuring the (Optional) DNP3.0 over Ethernet Port	19
3.7 Configuring the Second Rear Courier Port, RP2	20
3.8 Configuring the Ethernet Communication (Option)	21
3.9 Fiber Optic Converter (option)	21
3.10 Second Rear Port EIA(RS)-485 Example	22
3.11 Second Rear Port EIA(RS)-232 Example	22
3.12 SK5 Port Connection	22
4. Courier Interface	23
4.1 Courier Protocol	23
4.2 Front Courier Port	23
4.3 Supported Command Set	24
4.4 Courier Database	24
4.5 Setting Changes	25

4.5.1 Method 1.....	25
4.5.2 Method 2.....	25
4.5.3 Relay Settings.....	25
4.5.4 Setting Transfer Mode.....	26
4.6 Event Extraction.....	26
4.6.1 Automatic Event Extraction.....	26
4.6.2 Event Types.....	26
4.6.3 Event Format.....	26
4.6.4 Manual Event Record Extraction.....	27
4.7 Disturbance Record Extraction.....	28
4.8 Programmable Scheme Logic (PSL) Settings.....	28

5. IEC60870-5-103 Interface.....	30
5.1 Physical Connection and Link Layer.....	30
5.2 Initialization.....	30
5.3 Time Synchronization.....	30
5.4 Spontaneous Events.....	31
5.5 General Interrogation (GI).....	31
5.6 Cyclic Measurements.....	31
5.7 Commands.....	31
5.8 Test Mode.....	31
5.9 Disturbance Records.....	32
5.10 Blocking of Monitor Direction.....	32
5.11 Setting Changes through IEC103 Protocol.....	32

6. DNP3.0 Interface.....	34
6.1 DNP3.0 Protocol.....	34
6.2 DNP3.0 Menu Setting.....	34
6.3 Object 1 Binary Inputs.....	35
6.4 Object 10 Binary Outputs.....	35
6.5 Object 20 Binary Counters.....	36
6.6 Object 30 Analog Input.....	36
6.7 Object 40 Analog Output.....	37
6.8 DNP3.0 Configuration using Easergy Studio.....	37
6.8.1 DNP3.0 over Ethernet runs concurrently with IEC61850.....	38

7. IEC 61850 Ethernet Interface.....	40
7.1 Introduction.....	40
7.2 What is IEC 61850?.....	40
7.2.1 Interoperability.....	40
7.2.2 Data Model.....	40
7.3 IEC 61850 in MiCOM Relays.....	41
7.3.1 Capability.....	42

7.3.2 IEC 61850 Configuration	44
7.3.2.1 Configuration Banks	44
7.3.2.2 Network Connectivity	45
7.4 Data Model of MiCOM Relays	45
7.5 Communication Services of MiCOM Relays	45
7.6 Peer-to-Peer (GSE) Communications	45
7.6.1 Scope	46
7.6.2 Simulation GOOSE Configuration	46
7.6.3 High Performance GOOSE	47
7.7 Ethernet Functionality	47
7.7.1 Ethernet Disconnection	47
7.7.2 Redundant Ethernet Communication Ports (optional)	47
7.7.3 Loss of Power	47
7.7.4 Courier Tunneling via Secure Ethernet Communications	47
7.7.4.1 Introduction	47
7.7.4.2 Setting up a Connection	48

TABLES

Table 1 - Port configurations and communication protocols	10
Table 2 - Pin connections over EIA(RS)-232 and EIS(RS)-485	11
Table 3 - DNP3.0 menu in the Communications column	34
Table 4 - Unsolicited Responses configuration of DNP over Ethernet	38
Table 5 - Protocol running options for different board types	39
Table 6 - Abbreviations of Different IP	39

FIGURES

Figure 1 - EIA(RS)-485 bus connection arrangements	12
Figure 2 - Second rear port EIA(RS)-485 example	22
Figure 3 - Second rear port EIA(RS)-232 example	22
Figure 4 - Behaviour when control input is set to be pulsed or latched	35
Figure 5 - Data model layers in IEC 61850	41

Notes:

1. INTRODUCTION

This chapter describes the remote interfaces of the MiCOM relay in enough detail to allow integration in a substation communication network.

The supported protocols include:

- Courier
- MODBUS
- IEC-60870-5-103
- DNP3.0
- IEC 61850 Ethernet Interface

Note

MODBUS is not included in MiCOM P44y (P443 / P446), P445, P54x (P543 / P544 / P545 / P546), P841 and P74x (P741 / P742 / P743) products. DNP3.0 is not supported in MiCOM P24x (P241 / P242 / P243) and P74x (P741 / P742 / P743). IEC 60870-5-103 is not available for P74x.

1.1 Read Only Mode (Command Blocking)

A Read Only mode is available for the rear communication ports of the Px40 relays. When Read Only mode is enabled for a port, all setting changes and most commands/control actions are blocked (not accepted by the relay). The full functionality is described below. It is similar to the 'Command Blocking' setting of Px30 relays.

Read Only mode can be enabled/disabled for the following rear ports:

- Rear Port 1 – IEC 60870-5-103 and Courier protocols
- Rear Port 2 (if fitted) – Courier protocol
- Ethernet Port (if fitted) – Courier protocol (“tunnelled”)

Read Only mode is not currently required for IEC 61850, as there are no settings or controls implemented.

Read Only mode does not apply to the Front Port, that is intended for local connection only.

The following settings enable and disable the Read Only Mode:

- [09FB: CONFIGURATION, RP1 Read Only]
- [09FC: CONFIGURATION, RP2 Read Only]
- [09FD: CONFIGURATION, NIC Read Only]

Read Only mode can only be disabled from either the front panel User Interface or via the Front Port.

Read Only mode can be enabled/disabled in the PSL by using the DDB signals 'RP1 Read Only', 'RP2 Read Only', 'NIC Read Only'.

When Read Only mode is enabled, the commands that are blocked (not accepted by the relay) and the commands that are allowed (accepted by the relay) are as follows.

(1) IEC 60870-5-103 Protocol

Blocked:

INF16 auto-recloser on/off (ASDU20)
 INF17 teleprotection on/off (ASDU20)
 INF18 protection on/off (ASDU20)
 INF19 LED reset (ASDU20)
 private INFs e.g CB open/close, Control Inputs (ASDU20)

Allowed:

Poll Class 1 (read spontaneous events)
 Poll Class 2 (read measurands)

- General Interrogation (GI) sequence
- Transmission of Disturbance Records sequence
- Time Synchronisation (ASDU6)
- INF23 activate characteristic 1 (ASDU20)
- INF24 activate characteristic 2 (ASDU20)
- INF25 activate characteristic 3 (ASDU20)
- INF26 activate characteristic 4 (ASDU20)

(2) Courier Protocol

Blocked:

- All setting changes
- Reset Indication (Trip LED) command
- Operate Control Input commands
- CB operation commands
- Auto-reclose operation commands
- Reset demands / thermal etc... command
- Clear event / fault / maintenance / disturbance record commands
- Test LEDs & contacts commands

Allowed:

- Read settings, statuses, measurands
- Read records (event, fault, disturbance)
- Time Synchronization command
- Change active setting group command

2. CONNECTIONS TO THE COMMUNICATIONS PORTS

2.1 Front Port

The front communications port is not intended for permanent connection. The front communications port supports the Courier protocol and is implemented on an EIA(RS)232 connection. A 9-pin connector type, as described in the 'Getting Started' (GS) chapter of this manual, is used, and the cabling requirements are detailed in the 'Connection Diagrams' (CD) chapter of this manual.

2.2 Rear Communication Port - EIA(RS)-485

The rear EIA(RS)-485 communication port is provided by a 3-terminal screw connector on the back of the relay. See the Connection Diagrams chapter for details of the connection terminals. The rear port provides K-Bus/EIA(RS)-485 serial data communication and is intended for use with a permanently-wired connection to a remote control center. Of the three connections, two are for the signal connection, and the other is for the earth shield of the cable.

If the IEC60870-5-103, or the DNP3.0 protocols are specified as the interface for the rear port, then connections conform entirely to the EIA(RS)485 standards outline below. If, however, the Courier protocol is specified as the rear port protocol, the interface can be set either to EIA(RS)485 or K-Bus. The configuration of the port as either EIA(RS)485 or K-Bus is described later together with K-Bus details, but as connection to the port is affected by this choice, you should note these points:

- Connection to an EIA(RS)485 device is polarity sensitive, whereas K-Bus connection is not. In all other respects (bus wiring, topology, connection, biasing, and termination) K-Bus can be considered the same as EIA(RS)485.
- Whilst connection to or between an EIA(RS)485 port and an EIA(RS)232 port on a PC can be implemented using a general purpose EIA(RS)485 to EIA(RS)232 converter.

All rear port communication interfaces are fully isolated and suitable for permanent connection. EIA(RS)485 (and K-Bus) connections allow up to 32 devices to be 'daisy-chained' together using a simple twisted pair electrical connection.

The protocol provided by the relay is indicated in the relay menu in the **Communications** column. Using the keypad and LCD, first check that the **Comms. settings** cell in the **Configuration** column is set to **Visible**, then move to the **Communications** column. The first cell down the column shows the communication protocol that is being used by the rear port.

Note

Unless the K-Bus option is chosen for the rear port, correct polarity must be observed for the signal connections. In all other respects (bus wiring, topology, connection, biasing and termination) K-Bus can be considered the same as EIA(RS)485.

2.3 Second Rear Communications Port (RP2) (Courier)

Relays with Courier, MODBUS, IEC60870-5-103 or DNP3.0 protocol on the first rear communications port have the option of a second rear port, running the Courier language. The second port is typically for dial-up modem access by protection engineers or operators, when the main port is reserved for SCADA traffic. Communication is through one of three physical links: K-Bus, EIA(RS)-485 or EIA(RS)-232. The port supports full local or remote protection and control access using Easergy Studio.

When changing the port configuration between K-Bus, EIA(RS)-485 and EIA(RS)-232, reboot the relay to update the hardware configuration of the second rear port.

The EIA(RS)-485 and EIA(RS)-232 protocols can be configured to operate with a modem, using an IEC60870 10-bit frame.

If both rear communications ports are connected to the same bus, make sure their address settings are not the same to avoid message conflicts.

Port Configuration	Valid Communication Protocol
K-Bus	K-Bus
EIA(RS)-232	IEC60870 FT1.2, 11-bit frame IEC60870, 10-bit frame
EIA(RS)-485	IEC60870 FT1.2, 11-bit frame IEC60870, 10-bit frame

Table 1 - Port configurations and communication protocols

2.3.1 Courier Protocol

The second rear communications port is functionally the same as described in the previous section for a Courier rear communications port, with the following exceptions:

2.3.1.1 Event Extraction

Automatic event extraction is not supported when the first rear port protocol is Courier, MODBUS or CS103. It is supported when the first rear port protocol is DNP3.0.

2.3.1.2 Disturbance Record Extraction

Automatic disturbance record extraction is not supported when the first rear port protocol is Courier, MODBUS or CS103. It is supported when the first rear port protocol is DNP3.0.

2.3.2 Connection to the Second Rear Port

The second rear Courier port connects using the 9-way female D-type connector (SK4) in the middle of the card end plate (between the IRIG-B connector and lower D-type). The connection complies with EIA(RS)-574.

For IEC60870-5-2 over EIA(RS)-232		For K-bus or IEC60870-5-2 over EIA(RS)-485	
Pin	Connection	Pin*	Connection
1	No Connection		
2	RxD		
3	TxD		
4	DTR#	4	EIA(RS)-485 - 1 (+ ve)
5	Ground		
6	No Connection		
7	RTS#	7	EIA(RS)-485 - 2 (- ve)
8	CTS#		
9	No Connection		
# - These pins are control lines for use with a modem.		* - All other pins unconnected.	
<p>Notes</p> <p>Connector pins 4 and 7 are used by both the EIA(RS)-232 and EIA(RS)-485 physical layers, but for different purposes. Therefore, the cables should be removed during configuration switches.</p> <p>When using the EIA(RS)-485 protocol, an EIA(RS)-485 to EIA(RS)-232 converter is needed to connect the relay to a modem or PC running Easergy Studio. A Schneider Electric CK222 is recommended.</p> <p>EIA(RS)-485 is polarity sensitive, with pin 4 positive (+) and pin 7 negative (-).</p>			

Table 2 - Pin connections over EIA(RS)-232 and EIS(RS)-485

2.4 EIA(RS)-485 Bus

The EIA(RS)-485 two-wire connection provides a half-duplex fully isolated serial connection to the product. The connection is polarized and while the product's connection diagrams show the polarization of the connection terminals, there is no agreed definition of which terminal is which. If the master is unable to communicate with the product and the communication parameters match, make sure the two-wire connection is not reversed.

EIA(RS)-485 provides the capability to connect multiple devices to the same two-wire bus. MODBUS is a master-slave protocol, so one device is the master, and the remaining devices are slaves. It is not possible to connect two masters to the same bus, unless they negotiate bus access.

2.4.1 EIA(RS)-485 Bus Termination

The EIA(RS)-485 bus must have 120 Ω (Ohm) $\frac{1}{2}$ Watt terminating resistors fitted at either end across the signal wires, see the EIA(RS)-485 bus connection arrangements diagram below. Some devices may be able to provide the bus terminating resistors by different connection or configuration arrangements, in which case separate external components are not needed. However, this product does not provide such a facility, so if it is located at the bus terminus, an external termination resistor is needed.

2.4.2 EIA(RS)-485 Bus Connections & Topologies

The EIA(RS)-485 standard requires each device to be directly connected to the physical cable that is the communications bus. Stubs and tees are expressly forbidden, as are star topologies. Loop bus topologies are not part of the EIA(RS)-485 standard and are forbidden by it.

Two-core screened cable is recommended. The specification of the cable depends on the application, although a multi-strand 0.5 mm² per core is normally adequate. Total cable length must not exceed 1000 m. The screen must be continuous and connected at one end, normally at the master connection point. It is important to avoid circulating currents, especially when the cable runs between buildings, for both safety and noise reasons.

This product does not provide a signal ground connection. If the bus cable has a signal ground connection, it must be ignored. However, the signal ground must have continuity for the benefit of other devices connected to the bus. For both safety and noise reasons, the signal ground must never be connected to the cable's screen or to the product's chassis.

2.4.3 EIA(RS)-485 Biasing

It may also be necessary to bias the signal wires to prevent jabber. Jabber occurs when the signal level has an indeterminate state because the bus is not being actively driven. This can occur when all the slaves are in receive mode and the master is slow to switch from receive mode to transmit mode. This may be because the master purposefully waits in receive mode, or even in a high impedance state, until it has something to transmit. Jabber causes the receiving device(s) to miss the first bits of the first character in the packet, which results in the slave rejecting the message and consequentially not responding. Symptoms of this are poor response times (due to retries), increasing message error counters, erratic communications, and even a complete failure to communicate.

Biasing requires that the signal lines are weakly pulled to a defined voltage level of about 1 V. There should only be one bias point on the bus, which is best situated at the master connection point. The DC source used for the bias must be clean, otherwise noise is injected. Some devices may (optionally) be able to provide the bus bias, in which case external components are not required.

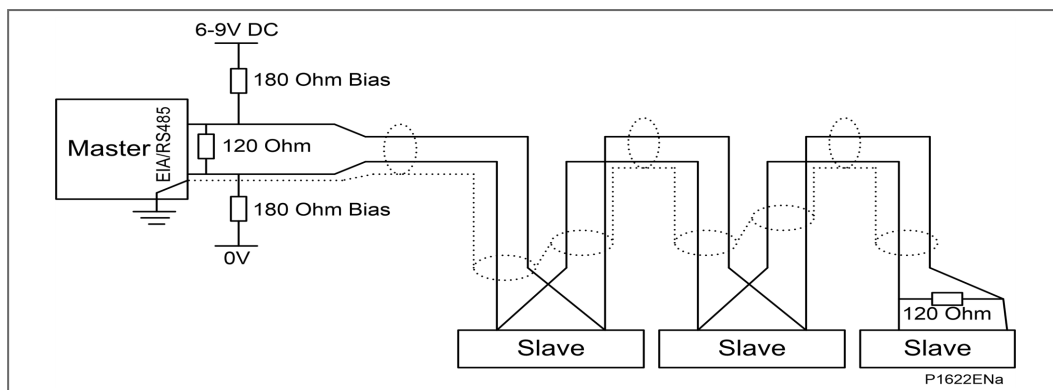

Figure 1 - EIA(RS)-485 bus connection arrangements

It is possible to use the product's field voltage output (48 V DC) to bias the bus using values of 2.2 k Ω ($\frac{1}{2}W$) as bias resistors instead of the 180 Ω resistors shown in the *EIA(RS)-485 bus connection arrangements* diagram. Note these warnings apply:

Warnings

It is extremely important that the 120 Ω termination resistors are fitted. Otherwise the bias voltage may be excessive and may damage the devices connected to the bus.

As the field voltage is much higher than that required, Schneider Electric cannot assume responsibility for any damage that may occur to a device connected to the network as a result of incorrect application of this voltage.

Ensure the field voltage is not used for other purposes, such as powering logic inputs, because noise may be passed to the communication network.

2.4.4 K-Bus Connections

K-Bus is a robust signaling method based on EIA(RS)485 voltage levels. K-Bus incorporates message framing and uses a 64 kbits/s synchronous HDLC protocol with FM0 modulation to increase speed and security. For this reason is not possible to use a standard EIA(RS)232 to EIA(RS)485 converter to connect with K-Bus devices. Nor is it possible to connect K-Bus to an EIA(RS)485 computer port.

As K-Bus is implemented on an EIA(RS)485 layer, the connection details are very similar to those described in the previous sections.

2.4.5 Courier Communications

Courier is the communication language developed to allow remote interrogation of its range of protection relays. Courier uses a master and slave. EIA(RS)-232 on the front panel allows only one slave but EIA(RS)-485 on the back panel allows up to 32 daisy-chained slaves. Each slave unit has a database of information and responds with information from its database when requested by the master unit.

The relay is a slave unit that is designed to be used with a Courier master unit such as Easergy Studio, MiCOM S10, PAS&T or a SCADA system. Easergy Studio is specifically designed for setting changes with the relay.

2.4.6 IEC 60870-5 CS 103 Communications

The IEC specification IEC 60870-5-103: Telecontrol Equipment and Systems, Part 5: Transmission Protocols Section 103 defines the use of standards IEC 60870-5-1 to IEC 60870-5-5 to perform communication with protection equipment. The standard configuration for the IEC 60870-5-103 protocol is to use a twisted pair connection over distances up to 1000 m. As an option for IEC 60870-5-103, the rear port can be specified to use a fiber optic

connection for direct connection to a master station. The relay operates as a slave in the system, responding to commands from a master station. The method of communication uses standardized messages which are based on the VDEW communication protocol.

To use the rear port with IEC 60870-5-103 communication, configure the relay's communication settings using the keypad and LCD user interface.

There are three settings associated with this cell; these are:

- **Disabled**
No blocking selected.
- **Monitor Blocking**
When the monitor blocking DDB Signal is active high, either by energizing an opto input or control input, reading of the status information and disturbance records is not permitted. When in this mode the relay returns a "Termination of general interrogation" message to the master station.
- **Command Blocking**
When the command blocking DDB signal is active high, either by energizing an opto input or control input, all remote commands are ignored, such as CB Trip/Close or change setting group. When in this mode the relay returns a **negative acknowledgement of command** message to the master station.

2.4.7 DNP3.0 Communication

The DNP3.0 protocol is defined and administered by the DNP User Group. Information about the user group, DNP3.0 in general and protocol specifications can be found on their website: www.dnp.org

The relay operates as a DNP3.0 slave and supports subset level 2 of the protocol plus some of the features from level 3. DNP3.0 communication is achieved using a twisted pair connection to the rear port and can be used over a distance of 1000 m with up to 32 slave devices.

3. CONFIGURING THE COMMUNICATIONS PORTS

3.1 Introduction

Courier works on a master/slave basis where the slave units contain information in the form of a database, and respond with information from the database when it is requested by a master unit.

The relay is a slave unit that is designed to be used with a Courier master unit such as Easergy Studio, PAS&T or a SCADA system.

3.2 Configuring the Front Courier Port

The front EIA(RS)232 9-pin port supports the Courier protocol for one-to-one communication. It is designed for use during installation, commissioning and maintenance and is not suitable for permanent connection. Since this interface is not intended to link the relay to a substation communication system, not all of the features of the Courier interface are supported; the port is not configurable and the following parameters apply:

Physical presentation	EIA(RS)232 via 9-pin connector
Frame format	IEC60870-5 FT1.2 = 11-bit (8 Even 1)
Address	1
Baud rate	19200 bps

Note
As part of the limited implementation of Courier on the front port, neither automatic extraction of event and disturbance records, nor busy response are supported.)

3.3 Configuring the First Rear Courier Port (RP1)

Once the physical connection is made to the relay, configure the relay's communication settings using the keypad and LCD user interface.

1. In the relay menu, select the **Configuration** column, then check that the **Comms. settings** cell is set to **Visible**.
2. Select the Communications column. Only two settings apply to the rear port using Courier, the relay's address and the inactivity timer. Synchronous communication uses a fixed baud rate of 64 kbits/s.
3. Move down the **Communications** column from the column heading to the first cell down. This shows the communication protocol.

RP1 Protocol Courier

4. The next cell down the column controls the address of the relay. As up to 32 relays can be connected to one K-Bus spur, each relay must have a unique address so messages from the master control station are accepted by one relay only. Courier uses an integer (from 0 to 254) for the relay address that is set with this cell.

Important:
No two relays should have the same Courier address. The master station uses the Courier address to communicate with the relay.

RP1 Address 1

5. The next cell down controls the inactivity timer.

RP1 Inactiv timer
10.00 mins.

The inactivity timer controls how long the relay waits without receiving any messages on the rear port before it reverts to its default state, including revoking any password access that was enabled. For the rear port this can be set between 1 and 30 minutes.

Note

Protection and disturbance recorder settings that are modified using an online editor such as PAS&T must be confirmed with a write to the 'Save changes' cell of the 'Configuration' column. Off-line editors such as Easergy Studio do not require this action for the setting changes to take effect.

The next cell down controls the physical media used for the communication.

RP1 Physical link
Copper

The default setting is to select the electrical (copper) connection. If the optional fiber optic interface is fitted to the relay, then this setting can be changed to '**Fiber optic**'. This cell is invisible if a second rear communications port or an Ethernet card is fitted, as they are mutually exclusive and occupy the same physical location.

6. If the Physical link selection is copper, the next cell down becomes visible to further define the configuration:

RP1 Port Config
KBus

The setting choice is between K-Bus and EIA(RS)485. Selecting K-Bus allows connection with K-series devices, but means that a converter must be used to make a connection. If the EIA(RS)485 selection is made, direct connections can be made to proprietary equipment such as MODEMs. If the EIA(RS)485 selection is made, then two further cells become visible to control the frame format and the communication speed:

7. The frame format is selected in the RP1 Comms mode setting:

RP1 Comms Mode
IEC60870 FT1.2

The standard default is the IEC 60870-FT1.2. This is an 11-bit framing.

Alternatively, a 10-bit framing may be selected for use with MODEMs that do not support 11-bit framing.

8. The final RP1 cell controls the communication speed or baud rate:

RP1 Baud Rate
19200 bits/s

Courier communications is asynchronous and three baud rate selections are available to allow the relay communication rate to be matched to that of the connected equipment. Three baud rates are supported by the relay, '9600 bits/s', '19200 bits/s' and '38400 bits/s'.

Important

If you modify protection and disturbance recorder settings using an on-line editor such as PAS&T, you must confirm them. To do this, from the Configuration column select the Save changes cell. Off-line editors such as Easergy Studio do not need this action for the setting changes to take effect.

3.4 Configuring the IEC 60870-5 CS 103 Rear Port, RP1

The IEC specification IEC 60870-5-103: Telecontrol Equipment and Systems, Part 5: Transmission Protocols Section 103 defines the use of standards IEC 60870-5-1 to IEC 60870-5-5 to perform communication with protection equipment. The standard configuration for the IEC 60870-5-103 protocol is to use a twisted pair connection over distances up to 1000 m. As an option for IEC 60870-5-103, the rear port can be specified to use a fiber optic connection for direct connection to a master station. The relay operates as a slave in the system, responding to commands from a master station. The method of communication uses standardized messages which are based on the VDEW communication protocol.

To use the rear port with IEC 60870-5-103 communication, configure the relay's communication settings using the keypad and LCD user interface.

1. In the relay menu, select the **Configuration** column, then check that the **Comms. settings** cell is set to **Visible**.
2. Select the **Communications** column. Four settings apply to the rear port using IEC 60870-5-103 that are described below. Move down the 'COMMUNICATIONS' column from the column heading to the first cell to confirm the communication protocol:

Protocol IEC60870-5-10r

3. The next cell sets the address of the relay on the IEC 60870-5-103 network:

Remote Address 162

Up to 32 relays can be connected to one IEC 60870-5-103 spur, and therefore it is necessary for each relay to have a unique address so that messages from the master control station are accepted by one relay only. IEC 60870-5-103 uses an integer number between 0 and 254 for the relay address. It is important that no two relays have the same address. The address is then used by the master station to communicate with the relay.

4. The next cell down the column controls the baud rate to be used:

Baud rate 9600 bits/s

IEC 60870-5-103 communication is asynchronous. Two baud rates are supported by the relay, '9600 bits/s' and '19200 bits/s'. It is important that whatever baud rate is selected on the relay is the same as that set on the IEC 60870-5-103 master station.

5. The next cell down controls the period between IEC 60870-5-103 measurements:

Measure't period 30.00 s

The IEC 60870-5-103 protocol allows the relay to supply measurements at regular intervals. The interval between measurements is controlled by this cell, and can be set between 1 and 60 seconds.

6. An optional fiber optic card is available in the relay to allow optical connection to the IEC 60870-5-103 communication to be made over an optical connection. When fitted, it converts between EIA(RS)485 signals and fiber optic signals and the following cell is visible in the menu column:

Physical link Copper

The default setting is to select the electrical (copper) connection. If the optional fiber optic interface is fitted to the relay, then this setting can be changed to 'Fiber optic'. This cell is invisible if a second rear communications port or an Ethernet card is fitted, as they are mutually exclusive and occupy the same physical location.

- The following cell which may be displayed, is not currently used but is available for future expansion.

InactivTimer

- The next cell down can be used for monitor or command blocking:

CS103 Blocking

There are three settings associated with this cell; these are:

- Disabled**
 No blocking selected.
- Monitor Blocking**
 When the monitor blocking DDB Signal is active high, either by energizing an opto input or control input, reading of the status information and disturbance records is not permitted. When in this mode the relay returns a "Termination of general interrogation" message to the master station.
- Command Blocking**
 When the command blocking DDB signal is active high, either by energizing an opto input or control input, all remote commands are ignored, such as CB Trip/Close or change setting group. When in this mode the relay returns a **negative acknowledgement of command** message to the master station.

3.5 Configuring DNP3.0 Communications Rear Port RP1

The DNP3.0 protocol is defined and administered by the DNP User Group. Information about the user group, DNP3.0 in general and protocol specifications can be found on their website: www.dnp.org

The relay operates as a DNP3.0 slave and supports subset level 2 of the protocol plus some of the features from level 3. DNP3.0 communication is achieved using a twisted pair connection to the rear port and can be used over a distance of 1000 m with up to 32 slave devices.

- To use the rear port with DNP3.0 communication, configure the relay's communication settings using the keypad and LCD user interface.
- In the relay menu, select the **Configuration** column, then check that the **Comms. settings** cell is set to **Visible**.
- Four settings apply to the rear port using IEC 60870-5-103 that are described below.
- Move down the 'COMMUNICATIONS' column from the column heading to the first cell that indicates the communications protocol:

RP1 Protocol
DNP3.0

- The next cell sets the device address on the DNP3.0 network:

RP1 Address
232

Up to 32 devices can be connected to one DNP3.0 spur, and therefore it is necessary for each device to have a unique address so that messages from the

master control station are accepted by only one device. DNP3.0 uses a decimal number between 1 and 65519 for the device address. It is important that no two devices have the same address. The address is then used by the DNP3.0 master station to communicate with the relay.

- 6. The next cell sets the baud rate to be used:

RP1 Baud Rate 9600 bits/s

DNP3.0 communication is asynchronous. Six baud rates are supported by the relay '1200bits/s', '2400bits/s', '4800bits/s', '9600bits/s', '19200bits/s' and '38400bits/s'. It is important that whatever baud rate is selected on the relay is the same as that set on the DNP3.0 master station.

- 7. The next cell controls the parity format used in the data frames:

RP1 Parity None

The parity can be set to be one of None, Odd or Even. It is important that whatever parity format is selected on the relay is the same as that set on the DNP3.0 master station. An optional fiber optic card is available in the relay to allow optical connection to the IEC 60870-5-103 communication to be made over an optical connection. When fitted, it converts between EIA(RS)485 signals and fiber optic signals and the following cell is visible in the menu column.

- 8. The next cell down the column controls the physical media used for the communication.

RP1 Physical link Copper

The default setting is to select the electrical (copper) connection. If the optional fiber optic interface is fitted to the relay, then this setting can be changed to Fiber optic. This cell is invisible if a second rear communications port or an Ethernet card is fitted, as they are mutually exclusive and occupy the same physical location.

- 9. The next cell down the column sets the time synchronization request from the master by the relay:

RP1 Time Sync. Enabled

The time synchronization can be set to either enabled or disabled. If enabled it allows the DNP3.0 master to synchronize the time.

- 10. Analogue values can be set to be reported in terms of primary, secondary or normalized (with respect to the CT/VT ratio setting) values:

Meas Scaling Primary

- 11. A message gap setting is provided:

Message Gap ϕ

This allows a gap between message frames to be set to enable compatibility with different master stations. The setting for enabling/disabling DNP3.0 time synchronization is described above. When DNP3.0 time sync is enabled, the required rate of synchronization, known as the "need time", needs to be set.

12. A setting allows different "need time" to be set with setting range from 1 - 30 minutes, step of 1 minute and default at 10 minutes:

DNP Need Time 10mins

The transmitted application fragment size can be set to ensure that a Master Station cannot be held too long before a complete reply is received and allow it to move on to next IED in a token ring polling setup.

13. The maximum overall response message length can be configured:

DNP App Fragment 2048

A single fragment size is 249. Depending on circumstances, a user may set the fragment size as a multiple of 249 in order to optimize segment packing efficiency in fragments. However it can also be useful to allow "odd" sizes for users to choose under specific circumstances, such as if sending data inside SMS frames, through packet radios, etc. In such cases it can be useful to select the fragment size such that each packet occupies a single "transmission media frame".

In some cases, communication to the outstation is made over slow, packet switched networks which can add seconds to the communication latency.

14. A setting is provided to allow the application layer timeout to be set:

DNP App Timeout 2s

15. Select Before Operate (SBO) timeouts can be set.

If the DNP3.0 "Select a trip command" causes the relay's internal logic to block automatic tripping, then a corruption of the DNP3.0 "Operate" message could delay the trip. The delay of tripping can be set:

DNP SBO Timeout 10s

16. The DNP link timeout can be set:

DNP Link Timeout 10s

3.6 Configuring the (Optional) DNP3.0 over Ethernet Port

When DNP3.0 is provided over Ethernet, settings similar to those described above for the EIA(RS)485 connection are provided for the following :-

- Time Sync.
- Meas. Scaling
- DNP Need Time
- DNP App Fragment
- DNP App Timeout
- DNP SBO Timeout

For these settings, please refer to the descriptions provided in the previous section.

As well as these, other settings as described below are provided to complete the configuration of the DNP3.0 over Ethernet configuration.

A timeout setting is added that defines how long the device will wait before an inactive tunnel connection to the master station is reset:

NIC Tunl Timeout
5 mins

The NIC Link Report configures how a failed/disconnected network link (copper or fiber) is reported. Options are to report an alarm, an event, or nothing:

NIC Link Report
Alarm

The duration of time elapsed, after a failed network link is detected and before communication by the alternative media interface is attempted, can be set:

NIC Link Timeout
60s

The rate at which the SNTP server is polled can be set:

SNTP Poll Rate
64s

3.7 Configuring the Second Rear Courier Port, RP2

For relays having the second rear (Courier) communications port fitted, the settings are located immediately below the ones for the first port described above. The second rear communications port only supports the Courier protocol and the settings are similar to those for Courier RP1. The first cell displays:

1. Move down the settings until the following sub heading is displayed.

Rear Port 2

2. The next cell defines the protocol, which is fixed at Courier for RP2.

RP2 protocol
Courier

3. The following cell indicates the status of the hardware.

RP2 card status
EIA(RS)232 OK

4. The following cell allows for selection of the port configuration.

RP2 port config.
EIA(RS)232

5. The port can be configured for EIA(RS)232, EIA(RS)485 or K-Bus.

As in the case of the first rear Courier port, if K-Bus is not selected certain other cells to control the communication mode and speed become visible. If either EIA(RS)232 or EIA(RS)485 is selected for the port configuration, the next cell is visible and selects the communication mode.

RP2 comms. Mode
IEC60870 FT1.2

6. The standard default is the IEC 60870 FT1.2 for normal operation with 11-bit modems. Alternatively, a 10-bit framing with no parity bit can be selected for special cases.
7. The next cell down sets the communications port address.

RP2 address
255

Since up to 32 devices can be connected to one K-bus spur, it is necessary for each device to have a unique address so that messages from the master control station are accepted by one device only. Courier uses an integer number between 0 and 254 for the device address that is set with this cell. It is important that no two devices have the same Courier address. The Courier address is then used by the master station to communicate with the device. The default value is 255 and must be changed to a value in the range 0 to 254 before use.

8. The following cell controls the inactivity timer.

RP2 InactivTimer 15 mins.

9. The inactivity timer controls how long the relay will wait without receiving any messages on the rear port before it reverts to its default state. This includes revoking any password access that was enabled. The inactivity timer can be set between 1 and 30 minutes.
10. If either EIA(RS)232 or EIA(RS)485 is selected for the port configuration, the following cell is visible and selects the communication speed (baud rate):

RP2 baud rate 19200

Courier communications is asynchronous and three selections are available to allow the relay communication rate to be matched to that of the connected equipment. The three baud rates supported by the relay are: '9600 bits/s', '19200 bits/s' and '38400 bits/s'.

3.8 Configuring the Ethernet Communication (Option)

It is possible to communicate through an Ethernet network using a Schneider Electric I4XS4UE (refer to the Redundant Ethernet Board (REB) chapter for the connections).

Connection for Ethernet communication can be made either by standard RJ45 electrical connections or by multi-mode optical fibers suitable for 1300 nm transmission and terminated with LC connectors.

3.9 Fiber Optic Converter (option)

An optional fiber optic card is available in this product. This converts the EIA(RS)485 protocols into a fiber optic output. This communication card is available for use on Courier, MODBUS (for products listed in the Supported Protocols table), IEC60870-5-103 and DNP3.0 it adds the following setting to the communication column. This controls the physical media used for the communication:

Physical link Copper

The default setting is to select the electrical EIA(RS)485 connection. If the optional fiber optic connectors are fitted to the relay, then this setting can be changed to 'Fiber optic'. This cell is also invisible if a second rear comms. port, or Ethernet card is fitted, as it is mutually exclusive with the fiber optic connectors, and occupies the same physical location.

Where this is used, connection should be made using either 50/125µm or 62.5/125µm multi-mode optical fibers terminated with BFOC/2.5 (ST) connectors.

3.10 Second Rear Port EIA(RS)-485 Example

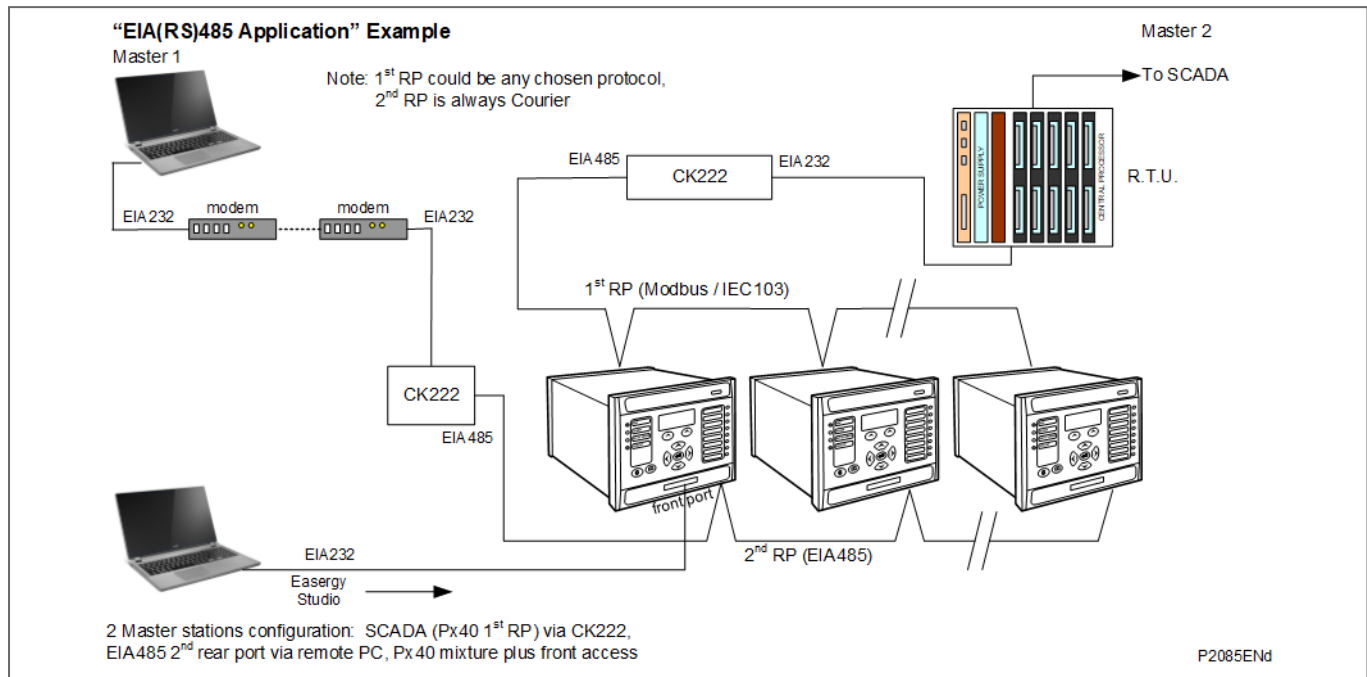

Figure 2 - Second rear port EIA(RS)-485 example

3.11 Second Rear Port EIA(RS)-232 Example

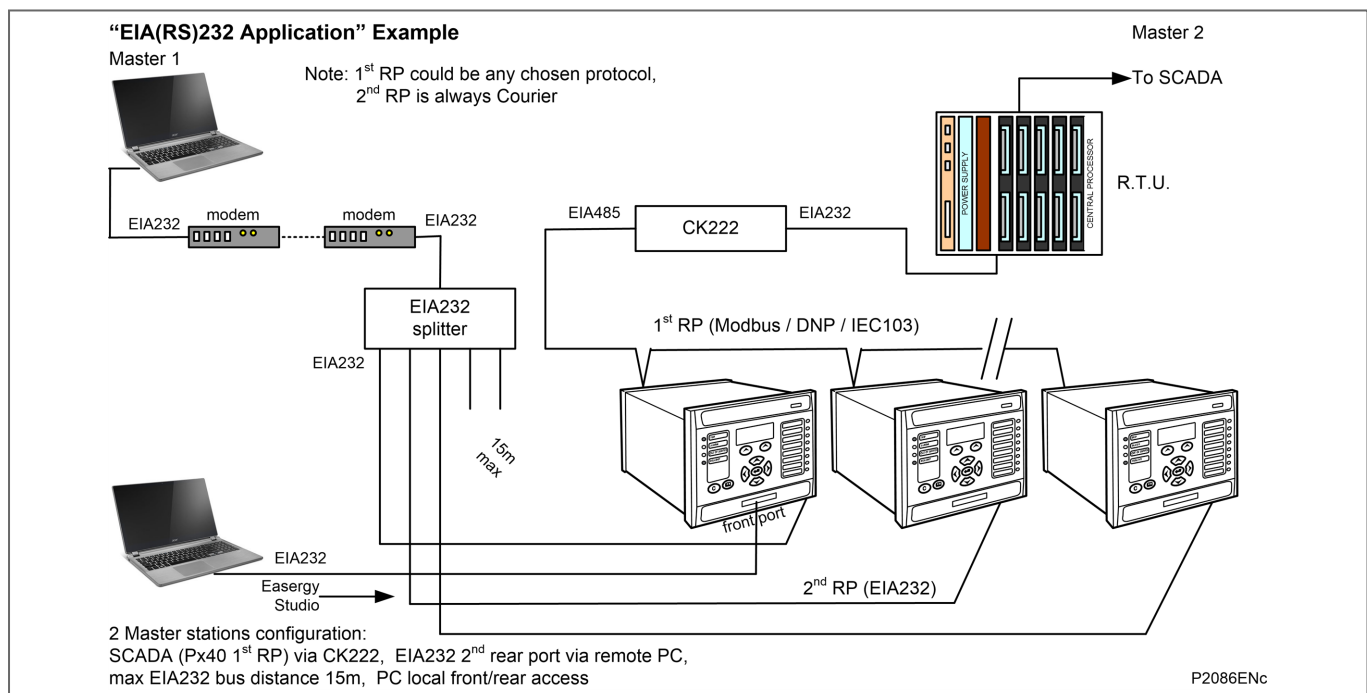

Figure 3 - Second rear port EIA(RS)-232 example

3.12 SK5 Port Connection

The lower 9-way D-type connector (SK5) is currently unsupported. Do not connect to this port.

4. COURIER INTERFACE

4.1 Courier Protocol

Courier is a Schneider Electric communication protocol. The concept of the protocol is that a standard set of commands is used to access a database of settings and data in the relay. This allows a generic master to be able to communicate with different slave devices. The application-specific aspects are contained in the database rather than the commands used to interrogate it, so the master station does not need to be preconfigured.

The same protocol can be used through two physical links K-Bus or EIA(RS)-232.

K-Bus is based on EIA(RS)-485 voltage levels with HDLC FM0 encoded synchronous signaling and its own frame format. The K-Bus twisted pair connection is unpolarized, whereas the EIA(RS)-485 and EIA(RS)-232 interfaces are polarized. The EIA(RS)-232 interface uses the IEC60870-5 FT1.2 frame format.

The relay supports an IEC60870-5 FT1.2 connection on the front-port. This is intended for temporary local connection and is not suitable for permanent connection. This interface uses a fixed baud rate, 11-bit frame, and a fixed device address.

The rear interface is used to provide a permanent connection for K-Bus and allows multidrop connection. Although K-Bus is based on EIA(RS)-485 voltage levels, it is a synchronous HDLC protocol using FM0 encoding. It is not possible to use a standard EIA(RS)-232 to EIA(RS)-485 converter to convert IEC60870-5 FT1.2 frames to K-Bus. Also it is not possible to connect K-Bus to an EIA(RS)-485 computer port.

For a detailed description of the Courier protocol, command-set and link description, see the following documentation:

R6509	K-Bus Interface Guide
R6510	IEC60870 Interface Guide
R6511	Courier Protocol
R6512	Courier User Guide

Alternatively for direct connections, the fiber optic converter card may be used to convert the rear EIA(RS)485 port into a fiber optic (ST) port. See the Fiber Optic Converter (option) section for more information.

4.2 Front Courier Port

The front EIA(RS)-232 9 pin port supports the Courier protocol for one-to-one communication. This port complies with EIA(RS)-574; the 9-pin version of EIA(RS)-232, see www.tiaonline.org. It is designed for use during installation and commissioning/maintenance and is not suitable for permanent connection. Since this interface is not used to link the relay to a substation communication system, some of the features of Courier are not implemented. These are as follows:

- Automatic extraction of Event Records:
 - Courier Status byte does not support the Event flag.
 - Send Event/Accept Event commands are not implemented.
- Automatic extraction of Disturbance records:
 - Courier Status byte does not support the Disturbance flag.
- Busy Response Layer:
 - Courier Status byte does not support the Busy flag, the only response to a request is the final data.
- Fixed Address:

- The address of the front Courier port is always 1; the Change Device address command is not supported.
- Fixed Baud Rate:
 - 19200 bps.
 - Although automatic extraction of event and disturbance records is not supported, it is possible to manually access this data through the front port.

4.3 Supported Command Set

The following Courier commands are supported by the relay:

- Protocol Layer:
 - Reset Remote Link
 - Poll Status
 - Poll Buffer*
- Setting Changes:
 - Enter Setting Mode
 - Preload Setting
 - Abort Setting
 - Execute Setting
 - Reset Menu Cell
 - Set Value
- Low Level Commands:
 - Send Event*
 - Accept Event*
 - Send Block
 - Store Block Identifier
 - Store Block Footer
- Control Commands:
 - Select Setting Group
 - Change Device Address*
 - Set Real Time
- Menu Browsing:
 - Get Column Headings
 - Get Column Text
 - Get Column Values
 - Get Strings
 - Get Text
 - Get Value
 - Get Column Setting Limits

Note

Commands marked with an asterisk (*) are not supported through the front Courier port.

4.4 Courier Database

The Courier database is two-dimensional. Each cell in the database is referenced by a row and column address. Both the column and the row can take a range from 0 to 255. Addresses in the database are specified as hexadecimal values, for example, 0A02 is column 0A (10 decimal) row 02. Associated settings or data are part of the same column. Row zero of the

column has a text string to identify the contents of the column and to act as a column heading.

The *Relay Menu Database* document contains the complete database definition for the relay. For each cell location the following information is stated:

- Cell Text
- Cell Data type
- Cell value
- Whether the cell is settable, if so
 - Minimum value
 - Maximum value
 - Step size
- Password Level required to allow setting changes
- String information (for Indexed String or Binary flag cells)

4.5 Setting Changes

(See R6512, Courier User Guide - Chapter 9)

Courier provides two mechanisms for making setting changes, both of these are supported by the relay. Either method can be used for editing any of the settings in the relay database.

4.5.1 Method 1

This uses a combination of three commands to perform a settings change:

- Enter Setting Mode
 - Checks that the cell is settable and returns the limits.
- Preload Setting
 - Places a new value to the cell. This value is echoed to ensure that setting corruption has not taken place. The validity of the setting is not checked by this action. Execute Setting Confirms the setting change. If the change is valid, a positive response is returned. If the setting change fails, an error response is returned.
- Abort Setting
 - This command can be used to abandon the setting change.

This is the most secure method. It is ideally suited to on-line editors because the setting limits are taken from the relay before the setting change is made. However, this method can be slow if many settings are being changed because three commands are required for each change.

4.5.2 Method 2

The **Set Value** command can be used to directly change a setting, the response to this command is either a positive confirm or an error code to indicate the nature of a failure. This command can be used to implement a setting more rapidly than the previous method, however the limits are not extracted from the relay. This method is most suitable for off-line setting editors such as Easergy Studio, or for issuing preconfigured (SCADA) control commands.

4.5.3 Relay Settings

There are three categories of settings in the relay database:

- Control and support
- Disturbance recorder
- Protection settings group

Setting changes made to the control and support settings are implemented immediately and stored in non-volatile memory. Changes made to either the Disturbance recorder settings or the Protection Settings Groups are stored in a 'scratchpad' memory and are not immediately implemented by the relay.

To action setting changes stored in the scratchpad the **Save Changes** cell in the **Configuration** column must be written to. This allows the changes to either be confirmed and stored in non-volatile memory, or the setting changes to be aborted.

4.5.4 Setting Transfer Mode

If it is necessary to transfer all of the relay settings to or from the relay, a cell in the **Communication System Data** column can be used. This cell (location BF03) when set to 1 makes all of the relay settings visible. Any setting changes made with the relay set in this mode are stored in scratchpad memory, including control and support settings. When the value of BF03 is set back to 0, any setting changes are verified and stored in non-volatile memory.

4.6 Event Extraction

Events can be extracted either automatically (rear port only) or manually (either Courier port). For automatic extraction all events are extracted in sequential order using the standard Courier event mechanism, this includes fault/maintenance data if appropriate. The manual approach allows the user to select events, faults, or maintenance data at random from the stored records.

4.6.1 Automatic Event Extraction

(See Chapter 7 Courier User Guide, publication R6512).

This method is intended for continuous extraction of event and fault information as it is produced. It is only supported through the rear Courier port.

When new event information is created, the Event bit is set in the Status byte. This indicates to the Master device that event information is available. The oldest, unextracted event can be extracted from the relay using the Send Event command. The relay responds with the event data, which is either a Courier Type 0 or Type 3 event. The Type 3 event is used for fault records and maintenance records.

Once an event has been extracted from the relay, the Accept Event can be used to confirm that the event has been successfully extracted. If all events have been extracted, the event bit is reset. If there are more events still to be extracted, the next event can be accessed using the Send Event command as before.

4.6.2 Event Types

Events are created by the relay under these circumstances:

- Change of state of output contact
- Change of state of opto input
- Protection element operation
- Alarm condition
- Setting change
- Password entered/timed-out
- Fault record (Type 3 Courier Event)
- Maintenance record (Type 3 Courier Event)

4.6.3 Event Format

The Send Event command results in these fields being returned by the relay:

- Cell reference
- Time stamp
- Cell text
- Cell value

The Relay Menu Database document for the relevant product, contains a table of the events created by the relay and indicates how the contents of the above fields are interpreted. Fault records and Maintenance records return a Courier Type 3 event, which contains the above fields with two additional fields:

- Event extraction column
- Event number

These events contain additional information that is extracted from the relay using the referenced extraction column. Row 01 of the extraction column contains a setting that allows the fault/maintenance record to be selected. This setting should be set to the event number value returned in the record. The extended data can be extracted from the relay by uploading the text and data from the column.

4.6.4 Manual Event Record Extraction

Column 01 of the database can be used for manual viewing of event, fault, and maintenance records. The contents of this column depend on the nature of the record selected. It is possible to select events by event number and to directly select a fault record or maintenance record by number.

Event Record selection (Row 01)

This cell can be set to a value between 0 to 249 to select from 250 stored events. 0 selects the most recent record and 249 the oldest stored record. For simple event records, (Type 0) cells 0102 to 0105 contain the event details. A single cell is used to represent each of the event fields. If the event selected is a fault or maintenance record (Type 3), the remainder of the column contains the additional information.

Fault Record Selection (Row 05)

This cell can be used to select a fault record directly, using a value between 0 and 4 to select one of up to five stored fault records. (0 is the most recent fault and 4 is the oldest). The column then contains the details of the fault record selected.

Maintenance Record Selection (Row F0)

This cell can be used to select a maintenance record using a value between 0 and 4. This cell operates in a similar way to the fault record selection.

If this column is used to extract event information from the relay, the number associated with a particular record changes when a new event or fault occurs.

Event Record selection (Row 01)

This cell can be set to a value between 0 to 249/511 (see Note) to select from 250/512 (see Note) stored events. 0 selects the most recent record and 249/511 (see Note) the oldest stored record. For simple event records, (Type 0) cells 0102 to 0105 contain the event details. A single cell is used to represent each of the event fields. If the event selected is a fault or maintenance record (Type 3), the remainder of the column contains the additional information.

Note

0 to 249 and 250 stored events for P14x, P341, P34x, P391, P445, P44y, P54x, P64x and P841.

0 to 511 and 512 stored events for P24x, P44x, P74x, P746 and P849.

Fault Record Selection (Row 05) (not applicable to MiCOM P849)

This cell can be used to select a fault record directly, using a value between 0 and 4 to select one of up to five stored fault records. (0 is the most recent fault and 4 is the oldest). The column then contains the details of the fault record selected.

Maintenance Record Selection (Row F0)

This cell can be used to select a maintenance record using a value between 0 and 4. This cell operates in a similar way to the fault record selection.

If this column is used to extract event information from the relay, the number associated with a particular record changes when a new event or fault occurs.

4.7 Disturbance Record Extraction

The stored disturbance records in the relay are accessible in a compressed format through the Courier interface. The records are extracted using column B4. Cells required for extraction of uncompressed disturbance records are not supported.

Select Record Number (Row 01)

This cell can be used to select the record to be extracted. Record 0 is the oldest unextracted record, already extracted older records are assigned positive values, and negative values are used for more recent records. To help automatic extraction through the rear port, the Disturbance bit of the Status byte is set by the relay whenever there are unextracted disturbance records.

Once a record has been selected, using the above cell, the time and date of the record can be read from cell 02. The disturbance record can be extracted using the block transfer mechanism from cell B00B. The file extracted from the relay is in a compressed format. Use Easergy Studio to decompress this file and save the disturbance record in the COMTRADE format.

As has been stated, the rear Courier port can be used to extract disturbance records automatically as they occur. This operates using the standard Courier mechanism, see Chapter 8 of the *Courier User Guide*. The front Courier port does not support automatic extraction although disturbance record data can be extracted manually from this port.

4.8 Programmable Scheme Logic (PSL) Settings

The Programmable Scheme Logic (PSL) settings can be uploaded from and downloaded to the relay using the block transfer mechanism defined in the Courier User Guide.

These cells are used to perform the extraction:

- B204 Domain
Used to select either PSL settings (upload or download) or PSL configuration data (upload only)
- B208 Sub-Domain
Used to select the Protection Setting Group to be uploaded or downloaded.
- B20C Version
Used on a download to check the compatibility of the file to be downloaded with the relay.
- B21C Transfer Mode
Used to set up the transfer process.
- B120 Data Transfer Cell
Used to perform upload or download.

The PSL settings can be uploaded and downloaded to and from the relay using this mechanism. If it is necessary to edit the settings, Easergy Studio must be used because the

data is compressed. Easergy Studio also performs checks on the validity of the settings before they are downloaded to the relay.

5. IEC60870-5-103 INTERFACE

The IEC60870-5-103 interface is a master/slave interface with the relay as the slave device. The relay conforms to compatibility level 2; compatibility level 3 is not supported. These IEC60870-5-103 facilities are supported by this interface:

- Initialization (Reset)
- Time Synchronization
- Event Record Extraction
- General Interrogation
- Cyclic Measurements
- General Commands
- Disturbance Record Extraction
- Private Codes

5.1 Physical Connection and Link Layer

Two connection options are available for IEC60870-5-103, either the rear EIA(RS)-485 port or an optional rear fiber optic port. If the fiber optic port is fitted, the active port can be selected using the front panel menu or the front Courier port. However the selection is only effective following the next relay power up.

For either of the two connection modes, both the relay address and baud rate can be selected using the front panel menu or the front Courier port. Following a change to either of these two settings a reset command is required to re-establish communications, see the description of the reset command in the Initialization section.

5.2 Initialization

Whenever the relay has been powered up, or if the communication parameters have been changed, a reset command is required to initialize the communications. The relay responds to either of the two reset commands (Reset CU or Reset FCB). However, the Reset CU clears any unsent messages in the relay's transmit buffer.

The relay responds to the reset command with an identification message ASDU 5. The Cause Of Transmission (COT) of this response is either Reset CU or Reset FCB depending on the nature of the reset command. For information on the content of ASDU 5 see section *IEC60870-5-103* in the *Relay Menu Database* document.

In addition to the ASDU 5 identification message, if the relay has been powered up it also produces a power-up event.

5.3 Time Synchronization

The relay time and date can be set using the time synchronization feature of the IEC60870-5-103 protocol. The relay corrects for the transmission delay as specified in IEC60870-5-103. If the time synchronization message is sent as a send / confirm message, the relay responds with a confirm. Whether the time-synchronization message is sent as a send / confirm or a broadcast (send / no reply) message, a time synchronization Class 1 event is generated.

If the relay clock is synchronised using the IRIG-B input, it is not possible to set the relay time using the IEC60870-5-103 interface. If the time is set using the interface, the relay creates an event using the current date and time from the internal clock, which is synchronised to IRIG-B.

5.4 Spontaneous Events

Events are categorized using the following information:

- Function Type
- Information Number

The *IEC60870-5-103* profile in the *Relay Menu Database* document, contains a complete listing of all events produced by the relay.

5.5 General Interrogation (GI)

The General Interrogation (GI) request can be used to read the status of the relay, the function numbers, and information numbers that are returned during the GI cycle. See *the IEC60870-5-103* profile in the *Relay Menu Database* document.

5.6 Cyclic Measurements

The relay produces measured values using ASDU 9 cyclically. This can be read from the relay using a Class 2 poll (note ADSU 3 is not used). The rate at which the relay produces new measured values can be controlled using the Measurement Period setting. This setting can be edited from the front panel menu or the front Courier port and is active immediately following a change.

The measurands transmitted by the relay are sent as a proportion of 2.4 times the rated value of the analog value.

5.7 Commands

A list of the supported commands is contained in the *Relay Menu Database* document. The relay responds to other commands with an ASDU 1, with a Cause of Transmission (COT) indicating 'negative acknowledgement'.

5.8 Test Mode

Using either the front panel menu or the front Courier port, it is possible to disable the relay output contacts to allow secondary injection testing to be performed. This is interpreted as 'test mode' by the IEC60870-5-103 standard. An event is produced to indicate both entry to and exit from test mode. Spontaneous events and cyclic measured data transmitted while the relay is in test mode has a COT of 'test mode'.

The **Test Mode** menu cell (in the **COMMISSION TESTS** column) is used to allow secondary injection testing to be performed on the relay.

To select test mode set the Test Mode menu cell to **Test Mode**. It causes an alarm condition to be recorded, the yellow ALARM LED to light and an alarm message **Test Mode Alm** to be generated.

Test Mode freezes any information stored in the **CB CONDITION** column and (in IEC60870-5-103 builds) changes the Cause Of Transmission (COT) to Test Mode. For relays supporting IEC 61850 Edition 2, the test bit for data quality attribute shall set to TRUE, and the Logical Device Mode will set to test.

Test Mode can also be enabled by energizing an opto mapped to the **Test Mode** signal.

To enable testing of output contacts set the **Test Mode** cell to **Contacts Blocked**. It causes an alarm condition to be recorded, the yellow ALARM LED to light and an alarm message 'Contacts Blk Alm' to be generated.

In **Contact Blocked** mode, the protection function still works but the contacts will not operate. Also, the **Test Pattern** and contact test functions are visible, which can be used to manually operate the output contacts. For relays supporting IEC 61850 Edition 2, the test bit for data quality attribute shall set to TRUE, and the Logical Device Mode will set to test/blocked.

Contacts Blocked can also be enabled by energizing an opto mapped to the **Contacts Blocked** signal.

Once testing is complete the cell must be set back to **Disabled** to restore the relay back to service.

WARNING

If you use or enable Test Mode, you must disable Test Mode before putting the relay back into active service.

IT IS POTENTIALLY EXTREMELY UNSAFE TO ATTEMPT TO USE ANY RELAY WHICH IS STILL IN TEST MODE IN ACTIVE SERVICE.

5.9 Disturbance Records

For Software Releases prior to B0 (i.e. 57 and earlier):

The disturbance records are stored in uncompressed format and can be extracted using the standard mechanisms described in IEC60870-5-103.

Note

IEC60870-5-103 only supports up to 8 records.

For Software Release B0 - A & B:

The disturbance records are stored in uncompressed format and can be extracted using the standard mechanisms described in IEC60870-5-103. The Enhanced Disturbance Recorder software releases mean the relay can store a minimum of 15 records, each of 1.5 seconds duration.

Using relays with IEC 60870-5 CS 103 communication means they can store the same total record length. However, the IEC 60870-5 CS 103 communication protocol dictates that only 8 records (of 3 seconds duration) can be extracted via the rear port.

For Other Software Releases:

The disturbance records are stored in uncompressed format and can be extracted using the standard mechanisms described in IEC60870-5-103.

Where available, the Enhanced Disturbance Recorder software releases mean the relay can store a minimum of 15 records, each of 3.0 seconds duration.

Using relays with IEC 60870-5 CS 103 communication means they can store the same total record length. However, the IEC 60870-5 CS 103 communication protocol dictates that only 8 records (of 3 seconds duration) can be extracted via the rear port.

5.10 Blocking of Monitor Direction

The relay supports a facility to block messages in the Monitor direction and in the Command direction. Messages can be blocked in the Monitor and Command directions using the menu commands, Communications - CS103 Blocking - Disabled / Monitor Blocking / Command Blocking or DDB signals Monitor Blocked and Command Blocked.

5.11 Setting Changes through IEC103 Protocol

The IEC 870-5-103 Standard suggests using the generic services for read/write operations on the proprietary data of different manufacture protection equipments, the directory structure specified by the standard for accessing the generic data is the same as the Px40 setting

structure. With the generic services selected in the Platform Software full access to the relay's database is possible over the first rear communications port using the IEC60870-5-103 protocol with Level 3 compatibility.

Each cell in the database has an attribute that defines whether it is included in the list of cells that are subject to a General Interrogation of Generic data.

The following Group 1,2,3 and 4 settings will be included in the GGI:

- Overcurrent, Neg Seq O/C, Broken Conductor, Earth Fault 1 and 2,
- SEF/REF Prot'n, Residual O/V NVD, Thermal Overload, NEG Sequence O/V,
- Cold Load Pickup, Selective Logic, Admit Protection, Power Protection,
- Volt Protection, Freq Protection, CB FAIL & I<, Supervision,
- Fault Locator, System Checks, Autoreclose, ADV.Frequency.

6. DNP3.0 INTERFACE

6.1 DNP3.0 Protocol

The DNP3.0 protocol is defined and administered by the DNP Users Group. For information on the user group, DNP3.0 in general and the protocol specifications, see

www.dnp.org

The descriptions given there are intended to accompany the device profile document that is included in the Relay Menu Database document. The DNP3.0 protocol is not described here, please refer to the documentation available from the user group. The device profile document specifies the full details of the DNP3.0 implementation for the relay. This is the standard format DNP3.0 document that specifies which objects; variations and qualifiers are supported. The device profile document also specifies what data is available from the relay using DNP3.0. The relay operates as a DNP3.0 slave and supports subset level 2 of the protocol, plus some of the features from level 3.

DNP3.0 communication uses the EIA(RS)-485 communication port at the rear of the relay. The data format is 1 start bit, 8 data bits, an optional parity bit and 1 stop bit. Parity is configurable (see menu settings below)

6.2 DNP3.0 Menu Setting

The following settings are in the DNP3.0 menu in the **Communications** column.

Settings	Range	Description
Remote Address	0 - 65519	DNP3.0 address of relay (decimal)
Baud Rate	1200, 2400, 4800, 9600, 19200, 38400	Selectable baud rate for DNP3.0 serial communication
Parity	None, Odd, Even	Parity setting
DNP Time Sync	Disabled, Enabled	Enables or disables the relay requesting time sync. from the master via IIN bit 4 word 1.
Meas Scaling	Primary, Secondary or Normalised	Setting to report analog values in terms of primary, secondary or normalized (with respect to the CT/VT ratio setting) values.
Message Gap (ms)	0-50	DNP3.0 versions only. This setting allows the master station to have an interframe gap.
DNP Need Time	1 - 30 mins	The length of time waited before requesting another time sync from the master.
DNP App Fragment	100 - 2048 bytes	The maximum message length (application fragment size) transmitted by the relay.
DNP App Timeout	1 - 120 s	The length of time waited after sending a message fragment and waiting for a confirmation from the master.
DNP SBO Timeout	1 - 10 s	The length of time waited after receiving a select command and waiting for an operate confirmation from the master.
DNP Link Timeout	0 - 120 s	The length of time the relay waits for a Data Link Confirm from the master. A value of 0 means data link support disabled and 1 to 120 seconds is the timeout setting.

Table 3 - DNP3.0 menu in the Communications column

6.3 Object 1 Binary Inputs

Object 1, binary inputs, contains information describing the state of signals in the relay, which mostly form part of the Digital Data Bus (DDB). In general these include the state of the output contacts and input optos, alarm signals and protection start and trip signals. The 'DDB number' column in the device profile document provides the DDB numbers for the DNP3.0 point data. These can be used to cross-reference to the DDB definition list. See the *Relay Menu Database* document. The binary input points can also be read as change events using object 2 and object 60 for class 1-3 event data.

6.4 Object 10 Binary Outputs

Object 10, binary outputs, contains commands that can be operated using DNP3.0. Therefore the points accept commands of type pulse on [null, trip, close] and latch on/off as detailed in the device profile in the Relay Menu Database document and execute the command once for either command. The other fields are ignored (queue, clear, trip/close, in time and off time).

There is an additional image of the control inputs. Described as alias control inputs, they reflect the state of the control input, but with a dynamic nature.

- If the Control Input DDB signal is already SET and a new DNP SET command is sent to the Control Input, the Control Input DDB signal goes momentarily to RESET and then back to SET.
- If the Control Input DDB signal is already RESET and a new DNP RESET command is sent to the Control Input, the Control Input DDB signal goes momentarily to SET and then back to RESET.

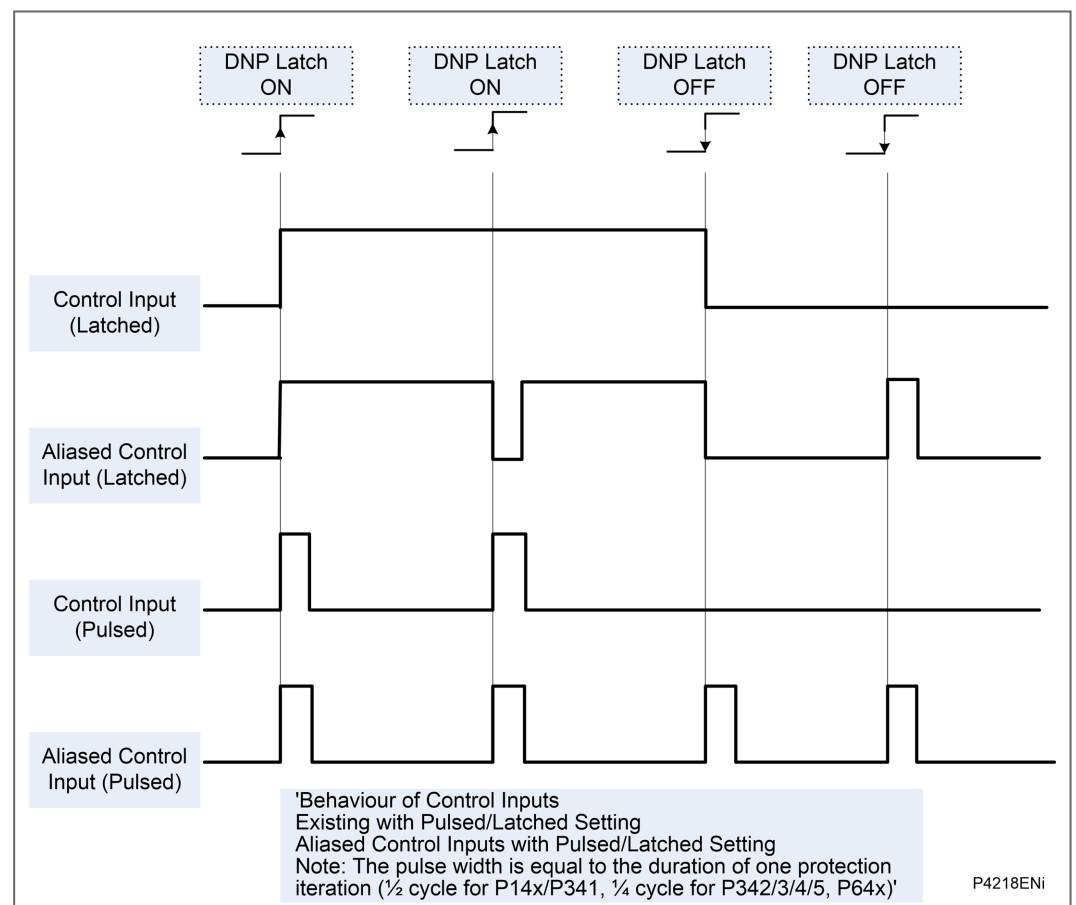

Figure 4 - Behaviour when control input is set to be pulsed or latched

Many of the relay's functions are configurable so some of the object 10 commands described in the following sections may not be available. A read from object 10 reports the point as off-line and an operate command to object 12 generates an error response.

Examples of object 10 points that maybe reported as off-line are:

- Activate setting groups:
Ensure setting groups are enabled
- CB trip/close:
Ensure remote CB control is enabled
- Reset NPS thermal:
Ensure NPS thermal protection is enabled
- Reset thermal O/L:
Ensure thermal overload protection is enabled
- Reset RTD flags
Ensure RTD Inputs is enabled
- Control inputs:
Ensure control inputs are enabled

6.5 Object 20 Binary Counters

Object 20, binary counters, contains cumulative counters and measurements. The binary counters can be read as their present 'running' value from object 20, or as a 'frozen' value from object 21. The running counters of object 20 accept the read, freeze and clear functions. The freeze function takes the current value of the object 20 running counter and stores it in the corresponding object 21 frozen counter. The freeze and clear function resets the object 20 running counter to zero after freezing its value.

Binary counter and frozen counter change event values are available for reporting from object 22 and object 23 respectively. Counter change events (object 22) only report the most recent change, so the maximum number of events supported is the same as the total number of counters. Frozen counter change events (object 23) are generated when ever a freeze operation is performed and a change has occurred since the previous freeze command. The frozen counter event queues will store the points for up to two freeze operations.

6.6 Object 30 Analog Input

Object 30, analog inputs, contains information from the relay's measurements columns in the menu. All Object 30 points can be reported as 16 or 32-bit integer values with flag, 16 or 32-bit integer values without flag, as well as short floating point values.

Analogue values can be reported to the master station as primary, secondary or normalized values (which takes into account the relay's CT and VT ratios) and this is settable in the DNP3.0 Communications Column in the relay. Corresponding deadband settings can be displayed in terms of a primary, secondary or normalized value. Deadband point values can be reported and written using Object 34 variations.

The deadband is the setting used to determine whether a change event should be generated for each point. The change events can be read using Object 32 or Object 60. These events are generated for any point which has a value changed by more than the deadband setting since the last time the data value was reported.

Any analog measurement that is unavailable when it is read is reported as offline. For example, the frequency when the current and voltage frequency is outside the tracking range of the relay or the thermal state when the thermal protection is disabled in the configuration column. All Object 30 points are reported as secondary values in DNP3.0 (with respect to CT and VT ratios).

The following fault data can be mapped in DNP3.0 protocol in serial and Ethernet connections:

- Fault voltages
- Fault currents
- Fault location
- Operating time of relay
- Operating time of breaker
- Fault time
- Fault date

The latest fault records only will be retrieved over DNP3.0.

6.7 Object 40 Analog Output

The conversion to fixed-point format requires the use of a scaling factor, which is configurable for the various types of data within the relay such as current, voltage, and phase angle. All Object 40 points report the integer scaling values and Object 41 is available to configure integer scaling quantities.

6.8 DNP3.0 Configuration using Easergy Studio

A PC support package for DNP3.0 is available as part of Easergy Studio to allow configuration of the relay's DNP3.0 response. The PC is connected to the relay using a serial cable to the 9-pin connector on the front of the relay, see the *Introduction* chapter.

The configuration data is uploaded from the relay to the PC in a block of compressed format data and downloaded to the relay in a similar manner after modification. The new DNP3.0 configuration takes effect in the relay after the download is complete. To restore the default configuration at any time, from the **Configuration** column, select the **Restore Defaults** cell then select **All Settings**.

In Easergy Studio, the DNP3.0 data is shown in four main folders, one folder each for the point configuration, integer scaling, default variation (data format) and DNP over Ethernet. The point configuration also includes screens for binary inputs, binary outputs, counters and analogue input configuration. Note that if the DNP3.0 over Ethernet plus IEC61850 option is chosen, DNP over Ethernet configuration will be used to configure DNP3.0 over Ethernet, and this part of configuration will be ignored by DNP3.0 serial.

For the IP configuration of DNP over Ethernet, please refer to the *DNP3.0 over Ethernet runs concurrently with IEC61850* section.

DNP3.0 over Ethernet includes support for unsolicited responses.

For the Unsolicited Responses configuration of DNP over Ethernet, please refer to this table:

Setting Name	Explanation
unsolAllowed	Determines whether unsolicited responses are allowed. If unsolAllowed is set to disabled, no unsolicited responses will be generated. Requests to enable or disable unsolicited responses will fail and the master station will reply indicating bad function information. If it is configured to allow unsolicited mode (enabled), the relay will be able to send event data in an unsolicited response after it receives a request from the master station containing function code ENABLE_UN SOLICITED(0x14) that enables some or all points to initiate unsolicited responses.
unsolMaxRetries	Specify the maximum number of unsolicited retries before changing to the 'offline' retry period (30 seconds).

Setting Name	Explanation
	unsolRetryDelay Specifies the time, in seconds, to delay after an unsolicited confirm timeout before retrying the unsolicited response.
unsolClass1MaxDelay	If unsolicited responses are enabled, unsolClassXMaxDelay specifies the maximum amount of time in seconds after an event in the corresponding class is received before an unsolicited response will be generated. A configured value of 0 indicates that responses are not delayed.
unsolClass2MaxDelay	
unsolClass3MaxDelay	
unsolClass1MaxEvents	If unsolicited responses are enabled, unsolClassXMaxEvents specifies the maximum number of events in the corresponding class to be allowed before an unsolicited response will be generated.
unsolClass2MaxEvents	
unsolClass3MaxEvents	

Table 4 - Unsolicited Responses configuration of DNP over Ethernet**Important**

At most 6 clients are supported to connect to device at the same time in DNP3.0 over Ethernet protocol.

6.8.1 DNP3.0 over Ethernet runs concurrently with IEC61850

DNP3.0 over Ethernet can run concurrently with IEC61850 if DNP3.0 over Ethernet plus IEC61850 option is chosen. Below table describes the different cases of the usage of DNP3.0 over Ethernet service and IEC61850 service. IEC61850 service will always run under this situation, but DNPoE service only runs when certain requirements are met.

Board Type	Dual or PRP / HSR / RSTP	Configuration file	Interface 1		Interface 2		Invalid DNPoE IP Alarm
			IP address	DNP3oE	IP address	DNP3oE	
Q or R	Doesn't matter	Default IEC61850 configuration No DNP setting or IP_DNP is 0.0.0.0	DEF_IP_1	Disabled	DEF_IP_2	Disabled	No
	Dual	Default IEC61850 configuration Customized DNP setting with valid IP_DNP	IP_DNP	Run	DEF_IP_2	N/A	No
	PRP/HSR/RSTP		DEF_IP_1	N/A	IP_DNP	Run	No
	Doesn't matter	Customized IEC61850 configuration No DNPoE setting or IP_DNP is 0.0.0.0	IP_1	Disabled	IP_2	Disabled	No
	Doesn't matter	Customized IEC61850 configuration Customized DNPoE setting where IP_DNP = IP_1	IP_1	Run	IP_2	N/A	No
	Doesn't matter	Customized IEC61850 configuration Customized DNPoE setting where IP_DNP = IP_2	IP_1	N/A	IP_2	Run	No
	Doesn't matter	Customized IEC61850 configuration Customized DNPoE setting where IP_DNP ≠ IP_1 and IP_DNP ≠ IP_2	IP_1	Disabled	IP_2	Disabled	Yes
S	N/A	Default IEC61850 configuration No DNPoE setting or IP_DNP is 0.0.0.0	DEF_IP_1	Disabled	N/A	N/A	No
	N/A	Default IEC61850 configuration Customized DNPoE setting with valid IP_DNP	IP_DNP	Run	N/A	N/A	No

Board Type	Dual or PRP / HSR / RSTP	Configuration file	Interface 1		Interface 2		Invalid DNPoE IP Alarm
			IP address	DNP3oE	IP address	DNP3oE	
	N/A	Customized IEC61850 configuration No DNPoE setting or IP_DNP is 0.0.0.0	IP_1	Disabled	N/A	N/A	No
	N/A	Customized IEC61850 configuration Customized DNPoE setting where IP_DNP = IP_1	IP_1	Run	N/A	N/A	No
	N/A	Customized IEC61850 configuration Customized DNPoE setting where IP_DNP ≠ IP_1	IP_1	Disabled	N/A	N/A	Yes

Note
For detailed information about different interfaces please refer to the *Dual IP in MiCOM* section in the Dual Redundant Ethernet Board (DREB) chapter.

Table 5 - Protocol running options for different board types

For these IP abbreviations please refer to this table:

Abbreviation	Description
DEF_IP_1	Default IP of interface 1 with default IEC61850 configuration
DEF_IP_2	Default IP of interface 2 with default IEC61850 configuration
IP_1	IP of interface 1 configured in a IEC61850 configuration file
IP_2	IP of interface 2 configured in a IEC61850 configuration file
IP_DNP	IP configured in DNP over Ethernet setting

Table 6 - Abbreviations of Different IP

Note
Running DNP3.0 serial and DNP3.0 over Ethernet concurrently is not recommended.

7. IEC 61850 ETHERNET INTERFACE

7.1 Introduction

IEC 61850 is the international standard for Ethernet-based communication in substations. It enables integration of all protection, control, measurement and monitoring functions in a substation, and provides the means for interlocking and inter-tripping. It combines the convenience of Ethernet with the security which is essential in substations today.

The MiCOM protection relays can integrate with the PACiS substation control systems, to complete Schneider Electric's offer of a full IEC 61850 solution for the substation. The majority of MiCOM Px3x and Px4x relay types can be supplied with Ethernet, in addition to traditional serial protocols. Relays which have already been delivered with UCA2.0 on Ethernet can be easily upgraded to IEC 61850.

7.2 What is IEC 61850?

IEC 61850 is a 14-part international standard, which defines a communication architecture for substations. It is more than just a protocol and provides:

- Standardized models for IEDs and other equipment in the substation
- Standardized communication services (the methods used to access and exchange data)
- Standardized formats for configuration files
- Peer-to-peer (for example, relay to relay) communication

The standard includes mapping of data onto Ethernet. Using Ethernet in the substation offers many advantages, most significantly including:

- High-speed data rates (currently 100 Mbits/s, rather than tens of kbits/s or less used by most serial protocols)
- Multiple masters (called "clients")
- Ethernet is an open standard in every-day use

Schneider Electric has been involved in the Working Groups which formed the standard, building on experience gained with UCA2.0, the predecessor of IEC 61850.

7.2.1 Interoperability

A major benefit of IEC 61850 is interoperability. IEC 61850 standardizes the data model of substation IEDs which simplifies integration of different vendors' products. Data is accessed in the same way in all IEDs, regardless of the vendor, even though the protection algorithms of different vendors' relays may be different.

IEC 61850-compliant devices are not interchangeable, you cannot replace one device with another (although they are interoperable). However, the terminology is predefined and anyone with knowledge of IEC 61850 can quickly integrate a new device without mapping all of the new data. IEC 61850 improves substation communications and interoperability at a lower cost to the end user.

7.2.2 Data Model

To ease understanding, the data model of any IEC 61850 IED can be viewed as a hierarchy of information. The categories and naming of this information is standardized in the IEC 61850 specification.

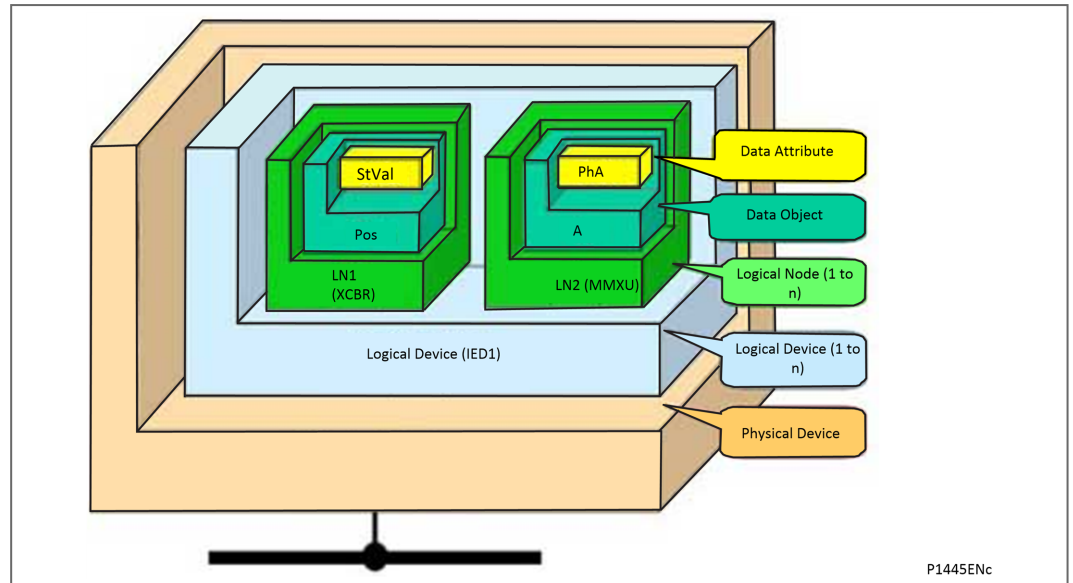

Figure 5 - Data model layers in IEC 61850

The levels of this hierarchy can be described as follows:

- **Physical Device**

Identifies the actual IED in a system. Typically the device's name or IP address can be used (for example **Feeder_1** or **10.0.0.2**).
- **Logical Device**

Identifies groups of related Logical Nodes in the Physical Device. For the MiCOM relays, five Logical Devices exist: **Control, Measurements, Protection, Records, System**.
- **Wrapper/Logical Node Instance**

Identifies the major functional areas in the IEC 61850 data model. Either 3 or 6 characters are used as a prefix to define the functional group (wrapper) while the actual functionality is identified by a 4 character Logical Node name, suffixed by an instance number. For example, XCBR1 (circuit breaker), MMXU1 (measurements), FrqPTOF2 (overfrequency protection, stage 2).
- **Data Object**

This next layer is used to identify the type of data presented. For example, **Pos** (position) of Logical Node type **XCBR**.
- **Data Attribute**

This is the actual data (such as measurement value, status, and description). For example, stVal (status value) indicates the actual position of the circuit breaker for Data Object type **Pos** of Logical Node type **XCBR**.

7.3 IEC 61850 in MiCOM Relays

IEC 61850 is implemented in MiCOM relays by use of a separate Ethernet card. This card manages the majority of the IEC 61850 implementation and data transfer to avoid any impact on the performance of the protection.

To communicate with an IEC 61850 IED on Ethernet, it is necessary only to know its IP address. This can then be configured into either:

- An IEC 61850 client (or master), for example a PACiS computer (MiCOM C264) or HMI, or
- An MMS browser, with which the full data model can be retrieved from the IED, without any prior knowledge

7.3.1 Capability

The IEC 61850 interface provides these capabilities:

- Read access to measurements

All measurands are presented using the measurement Logical Nodes (LNs), in the Measurements Logical Device (LD). Reported measurement values are refreshed by the relay once per second, in line with the relay user interface.

The following fault data have been mapped in LN RFLO1 of LD Records of IEC61850 data model:

 - Fault voltages, Fault currents and Fault location
 - Operating time of relay and Operating time of breaker
 - Fault time, Fault date, etc...

Only the latest fault record can be retrieved over IEC61850.
- Generation of unbuffered reports on change of status/measurement

Unbuffered reports, when enabled, report any change of state in statuses and measurements (according to deadband settings).
- Support for time synchronization over an Ethernet link

Time synchronization is supported using Simple Network Time Protocol (SNTP). This protocol is used to synchronize the internal real time clock of the relays.
- GOOSE peer-to-peer communication

GOOSE communications of statuses are included as part of the IEC 61850 implementation. See Peer-to-Peer (GSE) Communications for more details.
- Disturbance record extraction

Disturbance records can be extracted from MiCOM relays by file transfer, as ASCII format COMTRADE files.
- Controls

The following control services are available:

 - Direct Control
 - Direct Control with enhanced security
 - Select Before Operate (SBO) with enhanced security
 - Controls are applied to open and close circuit breakers using XCBR.Pos and DDB signals 'Control Trip' and 'Control Close'.
 - System/LLN0.LLN0.LEDRs are used to reset any trip LED indications.

Setting changes (e.g. of protection settings) are not supported in the current IEC 61850 implementation. In order to keep this process as simple as possible, such setting changes are done using Easergy Studio Settings & Records program. This can be done as previously using the front port serial connection of the relay, or now optionally over the Ethernet link if preferred (this is known as "tunneling").

- Reports

Reports only include data objects that have changed and not the complete dataset. The exceptions to this are a General Interrogation request and integrity reports.
- Buffered Reports

Eight Buffered Report Control Blocks, (BRCB), are provided in SYSTEM/LLN0 in Logical Device 'System'.

Buffered reports are configurable to use any configurable dataset located in the same Logical device as the BRCB (SYSTEM/LLN0).

- **Unbuffered Reports**

Sixteen Unbuffered Report Control Blocks (URCB) are provided in SYSTEM/LLN0 in Logical Device 'System'.

Unbuffered reports are configurable to use any configurable dataset located in the same Logical device as the URCB (SYSTEM/LLN0).
- **Configurable Data Sets**

It is possible to create and configure datasets in any Logical Node using the IED Configurator. The maximum number of datasets will be specified in an IED's ICD file. An IED is capable of handling 100 datasets.
- **Published GOOSE message**

Eight GOCBs are provided in SYSTEM/LLN0.
- **Uniqueness of control**

The Uniqueness of control mechanism is implemented to be consistent with the PACiS mechanism. This requires the relay to subscribe to the OrdRun signal from all devices in the system and be able to publish such a signal in a GOOSE message.
- **Select Active Setting Group**

Functional protection groups can be enabled or disabled using private mod/beh attributes in the Protection/LLN0.OcpMod object. Setting groups are selectable using the Setting Group Control Block class, (SGCB). The Active Setting Group can be selected using the System/LLN0.SP.SGCB.ActSG data attribute in Logical Device 'System'.
- **Quality for GOOSE**

It is possible to process the quality attributes of any Data Object in an incoming GOOSE message. Devices that do not support IEC61850 quality flags send quality attributes as all zeros. The supported quality attributes for outgoing GOOSE messages are described in the Protocol Implementation eXtra Information for Testing (PIXIT) document.
- **Address List**

An Address List document (to be titled ADL) is produced for each IED which shows the mapping between the IEC61850 data model and the internal data model of the IED. It includes a mapping in the reverse direction, which may be more useful. This document is separate from the PICS/MICS document.
- **Originator of Control**

Originator of control mechanism is implemented for operate response message and in the data model on the ST of the related control object, consistent with the PACiS mechanism.
- **Metering**

MMTR (metering) logical node is implemented in P14x products. All metered values in the MMTR logical node are of type BCR. The actVal attribute of the BCR class is of type INT128, but this type is not supported by the SISCO MMSLite library. Instead, an INT64 value will be encoded for transmission. A SPC data object named MTTRs has been included in the MMTR logical node. This control will reset the demand measurements. A SPC data object named MTTRs is also included in the PTTR logical node. This control will reset the thermal measurements.
- **Scaled Measurements**

The Unit definition, as per IEC specifies an SI unit and an optional multiplier for each measurement. This allows a magnitude of measurement to be specified e.g. mA, A, kA, MA.

- General Service Tracking

This allows a service to be reported, as soon as the tracking data object is a DataSet member of the DataSet associated to a buffered or unbuffered report control block (BRCB / URCB).

The service track only supports Buffered report tracking service and unbuffered report tracking service.

The multiplier will always be included in the Unit definition and will be configurable in SCL, but not settable at runtime. It will apply to the magnitude, rangeC.min & rangeC.max attributes. rangeC.min & rangeC.max will not be settable at runtime to be more consistent with Px30 and to reduce configuration problems regarding deadbands.

Setting changes, such as changes to protection settings, are done using Easergy Studio. These changes can also be done using the relay's front port serial connection or the relay's Ethernet link, and is known as "tunneling".

7.3.2 IEC 61850 Configuration

One of the main objectives of IEC 61850 is to allow IEDs to be directly configured from a configuration file generated at system configuration time. At the system configuration level, the capabilities of the IED are determined from an IED capability description file (ICD), which is provided with the product. Using a collection of these ICD files from different products, the entire protection of a substation can be designed, configured and tested (using simulation tools) before the product is even installed into the substation.

To help this process, the Easergy Studio Support Software provides an IEC61850 IED Configurator tool. Select **Tools > IEC61850 IED Configurator**. This tool allows the preconfigured IEC 61850 configuration file (SCD or CID) to be imported and transferred to the IED. The configuration files for MiCOM relays can also be created manually, based on their original IED Capability Description (ICD) file.

Other features include the extraction of configuration data for viewing and editing, and a sophisticated error-checking sequence. The error checking ensures the configuration data is valid for sending to the IED and ensures the IED functions correctly in the substation.

To help the user, some configuration data is available in the **IED CONFIGURATOR** column of the relay user interface, allowing read-only access to basic configuration data.

7.3.2.1 Configuration Banks

To promote version management and minimize down-time during system upgrades and maintenance, the MiCOM relays have incorporated a mechanism consisting of multiple configuration banks. These configuration banks are categorized as:

- Active Configuration Bank
- Inactive Configuration Bank

Any new configuration sent to the relay is automatically stored in the inactive configuration bank, therefore not immediately affecting the current configuration. Both active and inactive configuration banks can be extracted at any time.

When the upgrade or maintenance stage is complete, the IED Configurator tool can be used to transmit a command to a single IED. This command authorizes the activation of the new configuration contained in the inactive configuration bank, by switching the active and inactive configuration banks. This technique ensures that the system down-time is minimized to the start-up time of the new configuration. The capability to switch the configuration banks is also available using the **IED CONFIGURATOR** column.

For version management, data is available in the **IED CONFIGURATOR** column in the relay user interface, displaying the SCL Name and Revision attributes of both configuration banks.

7.3.2.2 Network Connectivity

Note

This section presumes a prior knowledge of IP addressing and related topics. Further details on this topic may be found on the Internet (search for IP Configuration) and in numerous relevant books.

Configuration of the relay IP parameters (IP Address, Subnet Mask, Gateway) and SNTP time synchronization parameters (SNTP Server 1, SNTP Server 2) is performed by the IED Configurator tool. If these parameters are not available using an SCL file, they must be configured manually.

If the assigned IP address is duplicated elsewhere on the same network, the remote communications do not operate in a fixed way. However, the relay checks for a conflict at power up and every time the IP configuration is changed. An alarm is raised if an IP conflict is detected.

Use the **Gateway** setting to configure the relay to accept data from networks other than the local network.

7.4 Data Model of MiCOM Relays

The data model naming adopted in the Px30 and Px40 relays has been standardized for consistency. The Logical Nodes are allocated to one of the five Logical Devices, as appropriate, and the wrapper names used to instantiate Logical Nodes are consistent between Px30 and Px40 relays.

The data model is described in the Model Implementation Conformance Statement (MICS) document, which is available separately. The MICS document provides lists of Logical Device definitions, Logical Node definitions, Common Data Class and Attribute definitions, Enumeration definitions, and MMS data type conversions. It generally follows the format used in Parts 7-3 and 7-4 of the IEC 61850 standard.

7.5 Communication Services of MiCOM Relays

The IEC 61850 communication services which are implemented in the Px30 and Px40 relays are described in the Protocol Implementation Conformance Statement (PICS) document, which is available separately. The PICS document provides the Abstract Communication Service Interface (ACSI) conformance statements as defined in Annex A of Part 7-2 of the IEC 61850 standard.

7.6 Peer-to-Peer (GSE) Communications

The implementation of IEC 61850 Generic Object Oriented Substation Event (GOOSE) sets the way for cheaper and faster inter-relay communications. The generic substation event model provides fast and reliable system-wide distribution of input and output data values. The generic substation event model is based on autonomous decentralization. This provides an efficient method of allowing simultaneous delivery of the same generic substation event information to more than one physical device, by using multicast services.

The use of multicast messaging means that IEC 61850 GOOSE uses a publisher-subscriber system to transfer information around the network*. When a device detects a change in one of its monitored status points, it publishes (sends) a new message. Any device that is interested in the information subscribes (listens) to the data message.

Note*

Multicast messages cannot be routed across networks without specialized equipment.

Each new message is retransmitted at user-configurable intervals until the maximum interval is reached, to overcome possible corruption due to interference and collisions. In practice,

the parameters which control the message transmission cannot be calculated. Time must be allocated to the testing of GOOSE schemes before or during commissioning; in just the same way a hardwired scheme must be tested.

7.6.1 Scope

A maximum of 32 virtual outputs and 32 virtual inputs are available within the PSL which can be mapped directly to a published dataset in a GOOSE message (only 1 fixed dataset is supported). All published GOOSE signals are BOOLEAN values.

Note

Previous releases of this product could use up to 32 virtual outputs. The B0 release allows you to use up to 32 virtual inputs.

Note

Analogue Goose subscribing: A new GGIO3 is provided for analogue value subscribing, the received analogue values will not be sent to the main card. The values will be stored only on the IEC 61850 data mode.

Each GOOSE signal contained in a subscribed GOOSE message can be mapped to any of the 32 virtual outputs and 32 virtual inputs within the PSL. The virtual inputs allow the mapping to internal logic functions for protection control, directly to output contacts or LEDs for monitoring.

The MiCOM relay can subscribe to all GOOSE messages but only these data types can be decoded and mapped to a virtual input:

- BOOLEAN
- BSTR2
- INT16
- INT32
- INT8
- UINT16
- UINT32
- UINT8

7.6.2 Simulation GOOSE Configuration

From Easergy Studio select Tools > IEC 61850 IED Configurator (Ed.2). Make sure the configuration is correct as this ensures efficient GOOSE scheme operation.

The relay can be set to publish/subscribe simulation/test GOOSE; it is important that this setting is returned to publish/receive normal GOOSE messages after testing to permit normal operation of the application and GOOSE messaging.

The relay provides a single setting to receive Simulated GOOSE, however it manages each subscribed GOOSE signal independently when the setting is set to simulated GOOSE. Each subscription (virtual input) will continue to respond to GOOSE messages without the simulation flag set; however once the relay receives a GOOSE for a subscription with the simulation flag set, it will respond to this and ignore messages without the simulation flag set. Other subscriptions (virtual inputs) which have not received a GOOSE message with the simulation flag will continue to operate as before. When the setting is reset back to normal GOOSE messaging the relay will ignore all GOOSE messages with the simulation flag set and act on GOOSE messages without the simulation flag.



WARNING

If you set the GOOSE in Simulation Mode, you MUST set it back to normal GOOSE after testing.

IT IS POTENTIALLY EXTREMELY UNSAFE TO ATTEMPT TO USE ANY RELAY WHICH IS STILL IN GOOSE SIMULATION MODE.

7.6.3 High Performance GOOSE

In addition, the Px40 device is designed to provide maximum performance through an optimized publishing mechanism. This optimized mechanism is enabled so that the published GOOSE message is mapped using only the data attributes rather than mapping a complete data object. If data objects are mapped, the GOOSE messaging will operate correctly; but without the benefit of the optimized mechanism.

A pre-configured dataset named as "HighPerformGOOSE" is available in Ed.2 ICD template, which include all data attributes of all virtual outputs. We recommend using this dataset to get the benefit of better GOOSE performance. The optimized mechanism also applies to Ed.1 but without such a pre-configured dataset.

7.7 Ethernet Functionality

Settings relating to a failed Ethernet link are available in the 'COMMUNICATIONS' column of the relay user interface.

Note

Setting relating to the failed link is removed for the new Ethernet and the behaviour is fixed as Event.

7.7.1 Ethernet Disconnection

IEC 61850 'Associations' are unique and made to the relay between the client (master) and server (IEC 61850 device). If the Ethernet is disconnected, such associations are lost and must be re-established by the client. The TCP_KEEPAALIVE function is implemented in the relay to monitor each association and terminate any which are no longer active.

7.7.2 Redundant Ethernet Communication Ports (optional)

For information regarding the Redundant Ethernet communication ports, refer to the stand alone document Px4x/EN REB/B11.

7.7.3 Loss of Power

If the relay's power is removed, the relay allows the client to re-establish associations without a negative impact on the relay's operation. As the relay acts as a server in this process, the client must request the association. Uncommitted settings are cancelled when power is lost. Reports requested by connected clients are reset and must be re-enabled by the client when the client next creates the new association to the relay.

7.7.4 Courier Tunneling via Secure Ethernet Communications

7.7.4.1 Introduction

When the IED and Easergy Studio are connected via the Ethernet port they will communicate securely using TLS.

The benefits of secure communication are:

- Help in the prevention of unwanted eavesdropping between Easergy Studio (MiCOM S1 Studio) and the IED
- Help in the prevention of modification of data between Easergy Studio (MiCOM S1 Studio) and the IED
- Ensure integrity of data
- Prevent replay of data at a later data

Note

The communication will be done using port 4422, ensure this port is left unblocked on your network.

7.7.4.2 Setting up a Connection

As a quick guide you need to do the following:

1. In Easergy Studio, click the Quick Connect... button
2. Select the relevant Device Type in the Quick Connect dialog box.
3. Select Ethernet port
4. Enter the relevant data i.e. IP address of IED
5. Click Finish
6. Easergy Studio will attempt to communicate with the device

Note

When attempting to connect to the IED via Ethernet Easergy Studio will first attempt to communicate with the IED via secure communication if this is not possible it will use open communication with no encryption.

For secure communication please ensure port 4422 is left unblocked on the firewalls on which Easergy Studio is running.

Notes:

INSTALLATION

CHAPTER 16

Applicability**Date:** 11/2023**Products covered by this chapter:**

This chapter covers the specific versions of the MiCOM products listed below.
This includes **only** the following combinations of Software Version and Hardware Suffix.

Hardware Suffix:

Product	Hardware Suffix
P141 / P142 / P143	J / L or later
P145	J / M or later
P241	J or later
P242 / P243	K or later
P342	J or later
P343 / P344 / P345	K or later
P341	J / L or later
P445	J / L or later
P44x (P442 / P444)	L / M or later
P44y (P443 / P446)	K / M or later
P54x (P543 / P544 / P545 / P546)	K / M or later
P642	J / L or later
P643 / P645	K / M or later
P74x (P741 / P742 / P743)	J / K or later
P746	K / M or later
P841	K / M or later
P849	K / M or later

Software Version:

Product	Software Version
P14x (P141 / P142 / P143 / P145)	43 / 44 / 46 / B0 / B1 / B2 or later
P24x (P241 / P242 / P243)	57 or later
P341	B0 / E0 or later
P342 / P343 / P344 / P345	36 or later
P445	35 / 36 / J4 or later
P44x (P442 / P444)	E0 / E1 or later
P44y (P443 / P446)	55 / H4 or later
P54x (P543 / P544 / P545 / P546)	45 / 55 / H4 or later
P64x (P642 / P643 / P645)	04 / A0 / B1 / B2 or later
P74x (P741 / P742 / P743)	51 / A0 / B1 or later
P746	A0 / B1 / B2 / C1 / C2 or later
P841	45 / 55 / G4 / H4 or later
P849	A0 / B1 or later

Connection Diagrams: This chapter list the connection diagram for the product:

P14x (P141, P142, P143 & P145):	10P141xx (xx = 01 to 02) 10P142xx (xx = 01 to 05) 10P143xx (xx = 01 to 11) 10P145xx (xx = 01 to 11)
P24x (P241, P242 & P243):	10P241xx (xx = 01 to 02) 10P242xx (xx = 01) 10P243xx (xx = 01)
P34x (P342, P343, P344, P345 & P391)	10P342xx (xx = 01 to 17) 10P343xx (xx = 01 to 19) 10P344xx (xx = 01 to 12) 10P345xx (xx = 01 to 07) 10P391xx (xx = 01 to 02)
P445:	10P445xx (xx = 01 to 04)
P44x (P442 & P444):	10P44101 (SH 1 & 2) 10P44201 (SH 1 & 2) 10P44202 (SH 1) 10P44203 (SH 1 & 2) 10P44401 (SH 1) 10P44402 (SH 1) 10P44403 (SH 1 & 2) 10P44404 (SH 1) 10P44405 (SH 1) 10P44407 (SH 1 & 2)
P44y:	10P44303 (SH 01 and 03) 10P44304 (SH 01 and 03) 10P44305 (SH 01 and 03) 10P44306 (SH 01 and 03) 10P44600 10P44601 (SH 1 to 2) 10P44602 (SH 1 to 2) 10P44603 (SH 1 to 2)
P54x (P543, P544, P545 & P546):	10P54302 (SH 1 to 2) 10P54303 (SH 1 to 2) 10P54304 (SH 1 to 2) 10P54400 10P54404 (SH 1 to 2) 10P54405 (SH 1 to 2) 10P54502 (SH 1 to 2) 10P54503 (SH 1 to 2) 10P54504 (SH 1 to 2) 10P54600 10P54604 (SH 1 to 2) 10P54605 (SH 1 to 2) 10P54606 (SH 1 to 2)
P547:	10P54702xx (xx = 01 to 02) 10P54703xx (xx = 01 to 02) 10P54704xx (xx = 01 to 02) 10P54705xx (xx = 01 to 02)
P64x (P642, P643 & P645):	10P642xx (xx = 1 to 10) 10P643xx (xx = 1 to 6) 10P645xx (xx = 1 to 9)

P74x:	10P740xx (xx = 01 to 07)
P746:	10P746xx (xx = 00 to 21)
P841:	10P84100 10P84101 (SH 1 to 2) 10P84102 (SH 1 to 2) 10P84103 (SH 1 to 2) 10P84104 (SH 1 to 2) 10P84105 (SH 1 to 2)
P849:	10P849xx (xx = 01 to 06)

CONTENTS

1. Introduction to MiCOM Range	7
2. Receipt, Handling, Storage and Unpacking Relays	8
2.1 Receipt of Relays.....	8
2.2 Handling of Electronic Equipment.....	8
2.3 Storage.....	9
2.4 Unpacking.....	9
3. Relay Mounting	10
3.1 Rack Mounting.....	11
3.2 Panel Mounting.....	12
4. Relay Wiring	14
4.1 Medium and Heavy Duty Terminal Block Connections.....	14
4.2 EIA(RS)485 Port.....	15
4.3 Current Loop Input Output (CLIO) Connections (if applicable).....	15
4.4 IRIG-B Connections (if applicable).....	15
4.5 EIA(RS)232 Port.....	15
4.6 Optical Fiber Connectors (when applicable).....	15
4.7 Ethernet Port for IEC 61850 and/or DNP30 (where applicable).....	16
4.7.1 Fiber Optic (FO) Port.....	16
4.7.2 RJ-45 Metallic Port.....	16
4.8 RTD Connections (if applicable).....	16
4.9 Download/Monitor Port.....	17
4.10 Second EIA(RS)232/485 Port.....	17
4.10.1 Connection to the Second Rear Port.....	18
4.10.1.1 For IEC 60870-5-2 over EIA(RS)232/574.....	18
4.10.1.2 For K-bus or IEC 60870-5-2 over EIA(RS)485.....	18
4.11 Earth Connection (Protective Conductor).....	19
5. Case Dimensions	20
5.1 40TE Case Dimensions.....	21
5.2 60TE Case Dimensions.....	22
5.3 80TE Case Dimensions.....	23

TABLES

Table 1 - Products, sizes and part numbers.....	11
Table 2 - Blanking plates.....	12

Table 3 - IP52 sealing rings.....	13
Table 4 - Signals on the Ethernet connector.....	16
Table 5 - Pin connections for IEC 60870-5-2 over EIA(RS)232/574.....	18
Table 6 - Pin connections for K-bus or IEC 60870-5-2 over EIA(RS)485.....	19
Table 7 - Products and case sizes.....	20

FIGURES

Figure 1 - Location of battery isolation strip.....	11
Figure 2 - Rack mounting of relays.....	12
Figure 3 - 40TE Case Dimensions.....	21
Figure 4 - 60TE Case Dimensions.....	22
Figure 5 - 80TE Case Dimensions.....	23

1. INTRODUCTION TO MICOM RANGE

About MiCOM Range

MiCOM is a comprehensive solution capable of meeting all electricity supply requirements. It comprises a range of components, systems and services from Schneider Electric.

Central to the MiCOM concept is flexibility. MiCOM provides the ability to define an application solution and, through extensive communication capabilities, integrate it with your power supply control system.

The components within MiCOM are:

- P range protection relays
- C range control products
- M range measurement products for accurate metering and monitoring
- S range versatile PC support and substation control packages

MiCOM products include extensive facilities for recording information on the state and behaviour of the power system using disturbance and fault records. They can also provide measurements of the system at regular intervals to a control centre enabling remote monitoring and control to take place. For up-to-date information, please see:

www.schneider-electric.com

MiCOM Px4x Products

The MiCOM Px4x series of protection devices provide a wide range of protection and control functions and meet the requirements of a wide market segment.

Different parts of the Px4x range provide different functions. These include:

Relay	Main Functions
P14x	Feeder Management relay suitable for MV and HV systems
P24x	Motors and rotating machine management relay for use on a wide range of synchronous and induction machines
P34x	Generator Protection for small to sophisticated generator systems and interconnection protection
P445	Full scheme Distance Protection relays for MV, HV and EHV systems
P44x	Full scheme Distance Protection relays for MV, HV and EHV systems
P44y	Full scheme Distance Protection relays for MV, HV and EHV systems
P54x	Line Differential protection relays for HV/EHV systems with multiple communication options and phase comparison protection for use with PLC
P547	Line Differential protection relays for HV/EHV systems with multiple communication options and phase comparison protection for use with PLC
P64x	Transformer Protection Relays
P74x	Numerical Busbar Protection for use on MV, HV and EHV busbars
P746	Numerical Busbar Protection for use on MV, HV and EHV busbars
P84x	Breaker Failure protection relays

Note

During 2011, the International Electrotechnical Commission classified the voltages into different levels (IEC 60038). The IEC defined LV, MV, HV and EHV as follows: LV is up to 1000V. MV is from 1000V up to 35 kV. HV is from 110 kV or 230 kV. EHV is above 230 KV. There is still ambiguity about where each band starts and ends. A voltage level defined as LV in one country or sector, may be described as MV in a different country or sector. Accordingly, LV, MV, HV and EHV suggests a possible range, rather than a fixed band. Please refer to your local Schneider Electric office for more guidance.

2. RECEIPT, HANDLING, STORAGE AND UNPACKING RELAYS

2.1 Receipt of Relays

Protective relays, although generally of robust construction, require careful treatment prior to installation on site.

Upon receipt, relays should be examined immediately to ensure no external damage has been sustained in transit. If damage has been sustained, a claim should be made to the transport contractor and Schneider Electric should be promptly notified.

Relays that are supplied unmounted and not intended for immediate installation should be returned to their protective polythene bags and delivery carton. See the Storage section for more information about the storage of relays.

2.2 Handling of Electronic Equipment



Warning

Before carrying out any work on the equipment, you should be familiar with the contents of the Safety Information chapter/Safety Guide SFTY/5L M/L11 or later issue, the Technical Data chapter and the ratings on the equipment rating label.

A person's normal movements can easily generate electrostatic potentials of several thousand volts. Discharge of these voltages into semiconductor devices when handling electronic circuits can cause serious damage which, although not always immediately apparent, will reduce the reliability of the circuit. This is particularly important to consider where the circuits use Complementary Metal Oxide Semiconductors (CMOS), as is the case with these relays.

The electronic circuits inside the relay are protected from electrostatic discharge when housed in the case. Do not expose them to risk by removing the front panel or Printed Circuit Boards (PCBs) unnecessarily.

Each PCB incorporates the highest practicable protection for its semiconductor devices. However, if it becomes necessary to remove a PCB, the following precautions should be taken to preserve the high reliability and long life for which the relay has been designed and manufactured.

- Before removing a PCB, ensure that you are at the same electrostatic potential as the equipment by touching the case.
- Handle analogue input modules by the front panel, frame or edges of the circuit boards. PCBs should only be handled by their edges. Avoid touching the electronic components, printed circuit tracks or connectors.
- Do not pass the module to another person without first ensuring you are both at the same electrostatic potential. Shaking hands achieves equipotential.
- Place the module on an anti-static surface, or on a conducting surface which is at the same potential as yourself.
- If it is necessary to store or transport printed circuit boards removed from the case, place them individually in electrically conducting anti-static bags.

In the unlikely event that you are making measurements on the internal electronic circuitry of a relay in service, it is preferable that you are earthed to the case with a conductive wrist strap. Wrist straps should have a resistance to ground between 500k Ω to 10M Ω . If a wrist strap is not available, you should maintain regular contact with the case to prevent a build-up of electrostatic potential. Instrumentation which may be used for making measurements should also be earthed to the case whenever possible.

More information on safe working procedures for all electronic equipment can be found in IEC 61340-5-1. It is strongly recommended that detailed investigations on electronic circuitry or modification work should be carried out in a special handling area such as described in the aforementioned Standard document.

2.3 Storage

If relays are not to be installed immediately upon receipt, they should be stored in a place free from dust and moisture in their original cartons. Where de-humidifier bags have been included in the packing they should be retained. The action of the de-humidifier crystals will be impaired if the bag is exposed to ambient conditions and may be restored by gently heating the bag for about an hour prior to replacing it in the carton.

To prevent battery drain during transportation and storage a battery isolation strip is fitted during manufacture. With the lower access cover open, presence of the battery isolation strip can be checked by a red tab protruding from the positive side.

Care should be taken on subsequent unpacking that any dust which has collected on the carton does not fall inside. In locations of high humidity the carton and packing may become impregnated with moisture and the de-humidifier crystals will lose their efficiency.

Prior to installation, relays should be stored at a temperature of between -40°C to +70°C (-13°F to +158°F).

2.4 Unpacking

Our products leave our factory in closed, sealed original packaging. If at receipt of the delivery the transport packaging is open or the seal is broken, the confidentiality and authenticity of the information contained in the products cannot be ensured.

Care must be taken when unpacking and installing the relays so that none of the parts are damaged and additional components are not accidentally left in the packing or lost. Make sure that any user's CDROM or technical documentation is NOT discarded, and accompanies the relay to its destination substation.

Note

With the lower access cover open, the red tab of the battery isolation strip will be seen protruding from the positive side of the battery compartment. Do not remove this strip because it prevents battery drain during transportation and storage and will be removed as part of the commissioning tests.

Relays must only be handled by skilled persons.

The site should be well lit to facilitate inspection, clean, dry and reasonably free from dust and excessive vibration. This particularly applies to installations which are being carried out at the same time as construction work.

3. RELAY MOUNTING

MiCOM relays are dispatched either individually or as part of a panel/rack assembly.

Individual relays are normally supplied with an outline diagram showing the dimensions for panel cut-outs and hole centres. This information can also be found in the product publication.

Secondary front covers can also be supplied as an option item to prevent unauthorised changing of settings and alarm status. They are available in sizes 40TE and 60TE. The 60TE cover also fits the 80TE case size of the relay.

The old GN0037/GN0038 part numbers are now obsolete.

They have been replaced by parts see **Note 1**.

Product	Size	Part No (Obsolete)	Replacement Part No
P40	40TE 60TE / 80TE	GN0037 001 GN0038 001	see Note 1 see Note 1
P14x	40TE 60TE / 80TE	GN0037 001 GN0038 001	see Note 1 see Note 1
P24xxxxxxxxxxxxA P24xxxxxxxxxxxxC	40TE 60TE / 80TE	GN0037 001 GN0038 001	see Note 1 see Note 1
P24xxxxxxxxxxxxJ P24xxxxxxxxxxxxK	40TE 60TE / 80TE		see Note 1 see Note 1
P34xxxxxxxxxxxxA P34xxxxxxxxxxxxC	40TE 60TE / 80TE	GN0037 001 GN0038 001	see Note 1 see Note 1
P34xxxxxxxxxxxxJ P34xxxxxxxxxxxxK	40TE 60TE / 80TE		see Note 1 see Note 1
P44x	40TE 60TE / 80TE	GN0037 001 GN0038 001	see Note 1 see Note 1
P44y	60TE / 80TE	GN0038 001	see Note 1
P445	40TE 60TE / 80TE	GN0037 001 GN0038 001	see Note 1 see Note 1
P54x	60TE / 80TE	GN0038 001	see Note 1
P547	60TE / 80TE	GN0038 001	see Note 1
P64xxxxxxxxxxxxA/B/C	40TE 60TE / 80TE	GN0037 001 GN0038 001	see Note 1 see Note 1
P64xxxxxxxxxxxxJ/K	40TE 60TE / 80TE		see Note 1 see Note 1
P74x P74x	40TE 60TE	GN0037 001 GN0038 001	see Note 1 see Note 1
P746	80TE	GN0038 001	see Note 1
P841	60TE / 80TE	GN0038 001	see Note 1
P849	80TE	GN0038 001	see Note 1

Product	Size	Part No (Obsolete)	Replacement Part No
Note			
Part Numbers suitable for rack-mounting have an "N" as the 10th digit.			
Part Numbers suitable for panel-mounting have an "M" as the 10th digit.			
Size 40TE may be GN0242 001 and 60TE/80TE as GN0243 001.			
Note 1			
All parts for panel mounted are centralized in a SAREL catalogue.			
This SAREL SE catalogue parts is available by asking at this email address:			
fr-iff-ue@schneider-electric.com			

Table 1 - Products, sizes and part numbers

The design of the relay is such that the fixing holes in the mounting flanges are only accessible when the access covers are open and hidden from sight when the covers are closed.

If a MiCOM P991 or Easergy test block is to be included with the relays, we recommend you position the test block on the right-hand side of the associated relays (when viewed from the front). This minimises the wiring between the relay and test block, and allows the correct test block to be easily identified during commissioning and maintenance tests.

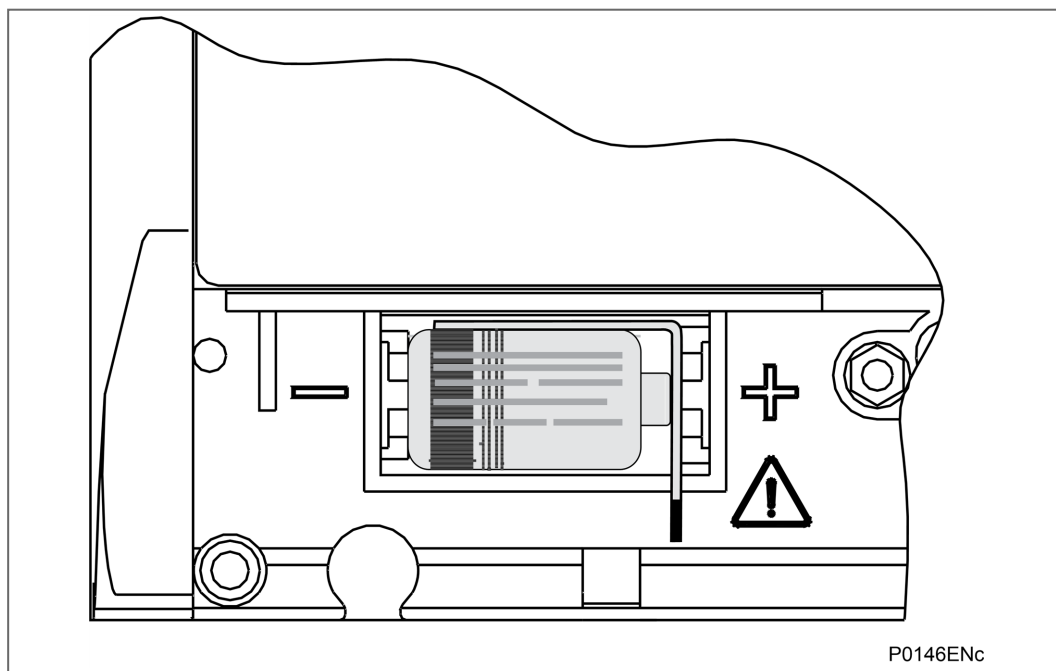

Figure 1 - Location of battery isolation strip

If you need to test correct relay operation during the installation, the battery isolation strip can be removed but should be replaced if commissioning of the scheme is not imminent. This will prevent unnecessary battery drain during transportation to site and installation. The red tab of the isolation strip can be seen protruding from the positive side of the battery compartment when the lower access cover is open. To remove the isolation strip, pull the red tab whilst lightly pressing the battery to prevent it falling out of the compartment. When replacing the battery isolation strip, ensure that the strip is refitted as shown in the Location of battery isolation strip diagram, i.e. with the strip behind the battery with the red tab protruding.

3.1 Rack Mounting

Virtually all MiCOM relays can be rack mounted using single tier rack frames (part number see **Note 1**), see the **Rack mounting of relays** diagram below. These frames have dimensions in accordance with IEC 60297 and are supplied pre-assembled ready to use. On

a standard 483 mm rack this enables combinations of case widths up to a total equivalent of size 80TE to be mounted side-by-side.

The two horizontal rails of the rack frame have holes drilled at approximately 26 mm intervals and the relays are attached via their mounting flanges using M4 Taptite self-tapping screws with captive 3 mm thick washers (also known as a SEMS unit). (see **Note 1**)



Warning
Risk of damage to the front cover moulding. Do not use conventional self-tapping screws, including those supplied for mounting other relays because they have slightly larger heads.

Once the tier is complete, the frames are fastened into the racks using mounting angles at each end of the tier.

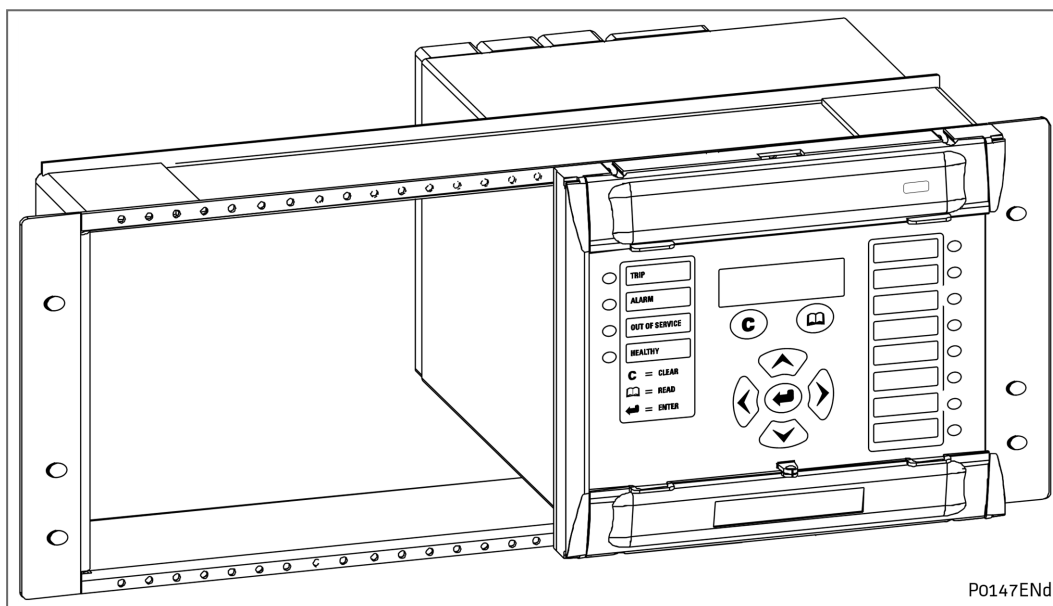

Figure 2 - Rack mounting of relays

Relays can be mechanically grouped into single tier (4U) or multi-tier arrangements by the rack frame. This enables schemes using MiCOM products to be pre-wired together prior to mounting.

Use blanking plates if there are empty spaces. The spaces may be for future installation of relays or because the total size is less than 80TE on any tier. Blanking plates can also be used to mount ancillary components. The following Blanking plates table shows the sizes that can be ordered.

Note
Blanking plates are only available in grey.

Case size summation	Blanking plate part number
10TE	see Note 1
20TE	see Note 1
30TE	see Note 1
40TE	see Note 1

Table 2 - Blanking plates

3.2 Panel Mounting

The relays can be flush mounted into panels using M4 SEMS Taptite self-tapping screws with captive 3 mm thick washers (also known as a SEMS unit). (see **Note 1**)

**Warning**

Risk of damage to the front cover moulding. Do not use conventional self-tapping screws, including those supplied for mounting other relays because they have slightly larger heads.

Alternatively tapped holes can be used if the panel has a minimum thickness of 2.5 mm.

If several relays are mounted in a single cut-out in the panel, mechanically group them together horizontally or vertically to form rigid assemblies prior to mounting in the panel.

Note

Fastening MiCOM relays with pop rivets is not advised because this does not allow easy removal if repair is necessary.

Rack-mounting panel-mounted versions: it is possible to rack-mount some relay versions which have been designed to be panel-mounted. The relay is mounted on a single-tier rack frame, which occupies the full width of the rack. To make sure a panel-mounted relay assembly complies with BS EN60529 IP52, fit a metallic sealing strip between adjoining relays (see **Note 1**) and a sealing ring from the following **IP52 sealing rings** table around the complete assembly.

Width	Single tier	Double tier
40TE	see Note 1	see Note 1
45TE	see Note 1	see Note 1
50TE	see Note 1	see Note 1
55TE	see Note 1	see Note 1
60TE	see Note 1	see Note 1
65TE	see Note 1	see Note 1
70TE	see Note 1	see Note 1
75TE	see Note 1	see Note 1
80TE	see Note 1	see Note 1

Table 3 - IP52 sealing rings

4. RELAY WIRING

This section serves as a guide to selecting the appropriate cable and connector type for each terminal on the MiCOM relay.



Warning

Before carrying out any work on the equipment, you should be familiar with the contents of the Safety Information chapter/Safety Guide SFTY/5L M/L11 or later issue, the Technical Data chapter and the ratings on the equipment rating label.

4.1 Medium and Heavy Duty Terminal Block Connections

Key:

Heavy duty terminal block:	CT and VT circuits, terminals with "C", "D", "E" or "F" prefix (depending on the relay)
Medium duty:	All other terminal blocks (grey color)

Loose relays are supplied with sufficient M4 screws for making connections to the rear mounted terminal blocks using ring terminals, with a recommended maximum of two ring terminals per relay terminal.

The following minimum wire sizes are recommended:

Current Transformers	2.5mm ²
Auxiliary Supply Vx	1.5mm ²
RS485 Port	See separate section
Rotor winding to P391	1.0mm ²
Other circuits	1.0mm ²

Due to the limitations of the ring terminal, the maximum wire size that can be used for any of the medium or heavy duty terminals is 6.0mm² using ring terminals that are not pre-insulated. Where it required to only use pre-insulated ring terminals, the maximum wire size that can be used is reduced to 2.63mm² per ring terminal. If a larger wire size is required, two wires should be used in parallel, each terminated in a separate ring terminal at the relay.

The wire used for all connections to the medium and heavy duty terminal blocks, except the RS485 port, should have a minimum voltage rating of 300Vrms.

It is recommended that the auxiliary supply wiring should be protected by a 16A maximum High Rupture Capacity (HRC) fuse of type NIT or TIA. For safety reasons, current transformer circuits must never be fused. Other circuits should be appropriately fused to protect the wire used.

Note

The high-break contacts optional fitted to P44y (P443/P446) and P54x relays are polarity sensitive. External wiring must respect the polarity requirements which are shown on the external connection diagram to ensure correct operation.

Each opto input has selectable filtering. This allows use of a pre-set filter of ½ cycle which renders the input immune to induced noise on the wiring: although this method is secure it can be slow, particularly for intertripping. This can be improved by switching off the ½ cycle filter in which case one of the following methods to reduce ac noise should be considered. The first method is to use double pole switching on the input, the second is to use screened twisted cable on the input circuit. The recognition time of the opto inputs without the filtering is <2 ms and with the filtering is <12 ms.

4.2 EIA(RS)485 Port

Connections to the first rear EIA(RS)485 port use ring terminals. 2-core screened cable is recommended with a maximum total length of 1000m or 200nF total cable capacitance.

A typical cable specification would be:

Each core:	16/0.2mm copper conductors. PVC insulated
Nominal conductor area:	0.5mm ² per core
Screen:	Overall braid, PVC sheathed

See the SCADA Communications chapter for details of setting up an EIA(RS)485 bus.

4.3 Current Loop Input Output (CLIO) Connections (if applicable)

Where current loop inputs and outputs are available on a MiCOM relay, the connections are made using screw clamp connectors, as per the RTD inputs, on the rear of the relay which can accept wire sizes between 0.1 mm² and 1.5 mm². It is recommended that connections between the relay and the current loop inputs and outputs are made using a screened cable. The wire should have a minimum voltage rating of 300 Vrms.

4.4 IRIG-B Connections (if applicable)

The IRIG-B input and BNC connector have a characteristic impedance of 50Ω. It is recommended that connections between the IRIG-B equipment and the relay are made using coaxial cable of type RG59LSF with a halogen free, fire retardant sheath.

4.5 EIA(RS)232 Port

Short term connections to the RS232 port, located behind the bottom access cover, can be made using a screened multi-core communication cable up to 15m long, or a total capacitance of 2500pF. The cable should be terminated at the relay end with a 9-way, metal shelled, D-type male plug. The Getting Started chapter of this manual details the pin allocations.

4.6 Optical Fiber Connectors (when applicable)



Warning

LASER LIGHT RAYS: Where fibre optic communication devices are fitted, never look into the end of a fiber optic due to the risk of causing serious damage to the eye. Optical power meters should be used to determine the operation or signal level of the device. Non-observance of this rule could possibly result in personal injury.

If electrical to optical converters are used, they must have management of character idle state capability (for when the fibre optic cable interface is "Light off").

Specific care should be taken with the bend radius of the fibres, and the use of optical shunts is not recommended as these can degrade the transmission path over time.

The relay uses 1300nm multi mode 100BaseFx and BFOC 2.5 - (ST/LC according to the MiCOM model) connectors (one Tx – optical emitter, one Rx – optical receiver).

4.7 Ethernet Port for IEC 61850 and/or DNP30 (where applicable)

4.7.1 Fiber Optic (FO) Port

The relays can have 100 Mbps Ethernet port. Fibre Optic (FO) connection is recommended for use in permanent connections in a substation environment. The 100 Mbit port uses a type LC connector (according to the MiCOM model), compatible with fiber multimode 50/125 μm or 62.5/125 μm to 1300 nm.

Note

The new LC fiber optical connector can be used with the Px40 Enhanced Ethernet Board.

4.7.2 RJ-45 Metallic Port

Due to possibility of noise and interference on this part, it is recommended that this connection type be used for short-term connections and over short distance. Ideally, where the relays and switches are located in the same cubicle.

The connector for the Ethernet port is a shielded RJ-45. The following Signals on the Ethernet connector table shows the signals and pins on the connector.

Pin	Signal Name	Signal Definition
1	TXP	Transmit (positive)
2	TXN	Transmit (negative)
3	RXP	Receive (positive)
4	-	Not used
5	-	Not used
6	RXN	Receive (negative)
7	-	Not used
8	-	Not used

Table 4 - Signals on the Ethernet connector

4.8 RTD Connections (if applicable)

Where RTD inputs are available on a MiCOM relay, the connections are made using screw clamp connectors on the rear of the relay that can accept wire sizes between 0.1 mm² and 1.5 mm². The connections between the relay and the RTDs must be made using a screened 3-core cable with a total resistance less than 10 Ω . The cable should have a minimum voltage rating of 300 Vrms.

A 3-core cable should be used even for 2-wire RTD applications, as it allows for the cable's resistance to be removed from the overall resistance measurement. In such cases the third wire is connected to the second wire at the point the cable is joined to the RTD.

The screen of each cable must only be earthed at one end, preferably at the relay end and must be continuous. Multiple earthing of the screen can cause circulating current to flow along the screen, which induces noise and is unsafe.

It is recommended to minimize noise pick-up in the RTD cables by keeping them close to earthed metal casings and avoiding areas of high electromagnetic and radio interference. The RTD cables should not be run adjacent to or in the same conduit as other high voltage or current cables.

A typical cable specification would be:

Each core:	7/0.2 mm copper conductors heat resistant PVC insulated
Nominal conductor area:	0.22 mm ² per core

Screen:	Nickel-plated copper wire braid heat resistant PVC sheathed
---------	---

The extract below may be useful in defining cable recommendations for the RTDs.

Noise pick-up by cables can be categorized in to three types:

- Resistive
- Capacitive
- Inductive

Resistive coupling requires there to be an electrical connection to the noise source. So assuming that the wire and cable insulation is sound and that the junctions are clean then this can be dismissed.

Capacitive coupling requires there to be sufficient capacitance for the impedance path to the noise source to be small enough to allow for significant coupling. This is a function of the dielectric strength between the signal cable on the noise source and the potential (i.e. power) of the noise source.

Inductive coupling occurs when the signal cable is adjacent to a cable/wire carrying the noise or it is exposed to a radiated EMF.

Standard screened cable is normally used to protect against capacitively coupled noise, but in order for it to be effective the screen must only be bonded to the system ground at one point, otherwise a current could flow and the noise would be coupled in to the signal wires of the cable. There are different types of screening available, but basically there are two types: aluminum foil wrap and tin-copper braid.

Foil screens are good for low to medium frequencies and braid is good for high frequencies. High-fidelity screen cables provide both types.

Protection against magnetic inductive coupling requires very careful cable routing and magnetic shielding. The latter can be achieved with steel-armored cable and the use of steel cable trays. It is important that the armor of the cable is grounded at both ends so that the EMF of the induced current cancels the field of the noise source and hence shields the cables conductors from it. (However, the design of the system ground must be considered and care taken to not bridge two isolated ground systems since this could be hazardous and defeat the objectives of the original ground design). The cable should be laid in the cable trays as close as possible to the metal of the tray and under no circumstance should any power cable be in or near to the tray. (Power cables should only cross the signal cables at 90 degrees and never be adjacent to them).

Both the capacitive and inductive screens must be contiguous from the RTD probes to the relay terminals.

The best types of cable are those provided by the RTD manufactures. These tend to be three conductors (a so-called "triad") which are screened with foil. Such triad cables are available in armored forms as well as multi-triad armored forms.

4.9 Download/Monitor Port

Short term connections to the download/monitor port, located behind the bottom access cover, can be made using a screened 25-core communication cable up to 4m long. The cable should be terminated at the relay end with a 25-way, metal shelled, D-type male plug.

The Getting Started and Commissioning chapters this manual details the pin allocations.

4.10 Second EIA(RS)232/485 Port

Relays with Courier, MODBUS, IEC 60870-5-103 or DNP3 protocol on the first rear communications port have the option of a second rear port, running Courier protocol.

Note: IEC-60870-5-103, DNP3.0 and MODBUS are not supported in P74x.

The second rear communications port can be used over one of three physical links:

- twisted pair K-Bus (non-polarity sensitive),
- twisted pair EIA(RS)485 (connection polarity sensitive) or
- EIA(RS)232. This EIA(RS)232 port is actually compliant to EIA(RS)574; the 9-pin version of EIA(RS)232, see www.tiaonline.org.

4.10.1 Connection to the Second Rear Port

The second rear Courier port connects via a 9-way female D-type connector (SK4) in the middle of the card end plate (in between IRIG-B connector and lower D-type). The connection is compliant to EIA(RS)574.

4.10.1.1 For IEC 60870-5-2 over EIA(RS)232/574

Pin	Connection
1	No Connection
2	RxD
3	TxD
4	DTR#
5	Ground
6	No Connection
7	RTS #
8	CTS #
9	No Connection
# - These pins are control lines for use with a modem.	

Table 5 - Pin connections for IEC 60870-5-2 over EIA(RS)232/574

Connections to the second rear port configured for EIA(RS)232 operation can be made using a screened multi-core communication cable up to 15 m long, or a total capacitance of 2500 pF. The cable should be terminated at the relay end with a 9-way, metal shelled, D-type male plug. The table above details the pin allocations.

4.10.1.2 For K-bus or IEC 60870-5-2 over EIA(RS)485

Pin*	Connection
4	EIA(RS)485 - 1 (+ ve)
7	EIA(RS)485 - 2 (- ve)
* - All other pins connected	
<p>Note</p> <p>Connector pins 4 and 7 are used by both the EIA(RS)232/574 and EIA(RS)485 physical layers, but for different purposes. Therefore, the cables should be removed during configuration switches.</p> <p>For the EIA(RS)485 protocol an EIA(RS)485 to EIA(RS)232/574 converter will be required to connect a modem or PC running MiCOM S1 Studio, to the relay. A Schneider Electric CK222 is recommended.</p> <p>EIA(RS)485 is polarity sensitive, with pin 4 positive (+) and pin 7 negative (-).</p> <p>The K-Bus protocol cannot be connected to a PC.</p> <p>It is recommended that a 2-core screened cable be used. To avoid exceeding the second communications port flash clearances it is recommended that the length of cable between the port and the communications equipment should be less than 300 m. This length can be increased to 1000 m or 200nF total cable capacitance if the communications cable is not laid in close proximity to high current carrying conductors. The cable screen should be earthed at one end only.</p>	

Table 6 - Pin connections for K-bus or IEC 60870-5-2 over EIA(RS)485

A typical cable specification would be:

Each core:	16/0.2mm copper conductors. PVC insulated
Nominal conductor area:	0.5mm ² per core
Screen:	Overall braid, PVC sheathed

4.11 Earth Connection (Protective Conductor)

Every relay must be connected to the local earth bar using the M4 earth studs in the bottom left hand corner of the relay case. The minimum recommended wire size is 2.5mm² and should have a ring terminal at the relay end.

Due to the limitations of the ring terminal, the maximum wire size that can be used for any of the medium or heavy duty terminals is 6.0mm² per wire. If a greater cross-sectional area is required, two parallel connected wires, each terminated in a separate ring terminal at the relay, or a metal earth bar could be used.

Note

To prevent any possibility of electrolytic action between brass or copper earth conductors and the rear panel of the relay, precautions should be taken to isolate them from one another. This could be achieved in a number of ways, including placing a nickel-plated or insulating washer between the conductor and the relay case, or using tinned ring terminals.



Warning

Before carrying out any work on the equipment, you should be familiar with the contents of the Safety Information chapter/Safety Guide SFTY/5L M/L11 or later issue, the Technical Data chapter and the ratings on the equipment rating label.

5. CASE DIMENSIONS

The MiCOM range of products are available in a series of different case sizes.

The case sizes available for each product are shown here:

Range	Case Size		
	40TE	60TE	80TE
P14x	P141, P142	P143, P145	P143
P24x	P241	P242	P243
P34x	P341, P342	P341, P342, P343	P343, P344, P345
P441	P441		
P44x		P442	P444
P44y			P443, P446
P445	P445	P445	
P541	P541		
P542		P542	
P54x		P543, P544	P545, P546
P547			P547
P64x	P642	P643, P645	P645
P74x	P742	P743	P741
P746			P746
P841		P841	P841
P849			P849

Table 7 - Products and case sizes

5.1 40TE Case Dimensions

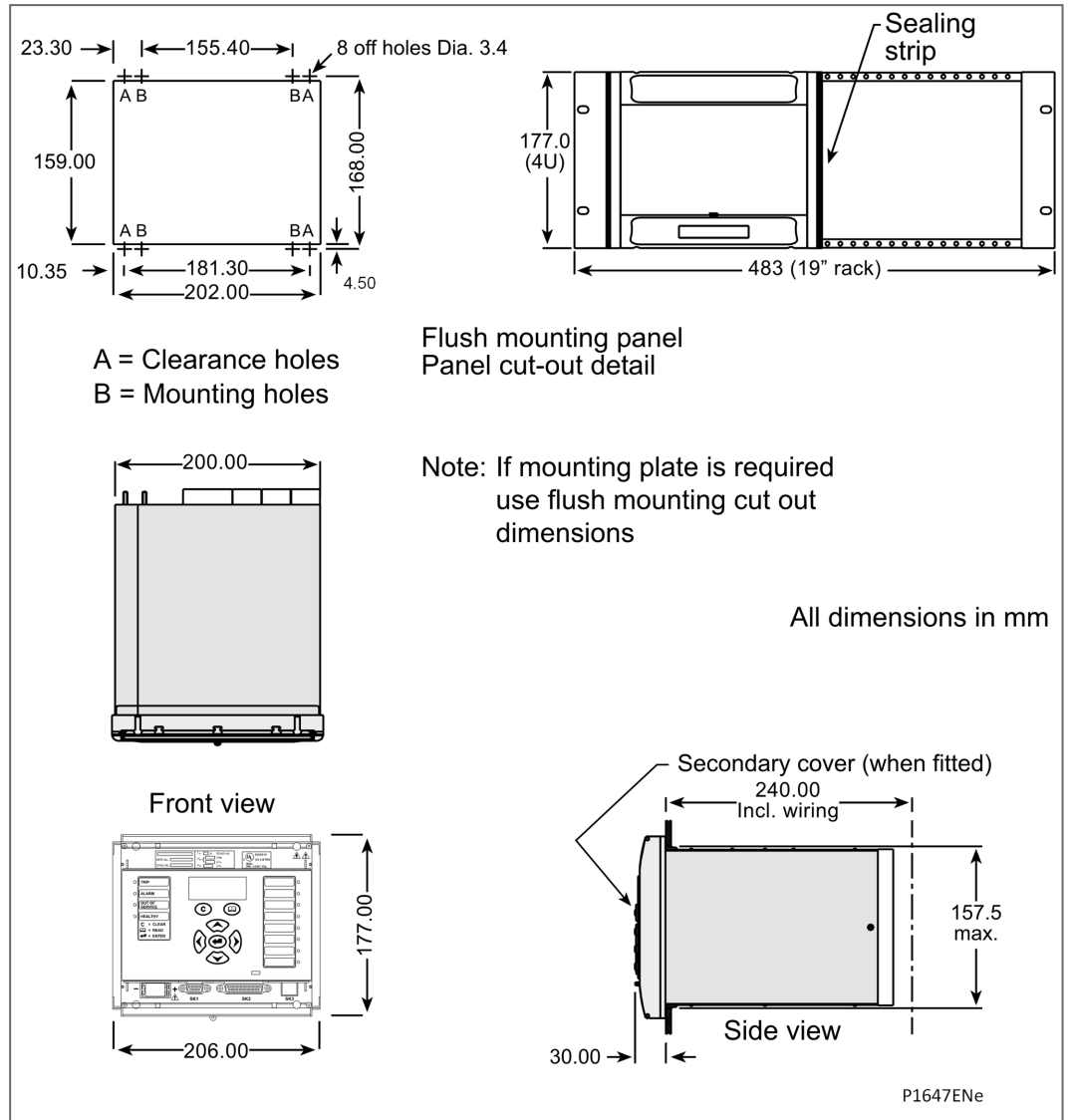

Figure 3 - 40TE Case Dimensions

5.2 60TE Case Dimensions

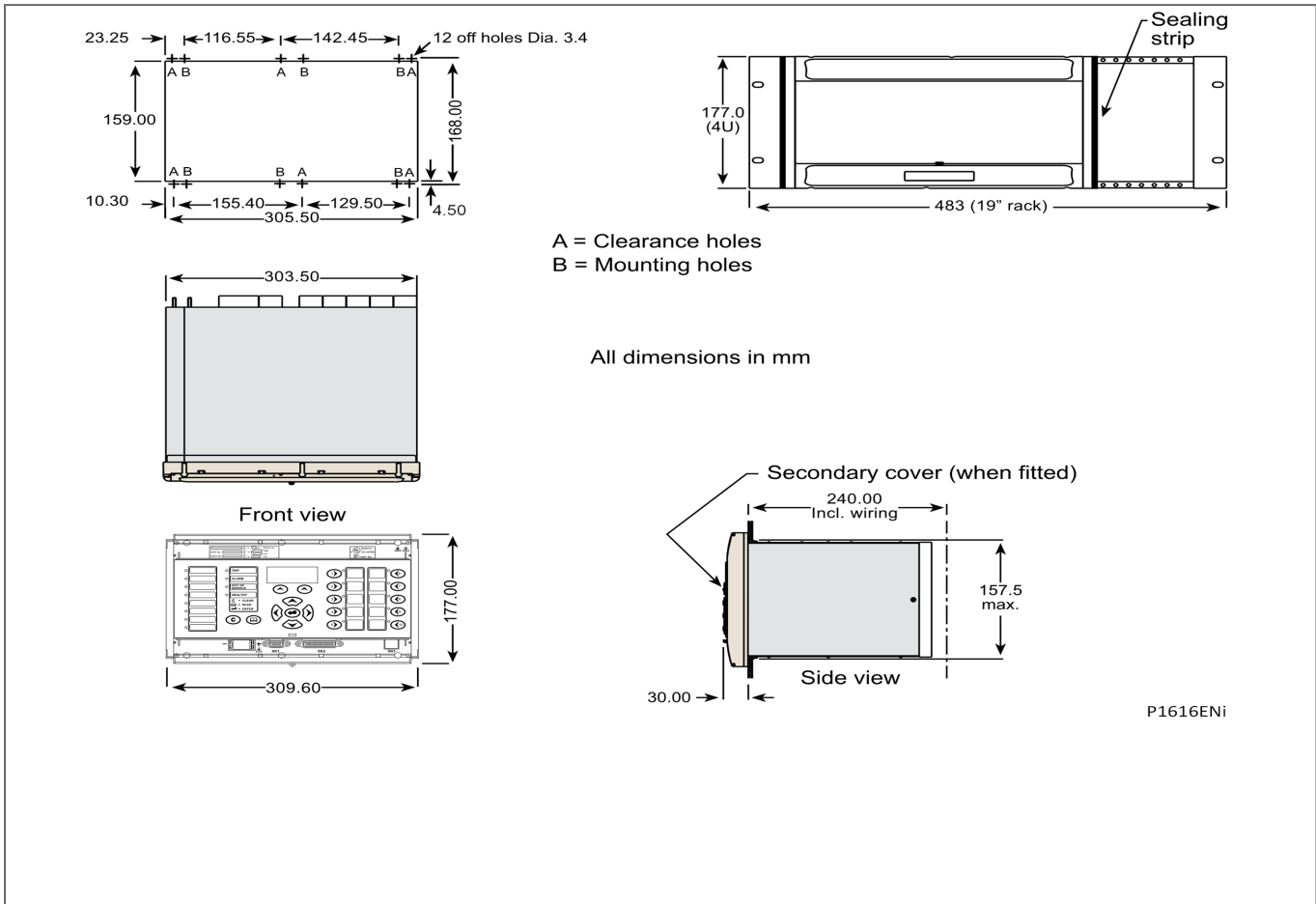

Figure 4 - 60TE Case Dimensions

5.3 80TE Case Dimensions

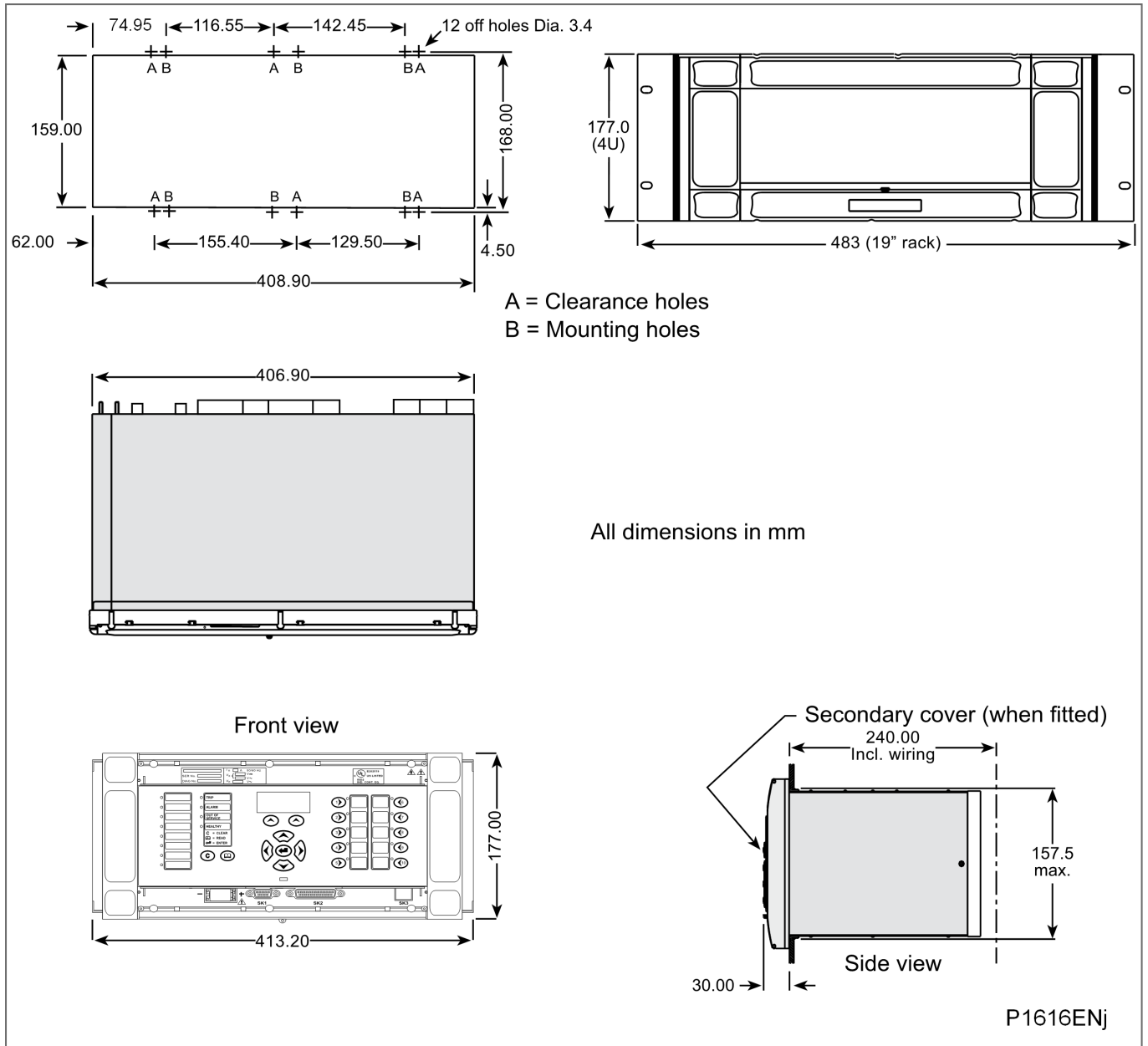

Figure 5 - 80TE Case Dimensions

Notes:

CONNECTION DIAGRAMS

CHAPTER 17

Applicability

Date: 02/2024

Products covered by this chapter:

This chapter covers the specific versions of the MiCOM products listed below. This includes **only** the following combinations of Software Version and Hardware Suffix.

Hardware Suffix:

MiCOM P445 | L

Software Version:

MiCOM P445 | K6

Connection Diagrams: This chapter list the connection diagram for the product:

P445: | 10P445xx (xx = 01 to 04)

CONTENTS

1. Introduction to the Connection Diagrams..... 4

2. Communication Options MiCOM Px40 Platform..... 5

3. External Connection Diagrams..... 8

FIGURES

Figure 1 - Communications Options MiCOM Px40 platform..... 5

Figure 2 - External communications option MiCOM Px40 platform..... 6

Figure 3 - P445 Model A with 8 digital inputs and 8 standard output contacts..... 9

Figure 4 - P445 Model A with 8 digital inputs and 8 standard output contacts.....10

Figure 5 - P445 Model B with 12 digital inputs and 12 standard output contacts.....11

Figure 6 - P445 Model B with 12 digital inputs and 12 standard output contacts.....12

Figure 7 - P445 Model C with 16 digital inputs and 16 standard output contacts.....13

Figure 8 - P445 Model C with 16 digital inputs and 16 standard output contacts.....14

Figure 9 - P445 Model D with 16 digital inputs, 12 standard output contacts and 4 high break contacts.....15

Figure 10 - P445 Model D with 16 digital inputs, 12 standard output contacts and 4 high break contacts..... 16

1. INTRODUCTION TO THE CONNECTION DIAGRAMS

The Installation chapter contains general information about the MiCOM unit. The Installation chapter covers many MiCOM P40 products. It includes items such as:

- Receiving, Handling, Storing and Unpacking the Relays
- Mounting the Relay
- Wiring the Relay
- Case Dimensions

This Connection Diagrams chapter is specific to this particular relay, and includes the detailed wiring diagrams which relate only to this particular relay.

Important:

You must be familiar with the contents of the Installation chapter, before using the information in this Connection Diagrams chapter.

2. COMMUNICATION OPTIONS MICOM PX40 PLATFORM

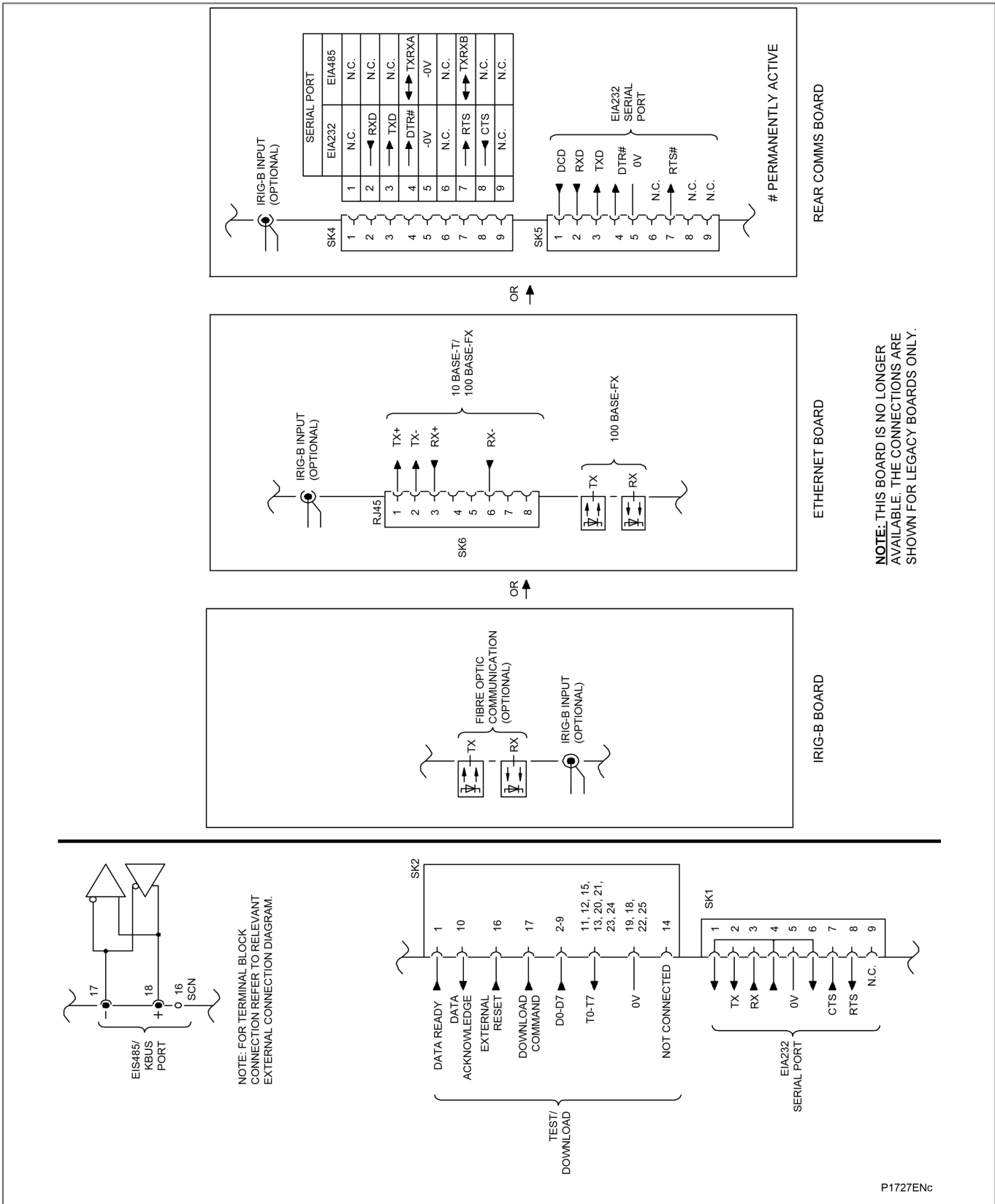

Figure 1 - Communications Options MiCOM Px40 platform

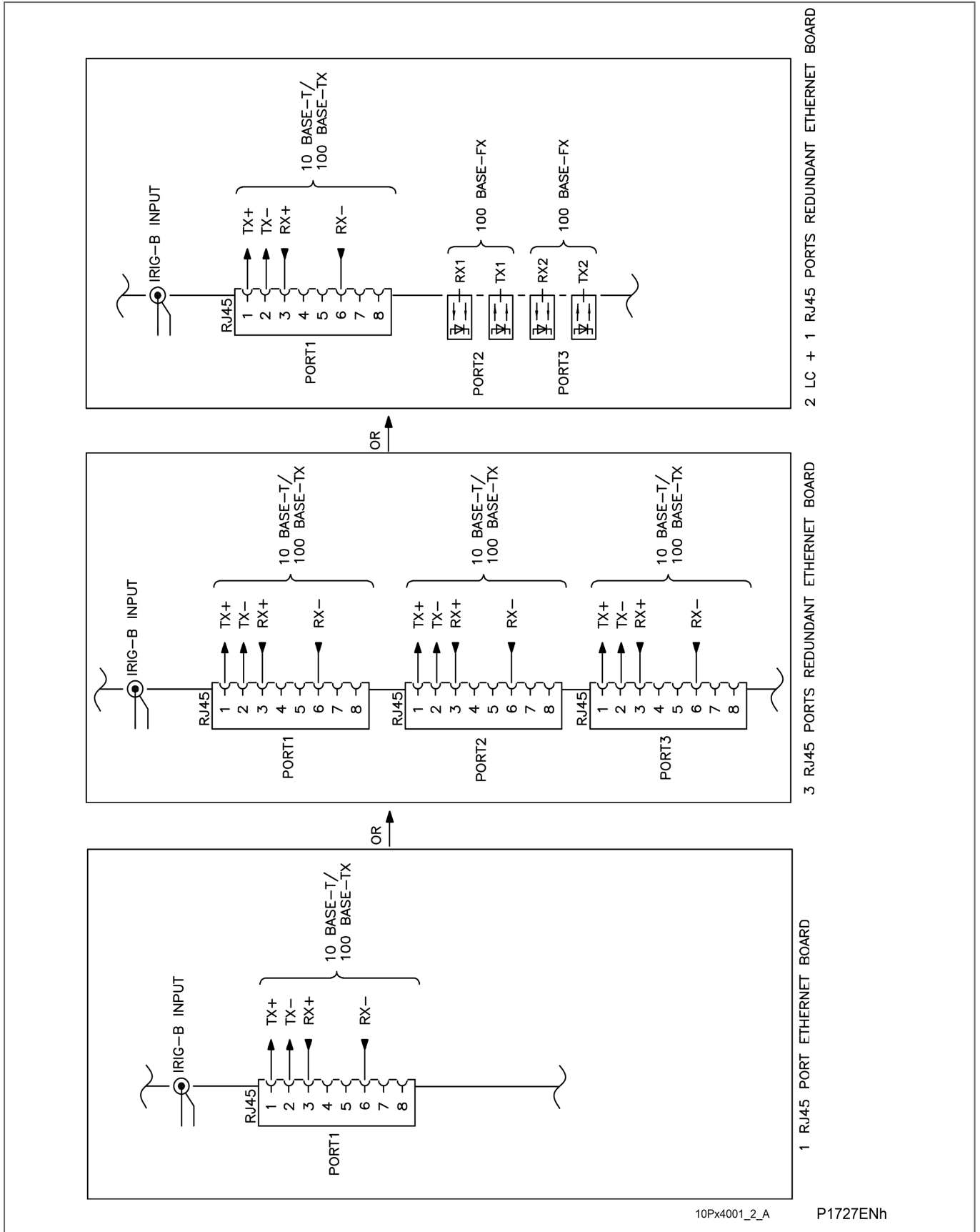

Figure 2 - External communications option MiCOM Px40 platform

Notes:

3. EXTERNAL CONNECTION DIAGRAMS

In this section, the figures may use these abbreviations:

- I/P = Input
- O/P = Output
- HB = High Break
- D/P = Directional Phase
- O/C = Overcurrent
- EF = Earth Fault
- SEF = Sensitive Earth Fault
- AR = Auto-reclose
- CS = Check Synchronizing
- RVI = Residual Voltage Input

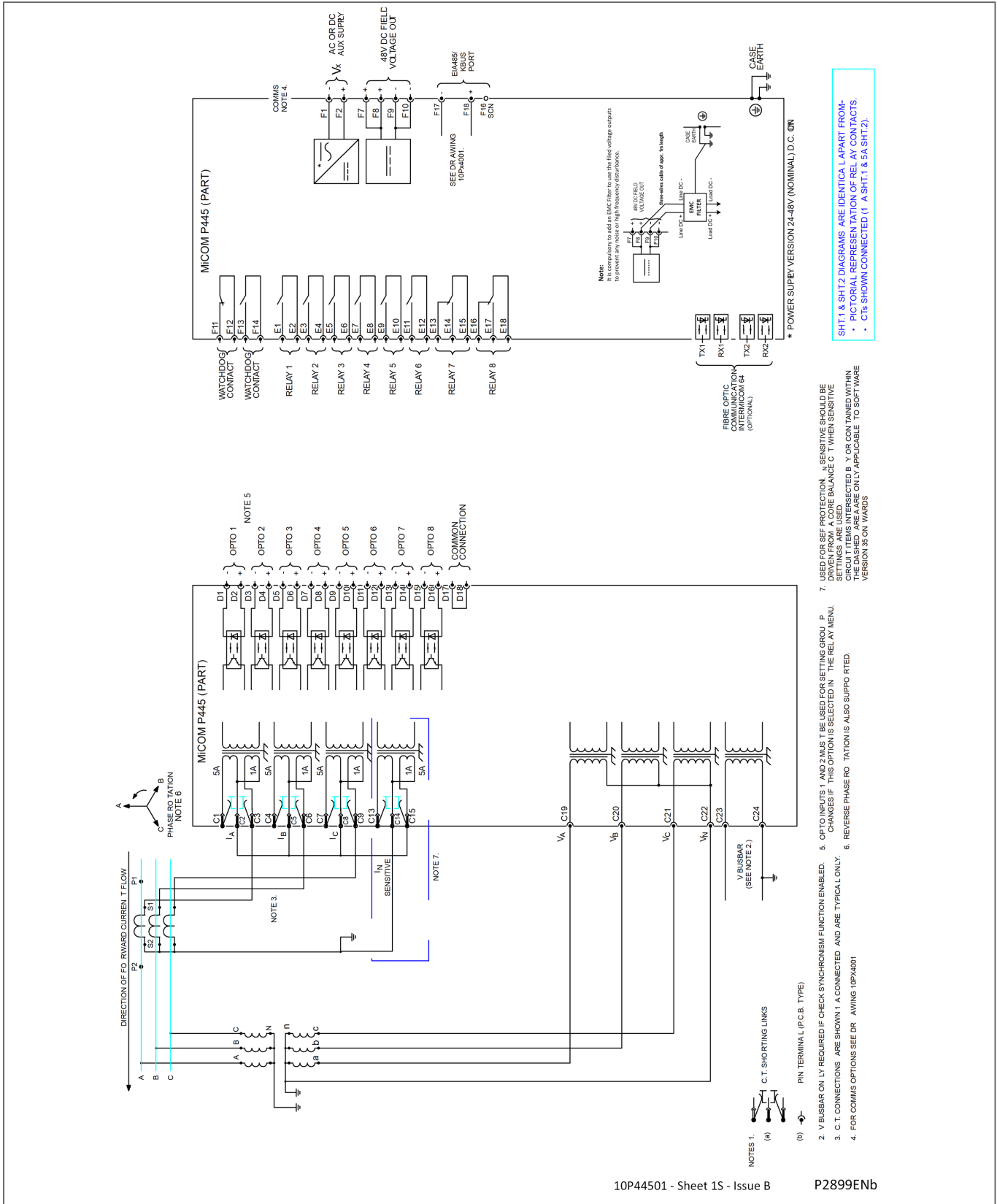

Figure 3 - P445 Model A with 8 digital inputs and 8 standard output contacts

SHT1 & SHT2 DIAGRAMS ARE IDENTICAL APART FROM:-
 • PICTORIAL REPRESENTATION OF RELAY CONTACTS
 • CTs SHOWN CONNECTED (1 A SHT1 & 5A SHT2).

7. USED FOR SEF PROTECTION. A SENSITIVE SHOULD BE DRIVEN FROM A CORE BALANCE C T WHEN SENSITIVE CIRCUIT ITEMS INTERSECTED. Y OR CON TAINED WITHIN THE DASHED AREA ARE ONLY APPLICABLE TO SOFTWARE VERSION 35 ON WARDS

5. OPTO INPUTS 1 AND 2 MUST BE USED FOR SETTING GROU P CHANGES IF THIS OPTION IS SELECTED IN THE RELAY MENU.
 6. REVERSE PHASE ROTATION IS ALSO SUPPOR TED.

2. V BUSBAR ONLY REQUIRED IF CHECK SYNCHRONISM FUNCTION ENABLED.
 3. C.T. CONNECTIONS ARE SHOWN IF A CONNECTED AND ARE TYPICAL ONLY.
 4. FOR COMMS OPTIONS SEE DRAWING 10P4401

NOTES 1. (a) C.T. SHORTING LINKS
 (b) PIN TERMINAL (P.C.B. TYPE)

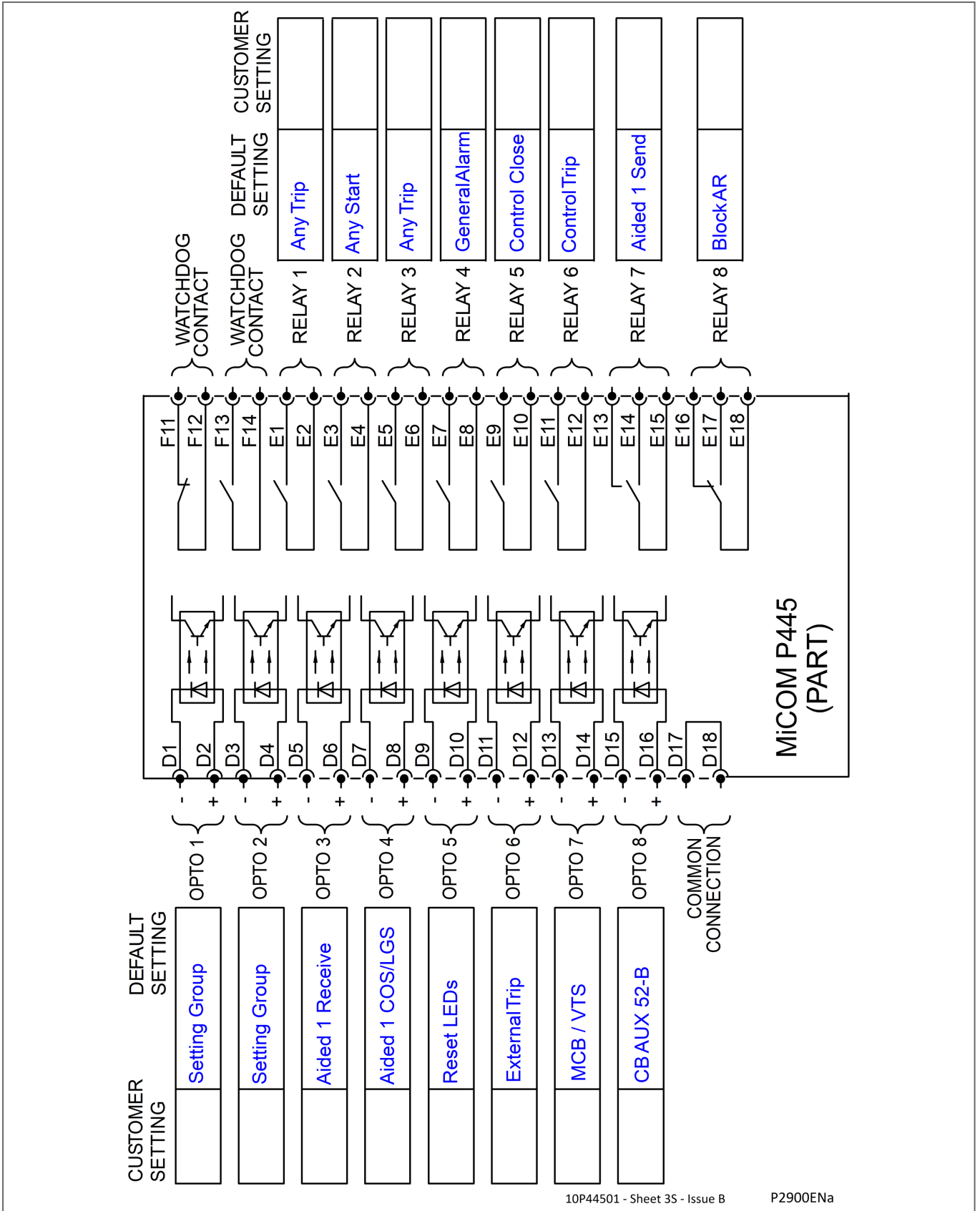

10P44501 - Sheet 35 - Issue B P2900ENa

Figure 4 - P445 Model A with 8 digital inputs and 8 standard output contacts

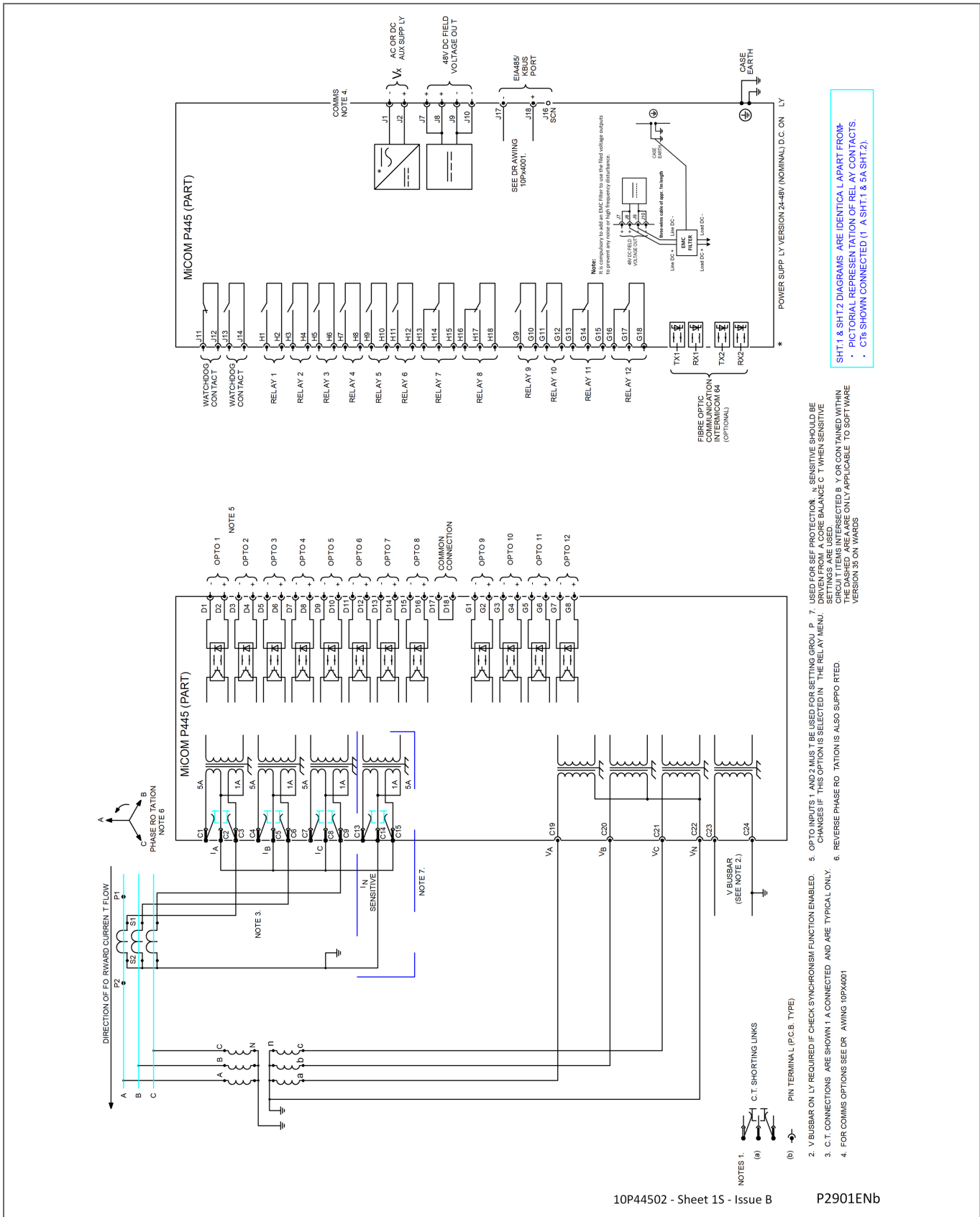

Figure 5 - P445 Model B with 12 digital inputs and 12 standard output contacts

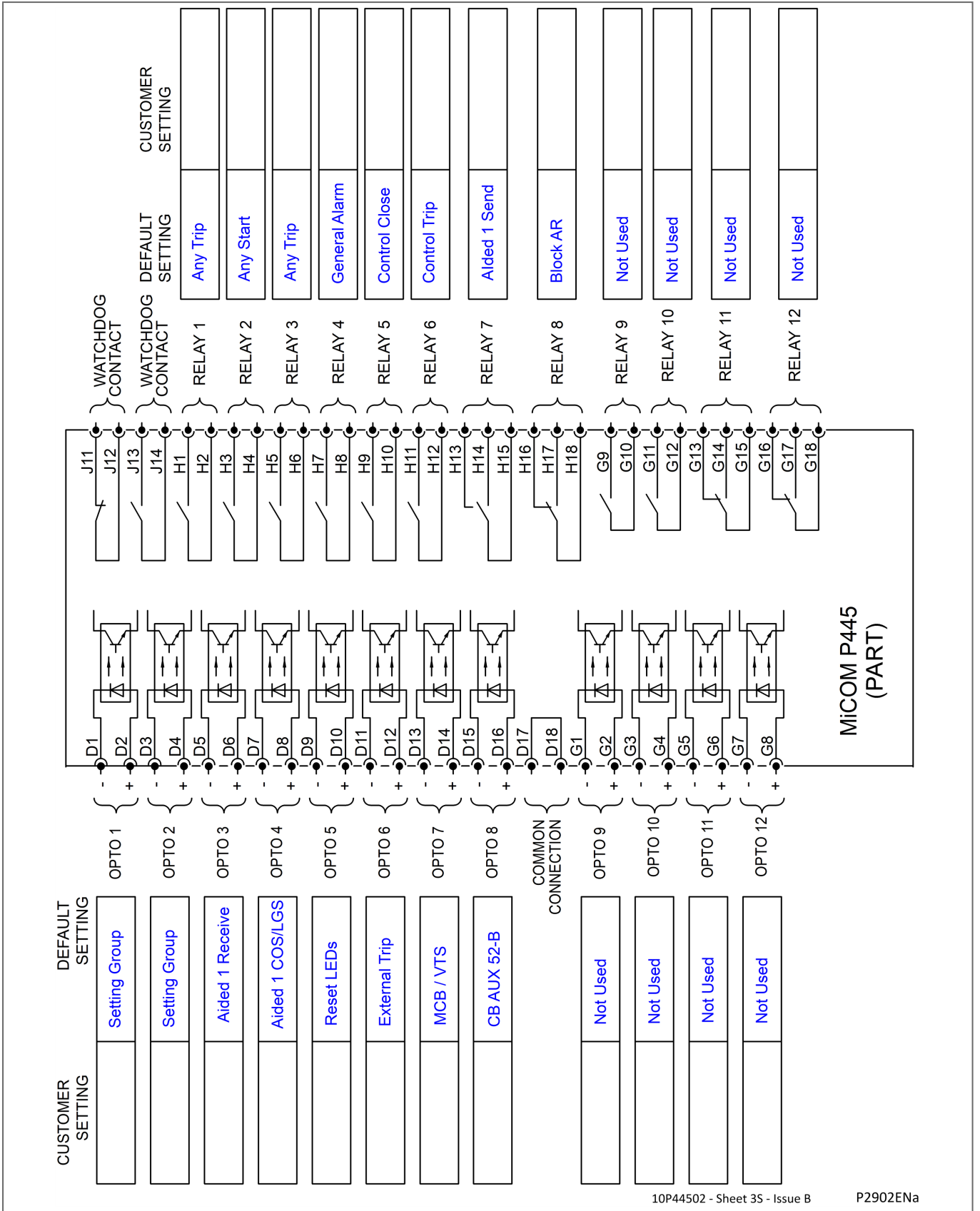
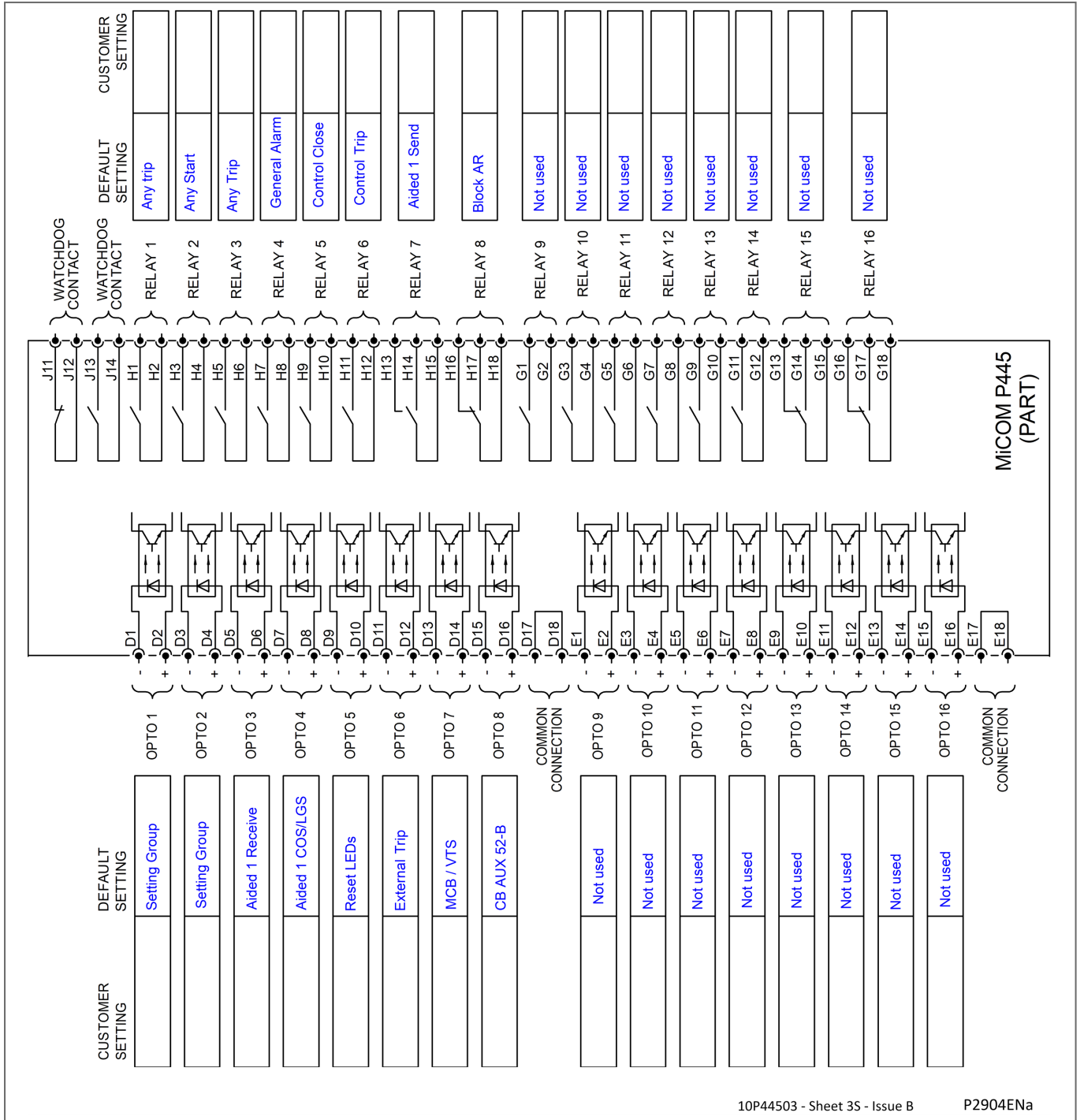

Figure 6 - P445 Model B with 12 digital inputs and 12 standard output contacts



10P44503 - Sheet 35 - Issue B

P2904ENa

Figure 8 - P445 Model C with 16 digital inputs and 16 standard output contacts

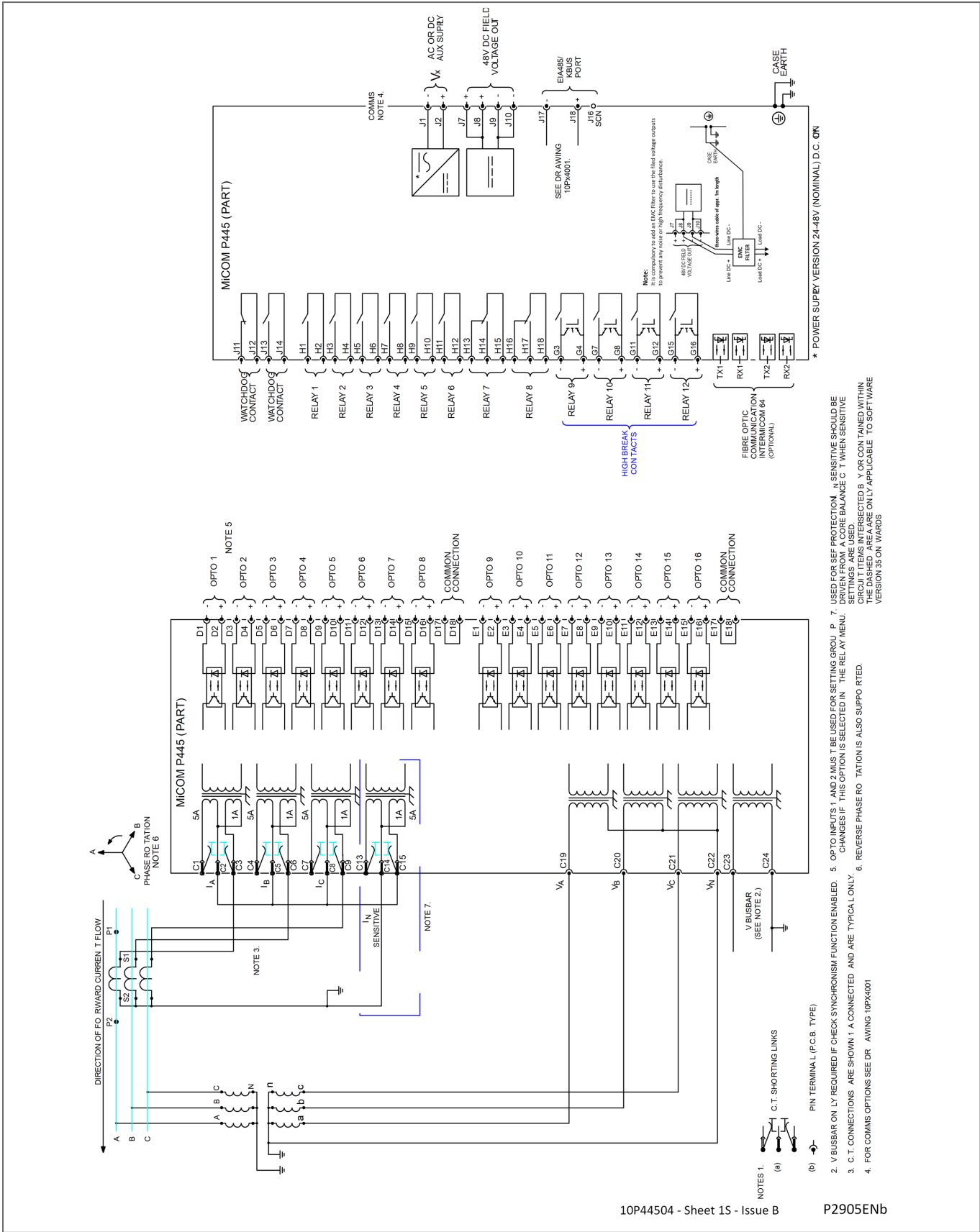
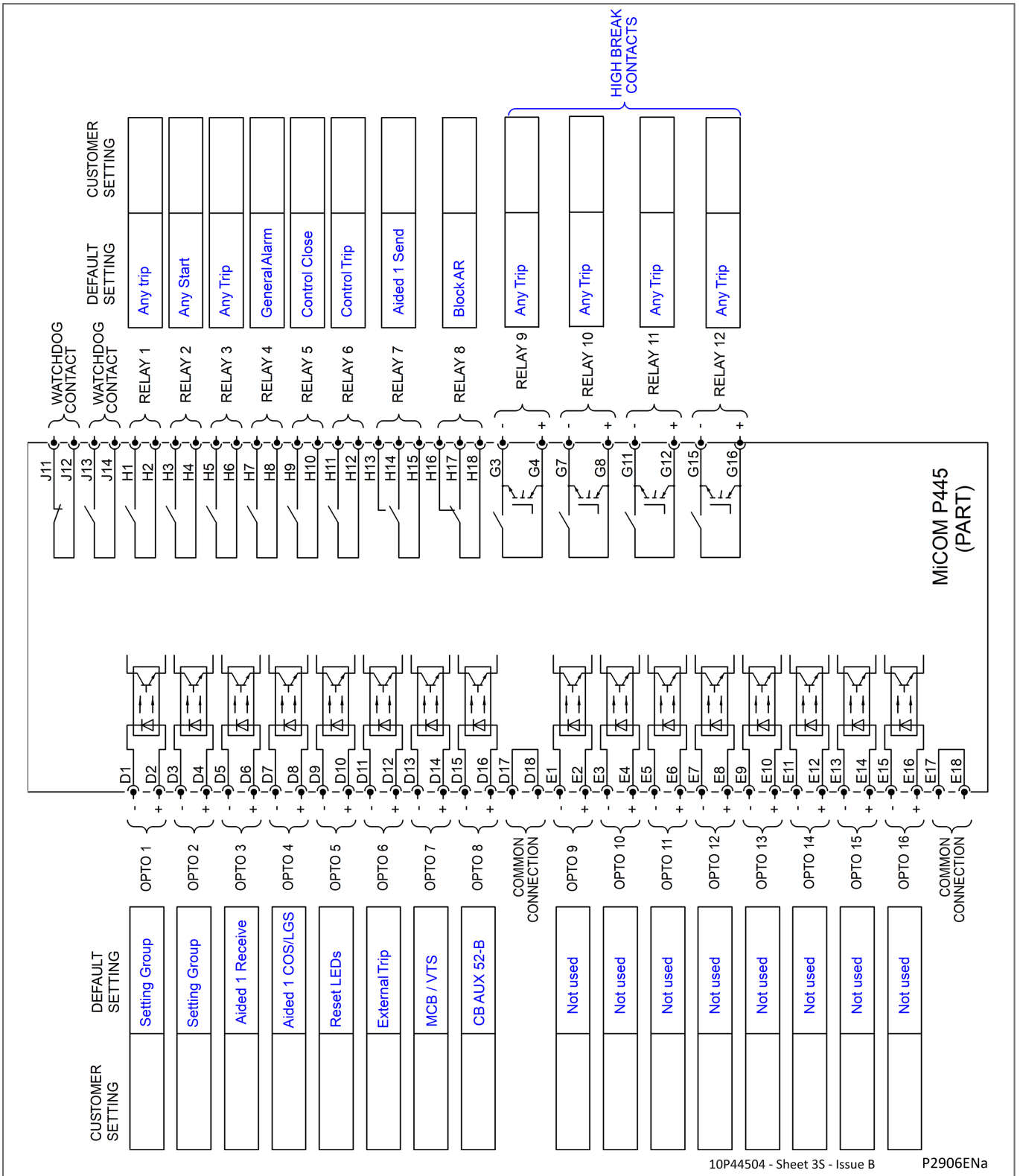

Figure 9 - P445 Model D with 16 digital inputs, 12 standard output contacts and 4 high break contacts



10P44504 - Sheet 3S - Issue B

P2906ENa

Figure 10 - P445 Model D with 16 digital inputs, 12 standard output contacts and 4 high break contacts

CYBER SECURITY

CHAPTER 18

Applicability**Date:** 10/2022**Products covered by this chapter:**

This chapter covers the specific versions of the MiCOM products listed below. This includes **only** the following combinations of Software Version and Hardware Suffix.

Hardware Suffix:

P141/P142/P143	L or later
P145	M or later
P241	L or later
P242/P243	M or later
P341	L or later
P342	L or later
P343/P344/P345	M or later
P391	A or later
P445	L or later
P44x (P442/P444)	M or later
P44y (P443/P446)	M or later
P54x (P543/P544/P545/P546)	M or later
P642	L or later
P643/P645	M or later
P742	L or later
P741/P743	M or later
P746	M or later
P841A (one circuit breaker)	M or later
P841B (two circuit breakers)	M or later
P849	M or later

Software Version:

P14x (P141/P142/P143/P145)	B5 or later
P24x (P241/P242/P243)	D2 or later
P341	B3/E3 or later
P34x (P342/P343/P344/P345/P391)	B3 or later
P44x (P442/P444)	E3 or later
P44y (P443/P446)	K1 or later
P445	K1 or later
P54x (P543/P544/P545/P546)	K1 or later
P64x (P642/P643/P645)	B4 or later
P74x (P741/P742/P743)	B1 or later
P746	B5/C5 or later
P841A (one circuit breaker)	L1 or later
P841B (two circuit breakers)	K1 or later
P849	B2 or later

Connection Diagrams: This chapter list the connection diagram for the product:	
P14x (P141, P142, P143 & P145):	10P141xx (xx = 01 to 02) 10P142xx (xx = 01 to 05) 10P143xx (xx = 01 to 11) 10P145xx (xx = 01 to 11)
P445:	10P445xx (xx = 01 to 04)
P44x (P442 & P444):	10P44201 (SH 1 & 2) 10P44202 (SH 1) 10P44203 (SH 1 & 2) 10P44401 (SH 1) 10P44402 (SH 1) 10P44403 (SH 1 & 2) 10P44404 (SH 1) 10P44405 (SH 1) 10P44407 (SH 1 & 2)
P44y:	10P44303 (SH 01 and 03) 10P44304 (SH 01 and 03) 10P44305 (SH 01 and 03) 10P44306 (SH 01 and 03) 10P44600 10P44601 (SH 1 to 2) 10P44602 (SH 1 to 2) 10P44603 (SH 1 to 2)
P54x (P543, P544, P545 & P546):	10P54302 (SH 1 to 2) 10P54303 (SH 1 to 2) 10P54304 (SH 1 to 2) 10P54400 10P54404 (SH 1 to 2) 10P54405 (SH 1 to 2) 10P54502 (SH 1 to 2) 10P54503 (SH 1 to 2) 10P54504 (SH 1 to 2) 10P54600 10P54604 (SH 1 to 2) 10P54605 (SH 1 to 2) 10P54606 (SH 1 to 2)
P64x (P642, P643 & P645):	10P642xx (xx = 1 to 10) 10P643xx (xx = 1 to 6) 10P645xx (xx = 1 to 9)
P746:	10P746xx (xx = 00 to 21)
P841:	10P84100 10P84101 (SH 1 to 2) 10P84102 (SH 1 to 2) 10P84103 (SH 1 to 2) 10P84104 (SH 1 to 2) 10P84105 (SH 1 to 2)
P849:	10P849xx (xx = 01 to 06)

Notes:

CONTENTS

1. Overview	7
1.1 Definition	7
1.2 Introduction to Cyber Security	7
1.3 Roles, Rights and relationship between IEC62351 and MiCOM Px4x	8
1.3.1 Role Based Access Control (RBAC).....	8
1.3.2 User Roles.....	9
1.3.3 Rights.....	10
1.3.4 Roles and their Access Rights.....	12
1.4 Cybersecurity Admin Expert (CAE) Software	12
2. MiCOM Px4x Cyber Security Implementation	15
2.1 MiCOM Px4x with CSL1 - Advanced Cyber Security	15
2.1.1 Password Management (via the CAE).....	16
2.1.2 RBAC Management (via the CAE).....	17
2.1.3 User Locking.....	17
2.1.4 Inactivity Timer.....	18
2.1.5 RBAC Recovery.....	18
2.1.5.1 Generate Security Code.....	18
2.1.5.2 Entry of the Recovery Password.....	19
2.1.6 Port Disabling (Equipment Hardening).....	19
2.1.7 Physical Security.....	20
2.1.8 Security Logs.....	20
2.1.9 Common Cyber Security Settings.....	21
2.1.10 Local Default Access.....	22
2.2 MiCOM Px4x with CSL0 - Simple Password Management	23
2.2.1 Password Management.....	23
2.2.2 Fixed Factory RBAC.....	23
2.2.3 Security Logs Service.....	24
2.2.4 Cyber Security Settings.....	24
2.2.5 Disable/Blank Password.....	24
3. How to Use Cyber Security Features	25
3.1 How to Login	25
3.1.1 Local Default Access.....	25
3.1.2 Auto Login.....	25
3.1.3 Login with Prompt User List.....	25
3.2 How to Logout	26
3.2.1 How to Logout at the IED.....	26
3.2.2 How to Logout at Easergy Studio.....	26
3.3 How to Disable a Physical Port	26
3.4 How to Disable a Logical Port	26
3.5 How to Secure a Function Key (when available)	27

4. Glossary for Cyber Security..... **28**

TABLES

Table 1 - RBAC object, subject, rights and roles definitions.....	9
Table 2 - RBAC permission and authorization rules.....	9
Table 3 - Default user roles summary for MiCOM Px4x.....	10
Table 4 - Pre-defined rights for IEC 62351-8.....	11
Table 5 - Specific rights for MiCOM Px4x.....	12
Table 6 - Pre-defined roles (and rights) for IEC 62351-8 and MiCOM Px4x.....	12
Table 7 - Main CAE user functions.....	14
Table 8 - MiCOM Px4x protocol options for cyber security options.....	15
Table 9 - Factory RBAC.....	17
Table 10 - Port hardening settings.....	19
Table 11 - Security logs recorded.....	21
Table 12 - Configurable cyber security settings.....	22
Table 13 - Un-configurable cyber security settings.....	22
Table 14 - Auto Login process.....	25
Table 15 - Glossary for cyber security.....	28

FIGURES

Figure 1 - Associated topics.....	7
Figure 2 - Continuous improvement process.....	8
Figure 3 - RBAC role structure.....	9

1. OVERVIEW

1.1 Definition

Cyber security is a domain that addresses attacks on or by computer systems and through computer networks that can result in accidental or intentional disruptions.

Cyber security addresses not only deliberate attacks, such as from disgruntled employees, industrial espionage, and terrorists, but also inadvertent compromises of the information infrastructure due to user errors, equipment failures, and natural disasters.

1.2 Introduction to Cyber Security

The objective of cyber security is to provide increased levels of protection for information and physical assets from theft, corruption, misuse, or accidents while maintaining access for their intended users.

To achieve this objective the owner of the grid must take into account Cyber Security at every level of his organization by the management of an ongoing process that encompasses procedures, policies, technical (software, and hardware asset) and regulatory constraints.

The following diagram outlines some of the associated topics.

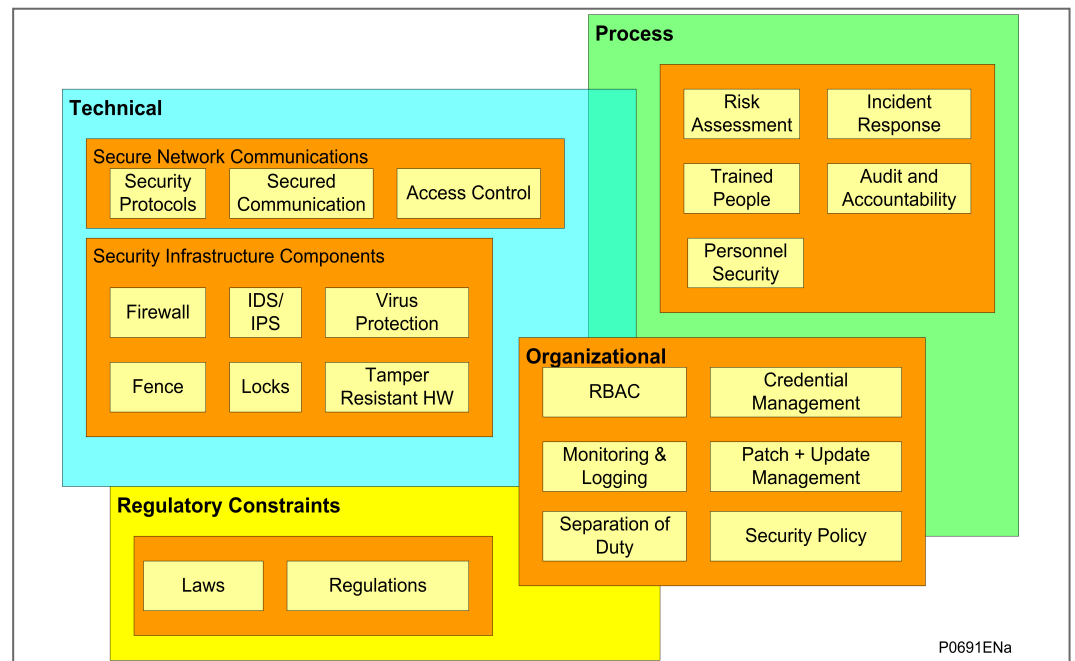

Figure 1 - Associated topics

The asset owner needs to run a continuous improvement process as outlined here:

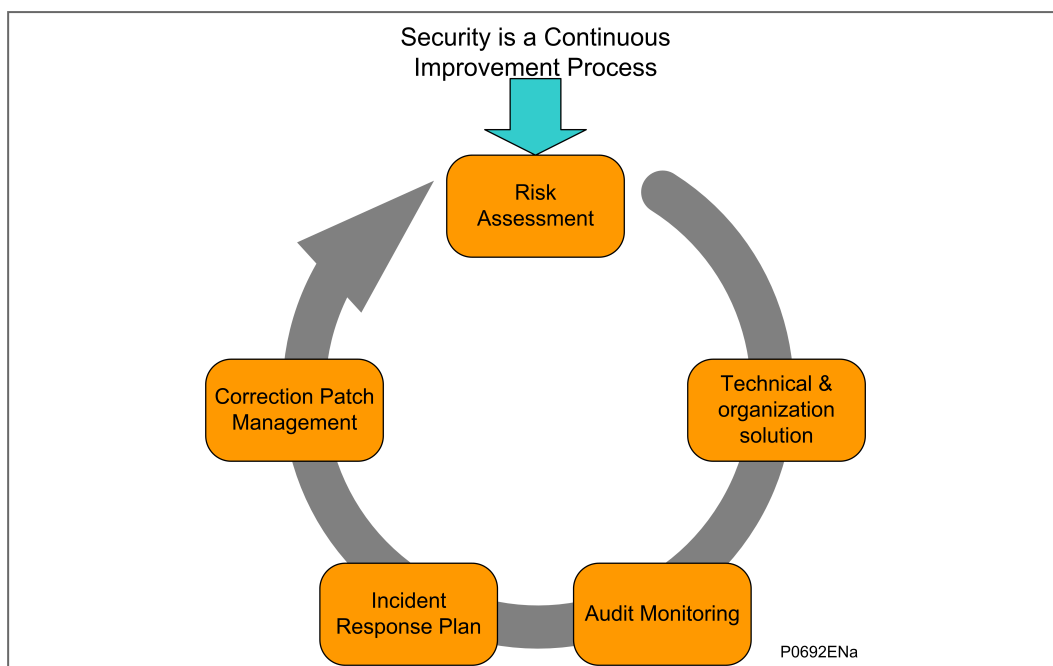

Figure 2 - Continuous improvement process

No single solution can provide adequate protection against all cyber attacks on the control network. Schneider Electric recommends employing a “defense in depth” approach using multiple security techniques to help mitigate risk.

A secured system is to offer:

- **Detective controls:** Monitor and record specific types of events: Security logs, Intrusion, detection systems, Video Surveillance etc.
- **Preventive controls:** Help blocking or controlling specific event: Antivirus, White listing, Firewall etc.
- **Recovery controls:** Help achieve Business continuity and Disaster recovery planning objectives in case of an incident: Backup and Restore solution.

As protective relay vendor, Schneider Electric helps the grid owner to achieve by providing technical features inside the IED, described in the next chapters.

Important

This product contains a cyber-security function, which manages the encryption of the data exchanged through some of the communication channels. The aim is to protect the data (configuration and process data) from any corruption, malice, attack. Subsequently, this product might be subject to control from customs authorities. It might be necessary to request special authorization from these customs authorities before any export/import operation. For any technical question relating to the characteristics of this encryption please contact your Customer Care Centre - www.schneider-electric.com/ccc.

1.3 Roles, Rights and relationship between IEC62351 and MiCOM Px4x

1.3.1 Role Based Access Control (RBAC)

The Role Based Access Control (RBAC) is a method to restrict resource access to authorized users. RBAC is an alternative to traditional Mandatory Access Control (MAC) and Discretionary Access Control (DAC).

A key feature of RBAC model is that all access is through roles. A role is essentially a collection of permissions, and all users receive permissions only through the roles to which they are assigned, or through roles they inherit through the role hierarchy.

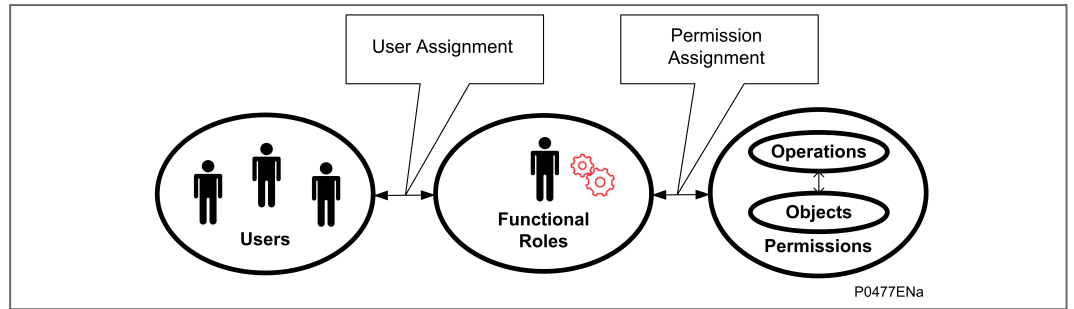

Figure 3 - RBAC role structure

Roles are created for various job activities. The **Permissions**, to perform certain operations, are assigned to specific roles. **Users** are assigned particular roles, and through those role assignments acquire the computer permissions to perform particular computer-system functions. Since users are not assigned permissions directly, but only acquire them through their role (or roles), management of individual user rights becomes a matter of simply assigning appropriate roles to the user’s account; this simplifies common operations, such as adding a user, or changing user’s account.

RBAC defines four different concepts:

RBAC Standard Definition	Description
Object	An object can represent information containers (e.g. files, directories in an operating system, tables and views in a database management system) or device resources, such as IEDs.
Subject	A subject is a user of the system. Note that a subject can be a person, or an automated agent / device.
Right	A right is the ability to access an object in order to perform certain operations (e.g. setting a data or reading a file)
Role	A role defines a certain authority level in the system. Rights are assigned to roles.

Table 1 - RBAC object, subject, rights and roles definitions

RBAC defines three primary rules:

RBAC Rule	Description
Role assignment	A subject can exercise a permission only if the subject has selected or been assigned a role.
Role authorization	A subject’s active role must be authorized for the subject. With rule 1 above, this rule ensures that users can take on only roles for which they are authorized.
Permission authorization	A subject can exercise permission only if the permission is authorized for the subject’s active role. With rules 1 and 2, this rule ensures that users can exercise only permissions for which they are authorized.

Table 2 - RBAC permission and authorization rules

1.3.2 User Roles

Different named roles are associated with different access rights. Roles and Rights are setup in a pre-defined arrangement, according to the IEC62351 standard, but customized to the MiCOM Px4x equipment.

When the user tries to access an IED, they need to login using their own username and their own password. The username/password combination is then checked against the records stored on the IED. If they are allowed to login, a message appears which shows them what Role they have been assigned to. It is the role that defines their access to the relevant parts of the system.

The default user roles for MiCOM Px4x are shown here:

Role	Description
VIEWER	Can View what objects are present within a Logical-Device by presenting the type ID of those objects.
OPERATOR	An Operator can view what objects and values are present within a Logical-Device by presenting the type ID of those objects as well as perform control actions.
ENGINEER	An Engineer can view what objects and values are present within a Logical-Device by presenting the type ID of those objects. Moreover, an engineer has full access to Datasets and Files and can configure the server locally or remotely.
SECADM	Security Administrator can change subject-to-role assignments (outside the device) and role-to-right assignment (inside the device) and security policy setting; change security setting such as certificates for subject authentication and access token verification.
SECAUD	Security Auditor can view audit logs

Table 3 - Default user roles summary for MiCOM Px4x

Each authorized user must be placed into at least ONE of these roles that most suits their job description. It is possible to assign a user into a different role; and/or to change the rights associated with a particular role. This means that the administrator can change the access rights for one role; and this will affect ALL the users who are assigned to that role.

It is possible for MiCOM Px4x to create the customized user roles.

1.3.3 Rights

In a similar way in which a set of pre-defined Roles have been created, a pre-defined set of Rights have been created.

These Rights give different permissions to look at what devices may be present, what those devices may contain, manage data within those devices (directly or by using files) and configure rights for other people.

A list of the pre-defined Rights for IEC 62351-8 is given here:

Right	Description
VIEW	Allows the subject/role to discover what objects are present within a Logical- Device by presenting the type ID of those objects. If this right is not granted to a subject/role, the Logical-Device for which the View right has not been granted shall not appear
READ	Allows the subject/role to obtain all or some of the values in addition to the type and ID of objects that are present within a Logical-Device
DATASET	Allows the subject/role to have full management rights for both permanent and non-permanent Datasets
REPORTING	Allows a subject/role to use buffered reporting as well as un-buffered reporting
FILEREAD	Allows the subject/role to have read rights for file objects
FILEWRITE	Allows the subject/role to have write rights for file objects. This right includes the FILEREAD right

Right	Description
CONTROL	allows a subject to perform control operations
CONFIG	Allows a subject to locally or remotely configure certain aspects of the server
SETTINGGROUP	Allows a subject to remotely configure Settings Groups
FILEMNGT	Allows the role to transfer files to the Logical-Device, as well as delete existing files on the Logical-Device.
SECURITY	Allows a subject/role to perform security functions at both a Server/Service Access Point and Logical-Device basis. To add Information about the concept of Rights.

Table 4 - Pre-defined rights for IEC 62351-8

The specific Rights for MiCOM Px4x are listed below. These are dependent on the IED data type. Please refer to each product MD file (Menu Database) for the IED data type.

Rights	Authorized Actions to IED	IED_DESC	IED_DATA	DISPLAY	IED_CONFIG	PROT_CONFIG	IEC_COMMAND	AUDIT	IED_FN_KEY	IED_CLEAR
Read Only (CAE default_access_right)	Read	x	x	x	x		x			
	Write	x								
IED Configuration (CAE configuration_right)	Read / Write / Upload / Download				x					
HMI Display Settings (CAE display_action_right)	Read / Write / Select			x						
Protection Configuration (CAE protection_configuration_right)	Read / Write					x				
IED Commands (CAE control_right)	Read / Write / Clear / Reset / Select						x			
Reading of Records & Events (CAE audit_read_right)	Read / Select / Upload							x		
Extraction of Records and Events (CAE audit_write_right)	Send / Accept							x		
IED Function Key (CAE fn_key_access_right)	Write								x	

Rights	Authorized Actions to IED	IED_DESC	IED_DATA	DISPLAY	IED_CONFIG	PROT_CONFIG	IEC_COMMAND	AUDIT	IED_FN_KEY	IED_CLEAR
IED Records Clear (CAE clear_right)	Read / Write / Clear									X

Table 5 - Specific rights for MiCOM Px4x

1.3.4 Roles and their Access Rights

A complete list of the Roles and their access Rights is shown in this table:

Rights		Roles				
		VIEWER	OPERATOR	ENGINEER	SECADM	SECAUD
Pre-defined Rights for IEC 62351	VIEW	X	X	X	X	X
	READ		X	X	X	X
	DATASET			X		
	REPORTING	X	X	X		X
	FILEREAD					X
	FILEWRITE			X	X	
	FILEMNGT			X	X	
	CONTROL		X		X	
	CONFIG			X	X	
	SETTINGGROUP				X	
	LOGS				X	X
SECURITY				X		
Specific Rights for MiCOM Px4x	Read Only	X	X	X		X
	IED Configuration			X		
	HMI Display Settings		X	X		
	Protection Configuration			X		
	IED Commands		X	X		
	Reading of Records and Events	X	X	X		X
	Extraction of Records and Events		X	X		X
	IED Function Key		X	X		
IED Clear			X			

Table 6 - Pre-defined roles (and rights) for IEC 62351-8 and MiCOM Px4x

Important

The reason why these are described as Default, is that it is possible to change the definitions of Roles and Rights, using the full version of the CAE software. Depending on the work done by the system administrator, it is possible that your own situation may vary from these initial recommendations.

1.4 Cybersecurity Admin Expert (CAE) Software

Important

This can only be used with Px4x relays with cyber security CSL1 features.

Important

For Dual Ethernet cards the CAE functionality is available from communication interface 1. The connection to the CAE would be available from interface 2 only when interface 1 is disconnected from the network.

The Cybersecurity Admin Expert (CAE) is the security configuration tool of MiCOM Px4x equipment. It allows the security administrator to define the security policy to the IEDs.

The Security Administrator manages RBAC and security policies data. Security Administrator defines needs to protect devices in accordance with user privileges. Thus, the system security can be configured easily and precisely.

The CAE is used by the Security Administrator to manage the system's security database and deploys security configurations to IED(s).

The CAE allows to Manage User Accounts, Roles, Permission, Elements to Secure (ETS) and Security Server parameters without connection with devices. Information is store on the MS SQL database. This is the Offline mode. CAE allows devices management connected on network. This is the online mode.

The Role Based Access Control (RBAC) is a method to restrict resource access to authorized users. Please refer to the "[System RBAC Management](#)" section for more details.

The following table contains the main user functions of the CAE:

Category	User Function	Note
Offline General Administration	User Accounts Management	User Account Functions: * Creation * Edition * Suppress * Viewing * Sorting * Filtering
	Server Configuration	
	Users Accounts & Roles association Management	Associate a role to the user account
Offline Advanced Administration	Roles Management	Roles Functions: * Creation * Edition * Suppress * Viewing * Sorting
	Element To Secure (ETS) Management	Define ETS which are in fact the PACiS assets present in the project (C264, PACiS Gateway, ECOSUI, IED and SAM). Add, Suppress and Sort permissions associated with the ETS.
	Global Security Management	The Global Security allows scope(s) and associate or disassociate role(s) management for each user account. The security administrator manages the current scope by the Roles: * View Roles List, User Account List and associations User-Roles or Role-Users * Associate / dissociate role(s) for each User

Category	User Function	Note
		Account * Add / Suppress User account(s) for each Role
	Permission access	Define parameters: * Password validity * Inactivity period * Automatic logout period * Maximum attempts of login and lockout period
Communication	Refresh IED list	
	Display IED Logs	
	Display SAM Logs	
	Push RBAC and Security Policies	Send Security Configuration to all Devices integrating Security features.

Table 7 - Main CAE user functions

The details of how to use the CAE are provided in the CAE documentation:

CAE (Cybersecurity Admin Expert) Documentation - User Guide

This is available from the Schneider Electric website: www.schneider-electric.com.

2. MICOM PX4X CYBER SECURITY IMPLEMENTATION

Considered some users may not want to use the cyber security, Schneider Electric offers MiCOM Px4x relays with CSL0 and CSL1 as below:

CSL0: Simple password management, No CAE required.

CSL1: Advanced cyber security, CAE required.

This depends on the model number, as CSL1 is depend on the Ethernet communication. Hence if the IED if supports only legacy protocol this will be CLS0 default as. The digit position number 9 (protocol options) in the Cortec / model number is used to distinguish it.

Protocol Option Number	Protocol Options	Cyber Security Options
1	K-Bus/Courier	CSL0
2	Modbus	CSL0
3	IEC 60870 -5 - 103	CSL0
4	DNP3.0	CSL0
6	IEC 61850 Edition 1 / 2 and Courier via rear K-Bus/RS485	CSL0
7	IEC 61850 Edition 1 / 2 and CS103 via rear port RS485	CSL0
B	IEC 61850 Edition 1 / 2 and DNP3oE and DNP Serial	CSL0
G	IEC 61850 Edition 1 / 2 and Courier via rear K-Bus/RS485	CSL1
H	IEC 61850 Edition 1 / 2 and CS103 via rear port RS485	CSL1
L	IEC 61850 Edition 1 / 2 and DNP3oE and DNP3 serial	CSL1

Table 8 - MiCOM Px4x protocol options for cyber security options

Important

Except for Courier tunneling via secured communication (TLS), the device does not have the capability to transmit data encrypted using the following protocols: IEC 61850, DNP3 over Ethernet, Courier serial, Modbus serial, IEC60870-5-103 serial, and DNP3 serial.

If other users gained access to your network, transmitted information can be disclosed or subject to tampering.

For transmitting data over an internal network, physically or logically segment the network and restrict access using standard controls such as firewalls and other relevant features supported by your device such as IPTable whitelisting.

For transmitting data over an external network, encrypt protocol transmissions over all external connections using an encrypted tunnel, TLS wrapper or a similar solution.

2.1 MiCOM Px4x with CSL1 - Advanced Cyber Security

For MiCOM Px4x IEDs which support CSL1, this means the IED supports advanced user account right management. Moreover, the IED supports security logs/events and secure administration capability.

If you want to use cyber security, you need to order the IED that supports CSL1. In this case, the Cybersecurity Admin Expert (CAE) is required for RBAC configuration.

At the IED level, these cyber security features have been implemented:

- Passwords management (via the CAE)
- RBAC Management (via the CAE)
- User Locking
- Inactivity Timer
- RBAC recovery
- Port Disablement (via Easergy Studio or the front panel)
- Security Logs

2.1.1 Password Management (via the CAE)

For the IED if CSL1 supported, there are two types of password possible for the IED access: alphanumeric password or Arrow Key password.

The alphanumeric password is only settable via the CAE:

- Passwords may be any length between 1 and 32 characters long
- Passwords may contain any ASCII character in the range ASCII code 33 (21 Hex) to ASCII code 122 (7A Hex) inclusive
- Passwords may or may not be NERC/IEEE 1686 compliant
- The alphanumeric password will be used for courier client access

For more details about NERC/IEEE 1686 password compliant, please check the standard.

The Arrow Key password is only settable via the CAE:

- The Arrow Key password is a combination of the four arrow keys on the front panel
- The Arrow Key password may be any length between 1 and 8 arrow keys long
- The Arrow Key password can only be used in the front panel
- The user also can disable the Arrow Key password by not setting it

Important

If the Arrow Key password is not configured, the alphanumeric password will be used for the front panel access. In this case, alphanumeric passwords longer than 16 characters are not allowed.

Easergy Studio and the front panel are not allowed to change the password.

Important
 The Schneider Electric password policy is one of the key elements of the Cyber Security Policy.

Good practice to improve the Password definition:

- Use common Cyber Security Good Practice for password complexity definition by using strong passwords.
- Change All Passwords from their default value when taking the protection device into use. (User must change password after first login).
- Change Passwords regularly. (User must update password after a certain period of time).
- Use NERC Compliant password as much as possible.
- Enforce the use of strong and complexes Password as : Caps characters + Lowercases characters + Numbers + Special characters in one password.
- Set the minimum password length to 10 characters.
- Switch off all Comm port not use on the device, if possible.
- Do not reuse old passwords.
- All P40 relays installed before January 2020 should be checked separately case by case to confirm the Cyber Security conformity to Standard/country law.

All user must be aware of best practice concerning passwords, these include:

- Not Sharing personal passwords.
- Not displaying passwords during password entry.
- Not transmitting passwords in email or by other means.
- Not saving the passwords on PC's or other devices.
- Not written password on any supports.
- Regularly reminding users about best practices concerning password.

2.1.2 RBAC Management (via the CAE)

By default, the IED includes a factory RBAC which has three users, and for each user, the Rights depend on the user Role. Please refer to the **Roles and their Access Rights** section for more details.

Username	Role	Default password
SecurityAdmin	SECADM	AAAAAAAA
EngineerLevel	ENGINEER	AAAA
OperatorLevel	OPERATOR	AAAA

Table 9 - Factory RBAC

A Local Default Access function also available for the default RBAC, with the VIEWER role, which allows everyone login the IED in the front panel with VIEWER role. For more details about the Local Default Access function, please refer to the **Local Default Access** section.

For more information about how the CAE management the RBAC and cyber security policies, please see the 1.4 - Cybersecurity Admin Expert (CAE) Software section.

2.1.3 User Locking

The user is locked out temporarily, after a defined number of failed password entry attempts.

Important
 If a user is locked out, the block is applied to that named user and to the all IED interfaces. The blocking of one user, does not apply blocks to others.
 If the user entry is blocked, recover the RBAC or push a new RBAC will not reset the blocked user entry, but IED reboot will reset the blocking time and attempts count, so the user entry will be unblocked.

An invalid password entry will display a 'Login Failed PW Incorrect' message for 2s. It also reduces the Attempts Remaining Counter (Attempts Remain) by 1 and it remains at this level

until the interface inactivity timer expires (CSL0 models) or until the Password Attempts Timer configured in CAE expires (CSL1 models) or another password entry is made. If Attempts Remain equals 1 then a '1 Attempt Left' warning will also be issued for 2s. When Attempts Remain equals 0 then a 'USER LOCKED OUT' warning is displayed for 2s and access for that user is blocked. If the Blocking Timer expires, or the correct password is entered before Attempts Remain reaches zero, then the Attempts Remain is reset to the Attempts Limit.

Once the user entry is blocked, the Blocking Timer is initiated. If the locked out user is selected whilst the Attempts Remain is zero a 'USER LOCKED OUT' error message is displayed.

2.1.4 Inactivity Timer

The MiCOM device runs an inactivity timer, which means that it records the last time an action was taken by a user who was logged in.

If the user does not perform an action within a pre-defined interval, the user will be logged off. This is to reduce the risk that a device can accidentally be left open to access by unauthorized people.

The inactivity timer is separate for each interface.

The inactivity timer is configurable by using the CAE.

Important
In case of a connection through an Ethernet interface, the actual inactive time depends on the setting value of both "Minimum inactivity period" & "[0E A7] ETH Tunl Timeout", the smaller value of both timers will be applied.

Refer to the 2.1.9 - Common Cyber Security Settings section for more details.

2.1.5 RBAC Recovery

RBAC recovery is the means by which the device can be reset to the factory RBAC settings if required. To obtain the recovery password, the customer must go to www.schneider-electric.com/ccs to raise a recovery password request and supply the IED Security Code.

Caution
The "recovery" password gives you access to the Factory RBAC Configuration. This action deletes all existing users (and their passwords), and restores to Factory RBAC Configuration. Recover the RBAC does not affect relay proper settings and does not provoke reboot of the relay - the protection functions of the relay are always maintained.

2.1.5.1 Generate Security Code

The security code is a 16-character ASCII string. It is a read-only parameter. The IED generates its own random security code. This is when a new code is generated:

- On power up
- On expiry of validity timer (see below)
- When the recovery password is entered

As soon as the security code is first displayed on the LCD display, a validity timer is started. This validity timer is set to 120 hours and is not configurable. The validity timer is not reset if you request a subsequent code within the 120 hour period.

To prevent accidental reading of the IED security code the cell will initially display a warning message on the front panel of the IED:

PRESS ENTER TO
READ SEC. COD

The security code will be displayed on confirmation, whereupon the validity timer will be started. Note that the security code can only be read from the front panel.

Important

The recover password will be invalid once the new Security Code is generated, so please make sure the IED is always powered on before you get the recover password, and make sure you input the recover password within 120 hours.

2.1.5.2 Entry of the Recovery Password

The “recovery” password is intended for recovery only. It is not a replacement password that can be used continually. It can only be used once – for password recovery.

Entry of the recovery password is done at the local front panel and it causes the IED to reset the RBAC back to default.

On this action, the following message is displayed on the front panel of the IED:

```
RBAC reset done
Press any key
```

2.1.6 Port Disabling (Equipment Hardening)

The availability of unused ports could provide a security risk. Hence, unused ports can be disabled (also known as equipment hardening) – either via the front panel or by Easergy Studio software. An Engineer role is needed to perform this action.

These physical ports and logical ports can be enabled/disabled:

Port Types	Menu Text	Col	Row	Default Setting	Available Value
Physical Ports	Front Port	25	05	Enable	Enable/Disable
	Rear Port 1	25	06	Enable	Enable/Disable
	Rear Port 2	25	07	Enable	Enable/Disable
	Ethernet Port 1	25	08	Enable	Enable/Disable
	Ethernet Port 1/2	25	09	Enable	Enable/Disable
	Ethernet Port 2/3	25	0A	Enable	Enable/Disable
	Ethernet Port 3	25	0B	Enable	Enable/Disable
Logical Ports	Courier Tunnel	25	0C	Enable	Enable/Disable
	IEC61850	25	0D	Enable	Enable/Disable
	DNP3oE	25	0E	Enable	Enable/Disable

Table 10 - Port hardening settings

Note

The port disabling setting cells are not provided in the settings file. In addition, it is not possible to disable simultaneously more than one physical port or Logical port. New redundant Ethernet boards have three physical ports but total two interfaces. The actual disabled physical port is depended on the redundant communication mode (PRP, HSR, RSTP or Dual IP). Refer to the Dual Redundant Ethernet Board (Upgrade) (DREB) chapter (Px4x/EN EB) for more details.

When the Ethernet board related physical ports or logical ports are disabled or enabled, the Ethernet card will reboot. The status of the ports will be available after reboot of the Ethernet board.

For more details about how to disable/enable the unused ports, please see sections:

- 3.3 - How to Disable a Physical Port
- 3.4 - How to Disable a Logical Port

2.1.7 Physical Security

MiCOM Px4x IED protects its front EIA(RS) - 232 serial (9 pin) and parallel (25 pin) ports with a sealable flip cover.

These two ports are normally NOT needed during device normal operation:

- The serial port is used for setting/events/records downloading and extraction during commissioning or post-fault analysis which can be done also via rear RS485 ports and Ethernet ports during normal operation.
- The parallel port is dedicated for firmware upgrade.

Thus, it is highly recommended to seal the flip cover during the normal operation to avoid exploiting those two ports by unauthorized personnel.

2.1.8 Security Logs

The Security Logs need to store logs from each item of equipment. These logs are generated by the system, and cannot be edited by the user. A variety of different items are recorded, including: bad/faulty access attempts, login attempts, authentication errors, changes to roles, users and access control lists, network backup and configuration changes, communication failures and so on.

Security logs emissions depend on the security standards that are configurable by the CAE.

The security logs will push to a Syslog server if the Syslog server IP address and Syslog server IP port are configured and connected.

CAE also can be used to explore the security logs but Easergy studio is not supported.

The settings for the security log standards and Syslog server IP address and ports are listed in the Configurable cyber security settings table. For more detail about the security log configuration, please refer to the CAE documentation.

Note

The Security logs time stamp may be time shifted by several milliseconds compared with local event log. The security logs will not be generated if the Ethernet card is starting up. If the Syslog server is unavailable, the new logs will be stored and overwriting the oldest logs.

This table lists the security logs categories available for each standard.

Log ID	Additional field	Explanation	Level	Standards					
				BDEW	E3	NERC CIP	IEEE 1686	IEC 62351	CS Phase 1
CONNECTION_SUCCESS	The additional field will contain the issuer of the connection: LOCAL or NETWORK	Successful connection	INFO	x	x	x	x		x
CONNECTION_FAILURE		Failed connection (wrong credentials)	WARNING	x	x	x	x		x
CONNECTION_FAILURE_AND_BLOCK		Failed connection (wrong credentials) triggering the blocking of the account on the IED	DANGER	x	x	x	x		x
CONNECTION_FAILURE_ALREADY_BLOCKED		Failed connection because of a blocked userID on this IED	DANGER	x	x	x	x		x
DISCONNECTION		Disconnection triggered by the peer /user	INFO	x	x	x	x		x

Log ID	Additional field	Explanation	Level	Standards					
				BDEW	E3	NERC CIP	IEEE 1686	IEC 62351	CS Phase 1
DISCONNECTION_TIMEOUT		Disconnection triggered by a timeout	INFO	x	x	x	x		x
CONTROL_OPERATION	Type & Data associated to the control	Trace and control / override of real data from a peer	INFO				x		
CONFIGURATION_DOWNLOAD	Version	Download of the configuration file from the device - Files include PSL, Courier setting, DNP setting, MCL/CID and user curves (crv)	INFO				x		
CONFIGURATION_UPLOAD	Version	Upload of a new configuration file into the device - Files include PSL, Courier setting, DNP setting, MCL and user curves (crv)	INFO				x		
RBAC_UPDATE	Version	Update of the RBAC cache in the IED	INFO				x		x
SEC_LOGS_RETRIEVAL	Version	Retrieval of the security logs of the IED	INFO				x		
TIME_CHANGE	New & Old time	Modification of the time of the IED	INFO				x		
REBOOT_ORDER	None	Reboot order sent to the IED / IED start up	DANGER				x		x
PORT_MANAGEMENT	Port, action (enable / disable)	Any comms port enabled / disabled	INFO						x
AUTHORIZATION_REQ	Action, object	Any authorization request sent to the CS brick	INFO			x		x	x

Table 11 - Security logs recorded

2.1.9 Common Cyber Security Settings

The System Administrator can customize the cyber security settings at the CAE. The following table shows the common cyber security settings. Parts of settings also are visible on the IED with specific Courier cells but not editable in IED or Easergy Studio. These are shown in the right-hand columns of this table:

Setting in CAE	Default Setting	Available Value	Menu in IED	Col	Row
Minimum inactivity period	15	1 to 99 Minutes	-	-	-
If the user does not perform any action within this interval, the user will be logged off.					
Allow user locking	Yes	Yes/No	-	-	-
Option allows user account locking					
Maximum login attempts	5	1 to 99	Attempts Limit	25	02
The maximum failed password entry attempts, the user will lock once the attempts reached.					
Password attempts timer	3	1 to 30 Minutes	Attempts timer	25	03
The time for reset the attempts count to 0. The user got to maximum login attempts.					
Automatic user account unlocking	Yes	Yes/No	-	-	-
Enable/disable the attempts times aromatic reset function.					
Locking period duration	240	1 to 86400 Seconds	Blocking timer	25	04
The Locking period duration (seconds)					
Password Complexity	None	None / IEEE1686/ NERC	-	-	-
Set the password compliant standard.					
Log and monitoring standard	BDEW	BDEW / E3 / NERC-CIP / IEE1686 / IEC62351/ CS_PH1	-	-	-
Setup security log emission standard					
Syslog server IP address	0.0.0.0		-	-	-
Syslog server IP address					
Syslog server IP port	601	1 to 65535	-	-	-
Syslog server IP port					

Table 12 - Configurable cyber security settings

These settings show some common information about cyber security, which are not configurable whether by CAE, or Easergy Studio or the front panel.

Menu in IED	Col	Row	Description
User Banner	25	01	Show user banner information: ACCESS ONLY FOR AUTHORISED USERS.
Attempts remain	25	11	Show the remains attempt times for user login
Blk time remain	25	12	Show the remains time for blocked user to unlock
User Name	25	21-2F	Configured user name (in CAE)
Security Code	25	FE	The security code used to recovery the password.
RBAC Password	25	FF	Enter 16 characters recover password to recovery password

Table 13 - Un-configurable cyber security settings

2.1.10 Local Default Access

Local Default Access function can be disabled/enabled in the CAE.

The intention for Local Default Access function is to allow the user easy to access the IED from the front panel and without any authorization required. This means if the Local Default Access function is enabled, everyone will be authorized to access the front panel with associated Rights.

By default, the Local Default Access has the VIEWER role, it is also possible to associate the other Roles to the Local Default Access, which is configurable in the CAE.

Local Default Access function is only available in the front panel.

The Local Default Access login/logout process is invisible for the user.

2.2 MiCOM Px4x with CSL0 - Simple Password Management

For MiCOM Px4x IED with CSL0, as the Cybersecurity Admin Expert (CAE) is not supported, all the cyber security features which need CAE support will not be available.

This section describes the different implementations by comparing with CLS1.

The cyber security features that are not mentioned in this section will default to be the same as CSL1.

2.2.1 Password Management

For MiCOM Px4x IED with CSL0, CAE is not supported for the configuration, so only the alphanumeric password can be used.

- The alphanumeric password is settable via Easergy Studio and the Front panel
- Passwords may be any length between 1 and 16 characters long
- Passwords may contain any ASCII character in the range ASCII code 33 (21 Hex) to ASCII code 122 (7A Hex) inclusive
- No password compliance is required
- The alphanumeric password will be used for Courier access and the front panel access

Arrow key password is not available for IED with CSL0.

Important

The Schneider Electric password policy is one of the key elements of the Cyber Security Policy.

Good practice to improve the Password definition:

- Use common Cyber Security Good Practice for password complexity definition by using strong passwords.
 - Change All Passwords from their default value when taking the protection device into use. (User must change password after first login).
 - Change Passwords regularly. (User must update password after a certain period of time).
 - Use NERC Compliant password as much as possible.
 - Enforce the use of strong and complex Password as : Caps characters + Lowercases characters + Numbers + Special characters in one password.
 - Set the minimum password length to 10 characters.
 - Switch off all Comm port not use on the device, if possible.
 - Do not reuse old passwords.
 - All P40 relays installed before January 2020 should be checked separately case by case to confirm the Cyber Security conformity to Standard/country law.
- All user must be aware of best practice concerning passwords, these include:**
- Not Sharing personal passwords.
 - Not displaying passwords during password entry.
 - Not transmitting passwords in email or by other means.
 - Not saving the passwords on PC's or other devices.
 - Not written password on any supports.
 - Regularly reminding users about best practices concerning password.

2.2.2 Fixed Factory RBAC

For MiCOM Px4x IED with CSL0, the user list and its role/right will be fixed as factory RBAC and not configurable. Refer to the *Factory RBAC* table for more details.

2.2.3 Security Logs Service

The security logs services are not available for MiCOM Px4x IED with CSL0.

2.2.4 Cyber Security Settings

For MiCOM Px4x IED with CSL0, all cyber security settings are fixed as default setting and un-configurable. Refer to the *Configurable cyber security settings* table for the default settings.

2.2.5 Disable/Blank Password

For MiCOM Px4x IED with CSL0, it is possible to remove the user password. In MiCOM S1 Studio, this is achieved by click the BOX "Disable the password". In the IED, this is achieved by setting the password as blank.

Once the password is disabled/blank, the user can login to the IED directly and there is no need to enter the password.

3. HOW TO USE CYBER SECURITY FEATURES

These sections shows the most common tasks associated with Cyber Security features. For many of these tasks, the steps you take are the same as you have performed previously; with the main changes being in the steps you use to login and/or logout.

3.1 How to Login

3.1.1 Local Default Access

If the Local Default Access is enabled, the user may login to the front panel with associated roles.

3.1.2 Auto Login

Auto login means the user will login the IED automatically and no need to select the user name and enter the password. In this case, the user will be authorized with relevant rights. The auto login will be applied in these cases:

CS Version	Interface	RBAC/PW Cases	Login Process
CSL1	Front panel	Factory RBAC	Auto login with EngineerLevel
		Customized RBAC	Local Default Access Enabled: Login with Local Default Access Local Default Access Disabled: Login with Prompt User List
	Courier Interface	All cases	Login with Prompt User List
CSL0	Front panel	Factory RBAC	Auto login with EngineerLevel
		Password changed	EngineerLevel password is "AAAA" or is disabled/blank: Auto login with EngineerLevel . OperatorLevel password is "AAAA" or is disabled/blank: Auto login with OperatorLevel . EngineerLevel and OperatorLevel password changed: Auto login with ViewerLevel Access
	Courier Interface	Factory RBAC	Auto login with EngineerLevel
		Password changed	EngineerLevel password is "AAAA" or is disabled/blank: Auto login with EngineerLevel . OperatorLevel password is "AAAA" or is disabled/blank: Auto login with OperatorLevel . EngineerLevel and OperatorLevel password changed: Login with Prompt User List

Table 14 - Auto Login process

For more details about the Factory RBAC, please refer to the 2.1.2 - RBAC Management (via the CAE) section.

3.1.3 Login with Prompt User List

This login process will happen if:

- The Auto login process is not applied.
- Or high authorization is required for the current operation.

In this case, the IED will prompt the user list, and the user needs to select proper user name and enter the password to login.

3.2 How to Logout

3.2.1 How to Logout at the IED

For security consideration, it would be better to “logout” the IED once the configuration done. You can do this by going up to the default display. When you are at the default display and you press the ‘Cancel’ button, you may be prompted to log out with the following display:

```
ENTER TO LOGOUT  
CLEAR TO CANCEL
```

You will be asked this question if you are logged in.

If you confirm, the following message is displayed for 2 seconds:

```
LOGGED OUT  
UserName
```

If you decide not to log out (i.e. you cancel), the following message is displayed for 2 seconds.

```
LOGOUT_CANCELLED  
UserName
```

Note

The MiCOM IED runs a timer, which logs the user out after a period of inactivity. For more details, refer to the [Inactivity Timer](#) section.

3.2.2 How to Logout at Easergy Studio

- Right-click on the device name and select Log Off.
- In the Log Off confirmation dialog click Yes.

3.3 How to Disable a Physical Port

Using Easergy Studio or the front panel it is possible to disable unused physical ports. This can not be done by the CAE. By default, an Engineer-role is needed to perform this action.

To prevent accidental disabling of a port, a warning message is displayed according to whichever port is required to be disabled. For example if rear port 1 is to be disabled, the following message appears:

```
REAR PORT 1 TO BE  
DISABLED.CONFIRM
```

There are between two and four ports eligible for disablement:

- Front port
- Rear port 1
- Rear port 2 (available in the specific models)
- Ethernet port (available in the specific models)

Important

It is not possible to disable a port from which the disabling port command originates.

3.4 How to Disable a Logical Port

Using Easergy Studio or the front panel it is possible to disable unused logical ports. This can't be done by the CAE. An Engineer-role is needed to perform this action.

**Caution****Disabling the Ethernet port will disable all Ethernet based communications.**

If it is not desirable to disable the Ethernet port, it is possible to disable selected protocols on the Ethernet card and leave others functioning.

These protocols can be disabled:

- IEC61850 (available in the specific models)
- Courier Tunnelling (available in the specific models)
- IEC61850 + DNPoE (available in the specific models)

Note

It is strongly recommended to disable the protocols which are not needed or when they are no longer needed to reduce attack surface to the MiCOM Px4x IED.

3.5 How to Secure a Function Key (when available)

In cyber security implementation, this function has been linked to the front panel authorization.

- When the function key pressed, if there is no user login in the front panel or the logged-in user is not authorized, a prompt message will be raised in the front panel to ask the user to login. Once the user is logged-in, they need to press the function key again to execute the command.
- If the user is already logged in and the authorization is OK, the command will be executed immediately.
- By default, the OPERATOR or ENGINEER Roles are able to operate the function keys.
- The function key will be executed immediately if the auto login process is applied and the user is authorized.
- If unauthorized users press the Function Key during the setting change, they need to commit the changes first then login with authorized user to operate the function key.

4. GLOSSARY FOR CYBER SECURITY

Term	Meaning
CAE	Cybersecurity Admin Expert TSF based application used to define and create security configuration
CIP Standards	Critical Infrastructure Protection standards. NERC CIP standards have been given the force of law by the Federal Energy Regulatory Commission (FERC)
DCS	Distributed Control System
HMI	Human Machine Interface
IED	Intelligent Electronic Device. It is a power industry term to describe microprocessor-based controllers of power system equipments (e.g. Circuit breaker, transformer, etc)
LOGS	All the operations related to the security (connection, configuration...) are automatically caught in events that are logged in order to provide a good visibility of the previous actions to the security administrators.
MIB	Management Information Base
NERC	North American Electric Reliability Corporation
RBAC	Role Based Access Control. Authentication and authorization mechanism based on roles granted to a user. Roles are made of rights, themselves being actions that can be applied on objects. Each user's action is authorized or not based on his roles
Roles	A role is a logical representation of a person activity. This activity authorizes or forbids operations within the tool suite thanks to permissions that are associated to the role. A role needs to be attached to a user account to have a real purpose.
SAM	Security Administration Module. Device in charge of security management on an IP-over-Ethernet network.
Secured IED	Devices embedding security mechanisms defined in the security architecture document
Security Administrator	A user of the system granted to manage its security
TAT	Transfer Administration Tool
Unsecured IED	Relay/IEDs with no security mechanisms.

Table 15 - Glossary for cyber security

DUAL REDUNDANT ETHERNET BOARD

CHAPTER 19

Applicability

Date:	09/2022
--------------	---------

Products covered by this chapter:

This chapter covers the specific versions of the MiCOM products listed below. This includes **only** the following combinations of Software Version and Hardware Suffix.

Hardware Suffix:

P141/P142/P143	L or later
P145	M or later
P445	L or later
P44x (P442/P444)	M or later
P44y (P443/P446)	M or later
P54x (P543/P544/P545/P546)	M or later
P746	M or later
P841A (one circuit breaker)	M or later
P841B (two circuit breakers)	M or later
P342	L or later
P343 / P344 / P345	M or later
P341	L or later
P849	M or later

Software Version:

P14x (P141/P142/P143/P145)	B5 or later
P445	K1 or later
P44x (P442/P444)	E3 or later
P44y (P443/P446)	K1 or later
P54x (P543/P544/P545/P546)	K1 or later
P746	B5/C5 or later
P841A (one circuit breaker)	L1 or later
P841B (two circuit breakers)	K1 or later
P341	B1/E1 or later
P342 / P343 / P344 / P345	B0/B1 or later
P849	B4 or later

Connection Diagrams: This chapter list the connection diagram for the product:

P14x (P141, P142, P143 & P145):	10P141xx (xx = 01 to 02) 10P142xx (xx = 01 to 05) 10P143xx (xx = 01 to 11) 10P145xx (xx = 01 to 11)
P44x (P442 & P444):	10P44201 (SH 1 & 2) 10P44202 (SH 1) 10P44203 (SH 1 & 2) 10P44401 (SH 1) 10P44402 (SH 1) 10P44403 (SH 1 & 2)

	10P44404 (SH 1) 10P44405 (SH 1) 10P44407 (SH 1 & 2)
P44y:	10P44303 (SH 01 and 03) 10P44304 (SH 01 and 03) 10P44305 (SH 01 and 03) 10P44306 (SH 01 and 03) 10P44600 10P44601 (SH 1 to 2) 10P44602 (SH 1 to 2) 10P44603 (SH 1 to 2)
P445:	10P445xx (xx = 01 to 04)
P54x (P543, P544, P545 & P546):	10P54302 (SH 1 to 2) 10P54303 (SH 1 to 2) 10P54304 (SH 1 to 2) 10P54400 10P54404 (SH 1 to 2) 10P54405 (SH 1 to 2) 10P54502 (SH 1 to 2) 10P54503 (SH 1 to 2) 10P54504 (SH 1 to 2) 10P54600 10P54604 (SH 1 to 2) 10P54605 (SH 1 to 2) 10P54606 (SH 1 to 2)
P64x (P642, P643 & P645):	10P642xx (xx = 1 to 10) 10P643xx (xx = 1 to 6) 10P645xx (xx = 1 to 9)
P746:	10P746xx (xx = 00 to 21)
P841:	10P84100 10P84101 (SH 1 to 2) 10P84102 (SH 1 to 2) 10P84103 (SH 1 to 2) 10P84104 (SH 1 to 2) 10P84105 (SH 1 to 2)
P849:	10P849xx (xx = 01 to 06)

Notes:

CONTENTS

1. Introduction	9
1.1 Standard Safety Statements	9
2. Hardware Description	10
2.1 IRIG-B Connector	11
2.2 LEDs	11
2.3 Optical Fibre Connectors	11
3. Redundancy Protocols	13
3.1 Parallel Redundancy Protocol (PRP)	13
3.1.1 PRP Network Structure.....	13
3.1.2 Example PRP Configuration.....	14
3.2 High-availability Seamless Redundancy (HSR)	14
3.2.1 HSR Network Structure.....	15
3.2.2 Example HSR Configuration.....	17
3.3 Rapid Spanning Tree Protocol (RSTP)	17
3.3.1 RSTP Network Structure.....	17
3.3.2 Example RSTP Configuration.....	17
3.4 Generic Functions for all Redundant Ethernet Boards (REBs)	18
3.4.1 Priority Tagging.....	18
3.4.2 Simple Network Time Protocol (SNTP).....	18
3.4.3 Dual Ethernet Communication (Dual IPs).....	18
3.4.3.1 Dual IP Introduction.....	18
3.4.3.2 Dual IP in MiCOM.....	18
3.4.3.3 Typical User Cases.....	19
3.4.4 Precision Time Protocol (PTP).....	20
3.4.4.1 Introduction to the IEEE1588 Standard.....	20
3.4.4.2 PTP Implementation.....	20
3.4.4.3 PTP Settings.....	20
3.4.4.4 IEC61850-9-3 PICS.....	20
4. Configuration	22
4.1 Configuring Ethernet Communication Mode	22
4.2 Configuring the IED Communication Parameters	22
4.3 Configuring GOOSE Publish Parameters	23
5. Commissioning	24
5.1 PRP Star Connection	24
5.2 HSR Ring Connection	24
5.3 RSTP Ring Connection	25
5.4 RSTP Star Connection	26
5.5 Large RSTP Networks combining Star and Ring	27

6. Technical Data	29
6.1 Board Hardware	29
6.1.1 100 Base TX Communications Interface	29
6.1.2 100 Base FX Communications Interface	29
6.1.3 Transmitter Optical Characteristics	29
6.1.4 Receiver Optical Characteristics	29
6.1.5 IRIG-B and Real-Time Clock	30
6.1.5.1 Performance	30
6.1.5.2 Features	30
6.1.5.3 Self-adapted Rear IRIG-B Interface (Modulated or Unmodulated)	30
6.2 Type Tests	30
6.2.1 Insulation	30
6.2.2 Creepage Distances and Clearances	30
6.2.3 High Voltage (Dielectric) Withstand	30
6.2.4 Impulse Voltage Withstand Test	31
6.3 ElectroMagnetic Compatibility (EMC)	31
6.3.1 1 MHz Burst High Frequency Disturbance Test	31
6.3.2 100 kHz and 1MHz Damped Oscillatory Test	31
6.3.3 Immunity to Electrostatic Discharge	31
6.3.4 Electrical Fast Transient or Burst Requirements	31
6.3.5 Surge Withstand Capability	32
6.3.6 Surge Immunity Test	32
6.3.7 Conducted/Radiated Immunity	32
6.3.8 Immunity to Radiated Electromagnetic Energy	32
6.3.9 Radiated Immunity from Digital Communications	32
6.3.10 Radiated Immunity from Digital Radio Telephones	32
6.3.11 Immunity to Conducted Disturbances Induced by Radio Frequency Fields	32
6.3.12 Power Frequency Magnetic Field Immunity	32
6.3.13 Conducted Emissions	32
6.3.14 Radiated Emissions	33
6.4 Environmental Conditions	33
6.4.1 Ambient Temperature Range	33
6.4.2 Ambient Humidity Range	33
6.4.3 Corrosive Environments	33
6.5 EU Directives	33
6.5.1 EMC Compliance	33
6.5.2 Product Safety	33
6.5.3 R&TTE Compliance	34
6.5.4 ATEX Compliance	34
6.5.5 UKCA Compliance	34
6.6 Mechanical Robustness	34
6.6.1 Vibration Test	34
6.6.2 Shock and Bump	34
6.6.3 Seismic Test	34
7. Cortec	35

TABLES

Table 1 - LED functionality.....	11
Table 2 - Optical fiber connector functionality.....	12
Table 3 - Ethernet ports operation mode.....	18
Table 4 - PTP Settings, Values and Descriptions.....	20
Table 5 - PICS Proforma Reference, Capability, Base and Support.....	21
Table 6 - Ethernet communication mode setting.....	22
Table 7 - First three bytes for default IP address.....	22
Table 8 - 100 Base TX interface.....	29
Table 9 - 100 Base FX interface.....	29
Table 10 - Tx optical characteristics.....	29
Table 11 - Rx optical characteristics.....	30
Table 12 - Cortec for Redundant Ethernet models.....	36

FIGURES

Figure 1 - Ethernet board connectors (3 RJ45 or 2 LC + RJ45 or 1 RJ45).....	11
Figure 2 - PRP example of general redundant network.....	14
Figure 3 - PRP Relay Configuration.....	14
Figure 4 - HSR example of ring configuration for multicast traffic.....	15
Figure 5 - HSR example of ring configuration for unicast traffic.....	16
Figure 6 - HSR Relay Configuration.....	17
Figure 7 - Px4x attached to a redundant Ethernet star or ring circuit.....	17
Figure 8 - PRP + Dual IP (Ethernet Mode PRP).....	19
Figure 9 - HSR + Dual IP (Ethernet Mode HSR).....	19
Figure 10 - Dual IP (Ethernet Mode Dual IP).....	19
Figure 11 - Communication Parameters for two Interfaces.....	22
Figure 12 - Goose Publish Parameters for two Interfaces.....	23
Figure 13 - PRP star connection.....	24
Figure 14 - HSR ring topology.....	25
Figure 15 - Dual Ethernet ring topology.....	26
Figure 16 - Dual Ethernet star topology.....	27
Figure 17 - Combined RSTP star and ring topology.....	28

Notes:

1. INTRODUCTION

The redundant Ethernet board assures redundancy at IED level. It is fitted into the following MiCOM IEDs from Schneider Electric.

- P14x = P141, P142, P143, P145
- P34x = P341, P342, P343, P344, P345
- P44x = P442, P444
- P44y = P443, P446
- P445
- P54x = P543, P544, P545, P546
- P64x = P642, P643, P645
- P746
- P841
- P849

1.1 Standard Safety Statements

For safety information please see the Safety Information chapter of the relevant Px4x Technical Manual.

2. HARDWARE DESCRIPTION

IEC 61850 works over Ethernet. Three boards are available:

- 1RJ45 Port Ethernet Board
- 3RJ45 Ports Redundant Ethernet Board
- 2LC+1RJ45 Ports Redundant Ethernet Board.

All are required for communications but 3RJ45 Ports and 2LC+1RJ45 Ports Redundant Ethernet Board allow an alternative path to be always available, providing bumpless redundancy.

Industrial network failure can be disastrous. Redundancy provides increased security and reliability, but also devices can be added to or removed from the network without network downtime.

The following list shows Schneider Electric's implementation of Ethernet redundancy, which has two variants with embedded IEC 61850 over Ethernet, plus PRP, HSR and RSTP redundancy protocols.

- Parallel Redundancy Protocol (PRP)/High-availability Seamless Redundancy (HSR)/Rapid Spanning Tree Protocol (RSTP) with 1310 nm multi mode 100BaseFx fiber optic Ethernet ports (LC connector) and modulated/un-modulated IRIG-B input. Part number 2072069A01.

Note

The board offers compatibility with any PRP/HSR/RSTP device.

- Parallel Redundancy Protocol (PRP)/High-availability Seamless Redundancy (HSR)/Rapid Spanning Tree Protocol(RSTP) with 100BaseTx Ethernet ports (RJ45) and modulated/un-modulated IRIG-B input. Part number 2072071A01.

Note

The board offers compatibility with any PRP/HSR/RSTP device.

The redundant Ethernet board is fitted into Slot A of the IED, which is the optional communications slot. Each Ethernet board has three MAC addresses for two groups, one group (PORT 1) including one host MAC address, the other group (PORT 2 & 3) used for redundant application, including one host MAC address and one redundant agency device MAC address. Two host MAC addresses of the IED are printed on the rear panel of the IED.

In addition above for HSR/PRP/RSTP redundant protocols, the redundant Ethernet board also can operate on Dual IP mode. In this case, each Ethernet board has two host MAC addresses.

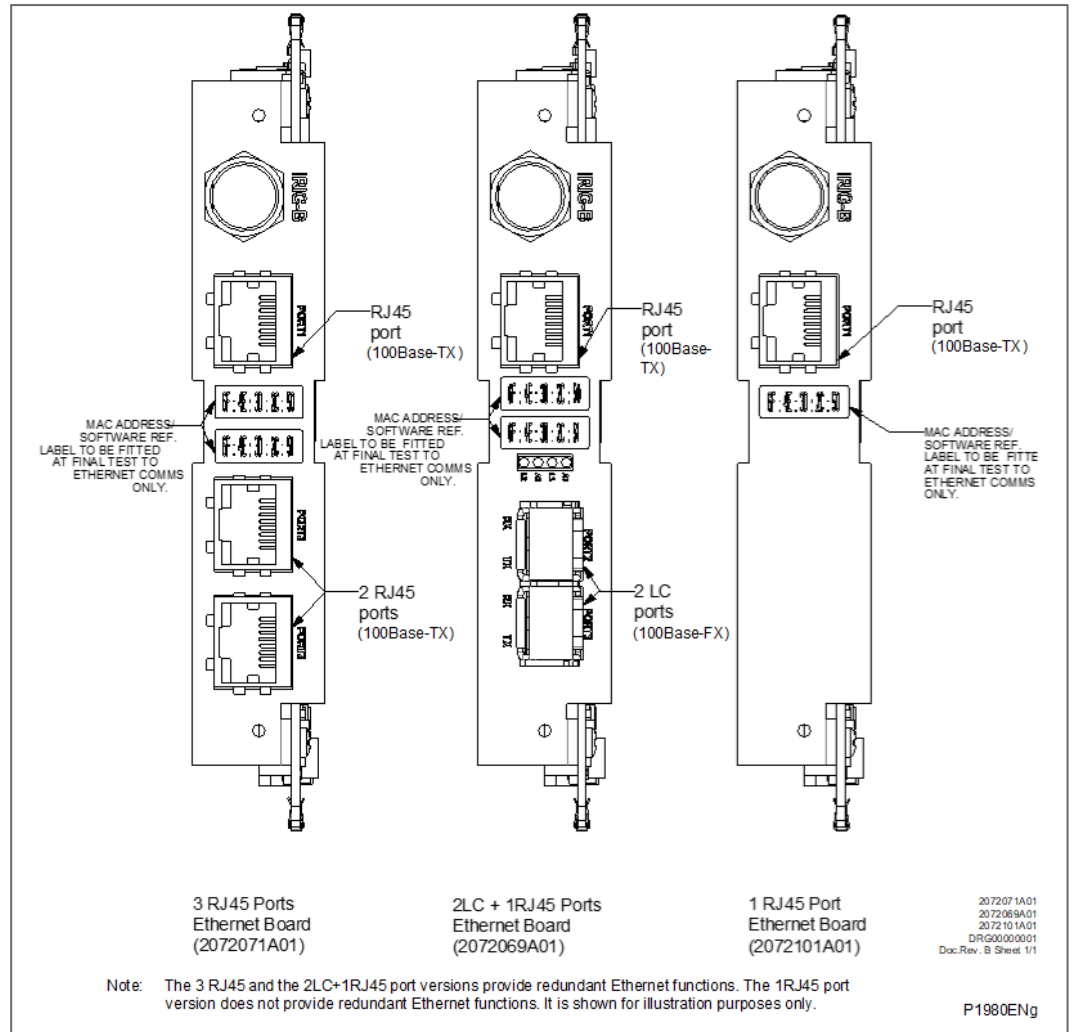

Figure 1 - Ethernet board connectors (3 RJ45 or 2 LC + RJ45 or 1 RJ45)

2.1 IRIG-B Connector

This is available as a modulated/un-modulated input.
See the 6.1 - Board Hardware section.

2.2 LEDs

LED	Function	On	Off	Flashing
Green	Link	Link ok	Link broken	
Yellow	Activity			Traffic activity

Table 1 - LED functionality

2.3 Optical Fibre Connectors

Use 1310 nm multi mode 100BaseFx and LC connectors.
See Figure 1 - Ethernet board connectors (3 RJ45 or 2 LC + RJ45 or 1 RJ45) and the 6.1 - Board Hardware section.

Connector	PRP	HSR	RSTP
2	Rx	Rx	Rx

Connector	PRP	HSR	RSTP
2	Tx	Tx	Tx
3	Rx	Rx	Rx
3	Tx	Tx	Tx

Table 2 - Optical fiber connector functionality

3. REDUNDANCY PROTOCOLS

These redundancy protocols are available:

- PRP (Parallel Redundancy Protocol)
- HSR (High-availability Seamless Redundancy)
- RSTP (Rapid Spanning Tree Protocol)

3.1 Parallel Redundancy Protocol (PRP)

When the upper protocol layers send a data packet, the PRP interface creates a “twin packet” from this. The PRP interface then transmits redundant data packet of the twin pair to each participating LAN simultaneously. As they are transmitted via different LANs, the data packets may have different run times.

The receiving PRP interface forwards the first packet of a pair towards the upper protocol layers and discards the second packet. When viewed from the application, a PRP interface functions like a standard Ethernet interface.

The PRP interface or a Redundancy Box (RedBox) injects a Redundancy Control Trailer (RCT) into each packet. The RCT is a 48-bit identification field and is responsible for the identification of duplicates. This field contains, LAN identification (LAN A or B), information about the length of the payload, and a 16-bit sequence number. The PRP interface increments the sequence number for each packet sent. Using the unique attributes included in each packet, such as Physical MAC source address and sequence number, the receiving RedBox or Double Attached Node (DAN) interface identifies and discards duplicates.

Depending on the packet size, with PRP it attains a throughput of 93 to 99% of the available bandwidth.

3.1.1 PRP Network Structure

PRP uses two independent LANs. The topology of each of these LANs is arbitrary, and ring, star, bus and meshed topologies are possible.

The main advantage of PRP is loss-free data transmission with an active (transit) LAN. When the terminal device receives no packets from one of the LANs, the second (transit) LAN maintains the connection. As long as 1 (transit) LAN is available, repairs and maintenance on the other (transit) LAN have no impact on the data packet transmission.

The elementary devices of a PRP network are known as RedBox (Redundancy Box) and DANP (Double Attached Node implementing PRP).

Both devices have one connection each to the (transit) LANs.

The devices in the (transit) LAN are conventional switches that do not require any PRP support. The devices transmit PRP data packets transparently, without evaluating the RCT information.

Terminal devices that are connected directly to a device in the (transit) LAN are known as SAN (Single Attached Node). If there is an interruption, these terminal devices cannot be reached via the redundant line. To use the uninterruptible redundancy of the PRP network, you integrate your device into the PRP network via a RedBox.

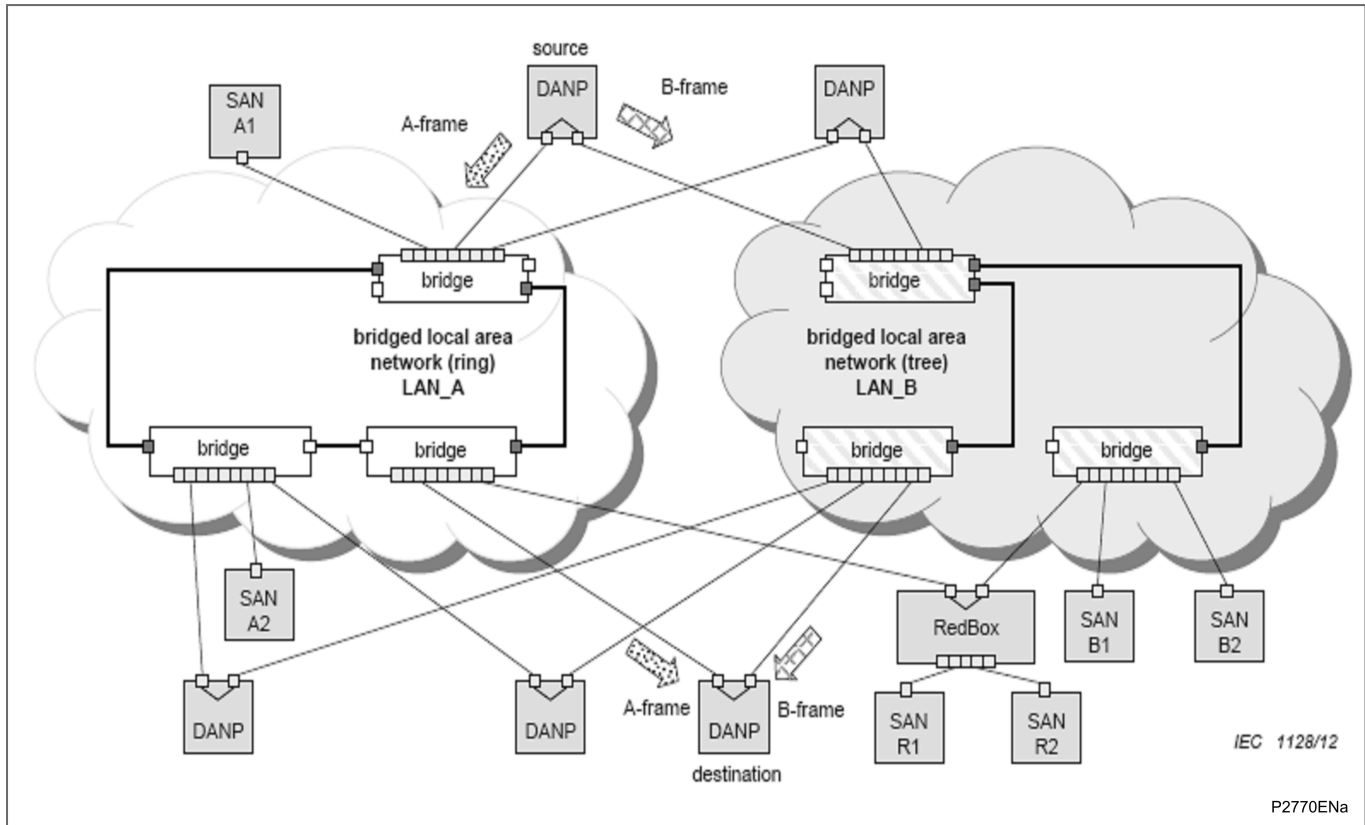

Figure 2 - PRP example of general redundant network

3.1.2 Example PRP Configuration

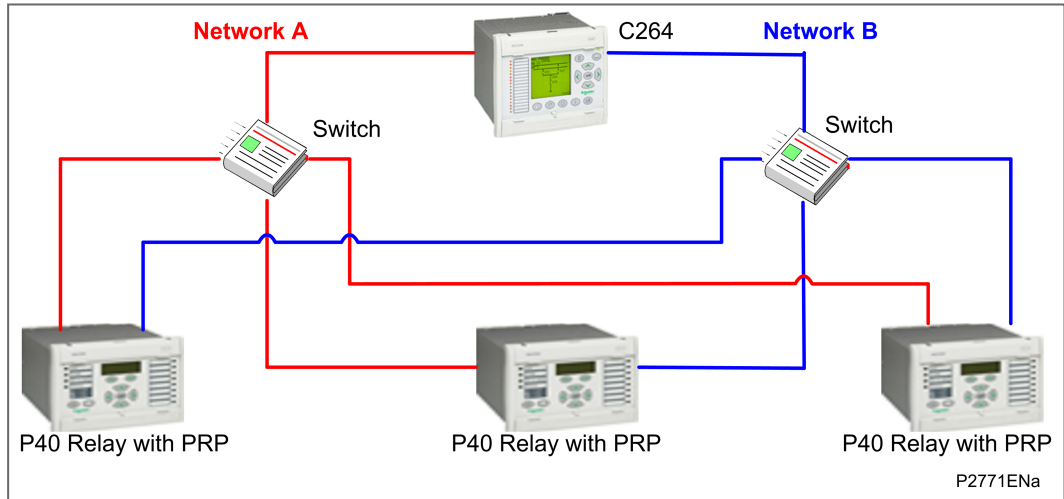

Figure 3 - PRP Relay Configuration

3.2 High-availability Seamless Redundancy (HSR)

High-availability Seamless Redundancy (HSR) can only be used in a ring topology, This section describes the application of the PRP principles (IEC 62439-3- Clause 4) to implement a High-availability Seamless Redundancy (HSR), retaining the PRP property of zero recovery time, applicable to rings. With respect to PRP, HSR allows you to greatly reduce the network infrastructure. With respect to rings based on IEEE 802.1D (RSTP), IEC 62439-2 (MRP), IEC 62439-6 (DRP) or IEC 62439-7 (RRP), the available network bandwidth for network traffic is somewhat reduced depending on the type of traffic. Nodes within the ring are restricted to be HSR-capable bridging nodes, thus avoiding the use of dedicated bridges.

Singly Attached Nodes (SANs) such as laptops or printers cannot be attached directly to the ring, but need attachment through a RedBox (redundancy box).

3.2.1 HSR Network Structure

As in PRP, a node has two ports operated in parallel; it is a DANH (Doubly Attached Node with HSR protocol).

A simple HSR network consists of doubly-attached bridging nodes, each having two ring ports, interconnected by full-duplex links, as shown in these examples for a ring topology:

- Figure 4 - HSR example of ring configuration for multicast traffic
- Figure 5 - HSR example of ring configuration for unicast traffic

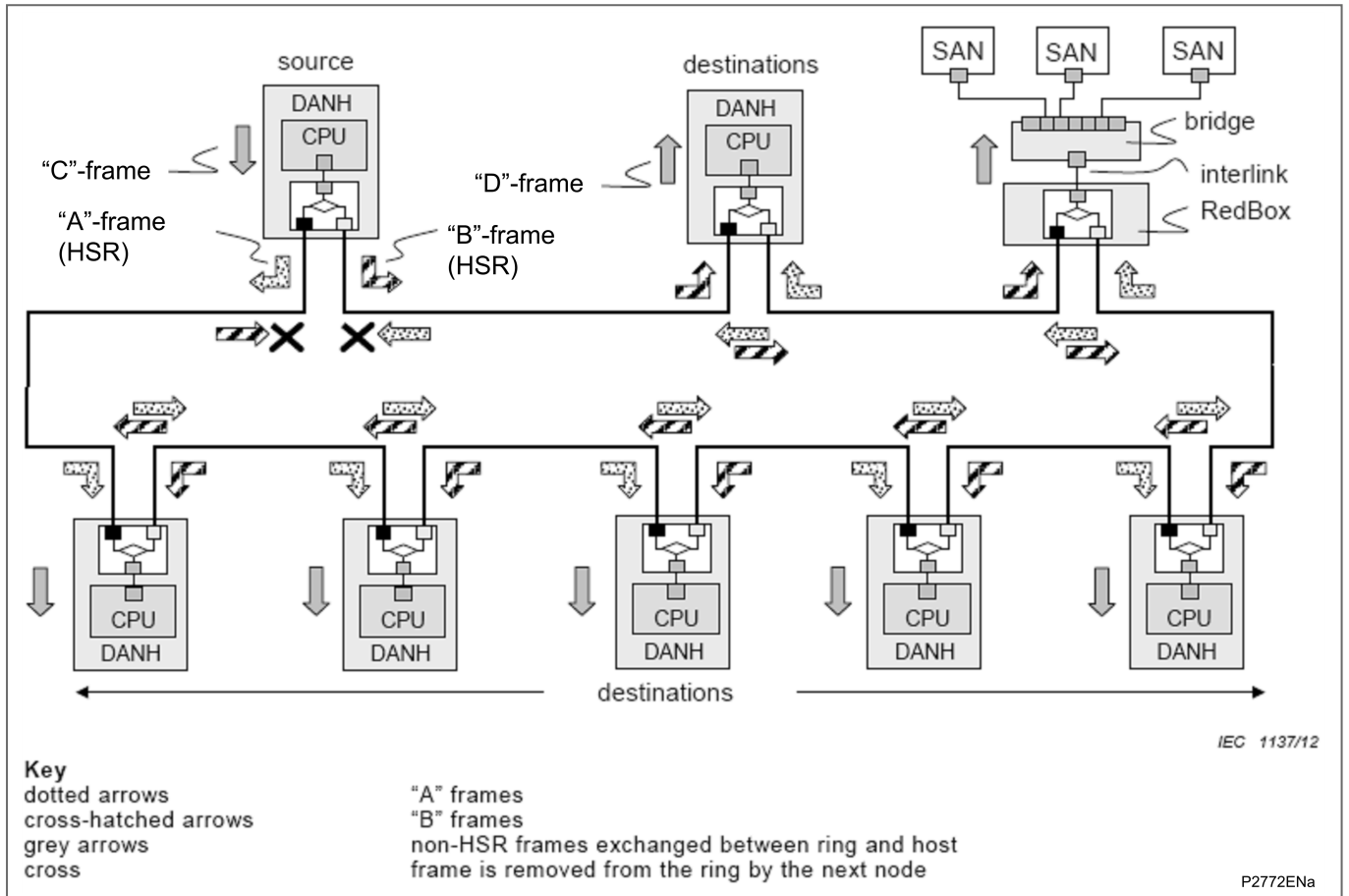

Figure 4 - HSR example of ring configuration for multicast traffic

A source DANH sends a frame passed from its upper layers (“C” frame), prefixes it by an HSR tag to identify frame duplicates and sends the frame over each port (“A”-frame and “B”-frame). A destination DANH receives, in the fault-free state, two identical frames from each port within a certain interval, removes the HSR tag of the first frame before passing it to its upper layers (“D”-frame) and discards any duplicate.

The nodes support the IEEE 802.1D bridge functionality and forward frames from one port to the other, except if they already sent the same frame in that same direction.

In particular, the node will not forward a frame that it injected into the ring.

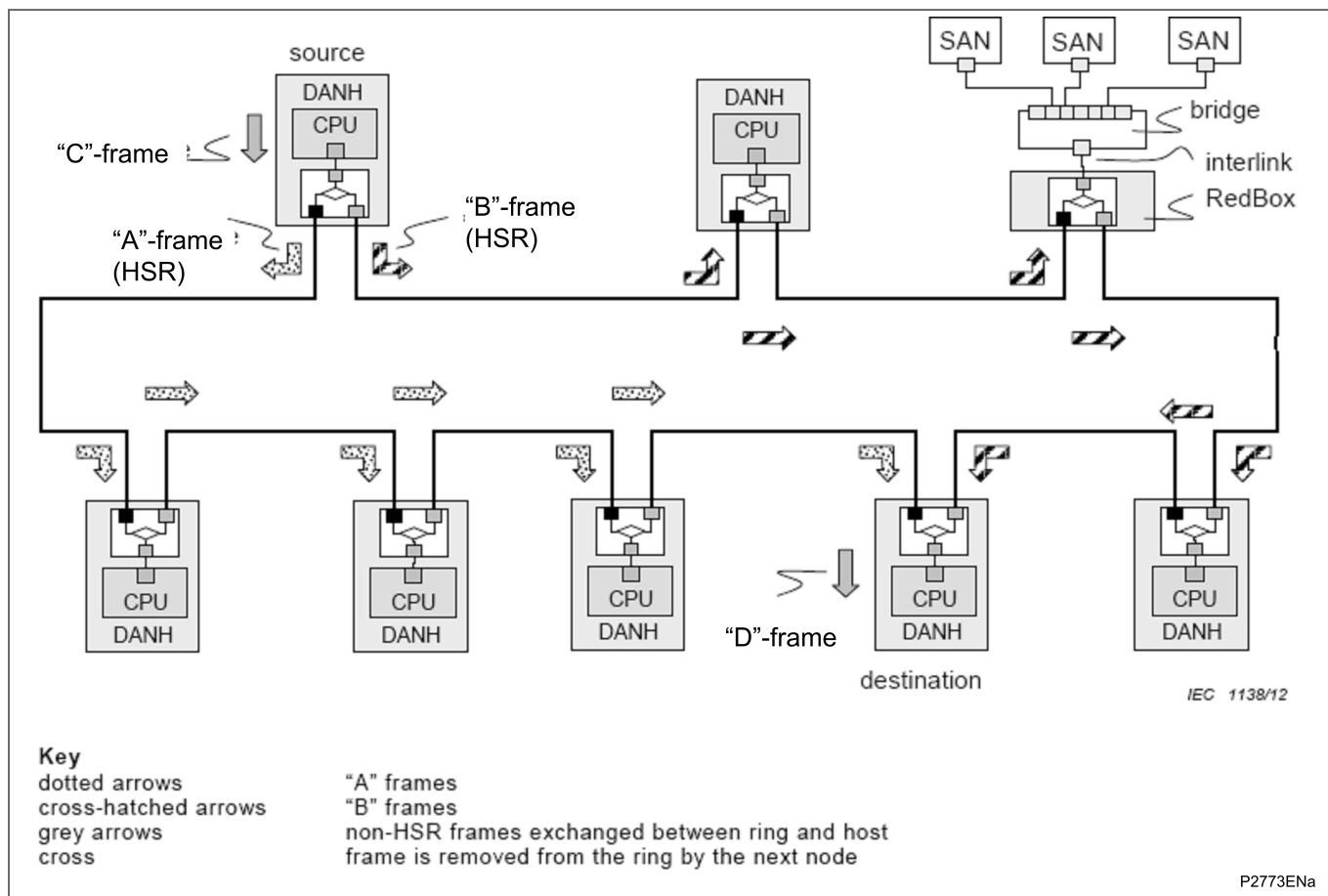

Figure 5 - HSR example of ring configuration for unicast traffic

A destination node of a unicast frame does not forward a frame for which it is the only destination, except for testing.

Frames circulating in the ring carry the HSR tag inserted by the source, which contains a sequence number. The doublet {source MAC address, sequence number} uniquely identifies copies of the same frame.

Singly Attached Nodes (SANs), for instance maintenance laptops or printers cannot be inserted directly into the ring since they have only one port and cannot interpret the HSR tag in the frames. SANs communicate with ring devices through a RedBox (redundancy box) that acts as a proxy for the SANs attached to it, as shown in the diagram. Connecting non-HSR nodes to ring ports, breaking the ring, is allowed to enable configuration. Non-HSR traffic within the closed ring is supported in an optional mode.

3.2.2 Example HSR Configuration

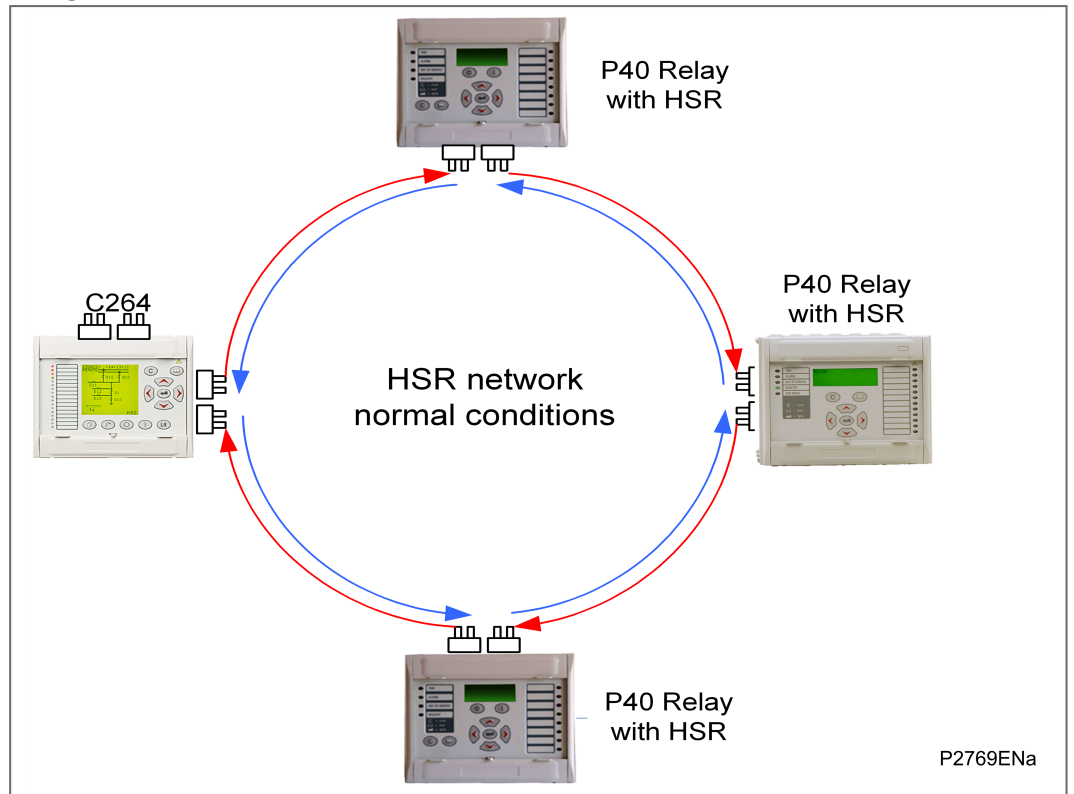

Figure 6 - HSR Relay Configuration

3.3 Rapid Spanning Tree Protocol (RSTP)

3.3.1 RSTP Network Structure

RSTP is a standard used to quickly reconnect a network fault by finding an alternative path, allowing loop-free network topology. Although RSTP can recover network faults quickly, the fault recovery time depends on the number of devices and the topology. The recovery time also depends on the time taken by the devices to determine the root bridge and compute the port roles (discarding, learning, forwarding). The devices do this by exchanging Bridge Protocol Data Units (BPDUs) containing information about bridge IDs and root path costs. See the IEEE 802.1D 2004 standard for further information.

3.3.2 Example RSTP Configuration

The Px4x redundant Ethernet board uses the RSTP protocol (802.1w), so a Px4x can attach onto a network as shown below:

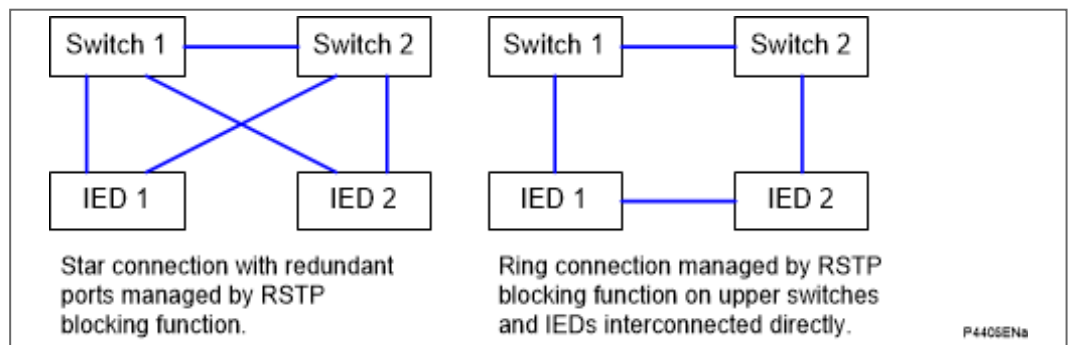

Figure 7 - Px4x attached to a redundant Ethernet star or ring circuit

The RSTP solution is based on open standards. It is therefore compatible with other manufacturers' IEDs that use the RSTP protocol. The RSTP recovery time is typically 300ms but it increases with network size.

3.4 Generic Functions for all Redundant Ethernet Boards (REBs)

The following apply to the redundant Ethernet protocols (PRP, HSR).

3.4.1 Priority Tagging

802.1p priority is enabled on all ports.

3.4.2 Simple Network Time Protocol (SNTP)

Simple Network Time Protocol (SNTP) is supported by both the IED and the redundant Ethernet switch. SNTP is used to synchronize the clocks of computer systems over packet-switched, variable-latency data networks. A jitter buffer is used to reduce the effects of variable latency introduced by queuing in packet switched networks, ensuring a continuous data stream over the network.

The IED receives the synchronization from the SNTP server. This is done using the IP address of the SNTP server entered into the IED from the IED Configurator software.

3.4.3 Dual Ethernet Communication (Dual IPs)

3.4.3.1 Dual IP Introduction

Dual IP means the IED provides two independent IEC 61850 interfaces, and both these interfaces support MMS and GOOSE message.

The IED which supports Dual IP can provide the customer with more flexible network connections: two fully segregated Station BUS networks, or one Station Bus and one Process Bus (for GOOSE message transmission).

Dual IP is not mutually exclusive with PRP/HSR/RSTP - Dual IP is automatically supported even if the IED is operate under PRP/HSR/RSTP mode.

3.4.3.2 Dual IP in MiCOM

Dual IP is only supported for devices with the new Ethernet board assembly. This is shown by the model number, where the 7th digit is either hardware option Q or R. These boards have three Ethernet ports, as shown in the Ethernet Board Connectors diagram.

A setting is provided in the HMI to switch the operation mode between PRP / HSR / RSTP / Dual IP.

Operation mode	Port 1	Port 2	Port 3
PRP	Interface 1	Interface 2 (PRP)	Interface 2 (PRP)
HSR	Interface 1	Interface 2 (HSR)	Interface 2 (HSR)
RSTP	Interface 1	Interface 2 (HSR)	Interface 2 (HSR)
Dual IP	* Interface 1 on Port 1 or Port 2		Interface 2
Note *			
In Dual IP mode, interface 1 can be available on port 1 or port 2.			
If both of port 1 and port 2 are connected, only port 1 will work.			

Table 3 - Ethernet ports operation mode

For each interface, the fully IEC 61850 functions (GOOSE and MMS services) are supported independently.

For outgoing GOOSE messages, you need to configure whether a message is to be transmitted across one or both Ethernet connections. You also need to configure the destination parameters such as multicast MAC address, ApplID, VLAN, etc.

Two communication parameters also need to be configured for each interface (IP address, MAC address, subnet mask). For the CID which is exported from SCD file, the second interface communication parameters are not configured. This needs to be done by manually editing in the IED configurator (this being invisible by the SCD file). This process needs to be completed before the exported CID file is downloaded to the IED. (this being invisible by the SCD file).

3.4.3.3 Typical User Cases

Below for Interface 1 and Interface 2, from a functional point of view it is same. The customer has flexibility to define the functionality according their requirements.

- Both for Station Bus to have duplicated network for DCS.
- One for Station Bus and one for process bus (Goose message)

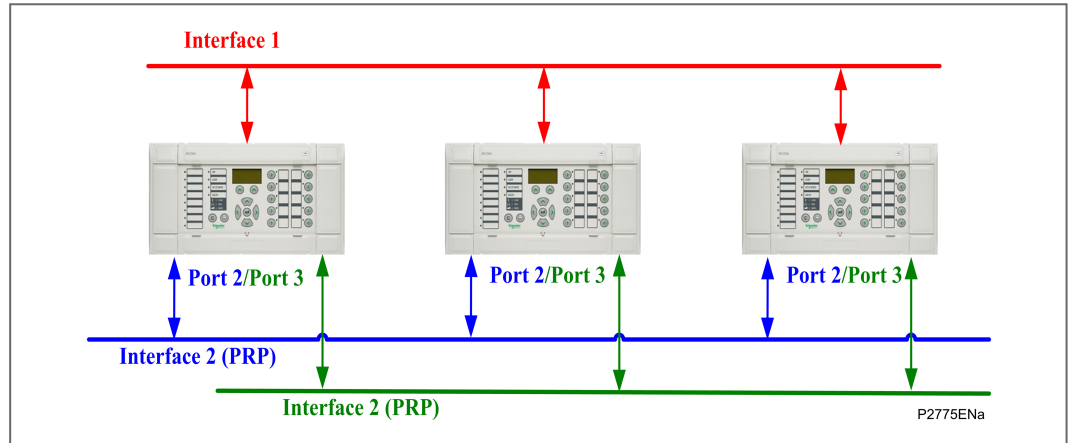

Figure 8 - PRP + Dual IP (Ethernet Mode PRP)

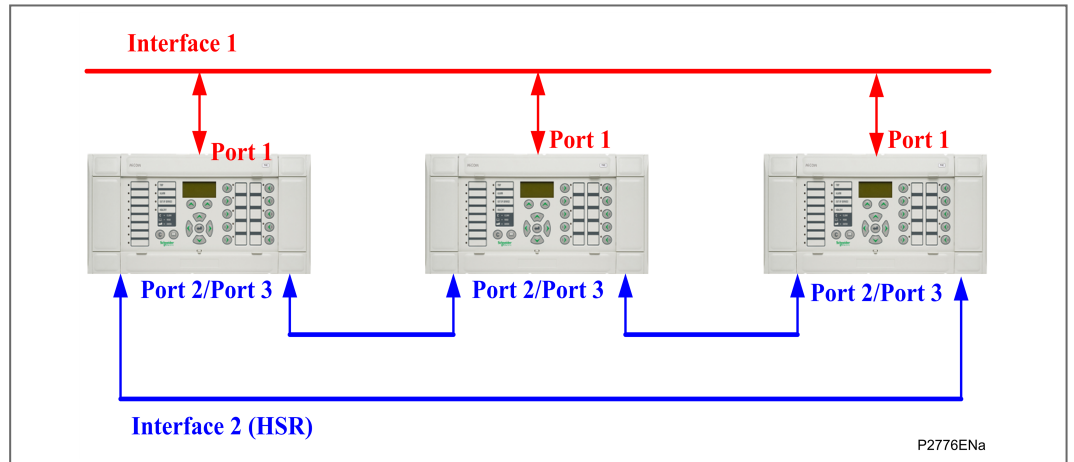

Figure 9 - HSR + Dual IP (Ethernet Mode HSR)

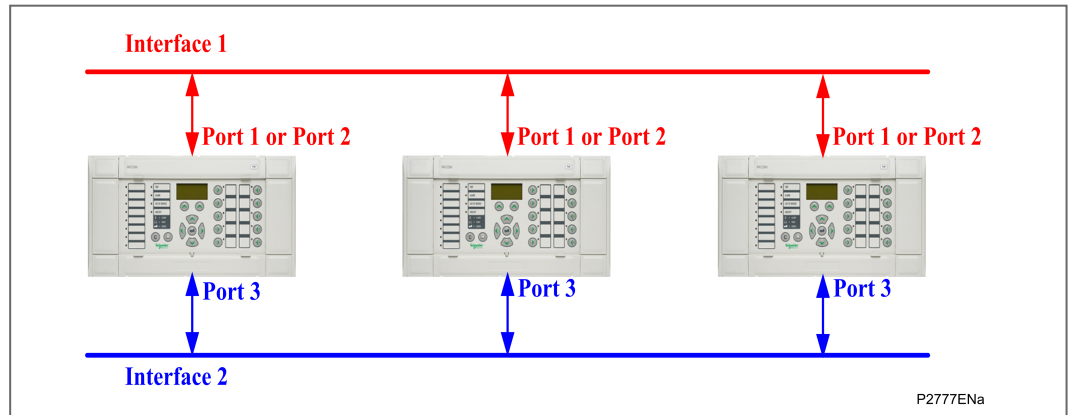

Figure 10 - Dual IP (Ethernet Mode Dual IP)

3.4.4 Precision Time Protocol (PTP)

Precision Time Protocol (PTP) provides higher time accuracy (500us) than IRIG-B.

PTP communication uses the IEEE 802.3 protocol.

3.4.4.1 Introduction to the IEEE1588 Standard

A protocol is provided in this standard that enables precise synchronization of clocks in measurement and control systems implemented with technologies such as network communication, local computing, and distributed objects. The protocol is applicable to systems communicating via packet networks. Heterogeneous systems are enabled that include clocks of various inherent precision, resolution, and stability to synchronize. System-wide synchronization accuracy and precision in the sub-microsecond range are supported with minimal network and local clock computing resources. Simple systems are installed and operated without requiring the management attention of users because the default behaviour of the protocol allows for it.

3.4.4.2 PTP Implementation

PTP implementation is compliant with IEC61850-9-3.

PTP communication is supported in all Ethernet interfaces (redundant ports or single port) with communication protocols (PRP/HSR).

A Slave only Ordinary Clock (OC) is supported by the single port of the Ethernet boards. A Transparent Clock (TC) is supported on the HSR ring.

Peer-to-Peer mode and Best Master Clock algorithm (BMCA) are supported.

The priority of time synchronization is PTP then, if not provided IRIG-B then, if not provided SNTP.

PTP is only supported by the model number, where the 7th digit is Q, R or S.

3.4.4.3 PTP Settings

PTP Settings	Value	Description
DATE AND TIME		
1588 Sync	0: Disabled 1: Interface1 Enabled 2: Interface2 Enabled 3: Interface1&2 Enabled	For Q or R board, the setting value can be 0,1,2,3. For S board, the setting value can be 0, 1. If the setting value is 0, PTP communication is disabled.
1588 DomainNum	[0, 255]	Define the permitted domainNumber of master clock. If the domainNumber in received PTP message header is different from the configuration parameter, the message will be rejected.
1588 PdelInterv	[0, 5]	Define the PDelay interval (20~25) sent by IED.

Table 4 - PTP Settings, Values and Descriptions

PTP is linked with Interface 2 configuration. If there is no IP configured for Interface 2, PTP on interface 2 will not work.

3.4.4.4 IEC61850-9-3 PICS

PICS proforma reference	Capability	Base	Support
CLOCK_TYPE_OC	clock is OC according to this base	m	True
CLOCK_TYPE_TC	clock is TC according to this base	m	True

PICS proforma reference	Capability	Base	Support
CLOCK_TYPE_BC	clock is BC according to this base	m	False
NR_PORTS	number of clock ports (total)	m	2
PORTS_STEP	1: all ports support 1- step on egress 2: all ports support 2- step on egress 3: all ports support both 1 - step and 2.	m	{1 or 2} For PRP/HSR/RSTP mode: - Port1 support 2 step on egress. - Port2&3 support 1 step on egress For Dual IP mode: - Port1&2 support 2 step on egress - Port3 support 1 step on egress
SLAVE_ONLY	all ports of the clock are slave - only	m	True
TIME_TRACEABLE	connectable to a time reference outside of PTP (e.g. GPS)	m	
FREQ_TRACEABLE	connectable to a frequency reference outside of PTP (e.g. GPS)	m	
DAC	doubly attached OC	o	True (in HSR, PRP or RSTP mode)
PORTS_PAISED	paired clock ports for redundancy (e.g. {3-4})	o	{0, 1} 0=A, 1=B
REDBOX_DATC	RedBox as TC	o	
REDBOX_SLTC	RedBox as Stateless TC	o	
REDBOX_TWBC	RedBox as three-way BC	o	
REDBOX_DABC	Redbox as DAC BC	o	
MIB_SNMP	supports MIB of IEC 2439-3 :2015, Annex E	m	False
MIB_61850	supports IEC 6 1859- 90- 4 Clock Objects	m	False
MIB_OTHER	clock supports fixed values or a mechanism defined by the manufacturer (If True, this list is appended to this PICS)	m	True Some management requests for time synchronization information are supported in PTP protocol. The following lists the supported datasets. CURRENT_DATA_SET - stepsRemoved - offsetFromMaster - meanPathDelay PORT_DATA_SET - portIdentity - portState - logMinDelayReqInterval - peerMeanPathDelay - logAnnounceInterval - announceReceiptTimeout - logSyncInterval - delayMechanism - logMinPdelayReqInterval - versionNumber

Table 5 - PICS Proforma Reference, Capability, Base and Support

4. CONFIGURATION

The new redundant Ethernet board supports three communication operation modes. These can be achieved by change the setting in HMI. It is not necessary to flash the firmware.

Also for the two interfaces, the communication parameters need to be configured. These include the IP address, MAC address, and subnet mask, etc.

For redundant protocols, the communication parameters for redundant agency device also need to be configured.

4.1 Configuring Ethernet Communication Mode

Menu Text	Cell Add.	Default Setting	Available Setting
ETH COMM Mode	0016	Dual IP	Dual IP, PRP, HSR or RSTP
Sets the redundancy protocol. This setting can only be changed via the UI. The setting is linked with Interface2. If there is no IP configured for Interface 2, the setting is not configurable. By default, this setting is configurable thanks to the default IP.			

Table 6 - Ethernet communication mode setting

4.2 Configuring the IED Communication Parameters

The communication parameter for each interface is configured using the IED Configurator software in MiCOM S1 Studio. **Customers can configure these parameters according to their needs, but the IP address for these two interfaces should not be in the same subnet.**

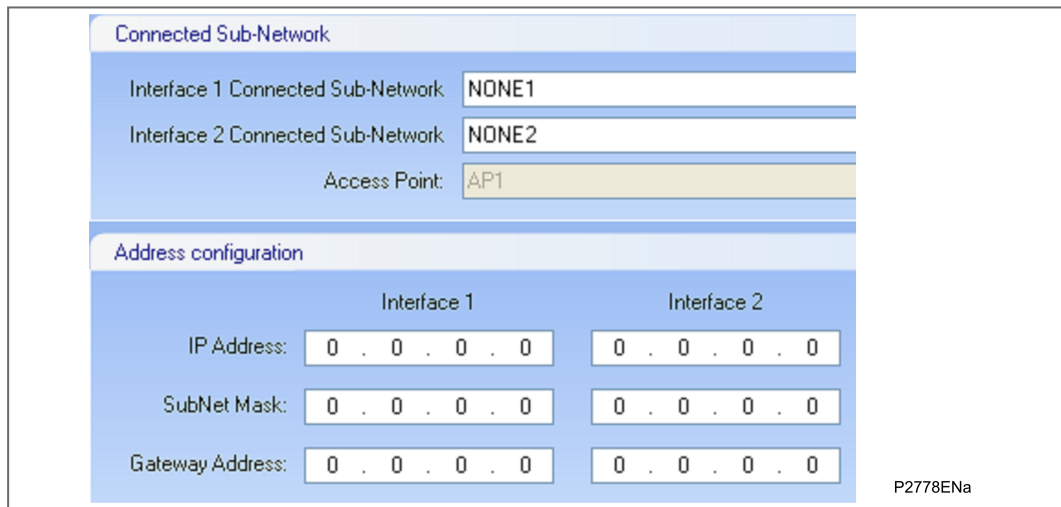

Figure 11 - Communication Parameters for two Interfaces

To use the device configuration with Courier Tunneling, for each interface, a default IP address has been applied. The default IP address for the first three bytes is fixed for each interface as below:

Interface	First three Bytes for IP address
Interface 1	169.254.0.xxx
Interface 2	169.254.1.yyy
Note xxx = Mod (the last byte MAC1 address, 128) + 1 yyy = Mod (the last byte MAC2 address, 128) + 1	

Table 7 - First three bytes for default IP address

The default IP address can be found in the IED CONFIGURATOR column. Also, you can also calculate it according the MAC address label which is mounted on the rear panel of the Ethernet card.

The default IP address is 169.254.2.zzz.

zzz = Mod (The last byte MAC3 address, 128) + 1

4.3 Configuring GOOSE Publish Parameters

For outgoing GOOSE messages, you need to configure whether a message is to be transmitted over one Ethernet connection. You also need to configure the destination parameters including multicast MAC address, AppID, VLAN, etc.

Network parameters

Multicast MAC Address: 01 - 0C - CD - 01 - 00 - 00

Application ID (hex): 0

VLAN Identifier (hex): 0

VLAN Priority: 4

Station Bus Publishing: Please select...
None
Interface 1
Interface 2
Please select...

Clear Publisher

P2779ENb

Figure 12 - Goose Publish Parameters for two Interfaces

5. COMMISSIONING

5.1 PRP Star Connection

The following diagram shows the Px4x IEDs with the PRP variant of Redundant Ethernet boards connected in a STAR topology. The STAR topology can have one or more high-end PRP-enabled Ethernet switches to interface with another network. The Ethernet switch is an HSR-enabled switch with a higher number of ports, which should be configured as the root bridge.

The number of IEDs that can be connected in the STAR can be up to 128.

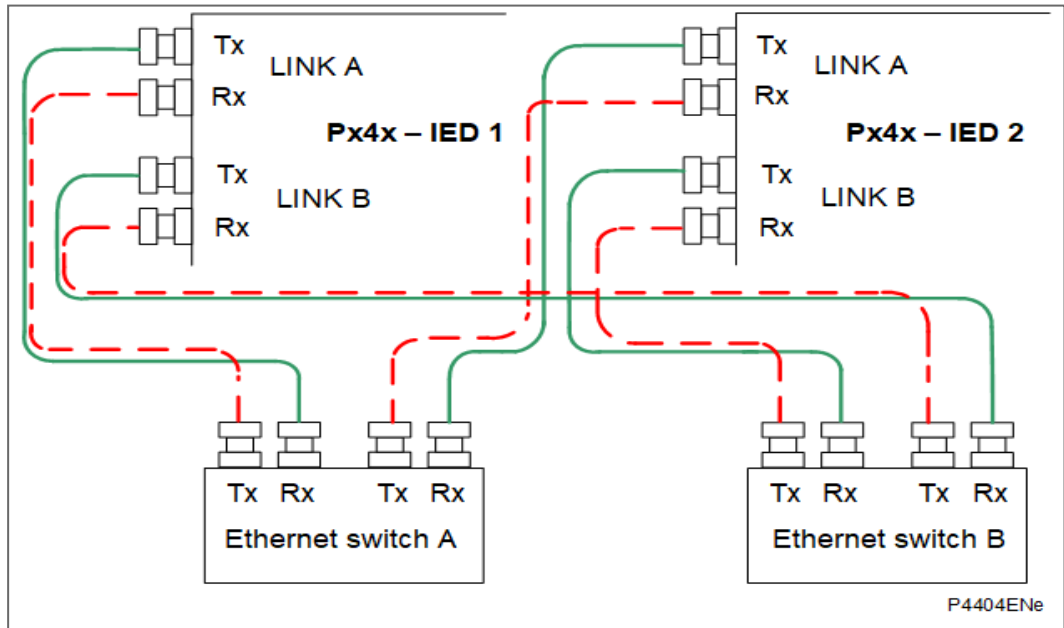

Figure 13 - PRP star connection

5.2 HSR Ring Connection

The following diagram shows the Px4x IEDs (Px4x - IED 1 to IED N) with the HSR variant of redundant Ethernet boards connected in a ring topology. The ring topology can have one or more high-end HSR-enabled Ethernet switches to interface with another network or a control center.

The Ethernet switch is an HSR enabled switch with a higher number of ports. The Ethernet switch, which is connected to the controlling PC, should be configured as the root bridge.

The number of IEDs that can be connected in the ring can be up to 128.

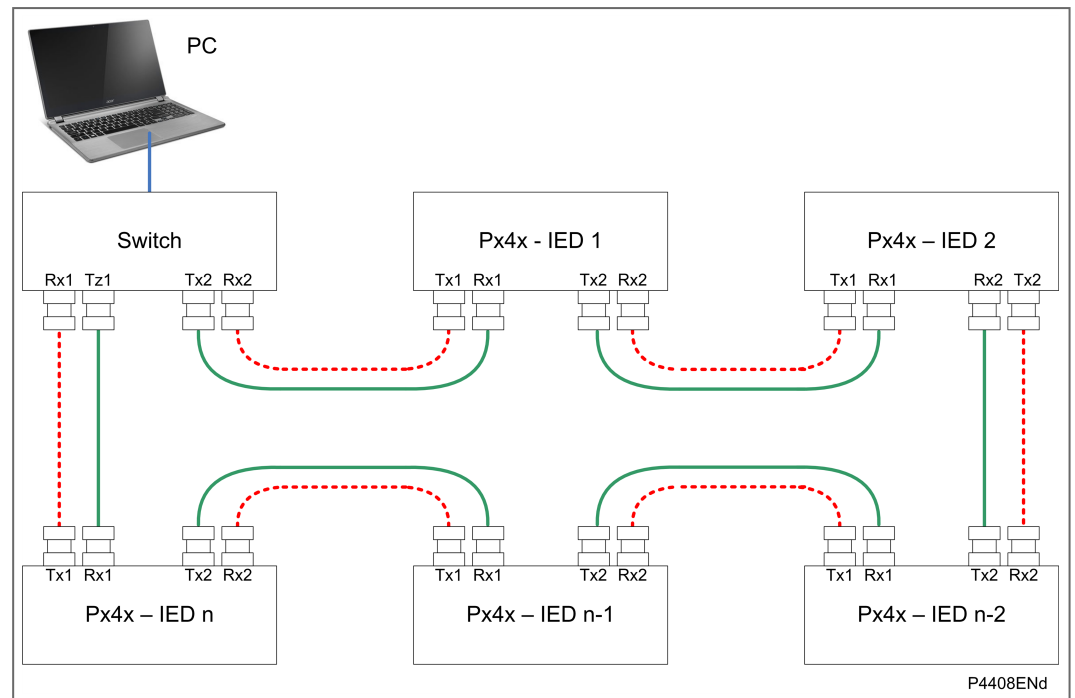

Figure 14 - HSR ring topology

5.3 RSTP Ring Connection

The next diagram shows the Px4x IEDs (Px4x – IED 1 to IED N) with the RSTP variant of redundant Ethernet boards connected in a ring topology. The ring topology can have one or more high-end RSTP-enabled Ethernet switches to interface with another network or control center.

The Ethernet switch is an RSTP enabled switch with a higher number of ports.

The Ethernet switch, which is connected to the controlling PC, should be configured as the root bridge. The bridge priority of the Ethernet switch should be configured to the minimum value in the network shown in the next diagram.

The maximum number of IEDs that can be connected in the ring network depends on the Max Age parameter configured in the root bridge, see the *Combined RSTP star and ring topology* diagram.

The Max Age parameter can be varied from 6 to 40 seconds.

If Max Age = 6 seconds, the maximum number of IEDs in the ring is $6 - 1 = 5$.

If Max Age = 40 seconds, the maximum number of IEDs in the ring is $40 - 1 = 39$.

Therefore, the number of IEDs that can be connected in the ring can vary from 5 to 39.

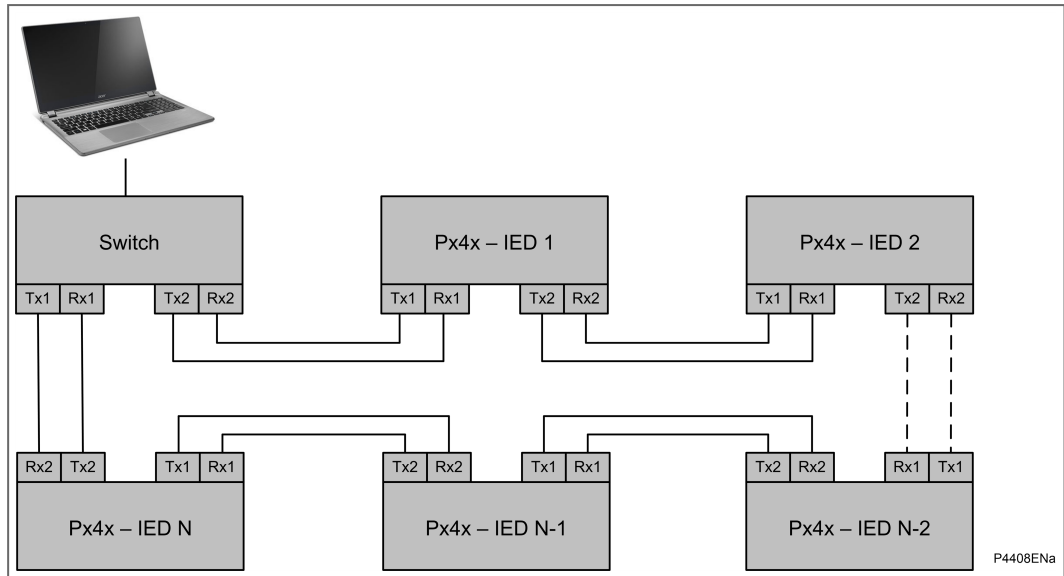

Figure 15 - Dual Ethernet ring topology

5.4 RSTP Star Connection

The next diagram shows the Px4x IEDs (Px4x – IED 1 to IED N) with the RSTP variant of redundant Ethernet boards connected in a star topology. The star topology can have one or more high-end RSTP-enabled Ethernet switches to interface with other networks, control centers, or Px4x IEDs.

The Ethernet switch is an RSTP enabled switch with a greater number of ports. The Ethernet switch, which is connected to the controlling PC, should be configured as the root bridge. The bridge priority of the Ethernet switch should be configured to the minimum value in the network shown below.

The Px4x IEDs are placed at two hop distance from the root bridge, therefore the Max Age meter has no impact on star topology.

The maximum number of IEDs that can be connected in the star network depends on the number of ports available in the Ethernet switch, provided that the hop count from the root bridge is less than the Max Age parameter.

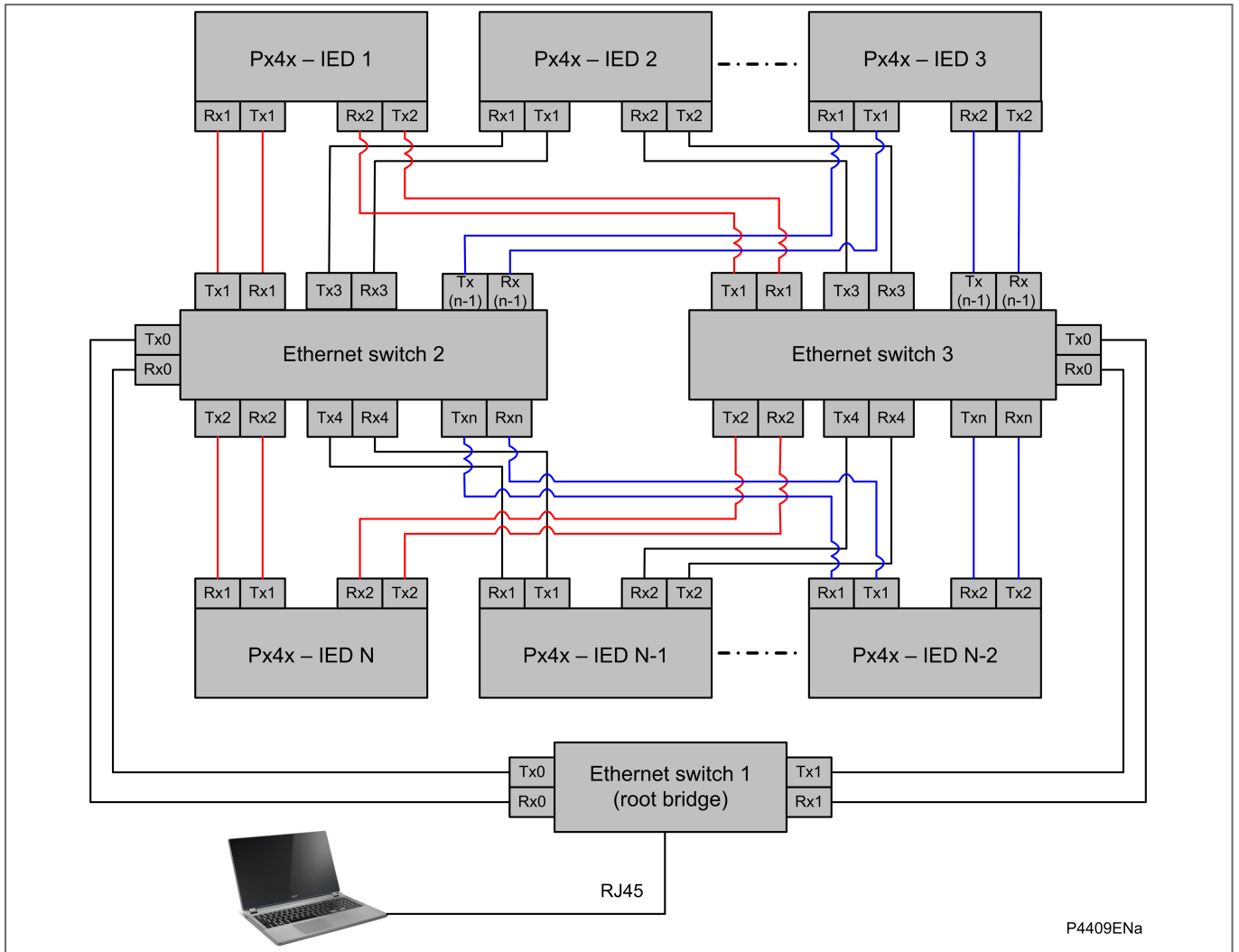

Figure 16 - Dual Ethernet star topology

5.5 Large RSTP Networks combining Star and Ring

The next diagram shows a star of four rings. Each ring is connected to the root bridge. The root bridge is a high-end RSTP enabled bridge with the maximum number of ports as required.

The devices A1, A2...Anmax, B1, B2...Bnmax, C1, C2...Cnmax, D1, D2...Dnmax, represent the RSTP variant of redundant Ethernet boards.

The maximum number of boards that can be connected in single ring in an RSTP-enabled network depends on the Max Age parameter. The hop count from the root bridge cannot be greater than the Max Age parameter.

The maximum number of RSTP bridges in a ring is given by:

$$N_{max} = (Max\ Age - 1)$$

Where:

N_{max} = maximum number of devices in a ring

Max Age = Max Age value configured in the root bridge

Assuming the default value of Max Age as 20 seconds in the topology shown 0, the maximum number of devices that can be connected in ring A is 19.

If Max Age is configured as 40 seconds, the maximum number of IEDs that can be connected in the network is $(40-1) = 39$. According to the IEEE 802.1D 2004 standard, the

maximum value for the Max Age parameter is limited to 40. To use the maximum number of IEDs in the ring, the following configuration should be used.

Max Age = 40 seconds

Forward Delay = 30 seconds

Hello Time = 2 seconds

Bridge Priority = As required by the end user

The IEEE 802.1D 2004 standard defines the relation between Max Age and Forward Delay as:

$$2 * (\text{Forward Delay} - 1.0 \text{ seconds}) \geq \text{Max Age}$$

To have the maximum number of nodes in the RSTP network, the number of rings can be increased, depending on the number of ports available in the root bridge.

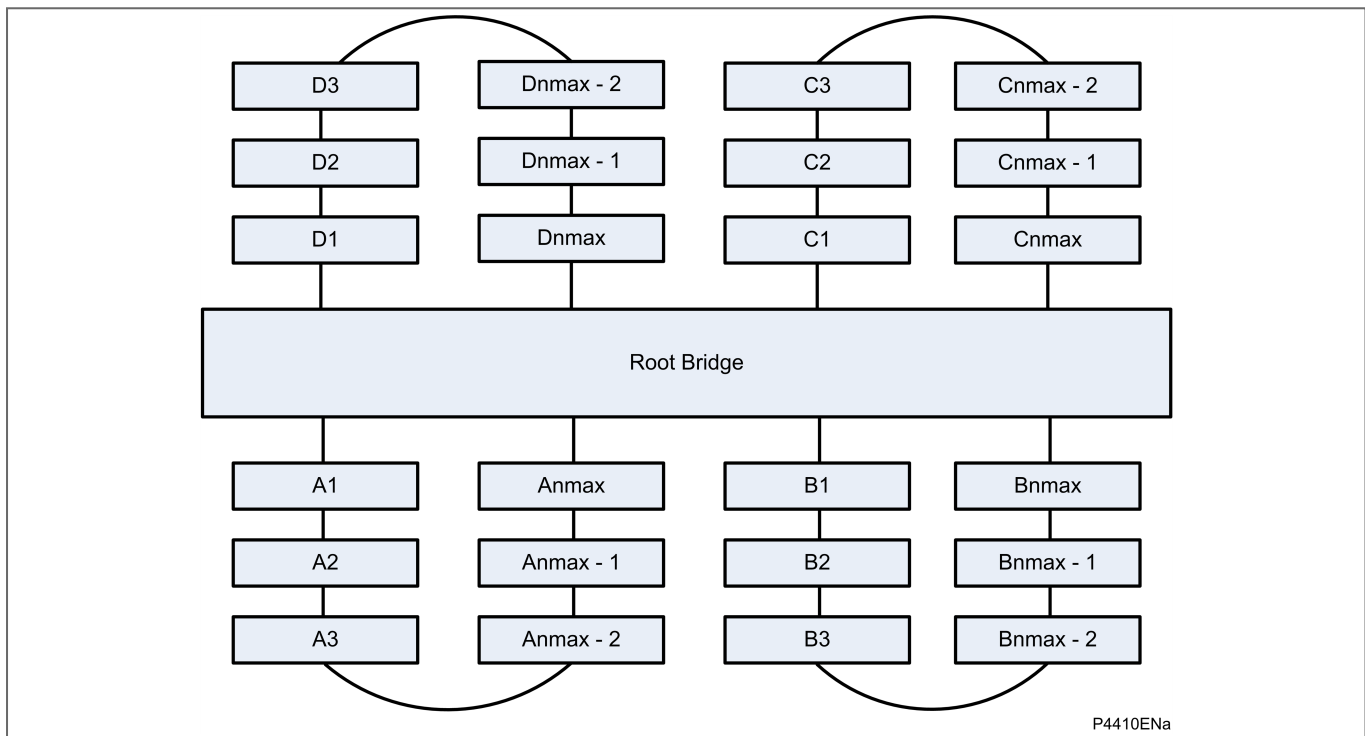

Figure 17 - Combined RSTP star and ring topology

6. TECHNICAL DATA

The redundant Ethernet board assures redundancy at IED level. It is fitted into the following MiCOM IEDs from Schneider Electric.

- P14x = P141, P142, P143, P145
- P34x = P341, P342, P343, P344, P345
- P44x = P442, P444
- P44y = P443, P446
- P445
- P54x = P543, P544, P545, P546
- P64x = P642, P643, P645
- P746
- P841
- P849

6.1 Board Hardware

6.1.1 100 Base TX Communications Interface

Cable type	Screened Twisted Pair (STP)
Connector type	RJ45
Maximum distance	100m
Full Duplex	100 Mbps

Table 8 - 100 Base TX interface

6.1.2 100 Base FX Communications Interface

Optical fiber cable	Multi-mode 50/125 μm or 62.5/125 μm
Center wavelength	1300 nm
Connector type	LC
Maximum distance	2 km
Full Duplex	100 Mbps

Table 9 - 100 Base FX interface

6.1.3 Transmitter Optical Characteristics

(TA = -40° C to 85° C)

Parameter	Sym	Min.	Typ.	Max.	Unit
Output Optical Power 62.5/125 μm , NA = 0.275 Fiber	PO	-20	-17.0	-14	dBm avg
Output Optical Power 50/125 μm , NA = 0.20 Fiber	PO	-23.5	-20.0	-14	dBm avg
Optical Extinction Ratio				10	dB
Output Optical Power at Logic "0" State	PO ("0")			-45	dBm avg

Table 10 - Tx optical characteristics

6.1.4 Receiver Optical Characteristics

(TA = -40° C to 85° C)

Parameter	Sym	Min.	Typ.	Max.	Unit
Input Optical Power	PIN	-31		-14	dBm avg

Table 11 - Rx optical characteristics

6.1.5 IRIG-B and Real-Time Clock

6.1.5.1 Performance

Year 2000: Compliant
 Real time accuracy: < ± 2 second / day
 External clock synchronisation: Conforms to IRIG standard 200-98, format B

6.1.5.2 Features

Real time 24 hour clock settable in hours, minutes and seconds
 Calendar settable from January 1994 to December 2092
 Clock and calendar maintained via battery after loss of auxiliary supply
 Internal clock synchronization using IRIG-B Interface for IRIG-B signal is BNC

6.1.5.3 Self-adapted Rear IRIG-B Interface (Modulated or Unmodulated)

BNC plug
 Isolation to SELV level.
 50 ohm coaxial cable.

6.2 Type Tests

6.2.1 Insulation

Per EN / IEC 60255-27:
 Insulation resistance > 100 M Ω at 500 Vdc
 (Using only electronic/brushless insulation tester).

6.2.2 Creepage Distances and Clearances

Per EN / IEC 60255-27:
 Pollution degree 2, Overvoltage category III,

6.2.3 High Voltage (Dielectric) Withstand

(EIA RS-232 ports excepted and normally-open contacts of output relays excepted).

(i) As for EN / IEC 60255-27:

2 kV rms AC, 1 minute:

Between all independent circuits.

Between independent circuits and case earth (ground).

1 kV rms AC for 1 minute, across open watchdog contacts.

1 kV rms AC for 1 minute, across open contacts of changeover output relays (not applicable for high break contacts due to electronics presence across the contact).

1 kV rms AC for 1 minute for all D-type EIA(RS)-232 or EIA(RS)-485 ports between the communications port terminals and protective (earth) conductor terminal.

1 kV rms AC for 1 minute between RJ45 ports and the case earth (ground).

1 kV rms AC for 1 minute between RJ45 ports and other independent circuits.

(ii) As for ANSI/IEEE C37.90:

1.5 kV rms AC for 1 minute, across open contacts of normally open output relays.

1 kV rms AC for 1 minute, across open watchdog contacts.

1 kV rms AC for 1 minute, across open contacts of changeover output relays (not applicable for high break contacts due to electronics presence across the contact).

6.2.4 Impulse Voltage Withstand Test

As for EN / IEC 60255-27:

(i) Front time: 1.2 μ s, Time to half-value: 50 μ s,

Peak value: 1.5kV, 0.5 J

Between RJ45 ports and the case earth (ground).

Between RJ45 ports and other independent circuits.

EIA(RS)-232 & EIA(RS)-485 ports and normally open contacts of output relays excepted.

(ii) Front time: 1.2 μ s, Time to half-value: 50 μ s,

Peak value: 5 kV, 0.5 J

Between all independent circuits.

Between independent circuits and case earth ground.

6.3 ElectroMagnetic Compatibility (EMC)

6.3.1 1 MHz Burst High Frequency Disturbance Test

As for EN / IEC 60255-22-1, Class III,

Common-mode test voltage: 2.5 kV,

Differential test voltage: 1.0 kV,

Test duration: 2 s,

Source impedance: 200 Ω

(EIA(RS)-232 ports excepted).

6.3.2 100 kHz and 1MHz Damped Oscillatory Test

EN / IEC 61000-4-18: Level 3

Common mode test voltage: 2.5 kV

Differential mode test voltage: 1 kV

6.3.3 Immunity to Electrostatic Discharge

As for EN / IEC 60255-22-2, EN / IEC 61000-4-2:

15kV discharge in air to user interface, display, communication ports and exposed metalwork.

6kV contact discharge to the screws on the front of the front communication ports.

8kV point contact discharge to any part of the front of the product.

6.3.4 Electrical Fast Transient or Burst Requirements

As for EN / IEC 60255-22-4, Class B:

\pm 4.0 kV, 5kHz and 100kHz applied to all inputs / outputs excluding communication ports

\pm 2.0 kV, 5kHz and 100kHz applied to all communication ports

As for EN / IEC 61000-4-4, severity level 4:

\pm 2.0 kV, 5kHz and 100kHz applied to all inputs / outputs and communication ports excluding power supply and earth.

\pm 4.0 kV, 5kHz and 100kHz applied to all power supply and earth port

Rise time of one pulse: 5 ns

Impulse duration (50% value): 50 ns

Burst duration: 15 ms or 0.75ms

Burst cycle: 300 ms

Source impedance: 50 Ω

6.3.5 Surge Withstand Capability

As for IEEE/ANSI C37.90.1:

4 kV fast transient and 2.5 kV oscillatory

applied directly across each output contact, optically isolated input, and power supply circuit.

6.3.6 Surge Immunity Test

As for EN / IEC 61000-4-5, EN / IEC 60255-26:

Time to half-value: 1.2 to 50 μ s,

Amplitude: 4 kV between all groups and case earth (ground),

Amplitude: 2 kV between terminals of each group.

Amplitude: 1kV for LAN ports

6.3.7 Conducted/Radiated Immunity

For RTDs used for tripping applications the conducted and radiated immunity performance is guaranteed only when using totally shielded RTD cables (twisted leads).

6.3.8 Immunity to Radiated Electromagnetic Energy

Per EN / IEC 61000-4-3 and EN / IEC 60255-22-3, Class 3

Test field strength, frequency band 80 to 1000 MHz and 1.4 GHz to 2.7GHz: 10 V/m,

Test using AM: 1 kHz / 80%

Spot tests at: 80, 160, 450, 900, 1850, 2150 MHz

Per IEEE/ANSI C37.90.2:

80MHz to 1000MHz, zero and 100% square wave modulated.

Field strength of 35V/m.

6.3.9 Radiated Immunity from Digital Communications

As for EN / IEC61000-4-3, Level 4:

Test field strength, frequency band 800 to 960 MHz,

and 1.4 to 2.0 GHz: 30 V/m, Test using AM: 1 kHz/80%.

6.3.10 Radiated Immunity from Digital Radio Telephones

As for EN / IEC 61000-4-3: 10 V/m, 900 MHz and 1.89 GHz.

6.3.11 Immunity to Conducted Disturbances Induced by Radio Frequency Fields

As for EN / IEC 61000-4-6, Level 3, Disturbing test voltage: 10 V.

6.3.12 Power Frequency Magnetic Field Immunity

As for EN / IEC 61000-4-8, Level 5,

100 A/m applied continuously, 1000 A/m applied for 3 s.

As for EN / IEC 61000-4-9, Level 5,

1000 A/m applied in all planes.

As for EN / IEC 61000-4-10, Level 5,

100 A/m applied in all planes at 100 kHz and 1 MHz with a burst duration of 2 s.

6.3.13 Conducted Emissions

As for CISPR 22 Class A:

Power supply:

0.15 - 0.5 MHz, 79 dB μ V (quasi peak) 66 dB μ V (average)

0.5 - 30 MHz, 73 dB μ V (quasi peak) 60 dB μ V (average)

Permanently connected communications ports:

0.15 - 0.5MHz, 97dB μ V (quasi peak) 84dB μ V (average)
0.5 - 30MHz, 87dB μ V (quasi peak) 74dB μ V (average)

6.3.14 Radiated Emissions

As for CISPR 22 Class A:

30 to 230 MHz, 40 dB μ V/m at 10m measurement distance.

230 to 1 GHz, 47 dB μ V/m at 10 m measurement distance.

1 – 3GHz, 76dB μ V/m (peak), 56dB μ V/m (average) at 3m measurement distance.

3 – 5GHz, 80dB μ V/m (peak), 60dB μ V/m (average) at 3m measurement distance.

6.4 Environmental Conditions

6.4.1 Ambient Temperature Range

Per EN 60068-2-1 & EN / IEC 60068-2-2

Operating temperature range: -25°C to +55°C (or -13°F to +131°F)

Storage and transit: -25°C to +70°C (or -13°F to +158°F)

6.4.2 Ambient Humidity Range

Per EN / IEC 60068-2-78:

56 days at 93% relative humidity and +40 °C

Per EN / IEC 60068-2-14

5 cycles, -25°C to +55 °C

1°C / min rate of change

Per EN / IEC 60068-2-30

Damp heat cyclic, six (12 + 12) hour cycles, +25 to +55°C

6.4.3 Corrosive Environments

Per EN / IEC 60068-2-60, Part 2, Test Ke, Method (class) 3

Industrial corrosive environment/poor environmental control, mixed gas flow test.

21 days at 75% relative humidity and +30°C

Exposure to elevated concentrations of H₂S, (100 ppb), NO₂, (200 ppb) & Cl₂ (20 ppb).

Per EN / IEC 60068-2-52 Salt mist (7 days)

Per EN / IEC 60068-2-43 for H₂S (21 days), 15 ppm

Per EN / IEC 60068-2-42 for SO₂ (21 days), 25 ppm

6.5 EU Directives

6.5.1 EMC Compliance

As for 2004/108/EC:

Compliance to the European Commission Directive on EMC is demonstrated using a Technical File. Product Specific Standards were used to establish conformity:

EN 60255-26

6.5.2 Product Safety

Per 2006/95/EC:

Compliance to the European Commission Low Voltage Directive (LVD) is demonstrated using a Technical File. A product-specific standard was used to establish conformity.

 EN 60255-27

6.5.3 R&TTE Compliance

Radio and Telecommunications Terminal Equipment (R&TTE) directive 99/5/EC.
Compliance demonstrated by compliance to both the EMC directive and the Low voltage directive, down to zero volts.
Applicable to rear communications ports.
Compliance demonstrated by Notified Body certificates of compliance.

6.5.4 ATEX Compliance

ATEX is the Potentially Explosive Atmospheres directive 94/9/EC.
Compliance with Article 1 of European directive 2014/34/EU.

6.5.5 UKCA Compliance

UK Type Examination regulation of the equipment.
Compliance with Article 3 of the UK directive SI 2016 No.1107.
For other approvals such as UL/CUL/CSA, consult Schneider Electric.

6.6 Mechanical Robustness

6.6.1 Vibration Test

Per EN / IEC 60255-21-1
Response Class 2
Endurance Class 2

6.6.2 Shock and Bump

Per EN / IEC 60255-21-2
Shock response Class 2
Shock withstand Class 1
Bump Class 1

6.6.3 Seismic Test

Per EN / IEC 60255-21-3: Class 2

7. CORTEC

This is a generic Cortec to cover all IEDs using the **Redundant Ethernet** boards. It does not necessarily include all the possible options for all products in the MiCOM Px4x range. Likewise, it is possible that options shown in this list, may not be available for all products.

Note: IEC-60870-5-103, DNP3.0 and MODBUS are not supported in P74x.

Variants	Order Number	1	2	3	4	5	6	7	8	9	10	11	12	13	14	15
MiCOM Protection	P															
Application/Platform																
Feeder Management		1	4	*												
Motor Protection		2	4	*												
Generator Protection Relay		3	4	*												
Distance Protection Relay		4	4	*												
Current Differential		5	4	*												
Transformer		6	4	*												
Busbar		7	4	*												
Breaker Fail		8	4	*												
Vx Aux Rating:																
24 - 32 Vdc						9										
48 - 110 Vdc						2										
110 - 250 Vdc (100 - 240 Vac)						3										
In/Vn Rating (model dependent):																
Product Dependent							*									
Communications Options (model dependent):																
Standard - no options								1								
IRIG-B only (modulated)								2								
Fibre optic converter only								3								
IRIG-B (modulated) & fibre optic converte								4								
Ethernet with 100Mits/s fibre-optic port								6								
Second Rear Comms Port (Courier EIA232/EIA485/k-bus)								7								
Second Rear Comms Port + IRIG-B (modulated) (Courier EIA232/EIA485/k-bus)								8								
InterMiCOM + Courier Rear Port								E								
InterMiCOM + Courier Rear Port + IRIG-B modulated								F								
Redundant Ethernet RSTP, 2 multi-mode fibre ports + Modulated IRIG-B								J								
Redundant Ethernet RSTP, 2 multi-mode fibre ports + Unmodulated IRIG-B								K								
Redundant Ethernet (100Mbit/s) PRP or HSR or RSTP and Dual IP, 2 LC ports + 1 RJ45 port + Modulated/Un-modulated IRIG-B + 1588								Q								
Redundant Ethernet (100Mbit/s) PRP or HSR or RSTP and Dual IP, 3 RJ45 ports + Modulated/Un-modulated IRIG-B + 1588								R								
Ethernet (100Mbit/s), 1 RJ45 port + Modulated/Un-modulated IRIG-B + 1588								S								
Product Specific Options (model dependent):																

Variants	Order Number	1	2	3	4	5	6	7	8	9	10	11	12	13	14	15
MiCOM Protection	P															
Product Dependent									*							
Protocol Options:																
K-Bus/Courier										1						
Modbus										2						
IEC60870-5-103 (VDEW)										3						
DNP3.0										4						
IEC 61850 over Ethernet and Courier via rear K-Bus/RS485 OR IEC 61850 Edition 1 and Edition 2 and Courier via rear K-Bus/RS485										6						
IEC 61850 over ethernet with CS103 rear port RS485 protocol OR IEC 61850 Edition 1 and Edition 2 and CS103 via rear port RS485										7						
IEC 61850 Edition 1 / 2 and DNPoE and DNP3 Serial with simple password management - (CSL0)										B						
IEC 61850 Edition 1 / 2 and Courier via rear K-Bus/RS485 with advanced Cyber Security - CSL1 - Cybersecurity Admin Expert (CAE) required										G						
IEC 61850 Edition 1 / 2 and CS103 via rear port RS485 with advanced Cyber Security - CSL1 - Cybersecurity Admin Expert (CAE) required										H						
IEC 61850 Edition 1 / 2 and DNPoE and DNP3 Serial with advanced Cyber Security - CSL1 - Cybersecurity Admin Expert (CAE) required										L						
Mounting Options:																
Flush Panel Mounting											M					
Rack Mounting (80TE only)											N					
Language Options:																
English, French, German, Spanish											0					
English, French, German, Russian											5					
Chinese, English or French via HMI, with English or French only via Communications port C											C					
Software Version:																
													*	*		
Customisation:																
Default																8
Customer Specific																9
Design Suffix:																
Phase 3 CPU																L
Extended Phase 3 CPU																M

Table 12 - Cortec for Redundant Ethernet models

PARALLEL REDUNDANCY PROTOCOL (PRP) NOTES

CHAPTER 20

Applicability

Date:	10/2022
--------------	---------

Products covered by this chapter:

This chapter covers the specific versions of the MiCOM products listed below. This includes **only** the following combinations of Software Version and Hardware Suffix.

Hardware Suffix:

P141/P142/P143	L or later
P145	M or later
P241	L or later
P242 / P243	M or later
P341	L or later
P342	L or later
P343 / P344 / P345	M or later
P391	A or later
P44x (P442 / P444)	M or later
P44y (P443/P446)	M or later
P445	L or later
P54x (P543 / P544 / P545 / P546)	M or later
P642	L or later
P643 / P645	M or later
P741 / P743	M or later
P742	L or later
P746	M or later
P841	M or later
P849	M or later

Software Version:

P14x (P141/P142/P143/P145)	B5 or later
P24x (P241 / P242 / P243)	D1 or later
P341	B3 / E3 or later
P342 / P343 / P344 / P345 / P391	B3 or later
P445	K1 or later
P44x (P442 / P444)	E3 or later
P44y (P443/P446)	K1 or later
P54x (P543/P544/P545/P546)	K1 or later
P64x (P642 / P643 / P645)	B4 or later
P74x (P741 / P742 / P743)	B1 or later
P746_1 / P746_2	B5 / C5 or later
P841A / P841B	L1 / K1 or later
P849	B2 or later

Connection Diagrams:	This chapter list the connection diagram for the product:
-----------------------------	---

P14x (P141, P142, P143 & P145):	10P141xx (xx = 01 to 02) 10P142xx (xx = 01 to 05) 10P143xx (xx = 01 to 11) 10P145xx (xx = 01 to 11)
P24x (P241, P242 & P243):	10P241xx (xx = 01 to 02) 10P242xx (xx = 01) 10P243xx (xx = 01)
P34x (P342, P343, P344, P345 & P391)	10P342xx (xx = 01 to 17) 10P343xx (xx = 01 to 19) 10P344xx (xx = 01 to 12) 10P345xx (xx = 01 to 07) 10P391xx (xx = 01 to 02)
P445:	10P445xx (xx = 01 to 04)
P44x (P442 & P444):	10P44201 (SH 1 & 2) 10P44202 (SH 1) 10P44203 (SH 1 & 2) 10P44401 (SH 1) 10P44402 (SH 1) 10P44403 (SH 1 & 2) 10P44404 (SH 1) 10P44405 (SH 1) 10P44407 (SH 1 & 2)
P44y:	10P44303 (SH 01 and 03) 10P44304 (SH 01 and 03) 10P44305 (SH 01 and 03) 10P44306 (SH 01 and 03) 10P44600 10P44601 (SH 1 to 2) 10P44602 (SH 1 to 2) 10P44603 (SH 1 to 2)
P54x (P543, P544, P545 & P546):	10P54302 (SH 1 to 2) 10P54303 (SH 1 to 2) 10P54304 (SH 1 to 2) 10P54400 10P54404 (SH 1 to 2) 10P54405 (SH 1 to 2) 10P54502 (SH 1 to 2) 10P54503 (SH 1 to 2) 10P54504 (SH 1 to 2) 10P54600 10P54604 (SH 1 to 2) 10P54605 (SH 1 to 2) 10P54606 (SH 1 to 2)
P547:	10P54702xx (xx = 01 to 02) 10P54703xx (xx = 01 to 02) 10P54704xx (xx = 01 to 02) 10P54705xx (xx = 01 to 02)
P64x (P642, P643 & P645):	10P642xx (xx = 1 to 10) 10P643xx (xx = 1 to 6) 10P645xx (xx = 1 to 9)
P74x:	10P740xx (xx = 01 to 07)

P746:	10P746xx (xx = 00 to 21)
P841:	10P84100 10P84101 (SH 1 to 2) 10P84102 (SH 1 to 2) 10P84103 (SH 1 to 2) 10P84104 (SH 1 to 2) 10P84105 (SH 1 to 2)
P849:	10P849xx (xx = 01 to 06)

CONTENTS

1. Parallel Redundancy Protocol (PRP) Notes	7
1.1 Introduction to PRP.....	7
1.2 Protocols.....	7
1.3 PRP Summary (IEC 62439-3 Clause 4).....	7
1.4 Example of a PRP Network.....	7
1.5 PRP Network Structure.....	8
1.6 Structure of a DAN.....	9
1.7 Communication between SANs and DANs.....	10
1.8 PRP Technical Data.....	12
2. PRP and MiCOM Functions	13
2.1 MiCOM Products and PRP.....	13
2.2 Easergy Studio and the PRP Function.....	13
2.3 MiCOM Relay Configuration and the PRP Function.....	13
2.4 Hardware Changes for PRP Protocol.....	13
2.5 PRP Parameters.....	14
2.6 Product Implementation Features.....	14
2.7 Abbreviations and Acronyms.....	15

TABLES

Table 1 - Hardware option numbers for PRP options.....	13
Table 2 - PRP parameter values (for PRP Protocol Version 1).....	14

FIGURES

Figure 1 - PRP Redundancy Network.....	8
Figure 2 - PRP example of general redundant network.....	9
Figure 3 - Communication between two DANs (in PRP).....	10
Figure 4 - Frames (basic, extended by an RCT and a VLAN tagged frame extended by RCT).....	12

Notes:

1. PARALLEL REDUNDANCY PROTOCOL (PRP) NOTES

1.1 Introduction to PRP

This section gives an introduction to the Parallel Redundancy Protocol (PRP); and how it is implemented on MiCOM-based products manufactured by Schneider Electric.

1.2 Protocols

Industrial real-time Ethernets typically need much better levels of availability and uninterrupted operation than normal office-type Ethernet solutions. For power networks, even a short loss of connectivity may result in a significant loss of functionality or impaired safety. To recover from a network failure, various redundancy schemes have been considered, including Parallel Redundancy Protocol (**PRP**). The key properties of this protocol are as follows:

PRP

This does not change the active topology as it uses two independent networks. Each message is replicated and sent over both networks. The first network node to receive it acts on it, with all later copies of the message being discarded. Importantly, these details are controlled by the low-level PRP layer of the network architecture, with the two networks being hidden from the higher level layers. Consequently, PRP-based networks are continuously available.

Power networks need to be able to respond to problems very quickly (typically in less than 10ms), and this is an available protocol which is robust enough to achieve this. This protocol is used in the MiCOM relay/IED and is defined in the IEC62439-3 (2016) standard and is configured using the existing redundant Ethernet card(s).

1.3 PRP Summary (IEC 62439-3 Clause 4)

A summary of the main PRP features is given below:

- Ethernet redundancy method independent of any industrial Ethernet protocol and typically used in a ring topology
 - Seamless switchover and recovery in case of failure, which supports real-time communication
 - Supervises redundancy continuously for better management of network devices
 - Suitable for hot swap, 24 hour/365 day operation in substations
 - Allows laptops and workstations to be connected to the network with standard Ethernet adapters (on double or single attached nodes)
 - Particularly suited for substation automation, high-speed drives and transportation
-

1.4 Example of a PRP Network

Essentially a PRP network is a pair of similar Local Area Networks (LANs) which can be any topology (tree, ring or mesh). An example of a PRP network is shown in this diagram:

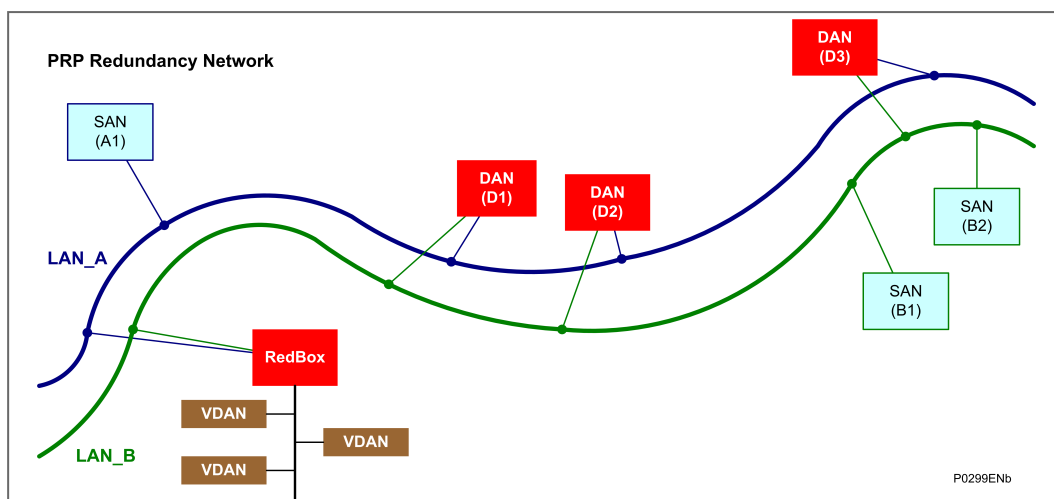

Figure 1 - PRP Redundancy Network

This shows two similar Local Area Networks (LANs) which have various Nodes in common. The key features of these networks include:

- With the exception of a RedBox (see below), no direct cable connections can be made between the two LANs.
- Each of these LANs can have one or more Single Attached Nodes (SANs). These are normally non-critical devices that are attached only to a single network. SANs can talk to one another, but only if they are on the same LAN.
- Matched pairs of devices which are critical to the operation of the overall scheme are connected one to each network as Doubly Attached Nodes (DANs).
- To be sure that network messages (also known as frames) are transferred correctly to each DAN, each DAN must have the same Media Access Control (MAC) code and Internet Protocol (IP) address. This will also mean that TCP/IP traffic will automatically communicate with both of the paired devices, so it will be unaware of any two-layer redundancy or frame duplication issues.
- A Redundancy Box (RedBox) is used when a single interface node has to be connected to both networks. The RedBox can talk to all other nodes. So far as other nodes are concerned, the RedBox behaves like a DAN, so a SAN that is connected through a RedBox is also called a Virtual Doubly Attached Node (VDAN). The RedBox must have its own unique IP address.
- Transmission delays can be different between related Nodes of the two LANs.
- Each LAN (i.e. LAN_A and LAN_B) must be powered from a different power source and must be failure independent.

The two LANs can differ in terms of performance and topology. The redundant Ethernet interface can be made using an optical fiber connection with an LC or ST connector type or with RJ45 copper connector type. There is no need for an optical interface away from the relay.

1.5 PRP Network Structure

PRP uses two independent LANs. The topology of each of these LANs is arbitrary, and ring, star, bus and meshed topologies are possible.

The main advantage of PRP is loss-free data transmission with an active (transit) LAN. When the terminal device receives no packets from one of the LANs, the second (transit) LAN maintains the connection. As long as 1 (transit) LAN is available, repairs and maintenance on the other (transit) LAN have no impact on the data packet transmission.

The elementary devices of a PRP network are known as RedBox (Redundancy Box) and DANP (Double Attached Node implementing PRP).

Both devices have one connection each to the (transit) LANs.

The devices in the (transit) LAN are conventional switches that do not require any PRP support. The devices transmit PRP data packets transparently, without evaluating the RCT information.

Terminal devices that are connected directly to a device in the (transit) LAN are known as SAN (Single Attached Node). If there is an interruption, these terminal devices cannot be reached via the redundant line. To use the uninterruptible redundancy of the PRP network, you integrate your device into the PRP network via a RedBox.

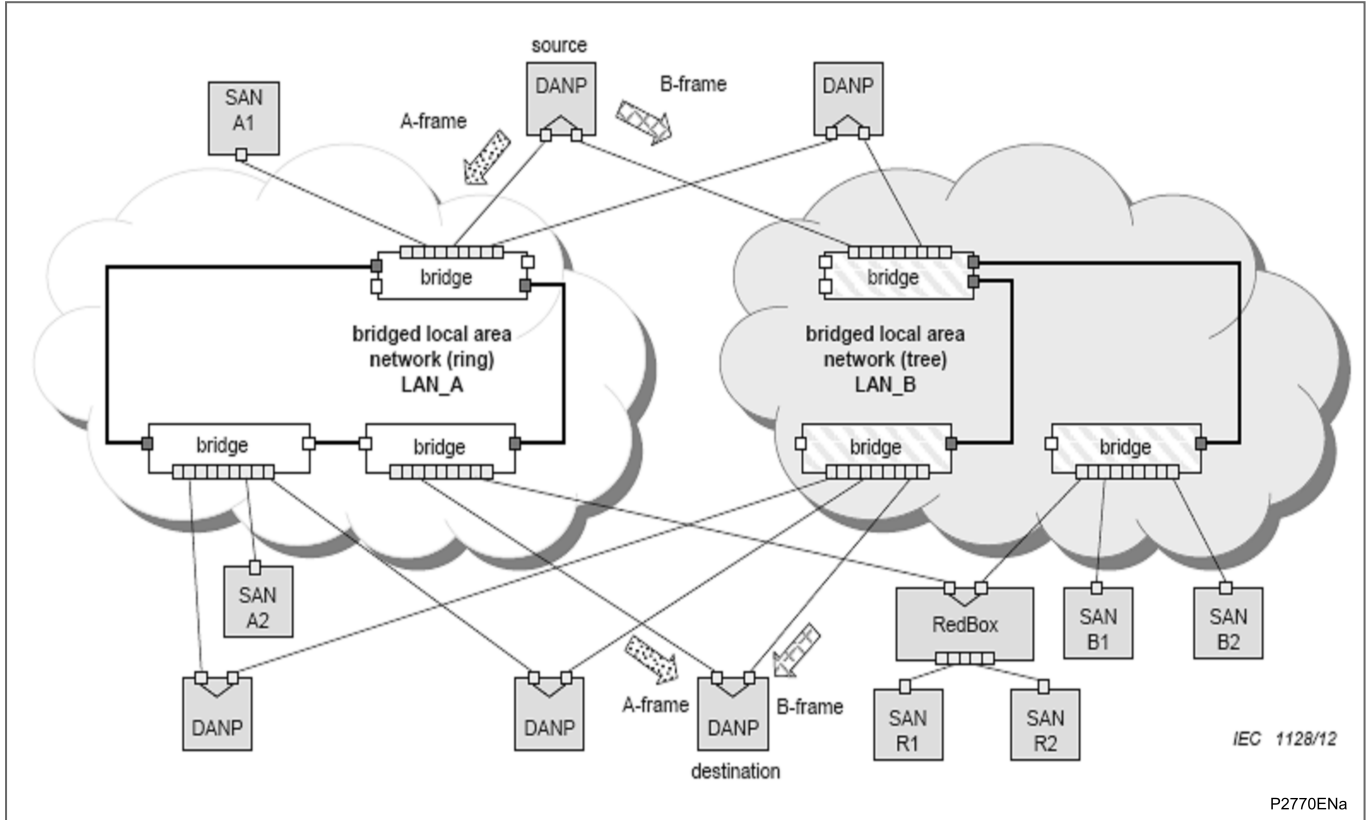

Figure 2 - PRP example of general redundant network

1.6 Structure of a DAN

A MiCOM P40 relay working in PRP Mode works as a DAN within the overall network topology. Each DAN has two ports that operate in parallel. They are attached to the upper layers of the communications stack through the Link Redundancy Entity (LRE) as shown here:

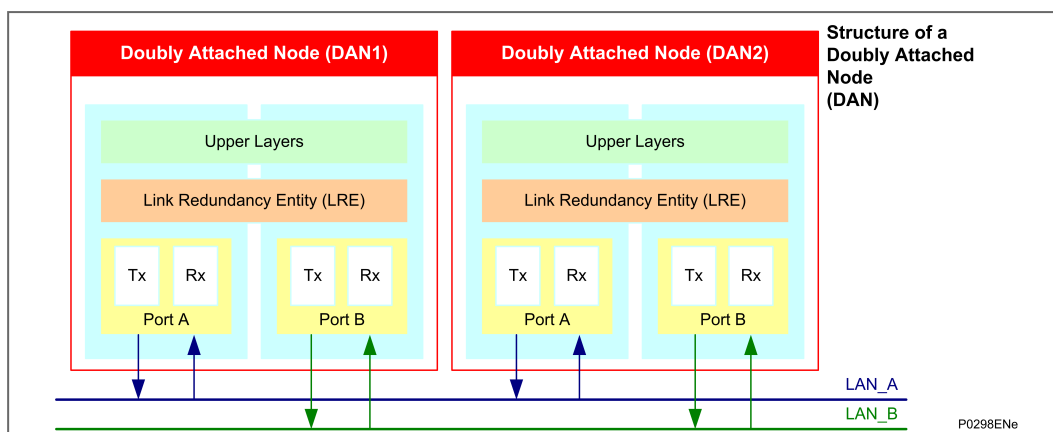

Figure 3 - Communication between two DANs (in PRP)

The LRE has two main tasks:

- handling message frames and
- management of redundancy

When an upper layer sends a frame to the LRE, the LRE replicates the frame and sends it through both its ports at nearly the same time. The two frames move through the two LANs with slightly different delays, ideally arriving at the destination node within a small time window.

When receiving frames, the LRE forwards the first frame it received to its upper layers and then discards the duplicate.

As both DAN nodes have the same MAC and IP addresses, this makes redundancy transparent to the upper layers. This allows the Address Resolution Protocol (ARP) to work in the same way as with a SAN. Accordingly, to the upper layers of a DAN, the LRE layer shows the same interface as the network adapter of a non-redundant adapter.

To manage redundancy, the LRE:

- Adds a 32-bit Redundancy Check Tag (RCT) to each frame it sends and
- Removes the RCT from each frame it receives

1.7 Communication between SANs and DANs

A SAN can be connected to any LAN and can communicate with any other SAN on the same LAN or any DAN. However, a SAN which connected to one LAN can not communicate directly to a SAN which is connected to the other LAN.

A DAN is connected to both LANs and can communicate with any RedBox or any other DANs or any SANs on either network. For communication purposes, a DAN “views” a SAN connected through a RedBox as a VDAN.

When a SAN generates a basic frame, it sends the frame only onto the LAN to which it is connected.

Originating at the SAN, a typical frame contains these parameters:

- dest_addr = Destination Address
- src_addr = Source Address
- type = Type
- data
- fcs = Frame Check Sequence (i.e. extra checksum characters added to allow error detection and correction)

The frame from the SAN is then received by the DAN; which sends the frame to its upper layers, which act accordingly.

When a DAN generates a frame, it needs to send the frame onto both of the LANs to which it is connected. When it does this, it extends the frame by adding the 48-bit Redundancy Control Trailer (RCT) into the frame.

The RCT consists of these parameters:

- 16-bit Sequence Number
- 4-bit LAN identifier, 1010 (0xA) for LAN_A and 1011 (0xB) for LAN_B
- 12-bit frame size
- PRP suffix

Note

The Sequence number is a measure of the number of messages which have been sent since the last system reset. Each time the link layer sends a frame to a particular destination the sender increases the sequence number corresponding to that destination and sends the (nearly) identical frames over both LANs.

Accordingly, originating at the DAN, a typical frame then contains these parameters:

- dest_addr = Destination Address
- src_addr = Source Address
- type = Type
- lsd_u = Link Service Data Unit
- Padding = if needed
- RCT data:
 - 16-bit sequence number:
 - 4-bit LAN identifier
 - 12-bit frame size
 - 16-bit PRP suffix (0X88 0XFB)
- fcs Frame Check Sequence

LSDU

The Link Service Data Unit (LSDU) data allows PRP frames to be distinguished from none-PRP frames.

Padding

After the LSDU data, there may be some data padding. This is added to frames which would otherwise be too short for conventional network traffic (minimum frame size is 64 octets).

Size

The frame size will vary depending on the contents of the frame and how it has been tagged by the various SANs and DANs. In VLANs, frame tags may be added or removed during transit through a switch. To make the length field independent of tagging, only the LSDU and the RCT are considered in the size.

The following diagrams shows the frame types with different types of data.

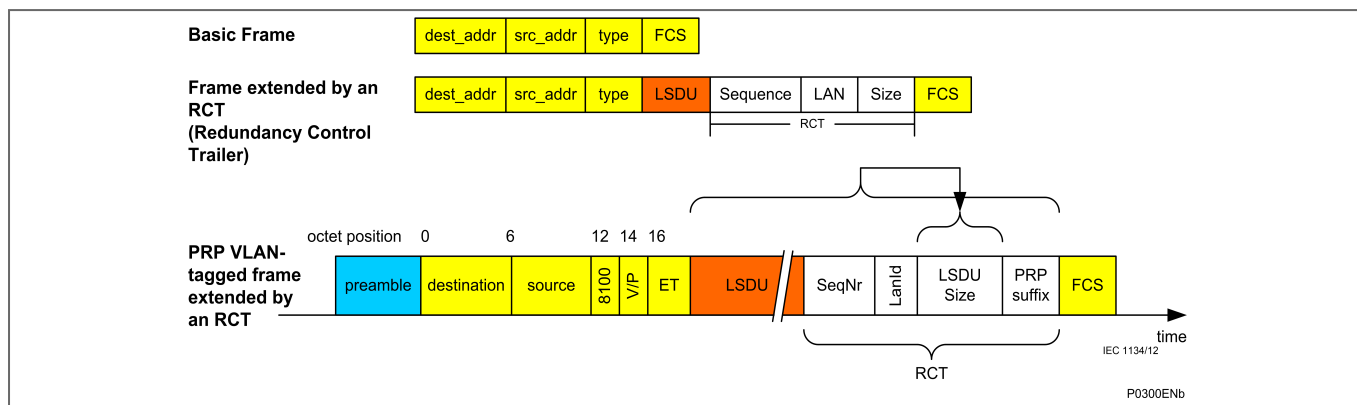

Figure 4 - Frames (basic, extended by an RCT and a VLAN tagged frame extended by RCT)

The key points about these differing frame structures is that:

- SANs do not implement any redundancy features, so they generate basic frames which SANs and DANs can understand.
- SANs can still understand the frames that come from DANs, as SANs ignore the RCT components in frames which come from DANs (a SAN cannot distinguish the RCT from the IEEE802.3 padding)
- If a DAN receives a frame which does not include the RCT component, it sends a single copy of the frame to its upper layers.
- If a DAN receives a frame which does include the RCT component, it does not send a duplicate copy of the frame to its upper layers.
- If a DANP cannot identify that the remote Node is a DAN, it inserts no RCT.

When using a Single Attached Nodes connected to the IED, a redbox is suggested to handle the case when the TPDU size for the client has been set above than 1024.

1.8 PRP Technical Data

- One VLAN tag supported
- Up to 128 devices supported
- Up to 100Mbit/s full duplex Ethernet
- Dynamic frame memory allocation (page manager)
- Configurable duplicate detection
- Wishbone interface for configuration and status registers
- CPU port interface - Ethernet or Wishbone
- Support for link-local protocols - CPU may send to specific ports only - CPU knows receive port
- Configurable frame memory and queue length
- Duplicate detection with configurable size and aging time
- MAC address filtering (8 filter masks for interlink port, 6 for CPU port)
- Support for interfaces with or without Ethernet preamble

Maximum Transmission Unit

According to the IEC 8802-3, the MTU (Ethernet maximum packet size) is:

- 1518 bytes without VLAN and without PRP
- 1522 bytes with VLAN and without PRP
- 1524 bytes without VLAN and with PRP
- 1528 bytes with VLAN and with PRP

Note

Check that the LAN switches setting for the MTU is at least 1528 bytes

2. PRP AND MICOM FUNCTIONS

2.1 MiCOM Products and PRP

The PRP functions being introduced as part of the overall MiCOM product range provide additional functionality, which is backwards compatible with existing Schneider Electric MiCOM equipment. This means that existing MiCOM relays/IEDs can be used on networks, which use PRP functions, with no changes being made to those relays/IEDs.

The new MiCOM products that use the PRP, will interrogate other equipment to determine the equipment model number, and then use the model number to decide (at runtime), whether that particular item of equipment can support PRP or not.

MiCOM models which include the following Ethernet board assembly provide the possibility of PRP function support. This is denoted by Digit 7 where the Hardware option is N, P, Q or R, as shown below:

Hardware Option	Type	Model No format
“N” at Digit No 7	2 ST ports redundant Ethernet board (Modulated IRIG-B)	Px4xxxNx6Mxxx8M
“P” at Digit No 7	2 ST ports redundant Ethernet board (Un-modulated IRIG-B)	Px4xxxPx6Mxxx8M
“Q” at Digit No 7	2 LC + 1 RJ45 ports redundant Ethernet board (Modulated/Un-modulated IRIG-B)	Px4xxxQx6Mxxx8M
“R” at Digit No 7	3 RJ45 ports redundant Ethernet board (Modulated/Un-modulated IRIG-B)	Px4xxxRx6Mxxx8M

Table 1 - Hardware option numbers for PRP options

The MiCOM relay/IED firmware has been modified to allow the PRP options to be accepted for the power-up tests in addition to the implementation of the supervision frame transmission.

2.2 Easergy Studio and the PRP Function

The addition of this function has no impact of the Easergy Studio support files so there is no need to upgrade any Easergy Studio software.

2.3 MiCOM Relay Configuration and the PRP Function

There is no need to change the configuration of any relay (as relays which include support for this function will be able to recognize other devices which support it).

2.4 Hardware Changes for PRP Protocol

This protocol is implemented using the existing redundant Ethernet and dual redundant Ethernet card as a starting point. The Frame management is achieved by re-programming the Field-Programmable Gate Array (FPGA).

The low-level management of the redundant frames is performed within the FPGA; this being defined as the Link Redundancy Entity (LRE). This will involve the addition of the Redundancy Check Tag (RCT) to a frame to be transmitted; this identifies the LAN and the sequence number of the message over the two networks. The FPGA is also responsible for the stripping of the RCT from received frames and discarding the duplicated messages such that only a single application frame is received by the Ethernet processor.

The LRE functionality of the supervision frame transmission is performed by the Ethernet processor card.

2.5 PRP Parameters

The Redundant Ethernet standard (IEC 62439-3:2012/FDIS) defines several parameters for the PRP protocol; these being fixed at a default value within this release. The following values are set:

Parameter	Value	Description
Supervision Frame Multicast Address	01-15-4E-00-01-00	Target MAC Address for multicast supervision frame.
Life Check Interval	2 seconds	Period between transmission of supervision frames.
PRP Mode	Duplicate Discard	This is normal PRP mode, Duplicate address will not be supported.
Node Forget Time	60 s	This is the time after which a node entry is cleared.
Entry Forget Time	400 ms	Duration that the received message Sequence number will be held to discard a duplicate message.
Node Reboot Interval	500ms	Duration following reboot for which no PRP frames should be transmitted

Table 2 - PRP parameter values (for PRP Protocol Version 1)

2.6 Product Implementation Features

Here is a list of the main Product Requirements for MiCOM products which support PRP:

- The MiCOM relay/IED provides two redundant Ethernet ports using PRP.
- The MiCOM relay/IED must be connected to the redundant Ethernet network as a Double Attached Node (DAN) using PRP (DAN using PRP is known as DANP)
- The redundant Ethernet interface can be made using an RJ45 or an optical fibre connection with an LC or ST connector type (Ethernet card dependent).
- The management of the PRP redundancy is transparent to the application data provided via the Ethernet interface.
- The PRP option is available with any of the existing protocol options via the Ethernet Interface (IEC61850 and/or DNPoE)
- Loss of one of the LAN connections to the device does not cause any loss or degradation to the Application data over the Ethernet interface.
- The MiCOM relay/IED supports the transmission of the PRP Supervision frame at a fixed time period (LifeCheckInterval) of 2s (+/- 100ms)
- Each supervision frame includes a sequence number as defined in the IEC 62439-3:2012 specification. This is incremented for each supervision message and the value starts from zero following a system restart.
- The MiCOM relay/IED does not process received supervision frames to provide supervision of the redundant network.
- The MiCOM relay/IED does not provide for the PRP management to be configured (via either the MiCOM relay/IED HMI or the Ethernet interface). Accordingly, the default values (as defined within this document) are used for all PRP parameters.
- The performance of the Ethernet Interface is not degraded by using the PRP interface.

2.7 Abbreviations and Acronyms

Abbreviations / Acronyms	Meaning
BPDU	Bridge Protocol Data Unit
CRC	Cyclic Redundancy Check
DAN	Doubly Attached Nodes
DANH	Doubly Attached Node implementing HSR
DANP	Doubly Attached Node implementing PRP
FPGA	Field-Programmable Gate Array
HMI	Human Machine Interface
HSR	High-availability Seamless Redundancy
IED	Intelligent Electronic Devices
IP	Internet Protocol
LAN	Local Area Network
LRE	Link Redundancy Entity
MAC	Media Access Control
MRP	Media Redundancy Protocol
PRP	Parallel Redundancy Protocol
RCT	Redundancy Check Tag
RedBox	Redundancy Box
RST BPDU	Rapid Spanning Tree BPDU
RSTP	Rapid Spanning Tree Protocol
SAN	Singly Attached Node
TCP	Transmission Control Protocol
VDAN	Virtual Doubly Attached Node

Notes:

HIGH-AVAILABILITY SEAMLESS REDUNDANCY (HSR) NOTES

CHAPTER 21

Applicability**Date:** 10/2022**Products covered by this chapter:**

This chapter covers the specific versions of the MiCOM products listed below.
This includes **only** the following combinations of Software Version and Hardware Suffix.

Hardware Suffix:

P141/P142/P143	L or later
P145	M or later
P241	L or later
P242 / P243	M or later
P341	L or later
P342	L or later
P343 / P344 / P345	M or later
P391	A or later
P44x (P442 / P444)	M or later
P44y (P443/P446)	M or later
P445	L or later
P54x (P543 / P544 / P545 / P546)	M or later
P642	L or later
P643 / P645	M or later
P741 / P743	M or later
P742	L or later
P746	M or later
P841	M or later
P849	M or later

Software Version:

P14x (P141/P142/P143/P145)	B5 or later
P24x (P241 / P242 / P243)	D1 or later
P341	B3 / E3 or later
P342 / P343 / P344 / P345 / P391	B3 or later
P445	K1 or later
P44x (P442 / P444)	E3 or later
P44y (P443/P446)	K1 or later
P54x (P543/P544/P545/P546)	K1 or later
P64x (P642 / P643 / P645)	B4 or later
P74x (P741 / P742 / P743)	B1 or later
P746_1 / P746_2	B5 / C5 or later
P841A / P841B	L1 / K1 or later
P849	B2 or later

Connection Diagrams: This chapter list the connection diagram for the product:

P14x (P141, P142, P143 & P145):	10P141xx (xx = 01 to 02) 10P142xx (xx = 01 to 05) 10P143xx (xx = 01 to 11) 10P145xx (xx = 01 to 11)
P24x (P241, P242 & P243):	10P241xx (xx = 01 to 02) 10P242xx (xx = 01) 10P243xx (xx = 01)
P34x (P342, P343, P344, P345 & P391)	10P342xx (xx = 01 to 17) 10P343xx (xx = 01 to 19) 10P344xx (xx = 01 to 12) 10P345xx (xx = 01 to 07) 10P391xx (xx = 01 to 02)
P445:	10P445xx (xx = 01 to 04)
P44x (P442 & P444):	10P44201 (SH 1 & 2) 10P44202 (SH 1) 10P44203 (SH 1 & 2) 10P44401 (SH 1) 10P44402 (SH 1) 10P44403 (SH 1 & 2) 10P44404 (SH 1) 10P44405 (SH 1) 10P44407 (SH 1 & 2)
P44y:	10P44303 (SH 01 and 03) 10P44304 (SH 01 and 03) 10P44305 (SH 01 and 03) 10P44306 (SH 01 and 03) 10P44600 10P44601 (SH 1 to 2) 10P44602 (SH 1 to 2) 10P44603 (SH 1 to 2)
P54x (P543, P544, P545 & P546):	10P54302 (SH 1 to 2) 10P54303 (SH 1 to 2) 10P54304 (SH 1 to 2) 10P54400 10P54404 (SH 1 to 2) 10P54405 (SH 1 to 2) 10P54502 (SH 1 to 2) 10P54503 (SH 1 to 2) 10P54504 (SH 1 to 2) 10P54600 10P54604 (SH 1 to 2) 10P54605 (SH 1 to 2) 10P54606 (SH 1 to 2)
P547:	10P54702xx (xx = 01 to 02) 10P54703xx (xx = 01 to 02) 10P54704xx (xx = 01 to 02) 10P54705xx (xx = 01 to 02)
P64x (P642, P643 & P645):	10P642xx (xx = 1 to 10) 10P643xx (xx = 1 to 6) 10P645xx (xx = 1 to 9)
P74x:	10P740xx (xx = 01 to 07)

P746:	10P746xx (xx = 00 to 21)
P841:	10P84100 10P84101 (SH 1 to 2) 10P84102 (SH 1 to 2) 10P84103 (SH 1 to 2) 10P84104 (SH 1 to 2) 10P84105 (SH 1 to 2)
P849:	10P849xx (xx = 01 to 06)

CONTENTS

1. Introduction to HSR	7
1.1 Introduction to High-Availability Seamless Redundancy (HSR)	7
1.2 Protocols	7
1.3 HSR Summary (IEC 62439-3 Clause 5)	7
1.4 Example of an HSR Network	7
1.5 Structure of a DAN	8
1.6 Structure of a RedBox	9
1.7 Communication between SANs, DANs and RedBoxes	9
1.8 HSR Technical Data	11
2. HSR and MiCOM Functions	13
2.1 MiCOM Products and HSR	13
2.2 Easergy Studio and the HSR Function	13
2.3 MiCOM Relay Configuration and the HSR Function	13
2.4 Hardware Changes for HSR Protocol	13
2.5 HSR Parameters	13
2.6 Product Implementation Features	14
2.7 Abbreviations and Acronyms	14

TABLES

Table 1 - Hardware option numbers with HSR functions	13
Table 2 - HSR parameter values.....	14

FIGURES

Figure 1 - HSR Redundancy Network.....	8
Figure 2 - DAN communication between two paths (in HSR).....	9
Figure 3 - HSR frame without a VLAN tag.....	11
Figure 4 - HSR frame with VLAN tag.....	11

Notes:

1. INTRODUCTION TO HSR

1.1 Introduction to High-Availability Seamless Redundancy (HSR)

This section gives an introduction to the High-availability Seamless Redundancy (HSR); and how it is implemented on MiCOM-based products manufactured by Schneider Electric.

1.2 Protocols

Industrial real-time Ethernets typically need much better levels of availability and uninterrupted operation than normal office-type Ethernet solutions. For power networks, even a short loss of connectivity may result in a significant loss of functionality or impaired safety. To recover from a network failure, various redundancy schemes have been considered, including High-availability Seamless Redundancy (**HSR**). The key properties of this protocol are as follows:

HSR

HSR basically uses ring topology, This Clause describes the application of the HSR principles (Clause 5) to implement a High-availability Seamless Redundancy (HSR), retaining the PRP property of zero recovery time, applicable to any topology, in particular rings and rings of rings. With respect to PRP, HSR allows to roughly halve the network infrastructure. With respect to rings based on IEEE 802.1D (RSTP), IEC 62439-2 (MRP), IEC 62439-6 (DRP) or IEC 62439-7 (RRP), the available network bandwidth for network traffic is somewhat reduced depending on the type of traffic. Nodes within the ring are restricted to be HSR-capable bridging nodes, thus avoiding the use of dedicated bridges. Singly Attached Nodes (SANs) such as laptops or printers cannot be attached directly to the ring, but need attachment through a RedBox (redundancy box).

Power networks need to be able to respond to problems very quickly (typically in less than 10ms), and this is an available protocol which is robust enough to achieve this. This protocol is used in the MiCOM relay/IED and is defined in the IEC62439-3 (2016) standard and is configured using the existing redundant Ethernet card(s).

1.3 HSR Summary (IEC 62439-3 Clause 5)

A summary of the main HSR features is given below:

- HSR Ethernet redundancy method independent of any industrial Ethernet protocol and typically used in a ring topology
 - Seamless switchover and recovery in case of failure, which supports real-time communication
 - Supervises redundancy continuously for better management of network devices
 - Suitable for hot swap, 24 hour/365 day operation in substations
 - Allows laptops and workstations to be connected to the network with HSR Redbox
 - Particularly suited for substation automation, high-speed drives and transportation
-

1.4 Example of an HSR Network

Essentially an HSR network is a ring topology. An example of an HSR network is shown in this diagram. This shows typical ring networks that have various Nodes in common.

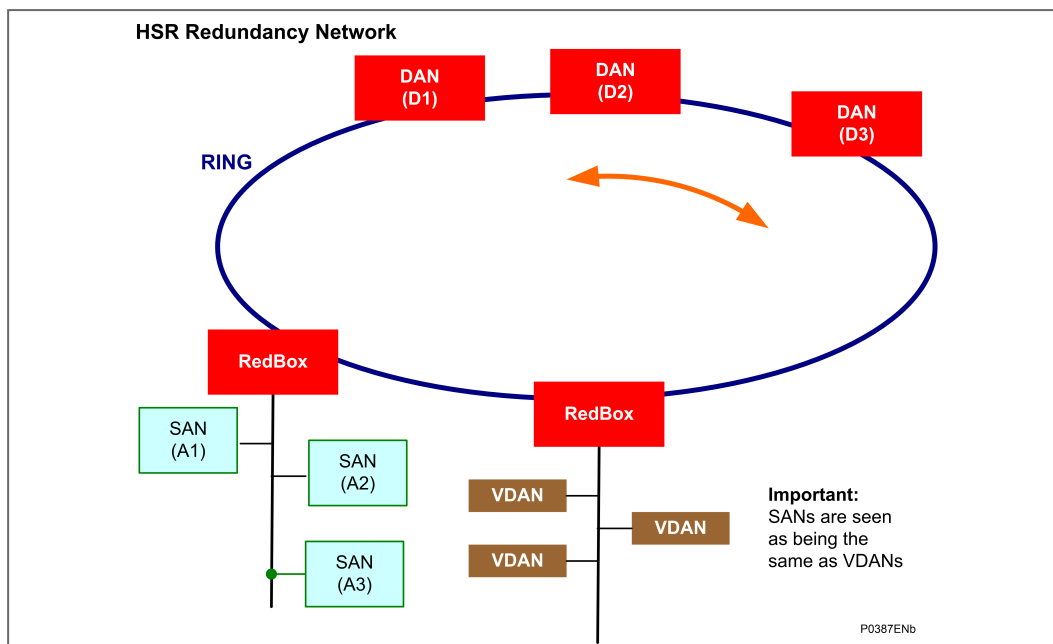

Figure 1 - HSR Redundancy Network

The key features of the network include:

- Nodes within the ring are restricted to be HSR-capable bridging nodes, thus avoiding the use of dedicated bridges
- Singly Attached Nodes (SANs) such as laptops or printers cannot be attached directly to the ring, but need attachment through a RedBox (redundancy box)
- A simple HSR network consists of doubly attached bridging nodes, each having two ports, interconnected by full-duplex link
- A source DANH sends a frame passed from its upper layers, prefixes it by an HSR tag to identify frame duplicates and sends the frame over each port
- A destination DANH receives, in the fault-free state, two identical frames from each port within a certain interval, if it is a multicast frame, it instantaneously forwards it on the ring (see Note *), removes the HSR tag of the first frame before passing it to its upper layers and discards any duplicate.

Note *

In particular, the node will not forward a frame that it injected into the ring.

Note *

A destination node of a unicast frame does not forward a frame for which it is the only destination, except for testing.

1.5 Structure of a DAN

A MiCOM P40 relay working in HSR Mode works as a DAN within the overall network topology. Each DAN has two ports that operate in parallel. As in the next diagram, the two HSR ports A and B and the device port C are connected by the LRE, which includes a switching matrix allowing to forward frames from one port to the other. The switching matrix allows cut-through bridging. The Link Redundancy Entity (LRE) presents to the higher layers the same interface as a standard Ethernet transceiver would do.

A source DANH sends a frame passed from its upper layers, and prefixes it by an HSR tag to identify frame duplicates and sends the frame over both ports.

A destination DANH receives, in the fault-free state, two identical frames from each port within a certain interval, if it is a multicast frame, it instantaneously forwards it on the ring*, removes the HSR tag of the first frame before passing it to its upper layers ("D"-frame) and discards any duplicate.

A typical frame contains these parameters:

- dest_addr = Destination Address
- src_addr = Source Address
- type = Type
- data
- fcs = Frame Check Sequence (i.e. extra checksum characters added to allow error detection and correction)

HSR frames are identified uniquely by their HSR tag.

The HSR tag consists of these parameters:

- 16-bit Ethertype (HSR_EtherType = 0x892F)
- 4-bit path identifier (PathId), 0000 for both HSR nodes A and B, and 0010-1111 for one of 7 PRP networks (A/B).
- 12-bit frame size (LSDUsize)
- 16-bit Sequence Number (SeqNr)

Accordingly, a typical HSR frame then contains these parameters:

- dest_addr = Destination Address
- src_addr = Source Address
- HSR tag data:
 - 16-bit Ethertype (HSR_EtherType = 0x892F)
 - 4-bit path identifier
 - 12-bit frame size
 - 16-bit sequence number:
- type = Type
- payload = Payload
- Padding = if needed
- fcs = Frame Check Sequence

Padding
After the payload data, there may be some data padding. This is added to frames which would otherwise be too short for conventional network traffic (minimum frame size is 70 octets).

Size
The frame size will vary depending on the contents of the frame and how it has been tagged by the various SANs and DANs. In VLANs, frame tags may be added or removed during transit through a switch. To make the length field independent of tagging, only the original LPDU and the HSR tag are considered in the size.

The following diagrams shows the frame types with different types of data.

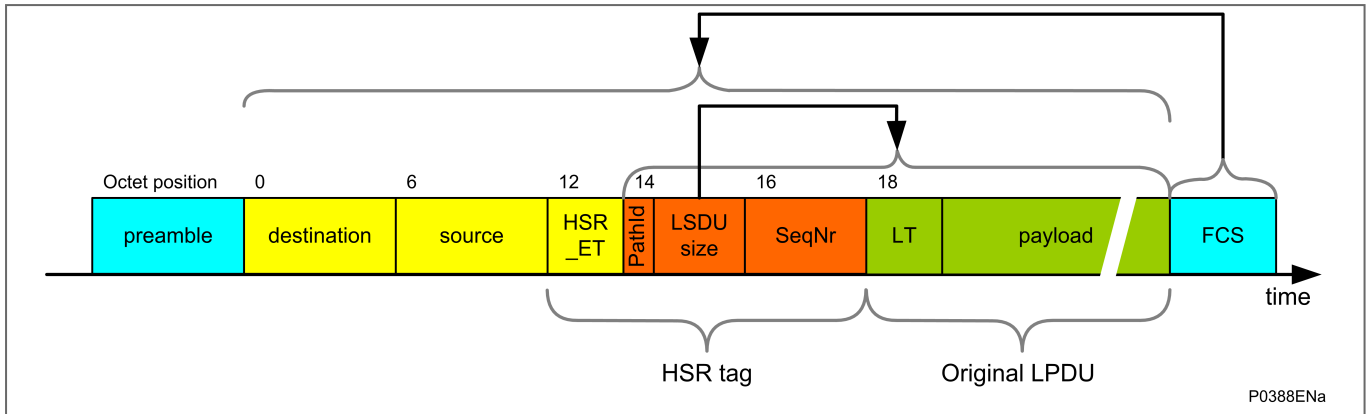
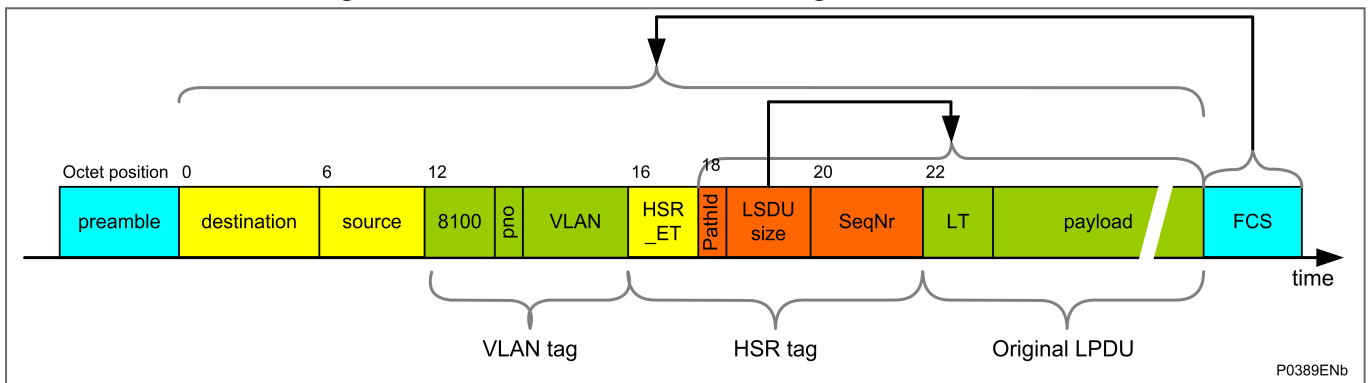
**Figure 3 - HSR frame without a VLAN tag****Figure 4 - HSR frame with VLAN tag**

The key points about these differing frame structures are that:

- Unlike PRP, SANs cannot be attached directly to such a duplicated network unless they are able to interpret the HSR tag.
- In particular, the node will not forward a frame that it injected into the ring.
- A destination node of a unicast frame does not forward a frame for which it is the only destination, except for testing.]
- DANH receiving from an HSR port, if this frame is not HSR-tagged and is a link local traffic, consume the frame and do not forward it.
- DANH receiving from an HSR port, if this frame is HSR-tagged and this node is not a destination, do not pass the frame to the link layer interface.
- A node accepts an HSR tagged frame also if the LanId does not correspond to the PortId and if the LSDUsize does not match the frame size.

1.8 HSR Technical Data

- One VLAN tag supported
- Up to 128 devices supported
- Up to 100Mbit/s full duplex Ethernet
- Dynamic frame memory allocation (page manager)
- Configurable duplicate detection
- Wishbone interface for configuration and status registers
- CPU port interface - Ethernet or Wishbone
- Support for link-local protocols - CPU may send to specific ports only - CPU knows receive port
- Configurable frame memory and queue length
- Duplicate detection with configurable size and aging time

- MAC address filtering (8 filter masks for interlink port, 6 for CPU port)
- Support for interfaces with or without Ethernet preamble

Limitations:

Number of IEDs on a same ring at 100Mbit/s:

Each hop (IED or RedBox) not only carries its own messages but also all the other IED messages thus the bandwidth used is proportional to the number of IEDs.

The maximum number of hops is around 20 when the GOOSE messages are highly used or 40 if the number and importance of GOOSE messages is not high.

When Precision Time Protocol («IEEE1588/IEC 61588») is used:

As the GPS receiver inaccuracy is 200ns and as each hop (IED or RedBox) can add a 50ns inaccuracy, the maximum number of hops is 16 if 1µs accuracy is required (PMU application or Process Bus)

2. HSR AND MICOM FUNCTIONS

2.1 MiCOM Products and HSR

The HSR functions being introduced as part of the overall MiCOM product range provide additional functionality, which is backwards compatible with existing Schneider Electric MiCOM equipment. This means that existing MiCOM relays/IEDs can be used on networks, which use HSR functions, with no changes being made to those relays/IEDs.

The new MiCOM products that use the HSR, will interrogate other equipment to determine the equipment model number, and then use the model number to decide (at runtime), whether that particular item of equipment can support HSR or not. MiCOM models which include the following Ethernet board assembly provide the possibility of HSR function support. This is denoted by Digit 7 where the Hardware option is Q or R, as shown below:

Hardware Option	Type	Model No format
“Q” at Digit No 7	2 LC + 1 RJ45 ports redundant Ethernet board (Modulated/ Un-modulated IRIG-B)	Px4xxxQx6Mxxx8M
“R” at Digit No 7	3 RJ45 ports redundant Ethernet board (Modulated/ Un-modulated IRIG-B)	Px4xxxRx6Mxxx8M

Table 1 - Hardware option numbers with HSR functions

The MiCOM relay/IED firmware has been modified to allow the HSR options to be accepted for the power-up tests in addition to the implementation of the supervision frame transmission.

2.2 Easergy Studio and the HSR Function

The addition of this function has no impact of the Easergy Studio support files so there is no need to upgrade any Easergy Studio software.

2.3 MiCOM Relay Configuration and the HSR Function

There is no need to change the configuration of any relay (as relays which include support for this function will be able to recognize other devices which support it).

2.4 Hardware Changes for HSR Protocol

This protocol is implemented using the redundant Ethernet card as a starting point. The Frame management is achieved by programming the Field-Programmable Gate Array (FPGA).

The low-level management of the redundant frames is performed within the FPGA; this being defined as the Link Redundancy Entity (LRE). This will add the HSR tag to a frame to be transmitted. The FPGA is also responsible for the stripping of the HSR tag from received frames and discarding the duplicated messages so that only a single application frame is received by the Ethernet processor.

The LRE functionality of the supervision frame transmission is performed by the NIOS II.

The new version of the redundant Ethernet card is based on the 2072069A01 and 2072071A01 (both have modulated and un-modulated IRIG-B).

2.5 HSR Parameters

The Redundant Ethernet standard (IEC 62439-3:2012/FDIS) defines several parameters for the HSR protocol; these being fixed at a default value within this release. The following

values are set:

Parameter	Value	Description
Supervision Frame Multicast Address	01-15-4E-00-01-00	Target MAC Address for multicast supervision frame.
Life Check Interval	2 seconds	Period between transmission of supervision frames.
HSR Mode	Duplicate Discard	This is normal HSR mode, Duplicate address will not be supported.
Node Forget Time	60 s	This is the time after which a node entry is cleared.
Entry Forget Time	400 ms	Duration that the received message Sequence number will be held to discard a duplicate message.
Node Reboot Interval	500ms	Duration following reboot for which no HSR frames should be transmitted
MulticastFilterSize	16	Number of multicast addresses to be filtered

Table 2 - HSR parameter values

2.6 Product Implementation Features

Here is a list of the main Product Requirements for MiCOM products that support HSR:

- The MiCOM relay/IED provides two redundant Ethernet ports using HSR.
- The MiCOM relay/IED must be connected to the redundant Ethernet network as a Double Attached Node (DAN) using HSR (DAN using HSR is known as DANH)
- The redundant Ethernet interface can be made using an RJ45 or an optical fibre connection with an LC connector type.
- The management of the HSR redundancy is transparent to the application data provided via the Ethernet interface.
- The HSR option is available with any of the existing protocol options via the Ethernet Interface (IEC61850)
- Loss of one of the Node connections to the device does not cause any loss or degradation to the Application data over the Ethernet interface.
- The MiCOM relay/IED supports the transmission of the HSR Supervision frame at a fixed time period (LifeCheckInterval) of 2s (+/- 100ms)
- Each supervision frame includes a sequence number as defined in the IEC 62439-3:2012/FDIS specification. This will be incremented for each supervision message and the value will start from zero following a system restart.
- The MiCOM relay/IED does not provide for the HSR management to be configured (via either the MiCOM relay/IED HMI or the Ethernet interface). Accordingly, the default values (as defined within this document) are used for all HSR parameters.
- The performance of the Ethernet Interface is not degraded by using the HSR interface.

2.7 Abbreviations and Acronyms

Abbreviations / Acronyms	Meaning
BPDU	Bridge Protocol Data Unit
CRC	Cyclic Redundancy Check
DAN	Doubly Attached Nodes

Abbreviations / Acronyms	Meaning
DANH	Doubly Attached Node implementing HSR
DANP	Doubly Attached Node implementing PRP
FPGA	Field-Programmable Gate Array
HMI	Human Machine Interface
HSR	High-availability Seamless Redundancy
IED	Intelligent Electronic Devices
IP	Internet Protocol
LAN	Local Area Network
LRE	Link Redundancy Entity
MAC	Media Access Control
MRP	Media Redundancy Protocol
PRP	Parallel Redundancy Protocol
RCT	Redundancy Check Tag
RedBox	Redundancy Box
RST BPDU	Rapid Spanning Tree BPDU
RSTP	Rapid Spanning Tree Protocol
SAN	Singly Attached Node
TCP	Transmission Control Protocol
VDAN	Virtual Doubly Attached Node

Notes:

RAPID SPANNING TREE PROTOCOL (RSTP) NOTES

CHAPTER 22

Applicability**Date:** 10/2022**Products covered by this chapter:**

This chapter covers the specific versions of the MiCOM products listed below. This includes **only** the following combinations of Software Version and Hardware Suffix.

Hardware Suffix:

P141/P142/P143	L or later
P145	M or later
P445	L or later
P44x (P442/P444)	M or later
P44y (P443/P446)	M or later
P54x (P543/P544/P545/P546)	M or later
P642	L or later
P643/P645	M or later
P746	M or later
P841A (one circuit breaker)	M or later
P841B (two circuit breakers)	M or later
P342	L or later
P343/P344/P345	M or later
P849	M or later

Software Version:

P14x (P141/P142/P143/P145)	B5 or later
P445	K1 or later
P44x (P442/P444)	E3 or later
P44y (P443/P446)	K1 or later
P54x (P543/P544/P545/P546)	K1 or later
P64x (B642/P643/P645)	B4 or later
P746	B5/C5 or later
P841A (one circuit breaker)	L1 or later
P841B (two circuit breakers)	K1 or later
P342/P343/P344/P345	B5 or later
P849	B4 or later

Connection Diagrams: This chapter list the connection diagram for the product:

P14x (P141, P142, P143 & P145):	10P141xx (xx = 01 to 02) 10P142xx (xx = 01 to 05) 10P143xx (xx = 01 to 11) 10P145xx (xx = 01 to 11)
P445:	10P445xx (xx = 01 to 04)
P44x (P442 & P444):	10P44201 (SH 1 & 2) 10P44202 (SH 1)

	10P44203 (SH 1 & 2) 10P44401 (SH 1) 10P44402 (SH 1) 10P44403 (SH 1 & 2) 10P44404 (SH 1) 10P44405 (SH 1) 10P44407 (SH 1 & 2)
P44y:	10P44303 (SH 01 and 03) 10P44304 (SH 01 and 03) 10P44305 (SH 01 and 03) 10P44306 (SH 01 and 03) 10P44600 10P44601 (SH 1 to 2) 10P44602 (SH 1 to 2) 10P44603 (SH 1 to 2)
P54x (P543, P544, P545 & P546):	10P54302 (SH 1 to 2) 10P54303 (SH 1 to 2) 10P54304 (SH 1 to 2) 10P54400 10P54404 (SH 1 to 2) 10P54405 (SH 1 to 2) 10P54502 (SH 1 to 2) 10P54503 (SH 1 to 2) 10P54504 (SH 1 to 2) 10P54600 10P54604 (SH 1 to 2) 10P54605 (SH 1 to 2) 10P54606 (SH 1 to 2)
P547:	10P54702xx (xx = 01 to 02) 10P54703xx (xx = 01 to 02) 10P54704xx (xx = 01 to 02) 10P54705xx (xx = 01 to 02)
P64x (P642, P643 & P645):	10P642xx (xx = 1 to 10) 10P643xx (xx = 1 to 6) 10P645xx (xx = 1 to 9)
P746:	10P746xx (xx = 00 to 21)
P841:	10P84100 10P84101 (SH 1 to 2) 10P84102 (SH 1 to 2) 10P84103 (SH 1 to 2) 10P84104 (SH 1 to 2) 10P84105 (SH 1 to 2)
P34x (P342, P343, P344, P345 & P391)	10P342xx (xx = 01 to 17) 10P343xx (xx = 01 to 19) 10P344xx (xx = 01 to 12) 10P345xx (xx = 01 to 07) 10P391xx (xx = 01 to 02)
P849:	10P849xx (xx = 01 to 06)

Notes:

CONTENTS

1. Rapid Spanning Tree Protocol (RSTP) Notes	7
1.1 Introduction to RSTP.....	7
1.2 Protocols.....	7
1.3 Example of an RSTP Network.....	7
2. RSTP and MiCOM Functions	8
2.1 MiCOM Products and RSTP.....	8
2.2 Easergy Studio and the RSTP Function.....	8
2.3 MiCOM Relay Configuration and the RSTP Function.....	8
2.4 Hardware Changes for RSTP Protocol.....	8
2.5 RSTP Parameters.....	8
2.6 Product Implementation Features.....	9
2.7 Abbreviations and Acronyms.....	10

TABLES

Table 1 - Hardware option numbers with RSTP functions	8
---	---

FIGURES

Figure 1 - Px4x attached to a redundant Ethernet star or ring circuit	7
---	---

Notes:

1. RAPID SPANNING TREE PROTOCOL (RSTP) NOTES

1.1 Introduction to RSTP

This section gives an introduction to the Rapid Spanning Tree Protocol (RSTP); and how it is implemented on MiCOM-based products manufactured by Schneider Electric.

1.2 Protocols

Industrial real-time Ethernets typically need much better levels of availability and uninterrupted operation than normal office-type Ethernet solutions. For power networks, even a short loss of connectivity may result in a significant loss of functionality or impaired safety. To recover from a network failure, various redundancy schemes have been considered, including Rapid Spanning Tree Protocol (**RSTP**). The key properties of this protocol are as follows:

RSTP

This uses mesh-based topologies or ring topology and computes a tree, based on path costs and priorities. In case of network failure, a typical reset time for RSTP-based system is normally a few seconds.

Power networks need to be able to respond to problems very quickly (typically in less than 10ms), and this is an available protocol which is robust enough to achieve this. This protocol is used in the MiCOM relay/IED and is defined in the IEC62439-3 (2016) standard and is configured using the existing redundant Ethernet card(s).

1.3 Example of an RSTP Network

The Px4x Redundant Ethernet board uses the RSTP protocol (IEEE 802.1D-2004, chapter 17), so a Px4x can attach onto a network as shown in this diagram.

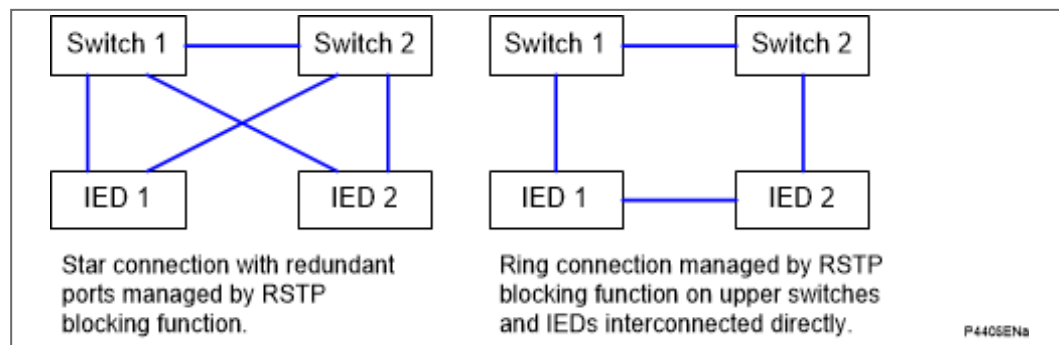

Figure 1 - Px4x attached to a redundant Ethernet star or ring circuit

The RSTP solution is based on open standards. It is therefore compatible with other manufacturers' IEDs that use the RSTP protocol. The RSTP recovery time is some tenth of ms in case of physical link failure (depend of network size and topology) and 3 HelloTime (usually 3x2s) in case of fault without link failure, but it increases with network size.

2. RSTP AND MICOM FUNCTIONS

2.1 MiCOM Products and RSTP

The RSTP functions being introduced as part of the overall MiCOM product range provide additional functionality, which is backwards compatible with existing Schneider Electric MiCOM equipment. This means that existing MiCOM relays/IEDS can be used on networks, which use RSTP functions, with no changes being made to those relays/IEDS.

The new MiCOM products that use the RSTP, will interrogate other equipment to determine the equipment model number, and then use the model number to decide (at runtime), whether that particular item of equipment can support RSTP or not. MiCOM models which include the following Ethernet board assembly provide the possibility of RSTP function support. This is denoted by Digit 7 where the Hardware option is Q or R, as shown below:

Hardware Option	Type	Model No format
“Q” at Digit No 7	2 LC + 1 RJ45 ports redundant Ethernet board (Modulated/ Un-modulated IRIG-B)	Px4xxx Q x6Mxxx8M
“R” at Digit No 7	3 RJ45 ports redundant Ethernet board (Modulated/ Un-modulated IRIG-B)	Px4xxx R x6Mxxx8M

Table 1 - Hardware option numbers with RSTP functions

The MiCOM relay/IED firmware has been modified to allow the RSTP options to be accepted for the power-up tests in addition to the implementation of the supervision frame transmission.

2.2 Easergy Studio and the RSTP Function

The addition of this function has no impact of the Easergy Studio support files so there is no need to upgrade any Easergy Studio software.

2.3 MiCOM Relay Configuration and the RSTP Function

There is no need to change the configuration of any relay (as relays which include support for this function will be able to recognize other devices which support it).

2.4 Hardware Changes for RSTP Protocol

This protocol is implemented using the redundant Ethernet card as a starting point. The Frame management is achieved by programming the Field-Programmable Gate Array (FPGA).

RSTP doesn't add a tag to the frame (unlike HSR or PRP), but uses low-level peer-to-peer dialog (RST BPDU) to enable or not a point-to-point link, so that there is no loop inside the network.

There is no supervision frame in RSTP, but there is a dedicated peer-to-peer dialog between ethernet ports.

The new version of the redundant Ethernet card is based on the 2072069A01 and 2072071A01 (both have modulated and un-modulated IRIG-B).

2.5 RSTP Parameters

You can use the following settings to configure the RSTP function. The IEEE 802.1D 2004 standard defines the relation between Max Age and Forward Delay as:

$$2 * (\text{Forward Delay} - 1.0 \text{ seconds}) \geq \text{Max Age}$$

RSTP Settings

RSTP Settings	Value	Description
COMMUNICATIONS		
RSTPPriority	0 to 61440 with step 4096	Bridge Priority
RSTPMaxAge	6.0 to 40.0 with step 0.1	The max age time of RSTP
RSTPForwardDelay	4.0 to 30.0 with step 0.1	The timer of the RSTP forward delay
RSTPHelloTime	1.0 to 2.0 with step 0.1	The RSTP hello time settings

RSTP Status

RSTP Status	Value	Description
COMMUNICATIONS		
RSTPPortAStatus	FORWARDING, DISCARDING, DISABLED	The status RSTP Port A
RSTPPortBStatus	FORWARDING, DISCARDING, DISABLED	The status RSTP Port B

Notes

These two parameters are only visible on front panel (HMI).
The following relays do not use any independent RSTP Configuration tool:
P14x (Software Version B4 and later)
P44x (Software Version E3 and later)
P445 (Software Version J9 and later)
P44y (Software Version H9 and later)
P54x (Software Version H9 and later)
P841 (Software Version G9 (P841A) & H9 (P841B) and later)
P64x (Software Version B4 and later)
P746 (Software Version B5/C5 and later)
All the RSTP parameters are configured via HMI and Easergy S1 Studio.

2.6 Product Implementation Features

Here is a list of the main Product Requirements for MiCOM products that support RSTP:

- The MiCOM relay/IED provides two redundant Ethernet ports using RSTP.
- The redundant Ethernet interface can be made using an RJ 45 or an optical fibre connection with an LC connector type.
- The management of the RSTP is transparent to the application data provided via the Ethernet interface.
- The RSTP option is available with any of the existing protocol options via the Ethernet Interface (IEC61850 and/or DNPoE)
- Loss of one of the Node connections to the device does not cause any loss or degradation to the Application data over the Ethernet interface.
- The MiCOM relay/IED supports the transmission of the RSTP RST BPDU at a fixed time interval.
- The MiCOM relay/IED provide for the RSTP management to be configured and RSTP status to be monitored via either the MiCOM relay or IED HMI.

- The performance of the Ethernet Interface is not degraded by using the RSTP interface.

2.7 Abbreviations and Acronyms

Abbreviations / Acronyms	Meaning
BPDU	Bridge Protocol Data Unit
CRC	Cyclic Redundancy Check
DAN	Doubly Attached Nodes
DANH	Doubly Attached Node implementing HSR
DANP	Doubly Attached Node implementing PRP
FPGA	Field-Programmable Gate Array
HMI	Human Machine Interface
HSR	High-availability Seamless Redundancy
IED	Intelligent Electronic Devices
IP	Internet Protocol
LAN	Local Area Network
LRE	Link Redundancy Entity
MAC	Media Access Control
MRP	Media Redundancy Protocol
PRP	Parallel Redundancy Protocol
RCT	Redundancy Check Tag
RedBox	Redundancy Box
RST BPDU	Rapid Spanning Tree BPDU
RSTP	Rapid Spanning Tree Protocol
SAN	Singly Attached Node
TCP	Transmission Control Protocol
VDAN	Virtual Doubly Attached Node

Notes:

VERSION HISTORY

CHAPTER 23

Date:	08/2023
Products covered by this chapter:	This chapter covers the specific versions of the MiCOM products listed below. This includes only the following combinations of Software Version and Hardware Suffix.
Hardware Suffix:	L
Software Version:	K6
Connection Diagrams:	10P445xx (xx = 01 to 04)

CONTENTS

Page (VH) 23-

1	Version History	5
2	Setting File and Relay Software	25
3	PSL File and Relay Software	26
4	Menu Text and Relay Software	27

TABLES

Page (VH) 23-

Table 1 - Software and Hardware Versions	24
Table 2 - Setting file and relay software versions	25
Table 3 - PSL file and relay software versions	26
Table 4 - Menu text and relay software versions	27

Notes:

1 VERSION HISTORY

The Easergy Studio software is updated periodically. These updates provide support for new features (such as allowing you to manage new MiCOM products, as well as using new software releases and hardware suffixes). The updates may also include fixes. **Accordingly, we strongly advise customers to use the latest Schneider Electric version of Easergy Studio.** This table shows the earliest version of the software which lets you use that feature. Unless otherwise stated in the Studio software, the latest version lets you to use all the features of previous versions.

If you need more information regarding bug fixes, please contact your **Schneider Electric** local support.

This table shows the Software Version together with the Hardware Suffix the particular software runs on. The changes introduced by each Software Version are shown with each change on one row.

Software Version		Hardware Suffix	Original date of Issue	Description of changes	Easergy Studio compatibility	Technical documentation
Major	Minor					
20	B	G	May 2004	Original Issue P443 only	V2.10	-
30	A	J	Dec 2004	Release of P443.	Patch available for V2.10 onwards	-
				Manufacturer details changed to AREVA.		
				Dual opto input operate/reset characteristics.		
				Fiber optic support for Courier/DNP3.0 protocols.		
				Fault record data available over IEC60870-5-103 protocol.		
				Improved time synchronization accuracy.		
				Improved measurement refresh.		
				Improved scheme logic stability.		
				Improved operation for powerswing conditions.		
				Improved operation for evolving faults.		
				Additional weak infeed detector added to block operation of ground elements with zero sequence infeed only		
31	A	J	Aug 2005	Release of P443 based on 30A.	As above	-
				Improved stability under powerswing conditions.		
				Accurate phase selection and directional stability for faults occurring during powerswing.		
				Permissive Overreach Weak Infeed scheme improved stability.		
				Improved operation of the phase selector and distance elements for evolving faults.		
32	A	J	Oct 2005	Release of P443 based on 31A.	As above	-
				Support for InterMiCOM ⁶⁴ fiber optic communications		
32	B	J	Nov 2005	Release of P443 & P445 based on 32A.	As above	-
				Check synchronization for manual closure corrected.		
				Non-volatile storage of control Inputs Implemented.		
				Launch of P445 model		
32	C	J	Nov 2005	Release of P443 & P445 based on 32B.	As above	-
				Correction to InterMiCOM ⁶⁴ fiber optic communications		
32	D	J	Jan 2006	Release of P443 & P445 based on 32C.	As above	-
				Correction to InterMiCOM ⁶⁴ fiber optic communications loopback alarm		

Software Version		Hardware Suffix	Original date of Issue	Description of changes	Easergy Studio compatibility	Technical documentation
Major	Minor					
33	A	J	May 2006	Release of P443 & P445 based on 32D. Out of step protection implemented (P443 only)	Patch available for V2.10 onwards V2.13 or Later	P44y/EN M/B21
33	B	J	15/05/2007	Release of P443 & P445 based on 33A.	Patch available for V2.10 onwards V2.13 or Later	P44y/EN M/B21
				Fixed CTS blocking of earth fault and broken conductor.		
				Prevented SOTF operating when it is disabled.		
				Out of step tripping Delta t step size		
				When check synch is blocked by under or over voltage, both bus and line voltage inputs need to be at the reset level rather than having independent operation, also CS Overvoltage problem.		
				Auto-reclose dead time/close cycle continues even if AR switched out of service.		
				Prevented P445 CS103 rebooting when extracting fault records.		
				Prevented P445 operation of delta scheme when AIDED 2 POR scheme selected.		
				Corrected Disturbance recorder scaling to prevent high current levels into 5A CT causing the Disturbance Recorder to saturate.		
				Restraining defaults appears not to change the 1/5A CT selection.		
				Auto-reclose dead time/close cycle continues even if AR switched out of service.		
				Distance setting are not updated in simple setting mode in setting groups other than the active one		
33	C	J	22/01/2008	Release of P443 & P445 based on 33B.	Patch available for V2.10 onwards V2.13 or Later	P44y/EN M/B21
				Fixed CT/VT ratios scaling of Zone 5 & Zone 6 settings.		
				Fixed a problem with week infeed inhibit.		
				Fixed a SOTF problem when there is a short duration pre-fault.		
				Corrected calculation of Z3 Gnd Rev Reach.		
				Corrections to over voltage stage 2 inhibit.		
				Corrected IM64 Test Mode Alarm which could remain even when IM64 is disabled		
33	D	J	20/08/2008	Release of P443 & P445 based on 33C.	as above	P44y/EN M/B21
				Fix to Blocking scheme.		
				Fix for DEF reverse operation.		
				Prevented CB Operating Time displaying 4.295Ms.		
				Bug fixes		

Software Version		Hardware Suffix	Original date of Issue	Description of changes	Easergy Studio compatibility	Technical documentation
Major	Minor					
33	E	J	12/05/2010	Release of P443 & P445 based on 33D.	Patch available for V2.10 onwards V2.13 or Later	P44y/EN M/B21
				Incorporated biased neutral level detector into earth fault elements.		
				Correction to the distance cross polarising when the memory expires.		
				Corrected the CS103 reading/operation of Control Inputs.		
				Fixed a small issue with the detection of slow swings.		
				Bug fixes.		
33	U	J	18/05/2011	Release of P443 & P445 based on 33U.	Patch available for V2.10 onwards V2.13 or Later	P44y/EN M/B21
				Rebranded as Schneider Electric. Minor change to software number.		
				Changes to allow model number 14th character to have SE reference format.		
				Default PSL Reference now reflects correct reference to SE model number format.		
35	B	J	25/06/2008	Release of P445 based on P443 54B. First release.	Patch available for V2.14 First release of Studio	P445/EN M/A11
35	C	J		Not released. Based on P445 35B. Correction to auto-reclose operation for switch on to fault condition.	as above	P445/EN M/A11
35	D	J	20/01/2009	Release of P445 based on P445 35C.	as above	P445/EN M/A11
				Corrections to default PSL.		
				Correction to the distance cross polarizing when the memory expires.		
				Corrected Thermal State measurement via DNP3.		
				Timestamp in fault record adjusted for the local time setting		
35	D	J	20/01/2009	Corrected Breaker Fail - WI Aided1 trips so they can be disabled via setting "WI Prot Reset"	as above	P445/EN M/A11
35	E	J	30/03/2009	Release of P445 based on P445 35D.	as above	P445/EN M/A11
				Prevents the loss of IEC61850 messages and fixed the handling of the ACD flag during GI.		
				Improved the Ethernet card boot code		
51	C	K	27/07/2006	Release of P443 based on 32B.	Patch available for V2.12 V2.13 or Later	P443/EN M/A22
				Standard and Inverted CT polarity setting for each set of CTs in the relay.		
				User interface with tri colored LED and Function keys.		
				IEC61850-8-1.		
				High Break options.		
				Unmodulated IRIG-B options.		

Software Version		Hardware Suffix	Original date of Issue	Description of changes	Easergy Studio compatibility	Technical documentation
Major	Minor					
				Reduction of distance minimum reach settings to 0.05 ohm.		
				Permissive Trip reinforcement.		
				Poledead modifications for Hydro Quebec.		
				CS103/Auto-reclose modifications.		
				Out of Step Tripping		
51	D	K	16/08/2006	Release of P443 based on 51C.	as above	P443/EN M/A22
				Prevents a possible reboot 15 minutes after browsing the front courier port but not making a setting change i.e. browsing using PAS&T.		
				Minor correction to add Aided Delta trip to POR scheme send carrier on trip logic in P443.		
				Extended GOOSE enrolment capability.		
				Correction to ICD files, enumeration (value) and fixed data mapping		
51	E	K	14/11/2006	Release of P443 based on 51D.	as above	P443/EN M/A22
				Prevent a reboot in 61850 builds when NIC link is inactive and avalanche of DDB activity.		
				Correctly report a fatal error generated by the sampling call-back.		
				Correct the operation of the GOOSE messaging and a problem with the download of an IED configuration file.		
				Correct the operation of the check sync.		
				Correct the operation of the overcurrent reset curves.		
				Removed check on the 14th position of model number.		
				Fixed Telegrams for public inf 64-67.		
				SOTF can operate even when it is disabled		
51	F	K	15/05/2007	Release of P443 non 61850 builds based on 51E.	as above	P443/EN M/A22
				Prevent a fatal error from an incorrect DNP address in not using DNP evolutions platform.		
				Default setting for 450B '< Current Set' reduced to 50mA.		
				French Translations for DDBs 1368-1371 corrected.		
				Dependencies for cells 3242 & 3245 corrected.		
				Fun & INF values related to CS103 Command Blocking corrected.		
				Angle for negative sequence phase overcurrent setting corrected.		
				Corrected operation when using MiCOM S1 is used to activate Settings group by right clicking on the group.		
				Corrected the latching of Function Key DDB signals on relay power up.		
				Corrected Disturbance recorder scaling to prevent high current levels into 5A		
				CT causing the Disturbance Recorder to saturate.		
				Restraining defaults appears not to change the 1/5A CT selection.		
				Corrected the performance of the IM64 Direct mode.		
				Auto-reclose dead time/close cycle continues even if AR switched out of service.		
				Distance setting are not updated in simple setting mode in setting groups other than the active one.		
				Ch2 Statistics may not be displayed		
51	G	K		P443 non 61850 builds based on 51F was approved for release but withdrawn before release.	as above	P443/EN M/A22

Software Version		Hardware Suffix	Original date of Issue	Description of changes	Easergy Studio compatibility	Technical documentation
Major	Minor					
				Corrections to enable/disable of auto-reclose		
51	H	K	04/07/2007	P443 non 61850 builds based on 51G released.	as above	P443/EN M/A22
				Corrections to enable/disable of Auto-reclose		
51	I	K	Jan 2010	Release of P543, P544, P545 & P546 non 61850 based on 51H.	Patch for V2.12	P443/EN M/A22
				Correction to the way latched LED/Relays are cleared.		
				Correction to the distance cross polarising when the memory expires.		
				Corrections to menu text.		
				Correction to autoreclose operation for switch on to fault condition.		
				Fix for DEF reverse operation.		
				Corrected some French and German text.		
				Prevented CB Operating Time displaying 4.295Ms.		
				Fix to Blocking scheme.		
				Fixed Inhibit CB Fail Protection in P446.		
				Improved co-processor error reporting.		
				Fixed a SOTF problem.		
51	J	K	Oct 2010	Release of P543, P544, P545 & P546 non 61850 based on 51J.	Patch for V2.12	P443/EN M/A22
				Fixed a problem with the co-processor stack check which could cause a re-boot.		
				Enhanced the OST feature to make it more stable when currents are low.		
				Improved the distance performance for 2ph-g and also cross country faults.		
52	A	K	Feb 2007	Release of P443 based on 51E.	Patch available for V2.14	P443/EN M/A22 + Addendum
				Chinese interface.		
				Replacing the existing DNP3 with the DNP3 evolutions.		
				Addition of a current but no volts trip option to Switch on to Fault and Trip on re-close feature (SOTF/TOR).		
				Replacement of existing negative sequence overcurrent with multi stage (2 IDMT + 2 DT) negative sequence overcurrent.		
				Addition of IDG curve, commonly used in Sweden, to Earth Fault & Sensitive Earth Fault (involves moving settings).		
				Reduction of all TMS step sizes to 0.005.		
				Changes to CTS so both techniques can be selected together.		
				Regrouping of CTS settings.		
				Addition of four stages of under frequency protection and two stages of Overfrequency protection.		
				Addition of df/dt protection.		
				Changes to Under and Overvoltage to enable each stage to be independently set.		
				Extensions to the checksync VT position setting.		
				Replacing fixed Trip on Close (TOC) delay with a setting		
				Improvements to slow power swing detection.		
				Includes local time zone settings for Date & Time.		

Software Version		Hardware Suffix	Original date of Issue	Description of changes	Easergy Studio compatibility	Technical documentation
Major	Minor					
				Addition of flexible settings for distance quadrilateral top line.		
				Reduced minimum setting for IN> I2pol set.		
				Addition of propagation delay times to Fault Record.		
				Default setting for 450B 'I< Current Set' reduced to 50mA.		
				Enhancement to self checking of output relays.		
				Change tunneled courier address to follow the 1st Rear Port's KBUS or CS103 address.		
52	B	K	04/07/2007	Release of P443 based on 52A.	as above	P443/EN M/A22 + Addendum
				Extra fiber options for P443.		
				Improvements to VTS.		
				Improvements to slow power swing detection.		
				Corrections to enable/disable of auto-reclose.		
				Resolved a problem relating to CT ratio's not being restored when restoring default settings.		
				Resolved a problem with the Disturbance Recorder which saturates for High current levels into 5A CT		
52	C	K	31/07/2007	Release of P443 based on 52B.	as above	as above
				Tilt angle of ground quadrilateral characteristic corrected.		
				Minor correction to fault record.		
				Corrections to over voltage stage 2 inhibit		
52	D	K	17/12/2007	Release of P443 based on 52C.	as above	as above
				Fixed a number of 61850/Goose problems.		
				Corrected some DDB German text.		
				Fixed a problem with week infeed inhibit.		
				Fixed a SOTF problem when there is a short duration pre-fault.		
				Fixed a primary scaling issue relating to Zone 5 & 6		
52	E	K	15/05/2008	Release of P443 based on 52D.	as above	P443/EN M/A22 + Addendum
				Fixed a number of 61850 problems.		
				Improved co-processor error reporting.		
				Fix to Blocking scheme		
52	F	K	24/10/2008	Not released. Based on 52E.	as above	as above
				Correction to auto-reclose operation for switch on to fault condition.		
				Prevented CB Operating Time displaying 4.295Ms.		
				Bug fixes		
52	G	K	28/10/2008	Release of P443 based on 52F.	as above	as above
				Correction to the distance cross polarizing when the memory expires		
52	H	K	21/09/2009	Release of P443 based on 52G.	as above	P443/EN M/A22 + Addendum
				Corrected some menu translations.		
				Corrected Breaker Fail - WI Aided1 trips so they can be disabled via setting "WI Prot Reset".		

Software Version		Hardware Suffix	Original date of Issue	Description of changes	Easergy Studio compatibility	Technical documentation
Major	Minor					
				Timestamp in fault record adjusted for the local time setting.		
				Corrected Thermal State measurement via DNP3.		
				Correction to the way latched LED/Relays are cleared .		
				Correction to Negative sequence overcurrent settings when 5A input used.		
				Prevent Z5 from setting slow swing when PSB is disabled.		
				Fixed problem which prevented residual overvoltage from initiating CB Fail.		
				Various improvements to DNP, CS103 & IEC61850 protocols.		
				Bug fixes		
53	A	K	01/08/2007	P443 only - Restricted Release (CS103 Comms only) based on 52C.	Patch available for V2.14. First release of Studio	P443/EN M/B42
				Extended I/O – status inputs increased from 24 to 32.		
				Positional information added to PSL.		
				Bug fixes		
53	B	K	24/08/2007	P443 only - Restricted Release (CS103 Comms only) based on 53A.	as above	as above
				Tilt angle of ground quadrilateral Characteristic corrected.		
				Minor correction to fault record.		
				Corrections to over voltage stage 2 inhibit		
54	A	K	08/05/2008	Release of P443 based on 52D.	as above	as above
				Positional information added to PSL.		
				DNP 3.0 Over Ethernet protocol added		
				Extended I/O - status inputs increased from 24 to 32.		
				Compensated overvoltage protection added.		
				IEC-103 generic services measurements added.		
				Set/Reset latch logic gates added to PSL.		
				Improved sensitivity range for DEF.		
				Fault record increased max number of fault records to 15.		
				DNP enhancements for SSE.		
				Bug fixes		
54	B	K	25/06/2008	Release of P443 based on 54A.	as above	P443/EN M/B42
				Fixed a number of 61850 problems.		
				Improved co-processor error reporting.		
				Fix to Blocking scheme.		
				Fix for DEF reverse operation.		
				Corrected some French and German text.		
				Prevented CB operating time displaying 4.295Ms.		
				Fixed a problem which prevented extraction of DNP3 setting files from dnp3 over Ethernet variants.		
				Bug fixes		
54	C	K	01/10/2008	Release of P443 based on 54B.	as above	P443/EN M/B42
				Correction to auto-reclose operation for switch on to fault condition		
54	D	K	20/01/2009	Release of P443 based on 54C.	as above	P443/EN M/B42

Software Version		Hardware Suffix	Original date of Issue	Description of changes	Easergy Studio compatibility	Technical documentation
Major	Minor					
				Correction to the distance cross polarizing when the memory expires.		
				Corrected Thermal State measurement via DNP3.		
				Timestamp in fault record adjusted for the local time setting.		
				Corrected Breaker Fail - WI Aided1 trips so they can be disabled via setting "WI Prot Reset"		
54	E	K	20/03/2009	Release of P443 based on 54D.	as above	P443/EN M/B42
				Prevents the loss of IEC61850 messages and fixed the handling of the ACD flag during GI.		
				Improved the Ethernet card boot code		
54	F	K	21/09/2009	Release of P443 based on 54E.	as above	P443/EN M/B42
				Corrected some menu translations.		
				Correction to the way latched LED/Relays are cleared .		
				Correction to Negative sequence overcurrent settings when 5A input used.		
				Prevent Z5 from setting slow swing when PSB is disabled.		
				Fixed problem which prevented residual overvoltage from initiating CB Fail.		
				Various improvements to DNP, CS103 & IEC61850 protocols.		
				Bug fixes		
54	G	K	19/10/2010	Release of P443 based on 54F.	Patch for V2.14 Studio ftp server	P443/EN M/B42
				Time stamping and status of IEC61850 Data attribute sofPSOF1.ST.general.Op improved.		
				Fixed a 61850 issue which blocked clients when one was disconnected.		
				Enhanced the OST feature to make it more stable when currents are low.		
				Improved the distance performance for cross country faults.		
				Improvements to Fault record display over courier and DNP3.		
				Bug fixes.		
54	U	K	18/04/2011	Release of P443 based on 54H.	Patch available for V2.14 First release of Studio	P443/EN M/B42 + P443/EN AD/C42
				Rebranded as Schneider Electric.		
				Minor change to software number plus changes to 61850 (New ICD files required).		
				Additional CB Monitoring data provided over CS103.		
				OST sensitivity now 60mA (was previously 180mA).		
				DEF Aided and Delta Aided setting 3 pole / 1 and 3pole visibility corrected.		
				Bug Fixes.		
54	V	K	15/12/2011	Release of P443 based on P443 54U.	Patch available for V2.14 First release of Studio	P443/EN M/B42 + P443/EN AD/C42
				Improved IEC61850 Status reporting of DDB signal changes.		
				Bug Fixes.		

Software Version		Hardware Suffix	Original date of Issue	Description of changes	Easergy Studio compatibility	Technical documentation
Major	Minor					
55	B	K	30/03/2009	Release of P443 & P446 based on 54E. New P446 which includes auto-reclose, check sync and CB monitoring	Patch for V2.14 Studio ftp server	P44y/EN M/C32
55	C	K	15/05/2009	Release of P443 & P446 based on 55B. Improvements to the Ethernet card startup and configuration. Correction to Negative sequence overcurrent settings when 5A input used. Correction to the way latched LED/Relays are cleared. Corrections to menu text. Bug Fixes	as above	P44y/EN M/C32
55	D	K	28/10/2009	Release of P443 & P446 based on 55C. Correction to slow power swing configuration. Prevent Z5 from setting slow swing when PSB is disabled. Bug Fixes	as above	P44y/EN M/C32
56	A	K	03/04/2008	Restricted Release of P443 (CS103 Comms only) based on 54A. Read Only Mode. Fix to Blocking scheme.	Bug fixes Patch for V2.14. Studio ftp server	P44y/EN M/C32 + P44y/EN AD/C42
37	A	J	10/12/2009	Limited Release of P443 & P446 based on 55D. IEC-61850 phase 2 and 2.1 implemented. Restricted Earth Fault Protection (REF). Separate measurements for each set of CT's. Interrupt Driven InterMICOM in all models. Read Only Mode	as above	P44y/EN M/C32 + P44y/EN AD/D32
37	B	J	10/02/2010	Release of P443 & P446 based on 57A. Fault locator measurements in ohms corrected when 5A CT used or displayed in primary. Frequency measurement in DNP3 fault record corrected	as above	P44y/EN M/C32 + P44y/EN AD/D32
37	D	J	15/10/2010	Release of P44y (P443 and P446) based on 57B Enhancement to GOOSE performance Fixes to 61850. Fixed Protection comms address problem in three ended scheme selected. Fixed dnp3 control of CB2. Fixed a small issue with the detection of slow swings. Incorrect mapping of XCBR(n).CBOpCap.stVal data attribute corrected. Time stamping and status of IEC61850 Data attribute soffPSOF1.ST.general.Op improved.	as above	P44y/EN M/C32 + P44y/EN AD/D32

Software Version		Hardware Suffix	Original date of Issue	Description of changes	Easergy Studio compatibility	Technical documentation
Major	Minor					
				Enhanced the OST feature to make it more stable when currents are low.		
				Improved the distance performance for cross country faults.		
				Improvements to Fault record display over courier and dnp3		
37	U	J	23/02/2011	Release of P44y (P443 and P446) based on 57D	Studio ftp server	P44y/EN M/C32 + P44y/EN AD/D32
				Rebranded as Schneider Electric.		
				Minor change to software number.		
				Changes to 61850 (New ICD files required). Changes to improve IEC61850 reporting on rapidly toggling status. Corrections to IEC61850 datamodel.		
				Improvements to processing of GOOSE messages when using managed Ethernet switch parameterised for VLAN.		
				Improvements to PSL Operation when non-latched and latched LEDs are used together.		
				Improvements to copro configuration (settings) failure detection.		
				Improvements to Zone 1 Extension Reset.		
				P443 Software Version 47 only - Corrected PSL Reference Cell in the PSL DATA menu column.		
				Bug Fixes.		
37	V	J	17/06/2011	Release of P44y (P443 and P446) based on 57U.	as above	P44y/EN M/C32 + P44y/EN AD/D32
				CB Fail reset time on fault clearance improvement.		
				CB Status monitoring improvement.		
37	W	J	27/12/2011	Release of P44y (P443 and P446) based on 57V.	as above	P44y/EN M/C32 + P44y/EN AD/D32
				Status report over IEC61850 not in line with DDB signals.		
				OST sensitivity now 60mA (was previously 180mA).		
				Protection communications Invalid Message Format Alarm Implementation corrected.		
				Directional negative sequence overcurrent will only reset from the tripped state by loss of current and not incorrect direction.		
				Improved IEC61850 Status reporting of DDB signal changes.		
				P544/P546 57V IEC61850 + CS103 variant Download: Relay does not occasionally re-boot with error code 0X351f03f5.		
				BugFixes.		
37	X	J	15/05/2012	Release of P44y (P443 and P446 based on 57W.	as above	P44y/EN M/C32 + P44y/EN AD/D32
				Improved IEC61850 Goose Performance		
				Distance zone 1 may mal-trip when simulated three-phase VT fail condition is applied.		
				Improvements to IEC61850.		
				Bug Fixes.		

Software Version		Hardware Suffix	Original date of Issue	Description of changes	Easergy Studio compatibility	Technical documentation
Major	Minor					
38	C	J	08/03/2010	Restricted Release of P443 (Courier / IEC61850 Comms only based on 55C.	Patch for V2.14 Studio ftp server	P44y/EN M/C32 + P44y/EN AD/C42 +P44y/EN AD/D52
				Replace the conventional analogue input module with the 9-2 LE NCIT module.		
				Support P545 CIT/NCIT 2-ended schema with the introduction of current adjust algorithm.		
E0	A	J	09/11/2011	Release of P44y (P443 and P446) based on 57U (Courier, CS103 and IEC61850+Courier Comms protocols only).	MiCOM S1 Studio v3.0.0	P445/EN M/E62
				Change to Schneider Electric Major release (alpha) software number plus changes to 61850 (New ICD files required).		
				Changes to improve IEC61850 reporting on rapidly toggling status.		
				Corrections to IEC61850 datamodel.		
				CB Fail reset time on fault clearance improvement.		
				Enhanced Disturbance Recorder - 20 Analog / 128 Digital Channels.		
				CT Ratio Enhancements (P544/P546 allow use of different CT1 and CT2 Ratios).		
				Additional CB Monitoring data provided over CS103.		
				OST sensitivity now 60mA (was previously 180mA).		
				Protection communications Invalid Message Format Alarm Implementation corrected.		
				Language Text for "IED CONFIGURATOR" menu column header uses selected language (previously only English).		
				Bug Fixes.		
E0	B	J	31/05/2012	Release of P44y (P443 and P446) based on B0A.	MiCOM S1 Studio v3.0.0	P445/EN M/E62
				DR code optimize to release additional memory for DR pre-trigger time.		
				Additional protocols release (DNP3, DNP3OE, IEC61850+IEC103) from A0/B0A.		
				Improved IEC61850 Goose Performance.		
				Changes to improve IEC61850 reporting on rapidly toggling status.		
				Status report over IEC61850 not in line with DDB signals		
				Schneider Electric use alpha character for software release version. Major version is not compatible with letters of cs103 protocol, both IED code and tools.		
				Bug Fixes		
E0	C	J	20/11/2013	Restricted release of P446 DNP3 (Protocol 4) and IEC61850+Courier (protocol 6) variant for Manitoba Hydro based on B0B.	MiCOM S1 Studio v4.0.0	P445/EN M/E62
				Improved IEC61850 Goose Performance - During iec61850 testing on P64x 04 software, buffered events cannot be sent to the client before GI reports.		
				The MMS communication of IEC61850 of device may get lost after perform control operations (Control\XCBR1\Pos) for several times.		

Software Version		Hardware Suffix	Original date of Issue	Description of changes	Easergy Studio compatibility	Technical documentation
Major	Minor					
				During the software testing by customer of MEA project in Thailand, XCBR1.POS.stVal reports unexpected status change during CB status change.		
				Dual CB Variants (P446/P544/P546/P841B) - Aided Scheme Echo on dual CB variants.		
				General IEC61850 Improvements.		
				IEC61850 Data Model Changes.		
				Bug Fixes.		
E0	D	J	02/07/2015	Release of P446 based on B0B and B0C	MiCOM S1 Studio v5.1.0	P445/EN M/E62
				Correction in DNP3 OE TCP slave regarding event management		
				IEC61850 minor bug corrections		
				The TrgOps GI is set by default after start-up		
				IED Subscribe GOOSE with inconformity AppID should be discarded.		
				IEC61850 corrections related to OrdRunGGIO LN.		
				A number 3600001 can be successfully set to BufTm.		
				Better GOOSE performance in case of high traffic of unicast (eventually multicast with the same MAC address as the goose subscription) frames.		
				IEC61850 minor bug corrections in control model.		
				Improvements in IEC61850 data included in reports managing.		
				IEC61850 minor bug corrections in GOOSE model.		
				Minor DNP3 corrections regarding units of analogue values.		
				Corrections in DR checksum calculation.		
				IEC61850 minor corrections related to BCR (Binary Counter Reading).		
				Corrections in logical note of OptGGIO1.ST.		
				Corrections in IEC61850 related to deadbands.		
				Minor corrections related to units of analogue values shown in DR.		
				"GosGGIO1\$DC" is readable when configure many datasets in IED dataset definitions.		
				Corrections in IEC61850 related to LN XCBR.POS.stVal.		
				Improvements in POR combined with Weak Infeed.		
				Bug fix related to Weak infeed detection function reduces ground fault current sensitivity.		
				IEC61850 interlocking control correction.		
				Corrections related to the manual close delay.		
				IEC61850 bug fixes related to intermediate state.		
				The maximum range of power factor in phase C is 660		
				P446 Power Factor greater than 1.000.		
				All Changes in version B0C		
				Bug Fixes		
F0	A	L	13/06/2012	Cyber Security Release of P44y distance protection based on P44y version B0A/B0B.	MiCOM S1 Studio v3.0.0	P445/EN M/E62

Software Version		Hard-ware Suffix	Original date of Issue	Description of changes	Easergy Studio compat-ibility	Technical document-ation
Major	Minor					
				Change to Schneider-Electric Major release (alpha) software number plus changes to 61850 (New ICD files required). Changes to improve IEC61850 reporting on rapidly toggling status. Corrections to IEC61850 datamodel.		
				Improved IEC61850 Goose Performance.		
				Status report over IEC61850 not in line with DDB signals.		
				CB Fail reset time on fault clearance improvement.		
				Enhanced Disturbance Recorder - 20 Analog / 128 Digital Channels.		
				Additional CB Monitoring data provided over CS103.		
				OST sensitivity now 60mA (was previously 180mA).		
				Language Text for "IED CONFIGURATOR" menu column header uses selected language (previously only English).		
				Improvements to processing of GOOSE messages when using managed Ethernet switch parameterised for VLAN.		
				Some new Cyber Security Cells (BF15, 00E1) needs to be accessible even if read only mode is enabled.		
				Status report over IEC61850 not in line with DDB signals.		
				Directional negative sequence overcurrent will only reset from the tripped state by loss of current and not incorrect direction.		
				Schneider use alpha character for software release version. Major version is not compatible with letters of cs103 protocol, both IED code and tools.		
				Distance zone 1 may mal-trip when simulated three-phase VT fail condition is applied.		
				Bug Fixes.		
F0	B	L	17/04/2013	Release of P443 & P446 based on D0A.	MiCOM S1 Studio v4.0.0	P445/EN M/E62
				Ethernet Parallel Redundancy Protocol (PRP) Functionality		
				Delta-V, Delta-f and Delta-phi Check Synch Measurements		
				Minor IEC61850 bug fix related to "Quality" Data Object (DO).		
				Minor bug correction related to the Logical Node System/ploGGIO1.		
				Bug fix related to IM64 Communications Max propagation delay.		
				Bug fixes related to the MiCOM S1 Language text files (.Ing).		
				Bug Fixes		
F0	D	L	20/08/2015	Release of P443 & P446 distance protection based on D0B.	MiCOM S1 Studio v5.1.0	P445/EN M/E62
				Downloaded the P446 version 57V IEC61850+CS103 variant to a relay, occasionally the relay re-boot with error code 0x351f03f5.		
				"GosGGIO1\$DC" is readable when configure many datasets in IED dataset definitions		
				Corrections in IEC61850 related to LN XCBR.POS.stVal		
				IEC61850 correction related to deadband.		
				Correction in DNP3 OE TCP slave regarding event management		
				The TrgOps GI is set by default after start-up		
				IED Subscribe GOOSE with inconformity AppID should be discard.		
				IEC61850 corrections related to OrdRunGGIO LN.		
				A number 3600001 can be successfully set to BufTm.		

Software Version		Hardware Suffix	Original date of Issue	Description of changes	Easergy Studio compatibility	Technical documentation
Major	Minor					
				IEC61850 minor bug corrections in control model.		
				All question mark “?” is messy code in HMI, when language is Chinese.		
				Edit password level 2, 3, when input blank password, Chinese HMI display wrong langtxt.		
				IEC61850 minor bug corrections in GOOSE model.		
				Minor DNP3 corrections regarding units of analogue values.		
				Corrections in DR checksum calculation.		
				IEC61850 minor corrections related to BCR (Binary Counter Reading).		
				Improvements in IEC61850 data included in reports managing.		
				Improvements in POR combined with Weak Infeed.		
				Bug fix related to IM64 Communications Max propagation delay.		
				Bug fix related to Weak infeed detection function reduces ground fault current sensitivity/		
				IEC61850 interlocking control correction.		
				The solution of CTCSE10202 will make four mandatory cases of IEC61850 conformance test fail, because of missing intermediate state.		
				The maximum range of power factor in phase C is 660.		
				All Changes in version D0C.		
				Bug Fixes.		
F0	F	L	21/02/2017	Release of P443 & P446 distance protection based on D0D.	MiCOM S1 Studio v5.1.0	P445/EN M/E62
				Occasionally the GOOSE absent alarm can not be reset when the IEC61850 communications is functioning correctly.		
				Where an Ethernet gateway is connected to the relay, if the gateway reboots sometimes the P446 will also reboot (when communicating via DNP3OE).		
				While extracting DNP3 configure file from relay, the relay reboots.		
				Communication interrupt of iec61850 (bug fix).		
				Bug Fixes.		
F1	A	L	31/08/2014	This release only applies to P443 (i.e. not P446)	MiCOM S1 Studio v5.0.0	P445/EN M/E62
				User Settable Labels for Virtual I/O		
				Setting File (Control) Inputs		
				DR- Force Disturbance Record		
				New Settings and DDB for check synchronism (25)		
				External DDB Reset for CB Fail Function		
				Tripping Mode Selection for all Distance Zones (21)		
				DR-Customised Labels for digital channels		
				SEF Enhancement of setting range (stage 3 and 4 max current is 2.0A) – Requested for P841, but added across P540D range (now consistent with P14x).		
				IEC-103 (VDEW) Protocol New Signals (Protection Enable)		
				Number of PSL Timers increased from 16 to 32		
				IRIG-B Status in DDB & SCADA (VDEW)		

Software Version		Hardware Suffix	Original date of Issue	Description of changes	Easergy Studio compatibility	Technical documentation
Major	Minor					
				Autoreclose Skip Shot 1 Functionality (DDB)		
				Slow operation of Reverse DEF element can lead to weak infeed echo for external faults		
				Better GOOSE performance in case of high traffic of unicast (eventually multicast with the same MAC address as the goose subscription) frames		
				Improved IEC61850 Goose Performance		
				Bug fixed related to MMS communication of IEC61850 of device may get lost after perform control operations (Control\XCBR1\Pos) for several times.		
				Bug fix related to XCBR1.POS.stVal reports unexpected status change during CB status change		
				Dual CB Variants (P446/P544/P546/P841B) - Aided Scheme Echo on dual CB variants.		
				General IEC61850 Improvements		
				IEC61850 Data Model Changes		
				P44y Power Factor measurement can be displayed as greater than 1.000		
				An additional four DDB Group Nodes can be mapped to individual or multiple DDBs in the PSL. These can be set to trigger the DR via the Disturbance Record menu.		
				Bug Fixes.		
F1	B	L	09/01/2015	Release of P44y distance protection based on D1A and D0B/D0C	MiCOM S1 Studio v5.1.0	P445/EN M/E62
				Check Synch Adaptive mode should close as close to 0 Degrees as possible		
				Missing IEC61850 reports for short duration trips		
				Circuit Breaker Control (IEC61850), error report on IEC61850 after changing CB position		
				Bug Fixes.		
F1	D	L	24/12/2015	Release of P44y distance protection based on D1B.	MiCOM S1 Studio v5.1.0	P445/EN M/E62
				Bug fix related to DR list.		
				Bug fix related to the 'orCat' and 'orIdent' value of the PloGGIO1 in the urcb,brcb and GOOSE.		
				Bug fix related to trigger time is not extracted correctly via CS103 in the configuration file.		
				Minor bug correction related to the Logical Node System/ploGGIO1		
				IED with 128 digital features. DR files extracted by IEC61850 are not the same with which extracted by MiCOM S1 studio.		
				Deadband read via DNP3 corrected to uint32."		
				Virtual Input/Output Labels are available for non IEC61850 variants.		
				Enhancements for IEC 61850		
				Corrections in IEC61850 related to LN XCBR.POS.stVal		
				IEC61850 interlocking control correction.		
				Bug fix related to Weak infeed detection function reduces ground fault current sensitivity/		
				Corrections made for range of power factors		

Software Version		Hardware Suffix	Original date of Issue	Description of changes	Easergy Studio compatibility	Technical documentation
Major	Minor					
				Improvements for mms service under high load situations		
				Bug Fixes.		
F1	E	L	30/05/2016	Release of P44y distance protection based on D1D.	MiCOM S1 Studio v5.1.0	P445/EN M/E62
				Time detected in IED Event list (P445, P545, P841) is not the same as time of signals packed in Report and sent via Network to IEC 61850 Client by MMS (i.e. SCADA servers, Gateways, IED scouts).		
				Ethernet Tunnel communication between MiCOM S1 and relays may become unreliable after several days to several months.		
				When the user attempts to read the "CT mismatch alarm" from HMI, the IED reboots with error code "0x0600012A".		
				IED can sometimes reboot with error code: 0x070A032F, when writing "control 10" to control input 33 to 48 in quick succession via dnp3 serial or dnp3 ethernet.		
				Menu cell "RP2 Read Only" is not visible for some protocol options.		
				When IEC61850 client try to select or operate a SPC/DPC with the parameter 'orIdent' as '00', Then Check ST of PlogGGIO. The 'OrIdent' value of PlogGGIO is " (or NULL), not '00'.		
				Whenever a ClearAllDisturbance command is executed, a DR_MEMORY_FULL_ALARM event is recorded.		
				Upgrade TPCL from 1.7 to 1.8.		
				Wrong value of menu cell "> Blocking" is displayed on the HMI. It is necessary to press the enter key to visualise the real settings for >Blocking in the relay display.		
				For IEC6150 Edition 1, Dbpos is a basic type, so the enumeration should be removed from ICD file.		
				IEC61850 - CDC mismatch in Logical Node ThmPTTR : Data Attribute AlmThm is now SPS (previously incorrectly specified as ACT).		
				The communication between the IED and CET SCADA system may be interrupted after operating correctly for several days and will only resume after rebooting the relay.		
				Correction to Control Inputs 33 to 48 event file textual descriptions.		
				Extraction of Group 1 PSL will generate two different events (PSL Config Upload By FP Group 1 and PSL Config Upload By FP Group 2).		
				When downloading a DNP setting to the relay, the event list incorrectly displays a new event "DNP Stng D/Load by DNP".		
				Occasionally, the GOOSE Absent alarm can not be reset when the IEC61850 communications is functioning correctly.		
				The IEC61850 energy measurement values were not consistent with the values displayed on User Interface.		
				MTRRs control response corrected.		
				Thermal State and Energy Measurement could not be reset by IEC61850 client in ED1.		

Software Version		Hardware Suffix	Original date of Issue	Description of changes	Easergy Studio compatibility	Technical documentation
Major	Minor					
				Changed to the value of the Primary/Secondary Setting Values menu cell [092E] apply to all interfaces (Internet, front courier/HMI, Rear RS485).		
				Remove readonly references to Software Reference cells [0011] and [0012] from system data in MiCOM S1.		
				Unlike the Ctrl Setg Input lables and Virtual Input/Output labels, Control Input labels are not associated to the IEC61850 communication logic nodes PIOGGIOx.		
				Adaptive check synch is incorrectly blocked by CS1 under some conditions.		
				Phase selector does not adapt correctly to some evolving faults.		
				Status of PriMMTR1/MTRRs.ST of PriMMTR1/MTRRs is not consistent with Set (control) value when Measurements/PriMMTR1/MTRRs are configured for direct control mode in the mcl file.		
				The user alarm label in the event file is not correct.		
				Bug Fixes.		
F2	A	L	19/04/2016	Release of P44y distance protection based on D1D.	MiCOM S1 Studio v5.1.0	P445/EN M/E62
				Add DDB(361) for BBRAM failure indicator.		
				Bug fix related to the same data set being used in a RCB and GOCB.		
				Bug fix related to time detected in IED Event list and IEC61850.		
				Menu cell "RP2 Read Only" is visible for all protocol options.		
				Bug fix related to DR_MEMORY_FULL_ALARM event is recorded.		
				Bug fixing HMI issue for "I>Blocking" value.		
				Bug fix related to CBF function starts/trips even if the protection element is not mapped in psl to the corresponding trip DDB signal.		
				Add DDB(1893) to configure the non-current protection triggering CB failure logic.		
				Improvements for Check Sync.		
				Enhancements for IEC61850.		
				Add Hysteresis to the UnderCurrent element. Fixed hysteresis threshold: 1.2.		
				Correction to communication interrupt of IEC61850.		
				Bug fix to CDC mismatch in LN PTTR.		
				Bug Fixes.		
F2	B	L	10/08/2016	Release of P44y distance protection based on D2A.	MiCOM S1 Studio v5.1.0	P445/EN M/E62
				Correction to Control Inputs 33 to 48 event file textual descriptions.		
				IEC61850 - CDC mismatch in Logical Node ThmPTTR : Data Attribute AlmThm is now SPS (previously incorrectly specified as ACT).		

Software Version		Hardware Suffix	Original date of Issue	Description of changes	Easergy Studio compatibility	Technical documentation
Major	Minor					
				Unlike the Ctrl Setg Input lables and Virtual Input/Output labels, Control Input labels are not associated to the IEC61850 communication logic nodes PIOGGIOx. Extraction of Group 1 PSL will generate two different events (PSL Config Upload By FP Group 1 and PSL Config Upload By FP Group 2).		
				When downloading a DNP setting to the relay, the event list incorrectly displays a new event "DNP Stng D/Load by DNP".		
				Occasionally, the GOOSE Absent alarm can not be reset when the IEC61850 communications is functioning correctly.		
				The IEC61850 energy measurement values were not consistent with the values displayed on User Interface.		
				MTRRs control response corrected.		
				Thermal State and Energy Measurement could not be reset by IEC61850 client in ED1.		
				Adaptive check synch is incorrectly blocked by CS1 under some conditions.		
				Status of PriMMTR1/MTRRs.ST of PriMMTR1/MTRRs is not consistent with Set (control) value when Measurements/PriMMTR1/MTRRs are configured for direct control mode in the mcl file.		
				The user alarm label in the event file is not correct.		
				The initial value of CILO.Mod.ctlModel in ICD template shall be 'status-only'. bType of stVal in DOType - INC_CTRL_D_PRIV (CDC:INC) shall be Enum not "INT32" dataNs and lnNs format is not correct.		
				IEC61850 Mapping error of P445 Control\AscRSYNx\Mod.		
				Circuit Breaker position could not be read by 61850 client in P54x version D1E and D2A.		
				For IEC6150 Edition 1, Dbpos is a basic type, so the enumeration should be removed from ICD file.		
				Minor Corrections to ICD file as a result of the IEC61850 changes.		
				Bug Fixes.		
D3	A	M	11/02/2017	Software release to meet Brazil customer requirement (AR15258) to expand the setting range of R5, R5' and R6, R6' in power swing function. Based on the previous F2B. Include some of the outstanding DTS issues.	Easergy Studio v8.0.0	P445/EN M/E62
J4	B	L	July 2016	Release with rejuvenated Ethernet card, IEC61850 Edition 2 + CS3. Based on D1B, P544/P546 Version H1 and P545 Version H3	Easergy Studio v8.0.0	P445/EN M/E62
				Virtual Input and Virtual Output labels included in all protocol options.		
				Protection Function Trip Supervision/Fault Detector Element available.		
				Improvements in Zone 1 distance tripping time.		
				New distance zone Q available. New distance mode of operation available. New timers available.		
				Correction in the distance directional top line of P44y.		

Software Version		Hardware Suffix	Original date of Issue	Description of changes	Easergy Studio compatibility	Technical documentation
Major	Minor					
				Distance phase selector correction.		
				"PSB Unblock Dly" setting range increased.		
				Protocols Mapping has been changed in this release. Details of the protocols used for each product are shown in the SCADA Communications chapter.		
				Product Ordering options have been changed for this release. For more details, see the Introduction chapter.		
				The rejuvenated Ethernet board as well as the Px40 rejuvenation project features (such as PRP/HSR/RSTP, IEC61850 Ed2, Dual IP and Cyber Security) have been included in this release. This includes new or replacement chapters for: Installation Cyber Security Dual Redundant Ethernet Board Parallel Redundancy Protocol (PRP) Notes High-availability Seamless Redundancy (HSR)		
				Some of the DDBs have been changed in order to show the Status of Auto-Reclose (AR) (1P, 3P) in the MiCOM P44y relays.		
				Enhancement of Setting Ranges in Stage 3 and Stage 4 Current settings. The Maximum Current in Stage 3 and Stage 4 Overcurrent settings has been changed, the range now being from 0.005 A to 2.00A.		
				IEC870-5-103 (VDEW) Protocol New Signals (Protection Enable). For more details, please see the Introduction chapter.		
				An additional communications protocol, for IEC61850 Edition 1 / 2 and DNP3 serial with simple password management - CSL0, has been added.		
				GPS / Protection communications drop-out improvements (when operating with some Multiplexer / radio links).		
				Improvements in Check Sync Adaptive Mode.		
				Settings chapter updated.		
				DDB descriptions and numbers updated.		
				The 3V2 formula in the Settings chapter has now been corrected.		
J6	A	L	January 2017	This is based on version G4B / H4B, with the addition of new protocol IEC61850 Edition 1 / 2 and DNPoE and DNP3 Serial.	Easergy Studio v8.0.0	P445/EN M/F72
				Courier Tunneling via Secured Communication.		
				Extended Fault Record added to DNP measurements.		
				Latest Fault Record via IEC61850.		
				New DDB: Logic 0 and Simul. GOOSE Alm.		
				Bug fix.		
J7	A	L	August 2017	Merge of P546 H5B and applicable H6A features.	Easergy Studio v8.0.0	P445/EN M/G82
				DNP3 unsolicited messages feature supported.		
				Resistive reach of Power Swing Zones has been increased.		

Software Version		Hardware Suffix	Original date of Issue	Description of changes	Easergy Studio compatibility	Technical documentation
Major	Minor					
				Step size of parameter UVD>Threshold has been modified.		
				Setting Value consistency (primary/secondary values) in all ports can be configurable now.		
				Bug fix.		
J8	A	L	Not released			P445/EN M/H92
J9	A	L	September 2018	PTP and RSTP has been added. SNMP has been removed. Pre-configured dataset High Performance GOOSE is removed.	V8.1.0	P445/EN M/la2
K1	A	L	August 2019	Independent initiation for external CBF. Independent current setting function for CBF and pole dead detection is added. Setting range of 59N is changed.	V8.1.1	P445/EN M/Jb2
K2	A	L	January 2020	Adding timer to check Synchro 1, 2 for reclose; Adding Main VT Location; Change step size of voltage protection to 0.1V in secondary.	V9.0.0	P445/EN M/Kc2
K3	A	L	March 2021	Adding OCD> and UVD> Hold Timer; Adding 54 output DDBs for Trip Supervision elements.	V9.1.0	P445/EN M/Ld2
K4	A	L	July 2021	Bug fix.	V9.3.1	P445/EN M/Me2
K5	B	L	June 2022	Support two gateways communication for two interfaces. DNP client number modified from 6 to 3. Bug fix.	V9.3.2 or later	P445/EN M/Nf2
K6	A	L	June 2022	Add service tracking (BrCb. Trk & Urcb.Trk). Bug fix.	V9.3.2 or later	P445/EN M/Og2
K6	B	L	Aug 2023	Correction of Analog channel primary, secondary in COMTRADE File .cfg, for IEC61850 (Ed1 and Ed2) or DNP3oE or CS103 when CT is 5A or VT is 440V. Easergy Studio update for DR files extraction via Courier. Correction of SR gate resetting when navigation keys are used. Correction to pass Nessus Scan test.	V9.3.5 or later	P445/EN M/Og2

The Easergy Studio software is updated periodically. These updates provide support for new features (such as allowing you to manage new MiCOM products, as well as using new software releases and hardware suffixes). The updates may also include fixes. **Accordingly, we strongly advise customers to use the latest Schneider Electric version of Easergy Studio.** This table shows the earliest version of the software which lets you use that feature. Unless otherwise stated in the Studio software, the latest version lets you to use all the features of previous versions. If you need more information regarding bug fixes, please contact your **Schneider Electric** local support.

This table shows the Software Version together with the Hardware Suffix the particular software runs on. The changes introduced by each Software Version are shown with each change on one row.

Table 1 - Software and Hardware Versions

2 SETTING FILE AND RELAY SOFTWARE

Setting file software version	Relay software version																									
	20	30	31	32	33	51	52	53	54	35	37	E0	F0	F1	F2	J4	J6	J7	J8	J9	K1	K2	K3	K4	K5	K6
20	✓	x	x	x	x	x	x	x	x	x	x	x	x	x	x	x	x	x	x	x	x	x	x	x	x	x
30	x	✓	x	x	x	x	x	x	x	x	x	x	x	x	x	x	x	x	x	x	x	x	x	x	x	x
31	x	x	✓	x	x	x	x	x	x	x	x	x	x	x	x	x	x	x	x	x	x	x	x	x	x	x
32	x	x	x	✓	x	x	x	x	x	x	x	x	x	x	x	x	x	x	x	x	x	x	x	x	x	x
33	x	x	x	x	✓	x	x	x	x	x	x	x	x	x	x	x	x	x	x	x	x	x	x	x	x	x
51	x	x	x	x	x	✓	x	x	x	x	x	x	x	x	x	x	x	x	x	x	x	x	x	x	x	x
52	x	x	x	x	x	x	✓	x	x	x	x	x	x	x	x	x	x	x	x	x	x	x	x	x	x	x
53	x	x	x	x	x	x	x	✓	x	x	x	x	x	x	x	x	x	x	x	x	x	x	x	x	x	x
54	x	x	x	x	x	x	x	x	✓	x	x	x	x	x	x	x	x	x	x	x	x	x	x	x	x	x
35	x	x	x	x	x	x	x	x	x	✓	x	x	x	x	x	x	x	x	x	x	x	x	x	x	x	x
37	x	x	x	x	x	x	x	x	x	x	✓	x	x	x	x	x	x	x	x	x	x	x	x	x	x	x
E0	x	x	x	x	x	x	x	x	x	x	x	✓	x	x	x	x	x	x	x	x	x	x	x	x	x	x
F0	x	x	x	x	x	x	x	x	x	x	x	x	✓	x	x	x	x	x	x	x	x	x	x	x	x	x
F1	x	x	x	x	x	x	x	x	x	x	x	x	x	✓	x	x	x	x	x	x	x	x	x	x	x	x
F2	x	x	x	x	x	x	x	x	x	x	x	x	x	x	✓	x	x	x	x	x	x	x	x	x	x	x
J4	x	x	x	x	x	x	x	x	x	x	x	x	x	x	x	✓	x	x	x	x	x	x	x	x	x	x
J6	x	x	x	x	x	x	x	x	x	x	x	x	x	x	x	x	✓	x	x	x	x	x	x	x	x	x
J7	x	x	x	x	x	x	x	x	x	x	x	x	x	x	x	x	x	✓	x	x	x	x	x	x	x	x
J8	x	x	x	x	x	x	x	x	x	x	x	x	x	x	x	x	x	x	x	x	x	x	x	x	x	x
J9	x	x	x	x	x	x	x	x	x	x	x	x	x	x	x	x	x	x	x	✓	x	x	x	x	x	x
K1	x	x	x	x	x	x	x	x	x	x	x	x	x	x	x	x	x	x	x	x	✓	x	x	x	x	x
K2	x	x	x	x	x	x	x	x	x	x	x	x	x	x	x	x	x	x	x	x	x	✓	x	x	x	x
K3	x	x	x	x	x	x	x	x	x	x	x	x	x	x	x	x	x	x	x	x	x	x	✓	x	x	x
K4	x	x	x	x	x	x	x	x	x	x	x	x	x	x	x	x	x	x	x	x	x	x	x	✓	x	x
K5	x	x	x	x	x	x	x	x	x	x	x	x	x	x	x	x	x	x	x	x	x	x	x	x	✓	x
K6	x	x	x	x	x	x	x	x	x	x	x	x	x	x	x	x	x	x	x	x	x	x	x	x	x	✓

Table 2 - Setting file and relay software versions

3 PSL FILE AND RELAY SOFTWARE

PSL file software version	Relay software version																									
	20	30	31	32	33	51	52	53	54	35	37	E0	F0	F1	F2	J4	J6	J7	J8	J9	K1	K2	K3	K4	K5	K6
20	✓	x	x	x	x	x	x	x	x	x	x	x	x	x	x	x	x	x	x	x	x	x	x	x	x	x
30	x	✓	x	x	x	x	x	x	x	x	x	x	x	x	x	x	x	x	x	x	x	x	x	x	x	x
31	x	x	✓	x	x	x	x	x	x	x	x	x	x	x	x	x	x	x	x	x	x	x	x	x	x	x
32	x	x	x	✓	x	x	x	x	x	x	x	x	x	x	x	x	x	x	x	x	x	x	x	x	x	x
33	x	x	x	x	✓	x	x	x	x	x	x	x	x	x	x	x	x	x	x	x	x	x	x	x	x	x
51	x	x	x	x	x	✓	x	x	x	x	x	x	x	x	x	x	x	x	x	x	x	x	x	x	x	x
52	x	x	x	x	x	x	✓	x	x	x	x	x	x	x	x	x	x	x	x	x	x	x	x	x	x	x
53	x	x	x	x	x	x	x	✓	x	x	x	x	x	x	x	x	x	x	x	x	x	x	x	x	x	x
54	x	x	x	x	x	x	x	x	✓	x	x	x	x	x	x	x	x	x	x	x	x	x	x	x	x	x
35	x	x	x	x	x	x	x	x	x	✓	x	x	x	x	x	x	x	x	x	x	x	x	x	x	x	x
37	x	x	x	x	x	x	x	x	x	x	✓	x	x	x	x	x	x	x	x	x	x	x	x	x	x	x
E0	x	x	x	x	x	x	x	x	x	x	x	✓	x	x	x	x	x	x	x	x	x	x	x	x	x	x
F0	x	x	x	x	x	x	x	x	x	x	x	x	✓	x	x	x	x	x	x	x	x	x	x	x	x	x
F1	x	x	x	x	x	x	x	x	x	x	x	x	x	✓	x	x	x	x	x	x	x	x	x	x	x	x
F2	x	x	x	x	x	x	x	x	x	x	x	x	x	x	✓	x	x	x	x	x	x	x	x	x	x	x
J4	x	x	x	x	x	x	x	x	x	x	x	x	x	x	x	✓	x	x	x	x	x	x	x	x	x	x
J6	x	x	x	x	x	x	x	x	x	x	x	x	x	x	x	x	✓	x	x	x	x	x	x	x	x	x
J7	x	x	x	x	x	x	x	x	x	x	x	x	x	x	x	x	x	✓	x	x	x	x	x	x	x	x
J8	x	x	x	x	x	x	x	x	x	x	x	x	x	x	x	x	x	x	✓	x	x	x	x	x	x	x
J9	x	x	x	x	x	x	x	x	x	x	x	x	x	x	x	x	x	x	x	✓	x	x	x	x	x	x
K1	x	x	x	x	x	x	x	x	x	x	x	x	x	x	x	x	x	x	x	x	✓	x	x	x	x	x
K2	x	x	x	x	x	x	x	x	x	x	x	x	x	x	x	x	x	x	x	x	x	✓	x	x	x	x
K3	x	x	x	x	x	x	x	x	x	x	x	x	x	x	x	x	x	x	x	x	x	x	✓	x	x	x
K4	x	x	x	x	x	x	x	x	x	x	x	x	x	x	x	x	x	x	x	x	x	x	x	✓	x	x
K5	x	x	x	x	x	x	x	x	x	x	x	x	x	x	x	x	x	x	x	x	x	x	x	x	✓	x
K6	x	x	x	x	x	x	x	x	x	x	x	x	x	x	x	x	x	x	x	x	x	x	x	x	x	✓

Table 3 - PSL file and relay software versions

4 MENU TEXT AND RELAY SOFTWARE

Menu text software version	Relay software version																									
	20	30	31	32	33	51	52	53	54	35	37	E0	F0	F1	F2	J4	J6	J7	J8	J9	K1	K2	K3	K4	K5	K6
20	✓	x	x	x	x	x	x	x	x	x	x	x	x	x	x	x	x	x	x	x	x	x	x	x	x	x
30	x	✓	x	x	x	x	x	x	x	x	x	x	x	x	x	x	x	x	x	x	x	x	x	x	x	x
31	x	x	✓	x	x	x	x	x	x	x	x	x	x	x	x	x	x	x	x	x	x	x	x	x	x	x
32	x	x	x	✓	x	x	x	x	x	x	x	x	x	x	x	x	x	x	x	x	x	x	x	x	x	x
33	x	x	x	x	✓	x	x	x	x	x	x	x	x	x	x	x	x	x	x	x	x	x	x	x	x	x
51	x	x	x	x	x	✓	x	x	x	x	x	x	x	x	x	x	x	x	x	x	x	x	x	x	x	x
52	x	x	x	x	x	x	✓	x	x	x	x	x	x	x	x	x	x	x	x	x	x	x	x	x	x	x
53	x	x	x	x	x	x	x	✓	x	x	x	x	x	x	x	x	x	x	x	x	x	x	x	x	x	x
54	x	x	x	x	x	x	x	x	✓	x	x	x	x	x	x	x	x	x	x	x	x	x	x	x	x	x
35	x	x	x	x	x	x	x	x	x	✓	x	x	x	x	x	x	x	x	x	x	x	x	x	x	x	x
37	x	x	x	x	x	x	x	x	x	x	✓	x	x	x	x	x	x	x	x	x	x	x	x	x	x	x
E0	x	x	x	x	x	x	x	x	x	x	x	✓	x	x	x	x	x	x	x	x	x	x	x	x	x	x
F0	x	x	x	x	x	x	x	x	x	x	x	x	✓	x	x	x	x	x	x	x	x	x	x	x	x	x
F1	x	x	x	x	x	x	x	x	x	x	x	x	x	✓	x	x	x	x	x	x	x	x	x	x	x	x
F2	x	x	x	x	x	x	x	x	x	x	x	x	x	x	✓	x	x	x	x	x	x	x	x	x	x	x
J4	x	x	x	x	x	x	x	x	x	x	x	x	x	x	x	✓	x	x	x	x	x	x	x	x	x	x
J6	x	x	x	x	x	x	x	x	x	x	x	x	x	x	x	x	✓	x	x	x	x	x	x	x	x	x
J7	x	x	x	x	x	x	x	x	x	x	x	x	x	x	x	x	x	✓	x	x	x	x	x	x	x	x
J8	x	x	x	x	x	x	x	x	x	x	x	x	x	x	x	x	x	x	x	x	x	x	x	x	x	x
J9	x	x	x	x	x	x	x	x	x	x	x	x	x	x	x	x	x	x	x	x	✓	x	x	x	x	x
K1	x	x	x	x	x	x	x	x	x	x	x	x	x	x	x	x	x	x	x	x	x	✓	x	x	x	x
K2	x	x	x	x	x	x	x	x	x	x	x	x	x	x	x	x	x	x	x	x	x	x	✓	x	x	x
K3	x	x	x	x	x	x	x	x	x	x	x	x	x	x	x	x	x	x	x	x	x	x	✓	x	x	x
K4	x	x	x	x	x	x	x	x	x	x	x	x	x	x	x	x	x	x	x	x	x	x	x	✓	x	x
K5	x	x	x	x	x	x	x	x	x	x	x	x	x	x	x	x	x	x	x	x	x	x	x	x	✓	x
K6	x	x	x	x	x	x	x	x	x	x	x	x	x	x	x	x	x	x	x	x	x	x	x	x	x	✓

Table 4 - Menu text and relay software versions

Notes:

SYMBOLS AND GLOSSARY

CHAPTER SG

Applicability	
Date:	11/2023
Products covered by this chapter:	
This chapter covers the specific versions of the MiCOM products listed below. This includes only the following combinations of Software Version and Hardware Suffix.	
Hardware Suffix:	
MiCOM Px4x	All
Software Version:	
MiCOM Px4x	All
Connection Diagrams:	
This chapter list the connection diagram for the product:	
P14x (P141, P142, P143 & P145):	10P141xx (xx = 01 to 02) 10P142xx (xx = 01 to 05) 10P143xx (xx = 01 to 11) 10P145xx (xx = 01 to 11)
P24x (P241, P242 & P243):	10P241xx (xx = 01 to 02) 10P242xx (xx = 01) 10P243xx (xx = 01)
P34x (P342, P343, P344, P345 & P391)	10P342xx (xx = 01 to 17) 10P343xx (xx = 01 to 19) 10P344xx (xx = 01 to 12) 10P345xx (xx = 01 to 07) 10P391xx (xx = 01 to 02)
P445:	10P445xx (xx = 01 to 04)
P44x (P442 & P444):	10P44101 (SH 1 & 2) 10P44201 (SH 1 & 2) 10P44202 (SH 1) 10P44203 (SH 1 & 2) 10P44401 (SH 1) 10P44402 (SH 1) 10P44403 (SH 1 & 2) 10P44404 (SH 1) 10P44405 (SH 1) 10P44407 (SH 1 & 2)
P44x (P442 & P444):	10P44201 (SH 1 & 2) 10P44202 (SH 1) 10P44203 (SH 1 & 2) 10P44401 (SH 1) 10P44402 (SH 1) 10P44403 (SH 1 & 2) 10P44404 (SH 1) 10P44405 (SH 1) 10P44407 (SH 1 & 2)
P44y:	10P44303 (SH 01 and 03) 10P44304 (SH 01 and 03) 10P44305 (SH 01 and 03) 10P44306 (SH 01 and 03)

	<p>10P44600 10P44601 (SH 1 to 2) 10P44602 (SH 1 to 2) 10P44603 (SH 1 to 2)</p>
P54x (P543, P544, P545 & P546):	<p>10P54302 (SH 1 to 2) 10P54303 (SH 1 to 2) 10P54304 (SH 1 to 2) 10P54400 10P54404 (SH 1 to 2) 10P54405 (SH 1 to 2) 10P54502 (SH 1 to 2) 10P54503 (SH 1 to 2) 10P54504 (SH 1 to 2) 10P54600 10P54604 (SH 1 to 2) 10P54605 (SH 1 to 2) 10P54606 (SH 1 to 2)</p>
P547:	<p>10P54702xx (xx = 01 to 02) 10P54703xx (xx = 01 to 02) 10P54704xx (xx = 01 to 02) 10P54705xx (xx = 01 to 02)</p>
P64x (P642, P643 & P645):	<p>10P642xx (xx = 1 to 10) 10P643xx (xx = 1 to 6) 10P645xx (xx = 1 to 9)</p>
P74x:	<p>10P740xx (xx = 01 to 07)</p>
P746:	<p>10P746xx (xx = 00 to 21)</p>
P841:	<p>10P84100 10P84101 (SH 1 to 2) 10P84102 (SH 1 to 2) 10P84103 (SH 1 to 2) 10P84104 (SH 1 to 2) 10P84105 (SH 1 to 2)</p>
P849:	<p>10P849xx (xx = 01 to 06)</p>

Notes:

CONTENTS

1. Acronyms and Abbreviations	7
2. Company Proprietary Terms	16
3. ANSI Terms	17
4. Concatenated Terms	21
5. Units for Digital Communications	22
6. American vs British English Terminology	23
7. Logic Symbols and Terms	24
8. Logic Timers	29
9. Logic Gates	31

TABLES

Table 1 - Acronyms and abbreviations.....	15
Table 2 - Company-proprietary terms.....	16
Table 3 - ANSI Abbreviations.....	17
Table 4 - ANSI Descriptions.....	20
Table 5 - Concatenated Terms.....	21
Table 6 - Units for Digital Communications.....	22
Table 7 - American vs British English terminology.....	23
Table 8 - Logic Symbols and Terms.....	28
Table 9 - Logic Timers.....	30

FIGURES

Figure 1 - Logic Gates - AND Gate.....	31
Figure 2 - Logic Gates - OR Gate.....	31
Figure 3 - Logic Gates - R-S Flip-Flop Gate.....	31
Figure 4 - Logic Gates - Exclusive OR Gate.....	31
Figure 5 - Logic Gates - Programmable Gate.....	32
Figure 6 - Logic Gates - NOT Gate.....	32

Notes:

1. ACRONYMS AND ABBREVIATIONS

Term	Description
<	Less than: Used to indicate an "under" threshold, such as undercurrent (current dropout).
>	Greater than: Used to indicate an "over" threshold, such as overcurrent (current overload)
A	Ampere
AA	Application Association
AC / ac	Alternating Current
ACSI	Abstract Communication Service Interface
ACSR	Aluminum Conductor Steel Reinforced
ALF	Accuracy Limit Factor
AM	Amplitude Modulation
ANSI	American National Standards Institute
AR	Auto-Reclose
ARIP	Auto-Reclose In Progress
ASCII	American Standard Code for Information Interchange
ATEX	ATEX is the Potentially Explosive Atmospheres directive 94/9/EC
AUX / Aux	Auxiliary
AWG	American Wire Gauge
BAR	Block Auto-Reclose signal
BCD	Binary Coded Decimal
BCR	Binary Counter Reading
BDEW	Bundesverband der Energie- und Wasserwirtschaft Startseite (i.e. German Association of Energy and Water Industries)
BIED	Breaker IED
BMP	BitMaP – a file format for a computer graphic
BN>	Neutral over susceptance protection element: Reactive component of admittance calculation from neutral current and residual voltage.
BOP	Blocking Overreach Protection - a blocking aided-channel scheme.
BPDU	Bridge Protocol Data Unit
BRCB	Buffered Report Control Block
BRP	Beacon Redundancy Protocol
BU	Backup: Typically a back-up protection element
C264	MiCOM C264 is the latest generation of modular substation computers. In addition to the traditional input/output (I/O) management, MiCOM C264 acts as a powerful communication gateway, an advanced measurement center and a fast automation processor. As a remote terminal unit, bay controller or protocol converter, MiCOM C264 is the compact solution to countless applications installed in demanding electromagnetic conditions.
C/O	A ChangeOver contact having normally-closed and normally-open connections: Often called a "form C" contact.
CB	Circuit Breaker
CB Aux.	Circuit Breaker auxiliary contacts: Indication of the breaker open/closed status.
CBF	Circuit Breaker Failure protection
CDC	Common Data Class

Term	Description
CF	Control Function
Ch	Channel: usually a communications or signaling channel
Check Synch	Check Synchronizing function
CLIO	Current Loop Input Output: 0-1 mA/0-10 mA/0-20 mA/4-20 mA transducer inputs and outputs CLI = current loop input - 0-1 mA/0-10 mA/0-20 mA/4-20 mA transducer input CLIO = current loop output - 0-1 mA/0-10 mA/0-20 mA/4-20 mA transducer output
CID	Configured IED Description
CIP	Critical Infrastructure Protection standards
CLK / Clk	Clock
CIs	Close - generally used in the context of close functions in circuit breaker control.
CMV	Complex Measured Value
CNV	Current No Volts
COMFEDE	Common Format for Event Data Exchange
CPNI	Centre for the Protection of National Infrastructure
CRC	Cyclic Redundancy Check
CRP	Cross-network Redundancy Protocol
CRV	Curve (file format for curve information)
CRx	Channel Receive: Typically used to indicate a teleprotection signal received.
CS	Cyber Security or Check Synchronism.
CSV	Comma Separated Values (a file format for database information)
CT	Current Transformer
CTRL	Control - as used for the Control Inputs function
CTS	Current Transformer Supervision: To detect CT input failure.
CTx	Channel Transmit: Typically used to indicate a teleprotection signal send.
CUL	Canadian Underwriters Laboratory
CVT	Capacitor-coupled Voltage Transformer - equivalent to terminology CCVT.
CZ	Abbreviation of "Check Zone": Zone taking into account only the feeders.
DA	Data Attribute
DAU	Data Acquisition Unit
DC	Data Concentrator
DC / dc	Direct Current
DCC	An Omicron compatible format
DCE	Data Communication Equipment
DDB	Digital Data Bus within the programmable scheme logic: A logic point that has a zero or 1 status. DDB signals are mapped in logic to customize the relay's operation.
DDR	Dynamic Disturbance Recorder
DEF	Directional Earth Fault protection: A directionalized ground fault aided scheme.
df/dt	Rate of Change of Frequency
df/dt>1	First stage of df/dt protection
DFT	Discrete Fourier Transform

Term	Description
DG	Distributed Generation
DHCP	Dynamic Host Configuration Protocol
DHM	Dual Homing Manager
DHP	Dual Homing Protocol
DHS	Dual Homing Star: Ethernet protocol allowing bumpless redundancy. Used with Redundant Ethernet board with dual homing protocol
Diff	Differential protection.
DIN	Deutsches Institut für Normung (German standards body)
Dist	Distance protection.
DITA	Darwinian Information Typing Architecture
DLDB	Dead-Line Dead-Bus : In system synchronism check, indication that both the line and bus are de-energised.
DLLB	Dead-Line Live-Bus : In system synchronism check, indication that the line is de-energised whilst the bus is energised.
DLR	Dynamic Line Rating
DLY / Dly	Time Delay
DMT	Definite Minimum Time
DNP	Distributed Network Protocol
DO	Data Object
DPWS	Device Profile for Web Services
DR	Disturbance Record
DSP	Digital Signal Processor
DST	Daylight Saving Time
DT	Definite Time: in the context of protection elements: An element which always responds with the same constant time delay on operation. Abbreviation of "Dead Time" in the context of auto-reclose:
DTD	Document Type Definition
DTOC	Definite Time Overcurrent
DTS	Date and Time Stamp
DVC	Direct Variable Cost
DZ	Abbreviation of "Dead Zone": Area between a CT and an open breaker or an open isolator.
EF or E/F	Earth Fault (directly equivalent to Ground Fault)
EIA	Electronic Industries Alliance
ELR	Environmental Lapse Rate
EMC	ElectroMagnetic Compatibility
ENA	Energy Networks Association
ER	Engineering Recommendation
ESD	ElectroStatic Discharge
FAA	Ageing Acceleration Factor: Used by Loss of Life (LOL) element
FFail	A field failure (loss of excitation) element: Could be labeled 40 in ANSI terminology.
FFT	Fast Fourier Transform

Term	Description
FIR	Finite Impulse Response
FLC	Full load current: The nominal rated current for the circuit.
FLT / Fit	Fault - typically used to indicate faulted phase selection.
Fn or FN	Function
FPGA	Field Programmable Gate Array
FPS	Frames Per Second
FTP	File Transfer Protocol or Foil Twisted Pair
FWD, Fwd or Fwd.	Indicates an element responding to a flow in the "Forward" direction
Gen Diff	A generator differential element: Could be labeled 87G in ANSI terminology.
Gen-Xformer Diff	A generator-transformer differential element: Could be labeled 87GT in ANSI terminology.
GI	General Interrogation
GIF	Graphic Interchange Format – a file format for a computer graphic
GN>	Neutral over conductance protection element: Real component of admittance calculation from neutral current and residual voltage.
GND / Gnd	Ground: used in distance settings to identify settings that relate to ground (earth) faults.
GoCB	GOOSE Control Block
GOOSE	Generic Object Oriented Substation Event
GPS	Global Positioning System
GRP / Grp	Group. Typically an alternative setting group.
GSE	General Substation Event
GSSE	Generic Substation Status Event
GUESS	Generator Unintentional Energization at StandStill.
GUI	Graphical User Interface
HMI	Human Machine Interface
HSR	High-Availability Seamless Ring or High Availability Seamless Redundancy
HTML	Hypertext Markup Language
I	Current
I/O	Input/Output
I/P	Input
IANA	Internet Assigned Numbers Authority
ICAO	International Civil Aviation Organization
ICD	IED Capability Description
ID	Identifier or Identification. Often a label used to track a software version installed.
IDMT	Inverse Definite Minimum Time. A characteristic whose trip time depends on the measured input (e.g. current) according to an inverse-time curve.
IEC	International Electro-technical Commission
IED	Intelligent Electronic Device - a term used to describe microprocessor-based controllers of power system equipment. Common types of IEDs include protective relaying devices, load tap changer controllers, circuit breaker controllers, capacitor bank switches, recloser controllers, voltage regulators, etc.

Term	Description
IEEE	Institute of Electrical and Electronics Engineers
IETF	Internet Engineering Task Force
IID	Instantiated/Individual IED Description
IIR	Infinite Impulse Response
IMU	Integrated MU
Inh	An Inhibit signal
Inst	An element with Instantaneous operation: i.e. having no deliberate time delay.
IP	Internet Protocol
IRIG	InterRange Instrumentation Group
ISA	International Standard Atmosphere
ISA	Instrumentation Systems and Automation Society
ISO	International Standards Organization
JPEF	Joint Photographic Experts Group – a file format for a computer graphic
L	Live
LAN	Local Area Network
LCB	Log Control Block
LCD	Liquid Crystal Display: The front-panel text display on the relay.
LD	Level Detector: An element responding to a current or voltage below its set threshold. or Logical Device
LDOV	Level Detector for OverVoltage
LDUV	Level Detector for UnderVoltage
LED	Light Emitting Diode: Red or green indicator on the front-panel.
LLDB	Live-Line Dead-Bus : In system synchronism check, indication that the line is energized whilst the bus is de-energized.
Ln	Natural logarithm
LN	Logical Node
LoL	A Loss of Load scheme, providing a fast distance trip without needing a signaling channel.
LPDU	Link Protocol Data Unit
LPHD	Logical Physical Device
LPIT	Low Power Instrument Transformers
MC	MultiCast
MCB	Miniature Circuit Breaker
MIB	Management Information Base
MICS	Model Implementation Conformance Statement
MIDOS	Modular Integrated DrawOut System
MMF	Magneto-Motive Force
MMS	Manufacturing Message Specification
MRP	Media Redundancy Protocol
MU	Merging Unit
MV	Measured Value
N	Neutral

Term	Description
N/A	Not Applicable
N/C	A Normally Closed or "break" contact: Often called a "form B" contact.
N/O	A Normally Open or "make" contact: Often called a "form A" contact.
NCIT	Non-Conventional Instrument Transformer
NERC	North American Reliability Corporation
NIC	Network Interface Card: i.e. the Ethernet card of the IED
NIST	National Institute of Standards and Technology
NPS	Negative Phase Sequence
NVD	Neutral Voltage Displacement: Equivalent to residual overvoltage protection.
NXT	Abbreviation of "Next": In connection with hotkey menu navigation.
°	A small circle on the input or output of a logic gate: Indicates a NOT (invert) function.
OC	Ordinary clock: A clock that has a single Precision Time Protocol (PTP) port in a domain and maintains the timescale used in the domain. It may serve as a source of time, i.e., be a master clock, or may synchronize to another clock, i.e., be a slave clock.
O/C	Overcurrent
O/P	Output
OCB	Oil Circuit Breaker
OID	Object IDentifier
Opto	An Optically coupled logic input. Alternative terminology: binary input.
OSI	Open Systems Interconnection
PCB	Printed Circuit Board
PCT	Protective Conductor Terminal (Ground)
PDC	Phasor Data Concentrator
Ph	Phase - used in distance settings to identify settings that relate to phase-phase faults.
PICS	Protocol Implementation Conformance Statement
PMU	Phasor Measurement Unit
PNG	Portable Network Graphics – a file format for a computer graphic
Pol	Polarize - typically the polarizing voltage used in making directional decisions.
POR	A Permissive OverReaching transfer trip scheme (alternative terminology: POTT).
PPS	Pulse Per Second
PRP	Parallel Redundancy Protocol
PSB	Power Swing Blocking, to detect power swing/out of step functions (ANSI 78).
PSL	Programmable Scheme Logic: The part of the relay's logic configuration that can be modified by the user, using the graphical editor within MiCOM S1 Studio software.
PSlip	A Pole slip (out of step - OOS) element: could be labeled 78 in ANSI terminology.
PT	Power Transformer
PTP	Precision Time Protocol
PUR	A Permissive UnderReaching transfer trip scheme (alternative terminology: PUTT).
Q	Quantity defined as per unit value
Qx	Isolator number x (from 1 to 6).
R	Resistance
R&TTE	Radio and Telecommunications Terminal Equipment

Term	Description
RBAC	Role Based Access Control
RBN	Lead burden for the neutral.
RBPh	Lead burden for the phases.
RCA	Relay Characteristic Angle - The center of the directional characteristic.
RCB	Report Control Block
REB	Redundant Ethernet Board
REF	Restricted Earth Fault
Rev.	Indicates an element responding to a flow in the "reverse" direction
RMS / rms	Root mean square. The equivalent a.c. current: Taking into account the fundamental, plus the equivalent heating effect of any harmonics.
RP	Rear Port: The communication ports on the rear of the IED
RS232	A common serial communications standard defined by the EIA
RS485	A common serial communications standard defined by the EIA (multi-drop)
RST or Rst	Reset generally used in the context of reset functions in circuit breaker control.
RSTP	Rapid Spanning Tree Protocol. Ethernet protocol allowing bumpless redundancy. Used with Redundant Ethernet board.
RTD	Resistance Temperature Device
RTU	Remote Terminal Unit
Rx	Receive: Typically used to indicate a communication transmit line/pin.
SBS	Straight Binary Second
SC	Synch-Check or system Synchronism Check.
SCADA	Supervisory Control and Data Acquisition
SCD	Substation Configuration Description
SCL	Substation Configuration Language. In IEC 61850, the definition of the configuration files.
SCSM	Specific Communication Service Mappings: In IEC 61850, the SCSMs define the actual information exchange mechanisms currently used (e.g. MMS).
SCU	Substation Control Unit
SDEF	Sensitive Differential Earth Fault Protection
SEF	Sensitive Earth Fault Protection
Sen	Sensitive
SGCB	Setting Group Control Block
SHM	Self-Healing Manager
SHP	Self Healing Protocol
SHR	Self Healing Ring: Ethernet protocol allowing bumpless redundancy. Used with Redundant Ethernet board with self-healing protocol.
SIED	Switch IED
SIR	Source Impedance Ratio
SLA	Service Level Agreement
SMV	Sampled Measured Values
SNTP	Simple Network Time Protocol

Term	Description
SOA	Service Oriented Architecture
SOAP	Simple Object Access Protocol
SOC	Second of Century
SOTF	Switch on to Fault protection. Modified protection on manual closure of the circuit breaker.
SP	Single pole.
SPAR	Single pole auto-reclose.
SPC	Single Point Controllable
SPDT	Single Pole Dead Time. The dead time used in single pole auto-reclose cycles.
SPS	Single Point Status
SQRT	Square Root
SSD	Solid State Device
SSL	Source Impedance Ratio
STP	Shielded Twisted Pair or Spanning Tree Protocol
SV	Sampled Values
SVC	Sampled Value Model
SVM	Sampled Value Model
TAF	Turbine Abnormal Frequency
TC	Transparent Clock: A device that measures the time taken for a Precision Time Protocol (PTP) event message to transit the device and provides this information to clocks receiving this PTP event message. See also: end-to-end transparent clock; peer-to-peer transparent clock.
TCP	Transmission Control Protocol
TCS	Second of Century
TCS	Trip Circuit Supervision
TD	Time Dial. The time dial multiplier setting: Applied to inverse-time curves (ANSI/IEEE).
TE	Unit for case measurements: One inch = 5TE units
THD	Total Harmonic Distortion
TICS	Technical Issues Conformance Statement
TIFF	Tagged Image File Format – a file format for a computer graphic
TLS	Transport Layer Security protocol
TMS	Time Multiplier Setting: Applied to inverse-time curves (IEC)
TOC	Trip On Close ("line check") protection. Offers SOTF and TOR functionality.
TOR	Trip On Reclose protection. Modified protection on autoreclosure of the circuit breaker.
TP	Two-Part
TS	Trip Supervision
TUC	Timed UnderCurrent
TVE	Total Vector Error
Tx	Transmit
UDP	User Datagram Protocol
UKCA	UK Type Examination regulation of the equipment
UL	Underwriters Laboratory
UPCT	User Programmable Curve Tool

Term	Description
UTC	Universal Time Coordinated
V	Voltage
VA	Phase A voltage: Sometimes L1, or red phase
VB	Phase B voltage: Sometimes L2, or yellow phase
VC	Phase C voltage: Sometimes L3, or blue phase
VCO	Voltage Controlled Overcurrent element
VDEP OC>	A voltage dependent overcurrent element: could be a voltage controlled or voltage restrained overcurrent element and could be labeled 51V in ANSI terminology.
VDR	Voltage Dependent Resistor
V/Hz	An overfluxing element, flux is proportional to voltage/frequency: could be labeled 24 in ANSI terminology.
VIP	Virtual Input
Vk	IEC knee point voltage of a current transformer.
VOP	Virtual Output
VT	Voltage Transformer
VTS	Voltage Transformer Supervision: To detect VT input failure.
WAN	Wide Area Network
Xformer	Transformer
XML	Extensible Markup Language
XSD	XML Schema Definition

Table 1 - Acronyms and abbreviations

2. COMPANY PROPRIETARY TERMS

Symbol	Description
Courier	Schneider Electric's proprietary SCADA communications protocol
Metrosil	Brand of non-linear resistor produced by M&I Materials Ltd.
MiCOM	Schneider Electric's brand of protection relays

Table 2 - Company-proprietary terms

3. ANSI TERMS

ANSI No.	Description
3PAR	Three pole auto-reclose.
3PDT	Three pole dead time. The dead time used in three pole auto-reclose cycles.
52a	A circuit breaker closed auxiliary contact: The contact is in the same state as the breaker primary contacts
52b	A circuit breaker open auxiliary contact: The contact is in the opposite state to the breaker primary contacts
64R	Rotor earth fault protection
64S	100% stator earth (ground) fault protection using a low frequency injection method.
89a	An Isolator closed auxiliary contact: The contact is in the same state as the breaker primary contacts.
89b	An Isolator open auxiliary contact: The contact is in the opposite state to the breaker primary contacts.

Table 3 - ANSI Abbreviations

ANSI No.	Function	Description
Current Protection Functions		
50/51	Phase overcurrent	Three-phase protection against overloads and phase-to-phase short-circuits.
50N/51N	Earth fault	Earth fault protection based on measured or calculated residual current values: <ul style="list-style-type: none"> • 50N/51N: residual current calculated or measured by 3 phase current sensors
50G/51G	Sensitive earth fault	Sensitive earth fault protection based on measured residual current values: <ul style="list-style-type: none"> • 50G/51G: residual current measured directly by a specific sensor such as a core balance CT
50BF	Breaker failure	If a breaker fails to be triggered by a tripping order, as detected by the non-extinction of the fault current, this backup protection sends a tripping order to the upstream or adjacent breakers.
46	Negative sequence / unbalance	Protection against phase unbalance, detected by the measurement of negative sequence current: <ul style="list-style-type: none"> • sensitive protection to detect 2-phase faults at the ends of long lines • protection of equipment against temperature build-up, caused by an unbalanced power supply, phase inversion or loss of phase, and against phase current unbalance
46BC	Broken conductor protection	Protection against phase imbalance, detected by measurement of I2/I1.
49RMS	Thermal overload	Protection against thermal damage caused by overloads on machines (transformers, motors or generators). The thermal capacity used is calculated according to a mathematical model which takes into account: <ul style="list-style-type: none"> • current RMS values • ambient temperature • negative sequence current, a cause of motor rotor temperature rise
Re-Closer		
79	Recloser	Automation device used to limit down time after tripping due to transient or semipermanent faults on overhead lines. The recloser orders automatic reclosing of the breaking device after the time delay required to restore the insulation has elapsed. Recloser operation is easy to adapt for different operating modes by parameter setting.

ANSI No.	Function	Description
Directional Current Protection		
67N/67NC type 1 and 67	Directional phase overcurrent	Phase-to-phase short-circuit protection, with selective tripping according to fault current direction. It comprises a phase overcurrent function associated with direction detection, and picks up if the phase overcurrent function in the chosen direction (line or busbar) is activated for at least one of the three phases.
67N/67NC	Directional earth fault	Earth fault protection, with selective tripping according to fault current direction. Three types of operation: <ul style="list-style-type: none"> • Type 1: the protection function uses the projection of the I0 vector • Type 2: the protection function uses the I0 vector magnitude with half-plane tripping zone • Type 3: the protection function uses the I0 vector magnitude with angular sector tripping zone
67N/67NC type 1	Directional current protection	Directional earth fault protection for impedant, isolated or compensated neutral systems, based on the projection of measured residual current.
67N/67NC type 2	Directional current protection	Directional overcurrent protection for impedance and solidly earthed systems, based on measured or calculated residual current. It comprises an earth fault function associated with direction detection, and picks up if the earth fault function in the chosen direction (line or busbar) is activated.
67N/67NC type 3	Directional current protection	Directional overcurrent protection for distribution networks in which the neutral earthing system varies according to the operating mode, based on measured residual current. It comprises an earth fault function associated with direction detection (angular sector tripping zone defined by 2 adjustable angles), and picks up if the earth fault function in the chosen direction (line or busbar) is activated.
Directional Power Protection Functions		
32P	Directional active overpower	Two-way protection based on calculated active power, for the following applications: <ul style="list-style-type: none"> • active overpower protection to detect overloads and allow load shedding • reverse active power protection: <ul style="list-style-type: none"> • against generators running like motors when the generators consume active power • against motors running like generators when the motors supply active power
32Q/40	Directional reactive overpower	Two-way protection based on calculated reactive power to detect field loss on synchronous machines: <ul style="list-style-type: none"> • reactive overpower protection for motors which consume more reactive power with field loss • reverse reactive overpower protection for generators which consume reactive power with field loss.
Machine Protection Functions		
37	Phase undercurrent	Protection of pumps against the consequences of a loss of priming by the detection of motor no-load operation. It is sensitive to a minimum of current in phase 1, remains stable during breaker tripping and may be inhibited by a logic input.
48/51LR/14	Locked rotor / excessive starting time	Protection of motors against overheating caused by: <ul style="list-style-type: none"> • excessive motor starting time due to overloads (e.g. conveyor) or insufficient supply voltage. The reacceleration of a motor that is not shut down, indicated by a logic input, may be considered as starting. • locked rotor due to motor load (e.g. crusher): <ul style="list-style-type: none"> • in normal operation, after a normal start • directly upon starting, before the detection of excessive starting time, with

ANSI No.	Function	Description
		detection of locked rotor by a zero speed detector connected to a logic input, or by the underspeed function.
66	Starts per hour	Protection against motor overheating caused by: <ul style="list-style-type: none"> • too frequent starts: motor energizing is inhibited when the maximum allowable number of starts is reached, after counting of: • starts per hour (or adjustable period) • consecutive motor hot or cold starts (reacceleration of a motor that is not shut down, indicated by a logic input, may be counted as a start) • starts too close together in time: motor re-energizing after a shutdown is only allowed after an adjustable waiting time.
50V/51V	Voltage-restrained overcurrent	Phase-to-phase short-circuit protection, for generators. The current tripping set point is voltage-adjusted in order to be sensitive to faults close to the generator which cause voltage drops and lowers the short-circuit current.
26/63	Thermostat / Buchholz	Protection of transformers against temperature rise and internal faults via logic inputs linked to devices integrated in the transformer.
38/49T	Temperature monitoring	Protection that detects abnormal temperature build-up by measuring the temperature inside equipment fitted with sensors: <ul style="list-style-type: none"> • transformer: protection of primary and secondary windings • motor and generator: protection of stator windings and bearings.
Voltage Protection Functions		
27D	Positive sequence undervoltage	Protection of motors against faulty operation due to insufficient or unbalanced network voltage, and detection of reverse rotation direction.
27R	Remanent undervoltage	Protection used to check that remanent voltage sustained by rotating machines has been cleared before allowing the busbar supplying the machines to be re-energized, to avoid electrical and mechanical transients.
27	Undervoltage	Protection of motors against voltage sags or detection of abnormally low network voltage to trigger automatic load shedding or source transfer. Works with phase-to-phase voltage.
59	Oversvoltage	Detection of abnormally high network voltage or checking for sufficient voltage to enable source transfer. Works with phase-to-phase or phase-to-neutral voltage, each voltage being monitored separately.
59N	Neutral voltage displacement	Detection of insulation faults by measuring residual voltage in isolated neutral systems.
47	Negative sequence overvoltage	Protection against phase unbalance resulting from phase inversion, unbalanced supply or distant fault, detected by the measurement of negative sequence voltage.
Frequency Protection Functions		
81O	Overfrequency	Detection of abnormally high frequency compared to the rated frequency, to monitor power supply quality. Other organizations may use 81H instead of 81O.
81U	Underfrequency	Detection of abnormally low frequency compared to the rated frequency, to monitor power supply quality. The protection may be used for overall tripping or load shedding. Protection stability is ensured in the event of the loss of the main source and presence of remanent voltage by a restraint in the event of a continuous decrease of the frequency, which is activated by parameter setting. Other organizations may use 81L instead of 81U.
81R	Rate of change of frequency	Protection function used for fast disconnection of a generator or load shedding control. Based on the calculation of the frequency variation, it is insensitive to transient voltage disturbances and therefore more stable than a phase-shift protection function.

ANSI No.	Function	Description
		<p>Disconnection In installations with autonomous production means connected to a utility, the “rate of change of frequency” protection function is used to detect loss of the main system in view of opening the incoming circuit breaker to:</p> <ul style="list-style-type: none"> • protect the generators from a reconnection without checking synchronization • avoid supplying loads outside the installation. <p>Load shedding The “rate of change of frequency” protection function is used for load shedding in combination with the underfrequency protection to:</p> <ul style="list-style-type: none"> • either accelerate shedding in the event of a large overload • or inhibit shedding following a sudden drop in frequency due to a problem that should not be solved by shedding.
Dynamic Line Rating (DLR) Protection Functions		
49DLR	Dynamic line rating (DLR)	<p>Protection of overhead lines based on calculation of rating or ampacity to dynamically take into account the effect of prevailing weather conditions as monitored by external sensors for:</p> <ul style="list-style-type: none"> • Ambient Temperature • Wind Velocity • Wind Direction • Solar Radiation

Table 4 - ANSI Descriptions

4. CONCATENATED TERMS

Term
Undercurrent
Overcurrent
Underfrequency
Overfrequency
Undervoltage
Overvoltage

Table 5 - Concatenated Terms

5. UNITS FOR DIGITAL COMMUNICATIONS

Unit	Description
b	bit
B	Byte
kB	Kilobit(s)
kbps	Kilobits per second
kB	Kilobyte(s)
Mb	Megabit(s)
Mbps	Megabits per second
MB	Megabyte(s)
Gb	Gigabit(s)
Gbps	Gigabits per second
GB	Gigabyte(s)
Tb	Terabit(s)
Tbps	Terabits per second
TB	Terabyte(s)

Table 6 - Units for Digital Communications

6. AMERICAN VS BRITISH ENGLISH TERMINOLOGY

British English	American English
...ae...	...e...
...ence	...ense
...ise	...ize
...oe...	...e...
...ogue	...og
...our	...or
...ourite	...orite
...que	...ck
...re	...er
...yse	...yze
Aluminium	Aluminum
Centre	Center
Earth	Ground
Fibre	Fiber
Ground	Earth
Speciality	Specialty

Table 7 - American vs British English terminology

7. LOGIC SYMBOLS AND TERMS

Symbol	Description	Units
&	Logical "AND": Used in logic diagrams to show an AND-gate function.	
Σ	"Sigma": Used to indicate a summation, such as cumulative current interrupted.	
τ	"Tau": Used to indicate a time constant, often associated with thermal characteristics.	
ω	System angular frequency	rad
<	Less than: Used to indicate an "under" threshold, such as undercurrent (current dropout).	
>	Greater than: Used to indicate an "over" threshold, such as overcurrent (current overload)	
o	A small circle on the input or output of a logic gate: Indicates a NOT (invert) function.	
1	Logical "OR": Used in logic diagrams to show an OR-gate function.	
ABC	Clockwise phase rotation.	
ACB	Anti-Clockwise phase rotation.	
C	Capacitance	A
df/dt	Rate of Change of Frequency protection	Hz/s
df/dt>1	First stage of df/dt protection	Hz/s
F<	Underfrequency protection: Could be labeled 81-U in ANSI terminology.	Hz
F>	Overfrequency protection: Could be labeled 81-O in ANSI terminology.	Hz
F<1	First stage of under frequency protection: Could be labeled 81-U in ANSI terminology.	Hz
F>1	First stage of over frequency protection: Could be labeled 81-O in ANSI terminology.	Hz
f _{max}	Maximum required operating frequency	Hz
f _{min}	Minimum required operating frequency	Hz
f _n	Nominal operating frequency	Hz
I	Current	A
I [^]	Current raised to a power: Such as when breaker statistics monitor the square of ruptured current squared (^ power = 2).	An
I ^{'f}	Maximum internal secondary fault current (may also be expressed as a multiple of I _n)	A
I<	An undercurrent element: Responds to current dropout.	A
I>>	Current setting of short circuit element	In
I>	A phase overcurrent protection: Could be labeled 50/51 in ANSI terminology.	A
I>1	First stage of phase overcurrent protection: Could be labeled 51-1 in ANSI terminology.	A
I>2	Second stage of phase overcurrent protection: Could be labeled 51-2 in ANSI terminology.	A
I>3	Third stage of phase overcurrent protection: Could be labeled 51-3 in ANSI terminology.	A
I>4	Fourth stage of phase overcurrent protection: Could be labeled 51-4 in ANSI terminology.	A
I>BB	Minimum pick-up phase threshold for the local trip order confirmation.	A
I>DZ	Minimum pick-up phase threshold for the Dead Zone protection.	A
I ₀	Earth fault current setting Zero sequence current: Equals one third of the measured neutral/residual current.	A
I ₁	Positive sequence current.	A
I ₂	Negative sequence current.	A
I ₂ >	Negative sequence overcurrent protection (NPS element).	A
I _{2pol}	Negative sequence polarizing current.	A

Symbol	Description	Units
I2therm>	A negative sequence thermal element: Could be labeled 46T in ANSI terminology.	A
IA	Phase A current: Might be phase L1, red phase.. or other, in customer terminology.	A
IB	Phase B current: Might be phase L2, yellow phase.. or other, in customer terminology.	A
IbiasPh> Cur.	SDEF blocking bias current threshold.	
IC	Phase C current: Might be phase L3, blue phase.. or other, in customer terminology.	A
ID>1	Minimum pick-up phase circuitry fault threshold.	
ID>2	Minimum pick-up differential phase element for all the zones.	
IDCZ>2	Minimum pick-up differential phase element for the Check Zone.	
Idiff	Current setting of biased differential element	A
IDN>1	Minimum pick-up neutral circuitry fault threshold.	
IDN>2	Minimum pick-up differential neutral element for all the zones.	
IDNCZ>2	Minimum pick-up differential neutral element for the Check Zone.	
IDZ	Minimum pick-up differential neutral element for the Check Zone.	
If	Maximum secondary through-fault current	A
If max	Maximum secondary fault current (same for all feeders)	A
If max int	Maximum secondary contribution from a feeder to an internal fault	A
If Z1	Maximum secondary phase fault current at Zone 1 reach point	A
Ife	Maximum secondary through fault earth current	A
IfeZ1	Maximum secondary earth fault current at Zone 1 reach point	A
Ifn	Maximum prospective secondary earth fault current or $31 \times I >$ setting (whichever is lowest)	A
Ifp	Maximum prospective secondary phase fault current or $31 \times I >$ setting (whichever is lowest)	A
Im	Mutual current	A
IM64	InterMiCOM64.	
IMx	InterMiCOM64 bit (x=1 to 16)	
In	Current transformer nominal secondary current. The rated nominal current of the relay: Software selectable as 1 amp or 5 amp to match the line CT input.	A
IN	Neutral current, or residual current: This results from an internal summation of the three measured phase currents.	A
IN>	A neutral (residual) overcurrent element: Detects earth/ground faults.	A
IN>1	First stage of ground overcurrent protection: Could be labeled 51N-1 in ANSI terminology.	A
IN>2	Second stage of ground overcurrent protection: Could be labeled 51N-2 in ANSI terminology.	A
IN>BB	Minimum pick-up neutral threshold for the local trip order confirmation.	
IN>DZ	Minimum pick-up neutral threshold for the Dead Zone protection.	
Inst	An element with "instantaneous" operation: i.e. having no deliberate time delay.	
I/O	Inputs and Outputs - used in connection with the number of optocoupled inputs and output contacts within the relay.	
I/P	Input	
Iref	Reference current of P63x calculated from the reference power and nominal voltage	A
IREF>	A Restricted Earth Fault overcurrent element: Detects earth (ground) faults. Could be labeled 64 in ANSI terminology.	A

Symbol	Description	Units
IRm2	Second knee-point bias current threshold setting of P63x biased differential element	A
Is	Value of stabilizing current	A
IS1	Differential current pick-up setting of biased differential element	A
IS2	Bias current threshold setting of biased differential element	A
ISEF>	Sensitive Earth Fault overcurrent element.	A
Isn	Rated secondary current (I secondary nominal)	A
Isp	Stage 2 and 3 setting	A
Ist	Motor start up current referred to CT secondary side	A
K	Dimensioning factor	
K1	Lower bias slope setting of biased differential element	%
K2	Higher bias slope setting of biased differential element	%
KCZ	Slope of the differential phase element for the Check Zone.	
Ke	Dimensioning factor for earth fault	
km	Distance in kilometers	
Kmax	Maximum dimensioning factor	
KNCZ	Slope of the differential neutral element for the Check Zone.	
Krpa	Dimensioning factor for reach point accuracy	
Ks	Dimensioning factor dependent upon through fault current	
Kssc	Rated symmetrical short-circuit current factor or ALF	
Kt	Dimensioning factor dependent upon operating time	
kZm	The mutual compensation factor (mutual compensation of distance elements and fault locator for parallel line coupling effects).	
kZN	The residual compensation factor: Ensuring correct reach for ground distance elements.	
L	Inductance A	A
m1	Lower bias slope setting of P63x biased differential element	None
m2	Higher bias slope setting of P63x biased differential element	None
mi	Distance in miles.	
N	Indication of "Neutral" involvement in a fault: i.e. a ground (earth) fault.	
-P>	A reverse power (W) element: could be labeled 32R in ANSI terminology.	
P>	An overpower (W) element: could be labeled 32O in ANSI terminology.	
P<	A low forward power (W) element: could be labeled 32L in ANSI terminology.	
P1	Used in IEC terminology to identify the primary CT terminal polarity: Replace by a dot when using ANSI standards.	
P2	Used in IEC terminology to identify the primary CT terminal polarity: The non-dot terminal.	
Pn	Rotating plant rated single phase power W	W
PN>	Wattmetric earth fault protection: Calculated using residual voltage and current quantities.	
Q<	A reactive under power (VAr) element	
R	Resistance (Ohms)	Ohms
R< or 64S R<	A 100% stator earth (ground) fault via low frequency injection under resistance element: could be labeled 64S in ANSI terminology.	
R Gnd.	A distance zone resistive reach setting: Used for ground (earth) faults.	
R Ph	A distance zone resistive reach setting used for Phase-Phase faults.	

Symbol	Description	Units
Rct	Secondary winding resistance	Ω
RCT	Current transformer secondary resistance	Ohms
RI	Resistance of single lead from relay to current transformer	Ohms
Rr	Resistance of any other protective relays sharing the current transformer	Ohms
Rm	Resistance of relay neutral current input	Ohms
Rrp	Resistance of relay phase current input	Ohms
Rs	Value of stabilizing resistor	Ohms
Rx	Receive: typically used to indicate a communication receive line/pin.	
S<	An apparent under power (VA) element	
S1	Used in IEC terminology to identify the secondary CT terminal polarity: Replace by a dot when using ANSI standards.	
S2	Used in IEC terminology to identify the secondary CT terminal polarity: The non-dot terminal. Also used to signify negative sequence apparent power, $S2 = V2 \times I2$.	
S2>	A negative sequence apparent power element, $S2 = V2 \times I2$.	
t	A time delay.	
t'	Duration of first current flow during auto-reclose cycle	s
T1	Primary system time constant	s
TF	Through Fault monitoring	
tfr	Auto-reclose dead time	s
Thermal I>	A stator thermal overload element: could be labeled 49 in ANSI terminology.	
Thru/TF	Through Fault monitoring	
tldiff	Current differential operating time s	s
Ts	Secondary system time constant s	s
Tx	Transmit: typically used to indicate a communication transmit line/pin.	
V	Voltage	V
V<	An undervoltage element: could be labeled 27 in ANSI terminology	V
V<1	First stage of undervoltage protection: Could be labeled 27-1 in ANSI terminology.	V
V<2	Second stage of undervoltage protection: Could be labeled 27-2 in ANSI terminology.	V
V<3	Third stage of undervoltage protection: Could be labeled 27-3 in ANSI terminology.	V
V>	An overvoltage element: could be labeled 59 in ANSI terminology	V
V>1	First stage of overvoltage protection: Could be labeled 59-1 in ANSI terminology.	V
V>2	Second stage of overvoltage protection: Could be labeled 59-2 in ANSI terminology.	V
V>3	Third stage of overvoltage protection: Could be labeled 59-3 in ANSI terminology.	V
V0	Zero sequence voltage: Equals one third of the measured neutral/residual voltage.	V
V1	Positive sequence voltage.	V
V2	Negative sequence voltage.	V
V2>	A negative phase sequence (NPS) overvoltage element: could be labeled 47 in ANSI terminology.	
V2pol	Negative sequence polarizing voltage.	V
VA	Phase A voltage: Might be phase L1, red phase.. or other, in customer terminology. V	V
VB	Phase B voltage: Might be phase L2, yellow phase.. or other, in customer terminology. V	V
VC	Phase C voltage: Might be phase L3, blue phase.. or other, in customer terminology.	V

Symbol	Description	Units
Vf	Theoretical maximum voltage produced if CT saturation did not occur	V
Vin	Input voltage e.g. to an opto-input	V
Vk	Required CT knee-point voltage. IEC knee point voltage of a current transformer.	V
VN	Neutral voltage displacement, or residual voltage.	V
VN>	A residual (neutral) overvoltage element: could be labeled 59N in ANSI terminology.	V
Vn	Nominal voltage	V
Vn	The rated nominal voltage of the relay: To match the line VT input.	V
VN>1	First stage of residual (neutral) overvoltage protection.	V
VN>2	Second stage of residual (neutral) overvoltage protection.	V
VN>3	Third stage of residual (neutral) overvoltage protection.	V
VN3H>	A 100% stator earth (ground) fault 3rd harmonic residual (neutral) overvoltage element: could be labeled 59TN in ANSI terminology.	
VN3H<	A 100% stator earth (ground) fault 3rd harmonic residual (neutral) undervoltage element: could be labeled 27TN in ANSI terminology.	
Vres.	Neutral voltage displacement, or residual voltage.	V
Vs	Value of stabilizing voltage	V
Vx	An auxiliary supply voltage: Typically the substation battery voltage used to power the relay.	V
WI	Weak Infeed logic used in teleprotection schemes.	
X	Reactance	None
X/R	Primary system reactance/resistance ratio	None
Xe/Re	Primary system reactance/resistance ratio for earth loop	None
Xt	Transformer reactance (per unit)	p.u.
Y	Admittance	p.u.
YN>	Neutral overadmittance protection element: Non-directional neutral admittance protection calculated from neutral current and residual voltage.	
Z	Impedance	p.u.
Z<	An under impedance element: could be labeled 21 in ANSI terminology.	
Z0	Zero sequence impedance.	
Z1	Positive sequence impedance.	
Z1	Zone 1 distance protection.	
Z1X	Reach-stepped Zone 1X, for zone extension schemes used with auto-reclosure.	
Z2	Negative sequence impedance.	
Z2	Zone 2 distance protection.	
ZP	Programmable distance zone that can be set forward or reverse looking.	
Zs	Used to signify the source impedance behind the relay location.	
Φal	Accuracy limit flux	Wb
Ψr	Remanent flux	Wb
Ψs	Saturation flux	Wb

Table 8 - Logic Symbols and Terms

8. LOGIC TIMERS

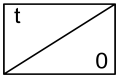
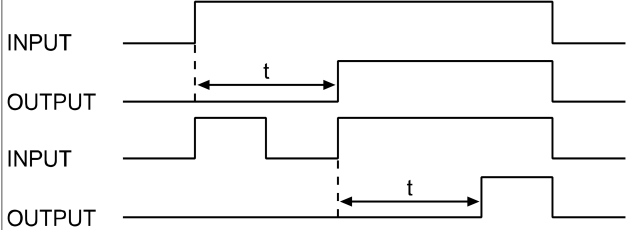
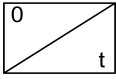
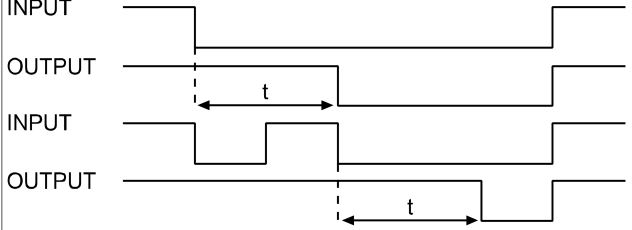
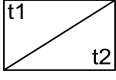
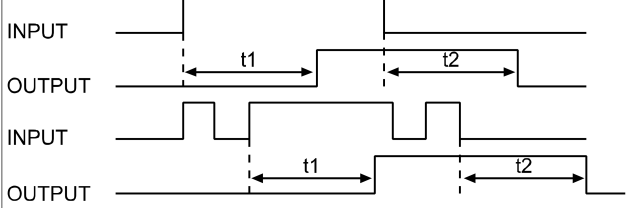
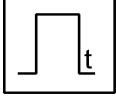
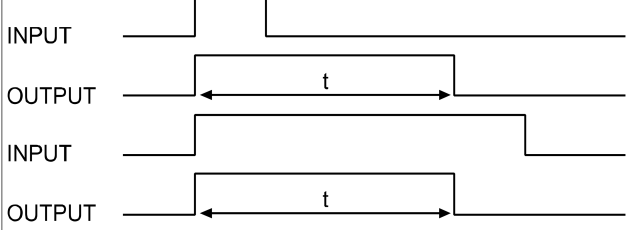
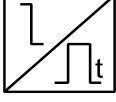
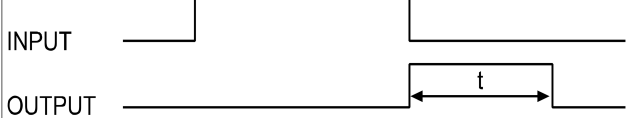
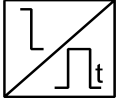
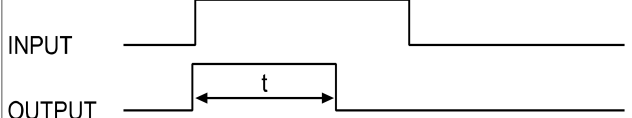
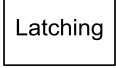
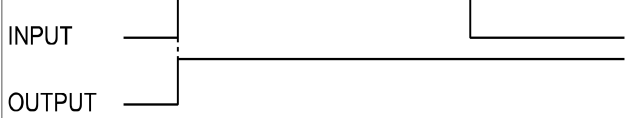
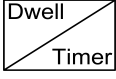
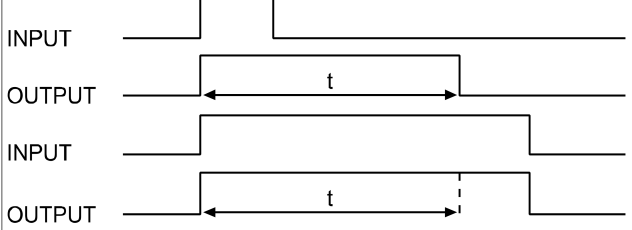
Logic symbols	Explanation	Time Chart
	Delay in pick-up timer, t	<p>INPUT</p>  <p>OUTPUT</p>
	Delay on drop-off timer, t	<p>INPUT</p>  <p>OUTPUT</p>
	Delay on pick-up/drop-off timer	<p>INPUT</p>  <p>OUTPUT</p>
	Pulse timer	<p>INPUT</p>  <p>OUTPUT</p>
	Pulse pick-up falling edge	<p>INPUT</p>  <p>OUTPUT</p>
	Pulse pick-up raising edge	<p>INPUT</p>  <p>OUTPUT</p>
	Latch	<p>INPUT</p>  <p>OUTPUT</p>
	Dwell timer	<p>INPUT</p>  <p>OUTPUT</p>



Logic symbols	Explanation	Time Chart
	Straight (non latching): Hold value until input reset signal	

Table 9 - Logic Timers

9. LOGIC GATES

AND GATE																																																											
Symbol	Truth Table	Symbol	Truth Table	Symbol	Truth Table																																																						
	<table border="1" style="margin: auto;"> <thead> <tr> <th colspan="2">IN</th> <th>OUT</th> </tr> <tr> <th>A</th> <th>B</th> <th>Y</th> </tr> </thead> <tbody> <tr><td>0</td><td>0</td><td>0</td></tr> <tr><td>0</td><td>1</td><td>0</td></tr> <tr><td>1</td><td>0</td><td>0</td></tr> <tr><td>1</td><td>1</td><td>1</td></tr> </tbody> </table>	IN		OUT	A	B	Y	0	0	0	0	1	0	1	0	0	1	1	1		<table border="1" style="margin: auto;"> <thead> <tr> <th colspan="2">IN</th> <th>OUT</th> </tr> <tr> <th>A</th> <th>B</th> <th>Y</th> </tr> </thead> <tbody> <tr><td>0</td><td>0</td><td>0</td></tr> <tr><td>0</td><td>1</td><td>1</td></tr> <tr><td>1</td><td>0</td><td>0</td></tr> <tr><td>1</td><td>1</td><td>0</td></tr> </tbody> </table>	IN		OUT	A	B	Y	0	0	0	0	1	1	1	0	0	1	1	0		<table border="1" style="margin: auto;"> <thead> <tr> <th colspan="2">IN</th> <th>OUT</th> </tr> <tr> <th>A</th> <th>B</th> <th>Y</th> </tr> </thead> <tbody> <tr><td>0</td><td>0</td><td>1</td></tr> <tr><td>0</td><td>1</td><td>1</td></tr> <tr><td>1</td><td>0</td><td>1</td></tr> <tr><td>1</td><td>1</td><td>0</td></tr> </tbody> </table>	IN		OUT	A	B	Y	0	0	1	0	1	1	1	0	1	1	1	0
IN		OUT																																																									
A	B	Y																																																									
0	0	0																																																									
0	1	0																																																									
1	0	0																																																									
1	1	1																																																									
IN		OUT																																																									
A	B	Y																																																									
0	0	0																																																									
0	1	1																																																									
1	0	0																																																									
1	1	0																																																									
IN		OUT																																																									
A	B	Y																																																									
0	0	1																																																									
0	1	1																																																									
1	0	1																																																									
1	1	0																																																									

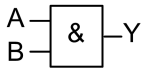
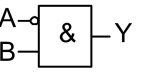
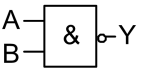

P4424ENb

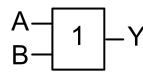
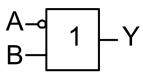
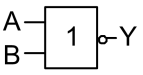
Figure 1 - Logic Gates - AND Gate

OR GATE																																																											
Symbol	Truth Table	Symbol	Truth Table	Symbol	Truth Table																																																						
	<table border="1" style="margin: auto;"> <thead> <tr> <th colspan="2">IN</th> <th>OUT</th> </tr> <tr> <th>A</th> <th>B</th> <th>Y</th> </tr> </thead> <tbody> <tr><td>0</td><td>0</td><td>0</td></tr> <tr><td>0</td><td>1</td><td>1</td></tr> <tr><td>1</td><td>0</td><td>1</td></tr> <tr><td>1</td><td>1</td><td>1</td></tr> </tbody> </table>	IN		OUT	A	B	Y	0	0	0	0	1	1	1	0	1	1	1	1		<table border="1" style="margin: auto;"> <thead> <tr> <th colspan="2">IN</th> <th>OUT</th> </tr> <tr> <th>A</th> <th>B</th> <th>Y</th> </tr> </thead> <tbody> <tr><td>0</td><td>0</td><td>1</td></tr> <tr><td>0</td><td>1</td><td>1</td></tr> <tr><td>1</td><td>0</td><td>0</td></tr> <tr><td>1</td><td>1</td><td>1</td></tr> </tbody> </table>	IN		OUT	A	B	Y	0	0	1	0	1	1	1	0	0	1	1	1		<table border="1" style="margin: auto;"> <thead> <tr> <th colspan="2">IN</th> <th>OUT</th> </tr> <tr> <th>A</th> <th>B</th> <th>Y</th> </tr> </thead> <tbody> <tr><td>0</td><td>0</td><td>1</td></tr> <tr><td>0</td><td>1</td><td>0</td></tr> <tr><td>1</td><td>0</td><td>0</td></tr> <tr><td>1</td><td>1</td><td>0</td></tr> </tbody> </table>	IN		OUT	A	B	Y	0	0	1	0	1	0	1	0	0	1	1	0
IN		OUT																																																									
A	B	Y																																																									
0	0	0																																																									
0	1	1																																																									
1	0	1																																																									
1	1	1																																																									
IN		OUT																																																									
A	B	Y																																																									
0	0	1																																																									
0	1	1																																																									
1	0	0																																																									
1	1	1																																																									
IN		OUT																																																									
A	B	Y																																																									
0	0	1																																																									
0	1	0																																																									
1	0	0																																																									
1	1	0																																																									

P4424ENc

Figure 2 - Logic Gates - OR Gate

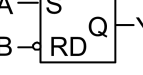
R – S FLIP-FLOP																																																																																																									
Symbol	Truth Table	Symbol	Truth Table	Symbol	Truth Table																																																																																																				
	<table border="1" style="margin: auto;"> <thead> <tr> <th>A</th> <th>B</th> <th>QN</th> <th>QN+</th> <th>Active Mode</th> </tr> </thead> <tbody> <tr><td>0</td><td>0</td><td></td><td></td><td>Hold Mode</td></tr> <tr><td>0</td><td>1</td><td>0</td><td></td><td>Hold Mode</td></tr> <tr><td></td><td>1</td><td>0</td><td>Reset</td><td>Reset</td></tr> <tr><td></td><td>0</td><td>1</td><td>Set</td><td>Set</td></tr> <tr><td>1</td><td>0</td><td>1</td><td></td><td>Hold Mode</td></tr> <tr><td>0</td><td>0</td><td>-</td><td>-</td><td>Inhibit Mode</td></tr> </tbody> </table>	A	B	QN	QN+	Active Mode	0	0			Hold Mode	0	1	0		Hold Mode		1	0	Reset	Reset		0	1	Set	Set	1	0	1		Hold Mode	0	0	-	-	Inhibit Mode		<table border="1" style="margin: auto;"> <thead> <tr> <th>A</th> <th>B</th> <th>QN</th> <th>QN+</th> <th>Active Mode</th> </tr> </thead> <tbody> <tr><td>0</td><td>0</td><td>0</td><td></td><td>Hold Mode</td></tr> <tr><td></td><td>1</td><td>0</td><td>Reset</td><td>Reset</td></tr> <tr><td>0</td><td>1</td><td></td><td></td><td>Hold Mode</td></tr> <tr><td>1</td><td>0</td><td>-</td><td>-</td><td>Inhibit Mode</td></tr> <tr><td></td><td>0</td><td>1</td><td>Set</td><td>Set</td></tr> <tr><td>0</td><td>1</td><td>1</td><td></td><td>Hold Mode</td></tr> </tbody> </table>	A	B	QN	QN+	Active Mode	0	0	0		Hold Mode		1	0	Reset	Reset	0	1			Hold Mode	1	0	-	-	Inhibit Mode		0	1	Set	Set	0	1	1		Hold Mode		<table border="1" style="margin: auto;"> <thead> <tr> <th>A</th> <th>B</th> <th>QN</th> <th>QN+</th> <th>Active Mode</th> </tr> </thead> <tbody> <tr><td>0</td><td>0</td><td></td><td></td><td>Hold Mode</td></tr> <tr><td>0</td><td>1</td><td></td><td></td><td>0</td></tr> <tr><td></td><td>0</td><td>1</td><td>Set</td><td>Set</td></tr> <tr><td>1</td><td>0</td><td>1</td><td></td><td>Hold Mode</td></tr> <tr><td>1</td><td>1</td><td></td><td></td><td>0</td></tr> </tbody> </table> <p style="font-size: small;">* RD = Reset Dominant</p>	A	B	QN	QN+	Active Mode	0	0			Hold Mode	0	1			0		0	1	Set	Set	1	0	1		Hold Mode	1	1			0
A	B	QN	QN+	Active Mode																																																																																																					
0	0			Hold Mode																																																																																																					
0	1	0		Hold Mode																																																																																																					
	1	0	Reset	Reset																																																																																																					
	0	1	Set	Set																																																																																																					
1	0	1		Hold Mode																																																																																																					
0	0	-	-	Inhibit Mode																																																																																																					
A	B	QN	QN+	Active Mode																																																																																																					
0	0	0		Hold Mode																																																																																																					
	1	0	Reset	Reset																																																																																																					
0	1			Hold Mode																																																																																																					
1	0	-	-	Inhibit Mode																																																																																																					
	0	1	Set	Set																																																																																																					
0	1	1		Hold Mode																																																																																																					
A	B	QN	QN+	Active Mode																																																																																																					
0	0			Hold Mode																																																																																																					
0	1			0																																																																																																					
	0	1	Set	Set																																																																																																					
1	0	1		Hold Mode																																																																																																					
1	1			0																																																																																																					

P4424ENd

Figure 3 - Logic Gates - R-S Flip-Flop Gate

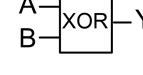
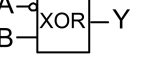
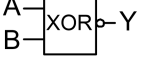
EXCLUSIVE OR GATE																																																											
Symbol	Truth Table	Symbol	Truth Table	Symbol	Truth Table																																																						
	<table border="1" style="margin: auto;"> <thead> <tr> <th colspan="2">IN</th> <th>OUT</th> </tr> <tr> <th>A</th> <th>B</th> <th>Y</th> </tr> </thead> <tbody> <tr><td>0</td><td>0</td><td>0</td></tr> <tr><td>0</td><td>1</td><td>1</td></tr> <tr><td>1</td><td>0</td><td>1</td></tr> <tr><td>1</td><td>1</td><td>0</td></tr> </tbody> </table>	IN		OUT	A	B	Y	0	0	0	0	1	1	1	0	1	1	1	0		<table border="1" style="margin: auto;"> <thead> <tr> <th colspan="2">IN</th> <th>OUT</th> </tr> <tr> <th>A</th> <th>B</th> <th>Y</th> </tr> </thead> <tbody> <tr><td>0</td><td>0</td><td>1</td></tr> <tr><td>0</td><td>1</td><td>1</td></tr> <tr><td>1</td><td>0</td><td>0</td></tr> <tr><td>1</td><td>1</td><td>1</td></tr> </tbody> </table>	IN		OUT	A	B	Y	0	0	1	0	1	1	1	0	0	1	1	1		<table border="1" style="margin: auto;"> <thead> <tr> <th colspan="2">IN</th> <th>OUT</th> </tr> <tr> <th>A</th> <th>B</th> <th>Y</th> </tr> </thead> <tbody> <tr><td>0</td><td>0</td><td>1</td></tr> <tr><td>0</td><td>1</td><td>0</td></tr> <tr><td>1</td><td>0</td><td>0</td></tr> <tr><td>1</td><td>1</td><td>1</td></tr> </tbody> </table>	IN		OUT	A	B	Y	0	0	1	0	1	0	1	0	0	1	1	1
IN		OUT																																																									
A	B	Y																																																									
0	0	0																																																									
0	1	1																																																									
1	0	1																																																									
1	1	0																																																									
IN		OUT																																																									
A	B	Y																																																									
0	0	1																																																									
0	1	1																																																									
1	0	0																																																									
1	1	1																																																									
IN		OUT																																																									
A	B	Y																																																									
0	0	1																																																									
0	1	0																																																									
1	0	0																																																									
1	1	1																																																									

P4424ENe

Figure 4 - Logic Gates - Exclusive OR Gate

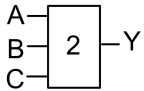
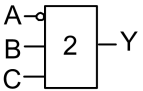
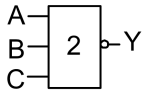
PROGRAMMABLE GATE																																																																																																																													
Symbol	Truth Table	Symbol	Truth Table	Symbol	Truth Table																																																																																																																								
	<table border="1" style="margin-left: auto; margin-right: auto;"> <thead> <tr> <th colspan="3">IN</th> <th>OUT</th> </tr> <tr> <th>A</th> <th>B</th> <th>C</th> <th>Y</th> </tr> </thead> <tbody> <tr><td>0</td><td>0</td><td>0</td><td>0</td></tr> <tr><td>0</td><td>0</td><td>1</td><td>0</td></tr> <tr><td>0</td><td>1</td><td>0</td><td>0</td></tr> <tr><td>0</td><td>1</td><td>1</td><td>1</td></tr> <tr><td>1</td><td>0</td><td>0</td><td>0</td></tr> <tr><td>1</td><td>0</td><td>1</td><td>1</td></tr> <tr><td>1</td><td>1</td><td>0</td><td>1</td></tr> <tr><td>1</td><td>1</td><td>1</td><td>1</td></tr> </tbody> </table>	IN			OUT	A	B	C	Y	0	0	0	0	0	0	1	0	0	1	0	0	0	1	1	1	1	0	0	0	1	0	1	1	1	1	0	1	1	1	1	1		<table border="1" style="margin-left: auto; margin-right: auto;"> <thead> <tr> <th colspan="3">IN</th> <th>OUT</th> </tr> <tr> <th>A</th> <th>B</th> <th>C</th> <th>Y</th> </tr> </thead> <tbody> <tr><td>0</td><td>0</td><td>0</td><td>0</td></tr> <tr><td>0</td><td>0</td><td>1</td><td>1</td></tr> <tr><td>0</td><td>1</td><td>0</td><td>1</td></tr> <tr><td>0</td><td>1</td><td>1</td><td>1</td></tr> <tr><td>1</td><td>0</td><td>0</td><td>0</td></tr> <tr><td>1</td><td>0</td><td>1</td><td>0</td></tr> <tr><td>1</td><td>1</td><td>0</td><td>0</td></tr> <tr><td>1</td><td>1</td><td>1</td><td>1</td></tr> </tbody> </table>	IN			OUT	A	B	C	Y	0	0	0	0	0	0	1	1	0	1	0	1	0	1	1	1	1	0	0	0	1	0	1	0	1	1	0	0	1	1	1	1		<table border="1" style="margin-left: auto; margin-right: auto;"> <thead> <tr> <th colspan="3">IN</th> <th>OUT</th> </tr> <tr> <th>A</th> <th>B</th> <th>C</th> <th>Y</th> </tr> </thead> <tbody> <tr><td>0</td><td>0</td><td>0</td><td>1</td></tr> <tr><td>0</td><td>0</td><td>1</td><td>1</td></tr> <tr><td>0</td><td>1</td><td>0</td><td>1</td></tr> <tr><td>0</td><td>1</td><td>1</td><td>0</td></tr> <tr><td>1</td><td>0</td><td>0</td><td>1</td></tr> <tr><td>1</td><td>0</td><td>1</td><td>0</td></tr> <tr><td>1</td><td>1</td><td>0</td><td>0</td></tr> <tr><td>1</td><td>1</td><td>1</td><td>0</td></tr> </tbody> </table>	IN			OUT	A	B	C	Y	0	0	0	1	0	0	1	1	0	1	0	1	0	1	1	0	1	0	0	1	1	0	1	0	1	1	0	0	1	1	1	0
IN			OUT																																																																																																																										
A	B	C	Y																																																																																																																										
0	0	0	0																																																																																																																										
0	0	1	0																																																																																																																										
0	1	0	0																																																																																																																										
0	1	1	1																																																																																																																										
1	0	0	0																																																																																																																										
1	0	1	1																																																																																																																										
1	1	0	1																																																																																																																										
1	1	1	1																																																																																																																										
IN			OUT																																																																																																																										
A	B	C	Y																																																																																																																										
0	0	0	0																																																																																																																										
0	0	1	1																																																																																																																										
0	1	0	1																																																																																																																										
0	1	1	1																																																																																																																										
1	0	0	0																																																																																																																										
1	0	1	0																																																																																																																										
1	1	0	0																																																																																																																										
1	1	1	1																																																																																																																										
IN			OUT																																																																																																																										
A	B	C	Y																																																																																																																										
0	0	0	1																																																																																																																										
0	0	1	1																																																																																																																										
0	1	0	1																																																																																																																										
0	1	1	0																																																																																																																										
1	0	0	1																																																																																																																										
1	0	1	0																																																																																																																										
1	1	0	0																																																																																																																										
1	1	1	0																																																																																																																										

P4424ENf

Figure 5 - Logic Gates - Programmable Gate

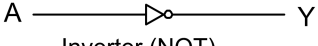
NOT GATE									
Symbol	Truth Table								
 <p>Inverter (NOT)</p>	<table border="1" style="margin-left: auto; margin-right: auto;"> <thead> <tr> <th>IN</th> <th>OUT</th> </tr> <tr> <th>A</th> <th>Y</th> </tr> </thead> <tbody> <tr><td>0</td><td>1</td></tr> <tr><td>1</td><td>0</td></tr> </tbody> </table>	IN	OUT	A	Y	0	1	1	0
IN	OUT								
A	Y								
0	1								
1	0								

P4424ENg

Figure 6 - Logic Gates - NOT Gate



Customer Care Centre

<http://www.se.com/cc>

Schneider Electric

35 rue Joseph Monier
92506 Rueil-Malmaison
FRANCE

Phone: +33 (0) 1 41 29 70 00

Fax: +33 (0) 1 41 29 71 00

www.se.com

Publisher: Schneider Electric

**Publication: Easergy MiCOM P445/EN M/Og2 Fast Multifunction Distance Protection Relay Software Version: K6
Hardware Suffix: L**

02/2024